

Ballantine



MODEL

5500B

AUTOMETRONIC
COUNTER-TIMER

INSTRUCTION MANUAL

MODEL

5500B

AUTOMETRONIC

COUNTER-TIMER

Includes revisions A/90100975A July 1977
Includes revisions for Serial No. Prefix 020- Nov 1977
Includes OPTION 35 & 35A Prescaler addendum

Ballantine Laboratories, Inc. • P. O. Box 97 • Boonton, New Jersey 07005 U.S.A.
Telephone: 201-335-0900 • TWX: 710-987-8380

WARRANTY

This Ballantine Laboratories, Inc. product is warranted against defects in materials and workmanship for a period of one year from the date of shipment, except for batteries, electron tubes, vacuum thermocouples, and certain other components, if any, listed in this manual. Ballantine Laboratories, Inc. will, at its option, repair or replace products which prove to be defective during the warranty period provided they are returned to Ballantine Laboratories, Inc. prepaid, and provided the proper preventive maintenance and calibration procedures as listed in this manual are followed. Repairs necessitated by misuse of the product are not covered by this warranty. NO OTHER WARRANTIES ARE EXPRESSED OR IMPLIED, INCLUDING BUT NOT LIMITED TO THE IMPLIED WARRANTIES OF MERCHANTABILITY AND FITNESS FOR A PARTICULAR PURPOSE. BALLANTINE LABORATORIES, INC. IS NOT LIABLE FOR CONSEQUENTIAL DAMAGES.

CERTIFICATION

Ballantine Laboratories, Inc. certifies that this equipment meets all applicable Ballantine specifications at time of shipment as determined by thorough testing and inspection. Ballantine further certifies that its measurements are traceable to the United States National Bureau of Standards. All instruments used in calibrating Ballantine products are standardized by systematic reference to NBS-traceable standards as described in the validation procedures shown below.

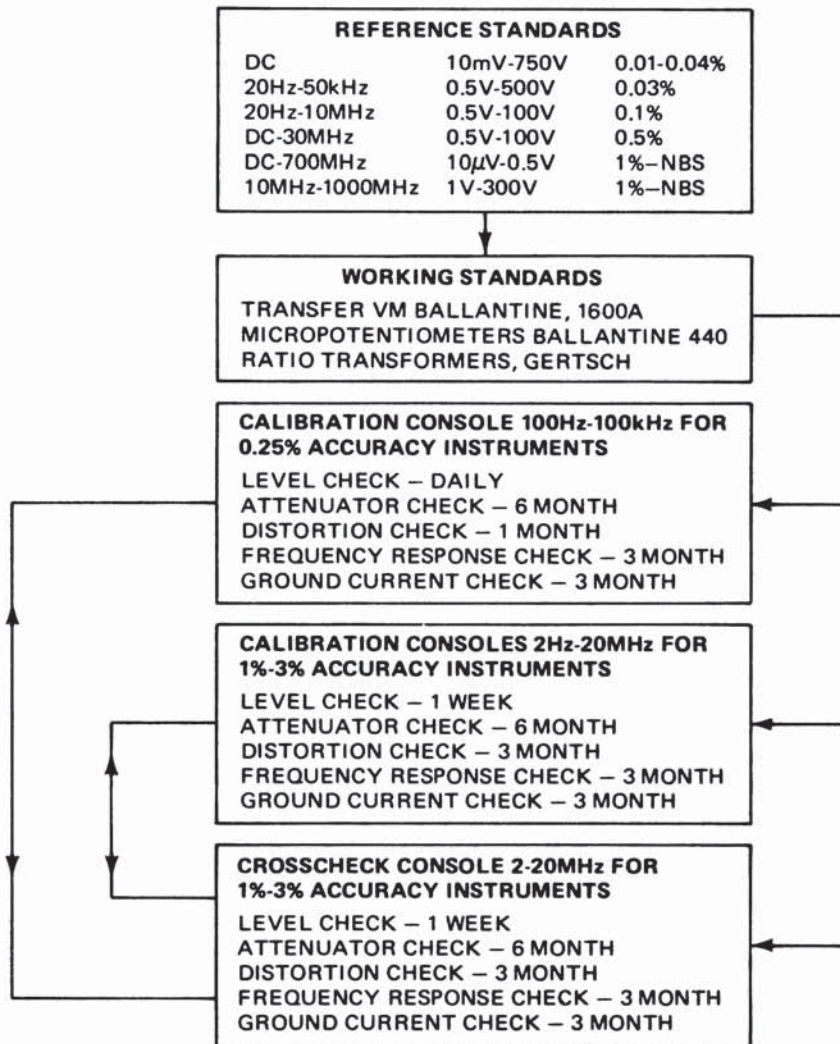

TABLE OF CONTENTS

<i>Paragraph</i>	<i>Page</i>	<i>Paragraph</i>	<i>Page</i>
SECTION 1. GENERAL INFORMATION			
1-1.	Introduction	1-1	
1-2.	Frequency Measurements	1-1	
1-3.	Period and Time Interval Measurements	1-2	
SECTION 2. INSTALLATION			
2-1.	Introduction	2-1	
2-2.	Unpacking and Inspection	2-1	
2-3.	Power Connection Caution	2-1	
2-4.	Cooling	2-1	
2-5.	Remote Programming	2-1	
2-6.	Digital Recorder	2-1	
2-7.	Clock Selection	2-1	
SECTION 3. OPERATION			
3-1.	Introduction	3-1	
3-2.	Controls, Connectors, and Indicators	3-1	
3-3.	Operating Modes	3-1	
3-4.	Input Circuit Control Settings	3-4	
3-5.	Performance Test	3-5	
3-6.	Operating Procedures	3-5	
SECTION 4. PRINCIPLES OF OPERATION			
4-1.	Introduction	4-1	
4-2.	Assembly Designations	4-1	
4-3.	Channel A Input Circuit	4-1	
4-4.	Channel B Input Circuit	4-6	
4-5.	10 MHz Oscillator	4-6	
4-6.	External Clock In/1 MHz Clock Out Circuit	4-6	
4-7.	Control Logic	4-6	
4-8.	Sample Rate and Reset Circuit	4-7	
4-9.	Gate Indicator, Transfer, and Print Command Circuits	4-7	
4-10.	Display Circuit	4-7	
4-11.	Power Supply	4-8	
4-12.	Options	4-8	
SECTION 5. MAINTENANCE AND CALIBRATION			
5-1.	Introduction	5-1	
5-2.	Test Equipment	5-1	
5-3.	Instrument Cover Removal	5-1	
5-4.	Cleaning	5-1	
5-5.	Visual Inspection	5-1	
5-6.	Repair and Replacement	5-1	
5-7.	Channel A Input Circuit Adjustment	5-2	
5-8.	Channel B Input Circuit Adjustment	5-2	
5-9.	Troubleshooting by Self-check	5-2	
5-10.	In-cabinet Performance Check	5-2	
5-11.	Oscillator Calibration	5-5	
5-12.	Packing	5-5	
SECTION 6. PARTS LIST			
SECTION 7. CIRCUIT DIAGRAMS			

LIST OF ILLUSTRATIONS

<i>Number</i>	<i>Page</i>	<i>Number</i>	<i>Page</i>
1-1.	Model 5500B Autometronic Counter-Timer	1-1	
1-2.	Conventional Frequency Counter Block Diagram	1-2	
1-3.	Conventional Period and Time Interval Meter Block Diagram	1-3	
3-1.	Model 5500B Controls, Connectors, and Indicators	3-3	
4-1.	Model 5500B Simplified Block Diagram	4-1	
4-2.	Total (Count) Mode Flow Diagram	4-2	
4-3.	Frequency Mode Flow Diagram	4-2	
4-4.	Period Mode Flow Diagram	4-3	
4-5.	Positive or Negative Pulsewidth Flow Diagram	4-3	
4-6.	Period Average Mode Flow Diagram	4-4	
4-7.	Time Interval A-B Mode Flow Diagram	4-4	
4-8.	Ratio A/NB Mode Flow Diagram	4-5	
4-9.	Elapsed Time Mode Flow Diagram	4-5	
7-1.	Front Panel Assembly A1 Component Locations	7-1	
7-2.	Rear Panel Assembly A2 Component Locations	7-1	
7-3.	Motherboard Assembly A3 Component Locations	7-2	
7-4.	Front Panel, Rear Panel, and Motherboard Schematic Diagram	7-3	
7-5.	Display Assembly A4 Component Locations	7-4	
7-6.	Display Assembly Schematic Diagram	7-5/7-6	
7-7.	BCD Printer Output, Option 01, and High Stability Oscillator, Option 14, Schematic Diagram	7-7/7-8	

SECTION 1

GENERAL INFORMATION

1-1. INTRODUCTION.

The Ballantine Autometronic Counter-Timer Model 5500B, shown in Figure 1-1, is a compact and lightweight instrument used for precise frequency and time measurements. It contains a unique autoranging circuit (patent pending) that enables time and frequency measurements to be made without the need for any operator adjustments. Specifications for the 5500B are given in Table 1-1.

To familiarize the operator with the automatic operation of the 5500B, the following short description will describe the operation of a conventional, manually operated, counter-timer, explain the difficulties involved in measuring frequency and time, and indicate how the problems are solved in the 5500B.

1-2. FREQUENCY MEASUREMENTS.

In a conventional, manually operated, electronic counter-timer, frequency measurements are performed as follows (see Figure 1-2):

The input signal is amplified and shaped (1) to present pulses of uniform amplitude and rise time to the decade counters (5), regardless of the frequency or waveform of the input signal. The signal gate (4) controls the flow of the shaped pulses to the decade counters. When the signal gate is enabled (opened) by a pulse from the time base dividers (3) the shaped pulses pass through and are counted

by the decade counters. The next pulse from the time base chain disables (closes) the gate. The count accumulated in the decade counters is decoded (6) to convert the information into useful signals to operate the display (7). The open gate interval is usually available in decade steps, derived from the basic clock period.

With conventional frequency counters, the operator must adjust the gate time selector (time base) and make measurements at several time base frequencies until maximum resolution is seen on the readout. This method of time base selection increases the measurement time, and complicates the design of systems incorporating frequency counters. Where signals of wide frequency range are to be measured, measurements are very difficult to make, if not impossible.

The autoranging feature enables the 5500B to overcome all the disadvantages of manual time base selection. The autoranging circuitry automatically adjusts the time base of the instrument so that:

- a. The display capacity is never exceeded.
- b. The best possible resolution is always obtained, automatically.
- c. Units of measurement (kHz, MHz) are automatically displayed.
- d. The decimal point is computed and automatically placed in its correct position.

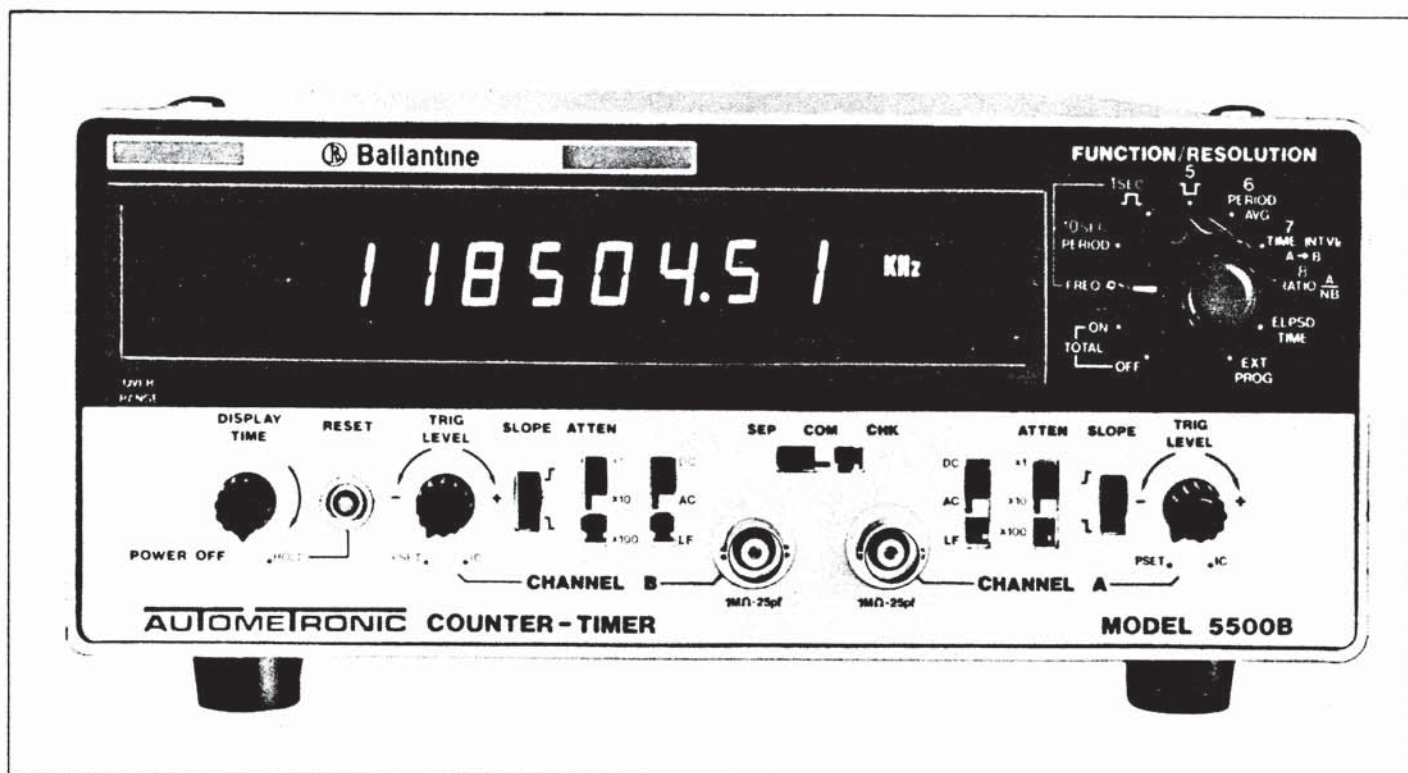

Figure 1-1. Model 5500B Autometronic Counter-Timer

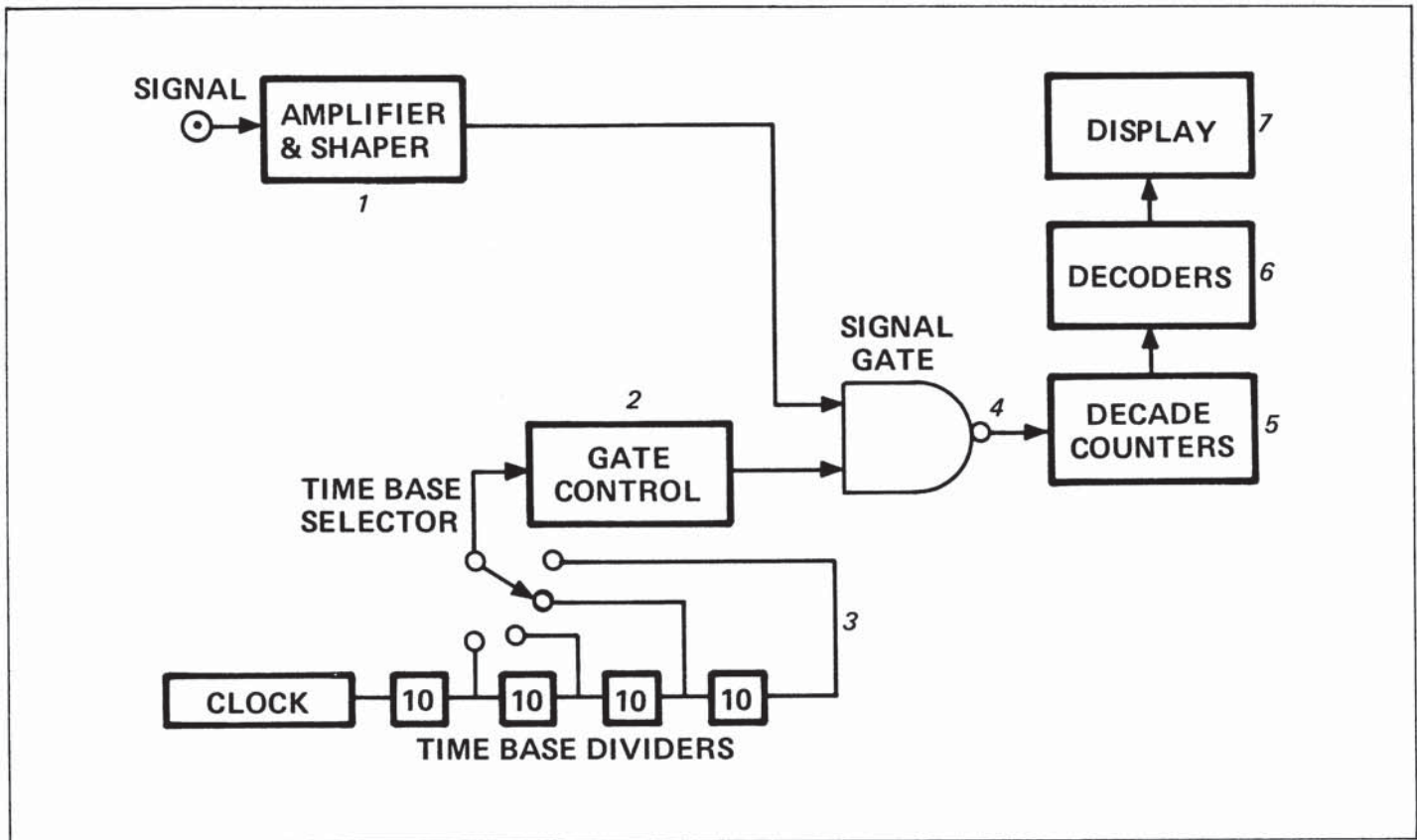

Figure 1-2. Conventional Frequency Counter Block Diagram

The automatic time base selection operation is concurrent with the measurement process. Thus maximum resolution is automatically obtained and needs no attention by the operator or additional programming operations in an automatic measuring system. This increases measurement speed and simplifies system design. Signals of wide frequency range are immediately computed and displayed with maximum resolution.

1-3. PERIOD AND TIME INTERVAL MEASUREMENTS.

In a conventional, manually operated, electronic counter-timer, period or time interval measurements are performed as follows (see Figure 1-3):

The input signal is applied to the amplifier and shaper (1) which converts the input signal to pulses of uniform amplitude and rise time. The shaped input signal operates a gate control circuit (2) which produces a gating pulse for the signal gate (4), equal in time to the period of the input signal. While the signal gate is enabled (open), pulses from the time base (3) pass through the signal gate to the decade counters (5). After the signal gate is closed, the count accumulated in the decade counters is decoded (6) to convert the information into useful signals to operate the display (7).

The difficulty in measuring period and time interval with the conventional method is that the operator has to know in advance the approximate duration of the signal in order to

select a suitable time base (range) which will give the required resolution and prevent display overflow. If the input signal is repetitive, the operator will try to select manually, by making a few measurements, a suitable time unit for best results. However, if the input signal is non-repetitive or the time interval to be measured is of random duration, measurements are very difficult to make, if not impossible.

The autoranging feature enables the 5500B to overcome all the disadvantages of manual time base selection. The autoranging circuitry automatically adjusts the time base units so that:

- a. The display capacity is never exceeded, except for impracticable long periods ($K \times 10^n$ seconds, where K is the lowest time unit and n the number of digits of the counter).
- b. The best possible resolution is always obtained, automatically.
- c. Units of measurement (microseconds, milliseconds, or seconds) are automatically displayed.
- d. The decimal point is computed and automatically placed in its correct position.

The automatic time base selection operation is concurrent with the measurement process, so that signals of random duration or duration changes are immediately computed and displayed with maximum resolution.

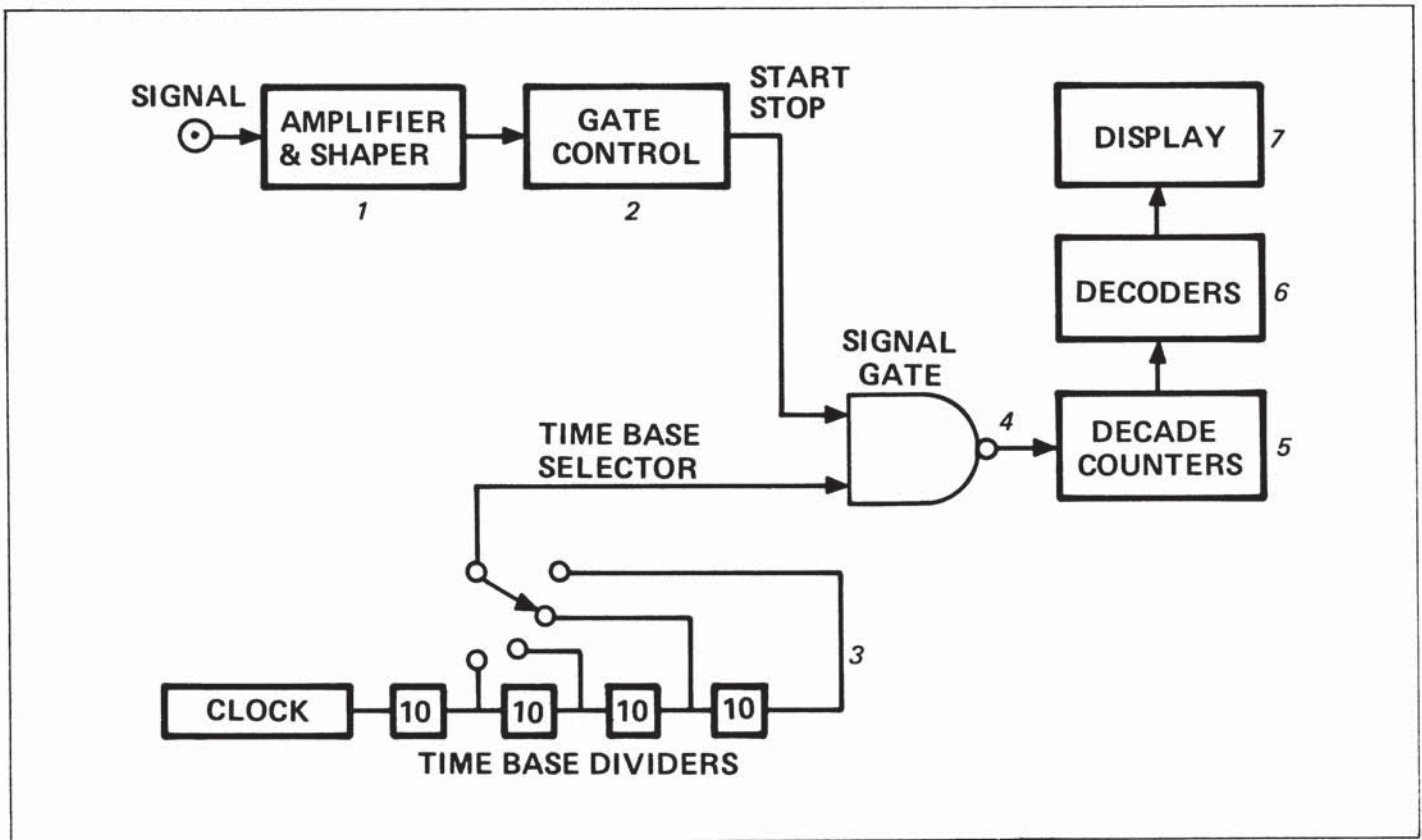

Figure 1-3. Conventional Period and Time Interval Meter Block Diagram

TABLE 1-1. SPECIFICATIONS

COUNT

Frequency: DC to 110 MHz.

Counter Range: 1 to 10^8 counts.

Input: Channel A.

Gate Time: Manually selected.

Accuracy: Absolute.

Readout: Dimensionless.

FREQUENCY

Range: DC to 110 MHz.

Input: Channel A.

Gate Time: Automatically selected to fill the display (up to 10 seconds), or 1 and 10 seconds manual. The number of digits displayed can be selected as 5, 6, 7 or 8 by a front-panel switch.

Accuracy: ± 1 count \pm time-base accuracy.

Readout: kHz or MHz, with automatically positioned decimal point.

PERIOD

Range: 100 ns to 10^8 seconds.

Input: Channel A.

Clock Frequency: 10 MHz to 1 Hz in decimal steps, automatically selected to fill the display. The number of digits displayed can be selected as 5, 6, 7, or 8 by a front-panel switch.

Resolution: 0.1 μ s to 1 second, automatically selected for maximum resolution.

Accuracy: \pm count \pm time-base accuracy \pm trigger error*.

Readout: μ SEC, mSEC or SEC, with automatically positioned decimal point.

POSITIVE OR NEGATIVE PULSE WIDTH

Range: 0.1 μ s to 10^8 seconds.

Input: Channel A.

Clock Frequency: 10 MHz to 1 Hz in decimal steps, automatically selected to fill the display. The number of digits displayed can be selected as 5, 6, 7, or 8 by a front-panel switch.

Slope Selection: Automatically selected.

Resolution: 0.1 μ s to 1 second, automatically selected for maximum resolution.

Accuracy: \pm count \pm time-base accuracy \pm trigger error*.

Readout: μ SEC, mSEC or SEC, with automatically positioned decimal point.

PERIOD AVERAGE

Range: 10 Hz to 1 MHz, 5-digit resolution.

1 Hz to 1 MHz, 6-digit resolution.

0.1 Hz to 1 MHz, 7-digit resolution.

0.01 Hz to 1 MHz, 8-digit resolution.

See footnotes at end of table.

TABLE 1-1. SPECIFICATIONS (Continued)

Input: Channel A.

Periods Averaged: 1 to 1000, automatically selected for maximum resolution.

Clock Frequency: 1 MHz.

Accuracy: \pm count \pm time-base accuracy \pm trigger error*.

Readout: μ SEC, with automatically positioned decimal point.

TIME INTERVAL A \rightarrow B

Range: 0.1 μ s to 10⁸ seconds.

Input: Start signal, Channel A. Stop signal, Channel B. Can be common or separate.

Clock Frequency: 10 MHz to 1 Hz in decimal steps, automatically selected to fill the display. The number of digits displayed can be selected as 5, 6, 7, or 8 by a front-panel switch.

Resolution: 0.1 μ s to 1 second automatically selected for maximum resolution.

Accuracy: \pm count \pm time-base accuracy \pm trigger error of A* \pm trigger error of B*.

Readout: μ SEC, mSEC, or SEC, with automatically positioned decimal point.

RATIO A/NB

Range: Channel A: DC to 110 MHz.
Channel B: DC to 10 MHz.

Input (F1): Channel A.

Input (F2): Channel B.

Measures: F1/F2.

Number of Cycles of F2 Averaged: 1 to 1000 automatically selected for maximum resolution.

Accuracy: \pm count of F1 \pm trigger error of F2*.

Readout: Dimensionless, with automatically positioned decimal point.

ELAPSED TIME

Range: 0.1 μ sec to 10⁸ seconds.

Clock Frequency: 10 MHz to 1 Hz in decimal steps, automatically selected to fill the display. The number of digits displayed can be selected as 5, 6, 7, or 8 by a front-panel switch.

Gate Signal: Rear panel connector. Contact closure to ground or saturated transistor will control the gate time.

Resolution: 0.1 μ s to 1 second, automatically selected for maximum resolution.

Accuracy: \pm count \pm time-base accuracy \pm gate error**.

Readout: μ SEC, mSEC or SEC, with automatically positioned decimal point.

INPUT CHANNELS A AND B

Range: Channel A, DC coupled: DC to 110 MHz.
AC coupled: 20 Hz to 110 MHz.
HF Rejection: Attenuates signals above 1 kHz approx.
Channel B, DC coupled: DC to 10 MHz.
AC coupled: 20 Hz to 10 MHz.
HF Rejection: Attenuates signals above 1 kHz approx.

Impedance: 1 megohm shunted by 25 pF approx.

Sensitivity: dc to 2 MHz - 25 mV rms (sine wave).
dc to 10 MHz - 50 mV rms (sine wave).
dc to 100 MHz - 100 mV rms (sine wave) Ch-A only.
dc to 110 MHz - 165 mV rms (sine wave) Ch-A only.
(to 118 MHz with Option 10)

Channel A, 0.3 V p-p pulse, 7 ns min. pulse width.
Channel B, 0.3 V p-p pulse, 50 ns min. pulse width.
C Input (Option 35 only)

50 MHz to 1 GHz - 25 mV rms.

110 MHz to 512 MHz - 15 mV rms.

All sensitivity measured at 23°C \pm 5°C and with TRIG LEVEL control set out of PSET and at best trigger sensitivity point.

Preset: PSET sets trigger reference to 0 volts. Simplifies triggering below 10-MHz input signals.

Attenuation: X1, X10, X100.

Trigger Level: Continuously adjustable \pm 1 V, \pm 10 V, \pm 100 V, dependent upon setting of attenuator.

Slope: Independent selection of positive or negative slope.

Overload Protection: 250 V rms on X10 and X100 attenuator settings, 120 V rms on X1 attenuator setting up to 1 kHz, decreasing to 10 V rms above 10 MHz.

Shaped Outputs A and B: Terminals on the rear panel for external monitoring of the triggering points on the input signals. >1 volt open circuit.

DISPLAY

Numerical: In units with Serial No. Prefix 020-, eight-digit, seven-segment LEDs, 0.43 inch high, high-efficiency red illumination. In earlier units, six-digit (eight-digit with Option 08), seven-segment LEDs, bright orange illumination. All segments test with reset push button. Units: kHz, MHz, μ sec msec or sec, automatically computed and displayed. All unwanted zeros to the left of the four right-hand digits are automatically blanked.

Decimal Point: Automatically selected.

Display Storage: Buffer storage holds prior reading while new reading is being made. Rear panel switch deactivates storage for continuous update.

Display Time: Display time is adjustable from 0.2 to 5 seconds or held indefinitely until reset.

Gate: Indicator lights when counter is open.

Overrange: Solid-state indicator lights when counter capacity is exceeded. Due to the automatic gate selection, the count capacity can be exceeded only when using the manually selected 1- and 10-second times in Frequency, Period Average, and Ratio models.

Manual Reset: Front-panel pushbutton switch resets the display and all registers, and initiates a new measurement. Also activates display test.

TIME BASE

Crystal Frequency: 10 MHz.

Crystal Oven: Self-regulating solid-state proportional oven.

See footnotes at end of table.

TABLE 1-1. SPECIFICATIONS (Continued)

Aging Rate: Less than 3 parts in 10^7 per month after 10 days of continuous operation. (less than 0.02 ppm per day).

Temperature Stability: Less than 2 parts in 10^6 from 0°C to $+50^{\circ}\text{C}$. (less than 0.04 ppm per $^{\circ}\text{C}$).

Line Voltage Stability: Less than 2 parts in 10^7 for $\pm 10\%$ line voltage change. (Nominally less than 0.05 ppm per % change).

Ext. Time Base Input: Via rear panel BNC connector, 1 kHz to 10 MHz, 0.5 V rms into 1 k Ω .

Int. Time Base Output: 1 MHz via rear panel BNC connector (10 MHz with Option 15).

GENERAL

Operating Temperature: 0°C ($+32^{\circ}\text{F}$) to $+50^{\circ}\text{C}$ ($+122^{\circ}\text{F}$).

Power Requirements: 115 or 230 volts $\pm 10\%$, 48 to 400 Hz, 25 watts.

Dimensions: 3-1/2" (88 mm) H x 8-3/8" (212 mm) W x 12-1/2" (316 mm) D.

Weight: 7 pounds (3.2 kg).

Accessories Furnished: Power Cord, Instruction Manual.

ACCESSORIES AVAILABLE

Probe Kit – Attenuator 10:1, 5 ft., Model 10601B.

50 ohm, 4 ft., BNC-to-BNC coaxial cable, Model 12249D.

Display Extender Board, P/N 89400001A.

6 ft. cable to connect the 5500B to a digital recorder; 12253A.

6 ft. cable to connect the 5500B for remote programming; 12254A.

Feed-through termination, 50-ohm BNC, 12630A.

50-ohm, 4 ft., BNC to alligator cable, 12250D.

OPTIONS AVAILABLE

PRINTER BCD OUTPUT (Option 01)

Type: Serial to parallel converter.

Logic: Positive true.

Form: 4-line BCD 1-2-4-8 TTL compatible. Buffered for fan-out of one.

"1" State = +3.5 V dc to 5.7 V dc.

"0" State = 0 to +0.4 V dc.

Display Overage: "1" signifies overrange.

Data Output Update Command: By "0" State of negative-going input pulse $\geq 10 \mu\text{s}$, or contact closure to digital common. New measurements made after update pulse will be displayed but will not appear at BCD outputs. Maximum allowable update command rate 3 per sec.

Continuous Data Output Update Command: By holding "0" State the BCD output is updated at internal trigger rate of typically 10 per sec.

Busy Flag (Printer Inhibit): "1" State at Busy Flag output signifies BCD output in process of updating. During this interval all Data Update command pulses from printer are ignored. "0" State signifies not Busy. Busy Flag internally modifiable to Ready.

Data Output "Pullup" Voltage: Normally "1" State (+5 V dc). Internal pullup through 15 k Ω . Modifiable to +12 V.

Connector: Mating connector (not supplied) Amphenol 57-30500-375 50-pin Blue Ribbon. Ballantine P/N 31-10050-0.

REMOTE PROGRAMMING (Option 02).

Permits function and resolution to be remotely selected by a single contact to ground or equivalent active circuit. TTL and DTL compatible. The time base is automatically selected for maximum resolution.

Mating connector, 24-pin Blue Ribbon, Amphenol 57-30240, Ballantine P/N 31100370A.

100V/200V POWER LINE VOLTAGE (Option 50)

8-DIGIT DISPLAY (Option 08)

(Standard in units with Serial No. Prefix 020-.)

*Trigger error is less than 0.3% of one period divided by the number of periods averaged, for signals with a signal-to-noise ratio of 40 dB or better, and 100 mV rms amplitude to 100 MHz, and 200 mV rms to 110 MHz.

**For any waveshape, trigger error is less than $\frac{0.0025}{\pm \text{Signal slope (V}/\mu\text{s)}} \mu\text{s}$.

SECTION 2 INSTALLATION

2-1. INTRODUCTION.

The 5500B as shipped requires no special preparation for use. This section contains unpacking, inspection, and installation information.

2-2. UNPACKING AND INSPECTION.

Examine the shipping carton for damage before unpacking the instrument. Carefully remove the instrument from the carton. Check immediately for loose or broken control knobs, bent or broken connectors, and damage to any cabinet part. If damage of any nature is found, refer to the warranty instructions.

2-3. POWER CONNECTION CAUTION.

This instrument is designed to operate from either a 115 Vac or 230 Vac $\pm 10\%$, 50 to 400 Hz, power source. The primary voltage selection is made by positioning a recessed slide switch on the rear panel. To change the position of the slide switch, insert a small screwdriver in the switch slot and set the switch to the required voltage position. Damage caused by using incorrect primary input voltage voids the instrument warranty.

WARNING

THE INSTRUMENT IS PROVIDED WITH A THREE-CONDUCTOR POWER CORD WHICH WILL GROUND THE CASE WHEN CONNECTED TO A THREE-CONNECTOR GROUNDING OUTLET. IF A GROUNDING OUTLET IS NOT AVAILABLE, AN ADAPTER MUST BE USED WHICH PROVIDES A GOOD GROUNDING CONNECTION.

Option 50 is available for use with 100/120/220/240-volt ac power source.

2-4. COOLING.

Cooling air enters the case through holes in the covers. Adequate clearance must be provided on all sides of the instrument to allow heat to be dissipated. Be sure that the instrument position permits adequate air circulation and that nearby equipment does not discharge hot air directly on the instrument.

2-5. REMOTE PROGRAMMING.

The EXT PROG connector on the rear panel is an optional feature which permits remote programming of the instrument. Table 2-1 lists each of the pins in this connector and the corresponding function. Note that instrument functions can only be remotely programmed when the front panel FUNCTION/RESOLUTION switch is set to EXT PROG. When the remote programming option is not required, two binding posts are installed, which provide a remote enable input to the instrument in the TIME INTVL mode. A logic "0" applied to the binding posts enables the internal gate and a logic "1" disables it.

The front panel controls that are programmable are the FUNCTION and RESOLUTION switches. The controls which are not programmable are: DISPLAY TIME, SEP-COM-CHK and the Channel A and Channel B controls. Selection of remote programming is made by setting the FUNCTION switch to EXT PROG. This provides a ground potential to pin 1 of the EXT PROG connector. This ground can be used as an enabling level for the remote programming unit. All lines may be controlled by TTL or DTL signals or contact closure to ground.

Note

When the unit is not being programmed, all the lines should be left open or pulled to +5 V by not less than 2 k Ω .

2-6. DIGITAL RECORDER.

The PRINTER connector on the rear panel is an optional feature which provides BCD outputs and control signals for operating a digital recorder. Table 2-2 lists each of the pins in the connector. The characteristics of each input and output are given in the specifications, Table 1-1.

2-7. CLOCK SELECTION.

An internal 10 MHz clock is provided. There is also provision for using an external clock for increased stability or to obtain a special time base. The clock selection is made by positioning the rear panel two-position recessed slide switch to the appropriate position.

TABLE 2-1. EXT PROG CONNECTOR (A2J3)

Notes:

1. When Remote Programming Option 02 is not part of the instrument, the 24-pin connector is replaced by banana jacks. The red banana jack is the ELPSD TIME input; the black banana jack is ground. (See Figure 4-9.)

2. To activate REMOTE operation, set FUNCTION switch to REM PGM and set RESOLUTION switch to 10 SEC. When pins 11, 13, 14, 15, and 16 are open, 10 SEC time is automatically activated.

3. When "C" Input 10:1 Prescaler Option 35 or 35A is part of the instrument, the 24-pin connector is replaced by BNC jacks. The left side BNC jack is the Prescaler input; the right side BNC jack is the ELPSD TIME input. (See figure 4-9.)

PIN	USE	PIN	USE
1	Common	13	5 Digit Resolution
2	Count Start	14	6 Digit Resolution
3	Freq	15	7 Digit Resolution
4	Period	16	8 Digit Resolution
5	Positive Pulsewidth	17	
6	Negative Pulsewidth	18	
7	Period Avg	19	
8	Time A→B	20	
9	A/NB	21	
10	Elapsed Time	22	Reset
11	1 Sec Timebase	23	Time Intvl Enable
12		24	Case Ground

TABLE 2-2. PRINTER CONNECTOR (A2J2)

PIN	USE	PIN	USE
1	10 ⁰ Decade BCD 1 Output	26	10 ⁰ Decade BCD 4 Output
2	10 ⁰ Decade BCD 2 Output	27	10 ⁰ Decade BCD 8 Output
3	10 ¹ Decade BCD 1 Output	28	10 ¹ Decade BCD 4 Output
4	10 ¹ Decade BCD 2 Output	29	10 ¹ Decade BCD 8 Output
5	10 ² Decade BCD 1 Output	30	10 ² Decade BCD 4 Output
6	10 ² Decade BCD 2 Output	31	10 ² Decade BCD 8 Output
7	10 ³ Decade BCD 1 Output	32	10 ³ Decade BCD 4 Output
8	10 ³ Decade BCD 2 Output	33	10 ³ Decade BCD 8 Output
9	10 ⁴ Decade BCD 1 Output	34	10 ⁴ Decade BCD 4 Output
10	10 ⁴ Decade BCD 2 Output	35	10 ⁴ Decade BCD 8 Output
11	10 ⁵ Decade BCD 1 Output	36	10 ⁵ Decade BCD 4 Output
12	10 ⁵ Decade BCD 2 Output	37	10 ⁵ Decade BCD 8 Output
13	10 ⁶ Decade BCD 1 Output	38	10 ⁶ Decade BCD 4 Output
14	10 ⁶ Decade BCD 2 Output	39	10 ⁶ Decade BCD 8 Output
15	10 ⁷ Decade BCD 1 Output	40	10 ⁷ Decade BCD 4 Output
16	10 ⁷ Decade BCD 2 Output	41	10 ⁷ Decade BCD 8 Output
17	μSEC*	42	SEC*
18	mSEC*	43	
19	Decimal Point 1 (rightmost)	44	Decimal Point 2
20		45	Decimal Point 3
21	KHz*	46	MHz*
22	Busy Flag	47	+5 Volt Reference
23	Data Update	48	Overrange
24	Continuous Update	49	Decimal Point 4
25	External Pull-up (<5.7 V)	50	Case Ground

*Units provide negative true logic.

SECTION 3 OPERATION

3-1. INTRODUCTION.

This section will familiarize the operator with the typical operating procedures of the 5500B. The front and rear panel controls, connectors, and indicators are described. Recommended operating procedures demonstrate instrument flexibility.

3-2. CONTROLS, CONNECTORS, AND INDICATORS.

Figure 3-1 shows the instrument's front and rear panels and Table 3-1 describes the functions of the controls, connectors, and indicators. These descriptions are not intended to be operating instructions but, briefly, to familiarize the operator with the instrument.

3-3. OPERATING MODES.

General. The 5500B has ten operating modes and a test mode. The operating modes are TOTAL, FREQ, PERIOD, \square (Positive Pulsewidth), \sqcap (Negative Pulsewidth), PERIOD AVG, TIME INTVL A→B, RATIO A/NB, ELPSD TIME, and EXT PROG. The EXT PROG mode permits remote operation of any of the instrument functions except the test mode. The following paragraphs describe each operating mode and a typical application. The test mode is described in paragraph 3-5.

PERIOD Mode. In the PERIOD mode, the period of a signal applied to the Channel A connector is measured by counting the pulses produced by the internal time base over

a single period of the input signal. The time base is automatically varied to provide the maximum resolution for the applied signal. The maximum number of digits displayed is variable from 5 to 6 (5 to 8 with Option 08 or in units with Serial No. Prefix 020-) by the FUNCTION/RESOLUTION switch. Table 3-3 lists the positions of this switch and gives the corresponding readouts for a range of input frequencies.

Positive and Negative Pulsewidth Modes. In the \square Positive Pulsewidth and \sqcap Negative Pulsewidth modes, the pulses produced by the internal time base are counted over the period of the input signal.

PERIOD AVG Mode. In the PERIOD AVG mode, the average period of a signal applied to the Channel A connector is measured by counting the pulses produced by the internal time base over from 1 to 10^3 periods of the input signal. The number of periods over which the frequency is averaged, is automatically selected to provide maximum resolution for the applied signal. Table 3-4 gives the seven-digit display readout, and the number of periods over which the frequency is averaged, for a range of input frequencies.

TIME A→B Mode. In the TIME A→B mode, the pulses produced by the internal time base are counted over the interval between the supply of a start pulse to the Channel A connector and the supply of a stop pulse to the Channel B connector. One application for the TIME A→B mode is the

TABLE 3-1. CONTROLS, CONNECTORS AND INDICATORS

INDEX NO.	ITEM	FUNCTION
1	OVER RANGE Indicator	A light emitting diode that lights up when the display range of the instrument has been exceeded.
2	Display	A six-digit numeric readout (eight-digit with Option 08 or in units with Serial No. Prefix 020-) with automatically positioned decimal point that indicates the magnitude of the quantity measured. The units for the readout are shown by indicators to the right of the display (μ SEC, mSEC, SEC, KHz, and MHz).
3	GATE Indicator	Indicator lamp that lights up when the instrument is counting.
4	μ SEC, mSEC, SEC, KHz, MHz Indicators	Indicator lamps to show the units of the readout.
5	FUNCTION/RESOLUTION Switch	A dual concentric switch assembly. Used to select the mode of operation and the number of digits to be displayed (resolution).
6	Channel A TRIG LEVEL Control	A potentiometer that varies the triggering level of the input waveform. A preset trigger level for easy trigger setup and suitable for symmetrical-to-ground waveforms is obtained when the control is set to PSET (fully counterclockwise). The IC position in full clockwise rotation is provided for triggering on positive going TTL, DTL and RTL logic integrated circuits.

TABLE 3-1. CONTROLS, CONNECTORS AND INDICATORS (Continued)

INDEX NO.	ITEM	FUNCTION
7	Channel A SLOPE Switch	A two-position slide switch that permits triggering on either positive or negative edges of a signal supplied to Channel A in the PERIOD, PERIOD AVG and TIME INTVL A→B modes. In all other modes, the slope selection is internal.
8	Channel A ATTEN Switch	A three-position slide switch that varies the attenuation (X1, X10, X100) of the signal applied to the Channel A connector.
9	Channel A Coupling Selector	A three-position slide switch that selects the coupling (AC or DC) or attenuates signals above 1 kHz (LF).
10	SEP-COM-CHK Switch	A three-position slide switch that connects Channel A and Channel B input circuits to a common input connector (input A) or to separate connectors. In the position CHK (check) the internal 1 MHz oscillator is applied simultaneously to both channels.
11	Channel B Coupling Selector	Similar to Channel A Coupling Selector.
12	Channel B ATTEN Switch	Similar to Channel A ATTEN Switch.
13	Channel B SLOPE Switch	Similar to Channel A SLOPE Switch.
14	Channel B TRIG LEVEL Control	Similar to Channel A TRIG LEVEL Control.
15	RESET Pushbutton	Resets display and internal count to zero and starts a new measurement. Also checks display by lighting all segments.
16	POWER OFF—DISPLAY TIME Control	A switch/potentiometer control that applies ac power to the instrument, and controls the display time.
17	EXT CLOCK IN — 1 MHz CLOCK OUT Switch	A recessed two-position slide switch that permits selection of either the internal clock or an external clock. When set to 1 MHz CLOCK OUT, a 1 MHz signal derived from the internal clock is available at the BNC connector.
18	Clock In—Clock Out Connector	A BNC connector for either connecting an external clock to the instrument or providing the internal clock from the instrument.
19	DISPLAY STORE Switch	A two-position slide switch. When set to ON, provides display storage while new measurement is being made. In OFF position, allows continuous display.
20	OSC ADJ	A trimmer capacitor used for oscillator adjustment.
21	EXT PROG Connector	A 24-pin connector for connecting remote programming signals to the instrument.
22	PRINTER Connector	A 50-pin connector for digital recorder interconnection.
23	AC Power Connector	IEC type with offset pin connected to instrument chassis.
24	Fuse	Protects primary power circuit from accidental overload.
25	LINE SELECTOR Switch	Selects the nominal line voltage to operate the instrument.
26	A OUT, B OUT Terminals	Used for monitoring the triggering points on the input signals.

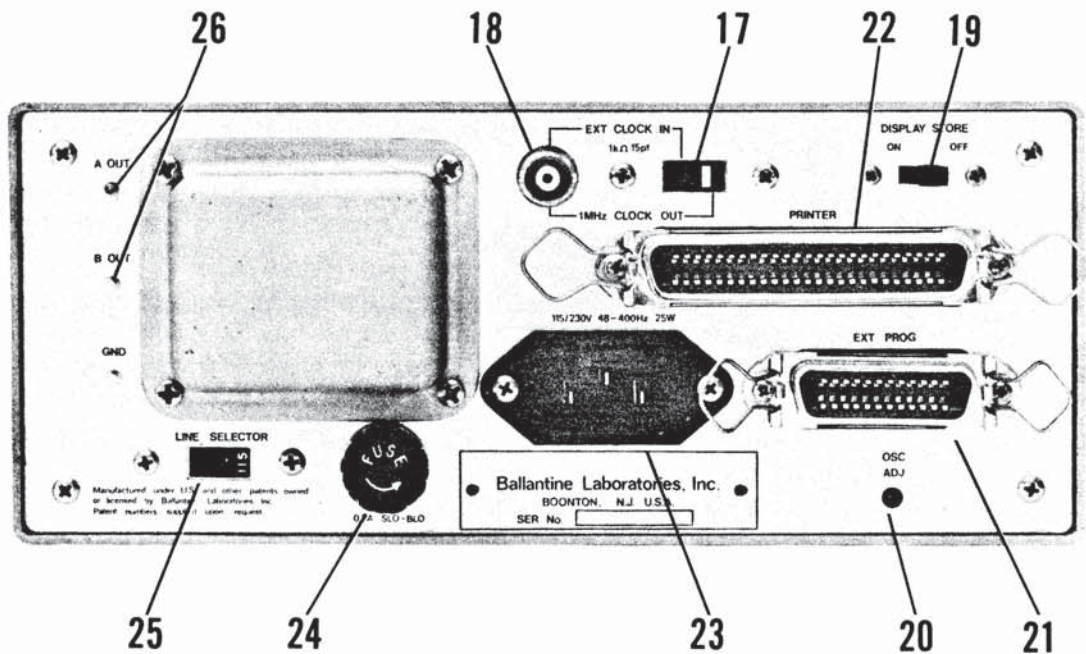
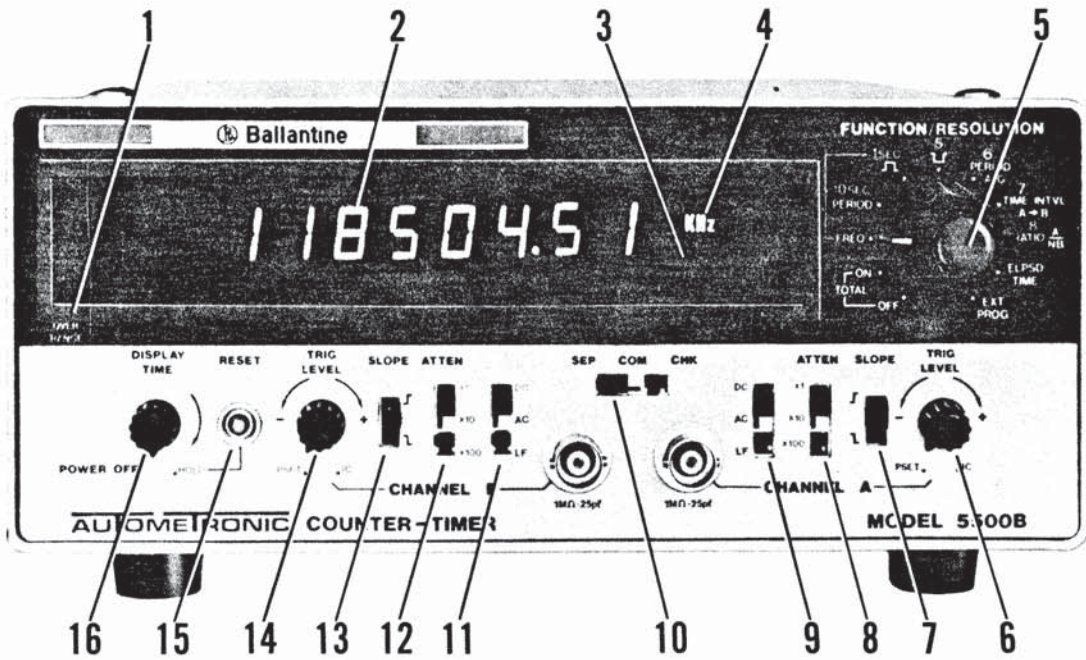

Figure 3-1. Controls, Connectors, and Indicators

TABLE 3-2. FREQUENCY MEASUREMENT DATA

INPUT FREQUENCY	SWITCH POSITION			
	5	6	7	8
10 MHz	10.000 MHz	10000.0 KHz	10000.00 KHz	10000.000 KHz
1 MHz	1000.0 KHz	1000.00 KHz	1000.000 KHz	1000.000 KHz
100 KHz	100.00 KHz	100.000 KHz	100.000 KHz	100.000 KHz
10 KHz	10.000 KHz	10.000 KHz	10.000 KHz	10.000 KHz
1 KHz	1.000 KHz	1.000 KHz	1.000 KHz	1.000 KHz
100 Hz	.100 KHz	.100 KHz	.100 KHz	.100 KHz
10 Hz	.010 KHz	.010 KHz	.010 KHz	.010 KHz

TABLE 3-3. PERIOD MEASUREMENT DATA

PERIOD OF INPUT SIGNAL	SWITCH POSITION			
	5	6	7	8
10 sec	10.000 sec	10000.0 msec	10000.00 msec	10000.000 msec
1 sec	1000.0 msec	1000.00 msec	1000.000 msec	1000000.0 μ sec
100 msec	100.00 msec	100.000 msec	100000.0 μ sec	100000.0 μ sec
10 msec	10.000 msec	10000.0 μ sec	10000.0 μ sec	10000.0 μ sec
1 msec	1000.0 μ sec	1000.0 μ sec	1000.0 μ sec	1000.0 μ sec
100 μ sec	100.0 μ sec	100.0 μ sec	100.0 μ sec	100.0 μ sec
10 μ sec	10.0 μ sec	10.0 μ sec	10.0 μ sec	10.0 μ sec
1 μ sec	1.0 μ sec	1.0 μ sec	1.0 μ sec	1.0 μ sec

TABLE 3-4. PERIOD AVERAGE MEASUREMENT DATA

PERIOD OF INPUT SIGNAL	NO. OF PERIODS AVERAGED	READOUT
1 sec	1	1000000 μ sec
100 msec	10	100000.0 μ sec
10 msec	100	10000.00 μ sec
1 msec	1000	1000.000 μ sec
100 μ sec	1000	100.000 μ sec
10 μ sec	1000	10.000 μ sec
1 μ sec	1000	1.000 μ sec

measurement of elapsed time between two signals. The TIME A→B mode can also be used to measure the elapsed time between two selected points on a single waveform.

RATIO A/NB Mode. In the RATIO A/NB mode, the ratio of two frequencies can be measured. The source of one frequency is applied to the Channel A connector and the source of the other frequency is applied to the Channel B connector. Both connectors are located on the front panel. The measurement is made by counting the number of A pulses occurring in 1 to 10^3 periods of B. The number of periods over which the A pulses are counted is selected automatically to provide maximum resolution, which gives a readout of the ratio of frequency A to frequency B with automatic positioning of the decimal point. The frequency limits of the A and B inputs must be observed.

ELPSD TIME Mode. In the ELPSD TIME mode, the pulses produced by the internal time base are counted over the interval determined by the remote count-enable input. Counting is enabled when the input is a logic 0 and is inhibited when the input is a logic 1. Thus, if a square wave (varying between the logic levels) is applied to the count-enable input, the instrument indicates half the period of the waveform. Resetting is not automatic in the ELPSD TIME mode. Unless the instrument is reset manually, the value obtained in the first interval will be stored and will add to the count obtained in subsequent intervals.

One application for the ELPSD TIME mode is the measurement of elapsed time, where the count-enable input is switched to a logic 0 at the start of the interval and then switched back to a logic 1 at the end of the interval. Other applications include measurements of pulsewidth, duty cycle and time A to B where A and B are separate start/stop times.

EXT PROG Mode. In the EXT PROG mode, all functions may be remotely selected by saturated transistor or contact closure to ground through pins on the optional rear-panel EXT PROG connector. The connector pin used for each function is given in Table 2-1.

3-4. INPUT CIRCUIT CONTROL SETTINGS.

The input controls for both Channel A and Channel B are identical. The correct setting of these controls is of prime importance in order to obtain the best possible results.

The choice of ac or dc coupling depends on the type of signal to be measured. If the signal has a small ac component riding on a dc level, ac coupling should be used. For symmetrical signals, ac coupling is desirable. For very asymmetrical signals, like pulses with low-duty cycle, dc coupling is preferable, particularly if the pulses are random. For waveforms below 1 kHz, the coupling selector switch should be set to LF. This position attenuates signals above 1 kHz and will filter out noise superimposed on the input waveform.

Attenuation should be selected as required: X1 (± 1 volt), X10 (± 10 volts) or X100 (± 100 volts). If the input signal is not known, begin with X100 attenuation and decrease as required.

The SLOPE switch selects whether the instrument triggers on the positive- or negative-going edge of the input waveform. For sinusoidal waveforms, the choice is usually arbitrary, but for other waveforms it is desirable to trigger on the steepest slope in order to minimize trigger error.

The TRIG LEVEL control sets the triggering point on the input waveform at any level between +1 and -1 volt. For input signals that cross ground level, the trigger level can be preset at zero crossover (PSET). Integrated circuit logic levels are accommodated in the IC position.

For the correct input circuit adjustment proceed as follows:

- a. Set the FUNCTION switch to TOTAL ON.
- b. Connect a signal to the Channel A BNC connector.
- c. Set the Coupling Selector and SLOPE switches as explained previously.
- d. Set ATTEN switch to X100 and rotate the Channel A TRIG LEVEL control from fully counterclockwise to fully clockwise observing the points at which the counting stops. Decrease ATTEN setting until proper counting is obtained through an angle of rotation of approximately 45 degrees.
- e. Set the TRIG LEVEL control about midway between the 45-degree angle.

During adjustment, the point of the waveform at which the counter is triggered may be observed on a high-input impedance oscilloscope connected to the A OUT pin on the rear panel.

The B Channel should be adjusted in the same way but in place of the display, an oscilloscope connected to the B OUT pin on the rear should be used for the correct count observation.

Note



To minimize interchannel crosstalk due to high-amplitude input signals in the TIME INTVL A→B and A/NB modes of operation, a low-impedance termination (50 ohms) should be connected to the BNC input connectors. Otherwise the input signals should be attenuated before application to the counter inputs.

3-5. PERFORMANCE TEST.

The 5500B has a built-in test circuit that provides a confidence check of the instrument's operation. This circuit

is used in the CHK mode, which checks most of the circuitry in the instrument.

The performance of the 5500B should be checked upon receipt from the factory, after maintenance has been performed, and before each use.

1. Set the SEP-COM-CHK switch to the CHK position.
2. Adjust both input circuits as outlined in paragraph 3-4.
3. Set the FUNCTION switch to TOTAL OFF.
4. Press the RESET push-button and check that all digits display "0".
5. Set FUNCTION switch to TOTAL ON and check that the counter totalizes and overflows, and that the GATE light is on with the RESOLUTION switch set to 5, 6, 7 or 8 digits resolution.
6. Set FUNCTION switch to TOTAL OFF. Check that the GATE light goes out and the display is held.
7. Set FUNCTION switch to FREQ. The display should read:
 - 1000.0 kHz with 5-digit resolution ± 1 count
 - 1000.00 kHz with 6-digit resolution ± 1 count
 - 1000.000 kHz with 7-digit resolution ± 1 count
 - 1000.0000 kHz with 8-digit resolution ± 1 count
8. Set FUNCTION switch to PERIOD. The display should read 1.0 μ SEC ± 1 count.
9. Set FUNCTION switch to  Positive Pulsewidth mode. The display should read 0.5 μ SEC ± 1 count. Note: A slight readjustment of the Channel A TRIG LEVEL control may be necessary to obtain this reading.
10. Set FUNCTION switch to  Negative Pulsewidth mode. The display should read 0.5 μ SEC ± 1 count. Note: A slight readjustment of the Channel A TRIG LEVEL control may be necessary to obtain this reading.
11. Set FUNCTION switch to PERIOD AVG. The display should read 1.000 μ SEC ± 1 count.
12. Set FUNCTION switch to TIME A→B. The display should read 1.0 μ SEC ± 1 count with both switches set to positive or negative slopes, and 0.5 μ SEC ± 1 count when the SLOPE switches are set to opposite polarity. Note: A slight readjustment of the Channel A TRIG LEVEL control may be necessary to obtain the readings.
13. Set FUNCTION switch to A/NB. The display should read 1.000 ± 1 count.
14. Set FUNCTION switch to TIME INTVL. If Option 02 is installed, short pin 23 of the EXT PROG connector to ground; otherwise short the two binding posts. Observe for correct timing on the display which should only update when the connection to ground is made.

3-6. OPERATING PROCEDURES.

Paragraphs 3-7 through 3-14 describe typical operating procedures. Note that the procedures assume an eight-digit display. Substitute six digits where only six are installed in the 5500B.

3-7. Operation in TOTAL mode.

1. Turn power switch on.
2. Connect signal to be counted to the Channel A connector.
3. Set SEP-COM-CHK switch to SEP.
4. Adjust the Channel A input circuit as outlined in paragraph 3-4.
5. Set FUNCTION switch to TOTAL OFF.
6. Press RESET pushbutton.
7. Start counting by setting the FUNCTION switch to TOTAL ON and stop by setting to TOTAL OFF. Note: If the OVER RANGE indicator is lit, the count indicated is not the total count.

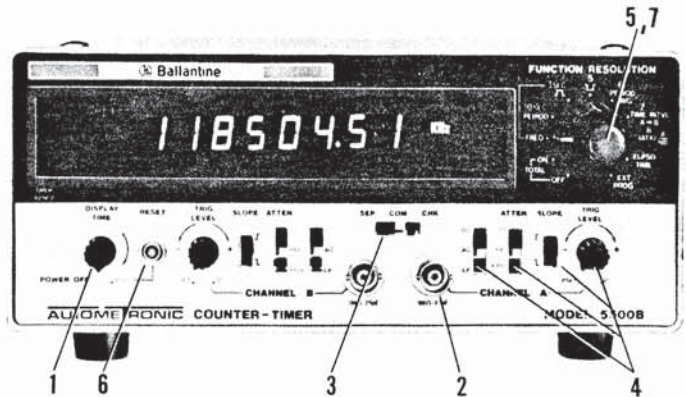
**3-8. Operation in FREQ mode.**

1. Turn power switch on.
2. Connect signal to be measured (0 to 110 MHz) to the Channel A connector.
3. Set SEP-COM-CHK switch to SEP.
4. Adjust the Channel A input circuit as outlined in paragraph 3-4.
5. Set FUNCTION switch to FREQ.
6. Set RESOLUTION switch to required resolution.
7. Adjust DISPLAY TIME control for convenient measurement interval.
8. The display indicates the frequency of the input signal. The unit and decimal point are internally computed and displayed automatically.

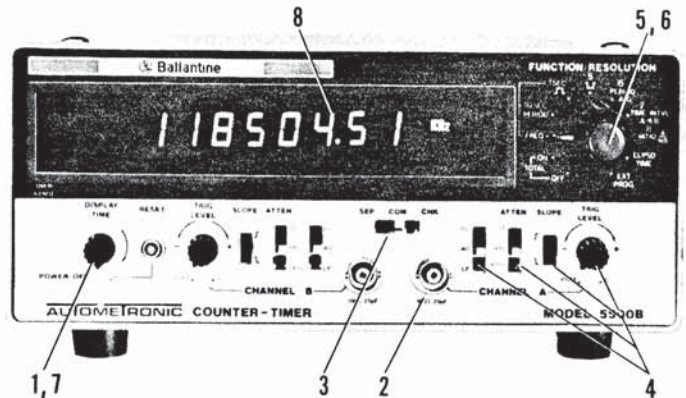
**3-9. Operation in PERIOD mode.**

1. Turn power switch on.
2. Connect signal to be measured (100 ns to 10^8 seconds) to the Channel A connector.
3. Set SEP-COM-CHK switch to SEP.
4. Adjust the Channel A input circuit as outlined in paragraph 3-4.
5. Set FUNCTION switch to PERIOD.
6. Set the RESOLUTION switch to the required resolution.
7. Adjust DISPLAY TIME control for convenient measurement interval.
8. The display indicates the period of the input signal. The unit and decimal point are internally computed and displayed automatically.

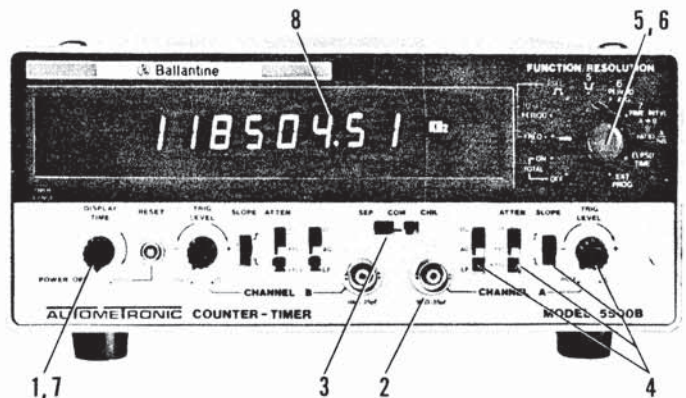

3-10. Operation in \square Positive Pulsewidth and \square Negative Pulsewidth Modes.

1. Turn power switch on.
2. Connect signal to be measured (100 ns to 10^8 seconds) to the Channel A connector.
3. Set SEP-COM-CHK switch to SEP.
4. Adjust the Channel A input circuit as outlined in paragraphs 3-4.
5. Set FUNCTION switch to \square Positive Pulsewidth or \square Negative Pulsewidth.
6. Set RESOLUTION switch to the required resolution.
7. Adjust DISPLAY TIME control for convenient measurement interval.
8. The display indicates the width of the positive or negative pulse. The unit and decimal point are internally computed and displayed automatically.

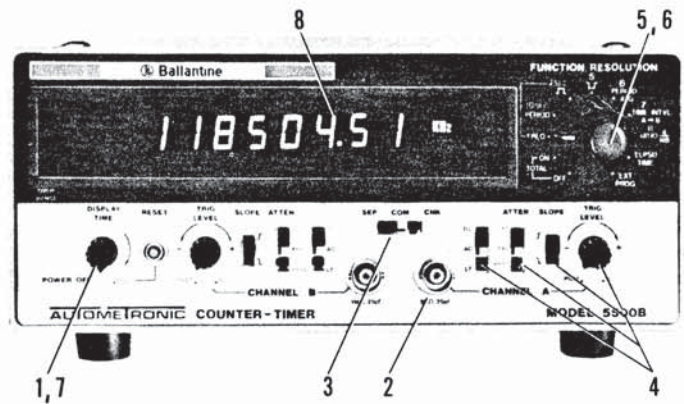

3-11. Operation in the PERIOD AVG mode.

1. Turn power switch on.
2. Connect signal to be measured (0.1 Hz to 1 MHz) to the Channel A connector.
3. Set SEP-COM-CHK switch to SEP.
4. Adjust the Channel A input circuit as outlined in paragraph 3-4.
5. Set FUNCTION switch to PERIOD AVG.
6. Set RESOLUTION switch to the required resolution.
7. Adjust DISPLAY TIME control for convenient measurement interval.
8. The display indicates the average period of the input signal in microseconds. Note: In this mode, the display range may be exceeded if the minimum frequency of the input signal is less than:
 - 10 Hz with 5-digit resolution
 - 1 Hz with 6-digit resolution
 - 0.1 Hz with 7-digit resolution
 - 0.01 Hz with 8-digit resolution

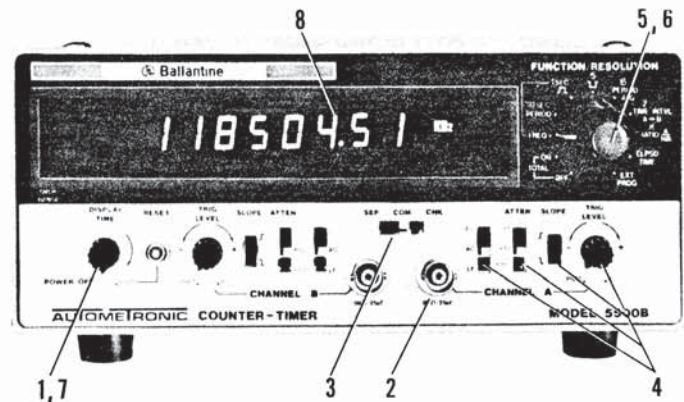

3-12. Operation in TIME INTVL A→B mode.

1. Turn power switch on.
2. If separate start and stop signals are to be used, set SEP-COM-CHK switch to SEP. Connect the start signal to Channel A connector and connect the stop signal to Channel B connector.
3. If one signal is to be used to start and stop the count, set SEP-COM-CHK switch to COM. Connect the signal to Channel A connector.
4. Adjust the Channel A and Channel B input circuits as outlined in paragraph 3-4.
5. Set the Channel A SLOPE switch to start the count on the desired slope.
6. Set the Channel B SLOPE switch to stop the count on the desired slope.
7. Set FUNCTION switch to TIME INTVL A→B.
8. Set RESOLUTION switch to required resolution.
9. Adjust DISPLAY TIME control for convenient measurement interval.
10. The display indicates the time interval between the start signal at Channel A and stop signal at Channel B. The unit and decimal point are internally computed and displayed automatically.

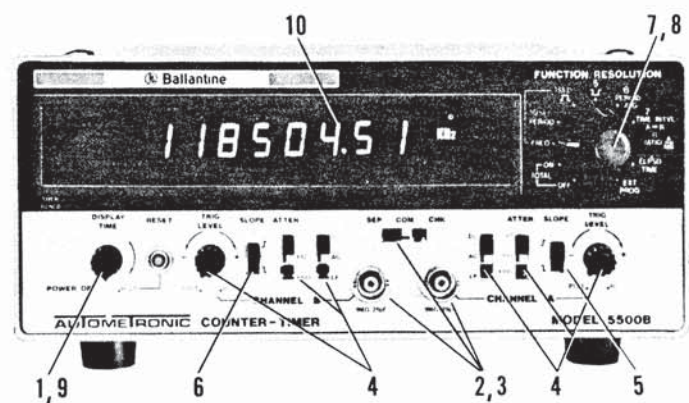

3-13. Operation in RATIO A/NB mode.

1. Turn power switch on.
2. Connect higher frequency input (DC to 110 MHz) to Channel A connector.
3. Connect lower frequency input (DC to 10 MHz) to Channel B connector.
4. Set SEP-COM-CHK switch to SEP.
5. Adjust the Channel A and Channel B input circuits as outlined in paragraph 3-4.
6. Set FUNCTION switch to RATIO A/NB.
7. Set RESOLUTION switch to required resolution.
8. Adjust DISPLAY TIME control for convenient measurement interval.
9. The display indicates the ratio F_A/F_B with an automatically positioned decimal point.

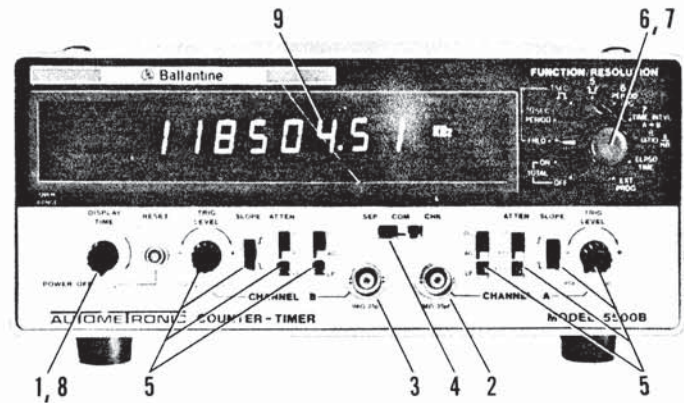
**3-14. Operation in ELPSD TIME mode.**

1. Turn power switch on.
2. Set FUNCTION switch to ELPSD TIME.
3. Set RESOLUTION switch to required resolution.
4. Press the RESET push-button to zero the display.
5. If Option 02 is installed, short pin 23 of the EXT PROG connector to ground; otherwise, short the two binding posts to start the timing interval, and open the terminals to stop the timing interval. This action may be repeated as many times as required. An external switch or saturated transistor to ground may be used to automate or remotely control the TIME INTVL A→B mode.
6. The display indicates the total time of operation while the connection of Step 5 is made. The unit and the decimal point are internally computed and displayed automatically.

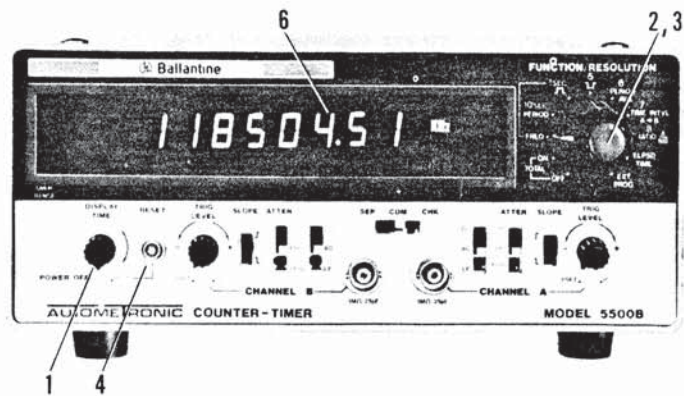

SECTION 4

PRINCIPLES OF OPERATION

4-1. INTRODUCTION.

This section of the manual contains a description of the circuitry used in the 5500B. A simplified block diagram is given in Figure 4-1 followed by signal-flow diagrams for each mode of operation (Figures 4-2 to 4-9). Complete schematics of each circuit are given in Section 7. Refer to these diagrams throughout the following circuit description.

4-2. ASSEMBLY DESIGNATIONS.

Table 4-1 lists the designations of the assemblies used in this instrument.

TABLE 4-1.
ASSEMBLY IDENTIFICATION

ASSY	NAME
A1	Front Panel Assembly
A2	Rear Panel Assembly
A3	Motherboard Assembly
A4	Display Assembly
—	LED Assembly

4-3. CHANNEL A INPUT CIRCUIT.

The Model 5500B has two input circuits designated as Channel A and Channel B. The Channel A input is used for all signal measurements. The Channel B input is an auxiliary input and is used when measuring time A→B and the ratio of two frequencies. Both circuits shape the input signal to provide well-defined edges for proper triggering.

The Channel A input signals are routed through A1J1 to coupling selector A1S6. Depending on the switch setting, the signals are either directly coupled to attenuator A1S5 (DC position) or taken via capacitor A1C1 (AC position). In the LF position, capacitor A1C5 is connected to ground and causes signals above 1 kHz to be attenuated.

When attenuator (ATTEN) A1S5 is set to X1, the full input signal is fed via SEP-COM-CHK switch A1S13 to the gate of A3Q18A. With A1S5 set to X10 or X100 the appropriate voltage divider is selected. The SEP-COM-CHK switch connects input A and B in parallel when set to COM, and connects a 1-MHz test signal to the A and B input circuits when set to CHK.

The signal to A3Q18A is limited by the diode-limiter A3CR5 and A3CR6. The limiter protects FET A3Q18 from overload.

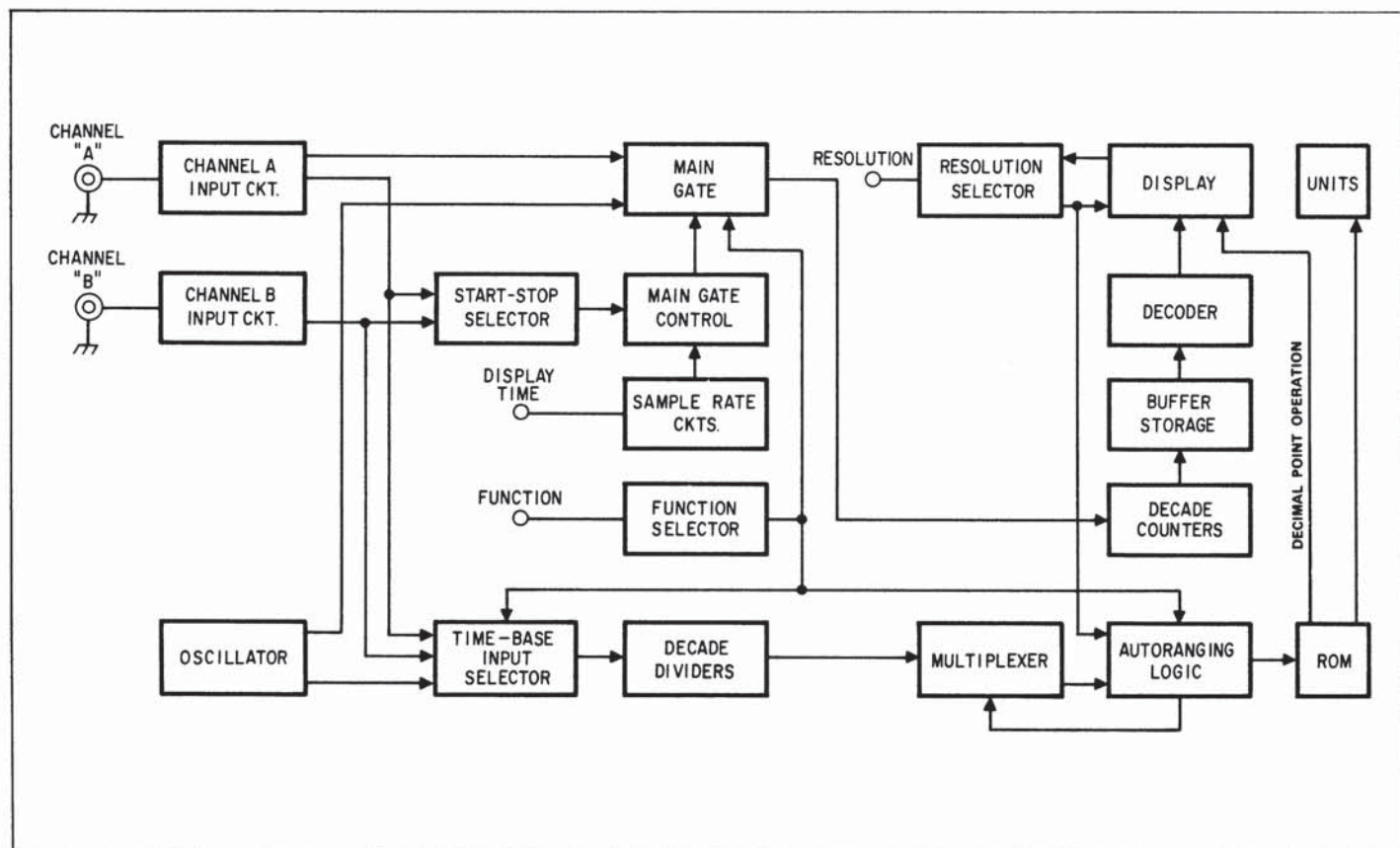

Figure 4-1. 5500B Simplified Block Diagram

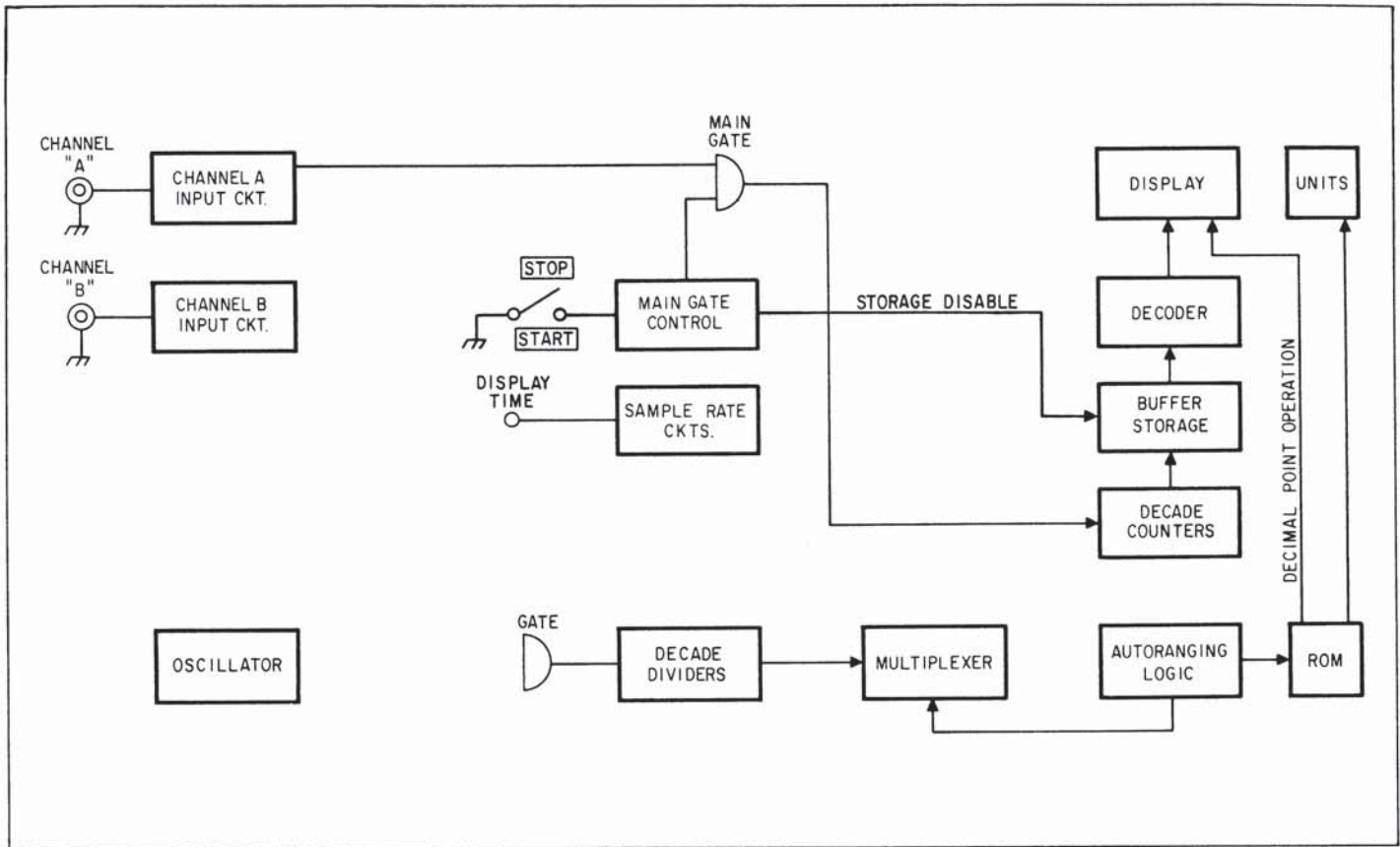

Figure 4-2. Total (Count) Mode Flow Diagram

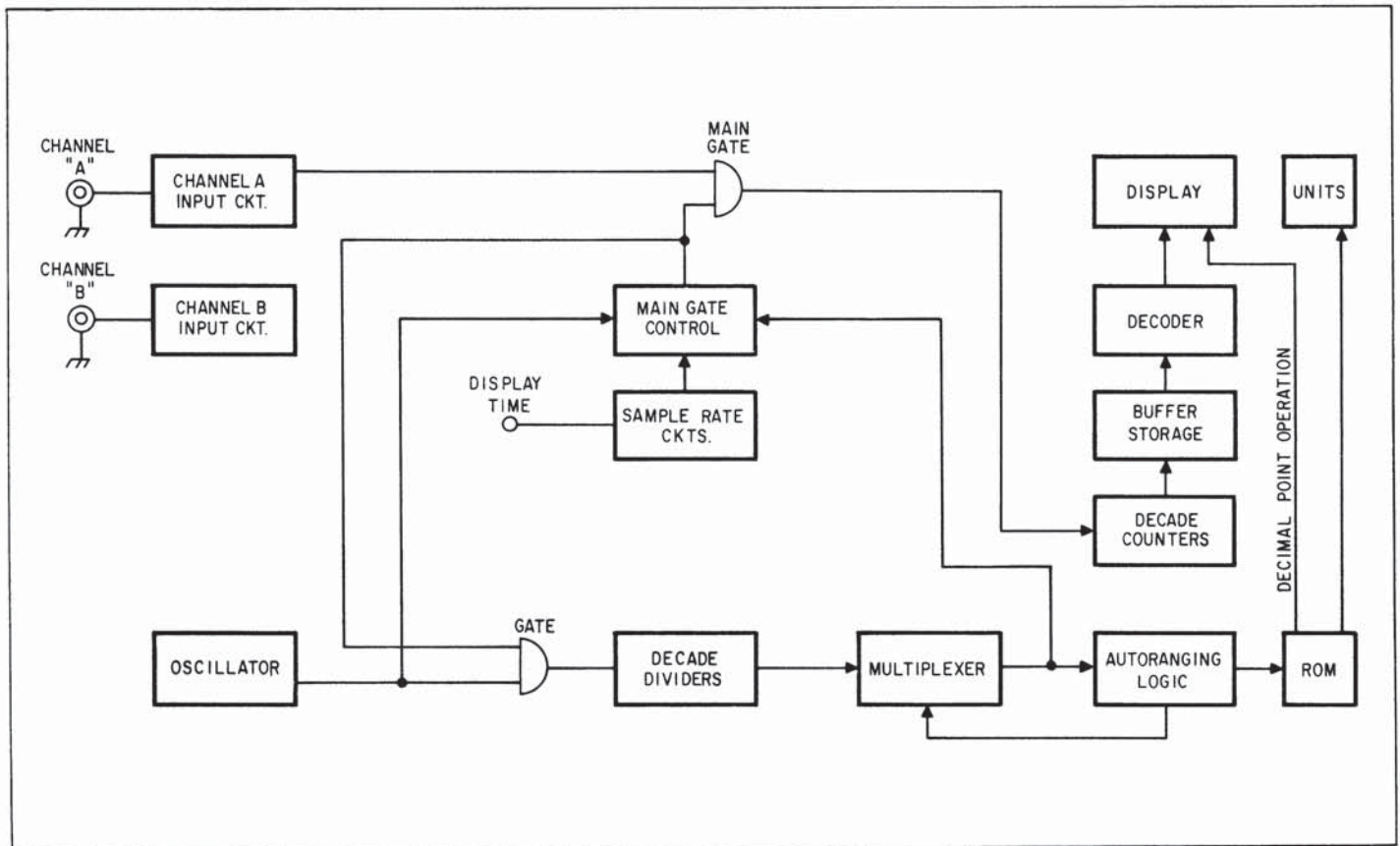

Figure 4-3. Frequency Mode Flow Diagram

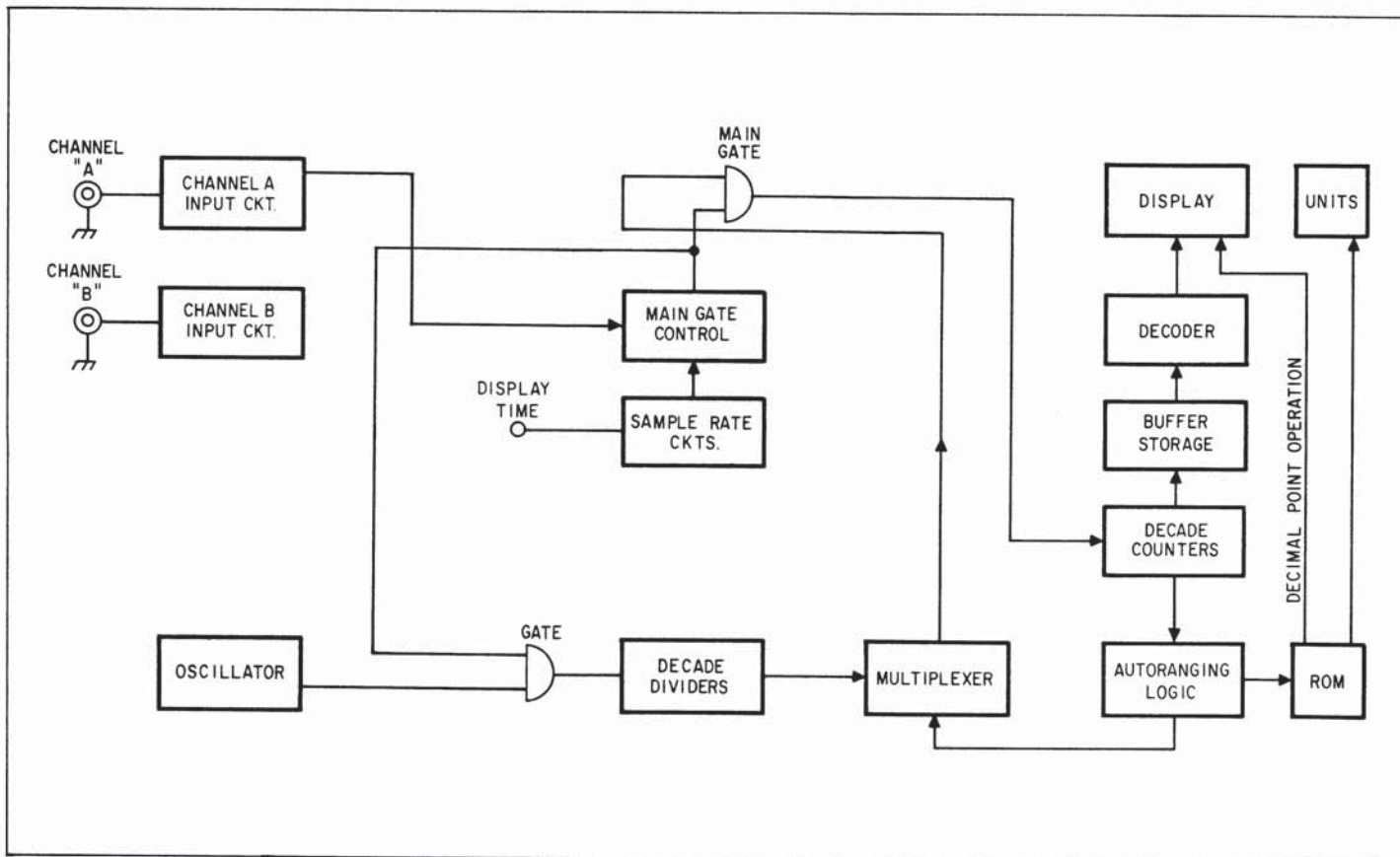

Figure 4-4. Period Mode Flow Diagram

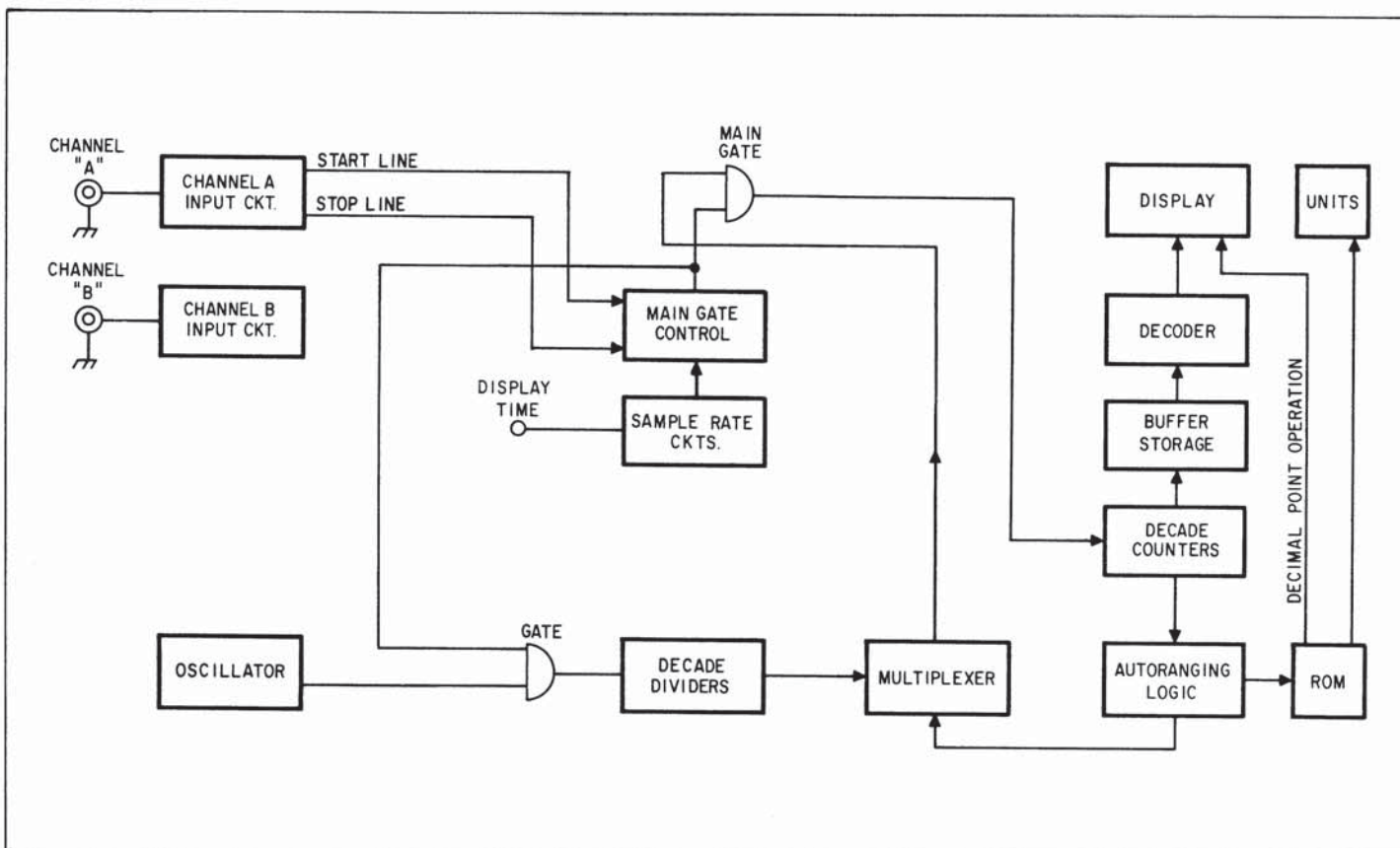

Figure 4-5. Positive or Negative Pulsewidth Flow Diagram

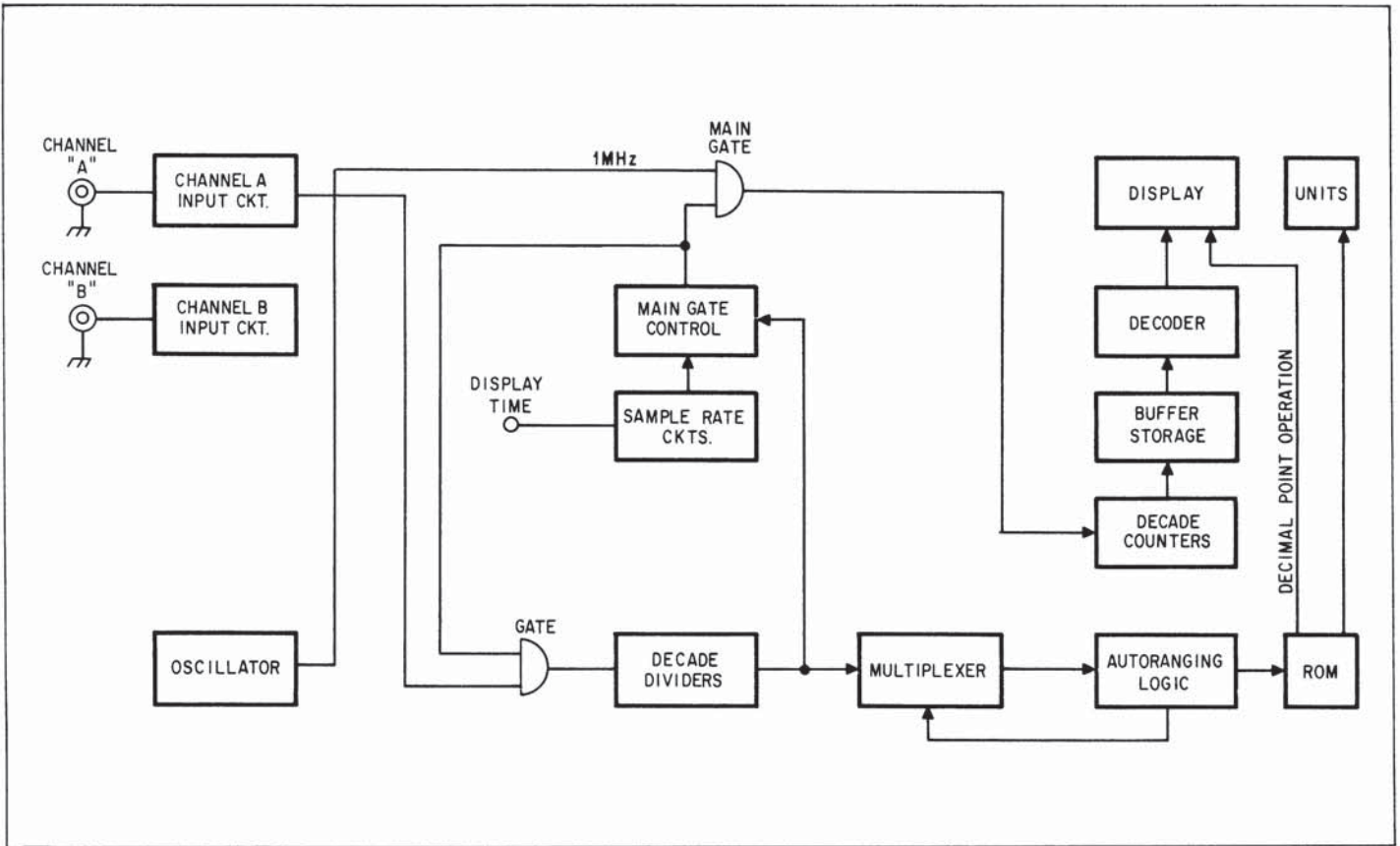

Figure 4-6. Period Average Mode Flow Diagram

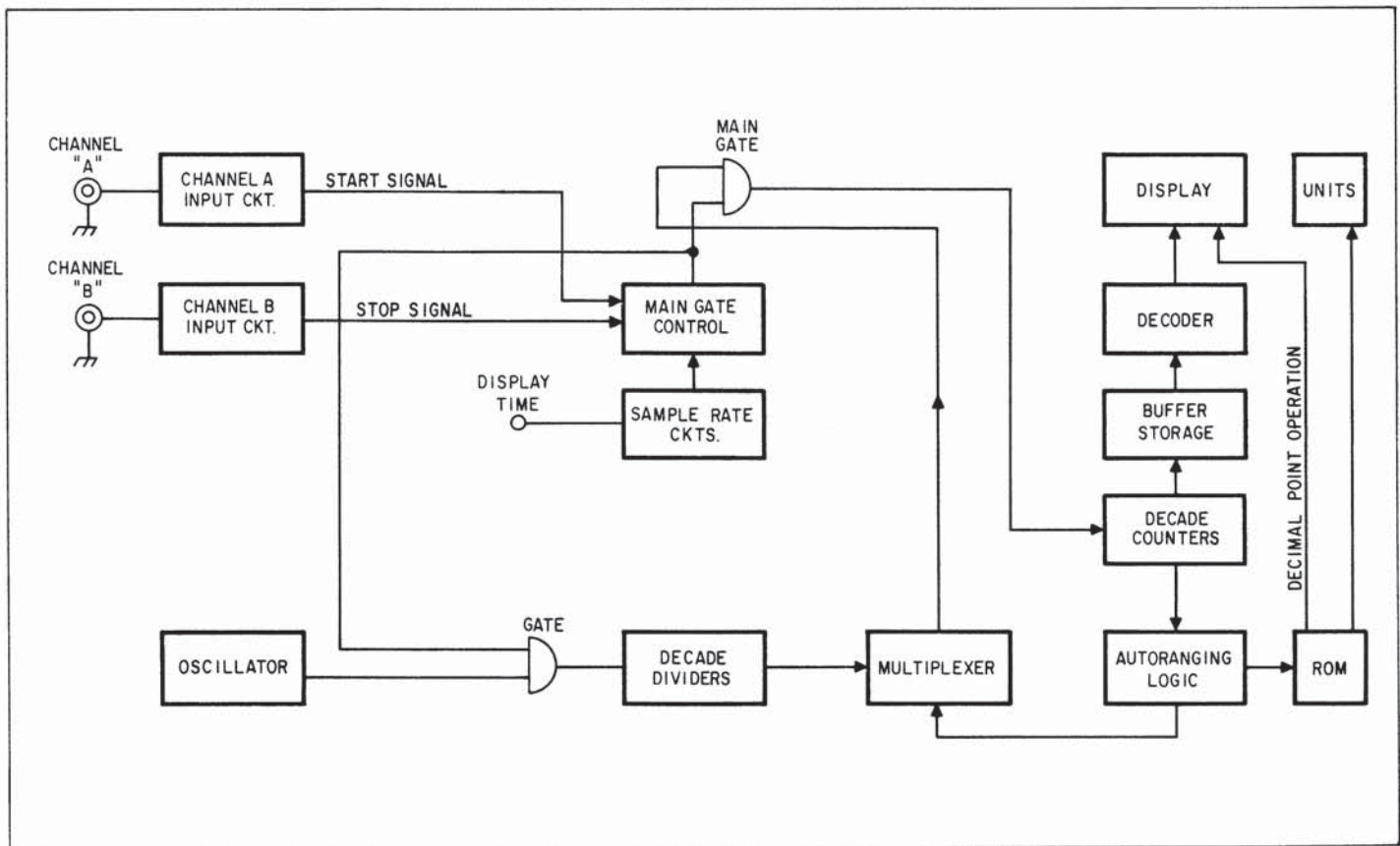

Figure 4-7. Time Interval A to B Mode Flow Diagram

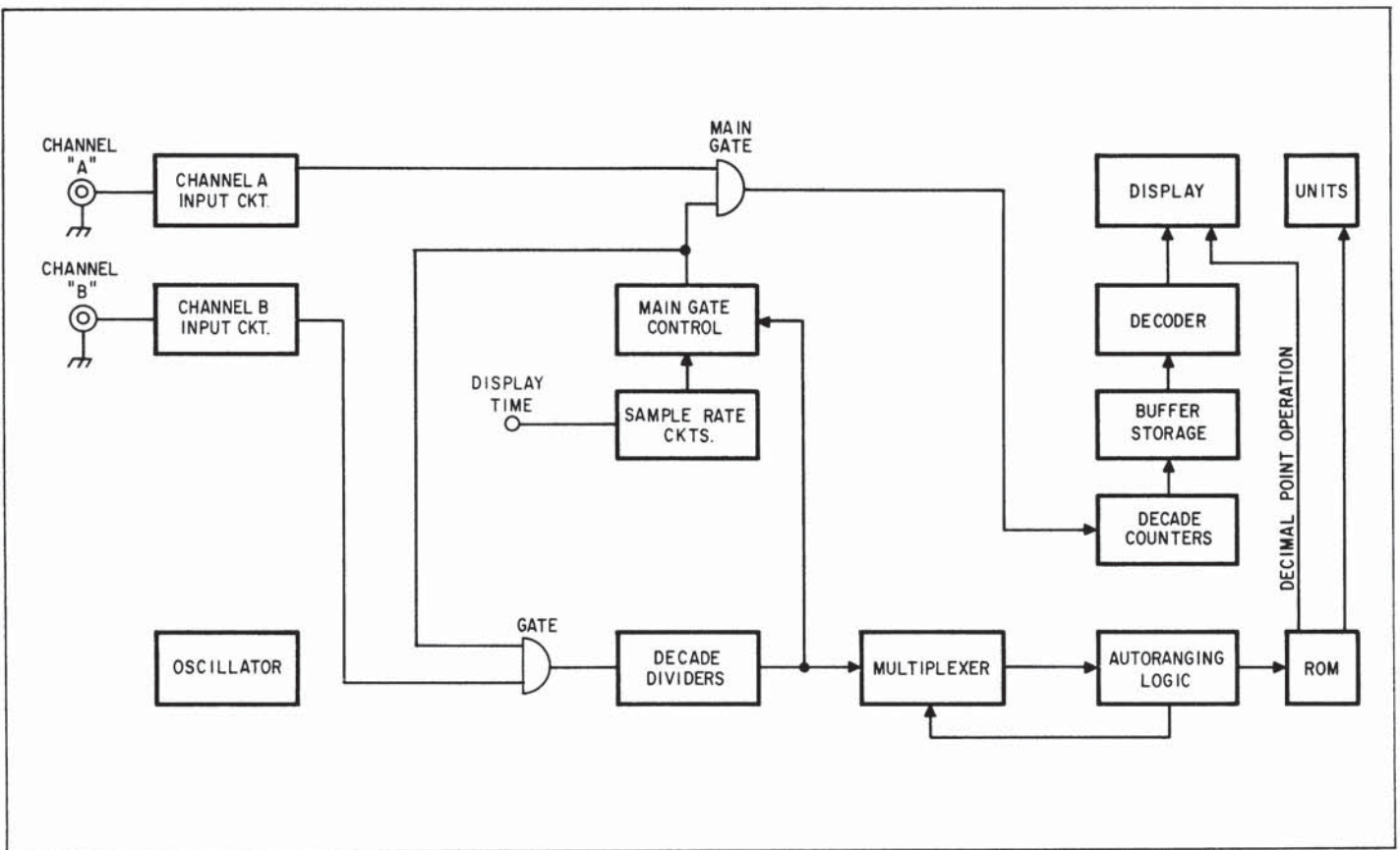

Figure 4-8. Ratio A/NB Mode Flow Diagram

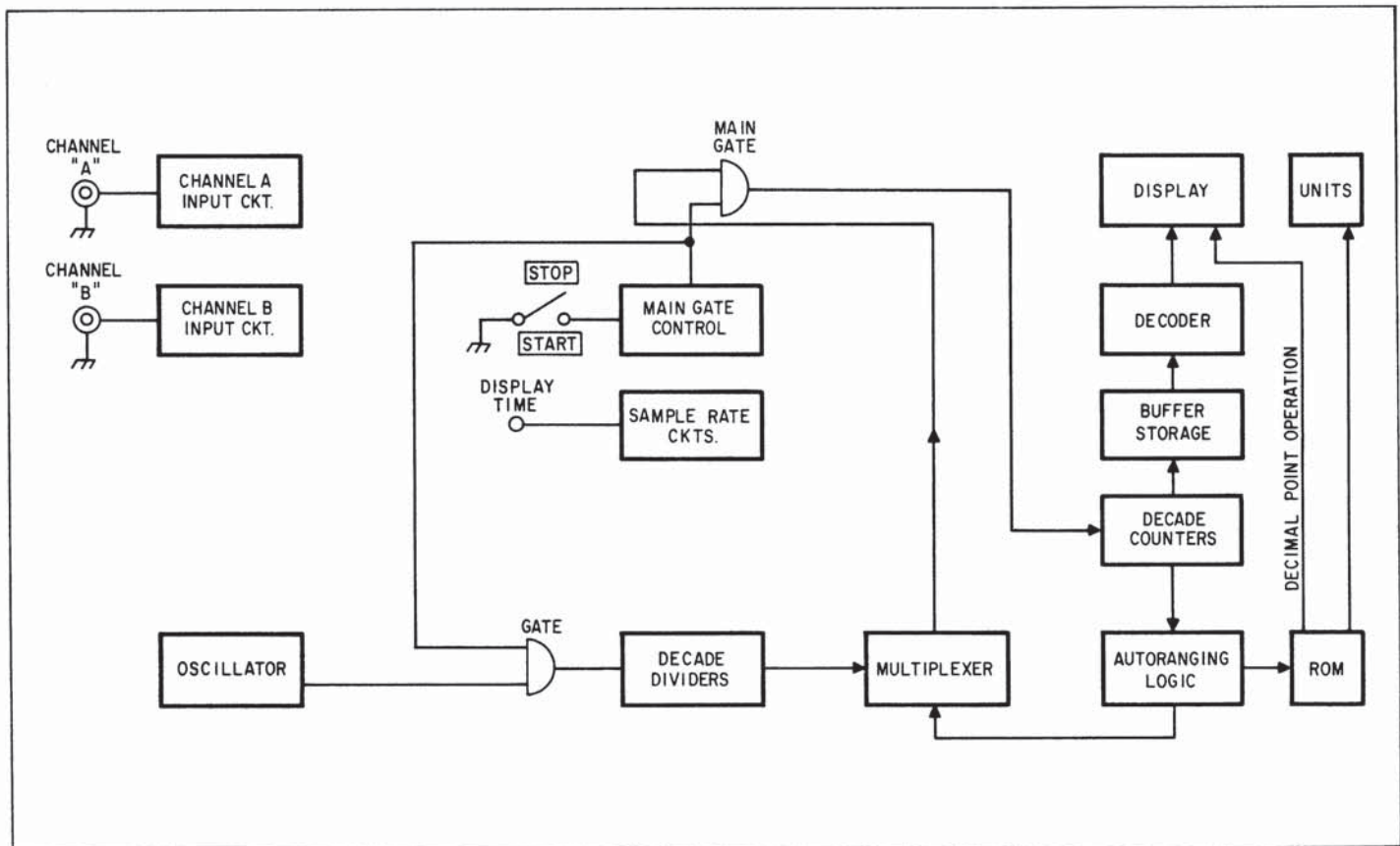

Figure 4-9. Elapsed Time Mode Flow Diagram

TRIG LEVEL control A1R9 selects the gate voltage of A3Q18B between -1 V and $+1\text{ V}$ approximately and thereby determines the triggering level. Maximum sensitivity is obtained when the triggering voltage is about zero volts. This is obtained when the TRIG LEVEL control is set to its mid position. A3R36 is a balance potentiometer which compensates for tolerance in the differential amplifier circuit.

The outputs of the differential amplifier A3Q19 and A3Q20 drive the emitter followers A3Q21 and A3Q22. These, in turn, drive differential amplifier A3U33A whose output is coupled to the input of Schmitt-trigger A3U33B. The Schmitt-trigger shapes the input waveform to provide well-defined edges for proper triggering.

4-4. CHANNEL B INPUT CIRCUIT.

The Channel B input signals are routed through A1J2, coupling selector A1S7, and attenuator A1S8 to the gate of A3Q30A. The coupling selector and attenuator are identical to those in the Channel A input circuit. Transistors A3Q30A, A3Q30B, A3Q31, and A3Q32 with their associated circuitry form a differential amplifier whose output is fed to the input of the integrated circuit Schmitt-trigger A3U37, which shapes the waveforms of the Channel B signal.

4-5. 10 MHz OSCILLATOR.

The 10 MHz oscillator consists of the integrated circuit A3U9 with its associated circuitry. A3U9A operates as an amplifier with positive feedback. It forms a very stable crystal-controlled oscillator, which can be adjusted to exactly 10 MHz by means of trimmer capacitors A3C5 and A3C7. The trimmer A3C7 is used for coarse adjustment while A3C5 is an eight-turn capacitor, accessible from the rear panel, which is used for fine adjustments. The oscillator output is fed to buffer amplifier A3U9B which minimizes the loading of the oscillator and prevents frequency variations due to loading.

4-6. EXT CLOCK IN/1 MHz CLOCK OUT CIRCUIT.

Connector A2J1 is used as an input point for an external clock and also for the output of a 1 MHz signal from the instrument. With switch A2S1 set to 1 MHz CLOCK OUT, the output of the oscillator buffer is fed to the Schmitt-trigger A3U9C and ECL to TTL level transistor A3Q1, A3Q2, and A3Q3, connected to the input of the decade divider A3U1. The 1 MHz clock signal at the output of A3U1 is supplied to the circuitry of the instrument and to A2J1. When the switch is set to EXT CLOCK IN, the external signal is applied to Schmitt-trigger A3U9C. When externally triggered, the input to A3U9C is protected against overload by a pair of diodes A3CR1 and A3CR2.

4-7. CONTROL LOGIC.

The control logic determines the start and stop functions for the count being taken, controls the routing of input

and time base signals, and the sequence of operation. The operation of the control logic will be described by an analysis of three of the operating modes.

Total (Count) Mode. With FUNCTION switch A1S1 set to TOTAL ON, the inputs to NAND gates A3U14C and A3U14D are low. The outputs of both gates are therefore high. This level is inverted to low at pin 6 of A3U14B. The high-gate signal from A3U14A enables main gate, pins 2 and 3 of A3U35A. Counting will continue until the FUNCTION switch is set to TOTAL OFF.

Frequency Mode. With the FUNCTION switch set to FREQ position, ground is applied to NAND gate A3U19A and inverter A3U18C. The high at the output of A3U19A enables A3U16A and A3U2A, and the high at the output of A3U18C enables A3U8B. All the inputs to NAND gate A3U20B are high, and the low at the output of the gate inhibits A3U16D. Main gate control flip-flops A3U15A and A3U15B are initially reset and the low at the Q output of A3U15B inhibits NAND gate A3U4C and enables NAND gates A3U6A and A3U6B. 1 MHz clock pulses are therefore routed through A3U8B, A3U8E, A3U16A, A3U16E, A3U6A and A3U6B to the clock input of D flip-flop A3U16B.

The first positive-going edge of the 1 MHz clock causes the Q output of A3U15B to adapt the state of the D input (i.e., logic high). In this state, all the inputs to A3U4C are high, and the low at the output of the gate prevents subsequent 1 MHz clock pulses from reaching the clock input of A3U15B. The low at the Q output of A3U15B toggles A3U15A to the set state and makes the gate signal at the output of A3U14A go high.

When the first four digits of the display have been filled (with RESOLUTION switch set to 5), or more exactly, when a count of 9900 is reached, the trigger input to J-K flip-flop A3U5A goes low and sets the flip-flop. When A3U5B is reset by the next pulse from the time base multiplexer, both inputs to NAND gate A3U17B are high and the low at its output sets flip-flop A3U4A, A3U4B. The low at the output of A3U4B is inverted to a high by A3U4C, which enables A3U6A. The next 1 MHz clock pulse is therefore routed to the clock input of A3U15B. Since its D input is low (because A3U15A is set) the positive-going edge of the 1 MHz clock makes the Q output of A3U15B go low, thereby ending the count interval.

The autoranging circuit, together with the circuit in the display unit which detects when a count of 9900 is reached, automatically selects the optimum gate time for maximum resolution, while preventing the display capacity from being exceeded. The time base multiplexer provides all the necessary timing signals beginning with a start pulse to indicate the measurement. This is followed by a succession of valid stop pulses at decade intervals of $1\ \mu\text{SEC}$, $10\ \mu\text{SEC}$, $100\ \mu\text{SEC}$ and so on up to 1 sec. The first available stop pulse following the 9900 count

is detected by J-K flip-flops A3U5A and A3U5B. The number of stop pulses counted by decade counter A3U12 before the display is filled determines the decimal point and unit information.

Operation in PERIOD mode is similar to operation in FREQ mode. However, in PERIOD mode the instrument counts the interval clock during one period of the input signal. Also, the decade counter in the autoranging circuit counts the "overflow" pulses from the most significant decade of the display unit, instead of the stop pulses from the time base multiplexer.

With the FUNCTION switch set at PERIOD, ground is applied to NAND gates A3U4C and A3U20B. The high at the output of A3U4C enables A3U6A, and the high at the output of A3U20B enables A3U16D, A3U17D and A3U8C. The signal from the Channel A input circuit is routed through A3U16D, A3U16E, A3U6A and A3U6B to the clock input of D flip-flop A3U15B. The first positive-going edge of the Channel A signal causes the Q output of A3U15B to go high. The low at the Q output sets A3U15A and makes the gate signal at the output of A3U14A go high.

The Channel A slope selection circuit comprises SLOPE switch A1S4, AND gates A3U31A to A3U31D, and NOR gates A3U31E, F. The circuit determines whether counting occurs between positive or negative edges of the input signal. When the switch is set at $\underline{\quad}$, ground is applied to NAND gate A3U31D and therefore the negative-going pulses from the input circuit are routed to the main gate control circuit.

When the gate signal goes high, 10 MHz clock pulses are routed through A3U8C, A3U8E, and A3U13B to the time base multiplexer. The output is fed through A3U17D and A3U17C to A3U34B. Since A3U34C is enabled, the internal clock is fed to the first decade counter stage. When the second positive-going edge of the Channel A signal appears, A3U15B changes state, thereby ending the count interval. The cycle is repeated when a reset pulse is generated.

While the instrument is counting, overflow pulses from the most significant decade are routed through A3U2C and A3U2D to decade counter A3U12. Until an "overflow" occurs, pulses at the highest time base frequency ($0.1 \mu\text{SEC}$) are routed to the first counter stage. When an overflow occurs, the next lower time base frequency is selected ($1 \mu\text{SEC}$). This process continues until the end of the count interval. The output of decade counter A3U12 provides the correct decimal point and unit indication.

4-8. SAMPLE RATE AND RESET CIRCUIT.

In order to ensure sufficient time for a visual readout of the measurement, a DISPLAY TIME control is provided on the front panel of the instrument. The purpose of this control is to provide a reset pulse for a selected time interval (0.2 to 5 seconds) after completion of a measurement. When the control is set to HOLD, the display is held indefinitely until the manual RESET pushbutton is depressed.

During the count interval, transistor A3Q7 is in saturation due to the high on its base from the main gate control circuit. At the end of the count interval, A3Q7 is cut off and causes capacitor A3C61 to start to charge. When the voltage across the capacitor reaches the unijunction transistor A3Q9 firing voltage, a negative-going pulse is produced and supplied to the reset multivibrator A3U30B and A3Q10. The output from A3Q10 resets the circuits in the instrument. A reset pulse can also be produced manually by operation of the RESET pushbutton A1S11. Setting of the DISPLAY TIME control to HOLD will cause the +15 V supply to be disconnected from the DISPLAY TIME control. Under this condition, A3C61 will not be charged and therefore no reset pulse will be generated.

The inhibit input is normally intended for use with an external digital printer, but if necessary, it can also be used independently to provide an external form of display control. A high level at A2J2-J22 will saturate A3Q8 and thereby inhibit the generation of a reset pulse.

4-9. GATE INDICATOR, TRANSFER, AND PRINT COMMAND CIRCUITS.

The gate indicator circuit controls the lighting of the GATE lamp. The output of NAND gate A3U14A, which is high during the count interval, is supplied through inverter A3U6C to NAND gate A3U28A and the pulse stretcher comprising A3U28B and A3U28D. The output of A3U28A is supplied to the display circuit for controlling the lighting of the GATE indicator. For short count intervals the pulse stretcher causes the GATE lamp to light for a longer interval, enabling it to be visible even when the count interval is very short.

The transfer circuit generates a positive-going pulse which transfers the content of the counting circuits to the storage and display units. The circuit also controls the transfer of decimal point and units information. The transfer pulse is generated automatically at the end of the count interval.

The print command circuit produces a positive-going pulse that instructs a digital printer to record the BCD information from the display circuits. The circuit comprises monostable A3U30A, A3U32C, and transistor A3Q5.

4-10. DISPLAY CIRCUIT.

The display circuit consists of eight decimal counting units, four eight-bit shift registers, a decoder, and eight numeric indicators. The display circuit also contains a coincidence circuit, a resolution selection circuit, and circuits for lighting the decimal points in the display numeric indicators and the GATE, OVER RANGE, and units indicator.

The 10^0 decimal counter comprises Shottky flip-flops U35 and U36 which are contained on the mother board. It counts the signal on the count line and when it reaches a

count of 10, it produces a carry pulse which is counted by the 10^1 decimal/BCD counter. The 10^1 counter drives the 10^2 counter, etc., in a similar manner.

The BCD outputs of the counters are fed to a multiplexing system having storage capability. Each bit of the 4-bit BCD code is supplied to one of the four 8-bit shift registers, A4U17 through A4U20. The registers are parallel-loadable with outputs fed back to the inputs to form a recirculating memory, storing the four BCD bits in parallel and the eight characters serially. The four lines of serial information are fed to the BCD-to-seven segment decoder unit A4U25 which drives the numerical display. All cathodes of the light-emitting diode numeric display are connected in parallel. Multiplexing of the numeric indicators is done by sequentially switching the anodes by the anode drivers A4Q1 through A4Q8, synchronous with the decoded BCD information from the shift registers.

For frequency measurements, the function of NAND gate A4U1 is to detect when a count of 999900 is reached. When this occurs, all the inputs to the gate go high and therefore the output goes low. This level causes the autoranging logic to select the first available stop pulse to end the gate time.

4-11. POWER SUPPLY.

The power supply provides ± 15 V and -5 V. The instrument may be operated from a 115-volt or 230-volt source. Switch A2S3 provides the proper power transformer connection according to the source used.

The +15 V output is regulated by the voltage regulator A3U38, while the -15 V output is regulated by A3U39. Both voltages are used as supply voltages for the input circuit.

The +5 V output is used as the supply voltage for all of the logic circuitry. Q12 is the series regulator and is driven by emitter follower A3Q11.

4-12. OPTIONS.

Parallel BCD Printer Output, Option 01. Option 01 provides for parallel BCD output for the eight digits of display in the Model 5500B. It is used for providing digital information for controlling a remote instrument or printer.

Specifications.

Type: Serial to parallel converter.

Logic: Positive true.

Form: Four-line BCD 1-2-4-8.

TTL compatible. Buffered for fan-out of one.

"1" state = 3.5 V dc to 5.7 V dc.

"0" state = 0 to 0.4 V dc.

Display Overrange: "1" signifies overrange.

Data Output Update Command: By "0" state of negative-going input pulse >10 μ s, or contact closure to digital common. New measurements made after update pulse will be displayed but will not appear at BCD

outputs. Maximum allowable update command rate, three per second.

Continuous Data Output Update Command: By holding "0" state, the BCD output is updated at an internal trigger rate of typically ten per second.

Busy Flag (Printer Inhibit): "1" state at Busy Flag output signifies BCD output in process of updating. During this interval, all Data Update command pulses from printer are ignored. "0" state signifies not Busy. Busy Flag internally modifiable to Ready.

Data Output "Pullup" Voltage: Normally "1" state (+5 V dc). Internal pullup through 15 k Ω . Modifiable to +12 V.

Connector: Mating connector (not supplied), Amphenol 57-30500-375, 50-pin Blue Ribbon, Ballantine P/N 31-10050-0A.

Input/Output Data. The input/output data available at the rear panel connector A2J2 is listed in Table 2-2. The pin assignments and the logic level requirements are listed in Table 4-2.

Note

The DISPLAY STORE switch A2S2 located on the rear panel must be in the ON position for proper BCD operation.

Data Update Input. The BCD output may be updated by either a Data Update pulse or a continuous update command. This feature operates as the conventional "inhibit" signal. The Data Update pulse at pin 23 of A2J2 must be a negative-going pulse having a width greater than 10 μ s. Measurement data accumulated by the counter after a Data Update pulse is received will not appear at the BCD output connector A2J2; however, the new data shown on the counter will be displayed. The DISPLAY STORE slide switch A2S2 on the rear panel of the counter must therefore always be in the ON position for meaningful BCD output operation.

The maximum allowable rate of Data Update is 50 kHz. The continuous Update command at pin 24, when held low, will cause the BCD output to be updated at the internal counter display multiplex refresh clock rate of approximately 5 kHz.

Busy Flag Output. The time period of actual updating of the BCD output serial to parallel converter is signified by a Busy Flag output at pin 22 of the BCD output connector A2J2. During this period all external update pulses are locked out and therefore ignored. A signal low shows not Busy. This feature operates as the conventional "print" command.

A simple modification on the BCD output printed circuit assembly permits the Busy Flag logic to be inverted and thereby used as a ready flag. A signal high on pin 22 of A2J2 will then show that the BCD output is ready for update. A signal low indicates not Ready since the serial to parallel converter is being updated by the counter.

To modify the Busy Flag, proceed as follows:

- a. Disconnect the power cord.
- b. Remove the top cover of the instrument case.
- c. Locate A8S71 (a wirelink switch near A8U74) on the BCD output assembly.
- d. Refer to the BCD schematic, Figure 7–7 and remove jumper wire A8S71-1, 2 to provide a ready flag.
- e. Replace the top cover and reconnect the power cord.

Data Output Pull-Up Voltage. The BCD output data lines are normally pulled up through 15 k Ω to the +5 V dc supply of the counter. A simple jumper modification at A8S72 on the BCD output assembly permits an external pull-up voltage (+5.7 V dc maximum) to be applied at pin 25 of the BCD output connector A2J2. To incorporate the external pull-up feature, proceed as follows:

- a. Disconnect the power cord.
- b. Remove the top cover of the instrument case.
- c. Locate A8S72 (a wire link switch) on the BCD output assembly.
- d. Refer to the BCD schematic, Figure 7–7, and remove jumper wire A8S72-4, 5 to disconnect the referral +5-volt supply.
- e. Install the jumper wire from A8S72-4 to A2J2-25 to provide the external pull-up voltage connection (maximum +5.7 V). Carefully solder the wire in place.
- f. Replace the top cover and reconnect the power cord.

BCD Output Cable. A six-foot long BCD output cable with mating 50-pin Blue Ribbon connectors (Ballantine Model 12253A) is available as an option.

Note

A2J2, pin 47, the 5-volt reference voltage output, is normally not supplied connected to the internal +5 volt supply. If this 5-volt reference is required, solder a small wire from A8J13-8 (dual in-line connector) to pin 47 of A2J2.

Schematic. See Figure 7–7 for a schematic of the parallel BCD output serial to parallel converter.

Remote Programming, Option 02. Option 02 permits remote electrical selection of all functions, time base ranges, and resolutions. A saturated transistor or contact closure to ground will provide the program command for one of nine functions and one of six time base/resolution ranges whenever the front-panel FUNCTION switch A1S1 is set to EXT PROG. Table 2–1 provides the connector pin assignments for A2J3.

Standard computer interface bus capability for the 5500B is available from Ballantine Laboratories. The micro-processor-based adapter unit is housed in a separate

enclosure and connects directly to A2J2 and A2J3 without modification of the 5500B.

High Stability Oscillator, Option 14. Option 14 is a high-stability, proportional oven quartz crystal oscillator with the following specifications:

Aging Rate After Warmup: ± 3 parts in 10^9 /day.

Fast Warmup Time: 4 minutes to ± 2 parts in 10^7 .

Typical Warmup For Off Periods To 1 Week: 72 hours to ± 5 parts in 10^9 /day.

Frequency Retrace For Off Periods To 24 Hours: 1 hour (typical) to reach ± 8 parts in 10^8 .

Short Term Aging Rate: ± 1 part in 10^9 rms for 10 seconds average.

Long Term Aging Rate: ± 3 parts in 10^8 in 30 days.

Temperature Variation: ± 1 part in 10^7 at 0°C to 50°C.

Line Voltage: $\pm 10\%$: ± 8 parts in 10^{10} .

The sealed oscillator assembly is mounted on assembly A8. It is powered from the +15-volt and –15-volt supplies. A 20-turn potentiometer control mounted on an accessible through the rear panel provides frequency adjustment.

Calibration.

- a. Connect a 10 MHz oscilloscope with X-Y capability, such as a Ballantine Model 1010B, to the clock output BNC connector A2J1 on the rear panel of the 5500B. Connect to the “Y” input of the oscilloscope.
- b. Connect a 1 MHz frequency standard, such as a WWV receiver or an atomic standard to the “X” input of the oscilloscope. Adjust the oscilloscope controls for an on-screen Lissajous figure display.
- c. Permit the 5500B counter and the frequency standard at least 72 to 96 hours of continuous warmup, with all covers on.
- d. Adjust the fine frequency screwdriver-adjustment control on the rear panel until a stable display is obtained on the oscilloscope. Observe the display for 3 to 10 minutes and make sure that the Lissajous figure holds stable and does not drift more than 90 electrical degrees.
- e. Continue the test for 8 hours and repeat Step d.

Calibration may also be made with a frequency standard and phase or frequency comparator capable of a resolution of one part in 10^{10} . Monitoring frequency drift with a chart recorder is recommended to determine drift over an extended period of time. See Figure 7–7 for a schematic of Option 14.

10 MHz Internal Clock Output Modification, Option 15. Option 15 modifies the output frequency from the normal 1 MHz to 10 MHz. This frequency is sometimes required in communications and factory-test applications. The modification described may be performed in the field by a qualified technician.

TABLE 4-2. INPUT/OUTPUT DATA AT CONNECTOR J2

Pin	Signal	Signal Logic		Logic Level	
		High	Low	"1"	"0"
1	Least Significant Digit	1	0	4.3 V to 5.7 V	0 to +0.4 V
2		2	0		
26		4	0		
27		8	0		
3	2nd Digit from LSD	1	0		
4		2	0		
28		4	0		
29		8	0		
5	3rd Digit from LSD	1	0		
6		2	0		
30		4	0		
30		8	0		
7	4th Digit from LSD	1	0		
8		2	0		
32		4	0		
33		8	0		
9	5th Digit from LSD	1	0		
10		2	0		
34		4	0		
35		8	0		
11	6th Digit from LSD	1	0		
12		2	0		
36		4	0		
37		8	0		
13	7th Digit from LSD	1	0		
14		2	0		
38		4	0		
39		8	0		
15	8th Digit from LSD (MSD)	1	0		
16		2	0		
40		4	0		
41		8	0		
17	μ SEC	—	μ SEC		
18	mSEC	—	mSEC		
42	SEC	—	SEC		
19	Decimal Point 1 (right)	On	—		
44	Decimal Point 2 (most)	On	—		
45	Decimal Point 3	On	—		
49	Decimal Point	On	—		
21	KHz	—	KHz		
46	MHz	—	MHz		
22	Busy Flag (Output)	Busy	Not Busy		
23	Data Update Pulse Input	—	Update (bus)		
24	Continuous Update Input	—	Update		
25	External Pull-up ($\pm 15V$)	—	—		
47	+5 Volt Reference (1 mA max)	—	—		
48	Overrange	—	Overrange		
50	Case Ground and Logic Command				

To modify the clock output of the 5500B for 10 MHz, proceed as follows:

- a. Disconnect and remove A3R1, a 220-ohm resistor. In its place, connect a 470-ohm, 1/2-watt, $\pm 5\%$ resistor (P/N 12127 120A), but connect one lead to pin 6 of A3U1 instead of to pin 5.
 - b. Add a 220 pF ceramic disc capacitor (P/N 07095750A) from the junction of A2S1 and A3R1 to ground.
- Set A2S1 for internal clock output at A2J1. The output is a 10-MHz waveform with high harmonic content. The

open-circuit voltage into a high-impedance oscilloscope probe is greater than 1 volt peak-to-peak.

A 50-ohm terminated coaxial cable distribution system is recommended for signal distribution. The signal level into a 50-ohm termination is greater than 250 mV peak-to-peak.

Although the clock output at A2J1 is short-circuit proof, no input voltage greater than 3 volts (dc + peak ac) should be applied.

SECTION 5

MAINTENANCE AND CALIBRATION

5-1. INTRODUCTION.

This section provides maintenance, calibration, and service information for the 5500B. Included are a table of recommended test equipment, input circuit adjustments, oscillator frequency adjustment, and an in-cabinet performance check which may be used to verify proper operation of the counter.

5-2. TEST EQUIPMENT.

Recommended test equipment for troubleshooting, alignment, and performance checking is listed in Table 5-1. Test instruments other than those listed may be used if their specifications equal or exceed the required characteristics.

5-3. INSTRUMENT COVER REMOVAL.

To remove the top or bottom cover, disconnect power cord and unlock four quarter-turn fasteners which secure cover to instrument. Then slide cover towards the top of instrument. To replace cover, reverse procedure.

WARNING

THE 115/230 VAC AND DC SUPPLY WIRES
ARE EXPOSED WHEN EITHER COVER IS
REMOVED. DISCONNECT THE POWER
CORD BEFORE REMOVING THE COVERS.

5-4. CLEANING.

The 5500B should be cleaned as often as operating conditions require. Accumulation of dirt in the instrument can cause overheating and component breakdown. Dirt on components acts as an insulating blanket and prevents efficient heat dissipation.

Thoroughly clean both the inside and outside of the instrument. Remove dust from inaccessible areas with low-pressure compressed air or vacuum cleaner. Use alcohol applied with a cleaning brush to remove accumulations of dirt or grease from connector contacts and component terminals. Clean the exterior of the instrument and the front panel with a mild detergent mixed with water, applying the solution with a soft, lint-free cloth.

5-5. VISUAL INSPECTION.

The 5500B should be inspected occasionally for such defects as broken connections, loose, broken or frayed wiring, dirty or pitted switch and connector contacts, and cracked or broken printed circuit boards. Often, before a total or partial failure occurs, a deteriorating component can be identified by discoloration or cracking. Care must be taken if heat-damaged parts are located; overheating is usually only a symptom of trouble. For this reason, it is essential to determine the actual cause of overheating before the heat-damaged part is replaced, otherwise, the damage may be repeated.

5-6. REPAIR AND REPLACEMENT.

Repair and replacement of electrical and mechanical parts must be accomplished with caution. Printed circuit component boards can become warped, cracked, or burned from excessive heat or mechanical stress. The following repair techniques are suggested to avoid inadvertent destruction or degradation of parts and assemblies.

Use ordinary 60/40 solder and a 35- to 40-watt pencil-type soldering iron on the circuit board. The tip of the iron

TABLE 5-1. RECOMMENDED TEST EQUIPMENT

REQUIREMENT	INSTRUMENT OR EQUIVALENT
50 kHz to 100 MHz, 5 mV to 5 V constant amplitude sinewave generator	Tektronix Type 191 Signal Generator
10 Hz to 10 MHz sinewave generator	HP Model 651A
10 MHz to 500 MHz oscillator	HP Model 3200 B
Oscilloscope having dc to 40 MHz minimum bandwidth. Dual Trace	Ballantine 1040A
Oscilloscope 15 MHz	Ballantine 1066A
Pulse Generator, 10 Hz to 50 MHz	EH Model G 710
1 MHz Frequency Standard	HP Model 105 A/B
Line Voltage Control Unit	General Radio W5MT3AW
True RMS Voltmeter	Ballantine 3620A
Digital Multimeter	Ballantine 3028A
Optional - Calibrator	Ballantine 6125A

should be clean and properly tinned for best heat transfer to the solder joint. A higher-wattage soldering iron may separate the circuit from the base material. To desolder components use a commercial "solder sipper."

Always replace a component with its exact duplicate as specified in the parts list.

To remove knobs simply pry off the end button of the knob. Hold the knob firmly with your fingers or a padded tool and use a screwdriver to loosen the clutch device holding the knob to the shaft. Do not loosen or tighten knob clutch by bearing against the end rotational stop of switches and potentiometers — always grasp the knob body firmly.

5-7. CHANNEL A INPUT CIRCUIT ADJUSTMENT.

- a. Connect a 50 kHz sinewave signal, 40 mV p-p, to the Channel A input.
- b. Set TRIG LEVEL to the PSET position.
- c. Connect an oscilloscope to the A OUT pin on the rear panel.
- d. Adjust trimpot R36 for best symmetry of waveform displayed on the oscilloscope.
- e. A slight readjustment might be necessary at the highest frequencies for the best result.

5-8. CHANNEL B INPUT CIRCUIT ADJUSTMENT.

- a. Connect a 1 MHz sinewave signal, 40 mV p-p, to the Channel B input.
- b. Connect probe of oscilloscope to the B OUT pin on the rear panel.
- c. Set TRIG LEVEL control to the PSET position.
- d. Adjust trimpot R37 for best symmetry of waveform displayed on oscilloscope.

5-9. TROUBLESHOOTING BY SELF-CHECK.

When a malfunction is suspected, disconnect all equipment from the counter and perform the self-check procedure given in paragraph 3-5. If counter does not self-check properly, refer to Section 4 for information on the operation of the circuits. If the counter self-checks properly, check that all inputs to the counter are within the limits of specifications. If malfunction still occurs, cause is internal to counter. Make performance checks (paragraph 5-10) to help determine the source of trouble.

5-10. IN-CABINET PERFORMANCE CHECK.

The following performance verifies proper operation of all circuits in the 5500B and may be used for any of the following:

- a. As part of an incoming inspection check of instrument specifications.
- b. Periodically, for instruments used in systems.

- c. As part of troubleshooting procedure.
- d. After any repairs or adjustments, before returning instrument to regular service.

Count Mode (Channel A).

1. Set TRIG LEVEL control to PSET.
2. Set SEP-COM-CHK switch to SEP.
3. Set DC-AC-LF switch to DC.
4. Set ATTEN switch to X1.
5. Connect sinewave signal 5 Hz to 1 MHz, 0.5 V p-p approximately to BNC input connector.
6. Press the RESET pushbutton.
7. Set FUNCTION switch to TOTAL ON.
8. Vary the frequency from 5 Hz to 1 MHz and verify correct counting for each digit separately.
9. Check the OVER RANGE indicator is operated when the counter capacity is exceeded for 5, 6, 7, or 8 digits resolution.
10. Set FUNCTION switch to TOTAL OFF. Check that the count stops and the reading is held.

Frequency Mode (Channel A).

1. Set FUNCTION switch to FREQ.
2. Set DC-AC-LF switch to DC.
3. Set SEP-COM-CHK switch to SEP.
4. Set ATTEN switch to X1.
5. Adjust input circuit as per paragraph 3-4.
6. Check the instrument according to Table 5-2. The exact input frequency is not important. Check for stable readings. The input BNC connector should be terminated into 50 ohms.
7. TRIG LEVEL control shall be set out of PSET and adjusted for best sensitivity at each frequency.

Period Mode (Channel A).

1. Set FUNCTION switch to PERIOD.
2. Set DC-AC-LF switch to DC.
3. Set SEP-COM-CHK switch to SEP.
4. Set ATTEN switch to X1.
5. Adjust input circuit as per paragraph 3-4, with a 100 ns pulse, 0.5 V amplitude and rate of approximately 1 kHz. The input BNC connector should be terminated into 50 ohms.
6. Check the instrument according to Table 5-3. The exact input period is not important. Check for stable readings.

Positive and Negative Pulse Modes (Channel A).

1. Set FUNCTION switch to positive pulse.
2. Set DC-AC-LF switch to DC.

TABLE 5-2. FREQUENCY MODE PERFORMANCE CHECK

NO.	RESOLUTION SWITCH	INPUT AMPLITUDE		FREQUENCY	READING
		mV rms	mV p-p		
1	5	165	460	110 MHz	110 MHz
2	6	165	460	110 MHz	110 MHz
3	7	165	460	110 MHz	110 MHz
4	8	165	460	110 MHz	110 MHz
5	5	50	140	10 MHz	10.000 MHz
6	6	50	140	10 MHz	10000.0 KHz
7	7	50	140	10 MHz	10000.00 KHz
8	8	50	140	10 MHz	10000.000 KHz
9	5	25	70	1 MHz	1000.0 KHz
10	6	25	70	1 MHz	1000.00 KHz
11	7	25	70	1 MHz	1000.000 KHz
12	8	25	70	1 MHz	1000.000 KHz
13	5	25	70	100 KHz	100.00 KHz
14	6	25	70	100 KHz	100.000 KHz
15	7	25	70	100 KHz	100.000 KHz
16	8	25	70	100 KHz	100.000 KHz
17	5	25	70	10 KHz	10.000 KHz
18	6	25	70	10 KHz	10.000 KHz
19	7	25	70	10 KHz	10.000 KHz
20	8	25	70	10 KHz	10.000 KHz
21	5	25	70	1 KHz	1.000 KHz
22	6	25	70	1 KHz	1.000 KHz
23	7	25	70	1 KHz	1.000 KHz
24	8	25	70	1 KHz	1.000 KHz
25	5	25	70	100 Hz	.100 KHz
26	6	25	70	100 Hz	.100 KHz
27	7	25	70	100 Hz	.100 KHz
28	8	25	70	100 Hz	.100 KHz
29	1 sec	25	70	100 Hz	.100 KHz
30	10 sec	25	70	100 Hz	.1000 KHz

3. Set SEP-COM-CHK switch to SEP.

4. Set ATTEN switch to X1.

5. Adjust input circuit as per paragraph 3-4 with a 20 μ s positive pulse and 1:4 duty ratio and 0.5 V amplitude.

6. Check for a reading of 20 μ SEC with the FUNCTION switch set to positive pulse and 80 μ SEC when set to negative pulse. Verify that the slope switches do not influence the readings.

Period Average Mode (Channel A).

1. Set FUNCTION switch to PERIOD AVG.

2. Set DC-AC-LF switch to DC.

3. Set SEP-COM-CHK switch to SEP.

4. Set ATTEN switch to X1.

5. Set TRIG LEVEL control to PSET.

6. Connect sinewave signal 5 Hz to 1 MHz, 0.5 V p-p, to BNC input connector.

7. Check the instrument according to Table 5-4.

8. Check 10 Hz (100 mSEC) signal with 5 digit resolution. Verify that the OVER RANGE indicator lights up.

Time A→B Mode.

1. Set FUNCTION switch to TIME A→B.

2. Set DC-AC-LF switch to DC (Channel A.)

3. Set SEP-COM-CHK switch to SEP.

4. Set ATTEN switch to X1.

5. Set the DISPLAY TIME control to about midway.

6. Set the SLOPE switches of Channels A and B according to Table 5-5. Verify the opening of the counter gate while rotating the Channel A TRIG LEVEL control from fully clockwise (+) to fully anticlockwise (-), or the opposite, and the closure of the gate, in the same way for Channel B.

TABLE 5-3. PERIOD MODE PERFORMANCE CHECK

NO.	RESOLUTION SWITCH	RATE	PERIOD	READING
1	5	0.1 Hz	10 sec	10.000 sec
2	6	0.1 Hz	10 sec	10000.0 msec
3	7	0.1 Hz	10 sec	10000.00 msec
4	8	0.1 Hz	10 sec	10000.000 msec
5	5	1 Hz	1 sec	1000.0 msec
6	6	1 Hz	1 sec	1000.00 msec
7	7	1 Hz	1 sec	1000.000 msec
8	8	1 Hz	1 sec	1000000.0 μ sec
9	5	10 Hz	0.1 sec	100.00 msec
10	6	10 Hz	0.1 sec	100.000 msec
11	7	10 Hz	0.1 sec	100000.0 μ sec
12	8	10 Hz	0.1 sec	1000000.0 μ sec
13	5	100 Hz	10 msec	10.000 msec
14	6	100 Hz	10 msec	10000.0 μ sec
15	7	100 Hz	10 msec	10000.0 μ sec
16	8	100 Hz	10 msec	10000.0 μ sec
17	5	1 KHz	1 msec	1000.0 μ sec
18	6	1 KHz	1 msec	1000.0 μ sec
19	7	1 KHz	1 msec	1000.0 μ sec
20	8	1 KHz	1 msec	1000.0 μ sec
21	5	10 KHz	100 μ sec	100.0 μ sec
22	6	10 KHz	100 μ sec	100.0 μ sec
23	7	10 KHz	100 μ sec	100.0 μ sec
24	8	10 KHz	100 μ sec	100.0 μ sec
25	5	100 KHz	10 μ sec	10.0 μ sec
26	6	100 KHz	10 μ sec	10.0 μ sec
27	7	100 KHz	10 μ sec	10.0 μ sec
28	8	100 KHz	10 μ sec	10.0 μ sec
29	5	1 MHz	1 μ sec	01.0 μ sec
30	5	3.3 MHz	0.3 μ sec	00.3 μ sec

TABLE 5-4. PERIOD AVERAGE PERFORMANCE CHECK

NO.	RESOLUTION SWITCH	RATE	PERIOD	READING
1	5	1 MHz	1 μ sec	1.000 μ sec
2	5	100 KHz	10 μ sec	10.000 μ sec
3	5	10 KHz	100 μ sec	100.00 μ sec
4	5	1 KHz	1 msec	1000.0 μ sec
5	5	100 Hz	10 msec	10000 μ sec
6	6	10 Hz	100 msec	100000 μ sec
7	7	5 Hz	0.2 sec	200000.0 μ sec
8	8	5 Hz	0.2 sec	200000.00 μ sec

7. Set SEP-COM-CHK switch to COM.

8. Adjust input circuit as per paragraph 3–4, with a 20 μ sec positive pulse and 1:4 duty ratio and 0.5 V amplitude.

9. Set SLOPE switches of Channels A and B according to Table 5–6 and verify the correct readings.

A/NB (Ratio) Mode.

1. Set FUNCTION switch to A/NB.

2. Connect internal oscillator output from rear panel BNC (1 MHz) to Channel A input. Adjust input circuit as per paragraph 3–4.

3. Set SEP-COM-CHK switch to SEP.

4. Connect sinewave oscillator to Channel B input. Terminate into 50 ohms. Adjust input circuit as per paragraph 3–4.

5. Check the instrument according to Table 5–7. The exact input frequency of Channel B is not important. Check for stable readings.

Time-Interval Mode.

1. Set FUNCTION switch to TIME INTVL.

2. Short the EXT PROG connectors on the rear panel to start timing, and open to stop. For instruments equipped with Option 02 (Remote Programming), short pins 23 and 24 to start timing, and open to stop.

3. Observe correct timing and operation of the GATE indicator.

5–11. OSCILLATOR CALIBRATION.

1. Trigger the oscilloscope from 1 MHz frequency standard or WWV receiver.

2. Observe 1 MHz signal from 1 MHz CLOCK OUT BNC on the rear panel of the 5500B on the vertical axis of the scope.

3. Adjust OSC ADJ trimmer on the rear panel of the 5500B with a plastic screwdriver until pattern on the oscilloscope stops drifting. It is important that this adjustment is made after at least 24 hours of continuous operation of the 5500B.

Note

NBS WWV standard ratio transmissions may also be used with a phase comparator system. Monitoring with a chart recorder is a good technique.

Instead of scope timebase triggering an X-Y Lissajous figure is also recommended to observe proper 5500B clock frequency adjust. Refer to paragraph 4–15.

5–12. PACKING.

The 5500B is a rugged instrument built to perform in severe environments. If the unit is to be shipped or stored for long periods of time the following packing procedure is recommended:

a. Place the 5500B into an oversize plastic bag and seal the bag.

b. Place the bagged 5500B into a heavy duty corrugated cardboard box. The box must contain at least 2 inches of rubberized hair or equivalent cushion on all six sides of the instrument. The counter must fit snugly into the cushion and the cushion must fit into the box to prevent any movement of the instrument in transit.

c. If accessories are also to be packed put them into a separate plastic bag and pack into the cushion leaving at least two inches of cushion between the instrument and the accessories as well as an extra cushion between accessories and the box.

d. Seal the box fully with 2- or 3-inch wide packing tape.

e. Properly label and address outside of box.

If shipment is to the factory, notify Ballantine in advance and include detailed reasons for return inside box along with your name, company name, and full mailing address. Also include your telephone number and purchase order number.

Ship prepaid to:

Ballantine Laboratories, Inc.
90 Fanny Road
Post Office Box 97
Boonton, NJ USA 07005

TABLE 5–5. TIME A→B PERFORMANCE CHECK

SLOPE A	SLOPE B	A TRIG LEVEL From → to	B TRIG LEVEL From → to
Pos Slope	Pos Slope	+ → –	+ → –
Pos Slope	Neg Slope	+ → –	– → +
Neg Slope	Neg Slope	– → +	– → +
Neg Slope	Pos Slope	– → +	+ → –

TABLE 5-6. TIME A→B SLOPE SELECTION CHECK

SLOPE A	SLOPE B	READING
Pos Slope	Pos Slope	100.0 μ sec
Pos Slope	Neg Slope	20.0 μ sec
Neg Slope	Neg Slope	100.0 μ sec
Neg Slope	Pos Slope	80.0 μ sec

TABLE 5-7. A/NB RATIO MODE

NO	RESOLUTION	CHANNEL B FREQUENCY	AMPLITUDE mV p-p	READING
1	5	10 MHz	130	.100
2	5	1 MHz	60	1.000
3	5	100 KHz	60	10.000
4	5	10 KHz	60	100.00
5	5	1 KHz	60	1000.0
6	5	100 Hz	60	10000
7	6	10 Hz	60	100000

SECTION 6

PARTS LIST

The replacement parts listed are available from the vendors listed or from Ballantine Laboratories. Your local Ballantine Field Engineering Representative may also carry a stock of parts and can assist you. If pricing quotations are required for parts and or repairs your local representative will give the most rapid service or you may contact the Ballantine Factory directly.

When ordering replacement parts always give the following information:

- a) Instrument Model number
- b) Serial number
- c) Ballantine Part number
- d) Schematic Symbol number
- e) Identification and description of the part

Ballantine will do its best to improve the instrument and make changes in style of components and replacement parts. Replacement parts may differ in appearance from those found in your instrument but are always equal or superior in performance. Where necessary minor mechanical modifications may be required in the replacement of the components.

Parts are generally available locally for most replacements. The parts list calls out the recommended vendors where applicable.

The instrument may substitute alternate components but the use of parts specified in this parts list is recommended. A part similar to the part initially installed at the factory may be used, i.e., a 5% composition resistor may be replaced with a similar part or a 5% film resistor or the preferred 1% metal film resistor. Use of the preferred component will always simplify calibration and speed repairs.

Any selected component is generally identified in this manual and may be replaced with a similarly valued part unless reselection is required due to replacement or change of its related part. The schematics and calibration procedures identify selected components and replacement procedures.

The Manufacturer Code is taken from Federal Supply Code Cataloging Handbooks H4-1, H4-2, and H4-3. Ballantine Code is 50423.

The following parts coding are used:

CVC	Capacitor, Variable, Ceramic
CCT	Capacitor, Ceramic, Tubular
CFP	Capacitor, Fixed, Plastic
CCD	Capacitor, Ceramic, Disc
CYF	Capacitor, Mylar, Foil
CMD	Capacitor, Mica, Dipped
CMM	Capacitor, Mica, Molded
CEA	Capacitor, Electrolytic, Aluminum
CET	Capacitor, Electrolytic, Tantalum
DGP	Diode, General Purpose
DZG	Diode, Zener, General Purpose
DRP	Diode, Bridge, Power
FLT	Filter
ICP	Integrated Circuit
TRQ	Transistor
RFF	Resistor, Fixed, Film
RFC	Resistor, Fixed, Composition
RVC	Resistor, Variable, Composition
RFW	Resistor, Fixed, Wirewound
SWC	Switch
LMP	Lamp
TRX	Transformer

Resistors may generally be replaced by Corning Electronics (CCW) type N-55, N-60 and C-32. Allen Bradley carbon composition resistors type EB may also be used but should generally be avoided (except for emergency replacements) in favor of the preferred part listed in this parts list.

5500B PARTS LIST

SCHEMATIC REF	BALLANTINE PART NO.	DESCRIPTION	MFR CODE	MFR PART NUMBER
A 1	---	FRONT PANEL ASSEMBLY	50423	
C 1	07100050A	CYF 22.0NF 600 V		STETNER-TRU MKT1813-322/6
C 2	07100060A	CCD 4.7PF 500 V DISC	90201	RMC TYPE CG
C 3	07100070A	CCD 47.0PF 500 V DISC	90201	RMC TYPE CG
C 4	07100080A	CCD 470.0PF 1000 V DISC	90201	RMC TYPE B
C 5	07025430A	CCD 1.5NF 3 KV M -20+80%	72982	ERIE 878 HI-K DISC Y5V
C 6	07100050A	CYF 22.0NF 600 V		STETNER-TRU MKT1813-322/6
C 7	07100060A	CCD 4.7PF 500 V DISC	90201	RMC TYPE CG
C 8	07100070A	CCD 47.0PF 500 V DISC	90201	RMC TYPE CG
C 9	07100080A	CCD 470.0PF 1000 V DISC	90201	RMC TYPE B
C 10	07025430A	CCD 1.5NF 3 KV M -20+80%	72982	ERIE 878 HI-K DISC Y5V
DS 1	16100000A	LMP PAN GALIUM ARSENIDE	28480	(HP)-5082-4440
J 1	31033790A	CON UG-1094/U BNC	29587	AMPHENOL UG-1094/U
J 2	31033790A	CON UG-1094/U BNC	29587	AMPHENOL UG-1094/U
R 1	12126000A	RFF 1.00M 500 MW F+-1%	16299	CGW TYP NA 65
R 2	12125000A	RFF 100.0 K 500 MW F+-1%	16299	CGW NA 60
R 3	12124000A	RFF 10.0 K 500 MW F+-1%	16299	CGW NA 60
R 4	12125000A	RFF 100.0 K 500 MW F+-1%	16299	CGW NA 60
R 5	12126000A	RFF 1.00M 500 MW F+-1%	16299	CGW TYP NA 65
R 6	12125000A	RFF 100.0 K 500 MW F+-1%	16299	CGW NA 60
R 7	12124000A	RFF 10.0 K 500 MW F+-1%	16299	CGW NA 60
R 8	12125000A	RFF 100.0 K 500 MW F+-1%	16299	CGW NA 60
R 9	09400001A	RVC 5.0 K .25W LINEAR/SPST	50423	
R 10	09400001A	RVC 5.0 K .25W LINEAR/SPST	50423	
R 11	09400011A	RVC 250.0 K .25 W LOG/SPST	50423	
S 1	25400201C	SWC ROT DUAL CONC SP12P/SP5P	50423	
S 2	25400201C	SWC ROT DUAL CONC SP12P/SP5P	50423	
S 3	---	SWC SPST SUPLD WITH R9		
S 4	25100220A	SWC SLIDE MIN DPDT	78488	STACKPOLE SS-91-1
S 5	25100210A	SWC SLIDE MIN DP3T	78488	STACKPOLE SS-.0
S 6	25100210A	SWC SLIDE MIN DP3T	78488	STACKPOLE SS-.0
S 7	25100210A	SWC SLIDE MIN DP3T	78488	STACKPOLE SS-.0
S 8	25100210A	SWC SLIDE MIN DP3T	78488	STACKPOLE SS-.0
S 9	25100220A	SWC SLIDE MIN DPDT	78488	STACKPOLE SS-91-1
S 10	---	SWC SPST SUPLD WITH R10		
S 11	25100020A	SWC MOM PB SPST NO	81073	GRAYHILL 30-1(0130-15)
S 12	---	SWC SPST SUPLD WITH R11		
S 13	25100210A	SWC SLIDE MIN DP3T	78488	STACKPOLE SS-.0
A 2	---	REAR PANEL ASSEMBLY	50423	
F 1	19034110A	FUS .5AMP SLOBLow TYPE 3AG	75915	LITTELFUSE 313.500
F1 1	14100000A	REG LINE SURGE SUPPRESSOR	24446	GE VP 150A10
J 1	31033790A	CON UG-1094/U BNC	29587	AMPHENOL UG-1094/U
J 2	31095130A	CON BLUE RIBBON, PANEL MTG.	29587	50 PIN AMPHENOL 57-40500
J 3	31095110A	REC	29587	AMPHENOLL#57-40240
J 4	31100000A	REC AC POWER	82389	SWITCHCRAFT
S 1	25077860A	SWC LINE VOLTAGE-SLIDE	82389	SWITCHCRAFT #46256LF
S 2	25100220A	SWC SLIDE MIN DPDT	78488	STACKPOLE SS-91-1
S 3	25077860A	SWC LINE VOLTAGE-SLIDE	82389	SWITCHCRAFT #46256LF
T 1	20400520A	TRX PWR XFORM FOR 5500B	50423	

5500B PARTS LIST - Continued

SCHEMATIC REF	BALLANTINE PART NO.	DESCRIPTION	MFR CODE	MFR PART NUMBER
A 3	89104471A	MOTHERBOARD ASSEMBLY	50423	
C 1	07100530A	CET 10.0UF 35.0V M	56289	SPRAGUE 1960106X0035A3
C 2	07095610A	CCD 1 NF 1 KV K 10%	84171	ARC TYP CCS-102
C 3	07025360A	CCD 20 NF	09023	GMC C-D TYPE BYB-6S2
C 4	07100530A	CET 10.0UF 35.0V M	56289	SPRAGUE 1960106X0035A3
C 5	07101880A	CVP 10.0PF 750.0 V 2-10PF	50423	JACKSON 5750/HPC RT ANGLE
C 6	07022410A	CMM 15 PF 500 V J 5%	84171	ARCO TYPE CM15-C-150-J
C 7	07102710A	CVC004.0-20PF TRIM. PC MOUNT	50423	ST-TR 105-06 TRIKO
C 8	07100530A	CET 10.0UF 35.0V M	56289	SPRAGUE 1960106X0035A3
C 9	07095590A	CCD 150 PF K 10%	84171	ARC TYP CCD-151
C 10	07025360A	CCD 20 NF	09023	GMC C-D TYPE BYB-6S2
C 11	07100530A	CET 10.0UF 35.0V M	56289	SPRAGUE 1960106X0035A3
C 12	07100130A	CCC 100 NF 50 V CHIPCAP	50423	
C 13	07100130A	CCC 100 NF 50 V CHIPCAP	50423	
C 14	07100530A	CET 10.0UF 35.0V M	56289	SPRAGUE 1960106X0035A3
C 15	07100860A	CCD 68.0PF 500 V	90201	RMC TYPE CG
C 16	07100530A	CET 10.0UF 35.0V M	56289	SPRAGUE 1960106X0035A3
C 17	07095600A	CCD 33 PF K 10%	84171	ARC TYP CCD-330
C 18	07100530A	CET 10.0UF 35.0V M	56289	SPRAGUE 1960106X0035A3
C 19	07100130A	CCC 100 NF 50 V CHIPCAP	50423	
C 20	07095610A	CCD 1 NF 1 KV K 10%	84171	ARC TYP CCS-102
C 21	07100130A	CCC 100 NF 50 V CHIPCAP	50423	
C 22	07100530A	CET 10.0UF 35.0V M	56289	SPRAGUE 1960106X0035A3
C 23	07095610A	CCD 1 NF 1 KV K 10%	84171	ARC TYP CCS-102
C 24	07100130A	CCC 100 NF 50 V CHIPCAP	50423	
C 25	07100130A	CCC 100 NF 50 V CHIPCAP	50423	
C 26	07100130A	CCC 100 NF 50 V CHIPCAP	50423	
C 27	07100130A	CCC 100 NF 50 V CHIPCAP	50423	
C 28	07100130A	CCC 100 NF 50 V CHIPCAP	50423	
C 29	07100530A	CET 10.0UF 35.0V M	56289	SPRAGUE 1960106X0035A3
C 30	07100810A	CCD 3.3PF 500. V	90201	RMC TYPE GG
C 31	07025360A	CCD 20 NF	09023	GMC C-D TYPE BYB-6S2
C 32	07100130A	CCC 100 NF 50 V CHIPCAP	50423	
C 33	07100530A	CET 10.0UF 35.0V M	56289	SPRAGUE 1960106X0035A3
C 34	07100830A	CET 1.5 UF 35 V DISC	56289	SPRAGUE 1960155X0035A3
C 35	07100830A	CET 1.5 UF 35 V DISC	56289	SPRAGUE 1960155X0035A3
C 36	07100080A	CCD 470.0PF 1000 V DISC	90201	RMC TYPE B
C 37	07095610A	CCD 1 NF 1 KV K 10%	84171	ARC TYP CCS-102
C 38	07100130A	CCC 100 NF 50 V CHIPCAP	50423	
C 39	07100530A	CET 10.0 UF 35.0 V M	56289	SPRAGUE 1960106X0035A3
C 40	07100130A	CCC 100 NF 50 V CHIPCAP	50423	
C 41	07100860A	CCD 68.0PF 500 V	90201	RMC TYPE CG
C 42	07095610A	CCD 1 NF 1 KV K 10%	84171	ARC TYP CCS-102
C 43	07100130A	CCC 100 NF 50 V CHIPCAP	50423	
C 44	07100530A	CET 10.0 UF 35.0 V M	56289	SPRAGUE 1960106X0035A3
C 45	07095590A	CCD 150 PF K 10%	84171	ARCO TYPE CCD-151
C 46	07095590A	CCD 150 PF K 10%	84171	ARCO TYPE CCD=151
C 47	07025360A	CCD 20 NF	09023	GMC C-D TYPE BYB-6S2
C 48	07025360A	CCD 20 NF	09023	GMC C-D TYPE BYB-6S2
C 49	07025360A	CCD 20 NF	09023	GMC C-D TYPE BYB-6S2
C 50	07025360A	CCD 20 NF	09023	GMC C-D TYPE BYB-6S2
C 51	07025360A	CCD 20 NF	09023	GMC C-D TYPE BYB-6S2
C 52	07025360A	CCD 20 NF	09023	GMC C-D TYPE BYB-6S2
C 53	07025360A	CCD 20 NF	09023	GMC C-D TYPE BYB-6S2
C 54	07025360A	CCD 20 NF	09023	GMC C-D TYPE BYB-6S2
C 55	07025360A	CCD 20 NF	09023	GMC C-D TYPE BYB-6S2
C 56	07025360A	CCD 20 NF	09023	GMC C-D TYPE BYB-6S2
C 57	07025360A	CCD 20 NF	09023	GMC C-D TYPE BYB-6S2
C 58	17100020A	FLE 2X5 NF LINE FILTER 250V	50423	

5500B PARTS LIST - Continued

SCHEMATIC REF	BALLANTINE PART NO.	DESCRIPTION	MFR CODE	MFR PART NUMBER
C 59	07025360A	CCD 20 NF	09023	GMC C-D TYPE BYB-6S2
C 60	07093710A	CEA 100 UF 6 V	56289	SPG TYP TE-1102
C 61A	07100530A	CET 10.0 UF 35.0 V M	56289	SPRAGUE 1960106X0035A3
C 61B	07100530A	CET 10.0 UF 35.0 V M	56289	SPRAGUE 1960106X0035A3
C 62	07095750A	CCD 220 PF 600 V K 10%	71590	CTL TYP DD-721
C 63	07025360A	CCD 20 NF	09023	GMC C-D TYPE BYB-6S2
C 64	07100920A	CEA 470.0UF 35. V		STET-TRUSH ERO EGK470/35
C 66	07104250A	CEA 4700 UF 16.0 V -10+50%	50423	
C 67	07100920A	CEA 470.0UF 35 V		STET-TRUSH ERO EGK470/35
C 68	07100830A	CET 1.5UF 35 V DISC	56289	SPRAGUE 1960155X0035A3
C 69	07100900A	CCD 47.0NF 160 V	34553	AMPEREX CO69B160H4732
C 70	07100820A	CCD 0.1UF 50. V	84171	ARCO TYPE CY30-C-1042
C 71	07093710A	CEA 100 UF 6 V	56289	SPG TYP TE-1102
C 72	07025360A	CCD 20 NF	09023	GMC C-D TYPE BYB-6S2
C 73	07100900A	CCD 47.0 NF 160 V	34553	AMPEREX CO69B160H4732
C 74	07025360A	CCD 20 NF	09023	GMC C-D TYPE BYB-6S2
C 75	07100530A	CET 10.0 UF 35.0 V M	56289	SPRAGUE 1960106X0035A3
C 76	07100920A	CEA 470.0UF 35. V		STET-TRUSH ERO EGK470/35
C 77	07100830A	CET 1.5UF 35 V DISC	56289	SPRAGUE 1960155X0035A3
C 78	07100530A	CET 10.0 UF 35.0 V M	56289	SPRAGUE 1960106X0035A3
C 79	07100920A	CEA 470.0UF 35. V		STET-TRUSH ERO EGK470/35
C 80	07025360A	CCD 20 NF	09023	GMC C-D TYPE BYB-6S2
C 81	07025360A	CCD 20 NF	09023	GMC C-D TYPE BYB-6S2
C 82	07025360A	CCD 20 NF	09023	GMC C-D TYPE BYB-6S2
C 83	07100830A	CET 1.5 UF 35 V DISC	56289	SPRAGUE 1960155X0035A3
C 84	07100130A	CCC 100 NF 50 V CHIPCAP	50423	
C 85	07100130A	CCC 100 NF 50 V CHIPCAP	50423	
C 88	07100830A	CET 1.5 UF 35 V DISC	56289	SPRAGUE 1960155X0035A3
C 89	07100060A	CCD 4.7 PF 500 V DISC	90201	RMC TYPE CG
C 90	07025360A	CCD 20 NF	09023	GMC C-D TYPE BYB-6S2
C 91	07025360A	CCD 20 NF	09023	GMC C-D TYPE BYB-6S2
C 92	07025360A	CCD 20 NF	09023	GMC C-D TYPE BYB-6S2
C 93	07025360A	CCD 20 NF	09023	GMC C-D TYPE BYB-6S2
C 94	07025360A	CCD 20 NF	09023	GMC C-D TYPE BYB-6S2
C 95	07025360A	CCD 20 NF	09023	GMC C-D TYPE BYB-6S2
C 96	07025360A	CCD 20 NF	09023	GMC C-D TYPE BYB-6S2
C 97	07025360A	CCD 20 NF	09023	GMC C-D TYPE BYB-6S2
CR 1	05100260A	DGP 1N4151 75 50M	24446	GE SI D035 4 2
CR 2	05100260A	DGP 1N4151 75 50M	24446	GE SI D035 4 2
CR 3	05100250A	DGP 1N281 75 .1A.08	15238	ITT GE D07
CR 4	05100250A	DGP 1N281 75 .1A.08	15238	ITT GE D07
CR 5	05094620A	DGP 5082-2800 70	28480	HPA SCHOTTKY 2
CR 6	05094620A	DGP 5082-2800 70	28480	HPA SCHOTTKY 2
CR 7	05100260A	DGP 1N4151 75 50M	24446	GE SI D035 4 2
CR 8	05100260A	DGP 1N4151 75 50M	24446	GE SI D035 4 2
CR 9	05100350A	DZG 1N758A 10 20M .4	04713	MOT SI
CR 10	05100170A	DGP 1N746A 3.3 20M .4	12954	DIC SI
CR 11	05100000A	DZG 1N753A 6.2 20M .4	12954	DIC SI
CR 12	05100260A	DGP 1N4151 75 50M	24446	GE SI D035 4 2
CR 13	05100250A	DGP 1N281 75 .1A.08	15238	ITT GE D07
CR 14	05094620A	DGP 5082-2800 70	28480	HPA SCHOTTKY 2
CR 16	05100270A	DRP 1N4999 200 3A	04713	MOT SI
CR 17	05100270A	DRP 1N4999 200 3A	04713	MOT SI
CR 18	05100820A	DGP W005 BRIDGE 1A/500		GI W005
CR 19	05100820A	DGP W005 BRIDGE 1A/500		GI W005
CR 20	05094910A	DGP 1N4003 200 1A	04713	MOT SI D041
L 1	---	FRB FERRITE BEAD SELECT	50423	
L 2	---	FRB FERRITE BEAD SELECT	50423	
L 3	---	FRB FERRITE BEAD SELECT	50423	

5500B PARTS LIST – Continued

SCHEMATIC REF		BALLANTINE PART NO.	DESCRIPTION	MFR CODE	MFR PART NUMBER
Q	1	10079340A	TRQ 2N3640 PNP 1 12 PTO-18	07263	FCH .500 300M 30
Q	2	10079340A	TRQ 2N3640 PNP 1 12 PTO-18	07263	FCH .500 300M 30
Q	3	10100330A	TRQ 2N3646 NPN 1 15 PTO-18	04713	FCH .5 350M 25
Q	5	10100340A	TRQ 2N4124 NPN 1 25 PTO-92	04713	MOT 1 300M 50
Q	6	10100340A	TRQ 2N4124 NPN 1 25 PTO-92	04713	MOT 1 300M 50
Q	7	10100340A	TRQ 2N4124 NPN 1 25 PTO-92	04713	MOT 1 300M 50
Q	8	10100340A	TRQ 2N4124 NPN 1 25 PTO-92	04713	MOT 1 300M 50
Q	9	10100360A	TRQ 2N4852 UNIT 1 M22A	04713	MOT .300
Q	10	10100340A	TRQ 2N4124 NPN 1 25 PTO-92	04713	MOT 1 300M 50
Q	11	10100320A	TRQ 2N1613 NPN 1 75 MTO-5	04713	MOT 3 35
Q	12	10100040A	TRQ MJE520 NPN 1 30 P77-03	04713	MOT 25 25
Q	13	10100340A	TRQ 2N4124 NPN 1 25 PTO-92	04713	MOTR 1 300M 50
Q	18	10100630A	TRQ 2N3955 JFET 2 50 PTO-71	07263	NSC .250 1K
Q	19	10100370A	TRQ 2N5179 NPN 1 12 MTO-72	04713	MOT .300 900M 25
Q	20	10100370A	TRQ 2N5179 NPN 1 12 MTO-72	04713	MOT .300 900M 25
Q	21	10100330A	TRQ 2N3646 NPN 1 15 PTO-18	04713	FCH .5 350M 25
Q	22	10100330A	TRQ 2N3646 NPN 1 15 PTO-18	04713	FCH .5 350M 25
Q	23	10079340A	TRQ 2N3640 PNP 1 12 PTO-18	07263	FCH .500 300M 30
Q	24	10079340A	TRQ 2N3640 PNP 1 12 PTO-18	07263	FCH .500 300M 30
Q	25	10100330A	TRQ 2N3646 NPN 1 15 PTO-18	04713	FCH .5 350M 25
Q	30	10100630A	TRQ 2N3955 JFET 2 50 PTO-71	07263	NSC .250 1K
Q	31	10100350A	TRQ 2N4126 PNP 1 25 PTO-92	04713	MOT 1 250M 60
Q	32	10100350A	TRQ 2N4126 PNP 1 25 PTO-92	04713	MOT 1 250M 60
R	1	12122320A	RFF 215.0 500 MW F+-1%	16299	CGW RN60D 2150 F
R	2	12121640A	RFF 46.4 500 MW F+-1%	16299	CGW RN60D 47R5 F
R	3	12123000A	RFF 1.0 K 500 MW F+-1%	16299	CGW RN60D 1001 F
R	4	12122640A	RFF 464.0 500 MW F+-1%	16299	CGW RN60D 4640 F
R	5	12123000A	RFF 1.0 K 500 MW F+-1%	16299	CGW RN60D 1001 F
R	6	12122640A	RFF 464.0 250.0 MW F+-1%	16299	CGW RN55D 4640 F
R	7	12122320A	RFF 215.0 500 MW F+-1%	16299	CGW RN60D 2150 F
R	8	12122320A	RFF 215.0 500 MW F+-1%	16299	CGW RN60D 2150 F
R	9	12122640A	RFF 464.0 500 MW F+-1%	16299	CGW RN60D 4640 F
R	10	12123000A	RFF 1.0 K 500 MW F+-1%	16299	CGW RN60D 1001 F
R	11	12122640A	RFF 464.0 500 MW F+-1%	16299	CGW RN60D 4640 F
R	12	12122640A	RFF 464.0 500 MW F+-1%	16299	CGW RN60D 4640 F
R	13	12122640A	RFF 464.0 500 MW F+-1%	16299	CGW RN60D 4640 F
R	14	12122640A	RFF 464.0 500 MW F+-1%	16299	CGW RN60D 4640 F
R	16	12122640A	RFF 464.0 500 MW F+-1%	16299	CGW RN60D 4640 F
R	17	12122640A	RFF 464.0 500 MW F+-1%	16299	CGW RN60D 4640 F
R	18	12123640A	RFF 4.64K 500 MW F+-1%	16299	CGW RN60D 4641 F
R	19	12123640A	RFF 4.64K 500 MW F+-1%	16299	CGW RN60D 4641 F
R	20	12123640A	RFF 4.64K 500 MW F+-1%	16299	CGW RN60D 4641 F
R	21	12123640A	RFF 4.64K 500 MW F+-1%	16299	CGW RN60D 4641 F
R	22	12122320A	RFF 215.0 250.0 MW F+-1%	16299	CGW RN55D 2150 F
R	23	12122640A	RFF 464.0 500 MW F+-1%	16299	CGW RN60D 4640 F
R	24	12122640A	RFF 464.0 500 MW F+-1%	16299	CGW RN60D 4640 F
R	25	12121640A	RFF 46.4 500 MW F+-1%	16299	CGW RN60D 47R5 F
R	26	12121640A	RFF 46.4 500 MW F+-1%	16299	CGW RN60D 47R5 F
R	27	12122000A	RFF 100.0 500 MW F+-1%	16299	CGW RN60D 1000 F
R	28	12124000A	RFF 10.0 K 500 MW F+-1%	16299	CGW RN60D 1002 F
R	29	12122800A	RFF 681.0 500 MW F+-1%	16299	CGW RN60D 6810 F
R	30	12122320A	RFF 215.0 500 MW F+-1%	16299	CGW RN60D 2150 F
R	31	12121800A	RFF 68.1 500 MW F+-1%	16299	CGW RN60D 68R1 F
R	32	12122160A	RFF 147.0 500 MW F+-1%	16299	CGW RN60D 1470 F
R	34	12122800A	RFF 681.0 500 MW F+-1%	16299	CGW RN60D 6810 F
R	35	12122000A	RFF 100.0 500 MW F+-1%	16299	CGW RN60D 1000 F
R	36	09101090A	RVC 20.0 50.0 MW	32997	BOURNS 3329H SERIES

5500B PARTS LIST - Continued

SCHEMATIC REF		BALLANTINE PART NO.	DESCRIPTION	MFR CODE	MFR PART NUMBER
R	37	09100450A	RVC 1.0 K PC TRIMPOT 5500A	32997	BOURNS 3329H SERIES
R	38	12123160A	RFF 1.47K 500 MW F+-1%	16299	CGW RN60D 1471 F
R	39	12122000A	RFF 100.0 500 MW F+-1%	16299	CGW RN60D 1000 F
R	40	12122160A	RFF 147.0 500 MW F+-1%	16299	CGW RN60D 1470 F
R	42	12122320A	RFF 215.0 500 MW F+-1%	16299	CGW RN60D 2150 F
R	43	12121800A	RFF 68.1 250.0 MW F+-1%	16299	CGW RN55D 68R1 F
R	44	12124000A	RFF 10.0 K 500 MW F+-1%	16299	CGW RN60D 1002 F
R	45	12122000A	RFF 100.0 500 MW F+-1%	16299	CGW RN60D 1000 F
R	46	12122800A	RFF 681.0 500 MW F+-1%	16299	CGW RN60D 6810 F
R	47	12122720A	RFF 562.0 500 MW F+-1%	16299	CGW RN60D 5620 F
R	48	12126000A	RFF 1.00M 500 MW F+-1%	16299	CGW RN60D 1004 F
R	49	12122720A	RFF 562.0 500 MW F+-1%	16299	CGW RN60D 5620 F
R	50	12126000A	RFF 1.00M 500 MW F+-1%	16299	CGW RN60D 1004 F
R	51	12123640A	RFF 4.64K 500 MW F+-1%	16299	CGW RN60D 4641 F
R	52	12122000A	RFF 100.0 500 MW F+-1%	16299	CGW RN60D 1000 F
R	53	12123160A	RFF 1.47K 500 MW F+-1%	16299	CGW RN60D 1471 F
R	54	12123160A	RFF 1.47K 500 MW F+-1%	16299	CGW RN60D 1471 F
R	55	12123640A	RFF 4.64K 500 MW F+-1%	16299	CGW RN60D 4641 F
R	56	12121000A	RFF 10.0 250.0 MW F+-1%	16299	CGW RN55D 10R0 F
R	57	12123640A	RFF 4.64K 500 MW F+-1%	16299	CGW RN60D 4641 F
R	58	12123640A	RFF 4.64K 500 MW F+-1%	16299	CGW RN60D 4641 F
R	60	12123640A	RFF 4.64K 500 MW F+-1%	16299	CGW RN60D 4641 F
R	61	12121000A	RFF 10.0 500 MW F+-1%	16299	CGW RN60D 10R0 F
R	62	12122640A	RFF 464.0 500 MW F+-1%	16299	CGW RN60D 4640 F
R	63	12122640A	RFF 464.0 500 MW F+-1%	16299	CGW RN60D 4640 F
R	64	12122720A	RFF 562.0 500 MW F+-1%	16299	CGW RN60D 5620 F
R	65	12122720A	RFF 562.0 500 MW F+-1%	16299	CGW RN60D 5620 F
R	66	12122320A	RFF 215.0 500 MW F+-1%	16299	CGW RN60D 2150 F
R	67	12122320A	RFF 215.0 500 MW F+-1%	16299	CGW RN60D 2150 F
R	68	12123000A	RFF 1.0 K 500 MW F+-1%	16299	CGW RN60D 1001 F
R	69	12123000A	RFF 1.0 K 500 MW F+-1%	16299	CGW RN60D 1001 F
R	70	12123640A	RFF 4.64K 500 MW F+-1%	16299	CGW RN60D 4641 F
R	71	12123640A	RFF 4.64K 500 MW F+-1%	16299	CGW RN60D 4641 F
R	72	12121000A	RFF 10.0 500 MW F+-1%	16299	CGW RN60D 10R0 F
R	73	12122640A	RFF 464.0 500 MW F+-1%	16299	CGW RN60D 4640 F
R	74	12122640A	RFF 464.0 500 MW F+-1%	16299	CGW RN60D 4640 F
R	75	12121880A	RFF 82.5 500 MW F+-1%	16299	CGW RN60D 82R5 F
R	76	12123000A	RFF 1.0 K 500 MW F+-1%	16299	CGW RN60D 1001 F
R	77	12122640A	RFF 464.0 500 MW F+-1%	16299	CGW RN60D 4640 F
R	78	12124400A	RFF 26.1 K 500 MW F+-1%	16299	CGW RN60D 2612 F
R	79	12123560A	RFF 3.83K 500 MW F+-1%	16299	CGW RN60D 3831 F
R	80	12121000A	RFF 10.0 500 MW F+-1%	16299	CGW RN60D 10R0 F
R	81	12121880A	RFF 82.5 500 MW F+-1%	16299	CGW RN60D 82R5 F
R	82	12122640A	RFF 464.0 500 MW F+-1%	16299	CGW RN60D 4640 F
R	83	12122640A	RFF 464.0 500 MW F+-1%	16299	CGW RN60D 4640 F
R	84	12121000A	RFF 10.0 500 MW F+-1%	16299	CGW RN60D 10R0 F
R	85	12121520A	RFF 34.8 500 MW F+-1%	16299	CGW RN60D 34R8 F
R	86	12122320A	RFF 215.0 500 MW F+-1%	16299	CGW RN60D 2150 F
R	87	12122560A	RFF 383.0 500 MW F+-1%	16299	CGW RN60D 3830 F
R	88	12122560A	RFF 383.0 500 MW F+-1%	16299	CGW RN60D 3830 F
R	89	12122000A	RFF 100.0 500 MW F+-1%	16299	CGW RN60D 1000 F
R	90	12123640A	RFF 4.64K 500 MW F+-1%	16299	CGW RN60D 4641 F
R	91	12123640A	RFF 4.64K 500 MW F+-1%	16299	CGW RN60D 4641 F
R	92	12123640A	RFF 4.64K 500 MW F+-1%	16299	CGW RN60D 4641 F
R	93	12123640A	RFF 4.64K 500 MW F+-1%	16299	CGW RN60D 4641 F
R	94	12123640A	RFF 4.64K 500 MW F+-1%	16299	CGW RN60D 4641 F
R	95	12123640A	RFF 4.64K 500 MW F+-1%	16299	CGW RN60D 4641 F

5500B PARTS LIST - Continued

SCHEMATIC REF	BALLANTINE PART NO.	DESCRIPTION	MFR CODE	MFR PART NUMBER
R 96	12123640A	RFF 4.64K 500 MW F+-1%	16299	CGW RN60D 4641 F
R 97	12123640A	RFF 4.64K 500 MW F+-1%	16299	CGW RN60D 4641 F
R 98	12123640A	RFF 4.64K 500 MW F+-1%	16299	CGW RN60D 4641 F
R 99	12123640A	RFF 4.64K 500 MW F+-1%	16299	CGW RN60D 4641 F
R 100	12123400A	RFF 2.61K 500 MW F+-1%	16299	CGW RN60D 2611 F
R 101	12122320A	RFF 215.0 500 MW F+-1%	16299	CGW RN60D 2150 F
R 102	12122320A	RFF 215.0 500 MW F+-1%	16299	CGW RN60D 2150 F
R 103	12122320A	RFF 215.0 500 MW F+-1%	16299	CGW RN60D 2150 F
R 104	12122640A	RFF 464.0 500 MW F+-1%	16299	CGW RN60D 4640 F
R 105	12123640A	RFF 4.64K 500 MW F+-1%	16299	CGW RN60D 4641 F
R 106	12121640A	RFF 46.4 500 MW F+-1%	16299	CGW RN60D 47R5 F
R 107	12123000A	RFF 1.0 K 500 MW F+-1%	16299	CGW RN60D 1001 F
R 108	12123000A	RFF 1.0 K 500 MW F+-1%	16299	CGW RN60D 1001 F
R 109	12124000A	RFF 10.0 K 500 MW F+-1%	16299	CGW RN60D 1002 F
R 110	12123000A	RFF 1.0 K 500 MW F+-1%	16299	CGW RN60D 1001 F
R 111	12123880A	RFF 8.25K 250.0 MW F+-1%	16299	CGW RN55D 8251 F
R 112	12124520A	RFF 34.8 K 500 MW F+-1%	16299	CGW RN60D 3482 F
R 113	12122560A	RFF 383.0 500 MW F+-1%	16299	CGW RN60D 3830 F
R 114	12123000A	RFF 1.0 K 500 MW F+-1%	16299	CGW RN60D 1001 F
R 115	12122000A	RFF 100.0 500 MW F+-1%	16299	CGW RN60D 1000 F
R 117	12123640A	RFF 4.64K 500 MW F+-1%	16299	CGW RN60D 4641 F
R 118	12123640A	RFF 4.64K 500 MW F+-1%	16299	CGW RN60D 4641 F
R 119	12123640A	RFF 4.64K 500 MW F+-1%	16299	CGW RN60D 4641 F
R 120	12123640A	RFF 4.64K 500 MW F+-1%	16299	CGW RN60D 4641 F
R 123	12123320A	RFF 2.15K 500 MW F+-1%	16299	CGW RN60D 2151 F
R 125	12122560A	RFF 383.0 500 MW F+-1%	16299	CGW RN60D 3830 F
R 126	12122560A	RFF 383.0 500 MW F+-1%	16299	CGW RN60D 3830 F
R 127	12122000A	RFF 100.0 500 MW F+-1%	16299	CGW RN60D 1000 F
R 128	12122560A	RFF 383.0 500 MW F+-1%	16299	CGW RN60D 3830 F
R 129	12122720A	RFF 562.0 500 MW F+-1%	16299	CGW RN60D 5620 F
R 130	12122720A	RFF 562.0 500 MW F+-1%	16299	CGW RN60D 5620 F
R 131	12123000A	RFF 1.0 K 500 MW F+-1%	16299	CGW RN60D 1001 F
R 132	12123520A	RFF 3.48K 500 MW F+-1%	16299	CGW RN60D 3481 F
R 133	12123000A	RFF 1.0 K 500 MW F+-1%	16299	CGW RN60D 1001 F
R 134	12123640A	RFF 4.64K 500 MW F+-1%	16299	CGW RN60D 4641 F
R 135	12123640A	RFF 4.64K 500 MW F+-1%	16299	CGW RN60D 4641 F
R 136	12123520A	RFF 3.48K 500 MW F+-1%	16299	CGW RN60D 3481 F
R 137	12123640A	RFF 4.64K 500 MW F+-1%	16299	CGW RN60D 4641 F
R 138	12122000A	RFF 100.0 500 MW F+-1%	16299	CGW RN60D 1000 F
R 139	12130540A	RFW 0.27 1.0 W	50423	
R 140	12123160A	RFF 1.47K 500 MW F+-1%	16299	CGW RN60D 1471 F
R 141	12123640A	RFF 4.64K 500 MW F+-1%	16299	CGW RN60D 4641 F
R 142	12123320A	RFF 2.15K 500 MW F+-1%	16299	CGW RN60D 2151 F
R 143	12123000A	RFF 1.0 K 500 MW F+-1%	16299	CGW RN60D 1001 F
U 1	24100260A	ICP 8290 TTL DEC-COUNTER	18324	SIGNETICS
U 2	24094070A	ICP T.I.SN7400N OR	56289	SPRAGUE USN7400A
U 3	24094070A	ICP T.I.SN7400N OR	56289	SPRAGUE USN7400A
U 4	24100170A	ICP 7410 TTL TRIP 3-INP	07263	FAIRCHILD
U 5	24094090A	ICP T.I. SN7473N OR	56289	SPRAGUE USN7473
U 6	24094070A	ICP T.I.SN7400N OR	56289	SPRAGUE USN7400A
U 8	24100200A	ICP 7453 TTL 4-INP AND/OR	04713	MOTOROLA
U 9	24100560A	ICP MC10216L HI SPEED AMP	04713	MOT OR NS
U 11	24100240A	ICP 9312 8-INP MULTIPX	04713	MOTOROLA/8230 SIGNETICS
U 12	24100140A	ICP 8280 TTL DEC.CTR	18324	SIGNETICS
U 13	24100180A	ICP 7440 TTL DUAL 4-INP BI	04713	MOTOROLA
U 14	24094070A	ICP T.I.SN7400N OR	56289	SPRAGUE USN7400A
U 15	24100020A	TCD SN7474N	01295	TEXAS INSTRUMENT

5500B PARTS LIST - Continued

SCHEMATIC REF	BALLANTINE PART NO.	DESCRIPTION	MFR CODE	MFR PART NUMBER
U 16	24100190A	ICP 7450 TTL DUAL 2-INP &D	04713	MOTOROLA
U 17	24094070A	ICP T.I.SN7400N OR	56289	SPRAGUE USN7400A
U 18	24100160A	ICP 7404 TTL HEX INVERTER	01295	TEXAS INSTRUMENT
U 19	24100170A	ICP 7410 TTL TRIP 3-INP	07263	FAIRCHILD
U 20	24094060A	ICP T.I.SN7420N OR	56289	SPRAGUE USN7420A
U 21	24100140A	ICP 8280 TTL DEC.CTR	18324	SIGNETICS
U 22	24100140A	ICP 8280 TTL DEC.CTR	18324	SIGNETICS
U 23	24100140A	ICP 8280 TTL DEC.CTR	18324	SIGNETICS
U 24	24100140A	ICP 8280 TTL DEC.CTR	18324	SIGNETICS
U 25	24100140A	ICP 8280 TTL DEC.CTR	18324	SIGNETICS
U 26	24100140A	ICP 8280 TTL DEC.CTR	18324	SIGNETICS
U 27	24100140A	ICP 8280 TTL DEC.CTR	18324	SIGNETICS
U 28	24094070A	ICP T.I.SN7400N OR	56289	SPRAGUE USN7400A
U 29	24094070A	ICP T.I.SN7400N OR	56289	SPRAGUE USN7400A
U 30	24100170A	ICP 7410 TTL TRIP 3-INP	07263	FAIRCHILD
U 31	24100190A	ICP 7450 TTL DUAL 2-INP &D	04713	MOTOROLA
U 32	24094070A	ICP T.I.SN7400N OR	56289	SPRAGUE USN7400A
U 33	24100410A	ICP LIN TRIP OD AMP 10116	04713	MOTOROLA MC10116P
U 34	24100300A	ICP 7400 TTL SCHOTTKY	01295	TEXAS INSTRUMENT
U 35	24100320A	ICP 74S112 DUAL JK SCHOTTKY	01245	TEXAS INSTRUMENT
U 36	24100320A	ICP 74S112 DUAL JK SCHOTTKY	01245	TEXAS INSTRUMENT
U 37	24100400A	ICP LIN COMPARATOR 710	07263	FAIRCHILD 8 PIN CAN
U 38	24100520A	ICP 15 VOLT REG LM340T-15	27014	NATL SEMI LM30T-15 OR EQV
U 39	24100520A	ICP 15 VOLT REG LM340T-15	27014	NATL SEMI LM30T-15 OR EQV
U 40	24100760A	ICP 5 VOLT REG 78M05C 1/2A	07263	FAIRCHILD 78M05C OR EQUIV
XY 1	42100000A	OVN OVEN SEMI CON TO-5 20V	01295	ULIXON TEXAS INST. MST1-2
Y 1	04400030A	CRS 10.0MHZ TO-5	50423	TABOR 08000000 ALSO ERC
A 4	89103341A	DISPLAY ASSEMBLY	50423	
C 1	07100080A	CCD 470.0PF 1000 V DISC	90201	RMC TYPE B
C 2	07100090A	CCD 2.2NF 500 V DISC	73345	AMPEREX C023B501E222P
C 3	07100530A	CET 10.0UF 35.0V M	56289	SPRAGUE 1960106X0035A3
C 4	07101200A	CCD 22.0 NF 25.0 V	71590	CLB UK 25223
C 5	07101200A	CCD 22.0 NF 25.0 V	71590	CLB UK 25223
C 6	07101200A	CCD 22.0 NF 25.0 V	71590	CLB UK 25223
C 7	07101200A	CCD 22.0 NF 25.0 V	71590	CLB UK 25223
C 8	07101200A	CCD 22.0 NF 25.0 V	71590	CLB UK 25223
C 9	07101200A	CCD 22.0 NF 25.0 V	71590	CLB UK 25223
C 10	07101200A	CCD 22.0 NF 25.0 V	71590	CLB UK 25223
C 11	07100530A	CET 10.0UF 35.0V M	56289	SPRAGUE 1960106X0035A3
C 12	07101200A	CCD 22.0 NF 25.0 V	71590	CLB UK 25223
C 13	07101200A	CCD 22.0 NF 25.0 V	71590	CLB UK 25223
CR 1	05100250A	DGP 1N281 75 .1A.08	15238	ITT GE D07
CR 2	05100250A	DGP 1N281 75 .1A.08	15238	ITT GE D07
CR 3	05100250A	DGP 1N281 75 .1A.08	15238	ITT GE D07
CR 4	05100250A	DGP 1N281 75 .1A.08	15238	ITT GE D07
CR 5	05100250A	DGP 1N281 75 .1A.08	15238	ITT GE D07
CR 6	05100250A	DGP 1N281 75 .1A.08	15238	ITT GE D07
CR 7	05100250A	DGP 1N281 75 .1A.08	15238	ITT GE D07
CR 8	05100250A	DGP 1N281 75 .1A.08	15238	ITT GE D07
CR 9	05100250A	DGP 1N281 75 .1A.08	15238	ITT GE D07
CR 10	05100250A	DGP 1N281 75 .1A.08	15238	ITT GE D07
CR 11	05100250A	DGP 1N281 75 .1A.08	15238	ITT GE D07
CR 12	05100250A	DGP 1N281 75 .1A.08	15238	ITT GE D07
CR 13	05100250A	DGP 1N281 75 .1A.08	15238	ITT GE D07

5500B PARTS LIST – Continued

SCHEMATIC REF		BALLANTINE PART NO.	DESCRIPTION	MFR CODE	MFR PART NUMBER
Q	1	10100340A	TRQ 2N4124 NPN 1 25 PTO-92	04713	MOT 1 300M 50
Q	2	10100340A	TRQ 2N4124 NPN 1 25 PTO-92	04713	MOT 1 300M 50
Q	3	10100340A	TRQ 2N4124 NPN 1 25 PTO-92	04713	MOT 1 300M 50
Q	4	10100340A	TRQ 2N4124 NPN 1 25 PTO-92	04713	MOT 1 300M 50
Q	5	10100340A	TRQ 2N4124 NPN 1 25 PTO-92	04713	MOT 1 300M 50
Q	6	10100340A	TRQ 2N4124 NPN 1 25 PTO-92	04713	MOT 1 300M 50
Q	7	10100340A	TRQ 2N4124 NPN 1 25 PTO-92	04713	MOT 1 300M 50
Q	8	10100340A	TRQ 2N4124 NPN 1 25 PTO-92	04713	MOT 1 300M 50
Q	9	10100340A	TRQ 2N4124 NPN 1 25 PTO-92	04713	MOT 1 300M 50
Q	10	10100830A	TRQ MPS4355 PNP 1 60 PTO-92	04713	MOT .625 100M 75
Q	11	10100830A	TRQ MPS4355 PNP 1 60 PTO-92	04713	MOT .625 100M 75
Q	12	10100830A	TRQ MPS4355 PNP 1 60 PTO-92	04713	MOT .625 100M 75
Q	13	10100830A	TRQ MPS4355 PNP 1 60 PTO-92	04713	MOT .625 100M 75
R	9	12123240A	RFF 1.78K 500 MW F+-1%	16299	CGW RN60D 1781 F
R	10	12123240A	RFF 1.78K 500 MW F+-1%	16299	CGW RN60D 1781 F
R	11	12123240A	RFF 1.78K 500 MW F+-1%	16299	CGW RN60D 1781 F
R	12	12123240A	RFF 1.78K 500 MW F+-1%	16299	CGW RN60D 1781 F
R	13*	12121520A	RFF 34.8 500 MW F+-1%	16299	CGW RN60D 34R8 F
R	14*	12121520A	RFF 34.8 500 MW F+-1%	16299	CGW RN60D 34R8 F
R	15*	12121520A	RFF 34.8 500 MW F+-1%	16299	CGW RN60D 34R8 F
R	16*	12121520A	RFF 34.8 500 MW F+-1%	16299	CGW RN60D 34R8 F
R	17*	12121520A	RFF 34.8 500 MW F+-1%	16299	CGW RN60D 34R8 F
R	18*	12121520A	RFF 34.8 500 MW F+-1%	16299	CGW RN60D 34R8 F
R	19*	12121520A	RFF 34.8 500 MW F+-1%	16299	CGW RN60D 34R8 F
R	21	12122520A	RFF 348.0 500.0 MW F+-1%	16299	CGW RN60D 3480 F
R	22	12124320A	RFF 21.5 250.0 MW F+-1%	16299	CGW RN55D 2152 F
R	23	12124320A	RFF 21.5 250.0 MW F+-1%	16299	CGW RN55D 2152 F
R	24	12123640A	RFF 4.64K 500 MW F+-1%	16299	CGW RN60D 4641 F
R	25	12123640A	RFF 4.64K 500 MW F+-1%	16299	CGW RN60D 4641 F
R	26	12123640A	RFF 4.64K 500 MW F+-1%	16299	CGW RN60D 4641 F
R	27	12122560A	RFF 383.0 500 MW F+-1%	16299	CGW RN60D 3830 F
R	28	12122560A	RFF 383.0 500 MW F+-1%	16299	CGW RN60D 3830 F
R	29	12123640A	RFF 4.64K 500 MW F+-1%	16299	CGW RN60D 4641 F
R	30	12123640A	RFF 4.64K 500 MW F+-1%	16299	CGW RN60D 4641 F
R	31	12123640A	RFF 4.64K 500 MW F+-1%	16299	CGW RN60D 4641 F
R	32	12123640A	RFF 4.64K 500 MW F+-1%	16299	CGW RN60D 4641 F
R	33	12123640A	RFF 4.64K 500 MW F+-1%	16299	CGW RN60D 4641 F
R	34	12121520A	RFF 34.8 500 MW F+-1%	16299	CGW RN60D 34R8 F
R	35	12121520A	RFF 34.8 500 MW F+-1%	16299	CGW RN60D 34R8 F
R	36	12121520A	RFF 34.8 500 MW F+-1%	16299	CGW RN60D 34R8 F
R	37	12122800A	RFF 681.0 500 MW F+-1%	16299	CGW RN60D 6810 F
R	38	12122800A	RFF 681.0 500 MW F+-1%	16299	CGW RN60D 6810 F
R	39	12121520A	RFF 34.8 500 MW F+-1%	16299	CGW RN60D 34R8 F
R	40*	12122170A	RFF 150.0 250 MW F+-1%	16299	CGW RN55D 1500 F
R	40	12122000A	RFF 100.0 250 MW F+-1%	16299	CGW RN55D 1000 F
R	41*	12122170A	RFF 150.0 250 MW F+-1%	16299	CGW RN55D 1500 F
R	41	12122000A	RFF 100.0 250 MW F+-1%	16299	CGW RN55D 1000 F
R	42*	12122170A	RFF 150.0 250 MW F+-1%	16299	CGW RN55D 1500 F
R	42	12122000A	RFF 100.0 250 MW F+-1%	16299	CGW RN55D 1000 F
R	43*	12122170A	RFF 150.0 250 MW F+-1%	16299	CGW RN55D 1500 F
R	43	12122000A	RFF 100.0 250 MW F+-1%	16299	CGW RN55D 1000 F
R	44*	12122170A	RFF 150.0 250 MW F+-1%	16299	CGW RN55D 1500 F
R	44	12122000A	RFF 100.0 250 MW F+-1%	16299	CGW RN55D 1000 F
R	45*	12122170A	RFF 150.0 250 MW F+-1%	16299	CGW RN55D 1500 F
R	45	12122000A	RFF 100.0 250 MW F+-1%	16299	CGW RN55D 1000 F
R	46*	12122170A	RFF 150.0 250 MW F+-1%	16299	CGW RN55D 1500 F
R	46	12122000A	RFF 100.0 250 MW F+-1%	16299	CGW RN55D 1000 F
R	47*	12122170A	RFF 150.0 250 MW F+-1%	16299	CGW RN55D 1500 F
R	47	12122000A	RFF 100.0 250 MW F+-1%	16299	CGW RN55D 1000 F
RN	2	13100520A	RNF 27 14 PIN DIP	91637	DALE LDP14-01-270G

* In units with Serial No. Prefix 020-, R40 through R47 (100 ohms) replace R40* through R47* (150 ohms), and RN2 replaces R13* through R19*.

5500B PARTS LIST - Continued

SCHEMATIC REF		BALLANTINE PART NO.	DESCRIPTION	MFR CODE	MFR PART NUMBER
U	1	24094140A	ICP T.I. SN7430N OR	01295	SPRAGUE USN7430A
U	2	24094070A	ICP T.I. SN7400N OR	56289	SPRAGUE USN7400A
U	3	24100160A	ICP 7404 TTL HEX INVERTER	01295	TEXAS INSTRUMENT
U	4	24094070A	ICP T.I. SN7400N OR	56289	SPRAGUE USN7400A
U	5	24100200A	ICP 7453 TTL 4-INP AND/OR	04713	MOTOROLA
U	6	24094070A	ICP T.I. SN7400N OR	56289	SPRAGUE USN7400A
U	7	24094070A	ICP T.I. SN7400N OR	56289	SPRAGUE USN7400A
U	8	24100260A	ICP 8290 TTL DEC-COUNTER	18324	SIGNETICS
U	9	24100140A	ICP 8280 TTL DEC.CTR	18324	SIGNETICS
U	10	24100140A	ICP 8280 TTL DEC.CTR	18324	SIGNETICS
U	11	24100140A	ICP 8280 TTL DEC.CTR	18324	SIGNETICS
U	12	24100140A	ICP 8280 TTL DEC.CTR	18324	SIGNETICS
U	13	24100140A	ICP 8280 TTL DEC.CTR	18324	SIGNETICS
U	14	24100140A	ICP 8280 TTL DEC.CTR	18324	SIGNETICS
U	15	24100160A	ICP 7404 TTL HEX INVERTER	01295	TEXAS INSTRUMENT
U	16	24100150A	ICP 7475 TTL	18324	SIGNETICS
U	17	24101060A	ICP 74165	04713	MOTOROLA
U	18	24101060A	ICP 74165	04713	MOTOROLA
U	19	24101060A	ICP 74165	04713	MOTOROLA
U	20	24101060A	ICP 74165	04713	MOTOROLA
U	21	24100220A	ICP 74145 TTL LATCH DECOR	01295	TEXAS INSTRUMENT
U	22	24100220A	ICP 74145 TTL LATCH DECOR	01295	TEXAS INSTRUMENT
U	23	24100220A	ICP 74145 TTL LATCH DECOR	01295	TEXAS INSTRUMENT
U	24	24100170A	ICP 7410 TTL TRIP 3-INP	07263	FAIRCHILD
U	25	24101070A	ICP 7448	04713	MOTOROLA
U	26	24100020A	TCD SN7474N	01295	TEXAS INSTRUMENT
U	27	24094070A	ICP T.I. SN7400N OR	56289	SPRAGUE USN7400A
U	28	24100220A	ICP 74145 TTL LATCH DECOR	01295	TEXAS INSTRUMENT
U	29	24094070A	ICP T.I. SN7400N OR	56289	SPRAGUE USN7400A
U	30	24100980A	ICP 8293 BI-QUIN CTR	18324	SIGNETICS 8293 OR EQUAL
A	4A1	89103351B	LED ASSEMBLY	50423	
DS	1*	21100110A	IND 0.4 IN. ORANGE LED	26483	MON 4610
DS	1	21100430A	IND 0.43 IN. RED LED	28480	HP 5082-7651
DS	2*	21100110A	IND 0.4 IN. ORANGE LED	26483	MON 4610
DS	2	21100430A	IND 0.43 IN. RED LED	28480	HP 5082-7651
DS	3*	21100110A	IND 0.4 IN. ORANGE LED	26483	MON 4610
DS	3	21100430A	IND 0.43 IN. RED LED	28480	HP 5082-7651
DS	4*	21100110A	IND 0.4 IN. ORANGE LED	26483	MON 4610
DS	4	21100430A	IND 0.43 IN. RED LED	28480	HP 5082-7651
DS	5*	21100110A	IND 0.4 IN. ORANGE LED	26483	MON 4610
DS	5	21100430A	IND 0.43 IN. RED LED	28480	HP 5082-7651
DS	6*	21100110A	IND 0.4 IN. ORANGE LED	26483	MON 4610
DS	6	21100430A	IND 0.43 IN. RED LED	28480	HP 5082-7651
DS	7*	21100110A	IND 0.4 IN. ORANGE LED	26483	MON 4610
DS	7	21100430A	IND 0.43 IN. RED LED	28480	HP 5082-7651
DS	8*	21100110A	IND 0.4 IN. ORANGE LED	26483	MON 4610
DS	8	21100430A	IND 0.43 IN. RED LED	28480	HP 5082-7651
Q	1	10100800A	TRQ 2N4403 PNP	04713	MOTR 2N4403
Q	2	10100800A	TRQ 2N4403 PNP	04713	MOTR 2N4403
Q	3	10100800A	TRQ 2N4403 PNP	04713	MOTR 2N4403
Q	4	10100800A	TRQ 2N4403 PNP	04713	MOTR 2N4403
Q	5	10100800A	TRQ 2N4403 PNP	04713	MOTR 2N4403
Q	6	10100800A	TRQ 2N4403 PNP	04713	MOTR 2N4403
Q	7	10100800A	TRQ 2N4403 PNP	04713	MOTR 2N4403
Q	8	10100800A	TRQ 2N4403 PNP	04713	MOTR 2N4403

* In units with Serial No. Prefix 020-, DS1 through DS8 replace DS1* through DS8*.

5500B PARTS LIST – Continued

SCHEMATIC REF		BALLANTINE PART NO.	DESCRIPTION	MFR CODE	MFR PART NUMBER
R	1*	12122000A	RFF 100.0 500 MW F+-1%	16299	CGW RN60D 1000 F
R	2*	12122000A	RFF 100.0 500 MW F+-1%	16299	CGW RN60D 1000 F
R	3*	12122000A	RFF 100.0 500 MW F+-1%	16299	CGW RN60D 1000 F
R	4*	12122000A	RFF 100.0 500 MW F+-1%	16299	CGW RN60D 1000 F
R	5*	12120000A	RFF 100.0 500 MW F+-1%	16299	CGW RN60D 1000 F
R	6*	12122000A	RFF 100.0 500 MW F+-1%	16299	CGW RN60D 1000 F
R	7*	12122000A	RFF 100.0 500 MW F+-1%	16299	CGW RN60D 1000 F
R	8*	12122000A	RFF 100.0 500 MW F+-1%	16299	CGW RN60D 1000 F
RN	1	13100530A	RNF 150 16 PIN DIP	91637	DALE LDP16-01-151G
U	1	24100220A	ICP 74145 TTL LATCH	01295	TI
A	4A2	---	ANNUNCIATOR ASSEMBLY	50423	
DS	1	16100050A	LMP 73/4 5 V 60 MA MIN	80368	SYL 6805/36405-0
DS	2	16100050A	LMP 73/4 5 V 60 MA MIN	80368	SYL 6805/36405-0
DS	3	16100050A	LMP 73/4 5 V 60 MA MIN	80368	SYL 6805/36405-0
DS	4	16100050A	LMP 73/4 5 V 60 MA MIN	80368	SYL 6805/36405-0
DS	5	16100050A	LMP 73/4 5 V 60 MA MIN	80368	SYL 6805/36405-0
DS	6	16100050A	LMP 73/4 5 V 60 MA MIN	80368	SYL 6805/36405-0
---		89104201A	OPTION 01, BCD OUTPUT	50423	
C	1	07101200A	CCD 22.0NF 25.0 VM	71590	CENTRLB UK25223 OR EQUIV
C	2	07101200A	CCD 22.0NF 25.0 VM	71590	CENTRLB UK25223 OR EQUIV
CR	1	05100260A	DGP 1N4151 75 50M	24446	GE SI DO35 4 2
CR	2	05100260A	DGP 1N4151 75 50M	24446	GE SI DO35 4 2
J	2	31095130A	CON BLUE RIBBON, PANEL MTG.	29587	50 PIN, AMPHENOL 57-40500
J	12	31101070A	CON 16 PIN IC ADAPTER PLUG	91506	AUGAT 616-BG1 MODEL 3620A
J	13	31101070A	CON 16 PIN IC ADAPTER PLUG	91506	AUGAT 616-BG1 MODEL 3620A
R	2	12123640A	RFF 4.64K 500 MW F+-1%	16299	CGW RN60D 4641 F
R	3	12123640A	RFF 4.64K 500 MW F+-1%	16299	CGW RN60D 4641 F
R	5	12124170A	RFF 15.0 K 500 MW F+-1%	16299	CGW RN60D 1502 F
R	6	12124170A	RFF 15.0 K 500 MW F+-1%	16299	CGW RN60D 1502 F
RN	1	13100070A	RNF 15.0 K 250 MW K8RES DIP	80053	BECKMAN 4116R-001-153
RN	2	13100070A	RNF 15.0 K 250 MW K8RES DIP	80053	BECKMAN 4116R-001-153
RN	3	13100070A	RNF 15.0 K 250 MW K8RES DIP	80053	BECKMAN 4116R-001-153
RN	4	13100070A	RNF 15.0 K 250 MW K8RES DIP	80053	BECKMAN 4116R-001-153
U	71	24094070A	ICP T.I. SN7400N OR	56289	SPRAGUE USN7400A
U	72	24100020A	TCD SN7474N	01295	TEXAS INSTRUMENT
U	73	24100020A	TCD SN7474N	01295	TEXAS INSTRUMENT
U	74	24094070A	ICP T.I. SN7400N OR	56289	SPRAGUE USN7400A
U	75	24101120A	ICP 74164 SHIFT REG 8BIT R	27014	NAT SEMI 74164 TTL
U	76	24101120A	ICP 74164 SHIFT REG 8BIT R	27014	NAT SEMI 74164 TTL
U	77	24101120A	ICP 74164 SHIFT REG 8BIT R	27014	NAT SEMI 74164 TTL
U	78	24101120A	ICP 74164 SHIFT REG 8BIT R	27014	NAT SEMI 74164 TTL
---		---	OPTION 14 HI-STABILITY CLOCK	50423	
R	1	09100490A	RVF 20.0 K PC CERMET TRMPOT	32997	BOURNS 3059P
Y	1	89401331A	ASY 5700A HI-STABILITY CLOCK	50423	

In units with Serial No. Prefix 020-, RN1 replaces R1 through R8*.

SECTION 7
DIAGRAMS

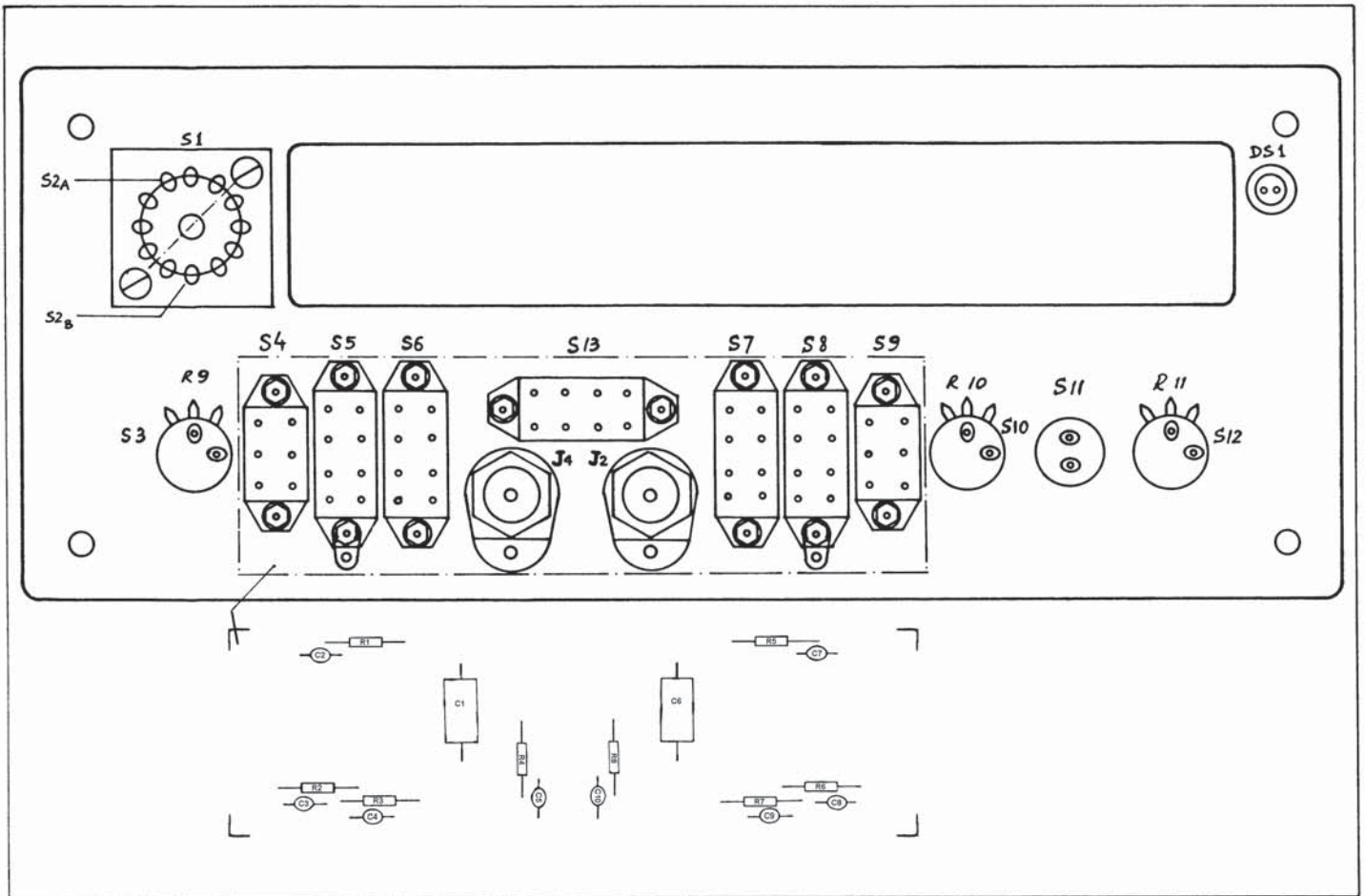

Figure 7-1. Front Panel Assembly A1 Component Locations

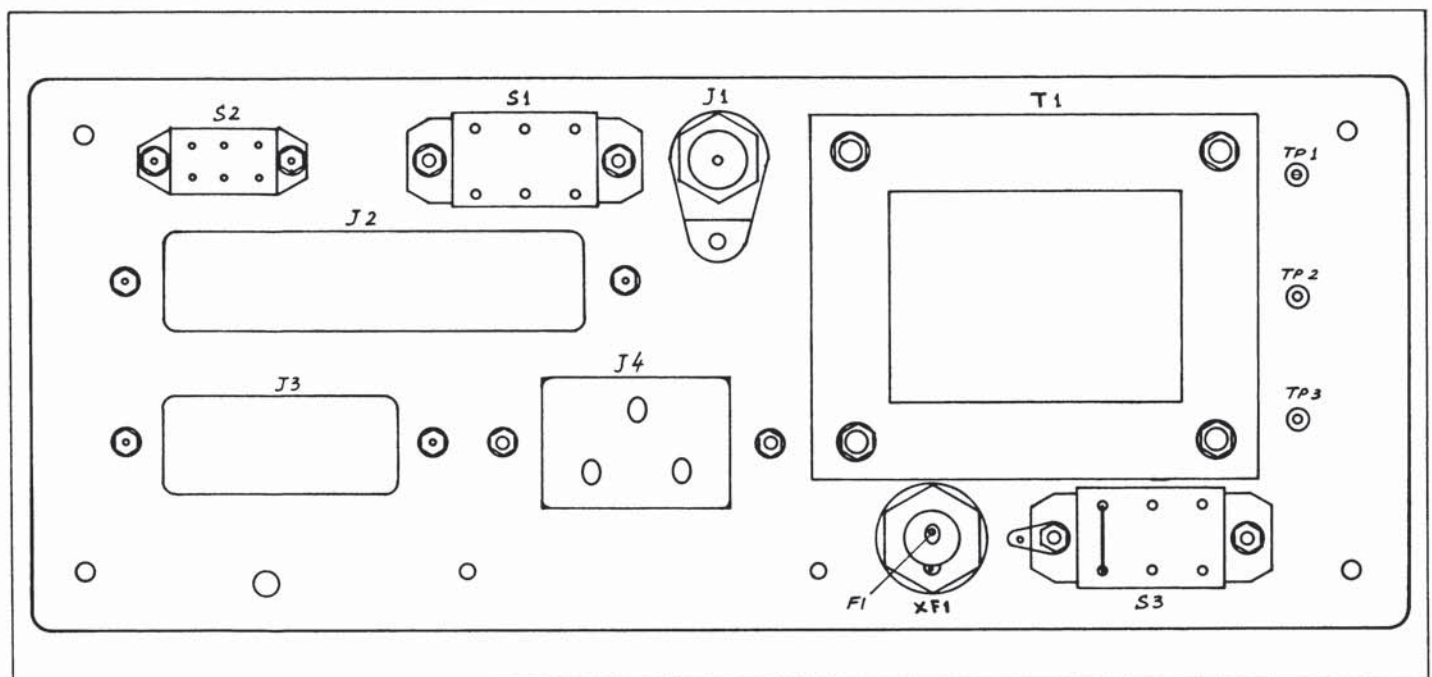

Figure 7-2. Rear Panel Assembly A2 Component Locations

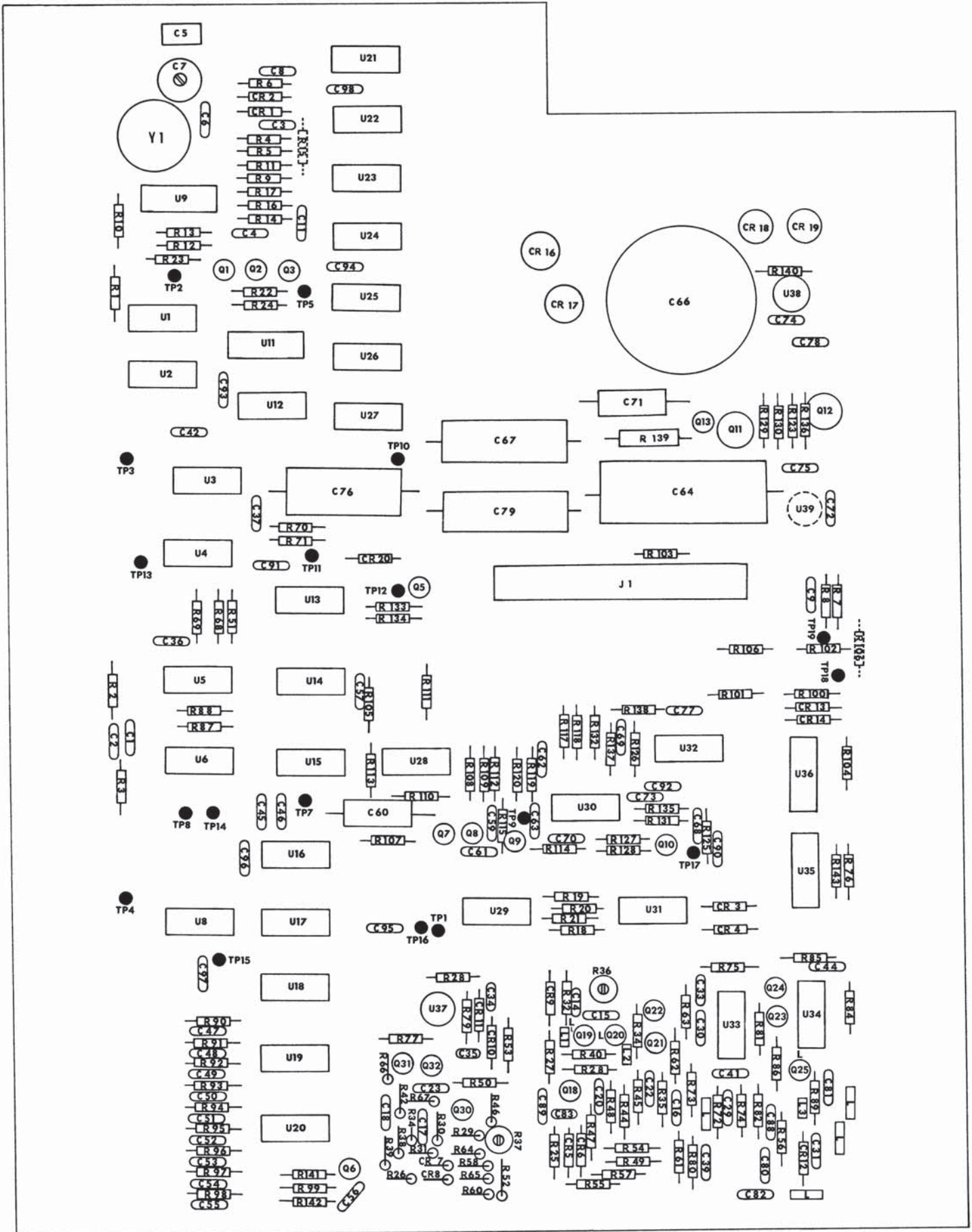
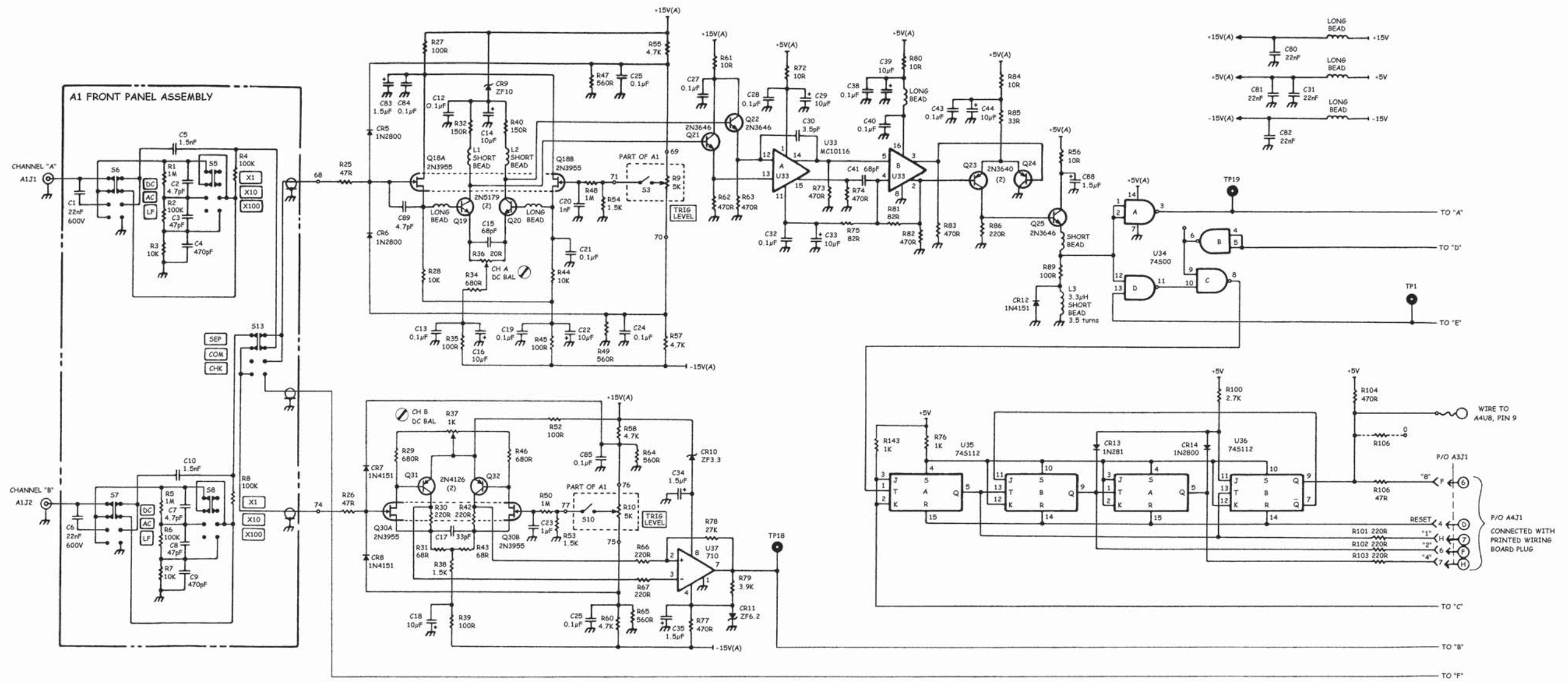

Figure 7-3. Motherboard Assembly A3 Component Locations



5500B

MOTHERBOARD ASSEMBLY A3

NOTE: NUMBERS AND LETTERS IN CIRCLES, SUCH AS (3)(C)(L) REFER TO CIRCUITS WHICH ARE CONTINUED ON FIGURE 7-6.

Figure 7-4a. Front Panel, Rear Panel, and Motherboard Schematic Diagram

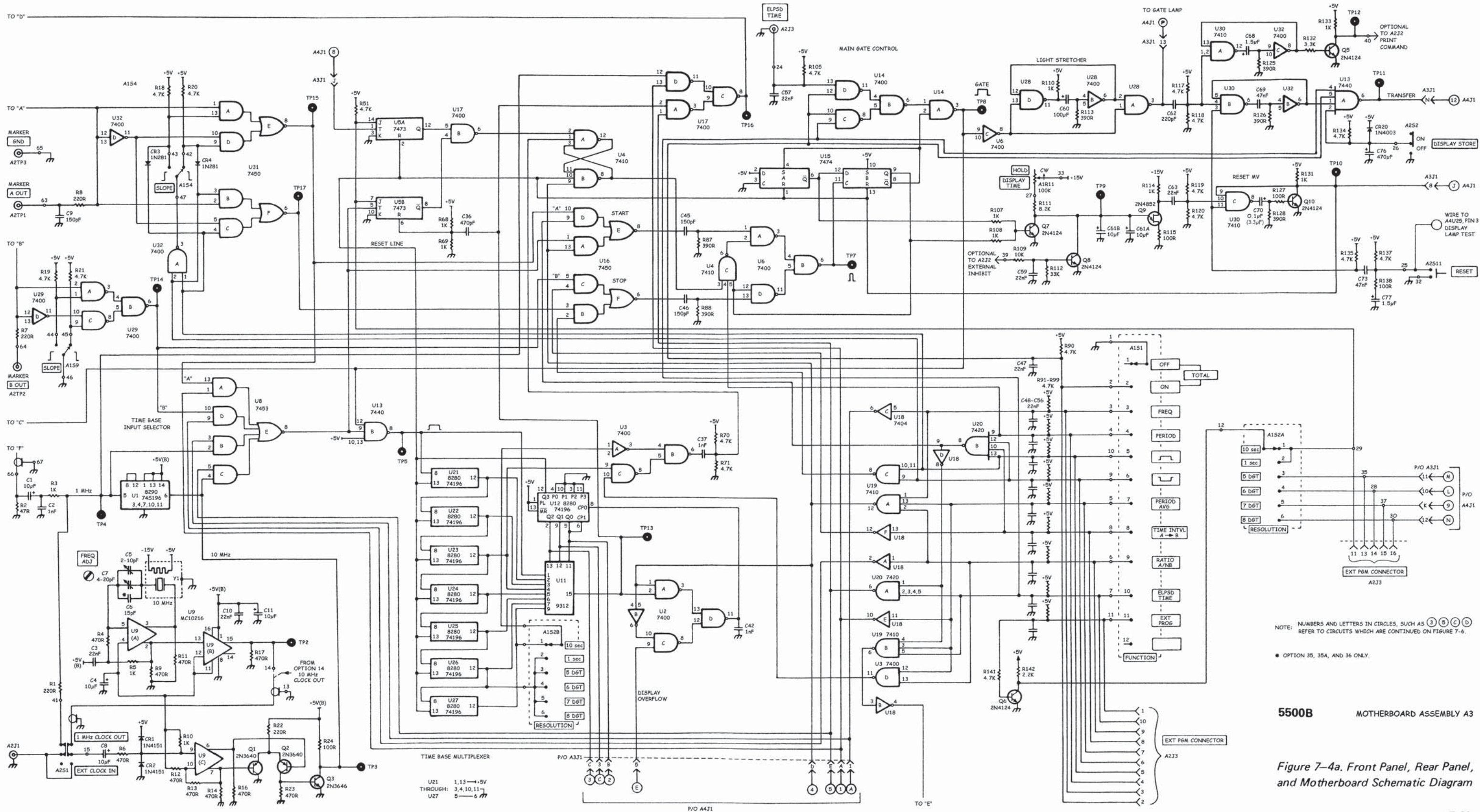

NOTE: NUMBERS AND LETTERS IN CIRCLES, SUCH AS (3)(9)(C)(D) REFER TO CIRCUITS WHICH ARE CONTINUED ON FIGURE 7-6.

* OPTION 35, 35A, AND 36 ONLY.

5500B MOTHERBOARD ASSEMBLY A3

Figure 7-4a. Front Panel, Rear Panel, and Motherboard Schematic Diagram

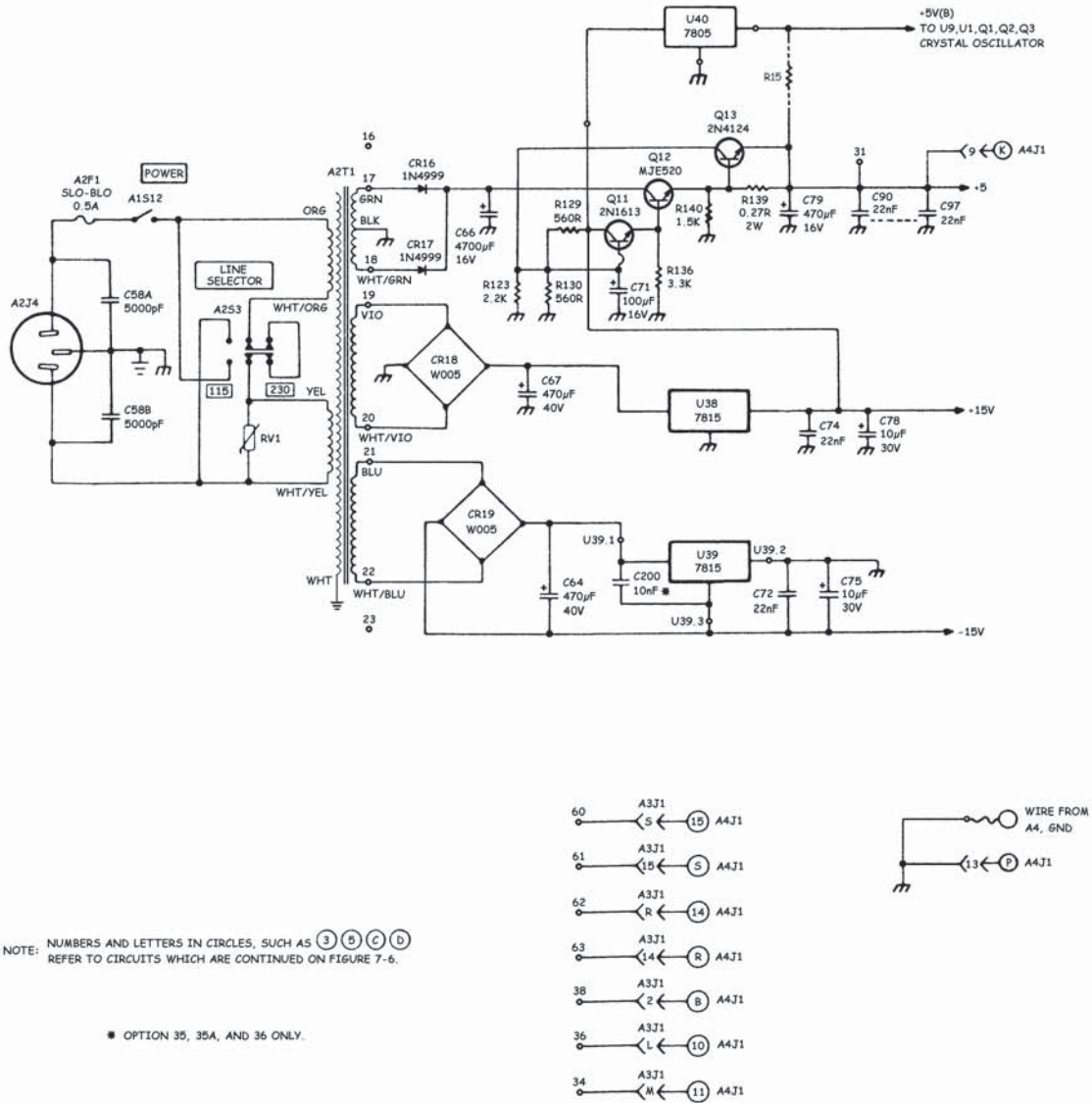
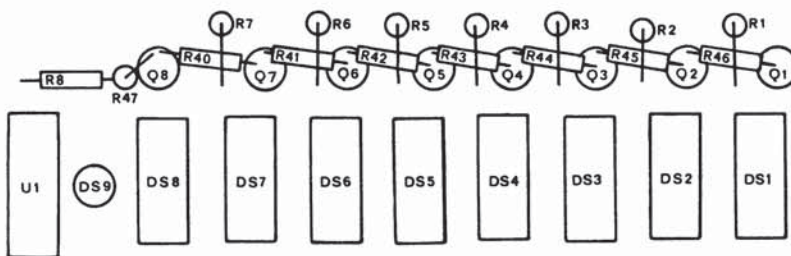
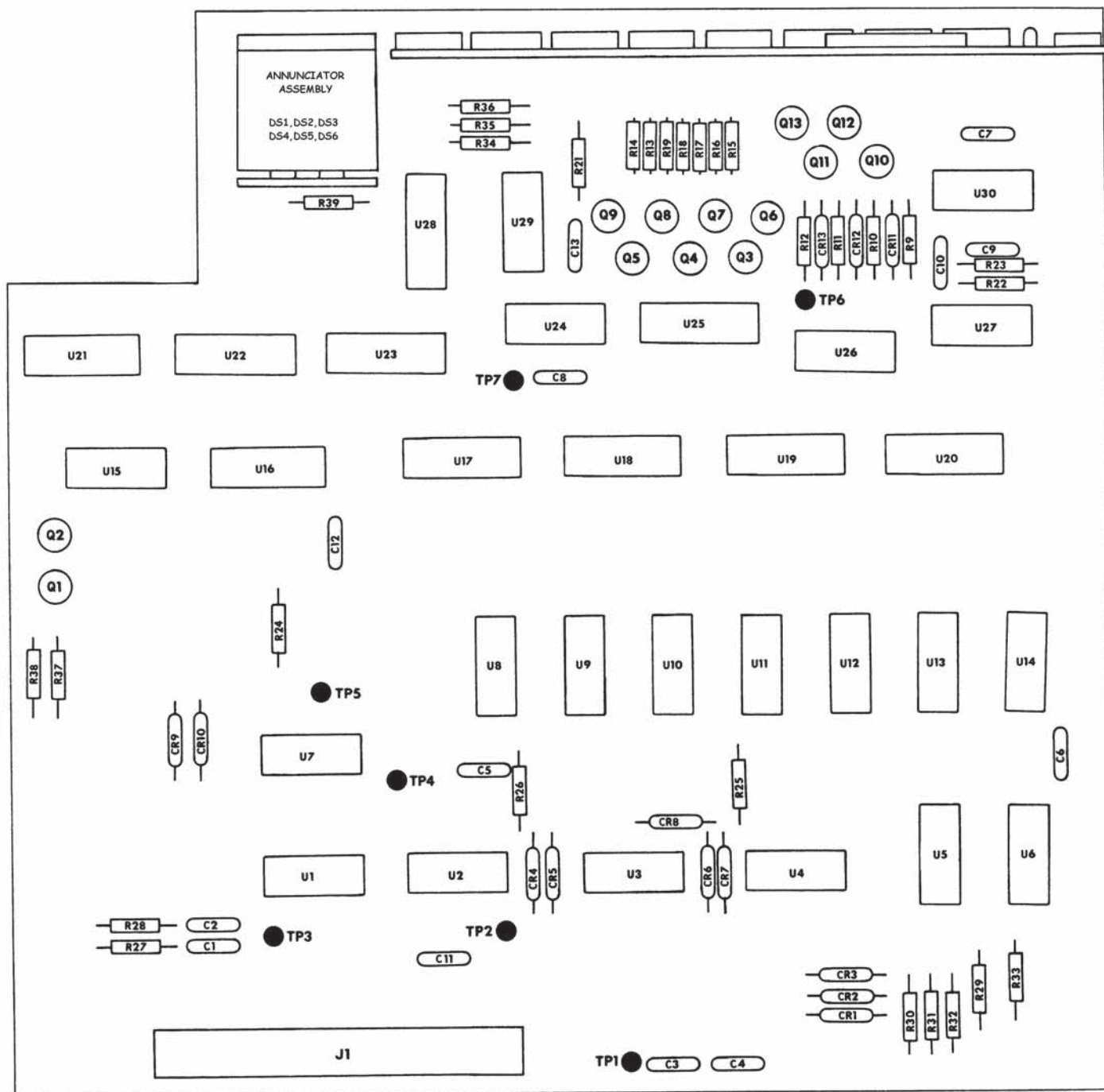

Figure 7-4c. Front Panel, Rear Panel, and Motherboard Schematic Diagram



— VIEW FROM FRONT —



— VIEW FROM REAR —

Figure 7-5. Display Assembly A4 Component Locations

Note: In Serial No. Prefix 020-, R1 through R8 are replaced by RN1, and R13 through R19 are replaced by RN2.

5500B
DISPLAY ASSEMBLY A4

Figure 7-6.
Display Assembly Schematic Diagram

NUMBERS AND LETTERS IN CIRCLES, SUCH AS
NOTE: (S) (R) (L) REFER TO CIRCUITS WHICH ARE
CONTINUED ON FIGURE 7-4 (DWG NO. 92-10129-5).

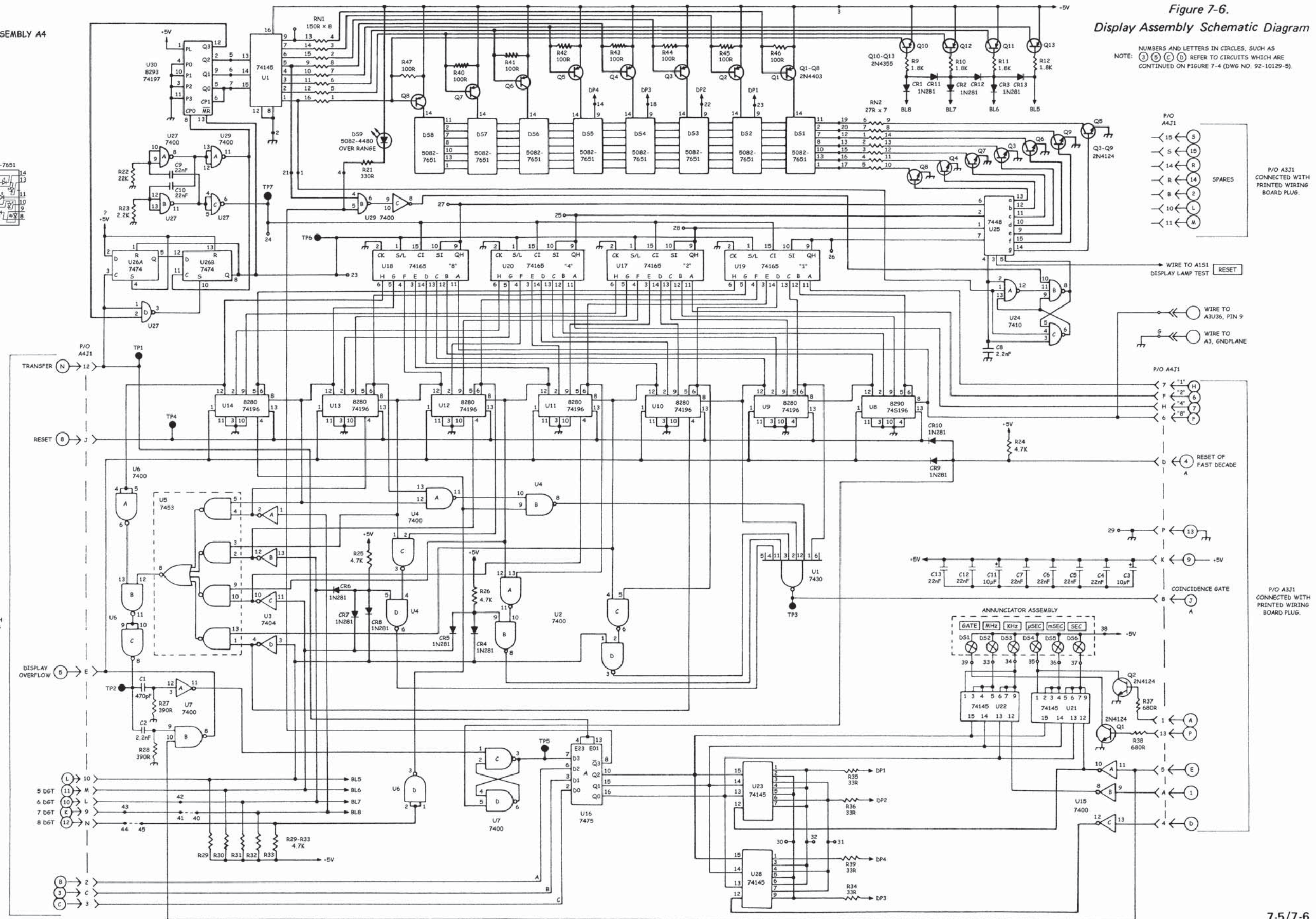

5500B

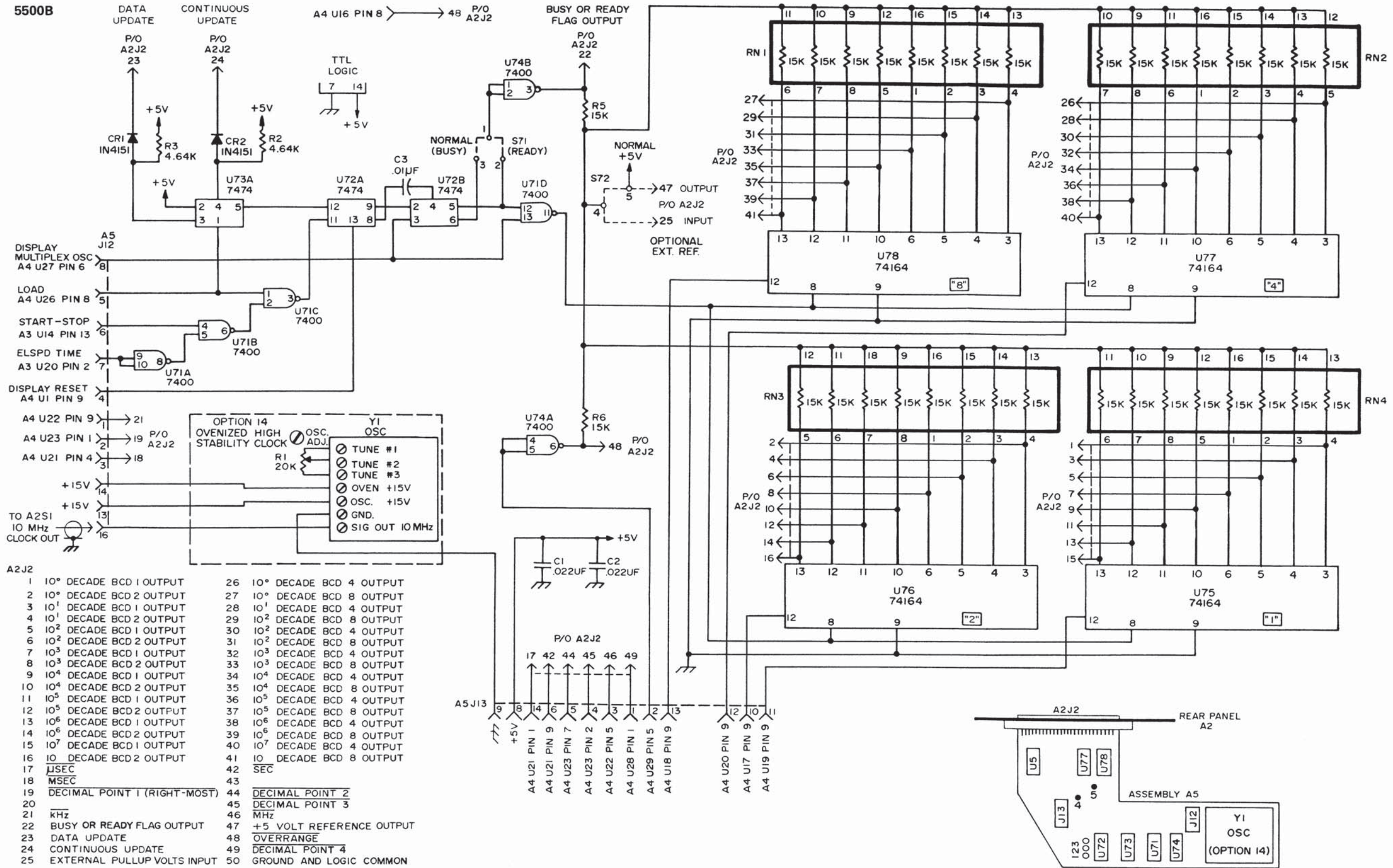

NOTES:

1. CONNECTIONS SHOWN --- ARE AT USER'S DISCRETION.
2. AN OVERLINE, FOR EXAMPLE μSEC, INDICATES "NEGATIVE TRUE".

Figure 7-7. BCD Printer Output, Option 01, and High Stability Oscillator, Option 14, Schematic Diagram

OPTION ASSEMBLY A5



I

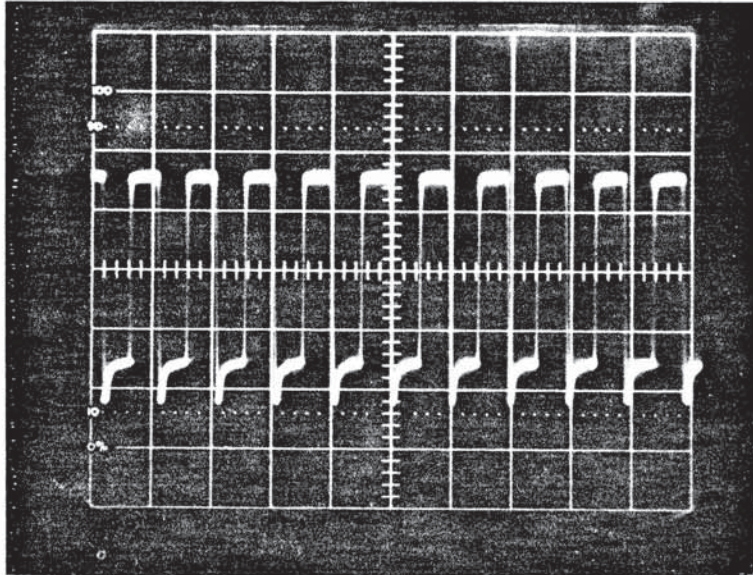

Pin 2 U34 in CHK MODE
.1 V/DIV X10 PROBE
1 μ S/DIV.

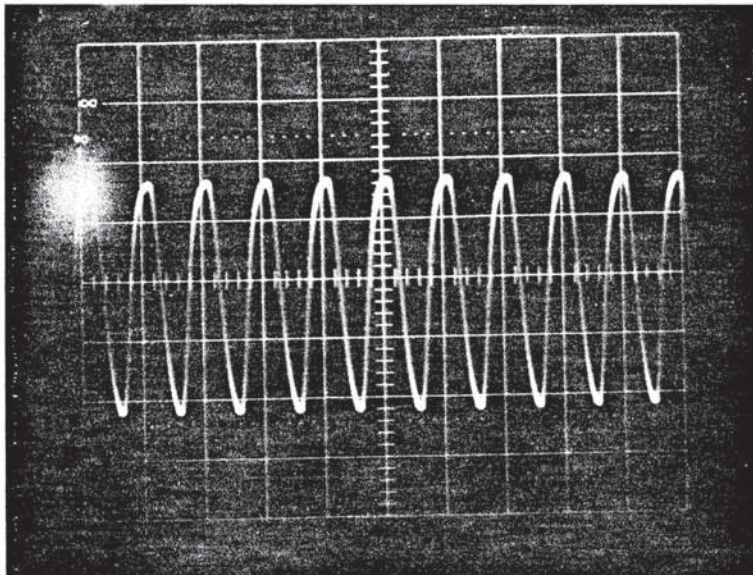

Pin 2,12 U34
100 mV at 10 MHz input
.1 V/DIV X10 Probe AC Coupled
.1 μ S/DIV.



II

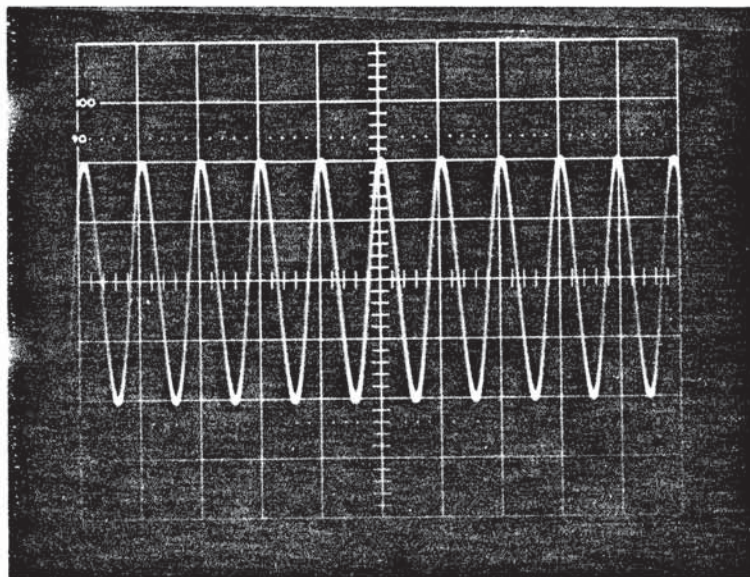

Pin 12, 13 U33
100 mV at 10 MHz Input
.02 V/DIV X10 Probe AC Coupled
.1 μ S/DIV.

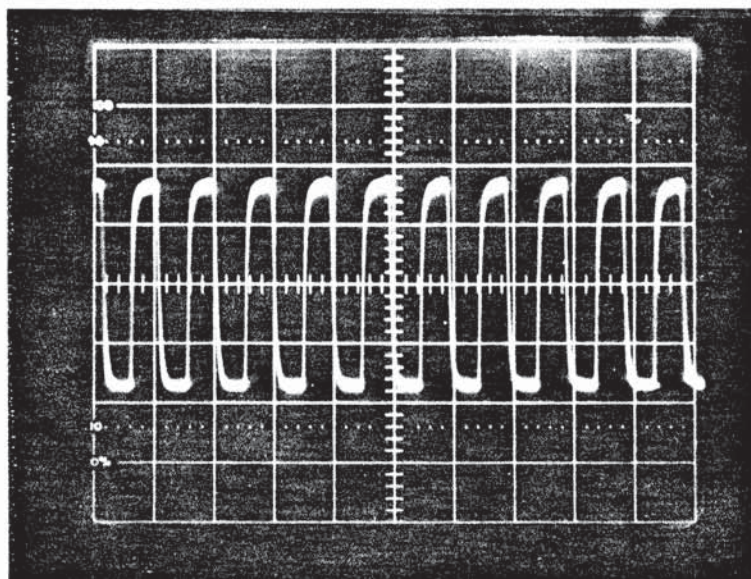

Channel A Output A2TP1
In CHK MODE
.1 V/DIV X10 Probe AC Coupled
1 μ S/DIV.



III

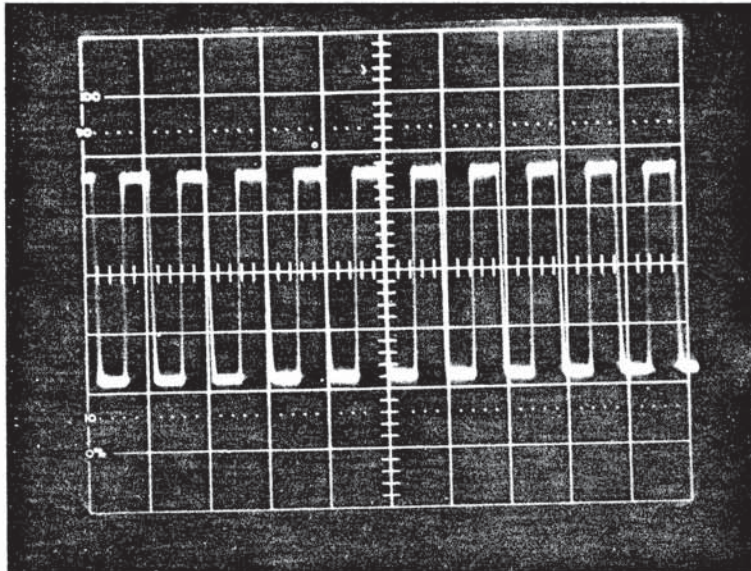

Channel B Output A2TP2
In CHK MODE
.1 V/DIV X10 Probe AC Coupled
1 μ S/DIV

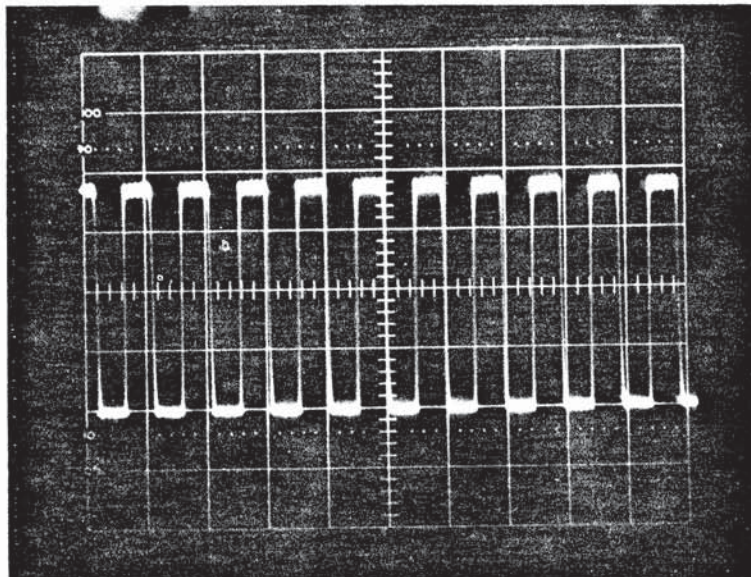

TP4 in CHK MODE
.1 V/DIV X10 Probe AC Coupled
1 μ S/DIV



IV

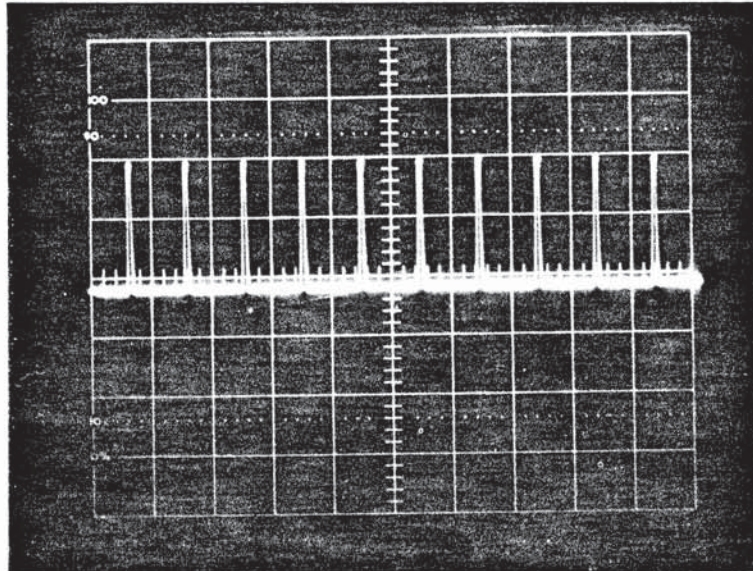

TP7 Reset in CHK MODE
.2 V/DIV X10 Probe AC Coupled
1 μ s/DIV

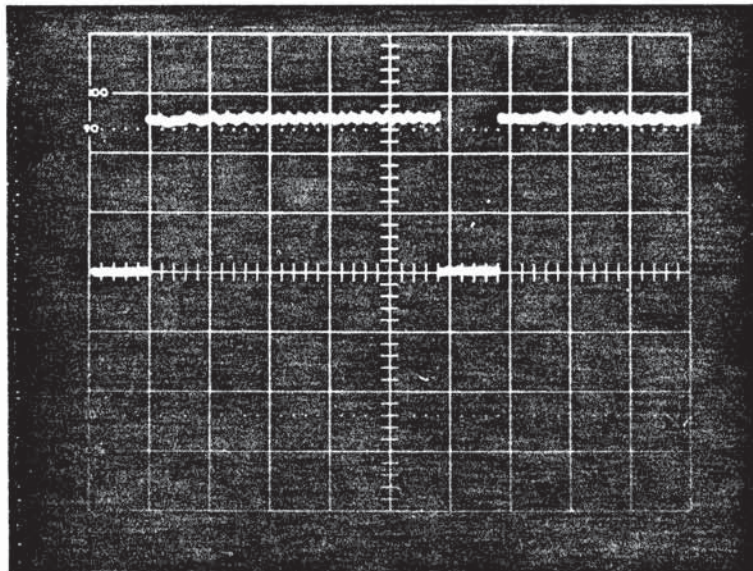

TP8 Gate in CHK MODE
.2 V/DIV X10 Probe DC Coupled
.2 ms/DIV



Ballantine Laboratories, Inc.

MODEL 5500B

V

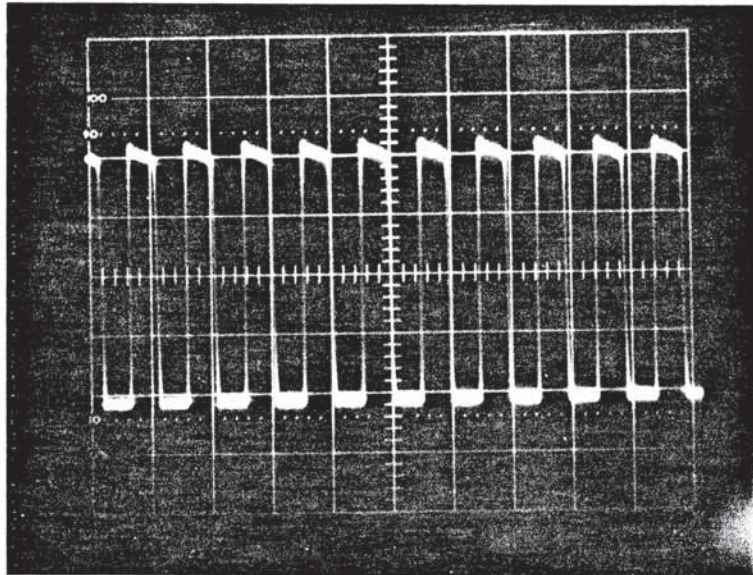

TP14 in CHK MODE
.1V/DIV X10 Probe AC Coupled
1 μ s/DIV

MODEL 5500B

NOTE:

Newer production instruments are built around
Low Power Schottky TTL logic as listed below.
All other component values remain unchanged.

A3 MOTHERBOARD ASSEMBLY

U1 N8290A
U2 74LS00
U3 74LS00
U4 74LS10
U5 74LS73
U6 74LS00
U8 7453
U9 MC10216P
U11 DM8312N
U12 74LS196
U13 74LS40
U14 74LS00
U15 7474
U16 7450
U17 74LS00
U18 74LS04
U19 74LS10
U20 74LS20
U21 74LS196
U22 74LS196
U23 74LS196
U24 74LS196
U25 74LS196
U26 74LS196
U27 74LS196
U28 74LS00
U29 74LS00
U30 74LS10
U31 7450
U32 74LS00
U33 MC10116P
U34 74S00
U35 74S112
U36 74S112
U37 UA710HCG
U38 LM340T-15
U39 LM340T-15
U40 UA7805UC

A4 DISPLAY ASSEMBLY

U1 74LS30
U2 74LS00
U3 74LS04
U4 74LS00
U5 7453
U6 74LS00
U7 74LS00
U8 74LS196
U9 74LS196
U10 74LS196
U11 74LS196
U12 74LS196
U13 74LS196
U14 74LS196
U15 74LS04
U16 74LS75
U17 74C165
U18 74C165
U19 74C165
U20 74C165
U21 74145
U22 74145
U23 74145
U24 74LS10
U25 74LS48
U26 74LS74
U27 74LS00
U28 74145
U29 74LS00
U30 74LS197

A4A1 LED ASSEMBLY

U1 74145



MODEL 5500B COUNTER-TIMER

OPTIONS 35 & 35A - "C" INPUT 10:1 PRESCALER

Manual P/N 90100975A, Dated November 1976

SPECIFICATIONS

Frequency: 50 MHz to 1 GHz, 25 mV rms; 110 MHz to 512 MHz, 15 mV rms.
Option 35A only: 25 MHz to 110 MHz, 50 mV rms.

Prescale Division: 10:1 with all automatic features of the basic unit operative.
1-second range scaled to 10 seconds; 10-second range scaled to 100 seconds averaging time.

Input Resistance: 50 ohms.

Input Overload: 15 mV to 1 volt rms normal operation. 3-volt continuous maximum input. Voltage above 5 volts rms opens input fuse (100 mA). Option 35A only includes input "C" protective fuse located in BNC panel connector.

Input Connector: BNC located on rear panel. Option 35A only includes input "C" protective fuse .

OPERATION

To activate "C" input, set FUNCTION switch to FREQ C and apply input signal to rear panel BNC J3000. Note that 10:1 prescaler alters counter timing to require 10 seconds time on 1 SEC RESOLUTION range and 100 seconds time on the 10 SEC range.

TEST PROCEDURE

- a. No internal adjustments are required.
- b. Apply 110-MHz sine wave, 15 mV rms to rear panel "C" input through a short 50-ohm RG-62A/U coaxial cable. Use calibrated attenuator on the signal generator or measure with RF millivoltmeter using a nonloading T-connector. Be certain that cable, connectors, and test equipment are in calibrated condition. Set counter to FREQ C and 8 digits. Note that counter reads 110 MHz stably.



MODEL 5500B COUNTER-TIMER

OPTIONS 35 & 35A-"C" INPUT 10:1 PRESCALER

Manual P/N 90100975A, Dated November 1976

TEST PROCEDURE - Continued

c. Change signal generator to 512 MHz and 15 mV rms. Note that counter reads 512 MHz stably.

d. Change signal generator to 1000 MHz and 25 mV rms. Note that counter reads 1000 MHz stably.

e. Option 35A only: Change signal generator to 25 MHz and 50 mV rms. Note that counter reads 25 MHz stably.

PARTS LIST

SCHEMATIC REF	BALLANTINE PART NO.	DESCRIPTION	MFR CODE	MFR PART NUMBER
C 3501	07101120A	CCC 100.0NF 50.0 V CHIP	71590	CENTRLB W050FH104M
C 3502	07101120A	CCC 100.0NF 50.0 V CHIP	71590	CENTRLB W050FH104M
C 3503	07101120A	CCC 100.0NF 50.0 V CHIP	71590	CENTRLB W050FH104M
C 3504	07101120A	CCC 100.0NF 50.0 V CHIP	71590	CENTRLB W050FH104M
C 3505	07101120A	CCC 100.0NF 50.0 V CHIP	71590	CENTRLB W050FH104M
C 3506	07100530A	CET 10.0UF 35.0V M	56289	SPRAGUE 1960106X0035A3
C 3507	07101120A	CCC 100.0NF 50.0 V CHIP	71590	CENTRLB W050FH104M
C 3508	07101120A	CCC 100.0NF 50.0 V CHIP	71590	CENTRLB W050FH104M
C 3509	07101200A	CCD 22.0NF 25.0 VM	71590	CENTRLB UK25223 OR EQUIV
C 3510	07101200A	CCD 22.0NF 25.0 VM	71590	CENTRLB UK25223 OR EQUIV
C 3511	07101200A	CCD 22.0NF 25.0 VM	71590	CENTRLB UK25223 OR EQUIV
C 3512	07101200A	CCD 22.0NF 25.0 VM	71590	CENTRLB UK25223 OR EQUIV
CR 3501	05094620A	DGP 5082-2800 70	28480	HPA SCHOTTKY 2
CR 3502	05100250A	DGP 1N281 75 .1A.08	15238	ITT GE D07
CR 3503	05100250A	DGP 1N281 75 .1A.08	15238	ITT GE D07
F 3501	19100060A	FUS 0.125 A PICO FUSE PIGTAIL	75915	LITTELFUSE 1/8 AMP 275.125
J 3501	31101391A	CON 5755A BNC SPECIAL	91836	KINGS KC-19-213
J 3502	31033790A	CON UG-1094/U BNC, DAGE	29587	STATE ELECT. PARTS
J 3503	31101690A	CON 14 PIN FLT CBL CRIMP	15912	ANSLEY 609 M 145
J 3504	31101690A	CON 14 PIN FLT CBL CRIMP	15912	ANSLEY 609 M 145
Q 3501	10100010A	TRQ 2N2369 NPN 1 15 MTO-18	04713	MOT 1.2 500M 20
Q 3502	10100010A	TRQ 2N2369 NPN 1 15 MTO-18	04713	MOT 1.2 500M 20
Q 3503	10100430A	TRQ 2N3904 NPN 1 40 PTO-92	04713	MOT 1 300M 40
R 3501	12121680A	RFF 51.1 500 MW F+-1%	16299	CGW RN55D 52R3 F
R 3502	12124000A	RFF 10.0 K 500 MW F+-1%	16299	CGW RN55D 1002 F
R 3503	12122360A	RFF 237.0 500 MW F+-1%	16299	CGW RN55D 2370 F
R 3504	12122760A	RFF 619.0 500 MW F+-1%	16299	CGW RN55D 6190 F
R 3505	12122600A	RFF 422.0 500 MW F+-1%	16299	CGW RN55D 4220 F
R 3506	12123440A	RFF 2.87K 500 MW F+-1%	16299	CGW RN55D 2871 F
R 3507	12123650A	RFF 4.75K 500 MW F+-1%	16299	CGW RN55D 4751 F
R 3508	12123320A	RFF 2.15K 500 MW F+-1%	16299	CGW RN55D 2151 F
R 3509	12123480A	RFF 3.16K 500 MW F+-1%	16299	CGW RN55D 3161 F
R 3510	12122500A	RFF 332.0 500 MW F+-1%	16299	CGW RN55D 3320 F
U 3501	24101041A	ICP 1.3 GHZ AMPLIFIER	50423	BLI-MOT1916 OPTIMAXCA1042
U 3502	24101660A	ICP SP8665B 1.0GHZ DIV BY 10	50587	PLESSEY SP8665B
U 3503	24100610A	ICP SHOTTKY QUADGATZ 74S00	01295	T.I. 74S00
U 3504	24100140A	ICP 8280 TTL DEC. CTR	18324	SIGNETICS N8280A
U 3505	24101670A	ICP CP7905 -5V REG. 1.5 AMP	04713	MOTOROLA MC7905CP OR EQUIV.

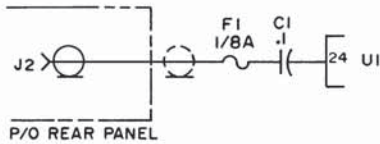

Input Circuit, Channel "C" (Option 35), Schematic Diagram

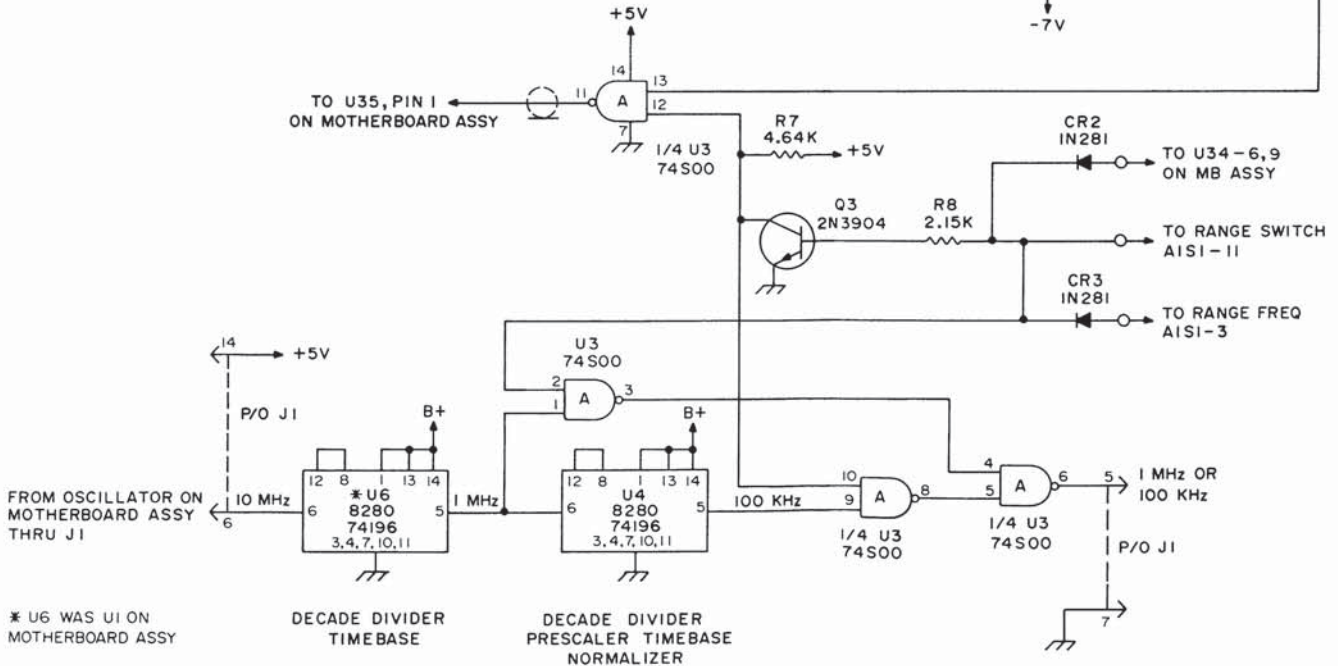
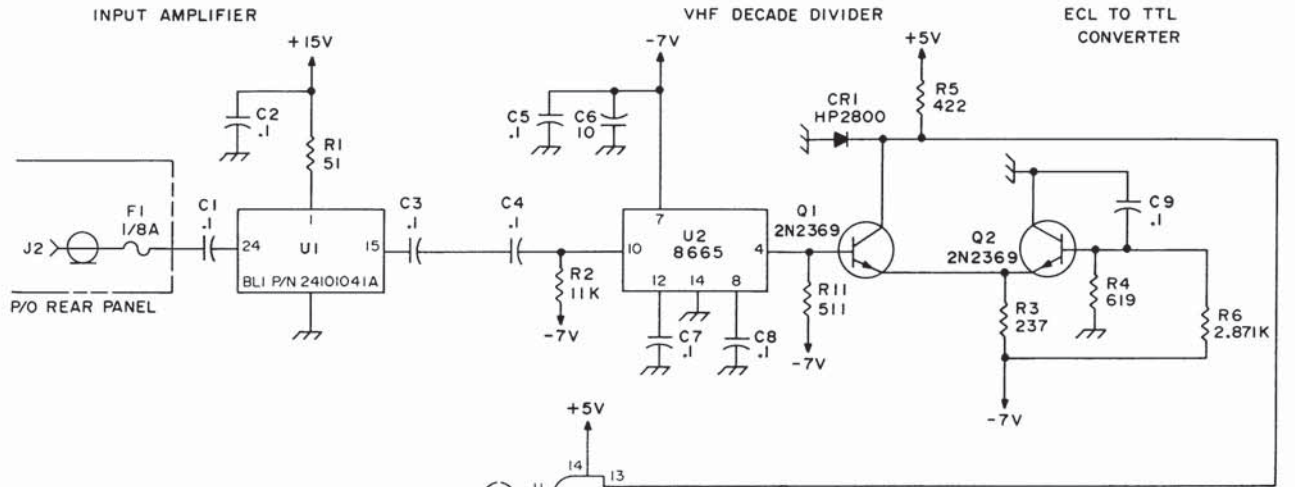

* U6 WAS U1 ON MOTHERBOARD ASSY

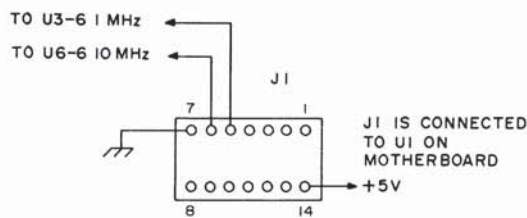
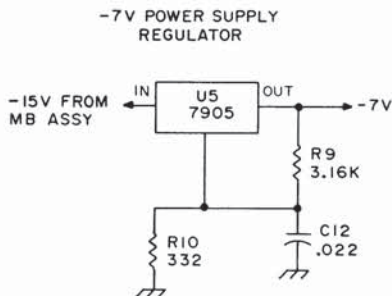



ADDENDUM

TO INSTRUCTION MANUAL:

MODEL No. 5500B

Change oscillator configuration on serial number prefix code 050 when required to obtain fast start-up of crystal oscillator on turn on.

Change is implemented on all units with prefix code 051.

Schematic change:

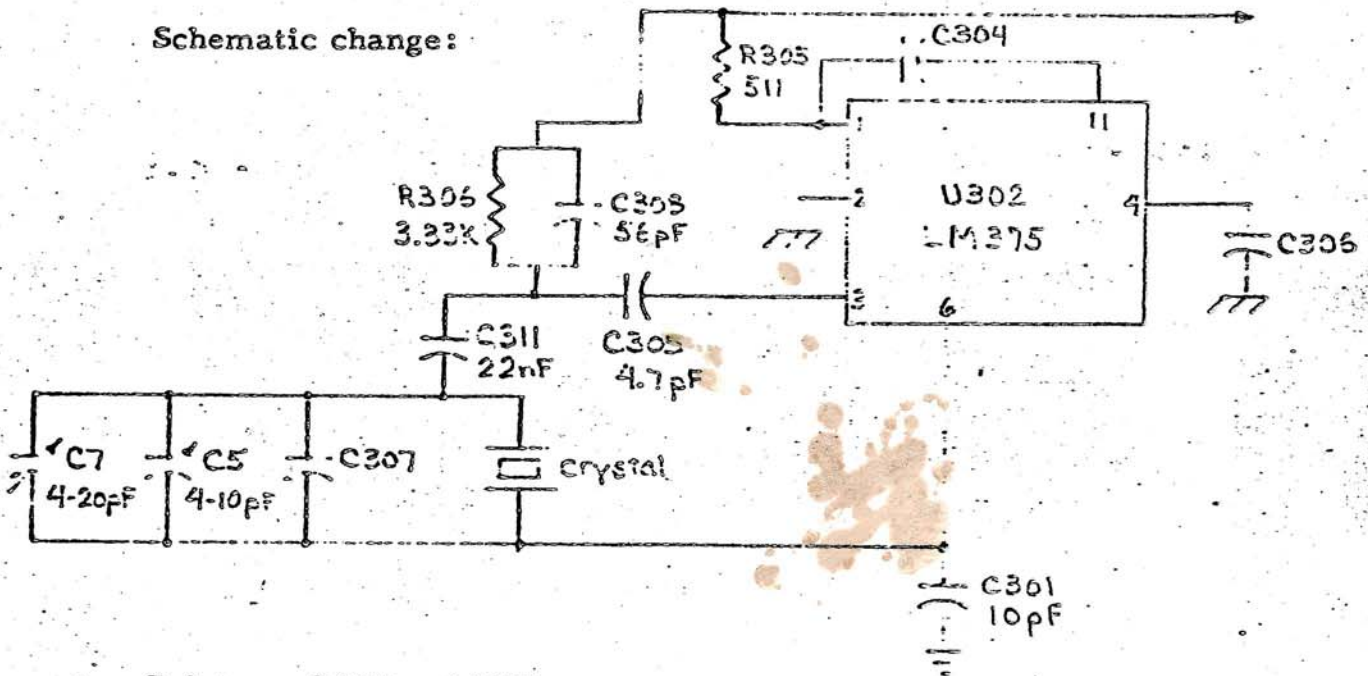

Delete: R305 and L300

Add:	R305	12122680A	RFF	511	1/2W, 1%
	R306	12123560A	RFF	3.83K	1/2W, 1%
	C311	07101200A	CFM	22 nF	200V, 10%



Ballantine Laboratories, Inc.

P.O. Box 97, Boonton, New Jersey 07005, U.S.A.

Telephone: 201-335-0900, TWX: 710-987-8380