

Ballantine



**MODEL
6125 B/C
TIME AND
AMPLITUDE
TEST SET**

INSTRUCTION MANUAL

MODEL 6125 B/C TIME AND AMPLITUDE TEST SET

Serial Prefix No. 021- & 022-

Ballantine Laboratories, Inc. • P.O. Box 97 • Boonton, New Jersey 07005 U.S.A.
Telephone: 201-335-0900 • TWX: 710-987-8380

WARRANTY

This Ballantine Laboratories, Inc. product is warranted against defects in materials and workmanship for a period of one year from the date of shipment, except for batteries, electron tubes, vacuum thermocouples, and certain other components, if any, listed in this manual. Ballantine Laboratories, Inc. will, at its option, repair or replace products which prove to be defective during the warranty period provided they are returned to Ballantine Laboratories, Inc. prepaid, and provided the proper preventive maintenance and calibration procedures as listed in this manual have been followed. Repairs necessitated by misuse of the product are not covered by this warranty. NO OTHER WARRANTIES ARE EXPRESSED OR IMPLIED, INCLUDING BUT NOT LIMITED TO THE IMPLIED WARRANTIES OF MERCHANTABILITY AND FITNESS FOR A PARTICULAR PURPOSE. BALLANTINE LABORATORIES, INC. IS NOT LIABLE FOR CONSEQUENTIAL DAMAGES.

CERTIFICATION

Ballantine Laboratories, Inc. certifies that this equipment meets all applicable Ballantine specifications at time of shipment from the factory as determined by thorough testing and inspection. Ballantine further certifies that its measurements are traceable to the United States National Bureau of Standards. All instruments used in calibrating Ballantine products are standardized by systematic reference to NBS-traceable standards as described in the validation procedures shown below.

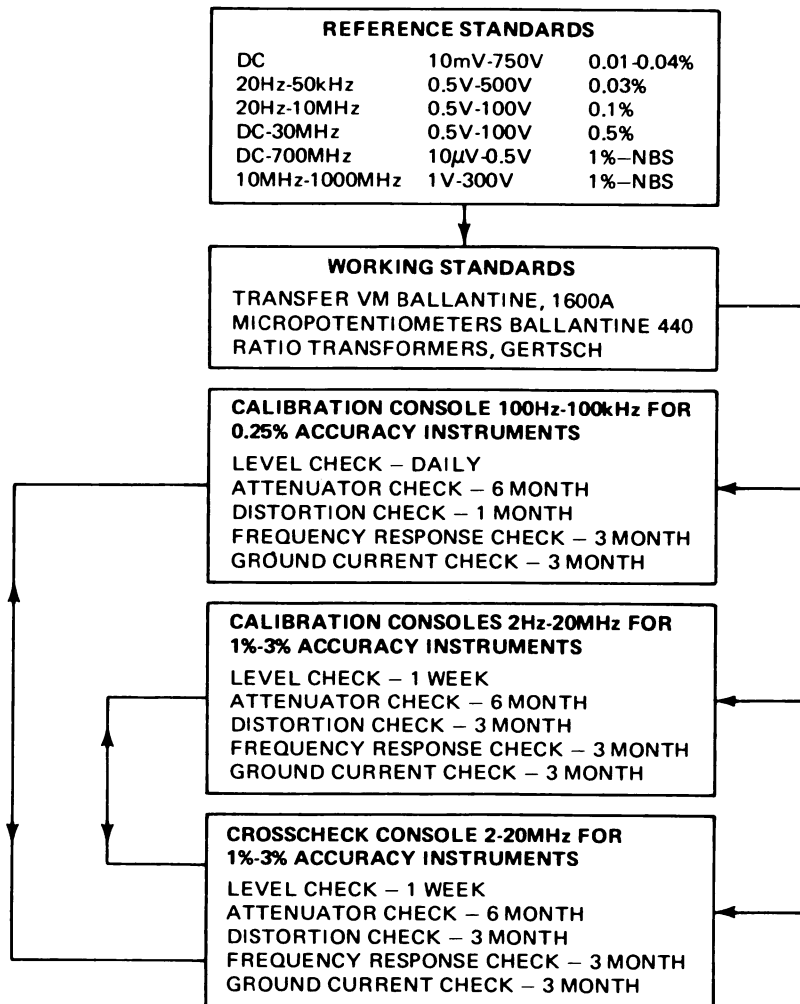

TABLE OF CONTENTS

<i>Paragraph</i>	<i>Page</i>	<i>Paragraph</i>	<i>Page</i>
SECTION 1. GENERAL INFORMATION			
1-1. Introduction	1-1	4-25. Volts Deviation Circuitry	4-3
1-3. Voltage Amplitude Calibrator	1-1	4-30. Volts Control Circuits	4-3
1-8. Time Calibration	1-1	4-36. Volts Remote Control (6125C only)	4-3
1-13. Risetime Calibrator	1-1	4-42. Time Calibrator	4-5
1-15. Synchronization/Trigger Check	1-1	4-43. General Description	4-5
1-17. Remote Operation (6125C)	1-2	4-45. 100 MHz Oscillator	4-5
1-20. Specifications	1-2	4-46. Counter Chain and Multiplexing	4-5
1-23. Accessories and Options	1-5	4-47. Mark/Space Ratio Encoder and Output Driver	4-5
SECTION 2. PREPARATION FOR USE AND SHIPMENT			
2-1. General	2-1	4-50. Time Generator Circuit Description	4-5
2-3. Unpacking and Initial Inspection	2-1	4-57. Marker Output Circuits	4-7
2-5. Performance Checks	2-1	4-63. Trigger Period Circuits	4-7
2-7. Power Requirements	2-1	4-67. Time Deviation Circuits	4-7
2-10. Grounding Requirements	2-1	4-70. Time Generator, Control Circuits	4-7
2-13. Installation and Mounting	2-1	4-77. Time Remote Control (6125C only)	4-9
2-18. Short Term Storage	2-1	SECTION 5. CALIBRATION AND MAINTENANCE INSTRUCTIONS	
2-20. Long Term Storage or Repackaging for Shipment	2-2	5-1. Introduction	5-1
2-22. 6125C Programming	2-2	5-4. Test Equipment	5-1
2-24. Safety	2-2	5-6. Performance Assurance Checks	5-1
SECTION 3. OPERATION			
3-1. Introduction	3-1	5-7. General	5-1
3-3. Controls, Indicators, and Connectors	3-1	5-8. Power Line Voltage Setting	5-1
3-5. Power Requirements	3-1	5-9. Oscillator Frequency Accuracy	5-1
3-7. Operating Instructions	3-1	5-10. Marker Output Amplitude	5-1
3-11. Voltage Calibration	3-1	5-11. Trigger Period	5-2
3-12. DC Voltage Output	3-1	5-12. Trigger Output Rise Time	5-2
3-15. Square Wave Voltage Output	3-4	5-13. High Frequency Output	5-2
3-18. Voltage Measurement Errors	3-5	5-14. External Clock Input	5-6
3-21. DC Offset Errors	3-5	5-15. Time Deviation Check	5-7
3-25. Ground Current Errors	3-6	5-16. Volt/Div Check	5-7
3-27. Warmup Errors	3-6	5-17. Volts Deviation Check	5-8
3-29. Time Calibration	3-6	5-18. Volts Output Mode Check	5-8
3-30. Time Mark Generator	3-6	5-19. Calibration and Alignments Procedures	5-8
3-42. HF Outputs	3-7	5-20. General	5-8
3-50. Trigger Output	3-8	5-21. Removal and Replacement of Covers	5-8
3-55. Risetime Measurements	3-8	5-22. Power Supply Check	5-8
3-62. Line Frequency Output	3-10	5-23. Volts Calibration	5-8
SECTION 4. THEORY OF OPERATION			
4-1. Introduction	4-1	5-24. Volts Output Source Resistance and Divider Check	5-8
4-4. Volts Generator	4-1	5-25. Volts Out Short Circuit Check	5-9
4-7. Programmable DC Supply	4-1	5-26. Volts Supply Checks	5-9
4-14. Square Wave Chopper Switch	4-1	5-27. Volts Out Ripple Check (Optional)	5-9
4-17. Output Mode Selection	4-2	5-28. Volts Circuit Load Regulation	5-11
4-20. Precision Attenuator	4-2	5-29. 200 Volt Calibration Adjust (A3R9)	5-11
		5-30. 60 dB Attenuator Cal. Adjust (A7R20)	5-11
		5-31. Square Wave Zero Level Adjust (A3R2)	5-11
		5-32. 60 dB Attenuator Frequency Adjust (A7C11)	5-12

TABLE OF CONTENTS – Continued

<i>Paragraph</i>	<i>Page</i>	<i>Paragraph</i>	<i>Page</i>
5-33. Digital Meter Calibration (A23, A24, and A27)	5-12	5-48. Line Freq. Amplitude	5-16
5-34. Meter Zero Adjust (A23R10)	5-12	5-49. Troubleshooting	5-15
5-35. Volts Deviation Range Adjust (A18R2)	5-13	5-51. Printed Wiring Board Repair and Cleaning	5-16
5-36. Volts Deviation Cal. (A23R7)	5-13	5-53. Replacement of Selected Components	5-17
5-37. Volts Remote Deviation Zero Adjust (A1R7 on assembly 8910815, 6125C only).	5-13		
5-38. Optional Optimum Setting of A3R9 and VOLTS MULTIPLIER Check	5-13		
5-40. Time Calibration	5-14		
5-41. Clock Frequency Adjust (A11C5)	5-14		
5-42. 5 ns (200 MHz) Adjustment (A15C4, A15C6, A15C21)	5-14		
5-43. Flatness Test Procedure	5-14		
5-44. 2 ns H.F. Out Adjust (A15C4, A15C6, A15C7, A15C9, A15C10, A15C11, A15C14)	5-15		
5-45. % Time Deviation Balance Adjust (A12R2)	5-15		
5-46. Meter Time Cal. Adjust (A18R8, A18R6)	5-15		
5-47. Remote Time Deviation Zero (A10R4 on assembly 8910817 6125C only)	5-16		

SECTION 6. PARTS LIST AND CIRCUIT DIAGRAMS

SECTION 7. OPTIONS AND ACCESSORIES

7-1. Introduction	7-1
7-3. High Stability Clock - Option 14	7-1
7-14. IEEE 488-1978 Bus Interface Option 60.	7-2
7-49. Using the Tektronix 4051 as the Controller.	7-4
7-53. Using the HP 9825 Calculator as the Controller.	7-4
7-64. IEEE 488 Bus Interface Option 61	7-7

LIST OF TABLES

<i>Number</i>	<i>Page</i>	<i>Number</i>	<i>Page</i>
2-1. Model 6125C Amplitude Program Input, A1J2	2-5	5-1. Test Equipment	5-3
2-2. Model 6125C Time Program Input, A10J1.	2-6	5-2. Volts/Div Accuracy Limits.	5-12
3-1. Front Panel Controls, Indicators, and Connectors	3-2	5-3. Troubleshooting Hints.	5-21
3-2. Rear Panel Controls, Indicators, and Connectors	3-4	5-4. Volts/Div Attenuator Check	5-24
3-3. Volts Output, Output Resistance and Loading Error.	3-7	5-5. Volts Multiplier Check	5-24
4-1. Output Model Selection States.	4-4	7-1. ASCII Code Chart	7-5
4-2. Precision Attenuator Control States.	4-4	7-2. Decimal to Binary and Octal Code Conversions.	7-6
4-3. Selection By Multiplexers A12, U12-U15.	4-6	7-3. Sequence of ASCII Control Codes.	7-7
4-4. T/DIV Control of Lowest Time Interval by Multiplexer A14 U3	4-8	7-4. 6125C Opt. 60 TIM/DIV ASCII Codes.	7-7
4-5. Multiplier Switch Control of A14 U6.	4-8	7-5. Trigger Select ASCII Code.	7-8
4-6. Trigger Period Selection, A13 U16.	4-8	7-6. 6125C Opt.60 only Deviation Level ASCII Code	7-8
4-7. Complete Time/Div Control and Logic States	4-10	7-7. Volts Mode ASCII Code.	7-9
		7-8. Output Mode ASCII Code	7-10
		7-9. Deviation Select ASCII Code.	7-10

LIST OF ILLUSTRATIONS

<i>Number</i>	<i>Page</i>	<i>Number</i>	<i>Page</i>
1-1.	Model 6125B/C Programmable Time and Amplitude Test Set	1-0	
1-2.	Determining Risetime	1-5	
2-1.	Voltage Selecting and Fused Receptacle Printed Circuit Board Location and Orientation	2-2	
2-2.	Model 6125B/C Outline Drawing	2-3	
2-3.	6125B/C Time and Amplitude Test Set Packing Diagram	2-4	
2-4.	Safety Considerations	2-7	
3-1.	Model 6125B Controls, Indicators, and Connectors	3-3	
3-2.	Model 6125C Front Panel Controls, Indicators, and Connectors	3-3	
3-3.	Model 6125C Rear Panel Controls, Indicators, and Connectors	3-3	
3-4.	Volts Out Display	3-5	
3-5.	Marker Out Display	3-7	
3-6.	Rise Time Display	3-8	
3-7.	Line Freq. Display	3-10	
4-1.	Functional Block Diagram, Volts circuits	4-2	
4-2.	Simplified Schematic, Programmable DC Supply	4-11	
4-3.	Simplified Schematic, Square Wave Chopper	4-13	
4-4.	Simplified Schematic, Output Mode Selection	4-15	
4-5.	Simplified Schematic, Precision Attenuator	4-16	
4-6.	Simplified Schematic, Amplitude Deviation Control	4-17	
4-7A.	Control Circuits, Volts/Div Multiplier	4-19	
4-7B.	Control Circuit, Volts Deviation	4-19	
4-8.	Functional Block Diagram, Time Circuits	4-20	
4-9.	Simplified Schematic, Timing Source Circuits	4-21	
4-10.	Simplified Schematic, Marker Pulse Circuits	4-23	
4-11.	Simplified Schematic, Trigger Signal Circuits	4-25	
4-12.	Simplified Schematic, Time Deviation Circuits	4-27	
4-13.	Time Deviation, Multiplier and Trigger Period Control Logic	4-29	
4-14.	Time/Div Control Lines	4-31	
5-1.	Clock Frequency Check, Bench Test Setup	5-5	
5-2.	Trigger and Marker Amplitude Check, Bench Test Setup	5-6	
5-3.	Trigger Rise Time and H.F. OUT Check, Bench Test Setup	5-7	
5-4.	External Clock Input Check, Bench Test Setup	5-10	
5-5.	Location of Adjustments 6125B/C	5-18	
5-6.	Model 6125B/C Circuit Board Location	5-19	
5-7.	Error Correcting Graph	5-25	
—	Performance Assurance Test Record Form	5-27	
6-1.	A1 6125B Volts Shorting Board	6-5	
6-2.	A1 6125C Volts Remote Program Input . . .	6-7	
6-3.	A2 6125B/C Programmable Volts Power Supply	6-9	
6-4.	A3 6125B/C Volts Power Supply Control	6-11	
6-5.	A4 6125B/C Volts Multiplier Select	6-13	
6-6.	A5 6125B/C 10 μ V to .5 mV Select	6-15	
6-7.	A6 6125B/C 1 mV to 20 V Select	6-17	
6-8.	A7 6125B/C Volts Output Mode Select	6-19	
6-9.	A8 6125C Volts/Div Display	6-21	
6-10.	A10 6125B Time Shorting Board	6-23	
6-11.	A10 6125C Time Remote Program Input . .	6-25	
6-12.	A11 6125B/C and Opt. 14 10 MHz Clock and (6125C) Time Display Drive	6-27	
6-13.	A12 6125B/C Time/Div Decoder	6-29	
6-14.	A13 6125B/C Time/Div Select	6-31	
6-15.	A14 6125B/C 100 MHz Phase Lock Loop and Divider	6-33	
6-16.	A15 6125B/C 200 MHz and 500 MHz Multiplier	6-35	
6-17.	A16 6125B/C Time Output Amplifier	6-37	
6-18.	A17 6125B/C (Not Option 60) DPM Interconnect Board	6-39	
6-19a.	A18 6125B/C Time Deviation Board (Serial Prefix 022-)	6-41	
6-19b.	A18 6125B/C Time Deviation Board (Serial Prefix 021-)	6-43	
6-20.	A20 6125C Time/Div Display	6-45	
6-21.	A23 and A24 DPM and DPM Display	6-47	
6-22.	A26 6125B/C Volt Interconnect	6-49	
6-23.	A27 Time Interconnect	6-51	
7-1.	IEEE 488 Bus Interface, Block Diagram . . .	7-4	
7-2.	Address Switch	7-5	
7-3.	A31 Volts/Div IEEE Remote Program	7-13	
7-4.	A32 Time/Div IEEE Remote Program	7-15	
7-5.	A33 Dpm Interconnect and Coupler	7-17	
7-6.	A28, A29, and A30 IEEE Bus, Option 60	7-19	



Figure 1-1. Model 6125B/C Programmable Time and Amplitude Test Set

SECTION 1

GENERAL INFORMATION

1-1. INTRODUCTION.

1-2. The Ballantine Model 6125B/C Time and Amplitude Calibrator is really a versatile instrument. It provides facilities normally required for calibrating modern precision oscilloscopes, digital frequency counters, spectrum analyzers and basic voltmeters. It is simple to use. The operator sets the amplitude and time controls to the values required, selects the appropriate function and multiplier settings and observes the waveform on the oscilloscope. If the trace does not coincide with the appropriate graticule marking, the deviation control is adjusted until it does. The error may then be read directly from the deviation meter as a percentage. In addition to the facilities for amplitude calibration and for checking synchronization/triggering at line frequency and at eight decade frequencies, the 6125C is fully programmable and provides an optional IEEE-488-1975 Bus capability. The Model 6125B/C is portable and may readily be taken to the field or factory for "on site" calibrations.

1-3. VOLTAGE AMPLITUDE CALIBRATOR.

1-4. An accurate DC voltage, either positive, negative or zero, or a selectable 10 kHz, 1 kHz, 100 Hz, 10 Hz positive going square wave is provided for amplitude calibration.

1-5. The VOLTS/DIV voltage control switch is designed to correspond with that on the oscilloscope. It is calibrated in 1, 2, 5 steps over the range 10 microvolts per division to 20 volts per division and in use, is set to the same setting as on the oscilloscope. A multiplier switch gives X 1, 2, 3, 4, 5, 6, 8 or 10 multiplication of the output so that the display may be expanded to suit the CRT graticule markings and to give a suitable display size. The multiplier may also be used to check linearity of a digital multimeter.

1-6. The deviation control enables the output to be adjusted until the trace coincides exactly with the graticule divisions of an oscilloscope or the cardinal points of a voltmeter under test. The deviation meter on the 6125 will then indicate the percentage error.

1-7. The square wave frequency is crystal controlled. The voltage reference is a high quality zener diode. The amplitude accuracy is 0.25%. The waveform has fast risetimes and flat tops to permit its use in the alignment of scope input attenuators.

1-8. TIME CALIBRATION.

1-9. A high quality time-mark generator provides pulses for time calibration. This section is split into two ranges, each

with an output connector. The main range covers from 10 nanoseconds per division to 5 seconds per division in 1, 2, 5 steps. The TIME/DIV switch settings correspond to those on the oscilloscope and as with the VOLTS/DIV switch, is set to the same setting as that on the oscilloscope. A multiplier switch gives X 1, 2, 5 or 10 multiplication of the output so that the display may be expanded to suit the CRT graticule markings and to extend the TIME/DIV calibrated range to 50 seconds per division.

1-10. As with voltage calibration, the deviation control varies the spacing until the waveform coincides exactly with the scale divisions. The percentage error can then be read directly from the deviation meter on the 6125B/C.

1-11. The pulses are in picket fence form and have fast rise-times. The width at the base of each pulse is digitally controlled to 5% of the pulse interval and jitter is normally less than 0.01% of the period.

1-12. The sinewave output range provides the faster marker periods of 2 and 5 nanoseconds. These sinewave outputs have no multiplication or deviation facilities. All time calibrations are synchronized to the Risetime Calibrator whose 8 decade repetition rates may be used to trigger the scope at a constant rate when changing time calibration output frequencies. This also permits the scope to be triggered at various repetition rates and a fixed time calibration to check display brightness variation and to check the effects of varying oscilloscope sweep repetition rates on sweep time calibration of any TIME/DIV range.

1-13. RISETIME CALIBRATOR.

1-14. An extremely fast risetime square wave output is provided for risetime measurements. The amplitude is continuously variable over the range 200 to 250 mV (into 50 ohms). There is sufficient adjustment to provide a display of 4 or 5 divisions on oscilloscopes of 50 mV/division without using the oscilloscope variable volts/division control. The risetime is less than 1 nanosecond with an extremely flat top to permit amplifier alignment of scopes having greater than 350 MHz bandwidth.

1-15. SYNCHRONIZATION/TRIGGER CHECK.

1-16. A line frequency sinewave output of variable amplitude is available for checking trigger level and trigger slope at line frequency.

1-17. REMOTE OPERATION (6125C only).

1-18. The 6125C is operable either from the front panel controls or remotely. Its front panel operation is identical to that of the 6125B. Its normal remote operation utilizes TTL compatible parallel signals through rear panel connections. Remote operation of the voltage and time calibration facilities are independent so that either one or both may be operated remotely. See paragraph 2-22 for connector information.

1-19. Option 60 in the 6125C provides a controller interface to the IEEE standard 488-1975 bus, so that the 6125C operations may be fully programmed from and read out to other equipment compatible to this discipline. See section 7 for programming information for 6125C option 60.

1-20. SPECIFICATIONS.

1-21. 6125B TIME AND AMPLITUDE TEST SET:

SPECIFICATIONS

VOLTAGE SOURCE

Ranges:

- (a) Volts/Division: 10 μ V to 20 V.
20 ranges in 1, 2, 5 sequence.
- (b) Multiplier: X1, 2, 3, 4, 5, 6, 8, 10.
- (c) Absolute Range: AC; 30 μ V to 220 Volts
 \pm DC; 300 μ V to 220 Volts

Output Modes:

AC Positive-going square wave. 10 kHz, 1 kHz, 100 Hz, 10 Hz in four ranges. Frequency crystal controlled to $\pm 0.01\%$ accuracy. 10 kHz square wave usable on all ranges but specified performance applies on all ranges greater than 50 mV.

DC positive.
DC negative.
GND

Accuracy: Better than $\pm 0.25\%$ of setting into open circuit.

Offset: Typically $\pm 35 \mu$ V below 50 mV. (After use on ranges above 50 mV, a five minute setting time is required to minimize thermal effects.) Typically $\pm 50 \mu$ V above 50 mV. Note: The same offset is obtained on all output modes including GND.

Ripple and Hum: Less than $\pm (0.2\%$ of set amplitude + 2 μ V p-p) on 20 V to 1 mV VOLTS/DIV ranges measured over a 30 kHz bandwidth at nominal ac mains voltage.

Square wave risetime: Less than 10 μ s.

Square wave overshoot: Less than 1% on the 20 V to 50 mV VOLTS/DIV ranges.

Reference: High Quality Zener diode.
(Temperature coefficient $\pm 0.005\%$ per $^{\circ}$ C).

Temperature Coefficient of Voltage Output (15-35 $^{\circ}$ C):
Better than $\pm (0.01\% + 3 \mu$ V) per $^{\circ}$ C.

Regulation (for 1 M Ω Load): Not greater than 0.27% depending on V/DIV range setting.

Deviation Range: $> \pm 10\%$ of setting with 0.01% resolution.

Deviation Accuracy: $\pm 2\%$ of deviation reading.

Short Circuit Protection: Output is protected for short circuits of limited duration.

Line Regulation for $\pm 10\%$ line voltage change: $\pm 0.02\%$ max.

Stability: $\pm 0.15\%$ per year (maximum).

TIME SOURCE

Ranges: 2 nsec to 50 second intervals.

- (a) Markers: 10 nsec to 5 sec/div - 27 ranges in 1, 2, 5 sequence. X1, X2, X5, X10 extends multiplier marker interval to 50 sec.
- (b) Sine Wave: 2 ns (500 MHz) - no deviation.
5 ns (200 MHz) - no deviation.
Sine wave output extendable to 1 GHz with 61251A Frequency Doubler.

Marker Amplitude:

- (a) 100 nsec/div to 50 sec/div:
 > 0.5 V peak to peak into 50 Ω . 1.0 V peak to peak (typical) into 50 Ω . (1.4 V peak to peak minimum into open circuit.)
- (b) 10, 20 and 50 nsec/div: > 0.3 V peak to peak into 50 Ω .
- (c) 2 and 5 nsec/div: > 0.4 V peak to peak into 50 Ω .

Marker Shape and Width:

- (a) 100 nsec/div to 50 sec/div: Pulse; digitally controlled at mid amplitude to 5% of Time/Div marker interval.
- (b) 10, 20 and 50 nsec/div: Quasi-sinusoidal Pulse; width varies from 40% to 20% of Time/Div marker interval.
- (c) 2 and 5 ns Output Shape: Sine wave.

Accuracy:

Crystal controlled markers and sine outputs accurate to within $\pm 0.01\%$ of setting.
 Crystal (clock) stability: 10 MHz, oven stabilized. Aging rate 3 parts in 10^{-7} per day after 72 hr. warmup. (See Option 14 for 3 parts in 10^{-9} per day aging rate.)
Note: Clock 10 MHz output (>250 mV rms) available at rear panel BNC. Also accepts 10 MHz external clock signal at 1 V rms into 1 k Ω .

Deviation Range (for 10 nsec/div to 50 sec/div markers):
 $>\pm 10\%$ with 0.01% resolution.

Deviation Accuracy: $\pm 0.2\%$ of deviation full scale.

RISETIME & TRIGGER OUTPUT (Refer to Figure 1-2)

Amplitude: 200 mV to 250 mV continuously variable into 50 Ω . (400 mV to 500 mV open circuit).

Risetime: Less than 1 nsec, positive going into 50 Ω .
 Risetime to <200 ps with optional 61252A.

Period: 100 ns to 1 second (10 MHz to 1 Hz) in 8 decade steps.

Waveform: Square Wave. Positive peak at ground reference.

Overshoot: Perturbations and overshoot; 3% before and after the rise.

Accuracy: Same as Time Source.

LINE FREQUENCY OUTPUT

Amplitude: Continuously variable from 0 to 1 volt peak-to-peak from max. 2 k Ω source.

Waveform: Follows powerline sine wave. Filtered to remove noise.

GENERAL INFORMATION

Deviation Meter: 3-1/2 digit display with automatic polarity reads out time or voltage deviation to $\pm 10.00\%$. High brightness, four digit, 0.4 inch LED display.

Power Requirements: 100, 120 or 220, 240 rms volts, $\pm 10\%$, 30W, 50 to 400 Hz.

Operating Temperature: 0°C to +50°C ambient.

Storage Temperature: -50°C to +85°C ambient.

Humidity: to 80% RH for full accuracy; to 95% RH operating.

Dimensions: 16-3/8" wide, 5-1/4" high x 12" deep overall. (415.6 mm x 133.5 mm x 304.8 mm).

Weight: 16 lbs. (7.0 kg).
 21 lbs. (9.5 kg) shipping weight.

Note: All accuracies specified at 23°C \pm 1°C with full compensation for output loading and referenced to a standard traceable to NBS with uncertainty of $\pm 0.01\%$.

1-22. 6125C PROGRAMMABLE TIME AND AMPLITUDE TEST SET:**VOLTAGE SOURCE****Ranges:**

- (a) Volts/Division: 10 μ V to 20 V.
20 ranges in 1, 2, 5 sequence.
- (b) Multiplier: X1, 2, 3, 4, 5, 6, 8, 10.
- (c) Absolute Range: AC; 30 μ V to 220 Volts
 \pm DC; 300 μ V to 220 Volts

Output Modes:

AC Positive-going square wave. 10 kHz, 1 kHz, 100 Hz, 10 Hz in four ranges. Frequency crystal controlled to $\pm 0.01\%$ accuracy. 10 kHz square wave usable on all ranges but specified performance applies on all ranges greater than 50 mV.

DC positive.
 DC negative.
 GND

Accuracy: Better than $\pm 0.25\%$ of setting into open circuit.

Offset: Typically ± 35 μ V below 50 mV. (After use on ranges above 50 mV, a five minute setting time is required to minimize thermal effects.) Typically ± 50 μ V above 50 mV. **Note:** The same offset is obtained on all output modes including GND.

Ripple and Hum: Less than $+(0.2\%$ of set amplitude +2 μ V p-p) on 20 V to 1 mV VOLTS/DIV ranges measured over a 30 kHz bandwidth at nominal ac mains voltage.

Square wave risetime: Less than 10 μ s.

Square wave overshoot: Less than 1% on the 20 V to 50 mV VOLTS/DIV ranges.

Regulation (for 1 M Ω Load): Not greater than 0.27% depending on V/DIV range setting.

Deviation Range: $>\pm 10\%$ of setting with 0.01% resolution.

Deviation Accuracy: $\pm 2\%$ of deviation reading.

Short Circuit Protection: Output is protected for short circuits of limited duration.

Reference: High Quality Zener diode.
 (Temperature coefficient $\pm 0.005\%$ per °C).

Temperature Coefficient of Voltage Output (15-35°C):
 Better than $\pm (0.01\% + 3 \mu$ V) per °C.

Line Regulation for $\pm 10\%$ line voltage change: $\pm 0.02\%$ max.

Stability: $\pm 0.15\%$ per year (maximum).

TIME SOURCE

Ranges: 2 nsec to 50 second intervals.

- (a) Markers: 10 nsec to 5 sec/div – 27 ranges in 1, 2, 5 sequence. X1, X2, X5, X10 extends multiplier marker interval to 50 sec.
- (b) Sine Wave: 2 ns (500 MHz) – no deviation.
5 ns (200 MHz) – no deviation.
Sine wave output extendable to 1 GHz with 61251A Frequency Doubler.

Marker Amplitude:

- (a) 100 nsec/div to 50 sec/div:
>0.5 V peak to peak into 50 Ω . 1.0 V peak to peak (typical) into 50 Ω . (1.4 V peak to peak minimum into open circuit.)
- (b) 10, 20 and 50 nsec/div: >0.3 V peak to peak into 50 Ω .
- (c) 2 and 5 nsec/div: >0.4 V peak to peak into 50 Ω .

Marker Shape and Width:

- (a) 100 nsec/div to 50 sec/div: Pulse; digitally controlled at mid amplitude to 5% of Time/Div marker interval.
- (b) 10, 20 and 50 nsec/div: Quasi-sinusoidal Pulse; width varies from 40% to 20% of Time/Div marker interval.
- (c) 2 and 5 ns Output Shape: Sine wave.

Accuracy:

Crystal controlled markers and sine outputs accurate to within $\pm 0.01\%$ of setting.

Crystal (clock) stability: 10 MHz, oven stabilized. Aging rate 3 parts in 10^{-7} per day after 72 hr. warmup. (See Option 14 for 3 parts in 10^{-9} per day aging rate.)

Note: Clock 10 MHz output (>250 mV rms) available at rear panel BNC. Also accepts 10 MHz external clock signal at 1 V rms into 1 k Ω .

Deviation Range (for 10 nsec/div to 50 sec/div markers):

> $\pm 10\%$ with 0.01% resolution.

Deviation Accuracy: $\pm 0.2\%$ of deviation full scale.

RISETIME & TRIGGER OUTPUT (Refer to Figure 1-2)

Amplitude: 200 mV to 250 mV continuously variable into 50 Ω . (400 mV to 500 mV open circuit).

Risetime: Less than 1 nsec, positive going into 50 Ω .
Risetime to <200 ps with optional 61252A.

Period: 100 ns to 1 second (10 MHz to 1 Hz) in 8 decade steps.

Waveform: Square Wave. Positive peak at ground reference.

Overshoot: Perturbations and overshoot; 3% before and after the rise.

Accuracy: Same as Time Source.

LINE FREQUENCY OUTPUT

Amplitude: Continuously variable from 0 to 1 volt peak-to-peak from max. 2 k Ω source.

Waveform: Follows powerline sine wave. Filtered to remove noise.

REMOTE PROGRAMMING

Programming of the Time and Amplitude sections is accomplished with binary coded TTL logic, positive true. Amplitude section programmable functions: Volts/Div, Multiplier, Output Mode, Deviation. Time Section programmable functions: Time/Div, Multiplier, Trigger Period. HF Output on continuously except in time deviation mode. Program inputs for each section through rear panel 24-Pin Amphenol Blue Ribbon connectors. All program lines coded with TTL compatible connect to ground commands. Option 60 IEEE 488 uses compatible connectors and offers deviation BCD readout.

GENERAL INFORMATION

Deviation Meter: 3-1/2 digit display with automatic polarity reads out time or voltage deviation to $\pm 10.00\%$. High brightness, four digit, 0.4 inch LED display.

Power Requirements: 100, 120 or 220, 240 rms volts, $\pm 10\%$, 30W, 50 to 400 Hz.

Operating Temperature: 0°C to +50° ambient.

Storage Temperature: -50°C to +85°C ambient.

Humidity: to 80% RH for full accuracy; to 95% RH operating.

Dimensions: 16-3/8" wide, 5-1/4" high x 12" deep overall. (415.6 mm x 133.5 mm x 304.8 mm).

Weight: 16 lbs. (7.0 kg).
21 lbs. (9.5 kg) shipping weight.

Note: All accuracies specified at 23°C $\pm 1^\circ$ C with full compensation for output loading and referenced to a standard traceable to NBS with uncertainty of $\pm 0.01\%$.

1-23. ACCESSORIES AND OPTIONS.

1-24. Options.

OPTION 14

High Stability 10 MHz Time Base.
 Proportional oven; (not compatible with 6125C opt 60.)
 <3 parts in 10^{-9} per day aging rate after 7 days.

OPTION 15

Provides two each rack mount side brackets P/N 89107531 and one set of two rack slides P/N 69100340 for mounting unit in standard 19 inch rack.

OPTION 60 (6125C only)

IEEE 488 Bus Interface compatible.
 Allows 6125C to be fully programmed and controlled, and to output deviation data via the IEEE Standard 488-1975 bus.

OPTION 61 (6125C only)

IEEE 488 Bus Interface compatible. Similar to Option 60 but remote deviation control is deactivated to permit front panel manual deviation adjustment. Used with Ballantine 4000A Automated Oscilloscope Calibration System.

1-25. Accessories .

- 61251A Frequency Doubler (to 1 GHz)
- 61252A Fast Risetime Generator <200 ps/50 Ω
- 12630A Feedthrough Termination (50 Ω ;2W) BNC Connectors
- 12249A Cable, Coax; BNC 4 ft.
- 12254A Cable, Program, 6 ft. with 24 pin Blue Ribbon Connectors
- 31100370 Mating Connector, 24 pm male (Amphenol 57-30240)
- 89107531 Rack Mounting Brackets (2 required)
- 10650A Input capacitance standardizer for oscilloscopes

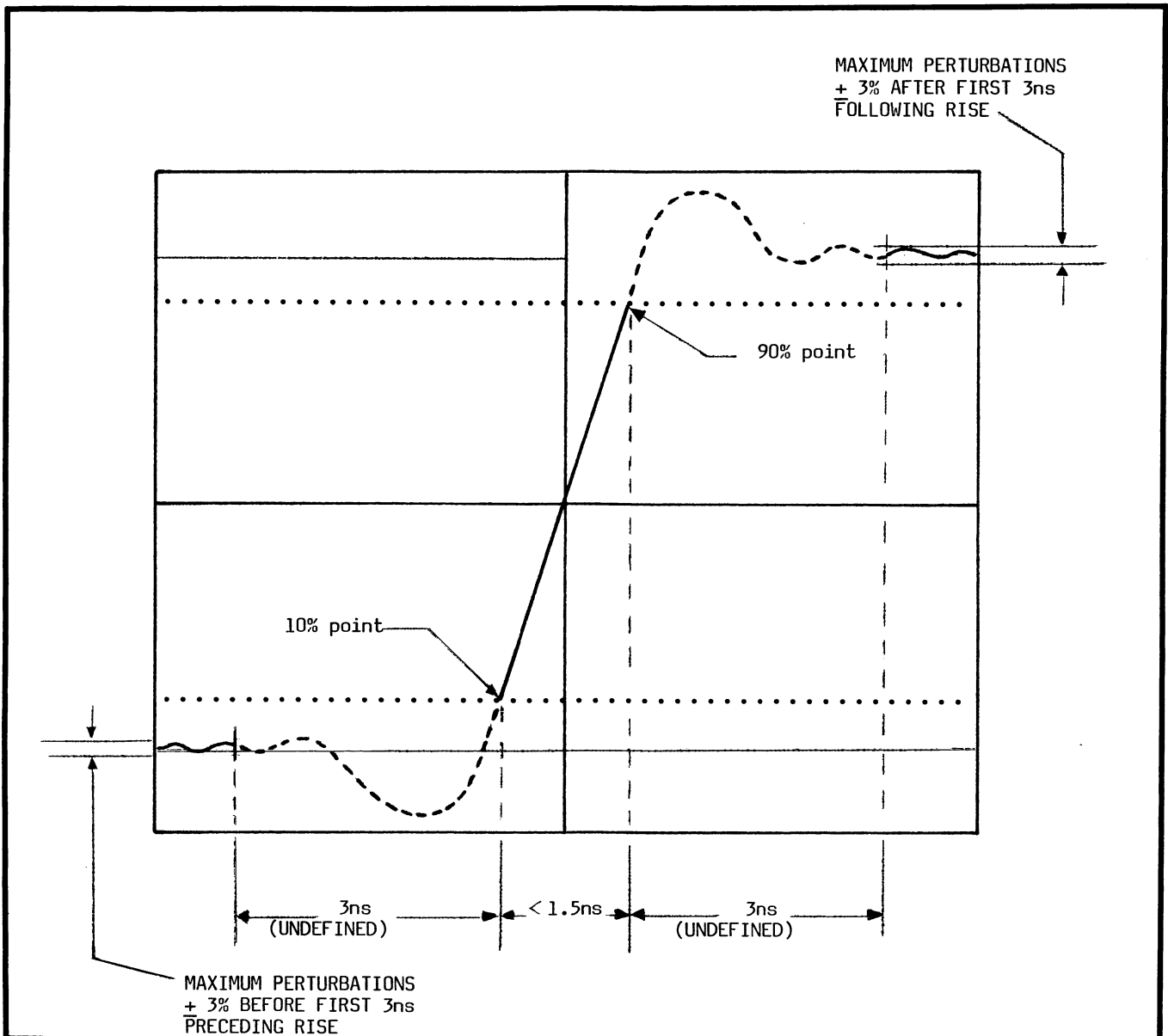
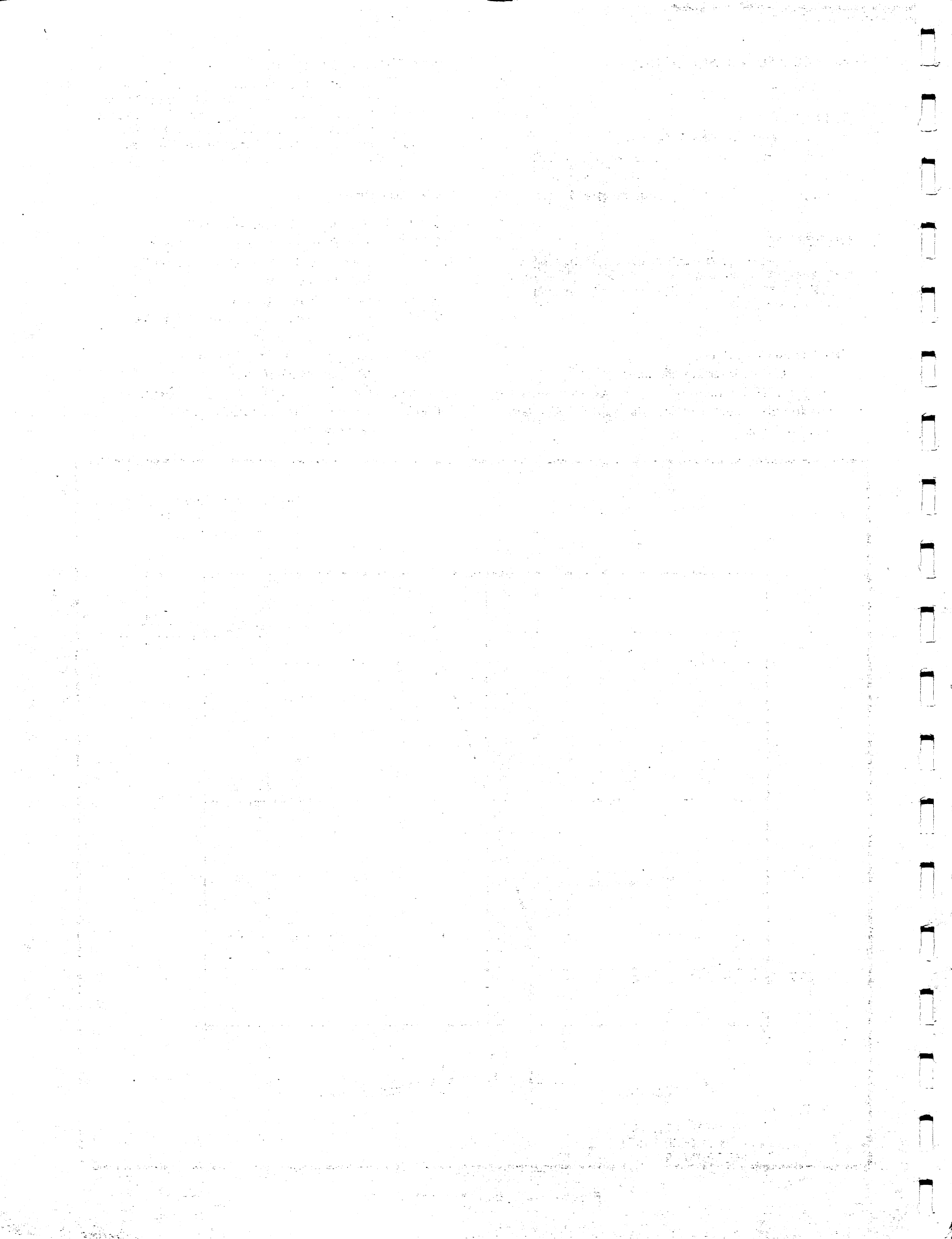

Figure 1-2. Determining Risetime



SECTION 2

PREPARATION FOR USE AND SHIPMENT

2-1. GENERAL.

2-2. This section contains information and instructions necessary for the installation and reshipment of the 6125B/C Time and Amplitude Test Set. Details are provided for initial inspection, performance checks, power connections, grounding safety requirements, installation information, and repacking instructions for storage or shipment.

2-3. UNPACKING AND INITIAL INSPECTION.

2-4. Unpacking and initial inspection of the generator require only the normal precautions and procedures applicable to the handling of sensitive electronic equipment. The contents of all shipping containers should be checked for included accessories and certified against the packing slip to ascertain that the shipment is complete.

2-5. PERFORMANCE CHECKS.

2-6. This instrument was carefully inspected for mechanical and electrical performance before shipment from the factory. It should be free of physical defects and in acceptable operating condition upon receipt. Check the instrument for possible damage incurred while in transit. Complete the performance checks beginning with paragraph 5-6. If there is any indication of damage or improper operation, refer to the warranty included in this manual, and notify the manufacturer or the manufacturer's field representative.

2-7. POWER REQUIREMENTS.

2-8. The generator may be operated from an ac voltage source rated at 100, 120, 220, or 240 volts rms at 50 to 400 Hz. The orientation of the printed circuit board in the ac power connector on the rear of the instrument matches the instrument to the ac voltage source. See Figure 2-1.

CAUTION

Failure to orient the printed circuit board properly will damage the instrument and void the warranty.

2-9. The instrument should be operated from a power source with its neutral at or near ground (earth) potential. The instrument is not intended for operation from two phases of a multiphase ac system or across the legs of a single-phase, three-wire ac power system. Crest factor (ratio of peak voltage to rms) should be typically within the range of 1.3 to 1.6 at $\pm 10\%$ of the nominal line voltage. Use a true rms responding voltmeter, such as the Ballantine Model 3620A, to measure the power line voltage.

2-10. GROUNDING REQUIREMENTS.

2-11. To insure the safety of operating personnel, the U.S. Occupational Safety and Health Act (OSHA) and

good engineering practice require that the instrument panel and enclosure be "earth" grounded. All Ballantine instruments are provided with a three-conductor power cable assembly which, when plugged into an appropriate power receptacle, grounds the instrument. The offset pin on the male end of the power cable is the ground wire connection to the connector on the rear panel of the instrument.

2-12. To preserve the safety protection feature, when operating the instrument from a two-contact power outlet, use a three-prong to two-prong adapter and connect the green lead or terminal on the adapter to "earth" ground.

In addition to the two methods of grounding stated, the instrument also incorporates a case ground lug on the rear panel.

2-13. INSTALLATION AND MOUNTING.

2-14. **General.** The generator is fully solid state and dissipates minimal heat. No special cooling is required; however, the instrument should not be operated where the ambient temperature exceeds 55°C (131°F) or when condensation due to high humidity appears anywhere on the instrument. Always maintain at least 1-3/4 inches of free air space on all sides of the instrument. Do not mount near heat radiating instruments. When rack mounting is employed, forced filtered air ventilation is recommended.

2-15. **Bench Mounting.** The generator is shipped with plastic bumper-feet and metal tilt-stand in place, ready for use as a bench instrument. Outline dimensions are shown in Figure 2-2.

2-16. **Rack Mounting.** The generator may be rack-mounted in a standard 19-inch EIA rack. Option 15 provides 2 each rack mount side brackets, P/N 89107531 and two rack slides P/N 69100340. These may be bolted to the side castings of the 6125B/C with the screws provided. Before installing the instrument in the rack, remove the plastic bumper-feet and tilt-stand. Do not discard these items, but store them for future use.

2-17. **Portable Use.** The instrument as supplied includes side carry-handles.

2-18. SHORT TERM STORAGE.

2-19. If the instrument is to be stored for a short period of time (less than three months), place cardboard over the panel and cover the instrument with a suitable protective covering, such as a plastic bag or strong, draft paper. Place power cable and other accessories with the instrument. Store the covered instrument in a clean, dry area that is not subject to extreme temperature variations or conditions which may cause moisture to condense on the instrument.

2-20. LONG TERM STORAGE OR REPACKAGING FOR SHIPMENT.

2-21. If the instrument is to be stored for a period longer than three months, or if it is to be repackaged for shipment, as a general guide, repackage the instrument as described in the following procedure and shown in Figure 2-3.

Use either the original packing material, if available, or material similar to that specified. Proceed as follows:

- Place the instrument accessories, if any, in a plastic bag and seal the bag.
- For long distance shipping only, use U.S. Government packaging method IIC and tape a two-unit bag of dissicant (MIL-D-3464) on the rear cover.
- Place a piece of sturdy cardboard over the front panel for protection. Enclose the instrument in a plastic bag and seal the bag.
- Wrap the bagged instrument and accessories in a 1-inch thick, flexible, cellular plastic-film, cushioning material (PPP-B-795) and place in a barrier bag (MIL-B-131). Extract the air from the bag and heat seal.
- Place the wrapped instrument and accessories into a fiberboard box (PPP-B-636) of suitable size. Fill spaces with rubberized hair or cellular plastic cushioning material. Close the box in accordance with container specifications. Seal with sturdy, water-resistant tape or with metal straps.
- Mark container "FRAGILE," "HANDLE WITH CARE" or similar precautionary notice. Affix shipping labels as required or mark in accordance with MIL-STD-129.

Note

If the instrument is to be returned to Ballantine Laboratories, Inc. for calibration or repair, attach a tag to the instrument identifying the owner; also, note the problem, symptoms, and service or repair desired. List the model and serial number of the instrument. Ship the instrument prepaid to Ballantine Laboratories, Inc., 90 Fanny Road, Boonton, New Jersey 07005, U.S.A. In any correspondence, identify the instrument by model number, serial number, work authorization order, and date and method of shipment.

2-22. 6125C PROGRAMMING

- The Amplitude Program Connector is located on the rear panel. Table 2-1 gives connector pin identification.
- The Time Program Connector is located on the rear panel. Table 2-2 gives connector pin identifications.

2-23. All program lines are TTL level compatible. A "0" denotes 0 to +0.5 volts while a "1" denotes 4.5 to 5.5 volts. Contact closures to digital ground, saturated transistors or TTL logic may be used to activate program logic lines.

2-24. SAFETY.

Figure 2-4 delineates the safety aspects of this instrument.

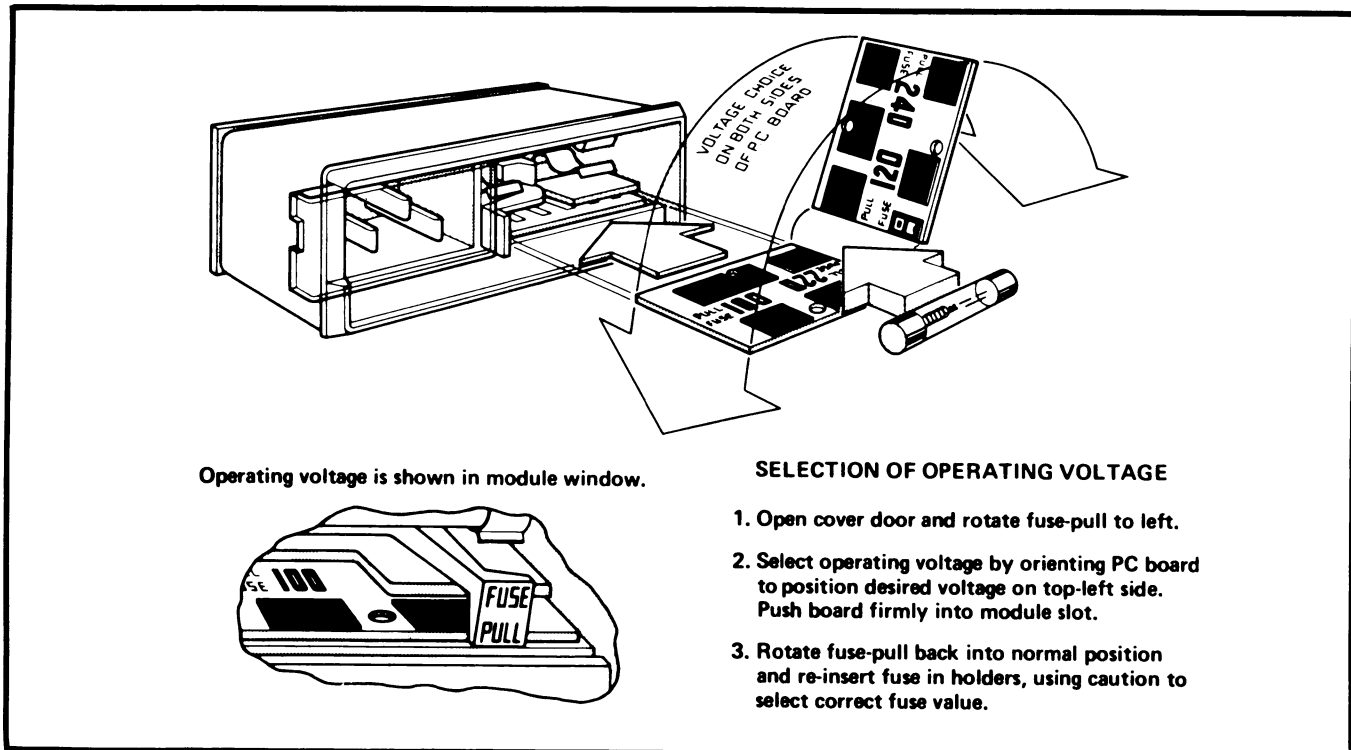

Figure 2-1. Voltage Selecting and Fused Receptacle Printed Circuit Board Location and Orientation

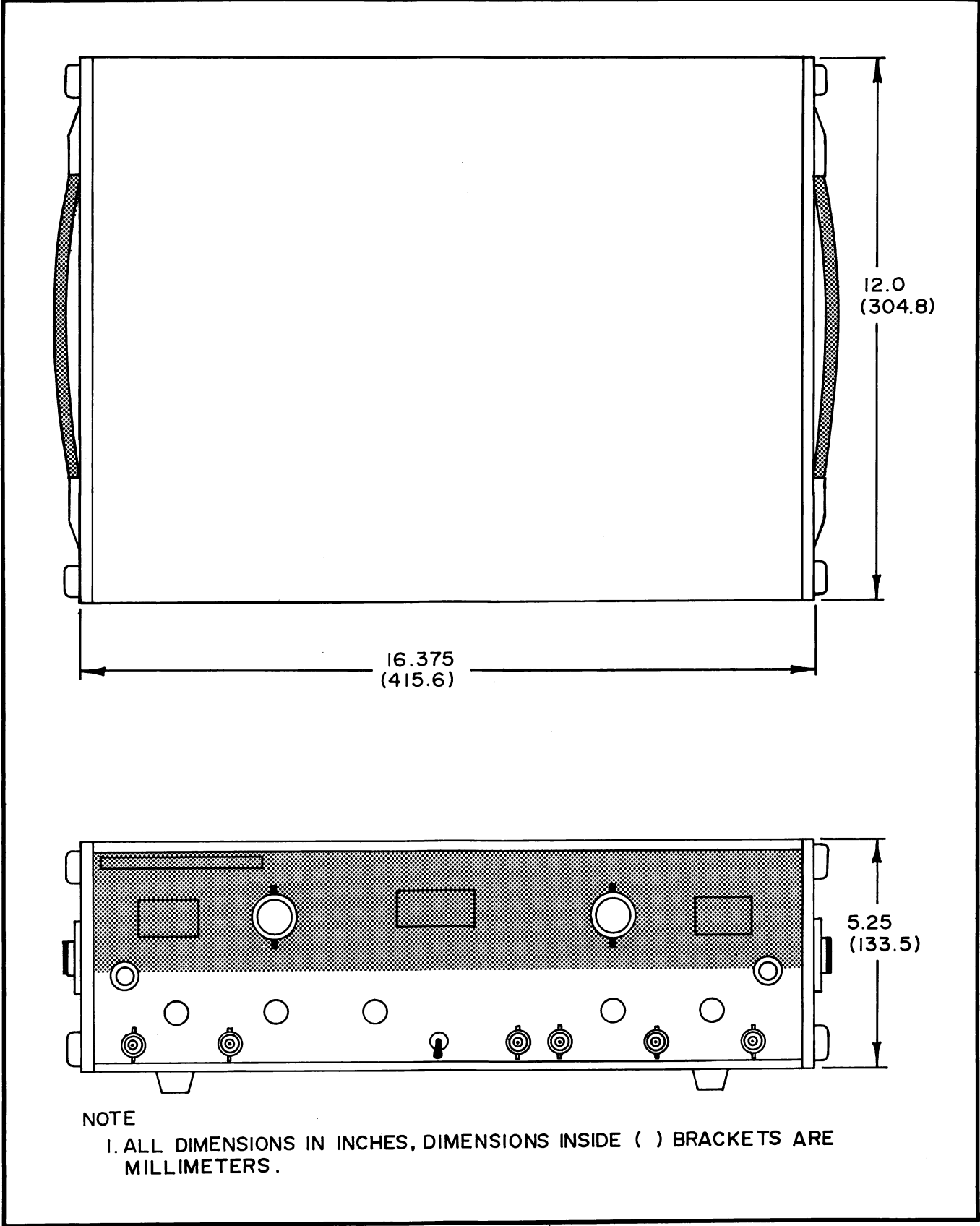

Figure 2-2. Model 6125B/C, Outline Drawing

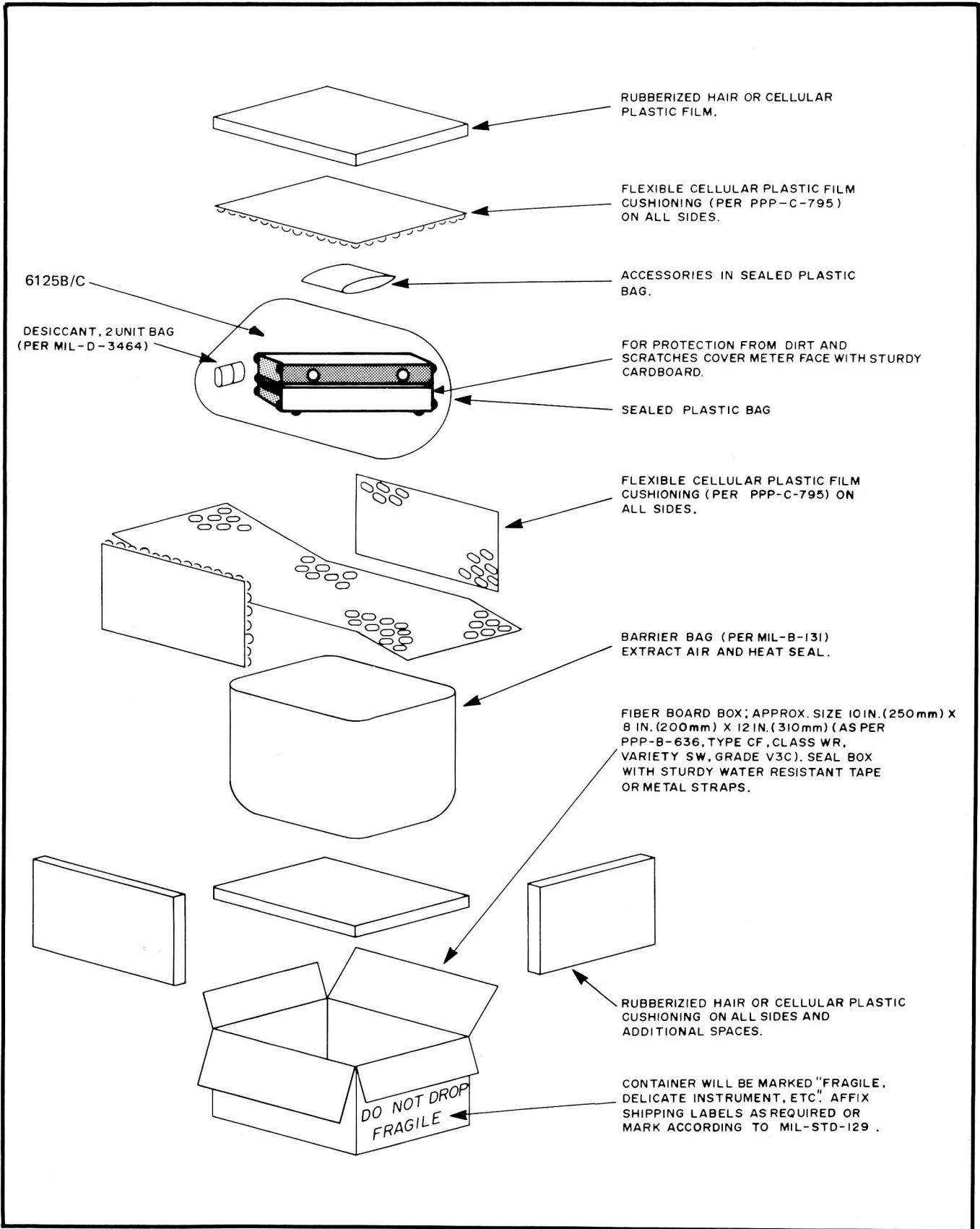

Figure 2-3. Model 6125B/C Time and Amplitude Test Set Packing Diagram.

TABLE 2-1. MODEL 6125C AMPLITUDE PROGRAM INPUT, A1J2

VOLTS/DIV. Switch	Amplitude Program Connector Pin Number				
	16	17	19	18	4
10 μ V	0	0	0	0	0
20 μ V	0	0	0	0	1
50 μ V	0	0	0	1	0
.1 mV	0	0	1	0	0
.2 mV	0	0	1	0	1
.5 mV	0	0	1	1	0
1 mV	0	1	0	0	0
2 mV	0	1	0	0	1
5 mV	0	1	0	1	0
10 mV	0	1	1	0	0
20 mV	0	1	1	0	1
50 mV	1	0	0	1	0
.1 V	1	0	1	0	0
.2 V	1	0	1	0	1
.5 V	1	0	1	1	0
1 V	1	1	0	0	0
2 V	1	1	0	0	1
5 V	1	1	0	1	0
10 V	1	1	1	0	0
20 V	1	1	1	0	1

OUTPUT MODE	Amplitude Program Connector Pin Number		
	14	1	2
—	1	1	0
GND	0	0	0
+	1	1	1
10 kHz	0	1	0
1 kHz	0	1	1
100 Hz	1	0	0
10 Hz	1	0	1

DEVIATION Switch	Amplitude Program Connector Pin Number
$\pm 10\%$ Volts Deviation	1
OFF	0

Local or Remote	Amplitude Program Connector Pin Number
Remote Overrides Local	1
Local	0

Deviation Pot	Amplitude Program Connector Pin Number							
	MSB							LSB
	A1	A2	A3	A4	A5	A6	A7	A8
	7	8	9	10	24	23	12	11
Max. Negative Deviation ($<-10\%$)	1	1	1	1	1	1	1	1
Max. Positive Deviation ($>+10\%$)	0	0	0	0	0	0	0	0

VOLTS/DIV. Multiplier	Amplitude Program Connector Pin Number		
	5	21	22
X1	0	0	0
X2	0	0	1
X3	0	1	0
X4	0	1	1
X5	1	0	0
X6	1	0	1
X8	1	1	0
X10	1	1	1

Pin #	Connection
3	 (GND)
6	+5V

TABLE 2-2. MODEL 6125C TIME PROGRAM INPUT, A10J1

TIME/DIV. Switch Setting	Time Program Connector Pin Number					
	21	22	24	23	18	19
10 ns	1	1	1	1	0	0
20 ns	1	1	1	1	0	1
50 ns	1	1	1	1	1	0
.1 μ s	1	1	1	0	0	0
.2 μ s	1	1	1	0	0	1
.5 μ s	1	1	1	0	1	0
1 μ s	1	0	0	0	0	0
2 μ s	1	0	0	0	0	1
5 μ s	1	0	0	0	1	0
10 μ s	0	0	0	0	0	0
20 μ s	0	0	0	0	0	1
50 μ s	0	0	0	0	1	0
.1 ms	0	0	0	1	0	0
.2 ms	0	0	0	1	0	1
.5 ms	0	0	0	1	1	0
1 ms	0	0	1	0	0	0
2 ms	0	0	1	0	0	1
5 ms	0	0	1	0	1	0
10 ms	0	0	1	1	0	0
20 ms	0	0	1	1	0	1
50 ms	0	0	1	1	1	0
.1 sec	0	1	0	0	0	0
.2 sec	0	1	0	0	1	0
1 sec	0	1	0	1	0	0
2 sec	0	1	0	1	0	1
5 sec	0	1	0	1	1	0

TRIGGER PERIOD Switch Setting	Time Program Connector Pin Number		
	12	11	9
100 ns	1	1	1
1 μ s	0	0	0
10 μ s	0	0	1
100 μ s	0	1	0
1 ms	0	1	1
10 ms	1	0	0
100 ms	1	0	1
1 sec	1	1	0

DEVIATION Switch	Time Program Connector Pin Number							
DEVIATION Switch	10							
$\pm 10\%$ Time Deviation	1							
OFF	0							
Deviation Pot	MSB							LSB
	A1	A2	A3	A4	A5	A6	A7	A8
	1	14	13	15	2	3	4	5
Max. Negative Deviation (<-10%)	1	1	1	1	1	1	1	1
Max. Positive Deviation (>+10%)	0	0	0	0	0	0	0	0

Local or Remote	Time Program Connector Pin Number	
	20	
Remote Overrides Local	1	
Local	0	

TIME/DIV Multiplier Switch Setting	Time Program Connector Pin Number	
	16	17
X1	1	1
X2	0	1
X5	1	0
X10	0	0

Pin #	Connection
6	+5V
7	 GND

SAFETY CONSIDERATIONS

GENERAL

This is a Safety Class I instrument. This instrument has been designed considering IEC Publication 348 and ANSIC C39.5, "Safety Requirements for Electronic Measuring Apparatus".

This manual contains information, cautions, and warnings which must be followed by the service person to ensure safe operation and to retain the instrument in safe condition.

WARNINGS

SAFETY

If this instrument is to be energized via an autotransformer for voltage reduction, make sure the common terminal is connected to the earthed pole of the power source.

BEFORE SWITCHING ON THIS INSTRUMENT, the protective earth terminals of this instrument must be connected to the protective conductor of the (mains) power cord. The mains plug shall only be inserted in a socket outlet provided with a protective earth contact. The protective action must not be negated by the use of an extension cord (power cable) without a protective conductor (grounding).

Make sure that only fuses with the required rated current and of the specified type (normal blow, time delay, etc.) are used for replacement. The use of repaired fuses and the short-circuiting of fuse holders must be avoided.

Whenever it is likely that the protection offered by fuses has been impaired, the instrument must be made inoperative and be secured against any unintended operation.

GROUNDING

Any interruption of the protective (grounding) conductor (inside or outside the instrument) or disconnecting the protective earth terminal is likely to make this instrument dangerous. Intentional interruption is prohibited.

HIGH VOLTAGE

Warning — These servicing instructions are for use by qualified personnel only. To avoid dangerous electric shock, do not perform any servicing other than that contained in the operating instructions unless you are qualified to do so.

CAUTIONS

LINE VOLTAGE SELECTION

BEFORE SWITCHING ON THIS INSTRUMENT, make sure the instrument is set to the voltage of the power source. Verify that the power transformer primary is matched to the available line voltage. Verify that the correct fuse is installed.

GROUNDING

BEFORE SWITCHING ON THIS INSTRUMENT, ensure that all devices connected to this instrument are connected to the protective (earth) ground. (Grounding one conductor of a two-conductor outlet is not sufficient.)



ATTENTION



This symbol: , which appears on the instrument means: Read the instruction manual before operating the instrument. If the instrument is operated without reading the instructions, it may not operate correctly.

Figure 2-4. Safety Considerations

[The page contains extremely faint and illegible text, likely bleed-through from the reverse side of the document. The text is too light to transcribe accurately.]

SECTION 3 OPERATION

3-1. INTRODUCTION.

3-2. This section contains instructions and information required for the operating of the instrument. Included are identification of controls, connectors, indicators and programming of the 6125C.

3-3. CONTROLS, INDICATORS, AND CONNECTORS.

3-4. The controls, indicators, and connectors for the 6125B/C are identified in Figures 3-1, 3-2 and 3-3 and described in Tables 3-1 and 3-2.

3-5. POWER REQUIREMENTS.

3-6. See Paragraphs 2-7 through 2-9. For grounding and safety earth connections, see Paragraphs 2-10 through 2-12. Always check rear panel voltage selector card in the power receptacle. Failure to apply the correct ac power mains voltage may cause serious damage to the instrument and will void the warranty.

3-7. OPERATING INSTRUCTIONS.

3-8. Turn power on by setting the power toggle switch to ON.

3-9. Output Connections.

3-10. Six BNC output connectors are provided.

a. LINE FREQ – Continuously variable 0 to 1 volt peak-to-peak sine wave at power mains frequency. Used for activating AC voltmeter ranges and for qualitatively checking oscilloscope trigger circuits for slope, trigger leveling and line frequency operation.

b. VOLTS-OUT – Provides accurate dc voltage with positive or negative polarity. Zero check and four positive going square wave outputs of 10 Hz, 100 Hz, 1 kHz and 10 kHz are also provided.

The square wave outputs may be used to check true rms ac voltmeters, to compensate attenuators, calibrate the amplitude of oscilloscopes and to check the response of input coupling filters and check solid-state dc amplifier thermal drift compensation. Amplitude deviation capability of $\pm 10\%$ is provided.

c. 5 nS HF OUTPUT – Provides 200 MHz sine wave output from a 50 ohm source impedance.

d. 2 nS HF OUTPUT – Provides 500 MHz sine wave output from a 50 ohm source impedance.

e. MARKER OUT – Provides outputs from 10 nS to 50 seconds in 1, 2, 5 steps. The associated MULTIPLIER provides time multiplication of these markers by X1, X2,

X5 and X10 to simplify time calibration of oscilloscopes and digital counters. Time deviation capability of $\pm 10\%$ is provided.

f. TRIG OUT – Provides an output square wave with a rise time of less than 1 nanosecond into 50 ohms. The square wave amplitude is continuously variable from 200 to 250 mV. The square wave period is variable from 1 second to 100 nanoseconds (frequency of 1 Hz to 10 MHz) in eight decade steps. An internal MARKER-TRIGGER INTERLOCK switch may be set to LOCKOUT to provide gated time coincidence between markers and triggers whenever the trigger period is longer than the marker period. In the LOCKOUT mode, the TRIG OUT signal will be automatically shut off when the TRIGGER period is equal to or shorter than the marker period.

3-11. VOLTAGE CALIBRATION.

3-12. DC VOLTAGE OUTPUT.

3-13. The VOLTS OUT BNC provides an accurate DC voltage of either positive or negative polarity or zero output as selected by the OUTPUT MODE switch. This dc output voltage may be used to calibrate analog and digital dc voltmeters and other dc level sensitive circuits. A typical test condition is illustrated below.

3-14. Checking or Calibrating a DC Voltmeter.

a. Check the voltmeter to be tested to be sure it is functioning properly and that its specified accuracy is commensurate with the $\pm 0.25\%$ of setting accuracy of the 6125B/C. The input resistance of the voltmeter under test should be 1 megohm or higher to avoid loading the 6125B/C and disturbing the accuracy of the measurement.

b. Set the voltmeter controls as follows:

Range:	Highest Voltage Range
Mode:	DC Voltage
Polarity:	Positive (or automatic)

c. Set the 6125B/C controls as follows:

VOLTS/DIV	10 μ V
OUTPUT MODE	DC +
MULTIPLIER	X10
DEVIATION	OFF

d. Connect the input of the voltmeter under test to the VOLTS OUT BNC of the 6125B/C. Connect the + or HI input connector of the voltmeter to the center pin of the VOLTS OUT BNC and the voltmeter common (LO or -) terminal to the BNC shell. Use short twisted leads or a shielded cable to interconnect the voltmeter to the 6125B/C.

TABLE 3-1. FRONT PANEL CONTROLS, INDICATORS, AND CONNECTORS

NO.	ITEM	FUNCTION
1	Line Freq. Amplitude	Controls variable line frequency amplitude from 0 to 1 V p-p.
2	Line Freq. Output	BNC connector for Line Freq. sinewave output.
3	OUTPUT MODE	Selects \pm DC or various squarewave voltage outputs.
4	VOLTS OUT	BNC connector for voltage output.
5	VOLTS/DIV	Selects voltage output from 10 μ V to 200V.
6	VOLTS/DIV Indicator	Shows VOLTS/DIV range selected – 6125C only.
7	Deviation Adj. (Volts)	Provides continuous adjustment of Volts deviation.
8	REMOTE (Volts) Lamp	Indicates Volts Out is under Remote Control – 6125C only.
9	MULTIPLIER (Volts)	Selects VOLTS/DIV multiplier range from X1 to X10.
10	Deviation (Volts) Lamp	Indicates VOLTS Deviation is on when illuminated
11	DEVIATION	Switch selects VOLT or TIME deviation or no deviation (OFF).
12	Deviation Meter	Indicates deviation from $>+10.00\%$ to $>-10.00\%$.
13	POWER ON	Toggle Switch turns ac mains power ON.
14	H.F. OUTPUT, 5 ns	BNC provides 5 ns (200 MHz) marker.
15	H.F. OUTPUT, 2 ns	BNC provides 2 ns (500 MHz) marker.
16	Deviation (Time) Lamp	Indicates TIME DEVIATION is on when illuminated
17	TIME/DIV	Selects Time Markers from 10 ns to 5 seconds.
18	Deviation Adj. (Time)	Provides continuous adjustment of Time deviation.
19	MULTIPLIER (Time)	Selects TIME/DIV multiplier range from X1 to X10.
20	MARKER OUT	BNC connector provides marker output from 10 ns to 50 seconds.
21	REMOTE (Time) Lamp	Indicates TIME outputs are under Remote control – 6125C only.
22	TIME/DIV Indicator	Shows TIME/DIV range selected – 6125C only.
23	TRIGGER PERIOD	Selector switch provides selection of Trigger Output square wave frequency.
24	FAST RISE & TRIG AMPLITUDE	Continuous adjustment of Trigger Out amplitude from 200 to 250 mV into 50 Ω .
25	TRIG OUT	BNC connector provides TRIGGER square wave output.

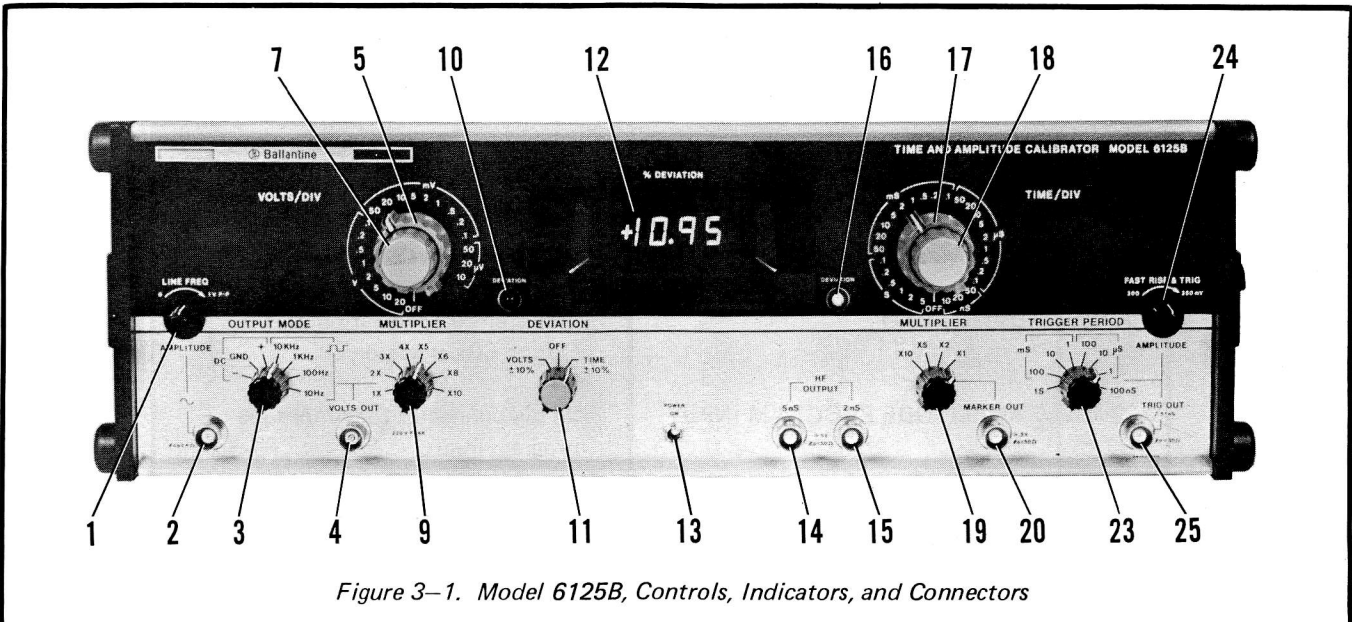

Figure 3-1. Model 6125B, Controls, Indicators, and Connectors

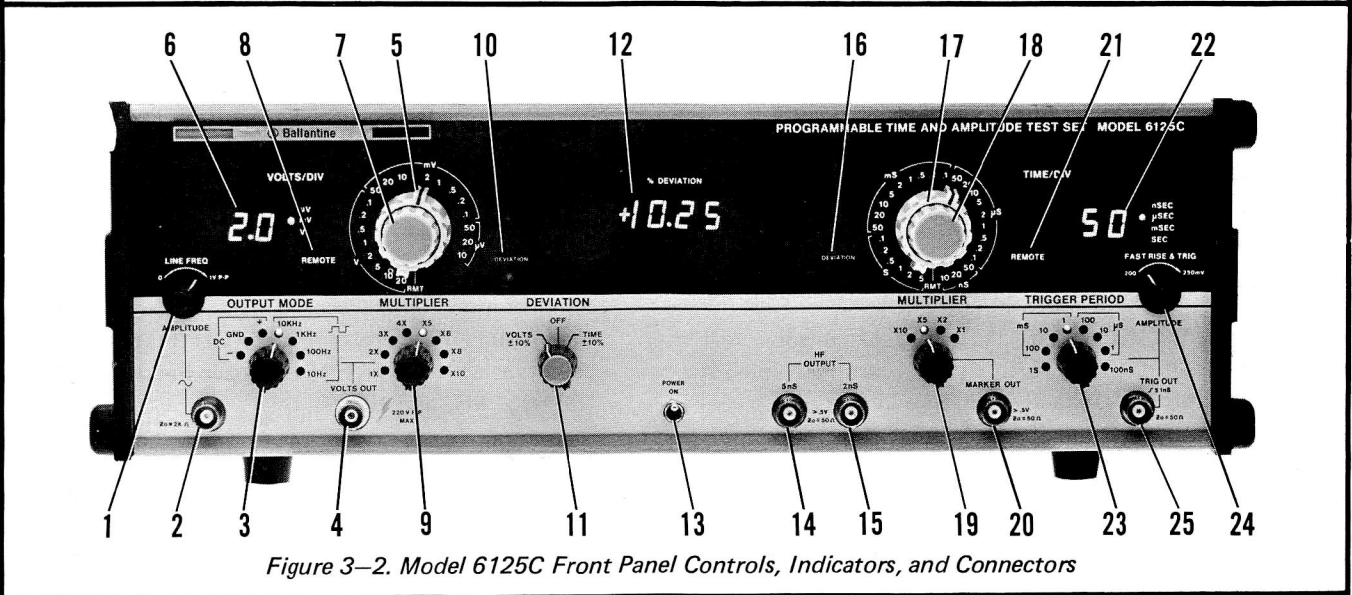

Figure 3-2. Model 6125C Front Panel Controls, Indicators, and Connectors

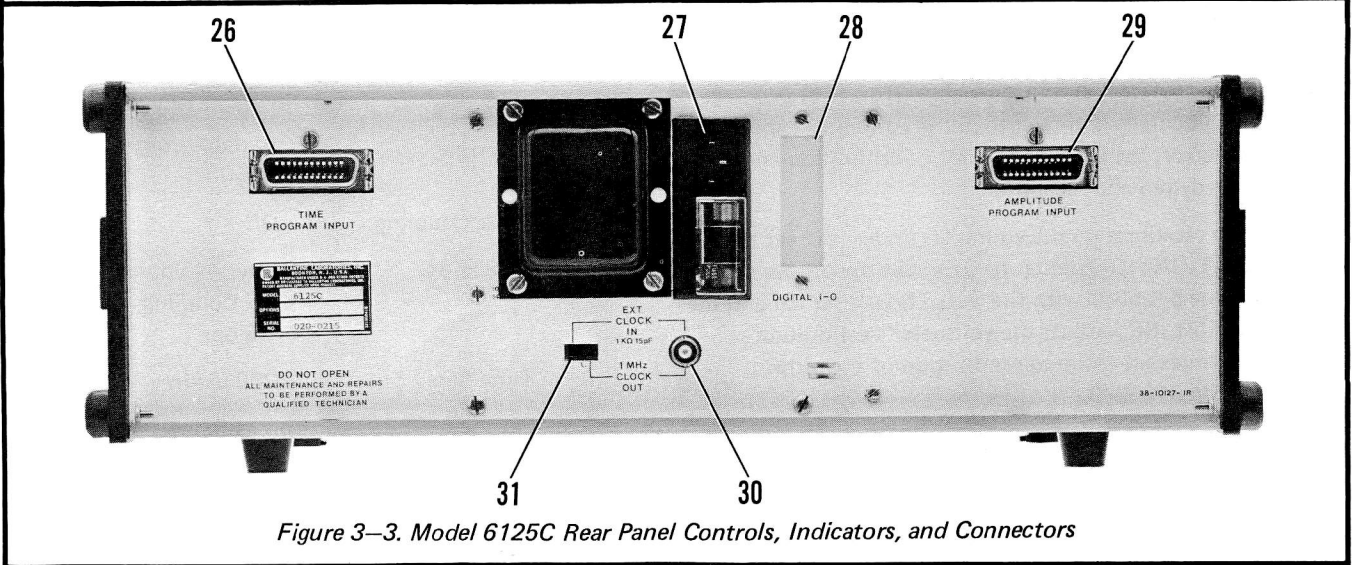

Figure 3-3. Model 6125C Rear Panel Controls, Indicators, and Connectors

TABLE 3-2. REAR PANEL CONTROLS, INDICATORS AND CONNECTORS 6125C

No.	Item	Function
26	TIME PROGRAM INPUT	24 pin connector for Time program input.
27	AC Power Connector	AC power input connector.
28	DIGITAL I-O	Provision for installation of Option 60 connector.
29	AMPLITUDE PROGRAM INPUT	24 pin connector for Amplitude program input.
30	EXT CLOCK IN/1 MHz CLOCK OUT	BNC connector for either EXT clock input or 1 MHz clock output.
31		Slide switch that selects either EXT clock in or 1 MHz clock out.

e. Rotate the VOLTS/DIV switch counter clockwise until the voltmeter under test reads approximately full scale. Note that the VOLTS/DIV setting is one tenth the full range setting of the voltmeter since the MULTIPLIER switch is set to increase the VOLTS/DIV potential by X10.

f. Set the DEVIATION switch to VOLTS $\pm 10\%$ and observe that the volts DEVIATION lamp is illuminated.

g. Rotate the VOLTS/DIV DEVIATION control (concentric with the VOLTS/DIV switch) until the voltmeter under test reads exactly full range indication. Note the reading of the digital DEVIATION meter on the 6125B/C; it represents the calibration error of the voltmeter under test.

For correction, note errors of calibration. See paragraph 3-18 and 3-21.

h. Check the accuracy specification of the voltmeter under test. Accept the calibration if the 6125B/C deviation meter reading is less than the allowable error. If the deviation percentage is greater than the voltmeter's specified calibration error, the voltmeter is out of calibration and should be repaired and recalibrated.

i. When recalibrating the voltmeter under test, set the 6125B/C DEVIATION switch to OFF. Set the proper output voltage of the 6125B/C with the VOLTS/DIV switch and the volts MULTIPLIER. Adjust the voltmeter's calibration control for an exact voltmeter indication of the output voltage of the 6125B/C.

j. Decading Check. To check voltmeter decading, simply set the VOLTS/DIV MULTIPLIER switch from X10 to any of the other seven cardinal points. Check accuracy of the voltmeter under test at any of these points and determine

calibration error as a percent of reading by using the 6125B/C VOLTS DEVIATION control. Proceed at each point as detailed above in paragraphs f, g and h.

3-15. SQUARE WAVE VOLTAGE OUTPUT.

3-16. The VOLTS OUT BNC provides an accurate zero based positive going square wave for amplitude, gain, and attenuator compensation in oscilloscopes, digital counters, amplifiers, and instrumentation systems. The OUTPUT MODE switch permits selection of four square wave frequencies - 10 Hz, 100 Hz, 1 kHz and 10 kHz.

3-17. Checking or Calibrating Oscilloscope Verticle Amplitude and Attenuator Compensation.

a. The crystal controlled square wave has a fast risetime and flat top that provides a suitable signal for the compensation of input attenuators.

b. Set the oscilloscope controls as follows:

- | | |
|-----------------|---|
| Volts/Div: | Lowest Voltage Range.
Variable control to calibrated position. |
| Volts Coupling: | DC |
| Triggering: | Internal Source
AC Coupling
+ Slope |
| Time Base: | 200 μ s/div |

c. Set the 6125B/C controls as follows:

- | | |
|-------------|---|
| VOLTS/DIV | Same volts/div as set on oscilloscope under test. |
| OUTPUT MODE | 1 kHz |

MULTIPLIER 5
 DEVIATION OFF

d. Connect the VOLTS OUT BNC of the 6125B/C to the oscilloscope vertical input connector.

e. Observe that the oscilloscope under test displays the square wave signal at approximately 5 divisions peak-to-peak. See Figure 3-4.

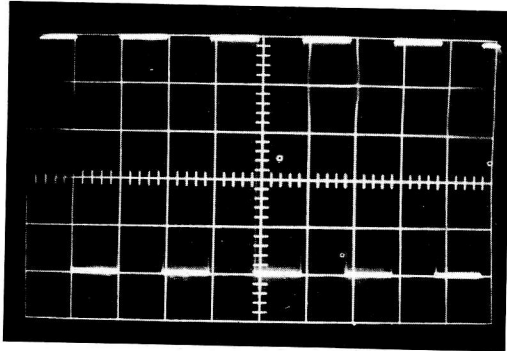

Figure 3-4. Volts Out Display

NOTE

A display of 5 divisions is only a suggested setting of the 6125B/C VOLTS/DIV controls for ease of reading. It may be more convenient, on an oscilloscope having an 8 centimeter high display, to select the X6 or X8 MULTIPLIER position on the 6125B/C and provide a signal that is closer to the full scale vertical deflection.

g. Set the DEVIATION switch to VOLTS ±10% and observe that the volts DEVIATION lamp is illuminated.

h. Rotate the VOLTS/DIV DEVIATION control (concentric with the VOLTS/DIV switch) until the oscilloscope indicates a square wave signal of exactly 5 divisions peak-to-peak. Note the reading of the digital DEVIATION meter on the 6125B/C; it represents the calibration error of the oscilloscope under test.

i. Check the accuracy specification of the oscilloscope under test. If the reading of the % DEVIATION digital meter is less than the specified calibration error allowance (typically ±3%) proceed to the next higher oscilloscope VOLTS/DIV range and the corresponding VOLTS/DIV setting of the 6125B/C.

j. If the reading of the % DEVIATION digital meter exceeds the allowable calibration error of the oscilloscope, note the reading and recalibrate the oscilloscope.

NOTE

When recalibrating the oscilloscope under test, set the DEVIATION switch to OFF. Adjust the oscilloscope calibration control for an exact indication of the output voltage of the 6125B/C.

k. Test each volts/div range on the oscilloscope, as indicated in the preceding steps, until all ranges are calibrated on each vertical channel.

3-18. VOLTAGE MEASUREMENT ERRORS.

3-19. Loading Errors.

3-20. The VOLTS OUT accuracy is specified into an open circuit. Very small errors are caused by load impedances over 100 KΩ since the source OUTPUT impedance of the VOLT OUT is very low. Changing the VOLTS/DIV MULTIPLIER setting will not materially change the output impedance or the loading error. See Table 3-2 for loading error tabulations. Note that 1 megohm loads cause negligible errors on most ranges but approach the 6125B/C 0.25% accuracy on the 10V, 5V, 10 mV and 5 mV ranges. 10 megohm loads cause errors too small that they may be ignored within the basic 6125B/C accuracy. Most modern digital voltmeters and oscilloscope attenuator probes represent 10 megohm loads and can be assumed not to contribute to loading errors. Loads less than 1 megohm should be avoided if the basic 6125B/C accuracy is to be maintained, although loading error may be corrected by the following computation:

- a. Determine the resistance of the load.
- b. Look up the 6125B/C VOLTS/DIV range source output resistance in Table 3-2.
- c. Calculate loading error.

$$\% \text{ loading error} = \frac{100 \times \text{Source Output Resistance}}{\text{Source Output Resistance} + \text{Load Resistance}}$$

3-21. DC OFFSET ERRORS.

3-22. At VOLTS/DIV switch settings above 50 mV, the output attenuator resistors must dissipate sufficient power to produce heat in the wire-wound resistors. This heat differential is especially noticeable on the DC+ and DC- modes where the attenuator dissipates twice the power of the square-wave output mode and when using the X5, X6, X8, X10 setting of the MULTIPLIER. The heating in the attenuator will result in thermoelectric effects which cause offsets of a few microvolts on the low level ranges of the VOLTS/DIV switch.

3-23. Always allow a waiting period of 3 to 5 minutes before using the low voltage output if the VOLTS/DIV switch has been set to ranges between 50 mV and 20 V. This assures the temperature in the attenuator to equalize so as to minimize errors caused by thermoelectric effects.

3-24. Use the GND mode to provide zero voltage reference for voltmeters or oscilloscopes. Do not use the switch on the oscilloscope itself or otherwise short the input terminals of the voltmeter under test. Using the GND mode eliminates

most of the remaining thermal effects in the attenuator of the 6125B/C. The voltmeter reading with GND input represents the thermal voltage of the 6125B/C, the connecting leads and the voltmeter. The GND reading is the minimum voltage of the entire measurement system and it must be measured and arithmetically added to the reading of the voltmeter for all calibrations below ± 10 mV. On some 6125B/C a front panel screwdriver control will permit cancelling the thermal voltage effects within their normal range of ± 100 μ V.

3-25. GROUND CURRENT ERRORS.

3-26. Always ground the power cord ground pins on the calibrator and the instrument under test to earth ground. This is especially important to avoid noise interference on low VOLTS/DIV ranges. The VOLT OUT circuitry is offset from ground by internal resistor R which is used to avoid circulating ground loop currents between the VOLTS OUT connector shell and the instrument under test. When using VOLTS/DIV ranges below 0.1 volt and the calibration is suspect or displays power frequency distortion, carefully check the instrument for input power circuit leakage problems. If the instruments are found safe, it is recommended that one or the other instrument be temporarily isolated from the power mains earth ground and that a well shielded and safe isolation transformer be used in its power input. This will remove or reduce circulating ground currents so that errors from this source may be minimized for low output voltage level applications. When the instrument under test uses differential input with common mode rejection, low level calibrations have best results when the 6125B/C is operated with its earth ground isolated and the instrument under test is externally triggered from the marker output.

WARNING

Disconnecting earth grounds may provide a personnel safety hazard in some instruments. Use extreme caution to avoid shock hazard and restore normal earth ground once low voltage calibrations are completed.

3-27. WARMUP ERRORS.

3-28. The unit is fully operative within one minute of POWER turn ON. The amplitude calibration drift during the first 20 minutes of operation in a constant temperature laboratory environment is less than ± 0.2 percent in normal or subsequent operation.

3-29. TIME CALIBRATION.

3-30. TIME MARK GENERATOR.

3-31. The MARKER OUT BNC is an accurate time signal in the shape of a pulse train. The positive going pulses

occupy 5 percent of the marker period for intervals longer than 0.1 μ s and approximately a square wave at 10 nanoseconds. The TIME/DIV MULTIPLIER permits decading checks as well as oscilloscope magnifier check and picket fence simulation in radar range calibration. Digital counters and signal sources may also be checked. The markers are rich in harmonics. They may be used to check spectrum analyzers. An external time base input provision permits use of a 10 MHz frequency standard for traceable calibration. The EXT clock input may be used to provide arbitrary TIME/DIV marker output selection below 0.1 μ s (10 MHz) as may be required for video markers, ultrasonic delay calibration and engineering unit readouts. A typical test procedure for oscilloscopes is outlined in the following paragraphs.

3-32. Checking Oscilloscope Time Base Calibration.

3-33. Connect the MARKER OUT BNC connector of the 6125B/C to the vertical amplifier of the oscilloscope to be tested. Use a 50 ohm coaxial cable terminated in 50 ohms at the input BNC of the oscilloscope. The Ballantine Model 12249D four foot BNC to BNC Cable and the Model 12630A 50 ohm Feed Thru Termination is recommended.

3-34. Set the 6125B/C controls as follows:

TIME/DIV	Same as the oscilloscope TIME/DIV range to be checked.
MULTIPLIER	X1
DEVIATION	OFF

3-35. Set the oscilloscope vertical attenuator to 0.2 VOLT/DIV and adjust the scope trigger circuits for proper internal triggering when the oscilloscope TIME/DIV switch and the 6125B/C TIME/DIV switch are set to the same range.

3-36. Use the oscilloscope position controls and properly center the display on the CRT. Figure 3-5 shows a typical presentation. Note that ten time intervals are defined on an approximately 5 division high display.

3-37. Position the first rise to the left most graticule line. Observe that one calibration marker falls on each graticule line. The error of marker alignment on the eleventh (right most) graticule line represents the observed calibration error.

3-38. Set the DEVIATION switch to TIME $\pm 10\%$ and note that the TIME/DIV deviation indicator lamp is illuminated. Rotate the TIME/DIV deviation control until the right hand marker pulse aligns with the right hand graticule line and a marker falls on each graticule line of the scale.

3-39. Read the % DEVIATION digital meter on the 6125B/C and note the measured error for the oscilloscope time base range under test. If this is within the oscilloscope calibration error allowance (usually $\pm 3\%$) proceed; if not, note the error and recalibrate the oscilloscope.

3-40. Observe the alignment of the leading edge of the marker on the second thru the tenth graticule lines. This is an indication of time base linearity.

3-41. Continue to check calibration accuracy of all the time base ranges of the oscilloscope under test. TIME/DIV settings slower than 1 ms may be easier to check when the TIME/DIV MULTIPLIER is set to X5 and even X10 for the slowest sweeps.

NOTE

Use triggered sweep synchronization for all TIME/DIV settings slower than 1 ms. Do not use AUTO triggering, since erratic synchronization for slow pulse rates will result in misalignment of the first marker pulse with the first CRT graticule line.

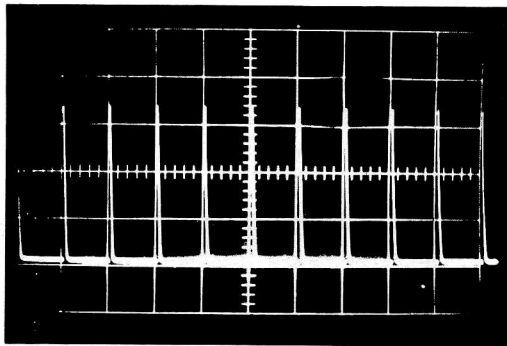

Figure 3-5. Marker Out Display

3-42. HF OUTPUTS.

3-43. For time calibration signals of 5 nanoseconds and 2 nanoseconds, the 6125B/C provides independent 200 MHz and 500 MHz sinewave outputs derived from the same master clock as the MARKER OUT and TRIG OUT signals. The 200 MHz and 500 MHz HF OUTPUTS are generated by frequency multiplication. Should an external clock input be used, it must be exactly 10 MHz or the multipliers will not activate.

NOTE

To use the HF OUTPUTS the DEVIATION switch MUST be set to OFF or the multipliers will not function and no output signals will appear at the 5 ns and 2 ns HF OUT connectors.

3-44. To connect the HF OUTPUTS to an oscilloscope, digital counter, spectrum analyzer or sweep generator marker

TABLE 3-3. VOLTS OUTPUT, OUTPUT RESISTANCE AND LOADING ERROR

VOLT/DIV RANGE	OUTPUT RESISTANCE	% ERROR	
		1 M Ω LOAD	10 M Ω LOAD
20 V	220 Ω	-.022%	-.002%
10 V	2.72 K Ω	-.272%	-.027%
5 V	2.09 K Ω	-.209%	-.021%
2 V	1.12 K Ω	-.112%	-.011%
1 V	695 Ω	-.070%	-.007%
.5 V	463 Ω	-.046%	-.005%
.2 V	319 Ω	-.032%	-.003%
.1 V	270 Ω	-.027%	-.003%
50 mV	245 Ω	-.025%	-.003%
20 mV	320 Ω	-.032%	-.003%
10 mV	2.72 K Ω	-.272%	-.003%
5 mV	2.09 K Ω	-.209%	-.021%
2 mV	1.12 K Ω	-.112%	-.011%
1 mV	495 Ω	-.070%	-.007%
.5 mV	463 Ω	-.046%	-.005%
.2 mV	319 Ω	-.032%	-.003%
.1 mV	270 Ω	-.027%	-.003%
50 μ V	245 Ω	-.025%	-.003%
20 μ V	230 Ω	-.023%	-.002%
10 μ V	225 Ω	-.023%	-.002%

input, use a short 50 ohm cable terminated in BNC connectors. If the instrument under test has a 50 ohm input impedance, no further termination is required. If the input impedance is high (such as a 1 megohm oscilloscope or counter) use a 50 ohm feed thru termination at the input connector of the instrument under test. The Ballantine Model 12630A feed thru termination is recommended. It is important to present a true 50 ohm terminated system to the HF outputs. VSWR higher than 1.1 on large capacitive loads may detune the multipliers and result in loss of output amplitude and increased distortion. If a high VSWR load is unavoidable, buffer it with a coaxial attenuator of 6 db or 10 db attenuation to minimize termination difficulties.

3-45. There is no DEVIATION capability for the 2 ns and 5 ns HF outputs and the DEVIATION control MUST be set to OFF or volts when HF outputs are to be used.

3-46. 1 ns (1 GHz) Output With Model 61251A Optional Multiplier.

3-47. The Model 61251A Frequency Doubler is an optional accessory which will double any frequency input over the range of 100 MHz to 1 GHz. It may be used to double the 100 MHz (10 ns marker) and provide 200 MHz output with full deviation capability to provide 180 to 220 MHz. The 61251A may also be used with the 5 ns HF OUT to provide 400 MHz and with the 2 ns HF OUT to provide 1 GHz signals locked to the master system clock oscillator or EXT 10 MHz clock input. No deviation capability is provided for the 2 ns and 5 ns HF outputs.

3-48. The 2.5 ns and 1 ns markers, provided by the optional 61251A Frequency Doubler, may be used to check digital frequency counters, sampling scope time calibration, markers on spectrum analyzers and sweep signal generators.

3-49. To use the 61251A Frequency Doubler simply insert it into the HF output cabling system described above and hook it into the BNC cable system at the input of the 50 ohm feed thru termination or the device under test. The 61251A is a 50 ohm input/output device and must be terminated by a low VSWR 50 ohm system.

3-50. TRIGGER OUTPUT.

3-51. The TRIG OUT connector of the 6125B/C provides a squarewave derived from the master clock of the system and with frequency independently variable of the MARKER OUT signal.

3-52. The TRIG OUT squarewave is used for checking ratio mode in digital counters and trigger circuits in oscilloscopes. The TRIG OUT signal has a very fast rise time (< 1 ns) and is therefore rich in harmonics for checking frequency calibration of spectrum analyzers and other frequency domain devices. The fast rise time is intended for checking the vertical amplifier alignment of oscilloscopes as detailed in paragraph 3-56.

3-53. External Triggering of Oscilloscopes.

a. Set the scope for external triggered operation. Connect the 6125B/C TRIG OUT signal to the scope's external trig input and use a 50 ohm termination at the scope.

b. In general, the trigger period should be slower than the marker period displayed on the scope. This avoids the appearance of an unmarked base line on the scope. Keeping trigger rate high will give the brightest display on the scope.

c. Varying the trigger period while checking calibration of any one scope time base range will check scope time base calibration, jitter factor and general trigger stability when signals of varying repetition rates are displayed on the oscilloscope during its normal use.

d. As a convenience the scope being calibrated with the 6125B/C may be externally triggered at a fixed rate (i.e. 1 ms). This avoids the need to adjust scope triggering when the faster sweep speed ranges are being calibrated or checked. This is the special advantage on scopes with poor trigger performance.

3-54. The internal MARKER-TRIGGER INTERLOCK switch in board assembly A16 is used in conjunction with external trigger operation for oscilloscopes, radar sets and other applications involving exact time coincidence between the TRIG OUT and MARKER OUT signals.

a. In the NORMAL setting of the internal MARKER-TRIGGER INTERLOCK switch, the digital dividers in the

trigger and marker circuits are independent ripple counters with no compensation for the few nanoseconds of accumulated delay which may be different in each divider chain. The NORMAL setting provides TRIG OUT for all settings of the TRIGGER PERIOD and TIME/DIV (and MULTIPLIER) settings.

b. Use of the NORMAL mode in externally triggered scope calibration may require reset of horizontal trace positioning when checking fast time base speed (faster than $1 \mu\text{s}/\text{DIV}$). The phasing changes of the TRIG OUT with respect to the MARKER OUT signals will require this trace realignment. As an extra convenience and speed up calibration (and programmed operation with the 6125C). The LOCKOUT mode is provided.

c. In the LOCKOUT mode a gating circuit provides exact time coincidence between the rise of the TRIG OUT and MARKER OUT signals. This time coincidence is advantageous when calibrating complex timing circuits such as radars and facilitates externally triggered sweep time calibration of oscilloscopes.

3-55. RISE TIME MEASUREMENTS.

3-56. The TRIG OUT square wave of the 6125B/C provides a clean, fast rise which is intended for use as a test signal for checking the bandwidth and high frequency alignment of wideband amplifiers such as the vertical amplifiers of oscilloscopes. See Figure 3-6.

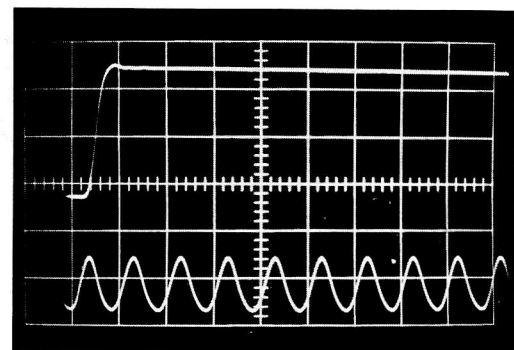

Figure 3-6. Rise Time Display

5-57. Amplitude For Rise Time Measurements.

a. It is usual to measure the rise time of an oscilloscope amplifier with the scope input attenuator set for maximum sensitivity (i.e. straight through with no attenuation).

b. The 6125B/C TRIG OUT square wave delivers 250 mV into 50 ohm or 500 mV unterminated. This is sufficient to produce 5 divisions of deflection at 50 mV or even 100 mV/DIV. Unterminated operation is not recommended for amplifiers having a bandwidth greater than 5 MHz.

c. The FAST RISE & TRIG AMPLITUDE control on the 6125B/C provides continuously variable TRIG OUT amplitude over the range of 200 mV to 250 mV when terminated in 50 ohms. This amplitude adjustment permits exact alignment of the rise time on the scope graticule for 4 and 5 divisions and avoids the necessity to use the scope variable gain control for exact trace alignment. The scope variable gain control often deteriorates the effective amplifier response and the 6125B/C AMPLITUDE control provides control without loss of fidelity.

d. For scopes and amplifiers having greater sensitivity (i.e. to 1 mV or 5 mV/DIV), an additional coaxial wideband attenuator (such as the GR874 Series) should be included in the 50 ohm transmission line from the TRIG OUT connector to the input of the amplifier. Always use a feed-thru 50 ohm termination such as the Ballantine 12630A directly at the input connector of the amplifier.

3-58. Cable Matching For Rise Time Measurements.

a. The impedance of the connecting cable and coaxial components should be 50 ohms $\pm 2\%$. Cable length should be kept as short as possible since long cables (longer than 1 meter) will degrade the rise time of the TRIG OUT square wave.

b. The 50 ohm cable should be terminated in 50 ohms. This also presents a low source impedance to drive the input impedance of the amplifier. It may be desirable to use a two times (or greater) divider as the 50 ohm termination so that the loading of the amplifier is minimized by the lower driving impedance. Many high frequency oscilloscopes are designed to be calibrated and checked from a 25 ohm source.

c. In practice the deteriorating effect of scope amplifier input loading on the properly terminated TRIG OUT fast rise signal is of importance only for scopes having greater than 50 MHz bandwidth (<7 nanosecond rise time).

3-59. Rise-Time Measurement Accuracy.

a. Before measuring the rise time of a scope amplifier, the time calibration of the scope time base should be checked at the speed and in the graticule area to be used for displaying the rise time signal.

NOTE

Always calibrate the time base of the oscilloscope in the region where rise time checks are usually made on the fastest sweep range and the operator must correct for beginning trace non-linearity and magnifier errors which often account for 8 to 10% timing error. Rise times should be measured some 50 or more nanoseconds from the beginning of the visible scope trace and near screen center for best results.

b. The 1 nanosecond positive going rise of the TRIG OUT square wave is adequate to check scopes having bandwidths to 250 MHz. The 1 nanosecond rise will increase the rise time displayed on the scope by only 1% for 50 MHz scopes having 7 nanosecond rise time. For slower oscilloscopes the displayed rise time may be taken as the true rise time of the scope amplifier. For faster scopes the true rise time is given by:

$$\text{True Rise Time} = \sqrt{(\text{Displayed rise time})^2 - (\text{Source Rise Time})^2}$$

3-60. Fast-Rise Measurement Procedures.

a. Connect the TRIG OUT to the amplifiers input by a short 50 ohm cable, any required coaxial attenuators and a 50 ohm termination at the input of the amplifier.

b. Select the desired TRIGGER PERIOD. Use a faster trigger rate to optimize display brightness.

c. Adjust the scope trigger circuit and Time/Div. control to display the fast rise on the CRT. Position the pulse past the first 50 nanoseconds of sweep and horizontally position it at the center of the graticule. Be sure the sweep has been accurately calibrated at this point and that the slope of the rise time extends over more than half a major graticule division.

d. Use the 6125B/C AMPLITUDE control to align the top and bottom of the rise to 0% and 100% reference line or use 5 graticule divisions. Measure the time between the 10% and 90% amplifier high frequency alignment.

3-61. Model 61252A Fast Rise Accessory.

a. The Model 61252A fast rise accessory provides a test rise time of <125 pico seconds (8 times faster than the TRIG OUT rise). This gives the 6125B/C Time and Amplitude Test Set the capability to check amplifiers and spectrum analyzers into the gigahertz bandwidth region.

b. The Model 61252A uses an ultra high speed tunnel diode to generate the rise.

c. Use the same test set-up and procedures indicated above to connect the 61252A accessory to the amplifier under test.

d. Connect the 61252A input to the VOLTS OUT connector on the 6125B/C. Apply 60 to 100 volt square wave at the highest output mode frequency that results in a stable display after adjusting the 61252A fast rise control.

3-62. LINE FREQUENCY OUTPUT.

a. The LINE FREQ output connector supplies continuously variable amplitudes from 0 to 1 volt peak to peak of power mains frequency. The power mains sine-wave is filtered to reduce noise and higher frequency interference.

b. The LINE FREQ signal is useful for checking low frequency operation (period and low frequency multipliers) of digital counters and for checking sensitivity, trigger level, range and slope for counters and oscilloscopes. See Figure 3-7.

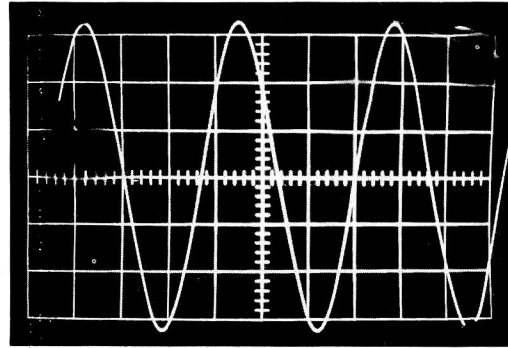

Figure 3-7. Line Freq. Display

SECTION 4

THEORY OF OPERATION

4-1. INTRODUCTION.

4-2. The 6125B and 6125C are identical in function except that remote programmability is featured in the 6125C. Each instrument is comprised of an independent amplitude generator and an independent time generator. Only the ac mains power transformer and the deviation meter are common. Both generators are electrically controlled for function and range so that the front panel controls do not carry measurement signals. The 6125C incorporates program output coders, buffers, A-D converters for digital control of deviation and indicator circuitry and displays to show setting of all front panel controls when remotely programmed.

4-3. The following discussion will separate the TIME and VOLTS generators. Each block diagram will indicate the assembly number in which each circuit block is located. Figure 4-1 shows the VOLT generator block diagram. Figure 4-8 shows the TIME block diagram. The basic discussion of theory will concentrate on the programmable 6125C. To understand the 6125B simply delete references to remote control functions and displays which are primarily located on the assembly, A1 for VOLTS and on assembly A10 for the TIME.

4-4. VOLTS GENERATOR.

4-5. General Description.

4-6. The basic VOLTS generator circuit consists of a resistance programmable regulated precision D.C. power supply, a high voltage low impedance transistor switch circuit used to generate square waves from the D.C. supply output, and a precision resistor multi-range attenuator. The combination of resistance programming of the power supply and range selection of the attenuator provides calibrated voltage from 200V down to 10 μ v in 1, 2, 5 steps. The output voltage may be positive or negative D.C., or positive square waves of 10, 100, 1000 or 10,000 Hz as determined by the MODE selection circuits. A deviation circuit permits calibrated, metered deviation of the output voltage for direct read out of percentage from the nominal settings. Model 6125C, in addition to the above features, provides local or remote programming of all output modes, ranges and deviation.

4-7. PROGRAMMABLE DC SUPPLY.

4-8. The programmable DC power supply utilizes circuitry located on PC boards A2, A3, and A4. It provides the precise initial DC voltage from which both DC and square wave output signals are derived. Refer to simplified schematic Figure 4-2, for the full wave rectifier bridge CR1, CR2, CR3, CR4 in power supply assembly A2. It provides a nominal 260 volts, unregulated, across C2.

A voltage doubler CR5, CR6 provides an additional 240 volts across C3. A 17-volt transformer secondary winding drives CR1 and CR2 of assembly A3 to provide 17 volts plus and minus from the reference "HI" voltage supply line.

4-9. A floating DC regulator, programmable from the front panel MULTIPLIER switch and DEVIATION controls, provides the precise initial DC voltage between DC voltage "HI" and "LO" supply lines. The zener voltage reference diode CR5 in A3 provides a comparison standard that controls the initial voltage. A constant current from Q5, Q6, Q7, Q8 of A2 is provided for zener A3 CR5. The ratio of the controlled voltage to the reference diode voltage is determined by precision resistors A3 R10, A3 R11, A3 R12 and precision resistors A4 R1 through A4 R8 in the multiplier selector assembly A4.

4-10. Adjustable potentiometer A3 R9 provides a precise calibration of the initial DC voltage when the DEVIATION switch is OFF or in its TIME positions. When the DEVIATION switch is turned to its VOLTS position, a variable voltage from the DEVIATION control provides for a variation of the "HI" to "LO" output volts of plus and minus 10 percent. This difference voltage is monitored by the deviation readout meter.

4-11. The voltage regulator operates with a high degree of negative feedback. Any decremental voltage difference between output line "HI" and the base of transistor A3 Q1-B causes a current change from the collector of A3 Q1-A, operating through Q4, Q3 and Q2 to make the correction.

4-12. The MULTIPLIER switch provides control signals J, K, L which select, by means of relays K1 through K7 in A4R, the precision resistors used for voltage comparison. The control is basically a resistance programmable precision output voltage.

4-13. In the DC modes, A3 Q3 remains saturated, and A3 Q4 and A3 Q5 remain open, so that the DC output voltage amplitude is exactly that set by the programmable power supply. In AC modes the above transistors are switched between open and saturation so that the AC output amplitude has the identical peak amplitude as in the +DC output mode.

4-14. SQUARE WAVE CHOPPER SWITCH.

4-15. Referring to Figure 4-3, the controlled voltage between line 26 from A2-7 and the "LO" DC supply line is directed into a chopper switch comprised of A3 Q3, A3 Q4 and A3 Q5. When square waves are called for by the OUTPUT MODE switch, chopper control signal at TP1

alternates between high and low logic. When it is at low level, A3 Q4 and A3 Q5 are open. A3 Q3 saturates, passing voltage from the controlled DC voltage line 26 to line "HI" which directs it to the mode selector assembly A7. When TP1 is high, A3 Q4 and A3 Q5 conduct, cutting off A3 Q3. The voltage level between "HI" and "LO" reduces to an exact zero level obtained by the adjustment of A3 R2, the square wave zero level adjust.

4-16. The timing of the TP1 signal is derived from a programmed divider A7 U1 which divides the frequency of its input signal on pin 3 by a power of 10 determined by input control lines X, Y and Z. The input signal at A7 U1-3 is a crystal-controlled 1 MHz signal received from the TIME generator A18 pin R. The output frequencies, frequency division states and input logic states are shown in the insert table of Figure 4-3. The output from A7 Q3 provides the floating output chopping wave TP1 to the chopper switch in A3.

4-17. OUTPUT MODE SELECTION.

4-18. Referring to Figure 4-4, the calibrated DC or calibrated chopped signal from the chopper stage in A3 is received on lines "HI" and "LO" at the OUTPUT MODE selector Assembly A7. The signal then passes through relays A7 K2 and A7 K4 and connect to the calibrated attenuator R22, R23. Relay A7 K2 functions as a reversing switch to provide negative

DC at the output terminal when energized. Relay A7 K4 connects the input end of the precision attenuator directly to the output return terminal to provide zero output volts when the OUTPUT MODE selects GND.

4-19. In the 6125B, control is provided only by the front panel output mode switch S1. This is connected through shorting board A1. In the 6125C, the operator may use the front panel controls, or the instrument may be controlled remotely through remote control interface assembly A1. Under either form of control, the mode selection is accomplished through control lines X, Y, and Z. These lines control the square wave frequency at A7 U1, and, operating through logic elements A7 U5 and A7 U6, control transistors A7 Q6 and Q7. They control relays A7 K2 and A7 K4 to provide positive, negative or zero dc output voltages. The seven output modes, the control line and logic states are summarized in Table 4-1.

4-20. PRECISION ATTENUATOR.

4-21. The precision attenuator comprises 2 stages.

4-22. Referring to Figure 4-5, the first stage in assembly A7 comprises precision resistors A7 R22 and A7 R23 which provide an attenuation of 1000 to 1 when relay A6 K6

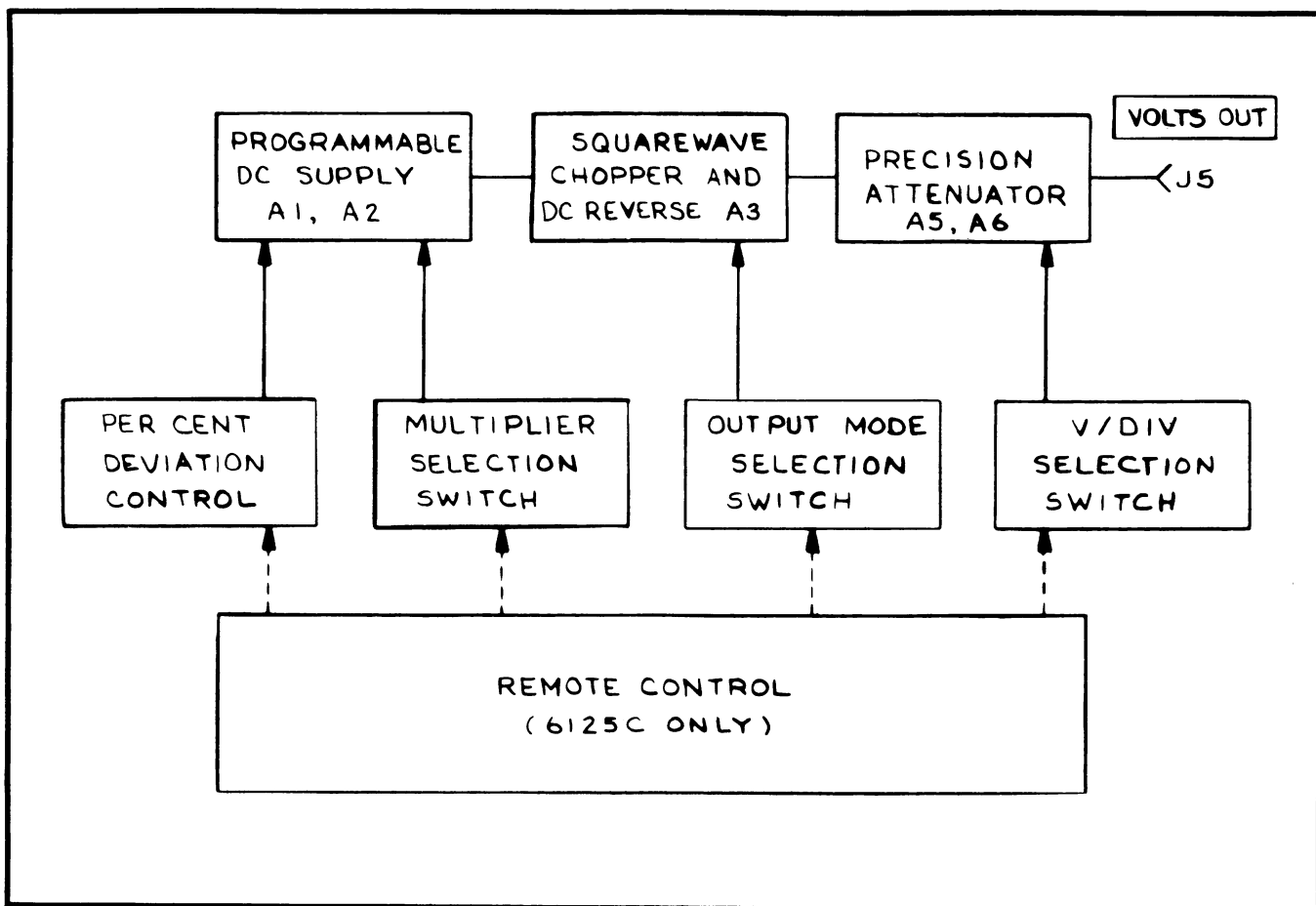

Figure 4-1. Functional Block Diagram, Volts Circuits.

is energized. Relays A6 K1 through A6 K5 are located on the 1 mv to 20 V divider assembly A6 and control the five steps from 20 volts to 1 volt or 20 mv to 1 mv depending on whether the 1000:1 attenuator is inserted.

4-23. Selection of the degree of attenuation originates at the VOLTS/DIV switch on the front panel which defines the logic states of control lines A, B, C, D, and E. These control lines operate decoders A6 U1 and A5 U1 which energize the relays needed for the required attenuation.

4-24. Table 4-2 summarizes the switch positions, the logic line states, the decoder and operating relay states.

4-25. VOLTS DEVIATION CIRCUITRY.

4-26. The VOLTS PERCENT DEVIATION feature of the 6125B/C comprises a controllable measured percent variation, plus or minus (high or low), available in all of the output voltage modes and amplitudes when the front panel DEVIATION switch is in the VOLTS position.

4-27. Voltage deviation takes place when current, either positive or negative, is injected at the base of transistor Q1-B in the programmable DC supply circuitry described in paragraph 4-7. This takes place (Figure 4-6) when relay K2 is energized by either local or remote voltage DEVIATION being selected. Current, proportioned to the amount of deviation then passes through resistors A18R1 and A18R2, the contact of A18K2 thru A17R1 back to A18K2 and A18R5 to the summing input of the sense amplifier A3Q1-B.

4-28. The control network in A7 comprises opto-isolator A7 U4 and transistor A7 Q4. The current provided is derived from the voltage at op amp A7 U3-6. This op amp is under the control of either front panel control DEVIATION potentiometer R1 or, in the case of the 6125C, from remotely programmed D-A converter A1U4 when relay A7 K1 is energized.

4-29. The VOLTS DEVIATION measurement voltage is taken through the relay contact of A18K2 which closes when the DEVIATION switch is in its VOLTS position. The voltage across A17R1 (for units with serial prefix 021-) or A18R22 (for units with serial prefix 022-) is then monitored by a digital voltmeter displayed on the 6125B/C front panel. Adjustment on the $\pm 10\%$ range is by A18R2.

4-30. VOLTS CONTROL CIRCUITS.

4-31. Control of the VOLTS generator of the 6125B/C circuitry utilizes control lines at high or low logic levels in accordance with the test condition required. In the case of the 6125B these lines are controlled by front panel switches. In the 6125C the control may be either at the front panel or from a remote station.

4-32. In summary, the front panel controls consist of an OUTPUT MODE switch, a VOLTS/DIV switch, a MULTI-

PLIER switch, a DEVIATION control switch and a DEVIATION adjustment control. A front panel indicator, which may be either a digital display or an analog meter, shows the percent deviations, plus or minus, of the amplitude signal. In the 6125C additional indicator lamps display the state of the controlling voltages.

4-33. The output mode control circuit is shown in Figure 4-4 and described in Section 4-17. The volts per division circuit is described in Section 4-20 and its control circuit states including intermediate logic, are shown in Table 4-2.

4-34. The volts per division MULTIPLIER circuit is shown in Figure 4-7A. The MULTIPLIER switch S2 operates control lines J, K, and L. The instruction, from the switch is conveyed to the multiplier selector assembly A4 through shorting board assembly A1 (6125B) or a Remote Control Program Volts assembly A1 (6125C). In assembly A4 the control lines operate through a multiplexer A4 U1 which puts a single selected output line at low logic, the other lines remaining at high logic. Seven of the output lines energize relays A4 K1 through A4 K7 whose contacts short out sections of a precision resistor chain to achieve a desired degree of attenuation as has been described in Section 4-6. If none of the relays are energized, the multiplication factor is X10.

4-35. The volts deviation control circuitry is shown in Figure 4-7B. When the DEVIATION switch is off or in one of its TIME positions, VL and V are at low logic, \bar{V} is at high logic, A18K2 is not energized, and no deviation voltage input takes place at A3-D. In the VOLTS DEVIATION position, VL and V are high, \bar{V} is low, relay A18K2 is energized, deviation control is provided at A18-H and the deviation display indicates volts percent DEVIATION. In the $\pm 10\%$ VOLTS DEVIATION switch position, switch contacts short out 3% resistors A18R3 and A18R4 which are only provided in the $\pm 3\%$ option.

4-36. VOLTS REMOTE CONTROL (6125C only).

4-37. Connections to the volts portion of the 6125C for remote control and readout is through Blue Ribbon connector A10 J2 and permits connection of an external program cable. Connector A10 J2 extends through the 6125C rear panel. For connector pin identification see Table 2-2.

4-38. The remote connections are enabled when the front panel VOLTS/DIV switch of the 6125C is in its RMT position. This puts a high logic on control line R and a low at the output of NOR gate A7 U5-1. Q8 opens, and puts a high logic level on control line L/R. In assembly A1 the high L/R signal switches multiplexers A1 U1, A1 U2 and A1 U3 to receive remote signals and energizes A1 Q1 which turns on REMOTE LED LAMP DS 10 on the front panel. A low L/R control signal disables the remote lines and enables the front panel lines. Remote overrides local.

TABLE 4-1. OUTPUT MODE SELECTION STATES.

OUTPUT MODE	CONTROL LINES			LOGIC ELEMENTS						RELAYS	
	X	Y	Z	U6-6	U5-4	U6-12	U5-13	U6-8	U5-10	K2	K4
DC-	1	1	0	0	0	1	1	0	1	ON	OFF
GND	0	0	0	1	1	1	0	1	0	OFF	ON
DC+	1	1	1	0	0	0	1	1	1	OFF	OFF
10 kHz SQUARE	0	1	0	1	0	1	0	1	1	OFF	OFF
1 kHz SQUARE	0	1	1	1	0	0	0	1	1	OFF	OFF
100 Hz SQUARE	1	0	0	1	0	1	0	1	1	OFF	OFF
10 Hz SQUARE	1	0	1	1	0	1	0	1	1	OFF	OFF

TABLE 4-2. PRECISION ATTENUATOR CONTROL STATES.

V/DIV SWITCH S2	CONTROL LINES					ENERGIZED A6 TRANSISTORS	DECODER IC LOW OUTPUT PIN	ENERGIZED RELAYS
	"A"	"B"	"C"	"D"	"E"			
20 V	1	1	1	0	1	Q3, Q1	A6U1-6	A6K7, A6K5
10	1	1	1	0	0	Q3, Q1	A6U1-7	A6K7, A6K4
5	1	1	0	1	0	Q3, Q1	A6U1-11	A6K7, A6K3
2	1	1	0	0	1	Q3, Q1	A6U1-10	A6K7, A6K2
1	1	1	0	0	0	Q3, Q1	A6U1-9	A6K7, A6K1
.5	1	0	1	1	0	Q3,	A5U1-5	A6K7, A5K6
.2	1	0	1	0	1	Q3,	A5U1-6	A6K7, A5K5
.1	1	0	1	0	0	Q3,	A5U1-7	A6K7, A5K4
50 mV	1	0	0	1	0	Q3,	A6U1-11	A6K7, A5K3
20	0	1	1	0	1	Q2, Q1	A6U1-6	A6K6, A6K5
10	0	1	1	0	0	Q2, Q1	A6U1-7	A6K6, A6K4
5	0	1	0	1	0	Q2, Q1	A6U1-11	A6K6, A6K3
2	0	1	0	0	1	Q2, Q1	A6U1-10	A6K6, A6K2
1	0	1	0	0	0	Q2, Q1	A6U1-9	A6K6, A6K1
.5	0	0	1	1	0	Q2,	A5U1-5	A6K6, A5K6
.2	0	0	1	0	1	Q2,	A5U1-6	A6K6, A5K5
.1	0	0	1	0	0	Q2,	A5U1-7	A6K6, A5K4
50 μ V	0	0	0	1	0	Q2	A5U1-11	A6K6, A5K3
20	0	0	0	0	1	Q2	A5U1-10	A6K6, A5K2
10	0	0	0	0	0	Q2	A5U1-9	A6K6, A5K1

4-39. The control lines switched between local and remote in A1 U1, A1 U2 and A1 U3 are (1) the V/DN lines A, B, C, D and E; (2) the multiplier lines J, K and L; (3) the volts deviation switching line V and (4) the output mode lines X, Y and Z. The remotely controlled analog deviation signal on line 14 originates in an 8 bit digital to analog converter A1 U4. The analog control signal passes through the relay contacts of A7 K1, through buffers A7 U3 and opto-isolator A7 U4 to control the precision DC power supply deviation between line "HI" and line "LO" on A3 through deviation line DV.

4-40. Decoders, A1 U5 and A1 U6, under instruction from the control lines X, Y, Z and A, B, C select low level output signals which operate identifying front panel LED'S. Inverter A1 U8-10 provides BCD input for A1 U7 which converts to 7-segment drive to provide a "1", a "2", or a "5" for the VOLTS/DIV digital display.

4-41. The volts division of the 6125C may be selected either remotely or by the front panel VOLTS/DIV switch independent of whether the TIME generator circuitry is being operated locally or remotely.

4-42. TIME CALIBRATOR.

4-43. GENERAL DESCRIPTION.

4-44. The Time Calibrator derives its basic reference from a 10 MHz crystal controlled oscillator. All other frequencies are derived from this reference by multiplication, division or phase locked loop techniques. The reference frequency is first used to phase lock a 100 MHz voltage controlled oscillator. The 100 MHz oscillator is multiplied by 2 and 5 to provide 5 ns and 2 ns output markers and is also divided in a 1, 2, 5, 10 sequence to provide markers with periods from 10 ns to 50 sec. A square wave trigger source with periods ranging from 100 ns to 1 sec is also provided. The square wave rise time is less than 1 ns permitting rise time checks of wideband amplifiers. A deviation measuring circuit provides direct reading time deviation measurements on all ranges except the 2 and 5 ns outputs. Remote programming of all ranges except the 2 ns and 5 ns outputs and all functions except the trigger amplitude are provided in the Model 6125C.

4-45. 100 MHz OSCILLATOR.

The 100 MHz oscillator is a voltage controlled oscillator which is phase locked to the 10 MHz reference crystal oscillator except when the deviation mode is selected. The oscillator is a Motorola MECL IC Type 1658 and as stated in the data sheets — frequency control is accomplished through the use of voltage-variable current sources which control the slew rate of a single external capacitor. In the calibrated mode the output of the VCO is applied to a decade counter (MC 10138) and the resultant 10 MHz output is phase compared to the 10 MHz crystal reference in a Motorola MC 4044 Phase Frequency Detector. The output of the

phase detector is then applied to the voltage control input of the MC 1658 to complete the phase locked loop and ensure that the 100 MHz oscillator frequency is as accurate and stable as the 10 MHz crystal reference except for some second order short term jitter. In the deviation mode the voltage control input of the oscillator is switched to a variable voltage source which is controlled by a front panel potentiometer for local programming or by a D/A converter for remote programming.

4-46. COUNTER CHAIN AND MULTIPLEXING.

The 100 MHz oscillator frequency is counted down in 1, 2, 5, 10 steps by a number of bi-quinary counters and binary flip-flops. From 10 ns periods to 50 ns periods MECL devices are used while from .1 μ s to 5 sec, low power Schottky TTL is used. For a given range, digital multiplexers then route the particular timing signal required to the output circuits for processing and shaping. One additional bi-quinary and binary counter and digital multiplexer provides 1, 2, 5 and 10 times multiplication of the time period selected by the range switching.

4-47. MARK/SPACE RATIO ENCODER AND OUTPUT DRIVER.

The marker outputs have a mark/space ratio of 5% on all ranges except the 10 and 20 ns ranges which have a 50% ratio and the 50 ns range which has a 20% mark/space ratio. The 5% mark/space ratio is produced by NORing .05T, .1T, .2T, .5T and T signals. Since all the signals are low for only 1/20 of the time period, the mark is 1/20th of T or 5%. This signal which is at MECL levels drives an output amplifier which provides the MARKER OUTPUT signals.

4-48. An AC mains frequency voltage of 0 to 1V peak to peak output is also provided. Its amplitude is continuously variable but not programmable.

4-49. A functional Block Diagram of the TIME Circuits is shown in Figure 4-8.

4-50. TIME GENERATOR CIRCUIT DESCRIPTION.

4-51. The timing functions of the 6125B/C may originate either internally or externally. Reference is made to the simplified drawing of Figure 4-9.

4-52. The internal timing source is a crystal controlled 10 MHz master oscillator with a drift rate of less than 3 parts in 10^7 per day. It is utilized in the timing circuits when a rear panel CLOCK switch S4 is in its INTERNAL position. In this switch position, a buffered 10 MHz output signal is available at a rear panel BNC J1. Option 14 will provide a high stability ovenized frequency standard with drift stability of 3 parts in 10^9 per day. If an external frequency standard is to be used, switch S4 is changed to its EXTERNAL position, and an external 10 MHz signal source may be connected through J1.

TABLE 4-3. SELECTION BY MULTIPLEXERS A13 U12-U15

T/DIV SELECTOR SWITCH S1	CONTROL LOGIC STATES									INPUT		OUTPUT AT A12 P1-J	
	\bar{A}	C	D	E	F	S1	S2	S3	I.C.	PIN	TIME INTERVAL	FREQUENCY	
5 s	1	0	1	1	0	1	1	0	U15	13	.5 sec	2 Hz	
2	1	0	1	0	1	1	1	0		14	.2 sec	5	
1	1	0	1	0	0	1	1	0		15	.1 sec	10	
.5 s	1	0	0	1	0	1	1	0	U15	2	50 ms	20 Hz	
.2	1	0	0	0	1	1	1	0		3	20	50	
.1	1	0	0	0	0	1	1	0		4	10	100	
50 ms	1	1	1	1	0	1	0	1	U14	13	5 ms	.2 kHz	
20	1	1	1	0	1	1	0	1		14	2	.5	
10	1	1	1	0	0	1	0	1		15	1	1	
5 ms	1	1	0	1	0	1	0	1	U14	2	.5 ms	2 kHz	
2	1	1	0	0	1	1	0	1		3	.2	5	
1	1	1	0	0	0	1	0	1		4	.1	10	
.5 ms	1	0	1	1	0	0	1	1	U13	13	50 μ s	20 kHz	
.2	1	0	1	0	1	0	1	1		14	20	50	
.1	1	0	1	0	0	0	1	1		15	10	100	
50 μ s	1	0	0	1	0	0	1	1	U13	2	5 μ s	.2 MHz	
20	1	0	0	0	1	0	1	1		3	2	.5	
10	1	0	0	0	0	0	1	1		4	1	1	
5 μ s	0	0	0	1	0	1	1	1	U12	2	.5 μ s	2 MHz	
2	0	0	0	0	1	1	1	1		3	.2	5	
1	0	0	0	0	0	1	1	1		4	.1	10	
.5 μ s	0	1	0	1	0	1	1	1	U12	13	none	none	
.2	0	1	0	0	1	1	1	1		14			
.1	0	1	0	0	0	1	1	1		15			
50 ns	0	1	1	1	0	1	1	1	U12	13	none	none	
20	0	1	1	0	1	1	1	1		14			
10	0	1	1	0	0	1	1	1		15			

4-53. When the front panel DEVIATION switch is OFF or in one of its VOLTS positions, all internal timing circuitry is locked to the internal or external primary source. When the DEVIATION switch is in the TIME position, the 2 n sec and 5n sec signals are disabled and the TIME marker and trigger periods may be varied by plus or minus 10 percent.

4-54. When DEVIATION is set to OFF, the 10 MHz crystal controlled reference signal is introduced into phase comparator A12 U2. Here a DC output signal at pin 8 is produced which depends on the relative phase of the reference signal and a controlled 10 MHz signal identified as "10 MHz LOCKED". The output of the phase comparator passes through an analog multiplexer A12 U1 to a voltage-controlled 100 MHz oscillator A14 U1 in A14 U2. The output of this VCO is divided ten to one in frequency in A14 U2 to provide the "10 MHz LOCKED" signal. The above forms a phase-locked loop in which all derived frequencies from the 100 MHz VCO are phase-locked to the 10 MHz primary source.

4-55. In the TIME Position of the DEVIATION switch, the 100 MHz oscillator receives its controlling DC voltage through the adjustable analog DEVIATION control source. In the 6125B this is the front panel DEVIATION control potentiometer R2. In the 6125C, DEVIATION may be controlled either from the front panel or remotely. From the 100 MHz and 10 MHz locked signals are derived all sub-multiple timing functions through digital counting circuits.

4-56. The 100 MHz locked signal also operates frequency multiplier circuits in A15. Frequency multiplier drive is disabled when the DEVIATION switch is in the TIME position. A15 Q1 cuts off 100 MHz amplifier A15 Q2 when a high logic signal on (line T) is applied to the base of A15 Q1. Frequency doubler A15 Q20 and A15 Q21 doubles the 100 MHz input to 200 MHz and provides the 5 ns time marker. Varactor A15 CR1 and associated tuned circuits act as a quintupler to provide a 500 MHz signal at the output of amplifier A15 Q3. A15 R7 provides adjustment for the operating bias of A15 Q3. A15 C12 and the tuned stripline couples the 500 MHz sine wave to the front panel 2 ns output BNC.

4-57. MARKER OUTPUT CIRCUITS.

4-58. As shown in the simplified schematic drawing of Figure 4-10, the "locked" 10 MHz signal (which may be variable frequency in the TIME DEVIATION mode) from A14 Q1 operates divide-by-five and divide-by-two counters in A13 to provide timing intervals which are multiples of 1, 2, and 5 ranging from 100 nanoseconds to 500 milliseconds. Multiplexers A13 U12 through A13 U15 select one of 21 time intervals under instructions from control lines A, C, D, E, F, S1, S2, and S3.

4-59. The selected frequency is connected (line 24) to input pin 6 of multiplexer A14 U3. Here control lines E' and F' select an output from input pin 3, 4, or 5 of A14 U3. The output signal at A14 U3-2, which may range between 10 nanoseconds and 500 milliseconds, provides a signal for counters A14 U4 and A14 U5 and multiplexer A14 U6. Control lines M' and N' from the multiplier switch increase the time interval by a factor X1, X2, X5 or X10.

4-60. The timing signals from pins 2 and 15 of A14 U6 are square wave signals representing selectable time intervals between 10 nanoseconds and 5 seconds. These may be directed along either one of two paths. For most of the positions of the TIME/DIV switch control, line 2 to U14 U7 is low, enabling decade frequency divider A14 U7. NOR-gate A14 U8-2 utilizes the four output signals from A14 U7 to synthesize a marker pulse with a 5 percent duty factor at 10 times the time period of the input wave at A14 U7-7. From the output at A14 U8-2 this shaped marker pulse has a period ranging from 100 nanoseconds to 50 seconds. This drives a marker pulse output circuit A16 Q5, A16 Q6, and A16 Q7, which provides the front panel MARKER OUTPUT signal at J2.

4-61. In order to obtain marker pulses having the three shortest time intervals of the T/DIV switch, control signal 1 is made low, enabling A14 U8-3, and control signal 2 is high, disabling A14 U7 and A14 U8-2. The square wave from A14-U6-15 with a selectable period of 10, 20, or 50 nanoseconds drives the marker pulse output circuits in A16.

4-62. The logic states that control the A13 multiplexer are summarized in Table 4-3. The logic states that summarize the A14 U3 selection are shown in Table 4-4. The logic states that control multiplexer A14 U6 selection are summarized in Table 4-5.

4-63. TRIGGER PERIOD CIRCUITS.

4-64. Referring to Figure 4-11, A 10 MHz locked signal from A14 Q1 operates a chain of decade frequency dividers A13 U5 through A13 U11 to provide timing pulses at intervals ranging between .1 microsecond and 1 second. These timing pulses are also used for the timing of the MARKER pulses.

4-65. A multiplexer A13 U16 selects a particular timing interval in accordance with control line J, K and L which carry instructions from TRIGGER PERIOD switch S3 on the front panel or, in the 6125C only, from a remote control location. Table 4-6 summarizes the selection process and the control signal states.

4-66. The signal from A13 U16 is directed to A16P1-D where it may be gated time coincident with the MARKER pulses in A16 U1 by MARKER TRIGGER INTERLOCK switch A16 S1. If synchronized A16 U1 utilizes a marker drive clock pulse from A16P1-1. From switch A16 S1 the trigger signal passes through a trigger pulse preamplifier comprising A16 Q2, A16 Q3 and A16 Q4, and then through a trigger pulse output amplifier comprising A27 Q1 and A27 Q2 on the TIME INTERCONNECT mother board to output BNC J1 on the front panel.

4-67. TIME DEVIATION CIRCUITS.

4-68. The time deviation circuits are shown in the simplified schematic drawing of Figure 4-12. When the Deviation switch S1 is in the $\pm 10\%$ TIME position, the voltage controlled 100 MHz oscillator A14 U1 is under the control of the front panel DEVIATION CONTROL potentiometer R2, so that any deviation of this oscillator from its nominal frequency causes all its derived timing functions to deviate from their nominal values by identical percentages. In the 6125C the percentage deviation may be controlled either at the front panel or remotely. The percentage deviation that results from the control of A14 U1 is measured quantitatively by comparing it in assembly A18 to a fixed 1 MHz frequency derived from the crystal controlled 10 MHz reference source by decade counter A18 U1.

4-69. A variable 2 MHz signal derived from A14 U1, whose deviation from nominal is to be measured, is introduced into a set of D flip-flops A18 U3, A18 U4, A18 U5 which are NAND gated in A18 U2. Any frequency deviation from the fixed 1 MHz reference signal produces a DC voltage output which varies directly with the percentage deviation. Positive and negative dc output voltages are provided by the 90° phase shift of A18 U4B. When A18 U3A is providing a pulse A18 U4B provides a steady DC output which is either high (positive) or low (negative) to define the direction of frequency deviation. The DC output voltage is filtered, controlled in amplitude and measured by the front panel DEVIATION meter.

4-70. TIME GENERATOR, CONTROL CIRCUITS.

4-71. Control of the time portion of the 6125B/C utilizes a set of control lines at high or low logic levels in accordance with the test condition required. In the 6125B front panel switches control these lines. In the 6125C control may be either remote or at the front panel.

TABLE 4-4. T/DIV CONTROL OF LOWEST TIME INTERVAL BY MULTIPLEXER A14 U3.

T/DIV SELECTOR SWITCH S1	CONTROL LOGIC STATES		U3 INPUT PIN	OUTPUT AT U3 PIN 2	
	E'	F'		TIME INTERVAL	FREQUENCY
.5 μ sec	1	0	4	50 n sec	20 MHz
.2	0	1	5	20	50
.1	0	0	3	10	100
50 n sec	1	0	4	50 n sec	20 MHz
20	0	1	5	20	50
10	0	0	3	10	100
All Others	1	1	6	Controlled by Multiplexers in A13 (see Table 4-3)	

TABLE 4-5. MULTIPLIER SWITCH CONTROL OF A14 U6

MULTIPLIER SWITCH S2	CONTROL LOGIC STATES		U6 INPUT PIN	OUTPUT AT U6 PINS 2 AND 15	
	M'	N'		TIME MULTIPLY	FREQUENCY DIVIDE
X 1	0	0	3	X 1	$\div 1$
X 2	0	1	5	X 2	$\div 2$
X 5	1	0	4	X 5	$\div 5$
X 10	1	1	6	X 10	$\div 10$

TABLE 4-6. TRIGGER PERIOD SELECTION, A13 U16

TRIGGER PERIOD SWITCH S3	CONTROL LOGIC STATES			U16 INPUT PIN	OUTPUT AT U16-5	
	J	K	L		TIME INTERVAL	FREQUENCY
100 ns	1	1	1	12	.1 μ s	10 MHz
1 μ s	0	0	0	4	1 μ s	1 MHz
10 μ s	0	0	1	3	10 μ s	100 kHz
100 μ s	0	1	0	2	.1 ms	10 kHz
1 ms	0	1	1	1	1 ms	1 kHz
10 ms	1	0	0	15	10 ms	100 Hz
100 ms	1	0	1	14	.1 sec	10 Hz
1 s	1	1	0	13	1 sec	1 Hz

4-72. Reference is made to the control circuits shown in Figure 4-13. The DEVIATION switch S1 shorts the control lines T_L and T to the Ground in the OFF or VOLTS DEVIATION positions of the switch. This condition enables the 200 and 500 MHz frequency multipliers in A15 and connects the 100 MHz voltage controlled oscillator in A12 to the phase comparator so that all derived frequencies are locked to crystal control. In the TIME DEVIATION switch position lines T_L and T are high, disabling the A15 multipliers and connecting the VCO in A12 to its time deviation control voltage. In the time deviation positions also the time deviation calibrating resistors A18 R6, A18 R7, A18 R8, A18 R9 are connected to +5 volts, permitting the measurement of TIME DEVIATION.

4-73. In the 6125C, the shorting board A10 is replaced by a Time Remote Program Interface assembly A10 which permits control either through switch control line T or through line TR in the remote interconnection Blue Ribbon Connector A10 J1 extending through the rear panel of the 6125C.

4-74. The TIME MULTIPLIER switch S2 utilizes control lines M and N extending through board A10 to become lines M and N, these are inverted in A12 to become lines M and N which control multiplexer A14 U6. The trigger switch control lines J, K and L pass through A10 to become lines J, K and L which control multiplexer A13 U16.

4-75. Control from the TIME/DIV switch includes some intermediate logic stages as shown in Figure 4-14. The primary control lines from front panel switch S1 pass through shorting board A10 and into an intermediate logic board A12. Control lines, C, D, E, F from A10 and A, S1,

S2, S3 from A12 are directed to assembly A13 where they control the selection of the marker pulse frequency going into the marker pulse shapers A14 U7 and A14 U8. Control lines E' and F' from A12 control multiplexer A14 U3 where the selection of marker pulse frequency either from assembly A13 or from a higher frequency source in A14 is determined. Control lines 1 and 2 from A12 select the chained of marker pulses either through the normal shaper circuits of A14 U7 and A14 U8 or through the bypass circuit with output at A14 U8-3.

4-76. The logic states of the TIME/DIV control lines are summarized in Table 4-7.

4-77. TIME REMOTE CONTROL (6125C only).

4-78. Connections to the time portion of the 6125C for remote control and readout is through multiple connector A10 J1 in remote program board A10 which extends through the rear panel. For connector pin identification see Table 2-1.

4-79. The remote connections are enabled when the TIME/DIV front panel switch is in its remote (RMT) position. This puts S in its high logic position. Operating through pins 2 and 4 of A10 U7, logic multiplexers A10 U1, A10 U2, A10 U3 throw control lines A, thru F, J thru L, M, N, and T from local (front panel) to remote control. Status LED's on the front panel are selected and driven by decoders A10 U5 and A10 U6. Also when A10 U7-4 is high the control line L/R connects deviation control of 100 MHz VCO (U1 in A14) to remote analog voltage control line "DEV" which comes from digital to analog converter A10 U4 through analog buffer A10 U8.

4-80. Option 60 adapts the 6125C to IEEE-488-1975 interface bus. See section 7 for details on options.

TABLE 4-7. COMPLETE TIME/DIV CONTROL AND LOGIC STATES

T/DIV	A	B	C	D	E	F	S _L	A12 U3-12	S3	S2	S1	\bar{A}	E'	F'	A12 U3-6	A12 U4-4
OFF	0	1	0	1	1	1	1	1	0	1	1	1	1	0	1	1
5 sec	0	1	0	1	1	0	0	1	0	1	1	1	1	1	1	0
	2	0	1	0	1	0	1	1	0	1	1	1	1	1	1	0
	1	0	1	0	1	0	0	1	0	1	1	1	1	1	1	0
.5	0	1	0	0	1	0	0	1	0	1	1	1	1	1	1	0
	.2	0	1	0	0	0	1	1	0	1	1	1	1	1	1	0
	.1	0	1	0	0	0	0	1	0	1	1	1	1	1	1	0
50 ms	0	0	1	1	1	0	0	1	1	0	1	1	1	1	1	0
	20	0	0	1	1	0	1	1	1	0	1	1	1	1	1	0
	10	0	0	1	1	0	0	1	1	0	1	1	1	1	1	0
5	0	0	1	0	1	0	0	1	1	0	1	1	1	1	1	0
	2	0	0	1	0	0	1	1	1	0	1	1	1	1	1	0
	1	0	0	1	0	0	0	1	1	0	1	1	1	1	1	0
.5	0	0	0	1	1	0	0	1	1	1	0	1	1	1	1	0
	.2	0	0	0	1	0	1	1	1	1	0	1	1	1	1	0
	.1	0	0	0	1	0	0	1	1	1	0	1	1	1	1	0
50 μ s	0	0	0	0	1	0	0	1	1	1	0	1	1	1	1	0
	20	0	0	0	0	0	1	1	1	1	0	1	1	1	1	0
	10	0	0	0	0	0	0	1	1	1	0	1	1	1	1	0
5	1	0	0	0	1	0	0	1	1	1	1	0	1	1	1	0
	2	1	0	0	0	0	1	1	1	1	1	0	1	1	1	0
	1	1	0	0	0	0	0	1	1	1	1	0	1	1	1	0
.5	1	1	1	0	1	0	0	0	1	1	1	0	1	0	1	0
	.2	1	1	1	0	0	1	0	1	1	1	0	0	1	1	0
	.1	1	1	1	0	0	0	0	1	1	1	0	0	0	1	0
50 ns	1	1	1	1	1	0	0	0	1	1	1	0	1	0	0	1
	20	1	1	1	1	0	1	0	1	1	1	0	0	1	0	1
	10	1	1	1	1	0	0	0	1	1	1	0	0	0	0	1

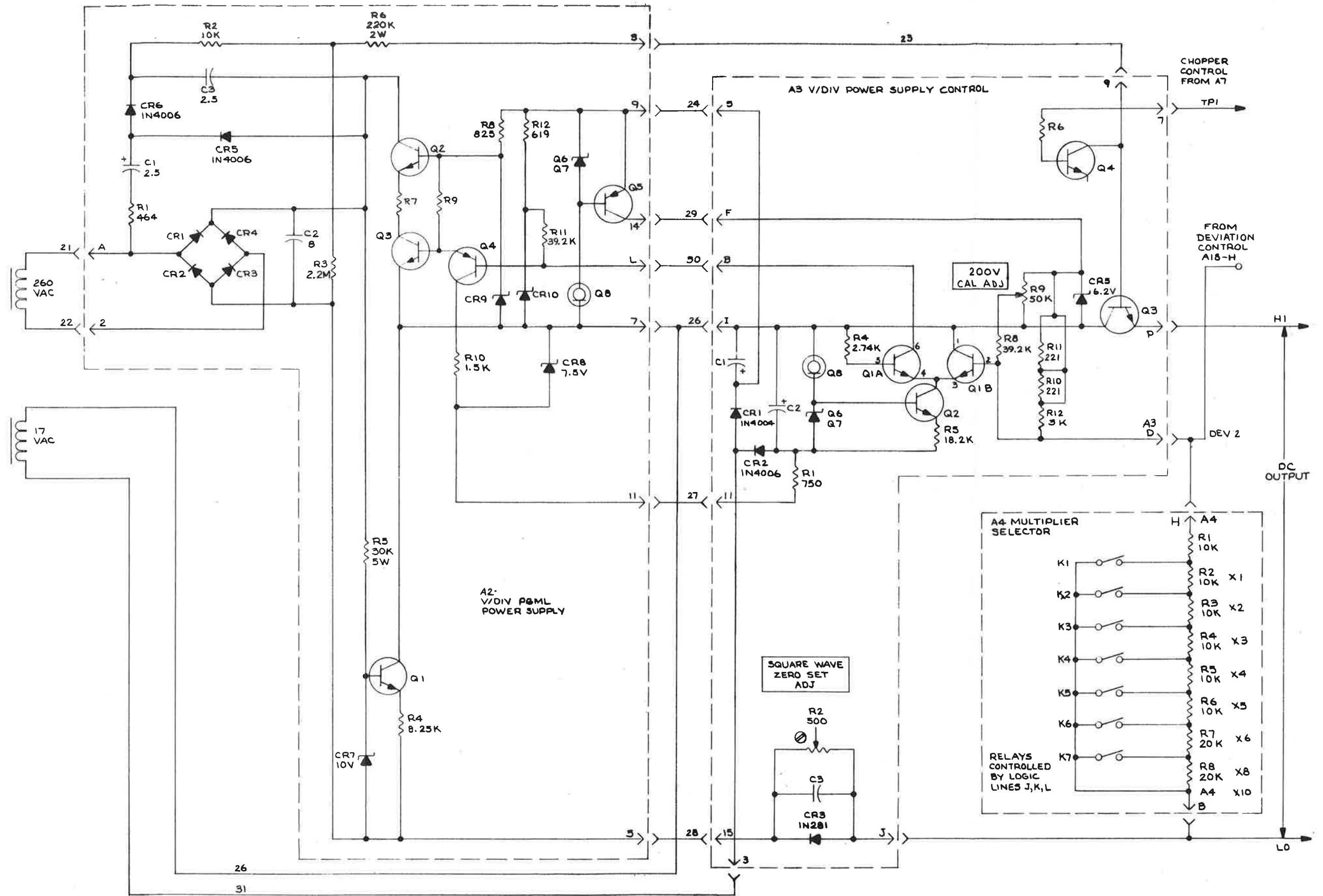

Figure 4-2. Simplified Schematic, Programmable DC Supply

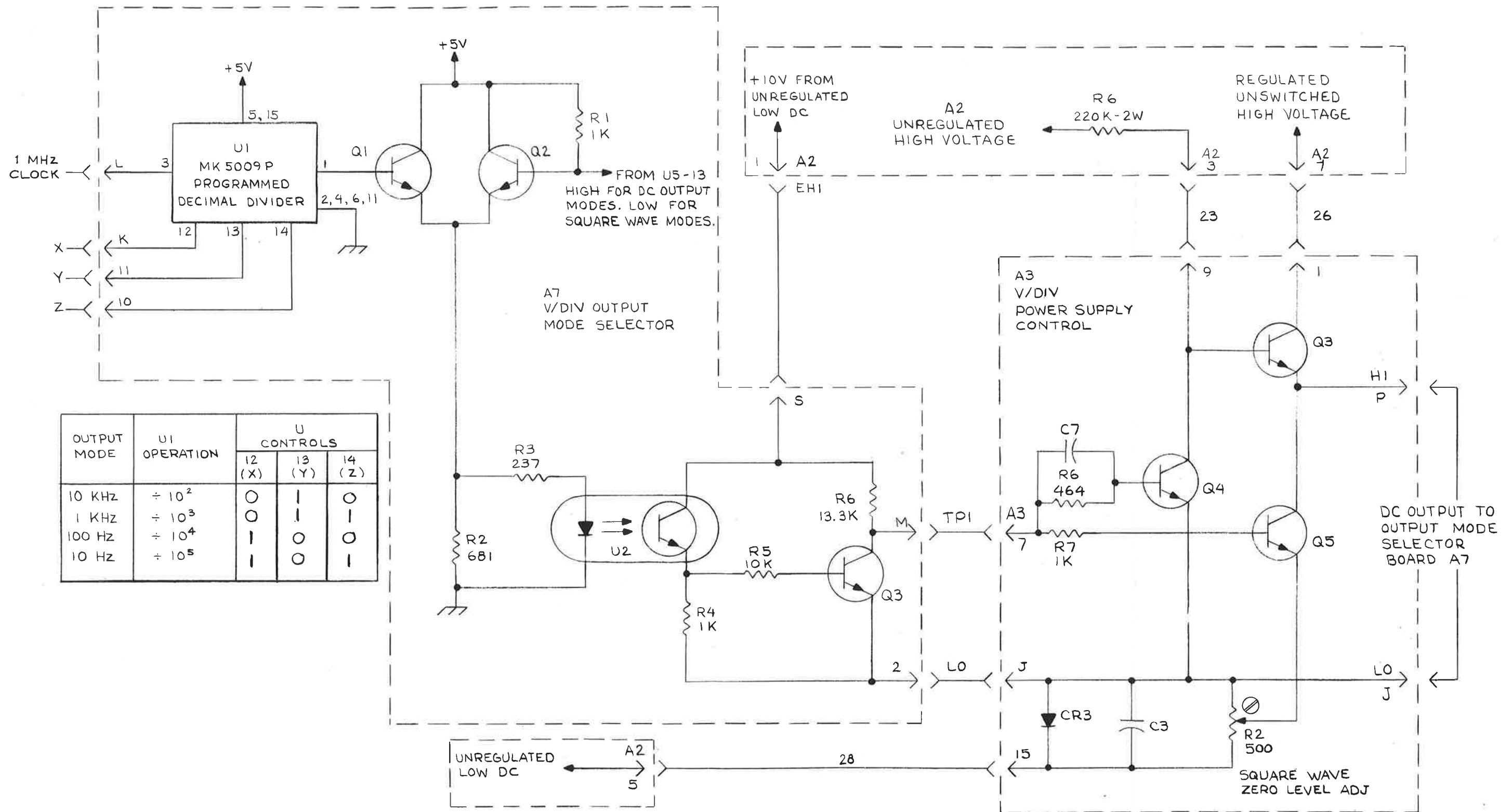

Figure 4-3. Simplified Schematic, Square Wave Chopper

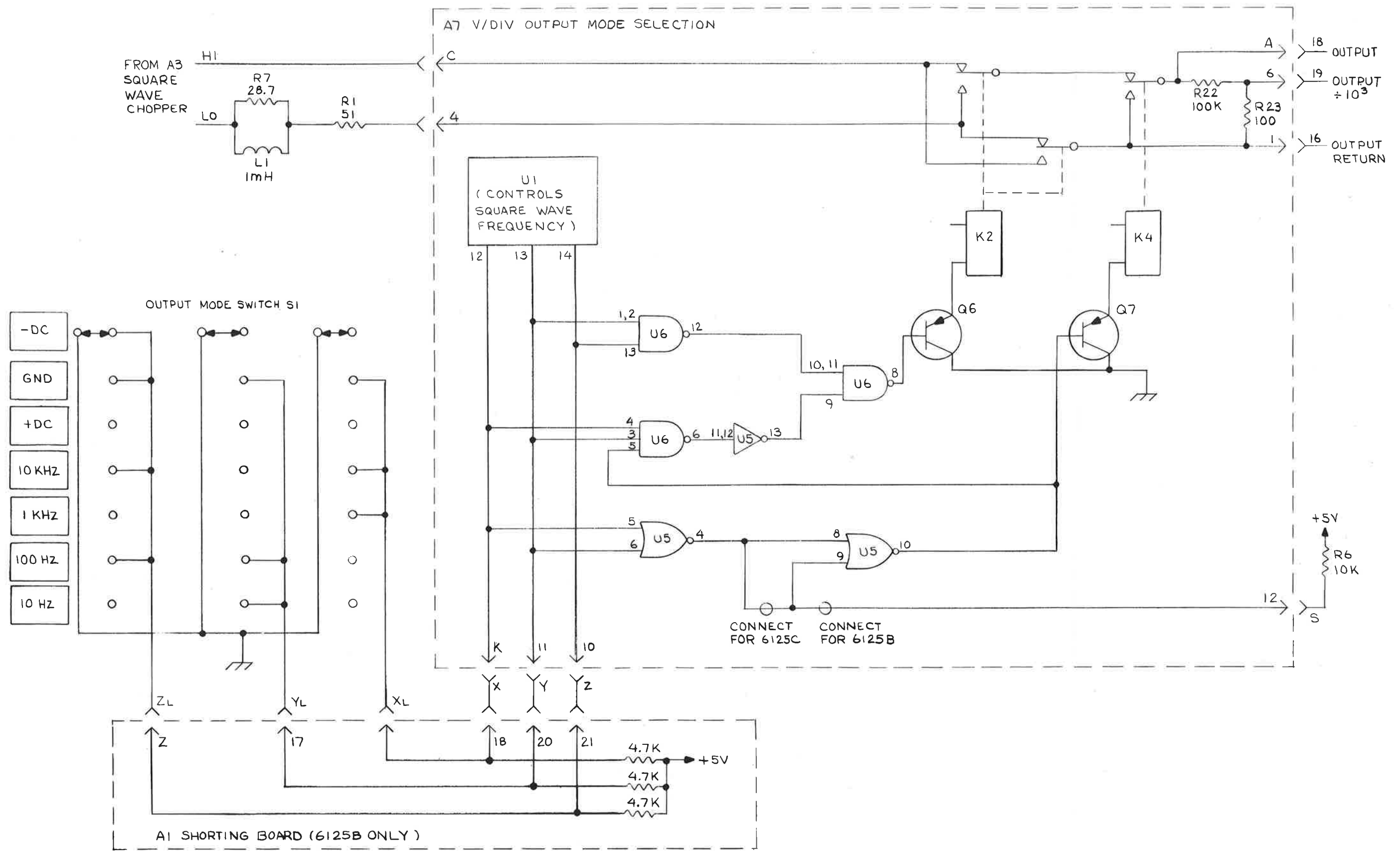

Figure 4-4. Simplified Schematic, Output Mode Selection

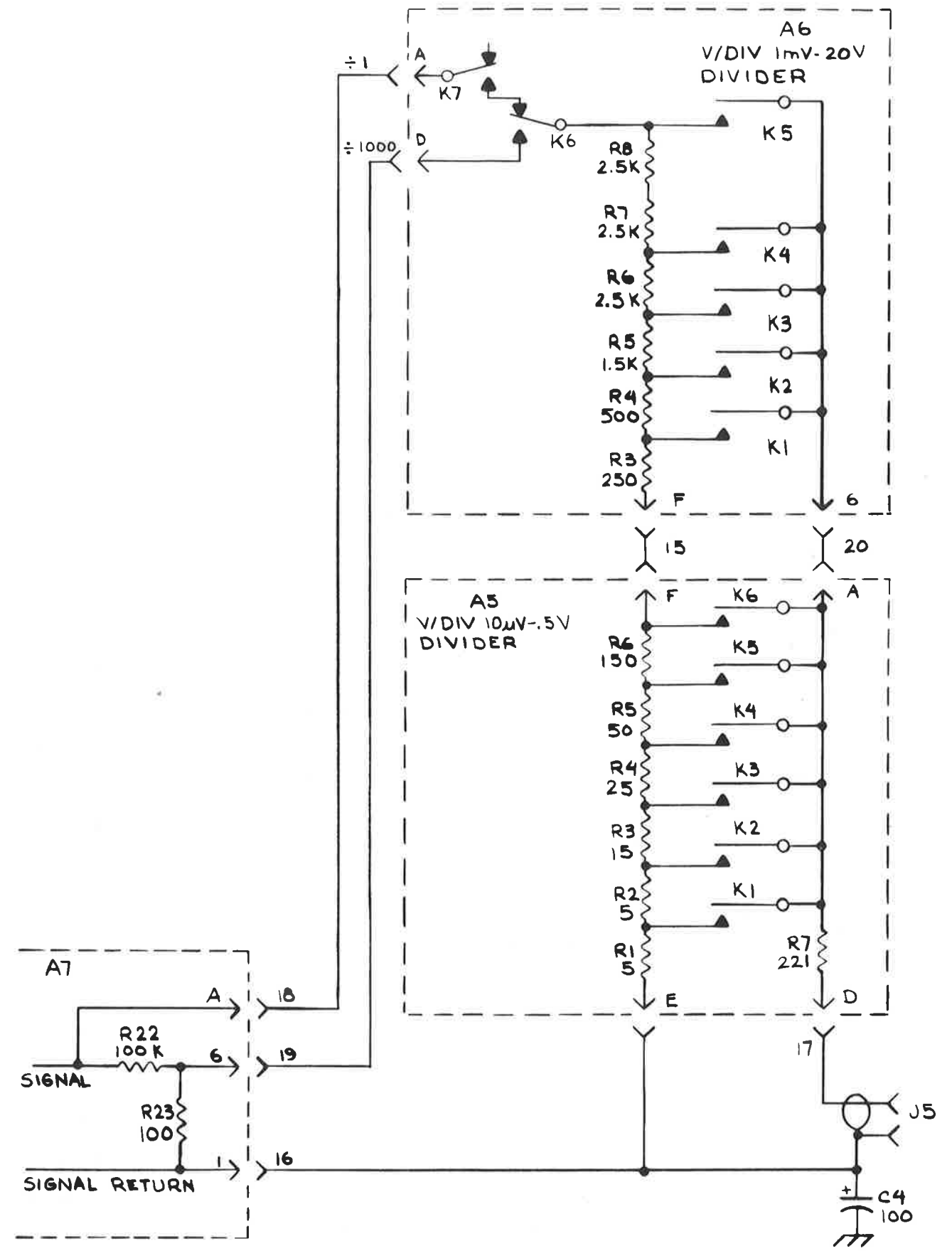

Figure 4-5. Simplified Schematic, Precision Attenuator

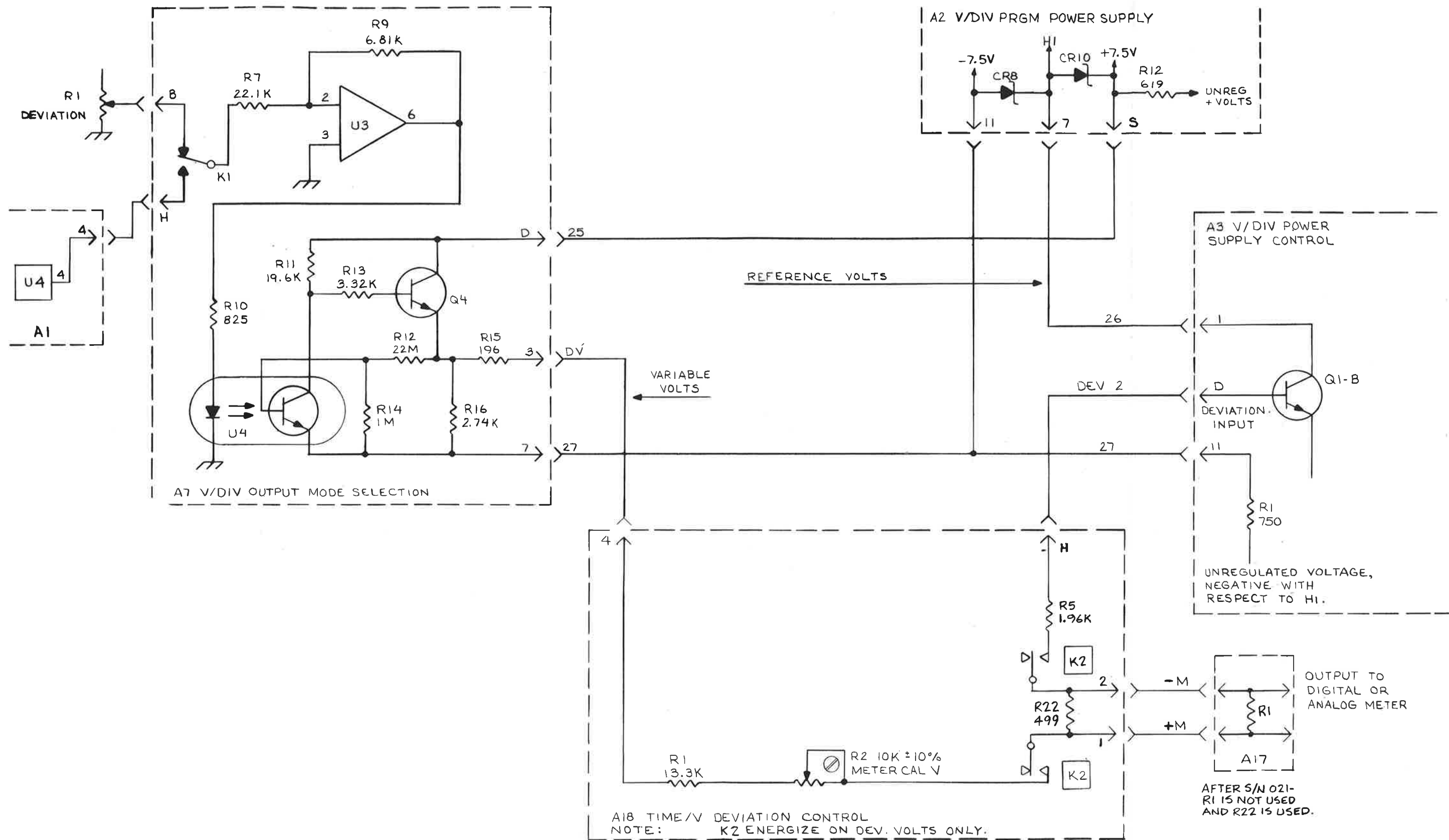

Figure 4-6. Simplified Schematic, Amplitude Deviation Control

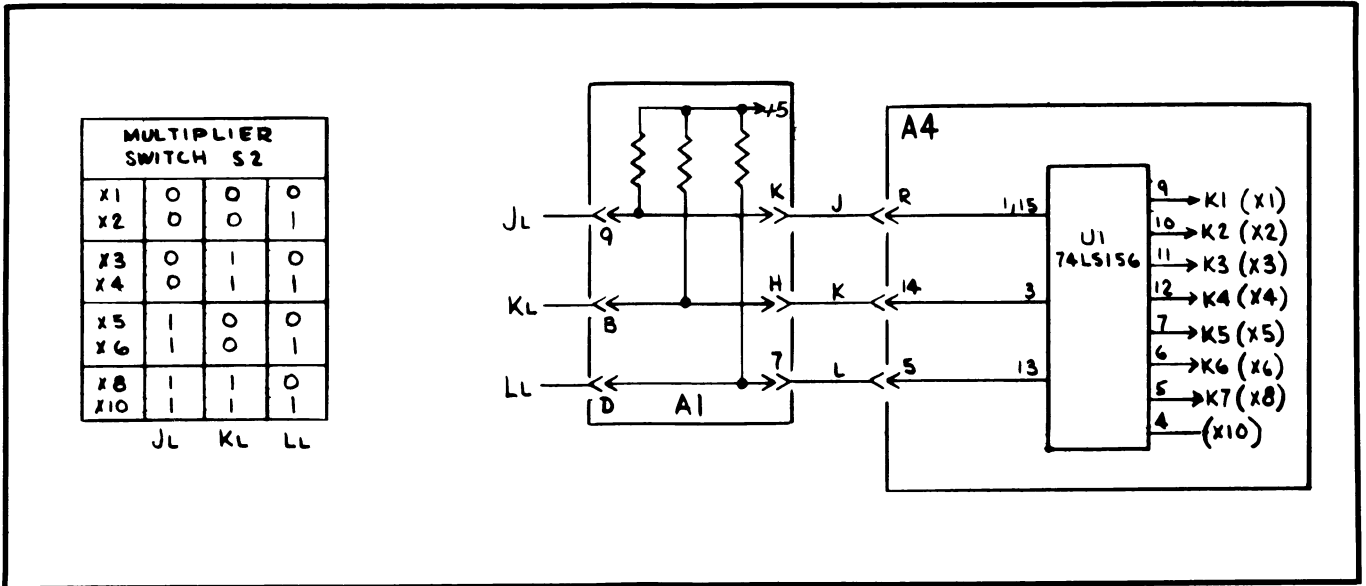

Figure 4-7A. Control Circuits, Volts/Div Multiplier

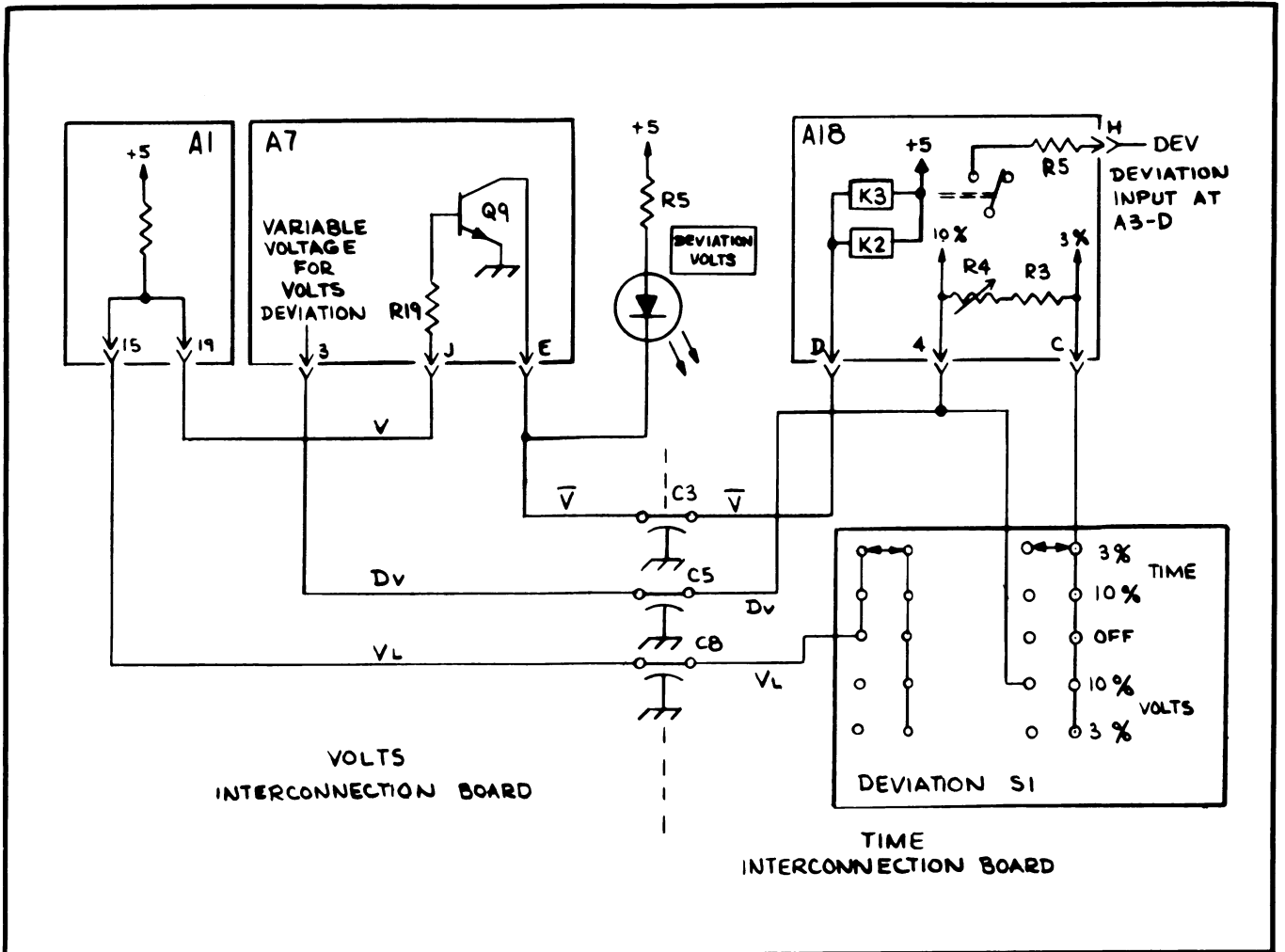

Figure 4-7B. Control Circuit, Volts Deviation

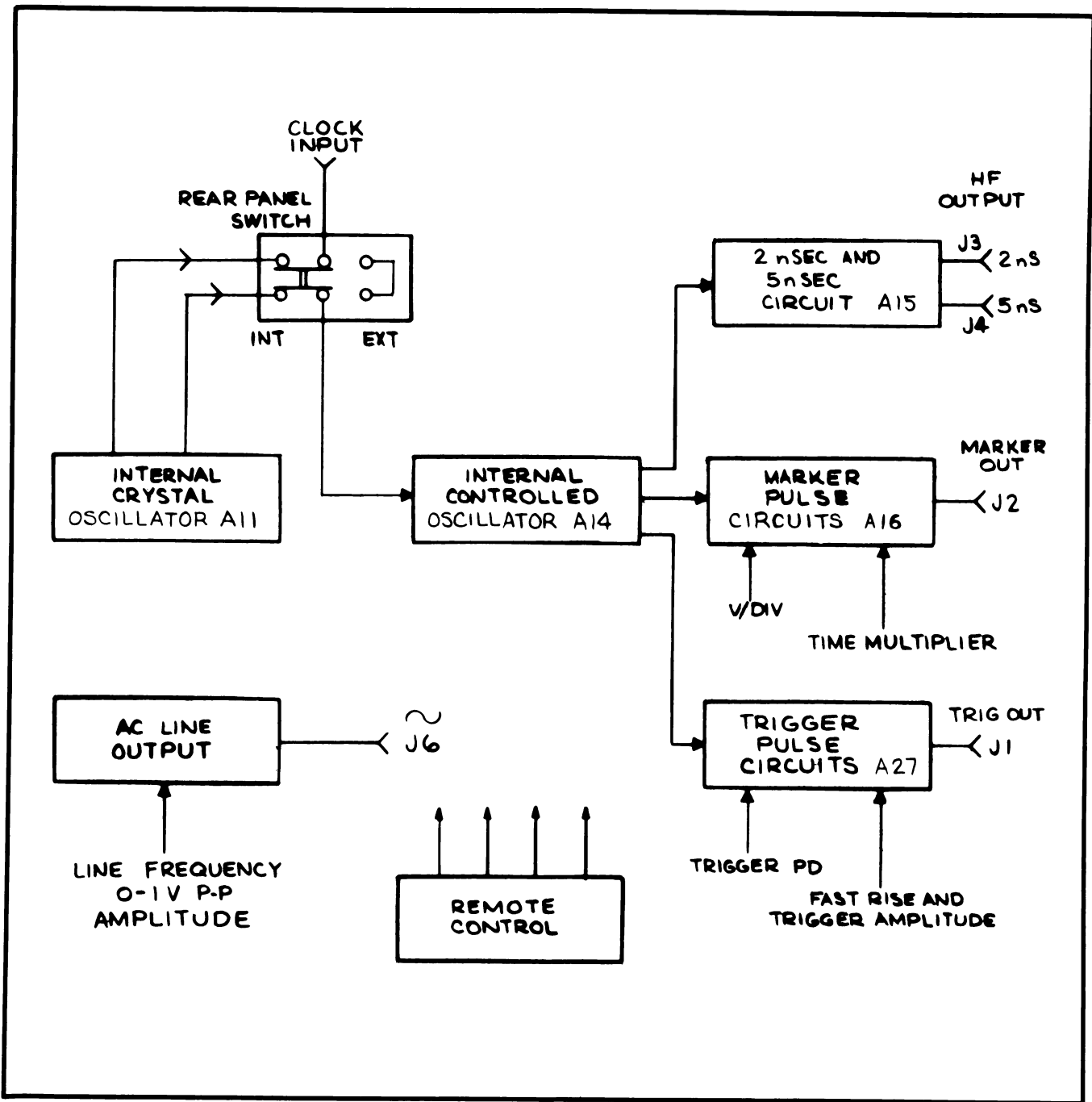

Figure 4-8. Functional Block Diagram, Time Circuits

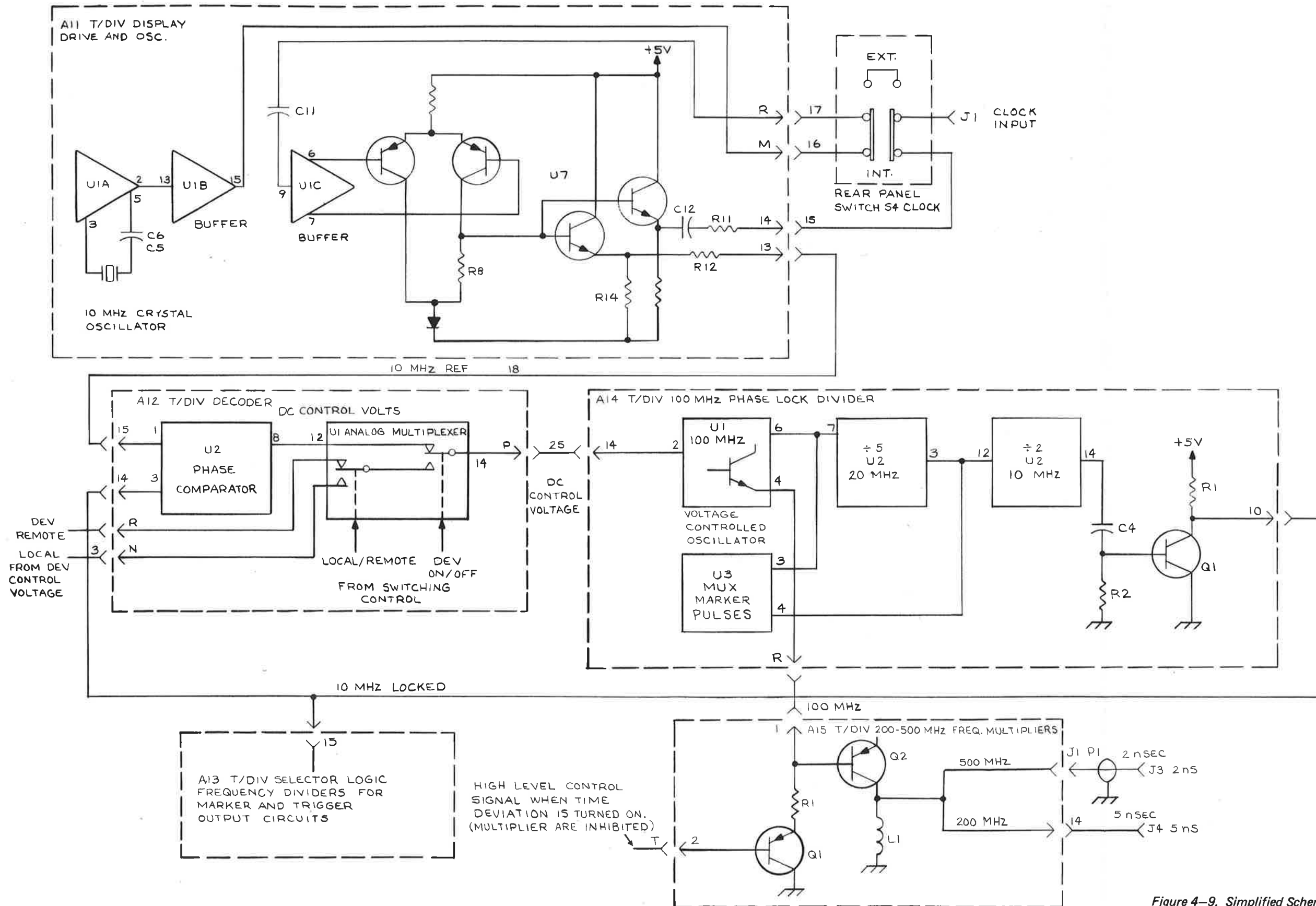

Figure 4-9. Simplified Schematic, Timing Source Circuits

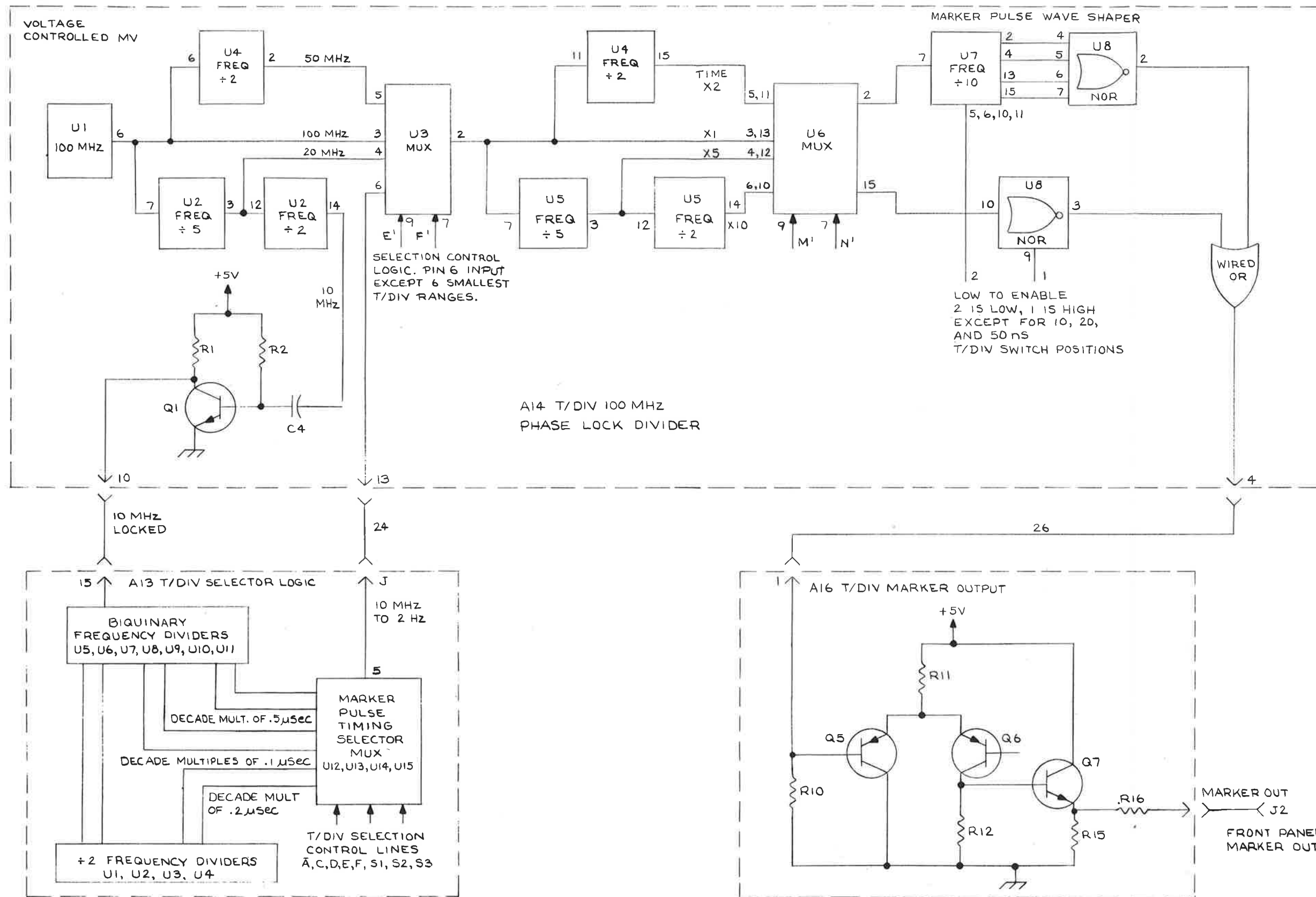

Figure 4-10. Simplified Schematic, Marker Pulse Circuits

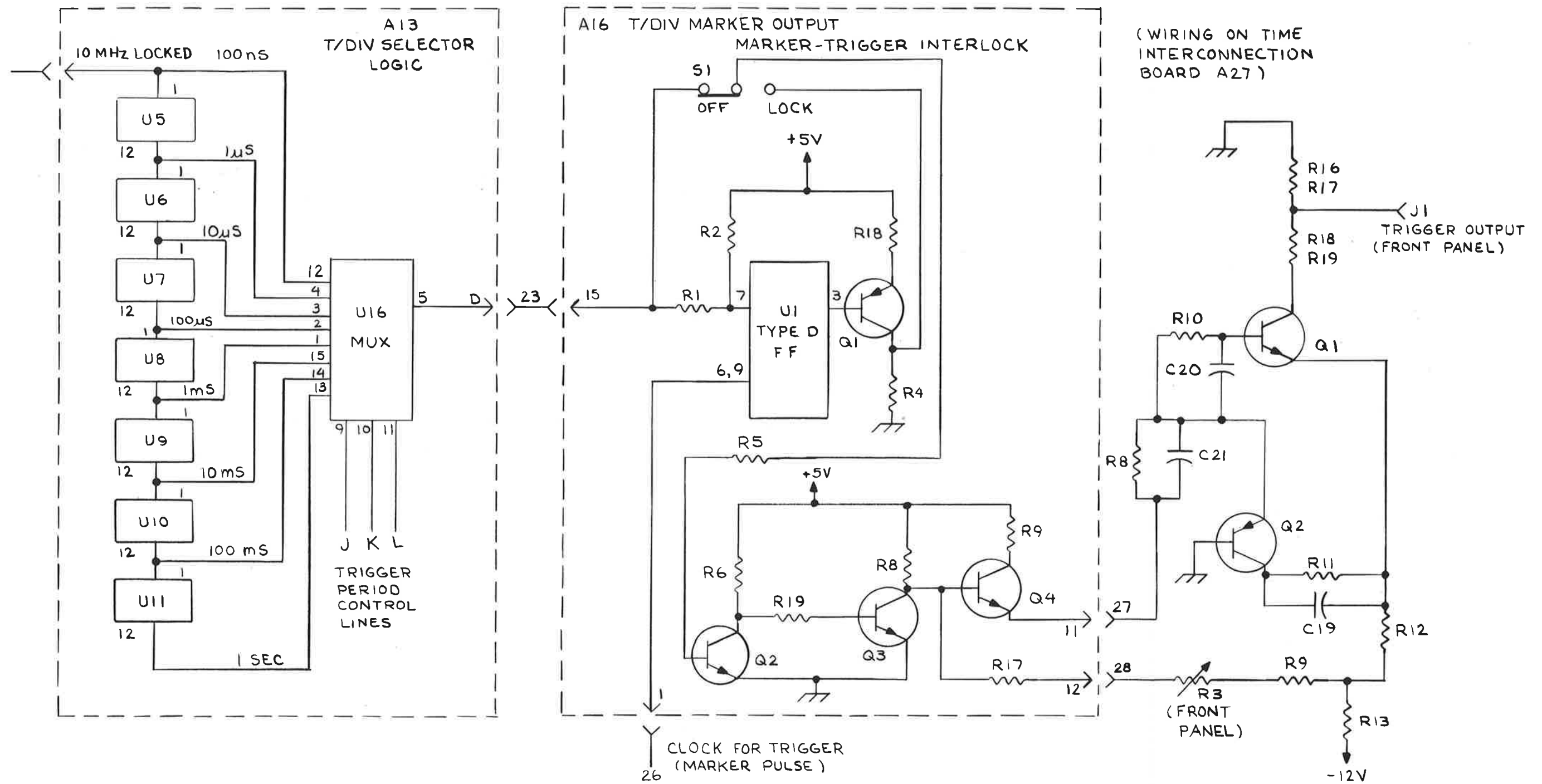

Figure 4-11. Simplified Schematic, Trigger Signal Circuits

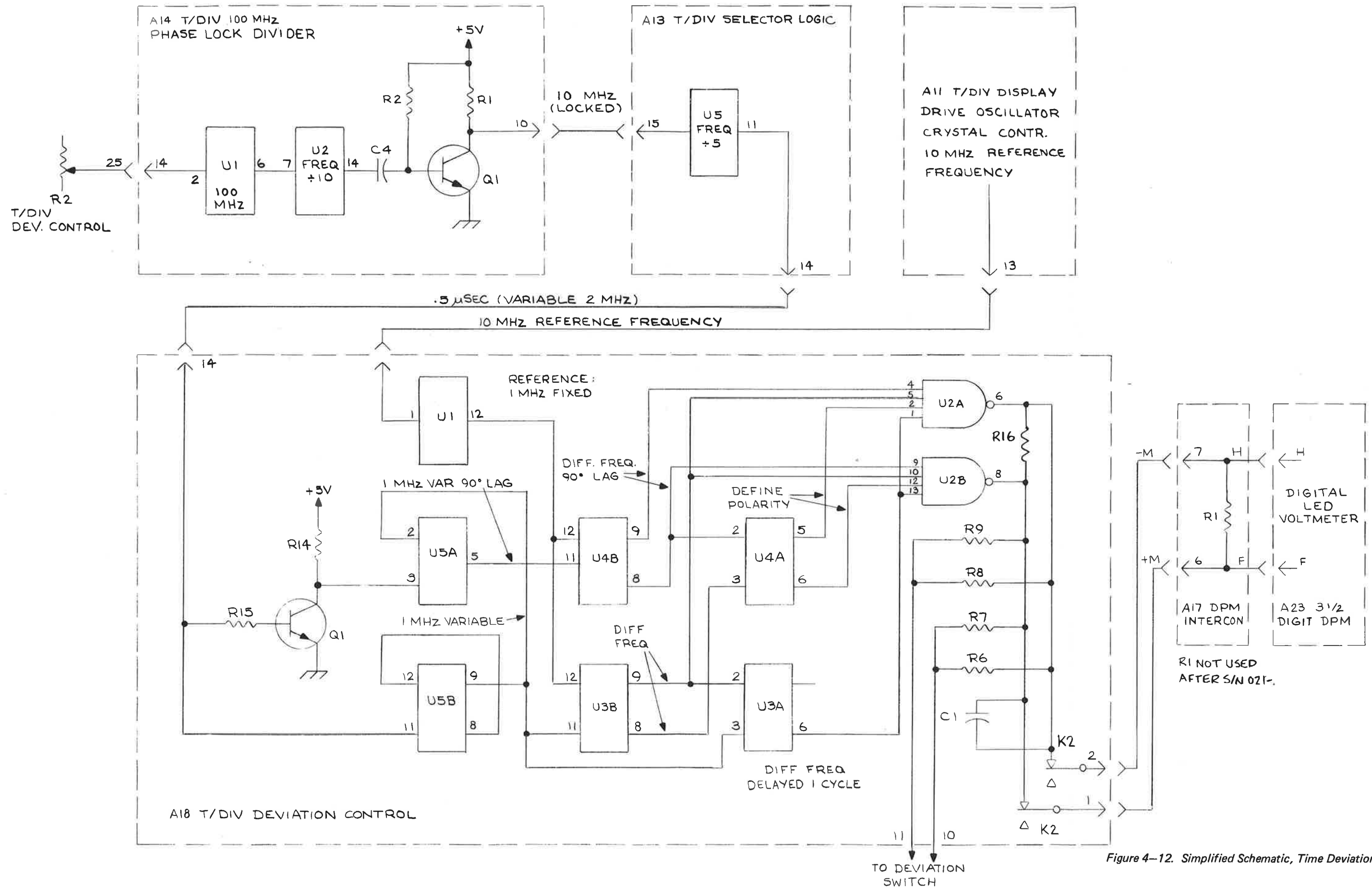

Figure 4-12. Simplified Schematic, Time Deviation Circuits

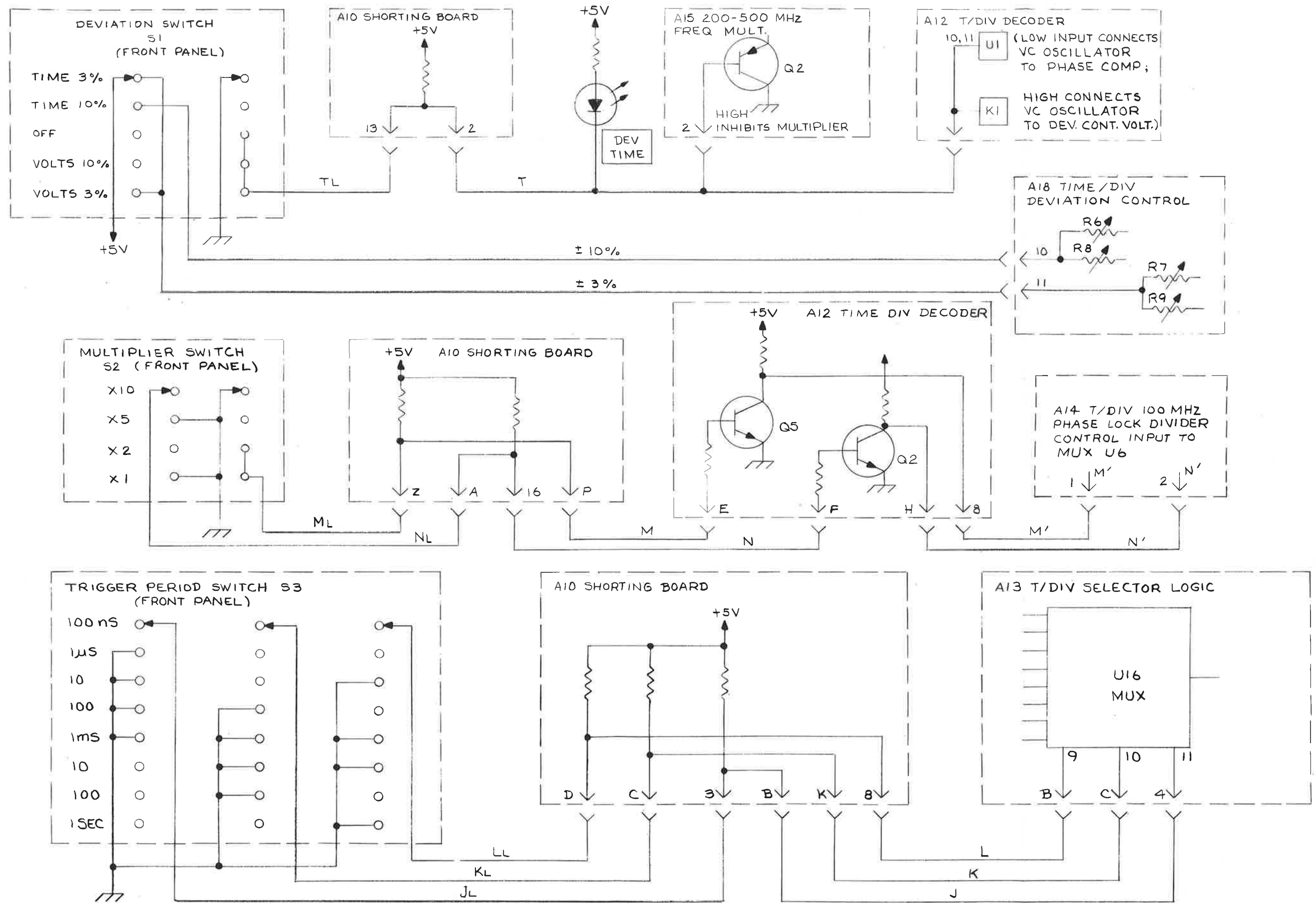

Figure 4-13. Time Deviation, Multiplier and Trigger Period Control Logic

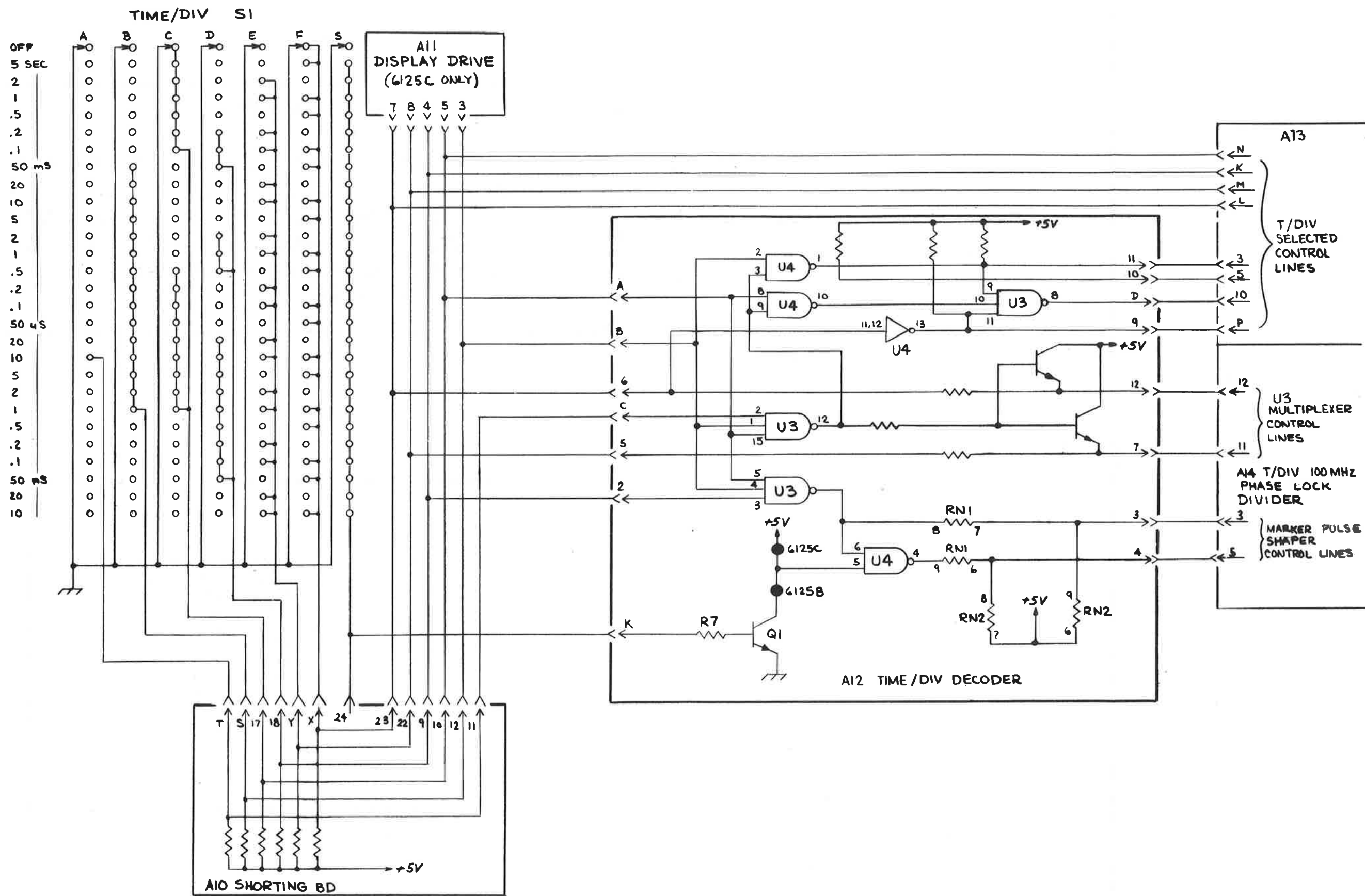

Figure 4-14. Time/Div Control Lines

WARNING

THE FOLLOWING SERVICING INSTRUCTIONS ARE FOR USE BY QUALIFIED PERSONNEL ONLY. TO AVOID PERSONAL INJURY, DO NOT PERFORM ANY SERVICING OTHER THAN THAT CONTAINED IN THE OPERATING INSTRUCTIONS UNLESS YOU ARE QUALIFIED TO DO SO.

CAUTION

Semi-conductor devices using metal oxide junctions are liable to suffer destructive damage from electrostatic discharges. Such devices appear with several names, such as MOS, MCMOS, CMOS, MOSFET, IGET, detector diode, etc. Whenever these devices or assemblies including such devices are handled, the operator must be grounded, and only grounded soldering irons can be used safely. To facilitate identification of assemblies containing metal oxide devices, Ballantine pc boards containing such devices are marked with this symbol:



SECTION 5

CALIBRATION AND MAINTENANCE INSTRUCTIONS

5-1. INTRODUCTION.

5-2. This section contains information required for maintenance of the 6125B/C Time and Amplitude Test Set, including performance checks, preventive maintenance, troubleshooting, adjustment, and calibration procedures.

5-3. The generator uses premium components and with proper usage and maintenance will provide many years of satisfactory service. The manufacturer recommends that if the instrument is used for routine laboratory service, performance checks and preventive maintenance be performed every six months.

5-4. TEST EQUIPMENT.

5-5. The test equipment required to check, calibrate, and maintain the generator is listed in Table 5-1. Equivalent test equipment may be substituted if the recommended items are not available.

5-6. PERFORMANCE ASSURANCE CHECKS.

5-7. **GENERAL.** The performance checks described in the following paragraphs are "in-cabinet" tests that compare the generator with the applicable specifications. A suggested test record form, starting on page 5-27, may be duplicated and used to record the results. These performance checks, paragraphs 5-8 through 5-18, should be performed and completed in the order listed before any attempt is made to calibrate the instrument. For optimum performance, after turn-on but before performing any checks, allow the instrument to warm up for at least 2 hours. Also, all performance checks and calibration should be performed at reference conditions of 22°C to 28°C (71.6°F to 82.4°F).

5-8. **POWER LINE VOLTAGE SETTING.** The primary winding of the transformer in the generator is connected to match the power line voltage being used by the orientation of the printed-circuit board in the rear panel mounted ac power receptacle. The instrument as supplied is set for operation from 120 volts ac. The performance checks which follow reference 120 volts as the nominal voltage setting for the 120 volt primary power line voltage. For the other power line voltages of 100, 220, and 240 volts ac, the following table lists the nominal midline voltages and the high-line and low-line voltages used for calibrating the instrument.

Line Voltage	Nominal Midline	Low Line	High Line
100 V	100 V	90 V	108 V
120 V	120 V	108 V	128 V
220 V	220 V	198 V	238 V
240 V	240 V	216 V	259 V

5-9. OSCILLATOR FREQUENCY ACCURACY.

a. Interconnect the generator and the test equipment as shown in Figure 5-1.

b. Set the generator TIME/DIV switch to .1 us and the MULTIPLIER switch to X1.

c. Connect the MARKER OUT connector to the A input of the frequency counter. Use a 50 ohm feed through termination at the counter BNC.

d. Set line voltage Variac to midline and allow 20 minutes warmup.

e. If available, use a 1 MHz atomic standard or a WWV receiver to clock the frequency counter to ensure absolute accuracy of the frequency measurement.

f. Measure the 0.1 us Time Marker (10 MHz frequency). The counter must stably display 9,999,919 to 10,000,081 Hz. If desired, allow 2 hour warmup. Repeat the measurement and observe 9,999,939 to 10,000,061 Hz. The tolerance bands assume 23°C ± 2° ambient, nominal line voltage and do not provide for aging of ± 30 Hz per month. 10 MHz ± 1000 Hz is satisfactory considering all variables but recalibrate outside this limit.

g. With line voltage set to low line, read $\leq \pm 50$ Hz from the frequency noted in step f. Recalibrate if outside 10 MHz ± 1000 Hz.

h. With line voltage set to high line, read $\leq \pm 50$ Hz from the frequency noted in step f. Recalibrate if outside 10 MHz ± 1000 Hz.

i. Reset the line voltage to midline.

5-10. MARKER OUTPUT AMPLITUDE

a. Interconnect the generator and the test equipment as shown in Figure 5-2.

b. Connect the MARKER OUT connector to the CH1 input connector of the Ballantine 1032A Oscilloscope. Connect a 50-ohm feed-through termination at the oscilloscope end of the connecting cable.

c. Set the TIME/DIV switch to .1 μS and the MULTIPLIER switch to X1.

d. Set the 1032A Oscilloscope controls as follows:

CH1 VOLTS/CM	.5 V
CH1 Coupling	DC
CH1 Position	Centered
CH2 Position	OFF
TIME/CM	1 μS
PULL x 10 MAG	Pulled Out (X10)
TRIG SELECT	CH1 +
Trigger Coupling	AC

e. Use trigger LEVEL control and trace-position controls to position a stable display on screen.

f. Observe a marker pulse on the oscilloscope at each vertical line of the CRT graticule. Continue to observe the same display but with somewhat narrower positive-going marker pulses at each TIME/DIV and oscilloscope sweep range through 0.5 second. Do not use X10 magnifier on the oscilloscope at time-base speeds slower than 0.5 μ s. Observe that the minimum marker pulse amplitude displayed on the oscilloscope is greater than 1 cm (0.5 volt) for each of the 27 TIME/DIV settings.

g. Set the MULTIPLIER control to X2 and the oscilloscope TIME/DIV switch at .5 SEC. Observe six pulses with each pulse coincident with alternate graticule lines, which checks the MULTIPLIER X2.

h. Set the MULTIPLIER control to X5. Observe three marker pulses on the screen, one at the left, one at the center, and one at the right graticule line, which checks the MULTIPLIER X5.

i. Set the MULTIPLIER control to X10. Observe two markers on the screen, one at the extreme left and one at the extreme right graticule line, which checks the 5-second marker and the MULTIPLIER X10.

j. With the MULTIPLIER control still set to X10, set the TIME/DIV switch to .2 S and the oscilloscope TIME/CM control to .2 Sec. Observe that only two pulses appear on the screen, which checks the MULTIPLIER X10.

5-11. TRIGGER PERIOD.

a. Refer back to the control settings of paragraph 5-10d and the test setup of Figure 5-2, except disconnect the cable from the MARKER OUTPUT connector and reconnect it to the TRIGGER OUT connector. Also, set the TRIGGER PERIOD to 100 nS and the oscilloscope TIME/CM switch to 1 μ s. Activate the X10 MAG knob to X10 magnifier position for a sweep of 0.1 μ s/cm.

b. Observe a square wave display on the oscilloscope screen. Its amplitude must be greater than 1 cm and the period of each full square wave must occupy 1 cm.

c. Change the TRIGGER PERIOD to 1 μ S and reset the oscilloscope. Pull X10 MAG knob to the X1 position (sweep of 1 μ s per cm). Observe a square wave as in the preceding step b.

d. In sequence, change the TRIGGER PERIOD and the oscilloscope TIME/CM settings to 10 μ S, 100 μ S (.1 mS), 1 mS, 10 mS, 100 mS (.1 SEC), and 1 s (1 SEC). Observe the same 1 cm square wave as in the preceding step b on each of the paired settings.

5-12. TRIGGER OUTPUT RISE TIME.

a. Interconnect the generator and the test equipment

as shown in Figure 5-3.

b. Connect the TRIG OUT connector of the instrument to the sampling oscilloscope through a short (8-inch) 50-ohm cable. Use a BNC to GR adapter to connect the cable to the 50-ohm BNC connector. Set the oscilloscope to 100 mV vertical sensitivity, internal trigger, and 1 ns per cm sweep speed.

c. Set the TRIGGER PERIOD to 100 nS.

d. Obtain a stable display of a positive-going edge of the square wave on the screen of the oscilloscope.

e. Observe that the leading edge of the waveform on display is at least 2.5 cm peak-to-peak. This amplitude verifies a trigger-out signal greater than 0.25 volts.

f. Observe that the overshoot on the top of the leading edge is no greater than 2% of the 0% to 100% peak-to-peak value of the TRIGGER OUT square wave.

g. Observe that the 10% to 90% rise time of the positive-going rise is no more than 1 ns (1 cm).

5-13. HIGH FREQUENCY OUTPUT.

a. Continue with the test setup shown in Figure 5-3. Disconnect the cable from the TRIG OUT connector and reconnect it to the H.F. OUTPUT 5 ns connector. Set the sampling oscilloscope time base to 5 ns per cm and the vertical sensitivity to 20 mV. Obtain a stable sine-wave display on the oscilloscope.

b. Observe a sine wave greater than 2.5 cm peak-to-peak, which indicates that the H.F. OUT signal is greater than 0.5 volt peak-to-peak into 50 ohms, since the oscilloscope sensitivity is 20 mV X10 or 200 mV per cm. Also, note that the cycle-to-cycle amplitude does not vary by more than 5% peak-to-peak.

c. Observe a sine wave for each graticule line to indicate that the H.F. OUT frequency is 5 ns. Then, disconnect the short BNC cable from the BNC to GR adapter and connect it into the 50-ohm (C) input of the 500 MHz frequency counter. Set the counter to 1 second for a nine-digit display. Observe that the counter reads in the range of 200,001,601 to 199,998,399 Hz. Reconnect the BNC cable to the oscilloscope.

d. In sequence, select the HF OUTPUT 2 ns BNC and set the sampling oscilloscope time base to 2 nS. Repeat the observations of amplitude as in the preceding step b. Repeat the sine-wave period check of 1 cycle/cm as in the preceding step c. For each HIGH FREQUENCY selection also make the digital counter frequency check detailed in preceding step c. Use the following limits:

5 nS:	199,998,399 through 200,001,601 Hz
2 nS:	499,995,999 through 500,004,001 Hz

TABLE 5-1. TEST EQUIPMENT

EQUIPMENT NO.	NOMENCLATURE	USE AND APPLICATION	MINIMUM SPECIFICATIONS
Ballantine Model 1032A	Oscilloscope	General fault finding.	5 mV, dual trace, 8 x 10 cm graticule, DC to 20 MHz; rise time < 17 ns. Signal delay. Sweep time < 50 ns/cm to > 1 s/cm.
Ballantine Model 3028B	Multimeter	Fault finding; power supply voltage and resistance checks.	DC, 1 mV to 1 kV. AC, 1 mV to 500 V, 10 Hz to 100 kHz rms responding. Ohms, 0.1 Ω to 20 MΩ, 0.2 V to 2 V measuring voltage. AC amperes, 100 mA to 1A. DC amperes, 100 mA to 1A. 3-1/2 digit display, battery and line operation.
Ballantine Model 3620A	AC/DC True RMS Digital Voltmeter	Line voltage measurement.	4-1/2 digit display. 10 mV to 1 kV full scale. 1 μV resolution. DC and ac to 1 MHz, dc coupled true rms response. Nominal accuracy 0.2%. Guarded and floating input.
Ballantine Model 5548A (with Option 14)	Digital Frequency Counter	Frequency calibration and check of frequency multipliers to 500 MHz (2 ns). Check of TIME DEVIATION range.	512-MHz nine-digit counter with high-stability clock (3 parts in 10 ⁹ per day) and NBS frequency traceability. External clock input capability. Sensitivity better than 15 mV rms at 500 MHz. PERIOD MEASUREMENT.
Fluke Model 885AB	Differential Voltmeter	DC Voltage Calibration	DC; 1 volt to 300 volts with 10 μV resolution. Accuracy 0.02%
1 Megohm Resistor 2.2 Megohm	RN65D RN70D	Volts Out Termination Square Wave Level check.	½ watt ±2%, film. ½ watt ±2%, film.

TABLE 5-1. TEST EQUIPMENT (Cont)

EQUIPMENT NO.	NOMENCLATURE	USE AND APPLICATION	MINIMUM SPECIFICATIONS
Ballantine Model 12620A	Adapter	Test equipment connections.	BNC female to General Radio GR-874 connector.
Ballantine Model 12625A	Adapter	Test equipment connections.	BNC male to General Radio GR-874 connector.
Ballantine Model 12630A	Termination	Termination, 50 ohms, 2 watts.	BNC/BNC feedthrough, 50 ohms, 2 watts.
Ballantine Model 12249A	Cable Assembly, 8 in.	Test equipment connections.	RG-58C/U cable with male BNC terminations.
General Radio Type GR-874 (Ballantine Model 12626A)	Attenuator, 20 dB	Input attenuator for high-sensitivity sampling oscilloscope.	50-ohm, 20-dB attenuator, dc to 1 GHz, flatness 0.1%, dc to 100 MHz.
General Radio Type W5MT3A	Metered Variac	Line voltage control; metered current and voltage.	(As required.)
Hewlett-Packard Model 651B or 652A	Test Oscillator	Test external clock input signal source.	10 Hz to 10 MHz (sine wave). 50-ohm output to 2 V rms. Distortion < ±0.25%.
JFD Part No. 5284	Adjustment Tool	Adjustment of variable capacitors, resistors, and inductors.	Low-capacity alignment tool with 3/32 inch screwdriver blade and 5/64 hexagon drive.
Rohde & Schwarz Model XSAM or Model XSA/XKA*	Frequency Standard, Atomic or WWV Receiver	To calibrate clock frequency.	Rubidium frequency standard, 1 MHz, or WWV receiver/comparator, 1 MHz.
Tektronix Type 547 (with 1S1 plug-in)	Oscilloscope	Check fast rise time (≤ 3 ns) of TRIGGER output square wave.	Frequency response to 1 GHz. Rise time < 0.35 ns. Internal and external triggering beyond 500 MHz. 50-ohm input. Sensitivity better than 50 mV/cm. Sweep time < 2 ns/cm to 0.1 μ s/cm.
UG-274A/U (Ballantine Model 12619A)	Adapter	Test equipment connections.	BNC tee adapter.

*Optional

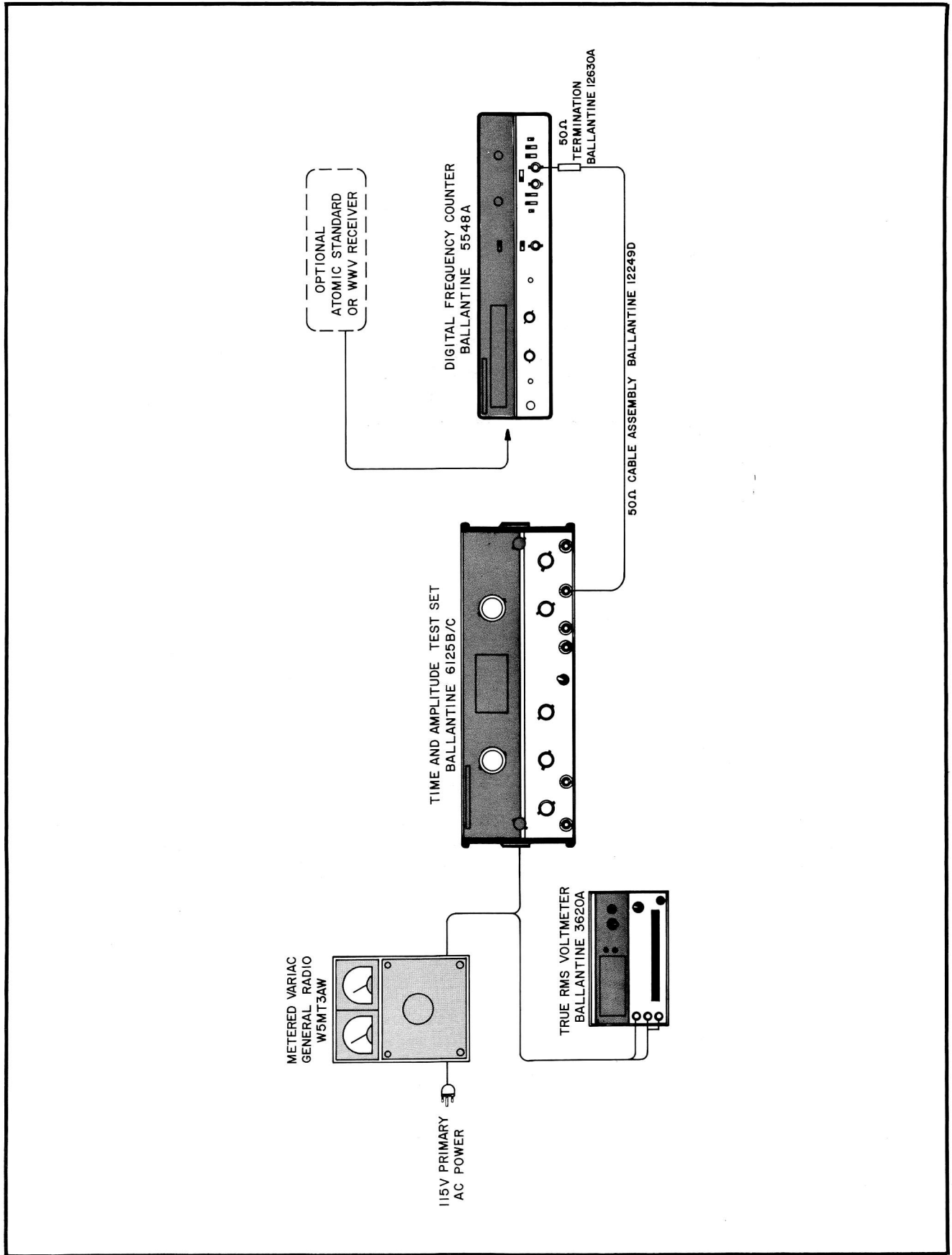

Figure 5-1. Clock Frequency Check. Bench Test Setup.

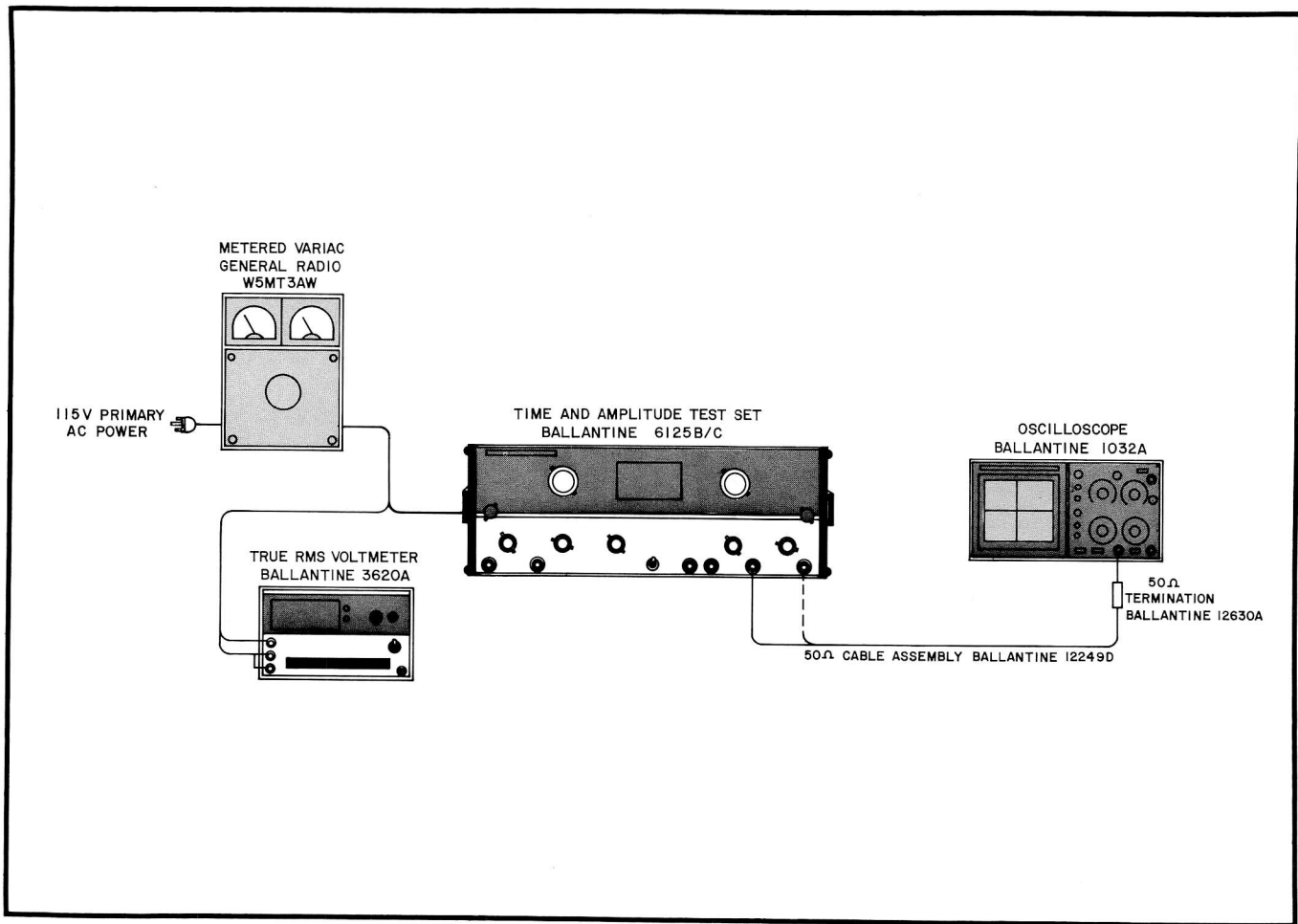

Figure 5-2. Trigger and Marker Amplitude Check, Bench Test Setup.

5-14. EXTERNAL CLOCK INPUT.

- a. Interconnect the generator and the test equipment as shown in Figure 5-4.
- b. Set the TIME/DIV switch to $1 \mu\text{s}$ and the MULTIPLIER to X1. Set the rear-panel INT-EXT clock switch to the EXT position. (These control positions check the shaper and digital-logic trigger circuitry for external clock input verification.)

c. Set the dual-trace oscilloscope controls as follows:

CH1 VOLT/CM	.5 V
CH1 Coupling	AC
CH1 Position	Centered
CH2 Position	OFF
TIME/CM	1 mS
TRIG SELECT	FREE RUN

The oscilloscope should display a free-running, unsynchronized display of CH1 only.

d. Set the 5548A frequency counter to 1 second and a

nine-digit display. Connect a 50-ohm feed-through termination to the high-impedance (A) input.

e. Connect the MARKER OUT through the 50-ohm termination to the high-impedance, low-frequency input of the 5548A counter. Connect a BNC Tee-connector to the CH1 input of the 1066B Oscilloscope and connect the 50-ohm output of the 10-MHz oscillator and the EXT clock input (INT-EXT clock switch set to EXT) to the Tee-connector arms.

f. Adjust the oscillator amplitude to produce a 4 cm peak-to-peak vertical display on the oscilloscope. Set the frequency of the oscillator to 10 MHz maintaining the oscilloscope display of a constant 4 cm (2 volts) peak-to-peak amplitude. Note the counter which should display a frequency of 1 MHz. This checks the external clock input of the 6125B/C.

NOTE

Use only a 10 MHz EXT Input Frequency. All other frequencies will cause incorrect outputs from the 6125B/C.

5-15. TIME DEVIATION CHECK.

- a. Set the instrument to DEVIATION OFF. Set the TIME/DIV control to $10\ \mu\text{S}$ and the MULTIPLIER to X1.
- b. Connect a frequency counter to the MARKER OUT BNC as shown in Figure 5-1. Observe a frequency of 100,000 Hz (± 50 Hz) displayed on the counter.
- c. Set the DEVIATION switch to TIME $\pm 10\%$. Observe that the time DEVIATION indicator is illuminated.
- d. Rotate the TIME/DIV deviation control to each extreme and observe that the 6125 digital deviation meter displays a deviation range greater than +10% and greater than -10%.
- e. Set the time deviation to +10%. Set the frequency counter to PERIOD AVERAGE and observe that the frequency counter reads 11.000 ($\pm .003$) μs .
- f. Set the time deviation to -10% and observe that the frequency counter reads 9.000 ($\pm .003$) μs .

5-16. VOLT/DIV CHECK.

- a. Connect a high resolution battery operated DC dif-

ferential voltmeter having 1 megohm input impedance at balance to the VOLTS OUT BNC connector. Be sure of the 1 megohm load resistance since the instrument is calibrated into this typical oscilloscope or voltmeter input resistance.

- b. Set the 6125 controls as follows:

VOLTS/DIV	20
MULTIPLIER	X10
OUTPUT MODE	+DC
DEVIATION	OFF

- c. Set the differential voltmeter dials to 200.00 volts and read the percent deviation on the voltmeter readout. The error should be equal to or less than ± 50 mV.

- d. Repeat step c for each of the next 13 ranges through the mV range and record data and calibration error on the test record form shown on page 29. These checks for ranges of 0.1 V and below are optional. Check voltmeter error to the $\pm 0.25\%$ error budget of the 6125B/C.

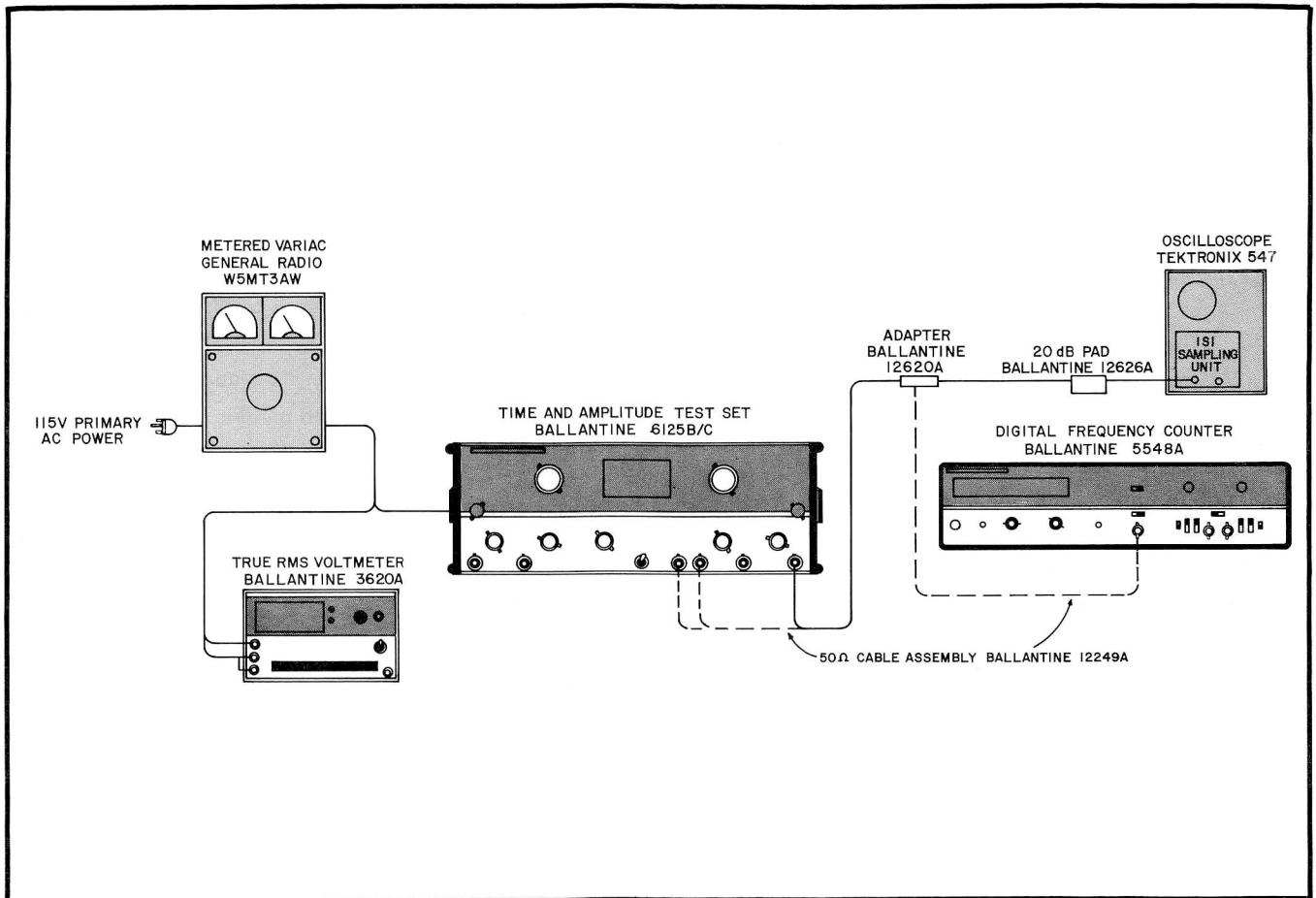

Figure 5-3. Trigger Rise Time and H.F. OUT Check, Bench Test Setup.

NOTE

Always measure the DC offset voltage by using the GND Mode. Arithmetically add this thermal voltage to all readings under ± 10 mV to obtain the exact output calibration voltage.

e. If errors exist for any reading, the instrument should be recalibrated as detailed in other paragraphs of this section.

f. Set the VOLTS/DC switch to 1 volt and the multiplier to X1, X2, X3, X4, X5, X6, and X8. Set the differential voltmeter to 1, 2, 3, 4, 5, 6 and 8 volts respectively and make the required calibration checks.

5-17. VOLTS DEVIATION CHECK.

a. Leave the differential voltmeter connected as indicated above.

b. Set the VOLTS/DIV switch to 1 volt and the MULTIPLIER to X10. Set the DEVIATION to volts $\pm 10\%$ and observe that the VOLTS DEVIATION lamp is illuminated.

c. Rotate the VOLTS/DIV DEVIATION control to both ends and observe that the digital deviation meter reads greater than $\pm 10\%$.

d. Set the VOLTS/DIV DEVIATION control for a digital meter reading $+10.00\%$. Set the differential voltmeter dials to 11.000 volts. Note that the differential meter reads an error equal to or less than 330 mV.

e. Set the VOLTS/DIV DEVIATION control for a digital meter reading of -10.00% . Set the differential voltmeter dials to 9.000 volts. Note that the differential voltmeter reads an error equal to or less than ± 270 mV.

5-18. VOLTS OUTPUT MODE CHECK.

a. Repeat steps 5-16b and 5-16c with the output mode set to -DC. Check proper output and disconnect the differential voltmeter.

b. Connect an oscilloscope to the VOLTS OUT BNC. Set the scope CH1 input to DC, 1 VOLT/DIV and the time base to 50 μ s with Auto Triggering.

c. Set the 6125 VOLTS/DIV SWITCH to 1 volt, the MULTIPLIER to X6 and the DEVIATION to OFF. Set the OUTPUT MODE to 10 kHz. Observe five cycles of 6 division p-p square wave displayed across the graticule of the CRT.

d. Repeat step b with OUTPUT MODE set to 1 kHz, 100 Hz and 10 Hz with the oscilloscope time base set to 500 μ s, 5 ms, and 50 ms. Use normal internal triggering (not AUTO) on the 50 μ s and 500 μ s settings. Observe five cycles of 6 division p-p square wave displayed across the graticule of the CRT.

5-19. CALIBRATION AND ALIGNMENT PROCEDURES.

5-20. GENERAL. The following alignment and calibration procedures are used to adjust and align the instrument to its performance specifications. If the instrument cannot be adjusted properly, refer to the troubleshooting and fault-finding procedures in paragraph 5-49. See Figure 5-5 for 6125B/C location of adjustments. See Figure 5-6 for location of 6125B/C circuit boards.

5-21. REMOVAL AND REPLACEMENT OF COVERS.

The top and bottom covers of the instrument are each retained by two machine screws located at the rear panel edge of the covers. Remove these screws and lift up at the rear of the cover. Slide the cover forward and remove the cover from the instrument. Reverse this procedure for replacing the covers.

5-22. POWER SUPPLY CHECK.

a. Connect the ac power line input to the generator through a Variac, or similar line voltage control unit, and use a true rms voltmeter, such as the Ballantine Model 3620A, to measure the input line voltage of the 6125B/C.

b. Connect a digital multimeter, such as the Ballantine Model 3028B to A27TP1 (TIME) (+5 volt supply) and any convenient case or circuit ground. Set the DMM to the 20-volt dc range.

c. Vary the ac input voltage from low line to high line and note that the +5 volt bus reads in the range of +4.7 to +5.3 volts with less than ± 0.1 volt change due to line voltage variation.

d. Repeat for the VOLTS +5V bus at A27TP2.

e. Connect the DMM to A27TP3 (-12 volt supply) and repeat the preceding step d. Check that the -12 volt bus reads in the range of -11.3 to -12.7 volts with less than ± 0.2 volt change due to line voltage variation.

f. Readjust the Variac to midline and disconnect the DMM.

5-23. VOLTS CALIBRATION.

5-24. VOLTS OUTPUT SOURCE RESISTANCE AND DIVIDER CHECK.

a. Turn OFF mains power on the 6125B/C Set OUTPUT MODE to GND, MULTIPLIER to X1 and DEVIATION to OFF.

b. Make all measurements indicated with the ohmmeter of the Ballantine 3028B DMM. Use LO ohms and read as close to full range (1999) as possible.

c. Measure resistance from 6125B/C case to shell of the floating VOLTS OUT BNC connector. This reading must be 80 to 120 ohms.

d. Measure resistance from the center pin to the shell of the floating VOLTS OUT BNC connector. This should be nominally 220 ohms with the VOLTS/DIV switch set to 10 μ V and increasing with each increased range until nominally 2.75K ohm is measured at 10 mV. See Table 3-3.

5-25. VOLTS OUT SHORT CIRCUIT CHECK.

a. Set mains power line voltage to midrange as indicated in paragraph 5-8.

b. Set 6125B/C controls as follows:

VOLTS/DIV	20 V
OUTPUT MODE	+DC
MULTIPLIER	X10
DEVIATION	OFF

WARNING

Observe the 200 volt signal levels and use care to avoid shock hazard.

CAUTION

Do not short the VOLTS OUT BNC continuously. Only short 2 to 5 seconds when performing the short circuit current measurement.

c. Use 3028B DMM to measure VOLTS OUT. Connect V- Ω to center pin and COMMON to shell of VOLTS OUT BNC connector. Set 3028B to V DC 1200 V range. Observe a reading of nominally +200 V DC.

d. Set the 3028B DMM to DC, A, 200m range. Transfer the test lead from the V- Ω binding post to the A binding post. The low ammeter shunt resistance will now short circuit the 6125B/C VOLT OUT BNC. Observe that the short circuit current falls within the limits of 25 to 40 mA. This serves to check the volts circuitry.

e. Repeat step c to check that the VOLTS OUTPUT is properly restored after the short circuit test.

5-26. VOLTS SUPPLY CHECKS.

a. Set the mains power line voltage to midrange as indicated in paragraph 5-8.

b. Select GND with the OUTPUT MODE switch. Set VOLTS/DIV to 20, DEVIATION to OFF and MULTIPLIER to X1.

c. Use the 3028B DMM to measure the internal unregulated power supply voltages as indicated below:

Test Point	Location	Measurement Units
A2TP1 to A2TP2	Across A2C2	260V to 320V DC
A2TP3 to A2TP4	A2Q1 collector to Junction of A2R4 and A2C2	15V to 20 V
A2TP5 to A2TP6	A2Q6 emitter to Junction of A2CR10 anode and A2C7	15 V to 20 V

5-27. VOLTS OUT RIPPLE CHECK (Optional).

a. This test is optional. It is provided to permit a low voltage power line check of the VOLTS circuitry.

b. Connect the 6125B/C power input through a variable line control unit. Monitor the power line voltage with a true rms voltmeter and set the voltage to low line as referenced in paragraph 5-8.

c. Set the 6125B/C controls as follows:

OUTPUT MODE	+DC
VOLTS/DIV	20 V
MULTIPLIER	X10
DEVIATION	OFF

d. Connect an oscilloscope to the VOLTS OUT BNC connector. Set the oscilloscope controls as follows:

CH1 Input	
VOLTS/DIV	0.1 V/DIV
Coupling	AC
Triggering	
Source	Internal CH1
Coupling	AC
Mode	Auto
Slope	+
Time Base	
Time/Div	10 ms
Magnifier	X1

e. Verify that the peak to peak ripple displayed on the CRT is less than 2 divisions (0.2 volts) peak to peak.

f. Reset power line voltage to midline.

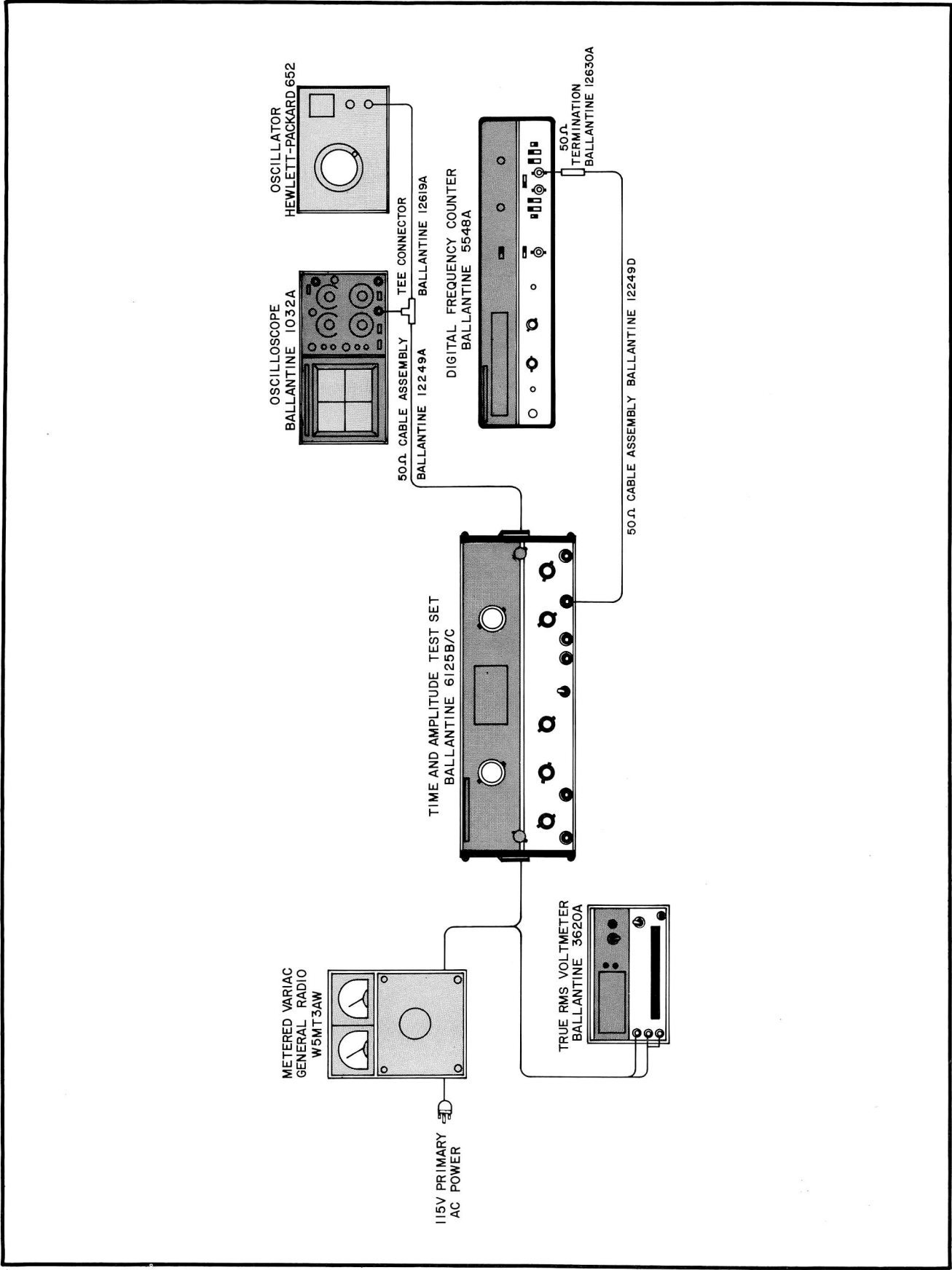

Figure 5-4. External Clock Input Check, Bench Test Setup.

5-28. VOLTS CIRCUIT LOAD REGULATION.

a. Connect the 6125B/C to the power line through a variable autotransformer and monitor the voltage to the power mains input of the 6125B/C.

b. Set the 6125B/C controls as follows:

VOLTS/DIV	20V
MULTIPLIER	X10
OUTPUT MODE	+DC
DEVIATION	OFF

c. Connect a BNC "T" connector to the VOLTS OUT BNC.

d. Use a differential voltmeter such as the Fluke 885AB to measure the VOLTS OUT. Connect the HI binding post of the differential voltmeter to the center pin of the BNC "T" and connect the LO binding post to the shell of the BNC "T" connector.

e. Set the power line voltage to midline. Refer to paragraph 5-8 for power line voltage details.

f. Balance the differential voltmeter on the ± 100 mV null range.

g. Lower the power line voltage to the low line limit. Note that the differential voltmeter null has not been unbalanced by more than ± 80 mV.

h. Raise the power line voltage to the high line limit. Note that the differential voltmeter null has not been unbalanced by more than ± 40 mV.

i. Reset the power line voltage to midline and rebalance the null of the differential voltmeter.

j. Connect a 1 megohm terminating resistor across the open leg of the BNC "T" connector on the VOLTS OUT BNC. Use a 1% resistor or simply connect the 1066B oscilloscope CH1 input to the BNC "T" with a BNC/BNC coaxial cable. Set the oscilloscope input coupling switch to dc and the scope attenuator will act as a 1 megohm termination.

k. Observe the change in output voltage when terminating with 1 megohm. This is read on the differential voltmeter and should not exceed ± 100 mV.

5-29. 200 VOLT CALIBRATION ADJUST (A3R9).

a. Maintain the test equipment setup of paragraph 5-28. Be sure the 1 Megohm terminating resistor is tied to the VOLTS OUT BNC T and that the power line voltage is set to midline.

b. Set the dials of the differential voltmeter to +200.00 volts and the null range to ± 100 mV. Allow 5 minutes for temperature stabilization.

c. Adjust A3R9, the 200 VOLT CALIBRATION Adj. potentiometer, until the differential voltmeter shows a null within ± 25 mV.

d. Change OUTPUT MODE to -DC and differential voltmeter to -200.00 volts. Observe that the differential voltmeter indicates null within ± 100 mV.

e. If A3R9 cannot be brought into range, add or delete one or both links located across A3R10 and A3R11.

f. If desired, check the VOLTS/DIV accuracy limits of Table 5-2 and see paragraphs 5-53 to 5-56.

5-30. 60 dB ATTENUATOR CAL ADJ (A7R20).

a. Refer to paragraph 5-29a for test equipment setup.

b. Perform the following check with test equipment adjusted as indicated in Figure 5-2.

NOTE

Always determine the measurement circuit offset voltage on each range step by switching the VOLTS OUTPUT MODE to GND. Then subtract this unwanted offset voltage from the range calibration being performed and the null limits indicated.

c. Set VOLTS/DIV switch to 20 mV and the MULTIPLIER to X10.

d. Set differential voltmeter dials to 0.20000 and the null range to ± 100 μ V. Allow 5 minutes for temperature stabilization.

e. Adjust A7R20 the 60 dB ATTENUATOR CAL Adj. until the differential voltmeter reads null ± 20 μ V.

f. Set OUTPUT MODE to -DC and differential voltmeter to -0.20000. Observe that the voltmeter reads null (± 20 μ V). If not, check the thermal offset voltage output by setting the OUTPUT MODE to GND. Note this thermal voltage and readjust A7R20 with the differential voltmeter set to 0.2000- (thermal voltage). Observe the polarity of this thermal offset voltage; i.e. add a negative thermal offset voltage. See paragraph 3-21.

5-31. SQUARE WAVE ZERO LEVEL ADJ (A3R2).

a. Set the VOLTS/DIV switch to 20 and the MULTIPLIER (volts) to X1.

b. Set the OUTPUT MODE switch to any of the ac positions.

c. Turn the POWER switch to the off position.

d. Remove the Volts Output Mode Select p.c. board assembly (A7) from its connector.

e. Remove integrated circuit, A7U1, from its socket and carefully set it aside.

- f. Re-install the A7 p.c. board assembly in its connector. Check that it is oriented correctly.
- g. Turn the POWER switch to ON.
- h. Connect an oscilloscope to the VOLTS OUT BNC connector.
- i. Adjust the oscilloscope vertical sensitivity to 50 mV/div.
- j. Adjust A3R2, the SQUARE WAVE ZERO LEVEL ADJ potentiometer, for an offset reading of less than 20 mV.
- k. Turn the POWER switch to the off position and re-install the integrated circuit in p.c. board assembly A7.

NOTE

On later A7 assemblies using Aromat relays P/N 14-10034-0A capacitive trimmers A7 C11 is deleted and paragraph 5-32 is no longer applicable.

5-32. 60 dB ATTENUATOR FREQ. ADJ. (A7C11).

a. Connect an oscilloscope to the VOLTS OUT BNC connector through a BNC/BNC coaxial cable having nominally 120 pF of capacity. The Ballantine 12249D cable is recommended.

b. Set the 6125B/C controls as follows:

VOLTS/DIV	50 mV
MULTIPLIER	X10
OUTPUT MODE	10 kHz
DEVIATION	OFF

c. Set the oscilloscope controls as follows:

CH1 only

VOLTS/DIV	0.1 V
Coupling	DC

Triggering

Source	Internal
Slope	+

Mode	Auto
Coupling	AC
Time Base	
TIME/DIV	50 μ s
Magnifier	X1

d. The oscilloscope monitors the VOLTS OUT square wave and should be adjusted to stably display 5 cycles of the 10 kHz square wave across the CRT. The square wave amplitude is nominally 5 divisions (500 mV) peak to peak.

e. Adjust the oscilloscope TIME/DIV to 20 μ s/DIV and display the leading edge of the square wave.

Measure the 10 to 90% rise time of the square wave and verify that it is equal to or faster than 6 microseconds.

f. Reduce the VOLTS/DIV switch setting to 20 mV.

g. Set the oscilloscope VOLTS/DIV switch to 50 mV/DIV and set the oscilloscope TIME/DIV switch to 20 μ s. Adjust the oscilloscope to display 2 cycles of square wave on the CRT with an amplitude of 4 divisions (200 mV).

h. Adjust A7C11 the 60 dB ATTENUATOR FREQUENCY Adj. for best square wave flatness with minimum rounding or overshoot.

i. Check a number of other VOLTS/DIV settings to be certain that there are no waveform abnormalities on other ranges.

5-33. DIGITAL METER CALIBRATION (A23 and A17)

a. Locate 499 ohm resistor A17R1 on the digital meter interconnect board A17 (for units with serial prefix 021-) or A18R22 on the time deviation board A18 (for units with serial prefix 022-). Connect a set of test leads across the input of the digital meter. Be sure the entire instrument has fully warmed up for at least 20 minutes before proceeding.

5-34. METER ZERO ADJUST (A23R10).

a. Tie the test leads connected across A17R1 together. Observe that the digital meter display (A24) reads 0.00 \pm 2 digits.

TABLE 5-2. VOLTS/DIV ACCURACY LIMITS

OUTPUT MODE	6125B/C VOLT/DIV	MULTIPLIER	DIFFERENTIAL VOLTMETER DIALS	NULL LIMITS
+DC	20 V	X10	+200.00	\pm 500 mV
+DC	10 V	X10	+100.00	\pm 250 mV
+DC	5 V	X10	+ 50.000	\pm 125 mV
+DC	2 V	X10	+ 20.000	\pm 50 mV
+DC	1 V	X10	+ 10.000	\pm 25 mV
+DC	0.5 V	X10	+ 5.0000	\pm 12.5 mV
+DC	0.2 V	X10	+ 2.0000	\pm 5 mV
+DC	0.1 V	X10	+ 1.0000	\pm 2.5 mV
+DC	50 mV	X10	+ .5000	\pm 1.25 mV

b. Adjust the ZERO Adj. potentiometer A23R10 until the digital display reads 0.00 and does not flash more than one digit once every ten seconds.

5-35. VOLTS DEVIATION RANGE ADJ. AND CENTERING ADJ. (A7 R2 and A7 R25)

- a. Set the DEVIATION switch to the VOLTS position.
- b. Rotate the VOLTS/DIV DEVIATION control to its maximum counter-clockwise position and note the DEVIATION reading.
- c. Rotate the VOLTS/DIV DEVIATION control to the maximum clockwise position and note the DEVIATION reading.

d. If necessary, adjust ^{A16} R2, the DEV RANGE ADJ control and A7 R25 the DEV CENTERING ADJ control so that the reading of the DEVIATION meter indicating > 15.00 at both extreme positioning of the VOLTS/DIV deviation control. The overrange counts on each side should be approximately balance after these interacting adjustments are completed.

5-36. VOLTS DEVIATION CAL. (A23R7)

- a. Set the 6125 controls as follows:

VOLTS/DIV	20
MULTIPLIER	X10
OUTPUT MODE	+DC
DEVIATION	VOLTS

- b. Connect a high resolution, battery operated DC differential voltmeter, such as the Fluke Model 885AB, to the VOLTS OUT BNC connector.
- c. Set the differential voltmeter dials to +220.00 volts dc and the null sensitivity to 100 mV.
- d. Adjust the VOLTS/DIV DEVIATION control for a balance on the differential voltmeter.
- e. Adjust A23R7, the VOLTS DEVIATION CAL. control, for +10.00 as indicated on the DEVIATION digital panel meter. (± 5 digits).

5-37. VOLTS REMOTE DEVIATION ZERO ADJ. (A1R7 on assembly 8910815, 6125C only)

- a. Connect the remote programming fixture to the AMPLITUDE PROGRAM INPUT connector (A1J2) on the rear of the 6125C.
- b. Refer to table 2-1 and program for maximum negative VOLTS DEVIATION by setting the appropriate input lines of connector A1J2 to logic "1" (+5 volts). Adjust A1R7 for a reading on the % DEVIATION meter of -10.50.
- c. Change the program to maximum positive VOLTS DEVIATION by setting the input lines to logic "0" (ground). Observe that the reading on the % DEVIATION meter is approximately +10.50.

d. Repeat steps b. and c. and adjust A1R7 so that the readings on the % DEVIATION meter are equal for both negative and positive maximum de-

viation and that both readings are greater than 10.00.

NOTE

The 0.00% VOLTS DEVIATION program command listed in table 2-1 will not necessarily yield zero percent deviation, since the transfer characteristic of the opto-isolator is not precisely linear. % DEVIATION programming of the 6125C is not quantitative; it is intended to be programmed in a stepped ramp mode until the unit under test appears in its calibrated mode. The 6125C % DEVIATION meter then indicates the amount, in percent deviation, that the 6125C had to be offset to compensate for the calibration error of the unit under test.

5-38. Optional Optimum Setting of A3R9 and VOLTS MULTIPLIER Check.

5-39. For optimum 200 volt calibration adjustment A3R9 and a check of the VOLTS MULTIPLIER accuracy perform the following optional check.

- a. Set the 6125B/C controls as follows:

DEVIATION	OFF
OUTPUT MODE	+DC
VOLTS/DIV	20V

- b. Connect a differential voltmeter to the VOLTS OUT BNC connector.
- c. See Table 5-5 and record the INITIAL ERROR in millivolts at the indicated MULTIPLIER settings.
- d. Plot a graph of INITIAL ERROR in mV against NOMINAL OUTPUT VOLTS as indicated in Figure 5-7. Spot all eight values of INITIAL ERROR.
- e. Draw two lines F and K from the graph origin at 0 volts through the two extreme INITIAL ERROR points. Lines F and K then provide the extremest values of slope.
- f. Draw a vertical line at 200 volts. Then measure the millivolt difference between the intersection of lines F and K with the 200 volt vertical line. This millivolt difference is the ERROR SPREAD in millivolts and should be recorded in Table 5-5.
- g. Find and mark the midpoint between the intersections of lines F and K and the vertical 200 volt line. This is half of the ERROR SPREAD of paragraph f and should be recorded as the MEAN ERROR in millivolts in Table 5-5.
- h. Change the polarity sign of the MEAN ERROR. Add this millivolt value to the X10 (200 volts) INITIAL ERROR and record in Table 5-5 as CORRECTING ERROR at 200 V.
- i. Again set the 6125B/C VOLTS MULTIPLIER to X10.

j. Note the OUTPUT voltage and adjust 200 volts calibration. Adjust potentiometer A3R9 to provide OUTPUT of 200 volts + CORRECTING ERROR at 200 V (in millivolts). This optimizes the absolute voltage calibration of the instrument.

5-40. TIME CALIBRATION.

a. **Preliminary Control Settings.** Prior to calibrating or adjusting the instrument set the controls initially as follows:

TIME/DIV.	0.1 μ s
MULTIPLIER	X1
TRIGGER PERIOD	100 μ s
FAST RISE & TRIG AMPLITUDE	Max. cw
DEVIATION	OFF
Marker Trigger Interlock (located internally on A16)	Lockout

5-41. CLOCK FREQUENCY ADJUST (A11C5).

NOTE

Before making any adjustment of the clock frequency or multiplier tuning, allow at least 2 hours warmup at reference conditions. Make all adjustment in the sequence listed.

a. Interconnect the generator and the required test equipment as shown in Figure 5-1. Use a frequency counter with a certified high-stability clock, such as the Ballantine Model 5548A with Option 14, connected to the MARKER OUT connector. Be sure that the clock frequency in the counter is fully stabilized and accurate. Use a frequency standard, if available, for the counter clock.

b. The frequency counter must read in the range of 10,000,081 to 9,999,919 Hz when measuring the 0.1 μ s MARKER OUT. If the frequency is near or over the limit, adjust A11C5 until the counter reads in the range of 10,000,010 to on 9,999,990 Hz. If A11C5 does not have sufficient range or is near its minimum setting, select a value of A11C6 (typical values for A11C6 are 5, 12, 20, 27, and 36 pF) to bring the adjustment of A11C5 within range, or replace the quartz crystal and oven assembly if the frequency adjustment cannot be centered on 10 MHz. If the clock of the generator is not set properly to 10 MHz, the accuracy on all generator outputs will be adversely affected.

5-42. 5 ns (200 MHz ADJUSTMENT) (A15 C21)

a. Interconnect the generator and the required test equipment as shown in figure 5-3. Connect a sampling oscilloscope, such as the Tektronix 547 with 1S1 plug-in, to the 5 ns H.F. OUTPUT connector. Set the sampling oscilloscope time base to

5 ns/cm. Connect the TRIGGER OUTPUT to the external trigger input of the sampling oscilloscope thru a 20 dB 50 ohm attenuator (Ballantine 12626A). Set the TRIGGER PULSE PERIOD to 100 ns. Set the oscilloscope to external positive trigger and adjust the sweep triggering for a stable triggered display.

b. Set the sampling oscilloscope vertical sensitivity to 20 mV/DIV. The oscilloscope is then calibrated to 200 mV/DIV since the input signal from the generator is reduced by a 20 dB coaxial attenuator. Set DEVIATION to OFF. Observe a 5 ns (200 MHz) sine wave on the oscilloscope.

c. Adjust A15 C21 for maximum sine-wave amplitude on the oscilloscope. This amplitude must exceed 550 mV p-p (2.25 DIV on scope). If no tuning or too little tuning is noted, check A15 Q20, A15 Q21, and A15 Q2, as well as their associated components. If more amplitude is required, carefully spread or compress coil A15 L1 for best performance.

d. Sine-wave cycle-to-cycle amplitude modulation should not exceed 10% at 25°C. If the intermodulation is excessive, replace A15 Q20 and A15 Q21 with transistors whose beta (current gain) is matched within 25%, and carefully adjust A15 T21 no more than one-half turn for optimum amplitude flatness of the 5 ns H.F. OUTPUT sine-wave. It may be necessary to check 5 ns (200 MHz) cycle-to-cycle flatness after the following 2 ns (500 MHz) adjustment since A15 C1 (200 MHz trap) may affect the 5 ns output. The cycle-to-cycle amplitude modulation tolerance is for reference only and is not a specification.

e. Again touch up A15 C21 for maximum peak-to-peak amplitude which must exceed 550 mV p-p at 25°C.

NOTE

If 0.55 V p-p amplitude is not obtainable, check A15 Q20 and A15 Q21 and associated components. Check A15 L1 and A15 T21 and replace if damaged or misshaped.

5-43. FLATNESS TEST PROCEDURE.

a. Adjust the vertical display on the sampling oscilloscope to 5 cm with the variable VOLTS/DIV control on the oscilloscope.

b. Remove the 20 dB (X10) coaxial attenuator from the vertical input of the oscilloscope. Each division on the oscilloscope graticule now represents 2% of the total signal amplitude.

c. Adjust the sampling oscilloscope vertical POSITION control to position the top of the sine-wave display on the screen.

d. Turn the oscilloscope Time/Div control to a range that will display at least 25 sine waves. Note the amplitude differences between the various peaks of the sine waves. The maximum to minimum crest difference should not

exceed 2.5 of a division or 5%. This tolerance is for reference only and is not a performance specification.

5-44. 2 ns H.F. OUTPUT ADJUST (A15 C7, A15 C9, A15 C11, A15 C14, A15 R7)

a. Interconnect the generator and test equipment as shown in figure 5-3. Change the sampling oscilloscope time base to 2 ns per division and change the cable at the 6125B/C from the 5 ns H.F. OUTPUT connector to the 2 ns OUTPUT connector. Observe a stable 500 MHz (2 ns) sine-wave on the oscilloscope.

NOTE

Do not use the PC card extender when making 2 ns H.F. OUTPUT adjustments. Do not extend the 50 ohm output cable within the instrument. Use a insulated alignment tool and allow the instrument to be fully warmed up before making adjustment. The 5 ns adjustment must be properly aligned before starting the 2 ns calibration.

b. Observe that the 2 ns frequency output provides one sine-wave per division on the scope graticule and that the sine-wave displayed is at least 0.50 volt (2.5 divisions) peak-to-peak.

c. Adjust A15 C4, A15 C9, A15 C10, A15 C11 and A15 R7 for maximum signal amplitude.

d. Adjust A15 C6 and A15 C7 for good flatness and maximum amplitude.

NOTE

The adjustment of A15 C4 (100 MHz filter), A15 C6 (200 MHz trap), A15 C9 (500 MHz Filter A) interact. Repeat steps c and d as necessary for best tuning. Also, do not make any of the capacitor adjustments randomly or too far removed from the original settings. The controls interact and a number of combinations may produce a 500 MHz (2 ns) output; however, only one combination produces maximum amplitude and flatness.

e. If a 0.50 volt amplitude is not achievable, check A15 Q3, A15 CR1, and the associated components, including all transformers and inductors in the 500 MHz quintupler. Since the 500 MHz output from A15 is buffered by buffer A116 Q1, always check this untuned amplifier on A116 to be certain that it and its associated components is functioning properly. Check that the printed circuit board and components are clean and free of flux or other contaminants which may lower the Q of tank circuits and the strip line filter so as to cause a reduction of the 2 ns output signal amplitude.

CAUTION

Never tamper with the coils on A15 since these are carefully adjusted at the factory. Always use the proper test equipment and good quality interconnects when attempting these adjustments.

NOTE

Because of the interaction between adjustments, the calibration of the 5 ns H.F. OUTPUT (paragraph 5-44) should be re-verified.

5-45. % TIME DEVIATION BALANCE ADJ. (A12R2).

a. Allow instrument to be thoroughly warmed up with covers on to retain interior temperature.

b. Connect a frequency counter to the TRIG OUT BNC as shown in Figure 5-3.

c. Set the 6125B/C controls as follows:

TRIGGER PERIOD	1 μ s
TIME/DIV	50 ns
MULTIPLIER	X1
DEVIATION	OFF

d. Observe a reading of 1,000,000 Hz (± 60 Hz).

e. Set DEVIATION to TIME $\pm 10\%$. Note that the TIME DEVIATION indicator lamp is illuminated.

f. Rotate the TIME/DIV DEVIATION control to each end and observe that the frequency counter varies at least from 900,000 Hz to 1,100,000 Hz.

Adjust A12R2 until the counter maximum and minimum frequency readings are approximately balanced for equal deviation from 1,000,000 Hz at each end of rotation of the TIME/DIV DEVIATION control.

5-46. METER TIME CAL ADJ. (A18R8, A18R6).

a. Use the same test setup detailed in paragraph 5-45. Set the counter to Period mode. Set the 6125B/C TRIGGER PERIOD switch to 100 μ s. Rotate the TIME/DIV control until the frequency counter reads 90 μ s. Adjust A18R6, the - TIME METER CAL adjust potentiometer until the 6125B/C digital meter reads -10.00 (+5 digits).

b. Rotate the TIME/DIV control until the frequency counter reads 110 μ s. Adjust A18R8 until the 6125B/C digital meter reads +10.00%, ± 5 digits.

c. A18R6 and A18R8 are somewhat interdependent. Therefore, repeat steps a and b until tracking is achieved.

5-47. REMOTE TIME DEVIATION ZERO ADJ.
(A10R4 on assembly 8910817, 6125C only).

- a. Connect the remote programming fixture to the TIME PROGRAM INPUT Connector (A10J1) on the rear of the 6125C.
- b. Refer to table 2-2 and program for maximum negative TIME DEVIATION by setting the appropriate input lines of connector A10J1 to logic "1" (+5 volts). Adjust A10R4 for a reading on the % DEVIATION meter of -10.50.
- c. Change the program to maximum positive VOLTS DEVIATION by setting the input lines to logic "0" (ground). Observe that the reading on the % DEVIATION meter is approximately +10.50.
- d. Repeat steps b. and c. and adjust A10R4 so that the reading on the % DEVIATION meter is equal for both negative and positive maximum deviation and that both readings are greater than 10.00.

NOTE

The 0.00% TIME DEVIATION program command listed in Table 2-2 will not necessarily yield zero percent deviation, since the 100 MHz VCO does not have a precisely linear relationship between the controlling voltage and frequency. % DEVIATION programming of the 6125C is not quantitative; it is intended to be programmed in a stepped ramp mode until the unit under test appears in its calibrated mode. The 6125C % DEVIATION meter then indicates the amount, in percent deviation, that the 6125C had to be offset to compensate for the calibration error of the unit under test.

5-48. LINE FREQ. AMPLITUDE.

- a. Connect an oscilloscope to the LINE FREQ. OUTPUT BNC connector of the 6125B/C.
- b. Set the oscilloscope sensitivity to 0.5 Volts/Div.
- c. Rotate the LINE FREQ. AMPLITUDE control and verify that at least 1 volt peak to peak sine wave output amplitude may be obtained. Check the sine wave displayed on the CRT and note that it is clean, free of noise and has negligible harmonic distortion.

5-49. TROUBLESHOOTING.

5-50. The troubleshooting procedures should be performed only when the instrument cannot be calibrated using the procedures of paragraphs 5-19 through 5-47. Should the instrument be inoperative or completely out of specifications, proceed with the following fault-finding procedures:

- a. Carefully examine the instrument and check for any visual evidence of trouble. Check for broken wires, burned resistors, loose components, and shorted, open, or defective solder joints on the printed circuit board. Check for separation of printed circuit board lands and pads. Check for open, defective, or intermittent switches. Check that connectors

are clean and mate properly. Check that the instrument circuit ground is connected to the chassis ground.

- b. Understand and be familiar with the circuit theory of Section 4. Use the functional block diagrams and simplified schematics in Section 4 to isolate the probable circuit areas which may cause the problem. Also refer to the schematic diagrams in Section 6. Always check the power supply voltages and check for oscillations in the circuitry.

- c. To locate faults see Table 5-3.

5-51. PRINTED WIRING BOARD REPAIR AND CLEANING.

5-52. The generator uses an etched-copper printed circuit board. The main printed circuit board uses plated-through holes. To prevent damage to the circuit board and components, observe the following instructions when soldering:

- a. Use a low-heat-capacity soldering iron with a 700° F tip, 1.5 mm (1/16 inch) to 2.5 mm (3/32 inch) wide, similar to Weller Model No. W-TCP, 60 watts.
- b. Be sure that the soldering iron tip is grounded to the power line "earth" ground to avoid possible overvoltage damage to semiconductor and electrolytic capacitors. Also, "earth" ground the case of the instrument.
- c. When removing a component, clip a heat sink, such as a long-nose tweezers, or alligator clips, to the component leads, as close as possible to the body of the component, to ensure minimum heating of the component when soldering.
- d. Place the soldering iron directly on the component lead on the conductor side of the printed circuit board. Use a desoldering tool such as the SOLDAPULLT, manufactured by Edsyn Products, to remove all solder and free the component lead.
- e. Straighten the component lead with long-nose pliers and remove the component from the board.
- f. If a component is obviously faulty or damaged, clip the leads close to the body of the component and remove the leads remaining from the conductor side of the board.
- g. Use a short soldering cycle since excessive or prolonged heat may destroy the laminate board and lift the copper conductors from the circuit board, or cause immediate degradation or latent damage of the components.
- h. Clean the component lead holes by heating the solder on the circuit board conductor pad, quickly removing the soldering iron, and inserting a pointed nonmetallic object, such as a toothpick, to clean the hole. Do not allow solder to cover the hole since new component leads may then push the pad away from the board.
- i. To install a new component, straighten and shape the leads. Insert the component into the proper holes. Bend the leads on the conductor side of the circuit board so that they extend to the foil of the incoming conductor path. Cut the bent lead approximately 2.5 mm (3/32 inch) from the hole.

Clip a heat sink to the component lead at the body of the component. Heat the lead and the pad with a soldering iron and use fresh solder (60/40) as required to cover the lead and form a meniscus over the hole to ensure a good electrical connection.

j. After either removing or inserting a component, clean excess flux from the connection and surrounding area. Use TF Freon spray cleaner, such as Miller Stevenson Chemical Co., Type MS-180 (Ballantine P/N 80-10004-0A), low air pressure (5 to 20 PSIG), and a humidity seal spray, such as Humiseal, Columbia Technical Corp., Type 1B15 (Ballantine P/N 80-10005-0A), to seal the board and protect it against humidity. To avoid unwanted leakage, which may affect performance if the instrument is exposed to high humidity, do not touch the cleaned board or handle the components excessively.

CAUTION

Be extremely careful when cleaning the multiplier coils and adjacent components. Never bend the coils. Distorted coils and transformers may drastically affect the functions, calibration, and performance of the instrument.

k. Do not permit water or solvents to get into switches, connectors, or sockets. Avoid using corrosive cleaners which may damage metal or plastic parts.

5-53. REPLACEMENT OF SELECTED COMPONENTS.

5-54. VOLTS/DIV Resistor Replacement.

5-55. When replacing any resistor in the VOLTS/DIV attenuator A5R1 through A5R6 and A6R3 through A6R8:

a. Set the 6125B/C to:

DEVIATION	OFF
OUTPUT MODE	+DC
VOLTS/DIV	20V
MULTIPLIER	X10

b. Allow 30 minutes warm up and readjust A3R9 to provide 200V ±20 mV.

c. Taking care not to touch any high voltage leads con-

nect the differential dc voltmeter across A5R1 and record the voltage reading.

d. Let the symbol V_m represent the above measured voltage and let E represent the error from the required voltage. E is measured in millivolts. Then:

$$V_m = 100 \text{ millivolts} + E$$

$$E = (V_m - 100)$$

e. Calculate the value of selected resistor A5R8 by the formula:

$$R = \frac{500}{E}$$

A5R8 must be a precision film resistor with a tolerance of ±1%. Turn power OFF when soldering A5R8 in parallel with A5R1.

f. Repeat step c but read and record the voltage across R5R2.

g. Calculate the value of selected resistor A5R9 as in step d by first calculating the error E .

$$E = (V_m - 100) \quad \text{and then: } R = \frac{500}{E}$$

A5R9 must be a precision resistor of ±1% tolerance. Turn power OFF when soldering A5R9 in parallel with A5R2.

h. Turn the instrument ON and allow 30 minutes warm up. Again measure the 200 volt output to check that it is within ±20 mV.

i. Measure the voltages across A5R1 and A5R2 to verify that they are each 100 millivolts ±125 microvolts.

j. Repeat step i after an additional 30 min. warm up and again verify that the voltages across A5R1 and A5R2 are each 200 millivolts ±125 microvolts.

k. Connect the differential voltmeter to the VOLTS OUT BNC and verify each of the VOLTS/DIV settings indicated in Table 5-4. Check the residual output voltage in GND mode and subtract this output from each of the measured readings before comparing the limits listed in Table 5-4.

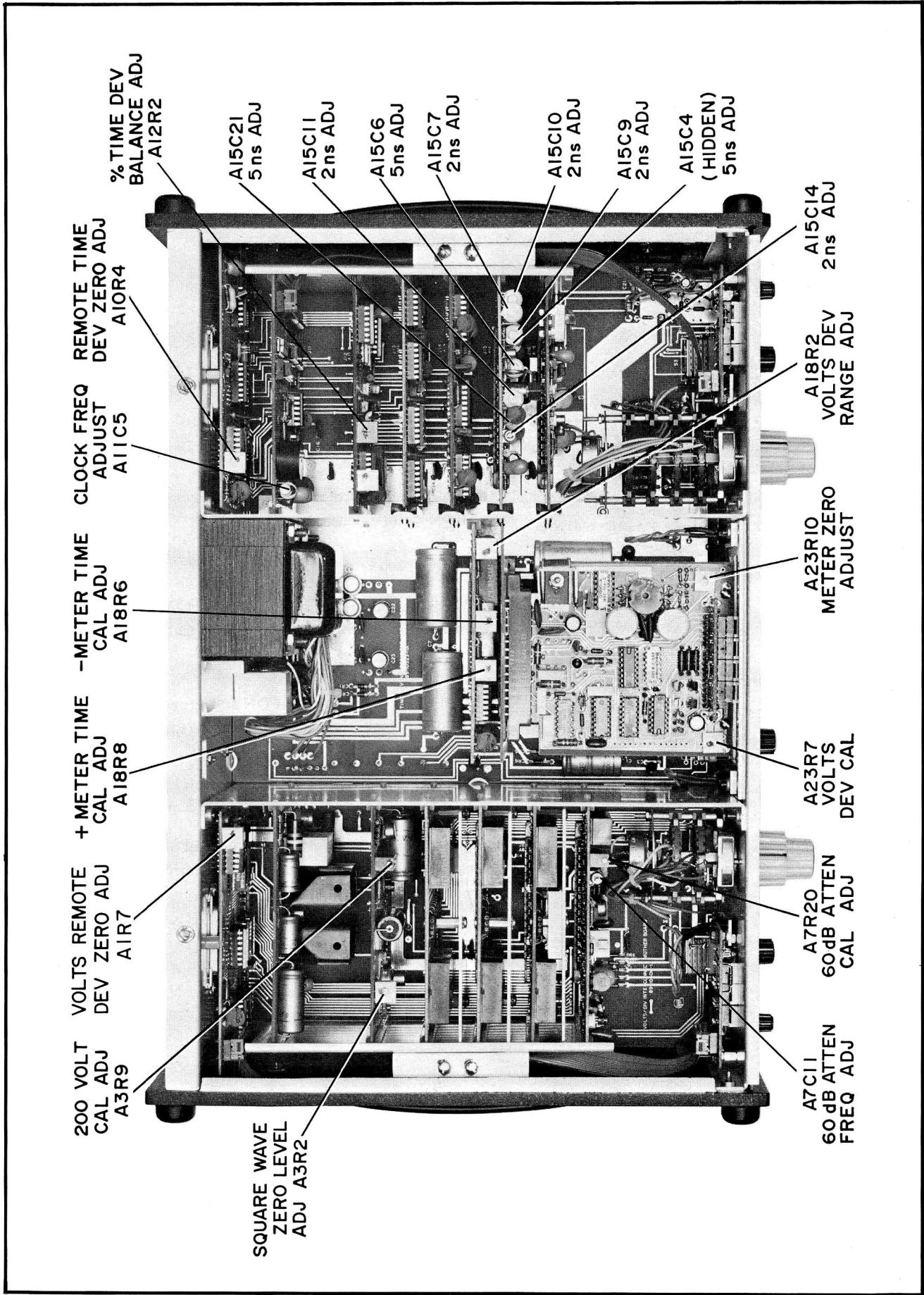

Figure 5-5. Location of Adjustments 6125B/C

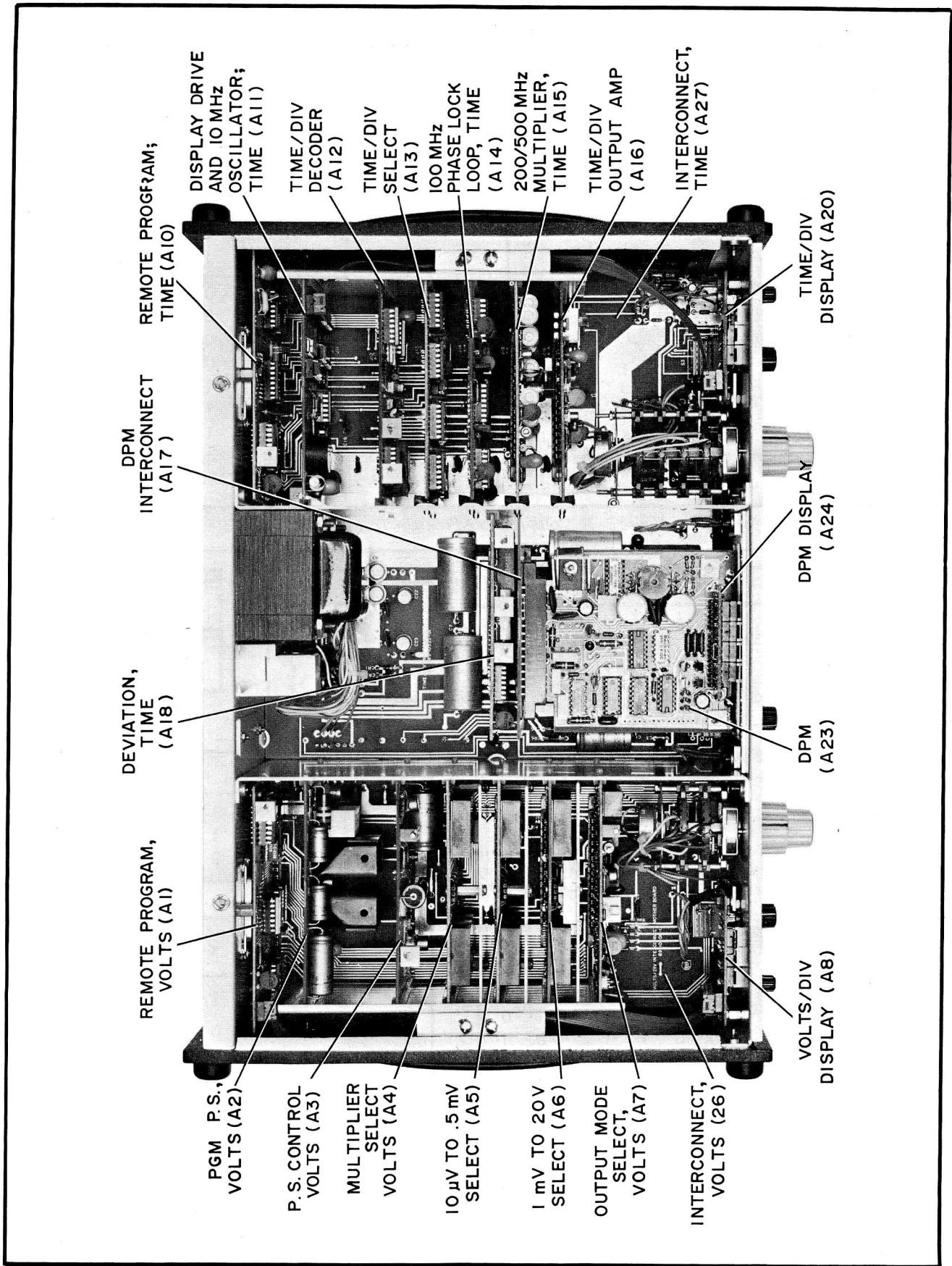

Figure 5-6. Model 6125B/C Circuit Board Location

VOLTS/DIV	A	B	C	D	E	S
10 μ V	0	0	0	0	0	0
20 μ V	0	0	0	0	1	0
50 μ V	0	0	0	1	0	0
.1 mV	0	0	1	0	0	0
.2	0	0	1	0	1	0
.5	0	0	1	1	0	0
1	0	1	0	0	0	0
2	0	1	0	0	1	0
5	0	1	0	1	0	0
10	0	1	1	0	0	0
20	0	1	1	0	1	0
50 mV	1	0	0	1	0	0
.1 V	1	0	1	0	0	0
.2	1	0	1	0	1	0
.5	1	0	1	1	0	0
1	1	1	0	0	0	0
2	1	1	0	0	1	0
5	1	1	0	1	0	0
10	1	1	1	0	0	0
20 V	1	1	1	0	1	0
RMT/OFF	X	X	X	X	X	1

FNCT	X	Y	Z
—	1	1	0
GND	0	0	0
+	1	1	1
10 KHz	0	1	0
1 KHz	0	1	1
100 Hz	1	0	0
10 Hz	1	0	1

MULT	J	K	L
X1	0	0	0
X2	0	0	1
X3	0	1	0
X4	0	1	1
X5	1	0	0
X6	1	0	1
X8	1	1	0
X10	1	1	1

Figure 5-8. Volts Remote Program Truth Tables

TIME/DIV	A	B	C	D	E	F	S
10 nsec	1	1	1	1	0	0	0
20 nsec	1	1	1	1	0	1	0
50 nsec	1	1	1	1	1	0	0
.1 μ sec	1	1	1	0	0	0	0
.20	1	1	1	0	0	1	0
.50	1	1	1	0	1	0	0
1	1	0	0	0	0	0	0
2	1	0	0	0	0	1	0
5	1	0	0	0	1	0	0
10	0	0	0	0	0	0	0
20	0	0	0	0	0	1	0
50 μ sec	0	0	0	0	1	0	0
.1 msec	0	0	0	1	0	0	0
.2	0	0	0	1	0	1	0
.5	0	0	0	1	1	0	0
1	0	0	1	0	0	0	0
2	0	0	1	0	0	1	0
5	0	0	1	0	1	0	0
10	0	0	1	1	0	0	0
20	0	0	1	1	0	1	0
50 msec	0	0	1	1	1	0	0
.1 sec	0	1	0	0	0	0	0
.2	0	1	0	0	0	1	0
.5	0	1	0	0	1	0	0
1	0	1	0	1	0	0	0
2	0	1	0	1	0	1	0
5 sec	0	1	0	1	1	0	0
REMOTE/OFF	X	X	X	X	X	X	1

MULT	M	N
X1	1	1
X2	1	0
X5	0	1
X10	0	0

TIME DEVIATION	T
ON	1
OFF	0

CONTROL	R	S	L/R
REMOTE	1	X	1
REMOTE	0	1	1
LOCAL	0	0	0

TRIGGER PERIOD	J	K	L
100 nsec	1	1	1
1 μ sec	0	0	0
10	0	0	1
100	0	1	1
1 msec	0	1	1
10	1	0	0
100	1	0	1
1 sec	1	1	0

Figure 5-9. Time Remote Program Truth Tables

TABLE 5-3. TROUBLESHOOTING HINTS

<p>Digital Deviation Meter display does not illuminate.</p>	<p>Check the Power Switch is on and AC mains cable is connected. Check that rear panel mains voltage selector switch is properly set. Check fuse in ac mains receptacle. Check that all assembly boards are properly seated in the correct connectors. Check power supply voltages per paragraph 5-22.</p>
<p>Digital Deviation Meter does not return to 0.00 ±3 counts when DEVIATION is OFF.</p>	<p>Check Digital Meter Zero adjust per paragraph 5-34. Check 100 MHz phase lock loop for out of lock condition.</p>
<p>Volts Calibration unstable with ac mains voltage change or contains mains frequency ripple.</p>	<p>Check that 2ns and 5ns outputs are within the maximum amplitude limits or temporarily remove A13. Check relay A18K2. Replace A18 and recalibrate A12R2 per paragraph 5-45 and A18R6, R8 per paragraph 5-46.</p>
<p>VOLTS MULTIPLIER Malfunctions.</p>	<p>Check ac mains voltage and rear panel selector switch. Check calibration on +DC mode with Deviation OFF, VOLTS/DIV set to 20 V and MULTIPLIER X10. Check voltages on A2 and replace faulty components. Replace A2. Check voltages on A3 and replace faulty components. Check main voltage reference A3 CR5 for 6.2 Volts + 5%. Replace A3. Temporarily remove R18 to check that relays are not malfunctioning so as to load the Volts generator.</p>
<p>Incorrect calibration of +200 Volt output or no ±200 Volt output.</p>	<p>Replace A4. Check resistors A4 R1 through R8. Check that all relays A4 K1 through K7 open in X10 mode. Check that only one relay closes for each step from X1 to X8.</p>
<p>+200 Volts and MULTIPLIER functioning but incorrect amplitude on 10 V to 50 mV VOLT/DIV ranges.</p>	<p>Check that A1 is installed. Check or replace A2 and A3. Recalibrate A3R9 per paragraph 5-29. Check relays A6 K5, K6 and K7 for pin continuity from A6 P1-A to A6 P1-6. Check A7 K2 reversal relay for presence of 200 Volts input and malfunction. Check that GND relay A7 K4 is open and not malfunctioning. Replace A7. Check for continuity from VOLTS OUT BNC to A5 R7 through A6 P1-6.</p>

TABLE 5-3. TROUBLESHOOTING HINTS (Continued)

<p>+200 Volts and MULTIPLIER functioning through 50 mV but 20 mV through 10 μV VOLTS/DIV ranges show errors.</p>	<p>Check A6 K6 for contact and function. Check calibration of A7R20 per paragraph 5-30. Check polarity reversal relay A7 K2. Replace A6 or A7. Check A1 or replace.</p>
<p>DC polarity selection does not function.</p>	<p>Check relay A7 K2. Check logic circuits on A7. Replace A7.</p>
<p>No Square Wave Voltage output modes or incorrect frequency.</p>	<p>Check 1 MHz input to A7 U1. Check steering of A7 U1 from A1 and/or replace A1 and A7. Check AC switch components A7 U4, A7 Q4, A3 Q3, A3 Q4, and A3 Q5. Check presence of square wave at A3 TP-1 at A3P1-7.</p>
<p>Poor square wave output wave shape 20 V to 50 mV VOLTS/DIV ranges.</p>	<p>Check A7 U1, A7 U4 and A7 Q4. Check faulty relay A18K2. Temporarily pull out A18 to isolate its fault contribution. Replace A7. Check that the oscilloscope is properly compensated and presents 1 MΩ and less than 50 pF load.</p>
<p>Poor square wave output wave shape 20 mV to 10 μV VOLTS/DIV ranges.</p>	<p>Adjust A7 C11 per paragraph 5-32. Check that the oscilloscope connected to VOLT OUTPUT is properly compensated and presents 1 MΩ and less than 50 pF of capacitive load.</p>
<p>Volts Deviation does not function.</p>	<p>Perform the calibration checks of A18R2 per paragraph 5-35. Check at A7 P1-B that the voltage varies as the VOLTS DEVIATION control is rotated. Check that relay A7 K1 is energized in the 6125C when using front panel deviation control. Check A1U4 A/D converter and that A7 K1 is unenergized when using remotely programmed deviation or replace A1. Check that A7 U3, A7 U4 and A7 Q4 are functioning. Replace A7. Check operation of relay A18 K2 or replace A18. Check and calibrate DPM and its interconnections or replace A23 and A24. Check A2 and A3 and connection of deviation voltage from A7 R15 to A3 R1 and A2 R10. Replace A2 and A3.</p>
<p>No Time Marker Output - Deviation OFF</p>	<p>Check that rear panel INT CLOCK OUT/EXT CLOCK input switch S4 is set to the INT CLOCK OUT position for internal clock operation. If using external clock input, check that it is 10 MHz and of sufficient amplitude. Check internal 10 MHz clock or replace A11. Check MARKER OUT amplifier on A16 or replace A16. Set TIME/DIV to 10 ns and MULTIPLIER X1 and check output with 100 MHz scope. If still no output, replace A12 and A14 and check A13 selector logic.</p>

TABLE 5-3. TROUBLESHOOTING HINTS (Continued)

<p>Time Markers inaccurate or jittery.</p>	<p>Check frequency of 10 MHz clock A11C5 per paragraph 5-41. Replace A11 and A12.</p>
<p>Time Markers not functioning for 10 ns, 20 ns and 50 ns.</p>	<p>Check A14 U2 through A14 U8 or replace A14. Check MARKER OUT amplifier on A16. Check Decoders and Logic Select on A10 A12 and A13.</p>
<p>Time Marker not functioning for 100 ns to 5 second ranges.</p>	<p>Check decoders and logic select on A10, A12 and A13. See theory section. Replace A13. Check output amplifier on A16.</p>
<p>TRIG OUT inoperative on any TRIGGER PERIOD Range.</p>	<p>Check output amplifier located on A27 and A16. Check transistors and check that TTL level pulse is measured at input of amplifier. Repeat with MARKER TRIGGER INTERLOCK slide switch A16S1, set to OFF. Check A11 on 6125C or replace A11. Check A13 U16 and its connections through U27 to the TRIGGER PERIOD Selector switch.</p>
<p>TRIGGER PERIOD range inoperative 100 ns on 100 ns or any of the faster ranges.</p>	<p>If TIME/DIV switch and MULTIPLIER are set for a period equal to or slower than the TRIGGER PERIOD, the TRIGGER will be inoperative when MARKER TRIGGER INTERLOCK switch A16 S1 is set to LOCKOUT. Check by setting A16 S1 to OFF and note that all functions are normal.</p>
<p>MULTIPLIER does not function.</p>	<p>Check A12 and A13 and replace.</p>
<p>Time DEVIATION inoperative.</p>	<p>Check that DEVIATION switch is set to TIME $\pm 10\%$. Check that rotation of front panel TIME/DIV DEVIATION control will vary the voltage at A12 R2. Replace A12. Check calibration of A12 R2 per paragraph 5-45. Check DPM and replace A23 and A24 if necessary. Check function of time deviation % frequency shift circuit of A18. Check relay A18 K2. Check 2 MHz input to A18 R15 from 0.5 μs output of A13. Check 10 MHz input to A18 U1 pin 1. Check 1 MHz output from A18 U1 pin 12 and at A13 P1-R. Replace A18 if necessary.</p>
<p>5 ns output is inoperative.</p>	<p>Check that DEVIATION Switch is set to OFF. Check connection from A15 P1-14 to 5 ns BNC on front panel. Check 100 MHz input to A15 P1-1 and base of A15 Q2. Check that switch A15 Q1 is not conducting and its base and emitter are near +5 volts. Check A15 Q20 and A15 Q21. Check calibration of A15C21 per paragraph 5-42. Replace A15.</p>

TABLE 5-3. TROUBLESHOOTING HINTS (Continued)

<p>2 ns output is inoperative.</p>	<p>Check that DEVIATION switch is OFF and that 5 ns output is operative. Check that miniature coax from A15 J1 SMA connector to front panel 2 ns BNC is not open or shorted. Check A15 Q3 and A15 CR1. Recalibrate the 500 MHz multiplier per paragraph 5-44 and set output amplitude as specified. Replace A15.</p>
------------------------------------	--

TABLE 5-4. VOLTS/DIV ATTENUATOR CHECK

6125B/C			VOLTMETER
OUTPUT MODE	VOLTS/DIV	MULTIPLIER	TYPICAL OUTPUT LIMITS
+DC	20 V	X10	+200 V ± 20 mV
-DC	20 V	X10	-200 V ± 20 mV
+DC	10 V	X10	+100 V ±140 mV
+DC	5 V	X10	+ 50 V ± 70 mV
+DC	2 V	X10	+ 20 V ± 28 mV
+DC	1 V	X10	+ 10 V ± 14 mV
+DC	0.5 V	X10	+ 5 V ± 7 mV
+DC	0.2 V	X10	+ 2 V ± 2.8 mV
+DC	0.1 V	X10	+ 1 V ± 1.4 mV
+DC	50 mV	X10	+ 0.5 V ±725 μV

TABLE 5-5. VOLTS MULTIPLIER CHECK

MULTIPLIER	NOMINAL OUTPUT VOLTS	INITIAL ERROR mV	ERROR SPREAD mV	MEAN ERROR mV	CORRECTING ERROR AT 200 V IN mV
X10	200 V				
X8	160 V				
X6	120 V				
X5	100 V				
X4	80 V				
X3	60 V				
X2	40 V				
X1	20 V				

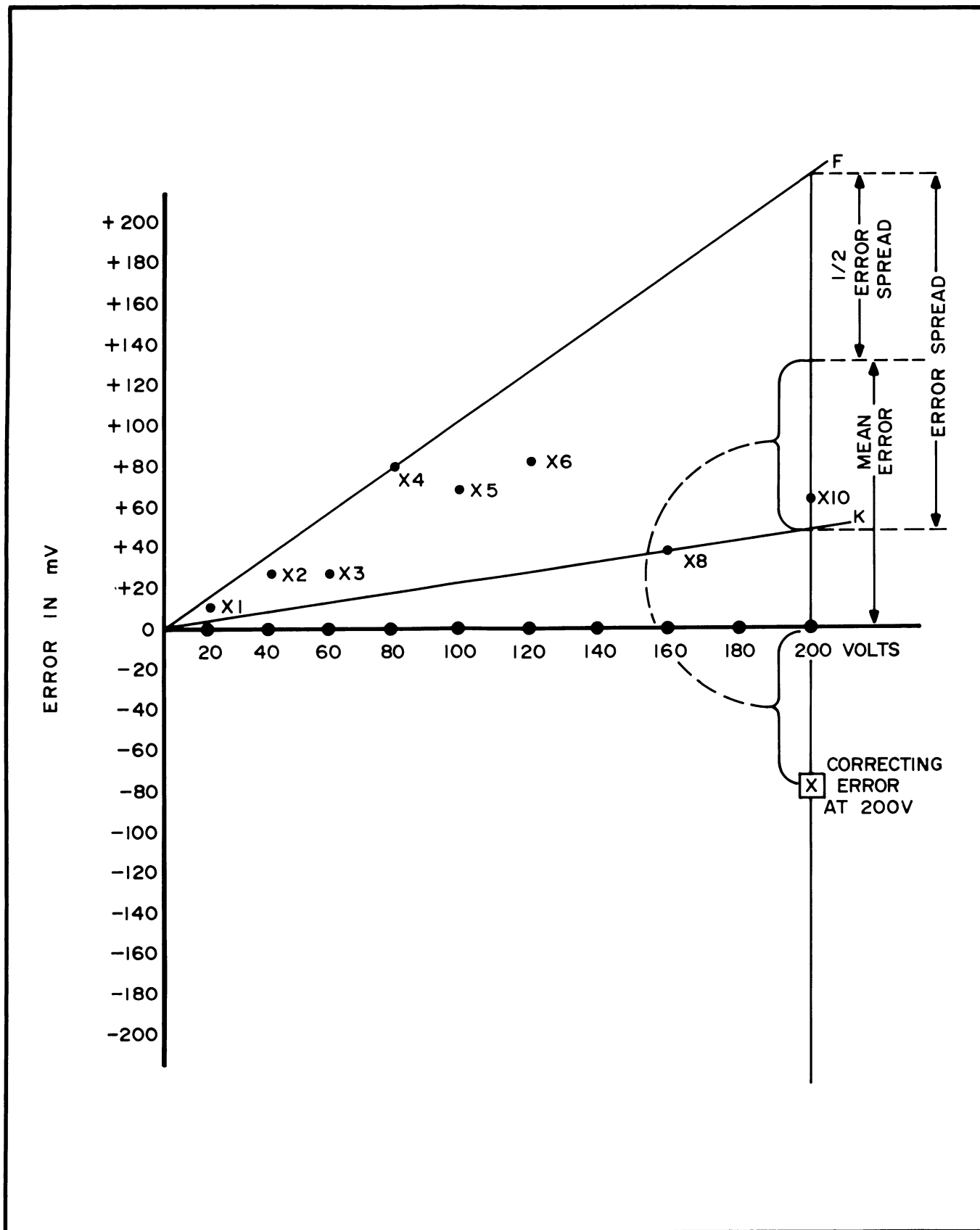
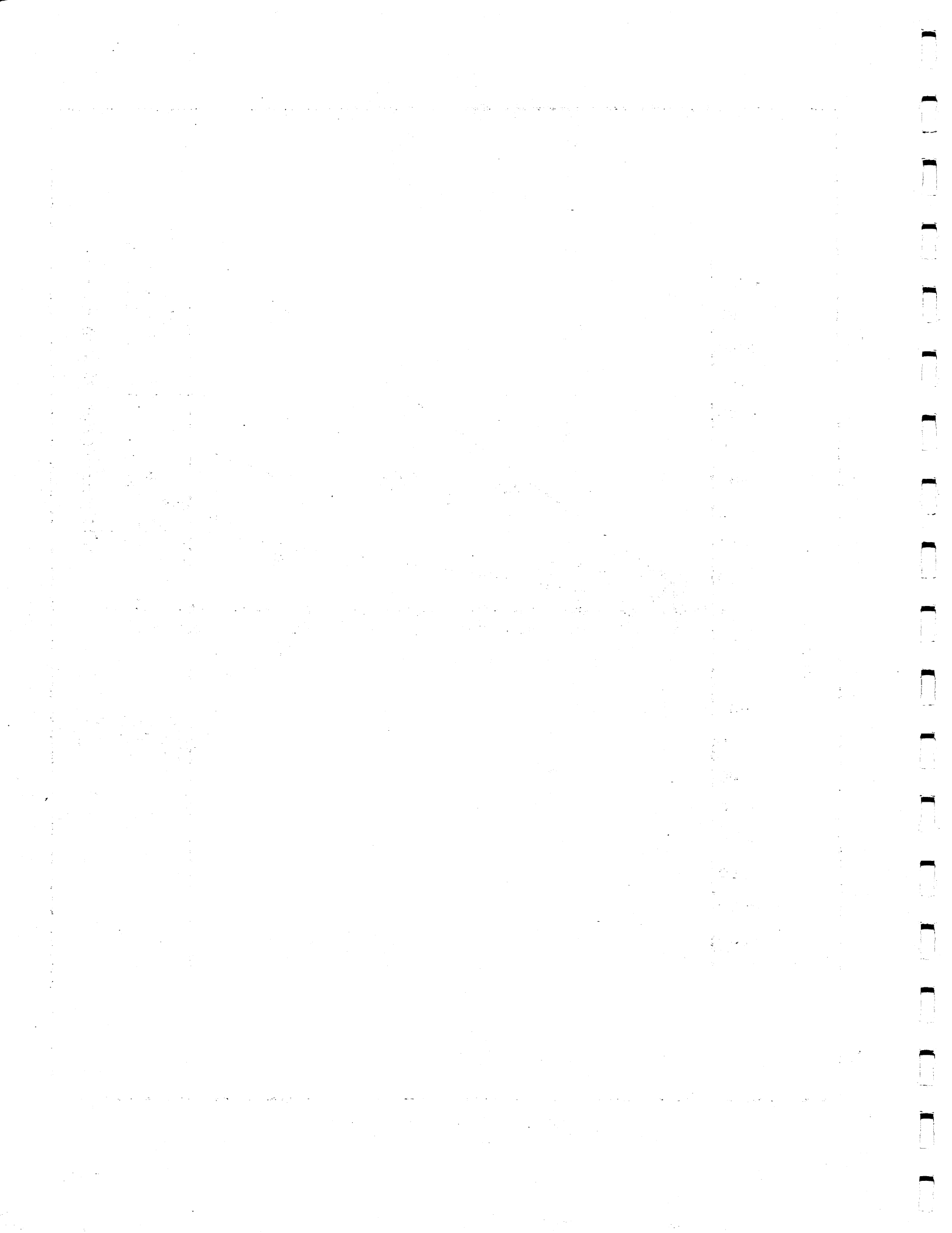

Figure 5-7. Error Correcting Graph



**PERFORMANCE ASSURANCE TEST RECORD
BALLANTINE MODEL 6125B/C**

Serial No. _____

Date _____

Options Installed _____

Performed By _____

Note: All tests shall be performed at reference conditions of 22°C to 28°C after warmup of two hours.

1. OSCILLATOR FREQUENCY ACCURACY (Paragraph 5-9)

- a. Nominal Power Line Frequency Check _____ MHz
- b. Low Line Voltage Check of Frequency _____ (✓)
- c. High Line Voltage Check of Frequency _____ (✓)

2. MARKER OUTPUT (Paragraph 5-10)

6125B/C		OSCILLOSCOPE		
TIME DIV	MULTIPLIER	TIME/DIV	MARKERS PER LINE	AMPLITUDE (✓) > 1 DIV
0.1 μs	X1	1 μs X10 (.1 μs)		
0.2 μs	X1	2 μs X10 (.2 μs)		
0.5 μs	X1	.5 μs		
1 μs	X1	1 μs		
2 μs	X1	2 μs		
5 μs	X1	5 μs		
10 μs	X1	10 μs		
20 μs	X1	20 μs		
50 μs	X1	50 μs		
.1 ms	X1	.1 ms		
.2 ms	X1	.2 ms		
.5 ms	X1	.5 ms		
1 ms	X1	1 ms		
2 ms	X1	2 ms		
5 ms	X1	5 ms		
10 ms	X1	10 ms		
20 ms	X1	20 ms		
50 ms	X1	50 ms		
.1 s	X1	.1 s		
.2 s	X1	.2 s		
.5 s	X1	.5 s		
.5 s	X2	.5 s		
.5 s	X5	.5 s		
.5 s	X10	.5 s		
.2 s	X10	.2 s		

3. TRIGGER PERIOD (Paragraph 5–11)

6125B/C TRIGGER PERIOD	OSCILLOSCOPE TIME/DIV	SQUARE WAVES PER DIV	AMPLITUDE > 250 mV
100 ns	1 μ s X10 (.1 μ s)		
1 μ s	1 μ s		
10 μ s	10 μ s		
100 μ s	100 μ s		
1 ms	1 ms		
10 ms	10 ms		
100 ms	100 ms		
1 s	1 s		

4. TRIGGER OUTPUT RISE TIME (Paragraph 5–12)

Amplitude > .25 volt _____ (✓)

Overshoot < 2% _____ (✓)

Rise Time < 1 ns, 10 to 90% _____ (✓)

5. HIGH FREQUENCY OUTPUT (Paragraph 5–13)

5 ns Amplitude (> 0.5 volt, < 0.6 volt p-p) _____ (✓)

5 ns Frequency (200 MHz \pm 1600 Hz) _____ MHz

2 ns Amplitude (> 0.5 volt) _____ (✓)

2 ns Frequency (> 0.5 volt, < 0.6 volt p-p) _____ MHz

6. EXTERNAL CLOCK INPUT (Paragraph 5–14)

10 MHz to 100 kHz at 2 V p-p drive _____ (✓)

7. TIME DEVIATION CHECK (Paragraph 5–15)

(> +10%) _____ (✓)

(> - 10%) _____ (✓)

8. VOLTS OUTPUT (Paragraph 5-16)

+DC Mode

(GND MODE DC Offset voltage _____ μV)

6125B/C			VOLTMETER
VOLTS/DIV.	MULTIPLIER	ERROR LIMITS	ERROR READING
20 V	X10	± 450 mV	
10 V	X10	± 250 mV	
5 V	X10	± 125 mV	
2 V	X10	± 50 mV	
1 V	X10	± 25 mV	
.5 V	X10	± 12.5 mV	
.2 V	X10	± 5 mV	
.1 V	X10	± 2.5 mV	
50 mV	X10	± 1.25 mV	
20 mV	X10	± 500 μV	
10 mV	X10	± 250 μV^*	
5 mV	X10	± 125 μV^*	
2 mV	X10	± 50 μV^*	
1 mV	X10	± 25 μV^*	
1 V	X1	± 2.5 mV	
1 V	X2	± 5 mV	
1 V	X3	± 7.5 mV	
1 V	X4	± 10 mV	
1 V	X5	± 11.5 mV	
1 V	X6	± 15 mV	
1 V	X8	± 20 mV	

*Add correction.

9. VOLTS DEVIATION CHECK (Paragraph 5-17)

(\triangleright +10%)

_____ (✓)

(\triangleright +10%)

_____ (✓)

10. VOLTS OUTPUT MODES AND SQUARE WAVE SHAPE (Paragraph 5-18)

6125B/C MODE	OUTPUT	SHAPE
-DC	_____ (✓)	
OFF	_____ (✓)	
10 kHz	_____ (✓)	_____ (✓)
1 kHz	_____ (✓)	_____ (✓)
100 Hz	_____ (✓)	_____ (✓)
10 Hz	_____ (✓)	_____ (✓)

11. 6126C REMOTE PROGRAM CHECK

_____ (√)

12. OPTIONS

a. IEEE 488-1975 Bus Check — Option 60

_____ (√)

b. 10 MHz ovenized oscillator — Option 14

_____ (√)

13. MECHANICAL CONDITION

Test Engineer

Date

SECTION 6 PARTS LIST & CIRCUIT DIAGRAMS

The replacement parts listed are available from the vendors listed or from Ballantine Laboratories. Your local Ballantine Field Engineering Representative may also carry a stock of parts and can assist you. If pricing quotations are required for parts and or repairs your local representative will give the most rapid service or you may contact the Ballantine Factory directly.

When ordering replacement parts always give the following information:

- a) Instrument Model number
- b) Serial number
- c) Ballantine Part number
- d) Schematic Symbol number
- e) Identification and description of part

Ballantine will do its best to improve the instrument and make changes in style of components and replacement parts. Replacement parts may differ in appearance from those found in your instrument but are always equal or superior in performance. Where necessary minor mechanical modifications may be required in the replacement of the components.

Parts are generally available locally for most replacements. The parts list calls out the recommended vendors where applicable.

The instrument may substitute alternate components but the use of parts specified in this parts list is recommended. A part similar to the part initially installed at the factory may be used, i.e., a 5% composition resistor may be replaced with a similar part or a 5% film resistor or the preferred 1% metal film resistor. Use of the preferred component will always simplify calibration and speed repairs.

Any selected component is generally identified in this manual and may be replaced with a similarly valued part unless re-selection is required due to replacement or change of its

related part. The schematics and calibration procedures identify selected components and replacement procedures.

The Manufacturer Code is taken from Federal Supply Code Cataloging Handbooks H4-1, H4-2, and H4-3. Ballantine Code is 50423.

The following parts coding are used:

CVC	Capacitor, Variable, Ceramic
CCT	Capacitor, Ceramic, Tubular
CFP	Capacitor, Fixed, Plastic
CCD	Capacitor, Ceramic, Disc
CYF	Capacitor, Mylar, Foil
CMD	Capacitor, Mlca, Dipped
CMM	Capacitor, Mica, Molded
CEA	Capacitor, Electrolytic, Aluminum
CET	Capacitor, Electrolytic, Tantalum
DGP	Diode, General Purpose
DZG	Diode, Zener, General Purpose
DRP	Diode, Bridge, Power
FLT	Filter
ICP	Integrated Circuit
TRQ	Transistor
RFF	Resistor, Fixed, Film
RFC	Resistor, Fixed, Composition
RVC	Resistor, Variable, Composition
RFW	Resistor, Fixed, Wirewound
SWC	Switch
LMP	Lamp
TRX	Transformer

Resistors may generally be replaced by Corning Electronics (CCW) type N-55, N-60 and C-32. Allen Bradley carbon composition resistors type EB may also be used but should generally be avoided (except for emergency replacements) in favor of the preferred part listed in this parts list.

REPLACEABLE ASSEMBLIES

ASSEMBLY	6125B	6125C	BALLANTINE P/N	DESCRIPTION
A1		✓	89-10815-1A	Remote Program - Volts
A1	✓		89-10498-1A	Shorting Board - Volts
A2	✓	✓	89-10499-1A	Programmable P.S. - Volts
A3	✓	✓	89-10500-1A	P.S. Control - Volts
A4	✓	✓	89-10501-1A	MULTIPLIER Select - Volts
A5	✓	✓	89-10502-1A	10 μ V to .5 mV Select - Volts
A6	✓	✓	89-10503-1A	1 mV to 20 V Select - Volts
A7	✓		89-10524-1A	Output Mode Select - Volts (6125B)
A7		✓	89-10504-1A	Output Mode Select - Volts (6125C)
A8		✓	89-10505-1A	VOLTS/DIV Display
A9		✓	89-10506-1A	OUTPUT MODE Display
A10	✓		89-10509-1A	Shorting Board - Time
A10		✓	89-10817-1A	Remote Program - Time
A11	✓		89-10525-1A	Display Drive and 10 MHz Osc. - Time
A11		✓	89-10511-1A	Display Drive and 10 MHz Osc. - Time
A12	✓	✓	89-10512-1A	Time/Div Decoder - Time
A13	✓	✓	89-10513-1A	Time/Div Select - Time
A14	✓	✓	89-10514-1A	100 MHz Phase Lockloop Time
A15	✓	✓	89-10515-1A	200 MHz and 500 MHz Multiplier - Time
A16	✓	✓	89-10516-1A	Time Output Amplifier - Time
A17	✓	✓	89-10517-1A	DPM Interconnect
A18	✓	✓	89-10526-1A	DEVIATION Board - Time
A20		✓	89-10520-1A	TIME/DIV Display - Time
A21		✓	89-10521-1A	MULTIPLIER Display - Volts
A22		✓	89-10522-1A	TRIGGER PERIOD Display - Time
A23	✓		89-10557-1A	DPM (6125B)
A23		✓	89-10560-1A	DPM (6125C)
A23		Opt. 60	89-10820-1A	DPM (Opt. 60)
A24	✓	✓	89-10558-1A	% DEVIATION Display
A25		✓	89-10507-1A	MULTIPLIER Display - Time
A26	✓	✓	89-10508-1A	Interconnect - Volts
A27	✓	✓	89-10523-1A	Interconnect - Time
A28		Opt. 60	89-10811-1A	488 Bus Adapter
A29		Opt. 60	89-10812-1A	Latch Assembly
A30		Opt. 60	89-10813-1A	488 Plug Adapter
A31		Opt. 60	89-10814-1A	Remote Program - Volts
A32		Opt. 60	89-10816-1A	Remote Program - Time
A33		Opt. 60	89-10819-1A	DPM Connect and Coupler

PARTS LIST, A101 FRONT PANEL COMMON MODEL 6125B/C (89-10671-1A)

SCHEMATIC REF	BALLANTINE PART NO.	DESCRIPTION	MFR CODE	MFR PART NUMBER
DS..2	16-10000-0A	LMP PAN GALIUM ARSENIIDE	28480	(HP)-5082-4440
DS..3	16-10000-0A	LMP PAN GALIUM ARSENIIDE	28480	(HP)-5082-4440
J...1	31-03379-0A	CON UG-1094/U BNC,DAGE	29587	STATE ELECT.PARTS
J...2	31-03379-0A	CON UG-1094/U BNC,DAGE	29587	STATE ELECT.PARTS
J...3	31-03379-0A	CON UG-1094/U BNC,DAGE	29587	STATE ELECT.PARTS
J...4	31-03379-0A	CON UG-1094/U BNC,DAGE	29587	STATE ELECT.PARTS
J...5	31-10164-0A	CON BNC FLOATING PANEL MOUNT	2260	AMPHENOL 31-010
J...6	31-03379-0A	CON UG-1094/U BNC,DAGE	29587	STATE ELECT.PARTS
R...1	09-10167-1B	RVC 500.0 500.0MW 6125B	50423	BLI
R...3	09-10168-1A	RVC 10.0 K 500.0MW M 6125B	11236	CTS SERIES 200
R...4	09-10169-1A	RVC 2.2 K 500.0MW M 6125B	11236	CTS SERIES 200
S...1	25-10136-1C	SWC 6125B T/DIV SWITCH	50423	BLI
S...2	25-10202-1B	SWC 6125B/C VOLTS/DIV CW-OFF	50423	BLI
S...3	25-10001-0A	SWC DPDT TOGGLE MINI	9353	C & K 7201

PARTS LIST, A101 FRONT PANEL MODEL 6125C ONLY (89-10529-1A)

SCHEMATIC REF	BALLANTINE PART NO.	DESCRIPTION	MFR CODE	MFR PART NUMBER
DS1	16-10000-0A	LMP PAN GALIUM ARSENIIDE	28480	(HP)-5082-4440
DS4	16-10000-0A	LMP PAN GALIUM ARSENIIDE	28480	(HP)-5082-4440

PARTS LIST, A100 REAR PANEL COMMON MODEL 6125B/C (89-10528-1A)

SCHEMATIC REF	BALLANTINE PART NO.	DESCRIPTION	MFR CODE	MFR PART NUMBER
J...1	31-03379-0A	CON UG-1094/U BNC,DAGE	29587	STATE ELECT.PARTS
J...2	31-10166-0A	REC UNIVERSAL IEEE FUSED REC	0	CORCOM VS 7F FILTERED 6J4
RV1	14-10000-0A	REG LINE SURGE SUPPRESSOR	24446	GE VP 150A10
RV2	14-10000-0A	REG LINE SURGE SUPPRESSOR	24446	GE VP 150A10
T....1	20-10063-1P	TRX 6125B/C REPLACEMENT	50423	BLI
U...1	24-10153-0A	ICP UA7805 5V REG.	7263	FCH UGH7805393
U...2	24-10153-0A	ICP UA7805 5V REG.	7263	FCH UGH7805393

PARTS LIST, A105 FINAL ASSEMBLY MODEL 6125B ONLY (89-10533-1A)

SCHEMATIC REF	BALLANTINE PART NO.	DESCRIPTION	MFR CODE	MFR PART NUMBER
J...1	88-10103-1A	CAA 6127A LOW DIST. OUTPUT	50423	BLI

1. The first part of the document discusses the importance of maintaining accurate records of all transactions. It emphasizes that proper record-keeping is essential for the integrity of the financial system and for the ability to detect and prevent fraud. The text notes that without reliable records, it would be difficult to verify the accuracy of financial statements and to identify any irregularities.

2. The second part of the document focuses on the role of internal controls in ensuring the reliability of financial information. It describes how internal controls are designed to prevent errors and fraud by establishing a clear separation of duties and by requiring proper authorization for all transactions. The text also highlights the importance of regular monitoring and evaluation of these controls to ensure they remain effective over time.

3. The third part of the document discusses the impact of external audits on the financial reporting process. It explains that external audits provide an independent assessment of the company's financial statements and help to build confidence among investors and other stakeholders. The text notes that companies that undergo regular audits are more likely to have accurate and reliable financial information.

4. The final part of the document concludes by summarizing the key points discussed. It reiterates that maintaining accurate records, implementing strong internal controls, and undergoing regular external audits are all critical components of a robust financial reporting system. The text encourages companies to take a proactive approach to financial management to ensure the long-term success and sustainability of their organization.

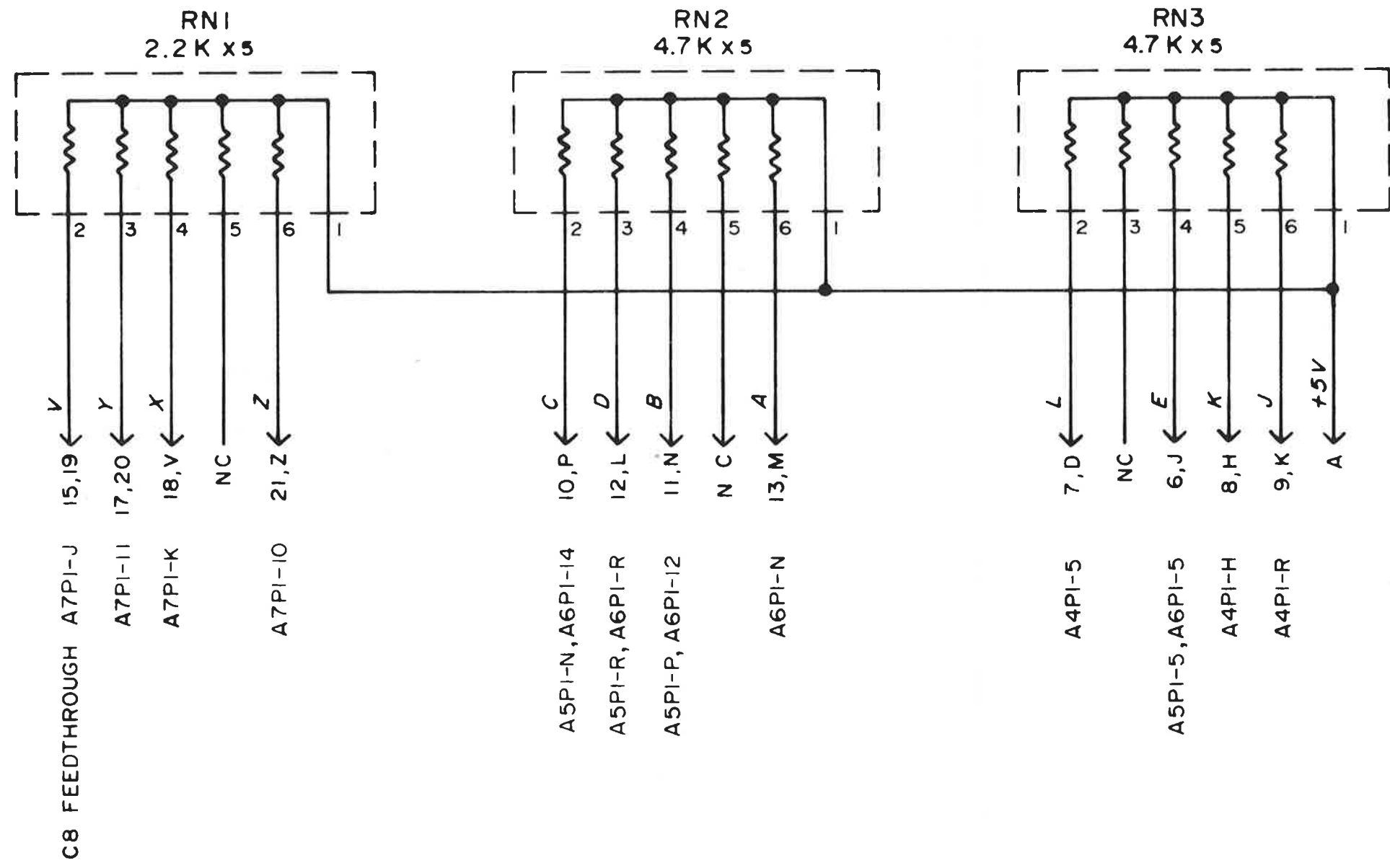

C8 FEEDTHROUGH

Figure 6-1. A1 6125B Volts Shorting Board

PARTS LIST, A1 SHORTING BOARD - VOLTS MODEL 6125B (89-10498-1A)

SCHEMATIC REF	BALLANTINE PART NO.	DESCRIPTION	MFR CODE	MFR PART NUMBER
RN..1	13-10056-0A	RNF 2.2 K 6 PIN SIP 5 RES	80053	BECKMAN #783-1-R-2.2K
RN..2	13-10047-0A	RNF 4.7 K 6 PIN SIP 5 RES.	80053	BECKMAN 783-1-R4.7K
RN..3	13-10047-0A	RNF 4.7 K 6 PIN SIP 5 RES.	80053	BECKMAN 783-1-R4.7K

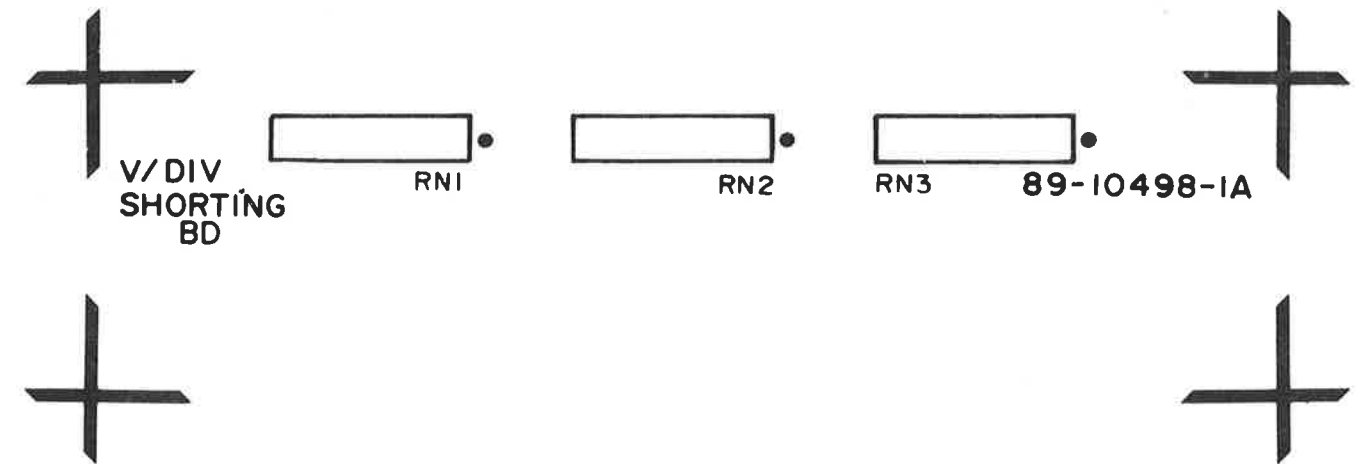

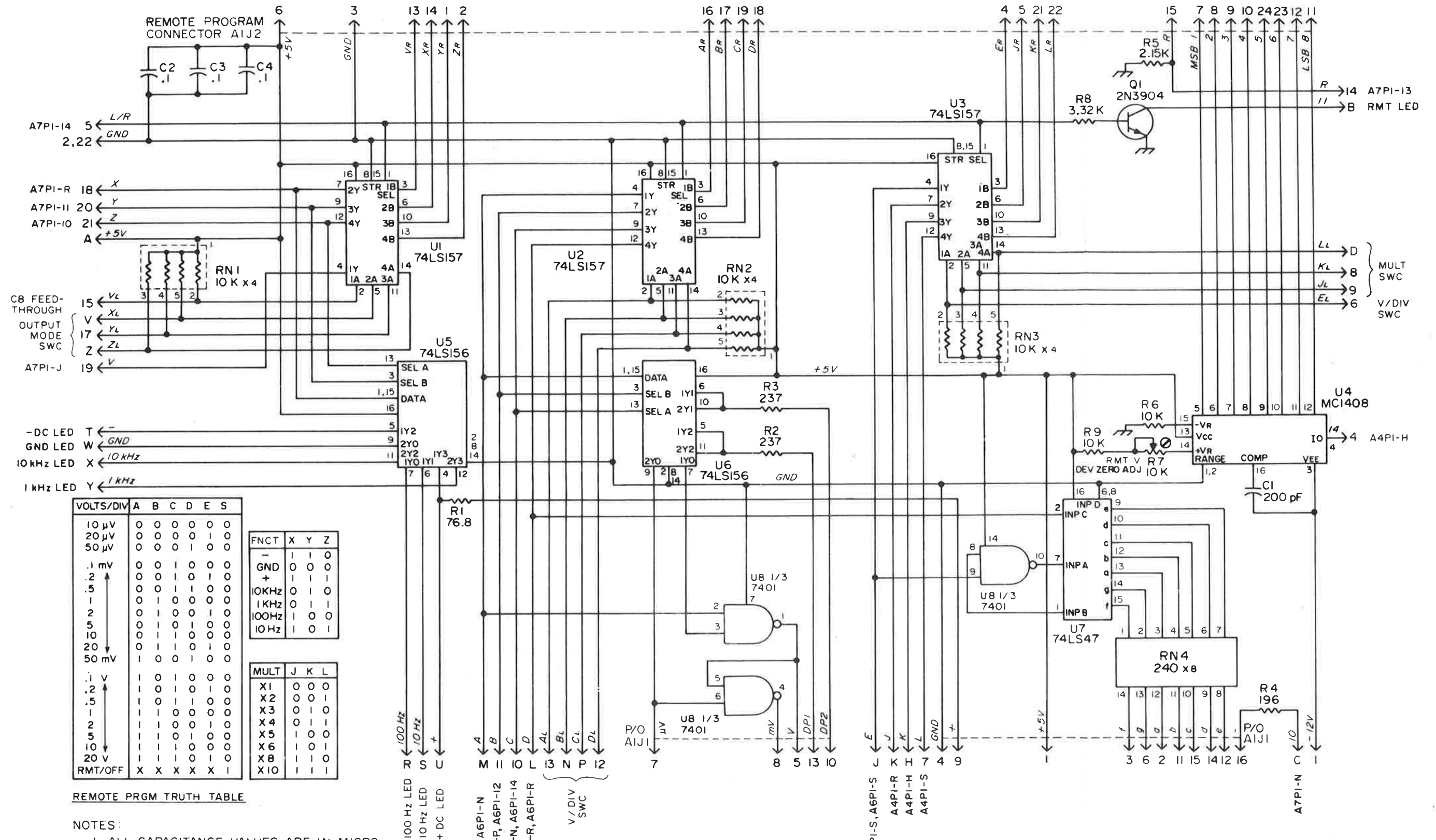

NOTES:

1. ALL CAPACITANCE VALUES ARE IN MICRO-FARADS AND ALL RESISTANCE VALUES ARE IN OHMS UNLESS NOTED OTHERWISE.
2. → DENOTES CONTACT OF AIPI, UNLESS NOTED OTHERWISE.

Figure 6-2. A1 6125C Volts Remote Program Input

PARTS LIST, A1 REMOTE PROGRAMMING MODEL 6125C (89-10815-1A)

SCHEMATIC REF	BALLANTINE PART NO.	DESCRIPTION	MFR CODE	MFR PART NUMBER
C...1	07-10351-0A	CMD 200.0PF 500.0 V TCE 5%	84171	ARCO DM15ED200J03 -ARCO
C...2	07-10562-0A	CCR 0.1 UF 50V .3 SPACE	0	AVX CERAMICS MD015E104ZAA
C...3	07-10562-0A	CCR 0.1 UF 50V .3 SPACE	0	AVX CERAMICS MD015E104ZAA
C...4	07-10562-0A	CCR 0.1 UF 50V .3 SPACE	0	AVX CERAMICS MD015E104ZAA
Q...1	10-10043-0A	TRQ 2N3904 NPN 1 40 PTO=92	4713	MOT 1 300M 40
R...1	12-12185-0A	RFF 76.8 250.0MW F+- 1%	16299	CGW RN55D 76R8 F
R...2	12-12236-0A	RFF 237.0 250 MW F+-1%	16299	CGW RN55D 2370 F
R...3	12-12236-0A	RFF 237.0 250 MW F+-1%	16299	CGW RN55D 2370 F
R...4	12-12228-0A	RFF 196.0 250 MW F+-1%	16299	CGW RN55D 1960 F
R...5	12-12332-0A	RFF 2.15K 250.0MW F+- 1%	16299	CGW RN55D 2151 F
R...6	12-12400-0A	RFF 10.0 K 250.0MW F+- 1%	16299	CGW RN55D 1002 F
R...7	09-10093-0A	RVF 10.0 K 500.0MW KVERT MT	73138	HELIPOT 72XW 10K
R...8	12-12350-0A	RFF 3.32K 250.0MW F+- 1%	16299	CGW RN55D 3321 F
R...9	12-12400-0A	RFF 10.0 K 250.0MW F+- 1%	16299	CGW RN55D 1002 F
RN...1	13-10018-0A	RNF 10.0 K 0.3 W F	80053	BECKMAN 783-1-R10K
RN...2	13-10018-0A	RNF 10.0 K 0.3 W F	80053	BECKMAN 783-1-R10K
RN...3	13-10018-0A	RNF 10.0 K 0.3 W F	80053	BECKMAN 783-1-R10K
RN...4	13-10022-0A	RNF 270.0 0.2 WF	0	BECKMAN 899-3R-270
U...1	24-10163-0A	ICP 74LS157 MULTIPLEXER	1295	T.I. SN74LS157
U...2	24-10163-0A	ICP 74LS157 MULTIPLEXER	1295	T.I. SN74LS157
U...3	24-10163-0A	ICP 74LS157 MULTIPLEXER	1295	T.I. SN74LS157
U...4	24-10175-0A	ICP 1408 D TO A CONVERTER	4713	MOTOROLA MC1408
U...5	24-10164-0A	ICP 74LS156 DEMULTIPLEXER	1295	T.I. SN74LS156
U...6	24-10164-0A	ICP 74LS156 DEMULTIPLEXER	1295	T.I. SN74LS156
U...7	24-10139-0A	ICP 74LS47 7SEG DRVR LO-PWR	27014	NAT.SEMI DM74LS47
U...8	24-10182-0A	ICP 7401 QUAD 2 IN NAND	1295	T.I. SN7401 OR EQUIP.

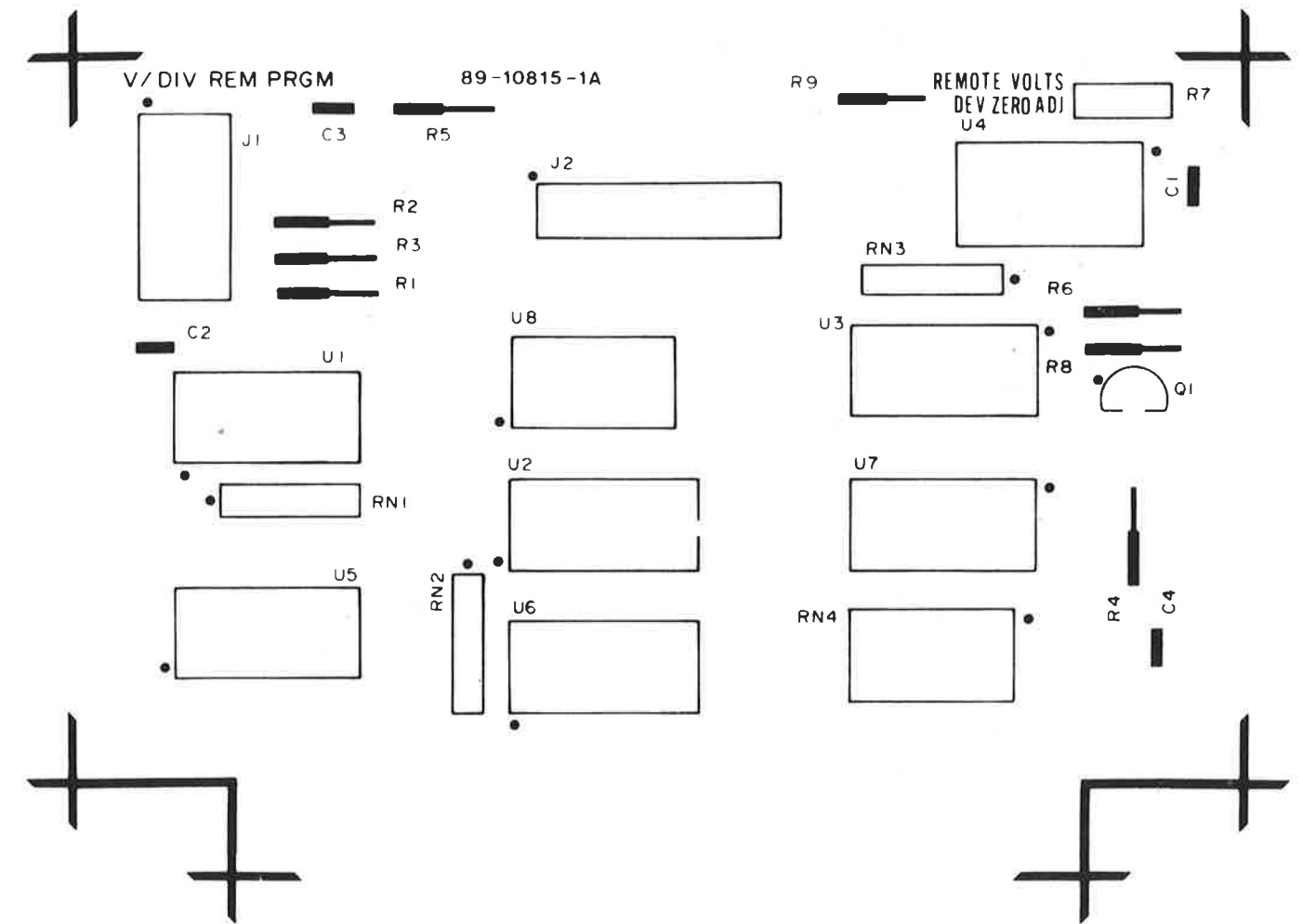

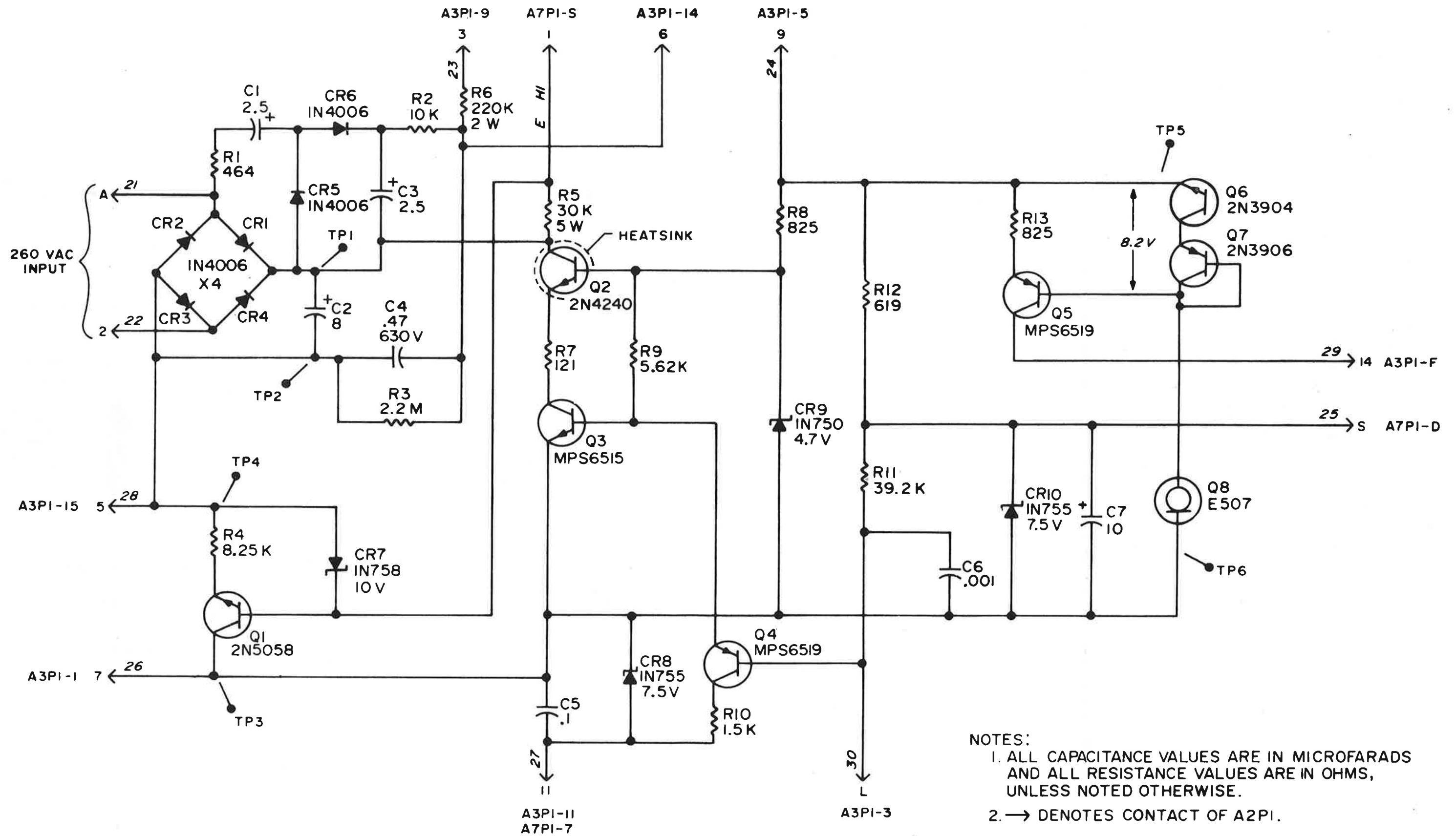
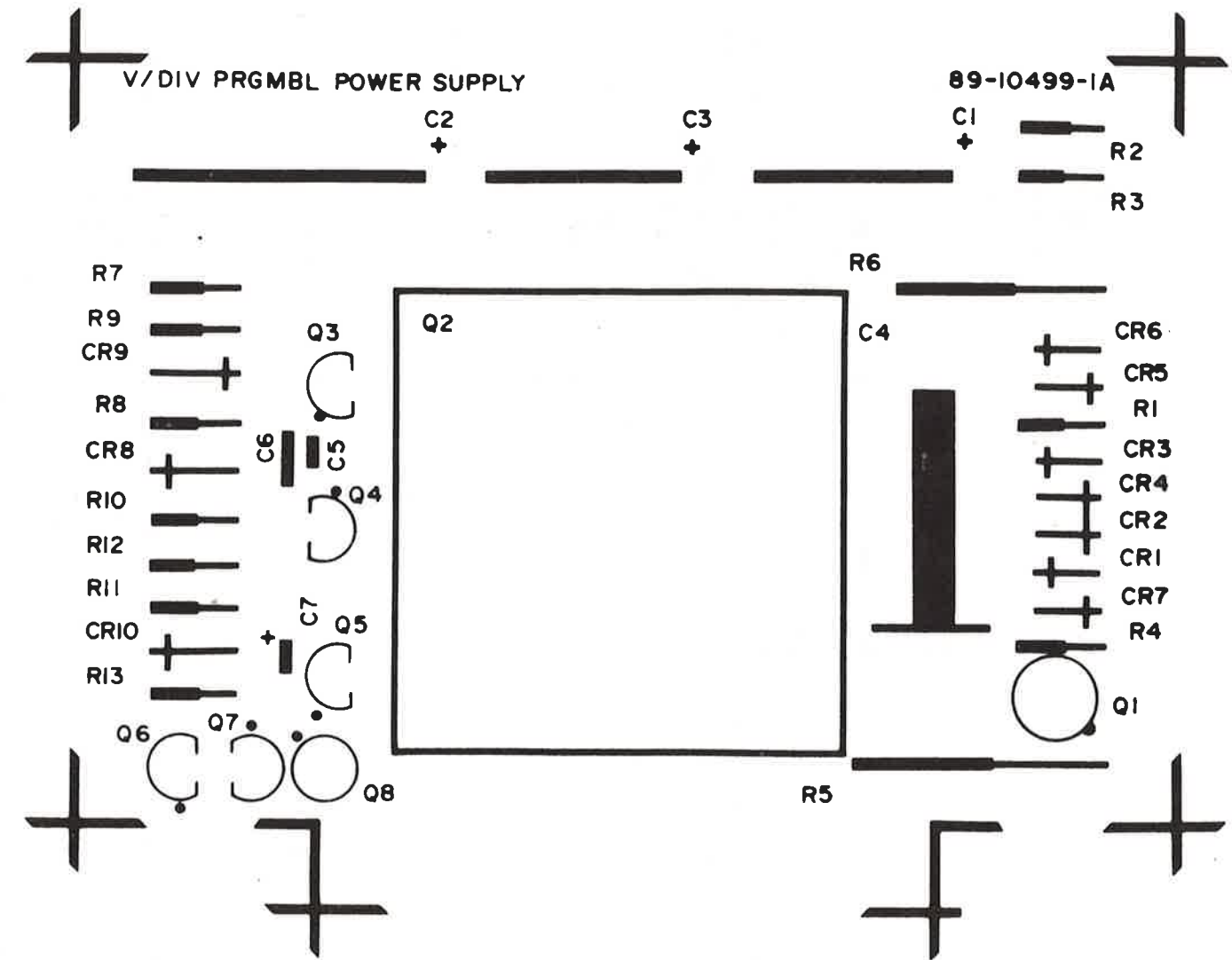
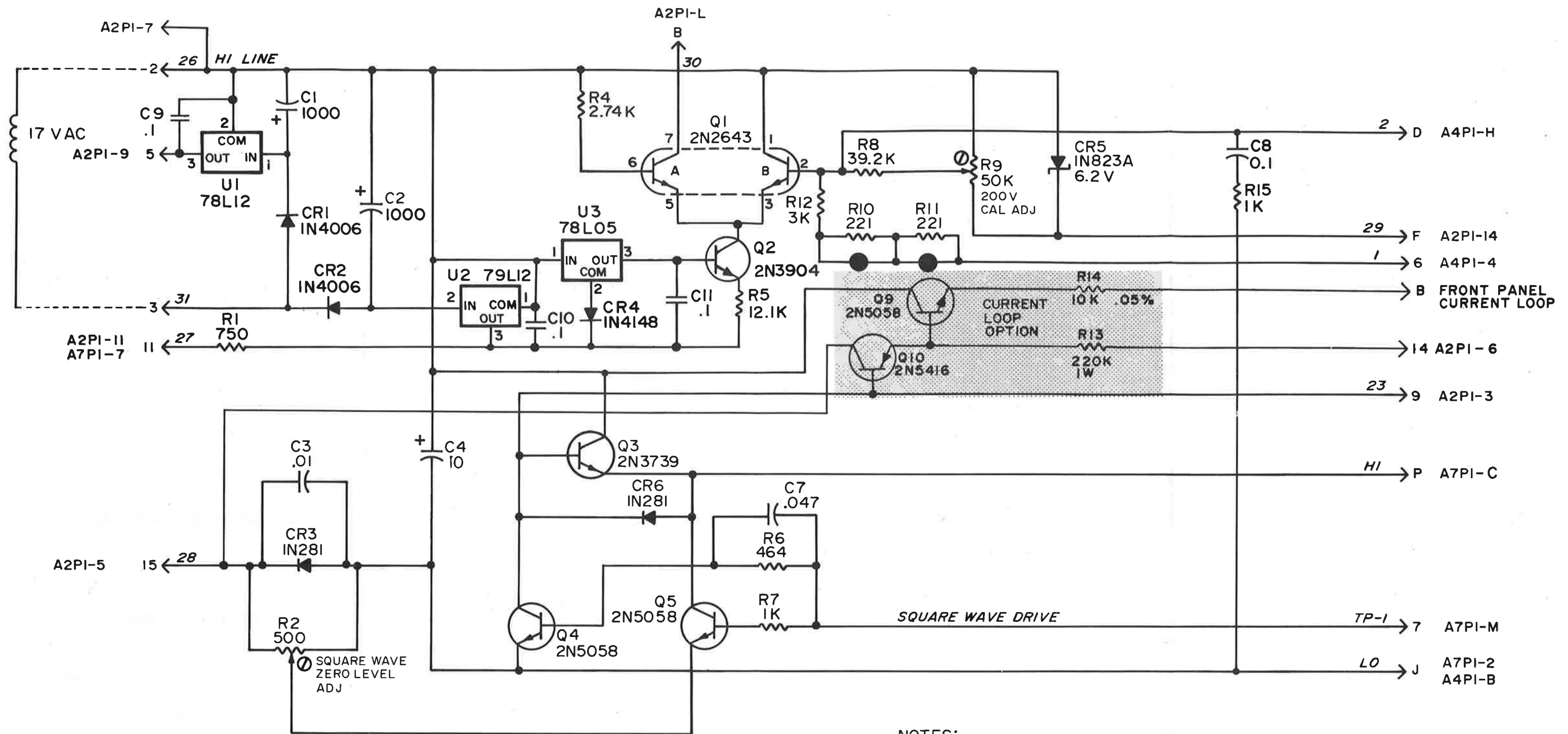

Figure 6-3. A2 6125B/C Programmable Volts Power Supply

PARTS LIST, A2 PROGRAMMABLE VOLTS POWER SUPPLY MODEL 6125B/C (89-10499-1A)

SCHEMATIC REF	BALLANTINE PART NO.	DESCRIPTION	MFR CODE	MFR PART NUMBER
C...1	07-10421-0A	CER 4.7UF 350.0 V-10+50%	80031	3072FE479T350SF
C...2	07-10420-0A	CEA 10UF 350.0 V-10+50%	80031	3072LF100T350SF
C...3	07-10421-0A	CER 4.7UF 350.0 V-10+50%	80031	3072FE479T350SF
C...4	07-10423-0A	CBM 470.0NF 630.0 VK	80031	MEPCO C280MCG/A470K
C...5	07-10562-0A	CCR 0.1 UF 50V .3 SPACE	0	AVX CERAMICS MD015E104ZAA
C...6	07-02592-0A	CCD 1.0NF 1.0KVK+-10%	84171	ARCO TYPE CCD-102
C...7	07-10053-0A	CET 10.0UF 35.0V M	56289	199D106X0035DA2
CR..1	05-08058-0A	DGP 1N4006 400 1A	15238	ITT SI D046
CR..2	05-08058-0A	DGP 1N4006 400 1A	15238	ITT SI D046
CR..3	05-08058-0A	DGP 1N4006 400 1A	15238	ITT SI D046
CR..4	05-08058-0A	DGP 1N4006 400 1A	15238	ITT SI D046
CR..5	05-08058-0A	DGP 1N4006 400 1A	15238	ITT SI D046
CR..6	05-08058-0A	DGP 1N4006 400 1A	15238	ITT SI D046
CR..7	05-10035-0A	DZG 1N 758A 10 20M .4	4713	MOT SI
CR..8	05-10007-0A	DZG 1N 755A 7.5 20M .4	4713	MOT SI
CR..9	05-10010-0A	DZG 1N 750A 4.7 20M .4	4713	MOT SI
CR.10	05-10007-0A	DZG 1N 755A 7.5 20M .4	4713	MOT SI
Q...1	10-10016-0A	TRQ 2N5058 NPN 1 300	7263	FCH 5 10
Q...2	10-10123-0A	TRQ 2N4240 HI VOLTAGE NPN	3607	RCA 2N4240
Q...3	10-10005-0A	TRQ MPS6515 NPN 1 25 PT0-92	4713	MOT .350 390M 150
Q...4	10-10009-0A	TRQ MPS6519 PNP 1 25 PT0-92	4713	MOT 1 340M 250
Q...5	10-10009-0A	TRQ MPS6519 PNP 1 25 PT0-92	4713	MOT 1 340M 250
Q...6	10-10043-0A	TRQ 2N3904 NPN 1 40 PT0-92	4713	MOT 1 300M 40
Q...7	10-09473-0A	TRQ 2N3906 PNP 1 40 PT0-92	4713	MOT 1 200M 60
Q...8	10-10099-0A	TRQ E507	17856	SILICONIX
R...1	12-12264-0A	RFF 464.0 250 MW F+-1%	16299	CGW RN55D 4640 F
R...2	12-12400-0A	RFF 10.0 K 250.0MW F+- 1%	16299	CGW RN55D 1002 F
R...3	12-09823-0A	RFC 2.2 M 250.0MW J+- 5%	1121	A-B TYP CB
R...4	12-12388-0A	RFF 8.25K 250.0MW F+- 1%	16299	CGW RN55D 8251 F
R...5	12-12734-0A	RFW 30.0 K 5.0 W F 20PPM	75042	IRC AS=5
R...6	12-13112-0A	RFC 220.0 K 2.0 W J	1121	A-B 220K HB TYPE 5%
R...7	12-12208-0A	RFF 121.0 250.0MW F+- 1%	16299	CGW RN55D 1210 F
R...8	12-12288-0A	RFF 825.0 250 MW F+-1%	16299	CGW RN55D 8250 F
R...9	12-12372-0A	RFF 5.62K 250.0MW F+- 1%	16299	CGW RN55D 5621 F
R...10	12-12317-0A	RFF 1.50K 250 MW F+-1%	16299	CGW RN55D 1501 F
R...11	12-12457-0A	RFF 39.2 K 250.0MW F+- 1%	16299	CGW RN55D 3922 F
R...12	12-12276-0A	RFF 619.0 250 MW F+-1%	61299	CGW RN55D 6190 F
R...13	12-12288-0A	RFF 825.0 250 MW F+-1%	16299	CGW RN55D 8250 F





NOTES:

1. ALL CAPACITANCE VALUES ARE IN MICROFARADS AND ALL RESISTANCE VALUES ARE IN OHMS, UNLESS NOTED OTHERWISE.
2. ● INDICATES A SOLDER CONNECTION WHICH MAY BE REMOVED TO ADJUST R9 CALIBRATION RANGE DURING TEST.
3. → DENOTES CONTACT OF A3PI.
4. ALL RESISTOR VALUES SHOWN ARE FOR 1% RESISTORS.

Figure 6-4. A3 6125B/C Volts Power Supply Control

PARTS LIST, A3 VOLTS POWER SUPPLY CONTROL MODEL 6125B/C (89-10500-1A)

SCHEMATIC REF	BALLANTINE PART NO.	DESCRIPTION	MFR CODE	MFR PART NUMBER
C...1	07-10422-0A	CEA1000.0UF 25.0 V -10+50%	80031	MEPCO ET102X025A03
C...2	07-10422-0A	CEA1000.0UF 25.0 V -10+50%	80031	MEPCO ET102X025A03
C...3	07-10373-0A	CCD 10.0NF 25.0 VK -20+80%	56289	SPRAGUE HY-520
C...4	07-10420-0A	CEA 10UF 350.0 V-10+50%	80031	3072LF100T350SF
C...7	07-10214-0A	CCD 47. NF 25. VM	56289	SPR C069B250J473M OR EQUV
C...8	07-10223-0A	CYF 100. NF 250. VK	73445	AMPREX C280AE/A100K
C9	07-20094-0A	CCD .1UF 25.0 V +-20%	91418	M25-1
C10	07-20094-0A	CCD .1UF 25.0 V +-20%	91418	M25-1
C11	07-20094-0A	CCD .1UF 25.0 V +-20%	91418	M25-1
CR..1	05-08058-0A	DGP 1N4006 400 1A	15238	ITT SI D046
CR..2	05-08058-0A	DGP 1N4006 400 1A	15238	ITT SI D046
CR..3	05-10025-0A	DGP 1N 281 75 1A.08	15238	ITT GE D07
CR..4	05-10049-0A	DGP 1N4148 100 10M	1295	TI SI D035 4 5 JAN
CR..5	05-10040-0A	DZG 1N 823A 6.2 7.5M .4	4713	MOT SI D07
CR..6	05-10025-0A	DGP 1N 281 75 1A.08	15238	ITT GE D07
Q...1	10-10013-0A	TRQ 2N2643 NPN 2 40 M65407	4713	MOT 1200 40M 100
Q...2	10-10043-0A	TRQ 2N3904 NPN 1 40 PT0-92	4713	MOT 1 300M 40
Q...3	10-10015-0A	TRQ 2N3739 NPN 1 300 MT0-66	4713	MOT 20 10M 30
Q...4	10-10016-0A	TRQ 2N5058 NPN 1 300	7263	FCH 5 10
Q...5	10-10016-0A	TRQ 2N5058 NPN 1 300	7263	FCH 5 10
R...1	12-12284-0A	RFF 750.0 250 MW F+-1%	16299	CGW RN550D 7500 F
R...2	09-10094-0A	RVF 500.0 500.0MW KVERT MT	73138	HELIPOT 72XW 500
R...4	12-12342-0A	RFF 2.74K 250.0MW F+- 1%	16299	CGW RN55D 2741 F
R...5	12-12408-0A	RFF 12.1 K 250.0MW F+- 1%	16299	CGW RN55D 1212 F
R...6	12-12264-0A	RFF 464.0 250 MW F+-1%	16299	CGW RN55D 4640 F
R...7	12-12300-0A	RFF 1.0 K 250 MW F+-1%	16299	CGW RN55D 1001 F
R...8	12-12457-0A	RFF 39.2 K 250.0MW F+- 1%	16299	CGW RN55D 3922 F
R...9	09-09956-0A	RVF 50.0 K 750.0MW	32997	HOU TYP 3069P
R...10	12-12233-0A	RFF 221.0 250 MW F+-1%	16299	CGW RN55D 2210 F
R...11	12-12233-0A	RFF 221.0 250 MW F+-1%	16299	CGW RN55D 2210 F
R...12	12-12630-0A	RFP 3.0 K 200.0MW +- .02%	0	VISHAY S102C 3 K .02%
R...15	12-12300-0A	RFF 1.0 K 250 MW F+-1%	16299	CGW RN55D 1001 F
U...1	24-10286-0A	ICP 12V 100MA REG. TU-92	7263	FAIRCHILD UA78L12 TO-92
U...2	24-10302-0A	ICP -12V 100MA REG 5% TU-92	0	MOT MC79L12ACP O/E
U...3	24-10301-0A	ICP 5V 100MA REG TU-92	0	MOT MC78L05ACP O/E

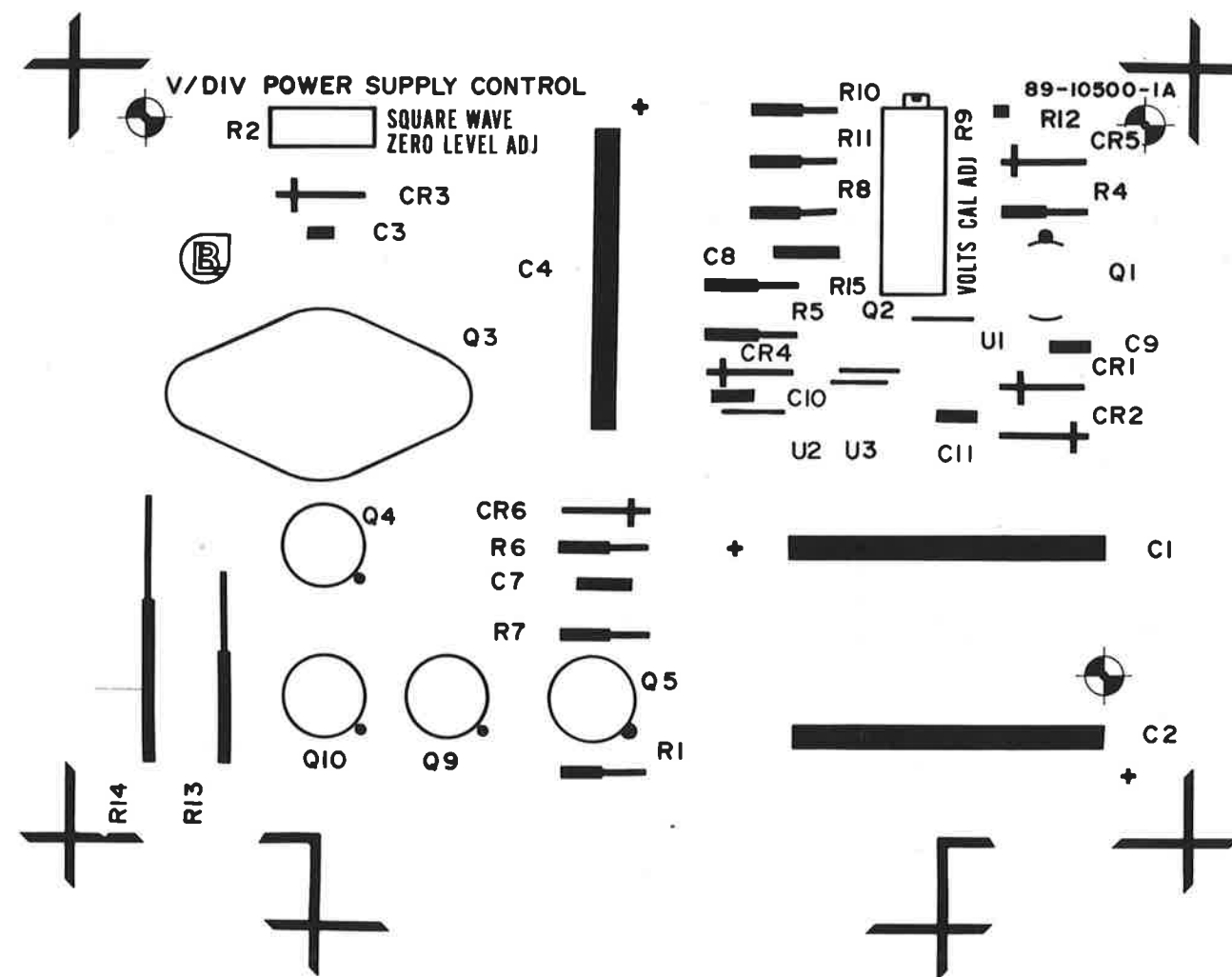

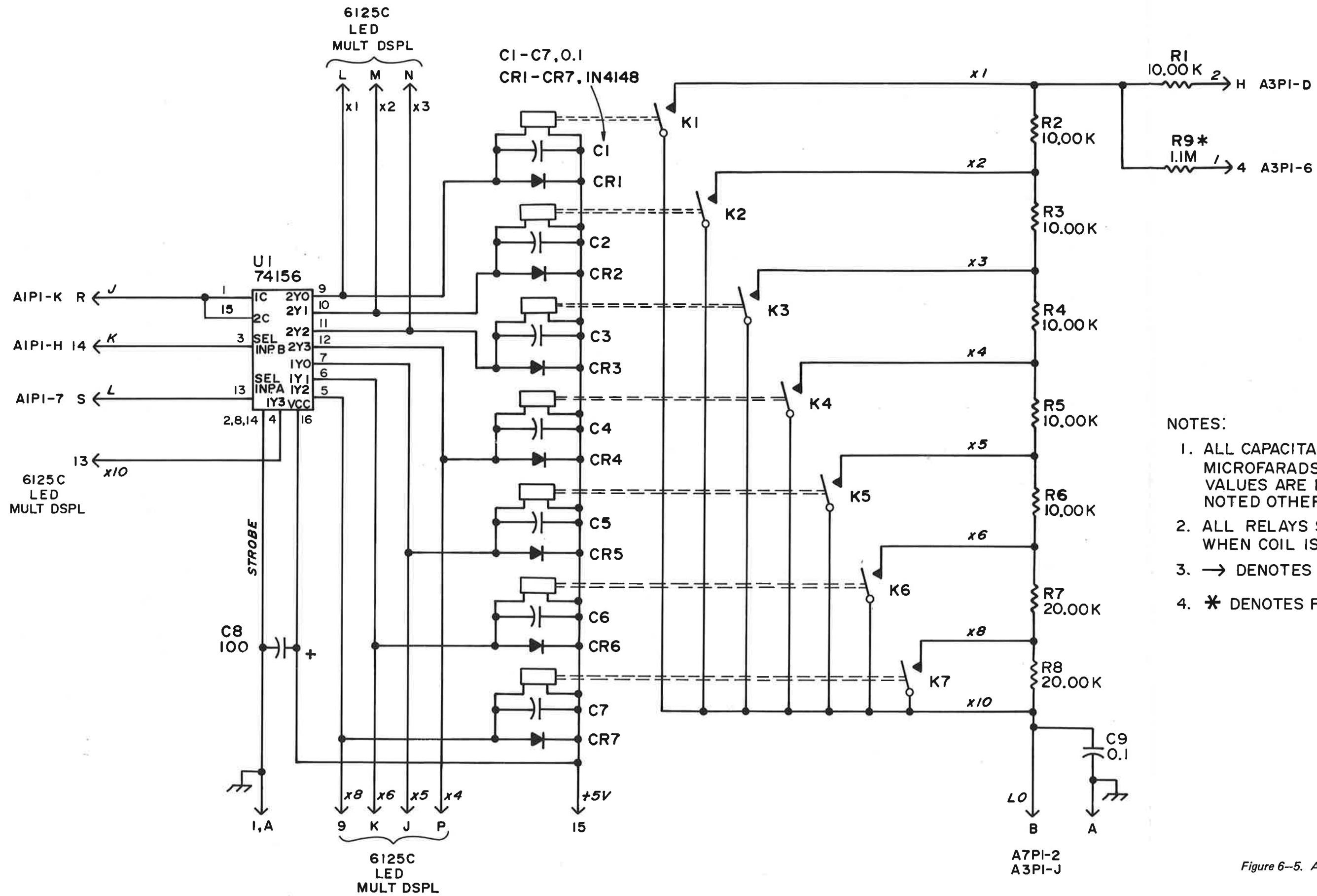

- NOTES:
1. ALL CAPACITANCE VALUES ARE IN MICROFARADS AND ALL RESISTANCE VALUES ARE IN OHMS, UNLESS NOTED OTHERWISE.
 2. ALL RELAYS SHOWN IN POSITION WHEN COIL IS NOT ENERGIZED.
 3. → DENOTES CONTACT OF A4PI.
 4. * DENOTES FACTORY SELECTED VALUE.

Figure 6-5. A4 6125B/C Volts Multiplier Select

PARTS LIST, A4 VOLTS MULTIPLIER SELECT MODEL 6125B/C (89-10501-1A)

SCHEMATIC REF	BALLANTINE PART NO.	DESCRIPTION	MFR CODE	MFR PART NUMBER
C...1	07-10562-0A	CCR 0.1 UF 50V .3 SPACE	0	AVX CERAMICS MD015E104ZAA
C...2	07-10562-0A	CCR 0.1 UF 50V .3 SPACE	0	AVX CERAMICS MD015E104ZAA
C...3	07-10562-0A	CCR 0.1 UF 50V .3 SPACE	0	AVX CERAMICS MD015E104ZAA
C...4	07-10562-0A	CCR 0.1 UF 50V .3 SPACE	0	AVX CERAMICS MD015E104ZAA
C...5	07-10562-0A	CCR 0.1 UF 50V .3 SPACE	0	AVX CERAMICS MD015E104ZAA
C...6	07-10562-0A	CCR 0.1 UF 50V .3 SPACE	0	AVX CERAMICS MD015E104ZAA
C...7	07-10562-0A	CCR 0.1 UF 50V .3 SPACE	0	AVX CERAMICS MD015E104ZAA
C...8	07-10184-0A	CET 100.0UF 10.0 VM DIP TAN	56289	SPRAGUE 196D107X0010-LA3
C...9	07-10223-0A	CYF 100. NF 250. VK	75445	AMPREX C280AE/A100K
CR..1	05-07920-0A	DGP 1N4148 75 10M	7263	FCH SI D035
CR..2	05-07920-0A	DGP 1N4148 75 10M	7263	FCH SI D035
CR..3	05-07920-0A	DGP 1N4148 75 10M	7263	FCH SI D035
CR..4	05-07920-0A	DGP 1N4148 75 10M	7263	FCH SI D035
CR..5	05-07920-0A	DGP 1N4148 75 10M	7263	FCH SI D035
CR..6	05-07920-0A	DGP 1N4148 75 10M	7263	FCH SI D035
CR..7	05-07920-0A	DGP 1N4148 75 10M	7263	FCH SI D035
K...1	14-10015-1A	RLY REED FORM A 6V 300 OHM	0	COTO-COIL E-9040
K...2	14-10015-1A	RLY REED FORM A 6V 300 OHM	0	COTO-COIL E-9040
K...3	14-10015-1A	RLY REED FORM A 6V 300 OHM	0	COTO-COIL E-9040
K...4	14-10015-1A	RLY REED FORM A 6V 300 OHM	0	COTO-COIL E-9040
K...5	14-10015-1A	RLY REED FORM A 6V 300 OHM	0	COTO-COIL E-9040
K...6	14-10015-1A	RLY REED FORM A 6V 300 OHM	0	COTO-COIL E-9040
K...7	14-10015-1A	RLY REED FORM A 6V 300 OHM	0	COTO-COIL E-9040
R...1	12-12632-0A	RFP 10.0 K 200.0MW +- .02%	0	VISHAY S102C 10K .02%
R...2	12-12632-0A	RFP 10.0 K 200.0MW +- .02%	0	VISHAY S102C 10K .02%
R...3	12-12632-0A	RFP 10.0 K 200.0MW +- .02%	0	VISHAY S102C 10K .02%
R...4	12-12632-0A	RFP 10.0 K 200.0MW +- .02%	0	VISHAY S102C 10K .02%
R...5	12-12632-0A	RFP 10.0 K 200.0MW +- .02%	0	VISHAY S102C 10K .02%
R...6	12-12632-0A	RFP 10.0 K 200.0MW +- .02%	0	VISHAY S102C 10K .02%
R...7	12-12633-0A	RFP 20.0K 200.0MW +- .02%	0	VISHAY S102C 20K .02%
R...8	12-12633-0A	RFP 20.0K 200.0MW +- .02%	0	VISHAY S102C 20K .02%
R...9	12-12604-0A	RFF 1.10M 500 MW F+-1%	16299	CGW RN60D 1104 F
U...1	24-10306-0A	ICP 74156 DEMULTIPLEXER	0	T.I SN74156N OR EQUAL

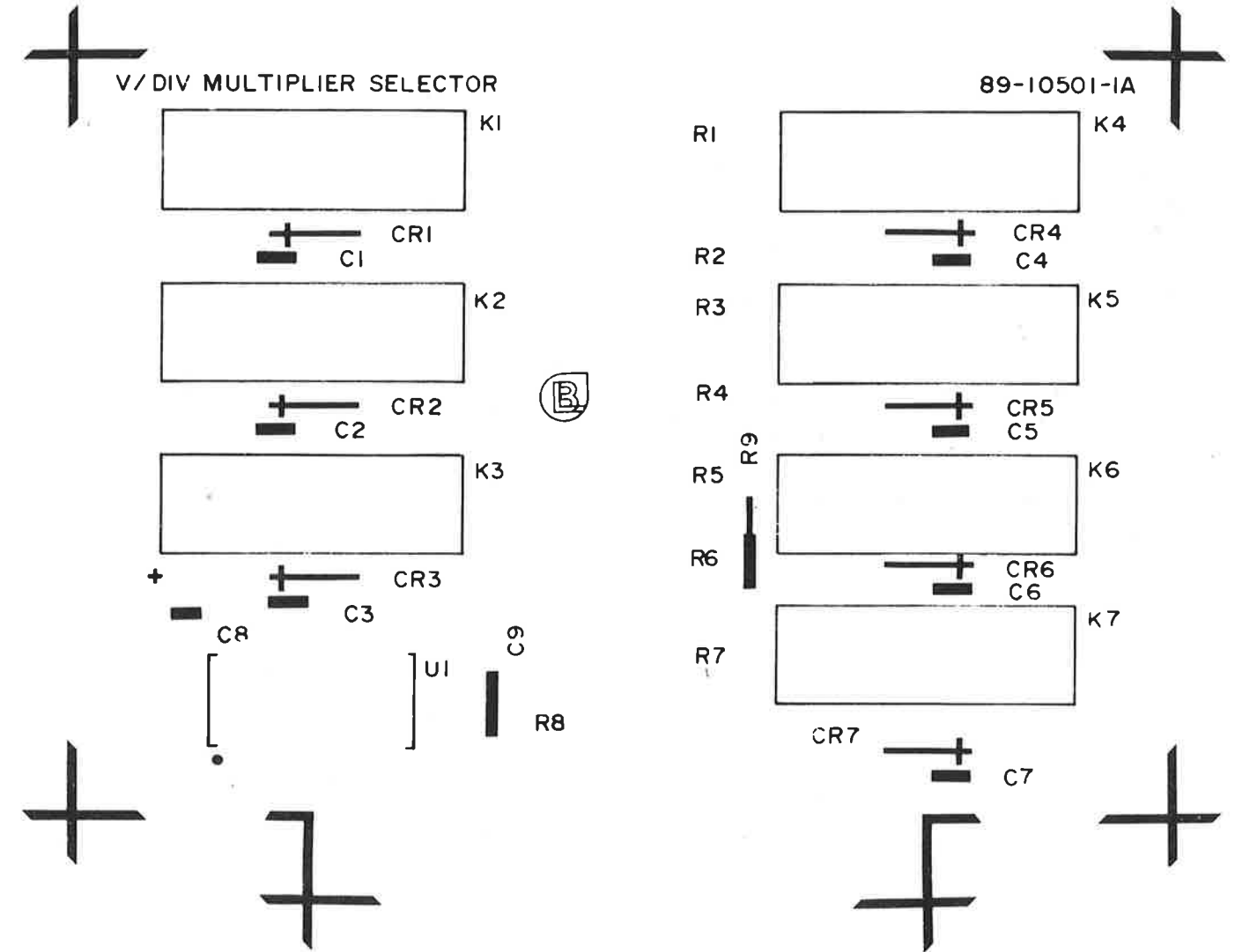

NOTES:

1. * DENOTES FACTORY SELECTED VALUE.
2. → DENOTES CONTACT OF A5PI.
3. ALL CAPACITANCE VALUES ARE IN MICROFARADS AND ALL RESISTANCE VALUES ARE IN OHMS, UNLESS NOTED OTHERWISE.
4. ALL RELAYS SHOWN IN POSITION WHEN COIL IS NOT ENERGIZED.

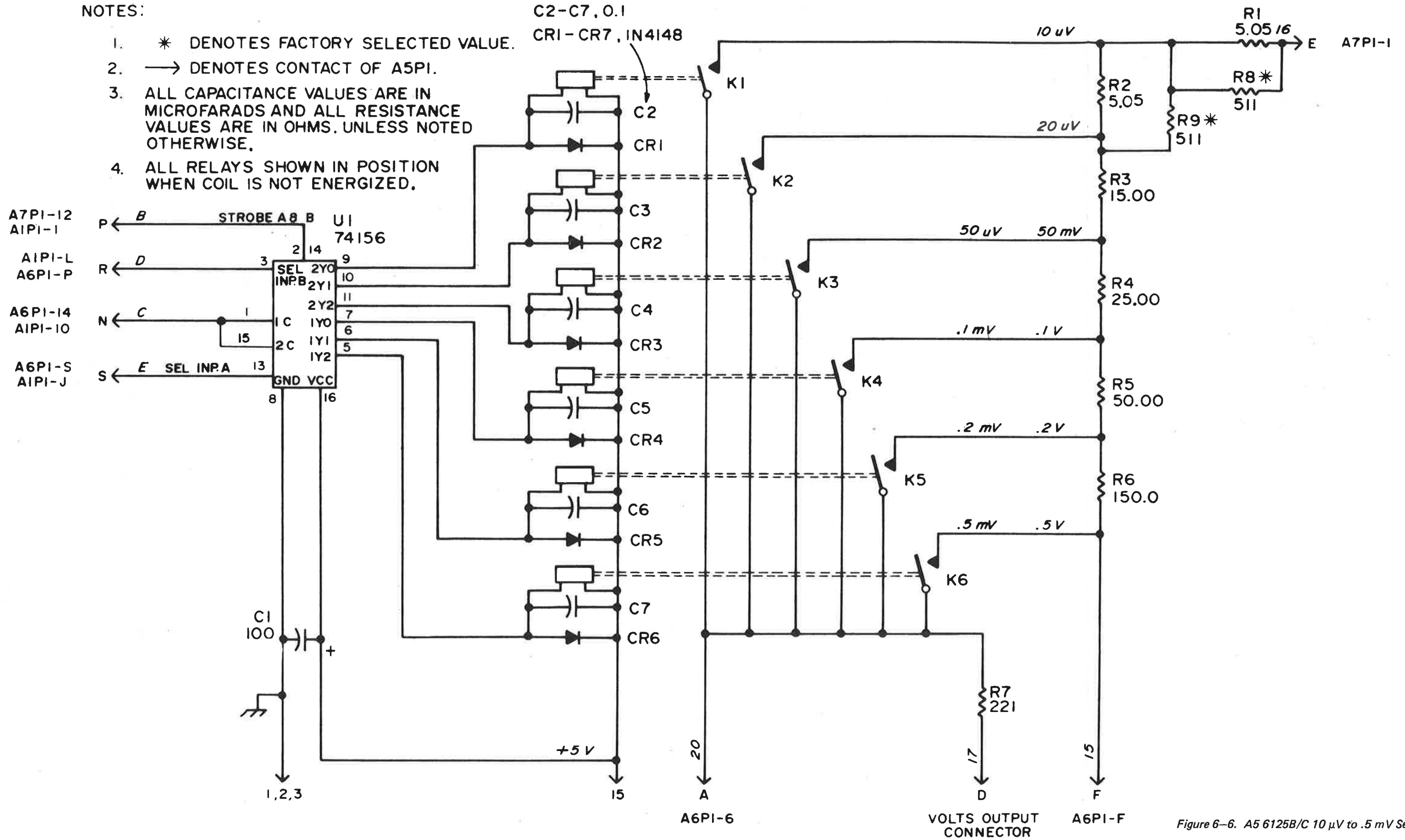
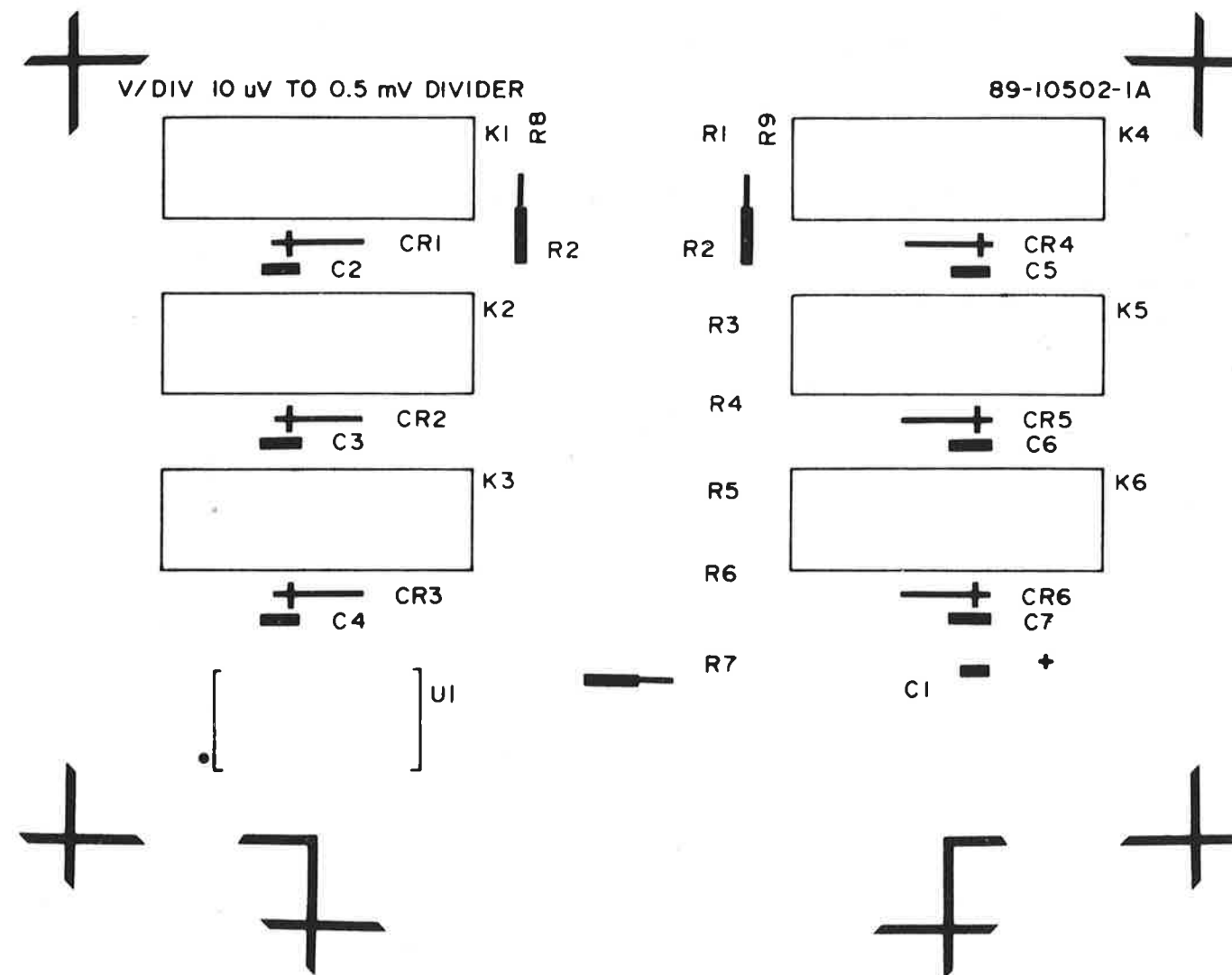

Figure 6-6. A5 6125B/C 10 μV to .5 mV Select

PARTS LIST, A5 VOLTS 10 uV TO .5 mV SELECT MODEL 6125B/C (89-10502-1A)

SCHEMATIC REF	BALLANTINE PART NO.	DESCRIPTION	MFR CODE	MFR PART NUMBER
C...1	07-10184-0A	CET 100.0UF 10.0 VM DIP TAN	56289	SPRAGUE 196D107X0010-LA3
C...2	07-10562-0A	CCR 0.1 UF 50V .3 SPACE	0	AVX CERAMICS MD015E104ZAA
C...3	07-10562-0A	CCR 0.1 UF 50V .3 SPACE	0	AVX CERAMICS MD015E104ZAA
C...4	07-10562-0A	CCR 0.1 UF 50V .3 SPACE	0	AVX CERAMICS MD015E104ZAA
C...5	07-10562-0A	CCR 0.1 UF 50V .3 SPACE	0	AVX CERAMICS MD015E104ZAA
C...6	07-10562-0A	CCR 0.1 UF 50V .3 SPACE	0	AVX CERAMICS MD015E104ZAA
C...7	07-10562-0A	CCR 0.1 UF 50V .3 SPACE	0	AVX CERAMICS MD015E104ZAA
CR..1	05-07920-0A	DGP 1N4148 75 10M	7263	FCH SI D035
CR..2	05-07920-0A	DGP 1N4148 75 10M	7263	FCH SI D035
CR..3	05-07920-0A	DGP 1N4148 75 10M	7263	FCH SI D035
CR..4	05-07920-0A	DGP 1N4148 75 10M	7263	FCH SI D035
CR..5	05-07920-0A	DGP 1N4148 75 10M	7263	FCH SI D035
CR..6	05-07920-0A	DGP 1N4148 75 10M	7263	FCH SI D035
K...1	14-10015-1A	RLY REED FORM A 6V 300 OHM	0	COTO-COIL E-9040
K...2	14-10015-1A	RLY REED FORM A 6V 300 OHM	0	COTO-COIL E-9040
K...3	14-10015-1A	RLY REED FORM A 6V 300 OHM	0	COTO-COIL E-9040
K...4	14-10015-1A	RLY REED FORM A 6V 300 OHM	0	COTO-COIL E-9040
K...5	14-10015-1A	RLY REED FORM A 6V 300 OHM	0	COTO-COIL E-9040
K...6	14-10015-1A	RLY REED FORM A 6V 300 OHM	0	COTO-COIL E-9040
R...1	12-12646-0A	RF 5.05 200.0MW +- .1%	0	
R...2	12-12646-0A	RF 5.05 200.0MW +- .1%	0	
R...3	12-12645-0A	KFP 15.0 200.0MW +- .1%	0	VISHAY S102C 15.0 .1%
R...4	12-12644-0A	RFP 25.0 200.0MW +- .02%	327	VISHAY S102C 25.0 .02%
R...5	12-12643-0A	RFP 50.0 200.0MW +- .02%	327	VISHAY S102C 50 .02%
R...6	12-12642-0A	RFP 150.0 200.0MW +- .02%	327	R VISHAY S102C 150.0 .02%
R...7	12-12233-0A	RFF 221.0 250 MW F+-1%	16299	CGW RN55D 2210 F
R...8	12-12268-0A	RFF 511.0 250 MW F+-1%	16299	CGW RN55D 5110 F
R...9	12-12268-0A	RFF 511.0 250 MW F+-1%	16299	CGW RN55D 5110 F
U...1	24-10306-0A	ICP 74156 DEMULTIPLEXER	0	T.1 SN74156N OR EQUAL



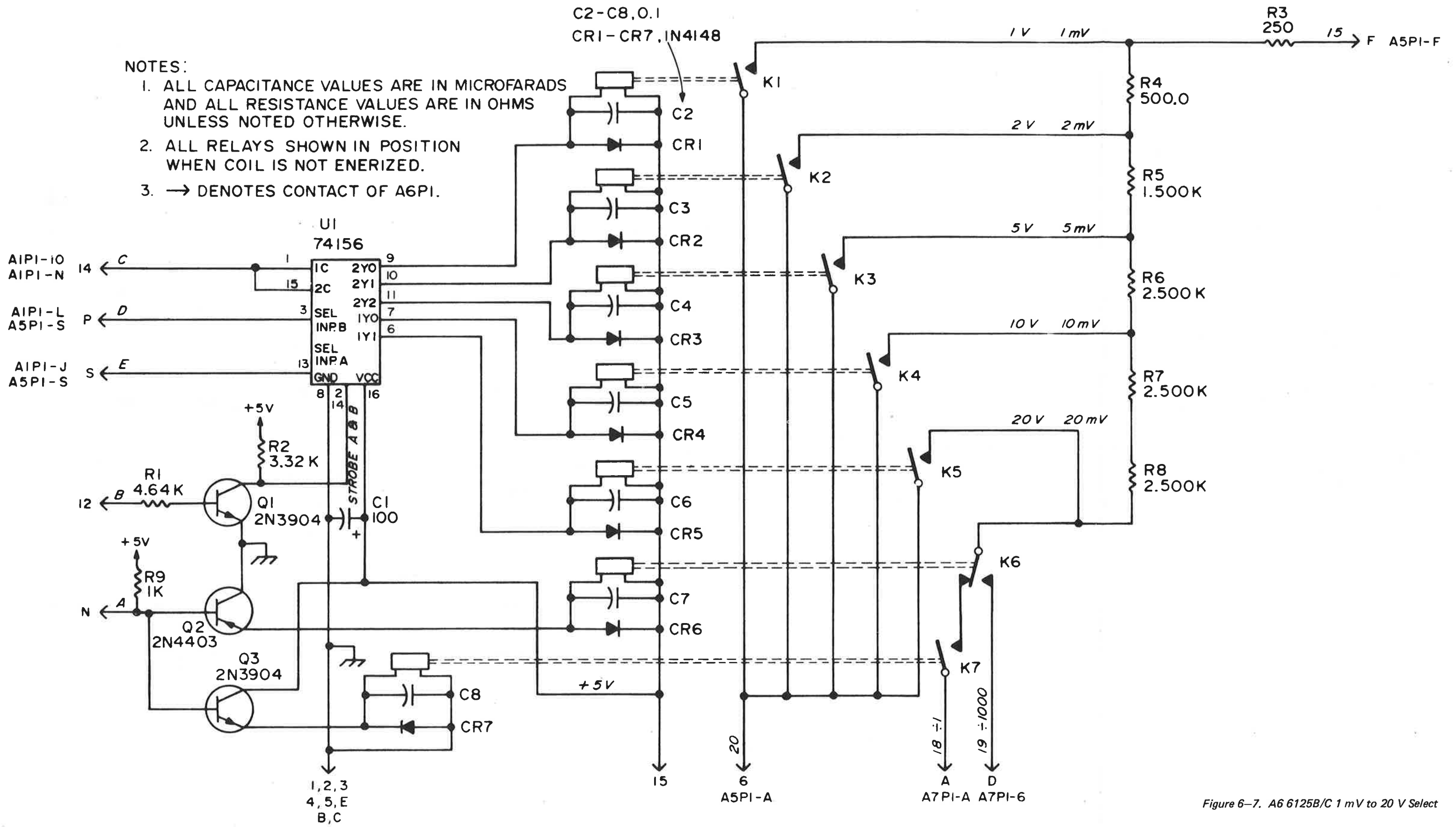
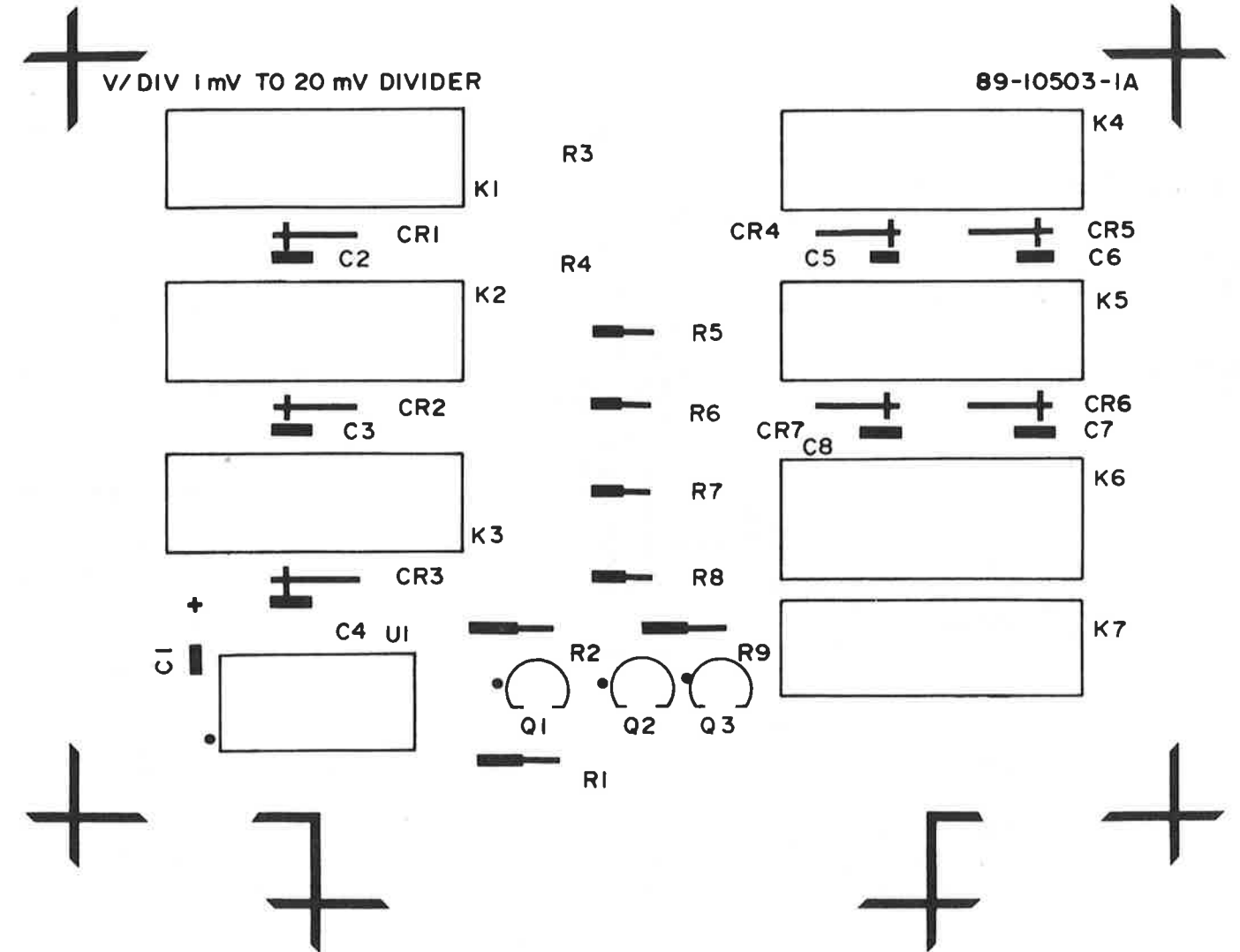

Figure 6-7. A6 6125B/C 1 mV to 20 V Select

PARTS LIST, A6 1 mV TO 20 V SELECT MODEL 6125B/C (89-10503-1A)

SCHEMATIC REF	BALLANTINE PART NO.	DESCRIPTION	MFR CODE	MFR PART NUMBER
A...6	53-10097-1G	SHD 6125B ATTEN SHIELD	50423	BLI
C...1	07-10184-0A	CET 100.0UF 10.0 VM DIP TAN	56289	SPRAGUE 196D107X0010-LA3
C...2	07-10562-0A	CCR 0.1 UF 50V .3 SPACE	0	AVX CERAMICS MD015E104ZAA
C...3	07-10562-0A	CCR 0.1 UF 50V .3 SPACE	0	AVX CERAMICS MD015E104ZAA
C...4	07-10562-0A	CCR 0.1 UF 50V .3 SPACE	0	AVX CERAMICS MD015E104ZAA
C...5	07-10562-0A	CCR 0.1 UF 50V .3 SPACE	0	AVX CERAMICS MD015E104ZAA
C...6	07-10562-0A	CCR 0.1 UF 50V .3 SPACE	0	AVX CERAMICS MD015E104ZAA
C...7	07-10562-0A	CCR 0.1 UF 50V .3 SPACE	0	AVX CERAMICS MD015E104ZAA
C...8	07-10562-0A	CCR 0.1 UF 50V .3 SPACE	0	AVX CERAMICS MD015E104ZAA
CR...1	05-07920-0A	DGP 1N4148 75 10M	7263	FCH SI D035
CR...2	05-07920-0A	DGP 1N4148 75 10M	7263	FCH SI D035
CR...3	05-07920-0A	DGP 1N4148 75 10M	7263	FCH SI D035
CR...4	05-07920-0A	DGP 1N4148 75 10M	7263	FCH SI D035
CR...5	05-07920-0A	DGP 1N4148 75 10M	7263	FCH SI D035
CR...6	05-07920-0A	DGP 1N4148 75 10M	7263	FCH SI D035
CR...7	05-07920-0A	DGP 1N4148 75 10M	7263	FCH SI D035
K...1	14-10015-1A	RLY REED FORM A 6V 300 OHM	0	COTO-COIL E-9040
K...2	14-10015-1A	RLY REED FORM A 6V 300 OHM	0	COTO-COIL E-9040
K...3	14-10015-1A	RLY REED FORM A 6V 300 OHM	0	COTO-COIL E-9040
K...4	14-10015-1A	RLY REED FORM A 6V 300 OHM	0	COTO-COIL E-9040
K...5	14-10015-1A	RLY REED FORM A 6V 300 OHM	0	COTO-COIL E-9040
K...6	14-10016-1A	RLY REED FORM C 6V 175 OHM	0	COTO-COIL E-9025
K...7	14-10015-1A	RLY REED FORM A 6V 300 OHM	0	COTO-COIL E-9040
Q...1	10-10043-0A	TRQ 2N3904 NPN 1 40 PTO-92	4713	MOT 1 300M 40
Q...2	10-10080-0A	TRQ 2N4403 PNP	4713	MOTOROLA
Q...3	10-10043-0A	TRQ 2N3904 NPN 1 40 PTO-92	4713	MOT 1 300M 40
R...1	12-12364-0A	RFF 4.64K 250.0MW F+- 1%	16299	CGW RN55D 4641 F
R...2	12-12350-0A	RFF 3.32K 250.0MW F+- 1%	16299	CGW RN55D 3321 F
R...3	12-12641-0A	RFP 250.0 200.0MW +- .02%	327	VISHAY S102C 250 .02%
R...4	12-12640-0A	RFP 500.0 200.0MW +- .02%	0	VISHAY S102C 500.0 .02%
R...5	12-12639-0A	RFP 1.5 K 1.0 W +- .02%	0	VISHAY S104 1.5K .02%
R...6	12-12638-0A	RFP 2.5 K 1.0 W +- .02%	327	VISHAY S104 2.5K .02%
R...7	12-12638-0A	RFP 2.5 K 1.0 W +- .02%	327	VISHAY S104 2.5K .02%
R...8	12-12638-0A	RFP 2.5 K 1.0 W +- .02%	327	VISHAY S104 2.5K .02%
R...9	12-12300-0A	KFF 1.0 K 250 MW F+- 1%	16299	CGW RN55D 1001 F
U...1	24-10306-0A	ICP 74156 DEMULTIPLEXER	0	T.I SN74156N OR EQUAL



SCHEMATIC REF	BALLANTINE PART NO.	DESCRIPTION	MFR CODE	MFR PART NUMBER
C...1	07-10025-0A	CCD 2.2NF 1.0KV DC	84171	ELMENCO LORCAP TYPECCD222
C...2	07-10184-0A	CET 100.0UF 10.0 VM DIP TAN	56289	SPRAGUE 196D107X0010-LA3
C...4	07-10562-0A	CCR 0.1 UF 50V .3 SPACE	0	AVX CERAMICS MD015E104ZAA
C...5	07-10184-0A	CET 100.0UF 10.0 VM DIP TAN	56289	SPRAGUE 196D107X0010-LA3
C...9	07-10037-0A	CCD 4.7NF 1.0 KV DC	84171	ELMENCO TYPE CCD472
C...10	07-10562-0A	CCR 0.1 UF 50V .3 SPACE	0	AVX CERAMICS MD015E104ZAA
C...12	07-10184-0A	CET 100.0UF 10.0 VM DIP TAN	56289	SPRAGUE 196D107X0010-LA3
CR...3	05-07920-0A	DGP 1N4148 75 10M	7263	FCH SI D035
CR...2	05-07920-0A	DGP 1N4148 75 10M	7263	FCH SI D035
CR...5	05-07920-0A	DGP 1N4148 75 10M	7263	FCH SI D035
CR...6	05-07920-0A	DGP 1N4148 75 10M	7263	FCH SI D035
*K...2	14-10034-0A	RLY 2A2B 5V COIL	0	ARUMAT S2E35V
*K...4	14-10034-0A	RLY 2A2B 5V COIL	0	ARUMAT S2E35V
Q...1	10-10043-0A	TRQ 2N3904 NPN 1 40 PTO-92	4713	MOT 1 300M 40
Q...2	10-10043-0A	TRQ 2N3904 NPN 1 40 PTO-92	4713	MOT 1 300M 40
Q...3	10-10001-0A	TRQ 2N2369 NPN 1 15 MTO-18	4713	MOT 1.2 500M 20
Q...4	10-09485-0A	TRQ MPS6521 NPN 1 25 PTO-92	4713	MOT 1 390M 100
Q...6	10-10080-0A	TRQ 2N4403 PNP	4713	MOTOROLA
Q...7	10-09473-0A	TRQ 2N3906 PNP 1 40 PTO-92	4713	MOT 1 200M 60
Q...8	10-10043-0A	TRQ 2N3904 NPN 1 40 PTO-92	4713	MOT 1 300M 40
Q...9	10-10154-0A	TRQ 2N4401 NPN 1 40V S T092	4713	MOT
R...1	12-12300-0A	RFF 1.0 K 250 MW F+-1%	16299	CGW RN55D 1001 F
R...2	12-12280-0A	RFF 681.0 250 MW F+-1%	16299	CGW RN55D 6810 F
R...3	12-12236-0A	RFF 237.0 250 MW F+-1%	16299	CGW RN55D 2370 F
R...4	12-12300-0A	RFF 1.0 K 250 MW F+-1%	16299	CGW RN55D 1001 F
R...5	12-12300-0A	RFF 1.0 K 250 MW F+-1%	16299	CGW RN55D 1001 F
R...6	12-12412-0A	RFF 13.3 K 250.0MW F+- 1%	16299	CGW RN55D 1332 F
R...7	12-12444-0A	RFF 28.7 K 250.0MW F+- 1%	16299	CGW RN55D 2872 F
R...8	12-12476-0A	RFF 61.9 K 250.0MW F+- 1%	16299	CGW RN55D 6192 F
R...9	12-12376-0A	RFF 6.19K 250.0MW F+- 1%	16299	CGW RN55D 6191 F
R...10	12-12248-0A	RFF 316.0 250 MW F+-1%	16299	CGW RN55D 3160 F
R...11	12-12428-0A	RFF 19.6 K 250.0MW F+- 1%	16299	CGW RN55D 1962 F
R...12	12-08044-0A	RFC 22.0 M 250.0MW J+- 5%	1121	A-B TYP CB
R...13	12-12350-0A	RFF 3.32K 250.0MW F+- 1%	16299	CGW RN55D 3321 F
R...14	12-08029-0A	RFC 1.0 M 250.0MW J+- 5%	1121	A-B TYP CB
R...15	12-12228-0A	RFF 196.0 250 MW F+-1%	16299	CGW RN55D 1960 F
R...16	12-12342-0A	RFF 2.74K 250.0MW F+- 1%	16299	CGW RN55D 2741 F
R...17	12-12350-0A	RFF 3.32K 250.0MW F+- 1%	16299	CGW RN55D 3321 F
R...18	12-12350-0A	RFF 3.32K 250.0MW F+- 1%	16299	CGW RN55D 3321 F
R...19	12-12300-0A	RFF 1.0 K 250 MW F+-1%	16299	CGW RN55D 1001 F
R...20	09-10181-0A	RVF 500.0 K 500.0MW K 20TURN	80294	BOURNS 3069P
R...21	12-12939-0A	RFF 4.0 M 500.0MW F1%50PPM	80031	MEPCO MF6C-C-4.0M-F
R...22	12-12635-0A	RFP 100.0 K 200.0MW +- .25%	0	VISHAY S102C 100K .25%
R...23	12-12200-0A	RFF 100.0 250.0MW F+- 1%	16299	CGW RN55D 1000 F
R...25	09-10094-0A	RVF 500.0 500.0MW KVERT MT	73138	HELIPOT 72XW 500
R...26	12-12228-0A	RFF 196.0 250 MW F+-1%	16299	CGW RN55D 1960 F
R...27	27-01154-0A	THR 100 K+-10%	83186	VTE TYPE 21E26
U...1	24-10060-0A	ICP TIMEBASE DIVIDER	50088	MOSTEK MK 5009P
U...2	24-10183-0A	ICP L111 OPT. INSULATOR	1295	T.I TIL111
U...3	24-09420-0A	ICP JA741C FAIRCHILD	7263	#U5B7741393
U...4	24-10183-0A	ICP L111 OPT. INSULATOR	1295	T.I TIL111
U...5	24-10181-0A	ICP 74LS02 QUAD 2 IN NOR	1295	T.I.SN74LS02
U...6	24-10179-0A	ICP 74LS10 TRI.3 IN NAND	1295	T.I.SN74S10

SCHEMATIC REF	BALLANTINE PART NO.	DESCRIPTION	MFR CODE	MFR PART NUMBER
CR...1	05-07920-0A	DGP 1N4148 75 10M	7263	FCH SI D035
K...1	14-10034-0A	RLY 2A2B 5V COIL	0	ARUMAT S2E35V

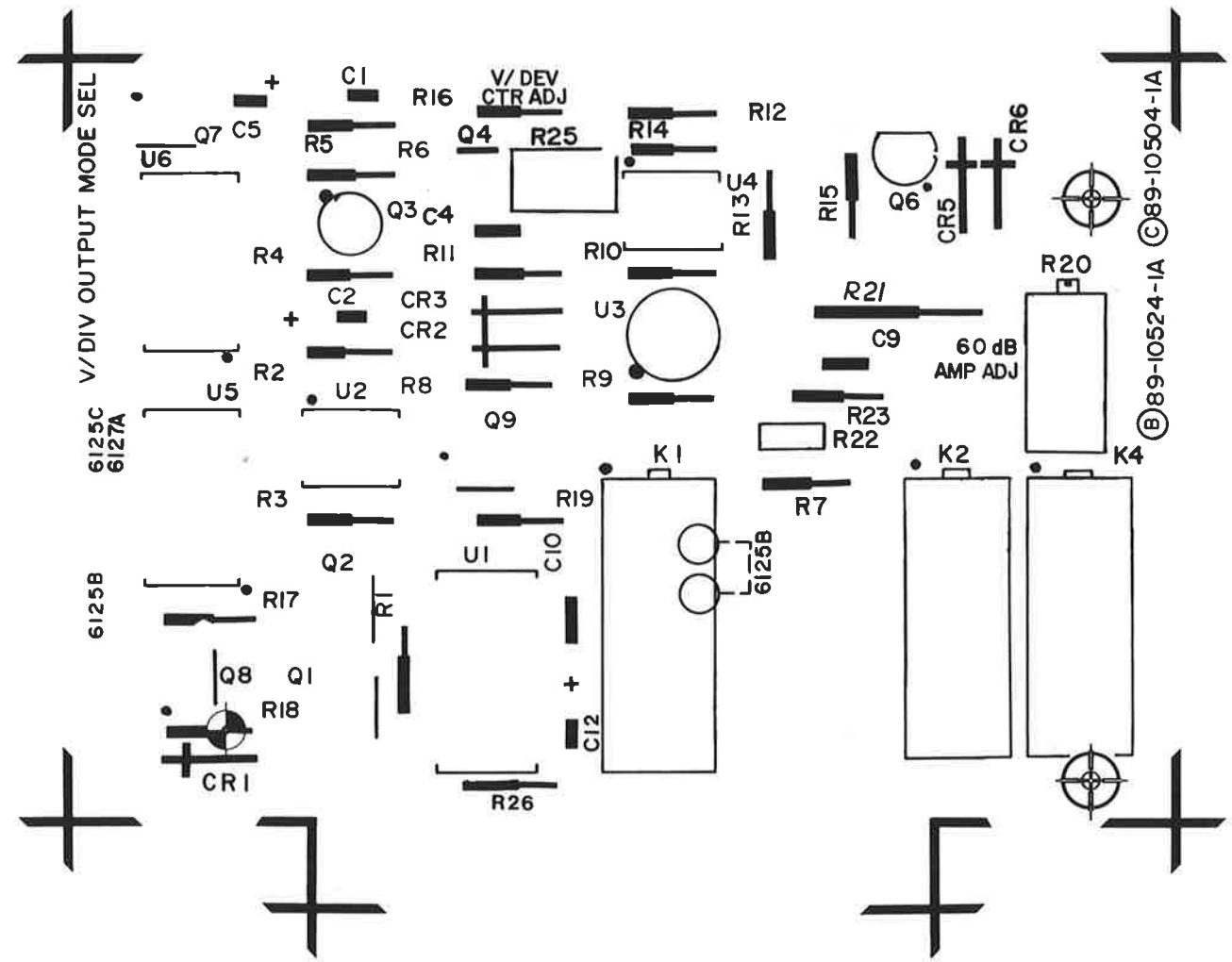

* Before ordering new relays A7K2 and A7K4, check your present relay to obtain the proper replacement part.

Low profile plastic relay P/N 14-10034-0A (Aromat).
 High profile plastic relay (Potter and Brumfield) P/N 14-10023-0A.
 Red pastic molded reed relay (Coto-Coil or MEKO) P/N 14-10016-1A.

P/N 14-10034-0A is the preferred part in current production.

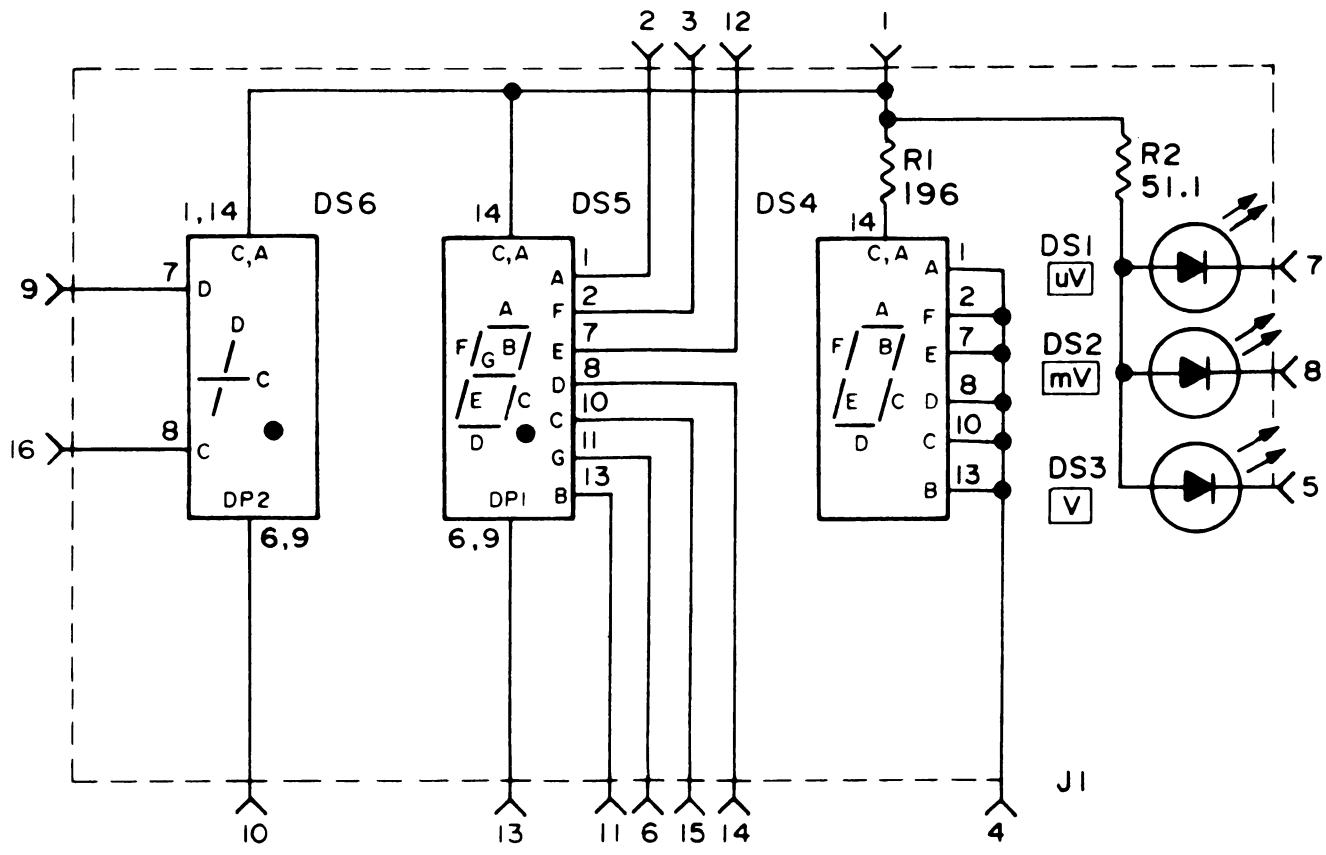

NOTES:

1. ALL CAPACITANCE VALUES ARE IN MICROFARADS AND ALL RESISTANCE VALUES ARE IN OHMS UNLESS NOTED OTHERWISE.

Figure 6-9. A8 6125C Volts/Div Display

PARTS LIST, A8 VOLTS/DIV DISPLAY MODEL 6125C (89-10505-1A)

SCHEMATIC REF	BALLANTINE PART NO.	DESCRIPTION	MFR CODE	MFR PART NUMBER
DS..1	16-10027-0A	LMP LED MINATURE 20 MA	28480	HP MV 5082-4480
DS..2	16-10027-0A	LMP LED MINATURE 20 MA	28480	HP MV 5082-4480
DS..3	16-10027-0A	LMP LED MINATURE 20 MA	28480	HP MV 5082-4480
DS..4	21-10011-0A	IND 0.4 IN ORANGE LED DIP	26483	MONSANTO 4610 RT DECIMAL
DS..5	21-10011-0A	IND 0.4 IN ORANGE LED DIP	26483	MONSANTO 4610 RT DECIMAL
DS..6	21-10012-0A	IND 0.4 IN ORANGE +1 LED	26483	MONSANTO 4630
R...1	12-12228-0A	RFF 196.0 250 MW F+-1%	16299	CGW RN55D 1960 F
R...2	12-12168-0A	RFF 51.1 250.0MW F+- 1%	16299	CGW RN55D 51R1 F

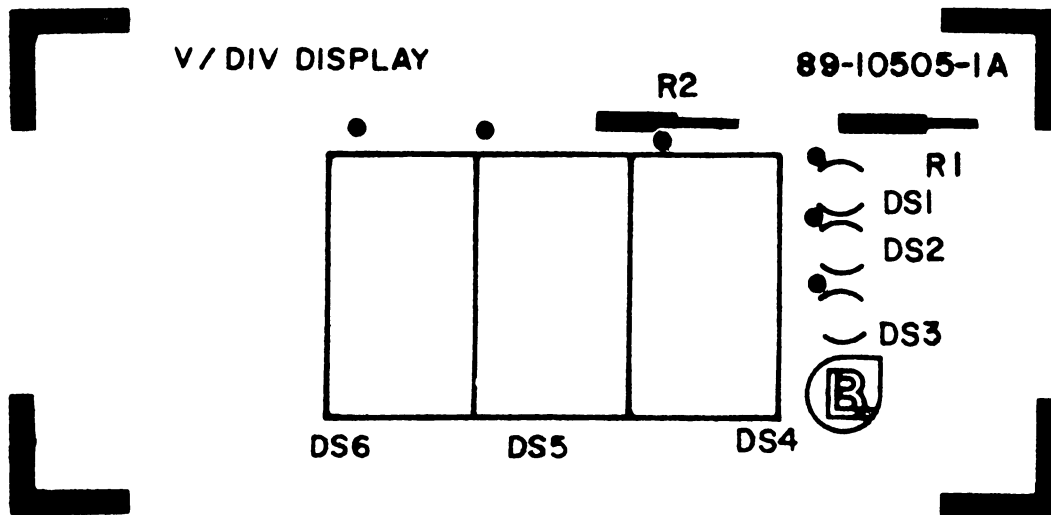

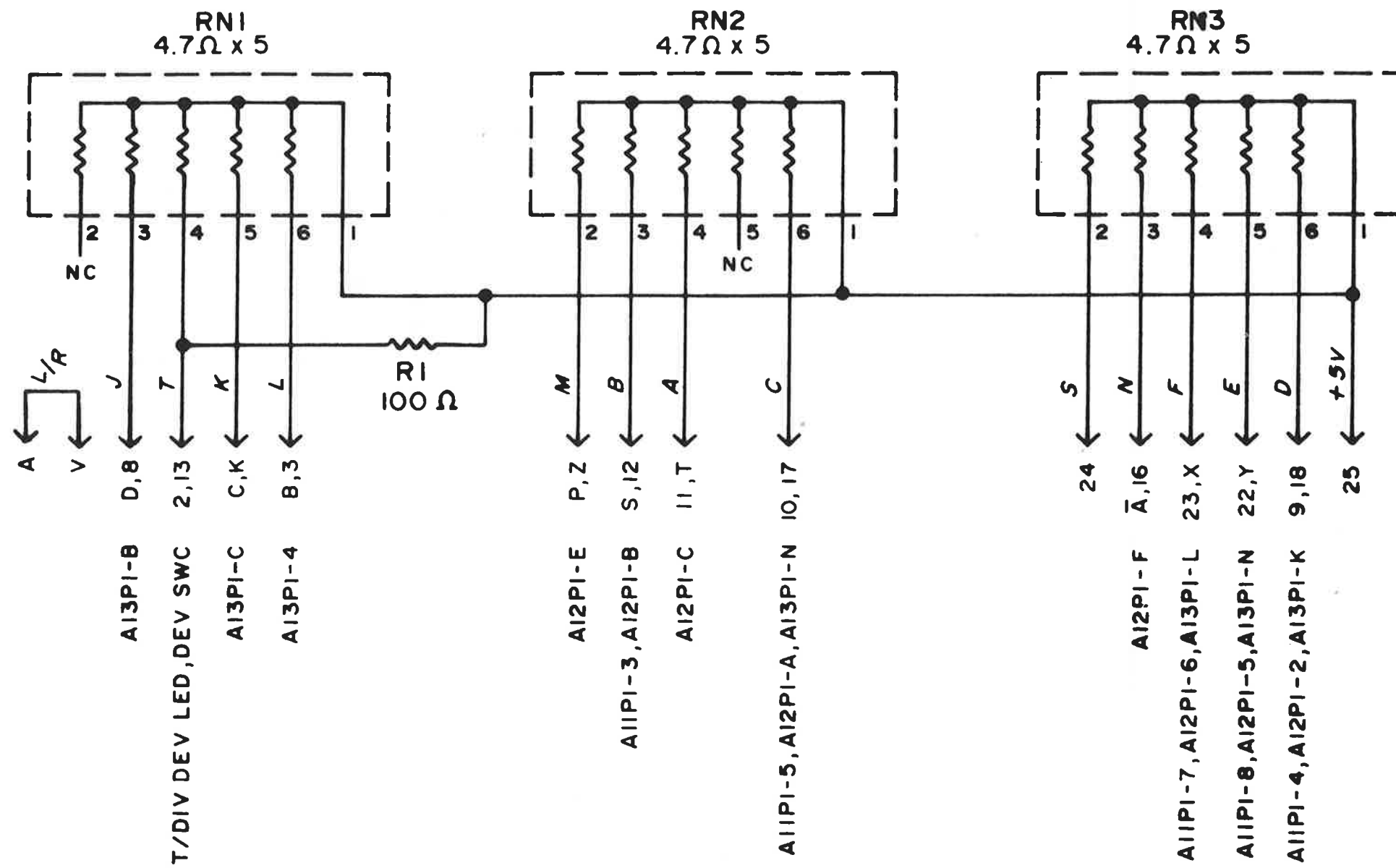
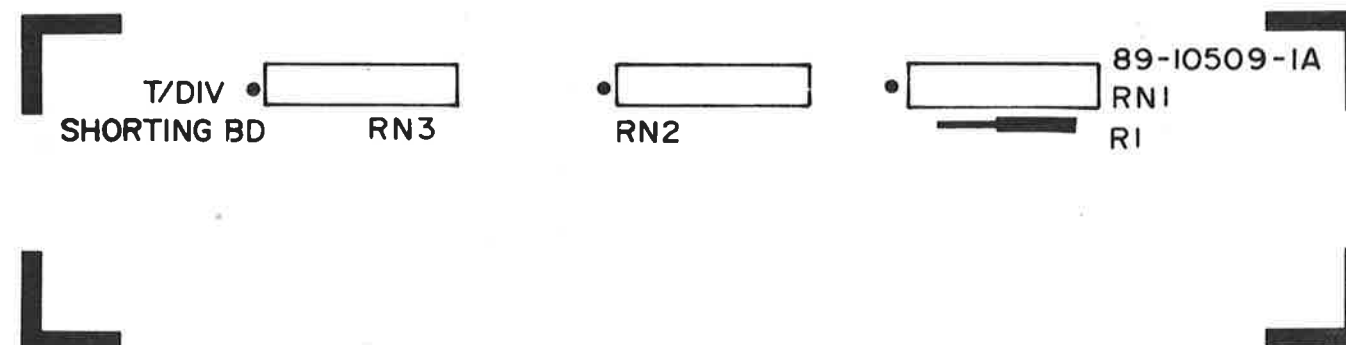
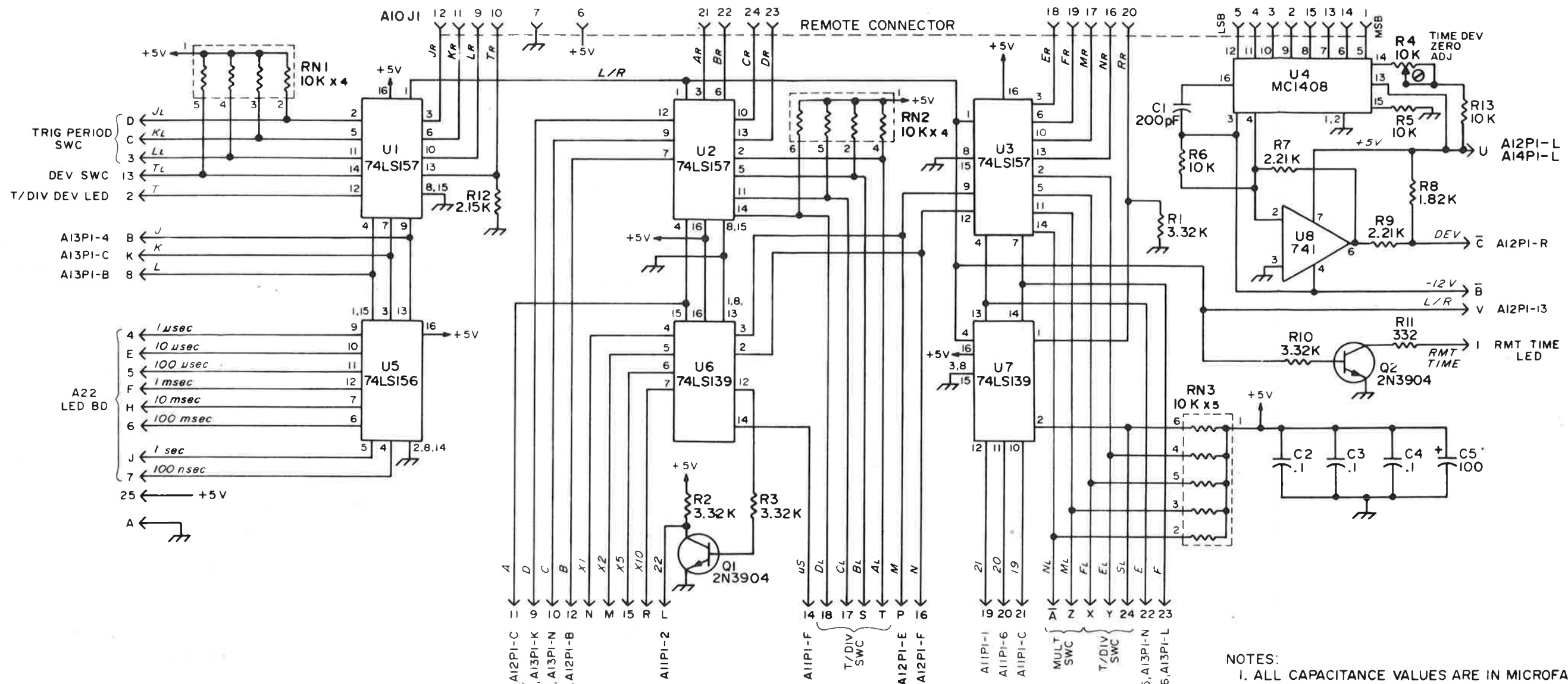

Figure 6-10. A10 6125B Time Shorting Board

PARTS LIST, A10 SHORTING TIME MODEL 6125B (89-10509-1A)

SCHEMATIC REF	BALLANTINE PART NO.	DESCRIPTION	MFR CODE	MFR PART NUMBER
R...1	12-12200-0A	RFF 100.0 250.0Mw F+- 1%	16299	CGW RN55D 1000 F
RN..1	13-10047-0A	RNF 4.7 K 6 PIN SIP 5 RES.	80053	BECKMAN 783-1-R4.7K
RN..2	13-10047-0A	RNF 4.7 K 6 PIN SIP 5 RES.	80053	BECKMAN 783-1-R4.7K
RN..3	13-10047-0A	RNF 4.7 K 6 PIN SIP 5 RES.	80053	BECKMAN 783-1-R4.7K





NOTES:
 1. ALL CAPACITANCE VALUES ARE IN MICROFARADS AND ALL RESISTANCE VALUES ARE IN OHMS UNLESS NOTED OTHERWISE.
 2. → DENOTES CONTACT OF AIOPI, UNLESS NOTED OTHERWISE.

TIME/DIV	A	B	C	D	E	F	S
10 nsec					0	0	0
20 nsec					0	0	0
50 nsec					0	0	0
.1 usec					0	0	0
.20					0	0	0
.50					0	0	0
1					0	0	0
2					0	0	0
5					0	0	0
10					0	0	0
20					0	0	0
50 usec					0	0	0
.1 msec					0	0	0
.2					0	0	0
.5					0	0	0
1					0	0	0
2					0	0	0
5					0	0	0
10					0	0	0
20					0	0	0
50 msec					0	0	0
.1 sec					0	0	0
.2					0	0	0
.5					0	0	0
1					0	0	0
2					0	0	0
5 sec					0	0	0
REMOTE/OFF	X	X	X	X	X	X	1

MULT	M	N
X1	1	1
X2	0	1
X5	1	0
X10	0	0

CONTROL	R	S	L/R
REMOTE	1	X	1
REMOTE	0	1	1
LOCAL	0	0	0

TIME DEVIATION	T
ON	1
OFF	0

TRIGGER PERIOD	J	K	L
100 nsec	1	1	1
.1 usec	0	0	0
10	0	0	1
100	0	1	0
1 msec	0	1	1
10	1	0	0
100	1	0	1
1 sec	1	1	0

Figure 6-11. A10 6125C Time Remote Program Input

PARTS LIST, A10 TIME REMOTE PROGRAM MODEL 6125C (89-10817-1A)

SCHEMATIC REF	BALLANTINE PART NO.	DESCRIPTION	MFR CODE	MFR PART NUMBER
C...1	07-10351-0A	CMD 200.0PF 500.0 V TCE 5%	84171	ARCO DM15ED200J03 -ARCO
C...2	07-10562-0A	CCR 0.1 UF 50V .3 SPACE	0	AVX CERAMICS MD015E104ZAA
C...3	07-10562-0A	CCR 0.1 UF 50V .3 SPACE	0	AVX CERAMICS MD015E104ZAA
C...4	07-10562-0A	CCR 0.1 UF 50V .3 SPACE	0	AVX CERAMICS MD015E104ZAA
C...5	07-10184-0A	CET 100.0UF 10.0 VM DIP TAN	56289	SPRAGUE 196D107X0010-LA3
Q...1	10-10043-0A	TRQ 2N3904 NPN 1 40 PTO-92	4713	MOT 1 300M 40
Q...2	10-10043-0A	TRQ 2N3904 NPN 1 40 PTO-92	4713	MOT 1 300M 40
R...1	12-12350-0A	RFF 3.32K 250.0MW F+- 1%	16299	CGW RN55D 3321 F
R...2	12-12350-0A	RFF 3.32K 250.0MW F+- 1%	16299	CGW RN55D 3321 F
R...3	12-12350-0A	RFF 3.32K 250.0MW F+- 1%	16299	CGW RN55D 3321 F
R...4	09-10093-0A	RVF 10.0 K 500.0MW KVERT MT	73138	HELIPOT 72XW 10K
R...5	12-12400-0A	RFF 10.0 K 250.0MW F+- 1%	16299	CGW RN55D 1002 F
R...6	12-12400-0A	RFF 10.0 K 250.0MW F+- 1%	16299	CGW RN55D 1002 F
R...7	12-12333-0A	RFF 2.21K 250.0MW F+- 1%	16299	CGW RN55D 2211 F
R...8	12-12325-0A	1.82K 250.0MW F+- 1%	16299	CGW RN55D 1821 F
R...9	12-12333-0A	RFF 2.21K 250.0MW F+- 1%	16299	CGW RN55D 2211 F
R...10	12-12350-0A	RFF 3.32K 250.0MW F+- 1%	16299	CGW RN55D 3321 F
R...11	12-12250-0A	RFF 332.0 250 MW F+-1%	16299	CGW RN55D 3320 F
R...12	12-12332-0A	RFF 2.15K 250.0MW F+- 1%	16299	CGW RN55D 2151 F
R...13	12-12432-0A	RFF 21.5 K 250.0MW F+- 1%	16299	CGW RN55D 2152 F
RN...1	13-10018-0A	RNF 10.0 K 0.3 W F	80053	BECKMAN 783-1-R10K
RN...2	13-10018-0A	RNF 10.0 K 0.3 W F	80053	BECKMAN 783-1-R10K
RN...3	13-10018-0A	RNF 10.0 K 0.3 W F	80053	BECKMAN 783-1-R10K
U...1	24-10163-0A	ICP 74LS157 MULTIPLEXER	1295	T.I. SN74LS157
U...2	24-10163-0A	ICP 74LS157 MULTIPLEXER	1295	T.I. SN74LS157
U...3	24-10163-0A	ICP 74LS157 MULTIPLEXER	1295	T.I. SN74LS157
U...4	24-10175-0A	ICP 1408 D TO A CONVERTER	4713	MOTOROLA MC1408
U...5	24-10164-0A	ICP 74LS156 DEMULTIPLEXER	1295	T.I. SN74LS156
U...6	24-10165-0A	ICP 74LS139 DEMULTIPLEXER	1295	T.I. SN74LS139
U...7	24-10165-0A	ICP 74LS139 DEMULTIPLEXER	1295	T.I. SN74LS139
U...8	24-09420-0A	ICP UA741C FAIRCHILD	7263	#U5B7741393

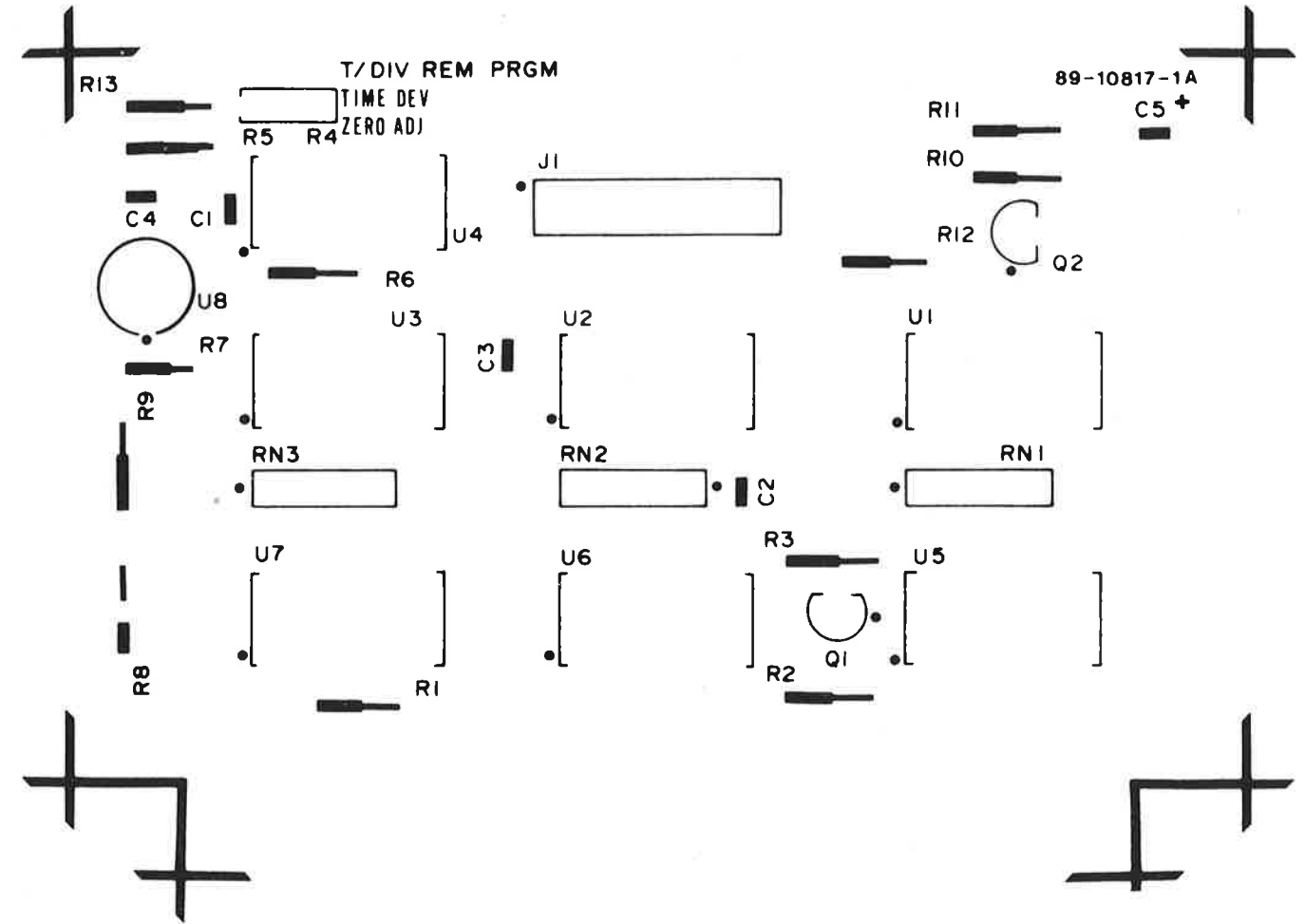

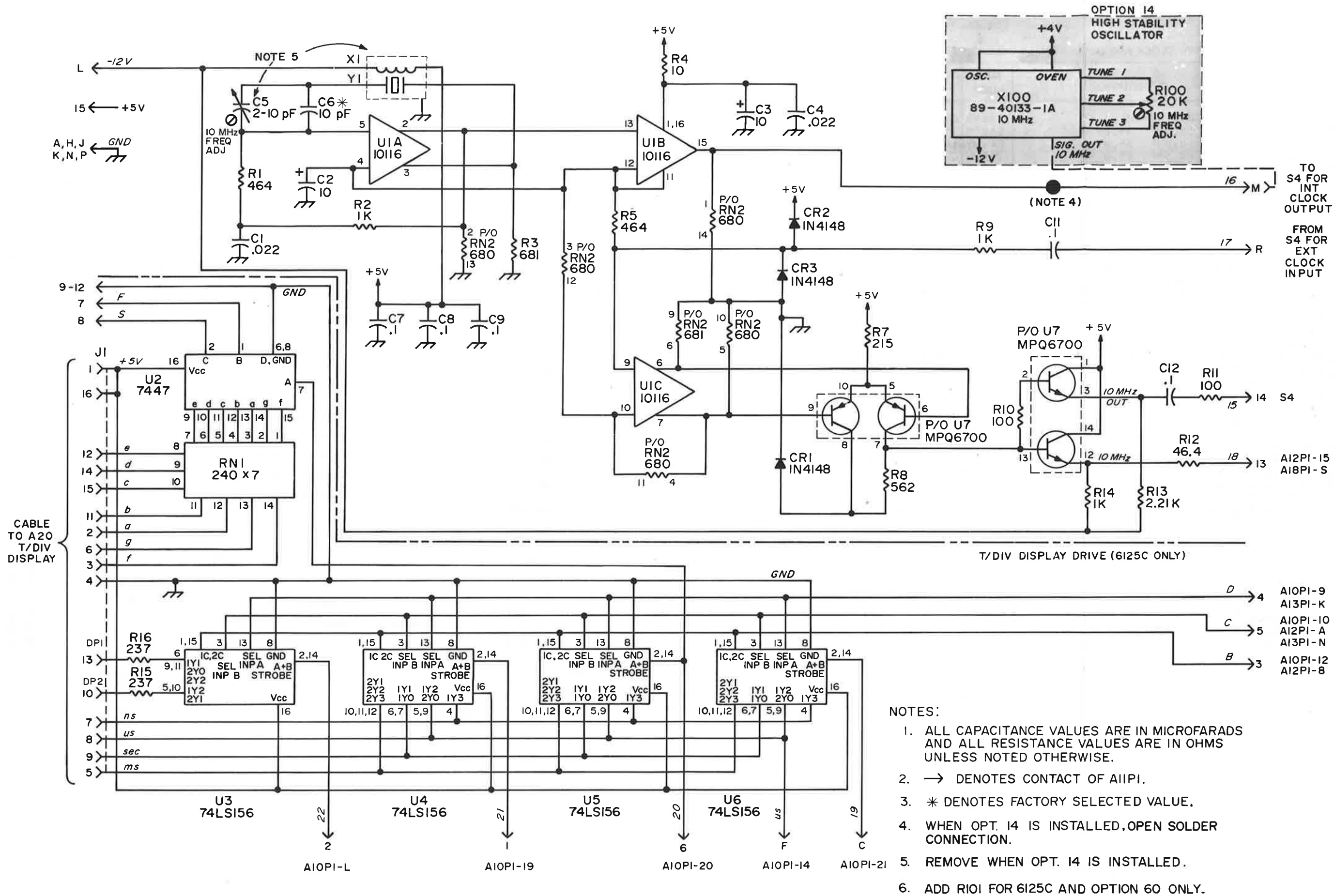

Figure 6-12. A11 6125B/C and Opt. 14 10 MHz Clock and 6125C Time Display Drive

PARTS LIST, A11 10 MHz CLOCK AND OSCILLATOR MODEL 6125B/C (89-10525-1A)

SCHEMATIC REF	BALLANTINE PART NO.	DESCRIPTION	MFR CODE	MFR PART NUMBER
C...1	07-10120-0A	CCD 22.0NF 25.0 VM	71590	CENTRLB UK25223 OR EQUIV
C...2	07-10053-0A	CET 10.0UF 35.0V M	56289	199D106X0035DA2
C...3	07-10053-0A	CET 10.0UF 35.0V M	56289	199D106X0035DA2
C...4	07-10120-0A	CCD 22.0NF 25.0 VM	71590	CENTRLB UK25223 OR EQUIV
C...5	07-10208-0A	CVC 2.0-10PF TRIMMER	50423	TABOR 15005020
C...6	07-10488-0A	CMD 10.0PF 300.0 VJ	84171	ARCO TYPE DM-15-BC10JN1
C...7	07-10562-0A	CCR 0.1 UF 50V .3 SPACE	0	AVX CERAMICS MD015E104ZAA
C...8	07-10562-0A	CCR 0.1 UF 50V .3 SPACE	0	AVX CERAMICS MD015E104ZAA
C...9	07-10562-0A	CCR 0.1 UF 50V .3 SPACE	0	AVX CERAMICS MD015E104ZAA
C...11	07-10562-0A	CCR 0.1 UF 50V .3 SPACE	0	AVX CERAMICS MD015E104ZAA
C...12	07-10562-0A	CCR 0.1 UF 50V .3 SPACE	0	AVX CERAMICS MD015E104ZAA
CR...1	05-07920-0A	DGP 1N4148 75 10M	7263	FCH SI D035
CR...2	05-07920-0A	DGP 1N4148 75 10M	7263	FCH SI D035
CR...3	05-07920-0A	DGP 1N4148 75 10M	7263	FCH SI D035
R...1	12-12264-0A	RFF 464.0 250 MW F+-1%	16299	CGW RN55D 4640 F
R...2	12-12300-0A	RFF 1.0 K 250 MW F+-1%	16299	CGW RN55D 1001 F
R...3	12-12280-0A	RFF 681.0 250 MW F+-1%	16299	CGW RN55D 6810 F
R...4	12-12100-0A	RFF 10.0 250.0MW F+- 1%	16299	CGW RN55D 10R0 F
R...5	12-12264-0A	RFF 464.0 250 MW F+-1%	16299	CGW RN55D 4640 F
R...7	12-12232-0A	RFF 215.0 250 MW F+-1%	16299	CGW RN55D 2150 F
R...8	12-12272-0A	RFF 562.0 250 MW F+-1%	16299	CGW RN55D 5620 F
R...9	12-12300-0A	RFF 1.0 K 250 MW F+-1%	16299	CGW RN55D 1001 F
R...10	12-12200-0A	RFF 100.0 250.0MW F+- 1%	16299	CGW RN55D 1000 F
R...11	12-12200-0A	RFF 100.0 250.0MW F+- 1%	16299	CGW RN55D 1000 F
R...12	12-12164-0A	RFF 46.4 250.0MW F+- 1%	16299	CGW RN55D 46R4 F
R...13	12-12333-0A	RFF 2.21K 250.0MW F+- 1%	16299	CGW RN55D 2211 F
R...14	12-12300-0A	RFF 1.0 K 250 MW F+-1%	16299	CGW RN55D 1001 F
RN...2	13-10023-0A	RNF 680.0 0.2 W F	0	BECKMAN 899-3R680 -F
U...1	24-10041-0A	ICP LIN DUAL OD AMP 10116	4713	MOTOROLA
U...7	10-10084-0A	TRQ MPQ6700 4 P14 DIP	4713	MOT .2400 200M
X...1	42-10000-0A	OVN OVEN SEMI CON T0-5 20V	1295	ULIXON TEXAS INST. MST1-2
Y...1	04-40003-0A	CRS 10.0MHZ T0-5	50423	TABOR 08000000 ALSO ERC

PARTS LIST, A11 DISPLAY DRIVE MODEL 6125C (89-10511-1A)

SCHEMATIC REF	BALLANTINE PART NO.	DESCRIPTION	MFR CODE	MFR PART NUMBER
R...15	12-12236-0A	RFF 237.0 250 MW F+-1%	16299	CGW RN55D 2370 F
R...16	12-12236-0A	RFF 237.0 250 MW F+-1%	16299	CGW RN55D 2370 F
RN...1	13-10022-0A	RNF 270.0 0.2 W F	0	BECKMAN 899-3R240 -F
U...2	24-10139-0A	ICP 74LS47 7SEG DRVR LO-PWR	27014	NAT.SEMI DM74LS47
U...3	24-10164-0A	ICP 74LS156 DEMULTIPLEXER	1295	T.I.SN72LS156
U...4	24-10164-0A	ICP 74LS156 DEMULTIPLEXER	1295	T.I.SN74LS156
U...5	24-10164-0A	ICP 74LS156 DEMULTIPLEXER	1295	T.I.SN74LS156
U...6	24-10164-0A	ICP 74LS156 DEMULTIPLEXER	1295	T.I.SN72LS156

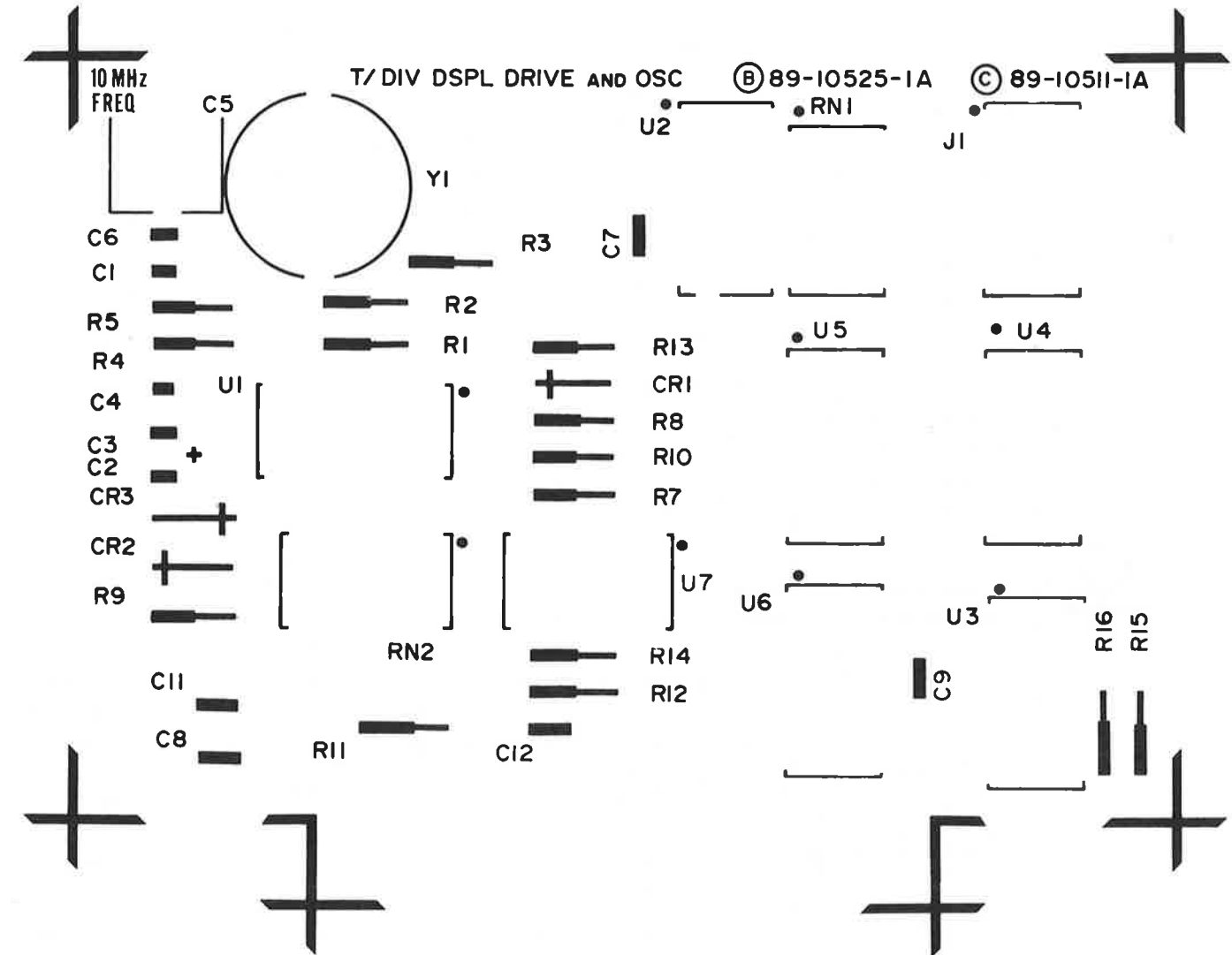

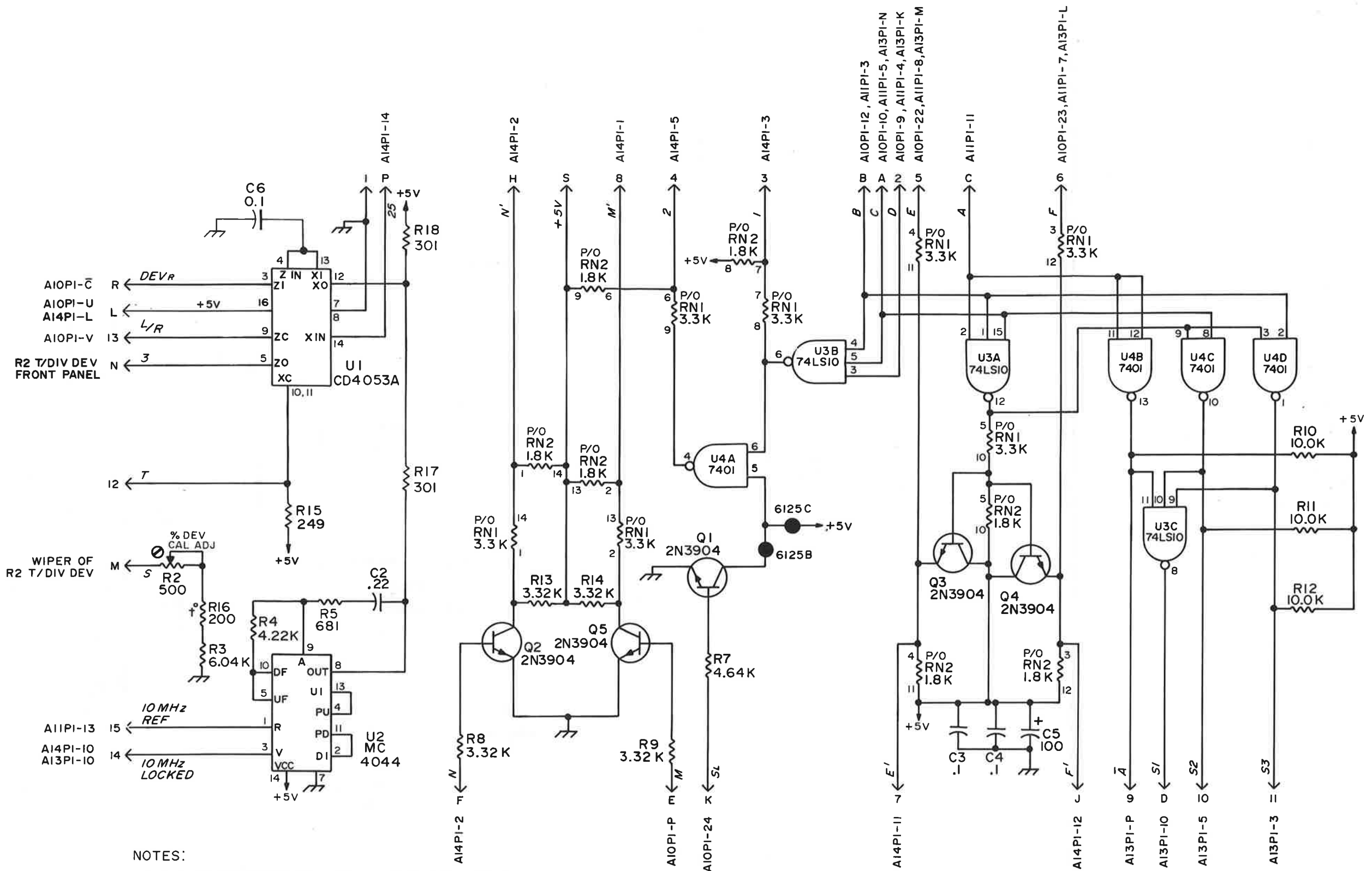

- NOTES:
1. ALL CAPACITANCE VALUES ARE IN MICROFARADS AND ALL RESISTANCE VALUES ARE IN OHMS, UNLESS NOTED OTHERWISE.
 2. → DENOTES CONTACT OF A12PI.
 3. * DENOTES FACTORY SELECTED VALUE.
 4. ● DENOTES A SOLDER CONNECTION.

Figure 6-13. A12 6125B/C Time/Div Decoder

PARTS LIST, A12 TIME/DIV DECODER MODEL 6125B/C (89-10512-1A)

SCHEMATIC REF	BALLANTINE PART NO.	DESCRIPTION	MFR CODE	MFR PART NUMBER
C...2	07-10430-0A	CBM 220.0NF 100.0 VK	80031	MEPCO C280 MAH/A220K
C...3	07-10562-0A	CCR 0.1 UF 50V .3 SPACE	0	AVX CERAMICS MD015E104ZAA
C...4	07-10562-0A	CCR 0.1 UF 50V .3 SPACE	0	AVX CERAMICS MD015E104ZAA
C...5	07-10184-0A	CET 100.0UF 10.0 VM DIP TAN	56289	SPRAGUE 196D107X0010-LA3
C...6	07-10562-0A	CCR 0.1 UF 50V .3 SPACE	0	AVX CERAMICS MD015E104ZAA
Q...1	10-10043-0A	TRQ 2N3904 NPN 1 40 PT0-92	4713	MOT 1 300M 40
Q...2	10-10043-0A	TRQ 2N3904 NPN 1 40 PT0-92	4713	MOT 1 300M 40
Q...3	10-10043-0A	TRQ 2N3904 NPN 1 40 PT0-92	4713	MOT 1 300M 40
Q...4	10-10043-0A	TRQ 2N3904 NPN 1 40 PT0-92	4713	MOT 1 300M 40
Q...5	10-10043-0A	TRQ 2N3904 NPN 1 40 PT0-92	4713	MOT 1 300M 40
R...2	09-10094-0A	RVF 500.0 500.0MW KVERT MT	73138	HELIPOT 72XW 500
R...3	12-12375-0A	RFF 6.04K 250.0MW F+- 1%	16299	CGW RN55D 6041 F
R4	12-12360-0A	RFF 4.22K 250.0MW F+- 1%	16299	CGW RN55D 4221 F
R...5	12-12280-0A	RFF 681.0 250 MW F+-1%	16299	CGW RN55D 6810 F
R...7	12-12364-0A	RFF 4.64K 250.0MW F+- 1%	16299	CGW RN55D 4641 F
R...8	12-12350-0A	RFF 3.32K 250.0MW F+- 1%	16299	CGW RN55D 3321 F
R...9	12-12350-0A	RFF 3.32K 250.0MW F+- 1%	16299	CGW RN55D 3321 F
R...10	12-12400-0A	RFF 10.0 K 250.0MW F+- 1%	16299	CGW RN55D 1002 F
R...11	12-12400-0A	RFF 10.0 K 250.0MW F+- 1%	16299	CGW RN55D 1002 F
R...12	12-12400-0A	RFF 10.0 K 250.0MW F+- 1%	16299	CGW RN55D 1002 F
R...13	12-12350-0A	RFF 3.32K 250.0MW F+- 1%	16299	CGW RN55D 3321 F
R...14	12-12350-0A	RFF 3.32K 250.0MW F+- 1%	16299	CGW RN55D 3321 F
R...15	12-12238-0A	RFF 249.0 250.0MW F+- 1%	16299	CGW RN55D 2490 F
R...16	27-01153-0A	THR-200 K+-10%	83186	VTE TYPE 22E9
R...17	12-12246-0A	RFF 301.0 250 MW F+-1%	16299	CGW RN55D 3010 F
R...18	12-12246-0A	RFF 301.0 250 MW F+-1%	16299	CGW RN55D 3010 F
RN...1	13-10021-0A	RNF 3.3 K 0.2 w F	0	BECKMAN 899-3R3,3K-F
RN...2	13-10020-0A	RNF 1.8 K 0.2 w F	0	BECKMAN 899-3R1.8K-F
U...1	24-10174-0A	ICP 4053 CMOS MULTIPLEXER	86684	RCA CD4053
U...2	24-10129-0A	ICP MC4044 PHASE LOCK LOOP	4713	MOT MC4044
U...3	24-10179-0A	ICP 74LS10 TRI,3 IN NAND	1295	T.I.SN74S10
U...4	24-10182-0A	ICP 7401 QUAD 2 IN NAND	1295	T.I.SN7401 OR EQUIP.

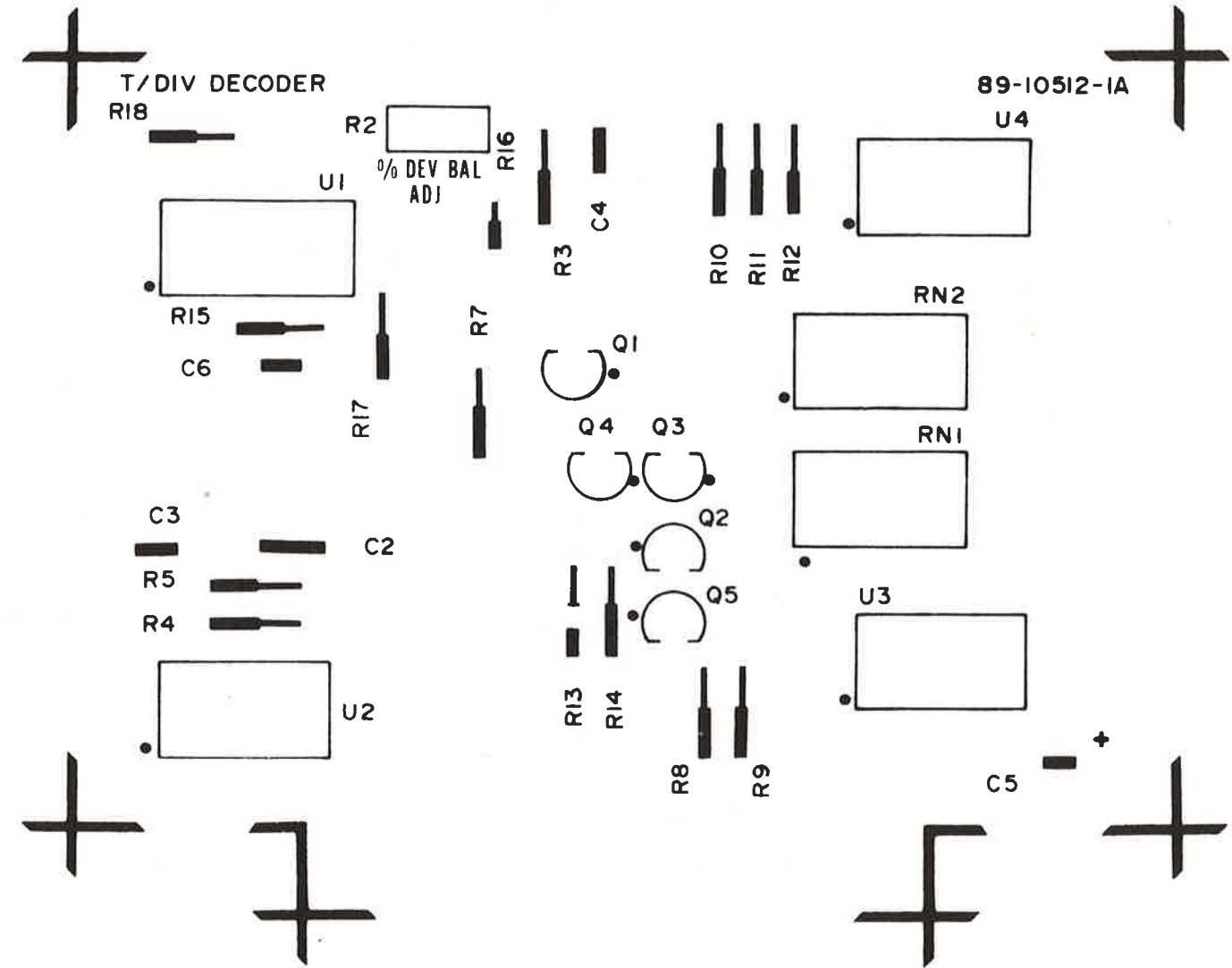

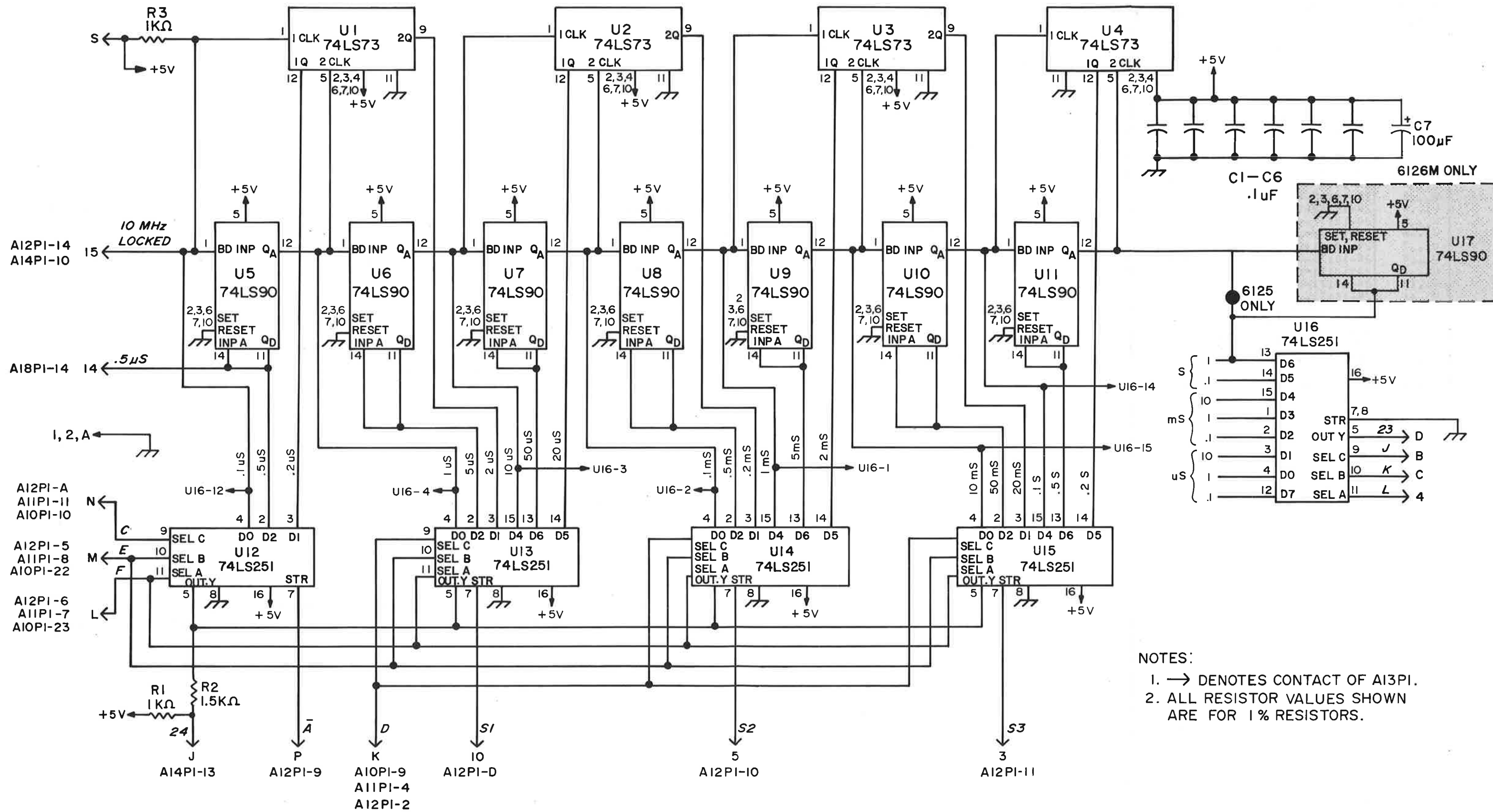

- NOTES:
- DENOTES CONTACT OF AI3PI.
 - ALL RESISTOR VALUES SHOWN ARE FOR 1% RESISTORS.

Figure 6-14. A13 6125B/C Time/Div Select

PARTS LIST, A13 TIME/DIV SELECT MODEL 6125B/C (89-10513-1A)

SCHEMATIC REF	BALLANTINE PART NO.	DESCRIPTION	MFR CODE	MFR PART NUMBER
C...1	07-10562-0A	CCR 0.1 UF 50V .3 SPACE	0	AVX CERAMICS MD015E104ZAA
C...2	07-10562-0A	CCR 0.1 UF 50V .3 SPACE	0	AVX CERAMICS MD015E104ZAA
C...3	07-10562-0A	CCR 0.1 UF 50V .3 SPACE	0	AVX CERAMICS MD015E104ZAA
C...4	07-10562-0A	CCR 0.1 UF 50V .3 SPACE	0	AVX CERAMICS MD015E104ZAA
C...5	07-10562-0A	CCR 0.1 UF 50V .3 SPACE	0	AVX CERAMICS MD015E104ZAA
C...6	07-10562-0A	CCR 0.1 UF 50V .3 SPACE	0	AVX CERAMICS MD015E104ZAA
C...7	07-10184-0A	CET 100.0UF 10.0 VM DIP TAN	56289	SPRAGUE 196D107X0010-LA3
R...1	12-12300-0A	RFF 1.0 K 250 MW F+-1%	16299	CGW RN55D 1001 F
R...2	12-12317-0A	RFF 1.50K 250 MW F+-1%	16299	CGW RN55D 1501 F
R...3	12-12300-0A	RFF 1.0 K 250 MW F+-1%	16299	CGW RN55D 1001 F
U...1	24-10169-0A	ICP 74LS73 DUAL JK FL.FL.	1295	T.I.SN74LS73
U...2	24-10169-0A	ICP 74LS73 DUAL JK FL.FL.	1295	T.I.SN74LS73
U...3	24-10169-0A	ICP 74LS73 DUAL JK FL.FL.	1295	T.I.SN74LS73
U...4	24-10169-0A	ICP 74LS73 DUAL JK FL.FL.	1295	T.I.SN74LS73
U...5	24-10171-0A	ICP 74LS90 DIVIDE BY 12	1295	T.I.SN74LS90
U...6	24-10171-0A	ICP 74LS90 DIVIDE BY 12	1295	T.I.SN74LS90
U...7	24-10171-0A	ICP 74LS90 DIVIDE BY 12	1295	T.I.SN74LS90
U...8	24-10171-0A	ICP 74LS90 DIVIDE BY 12	1295	T.I.SN74LS90
U...9	24-10171-0A	ICP 74LS90 DIVIDE BY 12	1295	T.I.SN74LS90
U...10	24-10171-0A	ICP 74LS90 DIVIDE BY 12	1295	T.I.SN74LS90
U...11	24-10171-0A	ICP 74LS90 DIVIDE BY 12	1295	T.I.SN74LS90
U...12	24-10170-0A	ICP 74LS251 DATA SELECTOR	1295	T.I.SN74LS251
U...13	24-10170-0A	ICP 74LS251 DATA SELECTOR	1295	T.I.SN74LS251
U...14	24-10170-0A	ICP 74LS251 DATA SELECTOR	1295	T.I.SN74LS251
U...15	24-10170-0A	ICP 74LS251 DATA SELECTOR	1295	T.I.SN74LS251
U...16	24-10170-0A	ICP 74LS251 DATA SELECTOR	1295	T.I.SN74LS251

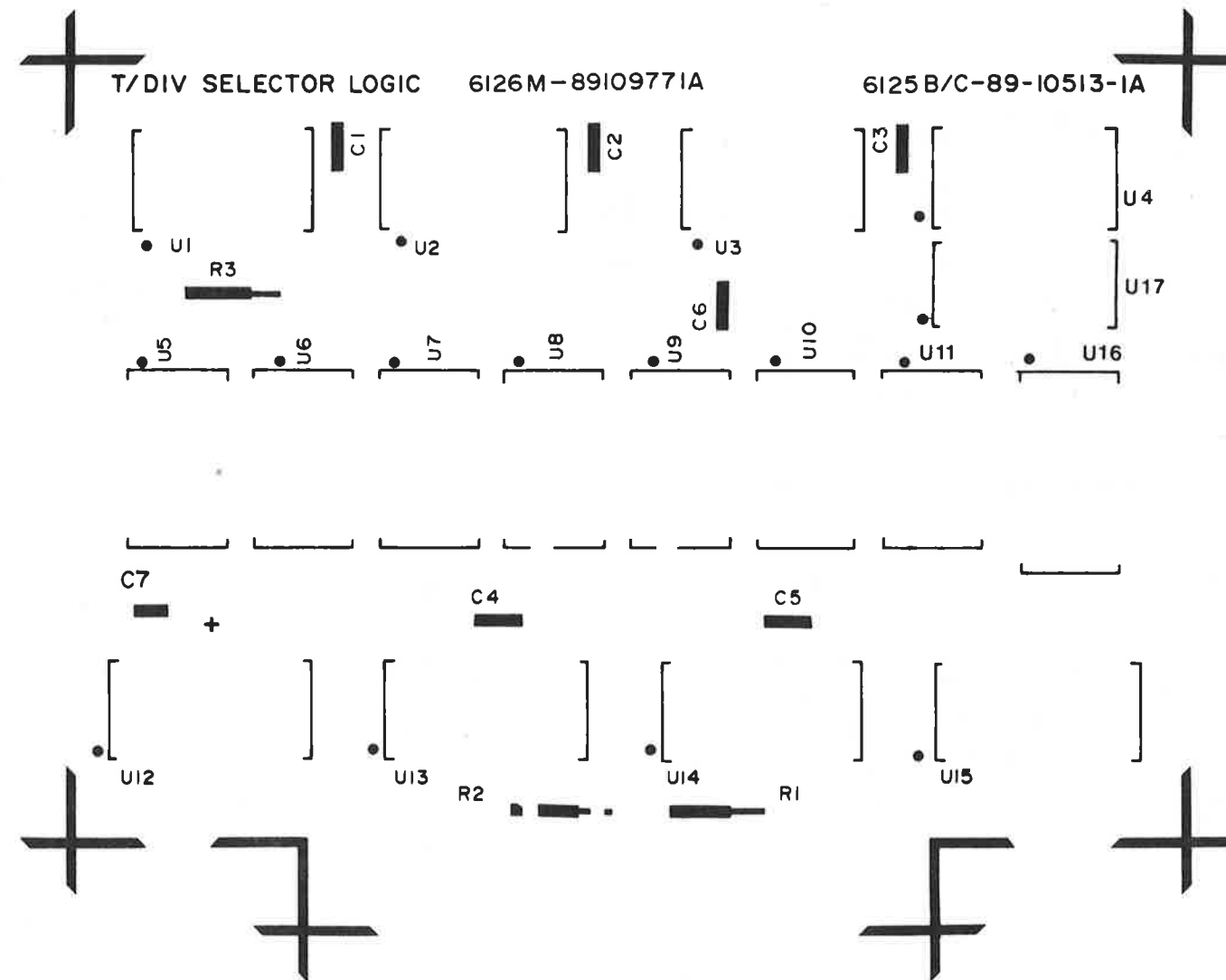

NOTES:

1. ALL CAPACITANCE VALUES ARE IN MICROFARADS AND ALL RESISTANCE VALUES ARE IN OHMS UNLESS NOTED OTHERWISE.
2. → DENOTES CONTACT OF A14PI.

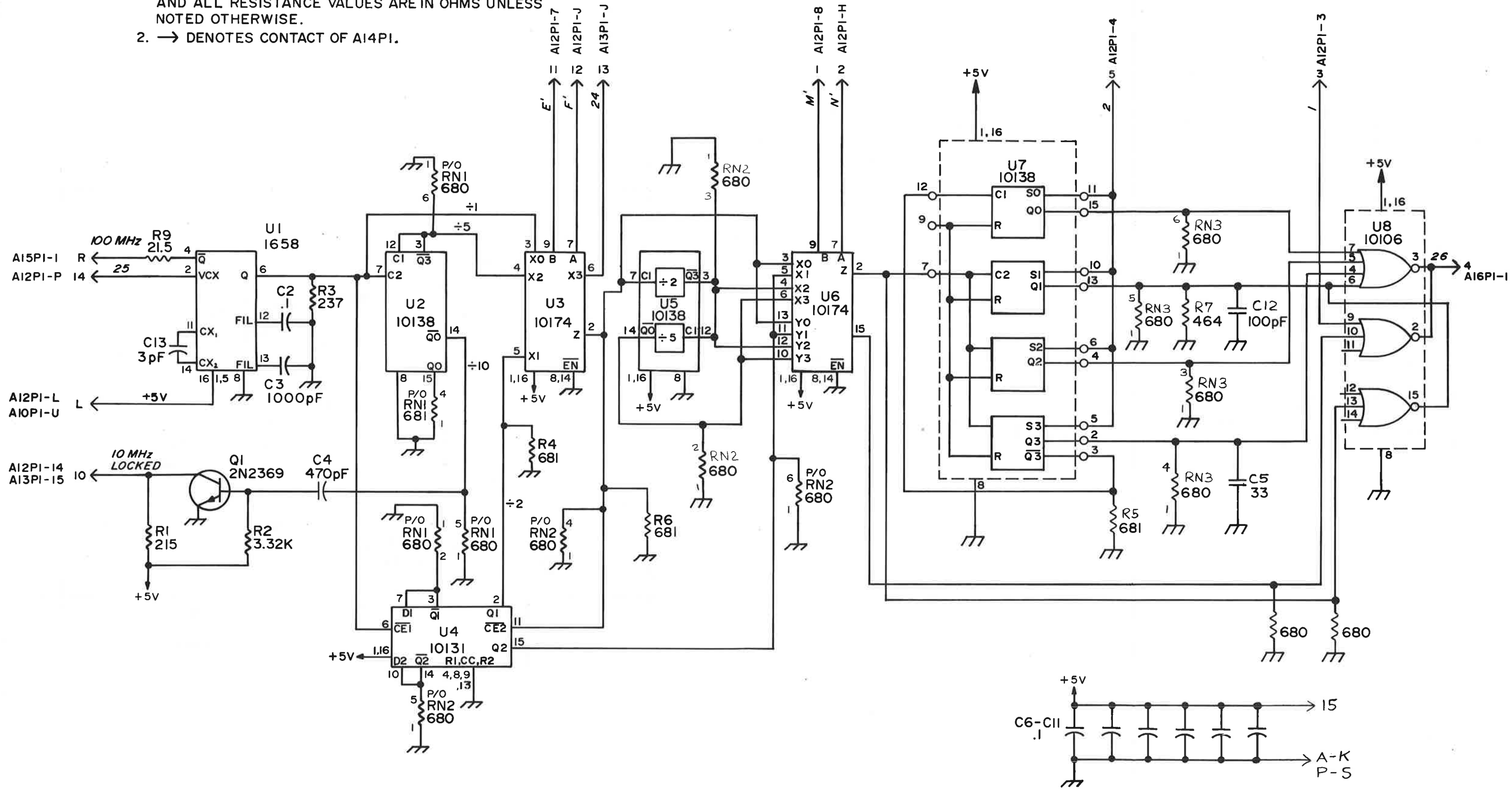
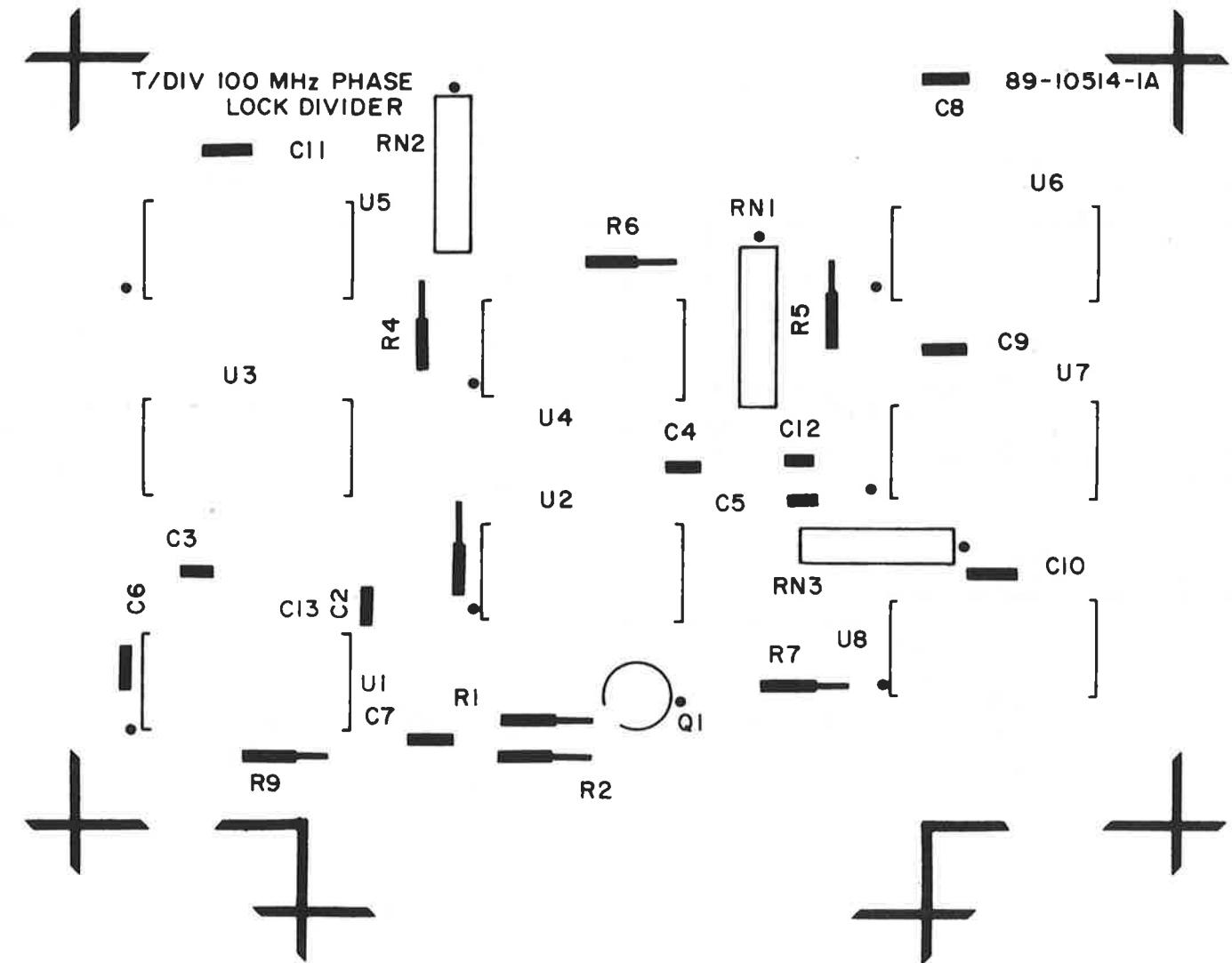

Figure 6-15. A14 6125B/C 100 MHz Phase Lock Divider

PARTS LIST, A14 100 MHz PHASE LOCK DIVIDER MODEL 6125B/C (89-10514-1A)

SCHEMATIC REF	BALLANTINE PART NO.	DESCRIPTION	MFR CODE	MFR PART NUMBER
C...2	07-10562-0A	CCR 0.1 UF 50V .3 SPACE	0	AVX CERAMICS MD015E104ZAA
C...3	07-02592-0A	CCD 1.0NF 1.0KVK+-10%	84171	ARCO TYPE CCD-102
C...4	07-02292-0A	CMD 470.0PF 500.0 FJ+- 5%	84171	ARCO DM-15-471-J
C...5	07-10197-0A	CCD 33.0PF 1.0KVJ NPO	56289	SPRAGUE C030B102G330J EQV
C...6	07-10562-0A	CCR 0.1 UF 50V .3 SPACE	0	AVX CERAMICS MD015E104ZAA
C...7	07-10562-0A	CCR 0.1 UF 50V .3 SPACE	0	AVX CERAMICS MD015E104ZAA
C...8	07-10562-0A	CCR 0.1 UF 50V .3 SPACE	0	AVX CERAMICS MD015E104ZAA
C...9	07-10562-0A	CCR 0.1 UF 50V .3 SPACE	0	AVX CERAMICS MD015E104ZAA
C...10	07-10562-0A	CCR 0.1 UF 50V .3 SPACE	0	AVX CERAMICS MD015E104ZAA
C...11	07-10562-0A	CCR 0.1 UF 50V .3 SPACE	0	AVX CERAMICS MD015E104ZAA
C...12	07-09552-0A	CCD 100 PF 1 KV K 10%	84171	ARC TYP CCD-1C1
C...13	07-10262-0A	CMD 3.0PF 300.0 +- 1PF	84171	ARCO DM5CC-030A
Q...1	10-10001-0A	TRQ 2N2369 NPN 1 15 MTU-18	4713	MOT 1.2 500M 20
R...1	12-12232-0A	RFF 215.0 250 MW F+-1%	16299	CGW RN55D 2150 F
R...2	12-12350-0A	RFF 3.32K 250.0MW F+- 1%	16299	CGW RN55D 3321 F
R...3	12-12236-0A	RFF 237.0 250 MW F+-1%	16299	CGW RN55D 2370 F
R...4	12-12280-0A	RFF 681.0 250 MW F+-1%	16299	CGW RN55D 6810 F
R...5	12-12280-0A	RFF 681.0 250 MW F+-1%	16299	CGW RN55D 6810 F
R...6	12-12280-0A	RFF 681.0 250 MW F+-1%	16299	CGW RN55D 6810 F
R...7	12-12264-0A	RFF 464.0 250 MW F+-1%	16299	CGW RN55D 4640 F
R...9	12-12132-0A	RFF 21.5 250.0MW F+- 1%	16299	CGW RN55D 21R5 F
RN...1	13-10019-0A	RNF 680.0 0.3 W F	80053	BECKMAN 783-1-R680
RN...2	13-10019-0A	RNF 680.0 0.3 W F	80053	BECKMAN 783-1-R680
RN...3	13-10019-0A	RNF 680.0 0.3 W F	80053	BECKMAN 783-1-R680
U...1	24-10172-0A	ICP 1658 VOLT. CONTROL MUBN	4713	MOTOROLA MC 1658
U...2	24-10176-0A	ICP 10138 BI QUINARY CONTR	4713	MOTOROLA MC10138
U...3	24-10177-0A	ICP 10174 DUAL 4 TO 1 MCTPR	4713	MOTOROLA MC10174
U...4	24-10180-0A	ICP 10131 DUAL D FL. FL.	86684	MOTOROLA MC10131
U...5	24-10176-0A	ICP 10138 BI QUINARY CONTR	4713	MOTOROLA MC10138
U...6	24-10177-0A	ICP 10174 DUAL 4 TO 1 MCTPR	4713	MOTOROLA MC10174
U...7	24-10176-0A	ICP 10138 BI QUINARY CONTR	4713	MOTOROLA MC10138
U...8	24-10178-0A	ICP 10106 TRI.4-3-3 IN. NOR	86684	MOTOROLA MC10106



NOTES:

1. ALL CAPACITANCE VALUES ARE IN MICROFARADS AND ALL RESISTANCE VALUES ARE IN OHMS, UNLESS NOTED OTHERWISE.
2. → DENOTES CONTACT OF A15PI.
3. ALL RESISTOR VALUES ARE FOR 1% RESISTORS.

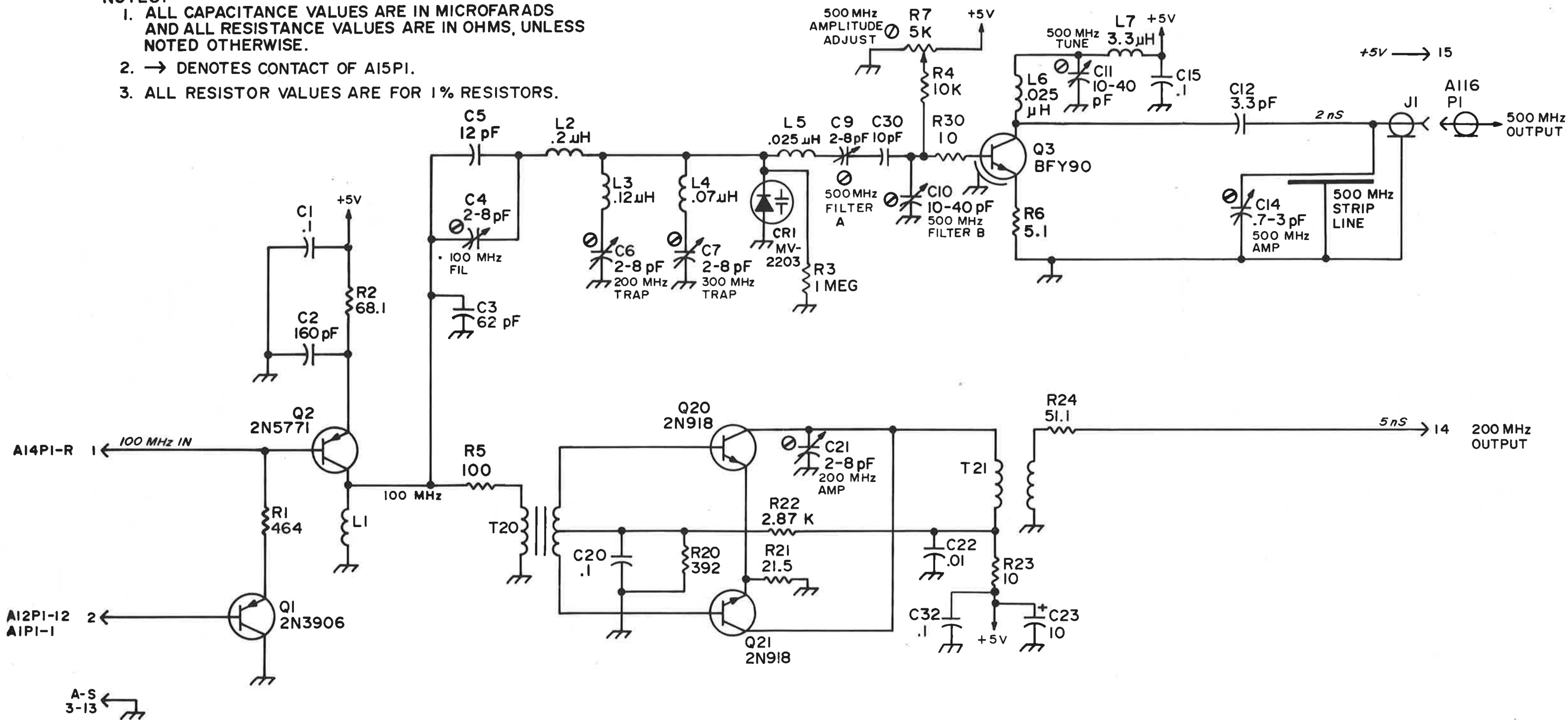
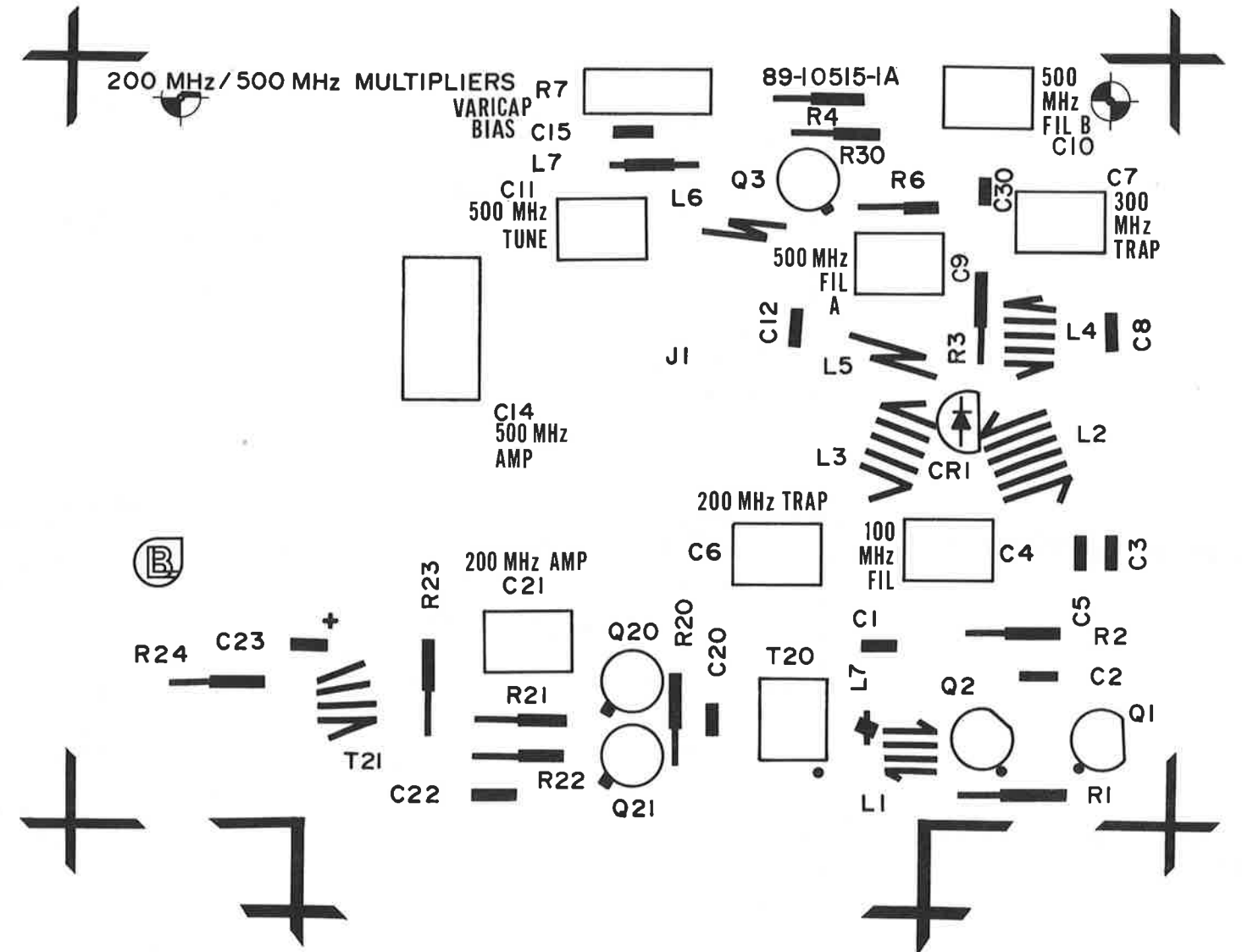
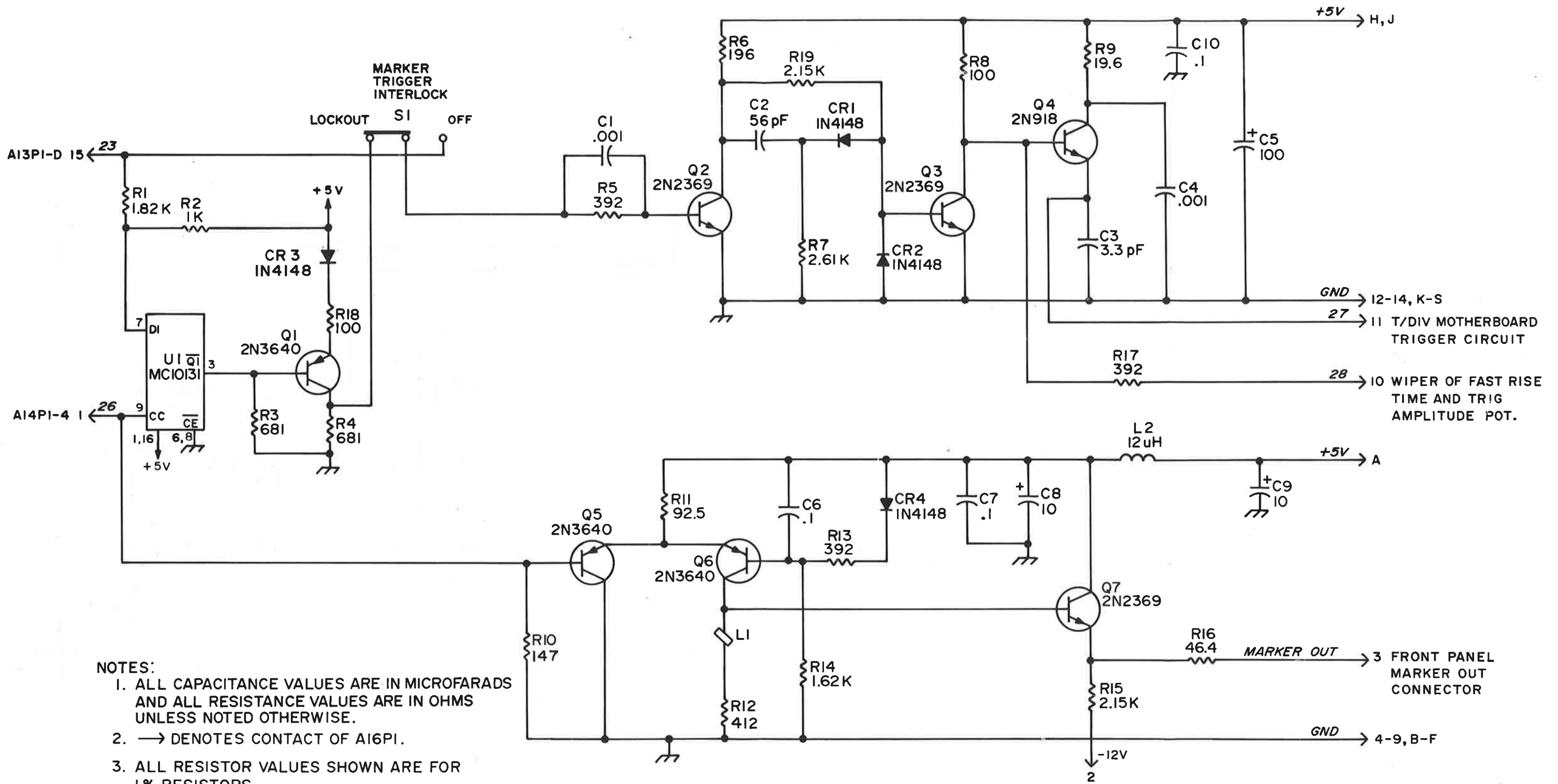

Figure 6-16. A15 6125B/C 200 MHz and 500 MHz Multiplier

SCHEMATIC REF	BALLANTINE PART NO.	DESCRIPTION	MFR CODE	MFR PART NUMBER
C...1	07-10562-0A	CCR 0.1 UF 50V .3 SPACE	0	AVX CERAMICS MD015E104ZAA
C...2	07-10137-0A	CMO 160. PF 500. VJ	72136	ELMENCO DM15FD161J03
C...3	07-10317-0A	62.0PF 300.0 VJ	53021	SNAGAMO CM05ED620J03 OR EQ
C...4	07-10429-0A	CVC 2-8PF 250.0 V -10+50%	50423	ST.TR.10STRIKO 24
C...5	07-10534-0A	CMD 12.0PF 500.0 VJ+- 5%	84171	ARCO CM04FD120J03 O/E
C...6	07-10429-0A	CVC 2-8PF 250.0 V -10+50%	50423	ST.TR.10STRIKO 24
C...7	07-10429-0A	CVC 2-8PF 250.0 V -10+50%	50423	ST.TR.10STRIKO 24
C...9	07-10429-0A	CVC 2-8PF 250.0 V -10+50%	50423	ST.TR.10STRIKO 24
C...10	07-10428-0A	CVC 10-40PF 250.0 V-10+50%	50423	ST.TR.10 STRIKO 24
C...11	07-10428-0A	CVC 10-40PF 250.0 V-10+50%	50423	ST.TR.10 STRIKO 24
C...12	07-10081-0A	CCD 3.3PF 500. V	90201	RMC TYPE GG
C...14	07-10427-0A	CVC 7-3PF 250.0 - 0+50%	50423	ST.TR R-TRIKO 122 09
C...20	07-10112-0A	CCC 100.0NF 50.0 V CHIP	71590	CENTRLB W005FH104M
C...21	07-10429-0A	CVC 2-8PF 250.0 V -10+50%	50423	ST.TR.10STRIKO 24
C...22	07-10563-0A	CCR 0.01UF 50V .3 SPACE	0	AVX CERAMICS MD015E103ZAA
C...23	07-10053-0A	CET 10.0UF 35.0V M	56289	199D106X0035DA2
C...30	07-10488-0A	CMD 10.0PF 300.0 VJ	84171	ARCO TYPE DM-15-BC10JN1
C...32	07-10112-0A	CCC 100.0NF 50.0 V CHIP	71590	CENTRLB W005FH104M
CR...1	05-10055-0A	DVC MV2203 25 10PF .28	4713	MOT SI VOLT VAR CAP
J...1A	31-10173-0A	CON COAX MIN PC JACK SNAP UN	98291	SEAELECTRO S1-051-0000 EQU
L...1	03-10055-1A	CIL AIR COIL	50423	BLI FOR 6125B
L...2	03-10044-1B	CIL .20 UH AIR COIL	50423	BLI
L...3	03-10083-1A	CIL 0.07- .12 UH AIR COIL	50423	BLI
L...4	03-10083-1A	CIL 0.07- .12 UH AIR COIL	50423	BLI
L...5	03-10045-1A	CIL .025 UH AIR COIL	50423	BLI
L...6	03-10045-1A	CIL .025 UH AIR COIL	50423	BLI
L...7	03-06289-0A	CLF 3.3UH	83125	NYTRONICS, DD-3.3
Q...1	10-09473-0A	TRQ 2N3906 PNP 1 40 PTD-92	4713	MOT 1 200M 60
Q...2	10-10168-0A	TRQ 2N5771	0	FAIRCHILD OR EQUIV 2N5771
Q...3	10-10157-0A	TRQ BFY90 NPN 1 15V S TO 72	0	SGS ATE5
Q...20	10-10104-1A	TRQ 2N 918 2 MATCH FOR BETA	50423	BLI PER 99100375A
Q...21	10-10104-1A	TRQ 2N 918 2 MATCH FOR BETA	50423	BLI PER 99100375A
R...1	12-12264-0A	RFF 464.0 250 MW F+-1%	16299	CGW RN55D 4640 F
R...2	12-12180-0A	RFF 68.1 250.0MW F+- 1%	16299	CGW RN55D 68R1 F
R...3	12-12600-0A	RFF 1.00M 500 MW F+-1%	16299	CGW RN60D 1004 F
R...4	12-12400-0A	RFF 10.0 K 250.0MW F+- 1%	16299	CGW RN55D 1002 F
R...5	12-12200-0A	RFF 100.0 250.0MW F+- 1%	16299	CGW RN55D 1000 F
R...6	12-09839-0A	RFC 5.1 250.0MW J+- 5%	75042	IRC TYP
R...7	09-10212-0A	RVF 5.0 K 500.0MW CERMET	73138	HEL TYPE 72XW
R...20	12-12257-0A	RFF 392.0 250 MW F+-1%	16299	CGW RN55D 3920 F
R...21	12-12132-0A	RFF 21.5 250.0MW F+- 1%	16299	CGW RN55D 21R5 F
R...22	12-12344-0A	RFF 2.87K 205.0MW F+- 1%	16299	CGW RN55D 2871 F
R...23	12-12100-0A	RFF 10.0 250.0MW F+- 1%	16299	CGW RN55D 10R0 F
R...24	12-12168-0A	RFF 51.1 250.0MW F+- 1%	16299	CGW RN55D 51R1 F
R...30	12-08046-0A	RFC 10.0 250.0MW J+- 5%	1121	A-B TYP CB
T...21	20-10026-1A	TRX RF AIR 6130A 200 MHZ	50423	





NOTES:

1. ALL CAPACITANCE VALUES ARE IN MICROFARADS AND ALL RESISTANCE VALUES ARE IN OHMS UNLESS NOTED OTHERWISE.
2. → DENOTES CONTACT OF A16PI.
3. ALL RESISTOR VALUES SHOWN ARE FOR 1% RESISTORS.

Figure 6-17. A16 6125B/C Time Output Amplifier

PARTS LIST, A16 TIME OUTPUT AMPLIFIER MODEL 6125B/C (89-10516-1A)

SCHEMATIC REF	BALLANTINE PART NO.	DESCRIPTION	MFR CODE	MFR PART NUMBER
C...1	07-02592-0A	CCD 1.0NF 1.0KVK+-10%	84171	ARCO TYPE CCD-102
C...2	07-02289-0A	CMD 56 PF 500 V T	84171	ARCO DM-15-560F SILVERED
C...3	07-10081-0A	CCD 3.3PF 500. V	90201	RMC TYPE GG
C...4	07-02592-0A	CCD 1.0NF 1.0KVK+-10%	84171	ARCO TYPE CCD-102
C...5	07-10106-0A	CTF 100.0UF 10.0 VM DIPTANT	22229	KEMEN T362C107M010AS
C...6	07-10562-0A	CCR 0.1 UF 50V .3 SPACE	0	AVX CERAMICS MD015E104ZAA
C...7	07-10562-0A	CCR 0.1 UF 50V .3 SPACE	0	AVX CERAMICS MD015E104ZAA
C...8	07-10053-0A	CET 10.0UF 35.0V M	56289	199D106X0035DA2
C...9	07-10053-0A	CET 10.0UF 35.0V M	56289	199D106X0035DA2
C...10	07-10112-0A	CCC 100.0NF 50.0 V CHIP	71590	CENTRLB W005FH104M
CR...1	05-07920-0A	DGP 1N4148 75 10M	7263	FCH SI D035
CR...2	05-07920-0A	DGP 1N4148 75 10M	7263	FCH SI D035
CR...3	05-07920-0A	DGP 1N4148 75 10M	7263	FCH SI D035
CR...4	05-07920-0A	DGP 1N4148 75 10M	7263	FCH SI D035
L...1	46-10000-0A	FRB FERRITE BEAD	78488	STACKPOLE 57-0180-70 MAT
L...2	03-10006-0A	CRF 12UH MOLOED +- 10%	76493	MILLER #9230-46
Q...1	10-07934-0A	TRQ 2N3640 PNP 1 12 TO-106	7263	FCH .500 300M 30
Q...2	10-10001-0A	TRQ 2N2369 NPN 1 15 MT0-18	4713	MOT 1.2 500M 20
Q...3	10-10001-0A	TRQ 2N2369 NPN 1 15 MT0-18	4713	MOT 1.2 500M 20
Q...4	10-08055-0A	TRQ 2N918 PNP 1 15 PT0-18	7263	FCH .300 900M 20
Q...5	10-07934-0A	TRQ 2N3640 PNP 1 12 TO-106	7263	FCH .500 300M 30
U...6	10-07934-0A	TRQ 2N3640 PNP 1 12 TO-106	7263	FCH .500 300M 30
U...7	10-10001-0A	TRQ 2N2369 NPN 1 15 MT0-18	4713	MOT 1.2 500M 20
R...1	12-12325-0A	1.82K 250.0MW F+- 1%	16299	CGW RN55D 1821 F
R...2	12-12300-0A	RFF 1.0 K 250 MW F+-1%	16299	CGW RN55D 1001 F
R...3	12-12280-0A	RFF 681.0 250 MW F+-1%	16299	CGW RN55D 6810 F
R...4	12-12280-0A	RFF 681.0 250 MW F+-1%	16299	CGW RN55D 6810 F
R...5	12-12257-0A	RFF 392.0 250 MW F+-1%	16299	CGW RN55D 3920 F
R...6	12-12228-0A	RFF 196.0 250 MW F+-1%	16299	CGW RN55D 1960 F
R...7	12-12340-0A	RFF 2.61K 250.0MW F+- 1%	16299	CGW RN55D 2611 F
R...8	12-12200-0A	RFF 100.0 250.0MW F+- 1%	16299	CGW RN55D 1000 F
R...9	12-12128-0A	RFF 19.6 250.0MW F+- 1%	16299	CGW RN55D 19R6 F
R...10	12-12216-0A	RFF 147.0 250.0MW F+- 1%	16299	CGW RN55D 1470 F
R...11	12-06074-0A	RCF 92.5 250.0MW F+- 1%	19701	ELT TYP MF5C CH-D
R...12	12-12259-0A	RFF 412.0 250 MW F+-1%	16299	CGW RN55D 4120 F
R...13	12-12257-0A	RFF 392.0 250 MW F+-1%	16299	CGW RN55D 3920 F
R...14	12-12320-0A	RFF 1.62k 250 MW F+-1%	16299	CGW RN55D 1621 F
R...15	12-12332-0A	RFF 2.15K 250.0MW F+- 1%	16299	CGW RN55D 2151 F
R...16	12-12164-0A	RFF 46.4 250.0MW F+- 1%	16299	CGW RN55D 46R4 F
R...17	12-12257-0A	RFF 392.0 250 MW F+-1%	16299	CGW RN55D 3920 F
R...18	12-12200-0A	RFF 100.0 250.0MW F+- 1%	16299	CGW RN55D 1000 F
R...19	12-12332-0A	RFF 2.15K 250.0MW F+- 1%	16299	CGW RN55D 2151 F
S...1	25-10022-0A	SWC SLIDE MIN DPDT	78488	STACKPOLE SS-91-1
U...1	24-10180-0A	ICP 10131 DUAL D FL. FL.	86684	MOTOROLA MC10131

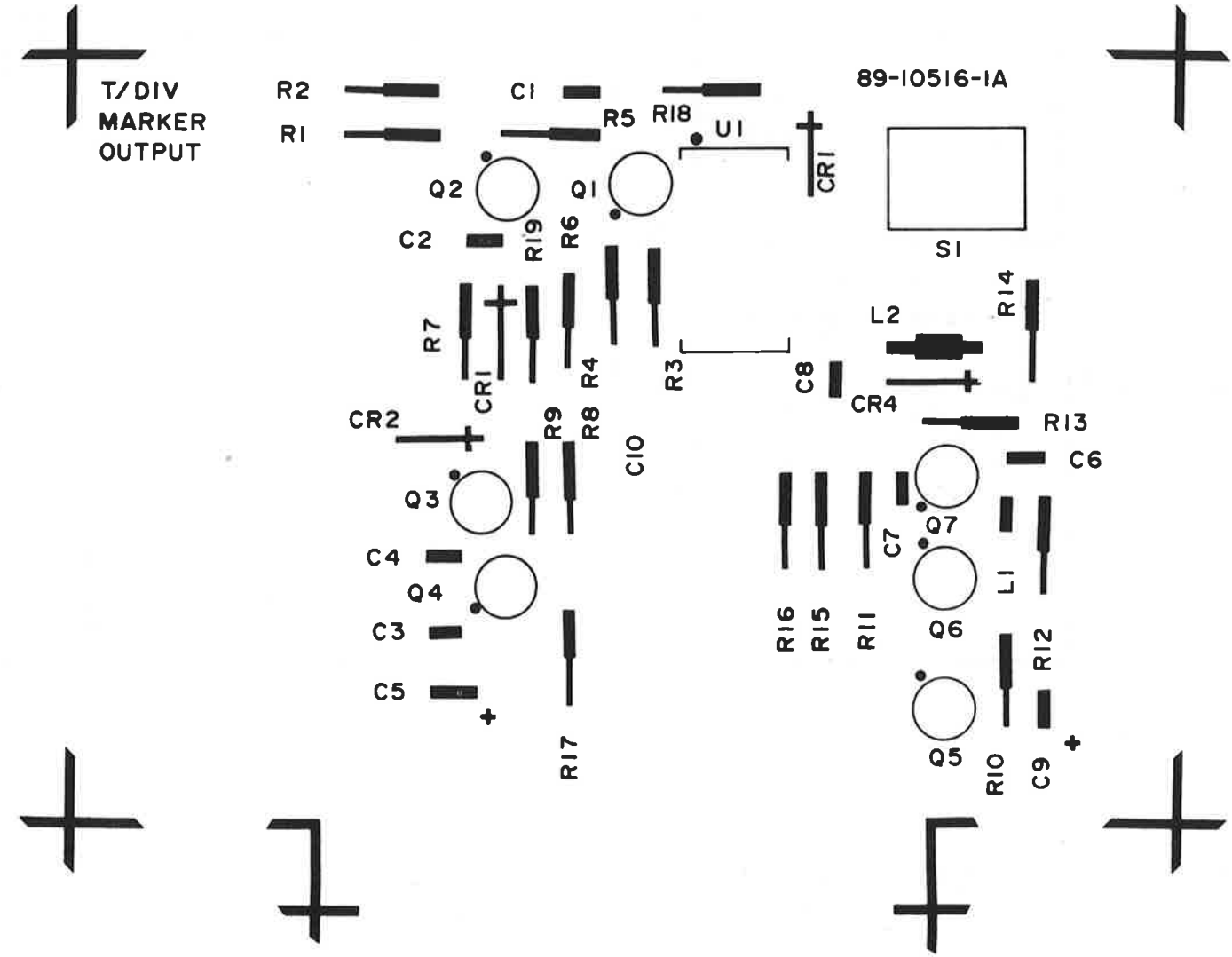

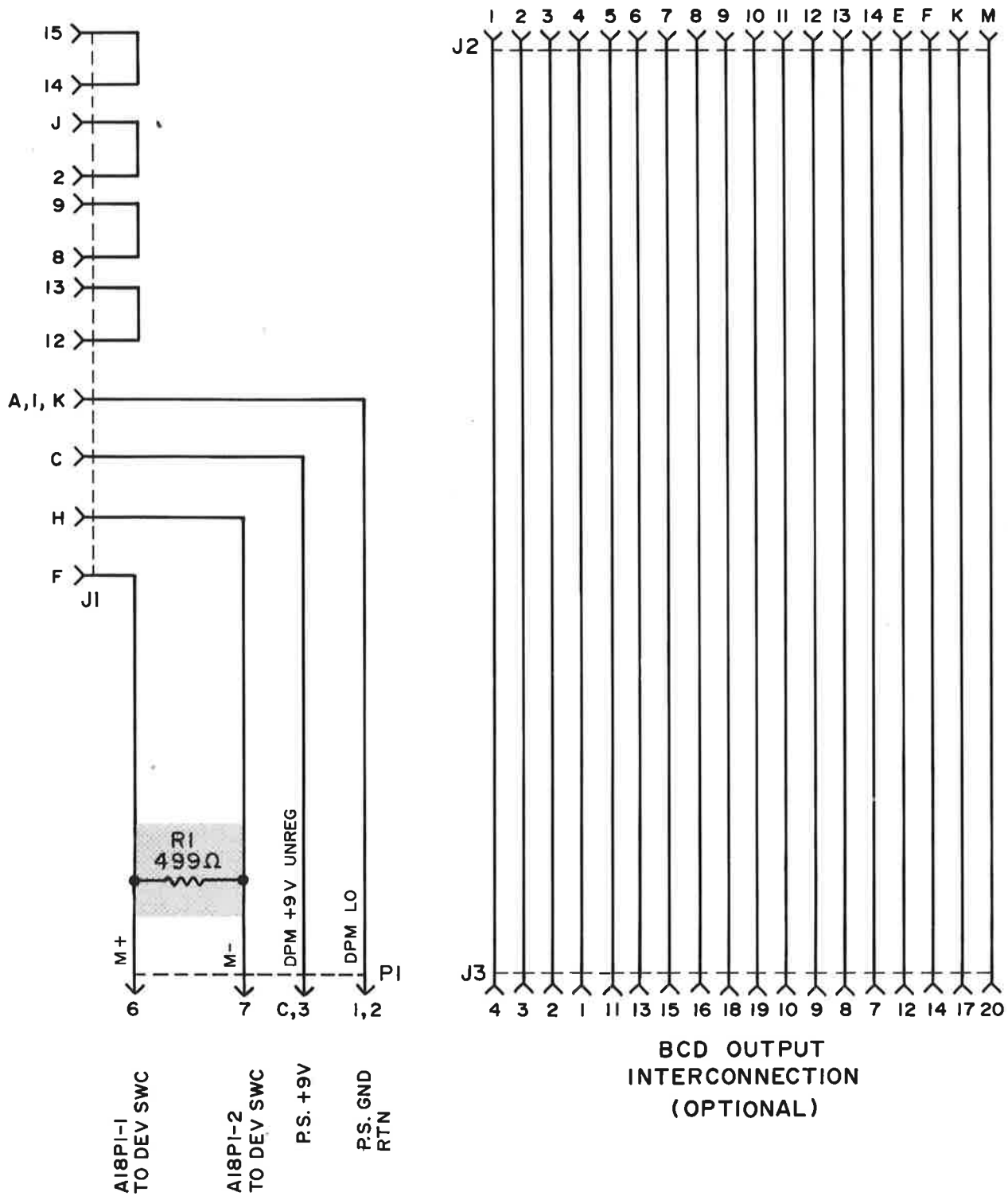

NOTE:
 RI NOT USED AFTER S/N 021 - .

Figure 6-18. A17 6125B/C DPM Interconnect Board

PARTS LIST, A17 DPM INTERCONNECT MODEL 6125B/C (89-10517-1A)

SCHEMATIC REF	BALLANTINE PART NO.	DESCRIPTION	MFR CODE	MFR PART NUMBER
J...1 R...1	51-10163-0A 12-20050-0A	CON 15 PIN CARD EDGE PC TYPE RFF 499.0 250.0MW F+- 1%	2260 81349	AMPHENOL 225-21521-110 RN5SC4990F TC+-50PPM

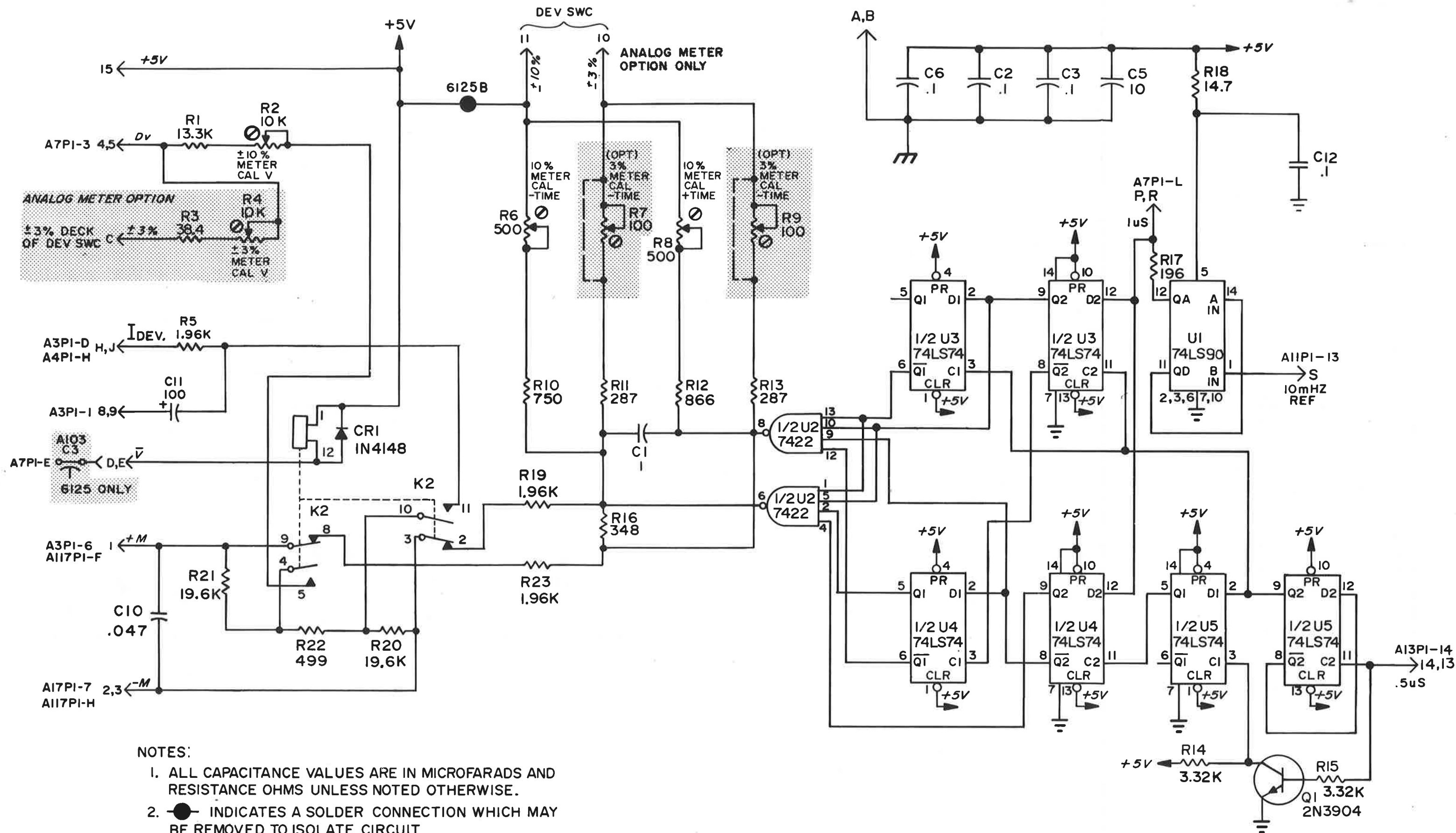

NOTES:

1. ALL CAPACITANCE VALUES ARE IN MICROFARADS AND RESISTANCE OHMS UNLESS NOTED OTHERWISE.
2. ● INDICATES A SOLDER CONNECTION WHICH MAY BE REMOVED TO ISOLATE CIRCUIT.
3. ALL RELAYS SHOWN IN POSITION WHEN COIL IS NOT ENERGIZED.
4. → DENOTES CONTACT OF A18PI.

Figure 6-19A. A18 6125B/C Time Deviation Board (Serial Prefix 022-)

PARTS LIST, A18 DEVIATION BOARD MODEL 6125B/C (89-10526-1A)

*Assembly 89-10526-1A has been replaced by Assembly 89-11244-1A. Assembly 89-10526-1A is applicable to units with serial prefix 021-. Assembly 89-11244-1A is applicable to units with serial prefix 022-. Assembly 89-10526-1A is the same as Assembly 89-11244-1A except for the following:

Delete reference designators R19 and R23 (P/N 12-12328-0A), R20 and R21 (P/N 12-12428-0A), R22 (P/N 12-12267-0A), C10 (P/N 07-10483-0A), delete R12 (P/N 12-12290-0A) and add R12 (P/N 12-12284-0A RFF 750.0 250 MW F+-1% 16299 CGW RN550D 7500F).

PARTS LIST, A18 DEVIATION BOARD MODEL 6125B/C (89-11244-1A)

SCHEMATIC REF	BALLANTINE PART NO.	DESCRIPTION	MFR CODE	MFR PART NUMBER
C...1	07-08134-0A	CYM 1.0UF 50 V M 20%	84411	TRW TYPE X663F
C...2	07-10562-0A	CCR 0.1 UF 50V .3 SPACE	0	AVX CERAMICS MD015E104ZAA
C...3	07-10562-0A	CCR 0.1 UF 50V .3 SPACE	0	AVX CERAMICS MD015E104ZAA
C...5	07-10053-0A	CET 10.0UF 35.0V M	56289	199D106X0035DA2
C...6	07-10562-0A	CCR 0.1 UF 50V .3 SPACE	0	AVX CERAMICS MD015E104ZAA
C..10	07-10483-0A	CCD 47.0NF 25.0V +-20%	56289	APRAGUE 563CY5SBA250AG473M
C..11	07-10184-0A	CET 100.0UF 10.0 VM DIP TAN	56289	SPRAGUE 196D107X0010-LA3
C12	07-20094-0A	CCD .1UF 25.0 V +-20%	91418	M25-1
CR..1	05-07920-0A	DGP 1N4148 75 10M	7263	FCH SI D035
K...2	14-10034-0A	RLY 2A2B 5V COIL	0	ARUMAT S2E35V
Q...1	10-10043-0A	TRQ 2N3904 NPN 1 40 PT0-92	4713	MOT 1 300M 40
R...1	12-12412-0A	RFF 13.3 K 250.0MW F+- 1%	16299	CGW RN55D 1332 F
R...2	09-10093-0A	RVF 10.0 K 500.0MW KVERT MT	73138	HELIPOT 72XW 10K
R...5	12-12328-0A	RFF 1.96K 250.0MW F+- 1%	16299	CGW RN55D 1961 F
R...6	09-10094-0A	RVF 500.0 500.0MW KVERT MT	73138	HELIPOT 72XW 500
R..8	09-10094-0A	RVF 500.0 500.0MW KVERT MT	73138	HELIPOT 72XW 500
R..10	12-12284-0A	RFF 750.0 250 MW F+-1%	16299	CGW RN55D 7500 F
R..11	12-12244-0A	RFF 287.0 250 MW F+-1%	16299	CGW RN55D 2870 F
R..12	12-12290-0A	RFF 866.0 250 MW F+-1%	16299	CGW RN55D 8660F
R..13	12-12244-0A	RFF 287.0 250 MW F+-1%	16299	CGW RN55D 2870 F
R..14	12-12350-0A	RFF 3.32K 250.0MW F+- 1%	16299	CGW RN55D 3321 F
R..15	12-12350-0A	RFF 3.32K 250.0MW F+- 1%	16299	CGW RN55D 3321 F
R..16	12-12252-0A	RFF 348.0 250 MW F+-1%	16299	CGW RN55D 3480 F
R17	12-12228-0A	RFF 196.0 250 MW F+-1%	16299	CGW RN55D 1960 F
R18	12-12116-0A	RFF 14.7 250.0MW F+- 1%	16299	CGW RN55D 14R7 F
R..19	12-12328-0A	RFF 1.9K 250.0MW F+-1%	16299	CGW RN55D 1961F
R..20	12-12428-0A	RFF 19.6K 250.0MW F+-1%	16299	CGW RN55D 1962F
R..21	12-12428-0A	RFF 19.6K 250.0MW F+-1%	16299	CGW RN55D 1962F
R..22	12-12267-0A	RFF 499.0 250.0MW F+-1%	16299	CGW RN55D 4990F
R..23	12-12328-0A	RFF 1.9K 250.0MW F+-1%	16299	CGW RN55D 1961F
U...1	24-10171-0A	ICP 74LS90 DIVIDE BY 12	1295	T.I. SN74LS90
U2	24-10353-0A	ICP 7422 DUAL 4 INPUT NAND	0	TI SN7422 OR EQUIV.
U...3	24-10143-0A	ICP 74LS74 D FIFL 14 DIP	1295	TI
U...4	24-10143-0A	ICP 74LS74 D FIFL 14 DIP	1295	TI
U...5	24-10143-0A	ICP 74LS74 D FIFL 14 DIP	1295	TI

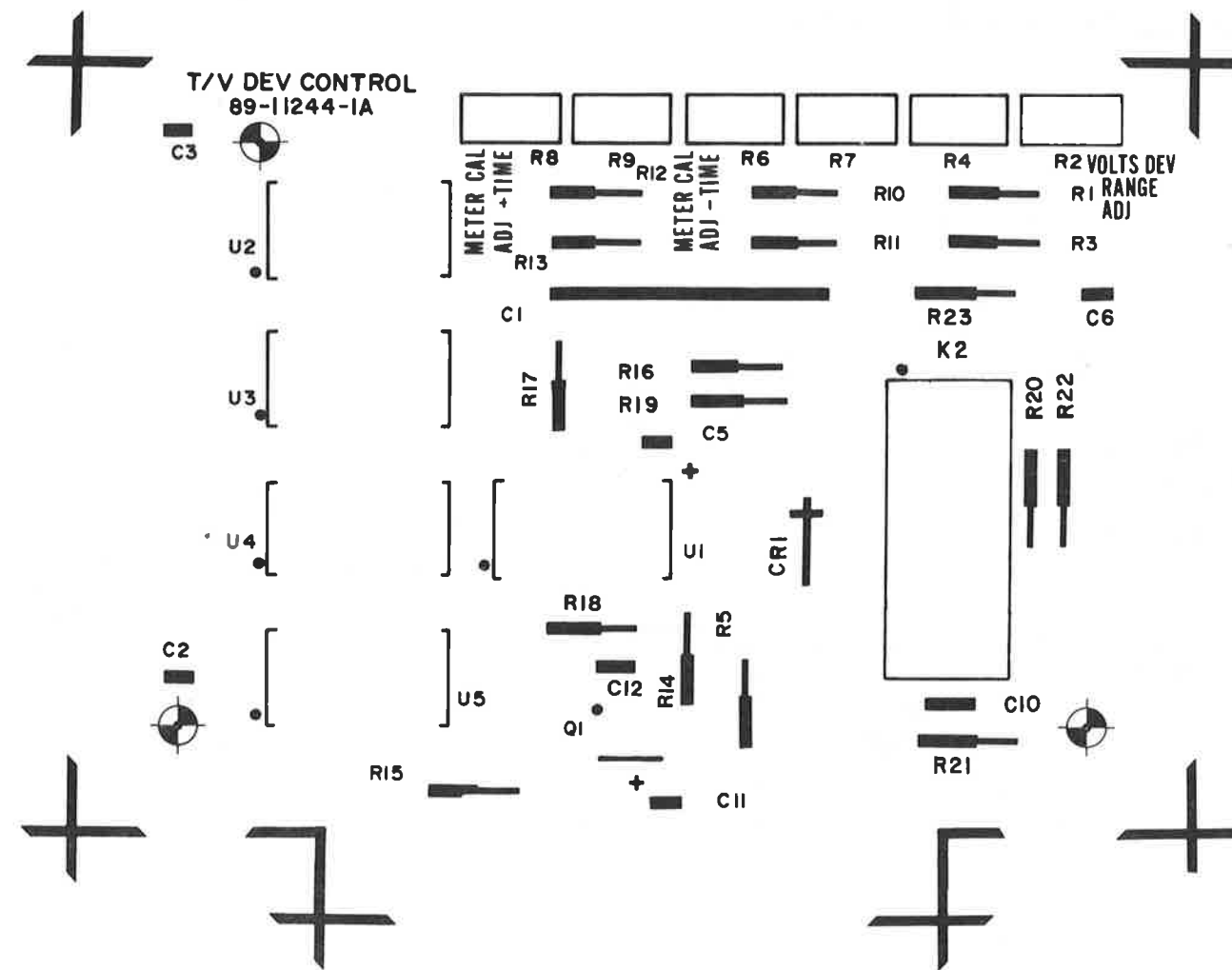

*Relay K2 P/N 14-10034-0A (DPDT) is applicable to units using one of the preferred low profile plastic relay made by Aromat. Early units using two molded reed relays made by Coto-Coil or MEKO must be replaced with P/N 14-10016-1A.

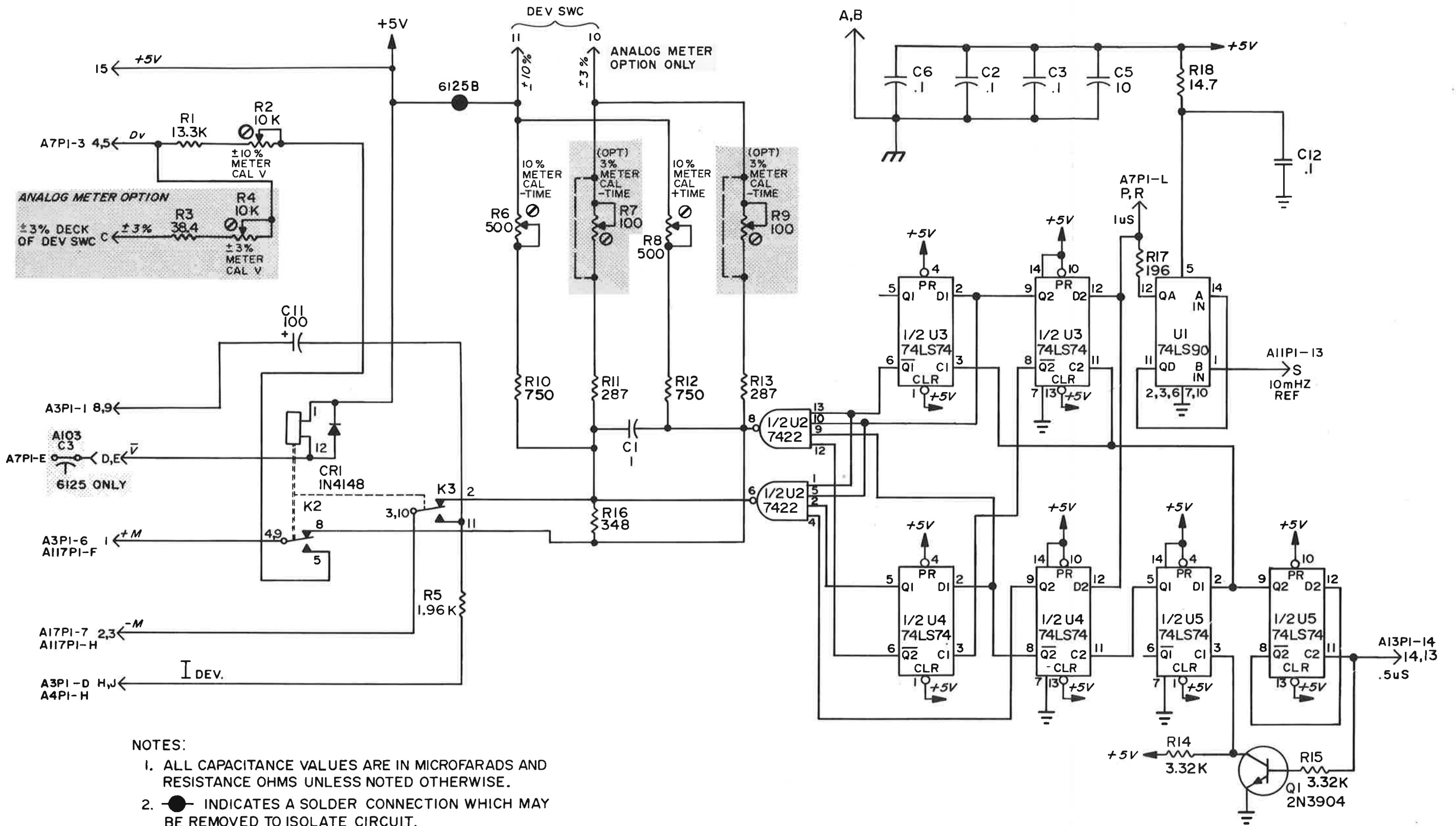
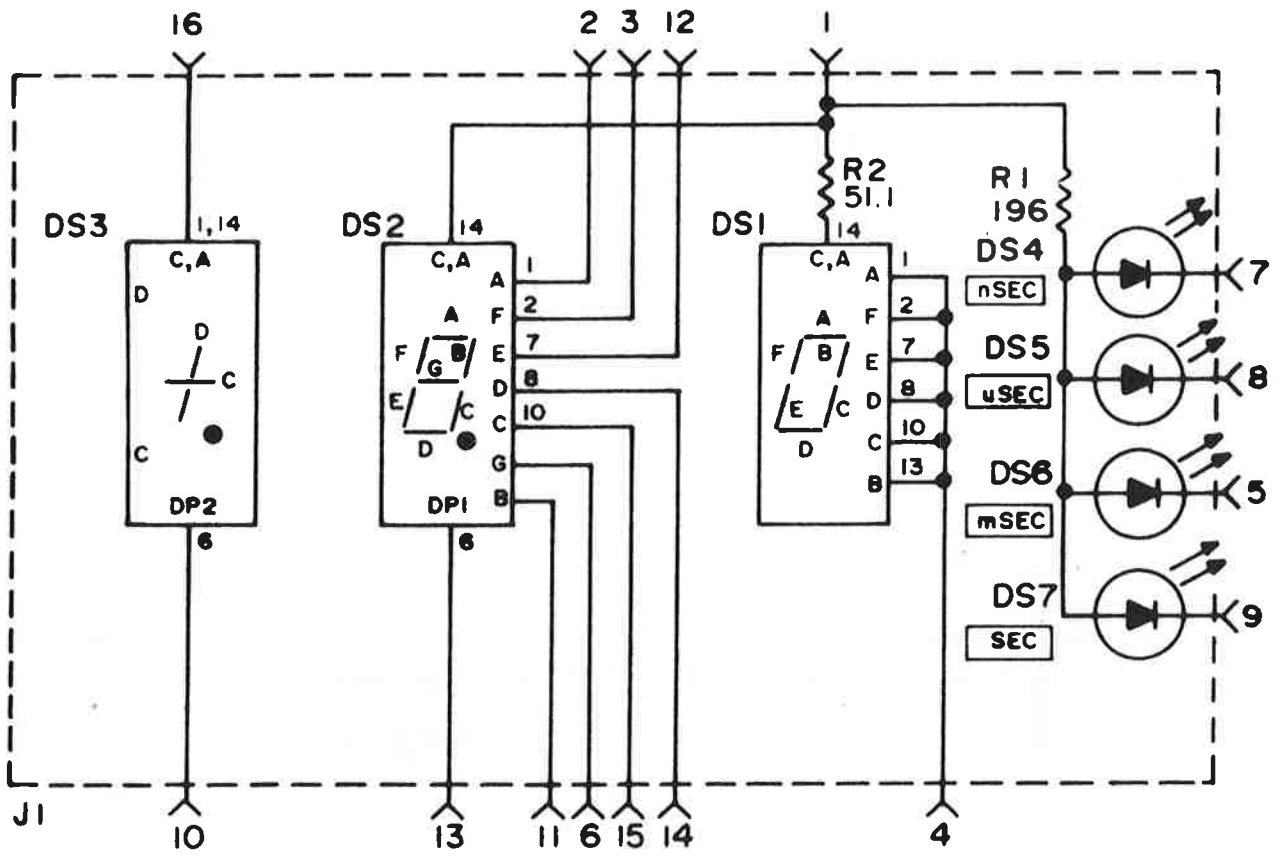

Figure 6-19B. A18 6125B/C Time Deviation Board (Serial Prefix 021-)



NOTES :

1. ALL CAPACITANCE VALUES ARE IN MICROFARADS AND ALL RESISTANCE VALUES ARE IN OHMS UNLESS NOTED OTHERWISE.

Figure 6-20. A20 6125C Time/Div Display

PARTS LIST, A20 TIME/DIV DISPLAY MODEL 6125C (89-10520-1A)

SCHEMATIC REF	BALLANTINE PART NO.	DESCRIPTION	MFR CODE	MFR PART NUMBER
DS..1	21-10011-0A	IND 0.4 IN ORANGE LED DIP	26483	MONSANTO 4610 RT DECIMAL
DS..2	21-10011-0A	IND 0.4 IN ORANGE LED DIP	26483	MONSANTO 4610 RT DECIMAL
DS..3	21-10012-0A	IND 0.4 IN ORANGE +1 LED	26483	MONSANTO 4630
DS..4	16-10027-0A	LMP LED MINATURE 20 MA	28480	HP MV 5082-4480
DS..5	16-10027-0A	LMP LED MINATURE 20 MA	28480	HP MV 5082-4480
DS..6	16-10027-0A	LMP LED MINATURE 20 MA	28480	HP MV 5082-4480
DS..7	16-10027-0A	LMP LED MINATURE 20 MA	28480	HP MV 5082-4480
R...1	12-12228-0A	RFF 196.0 250 MW F+-1%	16299	CGW RN55D 1960 F
R...2	12-12168-0A	RFF 51.1 250.0MW F+- 1%	16299	CGW RN55D 51R1 F

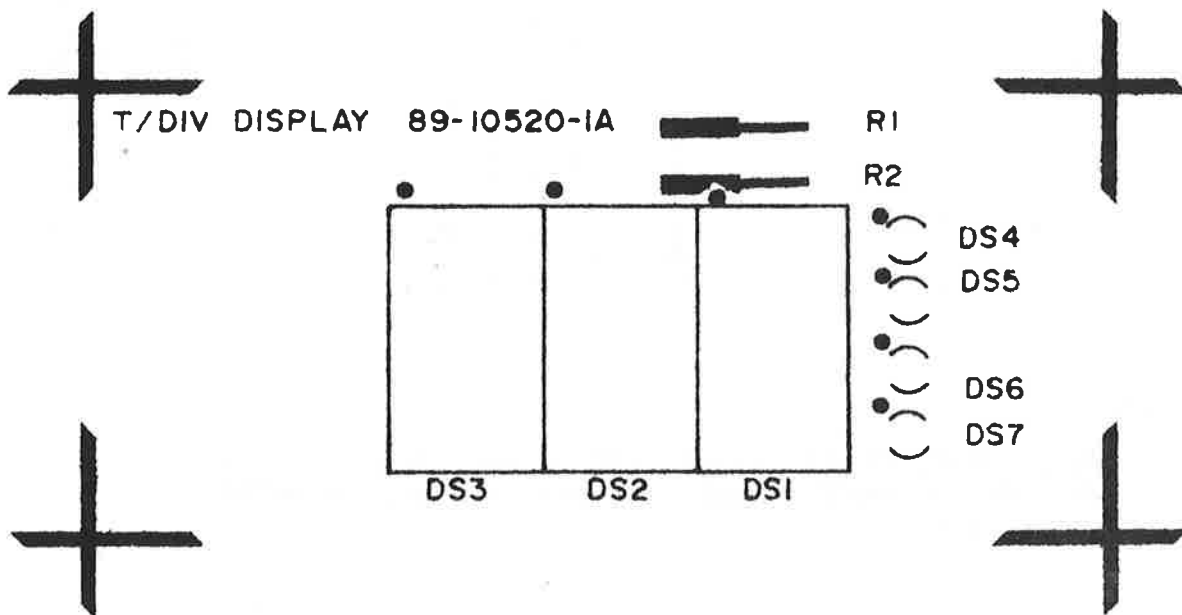

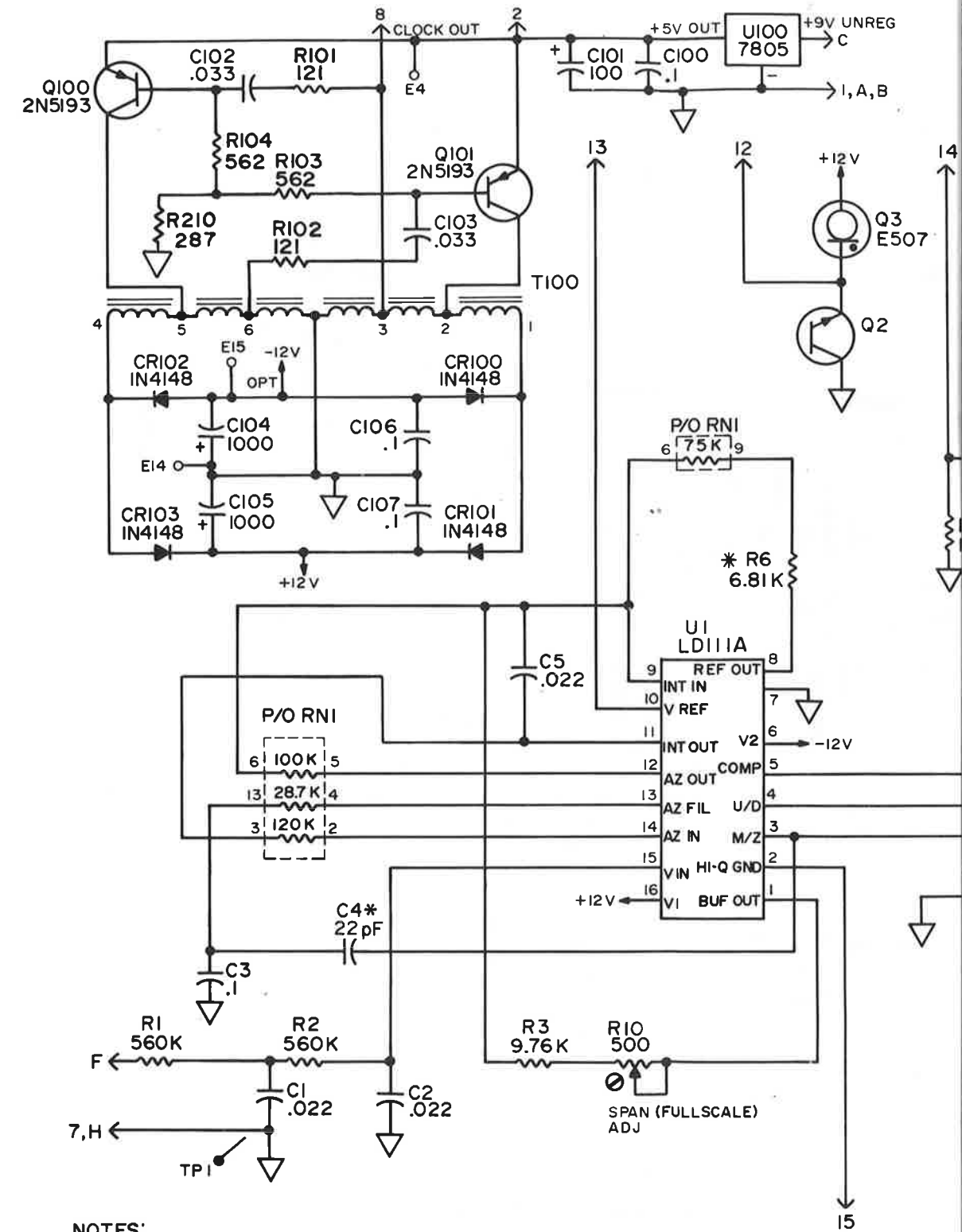

NOTES:

1. ALL CAPACITANCE VALUES ARE IN MICROFARADS AND AND ALL RESISTANCE VALUES ARE IN OHMS UNLESS NOTED OTHERWISE.
2. → DENOTES CONTACT OF A23PI.
3. * DENOTES FACTORY SELECTED VALUE.

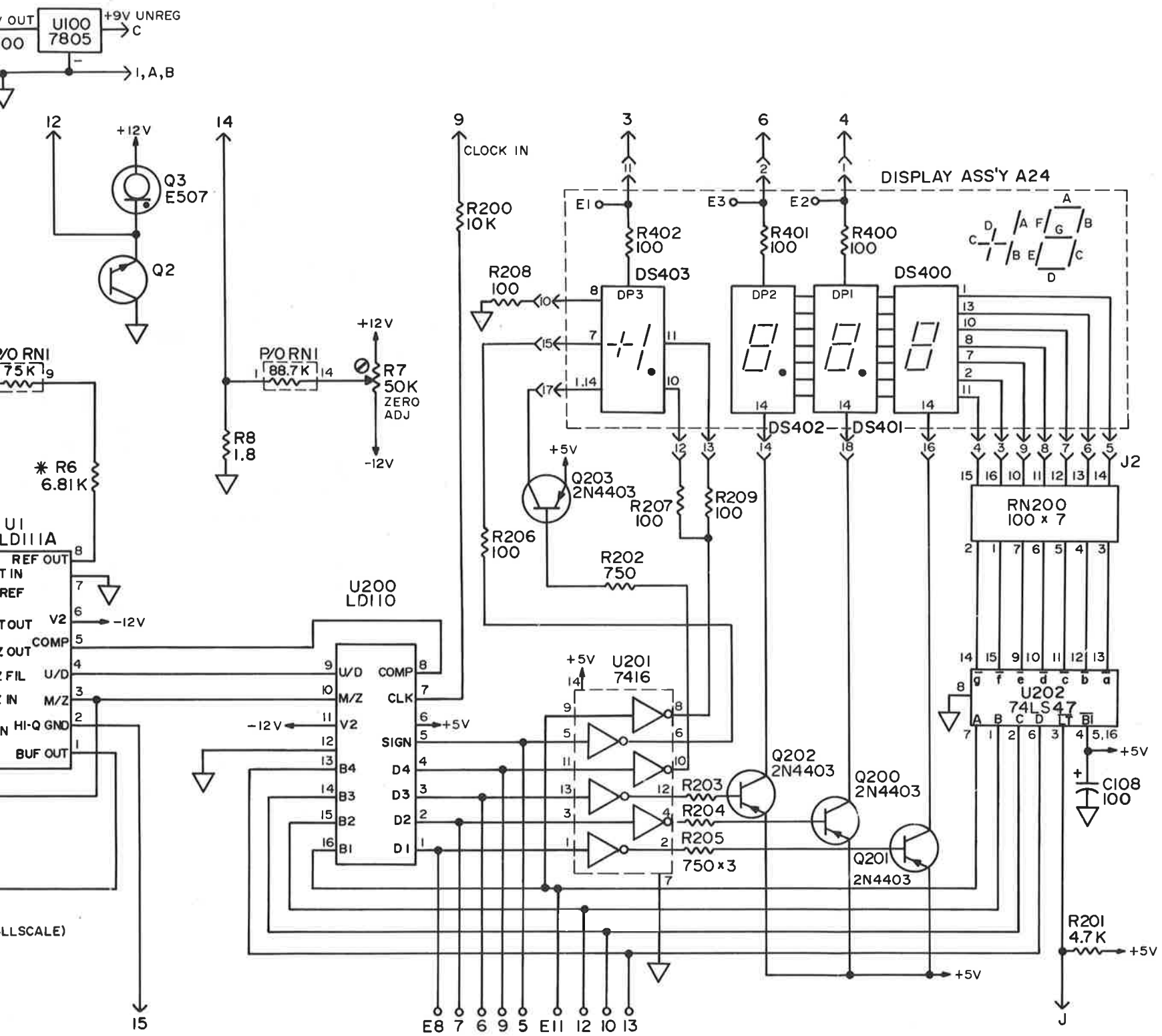

Figure 6

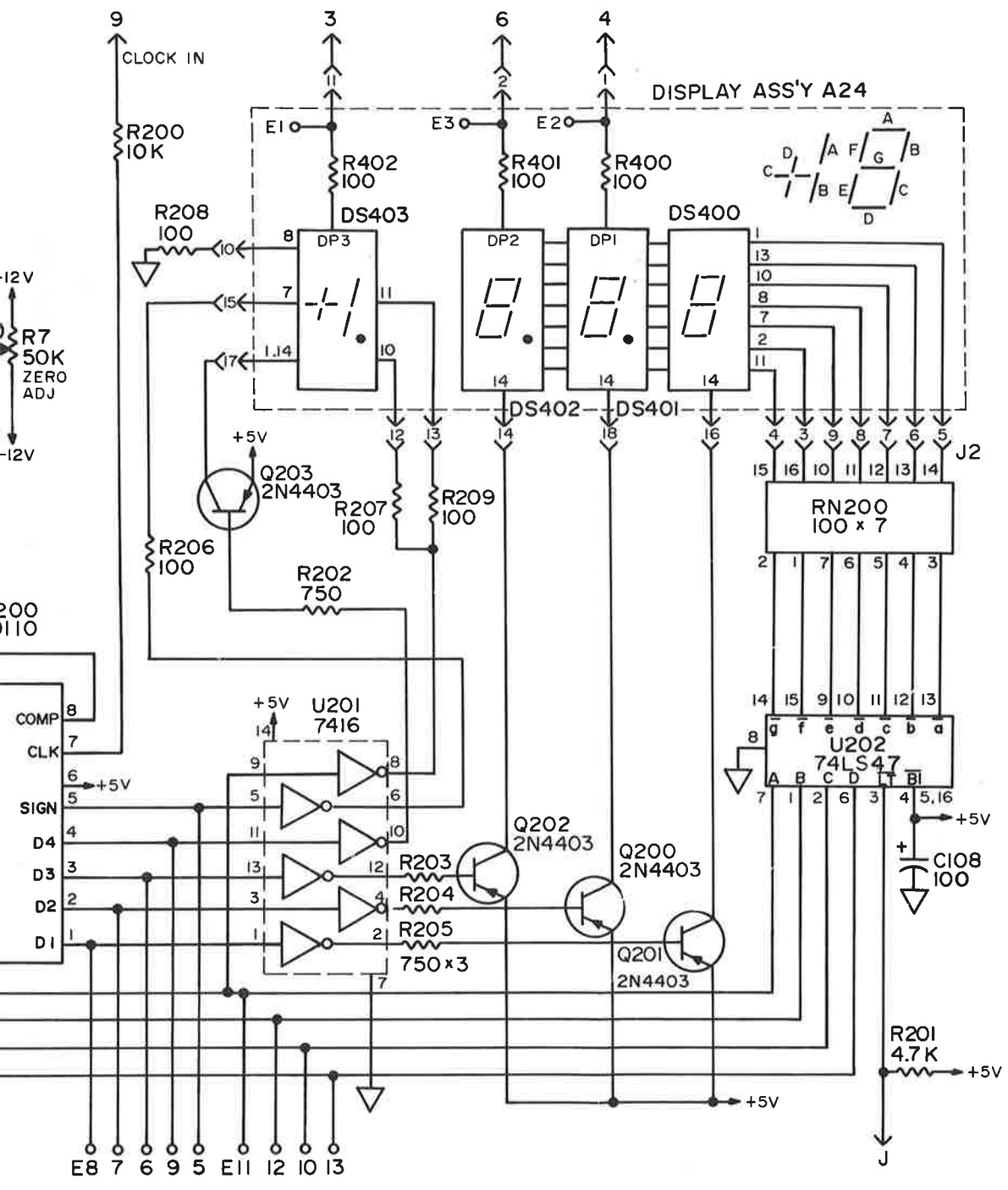
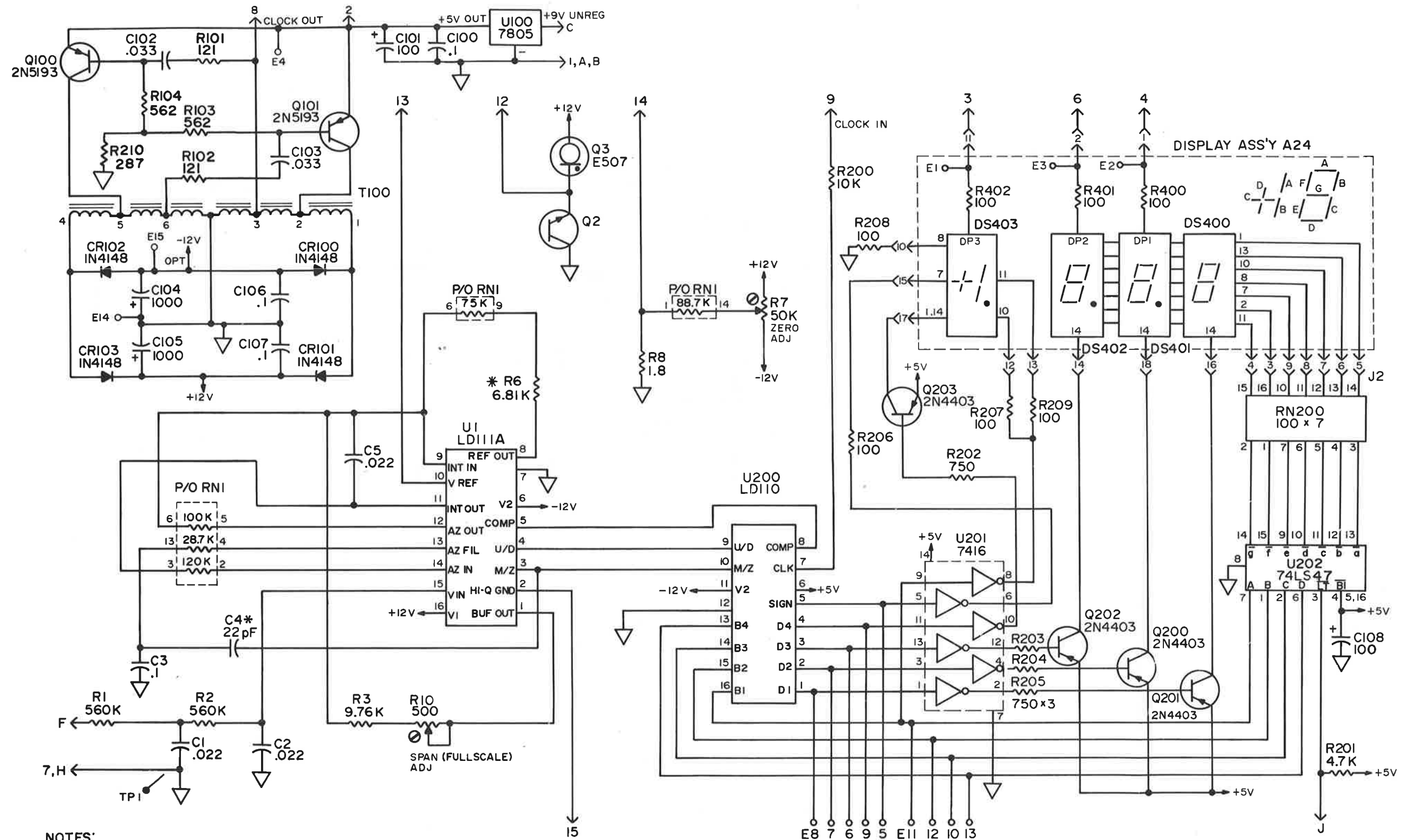

Figure 6-21. A23 and A24 DPM and DPM Display



NOTES:

1. ALL CAPACITANCE VALUES ARE IN MICROFARADS AND ALL RESISTANCE VALUES ARE IN OHMS UNLESS NOTED OTHERWISE.
2. → DENOTES CONTACT OF A23P1.
3. * DENOTES FACTORY SELECTED VALUE.

DESCRIPTION	MFR CODE	MFR PART NUMBER
CON SERIES WAFERS MALE	0	MOLEX A-4030-15A #22-03-2151

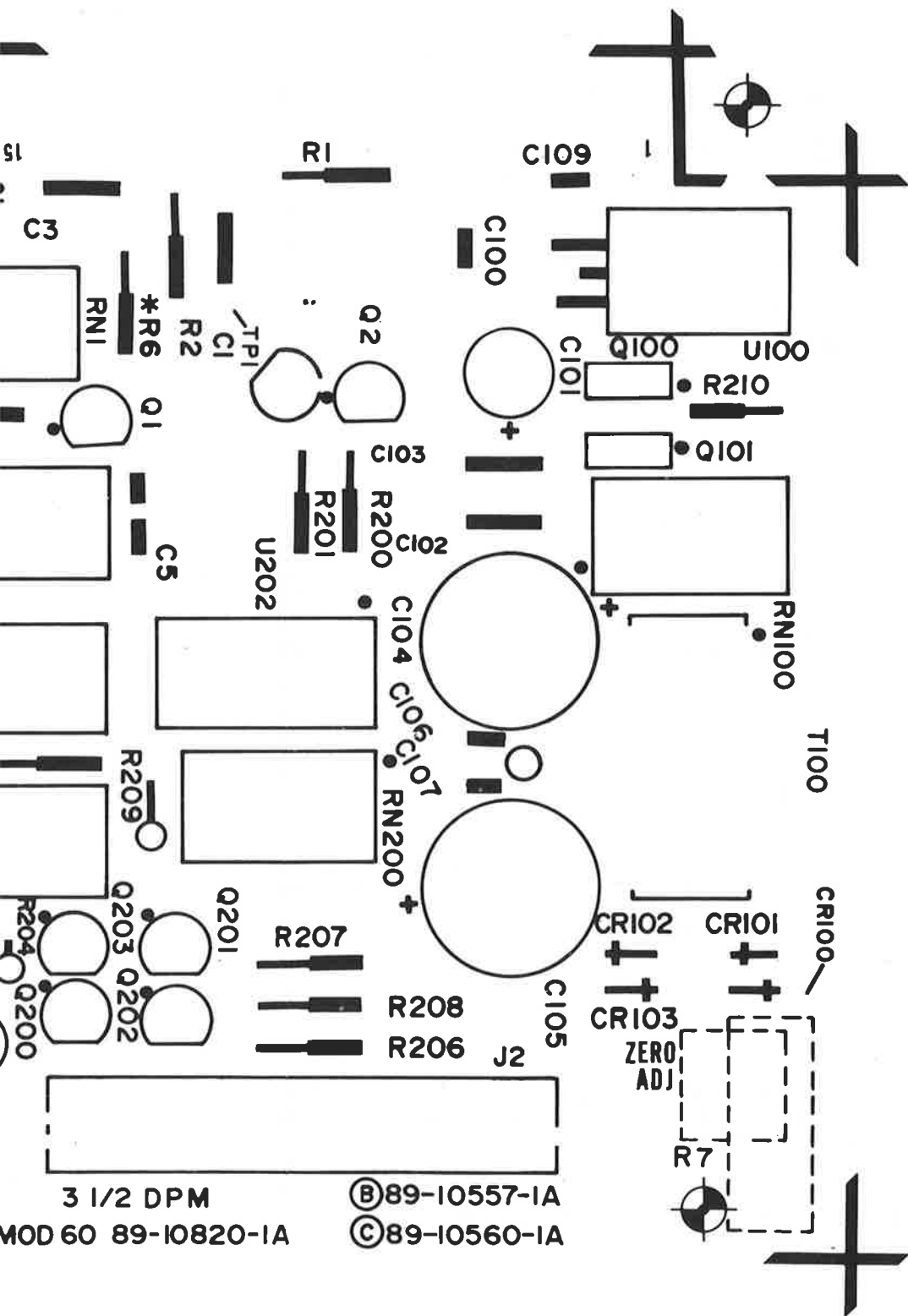

SCHEMATIC REF	BALLANTINE PART NO.	DESCRIPTION	MFR CODE	MFR PART NUMBER
DS400	21-10011-0A	IND 0.4 IN ORANGE LED DIP	26483	MONSANTO 4610 RT DECIMAL
DS401	21-10011-0A	IND 0.4 IN ORANGE LED DIP	26483	MONSANTO 4610 RT DECIMAL
DS402	21-10011-0A	IND 0.4 IN ORANGE LED DIP	26483	MONSANTO 4610 RT DECIMAL
DS403	21-10012-0A	IND 0.4 IN ORANGE +1 LED	26483	MONSANTO 4630
R.400	12-12200-0A	RFF 100.0 250.0MW F+- 1%	16299	CGW RN55D 1000 F
R.401	12-12200-0A	RFF 100.0 250.0MW F+- 1%	16299	CGW RN55D 1000 F
R.402	12-12200-0A	RFF 100.0 250.0MW F+- 1%	16299	CGW RN55D 1000 F

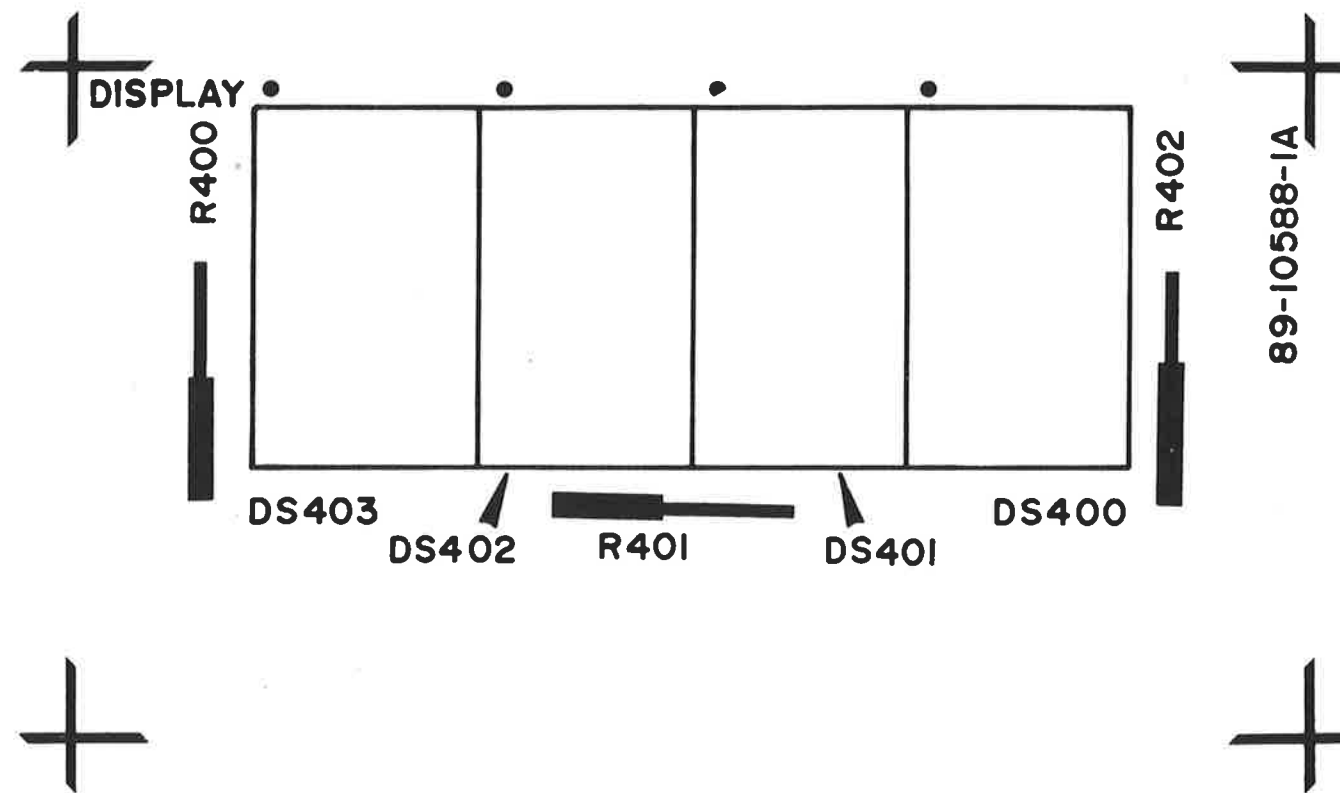

SCHEMATIC REF	BALLANTINE PART NO.	DESCRIPTION	MFR CODE	MFR PART NUMBER
C...1	07-10340-0A	CBM 22.0NF 400.0 V +-10%	80031	MEPCO C280MCF/A22K
C...2	07-10340-0A	CBM 22.0NF 400.0 V +-10%	80031	MEPCO C280MCF/A22K
C...3	07-10339-0A	CBM 100.0NF 100.0 V +-10%	80031	MEPCO C280MCH/A100K
C...4	07-20135-0A	CMD 22.0PF 5%	84171	DM15-220J OR EQUIV.
C...5	07-10340-0A	CBM 22.0NF 400.0 V +-10%	80031	MEPCO C280MCF/A22K
C.100	07-10198-0A	CCD 100.0NF 25.0 V NPO	56289	SPRAG C069A250M1042 OR EQ
C.101	07-10439-0A	CEA 100.0UF 6.3 V	0	CAPAR CRE 100UF/6.3V
C.102	07-10338-0A	CBM 33.0NF 400.0 V +-10%	80031	MEPCO C280MCF/A33K
C.103	07-10338-0A	CBM 33.0NF 400.0 V +-10%	80031	MEPCO C280MCF/A33K
C.104	07-10440-0A	CEA1000.0UF 16.0 V	0	CAPAR CRE 1000UF/16V
C.105	07-10440-0A	CEA1000.0UF 16.0 V	0	CAPAR CRE 1000UF/16V
C.106	07-10198-0A	CCD 100.0NF 25.0 V NPO	56289	SPRAG C069A250M1042 OR EQ
C.107	07-10198-0A	CCD 100.0NF 25.0 V NPO	56289	SPRAG C069A250M1042 OR EQ
C.108	07-10439-0A	CEA 100.0UF 6.3 V	0	CAPAR CRE 100UF/6.3V
C.109	07-10198-0A	CCD 100.0NF 25.0 V NPO	56289	SPRAG C069A250M1042 OR EQ
CR100	05-07920-0A	DGP 1N4148 75 10M	7263	FCH SI D035
CR101	05-07920-0A	DGP 1N4148 75 10M	7263	FCH SI D035
CR102	05-07920-0A	DGP 1N4148 75 10M	7263	FCH SI D035
CR103	05-07920-0A	DGP 1N4148 75 10M	7263	FCH SI D035
J...2	31-10150-0A	CON 18 DIGICLIPS IN HOLDER	26364	COMPONENTS COR MC1A18100T
Q...2	05-10076-1B	DZG 2N4274 6.8V 1.5M+-10%	50423	BLI SELECT.FROM 05100763B
Q...3	10-10099-0A	TRQ E507	17856	SILICONIX
Q.100	10-10087-0A	TRQ 2N5193 PNP 1 40 P77-03	4713	MOT 40 2M 10
Q.101	10-10087-0A	TRQ 2N5193 PNP 1 40 P77-03	4713	MOT 40 2M 10
Q.200	10-10080-0A	TRQ 2N4403 PNP	4713	MOTOROLA
Q.201	10-10080-0A	TRQ 2N4403 PNP	4713	MOTOROLA
Q.202	10-10080-0A	TRQ 2N4403 PNP	4713	MOTOROLA
Q.203	10-10080-0A	TRQ 2N4403 PNP	4713	MOTOROLA
R...1	12-12873-0A	RFC 560.0 K 500.0MW	1121	A-B TYPE E-B
R...2	12-12873-0A	RFC 560.0 K 500.0MW	1121	A-B TYPE E-B
R...3	12-12395-0A	RFF 9.76K 250.0MW F+- 1%	16299	CGW RN55D 9761 F
R...6	12-12380-0A	RFF 6.81K 250.0MW F+- 1%	16299	CGW RN55D 6811 F
R...7	09-10134-0A	RVF 50.0 K 0.5 W +-30%	73138	HELIPOT 72PM
R...8	12-12799-0A	RFC 5.6M 250.0MW J+-5%	1121	A-B TYPE CB
R...10	09-10001-0A	RVC 500.0 0.5 W K	73138	HEL TYP 72PM
R101	12-12208-0A	RFF 121.0 250.0MW F+- 1%	16299	CGW RN55D 1210 F
R102	12-12208-0A	RFF 121.0 250.0MW F+- 1%	16299	CGW RN55D 1210 F
R103	12-12272-0A	RFF 562.0 250 MW F+-1%	16299	CGW RN55D 5620 F
R104	12-12272-0A	RFF 562.0 250 MW F+-1%	16299	CGW RN55D 5620 F
R.200	12-12400-0A	RFF 10.0 K 250.0MW F+- 1%	16299	CGW RN55D 1002 F
R.201	12-01048-0A	RFC 4.7 K 500.0MW J+- 5%	1121	A-B TYP EB
R.202	12-09807-0A	RFC 750.0 250.0MW J+- 5%	1121	A-B TYP CB
R.203	12-09807-0A	RFC 750.0 250.0MW J+- 5%	1121	A-B TYP CB
R.204	12-09807-0A	RFC 750.0 250.0MW J+- 5%	1121	A-B TYP CB
R.205	12-09807-0A	RFC 750.0 250.0MW J+- 5%	1121	A-B TYP CB
R.206	12-12200-0A	RFF 100.0 250.0MW F+- 1%	16299	CGW RN55D 1000 F
R.207	12-12200-0A	RFF 100.0 250.0MW F+- 1%	16299	CGW RN55D 1000 F
R.208	12-12200-0A	RFF 100.0 250.0MW F+- 1%	16299	CGW RN55D 1000 F
R.209	12-12200-0A	RFF 100.0 250.0MW F+- 1%	16299	CGW RN55D 1000 F
R.210	12-12244-0A	RFF 287.0 250 MW F+-1%	16299	CGW RN55D 2870 F
KN...1	13-10000-1B	RNF 8RES. 14 DIP HI VALUE	80053	BECKMAN 89 CUSTOM
RN200	13-10044-0A	RNF 100.0 14 1.5W 14DIP 7R	80053	BECKMAN 899-3-R100
U...1	24-10202-1A	ICP LD111A MODIFIED DVM .03%	50423	SILICONIX ANALOG
U.100	24-10153-0A	ICP UA7805 5V REG.	7263	FCH UGH7805393
U.200	24-10094-1A	ICP DVM DIGITAL 3 1/2 DIGIT	17856	SILICONIX LD110 MODIFIED
U.201	24-10084-0A	ICP SN7416N HEX INV OPEN COL	33809	TI OR EQUIV
U.202	24-10139-0A	ICP 74LS47 7SEG DRVR LU=PWR	27014	NAT.SEMI UM74LS47
T.100	20-10029-1D	TRX 3028A DC/DC CONVTR	50423	

SCHEMATIC REF	BALLANTINE PART NO.	DESCRIPTION
J...2	31-10210-0A	CON SERIES WAFERS M

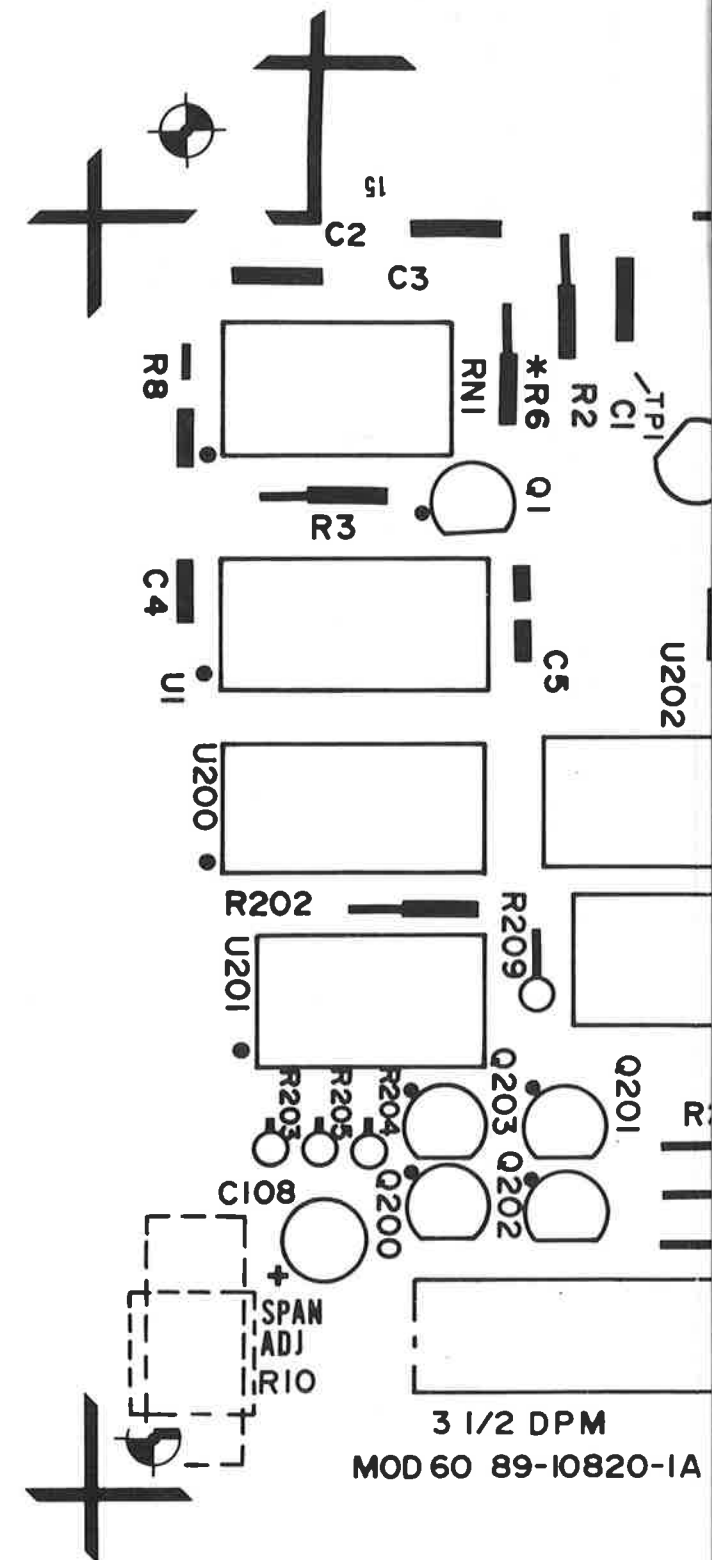

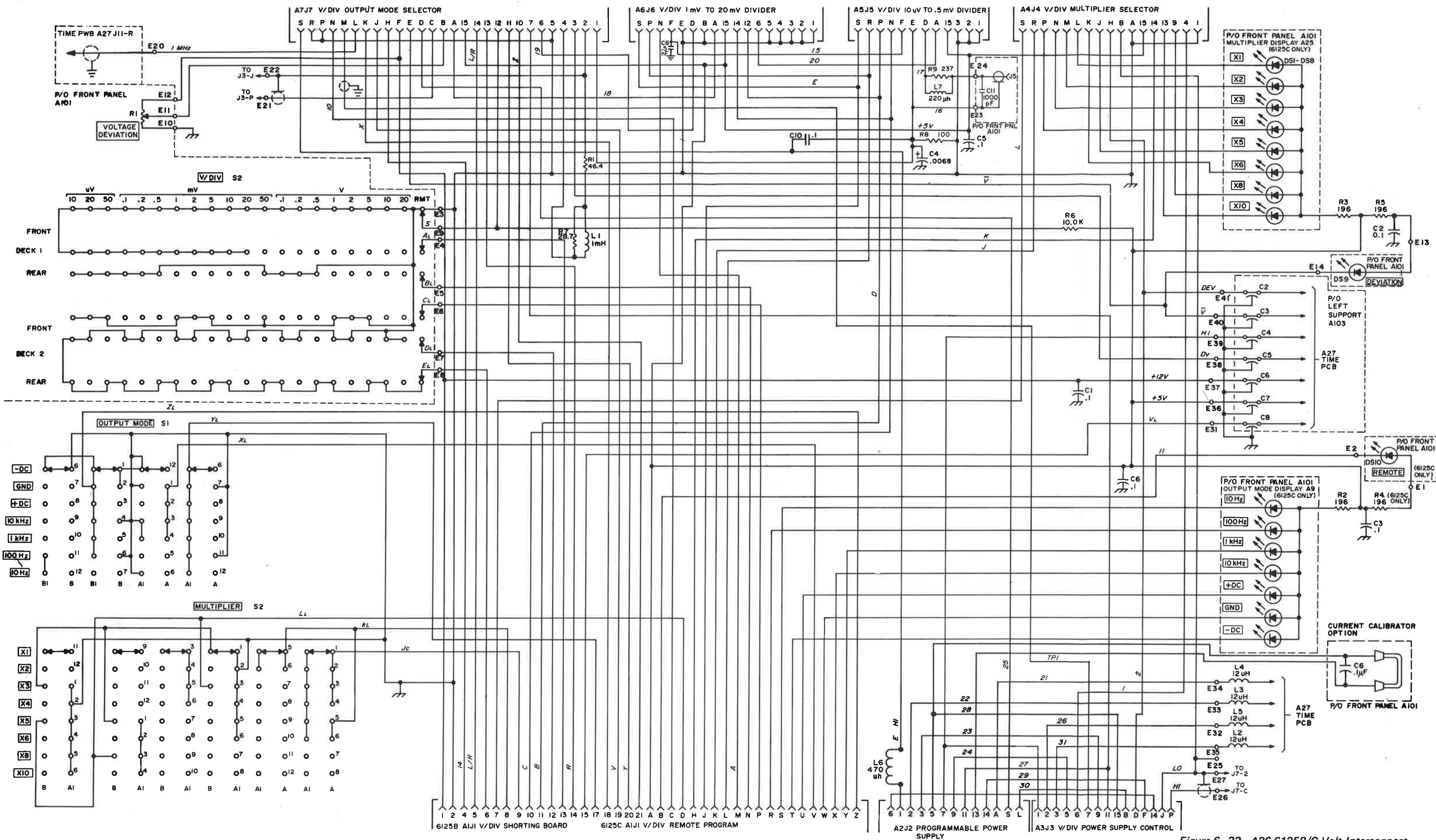
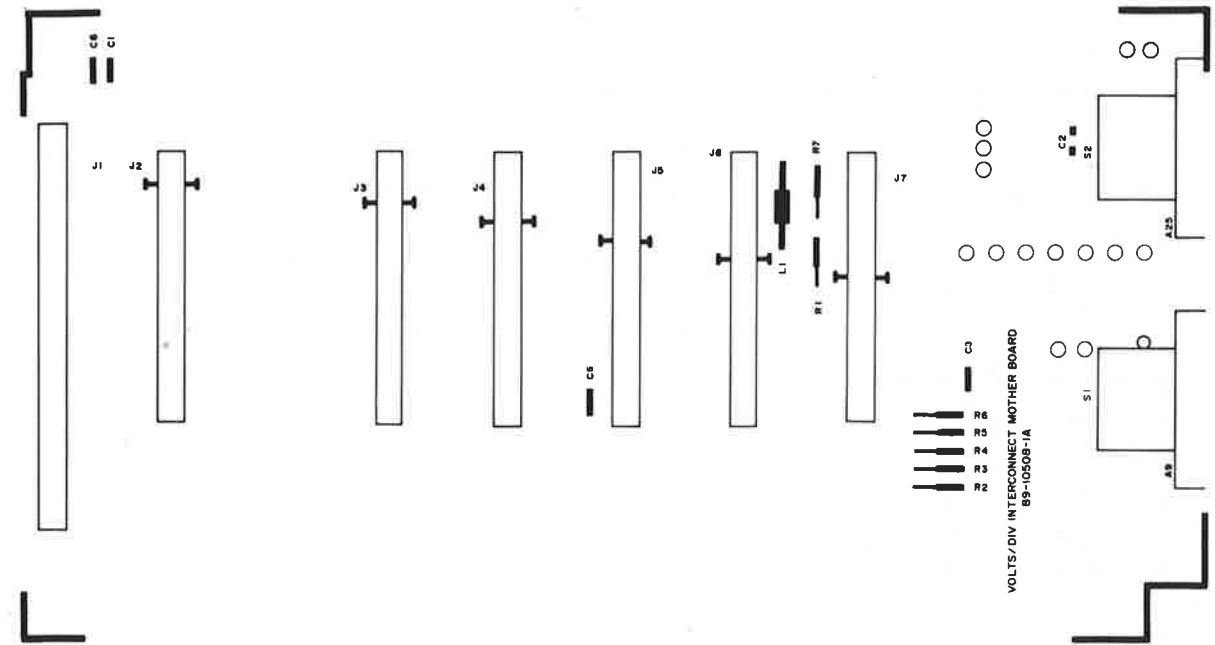

Figure 6-22. A26 6125B/C Volt Interconnect

PARTS LIST, A26 VOLTS INTERCONNECT MODEL 6125B/C (89-10508-1A)

SCHEMATIC REF	BALLANTINE PART NO.	DESCRIPTION	MFR CODE	MFR PART NUMBER
C...1	07-10562-0A	CCR 0.1 UF 50V .3 SPACE	0	AVX CERAMICS MD015E104ZAA
C...2	07-10562-0A	CCR 0.1 UF 50V .3 SPACE	0	AVX CERAMICS MD015E104ZAA
C...3	07-10562-0A	CCR 0.1 UF 50V .3 SPACE	0	AVX CERAMICS MD015E104ZAA
C...4	07-10472-0A	CBM 6.8NF 100.0 VJ	50587	ECI PLUCON I 6.8NF/5%/100V
C...5	07-10562-0A	CCR 0.1 UF 50V .3 SPACE	0	AVX CERAMICS MD015E104ZAA
C...6	07-10562-0A	CCR 0.1 UF 50V .3 SPACE	0	AVX CERAMICS MD015E104ZAA
C...8	07-02264-0A	CMD 500 PF 300 V J 5%	84171	ARCO TYPE DM-15-501J
C...10	07-08139-0A	CMD 100 NF 250 V M 20%	73445	AMPEREX C280 AE/P100K
C...11	07-02592-0A	CCD 1.0NF 1.0KVK+-10%	84171	ARCO TYPE CCD-102
J...1	31-10162-0A	CON 22 PIN CARD EDGE PC TYPE	2260	AMPHENOL 225-22221-110
J...2	31-10163-0A	CON 15 PIN CARD EDGE PC TYPE	2260	AMPHENOL 225-21521-110
J...3	31-10163-0A	CON 15 PIN CARD EDGE PC TYPE	2260	AMPHENOL 225-21521-110
J...4	31-10163-0A	CON 15 PIN CARD EDGE PC TYPE	2260	AMPHENOL 225-21521-110
J...5	31-10163-0A	CON 15 PIN CARD EDGE PC TYPE	2260	AMPHENOL 225-21521-110
J...6	31-10163-0A	CON 15 PIN CARD EDGE PC TYPE	2260	AMPHENOL 225-21521-110
L...1	03-10053-0A	CIL 1.0 MH INDUCTOR	71895	DELAVAN #5500-32
L...2	03-10006-0A	CRF 12UH MOLDED +- 10%	76493	MILLER #9230-46
L...3	03-10006-0A	CRF 12UH MOLDED +- 10%	76493	MILLER #9230-46
L...4	03-10006-0A	CRF 12UH MOLDED +- 10%	76493	MILLER #9230-46
L...5	03-10006-0A	CRF 12UH MOLDED +- 10%	76493	MILLER #9230-46
L...6	03-10034-0A	CRF 470UH, ENCAPSUL TD, AXIAL L	83125	NYTRONICS DU-470
L...7	03-062A5-0A	CIL 220 UH	76493	MILLER #9210-92
R...1	12-12164-0A	RFF 46.4 250.0MW F+- 1%	16299	CGW RN55D 46R4 F
R...2	12-12228-0A	RFF 196.0 250 MW F+-1%	16299	CGW RN55D 1960 F
R...3	12-12228-0A	RFF 196.0 250 MW F+-1%	16299	CGW RN55D 1960 F
R...4	12-12228-0A	RFF 196.0 250 MW F+-1%	16299	CGW RN55D 1960 F
R...5	12-12228-0A	RFF 196.0 250 MW F+-1%	16299	CGW RN55D 1960 F
R...6	12-12400-0A	RFF 10.0 K 250.0MW F+- 1%	16299	CGW RN55D 1002 F
R...7	12-12144-0A	RFF 28.7 250.0MW F+- 1%	16299	CGW RN55D 28R7 F
R...8	12-12200-0A	RFF 100.0 250.0MW F+- 1%	16299	CGW RN55D 1000 F
R...9	12-12236-0A	RFF 237.0 250 MW F+-1%	16299	CGW RN55D 2370 F
S...1	25-10131-1A	SWC 6125B FUNCTION-VOLTS	50423	
S...2	25-10132-1B	SWC 6125B MULTIPLIER-VOLTS	50423	BLI



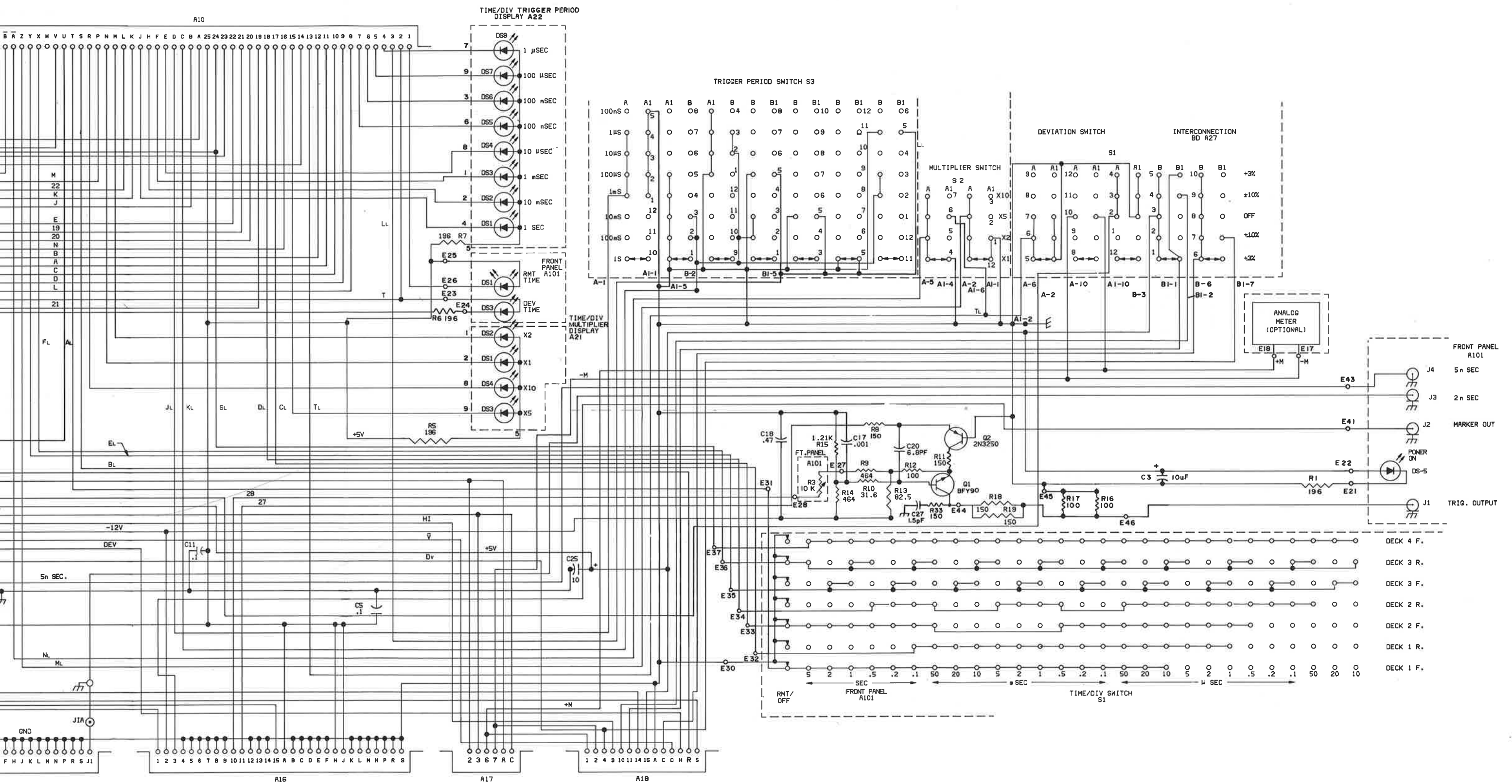
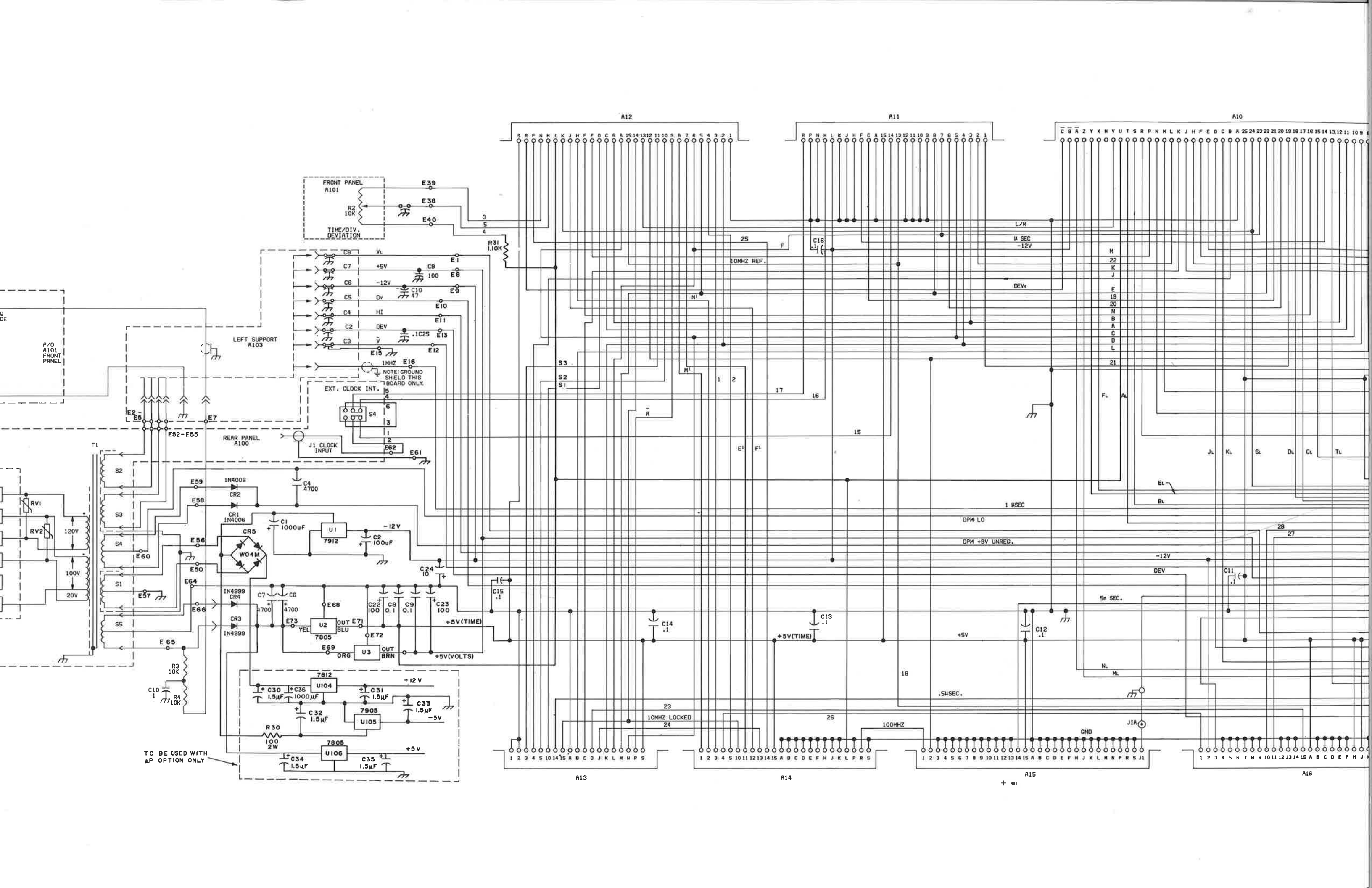
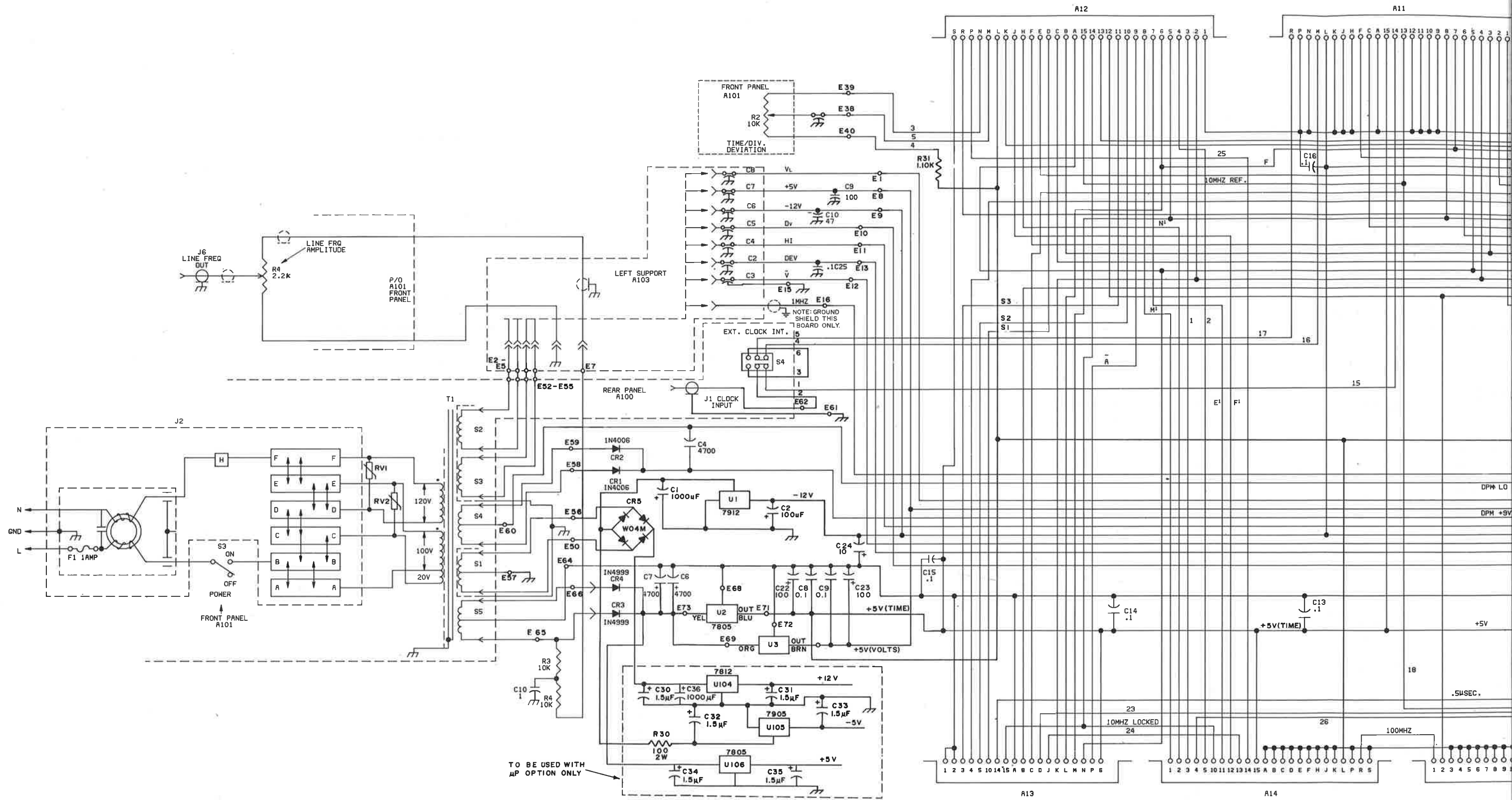

Figure 6-23. A27 Time Interconnect





PARTS LIST, A27 M/T CONN. MODEL 6125C-OPT. 60 ONLY (89-10821-1A)

DESCRIPTION	MFR CODE	MFR PART NUMBER
CET 1.5UF 35.0 V	56289	SPRAGUE 1960155X0035A3
CET 1.5UF 35.0 V	56289	SPRAGUE 1960155X0035A3
CET 1.5UF 35.0 V	56289	SPRAGUE 1960155X0035A3
CET 1.5UF 35.0 V	56289	SPRAGUE 1960155X0035A3
CET 1.5UF 35.0 V	56289	SPRAGUE 1960155X0035A3
CET 1.5UF 35.0 V	56289	SPRAGUE 1960155X0035A3
CEA1000.0UF 25.0 V -10+50%	80031	MEPCO ET102X025A03
RFC 22.0 2.0 W K+-10%	1121	A-B TYP HB OR EQUIV
ICP MC7812CP 12V 1AM REG	4713	MOT MC78126
ICP MC7905.2CP 1.5A05.2 VREG	4173	MOT MC7905.2CP
ICP UA7805 5V REG.	7263	FCH UGH7805393

PARTS LIST, A21 MULTIPLIER DISPLAY MODEL 6125C (89-10521-1A)

DESCRIPTION	MFR CODE	MFR PART NUMBER
LMP LED MINATURE 20 MA	28480	HP MV 5082-4480
LMP LED MINATURE 20 MA	28480	HP MV 5082-4480
LMP LED MINATURE 20 MA	28480	HP MV 5082-4480
LMP LED MINATURE 20 MA	28480	HP MV 5082-4480

PARTS LIST, A22 TRIG OUT DISPLAY MODEL 6125C (89-10522-1A)

DESCRIPTION	MFR CODE	MFR PART NUMBER
LMP LED MINATURE 20 MA	28480	HP MV 5082-4480
LMP LED MINATURE 20 MA	28480	HP MV 5082-4480
LMP LED MINATURE 20 MA	28480	HP MV 5082-4480
LMP LED MINATURE 20 MA	28480	HP MV 5082-4480
LMP LED MINATURE 20 MA	28480	HP MV 5082-4480
LMP LED MINATURE 20 MA	28480	HP MV 5082-4480
LMP LED MINATURE 20 MA	28480	HP MV 5082-4480
LMP LED MINATURE 20 MA	28480	HP MV 5082-4480
LMP LED MINATURE 20 MA	28480	HP MV 5082-4480
LMP LED MINATURE 20 MA	28480	HP MV 5082-4480

PARTS LIST, A103 SUP VER LEFT MODEL 6125B/C (89-10531-1A)

DESCRIPTION	MFR CODE	MFR PART NUMBER
CCB 1.0NF 500.0 V 1/4-28	72982	ERIE 2443-001 THD.FEEDTHR
CCB 1.0NF 500.0 V 1/4-28	72982	ERIE 2443-001 THD.FEEDTHR
CCB 1.0NF 500.0 V 1/4-28	72982	ERIE 2443-001 THD.FEEDTHR
CCB 1.0NF 500.0 V 1/4-28	72982	ERIE 2443-001 THD.FEEDTHR
CCB 1.0NF 500.0 V 1/4-28	72982	ERIE 2443-001 THD.FEEDTHR
CCB 1.0NF 500.0 V 1/4-28	72982	ERIE 2443-001 THD.FEEDTHR
CCB 1.0NF 500.0 V 1/4-28	72982	ERIE 2443-001 THD.FEEDTHR
CET 100.0UF 10.0 VM DIP TAN	56289	SPRAGUE 196D107X0010-LA3
CET 47.0UF 20.0 VM DIP TAN	56289	SPRAGUE 196D476X0020-LA3
CRF 12UH MOLDED +- 10%	76493	MILLER #9230-46
CRF 12UH MOLDED +- 10%	76493	MILLER #9230-46
CRF 12UH MOLDED +- 10%	76493	MILLER #9230-46
CRF 12UH MOLDED +- 10%	76493	MILLER #9230-46

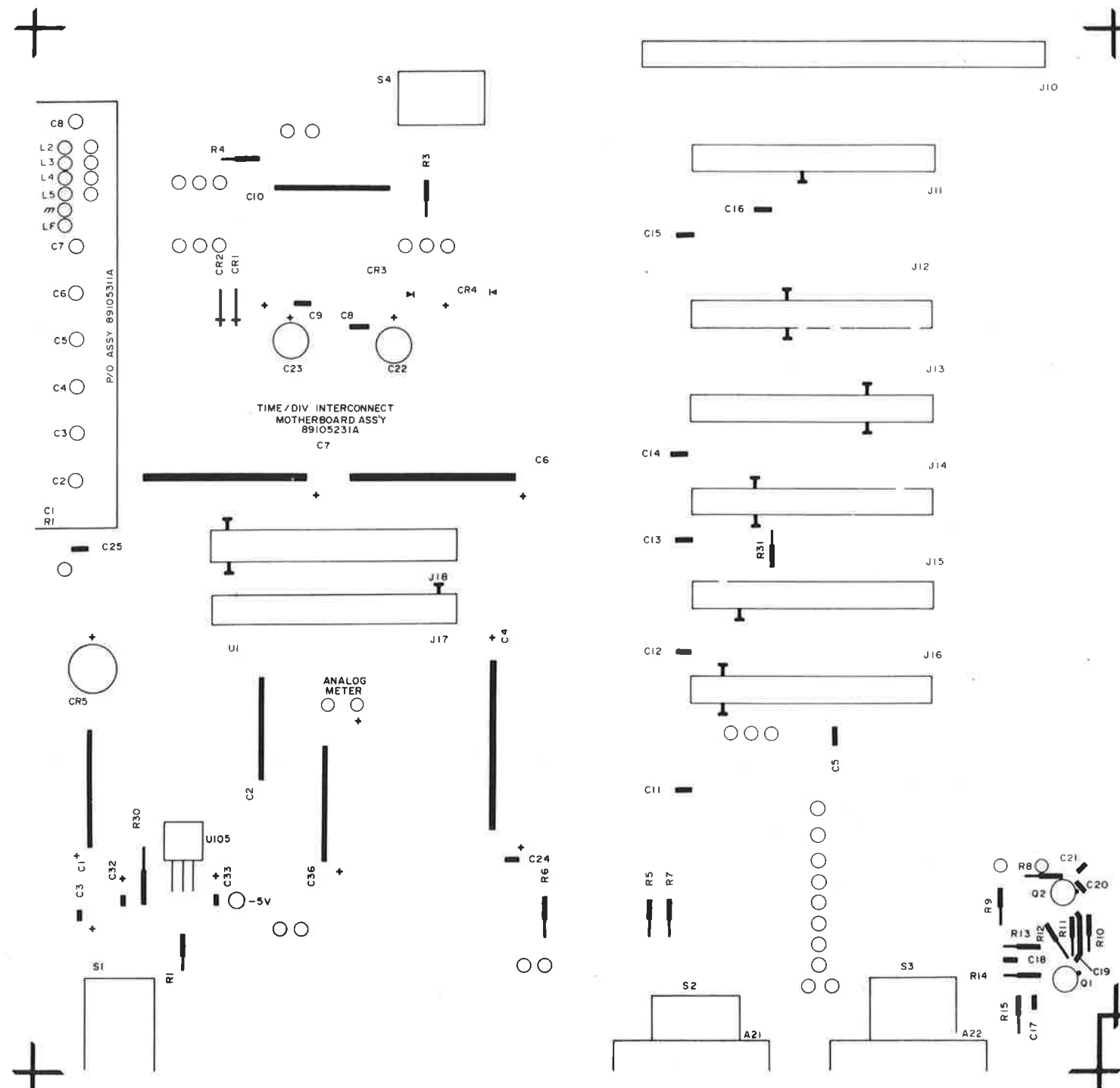

PARTS LIST, A27 TIME INTERCONNECT MODEL 6125B/C (89-10523-1A)

SCHEMATIC REF	BALLANTINE PART NO.	DESCRIPTION	MFR CODE	MFR PART NUMBER
C...1	07-10422-0A	CEA1000.0UF 25.0 V -10+50%	80031	MEPCO ET102X025A03
C...2	07-10406-0A	CEA 100.0UF 25.0 VT +75-10%	56289	SPRAGUE TE1211
C...3	07-10053-0A	CET 10.0UF 35.0V M	56289	199D106X0035DA2
C...4	07-10425-0A	CEA4700.0UF 16.0 V -10+50%	50423	ST.TR. EG 4T/16
C...5	07-10562-0A	CCR 0.1 UF 50V .3 SPACE	0	AVX CERAMICS MD015E104ZAA
C...6	07-10425-0A	CEA4700.0UF 16.0 V -10+50%	50423	ST.TR. EG 4T/16
C...7	07-10425-0A	CEA4700.0UF 16.0 V -10+50%	50423	ST.TR. EG 4T/16
C...8	07-10562-0A	CCR 0.1 UF 50V .3 SPACE	0	AVX CERAMICS MD015E104ZAA
C...9	07-10562-0A	CCR 0.1 UF 50V .3 SPACE	0	AVX CERAMICS MD015E104ZAA
C...11	07-10562-0A	CCR 0.1 UF 50V .3 SPACE	0	AVX CERAMICS MD015E104ZAA
C...12	07-10562-0A	CCR 0.1 UF 50V .3 SPACE	0	AVX CERAMICS MD015E104ZAA
C...13	07-10562-0A	CCR 0.1 UF 50V .3 SPACE	0	AVX CERAMICS MD015E104ZAA
C...14	07-10562-0A	CCR 0.1 UF 50V .3 SPACE	0	AVX CERAMICS MD015E104ZAA
C...15	07-10562-0A	CCR 0.1 UF 50V .3 SPACE	0	AVX CERAMICS MD015E104ZAA
C...16	07-10562-0A	CCR 0.1 UF 50V .3 SPACE	0	AVX CERAMICS MD015E104ZAA
C...17	07-09579-0A	CCD 1.0NF 150.0 VK+-10%	71590	CTL TYP CE-102
C...18	07-10214-0A	CCD 47. NF 25. VM	56289	SPR C069B250J473M DR EQUV
C...20	07-10211-0A	CCD 6.8PF 1.0 VK+-0.5PF	56289	SPRAGUE C0308102E6R8D
C...22	07-10439-0A	CEA 100.0UF 6.3 V	0	CAPAR CRE 100UF/6.3V
C...23	07-10439-0A	CEA 100.0UF 6.3 V	0	CAPAR CRE 100UF/6.3V
C...24	07-10183-0A	CET 47.0UF 20.0 VM DIP TAN	56289	SPRAGUE 196D476X0020-LA3
C...25	07-10562-0A	CCR 0.1 UF 50V .3 SPACE	0	AVX CERAMICS MD015E104ZAA
C...27	07-02544-0A	CCT 1.5PF 500 V J+- 5%	95121	QUALITY COMPONENTS TP QC
CR...1	05-08058-0A	DGP 1N4006 400 1A	15238	ITT SI D046
CR...2	05-08058-0A	DGP 1N4006 400 1A	15238	ITT SI D046
CR...3	05-10027-0A	DRP 1N4999 200 3A	4713	MOT SI
CR...4	05-10027-0A	DRP 1N4999 200 3A	4713	MOT SI
CR...5	05-10006-0A	DGP W04M 4000 1.5A	4713	GIC
J...10	31-10161-0A	CON 25 PIN CARD EDGE PC TYPE	2260	AMPHENOL 225-22521-110
J...11	31-10163-0A	CON 15 PIN CARD EDGE PC TYPE	2260	AMPHENOL 225-21521-110
J...12	31-10163-0A	CON 15 PIN CARD EDGE PC TYPE	2260	AMPHENOL 225-21521-110
J...13	31-10163-0A	CON 15 PIN CARD EDGE PC TYPE	2260	AMPHENOL 225-21521-110
J...14	31-10163-0A	CON 15 PIN CARD EDGE PC TYPE	2260	AMPHENOL 225-21521-110
J...15	31-10163-0A	CON 15 PIN CARD EDGE PC TYPE	2260	AMPHENOL 225-21521-110
J...16	31-10163-0A	CON 15 PIN CARD EDGE PC TYPE	2260	AMPHENOL 225-21521-110
J...17	31-10163-0A	CON 15 PIN CARD EDGE PC TYPE	2260	AMPHENOL 225-21521-110
J...18	31-10163-0A	CON 15 PIN CARD EDGE PC TYPE	2260	AMPHENOL 225-21521-110
W...1	10-10157-0A	TRQ BFY90 NPN 1 15V S TO 72	0	SGS ATE5
W...2	10-10017-0A	TRQ 2N3250 PNP 1 40 MTO-18	4713	MOT 1.2 250M 50
R...1	12-12228-0A	RFF 196.0 250 MW F+-1%	16299	CGW RN55D 1960 F
R...3	12-12400-0A	RFF 10.0 K 250.0MW F+- 1%	16299	CGW RN55D 1002 F
R...4	12-12400-0A	RFF 10.0 K 250.0MW F+- 1%	16299	CGW RN55D 1002 F
R...5	12-12228-0A	RFF 196.0 250 MW F+-1%	16299	CGW RN55D 1960 F
R...6	12-12252-0A	RFF 348.0 250 MW F+-1%	16299	CGW RN55D 3480 F
R...7	12-12228-0A	RFF 196.0 250 MW F+-1%	16299	CGW RN55D 1960 F
R...8	12-12217-0A	RFF 150.0 250.0MW F+- 1%	16299	CGW RN55D 1500 F
R...9	12-12264-0A	RFF 464.0 250 MW F+-1%	16299	CGW RN55D 4640 F
R...10	12-12148-0A	RFF 31.6 250.0MW F+- 1%	16299	CGW RN55D 31R6 F
R...11	12-12217-0A	RFF 150.0 250.0MW F+- 1%	16299	CGW RN55D 1500 F
R...12	12-12200-0A	RFF 100.0 250.0MW F+- 1%	16299	CGW RN55D 1000 F
R...13	12-12188-0A	RFF 82.5 250.0MW F+- 1%	16299	CGW RN55D 82R5 F
R...14	12-12264-0A	RFF 464.0 250 MW F+-1%	16299	CGW RN55D 4640 F
R...15	12-12308-0A	RFF 1.21K 250 MW F+-1%	16299	CGW RN55D 1211 F
R...16	12-12200-0A	RFF 100.0 250.0MW F+- 1%	16299	CGW RN55D 1000 F
R...17	12-12200-0A	RFF 100.0 250.0MW F+- 1%	16299	CGW RN55D 1000 F
R...18	12-12217-0A	RFF 150.0 250.0MW F+- 1%	16299	CGW RN55D 1500 F
R...19	12-12217-0A	RFF 150.0 250.0MW F+- 1%	16299	CGW RN55D 1500 F
R...31	12-12304-0A	RFF 1.10K 250 MW F+-1%	16299	CGW RN55D 1101 F
R...33	12-06090-0A	RCF 150.0 250.0MW F+- 1%	19701	ELT TYP MF5C
S...1	25-10130-1B	SWC 6125B MULTIPLIER-TIME	50423	BLI
S...1	25-10134-1A	SWC 6125C DEVIATION 10%	50423	
S...3	25-10129-1A	SWC 6125B TRIG.PERIOD-TIME	50423	
S...4	25-10062-1A	SWC SLIDE PC RT ANGLE DPDT	50423	SEE DRAWING
U...1	24-10185-0A	ICP 7912 NEG 12V REG T0220 1	7263	FARICHILD UA79M12AUC OR EQ

PARTS LIST, A27 M/T CONN. N

SCHEMATIC REF	BALLANTINE PART NO.	DESCRIP
C...30	07-10083-0A	CET 1.5UF 35.0
C...31	07-10083-0A	CET 1.5UF 35.0
C...32	07-10083-0A	CET 1.5UF 35.0
C...33	07-10083-0A	CET 1.5UF 35.0
C...34	07-10083-0A	CET 1.5UF 35.0
C...35	07-10083-0A	CET 1.5UF 35.0
C...36	07-10422-0A	CEA1000.0UF 25.0
R...30	12-12733-0A	RFC 22.0
U...104	24-10147-0A	ICP MC7812CP 12
U...105	24-10131-0A	ICP MC7905.2CP
U...106	24-10153-0A	ICP UA7805 5V

PARTS LIST, A21 MULTIPLIER

SCHEMATIC REF	BALLANTINE PART NO.	DESCRIP
DS...1	16-10027-0A	LMP LED MINATUR
DS...2	16-10027-0A	LMP LED MINATUR
DS...3	16-10027-0A	LMP LED MINATUR
DS...4	16-10027-0A	LMP LED MINATUR

PARTS LIST, A22 TRIG OUT

SCHEMATIC REF	BALLANTINE PART NO.	DESCRIP
DS...1	16-10027-0A	LMP LED MINATUR
DS...2	16-10027-0A	LMP LED MINATUR
DS...3	16-10027-0A	LMP LED MINATUR
DS...4	16-10027-0A	LMP LED MINATUR
DS...5	16-10027-0A	LMP LED MINATUR
DS...6	16-10027-0A	LMP LED MINATUR
DS...7	16-10027-0A	LMP LED MINATUR
DS...8	16-10027-0A	LMP LED MINATUR

PARTS LIST, A103 SUP VER

SCHEMATIC REF	BALLANTINE PART NO.	DESCRIP
C...2	07-10209-0A	CCB 1.0NF 500
C...3	07-10209-0A	CCB 1.0NF 500
C...4	07-10209-0A	CCB 1.0NF 500
C...5	07-10209-0A	CCB 1.0NF 500
C...6	07-10209-0A	CCB 1.0NF 500
C...7	07-10209-0A	CCB 1.0NF 500
C...8	07-10209-0A	CCB 1.0NF 500
C...9	07-10184-0A	CET 100.0UF 10
C...10	07-10183-0A	CET 47.0UF 20
L...1	03-10006-0A	CRF 12UH MOLDED
L...2	03-10006-0A	CRF 12UH MOLDED
L...3	03-10006-0A	CRF 12UH MOLDED
L...4	03-10006-0A	CRF 12UH MOLDED

SECTION 7 OPTIONS AND ACCESSORIES

7-1. INTRODUCTION.

7-2. Section 7 contains information on the options and accessories for the 6125B/C available at the time of printing this manual. Additional options and accessories may now be available. Contact your local Ballantine representative or the factory for information.

7-3. HIGH STABILITY CLOCK – OPTION 14.

7-4. The high stability ovenized clock option 14 replaces the standard 10 MHz clock with a precision frequency standard. Option 14 therefore, provides a laboratory secondary frequency standard for the 6125B/C.

7-5. Option 14 is not recommended when IEEE-488 bus microprocessor option is installed in the 6125C. Fast warm up is reduced to 60 minutes and maximum ambient temperature is limited to 40°C.

7-6. Specifications

Frequency: 10 MHz.

Aging Rate: <3 parts in 10^{-9} per day after 72 hours;
Typically <1 part 10^{-9} per day after 30 days.

Temperature Stability: ± 1 part in $10^{-8}/^{\circ}\text{C}$ from 0°C to 50°C.

Short Term Stability: $\pm 5 \times 10^{-9}$ RMS (10 second average).

Fast Warm Up: Dual proportional controlled oven pre-heats to bring oscillator to within 5 parts in 10^8 of turn-off frequency within 20 minutes of turn on (60 minutes for 6125C).

Line Voltage Stability: ± 8 parts in 10^{-10} for a + or - 10% line voltage change.

7-7. Theory of Operation.

7-8. The ovenized oscillator is a sealed self-contained unit. It is electrically tuned to frequency with an external potentiometer. The ovenized oscillator replaces the standard

10 MHz oscillator on Assembly A11. Additional power supply voltage regulators are provided for the ovenized oscillator. These are non-adjustable and are located on the vertical shield which separates the TIME side from the center compartment.

7-9. Calibration.

7-10. To calibrate the 10 MHz High Stability Oscillator, proceed as follows:

- a. Allow the 6125B/C to warm up for 24 to 48 continuous hours with covers on and ac mains at nominal.
- b. Connect an X-Y oscilloscope Y input to the rear panel BNC INT CLOCK OUTPUT.
- c. Connect a 10 MHz frequency standard traceable to WWV to the X input of the X-Y oscilloscope.
- d. Adjust the oscilloscope until an on screen Lissajous pattern is observed. The pattern will probably not appear locked.
- e. Remove the 6125B/C top cover and adjust multiturn potentiometer A11 R100 until the displayed Lissajous pattern is monotonic and is not rolling. Close the top cover and after ten minutes again observe the Lissajous pattern for roll. Readjust A11 R100 to stabilize the roll. Repeat several times until the display is stable.
- f. Without turning off the 6125B/C, continue the operation for 24 more hours. Again repeat step e and touch up A11 R100 if required. Proper adjustment will result in less than one roll of the display in 30 seconds when covers are on the 6125B/C.

7-11. Schematic and Parts List.

7-12. Schematic for A11 with ovenized oscillator Option 14 is shown in dotted outline on schematic for A11 in Section 6.

7-13. Parts list for Option 14 is shown below:

PARTS LIST

DESIGNATOR	DESCRIPTION	BALLANTINE P/N
Delete: A11	Standard Oscillator	89401331
Add: A11	Option 14	
Delete: A11 X1	OVN Crystal Oven	
A11 X1	XTL 10 MHz Crystal	
A11 C5	CCV 2-10 pF Trim Capacitor	
Add: A11 X100	OVE Ovenized High Stability 10 MHz Oscillator	
A11 R100	RVF 20K 20 turn Potentiometer	
A11 R101	(6125C-Option 60 only) RFC 20Ω, 10%, 2W	
Add:	+15 Volt Power Supply on Time Interconnect Assembly A27	
A27U	7812	
A27CR	Diode Bridge	
A27C	Capacitor	

7-14. IEEE 488-1978 BUS INTERFACE OPTION 60.

7-15. Description and Function.

7-16. The 6125C option 60 circuitry permits full Talker/ Listener operation of all programmable controls by means of the standard IEEE 488-1978 interface bus. Full compatibility with all bus standards is assured for easy interface in instrumentation and calibration systems. Various controllers including the Tektronix 4051 terminal, the Hewlett-Packard 9825 calculator and the Commodore PET computer are available

7-17. Standard address switches are accessible by removing the top cover of the 6125C-Option 60.

7-18. The 6125C front panel controls may be fully inhibited by a bus command or the front panel controls may be used to override the bus.

7-19. Technical Summary.

7-20. The Bus Interface block diagram is shown in Figure 7-1. The interface is a microprocessor based device that transfers data in a bidirectional fashion between the 6125C and the IEEE 488 instrument Bus. The 6125C contains the 488 Bus Driver/Receivers, program memory and a processor. The 6125C Bus driver/receiver transfer data between the IEEE 488 and the internal μ P. The μ P acts on the IEEE 488 bus input data or converts it into an output command word which is passed to the instrument control switches through the output logic of the μ P.

7-21. As shown in Figure 7-1, the 6125C Option 60 incorporates a μ P to handle the data between the IEEE 488 bus and the 6125C-Option 60, U2 is the restart circuit which initializes the μ P, when POWER is turned ON or after an IFC Bus Command. U1 is the μ P. It is clocked through 1 MHz crystal Y1. The program is stored in U3 which is an 8k prom (1k x 8). U15 is a PIA (Peripheral Interface Adapter), which transfers data and command to the 6125C through the 8 bit latches U203-U207. The PIA also accepts DATA from the 6125C deviation meter display through U4, U5, and U6 and transfers deviation data through the μ P to the IEEE 488 Bus.

7-22. The bidirectional data transfer from bus to the 6125C and the 6125C to the bus is done through line driver-receivers U8, U9, U10, U11 and U12. The μ P generates all the handshake commands for the bus through U12 which serves also as intermediate data storage from the bus or to the bus. U7 is an interface between the μ P internal DATA BUS and the address switch.

7-23. Address Switch. (For units with serial no. 021-0156 and below).

7-24. The address switch sets the 6125C Interface address and establishes the Talk or Listen Only modes. The address switch assembly is a miniature, eight position rocker switch located at the top of board assembly A 28 within the 6125C near the rear panel. From left to right, switches No. 1

to No. 5 are address bits 2⁰, 2¹, 2², 2³, 2⁴. See Figure 7-2. Switch No. 6 is LISTEN only and switch No. 7 is TALK only. Switch No. 8 is not used.

7-25. To set the Interface address, select an unused bus address between 0 and 30 (decimal). Convert the address to binary notation and write it left to right putting the LSB on the left. Set the five address switches to the binary value. To set the Interface to a Talk or Listen Only mode, set the T (Talk) or L (Listen) switch on. If unused, set either Talk or Listen switch OFF.

7-26. Operation.

7-27. Use an IEEE 488 Bus cable to connect the interface to the bus controller or to another bus compatible instrument. Set the address switch as indicated in paragraph 7-25. Plug the power cord into an AC power receptacle.

7-28. Depress the POWER switch to turn 6125C on. The POWER indicator will illuminate.

7-29. The Controller should send an IFC command to reset the 6125C interface. Messages sent to the 6125C being controlled should be preceded by programming the 6125C, Interface to Listen (6125C Listen address state). The Controller should take the 6125C Interface out of the Listen mode after the 6125C is programmed, to avoid accidentally changing the 6125C control settings as other data is transmitted over the bus.

7-30. Address Switch. (For units with serial no. 021-0157 and higher).

7-31. The address switch sets the 6125C Interface address and establishes the Talk or Listen only modes. The address switch assembly is a miniature, eight position rocker switch located at the top of board assembly A28 within the 6125C near the rear panel. From left to right, switches No. 1 to No. 5 are address bits 2⁰, 2¹, 2², 2³, 2⁴. See figure 7-2. Switch No. 6 is SRQ (Service Request) on/off. Switch No. 7 is EOI (End of Identity) terminator on/off. Switch No. 8 is CR/LF (Carriage Return/-Line Feed) when on, or CR (Carriage Return) when off.

7-32. To set the Interface address, select an unused bus address between 0 and 30 (decimal). Convert the address to binary notation and write it left to right putting least significant bit on the left. Set the five address switches to the binary value.

NOTE

The address switches use negative true logic. Off is high (true), On is low (false). Example: to set the address "7", the switches are set as follows:

Switch No.	Setting
1	OFF
2	OFF
3	OFF
4	ON
5	ON

7-33. Operation.

a. Switch No. 6, when ON, provides Service Request capability. When ON, it allows the 6125C to generate an SRQ on the bus (SRQ) management line when an illegal string is sent across the bus, or when a hardware read error occurs. The SRQ error codes are as follows:

Hexadecimal Error Code	Cause
1	Illegal Command
3	Command string exceeds allowable length (14 bytes)
20	Read pulse hardware failure (strobe marker for data byte 1 missing)
21	Same as 20, except data byte 3 missing
22	Same as 20, except data byte 2 missing
23	Same as 20, except data byte 4 missing

NOTE

To obtain the error code and clear the SRQ, a serial poll sequence must be initiated. The byte received in the serial poll sequence is the error code.

b. Switch No. 7, when ON enables the EOI (End of Identity) management line, to indicate the end of multiple byte sequences.

c. Switch No. 8 provides terminator definition for multiple byte transfer sequences. On is CR/LF, OFF is CR only.

7-34. Use an IEEE 488 Bus cable to connect the interface to the bus controller or to another bus compatible instrument. Set the address switch as indicated in paragraph 7-32. Plug the power cord into an AC power receptacle.

7-35. Depress the POWER switch to turn 6125C on. The POWER indicator will illuminate.

7-36. The following instruction relates to units using PROM 24-10266-1B (or 1A) only. The procedures noted are unnecessary when PROM 24-10266-1C is in use on the IEEE Bus Adapter board (Assembly 89-10811-1A). Messages sent to the 6125C being controlled should be preceded by programming the 6125C, Interface to Listen (6125C Listen address state). The Controller should take the 6125C Interface out of the Listen mode after the 6125C is programmed, to avoid accidentally changing the 6125C control settings as other data is transmitted over the bus.

7-37. 6125C-Option 60 Program Codes.

- a. Table 7-1 lists ASCII Standard Code Chart.
- b. Table 7-2 lists Decimal to Binary and Octal Code Conversions used for setting the Bus Address.

c. Table 7-3 lists the Control Instruction Sequence of Codes.

d. Table 7-4 lists the 6125C Opt. 60 TIME/DIV ASCII Codes.

e. Table 7-5 lists the Trigger Select ASCII Code.

f. Table 7-6 lists the Deviation Control Codes.(Opt.60 only)

g. Table 7-7 lists the Volts ASCII Code.

h. Table 7-8 lists the Output Mode ASCII Code.

i. Table 7-9 lists the Deviation Select ASCII Code.

7-38. Determining Deviation ASCII Code.

7-39. The total span of both the REMOTE TIME and REMOTE VOLTS DEVIATION range is 20% (from -10% to +10%). This span is covered by an eight bit binary count and the weighting is expressed in % DEVIATION.

% DEVIATION WEIGHTING CHART

MSD-3				MSD-4			
8	7	6	5	4	3	2	1
10%	5%	2.5%	1.25%	.625%	.312%	.156%	.078%

7-40. An example of determining the ASCII Code for 3% deviation is given in the following paragraphs.

NOTE

It is intended that the 6125C-Option 60 % DEVIATION be stepped by the Bus Controller from a maximum negative value toward a maximum positive value by incrementing and decrementing the controller DEVIATION command switches. The operator stops the DEVIATION step commands when the unit under test indicates "calibrated". The 6125C-Opt. 60 % DEVIATION meter output is then read, either by the controller software or by the operator, to determine if the unit under test is within its calibration specification. It is not intended that the DEVIATION commands to the 6125C-Option 60 provide a predetermined quantitative % DEVIATION.

Should the Calibration System require a programmed quantitative % DEVIATION in either VOLTS or TIME then the system software in the Bus Controller may be programmed to first step the DEVIATION output to the 6125C Option 60 from the minimum toward maximum. Next, the program should "read" the 6125C-Option 60 % DEVIATION output (2 digit value is sufficient for most applications so as to speed the reading) and stop the % DEVIATION

step advance when the output equals the required deviation percentage included in the Controller program for that specific calibration step of the unit under test.

7-41. The plus and minus % deviation is algebraically added to 10. In our example this is 13 for +3% deviation and 7 for -3%.

7-42. To find the ASCII Code for +3% deviation look at the weighting chart and combine those bits that most closely total 13.

MSD-3				MSD-4			
10%	-	2.5%	-	-	.312%	.156%	-
1	0	1	0	0	1	1	0
10%		+2.5%			+0.312%	+0.156%	
= 12.968%							

7-43. Assign a logic "1" to each bit weight that is added and a logic "0" to those that are not used.

7-44. Refer to Table 7-1, the ASCII Code Chart, and determine the ASCII characters for MSD-3 and MSD-4. In our example, this is **JF**.

7-45. For -3% deviation, look at the weighting chart and combine those bits that most closely total 7.

MSD-3				MSD-4			
-	5%	-	1.25%	.625%	-	-	.078%
0	1	0	1	1	0	0	1
	5%		+1.25%	+0.625%			+0.078%
= 6.953%							

7-46. Follow the same procedure as previously used for the plus deviation and again refer to Table 7-1 to determine the ASCII characters for MSD-3 and MSD-4. In our example, this is **EI**.

7-47. User Program Aids.

7-48. This section contains program steps designed to assist the user in getting the 6125C-Option 60 Bus Interface Coupler to operate with the Bus Controller. The typical Bus Controller may be an intelligent terminal, (Tektronix 4051), a programmable calculator (HP 9825, Wang 220) or a custom controller (includes minicomputer interfaces). While the following programs are written for the Tektronix 4051 Terminal and the HP 9825 Calculator. It can easily be modified for use on most programmable calculators and custom controllers.

7-49. USING THE TEKTRONIX 4051 AS THE CONTROLLER.

7-50. Talk Program.

Program uses Input command to input data and display it on the 4051 CRT. Use with single or extended address units.

a. **Initial Steps** - Compute the Tektronix 4051 system decimal address by adding the turned on address switch binary values as follows:

For System Address:

$$= 2^0 + 2^1 + 2^2 + 2^3 + 2^4$$

$$= 0 + 0 + 0 + 0 + 16$$

$$= 16 \text{ for octal address } 20, \text{ binary address is } 110000.$$

b. **Program:**

200 - INPUT @ (Address) 32:A \$ becomes

200 - INPUT @ 16, 32:A \$.

210 - PRINT A \$

220 - END

A \$ is a string variable and will input all data until it receives a carriage return. The "32" in line 200 causes the Tek. 4051 to delete the secondary address message. Enter "RUN" and the data will appear on the CRT in this format: $\pm 00.54\%$ for the sequential 4 digits.

7-51. The 6125C Option 60 will recognize the following commands through the 4051 controller:

a. Universal command DCL program 200 - WBYTE @ 20:

b. Addressed command SDC program 200 - WBYTE @ 32 + decimal switch address), 4: The "+" represents arithmetical addition.

c. Universal command LLO program 200 - WBYTE @ 17

d. On INIT from the Tek 4051 Controller the 6125C-Option 60 will clear off Bus and will go to local.

7-52. Listen Program for the Tek 4051 Controller.

a. Program uses higher level print command to output data. Compute the instrument address as shown in paragraph 7-38.

b. Program

200 - PRINT @ 16, 32: "ABCDEFGHJIJ"

200 - END

RUN

c. This program outputs 10 characters to the 6125C-Option 60 and lets the Tek 4051 do the address and number conversion. Note that some early 4051 terminals hold the EOI line "on" while outputting the numbers.

7-53. USING THE HP 9825 CALCULATOR AS THE CONTROLLER

7-54. The HP9825 calculator is programmed in HPL Language which is similar in many respects to the Tektronix

basic language. However, the user should keep the following differences in mind: The HP higher level 488 bus instructions do not return the devices on the 488 bus to the "unlisten" or "untalk" state as do the corresponding Tektronix commands. All talk sequences should be terminated with an "untalk" command. Also, the HP commands automatically end output transmissions (i.e. wrt) with a line feed and carriage return rather than with the EOI signal as does the Tektronix.

7-55. The following example was written for use on a HP 9825 calculator equipped with an Extended I/O ROM and is intended to assist the user in quickly getting his system on line.

7-56. Talk Program

a. The 9825A Calculator is factory set to an address of 21 and the HP-IB Interface Card is set to 7. When addressing an instrument, the HP9825A always requires a two-digit number; even if the instrument being "talked" to has been assigned a one-digit decimal number. For this, a leading zero must be used (e.g., 07).

b. Program

```
"output" : A $ & B $ → C $
wtb 707, C $
cmd 7, "_ ? "
```

Where C \$ is a ten byte string comprised of the 9 byte string A \$, containing the instrument set-up instructions and B \$, a single byte that tells the Model 6125C to "untalk".

7-57. Listen Program

a. To send data (% distortion) to the HP9825A Calculator, the 6125C becomes a "talker" and the 9825A a "listener".

b. Program

```
"read" : wait 3000
conv 13, 10
red 707.1, F $
CONV
prt F $
prt
```

Where F \$ is an eight byte string representing % deviation from the 6125C. The .1 in 707.1 informs the 9825A that a decimal point follows the first digit in the data being sent.

7-58. Typical Program

```
0: dim A$ [9],
   B$ [1], C$ [10],
   F$ [8]
1: fmt 1, c8
2: prt "THE 6125
   C TIME/AMPLITUD
   E"
```

```
3: prt "CALIBRAT
   OR ON THE *HP-
   IB*"
4: prt
5: prt
6: prt
7: char (13) → B$
8: gsb "reply"
9: "CLE @ FE @ → A
   $
10: gsb "output"
11: gsb "reply"
12: "K" M AM
   "→ A$
13: gsb "output"
14: gsb "reply"
15: "G C EC
   "→ A$
16: gsb "output"
17: gsb "reply"
18: "A K CK
   "→ A$
19: gsb "output"
20: gsb "reply"
21: "I G G
   "→ A$
22: gsb "output"
23: gsb "reply"
24: "E H
   "→ A$
25: gsb "output"
26: gsb "reply"
27: " @ B F
   "→ A$
28: gsb "output"
29: gsb "reply"
30: "H A
   "→ A$
31: gsb "output"
32: "D I
   "→ A$
33: gsb "output"
34: gsb "reply"
35: "B E
   "→ A$
36: gsb "outpt"
37: gsb "reply"
38: "J C
   "→ A$
39: gsb "output"
40: gsb "reply"
41: "F K
   "→ A$
```

42: gsb "output"	81: " GE
43: gsb "reply"	H"→ A\$
44: "A DH	82: gsb "output"
"→ A\$	83: gsb "read"
45: gsb "output"	84: gsb "reply"
46: gsb "reply"	85: "
47: "I B	D"→ A\$
"→ A\$	86: gsb "ouput"
48: gsb "output"	87: gsb "read"
49: gsb "reply"	88: gsb "reply"
50: "E J	89: prt "END OF
"→ A\$	6125C TEST PROG
51: gsb "output"	RAM"
52: gsb "reply"	90: prt
53: "C F	91: prt
"→ A\$	92: prt
54: gsb "output"	93: end
55: gsb "reply"	94: "reply" : dsp
56: "K A	"HIT 'CONTINUE'
"→ A\$	FOR NEXT SETTI
57: gsb "output"	NG"
58: gsb "reply"	95: stp
59: "G I	96: ret
"→ A\$	97: "output":A\$&
60: gsb "output"	B\$→ C\$
61: gsb "reply"	98: wtb 708, C\$
62: " @ I E	99: cmd 7, "-?"
"→ A\$	100: ret
63: gsb "output"	101: "read":wait
64: gsb "reply"	3000
65: "H C	102: conv 13, 10
"→ A\$	103: red 708.1,
66: gsb "output"	F\$
67: gsb "reply"	104: conv
68: "D K	105: prt F\$
"→ A\$	106: prt
69: gsb "output"	107: ret
70: gsb "reply"	*12927
71: "B	
"→ A\$	
72: gsb "output"	
73: gsb "reply"	
74: "J	
"→ A\$	
75: gsb "output:"	
76: gsb "reply"	
77: "F	
"→ A\$	
78: gsb "output"	
79: gsb "read"	
80: gsb "reply"	

7-59. The user is advised to fully familiarize himself with the software requirements of the Bus Controller to assure proper operation of the IEEE 488-1978 Bus Interface.

7-60. Operational Concepts, Parts lists and Schematics.

7-61. 6125C Option 60 replaces the following 6125C assemblies:

- A1 Remote Program - Volts
- A10 Remote Program - Time
- A17 DPM Interconnect Assembly

7-62. 6125C Option 60 adds assemblies A28, A29 and A30, the microprocessor control assemblies, power supply regulators and the IEEE 488 captive Blue Ribbon connectors.

7-63. Schematic diagrams are shown as follows:

- Figure 7-3 A31 Remote Program – Volts
- 7-4 A32 Remote Program – Time
- 7-5 A33 DPM Interconnect
- 7-6 { A28 488 Bus Adapter
- A29 Latch Assembly
- A30 Adapter

7-64. IEEE 488 BUS INTERFACE OPTION 61.

7-65. Description and Function.

7-66. Refer to Option 60 for all controls and functions except deviation. When remote deviation is selected deviation magnitude remains local (front panel of 6125C). Paragraphs 7-38 thru 7-47 do not apply.

7-67. Calibration.

No calibration or service adjustments are required for Option 60. Trouble shooting should be performed by first being sure the controller and manual modes of the 6125C are fully operative. Then check for burned or damaged parts on the interface assemblies and troubleshoot by parts replacement.

TABLE 7-1. ASCII CODE

BITS				CHARACTER	BITS				CHARACTER
4	3	2	1		4	3	2	1	
0	0	0	0	@	1	0	0	0	H
0	0	0	1	A	1	0	0	1	I
0	0	1	0	B	1	0	1	0	J
0	0	1	1	C	1	0	1	1	K
0	1	0	0	D	1	1	0	0	L
0	1	0	1	E	1	1	0	1	M
0	1	1	0	F	1	1	1	0	N
0	1	1	1	G	1	1	1	1	O

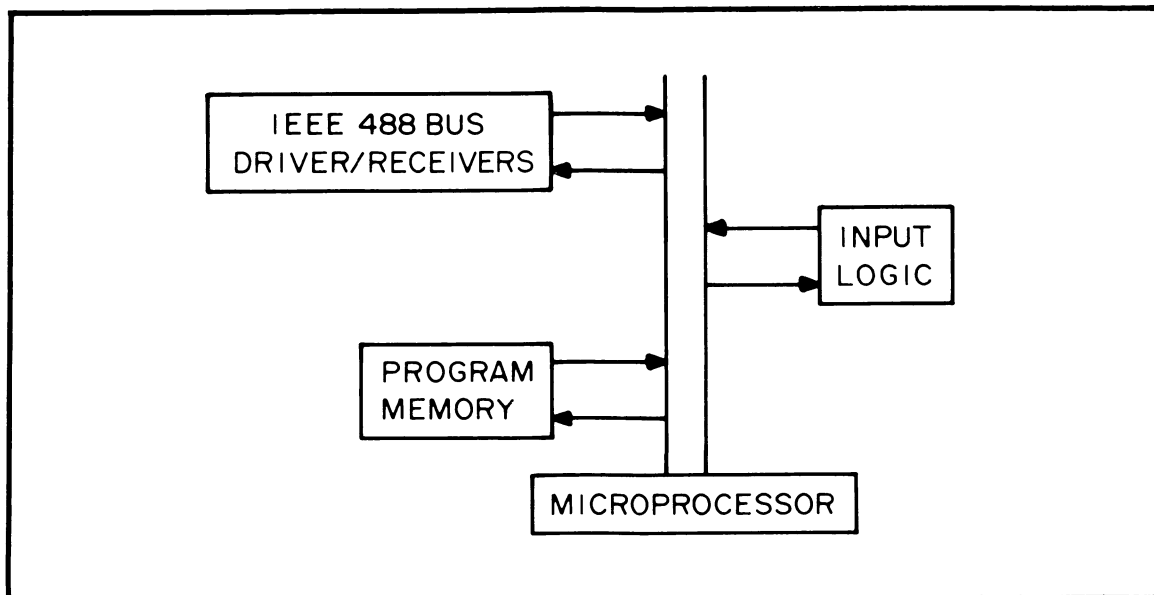

Figure 7-1. IEEE 488 Bus Interface, Block Diagram

TABLE 7-2. DECIMAL TO BINARY AND OCTAL CODE CONVERSION

DECIMAL	BINARY	OCTAL	DECIMAL	BINARY	OCTAL
0	0000	0	16	10000	20
1	0001	1	17	10001	21
2	0010	2	18	10010	22
3	0011	3	19	10011	23
4	0100	4	20	10100	24
5	0101	5	21	10101	25
6	0110	6	22	10110	26
7	0111	7	23	10111	27
8	1000	10	24	11000	30
9	1001	11	25	11001	31
10	1010	12	26	11010	32
11	1011	13	27	11011	33
12	1100	14	28	11100	34
13	1101	15	29	11101	35
14	1110	16	30	11110	36
15	1111	17			

TABLE 7-3. SEQUENCE OF ASCII CONTROL CODES

FUNCTION	TIME/DIV. & MULTIPLIER	TRIGGER PERIOD Remote/Local Select	DEVIATION LEVEL SELECT	VOLTS/DIV. & MULTIPLIER	VOLTS OUTPUT MODE Remote/Local Select	DEVIATION VOLTS/TIME/OFF			
PROGRAM DIGIT	1 (MSD)	2 (MSD-1)	3 (MSD-2)	4 (MSD-3)	5 (MSD-4)	6 (MSD-5)	7 (MSD-6)	8 (MSD-7)	9 (MSD-8)

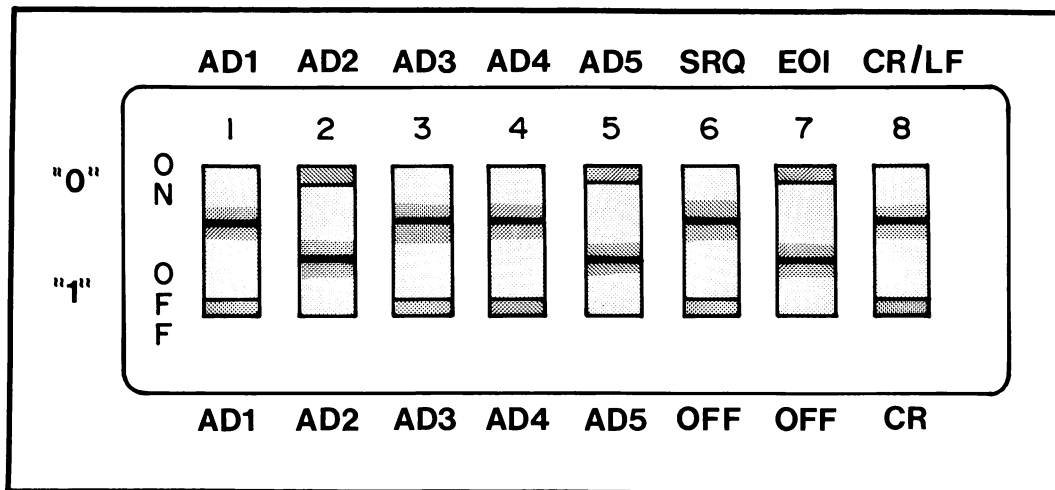

Figure 7-2. Address Switch

TABLE 7-4. 6125C OPT. 60 TIME/DIV ASCII CODES

TIME/DIV RANGE	MULTIPLIER	MSD	MSD-1
10nS	X1	C	O
	X2	C	N
	X5	C	M
	X10	C	L
20nS	X1	K	O
	X2	K	N
	X5	K	M
	X10	K	L
50nS	X1	G	O
	X2	G	N
	X5	G	M
	X10	G	L
.1μS	X1	A	O
	X2	A	N
	X5	A	M
	X10	A	L
.2μS	X1	I	O
	X2	I	N
	X5	I	M
	X10	I	L
.5μS	X1	E	O
	X2	E	N
	X5	E	M
	X10	E	L
1μS	X1	@	G
	X2	@	F
	X5	@	E
	X10	@	D
2μS	X1	H	G
	X2	H	F
	X5	H	E
	X10	H	D
5μS	X1	D	G
	X2	D	F
	X5	D	E
	X10	D	D
10μS	X1	@	C
	X2	@	B
	X5	@	A
	X10	@	@
20μS	X1	H	C
	X2	H	B
	X5	H	A
	X10	H	@

TABLE 7-4. 6125C OPT. 60 TIME/DIV ASCII CODES - Con't.

TIME/DIV RANGE	MULTIPLIER	MSD	MSD-1
50μS	X1	D	C
	X2	D	B
	X5	D	A
	X10	D	@
.1mS	X1	B	C
	X2	B	B
	X5	B	A
	X10	B	@
.2mS	X1	J	C
	X2	J	B
	X5	J	A
	X10	J	@
.5mS	X1	F	C
	X2	F	B
	X5	F	A
	X10	F	@
1mS	X1	A	C
	X2	A	B
	X5	A	A
	X10	A	@
2mS	X1	I	C
	X2	I	B
	X5	I	A
	X10	I	@
5mS	X1	E	C
	X2	E	B
	X5	E	A
	X10	E	@
10mS	X1	C	C
	X2	C	B
	X5	C	A
	X10	C	@
20mS	X1	K	C
	X2	K	B
	X5	K	A
	X10	K	@
50mS	X1	G	C
	X2	G	B
	X5	G	A
	X10	G	@
.1sec	X1	@	K
	X2	@	J
	X5	@	I
	X10	@	H

TABLE 7-4. 6125C OPT. 60 TIME/DIV ASCII CODES - Con't.

TIME/DIV RANGE	MULTIPLIER	MSD	MSD-1
.2 sec	X1	H	K
	X2	H	J
	X5	H	I
	X10	H	H
.5 sec	X1	D	K
	X2	D	J
	X5	D	I
	X10	D	H
1 sec	X1	B	K
	X2	B	J
	X5	B	I
	X10	B	H
2 sec	X1	J	K
	X2	J	J
	X5	J	I
	X10	J	H
5 sec	X1	F	K
	X2	F	J
	X5	F	I
	X10	F	H

TABLE 7-5. TRIGGER SELECT ASCII CODE

TRIGGER PERIOD	SELECT REMOTE	MSD-2
100 nS	Local	N
	Remote	O
1 μS	Local	@
	Remote	A
10 μS	Local	H
	Remote	I
100 μS	Local	D
	Remote	E
1 mS	Local	L
	Remote	M
10 mS	Local	B
	Remote	C
100 mS	Local	J
	Remote	K
1 sec	Local	F
	Remote	G

TABLE 7-6. 6125C OPT. 60 ONLY DEVIATION LEVEL ASCII CODE

DEVIATION LEVEL	MSD-3	MSD-4
< -10%	@	@
0%	H	@
> +10%	O	O

TABLE 7-7. VOLTS ASCII CODE

VOLTS/DIV.	MULTIPLIER	MSD-5	MSD-6
10 μ V	X1	@	@
	X2	@	D
	X3	@	B
	X4	@	F
	X5	@	A
	X6	@	E
	X8	@	C
20 μ V	X10	@	G
	X1	H	@
	X2	H	D
	X3	H	B
	X4	H	F
	X5	H	A
	X6	H	E
50 μ V	X8	H	C
	X10	H	G
	X1	D	@
	X2	D	D
	X3	D	B
	X4	D	F
	X5	D	A
.1mV	X6	D	E
	X8	D	C
	X10	D	G
	X1	B	@
	X2	B	D
	X3	B	B
	X4	B	F
.2mV	X5	B	A
	X6	B	E
	X8	B	C
	X10	B	G
	X1	J	@
	X2	J	D
	X3	J	B
.5mV	X4	J	F
	X5	J	A
	X6	J	E
	X8	J	C
	X10	J	G
	X1	F	@
	X2	F	D
1mV	X3	F	B
	X4	F	F
	X5	F	A
	X6	F	E
	X8	F	C
	X10	F	G

TABLE 7-7. VOLTS ASCII CODE - Con't.

VOLTS/DIV.	MULTIPLIER	MSD-5	MSD-6	
1mV	X1	A	@	
	X2	A	D	
	X3	A	B	
	X4	A	F	
	X5	A	A	
	X6	A	E	
	X8	A	C	
	X10	A	G	
	2mV	X1	I	@
		X2	I	D
X3		I	B	
X4		I	F	
X5		I	A	
X6		I	E	
X8		I	C	
X10		I	G	
5mV		X1	E	@
		X2	E	D
	X3	E	B	
	X4	E	F	
	X5	E	A	
	X6	E	E	
	X8	E	C	
	X10	E	G	
	10mV	X1	C	@
		X2	C	D
X3		C	B	
X4		C	F	
X5		C	A	
X6		C	E	
X8		C	C	
X10		C	G	
20mV		X1	K	@
		X2	K	D
	X3	K	B	
	X4	K	F	
	X5	K	A	
	X6	K	E	
	X8	K	C	
	X10	K	G	
	50mV	X1	D	H
		X2	D	L
X3		D	J	
X4		D	N	
X5		D	I	
X6		D	M	
X8		D	K	
X10		D	O	

TABLE 7-7. VOLTS ASCII CODE - Con't.

VOLTS/DIV.	MULTIPLIER	MSD-5	MSD-6	
.1V	X1	B	H	
	X2	B	L	
	X3	B	J	
	X4	B	N	
	X5	B	I	
	X6	B	M	
	X8	B	K	
	X10	B	O	
	.2V	X1	J	H
		X2	J	L
X3		J	J	
X4		J	N	
X5		J	I	
X6		J	M	
X8		J	K	
X10		J	O	
.5V		X1	F	H
		X2	F	L
	X3	F	J	
	X4	F	N	
	X5	F	I	
	X6	F	M	
	X8	F	K	
	X10	F	O	
	1V	X1	A	H
		X2	A	L
X3		A	J	
X4		A	N	
X5		A	I	
X6		A	M	
X8		A	K	
X10		A	O	
2V		X1	I	H
		X2	I	L
	X3	I	J	
	X4	I	N	
	X5	I	I	
	X6	I	M	
	X8	I	K	
	X10	I	O	
	5V	X1	E	H
		X2	E	L
X3		E	J	
X4		E	N	
X5		E	I	
X6		E	M	
X8		E	K	
X10		E	O	

TABLE 7-7. VOLTS ASCII CODE - Con't.

VOLTS/DIV.	MULTIPLIER	MSD-5	MSD-6	
10	X1	C	H	
	X2	C	L	
	X3	C	J	
	X4	C	N	
	X5	C	I	
	X6	C	M	
	X8	C	K	
	X10	C	O	
	20	X1	K	H
		X2	K	L
X3		K	J	
X4		K	N	
X5		K	I	
X6		K	M	
X8		K	K	
X10		K	O	

TABLE 7-8. OUTPUT MODE ASCII CODE

OUTPUT MODE	REMOTE LOCAL	MSD-7
-	Local	F
	Remote	G
GND	Local	@
	Remote	A
+	Local	N
	Remote	O
10KHz	Local	D
	Remote	E
1KHz	Local	L
	Remote	M
100Hz	Local	B
	Remote	C
10Hz	Local	J
	Remote	K

TABLE 7-9. DEVIATION SELECT ASCII CODE

DEVIATION SELECT	MSD-8
Time off	H
Volts	@
	D

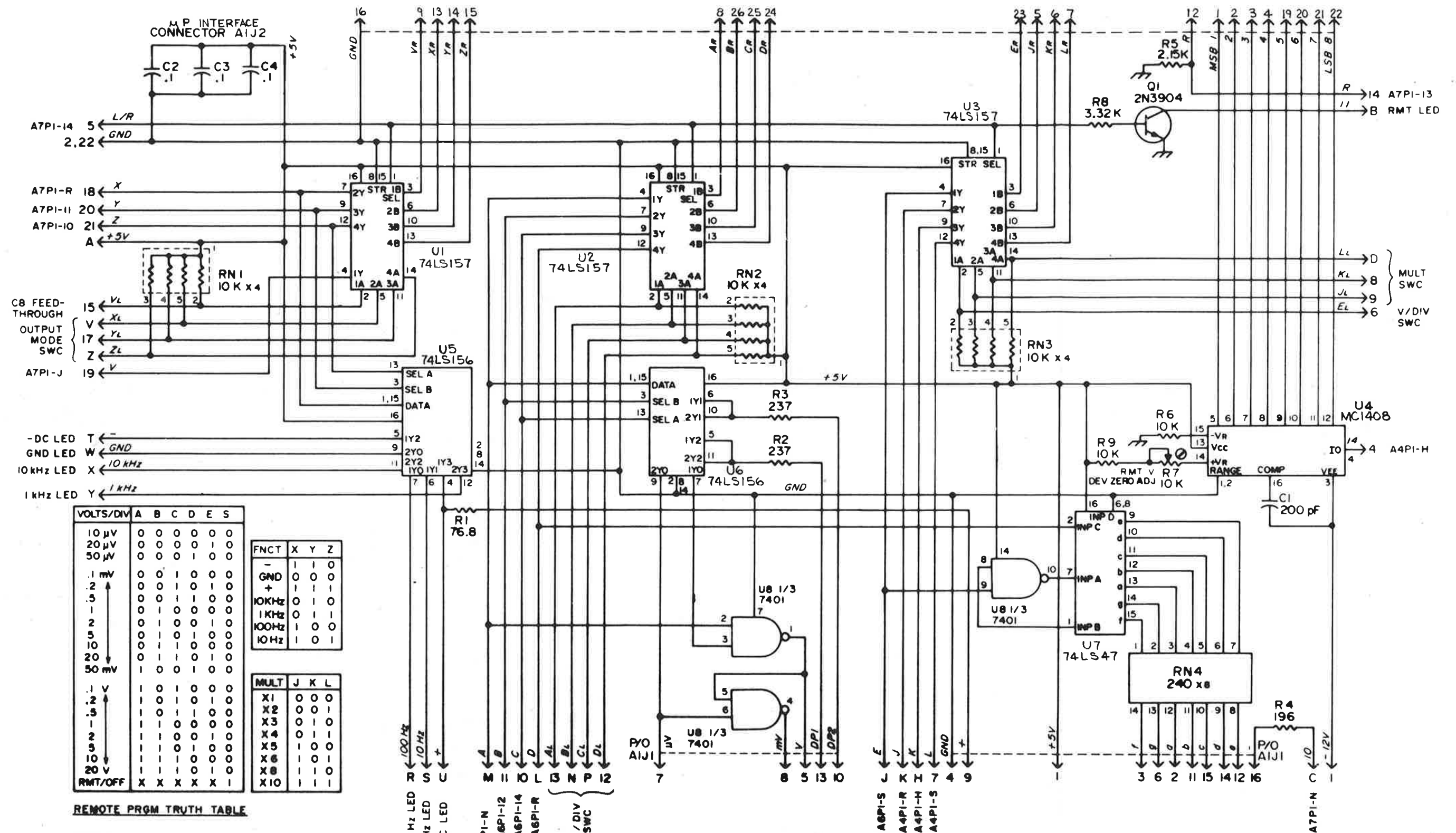

C8 FEED-THROUGH OUTPUT MODE SWC

-DC LED T
GND LED W
10kHz LED X
1kHz LED Y

VOLTS/DIV	A	B	C	D	E	S
10 μV	0	0	0	0	0	0
20 μV	0	0	0	0	0	1
50 μV	0	0	0	1	0	0
.1 mV	0	0	1	0	0	0
.2	0	0	1	0	0	0
.3	0	0	1	1	0	0
1	0	1	0	0	0	0
2	0	1	0	0	0	0
5	0	1	0	1	0	0
10	0	1	0	1	0	0
20	0	1	0	1	0	0
50 mV	1	0	0	1	0	0
.1 V	1	0	1	0	0	0
.2	1	0	1	0	0	0
.3	1	0	1	0	0	0
1	1	0	1	0	0	0
2	1	0	1	0	0	0
5	1	0	1	0	0	0
10	1	0	1	0	0	0
20 V	1	0	1	0	0	0
RMT/OFF	X	X	X	X	X	1

FNCT	X	Y	Z
-	1	1	0
GND	0	0	0
+	0	0	1
10kHz	0	1	1
1kHz	0	1	1
100Hz	1	0	0
10Hz	1	0	0

MULT	J	K	L
X1	0	0	0
X2	0	0	1
X3	0	1	0
X4	0	1	1
X5	1	0	0
X6	1	0	1
X8	1	1	0
X10	1	1	1

REMOTE PROM TRUTH TABLE

- NOTES:
1. ALL CAPACITANCE VALUES ARE IN MICRO-FARADS AND ALL RESISTANCE VALUES ARE IN OHMS UNLESS NOTED OTHERWISE.
 2. → DENOTES CONTACT OF AIPI, UNLESS NOTED OTHERWISE.

Figure 7-3. A31 Volt/Div IEEE Remote Program

PARTS LIST, A31 VOLTS/DIV IEEE REMOTE PROGRAM MODEL 6125C-OPT.60(89-10814-1A)

SCHEMATIC REF	BALLANTINE PART NO.	DESCRIPTION	MFR CODE	MFR PART NUMBER
C...1	07-10351-0A	CMD 200.0PF 500.0 V TCE 5%	84171	ARCO DM15ED200J03 -ARCO
C...2	07-10562-0A	CCR 0.1 UF 50V .3 SPACE	0	AVX CERAMICS MD015E104ZAA
C...3	07-10562-0A	CCR 0.1 UF 50V .3 SPACE	0	AVX CERAMICS MD015E104ZAA
C...4	07-10562-0A	CCR 0.1 UF 50V .3 SPACE	0	AVX CERAMICS MD015E104ZAA
Q...1	10-10043-0A	TRQ 2N3904 NPN 1 40 PTO-92	4713	MOT 1 300M 40
R...1	12-12185-0A	RFF 76.8 250.0MW F+- 1%	16299	CGW RN55D 76R8 F
R...2	12-12236-0A	RFF 237.0 250 MW F+-1%	16299	CGW RN55D 2370 F
R...3	12-12236-0A	RFF 237.0 250 MW F+-1%	16299	CGW RN55D 2370 F
R...4	12-12228-0A	RFF 196.0 250 MW F+-1%	16299	CGW RN55D 1960 F
R...5	12-12332-0A	RFF 2.15K 250.0MW F+- 1%	16299	CGW RN55D 2151 F
R...6	12-12400-0A	RFF 10.0 K 250.0MW F+- 1%	16299	CGW RN55D 1002 F
R...7	09-10093-0A	RVF 10.0 K 500.0MW KVERT MT	73138	HELIPOT 72XW 10K
R...8	12-12350-0A	RFF 3.32K 250.0MW F+- 1%	16299	CGW RN55D 3321 F
R...9	12-12400-0A	RFF 10.0 K 250.0MW F+- 1%	16299	CGW RN55D 1002 F
R..10	12-12256-0A	RFF 383.0 250 MW F+-1%	16299	CGW RN55D 3830 F
RN..1	13-10018-0A	RNF 10.0 K 0.3 W F	80053	BECKMAN 783-1-R10K
RN..2	13-10018-0A	RNF 10.0 K 0.3 W F	80053	BECKMAN 783-1-R10K
RN..3	13-10018-0A	RNF 10.0 K 0.3 W F	80053	BECKMAN 783-1-R10K
RN..4	13-10022-0A	RNF 270.0 0.2 WF	0	BECKMAN 899-3R-270
U...1	24-10163-0A	ICP 74LS157 MULTIPLEXER	1295	T.I. SN74LS157
U...2	24-10163-0A	ICP 74LS157 MULTIPLEXER	1295	T.I. SN74LS157
U...3	24-10163-0A	ICP 74LS157 MULTIPLEXER	1295	T.I. SN74LS157
U...4	24-10175-0A	ICP 1408 D TO A CONVERTER	4713	MOTOROLA MC1408
U...5	24-10164-0A	ICP 74LS156 DEMULTIPLEXER	1295	T.I. SN74LS156
U...6	24-10164-0A	ICP 74LS156 DEMULTIPLEXER	1295	T.I. SN74LS156
U...7	24-10139-0A	ICP 74LS47 7SEG DRVR LU-PWR	27014	NAT.SEMI DM74LS47
U...8	24-10182-0A	ICP 7401 QUAD 2 IN NAND	1295	T.I. SN7401 OR EQUIP.

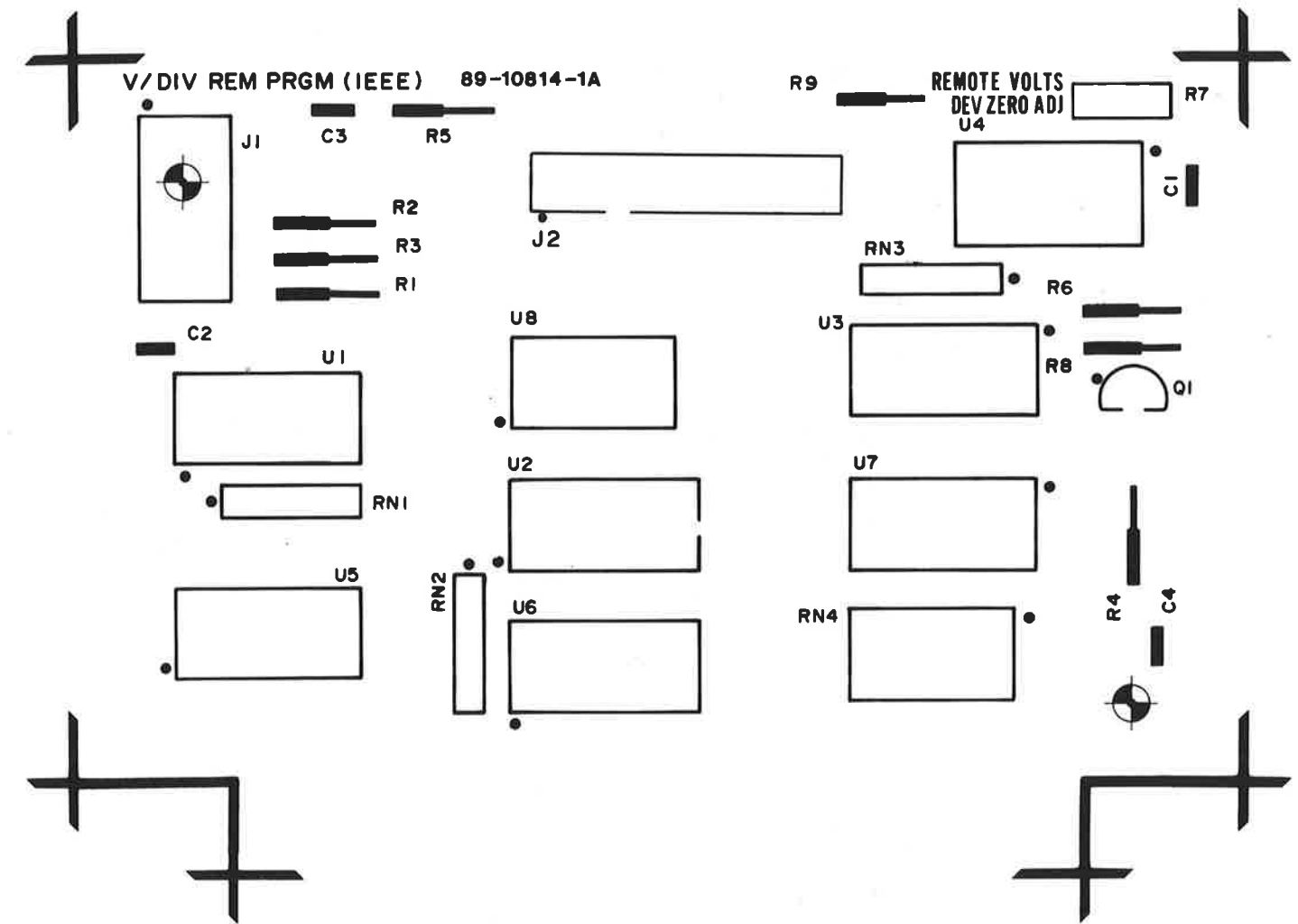

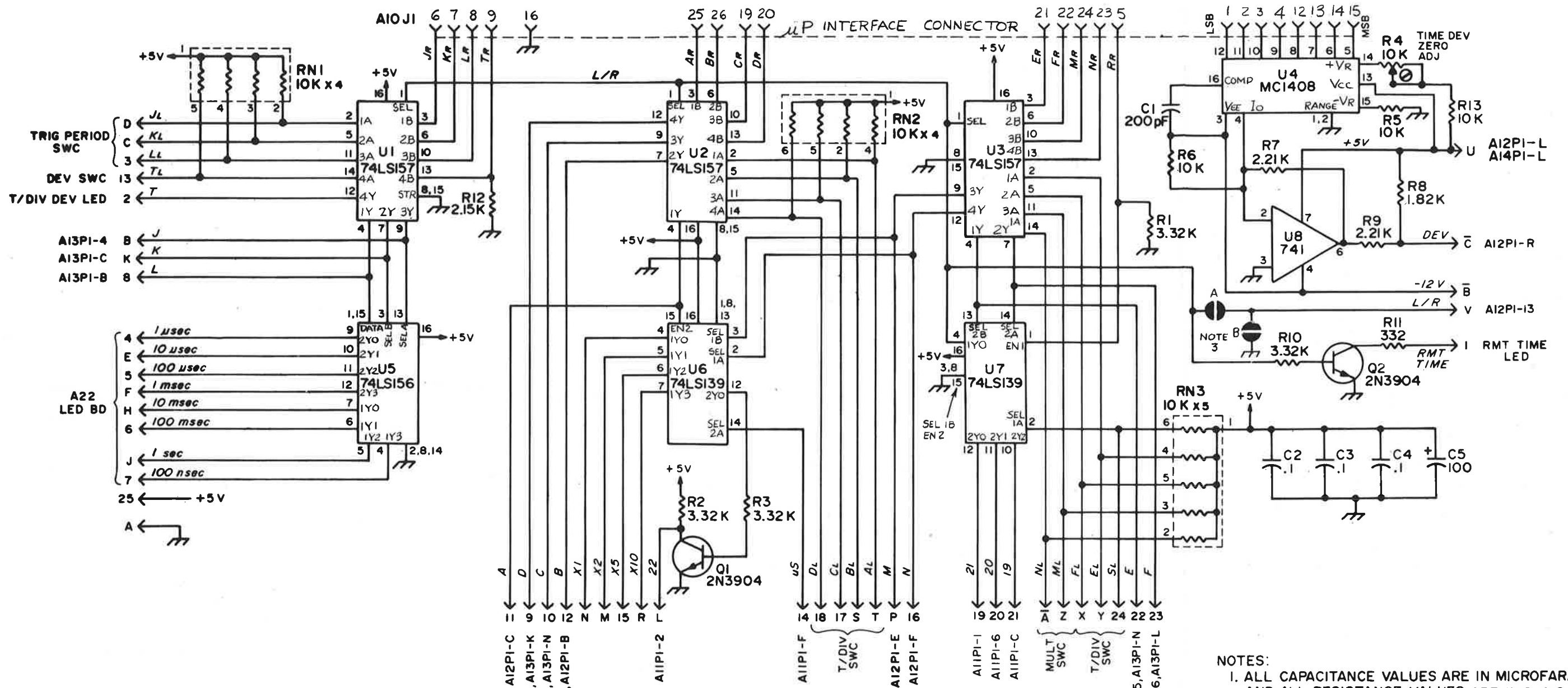

- NOTES:
1. ALL CAPACITANCE VALUES ARE IN MICROFARADS AND ALL RESISTANCE VALUES ARE IN OHMS UNLESS NOTED OTHERWISE.
 2. → DENOTES CONTACT OF AIOPI, UNLESS NOTED OTHERWISE.
 3. OPTION 6I B CLOSED A OPEN STANDARD A CLOSED B OPEN

TIME/DIV	A	B	C	D	E	F	S
10 nsec					0	0	0
20 nsec					0	0	0
50 nsec					0	0	0
.1 μsec					0	0	0
.20					0	0	0
.50					0	0	0
1					0	0	0
2		0	0	0	0	0	0
5		0	0	0	0	0	0
10		0	0	0	0	0	0
20		0	0	0	0	0	0
50 μsec		0	0	0	0	0	0
.1 msec		0	0	0	0	0	0
.2		0	0	0	0	0	0
.5		0	0	0	0	0	0
1		0	0	0	0	0	0
2		0	0	0	0	0	0
5		0	0	0	0	0	0
10		0	0	0	0	0	0
20		0	0	0	0	0	0
50 msec		0	0	0	0	0	0
.1 sec		0	0	0	0	0	0
.2		0	0	0	0	0	0
.5		0	0	0	0	0	0
1		0	0	0	0	0	0
2		0	0	0	0	0	0
5		0	0	0	0	0	0
REMOTE/OFF	X	X	X	X	X	X	-

MULT	M	N
X1	1	1
X2	1	0
X5	0	0
X10	0	0

CONTROL	R	S	L/R
REMOTE	1	X	1
REMOTE	0	1	1
LOCAL	0	0	0

TIME DEVIATION	T
ON	1
OFF	0

TRIGGER PERIOD	J	K	L
100 nsec	1	1	1
1 μsec	0	0	0
10	0	0	0
100	0	1	0
1 msec	0	1	0
10	1	0	0
100	1	0	0
1 sec	1	1	0

Figure 7-4. A32 Time/Div IEEE Remote Program

SCHEMATIC REF	BALLANTINE PART NO.	DESCRIPTION	MFR CODE	MFR PART NUMBER
C...1	07-10351-0A	CMD 200.0PF 500.0 V TCE 5%	84171	ARCO DM15ED200J03 -ARCO
C...2	07-10562-0A	CCR 0.1 UF 50V .3 SPACE	0	AVX CERAMICS MD015E104ZAA
C...3	07-10562-0A	CCR 0.1 UF 50V .3 SPACE	0	AVX CERAMICS MD015E104ZAA
C...4	07-10562-0A	CCR 0.1 UF 50V .3 SPACE	0	AVX CERAMICS MD015E104ZAA
C...5	07-10184-0A	CET 100.0UF 10.0 VM DIP TAN	56289	SPRAGUE 196D107X0010-LA3
W...1	10-10043-0A	TRQ 2N3904 NPN 1 40 PTO-92	4713	MOT 1 300M 40
Q...2	10-10043-0A	TRQ 2N3904 NPN 1 40 PTO-92	4713	MOT 1 300M 40
R...1	12-12350-0A	RFF 3.32K 250.0MW F+- 1%	16299	CGW RN55D 3321 F
R...2	12-12350-0A	RFF 3.32K 250.0MW F+- 1%	16299	CGW RN55D 3321 F
R...3	12-12350-0A	RFF 3.32K 250.0MW F+- 1%	16299	CGW RN55D 3321 F
R...4	09-10093-0A	RVF 10.0 K 500.0MW KVERT MT	73138	HELIPOT 72XW 10K
R...5	12-12400-0A	RFF 10.0 K 250.0MW F+- 1%	16299	CGW RN55D 1002 F
R...6	12-12400-0A	RFF 10.0 K 250.0MW F+- 1%	16299	CGW RN55D 1002 F
R...7	12-12333-0A	RFF 2.21K 250.0MW F+- 1%	16299	CGW RN55D 2211 F
R...8	12-12325-0A	1.82K 250.0MW F+- 1%	16299	CGW RN55D 1821 F
R...9	12-12333-0A	RFF 2.21K 250.0MW F+- 1%	16299	CGW RN55D 2211 F
R...10	12-12350-0A	RFF 3.32K 250.0MW F+- 1%	16299	CGW RN55D 3321 F
R...11	12-12250-0A	RFF 332.0 250 MW F+-1%	16299	CGW RN55D 3320 F
R...12	12-12332-0A	RFF 2.15K 250.0MW F+- 1%	16299	CGW RN55D 2151 F
R...13	12-12432-0A	RFF 21.5 K 250.0MW F+- 1%	16299	CGW RN55D 2152 F
RN...1	13-10018-0A	RNF 10.0 K 0.3 w F	80053	BECKMAN 783-1-R10K
RN...2	13-10018-0A	RNF 10.0 K 0.3 w F	80053	BECKMAN 783-1-R10K
RN...3	13-10018-0A	RNF 10.0 K 0.3 w F	80053	BECKMAN 783-1-R10K
U...1	24-10163-0A	ICP 74LS157 MULTIPLEXER	1295	T.I. SN74LS157
U...2	24-10163-0A	ICP 74LS157 MULTIPLEXER	1295	T.I. SN74LS157
U...3	24-10163-0A	ICP 74LS157 MULTIPLEXER	1295	T.I. SN74LS157
U...4	24-10175-0A	ICP 1408 D TO A CONVERTER	4713	MOTOROLA MC1408
U...5	24-10164-0A	ICP 74LS156 DEMULTIPLEXER	1295	T.I. SN74LS156
U...6	24-10165-0A	ICP 74LS139 DEMULTIPLEXER	1295	T.I. SN74LS139
U...7	24-10165-0A	ICP 74LS139 DEMULTIPLEXER	1295	T.I. SN74LS139
U...8	24-09420-0A	ICP UA741C FAIRCHILD	7263	#US87741393

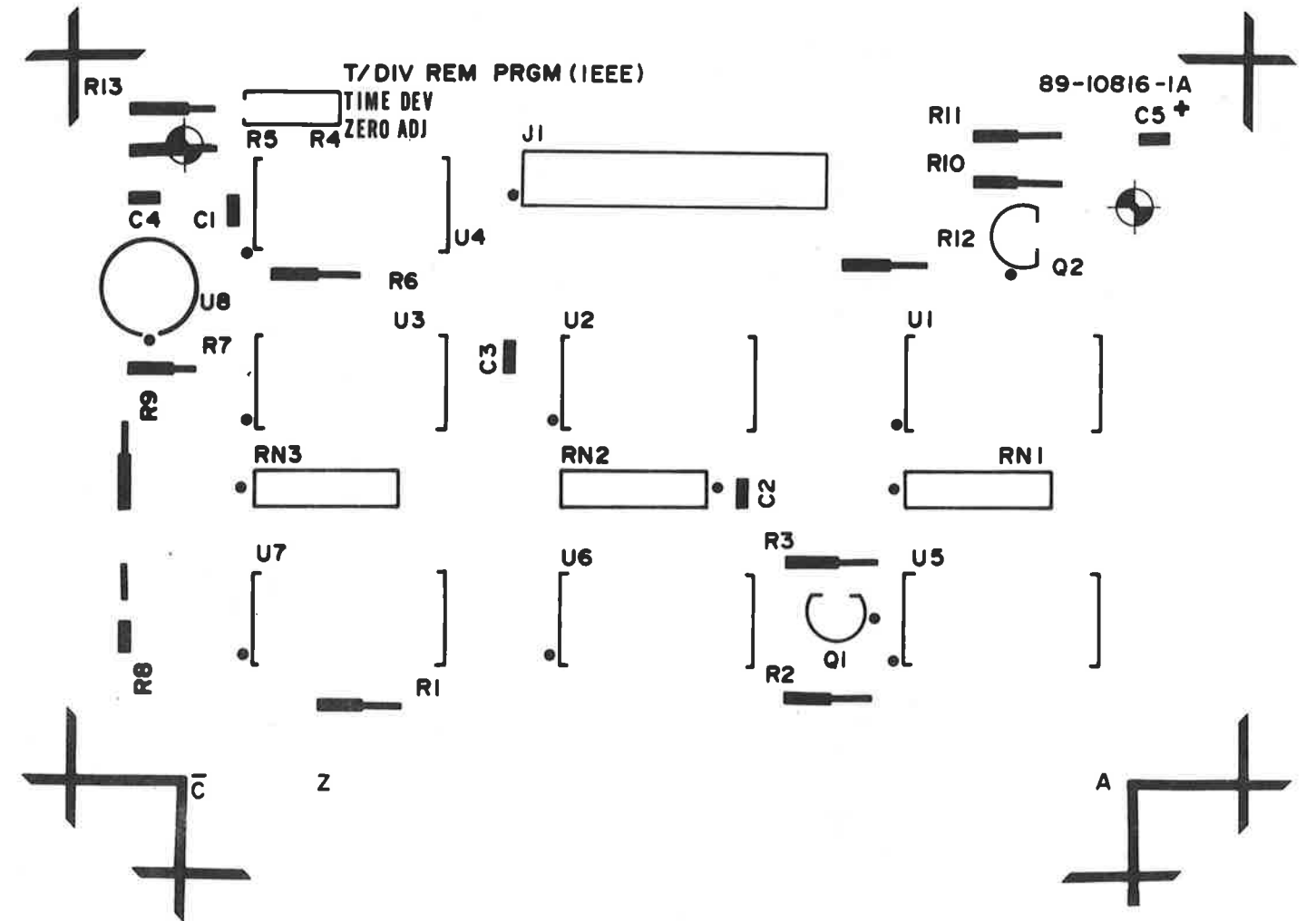

PARTS LIST, A33 DPM INTERCONNECT AND COUPLER MODEL 6125C-OPT.60 (89-10819-1A)

SCHEMATIC REF	BALLANTINE PART NO.	DESCRIPTION	MFR CODE	MFR PART NUMBER
C...1	07-09589-0A	CCD 100 NF 12 V M 20%	90201	RMC TYP M-12-0.1
R...2	12-12416-0A	RFF 14.7 K 250.0Mw F+- 1%	16299	CGW RN55D 1472 F
R...3	12-12416-0A	RFF 14.7 K 250.0Mw F+- 1%	16299	CGW RN55D 1472 F
R...4	12-12300-0A	RFF 1.0 K 250 Mw F+-1%	16299	CGW RN55D 1001 F
R...5	12-12300-0A	RFF 1.0 K 250 Mw F+-1%	16299	CGW RN55D 1001 F
R...6	12-12300-0A	RFF 1.0 K 250 Mw F+-1%	16299	CGW RN55D 1001 F
R...7	12-12300-0A	RFF 1.0 K 250 Mw F+-1%	16299	CGW RN55D 1001 F
R...8	12-12300-0A	RFF 1.0 K 250 Mw F+-1%	16299	CGW RN55D 1001 F
R...9	12-12300-0A	RFF 1.0 K 250 Mw F+-1%	16299	CGW RN55D 1001 F
R...10	12-12300-0A	RFF 1.0 K 250 Mw F+-1%	16299	CGW RN55D 1001 F
R...11	12-12300-0A	RFF 1.0 K 250 Mw F+-1%	16299	CGW RN55D 1001 F
R...12	12-12300-0A	RFF 1.0 K 250 Mw F+-1%	16299	CGW RN55D 1001 F
R...13	12-12600-0A	RFF 1.00M 500 Mw F+-1%	16299	CGW RN60D 1004 F
R...14	12-12600-0A	RFF 1.00M 500 Mw F+-1%	16299	CGW RN60D 1004 F
R...15	12-12600-0A	RFF 1.00M 500 Mw F+-1%	16299	CGW RN60D 1004 F
R...16	12-12600-0A	RFF 1.00M 500 Mw F+-1%	16299	CGW RN60D 1004 F
RN...1	13-10060-0A	RNF 15.0 K 8PIN SIP 4 RES.	80053	BECKMAN 764-1-R15K
U...1	24-10249-0A	ICP 74C90L HEX INV TT2 BUFFE	12040	NATIONAL MM74C901N
U...2	24-10249-0A	ICP 74C90L HEX INV TT2 BUFFE	12040	NATIONAL MM74C901N
U...3	24-10183-0A	ICP L111 OPT. INSULATOR	1295	T.I TIL111
U...4	24-10183-0A	ICP L111 OPT. INSULATOR	1295	T.I TIL111
U...5	24-10183-0A	ICP L111 OPT. INSULATOR	1295	T.I TIL111
U...6	24-10183-0A	ICP L111 OPT. INSULATOR	1295	T.I TIL111
U...7	24-10183-0A	ICP L111 OPT. INSULATOR	1295	T.I TIL111
U...8	24-10183-0A	ICP L111 OPT. INSULATOR	1295	T.I TIL111
U...9	24-10183-0A	ICP L111 OPT. INSULATOR	1295	T.I TIL111
U...10	24-10183-0A	ICP L111 OPT. INSULATOR	1295	T.I TIL111
U...11	24-10183-0A	ICP L111 OPT. INSULATOR	1295	T.I TIL111

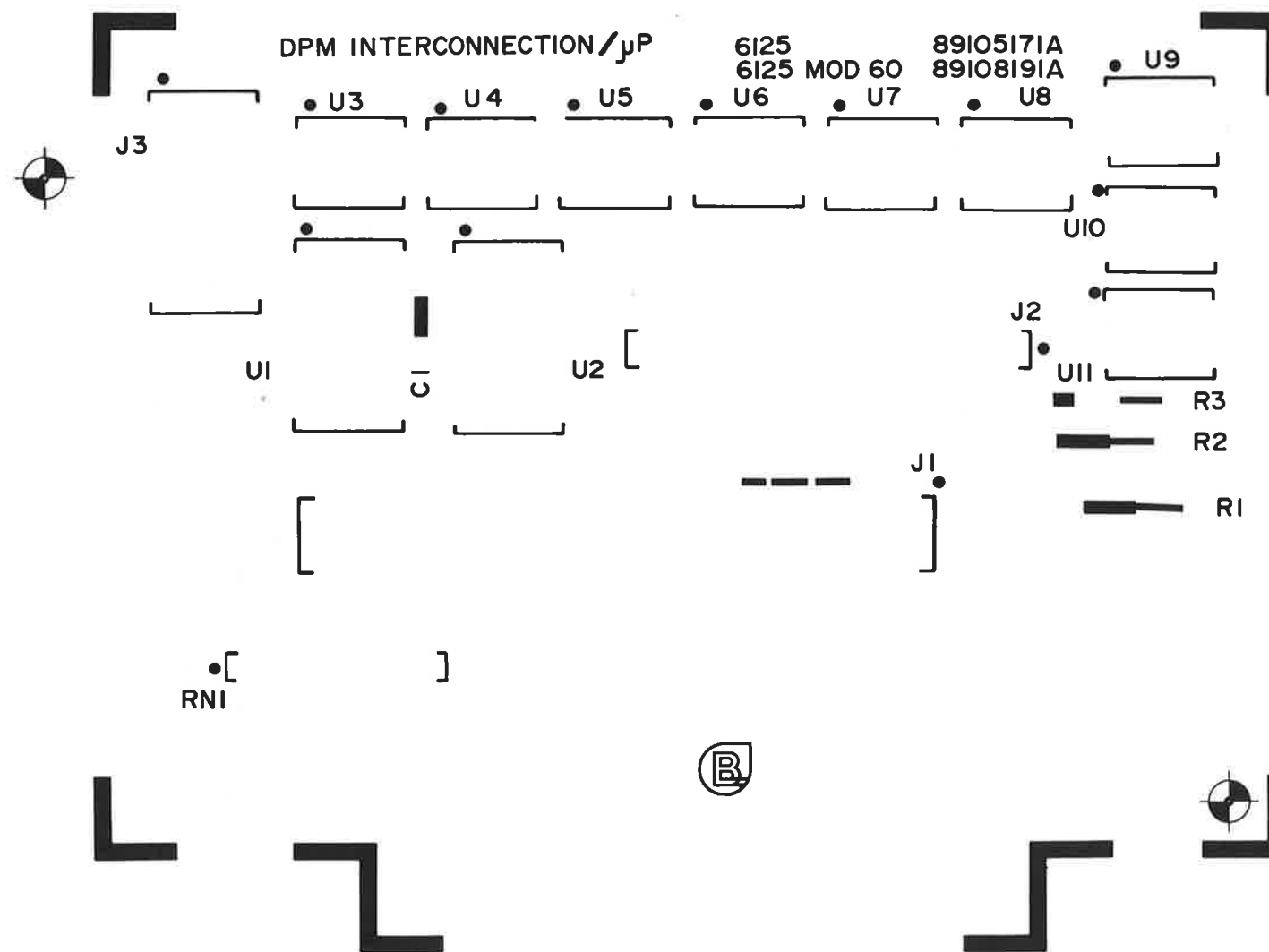

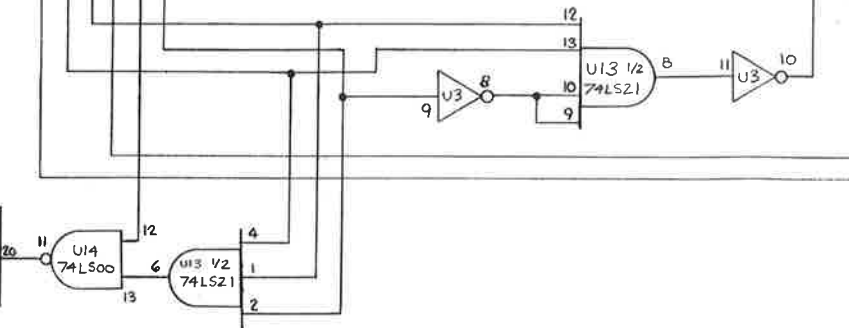
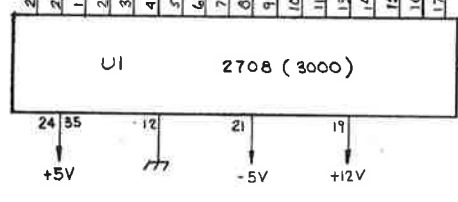
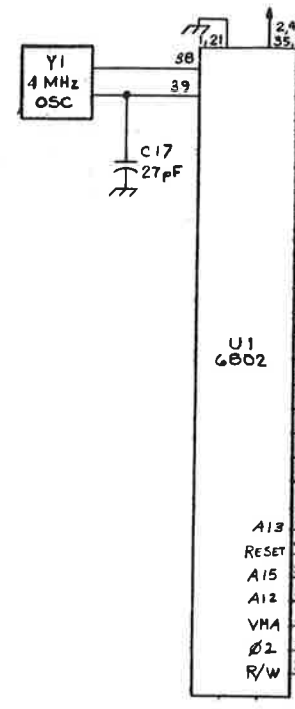
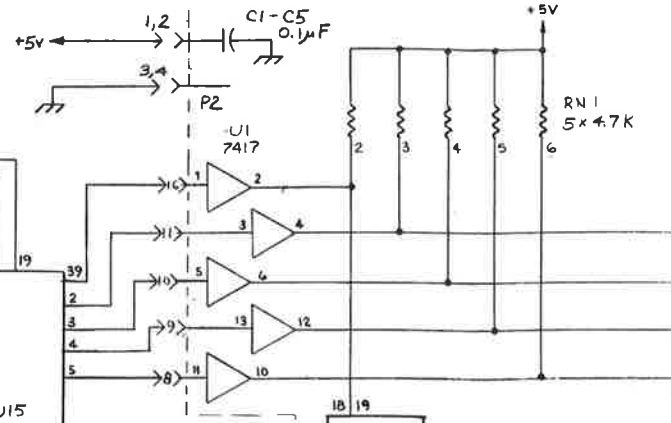
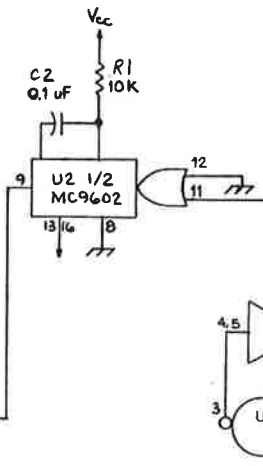
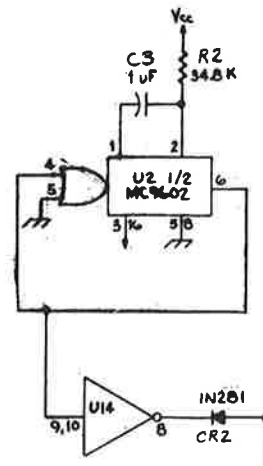
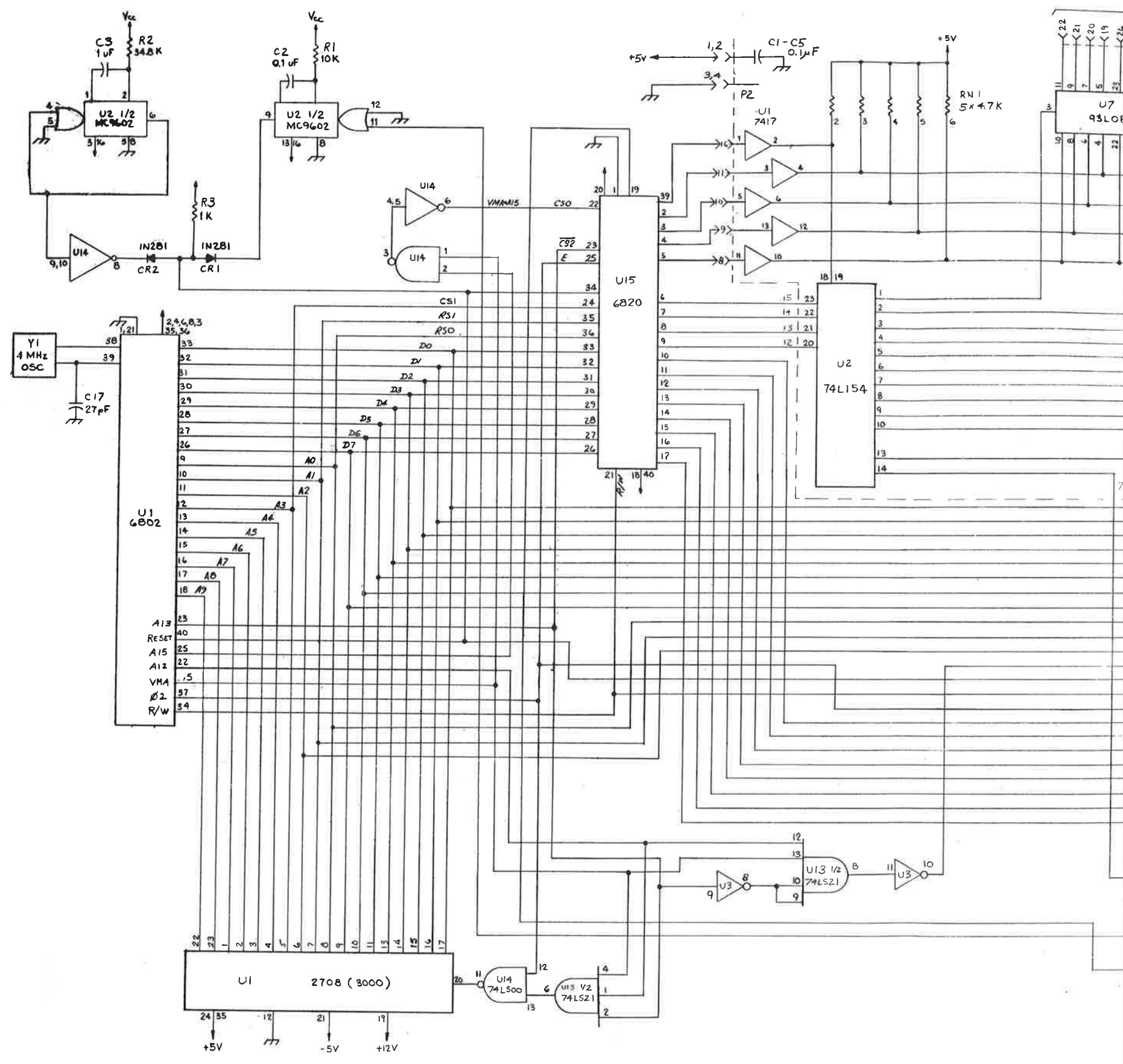

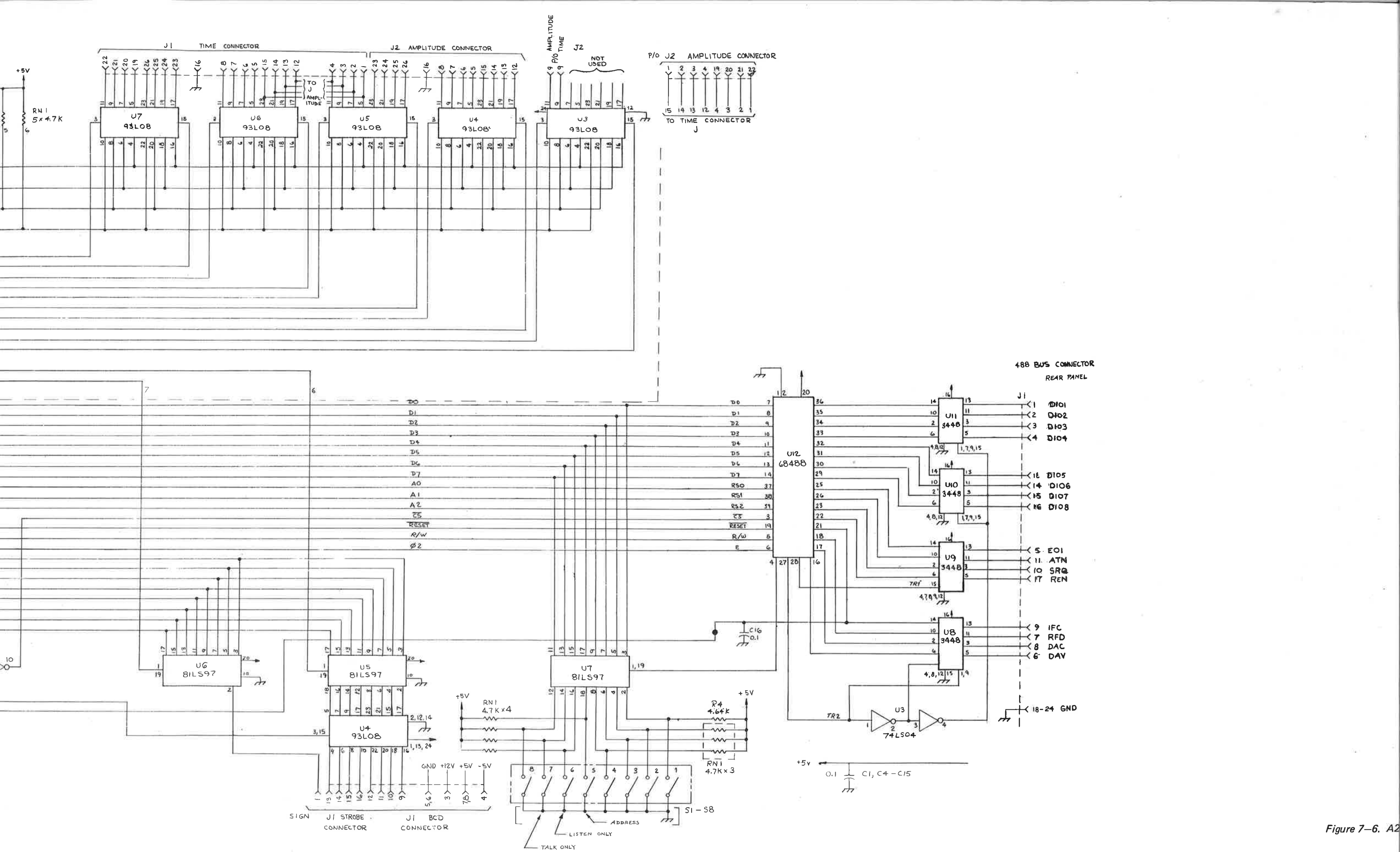

Figure 7-6. A2

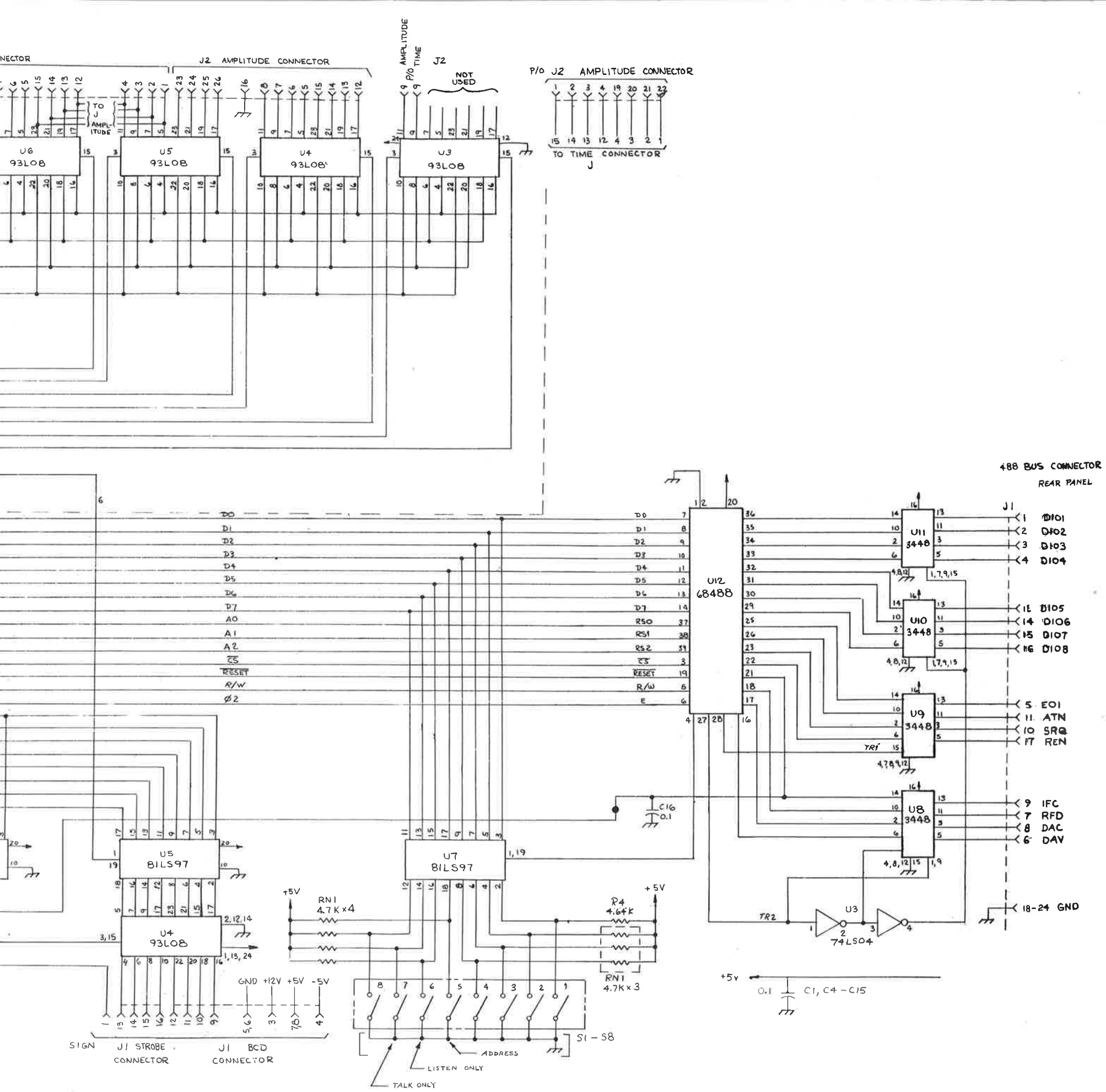
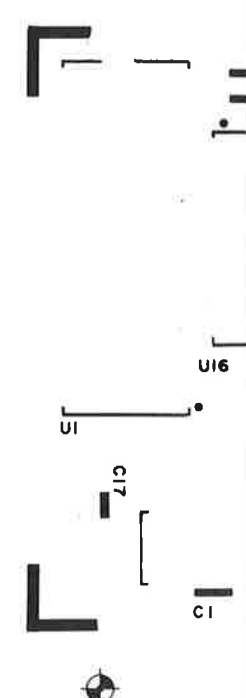

Figure 7-6. A28, A29, and A30 IEEE Bus, Option 60

PARTS LIST, A28 IEEE BUS ADAPTER MODEL 6125C-OPT.60 (89-10811-1A)

SCHEMATIC REF	BALLANTINE PART NO.	DESCRIPTION	MFR CODE	MFR PART NUMBER
C...1	07-10562-0A	CCR 0.1 UF 50V .3 SPACE	0	AVX CERAMICS MD015E104ZAA
C...2	07-10562-0A	CCR 0.1 UF 50V .3 SPACE	0	AVX CERAMICS MD015E104ZAA
C...3	07-09570-0A	CET 1 UF 25 V	56289	SPG TYP 5C023105X0250B3
C...4	07-10562-0A	CCR 0.1 UF 50V .3 SPACE	0	AVX CERAMICS MD015E104ZAA
C...5	07-10562-0A	CCR 0.1 UF 50V .3 SPACE	0	AVX CERAMICS MD015E104ZAA
C...6	07-10562-0A	CCR 0.1 UF 50V .3 SPACE	0	AVX CERAMICS MD015E104ZAA
C...7	07-10562-0A	CCR 0.1 UF 50V .3 SPACE	0	AVX CERAMICS MD015E104ZAA
C...8	07-10562-0A	CCR 0.1 UF 50V .3 SPACE	0	AVX CERAMICS MD015E104ZAA
C...9	07-10562-0A	CCR 0.1 UF 50V .3 SPACE	0	AVX CERAMICS MD015E104ZAA
C...10	07-10562-0A	CCR 0.1 UF 50V .3 SPACE	0	AVX CERAMICS MD015E104ZAA
C...11	07-10562-0A	CCR 0.1 UF 50V .3 SPACE	0	AVX CERAMICS MD015E104ZAA
C...12	07-10562-0A	CCR 0.1 UF 50V .3 SPACE	0	AVX CERAMICS MD015E104ZAA
C...13	07-10562-0A	CCR 0.1 UF 50V .3 SPACE	0	AVX CERAMICS MD015E104ZAA
C...14	07-10562-0A	CCR 0.1 UF 50V .3 SPACE	0	AVX CERAMICS MD015E104ZAA
C...15	07-10562-0A	CCR 0.1 UF 50V .3 SPACE	0	AVX CERAMICS MD015E104ZAA
C...16	07-10562-0A	CCR 0.1 UF 50V .3 SPACE	0	AVX CERAMICS MD015E104ZAA
C...17	07-20004-0A	CCD 27.OPF 500.0 VK +/-10%	71590	CTL DD-270
CR...2	05-10025-0A	DGP 1N 281 75 1A .08	15238	ITT GE D07
J...1	31-10203-0A	CON 16 DIGICLIP IN HOLDER	26364	COP CORP. MC-1A-16-100T
R...1	12-12400-0A	RFF 10.0 K 250.0MW F+- 1%	16299	CGW RN55D 1002 F
R...2	12-12452-0A	RFF 34.8 K 250.0MW F+- 1%	16299	CGW RN55D 3482 F
R...3	12-12300-0A	RFF 1.0 K 250 MW F+-1%	16299	CGW RN55D 1001 F
R...4	12-12364-0A	RFF 4.64K 250.0MW F+- 1%	16299	CGW RN55D 4641 F
R...5	12-12400-0A	RFF 10.0K 250.0MW F+-1%	16299	CGW RN55D 1002 F
RN...1	13-10051-0A	RNF 4.7 K 8PIN SIP 5%	80053	BECKMAN 764-1-R4.7K
S...1	25-10187-0A	SWC DIP SWC 8 POSITION	0	AMP 7000 SERIES 435166-5
U...1	24-10262-0A	ICP MC6802P 8 BIT MICRO	0	MOT MC6802P
U...2	24-10265-0A	ICP MC6802P DUAL RETRIGG OSH	4713	MOT MC6802P OR EQUAL
U...3	24-10142-0A	ICP 74LS04 HEX INV 14 DIP	1295	TI
U...4	24-10288-0A	ICP 93L08PC DUAL 4BIT LATCH	0	FAIRCHILD 93L08PC
U...5	24-10234-0A	ICP 81LS97 OCTAL DRIVER	12040	NAT'L SEMI.
U...6	24-10234-0A	ICP 81LS97 OCTAL DRIVER	12040	NAT'L SEMI.
U...7	24-10234-0A	ICP 81LS97 OCTAL DRIVER	12040	NAT'L SEMI.
U...8	24-10267-0A	ICP MC3448P QUAD BUS TRASIV	4713	MOT MC3448P OR EQUAL
U...9	24-10267-0A	ICP MC3448P QUAD BUS TRASIV	4713	MOT MC3448P OR EQUAL
U...10	24-10267-0A	ICP MC3448P QUAD BUS TRASIV	4713	MOT MC3448P OR EQUAL
U...11	24-10267-0A	ICP MC3448P QUAD BUS TRASIV	4713	MOT MC3448P OR EQUAL
U...12	24-10264-0A	ICP MC68488P GPI ADAPTER	4713	MOT MC68488P OR EQUAL
U...13	24-10268-0A	ICP 74LS21 DUAL 4 INP AND	1295	TI 74LS21 OR EQUAL
U...14	24-10145-0A	ICP 74LS00 QUAD NAND 14 DIP	1295	TI
U...15	24-10263-0A	ICP MC6820P PIA	4713	MOT MC6820P OR EQUAL
U...16	24-10266-1A	ICP MCM2708P 1024X8 PROM	4713	MOT MCM2708P OR EQUAL
Y...1	04-10021-0A	CRS 4 MHZ .01% H3W	0	CTS MP0 40



SCHEMATIC REF	BALLANTINE PART NO.	DESCRIPTION
C...1	07-09589-0A	CCD 100 NF 12 V M 20%
C...2	07-09589-0A	CCD 100 NF 12 V M 20%
C...3	07-09589-0A	CCD 100 NF 12 V M 20%
C...4	07-09589-0A	CCD 100 NF 12 V M 20%
C...5	07-09589-0A	CCD 100 NF 12 V M 20%
RN...1	13-10051-0A	RNF 4.7 K 8PIN SIP 5%
U...1	24-10085-0A	ICP SN7417N HEX BUF 15V COLL
U...2	24-10130-0A	ICP MC8311P 4 TO 16 MULTIPLX
U...3	24-10288-0A	ICP 93L08PC DUAL 4BIT LATCH
U...4	24-10288-0A	ICP 93L08PC DUAL 4BIT LATCH
U...5	24-10288-0A	ICP 93L08PC DUAL 4BIT LATCH
U...6	24-10288-0A	ICP 93L08PC DUAL 4BIT LATCH
U...7	24-10288-0A	ICP 93L08PC DUAL 4BIT LATCH

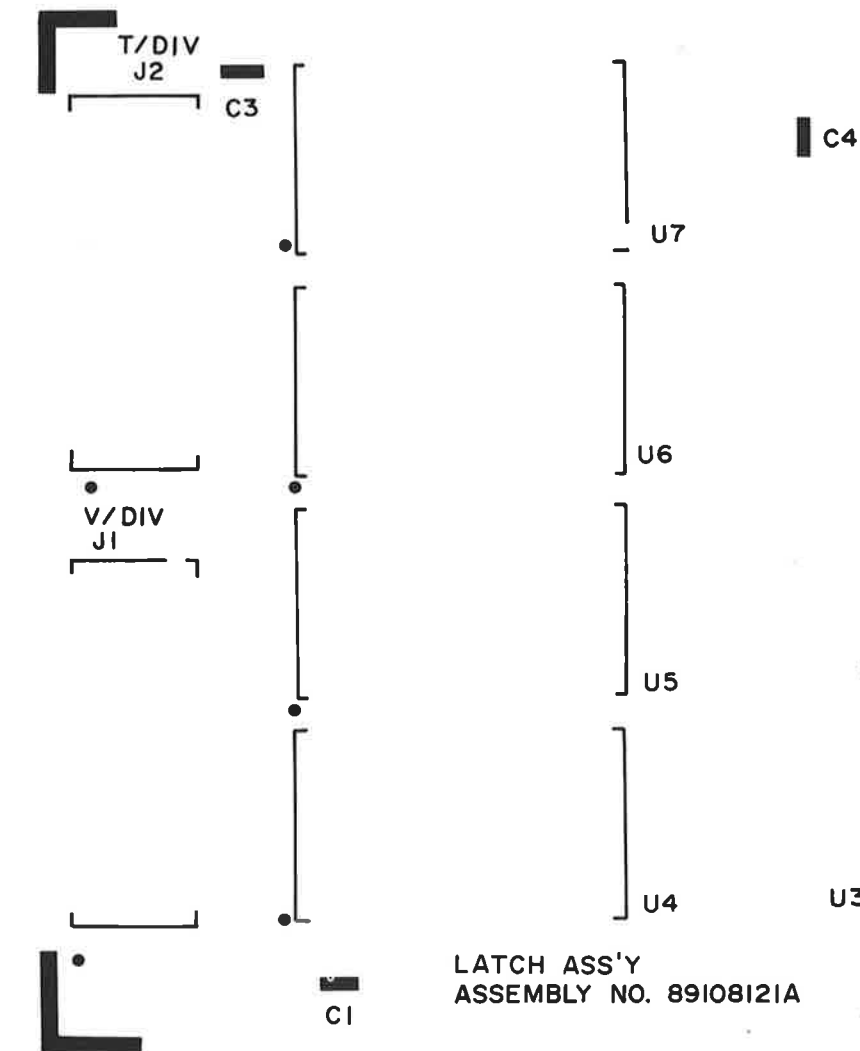
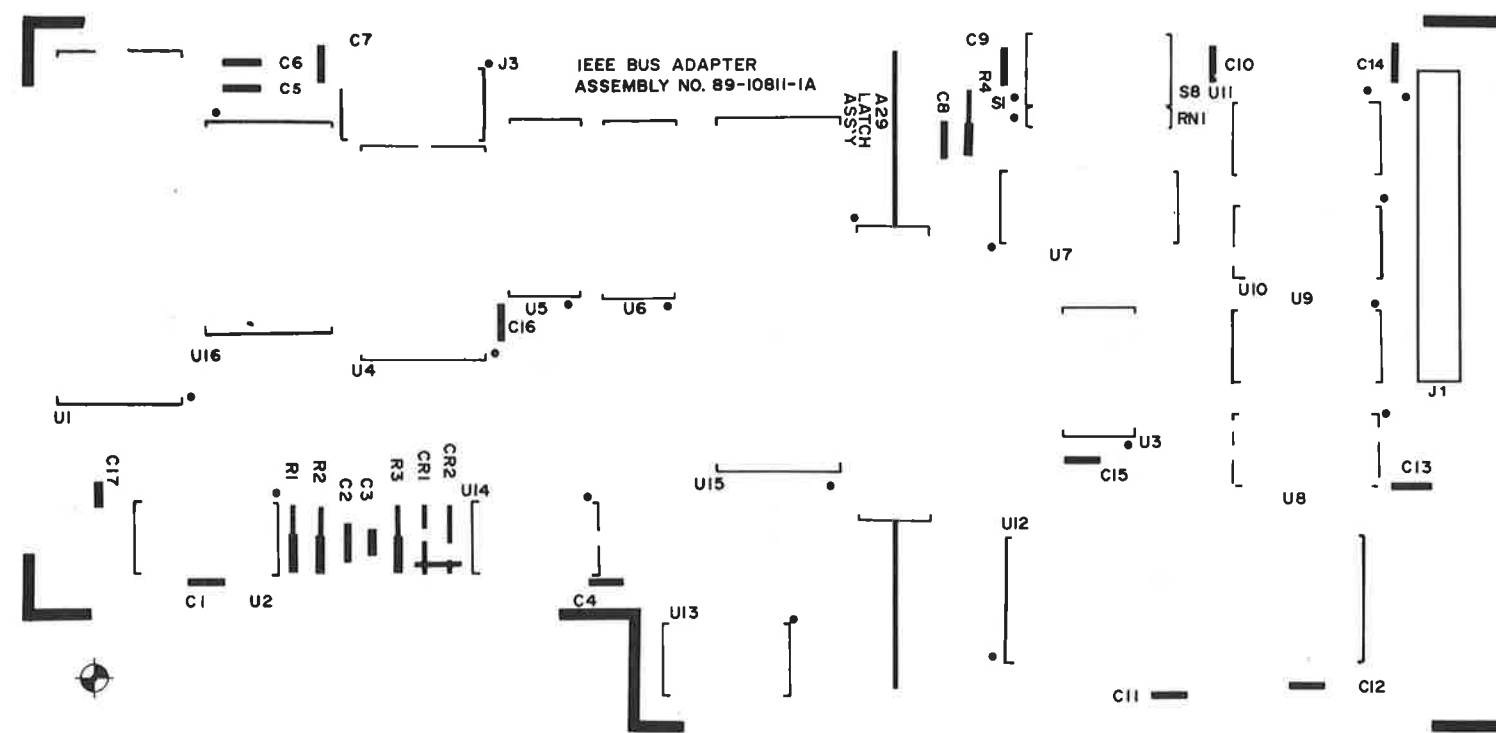

SCHEMATIC REF	BALLANTINE PART NO.	DESCRIPTION
J...1	31-10205-0A	CON 24 PIN BLUE RIBBON

PARTS LIST, A29 LATCH ASSEMBLY MODEL 6125C-OPT.60 (89-10812-1A)

SCHEMATIC REF	BALLANTINE PART NO.	DESCRIPTION	MFR CODE	MFR PART NUMBER
C...1	07-09589-0A	CCD 100 NF 12 V M 20%	90201	RMC TYP M-12-0.1
C...2	07-09589-0A	CCD 100 NF 12 V M 20%	90201	RMC TYP M-12-0.1
C...3	07-09589-0A	CCD 100 NF 12 V M 20%	90201	RMC TYP M-12-0.1
C...4	07-09589-0A	CCD 100 NF 12 V M 20%	90201	RMC TYP M-12-0.1
C...5	07-09589-0A	CCD 100 NF 12 V M 20%	90201	RMC TYP M-12-0.1
RN...1	13-10051-0A	RNF 4.7 K 8PIN SIP 5%	80053	BECKMAN 764-1-R4.7K
U...1	24-10085-0A	ICP SN7417N HEX BUF 15V COLL	33890	TI OR EQUIV
U...2	24-10130-0A	ICP MC8311P 4 TO 16 MULTIPLX	4713	MOT MC8311P
U...3	24-10288-0A	ICP 93L08PC DUAL 4BIT LATCH	0	FAIRCHILD 93L08PC
U...4	24-10288-0A	ICP 93L08PC DUAL 4BIT LATCH	0	FAIRCHILD 93L08PC
U...5	24-10288-0A	ICP 93L08PC DUAL 4BIT LATCH	0	FAIRCHILD 93L08PC
U...6	24-10288-0A	ICP 93L08PC DUAL 4BIT LATCH	0	FAIRCHILD 93L08PC
U...7	24-10288-0A	ICP 93L08PC DUAL 4BIT LATCH	0	FAIRCHILD 93L08PC

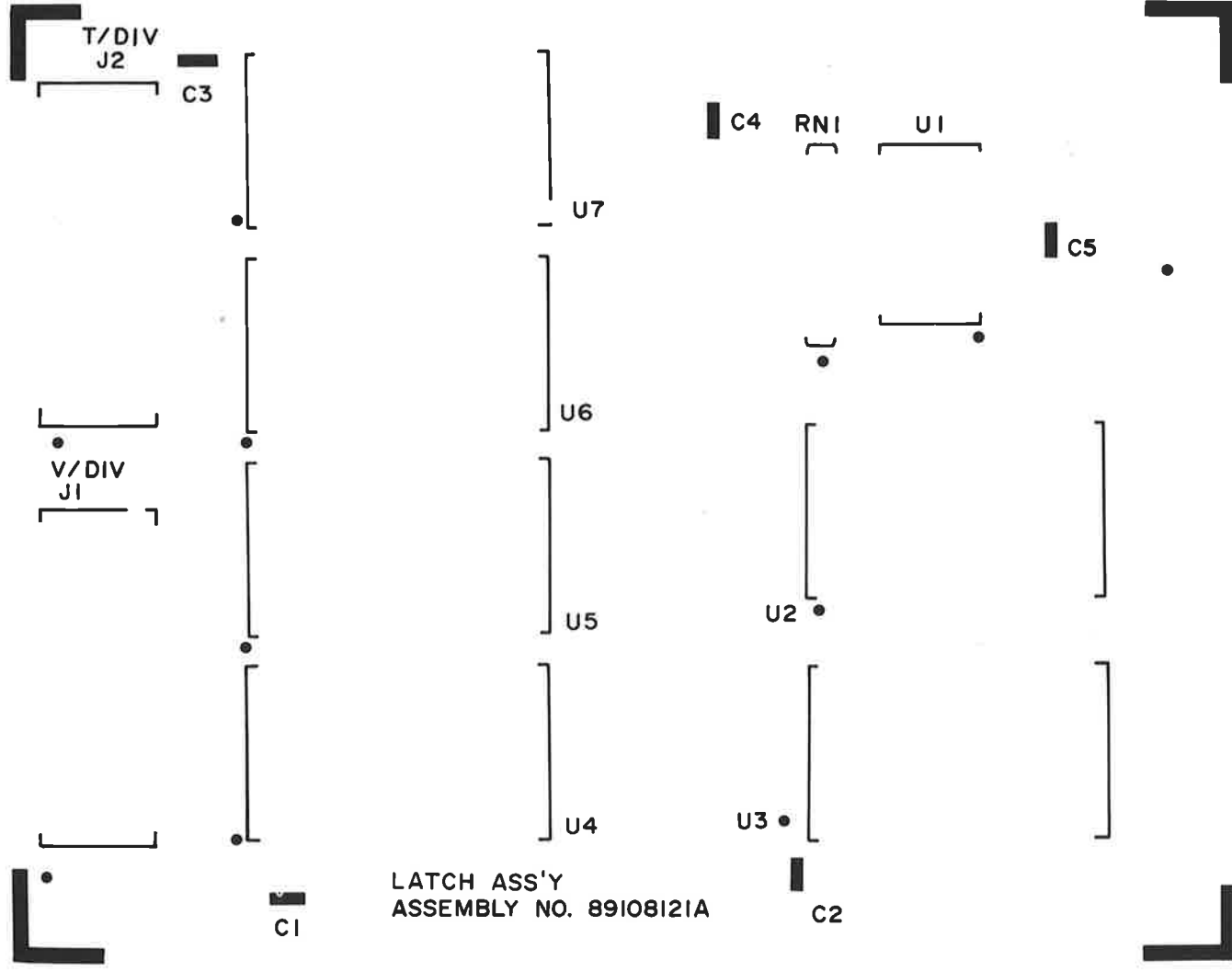
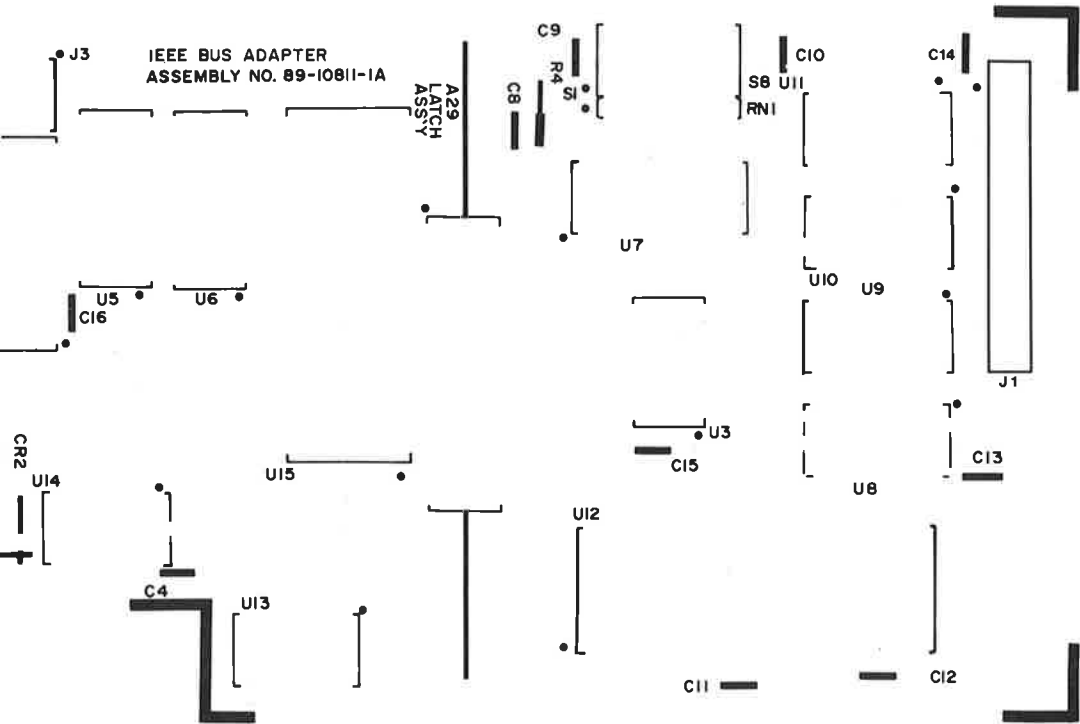

PARTS LIST, A30 IEEE BUS ADAPTER PLUG MODEL 6125C-OPT.60 (89-10813-1A)

SCHEMATIC REF	BALLANTINE PART NO.	DESCRIPTION	MFR CODE	MFR PART NUMBER
J...1	31-10205-0A	CON 24 PIN BLUE RIBBON	2260	AMPHENOL 57-20240-8

ADDENDUM

TO INSTRUCTION MANUAL:

MODEL No. 6125C

APPLICABLE TO ALL MODELS
#1 (90-10223-5B)

Page 5-14.

Paragraph 5-42e.

Change:

550 mV to 400 mV

Page 5-28.

5. HIGH FREQUENCY OUTPUT (Paragraph 5-13)

Change:

2 ns Amplitude (▷ 0.5 volt)

to

2 ns Amplitude (▷ 0.4 volt) -

ADDENDUM

TO INSTRUCTION MANUAL:

MODEL No. 6125B/C

Applies to Prefix code 022-
#2 (90-10223-5B)

Page 5-16.

Paragraph 5-47b.

Change to read:

b. Refer to Table 2-2 and program for maximum positive VOLTS DEVIATION by setting the input lines to logic "0" (ground). Adjust R14 for a reading of 13% on the % DEVIATION meter.

Paragraph 5-47c.

Change to read:

c. Refer to Table 2-2 and program for maximum negative TIME DEVIATION by setting the appropriate input lines of connector A10J1 to logic "1" (+5 volts). Adjust A10R4 for a reading on the % DEVIATION meter of 13%.

Paragraph 5-47d.

Change:

10.00 to 13%



Ballantine Laboratories, Inc.

PO. Box 97, Boonton, New Jersey 07005, U.S.A.

Telephone: 201-335-0900, TWX: 710-987-8380