

Draft: Controlled Circulation

personal copy for:

The items marked with this sign (•) are possibly new ideas which should not be disclosed before they are protected either by a patent application or by an official publication.

Proposal for instrumentation to calibrate DCCT's up to 24 kA

Introduction

The zero flux DC Current Transformer (DCCT) originated in CERN about 25 years ago. It was developed as an instrument to measure beam currents, but the potential applications of measuring and regulating the electric currents in beam transport magnets are already mentioned in the first publications [1][2]. The development work in CERN was always limited to beam instrumentation, with priorities on high resolution, fast response and large dynamic range. Beam currents covered the range from μA to 60 A. Beam lifetime measurements required a resolution of a few ppm (parts per million).

This technology has many potential applications and is specially interesting for very high precision current measurements in the standards laboratories. Beam current monitors, developed at CERN in 1981 [3] and again in 1990 [4], became national primary standards in Germany, certified and operated by the PTB in Berlin.

This note makes use of the existing know-how to present a new solution for precision current measurements in the SL-PC standards laboratory, with full scale ranges from 12 mA to 24 kA. The same technique could later be used to control the magnet currents in the LHC.

A programmable precision current source

The proposed primary standard for the SL-PC calibration laboratory is a precision current source. The nominal full-scale current range is ± 6 A but any other current range is possible. The output current value is obtained by multiplying a primary reference current in a precision dc ratio transformer. Digital programming of the output polarity and current value is in binary steps (27 bits or less). With reference to the conventional Digital to Analog Converter (DAC), this instrument will be called I-DAC. It should be a portable unit, which can be used in any location on the site, without any special precautions.

Primary current reference:

The primary current reference itself should have very low noise and a long-term stability of better than 1 ppm per year. This is a realistic specification when using the best available standard resistors, the best voltage references and a high quality operational amplifier to build

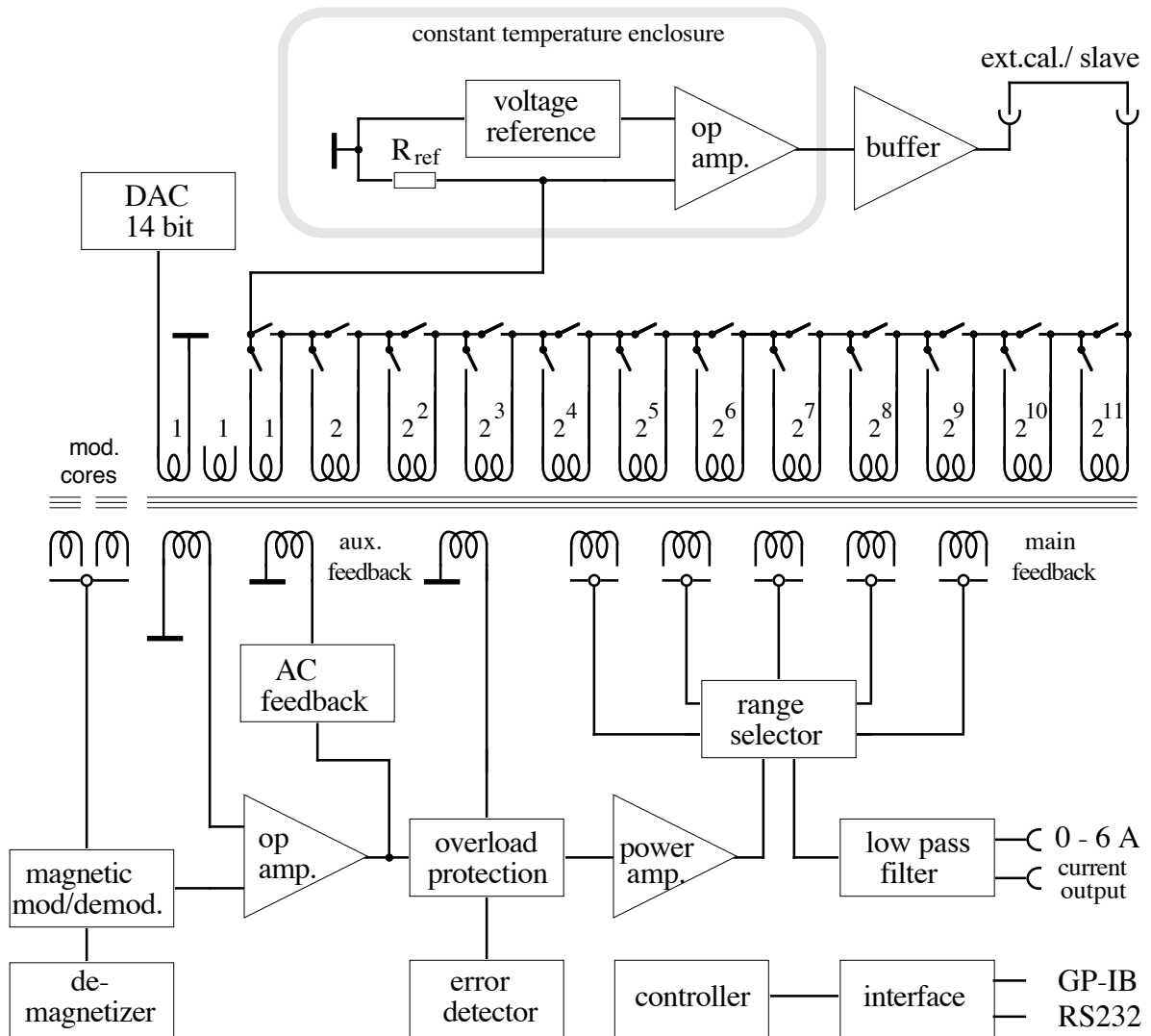

Fig. 1 Simplified schematic of programmable current source (I-DAC). Polarity reversal is not shown.

this current source (Fig.1). The reference resistors, the voltage, references and the amplifier have to be individually selected by monitoring their characteristics as a function of temperature and time. The resistor R_{ref} (1000 Ω) will probably consist of several matched components and the voltage reference will be the mean value of several subsurface Zener diodes (ultra precision reference: LTZ1000, Linear Technology, nominal output: ≈ 7.1 V). The reference current is therefore about 7 mA and the (constant) power dissipation in the resistor R_{ref} is 50 mW. All elements of the primary current reference are kept in a constant temperature enclosure.

- By using a Peltier element for heating or cooling, the temperature in this enclosure can be kept very close to the average room temperature ($\approx 25^\circ\text{C}$). This should help to reduce the long-term drift of the reference current source, which is expected to double for every 10 $^\circ\text{C}$ of increase of the operating temperature.

DC ratio transformer:

A programmable dc ratio transformer is used for scaling the output current. The turns ratio is selected by relay switches. The contact resistance and the thermal EMF's of these switches have no effect on the precision of the current ratio. The basic operating principle is very similar to the Kuster's bridge, but there are a number of significant improvements:

- It uses not only a simple magnetic modulator, but a true zero flux dc current transformer (Parametric Current Transformer - PCT [4]). The frequency response is therefore at least 4 orders of magnitude faster (≈ 100 kHz), an important condition to maintain (with the feedback) the ampere-turn balance even for fast current changes and to obtain an acceptable settling time for the final ppm level.
- The modulation frequency is about 7kHz or higher (50 Hz in the Kuster's bridge) and any residual modulation ripple in the output current can be eliminated with a passive low-pass filter.
- The dc-bias in the inductors of this ripple filter can be compensated, if the out-going and returning current circulate in different windings on the same magnetic cores.
- An overload protection circuit senses any error in the output current path, for example when the upper limit of the output voltage is exceeded (load resistance too high). The ampere-turn balance will be maintained (to prevent any magnetic memory effect) via an auxiliary feedback winding. These conditions will give an error indication, but normal operation is automatically resumed, if the faults are corrected.
- Only 12 ratio-windings with a binary weighting are used. They provide the 12 most significant bits plus one polarity bit. About 5 times as many separate windings are required for the 7-decade range of the Kuster's bridge.
- The interpolation for the 14 least significant bits comes from a conventional DAC feeding a single-turn winding.
- AC feedback in the auxiliary feedback winding provides a smooth ramping of the output current from the old setting to any new value, eliminating glitches which could be caused by the timing uncertainties of the relay switches.

Dynamic range:

The maximum current per turn is $7 \text{ mA} \times 4096 = 28.672 \text{ Aturns}$. The noise is estimated [4] to be less than $1 \mu\text{A turn}$ (for 1 second integration). The dynamic range of the ratio transformer alone is therefore better than $1 : \pm 28\,000\,000$ corresponding to a DAC with about 25 bits plus one polarity bit.

The output current can be scaled independently for any full scale range from 12 mA to 24 A. This scaling is a function of the number of feedback turns. A 4 turn feedback winding yields a full scale range of 6 A (with 20 % over-range capability).

Output amplifier:

The output amplifier has to provide a current of ± 6 A (+ 20 % over-range) with at least ± 20 V (better ± 40 V) output swing. This amplifier is part of the high gain feedback loop of the ratio transformer and has to maintain the ampere-turn balance.

- The ac feedback mentioned earlier bypasses the power amplifier stage and improves the phase-margin at higher frequencies.

Controller and interface:

All functions of the I-DAC are controlled by the built-in microprocessor. No attempt is made for analog adjustments in any of the circuits of the instrument. The calibration constants and correction factors are stored in a permanent memory. The temperature effects of the different components are stored in look-up tables. It is the function of the controller to interpret external control commands and apply all relevant corrections before executing the corresponding actions. The controller will either automatically or on request perform a number of self-test and calibration routines to insure data integrity.

Error budget:

The ratio error of the dc transformer is very small, probably less than 0.01 ppm, provided the loop gain of the system is higher than 160 dB. A loop gain of only 120 dB is required to keep the linearity error below 0.01 ppm. The magnitude of the loop gain will be automatically tested during the self-calibration routines. Leakage currents have to be kept below 0.01 ppm of the operating currents and this requires great care in insulation and proper guarding technics. The remaining errors in the current scaling are: the zero offset, the noise and the zero drift of the magnetic modulator. External magnetic fields including the earth's magnetic field will cause an additional zero offset. The ratio transformer therefore needs a very effective magnetic screen. A stable zero offset can be eliminated by a self-calibration routine. The magnetic noise of a good modulator core pair is $\approx 1 \mu\text{A turn}$ (1 second integration) and the temperature drift of the zero error is between 2 to 8 $\mu\text{A turns}$ for 1 °C [4].

- Temperature sensors in different parts of the instrument can be used for temperature compensation.

With temperature compensation, the remaining zero error and noise should be less than 4 $\mu\text{A turns}$ or less than 1 μA for the 6 A full scale range (4 feedback turns), corresponding to less than 0.2 ppm. The total uncertainty of the programmable current source is therefore:

I-DAC current: Uncertainty of the primary reference current source + 0.2 ppm

The primary reference current source itself is traceable to the primary standards of the national calibration laboratories.

A reference dc ratio transformer (24 kA range extender)

A reference dc ratio transformer is used to extend the current range of the of the I-DAC to more than 24 kA. This is a Parametric Current Transformer (PCT)[4] with a composite magnetic toroid, containing a magnetic modulator and a zero flux core. The mean diameter of the magnetic toroid is 250 to 400 mm, depending on the required full scale range. The ratio error of the reference dc ratio transformer is less than 0.01 ppm, provided that:

- a.) zero flux conditions are maintained around the entire circumference of the transformer core
- b.) the loop gain of the system is higher than 160 dB at dc.
- c.) leakage currents are less than 0.01 ppm of the operating currents

The zero offset, if less than 100 μA , is insignificant for currents beyond 5 kA (error less than 0.02 ppm), but external magnetic fields (in the vicinity of bus bars) can increase this offset by a very large amount. Effective magnetic shielding is therefore of crucial importance and the shield has to be placed inside the compensating winding, which is a zero flux space in respect of the current to be measured. The composite magnetic shield has to consist of many independent layers which must completely surround the magnetic modulator. The outermost layer will consist of 2 toroidal halve-shells of Armco steel, with sufficient cross-section as not to saturate at the highest field levels to be encountered.

- The multiple and separate inner layers of the magnetic shield will consist of amorphous magnetic foils (Vitrovac) and will serve, at the same time, as the zero flux core of the dc current transformer.
- the ac losses of the solid Armco steel casing will be used to damp the resonances of the feedback winding.

For a 24 kA full scale range, a feedback winding with 4000 turns is required. It will preferably consist of 2 separate windings of 2000 turns each, offering the possibility to test the ratio accuracy. In addition, this will allow to test the reference dc current transformer by applying a test current (for example with an I-DAC) to one of these windings and using only the other in the feedback loop (12 kA range). This is important for functional tests in the electronic laboratory, where the high current power supply is not readily available.

Different full scale ranges are possible by choosing the corresponding number of feedback turns. If 12 separate windings with binary weighting are chosen, the total feedback would be 4096 turns. Designed for a max. load current of 6 A, these feedback windings occupy a considerable space within the aperture of the toroidal core. It is one of our design goals to reduce the (preferably circular) cross-section of the composite magnetic toroid to a minimum, to keep the average length of one turn and the ohmic resistance of the feedback windings small.

The 24 kA range extender will increase the total error budget of the current measurement by less than 0.02 ppm, if the magnetic shield has the required quality. This should be technically possible and it can easily be verified by measuring the zero offset as a function of the highest expected external field level.

Application of the I-DAC in the calibration laboratory

The proposed set up for calibration of DCCT's is shown in Fig. 2. The I-DAC A sets the reference current $i_{ref A}$ and controls via the (20 kA) power supply the calibration current i_{cal} . This current is measured with the reference DCCT and a (scaled down) compensation current $i_{comp A}$ is compared with the original reference current $i_{ref A}$. The difference i_{RL} between these 2 currents has to flow into the load resistor and will give an error indication and a reading on the digital voltmeter DVM A, which is a measure of the actual deviation from the selected value of calibration current i_{cal} .

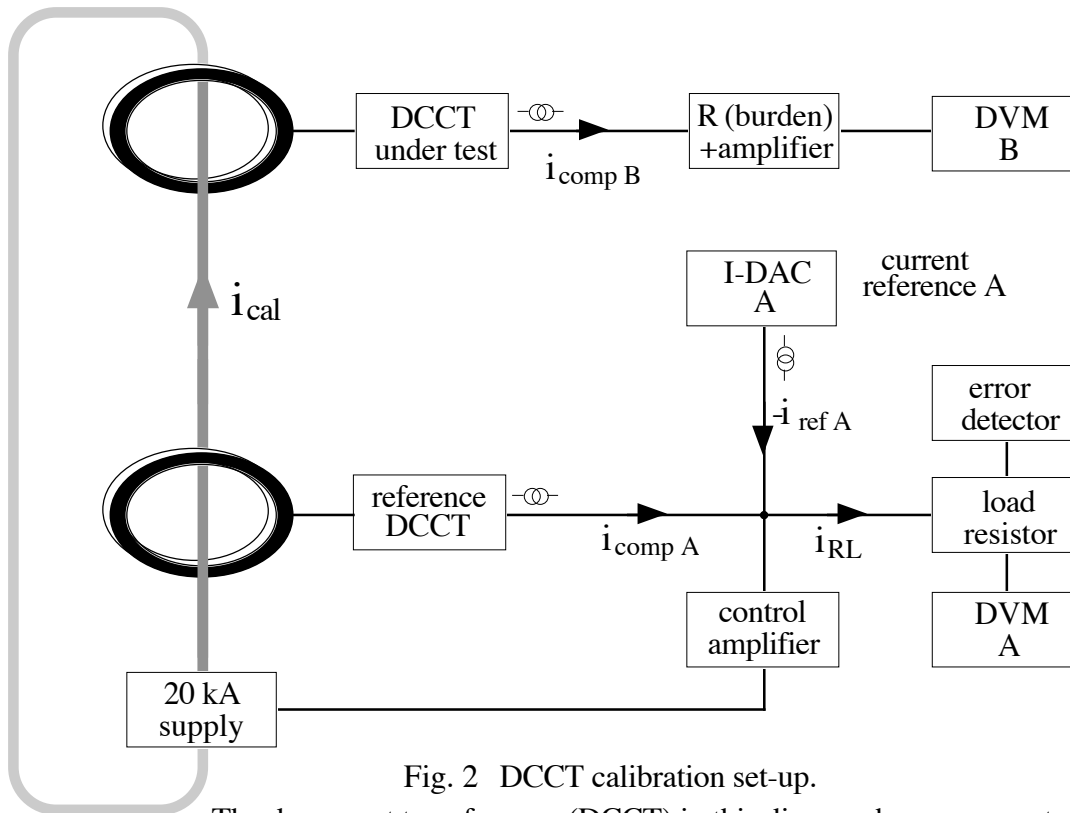

Fig. 2 DCCT calibration set-up.

The dc current transformers (DCCT) in this diagram have a current output and require an external load resistor (burden resistor). The arrows indicate the functional current flow and not the polarity.

It is not necessary for the high current regulation circuit, to follow the power supply control with absolute precision and this is one of the advantages of this scheme. The exact value of i_{cal} is always known by correcting the theoretical setting of I-DAC A with the error value indicated by the digital voltmeter DVM A. If this error value is kept small, the tolerance of the load resistor has a correspondingly small effect. Thermal EMF's in respect of the DVM readings have to be considered. They should not be a problem, because the dissipation in the load resistor is small and the sensitivity of the measurement could be increased by (automatic) switching to a higher value of load resistance. Polarity reversal of i_{cal} is also possible.

The DCCT under test can be measured in the classical way by connecting a digital voltmeter (DVM B) to its output. In this case, it is probably this digital voltmeter which is the largest source of error in the measurement system.

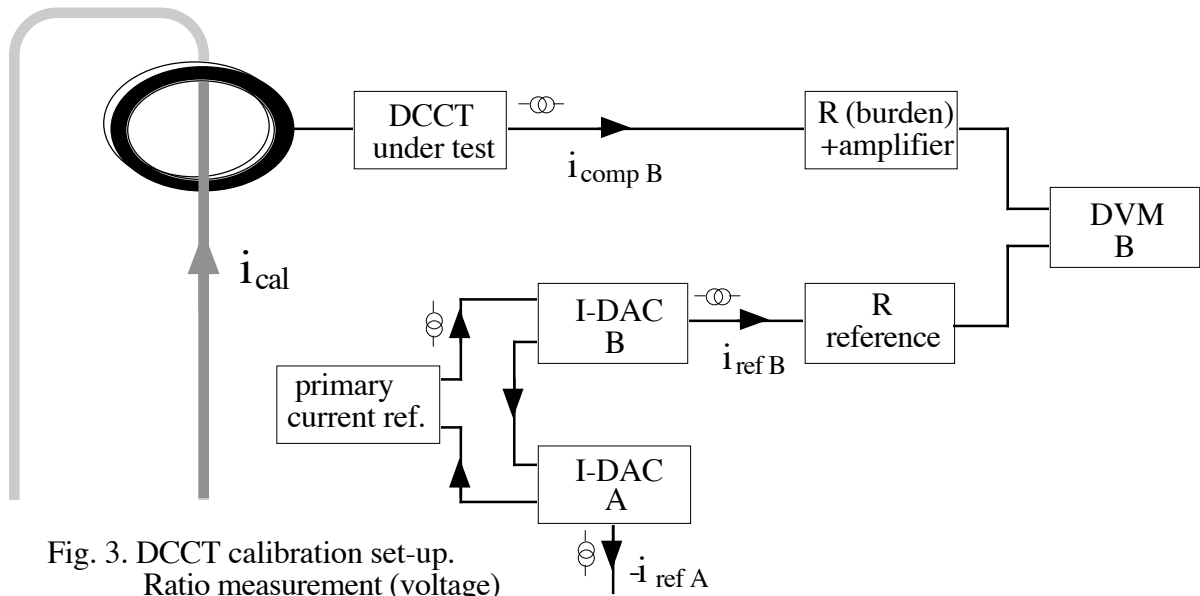

Fig. 3. DCCT calibration set-up.
Ratio measurement (voltage)

For higher accuracy requirements, the set-up in fig. 3 is preferred. The two I-DAC's (A and B) have a common primary current reference. They form together a dual programmable current source which supplies two independent output currents ($i_{ref A}$ and $i_{ref B}$), with a resolution and ratio uncertainty expected to be better than 0.2 ppm. The current ($i_{ref A}$) controls as in fig. 2 the high current power supply and the calibration current (i_{cal}). A stable and precise reference resistor ($R_{reference}$, 1 to 10 k Ω) makes with $i_{ref B}$ a reference voltage source, which should track the output signal of the burden resistor.

This is a ratio measurement which does not rely on the absolute precision or the stability of the primary current reference. The major error source is expected to be the reference resistor and thermal EMF's at the input of the digital voltmeter (DVM B), which is used in this example as a calibrated balance indicator.

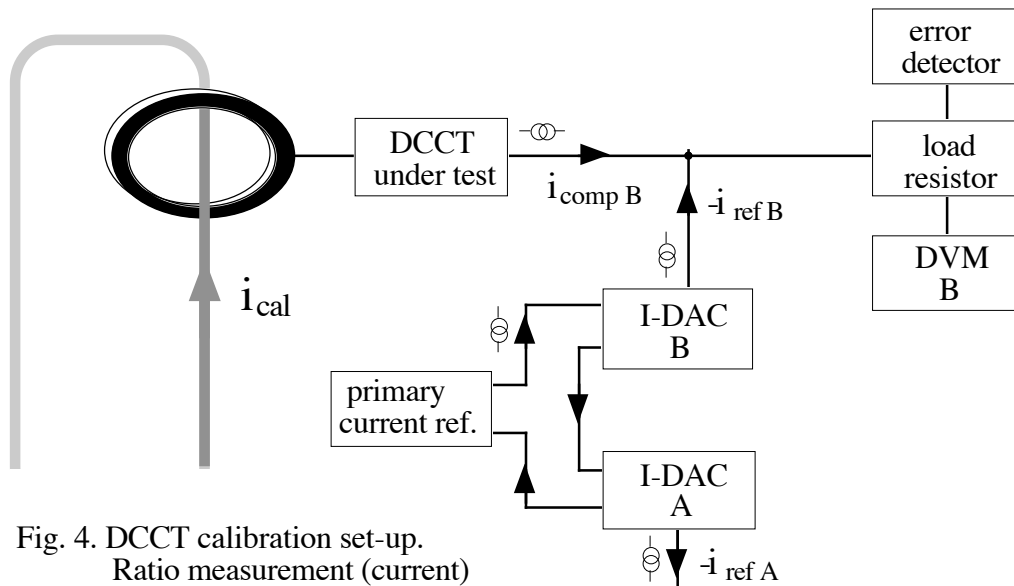

Fig. 4. DCCT calibration set-up.
Ratio measurement (current)

A DCCT without the burden resistor can be calibrated in the set-up of Fig. 4. Current control and measurements rely here exclusively on the I-DAC's current ratio and no other reference element

is required. The measurement uncertainty (expected to be less than 0.2 ppm) is lower than in the examples given before.

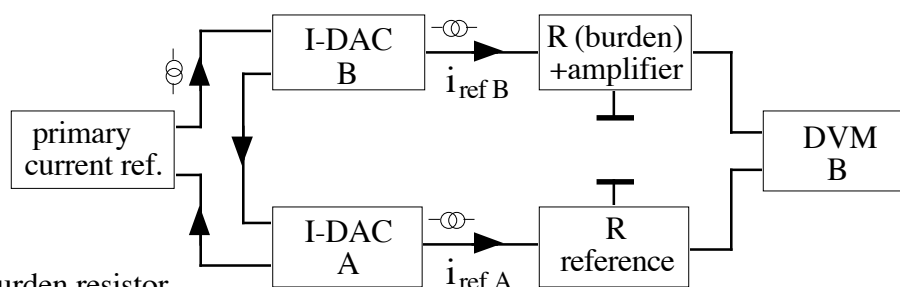

Fig. 5.
Calibration of burden resistor
Ratio measurement (voltage)

The I-DAC's can be used to calibrate the burden resistors directly (Fig. 5). The same configuration can be used as a general purpose transfer standard in the SL-PC calibration laboratory. The important feature is the independent programming of 2 galvanically isolated current sources ($i_{ref A}$ and $i_{ref B}$). Because it permits computer control, this is expected to replace the manually operated Kuster's bridge. The automation of calibration and measurements routines is considered today an absolute necessity to assure repeatability and reliability at this level of precision.

Calibration

The calibration of a standards laboratory instrument is a project by itself. Only a few basic ideas will be outlined. The primary current reference will be calibrated against the the best available voltage and resistance standards in house. It has later to be certified by a national standards laboratory. The most important issue is the stability of calibration in time and in respect of environmental effects. A certain number of current sources should be built and monitored over a time span from 6 months to several years.

The target specification for the primary current reference:

Uncertainty and noise: less than 1 ppm, with a long term drift of less than 0.5 ppm per year.

The error margin of the dc ratio transformers (including the 24 kA unit) have to be determined with a number of specific tests:

- A.) The zero (offset) errors have to be measured in respect of all environmental and operational conditions, for example temperature, barometric pressure, time, recovery from overload, external magnetic fields, mains variations etc.
- B.) Loop gain and frequency response (bode plot) will be measured by injecting test current signals into the feedback windings.
- C.) The upper limit of the ratio uncertainty can be determined with the following 2 experiments:
 - 1.) The weight of each ratio winding will be measured precisely by inter-comparison. An individual winding or a group of windings (adding together all the lower bit weights) are

compared with the next winding of the same bit weight by passing the same test current in opposite directions. At first the 2 one-unit windings are compared. The next step is the comparison of the sum of 2 one-unit windings with the two-unit winding. This test will continue in a similar fashion until all ratio windings are intercompared. Any deviation from zero offset which are detected at each step should be measured in A turns and divided by the nominal full scale range (24 A turns) to obtain the corresponding ratio error.

- 2.) The same test should be made with 2 identical test windings, covering each less than 1/16 of the total circumference. They occupy opposite positions on the toroid. This is a worst case situation and the measured error (A turns) in the comparison of these 2 special windings is an indication of the tolerance to imperfections in the distribution of the ratio windings around the circumference of the toroid.
- D.) The Kuster's bridge will be used for an independent verification of the ratio accuracy of the I-DAC.

Final remarks

Future developments could increase the programming speed of the I-DAC by replacing the relays with semiconductor switches. Such a device should be used to control directly the power supplies of the LHC magnets. Control and measurement of the magnet currents would no longer require the conversion from current to voltage with a (burden) resistor, eliminating the elements which are suspected to have the most important contribution to the final error budget.

This proposal was discussed with many members of the SL-PC group. The comments and suggestions, especially from G. Fernqvist and J. Pett contributed certainly to improve the content and the presentation of this note.

References

- [1] K. B. Unser, "Beam current transformer with DC to 200 MHz range", IEEE Trans. Nucl. Sci., NS-16, June 1969, pp. 934-938.
- [2] "High Precision DC Beam Current Transformer with Extended Frequency Range". CERN Technology Note B11 (March 1974)
- [3]. K. B. Unser, "A toroidal DC beam current transformer with high resolution", IEEE Trans. Nucl. Sci., NS-28, No. 3, June 1981, pp. 2344-2346.
- [4] K. B. Unser, "The Parametric Current Transformer, a beam current monitor developed for LEP" 1991 Accelerator Instrumentation Workshop, Newport News, March 1991, AIP