

DATA PROOF

OPERATING MANUAL

160A AND 320A

© Copyright DATA PROOF 1984
1950 POLK CT, MOUNTAIN VIEW, CA 94040
Telephone (415) 967-7195

IBM 925 1675 HT BASIC
TRANS error 800

VERMT - IBM OPTION 3 1625

286 receiver
works AT

CERTIFICATION

Data Proof certifies that this product was thoroughly tested and inspected and found to meet its published specifications when it was shipped from the factory.

WARRANTY

This product is warranted against defects in materials and workmanship for a period of one year from date of shipment. During the warranty period, Data Proof will, at its option, either repair or replace products which prove to be defective.

SERVICE

For warranty service or repair this product must be returned to the factory in Mountain View, Calif. The Buyer shall prepay shipping charges to Data Proof and Data Proof shall pay surface shipping charges to return the product to the Buyer. Permission must be obtained directly from the factory for warranty repair returns.

LIMITATIONS

The foregoing warranty shall not apply to defects resulting from improper or inadequate maintenance by the Buyer, or unauthorized modifications or misuse.

NO OTHER WARRANTY IS EXPRESSED OR IMPLIED

TABLE OF CONTENTS

SECTION	I: GENERAL DESCRIPTION	PAGE
1.1	DESCRIPTION	1-1
1.2	SPECIFICATIONS	1-2
1.3	REAR PANEL CONNECTIONS	1-3
1.4	STANDARD CELL PROTECTION SYSTEMS	1-3
SECTION II: INSTALLATION		PAGE
2.1	INITIAL INSPECTION	2-1
2.2	POWER REQUIREMENTS	2-1
2.3	LOCATION	2-1
SECTION III: OPERATION		PAGE
3.1	FRONT PANEL CONTROLS AND INDICATORS	3-1
3.2	REAR PANEL CONNECTIONS	3-2
3.3	FRONT PANEL OPERATION	3-3
3.4	OPERATION FROM INTERFACE BUS	3-3
3.5	RETURNING TO LOCAL	3-4
3.6	ADDRESS SELECTION	3-5
3.7	SAMPLE PROGRAMS	3-6
3.8	REMOTE LOCK	3-7
3.9	SERIES PROTECTION FOR MULTIPLE SCANNERS	3-7
SECTION IV: THEORY OF OPERATION		PAGE
4.0	INTRODUCTION	4-1
4.1	LATCHING RELAY	4-1
4.2	SCANNER CONFIGURATION	4-2
4.3	LOGIC CIRCUITS	4-3
4.4	STANDARD CELL PROTECTION	4-3
4.5	ISOTHERMAL BOX	4-4
4.6	NBS PROCEDURE FOR MEASURING CELLS	4-5
4.7	TEST RESULTS	4-6

TABLE OF CONTENTS (CONT'D)

SECTION V: MAINTENANCE AND TROUBLE SHOOTING	PAGE
5.0 PERIODIC MAINTENANCE	5-1
5.1 RELAY FAILURES	5-1
5.2 NOISY READINGS	5-1
5.3 SERIES PROTECTION LINE FAILURE	5-1
5.4 LOCATING SERIES PROTECT LINE FAILURE, PROTECT DEFEAT METHOD	5-2
5.5 LOCATING SERIES PROTECT LINE FAILURE, DIRECT METHOD	5-3
5.6 LOCATING THE CHANNEL RELAYS	5-4
5.7 REPLACING RELAYS	5-4
5.8 RELAY ADJUSTMENTS	5-5

SECTION VI: CIRCUIT DIAGRAMS AND REPLACEMENT PARTS LISTS	PAGE
6.1 INTRODUCTION	6-1
6.2 OBTAINING REPLACEMENT PARTS	6-1
6.3 ORDERING INFORMATION	6-1
6.4 NON-LISTED PARTS	6-1

CIRCUIT DIAGRAMS AND PARTS LISTS

160A SWITCH BOARD DIAGRAM	6-2
160A SWITCH BOARDS PARTS LIST	6-3
320A SWITCH BOARD DIAGRAM	6-4
320A SWITCH BOARDS PARTS LIST	6-5
CONTROL BOARD PARTS LIST	6-6
CONTROL BOARD DIAGRAM	6-7
BUS INTERFACE BOARD PARTS LIST	6-8
BUS INTERFACE BOARD DIAGRAM	6-9
CLOSE CIRCUIT PARTS LIST	6-10
CLOSE CIRCUIT BOARD DIAGRAM	6-11
CLEAR CIRCUIT PARTS LIST	6-12
CLEAR CIRCUIT BOARD DIAGRAM	6-13
RELAY BOARD PARTS LIST	6-14
RELAY BOARD DIAGRAM	6-15
POWER SUPPLY PARTS LIST	6-16
POWER SUPPLY CIRCUIT DIAGRAM	6-17
PARTS LOCATED ON REAR PANEL	6-18
PARTS LOCATED ON CHASSIS	6-18

SECTION I
GENERAL INFORMATION

1.1 DESCRIPTION

This scanner is designed specifically to aid in the measurement of groups of standard cells using the method recommended by NBS. It can also be used anywhere low thermal low current switching is required such as thermocouple measurements, potentiometer connections, etc. Special care has been taken to minimize thermals. The switches used are latching relays requiring only a few millisecond pulse to actuate. Several systems are used to help protect the cells from being damaged by operator error or scanner failure. It can be operated from the front panel or by commands sent over the general purpose interface bus.

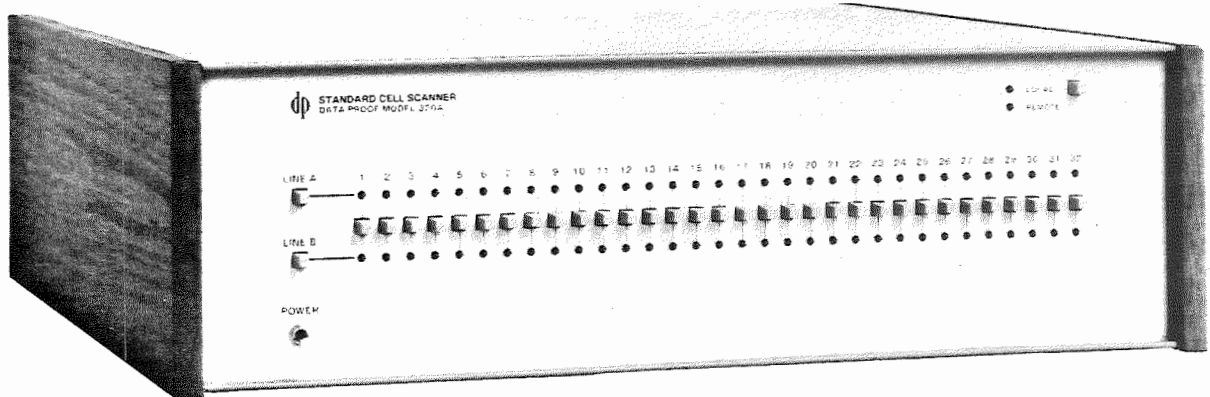

STANDARD CELL SCANNER
DATA PROOF MODEL 320A

1.2 SPECIFICATIONS

NUMBER OF INPUTS

16 for Model 160A
32 for Model 320A

THERMOELECTRIC POTENTIALS

100 nanovolts maximum

ERROR CONTRIBUTION

Standard deviation less than 30 nanovolts when the NBS 4x4 cell design is run with the inputs shorted

ENVIRONMENTAL LIMITS

Operating: 10 Deg C to 40 Deg C up to 80% R.H.
Storage: -20 Deg C to 65 Deg C up to 95% R.H.

NOTE: Specifications for thermoelectric potentials and error contribution apply only if temperature is stable within one degree and relative humidity is below 70 percent.

SCANNER CONTROL

Local using front panel push buttons
Remote via IEEE-488 bus (interface included)

LOGIC CIRCUIT DELAY

0.2 sec minimum between successive relay actuations

RELAY CONTACT RATINGS

0.5 amp at 24 volts DC
10,000,000 cycles minimum at low levels

SIZE - inches (millimeters)

Width - 17.7 (451)
Height - 5.2 (133)
Length - 16.5 (420)

WEIGHT - pounds (killograms)

Model 160A - 23 (10)
Model 320A - 27 (12)

POWER

115 VAC 50 to 60 Hz at 0.2 amp

FUSE

0.5 amp, Slow Blow Type 3AG

1.3 REAR PANEL CONNECTIONS

STANDARD CELL INPUTS

- Opt 1: Six foot cables. Untined solid copper wire in groups of 4 pairs.
- Opt 2: Low thermal binding posts. Tellurium copper, gold flashed per MIL-G-45204.

OUTPUT LINES

- Four low thermal binding posts
 - Line A
 - Line B
 - Line A common
 - Line B common

INTERFACE BUS

- 24 pin IEEE-488 connector, CINCH No. 57-20240

CELL PROTECT

Screw terminals connected to open collector TTL logic circuit. Terminal goes low (0 volts) when any relay is closed, and goes high (5 volts through 10 kohm) when all relays are open. This line can be connected in parallel with other scanners cascaded in a large system to protect cells from being shorted together. Two systems are provided, one for line A and one for line B.

1.4 STANDARD CELL PROTECTION SYSTEMS

Four systems are used to help protect standard cells from being damaged due to scanner failure or operator error. These systems are described briefly below. See the Theory of Operation Section for complete description.

- a. Two push buttons must be depressed at the same time to actuate any relay.
- b. A third set of contacts on each relay are connected in series so that all cell lines must be open before power is available to close a relay.
- c. The relays are driven from a decoder so that only one output circuit can be activated for any possible input combination.
- d. The power to activate the relays is supplied through a dropping resistor to a capacitor, storing enough energy to activate only one relay at a time.

SECTION II INSTALLATION

2.1 INITIAL INSPECTION

This instrument was carefully inspected both mechanically and electrically before shipment. It should be free of marks and scratches and in perfect electrical order upon receipt.

Unpack the instrument and retain the shipping container until the instrument has been inspected for damage in shipment. If in-shipment damage is observed, notify the carrier and obtain authorization for repairs before returning the instrument to the factory.

2.2 POWER REQUIREMENTS

The instrument is shipped with a three wire line cord and must be connected to a grounded ac power source supplying 105 to 128 volts at 50 to 60 Hz. The current required is 0.2 amps.

NOTE

The scanner may be purchased from the factory with provision for operation from 230 volts ac, 50 to 60 Hz.

WARNING

BEFORE SWITCHING ON THIS INSTRUMENT, THE PROTECTIVE TERMINAL OF THIS INSTRUMENT MUST BE CONNECTED TO A PROTECTIVE EARTH CONTACT. THE POWER LINE CORD SUPPLIED WILL PROVIDE THE PROTECTIVE GROUNDING WHEN INSERTED INTO A SOCKET OUTLET PROVIDED WITH AN EARTH CONTACT. THE PROTECTIVE ACTION MUST NOT BE NEGATED BY THE USE OF AN EXTENSION CORD OR ADAPTOR WITHOUT A PROTECTIVE GROUNDING CONDUCTOR.

2.3 LOCATION

To insure optimum performance, the scanner should be installed in an area having reasonably constant temperature, no strong electrostatic or magnetic fields, and a minimum amount of vibration. The unit should not be located near heating or cooling vents or in direct sunlight. Such locations can cause sudden temperature changes resulting in generation of thermal errors in the measurements.

SECTION III
OPERATION

3.1 FRONT PANEL CONTROLS AND INDICATORS (Model 320A shown)

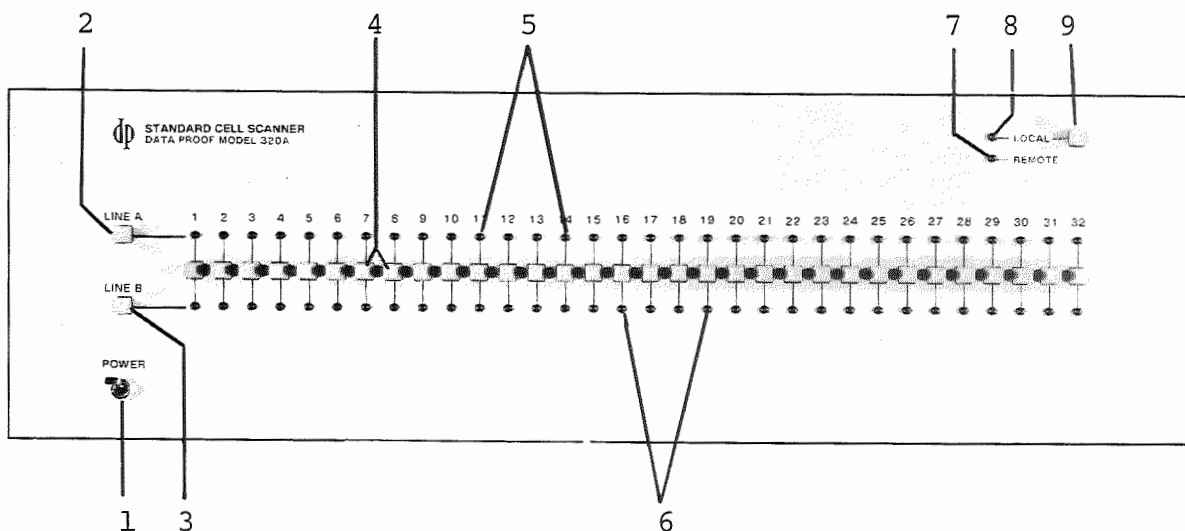

- 1 Line POWER on/off switch
- 2 LINE A pushbutton - when depressed will cause any relay on the A line to be cleared.
- 3 LINE B pushbutton - when depressed will cause any relay on the B line to be cleared.
- 4 Numbered relay control pushbuttons - when depressed at the same time that either the A LINE or the B LINE pushbutton is down will cause the corresponding relay to close.
- 5 LINE A lights - indicates which LINE A relay is closed.
- 6 LINE B lights - indicates which LINE B relay is closed.
- 7 REMOTE light - is illuminated when the scanner is in bus control. The front panel push buttons are inoperative.
- 8 LOCAL Light - is illuminated when the scanner is in front panel (local) control.
9. LOCAL push button - returns scanner to local control.

3.2 REAR PANEL CONNECTIONS (Model 320A option 2) is shown)

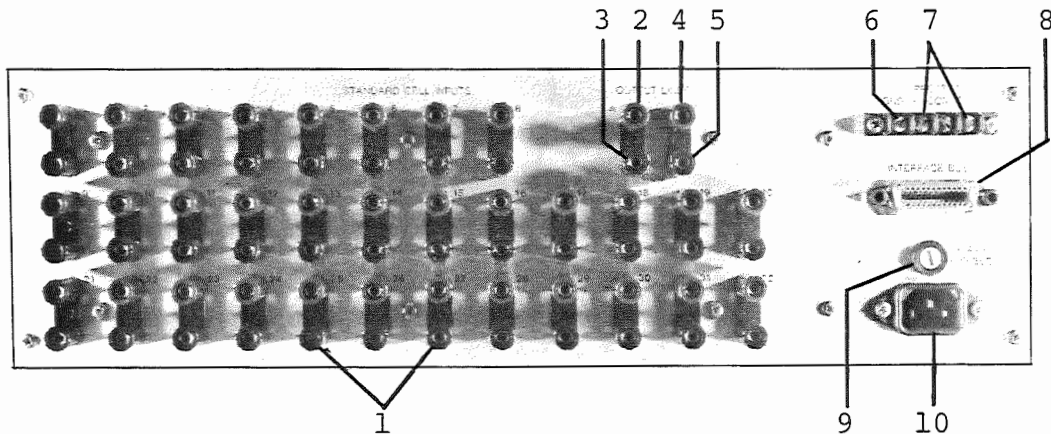

- 1 STANDARD CELL INPUTS - Terminal inputs, Opt 2 (shown)
Connect standard cell positives to red terminals and negatives to black terminals. Numbers correspond to front panel relay numbers.
- 1 STANDARD CELL INPUTS - Cable inputs, Opt 1 (not shown)
Cable lines are in groups of four pairs. The relay numbers are shown on the color code chart at the end of each cable. The lines in cable with red band are to be connected to the cell positives. Connect the cell negatives to the lines with the black band.
- 2 LINE A OUTPUT positive - Connect to positive terminal of measuring system.
- 3 LINE A OUTPUT COM - Usually connected to Line B output com.
- 4 LINE B OUTPUT positive - Connect to negative terminal of measuring system.
- 5 LINE B OUTPUT COM - Usually connected to Line A output com.
- 6 GND - Connected to chassis at relay isothermal box.

- 7 PROTECT CIRCUIT - Connect to same terminals on other scanners. Provides protection for cells in a multiple scanner system. See section 3.9 for details.
- 8 INTERFACE BUS - IEEE-488 bus connector used to connect scanner to controller.
- 9 FUSE - Use 0.5 amp, Type 3AG slow blow.
- 10 AC LINE INPUT - AC Power connector IEC Type with offset pin connected to chassis.

3.3 FRONT PANEL OPERATION

The scanner must be in local mode (LOCAL light on) to operate from the front panel. If the REMOTE light is on press the LOCAL pushbutton.

To connect one of the standard cell inputs to LINE A procede as follows:

- a. Press and hold down the LINE A pushbutton. This will cause any previously closed relay on the A LINE to be cleared.
- b. Press the numbered pushbutton corresponding to the input to be connected. This will cause the relay to actuate connecting the input line to the A output and also turn on the appropriate light.
- c. To actuate a LINE B relay repeate the above process except hold down the LINE B pushbutton.

NOTE: The pushbuttons can be depressed in either order and the end result will be the same; that is, any previously closed relay will be opened and the desired relay will be closed. The important thing is that two pushbuttons must be down for any relay to close.

3.4 OPPERATION FROM INTERFACE BUS

The interface cicruit is designed to accept coded data sent over the bus to actuate the relays. To operate with the bus the scanner must be set to a usable address and must be connected to the controller using a 24 pin IEEE-488 cable (not supplied).

The scanner was set at the factory for bus address 24. All the examples that follow assume 24 as the address. The address can be easily changed if necessary by means of a "DIP" switch on the interface board located under the top cover. Refer to paragraph 3.6 for the procedure to change the bus address.

To actuate a relay the bus interface must first receive the correct address, then a three character ASCII code designating the relay, and then a carriage return/line feed. For example using the HP 9836 computer, the statement:

```
OUTPUT 724;"A01"
```

would cause any relay on LINE A to be cleared, and then relay number 1 to be closed. In this example

```
7 is the controller IO address,  
24 is the scanner address and  
A01 is the code for relay 1 on line A.
```

Another way to send the code over the bus is as follows:

```
PRINTER IS 724  
PRINT "B15"
```

This would cause input number 15 to be connected to LINE B.

The same results would be obtained using the HP 9830 by executing the following commands:

```
CMD "?U8","A01"  
WAIT 200  
CMD "?U8","B15"
```

To clear the lines use the following commands (HP9836):

```
OUTPUT 724;"A00"  
WAIT .2  
OUTPUT 724;"B00"
```

Note that each actuation must be a separately addressed statement. For example, the following is not valid:

```
OUTPUT 724;"A00","B00" -- NOT VALID--
```

Note also that a delay of at least 200 milliseconds must occur between any two actuations. This is because of the standard cell protection circuitry. The capacitor that provides the energy to operate the relays must have time to recharge.

3.5 RETURNING TO LOCAL

When the scanner address is received over the bus the unit will go into remote, the REMOTE light will be turned on, and the front panel pushbuttons will not function. The scanner can be returned to local by any of the following:

- a. On power-up (turning scanner off and then back on).
- b. Either relay line cleared over the bus (sending A00 or B00).

c. Sending an address other than the scanners over the bus.
That is, when any other device on the bus is addressed the scanner will return to local.

d. Pressing the LOCAL pushbutton on the front panel.

The relay settings will not be changed by returning to local.

The scanner does not respond to status inquires.

3.6 ADDRESS SELECTION

The listen address of the scanner is selected by the "DIP" switches located on the interface board under the top cover. The five switches labeled 1 through 5 are used to select a unique address. The scanner normally leaves the factory with the switches set to a listen address of 8 (decimal code 24). Switch No. 6 is used to lock the scanner in remote only. The following table lists the address codes and corresponding switch settings:

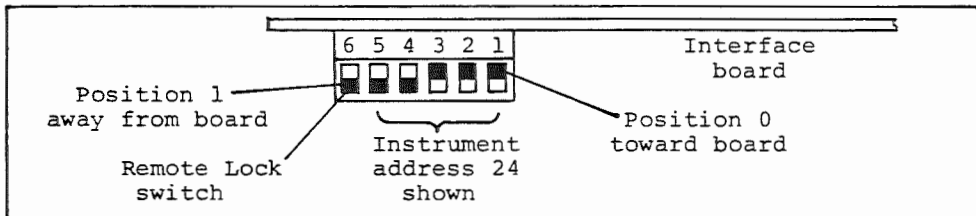

ASCII Code Character		Address switches					5 bit Decimal code
Listen	Talk	A5	A4	A3	A2	A1	
SP	@	0	0	0	0	0	00
!	A	0	0	0	0	1	01
"	B	0	0	0	1	0	02
#	C	0	0	0	1	1	03
\$	D	0	0	1	0	0	04
%	E	0	0	1	0	1	05
&	F	0	0	1	1	0	06
'	G	0	0	1	1	1	07
(H	0	1	0	0	0	08
(I	0	1	0	0	1	09
*	J	0	1	0	1	0	10
+	K	0	1	0	1	1	11
,	L	0	1	1	0	0	12
-	M	0	1	1	0	1	13
.	N	0	1	1	1	0	14
/	O	0	1	1	1	1	15
0	P	1	0	0	0	0	16
1	Q	1	0	0	0	1	17
2	R	1	0	0	1	0	18
3	S	1	0	0	1	1	19
4	T	1	0	1	0	0	20
5	U	1	0	1	0	1	21
6	V	1	0	1	1	0	22
7	W	1	0	1	1	1	23
8	X	1	1	0	0	0	24 ← FACTORY SETTING
9	Y	1	1	0	0	1	25
:	Z	1	1	0	1	0	26
;	[1	1	0	1	1	27
<	\	1	1	1	0	0	28
=]	1	1	1	0	1	29
>	~	1	1	1	1	0	30

TABLE 3-1 BUS ADDRESSES

3.7 SAMPLE PROGRAMS

The following program will exercise the scanner relays 1 through 16 and leave both lines clear. This program is for the HP 9835 or 9845. To run it on the 9836 change the WAIT statements from 500 to 0.5 and the OUTPUT to 724.

```
10 ! SCANNER TEST
20 DIM Relay$(32)
30 Relay$="01020304050607080910111213141516"
40 FOR I = 1 TO 16
50 OUTPUT 7,24;"A"&Relay$(2*I-1,2*I) ! CLOSSES A RELAY
60 WAIT 500
70 OUTPUT 7,24;"B"&Relay$(2*I-1,2*I) ! CLOSSES B RELAY
80 WAIT 500
90 NEXT I
100 OUTPUT 7,24;"A00" ! CLEARS LINE A
110 WAIT 200
120 OUTPUT 7,24;"B00" ! CLEARS LINE B
130 END
```

Note: A Wait of at least 200 milliseconds is required between relay accuations to allow time for the relay supply capacitor to recharge.

The second program has exactly the same result as the first program listed above, but uses the fact that the scanner logic only looks at the least significant bit in determining the A or B line. Thus "A05" is equivalent to "105", and "B14" is equivalent to "214". The following HP9845 program will also exercise the scanner relays.

```
10 ! SCANNER TEST
20 PRINTER IS 7,24 ! SETS PRINTER OUTPUT TO SCANNER
30 FOR I = 1 TO 16
40 PRINT USING "DDD";100+I ! CLOSSES A RELAY
50 WAIT 500
60 PRINT USING "DDD";200+I ! CLOSSES B RELAY
70 WAIT 500
80 NEXT I
90 PRINT "100" ! CLEARS A RELAY
100 WAIT 500
110 PRINT "200" ! CLEARS B RELAY
120 PRINTER IS 0 ! RETURNS PRINTER
130 END
```

Note that a formatted print statement is used to assure the first character that the scanner sees (after the address) is the line code and the next two characters are the relay code.

3-8 REMOTE LOCK

The pushbuttons can be locked out when it is desired to prevent tampering from the front panel. Position No. 6 of the "DIP" switch located on the Interface printed circuit board is used to lock the scanner in remote only. If the switch is the "0" position (towards the pc board) the REMOTE light will be on and the front panel pushbuttons will not operate. The scanner can be actuated only by the bus in the usual manner. The scanner address must still be used in the output command to actuate the relays.

3-9 SERIES PROTECTION FOR MULTIPLE SCANNERS

The series cell protection feature can be extended to multiple scanners in a large system by means of the rear panel PROTECT terminals. The series protection circuit prevents more than one relay on either the A Line or the B Line from being closed at the same time which prevents cells from being shorted together. Each relay has a set of contacts which close when the relay is in the open position. These contacts are all in series and the logic circuit will not allow a close pulse to occur unless all the relays on that same line are open. This protection can be extended to more than one scanner in a large system by connecting the PROTECT terminals together. Both the A and B PROTECT terminals are connected to an open collector TTL gate on the control board. When all relays are open the terminal will be high (5 volts through 10 kohm), and when any relay is closed the terminal will be low (near 0 volts) . Connecting either terminal to COM will prevent any relay on that line from being activated.

To extend this protection feature when two or more scanners are used in a system, connect all PROTECT A terminals together, all PROTECT B terminals together, and all PROTECT COM terminals together.

SECTION IV
THEORY OF OPERATION

4.0 INTRODUCTION

The need for a scanner with suitable characteristics for use in standard cell measurements has been needed for many years; especially as Group Voltage Measurement Assurance Programs have become more common. These Programs require standard cell intercomparisons among as many as six or eight sets of cells at a time. These measurements made daily during the exchange process take a lot of time. Also, the recent increase in accuracy of dc measuring equipment has created a need for better standards. This usually means more standard cells whose emf's are averaged using statistically controlled measurement techniques. All this requires a great deal of time and effort, and with it the obvious need for automated measurements.

The Data Proof Scanner allows the total process to be computer controlled, which reduces the time required from hours to minutes without degrading the measurement accuracy.

4.1 LATCHING RELAY

The device that makes this scanner possible is a sensitive latching relay manufactured by Executone for the telephone industry. The major problem with using conventional relays is the thermal voltage caused by the heat generated by the current in the relay coil. With this latching relay a short pulse of only 10 milliseconds is all that is required to toggle the contacts from one side to the other. Thus the heat generated is negligible.

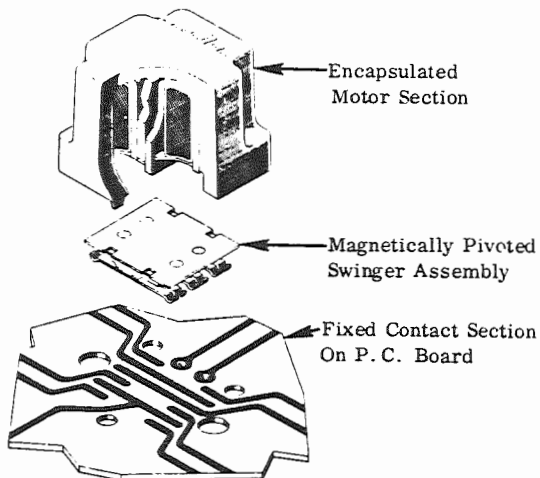

FIGURE 4.1 LATCHING RELAY ARRANGEMENT

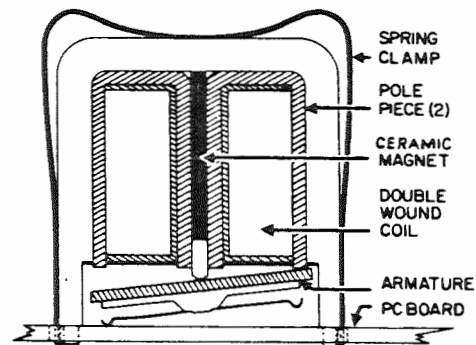

FIGURE 4.2 LATCHING RELAY CONSTRUCTION

Figure 4.1 shows how the relay is arranged. Figure 4.2 shows the construction details. The gold plated contacts attached to the relay armature make contact to hard gold pads on specially plated printed circuit boards. A permanent ceramic magnet holds the armature in place against one of the two pole pieces. If the coil on the side opposite is energized, the armature will toggle so that it is held against the other pole piece. Once the armature has toggled the current in the coil can be removed. This requires less than ten milliseconds.

The relays used in the scanner have 3-pole, 2-throw bifurcated contacts. The contacts short out parallel traces on the printed circuit board. When the relay is in the closed position two of the contacts connect the standard cell plus and minus terminals to the output. A third contact provides current to a light on the front panel to indicate which relay is closed.

When the relay is in the open position one contact is used as part of the standard cell protection system. The same contact for all relays on the same output line are connected in series. Logic circuits sense this series line and will prevent any relay on that line from being closed unless all relays are open.

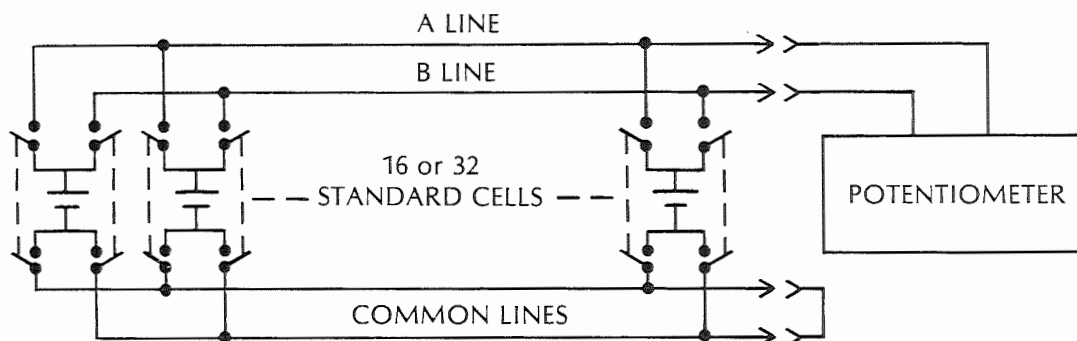

FIGURE 4.3 SCANNER CONFIGURATION

4.2 SCANNER CONFIGURATION

In order to compare standard cells using the NBS design, two cells at a time must be connected in series opposition with the cell negative terminals tied together. To accomplish this, two relays are connected to each cell with one relay switching to an output line marked A, and the other relay switching to a second output line marked B. A second contact on each relay connects the negative terminals to a common line. As shown in Figure 4.3 the A and B lines are connected to a measuring system to obtain the small difference between the two cell voltages.

Both the positive and negative terminal of the cell is switched so that when both relays are open the cell is completely floating to minimize leakage current problems. The two common lines are brought out to the rear panel, but are normally shorted together when using the NBS design procedure.

4.3 LOGIC CIRCUITS

The remaining design consideration after those of thermal emf's and cell protection was to make the scanner operate easily from both the IEEE-488 Bus and the front panel.

The information from the bus is in binary form sent serially, one ASCII character at a time. This serial format is changed to a parallel form by means of a decoder ROM on the interface board as can be seen in Figure 4.4.

To allow the system to operate from the front panel, the pushbutton data is converted to a form identical to parallel binary data from the bus interface circuit. A selector at this point switches between bus or pushbutton operation. A 6-to-64-line decoder after the selector converts the 6-bit parallel data to a single line output which may actuate one of the relay coil drivers.

4.4 STANDARD CELL PROTECTION

Also in Figure 4.4 can be seen three of the four cell protection schemes. The first one is in the logic itself. The data at the selector is in six bit binary. Thus only one of the 64 output lines can be activated for any possible combination of the six input lines. If a failure should occur in the bus interface, encoder or selector circuits, or if an incorrect message is sent over the bus, no cell will be shorted to another cell because only one relay can be closed.

The second protection scheme guards the cell from failures in the decoder and relay circuits. The energy to operate the relays comes from a capacitor which stores enough energy to actuate only one relay at a time. The capacitor is charged through a dropping resistor with a long charging time. Once a relay has been activated a wait of 200 milliseconds is required before another relay can be operated.

The third method for protecting the cells shown in the figure are the 'close gate' lines to the decoder circuits. The control circuit will allow these gates to open only if the series protection line is complete to ground. One of the contacts on each relay is connected in series, and will complete the series protection circuit only if all the relays on the line are in the clear position. Thus, no relay on the A line can be closed if any other relay on A line is already closed; and similarly no B line relay can be closed if any other relay on the B line is already closed.

These series protection lines are brought out to terminals on the rear panel. Thus if more than one scanner is used in a large system and these terminals are connected together, all cells in the system will be protected.

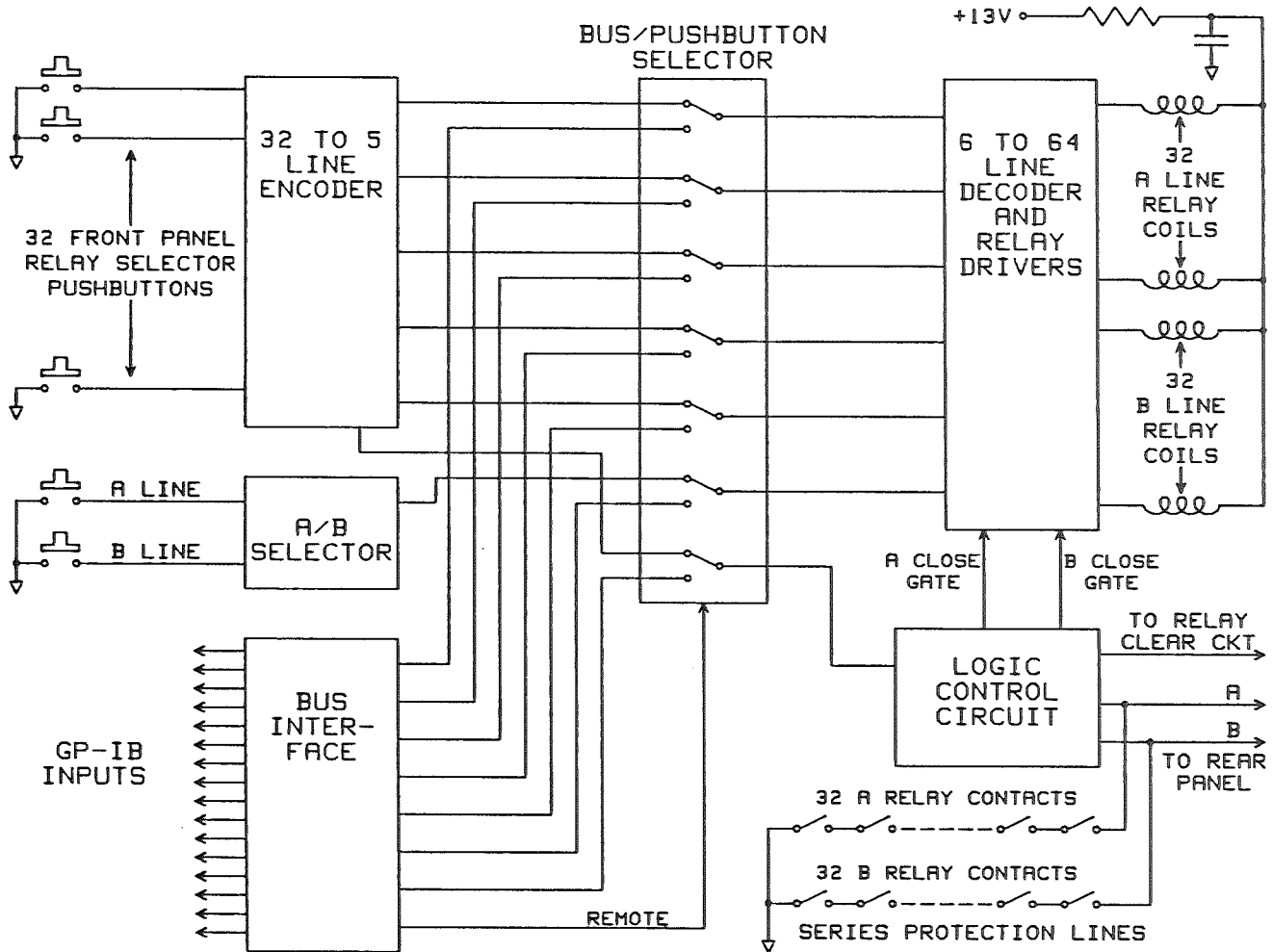

FIGURE 4.4 FUNCTIONAL DIAGRAM OF SCANNER

The fourth protection mechanism to protect the cells from damage is not shown on the diagram but is part of the control logic circuit. This is the requirement that two pushbuttons on the front panel must be pressed at the same time for any relay to actuate. These would be either the A or B line button and any of the 32 relay selector pushbuttons. This is to help prevent accidental operation. It takes two hands to operate the scanner from the front panel.

4.5 ISOTHERMAL BOX

Switching assemblies with eight relays to a PC board are housed in a heavy machined aluminum box. This isothermal enclosure helps to maintain a uniform temperature at each of the relay contacts. The printed circuit edge connectors carry only

the relay coil and panel light circuits. All the standard cell lines are soldered to the relay boards directly to prevent the thermal and noise voltages caused by connectors. The relays are attached to the boards with spring clips so that they can be easily removed for replacement if necessary.

4.6 NBS PROCEDURE FOR MEASURING CELLS

The NBS has recommended a method of intercomparing cells by measuring the difference between cells in pairs in a statistically balanced design. Usually the number of cell pair measurements is twice the number of cells being compared. One possible design for comparing two groups of four cells is shown in Figure 4.5.

READING	A LINE	B LINE
E1	= Group 1, Cell 1	- Group 2, Cell 1
E2	= Group 1, Cell 1	- Group 2, Cell 3
E3	= Group 1, Cell 3	- Group 2, Cell 3
E4	= Group 1, Cell 3	- Group 2, Cell 1
E5	= Group 1, Cell 2	- Group 2, Cell 2
E6	= Group 1, Cell 2	- Group 2, Cell 4
E7	= Group 1, Cell 4	- Group 2, Cell 4
E8	= Group 1, Cell 4	- Group 2, Cell 2
E9	= Group 2, Cell 2	- Group 1, Cell 1
E10	= Group 2, Cell 2	- Group 1, Cell 3
E11	= Group 2, Cell 4	- Group 1, Cell 3
E12	= Group 2, Cell 4	- Group 1, Cell 1
E13	= Group 2, Cell 1	- Group 1, Cell 2
E14	= Group 2, Cell 1	- Group 1, Cell 4
E15	= Group 2, Cell 3	- Group 1, Cell 4
E16	= Group 2, Cell 3	- Group 1, Cell 2

FIGURE 4.5: 4x4 MEASUREMENT DESIGN

As can be seen in the figure the eight cells are compared using 16 measurements. Note that each cell appears on the A side twice and on the B side twice.

When all the cell difference measurements are complete, a least squares fit of the data can be computed. The estimated, or least squares optimized, differences can be compared to the measured values to compute a standard deviation characterizing the random error of the measurements. This is a measure of the total system performance. Standard deviations typically 30 nanovolts or less can be expected with the scanner and a good measuring system.

STANDARD CELL OBSERVATIONS Std Dev= 0.016 A-B Comp= 0.005 06NOV83 17:01

OBS	A-LINE	B-LINE	READING	DEV	OBS	A-LINE	B-LINE	READING	DEV
1	A 1	D 4	0.050	0.004	33	E 1	H 4	0.032	0.002
2	A 2	D 4	0.051	0.010	34	E 2	H 4	0.008	-0.000
3	A 2	E 1	-0.012	-0.002	35	E 2	A 1	-0.010	-0.002
4	A 3	E 1	-0.063	-0.015	36	E 3	A 1	-0.007	0.004
5	A 3	E 2	-0.015	0.011	37	E 3	A 2	0.006	0.012
6	A 4	E 2	-0.051	-0.013	38	E 4	A 2	-0.018	-0.004
7	A 4	E 3	-0.026	0.009	39	E 4	A 3	0.029	0.005
8	B 1	E 3	0.043	0.007	40	F 1	A 3	0.008	-0.008
9	B 1	E 4	0.034	-0.011	41	F 1	A 4	0.015	-0.012
10	B 2	E 4	-0.013	0.011	42	F 2	A 4	0.031	0.008
11	B 2	F 1	-0.026	-0.011	43	F 2	B 1	-0.058	-0.010
12	B 3	F 1	-0.010	-0.010	44	F 3	B 1	-0.044	0.006
13	B 3	F 2	0.026	0.021	45	F 3	B 2	0.031	0.011
14	B 4	F 2	0.028	-0.022	46	F 4	B 2	0.026	-0.011
15	B 4	F 3	0.068	0.017	47	F 4	B 3	0.041	0.020
16	C 1	F 3	0.042	-0.000	48	G 1	B 3	0.030	-0.010
17	C 1	F 4	0.034	0.009	49	G 1	B 4	-0.010	-0.006
18	C 2	F 4	0.032	0.001	50	G 2	B 4	-0.009	0.001
19	C 2	G 1	0.002	-0.009	51	G 2	C 1	-0.008	-0.007
20	C 3	G 1	-0.012	-0.006	52	G 3	C 1	-0.009	0.015
21	C 3	G 2	0.021	0.021	53	G 3	C 2	-0.027	0.003
22	C 4	G 2	-0.021	-0.027	54	G 4	C 2	-0.021	-0.012
23	C 4	G 3	0.049	0.020	55	G 4	C 3	0.026	0.018
24	D 1	G 3	0.054	-0.001	56	H 1	C 3	0.021	-0.003
25	D 1	G 4	0.025	-0.009	57	H 1	C 4	0.008	-0.008
26	D 2	G 4	-0.000	0.015	58	H 2	C 4	-0.000	0.000
27	D 2	H 1	-0.049	-0.018	59	H 2	D 1	-0.034	-0.008
28	D 3	H 1	-0.036	0.008	60	H 3	D 1	-0.025	-0.002
29	D 3	H 2	-0.032	-0.005	61	H 3	D 2	0.026	-0.000
30	D 4	H 2	-0.029	-0.003	62	H 4	D 2	0.016	-0.003
31	D 4	H 3	-0.012	0.017	63	H 4	D 3	0.036	0.004
32	E 1	H 3	0.003	-0.019	64	A 1	D 3	0.046	-0.002

FIGURE 4-6: 32 CELL SYSTEM TEST WITH INPUTS SHORTED

4.7 TEST RESULTS

Figure 4.6 shows the results of an actual test run on a Model 320A Scanner. It is a run of 64 measurements simulating eight sets of four standard cells. For this test each of the 32 inputs was shorted individually with a short length of copper wire. Thus the printout shows the total errors in the measuring system.

The numbers in the READING column are the relay contact and connection thermal emf's plus the noise in the measuring system. As can be seen in the figure these are running between 20 and 50 nanovolts with 68 the highest. The largest deviation is 22 and the standard deviation is 16 nanovolts.

The measuring system used consists of a Leeds & Northrup Model 9829 Linear Amplifier connected to the scanner A and B output lines. The 9829 output is measured with an HP 3456 DVM. The controller is an HP 9845 Computer.

The two selected relays are closed which connects two cells in series opposition across the 9829 input. After a 10 second wait to allow the 9829 to settle, the computer takes 10 readings. The value printed in the READING column is the average of these ten readings. This value is the combined thermal emf's for four relay contacts and three shorting wires.

After all the measurements are completed the computer performs a least squares fit of the data and finds the standard deviation using a program supplied by NBS. The DEV column shows the difference between the actual reading and the predicted value from the calculation. The standard deviations for this measurement usually run between 10 and 30 nanovolts.

SECTION V
MAINTENANCE AND TROUBLE SHOOTING

5.0 PERIODIC MAINTENANCE

There are no adjustments or controls in the scanner. No periodic maintenance is required.

5.1 RELAY FAILURES

The most common problem encountered with the scanner will be the latching relay contacts not making good connection to the printed circuit board. This will show up either as a particular channel producing consistently bad readings; or if the bad contact is in one of the series protection lines, it could prevent that entire line from working at all. The relays used in this scanner are made from the highest quality material and they are 100% inspected and adjusted to assure that the gold contacts are mating properly with the gold pads on the boards. However, even with this inspection a relay will occasionally fail.

5.2 NOISY READINGS

If one channel produces noisy readings the most likely cause is a bad relay contact in that channel. Another source could be a bad connection anywhere between the relay board and the standard cell connected to it. A bad connection generally has an offset voltage as well as the noise; where as a bad relay contact just has the noise.

The relays are easy to change using the procedure outlined in section 5.7. Two spare relays are included with each scanner. They are located in a holder under the top cover.

If replacing the relay in the noisy channel does not solve the problem then the solder joints and terminal connections along the line must be checked. The solder connections can be reheated while holding the wires so that they do not move until the solder has hardened. Terminals may need to be cleaned or tightened.

5.3 SERIES PROTECTION LINE FAILURE

Each of the line A relays has a contact that is connected in series with all the other line A relays. Each of these contacts must make contact to complete the protection circuit or none of the relays on the line A will work. The same is true of the B Line. If the fault is in one of the line A relays protection contacts, the line A will not work but the line B will function normally. Conversely if the fault is in one of the line B relays the line A will still function.

If the failure is caused by surface contamination, a piece of lint or other foreign object between the contacts, then exercising the relay can create a permanent fix. However, if the failure is caused by weak spring pressure or misalignment of the contact, then the relay may work for awhile after it is exercised but will probably fail again. It is a good idea to jot down the number of any relay that caused trouble so that it can be replaced if it fails again.

The following sections will describe two methods of locating and exercising relays which have caused series protection line failure.

5.4 LOCATING SERIES PROTECT LINE FAILURE - PROTECT DEFEAT METHOD

There are two pushbuttons on the chassis under the top cover which will defeat the series protection system and allow the relays to be operated.

WARNING

WHEN USING THE PROTECT DEFEAT PUSHBUTTONS BE AWARE THAT IT IS POSSIBLE TO HAVE TWO RELAYS CLOSED AT THE SAME TIME WHICH WILL SHORT THE TWO INPUTS TOGETHER. EITHER DISCONNECT ANY SENSITIVE DEVICES SUCH AS STANDARD CELLS OR PROCEED CAUTIOUSLY TO BE SURE THAT ALL RELAYS ARE CLEAR BEFORE CLOSING THE NEXT ONE.

The defeat pushbuttons short the series protection lines to ground, and thus will defeat the system when the buttons are depressed. To try to clear the problem, proceed using the following procedure. If the Line A is not working exercise the A relays and if the problem is in Line B then exercise the B relays.

To operate the channel A1 relay, for example, depress and hold down the A Defeat, the Line A, and the channel 1 pushbutton simultaneously. The channel A1 front panel light will come on. To exercise the relay hold the A Defeat and the channel 1 pushbuttons down while pressing and releasing the Line A pushbutton several times. The A1 light should blink and a click should be heard each time the Line A button is pressed in.

Check to see if this action has cured the problem. Release the A Protect pushbutton and try to operate the relays in a normal manner. If the system now works, then the last relay exercised probably was the bad relay. If not, repeat the exercise procedure on the rest of the relays in turn until the system works or all the relays have been tested. If the system still does not work after all relays have been exercised then go on to the direct method in paragraph 5.5.

The relays close with enough force to shake the printed circuit board. Thus the last relay exercised before the system worked may or may not be the bad one because the vibration can cause the the bad contact to make. In fact tapping the relays can also clear a bad contact.

5.5 LOCATING SERIES PROTECT LINE FAILURES - DIRECT METHOD

The series protection lines are grounded at the highest numbered relay and follow a path through the relays in a descending order to relay number one where they are connected to the logic circuit.

For a 32 channel unit the protection contacts on relays A32 and B32 are connected to ground, and for a 16 channel unit the protection contacts on relays A16 and B16 are connected to ground. In both cases the contacts on A1 and B1 are connected to the logic circuit and plus 5 volts through 10 kilohms. See figure 4.4. If all relays are in the open position the logic circuit will see zero volts. If any relay on the line A is not making contact (series protection line open) then the line A logic input will be at plus 5 volts.

The continuity of the two series protection lines can be checked with a voltmeter by tracing the path on the relay boards. The relay boards can be accessed by removing the top cover of the cabinet and the cover of the isothermal box. See section 5.6 and figure 5.1 to locate the relays.

On all relays the series protection contacts are on the side towards the front panel. The contacts come out to a pair of feed through holes on the circuit board as can be seen in figure 5.1. These two holes are located just above the relay housing toward the front panel. Relay number four on each board has only one feed through hole.

WARNING

THE STANDARD CELL CONNECTIONS ARE MADE TO THE TOP OF THE RELAY BOARDS AND CONNECT TO THE RELAYS. DISCONNECT THE STANDARD CELLS OR USE AN INSULATED PROBE AND PROCEED CAUTIOUSLY SO AS NOT TO TOUCH ANY TRACES OTHER THAN THE SERIES PROTECTION LINE.

Once the check points have been located and the series path has been determined, the failed relay can be easily located. All check points should be at zero volts. The relay which is breaking the continuity to ground will have one side at zero volts and the other side at 5 volts. All relays with a lower channel number will also be at 5 volts.

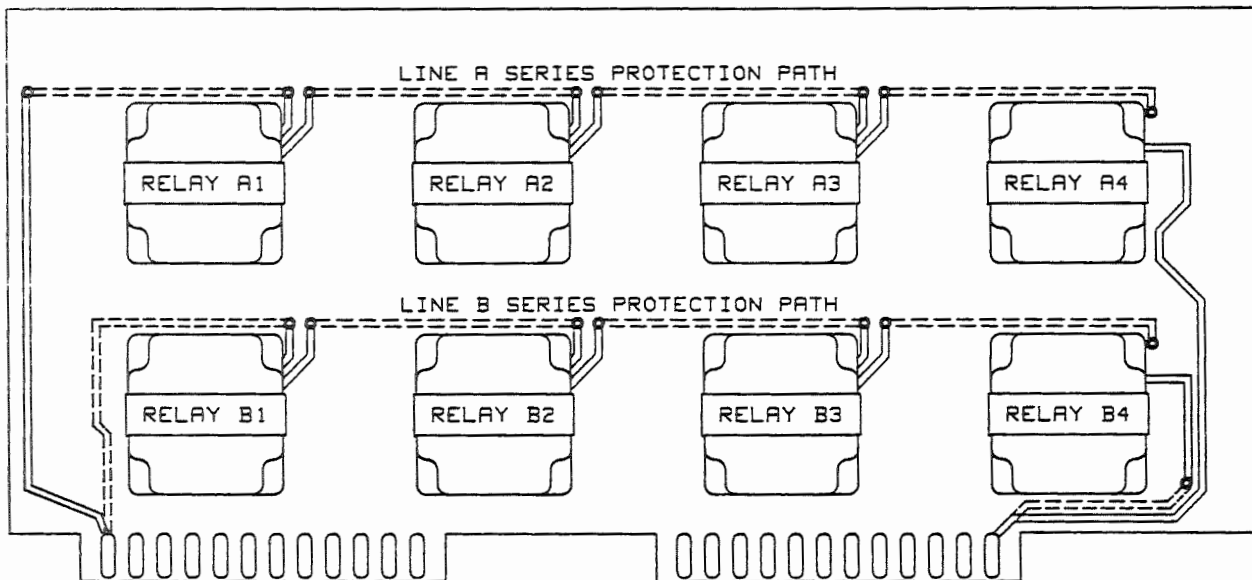

FIGURE 5.1 SERIES PROTECTION PATHS ON RELAY BOARD

5.6 LOCATING THE CHANNEL RELAYS

When the cover of the isothermal box is removed the relay boards can be seen. Each board holds four line A relays and four line B relays. Refer to figure 5.1. The line A relays are along the top of the board and the line B relays are at the bottom. The first relay is at the end of the board closest to the rear panel. Channels one through four are on the board closest to the power transformer. The next board has channels five through eight and so on. There are printed tags next to each board on the rear side of the box which indicate the channel numbers for the boards.

5.7 REPLACING RELAYS

The relays are held onto the boards with spring clips. They can easily be removed by slipping a knife blade between the clip and the relay housing and prying out. Relays in the top row can be replaced without removing the boards from their sockets. For relays in the lower row the board must be pulled out. There is enough slack in the standard cell lines to allow the board to be withdrawn far enough to replace the lower relays.

WARNING

STANDARD CELLS CONNECTED TO THE SCANNER COULD BE DAMAGED DURING THE PROCESS OF EXCHANGING RELAYS. IT IS RECOMMENDED THE CELLS BE DISCONNECTED FROM THE BOARD BEING WORKED ON.

To install a new relay on the board, center the alignment pins over the holes in the board and press the relay down until the housing is flush with the board. The clips will have to be pried out with a blade and then snapped into the larger holes.

Two spare relays are included with each scanner when shipped from the factory. They are located in a bracket near the power transformer. Relays which have been adjusted and tested can be obtained from the factory by requesting part number 49-01.

5.8 RELAY ADJUSTMENTS

Relays that are not making good contact can in most cases be adjusted so that they will work again. The following procedure describes the adjustment procedure.

Hold the relay so that the line of sight is parallel to and right along the base of the relay housing. The use of a magnifying lens is necessary. All twelve gold contacts should be visible above the edge of the housing. They should all be nearly the same height above the edge of the housing. If not, carefully bend the contacts so that they are equal. If one is bent too far out, the bottom edge of the contact lip will be seen. The best position is such that a little less than one half the contact thickness is visible above the edge of the housing.

Carefully toggle the relay armature with a knife blade to check the contacts on the other side. Leave the relay in the 'open' position when installing it on the board.

SECTION VI
CIRCUIT DIAGRAMS AND
REPLACEMENT PARTS LISTS

6.1 INTRODUCTION

This section contains circuit diagrams and information for ordering replacement parts. For each circuit board there is a circuit diagram, a component location diagram and a parts list. There is also a list of general parts that are located on the chassis and the rear panel.

6.2 OBTAINING REPLACEMENT PARTS

Replacement parts can usually be obtained locally by referring to the manufacturers part number listed on the parts list. The manufacturer is identified by a five digit code in the parts list. These codes are identified in table 6.1 below.

6.3 ORDERING INFORMATION

To obtain parts directly from the factory, send an order to the address shown on the first page of this manual. Identify parts by their Data Proof part number. Include the instrument model and serial numbers as well as the part description.

6.4 NON-LISTED PARTS

To obtain a part that is not listed, include the instrument model and serial numbers, description of the part as well as function and location of the part.

01121	Allen Bradley Co; Milwaukee, Wis.
01295	Texas Instruments, Inc.; Dallas, Texas
02660	Amphenol-Borg Electronics Corp.; Broadview, Ill.
04713	Motorola Semiconductor Div.; Phoenix, Arizona
05276	Pomona Electronics; Pomona, Calif.
07263	Fairchild Semiconductor Div.; Mtn View, Calif.
09353	C & K Components Inc.; Newton, Mass.
18324	Signetics Corp.; Sunnyvale, Calif.
21226	Executone, Inc.; Long Island City, N.Y.
28480	Hewlett-Packard Co.; Palo Alto, Calif.
56289	Sprague Electric Co.; North Adams, Mass.
70903	Belden Mfg. Co.; Chicago, Ill.
71590	Centralab; Milwaukee, Wis.
71785	Cinch Mfg. Co.; Chicago, Ill.
75915	Littlefuse, Inc.; Des Plaines, Ill.
81073	Grayhill Co.; LaGrange, Ill.
81095	Triad Transformer Corp.; Venice, Calif.
82389	Switchcraft, Inc.; Chicago, Ill.
91637	Dale Electronics Inc.; Columbus, Nebr.

TABLE 6-1 LIST OF MANUFACTURERS CODES

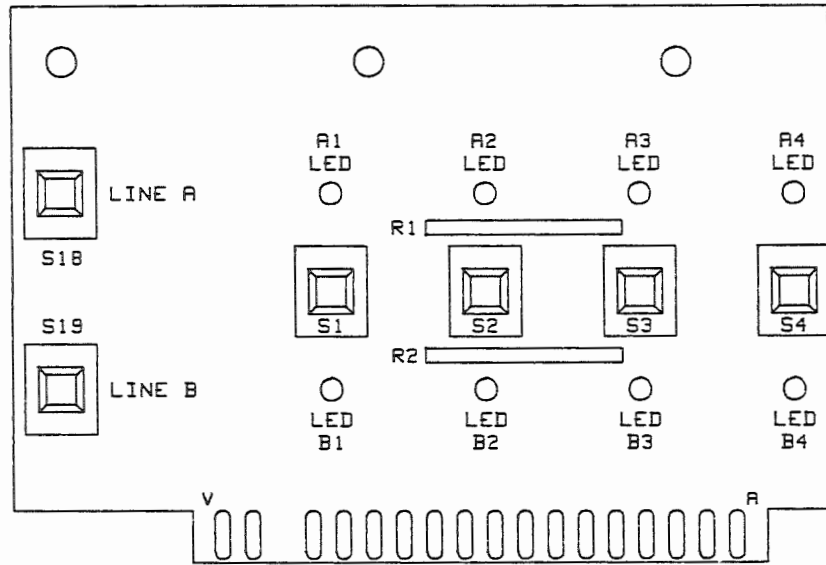

'A' BOARD COMPONENTS

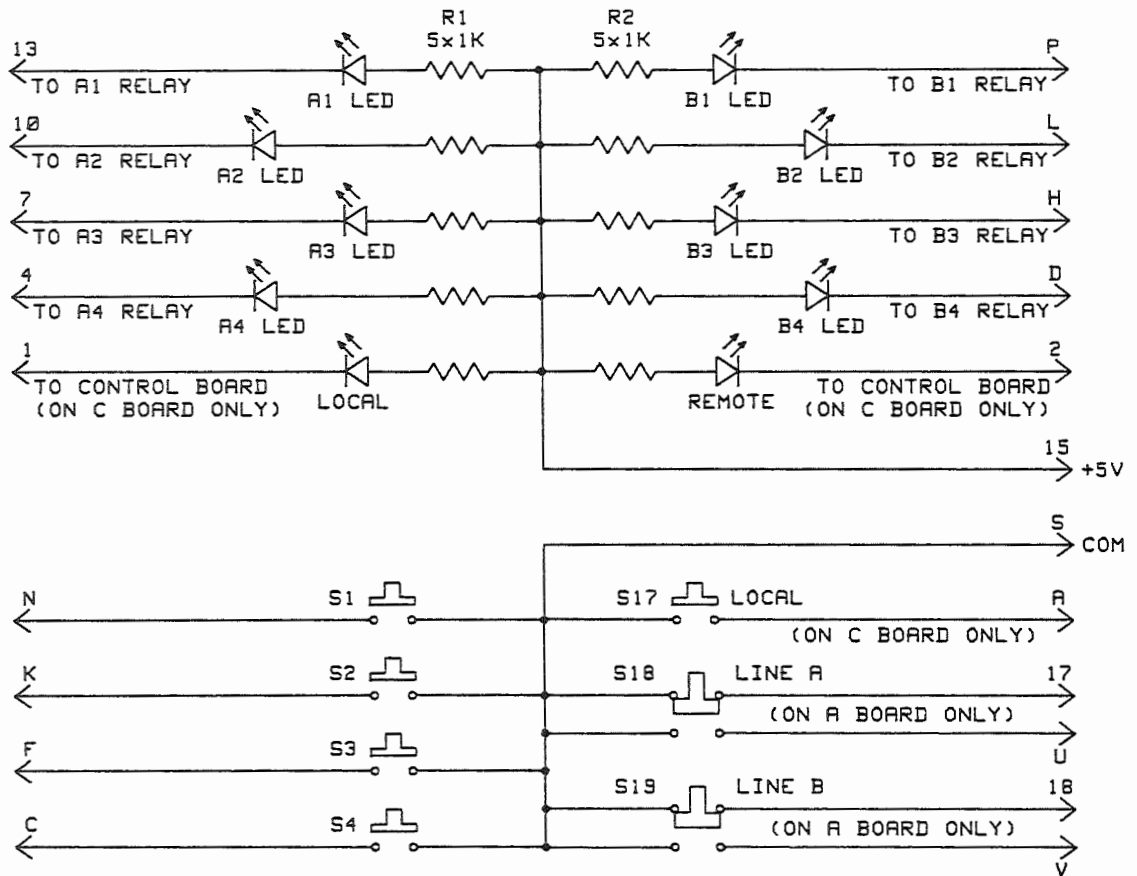

MODEL 160A
SWITCH BOARD DIAGRAM

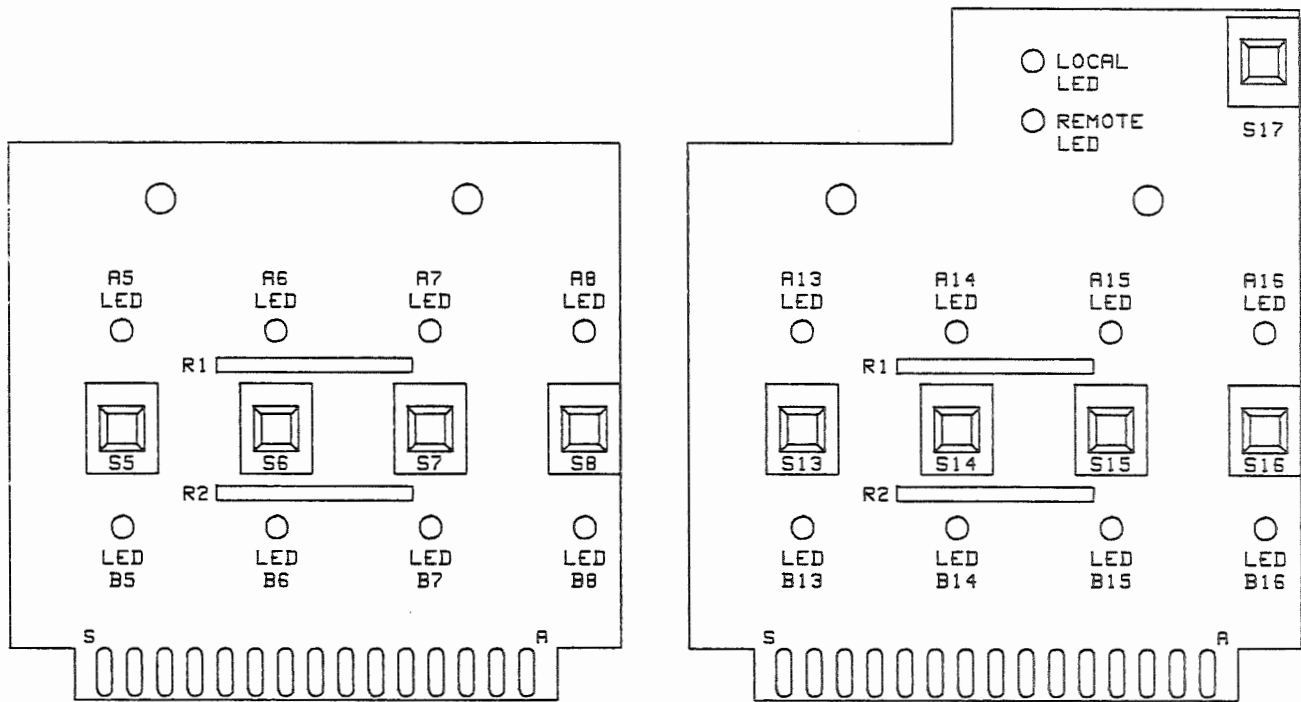

'B' BOARD COMPONENTS

'C' BOARD COMPONENTS

SWITCH BOARD COMPONENT LOCATIONS

- NOTES:
1. FOUR OF THESE SWITCH BOARDS ARE USED TO CONTROL ALL 32 LATCHING RELAYS.
 2. TWO 'B' BOARDS ARE USED FOR RELAYS A5 TO A12 AND B5 TO B12.
 3. THE SWITCH BOARD DIAGRAM IS TYPICAL FOR ALL FOUR BOARDS.

SWITCH BOARDS PARTS LIST

CIRCUIT DESIG	DP PART NUMBER	DESCRIPTION	MFG CODE	MFG PART NUMBER
a11 LED's	23-01	LIGHT EMITTING DIODE, Red	28480	HLMP-1301
S1 to S17	31-01	SWITCH, Pushbutton, SPST,(relay select)	71590	MPSK40112AA
S18,S19	31-02	SWITCH, Pushbutton, SPDT,(line select)	71590	MPSK40122AA
R1,2	68-01	RESISTOR NETWORK,9x1 Kohm,Cermet SIP	01121	110A102

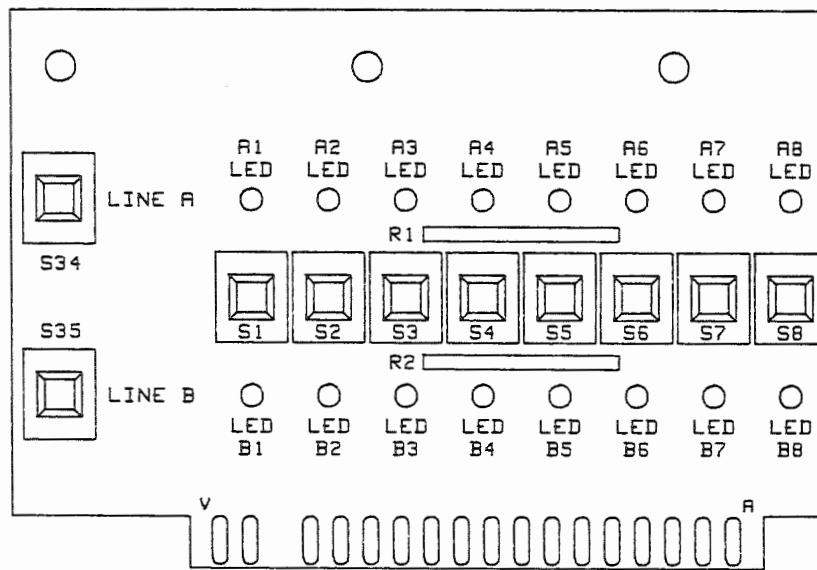

'A' BOARD COMPONENTS

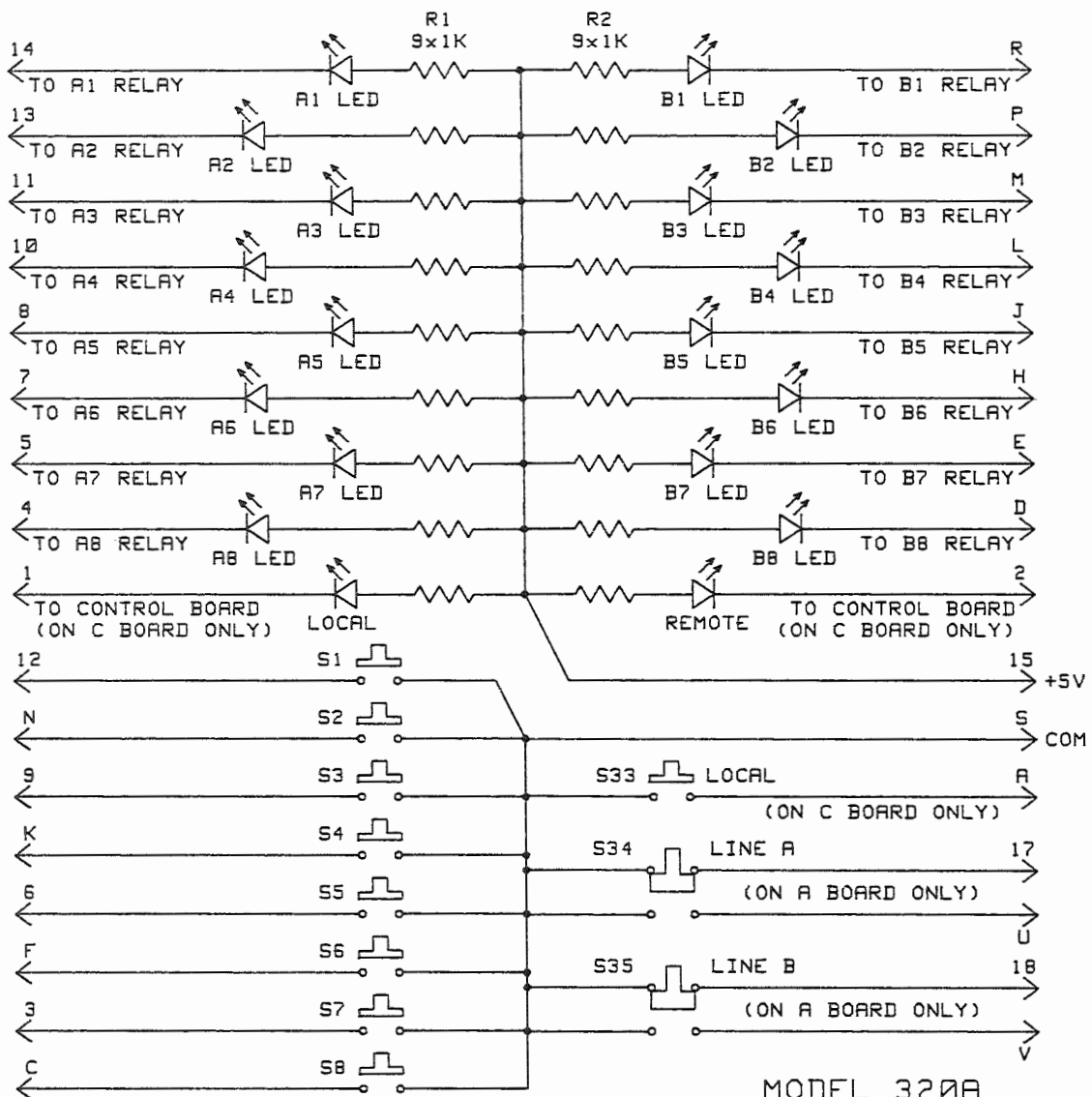

MODEL 320A
SWITCH BOARD DIAGRAM

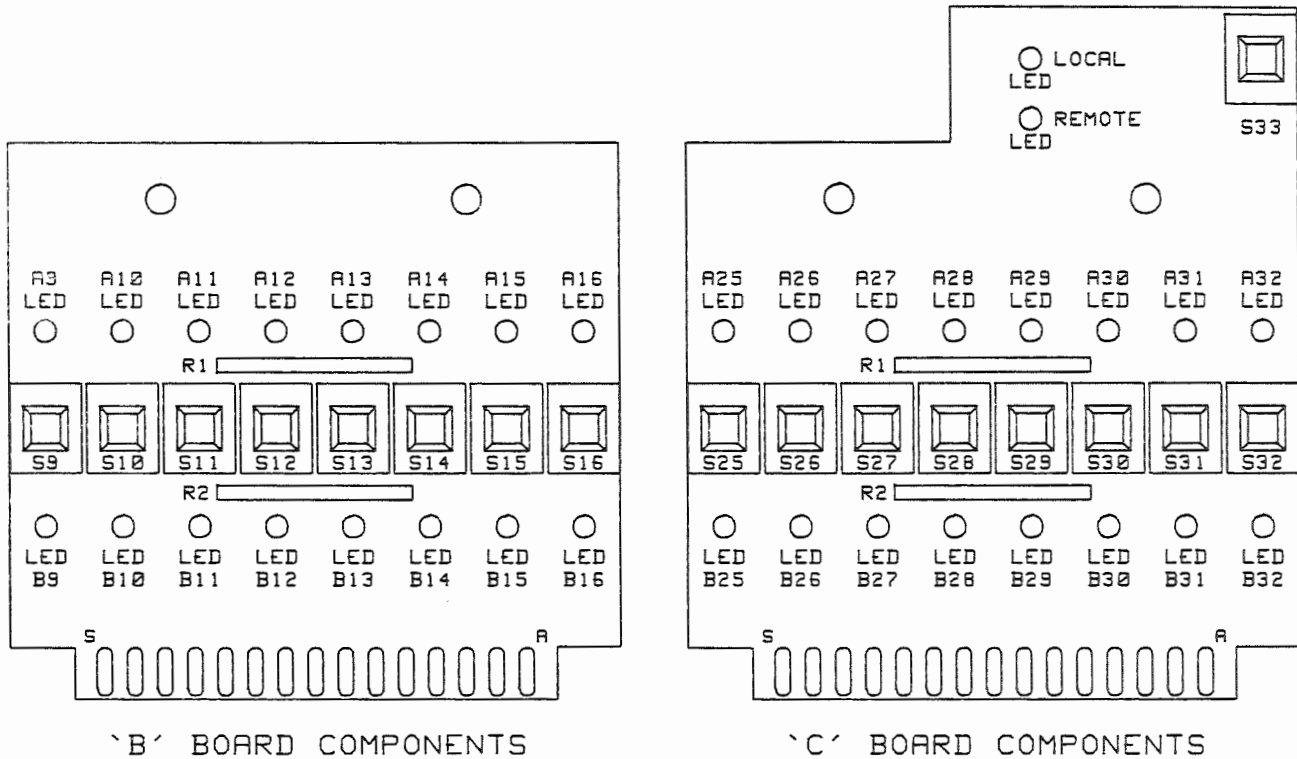

SWITCH BOARD COMPONENT LOCATIONS

- NOTES:
1. FOUR OF THESE SWITCH BOARDS ARE USED TO CONTROL ALL 64 LATCHING RELAYS.
 2. TWO 'B' BOARDS ARE USED FOR RELAYS A9 TO A24 AND B9 TO B24.
 3. THE SWITCH BOARD DIAGRAM IS TYPICAL FOR ALL FOUR BOARDS.

SWITCH BOARDS PARTS LIST

CIRCUIT DESIG	DP PART NUMBER	DESCRIPTION	MFG CODE	MFG PART NUMBER
a11 LED's	23-01	LIGHT EMITTING DIODE, Red	28480	HLMP-1301
S1 to S33	31-01	SWITCH, Pushbutton, SPST,(relay select)	71590	MPSK40112AA
S34,S35	31-02	SWITCH, Pushbutton, SPDT,(line select)	71590	MPSK40122AA
R1,2	68-01	RESISTOR NETWORK,9x1 Kohm,Cermet SIP	01121	110A102

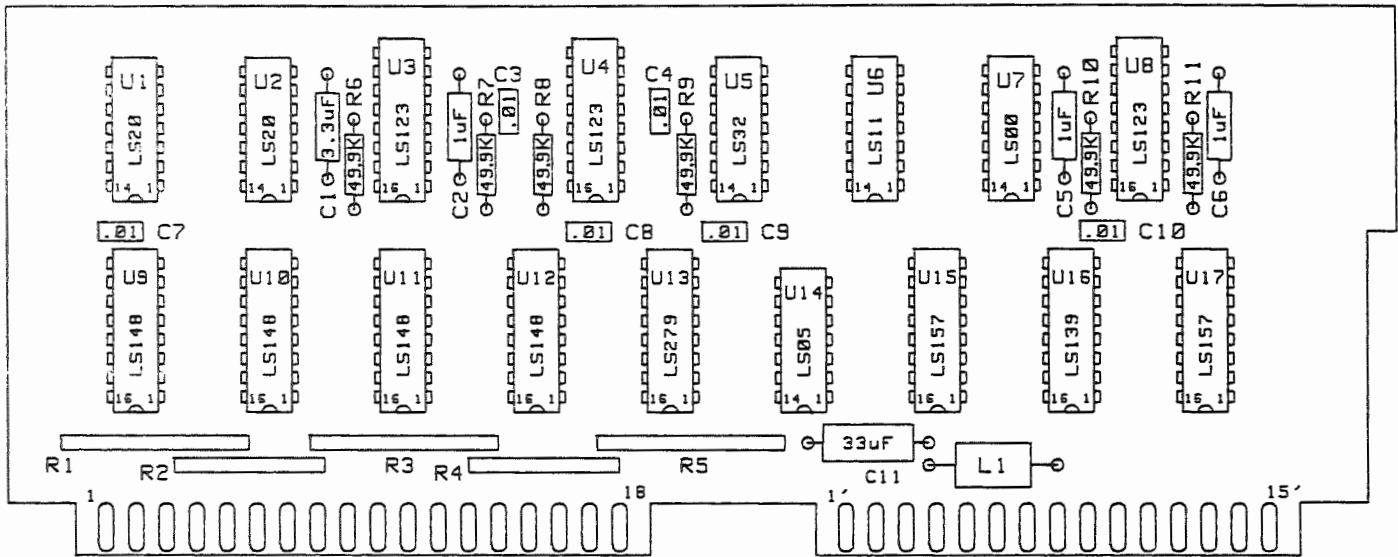

CONTROL BOARD PARTS LIST

CIRCUIT DESIG	DP PART NUMBER	DESCRIPTION	MFG CODE	MFG PART NUMBER
C1	18-02	CAPACITOR,FXD,3.3uF,15VDC,10%,Tant	56289	150D335x9015
C2,5,6	18-01	CAPACITOR,FXD,1uF,15VDC,10%,Tant	56289	150D105x9015
C3,4,7,8,9,10	16-02	CAPACITOR,FXD,.01uF,50VDC,10%,Monolithic	71590	CW15C103K
C11	18-04	CAPACITOR,FXD,33uF,10VDC,10%,Tant	56289	150D336x9010
L1	46-01	INDUCTOR,FXD,4.7uH	DP	46-01
R1,3,5	68-03	RESISTOR,NETWORK,9x10Kohm,2%,Cermet,SIP	01121	110A103
R2,4	68-02	RESISTOR,NETWORK,7x10Kohm,2%,Cermet,SIP	01121	108A103
R6,7,8,9,10,11	69-05	RESISTOR,FXD,49.9Kohm,.125W,1%,Metal flm	91637	CMF55-4992
U1,2	20-06	IC,Dual 4-Input NAND Gate, LS20	01295	SN74LS20N
U3,4,8	20-10	IC,Dual monostable MULTIVIBRATOR,LS123	01295	SN74LS123N
U5	20-07	IC,Quad 2-Input OR gate, LS32	01295	SN74LS32N
U6	20-04	IC,Triple 3-Input AND Gate, LS11	01295	SN74LS11N
U7	20-02	IC,Quad 2-Input NAND Gate, LS00	01295	SN74LS00N
U9,10,11,12	20-13	IC,8-T0-3 Line ENCODER, LS148	01295	SN74LS148N
U13	20-17	IC,Quad Set-Reset LATCH, LS279	01295	SN74LS279N
U14	20-03	IC,Hex INVERTER,Open col output,LS05	01295	SN74LS05N
U15,17	20-15	IC,Quad 2-Input DATA SELECTOR, LS157	01295	SN74LS157N
U16	20-13	IC,2-T0-4 Line DECODER, LS139	01295	SN74LS139N

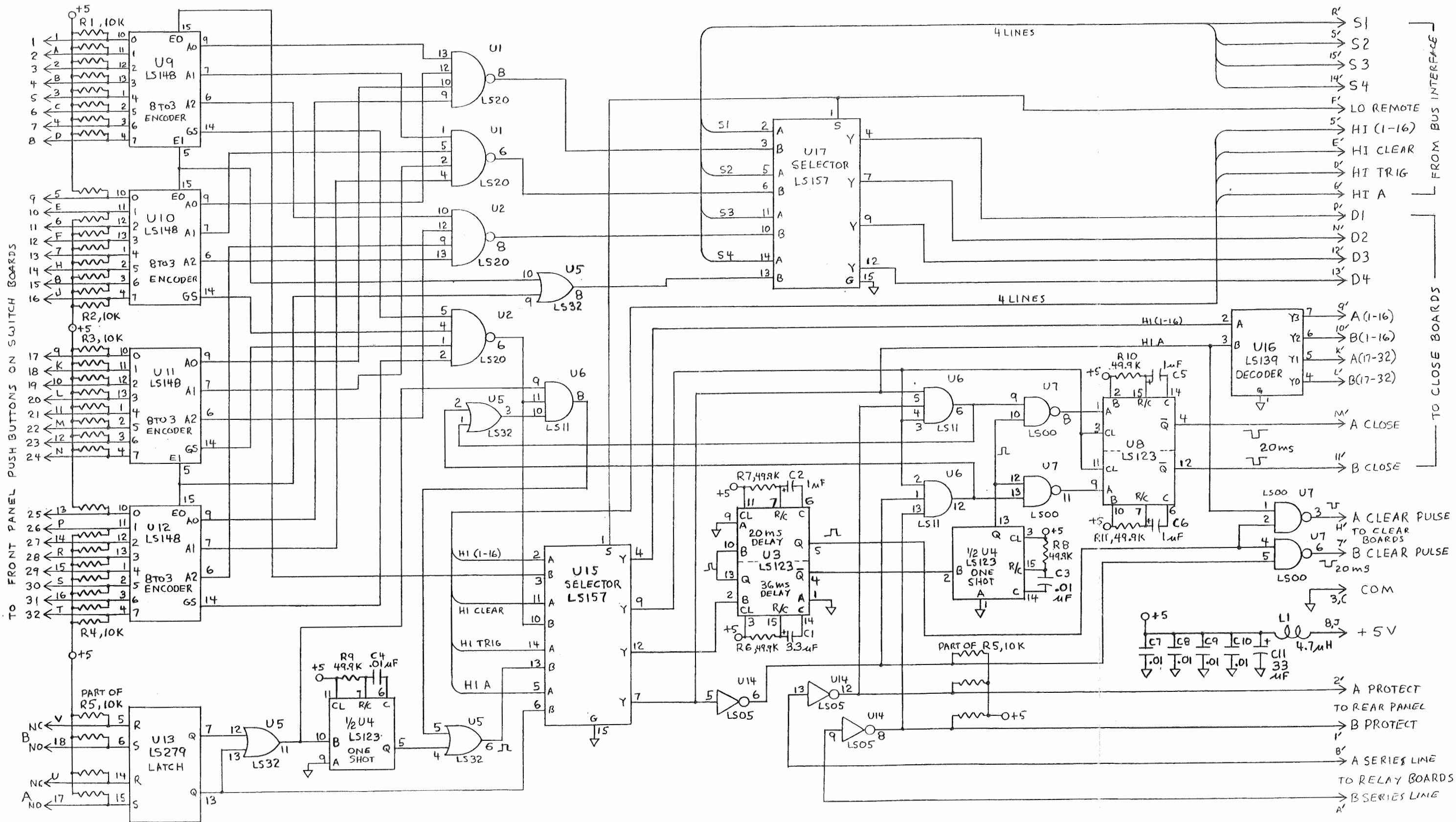

CONTROL BOARD CIRCUIT DIAGRAM

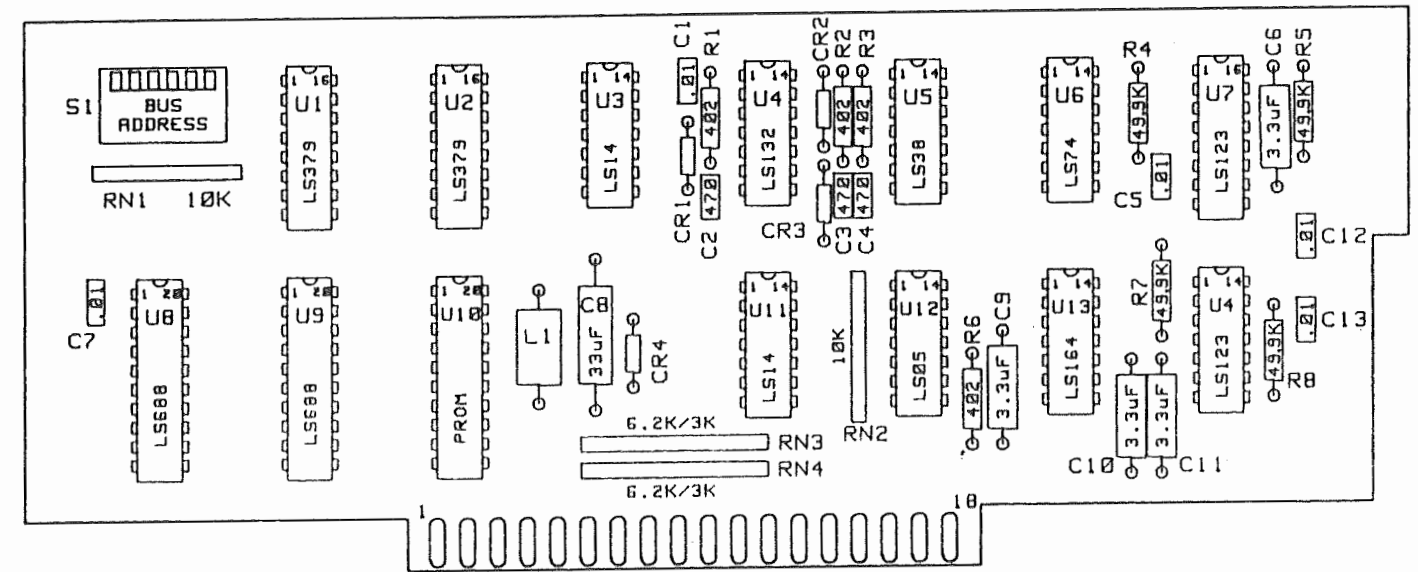

BUS INTERFACE BOARD PARTS LIST

CIRCUIT DESIG	DP PART NUMBER	DESCRIPTION	MFG. CODE	MFG PART NUMBER
C1,5,7,12,13	16-02	CAPACITOR,FXD,.01uFd,50VDC,10%,Monolithic	71590	CW15C103K
C2,3,4,C8	16-01	CAPACITOR,FXD,470pFd,50VDC,10%,Monolithic	71590	CW15C471K
C6,9,10,11	18-04	CAPACITOR,FXD,33uFd,10VDC,10%, Tantalum	56289	150D336x9010
C7	18-02	CAPACITOR,FXD,3.3uFd,15VDC,10%, Tantalum	56289	150D335x9015
CR1,2,3,4	22-01	DIODE,75VPIV,200mA, 1N3600	07263	1N3600
L1	46-01	INDUCTOR,FXD,4.7uH	64772	46-01
R1,2,3,6	69-02	RESISTOR,FXD,402 ohm,.125W,1%,Metal film	91637	CMF55-402
R4,5,7,8	69-05	RESISTOR,FXD,49.9Kohm,.125W,1%,Metal film	91637	CMF55-4992
RN1,2	68-02	RESISTOR,NETWORK,7x10Kohm,2%,Cermet,SIP	01121	108A103
RN3,4	68-04	RESISTOR,NETWORK,8x3&6.2Kohm,2%,Cer,SIP	01121	110E302622
S1	31-05	SWITCH,DIP,6 Position	81073	76PSB06
U1,2	20-18	IC,Quad D-Type FLIP-FLOP, LS379	01295	SN74LS379N
U3,11	20-05	IC,Hex Schmitt trigger INVERTOR,LS14	01295	SN74LS14N
U4	20-11	IC,Quad 2-Input Schmitt trig NAND,LS132	01295	SN74LS132N
U5	20-08	IC,Quad 2-Input NAND gate,open col, LS38	01295	SN74LS38N
U6	20-09	IC,Dual D-Type FLIP-FLOP, LS74	01295	SN74LS74AN
U7,14	20-10	IC,Dual monostable MULTIVIBRATOR,LS123	01295	SN74LS123N
U8,9	20-19	IC,8-BIT MAGNITUDE COMPARATOR, LS688	01295	SN74LS688N
U10	20-20	MEMORY CIRCUIT,512x8,Programmed	64772	20-20
U12	20-03	IC,Hex INVERTOR,Open col output, LS05	01295	SN74LS05N
U13	20-16	IC,8-BIT SHIFT REGISTER, LS164	01295	SN74LS164N

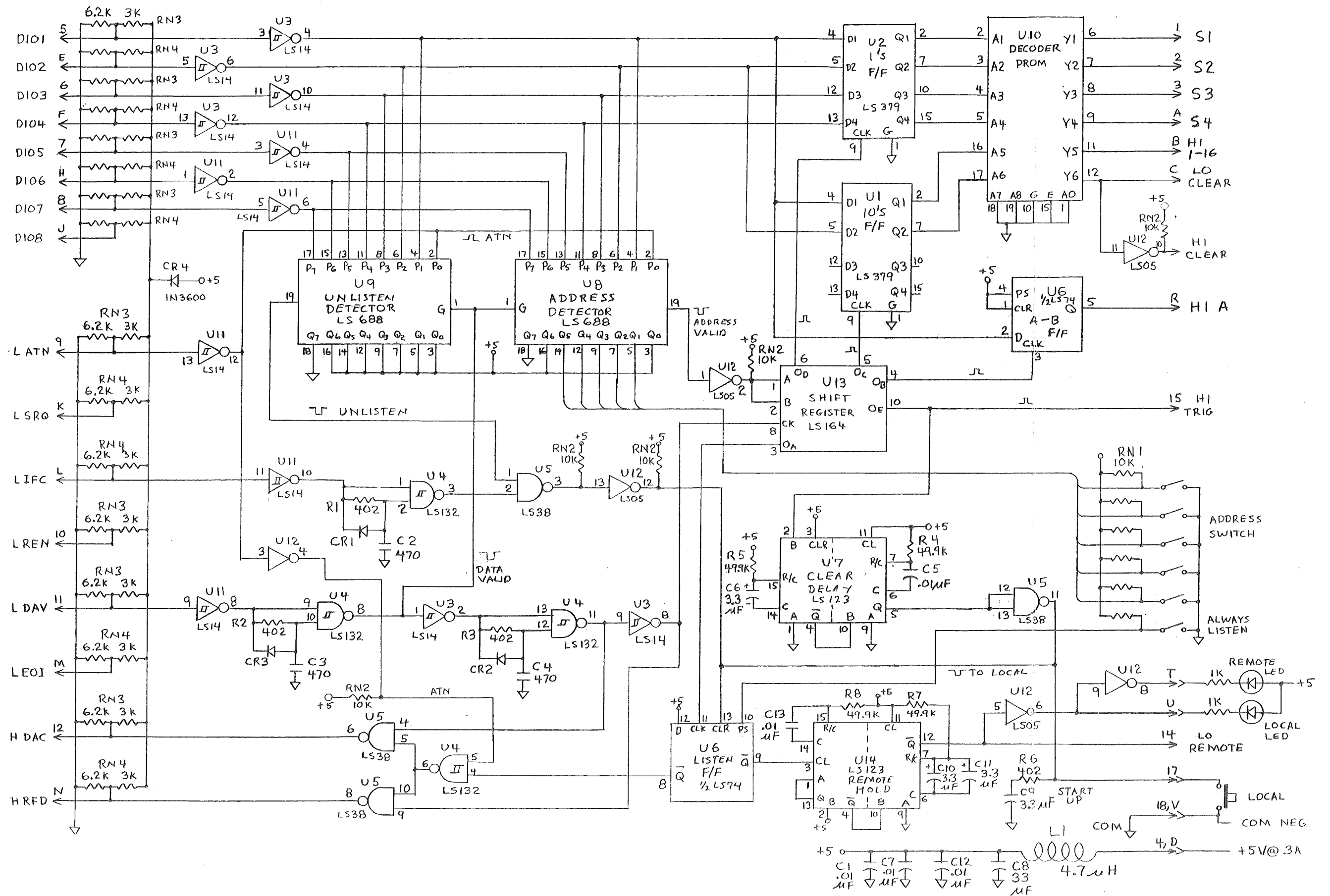

BUS INTERFACE CIRCUIT DIAGRAM

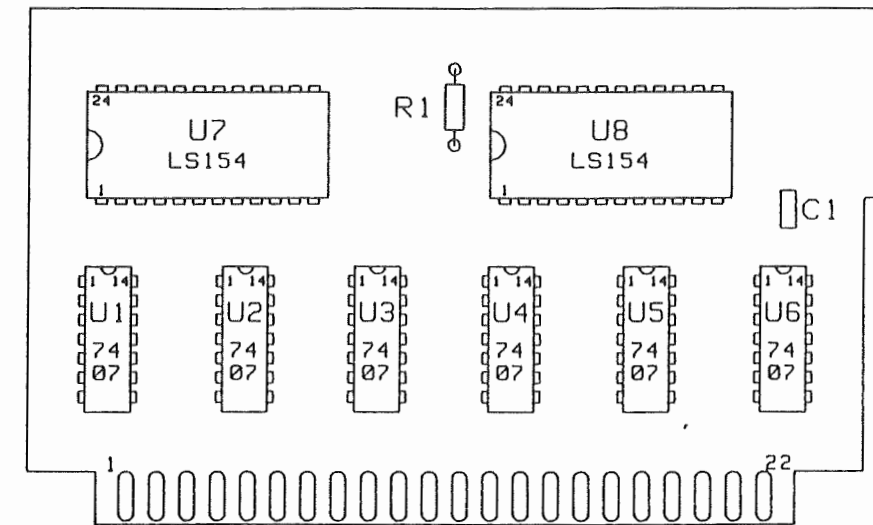

CLOSE BOARD COMPONENT LOCATIONS

- NOTES:
1. TWO OF THESE BOARDS ARE USED IN THE MODEL 320A WITH THE SECOND ONE CLOSING RELAYS 17 TO 32.
 2. THE RELAY COILS SHOWN ON THE CIRCUIT DIAGRAM ARE PART OF THE LATCHING RELAYS LOCATED ON THE RELAY BOARDS LOCATED INSIDE THE ISOTHERMAL BOX.
 3. THE DIODES SHOWN ON THE CIRCUIT DIAGRAM ARE LOCATED ON THE RELAY BOARD SOCKETS UNDER THE BOTTOM COVER OF THE ISOTHERMAL BOX.

CLOSE CIRCUIT PARTS LIST

CIRCUIT DESIG	DP PART NUMBER	DESCRIPTION	MFG CODE	MFG PART NUMBER
C1	16-02	CAPACITOR,FXD,.01uF,50VDC,10%,Monolithic	71590	CW15C103M
R1	69-03	RESISTOR,FIXED,1kohm,.125W,1%,Met film	91637	CMF55-1001
U1,2,3,4,5,6	20-01	Hex BUFFER,Open col,Hi voltage,7407	01295	SN7407
U7,8	20-14	4-T0-16 LINE DECODER,LS154	18324	SN74LS154N

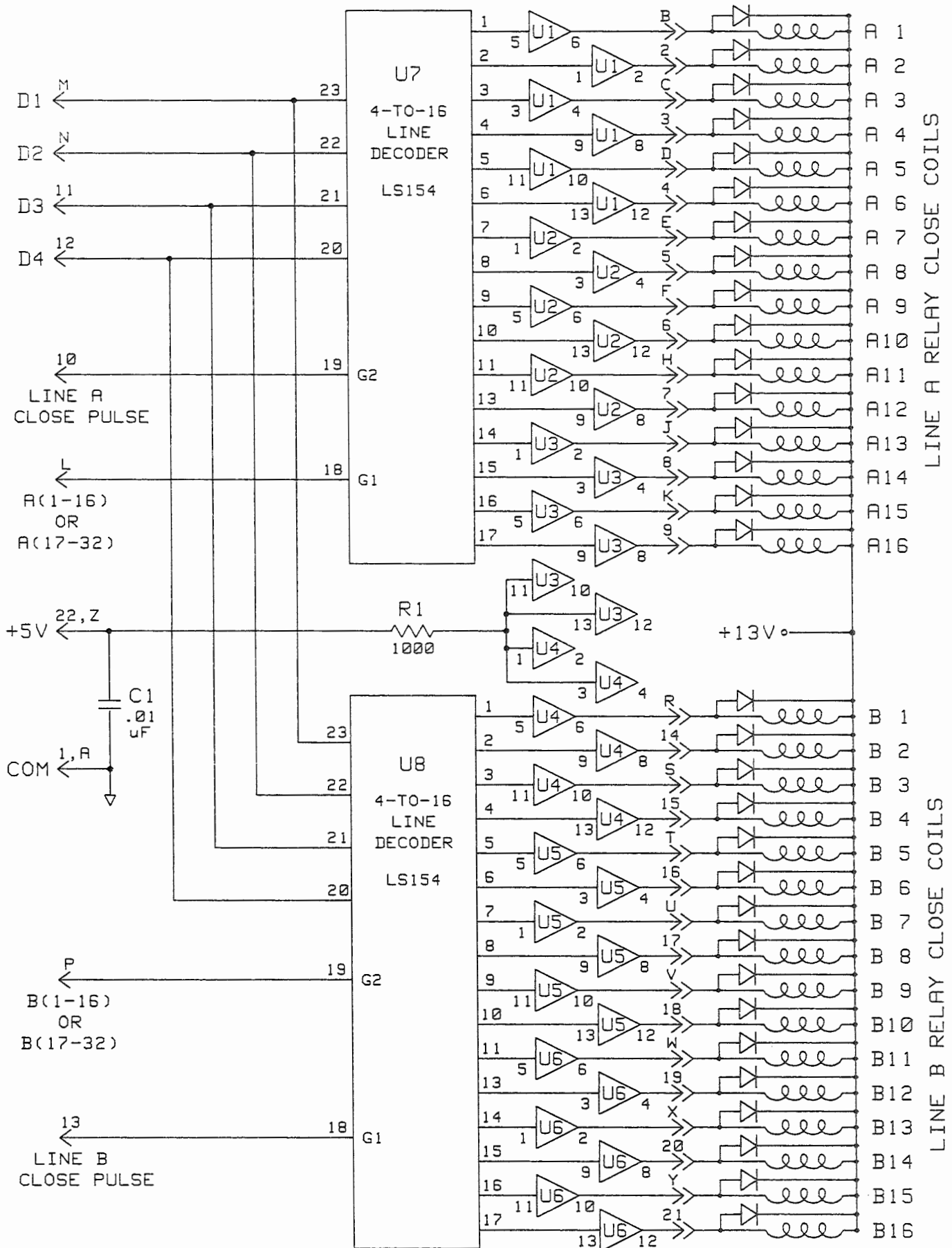

CLOSE BOARD CIRCUIT DIAGRAM

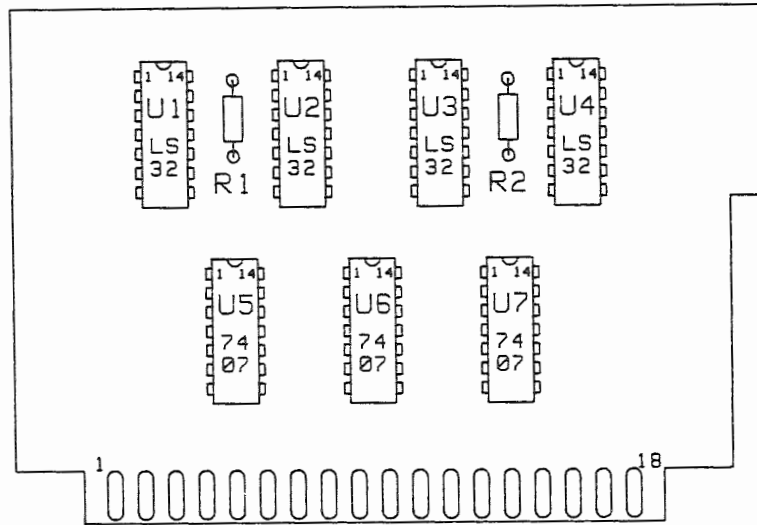

CLEAR BOARD COMPONENT LOCATIONS

- NOTES:
1. TWO OF THESE BOARDS ARE USED IN THE MODEL 160A AND FOUR ARE REQUIRED FOR THE MODEL 320A.
 2. THE RELAY COILS SHOWN ON THE CIRCUIT DIAGRAM ARE PART OF THE LATCHING RELAYS LOCATED ON THE RELAY BOARDS LOCATED INSIDE THE ISOTHERMAL BOX.
 3. THE DIODES SHOWN ON THE CIRCUIT DIAGRAM ARE LOCATED ON THE RELAY BOARD SOCKETS UNDER THE BOTTOM COVER OF THE ISOTHERMAL BOX.

CLEAR CIRCUIT PARTS LIST

CIRCUIT DESIG	DP PART NUMBER	DESCRIPTION	MFG CODE	MFG PART NUMBER
R1,2	69-03	RESISTOR, FIXED, 1kohm, .125W, 1%, Met film	91637	CMF55-1001
U1,2,3,4	20-07	Quad 2-input OR GATE, LS32	01295	SN74LS32N
U5,6,7	20-01	Hex BUFFER, 0pen col, Hi voltage, 7407	01295	SN7407

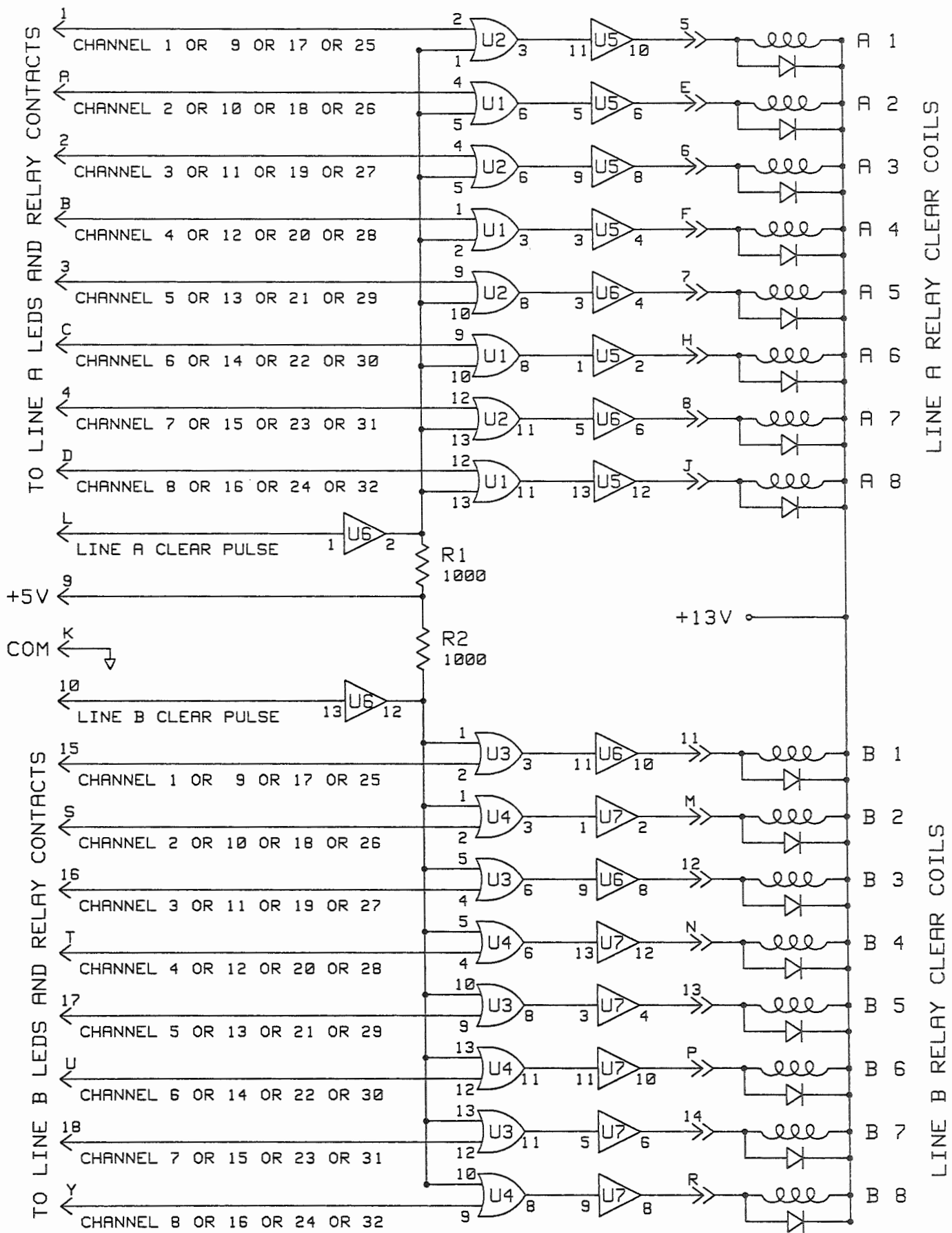

CLEAR BOARD CIRCUIT DIAGRAM

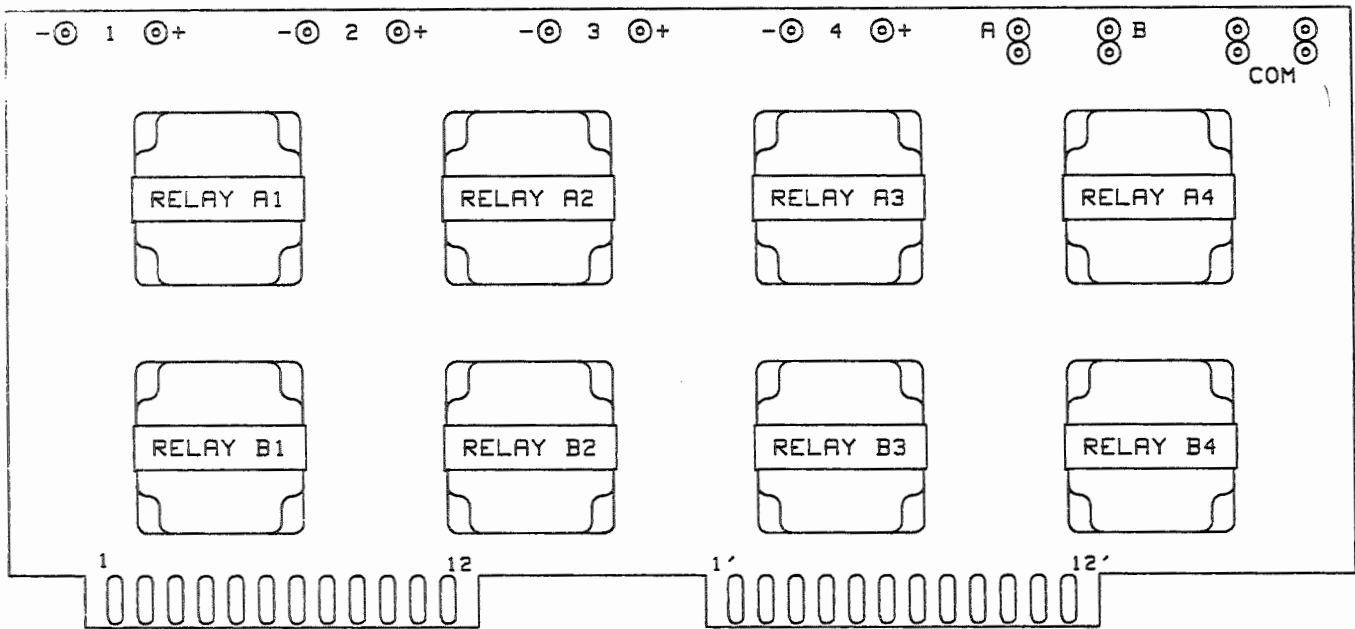

RELAY BOARD COMPONENT LOCATIONS

- NOTES: 1. EACH BOARD HOLDS THE LATCHING RELAYS FOR FOUR CHANNELS OF STANDARD CELL INPUTS.
2. FOUR OF THESE BOARDS ARE USED IN THE MODEL 160A AND EIGHT ARE USED IN THE 320A.
3. THE BOARDS ARE LOCATED UNDER THE TOP COVER OF THE ISOTHERMAL BOX.

RELAY BOARD PARTS LIST

CIRCUIT DESIG	DP PART NUMBER	DESCRIPTION	MFG CODE	MFG PART NUMBER
a11	49-01	RELAY,LATCHING,3-pole,2-throw,12V coil	21226	12BW3LD

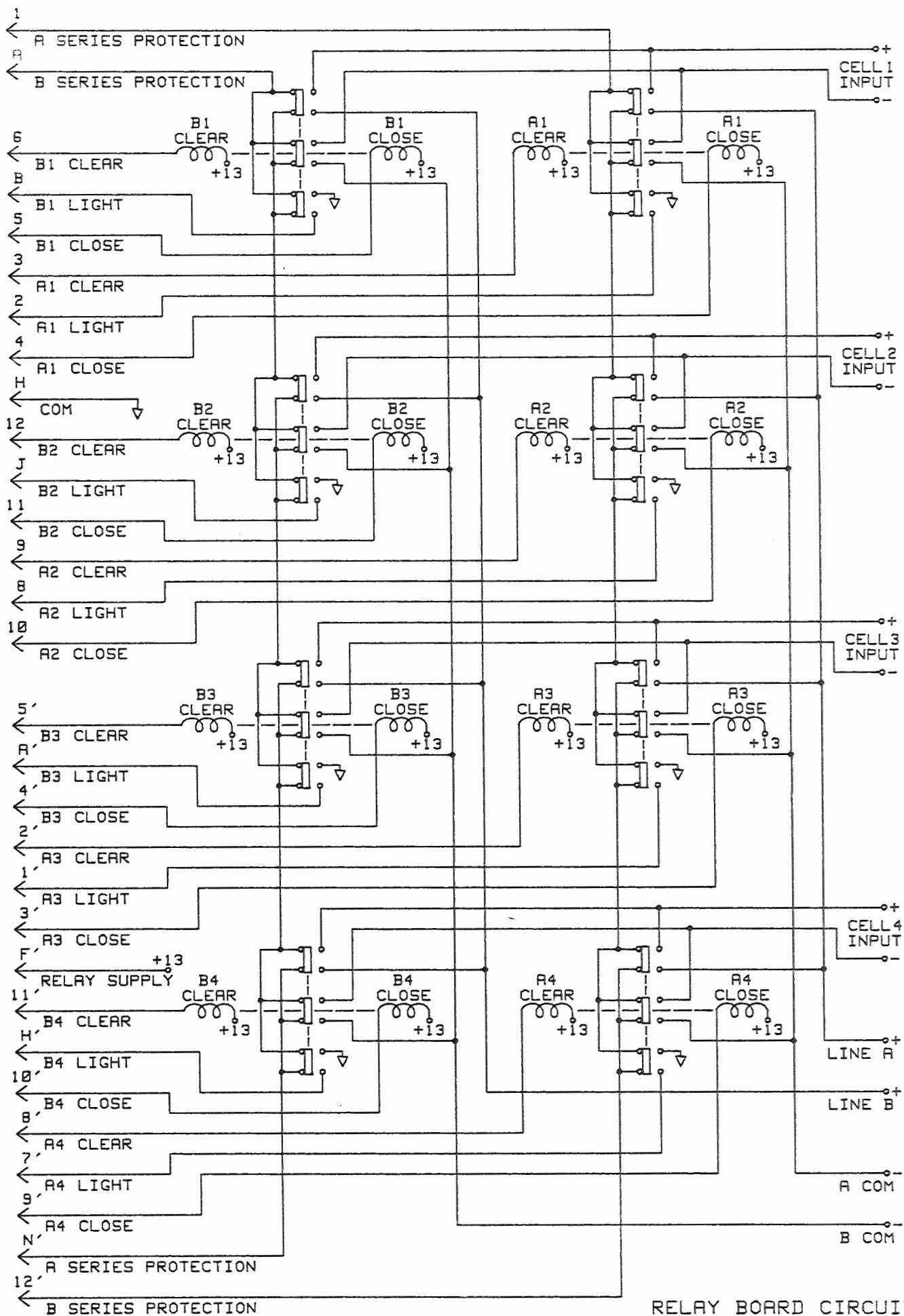

RELAY BOARD CIRCUIT

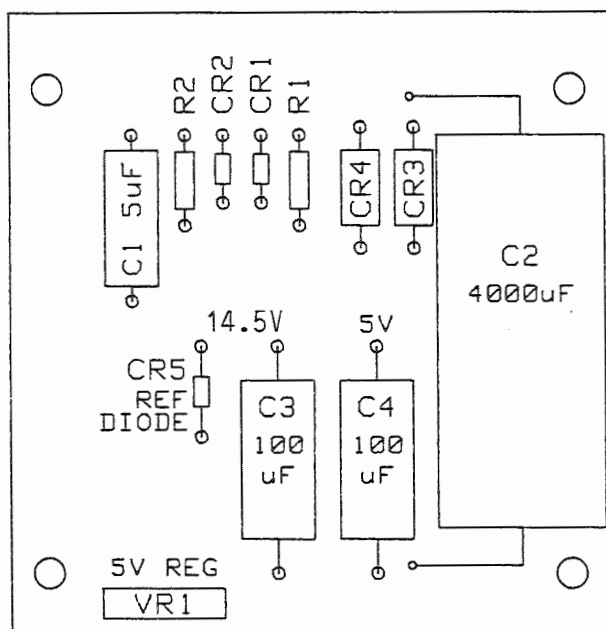

POWER SUPPLY PARTS LIST

CIRCUIT DESIG	DP PART NUMBER	DESCRIPTION	MFG CODE	MFG PART NUMBER
		***** PARTS LOCATED ON PC BOARD ****		
C1	18-03	CAPACITOR,FXD,5µF,50VDC,-10%/+50%,A1um	56289	500D505G050
C2	18-06	CAPACITOR,FXD,4000µF,15VDC,-10%/+75%,A1	56289	39D408G015JL
C3,4	18-05	CAPACITOR,FXD,100µF,16VDC,-10%/+50%,A1	56289	TE1162
CR1,2	22-01	DIODE,75VPIV,200mA, 1N3600	07263	1N3600
CR3,4	22-03	DIODE,50VPIV,3A	04713	MR500
CR5	22-02	DIODE,REFERENCE,15V,5%,400mW, 1N965B	07263	1N965B
R1,2	69-01	RESISTOR,FIXED,200 ohm,.125W,1%,Met film	91637	CMF55-200
VR1	21-01	VOLTAGE REGULATOR,5VDC,4%,2A	07263	uA7805UC
		***** PARTS LOCATED ON CHASSIS *****		
F1	11-01	FUSE,0.5A,3AG S10B10	75915	313-500
J1	50-02	RECEPTACLE	70903	17252
S1	31-03	SWITCH,TOGGLE,DPDT	09353	7201P3
T1	47-01	POWER TRANSFORMER,14V Center tapped,2A	81095	F251X

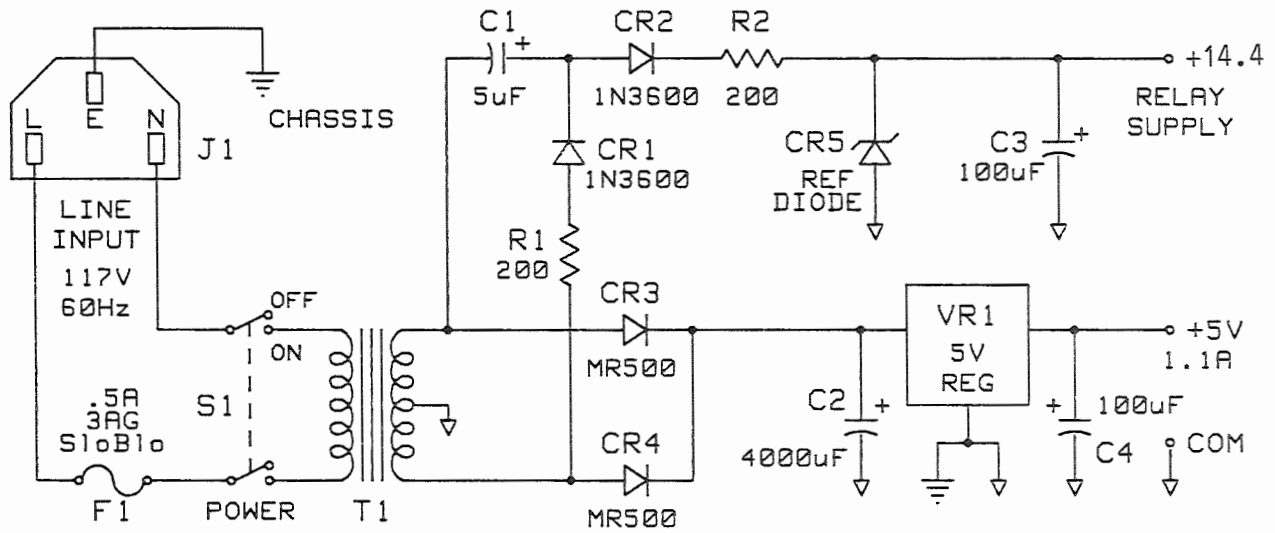

POWER SUPPLY CIRCUIT DIAGRAM

PARTS LOCATED ON REAR PANEL

	DP PART NUMBER	DESCRIPTION	MFG CODE	MFG PART NUMBER
	11-01	FUSE 0.5A, 3AG S1oB1o	75915	313-500
	11-02	FUSE HOLDER	75915	LFE345601
	50-01	CONNECTOR, BUS 24 Contact, Male	02660	57-20240-2
	50-02	RECEPTACLE, Line cord, 3 Conductor	70903	17252
	51-01	BINDING POST, Low thermal, Black	05276	3770-0
	51-02	BINDING POST, Low thermal, Red	05276	3770-2
	51-03	MOUNTING BASE, Black	05276	3862-0
	51-04	TERMINAL BLOCK, 4 Screw contacts	71785	4-176-3-10
	82-01	POWER CORD, 3 Conductor	70903	17250
	82-02	TELEPHONE CABLE, 4 Cond,(opt 1 only)	70903	9794

PARTS LOCATED ON CHASSIS

	DP PART NUMBER	DESCRIPTION	MFG CODE	MFG PART NUMBER
	22-01	DIODE, 75VPIV, 200mA,(on relay coils)	07263	1N3600
	31-03	SWITCH, Toggle, DPDT,(power)	09353	7201P3
	31-04	SWITCH, Pushbutton, SPST,(defeat)	82389	961
	47-01	POWER TRANSFORMER, 14VCT, 2A	81095	F251X
	50-03	CONNECTOR,Printed circuit, 12 Pos	71785	50-24A-30
	50-04	CONNECTOR,Printed circuit, 15 Pos	71785	50-30A-30
	50-05	CONNECTOR,Printed circuit, 18 Pos	71785	50-36A-30
	50-06	CONNECTOR,Printed circuit, 22 Pos	71785	50-44A-30