

SECTION 1

CALIBRATION

1.1 INTRODUCTION

1.1.1 Manufacturer's Initial Calibration

The 4000 is fully calibrated before leaving the factory, and remains within the appropriate specification for the time periods detailed in Section 6 of the User's Handbook.

1.1.2 Need to Recalibrate

Sections 1.2 to 1.5 detail the procedures necessary to recalibrate instrument functions to known specifications. The occasions for re-calibration are as follows:

(1) **PERIODIC ROUTINE AUTOCALIBRATION**

The specifications for the 4000 are based on standard intervals of up to 24 hours, 90 days or 1 year from calibration. User's may wish to choose alternative schemes, accounting for:

- (a) The accuracy required when in use,
- (b) The scheduled calibration intervals normally adopted by the user's organisation, and
- (c) The instrument specifications (User's Handbook Section 6)

(2) **RE-STANDARDISATION**

Occasions may arise when it is necessary to trim the instrument internal Master Reference.

For example, when the 4000 is to be made traceable to a different National Standard,

after transportation from one country to another.

The procedure for "STD" autocalibration is detailed in Section 1.2.8 (Refer to Section 1.28 para 3 note C).

(3) **BATTERY CHANGE**

The Lithium battery which powers the non-volatile calibration memory should be replaced after 5 years (Refer to Section 5.3).

After replacement, a full Pre-calibration (Precal – Section 1.4) followed by a Routine Autocalibration (Section 1.2) is required.

(4) **CRITICAL PARTS**

Recalibration will be required after replacement of a critical pcb assembly or critical component. These are listed in Table 1.1, indicating the extent of recalibration necessary.

1.1.3 Recalibration Procedures in this Section

Routine Autocalibration (Section 1.2)

The Routine Calibration procedures are sufficient for all normal recalibration purposes, except when "Pre-cal" is called for (Refer to Table 1.1).

Remote Calibration over the IEEE 488 Bus (Section 1.3)

Section 1.3 describes the device-dependent commands necessary for routine calibration of the 4000 over the IEEE 488 bus, as a supplement to Section 5 of the User's Handbook. A guideline example is given, but this needs to be adapted for the bus controller in use.

Pre-calibration Procedures (Section 1.4)

In an initial internal calibration process at manufacture, certain "Pre-cal" parameters are established in a special calibration memory. Under certain conditions (detailed in Table 1.1) these parameters need to be re-established by the "Pre-cal" procedure in Section 1.4, before the Routine Autocalibration of Section 1.2.

Ω Option Internal Adjustment (Section 1.5)

If a standard resistor value has been changed by subjecting to undue stress, it may be possible to recalibrate by internal adjustment. Refer to Section 5.4 for further information.

Table 1.1

PCB Assembly	Components Replaced	Precal (Sect. 1.4)	Routine Autocalibration (Sect. 1.2)
Digital (400442)	Complete Assembly	Full	Full
	Lithium Battery (Sect. 5.3)	Full	Full
	Non-volatile RAM (M10/26/27)	Full	Full
	Non-volatile RAM Supply Commutator components	Full	Full
Reference Divider (400444)	Complete Assembly	Full	Full
	Reference PCB Assembly (400452)	Full	Full
	Any set of main, guard or LSD switch FETs	Full	Full
	Reference Buffer Switch Driver Flip Flops or their preselected resistors R79	Full	Full
DC (400445)	Complete Assembly	—	DC (All Ranges) only. DC (1V, 100mV, 10mV, 1mV, 100 μ V Ranges) only.
	1V attenuator R73/R74	—	
	100mV attenuator R69/70/71 72/75/76	—	DC (100mV, 10mV, 1mV, 100 μ V Ranges) only.
	100V/1000V Attenuator R8/9/25/26/46/47/64/65 88/95/98	—	
I/ Ω (400448)	Complete Assembly (N.B. Internal Adjustment required – refer to Section 5.5)	—	I and Ω (All Ranges) only
	$\div 10$ attenuator (R43/44) (I Function)	—	I (All Ranges) only
	Current shunts R8/9/10/79/80 (I Function)	—	I (All Ranges) only
	Standard resistors, associated pre-selected or variable trimmer resistors (Ω Function)	Ω Option internal adjustment (Sect. 1.5)	Ω (Replaced Values) only

Table 1.1 List of Critical pcbs and components

1.2 ROUTINE AUTO CALIBRATION

1.2.1 Introduction

The 4000 possesses excellent short and long term stability. Some users will wish to maintain the highest accuracy by recalibrating at short intervals (e.g. every 24 Hours). In these cases, recalibration of the 4000 becomes a routine task. For this reason, Routine Autocalibration procedures are repeated in section 8 of the User's Handbook. It is emphasised that the 4000 can be used immediately after recalibration.

1.2.2 The 4000 Autocal Feature

Full or part calibration may be carried out for all routine purposes from the front panel. Removal of covers is unnecessary, therefore avoiding thermal disturbance. Calibration corrections are stored in an internal memory which remains energised by a battery even when the instrument power supply is switched off. The life of the battery is estimated at 10 years, and it is normally changed at 5-year intervals. On power-up, the 4000 performs a self-test which includes a check of the contents of the calibration memory.

1.2.3 Equipment Requirements

DC Voltage — A Standard DC Voltage source of suitable accuracy

Example: Series bank of 10 standard cells and Datron 4904 Standard Cell buffer.

— A Precision Divider:
Example: Datron 4902 High Voltage divider and Datron 4903 DC Switching Unit

— A battery-operated null detector with variable sensitivity, able to withstand 1200V across its input terminals
Example: Keithley Instruments Model 155

Resistance — a set of standard resistors covering 1Ω to $10M\Omega$. The 1Ω to $10k\Omega$ should be 4-wire type.

— an accurate resistance bridge, or other ratiometric device for measuring resistance to the required accuracy.

— a Datron 1071 used as a transfer-measurement device.

DC Current — A DC Voltage source, calibrated to suitable accuracy at approximately 1V and 100mV

Example: The standard voltage source used for DC Voltage, with the Datron 4903 DC Switching Unit.

— The battery-operated null detector used for DC Voltage.

— A set of calibrated current shunts of suitable accuracy.

N.B. To allow the same value to be set on the DC Voltage source for each range, the shunts may be of five decade values. Then the same Null Detector sensitivity can be used on each range.

CAUTION

When choosing a set of current shunts ensure that their power dissipation ratings are sufficient to avoid permanent degradation from the self-heating effects of the current being checked. This applies particularly to the 1 Amp shunt.

— alternatively, a dmm of sufficient accuracy may be used to measure the voltage across the set of calibrated current shunts.

Example: Datron 1071 using "compute" mode.

1.2.3.1 Notes on the Use of the Null Detector

The null detector is connected to the Hi lead between the DC Voltage Source and the 4000. A high-impedance-input device should be chosen to reduce off-null currents due to differences in the outputs of the DC voltage source and the 4000. A battery-operated instrument is preferred to ensure adequate isolation. Some null detectors possess high input impedance only when their readings are on-scale, so care should be taken to ensure that drain currents from the DC Voltage source do not become excessive. This applies particularly if the DC source is a standard cell or a bank of cells. Five points are important:

1. The null detector should be connected to the 4000 (or 4000 load resistor) only when the 4000 OUTPUT OFF LED is lit. (With Output OFF, the I+, I-, Hi and Lo terminals are at high impedance).
2. Always set the null detector to its lowest sensitivity before connecting up, and increase sensitivity only when the voltages output by the DC Voltage source and the 4000 are close in value.
3. Do not change polarity of the 4000 or DC Voltage source without first switching the 4000 OUTPUT OFF. Care must be taken to ensure that the correct-polarity ON key

is pressed, to avoid excessive voltages being connected across the null detector, particularly when checking the 4000 directly against a standard cell.

4. **WARNING** During Performance checks and calibration a common mode voltage equal to the full range voltage is present at the Null Detector input terminals. On $\pm 1000V$ checks this voltage is potentially lethal, so **EXTREME CAUTION** must be observed when making adjustments to the null detector sensitivity.

5. **CAUTION** The Null Detector used must be able to withstand voltages up to 1200V between its input terminals. Such voltages will be present during the time that the 4000 is ramping from zero to 1000V Full Range after setting OUTPUT ON. Inadvertent disconnection of the Precision Divider terminals can transfer full output across the Null detector.

1.2.4 Interconnections

Interconnection instructions in this section are necessarily simple and basic, and are mainly intended to show connections to the 4000. It is recognised that they may need to be adapted to meet an individual user's require-

ments. It is assumed that users will possess knowledge of the operation and use of standards equipment such as that mentioned above.

1.2.5 Calibration Modes

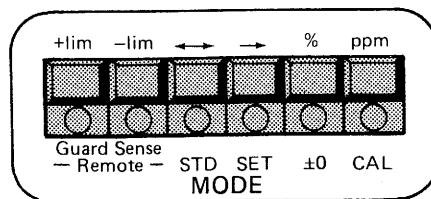

Four of the Mode Keys have 'Autocal' functions:

STD, SET, ± 0 and CAL

These are printed in red below the keys and are activated only when the cal legend is present on the MODE display. The normal key modes, (Spec, Error, Offset and Test) are disabled by the selection of CALIBRATION ENABLE on the rear-panel keyswitch. The STD, SET and ± 0 keys have toggle action (e.g, when a mode is set it may be deselected by a second key-press).

1.2.5.1 General Procedure

The OUTPUT display is set to the Calibration Standard value, the 4000 output is switched ON, and one of the calibration mode preselector keys (SET, STD or ± 0) is pressed. The 4000 output is adjusted to obtain a null at the Calibration Standard value, and the CAL key is pressed to execute the calibration.

1.2.5.2 Autocal Facilities

SET The SET key allows calibration to any value in the selected Range (e.g. at a standard cell voltage). If the value initially set on the OUTPUT display is below 2% of Full Range value, the 4000 assumes that an offset calibration is requested, and if at 2% or above, a gain calibration is assumed.

STD The STD key allows a user to trim the value of the internal Master Reference voltage. The facility can be used to correct for any long-term drift, or to avoid a full recalibration of the 4000 when Laboratory References have been re-standardised. STD calibration effectively changes the gain of all voltage and current ranges in the same ratio, by a simple procedure available either on 1V or 10V range.

±0 The ±0 key is used to align the ON+ and ON- zeros of all voltage and current ranges, by a two-part calibration on the 10V range. It is only necessary when the ON+ and ON- zeros on the 10V range do not coincide at the same null.

CAL only The CAL key executes the preselected AUTOCAL mode. If the CAL key is pressed without first pressing SET, ±0 or STD, the 4000 assumes that a calibration at either Zero or Full Range is required. It uses the value set on the OUTPUT display to distinguish between Zero (Offset calibration) and Full Range (Gain calibration) as for SET mode.

1.2.5.3 Autocal Availability

As the Autocal keys perform specific tasks, they are available only as defined by Table 1.2. The message "Error 3" appears on the MODE display for any attempt to select an inappropriate mode.

AUTOCAL Mode		DC Voltage (DC)	DC Current (I)	Resistance (Ω)	
				Local Sense (2-wire)	Remote Sense (4-wire)
SET and CAL	Zero offset for range at User's selected value	100mV–1000V Ranges only	All Ranges		
	Gain for range at User's standard value				
+0 and CAL	Alignment of internal ON+ and ON- zeros	10V Range only			
STD and CAL	Internal Reference gain at User's Standard value	1V and 10V Range only			
CAL ONLY	Zero offset for range	All Ranges	All	1 Ω –1M Ω	
	Gain for range at Full Range Value	10mV–1000V Ranges only	Ranges	Ranges only	All Ranges

Table 1.2 Autocal availability

1.2.6 Zero Calibration

It is common practice to accept a small offset in the output of a voltage calibration standard, providing that the same offset is present at all output values, including zero.

The output of the 4000 is fully floating, so its output may be referred to any common mode voltage within the range specified on page 6.1 of the User's Handbook. In particular, its zero may be aligned to absolute zero in Local Sense by calibration to a null across its Hi and Lo (Sense) terminals. But if it is then gain-calibrated

against an offset standard without re-zeroing to that standard's offset zero, normal mode gain errors will result.

It is therefore essential that each voltage and current range zero is first calibrated to a standard's zero before using that standard to calibrate the range gain.

If the 4000 zero output is to be regarded as absolute Laboratory Reference Zero, then AFTER range gain calibration its range zero output may be recalibrated to a null across the Hi and Lo (Sense) terminals.

1.2.7 Calibration Sequence

The sequence of operations for full calibration of a 4000 Autocal Standard is given below:

Preparation	Section 1.2.7.1
DC Voltage	1.2.8
DC Current	1.2.9
Resistance	1.2.10
Return to Use	1.2.7.2

If only a partial recalibration is to be done, step 1 of the DC Voltage sequence should be carried out immediately after the preparation.

WARNING During performance checks and calibration a common mode voltage equal to the full range voltage may be present at the Null Detector input terminals. On $\pm 1000\text{V}$ checks this voltage is potentially lethal, so **EXTREME CAUTION** must be observed when making adjustments to the null detector sensitivity.

CAUTION The Null Detector used must be able to withstand voltages up to 1200V between its input terminals. Such voltages will be present during the time that the 4000 is ramping from zero to 1000V. Full Range after setting OUTPUT ON. Inadvertent disconnection of the Precision Divider terminals can transfer full output across the Null detector.

1.2.7.1 Preparation

Before any calibration from the front panel is carried out, prepare the 4000 as follows:

1. Turn on the instrument to be checked and allow minimum of 4 hours to warm-up in the specified environment.

2. IEEE 488 Address switch:
Set to ADD 11111 as shown (Address 31)

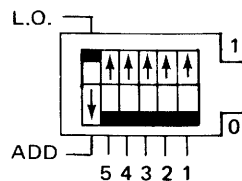

3. CALIBRATION ENABLE key switch:
Insert Calibration Key and turn to ENABLE.

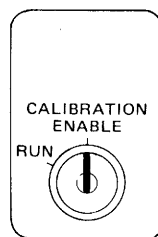

1.2.7.2 Return to Use

When any calibration is completed, return the 4000 to use as follows:

1. Ensure that OUTPUT OFF LED is lit.

2. CALIBRATION ENABLE key switch:
Turn to RUN and withdraw calibration key.

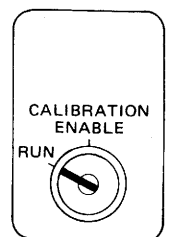

3. IEEE 488 Address switch:
Restore to correct address if the 4000 is to be used in an IEEE 488 system.

These actions activate the four calibration modes (labelled in red) and present the cal legend on the MODE display.

4. Ensure that OUTPUT OFF LED is lit.



DANGER HIGH VOLTAGE



**THIS INSTRUMENT IS CAPABLE
OF DELIVERING
A LETHAL ELECTRIC SHOCK!**

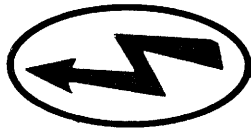

FRONT or REAR
terminals carry the
Full Output Voltage.

THIS CAN KILL!



Guard terminal is
sensitive to over-
voltage

**It can damage
your instrument!**

Unless **you** are **sure** that
it is **safe** to do so,
DO NOT TOUCH the
I+ I- Hi or **Lo leads**
and **terminals**

DANGER

1.2.8 DC VOLTAGE CALIBRATION

CAUTION First read the Notes on the use of the Null Detector in Section 1.2.3.1.

1. Ensure that the 4000 OUTPUT OFF LED is lit.

Select DC and connect the DC Voltage Calibration source and Null Detector to the 4000 terminals as shown in Fig. 1.1. Use short leads and ensure that Null Detector is set to Low Sensitivity.

Fig. 1.1 4000 connections for DC Voltage Calibration

(a) Low Voltage: 100 μ V – 10V Ranges

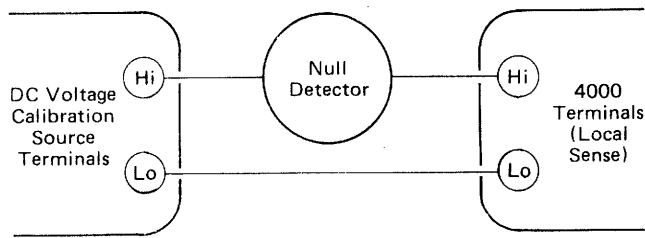

(b) High Voltage: 100V and 1000V Ranges

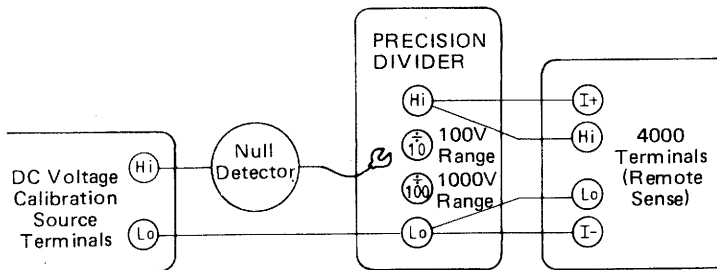

Ensure that the interconnecting circuit has thermally stabilised before carrying out each "Autocal" operation

2. Calibrate the DC Voltage Ranges in the step sequence of Table 1.3 using the Calibration Routine at each step (except steps 2 and 3).

3. **Calibration Routine:** Calibration of DC Voltage to a Standard voltage calibration source.

NOTES: A For calibration at any value, this routine may be used as printed.

B For calibration at zero or positive nominal Full Range only, operation (g) may be omitted.

C To trim internal Master Reference Voltage on 1v or 10V Range, substitute "STD" for "SET" at operation (g). (Refer to earlier description of "STD").

D In Table 1.3(a), use interconnections as Fig. 1.1(a) (Low Voltage), obtaining the correct calibration voltage from the source.

In Table 1.3(b), use interconnections as Fig. 1.1(b) (High Voltage) selecting $\div 10$ at steps 10 and 11, $\div 100$ at steps 12 and 13.

CAUTION Below 2% of Range, the 4000 corrects for an assumed offset error; at 2% of Range and above the correction is for an assumed gain error.

- a) Null Detector Set to Low sensitivity
- b) 4000 Ensure OUTPUT OFF
- c) DC Source Set to the required polarity and value
- d) 4000 Select correct FUNCTION and RANGE
- e) 4000 Use full Range, Zero or OUTPUT \uparrow/\downarrow keys to set the required polarity and value on OUTPUT display.

N.B. Operation (f) must be carried out before operation (g)

- f) 4000 Press the correct-polarity ON key
Omit Operation (g) if calibrating at zero or Full Range value
- g) 4000 Press SET Key:
SET LED lights green
OUTPUT display reading also appears on MODE display

- h) Null Detector Increase sensitivity to give an off-null reading and use 4000 OUTPUT \uparrow/\downarrow keys to back off to null. Repeat until null lies between two values of the OUTPUT display least-significant digit.

- j) Null Detector Set to LOW sensitivity

- k) 4000 Press CAL key
CAL LED flashes once
MODE display value is transferred to OUTPUT display
MODE display is cleared
SET LED goes OFF

The 4000 is now calibrated at this value.

4. **± 0 Alignment Routine:** Alignment of 10V Range positive and negative zeros if necessary at step 3 of Table 1.3.

- a) Null Detector Set to low sensitivity
- b) 4000 Ensure OUTPUT OFF on DC 10V Range.
- c) Calibration Source Ensure set to zero and thermally stable.
- d) 4000 Press OUTPUT Zero Key
Press ON+ Key
Press ± 0 Key:
 ± 0 LED lights, OUTPUT display at zero
- e) Null Detector Increase sensitivity to give an off-null reading and use 4000 OUTPUT \uparrow/\downarrow keys to back off to null. Repeat until null lies between two values of the OUTPUT display least-significant digit.
- f) 4000 Press CAL key:
CAL LED lights
No change to OUTPUT display.
- g) 4000 Press ON – key
- h) Null Detector Obtain accurate null as in (e) above
- j) 4000 Press CAL key:
CAL LED goes OFF
 ± 0 LED goes OFF
OUTPUT display falls to zero

The 4000 positive and negative zeros are now both aligned to the Calibration Source zero.

Table 1.3 DC Voltage Calibration

(a) Low Voltage – connect as Fig. 1.1 (a)

Step	Calibration Operation	4000 Range	Calibration Source Voltage (Nominal value) ^[1]	4000 Output Setting (Nominal value) ^[1]	AUTOCAL Key Used ^[2]
1	10V Range ON+ zero	10	0.000000V	(ON+) 0.000000V	—
2	10V Range ON- zero check only – do not calibrate	10	0.000000V	(ON-) 0.000000V	Check only 0.000000V
3	±0 Alignment	10	0.000000V	Refer to ±0 Alignment Routine	'±0'
4	100mV Range zero	100m	0.00000mV	0.00000mV	—
5	100mV Range gain	100m	+100.00000mV	(ON+) 100.00000mV	'SET' for non-nominal
6	1V Range zero	1	.0000000V	(ON+) .0000000V	—
7 ^[3]	1V Range Gain	1	+1.0000000V	(ON+) 1.0000000V	'SET' for non-nominal
8	10V Range zero	10	0.000000V	(ON+) 0.000000V	—
9 ^[3]	10V Range gain	10	+10.000000V	(ON+) 10.000000V	'SET' for non-nominal

(b) High Voltage – connect as Fig. 1.1 (b)

Step	Calibration Operation	4000 Range	Calibration Source Voltage	Precision Divider Select	4000 Output Setting (Nominal value) ^[1]	AUTOCAL Key Used ^[2]
10	100V Range zero	100	0.00000V	÷ 10	(ON+) 0.00000V	—
11	100V Range gain	100	+10.000000V	÷ 10	(ON+) 100.00000V	'SET' for non-nominal
12	1000V Range zero	1000	0.0000V	÷ 100	(ON+) 0.0000V	—
13	1000V Range Gain LETHAL VOLTAGE	1000	+10.000000V	÷ 100	(ON+) 1000.0000V* *Enter High Voltage state using interlock procedure (User's Handbook Sect. 4)	'SET' for non-nominal

- NOTES [1] it is expected that many users will wish to calibrate Range gains at values other than the nominals shown. In these cases set the Calibration Source voltage and 4000 OUTPUT display to in-house standard values near nominal.
- [2] Except for Step 2, use CAL key as trigger (Refer to Calibration Routine).
- [3] To trim the internal Master Reference voltage, substitute 'STD' for 'SET' for 1V or 10V Range (Refer to Calibration Routine and description of 'STD').

1.2.9 DC CURRENT CALIBRATION

1. Ensure that the 4000 OUTPUT OFF LED is lit. Select 1 and connect the DC Voltage calibration source, null detector and calibrated current shunt to the 4000 OUTPUT terminals as shown below. Do not connect null detector to shunt until the voltage across the shunt and the source voltage are close in value.

Fig. 1.2 4000 connections for DC Current Calibration

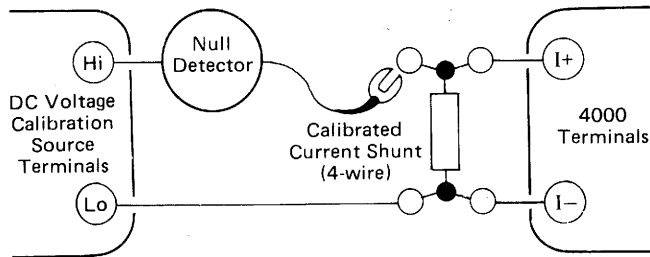

Preferred shunt values are as follows:

			Calibration Source Output Voltage for Full Range
100 μ A range	—	10k Ω 1mW min	1V
1mA range	—	1k Ω 10mW min	1V
10mA range	—	100 Ω 100mW min	1V
100mA range	—	10 Ω 1 Watt min	1V
1A range	—	0.1 Ω 1 Watt min	100mV

Ensure that the calibration source voltage is set to zero and that the interconnecting circuit has thermally stabilized.

2. Calibrate the DC Current ranges in the step sequence of Table 1.4, using the Calibration Routine at each step.
3. **Calibration Routine:** Calibration of DC Current using a DC Voltage Calibration Source and a series of calibrated current shunts.

- NOTES:**
- A. For calibration at any value, the routine may be used as printed.
 - B. For calibration at zero or positive nominal Full Range only, operation (g) may be omitted.

CAUTION: Below 2% of Range, the 4000 corrects for an assumed offset error; at 2% of Range and above the correction is for an assumed gain error.

- a) Null Detector Set to Low sensitivity
- b) 4000 Ensure OUTPUT OFF
- c) DC Source Set to the required polarity and value
- d) 4000 Select correct FUNCTION and RANGE
- e) 4000 Use Full Range, Zero or OUTPUT \uparrow/\downarrow keys to set the required polarity and value on OUTPUT display

N.B. Operation (f) must be carried out before operation (g)

- f) 4000 Press the correct polarity ON key
CAUTION: Pressing the wrong ON key will result in twice the OUTPUT being connected across the null detector.

Omit operation (g) if calibrating at Zero or Full Range value

- g) 4000 Press SET key:
SET LED lights green
OUTPUT display reading also appears on MODE display
 - h) Null Detector Increase sensitivity to give an off-null reading and use 4000 OUTPUT \uparrow/\downarrow keys to back off to null. Repeat until null lies between two values of the OUTPUT display least-significant digit.
 - j) Null Detector Set to LOW sensitivity
 - k) 4000 Press CAL key
CAL LED flashes once
MODE display value is transferred to OUTPUT display
MODE display is cleared
SET LED goes OFF
- Not applicable if operation (g) omitted

Table 1.4 DC Current Calibration

Step	Calibration Operation	Shunt Value	Calibration Source Voltage ^[1]	4000 OUTPUT Current		AUTOCAL Key Used ^[2]
				Range	OUTPUT Setting ^[1]	
1	100 μ A Range zero	10k Ω	.0000000V	100 μ	0.0000 μ A	—
2	100 μ A Range gain	10k Ω	+ 1.0000000V	100 μ	+100.0000 μ A	'SET' for non-nominal
3	1mA Range zero	1k Ω	.0000000V	1m	.000000mA	—
4	1mA Range gain	1k Ω	+ 1.0000000V	1m	+ 1.000000mA	'SET' for non-nominal
5	10mA Range zero	100 Ω	.0000000V	10m	0.00000mA	—
6	10mA Range gain	100 Ω	+ 1.0000000V	10m	+ 10.00000mA	'SET' for non-nominal
7	100mA Range zero	10 Ω	.0000000V	100m	0.0000mA	—
8	100mA Range gain	10 Ω	+ 1.0000000V	100m	+100.0000mA	'SET' for non-nominal
9	1A Range zero	0.1 Ω	0.00000mV	1	.000000A	—
10	1A Range gain	0.1 Ω	+100.00000mV	1	+ 1.000000A	'SET' for non-nominal

- NOTES [1] It is expected that many users will wish to calibrate Range gains at values other than the nominals shown. In these cases set the Calibration Source voltage and the 4000 OUTPUT display to in-house standard values near nominal.
- [2] At each step, use CAL key as a trigger (Refer to Calibration Routine).

1.2.10 RESISTANCE CALIBRATION

1. Calibration Memory

In Ω function, each RANGE key selects a nominal-value standard resistor. Routine adjustment of the resistor is not necessary. During calibration the actual value is measured and stored in the calibration memory to be displayed whenever that range is selected. Separate memory stores exist for Remote Sense (4-wire), Local Sense (2-wire) and Local Sense zero.

2. 4-Wire Calibration Limits

The value measured in 4-wire Remote Sense does not include the resistance of internal or external wiring. The 4000 accepts any value within ± 200 ppm of nominal as a valid calibration.

3. 2-Wire Calibration Limits

The value measured in 2-wire Local Sense is greater than for 4-wire Remote Sense, as it includes the resistance of internal wiring and relay contacts. The 4000 will not accept any 2-wire value less than the stored value for 4-wire, so the 4-wire Remote Sense calibration must be carried out before attempting 2-wire Local Sense. The extra internal resistance varies between Ranges, so the 4000 accepts the following values (x) as valid 2-wire calibrations:

Zero calibration.

1 Ω – 1M Ω Ranges:
 $0 \leq x \leq 0.900\Omega$

Value calibrations

1 Ω Range:

4-wire value $\leq x \leq$ (4-wire value + 0.999 Ω)

10 Ω – 1M Ω Ranges:

4-wire value $\leq x \leq$ (4-wire value + 1.999 Ω)

4. "Error 6" message

"Error 6" appears on the MODE display for any attempt to enter a value outside the 4-wire or 2-wire limits quoted above.

NOTE: When resistance is calibrated in Remote Sense, the 4000 overwrites the Local Sense calibration memory with the new 4-wire value.

5. 4-wire and 2-wire Connections

Fig. 1.3 (a)
4-wire calibration

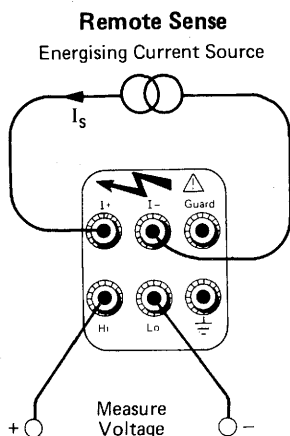
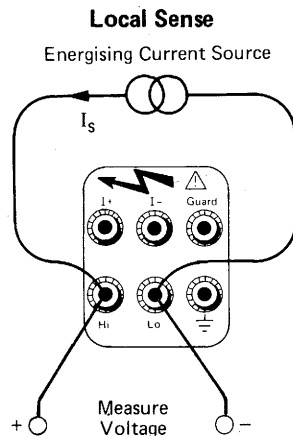

Fig. 1.3 (b)
2-wire calibration
(using 4-wire method externally)



6. Calibration sequence

Press Ω key and calibrate the resistors in the step sequence of Table 1.5 (a and b), using the Calibration Routine at para 7 (a or b). Refer to para 5 for connections to the measuring equipment. For 4-wire connections in Remote Sense, only the value of the internal Standard Resistor is measured. In Local Sense, a 4-wire method is used to exclude the resistance of the external leads from the measured value.

7. Calibration Routine: Measurement and Storage of the values of an internal resistor.

- a) **Remote Sense** (Internal 4-wire, connected as Fig. 1.3(a).)
 Full Range values – Routine for Table 1.5(a)
- 4000 Select OUTPUT OFF and Ω Select Remote Sense
 - 4000 Press required resistor (RANGE) key: The previously calibrated value appears on the OUTPUT display
 - 4000 and resistance-measuring equipment Press OUTPUT ON+ and measure the value of the internal resistor
 - 4000 OUTPUT \uparrow/\downarrow Keys Set the measured value on the OUTPUT display
 - 4000 CAL Key Press to store OUTPUT display value
 - 4000 Set OUTPUT OFF
 - Repeat operations (ii) to (vi) for each step of Table 1.5(a)
- b) **Local Sense** (Internal 2-wire, connected as Fig. 1.3(b).), Remote Sense OFF)
 Full Range and Zero values – Routine for table 1.5(b)
- 4000 Select OUTPUT OFF and Ω Deselect Remote Sense
 - 4000 Press required resistor (RANGE) Key: The previously-calibrated value appears on the OUTPUT display.
 - 4000 and resistance-measuring equipment Press OUTPUT ON+ and measure the value of the internal resistance
 - 4000 OUTPUT \uparrow/\downarrow Keys Set the measured value on the OUTPUT display
 - 4000 CAL Key Press to store OUTPUT display value
 - 4000 Zero Key Press and repeat operations (iii) to (v) for this RANGE selection.
 - 4000 Set OUTPUT OFF
 - Repeat operations (ii) to (vii) for each step of Table 1.5(b).

Resistance Calibration

Table 1.5 Internal Resistor value measurement and storage

- a) **Remote Sense** (Internal 4-wire, connect as Fig. 1.3(a).)
Calibration at Full Range. Resolution 7½ digits, Tolerance ±199.9ppm (±1999 digits).

Step	Range	Measured resistance value, Calibration Limits		
1	10MΩ	9.998,001	to	10.001,999 MΩ
2	1MΩ	.999,800,1	to	1.000,199,9 MΩ
3	100kΩ	99.980,01	to	100.019,99 kΩ
4	10kΩ	9.998,001	to	10.001,999 kΩ
5	1kΩ	.999,800,1	to	1.000,199,9 kΩ
6	100Ω	99.980,01	to	100.019,99 Ω
7	10Ω	9.998,001	to	10.001,999 Ω
8	1Ω	.999,800,1	to	1.000,199,9 Ω

- b) **Local Sense** (Internal 2-wire, connect as Fig. 1.3(b), Remote Sense OFF)
Calibration at Full Range and Zero. Resolution as listed in table.
Tolerances – 0Ω + 0.999Ω on 1 Ω Range, 0Ω + 1.999Ω on 10Ω – 1MΩ Ranges, –0Ω + 0.900Ω for zero on 1Ω – 1MΩ Ranges.

Step	Range	Resolution (digits)	Resistance value Limits	Zero Limits
9	1MΩ	7½	Step 2 value, –0 +19 digits	.000,000,0 to .000,000,9 MΩ
10	100kΩ	7½	Step 3 value, –0 +199 digits	0.000,00 to 0.000,90 kΩ
11	10kΩ	7½	Step 4 value, –0+1999 digits	0.000,000 to 0.000,900 kΩ
12	1kΩ	6½	Step 5 value, –0+1999 digits	.000,000 to 0.000,900 kΩ
13	100kΩ	5½	Step 6 value, –0+1999 digits	0.000 to 0.900 Ω
14	10Ω	4½	Step 7 value, –0+1999 digits	0.000 to 0.900 Ω
15	1Ω	3½	Step 8 value, –0 +999 digits	.000 to .900 Ω

1.3 REMOTE CALIBRATION GUIDELINES

1.3.1 Introduction

The operation of the 4000 in systems applications via the IEEE 488 Interface, is described in Section 5 of the User's Handbook.

In addition to its capability as a programming calibrator, the 4000 can itself be calibrated under remote control. Full autocalibration of the instrument over the bus implies availability of programmable standards, a programmable null-detector and a suitably-programmed controller.

The Datron 4900 Series DC Voltage Calibration System is designed to be programmable, requiring only the addition of a bank of ten standard cells and a null detector.

Fig. 1.4 Transfer of front-panel calibration controls to System Operation

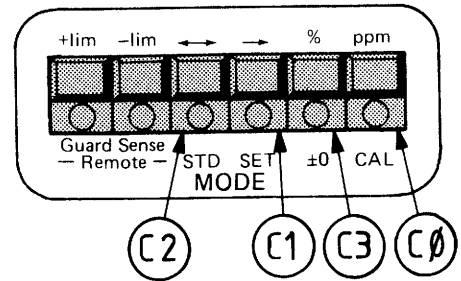

These commands can only be activated when two conditions have been fulfilled:

The CALIBRATION ENABLE Keyswitch on the 4000 Rear Panel must be set to ENABLE, and the IEEE Interface command-code W1 must have been received and activated.

1.3.2 Calibration Commands

Table 1.6 lists the device-dependent commands used in the 4000. The relevant calibration codes are described in Fig. 1.4 and Table 1.6.

When the 4000 is under remote control over the bus, the command-code Wφ disables the 'C' codes, regardless of the keyswitch setting.

Table 1.6 Availability of Command Codes

Command Codes	AUTOCAL Mode		DC Voltage (DC)	DC Current (I)	Resistance (Ω)	
					Local Sense (2-wire)	Remote Sense (4-wire)
C1 and Cφ	SET and CAL	Zero offset for range at User's selected value Gain for range at User's standard value	100mV-1000V Ranges only	All Ranges		
C3 and Cφ	±0 and CAL	Alignment of internal ON+ and ON- zeros	10V Range only			
C2 and Cφ	STD and CAL	Internal Reference gain at user's Standard value	1V and 10V Range Only			
Cφ Only	CAL Only	Zero offset for range	All Ranges	All Ranges	1Ω - 1MΩ Ranges Only	
		Gain for range at Full Range Value	100mV-1000V Ranges Only			All Ranges

1.3.2.1 General Procedure

The Main Register is set to the Calibration Standard value (M***...), the 4000 Output is switched ON (O1), and one of the calibration mode command

codes (C1, C2, C3) may be transmitted. The 'M' Code is adjusted to obtain a null at the Calibration Standard value, and C ϕ is transmitted to execute the calibration.

1.3.2.2 Command Code Facilities

C1 (SET)	C1 allows calibration to any value in the selected Range (e.g. at a standard cell voltage). If the value initially input by 'M' Code is less than $\pm 2\%$ of Full Range value, the 4000 assumes that an offset calibration is requested, and if at $\pm 2\%$ or greater, a gain calibration is assumed.	C3(± 0)	C3 is used to align the ON+ and ON- zeros of all voltage and current ranges, by a two-part calibration on the 10V range. It is only necessary when the ON+ and ON- zeros on the 10V range do not coincide at the same null.
C2 (STD)	C2 allows a user to trim the value of the internal Master Reference voltage. The facility can be used to correct for any long-term drift, or to avoid a full recalibration of the 4000 when Laboratory References have been re-standardised. C2 (STD) calibration effectively changes the gain of all voltage and current ranges in the same ratio, by a simple procedure available either on 1V or 10V range.	C ϕ (CAL only)	C ϕ executes the preselected AUTO-CAL mode. If it is sent without first sending SET, ± 0 or STD, the 4000 assumes that a calibration at either Zero or Full Range is required. It uses the value input by 'M' Code to distinguish between Zero (Offset calibration) and Full Range (gain calibration) as for C1 (SET) mode.

1.3.3. Guidelines – An Example

The following sequence suggests a method of calibrating the 4000 IV Range Gain against a standard cell value of +1.018057V. It is assumed that the 4000 is correctly addressed with its Calibration Keyswitch set to ENABLE, that the 4000 Output is OFF; and that a Null Detector set to Low Sensitivity is connected between Standard Cell buffer and 4000 Hi/Lo terminals as in Fig. 1.1 (a) of Section 1.2.8.

	4000 Codes
(a) Command the 4000:	
DC Volts	F ϕ
1V Range	R5
Local Guard and Sense	G ϕ S ϕ
Calibration Enable	W1
Output Value to calibration point M+1.018057	
Select "SET" Calibration mode	C1
Output ON	O1

- (b) Establish null tolerance limits
- (c) Command the null detector:
Recall Sensitivity Range and Reading
Increase Sensitivity Range and repeat recall until reading exceeds half-scale
- (d) Calculate 4000 setting for null
Set 4000 output to calculate value M***...
- (e) Repeat (c) and (d) until null is within limits
- (f) Command the 4000 to execute "CAL"C ϕ
The example suggests only the broad outline of one of many sequences which could be used to perform 4000 calibration.

1.4 PRECALIBRATION

For all normal purposes, the routine procedures detailed in Section 1.2 (and repeated in User's Handbook Section 8) are sufficient to maintain 4000 calibration.

In an initial internal calibration process at manufacture, certain 'pre-cal' parameters are established in a special calibration memory to define the overall linearity of the 4000, and to allow maximum routine calibration memory span for adjustments. Thus all routine calibrations may be performed from the front panel or over the IEEE Interface without removing any covers.

The stored parameters are invalidated by replacement of certain critical parts of the instrument:

- 1) The Lithium battery which powers the whole calibration memory when the instrument supply is switched off. This should be replaced at five-year intervals (refer to Section 5.3).

- | | | |
|---|---|---|
| <ol style="list-style-type: none"> 2) The Digital Assembly 3) The Reference Divider Assembly 4) Critical components in the Digital or Reference Divider assemblies | } | <p>Normally replaced only on failure. A full list is given in Section 1.1 Table 1.1</p> |
|---|---|---|

After replacement of any of these parts, new parameters are generated and stored in the "pre-cal" memory by the procedures detailed in this section.

Pre-calibration must be followed by a full Routine Calibration of the whole instrument (Section 1.2).

1.4.1 Pre-calibration Procedure

1.4.1.1 Validity

The adjustments detailed in the following sequences include intentionally clearing the instrument's calibration memory, which loses all previous calibration information. Therefore, before proceeding make certain that the reasons for carrying out a complete recalibration are valid. (If in any doubt, consult your Datron Service Centre)

1.4.1.2 Calibration Standards Equipment Required

1. A DC Voltage Calibration source of 10V ± 20 ppm
2. A $\div 2$ precision divider, capable of dividing 20,000,000V to 10,000,000V ± 0.1 ppm, D.C.
3. A battery-operated null detector with variable sensitivity.

Example: Keithley Instruments Model 155
Read the "Notes on the Use of the Null Detector" at Section 1.2.3.1.

1.4.1.3 Identification of Access Holes (Fig. 1.5)

- a) Release 6 screws retaining the top cover
- b) Lift the top cover at the front of the instrument and locate two holes giving access to the two-position "pre-cal Enable" switch and the press-button "Clear Calibration Memory" switch.

DO NOT OPERATE EITHER SWITCH YET

- c) Replace the top cover, do not secure

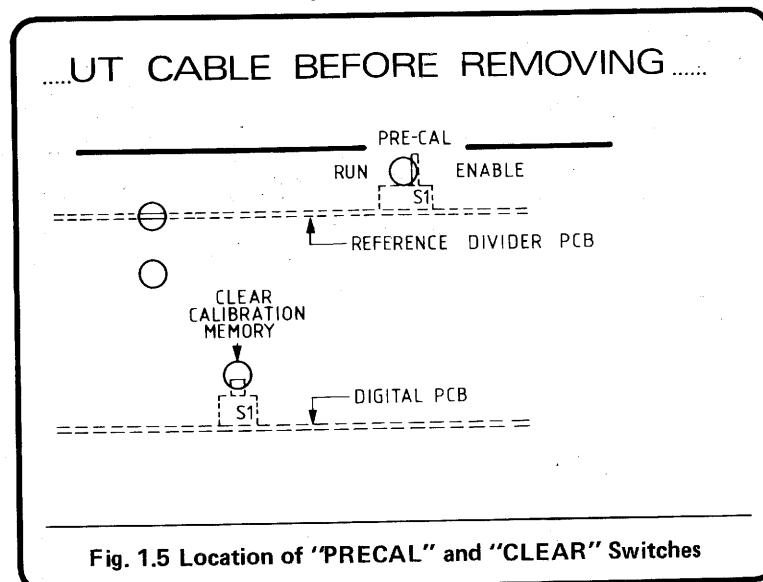

1.4.1.4 Preparation

Before any calibration is carried out, prepare the 4000 as follows:

1. Turn on the instrument to be checked and allow minimum of 4 hours to warm-up in the specified environment

2. IEEE 488 Address switch:
Set to ADD 11111 as shown (Address 31)

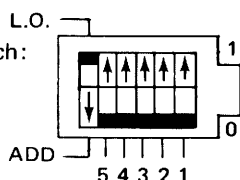

3. CALIBRATION ENABLE key switch:
Insert Calibration Key and turn to ENABLE.

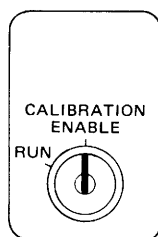

1.4.1.5 Interconnections

CAUTION: First read the Notes on the use of the Null Detector in Section 1.2.3.1.

- (a) Ensure that the 4000 OUTPUT OFF LED is lit.
- (b) Select DC and connect the DC Voltage Calibration source, Precision Divider and Null Detector to the 4000 terminals as shown. Use short leads.

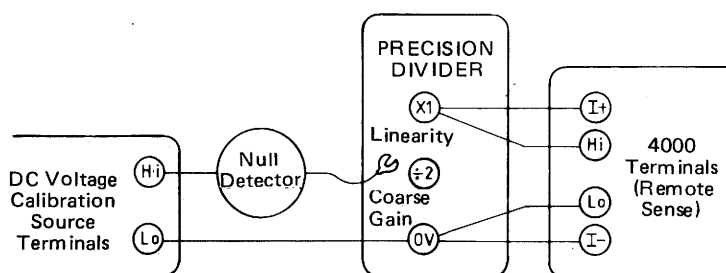

Fig. 1.6 Interconnections for Pre-calibration (Coarse Gain and Linearity)

- (c) Ensure that the calibration source voltage is set to zero and that the interconnecting circuit has thermally stabilized. Do not connect the Null Detector yet.

1.4.1.6 "Pre-cal Enable" and Calibration Memory "Clear" Switches

- (a) 4000
Lift the top cover at the front. Locate the hole which gives access to the pre-cal enable switch.
- (b) "Enable"
Insert an insulated tool in the hole and move the pre-cal switch to the right (Enable).
The legend Cal appears on the OUTPUT display also.
- (c)
Locate the hole which gives access to the Calibration Memory "Clear" push button.
- (d) "Clear"
Insert an insulated tool in the hole and press the button to clear the calibration memory. Refit the top cover but do not secure.

1.4.1.7 ± 0

- (a) Null Detector
Set to Low sensitivity.
- (b) 4000
Ensure OUTPUT OFF in 10V DC range. Ensure Remote Sense LED is unlit.
- (c) 4000
Press OUTPUT Zero Key
Connect the Null Detector between Hi and Lo terminals
Press ON+ Key
Press ± 0 Key: ± 0 LED lights, OUTPUT display at zero.
- (d) Null Detector
Increase sensitivity to give an off-null reading (approx. -20mV) and use 4000 OUTPUT \uparrow/\downarrow keys to back-off to null. Repeat until null lies between two values of the output display least-significant digit.
- (e) 4000
Press CAL key:
CAL LED lights
No change to OUTPUT display
- (f) 4000
Press ON- key
- (g) Null Detector
Obtain accurate null as in (d) above.
- (h) 4000
Press CAL key:
CAL LED goes OFF
 ± 0 LED goes OFF
OUTPUT display falls to zero
- (j) Null Detector
Set to Low sensitivity

The 4000 positive and negative zeros are now both aligned to zero.

- (k) 4000
Disconnect the Null Detector

1.4.1.8 Coarse Gain

- | | | | |
|-------------------|--|-------------------|--|
| (a) Null Detector | Set to Low sensitivity | | |
| (b) 4000 | Ensure OUTPUT OFF | | |
| (c) 4000 | Select Remote Sense and ensure LED is lit | (h) Null Detector | Increase sensitivity to give an off-null reading and use 4000 \uparrow/\downarrow keys to back-off to null. Repeat until null lies between two values of the OUTPUT display least-significant digit. |
| (d) 4000 | Press the SET Key:
SET LED lights green
OUTPUT display reading goes to zero. | | |
| (e) 4000 | Use OUTPUT \uparrow/\downarrow keys to set the OUTPUT display to +19.999,999V | (j) 4000 | Press CAL Key:
CAL LED flashes once.
OUTPUT display changes to +19.999,999V.
SET LED goes OFF |
| (f) 4000 | Press the ON+ Key | | |
| (g) Null Detector | Connect between Calibration Source Hi and Precision Divider $\div 2$ terminal (Fig. 1.6) | (k) Null Detector | Set to Low Sensitivity. |
| | | (l) 4000 | Set OUTPUT OFF |

1.4.1.9 Linearity

- | | | | |
|-------------------|--|-------------------|--|
| (a) Null Detector | Disconnect from Precision Divider | | |
| (b) 4000 | Ensure set to OUTPUT OFF
Select Remote Sense and ensure LED is lit. | (g) Null Detector | Increase sensitivity to give an off-null reading and use 4000 \uparrow/\downarrow keys to back-off to null. Repeat until null lies between two values of the OUTPUT display least-significant digit. |
| (c) 4000 | Press the STD Key:
STD LED lights green
OUTPUT display reading goes to zero. | | |
| (d) 4000 | Use OUTPUT \uparrow/\downarrow keys to set the OUTPUT display to +10.000,000V | (h) 4000 | Press CAL Key:
CAL LED flashes once
OUTPUT display changes to +10.000,000V
STD LED goes OFF. |
| (e) 4000 | Press the ON+ Key | | |
| (f) Null Detector | Connect between Calibration Source Hi and Precision Divider X1 terminal. | (j) Null Detector | Set to Low sensitivity.
Disconnect. |
| | | (k) 4000 | Set OUTPUT OFF. |

1.4.1.10 Pre-cal Enable Switch (See CAUTION below)

- (a) 4000
- Lift the top cover at the front.
- Locate the hole which gives access to the pre-cal Enable switch.
- Insert an insulated tool in the hole and move the pre-cal switch to the left (RUN).

The legend "cal" on the OUTPUT display disappears, but the same legend remains on the MODE display.

CAUTION: DO NOT re-press the calibration memory "clear" button. If this is done, the micro-zero, coarse gain and linearity adjustments will have to be repeated.

- (b) 4000
- Refit and secure the top cover.

1.4.1.11 Routine Calibration

The 4000 is now ready for full Routine Calibration as detailed in Section 1.2.

1.5 Ω OPTION INTERNAL ADJUSTMENT (Refer to Section 5.4)

The Autocal procedure for routine calibration of the 4000 Resistance Function is described in Section 1.2.10.

The method of calibration is to measure the value of each standard resistor, and store the measured value in non-volatile calibration memory. Subsequently, each time a resistance RANGE is selected, the previously calibrated value is displayed.

If a standard resistor has been subjected to undue stress, its value may have moved outside its tolerance (signalled by an Error 6 message during Routine Auto-calibration). If the value is less than approx. 50ppm outside tolerance, it can be adjusted internally using a variable trimmer. For values out of tolerance in excess of 50ppm it is likely that the resistor has been over-stressed – consult your Datron Service Centre.

1.5.1 Manual Trimming Procedure

The following procedure is a supplement to Routine Autocalibration. It is necessary only when the 4-wire calibration of Section 1.2.10 has resulted in an "Error 6" message.

It can also be used when, for operational reasons, it is necessary to calibrate a resistor at its nominal value. For this purpose a continuously-reading method of measurement is convenient.

- | | |
|---|---|
| <ul style="list-style-type: none"> (a) Release eight screws retaining the top cover. (b) Lift the top cover at the front of the instrument and locate the 8 holes giving access for "Ω OPTION ADJUSTMENT" | <ul style="list-style-type: none"> (c) Insert an insulated screw driver tool in the hole for the range selected, and adjust the preset resistor (rotating clockwise increases the resistance value) (d) Re-measure the 4-wire value and repeat operation (c) until the desired value is obtained (e) Re-calibrate the range for 4-wire and 2-wire connections as detailed in section 1.2.10. (f) Repeat the manual trimming procedure above for all ranges as required. (g) Finally refit and secure the top cover using the eight screws removed in (a), above. |
|---|---|
-

