

SERVICING HANDBOOK

4910 and 4911
DC Voltage Reference Standards

datron
WAVETEK

SERVICING HANDBOOK

for

THE DATRON 4910 and 4911 **DC VOLTAGE REFERENCE STANDARDS**

Maintenance Information
Technical Descriptions
Layout and Circuit Diagrams
Component Lists

For any assistance contact your nearest Datron Sales and Service center.
Addresses can be found at the back of this handbook.

850258

Issue 2 (APR 1991)

Due to our policy of continuously updating our products, this handbook may contain minor differences in specification, components and circuit design to the actual instrument actually supplied. Amendment sheets precisely matched to your instrument serial number are available on request.

(REV) 2 10 91



DANGER



**THIS INSTRUMENT IS CAPABLE
OF DELIVERING
A LETHAL ELECTRIC SHOCK !**

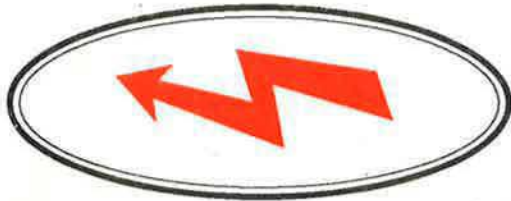

Line Voltage is
Present Internally
THIS CAN KILL !

Unless **you** are **sure** that it is **safe** to do so,
DO NOT TOUCH
any potential source of **high voltage**

**DO NOT APPLY HIGH VOLTAGE
TO ANY TERMINAL**

Terminals are sensitive to over-voltage
It can damage your instrument !

DANGER

Contents

General Description, Installation, Controls, Operation, Applications;
Specification, Specification Verification and Routine Calibration.

Refer to
User's Handbook

Section	Title	Page
1	ROUTINE SERVICING	
1.1	Calibration and Performance Checks	1-1
1.1.1	Routine Calibration	1-1
1.1.2	Calibration Confidence Check	1-1
1.2	Battery Pack Servicing	1-2
1.2.1	Battery Pack Check Procedures	1-2
1.2.2	Battery Pack Replacement	1-4
2	FAULT DIAGNOSIS AND REPAIR	
2.1	Internal Operations Not Affecting Instrument Warranty	2-1
2.2	Introduction	2-1
2.2.1	Fault Diagnosis and Repair Strategy	2-1
2.2.2	Use of Fault Diagnosis and Repair Tables	2-1
	Fault Diagnosis Tables:	
	LEDs:	
	Table 2.2.1: 'Line Supply' AND 'Battery Supply' LED RELATED FAULTS	2-2
	Table 2.2.2: CELL 'Battery' LED RELATED FAULTS	2-2
	Table 2.2.3: CELL 'Temp' LED FAULTS	2-3
	Table 2.2.4: CELL 'Average' LED FAULTS	2-3
	Outputs:	
	Table 2.2.5: CELL OUTPUT FAULTS	2-4
	Table 2.2.6: AVERAGE OUTPUT FAULTS	2-4
	Table 2.2.7: 4-WIRE OUTPUT BUFFER FAULTS	2-4
	Table 2.2.8: DIVIDED OUTPUT FAULTS	2-5
	Fuses:	
	Table 2.2.9: FUSE LOCATIONS AND RATINGS	2-5
	Power Supplies:	
	Table 2.2.10: POWER SUPPLY PCB SUPPLIES	2-6
	Table 2.2.11: MOTHER PCB SUPPLIES	2-6
	Table 2.2.12: CELL PCB SUPPLIES	2-7
	Table 2.2.13: OUTPUT PCB SUPPLIES	2-7
	Table 2.2.14: DIGITAL PCB SUPPLIES	2-7
	Adjustments:	
	Table 2.2.15: ADJUSTMENTS FOLLOWING REPLACEMENT OF ASSEMBLIES	2-8
3	DISMANTLING AND REASSEMBLY	
3.1	General Precautions	3-1
3.1.1	WARNING	3-1
3.1.2	CAUTIONS	3-1
3.2	General Mechanical Layout	3-1
3.2.1	Internal Construction	3-1
3.2.2	Rack Mounting	3-1
3.3	General Access	3-2
	Preliminary Precautions	3-2
3.3.1	Top Cover	3-2
3.3.2	Bottom Cover	3-2
3.4	Assemblies - Removal and Fitting	3-3
3.4.1	Battery Tray	3-3
3.4.2	Front Panel Assembly	3-3
3.4.3	Rear Panel Assembly	3-4
3.4.4	Cell PCB Assemblies	3-4
3.4.5	Output PCB Assembly	3-5
3.4.6	Output PCB Digital Sub-Assembly (4910 only)	3-5
3.4.7	Mother PCB Assembly	3-6
3.4.8	Digital PCB Assembly	3-7
3.4.9	Front Panel PCB Assembly	3-7
3.4.10	Power Supply PCB Assembly	3-8
3.4.11	Line Input Transformer	3-8
3.4.12	Battery Tray Assembly	3-9

Section	Title	Page
4 TECHNICAL DESCRIPTIONS		
4.1	Principles of Operation	4-1
4.1.1	Simplified Block Diagram	4-1
4.1.2	General Principles	4-1
4.1.2.1	Cell Outputs	4-1
4.1.2.2	AVERAGE Output	4-4
4.1.2.3	4-WIRE OUTPUT BUFFER (4910 only)	4-5
4.1.2.4	DIVIDED OUTPUTS (4910 only)	4-6
4.1.2.5	POWER SUPPLIES	4-7
4.2	PCB Descriptions	4-9
4.2.1	Cell PCB	4-9
4.2.1.1	Zener Reference Module and Output Amplifier	4-9
4.2.1.2	Primary Divider - Switch and Filter	4-12
4.2.1.3	Secondary Divider - Switch and Filter	4-13
4.2.1.4	Primary Divider - Timing Circuit	4-14
4.2.1.5	Secondary Divider - Timing Circuit	4-16
4.2.2	Output PCB	4-17
4.2.2.1	4-Wire Output Buffer	4-17
4.2.2.2	Internal Average Buffers	4-17
4.2.2.3	1.018V Divided Output - Primary Divider Switch and Filter	4-18
4.2.2.4	1.018V Divided Output - Secondary Switch and Filter	4-20
4.2.2.5	1.018V Divided Output - Primary Divider Control Logic	4-21
4.2.2.6	1.018V Divided Output - Secondary Divider Timing Circuit	4-22
4.2.2.7	1.000V Divided Output - Primary Switch and Filter	4-24
4.2.2.8	1.000V Divided Output - Secondary Switch and Output Buffer	4-26
4.2.2.9	1.000V Divided Output - Primary Divider Control Logic	4-26
4.2.2.10	1.000V Divided Output - Secondary Divider Timing Circuit	4-27
4.2.3	Output PCB Digital Sub-Assembly	4-28
4.2.3.1	1.018V Primary Divider Counter	4-28
4.2.3.2	1.000V Primary Divider Counter	4-28
4.2.4	Digital PCB	4-30
4.2.5	Power Supply PCB	4-32
4.2.6	Battery Tray PCB	4-34
4.2.7	Interconnection PCB	4-34
4.2.8	Mother PCB	4-34
4.2.8.1	Battery Monitors and Linear Voltage Regulators	4-34
4.2.8.2	External DC Supply	4-36
4.2.9	Front Panel PCB	4-38
4.2.9.1	Output Terminals	4-38
4.2.9.2	Front-panel CELL LEDs	4-38
4.2.9.3	Battery Supply LED	4-38
4.2.9.4	Line Supply LED	4-38

Sections 5 to 10 are Not Allocated

11 SERVICING DIAGRAMS AND PARTS LISTS		
11.1	Finished Assembly	11.1-1
11.2	Instrument Assembly	11.2-1
11.3	Front Panel Assembly	11.3-1
	Rear Panel Assembly	11.3-5
	Power Supply Assembly	11.3-7
11.4	Mother Assembly	11.4-1
	Interconnection Assembly	11.4-8
11.5	Cell Assembly	11.5-1
11.6	Digital Assembly	11.6-1
11.7	Output Assembly	11.7-1
	Output PCB Digital Assembly	11.7-7
11.8	Battery Tray Assembly	11.8-1
	Battery Tray PCB Assembly	11.8-3
11.9	Rack Mounting	11.9-1

SECTION 1 ROUTINE SERVICING

1.1 Calibration and Performance Checks

1.1.1 Routine Calibration

Although the output stability of the 4910 and 4911 DC Voltage Reference Standards is specified over periods of 30 days, 90 days and 1 year, there is no recommended recalibration interval for the unit.

As with all reference standards, it is up to the user to make a decision on how frequently the unit is recalibrated, based on the calibration confidence level which is required. This confidence level will depend as much on the recorded performance history of a particular 4910 or 4911 as on its data sheet stability specifications. However, Datron Instruments recommends that 1 year be regarded as the maximum recalibration interval to be adopted.

The procedure for calibrating a 4910 or 4911 against a second fully certified 4910 or 4911 is detailed in *Section 5* of the *'4910 and 4911 DC Voltage Reference Standards User's Handbook'*.

To check or re-calibrate a 4910 or 4911 against other standards, such as saturated Weston cells, refer to Datron Instruments for relevant information.

1.1.2 Calibration Confidence Check

As with any metrology standard, the highest calibration confidence level can only be achieved by frequent recalibration of the 4910 or 4911 to fully-traceable prime standards. However, for a 4911 a simple confidence check on the stability of the 10V outputs (the **CELL** and **AVERAGE** outputs) can be performed by comparing individual **CELL** outputs to the **AVERAGE** output.

For a 4910, the 10V outputs (the **CELL**, **AVERAGE** and **4-WIRE OUTPUT BUFFER** outputs) can be checked by comparing individual **CELL** outputs to the **AVERAGE** output, and by measuring the difference between the **4-WIRE OUTPUT BUFFER** output and the **AVERAGE** output.

Because each **CELL** output contributes only one quarter of the **AVERAGE** output, and because statistically all four **CELL** outputs are unlikely to exhibit identical drift, excessive drift in any **CELL** output will show up as a measurable change in the difference voltage between the **CELL** and **AVERAGE** outputs when compared to previously recorded data. The procedures to carry out these Confidence Checks, which only require the use of a null detector, are detailed in *Section 5* of the *'4910 and 4911 DC Voltage Reference Standards User's Handbook'*.

If a very linear voltage source (such as a Datron 4708 calibrator) or a high quality voltage divider is available, the **1.018V** and **1V DIVIDED OUTPUTS** can also be compared to the **AVERAGE** output. The method for using these pieces of equipment to check the **DIVIDED OUTPUTS** is contained in the Calibration Confidence Check procedure in *Section 5* and *Appendix D* of the *'4910 and 4911 DC Voltage Reference Standards User's Handbook'*.

The calibration confidence check procedures are simple enough to be carried out each time the 4910/4911 is used.

1.2 Battery Pack Servicing

The 4910/4911 contains fifteen sealed-electrolyte lead-acid batteries configured as five 18V battery supplies. These batteries enable the unit to remain fully operational for 9 hours at 25°C in **Normal** mode, or 168 hours at 25°C in **Transit** mode.

When the 4910/4911 is connected to an AC line supply the batteries are automatically recharged or float-charged depending on their state of discharge. In addition, when the unit is in **Transit** mode, an external DC supply can be used to take over from the batteries as the unit's primary source of power.

Over a period of several years, the unit's batteries will slowly deteriorate to a point at which they can no longer keep the unit operational for the **Normal** and **Transit** mode periods specified above. The rate at which they deteriorate will depend on a number of factors, including the number of discharge cycles they are subjected to, and whether or not they are ever allowed to approach their deep discharge point. The following checks can be carried out to determine the condition of the batteries.

1.2.1 Battery Pack Check Procedures

Caution: Do NOT carry out these tests unless the availability of an appropriate AC line supply at the end of the test is assured for a period of 48 hours so that the batteries can be recharged.

A simple check on the condition of the unit's battery pack can be performed as follows:

1. Set up the 4910/4911 in an ambient temperature of 20°C to 25°C.
2. Switch the unit to **Normal** mode and connect it to an appropriate AC line supply for at least 48 hours.
3. Check that all the **Battery** LEDs associated with the CELL outputs, and the **Battery Supply** LED are illuminated continuous green.
4. Disconnect the unit from its AC line supply and note the elapsed time before any one of the front panel **Battery** LEDs or the **Battery Supply** LED begins to flash alternate red and green.
5. Immediately reconnect the unit to an appropriate AC line supply and leave it connected for at least 48 hours to ensure that the batteries are fully recharged.

If the time noted in step 4 is greater than 7.5 hours, then it can be assumed that all the 4910/4911's batteries are in good condition. If the time noted is less than 7.5 hours, replacement of the unit's battery packs should be considered — refer to *Section 1.2.2*.

Caution: The elapsed time before the first LED changes from continuous green to flashing red/green is likely to be in the region of 6 to 10 hours, and it is essential that the unit is reconnected to an AC line supply within 0.5 hours of this first red/green flash condition occurring. On no account should any of the **Battery** LEDs be allowed to progress to the alternate red/off flashing condition, as this may cause correct temperature control of the unit's zener reference diodes to be lost. (If temperature control is lost, as indicated by one or more of the **Temp** LEDs illuminating red, the unit may require recalibration.)

If the appropriate test and measurement equipment is available, a better determination of the unit's battery pack condition can be performed as follows:

1. Set up the unit in an ambient temperature of 20°C to 25°C.
2. Switch the unit to **Normal** mode and connect it to an appropriate AC line supply for a period of at least 48 hours.
3. Check that all the **Battery** LEDs associated with the CELL outputs, and the **Battery Supply** LED are illuminated continuous green.

N.B. Take special care **not** to short together any pins of the BATTERY/CHARGE VOLTAGES connector.

4. Connect a 140Ω, 2.5W (or greater power rating) resistor across each of the Cell 18V battery supplies (battery supplies 1 to 4) via the unit's BATTERY/CHARGE VOLTAGES connector — refer to *Figure 1.2.1.1*. **DO NOT** connect a resistor across battery supply number 5.
5. Disconnect the unit from its AC line supply and record the terminal voltage of each 18V battery supply every 15 minutes via the unit's BATTERY/CHARGE VOLTAGES connector — refer to *Figure 1.2.1.1*.
6. Continue to monitor the terminal voltages of the batteries every 15 minutes until one of the batteries reaches a terminal voltage of 17.5V.
7. Immediately disconnect the 140Ω loads from the BATTERY/CHARGE VOLTAGES connector and reconnect the unit to an appropriate AC line supply before compiling the results of this discharge test. The unit should remain connected to the AC line supply for at least 48 hours to ensure that the batteries are fully recharged.
8. Plot the discharge curves for each of the five batteries for comparison with the curve shown in *Figure 1.2.1.2*.

If all of the discharge curves are closely aligned to the curve shown in *Figure 1.2.1.2*, then it can be assumed that the unit's batteries are in good condition.

N.B. Remember to leave the unit connected to an AC line supply for at least 48 hours to recharge the batteries.

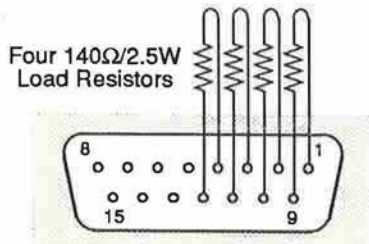

Pin	Name	Function	Pin	Name	Function
1	BATT 0V (4)	Battery 4 -ve	9	BATT +V (4)	Battery 4 +ve
2	BATT 0V (3)	Battery 3 -ve	10	BATT +V (3)	Battery 3 +ve
3	BATT 0V (2)	Battery 2 -ve	11	BATT +V (2)	Battery 2 +ve
4	BATT 0V (1)	Battery 1 -ve	12	BATT +V (1)	Battery 1 +ve
5	BATT 0V (5)	Battery 5 -ve	13	BATT +V (5)	Battery 5 +ve
6		No connection	14		No connection
7		No connection	15	Thermistor Hi	Temperature monitoring thermistor connection
8	Thermistor Lo	Temperature monitoring thermistor connection			

Fig 1.2.1.1 BATTERY CONDITION CHECKS - BATTERY/CHARGE VOLTAGES CONNECTOR - LOAD CONNECTIONS

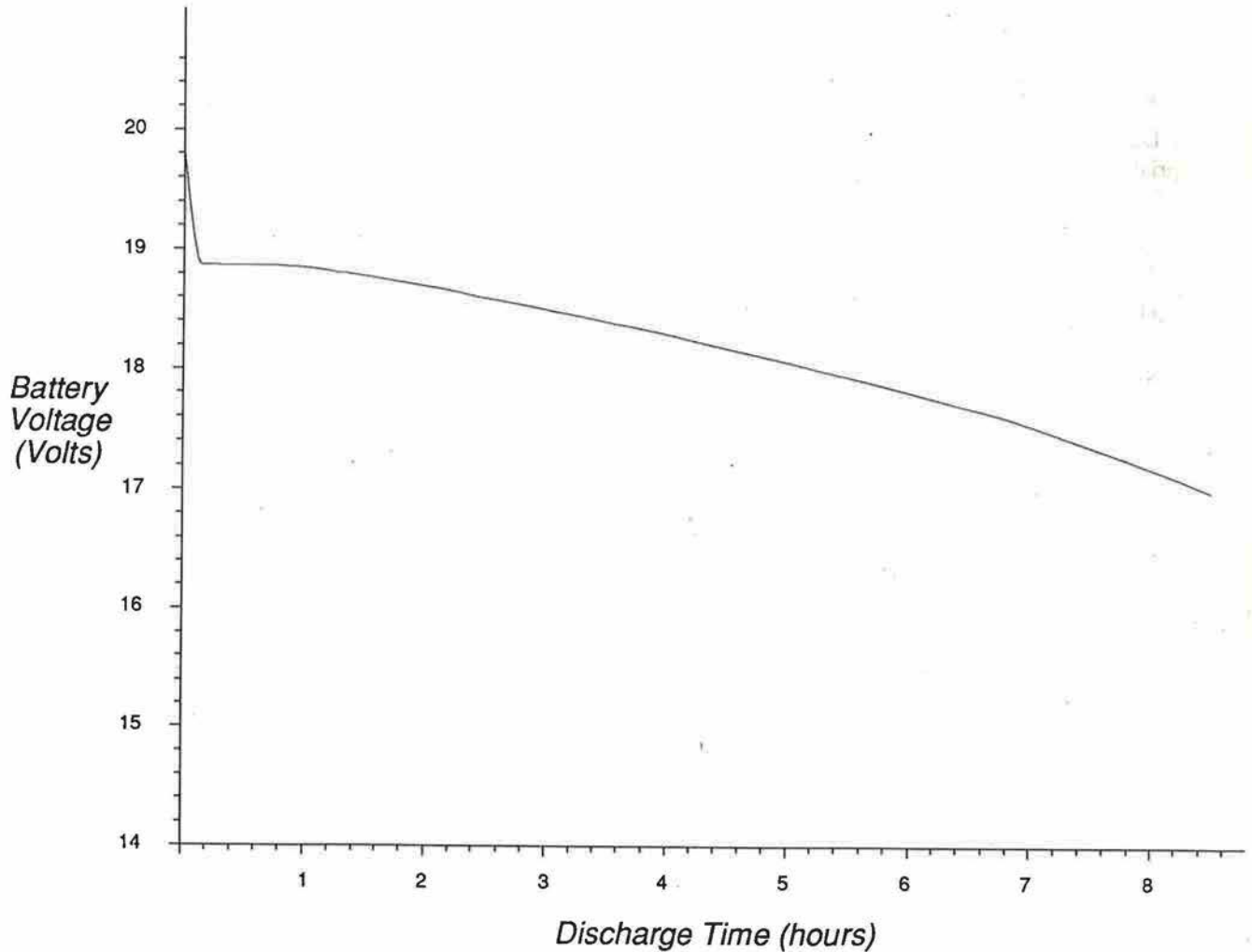

Fig 1.2.1.2 TYPICAL BATTERY DISCHARGE CURVE

1.2.2 Battery Pack Replacement

The decision as to whether the 4910/4911's battery pack requires replacement depends on a number of factors.

The battery checks detailed in *Section 1.2.1* will ascertain whether the batteries are in good enough condition to meet the instrument's 9-hour **Normal** mode or 168-hour **Transit** mode battery back-up specification.

However, if the unit is always operated from an AC line supply, or if it is only used in **Normal** mode for periods considerably less than 9 hours, and in **Transit** mode for periods less than 168 hours, it may not be necessary to replace the battery pack simply because it fails the *Section 1.2.1* battery checks.

Similarly, the unit's **EXTERNAL DC INPUT** facility can be used to reduce the **Transit** mode battery back-up requirement.

Hence the decision as to whether or not to replace the battery pack will depend to some extent on the intended usage of the 4910/4911.

The advantage of the battery check procedure which plots the discharge curves of the batteries, is that it provides a means of checking whether or not the unit's five battery supplies are degrading evenly.

If any one 18V battery supply shows markedly worse degradation than the other battery supplies in the unit, then it is likely that the instrument has developed a fault. In this case refer to the fault diagnosis checks detailed in *Section 2*.

If it is considered necessary to replace the battery pack, use the following procedure to do so:

1. Connect the unit to an appropriate AC line supply and switch the unit into its **Normal** operating mode.
2. Remove the two screws towards the rear of the unit's top cover and lift the top cover clear.
Caution: With the top cover removed from the unit, part of the power supply circuitry in the rear of the unit is exposed. Care should be taken to prevent accidental short-circuits which might result, for example, from careless use of screwdrivers or dropped screws.
3. Remove the two ribbon-cable plugs, P8 and P9, from the rear left hand side of the battery pack — refer to *Figure 1.2.2.1*.
4. Remove the eight screws and shakeproof washers which secure the battery pack to the side panels of the unit, and lift out the battery pack using the handle provided.
5. Slide the new battery pack (Datron Part Number 400885) into the unit and secure it with the eight securing screws and shakeproof washers.
6. Re-install ribbon-cable connectors P8 and P9.
7. Replace the top cover of the unit, securing it with the two top cover screws.
8. Check the following front-panel LED conditions:
Battery LEDs — continuous green
Temp LEDs — continuous green
Battery Supply LED — continuous green
Note: While ribbon-cable connectors P8 and P9 are disconnected, the front-panel **Battery** and **Battery Supply** LEDs may illuminate continuous red. This should **NOT** be interpreted as a fault condition.
9. Leave the unit connected to an appropriate AC line supply for at least 48 hours to ensure that the new battery pack is fully charged.

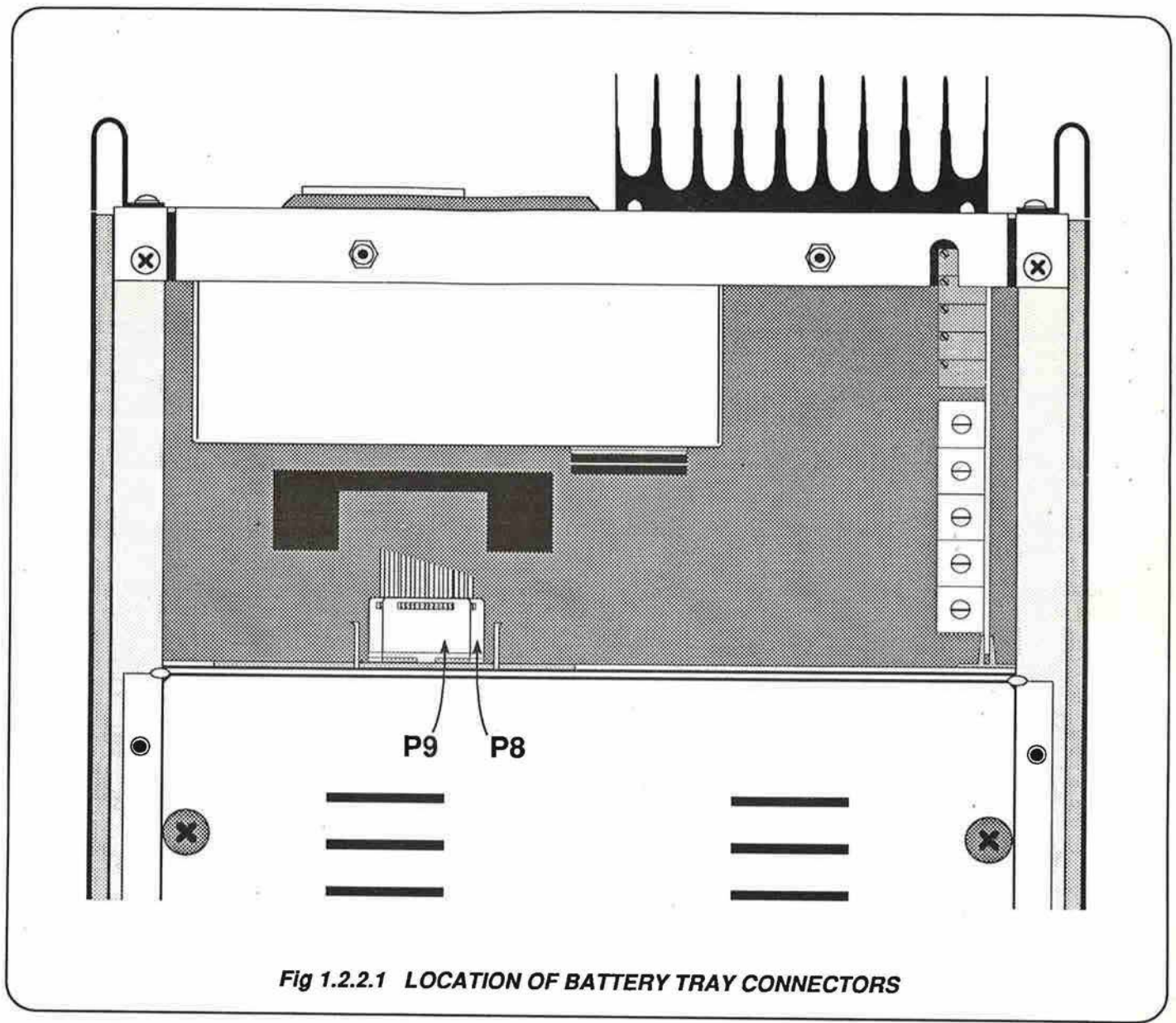

Fig 1.2.2.1 LOCATION OF BATTERY TRAY CONNECTORS

SECTION 2 FAULT DIAGNOSIS AND REPAIR

CAUTION:

During the 4910/4911's warranty period (for details, refer to the 'Terms and Conditions of Sale' which appear on the invoice for the unit), unauthorized repairs or modifications to the unit, other than those listed in Section 2.1 below, will invalidate the warranty.

2.1 Internal Operations Not Affecting Instrument Warranty.

The following internal operations **may** be carried out by the user during the 4910/4911's warranty period **without** invalidating the warranty:

1. Removal of the unit's top cover.
2. Internal battery connection after 'cold' shipment — refer to *Section 2 'Preparation for Operation — Cold Shipment'* of the *'4910 and 4911 DC Voltage Reference Standards User's Handbook'*.
3. Isolation of a **CELL** output from the **AVERAGE** output, or reconnection of a **CELL** output to the **AVERAGE** output — refer to *Section 3 'Average Switching'* of the *'4910 and 4911 DC Voltage Reference Standards User's Handbook'*. Note, however, that isolation of a **CELL** output from the **AVERAGE** output will invalidate the calibration certification of a 'hot' shipped 4910/4911.
4. Recalibration of the unit — refer to *Section 5 'Calibration'* of the *'4910 and 4911 DC Voltage Reference Standards User's Handbook'*.

2.2 Introduction

2.2.1 Fault Diagnosis and Repair Strategy

The 4910/4911 contains ultra-precision electronic circuitry. It is therefore recommended that all repairs to the unit are carried out by Datron Instruments or an authorized Datron Service Representative. (For a list of these representatives refer to *the end of this manual*.)

The diagnostic tables listed in this section are only intended to help a user to locate faults to assembly level — i.e. to a particular PCB or sub-assembly. It is recommended that repairs are effected by obtaining a complete replacement PCB or sub-assembly from Datron Instruments.

Unless **highly skilled** service personnel are available, it is **not** recommended that user's carry out fault diagnosis and repair to component level.

2.2.2 Use of Fault Diagnosis and Repair Tables

Tables 2.2.1 to 2.2.8 provide a useful guide to locating instrument faults down to assembly level unless otherwise stated. They apply with the instrument in **Normal** mode, and although not exhaustive, they cover most of the fault symptoms that are likely to be observed in the instrument.

Faults should be cured in the same order in which the tables are organized — i.e. fault symptoms in *Table 2.2.1* should be investigated before those detailed in *Table 2.2.2*, and those in *Table 2.2.2* investigated before those in *Table 2.2.3* etc.

The **FAULT LOCATION** column in the tables indicates the probable assembly which has failed. Where more than one assembly is listed, each assembly should be checked in turn using the information contained in *Section 4 'TECHNICAL DESCRIPTIONS'* of this manual.

Prior to any other checks on a particular assembly, check the following:

1. The condition of relevant fuses as detailed in *Table 2.2.9*.
2. The voltages and/or current-limits of the assembly's power supplies as detailed in *Table 2.2.10 to Table 2.2.14*.

The dismantling and reassembly procedures for gaining access to all of the unit's assemblies are detailed in *Section 3 'DISMANTLING AND RE-ASSEMBLY'* of this manual. An extender card (Datron Part Number 400947) is available, which allows the Cell and Output PCBs to be tested more easily.

After replacement or repair of an assembly, carry out the checks/adjustments detailed in *Table 2.2.15*.

FAULT DIAGNOSIS TABLES

TABLE 2.2.1 'Line Supply' AND 'Battery Supply' LED RELATED FAULTS

SYMPTOM	POSSIBLE FAULT	FAULT LOCATION	CHECKS	RELEVANT SECTION OF HANDBOOK
Line Supply LED fails to light when the unit is connected to an AC line supply.	Blown POWER INPUT module fuse.	Rear Panel.	Check fuse rating and line supply voltage selection.	User's Handbook, Section 2
	LED or LED drive circuit failure.	Power Supply, Mother or Front Panel PCB.	As required.	Section 4.2.9.4; Page 4-38.
Battery Supply LED flashes red/green prematurely after AC line supply disconnection.	Batteries insufficiently charged before AC line supply disconnection.		Recharge on an AC line supply for at least 48 hours.	
	Charging circuit failure.	Power Supply PCB.	As required.	Section 4.2.5; Page 4-32.
	Battery Pack failure.	Battery Tray Assembly.	As required.	Section 4.2.6; Page 4-34.
Battery Supply LED fails to return green within 48 hours of AC line supply connection.	Charging circuit failure.	Power Supply PCB.	As required.	Section 4.2.5; Page 4-32.
	Battery Pack failure.	Battery Tray Assembly.	As required.	Section 4.2.6; Page 4-34.
Battery Supply LED flashes red and green when the unit is in Transit mode and connected to an external DC supply.	External DC Supply input has fallen below 10V.		Check External DC Supply input is within the 10V to 40V limits, with the 4910/4911 connected to it.	
	External DC regulator circuit failure.	Mother PCB.	As required.	Section 4.2.8.2; Page 4-36.
	Battery Pack failure.	Battery Tray Assembly.	As required.	Section 4.2.6; Page 4-34.

TABLE 2.2.2 CELL 'Battery' LED RELATED FAULTS

SYMPTOM	POSSIBLE FAULT	FAULT LOCATION	CHECKS	RELEVANT SECTION OF HANDBOOK
Cell Battery LED flashes red/green prematurely after AC line supply disconnection.	Batteries insufficiently charged before AC line supply disconnection.		Recharge on an AC line supply for at least 48 hours.	
	Charging circuit failure.	Power Supply PCB.	As required.	Section 4.2.5; Page 4-32.
	Battery Pack failure.	Battery Tray Assembly.	As required.	Section 4.2.6; Page 4-34.
Cell Battery LED fails to return green within 48 hours of AC line supply connection.	Charging circuit failure.	Power Supply PCB.	As required.	Section 4.2.5; Page 4-32.
	Battery Pack failure.	Battery Tray Assembly.	As required.	Section 4.2.6; Page 4-34.
Cell Battery LED flashes red and green when the unit is in Transit mode and connected to an external DC supply.	External DC Supply input has fallen below 10V.		Check External DC Supply input is within the 10V to 40V limits, with the 4910/4911 connected to it.	
	External DC regulator circuit failure.	Mother PCB.	As required.	Section 4.2.8.2; Page 4-36.
	Battery Pack failure.	Battery Tray Assembly.	As required.	Section 4.2.6; Page 4-34.

TABLE 2.2.3 CELL 'Temp' LED FAULTS

SYMPTOM	POSSIBLE FAULT	FAULT LOCATION	CHECKS	RELEVANT SECTION OF HANDBOOK
Cell Temp LED fails to return green when rear-panel HEATER RESET switch is depressed five minutes after all Battery LEDs show green with unit in Normal mode.	Temperature control circuit failure.	Cell PCB.	As required.	Section 4.2.1.1; Page 4-9.
	Temperature monitoring circuit failure.	Cell PCB.	As required.	Section 4.2.1.1; Page 4-9.

TABLE 2.2.4 CELL 'Average' LED FAULTS

SYMPTOM	POSSIBLE FAULT	FAULT LOCATION	CHECKS	RELEVANT SECTION OF HANDBOOK
Average LED fails to light green when the appropriate cell is coupled to the AVERAGE output.	AVERAGE IN/OUT slide switches incorrectly positioned.	Cell PCB.	Check position of AVERAGE IN/OUT slide switches.	User's Handbook Section 3
	LED drive circuit failure.	Cell PCB.	As required.	Section 4.2.9.2; Page 4-38.
Average LED fails to light red when the appropriate cell is isolated from the AVERAGE output.	AVERAGE IN/OUT slide switches incorrectly positioned.	Cell PCB.	Check position of AVERAGE IN/OUT slide switches.	User's Handbook, Section 3
	LED drive circuit failure.	Cell PCB.	As required.	Section 4.2.9.2; Page 4-38.

TABLE 2.2.5 CELL OUTPUT FAULTS

SYMPTOM	POSSIBLE FAULT	FAULT LOCATION	CHECKS	RELEVANT SECTION OF HANDBOOK
All cell outputs are in error by the same amount.	PWM divider period timing fault.	Digital PCB.	As required.	Section 4.2.4; Page 4-30.
All outputs at approx. 0.7V.	PWM divider period timing fault.	Digital PCB.	As required.	Section 4.2.4; Page 4-30.
Individual cell output drifts by more than 152µV.	Cell primary divider failure.	Cell PCB.	As required.	Section 4.2.1.2; Page 4-12 and Section 4.2.1.4; Page 4-14.
	Cell reference module failure.	Cell PCB.	As required.	Section 4.2.1.1; Page 4-9.
	Cell output amplifier failure.	Cell PCB.	As required.	Section 4.2.1.1; Page 4-9.
Individual cell output drifts by less than 152µV.	Cell secondary divider failure.	Cell PCB.	As required.	Section 4.2.1.3; Page 4-13 and Section 4.2.1.5; Page 4-16.
	Cell reference module failure.	Cell PCB.	As required.	Section 4.2.1.1; Page 4-9.
	Cell output amplifier failure.	Cell PCB.	As required.	Section 4.2.1.1; Page 4-9.
Cell output has excessive 61Hz ripple or noise superimposed on its DC level.	Cell primary or secondary divider filter failure.	Cell PCB.	As required.	Section 4.2.1.2; Page 4-12 and Section 4.2.1.3; Page 4-13.
	Ground screen integrity failure.	Cell PCB or Digital PCB.	Check mechanical integrity of Cell PCB and Digital PCB cover-screen ground planes.	Section 3.4.4; Page 3-4 and Section 3.4.8; Page 3-7.

TABLE 2.2.6 AVERAGE OUTPUT FAULTS

SYMPTOM	POSSIBLE FAULT	FAULT LOCATION	CHECKS	RELEVANT SECTION OF HANDBOOK
AVERAGE output fails Calibration Confidence-check as detailed in Section 5 of the 4910 and 4911 DC Voltage Reference Standards User's Handbook.	AVERAGE IN/OUT links incorrectly positioned.	Cell PCB.	Check position of AVERAGE IN/OUT links.	User's Handbook, Section 3.
	Summing network failure.	Mother PCB.	As required.	Drawing DC400878 Sheet 6; Page 11.4-7.
	4-Wire Output Buffer or internal average buffer failure.	Output PCB.	Check AVERAGE ADJUST potentiometer adjustment then check as required.	Section 2.3.2; Page 2-9; Section 4.2.2.1 and Section 4.2.2.2; Page 4-17.

TABLE 2.2.7 4-WIRE OUTPUT BUFFER FAULTS

SYMPTOM	POSSIBLE FAULT	FAULT LOCATION	CHECKS	RELEVANT SECTION OF HANDBOOK
4-WIRE OUTPUT BUFFER differs from AVERAGE output by more than ±10µV at 23°C	4-Wire Output Buffer failure.	Output PCB.	Check 4-WIRE ADJUST potentiometer adjustment, then check as required.	Section 2.3.3; Page 2-10 and Section 4.2.2.1; Page 4-17.
4-WIRE OUTPUT BUFFER drops by more than 50µV for a load current of 15mA (measured using 4-wire sensing)	4-Wire Output Buffer failure.	Output PCB.	As required.	Section 4.2.2.1; Page 4-17.

TABLE 2.2.8 DIVIDED OUTPUT FAULTS

SYMPTOM	POSSIBLE FAULT	FAULT LOCATION	CHECKS	RELEVANT SECTION OF HANDBOOK
1.018V DIVIDED OUTPUT drifts by more than 152 μ V.	1.018V Divided Output primary divider failure.	Output PCB.	As required.	Section 4.2.2.3; Page 4-18; Section 4.2.2.5; Page 4-21 and Section 4.2.3.1; Page 4-28.
	1.018V Divided Output output buffer failure.	Output PCB.	As required.	Section 4.2.2.4; Page 4-20.
1.018V DIVIDED OUTPUT drifts by less than 152 μ V.	1.018V Divided Output secondary divider failure.	Output PCB.	As required.	Section 4.2.2.4; Page 4-20 and Section 4.2.2.6; Page 4-22.
	1.018V Divided Output output buffer failure.	Output PCB.	As required.	Section 4.2.2.4; Page 4-20.
1V DIVIDED OUTPUT drifts by more than 152 μ V.	1V Divided Output primary divider failure.	Output PCB.	As required.	Section 4.2.2.7; Page 4-24; Section 4.2.2.9; Page 4-26 and Section 4.2.3.2; Page 4-28.
	1V Divided Output output buffer failure.	Output PCB.	As required.	Section 4.2.2.8; Page 4-26.
1V DIVIDED OUTPUT drifts by less than 152 μ V.	1V Divided Output secondary divider failure.	Output PCB.	As required.	Section 4.2.2.8; Page 4-26 and Section 4.2.2.10; Page 4-27.
	1V Divided Output output buffer failure.	Output PCB.	As required.	Section 4.2.2.8; Page 4-26.

TABLE 2.2.9 FUSE LOCATIONS AND RATINGS

ASSEMBLY	FUSE	SIZE	FUSE SIZE AND RATING	DRAWING
Rear Panel Assembly	F1	32 mm	For 90V to 132V line supply: 800mA, 250V, T-type For 198V to 264V line supply: 400mA, 250V, T-type	DC400882 Sheet 1; Page 11.3.5.
Mother PCB	F601	20 mm	1.6A, 250V, F-type	DC400878 Sheet 6; Page 11.4.7.
Cell PCB	F101 [1]	7 mm	1A, 125V	DC400879 Sheet 1; Page 11.5-1.

Notes:

[1] To check these fuses, use the following procedure:

1. Connect all four CELL outputs to the AVERAGE output — see Section 3.
2. With the unit in **Normal** mode, measure each individual CELL output using a high impedance voltmeter (>1M Ω input impedance) and note the results.
3. Connect a 10k Ω resistor across the AVERAGE output terminals.
4. Measure each individual CELL output using a high impedance voltmeter (>1M Ω input impedance) and note the results.

Any CELL output, which drops by more than 10mV between steps (2) and (4), probably has a blown fuse F101 on its cell PCB.

POWER SUPPLIES

The following power supplies should be measured with the 4910/4911 in Normal mode

TABLE 2.2.10 POWER SUPPLY PCB SUPPLIES

SUPPLY	TEST POINT	TOLERANCE	DRAWING
I+(1)	J208-3 w.r.t J209-1	20.6V ± 0.25V [1]	DC400971 Sheet 1; Page 11.3-7
I+(2)	J208-6 w.r.t J209-3	20.6V ± 0.25V [1]	DC400971 Sheet 2; Page 11.3-8
I+(3)	J208-9 w.r.t J209-5	20.6V ± 0.25V [1]	DC400971 Sheet 3; Page 11.3-9
I+(4)	J208-12 w.r.t J209-7	20.6V ± 0.25V [1]	DC400971 Sheet 4; Page 11.3-10
I+(5)	J208-15 w.r.t J209-8	20.6V ± 0.25V [1]	DC400971 Sheet 5; Page 11.3-11
I+(1)	I+(1) in current limit [2]	305 mA ± 15 mA	DC400971 Sheet 1; Page 11.3-7
I+(2)	I+(2) in current limit [2]	305 mA ± 15 mA	DC400971 Sheet 2; Page 11.3-8
I+(3)	I+(3) in current limit [2]	305 mA ± 15 mA	DC400971 Sheet 3; Page 11.3-9
I+(4)	I+(4) in current limit [2]	305 mA ± 15 mA	DC400971 Sheet 4; Page 11.3-10
I+(5)	I+(5) in current limit [2]	425 mA ± 15 mA	DC400971 Sheet 5; Page 11.3-11

TABLE 2.2.11 MOTHER PCB SUPPLIES

SUPPLY	TEST POINT	TOLERANCE	DRAWING
I+(1)	TP102 w.r.t TP101	20.6V ± 0.25V [1]	DC400878 Sheet 1; Page 11.4-2
I+(2)	TP202 w.r.t TP201	20.6V ± 0.25V [1]	DC400878 Sheet 2; Page 11.4-3
I+(3)	TP302 w.r.t TP301	20.6V ± 0.25V [1]	DC400878 Sheet 3; Page 11.4-4
I+(4)	TP402 w.r.t TP401	20.6V ± 0.25V [1]	DC400878 Sheet 4; Page 11.4-5
I+(5)	TP502 w.r.t TP501	20.6V ± 0.25V [1]	DC400878 Sheet 5; Page 11.4-6
+12V REG(1)	TP104 w.r.t TP101	12V ± 0.6V	DC400878 Sheet 1; Page 11.4-2.
+12V REG(2)	TP204 w.r.t TP201	12V ± 0.6V	DC400878 Sheet 2; Page 11.4-3.
+12V REG(3)	TP304 w.r.t TP301	12V ± 0.6V	DC400878 Sheet 3; Page 11.4-4.
+12V REG(4)	TP404 w.r.t TP401	12V ± 0.6V	DC400878 Sheet 4; Page 11.4-5.
+13.5V REG(5)	TP503 w.r.t TP501	13.5V ± 0.675V	DC400878 Sheet 5; Page 11.4-6.
+12V TRANSIT (1)	J604-10 w.r.t TP101	12V ± 0.6V	DC400878 Sheet 1; Page 11.4-2.
+12V TRANSIT (2)	J605-10 w.r.t TP201	12V ± 0.6V	DC400878 Sheet 2; Page 11.4-3.
+12V TRANSIT (3)	J606-10 w.r.t TP301	12V ± 0.6V	DC400878 Sheet 3; Page 11.4-4.
+12V TRANSIT (4)	J607-10 w.r.t TP401	12V ± 0.6V	DC400878 Sheet 4; Page 11.4-5.
+VH(1)	TP103 w.r.t TP101 [3]	12V ± 0.6V	DC400878 Sheet 1; Page 11.4-2.
+VH(2)	TP203 w.r.t TP201 [3]	12V ± 0.6V	DC400878 Sheet 2; Page 11.4-3.
+VH(3)	TP303 w.r.t TP301 [3]	12V ± 0.6V	DC400878 Sheet 3; Page 11.4-4.
+VH(4)	TP403 w.r.t TP401 [3]	12V ± 0.6V	DC400878 Sheet 4; Page 11.4-5.

TABLE 2.2.12 CELL PCB SUPPLIES

SUPPLY	TEST POINT	TOLERANCE	DRAWING
+12V(A)	P604-10 w.r.t. TP102	12V \pm 0.6V	DC400879 Sheet 1; Page 11.5-1
+12V(B)	TP104 w.r.t. TP102	12V \pm 0.6V	DC400879 Sheet 1; Page 11.5-1
+V _H	P604-9 w.r.t. TP102	12V \pm 0.6V	DC400879 Sheet 1; Page 11.5-1
+5V(A)	TP107 w.r.t. TP102	5V \pm 0.25V	DC400879 Sheet 1; Page 11.5-1
+5V(5)	TP404 w.r.t. TP405	5V \pm 0.25V	DC400879 Sheet 4; Page 11.5-4
+6V(B)	D304 cathode w.r.t. TP102	6.2V \pm 0.4V	DC400879 Sheet 3; Page 11.5-3
+10V(B) [4]	D103 cathode w.r.t. TP108	10V \pm 0.5V	DC400879 Sheet 1; Page 11.5-1
+10V(A)	U302-2 w.r.t. TP108	+10V(B) \pm 15mV	DC400879 Sheet 3; Page 11.5.3

TABLE 2.2.13 OUTPUT PCB SUPPLIES

SUPPLY	TEST POINT	TOLERANCE	DRAWING
+13.5V-5	P608-A1 w.r.t. TP102	13.5V \pm 0.675V	DC400881 Sheet 1; Page 11.7.2
+5V_A	U106-1 w.r.t. TP102	5V \pm 0.25V	DC400881 Sheet 1; Page 11.7-2
+10V_B & +10V_C [4]	TP101 w.r.t. TP102	10V \pm 0.5V	DC400881 Sheet 1; Page 11.7-2
+5V_B	Across R122	5V \pm 0.35V	DC400881 Sheet 1; Page 11.7-2

TABLE 2.2.14 DIGITAL PCB SUPPLIES

SUPPLY	TEST POINT	TOLERANCE	DRAWING
+5V(5)	TP7 w.r.t. TP8	5V \pm 0.25V	DC400923 Sheet 1; Page 11.6-2

Notes:

w.r.t = with respect to

- [1] Figures shown are correct when the batteries are connected and the temperature of the battery-pack thermistors is 25°C. With batteries disconnected (no feedback from thermistors) the voltage should be between 24.0V and 25.0V
- [2] With battery pack disconnected and a 15V constant voltage load (e.g. a 15V, 7.5W zener diode) applied across test points.
- [3] Same as I+() in Transit mode.
- [4] If the unit is calibrated, voltage should be within the instrument's CELL output specification.

ADJUSTMENTS / CHECKS

TABLE 2.2.15 ADJUSTMENTS FOLLOWING REPLACEMENT OF ASSEMBLIES

ASSEMBLY	ADJUSTMENT REQUIRED	RELEVANT HANDBOOK SECTION
Battery Tray	<p>No adjustment required provided the 4910/4911 is powered from an AC line supply during the replacement procedure.</p> <p>Calibration check/re-calibration (recommended).</p>	<p>Section 1.2.2; Page 1-4.</p> <p>User's Handbook, Section 5.</p>
Line Input Transformer	<p>Common-mode adjustment.</p> <p>Calibration check/re-calibration.</p>	<p>Section 2.3.1; Page 2-9.</p> <p>User's Handbook, Section 5.</p>
Power Supply PCB	<p>Common-mode adjustment.</p> <p>Calibration check/re-calibration.</p>	<p>Section 2.3.1; Page 2-9.</p> <p>User's Handbook, Section 5.</p>
Mother PCB	Calibration check/re-calibration.	User's Handbook, Section 5.
Digital PCB	Calibration check/re-calibration.	User's Handbook, Section 5.
Front Panel PCB	Calibration check/re-calibration.	User's Handbook, Section 5.
Cell PCB	Re-calibration	User's Handbook, Section 5.
Output PCB	<p>AVERAGE ADJUST potentiometer check/adjustment.</p> <p>4-WIRE ADJUST potentiometer check/adjustment.</p> <p>Re-calibration.</p>	<p>Section 2.3.2; Page 2-9.</p> <p>Section 2.3.3; Page 2-10.</p> <p>User's Handbook, Section 5.</p>

2.3 Check/Adjustment Procedures

2.3.1 Common-Mode Adjustment

Equipment Required

Oscilloscope: Bandwidth >1MHz
Sensitivity better than 100mV/division
Coupling DC

1. Connect the front-panel **Guard** and **Case** terminals together with an external link.
 2. Ensure that all the **AVERAGE** links are in their **OUT OF AVERAGE** position. (Refer to the instructions on the PCB Internal Front Cover Screen adjacent to the links, or to *Section 3* of the '4910 and 4911 DC Voltage Reference Standards User's Handbook').
 3. Connect the unit to an appropriate AC line supply and check that the front-panel **Line Supply** LED is illuminated green.
 4. Check that all four **CELL** outputs are at a nominal 10V.
- N.B.** Take special care **not** to short together any pins of the **BATTERY/CHARGE VOLTAGES** connector.
5. Connect the low lead of the oscilloscope to the 4910/4911's **Case** terminal, and the high lead of the oscilloscope to pin 4 of the 4910/4911's rear-panel **BATTERY/CHARGE VOLTAGES** connector (see page I-3).
 6. With the oscilloscope DC coupled and, if possible, 'line locked' to the AC line supply frequency, adjust R101 on the Power Supply PCB to give a minimum amplitude trace, centered about zero, on the oscilloscope.
 7. Repeat steps 5 and 6 for pins 3,2,1 and 5 of the 4910/4911's **BATTERY/CHARGE VOLTAGES** connector, adjusting potentiometers R201, R301, R401 and R501 respectively.
 8. Repeat steps 5, 6, and 7 until all oscilloscope traces show an AC line frequency ripple of less than 0.5V pk-pk, balanced about zero.
 9. Place all the **AVERAGE** links in their **IN AVERAGE** position. (Refer to the instructions on the PCB Internal Front Cover Screen adjacent to the links, or to *Section 3* of the '4910 and 4911 DC Voltage Reference Standards User's Handbook').
 10. Check that the AC line frequency ripple on pin 5 of the rear-panel **BATTERY/CHARGE VOLTAGES** connector (oscilloscope low lead to 4910/4911 **Case** terminal, high lead to pin 5 of the connector) is still within the limits specified in step 8.
 11. Lock the position of potentiometers R101, R201, R301, R401 and R501 with a suitable locking compound.

2.3.2 AVERAGE ADJUST Potentiometer Adjustment (4910 only)

Note: For a replacement Output PCB supplied by Datron Instruments, this potentiometer setting will not need adjustment.

Equipment Required

Null Detector: Sensitivity <1 μ V
Noise < 200nV pk-pk
Input Impedance >1M Ω
(For example: Keithley 155)

1. Place all the **AVERAGE** links in their **IN AVERAGE** position. (Refer to the instructions on the PCB Internal Front Cover Screen adjacent to the links, or to *Section 3* of the '4910 and 4911 DC Voltage Reference Standards User's Handbook').
2. Connect the unit to an appropriate AC line supply, switch it to **Normal** mode and allow it to stabilize for a period of 2 hours.
3. Zero the null detector on its 10 μ V range.
4. Adjust the **AVERAGE ADJUST** potentiometer R135 until the arithmetic sum of the four Cell Hi to **AVERAGE** Hi voltages (as measured with the null detector) is less than $\pm 2\mu$ V.
5. Refit all screens, covers etc.

2.3.3 4-WIRE ADJUST Potentiometer Adjustment (4910 only)

Note: For a replacement Output PCB supplied by Datron Instruments, this potentiometer setting will not need adjustment.

Equipment Required

Null Detector: Sensitivity $<1\mu\text{V}$
Noise $<200\text{nV}$ pk-pk
Input Impedance $>1\text{M}\Omega$
(For example: Keithley 155)

1. Connect the shorting links provided with the 4910 between its front-panel 4-WIRE OUTPUT BUFFER **Hi** and **I+** terminals and between its 4-WIRE OUTPUT BUFFER **Lo** and **I-** terminals.
2. Connect the unit to an appropriate AC line supply, switch it to **Normal** mode and allow it to stabilize for a period of 2 hours.
3. Zero the null detector on its $10\mu\text{V}$ range and connect its negative lead to the 4910's front-panel **AVERAGE Hi** terminal, and its positive lead to the 4910's front-panel 4-WIRE OUTPUT BUFFER **Hi** terminal.
4. Adjust the **4-WIRE ADJUST** potentiometer R138 to give a null detector reading of **zero to $\pm 0.5\mu\text{V}$** .
5. Disconnect the AC line supply.
6. Refit all screens, covers etc..
7. Re-connect the unit to an appropriate AC line supply and allow it to stabilize for a period of 2 hours.
8. With the null detector connected as in step 4, check that the null detector reading is **zero $\pm 2\mu\text{V}$** .

SECTION 3 DISMANTLING AND REASSEMBLY

This section contains information and instructions for dismantling and reassembling the Datron 4910 or 4911 DC Voltage Reference Standard.

3.1 General Precautions

3.1.1 WARNING

ISOLATE THE INSTRUMENT FROM THE LINE SUPPLY BEFORE ATTEMPTING ANY DISMANTLING OR REASSEMBLY.

3.1.2 CAUTIONS

1. ANY DISMANTLING OF THE INSTRUMENT, OTHER THAN REMOVAL OF ITS TOP COVER TO CONNECT OR REPLACE THE BATTERY PACK, INVALIDATES THE MANUFACTURER'S CALIBRATION CERTIFICATION.
2. ALWAYS HANDLE THE INSTRUMENT CAREFULLY WHEN PARTIALLY DISMANTLED TO AVOID SHAKING UNSECURED ITEMS LOOSE.
3. DO NOT TOUCH THE CONTACTS OF ANY PCB CONNECTORS.
4. ENSURE THAT NO WIRES ARE TRAPPED WHEN FITTING COMPONENTS, SUB-ASSEMBLIES OR COVERS.
5. DO NOT ALLOW WASHERS, NUTS, ETC. TO FALL INTO THE INSTRUMENT.

3.2 General Mechanical Layout

(4910: Drawing DA400883 Sheets 1 to 4; Page and Facing Page 11.2-1 and Page and Facing Page 11.2-2)
(4911: Drawing DA400906 Sheets 1 to 4; Page and Facing Page 11.2-3 and Page and Facing Page 11.2-4)

3.2.1 Internal Construction

The 4910 and 4911 DC Voltage Reference Standards are built around a mechanical chassis assembly in which the various PCBs and electrical assemblies are mounted. Details of the chassis construction are shown in *Drawing DA400883 Sheet 1, Facing Page 11.2-1* for the 4910 and *Drawing DA400906 Sheet 1, Facing Page 11.2-3* for the 4911. The side panels are held together by the battery support box and the front card support panel. These chassis components should not be dismantled other than to replace a mechanically damaged chassis component.

The unit's Mother PCB mounts on the bottom of the side panels, and accepts the plug-in Cell and 4-Wire Output Buffer/Divided Output PCBs.

The unit's Front Panel Assembly slides into the forward end of the side panels. The Front Panel Assembly houses the Front Panel PCB which connects to the Mother PCB by two multi-contact connectors.

The Rear Panel Assembly, which supports the Line Input Transformer, Power Input Module and Power Supply PCB, mounts on the rear corners of the side panels.

The unit's back-up batteries are housed in a Battery Tray which is removable from the battery support box as a single unit.

3.2.2 Rack Mounting

The 4910/4911 Rack Mounting Kit (Option 90) allows a single 4910/4911, or two 4910/4911s positioned alongside each other, to be mounted in a 19-inch rack. For mechanical details of the Rack Mounting Kit refer to *Drawing DA440161 Sheet 1, Page 11.9-1*.

3.3 General Access

Preliminary Precautions

1. Ensure that the AC POWER INPUT cable is disconnected.
2. Note the General Precautions outlined in *Section 3.1*.
3. When dismantling the 4910 or 4911 it is advisable to remove the Battery Tray as detailed in *Section 3.4.1* to make the unit more manageable.

3.3.1 Top Cover

Removal

1. Remove the two screws towards the rear of the Top Cover and remove the cover by simultaneously lifting it and sliding it towards the rear of the unit.

Fitting

1. Place the front edge of the Top Cover into the groove in the top rear face of the front panel bezel and lower the cover so that it engages in the grooves along the top edges of the unit's side panel.
2. Secure the Top Cover using its two retaining screws.

3.3.2 Bottom Cover

Removal

1. Turn the unit upside down and rest it on a clean surface. (If possible, the unit should be placed on suitable padding so that it is not scratched or otherwise damaged while in the inverted position.)
2. Remove the six rubber feet by unscrewing the retaining screws which pass through their centers.
3. Remove the two Bottom Cover retaining screws and shakeproof washers located towards the rear of the Bottom Cover.
4. Remove the Bottom Cover by simultaneously lifting it and sliding it towards the rear of the unit.

Fitting

1. Place the front edge of the Bottom Cover into the groove in the bottom rear face of the front panel bezel. Lower the Bottom Cover so that it engages in the grooves along the bottom edges of the unit's side panels and secure the cover with its two retaining screws and shakeproof washers.
2. Replace the unit's rubber feet making sure that the screws which retain the feet are not over-tightened.

3.4 Assemblies - Removal and Fitting

3.4.1 Battery Tray

(4910: Drawing DA400883 Sheet 2; Page 11.2-1)

(4911: Drawing DA400906 Sheet 2; Page 11.2-3)

Removal

1. Remove the two ribbon cable plugs, P8 and P9, from the rear left-hand side of the Battery Tray. (They can be temporarily secured by folding the ribbon cables and clipping them into the ribbon-cable retaining clip on the line supply screening box.)
2. Remove the eight screws and shakeproof washers which secure the Battery Tray to the side panels of the unit, and lift out the Battery Tray using the handle provided.

If it is required to dismantle the Battery Tray refer to *Section 3.4.12*.

Fitting

Reverse the procedure given above for removing the Battery Tray.

3.4.2 Front Panel Assembly

(4910: Drawing DA400883 Sheet 2; Page 11.2-1)

(4911: Drawing DA400906 Sheet 2; Page 11.2-3)

Removal

1. Remove the two screws which secure the forward handle caps to the unit's side panels — marked 'A' in *Drawing DA400883 Sheet 3, Detail 8; Facing Page 11.2-2 (4910)* and *Drawing DA400906 Sheet 3, Detail 8; Facing Page 11.2-4 (4911)*. Remove the handle caps and ensure that the circular spacers beneath each cap are safely retained ready for reassembly.
2. Remove the four screws which secure the Front Panel Assembly to the unit's side panels — marked 'B' in *Drawing DA400883 Sheet 2, Detail 4; Page 11.2-1 (4910)* and *Drawing DA400906 Sheet 2, Detail 4; Page 11.2-3 (4911)*.
3. Ease the bottom of the Front Panel Assembly forward to disengage the connectors between the Front Panel PCB and the Mother PCB.
4. Ease the complete Front Panel Assembly clear of the side panels.

Fitting

Reverse the procedure given above for removing the Front Panel Assembly. When replacing the handle caps, insert the spring steel core of the handle into the groove in the cap before inserting the circular bush and securing screw. Also ensure that the handle caps are correctly located with one end flush with the front panel bezel.

3.4 Assemblies - Removal and Fitting (Contd.)

3.4.3 Rear Panel Assembly

(4910: Drawing DA400883 Sheet 1; Facing Page 11.2-1)
(4911: Drawing DA400906 Sheet 1; Facing Page 11.2-3)

Removal

1. Remove the unit's Top Cover as detailed in *Section 3.3.1*.
2. Remove the unit's Bottom Cover as detailed in *Section 3.3.2*.
3. Remove the ribbon cable connectors, P208 and P209, from the Power Supply PCB — see *Drawing DA400883 Sheet 3 Detail 7, Facing Page 11.2.2 (4910)*; or *Drawing DA400906 Sheet 3 Detail 7, Facing Page 11.2.4 (4911)*.
4. Remove the ribbon cables from the ribbon-cable retaining clip which is attached to the line supply input screening box.
5. Remove the knob from the rear-panel BATTERY MODE switch by prising off the end cap on the knob and unscrewing the internal retaining collet.
6. Remove the four Rear Panel Assembly retaining screws and shakeproof washers — marked 'C' in *Drawing DA400883 Sheet 1; Facing Page 11.2-1 (4910)* and *Drawing DA400906 Sheet 1; Facing Page 11.2-3 (4911)* — and gently ease the Rear Panel Assembly away from the unit.

Fitting

1. Slide the Rear Panel Assembly into the rear of the unit ensuring that the forward edge of the Power Supply PCB locates in the card guide on the rear face of the battery support box. Also ensure that neither of the ribbon cables connected to the Mother PCB is trapped or damaged.
2. Secure the Rear Panel Assembly to the unit's side panels with the two pan-head screws and shakeproof-washers on the underside of the unit, and the two countersunk screws on the top side. Ensure that the tag on the end of the green/yellow ground lead from the Mother PCB is secured under the shakeproof washer of the bottom right-hand Rear Panel Assembly securing screw.
3. Replace the knob on the BATTERY MODE switch by placing it on its shaft, correctly aligning its pointer, tightening its retaining collet and replacing its end-cap.
4. Insert ribbon cable connectors P208 and P209 into their sockets on the Power Supply PCB.
5. Replace the unit's Bottom Cover as detailed in *Section 3.3.2*.
6. Replace the unit's Top Cover as detailed in *Section 3.3.1*.

3.4.4 Cell PCB Assemblies

(4910: Drawing DA400883 Sheet 3; Facing Page 11.2-2)
(4911: Drawing DA400906 Sheet 3; Facing Page 11.2-4)

Removal

1. Remove the unit's Top Cover as detailed in *Section 3.3.1*.
2. Ensure that all the AVERAGE links are in their IN AVERAGE position. (Refer to the instructions on the PCB Internal Front Cover Screen adjacent to the links, or to *Section 3 of the '4910 and 4911 DC Voltage Reference Standards User's Handbook'*.)
3. Remove the three screws and wavy washers which retain the PCB Internal Front Cover Screen and remove the screen.
4. Remove the Cell PCB(s) using the ejector handles provided. (When removing the Cell-4 PCB great care should be taken not to foul PCB components on the front right-hand screen mounting point.)

If it is necessary to remove the Cell PCB's cover screens which surround its digital circuitry, proceed as follows:

5. Remove the four screws and wavy washers which secure the component-side screen to the Cell PCB.
6. Remove both the component-side and non-component-side screens from the Cell PCB.

Fitting

1. Reverse the procedure given above for removing the Cell PCB and its cover screens. (When fitting the Cell-4 PCB into the unit great care should be taken not to foul PCB components on the right-hand PCB Internal Front Cover Screen mounting point.)
2. Ensure that the AVERAGE switching links are replaced in the required IN AVERAGE or OUT OF AVERAGE positions after installation of the PCB Internal Front Cover Screen.

3.4.5 Output PCB Assembly (4910 only)

(Drawing DA400883 Sheet 3; Facing Page 11.2-2)

Removal

1. Remove the unit's Top Cover as detailed in *Section 3.3.1*.
2. Ensure that all the AVERAGE links are in their IN AVERAGE position. (Refer to the instructions on the PCB Internal Front Cover Screen adjacent to the links, or to *Section 3 of the '4910 and 4911 DC Voltage Reference Standards User's Handbook'*.)
3. Remove the three screws and shakeproof washers which retain the PCB Internal Front Cover Screen and remove the screen
4. Remove the Output PCB using the ejector handles provided.

If it is necessary to remove the Output PCB's cover screens which screen its digital circuitry, proceed as follows:-

5. Remove the four screws and wavy washers which secure the component-side screen to the Output PCB.
6. Remove both the component-side and non-component-side screens from the Output PCB.

Fitting

1. Reverse the procedure given above for removing the Output PCB and its cover screens.
2. Ensure that the AVERAGE switching links are replaced in the required IN AVERAGE or OUT OF AVERAGE positions after installation of the PCB Internal Front Cover Screen.

3.4.6 Output PCB Digital Sub-Assembly (4910 Only)

(Drawing DA400881 Sheet 2; Page 11.7-1)

Removal

1. Remove the Output PCB as detailed in *Section 3.4.5*.
2. Remove the four screws and wavy washers which secure the component-side cover screen to the Output PCB.
3. Remove both the component-side and non-component-side cover screens from the Output PCB.
4. Remove the screw and wavy washer which secure the Digital Sub-Assembly PCB to the Output PCB and gently prise the Digital Sub-Assembly PCB away from the Output PCB to disengage connector pair J9/P9.

Fitting

Reverse the procedure given above for removing the Digital Sub-Assembly PCB, ensuring that connector P9 is accurately aligned with the pins on connector J9 when the Digital Sub-Assembly PCB is positioned on the Output PCB.

3.4 Assemblies - Removal and Fitting (Contd.)

3.4.7 Mother PCB Assembly

(4910: Drawing DA400883 Sheet 2; Page 11.2-1)

(4911: Drawing DA400906 Sheet 2; Page 11.2-3)

Removal After Rear Panel Assembly Removal

1. Remove the Battery Tray as detailed in *Section 3.4.1*.
2. Remove the Cell PCBs as detailed in *Section 3.4.4*.
3. Remove the Output PCB as detailed in *Section 3.4.5* (4910 only).
4. Remove the Rear Panel Assembly as detailed in *Section 3.4.3*.
5. Remove the ten screws and wavy washers which secure the Mother PCB to the unit's side panels.
6. Slide the Mother PCB towards the rear of the unit to disengage the connectors which link the Mother PCB to the Front Panel PCB.
7. Lift the Mother PCB clear of the unit.

Fitting

Reverse the procedure given above for removing the Mother PCB.

Removal After Front Panel Assembly Removal

1. Remove the Battery Tray as detailed in *Section 3.4.1*.
2. Remove the Cell PCBs as detailed in *Section 3.4.4*.
3. Remove the Output PCB as detailed in *Section 3.4.5* (4910 only).
4. Remove the Front Panel Assembly as detailed in *Section 3.4.2*.
5. Disconnect connectors P208 and P209 which connect the Mother PCB ribbon cables to the Power Supply PCB.
6. Remove the screw and shakeproof washer which secure the bottom right-hand corner of the Rear Panel Assembly to the unit's side panel and release the green/yellow ground lead which connects the Mother PCB to the Rear Panel Assembly.
7. Remove the knob from the rear-panel BATTERY MODE switch by prising off the end cap on the knob and unscrewing the internal retaining collet.
8. Remove the ten screws and wavy washers which secure the Mother PCB to the unit's side panels.
9. Slide the Mother PCB towards the front of the unit to disengage the shaft of the BATTERY MODE switch from its hole in the rear panel.
10. Lift the Mother PCB clear of the unit.

Fitting

Reverse the procedure given above for removing the Mother PCB, but do NOT tighten the ten screws which secure the Mother PCB to the unit's side panels until after the Front Panel Assembly has been replaced. (This will avoid stressing the connectors which link the Mother PCB to the Front Panel PCB.)

3.4.8 Digital PCB Assembly

(Drawing DA400923 Sheets 1 and 2; Page 11.6-1 and Facing Page 11.6-2)

Removal

1. Remove the Mother PCB as detailed in *Section 3.4.7*.
2. Disconnect connector P501 from the Mother PCB.
3. Remove the twelve screws and shakeproof washers which secure the Digital PCB Assembly to the Mother PCB and lift the Digital PCB Assembly clear of the Mother PCB.
4. While supporting the underside of the Digital PCB Assembly (either in the palm of one hand or by placing it on a flat surface), remove the ten screws which secure the five 15-way D-connectors to the Digital PCB Assembly's upper screen.
5. While still supporting the underside of the assembly, turn it over and rest it on a flat surface.
6. Gently lift up the corner of the insulating card where it lies over the two feed-through connectors in the assembly's upper screen and unsolder the two feed-through connector wires as shown in *Figure 3.4.8.1*. (If gentle pressure is applied to the D-type connectors while heat is applied to the solder joints, the Digital PCB should lift clear of the two feed-through connector wires.)
7. Remove the Digital PCB from its screen, taking care to retain the RFI gaskets which sit over each D-type connector.

Fitting

1. Place one RFI gasket over each of the 15-way D-connectors.
2. Insert the Digital PCB into its upper screen, ensuring that none of the RFI gaskets is displaced and that the two wires from the feed-through connectors on the screen enter the appropriate holes in the Digital PCB.
3. Replace the ten countersunk screws which secure the D-type connectors to the screen.
4. Resolder the two wires from the feed-through connectors to the Digital PCB.
5. Ensure that the card insulator is attached to the bottom of the Digital PCB and secure the Digital PCB Assembly to the Mother PCB standoffs using the six countersunk screws along its forward edge and the six pan-head screws and wavy washers along its rear edge.
6. Reconnect connector P501 to the Mother PCB.

3.4.9 Front Panel PCB Assembly

(4910: Drawing DA400880 Sheet 2; Page 11.3-1)
(4911: Drawing DA400905 Sheet 2; Page 11.3-3)

Removal

1. Remove the Front Panel Assembly as described in *Section 3.4.2*.
2. Remove the gold plated nuts and washers which secure the Front Panel PCB to the front panel terminals.
3. Remove the screws and shakeproof washers which secure the Front Panel PCB to the front panel metalwork and lift off the Front Panel PCB.

Fitting

Reverse the procedure given above for removing the Front Panel PCB. If a torque screwdriver is available, the gold plated nuts which secure the Front Panel PCB to the front panel terminals should be tightened to a torque of 1.1 Nm. One drop of a suitable locking compound should be applied to each of these nuts after tightening.

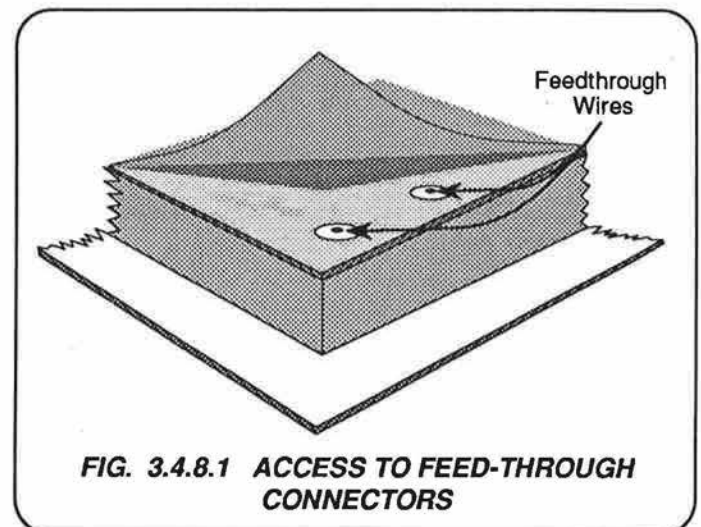

FIG. 3.4.8.1 ACCESS TO FEED-THROUGH CONNECTORS

3.4 Assemblies - Removal and Fitting (Contd.)

3.4.10 Power Supply PCB Assembly

(Drawing DA400882 Sheet 2; Page 11.3-6)

Note: The Power Supply PCB can be tested while it remains mounted on the Rear Panel Assembly. **Provided that adequate precautions are taken**, an AC line supply can be connected to the rear panel POWER INPUT connector to power the Power Supply PCB while it is tested.

Removal

1. Remove the Rear Panel Assembly as detailed in *Section 3.4.3*
2. Disconnect connector P101 from the Power Supply PCB.
3. Remove the five screws, shakeproof washers and insulating bushes which secure the power supply PCB voltage regulators U101, U201, U301, U401 and U501 to the rear panel.
4. Remove the two screws and wavy washers which retain the Power Supply PCB to its mounting brackets and remove the Power Supply PCB from the Rear Panel Assembly. Ensure that the thermally conducting insulating pads beneath the regulators are retained safely ready for reassembly (if the pads show signs of damage, new pads should be fitted in their place).

Fitting

Reverse the procedure given above for removing the Power Supply PCB, ensuring that the thermally conducting insulators under the voltage regulators are in position before inserting the insulating bushes, shakeproof washers and screws which secure the regulators to the rear panel.

3.4.11 Line Input Transformer

(Drawing DA400882 Sheet 1; Facing Page 11.3-5)

Removal

1. Remove the Rear Panel Assembly as detailed in *Section 3.4.3*.
2. Disconnect connector P101 from the Power Supply PCB.
3. Remove the three screws and shakeproof washers which retain the line supply screening box to the rear panel and remove the screening box.
4. Remove the nut and shakeproof washer from the rear panel ground stud and remove the transformer assembly's two green/yellow ground leads from the stud.
5. Unsolder the five transformer leads from the POWER INPUT module, making a note of their color coding.
6. Remove the two bolts and self-locking nuts which retain the line input transformer to the rear panel and remove the line input transformer.

Fitting

Reverse the procedure given above for removing the line input transformer, ensuring that when the line supply screening box is replaced, the rubber grommet on the transformer cable assembly correctly locates in the cut-out in the box. Also ensure that none of the three green/yellow grounding leads is trapped under the edge of the cover.

The colour coding of the wires which connect to the POWER INPUT module is shown on *Drawing DA400882 Sheet 1, Facing Page 11.3.5*.

3.4.12 Battery Tray Assembly

(Drawing DA400885 Sheets 1 to 3; Facing Page 11.8-1, Page 11.8-1 and Facing Page 11.8-2)

Dismantling

Note: Dismantling should only proceed as far as is required to replace or repair the faulty component(s).

1. Remove the Battery Tray as detailed in *Section 3.4.1*.
2. Remove the six screws and shakeproof washers which secure the Battery Tray top plate and remove the top plate.
3. Lift out the upper plastic spacer.
4. Disconnect the Battery Tray PCB Assembly's wiring harness from the upper layer of batteries.
5. Disconnect the remaining link cables from the upper layer battery terminals.
6. Lift out the batteries in the upper layer and remove the upper rubber battery cushioning sheet.
7. Remove the four screws and shakeproof washers securing the Battery Tray PCB to the rear wall of the Battery Tray.
8. Lift out the metal center plate, passing the Battery Tray PCB through the appropriate aperture as the plate is removed. (Note: Take care not to short circuit any of the tracks or connections on the Battery Tray PCB as it is passed through the center plate aperture.)
9. Lift out the lower plastic spacer, again passing the Battery Tray PCB through the appropriate aperture.
10. Disconnect the Battery Tray PCB Assembly's wiring harness from the lower layer of batteries.
11. Disconnect the remaining link cables from the lower layer battery terminals.
12. Lift out the batteries in the lower layer and remove the lower rubber battery cushioning sheet.

Reassembly

Reverse the procedure given above for dismantling the Battery Tray Assembly.

The colour coding for the wiring harness which connects the Battery Tray PCB to the batteries is shown on *Drawing DA400885 Sheets 2 and 3; Pages 11.8-1 and Facing Page 11.8-2*.

Installation details for the upper battery layer and lower battery layer link cables are shown on *Drawing DA400885 Sheets 1 and 3; Facing Page 11.8-1 and Facing Page 11.8-2* respectively. Take care not to short the batteries, and make sure that no wires become trapped between mechanical parts.

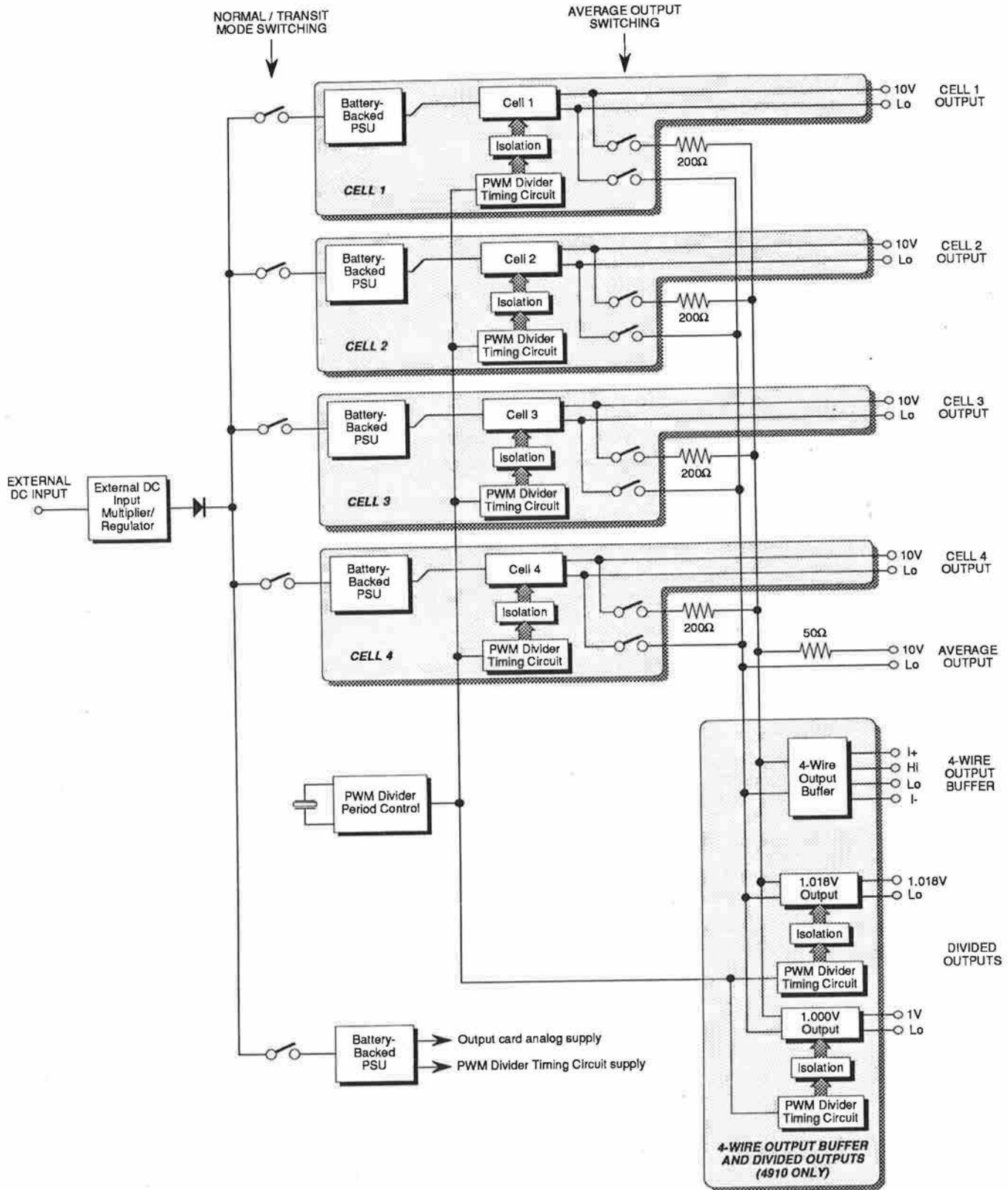
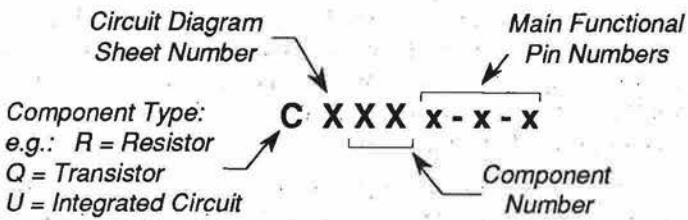

FIG. 4.1.1.1 4910/4911 SIMPLIFIED BLOCK DIAGRAM

SECTION 4 TECHNICAL DESCRIPTIONS

Note: The technical descriptions in this section use the following conventions to identify individual components:

Component Identification



Example: Op-amp U2013-2-1 would be found on Sheet 2 of the relevant circuit diagram as:

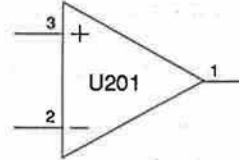

4.1 Principles of Operation

4.1.1 Simplified Block Diagram

Fig. 4.1.1.1 (opposite) illustrates the general functions and signal flow within the 4910/4911,

4.1.2 General Principles

4.1.2.1 Cell Outputs

The 4910/4911 has four separate 10V CELL outputs, each of which is fully isolated from all the other front-panel outputs, provided that it is not connected to the AVERAGE output (i.e. it has been isolated from the AVERAGE output according to the procedure detailed in Section 3 of the '4910 and 4911 DC Voltage Reference Standards User's Handbook'). To achieve the required isolation, each cell has its own voltage reference module and output amplifier, together with its own fully isolated power supply — refer to Figure 4.1.1.1.

The cell's zener diode reference module generates an ultra-stable output voltage of approximately 7.23V, which is amplified by a precision voltage amplifier to generate a 10V output. The gain of this amplifier cannot be defined by a conventional resistive feedback network because the temperature coefficient and ageing coefficient of even the best resistors would not allow the output stability specifications of the 4910/4911 to be met.

Instead, the cell's output amplifier utilizes a pulse-width modulation (PWM) voltage divider to achieve precision gain control — see Figure 4.1.2.1.

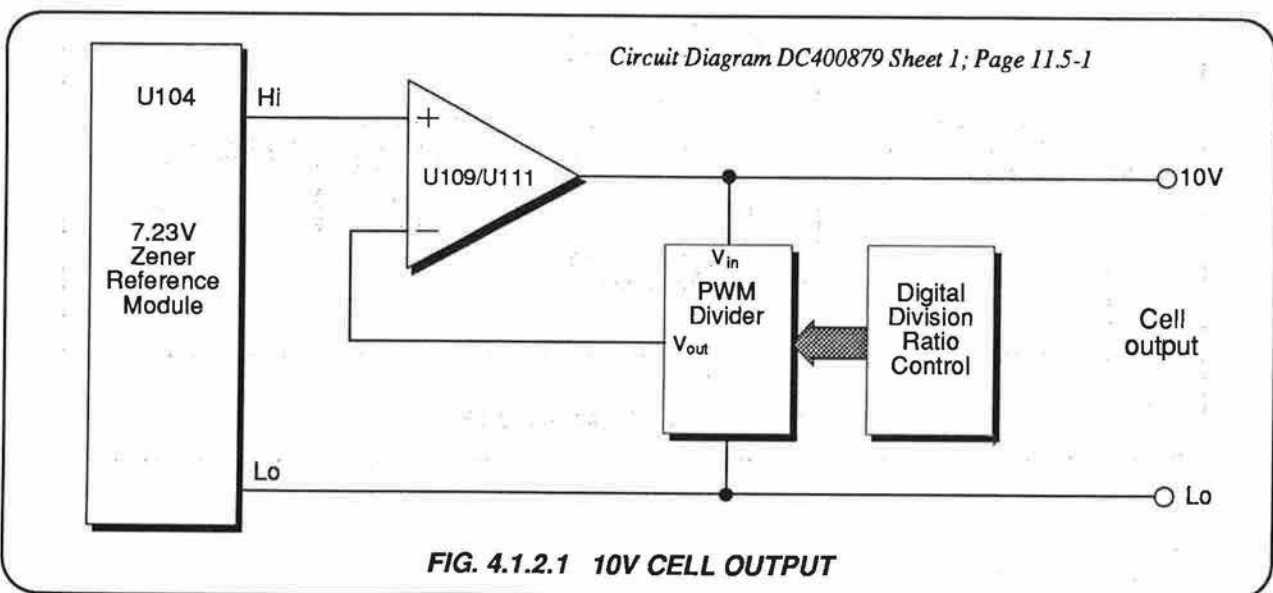

4.1.2.1 Cell Outputs (contd.)

PWM Divider

The PWM divider operates by chopping its DC input voltage to produce a rectangular wave of peak amplitude V_{in} and mark/period ratio $T1/(T1 + T2)$ — see Figure 4.1.2.2. This rectangular wave is then filtered by a mean-sensing low-pass filter to produce the divider's DC output voltage V_{out} . (The filter is specially designed to introduce no DC offset into the output signal.)

V_{out} is therefore the mean value of the rectangular wave and is given by the equation:-

$$V_{out} = V_{mean} = \frac{1}{2\pi} \int_0^{2\pi} v \cdot dt$$

$$= \frac{1}{T1 + T2} \int_0^{t_1} V_{in} \cdot dt + \int_{t_1}^{t_2} 0 \cdot dt$$

$$= \frac{T1}{T1 + T2} \times V_{in} \quad \text{since } V_{in} \text{ is a constant DC voltage}$$

In the 4910/4911 the total period $T1 + T2$ is held constant at 16.384ms.

Therefore:-

$$V_{out} = \frac{T1 \times V_{in}}{16.384 \times 10^{-3}} \quad \text{where } T1 \text{ is expressed in seconds}$$

Hence the division ratio of the divider can be controlled simply by varying the 'mark' period ($T1$) of the switching.

The stability of the division ratio is dependent almost entirely on the stability of the mark period ($T1$) and the total period ($T1 + T2$). In addition, because both the mark timing and total period timing are digitally derived from the same clock signal, it is only the short term stability of this timing source that matters. As a result, a simple uncompensated crystal oscillator is all that is needed to control the PWM divider timing.

In practice, to achieve the required setting resolution, two PWM dividers are used — see Figure 4.1.2.3. The primary divider is controlled by a 16-bit counter, allowing the division ratio to be set to 16-bit resolution (1 part in 65536).

The secondary divider operates in a similar way to the primary divider, but its output is resistively attenuated by R111/R113 to approximately 1/65,536 of the primary divider output. As a result of this attenuation, the full span of the secondary divider has the same effect on the amplifier's output as a one lsb (least-significant-bit) change in the primary divider.

Controlled by an 8-bit counter, the secondary divider therefore provides a further 8 bits of setting resolution — giving the composite divider a total resolution of 1 part in 2^{24} (1 part in 16,777,216).

With the dividers adjusted to give a 10V cell output, the output can therefore be set to 0.6µV resolution ($10V + 16777216$). The primary divider providing 152.6µV setting resolution, and the secondary divider filling in each of these 152.6µV steps to 0.6µV resolution.

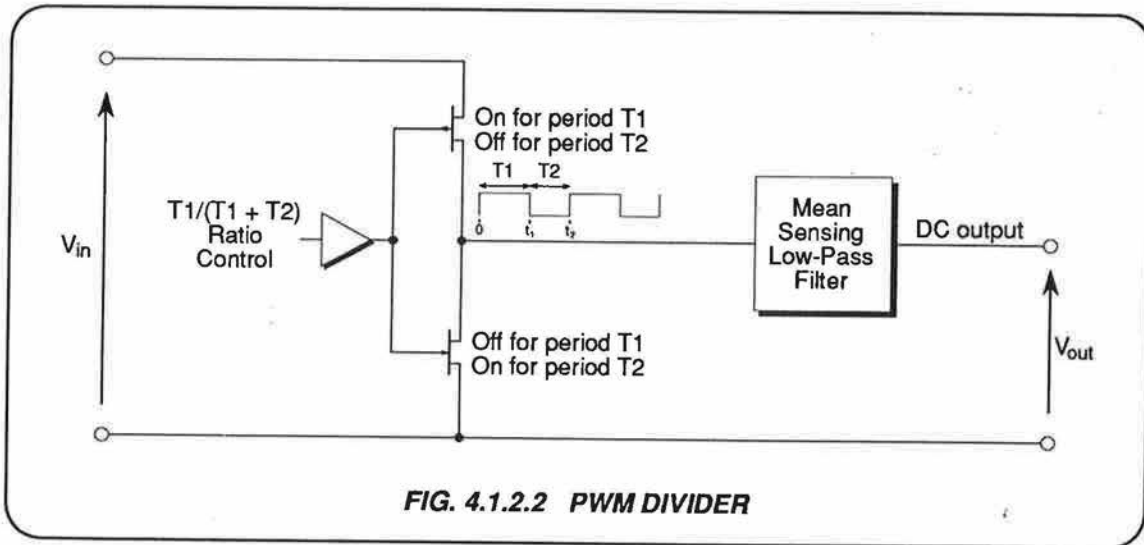

FIG. 4.1.2.2 PWM DIVIDER

Timing Circuits

Although each cell contains its own logic circuitry to control the mark period of the PWM voltage dividers, the total period of the dividers' chopping cycle ($T1 + T2$) is controlled by a single digital circuit which is common to all the cell outputs.

This circuit divides down the output of an 8 MHz crystal oscillator to produce a set of PWM divider control pulses which occur at a repetition rate of 61 Hz. To maintain isolation between the four cell outputs of the 4910/4911, these control pulses are transferred to each cell via pulse transformers or opto-isolators.

Temperature control

The only element in the cell which requires temperature control is the precision zener diode contained in the reference module. To minimize power dissipation and eliminate the requirement for a conventional temperature controlled oven, the zener diode has an on-chip temperature sensor and heating element. When the 4910/4911 is in **Normal** mode, linear control circuitry within the reference module senses the temperature of the zener diode, and controls the current through the heater to maintain the zener diode within a few m°C of a constant temperature (approximately 70°C).

However, when the 4910/4911 is switched to **Transit** mode the heater is externally driven by a pulse-width modulated signal to minimize power consumption and thereby extend the battery backup period.

In either mode, correct operation of the heater control circuitry is continuously monitored, and the front panel **TempLED** illuminates red if temperature control is lost.

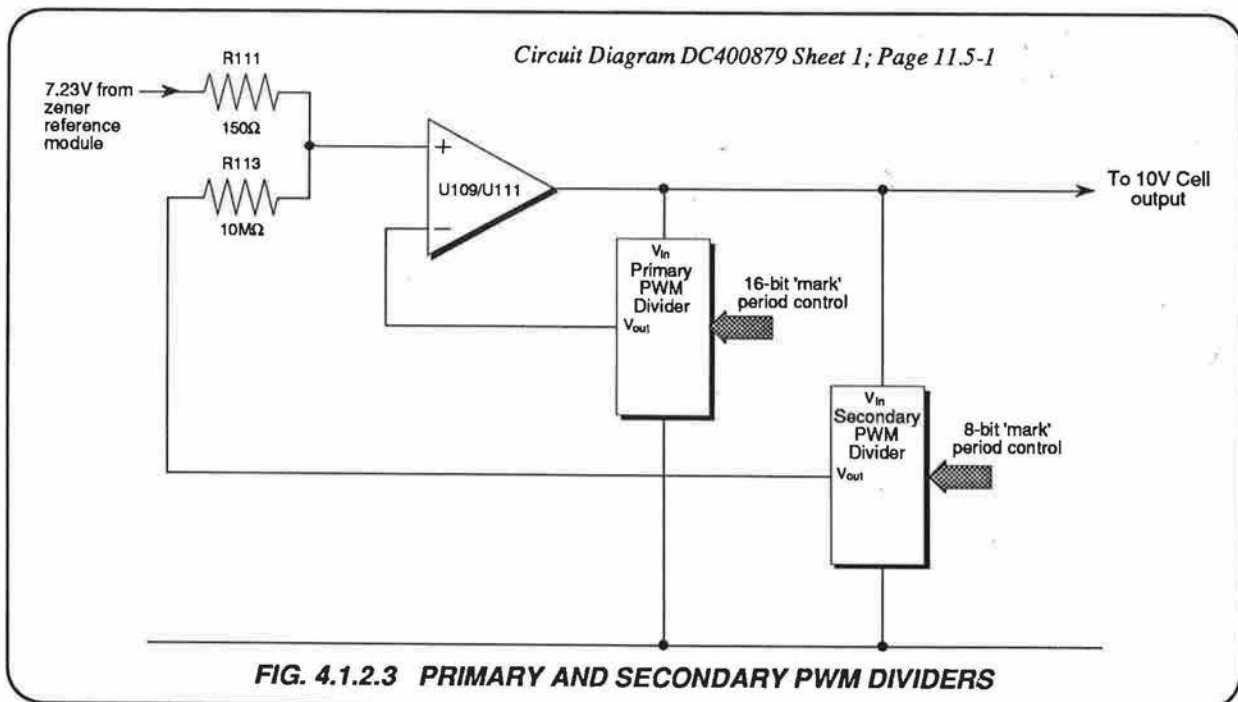

4.1.2.2 AVERAGE Output

Internal links are provided in the 4910/4911 so that individual CELL outputs can be connected to the unit's AVERAGE output. These links switch each cell's 10V output to the AVERAGE output via 200Ω resistors as shown in Figure 4.1.2.4.

Provided that no current is drawn from the AVERAGE output, the voltage at its terminals is the arithmetic mean of the cell outputs which are connected to it. In addition, random effects such as noise are reduced by a factor of \sqrt{n} , where n is the number of CELL outputs connected to the AVERAGE output — for example, with all four CELL outputs internally linked to the AVERAGE output, output noise is reduced by a factor of 2.

It should be noted that once any two CELL outputs are connected to the AVERAGE output, there is no longer any isolation between them. In addition, any CELL output which is connected to the AVERAGE output is not galvanically isolated from the AVERAGE output, nor from the 4-WIRE OUTPUT BUFFER and DIVIDED outputs.

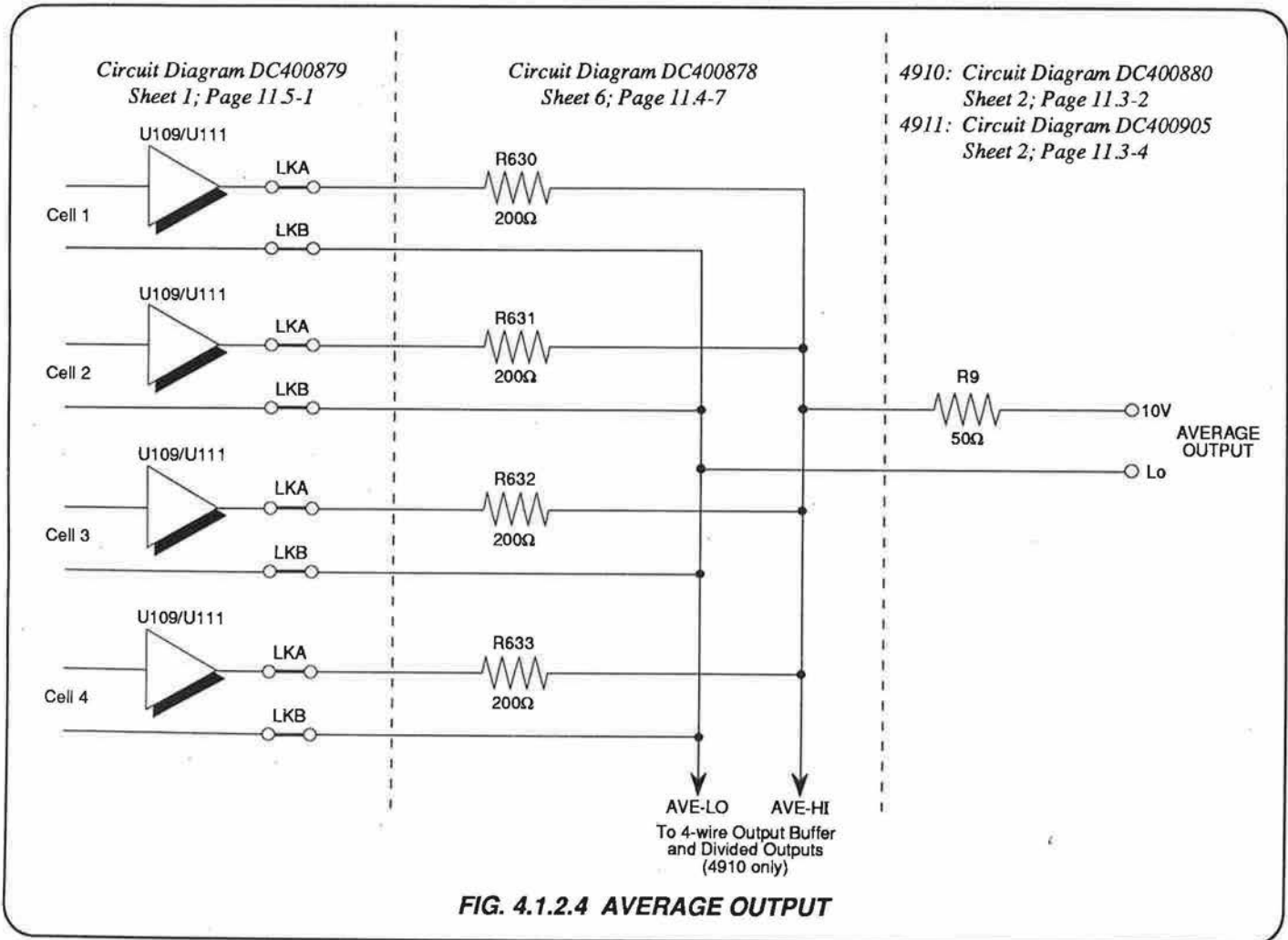
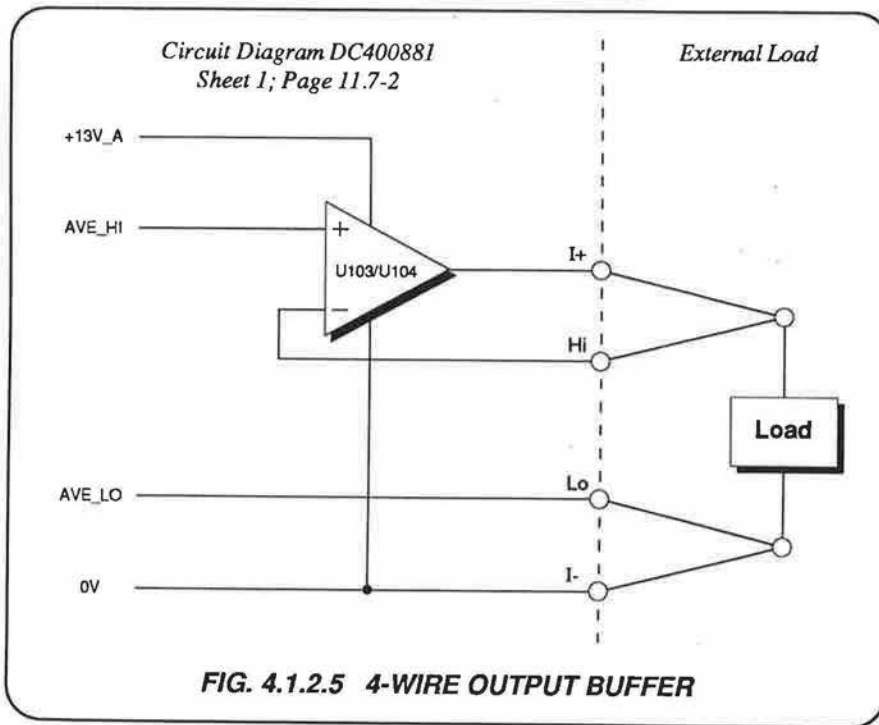

FIG. 4.1.2.4 AVERAGE OUTPUT

4.1.2.3 4-WIRE OUTPUT BUFFER (4910 only)

The 4910's **4-WIRE OUTPUT BUFFER** is a unity gain amplifier which buffers the voltage at the **AVERAGE** output so that the 4910 can source output currents as high as 15 mA — see *Figure 4.1.2.5*.

The amplifier is provided with true 4-wire sensing so that the effects of lead resistance between the 4910's **4-WIRE OUTPUT BUFFER** and the connected load can be eliminated.



4.1.2.4 DIVIDED OUTPUTS (4910 only)

The 4910's **DIVIDED OUTPUTS** provide highly stable buffered output voltages of 1.018V and 1.000V nominal. Both outputs are generated by dividing down the 10V **AVERAGE** output. To eliminate the temperature coefficient and ageing effects associated with resistive dividers, the 10V **AVERAGE** output is divided down by PWM dividers similar to the one used in the feedback path of the cell output circuitry.

Both the 1.018V and 1.000V outputs have a 16-bit primary divider which chops the 10V **AVERAGE** voltage into a variable mark/period ratio rectangular wave — see Figure 4.1.2.6. The mean-sensing filter in each divider filters the rectangular wave to produce a DC divider output which can be set to 152.6µV resolution ($10V + 2^{16}$). This voltage is buffered at unity gain to the appropriate **DIVIDED OUTPUT** terminals by the output amplifier U404/U405 (1.018V output) and U406/U407 (1V output).

In the case of the 1.018V output, a 12-bit secondary divider chops and filters the 10V **AVERAGE** voltage to provide a DC divider output that can be set to 2.44 mV resolution ($10V + 2^{12}$). This voltage is summed into the output amplifier at a gain of approximately 1/14,000 so that the effective **1.018V DIVIDED OUTPUT** setting resolution is 0.175µV ($2.44mV + 14,000$).

In the case of the 1.000V output, an 8-bit secondary divider chops and filters the 10V **AVERAGE** voltage with 39mV resolution ($10V + 2^8$), and its output is then summed into the output amplifier at a gain of 1/196,000 so that the effective **1V DIVIDED OUTPUT** setting resolution is 0.199µV ($39 mV + 196,000$).

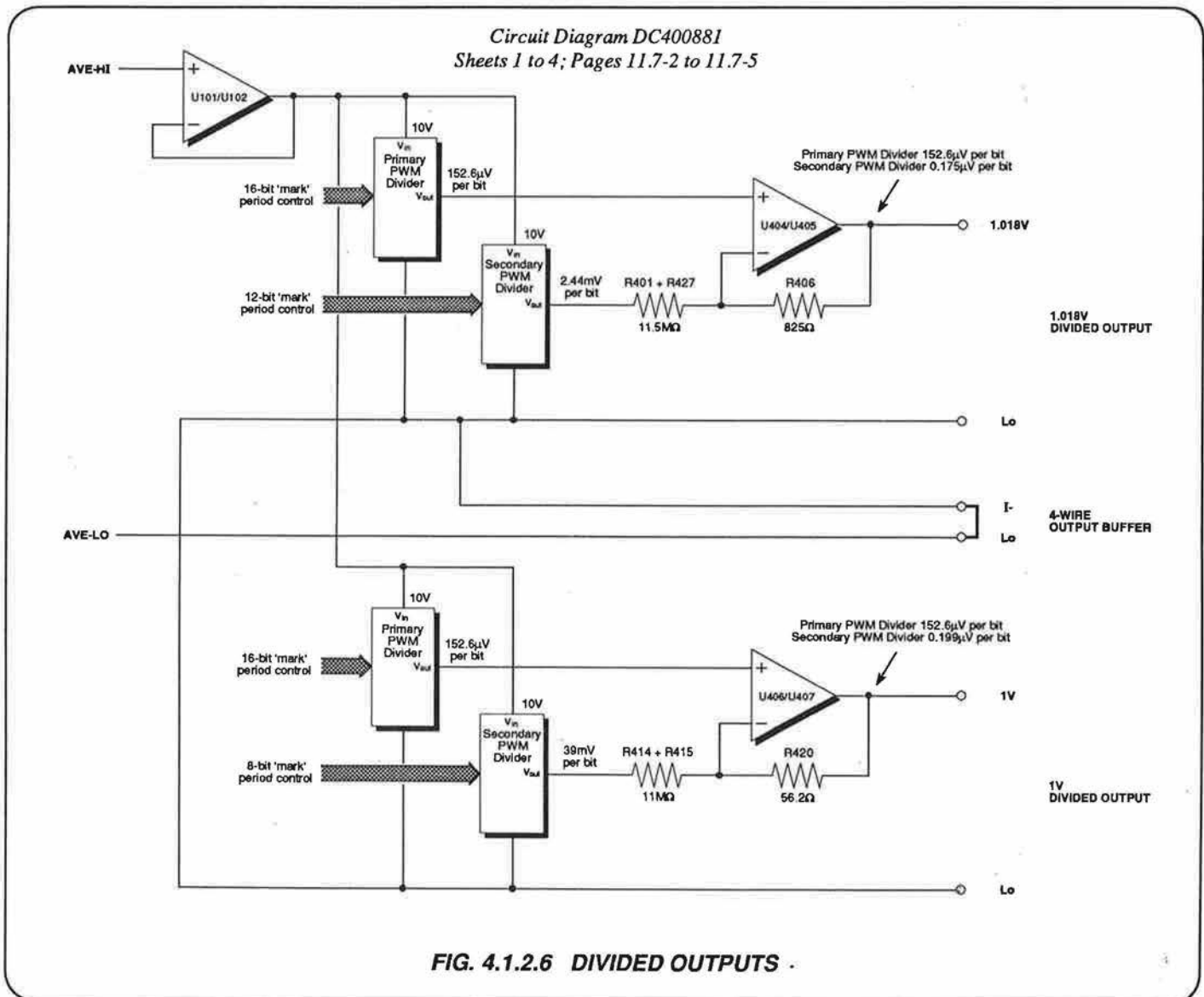

4.1.2.5 Power Supplies

Normal Mode Operation

In its **Normal** operating mode, each of the 4910/4911's four 'cells' is powered from a separate, fully isolated power supply — see *Figure 4.1.2.7*. This allows any **CELL** output to be floated with respect to other **CELL** outputs, provided that the cell is isolated from the **AVERAGE** output (the procedure is detailed in *Sect. 3 of the '4910 and 4911 DC Voltage Standards User's Handbook'*). These four power supplies share only the primary winding and core of line input transformer T1, which provides the necessary isolation between them.

The primary source of power for each cell comprises three 6V sealed-electrolyte lead-acid batteries which are connected in series to provide an 18V supply. When the 4910/4911 is connected to an AC line supply, these batteries are either float-charged, or charged at constant current, depending on their state of discharge. During float-charging, the charging voltage is automatically adjusted according to the temperature of the batteries to ensure the optimum charging conditions required to prolong battery life.

The 18V output from each cell's battery supply is continuously monitored for both under-voltage and over-voltage conditions by the battery voltage monitor circuits. These circuits drive the red/green front panel **Battery** LEDs to indicate the condition of each cell's battery supply (See *Section 3 of the '4910 and 4911 DC Voltage Standards User's Handbook'*) and will automatically disconnect the battery supply from the cell under certain failure conditions. A 12V regulator in each cell's power supply produces a regulated 12V supply from the 18V battery supply to power the cell's analog and digital circuitry.

A fifth isolated power supply, similar in most respects to those which power the individual cell outputs, provides a 13.5V supply for the **4-WIRE OUTPUT BUFFER** and the **DIVIDED OUTPUT** circuitry. A 5V regulator on this supply also provides power for various digital timing circuits within the 4910/4911.

Transit Mode Operation

When the 4910/4911 is switched to **Transit** mode, all five of the 18V battery packs are connected in parallel to produce a single high-capacity 18V supply. At the same time Normal/Transit mode switching disconnects most of the 4910/4911's analog and digital circuits from their power supplies to conserve battery power. Only the zener reference module temperature monitoring and control circuits remain active.

Switching the unit into **Transit** mode switches the reference module's heater drive circuit from a linear mode into a high-efficiency PWM (pulse-width modulation) mode, powered from the unregulated 18V battery voltage, which also helps to conserve battery power.

Normal/Transit mode switching also introduces the 10V-40V **EXTERNAL DC INPUT** into the battery circuit. Voltage monitoring circuits on the DC input automatically activate a voltage doubler/tripler in order to provide sufficient input to the external DC input's 18V regulator. The output from this regulator is diode-coupled into the battery circuit so that it can take over from the batteries in supplying Transit mode power to the 4910/4911.

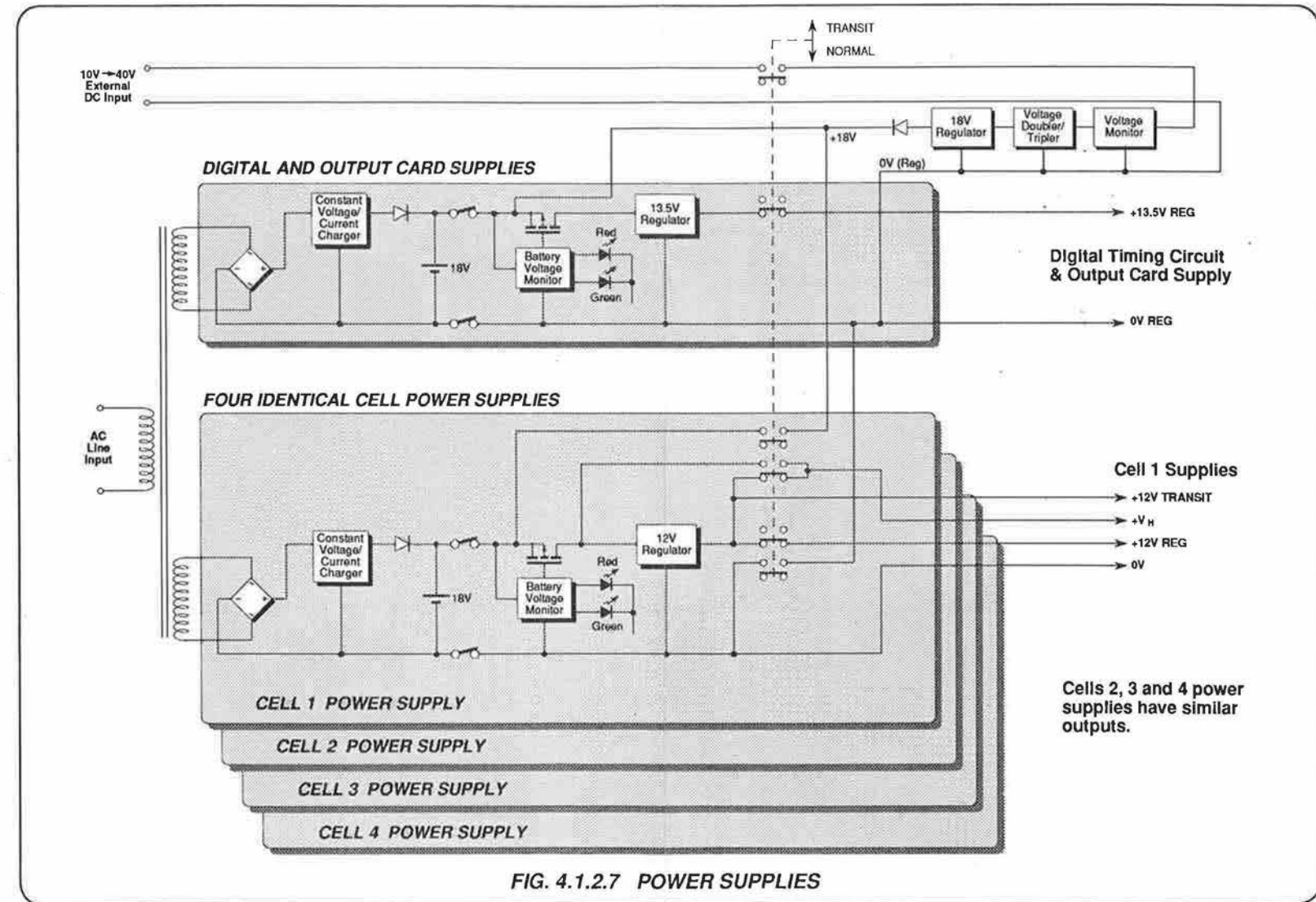

4.2 PCB Descriptions

4.2.1 Cell PCB

4.2.1.1 Zener Reference Module and Output Amplifier (Circuit Diagram DC400879 Sheet 1; Page 11.5-1)

U104

The zener reference module U104 generates a highly stable 7.23V output on pins U104₉₋₁₀. Internally, it comprises two circuits — a precision zener diode reference circuit, and a temperature control circuit which maintains the zener diode at a constant elevated temperature. Temperature control is performed by controlling the power dissipation in the zener diode's on-chip substrate heater. Both of these circuits remain fully operational irrespective of whether the 4910/4911 is in **Normal** or **Transit** mode, and whether or not it is connected to an AC line supply.

The heater circuit is powered via U104₈ from the cell's 18V battery supply, while the zener diode circuitry is powered via U104₁₂ from a 12V regulated supply which is derived from the 18V battery voltage.

When the 4910/4911 is in **Normal** mode, the +12V(B) supply which drives the gate of Q106 is connected to the cell's regulated 12V supply so that Q106 is on — providing a ground return for current in the zener diode's substrate heater. In this mode, temperature control of the zener diode is performed entirely by circuitry within the zener reference module U104.

U101₄₋₅₋₂/U101₇₋₆₋₁

When the 4910/4911 is switched to **Transit** mode, +12V(B) is disconnected from the cell's regulated 12V supply causing Q106 to turn off. In **Transit** mode, the current in the substrate heater is switched by Q107. (In **Normal** mode Q107 is held off by +12V(B) operating through R145/D101/U101₇₋₆₋₁.) When +12V(B) falls to zero, reverse biasing D101, the astable multivibrator built around U101₄₋₅₋₂ starts up and generates a triangular 1kHz (approx) waveform at the junction of C101 and R101₄₋₃. This waveform is one input to comparator U101₇₋₆₋₁.

The other input to comparator U101₇₋₆₋₁ comes from PIN 'A' on the zener reference module U104. This signal is derived from an error amplifier in the module which compares a voltage representing the actual temperature of the zener diode with one representing the required zener diode temperature. As this error signal moves positively and negatively with respect to the triangular wave present at U101₇, a pulse-width modulated signal is generated at U101₁ which pulse-width modulates the substrate heater current via Q107. This circuit is arranged to provide negative feedback in the temperature control loop so that the zener diode temperature remains constant. Switchmode control of the heater current is used in **Transit** mode to conserve battery power.

U102

In **Transit** mode, battery power is also conserved by stabilizing the zener diode at a lower constant temperature than in **Normal** mode. When the 4910/4911 is switched from **Normal** to **Transit** mode, the loss of the +12V(B) supply voltage at U108₁₋₂ causes U108₃ to rise to 12V. This allows C105 to charge up slowly via R107 so that over a period of around 20 minutes the output of unity gain buffer U102₃₋₂₋₆ rises towards 12V. When this happens, D108 becomes forward biased and introduces an offset voltage into the zener reference module's temperature error amplifier via U104₆. This offset operates so as to move the operating point of the temperature control circuit down from 70°C to around 50°C. The reverse process takes place when the 4910/4911 is switched back to **Normal** mode.

U110/U101₉₋₈₋₁₄/U101₁₁₋₁₀₋₁₃

The two inputs to the zener reference module's temperature error amplifier are continuously monitored by amplifier U110₃₋₂₋₆ and comparators U101₉₋₈₋₁₄ and U101₁₁₋₁₀₋₁₃. If the difference between the two error inputs exceeds approximately 67mV, indicating that excessive temperature deviation has occurred (i.e. temperature control has been lost), open collector output U101₁₄ or U101₁₃ goes low. Via U108₁₂₋₁₃₋₁₁ this transition sets latch U107₈₋₁₀₋₁₃₋₁₂ causing its Q output U107₁₃ to go high and its \bar{Q} output U107₁₂ to go low. Via drive transistors Q105 and Q104, these transitions turn on the cell's red front-panel **Temp** LED and turn off its green **Temp** LED. The set state of U107₈₋₁₀₋₁₃₋₁₂ remains latched until the rear-panel **HEATER RESET** switch is depressed, forcing U107₁₀ (reset input) to a high level. Note that if correct temperature control of the zener diode has not been regained when the rear-panel **HEATER RESET** button is depressed (i.e. pin U101₁₄ or U101₁₃ is still pulling R135 low), U107 will not reset.

U112

A 12V level at U108₃, which appears when the 4910/4911 is switched from **Normal** to **Transit** mode, enables astable multivibrator U112, the output of which is used to pulse the current in the front panel LEDs. This is a further measure taken in **Transit** mode to conserve battery power.

U109/U111/Q102

The stable 7.23V reference voltage generated by the zener reference module at U104₉₋₁₀ is amplified to 10V by a composite amplifier built around U109 and U111 — see *Figure 4.2.1.1*. This amplifier has two control loops — a high speed control loop to minimize output noise, and an ultra-stable precision gain control loop to provide long-term output stability.

The high speed control loop comprises U111/Q102 and resistive feedback network R122/R124 in a conventional non-inverting amplifier configuration. The gain of this loop is set at 1.37 by the ratio of R122 and R124, so that the 7.23V input to U111₃ is amplified to 10V.

The precision gain control loop is built around U109 — a chopper-stabilized op-amp with an extremely low input offset drift of typically only 0.01 $\mu\text{V}/^\circ\text{C}$ and 100 $\text{nV}/\sqrt{\text{month}}$. Precision gain around this loop is controlled by two PWM voltage dividers. Under steady state conditions no current flows onto the integrator capacitor C113 via R112, and therefore the voltage at the junction of R111 and R113 must equal the primary divider's output voltage which provides feedback to U109₃ — see *Figure 4.2.1.1*.

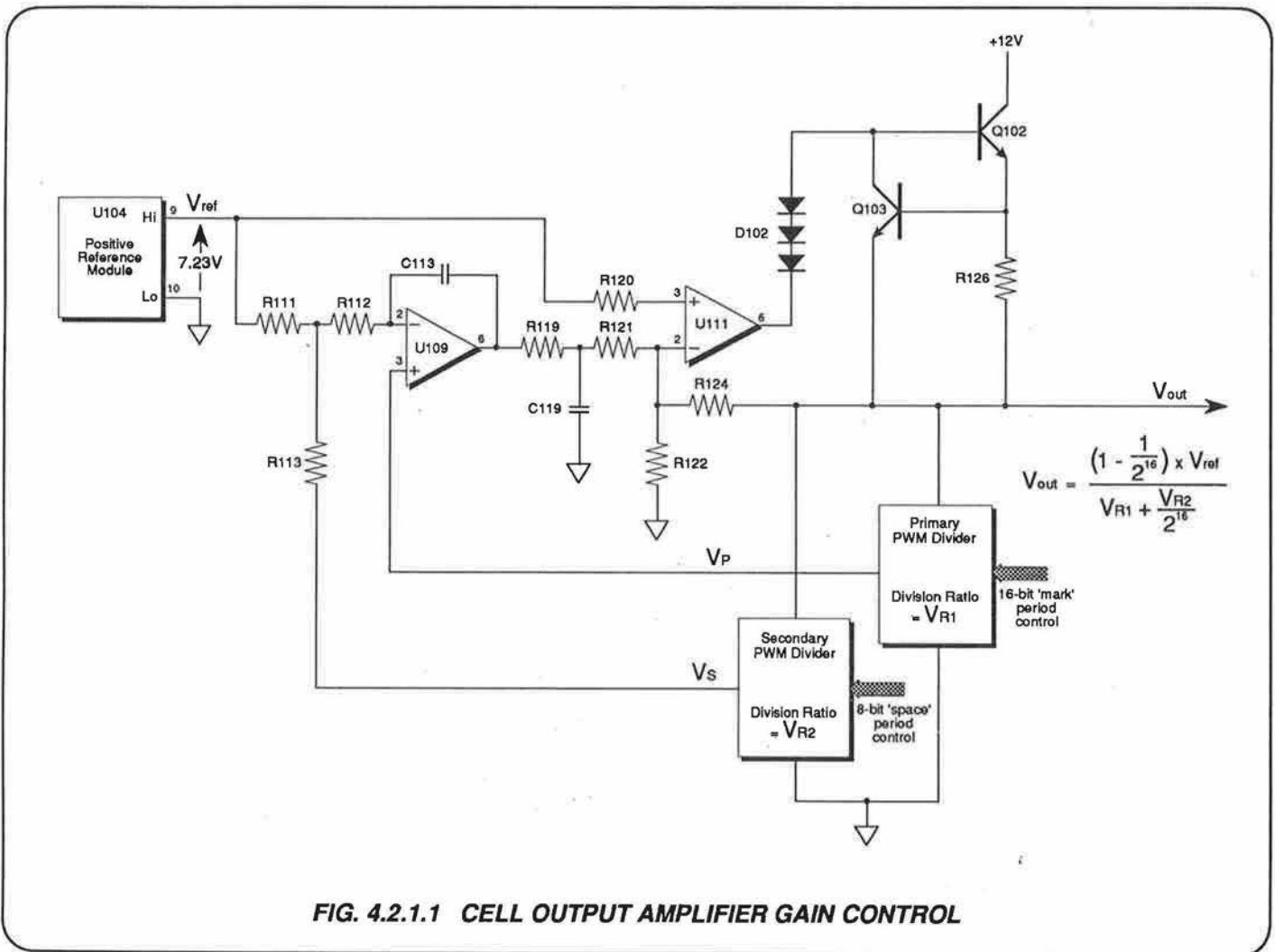

Hence:-

$$V_S + \frac{R_{113}}{R_{111} + R_{113}} \times (V_{\text{ref}} - V_S) = V_P \quad (1)$$

V_P and V_S are given by the equations:

$$V_P = V_{\text{out}} \times V_{R1} \quad (2)$$

$$V_S = V_{\text{out}} \times V_{R2} \quad (3)$$

where V_{R1} and V_{R2} are the division ratios of the primary and secondary PWM dividers respectively.

The values of R_{111} and R_{113} are arranged such that:-

$$\frac{R_{113}}{R_{111} + R_{113}} = 1 - \frac{1}{2^{16}} \quad (4)$$

Substituting (2), (3) and (4) into (1) and solving for V_{out} gives:-

$$V_{\text{out}} = \frac{\left(1 - \frac{1}{2^{16}}\right) \times V_{\text{ref}}}{V_{R1} + \frac{V_{R2}}{2^{16}}} \quad (5)$$

It can be seen from this equation that while the primary divider scales V_{ref} virtually directly, the secondary divider has only $1/2^{16}$ the weighting of the primary divider.

The primary divider timing is controlled by a 16-bit counter which allows its division ratio to be set to a resolution of 1 part in 2^{16} (1 part in 65,536). With its division ratio set to provide a cell output of 10V, it therefore provides an output setting resolution of 152.6 μV per bit.

The secondary divider's timing is controlled by an 8-bit counter, giving it a division ratio resolution of 1 part in 2^8 (1 part in 256). For a 10V cell output this represents 39 mV per bit at the divider's output. However, because the secondary divider has $1/2^{16}$ the weighting of the primary divider, its effective setting resolution at the cell output is reduced to:-

$$39\text{mV} / 2^{16} = 0.6 \mu\text{V per bit}$$

D102 and Q102 level shift and buffer the output at U1116 so that the cell can generate a 10V output while operating from a 12V supply. If the cell output is inadvertently short circuited, Q103 and R126 current limit the cell's output current to approximately 18mA.

4.2.1.2 Primary Divider - Switch and Filter

(Circuit Diagram DC400879 Sheet 2; Page 11.5-2)

Introduction

The primary divider comprises a precision switching circuit and a 7-pole active filter. The switching circuit chops the 10V cell output voltage into a variable mark/period ratio rectangular wave, and the active filter generates a DC output voltage equal to the mean value of this rectangular waveform.

Q204/Q205/Q206

JFETs Q204, Q205 and Q206 are the main switching elements which chop the 10V cell output into a variable mark/period ratio rectangular wave. Complementary JFETs Q204 and Q205 are chosen to have very similar switching characteristics, ensuring that the rising and falling edges of the rectangular wave are well matched. This minimizes transition-time dependent switching errors. However, because Q205 is a p-channel device, it has a higher on-resistance than the n-channel transistor Q204, which could lead to unacceptable temperature coefficient performance in the switch.

To compensate for the higher on-resistance of Q205, n-channel JFET Q206 is included in the switch. The on-resistance of Q206 is matched to that of Q204 and it is switched in parallel with Q205 to balance the on-resistance of the two halves of the switch. To avoid interference with the switching edges, Q206 is switched on 250nsec after Q205 is switched on, and is switched off 250nsec before Q205 is switched off.

U204/Q202/Q203

FET driver U204 and JFETs Q202 and Q203 form the driver circuitry for the main switching JFETs Q204 and Q205. Complementary JFETs Q202 and Q203, which are driven on alternately by output U204₇, turn Q205 and Q204 on respectively. However Q202 and Q203 are not capable of driving Q204 and Q205 into the off state, since this requires that the gates of Q204 and Q205 are driven outside the 10V supply rails (cell output voltage) on which they operate.

Turn off of Q204 and Q205 is performed by U204₄₋₅ and capacitors C207 and C208. When U204₇ is low, driving Q203 on, the high output at U204₅ allows C208 to charge up to 10V. A subsequent low to high transition at U204₇ turns Q203 off, while the corresponding high to low transition at U204₅ drives the +ve end of C208 to 0V. As a result the -ve end of C208 (and hence the gate of Q204) is driven to -10V, turning Q204 off.

Similarly, when U204₅ goes through a low to high transition, the charge on C207 causes the gate of Q205 to be driven to +20V, causing Q205 to turn off.

U203/Q201/Q207/Q208

FET driver U203, JFET Q201 and enhancement mode MOSFETs Q207 and Q208 form the driver for the compensating switch Q206. A low level at U203₅ drives Q207 into the on state. It also turns Q201 on, which drives Q208 into the off state (source and gate are both at 0V). With Q207 off and Q208 on, the gate of Q206 is pulled to +10V turning Q206 on.

While Q201 is on, C203 charges up to 10V via the high output on U203₇. A subsequent low to high transition on U203₅ causes Q207 and Q201 to turn off. The corresponding high to low transition on U203₇ drives the positive end of C203 to 0V, which means that the negative end of C203 (and hence the source of Q208) falls to -10V. With its gate now 10V more positive than its source, Q208 turns on, forcing Q206 to turn off.

U201

Dual flip-flop U201 controls the FET drivers U203 and U204 in response to three signals from the primary divider's timing circuitry. The signal SETA, which is transferred across the cell's isolation barrier via opto-isolator U202₄₋₃₋₆, defines the data input to the U201 flip-flops and hence the state of these flip-flops when the next clock pulses appear at their respective clock inputs.

If U202₆ is low when the clock pulses occur, the primary divider is placed in its 'mark' condition (output at TP201 connected to the +10V cell output). If U202₆ is high when the clock pulses occur, the divider is placed into its 'space' condition (TP201 connected to the cell's 0V output).

The two flip-flops in U201 are clocked by strobe signals STRB A_L and STRB B_L which are transferred across the cell's isolation barrier by pulse transformers T202 and T201 respectively. STRB B_L occurs 250nsec after STRB A_L during a space-to-mark transition and 250nsec before STRB A_L during a mark-to-space transition. This results in Q206 turning on 250nsec after Q205 turns on, and turning off 250nsec before Q205 turns off. The divider's mark period, T₁, therefore comprises three phases as illustrated in *Figure 4.2.1.2*. During T₁₁ Q205 is on, and both Q204 and Q206 are off. During T₁₂ Q205 and Q206 are on while Q204 remains off. The conditions during T₁₃ are the same as those for T₁₁.

U207/U208/U209

Op-amps U207, U208 and U209, together with dual matched FETs U205 and U206 and associated capacitors and resistors, form a mean sensing 7-pole Bessel function active low-pass filter. This circuit configuration is chosen because C210 and C216 prevent the filter from introducing any DC errors into the output of the filter. The filter provides approximately 113dB of attenuation at the chopping frequency of 61 Hz, increasing thereafter at a rate of 140dB/decade. An additional RC filter, R216/C217 is included at the output of the filter to eliminate rf noise.

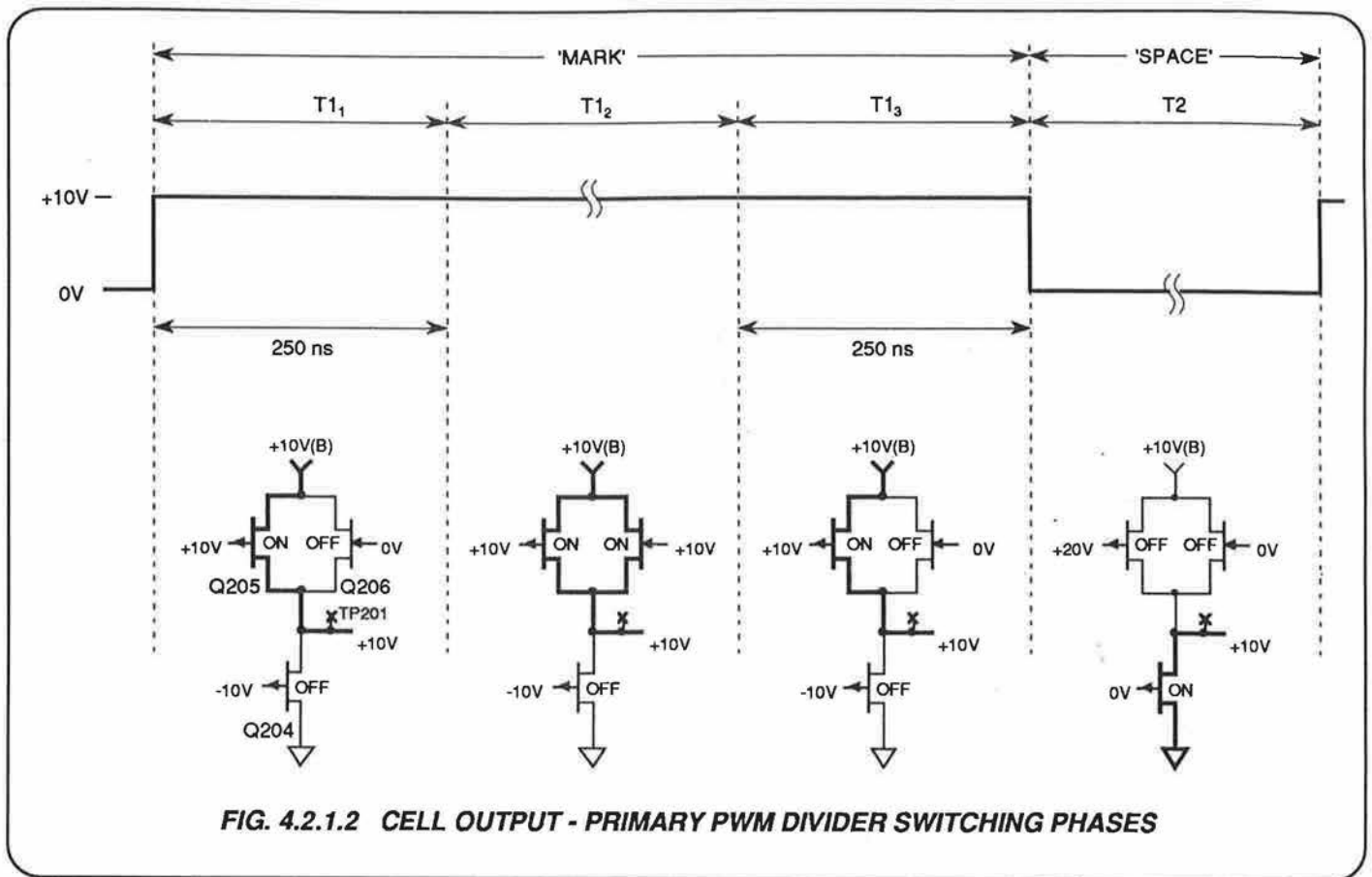

4.2.1.3 Secondary Divider - Switch and Filter (Circuit Diagram DC400879 Sheet 3; Page 11 5-3)

U301/Q301/Q302/Q303/Q304

In most respects the secondary divider is similar to the primary divider described in Section 4.2.1.2. However, because the contribution of the secondary divider to gain definition in the cell's output amplifier is only $1/2^{16}$ that of the primary divider, its switching characteristics are less critical — resulting in a somewhat simpler design.

For example, in the secondary divider a simple pair of complementary JFETs, Q302 and Q303, is all that is needed to chop the 10V cell output into a variable mark/period rectangular wave. In addition, because timing constraints in the secondary divider are less critical, there is no need for synchronization flip-flops. As a result mark-to-space and space-to-mark switching is controlled by a single control signal SETB_L, which is transferred across the cell's isolation barrier via U202₁₋₂₋₇. Q302 and Q303 are turned on by complementary JFETs Q301 and Q304 respectively, which are driven directly by U301₇. The inverted output at U301₅ drives charge pump capacitors C303 and C304 to provide the +20V and -10V levels necessary to turn Q302 and Q303 off respectively.

U303

U303₃₋₂₋₁ and its associated resistors and capacitors form a mean sensing 3-pole Bessel function active low-pass filter. Its 56dB attenuation at 61Hz and 60dB/decade roll-off are more than sufficient to reduce output ripple to insignificant levels because of the considerably reduced weighting of the secondary divider.

U302/Q305

U302 and Q305 form a unity gain buffer which produces an output that accurately tracks the cell's 10V output voltage. This tracking supply +10V(A) is used to power the drive circuits for the switching JFETs to ensure correct operation at all output voltages. D301 and D302 allow the buffer, and hence the PWM dividers, to start up correctly when the 4910/4911 is switched from Transit mode to Normal mode.

4.2.1.4 Primary Divider - Timing Circuit

(Circuit Diagram DC400879 Sheet 4; Page 11.5-4)

Introduction

The total period of the primary divider's chopping cycle is set by logic circuitry on the 4910/4911's Digital PCB — see Section 4.2.4. This circuitry generates four control pulses (ZØ_L, Z1_L, Z2_L and SETA) and a continuous 4 MHz clock signal (C4), which are driven in parallel onto all four of the 4910/4911's cell PCBs. The four control pulses occur in the sequence shown in Figure 4.2.1.3 every 16.384 msec.

U4054-1-5-6/U408

Flip-flop U4054-1-5-6, which operates as an inverter (its SET input overrides its RESET input), together with differentiator network C401/R406, produces the SYNC signal — a 4MHz clock signal in anti-phase to C4 with a mark period of around 60nsec. The SYNC signal, gated by U4081-2-3 and U4084-5-6 to produce single pulses, becomes the pulse waveform for the STRB A_L and STRB B_L signals which drive the primary divider's isolating pulse transformers.

To initiate the mark period of the primary voltage divider, ZØ_L (inverted by U40812-11) gates SYNC to produce a STRB A_L pulse. In conjunction with SETA, which is coupled and inverted by opto-isolator U2024-3-6, this STRB A_L pulse places the divider into its T1 mark state as described in section 4.2.1.2.

A period of 250nsec later, Z2_L (inverted by U40810-8) gates SYNC through U4084-5-6 to produce a STRB B_L pulse. In conjunction with SETA, this STRB B_L pulse places the primary divider into its T1 mark state.

U401/U402

Preloadable counters U401 and U402 are configured as a 16-bit binary down counter. Control signal Z1_L, which occurs halfway between ZØ_L and Z2_L, preloads this counter with a binary value determined by hexadecimal control switches S401, S402, S403 and the fixed logic levels on U40210-11-12-13 (U40210-11-12-13 are fixed at a binary value of 1011, limiting the control of the hexadecimal switches to output voltages in the approximate range of 9.64V to 10.52V.)

The Z2_L control pulse (which occurs 125nsec after Z1_L) sets flip-flop U4074-1-5-6 causing its Q output U4076 to go low and the 16-bit down counter to be enabled via U4013. The counter is then counted down by the 4MHz clock C4 to define the mark period of the primary divider.

When the counter reaches zero, MØ_L (the carry output on U40214) goes low for one clock period. This pulse, inverted by U4089-8, gates SYNC through U4084-5-6 to produce a second STRB B_L pulse. In conjunction with SETA, which at this point is low, this STRB B_L pulse places the primary divider into its T1 mark condition as described in Section 4.2.1.2.

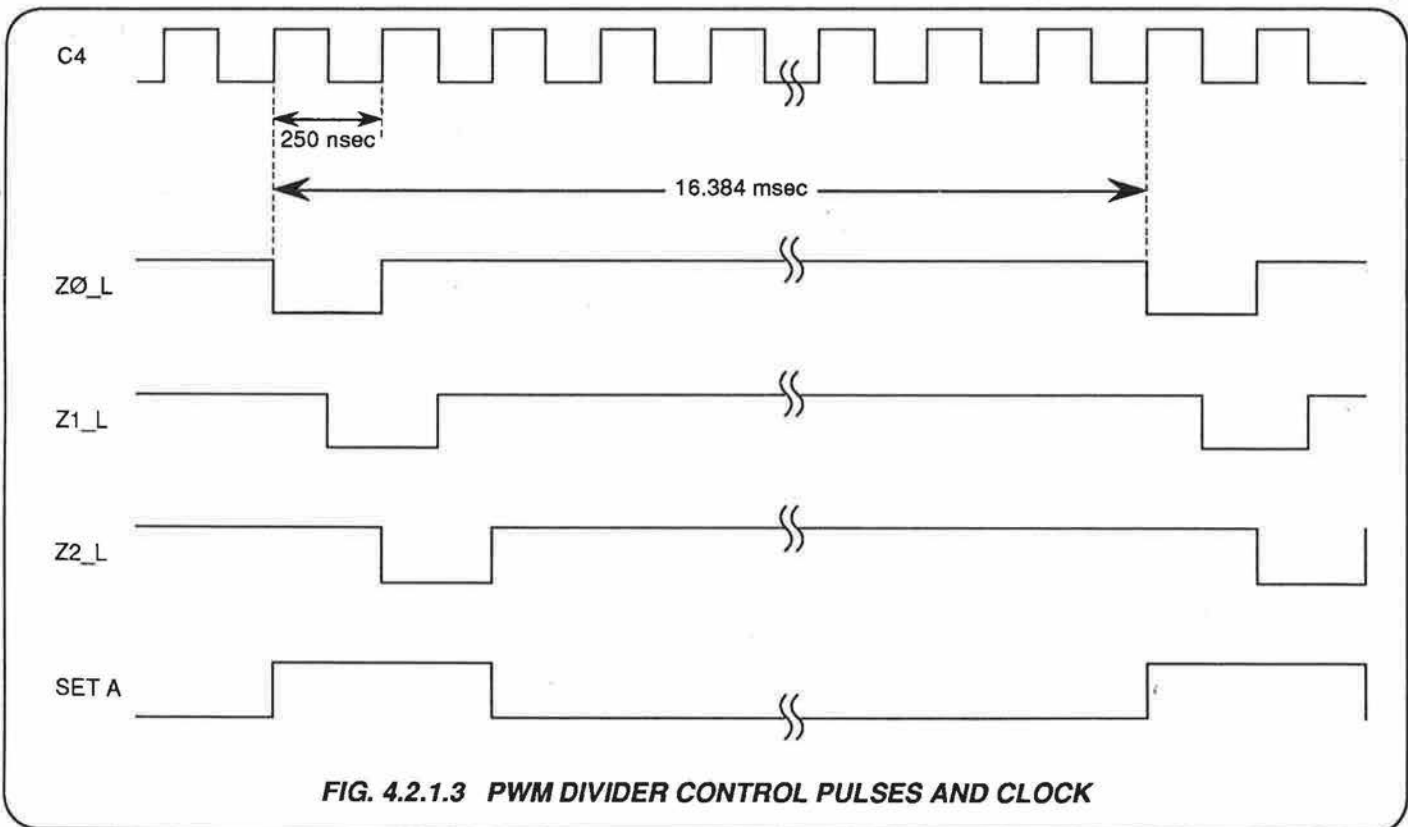

FIG. 4.2.1.3 PWM DIVIDER CONTROL PULSES AND CLOCK

MØ_L is clocked by the SYNC signal into the first stage of the two-stage shift register formed by the flip-flops in U406, and is clocked into the second stage of the shift register by the C4 clock. As a result the MØ_L is delayed by 250nsec to produce M2_L, which after inversion by U408₁₃₋₁₁ gates SYNC through U408₁₋₂₋₃ to produce a second STRB A_L pulse. In conjunction with SETA, this STRB A_L pulse places the primary divider into

its T2 space condition as described in Section 4.2.1.2. M2_L also resets U407₄₋₁₋₅₋₆, causing its \bar{Q} output to go high and further counting in U401/U402 to be inhibited.

The timing diagram for the primary divider timing circuitry is shown in Figure 4.2.1.4.

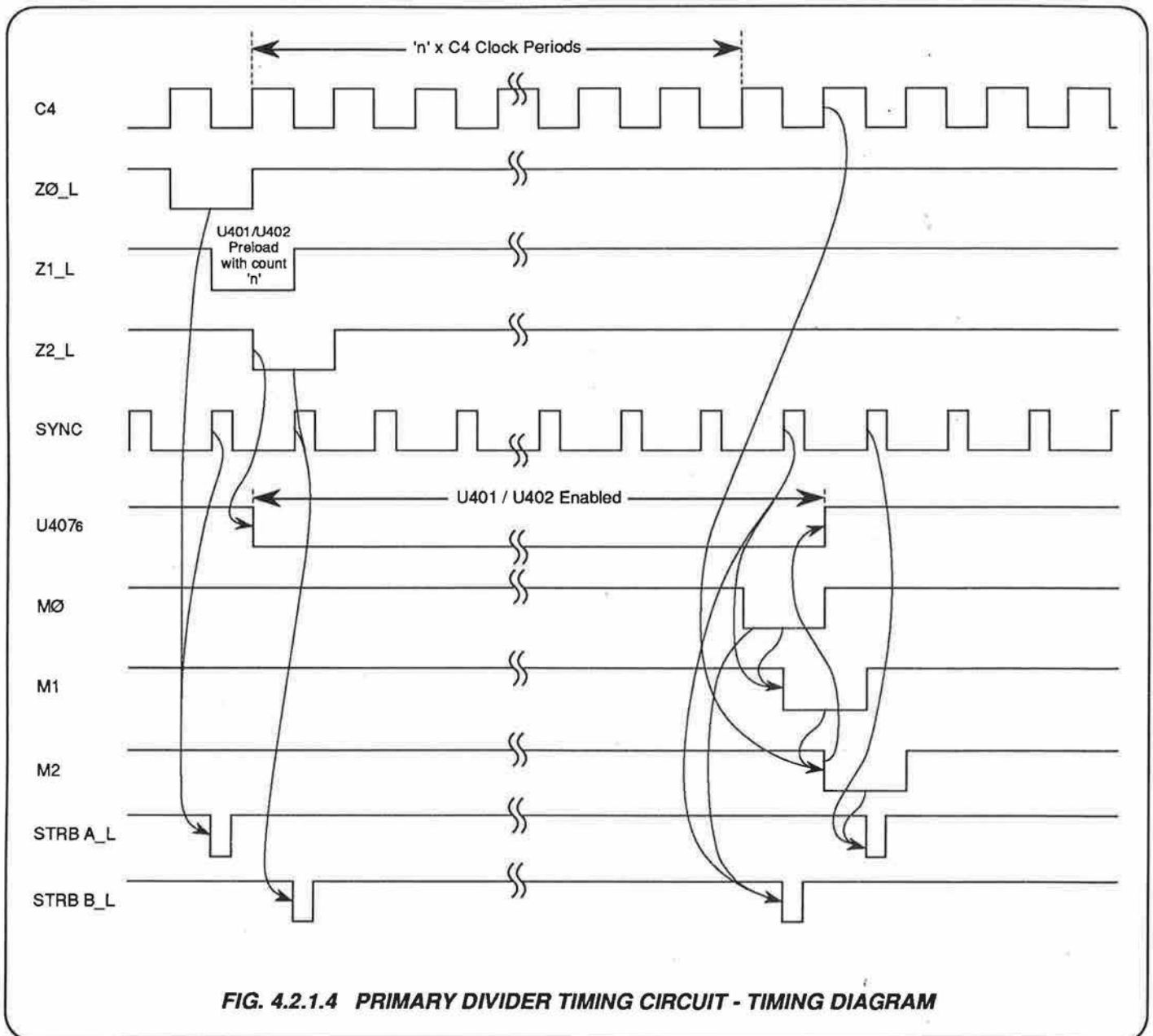

FIG. 4.2.1.4 PRIMARY DIVIDER TIMING CIRCUIT - TIMING DIAGRAM

4.2.1.5 Secondary Divider - Timing Circuit

(Circuit Diagram DC400879 Sheet 4; Page 11.5-4)

The total period of the secondary divider's chopping cycle is set by logic circuitry on the 4910/4911's Digital PCB — see Section 4.2.4. This circuitry generates four control pulses (Z0_L, Z1_L, Z2_L and SETA) and a continuous 4 MHz clock signal (C4), which are driven in parallel onto all four of the 4910/4911's cell PCBs. The four control pulses occur in the sequence shown in Figure 4.2.1.3 every 16.384 msec.

U407₁₀₋₁₃₋₉₋₈

Control signal Z2_L sets flip-flop U407₁₀₋₁₃₋₉₋₈ causing its Q output SETB_L to go high. SETB_L, transferred across the cell's isolation barrier via U202₁₋₂₋₇ (Circuit Diagram DC400879 Sheet 3; Page 11.5-3), places the secondary divider into its T1 space condition.

U403/U404

Preloadable counters U403 and U404 are configured as a 16-bit binary down counter. Control signal Z1_L, which occurs halfway between Z0_L and Z2_L, preloads this counter with a binary value determined by hexadecimal control switches S404, S405 and the fixed logic levels on U403₄₋₅₋₆₋₇₋₁₀₋₁₁₋₁₂₋₁₃ (All these logic levels are at a binary 0, so that U403 operates as a 'divide by 256' frequency pre-scaler for U404. The secondary divider is therefore only settable to the 8-bit resolution provided by U404.)

When the Z2_L control pulse sets flip-flop U407₁₀₋₁₃₋₉₋₈, its \bar{Q} output U407₈ goes low — enabling the 16-bit down counter via U403₃. The counter is then counted down by the 4MHz clock C4 to define the space period of the secondary divider.

When the counter reaches zero, the carry output on U404₁₄ goes low for one clock period. This output is clocked by C4 into flip-flop U405₁₂₋₁₁₋₉₋₈ which delays the carry out pulse by 250nsec. The delayed pulse resets flip flop U407₁₀₋₁₃₋₉₋₈ causing SETB_L to go low and the secondary divider to be placed into its T2 mark condition.

Note that the secondary divider works in anti-phase to the primary divider — i.e. the 16-bit binary down counter defines the space period of the secondary divider switch instead of its mark period. As a result, the output voltage from the secondary divider decreases as the hexadecimal value loaded into its counter increases. This is done to compensate for the fact that the output of the secondary divider subtracts from the output of the primary divider instead of adding to it — see Section 4.2.1.1 Equation 5 — ensuring that all the hexadecimal switches rotate in the same direction to increase/decrease the cell's output. The timing diagram for the secondary divider timing circuitry is shown in Figure 4.2.1.5.

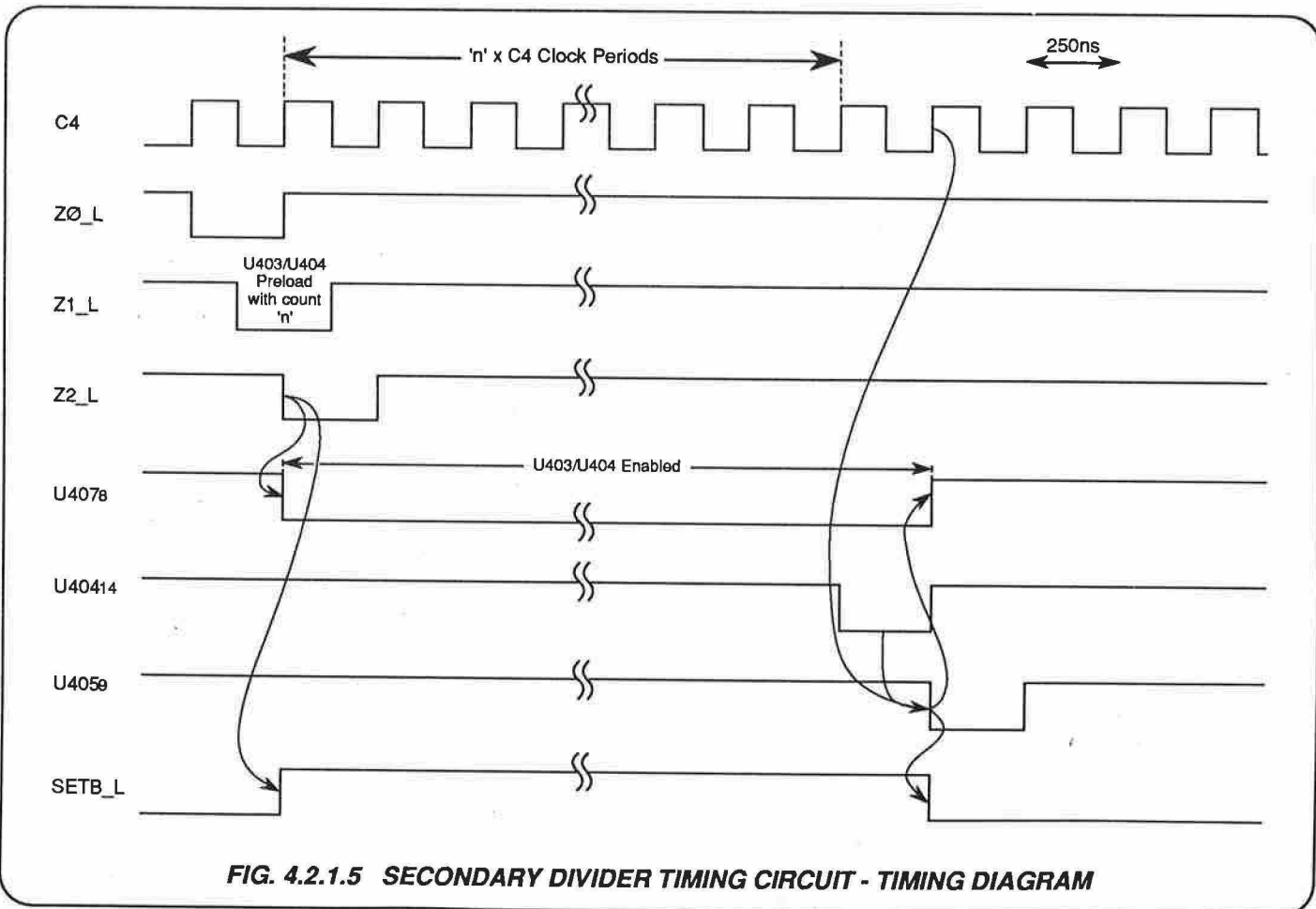

FIG. 4.2.1.5 SECONDARY DIVIDER TIMING CIRCUIT - TIMING DIAGRAM

4.2.2 Output PCB (4910 only)

4.2.2.1 4-Wire Output Buffer

(Circuit Diagram DC400881 Sheet 1; Page 11.7-2)

Introduction

The 4910/4911's four CELL outputs can be selectively connected to the unit's AVERAGE output using the links on the cell PCBs. Averaging is performed by 200Ω resistors on the unit's Mother PCB, and in the 4910 the averaged output is fed via connector P608A7/B7 and P608A8/B8 to the 4-wire output buffer and divided output circuitry on the Output PCB.

U103/U104/Q102

U104 and Q102 form a unity gain buffer amplifier which is capable of driving a current of at least 15mA into the 4-WIRE OUTPUT BUFFER I+ terminal. Negative feedback to U104 is derived from the 4-WIRE OUTPUT BUFFER Hi terminal so that the positive external load voltage can be remotely sensed to eliminate the effect of lead resistance. When no remotely sensed external load or front panel shorting link is connected between the 4-WIRE OUTPUT BUFFER Hi and I+ terminals, diodes D106, D108, D114 and D115 clamp I+ and Hi to within approximately 1.0V of each other. This prevents U104 from operating open-loop under these conditions.

To prevent leakage currents in these diodes flowing in the Hi lead when there is significant external lead resistance, the junction of D106 and D114, and of D108 and D115, are connected to the buffered 10V average generated by unity gain buffer U105/Q104, keeping the voltage across D106 and D108 close to zero.

U103 is an ultra-low input offset chopper-stabilized op-amp which continuously monitors the input offset of U104 and compensates it to zero via U104's balance input U104s. The 4-WIRE ADJUST potentiometer R138 allows any residual offset between the AVERAGE output and the output of the 4-WIRE OUTPUT BUFFER to be nulled to zero.

The 4-WIRE OUTPUT BUFFER's Lo terminal is connected directly to AVERAGE Lo (AVE_Lo), and via AVE_Lo to the Lo terminals of connected CELL outputs. This ensures that all the reference voltage sources which contribute to the 4-WIRE OUTPUT BUFFER output (i.e. the zener reference modules in each cell) are connected directly to the negative end of the external load. A separate return path for the load current is provided by the 4-WIRE OUTPUT BUFFER I- terminal which is connected to the 4910's power supply common.

D104 and D105 are included to clamp the 4-WIRE OUTPUT BUFFER Lo terminal to within ±0.6V of the power supply common when no external load or Lo to I- shorting link is connected to the output of the 4-WIRE OUTPUT BUFFER.

The 8.7V source formed by D109/R124, and the diodes D110 and D111, clamp the output of the 4-WIRE OUTPUT BUFFER at approximately 8.2V when no CELL outputs are connected to the AVERAGE output.

4.2.2.2 Internal Average Buffers

(Circuit Diagram DC400881 Sheet 1; Page 11.7-2)

U101/U102

U101, U102 and Q101 form a unity gain amplifier which buffers the averaged cell voltage AVE_HI. The buffered average (+10V_B) is used as the input voltage for the two PWM voltage dividers which generate the 1V and 1.018V DIVIDED OUTPUTS.

U101 is an ultra-low input offset chopper-stabilized op-amp which continuously monitors the input offset of U102 and compensates it to zero via U102's balance input U102s. The AVERAGE ADJUST potentiometer R135 allows the bias current drawn by U101, U102, U103 and U104 to be nulled to zero.

U105/Q104

The unity gain buffer formed by U105 and Q104 further buffers the output of the amplifier formed by U101/U102/Q101 to provide a low impedance supply voltage (+10V_A) for the divided output PWM divider switch drivers.

4.2.2.3 1.018V Divided Output - Primary Divider Switch and Filter

(Circuit Diagram DC400881 Sheet 2; Page 11.7-3)

Introduction

The 1.018V primary divider comprises a precision switching circuit which chops the 10V average voltage (+10V_B) into a variable mark/period ratio rectangular wave, and an active filter which generates a DC output voltage equal to the mean value of this rectangular waveform.

Q204/Q205/Q206

JFETs Q204, Q205 and Q206 are the main switching elements which chop the 10V average output into a variable mark/period ratio rectangular wave. Complementary JFETs Q204 and Q206 are chosen to have very similar switching characteristics, ensuring that the rising and falling edges of the rectangular wave are well matched. This minimizes transition-time dependent switching errors. However, because Q204 is a p-channel device, it has a higher on-resistance than the n-channel Q206, which could lead to unacceptable temperature coefficient performance in the switch.

To compensate for the higher on-resistance of Q204, n-channel JFET Q205 is included in the switch. The on-resistance of Q205 is matched to that of Q206 and it is switched in parallel with Q204 to balance the on-resistance of the two halves of the switch. To avoid interference with the switching edges, Q205 is switched on 250nsec after Q204 is switched on, and is switched off 250nsec before Q204 is switched off.

U204/Q202/Q203

FET driver U204 and JFETs Q202 and Q203 form the driver circuitry for the main switching JFETs Q204 and Q206. Complementary JFETs Q202 and Q203, which are driven on alternately by U204₇, turn on Q204 and Q206 respectively. However, Q202 and Q203 are not capable of driving Q204 and Q206 into the off state, since this requires that the gates of Q204 and Q206 are driven outside the 10V supply (the buffered 10V average) on which they operate.

Turn off of Q204 and Q206 is performed by U204₄₋₅ and capacitors C203 and C204. When U204₇ is low, driving Q203 on, the high output at U204₅ allows C204 to charge up to 10V. A subsequent low to high transition at U204₇ turns Q203 off, while the corresponding high to low transition at U204₅ drives the +ve end of C204 to 0V. As a result the -ve end of C204 (and hence the gate of Q206) is driven to -10V, turning Q206 off.

Similarly, when U204₅ goes through a low to high transition, the charge on C203 causes the gate of Q204 to be driven to +20V, turning off Q204.

U203/Q201/Q207/Q208

FET driver U203, JFET Q201 and enhancement mode MOSFETs Q207 and Q208 form the driver for the compensation switch Q205. A low level at U203₅ drives Q207 into the on state. It also turns Q201 on, which drives Q208 into the off state (source and gate are both at 0V), and allows C202 to charge up to 10V via the high output on U203₇. With Q207 on and Q208 off, the gate of Q205 is pulled to +10V allowing it to turn on.

A low to high transition on U203₅ causes Q207 and Q201 to turn off. The corresponding high to low transition on U203₇ drives the positive end of C202 to 0V, which means that the negative end of C202 (and hence the source of Q208) falls to -10V. With its gate now 10V more positive than its source, Q208 turns on, forcing Q205 to turn off.

U202

Dual flip-flop U202 controls FET drivers U203 and U204 in response to three signals from the primary divider's timing circuitry. The signal SETA, which is transferred across the cell's isolation barrier via opto-isolator U201₂₋₃₋₆, defines the data input to the U202 flip-flops and hence the state of these flip-flops when the next clock pulses appear at their respective clock inputs.

If U201₆ is low when the clock pulses occur, the primary divider is placed into its mark condition (output at TP201 connected to the +10V_B). If U202₆ is high when the clock pulses occur, the divider is placed into its space condition (TP201 connected to 0V).

The two flip-flops in U202 are clocked by strobe signals STRBA_1.018V and STRBB_1.018V which are transferred across the cell's isolation barrier via pulse transformers T202 and T201 respectively. STRBB_1.018V occurs 250nsec after STRBA_1.018V during a space-to-mark transition and 250nsec before STRBA_1.018V during a mark-to-space transition. As a result, Q205 turns on 250nsec after Q204 turns on, but it turns off 250nsec before Q204 turns off. The divider's mark period, T₁, therefore comprises three phases as illustrated in *Figure 4.2.2.1*. During T₁₁ Q204 is on, and both Q205 and Q206 are off. During T₁₂ Q204 and Q205 are on while Q206 remains off. The conditions during T₁₃ are the same as those for T₁₁.

U205/U206/U207

Op-amps U205, U206 and U207, together with dual matched FETs Q209 and Q210 and associated capacitors and resistors, form a mean sensing 7-pole Bessel function active low-pass filter. This configuration is chosen because C205 and C206 prevent the filter from introducing any DC errors into the output of the filter. The filter provides approximately 113dB of attenuation at the chopping frequency of 61 Hz, increasing thereafter at a rate of 140 db/decade. An additional RC filter, R219/C217 is included at the output of the filter to eliminate RF noise.

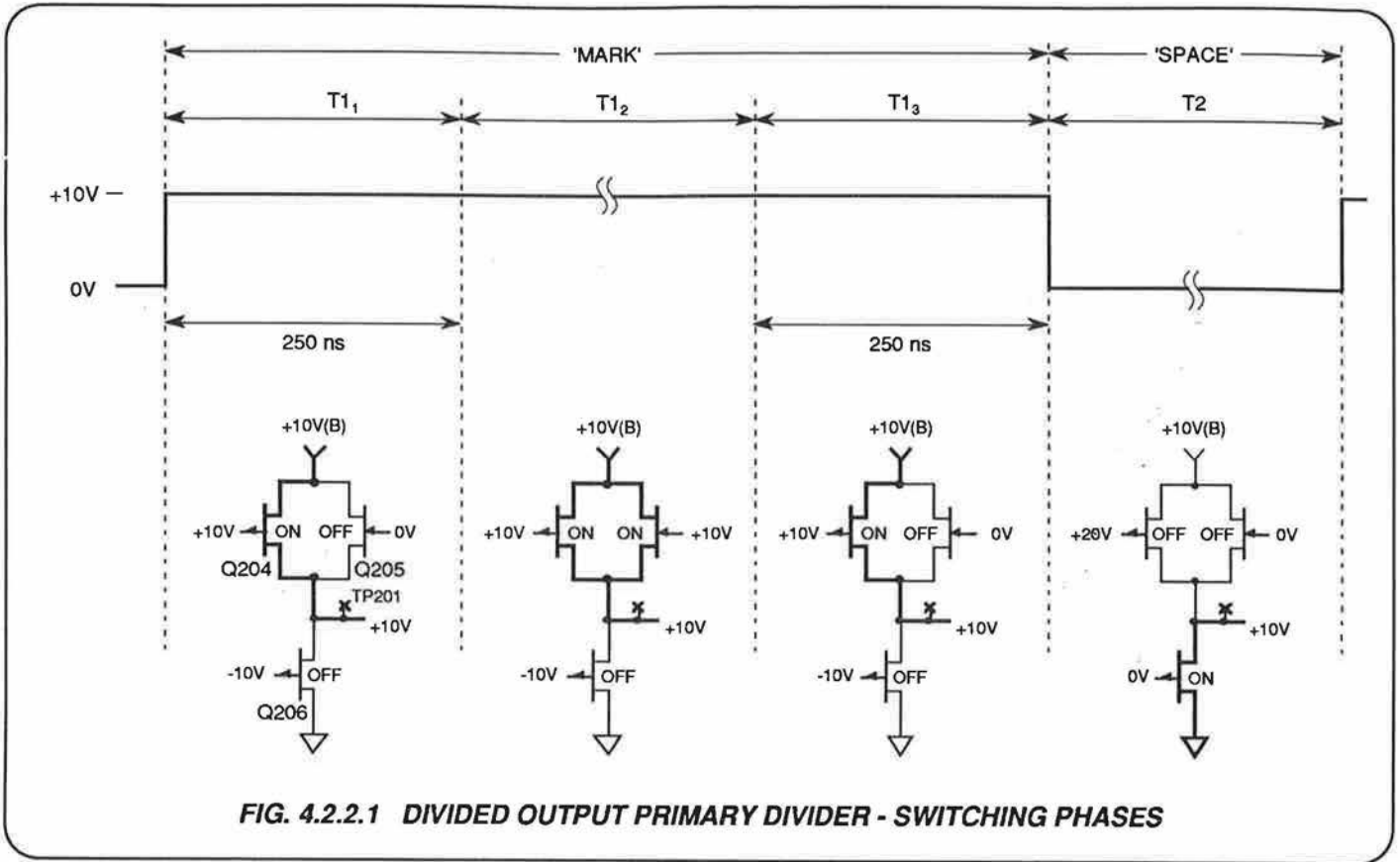

FIG. 4.2.2.1 DIVIDED OUTPUT PRIMARY DIVIDER - SWITCHING PHASES

4.2.2.4 1.018V Divided Output - Secondary Switch and Output Buffer

(Circuit Diagram DC400881 Sheet 4; Page 11.7-5)

U401/U402

Opto-isolator U401₁₋₂₋₇ and bi-lateral CMOS switches U402₁₋₂₋₃ and U402₁₆₋₁₅₋₁₄ form the secondary divider switch for the 1.018V output. In this switch, where switch timing is less critical than in the primary divider, the opto-isolator drives the bi-lateral CMOS switches directly.

U403

Op-amp U403 and its associated resistor and capacitor network form a three-pole Bessel function low-pass filter which determines the mean value of the chopped waveform generated by the switch.

U404/U405/Q402

Op-amps U404 and U405 form a composite amplifier for which U404₃ is the non-inverting input and U404₂ is the inverting input. Referring to Figure 4.2.2.2 it can be seen that:

$$V_s - \frac{R_{401} + R_{427}}{R_{401} + R_{427} + R_{406}} \times (V_s - V_{out}) = V_P$$

which solves to:-

$$V_{out} =$$

$$\frac{R_{401} + R_{427} + R_{406}}{R_{401} + R_{427}} \times V_P + \left(1 - \frac{R_{401} + R_{427} + R_{406}}{R_{401} + R_{427}}\right) \times V_s$$

Substituting the values for R401, R406 and R427 gives:-

$$V_{out} = 1.000071739 \times V_P - 71.739 \times 10^{-6} \times V_s \quad (1)$$

It can be seen from this equation that the gain of the buffer amplifier to the output of the primary divider is virtually 1, while its gain to the output of the secondary divider is -71.739×10^{-6} . The effect on the divided output of the secondary divider is therefore only 1/13940 that of the primary divider.

U404 is an ultra-low input offset, chopper-stabilized op-amp which imparts its superior DC performance to the output amplifier. U405 is a wide bandwidth op-amp which, operating with resistive feedback, minimizes output noise. Resistive divider R408/R409, which is driven by +10V_C, biases the non-inverting input of U405 to 5V. Gain defining network R405/R407 provides a feedback loop around this high-bandwidth op-amp which sets its output to approximately 1.07V. U404 then adjusts the bias point of the non-inverting input of U405 to provide accurate DC gain definition for the composite amplifier.

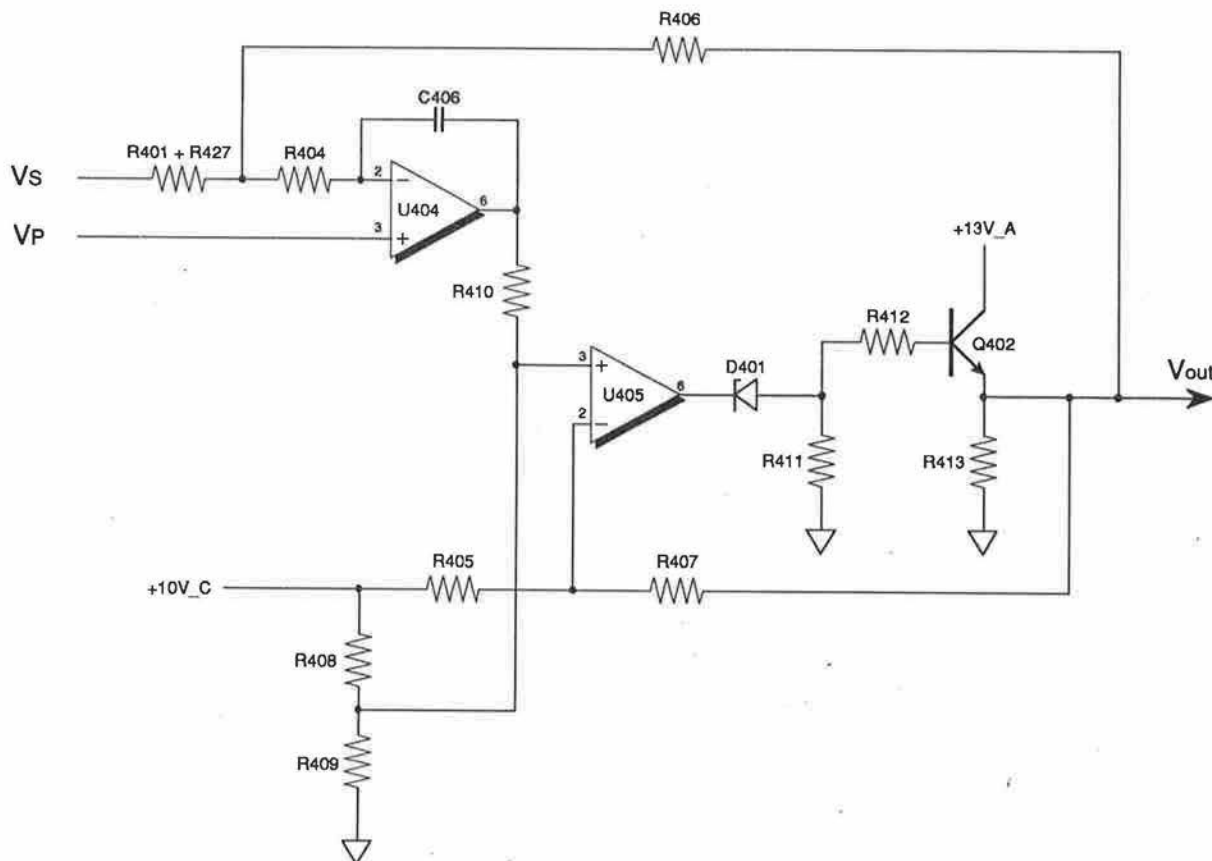

FIG. 4.2.2.2 1.018V DIVIDED OUTPUT - OUTPUT BUFFER

4.2.2.5 1.018V Divided Output - Primary Divider Control Logic*(Circuit Diagram DC400881 Sheet 5; Page 11.7-6)***U504/U505/U506**

Nand gate U504₁₂₋₁₃₋₁₁, which operates as an inverter, together with differentiator network C501/R502, produces the SYNC signal — a 4MHz clock signal in anti-phase to C4 with a mark period of around 60nsec. The SYNC signal, gated by U506₁₂₋₁₃₋₁₁ and U506₉₋₁₀₋₈ to produce single pulses, defines the pulse waveform for the STRBA_1.018V and STRBB_1.018V signals which drive the 1.018V primary divider's isolating pulse transformers.

To initiate the mark period of the primary divider, ZØ_L (inverted by U505₁₃₋₁₁) gates SYNC to produce a STRBA_1.018V pulse. In conjunction with the high level on SETA, which is coupled and inverted by opto-isolator U201₂₋₃₋₆ (*Circuit Diagram DC400881 Sheet 2; Page 11.7-3*), this STRBA_1.018V pulse places the primary divider into its T₁ mark state as described in *section 4.2.2.3*.

A period of 250nsec later, Z2_L (inverted by U505₁₀₋₈) gates SYNC through U506₉₋₁₀₋₈ to produce a STRBB_1.018V pulse. In conjunction with the high level on SETA, this STRBB_1.018V pulse places the primary divider into its T₁₂ mark state.

When the 1.018V primary divider's 16-bit mark counter on the Output PCB Digital Sub-Assembly reaches zero, it generates two control signals MØ_1.018V and M2_1.018V, which are separated by 250nsec. MØ_1.018V, inverted by U505₉₋₈, gates SYNC through U506₉₋₁₀₋₈ to produce a second STRBB_1.018V pulse. In conjunction with the low level on SETA, this STRBB_1.018V pulse places the primary divider into its T₁₃ mark state.

A period of 250nsec later, M2_1.018V, inverted by U505₁₂₋₁₁, gates SYNC through U506₁₂₋₁₃₋₁₁ to produce a second STRBA_1.018V pulse. In conjunction with the low level on SETA, this STRBA_1.018V pulse places the primary divider into its T₂ space condition.

4.2.2.6 1.018V Divided Output - Secondary Divider Timing Circuit

(Circuit Diagram DC400881 Sheet 5; Page 11.7-6)

U503₄₋₂₋₃₋₁₋₅₋₆

Control signal Z2_L sets flip-flop U503₄₋₂₋₃₋₁₋₅₋₆, causing its Q output SETB_1.018V to go high. The high level on SETB_1.018V, transferred across the cell's isolation barrier via U401₁₋₂₋₇ (Circuit Diagram DC400881 Sheet 4; Page 11.7-5), sets the secondary divider into its space condition.

U501/U502

Preloadable counters U501 and U502 are configured as a 16-bit binary down counter. However, because only the 12 most significant bits of the counter are controllable, it is only settable to 12-bit resolution.

Control signal Z1_L, which occurs halfway between ZØ_L and Z2_L, preloads this counter with a binary value determined by hexadecimal control switches S501, S502 and S503.

When the Z2_L control pulse sets flip-flop U503₄₋₂₋₃₋₁₋₅₋₆ as described above, its \bar{Q} output U503₆ goes low, enabling the 16-bit down counter via U501₃. The counter is then counted down by the 4MHz clock C4 to define the space period of the secondary divider.

When the counter reaches zero, carry output U502₁₄ goes low for one clock period. SYNC clocks this output into U503₄₋₂₋₃₋₁₋₅₋₆, causing its Q output SETB_1.018V to go low. The low level on SETB_1.018V, transferred across the cell's isolation barrier via U401₁₋₂₋₇, sets the secondary divider into its mark condition.

Note that the secondary divider works in anti-phase to the primary divider — i.e. the secondary divider's down counter defines the space period of the secondary divider switch instead of its mark period. As a result, the output voltage from the secondary divider decreases as the binary value loaded into its counter increases. This is done to compensate for the fact that the output of the secondary divider subtracts from the output of the primary divider instead of adding to it — Refer to Section 4.2.2.4 Equation 1 — ensuring that all the hexadecimal switches rotate in the same direction to increase/decrease the cell's output.

The timing diagram for the 1.018V secondary divider timing circuitry is shown in Figure 4.2.2.3.

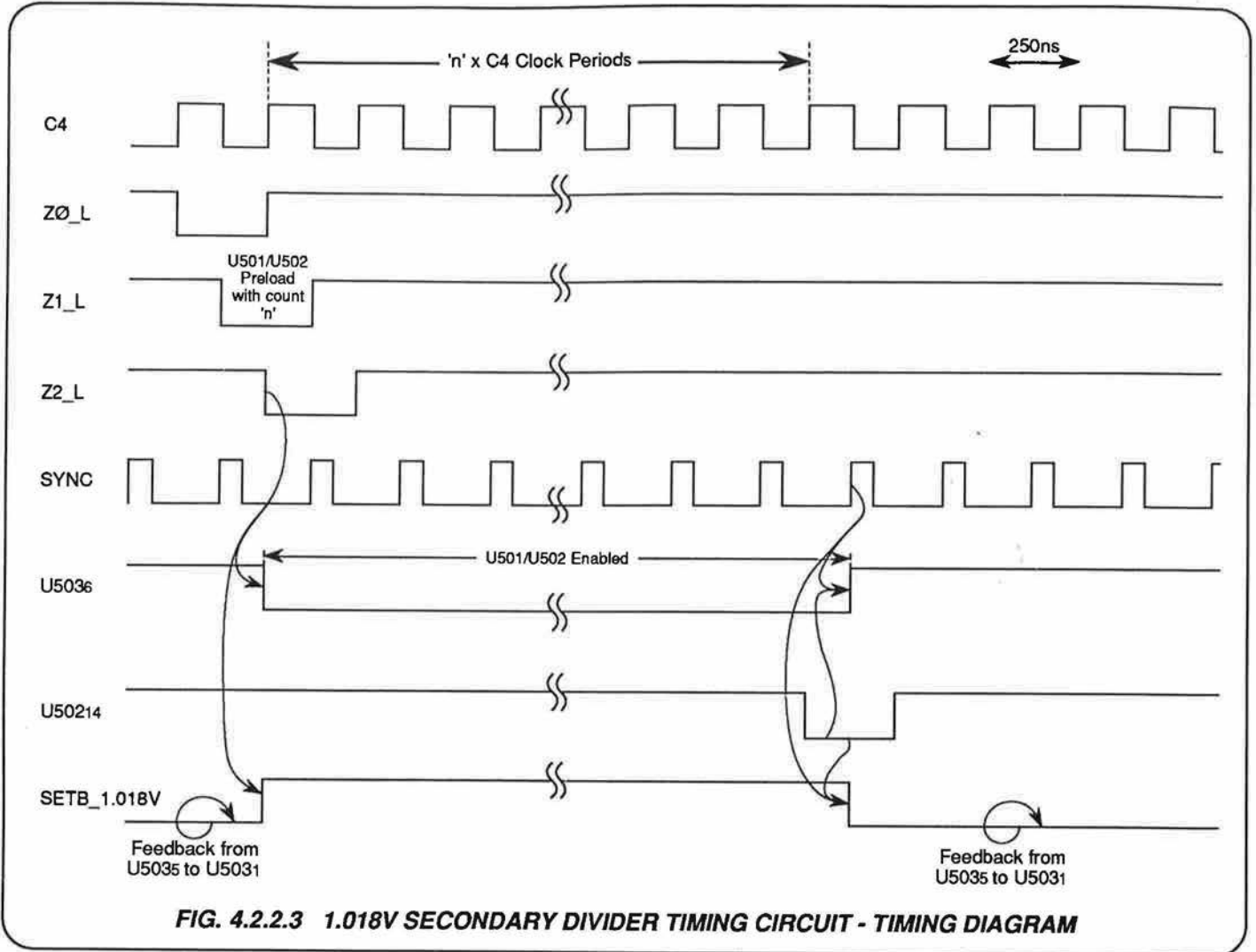

FIG. 4.2.2.3 1.018V SECONDARY DIVIDER TIMING CIRCUIT - TIMING DIAGRAM

4.2.2.7 1.000V Divided Output - Primary Switch and Filter

(Circuit Diagram DC400881 Sheet 3; Page 11.7-4)

Introduction

The 1.000V primary divider comprises a precision switching circuit which chops the 10V average voltage (+10V_B) into a variable mark/period ratio rectangular wave, and an active filter which generates a DC output voltage equal to the mean value of this rectangular waveform.

Q304/Q305/Q306

JFETs Q304, Q305 and Q306 are the main switching elements which chop the 10V average output into a variable mark/period ratio rectangular wave. Complementary JFETs Q304 and Q306 are chosen to have very similar switching characteristics, ensuring that the rising and falling edges of the rectangular wave are well matched. This minimizes transition-time dependent switching errors. However, because Q304 is a p-channel device, it has a higher on-resistance than the n-channel Q306, which could lead to unacceptable temperature coefficient performance in the switch.

To compensate for the higher on-resistance of Q304, n-channel JFET Q305 is included in the switch. The on-resistance of Q305 is matched to that of Q306 and it is switched in parallel with Q304 to balance the on-resistance of the two halves of the switch. To avoid interference with the switching edges, Q305 is switched on 250nsec after Q304 is switched on, and is switched off 250nsec before Q304 is switched off.

U304/Q302/Q303

FET driver U304 and JFETs Q302 and Q303 form the driver circuitry for the main switching JFETs Q304 and Q306. Complementary JFETs Q302 and Q303, which are driven on alternately by U304, turn on Q304 and Q306 respectively. However, Q302 and Q303 are not capable of driving Q304 and Q306 into the off state, since this requires that the gates of Q304 and Q306 are driven outside the 10V supply (the buffered 10V average) on which they operate.

Turn off of Q304 and Q306 is performed by U304₄₋₅ and capacitors C303 and C304. When U304₇ is low, driving Q303 on, the high output at U304₅ allows C304 to charge up to 10V. A subsequent low to high transition at U304₇ turns Q303 off, while the corresponding high to low transition at U304₅ drives the +ve end of C304 to 0V. As a result the -ve end of C304 (and hence the gate of Q306) is driven to -10V, turning Q306 off.

Similarly, when U304₅ goes through a low to high transition, the charge on C303 causes the gate of Q304 to be driven to +20V, turning off Q304.

U303/Q301/Q307/Q308

FET driver U303, JFET Q301 and enhancement mode MOSFETs Q307 and Q308 form the driver for the compensation switch Q305. A low level at U303₅ drives Q307 into the on state. It also turns Q301 on, which drives Q308 into the off state (source and gate are both at 0V), and allows C302 to charge up to 10V via the high output on U303₇. With Q307 on and Q308 off, the gate of Q305 is pulled to +10V allowing it to turn on.

A low to high transition on U303₅ causes Q307 and Q301 to turn off. The corresponding high to low transition on U303₇ drives the positive end of C302 to 0V, which means that the negative end of C302 (and hence the source of Q308) falls to -10V. With its gate now 10V more positive than its source, Q308 turns on, forcing Q305 to turn off.

U302

Dual flip-flop U302 controls FET drivers U303 and U304 in response to three signals from the primary voltage divider's timing circuitry. The signal SETA, which is transferred across the cell's isolation barrier via opto-isolator U201₂₋₃₋₆ (Circuit Diagram DC400881 Sheet 2; Page 11.7-3) to become SETA_1.000V, defines the data input to the U302 flip-flops and hence the state of these flip-flops when the next clock pulses appear at their respective clock inputs.

If SETA_1.000V is low when the clock pulses occur, the primary divider is placed into its mark condition (output at TP301 connected to the +10V_B). If SETA_1.000V is high when the clock pulses occur, the divider is placed into its space condition (TP301 connected to 0V).

The two flip-flops in U302 are clocked by strobe signals STRBA_1.000V and STRBB_1.000V which are transferred across the cell's isolation barrier via pulse transformers T302 and T301 respectively. STRBB_1.000V occurs 250nsec after STRBA_1.000V during a space-to-mark transition and 250nsec before STRBA_1.000V during a mark-to-space transition. As a result, Q305 turns on 250nsec after Q304 turns on, but it turns off 250nsec before Q304 turns off. The divider's mark period, T₁, therefore comprises three phases as illustrated in Figure 4.2.2.4. During T₁, Q304 is on, and both Q305 and Q306 are off. During T₁, Q304 and Q305 are on while Q306 remains off. The conditions during T₁, are the same as those for T₁.

U305/U306/U307

Op-amps U305, U306 and U307, together with dual matched FETs Q309 and Q310 and associated capacitors and resistors, form a mean sensing 7-pole Bessel function active low-pass filter. This configuration is chosen because C305 and C306 prevent the filter from introducing any DC errors into the output of the filter. The filter provides approximately 113dB of attenuation at the chopping frequency of 61Hz, increasing thereafter at a rate of 140dB/decade. An additional RC filter, R319/C317 is included at the output of the filter to eliminate RF noise.

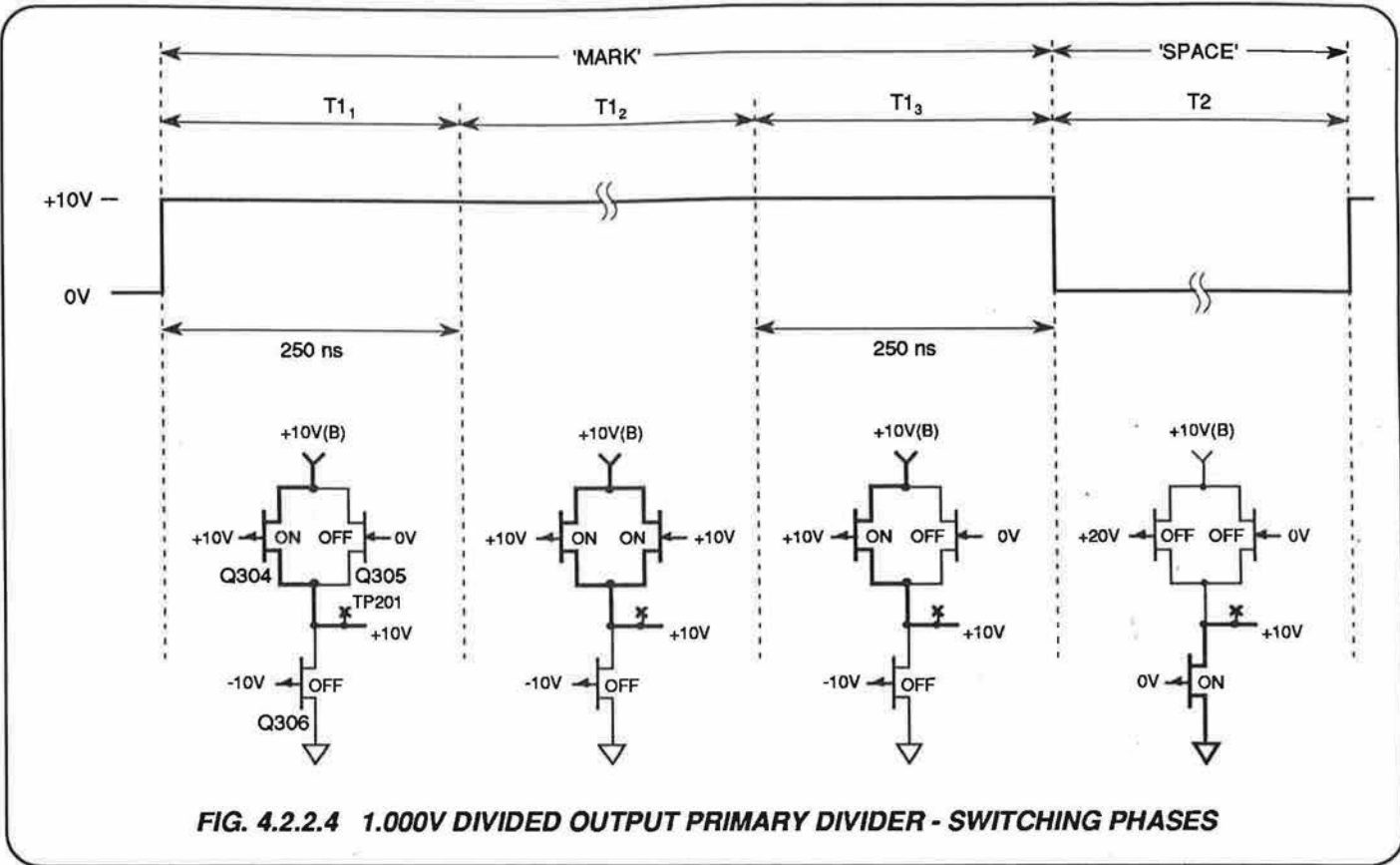

FIG. 4.2.2.4 1.000V DIVIDED OUTPUT PRIMARY DIVIDER - SWITCHING PHASES

4.2.2.8 1.000V Divided Output - Secondary Switch and Output Buffer

(Circuit Diagram DC400881 Sheet 4; Page 11.7-5)

U401/U402

Opto-isolator U401₄₋₃₋₆ and bi-lateral CMOS switches U402₈₋₇₋₆ and U402₉₋₁₀₋₁₁ form the secondary divider switch for the 1.000V output. In this switch, where switch timing is less critical than in the primary divider, the opto-isolator drives the bi-lateral CMOS switches directly.

R414/C411

R414 and C411 form a simple RC filter which smoothes the output of the 1.000V secondary divider switch to its mean DC level. Because of the very small span of the 1.000V secondary divider at the 1V DIVIDED OUTPUT, this single pole filter is more than sufficient to reduce output ripple to an insignificant level.

U406/U407Q404

Op-amps U406 and U407 form a composite amplifier for which U406₃ is the non-inverting input and U406₂ is the inverting input. The transfer function for this amplifier can be derived in the same way as that described for the 1.018V divided output in Section 4.2.2.4 taking into account the additional current introduced by R416. The equation solves to:-

$$V_{out} = 1.000005109 \times V_P + 5.10909 \times V_s - 38.908 \times 10^{-6}$$

It can be seen from this equation that the gain of the buffer amplifier to the output of the primary divider is virtually 1, while its gain to the output of the secondary divider is -5.109×10^{-6} . The effect on the divided output of the secondary divider is therefore only $1/195734$ that of the primary divider.

The effect of R416 is to introduce a DC offset into the output of the amplifier which centres the span of the 1.000V primary and secondary dividers at 1V.

U406 is an ultra-low input offset, chopper-stabilized op-amp which imparts its superior DC performance to the output amplifier. U407 is a wide bandwidth op-amp which, operating with resistive feedback, minimizes output noise. Resistive divider R421/R422, which is driven by +10V_C, biases the non-inverting input of U407 to 5V. Gain defining network R418/R419 provides a feedback loop around this high-bandwidth op-amp which sets its output to approximately 1.07V. U406 then adjusts the bias point of the non-inverting input of U407 to provide accurate DC gain definition for the composite amplifier.

4.2.2.9 1.000V Divided Output - Primary Divider Control Logic

(Circuit Diagram DC400881 Sheet 5; Page 11.7-6)

U504/U505/U506

Nand gate U504₁₂₋₁₃₋₁₁, which operates as an inverter, together with differentiator network C501/R502, produces the SYNC signal — a 4MHz clock signal in anti-phase to C4 with a mark period of around 60nsec. The SYNC signal, gated by U506₁₋₂₋₃ and U506₄₋₅₋₆ to produce single pulses, defines the pulse waveform for the STRBA_1.000V and STRBB_1.000V signals which drive the 1.000V primary divider's isolating pulse transformers.

To initiate the mark period of the primary divider, ZØ_L (inverted by U505₁₋₃) gates SYNC through U506₁₋₂₋₃ to produce a STRBA_1.000V pulse. In conjunction with the high level on SETA, which is coupled and inverted by opto-isolator U201₂₋₃₋₆ (Circuit Diagram DC400881 Sheet 2; Page 11.7-3) to produce SETA_1.000V, this STRBA_1.000V pulse places the primary divider into its T1₁ mark state as described in section 4.2.2.7.

A period of 250nsec later, Z2_L (inverted by U505₄₋₆) gates SYNC through U506₄₋₅₋₆ to produce a STRBB_1.000V pulse. In conjunction with the high level on SETA, this STRBB_1.000V pulse places the primary divider into its T1₂ mark state.

When the 1.000V primary divider's 16-bit mark counter on the Output PCB Digital Sub-Assembly reaches zero, it generates two control signals MØ_1.000V and M2_1.000V, which are separated by 250nsec. MØ_1.000V, inverted by U505₅₋₆, gates SYNC through U506₄₋₅₋₆ to produce a second STRBB_1.000V pulse. In conjunction with the low level on SETA, this STRBB_1.000V pulse places the primary divider into its T1₃ mark state.

A period of 250nsec later, M2_1.000V, inverted by U505₂₋₃, gates SYNC through U506₁₋₂₋₃ to produce a second STRBA_1.000V pulse. In conjunction with the low level on SETA, this STRBA_1.000V pulse places the primary divider into its T2 space condition.

4.2.2.10 1.000V Divided Output - Secondary Divider Timing Circuit

(Circuit Diagram DC400881 Sheet 5; Page 11.7-6)

U503₁₀₋₁₂₋₁₁₋₁₃₋₉₋₈

Control signal Z2_L sets flip-flop U503₁₀₋₁₂₋₁₁₋₁₃₋₉₋₈, causing its Q output SETB_1.000V to go high. The high level on SETB_1.000V, transferred across the cell's isolation barrier via U401₄₋₃₋₆ (Circuit Diagram DC400881 Sheet 4; Page 11.7-5), sets the secondary divider into its space condition.

U507/U508

Preloadable binary counters U507 and U508 are configured as a 16-bit binary down counter. However, because only the 8 most significant bits of the counter are controllable, it is only settable to 8-bit resolution.

Control signal Z1_L, which occurs halfway between Z0_L and Z2_L, preloads this counter with a binary value determined by hexadecimal control switches S504 and S505. When the Z2_L control pulse sets flip-flop U503₁₀₋₁₂₋₁₁₋₁₃₋₉₋₈ as described above, its Q output U503₈ goes low, enabling the 16-bit down counter via U507₃. The counter is then counted down by the 4MHz clock C4 to define the space period of the secondary divider.

When the counter reaches zero, the carry output on U508₁₄ goes low for one clock period. This output is clocked by SYNC into U503₁₀₋₁₂₋₁₁₋₁₃₋₉₋₈ causing its Q output SETB_1.000V to go low. The low level on SETB_1.000V, transferred across the cell's isolation barrier via U401₄₋₃₋₆, sets the secondary divider into its mark condition.

Note that the secondary divider works in anti-phase to the primary divider — i.e. the secondary divider's down counter defines the space period of the secondary divider switch instead of its mark period. As a result, the output voltage from the secondary divider decreases as the binary value loaded into its counter increases. This is done to compensate for the fact that the output of the secondary divider subtracts from the output of the primary divider instead of adding to it — see Section 4.2.2.8 Equation 1 — ensuring that all the hexadecimal switches rotate in the same direction to increase/decrease the cell's output.

The timing diagram for the 1.000V secondary divider timing circuitry is shown in Figure 4.2.2.5.

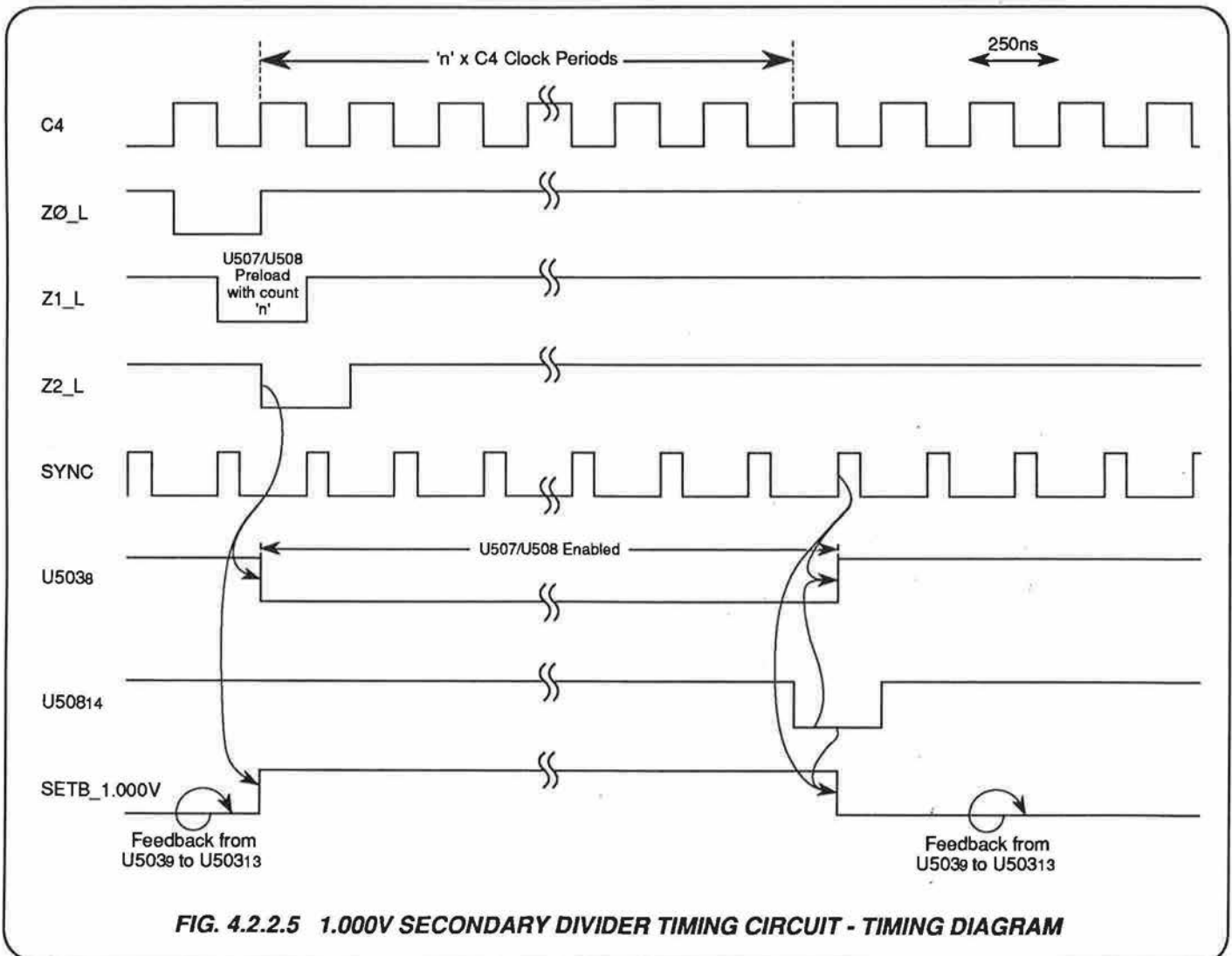

4.2.3 Output PCB Digital Sub-Assembly

(Circuit Diagram DC400940 Sheet 1; Page 11.7-7)

The Output PCB Digital Sub-Assembly is mounted on the Output PCB and contains the counters for the 1.018V and 1.000V divided output primary dividers.

4.2.3.1 1.018V Primary Divider Counter

U101/U102/U104₁₋₅₋₆

Preloadable counters U101 and U102 are configured as a 16-bit binary down counter. Control signal Z1_L preloads this counter with a binary value determined by DIP switch S101 and the fixed logic levels on U101₁₁₋₁₂₋₁₃ and U102₄₋₅₋₆₋₇₋₁₀₋₁₁₋₁₂₋₁₃. DIP switch S101 allows the span of the secondary divider on the output PCB to be centred around the desired 1.018V level. Because the DIP switches control the least significant bits of this counter, the counter has a setting resolution of 1 part in 2^{16} (152.6 μ V steps for a 10V input), but is controllable only over a limited control span.

The Z2_L control pulse, which occurs 125nsec after Z1_L, sets flip-flop U104₁₋₅₋₆ causing its \bar{Q} output U104₆ to go low and the 16-bit down counter to be enabled via U101₃. The counter is then counted down by the 4MHz clock C4 to define the mark period of the primary divider.

U103

When the counter reaches zero, MØ_1.018V (the carry output at U102₁₄) goes low for one clock period. MØ_1.018V is clocked by the SYNC signal into the first stage of the two-stage shift register formed by the flip-flops in U103. It is then clocked into the second stage of the shift register by the C4 clock. As a result, the MØ_1.018V pulse is delayed by 250nsec to produce M2_1.018V. M2_1.018V, in addition to being output onto the Output PCB, also resets U104₁₋₅₋₆, causing its \bar{Q} output to go high and further counting in U101/U102 to be inhibited.

4.2.3.2 1.000V Primary Divider Counter

U105/U106/U104₁₀₋₁₃₋₉₋₈

Preloadable counters U105 and U106 are configured as a 16-bit binary down counter. Control signal Z1_L preloads this counter with a binary value determined by the fixed logic levels on U105₄₋₅₋₆₋₇₋₁₀₋₁₁₋₁₂₋₁₃ and U106₄₋₅₋₆₋₇₋₁₀₋₁₁₋₁₂₋₁₃. These fixed logic levels give the primary divider a fixed division ratio of 0.099976.

The Z2_L control pulse, which occurs 125nsec after Z1_L, sets flip-flop U104₁₀₋₁₃₋₉₋₈ causing its \bar{Q} output U104₈ to go low and the 16-bit down counter to be enabled via U105₃. The counter is then counted down by the 4MHz clock C4 to define the mark period of the primary divider.

U107

When the counter reaches zero, MØ_1.000V (the carry output at U106₁₄) goes low for one clock period. MØ_1.000V is clocked by the SYNC signal into the first stage of the two-stage shift register formed by the flip-flops in U107. It is then clocked into the second stage of the shift register by the C4 clock. As a result, the MØ_1.000V pulse is delayed by 250nsec to produce M2_1.000V. M2_1.000V, in addition to being output onto the Output PCB, also resets U104₁₀₋₁₃₋₉₋₈, causing its \bar{Q} output to go high and further counting in U105/U106 to be inhibited.

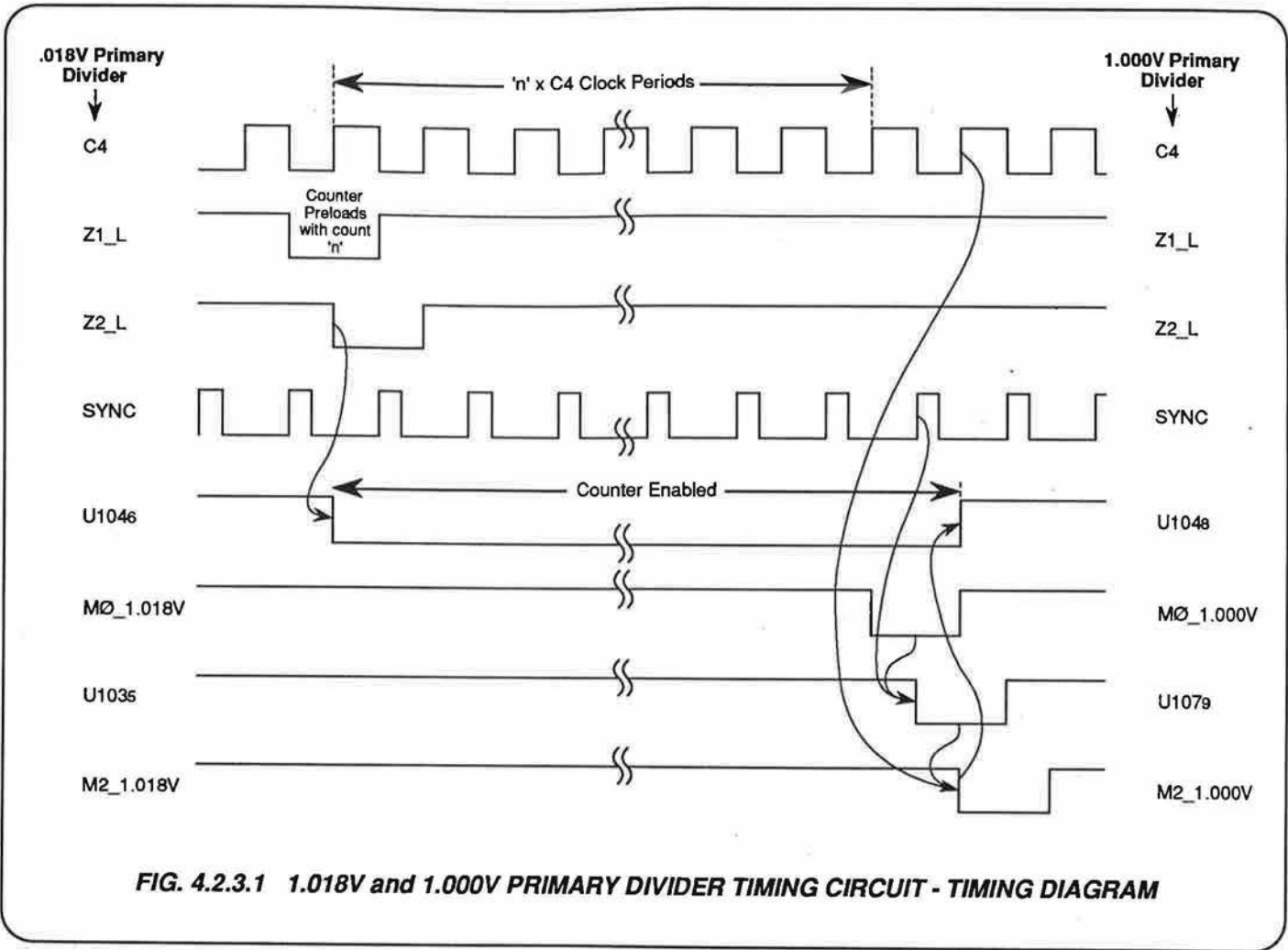

FIG. 4.2.3.1 1.018V and 1.000V PRIMARY DIVIDER TIMING CIRCUIT - TIMING DIAGRAM

4.2.4 Digital PCB

(Circuit Diagram DC400923 Sheet 1; Page 11.6-2)

The Digital PCB generates the 4MHz C4 clock signal and the timing pulses ZØ_L, Z1_L, Z2_L and SETA which control the PWM voltage dividers on the Cell PCBs and the Output PCB.

Y1/U1

Crystal oscillator Y1 generates an 8MHz output which undergoes division by 2 in flip-flop U1₁₂₋₃₋₂ to produce the 4MHz C4 clock signal at its Q output.

U2/U3

Binary counters U2 and U3 are configured as a single 16-bit binary counter which divides the frequency of C4 by 2¹⁶, producing a 250nsec duration negative pulse at U3₁₄ once every 16.384 msec. This output is used as control pulse ZØ_L.

U4

The two flip-flops contained in U4 form a two-stage shift register. ZØ_L is clocked into the first stage by the Q̄ output of U1₁₂₋₃₋₂ (a 4MHz clock signal which is in anti-phase to C4), producing control pulse Z1_L at U4₅ which is delayed with respect to ZØ_L by 125nsec.

Z1_L is clocked into the second stage of the shift register by C4, producing control pulse Z2_L at U4₉, which is delayed with respect to Z1_L by 125nsec and with respect to ZØ_L by 250nsec.

U5

Nand gate U5₁₋₂₋₃ acts as an OR-gate for negative pulses ZØ_L and Z2_L to produce a 500nsec duration SETA control pulse.

U6/U7/U8/U9/U10

Non-inverting buffers U6, U7, U8, U9 and U10 drive the clock and control signals in parallel onto the Cell 4, Cell 3, Cell 2, Cell 1 and Output PCBs respectively.

The timing diagram for the Digital PCB circuitry is shown in *Figure 4.2.4.1*.

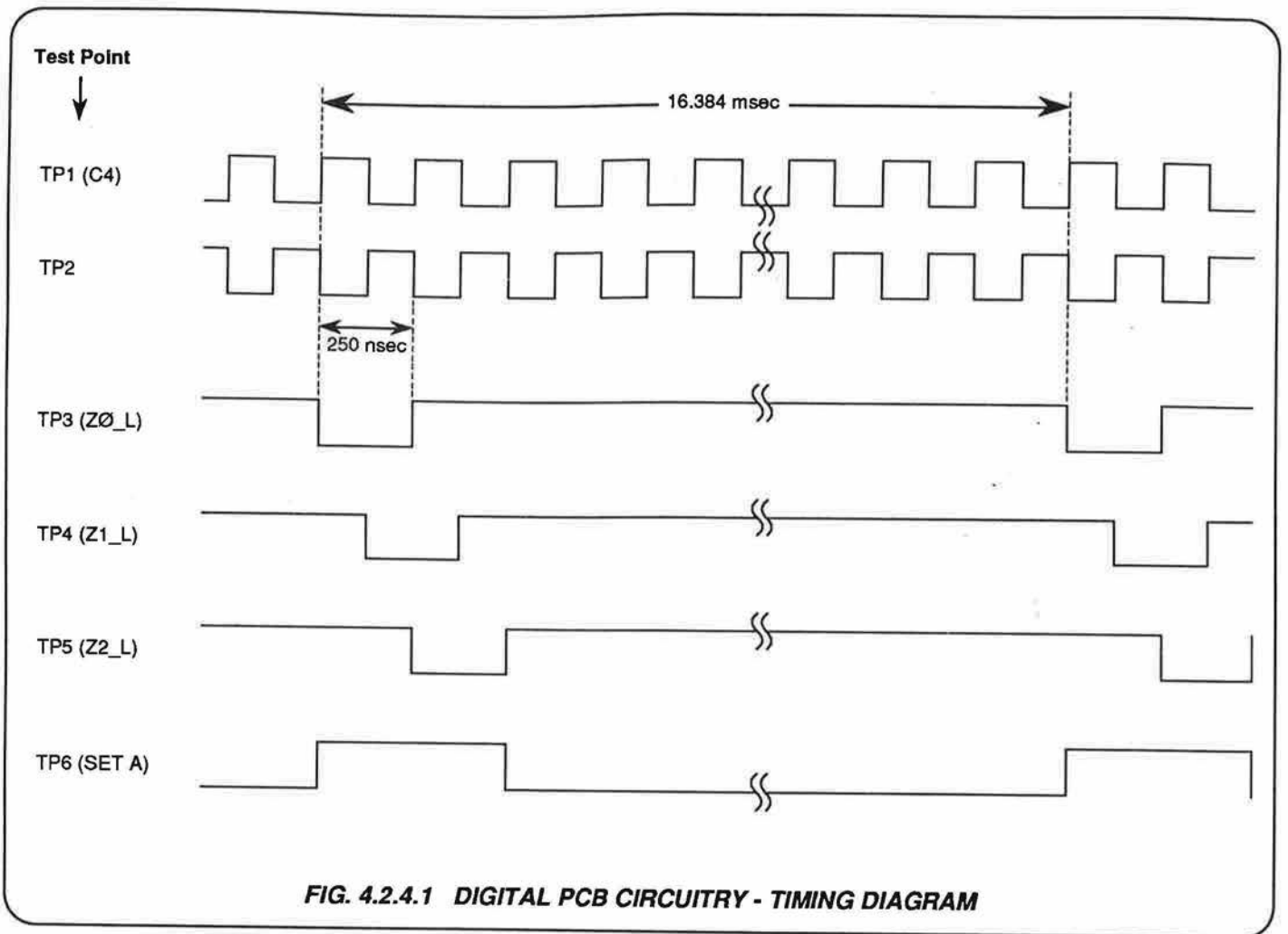

FIG. 4.2.4.1 DIGITAL PCB CIRCUITRY - TIMING DIAGRAM

4.2.5 Power Supply PCB

(Circuit Diagram DC400971 Sheets 1 to 5; Pages 11.3-7 to 11.3-11)

For the following description, refer to *Circuit Diagram DC400971 Sheet 1; Page 11.3-7*. The Power Supply PCB contains five separate battery chargers, each of which serves one of the 4910/4911's five 18V battery supplies. Depending on the battery supply's discharge state, charging takes place either at constant current (charging from discharged state) or at constant voltage (float charging). Each charging circuit is driven from a separate secondary winding on the 4910/4911's line input transformer.

D101/R101/C101

Bridge rectifier D101 rectifies the AC voltage generated by the appropriate secondary winding on the line input transformer. 'CM ADJ' potentiometer R101 and C101 inject a portion of the secondary winding AC voltage onto the transformer's guard screen to null out AC pick-up on the guard screen, and thereby eliminate line frequency common-mode voltages on the unit's front panel outputs.

U101/U102

Regulator U101 and the two op-amps contained in U102 form a current-limited constant-voltage regulator. To ensure proper operation of U101 under all input conditions it operates on a 'virtual ground' generated by zener diode D103. D103 also provides a negative supply (with respect to the virtual ground) for U102. D102 provides the +ve supply for U102.

Output feedback for the regulator is generated by the divider chain R112/R109/R110 which operates in conjunction with a temperature sensing thermistor bolted to one of the appropriate

battery supply terminals. Electrically, this thermistor is connected between the charging circuit's I+ and VS terminals, and the battery supply is connected between the charger's I+ and 0V terminals — see *Figure 4.2.5.1*.

Unity gain op-amp U102₃₋₂₋₁ buffers the feedback voltage before applying it to op-amp U102₅₋₆₋₇. U102₅₋₆₋₇ level shifts the output of U102₃₋₂₋₁ by the voltage developed across D103 (approximately 10V), generating at U102₇ a voltage with respect to the virtual ground which is equal to the feedback voltage — see *Figure 4.2.5.1*. This level shifted voltage, attenuated by adjustable divider R107/R106/R104, provides the feedback signal required at U101's REF input (U101₄).

The negative temperature coefficient thermistor in parallel with R112 causes the output voltage of the charger circuit to decrease as the battery temperature increases — see *Figure 4.2.5.2*. During float charging, this matches the charging voltage to the temperature versus terminal-voltage curve of the battery supply. When the battery is partially discharged, R102 limits the output current to approximately 305mA.

Operation of the charging circuits for the other cells' battery supplies and for the battery supply which powers the digital timing circuits and the 4910's 4-wire output buffer and divided outputs is the same as that described above. (It is only necessary to replace component designators of the form x1xx by x2xx, x3xx, x4xx or x5xx as appropriate to make the description fit.) Note however, that the current limit in the charger circuit which charges the battery supply for the digital timing circuits and the 4910's 4-wire output buffer and divided outputs is set at approximately 425mA by R502.

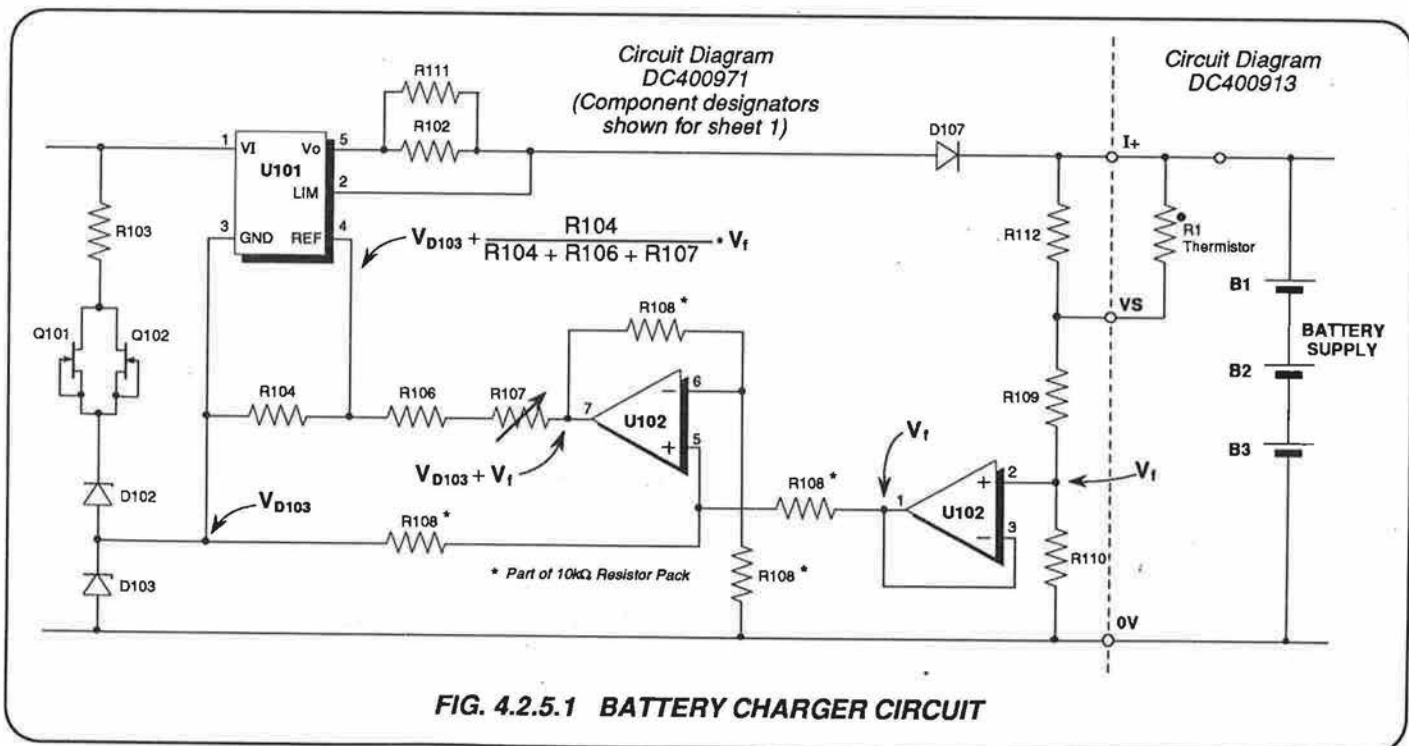

FIG. 4.2.5.1 BATTERY CHARGER CIRCUIT

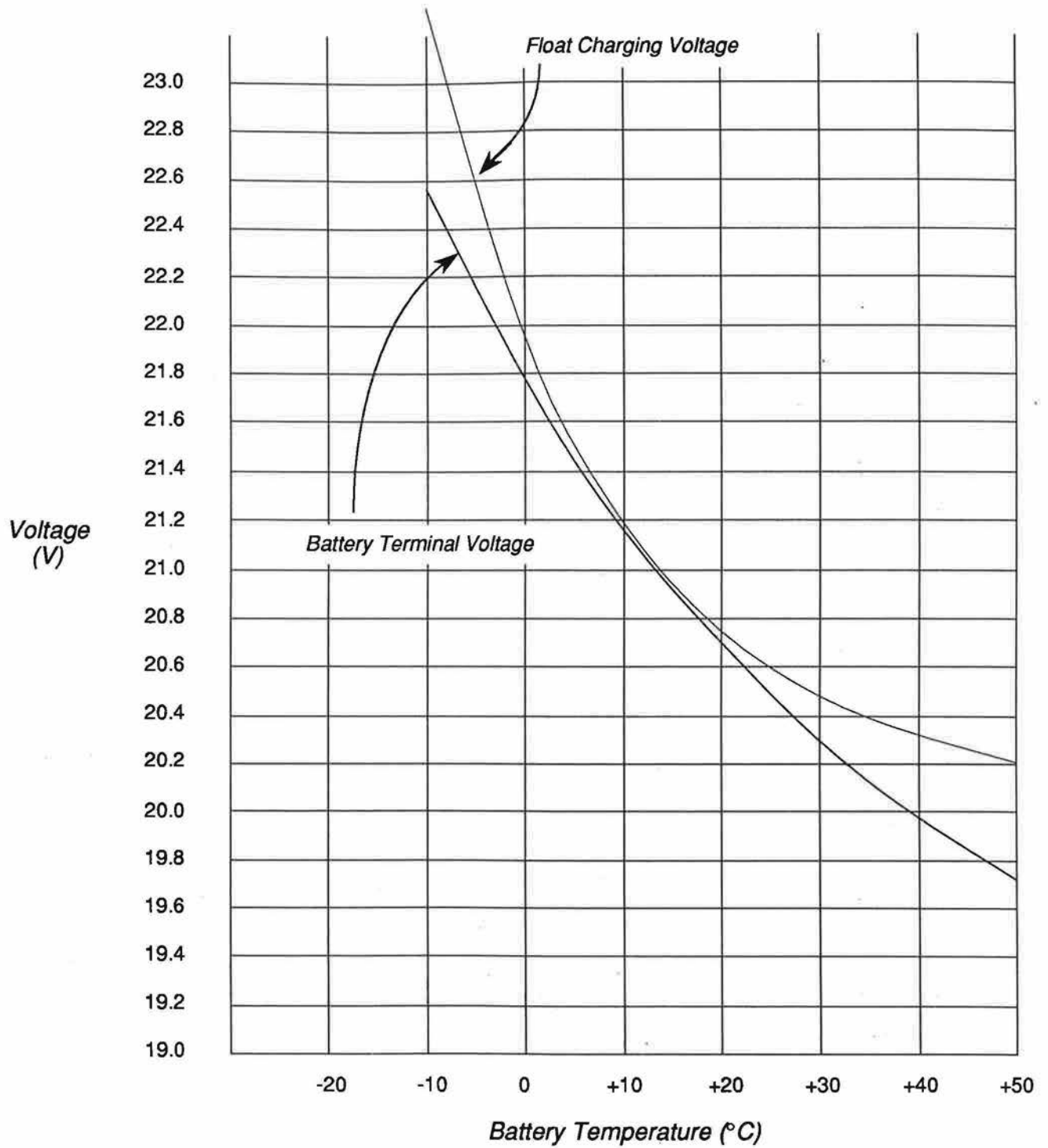

FIG. 4.2.5.2 BATTERY PACK AND BATTERY CHARGER VOLTAGE VERSUS TEMPERATURE CHARACTERISTIC

4.2.6 Battery Tray PCB

(Circuit Diagram DC400913 Sheet 1; Page 11.8-3)

The Battery Tray PCB houses ten self-resetting 500mA fuses which protect the 4910/4911's batteries. One fuse is situated in each of the I+ leads from the battery chargers, and one is situated in each of the BAT+V leads which feed current to the 4910/4911's regulated power supplies.

The temperature sensing thermistors which monitor the battery supply temperatures and control the charging voltage are physically mounted on the +ve battery supply terminals.

4.2.8 Mother PCB

In addition to providing plug-in connectors and interconnections for the 4910/4911's other PCBs, the Mother PCB also houses five linear voltage regulators which supply the four Cell PCBs, the digital timing circuits and the 4910's Output PCB. In Normal mode each of the five regulators is powered from a separate battery supply.

4.2.8.1 Battery Monitors and Linear Voltage Regulators

(Circuit Diagram DC400878 Sheets 1 to 5; Pages 11.4-2 to 11.4-6)

The following description should be read in conjunction with *Circuit Diagram DC400878 Sheet 1; Page 11.4-2*.

S101

Switch S101 allows the battery supply to be disconnected from the battery monitoring and voltage regulator circuits for test purposes.

Q101/U103/U104

The four voltage comparators contained in U103 each have one input connected to the 2.44V reference voltage generated by D105 and D106. The other inputs to these comparators are driven from taps on voltage divider R112/R113/R114/R115/R116 which is connected across the battery supply terminals. As the battery voltage fluctuates, the outputs of the voltage comparators undergo the transitions shown in the table below.

When the battery supply is in its charged state, above 17.5V, the low level output at U103₂ forces U104₄ high. Via inverter U104₁₂₋₁₃₋₁₁, the high level at U104₄ switches Q105 and the front-panel red **Battery LED** off, and via U104₁₋₂₋₃ and U104₈₋₉₋₁₀ it switches Q104 and the front panel green **Battery LED** on.

A low to high transition at U103₂, which occurs when the battery voltage falls below 17.5V, provides the first indication that the batteries are becoming discharged. This transition enables the

4.2.7 Interconnection PCB

(Circuit Diagram DC400970 Sheet 1; Page 11.4-8)

The Interconnection PCB intercepts the ribbon cable connection between the Power Supply PCB and the Battery Tray PCB, transferring relevant power supply lines onto the Mother PCB. The Interconnection PCB contains no active circuitry.

astable multivibrator formed by U104₅₋₆₋₄, which starts to oscillate at a frequency of around 1Hz. Via inverter U104₁₂₋₁₃₋₁₁, the 1Hz square wave at U101₄ switches Q105 on and off, causing the front-panel red **Battery LED** to flash. Via U104₁₋₂₋₃ (which is enabled by the high level at U103₁₄) and U104₈₋₉₋₁₀, the 1Hz square wave at U104₄ also switches Q104 on and off, causing the front-panel green **Battery LED** to flash in anti-phase to the red LED.

When the battery voltage falls further to below 17.2V, the high to low transition at U103₁₄ disables U104₁₋₂₋₃ via U104₁, forcing Q104 and the front-panel green **Battery LED** off. The front panel red **Battery LED** continues to flash.

A low to high transition at U103₁₃, which occurs when the battery voltage falls below 16.4V, causes Q101 to turn off. This disconnects the battery supply from voltage regulator U102/Q102, preventing the battery supply from entering a deep discharge state from which it cannot fully recover.

If the battery voltage exceeds 23.2V, the high to low transition at U103₁ pulls U104₂ and U104_{12/13} low. This forces Q104 and the front panel green **Battery LED** off, and Q105 and the front-panel red **Battery LED** on.

Comparator	Transition	Battery Voltage Output
U103 ₂	Low to High	Battery voltage falls below 17.5V
U103 ₁₄	High to Low	Battery voltage falls below 17.2V
U103 ₁₃	Low to High	Battery voltage falls below 16.4V
U103 ₁	High to Low	Battery voltage rises above 23.2V

U102/Q102

Q102 is the series pass transistor for voltage regulator U102. In this configuration U102 achieves control by driving its output current into R109. This output current, plus the ground pin current of the regulator (which is typically only a few hundred μA) flows in R107 to provide the gate control voltage for Q102. Voltage feedback to U102 is generated by divider R110/R111.

S601

Multi-way switch S601 performs the power supply switching necessary to switch the 4910 between its **Normal** and **Transit** operating modes. In the cells' voltage regulator circuitry it performs the following switching functions:

- a. Disconnection of the appropriate Cell PCB's analog circuitry and onboard 5V regulator from the regulated 12V supply (+12V REG).
- b. Transfer of the appropriate Cell PCB's zener reference module heater supply ($+V_H$) from the 12V regulated supply in **Normal** mode to the un-regulated battery supply in **Transit** mode.

Operation of the battery monitoring and voltage regulator circuits for the other cells is the same as that described above. (It is only necessary to replace component designators of the form x1xx by x2xx, x3xx, x4xx as appropriate to make the description fit.)

Operation of the fifth voltage regulator, which powers the digital timing circuits and the 4910's 4-wire output buffer and divided output circuitry, is essentially the same as that described above. However, its output voltage is set at 13.5V instead of 12V by feedback divider R510/R511. In addition, switch S601 simply disconnects the regulator from all the circuits which it supplies when the 4910/4911 is switched to **Transit** mode.

4.2.8.2 External DC Supply

(Circuit Diagram DC400878 Sheet 6; Page 11.4-7)

The external DC supply circuitry accepts an input voltage of between 10V and 40V, from which it generates an 18V regulated supply.

S601

Multi-way switch S601 performs the power supply switching necessary to switch the 4910/4911 between its **Normal** and **Transit** operating modes. Around the external DC supply circuitry it performs the following switching functions:-

- a. Isolation of both the input and output of the external DC supply circuit when the 4910/4911 is in **Normal** mode.
- b. Connection of the external DC supply circuitry to the **EXTERNAL DC INPUT** connector when the 4910/4911 is in **Transit** mode.
- c. Connection of the +18V output and ground of the external DC supply regulator to all four of the cell battery supplies in parallel when the 4910/4911 is in **Transit** mode.

Note that the output of the external DC supply regulator is permanently connected to the battery supply which powers the digital timing circuits and the 4910's 4-wire output buffer and divided outputs. Also note that in **Transit** mode all five battery supplies are effectively connected in parallel with one another.

U601

To provide the necessary input voltage to voltage regulator U603, the voltage applied to the **EXTERNAL DC INPUT** connector may require to be either doubled, tripled or applied directly to the regulator input. The table below indicates the different requirements over the 10V to 40V external DC supply range.

External DC Input	Requirement Voltage
10V to 14V	Tripled input voltage
14V to 25V	Doubled input voltage
25V to 40V	Input voltage applied direct

Resistive divider R603/R604/R605/R606, driven from the 12V supply generated by regulator U604, sets threshold voltages of 1.6V at U6017, 2.2V at U6019 and 4.1V at U60111. The other inputs to these comparators are connected to the junction of R601 and R602 which attenuate the external DC input voltage by a factor of six.

If the external DC input is less than 10V, comparator output U6011 is high, turning the rear-panel external DC input LED off to indicate that the input voltage is not high enough to power the unit. As soon as the external DC input rises above 10V, U6011 goes low, turning the LED on.

With external DC input voltages of between 10V and 40V, the open collector comparator output U601₁₃ is at high impedance, allowing the astable multivibrator built around U601₅₋₄₋₂ to oscillate (at approximately 680 Hz). The square wave output at U601₂ and the inverted square wave at U602₃ turn drive transistors Q601/Q602 and Q604/Q605 on and off in anti-phase to one another. These drive transistors then drive FETS Q607/Q608 and Q609/Q610 on and off in anti-phase to one another.

When Q608 is on (Q607 off), capacitor C602 charges up to the external DC input voltage via D607. When Q607 turns on, the negative end of C602 is connected to the external DC input voltage, driving its positive end up to twice the input voltage. During the period that Q607 is on, Q610 is also on, allowing C602 to transfer part of its charge, via D608, onto C603. Under steady state conditions in which the voltage droop on these capacitors due to the net flow of external DC input current into the 4910/4911 is small, C603 charges to approximately twice the external DC input voltage.

When Q609 subsequently turns on, the negative end of C603 is connected to the external DC input voltage, driving its positive end up to three times the input voltage. Under these conditions, C603 transfers some of its charge to C604 and C605 via D609.

When the input voltage increases above 14V, comparator output U601₁₄ goes low, forcing the output of U602₁₋₂₋₃ high and disabling the 680 Hz switching of Q609 and Q610. Q607, Q608 and C602 continue to operate as a voltage doubler.

When the input voltage increases above 25V, comparator output U601₁₃ goes low disabling the 680Hz oscillator. With neither the voltage doubler or tripler operating, the external DC input is fed directly to the input of voltage regulator U603 via diodes D607, D608 and D609.

U603

Voltage regulator U603 produces a regulated 18V output which drives the battery supplies via D610. R624 limits the maximum output current of U603 to approximately 220mA.

U604

Voltage regulator U604 generates a 12V supply from the 18V battery supply voltage. The output of this regulator drives the control logic for the external DC input voltage doubler/tripler circuitry.

N.B. When testing this circuitry, note that the unit's batteries must be installed in order for the voltage doubler/tripler to start up correctly.

4.2.9 Front Panel PCB

4.2.9.1 Output Terminals

(4910: Circuit Diagram DC400880 Sheet 2; Page 11.3-2)

(4911: Circuit Diagram DC400905 Sheet 2; Page 11.3-4)

Each of the 10V CELL outputs; and for the 4910, the 1.018V DIVIDED OUTPUT and the 1V DIVIDED OUTPUT have a low-pass T-filter circuit immediately behind their front-panel terminals. These filters comprise two 49.9Ω resistors and a 1μF capacitor (e.g. R1, R2 and C1). The filters give all of these outputs a nominal output resistance of 100Ω.

The filter for the AVERAGE output comprises the front-panel components R9 and C13, together with the four Mother PCB mounted 200Ω averaging resistors (R630, R631, R632 and R633 on *Circuit Diagram DC400878 Sheet 6; Page 11.4-7*). It should be noted that the output resistance depends on the number of CELL outputs 'n' connected to the AVERAGE output according to the equation:

$$\text{Output resistance} = \frac{200}{n} + 50 \text{ ohms}$$

All of the above outputs include a 330pF capacitor between their high and low output terminals, and a 330pF capacitor between their low terminals and instrument ground to provide RF filtering. All of these outputs also include a gas discharge spark arrester directly across their output terminals (e.g. DS1, DS2, DS3 etc.).

The 4-WIRE OUTPUT BUFFER has a 10Ω series resistor and a π-filter comprising C22, L1 and C24 in its I+ lead. Its Hi lead has a 100Ω series resistor. Spark arresters DS8 across its I+ and I- terminals and DS9 across its Hi and Lo terminals protect the 4-WIRE OUTPUT BUFFER from high voltage discharges. C27 and C28 provide RF filtering to instrument ground.

4.2.9.2 Front-panel CELL LEDs

(4910: Circuit Diagram DC400880 Sheet 1; Facing Page 11.3-2)

(4911: Circuit Diagram DC400905 Sheet 1; Facing Page 11.3-4)

The 4910/4911 front panel LEDs indicate the discharge state of each cell's battery supply, the integrity of each cell's zener reference module temperature control, and whether or not each cell is connected to the AVERAGE output. They are all common cathode bi-colour LEDs capable of illuminating red or green. All the LEDs and associated switching elements for a particular CELL output are connected in series across the cell's 12V regulated supply as shown in *Figure 4.2.9.1*.

4.2.9.3 Battery Supply LED

(4910: Circuit Diagram DC400880 Sheet 1; Facing Page 11.3-2)

(4911: Circuit Diagram DC400905 Sheet 1; Facing Page 11.3-4)

The **Battery Supply LED**, D1, indicates the discharge state of the fifth battery supply which powers the digital timing circuits and the 4910's 4-wire output buffer and divided output circuitry. It is powered from the regulated 13.5V output which supplies these circuits and is controlled by the battery voltage monitoring circuit on *Circuit Diagram DC400878 Sheet 5; page 11.4-6*.

4.2.9.4 Line Supply LED

(4910: Circuit Diagram DC400880 Sheet 1; Facing Page 11.3-2)

(4911: Circuit Diagram DC400905 Sheet 1; Facing Page 11.3-4)

The green **Power Supply LED**, D2, is powered from bridge rectifier D507 on the Mother PCB (*Circuit Diagram DC400878 Sheet 5; page 11.4-6*). This bridge rectifier derives its AC input from a secondary winding on line input transformer (the one which drives the charger/power supply for the digital timing circuits and the 4910's 4-wire output buffer and divided output circuitry. It therefore illuminates green whenever the 4910/4911 is connected to an AC line supply.

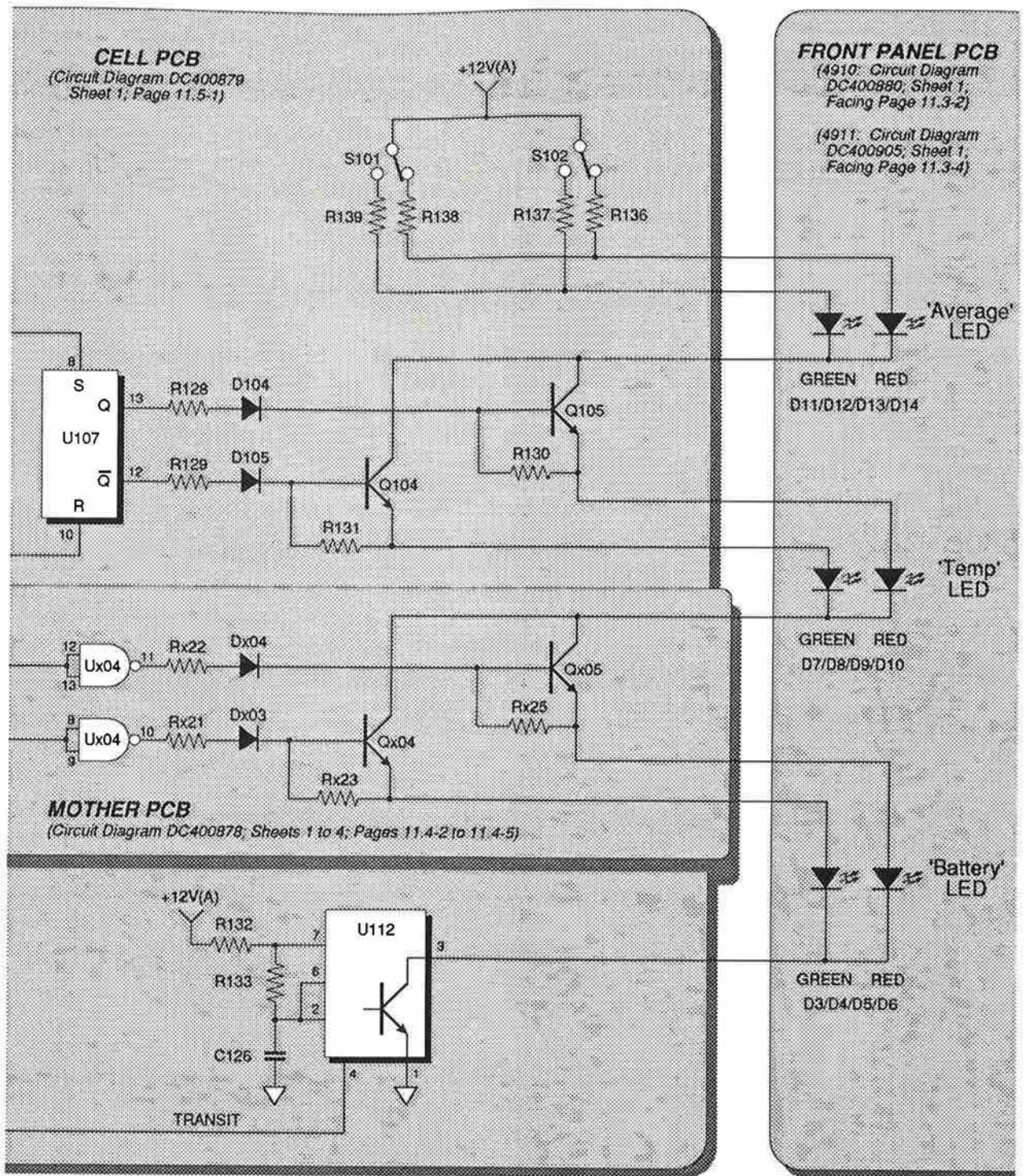

FIG. 4.2.9.1 FRONT PANEL LED SWITCHING

4910/4911 Servicing Handbook

Contents

SECTIONS 1 to 10 are in course of preparation

SECTION 11 4910/4911 Servicing Diagrams and Parts Lists

N.B. The parts list for an assembly is at the rear of the assembly's sub-section.

11.1	Finished Assembly	
	Parts Lists only	11.1-1
11.2	Instrument Assembly	
	4910 Instrument Assembly	11.2-1
	4911 Instrument Assembly	11.2-3
11.3	Panel Assemblies	
	4910 Front Panel Assembly	11.3-1
	4911 Front Panel Assembly	11.3-3
	Rear Panel Assembly	11.3-5
	Power Supply Assembly	11.3-7
11.4	Mother PCB Assembly	
	Mother PCB Assembly	11.4-1
	Interconnection PCB Assembly	11.4-8
11.5	Cell PCB Assembly	
	Cell PCB Assembly	11.5-1
11.6	Digital Assembly	
	Digital Assembly	11.6-1
11.7	4910 Output PCB Assemblies	
	Output PCB Assembly	11.7-1
	Output PCB Digital Sub-Assembly	11.7-7
11.8	Battery Assemblies	
	Battery Tray Assembly	11.8-1
	Battery Tray PCB Assembly	11.8-3
11.9	Option 90 - Rack Mounting	
	Rack Mounting Kit	11.9-1

FINISHED ASSEMBLY

No Assembly or Circuit Drawings issued - Parts Lists Overleaf © Datron Instruments 1991

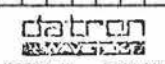

DRAWING No. LD400884		CHEK'D																										
DOCUMENT LIST		DATE																										
DISTRIBUTION		ECO																										
		REVISION																										
		ISSUE	1.0	3583.17.789	APC																							
			1.1	3465.22.11.89.	APC																							
			1.2	3520.22.1.90	APC																							
			2.0	3600.16.6.90	APC																							
			2.1	3601.31.7.90	APC																							
DESCRIPTION	DRAWING NUMBER	SHEET NUMBER	ISSUE - REVISION																									
PARTS LIST.	LP400884	1	1.0	1.1	1.2	2.0	2.1																					
ASSEMBLY DRAWING.																												
CIRCUIT DIAGRAM.																												
TEST PROCEDURE.																												
TEST SPECIFICATION.																												
PCB.																												
NOTES						DATE	CHEK'D	APPRO	TITLE	DRAWING NO.																		
☐ DENOTES NO CHANGE TO DCS AT ISSUE LEVEL CHANGE			HORSFIELD ENGLAND			17JUL89	Rkc	RwF	4910 FINISHED INSTRUMENT ASSY.	LD400884																		

DATRON INSTRUMENTS LTD PARTS LIST 07-May-91 DESC: ASSY FINISHED INST 4910 DRG NO: LP400884-2 REV: 1 PAGE NO: 1

DESIG	PART NO	DESCRIPTION	PRINC MANUF	MANUF PART NUMBER	CLASS	UM	QUANTITY	CHANGES
	400883-2	ASSY INST 4910	DATRON	SEE DRG			EA	1
	400959-1	ASSY SOFT CARRY CASE 4910	DATRON	SEE DRG			EA	-
	440161-1	KIT RACK MOUNT 4910	DATRON	SEE DRG			EA	-
	440168-2	KIT TRANSIT CASE 4910	DATRON	SEE DRG			EA	-
	440169-1	KIT 115V 4910/11	DATRON	SEE DRG			EA	-
	450774-2	PACKING BOX 4910		SEE DRG			EA	1
	604114	PLUG 15 WAY SHIELDED D TYPE	AMP	748048-1			EA	1
	605195	SOCKET 9-WAY D TYPE SHIELDED	AMP	748047-1			EA	1
	850254-1	HANDBOOK USERS 4910/4911		SEE DRG			EA	1
	850258-1	HANDBOOK SERV 4910/4911		SEE DRG			EA	1
	900016	CLEANING FLUID	RS COMPONENTS	556-654			AR	1
	920012	MAINS LEAD/CONN	BELLING LEE	L1949			EA	1
	920234	FUSE 400mA 250V 32mm SLOW BLOW	LITTLEFUSE	313.400			EA	1

End

STEP 1

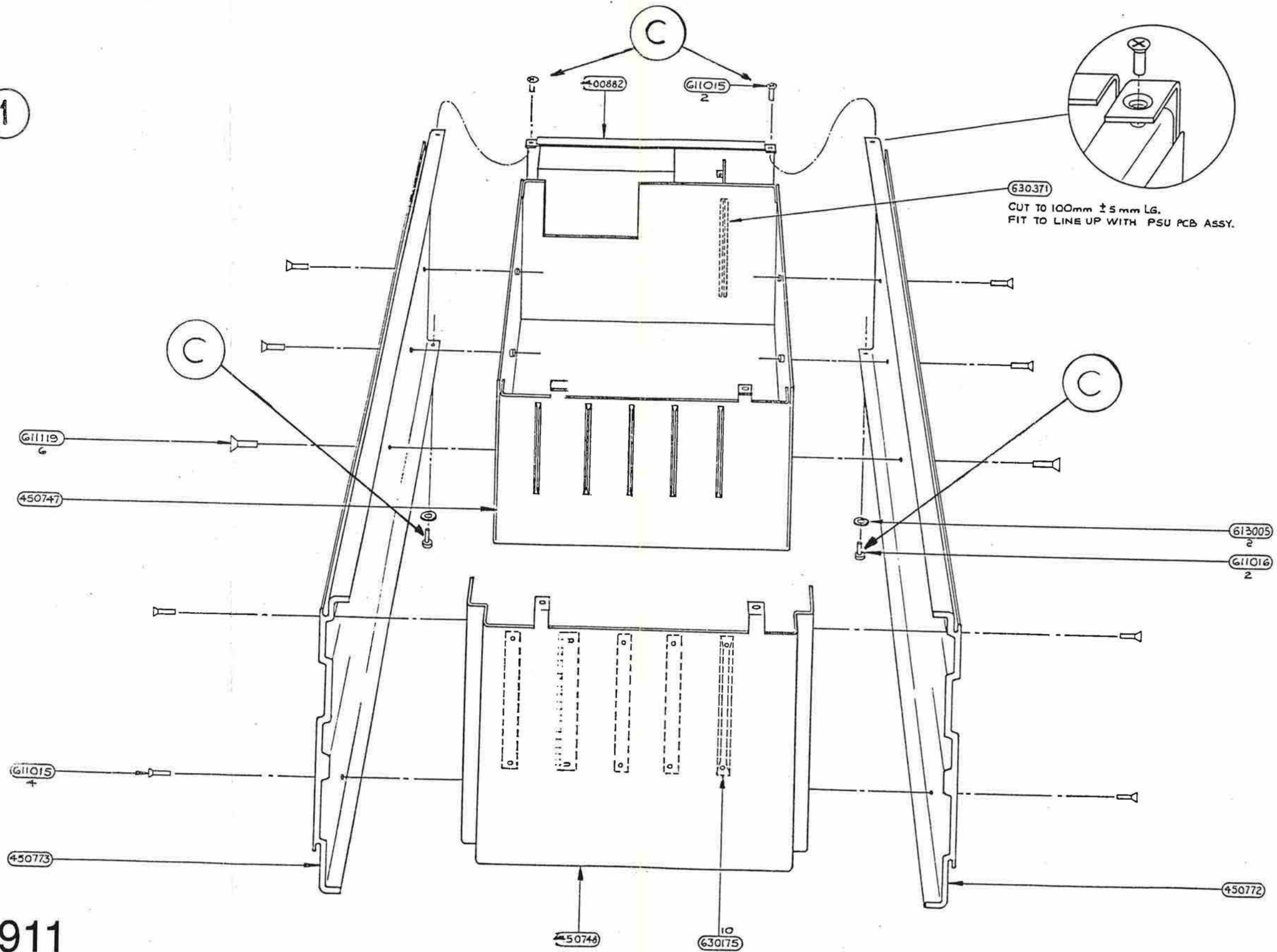

4910/4911
datron
WAVETEK

© Datron Instruments 1991

4910 INSTRUMENT ASSEMBLY

Drawing No. DA400883

Sheet 1

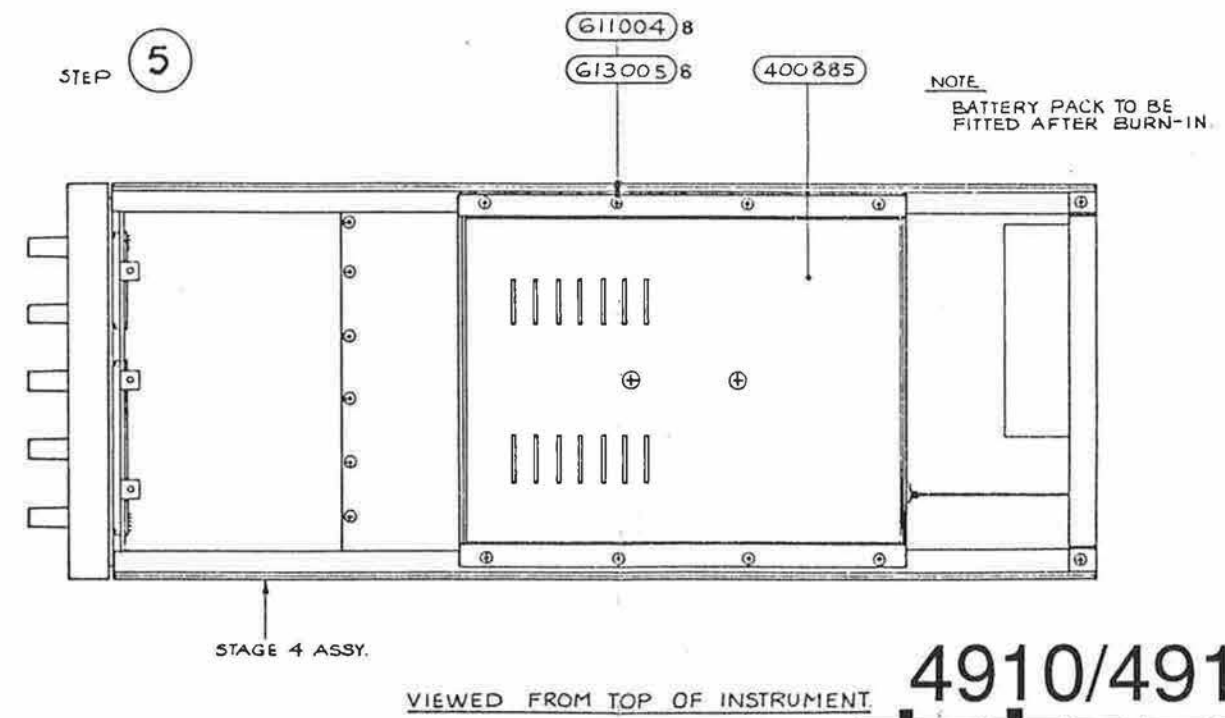
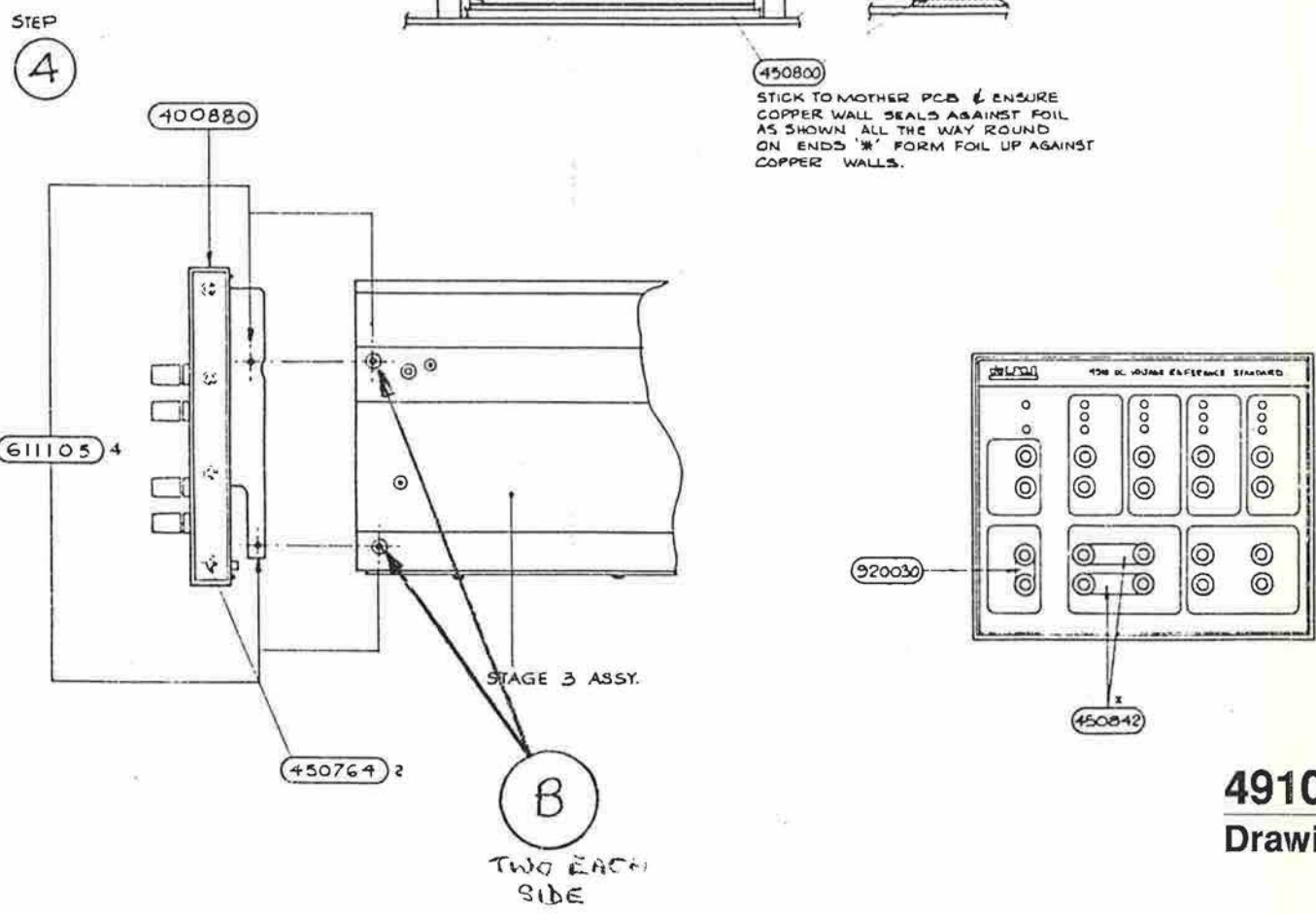
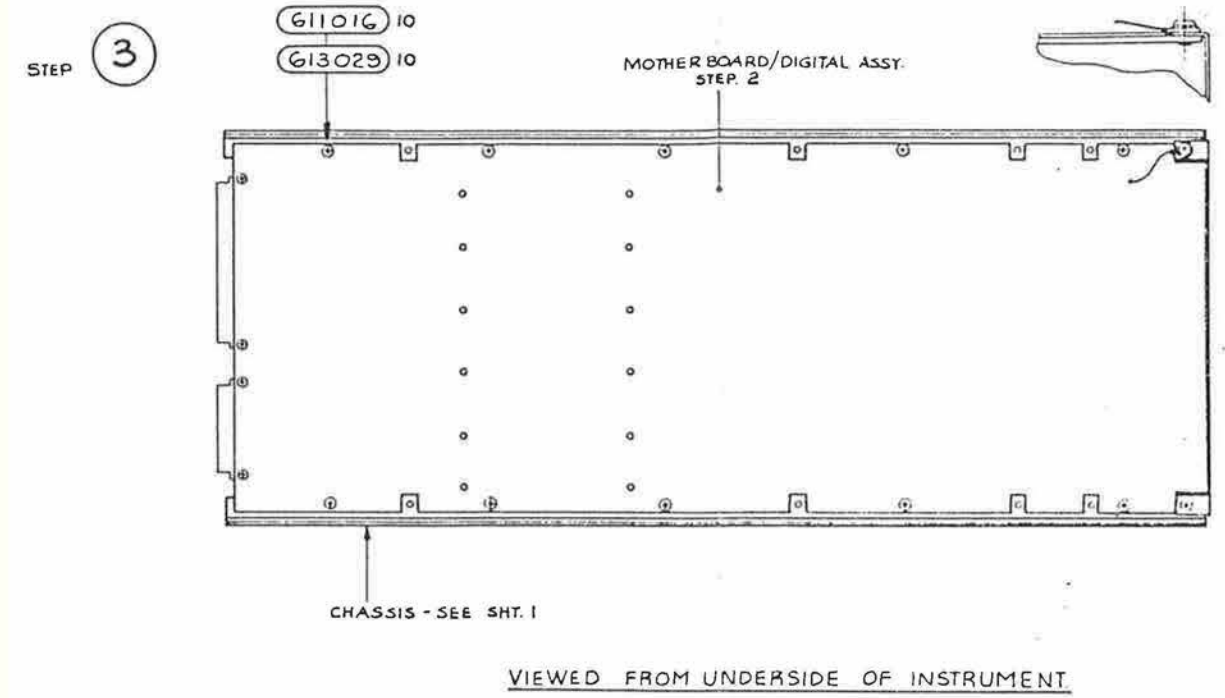
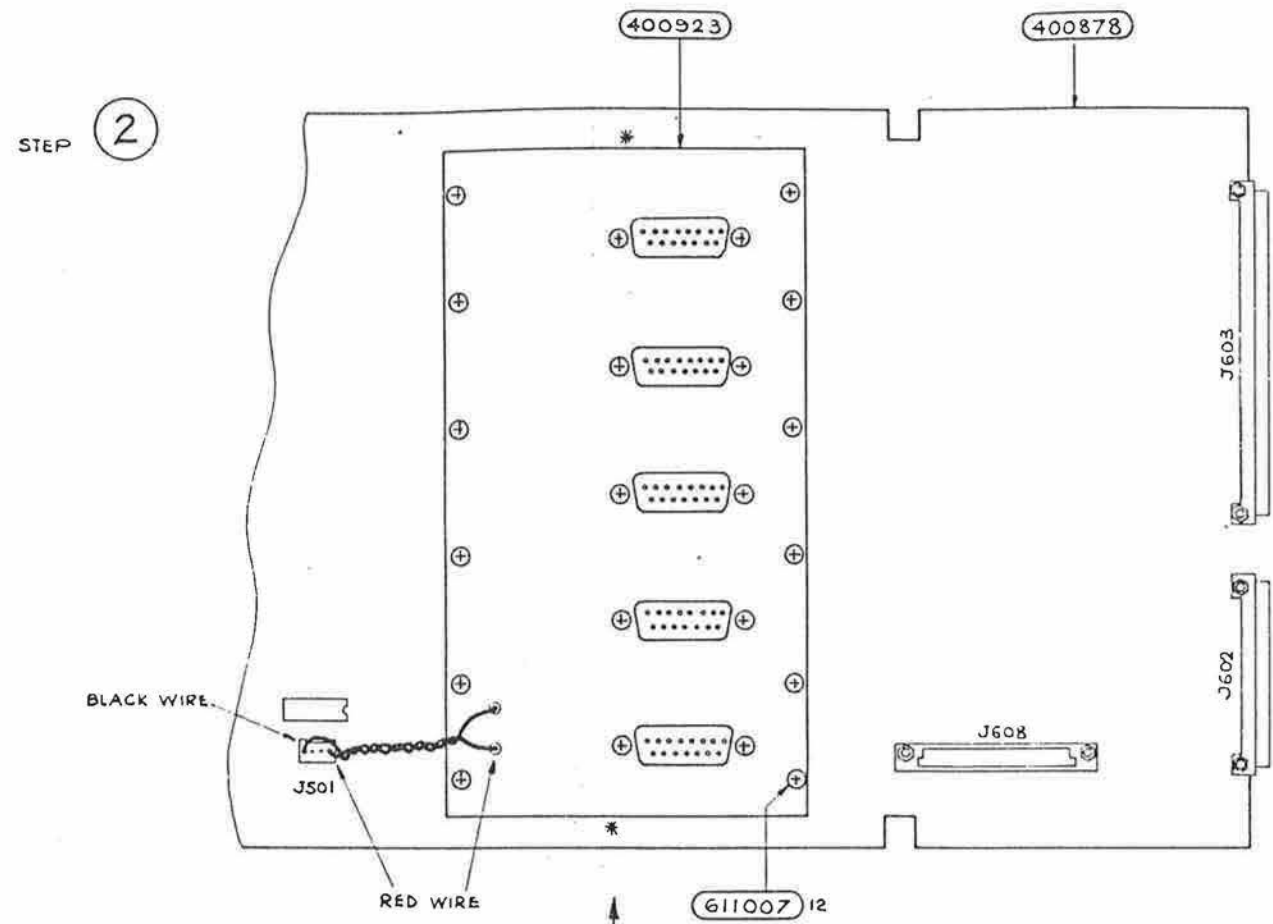

4910 INSTRUMENT ASSEMBLY
 Drawing No. DA400883 Sheet 2



© Datron Instruments 1991

STEP 6

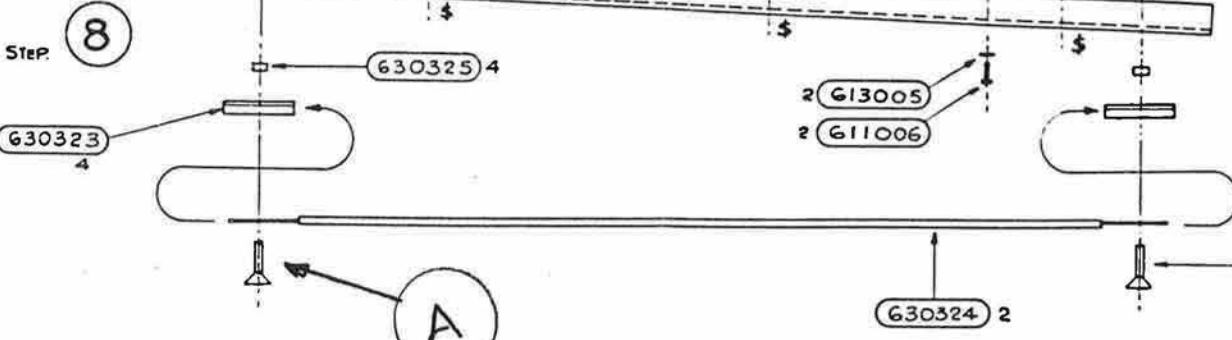
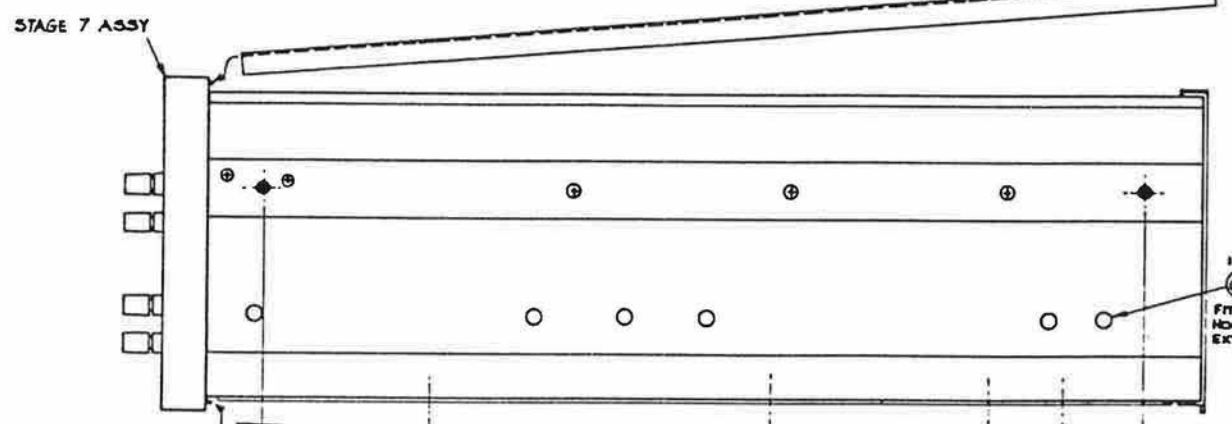
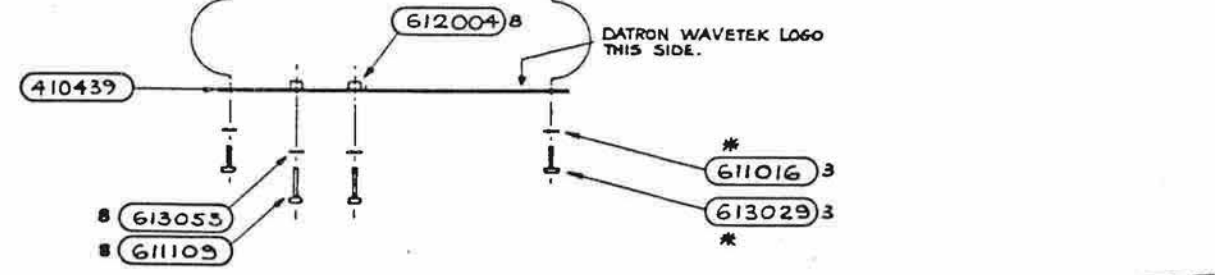
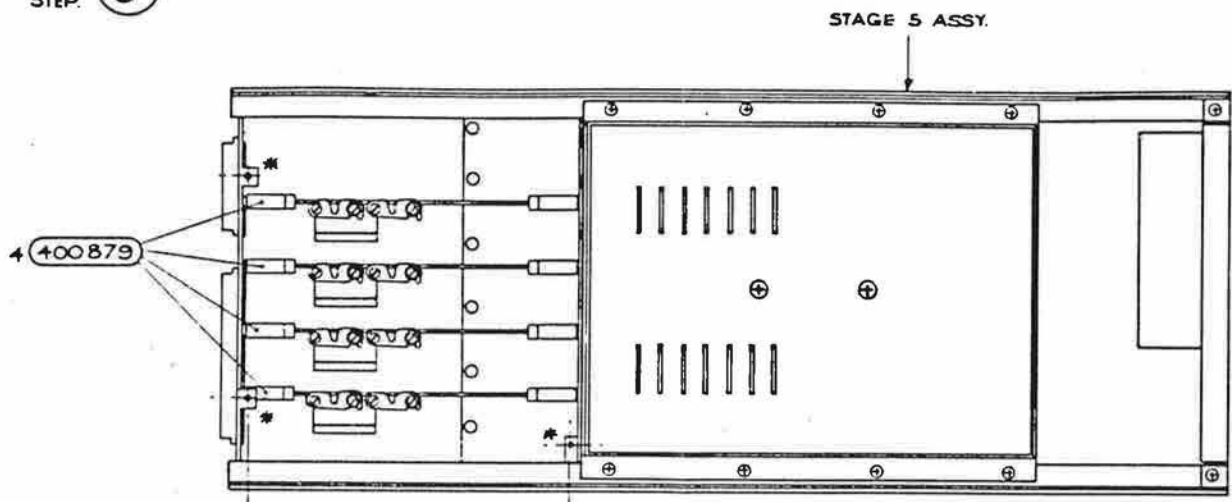

STEP 8

4910/4911
datron
 WAVETEK
 © Datron Instruments 1991

ONE EACH SIDE

4911 INSTRUMENT ASSEMBLY
 Drawing No. DA400906 Sheet 3

STEP 7

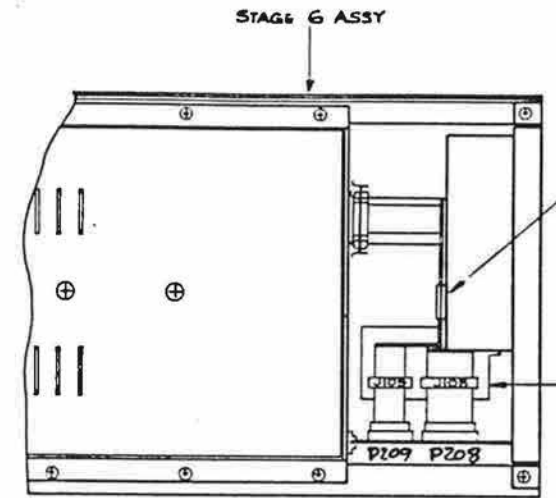

NOTE
 PLUG 9WAY 4 ISWAY CONNECTORS INTO PSU. ASSY. FOLD RIBBON CABLES TO ENABLE OTHER END TO PLUG INTO RESPECTIVE BATTERY BOX SKTS. DO NOT CONNECT THIS END, BUT FOLD CABLES BACK AGAIN TO STOW IN CABLE CLIP ON GUARD BOX.

STEP 9

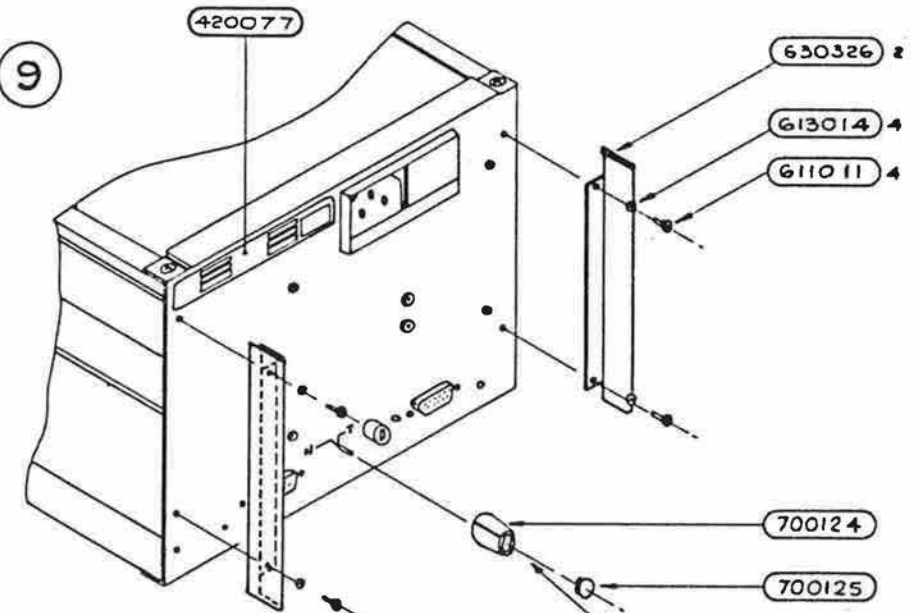

ENSURE KNOB POINTER LINES UP IN APPROPRIATE SWITCH POSITION. TIGHTEN COLLET NUT USING TOOL N° 596110.

N.B. DO NOT OVERTIGHTEN THESE SCREWS, CAUSING DAMAGE TO FEET MAT.

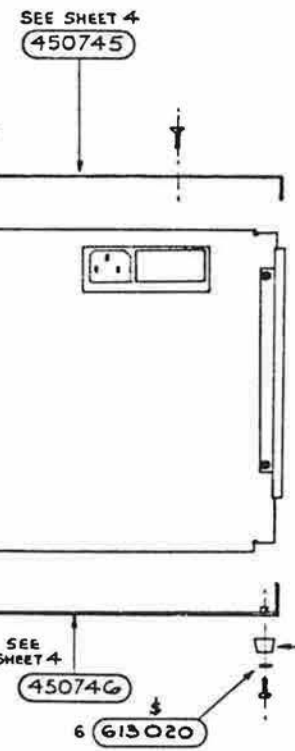

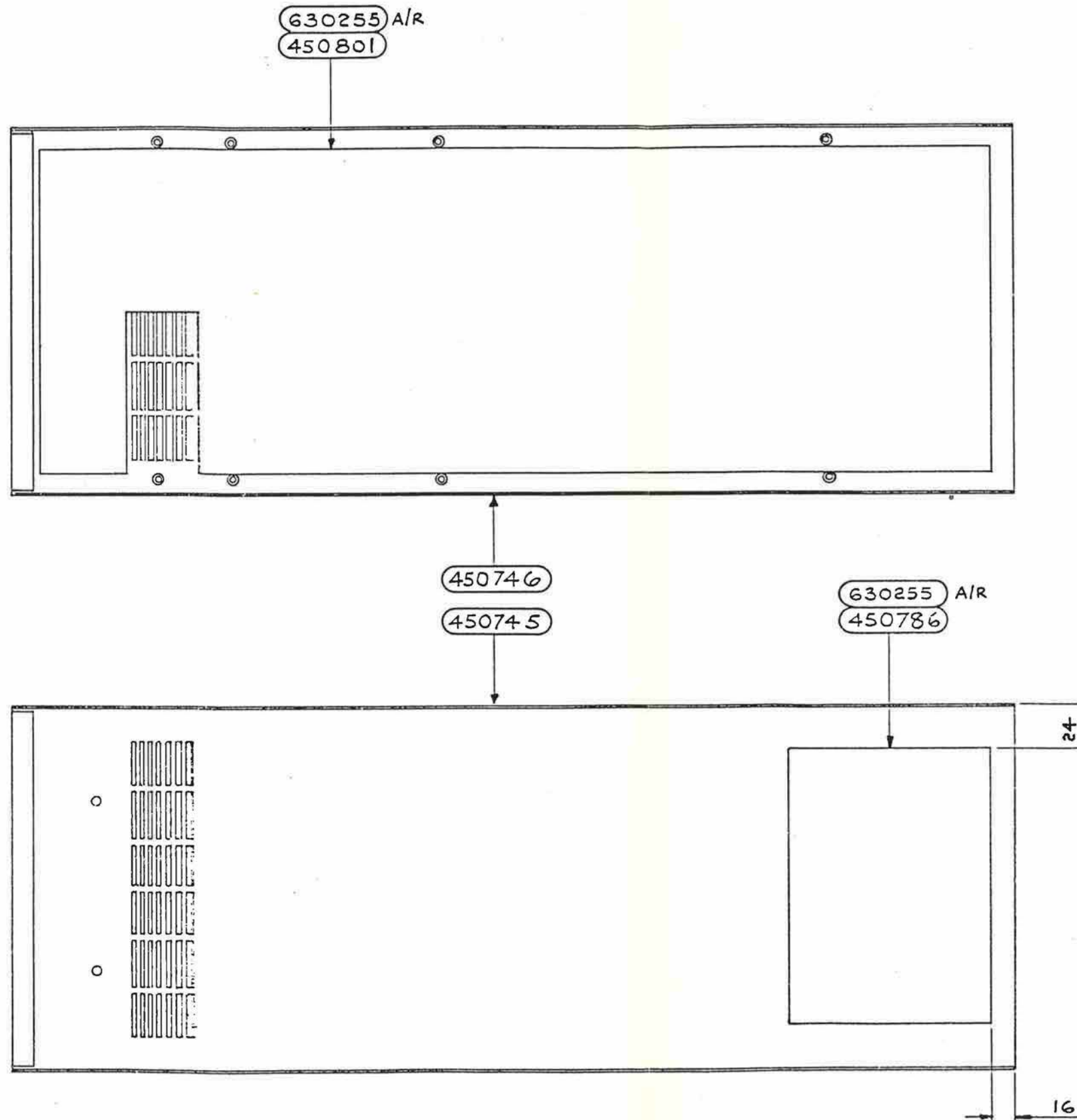

4910 INSTRUMENT ASSEMBLY
 Drawing No. DA400883 Sheet 4



© Datron Instruments 1991

STEP 1

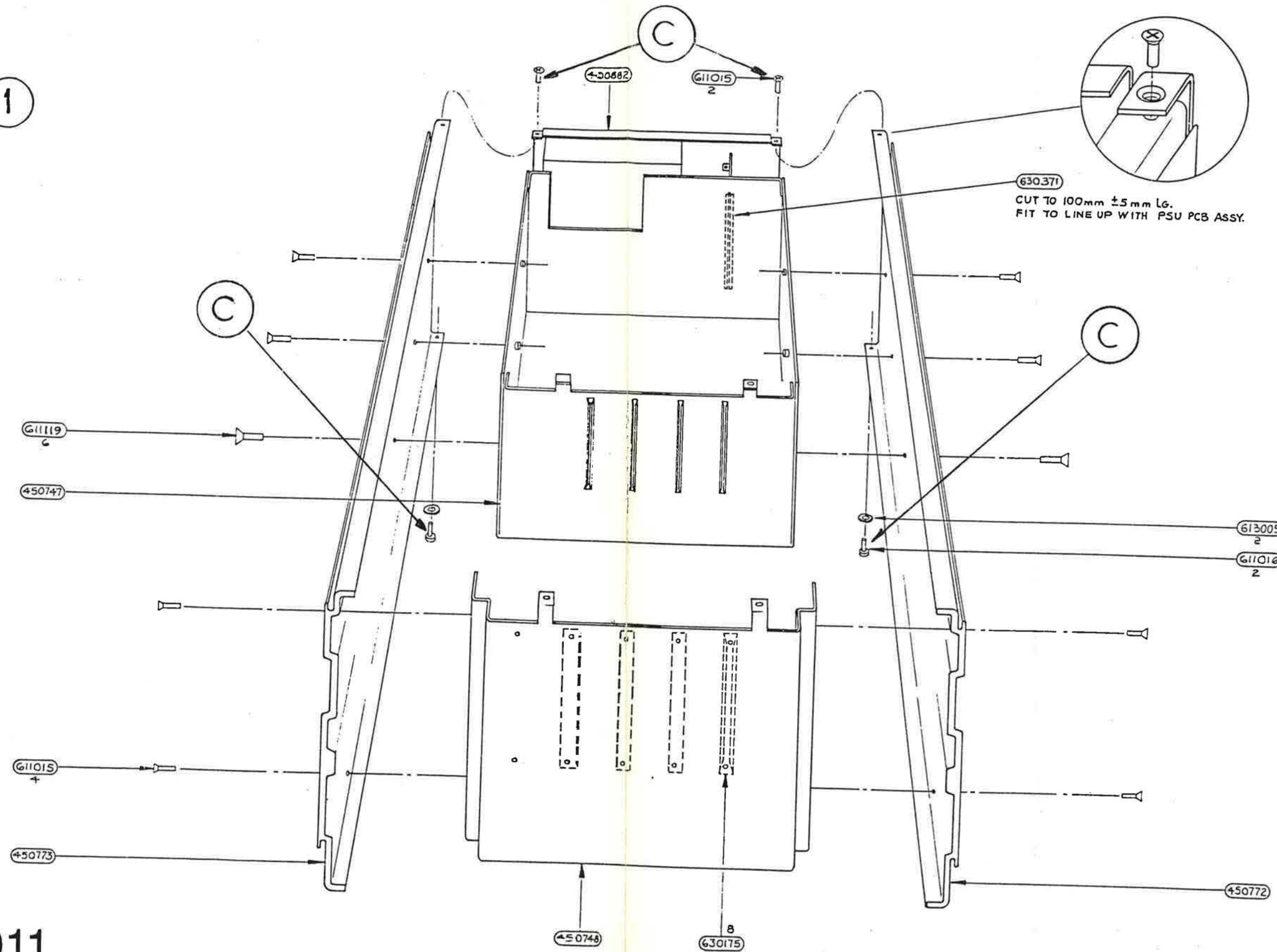

4910/4911
datron
WAVETEK

© Datron Instruments 1991

4911 INSTRUMENT ASSEMBLY
Drawing No. DA400906 Sheet 1

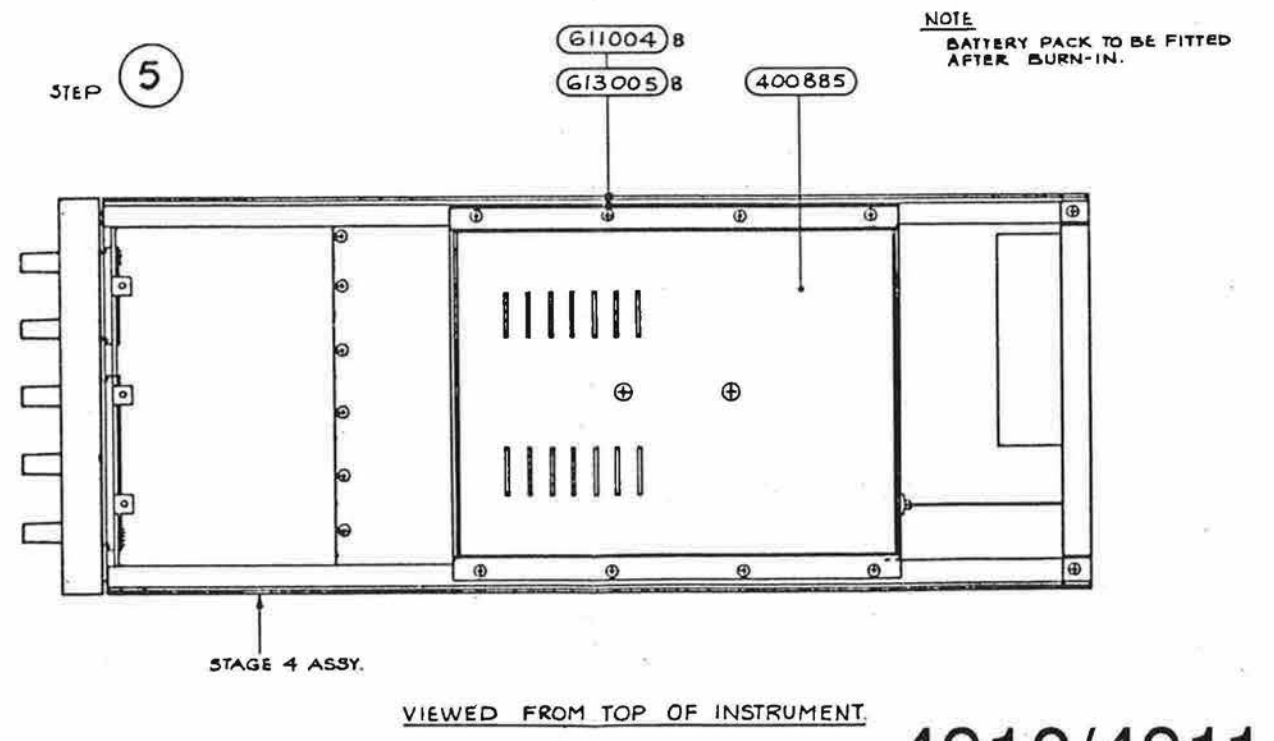
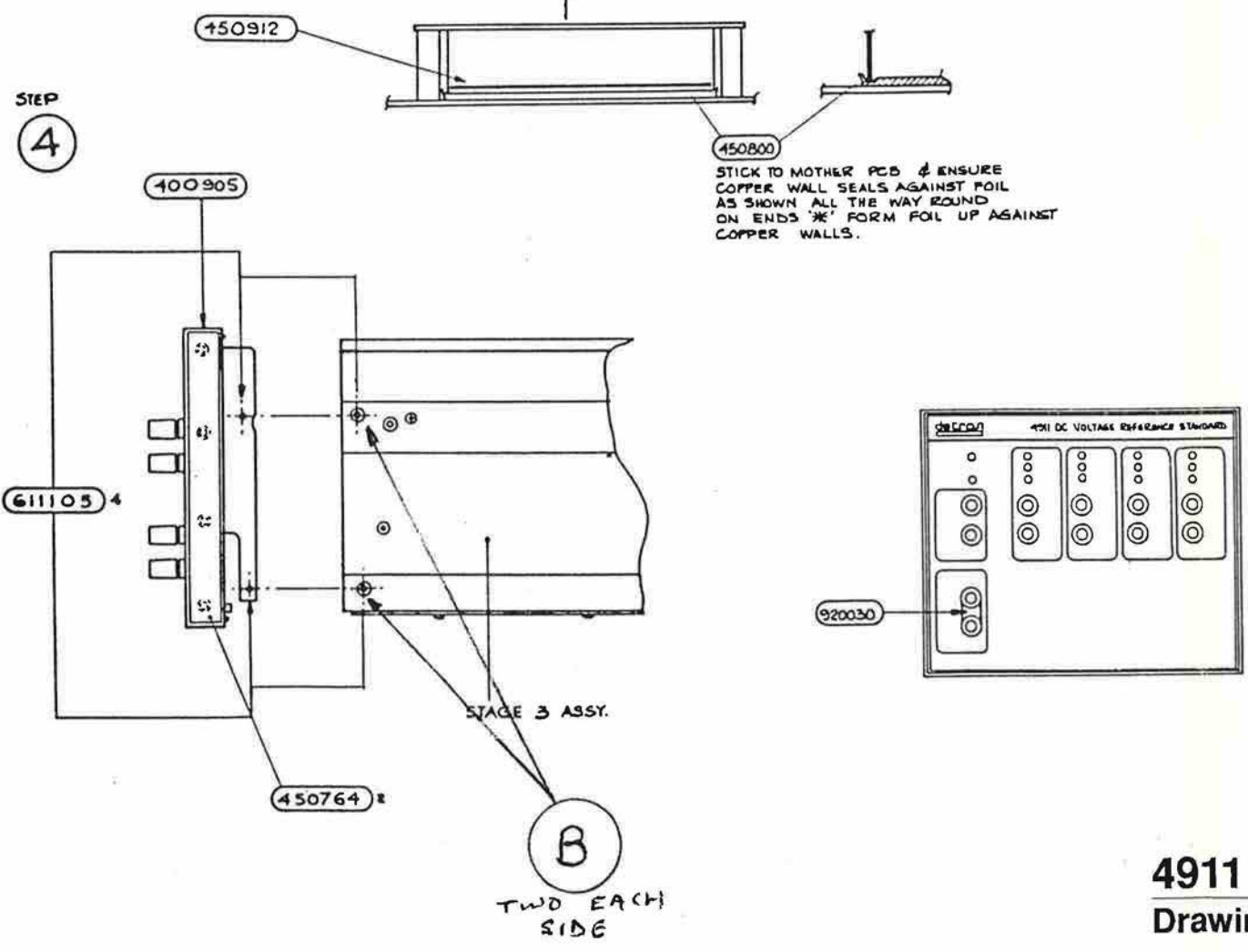
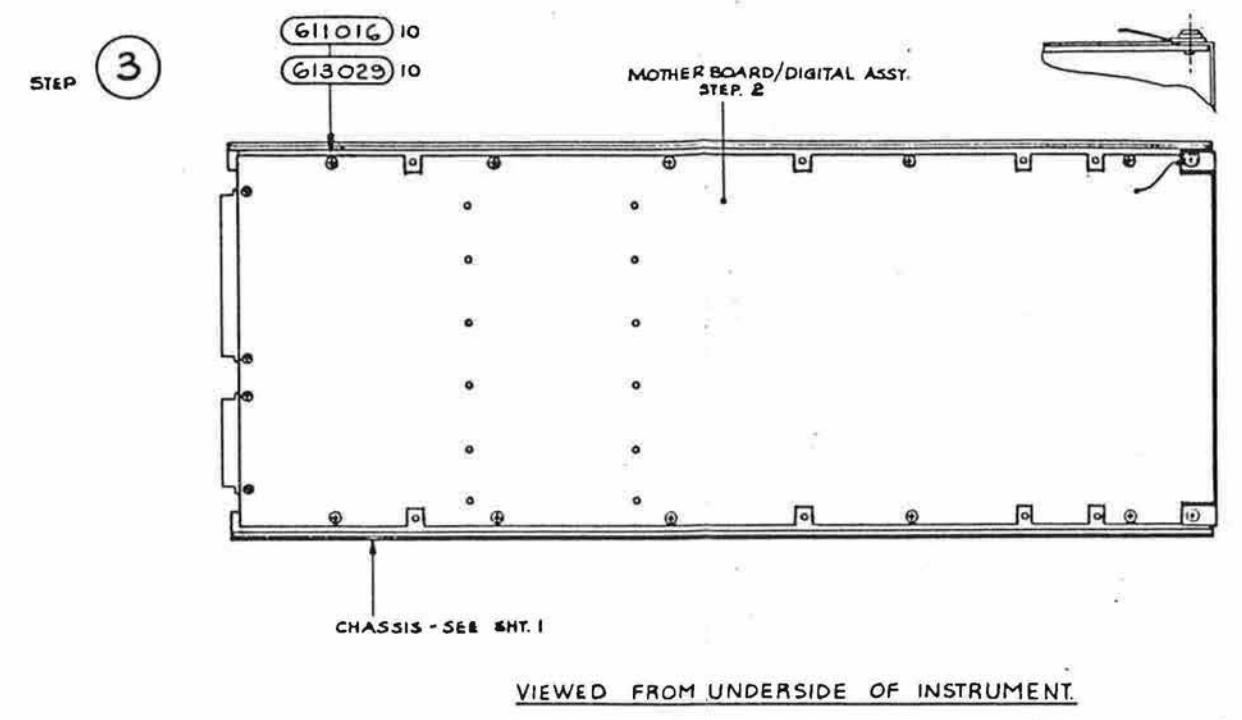
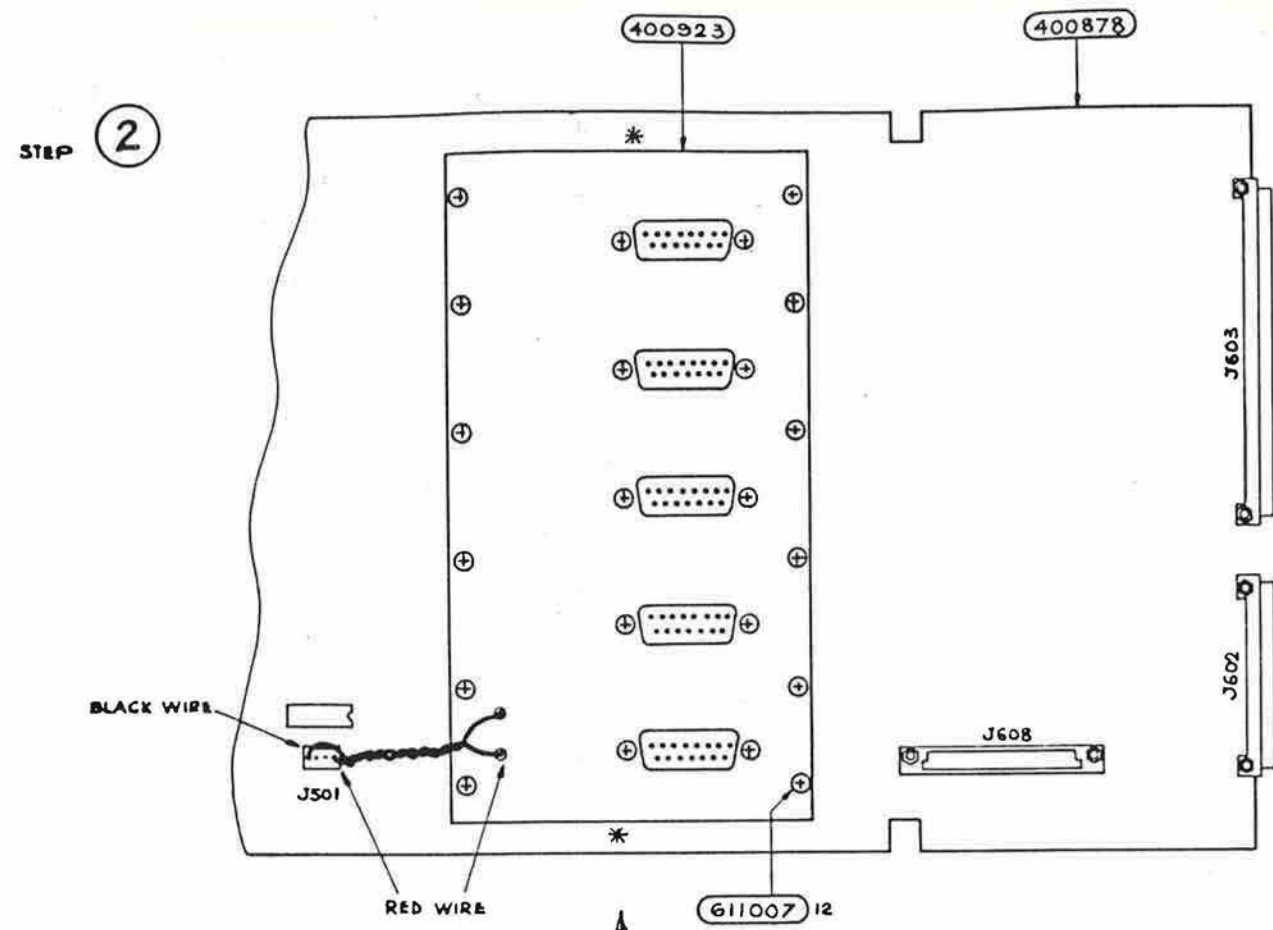

4911 INSTRUMENT ASSEMBLY
 Drawing No. DA400906 Sheet 2

4910/4911
Datron
WAVETEK
 © Datron Instruments 1991

STEP 6

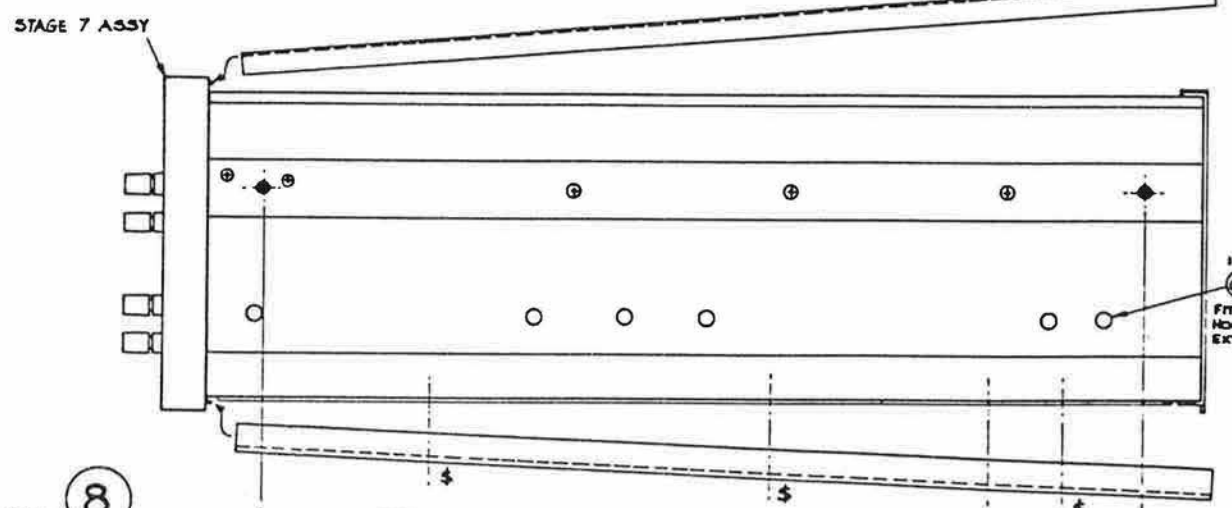
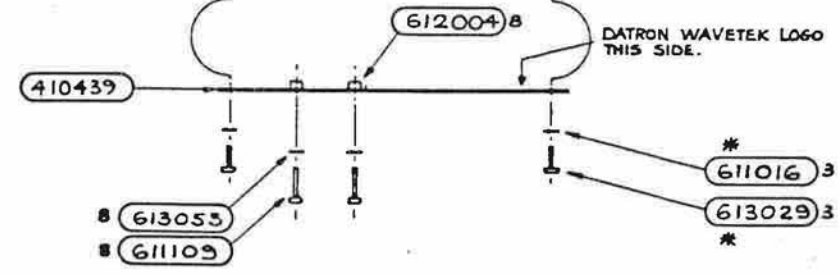
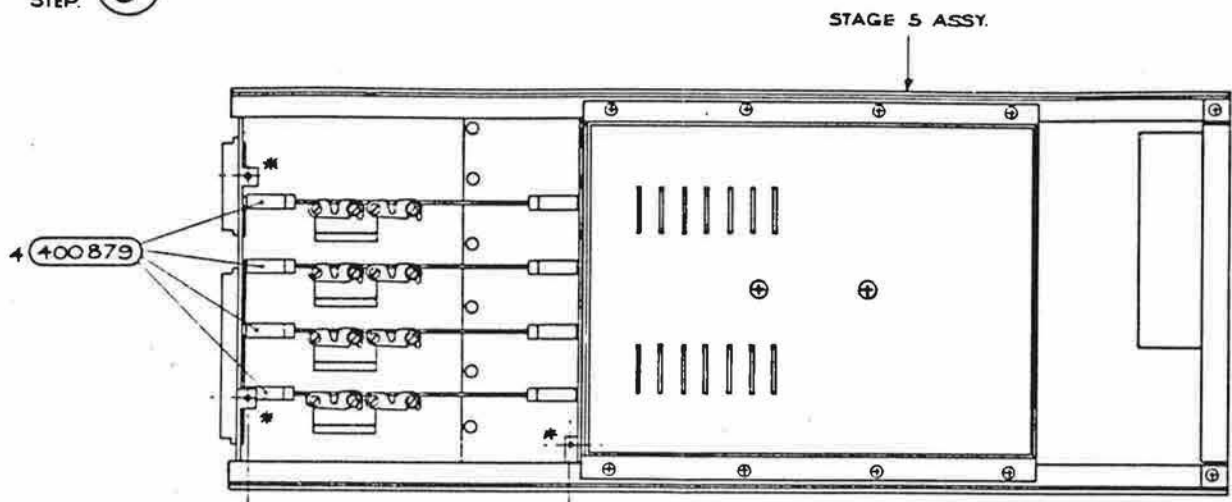

STEP 8

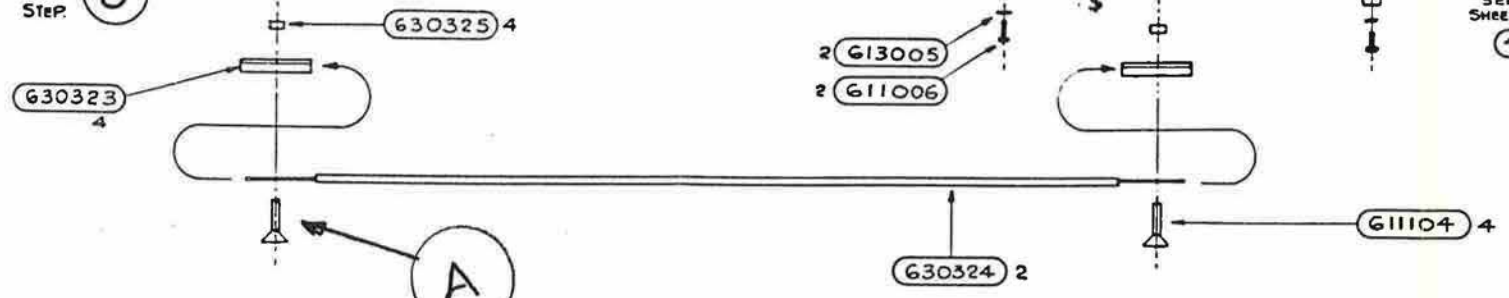

A

ONE EACH SIDE

STEP 7

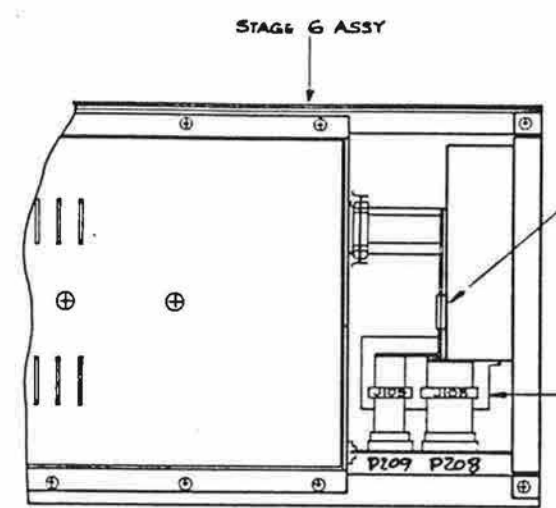

NOTE
 PLUG 9WAY 4 ISWAY CONNECTORS INTO PSU. ASSY. FOLD RIBBON CABLES TO ENABLE OTHER END TO PLUG INTO RESPECTIVE BATTERY BOX SKTS.
 DO NOT CONNECT THIS END, BUT FOLD CABLES BACK AGAIN TO STOW IN CABLE CLIP ON GUARD BOX.

STEP 9

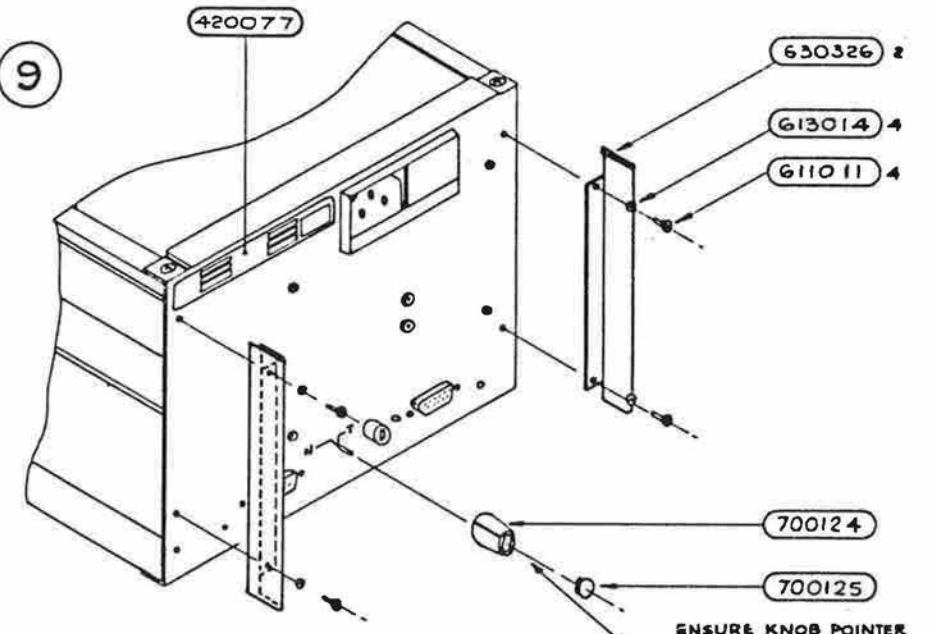

ENSURE KNOB POINTER LINES UP IN APPROPRIATE SWITCH POSITION. TIGHTEN COLLET NUT USING TOOL N° 596110.

N.B. DO NOT OVERTIGHTEN THESE SCREWS, CAUSING DAMAGE TO FEET MAT.

4910/4911
datron
 WAVETEK

© Datron Instruments 1991

4911 INSTRUMENT ASSEMBLY
 Drawing No. DA400906 Sheet 3

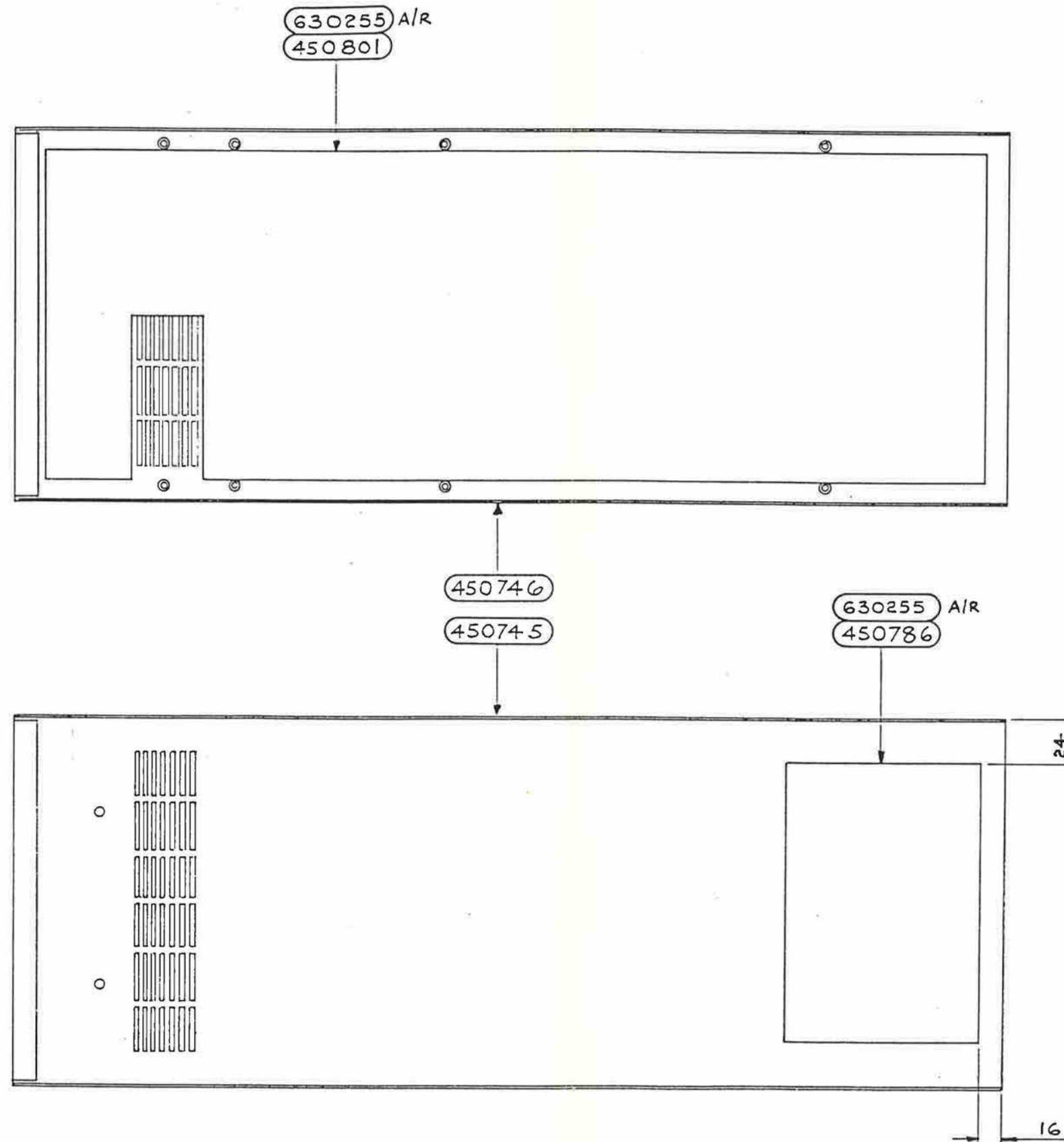

4911 INSTRUMENT ASSEMBLY
 Drawing No. DA400906 Sheet 4

DESIG	PART NO	DESCRIPTION	PRINC MANUF	MANUF PART NUMBER	CLASS	UM	QUANTITY	CHANGES
	630325	HANDLE BUSHING	WAVETEK	1400-01-9383	EA		4	
	630326	REAR TRIM CAP	WAVETEK	1400-02-2672	EA		2	
	630333	FOOT TPR 15.9 BLK	MOSS PLASTIC PARTS	15129	EA		6	
	630371	PCB GUIDE 204MM SELF-ADH	RS COMPONENTS	543-636	AR		1	
	700124	KNOB 15MM BK WITH POINTER	SIPAM	SP150 004	EA		1	
	700125	CAP 15MM BK	SIPAM	C150	EA		1	
	920030-1	LINK SHORTING		SEE DRG	EA		1	

End

DESIG	PART NO	DESCRIPTION	PRINC MANUF	MANUF PART NUMBER	CLASS UM	QUANTITY	CHANGES
	630333	FOOT TPR 15.9 BLK	MOSS PLASTIC PARTS	15129	EA	6	
	630371	PCB GUIDE 204MM SELF-ADH	RS COMPONENTS	543-636	AR	1	
	700124	KNOB 15MM BK WITH POINTER	SIFAM	SP150 004	EA	1	
	700125	CAP 15MM BK	SIFAM	C150	EA	1	
	920030-1	LINK SHORTING		SEE DRG	EA	1	

End

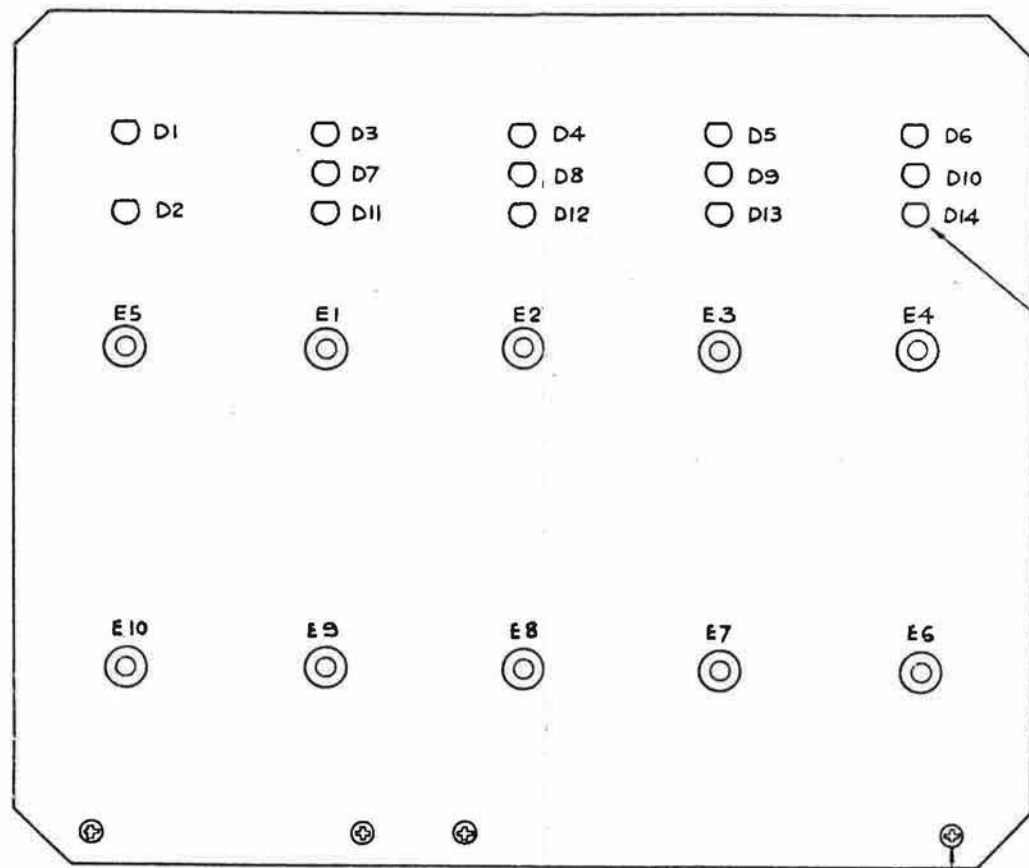

- 611011 4
- 613047 4
- 615006 4

COMPONENT SIDE OF PCB.

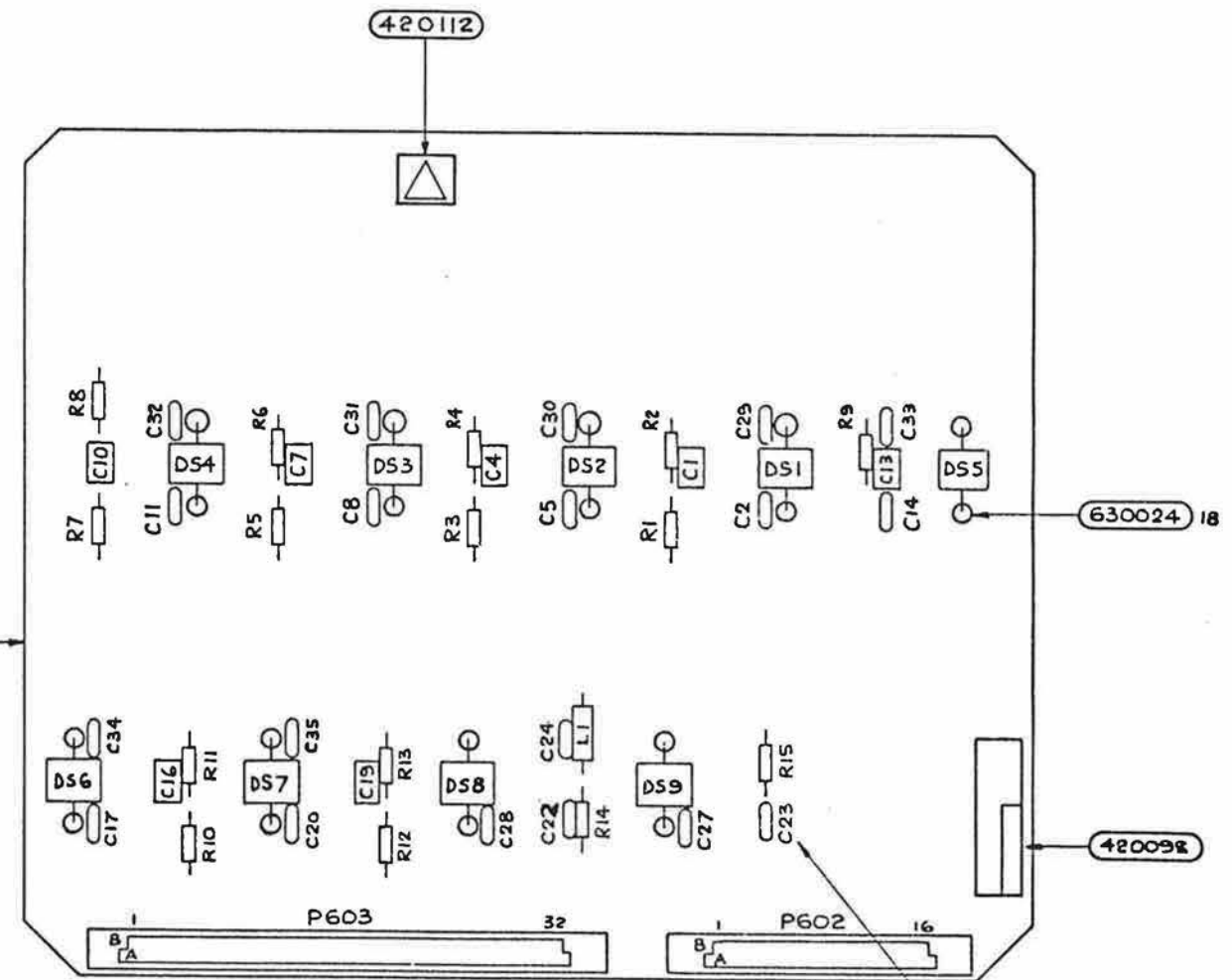

SOLDER SIDE OF PCB.

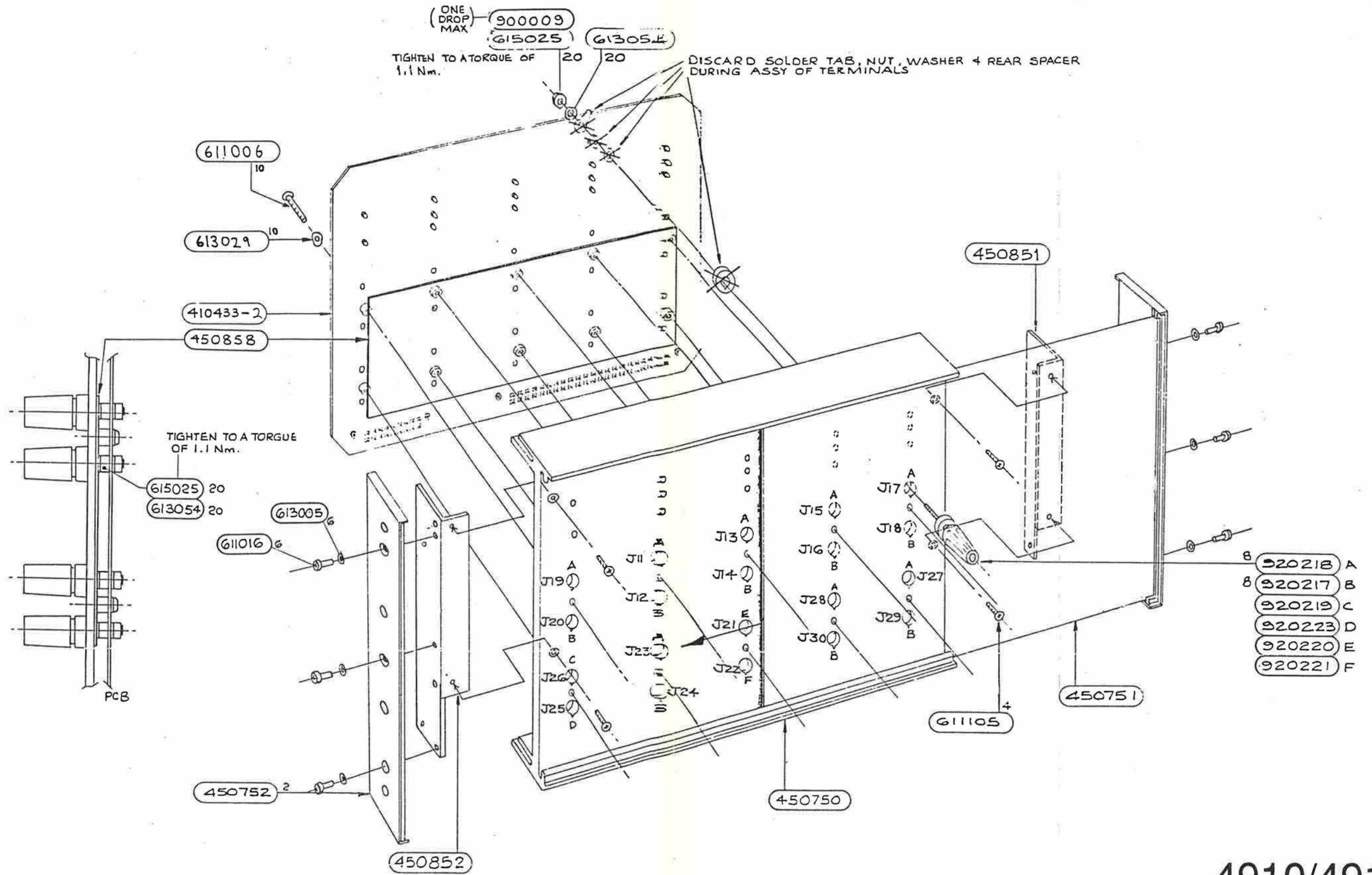

4910 FRONT PANEL ASSEMBLY
 Drawing No. DA400880 Sheet 2



© Datron Instruments 1991

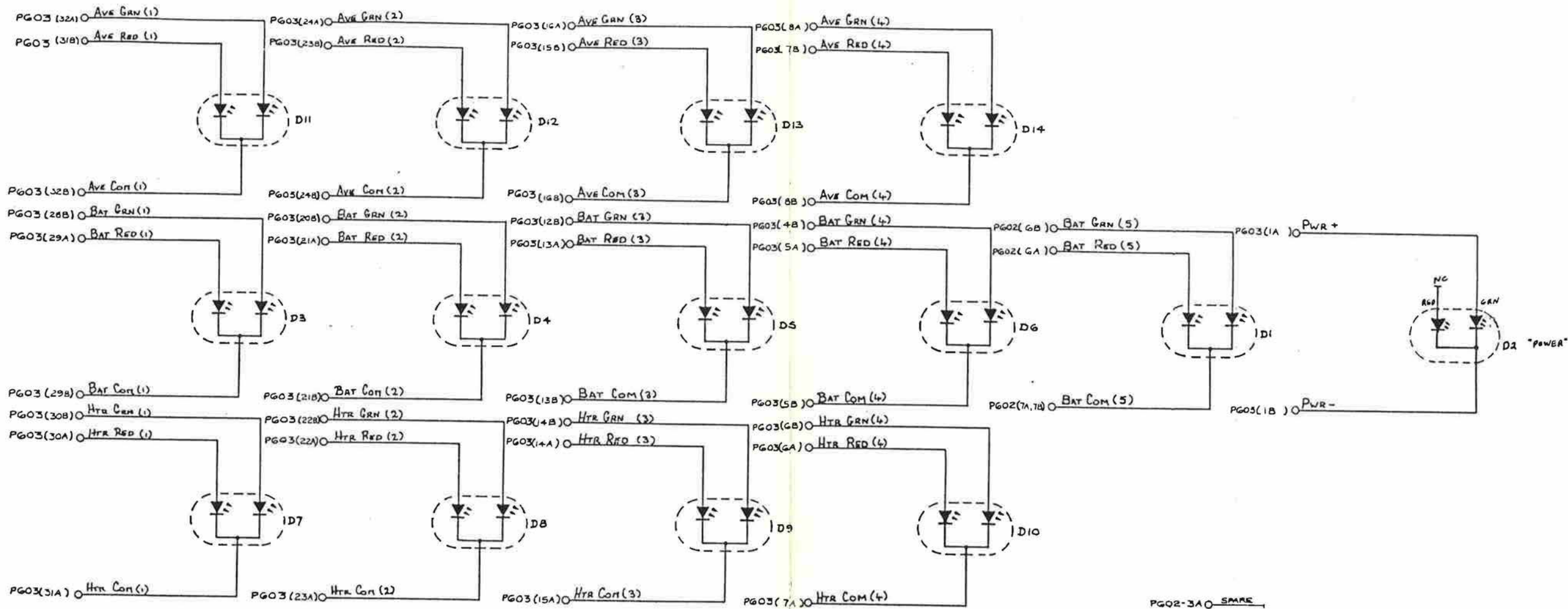

- PG02-3A ○ SPARE
- PG02-3B ○ SPARE
- PG03-2A ○ SPARE
- PG03-2B ○ SPARE
- PG03-3A ○ SPARE
- PG03-3B ○ SPARE
- PG03-4A ○ SPARE
- PG03-11A ○ SPARE
- PG03-11B ○ SPARE
- PG03-12A ○ SPARE
- PG03-13A ○ SPARE
- PG03-13B ○ SPARE
- PG03-20A ○ SPARE
- PG03-27A ○ SPARE
- PG03-27B ○ SPARE
- PG03-28A ○ SPARE

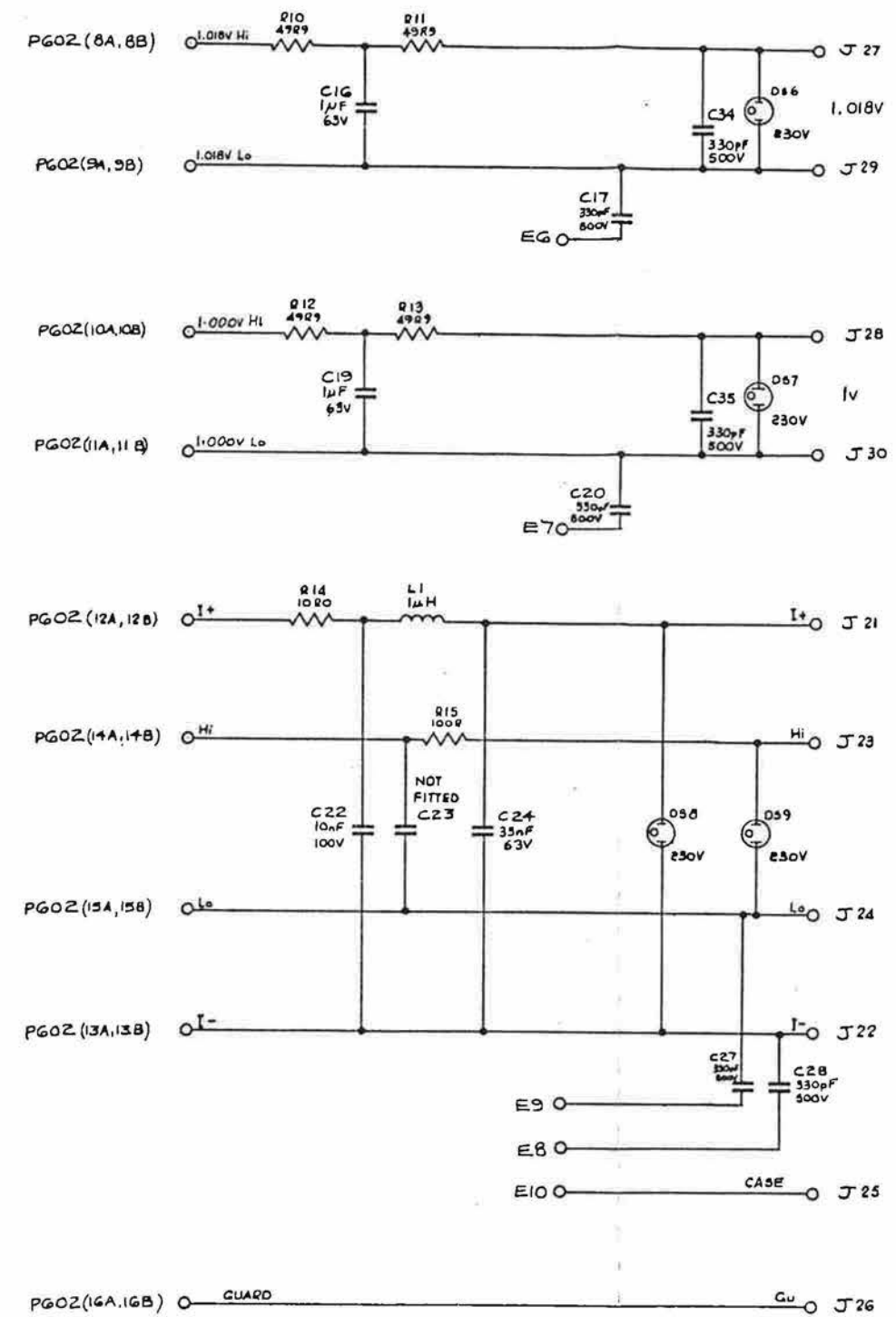
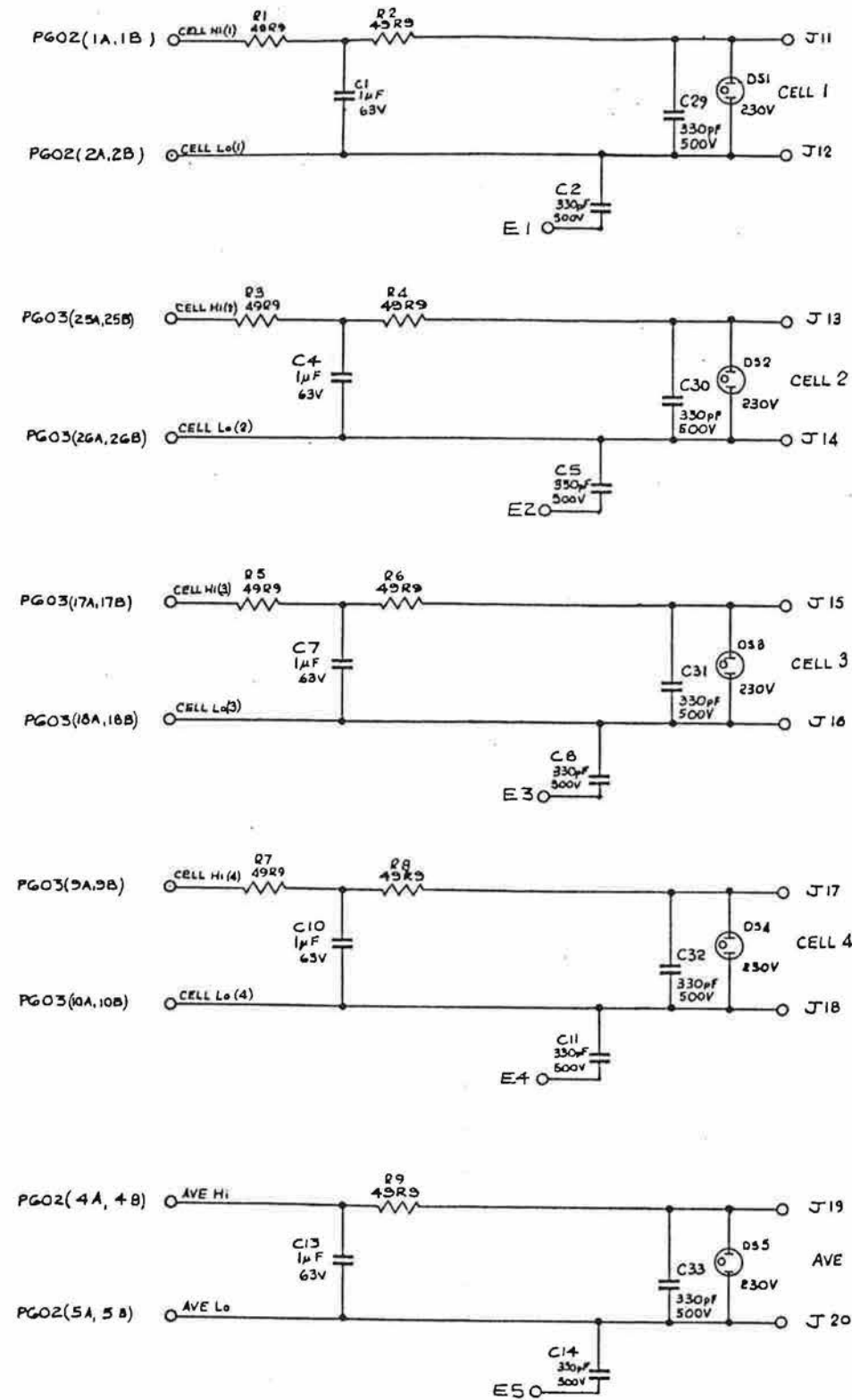

4910 FRONT PANEL ASSEMBLY

Drawing No. DC400880 Sheet 2



© Datron Instruments 1991

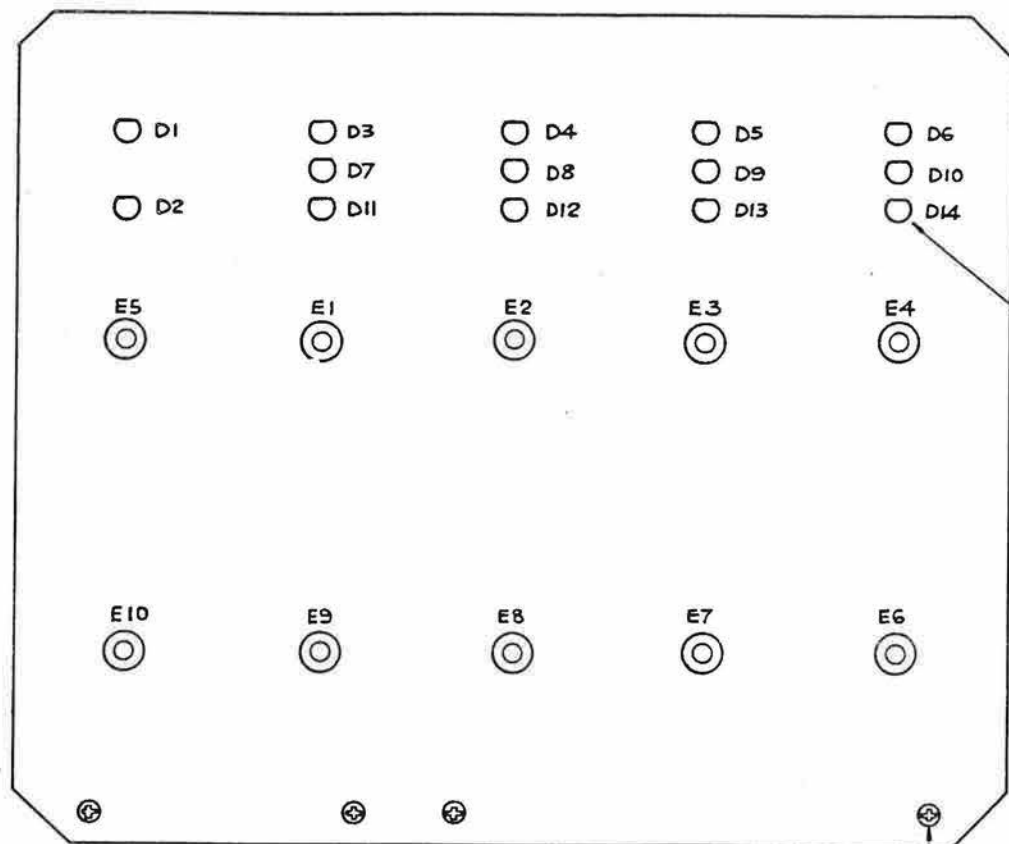

G11011 4
 G13047 4
 G15006 4

COMPONENT SIDE OF PCB.

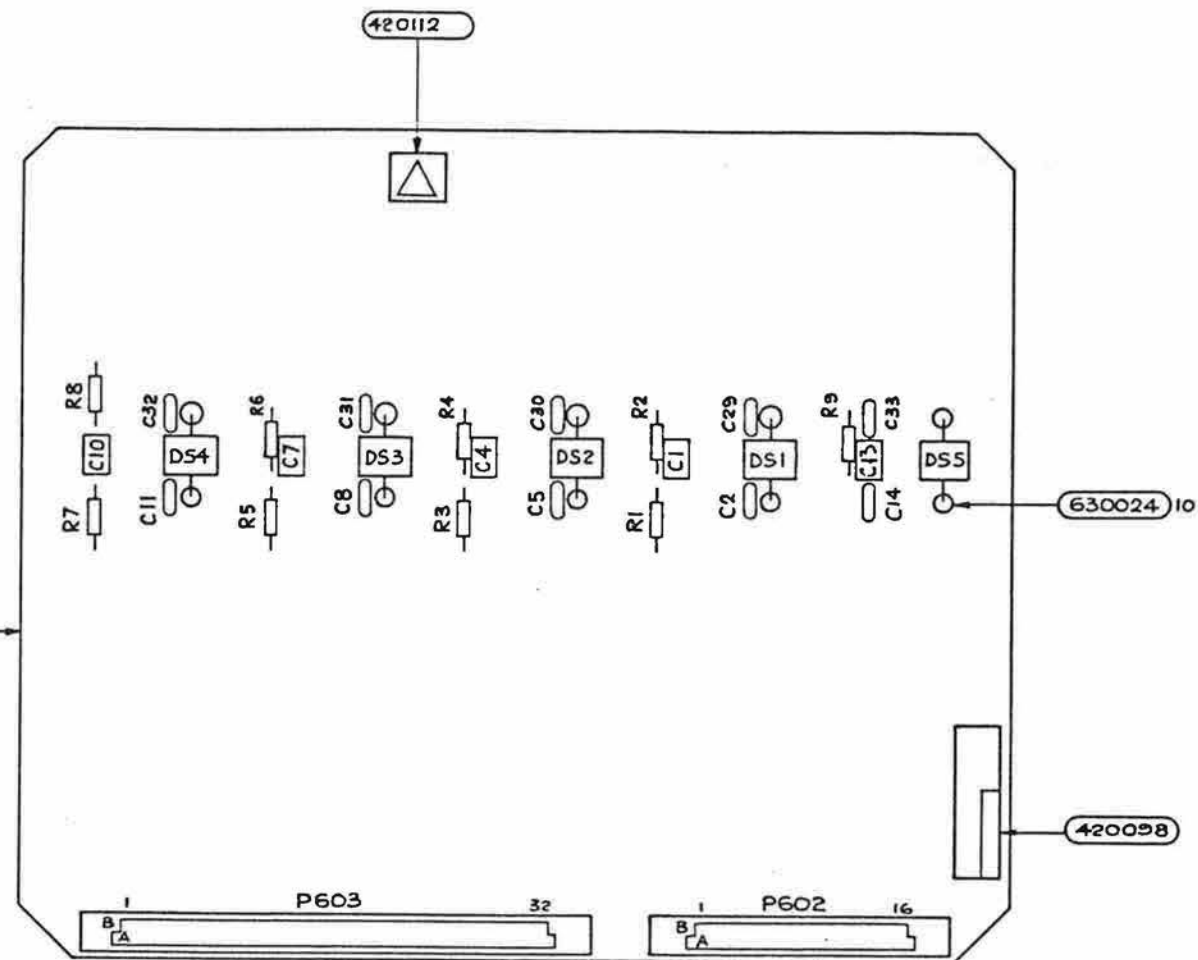

SOLDER SIDE OF PCB.

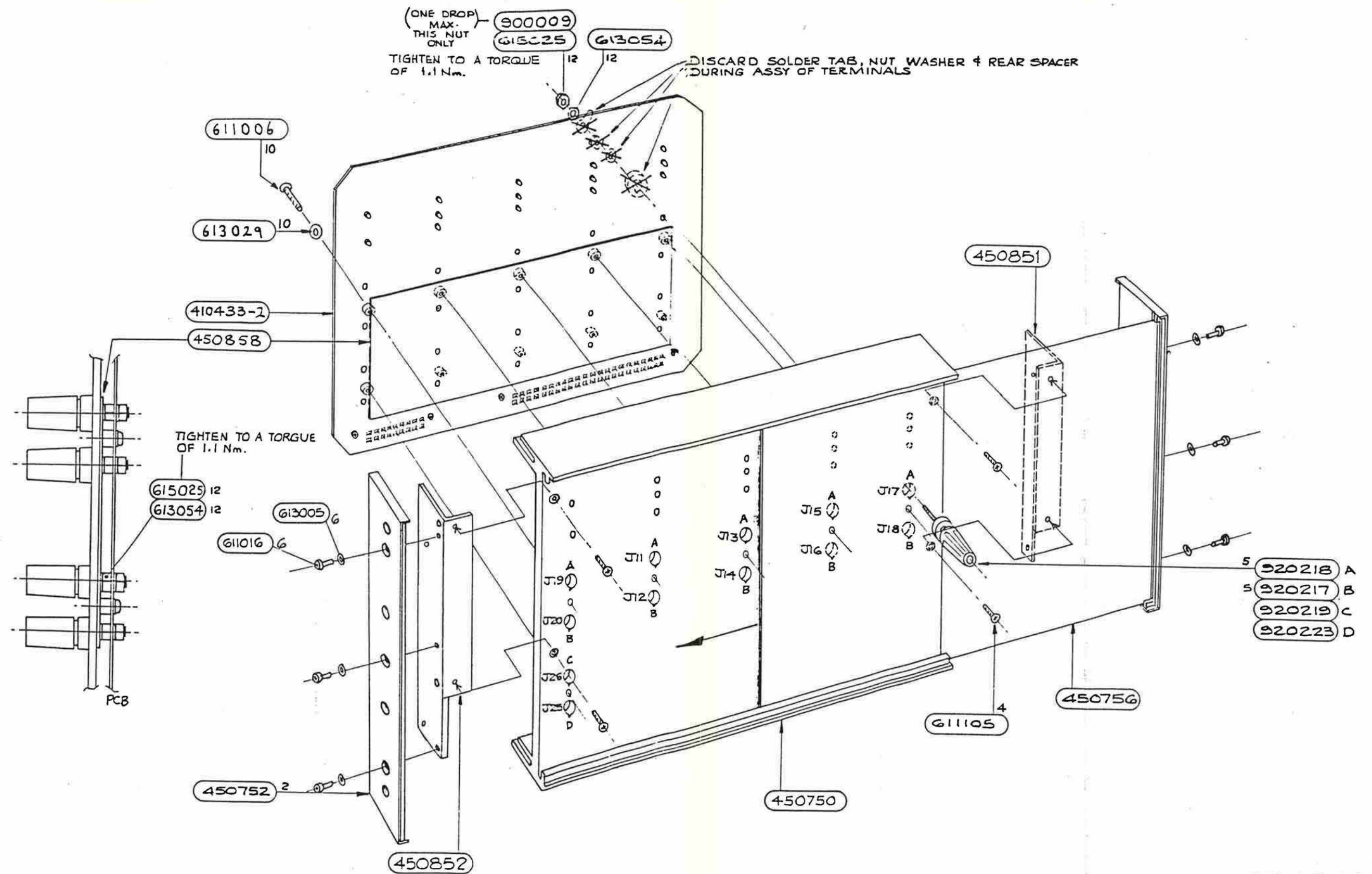

4911 FRONT PANEL ASSEMBLY
 Drawing No. DA400905 Sheet 2



© Datron Instruments 1991

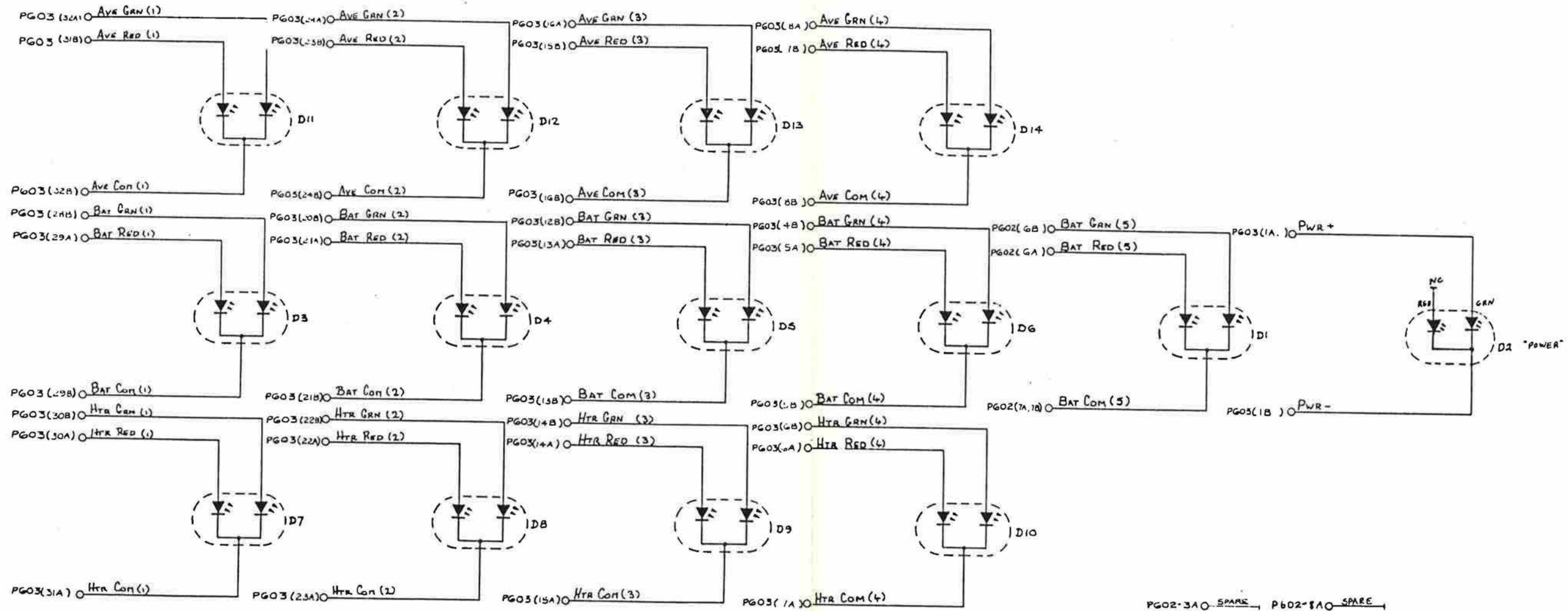

PG02-3A0	SPARE	P602-8A0	SPARE
PG02-3B0	SPARE	P602-8B0	SPARE
PG03-2A0	SPARE	P602-9A0	SPARE
PG03-2B0	SPARE	P602-9B0	SPARE
PG03-3A0	SPARE	P602-10A0	SPARE
PG03-3B0	SPARE	P602-10B0	SPARE
PG03-4A0	SPARE	P602-11A0	SPARE
PG03-11A0	SPARE	P602-11B0	SPARE
PG03-11B0	SPARE	P602-11A0	SPARE
PG03-12A0	SPARE	P602-12B0	SPARE
PG03-13A0	SPARE	P602-13A0	SPARE
PG03-13B0	SPARE	P602-13B0	SPARE
PG03-20A0	SPARE	P602-14A0	SPARE
PG03-22A0	SPARE	P602-14B0	SPARE
PG03-27B0	SPARE	P602-15A0	SPARE
PG03-28A0	SPARE	P602-15B0	SPARE

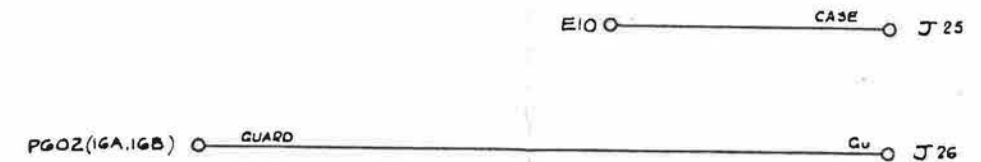
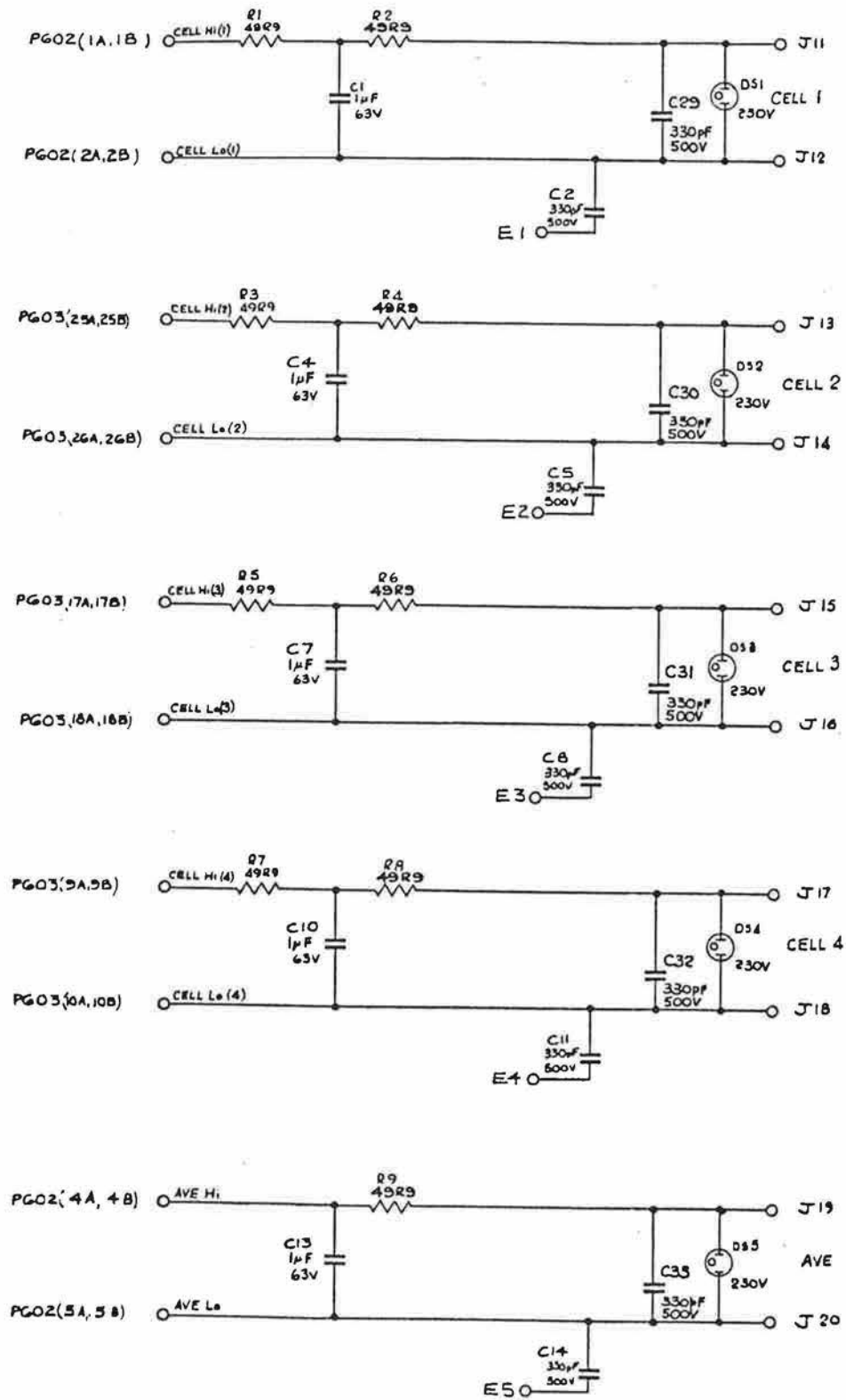

4911 FRONT PANEL ASSEMBLY
 Drawing No. DC400905 Sheet 2



© Datron Instruments 1991

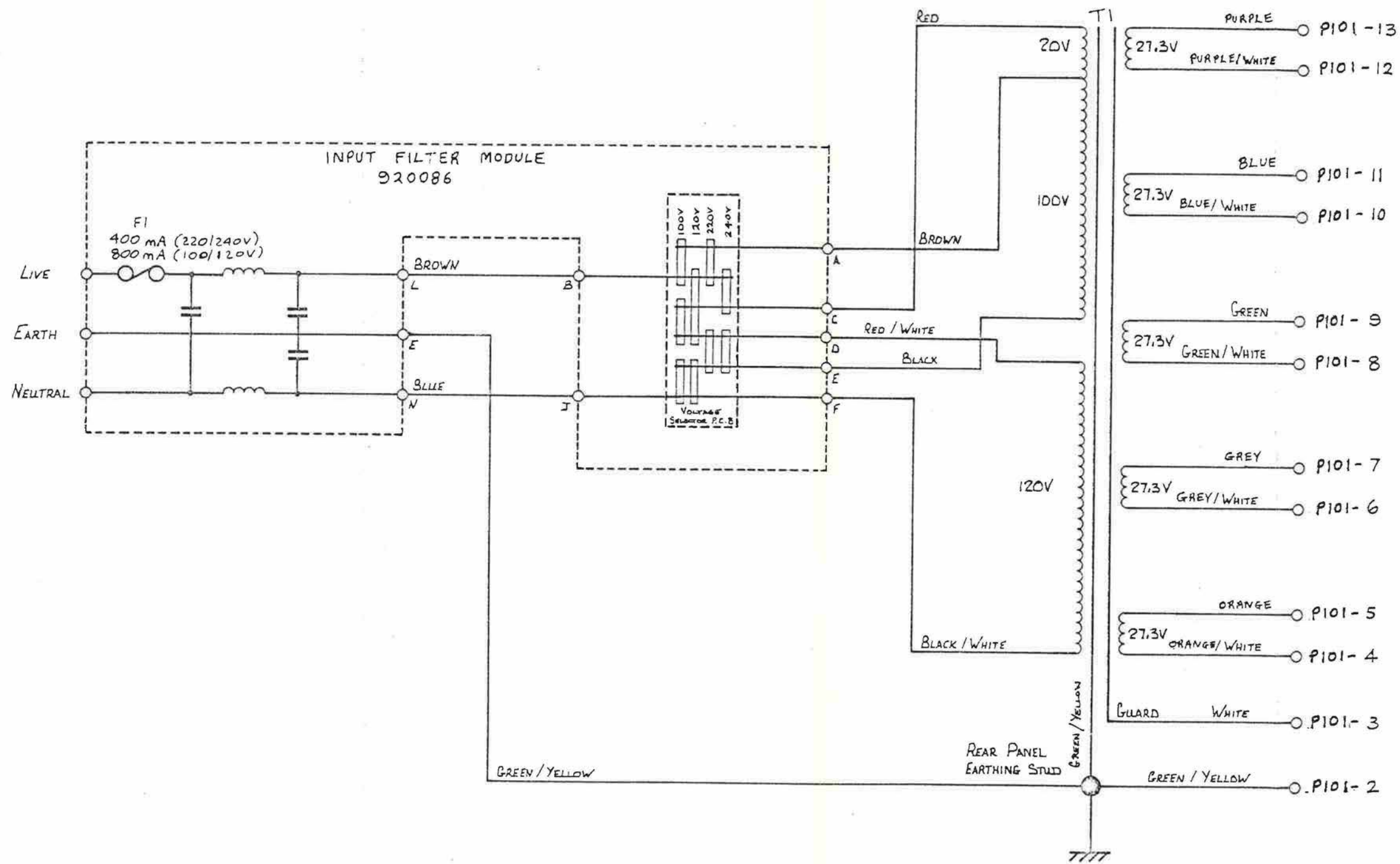

REAR PANEL ASSEMBLY
 Drawing No. DC400882 Sheet 1



© Datron Instruments 1991

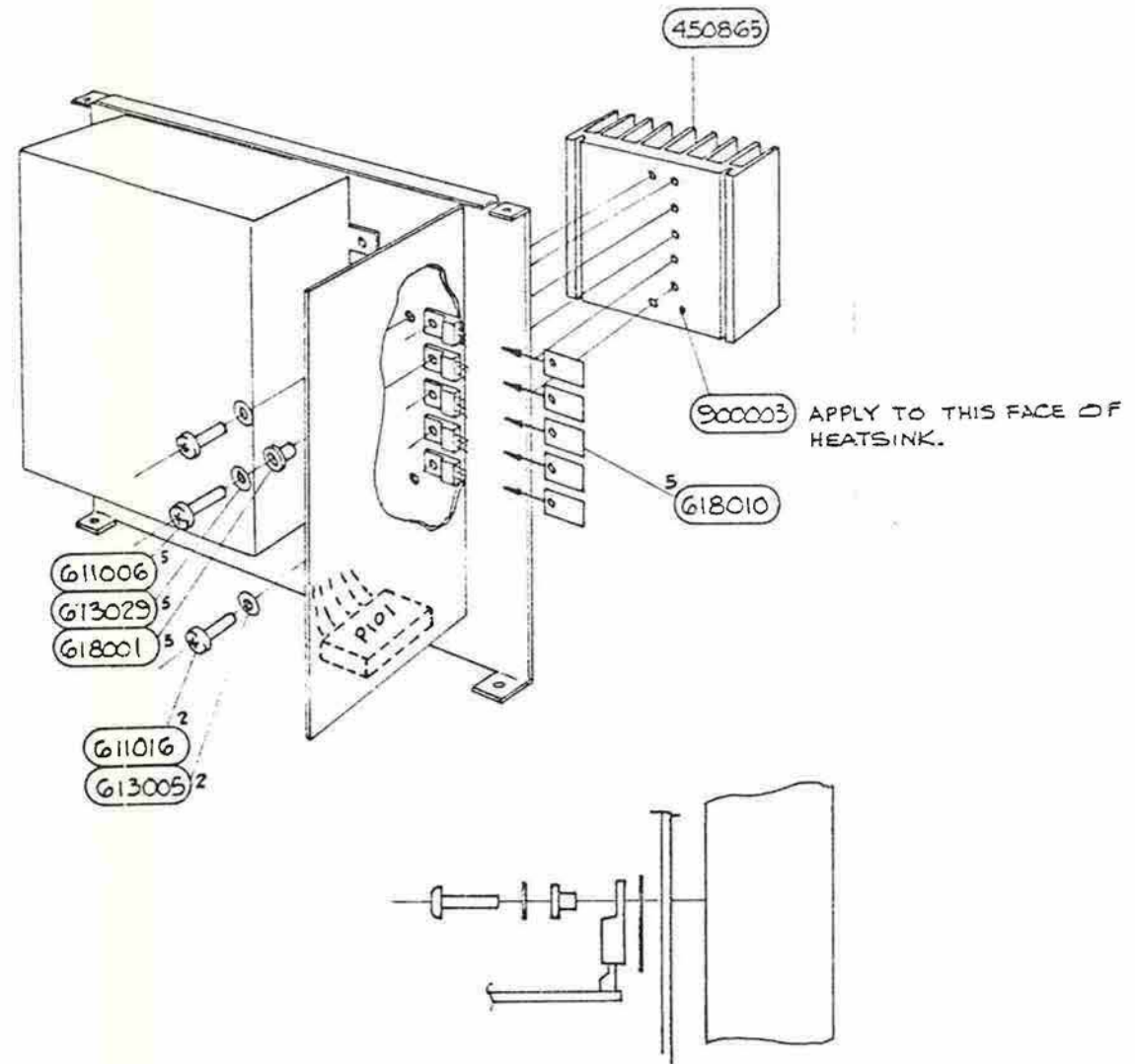
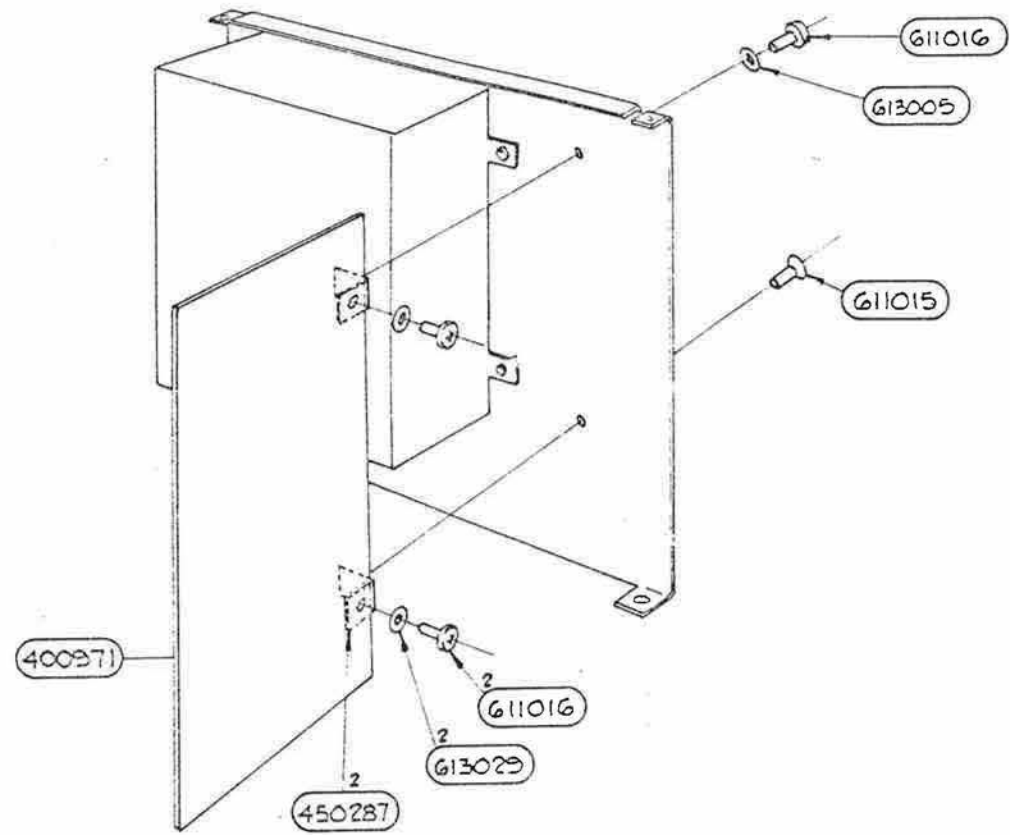

REAR PANEL ASSEMBLY

Drawing No. DA400882 Sheet 2



© Datron Instruments 1991

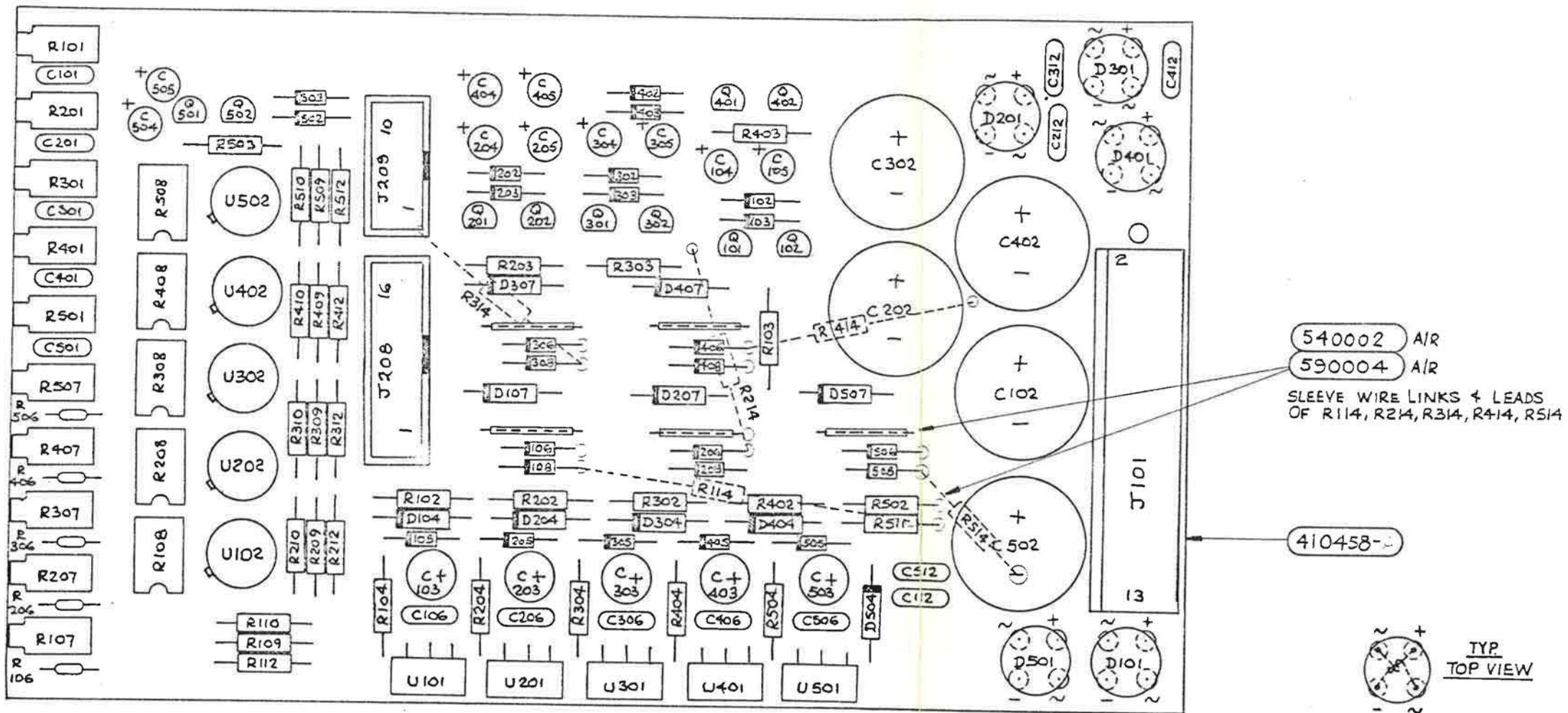

540002 A/R
 590004 A/R
 SLEEVE WIRE LINKS & LEADS
 OF R114, R214, R314, R414, R514

410458

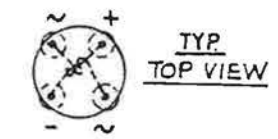

SLEEVE BOTH AC (~) LEADS
 WITH 10mm SLEEVE 590004
 THIS APPLIES TO D101, D201,
 D301, D401 & D501. DEVICES
 USED SHOULD BE G.I. WOIM.

FIT RESISTOR BELOW EACH
 LEG OF BRIDGE. CONNECT
 OTHER END OF 4 RESISTOR
 TOGETHER AS SHOWN

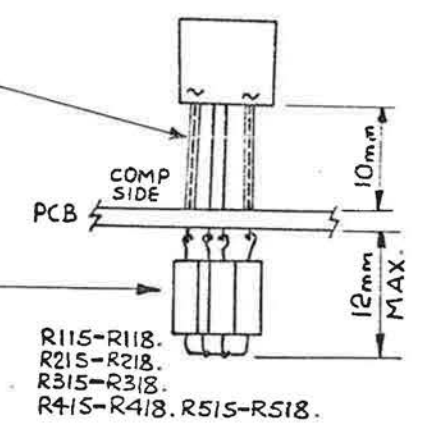

R115-R118.
 R215-R218.
 R315-R318.
 R415-R418. R515-R518.

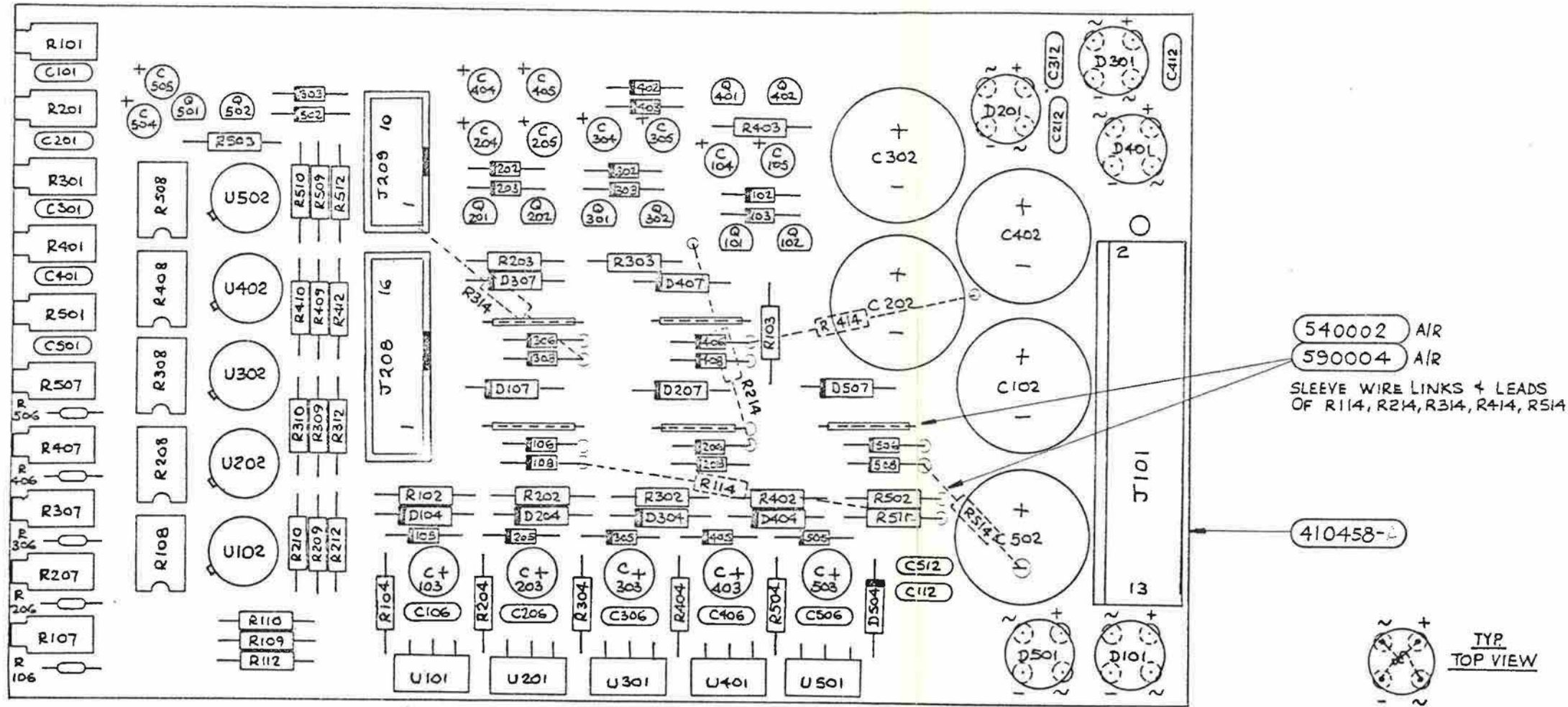

SLEEVE BOTH AC (~) LEADS WITH 10mm SLEEVE 590004 THIS APPLIES TO D101, D201, D301, D401 + D501. DEVICES USED SHOULD BE G.I. WOIM.

FIT RESISTOR BELOW EACH LEG OF BRIDGE. CONNECT OTHER END OF 4 RESISTOR TOGETHER AS SHOWN

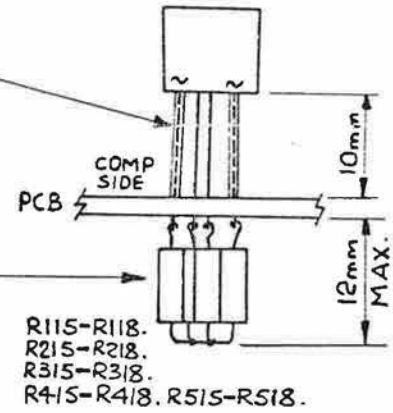

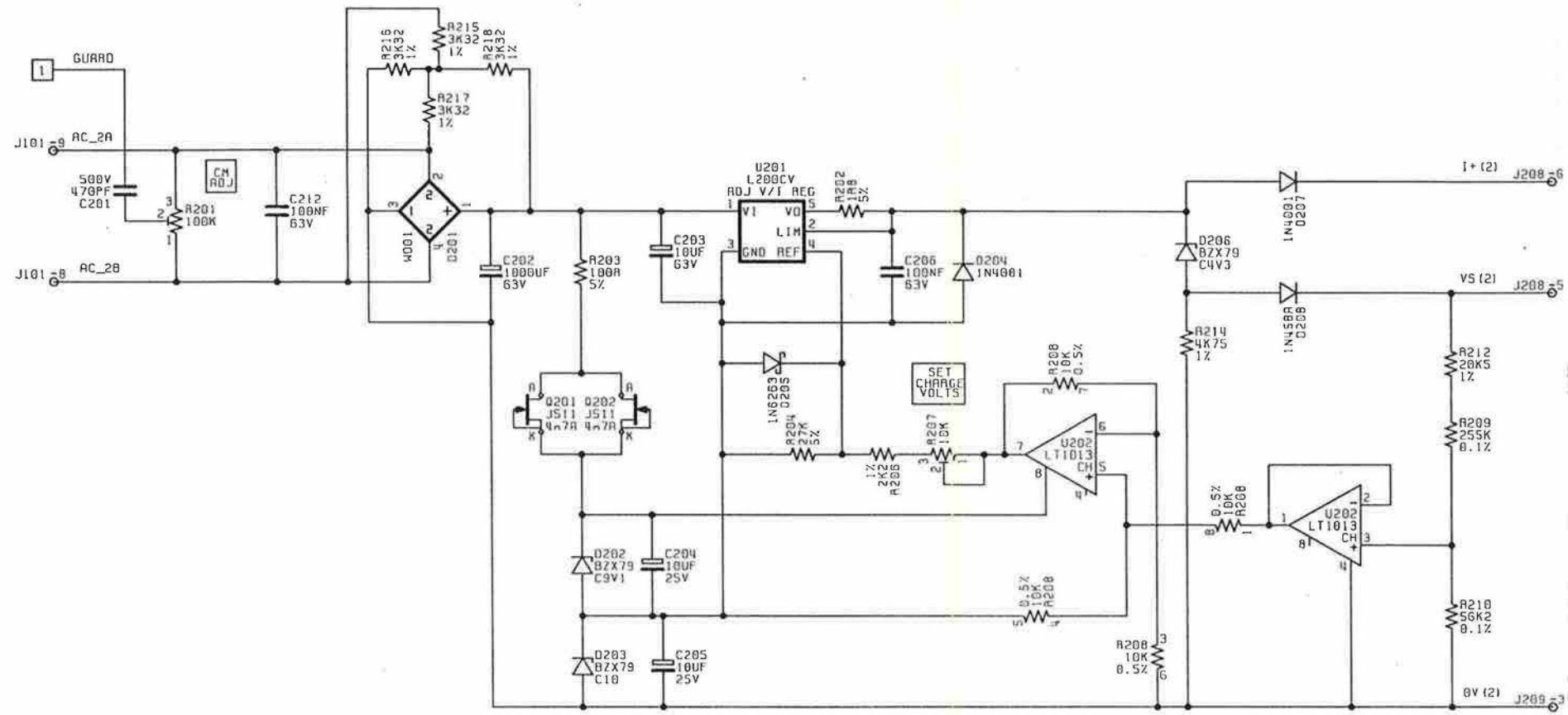

POWER SUPPLY ASSEMBLY
 Drawing No. DC400971 Sheet 2



© Datron Instruments 1991

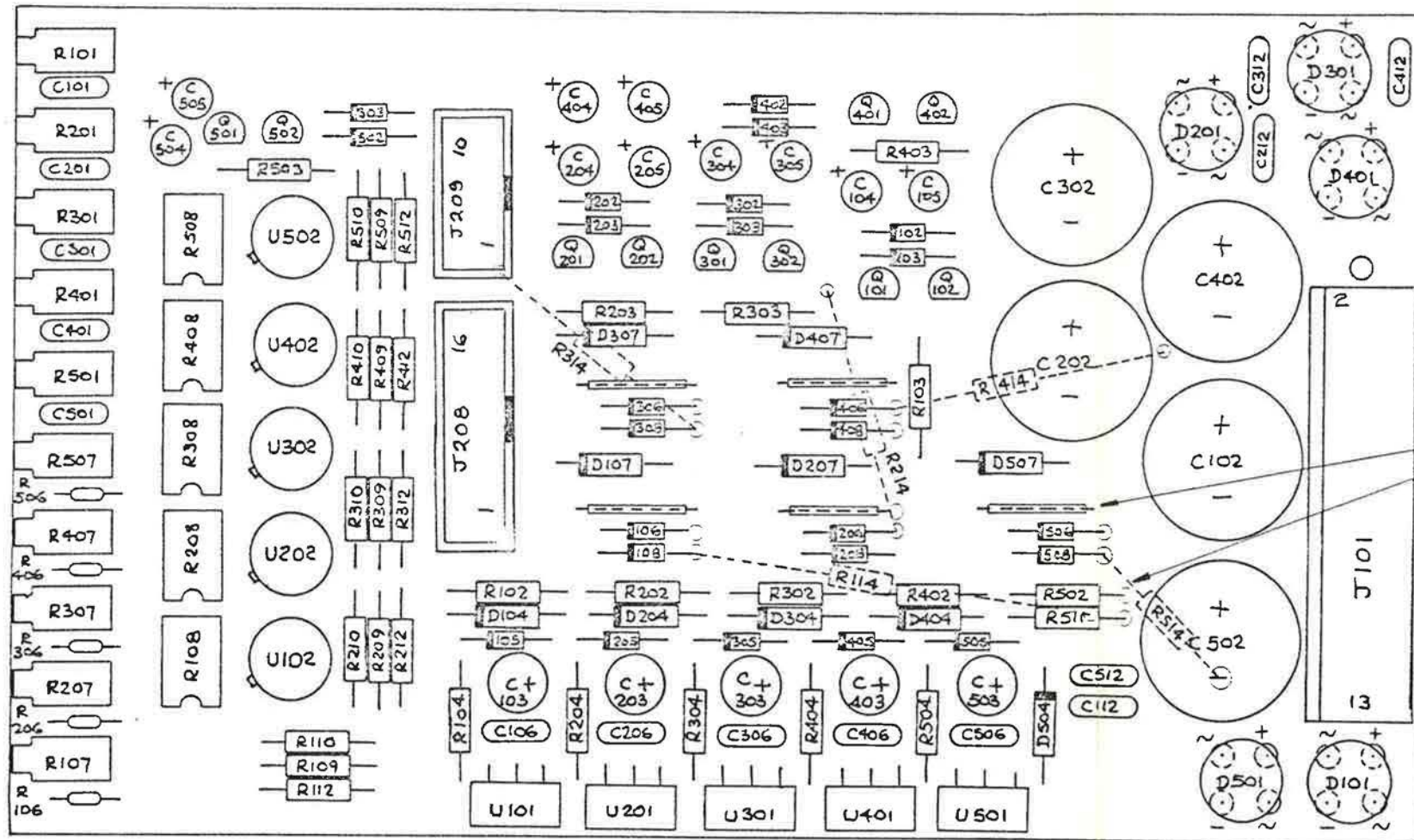

540002 AIR
 590004 AIR
 SLEEVE WIRE LINKS & LEADS
 OF R114, R214, R314, R414, R514

410458-

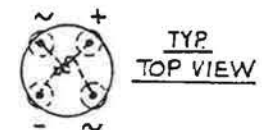

SLEEVE BOTH AC (~) LEADS
 WITH 10mm SLEEVE 590004
 THIS APPLIES TO D101, D201,
 D301, D401 & D501. DEVICES
 USED SHOULD BE G.I. WOIM.

FIT RESISTOR BELOW EACH
 LEG OF BRIDGE. CONNECT
 OTHER END OF 4 RESISTOR
 TOGETHER AS SHOWN

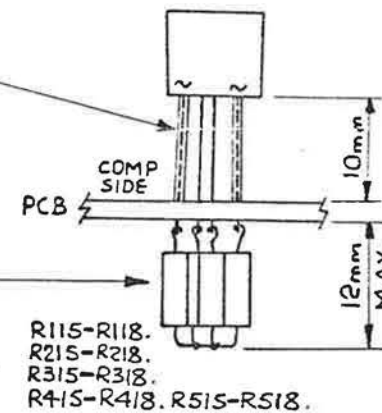

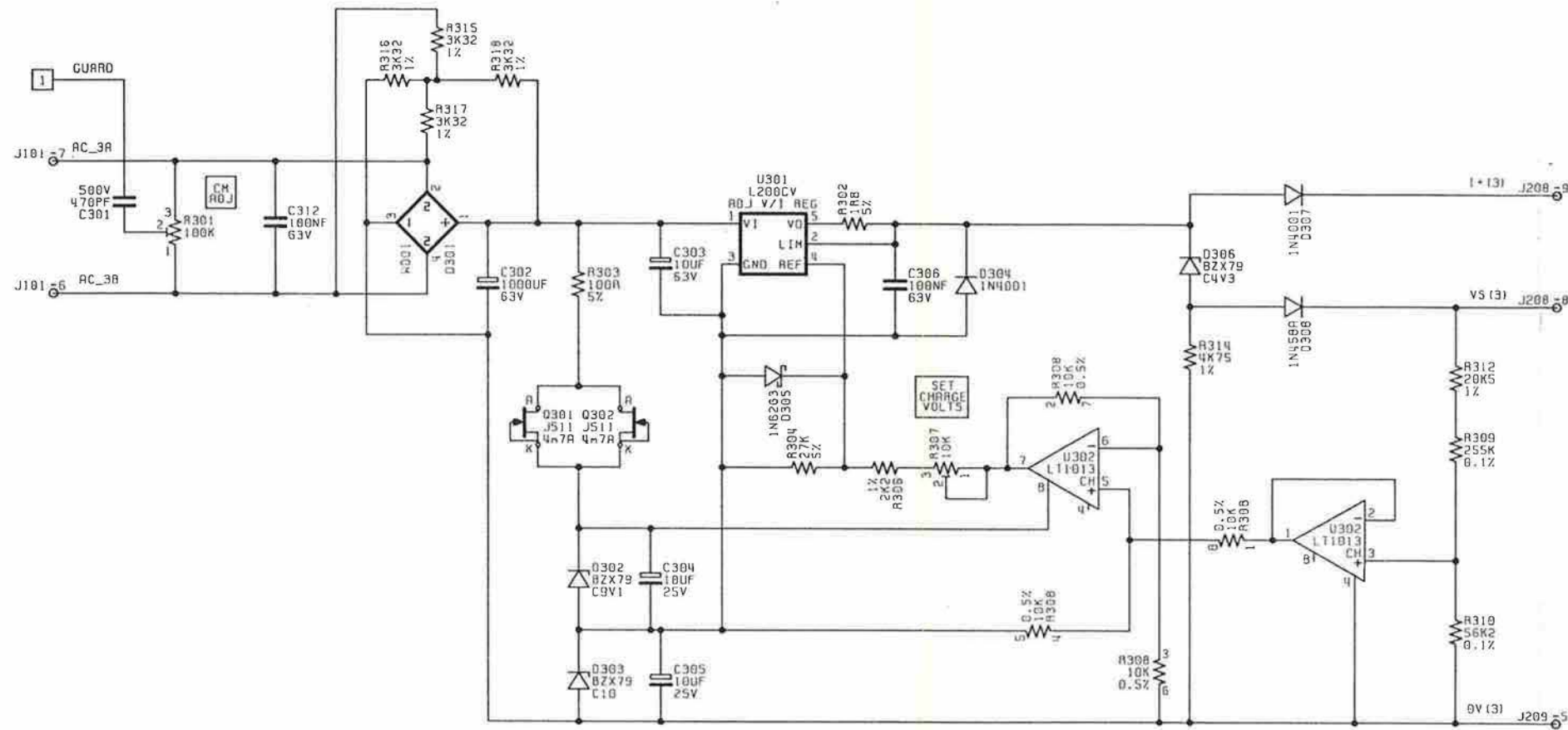

POWER SUPPLY ASSEMBLY
 Drawing No. DC400971 Sheet 3

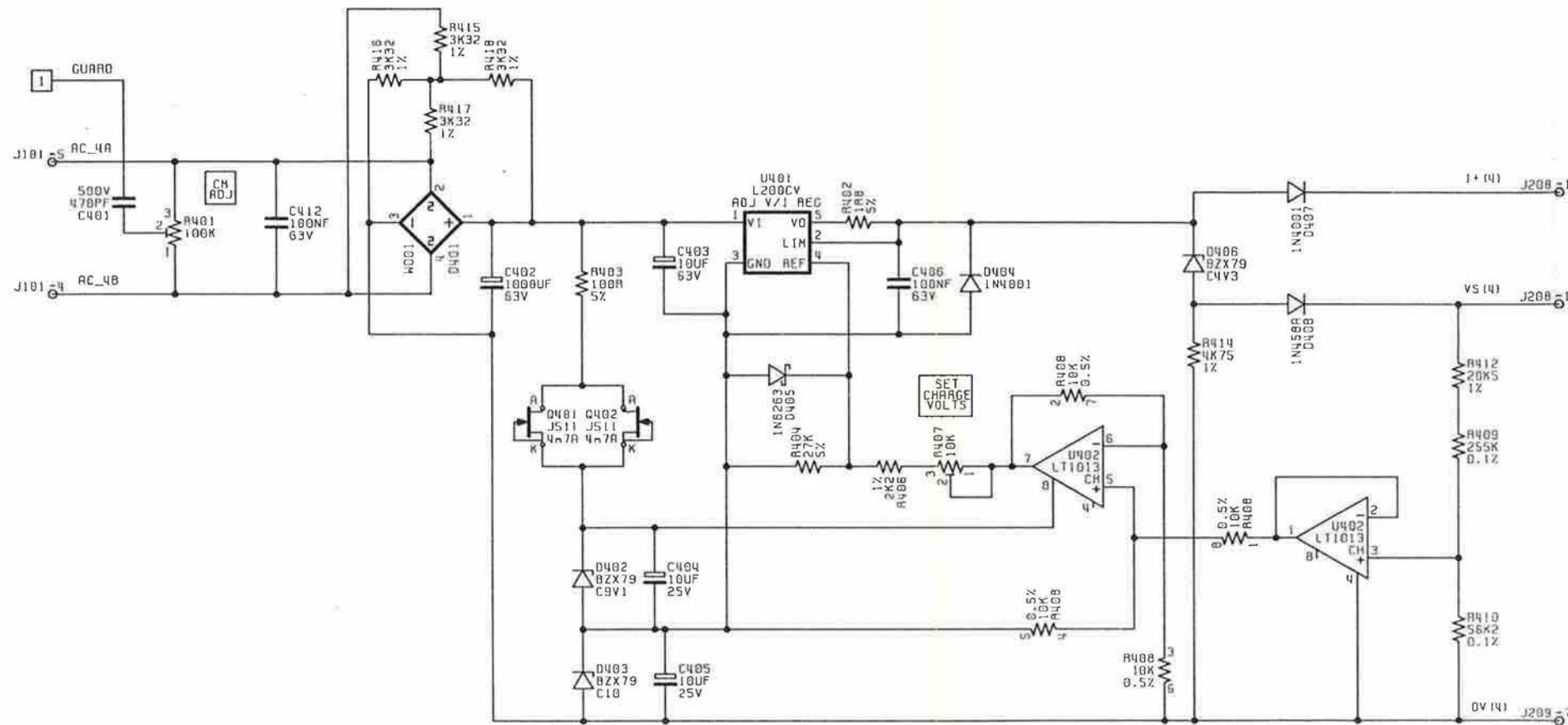

POWER SUPPLY ASSEMBLY
 Drawing No. DC400971 Sheet 4



© Datron Instruments 1991

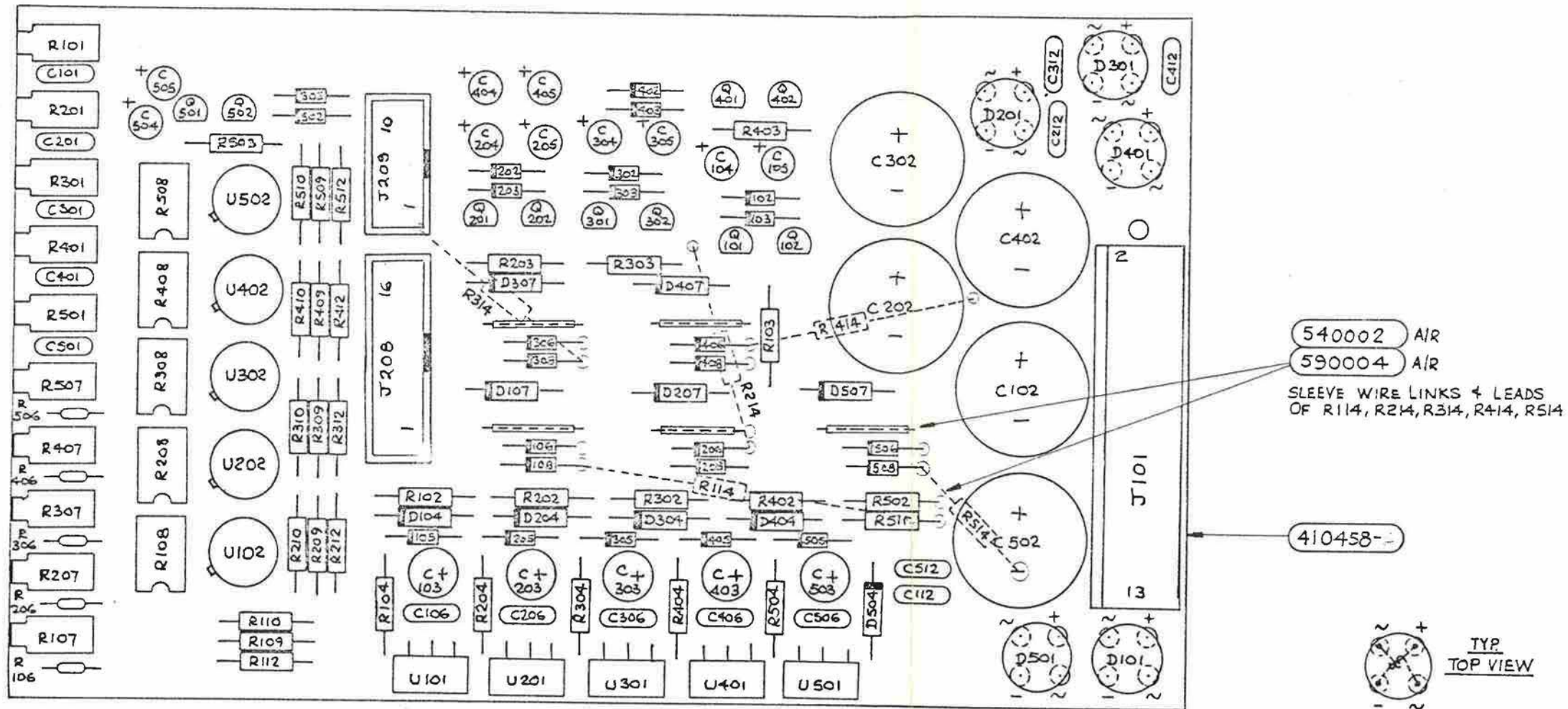

SLEEVE BOTH AC (~) LEADS WITH 10mm SLEEVE 590004 THIS APPLIES TO D101, D201, D301, D401 & D501. DEVICES USED SHOULD BE G.I. WOIM.

FIT RESISTOR BELOW EACH LEG OF BRIDGE. CONNECT OTHER END OF 4 RESISTOR TOGETHER AS SHOWN

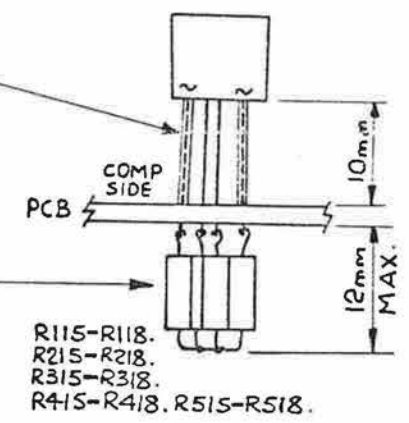

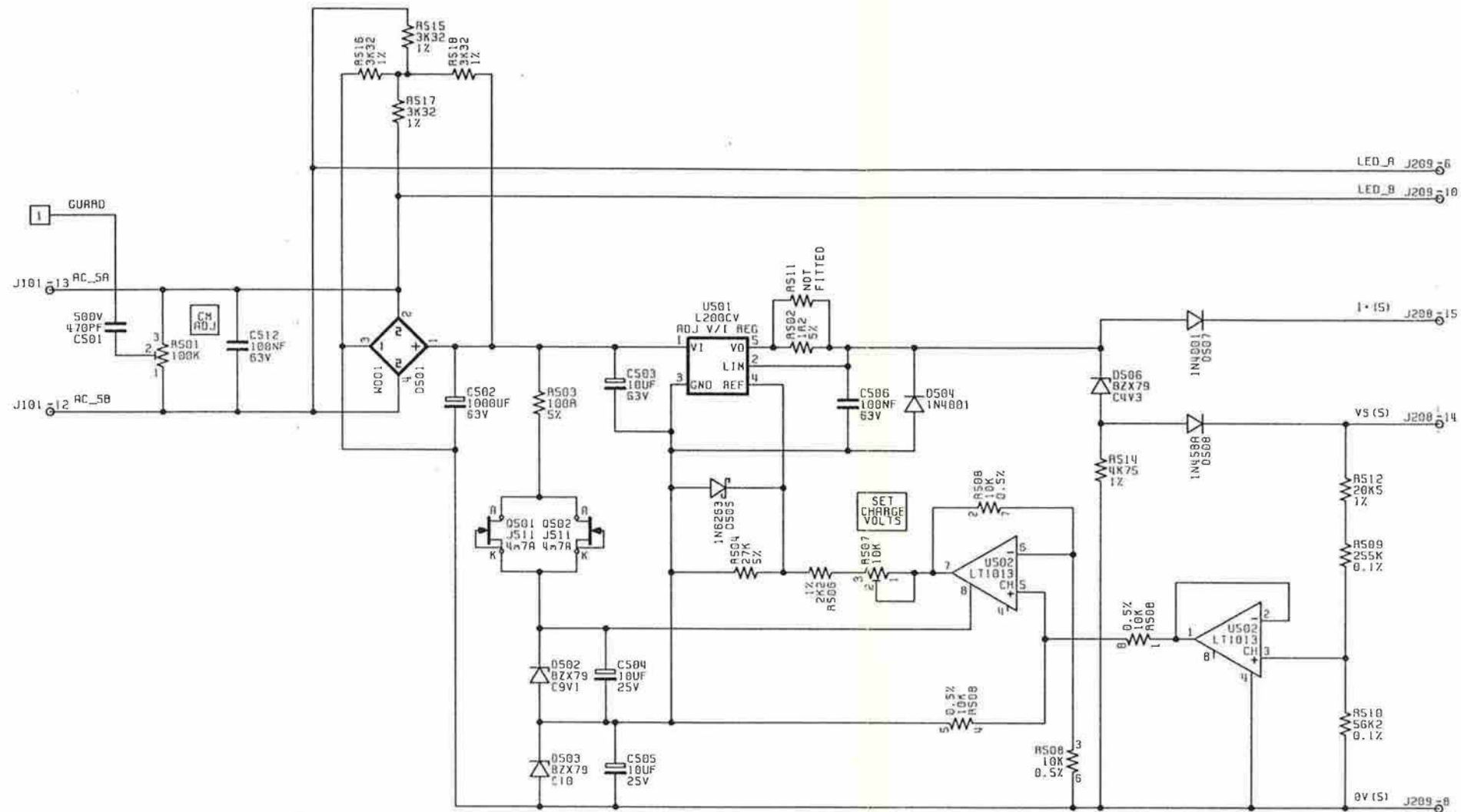

POWER SUPPLY ASSEMBLY
 Drawing No. DC400971 Sheet 5



© Datron Instruments 1991

DESIG	PART NO	DESCRIPTION	PRINC MANUF	MANUF PART NUMBER	CLASS	UM	QUANTITY	CHANGES
D5	220024	DIODE LE RED/GRN	AEG/TELEFUNKEN	CQX95	EA	-		
D6	220024	DIODE LE RED/GRN	AEG/TELEFUNKEN	CQX95	EA	-		
D7	220024	DIODE LE RED/GRN	AEG/TELEFUNKEN	CQX95	EA	-		
D8	220024	DIODE LE RED/GRN	AEG/TELEFUNKEN	CQX95	EA	-		
D9	220024	DIODE LE RED/GRN	AEG/TELEFUNKEN	CQX95	EA	-		
D10	220024	DIODE LE RED/GRN	AEG/TELEFUNKEN	CQX95	EA	-		
D11	220024	DIODE LE RED/GRN	AEG/TELEFUNKEN	CQX95	EA	-		
D12	220024	DIODE LE RED/GRN	AEG/TELEFUNKEN	CQX95	EA	-		
D13	220024	DIODE LE RED/GRN	AEG/TELEFUNKEN	CQX95	EA	-		
D14	220024	DIODE LE RED/GRN	AEG/TELEFUNKEN	CQX95	EA	-		
L1	370026	CHOKE RF 1UH 680mA	SIGMA	SC10	EA	1		
P602	605185	SOCKET PCB 32-WAY (2 X 16)	BICC-VERO	905-72270K	EA	1		
P603	605184	SOCKET PCB 64-WAY (2 X 32)	BICC-VERO	905-72209D	EA	1		
J11	920218-1	TERMINAL GREY/RED	CLIFF	SEE DRG	EA	8		
J12	920217-1	TERMINAL GREY/BLACK	CLIFF	SEE DRG	EA	8		
J13	920218-1	TERMINAL GREY/RED	CLIFF	SEE DRG	EA	-		
J14	920217-1	TERMINAL GREY/BLACK	CLIFF	SEE DRG	EA	-		
J15	920218-1	TERMINAL GREY/RED	CLIFF	SEE DRG	EA	-		
J16	920217-1	TERMINAL GREY/BLACK	CLIFF	SEE DRG	EA	-		
J17	920218-1	TERMINAL GREY/RED	CLIFF	SEE DRG	EA	-		
J18	920217-1	TERMINAL GREY/BLACK	CLIFF	SEE DRG	EA	-		
J19	920218-1	TERMINAL GREY/RED	CLIFF	SEE DRG	EA	-		
J20	920217-1	TERMINAL GREY/BLACK	CLIFF	SEE DRG	EA	-		
J21	920220-1	TERMINAL GREY/BROWN	CLIFF	SEE DRG	EA	1		
J22	920221-1	TERMINAL GREY/BLUE	CLIFF	SEE DRG	EA	1		
J23	920218-1	TERMINAL GREY/RED	CLIFF	SEE DRG	EA	-		
J24	920217-1	TERMINAL GREY/BLACK	CLIFF	SEE DRG	EA	-		
J25	920223-1	TERMINAL GREY/GREEN	CLIFF	SEE DRG	EA	1		
J26	920219-1	TERMINAL GREY/WHITE	CLIFF	SEE DRG	EA	1		
J27	920218-1	TERMINAL GREY/RED	CLIFF	SEE DRG	EA	-		
J28	920218-1	TERMINAL GREY/RED	CLIFF	SEE DRG	EA	-		
J29	920217-1	TERMINAL GREY/BLACK	CLIFF	SEE DRG	EA	-		
J30	920217-1	TERMINAL GREY/BLACK	CLIFF	SEE DRG	EA	-		
E1	614012-1	SPACER M3 CLEAR X 5		SEE DRG	EA	10		
E2	614012-1	SPACER M3 CLEAR X 5		SEE DRG	EA	-		
E3	614012-1	SPACER M3 CLEAR X 5		SEE DRG	EA	-		
E4	614012-1	SPACER M3 CLEAR X 5		SEE DRG	EA	-		
E5	614012-1	SPACER M3 CLEAR X 5		SEE DRG	EA	-		
E6	614012-1	SPACER M3 CLEAR X 5		SEE DRG	EA	-		
E7	614012-1	SPACER M3 CLEAR X 5		SEE DRG	EA	-		
E8	614012-1	SPACER M3 CLEAR X 5		SEE DRG	EA	-		
E9	614012-1	SPACER M3 CLEAR X 5		SEE DRG	EA	-		
E10	614012-1	SPACER M3 CLEAR X 5		SEE DRG	EA	-		
DS1	920226	GAS ARRESTER 230V DC SPARKOVER	BESWICK	GTD911D	EA	9		
DS2	920226	GAS ARRESTER 230V DC SPARKOVER	BESWICK	GTD911D	EA	-		

DESIG	PART NO	DESCRIPTION	PRINC MANUF	MANUF PART NUMBER	CLASS	UM	QUANTITY	CHANGES
DS3	920226	GAS ARRESTER 230V DC SPARKOVER	BESWICK	GTD911D	EA	-		
DS4	920226	GAS ARRESTER 230V DC SPARKOVER	BESWICK	GTD911D	EA	-		
DS5	920226	GAS ARRESTER 230V DC SPARKOVER	BESWICK	GTD911D	EA	-		
DS6	920226	GAS ARRESTER 230V DC SPARKOVER	BESWICK	GTD911D	EA	-		
DS7	920226	GAS ARRESTER 230V DC SPARKOVER	BESWICK	GTD911D	EA	-		
DS8	920226	GAS ARRESTER 230V DC SPARKOVER	BESWICK	GTD911D	EA	-		
DS9	920226	GAS ARRESTER 230V DC SPARKOVER	BESWICK	GTD911D	EA	-		
	410433-2	PCB FRONT 4910		SEE DRG	EA	1		
	420098	LABEL SERIAL/ASSY No.	RS COMPONENTS	554-793	EA	1		
	420112-1	LABEL SSD WARNING 12 X 12mm	TEKNIS	LN1212	A	EA	1	
	450750-3	FRONT PANEL 4910		SEE DRG	EA	1		
	450751-2	OVERLAY 4910		SEE DRG	EA	1		
	450752-3	VERTICAL CORNER TRIM 4910		SEE DRG	EA	2		
	450851-1	CORNER BRACKET RIGHT 4910		SEE DRG	EA	1		
	450852-1	CORNER BRACKET LEFT 4910		SEE DRG	EA	1		
	450858-1	INSULATOR FRONT PANEL 4910		SEE DRG	EA	1		
	611006	SCREW M3 X 10 POZIPAN SZP			EA	10		
	611011	SCREW M2.5 X 6 POZIPAN SZP			EA	4		
	611016	SCREW M3 X 8 POZIPAN SZP			EA	6		
	611105	SCREW 8-32 X 3/8 POZICSK SZP			EA	4		
	613005	WASHER M3 INT SHAKP SZP			EA	6		
	613029	WASHER M3 WAVY SS			EA	10		
	613047	WASHER M2.5 WAVY SS			EA	4		
	613054-1	WASHER 4BA BRASS GL.PL.		SEE DRG	EA	40		
	615006	NUT FULL M2.5 SZP			EA	4		
	615025-1	NUT FULL 4BA BRASS GL.PL.		SEE DRG	EA	40		
	630024	BEAD CERAMIC 16 SWG	PARK ROYAL PORCELAIN	No2	EA	18		
	900009	LOCKING COMPOUND	LOCTITE	222	AR	1		

End

DESIG	PART NO	DESCRIPTION	PRINC MANUF	MANUF PART NUMBER	CLASS	UM	QUANTITY	CHANGES
J16	920217-1	TERMINAL GREY/BLACK	CLIFF	SEE DRG			EA	-
J17	920216-1	TERMINAL GREY/RED	CLIFF	SEE DRG			EA	-
J18	920217-1	TERMINAL GREY/BLACK	CLIFF	SEE DRG			EA	-
J19	920218-1	TERMINAL GREY/RED	CLIFF	SEE DRG			EA	-
J20	920217-1	TERMINAL GREY/BLACK	CLIFF	SEE DRG			EA	-
J25	920223-1	TERMINAL GREY/GREEN	CLIFF	SEE DRG			EA	1
J26	920219-1	TERMINAL GREY/WHITE	CLIFF	SEE DRG			EA	1
E1	614012-1	SPACER M3 CLEAR X 5		SEE DRG			EA	10
E2	614012-1	SPACER M3 CLEAR X 5		SEE DRG			EA	-
E3	614012-1	SPACER M3 CLEAR X 5		SEE DRG			EA	-
E4	614012-1	SPACER M3 CLEAR X 5		SEE DRG			EA	-
E5	614012-1	SPACER M3 CLEAR X 5		SEE DRG			EA	-
E6	614012-1	SPACER M3 CLEAR X 5		SEE DRG			EA	-
E7	614012-1	SPACER M3 CLEAR X 5		SEE DRG			EA	-
E8	614012-1	SPACER M3 CLEAR X 5		SEE DRG			EA	-
E9	614012-1	SPACER M3 CLEAR X 5		SEE DRG			EA	-
E10	614012-1	SPACER M3 CLEAR X 5		SEE DRG			EA	-
DS1	920226	GAS ARRESTER 230V DC SPARKOVER	BESWICK	GTD911D			EA	5
DS2	920226	GAS ARRESTER 230V DC SPARKOVER	BESWICK	GTD911D			EA	-
DS3	920226	GAS ARRESTER 230V DC SPARKOVER	BESWICK	GTD911D			EA	-
DS4	920226	GAS ARRESTER 230V DC SPARKOVER	BESWICK	GTD911D			EA	-
DS5	920226	GAS ARRESTER 230V DC SPARKOVER	BESWICK	GTD911D			EA	-
	410433-2	PCB FRONT 4910		SEE DRG			EA	1
	420098	LABEL SERIAL/ASSY No.	RS COMPONENTS	554-793			EA	1
	420112-1	LABEL SSD WARNING 12 X 12mm	TEKNIS	LN1212	A		EA	1
	450750-3	FRONT PANEL 4910		SEE DRG			EA	1
	450752-3	VERTICAL CORNER TRIM 4910		SEE DRG			EA	2
	450756-2	OVERLAY 4911		SEE DRG			EA	1
	450851-1	CORNER BRACKET RIGHT 4910		SEE DRG			EA	1
	450852-1	CORNER BRACKET LEFT 4910		SEE DRG			EA	1
	450858-1	INSULATOR FRONT PANEL 4910		SEE DRG			EA	1
	611006	SCREW M3 X 10 POZIPAN SZP					EA	10
	611011	SCREW M2.5 X 6 POZIPAN SZP					EA	4
	611016	SCREW M3 X 8 POZIPAN SZP					EA	6
	611105	SCREW 8-32 X 3/8 POZICSK SZP					EA	4
	613005	WASHER M3 INT SHAKP SZP					EA	6
	613029	WASHER M3 WAVY SS					EA	10
	613047	WASHER M2.5 WAVY SS					EA	4
	613054-1	WASHER 4BA BRASS GL.PL.		SEE DRG			EA	24
	615006	NUT FULL M2.5 SZP					EA	4
	615025-1	NUT FULL 4BA BRASS GL.PL.		SEE DRG			EA	24
	630024	BEAD CERAMIC 16 SWG	PARK ROYAL PORCELAIN	No2			EA	10
	900009	LOCKING COMPOUND	LOCTITE	222			AR	1

End

DRAWING No. LD400971		CHK'D	3600 23.5.90		3667 31.7.90		3681 21.8.90	
DOCUMENT LIST		DATE	3600 23.5.90		3667 31.7.90		3681 21.8.90	
DISTRIBUTION		ECO	1.0		1.1		2.0	
		REVISION	1.0		1.1		2.0	
		ISSUE	1.0		1.1		2.0	
DESCRIPTION	DRAWING NUMBER	SHEET NUMBER	ISSUE - REVISION					
PARTS LIST	LP400971	ALL	1.0	1.0	2.0			
ASSEMBLY DRAWING	DA400971	1	1.0	1.1	2.0			
CIRCUIT DIAGRAM	DC400971	1	1.0	1.0	2.0			
"	DC400971	2	1.0	1.0	2.0			
"	DC400971	3	1.0	1.0	2.0			
"	DC400971	4	1.0	1.0	2.0			
"	DC400971	5	1.0	1.0	2.0			
TEST PROCEDURE								
TEST SPECIFICATION								
PCB	410458		A.0					
NOTES		datron WAVETEK NORWICH ENGLAND		DRN I.J.L. DATE 23 MAY 90	CHK'D R.H. COGGAN DATE 29 MAY 90	APP'D K. FISHER DATE 31 MAY 90	TITLE 4910/4911 POWER SUPPLY ASSY.	DRAWING No. LD400971 SHEET 1 OF 1

DATRON INSTRUMENTS LTD PARTS LIST 29-Apr-91 DESC: ASSY PCB POWER SUPPLY 4910 DRG NO: LP400971-2 REV: 0 PAGE NO: 1

DESIG	PART NO	DESCRIPTION	PRINC MANUF	MANUP PART NUMBER	CLASS	UM	QUANTITY	CHANGES
R101	065017	RES CT 100K VERT M/T	BOURNS	3296X-1-104	A	EA	5	
R102	000188	RES CP 1R8 5% .25W	NEOHM	CPK25	A	EA	4	
R103	000101	RES CP 100R 5% .25W	NEOHM	CPK25	A	EA	5	
R104	000273	RES CP 27K 5% .25W	NEOHM	CPK25	A	EA	5	
R106	050116	RES MF 2K2 1% .4W 100PPM	NEOHM	LR0204	A	EA	5	
R107	067103	RES CT 10K VERT M/T	BECKMAN	68X	A	EA	5	
R109	090142	RES PACK 10K X 4 .5%	BECKMAN	694-3-R10KD	A	EA	5	
R109	050151	RES MF 255K 0.1% .12W 15PPM	HOLSWORTHY	H8	A	EA	5	
R110	050152	RES MF 56K2 0.1% .12W 15PPM	HOLSWORTHY	H8	A	EA	5	
R112	012052	RES MF 20K5 1% .12W 50PPM	HOLSWORTHY	H8C	A	EA	5	
R114	014751	RES MF 4K75 1% .12W 50PPM	HOLSWORTHY	H8C	A	EA	5	
R115	013321	RES MF 3K32 1% .12W 50PPM	HOLSWORTHY	H8C	A	EA	20	
R116	013321	RES MF 3K32 1% .12W 50PPM	HOLSWORTHY	H8C	A	EA	-	
R117	013321	RES MF 3K32 1% .12W 50PPM	HOLSWORTHY	H8C	A	EA	-	
R118	013321	RES MF 3K32 1% .12W 50PPM	HOLSWORTHY	H8C	A	EA	-	
R201	065017	RES CT 100K VERT M/T	BOURNS	3296X-1-104	A	EA	-	
R202	000188	RES CP 1R8 5% .25W	NEOHM	CPK25	A	EA	-	
R203	000101	RES CP 100R 5% .25W	NEOHM	CPK25	A	EA	-	
R204	000273	RES CP 27K 5% .25W	NEOHM	CPK25	A	EA	-	
R206	050116	RES MF 2K2 1% .4W 100PPM	NEOHM	LR0204	A	EA	-	
R207	067103	RES CT 10K VERT M/T	BECKMAN	68X	A	EA	-	
R208	090142	RES PACK 10K X 4 .5%	BECKMAN	694-3-R10KD	A	EA	-	
R209	050151	RES MF 255K 0.1% .12W 15PPM	HOLSWORTHY	H8	A	EA	-	
R210	050152	RES MF 56K2 0.1% .12W 15PPM	HOLSWORTHY	H8	A	EA	-	
R212	012052	RES MF 20K5 1% .12W 50PPM	HOLSWORTHY	H8C	A	EA	-	
R214	014751	RES MF 4K75 1% .12W 50PPM	HOLSWORTHY	H8C	A	EA	-	
R215	013321	RES MF 3K32 1% .12W 50PPM	HOLSWORTHY	H8C	A	EA	-	
R216	013321	RES MF 3K32 1% .12W 50PPM	HOLSWORTHY	H8C	A	EA	-	
R217	013321	RES MF 3K32 1% .12W 50PPM	HOLSWORTHY	H8C	A	EA	-	
R218	013321	RES MF 3K32 1% .12W 50PPM	HOLSWORTHY	H8C	A	EA	-	
R301	065017	RES CT 100K VERT M/T	BOURNS	3296X-1-104	A	EA	-	
R302	000188	RES CP 1R8 5% .25W	NEOHM	CPK25	A	EA	-	
R303	000101	RES CP 100R 5% .25W	NEOHM	CPK25	A	EA	-	
R304	000273	RES CP 27K 5% .25W	NEOHM	CPK25	A	EA	-	
R306	050116	RES MF 2K2 1% .4W 100PPM	NEOHM	LR0204	A	EA	-	
R307	067103	RES CT 10K VERT M/T	BECKMAN	68X	A	EA	-	
R308	090142	RES PACK 10K X 4 .5%	BECKMAN	694-3-R10KD	A	EA	-	
R309	050151	RES MF 255K 0.1% .12W 15PPM	HOLSWORTHY	H8	A	EA	-	
R310	050152	RES MF 56K2 0.1% .12W 15PPM	HOLSWORTHY	H8	A	EA	-	
R312	012052	RES MF 20K5 1% .12W 50PPM	HOLSWORTHY	H8C	A	EA	-	
R314	014751	RES MF 4K75 1% .12W 50PPM	HOLSWORTHY	H8C	A	EA	-	
R315	013321	RES MF 3K32 1% .12W 50PPM	HOLSWORTHY	H8C	A	EA	-	
R316	013321	RES MF 3K32 1% .12W 50PPM	HOLSWORTHY	H8C	A	EA	-	
R317	013321	RES MF 3K32 1% .12W 50PPM	HOLSWORTHY	H8C	A	EA	-	
R318	013321	RES MF 3K32 1% .12W 50PPM	HOLSWORTHY	H8C	A	EA	-	

DESIG	PART NO	DESCRIPTION	PRINC MANUF	MANUF PART NUMBER	CLASS	UM	QUANTITY	CHANGES
R401	065017	RES CT 100K VERT M/T	BOURNS	3296X-1-104		EA	-	
R402	000188	RES CP 1R8 5% .25W	NEOHM	CFR25	A	EA	-	
R403	000101	RES CP 100R 5% .25W	NEOHM	CFR25	A	EA	-	
R404	000273	RES CP 27K 5% .25W	NEOHM	CFR25	A	EA	-	
R406	050116	RES MF 2K2 1% .4W 100PPM	NEOHM	LR0204	A	EA	-	
R407	067103	RES CT 10K VERT M/T	BECKMAN	68X	A	EA	-	
R408	090142	RES PACK 10K X 4 .5%	BECKMAN	694-3-R10KD		EA	-	
R409	050151	RES MF 255K 0.1% .12W 15PPM	HOLSWORTHY	H8		EA	-	
R410	050152	RES MF 56K2 0.1% .12W 15PPM	HOLSWORTHY	H8		EA	-	
R412	012052	RES MF 20K5 1% .12W 50PPM	HOLSWORTHY	H8C	A	EA	-	
R414	014751	RES MF 4K75 1% .12W 50PPM	HOLSWORTHY	H8C	A	EA	-	
R415	013321	RES MF 3K32 1% .12W 50PPM	HOLSWORTHY	H8C	A	EA	-	
R416	013321	RES MF 3K32 1% .12W 50PPM	HOLSWORTHY	H8C	A	EA	-	
R417	013321	RES MF 3K32 1% .12W 50PPM	HOLSWORTHY	H8C	A	EA	-	
R418	013321	RES MF 3K32 1% .12W 50PPM	HOLSWORTHY	H8C	A	EA	-	
R501	065017	RES CT 100K VERT M/T	BOURNS	3296X-1-104		EA	-	
R502	000128	RES CP 1R2 5% .25W	NEOHM	CFR25	A	EA	1	
R503	000101	RES CP 100R 5% .25W	NEOHM	CFR25	A	EA	-	
R504	000273	RES CP 27K 5% .25W	NEOHM	CFR25	A	EA	-	
R506	050116	RES MF 2K2 1% .4W 100PPM	NEOHM	LR0204	A	EA	-	
R507	067103	RES CT 10K VERT M/T	BECKMAN	68X	A	EA	-	
R508	090142	RES PACK 10K X 4 .5%	BECKMAN	694-3-R10KD		EA	-	
R509	050151	RES MF 255K 0.1% .12W 15PPM	HOLSWORTHY	H8		EA	-	
R510	050152	RES MF 56K2 0.1% .12W 15PPM	HOLSWORTHY	H8		EA	-	
R511	000000	NOT FITTED				EA	1	
R512	012052	RES MF 20K5 1% .12W 50PPM	HOLSWORTHY	H8C	A	EA	-	
R514	014751	RES MF 4K75 1% .12W 50PPM	HOLSWORTHY	H8C	A	EA	-	
R515	013321	RES MF 3K32 1% .12W 50PPM	HOLSWORTHY	H8C	A	EA	-	
R516	013321	RES MF 3K32 1% .12W 50PPM	HOLSWORTHY	H8C	A	EA	-	
R517	013321	RES MF 3K32 1% .12W 50PPM	HOLSWORTHY	H8C	A	EA	-	
R518	013321	RES MF 3K32 1% .12W 50PPM	HOLSWORTHY	H8C	A	EA	-	
C101	102471	CAP CP 470PF 10% 500V N330	BECK	CD10EM470PMSCR	A	EA	5	
C102	180069	CAP AE 1000UF 20% 63V	NIPPON CHEMI-CON	SMVB/1000-63-20		EA	5	
C103	180070	CAP AE 10UF 20% 63V	NIPPON CHEMI-CON	SMVB/10-63-20		EA	5	
C104	150020	CAP DT 10UF 20% 25V	AVX	TAP10M25F	A	EA	10	
C105	150020	CAP DT 10UF 20% 25V	AVX	TAP10M25F	A	EA	-	
C106	110042	CAP PE 100NF 20% 63V	WIMA	MKS2		EA	10	
C112	110042	CAP PE 100NF 20% 63V	WIMA	MKS2		EA	-	
C201	102471	CAP CP 470PF 10% 500V N330	BECK	CD10EM470PMSCR	A	EA	-	
C202	180069	CAP AE 1000UF 20% 63V	NIPPON CHEMI-CON	SMVB/1000-63-20		EA	-	
C203	180070	CAP AE 10UF 20% 63V	NIPPON CHEMI-CON	SMVB/10-63-20		EA	-	
C204	150020	CAP DT 10UF 20% 25V	AVX	TAP10M25F	A	EA	-	
C205	150020	CAP DT 10UF 20% 25V	AVX	TAP10M25F	A	EA	-	
C206	110042	CAP PE 100NF 20% 63V	WIMA	MKS2		EA	-	
C212	110042	CAP PE 100NF 20% 63V	WIMA	MKS2		EA	-	

DESIG	PART NO	DESCRIPTION	PRINC MANUF	MANUF PART NUMBER	CLASS	UM	QUANTITY	CHANGES
C301	102471	CAP CP 470PF 10% 500V N330	BECK	CD10EM470PMSCR	A	EA	-	
C302	180069	CAP AE 1000UF 20% 63V	NIPPON CHEMI-CON	SMVB/1000-63-20		EA	-	
C303	180070	CAP AE 10UF 20% 63V	NIPPON CHEMI-CON	SMVB/10-63-20		EA	-	
C304	150020	CAP DT 10UF 20% 25V	AVX	TAP10M25F	A	EA	-	
C305	150020	CAP DT 10UF 20% 25V	AVX	TAP10M25F	A	EA	-	
C306	110042	CAP PE 100NF 20% 63V	WIMA	MKS2		EA	-	
C312	110042	CAP PE 100NF 20% 63V	WIMA	MKS2		EA	-	
C401	102471	CAP CP 470PF 10% 500V N330	BECK	CD10EM470PMSCR	A	EA	-	
C402	180069	CAP AE 1000UF 20% 63V	NIPPON CHEMI-CON	SMVB/1000-63-20		EA	-	
C403	180070	CAP AE 10UF 20% 63V	NIPPON CHEMI-CON	SMVB/10-63-20		EA	-	
C404	150020	CAP DT 10UF 20% 25V	AVX	TAP10M25F	A	EA	-	
C405	150020	CAP DT 10UF 20% 25V	AVX	TAP10M25F	A	EA	-	
C406	110042	CAP PE 100NF 20% 63V	WIMA	MKS2		EA	-	
C412	110042	CAP PE 100NF 20% 63V	WIMA	MKS2		EA	-	
C501	102471	CAP CP 470PF 10% 500V N330	BECK	CD10EM470PMSCR	A	EA	-	
C502	180069	CAP AE 1000UF 20% 63V	NIPPON CHEMI-CON	SMVB/1000-63-20		EA	-	
C503	180070	CAP AE 10UF 20% 63V	NIPPON CHEMI-CON	SMVB/10-63-20		EA	-	
C504	150020	CAP DT 10UF 20% 25V	AVX	TAP10M25F	A	EA	-	
C505	150020	CAP DT 10UF 20% 25V	AVX	TAP10M25F	A	EA	-	
C506	110042	CAP PE 100NF 20% 63V	WIMA	MKS2		EA	-	
C512	110042	CAP PE 100NF 20% 63V	WIMA	MKS2		EA	-	
D101	209003	DIODE BR 1A5 100V	GI	W01G	A	EA	5	
D102	210091	DIODE ZN 9V1 400mW	PHILIPS	BZX79C9V1	A	EA	5	
D103	210100	DIODE ZN 10V 400mW	PHILIPS	BZX79C10	A	EA	5	
D104	200002	DIODE GP 1A 50V	FAIRCHILD	1N4001	A	EA	10	
D105	220010	DIODE SB	H.P.	1N5711/1N6263	A	EA	5	
D106	210043	DIODE ZN 4V3 400mW	PHILIPS	BZX79C4V3	A	EA	5	
D107	200002	DIODE GP 1A 50V	FAIRCHILD	1N4001	A	EA	-	
D108	200008	DIODE GP 200mA 125V	FAIRCHILD	1N458A	A	EA	5	
D201	209003	DIODE BR 1A5 100V	GI	W01G	A	EA	-	
D202	210091	DIODE ZN 9V1 400mW	PHILIPS	BZX79C9V1	A	EA	-	
D203	210100	DIODE ZN 10V 400mW	PHILIPS	BZX79C10	A	EA	-	
D204	200002	DIODE GP 1A 50V	FAIRCHILD	1N4001	A	EA	-	
D205	220010	DIODE SB	H.P.	1N5711/1N6263	A	EA	-	
D206	210043	DIODE ZN 4V3 400mW	PHILIPS	BZX79C4V3	A	EA	-	
D207	200002	DIODE GP 1A 50V	FAIRCHILD	1N4001	A	EA	-	
D208	200008	DIODE GP 200mA 125V	FAIRCHILD	1N458A	A	EA	-	
D301	209003	DIODE BR 1A5 100V	GI	W01G	A	EA	-	
D302	210091	DIODE ZN 9V1 400mW	PHILIPS	BZX79C9V1	A	EA	-	
D303	210100	DIODE ZN 10V 400mW	PHILIPS	BZX79C10	A	EA	-	
D304	200002	DIODE GP 1A 50V	FAIRCHILD	1N4001	A	EA	-	
D305	220010	DIODE SB	H.P.	1N5711/1N6263	A	EA	-	
D306	210043	DIODE ZN 4V3 400mW	PHILIPS	BZX79C4V3	A	EA	-	
D307	200002	DIODE GP 1A 50V	FAIRCHILD	1N4001	A	EA	-	
D308	200008	DIODE GP 200mA 125V	FAIRCHILD	1N458A	A	EA	-	

DESIG	PART NO	DESCRIPTION	PRINC MANUF	MANUF PART NUMBER	CLASS	UM	QUANTITY	CHANGES
D401	209003	DIODE BR 1A5 100V	GI	W01G	A	EA	-	
D402	210091	DIODE ZN 9V1 400mW	PHILIPS	BZX79C9V1	A	EA	-	
D403	210100	DIODE ZN 10V 400mW	PHILIPS	BZX79C10	A	EA	-	
D404	200002	DIODE GP 1A 50V	FAIRCHILD	1N4001	A	EA	-	
D405	220010	DIODE SB	H.P.	1N5711/1N6263	A	EA	-	
D406	210043	DIODE ZN 4V3 400mW	PHILIPS	BZX79C4V3	A	EA	-	
D407	200002	DIODE GP 1A 50V	FAIRCHILD	1N4001	A	EA	-	
D408	200008	DIODE GP 200mA 125V	FAIRCHILD	1N458A	A	EA	-	
D501	209003	DIODE BR 1A5 100V	GI	W01G	A	EA	-	
D502	210091	DIODE ZN 9V1 400mW	PHILIPS	BZX79C9V1	A	EA	-	
D503	210100	DIODE ZN 10V 400mW	PHILIPS	BZX79C10	A	EA	-	
D504	200002	DIODE GP 1A 50V	FAIRCHILD	1N4001	A	EA	-	
D505	220010	DIODE SB	H.P.	1N5711/1N6263	A	EA	-	
D506	210043	DIODE ZN 4V3 400mW	PHILIPS	BZX79C4V3	A	EA	-	
D507	200002	DIODE GP 1A 50V	FAIRCHILD	1N4001	A	EA	-	
D508	200008	DIODE GP 200mA 125V	FAIRCHILD	1N458A	A	EA	-	
Q101	230065	TRAN JPET I LIM 4m7A	SILICONIX	J511		EA	10	
Q102	230065	TRAN JPET I LIM 4m7A	SILICONIX	J511		EA	-	
Q201	230065	TRAN JPET I LIM 4m7A	SILICONIX	J511		EA	-	
Q202	230065	TRAN JPET I LIM 4m7A	SILICONIX	J511		EA	-	
Q301	230065	TRAN JPET I LIM 4m7A	SILICONIX	J511		EA	-	
Q302	230065	TRAN JPET I LIM 4m7A	SILICONIX	J511		EA	-	
Q401	230065	TRAN JPET I LIM 4m7A	SILICONIX	J511		EA	-	
Q402	230065	TRAN JPET I LIM 4m7A	SILICONIX	J511		EA	-	
Q501	230065	TRAN JPET I LIM 4m7A	SILICONIX	J511		EA	-	
Q502	230065	TRAN JPET I LIM 4m7A	SILICONIX	J511		EA	-	
U101	260125	IC LIN REG ADJ VOLTAGE	SGS	L200 CV		EA	5	
U102	260088	IC LIN OP AMP DUAL PREC	LINEAR TECHNOLOGY	LT1013CH		EA	5	
U201	260125	IC LIN REG ADJ VOLTAGE	SGS	L200 CV		EA	-	
U202	260088	IC LIN OP AMP DUAL PREC	LINEAR TECHNOLOGY	LT1013CH		EA	-	
U301	260125	IC LIN REG ADJ VOLTAGE	SGS	L200 CV		EA	-	
U302	260088	IC LIN OP AMP DUAL PREC	LINEAR TECHNOLOGY	LT1013CH		EA	-	
U401	260125	IC LIN REG ADJ VOLTAGE	SGS	L200 CV		EA	-	
U402	260088	IC LIN OP AMP DUAL PREC	LINEAR TECHNOLOGY	LT1013CH		EA	-	
U501	260125	IC LIN REG ADJ VOLTAGE	SGS	L200 CV		EA	-	
U502	260088	IC LIN OP AMP DUAL PREC	LINEAR TECHNOLOGY	LT1013CH		EA	-	
J101	604072	PLUG PCB 12-WAY .156 GD PL	MOLEX	09-72-2121		EA	1	
J208	604076	PLUG PCB 16-WAY .1"X.1" GRID	3M	3599-6002UN		EA	1	
J209	604115	PLUG PCB 10-WAY .1" LP GP	3M	3634-6002		EA	1	
	410458-A	PCB POWER SUPPLY 4910		SEE DRG		EA	1	
	540002	WIRE 1/.7 TINNED COPPER	B54109	22SWG		AR	1	
	590004	SLEEVE PTPE 1mm BLK	HELLERMANN	FE10		AR	1	

End

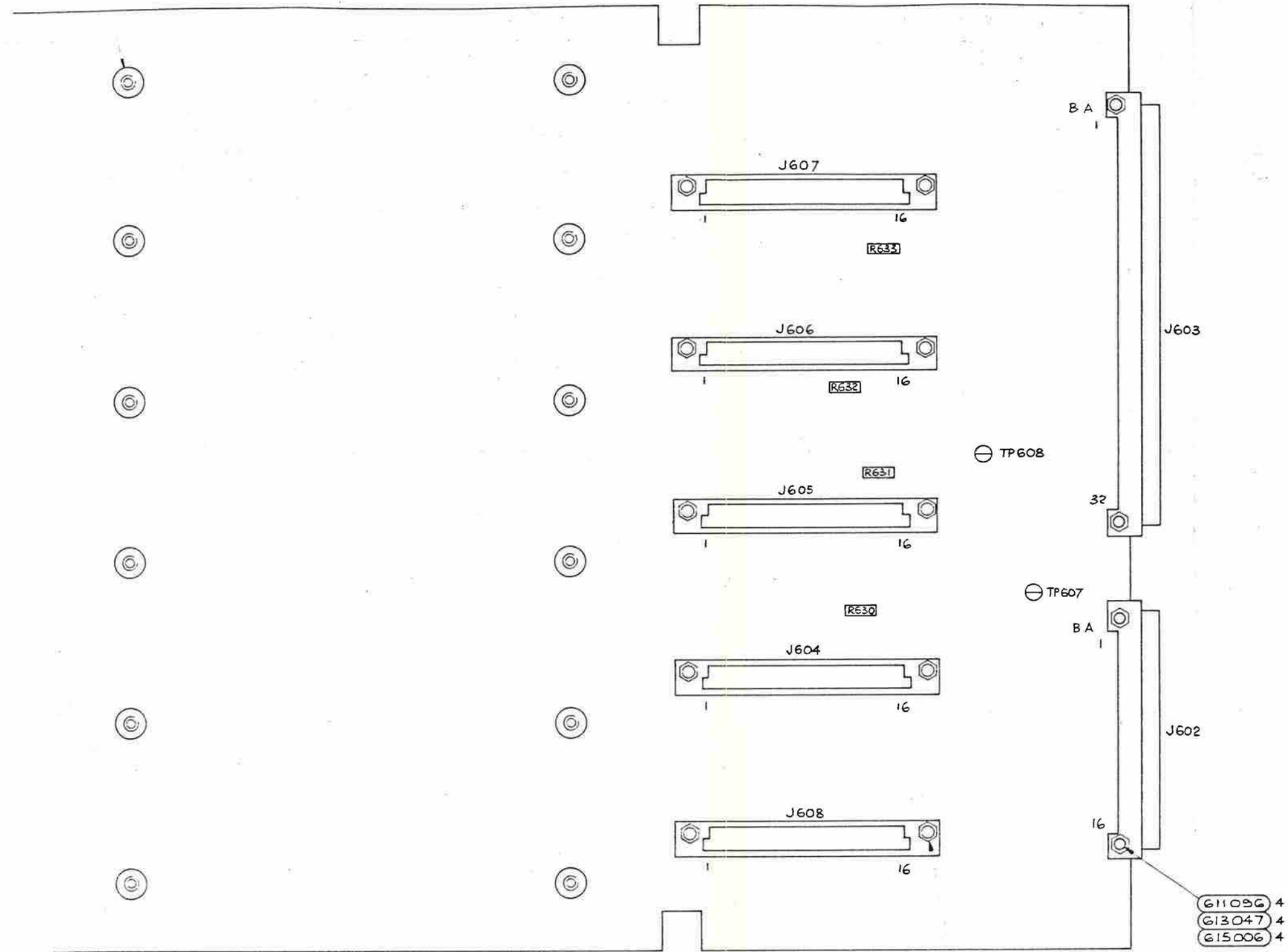

NOTE : SEE SHT. 1 FOR DETAILS OF OTHER HALF OF BOARD ASSY.

MOTHER PCB ASSEMBLY

Drawing No. DA400878 Sheet 2



© Datron Instruments 1991

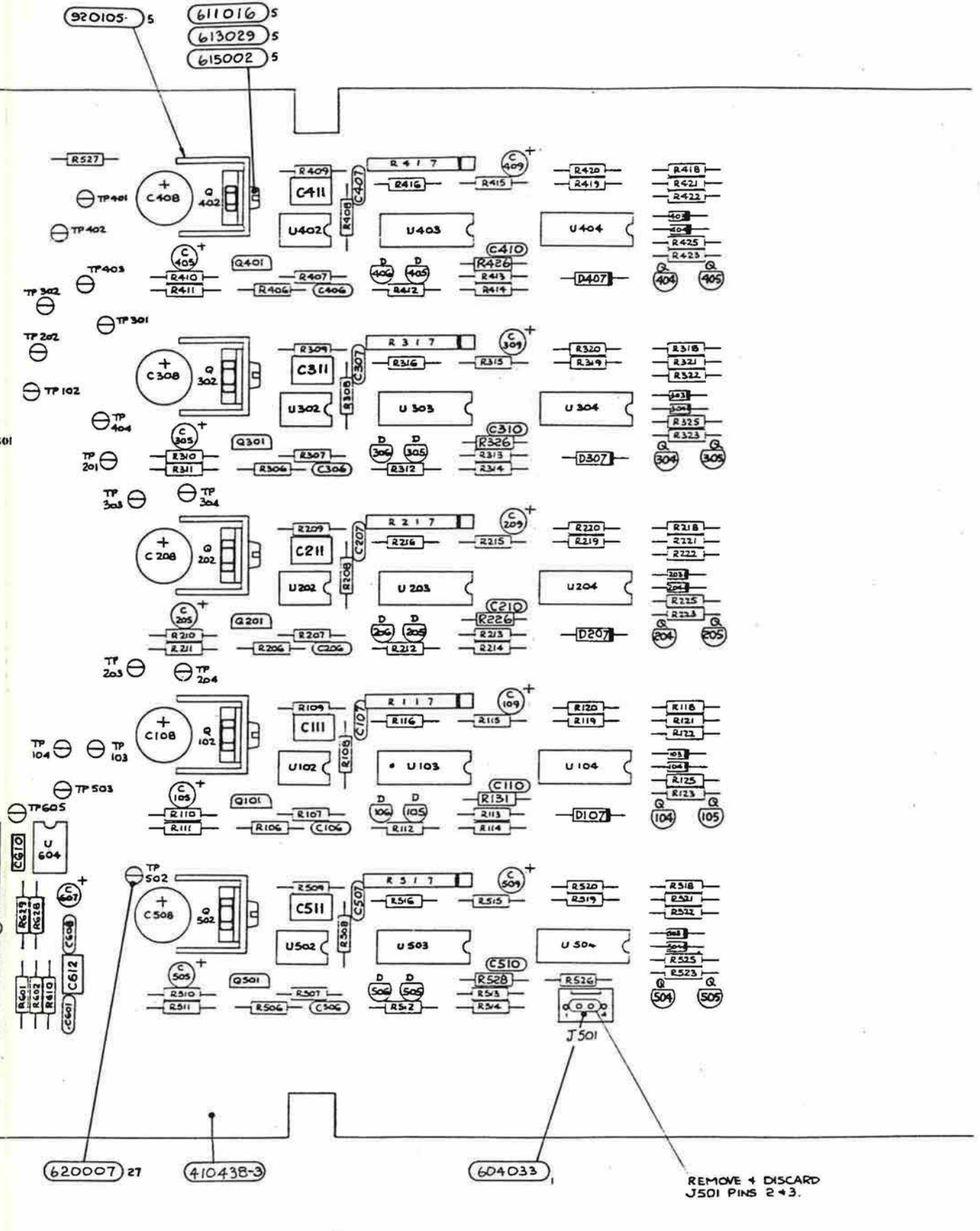
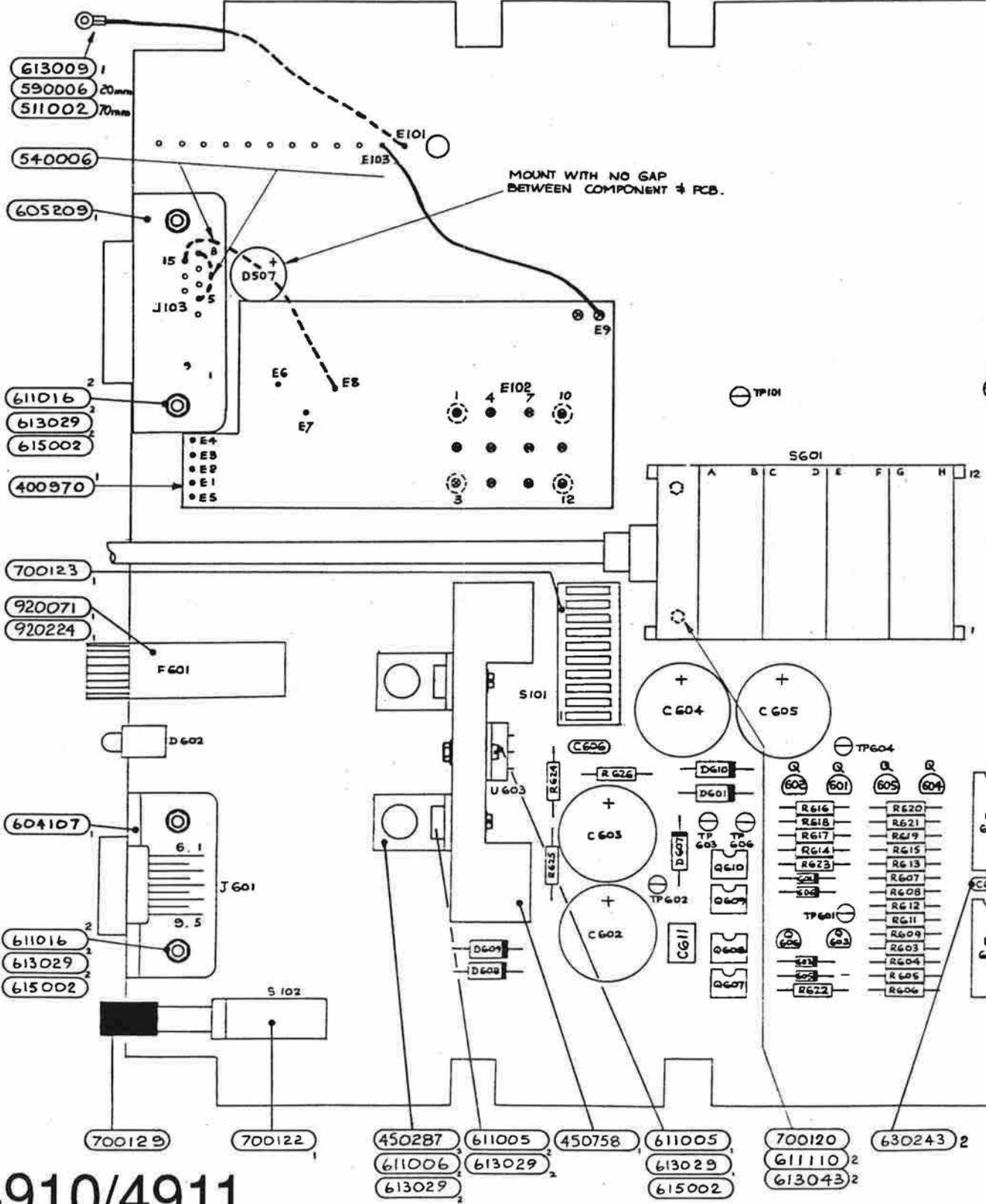
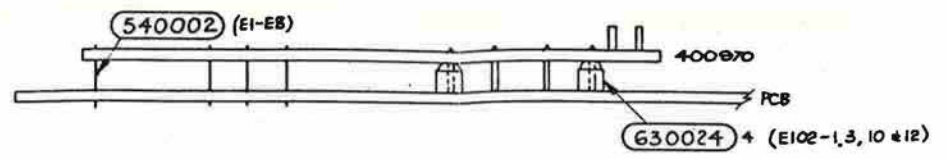

© Datron Instruments 1991

MOTHER PCB ASSEMBLY
 Drawing No. DA400878 Sheet 1

NOTE: SEE SHT. 2 FOR DETAILS OF OTHER HALF OF BOARD ASSY.

REMOVE & DISCARD J501 PINS 2 & 3.

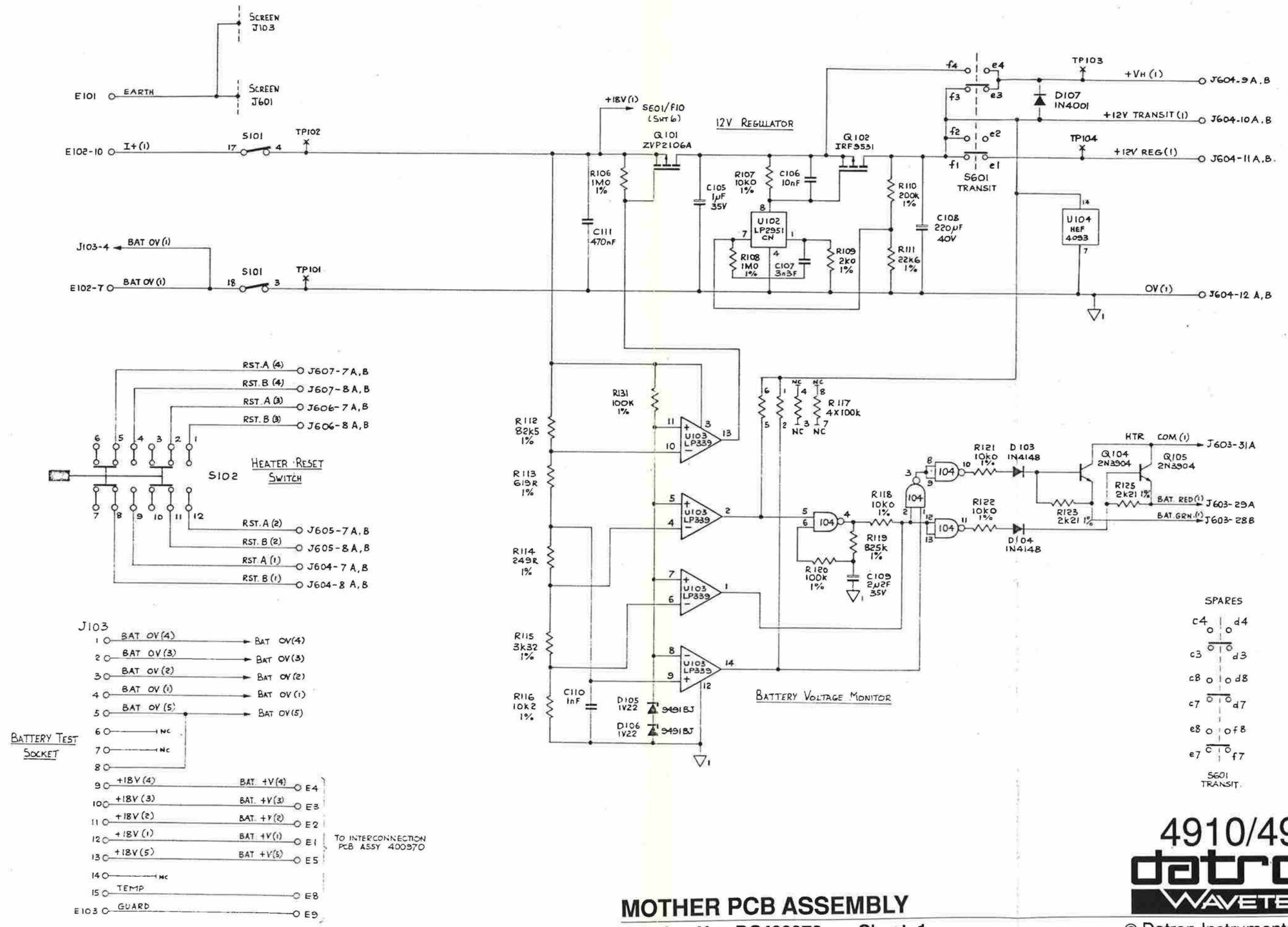

BATTERY TEST SOCKET

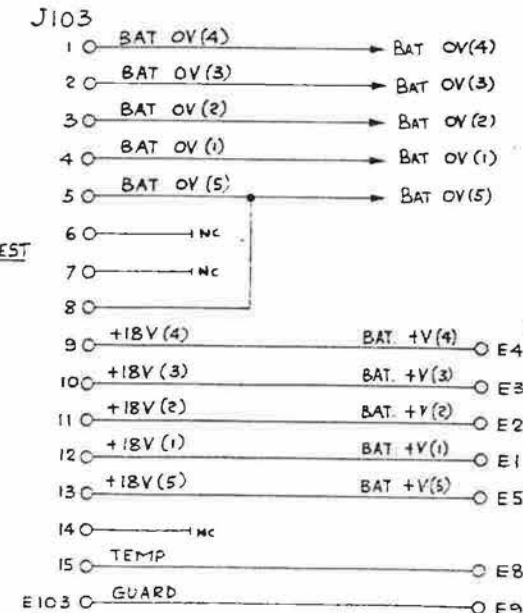

TO INTERCONNECTION PCB ASSY 400970

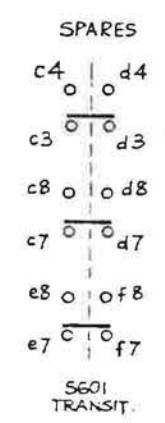

MOTHER PCB ASSEMBLY

Drawing No. DC400878 Sheet 1



© Datron Instruments 1991

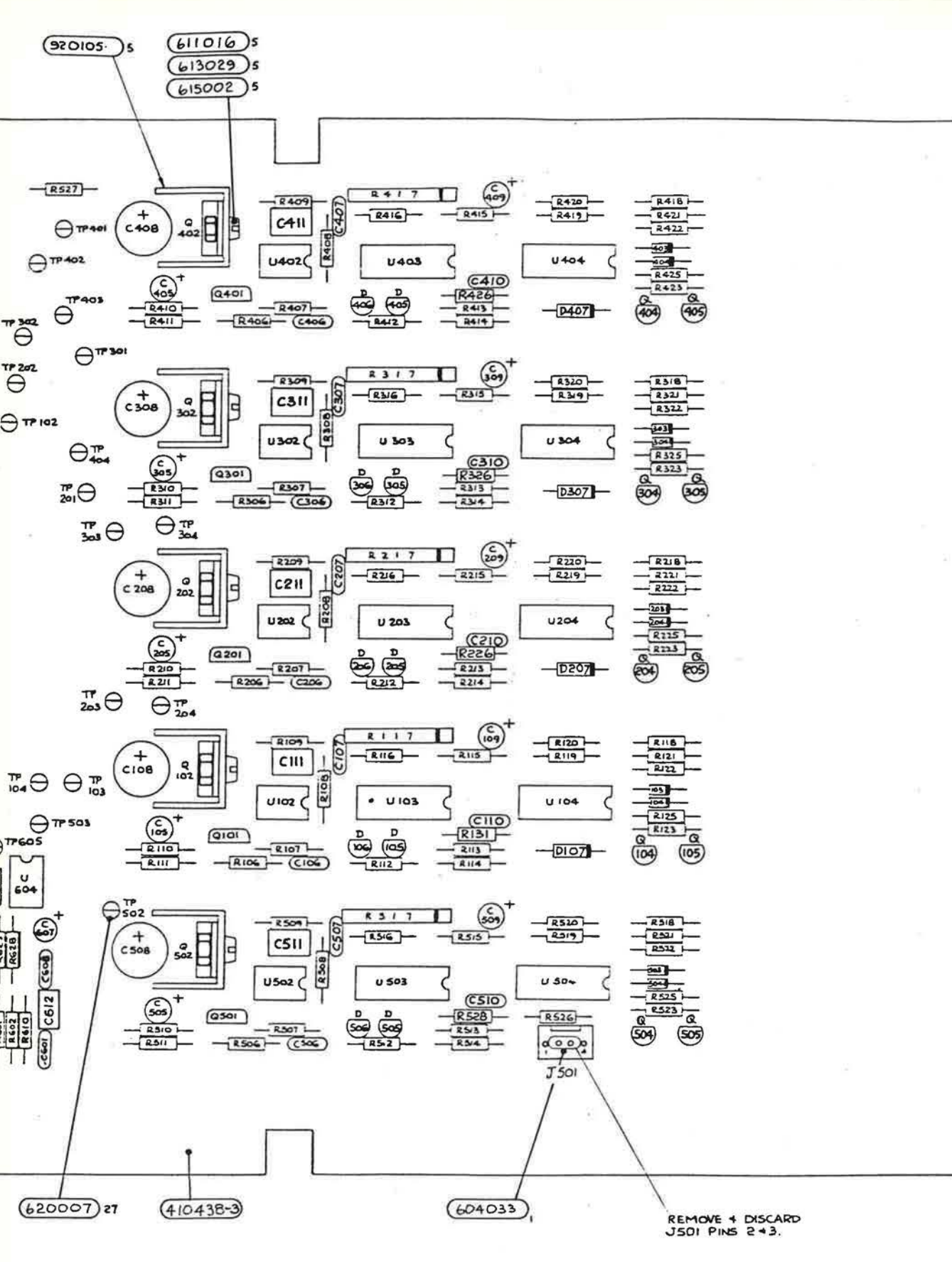
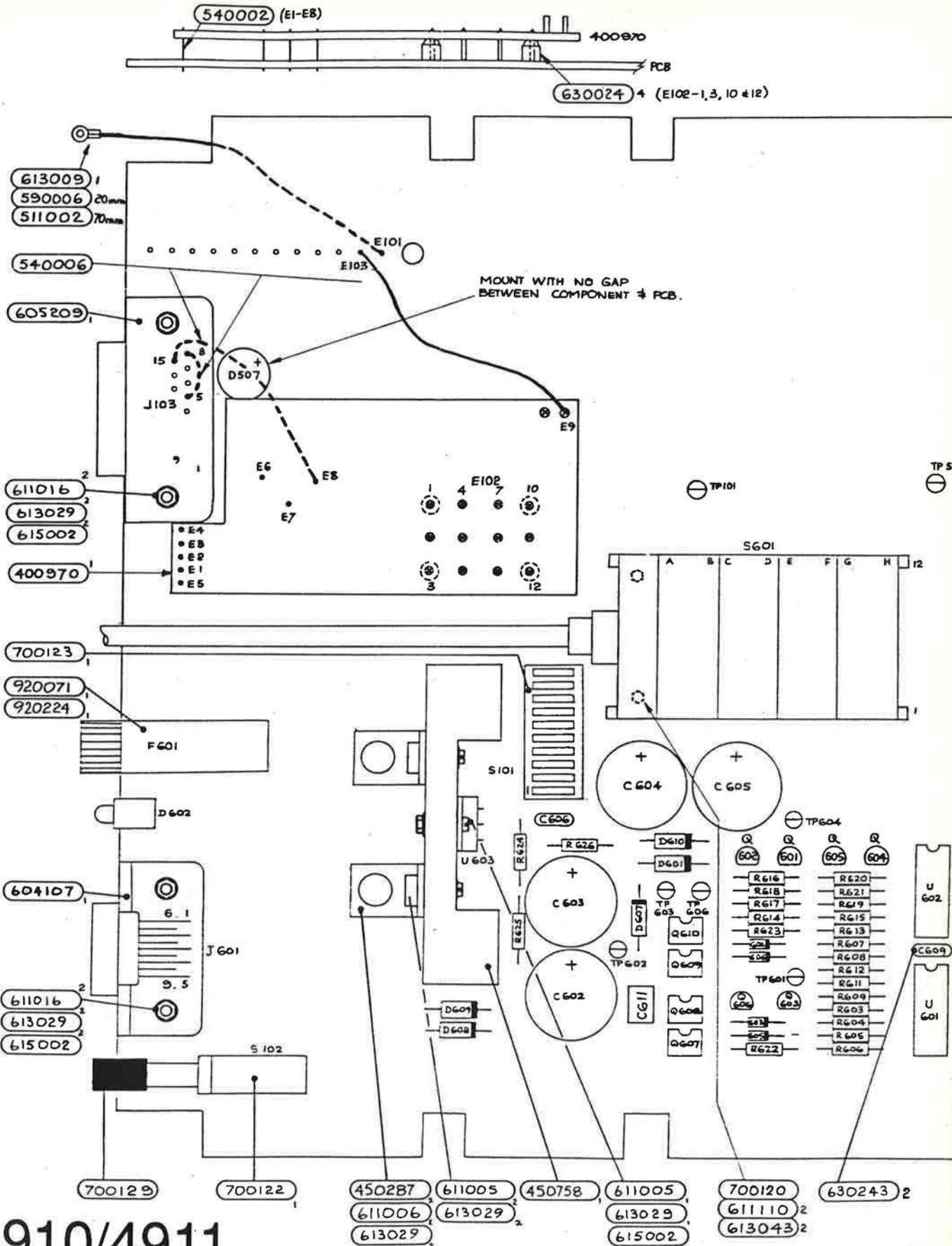

NOTE: SEE SHT. 2 FOR DETAILS OF OTHER HALF OF BOARD ASSY.

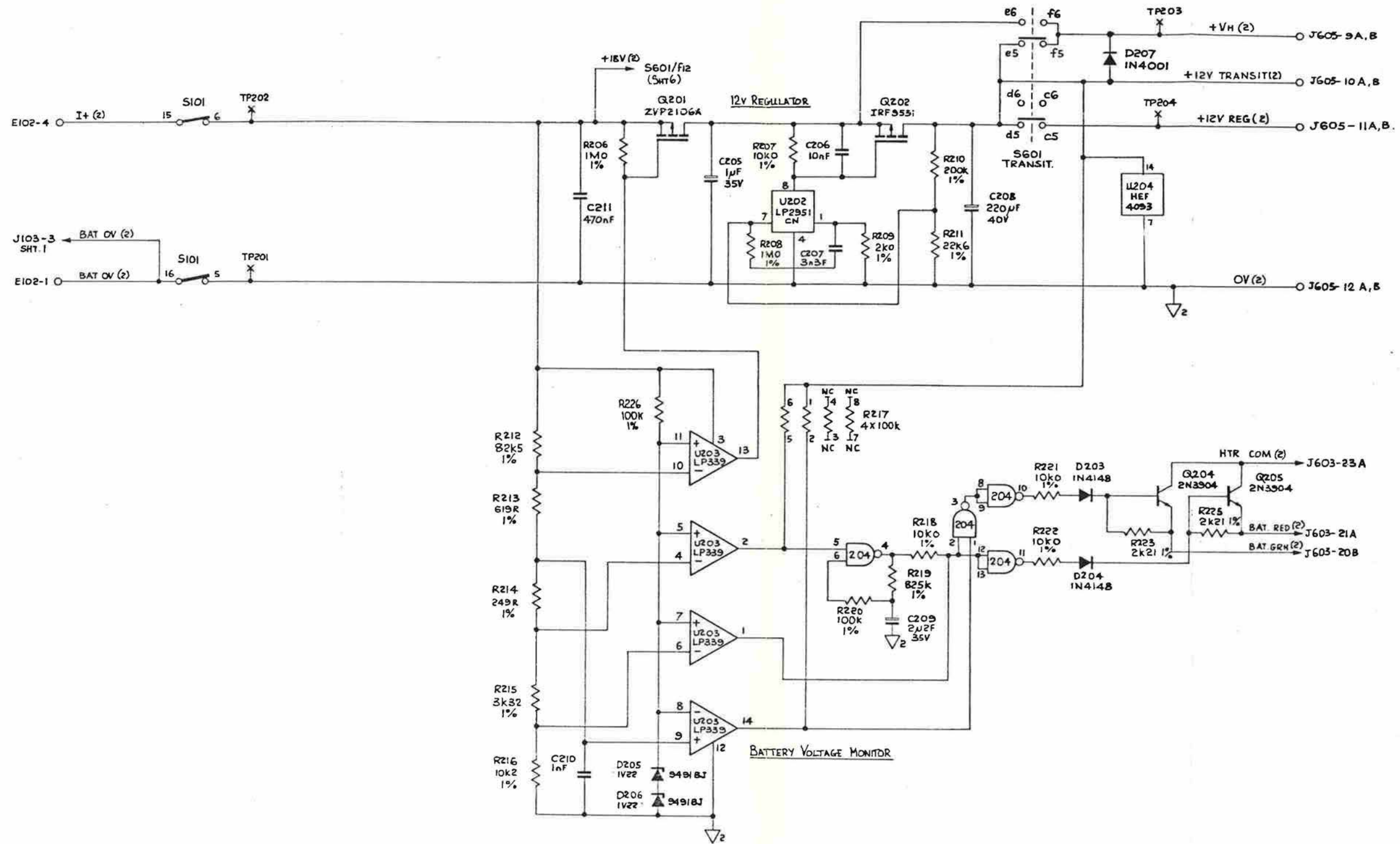

MOTHER PCB ASSEMBLY

Drawing No. DC400878 Sheet 2



© Datron Instruments 1991

MOTHER PCB ASSEMBLY

Drawing No. DA400878

Sheet 1

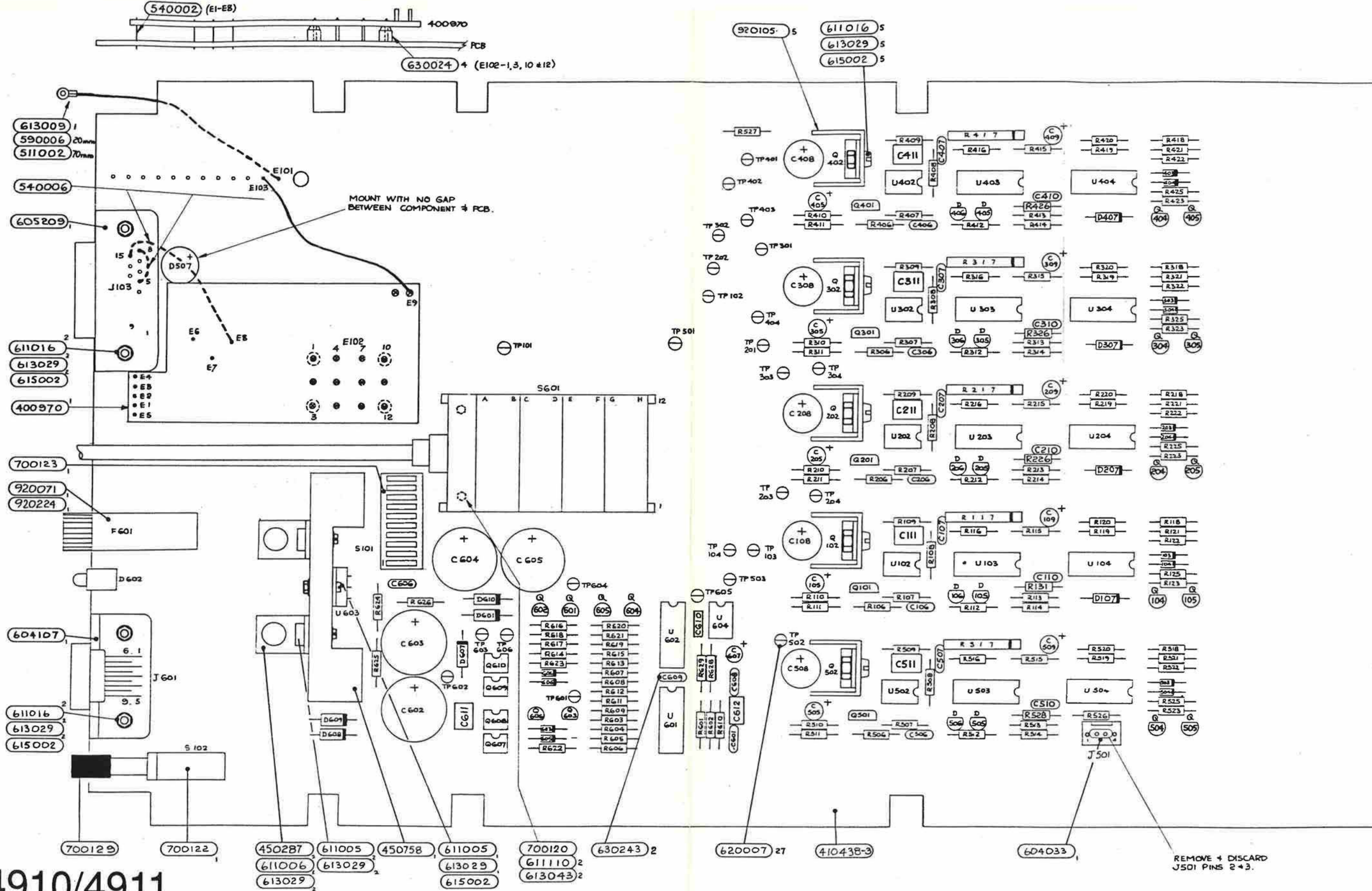

NOTE: SEE SHT. 2 FOR DETAILS OF OTHER HALF OF BOARD ASSY.

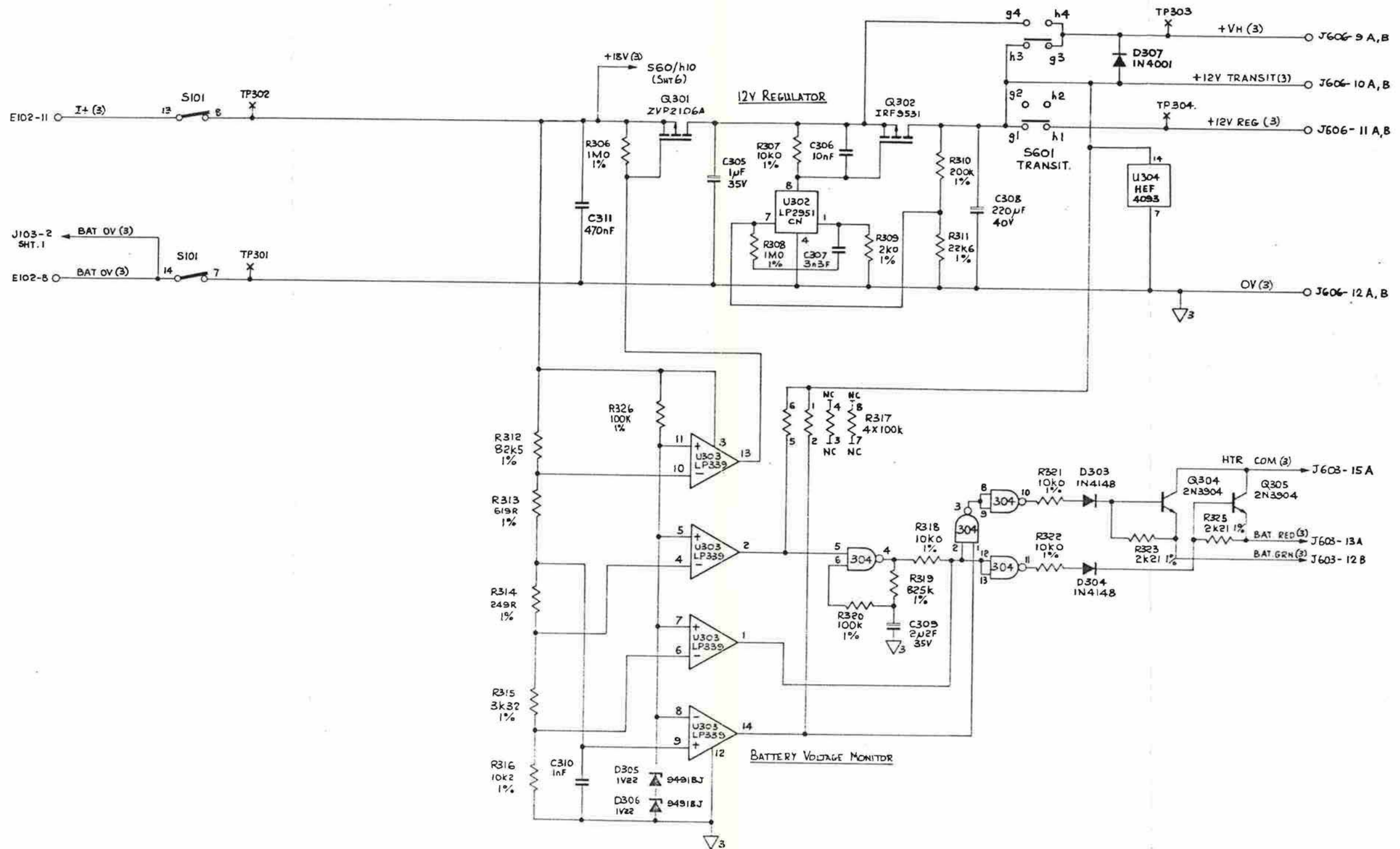

MOTHER PCB ASSEMBLY

Drawing No. DC400878 Sheet 3



© Datron Instruments 1991

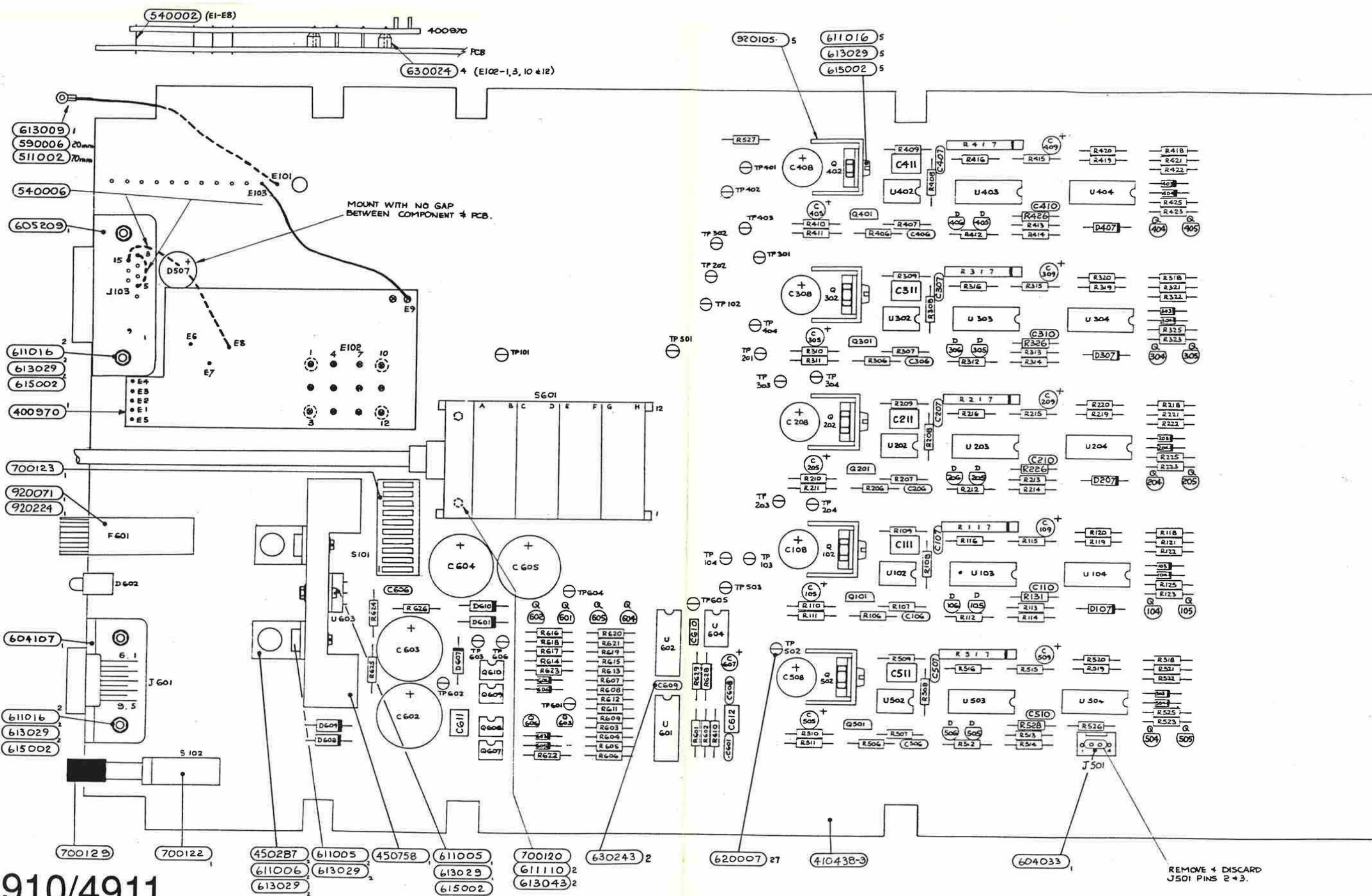

NOTE: SEE SHT. 2 FOR DETAILS OF OTHER HALF OF BOARD ASSY.

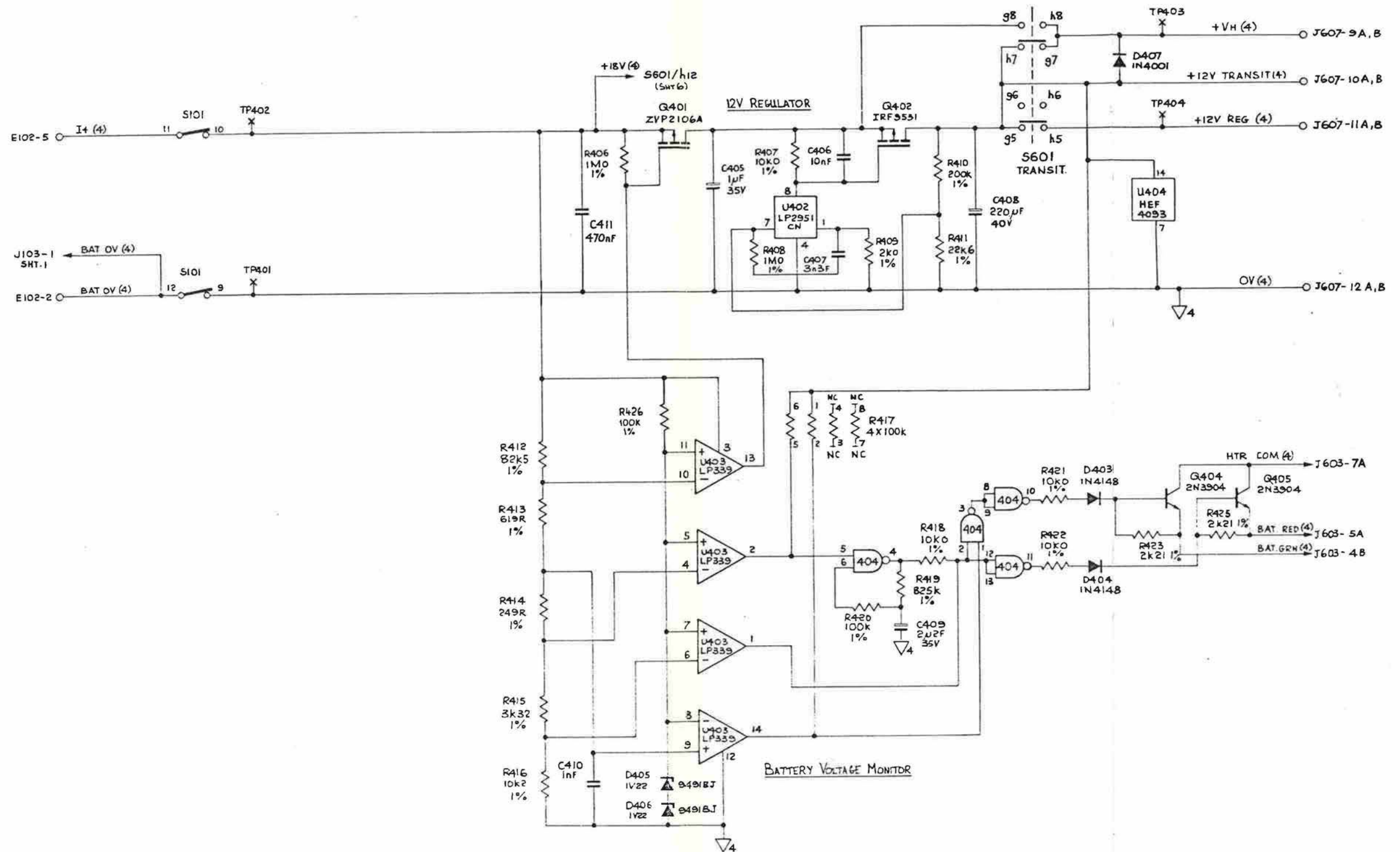

MOTHER PCB ASSEMBLY

Drawing No. DC400878 Sheet 4



© Datron Instruments 1991

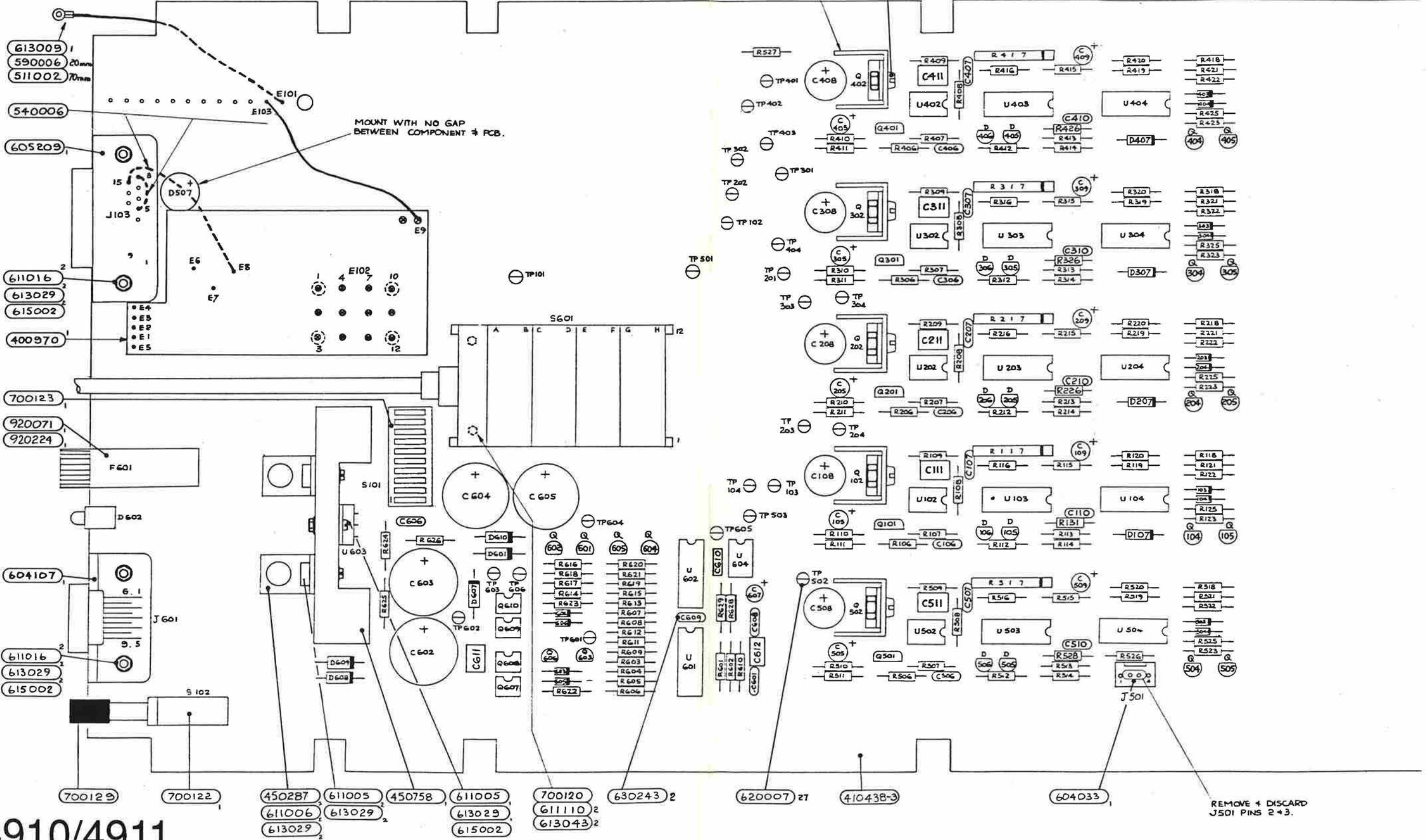
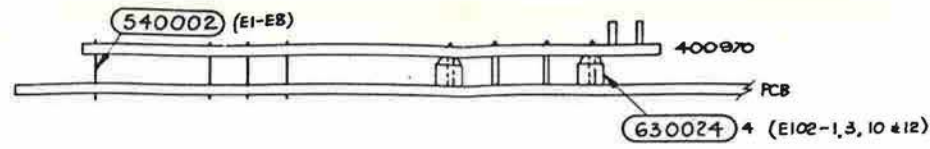

- 613009 1
- 590006 20mm
- 511002 70mm
- 540006
- 605209
- 611016 2
- 613029 2
- 615002 2
- 400970 1

- 700123 1
- 920071
- 920224

- 604107
- 611016 2
- 613029 2
- 615002 2

- 700129
- 700122
- 450287
- 611005
- 450758
- 611005
- 611006
- 613029 2
- 613029 2
- 613029 2
- 700120
- 611110 2
- 613043 2
- 630243 2

- 920105 5
- 611016 5
- 613029 5
- 615002 5
- 620007 27
- 410438-3
- 604033 1

REMOVE & DISCARD J501 PINS 2+3.



© Datron Instruments 1991

MOTHER PCB ASSEMBLY
Drawing No. DA400878

NOTE: SEE SHT. 2 FOR DETAILS OF OTHER HALF OF BOARD ASSY.

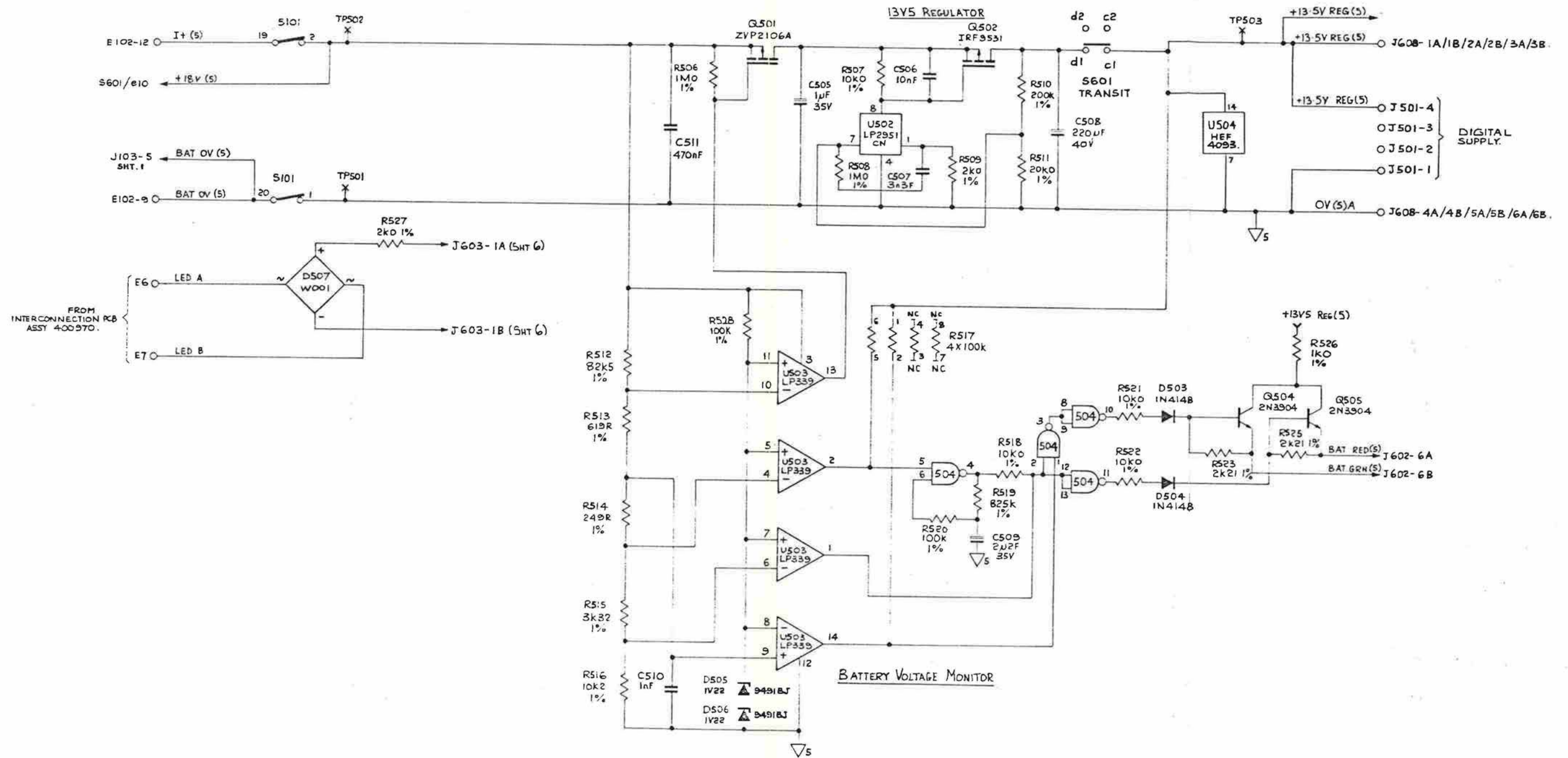

MOTHER PCB ASSEMBLY
 Drawing No. DC400878 Sheet 5

© Datron Instruments 1991

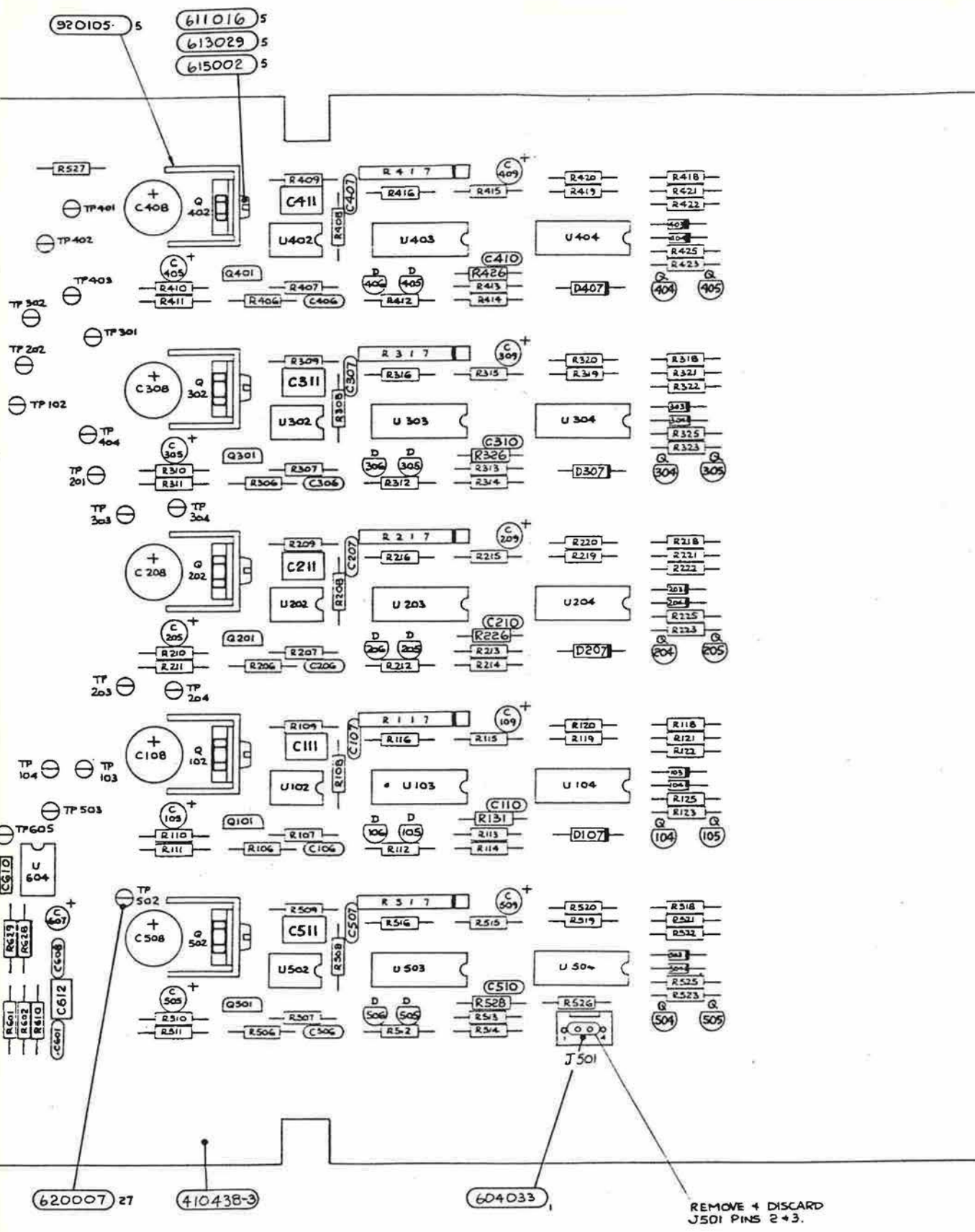
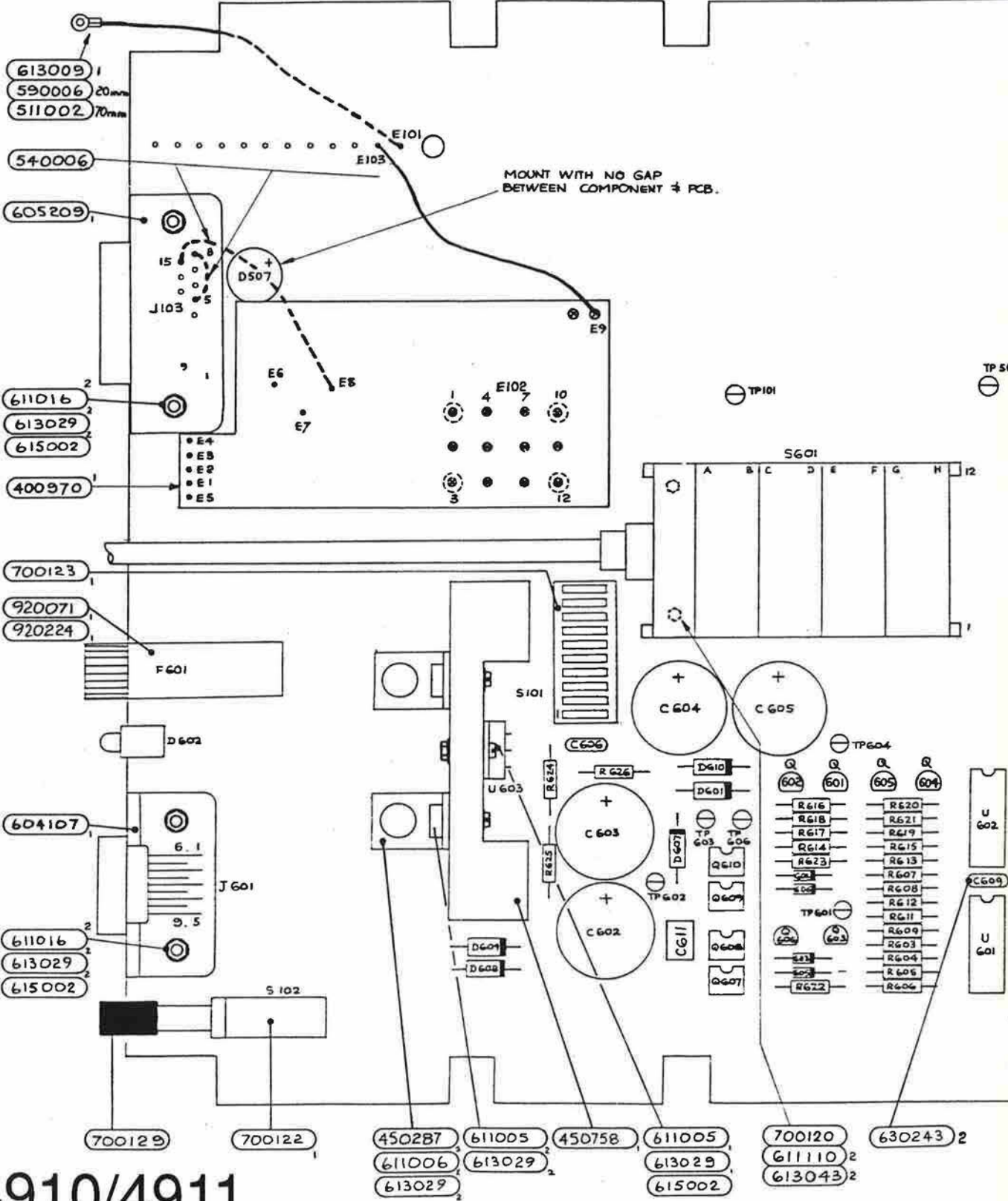
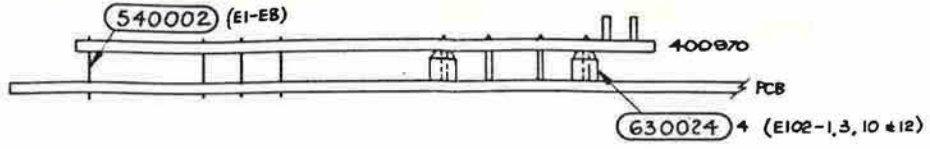

© Datron Instruments 1991

MOTHER PCB ASSEMBLY
Drawing No. DA400878 Sheet 1

NOTE: SEE SHT. 2 FOR DETAILS OF OTHER HALF OF BOARD ASSY.

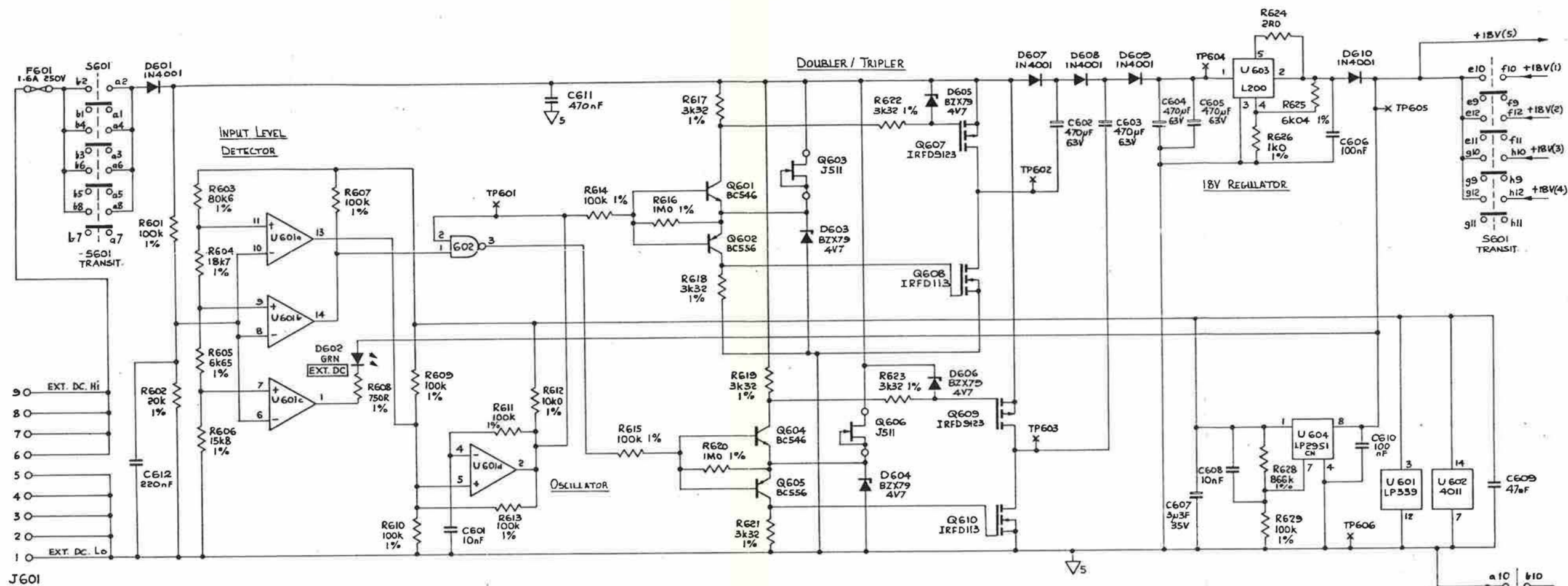

J601

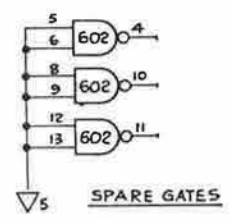

SPARE GATES

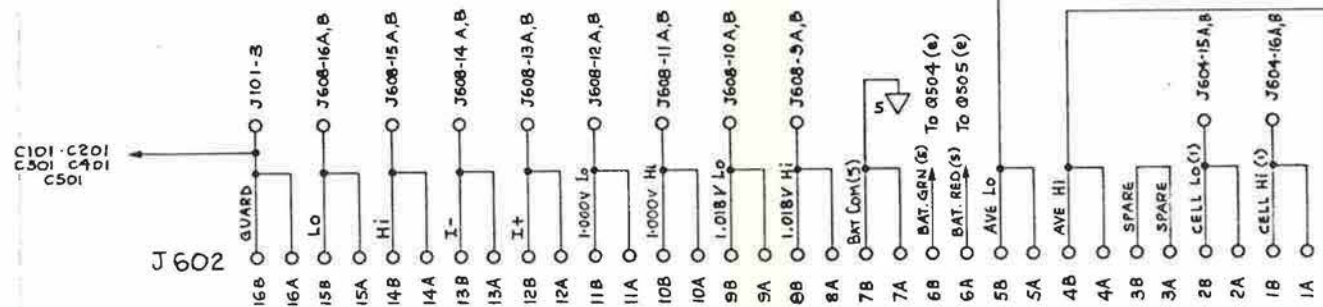

J602

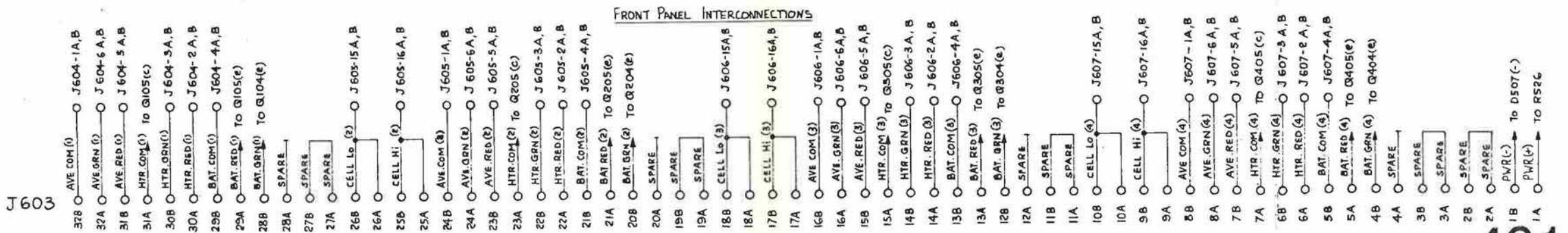
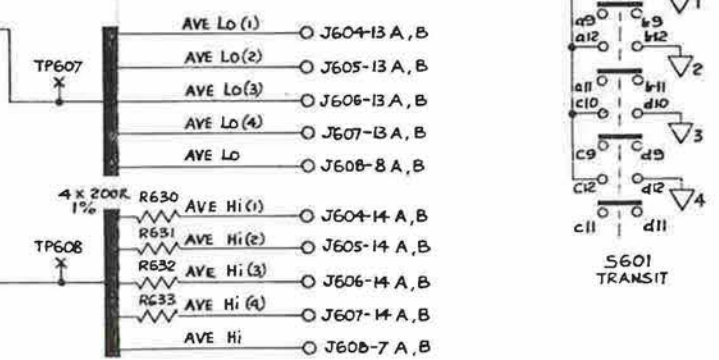

J603



MOTHER PCB ASSEMBLY

Drawing No. DC400878 Sheet 6

© Datron Instruments 1991

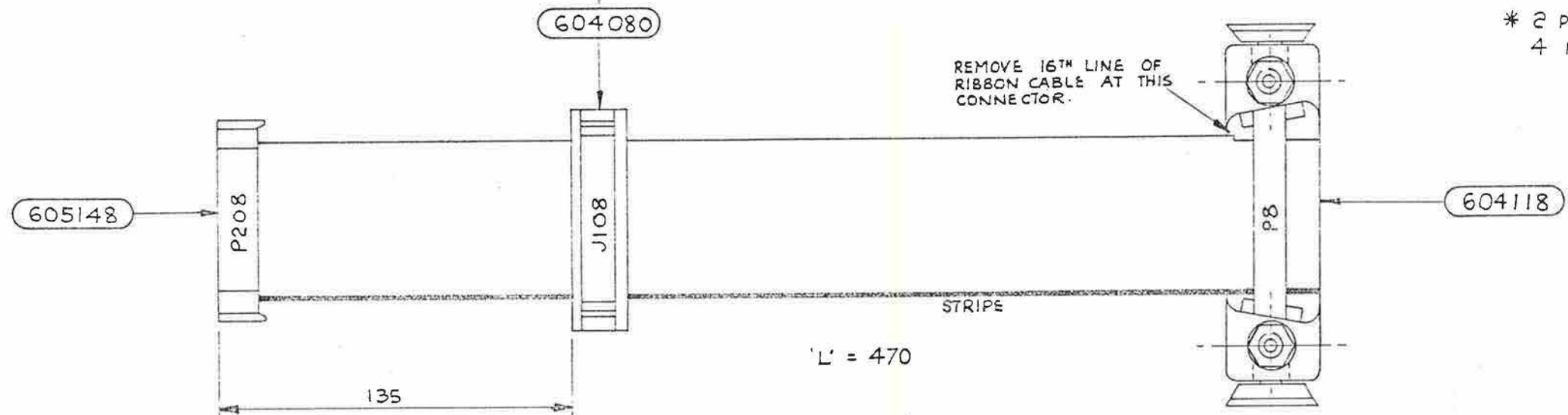
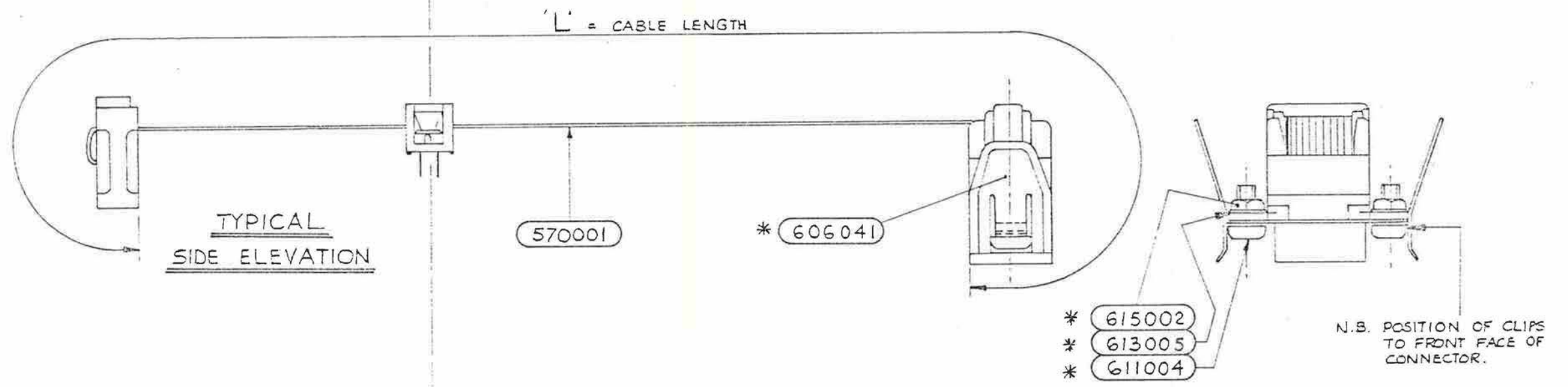
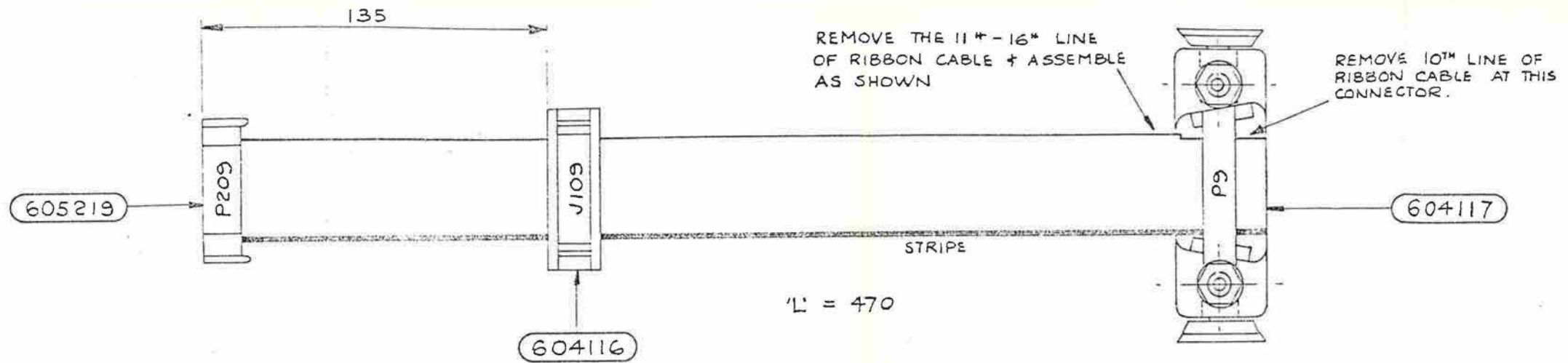

INTERCONN. PCB CABLE ASSEMBLIES
 Drawing No. DA400970 Sheet 1



© Datron Instruments 1991

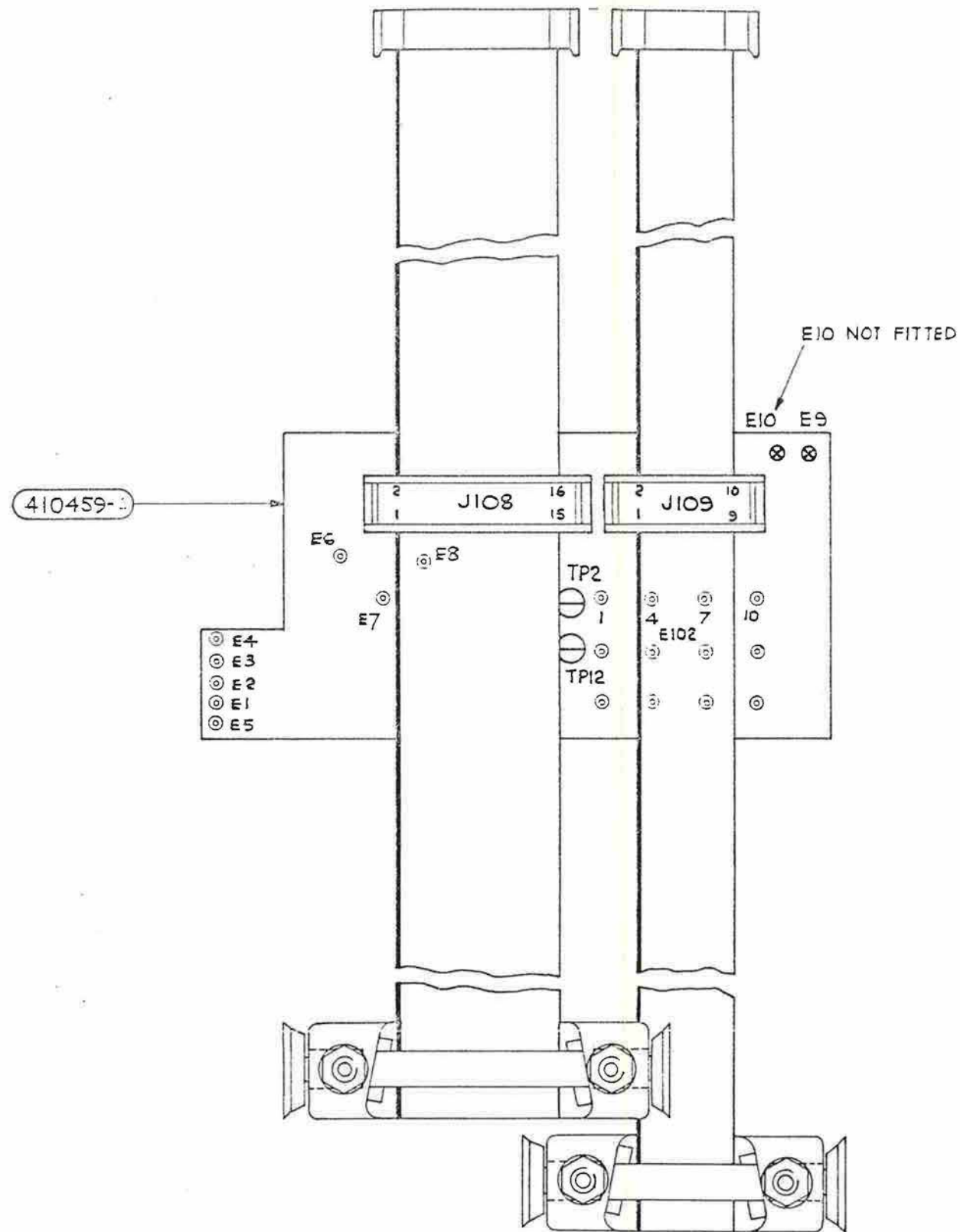

CHARGER/PSU PCB ASSEMBLY 400971

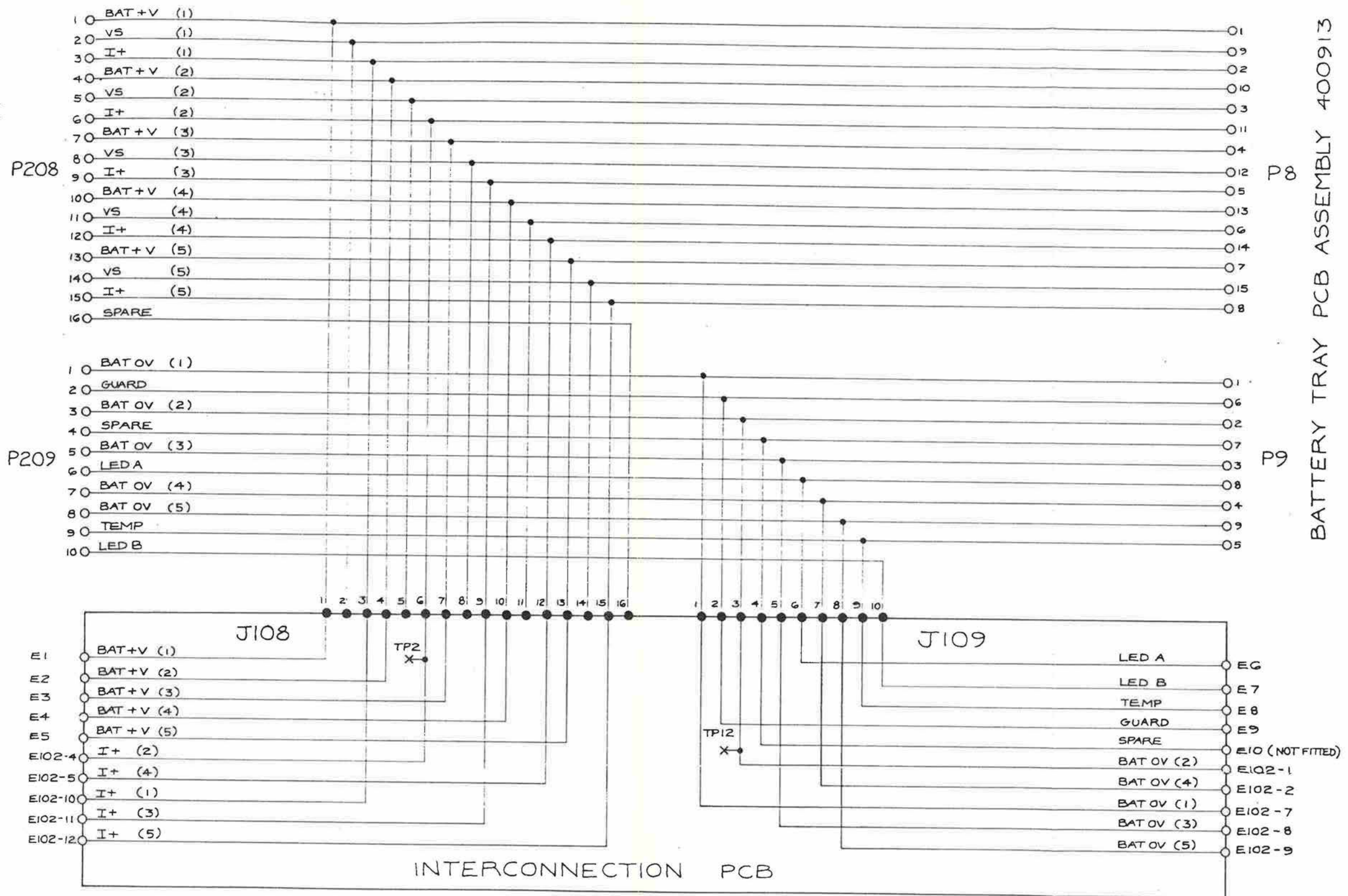

BATTERY TRAY PCB ASSEMBLY 400913

INTERCONNECTION PCB ASSEMBLY
 Drawing No. DC400970 Sheet 1



© Datron Instruments 1991

DRAWING No.		CHK'D				
LD400878						
DOCUMENT LIST		DATE				
DISTRIBUTION		1.0 3310 23/6/85				
ECO		1.1 3422 19/9/89				
REVISION		1.2 3477 29/11/89				
ISSUE		1.3 3499 11/12/89				
		1.4 3546 1/3/90				
		1.5 3573 29/3/90				
		2.0 3600 14/6/90				
		2.1 3667 16/8/90				
DESCRIPTION			ISSUE - REVISION			
PARTS LIST	DRAWING NUMBER	SHEET NUMBER				
	LP400878	ALL	1.0	1.0	1.0	
ASSEMBLY DRAWING	DA400878	1	1.0	1.0	1.1	
	DA400878	2		1.2	1.3	
				1.1	1.3	
				1.2	1.4	
				1.3	1.5	
				2.0	2.0	
				2.1		
CIRCUIT DIAGRAM	DRAWING NUMBER	SHEET NUMBER				
	DC400878	1	1.0	1.0	1.0	
	DC400878	2		1.1	1.1	
	DC400878	3		1.2	1.2	
	DC400878	4		1.1	1.1	
	DC400878	5		1.3	1.2	
	DC400878	6		1.4		
				2.0	2.0	
TEST PROCEDURE	DRAWING NUMBER	SHEET NUMBER				
	PT400878	ALL	1.0	1.0	1.0	
TEST SPECIFICATION	DRAWING NUMBER	SHEET NUMBER				
PCB	DRAWING NUMBER	SHEET NUMBER				
	410438	1	2.0		3.0	

<input type="checkbox"/> DENOTES NO CHANGE TO DOCS AT ISSUE LEVEL CHANGE	datron INSTRUMENTS LTD NORWICH ENGLAND	URM 11 DATE 6 APR 89	CHK'D Rbc DATE 23 JUN 89	APP'D RWF DATE 29 JUL 89	TITLE 4910 MOTHER PCB. ASSY	DRAWING No. LD400878 SHEET 1 OF 1
--	---	-------------------------	-----------------------------	-----------------------------	--------------------------------	--------------------------------------

DATRON INSTRUMENTS LTD PARTS LIST 29-Apr-91 DESC: ASSY PCB MOTHER 4910 DRG NO: LP400878-2 REV: 0 PAGE NO: 1

DESIG	PART NO	DESCRIPTION	PRINC MANUF	MANUF PART NUMBER	CLASS	UM	QUANTITY	CHANGES
R106	041004	RES MF 1M00 1% .12W 50PPM	HOLSWORTHY	H8C	A		EA 12	
R107	011002	RES MF 10K0 1% .12W 50PPM	HOLSWORTHY	H8C	A		EA 21	
R108	041004	RES MF 1M00 1% .12W 50PPM	HOLSWORTHY	H8C	A		EA -	
K109	012001	RES MF 2K00 1% .12W 50PPM	HOLSWORTHY	H8C	A		EA 6	
R110	012003	RES MF 200K 1% .12W 50PPM	HOLSWORTHY	H8C	A		EA 5	
R111	012262	RES MF 22K6 1% .12W 50PPM	HOLSWORTHY	H8C	A		EA 4	
R112	018252	RES MF 82K5 1% .12W 50PPM	HOLSWORTHY	H8C	A		EA 5	
R113	016190	RES MF 619R 1% .12W 50PPM	HOLSWORTHY	H8C	A		EA 5	
R114	012490	RES MF 249R 1% .12W 50PPM	HOLSWORTHY	H8C	A		EA 5	
R115	013321	RES MF 3K32 1% .12W 50PPM	HOLSWORTHY	H8C	A		EA 11	
R116	011022	RES MF 10K2 1% .12W 50PPM	HOLSWORTHY	H8C	A		EA 5	
R117	090167	RES PACK 100K X 4 2%	BECKMAN	LOB-3S-R100K	A		EA 5	
R118	011002	RES MF 10K0 1% .12W 50PPM	HOLSWORTHY	H8C	A		EA -	
R119	048253	RES MF 825K 1% .12W 50PPM	HOLSWORTHY	H8C	A		EA 5	
R120	011003	RES MF 100K 1% .12W 50PPM	HOLSWORTHY	H8C	A		EA 19	
R121	011002	RES MF 10K0 1% .12W 50PPM	HOLSWORTHY	H8C	A		EA -	
R122	011002	RES MF 10K0 1% .12W 50PPM	HOLSWORTHY	H8C	A		EA -	
R123	012211	RES MF 2K21 1% .12W 50PPM	HOLSWORTHY	H8C	A		EA 10	
R125	012211	RES MF 2K21 1% .12W 50PPM	HOLSWORTHY	H8C	A		EA -	
R131	011003	RES MF 100K 1% .12W 50PPM	HOLSWORTHY	H8C	A		EA -	
R206	041004	RES MF 1M00 1% .12W 50PPM	HOLSWORTHY	H8C	A		EA -	
R207	011002	RES MF 10K0 1% .12W 50PPM	HOLSWORTHY	H8C	A		EA -	
R208	041004	RES MF 1M00 1% .12W 50PPM	HOLSWORTHY	H8C	A		EA -	
R209	012001	RES MF 2K00 1% .12W 50PPM	HOLSWORTHY	H8C	A		EA -	
R210	012003	RES MF 200K 1% .12W 50PPM	HOLSWORTHY	H8C	A		EA -	
R211	012262	RES MF 22K6 1% .12W 50PPM	HOLSWORTHY	H8C	A		EA -	
R212	018252	RES MF 82K5 1% .12W 50PPM	HOLSWORTHY	H8C	A		EA -	
R213	016190	RES MF 619R 1% .12W 50PPM	HOLSWORTHY	H8C	A		EA -	
R214	012490	RES MF 249R 1% .12W 50PPM	HOLSWORTHY	H8C	A		EA -	
R215	013321	RES MF 3K32 1% .12W 50PPM	HOLSWORTHY	H8C	A		EA -	
R216	011022	RES MF 10K2 1% .12W 50PPM	HOLSWORTHY	H8C	A		EA -	
R217	090167	RES PACK 100K X 4 2%	BECKMAN	LOB-3S-R100K	A		EA -	
R218	011002	RES MF 10K0 1% .12W 50PPM	HOLSWORTHY	H8C	A		EA -	
R219	048253	RES MF 825K 1% .12W 50PPM	HOLSWORTHY	H8C	A		EA -	
R220	011003	RES MF 100K 1% .12W 50PPM	HOLSWORTHY	H8C	A		EA -	
R221	011002	RES MF 10K0 1% .12W 50PPM	HOLSWORTHY	H8C	A		EA -	
R222	011002	RES MF 10K0 1% .12W 50PPM	HOLSWORTHY	H8C	A		EA -	
R223	012211	RES MF 2K21 1% .12W 50PPM	HOLSWORTHY	H8C	A		EA -	
R225	012211	RES MF 2K21 1% .12W 50PPM	HOLSWORTHY	H8C	A		EA -	
R226	011003	RES MF 100K 1% .12W 50PPM	HOLSWORTHY	H8C	A		EA -	
R306	041004	RES MF 1M00 1% .12W 50PPM	HOLSWORTHY	H8C	A		EA -	
R307	011002	RES MF 10K0 1% .12W 50PPM	HOLSWORTHY	H8C	A		EA -	
R308	041004	RES MF 1M00 1% .12W 50PPM	HOLSWORTHY	H8C	A		EA -	
R309	012001	RES MF 2K00 1% .12W 50PPM	HOLSWORTHY	H8C	A		EA -	
R310	012003	RES MF 200K 1% .12W 50PPM	HOLSWORTHY	H8C	A		EA -	

DESIG	PART NO	DESCRIPTION	PRINC MANUF	MANUF PART NUMBER	CLASS	UM	QUANTITY	CHANGES
R311	012262	RES MF 22K6 1% .12W 50PPM	HOLSWORTHY	H8C	A	EA	-	
R312	018252	RES MF 82K5 1% .12W 50PPM	HOLSWORTHY	H8C	A	EA	-	
R313	016190	RES MF 619R 1% .12W 50PPM	HOLSWORTHY	H8C	A	EA	-	
R314	012490	RES MF 249R 1% .12W 50PPM	HOLSWORTHY	H8C	A	EA	-	
R315	013321	RES MF 3K32 1% .12W 50PPM	HOLSWORTHY	H8C	A	EA	-	
R316	011022	RES MF 10K2 1% .12W 50PPM	HOLSWORTHY	H8C	A	EA	-	
R317	090167	RES PACK 100K X 4 2%	BECKMAN	LOB-3S-R100K	A	EA	-	
R318	011002	RES MF 10K0 1% .12W 50PPM	HOLSWORTHY	H8C	A	EA	-	
R319	048253	RES MF 825K 1% .12W 50PPM	HOLSWORTHY	H8C	A	EA	-	
R320	011003	RES MF 100K 1% .12W 50PPM	HOLSWORTHY	H8C	A	EA	-	
R321	011002	RES MF 10K0 1% .12W 50PPM	HOLSWORTHY	H8C	A	EA	-	
R322	011002	RES MF 10K0 1% .12W 50PPM	HOLSWORTHY	H8C	A	EA	-	
R323	012211	RES MF 2K21 1% .12W 50PPM	HOLSWORTHY	H8C	A	EA	-	
R325	012211	RES MF 2K21 1% .12W 50PPM	HOLSWORTHY	H8C	A	EA	-	
R326	011003	RES MF 100K 1% .12W 50PPM	HOLSWORTHY	H8C	A	EA	-	
R406	041004	RES MF 1M00 1% .12W 50PPM	HOLSWORTHY	H8C	A	EA	-	
R407	011002	RES MF 10K0 1% .12W 50PPM	HOLSWORTHY	H8C	A	EA	-	
R408	041004	RES MF 1M00 1% .12W 50PPM	HOLSWORTHY	H8C	A	EA	-	
R409	012001	RES MF 2K00 1% .12W 50PPM	HOLSWORTHY	H8C	A	EA	-	
R410	012003	RES MF 200K 1% .12W 50PPM	HOLSWORTHY	H8C	A	EA	-	
R411	012262	RES MF 22K6 1% .12W 50PPM	HOLSWORTHY	H8C	A	EA	-	
R412	018252	RES MF 82K5 1% .12W 50PPM	HOLSWORTHY	H8C	A	EA	-	
R413	016190	RES MF 619R 1% .12W 50PPM	HOLSWORTHY	H8C	A	EA	-	
R414	012490	RES MF 249R 1% .12W 50PPM	HOLSWORTHY	H8C	A	EA	-	
R415	013321	RES MF 3K32 1% .12W 50PPM	HOLSWORTHY	H8C	A	EA	-	
R416	011022	RES MF 10K2 1% .12W 50PPM	HOLSWORTHY	H8C	A	EA	-	
R417	090167	RES PACK 100K X 4 2%	BECKMAN	LOB-3S-R100K	A	EA	-	
R418	011002	RES MF 10K0 1% .12W 50PPM	HOLSWORTHY	H8C	A	EA	-	
R419	048253	RES MF 825K 1% .12W 50PPM	HOLSWORTHY	H8C	A	EA	-	
R420	011003	RES MF 100K 1% .12W 50PPM	HOLSWORTHY	H8C	A	EA	-	
R421	011002	RES MF 10K0 1% .12W 50PPM	HOLSWORTHY	H8C	A	EA	-	
R422	011002	RES MF 10K0 1% .12W 50PPM	HOLSWORTHY	H8C	A	EA	-	
R423	012211	RES MF 2K21 1% .12W 50PPM	HOLSWORTHY	H8C	A	EA	-	
R425	012211	RES MF 2K21 1% .12W 50PPM	HOLSWORTHY	H8C	A	EA	-	
R426	011003	RES MF 100K 1% .12W 50PPM	HOLSWORTHY	H8C	A	EA	-	
R506	041004	RES MF 1M00 1% .12W 50PPM	HOLSWORTHY	H8C	A	EA	-	
R507	011002	RES MF 10K0 1% .12W 50PPM	HOLSWORTHY	H8C	A	EA	-	
R508	041004	RES MF 1M00 1% .12W 50PPM	HOLSWORTHY	H8C	A	EA	-	
R509	012001	RES MF 2K00 1% .12W 50PPM	HOLSWORTHY	H8C	A	EA	-	
R510	012003	RES MF 200K 1% .12W 50PPM	HOLSWORTHY	H8C	A	EA	-	
R511	012002	RES MF 20K0 1% .12W 50PPM	HOLSWORTHY	H8C	A	EA	2	
R512	018252	RES MF 82K5 1% .12W 50PPM	HOLSWORTHY	H8C	A	EA	-	
R513	016190	RES MF 619R 1% .12W 50PPM	HOLSWORTHY	H8C	A	EA	-	
R514	012490	RES MF 249R 1% .12W 50PPM	HOLSWORTHY	H8C	A	EA	-	
R515	013321	RES MF 3K32 1% .12W 50PPM	HOLSWORTHY	H8C	A	EA	-	

DESIG	PART NO	DESCRIPTION	PRINC MANUF	MANUF PART NUMBER	CLASS	UM	QUANTITY	CHANGES
R516	011022	RES MF 10K2 1% .12W 50PPM	HOLSWORTHY	H8C	A	EA	-	
R517	090167	RES PACK 100K X 4 2%	BECKMAN	LOB-3S-R100K	A	EA	-	
R518	011002	RES MF 10K0 1% .12W 50PPM	HOLSWORTHY	H8C	A	EA	-	
R519	048253	RES MF 825K 1% .12W 50PPM	HOLSWORTHY	H8C	A	EA	-	
R520	011003	RES MF 100K 1% .12W 50PPM	HOLSWORTHY	H8C	A	EA	-	
R521	011002	RES MF 10K0 1% .12W 50PPM	HOLSWORTHY	H8C	A	EA	-	
R522	011002	RES MF 10K0 1% .12W 50PPM	HOLSWORTHY	H8C	A	EA	-	
R523	012211	RES MF 2K21 1% .12W 50PPM	HOLSWORTHY	H8C	A	EA	-	
R525	012211	RES MF 2K21 1% .12W 50PPM	HOLSWORTHY	H8C	A	EA	-	
R526	011001	RES MF 1K00 1% .12W 50PPM	HOLSWORTHY	H8C	A	EA	2	
R527	012001	RES MF 2K00 1% .12W 50PPM	HOLSWORTHY	H8C	A	EA	-	
R528	011003	RES MF 100K 1% .12W 50PPM	HOLSWORTHY	H8C	A	EA	-	
R601	011003	RES MF 100K 1% .12W 50PPM	HOLSWORTHY	H8C	A	EA	-	
R602	012002	RES MF 20K0 1% .12W 50PPM	HOLSWORTHY	H8C	A	EA	-	
R603	018062	RES MF 80K6 1% .12W 50PPM	HOLSWORTHY	H8C	A	EA	1	
R604	011872	RES MF 18K7 1% .12W 50PPM	HOLSWORTHY	H8C	A	EA	1	
R605	016651	RES MF 6K65 1% .12W 50PPM	HOLSWORTHY	H8C	A	EA	1	
R606	011582	RES MF 15K8 1% .12W 50PPM	HOLSWORTHY	H8C	A	EA	1	
R607	011003	RES MF 100K 1% .12W 50PPM	HOLSWORTHY	H8C	A	EA	-	
R608	017500	RES MF 750R 1% .12W 50PPM	HOLSWORTHY	H8C	A	EA	1	
R609	011003	RES MF 100K 1% .12W 50PPM	HOLSWORTHY	H8C	A	EA	-	
R610	011003	RES MF 100K 1% .12W 50PPM	HOLSWORTHY	H8C	A	EA	-	
R611	011003	RES MF 100K 1% .12W 50PPM	HOLSWORTHY	H8C	A	EA	-	
R612	011002	RES MF 10K0 1% .12W 50PPM	HOLSWORTHY	H8C	A	EA	-	
R613	011003	RES MF 100K 1% .12W 50PPM	HOLSWORTHY	H8C	A	EA	-	
R614	011003	RES MF 100K 1% .12W 50PPM	HOLSWORTHY	H8C	A	EA	-	
R615	011003	RES MF 100K 1% .12W 50PPM	HOLSWORTHY	H8C	A	EA	-	
R616	041004	RES MF 1M00 1% .12W 50PPM	HOLSWORTHY	H8C	A	EA	-	
R617	013321	RES MF 3K32 1% .12W 50PPM	HOLSWORTHY	H8C	A	EA	-	
R618	013321	RES MF 3K32 1% .12W 50PPM	HOLSWORTHY	H8C	A	EA	-	
R619	013321	RES MF 3K32 1% .12W 50PPM	HOLSWORTHY	H8C	A	EA	-	
R620	041004	RES MF 1M00 1% .12W 50PPM	HOLSWORTHY	H8C	A	EA	-	
R621	013321	RES MF 3K32 1% .12W 50PPM	HOLSWORTHY	H8C	A	EA	-	
R622	013321	RES MF 3K32 1% .12W 50PPM	HOLSWORTHY	H8C	A	EA	-	
R623	013321	RES MF 3K32 1% .12W 50PPM	HOLSWORTHY	H8C	A	EA	-	
R624	000208	RES CP 2R0 5% .25W	NEOHM	CPR25	A	EA	1	
R625	016041	RES MF 6K04 1% .12W 50PPM	HOLSWORTHY	H8C	A	EA	1	
R626	011001	RES MF 1K00 1% .12W 50PPM	HOLSWORTHY	H8C	A	EA	-	
R628	048663	RES MF 866K 1% .12W 50PPM	HOLSWORTHY	H8C	A	EA	1	
R629	011003	RES MF 100K 1% .12W 50PPM	HOLSWORTHY	H8C	A	EA	-	
R630	012000	RES MF 200R 1% .12W 50PPM	HOLSWORTHY	H8C	A	EA	4	
R631	012000	RES MF 200R 1% .12W 50PPM	HOLSWORTHY	H8C	A	EA	-	
R632	012000	RES MF 200R 1% .12W 50PPM	HOLSWORTHY	H8C	A	EA	-	
R633	012000	RES MF 200R 1% .12W 50PPM	HOLSWORTHY	H8C	A	EA	-	
C105	150016	CAP DT 1UF 20% 35V	AVX	TAP1R0M35F	A	EA	5	

DESIG	PART NO	DESCRIPTION	PRINC MANUF	MANUF PART NUMBER	CLASS	UM	QUANTITY	CHANGES
C106	110041	CAP PE 10NF 20% 100V	WIMA	PKS2			EA	7
C107	110027	CAP PE 3N3F 20% 100V	WIMA	PKS2			EA	5
C108	180044	CAP AE 220UF 40V	STEATITE	EKMOODE 322G			EA	5
C109	150022	CAP DT 2U2F 20% 35V	AVX	TAP2R2M35F	A		EA	5
C110	100102	CAP CP 1NF 10% 100V	PHILIPS	2222 630 19102			EA	5
C111	110039	CAP PE 470NF 20% 63V	WIMA	MKS2			EA	6
C205	150016	CAP DT 1UF 20% 35V	AVX	TAP1R0M35F	A		EA	-
C206	110041	CAP PE 10NF 20% 100V	WIMA	PKS2			EA	-
C207	110027	CAP PE 3N3F 20% 100V	WIMA	PKS2			EA	-
C208	180044	CAP AE 220UF 40V	STEATITE	EKMOODE 322G			EA	-
C209	150022	CAP DT 2U2F 20% 35V	AVX	TAP2R2M35F	A		EA	-
C210	100102	CAP CP 1NF 10% 100V	PHILIPS	2222 630 19102			EA	-
C211	110039	CAP PE 470NF 20% 63V	WIMA	MKS2			EA	-
C305	150016	CAP DT 1UF 20% 35V	AVX	TAP1R0M35F	A		EA	-
C306	110041	CAP PE 10NF 20% 100V	WIMA	PKS2			EA	-
C307	110027	CAP PE 3N3F 20% 100V	WIMA	PKS2			EA	-
C308	180044	CAP AE 220UF 40V	STEATITE	EKMOODE 322G			EA	-
C309	150022	CAP DT 2U2F 20% 35V	AVX	TAP2R2M35F	A		EA	-
C310	100102	CAP CP 1NF 10% 100V	PHILIPS	2222 630 19102			EA	-
C311	110039	CAP PE 470NF 20% 63V	WIMA	MKS2			EA	-
C405	150016	CAP DT 1UF 20% 35V	AVX	TAP1R0M35F	A		EA	-
C406	110041	CAP PE 10NF 20% 100V	WIMA	PKS2			EA	-
C407	110027	CAP PE 3N3F 20% 100V	WIMA	PKS2			EA	-
C408	180044	CAP AE 220UF 40V	STEATITE	EKMOODE 322G			EA	-
C409	150022	CAP DT 2U2F 20% 35V	AVX	TAP2R2M35F	A		EA	-
C410	100102	CAP CP 1NF 10% 100V	PHILIPS	2222 630 19102			EA	-
C411	110039	CAP PE 470NF 20% 63V	WIMA	MKS2			EA	-
C505	150016	CAP DT 1UF 20% 35V	AVX	TAP1R0M35F	A		EA	-
C506	110041	CAP PE 10NF 20% 100V	WIMA	PKS2			EA	-
C507	110027	CAP PE 3N3F 20% 100V	WIMA	PKS2			EA	-
C508	180044	CAP AE 220UF 40V	STEATITE	EKMOODE 322G			EA	-
C509	150022	CAP DT 2U2F 20% 35V	AVX	TAP2R2M35F	A		EA	-
C510	100102	CAP CP 1NF 10% 100V	PHILIPS	2222 630 19102			EA	-
C511	110039	CAP PE 470NF 20% 63V	WIMA	MKS2			EA	-
C601	110041	CAP PE 10NF 20% 100V	WIMA	PKS2			EA	-
C602	180048	CAP AE 470UF 63V	NIPPON CHEMI-CON	SMVB/470-63			EA	4
C603	180048	CAP AE 470UF 63V	NIPPON CHEMI-CON	SMVB/470-63			EA	-
C604	180048	CAP AE 470UF 63V	NIPPON CHEMI-CON	SMVB/470-63			EA	-
C605	180048	CAP AE 470UF 63V	NIPPON CHEMI-CON	SMVB/470-63			EA	-
C606	110042	CAP PE 100NF 20% 63V	WIMA	MKS2			EA	2
C607	150025	CAP DT 3U3F 20% 35V	AVX	TAP3R3M35F	A		EA	1
C608	110041	CAP PE 10NF 20% 100V	WIMA	PKS2			EA	-
C609	104026	CAP CM 47NF +80%-20% 50V	AVX	SR175E473ZA	A		EA	1
C610	110042	CAP PE 100NF 20% 63V	WIMA	MKS2			EA	-
C611	110039	CAP PE 470NF 20% 63V	WIMA	MKS2			EA	-

DESIG	PART NO	DESCRIPTION	PRINC MANUF	MANUF PART NUMBER	CLASS	UM	QUANTITY	CHANGES
C612	110035	CAP PE 220NF 20% 63V	WIMA	MKS2			EA	1
D103	200001	DIODE GP 75mA 75V	FAIRCHILD	1N4148			EA	10
D104	200001	DIODE GP 75mA 75V	FAIRCHILD	1N4148			EA	-
D105	214014	DIODE ZN 1V22 100PPM	TELEDYNE	9491BJ	A		EA	10
D106	214014	DIODE ZN 1V22 100PPM	TELEDYNE	9491BJ	A		EA	-
D107	200002	DIODE GP 1A 50V	FAIRCHILD	1N4001			EA	9
D203	200001	DIODE GP 75mA 75V	FAIRCHILD	1N4148			EA	-
D204	200001	DIODE GP 75mA 75V	FAIRCHILD	1N4148			EA	-
D205	214014	DIODE ZN 1V22 100PPM	TELEDYNE	9491BJ	A		EA	-
D206	214014	DIODE ZN 1V22 100PPM	TELEDYNE	9491BJ	A		EA	-
D207	200002	DIODE GP 1A 50V	FAIRCHILD	1N4001			EA	-
D303	200001	DIODE GP 75mA 75V	FAIRCHILD	1N4148			EA	-
D304	200001	DIODE GP 75mA 75V	FAIRCHILD	1N4148			EA	-
D305	214014	DIODE ZN 1V22 100PPM	TELEDYNE	9491BJ	A		EA	-
D306	214014	DIODE ZN 1V22 100PPM	TELEDYNE	9491BJ	A		EA	-
D307	200002	DIODE GP 1A 50V	FAIRCHILD	1N4001			EA	-
D403	200001	DIODE GP 75mA 75V	FAIRCHILD	1N4148			EA	-
D404	200001	DIODE GP 75mA 75V	FAIRCHILD	1N4148			EA	-
D405	214014	DIODE ZN 1V22 100PPM	TELEDYNE	9491BJ	A		EA	-
D406	214014	DIODE ZN 1V22 100PPM	TELEDYNE	9491BJ	A		EA	-
D407	200002	DIODE GP 1A 50V	FAIRCHILD	1N4001			EA	-
D503	200001	DIODE GP 75mA 75V	FAIRCHILD	1N4148			EA	-
D504	200001	DIODE GP 75mA 75V	FAIRCHILD	1N4148			EA	-
D505	214014	DIODE ZN 1V22 100PPM	TELEDYNE	9491BJ	A		EA	-
D506	214014	DIODE ZN 1V22 100PPM	TELEDYNE	9491BJ	A		EA	-
D507	209003	DIODE BR 1A5 100V	GI	W01G	A		EA	1
D601	200002	DIODE GP 1A 50V	FAIRCHILD	1N4001			EA	-
D602	220049	DIODE LE GREEN	H.P.	HLMP5050			EA	1
D603	210047	DIODE ZN 4V7 400mW	PHILIPS	BZX79C4V7	A		EA	4
D604	210047	DIODE ZN 4V7 400mW	PHILIPS	BZX79C4V7	A		EA	-
D605	210047	DIODE ZN 4V7 400mW	PHILIPS	BZX79C4V7	A		EA	-
D606	210047	DIODE ZN 4V7 400mW	PHILIPS	BZX79C4V7	A		EA	-
D607	200002	DIODE GP 1A 50V	FAIRCHILD	1N4001			EA	-
D608	200002	DIODE GP 1A 50V	FAIRCHILD	1N4001			EA	-
D609	200002	DIODE GP 1A 50V	FAIRCHILD	1N4001			EA	-
D610	200002	DIODE GP 1A 50V	FAIRCHILD	1N4001			EA	-
Q101	230086	TRAN MOSFET P-CHAN 60V	FERRANTI	ZVP2106A	A		EA	5
Q102	230085	TRAN MOSFET P-CHAN 60V	INT RECIPIER	IRF9531	A		EA	5
Q104	240006	TRAN NPN TO92	MOTOROLA	2N3904			EA	10
Q105	240006	TRAN NPN TO92	MOTOROLA	2N3904			EA	-
Q201	230086	TRAN MOSFET P-CHAN 60V	FERRANTI	ZVP2106A	A		EA	-
Q202	230085	TRAN MOSFET P-CHAN 60V	INT RECIPIER	IRF9531	A		EA	-
Q204	240006	TRAN NPN TO92	MOTOROLA	2N3904			EA	-
Q205	240006	TRAN NPN TO92	MOTOROLA	2N3904			EA	-
Q301	230086	TRAN MOSFET P-CHAN 60V	FERRANTI	ZVP2106A	A		EA	-

DESIG	PART NO	DESCRIPTION	PRINC MANUF	MANUF PART NUMBER	CLASS	UM	QUANTITY	CHANGES
Q302	230085	TRAN MOSFET P-CHAN 60V	INT RECTIFIER	IRF9531	A	EA	-	
Q304	240006	TRAN NPN TO92	MOTOROLA	2N3904		EA	-	
Q305	240006	TRAN NPN TO92	MOTOROLA	2N3904		EA	-	
Q401	230086	TRAN MOSFET P-CHAN 60V	FERRANTI	ZVP2106A	A	EA	-	
Q402	230085	TRAN MOSFET P-CHAN 60V	INT RECTIFIER	IRF9531	A	EA	-	
Q404	240006	TRAN NPN TO92	MOTOROLA	2N3904		EA	-	
Q405	240006	TRAN NPN TO92	MOTOROLA	2N3904		EA	-	
Q501	230086	TRAN MOSFET P-CHAN 60V	FERRANTI	ZVP2106A	A	EA	-	
Q502	230085	TRAN MOSFET P-CHAN 60V	INT RECTIFIER	IRF9531	A	EA	-	
Q504	240006	TRAN NPN TO92	MOTOROLA	2N3904		EA	-	
Q505	240006	TRAN NPN TO92	MOTOROLA	2N3904		EA	-	
Q601	240029	TRAN NPN	MOTOROLA	BC546		EA	2	
Q602	250018	TRAN PNP	MOTOROLA	BC556		EA	2	
Q603	230065	TRAN JFET I LIM 4m7A	SILICONIX	J511		EA	2	
Q604	240029	TRAN NPN	MOTOROLA	BC546		EA	2	
Q605	250018	TRAN PNP	MOTOROLA	BC556		EA	-	
Q606	230065	TRAN JFET I LIM 4m7A	SILICONIX	J511		EA	-	
Q607	230104	TRAN MOSFET P CHAN 60V/0.8A	IR	IRFD9123		EA	2	
Q608	230100	TRAN MOSFET N CHAN 60V 0.8A	IR	IRFD113		EA	2	
Q609	230104	TRAN MOSFET P CHAN 60V/0.8A	IR	IRFD9123		EA	-	
Q610	230100	TRAN MOSFET N CHAN 60V 0.8A	IR	IRFD113		EA	-	
U102	260126	IC LIN REG ADJ VOLTAGE LP	NATIONAL	LP2951CN		EA	6	
U103	260124	IC LIN QUAD ULP COMPARATOR	NATIONAL	LP339N		EA	6	
U104	280193	IC DIG NAND2 SCHMITT X4	PHILIPS	HEF4093BP		EA	5	
U202	260126	IC LIN REG ADJ VOLTAGE LP	NATIONAL	LP2951CN		EA	-	
U203	260124	IC LIN QUAD ULP COMPARATOR	NATIONAL	LP339N		EA	-	
U204	280193	IC DIG NAND2 SCHMITT X4	PHILIPS	HEF4093BP		EA	-	
U302	260126	IC LIN REG ADJ VOLTAGE LP	NATIONAL	LP2951CN		EA	-	
U303	260124	IC LIN QUAD ULP COMPARATOR	NATIONAL	LP339N		EA	-	
U304	280193	IC DIG NAND2 SCHMITT X4	PHILIPS	HEF4093BP		EA	-	
U402	260126	IC LIN REG ADJ VOLTAGE LP	NATIONAL	LP2951CN		EA	-	
U403	260124	IC LIN QUAD ULP COMPARATOR	NATIONAL	LP339N		EA	-	
U404	280193	IC DIG NAND2 SCHMITT X4	PHILIPS	HEF4093BP		EA	-	
U502	260126	IC LIN REG ADJ VOLTAGE LP	NATIONAL	LP2951CN		EA	-	
U503	260124	IC LIN QUAD ULP COMPARATOR	NATIONAL	LP339N		EA	-	
U504	280193	IC DIG NAND2 SCHMITT X4	PHILIPS	HEF4093BP		EA	-	
U601	260124	IC LIN QUAD ULP COMPARATOR	NATIONAL	LP339N		EA	-	
U602	280008	IC DIG NAND2 X4	MOTOROLA	MC14011BCP		EA	1	
U603	260125	IC LIN REG ADJ VOLTAGE	SGS	L200 CV		EA	1	
U604	260126	IC LIN REG ADJ VOLTAGE LP	NATIONAL	LP2951CN		EA	-	
J103	605209	SOCKET PCB 15-WAY D	AMP	343706-2		EA	1	
J501	604033	PLUG PCB 4-WAY .1"	MOLEX	22-29-2041		EA	1	
J601	604107	PLUG PCB 9-WAY D TYPE	AMP	343701-2		EA	1	
J602	604106	PLUG PCB 32-WAY	BICC-VERO	905-72216J		EA	1	
J603	604105	PLUG PCB 64-WAY (2 X 32)	BICC-VERO	TYPE B 905-72208G		EA	1	

DESIG	PART NO	DESCRIPTION	PRINC MANUF	MANUF PART NUMBER	CLASS	UM	QUANTITY	CHANGES
J604	605185	SOCKET PCB 32-WAY (2 X 16)	BICC-VERO	905-72270K		EA	5	
J605	605185	SOCKET PCB 32-WAY (2 X 16)	BICC-VERO	905-72270K		EA	-	
J606	605185	SOCKET PCB 32-WAY (2 X 16)	BICC-VERO	905-72270K		EA	-	
J607	605185	SOCKET PCB 32-WAY (2 X 16)	BICC-VERO	905-72270K		EA	-	
J608	605185	SOCKET PCB 32-WAY (2 X 16)	BICC-VERO	905-72270K		EA	-	
E102-1	620015	PIN SOLDER	HARWIN	H2101A01		EA	12	
E102-2	620015	PIN SOLDER	HARWIN	H2101A01		EA	-	
E102-3	620015	PIN SOLDER	HARWIN	H2101A01		EA	-	
E102-4	620015	PIN SOLDER	HARWIN	H2101A01		EA	-	
E102-5	620015	PIN SOLDER	HARWIN	H2101A01		EA	-	
E102-6	620015	PIN SOLDER	HARWIN	H2101A01		EA	-	
E102-7	620015	PIN SOLDER	HARWIN	H2101A01		EA	-	
E102-8	620015	PIN SOLDER	HARWIN	H2101A01		EA	-	
E102-9	620015	PIN SOLDER	HARWIN	H2101A01		EA	-	
E102-10	620015	PIN SOLDER	HARWIN	H2101A01		EA	-	
E102-11	620015	PIN SOLDER	HARWIN	H2101A01		EA	-	
E102-12	620015	PIN SOLDER	HARWIN	H2101A01		EA	-	
S101	700123	SWITCH 1PST X 10 DIL	HIGHLAND	76SB10		EA	1	
S102	700122	SWITCH 4PCO PUSH	ITT	PHS440A		EA	1	
S601	700120-1	SWITCH 24P2W ROTARY	NSF	SEE DRG		EA	1	
F601	920071	FUSE 1.6A 250V 20MM F	BESWICK	S501	A	EA	1	
	400970-1	ASSY PCB INTERCONNECTION 4910	DATHON	SEE DRG		EA	1	
	410438-3	PCB MOTHER 4910		SEE DRG		EA	1	
	450287-1	BRACKET HEATSINK		SEE DRG		EA	2	
	450758-1	HEATSINK MACHINED		SEE DRG		EA	1	
	511002	WIRE 7/.2 PVC 1KV GRN/YEL				AR	1	
	540002	WIRE 1/.7 TINNED COPPER	BS4109	22SWG		AR	1	
	540006	WIRE 1/.4 PTFE 250V BLK	BSG210	TYPE A		AR	1	
	590006	SLEEVE HS 2.4mm YLW.	RS COMPONENTS	399-495		AR	1	
	611005	SCREW M3 X 12 POZIPAN SZP				EA	3	
	611006	SCREW M3 X 10 POZIPAN SZP				EA	2	
	611016	SCREW M3 X 8 POZIPAN SZP				EA	9	
	611023	SCREW M2.5 X 10 POZIPAN SZP				EA	10	
	611096	SCREW M2.5 X 12 POZIPAN SZP				EA	4	
	611110	SCREW M2 X 4 POZIPAN SZP				EA	2	
	612003-1	STANDOFF M3 X 20		SEE DRG		EA	12	
	613009	SOLDER TAG 4 BA BTP				EA	1	
	613029	WASHER M3 WAVY SS				EA	14	
	613043	WASHER M2 WAVY SS				EA	2	
	613047	WASHER M2.5 WAVY SS				EA	14	
	615002	NUT FULL M3 SZP				EA	10	
	615006	NUT FULL M2.5 SZP				EA	14	
	620007	TEST POINT TERMINAL				EA	27	
	630024	BEAD CERAMIC 16 SWG	MICROVAR	TYPE C30		EA	4	
	630243	BEAD GLASS 2.4 X 0.81 X 1.8	PARK ROYAL PORCELAIN	No2		EA	4	
			MANSOL (PREFORMS) LT	M5363B/3		EA	2	

DESIG	PART NO	DESCRIPTION	PRINC MANUF	MANUF PART NUMBER	CLASS	UM	QUANTITY	CHANGES
	700129	BUTTON 5MM DIA BK	RS COMPONENTS	333-631			EA 1	
	920105-1	HEATSINK TO-202	AAVID	SEE DRG			EA 5	
	920224	FUSEHOLDER 20MM PCB					EA 1	

End

DRAWING NO.		LD400970		CHK'D	1.0	3600	6.6.90																	
DOCUMENT LIST								DATE	1.1	3669	28.90													
DISTRIBUTION								ECO																
								REVISION	1.0															
								ISSUE	1.1															
DESCRIPTION	DRAWING NUMBER	SHEET NUMBER	ISSUE - REVISION																					
PARTS LIST	LP400970	ALL	1.0	1.1																				
ASSEMBLY DRAWING	DA400970	1	1.0	1.1																				
	DA400970	2	1.0	1.1																				
CIRCUIT DIAGRAM	DC400970	1	1.0	1.1																				
TEST PROCEDURE																								
TEST SPECIFICATION																								
PCB	410459		A																					
NOTES		DENOTES NO CHANGE TO DOCS AT ISSUE LEVEL CHANGE				DRN I/L DATE 6JUN 90	CHK'D MJD DATE 8JUN 90	MFD M.F. DATE 15.6.90	TITLE 4910/4911 INTERCONNECTION PCB ASSY.	DRAWING No. LD400970 SHEET 1 OF 1														

09 AUG 1990

DATRON INSTRUMENTS LTD PARTS LIST 02-Aug-90 DESC: ASSY PCB INTERCONNECTION 4910 DRG NO: LP400970-1 REV: 1 PAGE NO: 1

DESIG	PART NO	DESCRIPTION	PRINC MANUF	MANUF PART NUMBER	CLASS UN	QUANTITY	CHANGES
P8	604118	PLUG 15-WAY IDC 'D' TYPE	AMPHENOL	17DEFRA15P	EA	1	
P9	604117	PLUG 9-WAY IDC 'D' TYPE	AMPHENOL	17DEFRA9P	EA	1	
P208	605148	SOCKET CAB 16-WAY IDC .1"	3M	3452-6610EY	EA	1	
P209	605219	SOCKET CAB 10-WAY IDC .1"	3M	3473-6610EY	EA	1	
J108	604080	PLUG PCB 16-WAY TRANSITION .1"	3M	3916-0000T	EA	1	
J109	604116	PLUG PCB 10-WAY TRANSITION .1"	3M	3910-0000T	EA	1	
E9	620006	SOLDER TURRET	HAKWIN	H9001-01	EA	1	
E10	00000H	NOT FITTED			EA	1	
TP2	620007	TEST POINT TERMINAL	MICROVAR	TYPE C30	EA	2	
TP12	620007	TEST POINT TERMINAL	MICROVAR	TYPE C30	EA	-	
	410459-A	PCB INTERCONNECTION 4910		SEE DRG	EA	1	
	570001	CABLE RIBBON 16 WAY		3365/16	AR	1	
	606041	'D' COIN SPRING LATCH	3M	0967-000-9907	EA	4	
	611004	SCREW M3 X 6 POZIPAN SZP	HARTING		EA	4	
	613005	WASHER M3 INT SHAKEPROOF			EA	4	
	615002	NUT FULL M3 SZP			EA	4	

End

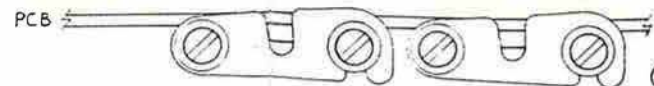

FOLD ALL ETCHED COPPER PARTS
WITH ETCHES INSIDE.

U104
REMOVE LINKS A,C & F
FIT LINKS B,D & E
AS SHOWN ON 480699

590001 2

61109 4
613053 4
615024 4
450739 4
450740 2

FOLD TO RETAIN
NUT (8 POS'S)

420112

BEFORE MODULE
IS FITTED TO CELL
PCB ASST:
SOLDER 24 SWG
B.T.C. WIRE LINK
BETWEEN PINS 3 & 4
OF AN1



VIEW SHOWING SOLDER
SIDE OF REF. MODULE
PCB.

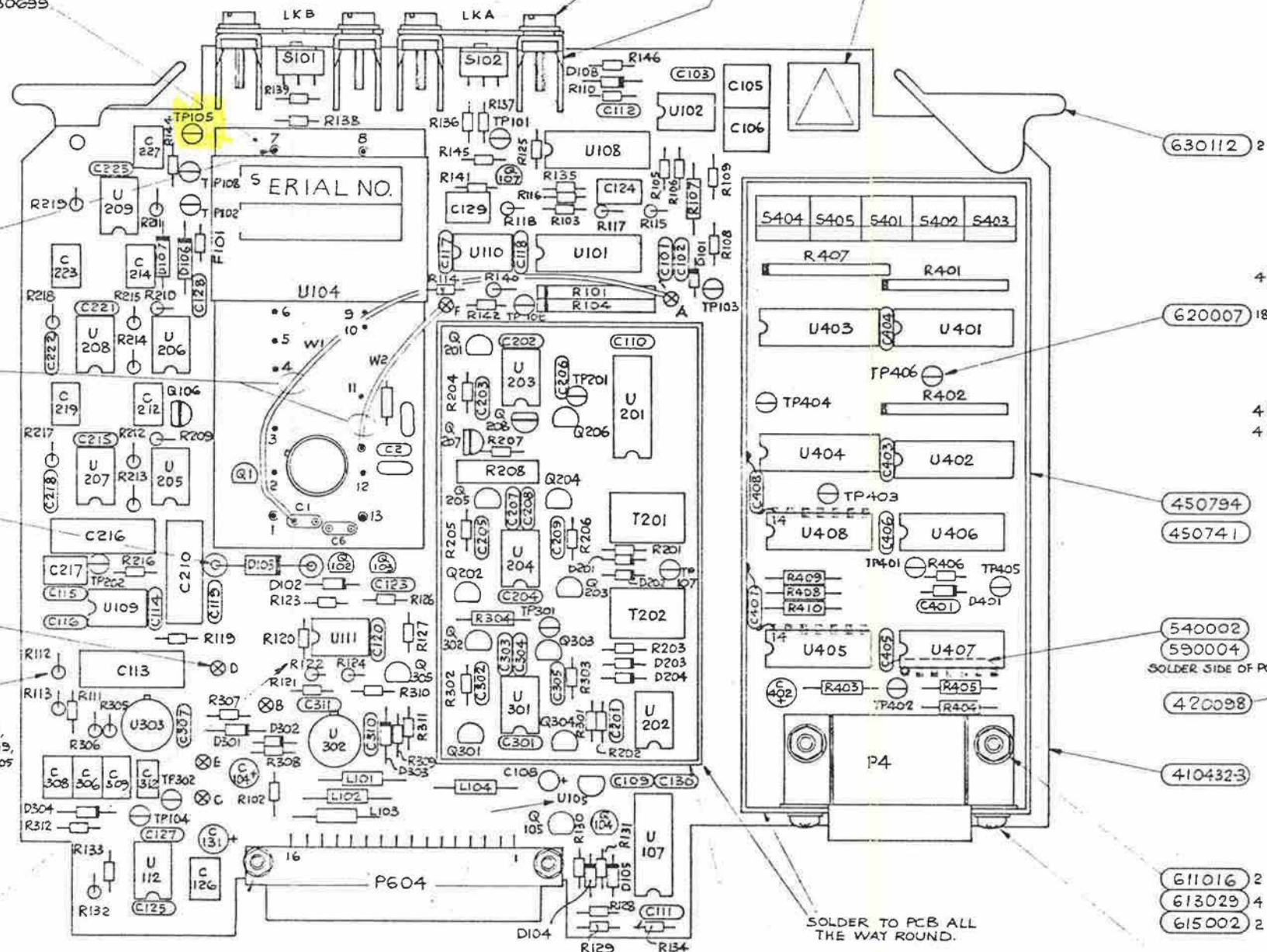

590004
PINS 1,7,8 & 13

540006

630024 2

620003 6
A-F

618015 21

R112, R113, R115, R117, R118,
R122, R124, R132, R140, R205,
R210, R215, R217, R219, R205
& R306.

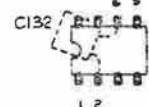

MOUNT C132 BETWEEN U111-2 & U111-6
ON SOLDER SIDE OF PCB.

611036 2
613047 4
615006 2

N.B. U105 PADS ARE NON-STANDARD
BEND MIDDLE LEG TO ROUND.

630243 53

450795
450742

C103, C109-C112, C114, C117, C118,
C120, C125, C128, C201, C202,
C204, C206, C209, C215, C221, C225,
C301, C305, C307, C310,
C403-C406.

N.B. C205, C302, D106 & D107
NOT FITTED.

SOLDER TO PCB ALL
THE WAY ROUND.

620007 18
SWAGE TO
SCREEN.

4 614016
4 611115
4 613029

450794
450741

540002
590004
SOLDER SIDE OF PCB.

420098

410432-3

611016 2
613029 4
615002 2

611016 2
613029 2

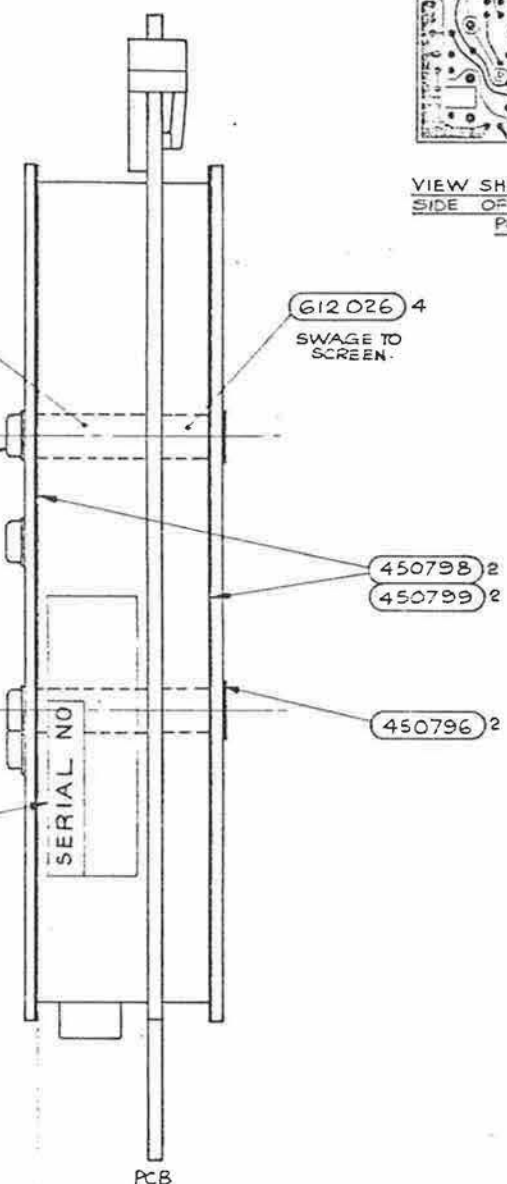

12.0 MAX. COMPONENT
HEIGHT UNDER SCREENS



© Datron Instruments 1991

CELL PCB ASSEMBLY

Drawing No. DA400879 Sheet 1

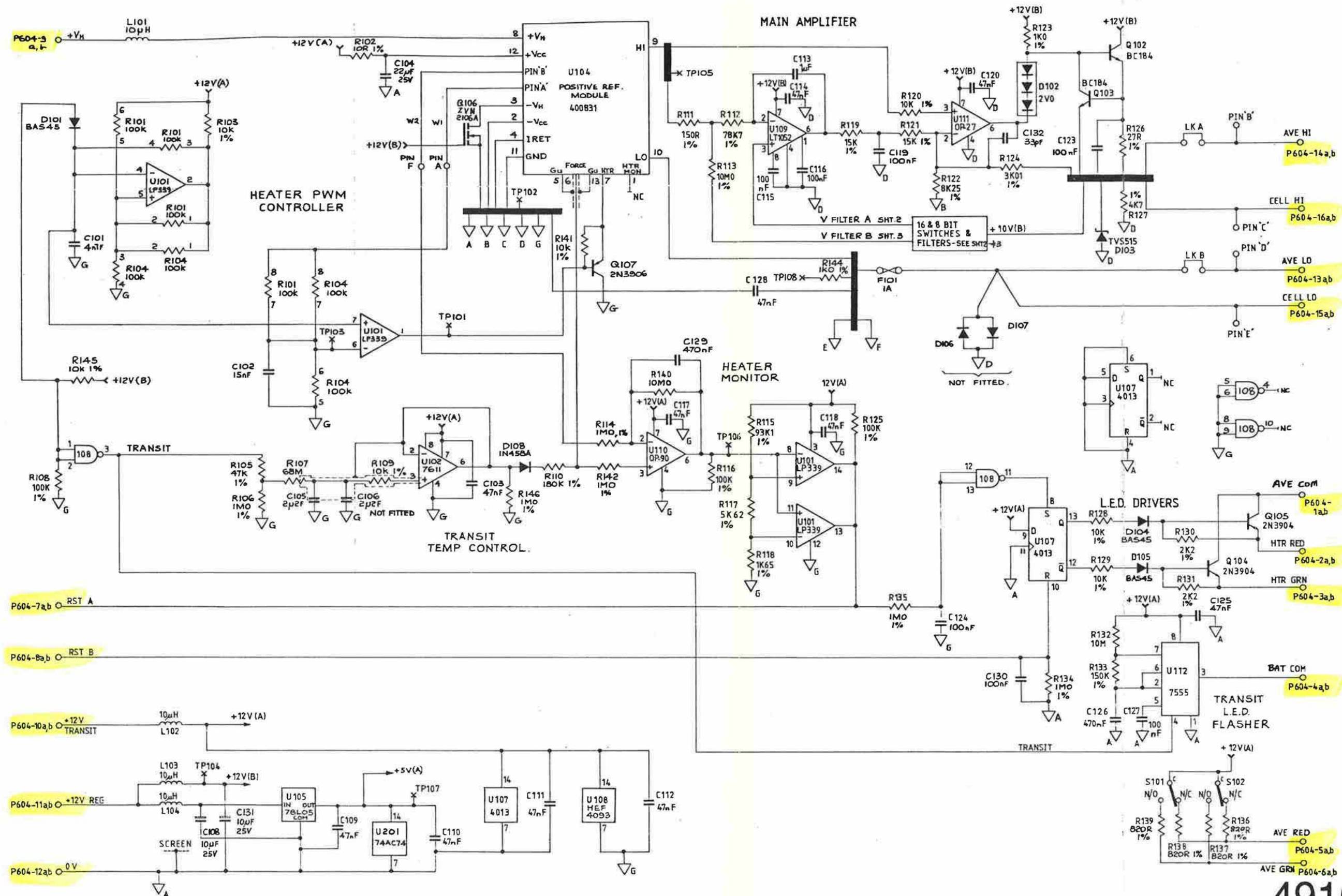

CELL PCB ASSEMBLY

Drawing No. DC400879 Sheet 1



© Datron Instruments 1991

FOLD ALL ETCHED COPPER PARTS
WITH ETCHES INSIDE.



U104
REMOVE LINKS A,C & F
FIT LINKS B,D & E
AS SHOWN ON 480699

- 61109 4
- 613053 4
- 615024 4
- 450739 4
- 450740 2

FOLD TO RETAIN
NUT (8 POS*5)

420112

BEFORE MODULE
IS FITTED TO CELL
PCB ASST:

SOLDER 24 SWG
B.T.C. WIRE LINK
BETWEEN PINS 3 & 4
OF AN1



VIEW SHOWING SOLDER
SIDE OF REF. MODULE
PCB

590004
PINS 1,7,8 & 13

540006

630024 2

620003 6
A-F

618015 21

R112, R113, R115, R117, R118,
R122, R124, R132, R140, R209,
R210, R215, R217-R219, R305
& R306.

C132

MOUNT C132 BETWEEN U111-2 & U111-6
ON SOLDER SIDE OF PCB.

- 611096 2
- 613047 4
- 615006 2

N.B. U105 PADS ARE NON-STANDARD
BEND MIDDLE LEG TO ROUND.

630243 53

450795
450742

C103, C109-C112, C114, C117, C118,
C120, C125, C128, C201, C202,
C204, C206, C209, C215, C221, C225
C301, C305, C307, C310,
C403-C406.

N.B. C205 C302 D106 & D107
NOT FITTED.

630112 2

620007 18

611115 4
613029 4

450794

450741

540002
590004

SOLDER SIDE OF PCB.

420098

4104323

611016 2

613029 4

615002 2

611016 2

613029 2

614016 4

SWAGE TO SCREEN.

611115 4
613029 4

450794

450741

540002
590004

SOLDER SIDE OF PCB.

420098

4104323

611016 2

613029 4

615002 2

611016 2

613029 2

612026 4

SWAGE TO SCREEN.

611115 4
613029 4

450794

450741

540002
590004

SOLDER SIDE OF PCB.

420098

4104323

611016 2

613029 4

615002 2

611016 2

613029 2

12.0 MAX. COMPONENT
HEIGHT UNDER SCREENS

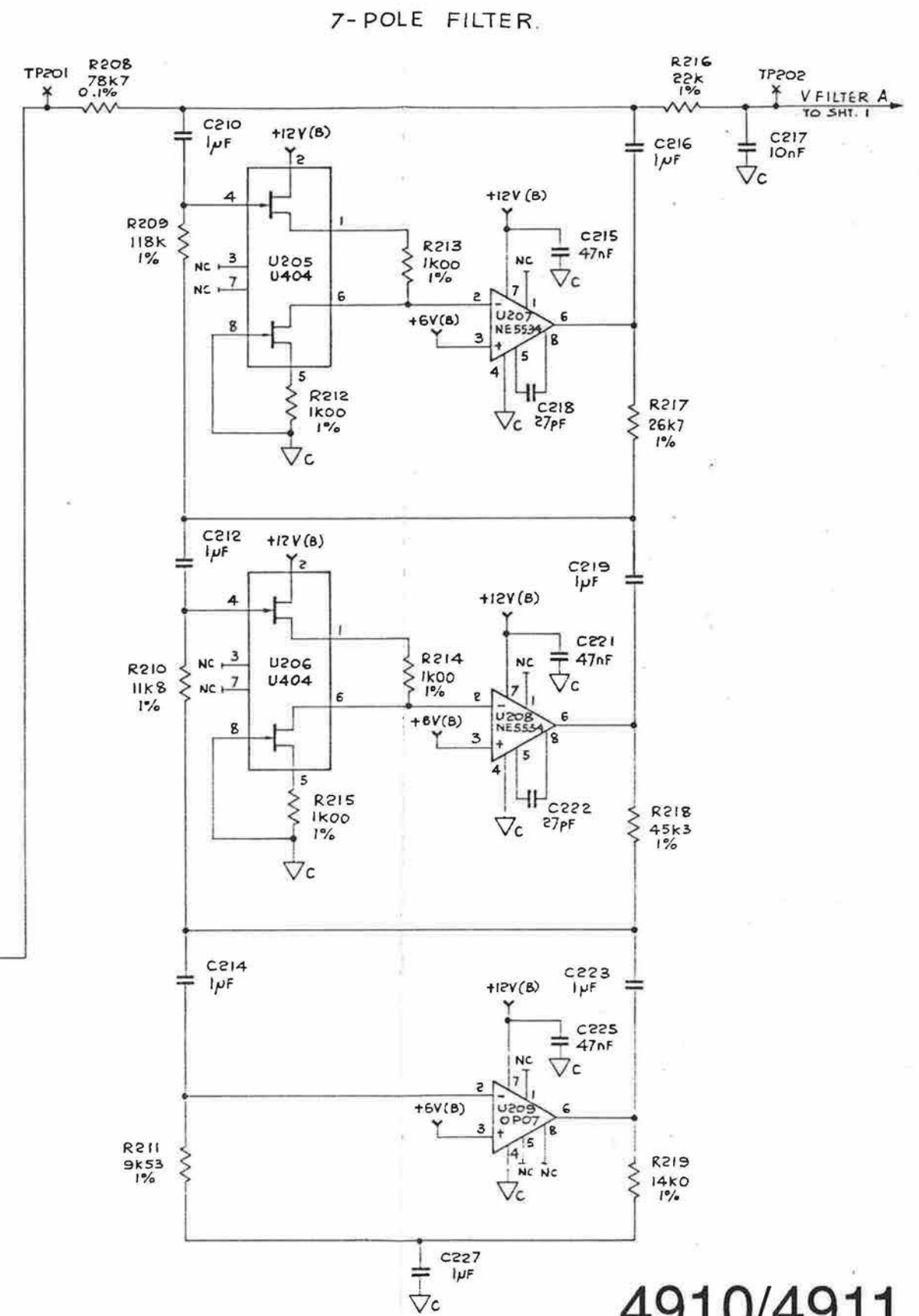
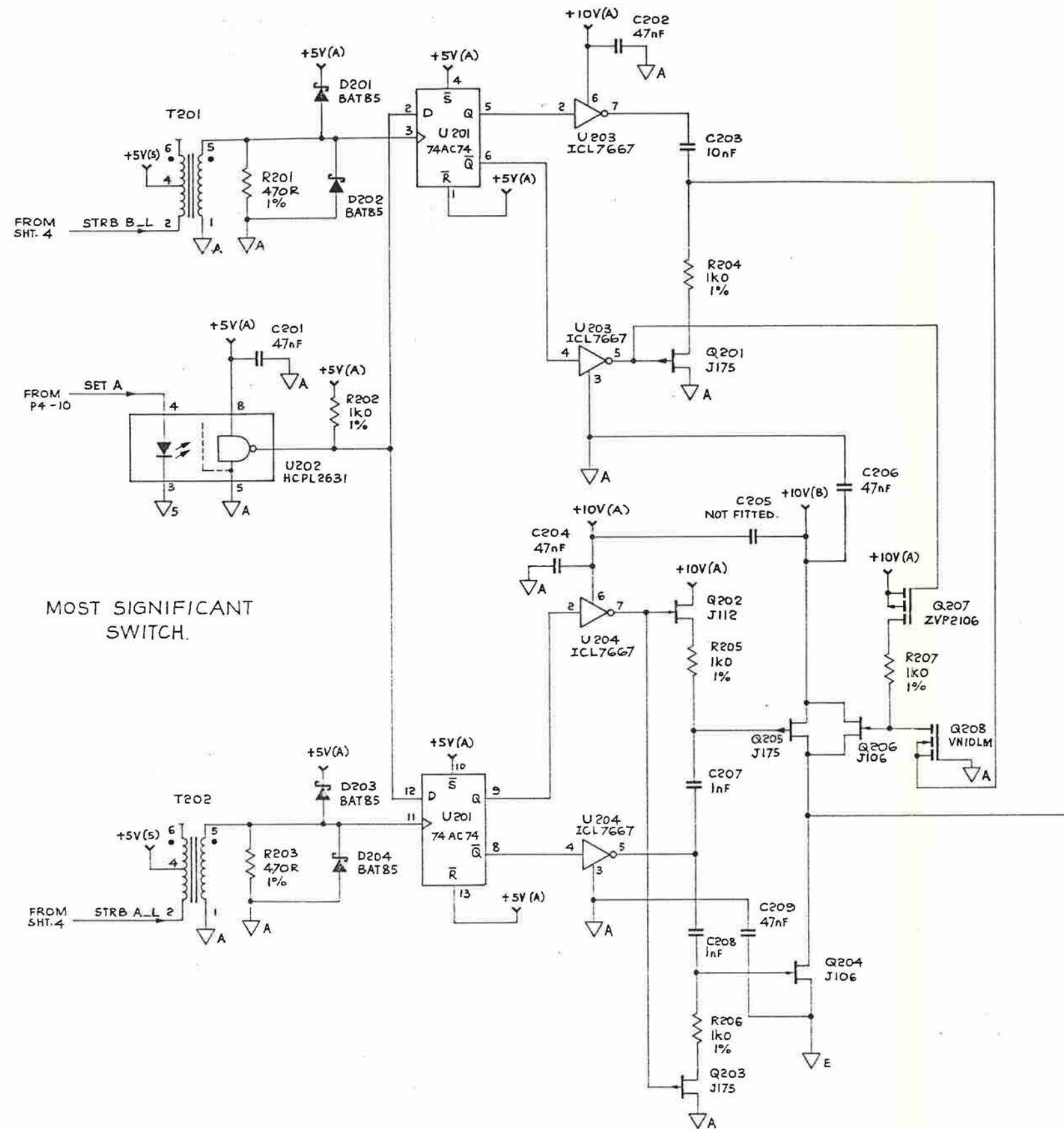

MOST SIGNIFICANT SWITCH.

CELL PCB ASSEMBLY

Drawing No. DC400879 Sheet 2



© Datron Instruments 1991

FOLD ALL ETCHED COPPER PARTS
WITH ETCHES INSIDE.



U104
REMOVE LINKS A,C & F
FIT LINKS B,D & E
AS SHOWN ON 480699.

- 611109 4
- 613053 4
- 615024 4
- 450739 4
- 450740 2

FOLD TO RETAIN
NUT (8 POS'S)

BEFORE MODULE
IS FITTED TO CELL
PCB ASSY:

SOLDER 24 SWG
B.T.C. WIRE LINK
BETWEEN PINS 3 & 4
OF ANI

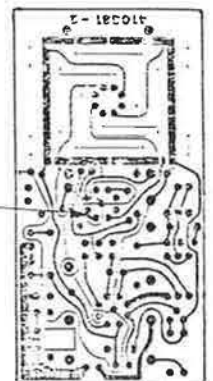

VIEW SHOWING SOLDER
SIDE OF REF. MODULE
PCB.

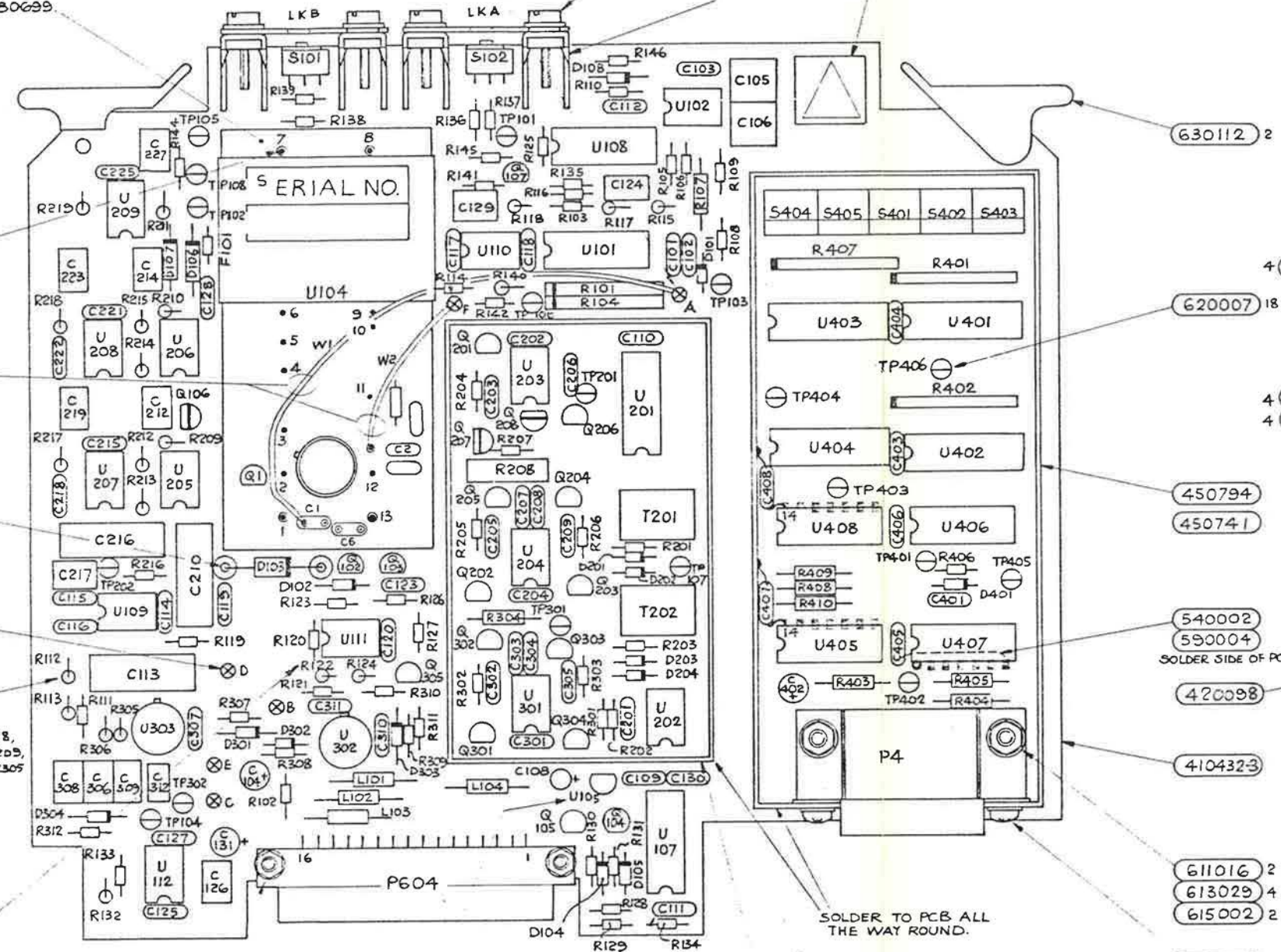

590004
PINS 1,7,8 & 13.

540006

630024 2

620003 6
A-F

618015 21

R112, R113, R115, R117, R118,
R122, R124, R132, R140, R205,
R210, R215, R217-R219, R305
& R306.

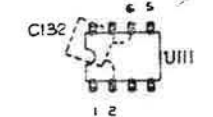

MOUNT C132 BETWEEN U111-2 & U111-6
ON SOLDER SIDE OF PCB.

- 611096 2
- 613047 4
- 615006 2

N.B. U105 PADS ARE NON-STANDARD
BEND MIDDLE LEG TO ROUND.

- 630243 53
- 450795
- 450742

C103, C109-C112, C114, C117, C118,
C120, C125, C128, C201, C202,
C204, C206, C209, C215, C221, C225
C301, C305, C307, C310,
C403-C406.

N.B. C205 C302 D106 & D107
NOT FITTED.

SOLDER TO PCB ALL
THE WAY ROUND.

630112 2

4 614016
620007 18
SWAGE TO SCREEN.

612026 4
SWAGE TO SCREEN.

4 611115
4 613029

450794
450741

450798 2
450799 2

540002
590004
SOLDER SIDE OF PCB.

450796 2

420098

611016 2
613029 4
615002 2

611016 2
613029 2

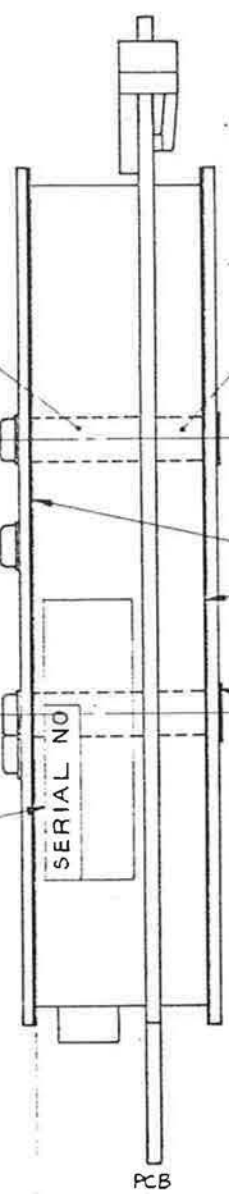

12.0 MAX. COMPONENT
HEIGHT UNDER SCREENS



© Datron Instruments 1991

CELL PCB ASSEMBLY
Drawing No. DA400879

Sheet 1

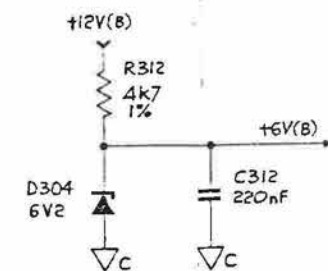
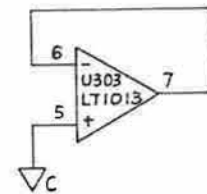
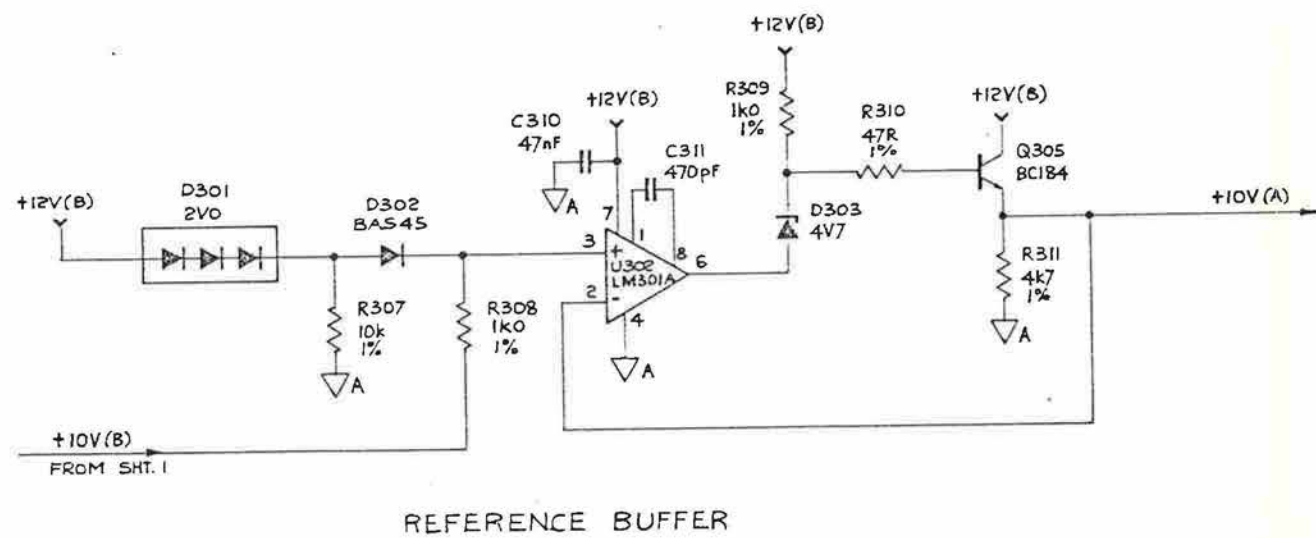
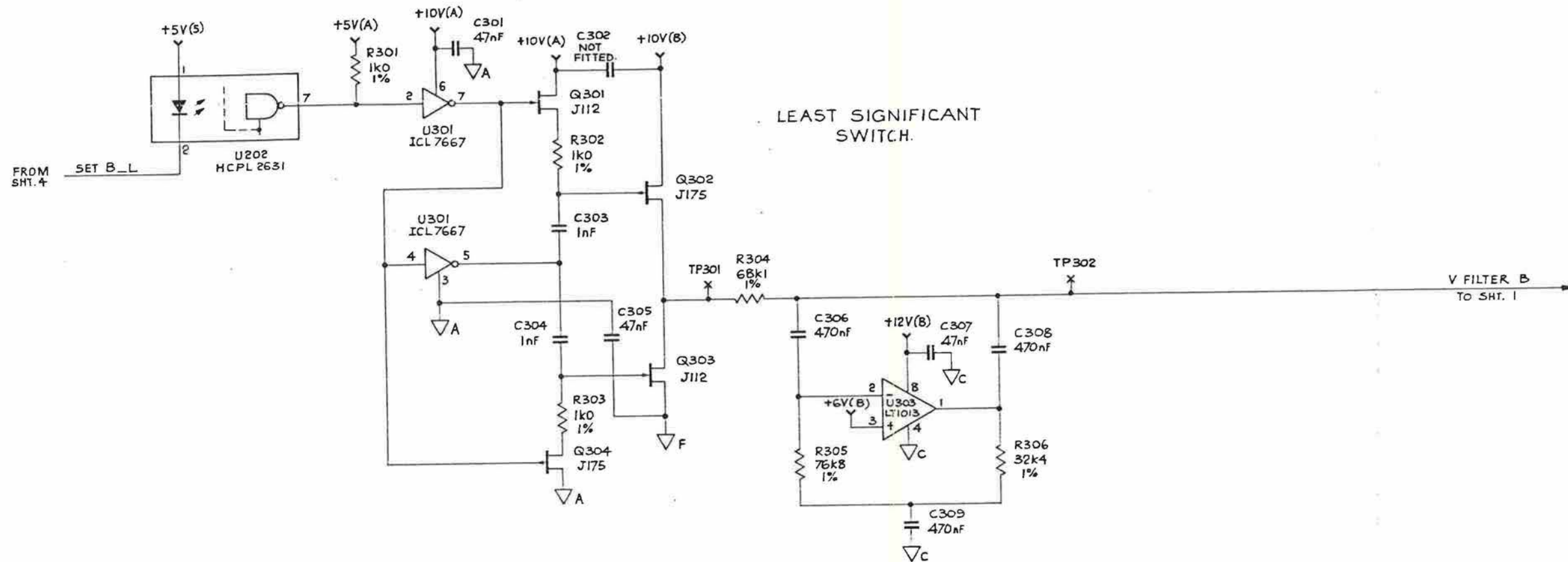

CELL PCB ASSEMBLY

Drawing No. DC400879 Sheet 3



© Datron Instruments 1991

FOLD ALL ETCHED COPPER PARTS
WITH ETCHES INSIDE.

U104
REMOVE LINKS A,C & F
FIT LINKS B,D & E
AS SHOWN ON 480699

FOLD TO RETAIN
NUT (8 POS'S)

BEFORE MODULE
IS FITTED TO CELL
PCB ASSY:
SOLDER 24 SWG
B.T.C WIRE LINK
BETWEEN PINS 3 & 4
OF ANI

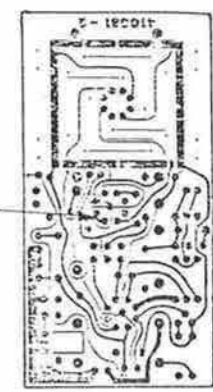

VIEW SHOWING SOLDER
SIDE OF REF. MODULE
PCB.

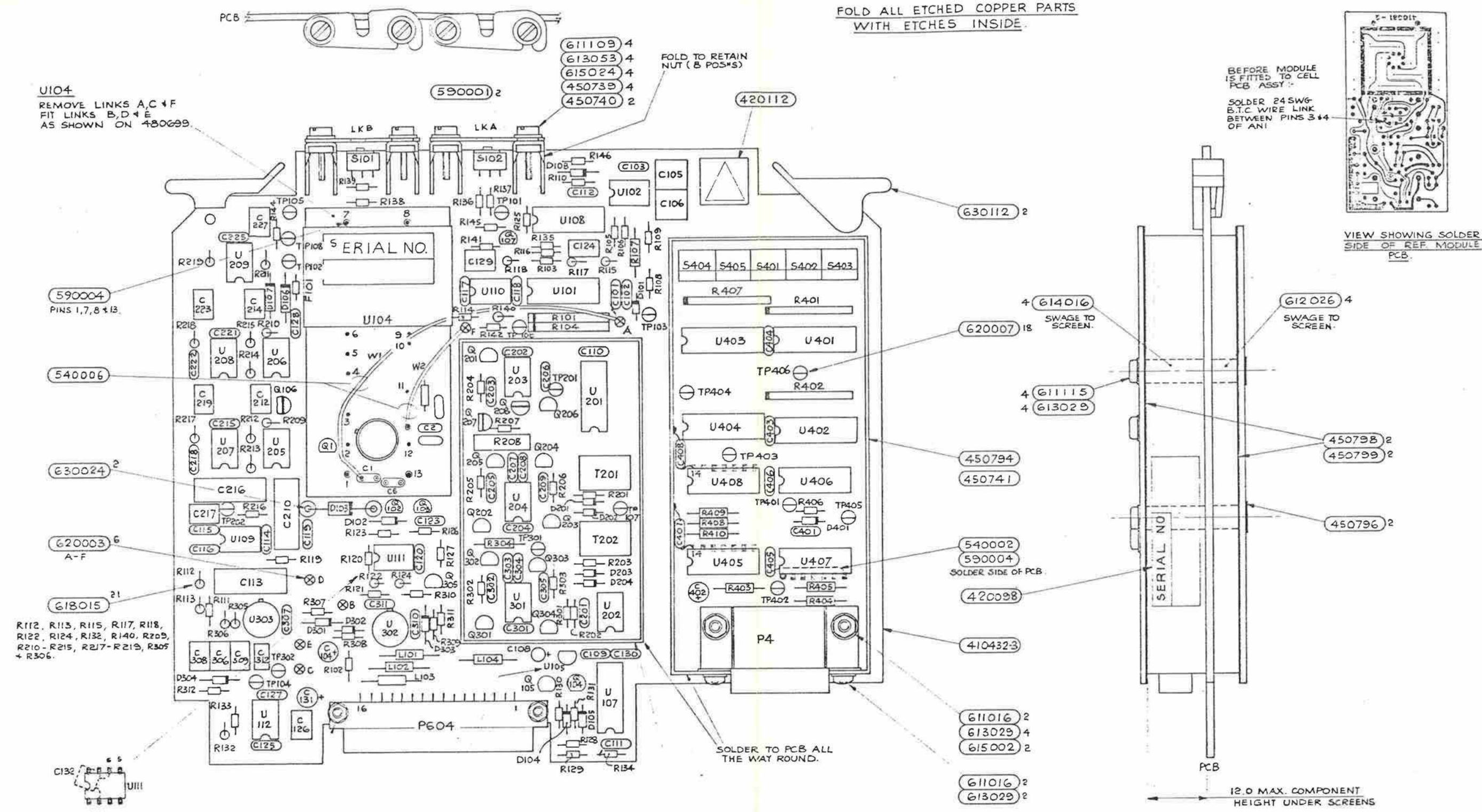

590004
PINS 1,7,8 & 13

540006

630024

620003
A-F

618015

R112, R113, R115, R117, R118,
R122, R124, R132, R140, R209,
R210, R215, R217, R219, R305
& R306.

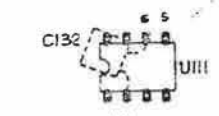

MOUNT C132 BETWEEN U111-2 & U111-6
ON SOLDER SIDE OF PCB.

N.B. U105 PADS ARE NON-STANDARD
BEND MIDDLE LEG TO ROUND.

611096 2
613047 4
615006 2

630243 53
C103, C109-C112, C114, C117, C118,
C120, C125, C128, C201, C202,
C204, C206, C209, C215, C221, C225
C301, C305, C307, C310,
C403-C406.

N.B. C205, C302, D106 & D107
NOT FITTED.

450795
450742



© Datron Instruments 1991

CELL PCB ASSEMBLY

Drawing No. DA400879 Sheet 1

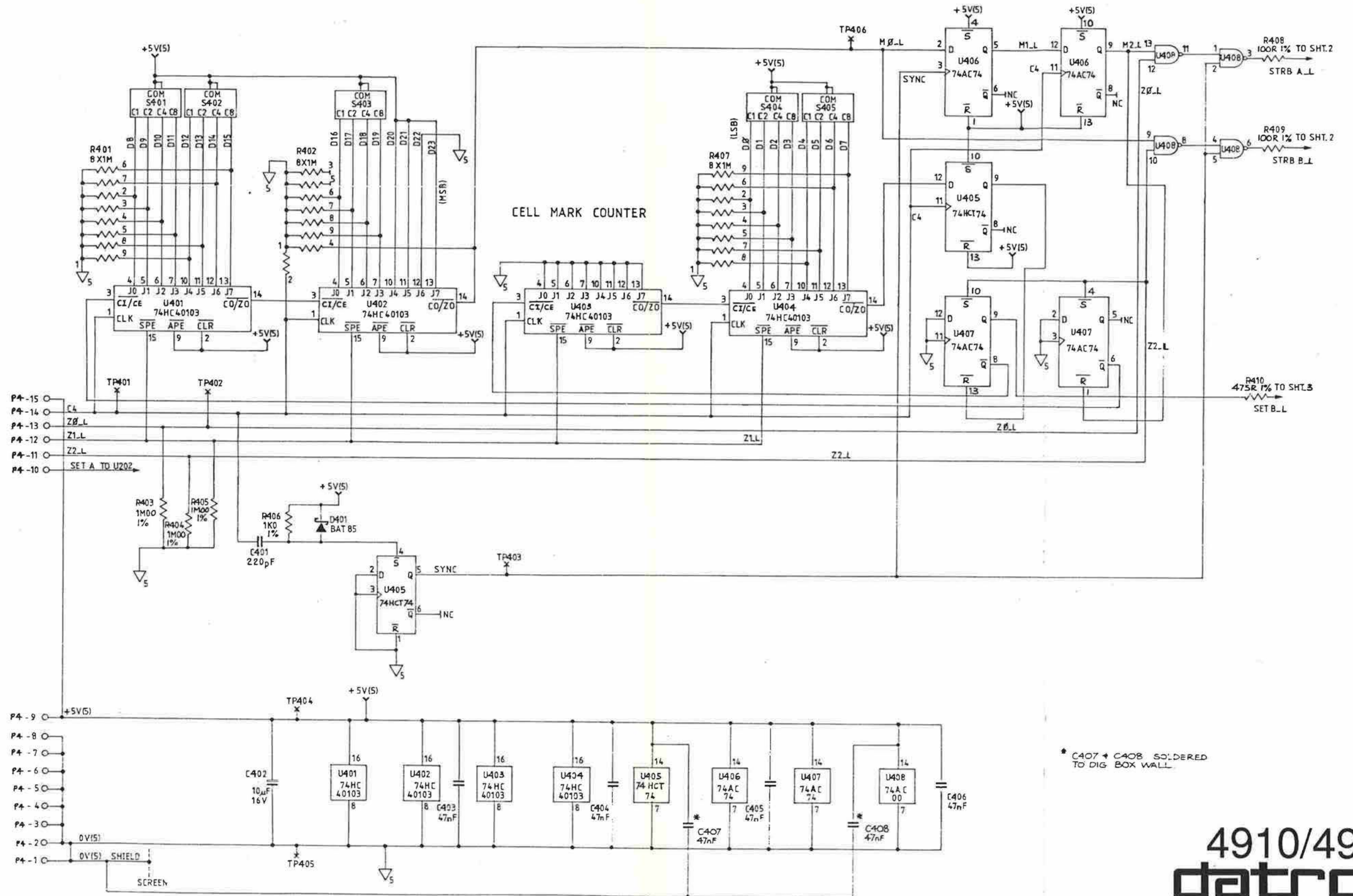

* CA07 + CA08 SOLDERED TO DIG BOX WALL

CELL PCB ASSEMBLY
 Drawing No. DC400879 Sheet 4



© Datron Instruments 1991

DESIG	PART NO	DESCRIPTION	PRINC MANUF	MANUF PART NUMBER	CLASS	UM	QUANTITY	CHANGES
R201	050108	RES MF 470R 1% .4W 100PPM	NEOHM	LR0204	A	EA	2	
R202	050112	RES MF 1K0 1% .4W 100PPM	NEOHM	LR0204	A	EA	-	
R203	050108	RES MF 470R 1% .4W 100PPM	NEOHM	LR0204	A	EA	-	
R204	050112	RES MF 1K0 1% .4W 100PPM	NEOHM	LR0204	A	EA	-	
R205	050112	RES MF 1K0 1% .4W 100PPM	NEOHM	LR0204	A	EA	-	
R206	050112	RES MF 1K0 1% .4W 100PPM	NEOHM	LR0204	A	EA	-	
R207	050112	RES MF 1K0 1% .4W 100PPM	NEOHM	LR0204	A	EA	-	
R208	060032	RES MF 70K7 .1% 10PPM	VISHAY MANN	V53CS 76K700 0.1%	A	EA	1	
R209	011183	RES MF 11K8 1% .12W 50PPM	HOLSWORTHY	HBC	A	EA	1	
R210	011182	RES MF 11K8 1% .12W 50PPM	HOLSWORTHY	HBC	A	EA	1	
R211	019531	RES MF 9K53 1% .12W 50PPM	HOLSWORTHY	HBC	A	EA	1	
R212	011001	RES MF 1K00 1% .12W 50PPM	HOLSWORTHY	HBC	A	EA	4	
R213	011001	RES MF 1K00 1% .12W 50PPM	HOLSWORTHY	HBC	A	EA	-	
R214	011001	RES MF 1K00 1% .12W 50PPM	HOLSWORTHY	HBC	A	EA	-	
R215	011001	RES MF 1K00 1% .12W 50PPM	HOLSWORTHY	HBC	A	EA	-	
R216	050128	RES MF 22K 1% .4W 100PPM	NEOHM	LR0204	A	EA	1	
R217	012672	RES MF 26K7 1% .12W 50PPM	HOLSWORTHY	HBC	A	EA	1	
R218	014532	RES MF 45K3 1% .12W 50PPM	HOLSWORTHY	HBC	A	EA	1	
R219	011402	RES MF 14K0 1% .12W 50PPM	HOLSWORTHY	HBC	A	EA	1	
R301	050112	RES MF 1K0 1% .4W 100PPM	NEOHM	LR0204	A	EA	-	
R302	050112	RES MF 1K0 1% .4W 100PPM	NEOHM	LR0204	A	EA	-	
R303	050112	RES MF 1K0 1% .4W 100PPM	NEOHM	LR0204	A	EA	-	
R304	016812	RES MF 68K1 1% .12W 50PPM	HOLSWORTHY	HBC	A	EA	1	
R305	017682	RES MF 76K8 1% .12W 50PPM	HOLSWORTHY	HBC	A	EA	1	
R306	013242	RES MF 32K4 1% .12W 50PPM	HOLSWORTHY	HBC	A	EA	1	
R307	050124	RES MF 10K 1% .4W 100PPM	NEOHM	LR0204	A	EA	-	
R308	050112	RES MF 1K0 1% .4W 100PPM	NEOHM	LR0204	A	EA	-	
R309	050112	RES MF 1K0 1% .4W 100PPM	NEOHM	LR0204	A	EA	-	
R310	050096	RES MF 47R 1% .4W 100PPM	NEOHM	LR0204	A	EA	1	
R311	050120	RES MF 4K7 1% .4W 100PPM	NEOHM	LR0204	A	EA	-	
R312	050120	RES MF 4K7 1% .4W 100PPM	NEOHM	LR0204	A	EA	-	
R401	090096	RES NTWK 1M X 8 2%	BECKMAN	LO9-1S-R1M	A	EA	3	
R402	090096	RES NTWK 1M X 8 2%	BECKMAN	LO9-1S-R1M	A	EA	-	
R403	041004	RES MF 1M00 1% .12W 50PPM	HOLSWORTHY	HBC	A	EA	3	
R404	041004	RES MF 1M00 1% .12W 50PPM	HOLSWORTHY	HBC	A	EA	-	
R405	041004	RES MF 1M00 1% .12W 50PPM	HOLSWORTHY	HBC	A	EA	-	
R406	050112	RES MF 1K0 1% .4W 100PPM	NEOHM	LR0204	A	EA	-	
R407	090096	RES NTWK 1M X 8 2%	BECKMAN	LO9-1S-R1M	A	EA	-	
R408	011000	RES MF 100R 1% .12W 50PPM	HOLSWORTHY	HBC	A	EA	2	
R409	011000	RES MF 100R 1% .12W 50PPM	HOLSWORTHY	HBC	A	EA	-	
R410	014750	RES MF 475R 1% .12W 50PPM	HOLSWORTHY	HBC	A	EA	1	
C101	100472	CAP CP 4N7F 10% 100V	PHILIPS	2222 630 19472	A	EA	1	
C102	110015	CAP PE 15NF 20% 63V	WIMA	MKS2	A	EA	1	
C103	104026	CAP CM 47NF +80%-20% 50V	AVX	SR175E4732A	A	EA	29	
C104	150021	CAP DT 22UF 20% 25V	AVX	TAP22M25F	A	EA	1	

DESIG	PART NO	DESCRIPTION	PRINC MANUF	MANUF PART NUMBER	CLASS	UM	QUANTITY	CHANGES
C105	110066	CAP PE 202F 20% 50V	WIMA	MKS2	A	EA	1	
C106	00000N	NOT FITTED					5	
C108	150020	CAP DT 10UF 20% 25V	AVX	TAP10M25F	A	EA	2	
C109	104026	CAP CM 47NF +80%-20% 50V	AVX	SR175E4732A	A	EA	-	
C110	104026	CAP CM 47NF +80%-20% 50V	AVX	SR175E4732A	A	EA	-	
C111	104026	CAP CM 47NF +80%-20% 50V	AVX	SR175E4732A	A	EA	-	
C112	104026	CAP CM 47NF +80%-20% 50V	AVX	SR175E4732A	A	EA	-	
C113	120019	CAP PC 1UF 10% 63V	ASHCROFT	M2B10201B	A	EA	3	
C114	104026	CAP CM 47NF +80%-20% 50V	AVX	SR175E4732A	A	EA	-	
C115	110042	CAP PE 100NF 20% 63V	WIMA	MKS2	A	EA	7	
C116	110042	CAP PE 100NF 20% 63V	WIMA	MKS2	A	EA	-	
C117	104026	CAP CM 47NF +80%-20% 50V	AVX	SR175E4732A	A	EA	-	
C118	104026	CAP CM 47NF +80%-20% 50V	AVX	SR175E4732A	A	EA	-	
C119	110042	CAP PE 100NF 20% 63V	WIMA	MKS2	A	EA	-	
C120	104026	CAP CM 47NF +80%-20% 50V	AVX	SR175E4732A	A	EA	-	
C123	110042	CAP PE 100NF 20% 63V	WIMA	MKS2	A	EA	-	
C124	110042	CAP PE 100NF 20% 63V	WIMA	MKS2	A	EA	-	
C125	104026	CAP CM 47NF +80%-20% 50V	AVX	SR175E4732A	A	EA	-	
C126	110039	CAP PE 470NF 20% 63V	WIMA	MKS2	A	EA	5	
C127	110042	CAP PE 100NF 20% 63V	WIMA	MKS2	A	EA	-	
C128	104026	CAP CM 47NF +80%-20% 50V	AVX	SR175E4732A	A	EA	-	
C129	110039	CAP PE 470NF 20% 63V	WIMA	MKS2	A	EA	-	
C130	110042	CAP PE 100NF 20% 63V	WIMA	MKS2	A	EA	-	
C131	150020	CAP DT 10UF 20% 25V	AVX	TAP10M25F	A	EA	-	
C132	100330	CAP CP 33PF 2% 100V	PHILIPS	2222 683 34339	A	EA	1	
C201	104026	CAP CM 47NF +80%-20% 50V	AVX	SR175E4732A	A	EA	-	
C202	104026	CAP CM 47NF +80%-20% 50V	AVX	SR175E4732A	A	EA	-	
C203	110041	CAP PE 10NF 20% 100V	WIMA	FKS2	A	EA	1	
C204	104026	CAP CM 47NF +80%-20% 50V	AVX	SR175E4732A	A	EA	-	
C205	00000N	NOT FITTED					-	
C206	104026	CAP CM 47NF +80%-20% 50V	AVX	SR175E4732A	A	EA	-	
C207	110030	CAP PE 1NF 20% 100V	WIMA	FKS2	A	EA	4	
C208	110030	CAP PE 1NF 20% 100V	WIMA	FKS2	A	EA	-	
C209	104026	CAP CM 47NF +80%-20% 50V	AVX	SR175E4732A	A	EA	-	
C210	120019	CAP PC 1UF 10% 63V	ASHCROFT	M2B10201B	A	EA	-	
C212	110046	CAP PE 1UF 20% 50V	WIMA	MKS2 1UF 20% 50V	A	EA	5	
C214	110046	CAP PE 1UF 20% 50V	WIMA	MKS2 1UF 20% 50V	A	EA	-	
C215	104026	CAP CM 47NF +80%-20% 50V	AVX	SR175E4732A	A	EA	-	
C216	120019	CAP PC 1UF 10% 63V	ASHCROFT	M2B10201B	A	EA	-	
C217	140086	CAP PP 10NF 5% 63V	WIMA	FKP2	A	EA	1	
C218	100270	CAP CP 27PF 2% 100V	PHILIPS	2222 683 34279	A	EA	2	
C219	110046	CAP PE 1UF 20% 50V	WIMA	MKS2 1UF 20% 50V	A	EA	-	
C221	104026	CAP CM 47NF +80%-20% 50V	AVX	SR175E4732A	A	EA	-	
C222	100270	CAP CP 27PF 2% 100V	PHILIPS	2222 683 34279	A	EA	-	
C223	110046	CAP PE 1UF 20% 50V	WIMA	MKS2 1UF 20% 50V	A	EA	-	

DESIG	PART NO	DESCRIPTION	PRINC MANUF	MANUF PART NUMBER	CLASS	UM	QUANTITY	CHANGES
C225	104026	CAP CM 47NF +80%-20% 50V	AVX	SR175E4732A	A	EA	-	
C227	110046	CAP PE 1UF 20% 50V	WIMA	MKS2 1UF 20% 50V	A	EA	-	
C301	104026	CAP CM 47NF +80%-20% 50V	AVX	SR175E4732A	A	EA	-	
C302	00000N	NOT FITTED				EA	-	
C303	110030	CAP PE 1NF 20% 100V	WIMA	FKS2		EA	-	
C304	110030	CAP PE 1NF 20% 100V	WIMA	FKS2		EA	-	
C305	104026	CAP CM 47NF +80%-20% 50V	AVX	SR175E4732A	A	EA	-	
C306	110039	CAP PE 470NF 20% 63V	WIMA	MKS2		EA	-	
C307	104026	CAP CM 47NF +80%-20% 50V	AVX	SR175E4732A	A	EA	-	
C308	110039	CAP PE 470NF 20% 63V	WIMA	MKS2		EA	-	
C309	110039	CAP PE 470NF 20% 63V	WIMA	MKS2		EA	-	
C310	104026	CAP CM 47NF +80%-20% 50V	AVX	SR175E4732A	A	EA	-	
C311	100471	CAP CP 470PF 10% 100V	PHILIPS	2222 630 19471		EA	1	
C312	110035	CAP PE 220NF 20% 63V	WIMA	MKS2		EA	1	
C401	100221	CAP CP 220PF 2% 100V	PHILIPS	2222 6B3 58221		EA	1	
C402	150002	CAP DT 10UF 20% 16V	AVX	TAP10M16P	A	EA	1	
C403	104026	CAP CM 47NF +80%-20% 50V	AVX	SR175E4732A	A	EA	-	
C404	104026	CAP CM 47NF +80%-20% 50V	AVX	SR175E4732A	A	EA	-	
C405	104026	CAP CM 47NF +80%-20% 50V	AVX	SR175E4732A	A	EA	-	
C406	104026	CAP CM 47NF +80%-20% 50V	AVX	SR175E4732A	A	EA	-	
C407	104026	CAP CM 47NF +80%-20% 50V	AVX	SR175E4732A	A	EA	-	
C408	104026	CAP CM 47NF +80%-20% 50V	AVX	SR175E4732A	A	EA	-	
D101	200025	DIODE LL 450mA 125V	PHILIPS	BAS45		EA	4	
D102	213012	DIODE VR 2V0 250mW	PHILIPS	BZV86-2V0		EA	2	
D103	213009	DIODE TS 15V 5/500W	UNIFRODE	TVS15	A	EA	1	
D104	200025	DIODE LL 450mA 125V	PHILIPS	BAS45		EA	-	
D105	200025	DIODE LL 450mA 125V	PHILIPS	BAS45		EA	-	
D106	00000N	NOT FITTED				EA	-	
D107	00000N	NOT FITTED				EA	-	
D108	200000	DIODE GP 200mA 125V	FAIRCHILD	1N458A	A	EA	1	
D201	200005	DIODE SB 200mA 30V	PHILIPS	BAT85		EA	5	
D202	200005	DIODE SB 200mA 30V	PHILIPS	BAT85		EA	-	
D203	200005	DIODE SB 200mA 30V	PHILIPS	BAT85		EA	-	
D204	200005	DIODE SB 200mA 30V	PHILIPS	BAT85		EA	-	
D301	213012	DIODE VR 2V0 250mW	PHILIPS	BZV86-2V0		EA	-	
D302	200025	DIODE LL 450mA 125V	PHILIPS	BAS45		EA	-	
D303	210047	DIODE ZN 4V7 400mW	PHILIPS	DZX79CAV7	A	EA	1	
D304	210062	DIODE ZN 6V2 400mW	PHILIPS	BZX79CV2	A	EA	1	
D401	200005	DIODE SB 200mA 30V	PHILIPS	BAT85		EA	-	
Q102	240001	TRAN NPN	MOTOROLA	BC104		EA	3	
Q103	240001	TRAN NPN	MOTOROLA	BC104		EA	-	
Q104	240006	TRAN NPN TO92	MOTOROLA	2N3904		EA	2	
Q105	240006	TRAN NPN TO92	MOTOROLA	2N3904		EA	-	
Q106	230096	TRAN MOSFET N CHAN 60V	FERRANTI	ZVN2106A		EA	1	
Q107	250004	TRAN PNP TO92	MOTOROLA	2N3906		EA	1	

DESIG	PART NO	DESCRIPTION	PRINC MANUF	MANUF PART NUMBER	CLASS	UM	QUANTITY	CHANGES
Q201	230039	TRAN JPET P CHAN	SILICONIX	J175		EA	5	
Q202	230038	TRAN JPET N-CHAN	SILICONIX	J112		EA	3	
Q203	230039	TRAN JPET P CHAN	SILICONIX	J175		EA	-	
Q204	239087-1	TRAN JPET SET J106 X 2	DATRON	SEE DRG		S2	1	
Q205	230039	TRAN JPET P CHAN	SILICONIX	J175		EA	-	
Q206	239087-1	TRAN JPET SET J106 X 2	DATRON	SEE DRG		S2	-	
Q207	230086	TRAN MOSFET P-CHAN 60V	FERRANTI	ZVP2106A	A	EA	1	
Q208	230082	TRAN MOSFET N-CHAN 60V	SILICONIX	VN10LM		EA	1	
Q301	230038	TRAN JPET N-CHAN	SILICONIX	J112		EA	-	
Q302	230039	TRAN JPET P CHAN	SILICONIX	J175		EA	-	
Q303	230038	TRAN JPET N-CHAN	SILICONIX	J112		EA	-	
Q304	230039	TRAN JPET P CHAN	SILICONIX	J175		EA	-	
Q305	240001	TRAN NPN	MOTOROLA	BC104		EA	-	
U101	260124	IC LIN QUAD ULP COMPARATOR	NATIONAL	LP339N		EA	1	
U102	260048	IC LIN OP AMP CMOS	INTERSTL	ICL7611 DCPA		EA	1	
U104	400831-1	ASSY REF MODULE POS 4910	DATRON	SEE DRG		EA	1	
U105	260033	IC LIN REC SV 1A	MOTOROLA	MC78L05ACP	A	EA	1	
U107	280011	IC DIG FLIP FLOP D X2	MOTOROLA	MC14013BCP		EA	1	
U108	280193	IC DIG NAND2 SCHMITT X4	PHILIPS	HEP4093BP		EA	1	
U109	260082	IC LIN OP AMP CHOPPR	LINEAR TECHNOLOGY	LTC1052CN8		EA	1	
U110	260132	IC LIN OP AMP PREC LOW VOLT	PMI	OP90GP		EA	1	
U111	260065	IC LIN OP AMP	PMI	OP27P2	A	EA	1	
U112	290149	IC DIG CMOS TIMER	INTERSTL	ICM7555 1PA		EA	1	
U201	280182	IC DIG FLIP FLOP D X2	NATIONAL	74AC74PC		EA	3	
U202	220041	OPTO ISOL 3KV DUAL	H.P.	HCPL-2631	A	EA	1	
U203	280185	IC DIG INV MOSFET DRIVER X2	INTERSTL	ICL7667CPA		EA	3	
U204	280185	IC DIG INV MOSFET DRIVER X2	INTERSTL	ICL7667CPA		EA	-	
U205	230031	TRAN JPET N-CHAN DUAL	SILICONIX	U404		EA	2	
U206	230031	TRAN JPET N-CHAN DUAL	SILICONIX	U404		EA	-	
U207	260057	IC LIN OP AMP	SIGNETICS	NE5534N		EA	2	
U208	260057	IC LIN OP AMP	SIGNETICS	NE5534N		EA	-	
U209	260107	IC LIN OP AMP	PRECISION MONOLITHIC	OP07CP		EA	1	
U301	280185	IC DIG INV MOSFET DRIVER X2	INTERSTL	ICL7667CPA		EA	-	
U302	260025	IC LIN OP AMP	NATIONAL	LM101AH		EA	1	
U303	260088	IC LIN OP AMP DUAL PREC	LINEAR TECHNOLOGY	LT1013CH		EA	1	
U401	280141	IC DIG COUNT8 SYNC BIN PL DN	SGS	M74HC4103B1		EA	4	
U402	280141	IC DIG COUNT8 SYNC BIN PL DN	SGS	M74HC4103B1		EA	-	
U403	280141	IC DIG COUNT8 SYNC BIN PL DN	SGS	M74HC4103B1		EA	-	
U404	280141	IC DIG COUNT8 SYNC BIN PL DN	SGS	M74HC4103B1		EA	-	
U405	280160	IC DIG FLIP FLOP D X2	TEXAS	SN74HCT74N		EA	1	
U406	280182	IC DIG FLIP FLOP D X2	NATIONAL	74AC74PC		EA	-	
U407	280182	IC DIG FLIP FLOP D X2	NATIONAL	74AC74PC		EA	-	
U408	280188	IC DIG NAND2 X4	RCA	CD74AC00E		EA	1	
T201	310002-2	TRANSF PULSE	NEWPORT	SEE DRG		EA	2	
T202	310002-2	TRANSF PULSE	NEWPORT	SEE DRG		EA	-	

DESIG	PART NO	DESCRIPTION	PRINC MANUF	MANUF PART NUMBER	CLASS	UM	QUANTITY	CHANGES
L101	370001	CHOKERF 10UH	SIGMA	SC10/25	A	EA	4	
L102	370001	CHOKERF 10UH	SIGMA	SC10/25	A	EA	-	
L103	370001	CHOKERF 10UH	SIGMA	SC10/25	A	EA	-	
L104	370001	CHOKERF 10UH	SIGMA	SC10/25	A	EA	-	
P4	604111	PLUG 15-WAY PCB 10.3 D TYPE	AMP	343647-2		EA	1	
PG34	604106	PLUG PCB 32-WAY	BICC-VERO	905-72216J		EA	1	
TP101	620007	TEST POINT TERMINAL	MICROVAR	TYPE C30		EA	10	
TP102	620007	TEST POINT TERMINAL	MICROVAR	TYPE C30		EA	-	
TP103	620007	TEST POINT TERMINAL	MICROVAR	TYPE C30		EA	-	
TP104	620007	TEST POINT TERMINAL	MICROVAR	TYPE C30		EA	-	
TP105	620007	TEST POINT TERMINAL	MICROVAR	TYPE C30		EA	-	
TP106	620007	TEST POINT TERMINAL	MICROVAR	TYPE C30		EA	-	
TP107	620007	TEST POINT TERMINAL	MICROVAR	TYPE C30		EA	-	
TP108	620007	TEST POINT TERMINAL	MICROVAR	TYPE C30		EA	-	
TP201	620007	TEST POINT TERMINAL	MICROVAR	TYPE C30		EA	-	
TP202	620007	TEST POINT TERMINAL	MICROVAR	TYPE C30		EA	-	
TP301	620007	TEST POINT TERMINAL	MICROVAR	TYPE C30		EA	-	
TP302	620007	TEST POINT TERMINAL	MICROVAR	TYPE C30		EA	-	
TP401	620007	TEST POINT TERMINAL	MICROVAR	TYPE C30		EA	-	
TP402	620007	TEST POINT TERMINAL	MICROVAR	TYPE C30		EA	-	
TP403	620007	TEST POINT TERMINAL	MICROVAR	TYPE C30		EA	-	
TP404	620007	TEST POINT TERMINAL	MICROVAR	TYPE C30		EA	-	
TP405	620007	TEST POINT TERMINAL	MICROVAR	TYPE C30		EA	-	
TP406	620007	TEST POINT TERMINAL	MICROVAR	TYPE C30		EA	-	
S101	700131	SWITCH 1PCO SLIDE	SECME	090320102		EA	2	
S102	700131	SWITCH 1PCO SLIDE	SECME	090320102		EA	-	
S401	700118	SWITCH 16 POS ROTARY DIP	OMRON	A6CR-16R		EA	5	
S402	700118	SWITCH 16 POS ROTARY DIP	OMRON	A6CR-16R		EA	-	
S403	700118	SWITCH 16 POS ROTARY DIP	OMRON	A6CR-16R		EA	-	
S404	700118	SWITCH 16 POS ROTARY DIP	OMRON	A6CR-16R		EA	-	
S405	700118	SWITCH 16 POS ROTARY DIP	OMRON	A6CR-16R		EA	-	
F101	920120	FUSE 1A 125V 7MM	LITTLEFUSE	275.025		EA	1	
	410432-3	PCB CELL 4910		SEE DRG		EA	1	
	420098	LABEL SERIAL/ASSY No.	RS COMPONENTS	554-793		EA	1	
	420112-1	LABEL SSD WARNING 12 X 12mm	TEKNIS	LN1212	A	EA	1	
	450739-2	LINK SUPPORT BLOCK		SEE DRG		EA	4	
	450740-2	LOW EMP THERMAL LINK		SEE DRG		EA	2	
	450741-3	SCREEN WALL 4MHz LOWER 4910		SEE DRG		EA	1	
	450742-1	SCREEN WALL 60Hz LOWER 4910		SEE DRG		EA	1	
	450794-2	SCREEN WALL 4MHz UPPER 4910		SEE DRG		EA	1	
	450795-1	SCREEN WALL 60Hz UPPER		SEE DRG		EA	1	
	450796-1	SCREEN COVER 60Hz CELL 4910		SEE DRG		EA	2	
	450798-1	SCREEN GASKET 4MHz CELL 4910		SEE DRG		EA	2	
	450799-1	SCREEN GASKET 60Hz CELL 4910		SEE DRG		EA	2	
	540002	WIRE 1/.7 TINNED COPPER	B54109	22SWG		AR	1	

DESIG	PART NO	DESCRIPTION	PRINC MANUF	MANUF PART NUMBER	CLASS	UM	QUANTITY	CHANGES
	540006	WIRE 1/.4 PTFE 250V BLK	BSG210	TYPE A		AR	1	
	590001	SLEEVE NP 1.5 X 20MM BLK	HELLERMANN	H15 X 20MM BLK		EA	2	
	590004	SLEEVE PTFE 1mm BLK	HELLERMANN	FE10		AR	1	
	611016	SCREW M3 X 8 POZIPAN SZP				EA	4	
	611096	SCREW M2.5 X 12 POZIPAN SZP				EA	2	
	611109-1	SCREW M3 X 12 SLT CH GL.PL				EA	4	
	611115	SCREW M3 X 25 POZIPAN SZP				EA	4	
	612026-1	STANDOFF M3 X 6		SEE DRG		EA	4	
	613029	WASHER M3 WAVY SS				EA	10	
	613047	WASHER M2.5 WAVY SS				EA	4	
	613053-1	WASHER M3 PLAIN CU GL.PL				EA	4	
	614016-1	SPACER M3 X 14 CLEAR		SEE DRG		EA	4	
	615002	NUT FULL M3 SZP				EA	2	
	615006	NUT FULL M2.5 SZP				EA	2	
	615024	NUT SQ M3 ST BZP				EA	4	
	618015	COMPONENT CARRIER	JERMYN	J22-4019		EA	21	
	620003	PIN SOLDER	MILL-MAX	3130200010000080		EA	6	
	630024	BEAD CERAMIC 16 SWG	PARK ROYAL PORCELAIN	No2		EA	2	
	630112	PCB EJECTOR BLACK	RICHCO	CBE		EA	2	
	630243	BEAD GLASS 2.4 X 0.81 X 1.8	MANSOL (PREFORMS)	LT M5363B/3		EA	54	

End

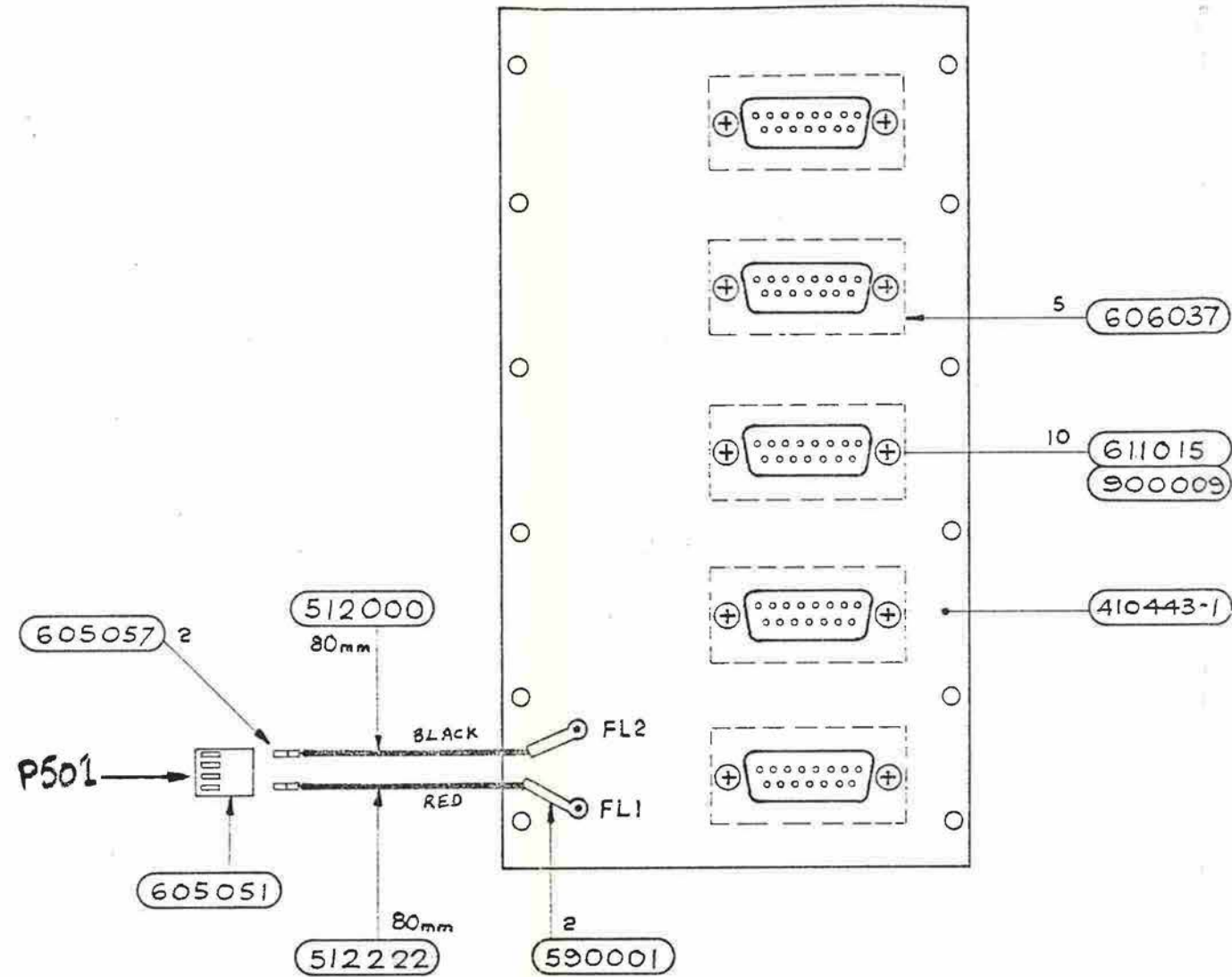
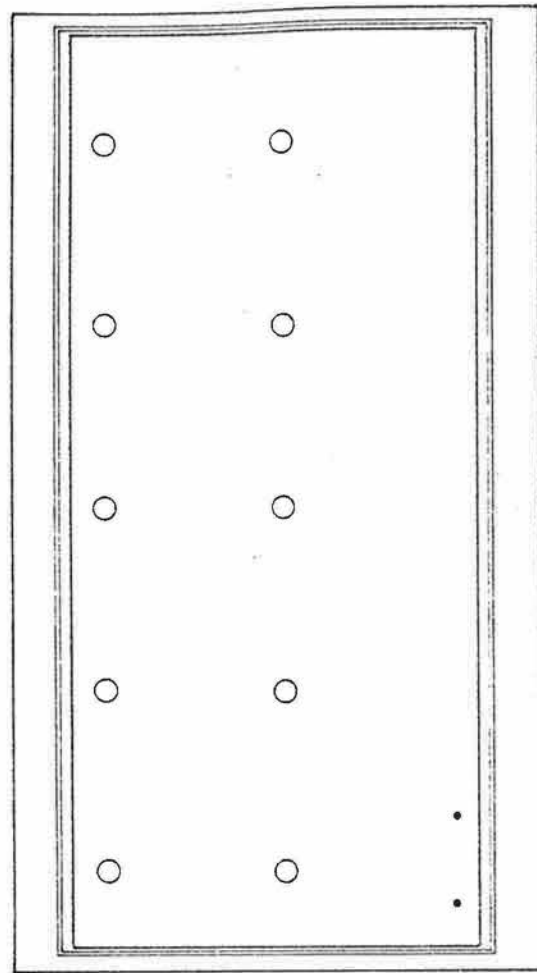

MOUNT BETWEEN
CONNECTOR FLANGE
AND PCB.

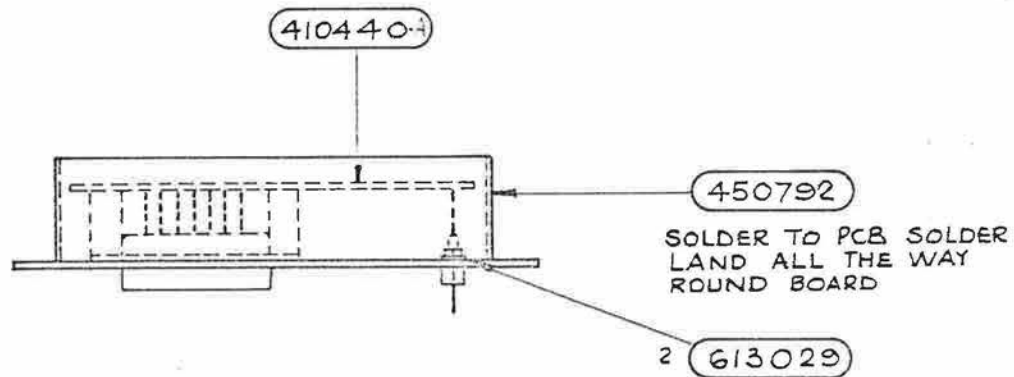

DIGITAL ASSEMBLY

Drawing No. DA400923 Sheet 2



© Datron Instruments 1991

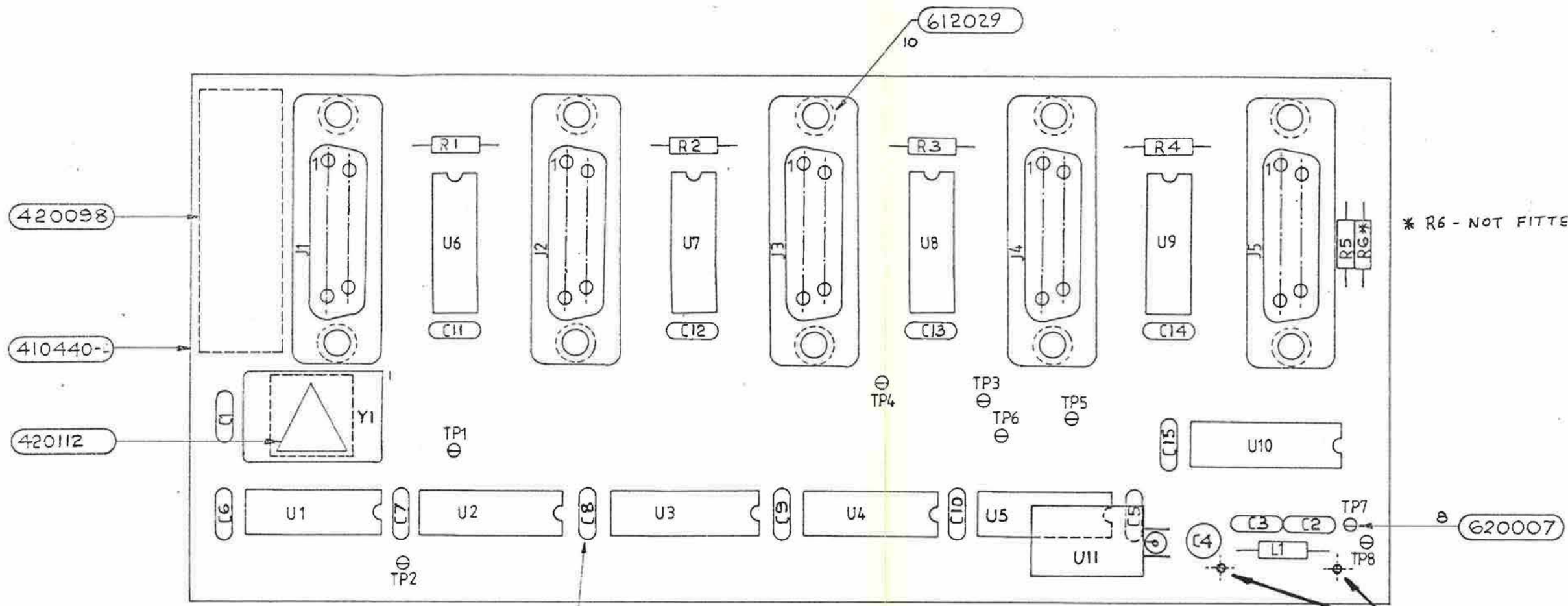

28

630243

FIT TO C1, C2, C3, C5 - C15
ONE PER LEG.

MAX.
COMP.
HEIGHT
11

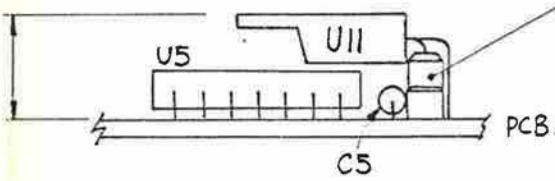

630036 2

FIT OVER CENTRE
LEG OF U11

Feedthrough
Wires

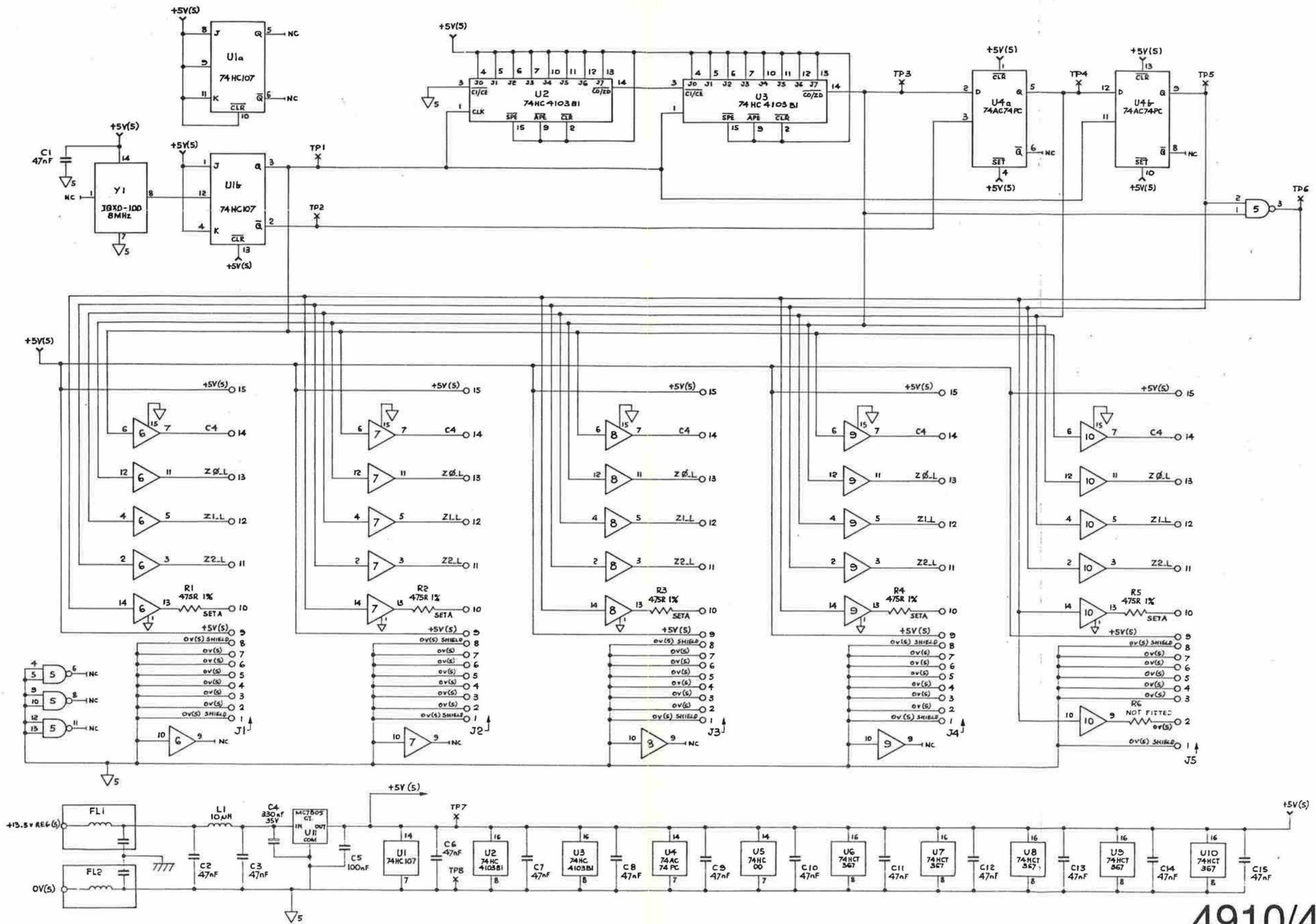

DIGITAL ASSEMBLY

Drawing No. DC400923 Sheet 1



© Datron Instruments 1991

DESIG	PART NO	DESCRIPTION	PRINC MANUF	MANUF PART NUMBER	CLASS	UM	QUANTITY	CHANGES
TP8	620007	TEST POINT TERMINAL	MICROVAR	TYPE C30		EA	-	
Y1	800037	CRYSTAL OSC 8MHz	EUROQUARTZ	EQXO-1100HC		EA	1	
FL1	390004	FILTER RFI SUPP CHASSIS MTG	OXLEY	DLT4/L/22000		EA	2	
FL2	390004	FILTER RFI SUPP CHASSIS MTG	OXLEY	DLT4/L/22000		EA	-	
	410440-A	PCB DIGITAL 4910		SEE DRG		EA	1	
	410443-1	PCB DIGITAL SCREEN 4910		SEE DRG		EA	1	
	420098	LABEL SERIAL/ASSY No.	RS COMPONENTS	554-793		EA	1	
	420112-1	LABEL SSD WARNING 12 X 12mm	TEKNIS	LN1212	A	EA	1	
	450792-1	SCREEN ETCHED COPPER 4910		SEE DRG		EA	1	
	512000	WIRE 7/.2 PTFE 1KV BLK	BSG210	TYPE C		AR	1	
	512222	WIRE 7/.2 PTFE 1KV RED	BSG210	TYPE C		AR	1	
	590001	SLEEVE NP 1.5 X 20MM BLK	HELLERMANN	H15 X 20MM BLK		EA	2	
	605051	HOUSING 4-WAY	MOLEX	6471 SERIES 22-01-20		EA	1	
	605057	CRIMP TERMINAL GD PL	MOLEX	08-56-0120 TO DRG		EA	2	
	606037	GASKET RFI (15-WAY)	AMP	747025-3		EA	5	
	611015	SCREW M3 X 8 POZICSK SZP				EA	10	
	612029-1	STANDOFF M3 X 12		SEE DRG		EA	10	
	613029	WASHER M3 WAVY SS				EA	2	
	630036	BEAD CERAMIC 18 SWG	PARK ROYAL PORCELAIN	No1		EA	2	
	630243	BEAD GLASS 2.4 X 0.81 X 1.8	MANSOL (PREFORMS) LT	M5363B/3		EA	28	
	900009	LOCKING COMPOUND	LOCTITE	222		AR	1	

End

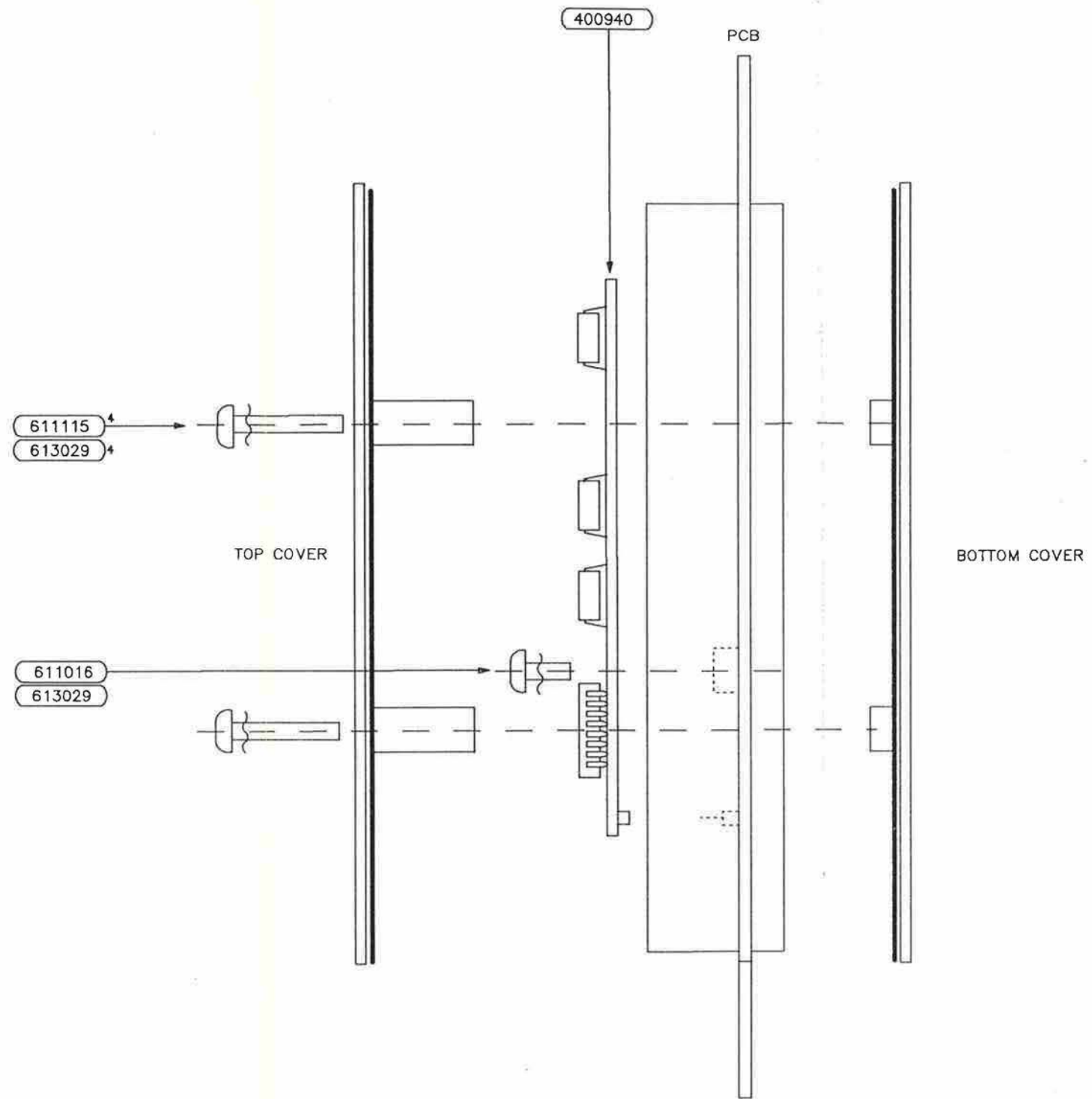
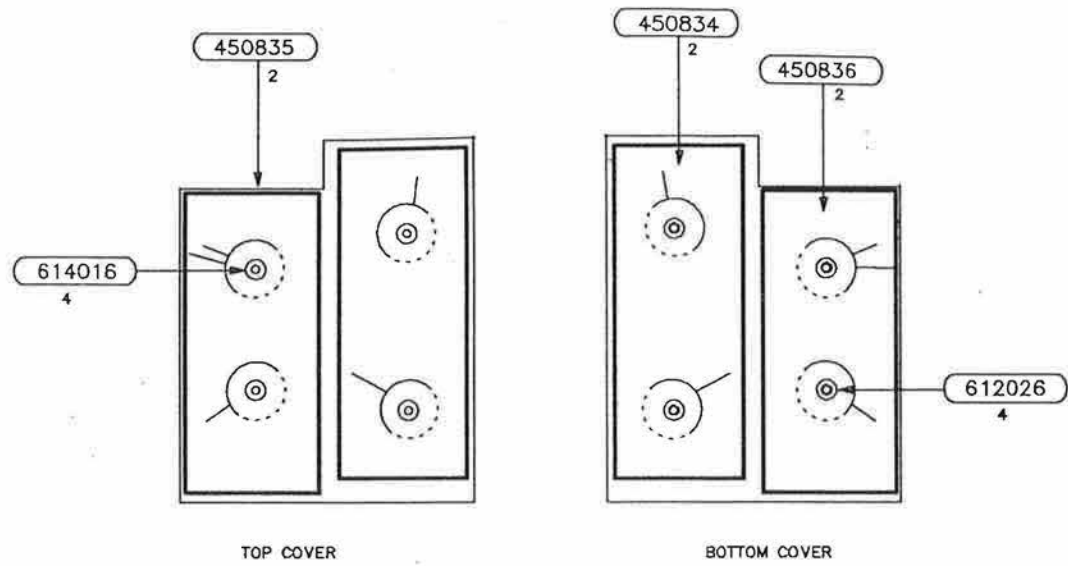

OUTPUT PCB ASSEMBLY

Drawing No. DA400881 Sheet 2



© Datron Instruments 1991

LOWER 450825
UPPER 450824

LOWER 450741
UPPER 450794

630024 58

FIT ONE GLASS BEAD PER LEAD ON :-
C104, 105, 109, 110, 112, 114, 201, 208,
212, 215, 218, 219, 220, 221, 222,
223, 308, 312, 315, 318, 319, 320,
322, 401, 405, 409, 410, 415 AND 416.

MOUNT C121 BETWEEN U102-2 & U102-6
ON SOLDER SIDE OF PCB

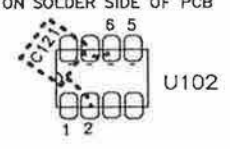

MOUNT THE FOLLOWING COMPONENTS
ON CARRIERS :- R134, 139,
209, 212, 213, 216, 217, 218,
309, 312, 313, 316, 317, 318,
402, 405, 407, 415, 416, 418,
419, 420 AND 427.

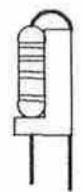

THE FOLLOWING COMPONENTS ARE
NOT FITTED :-
R432, R436, E502, E503, E504,
E505, C219, C319, C321 AND C323.

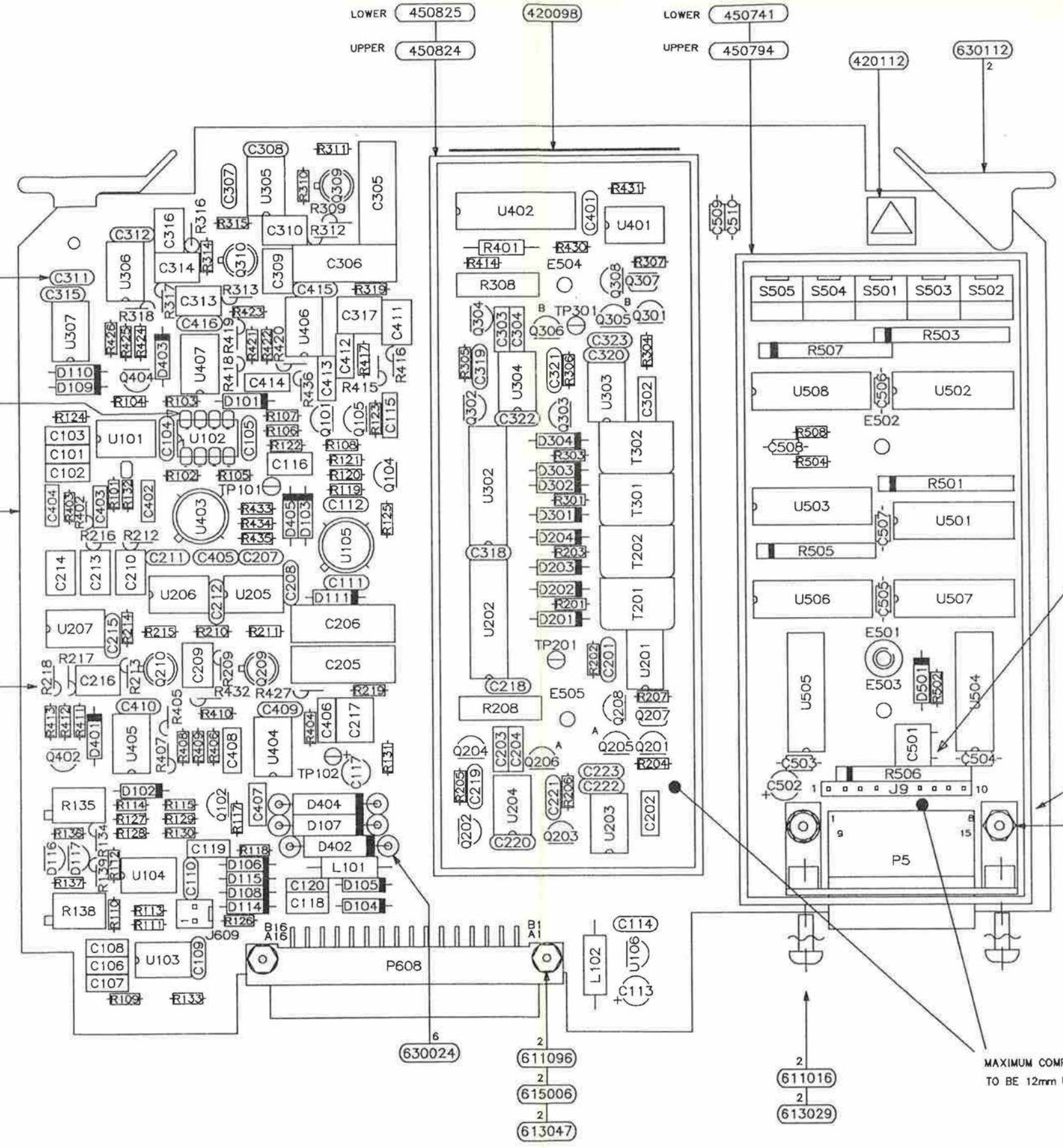

MATCHED FET PAIRS:-
A : Q205 & Q206
B : Q305 & Q306

C501 TO LAY FLAT
AGAINST PCB

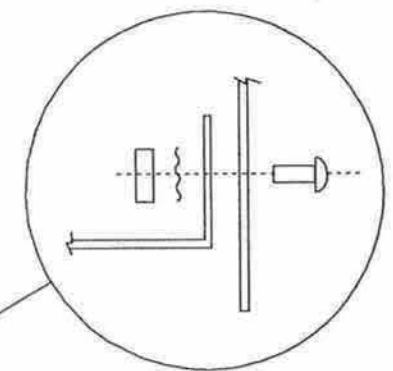

MAXIMUM COMPONENT HEIGHT
TO BE 12mm UNDER SRCEENS

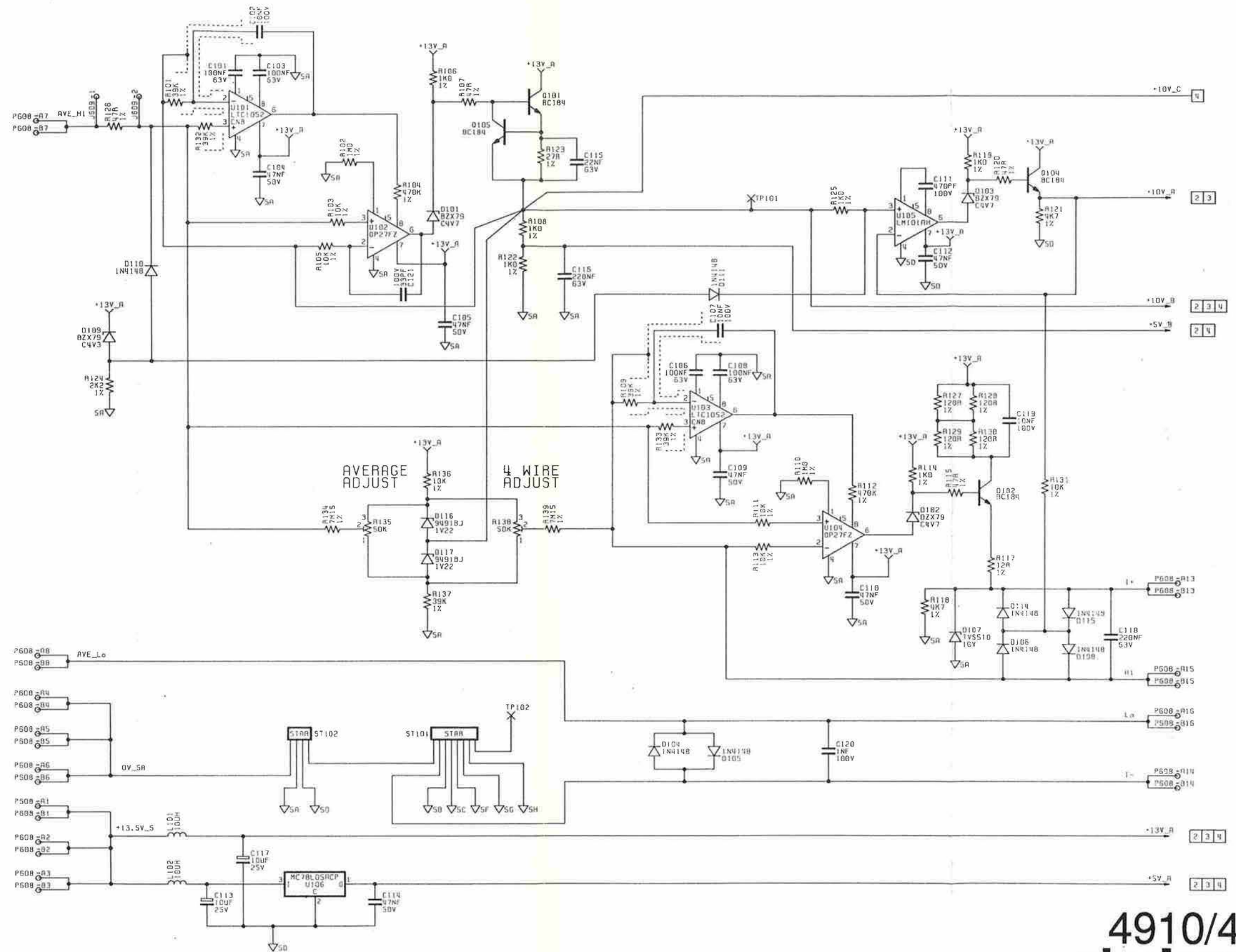

OUTPUT PCB ASSEMBLY
 Drawing No. DC400881 Sheet 1



© Datron Instruments 1991

LOWER 450825
UPPER 450824

LOWER 450741
UPPER 450794

420098

420112

630112
2

630024
58

FIT ONE GLASS BEAD PER LEAD ON :-
C104, 105, 109, 110, 112, 114, 201, 208,
212, 215, 218, 219, 220, 221, 222,
223, 308, 312, 315, 318, 319, 320,
322, 401, 405, 409, 410, 415 AND 416.

MOUNT C121 BETWEEN U102-2 & U102-8
ON SOLDER SIDE OF PCB

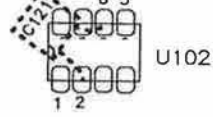

MOUNT THE FOLLOWING COMPONENTS
ON CARRIERS :- R134, 139,
209, 212, 213, 216, 217, 218,
309, 312, 313, 316, 317, 318,
402, 405, 407, 415, 416, 418,
419, 420 AND 427.

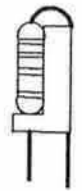

THE FOLLOWING COMPONENTS ARE
NOT FITTED :-
R432, R436, E502, E503, E504,
E505, C219, C319, C321 AND C323.

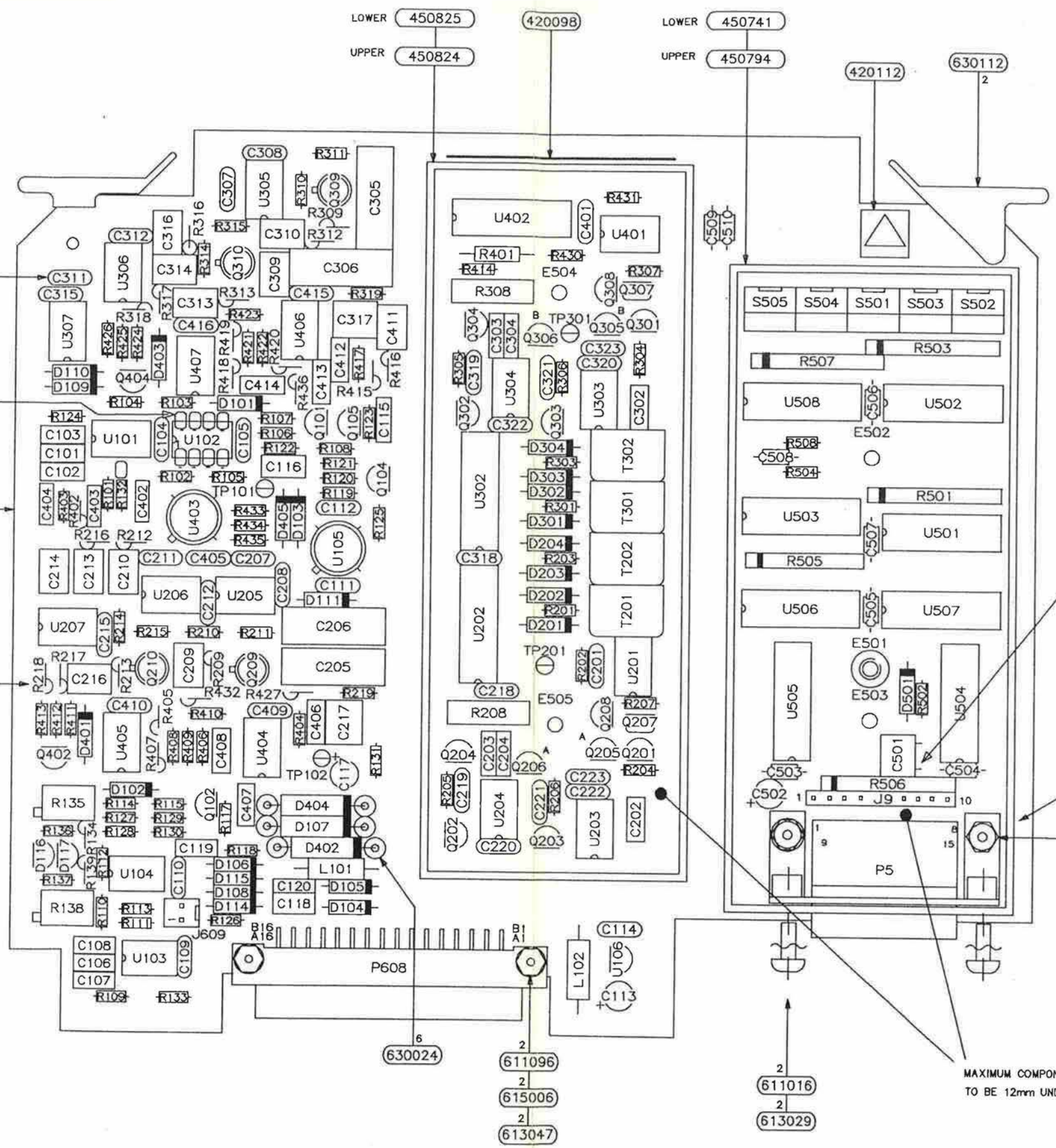

MATCHED FET PAIRS:-
A : Q205 & Q206
B : Q305 & Q306

C501 TO LAY FLAT
AGAINST PCB

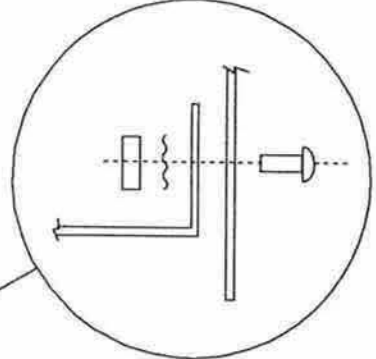

MAXIMUM COMPONENT HEIGHT
TO BE 12mm UNDER SRCEENS

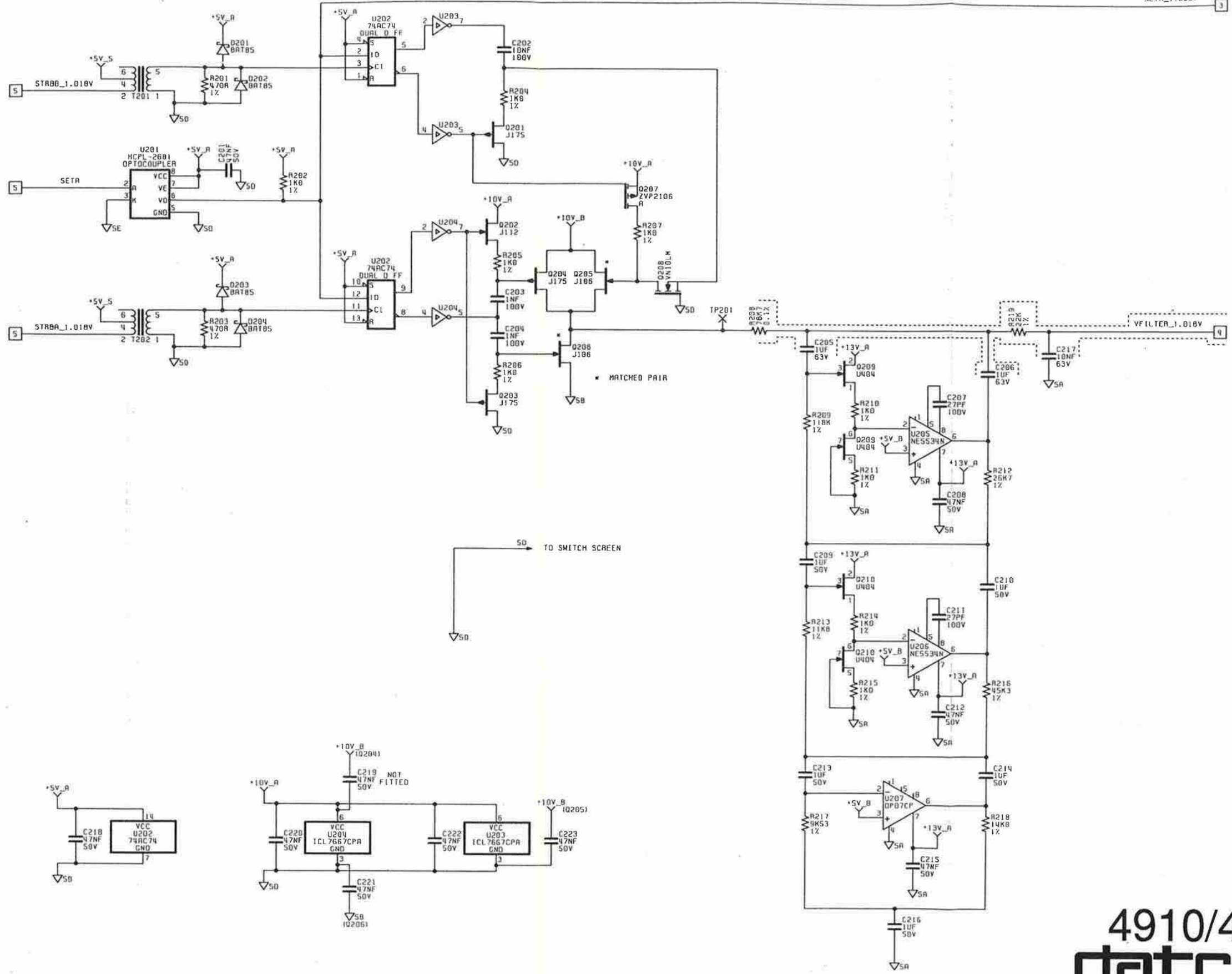

OUTPUT PCB ASSEMBLY
 Drawing No. DC400881 Sheet 2



© Datron Instruments 1991

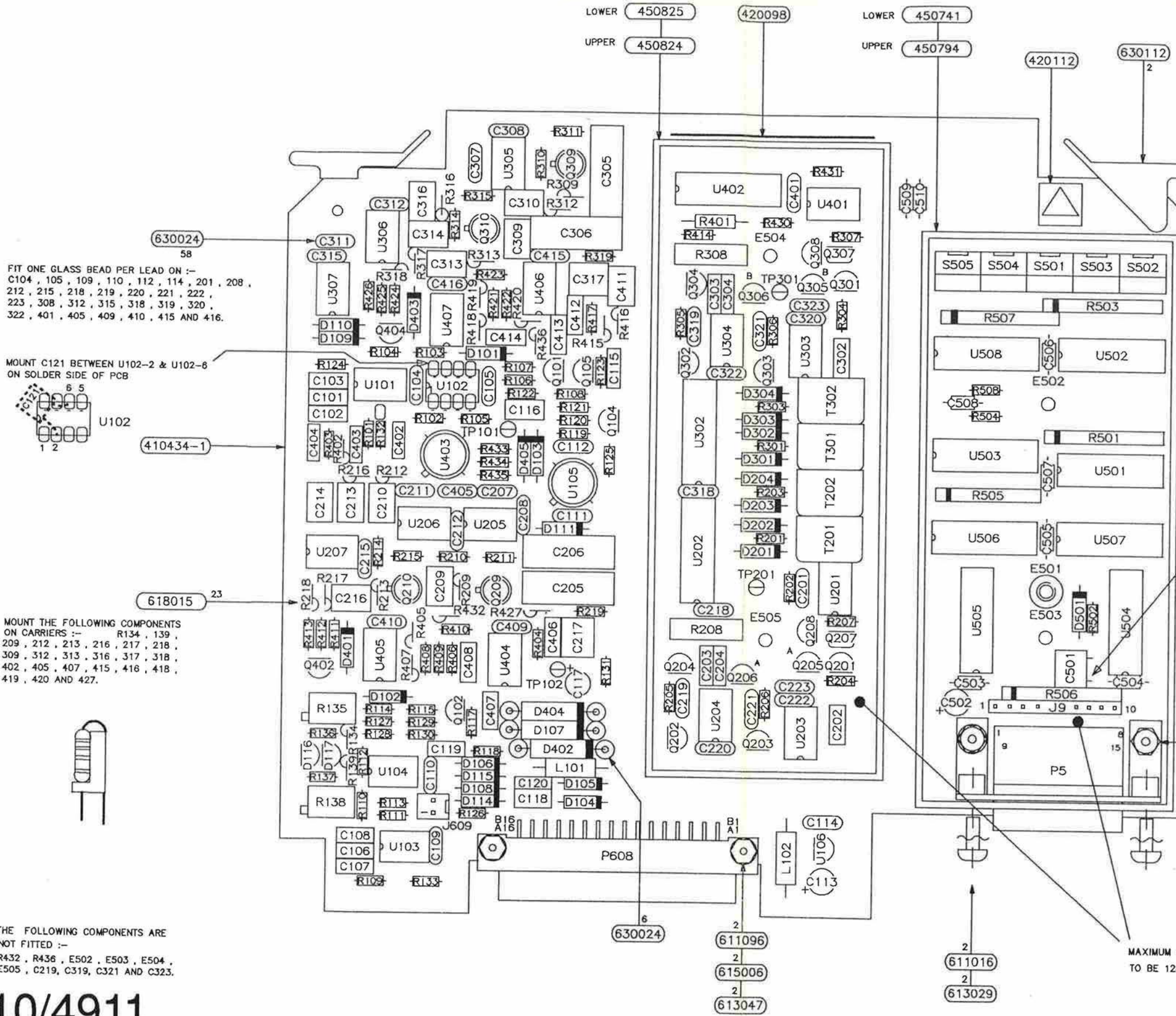

FIT ONE GLASS BEAD PER LEAD ON :-
 C104, 105, 109, 110, 112, 114, 201, 208,
 212, 215, 218, 219, 220, 221, 222,
 223, 308, 312, 315, 318, 319, 320,
 322, 401, 405, 409, 410, 415 AND 416.

MOUNT C121 BETWEEN U102-2 & U102-8
 ON SOLDER SIDE OF PCB

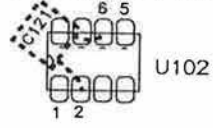

MOUNT THE FOLLOWING COMPONENTS
 ON CARRIERS :- R134, 139,
 209, 212, 213, 216, 217, 218,
 309, 312, 313, 316, 317, 318,
 402, 405, 407, 415, 416, 418,
 419, 420 AND 427.

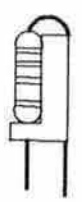

MATCHED FET PAIRS:-
 A : Q205 & Q206
 B : Q305 & Q306

C501 TO LAY FLAT
 AGAINST PCB

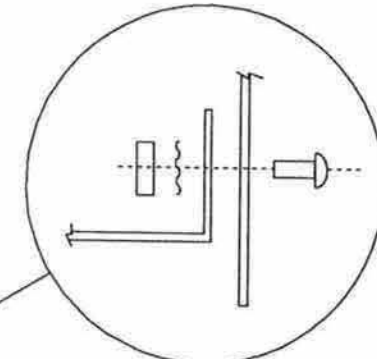

MAXIMUM COMPONENT HEIGHT
 TO BE 12mm UNDER SRCEENS

THE FOLLOWING COMPONENTS ARE
 NOT FITTED :-
 R432, R436, E502, E503, E504,
 E505, C219, C319, C321 AND C323.

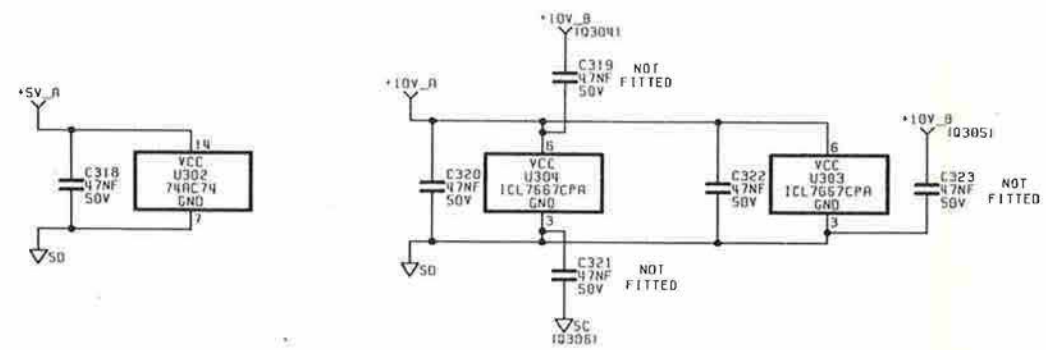
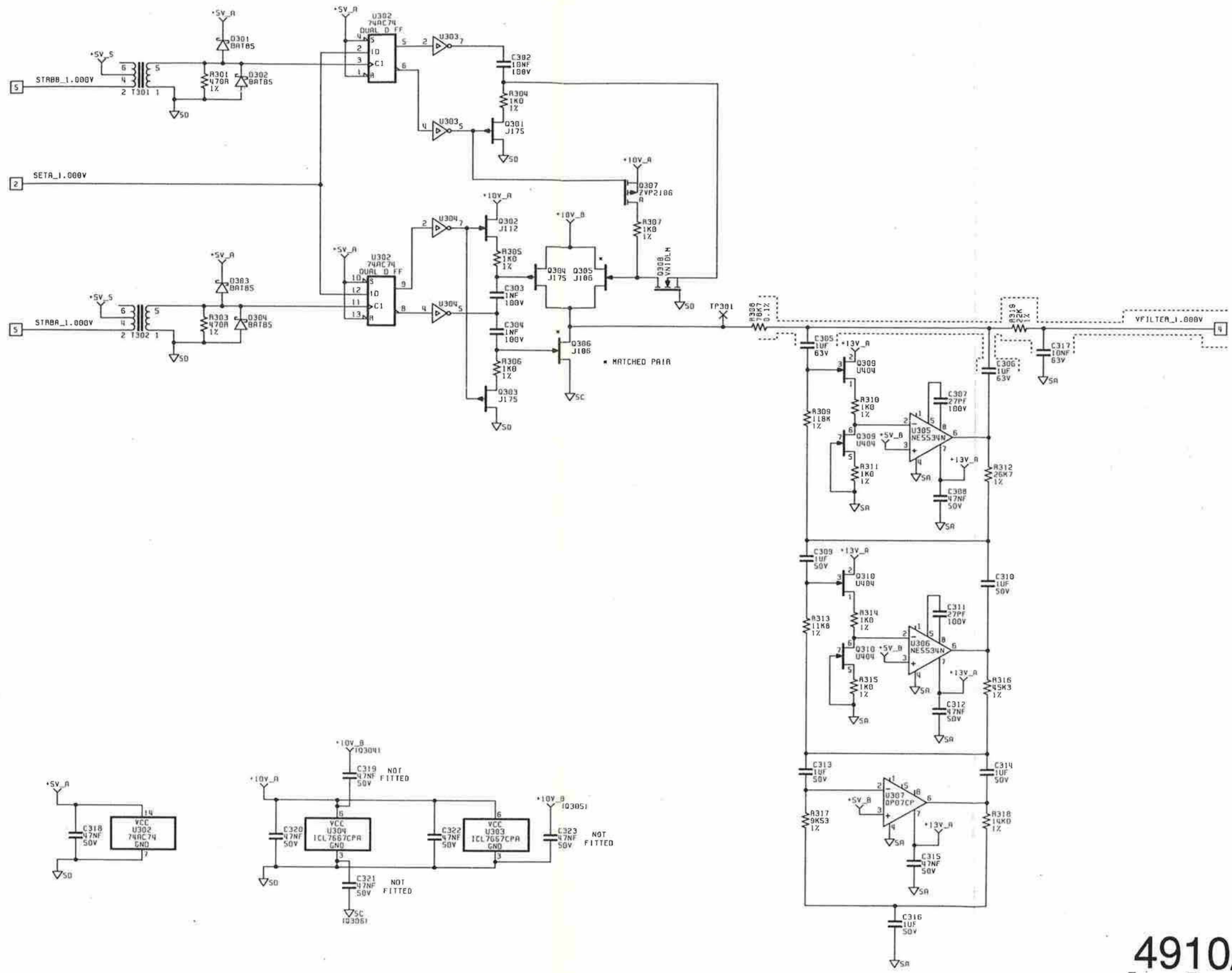

OUTPUT PCB ASSEMBLY
 Drawing No. DC400881 Sheet 3



© Datron Instruments 1991

LOWER 450825
UPPER 450824

LOWER 450741
UPPER 450794

420098

420112

630112

630024

58

FIT ONE GLASS BEAD PER LEAD ON :-
C104, 105, 109, 110, 112, 114, 201, 208,
212, 215, 218, 219, 220, 221, 222,
223, 308, 312, 315, 318, 319, 320,
322, 401, 405, 409, 410, 415 AND 416.

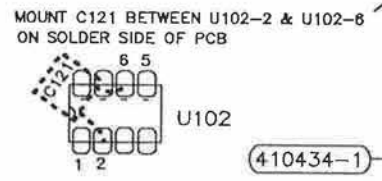

MOUNT THE FOLLOWING COMPONENTS
ON CARRIERS :- R134, 139,
209, 212, 213, 216, 217, 218,
309, 312, 313, 316, 317, 318,
402, 405, 407, 415, 416, 418,
419, 420 AND 427.

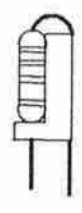

THE FOLLOWING COMPONENTS ARE
NOT FITTED :-
R432, R436, E502, E503, E504,
E505, C219, C319, C321 AND C323.

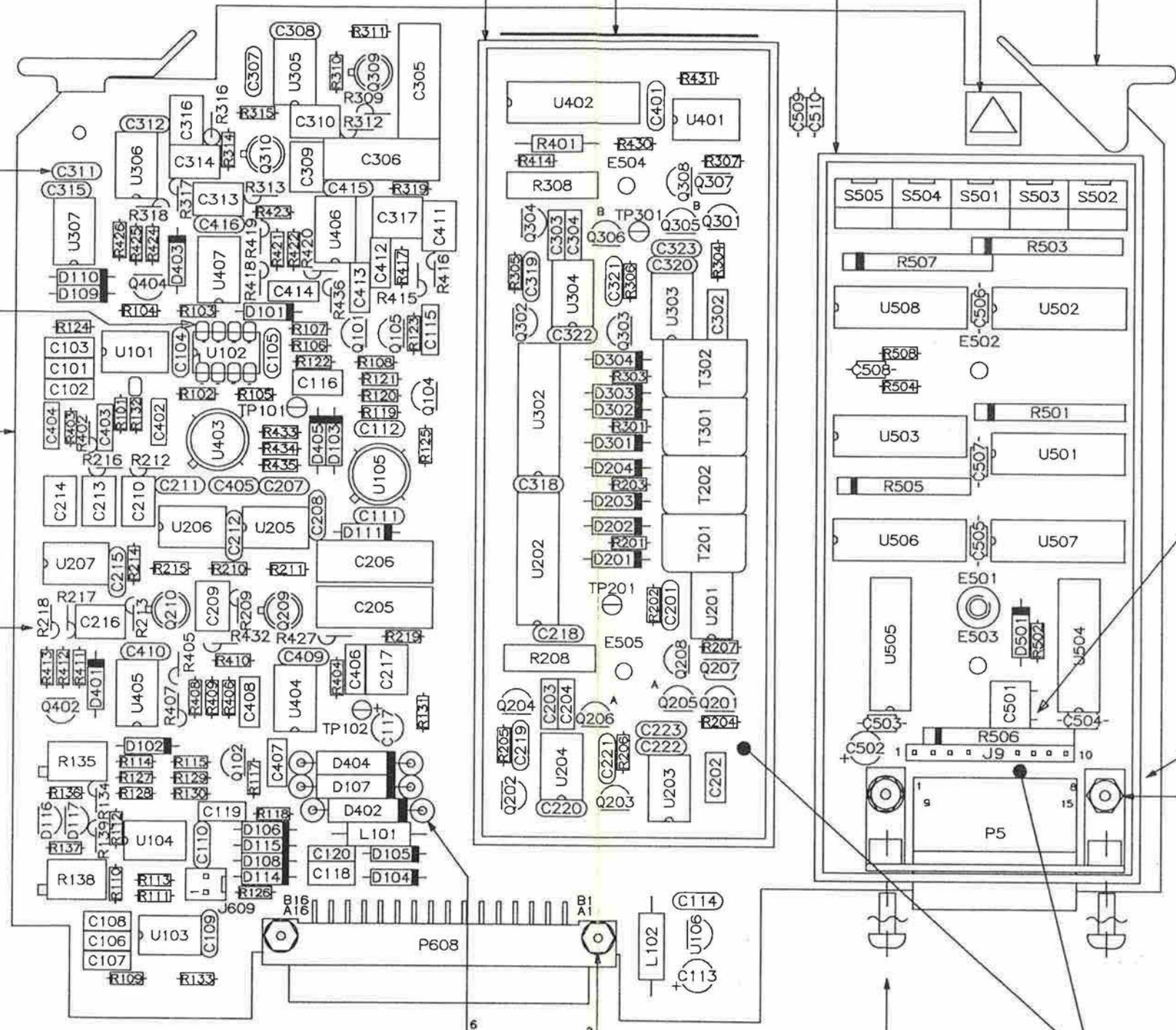

MATCHED FET PAIRS:-
A : Q205 & Q206
B : Q305 & Q306

C501 TO LAY FLAT
AGAINST PCB

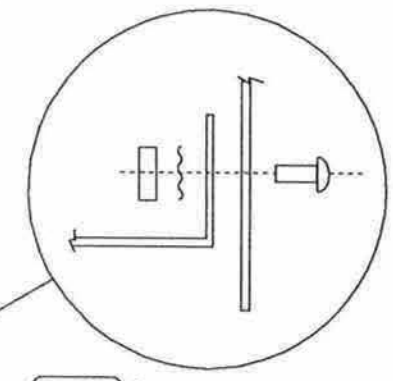

611016 2
613029 2
615002 2

MAXIMUM COMPONENT HEIGHT
TO BE 12mm UNDER SCREENS

630024

611096

615006

613047

611016 2
613029 2

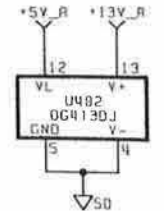
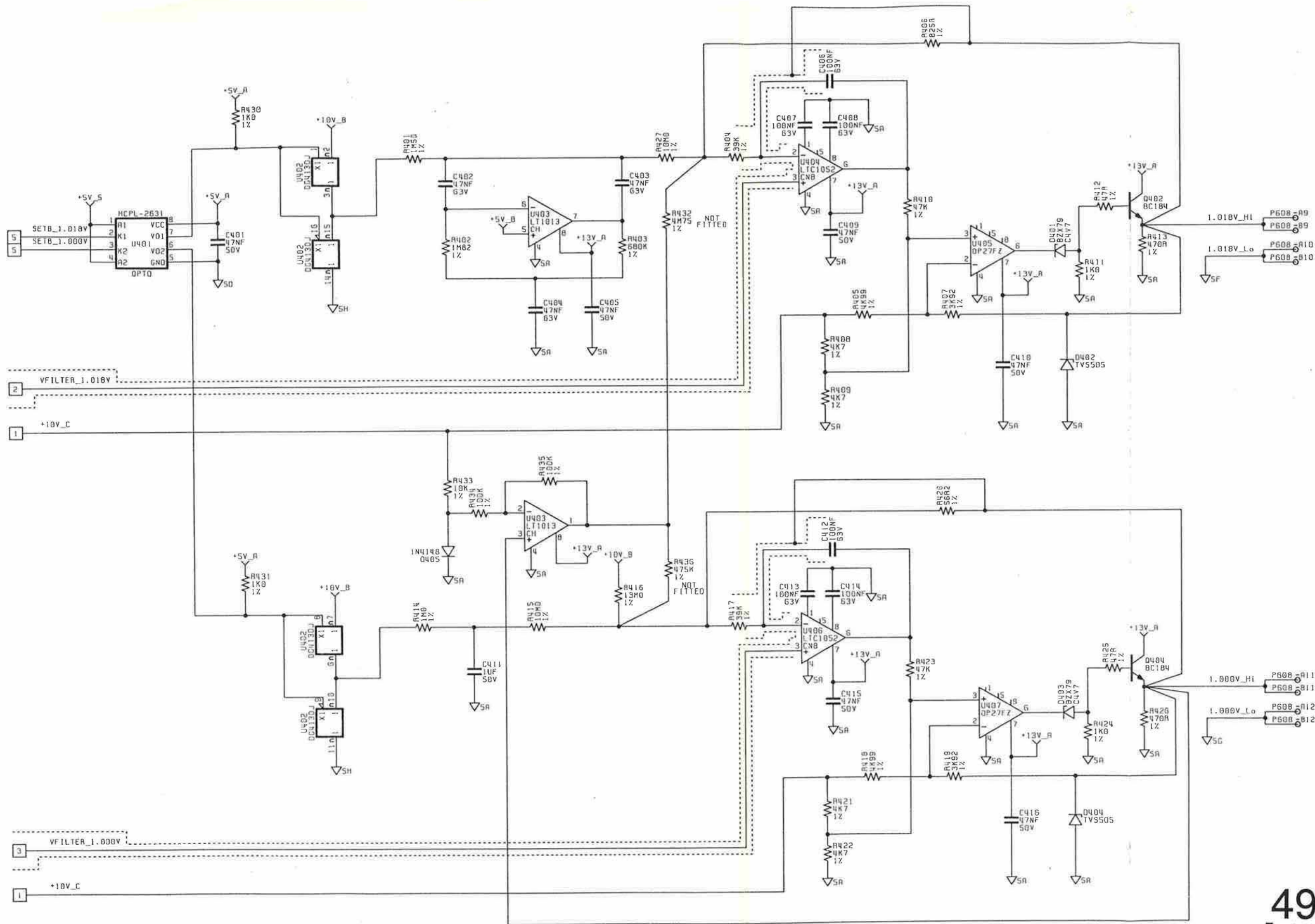

OUTPUT PCB ASSEMBLY
 Drawing No. DC400881 Sheet 4



© Datron Instruments 1991

LOWER 450825
UPPER 450824

LOWER 420098
UPPER 420098

LOWER 450741
UPPER 450794

420112
630112

630024
58

FIT ONE GLASS BEAD PER LEAD ON :-
C104, 105, 109, 110, 112, 114, 201, 208,
212, 215, 218, 219, 220, 221, 222,
223, 308, 312, 315, 318, 319, 320,
322, 401, 405, 409, 410, 415 AND 416.

MOUNT C121 BETWEEN U102-2 & U102-6
ON SOLDER SIDE OF PCB

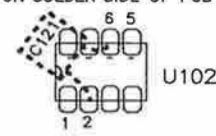

410434-1

MOUNT THE FOLLOWING COMPONENTS
ON CARRIERS :- R134, 139,
209, 212, 213, 216, 217, 218,
309, 312, 313, 316, 317, 318,
402, 405, 407, 415, 416, 418,
419, 420 AND 427.

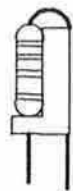

618015 23

THE FOLLOWING COMPONENTS ARE
NOT FITTED :-
R432, R436, E502, E503, E504,
E505, C219, C319, C321 AND C323.

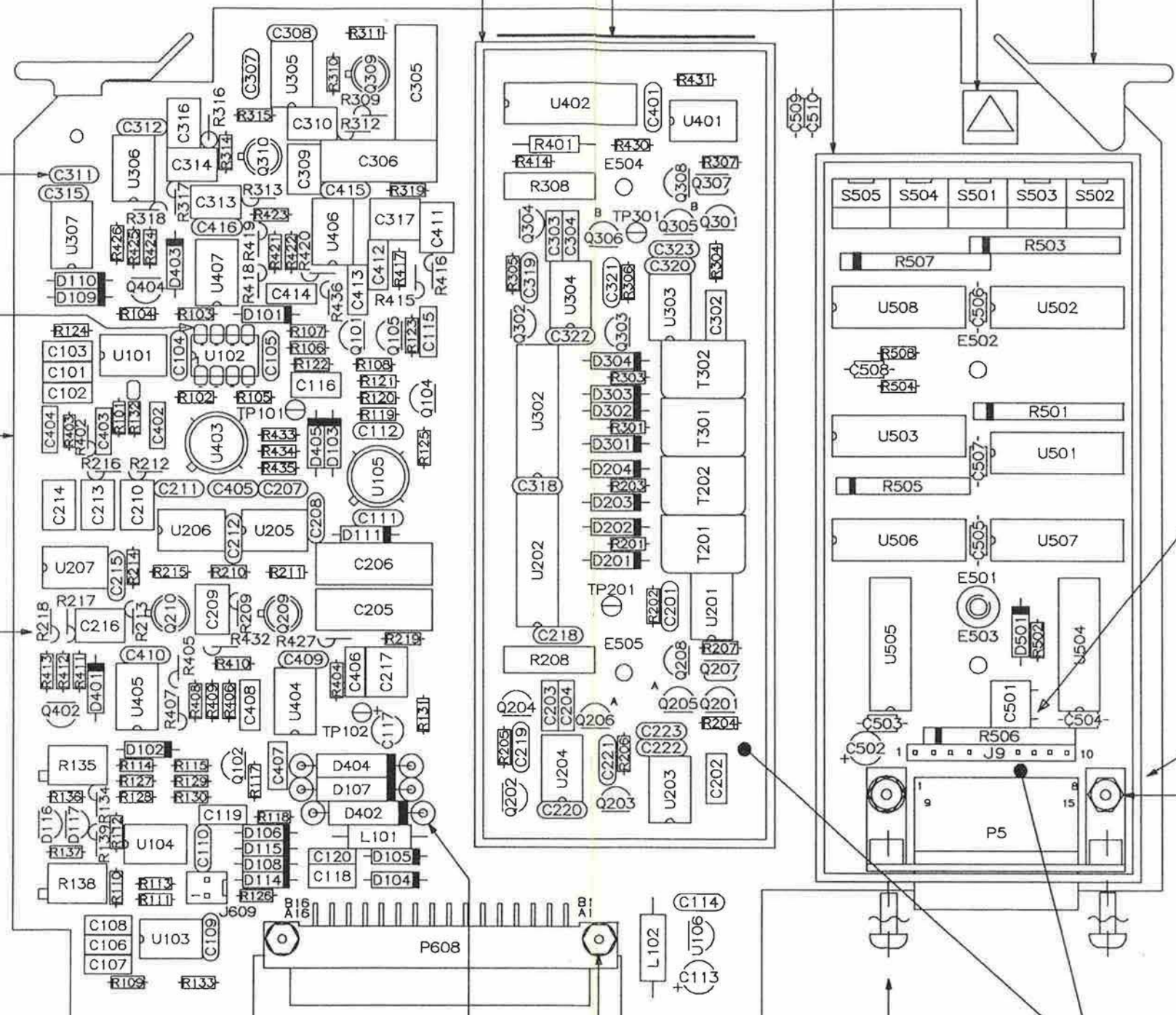

MATCHED FET PAIRS:-
A : Q205 & Q206
B : Q305 & Q306

C501 TO LAY FLAT
AGAINST PCB

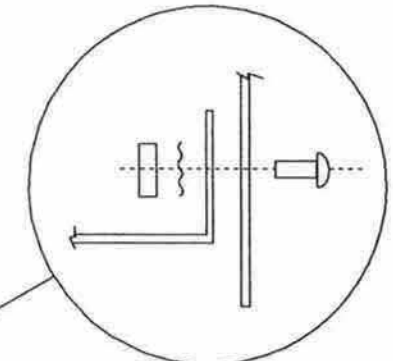

611016 2
613029 2
615002 2

MAXIMUM COMPONENT HEIGHT
TO BE 12mm UNDER SRCEENS

611016 2
613029 2



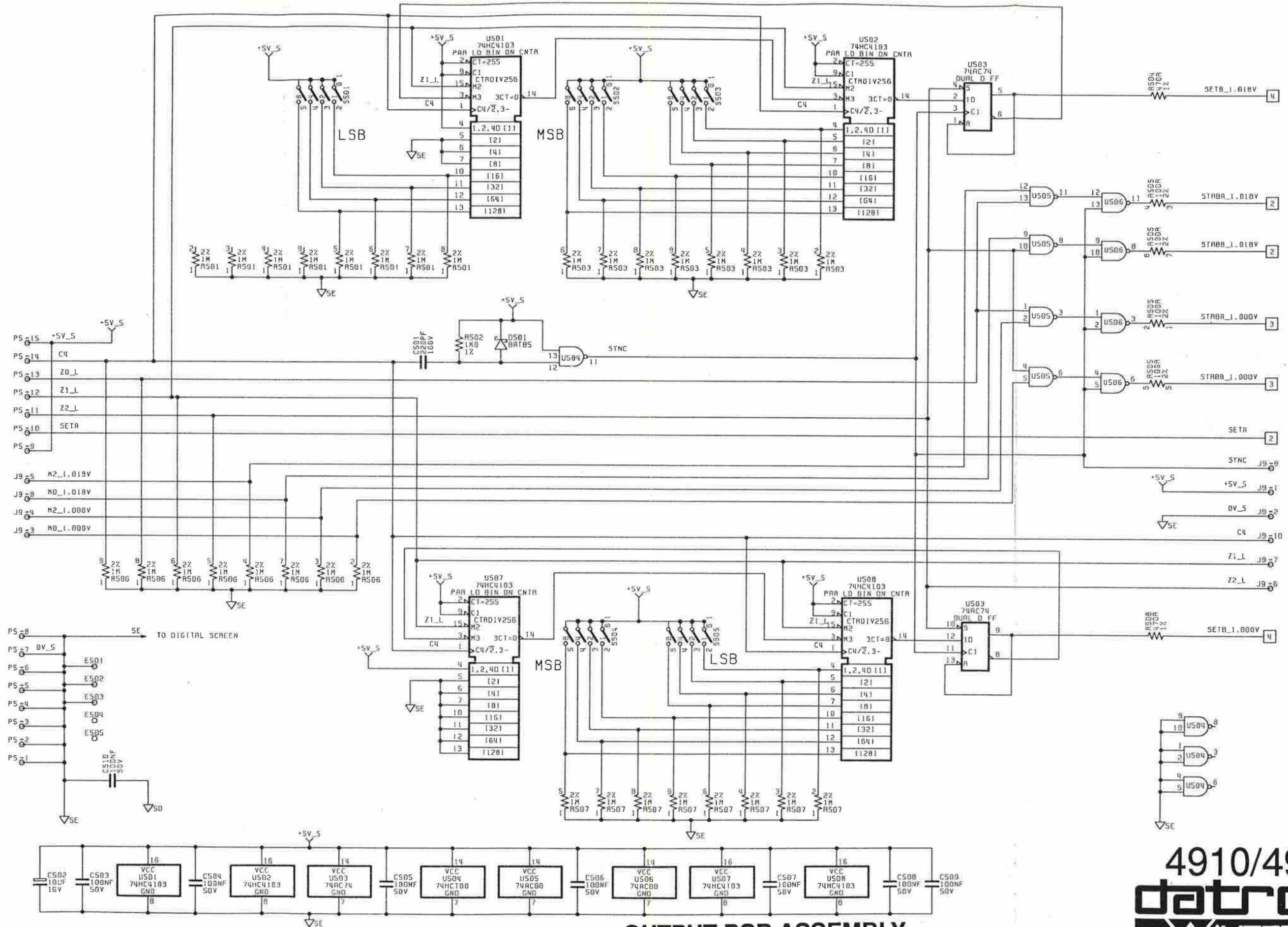

OUTPUT PCB ASSEMBLY

Drawing No. DC400881 Sheet 5



© Datron Instruments 1991

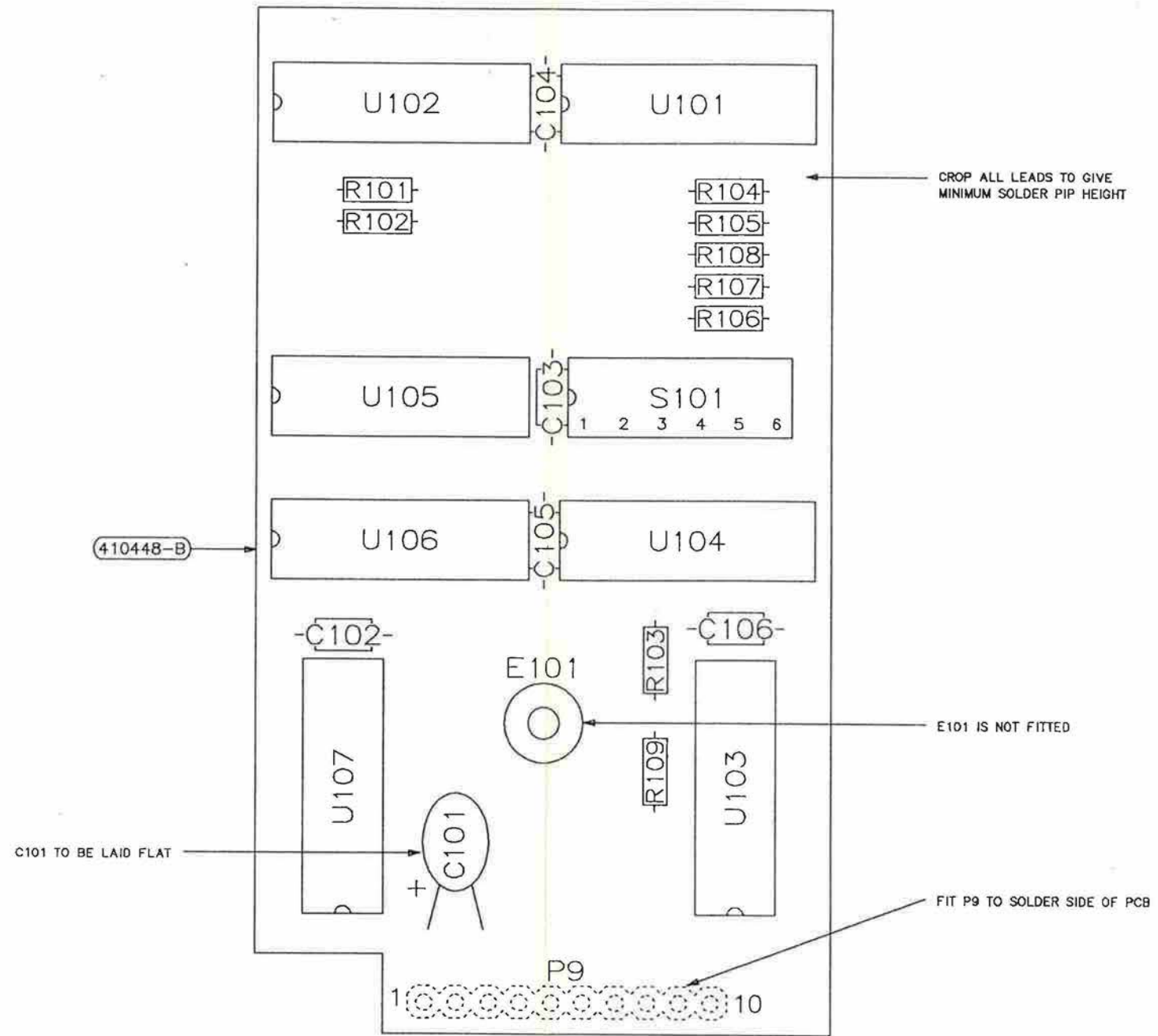

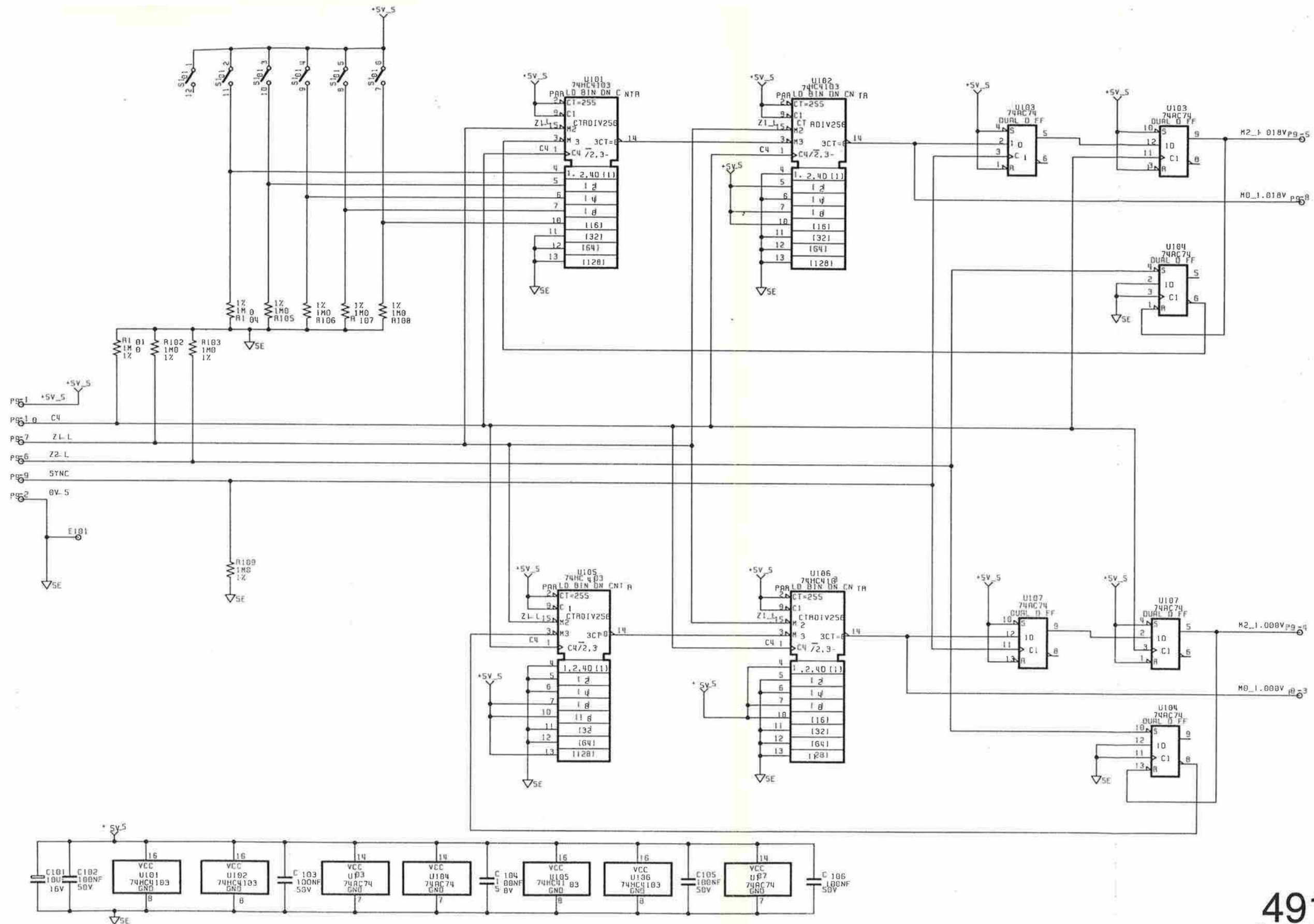

OUTPUT PCB ASSEMBLY
Digital Sub-Assembly
 Drawing No. DC400940 Sheet 1

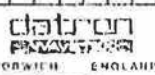

© Datron Instruments 1991

DRAWING NO LD400881		DATE 1.0 3539 13.90	ISSUE 1.1 3575 6.4.90	ISSUE 1.2 3751 14.1.91	ISSUE 1.3 3765 28.2.91	
DOCUMENT LIST		ISSUE - REVISION				
DESCRIPTION	DRAWING NUMBER	SHEET NUMBER	1.0	1.1	1.2	1.3
PARTS LIST	LP400881	ALL	1.0	1.1	1.2	1.3
ASSEMBLY DRAWING	DA400881	1	1.0	1.1	1.2	1.3
	DA400881	2	1.0	1.1	1.2	1.3
SCHEMATIC DIAGRAM	DC400881	1	1.0	1.1	1.2	1.3
	DC400881	2	1.0	1.1	1.2	1.3
	DC400881	3	1.0	1.1	1.2	1.3
	DC400881	4	1.0	1.1	1.2	1.3
	DC400881	5	1.0	1.1	1.2	1.3
OTHER	410434	1-7	1.0	1.1	1.2	1.3
<input type="checkbox"/> REVISIONS AND CHANGE TO EXCS AT ISSUE LEVEL CHANGE				DATE 13 DEC 89	DATE 16 FEB 90	DATE 21 FEB 90
TITLE OUTPUT PCB ASSY.				DRAWING No. LD400881		
SHEET 1 of 1						

DATRON INSTRUMENTS LTD PARTS LIST 29-Apr-91 DESC: ASSY PCB OUTPUT 4910 DRG NO: LP400881-1 REV: 2 PAGE NO: 1

DESIG	PART NO	DESCRIPTION	PRINC MANUF	MANUF PART NUMBER	CLASS	UM	QUANTITY	CHANGES
R101	050131	RES MF 39K 1% .4W 100PPM	NEOHM	LR0204	A	EA	7	
R102	050148	RES MF 1M0 1% .4W 100PPM	NEOHM	LR0204	A	EA	3	
R103	050124	RES MF 10K 1% .4W 100PPM	NEOHM	LR0204	A	EA	7	
R104	050144	RES MF 470K 1% .4W 100PPM	NEOHM	LR0204	A	EA	2	
R105	050124	RES MF 10K 1% .4W 100PPM	NEOHM	LR0204	A	EA	-	
R106	050112	RES MF 1K0 1% .4W 100PPM	NEOHM	LR0204	A	EA	20	
R107	050096	RES MF 47R 1% .4W 100PPM	NEOHM	LR0204	A	EA	6	
R108	050112	RES MF 1K0 1% .4W 100PPM	NEOHM	LR0204	A	EA	-	
R109	050131	RES MF 39K 1% .4W 100PPM	NEOHM	LR0204	A	EA	-	
R110	050148	RES MF 1M0 1% .4W 100PPM	NEOHM	LR0204	A	EA	-	
R111	050124	RES MF 10K 1% .4W 100PPM	NEOHM	LR0204	A	EA	-	
R112	050144	RES MF 470K 1% .4W 100PPM	NEOHM	LR0204	A	EA	-	
R113	050124	RES MF 10K 1% .4W 100PPM	NEOHM	LR0204	A	EA	-	
R114	050112	RES MF 1K0 1% .4W 100PPM	NEOHM	LR0204	A	EA	-	
R115	050096	RES MF 47R 1% .4W 100PPM	NEOHM	LR0204	A	EA	-	
R117	050089	RES MF 12R 1% .4W 100PPM	NEOHM	LR0204	A	EA	1	
R118	050120	RES MF 4K7 1% .4W 100PPM	NEOHM	LR0204	A	EA	6	
R119	050112	RES MF 1K0 1% .4W 100PPM	NEOHM	LR0204	A	EA	-	
R120	050096	RES MF 47R 1% .4W 100PPM	NEOHM	LR0204	A	EA	-	
R121	050120	RES MF 4K7 1% .4W 100PPM	NEOHM	LR0204	A	EA	-	
R122	050112	RES MF 1K0 1% .4W 100PPM	NEOHM	LR0204	A	EA	-	
R123	050093	RES MF 27R 1% .4W 100PPM	NEOHM	LR0204	A	EA	1	
R124	050116	RES MF 2K2 1% .4W 100PPM	NEOHM	LR0204	A	EA	1	
R125	050112	RES MF 1K0 1% .4W 100PPM	NEOHM	LR0204	A	EA	-	
R126	050096	RES MF 47R 1% .4W 100PPM	NEOHM	LR0204	A	EA	-	
R127	050101	RES MF 120R 1% .4W 100PPM	NEOHM	LR0204	A	EA	4	
R128	050101	RES MF 120R 1% .4W 100PPM	NEOHM	LR0204	A	EA	-	
R129	050101	RES MF 120R 1% .4W 100PPM	NEOHM	LR0204	A	EA	-	
R130	050101	RES MF 120R 1% .4W 100PPM	NEOHM	LR0204	A	EA	-	
R131	050124	RES MF 10K 1% .4W 100PPM	NEOHM	LR0204	A	EA	-	
R132	050131	RES MF 39K 1% .4W 100PPM	NEOHM	LR0204	A	EA	-	
R133	050131	RES MF 39K 1% .4W 100PPM	NEOHM	LR0204	A	EA	-	
R134	047154	RES MF 7M15 1% .12W 100PPM	STEATITE	MK2	A	EA	2	
R135	067503	RES CT 50K VERT M/T	BECKMAN	68X	A	EA	2	
R136	050124	RES MF 10K 1% .4W 100PPM	NEOHM	LR0204	A	EA	-	
R137	050131	RES MF 39K 1% .4W 100PPM	NEOHM	LR0204	A	EA	-	
R138	067503	RES CT 50K VERT M/T	BECKMAN	68X	A	EA	-	
R139	047154	RES MF 7M15 1% .12W 100PPM	STEATITE	MK2	A	EA	-	
R201	050108	RES MF 470R 1% .4W 100PPM	NEOHM	LR0204	A	EA	0	
R202	050112	RES MF 1K0 1% .4W 100PPM	NEOHM	LR0204	A	EA	-	
R203	050108	RES MF 470R 1% .4W 100PPM	NEOHM	LR0204	A	EA	-	
R204	050112	RES MF 1K0 1% .4W 100PPM	NEOHM	LR0204	A	EA	-	
R205	050112	RES MF 1K0 1% .4W 100PPM	NEOHM	LR0204	A	EA	-	
R206	050112	RES MF 1K0 1% .4W 100PPM	NEOHM	LR0204	A	EA	-	
R207	050112	RES MF 1K0 1% .4W 100PPM	NEOHM	LR0204	A	EA	-	

DESIG	PART NO	DESCRIPTION	PRINC MANUF	MANUF PART NUMBER	CLASS	UM	QUANTITY	CHANGES
R208	080032	RES MF 78K7 1% .12W 10PPM	VISHAY MANN	Y53C5 78K700 0.1%			EA 2	
R209	011183	RES MF 118K 1% .12W 50PPM	HOLSWORTHY	H8C	A		EA 2	
R210	050112	RES MF 1K0 1% .4W 100PPM	NEOHM	LR0204	A		EA -	
R211	050112	RES MF 1K0 1% .4W 100PPM	NEOHM	LR0204	A		EA -	
R212	012672	RES MF 26K7 1% .12W 50PPM	HOLSWORTHY	H8C	A		EA 2	
R213	011182	RES MF 11K8 1% .12W 50PPM	HOLSWORTHY	H8C	A		EA 2	
R214	050112	RES MF 1K0 1% .4W 100PPM	NEOHM	LR0204	A		EA -	
R215	050112	RES MF 1K0 1% .4W 100PPM	NEOHM	LR0204	A		EA -	
R216	014532	RES MF 45K3 1% .12W 50PPM	HOLSWORTHY	H8C	A		EA 2	
R217	019531	RES MF 9K53 1% .12W 50PPM	HOLSWORTHY	H8C	A		EA 2	
R218	011402	RES MF 14K0 1% .12W 50PPM	HOLSWORTHY	H8C	A		EA 2	
R219	050128	RES MF 22K 1% .4W 100PPM	NEOHM	LR0204	A		EA 2	
R301	050108	RES MF 470R 1% .4W 100PPM	NEOHM	LR0204	A		EA -	
R303	050108	RES MF 470R 1% .4W 100PPM	NEOHM	LR0204	A		EA -	
R304	050112	RES MF 1K0 1% .4W 100PPM	NEOHM	LR0204	A		EA -	
R305	050112	RES MF 1K0 1% .4W 100PPM	NEOHM	LR0204	A		EA -	
R306	050112	RES MF 1K0 1% .4W 100PPM	NEOHM	LR0204	A		EA -	
R307	050112	RES MF 1K0 1% .4W 100PPM	NEOHM	LR0204	A		EA -	
R308	080032	RES MF 78K7 1% .12W 10PPM	VISHAY MANN	Y53C5 78K700 0.1%			EA -	
R309	011183	RES MF 118K 1% .12W 50PPM	HOLSWORTHY	H8C	A		EA -	
R310	050112	RES MF 1K0 1% .4W 100PPM	NEOHM	LR0204	A		EA -	
R311	050112	RES MF 1K0 1% .4W 100PPM	NEOHM	LR0204	A		EA -	
R312	012672	RES MF 26K7 1% .12W 50PPM	HOLSWORTHY	H8C	A		EA -	
R313	011182	RES MF 11K8 1% .12W 50PPM	HOLSWORTHY	H8C	A		EA -	
R314	050112	RES MF 1K0 1% .4W 100PPM	NEOHM	LR0204	A		EA -	
R315	050112	RES MF 1K0 1% .4W 100PPM	NEOHM	LR0204	A		EA -	
R316	014532	RES MF 45K3 1% .12W 50PPM	HOLSWORTHY	H8C	A		EA -	
R317	019531	RES MF 9K53 1% .12W 50PPM	HOLSWORTHY	H8C	A		EA -	
R318	011402	RES MF 14K0 1% .12W 50PPM	HOLSWORTHY	H8C	A		EA -	
R319	050128	RES MF 22K 1% .4W 100PPM	NEOHM	LR0204	A		EA -	
R401	041504	RES MF 1M50 1% .12W 100PPM	HOLSWORTHY	H8C	A		EA 1	
R402	041824	RES MF 1M82 1% .12W 100PPM	HOLSWORTHY	H8C	A		EA 1	
R403	050146	RES MF 680K 1% .4W 100PPM	NEOHM	LR0204	A		EA 1	
R404	050131	RES MF 39K 1% .4W 100PPM	NEOHM	LR0204	A		EA -	
R405	014991	RES MF 4K99 1% .12W 50PPM	HOLSWORTHY	H8C	A		EA 2	
R406	050034	RES MF 825R 1% .1W 15PPM	HOLSWORTHY	H10	A		EA 1	
R407	013921	RES MF 3K92 1% .12W 50PPM	HOLSWORTHY	H8C	A		EA 2	
R408	050120	RES MF 4K7 1% .4W 100PPM	NEOHM	LR0204	A		EA -	
R409	050120	RES MF 4K7 1% .4W 100PPM	NEOHM	LR0204	A		EA -	
R410	050132	RES MF 47K 1% .4W 100PPM	NEOHM	LR0204	A		EA 2	
R411	050112	RES MF 1K0 1% .4W 100PPM	NEOHM	LR0204	A		EA -	
R412	050096	RES MF 47R 1% .4W 100PPM	NEOHM	LR0204	A		EA -	
R413	050108	RES MF 470R 1% .4W 100PPM	NEOHM	LR0204	A		EA -	
R414	050148	RES MF 1M0 1% .4W 100PPM	NEOHM	LR0204	A		EA -	
R415	041005	RES MF 10M0 1% .12W 100PPM	STEATITE	MK2	A		EA 2	

DESIG	PART NO	DESCRIPTION	PRINC MANUF	MANUF PART NUMBER	CLASS	UM	QUANTITY	CHANGES
R416	041305	RES MF 13M0 1% .12W 150PPM	MEPCO	5053YL	A		EA 1	
R417	050131	RES MF 39K 1% .4W 100PPM	NEOHM	LR0204	A		EA -	
R418	014991	RES MF 4K99 1% .12W 50PPM	HOLSWORTHY	H8C	A		EA -	
R419	013921	RES MF 3K92 1% .12W 50PPM	HOLSWORTHY	H8C	A		EA -	
R420	015628	RES MF 56R2 1% .12W 50PPM	HOLSWORTHY	H8C	A		EA 1	
R421	050120	RES MF 4K7 1% .4W 100PPM	NEOHM	LR0204	A		EA -	
R422	050120	RES MF 4K7 1% .4W 100PPM	NEOHM	LR0204	A		EA -	
R423	050132	RES MF 47K 1% .4W 100PPM	NEOHM	LR0204	A		EA -	
R424	050112	RES MF 1K0 1% .4W 100PPM	NEOHM	LR0204	A		EA -	
R425	050096	RES MF 47R 1% .4W 100PPM	NEOHM	LR0204	A		EA -	
R426	050108	RES MF 470R 1% .4W 100PPM	NEOHM	LR0204	A		EA -	
R427	041005	RES MF 10M0 1% .12W 100PPM	STEATITE	MK2	A		EA -	
R430	050112	RES MF 1K0 1% .4W 100PPM	NEOHM	LR0204	A		EA -	
R431	050112	RES MF 1K0 1% .4W 100PPM	NEOHM	LR0204	A		EA -	
R432	00000N	NOT FITTED					EA 10	
R433	050124	RES MF 10K 1% .4W 100PPM	NEOHM	LR0204	A		EA -	
R434	050136	RES MF 100K 1% .4W 100PPM	NEOHM	LR0204	A		EA 2	
R435	050136	RES MF 100K 1% .4W 100PPM	NEOHM	LR0204	A		EA -	
R436	00000N	NOT FITTED					EA -	
R501	090096	RES NPWK 1M X B 2%	BECKMAN	LO9-1S-R1M	A		EA 4	
R502	050112	RES MF 1K0 1% .4W 100PPM	NEOHM	LR0204	A		EA -	
R503	090096	RES NPWK 1M X B 2%	BECKMAN	LO9-1S-R1M	A		EA -	
R504	050108	RES MF 470R 1% .4W 100PPM	NEOHM	LR0204	A		EA -	
R505	090105	RES PACK 100R X 4 2%	BECKMAN	LO8-3S-R100	A		EA 1	
R506	090096	RES NPWK 1M X B 2%	BECKMAN	LO9-1S-R1M	A		EA -	
R507	090096	RES NPWK 1M X B 2%	BECKMAN	LO9-1S-R1M	A		EA -	
R508	050108	RES MF 470R 1% .4W 100PPM	NEOHM	LR0204	A		EA -	
C101	110042	CAP PE 100NF 20% 63V	WIMA	MKS2	A		EA 10	
C102	110041	CAP PE 10NF 20% 100V	WIMA	PKS2	A		EA 5	
C103	110042	CAP PE 100NF 20% 63V	WIMA	MKS2	A		EA -	
C104	104026	CAP CM 47NF +80%-20% 50V	AVX	SR175E4732A	A		EA 27	
C105	104026	CAP CM 47NF +80%-20% 50V	AVX	SR175E4732A	A		EA -	
C106	110042	CAP PE 100NF 20% 63V	WIMA	MKS2	A		EA -	
C107	110041	CAP PE 16NF 20% 100V	WIMA	PKS2	A		EA -	
C108	110042	CAP PE 100NF 20% 63V	WIMA	MKS2	A		EA -	
C109	104026	CAP CM 47NF +80%-20% 50V	AVX	SR175E4732A	A		EA -	
C110	104026	CAP CM 47NF +80%-20% 50V	AVX	SR175E4732A	A		EA -	
C111	100471	CAP CP 470PF 10% 100V	PHILIPS	2222 630 19471	A		EA 1	
C112	104026	CAP CM 47NF +80%-20% 50V	AVX	SR175E4732A	A		EA -	
C113	150020	CAP DT 10UF 20% 25V	AVX	TAP10M25P	A		EA 2	
C114	104026	CAP CM 47NF +80%-20% 50V	AVX	SR175E4732A	A		EA -	
C115	110050	CAP PE 22NF 10% 63V	WIMA	MKS4	A		EA 1	
C116	110035	CAP PE 220NF 20% 63V	WIMA	MKS2	A		EA 2	
C117	150020	CAP DT 10UF 20% 25V	AVX	TAP10M25P	A		EA -	
C118	110035	CAP PE 220NF 20% 63V	WIMA	MKS2	A		EA -	

DESIG	PART NO	DESCRIPTION	PRINC MANUF	MANUF PART NUMBER	CLASS	UM	QUANTITY	CHANGES
C119	110041	CAP PE 10NF 20% 100V	WIMA	FKS2			EA	-
C120	110030	CAP PE 1NF 20% 100V	WIMA	FKS2			EA	5
C121	100330	CAP CP 33PF 2% 100V	PHILIPS	2222 683 34339			EA	1
C201	104026	CAP CM 47NF +80%-20% 50V	AVX	SR175E473ZA	A		EA	-
C202	110041	CAP PE 10NF 20% 100V	WIMA	FKS2			EA	-
C203	110030	CAP PE 1NF 20% 100V	WIMA	FKS2			EA	-
C204	110030	CAP PE 1NF 20% 100V	WIMA	FKS2			EA	-
C205	120019	CAP PC 1UF 10% 63V	ASHCROFT	M2B10201B			EA	4
C266	120019	CAP PC 1UF 10% 63V	ASHCROFT	M2B10201B			EA	-
C207	100270	CAP CP 27PF 2% 100V	PHILIPS	2222 683 34279			EA	4
C208	104026	CAP CM 47NF +80%-20% 50V	AVX	SR175E473ZA	A		EA	-
C209	110046	CAP PE 1UF 20% 50V	WIMA	MKS2 1UF 20% 50V	A		EA	11
C210	110046	CAP PE 1UF 20% 50V	WIMA	MKS2 1UF 20% 50V	A		EA	-
C211	100270	CAP CP 27PF 2% 100V	PHILIPS	2222 683 34279			EA	-
C212	104026	CAP CM 47NF +80%-20% 50V	AVX	SR175E473ZA	A		EA	-
C213	110046	CAP PE 1UF 20% 50V	WIMA	MKS2 1UF 20% 50V	A		EA	-
C214	110046	CAP PE 1UF 20% 50V	WIMA	MKS2 1UF 20% 50V	A		EA	-
C215	104026	CAP CM 47NF +80%-20% 50V	AVX	SR175E473ZA	A		EA	-
C216	110046	CAP PE 1UF 20% 50V	WIMA	MKS2 1UF 20% 50V	A		EA	-
C217	140086	CAP PP 10NF 5% 63V	WIMA	FKP2			EA	2
C218	104026	CAP CM 47NF +80%-20% 50V	AVX	SR175E473ZA	A		EA	-
C219	00000N	NOT FITTED					EA	-
C220	104026	CAP CM 47NF +80%-20% 50V	AVX	SR175E473ZA	A		EA	-
C221	104026	CAP CM 47NF +80%-20% 50V	AVX	SR175E473ZA	A		EA	-
C222	104026	CAP CM 47NF +80%-20% 50V	AVX	SR175E473ZA	A		EA	-
C223	104026	CAP CM 47NF +80%-20% 50V	AVX	SR175E473ZA	A		EA	-
C202	110041	CAP PE 10NF 20% 100V	WIMA	FKS2			EA	-
C303	110030	CAP PE 1NF 20% 100V	WIMA	FKS2			EA	-
C304	110030	CAP PE 1NF 20% 100V	WIMA	FKS2			EA	-
C305	120019	CAP PC 1UF 10% 63V	ASHCROFT	M2B10201B			EA	-
C306	120019	CAP PC 1UF 10% 63V	ASHCROFT	M2B10201B			EA	-
C307	100270	CAP CP 27PF 2% 100V	PHILIPS	2222 683 34279			EA	-
C308	104026	CAP CM 47NF +80%-20% 50V	AVX	SR175E473ZA	A		EA	-
C309	110046	CAP PE 1UF 20% 50V	WIMA	MKS2 1UF 20% 50V	A		EA	-
C310	110046	CAP PE 1UF 20% 50V	WIMA	MKS2 1UF 20% 50V	A		EA	-
C311	100270	CAP CP 27PF 2% 100V	PHILIPS	2222 683 34279			EA	-
C312	104026	CAP CM 47NF +80%-20% 50V	AVX	SR175E473ZA	A		EA	-
C313	110046	CAP PE 1UF 20% 50V	WIMA	MKS2 1UF 20% 50V	A		EA	-
C314	110046	CAP PE 1UF 20% 50V	WIMA	MKS2 1UF 20% 50V	A		EA	-
C315	104026	CAP CM 47NF +80%-20% 50V	AVX	SR175E473ZA	A		EA	-
C316	110046	CAP PE 1UF 20% 50V	WIMA	MKS2 1UF 20% 50V	A		EA	-
C317	140086	CAP PP 10NF 5% 63V	WIMA	FKP2			EA	-
C318	104026	CAP CM 47NF +80%-20% 50V	AVX	SR175E473ZA	A		EA	-
C319	00000N	NOT FITTED					EA	-
C320	104026	CAP CM 47NF +80%-20% 50V	AVX	SR175E473ZA	A		EA	-

DESIG	PART NO	DESCRIPTION	PRINC MANUF	MANUF PART NUMBER	CLASS	UM	QUANTITY	CHANGES
C321	00000N	NOT FITTED					EA	-
C322	104026	CAP CM 47NF +80%-20% 50V	AVX	SR175E473ZA	A		EA	-
C323	00000N	NOT FITTED					EA	-
C401	104026	CAP CM 47NF +80%-20% 50V	AVX	SR175E473ZA	A		EA	-
C402	110020	CAP PE 47NF 20% 63V	WIMA	MKS2			EA	3
C403	110020	CAP PE 47NF 20% 63V	WIMA	MKS2			EA	-
C404	110020	CAP PE 47NF 20% 63V	WIMA	MKS2			EA	-
C405	104026	CAP CM 47NF +80%-20% 50V	AVX	SR175E473ZA	A		EA	-
C406	110042	CAP PE 100NF 20% 63V	WIMA	MKS2			EA	-
C407	110042	CAP PE 100NF 20% 63V	WIMA	MKS2			EA	-
C408	110042	CAP PE 100NF 20% 63V	WIMA	MKS2			EA	-
C409	104026	CAP CM 47NF +80%-20% 50V	AVX	SR175E473ZA	A		EA	-
C410	104026	CAP CM 47NF +80%-20% 50V	AVX	SR175E473ZA	A		EA	-
C411	110046	CAP PE 1UF 20% 50V	WIMA	MKS2 1UF 20% 50V	A		EA	-
C412	110042	CAP PE 100NF 20% 63V	WIMA	MKS2			EA	-
C413	110042	CAP PE 100NF 20% 63V	WIMA	MKS2			EA	-
C414	110042	CAP PE 100NF 20% 63V	WIMA	MKS2			EA	-
C415	104026	CAP CM 47NF +80%-20% 50V	AVX	SR175E473ZA	A		EA	-
C416	104026	CAP CM 47NF +80%-20% 50V	AVX	SR175E473ZA	A		EA	-
C501	100221	CAP CP 220PF 2% 100V	PHILIPS	2222 683 58221			EA	1
C502	150002	CAP DT 10UF 20% 16V	AVX	TAP10M16P	A		EA	1
C503	104067	CAP CA 100NF +80%-20% 50V	AVX	SA105E104ZAA	A		EA	B
C504	104067	CAP CA 100NF +80%-20% 50V	AVX	SA105E104ZAA	A		EA	-
C505	104067	CAP CA 100NF +80%-20% 50V	AVX	SA105E104ZAA	A		EA	-
C506	104067	CAP CA 100NF +80%-20% 50V	AVX	SA105E104ZAA	A		EA	-
C507	104067	CAP CA 100NF +80%-20% 50V	AVX	SA105E104ZAA	A		EA	-
C508	104067	CAP CA 100NF +80%-20% 50V	AVX	SA105E104ZAA	A		EA	-
C509	104067	CAP CA 100NF +80%-20% 50V	AVX	SA105E104ZAA	A		EA	-
C510	104067	CAP CA 100NF +80%-20% 50V	AVX	SA105E104ZAA	A		EA	-
D101	210047	DIODE ZN 4V7 400mW	PHILIPS	BZX79C4V7	A		EA	5
D102	210047	DIODE ZN 4V7 400mW	PHILIPS	BZX79C4V7	A		EA	-
D103	210047	DIODE ZN 4V7 400mW	PHILIPS	BZX79C4V7	A		EA	-
D104	200001	DIODE GP 75mA 75V	FAIRCHILD	1N4148			EA	9
D105	200001	DIODE GP 75mA 75V	FAIRCHILD	1N4148			EA	-
D106	200001	DIODE GP 75mA 75V	FAIRCHILD	1N4148			EA	-
D107	213022	DIODE TS 10V 5/500W	UNI-PROBE	TVS510	A		EA	1
D108	200001	DIODE GP 75mA 75V	FAIRCHILD	1N4148			EA	-
D109	210043	DIODE ZN 4V3 400mW	PHILIPS	BZX79C4V3	A		EA	1
D110	200001	DIODE GP 75mA 75V	FAIRCHILD	1N4148			EA	-
D111	200001	DIODE GP 75mA 75V	FAIRCHILD	1N4148			EA	-
D114	200001	DIODE GP 75mA 75V	FAIRCHILD	1N4148			EA	-
D115	200001	DIODE GP 75mA 75V	FAIRCHILD	1N4148			EA	-
D116	214014	DIODE ZN 1V22 100PPM	TELEDYNE	9491BJ	A		EA	2
D117	214014	DIODE ZN 1V22 100PPM	TELEDYNE	9491BJ	A		EA	-
D201	260005	DIODE SB 200mA 30V	PHILIPS	BA765			EA	9

DESIG	PART NO	DESCRIPTION	PRINC MANUF	MANUF PART NUMBER	CLASS	UM	QUANTITY	CHANGES
D202	200005	DIODE SB 200mA 30V	PHILIPS	BAT85		EA	-	
D303	200005	DIODE SB 200mA 30V	PHILIPS	BAT85		EA	-	
D204	200005	DIODE SB 200mA 30V	PHILIPS	BAT85		EA	-	
D301	200005	DIODE SB 200mA 30V	PHILIPS	BAT85		EA	-	
D302	200005	DIODE SB 200mA 30V	PHILIPS	BAT85		EA	-	
D303	200005	DIODE SB 200mA 30V	PHILIPS	BAT85		EA	-	
D304	200005	DIODE SB 200mA 30V	PHILIPS	BAT85		EA	-	
D401	210047	DIODE 2N 4V7 400mW	PHILIPS	BZX79C4V7	A	EA	-	
D402	213006	DIODE TS 5V 5/500W	UNITRODE	TVSS05	A	EA	2	
D403	210047	DIODE 2N 4V7 400mW	PHILIPS	BZX79C4V7	A	EA	-	
D404	213006	DIODE TS 5V 5/500W	UNITRODE	TVSS05	A	EA	-	
D405	200001	DIODE GP 75mA 75V	FAIRCHILD	1N4148		EA	-	
D501	200005	DIODE SB 200mA 30V	PHILIPS	BAT85		EA	-	
Q101	240001	TRAN NPN	MOTOROLA	BC184		EA	6	
Q102	240001	TRAN NPN	MOTOROLA	BC184		EA	-	
Q104	240001	TRAN NPN	MOTOROLA	BC184		EA	-	
Q105	240001	TRAN NPN	MOTOROLA	BC184		EA	-	
Q201	230039	TRAN JFET P CHAN	SILICONIX	J175		EA	6	
Q202	230038	TRAN JFET N-CHAN	SILICONIX	J112		EA	2	
Q203	230039	TRAN JFET P CHAN	SILICONIX	J175		EA	-	
Q204	230039	TRAN JFET P CHAN	SILICONIX	J175		EA	-	
Q205	239087-1	TRAN JFET SET J106 X 2	DATRON	SEE DRG		S2	2	
Q206	239087-1	TRAN JFET SET J106 X 2	DATRON	SEE DRG		S2	-	
Q207	230086	TRAN MOSFET P-CHAN 60V	FERRANTI	ZVP2106A	A	EA	2	
Q208	230082	TRAN MOSFET N-CHAN 60V	SILICONIX	VN10LM		EA	2	
Q209	230031	TRAN JFET N-CHAN DUAL	SILICONIX	U404		EA	4	
Q210	230031	TRAN JFET N-CHAN DUAL	SILICONIX	U404		EA	-	
Q301	230039	TRAN JFET P CHAN	SILICONIX	J175		EA	-	
Q302	230038	TRAN JFET N-CHAN	SILICONIX	J112		EA	-	
Q303	230039	TRAN JFET P CHAN	SILICONIX	J175		EA	-	
Q304	230039	TRAN JFET P CHAN	SILICONIX	J175		EA	-	
Q305	239087-1	TRAN JFET SET J106 X 2	DATRON	SEE DRG		S2	-	
Q306	239087-1	TRAN JFET SET J106 X 2	DATRON	SEE DRG		S2	-	
Q307	230066	TRAN MOSFET P-CHAN 60V	FERRANTI	ZVP2106A	A	EA	-	
Q308	230082	TRAN MOSFET N-CHAN 60V	SILICONIX	VN10LM		EA	-	
Q309	230031	TRAN JFET N-CHAN DUAL	SILICONIX	U404		EA	-	
Q310	230031	TRAN JFET N-CHAN DUAL	SILICONIX	U404		EA	-	
Q402	240001	TRAN NPN	MOTOROLA	BC184		EA	-	
Q404	240001	TRAN NPN	MOTOROLA	BC184		EA	-	
U101	260082	IC LIN OP AMP CHOPPER	LINEAR TECHNOLOGY	LTC1052CN8		EA	4	
U102	260065	IC LIN OP AMP	PMI	OP27FZ	A	EA	4	
U103	260082	IC LIN OP AMP CHOPPER	LINEAR TECHNOLOGY	LTC1052CN8		EA	-	
U104	260065	IC LIN OP AMP	PMI	OP27FZ	A	EA	-	
U105	260025	IC LIN OP AMP	NATIONAL	LM101AH		EA	1	
U106	260033	IC LIN REG 5V .1A	MOTOROLA	MC78L05ACP	A	EA	1	

DESIG	PART NO	DESCRIPTION	PRINC MANUF	MANUF PART NUMBER	CLASS	UM	QUANTITY	CHANGES
U201	220027	OPTO ISOL HIGH CMR	H.P.	HCPL-2601	A	EA	1	
U202	280182	IC DIG FLIP FLOP D X2	NATIONAL	74AC74PC		EA	3	
U203	280185	IC DIG INV MOSFET DRIVER X2	INTERMIL	ICL7667CPA		EA	4	
U204	280185	IC DIG INV MOSFET DRIVER X2	INTERMIL	ICL7667CPA		EA	-	
U205	260057	IC LIN OP AMP	SIGNETICS	NE5534N		EA	4	
U206	260057	IC LIN OP AMP	SIGNETICS	NE5534N		EA	-	
U207	260107	IC LIN OP AMP	PRECISION MONOLITHIC	OP07CP		EA	2	
U302	280182	IC DIG FLIP FLOP D X2	NATIONAL	74AC74PC		EA	-	
U303	280185	IC DIG INV MOSFET DRIVER X2	INTERMIL	ICL7667CPA		EA	-	
U304	280185	IC DIG INV MOSFET DRIVER X2	INTERMIL	ICL7667CPA		EA	-	
U305	260057	IC LIN OP AMP	SIGNETICS	NE5534N		EA	-	
U306	260057	IC LIN OP AMP	SIGNETICS	NE5534N		EA	-	
U307	260107	IC LIN OP AMP	PRECISION MONOLITHIC	OP07CP		EA	-	
U401	220041	OPTO ISOL 3KV DUAL	H.P.	HCPL-2631	A	EA	1	
U402	280190	IC DIG SWITCH ANALOG 2NO 2NC	SILICONIX	DG413DJ		EA	1	
U403	260088	IC LIN OP AMP DUAL PREC	LINEAR TECHNOLOGY	LT1013CH		EA	1	
U404	260082	IC LIN OP AMP CHOPPER	LINEAR TECHNOLOGY	LTC1052CN8		EA	-	
U405	260065	IC LIN OP AMP	PMI	OP27FZ	A	EA	-	
U406	260082	IC LIN OP AMP CHOPPER	LINEAR TECHNOLOGY	LTC1052CN8		EA	-	
U407	260065	IC LIN OP AMP	PMI	OP27FZ	A	EA	-	
U501	280141	IC DIG COUNTS SYNC BIN PL DN	SGS	M74HC4103B1		EA	4	
U502	280141	IC DIG COUNTS SYNC BIN PL DN	SGS	M74HC4103B1		EA	-	
U503	280182	IC DIG FLIP FLOP D X2	NATIONAL	74AC74PC		EA	-	
U504	280166	IC DIG NAND2 X4	TEXAS	SN74HCT00N	A	EA	1	
U505	280188	IC DIG NAND2 X4	RCA	CD74AC00E		EA	2	
U506	280188	IC DIG NAND2 X4	RCA	CD74AC00E		EA	-	
U507	280141	IC DIG COUNTS SYNC BIN PL DN	SGS	M74HC4103B1		EA	-	
U508	280141	IC DIG COUNTS SYNC BIN PL DN	SGS	M74HC4103B1		EA	-	
T201	310002-2	TRANSF PULSE	NEWPORT	SEE DRG		EA	4	
T202	310002-2	TRANSF PULSE	NEWPORT	SEE DRG		EA	-	
T301	310002-2	TRANSF PULSE	NEWPORT	SEE DRG		EA	-	
T302	310002-2	TRANSF PULSE	NEWPORT	SEE DRG		EA	-	
L101	370001	CHOKE RF 10UH	SIGMA	SC10/25	A	EA	2	
L102	370001	CHOKE RF 10UH	SIGMA	SC10/25	A	EA	-	
P5	604111	PLUG 15-WAY PCB 10.3 D TYPE	AMP	343647-2		EA	1	
P608	604106	PLUG PCB 32-WAY	BICC-VERO	905-72216J		EA	1	
J9	604113	PLUG PCB 10-WAY .1" SIL	SAMTEK	BBL-110-G-E		EA	1	
J609	604085	PLUG PCB 2-WAY .1"	MOLEX	22-29-2021		EA	1	
E501	612026-1	STANDOFF M3 X 6		SEE DRG		EA	5	
E502	00000N	NOT FITTED				EA	-	
E503	00000N	NOT FITTED				EA	-	
E504	00000N	NOT FITTED				EA	-	
E505	00000N	NOT FITTED				EA	-	
TP101	620007	TEST POINT TERMINAL	MICROVAR	TYPE C30		EA	4	
TP102	620007	TEST POINT TERMINAL	MICROVAR	TYPE C30		EA	-	

DESIG	PART NO	DESCRIPTION	PRINC MANUF	MANUF PART NUMBER	CLASS	UM	QUANTITY	CHANGES
TP201	620007	TEST POINT TERMINAL	MICROVAR	TYPE C30	EA	-		
TP301	620007	TEST POINT TERMINAL	MICROVAR	TYPE C30	EA	-		
S501	700118	SWITCH 16 POS ROTARY DIP	OMRON	A6CR-16R	EA	5		
S502	700118	SWITCH 16 POS ROTARY DIP	OMRON	A6CR-16R	EA	-		
S503	700118	SWITCH 16 POS ROTARY DIP	OMRON	A6CR-16R	EA	-		
S504	700118	SWITCH 16 POS ROTARY DIP	OMRON	A6CR-16R	EA	-		
S505	700118	SWITCH 16 POS ROTARY DIP	OMRON	A6CR-16R	EA	-		
	400940-1	ASSY PCB COUNTER PLUG IN 4910	DATRON	SEE DRG	EA	1		
	410434-1	PCB OUTPUT 4910		SEE DRG	EA	1		
	420098	LABEL SERIAL/ASSY No.	RS COMPONENTS	554-793	EA	1		
	420112-1	LABEL SSD WARNING 12 X 12mm	TEKNIS	LN1212	A	EA	1	
	450741-3	SCREEN WALL 4MHZ LOWER 4910		SEE DRG	EA	1		
	450794-2	SCREEN WALL 4MHZ UPPER 4910		SEE DRG	EA	1		
	450824-1	SCREEN WALL 60HZ UPPER OUPUT		SEE DRG	EA	1		
	450825-1	SCREEN WALL 60HZ LOWER OUPUT		SEE DRG	EA	1		
	450834-A	SCREEN GASKET 60HZ OUTPUT 4910		SEE DRG	EA	2		
	450835-A	SCREEN COVER OUPPUT 4910		SEE DRG	EA	2		
	450836-A	SCREEN GASKET 4MHZ OUTPUT 4910		SEE DRG	EA	2		
	540006	WIRE 1/.4 PTFE 250V BLK	BSG210	TYPE A	AR	1		
	611016	SCREW M3 X 8 POZIPAN SZP			EA	5		
	611096	SCREW M2.5 X 12 POZIPAN SZP			EA	2		
	611115	SCREW M3 X 25 POZIPAN SZP			EA	4		
	612026-1	STANDOFF M3 X 6		SEE DRG	EA	-		
	613029	WASHER M3 WAVY SS			EA	7		
	613047	WASHER M2.5 WAVY SS			EA	2		
	614016-1	SPACER M3 X 14 CLEAR		SEE DRG	EA	4		
	615002	NUT FULL M3 SZP			EA	2		
	615006	NUT FULL M2.5 SZP			EA	2		
	618015	COMPONENT CARRIER	JERMYN	J22-4019	EA	23		
	630024	BEAD CERAMIC 16 SWG	PARK ROYAL PORCELAIN	No2	EA	6		
	630112	PCB EJECTOR BLACK	RICHCO	CBE	EA	2		
	630243	BEAD GLASS 2.4 X 0.81 X 1.8	MANSOL (PREFORMS)	LT M5363B/3	EA	58		
ST101	99908S	STAR-POINT 08 NOT FITTED			EA	1		
ST102	99904S	STAR-POINT 04 NOT FITTED			EA	1		

End

DESIG	PART NO	DESCRIPTION	PRINC MANUF	MANUF PART NUMBER	CLASS	UM	QUANTITY	CHANGES
R208	080032	RES MF 78K7 1% .12W 10PPM	VISHAY MANN	Y53C5 78K700 0.1%	A	EA	2	
R209	011183	RES MF 118K 1% .12W 50PPM	HOLSWORTHY	H8C	A	EA	2	
R210	050112	RES MF 1K0 1% .4W 100PPM	NEOHM	LR0204	A	EA	-	
R211	050112	RES MF 1K0 1% .4W 100PPM	NEOHM	LR0204	A	EA	-	
R212	012672	RES MF 26K7 1% .12W 50PPM	HOLSWORTHY	H8C	A	EA	2	
R213	011182	RES MF 11K8 1% .12W 50PPM	HOLSWORTHY	H8C	A	EA	2	
R214	050112	RES MF 1K0 1% .4W 100PPM	NEOHM	LR0204	A	EA	-	
R215	050112	RES MF 1K0 1% .4W 100PPM	NEOHM	LR0204	A	EA	-	
R216	014532	RES MF 45K3 1% .12W 50PPM	HOLSWORTHY	H8C	A	EA	2	
R217	019531	RES MF 9K53 1% .12W 50PPM	HOLSWORTHY	H8C	A	EA	2	
R218	011402	RES MF 14K0 1% .12W 50PPM	HOLSWORTHY	H8C	A	EA	2	
R219	050128	RES MF 22K 1% .4W 100PPM	NEOHM	LR0204	A	EA	2	
R301	050108	RES MF 470R 1% .4W 100PPM	NEOHM	LR0204	A	EA	-	
R303	050108	RES MF 470R 1% .4W 100PPM	NEOHM	LR0204	A	EA	-	
R304	050112	RES MF 1K0 1% .4W 100PPM	NEOHM	LR0204	A	EA	-	
R305	050112	RES MF 1K0 1% .4W 100PPM	NEOHM	LR0204	A	EA	-	
R306	050112	RES MF 1K0 1% .4W 100PPM	NEOHM	LR0204	A	EA	-	
R307	050112	RES MF 1K0 1% .4W 100PPM	NEOHM	LR0204	A	EA	-	
R308	080032	RES MF 78K7 1% .12W 10PPM	VISHAY MANN	Y53C5 78K700 0.1%	A	EA	-	
R309	011183	RES MF 118K 1% .12W 50PPM	HOLSWORTHY	H8C	A	EA	-	
R310	050112	RES MF 1K0 1% .4W 100PPM	NEOHM	LR0204	A	EA	-	
R311	050112	RES MF 1K0 1% .4W 100PPM	NEOHM	LR0204	A	EA	-	
R312	012672	RES MF 26K7 1% .12W 50PPM	HOLSWORTHY	H8C	A	EA	-	
R313	011182	RES MF 11K8 1% .12W 50PPM	HOLSWORTHY	H8C	A	EA	-	
R314	050112	RES MF 1K0 1% .4W 100PPM	NEOHM	LR0204	A	EA	-	
R315	050112	RES MF 1K0 1% .4W 100PPM	NEOHM	LR0204	A	EA	-	
R316	014532	RES MF 45K3 1% .12W 50PPM	HOLSWORTHY	H8C	A	EA	-	
R317	019531	RES MF 9K53 1% .12W 50PPM	HOLSWORTHY	H8C	A	EA	-	
R318	011402	RES MF 14K0 1% .12W 50PPM	HOLSWORTHY	H8C	A	EA	-	
R319	050128	RES MF 22K 1% .4W 100PPM	NEOHM	LR0204	A	EA	-	
R401	041504	RES MF 1M50 1% .12W 100PPM	HOLSWORTHY	H8C	A	EA	1	
R402	041824	RES MF 1M82 1% .12W 100PPM	HOLSWORTHY	H8C	A	EA	1	
R403	050146	RES MF 680K 1% .4W 100PPM	NEOHM	LR0204	A	EA	1	
R404	050131	RES MF 39K 1% .4W 100PPM	NEOHM	LR0204	A	EA	-	
R405	014991	RES MF 4K99 1% .12W 50PPM	HOLSWORTHY	H8C	A	EA	2	
R406	050034	RES MF 825R 1% .1W 15PPM	HOLSWORTHY	H10	A	EA	1	
R407	013921	RES MF 3K92 1% .12W 50PPM	HOLSWORTHY	H8C	A	EA	2	
R408	050120	RES MF 4K7 1% .4W 100PPM	NEOHM	LR0204	A	EA	-	
R409	050120	RES MF 4K7 1% .4W 100PPM	NEOHM	LR0204	A	EA	-	
R410	050132	RES MF 47K 1% .4W 100PPM	NEOHM	LR0204	A	EA	2	
R411	050112	RES MF 1K0 1% .4W 100PPM	NEOHM	LR0204	A	EA	-	
R412	050096	RES MF 47R 1% .4W 100PPM	NEOHM	LR0204	A	EA	-	
R413	050108	RES MF 470R 1% .4W 100PPM	NEOHM	LR0204	A	EA	-	
R414	050148	RES MF 1M0 1% .4W 100PPM	NEOHM	LR0204	A	EA	-	
R415	041005	RES MF 10M0 1% .12W 100PPM	STREATITE	MK2	A	EA	2	

DESIG	PART NO	DESCRIPTION	PRINC MANUF	MANUF PART NUMBER	CLASS	UM	QUANTITY	CHANGES
R416	041305	RES MF 13M0 1% .12W 150PPM	MEPCO	5053YL	A	EA	1	
R417	050131	RES MF 39K 1% .4W 100PPM	NEOHM	LR0204	A	EA	-	
R418	014991	RES MF 4K99 1% .12W 50PPM	HOLSWORTHY	H8C	A	EA	-	
R419	013921	RES MF 3K92 1% .12W 50PPM	HOLSWORTHY	H8C	A	EA	-	
R420	015628	RES MF 56R2 1% .12W 50PPM	HOLSWORTHY	H8C	A	EA	1	
R421	050120	RES MF 4K7 1% .4W 100PPM	NEOHM	LR0204	A	EA	-	
R422	050120	RES MF 4K7 1% .4W 100PPM	NEOHM	LR0204	A	EA	-	
R423	050132	RES MF 47K 1% .4W 100PPM	NEOHM	LR0204	A	EA	-	
R424	050112	RES MF 1K0 1% .4W 100PPM	NEOHM	LR0204	A	EA	-	
R425	050096	RES MF 47R 1% .4W 100PPM	NEOHM	LR0204	A	EA	-	
R426	050108	RES MF 470R 1% .4W 100PPM	NEOHM	LR0204	A	EA	-	
R427	041005	RES MF 10M0 1% .12W 100PPM	STREATITE	MK2	A	EA	-	
R430	050112	RES MF 1K0 1% .4W 100PPM	NEOHM	LR0204	A	EA	-	
R431	050112	RES MF 1K0 1% .4W 100PPM	NEOHM	LR0204	A	EA	-	
R432	00000N	NOT FITTED					EA	10
R433	050124	RES MF 10K 1% .4W 100PPM	NEOHM	LR0204	A	EA	-	
R434	050136	RES MF 100K 1% .4W 100PPM	NEOHM	LR0204	A	EA	2	
R435	050136	RES MF 100K 1% .4W 100PPM	NEOHM	LR0204	A	EA	-	
R436	00000N	NOT FITTED					EA	-
R501	090096	RES NPWK 1M X B 2%	BECKMAN	LO9-1S-R1M	A	EA	4	
R502	050112	RES MF 1K0 1% .4W 100PPM	NEOHM	LR0204	A	EA	-	
R503	090096	RES NPWK 1M X B 2%	BECKMAN	LO9-1S-R1M	A	EA	-	
R504	050108	RES MF 470R 1% .4W 100PPM	NEOHM	LR0204	A	EA	-	
R505	090105	RES PACK 100R X 4 2%	BECKMAN	LO8-3S-R100	A	EA	1	
R506	090096	RES NPWK 1M X B 2%	BECKMAN	LO9-1S-R1M	A	EA	-	
R507	090096	RES NPWK 1M X B 2%	BECKMAN	LO9-1S-R1M	A	EA	-	
R508	050108	RES MF 470R 1% .4W 100PPM	NEOHM	LR0204	A	EA	-	
C101	110042	CAP PE 100NF 20% 63V	WIMA	MKS2	A	EA	10	
C102	110041	CAP PE 10NF 20% 100V	WIMA	PKS2	A	EA	5	
C103	110042	CAP PE 100NF 20% 63V	WIMA	MKS2	A	EA	-	
C104	104026	CAP CM 47NF +80%-20% 50V	AVX	SR175E4732A	A	EA	27	
C105	104026	CAP CM 47NF +80%-20% 50V	AVX	SR175E4732A	A	EA	-	
C106	110042	CAP PE 100NF 20% 63V	WIMA	MKS2	A	EA	-	
C107	110041	CAP PE 16NF 20% 100V	WIMA	PKS2	A	EA	-	
C108	110042	CAP PE 100NF 20% 63V	WIMA	MKS2	A	EA	-	
C109	104026	CAP CM 47NF +80%-20% 50V	AVX	SR175E4732A	A	EA	-	
C110	104026	CAP CM 47NF +80%-20% 50V	AVX	SR175E4732A	A	EA	-	
C111	100471	CAP CP 470PF 10% 100V	PHILIPS	2222 630 19471	A	EA	1	
C112	104026	CAP CM 47NF +80%-20% 50V	AVX	SR175E4732A	A	EA	-	
C113	150020	CAP DT 10UF 20% 25V	AVX	TAP10M25P	A	EA	2	
C114	104026	CAP CM 47NF +80%-20% 50V	AVX	SR175E4732A	A	EA	-	
C115	110050	CAP PE 22NF 10% 63V	WIMA	MKS4	A	EA	1	
C116	110035	CAP PE 220NF 20% 63V	WIMA	MKS2	A	EA	2	
C117	150020	CAP DT 10UF 20% 25V	AVX	TAP10M25P	A	EA	-	
C118	110035	CAP PE 220NF 20% 63V	WIMA	MKS2	A	EA	-	

DESIG	PART NO	DESCRIPTION	PRINC MANUF	MANUF PART NUMBER	CLASS	UM	QUANTITY	CHANGES
C119	110041	CAP PE 10NF 20% 100V	WIMA	FKS2			EA	-
C120	110030	CAP PE 1NF 20% 100V	WIMA	FKS2			EA	5
C121	100330	CAP CP 33PF 2% 100V	PHILIPS	2222 683 34339			EA	1
C201	104026	CAP CM 47NF +80%-20% 50V	AVX	SR175E473ZA	A		EA	-
C202	110041	CAP PE 10NF 20% 100V	WIMA	FKS2			EA	-
C203	110030	CAP PE 1NF 20% 100V	WIMA	FKS2			EA	-
C204	110030	CAP PE 1NF 20% 100V	WIMA	FKS2			EA	-
C205	120019	CAP PC 1UF 10% 63V	ASHCROFT	M2B10201B			EA	4
C266	126019	CAP PC 1UF 10% 63V	ASHCROFT	M2B10201B			EA	-
C207	100270	CAP CP 27PF 2% 100V	PHILIPS	2222 683 34279			EA	4
C208	104026	CAP CM 47NF +80%-20% 50V	AVX	SR175E473ZA	A		EA	-
C209	110046	CAP PE 1UF 20% 50V	WIMA	MKS2 1UF 20% 50V	A		EA	11
C210	110046	CAP PE 1UF 20% 50V	WIMA	MKS2 1UF 20% 50V	A		EA	-
C211	100270	CAP CP 27PF 2% 100V	PHILIPS	2222 683 34279			EA	-
C212	104026	CAP CM 47NF +80%-20% 50V	AVX	SR175E473ZA	A		EA	-
C213	110046	CAP PE 1UF 20% 50V	WIMA	MKS2 1UF 20% 50V	A		EA	-
C214	110046	CAP PE 1UF 20% 50V	WIMA	MKS2 1UF 20% 50V	A		EA	-
C215	104026	CAP CM 47NF +80%-20% 50V	AVX	SR175E473ZA	A		EA	-
C216	110046	CAP PE 1UF 20% 50V	WIMA	MKS2 1UF 20% 50V	A		EA	-
C217	140086	CAP PP 10NF 5% 63V	WIMA	FKP2			EA	2
C218	104026	CAP CM 47NF +80%-20% 50V	AVX	SR175E473ZA	A		EA	-
C219	00000N	NOT FITTED					EA	-
C220	104026	CAP CM 47NF +80%-20% 50V	AVX	SR175E473ZA	A		EA	-
C221	104026	CAP CM 47NF +80%-20% 50V	AVX	SR175E473ZA	A		EA	-
C222	104026	CAP CM 47NF +80%-20% 50V	AVX	SR175E473ZA	A		EA	-
C223	104026	CAP CM 47NF +80%-20% 50V	AVX	SR175E473ZA	A		EA	-
C192	110041	CAP PE 10NF 20% 100V	WIMA	FKS2			EA	-
C303	110030	CAP PE 1NF 20% 100V	WIMA	FKS2			EA	-
C304	110030	CAP PE 1NF 20% 100V	WIMA	FKS2			EA	-
C305	120019	CAP PC 1UF 10% 63V	ASHCROFT	M2B10201B			EA	-
C306	120019	CAP PC 1UF 10% 63V	ASHCROFT	M2B10201B			EA	-
C307	100270	CAP CP 27PF 2% 100V	PHILIPS	2222 683 34279			EA	-
C308	104026	CAP CM 47NF +80%-20% 50V	AVX	SR175E473ZA	A		EA	-
C309	110046	CAP PE 1UF 20% 50V	WIMA	MKS2 1UF 20% 50V	A		EA	-
C310	110046	CAP PE 1UF 20% 50V	WIMA	MKS2 1UF 20% 50V	A		EA	-
C311	100270	CAP CP 27PF 2% 100V	PHILIPS	2222 683 34279			EA	-
C312	104026	CAP CM 47NF +80%-20% 50V	AVX	SR175E473ZA	A		EA	-
C313	110046	CAP PE 1UF 20% 50V	WIMA	MKS2 1UF 20% 50V	A		EA	-
C314	110046	CAP PE 1UF 20% 50V	WIMA	MKS2 1UF 20% 50V	A		EA	-
C315	104026	CAP CM 47NF +80%-20% 50V	AVX	SR175E473ZA	A		EA	-
C316	110046	CAP PE 1UF 20% 50V	WIMA	MKS2 1UF 20% 50V	A		EA	-
C317	140086	CAP PP 10NF 5% 63V	WIMA	FKP2			EA	-
C318	104026	CAP CM 47NF +80%-20% 50V	AVX	SR175E473ZA	A		EA	-
C319	00000N	NOT FITTED					EA	-
C320	104026	CAP CM 47NF +80%-20% 50V	AVX	SR175E473ZA	A		EA	-

DESIG	PART NO	DESCRIPTION	PRINC MANUF	MANUF PART NUMBER	CLASS	UM	QUANTITY	CHANGES
C321	00000N	NOT FITTED					EA	-
C322	104026	CAP CM 47NF +80%-20% 50V	AVX	SR175E473ZA	A		EA	-
C323	00000N	NOT FITTED					EA	-
C401	104026	CAP CM 47NF +80%-20% 50V	AVX	SR175E473ZA	A		EA	-
C402	110020	CAP PE 47NF 20% 63V	WIMA	MKS2			EA	3
C403	110020	CAP PE 47NF 20% 63V	WIMA	MKS2			EA	-
C404	110020	CAP PE 47NF 20% 63V	WIMA	MKS2			EA	-
C405	104026	CAP CM 47NF +80%-20% 50V	AVX	SR175E473ZA	A		EA	-
C406	110042	CAP PE 100NF 20% 63V	WIMA	MKS2			EA	-
C407	110042	CAP PE 100NF 20% 63V	WIMA	MKS2			EA	-
C408	110042	CAP PE 100NF 20% 63V	WIMA	MKS2			EA	-
C409	104026	CAP CM 47NF +80%-20% 50V	AVX	SR175E473ZA	A		EA	-
C410	104026	CAP CM 47NF +80%-20% 50V	AVX	SR175E473ZA	A		EA	-
C411	110046	CAP PE 1UF 20% 50V	WIMA	MKS2 1UF 20% 50V	A		EA	-
C412	110042	CAP PE 100NF 20% 63V	WIMA	MKS2			EA	-
C413	110042	CAP PE 100NF 20% 63V	WIMA	MKS2			EA	-
C414	110042	CAP PE 100NF 20% 63V	WIMA	MKS2			EA	-
C415	104026	CAP CM 47NF +80%-20% 50V	AVX	SR175E473ZA	A		EA	-
C416	104026	CAP CM 47NF +80%-20% 50V	AVX	SR175E473ZA	A		EA	-
C501	160221	CAP CP 220PF 2% 100V	PHILIPS	2222 683 58221			EA	1
C502	150002	CAP DT 10UF 20% 16V	AVX	TAP10M16P	A		EA	1
C503	104067	CAP CA 100NF +80%-20% 50V	AVX	SA105E104ZAA	A		EA	B
C504	104067	CAP CA 100NF +80%-20% 50V	AVX	SA105E104ZAA	A		EA	-
C505	104067	CAP CA 100NF +80%-20% 50V	AVX	SA105E104ZAA	A		EA	-
C506	104067	CAP CA 100NF +80%-20% 50V	AVX	SA105E104ZAA	A		EA	-
C507	104067	CAP CA 100NF +80%-20% 50V	AVX	SA105E104ZAA	A		EA	-
C508	104067	CAP CA 100NF +80%-20% 50V	AVX	SA105E104ZAA	A		EA	-
C509	104067	CAP CA 100NF +80%-20% 50V	AVX	SA105E104ZAA	A		EA	-
C510	104067	CAP CA 100NF +80%-20% 50V	AVX	SA105E104ZAA	A		EA	-
D101	210047	DIODE ZN 4V7 400mW	PHILIPS	BZX79C4V7	A		EA	5
D102	210047	DIODE ZN 4V7 400mW	PHILIPS	BZX79C4V7	A		EA	-
D103	210047	DIODE ZN 4V7 400mW	PHILIPS	BZX79C4V7	A		EA	-
D104	200001	DIODE GP 75mA 75V	FAIRCHILD	1N4148			EA	9
D105	200001	DIODE GP 75mA 75V	FAIRCHILD	1N4148			EA	-
D106	200001	DIODE GP 75mA 75V	FAIRCHILD	1N4148			EA	-
D107	213022	DIODE TS 10V 5/500W	UNI-PROBE	TVS510	A		EA	1
D108	200001	DIODE GP 75mA 75V	FAIRCHILD	1N4148			EA	-
D109	210043	DIODE ZN 4V3 400mW	PHILIPS	BZX79C4V3	A		EA	1
D110	200001	DIODE GP 75mA 75V	FAIRCHILD	1N4148			EA	-
D111	200001	DIODE GP 75mA 75V	FAIRCHILD	1N4148			EA	-
D114	200001	DIODE GP 75mA 75V	FAIRCHILD	1N4148			EA	-
D115	200001	DIODE GP 75mA 75V	FAIRCHILD	1N4148			EA	-
D116	214014	DIODE ZN 1V22 100PPM	TELEDYNE	9491BJ	A		EA	2
D117	214014	DIODE ZN 1V22 100PPM	TELEDYNE	9491BJ	A		EA	-
D201	260005	DIODE SB 200mA 30V	PHILIPS	BA765			EA	9

DESIG	PART NO	DESCRIPTION	PRINC MANUF	MANUF PART NUMBER	CLASS	UM	QUANTITY	CHANGES
D202	200005	DIODE SB 200mA 30V	PHILIPS	BAT85		EA	-	
D303	200005	DIODE SB 200mA 30V	PHILIPS	BAT85		EA	-	
D204	200005	DIODE SB 200mA 30V	PHILIPS	BAT85		EA	-	
D301	200005	DIODE SB 200mA 30V	PHILIPS	BAT85		EA	-	
D302	200005	DIODE SB 200mA 30V	PHILIPS	BAT85		EA	-	
D303	200005	DIODE SB 200mA 30V	PHILIPS	BAT85		EA	-	
D304	200005	DIODE SB 200mA 30V	PHILIPS	BAT85		EA	-	
D401	210047	DIODE 2N 4V7 400mW	PHILIPS	BZX79C4V7	A	EA	-	
D402	213006	DIODE TS 5V 5/500W	UNITRODE	TVSS05	A	EA	2	
D403	210047	DIODE 2N 4V7 400mW	PHILIPS	BZX79C4V7	A	EA	-	
D404	213006	DIODE TS 5V 5/500W	UNITRODE	TVSS05	A	EA	-	
D405	200001	DIODE GP 75mA 75V	FAIRCHILD	1N4148		EA	-	
D501	200005	DIODE SB 200mA 30V	PHILIPS	BAT85		EA	-	
Q101	240001	TRAN NPN	MOTOROLA	BC184		EA	6	
Q102	240001	TRAN NPN	MOTOROLA	BC184		EA	-	
Q104	240001	TRAN NPN	MOTOROLA	BC184		EA	-	
Q105	240001	TRAN NPN	MOTOROLA	BC184		EA	-	
Q201	230039	TRAN JFET P CHAN	SILICONIX	J175		EA	6	
Q202	230038	TRAN JFET N-CHAN	SILICONIX	J112		EA	2	
Q203	230039	TRAN JFET P CHAN	SILICONIX	J175		EA	-	
Q204	230039	TRAN JFET P CHAN	SILICONIX	J175		EA	-	
Q205	239087-1	TRAN JFET SET J106 X 2	DATRON	SEE DRG		S2	2	
Q206	239087-1	TRAN JFET SET J106 X 2	DATRON	SEE DRG		S2	-	
Q207	230086	TRAN MOSFET P-CHAN 60V	FERRANTI	ZVP2106A	A	EA	2	
Q208	230082	TRAN MOSFET N-CHAN 60V	SILICONIX	VN10LM		EA	2	
Q209	230031	TRAN JFET N-CHAN DUAL	SILICONIX	U404		EA	4	
Q210	230031	TRAN JFET N-CHAN DUAL	SILICONIX	U404		EA	-	
Q301	230039	TRAN JFET P CHAN	SILICONIX	J175		EA	-	
Q302	230038	TRAN JFET N-CHAN	SILICONIX	J112		EA	-	
Q303	230039	TRAN JFET P CHAN	SILICONIX	J175		EA	-	
Q304	230039	TRAN JFET P CHAN	SILICONIX	J175		EA	-	
Q305	239087-1	TRAN JFET SET J106 X 2	DATRON	SEE DRG		S2	-	
Q306	239087-1	TRAN JFET SET J106 X 2	DATRON	SEE DRG		S2	-	
Q307	230066	TRAN MOSFET P-CHAN 60V	FERRANTI	ZVP2106A	A	EA	-	
Q308	230082	TRAN MOSFET N-CHAN 60V	SILICONIX	VN10LM		EA	-	
Q309	230031	TRAN JFET N-CHAN DUAL	SILICONIX	U404		EA	-	
Q310	230031	TRAN JFET N-CHAN DUAL	SILICONIX	U404		EA	-	
Q402	240001	TRAN NPN	MOTOROLA	BC184		EA	-	
Q404	240001	TRAN NPN	MOTOROLA	BC184		EA	-	
U101	260082	IC LIN OP AMP CHOPPER	LINEAR TECHNOLOGY	LTC1052CN8		EA	4	
U102	260065	IC LIN OP AMP	PMI	OP27FZ	A	EA	4	
U103	260082	IC LIN OP AMP CHOPPER	LINEAR TECHNOLOGY	LTC1052CN8		EA	-	
U104	260065	IC LIN OP AMP	PMI	OP27FZ	A	EA	-	
U105	260025	IC LIN OP AMP	NATIONAL	LM101AH		EA	1	
U106	260033	IC LIN REG 5V .1A	MOTOROLA	MC78L05ACP	A	EA	1	

DESIG	PART NO	DESCRIPTION	PRINC MANUF	MANUF PART NUMBER	CLASS	UM	QUANTITY	CHANGES
U201	220027	OPTO ISOL HIGH CMR	H.P.	HCPL-2601	A	EA	1	
U202	280182	IC DIG FLIP FLOP D X2	NATIONAL	74AC74PC		EA	3	
U203	280185	IC DIG INV MOSFET DRIVER X2	INTERMIL	ICL7667CPA		EA	4	
U204	280185	IC DIG INV MOSFET DRIVER X2	INTERMIL	ICL7667CPA		EA	-	
U205	260057	IC LIN OP AMP	SIGNETICS	NE5534N		EA	4	
U206	260057	IC LIN OP AMP	SIGNETICS	NE5534N		EA	-	
U207	260107	IC LIN OP AMP	PRECISION MONOLITHIC	OP07CP		EA	2	
U302	280182	IC DIG FLIP FLOP D X2	NATIONAL	74AC74PC		EA	-	
U303	280185	IC DIG INV MOSFET DRIVER X2	INTERMIL	ICL7667CPA		EA	-	
U304	280185	IC DIG INV MOSFET DRIVER X2	INTERMIL	ICL7667CPA		EA	-	
U305	260057	IC LIN OP AMP	SIGNETICS	NE5534N		EA	-	
U306	260057	IC LIN OP AMP	SIGNETICS	NE5534N		EA	-	
U307	260107	IC LIN OP AMP	PRECISION MONOLITHIC	OP07CP		EA	-	
U401	220041	OPTO ISOL 3KV DUAL	H.P.	HCPL-2631	A	EA	1	
U402	280190	IC DIG SWITCH ANALOG 2NO 2NC	SILICONIX	DG413DJ		EA	1	
U403	260088	IC LIN OP AMP DUAL PREC	LINEAR TECHNOLOGY	LT1013CH		EA	1	
U404	260082	IC LIN OP AMP CHOPPER	LINEAR TECHNOLOGY	LTC1052CN8		EA	-	
U405	260065	IC LIN OP AMP	PMI	OP27FZ	A	EA	-	
U406	260082	IC LIN OP AMP CHOPPER	LINEAR TECHNOLOGY	LTC1052CN8		EA	-	
U407	260065	IC LIN OP AMP	PMI	OP27FZ	A	EA	-	
U501	280141	IC DIG COUNTS SYNC BIN PL DN	SGS	M74HC4103B1		EA	4	
U502	280141	IC DIG COUNTS SYNC BIN PL DN	SGS	M74HC4103B1		EA	-	
U503	280182	IC DIG FLIP FLOP D X2	NATIONAL	74AC74PC		EA	-	
U504	280166	IC DIG NAND2 X4	TEXAS	SN74HCT00N	A	EA	1	
U505	280188	IC DIG NAND2 X4	RCA	CD74AC00E		EA	2	
U506	280188	IC DIG NAND2 X4	RCA	CD74AC00E		EA	-	
U507	280141	IC DIG COUNTS SYNC BIN PL DN	SGS	M74HC4103B1		EA	-	
U508	280141	IC DIG COUNTS SYNC BIN PL DN	SGS	M74HC4103B1		EA	-	
T201	310002-2	TRANSF PULSE	NEWPORT	SEE DRG		EA	4	
T202	310002-2	TRANSF PULSE	NEWPORT	SEE DRG		EA	-	
T301	310002-2	TRANSF PULSE	NEWPORT	SEE DRG		EA	-	
T302	310002-2	TRANSF PULSE	NEWPORT	SEE DRG		EA	-	
L101	370001	CHOKE RF 10UH	SIGMA	SC10/25	A	EA	2	
L102	370001	CHOKE RF 10UH	SIGMA	SC10/25	A	EA	-	
P5	604111	PLUG 15-WAY PCB 10.3 D TYPE	AMP	343647-2		EA	1	
P608	604106	PLUG PCB 32-WAY	BICC-VERO	905-72216J		EA	1	
J9	604113	PLUG PCB 10-WAY .1" SIL	SAMTEK	BBL-110-G-E		EA	1	
J609	604085	PLUG PCB 2-WAY .1"	MOLEX	22-29-2021		EA	1	
E501	612026-1	STANDOFF M3 X 6		SEE DRG		EA	5	
E502	00000N	NOT FITTED				EA	-	
E503	00000N	NOT FITTED				EA	-	
E504	00000N	NOT FITTED				EA	-	
E505	00000N	NOT FITTED				EA	-	
TP101	620007	TEST POINT TERMINAL	MICROVAR	TYPE C30		EA	4	
TP102	620007	TEST POINT TERMINAL	MICROVAR	TYPE C30		EA	-	

DESIG	PART NO	DESCRIPTION	PRINC MANUF	MANUF PART NUMBER	CLASS	UM	QUANTITY	CHANGES
TP201	620007	TEST POINT TERMINAL	MICROVAR	TYPE C30	EA	-		
TP301	620007	TEST POINT TERMINAL	MICROVAR	TYPE C30	EA	-		
S501	700118	SWITCH 16 POS ROTARY DIP	OMRON	A6CR-16R	EA	5		
S502	700118	SWITCH 16 POS ROTARY DIP	OMRON	A6CR-16R	EA	-		
S503	700118	SWITCH 16 POS ROTARY DIP	OMRON	A6CR-16R	EA	-		
S504	700118	SWITCH 16 POS ROTARY DIP	OMRON	A6CR-16R	EA	-		
S505	700118	SWITCH 16 POS ROTARY DIP	OMRON	A6CR-16R	EA	-		
	400940-1	ASSY PCB COUNTER PLUG IN 4910	DATRON	SEE DRG	EA	1		
	410434-1	PCB OUTPUT 4910		SEE DRG	EA	1		
	420098	LABEL SERIAL/ASSY No.	RS COMPONENTS	554-793	EA	1		
	420112-1	LABEL SSD WARNING 12 X 12mm	TEKNIS	LN1212	A	EA	1	
	450741-3	SCREEN WALL 4MHZ LOWER 4910		SEE DRG	EA	1		
	450794-2	SCREEN WALL 4MHZ UPPER 4910		SEE DRG	EA	1		
	450824-1	SCREEN WALL 60HZ UPPER OUPUT		SEE DRG	EA	1		
	450825-1	SCREEN WALL 60HZ LOWER OUPUT		SEE DRG	EA	1		
	450834-A	SCREEN GASKET 60HZ OUTPUT 4910		SEE DRG	EA	2		
	450835-A	SCREEN COVER OUPPUT 4910		SEE DRG	EA	2		
	450836-A	SCREEN GASKET 4MHZ OUTPUT 4910		SEE DRG	EA	2		
	540006	WIRE 1/.4 PTFE 250V BLK	BSG210	TYPE A	AR	1		
	611016	SCREW M3 X 8 POZIPAN SZP			EA	5		
	611096	SCREW M2.5 X 12 POZIPAN SZP			EA	2		
	611115	SCREW M3 X 25 POZIPAN SZP			EA	4		
	612026-1	STANDOFF M3 X 6		SEE DRG	EA	-		
	613029	WASHER M3 WAVY SS			EA	7		
	613047	WASHER M2.5 WAVY SS			EA	2		
	614016-1	SPACER M3 X 14 CLEAR		SEE DRG	EA	4		
	615002	NUT FULL M3 SZP			EA	2		
	615006	NUT FULL M2.5 SZP			EA	2		
	618015	COMPONENT CARRIER	JERMYN	J22-4019	EA	23		
	630024	BEAD CERAMIC 16 SWG	PARK ROYAL PORCELAIN	No2	EA	6		
	630112	PCB EJECTOR BLACK	RICHCO	CBE	EA	2		
	630243	BEAD GLASS 2.4 X 0.81 X 1.8	MANSOL (PREFORMS)	LT M5363B/3	EA	58		
ST101	99908S	STAR-POINT 08 NOT FITTED			EA	1		
ST102	99904S	STAR-POINT 04 NOT FITTED			EA	1		

End

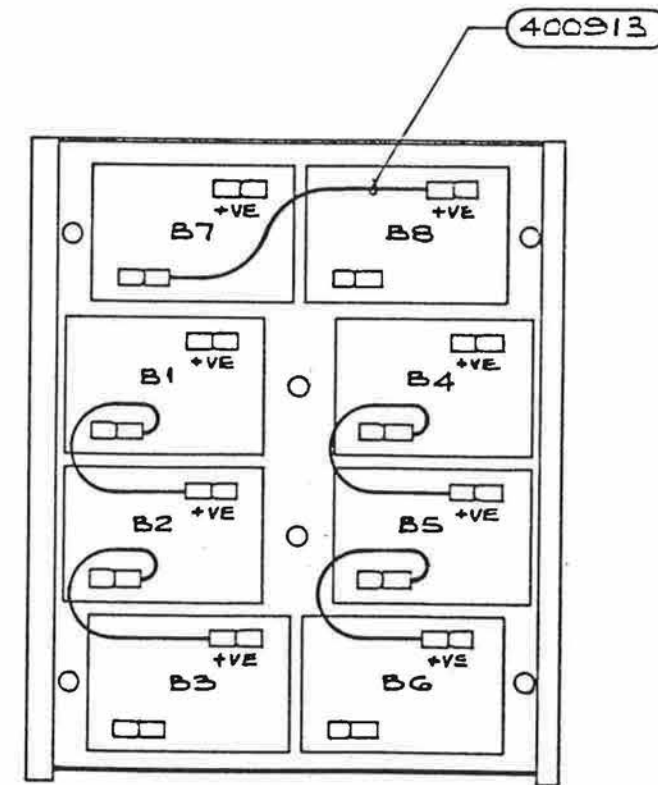
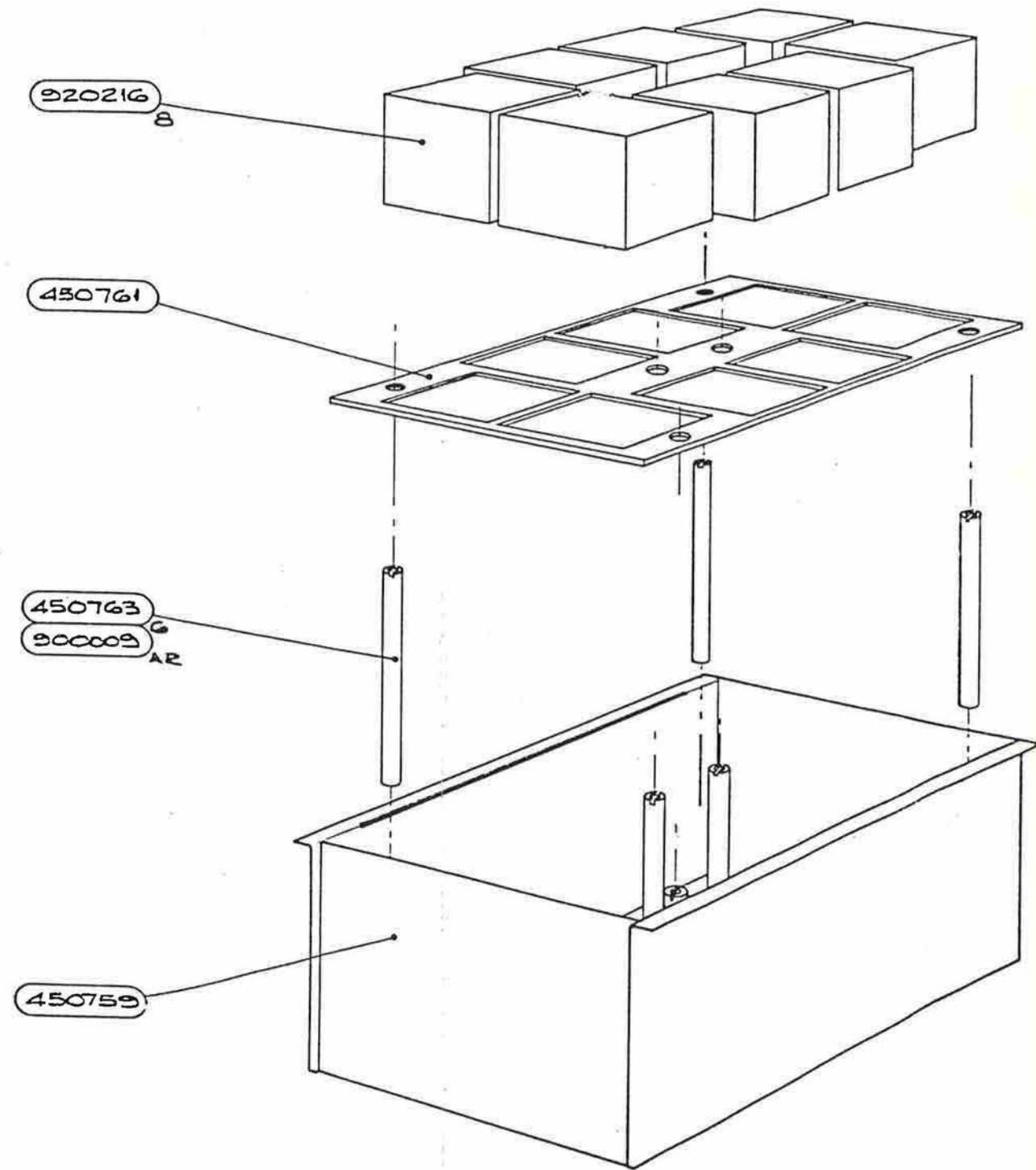

BOTTOM LAYER BATTERY WIRING
DETAILS

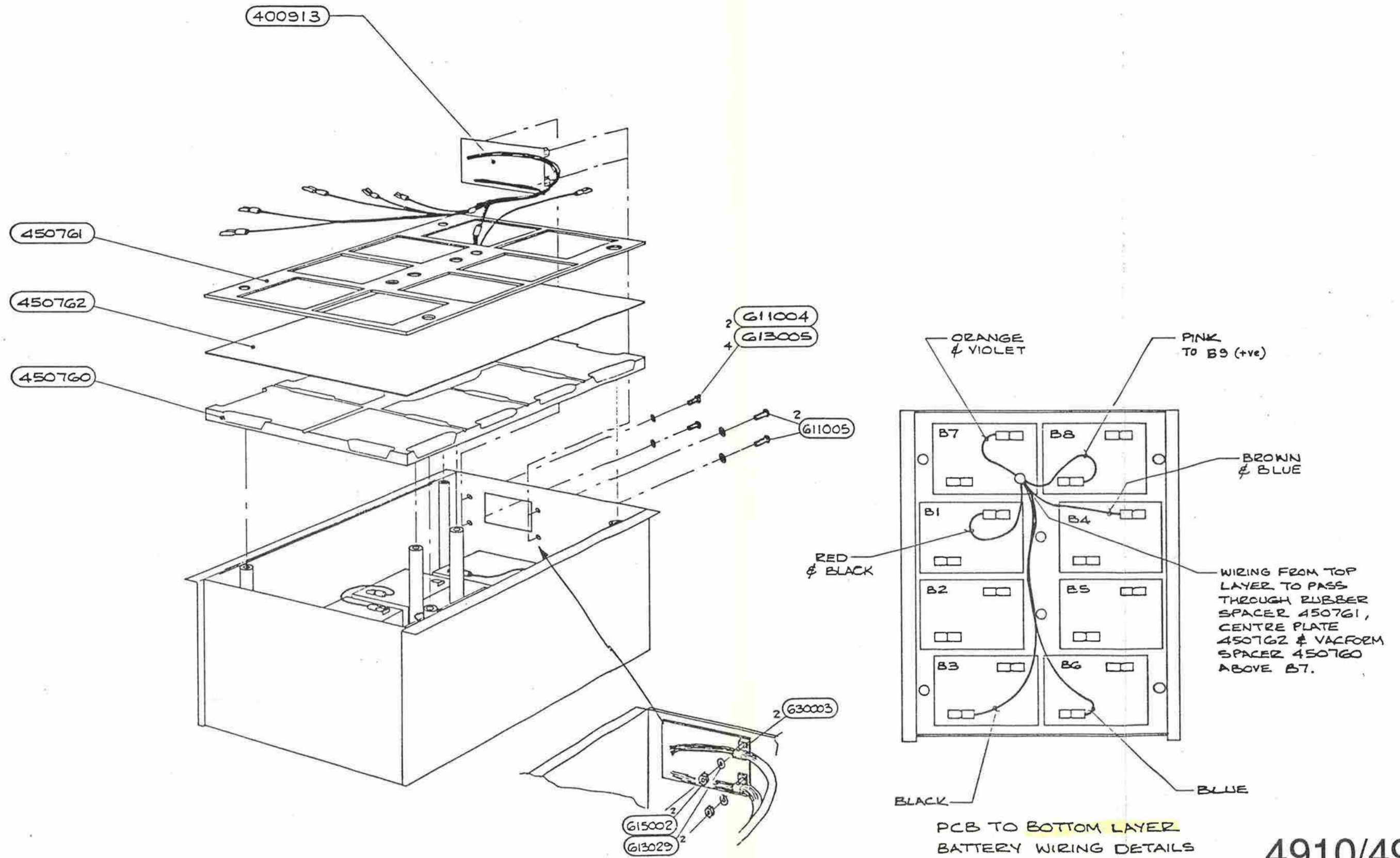

BATTERY TRAY ASSEMBLY

Drawing No. DA400885 Sheet 2



© Datron Instruments 1991

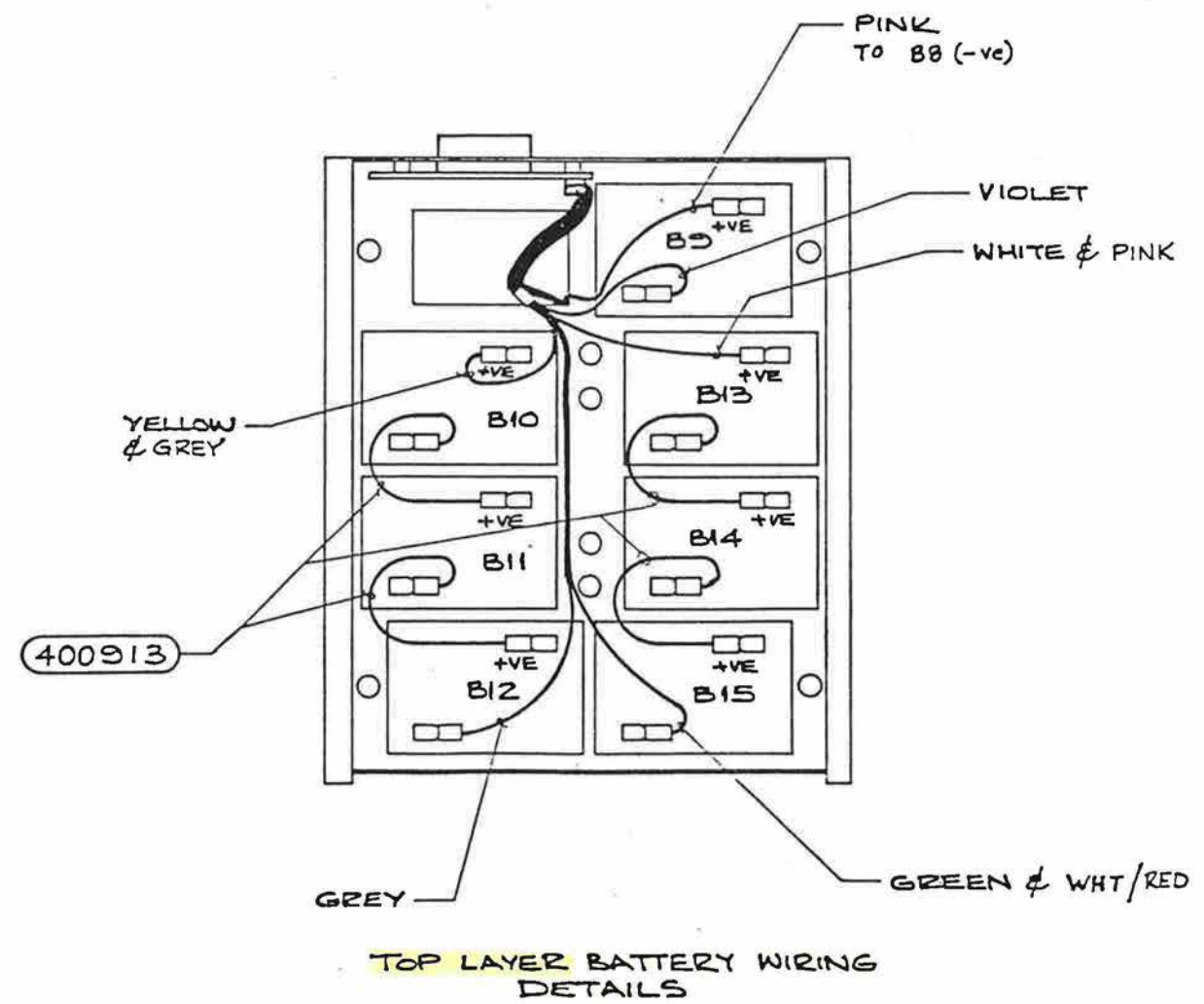
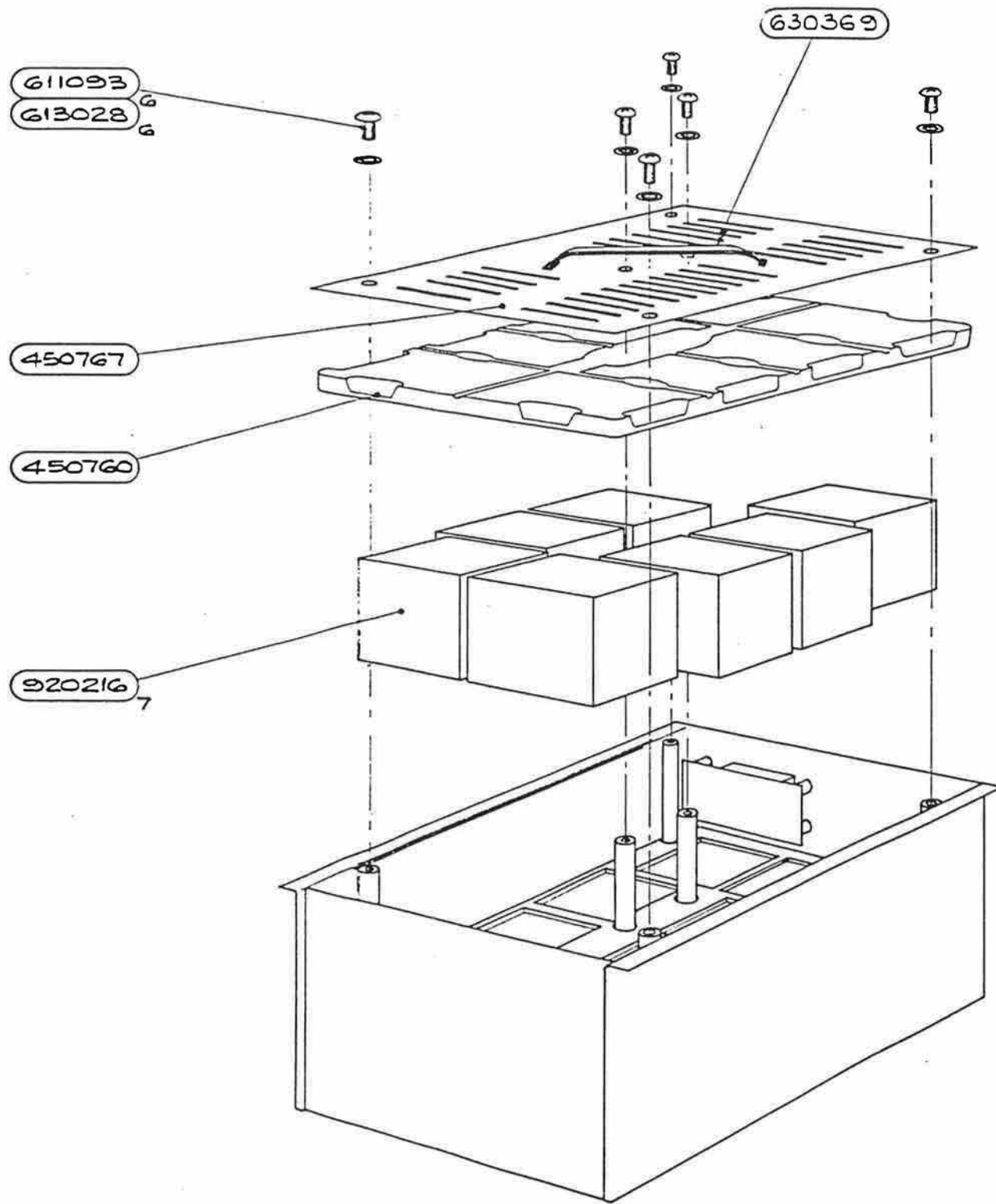

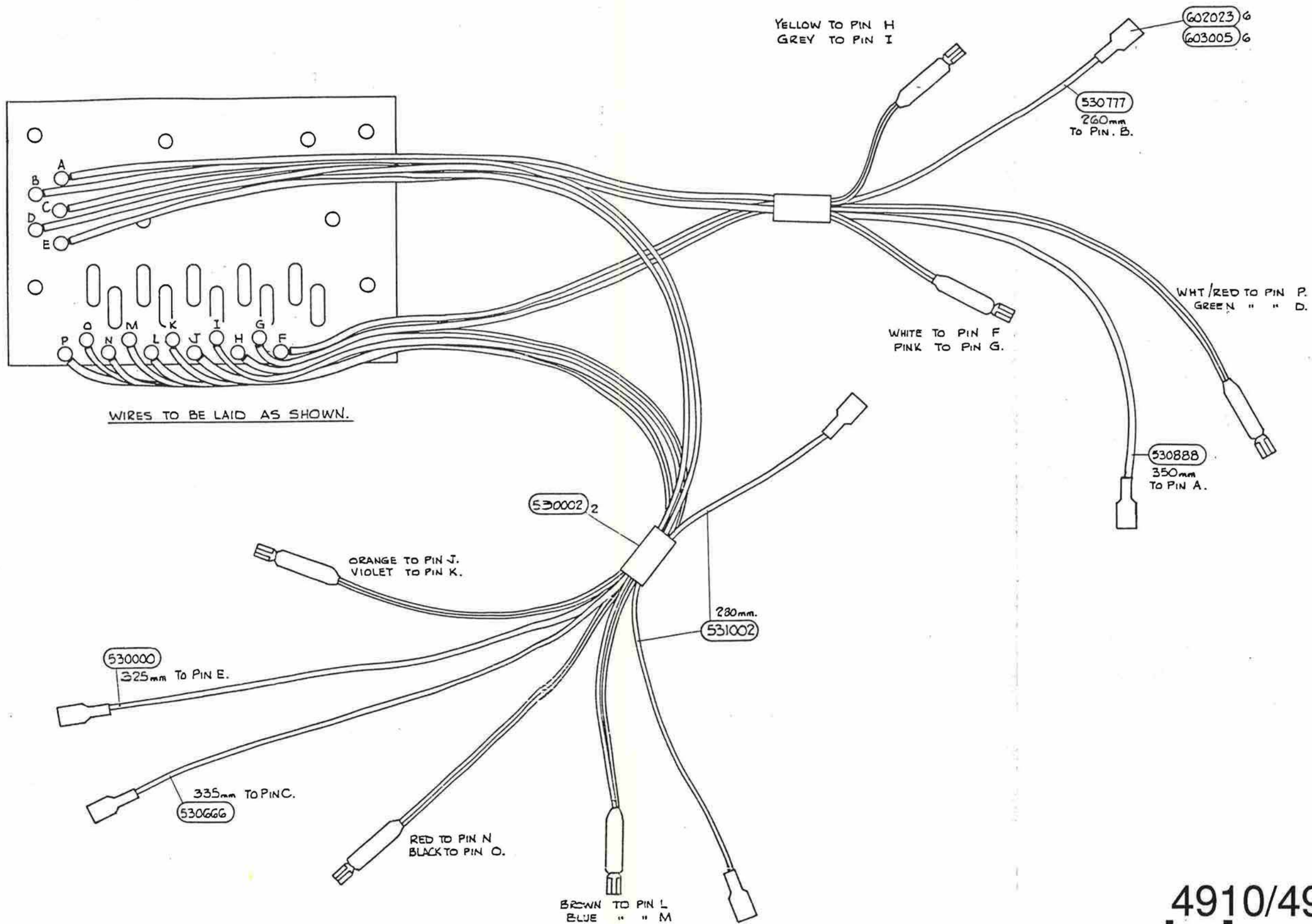

BATTERY TRAY PCB ASSEMBLY
 Drawing No. DA400913 Sheet 2



© Datron Instruments 1991

NOTE! FIT THESE STANDOFF'S FIRST.

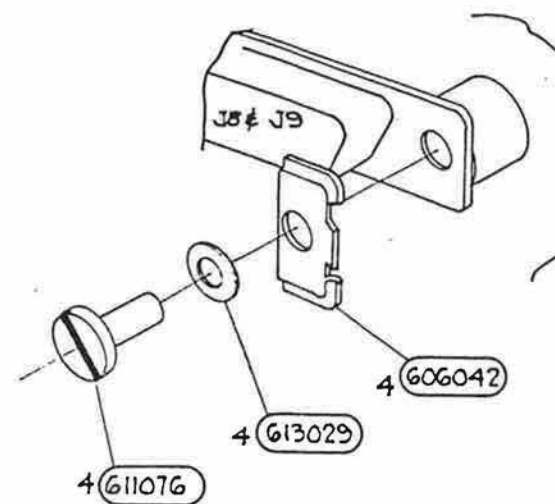
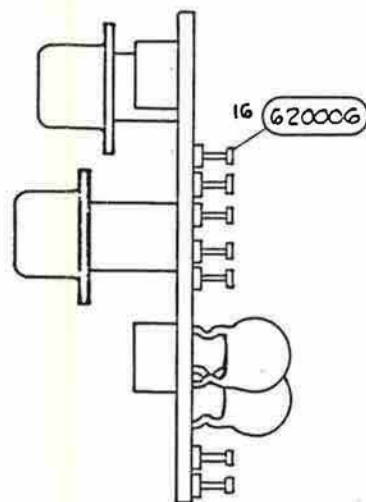
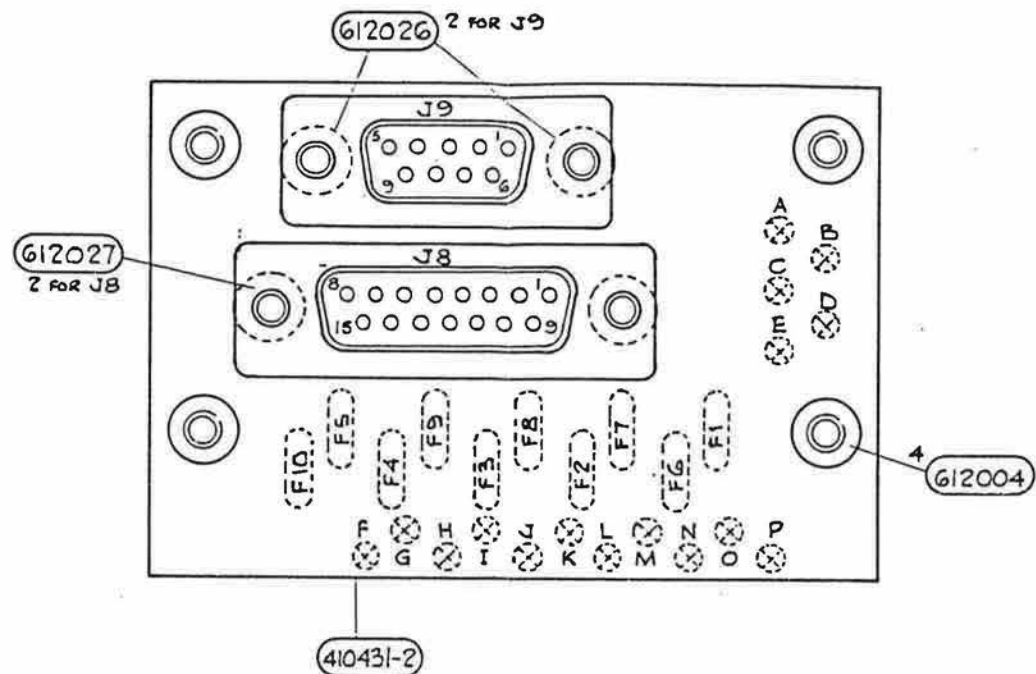

NOTE. USE CRIMP TOOL HTR1031E PdsN. B. FOR TERMINALS 602023.

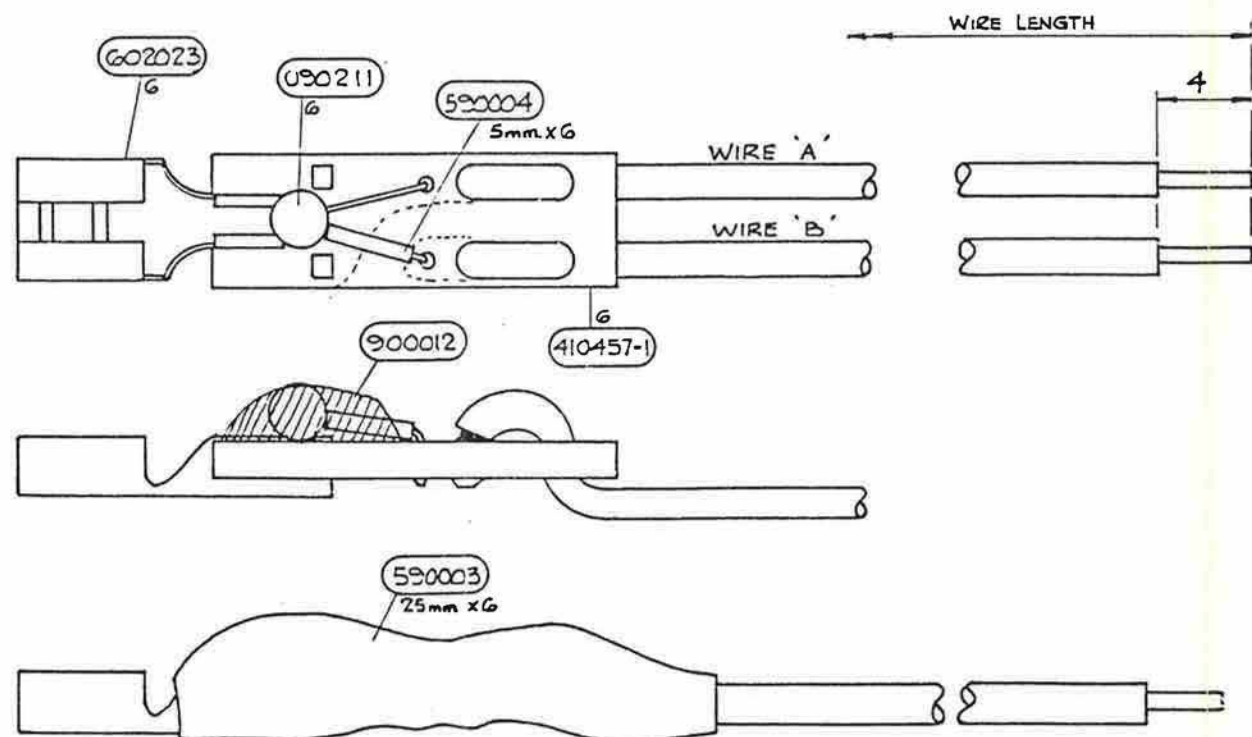

QUANTITY	WIRE 'A' COLOUR (PART No.)	WIRE 'B' COLOUR (PART No.)	WIRE LENGTH	DESIGNATOR
1	GREEN. (512555)	WHT/RED (512992)	360 mm	R5
1	RED. (512222)	BLACK (512000)	280 mm	R1
1	BROWN (512111)	BLUE (512666)	230 mm	R2
1	ORANGE (512333)	VIOLET (512777)	255 mm	R3
1	YELLOW (512444)	GREY (512888)	275 mm	R4
1	WHITE (512999)	PINK (513001)	255 mm	R6

9 OFF THESE WIRE ASSY'S REQUIRED.

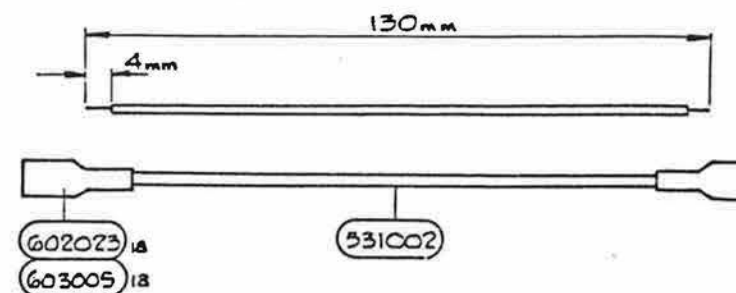

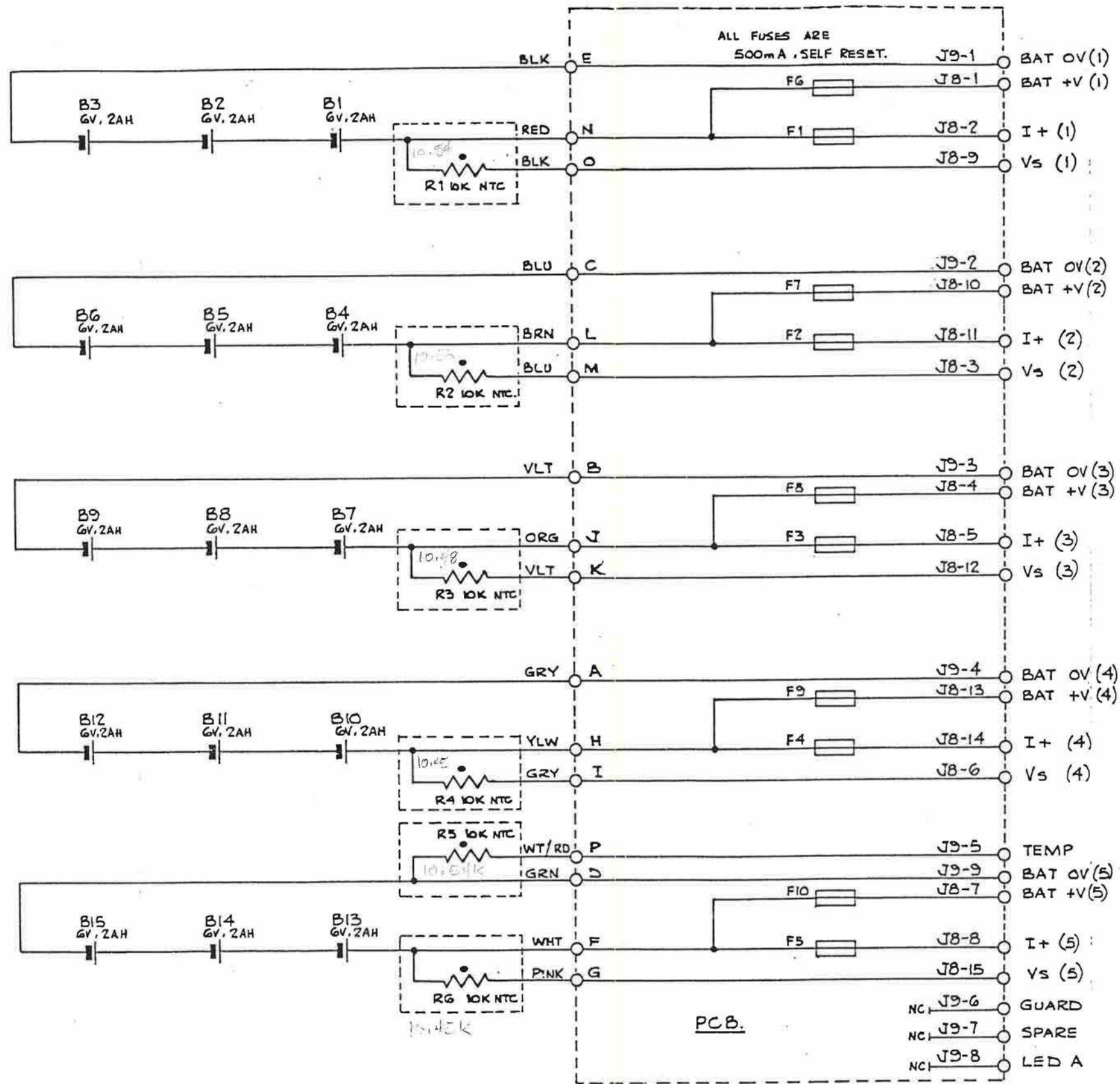

BATTERY TRAY PCB ASSEMBLY
 Drawing No. DC400913 Sheet 1



© Datron Instruments 1991

DESIG	PART NO	DESCRIPTION	PRINC MANUP	MANUP PART NUMBER	CLASS	UM	QUANTITY	CHANGES
	612026-1	STANDOFF M3 X 6		SEE DRG			EA 2	
	612027-1	STANDOFF M3 X 8		SEE DRG			EA 2	
	613029	WASHER M3 WAVY SS					EA 4	
	620006	SOLDER TURRET	HARWIN	H9001-01			EA 16	
	900012	ADHESIVE EPOXY RAPID	CIBA-GEIGY	ARALDITE RAPID			AR 1	

End

611061 2 (4) QUANTITY IN BRACKETS
WHEN MOUNTING TWO INSTRUMENTS.

613021 2 (4)

613020 2(4)

611056 4

613033 4

615019 4

450846 (2)

615018 8

613020 8

611061 8

450848 2

450859 2

611059 8

450844

615019 8

450847 (-1)

611106 4

REMOVE ADHESIVE SIDE TRIM
FROM EACH SIDE OF INSTRUMENT.

450843 2

450845

613033 10

611056 10

NOTE.
TOTAL WEIGHT FOR RACK
MOUNTING TWO INSTRUMENTS
CAN BE UP TO 45KG.

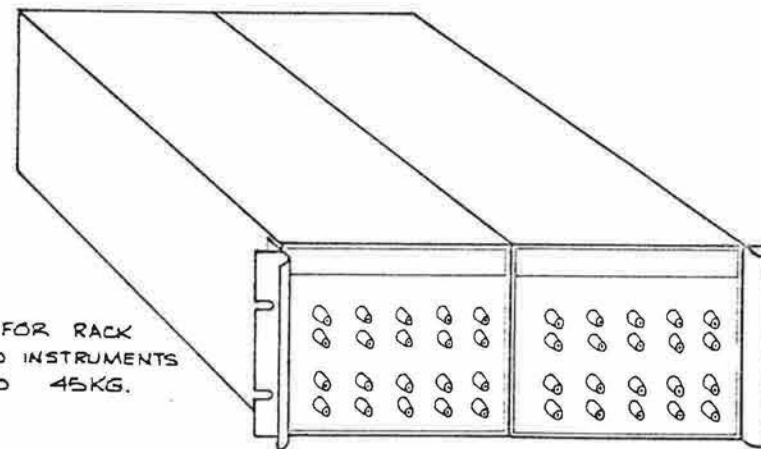





WHEN TWO INSTRUMENTS MOUNTED
AS ABOVE INSIDE HANDLE OF
EACH INSTRUMENT MUST BE REMOVED.

**OPTION 90
RACK MOUNTING KIT**

Drawing No. DA440161 Sheet 1



© Datron Instruments 1991

LD 4401G1		CHECK	DATE
DOCUMENT LIST		1.0	13.2.90
DISTRIBUTION		1.1	6.7.90
REVISION		1.0	1.0
ISSUE		1.1	1.1
ISSUE / REVISION			
ISSUE	LP4401G1	1	1.0
ISSUE	DA4401G1	1	1.1
CIRCUIT DIAGRAM	---		
TEST PROCEDURE	---		
TEST SPECIFICATION	---		
PCB	---		
NOTES		   	
<input type="checkbox"/> DENOTES NO CHANGE TO DOCS AT ISSUE LEVEL CHANGE		TITLE 4910 RACK MOUNTING KIT	
		DRAWING No. LD 4401G1 SHEET 1 OF 1	

DATRON INSTRUMENTS LTD PARTS LIST 29-Apr-91 DESC: KIT RACK MOUNT 4910 DRG NO: LP440161-1 REV: 1 PAGE NO: 1

DESIG	PART NO	DESCRIPTION	PRINC MANUF	MANUF PART NUMBER	CLASS	UM	QUANTITY	CHANGES
	450843-2	RACK EAR/HANDLE 4U 4910		SEE DRG	EA	2		
	450844-1	RACK MOUNTING TRAY 4910		SEE DRG	EA	1		
	450845-2	BLANKING PLATE 1U 4910		SEE DRG	EA	1		
	450846-1	BRACKET REAR CLAMP 4910		SEE DRG	EA	2		
	450847-2	BLANKING PLATE HALF RACK 4910		SEE DRG	EA	1		
	450848-1	BRACKET REAR SUPPORT 4910		SEE DRG	EA	2		
	450859-1	BRACKET RACK TRAY SUPPORT		SEE DRG	EA	2		
	611056	SCREW M6 X 16 POZIPAN ST.CR.PL			EA	14		
	611059	SCREW M4 X 12 POZICKS S2P			EA	8		
	611061	SCREW M4 X 12 POZIPAN S2P			EA	12		
	611106	SCREW 8-32 X 5/8 POZICKS S2P			EA	4		
	613020	WASHER M4 S2P			EA	12		
	613021	WASHER M4 INT SHAKP S2P			EA	4		
	613033	WASHER M6 S2P	SCHROFF	21100-104	EA	14		
	615018	NUT NYLOCK M4 S2P			EA	8		
	615019	NUT CAGE M6 S2P	SCHROFF	21100-004	EA	12		

End

DATRON INSTRUMENTS FAILURE REPORT.

Please complete all sections and return with your instrument.

Company:
Division: Department/Mail Stop
User, Name: Telephone Ext
Serial number:
Datron Return Authorisation number Date of failure

Brief description of fault:
.....
.....
.....

Fault details:

is the fault present on all cells? Yes No Not Applicable
if no describe:
is the fault present on all outputs? Yes No Not Applicable
is the fault: Permanent Intermittent
if intermittent under what conditions does the fault re-appear?

Any fail LED indication:
Now?: Yes No if yes describe

At the time of fault?: Yes No
if yes describe

Prior to fault?: Yes No
if yes describe

Is the instrument used on I.E.E.E 488 bus? Yes No
Is the instrument normally enclosed in a rack? Yes No
Approximate ambient temperature

TERMS AND CONDITIONS OF SALE

1. GENERAL

The acceptance of a quotation, of any goods supplied, advice given or service rendered includes the acceptance of the following terms and conditions and no variation of or addition to the same shall be binding upon us unless expressly agreed in writing by us. Any order shall be subject to our written acceptance.

2. QUOTATION

Unless previously withdrawn our quotation is open to acceptance in writing within the period stated or where no period is stated within thirty (30) days after its date. We reserve the right to correct any errors or omissions in our quotation. Unless otherwise stated all quotations are firm and fixed. The prices quoted are based on manufacture of the quantity and type ordered and are subject to revision when interruptions, engineering changes or changes in quantity are caused or requested by the customer.

3. LIABILITY FOR DELAY

Any delivery times quoted are from the date of our written acceptance of any order and on receipt of all information and drawings to enable us to put the work in hand. Where delivery is to take place by instalments each such instalment shall constitute a separate contract. We will use our best endeavours to complete delivery of the goods or services in the period stated but accept no liability in damages or otherwise for failure to do so for any cause whatsoever. In all cases of delay the delivery time shall be extended by reasonable period having regard to the cause of delay.

4. PAYMENT

Payment shall be made net cash within thirty (30) days of delivery or in accordance with the payment terms set out in the quotation. Unless specifically stated to the contrary payment shall be in pounds sterling. In the event of any payment to us being overdue we may without prejudice to any other right suspend delivery to you or terminate the contract and/or charge you simple interest on overdue amounts at the rate of 2.5% above the ruling Bank of England Minimum Lending Rate. No payment to us shall in any circumstance be offset against any sum owing by us to you whether in respect of the present transaction or otherwise.

5. INSPECTION & TEST

All goods are fully inspected at our works and where practicable subjected to our standard tests before despatch. If tests are required to be witnessed by your representative notice of this must be given at the time of placing the order and notice of readiness will then be given to you seven (7) days in advance of such tests being carried out. In the event of any delay on your part in attending such tests or in carrying out inspection by you after seven (7) days notice of readiness the tests will proceed in your absence and shall be deemed to have been made in your presence and the inspection deemed to have been made by you. In any event you shall be required promptly after witnessing a test or receiving test results of witnessed or unwitnessed tests to notify us in writing of any claimed defects in the goods or of any respect in which it is claimed that the goods do not conform with the contract. Before you become entitled to reject any goods we are to be given reasonable time and opportunity to rectify them. You assume the responsibility that the goods stipulated by you are sufficient and suitable for your purpose and take all steps to ensure that the goods will be safe and without risk to health when properly used. Any additional certification demanded may incur extra cost for which a special quotation will be issued.

6. DELIVERY AND PACKING

All shipments are, unless otherwise specifically provided, Ex-works which is the address given on the invoice. An additional charge will be made for carriage and insurance as necessary with the provision that all shipments shall be insured and this insurance expense shall be paid by the purchaser. Where special domestic or export packing is specified a charge will be made to cover the extra expense involved.

7. DAMAGE IN TRANSIT

Claims for damage in transit or loss in delivery of the goods will only be considered if the carriers and ourselves receive notice of such damage within seven (7) days of delivery or in the event of loss of goods in transit within fourteen (14) days of consignment.

8. TRANSFER OF PROPERTY & RISK

Title and property of the goods shall pass when full payment has been received of all sums due to us whether in respect of the present transaction or not. The risk in the goods shall be deemed to have passed on delivery.

9. WARRANTY

We agree to correct, either by repair, or at our election, by replacement, any defects of material or workmanship which develop within the warranty period specified in the sales literature or quotation after delivery to the original purchaser. All items claimed defective must be promptly returned to us carriage paid unless otherwise arranged and will be returned to you free of charge. Unless otherwise agreed no warranty is made concerning components or accessories not manufactured by us. We will be released from all obligations under warranty in the event of repairs or modifications made by persons other than our own authorised service personnel unless such repairs are made with our prior written consent.

10. PATENTS

We will indemnify you against any claim of infringement of Letters Patent, Registered Design, Trade Mark or Copyright (published at the date of the contract) by the use or sale of any goods supplied or service rendered by us to you and against all costs and damages which you may incur and for which you may become liable in any action for such infringement. Provided always that this indemnity shall not apply to any infringement which is due to our having followed a design or instruction furnished or given by you or to the use of such goods or service in association or combination with any other article, material or service not supplied by us. This indemnity is conditional on your giving to us the earliest possible notice in writing of any claim being made or action threatened or brought against you and on your permitting us at our own expense to conduct litigation that may ensue and all negotiations for a settlement of the claim or action. You on your part warrant that any design or instruction furnished or given by you shall not cause us to infringe any Letter Patent, Registered Design, Trade Mark or Copyright in the execution of your order.

11. DOCUMENTATION

All drawings, plans, designs, software specifications, manuals and technical documents and information supplied by us for your use or information shall remain at all times our exclusive property and must not be copied, reproduced, transmitted or communicated to a third party without our prior written consent.

12. FRUSTRATION

If any contract or any part of it shall become impossible of performance or otherwise frustrated we shall be entitled to a fair and reasonable proportion of the price in respect of the work done up to the date thereof. For this purpose any monies previously paid by you shall be retained against the sum due to us under this provision. We may dispose of the goods as we think fit due allowance being made to you for the net proceeds thereof.

13. BANKRUPTCY

If the purchaser shall become bankrupt or insolvent, or being a Limited Company commence to be wound up or suffer a Receiver to be appointed, we shall be at liberty to treat the contract as terminated and be relieved of further obligations. This shall be without prejudice to our right to claim for damages for breach of contract.

14. LEGAL INTERPRETATION

Any contract will be deemed to be made in England and shall be governed and construed for all purposes and in all respects in accordance with English Law and only the Courts of England shall have jurisdiction.



Datron Sales and Service Representatives Worldwide

COUNTRY and REPRESENTATIVE	Telephone	Telex	Fax
AUSTRALIA			
Scientific Devices Pty. Ltd 2 Jacks Road, South Oakleigh, Victoria 3167	3 579 3622	AA32742	3 579 0971
AUSTRIA			
Walter Rekirsch Elektronisch Geraete GmbH & Co. Obachgasse 28, A-1220 Wien	222 253626	134759	222 2572 75
BELGIUM			
Air-Parts International B. V. Avenue Huart-Hamoir, 1-Box 34, 1030 Bruxelles	2 241 6460		2 241 8130
BRAZIL			
Sistronics Instrumentacao E Sistemas Ltda Av. Alfredo Egidio de Souza Aranha 75-3 & 4 Andares-Jd. Santo Antonio, CEP 04726 Sao Paulo	11 247558	57155 SNCS	11 5238457
CHINA			
Tianjin Zhong Huan Scientific Instruments Corp. No. 59 Zhao Jia Chang Street, Hong Qiao Section, Tianjin	Tianjin 753732	-----	-----
DENMARK			
Instrutek A/S, Christiansholmsgade 8700 Horsens	5 611100	61656	5 615 658
EASTERN EUROPE			
Amtest Associates Ltd Amtest House, 75-79 Guildford Street, Chertsey, Surrey KT16 9AS, England	0932 568355	928855	0932 561919
EGYPT & MIDDLE EAST			
EPIC 20-22 Ashmoun St, PO Box 2682, Horriya, Heliopolis	2 661767 2 669861	23033 CHAKA UN 23315 EPIC UN	2 662839 2 668924
FINLAND			
Profelec OY PO Box 67, 00421 Helsinki 42	0 566 4477	125225 PROFE SF	0 566 2998

Sales and Service

COUNTRY and REPRESENTATIVE	Telephone	Telex	Fax
FRANCE			
M. B. Electronique 606 Rue Fourny, Zi de Buc, 78530 Buc	1 39 568131	695414	1 39 565344
WEST GERMANY			
WAVETEK Electronics GmbH Freisinger Straße 34, 8045 Ismaning	0 89 96 09 49-0	5 212 996 WVTK D	0 89 96 71 70
GREECE			
American Technical Enterprises SA PO Box 3156 39, Agiou Konstantinou Street, Athens 10210.	5240620 5240740	216046 ATE GR	5249995
HONG KONG			
Eurotherm (Far East) Ltd 18/F., Gee Chang Hong Centre, 65 Wong Chuk Hang Road, Hong Kong	8140311 (Sales) 546391 (Service)	72449 EFELD HX 72449 EFELD HX	8735974 8700497
INDIA			
Technical Trade Links • Deodahar Centre, Gyani Compound, 424 Marol Maroshi Road, Andheri (East), Bombay 400 059	22 6362412	1179261 TTL IN	9122 634 2204
• 413, Pratap Chambers, Gurudwara Road, Karol Bagh, New Delhi - 110 005			
IRELAND			
Euro Electronic Systems Unit 1, Sandyford Park, Sandyford Ind. Est., Dublin 18.	01 952326	-----	01 952246
ISRAEL			
DAN-EL Technologies Office 60, Pinkas St. Tel-Aviv 62151.	3 453157	342105	3 5441468
ITALY(1)			
Sistrel SPA Via Pellizza da Volpedo 59 20092 Cinisello Balsamo, Milano	02 618 1893	334643	02 618 2440
ITALY(2)			
Sistrel SPA Viale Erminio Spalla 41 00142 Roma	06 504 0273	625857	06 504 0067
ITALY(3)			
Sistrel SPA Via Cintia Parco S. Paolo 35 80126 Napoli	081 767 9700	-----	081 766 1361
JAPAN			
G & G Japan Inc No. 406, 12-16, 4-Chome, Hongoh, Bunkyo-ku, Tokyo	3 8130971	2722884 ICHAIN J	3 8159216

COUNTRY and REPRESENTATIVE	Telephone	Telex	Fax
KOREA Sama Electronics Corporation CPO Box 9517, Seoul	2 271 2761	K26375 SAMATR	2 271 2764
MALAYSIA TME Systems Pte Ltd 21 Moonstone Lane, No. 06-01, Poh Leng Building, Singapore 1232	298 2608	37545	291 1935
MOROCCO Minhol SA 64 Rue El Mortada, Casablanca 02.	254945	24064	254969
NETHERLANDS Air Parts International BV PO Box 255, 12 Kalkovenweg, 2400 AG Alphen aan den Rijn	1720 43221	39564	1720 20651
NEW ZEALAND G. T. S. Engineering Ltd 5 Porters Avenue, Eden Terrace, PO Box 9613 Newmarket AUCKLAND	9 3092464	-----	9 3092968
NORWAY Morgenstjerne & Co. Olaf Helsets vei 1, P.O. box 15 - Bogerud N-0621 Oslo 6	2 289490	71719 MOROF N	2 289494
PORTUGAL Decada SA Rua Margarida, Palla. 11, 1495 Alges Lisbon.	1 4103420	24476 ESPEC P	1 4101844
SAUDI ARABIA Electronic Equipment Marketing PO Box 3750, Riyadh 11481,	1 4771650	401120	1 4785140
SINGAPORE Mecomb Singapore Ltd Sime Darby Centre, 895 Dunearn Road, 04-2 Singapore 2158	469 8833	RS 23178	467 1905
SOUTH AFRICA Altech Instruments (Pty) Ltd PO Box 39451, Wynberg 2018	11 887 6940	422033	11 887 7455
SPAIN ESSA (Equipos y Systemas SA) C/Apolonio Morales 13-B, Madrid 16	1 458 0150	42856	1 450 0150
SWEDEN Ferner Elektronik AB Järfällavägen 186, S-175 40 Järfälla	+46 758 189 90	10312 FERNER S	+46 758 179 90

Sales and Service

COUNTRY and REPRESENTATIVE	Telephone	Telex	Fax
SWITZERLAND Kontron Electronic AG Physical Address: In der Luberzen 1, CH-8902 Urdorf Postal Address: P.O. Box CH-8010 Zurich	(01) 736 4111	822196 + KOEL CH	(01) 734 2448
TAIWAN Evergo Corporation Room A, 9th Floor, 305 Section, 3 Nan King East Road, P. O. Box 96-546, Taipei	2 7150283/4/5		2 7122466
TURKEY Turkelek Hatay Sokak 8, Ankara	4 1189483 4 1252109	44580	----
UNITED KINGDOM Datron Instruments Ltd Hurricane Way, Norwich Airport, Norwich, Norfolk NR6 6JB, England	0603 404824	975173	0603 483670
UNITED STATES of AMERICA Datron Instruments Inc c/o Wavetek RF Products Inc. 5808 Churchman Bypass, Indianapolis, Indiana 46203	(317) 787 3915	TWX (810) 341 3226	(317) 788 5999
Wavetek Northeast Area Sales 35 Pinelawn Road, Suite 209W, Melville, New York 11747	(516) 454 8440	----	(516) 454 8446
Wavetek Western Area Sales 9045 Balboa Avenue, San Diego, California 92123	(619) 565 9315	TWX (910) 335 2007	(619) 227 6221

For customers in countries not listed please contact DATRON INSTRUMENTS in the United Kingdom:

Datron Instruments Ltd Hurricane Way, Norwich Airport, Norwich, Norfolk NR6 6JB, England	0603 404824	975173	0603 483670
---	-------------	--------	-------------

