

Model 501J



*$\pm 100\text{mV}$ to $\pm 10\text{V}$
Programmable
DC Voltage Calibrator*

**KH KROHN-HITE
CORPORATION**

Operating Manual

This page intentionally left blank.

**PROGRAMMABLE
DC VOLTAGE CALIBRATOR
Model 501-J**

Serial No. _____

The following installed in S/N						
OPTIONS				ACCESSORES		
B		J		AM-1		MR-1
C		L		AM-2		IS-40
D				KT-488		

This page intentionally left blank.

Model 501 OPERATORS MANUAL



Copyright © 1998

Krohn-Hite Corporation
15 Jonathan Drive Unit 4
Brockton, Massachusetts 02301
E-mail: Info@krohn-hite.com
www.krohn-hite.com

All rights reserved. No part of this publication may be reproduced, stored in a retrieval system or transmitted in any form by any means, electronic, mechanical photocopying, recording, or otherwise, without the prior written permission of Krohn-Hite Corporation.

Printed in U.S.A.
Revised March 2001

Information furnished in this manual is believed to be accurate and reliable. However, no responsibility is assumed by Krohn-Hite Corporation for its use; nor for any infringements of patents or other rights of third parties which may result from its use.

TABLE OF CONTENTS

<u>SECTION</u>	<u>TITLE</u>
i	List of Drawings
ii	Limited Warranty
iii	Factory Service Request and Authorization
iv	Packing Suggestions
1.0.0	General Description and Applications
1.1.0	Output Specifications
1.2.0	Mechanical Specifications
2.0.0	Installation
2.1.0	Mounting
2.2.0	Input - Output Connectors 
2.3.0	Grounding Considerations
3.0.0	Operation of Instrument
3.1.0	Front Panel Controls
4.0.0	Theory of Operation
4.1.0	Power Supply
4.2.0	Data Control and Indicator Lights
4.3.0	20 - 24 Bit DAC, Operational Amplifiers and Current Booster
4.4.0	Overload Signal Processor
4.5.0	100 mV Range
4.6.0	Bipolar Operation
5.0.0	General Calibration
5.1.0	Calibration - BCD format
5.2.0	Calibration - Binary format
5.3.0	Noise Measurements
6.0.0	Options, Accessories, Auxiliary Instruments and Supplemental Instructions
6.1.0	Memory Register p/n MR-1 Accessory
6.2.0	Model PCS-2, Auxiliary Instrument
6.3.0	488 Interface p/n KT-488 Accessory
6.4.0	p/n IS-40 Accessory
6.5.0	KT-488 in nonstandard system
6.6.0	p/n AK-1 Accessory
7.0.0	Recommended Spare Parts

NOTE: Errata and addendum (if any) will appear in the back of this manual.

SCHEMATICS AND LAYOUTS

DESCRIPTION	DRAWING #.
Option MR-1, Memory Register	CA-2761A
Option AK-1, Logic Inverter	CA-2935
Option D, 100 mV Range	CA-4747B
Option C, Standby/Ready Signal Control Logic	A-3124
Range Logic	*A-3125
Power Supply (501)	A-3552A
501 DAC Reference	*A-3196C
501 Voltage Amplifier	*B-2750A
Bipolar DAC	*B-2750B
Option: IS-48	*B-2751
Option: MR-488, Latches	B-2995-F
Option: MR-488, Control Logic	B-3335H
Option: IS-40	B-3336I
501 Adjustments and Test Points	B-4815
	*B-2791-C
Reference Drawing	930727A

* Basic 501 Model

LIMITED WARRANTY

The Krohn-Hite Corporation (K-H) warrants to the original purchaser each instrument manufactured by them to be free from defects in material and workmanship. This warranty is limited to servicing, repairing and/or replacing any instrument or part thereof returned to the K-H factory for that purpose in accordance with the instructions set forth below; and furthermore to repair or replace all materials, except tubes, fuses, transistors and other semiconductor devices which shall within ONE YEAR of shipment to the original purchaser be returned to the K-H factory and upon examination be deemed defective.

K-H instruments may not be returned to the factory under the terms of this warranty without the prior authorization of the K-H Service Department. All instruments returned to K-H for service hereunder should be carefully packed and shipped. All transportation charges shall be paid by the purchaser.

K-H reserves the right to discontinue instruments without notice and to make changes to any instrument at any time without incurring any obligation to so modify instruments previously sold.

This warranty is expressly in lieu of all other obligations or liabilities on the part of K-H. No other person or persons is authorized to assume in the behalf of K-H any liability in the connection with the sale of its instruments.

CAUTION: *The instrument you have purchased is a precision instrument manufactured under exacting standards. Any attempts to repair, modify or otherwise tamper with the instrument by anyone other than an K-H employee or authorized representative may result in this warranty becoming void.*

FACTORY SERVICE REQUEST AND AUTHORIZATION

WARRANTY SERVICE

Instruments may be returned only on prior authorization. Please obtain a RETURN AUTHORIZATION NUMBER either directly from the factory or from an authorized K-H Representative. (See General Information below.)

CHARGEABLE REPAIRS

If requested, an estimate of charges will be submitted prior to repairs. We suggest that you request a RETURN AUTHORIZATION NUMBER to facilitate handling.

GENERAL INFORMATION

A) Please provide the following information in order to expedite the repair:

- 1) Indicate MODEL
- 2) Serial Number
- 3) Complete description of the trouble:

Symptoms, measurements taken, equipment used, lash-up procedures, attempted repairs, suspected location of failure and any other pertinent information.

B) Freight Charges must be PREPAID.

C) The RETURN AUTHORIZATION NUMBER should be noted on your documentation.

D) See Packing Suggestions - next page.

PACKING SUGGESTION

Although your K-H instrument is built for laboratory, production environment and some field environment, it is NOT ruggedized.

Therefore

1. Be sure the carton is **STRONG** enough to carry the weight of the instrument, e.g. use double wall corrugation.
2. Be sure the carton is **LARGE** enough to allow for sufficient packing material, e.g., at least 2 inches all around the instrument. The packing material should be able to be compressed and then return to its approximate original volume.
3. For better handling, the shipment should always be by **AIR FREIGHT** (expect for short distances). You might use either UPS "blue label" or common air freight carrier, second day air.

Please do not bounce it across the country in a truck. It may not hurt it, but it certainly is not going to do a laboratory instrument much good.

4. **QUESTIONS?** Just contact us. We will be pleased to help you.

SECTION I

1.0.0 GENERAL DESCRIPTION AND APPLICATIONS

- 1.0.1 The Model 501 Programmable DC Voltage Standard is a highly versatile reference source, designed to meet the needs of computer systems, production line testing, automated calibration and standards laboratories.
- 1.0.2 The instruments have a specified accuracy, and are traceable through a bank of saturated standard cells to the U. S. National Institute of Standards & Technology.
- 1.0.3 Depending on the model of the instrument, resolution of 1 ppm are attainable.
- 1.0.4 The instruments are highly accurate references which can be used for calibration of digital voltmeters, analog meters, semiconductor analyzing systems, analog references for computers, analog-to-digital converters, telemetry and data acquisition systems, and wherever a stable source is required.
- 1.0.5 There are no adjustments made during normal operation; the trims are made during calibration and are described under the calibration procedure.
- 1.0.6 The circuitry is completely solid state made of discrete, hybrid and/or integrated circuits packaged on etched glass circuit boards. These are proven circuits, using derated components to insure long life and maximum reliability.
- 1.0.7 The instrument is overload and short-circuit proof, and is fully operational in normal environmental conditions.
- 1.0.8 The Standard Source will drive a short circuit indefinitely without damage to the instrument, and will recover to rated specification in less than 10 ms.

1.1.0 Output Specifications

1.1.1 Output Voltages:

	<u>BCD Units</u>	<u>BINARY Units</u>
Basic Model	+9.9999 Vdc	10.24 Vdc Max F S
Option D	+99.999 mVdc	102.4 mVdc Max F S
Option J	Bipolar Operation	

1.1.2 Resolution:

Basic Model	10 V range	=10 ppm or 100 μ V
Option D	100 mV range	=10 ppm or 1 μ V
Option B	10 V range	=1 ppm or 10 μ V
Options B & D	100 mV range	=1 ppm or 0.1 μ V

1.1.3 Accuracy:

$\pm(0.002\%$ of programmed value + 0.0005% or range +3 μ V). The accuracy is based on the "Limit of Error" (or "Worst Case" Method. All other specifications noted hereafter, which effect accuracy, e.g., line, load, temperature, and drift are included in the accuracy statement. Thus, all other specifications listed are (*) NON-ADDITIVE.

1.1.4 Settling Time:

100 μ s (50 μ s nominal) to rated accuracy for voltage change. 10 ms (approx.) recovery from short-circuit.
100 μ s (max) for polarity change.
60 ms (max) for range change.

1.1.5 Stability (non-additive specifications)

24 hrs: 0.001%; 90 days: $\pm 0.0015\%$; 6 months: $\pm 0.002\%$

1.1.6 Ripple and Noise:

Observe in a band pass of 0.1 Hz to 100 kHz with NO random spikes. (0.0005% of range +2 μ V) rms.

1.1.7 Output Current:

10 V range: 50 mA
100 mV range: Not Applicable. (Output voltage is within stated accuracy if load impedance is greater than 60 k Ω .)

- 1.1.8 Output Impedance:
 10 V range: 0.03Ω
 100 mV range: 3.0Ω (constant)
- 1.1.9 Regulation: (*non-additive)
 Line and Load = $\pm 0.0005\%$
- 1.1.10 Temperature Coefficient: (*non-additive)
 Ambient: $\pm 0.0005\%/^{\circ}\text{C}$
 Operating limit: $\pm 0.001\%/^{\circ}\text{C}$
- 1.1.11 Monotonicity
 Monotonicity is guaranteed for digital increments greater than 15 ppm of the programmed value.
- 1.1.12 A DAC (calibrator) is said to be monotonic if the output either increases or remains constant as the digital input increases, with the result that the output will always be a single-valued function of the input.
- 1.2.0 Mechanical Specifications
- 1.2.1 Power Requirements
 40 watts: 115 Vac or 220 Vac $\pm 10\%$ 50/60 Hz
- 1.2.2 Dimensions:
 W 19 x H 5.25 x D 14 inches
 W 485 x H 133 x D 362 mm
- 1.2.3 Weight:
 12.5 lbs.; 5.7 kg
 Shipping weight: 16.5 lbs.; 7.5 kg
- 1.2.4 Temperature:
 Calibration Temperature: $23^{\circ} \pm 1^{\circ}\text{C}$
 Ambient Temperature: 20°C to 30°C
 Operating Limit: 10°C to 50°C
 Storage Limit: -40°C to 85°C

SECTION II

2.0.0 INSTALLATION

2.1.0 Mounting.

2.1.1 The 501 is designed for mounting in a standard 19" relay rack. When installing in the rack it is recommended that nylon washers be placed under the mounting screws to prevent scratching the paint.

2.2.0 Input - Output Connectors.

2.2.1 All instruments are supplied with a mating AC power cord, output connector, and input connectors. These are:

	<u>Nomenclature</u>	<u>Part no.</u>	
(1)	AC Power Cord	P 2392	1 each
(2)	Output Connector	3106A-14S-6P	1 each
(3)	Program Connectors *	MP-0156-25-SP-1	1 each

2.3.0 Grounding Consideration.

2.3.1 Special attention should be given to system grounds to avoid ground loop errors in units without optical isolation. In particular: DO NOT connect logic ground to arc ground at one point in the system and analog ground to arch ground at another point in the system. DO NOT connect output connector pin A to pins C, D or E if there is another earth ground in the system.

2.4.0 Line Voltage Setting.

2.4.1 A two position slide switch is mounted on the rear panel which is used to set the line voltage requirements to 115 Vac or 230 Vac. Make sure this switch is in the proper position for your line power prior to turning the instrument on for the first time.

* This connector is not supplied and is not required when the KT-488 bus option is installed.

SECTION III

3.0.0 OPERATION OF INSTRUMENT

3.1.0 Front Panel Controls

3.1.1 Power Switch: Rocker off-on, line power with associated indicator.

3.1.2 Program-Manual Mode Switch: This switch has two settings. In the "manual" position the instrument's output is controlled by the other front panel switches. In the "program" position the instrument is programmed by the data fed into the rear input connectors. This switch in the "manual" mode, overrides all programmed input signals to the program connector.

3.1.3 Polarity Switch: (Option J) (Operational in the "manual" mode.) This switch has two settings. It determines the output polarity when the Program-Manual switch is in the manual position. "+" polarity denotes that output terminal B, (or red terminal) is positive with respect to output terminal C (or black terminal) and vice versa.

3.1.4 Voltage Select Switches: (Option AM-1) (operational in the "manual" mode.) These are grouped in sets of 4. Each set of four controls 1 digit of the voltage. The most significant digit set is labeled "MSD", the least significant set is labeled "LSD". To manually set the output voltage, set the program-manual switch to manual and turn on (up) the appropriate voltage switches. Each digit is set using the 8-4-2-1 BCD Code. The value of a particular digit is equal to the sum of the numbers of the switches turned on in that digit set. Figure 3-1A summarizes the 8-4-2-1 code.

The following applies for Binary units.

3.1.4.1 Binary Voltage Select Switches: (Option AM-2) (Operational in the "manual" mode.) The value of each voltage select switch is equal to 2^{-n} times full scale of range (either 10.24 V or 102.4 mV). These values are tabulated in Figure 3.1.

501J WITH 20 BIT BINARY PROGRAMMING (FIG. 3.1)

N	$V(N) = \frac{10.24^*}{2^n}$	MAXIMUM ALLOWABLE DEVIATION IN $\mu V = 20[V(N)] + 53$
1	5.120000	155.4
2	2.560000	104.2
3	1.280000	78.6
4	.640000	65.8
5	.320000	59.4
6	.160000	56.2
7	.080000	54.6
8	.040000	53.8
9	.020000	53.4
10	.010000	53.2
11	.005000	53.1
12	.002500	53
13	.001250	53
14	.000625	53
15	.000313	53
16	.000156	53
17	.000078	53
18	.000039	53
19	.000020	53
20	.000010	53

* ROUNDED OFF TO NEAREST μV
AM2 Binary

3.1.4.2 Voltage Select Switches (continued) AM-1

	Value <u>output</u>	Switch <u>8 4 2 1</u>	
	0	0 0 0 0	
	1	0 0 0 1	
	2	0 0 1 0	
	3	0 0 1 1	where: "1" = switch ON
	4	0 1 0 0	and "0" = switch OFF
	5	0 1 0 1	
	6	0 1 1 0	
	7	0 1 1 1	
	8	1 0 0 0	
	9	1 0 0 1	
<hr/>			
"Illegal" Codes (1)	10	1 0 1 0	
	11	1 0 1 1	
	12	1 1 0 0	
	13	1 1 0 1	
	14	1 1 1 0	
	15	1 1 1 1	

BCD Truth Table
Fig. 3-1 A

- (1) Notice: The use of "illegal" BCD codes may be employed. However, the operator should note that the analog output is inhibited to a maximum output of approximately 11 Volts.

3.1.5 Range Switch: (Option D.) (Operational in the "manual" mode.) This switch has

two settings. It determines the full scale voltage when the program-manual switch is in the manual mode the "V" position denote 10 volts full scale, (MSD = 1 volt per step). The "mV" position denotes 100 mV full scale, (MSD = 10 mV per step).

3.1.6

Remote Programming: - Parallel Entry.

Note: To remotely program the 501 turn the program-manual switch to "program" and connect appropriate TTL compatible inputs to the rear input connectors. The rear input connector pin connections are shown in Fig. 3-2. The pins for magnitude by parallel entry are B-1 through B-24. Logic ground is pin A-8. Polarity control (Option J) is pin A-24. Logic Zero (0) is plus (+) polarity and logic one (1) is negative (-) polarity. Range control, (Option D) is pin A-22, 1 is 10 V full scale, 0 is 100 mV full scale. The strobe input, pin A-21, when set to logic 0, will force the analog output to zero, regardless of the programmed data. The ready-flag (Option C) output is on pin A-25 and indicates either a normal or overloaded condition. 0 is normal, 1 is overload. Pin A-20 indicates program or manual mode, 1 is Program, 0, is Manual.

Pin A-20 is an isolated program/manual output flag when used with the opto-isolator IS-40 option.

A-4 p/m Non-opto isolated p/m output flag: indicates program/manual, 1 is Program, 0 is Manual.

Pin #	Designation	Description
A 1	MV/OR	+
A 2	AR-1	+
A 3	AR-2	+
*A 4	P/M	Non-isolated Output Flag: Indicates program/manual Mode
*A 5	STR(1)	Over-ride Strobe: Zero output in either Program or Manual Modes.
#A 6	IL +5	Isolated +5 Vdc output
A 7	IG	Isolated ground
*A 8	G	Logic Ground
A 9	Spare	
##A10	+5	Logic +5 V output
*A11	R2P	Range control bit
*A12	R8P	Range control bit
A13	Spare	
A14	Spare	
A15	AR-4	+
*A16	R4P	Range control bit
A17	AR8	+
A18	AP	+
A19	Spare	
A20	IS-40 P/M	IS40 isolated P/M Output Flag
*A21	STR(2)	Zero output (in program mode, only)
*A22	R1P	Range Control bit
*A23	MR	Follow/Latch (for accessory MR-1)
*A24	P	Polarity control (for option J)
*A25	RF	Stand-by/Ready Output Flag
<p>* These bit lines are used for PARALLEL PROGRAMMING for function only. See Program Connector B for magnitude control.</p> <p>+ These are output bits used to control the Auxiliary instruments.</p> <p># 150 mA max.</p> <p>## 200 mA max. w/488, MR-2. 1000 mA max w/Dummy boards.</p> <p>NOTE: IEEE-488 (GP-IB) and SERIAL PROGRAMMING are accomplished via connector "F".</p>		

BCD FORMAT			BINARY FORMAT		
PIN#	DESIGNATION	DESCRIPTION	PIN#	DESIGNATION	DESCRIPTION
B 1	61	1 LSD ₂ (OPT. B)	B 1	spare	
B 2	62	2 LSD ₂ (OPT. B)	B 2	spare	
B 3	64	4 LSD ₂ (OPT. B)	B 3	spare	
B 4	68	8 LSD ₂ (OPT. B)	B 4	spare	
B 5	51	1 LSD	B 5	2 ⁻²⁰	10 μV
B 6	52	2 LSD	B 6	2 ⁻¹⁹	20 μV
B 7	54	3 LSD	B 7	2 ⁻¹⁸	39 μV
B 8	58	8 LSD	B 8	2 ⁻¹⁷	78 μV
B 9	41	1 4 SD	B 9	2 ⁻¹⁶	156 μV
B10	42	2 4 SD	B10	2 ⁻¹⁵	313 μV
B11	44	4 4 SD	B11	2 ⁻¹⁴	625 μV
B12	48	8 4 SD	B12	2 ⁻¹³	1250 μV
B13	31	1 3 SD	B13	2 ⁻¹²	2500 μV
B14	32	2 3 SD	B14	2 ⁻¹¹	5 mV
B15	34	4 3 SD	B15	2 ⁻¹⁰	10 mV
B16	38	8 3 SD	B16	2 ⁻⁹	20 mV
B17	21	1 2 SD	B17	2 ⁻⁸	40 mV
B18	22	2 2 SD	B18	2 ⁻⁷	80 mV
B19	24	4 2 SD	B19	2 ⁻⁶	160 mV
B20	28	8 2 SD	B20	2 ⁻⁵	320 mV
B21	11	1 MSD	B21	2 ⁻⁴	640 mV
B22	12	2 MSD	B22	2 ⁻³	1.28 V
B23	14	4 MSD	B23	2 ⁻²	2.56 V
B24	18	8 MSD	B24	2 ⁻¹	5.12 V
B25	G	Logic Gnd.	B25	G	Logic Gnd.

PROGRAMMING CONNECTORS (Fig. 3-2)

RANGE CONTROL LOGIC

PIN#	DESIGNATION	100 mV (OPT. D)	10V	100 V (RA-3) 100 V (RA-4) 10 mA (PCS-1)	200 V (RA-3) 1000 V (RA-4) 100 mA (PCS-1)
A-22	R1P	0	1	0	1
A-11	R2P	0	0	0	1
A-16	R4P	0	0	0	0
A-12	R8P	0	0	0	0

FIG. 3-3

3.1.7

Indicator Lights:

The indicator lights indicate the state of a particular bit in both the program and manual modes. A voltage bit indicator light on indicates that voltage bit is on, i.e. that the appropriate switch in the DAC is on. This is a convenient method to verify the proper data entry from the programmer.

3.1.8

Output Connections:

The output connector points are:

*A - Chassis ground (and metal binding post)

B - + output (and red binding post)

F - + sense

C - - output (and black binding post)

E - - sense

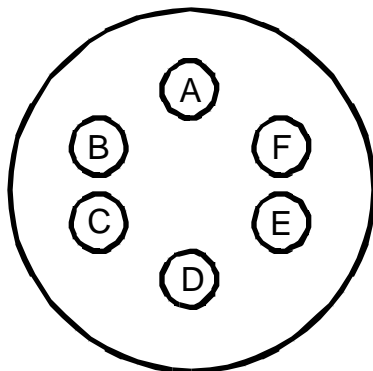

*Special attention to grounds:

See paragraph 2.3.0

Grounding Consideration

If a high impedance or low current load is connected, short pin B to pin F and short pin C to pin E. If an appreciable current is desired, the remote sense capability should be used. The 501 utilizes a unique 4 wire output, eliminating the effect of IR drops on the instrument's accuracy.

Please refer to Figure 3 on Reference Drawing 930727 in the rear of this manual.

NOTE: One of the Configurations Shown below must Be Used. Pins B Through F must All Be Used.

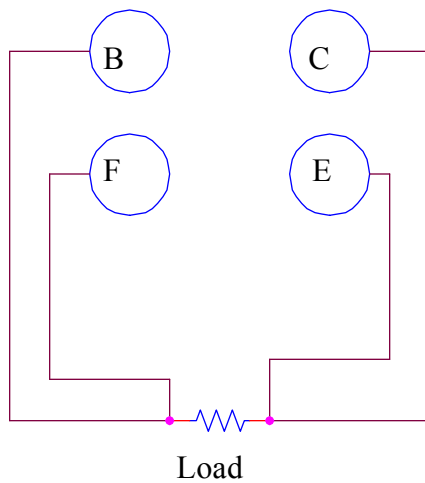

CONFIGURATION A
(4 Wires Between 501 &
Load) Correct for Large
Loads.

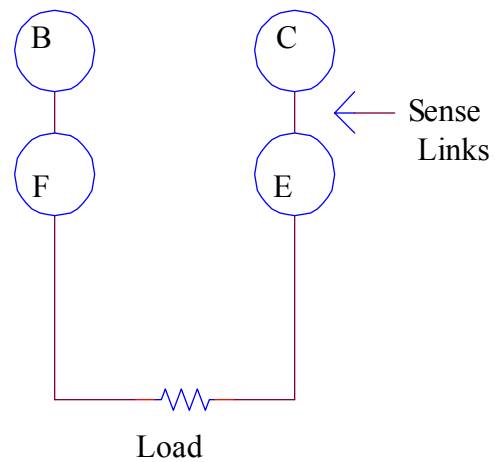

CONFIGURATION B
(2 Wires Between 501 & Load)
Incorrect for Large Loads,
Acceptable for Small Loads

SECTION VI

6.0.0 OPTIONS, ACCESSORIES, AUXILIARY INSTRUMENTS AND SUPPLEMENTAL INSTRUCTIONS

This section contains information for all field Installable Accessories and Auxiliary Instruments.

NOTE: Your instrument may not contain all of the optional equipment listed herein. See Installation notations indicated on the cover page of this manual or on the back panel of the Model 501 main-frame instrument.

6.1.0 Memory Register - Accessory MR-1

6.1.1 The analog output will follow the digital input data as long as the memory control line (pin A-23) is at logical 1. When pin A-23 is dropped to logical 0, the data that was present at the input pins A-22, A-24 and B-1 through B-24, will be stored. (The pin numbers will depend on the options ordered.) Refer to FIG. 3-2.

6.1.2 The strobe input (pin A-21) when set to logical 0, will reduce the analog output to 0, regardless of the state of the other input data. However, strobing the 501 to C will not erase the information stored in the memory. After a 0 to 1 transition on pin A-21, the analog output will follow the previously stored digital data. Refer to schematic A2761.

6.1.3 MR-1 Installation Instructions. Remove jumper board (PC No. P2756/7) in mother board edge connector with components facing the front panel.

6.2.0 Model PCS-2, Auxiliary Instrument

Complete instructions and drawings for this model are contained in a separate manual designated:

Models PCS-2/3200

6.3.0 488 Interface (GP/IB) Accessory KT-488

6.3.1 The K-H model 501 is compatible with the IEEE Std. 488/1975 with the installation of the accessory kit KT-488.

The accessories are plug in configuration and installation may be easily accomplished in the field.

All interface information is in compliance with the publication and the user should be familiar with:

IEEE STANDARD DIGITAL INTERFACE FOR PROGRAMMABLE INSTRUMENTATION (IEEE STD 488/1975)

Publisher: The Institute of Electrical and
Electronics Engineers, Inc.
345 East 47th Street
New York, NY 10017

6.3.2 The interface kit is comprised of the following:
p/n MR-488 Serial to Parallel Converter (PC Board)
p/n IS-48 Opto-Isolator (PC Board)

6.3.3 Programming Procedures. Set the listen address on the "dip" switch assembly located on the MR-488 PC Board. Use switches 1 through 5. This is arranged in Binary Code 1 = 1, 2 = 2, 3 = 4, etc. On = True, Off = False. (For further description see 6.3.5.1)

6.3.4 Programming Sequence

<u>CHAR.#</u>	<u>CODE</u>	<u>DESCRIPTION</u>
	pon	Power-On Clear. Same status as IFC.
0	IFC	Interface Clear. This message may be sent at any time and sets the 501 output to: PLUS (+), ZERO (0) on the 100 mV range. It is not necessary to send IFC at the beginning of each word.
1	MLA	My Listen Address
2	POL	Polarity
3	DIGIT	MSD
4	DIGIT	2SD
5	DIGIT	3SD
6	DIGIT	4SD
7	DIGIT	5SD
8	DIGIT	LSD
9	RAN	RANGE b ₁ b ₂ b ₃ b ₄

There are 4 range lines (4 bits) to control 16 range designations. The range control bits for all K-H Auxiliary Instruments (eg., PCS and RA type) are listed in the section of this manual that pertains to that instrument.

The analog value will change from the old to the new value on the "Range" entry (Byte). Note: The 501 does remain on the "Listen" state.

10A	UNL	<p>"Un-listen" the model 501 will disengage from the buss on this command. All previously programmed instructions will be retained.</p> <p><u>To poll</u> the instrument(s): MLA (character #1) immediately followed by "UNL" (character #10A). All previously programmed instructions will be retained.</p>
10B	SP	<p>"space". The entry of this character keeps the 501 in the "listen" state to permit the entry of a new value <u>without</u> re-entering the attention and address command "MLA" (character #1, above). To enter a new value see characters 2 through 9 above.</p>

6.3.5 MR-488 Programming Table

STEPS	ACCEPTABLE ASCII CHARACTERS	BITS								
		FUNC	1	2	3	4	5	6	7	
1	*# (See A Below)	MLA	A	A	A	A	A	1	0	
2	See B POLARITY	POL	B ₁	B ₂	B ₃	B ₄		1	1	0
3	0 THRU 9	1SD	C	C	C	C		1	1	0
4	0 THRU 9	2SD	C	C	C	C		1	1	0
5	0 THRU 9	3SD	C	C	C	C		1	1	0
6	0 THRU 9	4SD	C	C	C	C		1	1	0
7	0 THRU 9	5SD	C	C	C	C		1	1	0
8	0 THRU 9	6SD	C	C	C	C		1	1	0
9	0 THRU 9 :<;> = ?	RAN	D ₁	D ₂	D ₃	D ₄		1	1	0
10A	# ATN plus ?	UNL	1	1	1	1		1	1	0
10B	SPACE	SP	0	0	0	0		0	1	0

Bits: 1 = true; 0 = false

6.3.5.1 My Listen Address (MLA)

* A - MY LISTEN ADDRESS - the character entered here is dependent on the instrument's that has been entered on the DIP switch located on the MR-488 p.c. board.

To set the MLA, select a 5 bit BINARY number between 0 and 30 (See fig. 6.3) and set the dip switch on the MR-488 p.c. board using A-1 through A-5 only.

Since 501J is a "Listen Only" instrument, we have hard-wired bits A-6 and A-7.

Illustration of a bus address and command: See "Sample Program" para 6.3.9 Note bus command line 120.

See paragraph 6.3.3 of this manual and page 77 of IEEE Std. 488.

CAUTION: DO NOT set all DIP switches to: 11111.

#ATN must be true on the MLA and UNL only.
(ATN must be false on all data byte entries.)

ASCII Code Character		Address switch					
Listen A7 A6	Talk A7 A6	(Binary) A5 A4 A3 A2 A1					Decimal
0 1	1 0						
Space	@	0	0	0	0	0	00
!	A	0	0	0	0	1	01
“	B	0	0	0	1	0	02
#	C	0	0	0	1	1	03
\$	D	0	0	1	0	0	04
%	E	0	0	1	0	1	05
&	F	0	0	1	1	0	06
‘	G	0	0	1	1	1	07
(H	0	1	0	0	0	08
)	I	0	1	0	0	1	09
*	J	0	1	0	1	0	10
+	K	0	1	0	1	1	11
,	L	0	1	1	0	0	12
-	M	0	1	1	0	1	13
.	N	0	1	1	1	0	14
/	O	0	1	1	1	1	15
0	P	1	0	0	0	0	16
1	Q	1	0	0	0	1	17
2	R	1	0	0	1	0	18
3	S	1	0	0	1	1	19
4	T	1	0	1	0	0	20
5	U	1	0	1	0	1	21
6	V	1	0	1	1	0	22
7	W	1	0	1	1	1	23
8	X	1	1	0	0	0	24
9	Y	1	1	0	0	1	25
:	Z	1	1	0	1	0	26
;	[1	1	0	1	1	27
<	\	1	1	1	0	0	28
=]	1	1	1	0	1	29
>	^	1	1	1	1	0	30

Fig 6.3 Address selection

The 501/J is a LISTEN ONLY instrument. Therefore, switch A-7 is hard wired “lo” (0) and switch A-6 is hard wired “hi” (1).

B - POLARITY where: $B_3 = 0 = +$ (Pos Polarity)
 $B_3 = 1 = -$ (Neg Polarity)

ASCII CHARACTERS: for + (Positive) Enter: +
 for - (Negative) Enter: -

If Option J, Bipolar Operation, is not installed in your 501, the ASCII Character + (plus) must be entered in Step 2.

C - MAGNITUDE Enter appropriate ASCII Character.

If Option B, Additional Resolution (LSD_2), is not installed in your 501, the ASCII Character 0 (zero) must be entered in Step 8.

D - RANGE

b_1	b_2	b_3	b_4	501 RANGE	ASCII CHAR.	PCS-2	PCS-1	RA-3	RA-4
0	0	0	0	100 mV	0	Standby			
1	0	0	0	10 V	1	Standby			
0	1	0	0		2	Standby	10 mA	100 V	100 V
1	1	0	0		3	Standby	100 mA	200 V	1000 V
0	0	1	0		4	Standby			
1	0	1	0		5	Standby			
0	1	1	0		6	Standby			
1	1	1	0		7	Standby			
0	0	0	1		8	Standby			
1	0	0	1		9	1 mA			
0	1	0	1		:	10 mA			
1	1	0	1		;	100 mA			
0	0	1	1		<	1 A			
1	0	1	1		=	10 A			
0	1	1	1		>	Standby			
1	1	1	1		?	Standby			

6.3.6 Manual-Program control switch.

NOTE: These paragraphs apply only to the 501 instruments that have the Front Panel Control & Display Accessory AM-1 or AM-2 installed.

The front panel control is normally set to the "program" position. However, to use in "manual" the program lines do not have to be disconnected. The 501 will continue to receive and store any programmed instructions.

When set in the "manual" mode, the analog output will not respond to the programmed data. It will respond to the manually entered information.

6.3.7 Field Installation of KT-488.

- 1) Remove jumper boards P2756/7 from connectors J-1 and J-2.
Refer to drawing B-2791.
- 2) Install IS-48 (opto-isolator) in connector J-1 with component side facing front panel.
- 3) Install MR-488 in connector J-2 with component side facing the front panel.
- 4) Install board retainer bar.

6.3.8 Handshake Process Timing Sequence. See Appendix B of IEEE STD 488-1975 for a detailed discussion of the process. The timing sequence for the MR-488 is shown below.

6.3.8.1 MR-488 Handshake Process Timing Sequence.

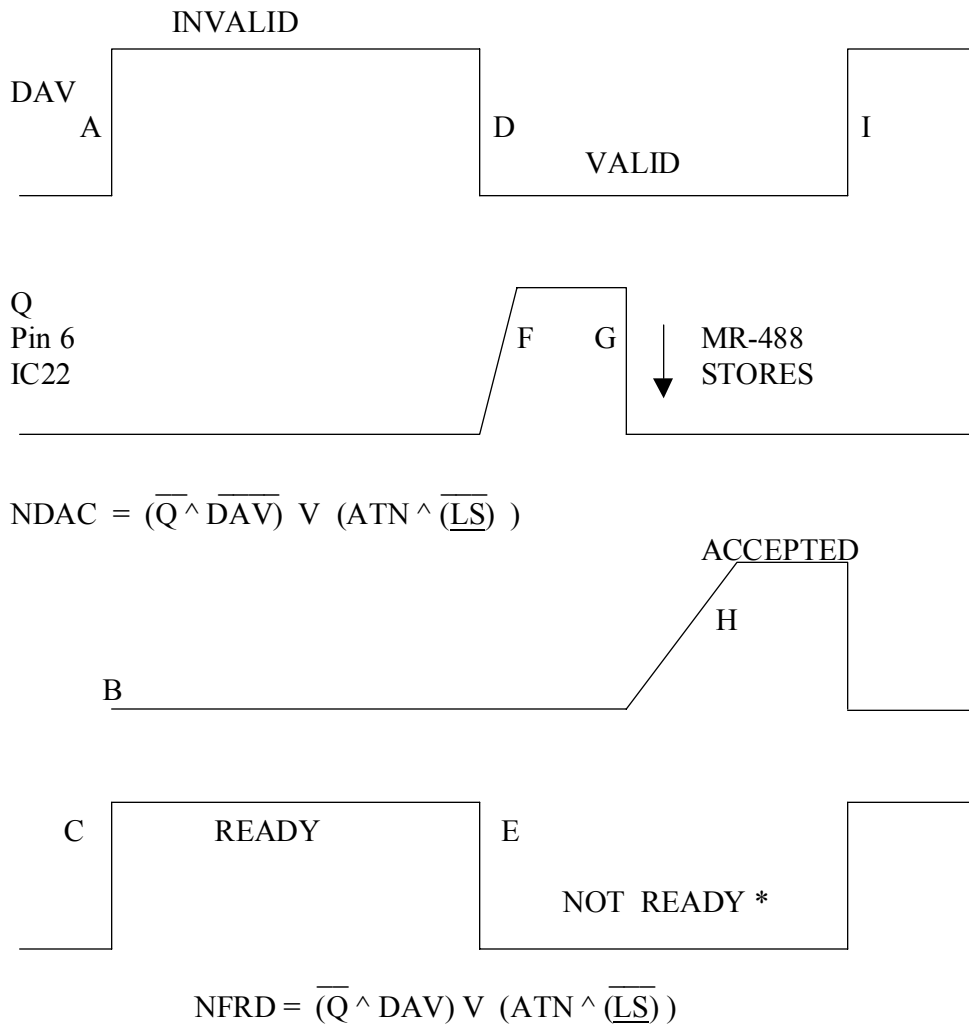

* *NOTE:* The Auxiliary instruments, PCS and RA type, require more switching and settling time than when the 501 (main frame) is used alone. Thus, the NFRD (not ready for data) flag will remain in the “not ready” state for a longer period than when the 501 is used without the Auxiliary instruments

6.3.9 Sample Programs

The following programs are included as a guide.

Interface: IEEE 488/1978 (GP-IB)

Address: The set address for the K-H Model 501/J for all the following examples is 5.

1	2	3	4	5	6	7
ON	OFF	ON	OFF	OFF	OFF	OFF

6.3.9.1 *Listed Below Is a Short Sample Program For The 501. This Program Is in Quick Basic Using a National 488 Driver Card.*

```
REM $INCLUDE: 'qbdecl.bas'
A5 = 5: REM 501 ADDRESS
3 CALL SendIFC(0)
CLS
CR$ = CHR$(13)
GOTO 10000
1700 REM 501 INPUT SUB
CALL Send(0, (A5), DM$, NLen)
RETURN
10000 CLS : GA$ = ""
LOCATE 6, 23: PRINT ""; TIME$; " 501 ADDR = "; A5
LOCATE 9, 20: PRINT "  PRESS (1) FOR TEST"
LOCATE 11, 20: PRINT "  PRESS (2) TO EXIT PROGRAM "
LOCATE 13, 20: PRINT "  PRESS (3) TO CHANGE ADDRESS "
LOCATE 6, 23
PRINT ""; TIME$
10270 LOCATE 6, 23: PRINT ""; TIME$: GG = VAL(INKEY$): IF GG = 0 OR GG > 3
THEN 10270
IF GG = 2 THEN 50200
IF GG = 3 THEN GOTO 14500
11100 CLS
LOCATE 9, 20: PRINT " USE THE LETTER J FOR 10"
LOCATE 11, 20: INPUT " ENTER POLARITY + OF - "; POL$
11500 LOCATE 11,20:INPUT "ENTER MAGNITUDE IN SIX CHARACTERS "; MAG$
IF LEN(MAG$) <> 6 THEN MAG$ = "": GOTO 11500
LOCATE 11, 20: INPUT " ENTER RANGE 0 FOR MILLIVOLTS OR 1 FOR    10
VOLTS"; RG$
DM$ = POL$ + MAG$ + RG$
GOSUB 1700: REM SEND TO 501
GOTO 10000
14500 REM ADDR CHANGE
CLS : LOCATE 6, 23: PRINT "501 ADDR = "; A5
INPUT "ENTER 501 ADDRESS"; A5
GOTO 3
50200 CALL SendIFC(0)
END
```

6.3.9.2

Sample program using FLUKE MODEL 1720A controller to operate K-H model 501/J

Language: Basic

```
10 INIT PORT 0
20 REMOTE @5
30 Print @5, _"+2500001_"
40 Print @5, _"+0000001_"
50 GOTO _30
RUN (RET)
```

NOTE: _ Designates space

The program listed above will program the Model 501/J to have an analog output characteristic as shown in the figure below.

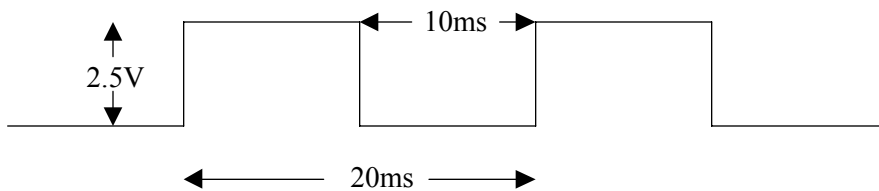

EDC 501/J analog (Voltage) output per the Sample program in paragraph 6.5.7.3

6.4.0 OPTO-ISOLATOR

Accessory: p/n IS-40

6.4.1 Accessory, p/n IS-40 consists of a plug in P.C. card, P2805/6, that contains a maximum of up to 39 opto-isolator units. The number of actual opto-isolators depends upon which other options and accessories are installed.

6.4.2 Program line inputs. Current level requirements per line:

Logical zero - 10 mA sink current

Logical one - open circuit

6.4.3 Connect the programmer logic common to isolated ground, Pin A7. The sink currents are drawn from the appropriate bit lines back to the isolated ground.

6.4.4 Two signals from the 501J are opto-isolated and develop a TTL compatible level with respect to the isolated ground.

1) PM, Mode Indicator: manual/program - Pin A20

2) RF, Analog Standby/Ready Flag - Pin A25 (Option C)

6.4.5 The latter is provided when the option is provided.

6.4.6 Thee 501J may be restored to non-opto-isolated operation by removing the opto-isolator card, and inserting jumper card, P2756/7. However, now computer ground must be connected to logic ground, Pin A8, as described previously in the manual. (See paragraph 3.1.6.)

6.4.7 The opto-isolator board is installed in the rear edge connector with the components facing the rear.

NOTICE: Paragraph 6.4.7 applied to the IS-40 board only.
(Do not confuse with the IS-48.)

6.5.0 Serial to Parallel Programming

(When not using the IEEE-488 Convention)

6.5.1 If it is desired not to use the IEEE STD. 488/1975 hermaphroditic cables, use a Cinch 57-30240 connector. The pinout is shown below:

<u>Contact</u>	<u>Signal Line</u>	<u>Contact</u>	<u>Signal Line</u>
1	DIO1	13	DIO5
2	DIO2	14	DIO6
3	DIO3	15	DIO7
4	DIO4	16	DIO8
6	DAV	18	Gnd. (6)
7	NRFD	19	Gnd. (7)
8	NDAC	20	Gnd. (8)
9	IFC	21	Gnd. (9)
		22	Gnd. (10)
11	ATN	23	Gnd. (11)
12	SHIELD	24	Gnd. LOGIC

NOTE: Gnd.(n) refers to the signal ground return of the referenced contact.

6.5.2 The interface may be driven with an 8 bit system, with a separate DAV (Data Valid), line. Use bit 8 for the ATN function. The flags NRFD and NDAC may be ignored, if at least 100 μ s is allowed between characters and words.

6.5.3 The IEEE-488 specifies NEGATIVE TRUE LOGIC.

Where: TRUE = $< +0.8$ Vdc
FALSE = $> +2$ V dc

In the IS-48 (Opto-Isolator P. C. Card) the IC₁ and IC₂ are the type 7406 I.C., which provides for the 488 specified NEGATIVE TRUE LOGIC in B₁ through b₇. However, if POSITIVE true logic is desired, then, IC₁ and IC₂ may be changed to a type 7407.

6.6.0 Negative Programming Logic - Option AK-1

6.6.1 Option AK-1 consists of 30 logic inverters contained in a plug in P. C. card, P2936/7.

6.6.2 The following data inputs from the data input connectors are inverted:

- 1) Code 18 through 61 (24 BCD magnitude bits) for BCD units
- 2) Code B1 through B20 (20 Binary magnitude bits) for binary units

(A TTL logical zero will now turn on these bit lines)

- 3) POL 1 - Pos. Polarity 0 - Neg. Polarity (Option J)
- 4) RAN 1 - 100 mV Range 0 - 10 V Range (Option D)
- 5) STR 0 - Unit on 1 - zero analog output
- 6) MR1 1 - Memorize 0 - Follow (Option MR-1)
- 7) PMM Mode Indicator 1 - M 0 - P
- 8) RF 0 - Overload 1 - Normal

6.6.3 Notes: 7) and 8) above are signals from the 501 to the rear data connectors. The strobe line must be grounded to obtain a non-zero analog output.

6.6.4 The 501 may be restored to positive logic operation by removing the P.C. card P 2936/7 and inserting the jumper card P2756/7.

Refer to schematic drawing A-2935.

SENSE CONNECTIONS

HIGH CURRENT LOAD

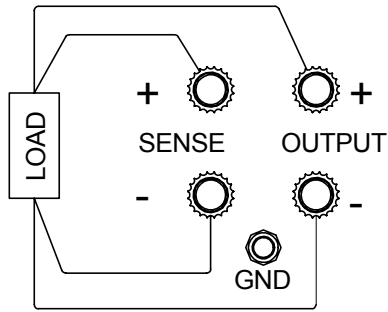
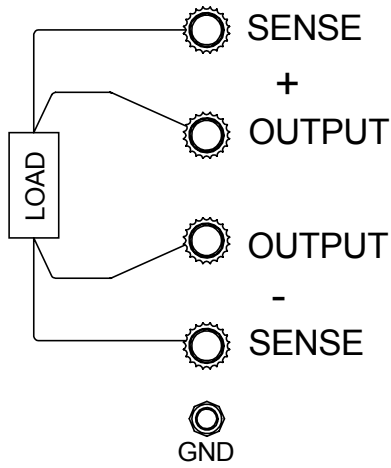

[Sense Links Removed]

FIG 1

LIGHT LOAD

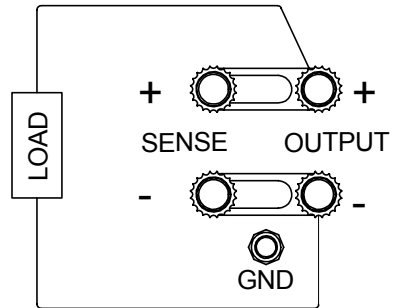
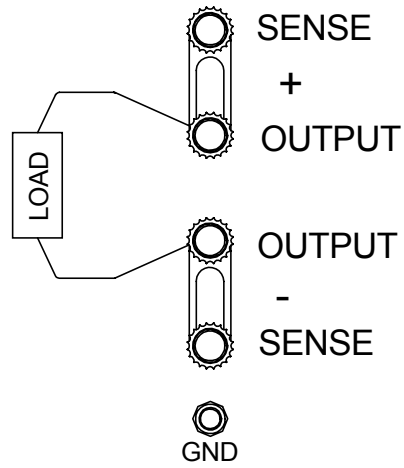

[Sense Links Installed]

FIG 2

OUTPUT CONNECTOR PIN FUNCTIONS

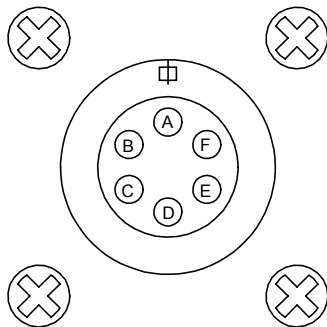

- PIN A Chassis Ground
- PIN B + Output
- PIN C - Output
- Pin D Not Used
- Pin E - Sense
- Pin F + Sense

FIG 3