

Instruction Manual
February 1975
REPLACES FEBRUARY 1974

© Copyright 1974, 1975 by
Electro Scientific Industries, Inc.
All rights reserved

MODEL 251

Digital Impedance Meter

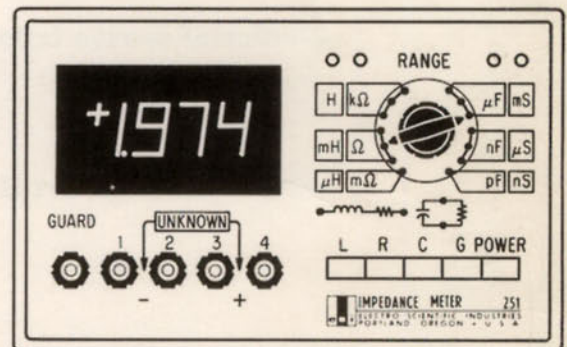

SERIAL NUMBER: _____
PART NUMBER: 27049

esi®
Electro Scientific Industries, Inc.
13900 N.W. SCIENCE PARK DRIVE, PORTLAND, OREGON 97229
TELEPHONE: (503) 646-4141, TELEX: 36-0273

TABLE OF CONTENTS

DESCRIPTION

1.1 INTRODUCTION 1-1
1.2 SPECIFICATIONS 1-1

OPERATION

2.1 CONNECTIONS AND CONNECTORS 2-1
2.1.1 Front Panel 2-1
2.1.2 Rear Panel 2-2
2.2 OPERATING PROCEDURES 2-3
2.2.1 CAUTION! 2-3
2.2.2 General Procedure 2-3
2.2.3 Noise or Resistance Measurements at 1 kHz 2-3
2.2.4 Noise or Resistance Measurements 2-4

When making two terminal measurements, terminals 1 and

2 must be connected together and terminals 3 and 4 must also be connected together. The unknown must be connected across terminals 2 and 3.

Failure to make the above connections will result in incorrect readings from your instrument.

DESCRIPTIONS

3.1.1 Precision Differential Amplifier 3-1
3.1.2 Range Differential Amplifier 3-1
3.1.3 Resistance Detector and Phase Sensitive Detector 3-2
3.1.4 Digital Read Meter (DPM) Phase Sensitive Detector 3-2
3.1.5 Guard Ring Amplifier 3-2
3.1.6 200 Ohm Amplifier 3-2
3.1.7 Overcurrent Warning Circuit 3-2
3.1.8 Digital Trigger 3-2
3.2 DIGITAL PANEL LOGIC TRIGGER COMMANDS 3-3
3.2.1 Sample Trigger 3-3
3.2.2 Hold Trigger 3-3
3.2.3 Trigger Rate Adjustment 3-4

Part No. 23141

MAINTENANCE

4.1 CALIBRATION PROCEDURE 4-1

PARTS LIST AND SCHEMATIC DIAGRAMS

5.1 MAINFRAME 5-1
5.2 RCL METER CIRCUIT BOARD ASSEMBLY 5-2
5.3 RANGE SWITCH ASSEMBLY 9/74 5-4

e|s|i.

TABLE OF CONTENTS

1.	DESCRIPTION		
1.1	INTRODUCTION		1-1
1.2	SPECIFICATIONS		1-1
2.	OPERATION		
2.1	CONTROLS AND CONNECTORS		2-1
2.1.1	Front Panel		2-1
2.1.2	Rear Panel		2-2
2.2	OPERATING PROCEDURE		2-3
2.2.1	Preliminary		2-3
2.2.2	General Procedure		2-3
2.2.3	Notes on Resistance Measurements at 1 kHz		2-3
2.2.4	Notes on Capacitance Measurements		2-4
2.2.5	Notes on Inductance Measurements		2-4
2.2.6	Determining Quality Factor (Q) of Inductors		2-5
2.2.7	Determining Dissipation Factor (D) of Capacitors		2-5
2.2.8	Using the Bias Feature		2-6
2.2.9	Measuring Grounded Unknowns		2-6
2.2.10	Measuring Series Resistance and Series Capacitance of Batteries		2-6
3.	CIRCUIT DESCRIPTIONS		
3.1	GENERAL DESCRIPTION		3-1
3.2	DETAILED CIRCUIT DESCRIPTIONS		3-2
3.2.1	1 kHz Oscillator		3-2
3.2.2	Unknown Differential Amplifier		3-2
3.2.3	Range Differential Amplifier		3-2
3.2.4	Reference Generator and Phase Sensitive Detector		3-2
3.2.5	Digital Panel Meter (DPM) Phase Sensitive Detector		3-3
3.2.6	Guard Buffer Amplifier		3-3
3.2.7	x10 Amplifier		3-3
3.2.8	Overload Blanking Circuit		3-3
3.2.9	Digital Panel Meter		3-3
3.3	DIGITAL PANEL METER TRIGGER COMMANDS		3-6
3.3.1	External Trigger		3-6
3.3.2	Hold and Read		3-6
3.3.3	Internal Sample Rate Adjustment		3-6
4.	MAINTENANCE		
4.1	CALIBRATION PROCEDURE		4-1
5.	PARTS LIST AND SCHEMATIC DIAGRAMS		
5.1	MAINFRAME		5-1
5.2	RCL METER CIRCUIT BOARD ASSEMBLY A1		5-2
5.3	RANGE SWITCH ASSEMBLY A2		5-4

SECTION 1

DESCRIPTION

1.1 INTRODUCTION

The ESI Model 251 Digital Impedance Meter is a semi-automatic instrument which permits rapid measurement of inductance, resistance, capacitance, and conductance at a test frequency of 1 kHz. Measurement accuracy and versatility satisfies most demanding engineering or scientific applications, while simplicity of operation permits use by even technically unskilled personnel. After selecting the proper function and range, rapid four-terminal measurements can be made, using the test leads provided, the optional Model 1304 Four-Terminal Sorting Fixture, or other device.

Excellent reliability of the Model 251 is assured through use of solid state devices and etched circuit board construction. Its small size is welcomed for use on bench-tops where work space may be at a premium. Extending the bail attached to the front mounting feet will permit tilting the unit for easier viewing of the front panel controls. An optional adapter is available for rack-mounting.

1.2 SPECIFICATIONS

Table 1-1. Model 251 Functions, Ranges and Accuracy

Function	7 Ranges per Function	Accuracy
Series Inductance (L_S)	199.9 μ H to 199.9 H	$\pm[0.25\% + (1 + 0.001R_S^*) \text{ digits}]$
Series Resistance (R_S)	1999 m Ω to 1999 k Ω	$\pm[0.25\% + (1 + 0.001L_S^*) \text{ digits}]$
Parallel Capacitance (C_P)	199.9 pF to 199.9 μ F	$\pm[0.25\% + (1 + 0.001G_P^*) \text{ digits}]$
Parallel Conductance (G_P)	1999 nS to 1999 mS**	$\pm[0.25\% + (1 + 0.001C_P^*) \text{ digits}]$

*Digit count, same range; for lowest and highest ranges only, multiply digit count by 2.

**1 Siemens = 1 mho = $\frac{1}{\text{ohm}}$

Measurement Speed: Two per second is standard; one second required for first reading after connecting unknown to terminals. Can be increased to 10 per second by internal circuit change (see Section 4).

Display: 3½ digits with decimal point; blanked for overload conditions.

Test Frequency: 1 kHz $\pm 0.1\%$

Output: Analog signal of 1 V per 1,000 counts, 5 mA maximum, available at rear panel.

Bias: Rear terminals and OFF-ON switch provided for connection of zero-to-50 V DC external supply.

Connection to Unknown: Four terminals plus guard provided on front panel.

Excitation between UNKNOWN Terminals: The 1 kHz voltage (V_x) and current (I_x) levels listed in Table 1-2 are held constant by an internal amplitude control circuit.

Table 1-2. Voltage and Current Levels Between UNKNOWN Terminals

RANGE Position	V_x for C_p, G_p	C_p	G_p	I_x for R_s, L_s	R_s	L_s
*1	0.1 V rms	200 μ F	2,000 mS	100 mA	2,000 m Ω	200 μ H
2	0.1 V rms	20 μ F	200 mS	10 mA	20 Ω	2 mH
3	0.1 V rms	2 μ F	20 mS	1 mA	200 Ω	20 mH
4	1.0 V rms	200 nF	2,000 μ S	1 mA	2,000 Ω	200 mH
5	1.0 V rms	20 nF	200 μ S	100 μ A	20 k Ω	2 H
6	1.0 V rms	2 nF	20 μ S	10 μ A	200 k Ω	20 H
7	1.0 V rms	200 pF	2,000 nS	1 μ A	2,000 k Ω	200 H

*Most counterclockwise position

Power Requirements: 100 to 125 V or 200 to 250 V, 50/60 Hz, 30 W

Dimensions: Height 5.7 in (14.5 cm) with feet; width 8.5 in (21.6 cm) depth 14.25 in (36.2 cm) overall

Weight: 10 lb (4.5 kg) net

SECTION 2

OPERATION

2.1 CONTROLS AND CONNECTORS

2.1.1 Front Panel

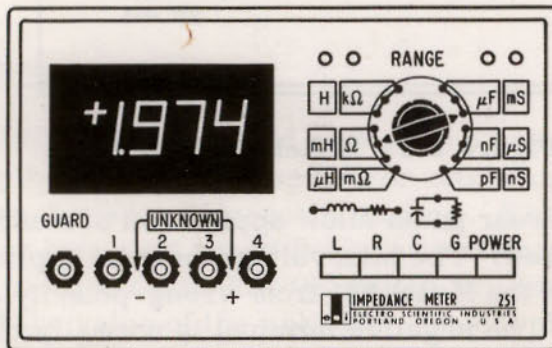

Figure 2-1. Model 251 Front Panel

RANGE selects the decimal multiplier and units of measurement for the meter circuit being used. For maximum accuracy, use the range that gives the highest digital count, unless the unknown is voltage or current sensitive (see Table 1-2).

L, R, C, and G function pushbuttons select the type of meter circuit that will measure series inductance and resistance or parallel capacitance and conductance. An energized LED indicates the function being used.

POWER switch is a push-on, push-release button.

The four UNKNOWN terminals and GUARD terminal are spaced to receive a standard ESI cable assembly, such as KELVIN KLIPS® Four-Terminal Clips Assembly (ESI Part No. 6843) or Model 1304 Four-Terminal Sorting Fixture. The polarity marking on the terminals has significance only when a bias voltage is applied to the rear panel terminals; the signal on the terminals is a 1 kHz sine wave about the zero line. Connections to terminals 1 and 2 should be shielded when measuring high impedance unknowns (Ranges 5 through 7); the shield should be connected to the GUARD terminal. The signal at the GUARD terminal is identical to that at front panel terminal 2 and will vary with range position in Table 1-2 and unknown value.

2.1.2 Rear Panel

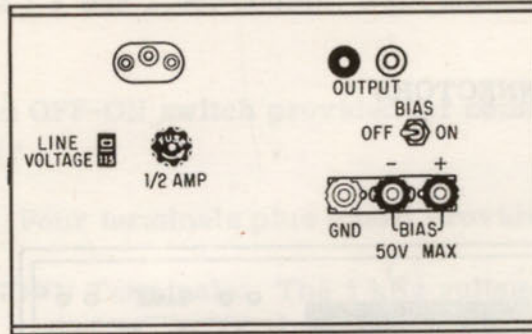

Figure 2-2. Model 251 Rear Panel

The BIAS terminals on the rear panel allow application of a zero-to-50 V DC bias to the capacitor being measured. The bias voltage must be applied in the polarity indicated; a diode protects the Model 251 from wrong-polarity damage but will result in power supply loading. The negative terminal is normally tied to case ground with a shorting link. The bias feature is used to measure diode capacitance, or some types of tantalum or electrolytic capacitors.

The BIAS switch allows bias to be conveniently removed without disconnection. A strap between the BIAS terminals assures proper operation should the switch be inadvertently set to ON with no bias connected.

OUTPUT terminals provide an analog signal of 1 V per 1000 counts at 5 mA maximum with an accuracy of $\pm(0.25\%$ of reading + 1 mV). This signal is used with an external DVM to increase full scale reading or resolution capability. It can also be used with a chart recorder to evaluate unknowns with changing impedances.

LINE VOLTAGE switch selects a nominal input line voltage of 115 V or 230 V.

2.2 OPERATING PROCEDURE

2.2.1 Preliminary

To energize the unit, first switch to the correct line voltage on the back panel. Then, plug in the power cord and press the POWER button. This will cause the front-panel readout to light. For quick connection of the unknown to the meter, plug in the KELVIN KLIPS® Four-Terminal Cable Assembly or sorting fixture to the front-panel terminals.

2.2.2 General Procedure

Press the appropriate FUNCTION button and connect the unknown to the front-panel terminals as indicated in the above paragraph. For maximum accuracy, select the RANGE position that gives the largest on-scale reading. The measurement is displayed after one second or less, and repetitive measurements are made at the rate of two per second. The position of the RANGE switch will indicate the readout units (e.g. μH , mH , or H). If the value of the unknown exceeds the range selected, the display will remain blanked.

If a negative sign appears on the display when measuring an unknown, it indicates one of the following:

- "C" button has been pushed when measuring an inductor.
- "L" button has been pushed when measuring a capacitor.
- The unknown is more capacitive (or inductive) than suspected. For example, a "capacitor" exhibits more inductive reactance than capacitive.
- A diode requires bias voltage (it may be more inductive than capacitive if the bias voltage is not applied).

2.2.3 Notes on Resistance Measurements at 1 kHz

When using the resistance function, maximum measurement capability is up to 1999 kilohms. For measurements from 1999 kilohms to 1000 megohms, use the CONDUCTANCE function where $G = 1/R$ or $R = 1/G$. Accuracy of measurement will be determined by $\pm(0.25\% + 1 \text{ digit})$ where 1 digit will be $\pm 100\%$ at 1000 megohms, $\pm 10\%$ at 100 megohms, and $\pm 1\%$ at 10 megohms.

High-value, bobbin-type, wire-wound resistors have shunt capacitance which may affect measurements by appearing as " $-L_S$ ". This would cause some difference between ac and dc resistance measurement values.

2.2.4 Notes on Capacitance Measurements

Most two- and four-terminal cables or sorting fixtures are not guarded immediately adjacent to where the unknown capacitor is connected, and zero capacitance can change a few picofarads whenever the ends of the cable or fixture terminals are physically moved. Always maintain the physical orientation of the leads or terminals after checking for zero capacitance. Subtract zero-capacitance reading from the capacitance reading for the UNKNOWN.

Electrolytic capacitors with values greater than 200 μF may require the use of the L_S function to measure the capacitance. Use the equation:

$$C_S = 1/(2\pi f)^2 L_S$$

where: f = frequency in hertz, L_S = series inductance in henries and C_S = series capacitance in farads. The meter will read "- L_S " for series capacitance.

Model 251 measures parallel capacitance only. The relation between parallel and series capacitance is:

$$C_S = (1 + D^2) C_P \text{ where } D = G_P/2\pi f C_P$$

2.2.5 Notes on Inductance Measurements

The meter measures the total impedance connected to its terminals. Both the unknown inductor and its leads contribute to this impedance. The leads have some resistance and inductance which affect the value read from the meter.

In making high inductance measurements, avoid ac pickup and keep the stray capacitance to a minimum. To minimize both effects, keep hands as far as possible from the inductor being measured. Keep the leads as short and direct as possible. If extended leads are necessary, the leads from terminals 1 and 2 should be shielded. Take care to avoid coupling stray magnetic fields into the inductor.

For greatest accuracy on low inductance measurements, minimize the lead impedance. If the leads of the inductor cannot be directly connected to the front-panel terminals, short heavy leads will reduce the resistance and closely spaced, twisted leads will reduce the inductance and the pickup of stray fields. The KELVIN KLIPS® Cable Assembly will add about 0.5 μH to L_S and zero $\text{m}\Omega$ to R_S . Short the test leads and subtract the reading from the unknown inductance measured.

Measuring leakage inductance of transformer windings is an easy task for the Model 251 since there are no "false nulls" as found in manually-balanced bridges.

2.2.6 Determining Quality Factor (Q) of Inductors

Measure the inductance of the unknown and record the readout display in digits only. With the RANGE switch in the same position, press the R button and note the readout display in digits, only. Do not record the decimal point or range multiplier for L_S or R_S ; they are not required. Turn to Figure 2-3 for the D-Q nomograph. With a straight edge, line up the L_S digits recorded (left-hand scale) with the R_S digits recorded (right-hand scale). Q is taken from the left-hand side of the center scale where the straight edge crosses it. For example, with an L_S digital display of "300" and an R_S digital display of "010," Q will be 20. Accuracy of Q will be primarily limited by interpolation of the nomograph.

Although the nomograph provides a convenient way to approximate Q , it may be determined more accurately by the formula:

$$Q = 2\pi fL_S/R_S$$

where f = frequency in hertz (1000 Hz for the Model 251)
 $\pi = 3.14$
 L_S = inductance in henrys
 R_S = resistance in ohms
See Table 1-1 for accuracy of L_S and R_S measurements.

2.2.7 Determining Dissipation Factor (D) of Capacitors

Measure capacitance of the unknown and record the readout display in digits only; do not record decimal point. With the RANGE switch left in the same position, push the G button and note the readout display in digits only; do not record decimal point. Turn to Figure 2-3 for the D-Q nomograph. With a straight edge, line up the C_P digits recorded (left-hand scale) with the G_P digits recorded (right-hand scale). D is taken from the right-hand side of the center scale where the straight edge crosses it. For example, with a C_P digital display of "900" and a G_P digital display of "001," D will be 0.0018. Accuracy of D will be primarily limited by interpolation of the nomograph.

Dissipation factor may be determined more accurately by the formula:

$$D = G_P/2\pi fC_P$$

where G_P = Parallel conductance in siemens (mhos)
 $\pi = 3.14$
 f = Frequency in hertz (1000 Hz for the Model 251)
 C_P = Parallel capacitance in farads

See Table 1-1 for accuracy of C_P and G_P measurements.

Electrolytic capacitors with high dissipation are usually unstable and the D factor may drift continuously.

2.2.8 Using the Bias Feature

Bias voltage is necessary or desirable when measuring the capacitance of diodes or some electrolytic or tantalum capacitors. NOTE: Do not use the BIAS feature for grounded capacitors.

Rear-panel provision is made for connecting an external bias source of zero-to-50 V DC. The input is diode-protected to prevent reverse polarity from being applied, and a switch allows removal of the bias without disconnecting it.

With no bias supply connected, the rear-panel terminals should be strapped together to prevent inoperation if the switch should be inadvertently set to the ON position.

2.2.9 Measuring Grounded Unknowns

The Model 251 is designed for measuring ungrounded unknowns. Sometimes, however, one side of an unknown impedance is connected to earth ground. To measure such an impedance, remove the ground link between the rear panel (-) BIAS and GND terminals. Then, connect UNKNOWN terminals 3 and 4 to the grounded end of the unknown impedance and terminals 1 and 2 to the ungrounded end. Select the proper RANGE and FUNCTION and read the value of L, R or C, G. For low capacitance measurements make a zero-capacitance correction by noting the meter reading with only the UNKNOWN terminals 3 and 4 connected to the unknown impedance. Subtract this from the reading for the unknown capacitance.

2.2.10 Measuring Series Resistance and Series Capacitance of Batteries

To measure series resistance of a battery up to 50 V, use the R_S function. Set the BIAS switch on the back panel to the ON position and remove the shorting link. With the switch in this position and the shorting link removed, no current will be drawn from the battery because the bridge circuit is blocked from dc by internal capacitors. (See simplified diagram on page 3-1.) The L_S function must be used to measure series capacitance. The BIAS switch and shorting link must be in the same positions as in the R_S measurement. A negative reading will be shown, and the following equation must be used to convert the " $-L_S$ " reading to "+ C_S " values:

$$C_S = 1 / (2\pi f)^2 L_S$$

where: f = frequency in hertz
 C_S = series capacitance in farads
 L_S = series inductance in henries

Care must be taken so that the measurement current level of the internal source of the Model 251 does not exceed the rating of the battery being tested. See Table 1-2 for range test currents.

L_S^* OR C_P^*

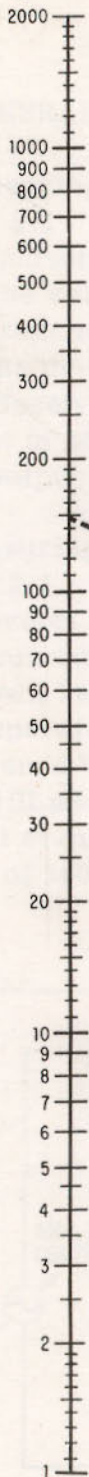

Q D

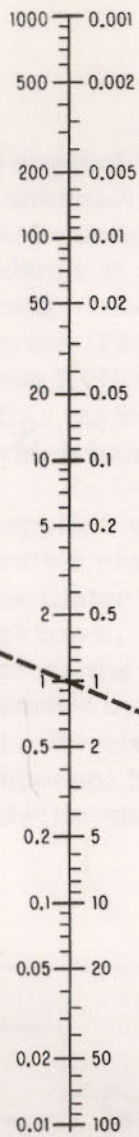

R_S^* OR G_P^*

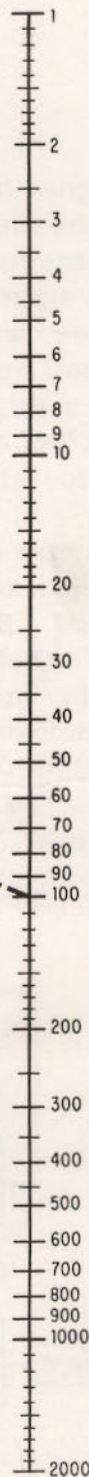

$$D = \frac{1}{Q} = 1.59 \times \left(\frac{R_S}{L_S} \right)^* \quad \text{OR} \quad 1.59 \times \left(\frac{G_P}{C_P} \right)^*$$

*READING IN DIGITS, SAME RANGE

Figure 2-3. Model 251 D-Q Nomograph

SECTION 3

CIRCUIT DESCRIPTIONS

3.1 GENERAL DESCRIPTION

When measuring C_p or G_p , a voltage is applied across the unknown and range resistor in Figure 3-1. The voltage across the *unknown* is held constant to within one part in several thousand by the 1 kHz oscillator feedback control circuit. A current proportional to the value of the unknown impedance is produced through the range resistor. The resultant voltage drop across the range resistor is separated into two vector components by the Phase Sensitive Detector (PSD) and Reference Voltage Generator (RVG). Receiving its gating signals from RVG, the PSD will measure either G_p , the component in phase (0°) with RVG; or C_p , the component at quadrature (90°). The detector output is then fed to the DPM which has a readout of 1000 counts/volt.

When measuring L_s or R_s , a voltage is applied across the unknown and range resistor in Figure 3-1. The voltage across the *range resistor* is held constant to within one part in several thousand by the 1 kHz oscillator feedback control circuit. With a constant current flowing through the unknown, a voltage proportional to the value of the unknown impedance is developed across the unknown. The resultant voltage drop is separated into two vector components by the Phase Sensitive Detector (PSD) and Reference Voltage Generator (RVG). Receiving its gating signals from the RVG, the PSD will measure either R_s , the component in phase (0°) with the RVG; or L_s , the component at quadrature (90°). The detector output is then fed to the DPM which has a readout of 1000 counts/volt.

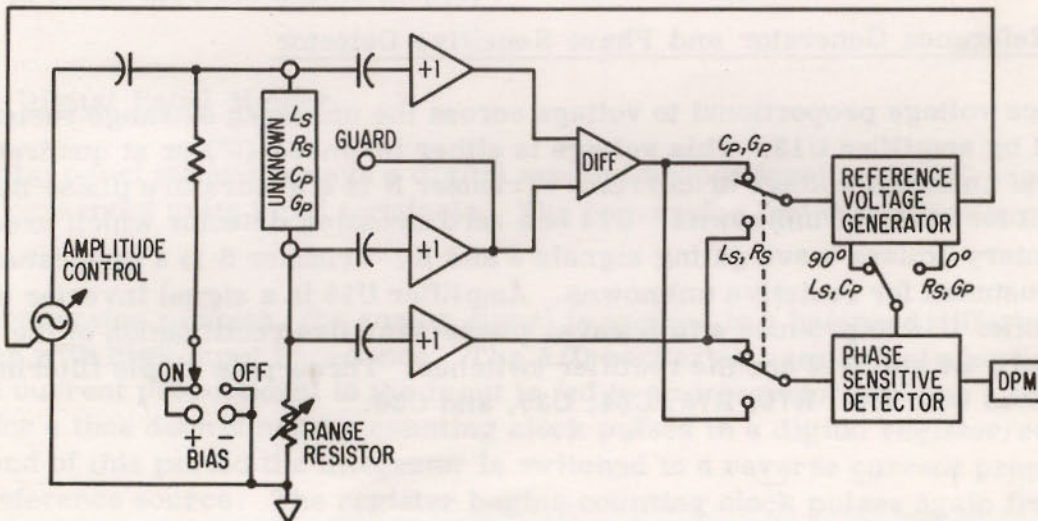

Figure 3-1. Simplified Diagram of the 251

3.2 DETAILED CIRCUIT DESCRIPTIONS

3.2.1 1 kHz Oscillator

The 1 kHz signal applied to the unknown and range resistor is generated by U5, a Wien bridge oscillator, with C6, C7, R10, R12, and R13 controlling the frequency. Transistors Q1 through Q4 provide current amplification for the oscillator output and capacitor C8 blocks externally-applied dc bias voltages. Amplitude control for the oscillator is provided by U3 working as a reference voltage null integrator and U4 as the feedback control element.

3.2.2 Unknown Differential Amplifier

The voltage drop across the unknown is measured by differential amplifier U8. Amplifiers U9 and U7 act as high impedance ac-coupled buffers to prevent loading at UNKNOWN terminals 2 and 3. Resistors R32, R33, R37, and R38 determine the gain (x1) of U8. Trimmers R106 and R107 are adjustments for common-mode voltage rejection.

3.2.3 Range Differential Amplifier

The voltage drop across the range resistor (R42 through R46) is measured by differential amplifier U12. Amplifier U11 acts as a high impedance, ac-coupled buffer to prevent loading of the range resistor. R57, R58, R59, and R60 determine the gain (x-1) of U12. Trimmer R109 is a phase adjustment for U12.

3.2.4 Reference Generator and Phase Sensitive Detector

A reference voltage proportional to voltage across the unknown or range resistor is generated by amplifier U13. This voltage is either in-phase (0°) or at quadrature (90°) to the unknown voltage or current. Trimmer N is a quadrature phase-match adjustment for reactive unknowns. U14 is a zero-crossing detector which produces complimentary square-wave gating signals J and K. Trimmer S is a quadrature phase adjustment for resistive unknowns. Amplifier U15 is a signal inverter used with amplifier U16 to produce a full-wave, phase-sensitive rectification of the reference signal. Q9 and Q10 are the rectifier switches. Three-pole ripple filtering is accomplished with R70, R71, R78, C34, C35, and C36.

3.2.5 Digital Panel Meter (DPM) Phase Sensitive Detector

Voltage across the unknown (R_S or L_S) or across the range resistor (for C_p or G_p) is measured by the DPM phase-sensitive detector circuit. Amplifier U18 is a signal inverter used with amplifier U19 to produce a full-wave, phase-sensitive rectification of signal voltage proportional to the unknown value. FET switches Q11 and Q12 are the rectifier gates actuated by signals J and K. Ripple filtering is done by R84, R97, R93, C38, C39, and C40. Trimmer W is used for full-scale calibration of L_S and C_p . Amplifier U20 is used as a unity-gain buffer for the analog output function.

3.2.6 Guard Buffer Amplifier

Amplifier U6 acts as a unity-gain buffer between the guard potential output of U9 and loads connected to the GUARD terminal. Transistors Q5 through Q8 provide current amplification for the output of U6.

3.2.7 x10 Amplifier

Amplifier U10 is connected for a non-inverting gain of 10 as determined by feedback resistors R52 and R53. Trimmer P is used for phase adjustment of this circuit.

3.2.8 Overload Blanking Circuit

U17 is connected as a comparator amplifier. It monitors the output levels of null integrator amplifier U3 and DPM signal amplifier U18. When either of these levels exceeds a preset value, comparator U17 goes to a low (overload) state. This output is used to blank the DPM digital display.

3.2.9 Digital Panel Meter*

The digital panel meter displays a digital readout proportional to the DC analog voltage presented to its input terminals. The conversion factor is 1000 counts per 1 V input.

In the conversion process, the analog signal is applied to a balanced differential input amplifier with high input impedance. The A/D converter uses a dual-slope process in which a current proportional to the input is fed to an integrator through a switch closed for a time determined by counting clock pulses in a digital register/counter. At the end of this period the integrator is switched to a reverse current proportional to the reference source. The register begins counting clock pulses again from zero. The upward ramp of the integrator waveform of the timing diagram (see Figure 3-3)

*See footnote on page 3-4.

describes this phase of the conversion. The magnitude of the reference current is set at a value corresponding to full scale analog input; therefore, for a full scale input, the count will reach 100% of full scale just as the integrator returns to its initial conditions. If the input is lower, the integrator will return sooner, registering a corresponding lower count.

Refer to Figure 3-2 for a functional block diagram and terminal designations of the digital panel meter. Refer to Figure 3-3 for a timing diagram and associated waveforms.

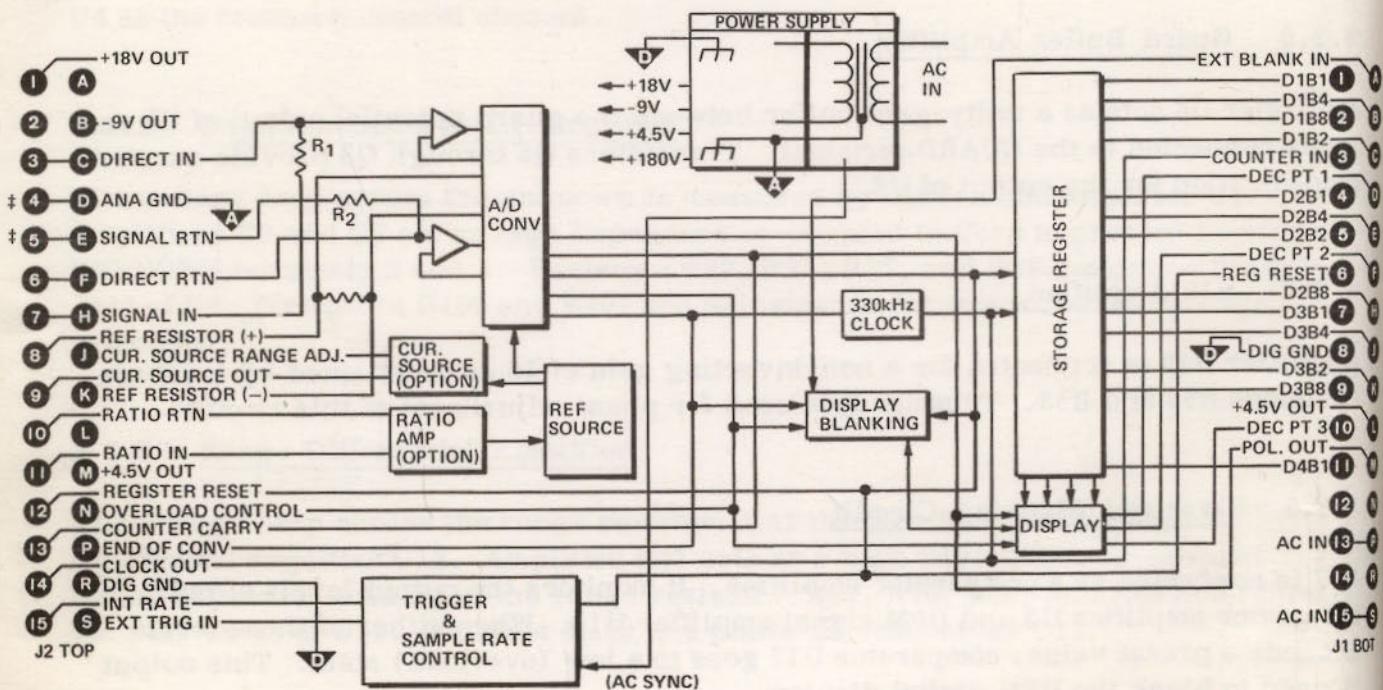

† These terminals must be system connected so that no more than 3.5V difference of potential exists between them.

Figure 3-2. Functional Block Diagram and Terminal Designations*

*Sections 3.2.9 and 3.3 Copyright© by Analogic Corporation, used by permission. Due to the proprietary nature of the information, no rights to duplicate or use it are granted except for supporting installation, operation or maintenance of the equipment.

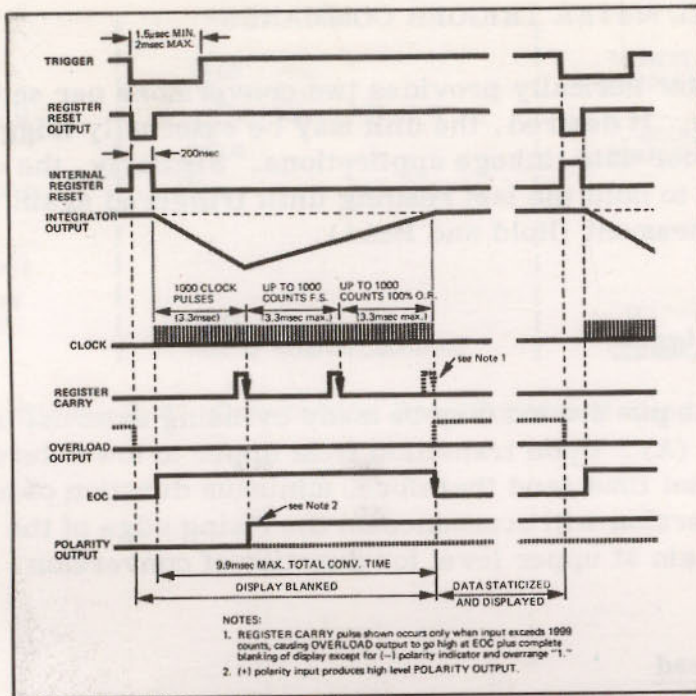

Figure 3-3. Timing Diagram and Waveforms*

*See footnote on page 3-4.

3.3 DIGITAL PANEL METER TRIGGER COMMANDS*

The digital panel meter normally provides two conversions per second for maximum useful visual display. If desired, the unit may be externally triggered to provide much higher speeds for data linkage applications. Similarly, the display may be externally triggered to hold the last reading until triggered again to indicate the value of a new measurement (Hold and Read).

3.3.1 External Trigger

Up to 100 conversions per second may be made by using external triggering as shown in Figure 3-4 (A). Upon transition from upper to lower level, the unit resets. Minimum reset time (and therefore, minimum duration of lower level) is 1.5 μ s. A new conversion will commence on the rising edge of the trigger signal which must then remain at upper level for duration of conversion.

3.3.2 Hold and Read

Hold and Read operation may be provided with the external circuit configuration of Figure 3-4 (B).

3.3.3 Internal Sample Rate Adjustment

The Internal Sample Rate may be varied by externally adjusting the internal circuit as shown in Figure 3-4 (C). To change from the normal measurement speed of two per second, do one of the following:

1. To increase, add resistance externally between J2 pins 1 and 15.
2. To decrease, add capacitance externally between J2 pins 15 and R.

Measurement speed will be determined by the formula:

$$\text{Speed} = 0.7 RC \text{ seconds per measurement} = 0.5 \text{ second (normal)}$$

where $R = 1.0 \text{ M}\Omega$ (permanently wired internally across the DPM pins)

$C = 0.68 \text{ }\mu\text{F}$ (permanently wired internally across the DPM pins)

For example, adding a 1.0 $\text{M}\Omega$ resistor (in parallel) will double the normal speed of two measurements per second. Adding a 0.68 μF capacitor (in parallel) will halve the normal speed.

*See footnote on page 3-4.

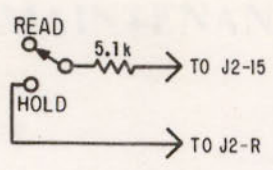
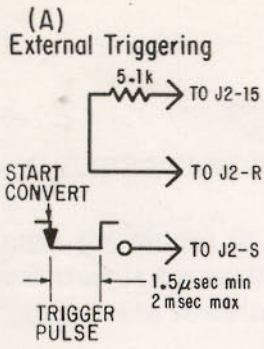

(B) Hold & Read on Command

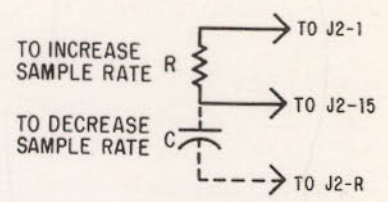

Sample rate (in samples/second) = $0.7 RC$
 where $R = 1 \text{ Megohm}$
 $C = 0.68 \mu\text{F}$

(C) Internal Sample Rate Adjustment

Figure 3-4. Conversion Rate Control Methods*

*See footnote on page 3-4.

SECTION 4

MAINTENANCE

4.1 CALIBRATION PROCEDURE

Although the Model 251 is an inherently stable instrument, good maintenance practices suggest that it be calibrated every six months; oftener if used in extreme environments or if inaccurate readings are suspected.

<u>Equipment Required</u>	<u>Minimum Specifications</u>
Frequency Counter	Measure 1000 Hz with resolution of 0.2 Hz
Digital Voltmeter	Resolution of 100 μ V DC
Standard Resistors	1000 Ω \pm 0.05%, non-inductive such as ESI Model SR 1. 100 Ω \pm 10%, non-inductive; composition type.
Standard Capacitors	100.0 nF calibrated to \pm 0.05% with D < 0.0002. 100 pF \pm 10%, with air or polystyrene dielectric.
KELVIN KLIPS [®] Four-Terminal Clips	ESI Part No. 6843

Refer to Figure 4-1 for adjustment locations. Note that position #1 on the RANGE switch is the most counter clockwise position for each function.

1. POWER SUPPLY. Setup - Turn on instrument and allow thirty minute warm-up period; then remove top cover. Check - Power supply voltages at C3 and C4 should be + and -15 V \pm 5% (14.25 to 15.75 V).
2. OSCILLATOR ADJUSTMENT. Setup - Press G function button. Set RANGE switch to position 4 and connect frequency counter input to D end of C8 and DVM input to C end of C5. Use rear panel (-) BIAS terminal for circuit common. Adjustment - Adjust trimmer V (R13) for 1000 \pm 0.2 Hz on the counter and trimmer U (R16) for 0 \pm 0.5 V on DVM. These adjustments interact; repeat above procedure.
3. DPM PHASE-SENSITIVE DETECTOR ZERO TRIM. Setup - Press G function button and set RANGE switch to position 4 (CW). Connect DVM lo input to rear panel black OUTPUT terminal and DVM hi input to L point of C40. Adjustment - With UNKNOWN terminals open-circuited, adjust trimmer Y (R91) for 0 \pm 0.1 mV on DVM. Move hi DVM input to read OUTPUT terminal and adjust trimmer X (R85) for 0 \pm 0.1 mV on the DVM.

4. R, G PHASE TRIM. Setup - Set RANGE switch to position 4 (CW). Connect 1000 Ω standard to the UNKNOWN terminals using KELVIN KLIPS® test leads. Connect DVM input to rear panel OUTPUT terminals. Adjustment - Press L function button and note DVM reading. Press C function button and adjust trimmer CC (R109) until the same (± 0.1 mV) DVM reading results for both L and C selection. Next, adjust trimmer S (R65) for a DVM reading of $0V \pm 0.1$ mV for either L or C function. Repeat CC and S trim procedure if necessary.
5. L, R U8 COMMON MODE TRIM. Setup - Set RANGE switch to position 3 (CW) and short the KELVIN KLIPS test leads together. Connect DVM input to rear panel OUTPUT terminals. Adjustment - Press L function button and adjust trimmer AA (R106) for a DVM reading of $0V \pm 0.1$ mV. Press R button and adjust trimmer BB (R107) for a DVM reading of $0V \pm 0.1$ mV. Repeat AA and BB trim procedure if necessary. Connect DVM to point 22 on the circuit board. Adjust R trimmer Z (R62) for a DVM reading of $0V \pm 1$ mV.
6. L, C PHASE TRIM. Setup - Press G function button and set RANGE switch to position 4 (CW). Connect DVM input to rear panel OUTPUT terminals. Connect 100.0 nF standard capacitor ($D < 0.0002$) to the UNKNOWN terminals using KLIPS test leads. Adjustment - Adjust trimmer N (C29) for DVM reading of $0V \pm 0.2$ mV.
7. R, G FULL SCALE TRIM. Setup - Set RANGE switch to position 4 (CW). Connect 1000 Ω standard to the UNKNOWN terminals using KELVIN KLIPS test leads. Press R function button. Adjustment - Adjust trimmer T (R4) for a digital panel meter reading of 1000.
8. L, C FULL SCALE TRIM. Setup - Set RANGE switch to position 4 (CW). Connect a 100.0 nF standard capacitor to the UNKNOWN terminals using KELVIN KLIPS test leads. Press C function button. Adjustment - Adjust trimmer W (R96) for a digital panel meter reading of 100.0.
9. x10 AMPLIFIER PHASE TRIM. Setup - Press L function button and set RANGE switch to position 3 (CW). Connect DVM input to rear panel OUTPUT terminals. Connect 100 Ω composition type resistor to the UNKNOWN terminals using KELVIN KLIPS test leads. Adjustment - Adjust trimmer P (C22) for DVM reading of $0V \pm 0.2$ mV.
10. C, G ZERO TRIM. Setup - Set RANGE switch to position 7 (CW). With the KELVIN KLIPS test leads connected to the UNKNOWN terminals, space the clips at least two feet apart. Adjustment - Press C function button and adjust trimmer R (R47) for a panel meter reading of 00.0. Press G button and adjust trimmer O (R105) for a panel meter reading of 000. Repeat these adjustments if necessary.
11. RANGE 7 PHASE TRIM. Setup - Set RANGE switch to position 7 (CW). Connect a 100 pF capacitor ($D < 0.0002$) to the UNKNOWN terminals using the KELVIN KLIPS test leads. Adjustment - Press G function button and adjust trimmer C41 on the RANGE switch (not shown in Figure 4-1) for a panel meter reading of 000.

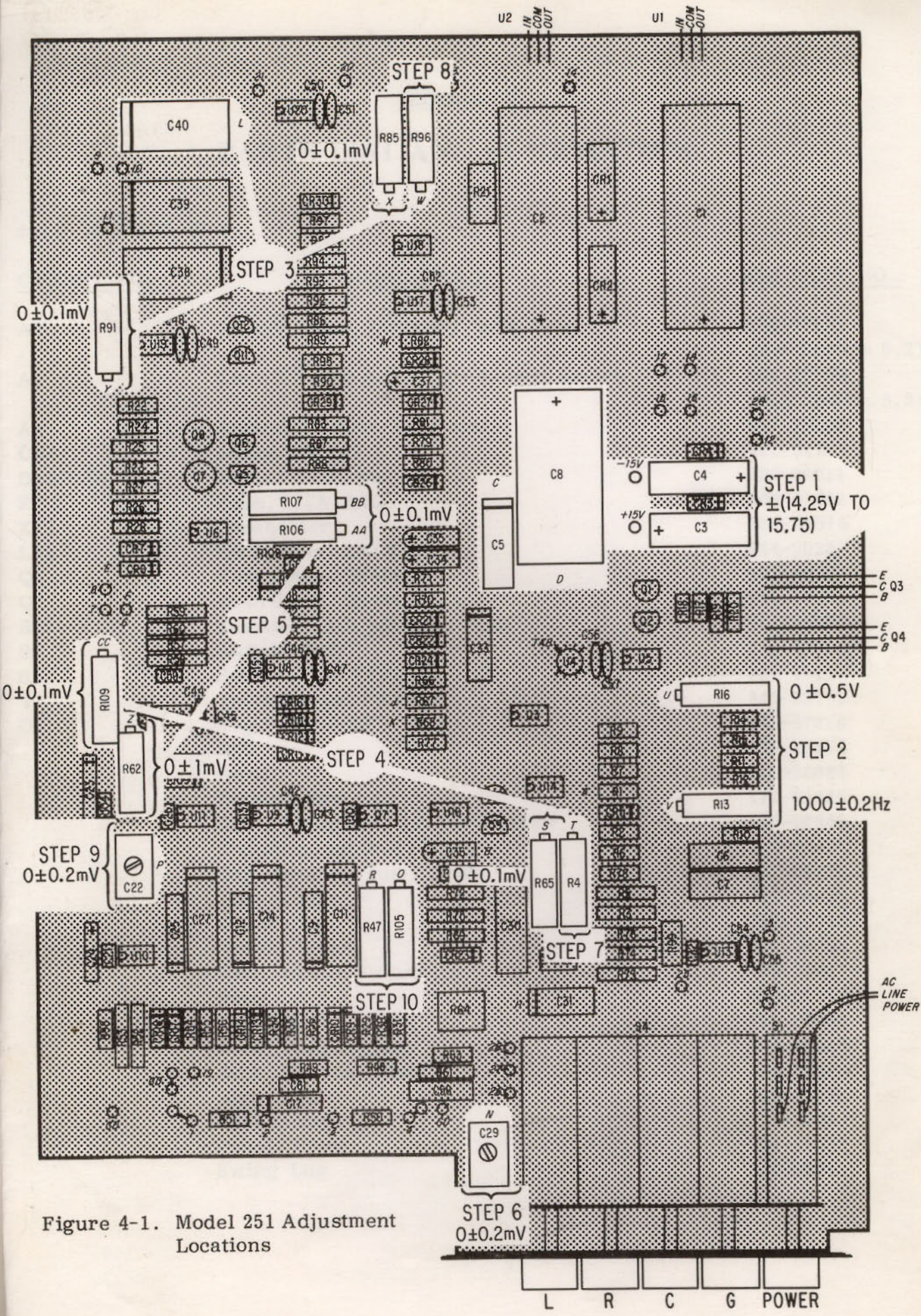

Figure 4-1. Model 251 Adjustment Locations

SECTION 5

PARTS LIST AND SCHEMATICS

5.1 MAINFRAME

<u>CIRCUIT NO.</u>	<u>DESCRIPTION</u>	<u>ESI PART NO.</u>
A1	Circuit Board Assembly, RCL Meter	505-27050 (See Section 5.2)
A2	Circuit Board Assembly, RANGE Switch	201-29169 (See Section 5.3)
A3	Assembly, DPM (Analogic)	337-29168
CR6	Diode, 1N4005	321-01779
DS1-DS4	Diode, LED, OSL-3L	336-26021
F1	Fuse, 1/2A 3AG	333-01802
XF1	Fuseholder	334-03074
LF1	Receptacle, EMI Filter	504-20282
Q3	Transistor, 2N4921	321-18752
Q4	Transistor, 2N4918	321-18753
R101-R103	Resistor, 150 k Ω 10%, 1/4W	307-13947
S3	Switch, SPDT	330-18769
S5	Switch, 115 V/230 V	330-18424
T1	Transformer, Power	340-20135
U1, U2	Regulator, 15 V	343-27816
	Bail	436-13174
	Bezel	710-26031
	Binding Post	112-01435
	Cable Assembly, KELVIN KLIPS®	520-06843
	Cap, Binding Post, Black	112-01170
	Cap, Binding Post, Gold	112-01172
	Cover, Side	711-26030
	Cover, Top	711-26032
	Cover, Bottom	711-26033
	Dial, RANGE Switch	710-26031
	Feet	436-08715
	Heat Sink	710-27058
	Jack, Banana, Red	504-02518
	Jack, Banana, Black	504-02540
	Line Cord	520-13178
	Panel, Back	720-27053
	Panel, Front	708-27052
	Swing Lug	140-03247

5.2 RCL METER CIRCUIT BOARD ASSEMBLY A1

<u>CIRCUIT NO.</u>	<u>DESCRIPTION</u>	<u>ESI PART NO.</u>
	Complete Assembly	505-27050
C1, C2	Capacitor, 500 μ F 50 V Electrolytic	314-01942
C3, C4	Capacitor, 100 μ F 25 V Electrolytic	314-13683
C5	Capacitor, 0.068 μ F Mylar	313-18841
C6, C7	Capacitor, 0.0159 μ F	313-18845
C8	Capacitor, 100 μ F 100 V	314-27068
C9, C12, C25	Capacitor, 0.22 μ F Mylar	313-12238
C10, C13, C21, C60	Capacitor, 20 pF Poly	313-20926
C11, C14, C27	Capacitor, 0.47 μ F Mylar	313-12122
C15, C26, C28, C32	Capacitor, 10 pF Poly	313-20210
C17	Capacitor, 0.01 μ F Mylar	313-12260
C22	Trimmer, 90 to 400 pF	316-20352
C23	Capacitor, 0.0022 μ F	313-12399
C24	Capacitor, 6.8 μ F 35 V	314-25339
C29	Trimmer, 14 to 150 pF	316-02166
C30	Capacitor, 0.01 μ F 1% Silver Mica	312-01929
C31, C33	Capacitor, 0.01 μ F Poly	313-18820
C34-C37	Capacitor, 1.0 μ F 35 V Tantalum	314-06472
C38-C40	Capacitor, 1.0 μ F Mylar	313-18843
C42-C57	Capacitor, 0.01 μ F Disc	311-12144
C58	Capacitor, 330 pF Poly	313-27059
C59	Capacitor, 100 pF Poly	313-18760
CR1, CR2	Rectifier, Bridge KBP-02	321-21236
CR3, CR4, CR7, CR8	Diode, 1N4005	321-01779
CR5	Diode, Zener 1N825 6.2 V	321-20868
CR9-CR27, CR29, CR30	Diode, 1N914A	321-12356
CR28	Diode, Zener 1N4733 5.1 V	321-24555
Q1, Q5	Transistor, 2N3906	321-18754
Q2, Q6	Transistor, 2N3904	321-18751
Q7	Transistor, 2N3053	321-12232
Q8	Transistor, 2N4037	321-13590
Q9, Q12	Transistor, 2N5462, FET	321-20143
Q10, Q11	Transistor, 2N5459, FET	325-19183
R1	Resistor, 1.24 k Ω 1% 1/8 W	305-21731
R2	Resistor, Selected	
R3	Resistor, 40 k Ω 0.02%	240-21112
R4	Potentiometer, 2 k Ω	306-12084
R5	Resistor, 32 k Ω 0.1%	240-24945
R6, R48	Resistor, 220 k Ω 10% 1/4 W	307-13949
R7, R9	Resistor, 100 k Ω 10% 1/4 W	307-13945
R8, R50, R51	Resistor, 100 Ω 10% 1/4 W	307-13907
R10	Resistor, 10 k Ω 1% 1/8 W	305-21740
R11	Resistor, 4.02 k Ω 1% 1/8 W	305-21736

<u>CIRCUIT NO.</u>	<u>DESCRIPTION</u>	<u>ESI PART NO.</u>
R12	Resistor, 9.53 k Ω 1% 1/8 W	305-21762
R13	Potentiometer, 1 k Ω	306-18469
R14	Resistor, 2.49 k Ω 1% 1/8 W	305-21734
R15	Resistor, 8.06 k Ω 1% 1/8 W	305-21739
R16, R96	Potentiometer, 5 k Ω	306-12092
R17, R18, R22, R24, R29, R34, R54, R70, R82, R97	Resistor, 1 k Ω 10% 1/4 W	307-13920
R19, R20, R26, R27	Resistor, 2.7 Ω 10% 1/4 W	307-13887
R21	Resistor 1 k Ω 10% 1 W	304-20559
R23, R25	Resistor 47 Ω , 10% 1/2 W	304-02024
R28	Resistor, 4.7 Ω 10% 1/4 W	307-13890
R30, R31, R35, R36, R55, R56	Resistor, 330 k Ω 10% 1/4 W	307-13951
R32, R33, R37, R38, R52, R57-R60, R73, R74, R83, R87-R89	Resistor, 10 k Ω 0.02%	240-25944
R47, R105	Potentiometer, 500 k Ω	306-23074
R49	Resistor, 3.3 M Ω 10% 1/4 W	307-13966
R53	Resistor, 1.112 k Ω 0.02%	240-24942
R61	Resistor, 11.8 k Ω 0.02%	240-24946
R62, R65, R85, R91	Potentiometer, 10 k Ω	306-20145
R63	Resistor, 1 k Ω 1% 1/8 W	306-21730
R64	Resistor, 64 k Ω 0.1%	240-24947
R66	Resistor, 80.6 k Ω 1%, 1/8 W	305-21749
R67, R68, R77	Resistor, 10 k Ω 10% 1/4 W	307-13933
R69, R72, R75, R76, R86, R92	Resistor, 20 k Ω 0.02%	240-23647
R71, R84	Resistor, 68 Ω 10% 1/4 W	307-13902
R78	Resistor, 1.58 k Ω 1% 1/8 W	305-21732
R79	Resistor, 63.4 k Ω 1% 1/8 W	305-21748
R80	Resistor, 20 k Ω 1% 1/8 W	305-21743
R81	Resistor, 24.9 k Ω 1% 1/8 W	305-21744
R93	Resistor, 1.5 k Ω 0.05%	240-24943
R94	Resistor, 1.87 k Ω 0.05%	240-24944
R95	Resistor, 7.5 k Ω 1% 1/8 W	305-21773
R99	Resistor, 470 Ω 10% 1/2 W	304-15973
R104	Resistor, 2.2 M	307-13962
R106, R107, R109	Potentiometer, 50 k Ω	306-12091
R108	Resistor, 10 M Ω 10% 1/4 W	307-13974
S1, S4	Switch Assembly, Mode & Power	330-27054
U3, U5, U6, U15-U20	Operational Amplifier, 741	343-20668
U7-U14	Operational Amplifier, 301A	343-20669
U4	Operational Amplifier, 3080	352-20723

5.3 RANGE SWITCH ASSEMBLY A2

<u>CIRCUIT NO.</u>	<u>DESCRIPTION</u>	<u>ESI PART NO.</u>
	Complete Assembly	201-29169
C16	Capacitor, 0.022 μ F	201-02174
C18	Capacitor, 470 pF Poly	313-25921
C19	Capacitor, 0.0047 μ F Mylar	313-13299
C20	Capacitor, 0.068 μ F Mylar	313-18841
C41	Trimmer, 14 to 150 pF	316-02166
C62	Capacitor, 1000 pF Poly	313-07094
C63	Capacitor, 100 pF Poly	313-18760
R39	Resistor, 22 k Ω 10% 1/4 W	307-13937
R40	Resistor, 4.7 k Ω 10% 1/4 W	307-13927
R41	Resistor, 470 Ω 10% 1/4 W	307-13915
R42	Resistor, 90 k Ω 0.02%	240-24937
R43	Resistor, 10 k Ω 0.02%	240-24941
R44	Resistor, 1 k Ω 0.02%	240-24940
R45	Resistor, 100 Ω 0.02%	240-24939
R46	Resistor, 10 Ω 0.02%	240-24938
S2	Switch, 7 Position	201-29167

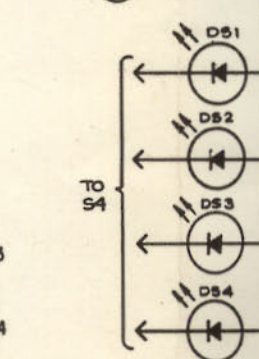
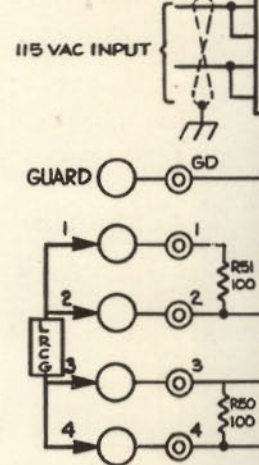
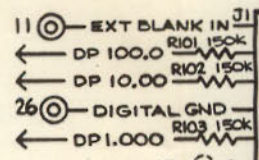
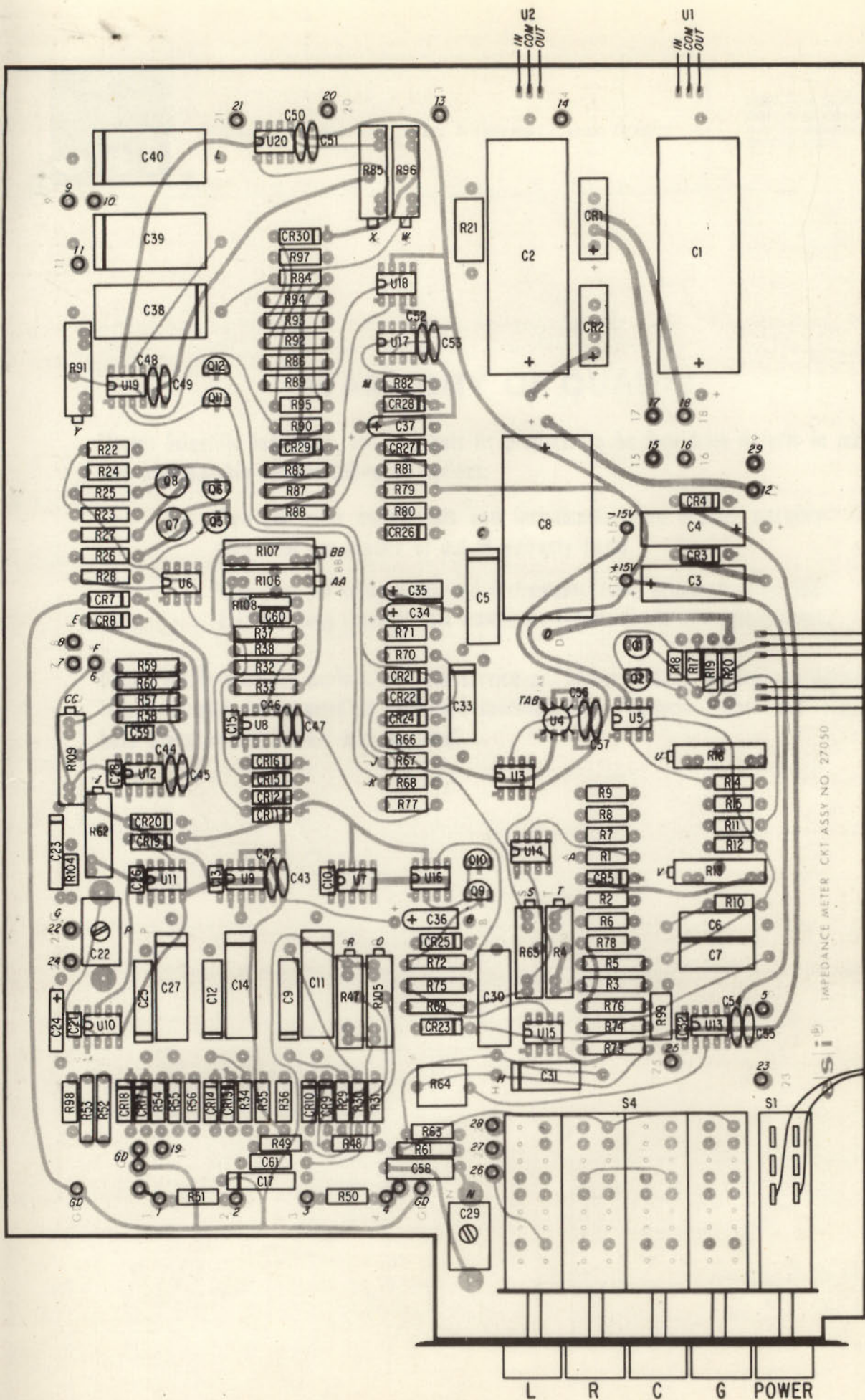

IMPEDANCE METER CKT ASSY NO. 27050

AC LINE POWER

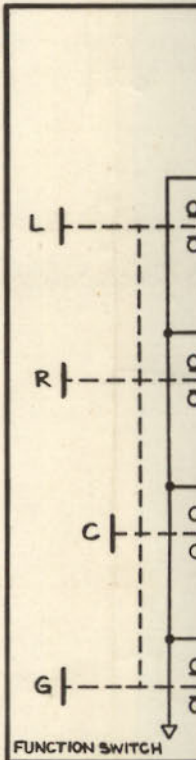

L R C G POWER

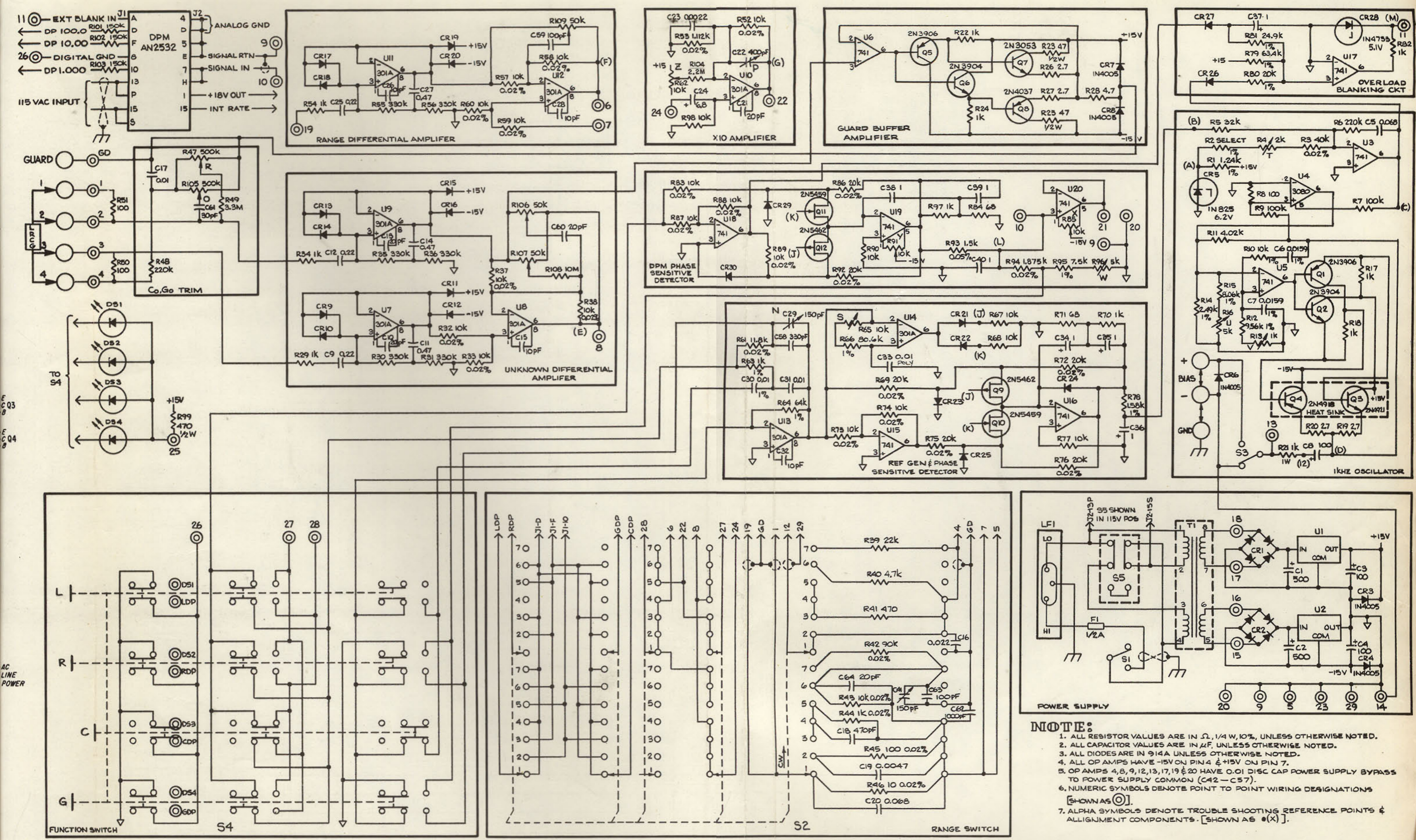

Figure 5-1. Model 251 Circuit Board Components Locations and Schematic Diagram



Electro Scientific Industries, Inc.

13900 N.W. SCIENCE PARK DRIVE
PORTLAND, OREGON 97229
(area code 503) 646-4141
TELEX No. 360273

ESI technical publications are listed on the back of this page. If you would like any of these, simply check the appropriate box and fill in your address below. Also, please add any comments or instructions for instruction manual. We value your feedback.

WARRANTY OF QUALITY

Electro Scientific Industries, Inc. warrants its products to be free from defects in material and workmanship for the following periods:

1. Two years for components and instruments using passive circuitry.
One year for repairs of out-of-warranty items.
2. One year for components and instruments using active circuitry (see ESI Metrology Catalog). Six months for repairs of out-of-warranty items.

During the in-warranty periods, we will service or, at our option, replace any device that fails in normal use to meet its published specifications. Batteries, tubes and relays that have given normal service are excepted.

Mail this page to

Electro Scientific Industries, Inc.
13900 N.W. Science Park Drive
Portland, Oregon 97229
Attention: Metrology Department

Would you like more information?



ESI technical publications are listed on the back of this page. If you would like any of these, simply check the appropriate box and fill in your address below. Also, please add any comments you have concerning the instrument or instruction manual. We value your feedback to help us improve or correct our manuals.

Instrument Description: Model No. _____ Serial No. _____
(Please Print)

Name _____ Title _____

Department _____ Mail Stop _____

Company _____

Address _____

City _____ State _____ Zip Code _____

Comments or corrections _____

Mail this page to:



Electro Scientific Industries, Inc.

13900 N.W. Science Park Drive
Portland, Oregon 97229

Attention: Literature Department

- applications data
- technical articles
- engineering bulletins

- EB10 Effects of Output Loading on Resistive Voltage Dividers, *October 1969*
- EB15 Low Input Resistance Voltage Dividers, *Feb. 1970*
- EB17 Accuracy vs. Frequency of Models 290B and 250DE Universal Impedance Bridges, *(revised May 1969)*
- EB26 International System of Units, *August 1969*
- EB29 DC and Low Frequency AC Ratio Measurements, *Dr. Merle L. Morgan, September 1962*
- EB30 Traceability of Resistance Measurement, *Jack Riley, January 1964*
- EB34 Resistance Transfer Technique, *Lawrence H. White, (revised April 1968)*
- EB35 An Improved Technique for Establishing Resistance Ratios, *R. M. Pailthorp and J. C. Riley, November 1962*
- EB41 Derivation of Electrical Units from Fundamental Standards. *R. D. Kuykendall and R. M. Pailthorp, July 1964*
- EB44 DC Measurements Using Ratio Techniques, *Jack C. Riley, September 1965*
- TA-2 A Ratio Transformer Bridge for Standardization of Inductors and Capacitors, *D. L. Hillhouse and H. W. Kline, August 1960*
- TA6 The Accuracy of Series and Parallel Connections of Four-Terminal Resistors, *Jack C. Riley, April 1965*
- TA8 AC Measurements Using Ratio Techniques, *Jack C. Riley, May 1965*
- TA9 Strength for the Weak Spot in DC Potentiometry, *George D. Vincent and M. L. Roberts, October 1965*
- TA14 The Advantages of a Ten Kilohm Transportable Resistance Standard, *Robert M. Pailthorp, September 1967*
- TA16 Which Bridge for Precise Resistance Measurements? *Edward J. Swenson and George D. Vincent, December 1967*
- TA17 Experimental Verification of the Five-Terminal, Ten-Kilohm Resistor As a Device for Dissemination of the Ohm, *R. M. Pailthorp and George Vincent, December 1968*
- TA22A Laser Resistance Trimming from the Measurement Point of View, *Arthur G. Albin and Edward J. Swenson, June 1971*
- TA23 Precision Measurement of Resistor Networks, *Robert M. Pailthorp and Jack C. Riley, June 1971*
- TA24 Predictive Adjustment of Tantalum Film Resistors by Anodization, *Donald R. Cutler and Edward J. Swenson, July 1971*
- TA25 Laser Trimming Analysis Using a Resistive Sheet Analogy, *Swenson, Vincent, Riley, December 1972*
- TA26 The Effects of Laser Trimming on Birox and 1100 Series Thick Film Composition, *N. S. Spann, R. Headley, G. D. Vincent and E. J. Swenson, Oct. 1971*
- TA27 Laser Trimming Thin Film Precision Resistor Networks With an Automated System, *Leonhard Groth, January 1974*
- TA28 YAG Laser Trimming of Thick Film Resistors, *Headley, Popowich, Anders, January 1974*
- TA-29 An Overview of Laser Functional Trimming Techniques, *Gunnar Hurtig III and Edward J. Swenson, August 1974*
- TA-30 Measurement Subsystem For an AC Network Laser Trimmer, *R. A. Schomburg, August 1974*

