

Instruction Manual

Linear Active Pirani Gauge

Description	Item Number
APGX-M-NW16 AL	D023-71-000
APGX-M-NW16 ST/ST	D023-75-000
APGX-M-NW25 ST/ST	D023-72-000
APGX-M-15MM OD ST/ST	D023-76-000
APGX-MP-NW16 ST/ST	D023-85-000
APGX-MP-15MM OD ST/ST	D023-86-000
APGX-L-NW16 AL	D023-73-000
APGX-L-NW16 ST/ST	D023-77-000
APGX-L-NW25 ST/ST	D023-74-000
APGX-L-15MM OD ST/ST	D023-78-000





Declaration of Conformity

We, Edwards Limited,
Crawley Business Quarter,
Manor Royal,
Crawley,
West Sussex, RH10 9LW, UK

declare under our sole responsibility, as manufacturer and person within the EU authorised to assemble the technical file, that the product(s)

APGX-M-NW16 AL	D023-71-000
APGX-M-NW16 ST/ST	D023-75-000
APGX-M-NW25 ST/ST	D023-72-000
APGX-M-15mm OD ST/ST	D023-76-000
APGX-MP-NW16 ST/ST	D023-85-000
APGX-MP-NW25 ST/ST	D023-82-000
APGX-MP-15mm OD ST/ST	D023-86-000
APGX-L-NW16 AL	D023-73-000
APGX-L-NW16 ST/ST	D023-77-000
APGX-L-NW25 ST/ST	D023-74-000
APGX-L-15mm OD ST/ST	D023-78-000

to which this declaration relates is in conformity with the following standard(s) or other normative document(s)

EN61326-2-3: 2013 (Class B Emissions, Industrial Immunity)	Electrical equipment for measurement, control and laboratory Use. EMC requirements. Particular requirements. Test configuration, operational conditions and performance criteria for transducers with integrated or remote signal conditioning
EN50581: 2012	Technical Documentation for the Assessment of Electrical and Electronic Products with respect to the Restriction of Hazardous Substances

and fulfils all the relevant provisions of

2014/30/EU	Electromagnetic Compatibility (EMC) Directive
2011/65/EU	Restriction of Certain Hazardous Substances (RoHS) Directive
2012/19/EU	Waste from Electrical and Electronic Equipment (WEEE) Directive

Note: This declaration covers all product serial numbers from the date this Declaration was signed onwards.

Larry Marini, Senior Technical Manager

07.07.2015, Eastbourne

Date and Place

This product has been manufactured under a quality management system certified to ISO 9001:2008

Contents

Section	Page
1	Introduction 1
1.1	Scope and definitions 1
1.2	Description 1
1.3	Gas dependency 2
2	Technical data 3
2.1	Mechanical data 3
2.2	Performance, operating and storage conditions 3
2.3	Electrical data 3
2.4	Materials exposed to vacuum 4
3	Installation 7
3.1	Unpack and inspect 7
3.2	Fit the APGX to the vacuum system 7
3.3	Electrical connections 7
3.3.1	Connect to Edwards controllers or AGD display 7
3.3.2	Connect to your own supply and control equipment 7
4	Operation 9
4.1	Pressure measurement 9
4.2	Set-point adjustment 10
4.3	Error monitoring 11
5	Maintenance 13
5.1	Atmosphere and vacuum adjustment 13
5.2	Clean the filter 13
5.3	Fault finding 14
5.4	Calibration service 14
6	Storage and disposal 15
6.1	Storage 15
6.2	Disposal 15
7	Spares and accessories 17
7.1	Introduction 17
7.2	Spares 17
7.3	Accessories 17

For return of equipment, complete the HS Forms at the end of this manual.

Illustrations

Figure	Page
1 General view of the APGX (NW16 APGX shown)	2
2 Dimensions (mm) (NW16 APGX shown)	5
3 Schematic diagram of typical electrical connections	8
4 Pressure - voltage characteristics of the APGX-L	10
5 Pressure - voltage characteristics of the APGX-M and APGX-MP	10
6 Adjust the set-point pressure	12

Tables

Table	Page
1 Pins on the APGX electrical connector socket	8
2 Error indications	11

Trademark credits

Cajon Ultratorr™ is a registered trademark of Swagelok Company

1 Introduction

1.1 Scope and definitions

This manual provides installation, operation and maintenance instructions for the Edwards APGX (Linear Active Pirani Gauge). You must use the APGX as specified in this manual.

Read this manual before you install and operate the APGX. Important safety information is highlighted as WARNING and CAUTION instructions; you must obey these instructions. The use of WARNINGS and CAUTIONS is defined below.



WARNING

Warnings are given where failure to observe the instructions could result in injury or death to people.

CAUTION

Cautions are given where failure to observe the instructions could result in damage to the equipment, associated equipment or process.

The units used throughout this manual conform to the SI international system of measurement.

The following symbol is on the APGX:



From August 2005, Edwards will offer European customers a recycling service.

1.2 Description

The APGX requires a 15 to 36 V d.c. power supply: it has a 2 to 9 V d.c. analogue linear output which is related to pressure. The APGX is compatible with all of the Edwards AGC's (Active Gauge Controllers), and with the appropriate versions of the Edwards AGD's (Active Gauge Displays). Alternatively, you can use an independent power supply for the APGX and you can read the APGX output signal with a voltmeter or an analogue-to-digital converter.

An 8-way electrical connector socket on the APGX (Figure 1, item 2) is used to connect the APGX to your AGC, AGD or electrical supply and voltmeter. Electrical cables fitted with suitable connector plugs are available as accessories. A gauge identification signal is available on the electrical connector: this signal is used by Edwards AGC's to identify which type of Active gauge is connected. All the APGX gauges use the same identification signal.

The APGX vacuum connection is an NW16, NW25 or plain 15 mm outside diameter tube. The gauge tube is either stainless steel or aluminium.

A stainless steel mesh filter is fitted to the end of the gauge tube to protect the gauge filament from contamination and from the effects of turbulence in the vacuum system when it is pumped down or vented to atmospheric pressure.

The APGX contains two patented temperature sensing devices. The APGX uses these devices to compensate the output for the effects of changes in ambient temperature.

Three push button switches are available on the APGX (see Figure 6). The first one is for setting the atmospheric and vacuum reading. The other two switches allow you to change the operating pressure of the two set-point devices.

The set-point device is a transistor which acts like a switch. At high pressure (above the set-point), the output of the transistor is off (open or high impedance). When the pressure falls to the set-point value, the transistor output changes to on (closed or low impedance). The transistor has a fixed hysteresis of 500 mV: the output goes off when the pressure rises to 500 mV above the set-point pressure. Note that, if you use an Edwards AGC controller or AGD display, the APGX set-point is not used.

1.3 Gas dependency

The rate of heat transfer through a gas is dependent upon both the pressure, and the RMM (relative molecular mass) of the gas. Therefore, the output signal of the APGX is also gas dependent.

The output signal voltage to pressure conversions equation applies for nitrogen and dry air, but can also be used when you measure the pressure of gases which have a similar RMM, such as oxygen and carbon monoxide.

Generally:

- with gases which have a lower RMM than nitrogen, the pressure indicated by the APGX will be higher than the actual gas pressure
- with gases which have a higher RMM than nitrogen, the pressure indicated by the APGX will be lower than the actual gas pressure

Graphs which show the APGX pressure and voltage characteristics for argon, neon, krypton, helium and carbon dioxide are available on request; contact your supplier or Edwards.

Figure 1 - General view of the APGX (NW16 APGX shown)

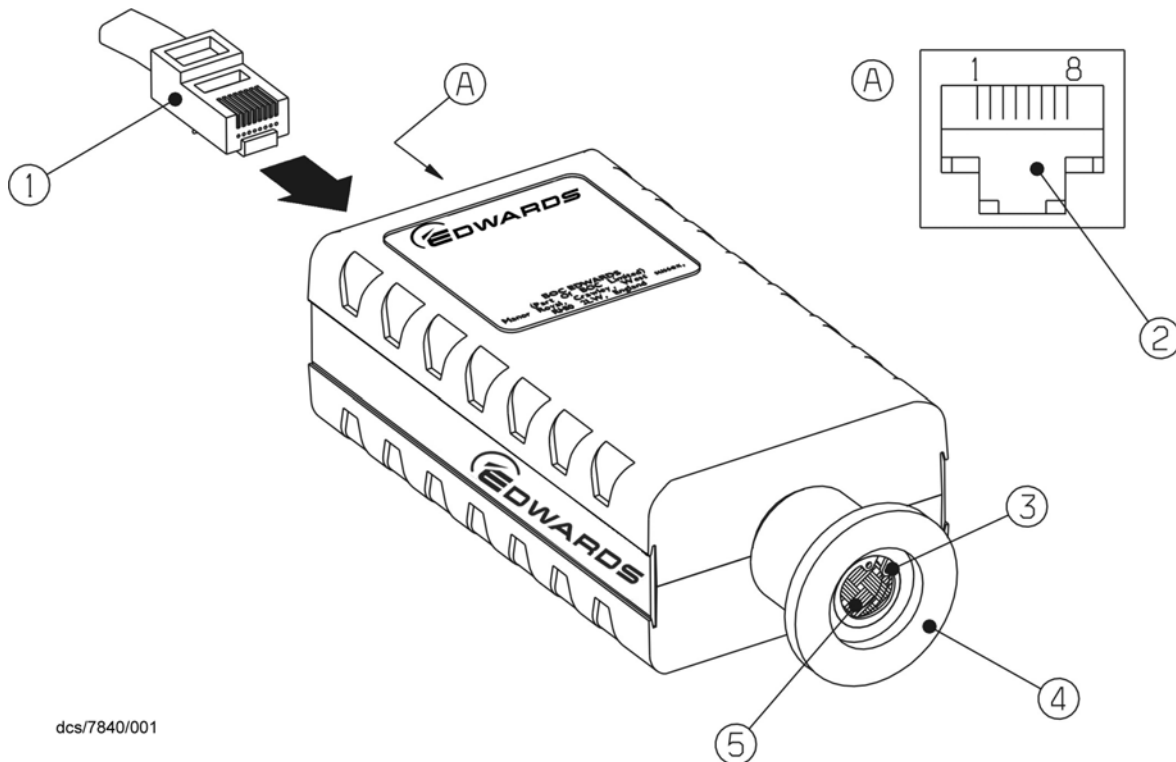

dcs/7840/001

- | | |
|-----------------------------|------------------|
| 1. Cable connector plug | 4. Vacuum flange |
| 2. APGX connector socket | 5. Filter |
| 3. Filter-retaining circlip | |

2 Technical data

2.1 Mechanical data

Dimensions	See Figure 2
Mass	
Aluminium tube	120 g
Stainless steel tube	200 g
Volume of gauge tube	
NW16/NW25	6 cm ³
15 mm OD	10 cm ³
Enclosure rating	IP40 (EN 60529)

2.2 Performance, operating and storage conditions

Note: The APGX gauges will indicate up to 1000 mbar (760 torr) at reduced accuracy.

Ambient temperature	
Operation	5 to 55 °C
Storage	-30 to 70 °C
Compensated pressure	
Temperature range	5 to 55 °C
Ambient humidity (operation)	10 to 90% (non-condensing)
Maximum operating altitude	2000 m
Maximum internal pressure	10 bar absolute (9 bar gauge)
Pressure range	
APGX-M/APGX-MP	100 to 1 x 10 ⁻³ mbar
APGX-L	10 to 1 x 10 ⁻⁴ mbar
Filament operating temperature (approximate)	100 °C
Pollution category	IEC1010 Category 2

2.3 Electrical data

- Notes:**
1. The electrical power consumption of the APGX is reduced when the system is at vacuum.
 2. The relationship between output signal voltage and pressure is described in [Section 4.1](#).

Electrical supply	
Voltage	+14.5 to +36 V d.c.
Max voltage ripple	1 V peak to peak
Max source resistance	100 Ω
Maximum power consumption	
	1.5 W (APGX-M and -MP)
	2.0 W (APGX-L)

Electrical connector	FCC68/RJ45 type, 8-way
Pressure output signal	
Range	$2 \leq \text{output} \leq 9 \text{ V d.c.}$
Error range	output < 2 V d.c. or output > 9 V d.c.
impedance	0.1 Ω
Min load	10 k Ω
Max current source	1 mA
Set-point	
Adjustment range	
APGX-L	1.8 to 9.2 V
APGX-M, -MP	2.8 to 9.2 V
Fixed hysteresis	500 mV
Resolution	$\pm 10 \text{ mV}$
External load rating	40 V d.c., 100 mA max
Back EMF suppression diode *	
Min. surge rating	1 A
Min. reverse voltage rating	100 V
Gauge identification resistance	36 k $\Omega \pm 2\%$ (APGX-M and -MP) 43 k $\Omega \pm 2\%$ (APGX-L)

* Required when you use an external d.c. relay connected to the set-point output.

2.4 Materials exposed to vacuum

Filament	
APGX-M/APGX-L	Gold plated tungsten
APGX-MP	Platinum / Rhodium (90/10)
Filter	Stainless steel (AISI 316L)
Gauge tube	Aluminium (HE30TF) or stainless steel (AISI 316L)
Other	Nickel, fluoroelastomer, PTFE

Figure 2 - Dimensions (mm) (NW16 APGX shown)

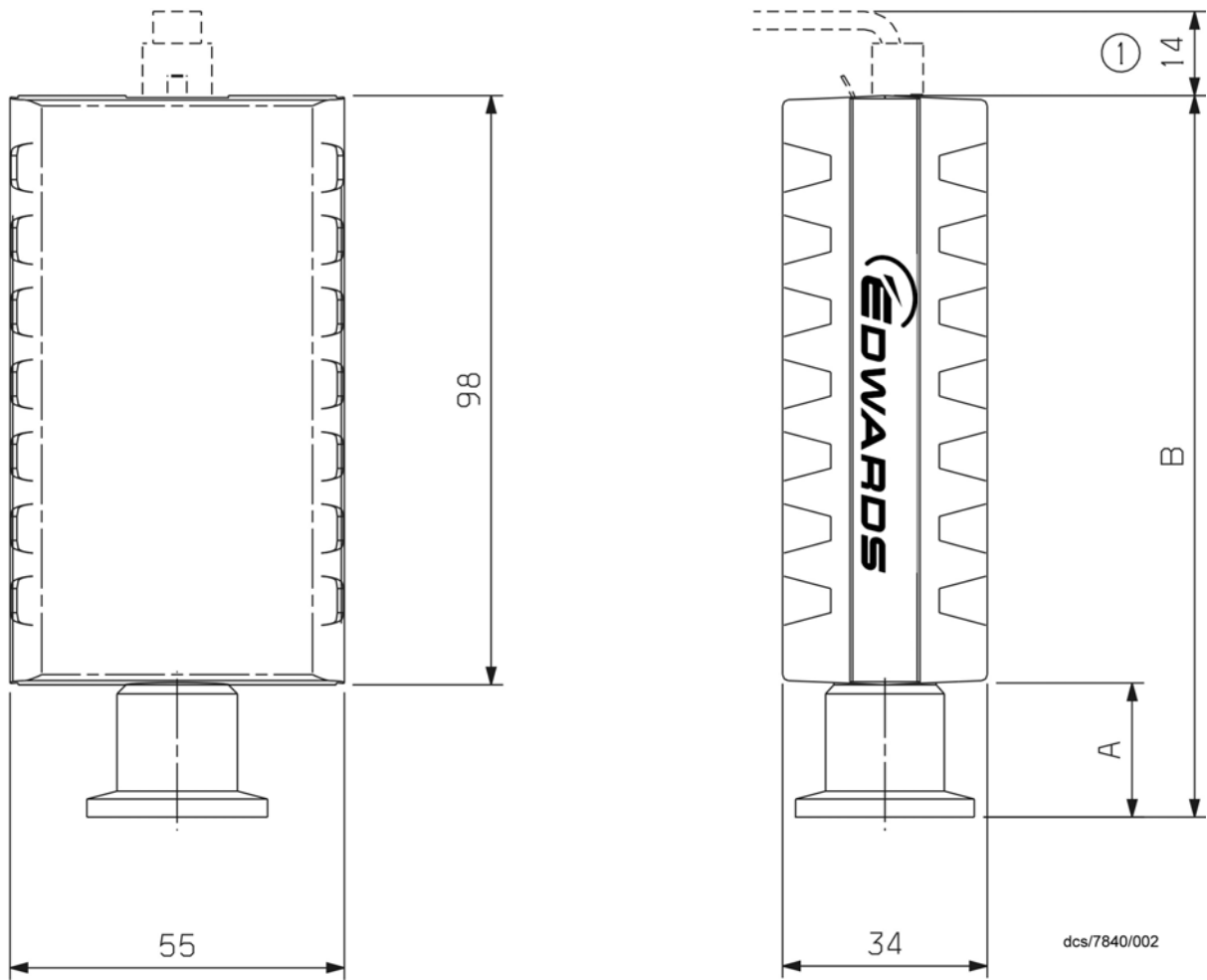

1. Clearance required for electrical cable

	A	B
NW16	22	120
NW25	26	124
150D	52	150

This page has been intentionally left blank.

3 Installation

3.1 Unpack and inspect

Remove all packing materials and protective covers and check the APGX.

If the APGX is damaged, notify your supplier and the carrier in writing within three days; state the Item Number of the gauge together with your order number and your supplier's invoice number. Retain all packing materials for inspection. Do not use the APGX if it is damaged.

If the APGX is not to be used immediately, replace the protective covers. Store the APGX in suitable conditions as described in [Section 6](#).

3.2 Fit the APGX to the vacuum system

The APGX can be mounted in any orientation. To avoid the build-up of debris or condensable material in the body tube of the APGX (which will probably cause pressure measurement errors), we recommend that you install the gauge vertically as shown in [Figure 2](#).

To connect the APGX to your vacuum system:

- Use an 'O' ring / centring ring or Co-seal and clamp to connect an NW16 or NW25 flange to a similar flange on the vacuum system.
- Use a stepped 'O' ring carrier or Co-seal to connect an APGX with an NW16 flange to an NW10 flange.
- Use Cajon Ultratorr™ type compression couplings to connect an APGX with a 15 mm OD tube connection to your system.

The presence of process contaminants can adversely effect the performance of the gauge. In such applications, the use of sintered filters can often substantially increase the life of the gauge. For a suitable sintered filter, please refer to [Section 7.3](#).

3.3 Electrical connections



WARNING

If the APGX malfunctions, the APGX pressure output may be incorrect. If such a failure could cause injury to people or damage equipment, you must install a suitable control system to indicate the failure and, if necessary, to close down your process system.

When using a cable longer than 30 m, full compliance with the EN61326 requires an in-line surge suppressor (please refer to [Section 7.3](#)).

3.3.1 Connect to Edwards controllers or AGD display

Connect the APGX to the controller or display with a cable which is terminated in suitable connectors. Suitable cables are available from Edwards (refer to [Section 7](#)).

3.3.2 Connect to your own supply and control equipment

Note: Do not connect the electrical supply common (pin 2) to the signal common (pin 5). If you do, the APGX output signal will be inaccurate.

A schematic diagram of the recommended electrical connections to the APGX is shown in [Figure 3](#).

The pins on the APGX electrical connection socket are used as shown in Table 1. The specification of the electrical supply, d.c. relay and back EMF suppression diode are given in Section 2.

Table 1 - Pins on the APGX electrical connector socket

Pin Number	Use
1	Electrical supply positive voltage
2	Electrical supply common
3	Pressure measurement output signal
4	Gauge identification signal
5	Signal common
6	Set-point (1) output signal
7	Remote calibration input
8	Set-point (2) output signal

The connections to pins 6, 7 and 8 are optional. Make the connection to pin 6 and 8 if you want to connect the set-point signal to a d.c. relay: you must connect a suppression diode between pins 1 and 6 and between 1 and 8 to protect the APGX from transient voltages generated when the d.c. relay is switched off.

Connecting pins 2 and 7 will enable setting of the atmospheric output when the gauge is at atmosphere and the vacuum output when the gauge is at vacuum. If you want to measure the gauge identification signal (to identify the type of APGX), measure the resistance between pins 4 and 5.

Figure 3 - Schematic diagram of typical electrical connections

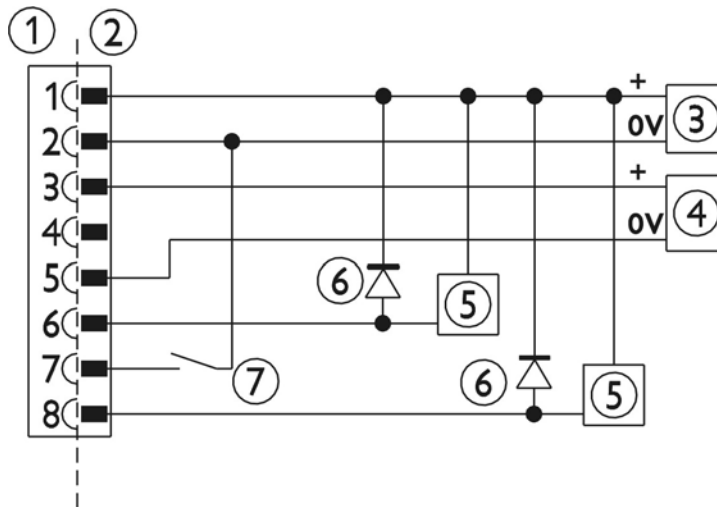

- 1. APGX electrical connector socket
- 2. Cable electrical connector plug
- 3. Electrical supply
- 4. Voltmeter
- 5. D.C. Relay (optional)
- 6. Back EMF suppression diode (optional)
- 7. Grounding switch (optional)

4 Operation



WARNING

Do not use the APGX to measure the pressure of explosive or flammable gases or mixtures. The gauge contains a heated filament which normally operates at 80 °C above ambient temperature. The temperature of the filament can be higher under fault conditions.



WARNING

When the pressure of gases of high molecular weight are measured, the pressure indicated can be below the true pressure. Ensure that the APGX is not over-pressurised when you use heavy gases.

CAUTION

Never disconnect the APGX to vent the vacuum system. The resulting turbulence may damage the gauge filament.

CAUTION

Contamination can affect the performance of the gauge. Users are expected to take necessary actions to reduce gauge exposure to sources of contamination.

4.1 Pressure measurement

For most accurate pressure measurement, allow the APGX to warm-up for about 10 minutes and then use the procedure in [Section 5.1](#) to adjust the APGX.

If you connected the APGX to an Edwards AGC controller or AGD display, the pressure measured by the gauge is shown on the display.

If you connected the signal output of the APGX to a voltmeter, convert the measured voltage to the corresponding pressure value using the following equation:

$$\begin{aligned}
 P &= 10^{V-6} \text{ mbar} \\
 &= 10^{V-4} \text{ Pascal} \\
 &= 10^{V-6.125} \text{ torr}
 \end{aligned}$$

Where V is the measured voltage in volts. For example, if the measured voltage V = 4 volts, then pressure P = 10⁻² mbar. Refer to [Figure 4](#) and [5](#).

The output of the APGX-M and APGX-MP will drop from 3 V to 2 V when the pressure goes below 10⁻³ mbar. See [Figure 5](#).

Figure 4 - Pressure - voltage characteristics of the APGX-L

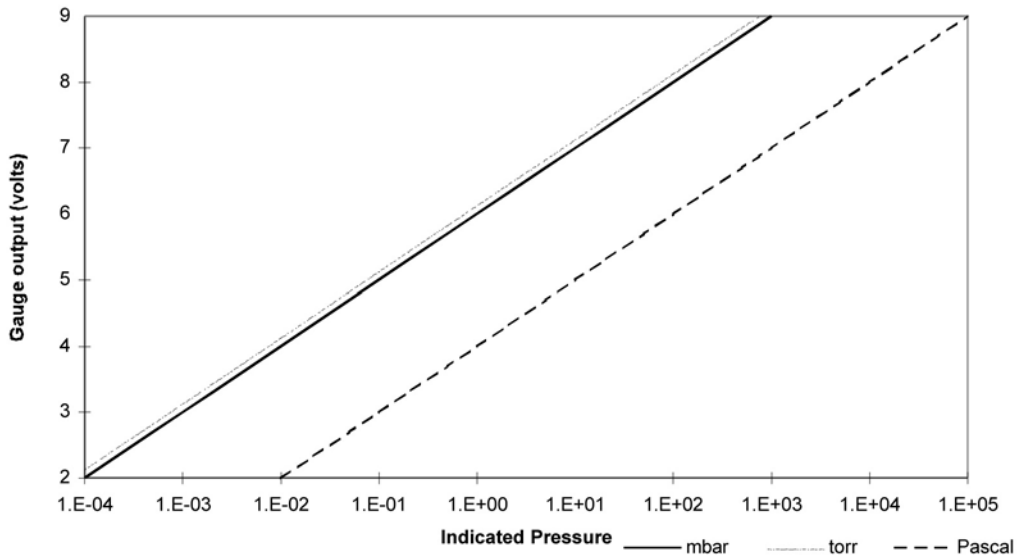
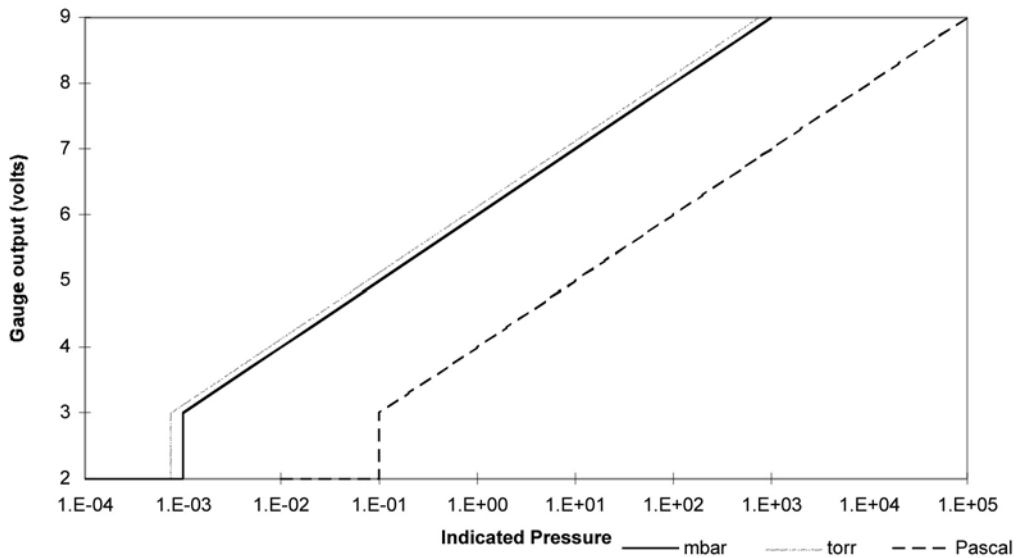

Figure 5 - Pressure - voltage characteristics of the APGX-M and APGX-MP



4.2 Set-point adjustment

To read the voltage at which the set-point output signals are activated, press the required set trip switch (see Figure 6) with an appropriate tool. The output of the gauge will indicate the set trip level for 3 seconds after which the output will read the normal voltage output.

To adjust the voltage at which the set-point output signal is activated, press the required set trip switch and hold it down for more than 3 seconds. The set-point voltage will start scrolling upwards. Remove pressure from the switch as soon as you reach the required trip voltage. To make a finer adjustment, remove pressure from the set trip switch and immediately depress the switch as many times as required. Each depression will increase the set trip voltage by approximately 10 mV. Refer to [Section 4.1](#) to determine the operating voltage which corresponds to a given pressure.

The APGX has an error monitoring facility, which ensures that the set-point output signal is off:

- For 1 second immediately after the APGX is switched ON.
- When the pressure output signal is out of range.
- When an error voltage is detected. See [Section 4.3](#).

If required, the set-point operating voltage can be adjusted to 1.8 V for the APGX-L and 2.8 V for the APGX-M and APGX-MP. This ensures that the set-point output is permanently off.

If required, the set-point signal can be used to indicate when the gauge is operating correctly. Adjust the set-point operating voltage to > 9.2 V. The set-point output will then be ON if the gauge is operating normally, and OFF if an error condition is detected.

4.3 Error monitoring

The gauge is able to perform some internal error monitoring functions, and respond in a defined manner, as summarised below.

The error condition is reset (cleared) when the gauge is disabled or power is removed.

Table 2 - Error indications

Error Indications	Output Voltage	Edwards Controllers Output
Broken filament	9.5 V	Error E
Calibration error	9.6 V	Error F

The set-point will be disabled as soon as one of the above errors is detected.

Figure 6 - Adjust the set-point pressure

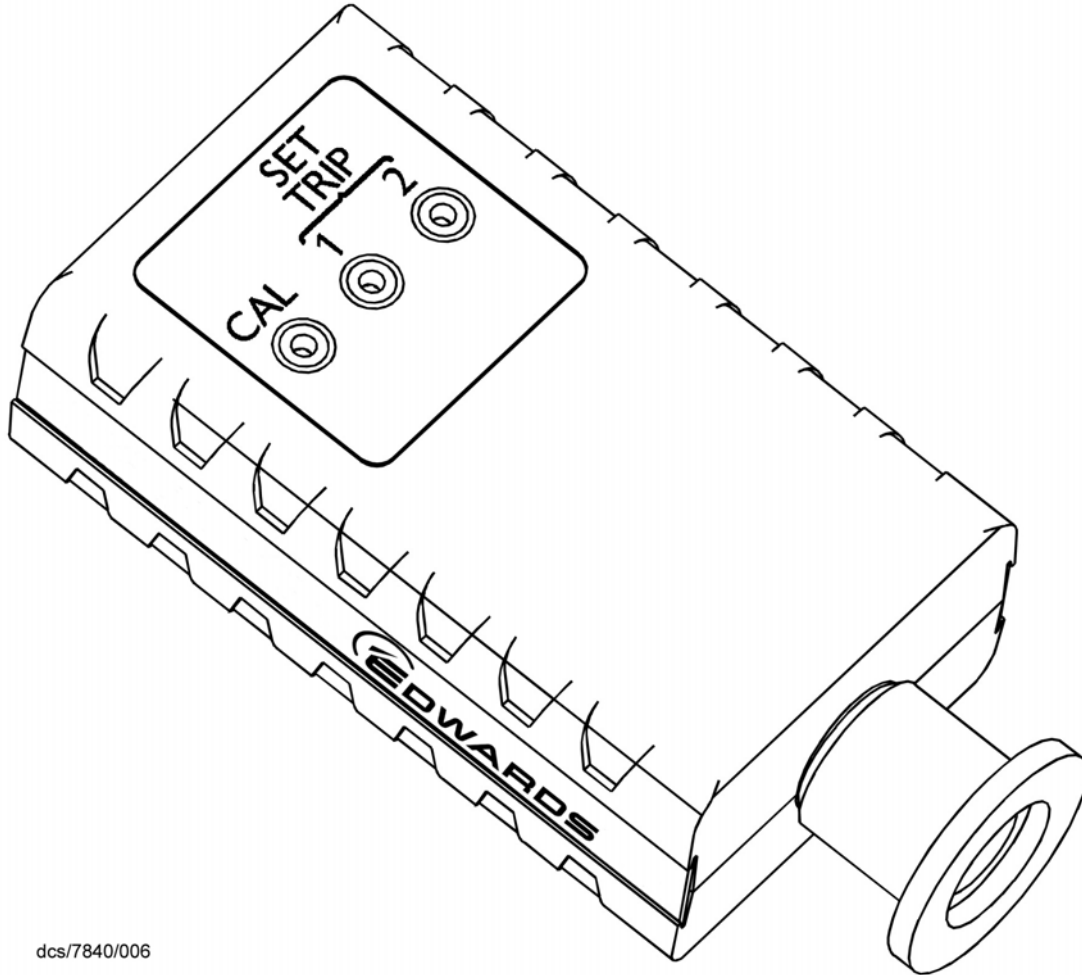

dcs/7840/006

5 Maintenance

CAUTION

Do not clean the interior of the gauge tube as you can damage the filament.

You can only replace the filter and its retaining circlip (refer to [Section 5.2](#)).

5.1 Atmosphere and vacuum adjustment

Use the CAL push button switch to adjust the APGX.

1. Switch on the power supply to the APGX and allow it to operate for 10 minutes.
2. With the vacuum system at atmospheric pressure, press the CAL switch for more than 1 second. The output will read approximately 9 V.
3. Reduce the system pressure to 1×10^{-4} mbar (or below) for the APGX-M or APGX-MP gauge, or to 1×10^{-5} mbar (or below) for the APGX-L gauge.
4. Press the CAL switch for more than 1 second. The output will read approximately 2 V.
5. Vent the system to atmospheric pressure and look at the output signal:
 - If the output signal is $9 \text{ V} \pm 100 \text{ mV}$ (atm), the adjustment procedure is complete.
 - If the output signal is outside this range, repeat this procedure from [Step 2](#).
 - If you have repeated the procedure and the output signal is outside the required range, refer to [Section 5.3](#).

5.2 Clean the filter



WARNING

You must remove the filter to clean it. Do not clean the filter in position in the body tube.

Refer to [Figure 1](#) and use the following procedure to clean the filter.

1. Switch off the electrical supply, ensure that the vacuum system is at atmospheric pressure and remove the APGX from the vacuum system.
2. Use circlip pliers to remove the filter-retaining circlip (3); ensure that you do not damage the inside of the body tube. Remove the filter (5).
3. Inspect the filter. If the filter is damaged or cannot be cleaned, replace the filter; a filter replacement kit is available as a spare (refer to [Section 7](#)).
4. Use a suitable cleaning solution to degrease the filter, then wash the filter repeatedly in clean water.
5. Wash the filter with methanol to remove all traces of water and then thoroughly dry the filter.
6. Refit the filter into the body tube and refit the circlip.

5.3 Fault finding

If you cannot adjust the pressure output signal from the APGX so that the signal is in the range $2\text{ V} \leq \text{output} \leq 9\text{ V}$ (that is, the signal is in the fault range), check the electrical connections and ensure that the electrical supply voltage is in the correct range (see [Section 2](#)).

If the connections and the electrical supply are correct, then the APGX is faulty and should be returned to Edwards for exchange or replacement.

5.4 Calibration service

A calibration service is available for all Edwards gauges. Calibration is by comparison with reference gauges, traceable to National Standards. Contact Edwards for details.

6 Storage and disposal

6.1 Storage

Return the APGX to its protective packaging and store the gauge in clean, dry conditions until required for use. Do not exceed the storage temperature conditions specified in [Section 2](#).

When required for use, prepare and install the APGX as described in [Section 3](#).

6.2 Disposal

Dispose of the APGX and any components safely in accordance with all local and national safety and environmental requirements.

Alternatively, you may be able to recycle the APGX and/or cables; contact Edwards or your supplier for advice (also see below).

The APGX and associated cables are within the scope of the European Directive on Waste Electrical and Electronic Equipment, 2002/96/EC. From August 2005, Edwards will offer European customers a recycling service for the APGX/cables at the end of the product's life. Contact Edwards for advice on how to return the APGX/cables for recycling.

Particular care must be taken if the APGX has been contaminated with dangerous process substances or if the gauge has been overheated or has been in a fire. Fluoroelastomers are used in the APGX; these are safe in normal use, but can decompose into dangerous breakdown products if heated to 260 °C and above.

This page has been intentionally left blank.

7 Spares and accessories

7.1 Introduction

Edwards products, spares and accessories are available from Edwards companies in Belgium, Brazil, Canada, France, Germany, Hong Kong, Italy, Japan, Korea, Switzerland, United Kingdom, U.S.A., and a world wide network of distributors. The majority of these centres employ Service Engineers who have undergone comprehensive Edwards training courses.

Order spare parts and accessories from your nearest Edwards company or distributor. When you order, please state for each part required:

- Model and Item Number of your equipment
- Serial number (if any)
- Item Number and description of part

7.2 Spares

The Filter Replacement Kit contains 5 filter-retaining circlips and 5 filters.

Spare	Item Number
Filter Replacement Kit	D021-71-810

7.3 Accessories

Accessory	Item Number
NW16/10 phosphor/bronze sintered filter	D021-10-760

The cables suitable for use with the APGX are as follows. These cables are supplied with 8-way male electrical connectors on both ends.

Cable length		Item Number
0.5 m	18 inches	D400-01-005
1 m	3 feet	D400-01-010
3 m	10 feet	D400-01-030
5 m	15 feet	D400-01-050
10 m	30 feet	D400-01-100
15 m	50 feet	D400-01-150
25 m	80 feet	D400-01-250
50 m	150 feet	D400-01-500
100 m	325 feet	D400-01-999
Surge suppressor		D400-06-000

This page has been intentionally left blank.