

#### NOTE

This manual documents the Model 1953A and its assemblies at the revision levels shown in Appendix 7A. If your instrument contains assemblies with different revision letters, it will be necessary for you to either update or backdate this manual. Refer to the supplemental change/errata sheet for newer assemblies, or the backdating sheet in Appendix 7A for older assemblies.

# 1953A Counter-Timer

## Instruction Manual

P/N 396622  
January 1975  
Rev. 4 1/79



# WARRANTY

Notwithstanding any provision of any agreement the following warranty is exclusive:

The JOHN FLUKE MFG. CO., INC., warrants each instrument it manufactures to be free from defects in material and workmanship under normal use and service for the period of 1-year from date of purchase. This warranty extends only to the original purchaser. This warranty shall not apply to fuses, disposable batteries (rechargeable type batteries are warranted for 90-days), or any product or parts which have been subject to misuse, neglect, accident, or abnormal conditions of operations.

In the event of failure of a product covered by this warranty, John Fluke Mfg. Co., Inc., will repair and calibrate an instrument returned to an authorized Service Facility within 1 year of the original purchase; provided the warrantor's examination discloses to its satisfaction that the product was defective. The warrantor may, at its option, replace the product in lieu of repair. With regard to any instrument returned within 1 year of the original purchase, said repairs or replacement will be made without charge. If the failure has been caused by misuse, neglect, accident, or abnormal conditions of operations, repairs will be billed at a nominal cost. In such case, an estimate will be submitted before work is started, if requested.

THE FOREGOING WARRANTY IS IN LIEU OF ALL OTHER WARRANTIES, EXPRESS OR IMPLIED, INCLUDING BUT NOT LIMITED TO ANY IMPLIED WARRANTY OF MERCHANTABILITY, FITNESS, OR ADEQUACY FOR ANY PARTICULAR PURPOSE OR USE. JOHN FLUKE MFG. CO., INC., SHALL NOT BE LIABLE FOR ANY SPECIAL, INCIDENTAL, OR CONSEQUENTIAL DAMAGES, WHETHER IN CONTRACT, TORT, OR OTHERWISE.

**If any failure occurs, the following steps should be taken:**

1. Notify the JOHN FLUKE MFG. CO., INC., or nearest Service facility, giving full details of the difficulty, and include the model number, type number, and serial number. On receipt of this information, service data, or shipping instructions will be forwarded to you.
2. On receipt of the shipping instructions, forward the instrument, transportation prepaid. Repairs will be made at the Service Facility and the instrument returned, transportation prepaid.

## **SHIPPING TO MANUFACTURER FOR REPAIR OR ADJUSTMENT**

All shipments of JOHN FLUKE MFG. CO., INC., instruments should be made via United Parcel Service or "Best Way" prepaid. The instrument should be shipped in the original packing carton; or if it is not available, use any suitable container that is rigid and of adequate size. If a substitute container is used, the instrument should be wrapped in paper and surrounded with at least four inches of excelsior or similar shock-absorbing material.

## **CLAIM FOR DAMAGE IN SHIPMENT TO ORIGINAL PURCHASER**

The instrument should be thoroughly inspected immediately upon original delivery to purchaser. All material in the container should be checked against the enclosed packing list. The manufacturer will not be responsible for shortages against the packing sheet unless notified immediately. If the instrument is damaged in any way, a claim should be filed with the carrier immediately. (To obtain a quotation to repair shipment damage, contact the nearest Fluke Technical Center.) Final claim and negotiations with the carrier must be completed by the customer.

The JOHN FLUKE MFG. CO., INC., will be happy to answer all applications or use questions, which will enhance your use of this instrument. Please address your requests or correspondence to: JOHN FLUKE MFG. CO., INC., P.O. BOX C9090, EVERETT, WASHINGTON 98206. ATTN: Sales Dept. For European Customers: Fluke (Holland) B.V., P.O. Box 5053, 5004 EB, Tilburg, The Netherlands.

\*For European customers, Air Freight prepaid.

**John Fluke Mfg. Co., Inc., P.O. Box C9090, Everett, Washington 98206**

Rev. 6/81

**CHANGE/ERRATA INFORMATION**

**ISSUE NO: 4      4/85**

This change/errata contains information necessary to ensure the accuracy of the following manual. Enter the corrections in the manual if either one of the following conditions exist:

1. The revision letter stamped on the indicated PCB is equal to or higher than that given with each change.
2. No revision letter is indicated at the beginning of the change/errata.

**MANUAL**

Title:                    1953A  
Print Date:            January 1975  
Rev.- Date:            4-1/79

**C/E PAGE EFFECTIVITY**

Page No.	Print Date
1	4/85
2	4/85
3	4/85
4	4/85
5	4/85
6	4/85
7	4/85
8	4/85
9	4/85
10	4/85
11	4/85
12	4/85
13	4/85
14	4/85
15	4/85
16	4/85
17	4/85

## NOTE

Carbon film resistors may be substituted for all carbon composition,  $\pm 5\%$ , 1/4W resistors used in the 1953A. Such substitution may also occur when ordering carbon composition resistors by their Fluke P/N.

## ERRATA #1

On page 1-4, Table 1-2, under the heading TIME BASE, in the STANDARD column, make the following change:

CHANGE:  $< \pm 2 \times 10^{-8}$   
 TO:  $< \pm 2 \times 10^{-6}$

On page 4-7, paragraph 4-55, change steps a, b, and d to read:

Step a line 5,

FUNCTION switch to FREQ (A/B)

Step b lines 2 and 3,

and the RF Voltmeter Probe to the Channel A input connector through a  $50\ \Omega$  termination.

Step d,

The display should be stable and read 1.000. (Ratio)

On page 602-3, Table 602-1, under the FUNCTION column, change pins 10, R, and 17, respectively, to read:

3SD-BCD 2  
 5SD-BCD 1  
 6SD-BCD 8

On page 615-3, paragraph 615-19, change the heading to read:

Trigger Level and Slope Instructions

Add the following step to the end of paragraph 615-24:

615-24a. The character T is a trigger command for the frequency A and C modes. It is an arm command for the period, time, interval, ratio, and A gated by the B modes where the signal to be measured actually does the triggering for the sample after being armed. For these applications where the input signal is to be held off, until the signal is present, and is to be held off until the character T is sent, before the F2, F3, F4, or F5 function command characters are sent, to ensure proper hold-off operation.

**ERRATA #2**

On page 1-4, Table 1-2, under EXTERNAL TIME BASE INPUT, make the following change:

CHANGE: Impedance . . . . . 1 M $\Omega$ , 20 pF.  
 TO: Impedance . . . . . 1 k $\Omega$ , 20 pF.

**ERRATA #3**

On page 4-4, Table 4-3, under the heading of READOUT\*, make the following change:

CHANGE: 1000.0000  
 TO: 100.0000

On page 4-6, paragraph 4-44, step g, change the first sentence to read:

Turn the CHANNEL B TRIGGER LEVEL control cw until the + TRIG STAT annunciator lights.

**ERRATA #4**

On page 4-7, add the following step to the end of paragraph 4-55,

m. If Option -15 IEEE-488 Standard Interface is installed, an additional adjustment (Trigger Level Zero Adjustment) must now be performed. See Option -15 IEEE-488 Standard Interface in Section 6 of this manual.

On page 615-5, add the following procedure after paragraph 615-51,

615-51a. TRIGGER LEVEL ZERO ADJUSTMENT

615-51b. This procedure zero adjust the IEEE-488 interface's Digital - To - Analog converters. However, it should not be performed until the Trigger Level Present Adjustments in Section 4 of this manual has been successfully completed. To perform this procedure, you will need the following equipment or their equivalents; IEEE-488 instrument controller (Fluke 1722A), low frequency source (Fluke 6011A), and an oscilloscope with a Z-axis input (Tektronix 465).

1. Set the oscilloscope input coupling to dc and center the trace.
2. Adjust the low frequency (LF) source for 1 kHz and a 50 mV output level.
3. Connect the LF source and the oscilloscope to the 1953A CH. A input through a BNC tee connector. DO NOT USE A TERMINATION. Connect the 1953A MARKER Connector to the oscilloscope's Z-axis (CRT, cathode) input. Connect the IEEE-488 controller GPIB port to the 1953A rear panel IEEE-488 connector.

## 4. Program the 1953A with the command string:

CF4S1A+1B-1

Adjust the oscilloscope for a display of two or three cycles of the input signal.

## 5. Adjust R16 on the IEEE-488 board to have the beginning of the bright portion of the trace be 0V, and then adjust R22 so that the end of the bright portion of the trace is a 0V.

## 6. Alternately send the commands:

A-B+ and A+B-

While adjusting R16 and R22 so that the beginning and end of the bright portions of the trace on the oscilloscope are equidistant from 0V with either command.

**ERRATA #5**

On pages 5-8 and 5-12, Table 5-3, make the following changes:

CHANGE: C2 | CAP, TA, 10 UF  $\pm 20\%$ , 15V | 193623 | 56289  
 | 196D106X0015KA4 | 26  
 TO: C2 | CAP, TA, 10 UF  $\pm 20\%$ , 15V | 193623 | 56289  
 | 196D106X0015A1 | 32

ADD: C135-C140 | CAP, TA, 10 UF  $\pm 20\%$ , 15V | 193623 | 56289  
 | 196D106X0015A1 | REF

On pages 5-15, 8-4, 8-6, 8-7 and 8-13, Figures 5-3 and 8-2 (2 of 8 and 3 of 8), make the above changes as shown in Figures 3, 4, and 5 of this change/errata.

ADD: R148,R149,R151,R152 | RES. DEP. CAR. 100  $\pm 5\%$ , 1/4W | 348771  
 | 80031 | CR251-4-5P100E | 4

**CHANGE #1 - 11811**

Rev.-Z, A1A1 Main PCB Assembly (1953A-4001)

On page 5-14, Table 5-3, make the following change:

FROM: XU65 | SOCKET, IC, 40-PIN DIP | 386060 | 89536 | 386060 | 1  
 TO: XU65 | SOCKET, IC, 40-PIN DIP | 429282 | 09922 | D1LB40P-108 | 1

**CHANGE #2 - 11968**

Rev.-H, A13 Remote Control Unit #3 PCB Assembly (1953A-4023)

On page 612-10, Table 612-5, make the following changes:

CHANGE: R764,R765 | RES. COMP, 4.7M  $\pm 5\%$ , 1/4W | 220046 | 01121  
 | CB4755 | 2  
 TO: R764,R765 | RES. CF, 2.2M  $\pm 5\%$ , 1/4W | 342659 | 80031  
 | CR251-4-5P2M2 | 2

On page 8-39, Figure 8-15, change the values of R764 and R765.

#### ERRATA #6

On page 5-16, Table 5-4, make the following changes:

CHANGE: F91 | FUSE, 1 AMP | 369819 | 71400 | AGC1 | 1  
 TO: F1 | FUSE, 1 AMP, FAST, 250V | 369819 | 71400 | AGC1 | 1

#### CHANGE #3 - 12545

Final Assembly

On page 5-3, Table 5-1, make the following changes:

CHANGE: U7 | TCXO (STANDARD OSCILLATOR) | 461871 | 89536 | 461871 | 1  
 TO: U7 | TCXO (STANDARD OSCILLATOR) | 516120 | 89536 | 516120 | 1

On page 604-1/604-2, change paragraph 604-4 to read:

604-4. Parts for Option -04 consist only of the TCXO which replaces the standard oscillator, U7. Replacements can be ordered using the Fluke Part No. 516120. The Manufacturing Federal Supply Code is 89536 and the Manufacturer's Part No. is 516120. See Figure 604-1.

#### ERRATA #7

On page 612-3, Table 612-1, and page 612-5, paragraphs 612-18c1 and 612-d1:

Change the description of Pin 1 to read:

FROM: EXT - T  
 TO: EXT - T LEVEL

On page 8-7, Figure 8-2 (3 of 8), change flag note 11 to read:

If U13 is installed for the 1 GHz and 1.3 GHz Options -13 and -14, disable W2 by drilling out the pad and hole-through plating (use a drill bit #52). Short W3 by installing a jumper between both pads of W3 and solder both sides.

**CHANGE #4 - 12911**

Rev.-J, A13 Remote Control Unit #3 PCB Assembly (1953A-4023)

On pages 612-9 and 612-10, Table 612-5, make the following change:

ADD: C713 | CAP, CER, 0.0012 UF  $\pm 10\%$ , 500V | 106732 | 71590 | CF122 | 1CHANGE: R754, R756 | RES. COMP, 100K  $\pm 5\%$ , 1/4W | 148189 | 01121  
| CB1045 | 3TO: R754, R756 | RES. DEP. CAR. 100K  $\pm 5\%$ , 1/4W | 348920 | 80031  
| CR251-4-5P100K | 3CHANGE: R757 | RES, COMP, 100K,  $\pm 5\%$ , 1/4W | 148189 | 01121  
| CB1045 | REFTO: R757 | RES. CF. 10  $\pm 5\%$ , 1/4W | 340075 | 80031 |  
CR251-4-5P10E | 1

On pages 612-11/612-12, and 8-38, Figures 612-5 and 8-15, add C713 and R757 as shown in Figure 1.

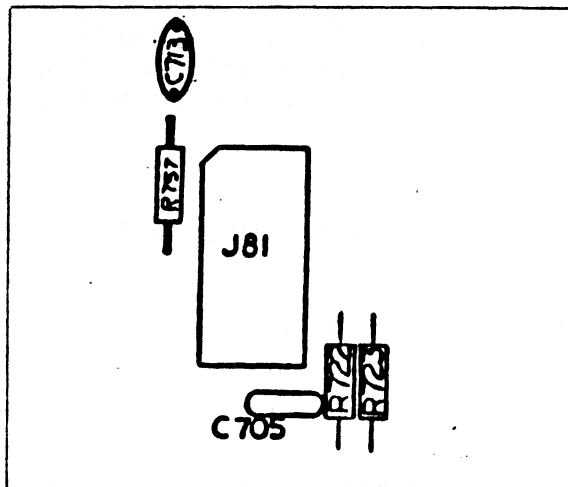

Figure 1.

On page 8-40 (2 of 2), Figure 8-15, add C713 and R757 as shown in Figure 2.

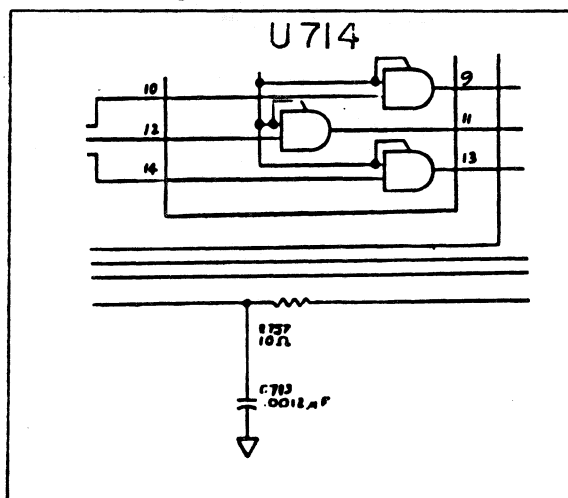

Figure 2.



**CHANGE #5 - 13113**

Rev.-P, A1A1 Main PCB Assembly (1953A-4001)

On pages 5-8, 5-12, and 5-14, Table 5-3, make the following changes:

Change the TOT QTY of C1, FROM: 4 TO: 2

CHANGE: C56,C57| CAP, CER. 47 PF  $\pm 20\%$ , 1000V| 369132| 56289  
 | C030B102H470J| REF  
 TO: C56,C57| CAP, CER. 100 PF  $\pm 10\%$ , 1KV | 105593| 71590  
 | DD-101 | 2

DELETE: U4| IC, ECL, TRIPLE 4-3-3 INPUT OR GATE| 402735| 07263  
 F95106DC| 1| 1

CHANGE: U1,U2,| IC, ECL, TRIPLE DIFF LINE RECEIVER | 402727| 07263  
 | F95116DC| 2| 1  
 TO: U1,U2,U4| IC, ECL, TRIPLE LINE RECEIVER 16-PIN DIP| 369702| 18324  
 | N10116B | 3| 1

CHANGE: XU4,XU6,XU31,XU32 | SOCKET, IC, 16-PIN DIP| 370312| 01295  
 | C931602 | 4  
 TO: XU1,XU2,XU4,XU6,XU31,XU32| SOCKET, IC, 16-PIN DIP| 370312| 91506  
 | 316-AG39D| 6

On pages 5-15, 8-4, 8-6 (2 of 8), and 8-13, Figures 5-3 and 8-2, make the above changes as shown in Figures 3 and 4 of this change/errata.

**CHANGE #6 - 13909**

Rev.-Z, A1A1 Main PCB Assembly (1953A-4001)

On pages 5-11 and 5-12, Table 5-3, make the following changes:

CHANGE: R59,61| RES. COMP, 240  $\pm 5\%$ , 1/4W| 221895| 01121  
 | CB1225 | 2  
 TO: R59,61| RES. CF, 240  $\pm 5\%$ , 1/4W | 573063| 80031  
 | CR251-4-5P240E| 2

ADD: R150| RES. DEP. CAR. 1.5K  $\pm 5\%$ , 1/4W| 343418| 80031  
 | CR251-4-5P1K5T| 1

On pages 5-15, 8-4, 8-7 (3 of 8), and 8-13, Figures 5-3 and 8-2, make the above changes as shown on Figures 3 and 5 of this change/errata.

CHANGE: R148,R149,R151,R152| RES. DEP. CAR. 100  $\pm 5\%$ , 1/4W | 348771  
 | 80031| CR251-4-5P100E| 4  
 TO: R148,R149,R151,R152| RES. DEP. CAR, 51  $\Omega$   $\pm 5\%$ , 1/4W| 414540  
 | 80031 | CR251-4-5P51E| 4

**CHANGE #7 - 14037**

Rev.-AE, A1A1 Main PCB Assembly (1953A-4001)

On page 5-9, Table 5-3, make the following changes:

Change the TOT QTY of L1, FROM: 1 TO: 3

DELETE: R149,R152| RES. DEP. CAR, 51  $\pm 5\%$ , 1/4W| 414540| 80031  
| CR251-4-5P51E| 2

ADD: L2,L3| INDUCTOR, 6-TURN| 320911| 89356| 320911| REF

On pages 5-15, 8-4, 8-7 (3 of 8), and 8-13, Figures 5-3 and 8-2, make the above changes as shown on Figures 3 and 5 of this change/errata.

**CHANGE #8 - 14936**

Rev.-AF, A1A1 Main PCB Assembly (1953A-4001)

On pages 5-11 and 5-12, Table 5-3, make the following changes:

Change the TOT QTY of R29, FROM: 7 TO: 6

CHANGE: R96| RES. COMP 5.6K  $\pm 5\%$ , 1/4W| 148080| 01121  
| CB5625 | REFTO: R96| RES. CF 5.1K  $\pm 5\%$ , 1/4W | 573329| 80031  
| CR251-4-5P5K1| 1

On pages 5-15, 8-4, and 8-13, replace Figures 5-3 and 8-2 with Figure 3.

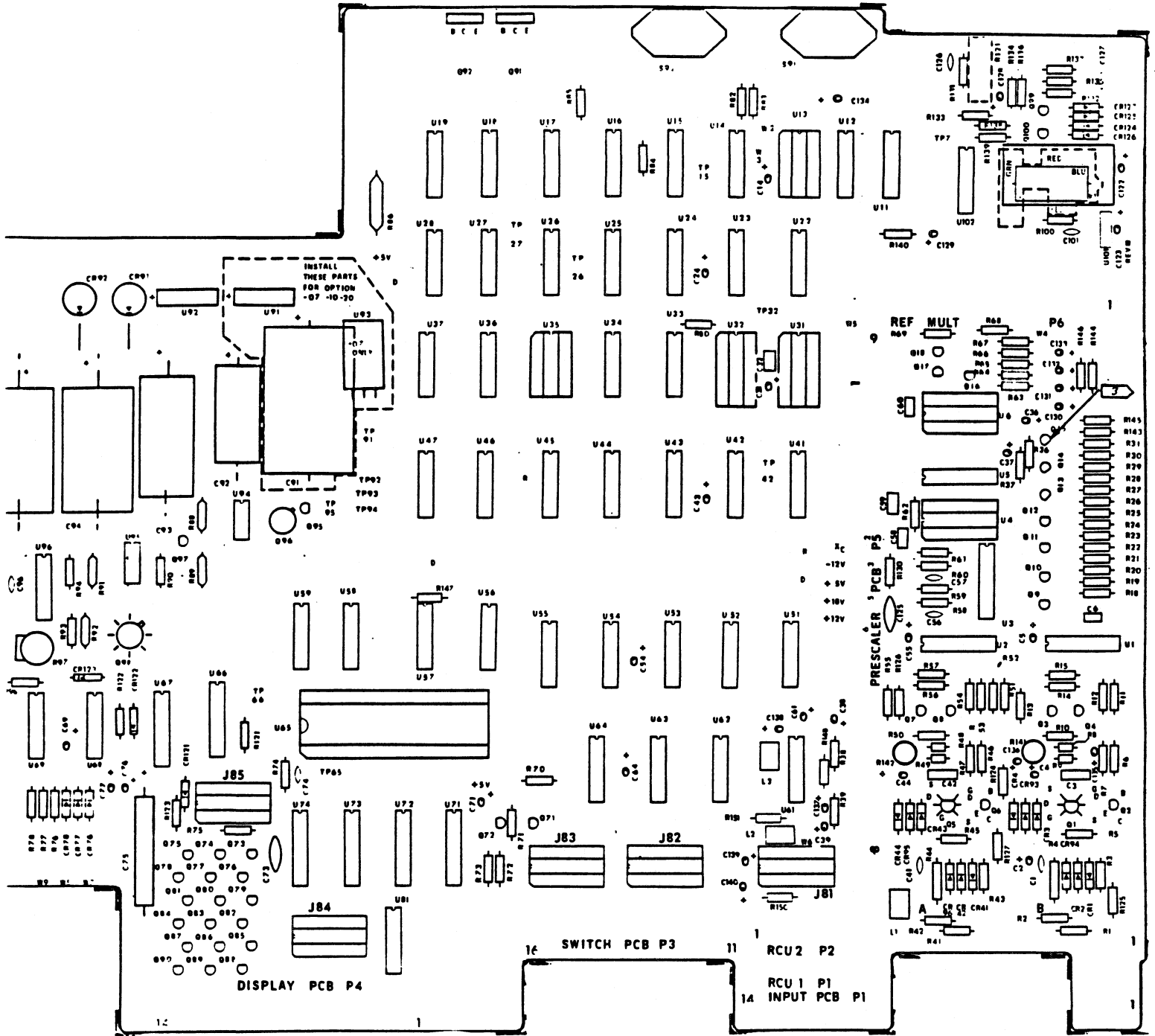

3 ITEM 10, REF DES Q15, MUST BE INSTALLED BACKWARDS, OR ROTATED 180° FROM Q9 THRU Q14. WHEN THIS TRANSISTOR IS PAINTED WITH A RED DOT.  
NOTE: TRANSISTORS WITH RED DOT MUST BE PREPPED REVERSE OF STANDARD DEVICE.

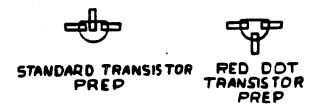

Figure 3.

On pages 8-6 and 8-7, Figure 8-2, replace sheets (2 of 8 and 3 of 8) with Figures 4 and 5.

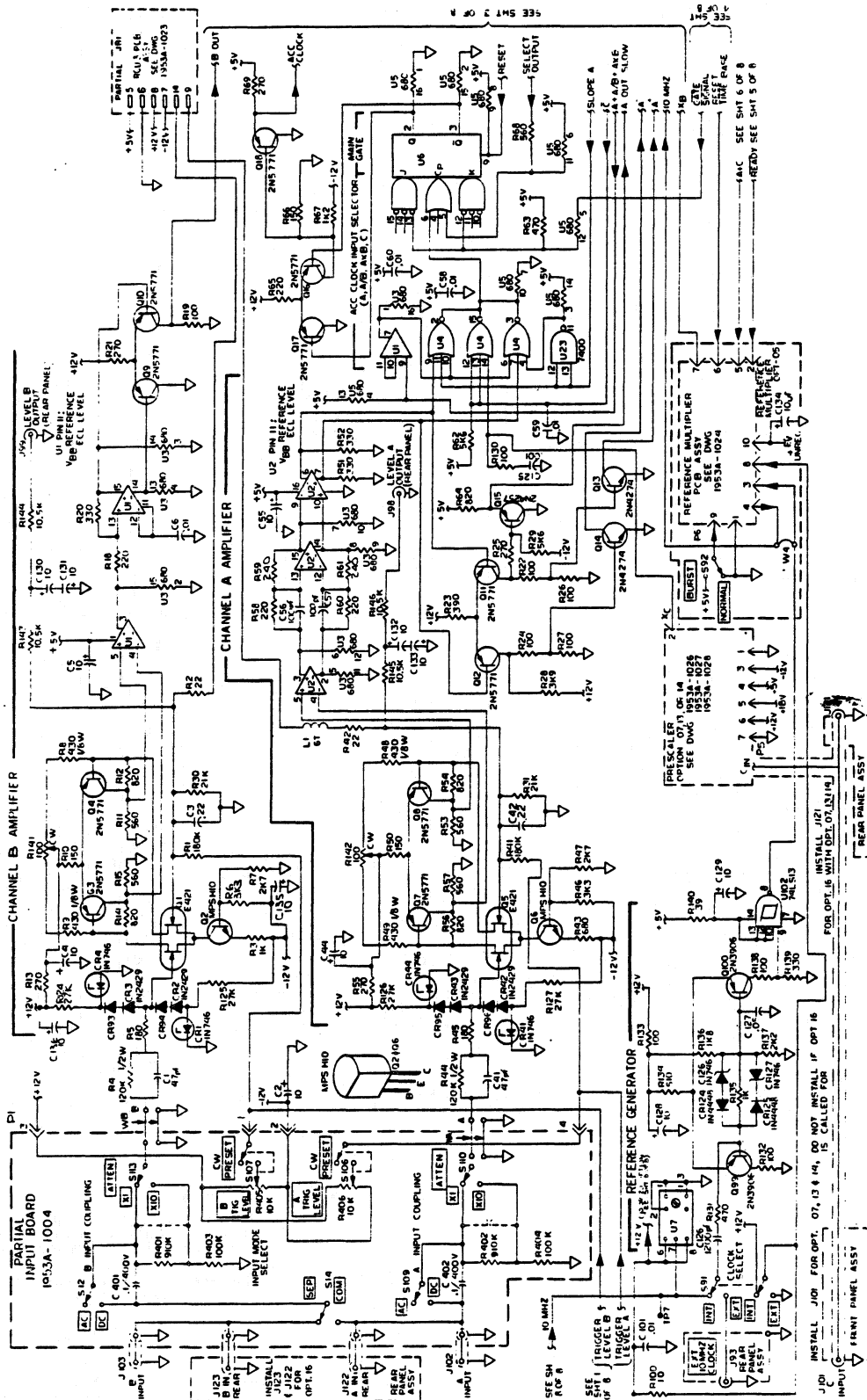

Figure 4.

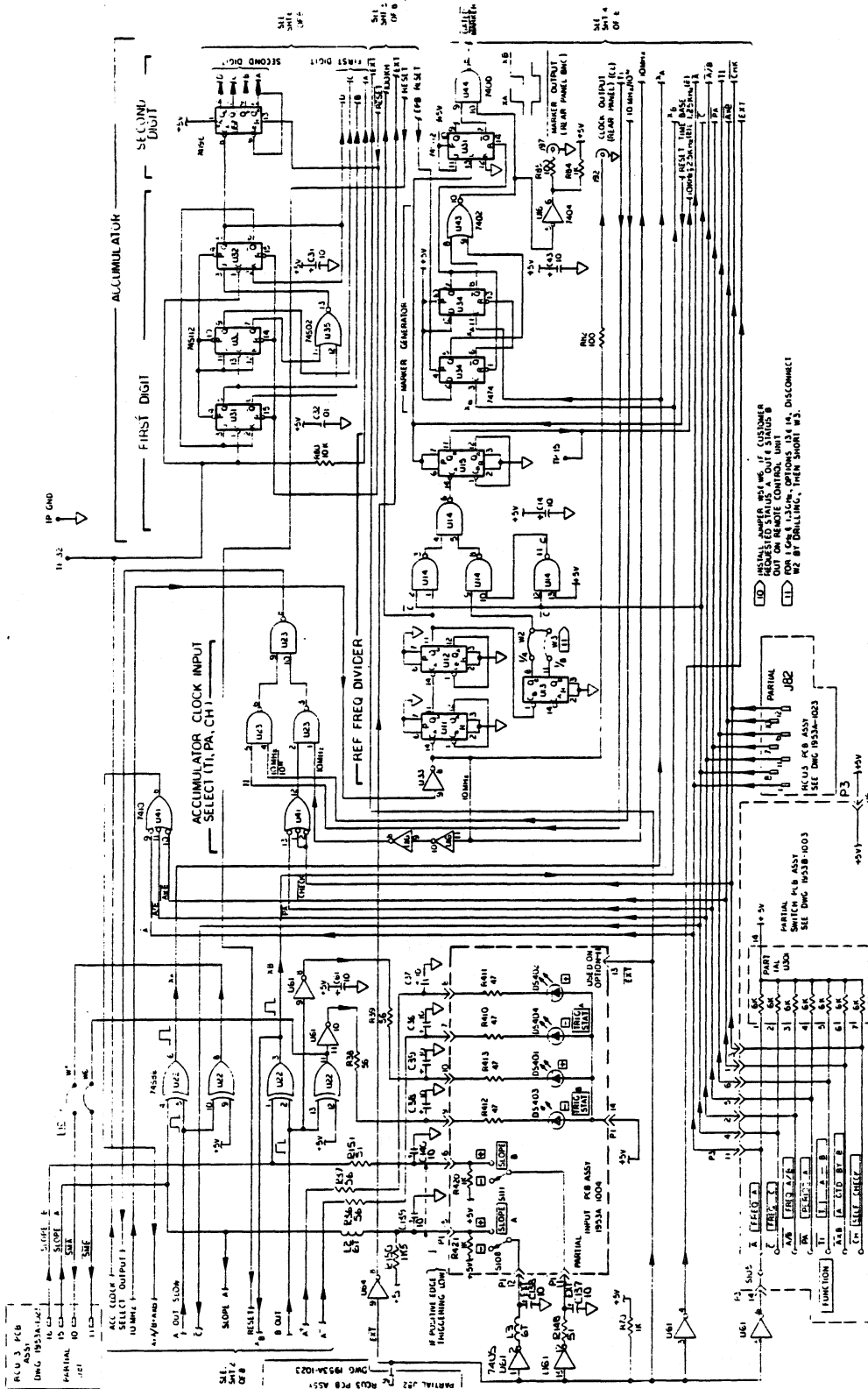

Figure 5.

**CHANGE #9 - 15730**

Rev.-K, A9 520 MHz Prescaler PCB Assembly (1953A-4026)

On page 607-4, Table 607-2, make the following changes:

CHANGE:	CR6,CR7	DIODE, HOT CARRIER	369595	07263
	FHL100	2		
TO:	CR6,CR7	DIODE, SI, SCHOTTKY BARRIER, SMALL SIGNAL	313247	28484
	HP5082-6264	2		

Rev.-N, A14 100 MHz Prescaler PCB Assembly (1953A-4027T)

On page 613-4, Table 613-2, make the following changes:

CHANGE:	CR1,CR2	DIODE, HOT CARRIER	369595	07263
	FHL100	2		
TO:	CR1,CR2	DIODE, SI, SCHOTTKY BARRIER, SMALL SIGNAL	313247	28484
	HP5082-6264	2		

Rev.-N, A15 1250 MHz Prescaler PCB Assembly (1953A-4028T)

On page 614-4, Table 614-2, make the following changes:

CHANGE:	CR1,CR2	DIODE, HOT CARRIER	369595	07263
	FHL100	2		
TO:	CR1,CR2	DIODE, SI, SCHOTTKY BARRIER, SMALL SIGNAL	313247	28484
	HP5082-6264	2		

**CHANGE #10 - 16460**

Rev.-K, A12 Remote Control Unit #2 PCB Assembly (1953A-4022)

On page 612-8, Table 612-4, make the following changes:

ADD:	R8,R9	RES, CF, 1K, $\pm 5\%$ , 1/4W	343426	80031	CR251-4-5P1K	2
------	-------	-------------------------------	--------	-------	--------------	---

On pages 612-8 and 8-36, Figures 612-4 and 8-14, add R8 and R9 as shown in Figure 6.

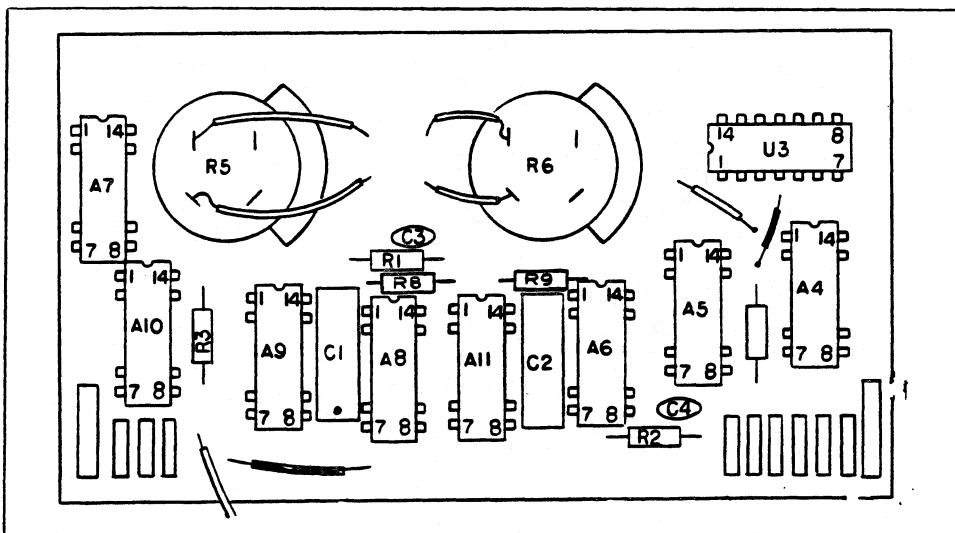

Figure 6.

On page 8-37, Figure 8-14, add R8 and R9 as shown in Figure 7.

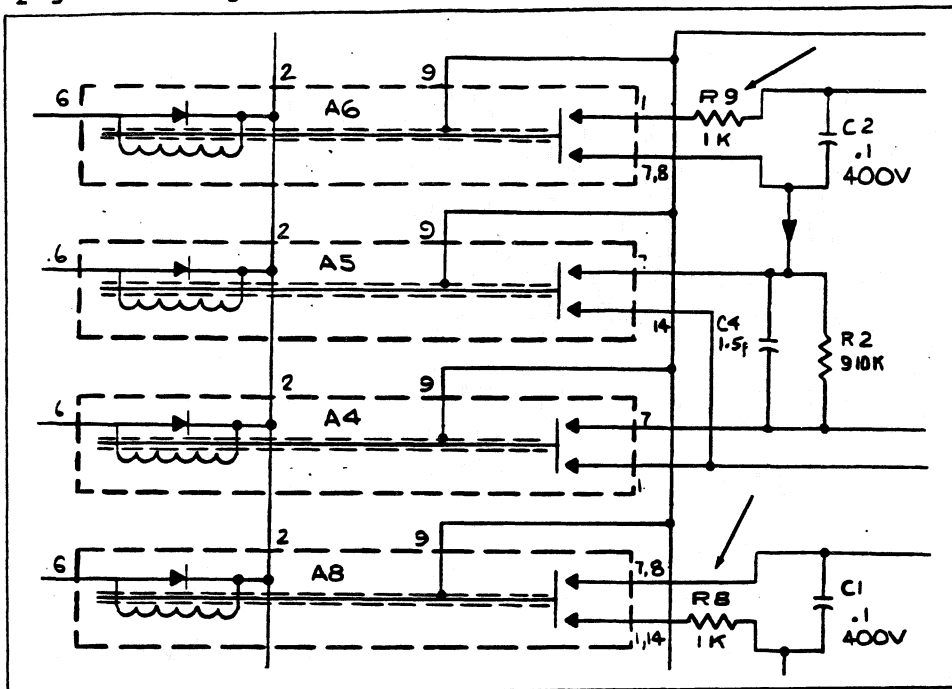

Figure 7.

**CHANGE #11 19955**

Rev.-N, A13 Remote Control Unit #3 PCB Assembly (1953A-4023)

On page 612-9, Table 612-5, make the following changes:

Change the TOT QTY of CR706, FROM: REF TO: 1

CHANGE: CR701 | DIODE, ZENER, 12V, 400MW | 110726

| 07910 | 1N964B | 3 | | 1

TO: CR701 | DIODE, ZENER, UNCOMP, 6.2V, 5%, 20.0MA, 1/4W | 325811

| 07910 | 1N753A | 4 | | 1

CHANGE: CR707 | DIODE, ZENER, 12V, 400MW | 110726

| 07910 | 1N964B | 3 | | 1

TO: CR707 | DIODE, ZENER, UNCOMP, 6.2V, 5%, 20.0MA, 1/4W | 325811

| 07910 | 1N753A | 4 | | 1

ADD: CR708, CR709 | DIODE, ZENER, UNCOMP, 6.2V, 5%, 20.0MA, 1/4W | 325811

| 07910 | 1N753A | REF | | 1

On pages 612-11/612-12, and 8-38, Figures 612-5 and 8-15, add CR708 and CR 709 as shown in Figure 8.

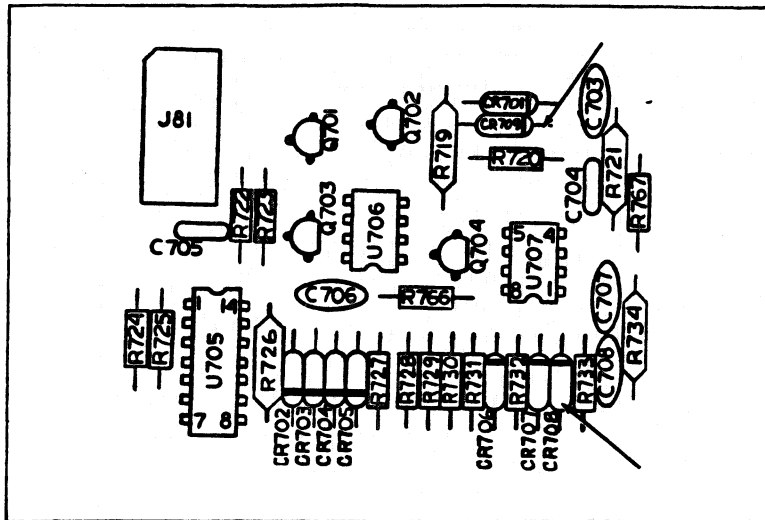

Figure 8.

On page 8-39, Figure 8-15, make the changes listed on the previous page as shown in Figure 9.

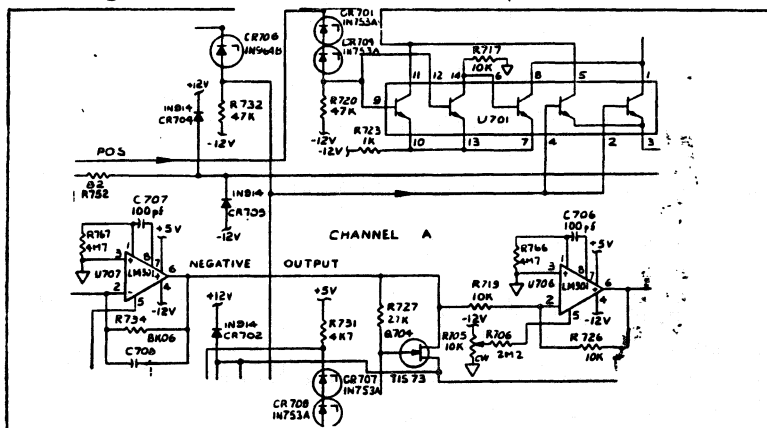

Figure 9.

### CHANGE #12 - 19956

Rev.-M, A9 520 MHz Prescaler PCB Assembly (1953A-4026T)

On page 607-5/607-6, Table 607-2, make the following changes:

CHANGE:	XF1, XF2   FUSE SOCKET, SPRING TYPE	403642   00779
	50863-8   4	
TO:	XF1, XF2   SOCKET 1 ROW, FWB, 0.100 CTR, 2 POS	436055   22526
	65358-001   2	

### ERRATA #9

On page 615-10, Table 615-9, make the following change:

CHANGE:	H1   SCREW, CONNECTOR MOUNTING	423472   89536   2
TO:	H1   SCREW, CONNECTOR MOUNTING	429472   89536   2



**CHANGE #13 - 20435**

Rev.-H A17 IEEE-488 1975 Processor PCB Assembly (1953A-4041)

Change #13 documents the steps to be taken when replacing U28, P/N 404459, on the 1953A-4041 PCB assembly. When ordering a replacement for U28, order kit 1953A-7015K, P/N 762070. Installation instructions are included in the kit. Complete the following changes in your manual when you have received the replacement kit.

On pages 615-15 and 615-16, Table 615-13, make the following changes:

DELETE: C5 | CAP, TA, 0.47 UF  $\pm 20\%$ , 250V | 161349 | 56289  
| 196D474X0035HA1 | 1

DELETE: C6,C7 | CAP, MICA, 22 PF  $\pm 5\%$ , 500V | 148551 | 72136 | DM15C220J | 2

DELETE: CR1 | DIODE, SI | 203323 | 07910 | 1N4448 | 3

Change the TOT QTY of CR2, FROM: REF TO: 2

DELETE: R1 | RES, COMP, 51  $\pm 5\%$ , 1/4W | 221879 | 01121 | CB5105 | 1

DELETE: R2 | RES, COMP, 680K  $\pm 5\%$ , 1/4W | 188433 | 01121 | CB6845 | 1

CHANGE: U28 | IC, CLOCK GENERATOR, MICRO-COMPUTER SET | 404459 | 34649  
| C4201 | 1 | 1

TO: U28 | IC, CLOCK GENERATOR PCB ASSY TESTED | 752279 | 89356  
| 752279 | 1 | 1

DELETE: Y1 | CRYSTAL, 5.185 MHZ,  $\pm 0.02\%$ , HC-18/U | 408518 | 89536  
| 408518 | 1

On page 8-33, Figure 8-12, make the changes previously listed as shown in Figure 10.

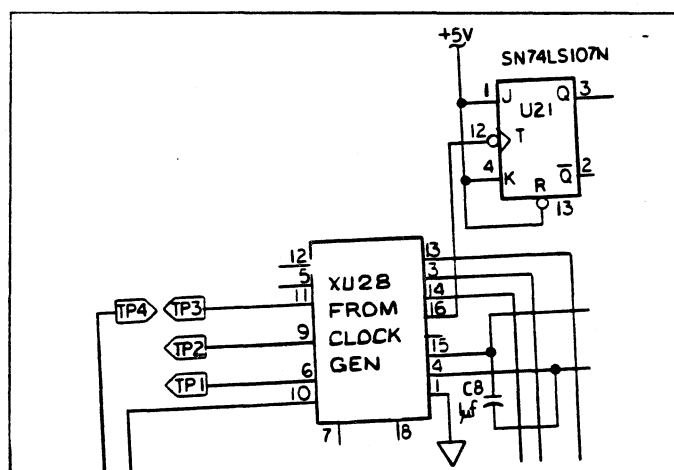

Figure 10.

On page 615-16, add Table 615-13a., Figures 615-10 and 615-11.

Table 615-13a. Clock Generator PCB Assembly

IEEE-488-1975 CLOCK GENERATOR PCB ASSEMBLY

(1953A-4043T)

C1-C3| CAP, CER, 0.01 UF, +80-20% Y5U, 25V| 335786| 72982| 5835-000Y5-U103Z

| 3

C4| CAP, MICA, 50 PF,  $\pm 5\%$ , 500V| 277210| 14655| CD15ED510J0| 1

C5,C6| CAP, TA 2.2 UF,  $\pm 10\%$ , 15V| 364216| 56289| 1960225X0015HA1| 2

C7| CAP, TA 15 UF,  $\pm 20\%$ , 20V| 519686| 56289| 196D156X0020KE4| 1

Q1| TRANSISTOR, SI, PNP, SMALL SIGNAL| 195974| 64713| 2N3906| 1

Q2| TRANSISTOR, SI, NPN, SMALL SIGNAL| 218396| 64713| 2N3904| 1

R1,R2| RES, CC, 820,  $\pm 5\%$ , 1/4W| 148015| 01121| CB8215| 2

R3,R4| RES, CC, 110,  $\pm 5\%$ , 1/4W| 193474| 01121| CB1115| 2

R5,R6| RES, CC, 5.6K,  $\pm 5\%$ , 1/4W| 148080| 01121| CB5625| 2

R7| RES, CF, 1K, 5%, 1/4W| 343426| 80031| CR251-4-5P1K| 1

R8,R10,R11,R12| RES, CC, 10K, 5%, 1/4W| 148106| 01121| CB1035| 4

R9| RES, CC, 680K, 5%, 1/4W| 188433| 01121| CB6845| 1

U1| IC, TTL, 4-BIT SYNCHRONOUS COUNTER| 340463| 01295| SN74163N| 1

U2| IC, STTL, QUAD 2 INPUT NAND GATE| 363580| 01295| SN7400SN| 1

U3| IC, STTL, HEX INVERTER| 418004| 01295| SN74S04N| 1

U4| IC, TTL, 5 MHZ 2 PHASE MOS CLOCK DRIVER| 408567| 12040| M0026CN| 1

Y1| CRYSTAL, 5.185 MHZ,  $\pm 0.02\%$ , HC-18/U| 408518| 89536| 408518| 1

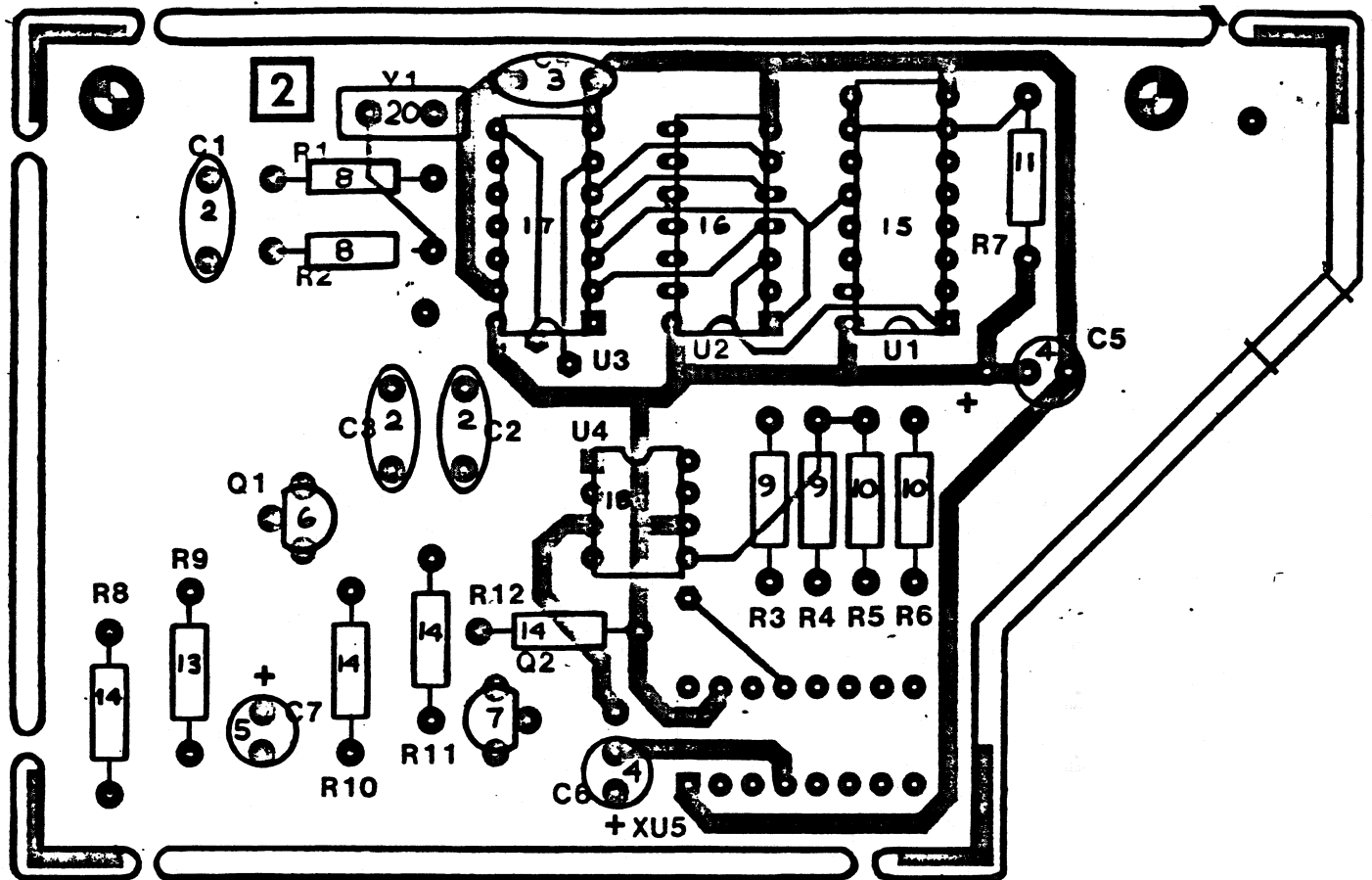

Figure 615-10.

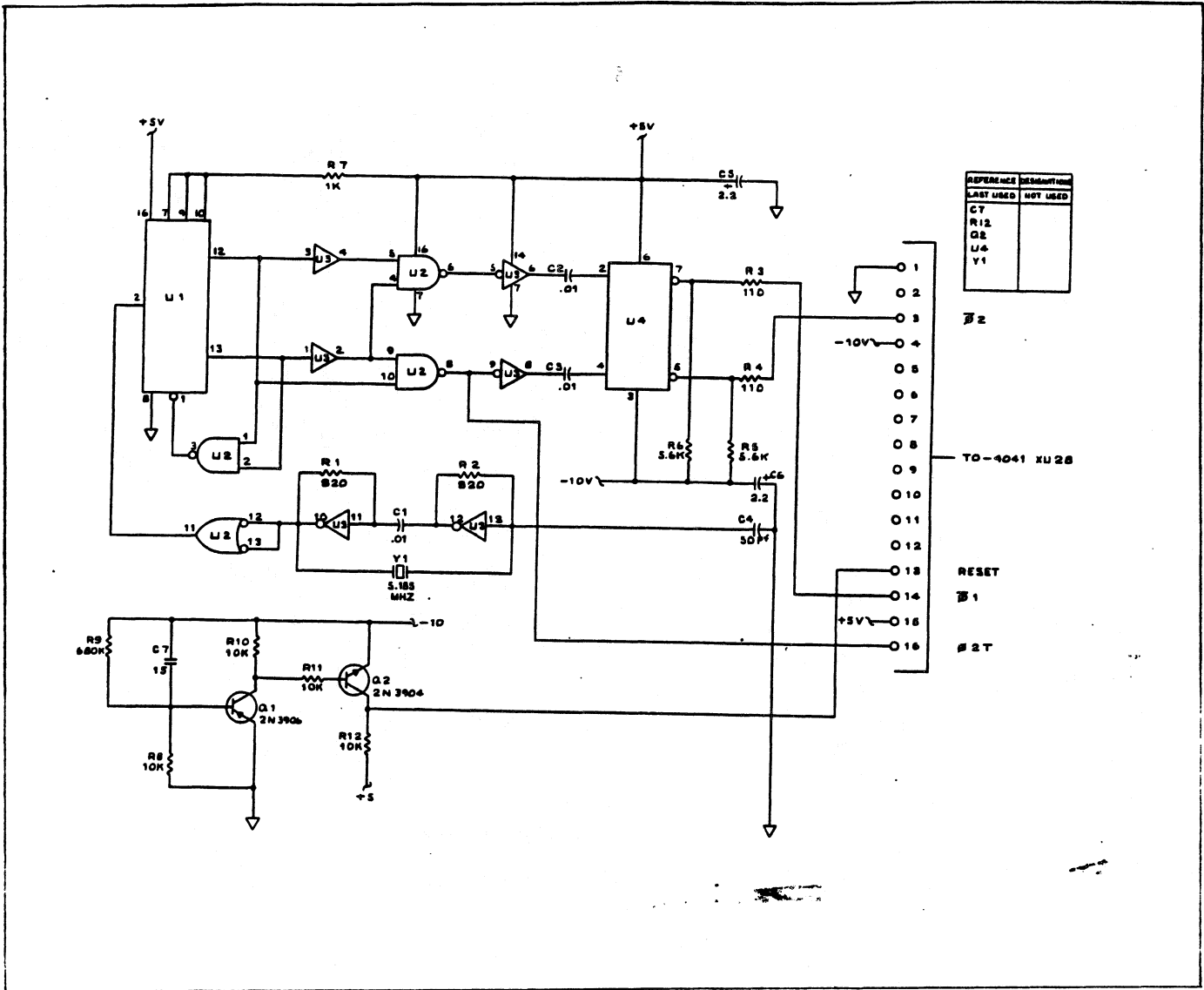

Figure 615-11.

**ERRATA #10**

On page 620-1, paragraph 620-4, replace step i with the following:

- i. Turn on the 1953A and apply 100 MHz (referenced to the house standard). Set the 1953A FUNCTION control to FREQ A and the RESOLUTION control to 1 sec. Verify that the coarse adjustment (the trimmer on the oscillator) and the fine adjustment (R121 on the 1953A rear panel) vary the displayed frequency about the center frequency of 100 MHz. Center R121 and adjust the trimmer on the oscillator for a display of 100000.000 kHz,  $\pm 2$  counts. Disconnect the 100 MHz input.

# Table of Contents

SECTION	TITLE	PAGE
<b>1</b>	<b>INTRODUCTION AND SPECIFICATIONS</b> .....	<b>1-1</b>
	1-1. INTRODUCTION .....	1-1
	1-10. SPECIFICATIONS .....	1-2
<b>2</b>	<b>OPERATING INSTRUCTIONS</b> .....	<b>2-1</b>
	2-1. INTRODUCTION .....	2-1
	2-3. SHIPPING INFORMATION .....	2-1
	2-6. INPUT POWER .....	2-1
	2-8. RACK INSTALLATION .....	2-1
	2-10. OPERATING FEATURES .....	2-1
	2-12. OPERATING NOTES .....	2-6
	2-14. Measurement Errors .....	2-6
	2-16. Input Channels A and B .....	2-6
	2-20. SEP/COM Switch .....	2-6
	2-22. Signal Conditioning .....	2-7
	2-25. Marker Output .....	2-7
	2-28. Gate Time Output .....	2-7
	2-30. OPERATION .....	2-8
	2-31. Turn-On Procedure .....	2-8
	2-33. Operating Functions .....	2-8
<b>3</b>	<b>THEORY OF OPERATION</b> .....	<b>3-1</b>
	3-1. INTRODUCTION .....	3-1
	3-3. OVERALL FUNCTIONAL DESCRIPTION .....	3-1
	3-9. BLOCK DIAGRAM ANALYSIS .....	3-3
	3-10. Channel A Amplifier .....	3-3
	3-13. Channel B Amplifier .....	3-3
	3-15. Reference Generator .....	3-3
	3-17. Function Control Logic .....	3-3
	3-40. Accumulator .....	3-8
	3-46. Display Logic .....	3-10
	3-51. Display .....	3-10

## TABLE OF CONTENTS (continued)

SECTION	TITLE	PAGE
<b>4</b>	<b>MAINTENANCE</b> .....	<b>4-1</b>
4-1.	INTRODUCTION .....	4-1
4-3.	SERVICE INFORMATION .....	4-1
4-6.	GENERAL MAINTENANCE .....	4-1
4-7.	Access and Removal Information .....	4-1
4-17.	Cleaning .....	4-2
4-19.	Fuse Replacement .....	4-2
4-21.	Service Tools .....	4-2
4-23.	PERFORMANCE TEST .....	4-2
4-25.	Set-Up Procedure .....	4-3
4-27.	Channel A Amplifier Test .....	4-3
4-29.	Channel B Amplifier Test .....	4-3
4-31.	Display Test .....	4-3
4-33.	Frequency A Test .....	4-4
4-35.	Frequency C Test .....	4-4
4-37.	Ratio Test .....	4-4
4-39.	Period A Test .....	4-5
4-41.	Time Interval Test .....	4-5
4-43.	Totalize Test .....	4-5
4-45.	Self-Check Test .....	4-6
4-47.	CALIBRATION .....	4-6
4-49.	+12 Volts Power Supply Adjustment .....	4-6
4-52.	Trigger Level Preset Adjustments .....	4-6
4-56.	Reference Generator Adjustment .....	4-7
4-58.	TROUBLESHOOTING .....	4-8
<b>5</b>	<b>LIST OF REPLACEABLE PARTS</b> .....	<b>5-1</b>
	TABLE OF CONTENTS .....	5-1
5-1.	INTRODUCTION .....	5-2
5-4.	HOW TO OBTAIN PARTS .....	5-2
<b>6</b>	<b>OPTION AND ACCESSORY INFORMATION</b> .....	<b>6-1</b>
	TABLE OF CONTENTS .....	6-1
<b>7</b>	<b>GENERAL INFORMATION</b> .....	<b>7-1</b>
<b>7A</b>	<b>MANUAL CHANGE INFORMATION</b> .....	<b>7A-1</b>
<b>8</b>	<b>SCHEMATIC DIAGRAMS</b> .....	<b>8-1</b>
	TABLE OF CONTENTS .....	8-1

## List of Illustrations

FIGURE	TITLE	PAGE
1-1.	Model 1953A Dimensions .....	1-6
2-1.	Front Panel Controls, Indicators and Connectors .....	2-2
2-2.	Rear Panel Controls and Connectors .....	2-5
2-3.	Effect of Input Wave Shape on Status Indicators .....	2-7
3-1.	Model 1953A Simplified Block Diagram .....	3-1
3-2.	Channel A Input Amplifier .....	3-3
3-3.	Channel B Input Amplifier .....	3-4
3-4.	Reference Generator .....	3-4
3-5.	Function Control Logic: Freq. A .....	3-5
3-6.	Function Control Logic: Freq. C .....	3-6
3-7.	Function Control Logic: Freq. (A/B) .....	3-6
3-8.	Function Control Logic: Period A .....	3-6
3-9.	Function Control Logic: TI A-B .....	3-7
3-10.	Function Control Logic: A GTD BY B .....	3-8
3-11.	Function Control Logic: Self-Check .....	3-8
3-12.	Accumulator Block Diagram .....	3-9
3-13.	Annunciator Control Logic .....	3-10
3-14.	Decimal Point Control Logic .....	3-10
3-15.	Update and Reset Control Logic .....	3-11
3-16.	Display Section Block Diagram .....	3-11
4-1.	Test Point Locations Main PCB .....	4-9

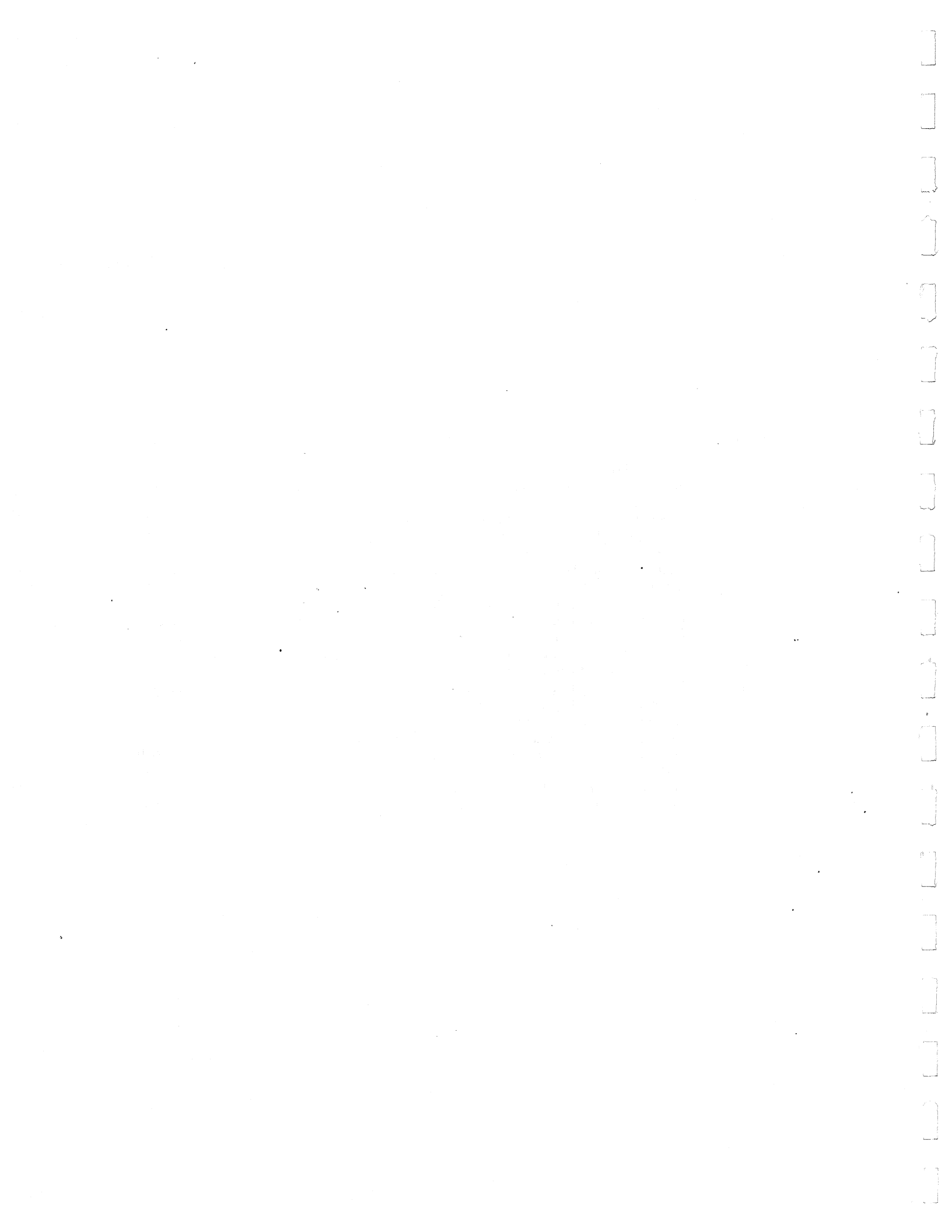



# List of Tables

<b>TABLE</b>	<b>TITLE</b>	<b>PAGE</b>
1-1.	Available Options .....	1-2
1-2.	Model 1953A Specifications .....	1-2
1-3.	Option Specifications .....	1-5
2-1.	Front Panel Controls, Indicators and Connectors .....	2-2
2-2.	Rear Panel Controls and Connectors .....	2-5
2-3.	Display For Self-Check .....	2-8
3-1.	Accumulator Input Signal Summary .....	3-2
4-1.	Test Equipment Required For 1953A Maintenance .....	4-4
4-2.	Display Readout Test .....	4-4
4-3.	Frequency A Test .....	4-5
4-4.	Ratio Test .....	4-5
4-5.	Period A Test .....	4-5
4-6.	Time Interval Test .....	4-5
4-7.	Self-Check Test .....	4-6
4-8.	Troubleshooting Guide .....	4-10

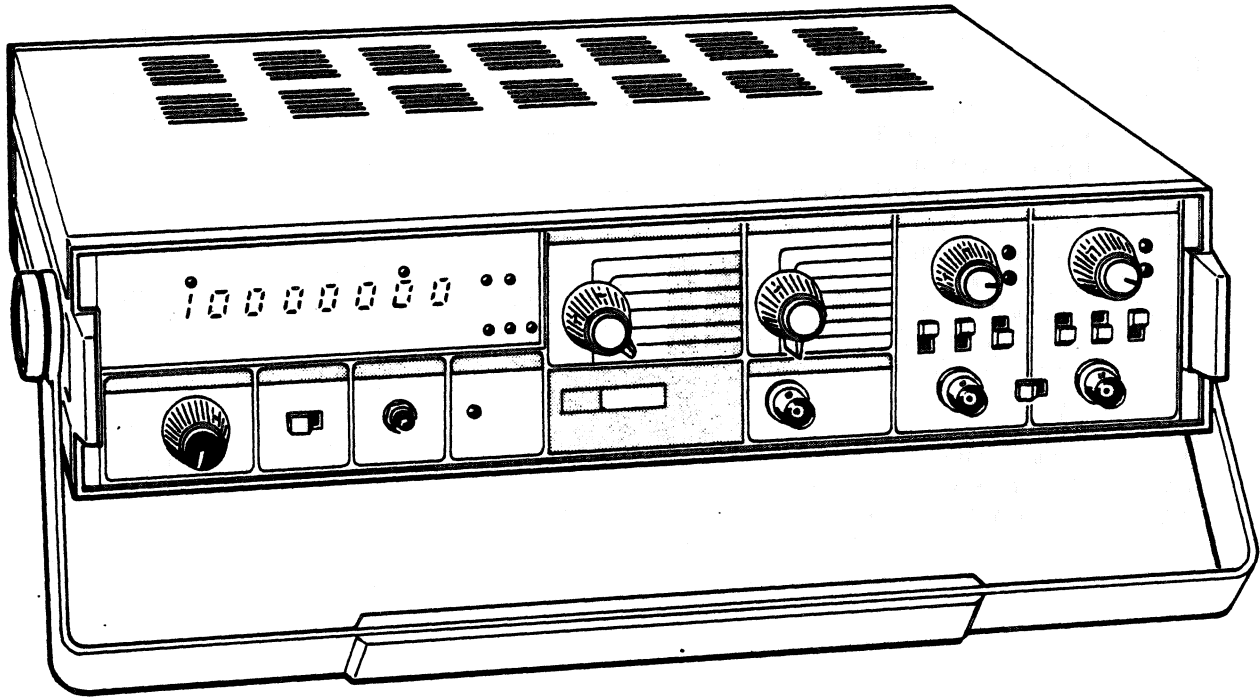

Model 1953A Counter-Timer

## Section 1

# Introduction & Specifications

### 1-1. INTRODUCTION

1-2. The Fluke Model 1953A is a universal, 0-to-125 MHz digital counter/timer capable of precisely measuring frequency, frequency ratio, period, time interval and total events. Each measurement function is switch selectable and uses any of six sampling ranges, also switch selectable. Measurement results are displayed by a nine-digit readout, with overflow indication and leading-zero suppression. Frequency is displayed in units of either kHz or MHz; time in units of us, ms, or s. The unit also features a self-check function and selection of automatic or manual measurement cycle triggering. Signal input is via BNC connectors.

1-3. The Model 1953A has three input channels designated A, B, and C. Channels A and B are the main input channels. Each is provided with a trigger-level control and signal conditioning switches. Channel C is provided for use with one of three option, plug-in prescalers. The prescalers extend the measuring capability of the unit to 520 MHz, 1 GHz, and 1.25 GHz, respectively.

1-4. The trigger-level controls for channels A and B allow the operator to select a preset trigger level (0V dc), or to vary the level at which the input signal will trigger the counter. Two light-emitting diode (LED) indicators operate in conjunction with each level control to indicate whether the input signal is more positive or more negative than the selected trigger level. Three conditioning switches allow the operator to select positive or negative slope triggering, ac or dc coupling, and X1 or X10 attenuation of the input signal.

1-5. Each measurement cycle is triggered by a reset signal. The reset signal can be automatically and continuously generated (at an adjustable rate), manually generated (at an adjustable rate), manually generated (by pushbutton switch) once for each measurement cycle

desired, or externally generated (optional). The external reset signal is introduced to the 1953A by way of a pin on an optional rear panel connector and may be either manually or automatically generated.

1-6. The front panel display on the 1953A consists of a nine-digit readout, plus one overflow and five measurement unit annunciators (indicators). The readout has leading-zero suppression for all but the right-most digit (the least significant digit). The decimal point and the unit annunciators are controlled by the selected function and the selected range.

1-7. The self-check function provides a convenient method of verifying the operation of the 1953A and is very useful during troubleshooting. During this function the counter automatically selects the 10 MHz output of the internal frequency standard to be the input signal for the digital counter circuits. A valid readout for each of the six selected ranges verifies proper digital operation. This function does not, however, verify the accuracy of the unit. Since the internal frequency standard is being used as the time base, as well as the input signal, detection of inaccuracy in the internal frequency standard is not possible. In addition, when the self-check function is selected and the manual reset switch is depressed, every display LED segment that is operating properly will illuminate.

1-8. Several options are available with the 1953A. Each is listed by option number and name in Table 1-1. A detailed description of each option is included in Section 6, Option and Accessory Information.

1-9. The Model 1953A is designed as a bench-top instrument. However, an accessory rack mounting kit (part number of kit without slides is M00-200-622, that for kit with slides is M00-200-626) is available that will permit the unit to be mounted in a standard 19-inch equipment rack. Input power requirements are 100,120,

220 or 240V ac ±10 percent, 50 to 400 Hz, 30W. The input voltage is selectable by positioning a pcb in the power receptacle to display the desired voltage in the viewing port.

**1-10. SPECIFICATIONS**

1-11. The specifications for the Model 1953A are listed in Table 1-2. Physical dimensions of the unit are shown in Figure 1-1. Option specifications are given in Table 1-3.

**Table 1-1. Available Options**

OPTION	NAME	INSTALLATION	
		FACTORY	FIELD (SERVICE CENTER)
-02	Data Output Unit (DOU)	Yes	Yes
-04	Temperature Compensated Crystal Oscillator (TCXO)	Yes	No
-05	External Time Base Multiplier	Yes	No
-07	520 MHz Prescaler	Yes	No
-10	Oven-Stabilized Time Base	Yes	No
-11	Basic Remote Control Unit (RCU)	Yes	No
-12	Full Remote Control Unit (RCU)	Yes	No
-13	1000 MHz Prescaler	Yes	No
-14	1250 MHz Prescaler	Yes	No
-15	IEEE-488 Standard Interface	Yes	No
-16	Rear Panel Inputs	Yes	No
-20	Superior Oven-Stabilized Time Base	Yes	No

**Table 1-2. 1953A Specifications**

<b>FREQUENCY MEASUREMENTS</b>	
Range . . . . .	0 to 125 MHz (dc coupled) 5 Hz to 125 MHz (ac coupled). Optional prescalers to 1250 MHz (see Options -07, -13, -14).
Gate Time . . . . .	0.1 ms to 10s in 6 decade steps (prescaled input increases gate time by a factor of 4 or 8).
Resolution . . . . .	0.1 Hz at 10s gate time to 10 kHz at 0.1 ms gate time.
Accuracy . . . . .	Time Base accuracy ±1 count.
Readout . . . . .	kHz or MHz automatically displayed with decimal point.
<b>RATIO MEASUREMENTS</b>	
Displays . . . . .	$f_1/f_2$ , where $f_1$ and $f_2$ are applied at the two input channels, A and B, respectively.
Range . . . . .	$f_1$ : 0 to 120 MHz (dc coupled). 5 Hz to 120 MHz (ac coupled). $f_2$ : 0 to 25 MHz (dc coupled). 5 Hz to 25 MHz (ac coupled).
Accuracy . . . . .	±1 count of signal on input A + trigger error of signal on input B*.
Readout . . . . .	Decimal point without unit annunciation.

Table 1-2. 1953A Specifications (cont)

**PERIOD MEASUREMENTS**

Range . . . . .	0 to 25 MHz (dc coupled), 5 Hz to 25 MHz (ac coupled).
Periods Averaged . . . . .	1 period to 10 <sup>5</sup> periods.
Frequency Counted . . . . .	10 MHz.
Resolution . . . . .	1 ps at 10 <sup>5</sup> periods to 0.1 μs at 1 period.
Accuracy . . . . .	Time Base accuracy ±1 count + trigger error of signal on input A*.
Readout . . . . .	ms or μs automatically displayed with decimal point.

**TIME INTERVAL MEASUREMENT**

Range . . . . .	0.1 μs to 10 <sup>7</sup> s.
Input . . . . .	Channels A and B; common or separate.
Resolution . . . . .	0.1 μs to 10 ms in 6 decade steps.
Accuracy . . . . .	±1 count + time base accuracy + trigger error**.
Readout . . . . .	ms or s automatically displayed with decimal point.

**TOTALIZE MEASUREMENT**

Totalizing . . . . .	A gated by B.
Range . . . . .	0-125 MHz (dc coupled). 5 Hz-125 MHz (ac coupled).

**SENSITIVITY**

**Channel A**

Sinewave . . . . .	30 mV rms from dc to 75 MHz increasing to 50 mV at 125 MHz.
Pulse . . . . .	100 mV pulse amplitude with minimum pulse width of 10 ns.

**Channel B**

Sinewave . . . . .	30 mV rms from dc to 25 MHz.
Pulse . . . . .	100 mV, with minimum pulse width of 50 ns.

**Channel C**

(Prescaled) . . . . .	15 mV from 50 MHz to 520 MHz (AGC) (Option -07). 15 mV from 50 MHz to 1000 MHz (Options -13 or -14), increasing to 30 mV at 1250 MHz (Option -14 only).
-----------------------	---

**INPUT IMPEDANCE**

Channel A or B . . . . .	1 mΩ in parallel with 30 pf maximum.
Channel C (Prescaled) . . . . .	50Ω nominal, VSWR 2:1 max when not limiting.
Dynamic Range without Limiting . . . . .	-3.5 to +3.5V (Channel A and B) 1V rms (Channel C).
Impedance in Limiting Condition . . . . .	120 kΩ in parallel with 75 pf (Channel A and B). VSWR less than 3:1 (Channel C).

**ATTENUATOR**

Channel A and B only . . . . .	Sensitivity is decreased by a factor of approximately 10 in the X10 position.
--------------------------------	---



Table 1-3. Option Specifications

**-02 DATA OUTPUT UNIT (PARALLEL)**

Provides BCD TTL outputs for each digit, plus overflow, unit annunciation, decimal point and print command.

**-04 TEMPERATURE COMPENSATED CRYSTAL OSCILLATOR (TCXO)**

See time base specifications.

**-05 EXTERNAL TIME BASE MULTIPLIER**

Allows use of external 1, 5 or 10 MHz reference clock (standard unit accepts 10 MHz). This option also permits burst measurements to be made when a "level" signal is available.

**-07 520 MHz PRESCALER**

Covers frequency range of 50 to 520 MHz, using a scaling ratio of 4. Sensitivity is 15 mV rms (AGC). Maximum allowable input is 5V rms (fuse protected). VSWR less than 2:1 into 50Ω for levels less than 1V rms.

**-10 OVEN-STABILIZED TIME BASE**

Oven is activated whenever instrument is connected to the AC line (see time base specifications).

**-11 BASIC REMOTE CONTROL UNIT**

Allows single-line programming (TTL or contact closure) of range, mode, slope and reset functions. Allows analog programming of trigger levels, and provides power sense, overflow status, and system ready outputs. Front panel lockout is provided.

**-12 FULL REMOTE CONTROL UNIT**

Includes all the features of Option -11, plus programming of ac/dc coupling, attenuation, separate/common, and digital trigger level. Trigger level of channels A and B is programmable over a +1V to -1V range (2 BCD digits plus sign), giving a resolution of 1% and an accuracy of 5% plus 2 mV. Temperature stability is better than 200 μV/°C. Two analog input/output lines are provided for either checking the D/A performance, or programming via analog levels. Option -12 increases input capacitance to 37 pF maximum.

**-13 1000 MHz PRESCALER**

Covers 50 to 1000 MHz using a scaling ratio of 8. Sensitivity is 15 mV rms, and maximum allowable input is 5V rms (fuse protected). VSWR less than 2.5:1 (50Ω) for levels less than 1V rms.

**-14 1250 MHz PRESCALER**

Covers 50 to 1250 MHz using a scaling ratio of 8. Sensitivity is 15 mV to 1000 MHz, increasing to 30 mV rms at 1250 MHz. Maximum input 5V rms (fuse protected), and VSWR less than 2.5:1 for levels less than 1V rms.

**-15 IEEE STD-488 INTERFACE (SERIAL)**

Full remote programming of function, range, and all signal conditioning controls including trigger levels. Directly compatible with IEEE Interface Standard. Data output includes 9-digits of display information, decimal point and exponent for time or frequency units. Front panel lockout is provided. Write for application bulletin covering this option.

**-16 REAR PANEL INPUTS**

Two rear inputs in parallel with A and B front inputs (capacity 85 pF), plus one rear input for channel C.

**-20 SUPERIOR OVEN-STABILIZED TIME BASE**

Oven is activated whenever instrument is connected to the AC line if the rear panel power switch is set to on. (See time base specifications).

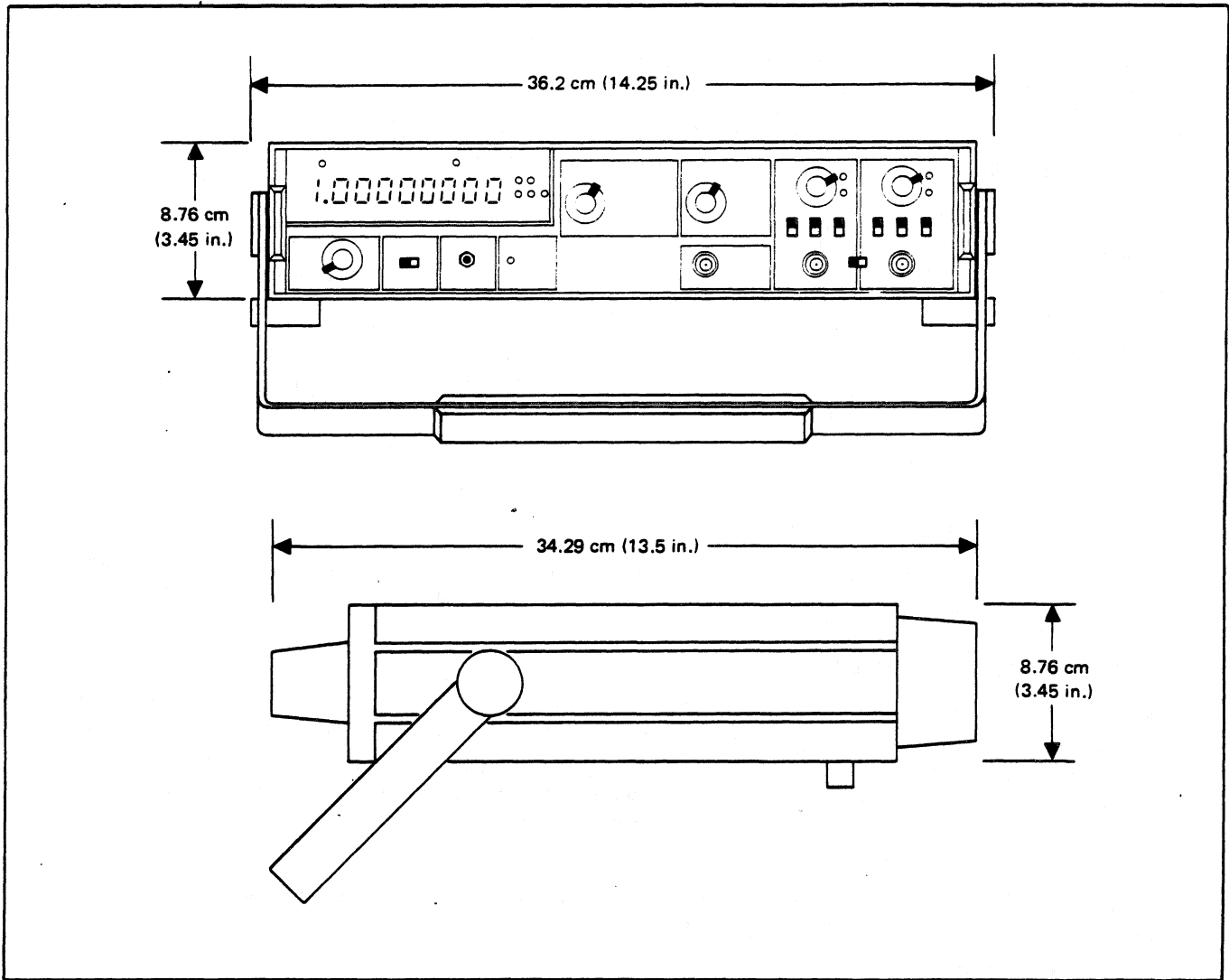

Figure 1-1. Model 1953A Dimensions



## Section 2

# Operating Instructions

### 2-1. INTRODUCTION

2-2. This section of the manual contains information regarding installation and operation of the Model 1953A Counter/Timer. It is recommended that the contents of this section be read and understood before any attempt is made to operate the counter. Should any difficulties arise during operation, please contact your nearest Fluke Sales Representative, or contact the John Fluke Mfg. Co., Inc. P.O. Box 43210, Mountlake Terrace, WA 98043; telephone (206) 774-2211. A list of Sales Representatives and their addresses is given in Section 7.

### 2-3. SHIPPING INFORMATION

2-4. The Model 1953A is packaged and shipped in a protective container. Upon receipt of the equipment, a thorough inspection should be made to reveal any possible shipping damage. Special instructions for inspection and claims are included on the shipping carton.

2-5. If reshipment of the equipment is necessary, the original container should be used. If the original container is not available, a new container can be obtained from the John Fluke Mfg. Co., Inc. Please specify the equipment model number when requesting a new shipping container.

### 2-6. INPUT POWER

2-7. The Model 1953A can be operated from a line voltage of either 100, 120, 220 or 240 volts. Before connecting the equipment to primary power visually inspect the present setting of the line switch. It can be read through the clear cover of the combination power receptacle/fuse holder on the rear panel. Use the following procedure to change to a different setting if required.

- a. Disconnect the line power cord from the receptacle.
- b. Slide the clear cover to the left to cover the power receptacle.
- c. Grasp and pull to the left the handle labeled FUSE PULL until access to the fuse and pcb is clear.
- d. Remove the fuse.
- e. Remove the pcb and position it so the desired voltage figure is on top and to the left, i.e., toward the connector.
- f. Replace the pcb and fuse. The desired voltage setting should be visible in the opening.
- g. Replace the fuse with the applicable value for the line voltage selected (1A slo-blo for 115V ac, 0.5A slo-blo for 230V ac).
- h. Return the holder to its normal position, slide the cover the right and connect the line power cord.

### 2-8. RACK INSTALLATION

2-9. The 1953A is designed for bench-top use or for installation in a standard 19-inch equipment rack using one of the option accessory rack mounting kits (part number M00-200-622 or M00-200-626). Installation instructions are supplied with the rack mounting kit and are also given in Section 6 of this manual.

### 2-10. OPERATING FEATURES

2-11. The 1953A front panel controls, indicators and connectors are shown in Figure 2-1 and described in Table 2-1. The same rear panel information is given in Figure 2-2 and Table 2-2, respectively.

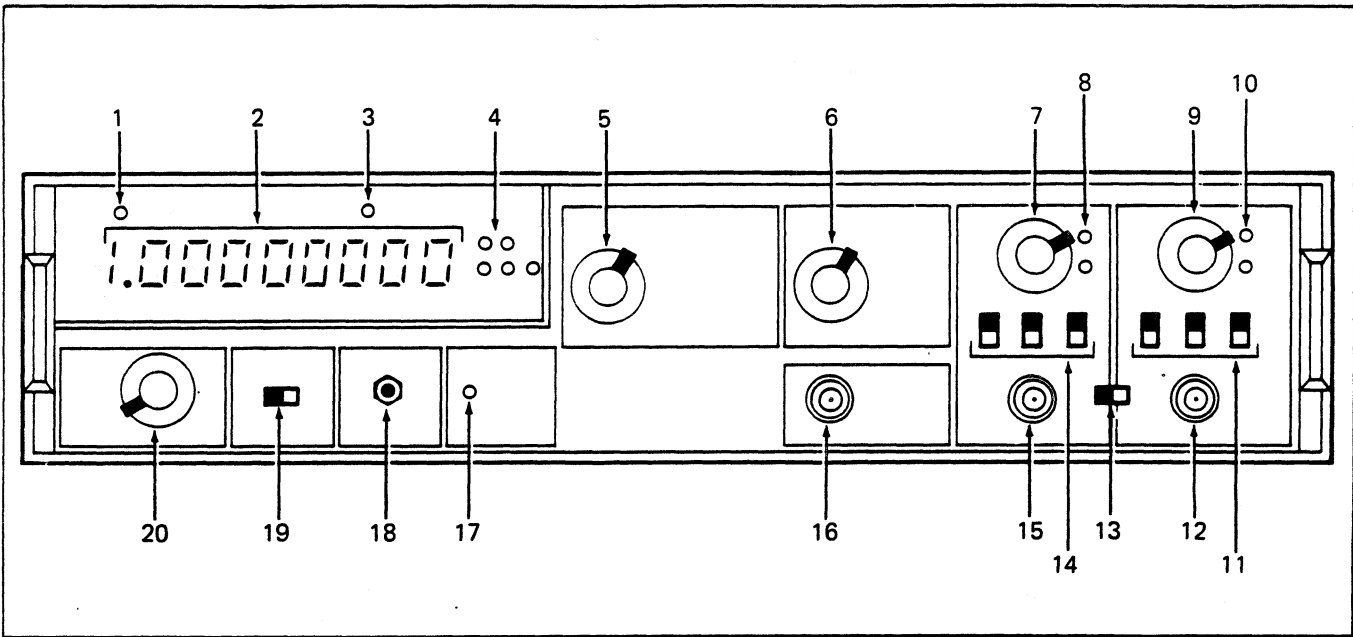

Figure 2-1. Front Panel Controls, Indicators and Connectors

Table 2-1. Front Panel Controls, Indicators and Connectors

ITEM NO.	NAME	FUNCTION
1	OVERFLOW Indicator	An LED that lights to indicate that the measurement has exceeded the display capacity.
2	Measurement Display	Nine-digit readout that digitally displays measurement results. The position of the decimal point, when present, is determined by positions of the RANGE and FUNCTION switches.
3	Remote Indicator	An LED that lights to indicate the instrument is under control of a remote device. Active with Option -11, -12 or -15 installed.
4	Measurement Unit Annunciator	Five LED's, one of which lights to define the displayed data. For frequency functions, kHz or MHz annunciator lights, for time functions, ms, $\mu$ s or s annunciator lights; and for ratio, totalized and self-check functions none are lit. (Unit annunciators are controlled by the position of the RANGE and FUNCTION switches.)
5	RANGE Switch	Selects desired range for selected function. Switch positions are as follows: GATE . . . . . Duration of measurement cycle (for frequency function). PER. AVGD . . . . . Number of periods averaged (for period functions). T.I. RES. . . . . Resolution or value of rightmost digit (for time interval function).
6	FUNCTION Switch	Selects operating function (type of measurement to be made) as follows: FREQ A . . . . . Enables frequency measurement of channel A input.

Table 2-1. Front Panel Controls, Indicators and Connectors (cont)

ITEM NO.	NAME	FUNCTION
		FREQ C . . . . Enables frequency measurement of channel C input (channel C is operational only if Option -07, -13 or -14 is installed).
		FREQ (A/B) . . . Enables ratio measurement of channel A frequency to channel B frequency.
		PERIOD A . . . . Enables period measurement of channel A input.
		T.I. A-B . . . . Enables measurement of time interval between start signal at channel A and stop signal at channel B. Start and stop signals may be from separate sources or from the same source (see SEP/COM Switch).
		A GTD BY B . . . Enable the measurement of total events occurring at channel A during time established by external Gate signal at channel B. (RANGE switch is inoperative during this totalize function).
		SELF-CHECK . . . Enables check of counter and display circuits; all inputs are ignored and an internal 10 MHz clock frequency is counted and displayed.
7	CHANNEL A TRIGGER LEVEL Control	Controls the dc trigger level for input channel A. When set to PRESET (fully ccw), trigger level is 0V dc; when rotated cw, trigger level varies from approximately -1.2V dc (just off PRESET) to + 1.2V dc (fully cw).
8	CHANNEL A TRIG STAT + and - (Annunciators)	Two LED's that light alternately to indicate when the input signal level is more positive (+) or more negative (-) than the channel A Trigger Level setting.
9	CHANNEL B TRIGGER LEVEL Control	Same as item 7, but for channel B.
10	CHANNEL B TRIG STAT + and - (Annunciators)	Same as item 8, but for channel B.
11	CHANNEL B Input Signal Conditioners	Three slide switches that select trigger slope, coupling, and attenuation for channel B input signal. SLOPE Switch . . . Selects either positive or negative-going slope of input signal to be used to trigger counter. (+/-) Coupling Switch . . . Selects either ac (capacitive) or dc (direct) (AC/DC) coupling for input signal. ATTEN Switch . . . Selects either no attenuation (X1) or approximately 20 dB attenuation of input signal (X1/X10) voltage for larger input signals. This allows TRIGGER LEVEL controls to adjust trigger level from approximately -12V to +12V dc.

Table 2-1. Front Panel Controls, Indicators and Connectors (cont)

ITEM NO.	NAME	FUNCTION
12	CHANNEL B Input Connector	A BNC Connector used to connect an input signal to channel B.
13	SEP/COM Switch	Sets up signal input connectors to receive either separate signals or a common signal, as desired. When set to COM channel A input is connected to channel A and channel B preamplifiers; when set to SEP, they are isolated.
14	CHANNEL A Input Signal Conditioners	Same as item 11, but for channel A.
15	CHANNEL A Input Connector	Same as item 12, but for channel A.
16	CHANNEL C Input Connector	Same as item 12, but for channel C (Channel C connector is supplied only with Option -07, -13 or -14).
17	GATE Indicator	An LED that lights to indicate that a measurement cycle is being executed.
18	RESET Push-Button	Resets readout to zero and initiates new measurement cycle.
19	MODE Switch (CONT/TRIG)	Selects either automatic or manual triggering of measurement cycles. When switch is set to CONT, measurement cycles are automatically and continuously initiated at adjustable repetition rate; when switch is set to TRIG, single measurement cycle is initiated each time RESET switch is pressed or whenever ground is applied to external reset pin on optional rear panel REMOTE CONTROL connector. (Automatic triggering is locked out in TRIG position, but manual and external triggering remain operational in CONT position.)
20	POWER/CYCLE RATE Control	Adjusts repetition rate of automatic measurement cycle triggering from approximately 0.2 to 2.0 seconds. When rotated to OFF detent (fully ccw), power to unit is turned off. For Options -11 and -12, controls the Remote/Local Status. For Options -10 and -20, provides standby power to the instrument. With one of each type of option installed (RCU and ovenized time base) the RCU feature is used and all power control of the instrument will be from the rear panel.

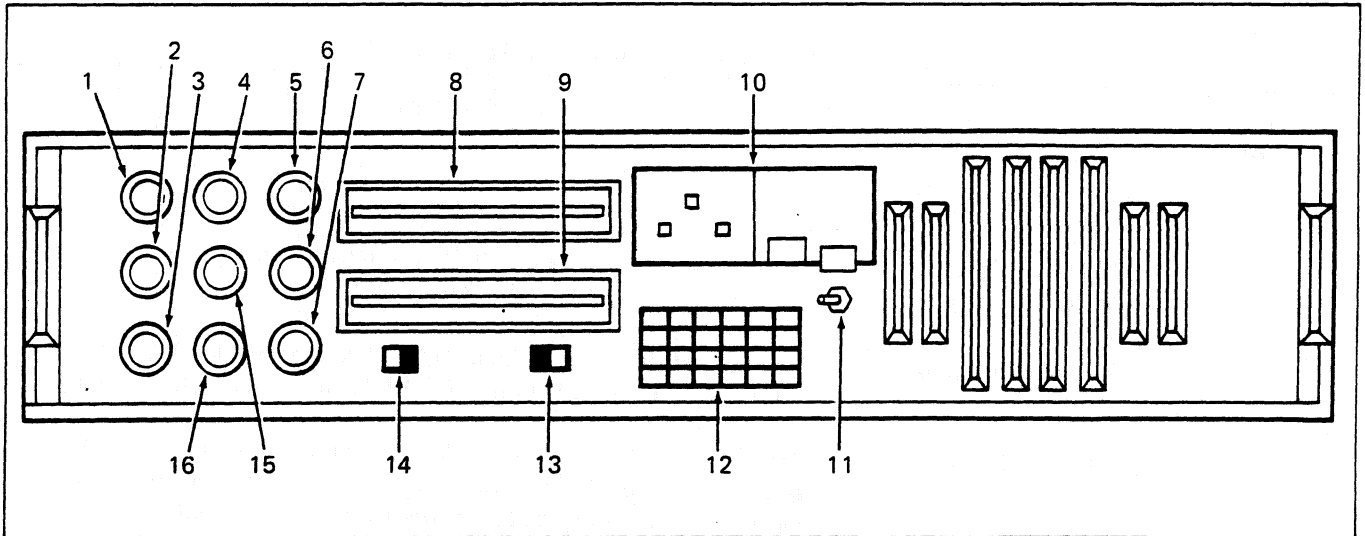

Figure 2-2. Rear Panel Controls and Connectors

Table 2-2. Rear Panel Controls and Connectors

ITEM NO.	NAME	FUNCTION
1	CHANNEL A Input Connector	Connector (J122) serves as rear panel input to channel A. This is part of Option -16 (see Section 6).
2	CHANNEL B Input Connector	Same as 1, but for channel B (J123).
3	CHANNEL C Input Connector	Same as 1, but for channel C, prescaled input (J121). Front panel channel C connector is not installed when rear panel channel C connector is installed (see Section 6).
4	MARKER Connector	Provides connection (J97) for Marker output signal. This signal is applied to Z-axis input of oscilloscope displaying 1953A input signal. The result is an intensified zone that indicates start-to-stop time of time interval measurement. In agreement with modulation requirements for Z-axis inputs of most oscilloscopes, the pulse is low active (and high, or +5V, when inactive).
5	GATE TIME Connector	Provides connection (J91) for Gate Time output signal. This signal is an active high, TTL-compatible pulse generated for duration of measurement period.
6	CLOCK OUTPUT Connector	Provides connection (J92) to 10 MHz clock signal (internal or external) for use as time base standard. The output is buffered and is TTL compatible.
7	EXT 10 MHz CLOCK Connector	Provides connection for external 10 MHz clock input signal (J93). Minimum input level required is 100 mV, and input impedance is 1 Megohm.
8	BCD OUTPUT/IEEE ADDRESS Connector	Provides connection, when installed, for BCD parallel output (part of Option -02) or access to IEEE address controls (part of Option -15).

Table 2-2. Rear Panel Controls and Connectors (cont)

ITEM NO.	NAME	FUNCTION
9	REMOTE CONTROL Connector	Provides connection, when installed, for remote control of 1953A. (This is part of Options -11, -12 and -15.)
10	Input Power Connector	Provides connection for ac input power. Contains fuse receptacle and selection pcb to select between 100, 120, 220 or 240 input line voltage.
11	Rear Panel Power Switch	Part of Option -10, 11, 12 and -20. When on, with -10 or -20 installed and neither -11 or -12 installed, provides power to the oven filaments independent of the front panel power switch. When on with -11 or -12 installed, supplies operating power to the instrument, and the front panel power switch controls the remote/local command. When off, disconnects entire unit from line power.
12	Option Decal	Log of installed options.
13	NORMAL/BURST Select Switch	Installed as part of Option -05 (see Section 6), allows choice of normal signal measurements or RF burst measurements.
14	Clock Select Switch	Selects either internal or external clock for use as 1953A time base standard: INT . . . . . Selects output of internal clock. EXT . . . . . Selects external clock connected to Item 7.
15	LEVEL A Connector	A BNC Connector (J99) for monitoring the dc trigger level setting of channel A. The output level range is -1.2 to +1.2V dc and does not change with attenuator setting. With a X10 attenuator setting, an output level of 1.0 volts indicates a 10 volt trigger level setting.
16	LEVEL B Connector	Same as Item 15, but for trigger level B (J98).

## 2-12. OPERATING NOTES

2-13. The following paragraphs describe various conditions that should be considered before operating the Model 1953A Counter/Timer.

### 2-14. Measurement Errors

2-15. The 1953A, like all counters, is designed to respond to voltage transitions at the input channel. Since the input sensitivity of the 1953A is 30 mV minimum, care must be taken to suppress unwanted low-level transitions (noise, transients, spurs, etc.) that may accompany the measurement frequency. Otherwise, the unwanted transitions will be counted and displayed as a representation of the input frequency. To ensure the

rejection of unwanted signals use the following guidelines, where applicable.

- a. Use a scope to identify the presence of unwanted input signals.
- b. Set the input attenuator to X10 if the unwanted signal is  $\leq 300$  mV, and the measurement signal is  $\geq 300$  mV.
- c. Use a scope probe (X10) as an input cable when measuring high impedance circuits.
- d. Use a low pass filter attenuator when possible, to suppress unwanted noise and transients. The Fluke Model Y7201 (see accessories, Section 6) is designed for this purpose.

## 2-16. Input Channels A and B

2-17. Input Channels A and B are electrically similar, with bandwidths extending from 0 to 125 MHz for channel A, and 0 to 25 MHz for channel B. The output rise times for channels A and B are 5 ns and 20 ns, respectively. The input impedance of each channel is 1 megohm. A clamping circuit limits the voltage to the first stage of the input amplifier to  $\pm 3.5V$ , nominal. When the ATTEN switch is set to X1, the input impedance will decrease sharply to 120 kilohms for that portion of the input signal that exceeds the limit voltage. When the ATTEN switch is set to X10, the input impedance remains at 1 megohm for all input signal levels.

2-18. The sensitivity of channel A for sinewave inputs is 30 mV rms minimum from 0 to 75 MHz. The sensitivity gradually decreases to 50 mV rms minimum at 125 MHz. For channel B the sensitivity for sine wave inputs is 30 mV over the entire bandwidth (0 to 25 MHz). For pulse inputs the sensitivity is 100 mV peak-to-peak minimum for both channels with a minimum pulse width of 10 ns for channel A, and 50 ns for channel B.

2-19. Overload protection for input channels A and B permits a maximum signal level of 150V rms, from dc to 1 kHz, to be applied to either input without damaging the unit. The maximum allowable input signal level gradually decrease to 5V rms at 125 MHz when the ATTEN switches are set to X1; or to 50V rms, when set to X10.

## 2-20. SEP/COM Switch

2-21. The SEP/COM switch is used to isolate the A and B inputs when the switch is set to SEP, or to connect channel A input to both channel A and B pre-amplifiers when set to COM. The switch is normally left at SEP except in the case of time interval measurements using a single input signal. With the switch set to COM, channel A is used to establish the Start Signal trigger level conditions and channel B is used to establish the Stop Signal trigger level conditions.

## 2-22. Signal Conditioning

2-23. The signal conditioning features provided for each of the two main input channels (A and B) consist of a TRIGGER LEVEL control, a trigger status indicator (TRIG STAT), and three slide switches. The slide switches condition the input signal before it is used to trigger the counter, by selecting the desired trigger slope (+ or -), coupling (ac or dc) and attenuation (X1 or X10). The TRIGGER LEVEL control is continuously variable from approximately  $-1.2V$  to  $+1.2V$  dc (with the X1 attenuation selected; selecting the X10 attenuation increases the range of the TRIGGER LEVEL control by a factor of 10). When the control is rotated fully ccw to PRESET, the trigger level will be 0V dc. The trigger levels can be monitored separately by connecting a dc voltmeter to rear panel connector LEVEL A or LEVEL B.

2-24. The TRIG STAT indicator consists of two LED's, one marked +, the other marked -. For sine wave inputs these LED's indicate the relative trigger level selected. With the TRIGGER LEVEL control set to PRESET (0V dc trigger level), the two LED's will light with equal intensity. If the TRIGGER LEVEL control were adjusted to produce a  $-0.7V$  trigger level, as in case 1 of Figure 2-3, the + LED would light more brightly than the -LED. This is due to the fact that the LED's are driven on a complementary basis. With negative trigger level, the +LED is on for a longer portion of the input waveform than the -LED and thus, appears to be brighter. For pulse inputs, the LED's fail to indicate relative trigger level since their brightness is related to the relative duty cycle of the waveform. With the pulse input waveform shown in case 2 of Figure 2-3, the -LED would glow more brightly regardless of the trigger level. In case 3, the LED's would have equal intensity, again regardless of the trigger level. However, if the waveform in case 3 were just half the peak voltage of that shown, the STAT TRIG indicators then provide a means of determining the effective range of the TRIGGER LEVEL control. When the TRIGGER LEVEL control is rotated either direction from the midpoint (approx 0V dc), as soon as the trigger level exceeds the peak voltage of the waveform, the corresponding LED will no longer light. This is best seen with pulse inputs, where the transition is sudden; with sinewaves the transition is gradual. Very narrow pulses may not light an LED to the point where it can be seen, even though proper triggering of the counter occurs.

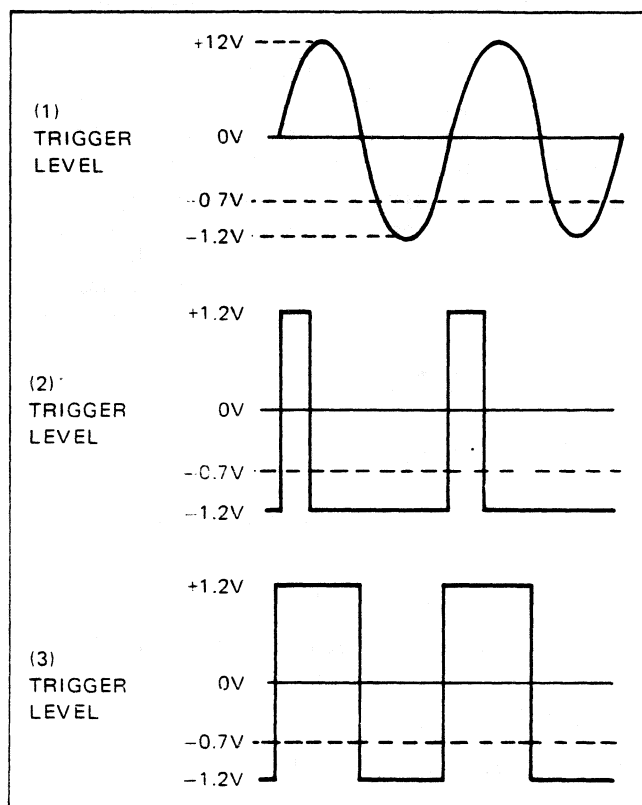

Figure 2-3. Effect of Input Wave Shape on Status Indicators

## 2-25. Marker Output

2-26. In the time interval function, a negative-going (low true) pulse is generated at the MARKER connector to provide an indication of the actual time interval being measured. The width of the Marker pulse is variable, depending on the trigger levels selected for channels A and B (Start and Stop signals). When the input signal is fed to the vertical input of an oscilloscope the marker pulse can be used to drive the Z-axis of the scope and cause the measured portion of the input signal to be intensified. Using this technique, the trigger levels for channels A and B (Start and Stop signals) can be individually adjusted for precise time interval measurements.

2-27. In the frequency A function, the Marker pulse can be used to precisely set the trigger level for channel A. However, the trigger level for channel B must also be adjusted to reset the Marker Generator. This is accomplished by setting the SEP/COM switch to COM and adjusting the TRIGGER LEVEL control for channel B so that the intensified zone is terminated shortly after it begins. Then adjust the TRIGGER LEVEL control for channel A to the desired position.

## 2-28. Gate Time Output

2-29. The GATE connector provides a high TTL output while the counter is executing a measurement cycle in any of the available functions. For Frequency A and C functions, the duration of the Gate signal is equal to the Gate time (GATE) selected by the RANGE switch. The signal is intended for use in remote applications; however, it can be used as a scope trigger or an external time gate. The GATE indicator lights for the duration of the Gate signal, plus approximately 100 ms. The extra 100 ms is provided by a pulse stretcher to ensure a sufficient on-time (duty cycle) for the GATE indicator to be seen when the shortest gate times are selected.

## 2-30. OPERATION

### 2-31. Turn-On Procedure

2-32. Use of the following procedure is suggested for initial turn-on of the 1953A:

- Connect the 1953A to ac power line.
- Turn the CYCLE RATE control cw, out of the OFF detent. The front panel display should illuminate.

### 2-33. Operating Functions

2-34. The following paragraphs describe the self-check frequency, ratio, period, time interval and totalize

functions and give the procedures necessary to operate the 1953A in each mode. Complete the Turn-On Procedure before attempting to operate the unit.

### 2-35. SELF-CHECK

2-36. The self-check function is used to verify the digital operation of the 1953A. The frequency of the 10 MHz oscillator is measured to produce a predictable readout for each setting of the RANGE switch. Pressing the RESET switch when the counter is in the SELF-CHECK mode causes all digit segments to be illuminated. This provides immediate verification that all segments of the display LED's are operational. This LED check takes effect regardless of the position of the CONT TRIG switch.

2-37. Use the following procedure to operate the 1953A in the Self-Check mode:

- Set the rear panel Clock Select switch to INT.
- Set FUNCTION switch to SELF-CHECK.
- Set CONT/TRIG switch to CONT.
- Adjust CYCLE RATE control for desired display period.
- Sequentially select each GATE position of RANGE switch, pausing at each position to verify proper display in readout. (Table 2-3 shows proper display for each switch setting.)

Table 2-3. Display for Self-Check

GATE	READOUT*
0.1 ms	1000
1.0 ms	10000
10 ms	100000
0.1s	1000000
1.0s	10000000
10s	100000000

\*±1 digit

### 2-38. FREQUENCY

2-39. Standard frequency measurements from 0 to 125 MHz are made using the frequency A function. The gate times available for each frequency measurement range from 0.1 ms to 10s in six decade steps and are selected by means of the RANGE switch. For a given input signal there will be a RANGE setting (gate time) which will give optimum resolution of the displayed frequency.



2-40. Use the following procedure to operate the 1953A in frequency A mode:

- a. Set FUNCTION switch to **FREQ A**.
- b. Set **CONT/TRIG** switch to **CONT**.
- c. Connect input signal to be measured to **CHANNEL A** input connector.
- d. Adjust **CHANNEL A TRIGGER LEVEL** control to establish desired trigger conditions. (Normal triggering occurs when both the + and - **TRIG STAT** indicators are lit.)
- e. Adjust **CYCLE RATE** control for desired display period.
- f. Set **RANGE** switch to obtain optimum resolution of the frequency displayed.

2-41. Used with any one of three optional prescalers, the frequency C function increase the frequency measurement capability of the 1953A to frequency ranges extending from 50 MHz to 520 MHz (using Option -07), or from 50 MHz to 1 GHz (using Option -13), or from 50 MHz to 1.25 GHz (using Option -14). Refer to Section 6 for operating instructions for the frequency C function.

#### 2-42. RATIO

2-43. The ratio function is used to measure the frequency ratio of two input signals. One signal is coupled into channel A, the other into channel B. The resolution of the measurement can be increased or decreased by changing the setting of the **RANGE** switch. The higher frequency input signal must be connected to the **CHANNEL A** input or a zero reading will result.

#### NOTE

*The channel B input frequency is limited to 25 MHz maximum.*

2-44. Use the following procedure to operate the 1953A for the ratio function:

- a. Set **FUNCTION** switch to **FREQ (A/B)**.
- b. Set **CONT/TRIG** switch to **CONT**.
- c. Set **SEP/COM** switch to **SEP**.
- d. Connect the higher of two frequencies to be measured to **CHANNEL A** input connector.
- e. Connect other frequency to **CHANNEL B** input connector.
- f. Adjust the **CHANNEL A** and the **CHANNEL B TRIGGER LEVEL** controls to establish desired trigger conditions. (Proper triggering occurs when both + and - **TRIG STAT** indicators are lit.)

g. Adjust **CYCLE RATE** control for desired display period.

h. Set **RANGE** switch to obtain optimum resolution of ratio displayed.

#### 2-45. PERIOD

2-46. The period function is used to measure the period of input signals with frequencies up to 25 MHz. This function is also intended for use in measuring low frequencies, since a low frequency can be determined with higher resolution through a period measurement than through a direct frequency measurement. The measurement resolution increases with the number of periods used to obtain the average. For example, if the **RANGE** switch is set to  $10^0$  (**PER AVGD**, column), and an input frequency of 1 Hz is applied to channel A, the readout will display 1000.0000 ms (resolved to 100 ns). In the frequency mode, however, with a 1 Hz signal and a 10 second gate time the maximum resolution is 1 Hz. The setting of the **RANGE** switch indicates, in powers of ten, the number of periods (cycles) of the input signal that are sampled to produce the final display.

2-47. Use the following procedure to operate the 1953A in the period average mode:

- a. Set **FUNCTION** switch to **PERIOD A**.
- b. Set **CONT/TRIG** switch to **CONT**.
- c. Connect signal to be measured to **CHANNEL A** input connector.
- d. Adjust **CHANNEL A TRIGGER LEVEL** control to ensure proper triggering.
- e. Adjust **CYCLE RATE** control for desired display period.
- f. Set **RANGE** switch to the **PER AVGD** position that provides desired resolution.

#### 2-48. TIME INTERVAL

2-49. With the time interval function, accurate measurements can be made of the time interval between the occurrence of two separate input signals or between two points on a single input signal. In either case, channel A is used to provide a Start signal, and channel B is used to provide a Stop signal. When a single input signal is to provide both the Start and Stop signals, the **SEP/COM** is set to **COM** so that both channels A and B receive the same signals. The **SEP/COM** switch is set the **SEP** when the Start and the Stop signals are to be provided by separate input signals.

2-50. Accurate pulse width, rise time and fall time measurements can be made with the time interval function. However, their accuracy depends upon the

trigger levels being set so that the Start and Stop signals occur at precise voltage levels of the input signal. The trigger levels can be visually set using an oscilloscope to display the input signal, while driving the Z-axis of the scope with the Marker signal (available at the rear panel). The measured time interval appears as an intensified zone on the scope trace and can be adjusted using the CHANNEL A and CHANNEL B TRIGGER LEVEL controls. Refer to the discussion of the MARKER output given earlier in this section under Operating Notes.

2-51. Use the following procedure to operate the 1953A in the time interval mode:

- a. Set CONT TRIG switch to CONT.
- b. Set FUNCTION switch to TI A-B.
- c. Set SEP COM switch to SEP if Start/Stop signals are to be derived from separate input signals, or to COM, if from single input signal.
- d. If separate input signals are used, connect Start signals to CHANNEL A input connector, and the Stop signal to CHANNEL B input connector. If single input is used, connect it to either input connector.
- e. Adjust CHANNEL A and CHANNEL B TRIGGER LEVEL controls to establish desired Start/Stop trigger levels. Use the Marker output in conjunction with an oscilloscope to establish precise trigger levels.
- f. Adjust CYCLE RATE control for desired display period.
- g. Set RANGE switch to TI RES position that provides desired resolution.

## 2-52. TOTALIZE

2-53. In the totalize function, the 1953A can be used as a gateable totalizer. Each event that occurs at the CHANNEL A input connector is accumulated (totalized) during the time that a signal at the CHANNEL B input connector produces a gate pulse for the accumulator. The CHANNEL B SLOPE switch selects the portion of the channel B waveform that will produce the gate pulse. When the SLOPE switch is in the

+ position a gate pulse will be produced during the time the input waveform is more positive than the trigger level established for channel B; when in the - position, during the time the input signal is more negative. The RANGE switch is inoperative during this function.

### NOTE

*To prevent the enabling edge of the CHANNEL B gate pulse from triggering the counter, the SLOPE switch for channel A should be set to indicate the active polarity of the channel A input signal.*

2-54. Use the following procedure to operate the 1953A in the totalize mode:

- a. Set FUNCTION switch to A GTD BY B.
- b. Set SEP COM switch to SEP.
- c. Connect signal to be totalized to CHANNEL A input connector.
- d. Connect a signal to be used for gating to CHANNEL B input connector.
- e. Adjust the CHANNEL A and CHANNEL B TRIGGER LEVEL controls to ensure proper triggering. The counter will totalize events on channel A as long as the channel B input is at an active level. In this mode the display will be updated only when the RESET switch is pressed, or when an External Reset signal is activated (no automatic recycling).

### NOTE

*If an input signal to channel B is not required or available, the gating of the accumulator can be manually controlled by the CHANNEL B SLOPE switch. Turn the CHANNEL B TRIGGER LEVEL control fully cw. Setting the SLOPE switch for CHANNEL B to - will now gate the accumulator, and the 1953A will totalize. Setting it back to + will inhibit the accumulator, and the totalizing will halt. To resume totalizing, set the SLOPE switch to - again; to start over from zero, momentarily press the RESET switch.*

## Section 3

# Theory of Operation

### 3-1. INTRODUCTION

3-2. This section of the manual contains an overall functional description followed by a block diagram analysis of the Model 1953A counter. Block diagrams are used to supplement the text. A complete set of schematic diagrams is included in Section 8.

### 3-3. OVERALL FUNCTIONAL DESCRIPTION

3-4. Figure 3-1 is a simplified block diagram of the 1953A. It shows the major functional elements of the

unit. The heart of the 1953A is the accumulator. The accumulator counts the clock pulses applied to it during the gate pulse. It retains this count, until a new measurement cycle is initiated, for use in driving the measurement results readout (nine-digit readout and overflow indicator). The accumulator receives the clock pulses from the function control logic circuits. In three functions (Frequency A, Ratio A/B and A Gtd by B) the clock pulses are fed straight through to the accumulator from channel A for the duration of the gate pulse. Under control of the FUNCTION switch, the function control logic circuits select the sources from which to derive the

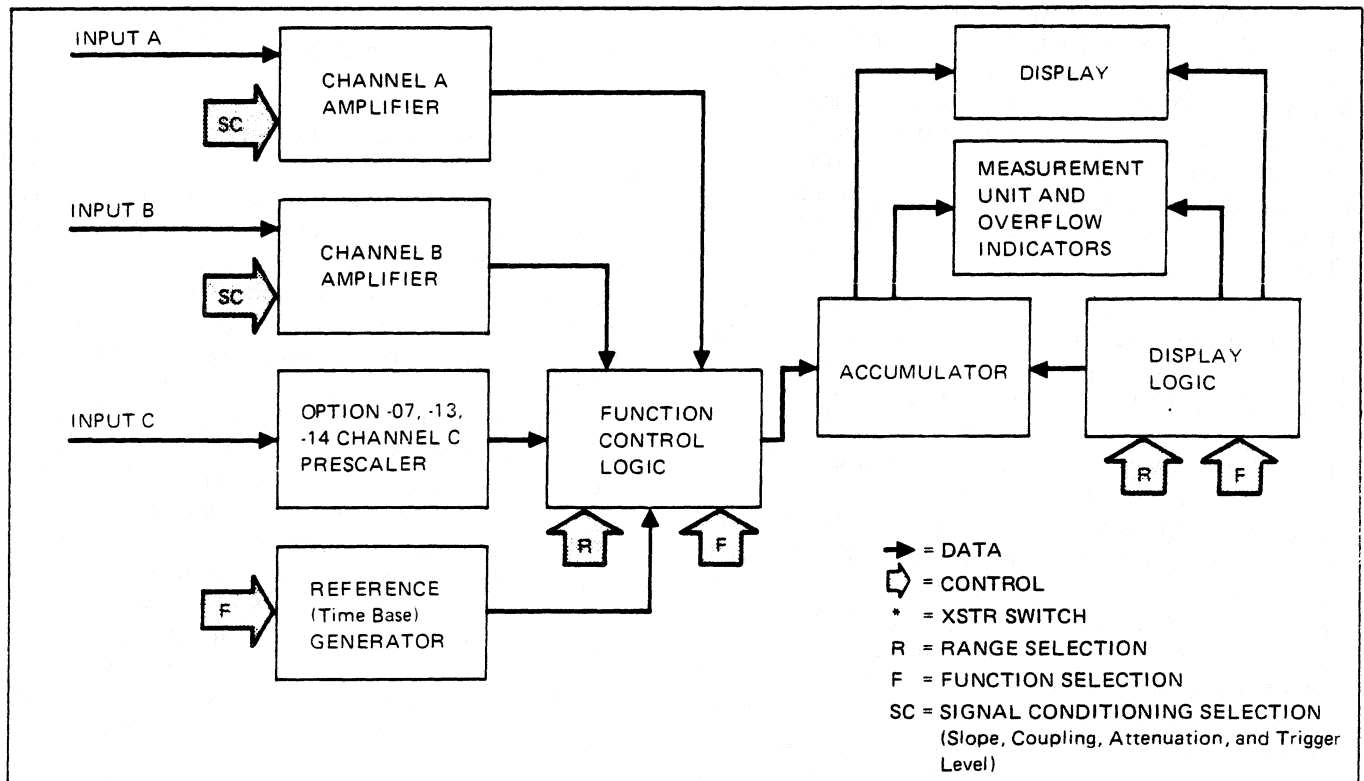

Figure 3-1. Model 1953A Simplified Block Diagram

Table 3-1. Accumulator Input Signal Summary

FUNCTION SWITCH	CLOCK DERIVED FROM	GATE DERIVED FROM
FREQ A	Channel A*	Ref. Generator
FREQ C	Channel C	Ref. Generator
FREQ A/B	Channel A*	Channel B
PERIOD A	Ref. Generator	Channel A
TI A-B	Ref. Generator	Channels A & B
A GTD BY B	Channel A*	Channel B**
SELF-CHECK	Ref. Generator	

\* Direct feed-through, not derived.

\*\* RANGE switch has no effect of gate pulse.

clock and the gate pulses. Table 3-1 lists sources for each measurement function. The duration of the gate pulse is a function of the RANGE switch. Decimal point location and measurement unit indication are automatically controlled by the RANGE and the FUNCTION switches through the display logic circuits.

3-5. When performing frequency measurements (with FREQ A or FREQ C of the FUNCTION selection), the counter accumulates cycles of the unknown input frequency for a pre-selected time interval termed the gate time. The total number of cycles accumulated is displayed in the readout and converted by the automatic placement of a decimal point into units of kHz or MHz (the units are indicated by the annunciators). There are six gate times available in the 1953A ranging from .1 ms to 10s in decade steps. These gate times are derived from the 10 MHz reference generator via the associated time base divider circuitry and are selected by means of the RANGE switch. In channel A frequency measurements the gate times are selected directly from the RANGE, while in channel C (prescaled frequency measurements) the gate times show in the RANGE are multiplied by a factor of either four (with Option -07) or eight (with Options -13 and -14).

3-6. Basically, measurements of period or of time intervals involve the counting of periods of the reference time base during a gate interval derived from an input signal. When performing period measurements on an input signal the counter accumulates clock pulses from the 10 MHz reference generator during a gate interval determined by a pre-selected number of periods of the input signal. The number of periods which establish the gate time are selected from the Periods Averaged column of the RANGE, which is scaled in six powers of ten giving from 1 to  $10^5$  periods of gating time. Direct period measurements are made when the gate interval is determined by a single period of the input signal, and period average measurements are made when more than one period comprises the gate interval. Since each cycle of the reference frequency has a period of 0.1  $\mu$ s, the accumulator actually counts the number of 0.1  $\mu$ s periods that occur during the gate time. This number is displayed

in the readout and converted by the automatic placement of a decimal point and units annunciation, into units of either microseconds or milliseconds. To make time interval measurements, the counter accumulates cycles of a signal derived from the time base divider circuitry, during the gate interval. The 10 MHz reference time base is divided by power of ten to yield a selection of six reference signals ranging from 10 MHz to 100 Hz. Any of the six frequencies may be selected from the RANGE to be used as the clock input to the accumulator. This selected frequency is counted for the duration of the gate pulse. The duration of the gate pulse in time interval measurements is determined by the specific slope and trigger level conditions set on channels A and B in relation to the signals present on the respective channels. Channel A sets the conditions for the start of the gate pulse, channel B for the end of the gate pulse. The same signal may be used on both channels, or separate signals may be used on each channel.

3-7. During ratio and totalize functions (RATIO A, B and A GTD BY B), clock pulses from channel A are counted while the accumulator is gated by channel B. The number of pulses counted is displayed in the readout with no measurement units. When the ratio function is selected, the cycles of the channel A frequency are counted for a gate interval determined by a pre-selected number of cycles of the channel B frequency (the number of cycles is selected from the RANGE). The number, n, thus displayed, with decimal point automatically placed, is implied to be the ratio n:1. When the totalize function is selected, the number displayed represents the total number of triggering events that occurred at channel A during an operator-controlled or an externally programmed period of time. For this function, the gate pulse is a dc level obtained directly from channel B, rather than being a pulse derived from an input frequency as in the ratio function. Automatic recycling (resetting) is inhibited in the totalize function, and successive gate pulses cause the accumulator to resume counting without resetting to zero first. However, pressing the RESET button, or applying an external reset signal will manually reset the accumulator to zero.

3-8. The self-check function is used to test the 1953A for correct operation of the counting, gating and display circuits. In this function the display shows the total number of cycles of the 10 MHz reference frequency counted during a pre-selected gate time. The number displayed has no units annunciator, and the gate time used is any of the six available in the RANGE, as in the frequency measurement functions. The digit-check subfunction is used to test the display LED's. When a reset signal (either manual or external) is applied in the self-check mode, all of the segment drivers are enabled and all correctly operating segments illuminate (decimal points are not lit).

### 3-9. BLOCK DIAGRAM ANALYSIS

#### 3-10. Channel A Amplifier

3-11. The function of the channel A input amplifier is to condition the input signal (type of coupling and attenuation), amplify it, and shape the signal before it is applied to the accumulator clock selector in the function control logic. As shown in Figure 3-2, the input signal to channel A can either be coupled across capacitor C402 (for AC coupling) or, by placing the front panel control to the DC position, applied directly to the attenuator. The attenuator switch can be placed to the X1 position to use the full amplitude of low level input signals or to the X10 position to reduce the input signal level by approximately ten.

3-12. The conditioned signal is then applied to one side of dual FET Q5. The voltage level applied to the other side of the FET is determined by the TRIGGER LEVEL control (R406). The push-pull amplifier (Q7 and Q8) provides U2 with an input that can be shaped by the

amplifier and Schmitt trigger section. The output of U2 is then applied to the accumulator clock input selector and to the TRIG STAT driver section, Q11 through Q15. The drivers insure that for higher frequency inputs the TRIG STAT indicators on the front panel will light.

#### 3-13. Channel B Amplifier

3-14. As shown in Figure 3-3, the signal conditioning for the input signals applied to channel B (input coupling and attenuation) is the same as that for channel A. The buffer amplifier (Q1, Q3 and Q4) also comprises a dual-FET, push-pull amplifier configuration the same as that in channel A, with the trigger level being determined by the TRIGGER LEVEL control (R405) for channel B. The difference between the two input channels is in the final stage of the channel B wave shaping circuit (U1, Q9, and Q10). the outputs of the Schmitt trigger portion of U1 are applied to the bases of Q9 and Q10 so that the output of the channel B amplifier is at a true TTL level.

#### 3-15. Reference Generator

3-16. The 10 MHz basic signal for the reference oscillator (Figure 3-4) is provided either by the internal oscillator (U7) or through the EXT 10 MHz clock input jack on the rear panel of the instrument. The 10 MHz signal is applied to the base of Q99, which is used to buffer the input of the Schmitt trigger U102.

#### 3-17. Function Control Logic

3-18. The function control logic receives signal data from the channel A, channel B and channel C input amplifiers and from the reference generator. From these inputs, the control logic, as directed by the range and

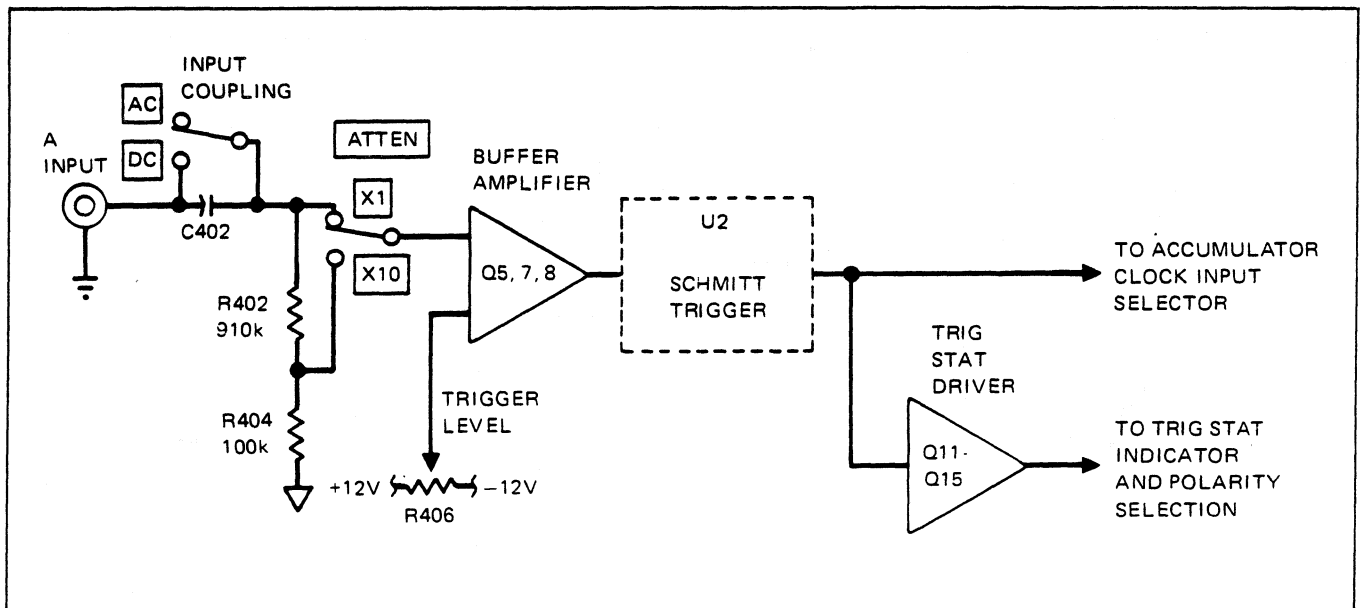

Figure 3-2. Channel A Input Amplifier

function switch positions, selects the signal to be applied to the accumulator and controls the time interval for which it is applied. The operation of the function control logic will be discussed for each separate position of the function switch.

3-19. FREQUENCY A

3-20. The basic signal processing that takes place in the control logic when the FREQ A function is selected is illustrated in Figure 3-5. The input selector (U4) will select either the leading or trailing edge (+ SLOPE, or -SLOPE) of the input A signal for triggering. The input A signal is then applied to one input of the main gate (U6).

3-21. The other input to U6 is the gate time signal. The gate time signal for the FREQ A function is derived from

the 10 MHz reference generator signal. The 10 MHz signal is first applied to the reference frequency divider (U11-U15) where it is reduced to a 10 kHz output. Reference divider input select gate U24 is directed by the FREQ A function command to apply the 10 kHz reference to the reference divider. The reference divider comprises a series of five decade counters that produce six separate frequency outputs; 10 kHz, 1 kHz, 100 Hz, 10 Hz, 1 Hz, and 0.1 Hz. The frequency at the range selector output (U26, U27, and U28) is controlled by the particular range selected. The gate selector (U42), also controlled by the FREQ A function command, applies the range selector output to the main gate. The main gate is enabled for one cycle of the gate time signal. The cycles of the input A frequency that occur during this single cycle of the gate time frequency are accumulated.

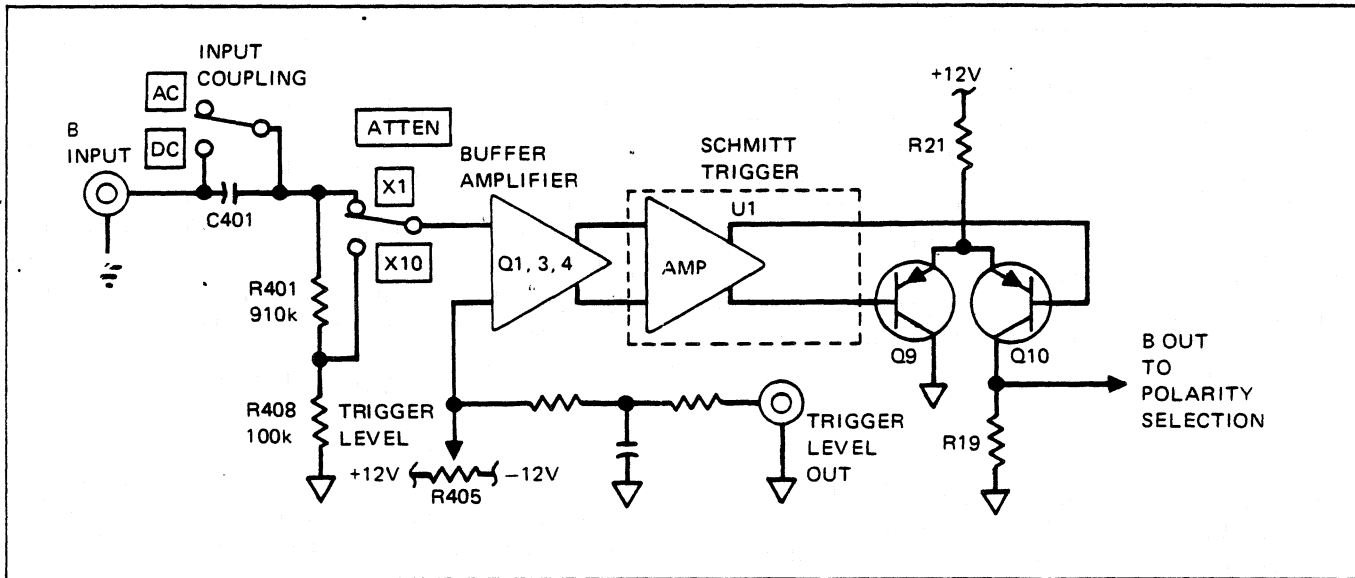

Figure 3-3. Channel B Input Amplifier

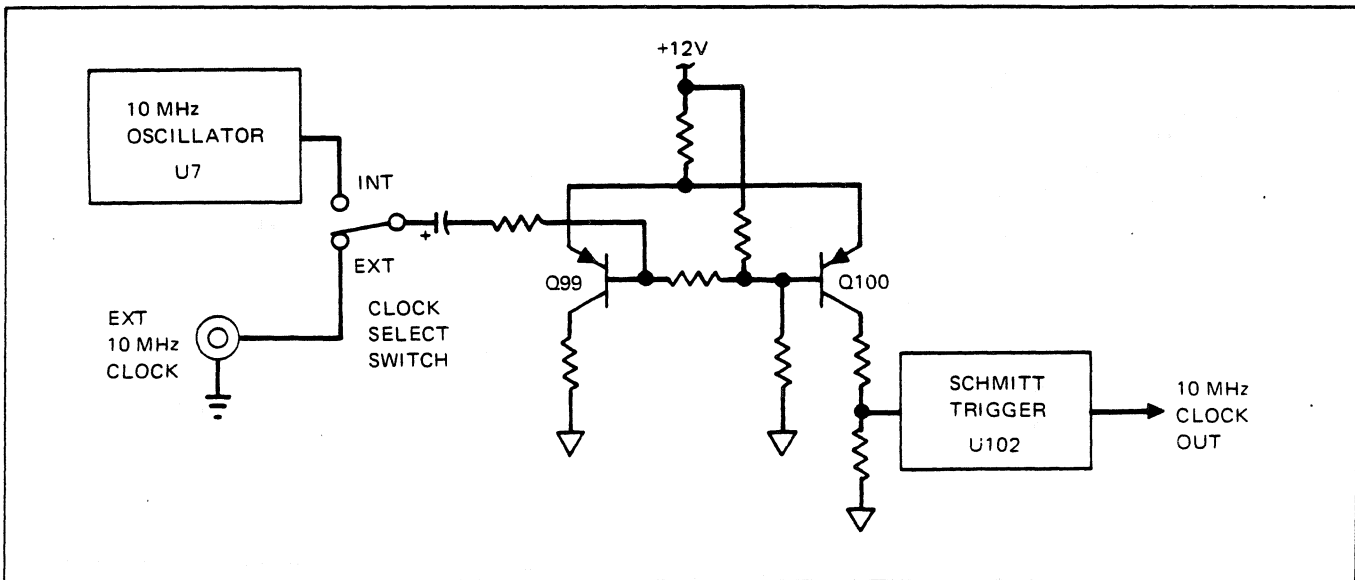

Figure 3-4. Reference Generator

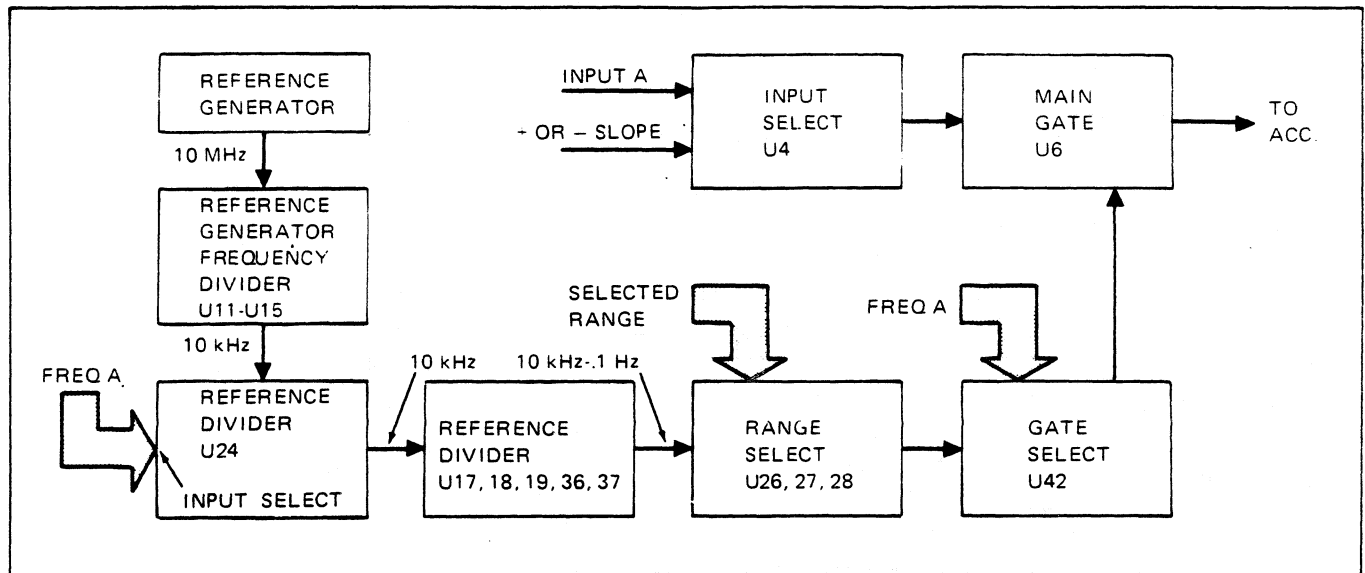

Figure 3-5. Function Control Logic: Frequency A

### 3-22. FREQUENCY C

3-23. The operation of the function control logic for the FREQ C function (see Figure 3-6) is similar to that for the FREQ A function. The input select gate (U4) applies the signal output from the prescaler (Options-07, -13 and -14) to the main gate input as directed by the FREQ C function command.

3-24. The gate time for this function is again derived from the 10 MHz reference generator. The reference frequency divider circuit, however, receives a command from the function switch that introduces an additional division factor. The 10 MHz reference frequency is divided by four (Option -07) or eight (Options -13 and -14) to compensate for a similar frequency division applied to the channel C input signal by the respective prescaler options. The reference divider input select gate (U24) directs this modified reference frequency to the reference divider circuit. The reference divider again provides six separate output frequencies, one for each range switch setting. The range selector gate (U26, U27, and U28), as directed by the RANGE switch, selects the proper gate signal to be applied to U42. The gate selector (U42) then applies this signal to the main gate to enable it to pass the input C signal to the accumulator.

### 3-25. FREQUENCY A/B

3-26. In this mode of operation the instrument will count the number of cycles of the input A signal that occur during a selected number of cycles of the input B signal. This configuration is illustrated in Figure 3-7.

3-27. The output of the channel B input amplifier is selected by the reference divider input select gate, in the FREQ A, B function, to be used as the reference signal. The input B signal is applied to the reference divider

where it is divided by powers of ten from  $10^0$  through  $10^5$ . The range selector will then select one of the six outputs of the reference divider, as determined by the range switch position, and apply it to the main gate to enable the gate to pass the input A signal to the accumulator.

### 3-28. PERIOD A

3-29. The input signal applied to channel A is used as the reference frequency to enable the main gate while the 10 MHz reference generator signal is counted by the accumulator. Figure 3-8 illustrates this function control logic configuration.

3-30. The 10 MHz reference generator signal is directed, in the PERIOD A function, through the input selector (U23 and U41) to the main gate. The output frequency of the channel A input amplifier is selected by the reference divider input select gate (U24) and applied to the reference divider. The six outputs of the reference divider consist, respectively, of the input A frequency divided by successive powers of 10 from  $10^0$  through  $10^5$ . The range selector applies the proper frequency, as determined by the range switch position, to the gate selector. The gate selector then enables the main gate for the duration of one cycle of the selected frequency, during which time the 10 MHz reference generator signal is counted by the accumulator.

### 3-31. TIME INTERVAL A TO B

3-32. In the TI A-B function the instrument uses the input signal on channel A to start the gate time pulse and the input signal on channel B to stop it. The time is measured by counting the number of cycles of the 10 MHz reference generator signal that occur during this period. Figure 3-9 shows the function control logic configuration for the TI A-B function.

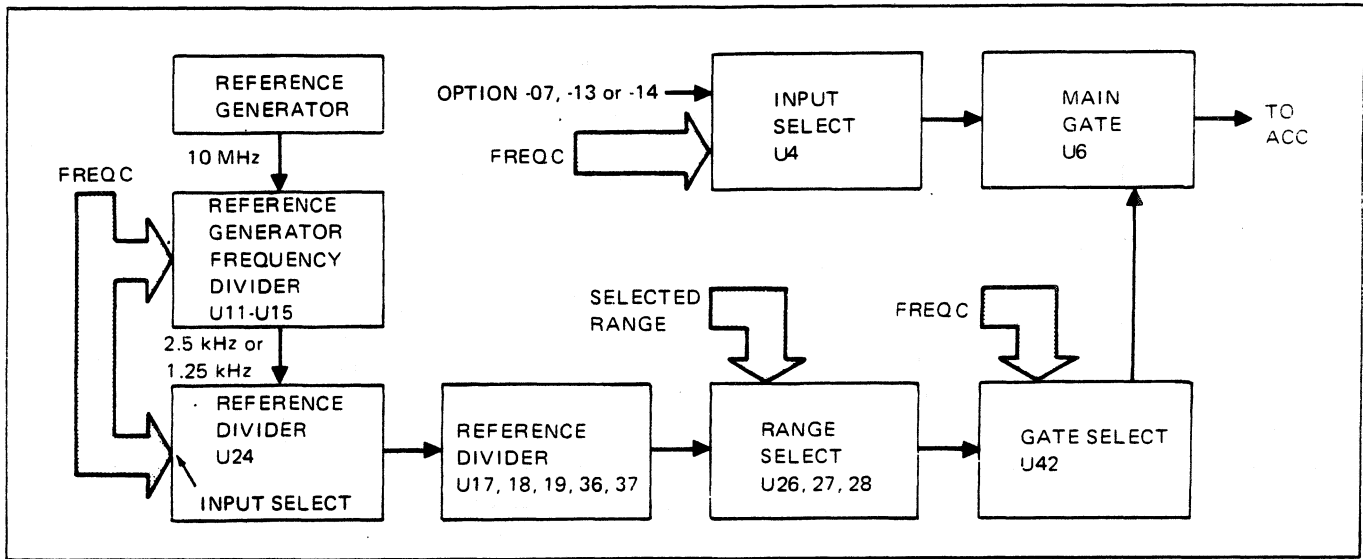

Figure 3-6. Function Control Logic: Frequency C

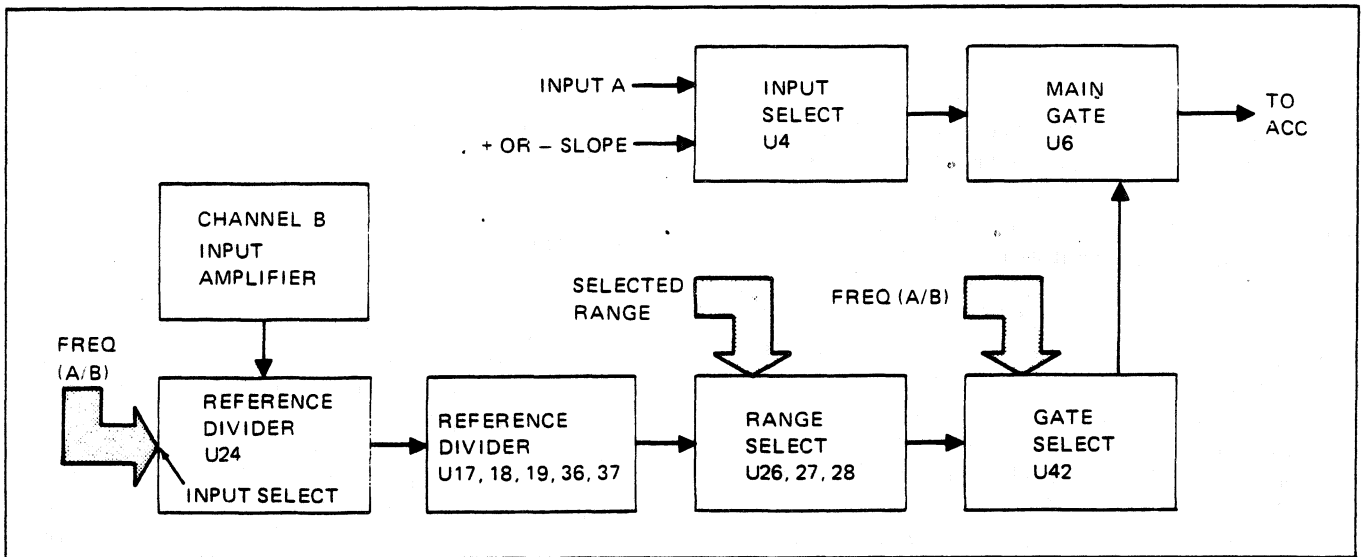

Figure 3-7. Function Control Logic: Frequency A/B

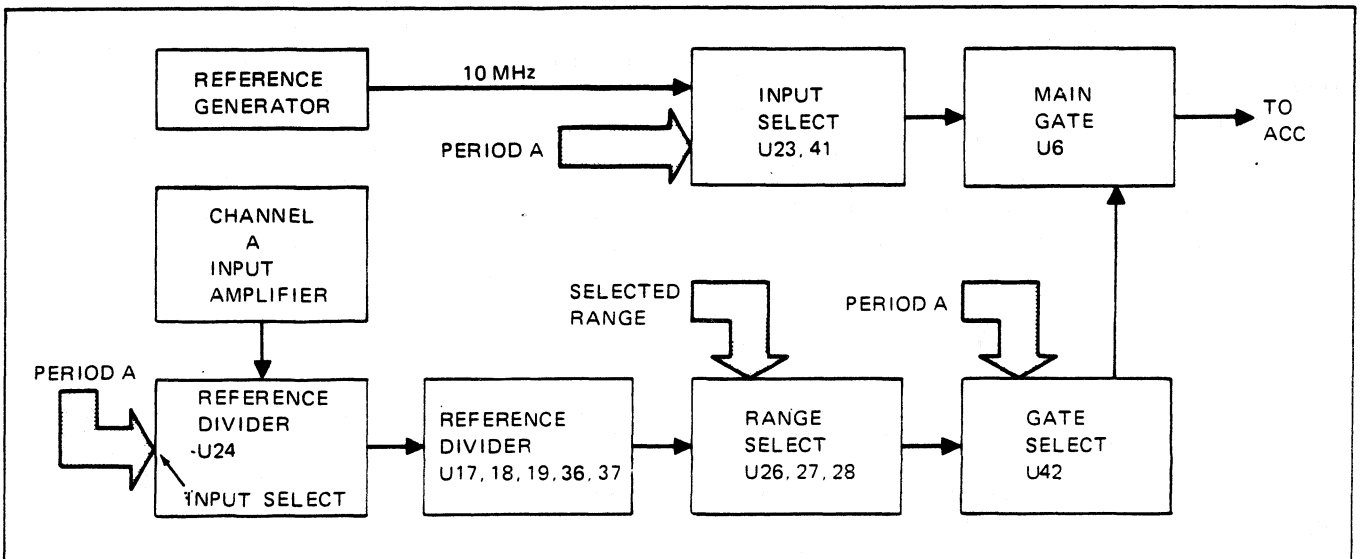

Figure 3-8. Function Control Logic: Period A



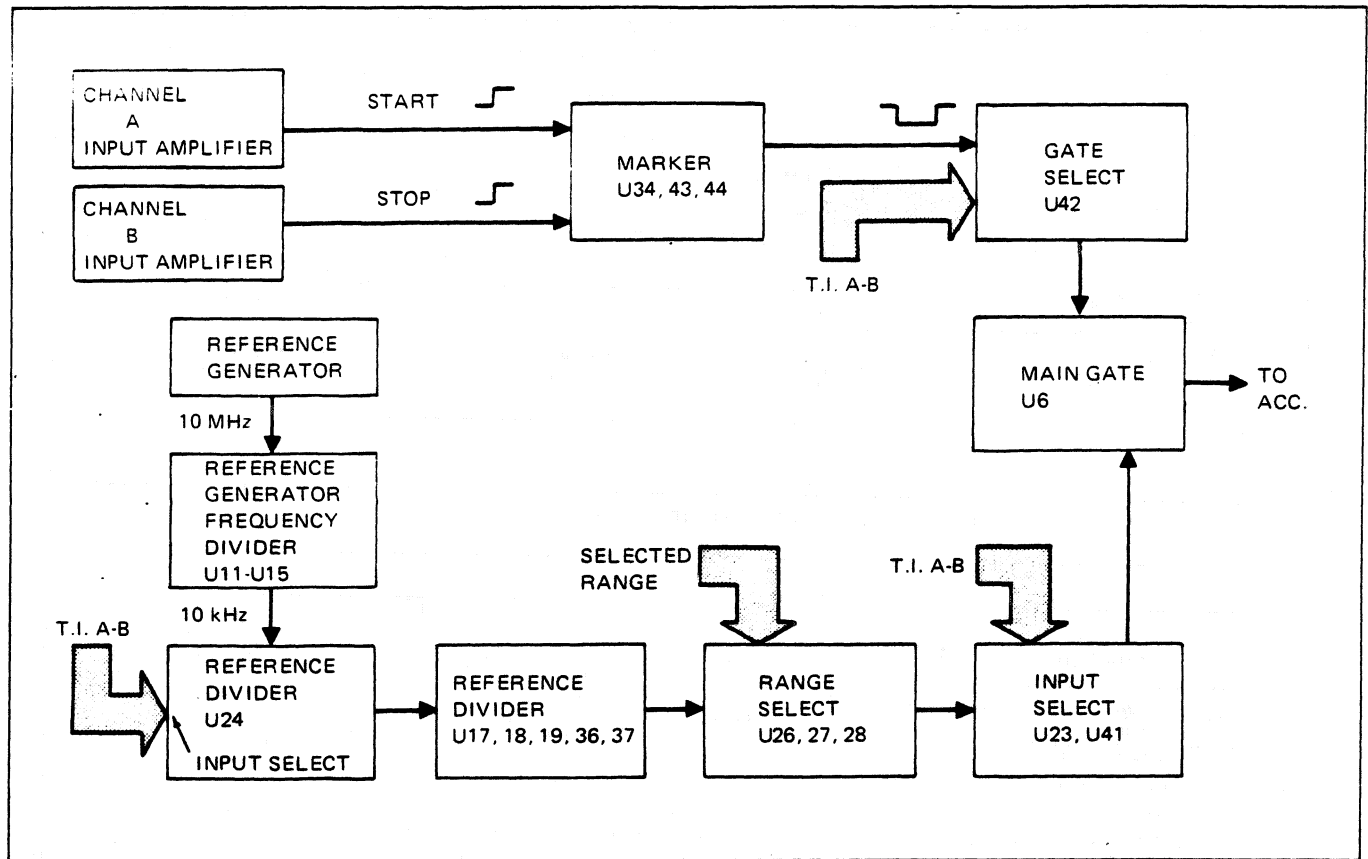

Figure 3-9. Function Control Logic: TI A-B

3-32. In the TI A-B function the instrument uses the input signal on channel A to start the gate time pulse and the input signal on channel B to stop it. The time is measured by counting the number of cycles of the 10 MHz reference generator signal that occur during this period. Figure 3-9 shows the function control logic configuration for the TI A-B function.

3-33. The 10 MHz reference generator signal is directed through the reference divider input select (U24) to the reference divider. The six outputs of the dividers are: 10 MHz, 1 MHz, 100 kHz, 10 kHz, 1 kHz, and 100 Hz. The range switch selects one frequency and applies it to the input selector which in turn applies it to the main gate. The gate time signal on the other input of the main gate is generated by the marker (U34, U43, U44) from the channel A and channel B inputs. The leading edge of the channel A input amplifier signal causes the output of the marker circuit to go low. This low signal causes the gate selector to enable the main gate. The leading edge of the channel B input amplifier signal causes the marker output to go high, which inhibits the main gate. The number of cycles of the reference frequency counted during this time is displayed as an amount of time in  $\mu$ s or ms.

#### 3-34. CHANNEL A GATED BY B

3-35. In the A GTD BY B function the instrument will totalize the events that occur on the channel A input for a

length of time determined by the channel B input. The function control logic for this mode of operation is illustrated in Figure 3-10.

3-36. The channel A input is directed through the input select gate (U4) to the main gate, in the A GTD BY B function. The enable signal for the main gate comes from the channel B input amplifier through gate selector U42 and enables the main gate to pass the input A signal to the accumulator for counting.

#### 3-37. SELF-CHECK

3-38. The Self-Check function will check the control logic circuits for proper operation. Figure 3-11 shows the portions of the control logic used to perform the Self-Check function.

3-39. Both the clock input to the main gate and the gate time are derived from the 10 MHz reference generator. The input selector (U4) directs the 10 MHz signal to one input of the main gate, in the Self-Check function. The signal on the other input comes from the reference generator through the reference generator frequency divider to the reference divider input select gate. In the Self-Check mode, a 10 kHz signal is directed to the reference divider. The Range selector directs one of the six reference divider output frequencies to the gate selector. The selected output frequency is applied to the main gate by the gate selector, and constitutes the main gate enable signal.

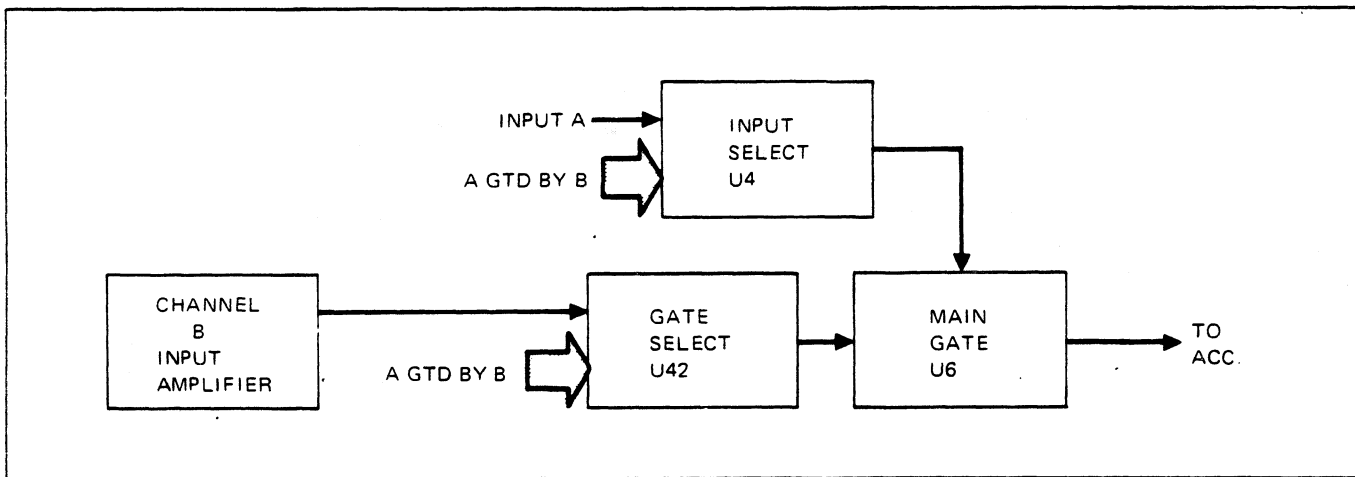

Figure 3-10. Function Control Logic A GTD by B

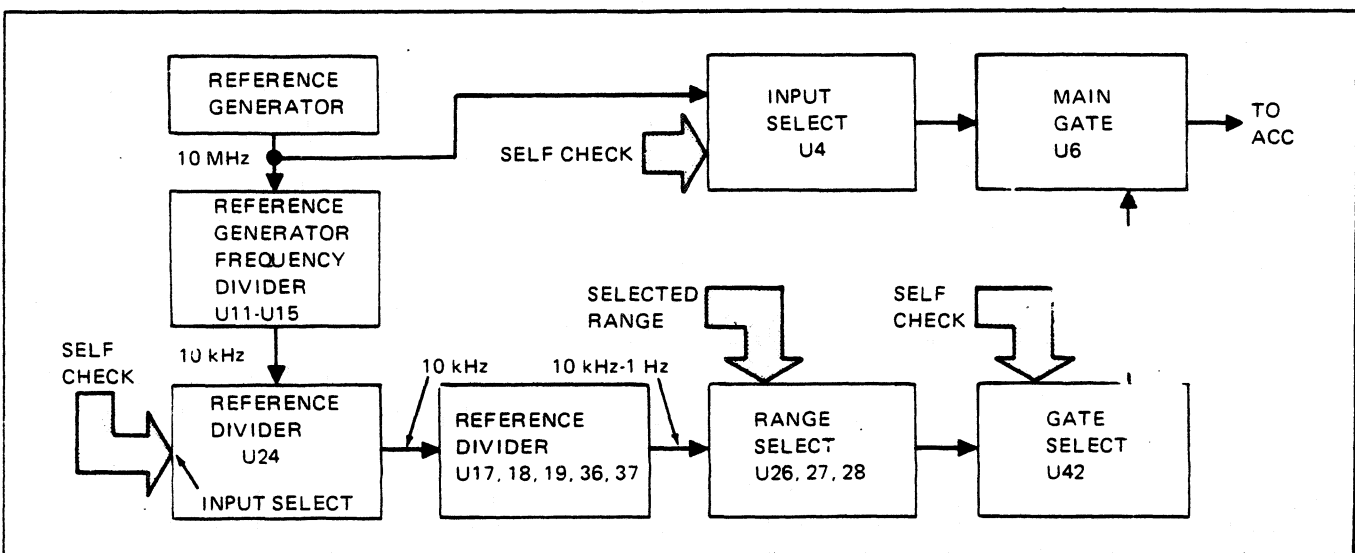

Figure 3-11. Function Control Logic: Self-Check

### 3-40. Accumulator

3-41. The frequency of the accumulator input signal is equal to one-half the frequency of the signal applied to the main gate, U6. The gate is a J-K flip-flop with the input being applied to the clock terminal and the output taken from the  $\Omega$  terminal. The output of the main gate becomes the BCD A of the first digit. Figure 3-12 is a basic illustration of the accumulator.

3-42. Since the main gate is an integral part of the first decade counter of the accumulator, it is represented in this block diagram as the CLK IN and J-K IN to the first decade counter. The first digit of LSD (Least Significant Digit) produces a BCD output (A-B-C-D signals) and applies it to the LSI chip, U65. The carry output from the LSD is connected to the clock input of the next decade counter, U57. This counter also produces a BCD output which is applied to U65. The carry output is applied to the

LSI chip U65 which contains the remaining seven decade counters used to produce the nine digits of the display.

3-43. When the decade counters have counted the input signal frequency for the duration of the main gate enable signal, the BCD output of each decade counter is applied to a four-bit latch. The memory update command that enables the latches to receive the BCD input is triggered by the trailing edge of the main gate enable signal.

3-44. The BCD digit information is moved from the latches to the display one digit at a time. An oscillator and a ten stage ring counter within U65 produce sequential enable signals for the four-bit gates and their corresponding digit drivers. The BCD digit information is gated out of the four-bit gates to the BCD-to-seven segment decoder. The seven-segment digit information for each significant digit is strobed by the digit driver signal so that it is displayed on the corresponding digit position of the display.

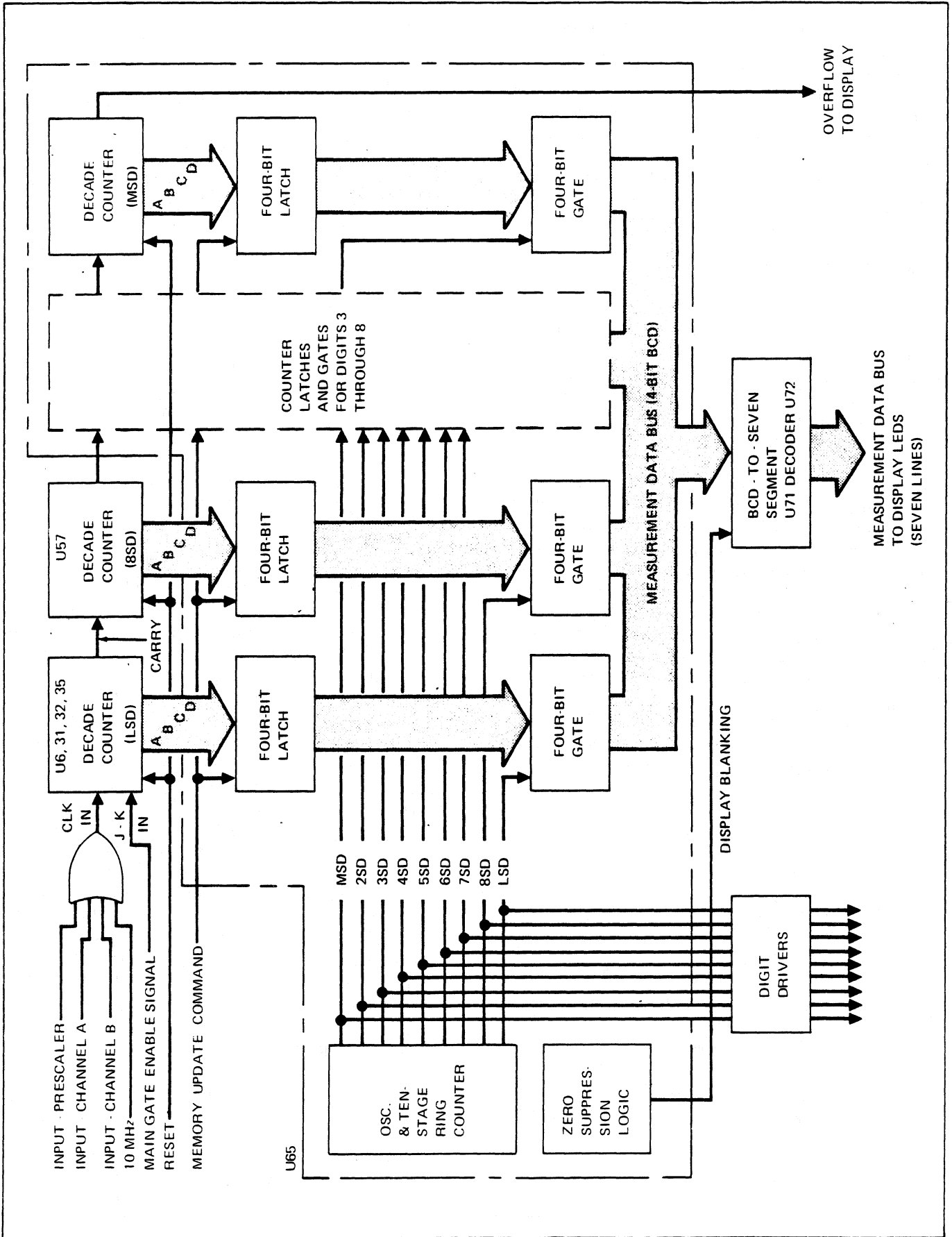

Figure 3-12. Accumulator Block Diagram

3-45. The zero suppression logic within the LSI chip will blank zeros to the left of the most significant digit displayed. If the most significant digit is to the right of the decimal point, suppression will occur to the left of the decimal point only. If the frequency of the signal applied to the accumulator clock input is high enough and the gate enable signal long enough the most significant digit (MSD) will produce a carry signal that will light the overflow indicator on the front panel. A reset command from the display logic circuit will return the decade counter to zero for each new measurement cycle.

**3-46. Display Logic**

3-47. The display logic performs three basic functions. First, it illuminates the proper annunciator (MHz, kHz,  $\mu$ s, ms or s) as needed for each function and range setting. Secondly, it enables the correct decimal point, as directed by the range and function controls. Finally, it will update the display and reset the counters as directed by the gate enable signal and cycle rate control.

3-48. The annunciator control is illustrated in Figure 3-13 in a simplified form. In the Frequency A or Frequency C function the MHz annunciator will light when the range switch is positioned to ranges 1, 2, or 3 (0.1 ms, 1.0 ms or 10 ms). When the range switch is positioned to ranges 5, 6, or 7 (0.1s, 1.0 or 10s) the output of U63 changes from a high to a low logic level. The low output, representing ranges 4, 5, or 6, is inverted and applied to one AND gate section of U62 to light the kHz annunciator. The T.I. A-B function will cause the ms annunciator to light in ranges 1, 2, and 3 and the  $\mu$ s annunciator to light in ranges 4, 5, or 6. The PERIOD A mode in ranges 1, 2, or 3 causes the ms annunciator to light and in the 4, 5, or 6 range the s annunciator will light.

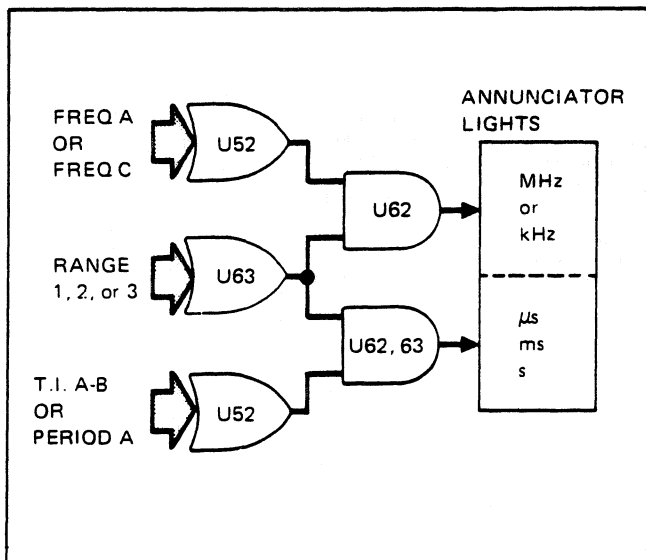

Figure 3-13. Annunciator Control Logic

3-49. The decimal point logic enables one input of one-of-six AND gates so that the correct decimal point will light when a strobe signal is applied to the other input of the gate (see Figure 3-14). The range inputs are paired by NOR gate U52 and U53 (1 and 4, 2 and 5, 3 and 6) so that the decimal point will return to the same digit when either range is selected. This is used in the FREQ A, FREQ C, and T.I. A-B Functions because the annunciator changes the scale of the display between ranges 3 and 4. The function command input is combined with individual range commands, in order to place the decimal point at the proper digit.

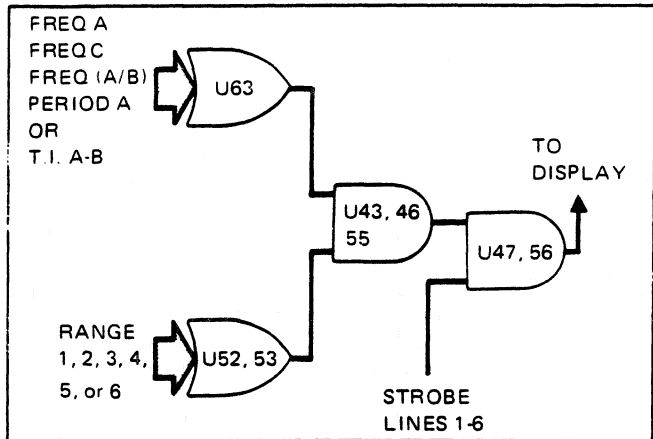

Figure 3-14. Decimal Point Control Logic

3-50. The update and reset control provides commands, at the proper time, to update the digit information being displayed and to reset the decade counters for a new input (see Figure 3-15). At the end of the main gate enable pulse, U59 is set which enables U67 and the 100 kHz signal input to U66. The reaction time of U67 is controlled by the cycle rate control on the front panel, which delays the set command from U59 by 0.2 to 2 seconds. While the cycle rate delay is taking place the 100 kHz signal is clocking U66 through its outputs. The first cycle of the 100 kHz signal is used as a spacer between commands. The second cycle, however, causes U66 to output an update command. The third is again a spacer and the fourth causes the reset command output. The fifth cycle in will disable the 100 kHz input signal to stop the action in U66. At the end of the cycle rate delay, U67 will reset U59 which in turn resets U66, preparing the circuit for a new measurement cycle.

**3-51. Display**

3-52. The display consists of nine, seven-segment LED's. Figure 3-16 illustrates how the seven-segment digit information and the decimal point information is applied to all nine display chips at the same time. The strobe lines, one to each display LED, enable the display digit that corresponds to the decade counter digit of the accumulator producing the digit information at that strobe time.

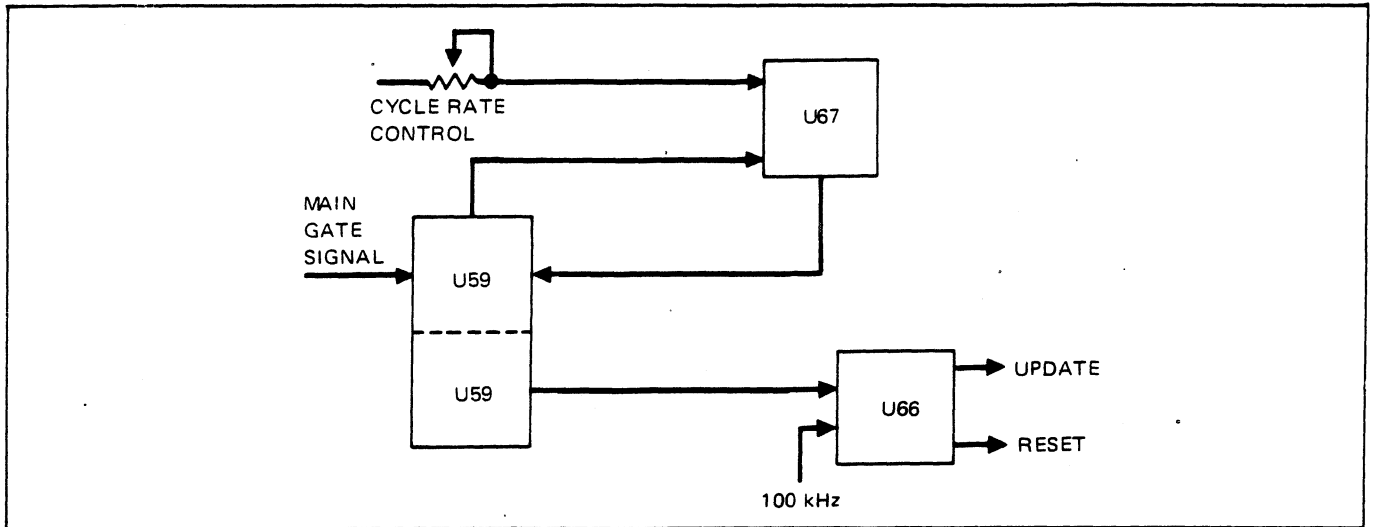

Figure 3-15. Update and Reset Control Logic

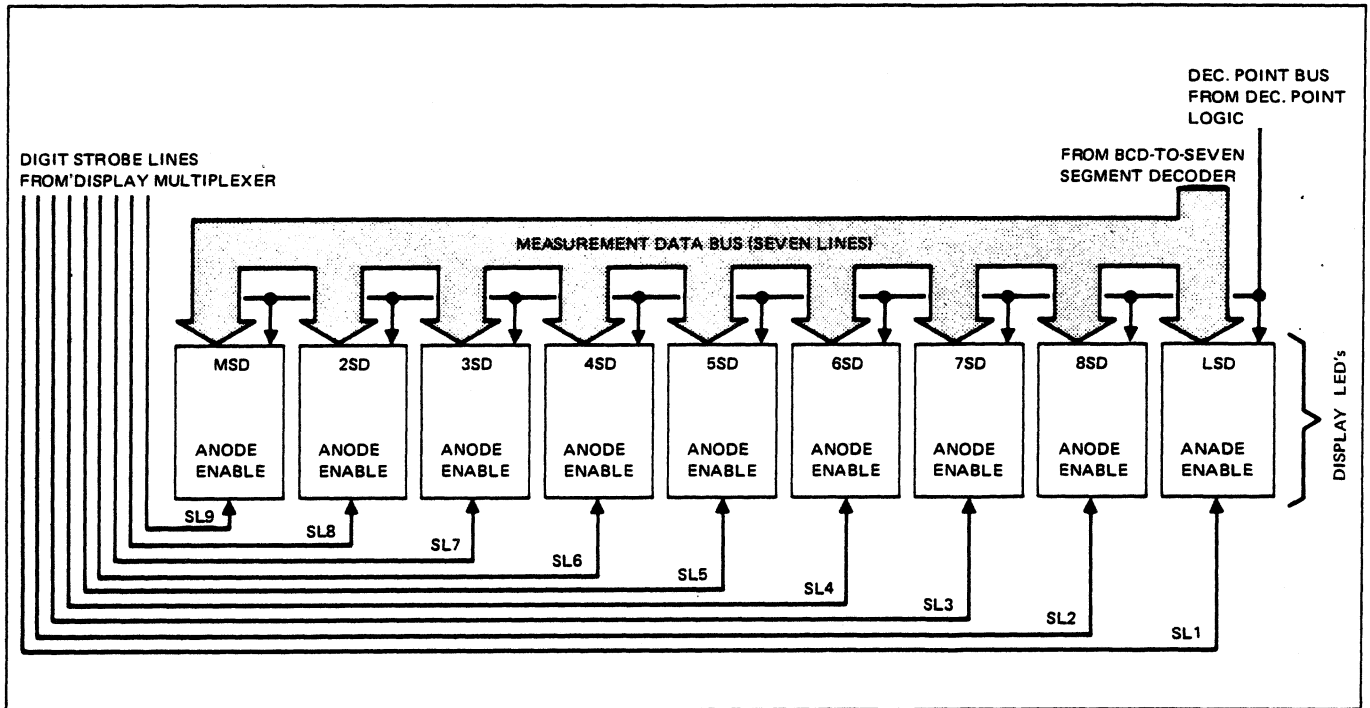
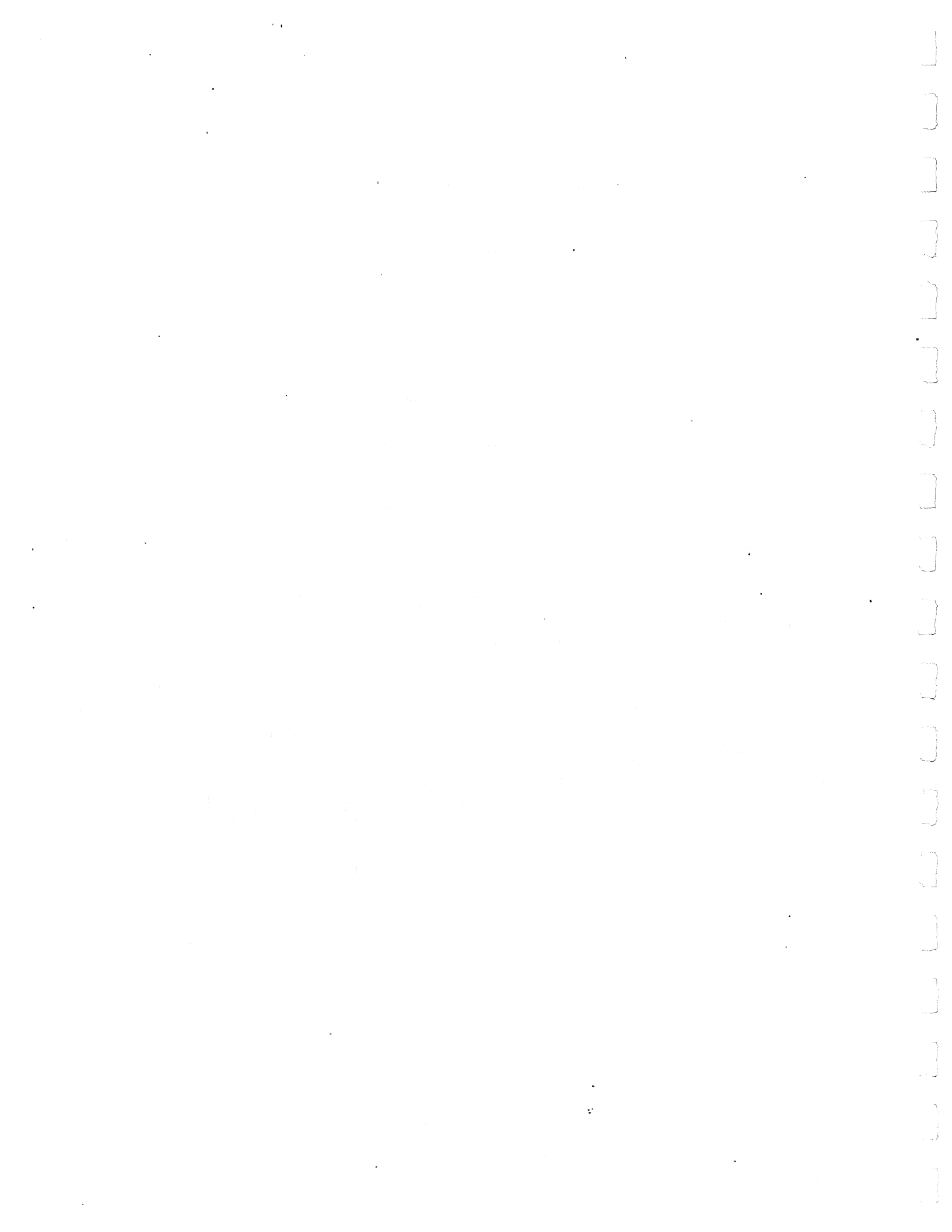

Figure 3-16. Display Section Block Diagram





# static awareness



A Message From  
**John Fluke Mfg. Co., Inc.**

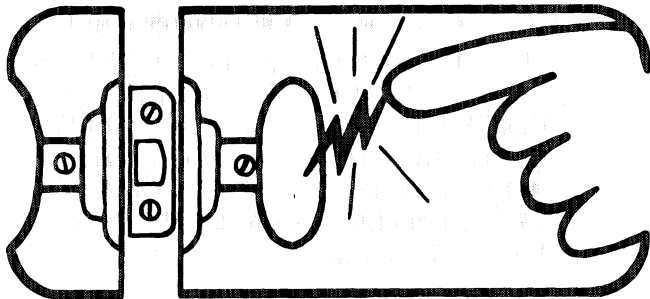

Some semiconductors and custom IC's can be damaged by electrostatic discharge during handling. This notice explains how you can minimize the chances of destroying such devices by:

1. Knowing that there is a problem.
2. Learning the guidelines for handling them.
3. Using the procedures, and packaging and bench techniques that are recommended.

The Static Sensitive (S.S.) devices are identified in the Fluke technical manual parts list with the symbol "⊗"

The following practices should be followed to minimize damage to S.S. devices.

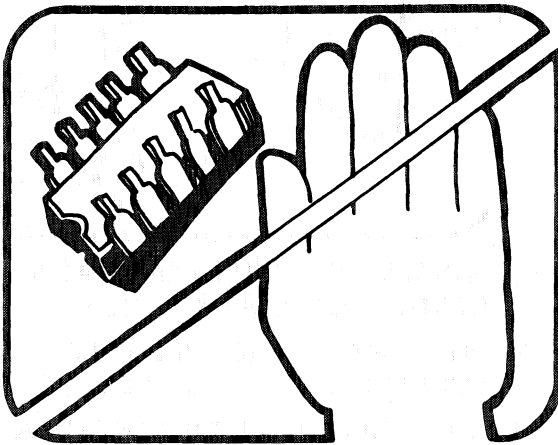

1. MINIMIZE HANDLING

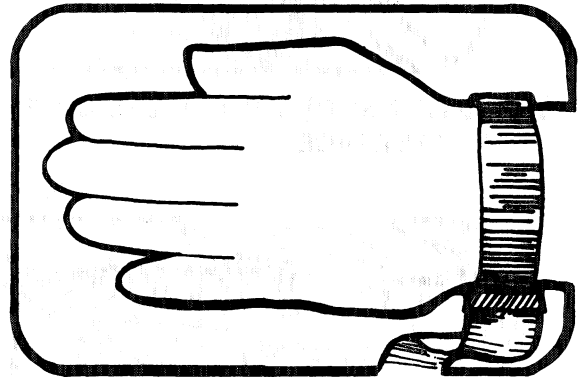

3. DISCHARGE PERSONAL STATIC BEFORE HANDLING DEVICES. USE A HIGH RESISTANCE GROUNDING WRIST STRAP.

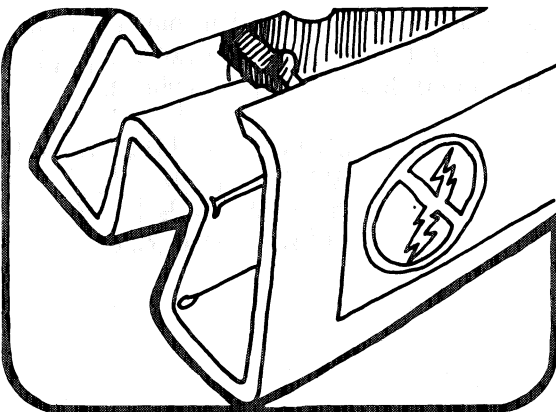

2. KEEP PARTS IN ORIGINAL CONTAINERS UNTIL READY FOR USE.

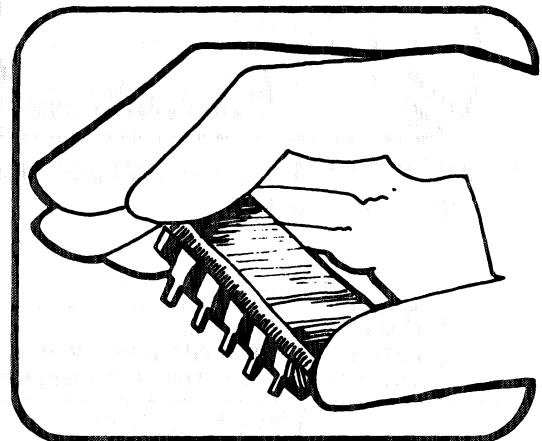

4. HANDLE S.S. DEVICES BY THE BODY

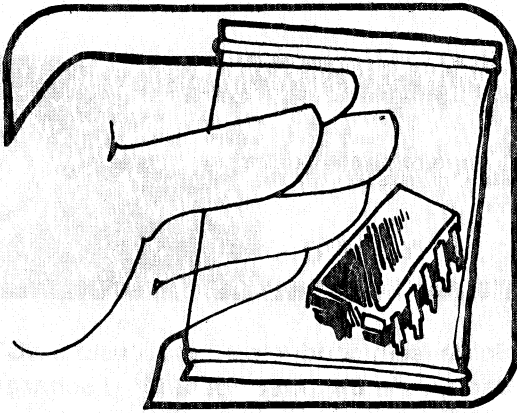

5. USE STATIC SHIELDING CONTAINERS FOR HANDLING AND TRANSPORT

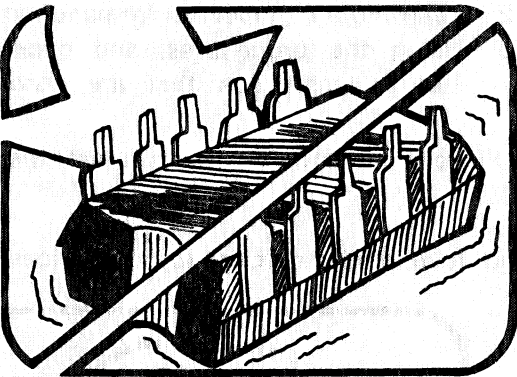

6. DO NOT SLIDE S.S. DEVICES OVER ANY SURFACE

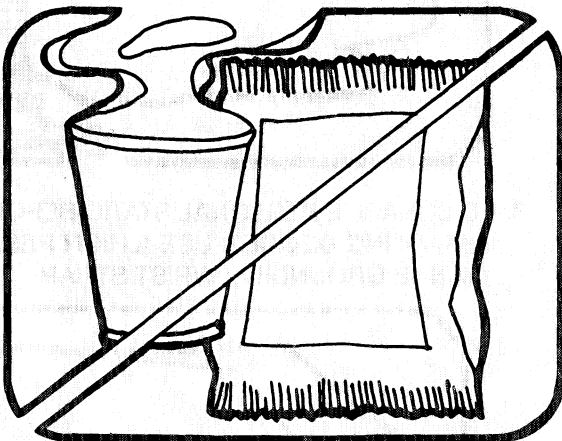

7. AVOID PLASTIC, VINYL AND STYROFOAM® IN WORK AREA

PORTIONS REPRINTED  
WITH PERMISSION FROM TEKTRONIX, INC.  
AND GENERAL DYNAMICS, POMONA DIV.

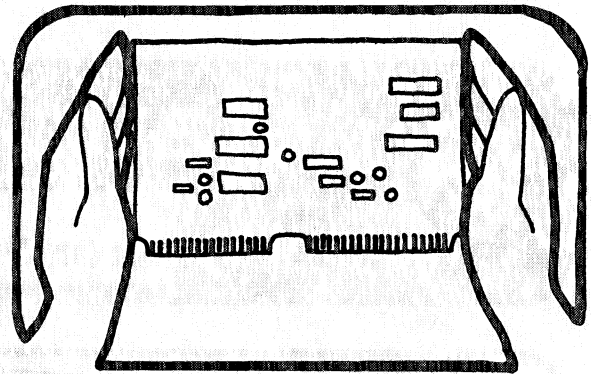

8. WHEN REMOVING PLUG-IN ASSEMBLIES, HANDLE ONLY BY NON-CONDUCTIVE EDGES AND NEVER TOUCH OPEN EDGE CONNECTOR EXCEPT AT STATIC-FREE WORK STATION. PLACING SHORTING STRIPS ON EDGE CONNECTOR HELPS TO PROTECT INSTALLED SS DEVICES.

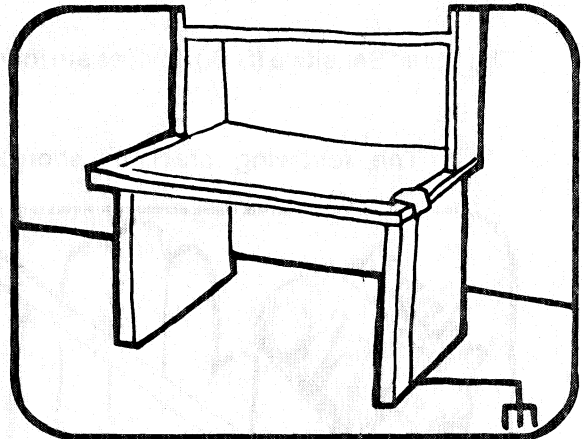

9. HANDLE S.S. DEVICES ONLY AT A STATIC-FREE WORK STATION
10. ONLY ANTI-STATIC TYPE SOLDER-SUCKERS SHOULD BE USED.
11. ONLY GROUNDED TIP SOLDERING IRONS SHOULD BE USED.

A complete line of static shielding bags and accessories is available from Fluke Parts Department, Telephone 800-526-4731 or write to:

JOHN FLUKE MFG. CO., INC.  
PARTS DEPT. M/S 86  
9028 EVERGREEN WAY  
EVERETT, WA 98204



## Section 4

# Maintenance

### 4-1. INTRODUCTION

4-2. This section contains maintenance information for the Model 1953A Counter/Timer. This includes service information, general maintenance, performance test, calibration and troubleshooting. The performance test is recommended as a preventive maintenance tool and should be executed every 90 days to verify proper instrument operation. Troubleshooting information is given in the form of flowcharts at the end of this section. Table 4-1 lists the recommended test equipment required for maintenance of the 1953A.

### 4-3. SERVICE INFORMATION

4-4. Each instrument that is manufactured by the John Fluke Mfg. Co., Inc. is warranted for a period of 1 year

upon delivery to the original purchaser. The warranty is given on the back of the title page located in the front of this manual.

4-5. Factory authorized calibration and service for each Fluke product is available at various worldwide locations. A complete list of these service centers is included in Section 7. Shipping information is given in Section 2 of this manual. If requested, an estimate will be provided to the customer before work is begun on instruments that are beyond the warranty period.

### 4-6. GENERAL MAINTENANCE

#### 4-7. Access and Removal Information

4-8. All pcb assemblies used in the 1953A can be accessed for maintenance purposes by removing the top

**Table 4-1. Test Equipment Required for 1953A Maintenance**

EQUIPMENT NOMENCLATURE	RECOMMENDED MODEL	WHERE USED
Quartz oscillator frequency standard with 10 MHz output	Select model with stability 10 times better than time base installed in 1953A.	Time base oscillator adjustment
Low frequency oscillator	HP204D	Performance check, calibration
High frequency oscillator	HP8654A HP612A (for 1 GHZ and 1.25 GHZ options)	Performance check, calibration
RF millivoltmeter with 50 Ohm termination	Boonton 91C	Performance check, calibration
Multimeter	Fluke 8000A	Troubleshooting
Oscilloscope	Tektronix 465	Troubleshooting

and the bottom dust covers from the instrument. Six phillips-head screws hold each dust cover in place. Once both dust covers have been removed, the front panel assembly can be removed from the unit. Then the display, the switch, and the input pcb assemblies can be removed from the Front Panel assembly. Use the procedures given in the following paragraphs to remove these pcb's from the unit. Repaired or replacement pcb's can be installed by logically reversing the procedures.

#### 4-9. FRONT PANEL

4-10. Remove the Front Panel from the 1953A as follows:

- a. Remove top and bottom dust covers, by removing six phillips screws from each cover.
- b. Unsolder input connector wires from input BNC jacks.
- c. Remove all front panel control knobs and the mounting nuts for the RESET button, and RANGE and FUNCTION switches.
- d. Remove signal screw, holding Main PCB to Front Panel support bracket (front center, underside of Main PCB).
- e. Remove the two screws that hold the Display PCB and Input PCB to the front panel.
- f. Remove four screws holding Front Panel to side brackets (two on each side).

#### CAUTION

**During the next step, exercise care not to bend any of the pins that electrically interconnect the three pcb's to the Main PCB.**

- g. Slide the front panel straight forward until it clears the switch shafts.

#### 4-11. DISPLAY PCB ASSEMBLY

4-12. Remove the Display PCB Assembly from the Front Panel Assembly as follows:

- a. Remove the Front Panel.
- b. Pull Display PCB away from front panel.
- c. Unplug the data input cable from J4 on the Main PCB.

- d. If power switch, CYCLE RATE control or entire pcb is to be replaced, unsolder wires from power switch at rear of CYCLE RATE control.

#### 4-13. SWITCH PCB ASSEMBLY

4-14. Remove the Switch PCB assembly from the Front Panel as follows:

- a. Remove the Front Panel.
- b. Pull Switch PCB away from front panel.

#### 4-15. INPUT PCB ASSEMBLY

4-16. Remove the Input PCB Assembly from the Front Panel Assembly as follows:

- a. Remove the Front Panel.
- b. Unsolder input connector leads.
- c. Pull Input PCB away from front panel.

#### 4-17. Cleaning

4-18. Clean the 1953A periodically to remove dust, grease and other contamination. Use the following procedure:

- a. Clean the surface of all pcb's using clean, dry air, at low pressure ( $\leq 20$  psi). If grease is encountered, spray with Freon T.F. Degreaser and remove grime with clean, dry air at low pressure.
- b. Clean the front panel with a soft cloth dampened with a mild solution of detergent and water.

#### 4-19. Fuse Replacement

4-20. The power fuse, F1, is located on the rear panel of the 1953A. If replacement is necessary, use a 1A slo-blo for 115V operation and a .5A slo-blo for 230V operation.

#### 4-21. Service Tools

4-22. No special tools are required to maintain or repair the 1953A.

#### 4-23. PERFORMANCE TEST

4-24. The performance test is designed to verify the overall operation of the 1953A. This test can be used as an acceptance check and or periodic maintenance check. Table 4-1 lists the equipment required to perform this test. If the counter fails any part of the performance test, corrective action is indicated. Troubleshooting information for fault isolation is given later in this section.

#### 4-25. Set-Up Procedure

4-26. Prior to executing the performance test, complete the following set-up procedure:

- a. Connect the 1953A to line power.
- b. Rotate CYCLE RATE control cw, from the OFF detent and set to maximum cw position. The front panel display should light.

#### NOTE

*If the 1953A is equipped with the -10, -11 or -12 Option the rear panel Main Power switch must be in the ON position.*

- c. Set rear panel EXT/INT switch to INT.
- d. Set SEP/COM switch to SEP.
- e. Set CHANNEL A and CHANNEL B controls to following positions:
  1. TRIGGER LEVEL control to PRESET
  2. SLOPE switch to +
  3. Coupling (AC/DC) switch to AC
  4. ATTEN switch to X1

#### 4-27. Channel A Amplifier Test

4-28. Use the following procedure to test the Channel A amplifier:

- a. Complete Set-Up Procedure.
- b. Connect a 2V rms, 1 kHz signal to CHANNEL A connector.
- c. Observe TRIG STAT annunciators. Both (+ and -) should be lit.
- d. Change settings of SLOPE, coupling and ATTEN switches. Both TRIG STAT annunciators should remain lit.
- e. Set the ATTEN switch to X10 and Coupling switch to AC.
- f. Turn TRIGGER LEVEL control cw, too just off PRESET detent. The + TRIG STAT annunciator should be lit, and the - annunciator off.
- g. Turn TRIGGER LEVEL control cw to center of its travel. Both TRIG STAT annunciators should be lit.
- h. Turn TRIGGER LEVEL control fully cw. The -TRIG STAT annunciator should be lit, and the + annunciator off.

#### 4-29. Channel B Amplifier Test

4-30. To test the channel B amplifier, repeat the procedure given in the previous paragraph, but use the CHANNEL B controls, indicators and connectors.

#### 4-31. Display Test

4-32. Use the following procedure to test the front panel display:

- a. Complete Set-Up Procedure.
- b. Sequentially select each position of RANGE switch for each position of FUNCTION switch (except A GTD BY B). As each range is selected, verify that display is as described in Table 4-2. (A GTD BY B position requires external inputs to test readout display.)
- c. Set FUNCTION switch to A GTD BY B.
- d. Connect a 1V rms, 5 Hz signal to CHANNEL A connector.
- e. Set CHANNEL A Coupling switch to DC.
- f. Set CHANNEL B SLOPE switch to -.
- g. Turn CHANNEL B TRIGGER LEVEL control cw until readout begins to display channel A input frequency. Observe least significant digit of readout and verify that each of 10 possible numerals (0 through 9) are displayed in sequence.
- h. Increase input frequency to 10 Hz, 100 Hz, 1 kHz, 10 kHz, 100 kHz, and 1 MHz, pausing at each to verify proper operation of digits 2 through 7, respectively. (Digits are numbered from right to left.)
- i. Use a 10 MHz signal to test digit 8 and a 100 MHz signal to test digit 9. Each digit will step through all ten numerals in ten seconds. Lower frequency signals will involve longer time intervals.
- j. Verify the OVERFLOW indicator lights as digit 9 steps from a 9 to a 0.
- k. Press RESET button (momentarily). Verify that OVERFLOW indicator goes out, readout resets to zero and totalizing process starts over.

Table 4-2. Display Readout Test

FUNCTION SWITCH	RANGE SW	DISPLAY FOR AVAILABLE RANGE SETTINGS					
	INDICATIONS	1	2	3	4	5	6
DIGIT CHECK (SELF-CHECK WITH RESET DEPRESSED)	READOUT	888888888	(SAME)	(SAME)	(SAME)	(SAME)	(SAME)
	ANNUNCIATOR	(NONE)	(NONE)	(NONE)	(NONE)	(NONE)	(NONE)
SELF-CHECK	GATE	0.1 ms	1.0 ms	10 ms	0.1s	1.0s	10s
	READOUT	1000	10000	100000	1000000	1000000	10000000
	ANNUNCIATOR	(NONE)	(NONE)	(NONE)	(NONE)	(NONE)	(NONE)
T.I. A-B	T.I. RES	0.1 $\mu$ s	1.0 $\mu$ s	10 $\mu$ s	0.1 ms	1.0 ms	10 ms
	READOUT	.0000	.000	.00	.0000	.000	.00
	ANNUNCIATOR	ms	ms	ms	s	s	s
PERIOD A	PER. AVGD.	10 <sup>0</sup>	10 <sup>1</sup>	10 <sup>2</sup>	10 <sup>3</sup>	10 <sup>4</sup>	10 <sup>5</sup>
	READOUT	.0000	.00000	.000000	.0000	.00000	.000000
	ANNUNCIATOR	ms	ms	ms	$\mu$ s	$\mu$ s	$\mu$ s
FREQA/B	PER. AVGD.	10 <sup>0</sup>	10 <sup>1</sup>	10 <sup>2</sup>	10 <sup>3</sup>	10 <sup>4</sup>	10 <sup>5</sup>
	READOUT	0	.0	.00	.000	.0000	.00000
	ANNUNCIATOR	(NONE)	(NONE)	(NONE)	(NONE)	(NONE)	(NONE)
FREQ C	GATE	0.1 ms	1.0 ms	10 ms	0.1s	1.0s	10s
	READOUT	.00	.000	.0000	.00	.000	.0000
	ANNUNCIATOR	MHz	MHz	MHz	kHz	kHz	kHz
FREQ A	GATE	0.1 ms	1.0 ms	10 ms	0.1s	1.0s	10s
	READOUT	.00	.000	.0000	.00	.000	.0000
	ANNUNCIATOR	MHz	MHz	MHz	kHz	kHz	kHz

### 4-33. Frequency A Test

4-34. Using the following procedure to test the frequency function:

- Complete Set-Up Procedure.
- Set FUNCTION switch to FREQ A.
- Connect 1V rms, 100 kHz signal to CHANNEL A connector.
- Sequentially select each GATE position of the RANGE switch, pausing at each to verify that the readout and measurement unit display are as described in Table 4-3.

Table 4-3. Frequency A Test

GATE	READOUT*	UNIT ANNUNCIATOR
0.1 ms	.10	MHz
1.0 ms	.100	MHz
10 ms	.1000	MHz
0.1s	100.00	kHz
1.0s	100.000	kHz
10s	1000.0000	kHz

\*The accuracy of the readout is dependent upon the accuracy of the 100 kHz input signal.

### 4-35. Frequency C Test

4-36. The frequency C function is operational only when one of the Prescaler Options (-07, -13, or -14) has been installed. Refer to the appropriate option in Section 6 of this manual for performance test information.

### 4-37. Ratio Test

4-38. Use the following procedure to test the ratio (frequency A B) function:

- Complete Set-Up Procedure.

- b. Set FUNCTION switch to FREQ A B.
- c. Set SEP COM switch to COM.
- d. Connect 1V rms 100 kHz signal to CHANNEL A connector.
- e. Sequentially select each PER AVGD (periods averaged) position of RANGE switch, pausing at each to verify the readout display is as shown in Table 4-4. (No measurement unit annunciator will light.)

Table 4-4. Ratio Test

PER AVGD.	READOUT
$10^0$	1
$10^1$	1.0
$10^2$	1.00
$10^3$	1.000
$10^4$	1.0000
$10^5$	1.00000

**4-39. Period A Test**

4-40. Use the following procedure to test the period A function:

- a. Complete Set-Up Procedure.
- b. Set FUNCTION switch to FREQ A.
- c. Connect 1V rms, 10 kHz signal to CHANNEL A connector.
- d. Set RANGE switch to 10s (GATE) and adjust signal source to produce display of 10.000 kHz on readout.
- e. Set FUNCTION switch to PERIOD A.
- f. Sequentially select each PER AVGD position of RANGE switch, pausing at each to verify that display is as described in Table 4-5.

Table 4-5. Period A Test

PER AVGD.	READOUT	ANNUNCIATOR
$10^0$	.1000	ms
$10^1$	.10000	ms
$10^2$	.100000	ms
$10^3$	100.0000	$\mu$ s
$10^4$	100.00000	$\mu$ s
$10^5$	100.000000	$\mu$ s

*\*The accuracy of the readout is dependent on the accuracy of the 10 kHz input signal.*

**4-41. Time Interval Test**

4-42. Use the following procedure to test the time interval function:

- a. Complete Set-Up procedure.
- b. Set FUNCTION switch to FREQ A.
- c. Connect 1V rms, 5 Hz signal to CHANNEL A connector. (Use a squarewave with rise and fall times  $\leq 15$  ns.)
- d. Set RANGE switch to 10s (GATE) and adjust signal source to produce display of .0050 on readout, (with kHz annunciator lit).
- e. Set FUNCTION switch to T.I. A-B.
- f. Set trigger level controls of channels A and B to PRESET. Set CHANNEL A slope switch to + and CHANNEL B slope switch to -.
- g. Set SEP/COM switch to COM.
- h. Sequentially select each T.I. RES. (Time Interval Resolution) position of RANGE switch, pausing at each to verify that display is as described in Table 4-6.

Table 4-6. Time Interval Test

T.I. RES	READOUT*	ANNUNCIATOR
0.1 $\mu$ s	100.0000	ms
1.0 $\mu$ s	100.000	ms
10 $\mu$ s	100.00	ms
0.1 ms	.1000	s
1.0 ms	.100	s
10 ms	.10	s

*\*The accuracy of the readout is dependent upon the accuracy of the 5 Hz input signal.*

**4-43. Totalize Test**

4-44. Use the following procedure to test the totalize (A gated by B) function:

- a. Complete Set-Up Procedure.
- b. Set FUNCTION switch to A GTD BY B.
- c. Connect 1V rms, 100 Hz signal to CHANNEL A connector.
- d. Turn CHANNEL B TRIGGER LEVEL control cw until -TRIG STAT annunciator lights.
- e. Press and release RESET button. Readout should display 0 (zero). (Decimal point and measurement units are not displayed.)

f. Turn CHANNEL B TRIGGER LEVEL control ccw until the + TRIG STAT annunciator lights. The 1953A should begin to count and display the total cycles of the 100 Hz input frequency. (Digit 3 should increment once per second.)

g. Turn CHANNEL B TRIGGER LEVEL control ccw until TRIG STAT annunciator lights. The 1953A should stop counting and display accumulated total.

h. Repeat steps f and g. The accumulation process should take place as long as +TRIG STAT annunciator is lit. Notice that as steps f and g are repeated, displayed total is not reset. Instead, new inputs are added to previous total (totalized).

**4-45. Self-Check Test**

4-46. Use the following procedure to test self-check function:

- a. Complete Set-Up Procedure.
- b. Set FUNCTION switch to SELF-CHECK.
- c. Depress the RESET switch. All display digit segments should illuminate. (The measurement unit annunciators and decimal points will not be lit.)
- d. Sequentially select each GATE position of the RANGE switch, pausing at each to verify display is as shown in Table 4-7. (No measurement unit annunciator will light).

**Table 4-7. Self-Check Test**

GATE	READOUT
0.1 ms	1000
1.0 ms	10000
10 ms	100000
0.1s	1000000
1.0s	10000000
10s	100000000

**4-47. CALIBRATION**

4-48. The 1953A should be calibrated every 90 days or whenever repairs have been made. Calibration should be done at an ambient room temperature of 25° ±5°C. Table 4-1 lists the required test equipment. Test points locations are shown in Figure 4-1.

**4-49. +12 Volt Power Supply Adjustment**

4-50. The +5 volt and -12 volt power supplies depend on the +12 volt supply for regulating and operating power. The adjustment of the +12 volt power supply will affect the other power supplies.

4-51. Calibrate the +12 volt supply as follows:

- a. Connect 1953A to line power.
- b. Connect positive input lead of DMM to +12V test point (TP94).
- c. Connect return lead of DMM to chassis ground.
- d. Set DMM to VDC on the 20 volt range.
- e. Turn CYCLE RATE control cw, off the OFF detent.
- f. Adjust the +12V adjustment (R97) for +12 ±0.1V.

**4-52. Trigger Level Preset Adjustment**

4-53. This procedure outlines a check of the trigger level settings and, if required, an adjustment procedure. If desired the adjustment may be performed to achieve maximum sensitivity even though the trigger levels are within the listed specifications.

4-54. Check the channel A preset trigger as follows:

- a. Perform or verify the following settings:

1953A connected to ac line power  
 POWER/CYCLE RATE fully clockwise  
 CONT-TRIG switch to CONT  
 RANGE to GATE - 10 msec  
 FUNCTION switch to FREQ A  
 CHANNEL A controls -  
     TRIGGER LEVEL to PRESET  
     SLOPE to +  
     AC-DC to AC  
     ATTEN to X1  
 CHANNEL B controls -  
     TRIGGER LEVEL to PRESET  
     SLOPE to +  
     AC-DC to AC  
     ATTEN to X1  
 SEP-COM switch to SEP

- b. Connect the High Frequency Signal Generator and the RF Voltmeter Probe to the CHANNEL A

input connector through a 50 $\Omega$  termination. Use a BNC "T" connector.

c. Set the High Frequency Signal Generator for an input to the 1953A of 75 MHz at 30 mV rms.

d. The display should be stable and read the input frequency.

e. Set the High Frequency Signal Generator for and input to the 1953A of 125 MHz at 50V rms.

f. The display should be stable and read the input frequency.

g. If either reading is unstable perform the adjustment procedure in the following step. If acceptable, proceed to the next paragraph.

h. Set the High Frequency Signal Generator for an input to the 1953A of 125 MHz at 45 mV rms.

i. Set the channel A internal trigger level trimpot, R142, fully counterclockwise. Rotate R142 slowly clockwise until the display is stable at the input frequency of 125 MHz. Note the position of the R142 setting.

j. Continue rotating R142 clockwise until the display becomes unstable again. Note the position of the R142 setting.

k. Set R142 at the midpoint between the two settings obtained in steps i and j.

l. Set the CHANNEL A SLOPE switch to - (minus) and verify that the display remains stable. Return the SLOPE switch to the + position.

m. Lower the amplitude of the Signal Generator until the display starts to become unstable.

n. Repeat steps i through m until maximum sensitivity is achieved.

4-55. Check the channel B preset trigger as follows:

a. Perform or verify the following settings:

1953A connected to ac line power  
POWER/CYCLE RATE fully clockwise  
CONT-TRIG switch to CONT  
Range to PER AVGD -10<sup>3</sup>  
FUNCTION switch to FREQ (B)  
CHANNEL A controls-  
TRIGGER LEVEL to PRESET  
SLOPE to +  
AC-DC to AC

ATTEN to X1  
CHANNEL B controls-  
TRIGGER LEVEL to PRESET  
SLOPE to +  
AC-DC to AC  
ATTEN to X1  
SEP/COM switch to COM

b. Connect the High Frequency Signal Generator and the RF Voltmeter Probe to the CHANNEL B input connector through a 50 $\Omega$  terminal. Use a BNC "T" connector.

c. Set the High Frequency Signal Generator for an input to the 1953A of 25 MHz at 30 mV.

d. The display should be stable and read the input frequency.

e. If the reading is unstable perform the adjustment procedure in the following steps. If acceptable, proceed to the next paragraph.

f. Set the High Frequency Signal Generator for an input to the 1953A of 25 MHz at 25 mV.

g. Set the channel B internal trigger level trimpot, R141, slowly clockwise until the display is stable at the input frequency of 25 MHz. Note the position of the R141 setting.

h. Continue rotating R141 clockwise until the display becomes unstable again. Note the position of the R141 setting.

i. Set R141 at the midpoint between the two settings obtained in steps g and h.

j. Set the CHANNEL B SLOPE switch to - and verify that the display remains stable. Return the SLOPE switch to the + position.

k. Lower the amplitude of the Signal Generator until the display starts to become unstable.

l. Repeat steps g through k until maximum sensitivity is achieved.

#### 4-56. Reference Generator Adjustment

4-57. Calibrate the 10 MHz reference oscillator as follows:

a. Connect 1953A to ac line power.

b. Turn CYCLE RATE control cw, off the OFF detent. Allow the unit to warm up for at least 1 hour.

- c. Set the FUNCTION switch to FREQ A.
  - d. Set CONT TRIG switch to TRIG.
  - e. Connect 10 MHz frequency standard to CHANNEL A connector.
  - f. Adjust CHANNEL A trigger level control to establish desired trigger condition. (Proper triggering occurs when + and - TRIG STAT annunciators are both lit.)
  - g. Set RANGE switch to 1s (GATE).
  - h. Momentarily press RESET switch. After 1 second 1953A should light and display 10000.0000 kHz.
  - i. If display is incorrect, locate adjustment screw on TCXO (U7) on Main Board (bottom dust cover has hole to admit tuning tool). Using insulated tuning tool, turn adjustment slightly. If the unit is equipped with an oven stabilized time base (Option -20) calibration access hole is on rear panel.
  - j. Repeat steps h and i until proper display is obtained.
- b. Perform all repairs at a static-free work station.
  - c. Do not handle IC's or pcb's by their connectors.
  - d. Use static ground straps to discharge repair personnel.
  - e. Use conductive foam to store replacement or removed IC's.
  - f. Remove all plastic, vinyl and styrofoam products from the work area.
  - g. Use a grounded soldering iron.

#### 4-58. TROUBLESHOOTING

##### CAUTION

Static discharge can damage MOS components contained in the 1953A. To prevent this possibility use the following precautions when troubleshooting and/or repairing the unit.

- a. Never remove, install or otherwise connect or disconnect pcb's and/or components without first turning the POWER switch to OFF.

4-59. A troubleshooting guide for the 1953A is given in Table 4-8. The guide is in the form of a tabular flow chart and is recommended for use in isolating a mainframe malfunction to a component group. Details necessary to troubleshoot a component group to the component level can be derived from the schematic diagrams given in Section 8 and the Theory of Operation in Section 3.

4-60. When troubleshooting the unit in accordance with Table 4-8. The following notes apply.

- a. Do not start in the middle of the procedure. Any given step assumes that the previous steps have been completed.
- b. All measurements using external test equipment are referenced to logic common unless otherwise specified.
- c. All connectors referenced for measurement are accessible from the top of the unit when the dust cover is removed. See Figure 4-1 for Test point identification.



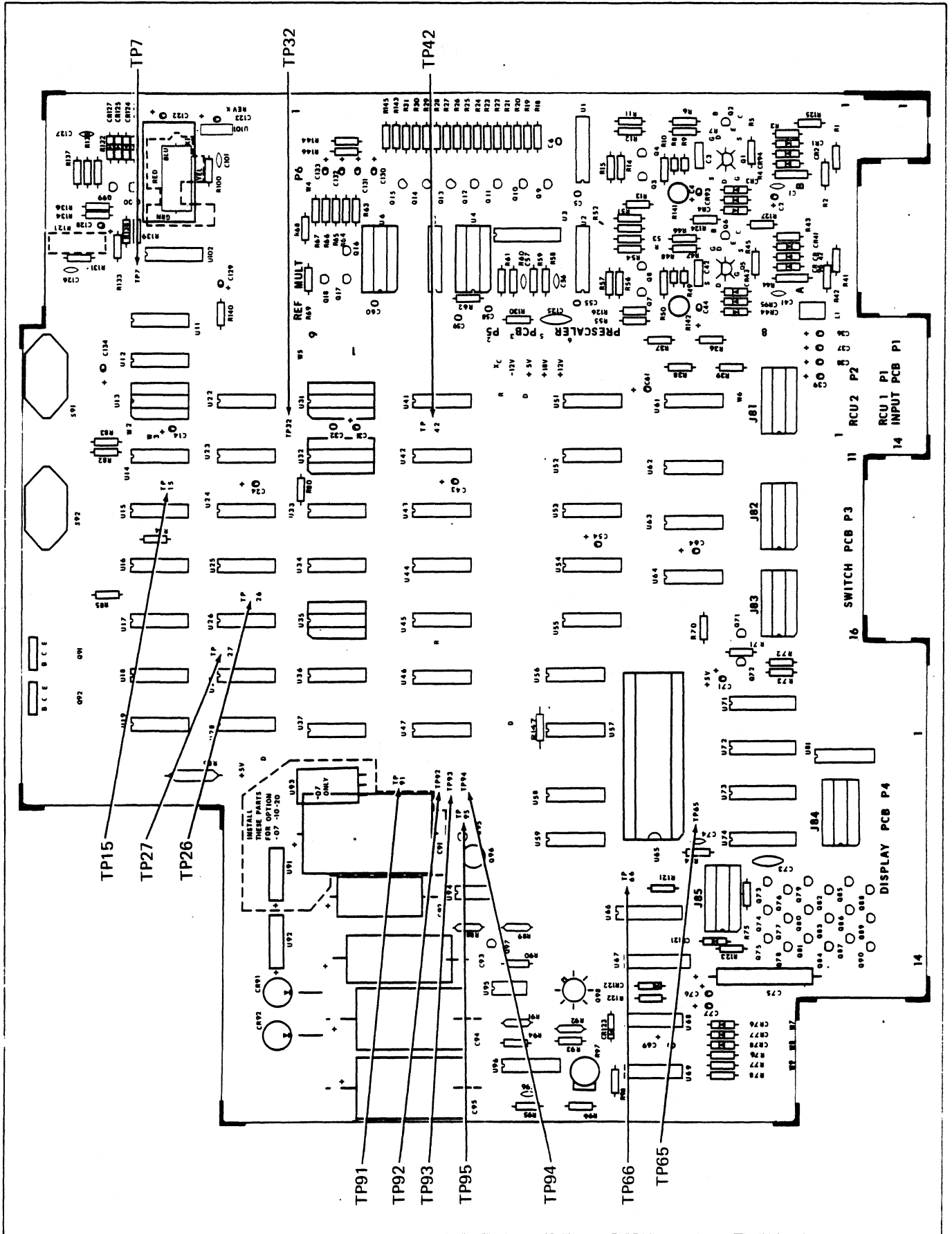

Figure 4-1. Test Point Locations, Main PCB

Table 4-8. Troubleshooting Guide

STEP NO.	INSTRUCTION	YES	NO	GO TO
1	Complete the set-up procedure given in paragraph 4-25.			2
2	Does the front panel display illuminate?	4	3	
3	Check power connection, fuse, 115/230 voltage selection switch, and/or the +5V dc power supply.			1
4	Execute steps a through c of the channel B Amplifier Test (part of the Performance Test).			5
5	Are both status indicators lit?	9	6	
6	Is one of the status indicators lit?	8	7	
7	Check + and - status indicator LED's and their drivers.			4
8	Check TRIG STAT LED's and Q11, Q12, Q13 and Q14 for channel B test. If channel A is being tested, check U61 and TRIG STAT LED's.			4
9	Execute the step d of the channel B Amplifier Test.			10
10	Do both status indicators remain on?	12	11	
11	Calibrate the channel's (A or B as req.) preset trigger level.			9
12	Execute steps e through f of the channel B Amplifier Test.			13
13	Do the status indicator LED's respond properly?	15	14	
14	Check the trigger level potentiometer.			12
15	Test channel A Amplifier by repeating steps 4 through 14 of this procedure and substituting channel A for channel B.			16
16	Perform steps a and b of the Display Test (part of Performance Test).			17
17	Are all of the measurement units displayed correctly?	19	18	
18	Check the measurement units LED's and U31, U52, U62, U63 and U64.			16
19	Are the decimal points correct?	21	20	
20	Check the control gates in the decimal point logic and the decimal point blanking and/or multiplexing logic.			16
21	Perform steps c through j of the Display Test.			22
22	Do all display decades respond correctly?	24	23	
23	If a segment of each display decade does not light, check the bcd-to-seven segment decoder, U71 and U72. If an entire digit will not light, check the associated strobe driver.			21
24	Does the OVERFLOW LED light when an overflow occurs?	26	25	
25	Check the overflow logic and the OVERFLOW LED.			21
26	Perform step k of the Display Test.			27
27	Does the display reset properly?	29	28	

Table 4-8. Troubleshooting Guide (cont)

STEP NO.	INSTRUCTION	YES	NO	GOTO
28	Check the memory update and counter reset control section, U66, U68 and U58.			26
29	Perform steps a through d of the Frequency A Test (part of Performance Test).			30
30	Are all measurements displayed correctly?	39	31	
31	Does the channel A input signal reach the main gate?	33	32	
32	Troubleshoot the channel A Input Amplifier.			29
33	Is the 10 MHz time base signal present at U11-14?	35	34	
34	Troubleshoot the Reference Generator.			29
35	Is the 10 kHz clock present at TP26?	37	36	
36	Check the reference frequency dividers U11 through U15, and/or the reference counter inputs selector gate U24, U33 and U41.			29
37	Is the gate signal present at the main gate, U6?	39	38	
38	Check the reference divider circuit and range select gate. Also check the clock input to the accumulator.			29
39	Perform steps a through e of the Ratio Test (part of Performance Test).			40
40	Are all measurements displayed correctly?	45	41	
41	Does the channel A output frequency appear at the output of U6-6?	43	42	
42	Troubleshoot the channel A input amplifier.			39
43	Does the channel B output frequency appear at TP26?	45	44	
44	Check channel B input amplifier and reference counter input selector.			39
45	Perform steps a through f of the Period A Test (part of Performance Test).			46
46	Are all measurements displayed correctly?	51	47	
47	Does the 10 MHz time base clock appear at U6-5?	49	48	
48	Check the operation of the accumulator input gate U41 and U23.			45
49	Does the channel A output frequency appear at TP26?	51	50	
50	Check the operation of the reference counter clock selector; U24, U33, U41 and U44.			45
51	Perform steps a through g of the Time Interval Test (part of Performance Test).			52
52	Are all measurements displayed correctly?	59	53	
53	Does the 10 MHz time base clock appear at the rear panel CLOCK OUTPUT connector?	55	54	
54	Troubleshoot the reference generator.			51
55	Does the front panel GATE LED cycle on and off?	57	56	
56	Check the gate selector and U67.			51
57	Does the display advance from zero?	59	58	

Table 4-8. Troubleshooting Guide (cont)

STEP NO.	INSTRUCTION	YES	NO	GOTO
58	Check the reference divider and the main gate.			51
59	This completes the troubleshooting procedure. The 1953A is operational.			----

## Section 5

# List of Replaceable Parts

### TABLE OF CONTENTS

ASSEMBLY NAME	TABLE	PAGE	FIGURE	PAGE
Final Assembly, 1953A .....	5-1	5-3	5-1	5-4
A1 Main Assembly, Standard .....	5-2	5-6	5-2	5-7
A1A1 Main PCB Assembly .....	5-3	5-8	5-3	5-15
A1A2 Rear Panel Assembly .....	5-4	5-16	5-4	5-17
A1A3 Input PCB Assembly .....	5-5	5-18	5-5	5-18
A2 Front Panel Assembly .....	5-6	5-19	5-6	5-19
A3 Display PCB Assembly .....	5-7	5-10	5-7	5-20
A4 Switch PCB Assembly .....	5-8	5-21	5-8	5-21

## 5-1 INTRODUCTION

5-2. This section contains an illustrated parts breakdown of the instrument. Components are listed alpha-numerically by assembly. Electrical components are listed by reference designation and mechanical components are listed by item number. Each listed part is shown in an accompanying illustration.

5-3. Parts lists include the following information:

- a. Reference Designation or Item Number.
- b. Description of each part.
- c. Fluke Stock Number.
- d. Federal Supply Code for Manufacturers. (See Section 7 for Code-to-Name list.)
- e. Manufacturer's Part Number or Type.
- f. Total Quantity per assembly or component.
- g. Recommended Quantity: This entry indicates the recommended number of spare parts necessary to support one to five instruments for a period of two years. This list presumes an availability of common electronic parts at the maintenance site. For maintenance for 1-year or more at an isolated site it is recommended that at least one of each assembly in the instrument be stocked. In the case of optional subassemblies, plug-ins, etc. that are not always part of the instrument, or are deviations

from the basic instrument mode, the REC QTY column lists the recommended quantity of the item in that particular assembly.

## 5-4. HOW TO OBTAIN PARTS

5-5. Components may be ordered directly from the manufacturer by using the manufacturer's part number, or from the John Fluke Mfg. Co., Inc. factory or authorized representative by using the FLUKE STOCK NUMBER. In the event the part you order has been replaced by a new or improved part, the replacement will be accompanied by an explanatory note and installation instructions, if necessary.

5-6. To ensure prompt and efficient handling of your order, include the following information:

- a. Quantity
- b. FLUKE Stock Number
- c. Description
- d. Reference Designation or Item Number
- e. Printed Circuit Board Part Number and Rev Letter
- f. Instrument Model and Serial Number.

### **⊗ CAUTION**

**Indicated devices are subject to damage by static discharge.**

Table 5-1. Final Assembly

ITEM NO.	DESCRIPTION	FLUKE STOCK NO.	MFG SPLY CODE	MFG PART NO. OR TYPE	TOT QTY	REC QTY	USE CDE
FINAL ASSEMBLY, 1953A							
FIGURE 5-1							
A1	MAIN ASSEMBLY, STANDARD	396317	89536	396317	1		
A2	FRONT PANEL ASSEMBLY	396358	89536	396358	1		
A3	DISPLAY PCB ASSEMBLY	396218	89536	396218	1		
A4	SWITCH PCB ASSEMBLY	396119	89536	396119	1		
MP1	KNOB, PUTTY GREY	341388	89536	341388	2		
MP2	KNOB, POINTER, PUTTY GREY	341404	89536	341404	2		
MP3	KNOB, PUTTY GREY, GREEN DECAL	365015	89536	365015	1		
MP4	COVER, BOTTOM	395970	89536	395970	1		
MP5	COVER, TOP	395962	89536	395962	1		
MP6	FOOT, PLASTIC	292870	89536	292870	4		
MP7	INSERT, FOOT, NON-SKID	302026	89536	302026	4		
MP8	LENS	395921	89536	395921	1		
MP9	HANDLE, FRAME	398198	89536	398198	1		
MP10	GRIP, HANDLE	284836	89536	284836	2		
MP11	WASHER, FLAT, HANDLE	309054	89536	309054	2		
MP12	WASHER, SHOULDER, HANDLE	309047	89536	309047	2		
MP13	WASHER, SPRING, HANDLE	228981	89536	228981	2		
MP14	DECAL, HANDLE WASHER	285221	89536	285221	2		
MP15	LINE CORD (NOT SHOWN)	343723	89536	343723	1		
U7	TCXO (STANDARD OSCILLATOR)	461871	89536	461871	1		





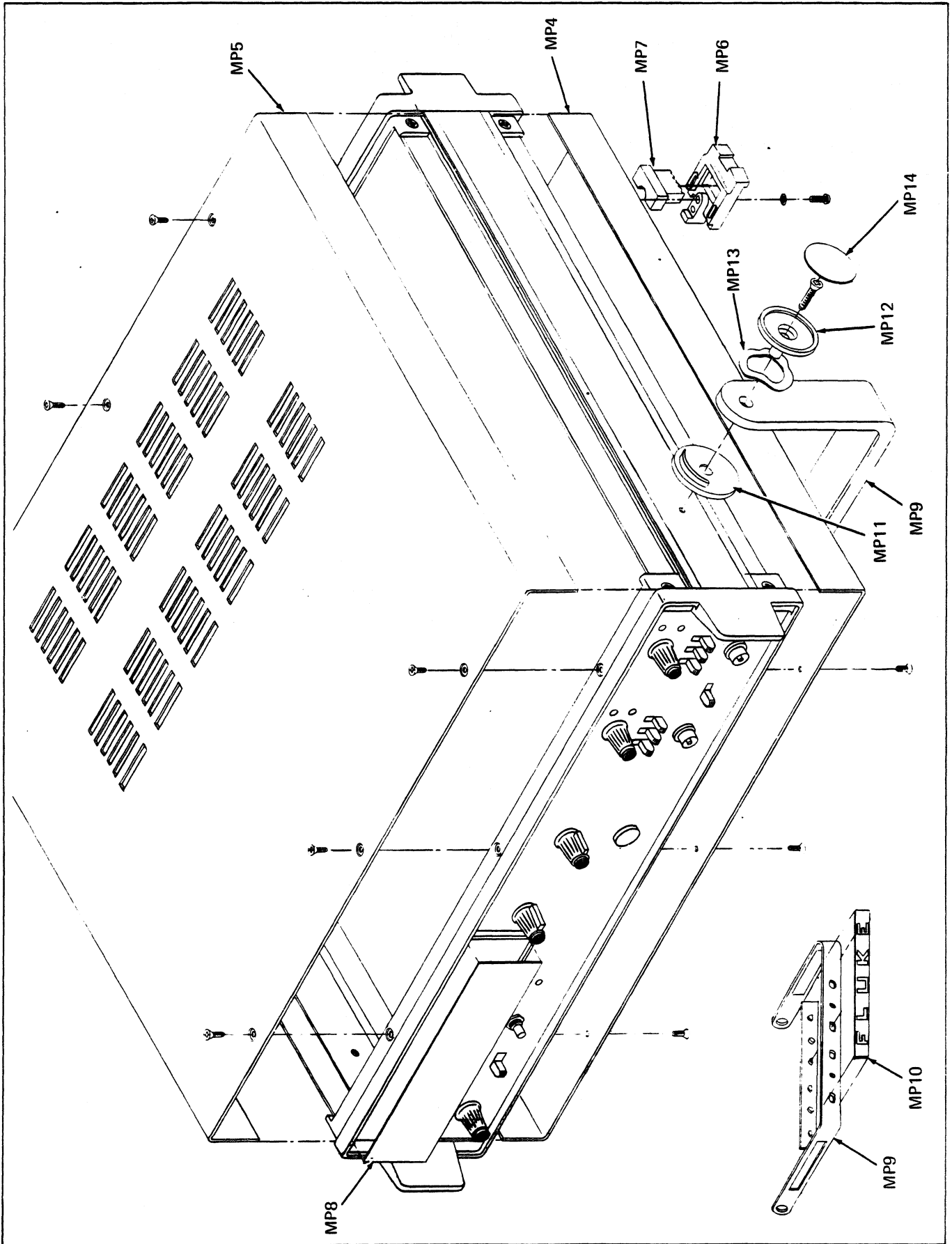

Figure 5-1. Final Assembly (cont)

Table 5-2. A1 Main Assembly

ITEM NO.	DESCRIPTION	FLUKE STOCK NO.	MFG SPLY CODE	MFG PART NO. OR TYPE	TOT QTY	REC QTY	USE CDE
A1	MAIN ASSEMBLY (1953A-4101) FIGURE 5-2	396317	89536	396317			REF
A1A1	MAIN PCB ASSEMBLY	396093	89536	396093		1	
A1A2	REAR PANEL ASSEMBLY	396366	89536	396366		1	
A1A3	INPUT PCB ASSEMBLY	396127	89536	396127		1	
MP1	CHASSIS, SIDE, LEFT	395954	89536	395954		1	
MP2	CHASSIS, SIDE, RIGHT	395947	89536	395947		1	
MP3	DECAL, SIDE	401224	89536	401224		1	

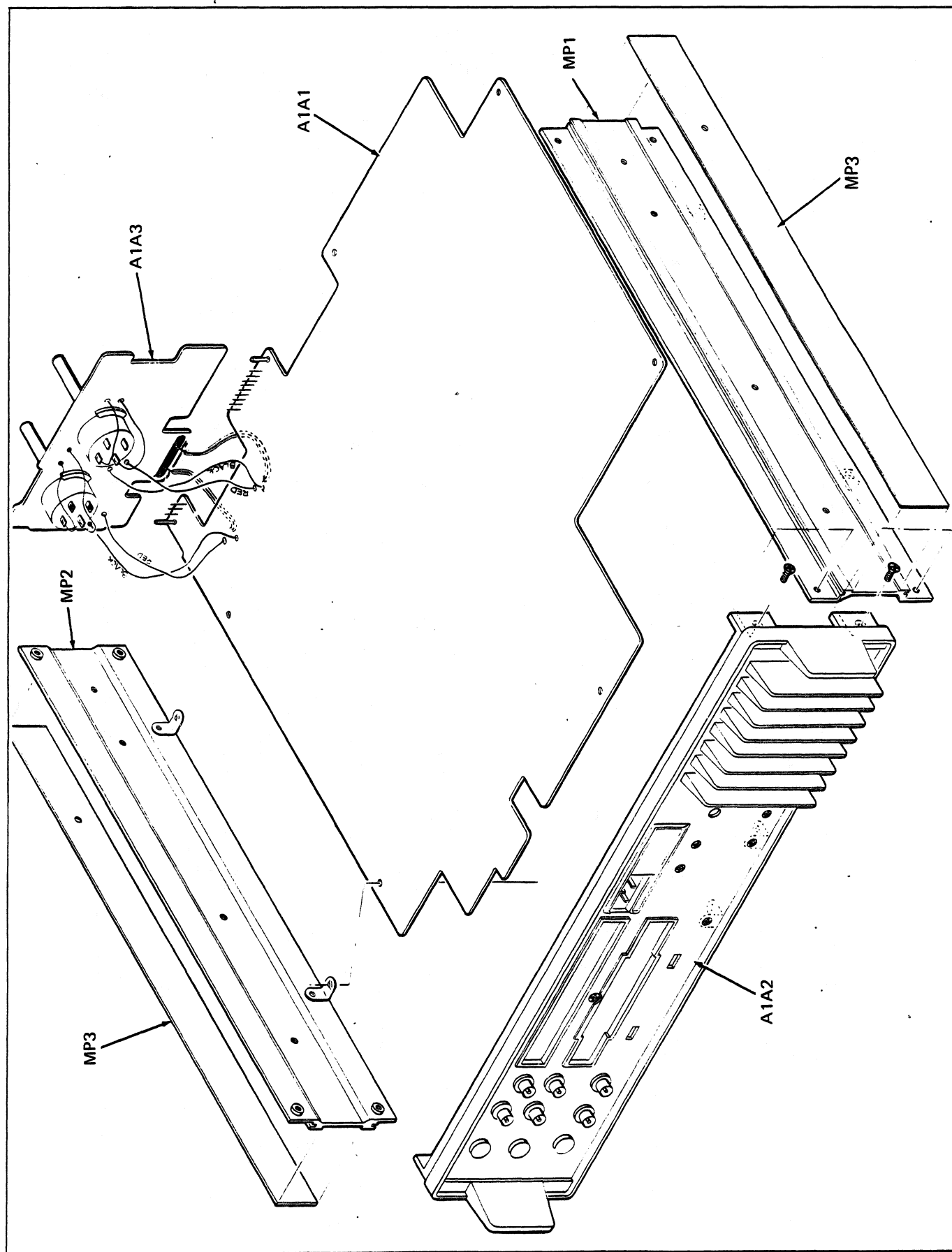

Figure 5-2. A1 Main Assembly

Table 5-3. A1A1 Main PCB Assembly

ITEM NO.	DESCRIPTION	FLUKE STOCK NO.	MFG SPLY CODE	MFG PART NO. OR TYPE	TOT QTY	REC QTY	USE CDE
A1A1	Ø MAIN PCB ASSEMBLY (1953A-4001) FIGURE 5-3	396200	89536	396200			REF
C1	CAP, CER, 47 PF +/-20%, 1000V	369132	56289	C030B102H470J		4	
C2	CAP, TA, 10 UF +/-20%, 15V	193623	56289	196D106X0015KA4		26	
C3	CAP, CER, 0.22 UF +/-20%, 50V	309849	71590	CW30C224K		2	
C4	CAP, TA, 10 UF +/-20%, 15V	193623	56289	196D106X0015KA4			REF
C5	CAP, TA, 10 UF +/-20%, 15V	193623	56289	196D106X0015KA4			REF
C6	CAP, CER, 0.01 UF +/-20%, 100V	407361	72982	8121-A100-W5R-103M		5	
C24	CAP, TA, 10 UF +/-20%, 15V	193623	56289	196D106X0015KA4			REF
C31	CAP, TA, 10 UF +/-20%, 15V	193623	56289	196D106X0015KA4			REF
C32	CAP, CER, 0.01 UF +/-20%, 100V	407361	72982	8121-A100-W5R-103M			REF
C36	CAP, TA, 10 UF +/-20%, 15V	193623	56289	196D106X0015KA4			REF
C38	CAP, TA, 10 UF +/-20%, 15V	193623	56289	196D106X0015KA4			REF
C39	CAP, TA, 10 UF +/-20%, 15V	193623	56289	196D106X0015KA4			REF
C41	CAP, CER, 47 PF +/-20%, 1000V	369132	56289	C030B102H470J			REF
C42	CAP, CER, 0.22 UF +/-20%, 50V	309849	71590	CW30C224K			REF
C43	CAP, TA, 10 UF +/-20%, 15V	193623	56289	196D106X0015KA4			REF
C44	CAP, TA, 10 UF +/-20%, 15V	193623	56289	196D106X0015KA4			REF
C54	CAP, TA, 10 UF +/-20%, 15V	193623	56289	196D106X0015KA4			REF
C55	CAP, TA, 10 UF +/-20%, 15V	193623	56289	196D106X0015KA4			REF
C56	CAP, CER, 47 PF +/-20%, 1000V	369132	56289	C030B102H470J			REF
C57	CAP, CER, 47 PF +/-20%, 1000V	369132	56289	C030B102H470J			REF
C58	CAP, CER, 0.01 UF +/-20%, 100V	407361	72982	8121-A100-W5R-103M			REF
C59	CAP, CER, 0.01 UF +/-20%, 100V	407361	72982	8121-A100-W5R-103M			REF
C60	CAP, CER, 0.01 UF +/-20%, 100V	407361	72982	8121-A100-W5R-103M			REF
C61	CAP, TA, 10 UF +/-20%, 15V	193623	56289	196D106X0015KA4			REF
C64	CAP, TA, 10 UF +/-20%, 15V	193623	56289	196D106X0015KA4			REF
C69	CAP, TA, 10 UF +/-20%, 15V	193623	56289	196D106X0015KA4			REF
C71	CAP, TA, 22 UF +/-20%, 25V	357780	56289	196D226X0025-PE4		1	
C73	CAP, CER, 1000 PF +/-10%, 500V	357806	56289	C106B102G102		2	
C74	CAP, CER, 10 PF +/-10%, 3 KV	105536	56289	40C362A1		1	
C75	CAP, ELECT, 220 UF, -10/+50%, 35V	369181	25403	ET221X025A00		1	1
C76	CAP, TA, 10 UF +/-20%, 15V	193623	56289	196D106X0015KA4			REF
C77	CAP, TA, 10 UF +/-20%, 15V	193623	56289	196D106X0015KA4			REF
C92	CAP, ELECT, 470 UF, -10/+50%, 25V	168153	73445	ET471X0025A0-1		1	1
C93	CAP, ELECT, 1000 UF, -10/+100%, 40V	340901	80031	3050FJ202U015		1	1
C94	CAP, ELECT, 4700 UF, -10/+100%, 15V	379370	80031	3050HJ472U015		1	1
C95	CAP, ELECT, 4700 UF, -10/+100%, 15V	379370	80031	3050HJ472U015			REF
C96	CAP, CER, 500 PF +/-10%, 500V	105692	71590	2DDH60N501K		1	
C101	CAP, CER, 0.01UF, -20/+100%, 40V	369579	72982	8121-A050-651-103Z		1	
C125	CAP, CER, 1000 PF +/-10%, 500V	357806	56289	C106B102G102			REF
C126	CAP, CER, 1200 PF +/-10%, 500V	106732	71590	CF-122		1	
C127	CAP, CER, 0.05 UF, -20/+80%, 25V	148924	72982	5855-000-Y5U0-104Z		1	
C128	CAP, TA, 10 UF +/-20%, 15V	193623	56289	196D106X0015KA4			REF
C129	CAP, TA, 10 UF +/-20%, 15V	193623	56289	196D106X0015KA4			REF
C130	CAP, TA, 10 UF +/-20%, 15V	193623	56289	196D106X0015KA4			REF
C131	CAP, TA, 10 UF +/-20%, 15V	193623	56289	196D106X0015KA4			REF
C132	CAP, TA, 10 UF +/-20%, 15V	193623	56289	196D106X0015KA4			REF
C133	CAP, TA, 10 UF +/-20%, 15V	193623	56289	196D106X0015KA4			REF
C134	CAP, TA, 10 UF +/-20%, 15V	193623	56289	196D106X0015KA4			REF

Table 5-3. A1A1 Main PCB Assembly (cont)

ITEM NO.	DESCRIPTION	FLUKE STOCK NO.	MFG SPLY CODE	MFG PART NO. OR TYPE	TOT QTY	REC QTY	USE CDE
CR1	DIODE, ZENER, 3.3V +5%	309799	07263	1N746A	6	1	
CR2	DIODE, SI	381806	07263	1N3062	4	1	
CR3	DIODE, SI	381806	07263	1N3062	REF		
CR4	DIODE, ZENER, 3.3V +5%	309799	07263	1N746A	REF		
CR41	DIODE, ZENER, 3.3V +5%	309799	07263	1N746A	REF		
CR42	DIODE, SI	381806	07263	1N3062	REF		
CR43	DIODE, SI	381806	07263	1N3062	REF		
CR44	DIODE, ZENER, 3.3V +5%	309799	07263	1N746A	REF		
CR76	DIODE, SI	203323	07910	1N4448	8	2	
CR77	DIODE, SI	203323	07910	1N4448	REF		
CR78	DIODE, SI	203323	07910	1N4448	REF		
CR85	DIODE BRIDGE, 100V, 2A, FULLWAVE(CR85-CR88)	296509	14936	KBF02	REF		
CR86	DIODE BRIDGE, 100V, 2A, FULLWAVE(CR85-CR88)	296509	14936	KBF02	REF		
CR87	DIODE BRIDGE, 100V, 2A, FULLWAVE(CR85-CR88)	296509	14936	KBF02	REF		
CR88	DIODE BRIDGE, 100V, 2A, FULLWAVE(CR85-CR88)	296509	14936	KBF02	REF		
CR91	DIODE, SI	187716	04713	MR1032B/1N4999	2	1	
CR92	DIODE, SI	187716	04713	MR1032B/1N4999	REF		
CR93	DIODE, SI	272252	07263	FD333	4	1	
CR94	DIODE, SI	272252	07263	FD333	REF		
CR95	DIODE, SI	272252	07263	FD333	REF		
CR96	DIODE, SI	272252	07263	FD333	REF		
CR121	DIODE, SI	203323	07910	1N4448	REF		
CR122	DIODE, SI	203323	07910	1N4448	REF		
CR123	DIODE, SI	203323	07910	1N4448	REF		
CR124	DIODE, SI	203323	07910	1N4448	REF		
CR125	DIODE, SI	203323	07910	1N4448	REF		
CR126	DIODE, ZENER, 3.3V +5%	309799	07263	1N746A	REF		
CR127	DIODE, ZENER, 3.3V +5%	309799	07263	1N746A	REF		
H1	CONNECTOR PIN, MALE	376574	00779	3-87022-1	60		
H2	CONNECTOR PIN, TEST POINT	379438	00779	1-87022-0	15		
J81	SOCKET, IC, 16 PIN DIP	387324	91506	316G37D	5		
J82	SOCKET, IC, 16 PIN DIP	387324	91506	316G37D	REF		
J83	SOCKET, IC, 16 PIN DIP	387324	91506	316G37D	REF		
J84	SOCKET, IC, 16 PIN DIP	387324	91506	316G37D	REF		
J85	SOCKET, IC, 16 PIN DIP	387324	91506	316G37D	REF		
L1	INDUCTOR, 6-TURN	320911	89536	320911	1		
Q1	XSTR, DUAL FET, N-CHANNEL	379271	17856	E421	2	1	
Q2	XSTR, SI, NPN	333898	04713	MPSH10	2	1	
Q3	XSTR, SI, PNP	369629	07263	2N5771	11	3	
Q4	XSTR, SI, PNP	369629	07263	2N5771	REF		
Q5	XSTR, DUAL FET, N-CHANNEL	379271	17856	E421	REF		
Q6	XSTR, SI, NPN	333898	04713	MPSH10	REF		
Q7	XSTR, SI, PNP	369629	07263	2N5771	REF		
Q8	XSTR, SI, PNP	369629	07263	2N5771	REF		
Q9	XSTR, SI, PNP	369629	07263	2N5771	REF		
Q10	XSTR, SI, PNP	369629	07263	2N5771	REF		
Q11	XSTR, SI, PNP	369629	07263	2N5771	REF		
Q13	XSTR, SI, NPN	369645	07263	2N4274	2	1	
Q14	XSTR, SI, NPN	369645	07263	2N4274	REF		
Q15	XSTR, SI, PNP	369603	07263	2N4257	1	1	

Table 5-3. A1A1 Main PCB Assembly (cont)

ITEM NO.	DESCRIPTION	FLUKE STOCK NO.	MFG SPLY CODE	MFG PART NO. OR TYPE	TOT QTY	REC QTY	USE CDE
Q16	XSTR, SI, PNP	369629	07263	2N5771	REF		
Q17	XSTR, SI, PNP	369629	07263	2N5771	REF		
Q18	XSTR, SI, PNP	369629	07263	2N5771	REF		
Q71	XSTR, SI PNP	218396	04713	2N3904	12	3	
Q72	XSTR, SI PNP	218396	04713	2N3904	REF		
Q73	XSTR, SI PNP	218396	04713	2N3904	REF		
Q74	XSTR, SI PNP	218396	04713	2N3904	REF		
Q75	XSTR, SI PNP	218396	04713	2N3904	REF		
Q76	XSTR, SI, PNP	352369	12040	2N4403	10	2	
Q77	XSTR, SI, PNP	352369	12040	2N4403	REF		
Q78	XSTR, SI, PNP	352369	12040	2N4403	REF		
Q79	XSTR, SI PNP	218396	04713	2N3904	REF		
Q80	XSTR, SI PNP	218396	04713	2N3904	REF		
Q81	XSTR, SI PNP	218396	04713	2N3904	REF		
Q82	XSTR, SI, PNP	352369	12040	2N4403	REF		
Q83	XSTR, SI, PNP	352369	12040	2N4403	REF		
Q84	XSTR, SI, PNP	352369	12040	2N4403	REF		
Q85	XSTR, SI PNP	218396	04713	2N3904	REF		
Q86	XSTR, SI PNP	218396	04713	2N3904	REF		
Q87	XSTR, SI PNP	218396	04713	2N3904	REF		
Q88	XSTR, SI, PNP	352369	12040	2N4403	REF		
Q89	XSTR, SI, PNP	352369	12040	2N4403	REF		
Q90	XSTR, SI, PNP	352369	12040	2N4403	REF		
Q95	XSTR, SI PNP	218396	04713	2N3904	REF		
Q96	XSTR, SI, NPN	150359	07263	2N3053	1	1	
Q97	XSTR, SI, PNP	35269	12040	2N4403	REF		
Q98	XSTR, SI, PNP	269076	04713	2N4890	1	1	
Q99	XSTR, SI NPN	195974	04713	2N3906	2		
Q100	XSTR, SI NPN	195974	04713	2N3906	REF		
R1	RES, COMP, 180K +/-5%, 1/4W	193441	01121	CB1845	2		
R2	RES, COMP, 22 +/-5%, 1/4W	147884	01121	CB2205	2		
R3	RES, COMP, 1K +/-5%, 1/4W	148023	01121	CB1025	6		
R4	RES, COMP, 120K +/-5%, 1/2W	108779	01121	EB1245	2		
R5	RES, COMP, 180 +/-5%, 1/4W	147942	01121	CB1813	2		
R6	RES, COMP, 3.3K +/-5%, 1/4W	148056	01121	CB3325	3		
R7	RES, COMP, 2.7K +/-5%, 1/4W	170720	01121	CB2725	2		
R8	RES, COMP, 430 +/-5%, 1/8W	461012	01121	BB4315	4		
R9	RES, COMP, 430 +/-5%, 1/8W	461012	01121	BB4315	REF		
R10	RES, COMP, 150 +/-5%, 1/4W	147934	01121	CB1515	3		
R11	RES. COMP, 560 +/-5%, 1/4W	147991	01121	CB5615	5		
R12	RES, COMP, 820 +/-5%, 1/4W	148015	01121	CB8215	5		
R13	RES, COMP, 270 +/-5%, 1/4W	160804	01121	CB2715	5		
R14	RES, COMP, 820 +/-5%, 1/4W	148015	01121	CB8215	REF		
R15	RES. COMP, 560 +/-5%, 1/4W	147991	01121	CB5615	REF		
R18	RES, COMP, 220 +/-5%, 1/4W	147959	01121	CB2215	4		
R19	RES, COMP, 100 +/-5%, 1/4W	147926	01121	CB1015	12		
R20	RES, COMP, 330 +/-5%, 1/4W	147967	01121	CB3315	4		
R21	RES, COMP, 270 +/-5%, 1/4W	160804	01121	CB2715	REF		
R22	RES, COMP, 100 +/-5%, 1/4W	147926	01121	CB1015	REF		

Table 5-3. A1A1 Main PCB Assembly (cont)

ITEM NO.	DESCRIPTION	FLUKE STOCK NO.	MFG SPLY CODE	MFG PART NO. OR TYPE	TOT QTY	REC QTY	USE CDE
R23	RES, COMP, 390 +/-5%, 1/4W	147975	01121	CB3915	1		
R24	RES, COMP, 100 +/-5%, 1/4W	147926	01121	CB1015	REF		
R25	RES, COMP, 270 +/-5%, 1/4W	160804	01121	CB2715	REF		
R26	RES, COMP, 100 +/-5%, 1/4W	147926	01121	CB1015	REF		
R27	RES, COMP, 100 +/-5%, 1/4W	147926	01121	CB1015	REF		
R28	RES, COMP, -3.9K +/-5%, 1/4W	148064	01121	CB3925	1		
R29	RES, COMP, 5.6K +/-5%, 1/4W	148080	01121	CB5625	7		
R30	RES, COMP, 21 +/-5%, 1/4W	229484	01121	CB2135	2		
R31	RES, COMP, 21 +/-5%, 1/4W	229484	01121	CB2135	REF		
R36	RES, COMP, 56 +/-5%, 1/4W	147900	01121	CB5605	5		
R37	RES, COMP, 56 +/-5%, 1/4W	147900	01121	CB5605	REF		
R38	RES, COMP, 56 +/-5%, 1/4W	147900	01121	CB5605	REF		
R39	RES, COMP, 56 +/-5%, 1/4W	147900	01121	CB5605	REF		
R41	RES, COMP, 180K +/-5%, 1/4W	193441	01121	CB1845	REF		
R42	RES, COMP, 22 +/-5%, 1/4W	147884	01121	CB2205	REF		
R43	RES, COMP, 680 +/-5%, 1/4W	148007	01121	CB6815	1		
R44	RES, COMP, 120K +/-5%, 1/2W	108779	01121	EB1245	REF		
R45	RES, COMP, 180 +/-5%, 1/4W	147942	01121	CB1813	REF		
R46	RES, COMP, 3.3K +/-5%, 1/4W	148056	01121	CB3325	REF		
R47	RES, COMP, 2.7K +/-5%, 1/4W	170720	01121	CB2725	REF		
R48	RES, COMP, 430 +/-5%, 1/8W	461012	01121	BB4315	REF		
R49	RES, COMP, 430 +/-5%, 1/8W	461012	01121	BB4315	REF		
R50	RES, COMP, 150 +/-5%, 1/4W	147934	01121	CB1515	REF		
R51	RES, COMP, 330 +/-5%, 1/4W	147967	01121	CB3315	REF		
R52	RES, COMP, 330 +/-5%, 1/4W	147967	01121	CB3315	REF		
R53	RES, COMP, 560 +/-5%, 1/4W	147991	01121	CB5615	REF		
R54	RES, COMP, 820 +/-5%, 1/4W	148015	01121	CB8215	REF		
R55	RES, COMP, 270 +/-5%, 1/4W	160804	01121	CB2715	REF		
R56	RES, COMP, 820 +/-5%, 1/4W	148015	01121	CB8215	REF		
R57	RES, COMP, 560 +/-5%, 1/4W	147991	01121	CB5615	REF		
R58	RES, COMP, 220 +/-5%, 1/4W	147959	01121	CB2215	REF		
R59	RES, COMP, 240 +/-5%, 1/4W	221895	01121	CB1225	2		
R60	RES, COMP, 220 +/-5%, 1/4W	147959	01121	CB2215	REF		
R61	RES, COMP, 240 +/-5%, 1/4W	221895	01121	CB1225	REF		
R63	RES, COMP, 470 +/-5%, 1/4W	147983	01121	CB4715	3		
R64	RES, COMP, 820 +/-5%, 1/4W	148015	01121	CB8215	REF		
R65	RES, COMP, 220 +/-5%, 1/4W	147959	01121	CB2215	REF		
R66	RES, COMP, 150 +/-5%, 1/4W	147934	01121	CB1515	REF		
R67	RES, COMP, 1.2K +/-5%, 1/4W	190371	01121	CB1225	1		
R68	RES, COMP, 560 +/-5%, 1/4W	147991	01121	CB5615	REF		
R69	RES, COMP, 270 +/-5%, 1/4W	160804	01121	CB2715	REF		
R70	RES, COMP, 1K +/-5%, 1/4W	148023	01121	CB1025	REF		
R71	RES, COMP, 5.6K +/-5%, 1/4W	148080	01121	CB5625	REF		
R72	RES, COMP, 47 +/-5%, 1/4W	147982	01121	CB4705	1		
R73	RES, COMP, 5.6K +/-5%, 1/4W	148080	01121	CB5625	REF		
R74	RES, COMP, 100K +/-5%, 1/4W	148189	01121	CB1045	1		
R75	RES, COMP, 470 +/-5%, 1/4W	147983	01121	CB4715	REF		
R76	RES, COMP, 5.6K +/-5%, 1/4W	148080	01121	CB5625	REF		
R77	RES, COMP, 2.2K +/-5%, 1/4W	148049	01121	CB2225	2		
R78	RES, COMP, 10K +/-5%, 1/4W	148106	01121	CB1035	3		

Table 5-3. A1A1 Main PCB Assembly (cont)

ITEM NO.	DESCRIPTION	FLUKE STOCK NO.	MFG SPLY CODE	MFG PART NO. OR TYPE	TOT QTY	REC QTY	USE CODE
R80	RES, COMP, 10K +/-5%, 1/4W	148106	01121	CB1035	REF		
R82	RES, COMP, 100 +/-5%, 1/4W	147926	01121	CB1015	REF		
R83	RES, COMP, 100 +/-5%, 1/4W	147926	01121	CB1015	REF		
R84	RES, COMP, 1K +/-5%, 1/4W	148023	01121	CB1025	REF		
R85	RES, COMP, 100 +/-5%, 1/4W	147926	01121	CB1015	REF		
R86	RES, WW, 0.2 +/-5%, 2W	352914	75042	AS-2	1	1	
R88	RES, MF, 10K +/-1%, 1/8W	168260	91637	MFF1-81002F	3		
R89	RES, MF, 14K +/-1%, 1/8W	379057	91637	MFF1-81402F	1		
R90	RES, COMP, 2.7 +/-5%, 1/4W	246744	01121	CB27G5	1		
R91	RES, MF, 10K +/-1%, 1/8W	168260	91637	MFF1-81002F	REF		
R92	RES, MF, 10K +/-1%, 1/8W	168260	91637	MFF1-81002F	REF		
R93	RES, MF, 1 +/-5%, 1/4W	357665	80031	CR251-4P51E	1		
R94	RES, COMP, 56 +/-5%, 1/4W	147900	01121	CB5605	REF		
R95	RES, COMP, 3.3K +/-5%, 1/4W	148056	01121	CB3325	REF		
R96	RES, COMP, 5.6K +/-5%, 1/4W	148080	01121	CB5625	REF		
R97	RES, VAR, 1K +/-20%, 0.2W	402685	PIHER	PT10V-1K	1		
R98	RES, COMP, 5.6K +/-5%, 1/4W	148080	01121	CB5625	REF		
R100	RES, COMP, 10 +/-5%, 1/4W	147868	01121	CB1005	1		
R121	RES, COMP, 1K +/-5%, 1/4W	148023	01121	CB1025	REF		
R122	RES, COMP, 1K +/-5%, 1/4W	148023	01121	CB1025	REF		
R123	RES, COMP, 10K +/-5%, 1/4W	148106	01121	CB1035	REF		
R124	RES, COMP, 27K +/-5%, 1/4W	148148	01121	CB2735	4		
R125	RES, COMP, 27K +/-5%, 1/4W	148148	01121	CB2735	REF		
R126	RES, COMP, 27K +/-5%, 1/4W	148148	01121	CB2735	REF		
R127	RES, COMP, 27K +/-5%, 1/4W	148148	01121	CB2735	REF		
R130	RES, COMP, 100 +/-5%, 1/4W	147926	01121	CB1015	REF		
R131	RES, COMP, 470 +/-5%, 1/4W	147983	01121	CB4715	REF		
R132	RES, COMP, 100 +/-5%, 1/4W	147926	01121	CB1015	REF		
R133	RES, COMP, 100 +/-5%, 1/4W	147926	01121	CB1015	REF		
R134	RES, COMP, 510 +/-5%, 1/4W	218032	01121	CB5115	1		
R135	RES, COMP, 1K +/-5%, 1/4W	148023	01121	CB1025	REF		
R136	RES, COMP, 1.8K +/-5%, 1/4W	175042	01121	CB1825	1		
R137	RES, COMP, 2.2K +/-5%, 1/4W	148049	01121	CB2225	REF		
R138	RES, COMP, 100 +/-5%, 1/4W	147926	01121	CB1015	REF		
R139	RES, COMP, 330 +/-5%, 1/4W	147967	01121	CB3315	REF		
R140	RES, COMP, 39 +/-5%, 1/4W	193391	01121	CB3905	1		
R141	RES, VAR, 100 +/-20%, 1/2W	193052	80031	ET50W101	2		
R142	RES, VAR, 100 +/-20%, 1/2W	193052	80031	ET50W101	REF		
R143	RES, MF, 10.5K +/-1%, 1/4W	234096	91637	MFF1-41052F	4		
S91	SWITCH, SLIDE, DPDT	404814	79727	G1-52	2	1	
S92	SWITCH, SLIDE, DPDT	404814	79727	G1-52	REF		
U1	IC, ECL TRIPLE DIFF LINE RECEIVER	402727	07263	F95116DC	2	1	
U2	IC, ECL TRIPLE DIFF LINE RECEIVER	402727	07263	F95116DC	REF		
U3	RES, NETWORK, 680 +/-5%, 1/4 (OR 8 DISCRETE RESISTORS P/N 147892)	402644	89536	402644	2	1	
U4	IC, ECL, TRIPLE 4-3-3-INPUT OR GATE	402735	07263	F95106DC	1	1	
U5	RES, NETWORK, 680 +/-5%, 1/4 (OR 8 DISCRETE RESISTORS P/N 147892)	402644	89536	402644	REF		
U6	IC, ECL, EDGE-TRIGGERED JK FLIP-FLOP	402743	07263	F95029DC	1	1	
U7	OSCILLATOR, CRYSTAL (SEE FINAL ASSY)						



Table 5-3. A1A1 Main PCB Assembly (cont)

ITEM NO.	DESCRIPTION	FLUKE STOCK NO.	MFG SPLY CODE	MFG PART NO. OR TYPE	TOT QTY	REC QTY	USE CDE
U11	IC, TTL, MSI, DECADE COUNTER	402545	01295	SN74LS90N	3	1	
U12	IC, TTL, MSI, DECADE COUNTER	402545	01295	SN74LS90N	REF		
U14	IC, TTL, QUAD 2-INPUT AND GATE	393033	01295	SN74LS00N	6	2	
U15	IC, TTL, MSI, DECADE COUNTER	402545	01295	SN74LS90N	REF		
U16	IC, TTL, HEX INVERTER	393058	01295	SN74LS04N	4	1	
U17	IC, TTL, DECADE COUNTER	473314	01295	SN7490AN	1	1	
U18	IC, TTL, MSI, DECADE COUNTER	293159	01295	SN7490N	4		
U19	IC, TTL, MSI, DECADE COUNTER	293159	01295	SN7490N	REF		
U22	IC, TTL, QUAD 2-INPUT EXCLUSIVE OR GATE	379297	01295	SN74S86N	1	1	
U23	IC, TTL, QUAD 2-INPUT AND GATE	393033	01295	SN74LS00N	REF		
U24	IC, TTL, 4-2-3-2-INPUT AND-OR-INVERT GATE	379289	01295	SN74S64N	2	1	
U25	IC, TTL, DUAL D-FLIP-FLOP	418269	01295	SN74S74N	1	1	
U26	IC, TTL, QUAD 2-INPUT OR GATE	393108	01295	SN74LS32N	2	1	
U27	IC, TTL, 8-INPUT NAND	407338	01295	SN74S30N	1	1	
U28	IC, TTL, QUAD 2-INPUT OR GATE	393108	01295	SN74LS32N	REF		
U31	IC, TTL, DUAL J-K FLIP-FLOP	363440	01295	SN74S112N	2	1	
U32	IC, TTL, DUAL J-K FLIP-FLOP	363440	01295	SN74S112N	REF		
U33	IC, TTL, HEX INVERTER	393058	01295	SN74LS04N	REF		
U34	IC, TTL, DUAL D-TYPE EDGE-TRIGGERED F-F	393124	01295	SN74LS74N	1	1	
U35	IC, TTL, QUAD 2-INPUT NOR GATE	403626	01295	SN74S02N	1	1	
U36	IC, TTL, MSI, DECADE COUNTER	293159	01295	SN7490N	REF		
U37	IC, TTL, MSI, DECADE COUNTER	293159	01295	SN7490N	REF		
U41	IC, TTL, TRIPLE 3-INPUT NAND GATE	393074	01295	SN74LS10N	1	1	
U42	IC, TTL, 4-2-3-2-INPUT AND-OR-INVERT GATE	379289	01295	SN74S64N	REF		
U43	IC, TTL, QUAD 2-INPUT NOR GATE	288845	01295	SN7402N	1		
U44	IC, TTL, QUAD 2-INPUT AND GATE	393033	01295	SN74LS00N	REF		
U45	IC, TTL, QUAD 2-INPUT AND GATE	393033	01295	SN74LS00N	REF		
U46	IC, TTL, QUAD 2-INPUT OR GATE	393108	01295	SN74LS32N	1	1	
U47	IC, TTL, QUAD 2-INPUT NAND GATE OPEN COLLECTORS	292961	01295	SN7403N	2	1	
U51	IC, TTL, 8-INPUT NAND GATE	404889	01295	SN74LS30N	1	1	
U52	IC, TTL, QUAD 2-INPUT AND GATE	393033	01295	SN74LS00N	REF		
U53	IC, TTL, QUAD 2-INPUT AND GATE	393033	01295	SN74LS00N	REF		
U54	IC, TTL, QUAD 2-INPUT NOR GATE	393041	01295	SN74LS02N	3	1	
U55	IC, TTL, QUAD 2-INPUT NOR GATE	393041	01295	SN74LS02N	REF		
U56	IC, TTL, QUAD 2-INPUT NAND GATE OPEN COLLECTORS	292961	01295	SN7403N	REF REF		
U57	IC, TTL, DECADE COUNTER	320754	01295	SN74196N	1	1	
U58	IC, TTL, HEX INVERTER	393058	01295	SN74LS04N	REF		
U59	IC, TTL, DUAL D-TYPE EDGE-TRIGGERED F-F	310227	01295	SN7474N	1		
U61	IC, TTL, HEX INVERTER, OPEN COLLECTORS	379305	01295	SN7405N	1	1	
U62	IC, TTL, QUAD 2-INPUT AND GATE	292953	01295	SN7400N	1		
U63	IC, TTL, TRIPLE 3-INPUT NAND GATE	292995	01295	SN7410N	1		
U64	IC, TTL, HEX INVERTER	393058	01295	SN74LS04N	REF		
U65	IC, MOS, 2.5 MHZ, SEVEN DECADE COUNTER	380238	89536	380238	1	1	
U66	IC, TTL, DUAL 5-BIT SHIFT REGISTER	293399	01295	SN7496N	1	1	
U67	IC, TTL, DUAL MONOSTABLE MULTIVIBRATOR	310235	01295	SN74123N	1	1	
U68	IC, TTL, QUAD 2-INPUT NOR GATE	393041	01295	SN74LS02N	REF		
U69	IC, TTL, DUAL 4-INPUT NAND GATE	393280	01295	SN74LS20N	1	1	
U71	IC, TTL, BCD-TO-7 SEGMENT DECODER/DRIVER	340109	01295	SN7447N	2	1	

Table 5-3. A1A1 Main PCB Assembly (cont)

ITEM NO.	DESCRIPTION	FLUKE STOCK NO.	MFG SPLY CODE	MFG PART NO. OR TYPE	TOT QTY	REC QTY	USE CDE
U72	IC, TTL, BCD-TO-7 SEGMENT DECODER/DRIVER	340109	01295	SN7447N	REF		
U73	⊗IC, CMOS, HEX BUFFER/INVERTER	381830	95303	SD4050AE	2		1
U74	⊗IC, CMOS, HEX BUFFER/INVERTER	381830	95303	SD4050AE	REF		
U81	RES, NETWORK, 47 +/-5%, 1/4W (OR 7 DISCRETE RESISTORS, P/N 147892)	402636	89536	402636	1		1
U92	DIODE BRIDGE, 100V, 2A, FULLWAVE (CR85-CR88)	296509	14936	KBF02	1		1
U94	IC, LINEAR, OP AMP	402750	07263	741TC	2		1
U95	IC, LINEAR, OP AMP	402750	07263	741TC	REF		
U96	IC, LINEAR, VOLTAGE REGULATOR	379420	04713	MC1723C	1		1
U102	IC, TTL, DUAL NAND SCHMITT TRIGGER	453076	01295	SN74LS13	1		
	HEAT SINK, XSTR Q98	104646	05820	204CB	1		
	TRANSIPAD, Q96, Q98	152207	07047	10123-DAP	2		
XU4	SOCKET, IC, 16-PIN DIP	370312	01295	C931602	4		
XU6	SOCKET, IC, 16-PIN DIP	370312	01295	C931602	REF		
XU13	SOCKET, IC, 14-PIN DIP	291542	00779	582527-1	2		
XU31	SOCKET, IC, 16-PIN DIP	370312	01295	C931602	REF		
XU32	SOCKET, IC, 16-PIN DIP	370312	01295	C931602	REF		
XU35	SOCKET, IC, 14-PIN DIP	291542	00779	582527-1	REF		
XU65	SOCKET, IC, 40-PIN DIP	386060	89536	386060	1		

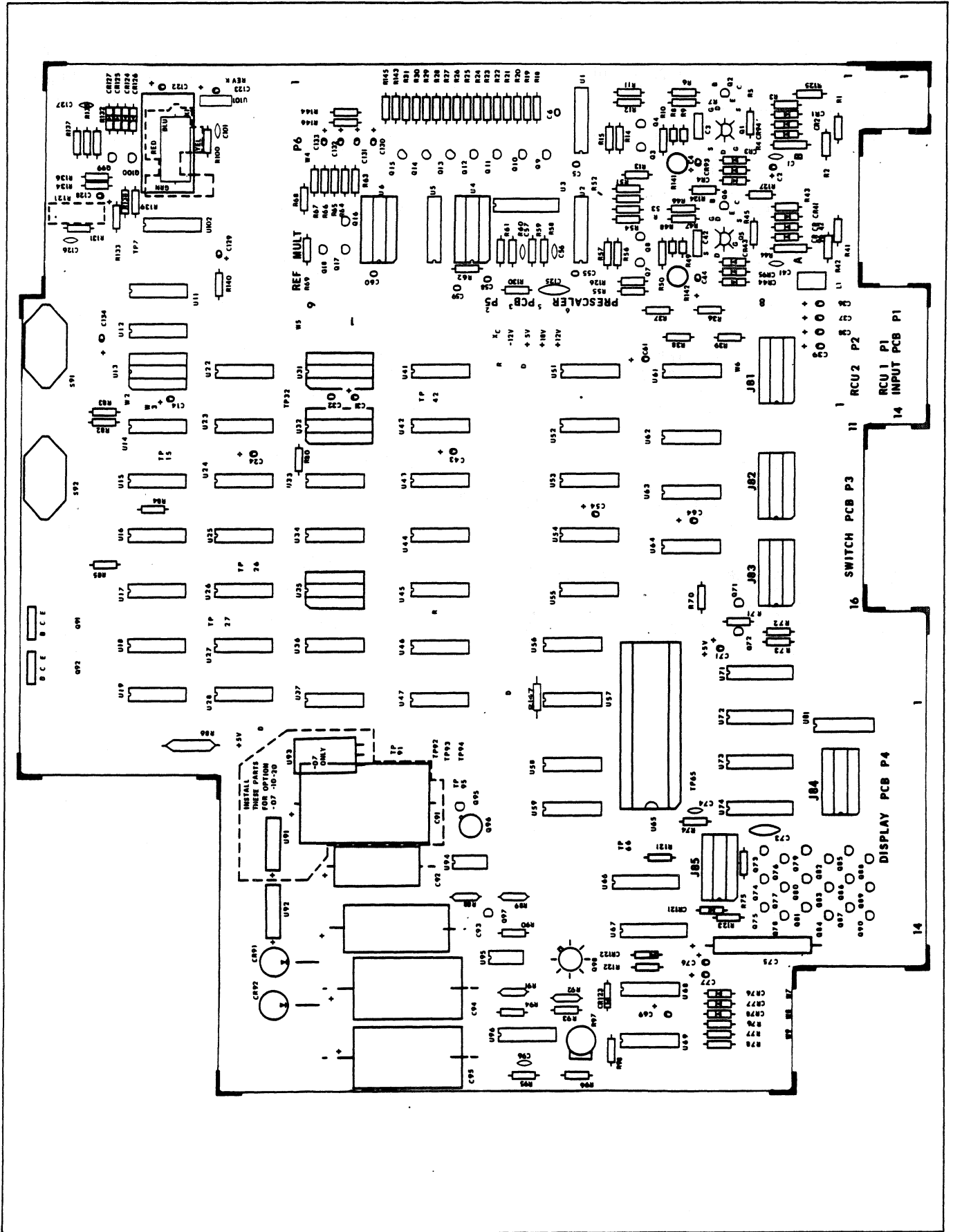

Figure 5-3. A1A1 Main PCB Assembly

Table 5-4. A1A2 Rear Panel Assembly

ITEM NO.	DESCRIPTION	FLUKE STOCK NO.	MFG SPLY CODE	MFG PART NO. OR TYPE	TOT QTY	REC QTY	USE CDE
A1A2	REAR PANEL ASSEMBLY (1953A-4452) FIGURE 5-4	396366	89536	396366	REF		
F91	FUSE, 1 AMP	369819	71400	AGC1	1		
J91	CONNECTOR, BNC	152033	13511	UG1094A/U	6		
J92	CONNECTOR, BNC	152033	13511	UG1094A/U	REF		
J93	CONNECTOR, BNC	152033	13511	UG1094A/U	REF		
J97	CONNECTOR, BNC	152033	13511	UG1094A/U	REF		
J98	CONNECTOR, BNC	152033	13511	UG1094A/U	REF		
J99	CONNECTOR, BNC	152033	13511	UG1094A/U	REF		
MP1	REAR PANEL	449469	89536	449469	1		
MP2	DECAL, REAR PANEL	452748	89536	452748	1		
MP3	COVER, CONNECTOR PORT	398024	89536	398024	1		
MP4	PLUG, BUTTON	101766	83330	654	1		
MP5	LUG, SOLDER, BNC	441972	83330	761	6		
MP6	BRACKET, ANGLE	401869	89536	401869	2		
MP7	PLUG, BUTTON	398206	89536	398206	3		
P96	PWR RECEPTACLE ASSY (S93,P96,XF91) FUSEHOLDER & VOLTAGE CHANGE OVER SWITCH	446328	89536	446328	1		
Q91	XSTR, SI, PNP	369660	01295	TIP32	2		
Q92	XSTR, SI, PNP	369660	01295	TIP32	REF		
S93	PWR RECEPTACLE ASSY (S93,P96,XF91) FUSEHOLDER & VOLTAGE CHANGE OVER SWITCH	446328	89536	446328	REF		
T91	TRANSFORMER, POWER	449843	89536	449843	1		
XF91	PWR RECEPTACLE ASSY (S93,P96,XF91) FUSEHOLDER & VOLTAGE CHANGE OVER SWITCH	446328	89536	446328	REF		

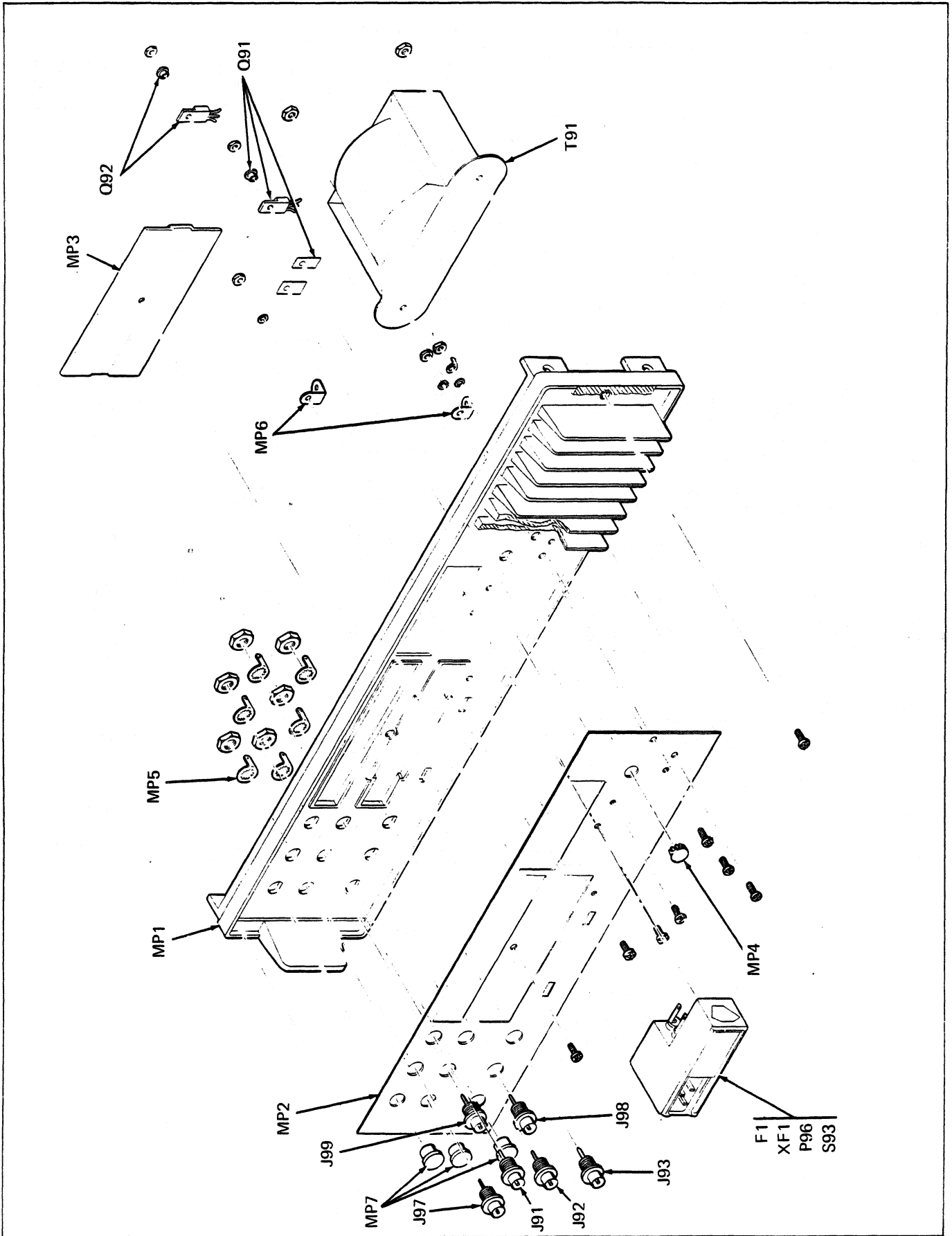

Figure 5-4. A1A2 Rear Panel Assembly

Table 5-5. A1A3 Input PCB Assembly

ITEM NO.	DESCRIPTION	FLUKE STOCK NO.	MFG SPLY CODE	MFG PART NO. OR TYPE	TOT QTY	REC QTY	USE CDE
A1A3	INPUT PCB ASSEMBLY (1953A-4004) FIGURE 5-5	396234	89536	396234	REF		
C401	CAP, MYLAR 0.1 UF +10%, 400V	447573	73445	C280MF/A100K	2		
C402	CAP, MYLAR 0.1 UF +10%, 400V	447573	73445	C280MF/A100K	REF		
DS401	LIGHT, EMITTING DIODE	385898	28480	5082-4887	2		
DS402	LIGHT, EMITTING DIODE	385898	28480	5082-4887	REF		
DS403	LIGHT, EMITTING DIODE	385898	28480	5082-4887	REF		
DS404	LIGHT, EMITTING DIODE	385898	28480	5082-4887	REF		
J1	CONNECTOR PIN, FEMALE, SMALL	375329	00779	35863-3	12		
	PIN, FEMALE, LARGE	149112	74970	105-0753	2		
R401	RES, COMP, 910K +/-5%, 1/4W	285338	01121	CB9145	2		
R402	RES, COMP, 910K +/-5%, 1/4W	285338	01121	CB9145	REF		
R403	RES, COMP, 100K, +/-5%, 1/4W	148189	01121	CB1045	2		
R404	RES, COMP, 100K, +/-5%, 1/4W	148189	01121	CB1045	REF		
R405	RES, VAR, 10K, +/-30%, 1/2W W/ SPDT SWITCH	370247	71450	FR-VF-UPE45-4	2	1	
R406	RES, VAR, 10K, +/-30%, 1/2W W/ SPDT SWITCH	370247	71450	FR-VF-UPE45-4	REF		
R410	RES, COMP, 47 OHMS +/-5%, 1/4W	147892	01121	CB4705	4		
R411	RES, COMP, 47 OHMS +/-5%, 1/4W	147892	01121	CB4705	REF		
R412	RES, COMP, 47 OHMS +/-5%, 1/4W	147892	01121	CB4705	REF		
R413	RES, COMP, 47 OHMS +/-5%, 1/4W	147892	01121	CB4705	REF		
R420	RES, COMP, 1K +/-5%, 1/4W	148023	01121	CB1025	2		
R421	RES, COMP, 1K +/-5%, 1/4W	148023	01121	CB1025	REF		
S106	PART OF R406						
S107	PART OF R405						
S108	SWITCH, SLIDE, SPDT	380113	79727	GF-124-SPDT	6	2	
S109	SWITCH, SLIDE, SPDT	380113	79727	GF-124-SPDT	REF		
S110	SWITCH, SLIDE, SPDT	380113	79727	GF-124-SPDT	REF		
S111	SWITCH, SLIDE, SPDT	380113	79727	GF-124-SPDT	REF		
S112	SWITCH, SLIDE, SPDT	380113	79727	GF-124-SPDT	REF		
S113	SWITCH, SLIDE, SPDT	380113	79727	GF-124-SPDT	REF		
S114	SWITCH, SLIDE, DPDT	436691	34828	GF-126	1	1	

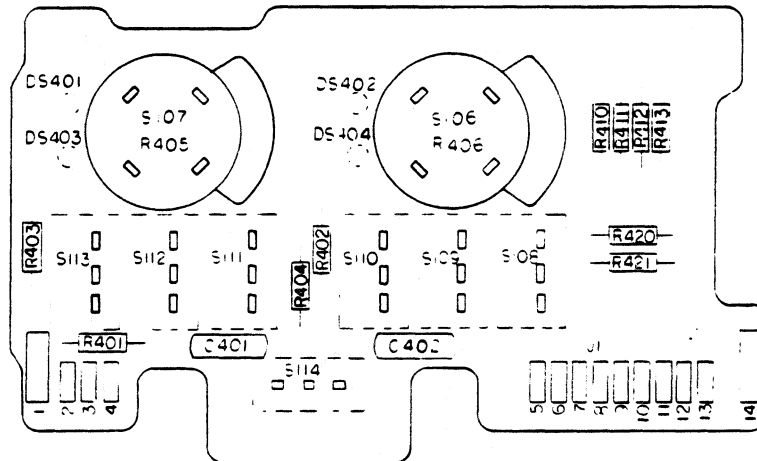

Figure 5-5. A1A3 Input PCB Assembly

Table 5-6. A2 Front Panel Assembly

ITEM NO.	DESCRIPTION	FLUKE STOCK NO.	MFG SPLY CODE	MFG PART NO. OR TYPE	TOT QTY	REC QTY	USE CDE
A2	FRONT PANEL ASSEMBLY (1953A-4451) FIGURE 5-6	396358	89536	396358			REF
H1	LUG, SOLDER, BNC	441972	83330	761	2		
J102	CONNECTOR, BNC	152033	13511	UG1094A/U	2		
J103	CONNECTOR, BNC	152033	13511	UG1094A/U			REF
MP1	FRONT PANEL	433516	89536	433516	1		
MP2	DECAL, FRONT PANEL	394106	89536	394106	1		
MP3	BRACKET, ANGLE	401869	89536	401869	1		
MP4	PLUG, BUTTON	398206	89536	398206	1		
MP5	NAMEPLATE	393975	89536	393975	1		

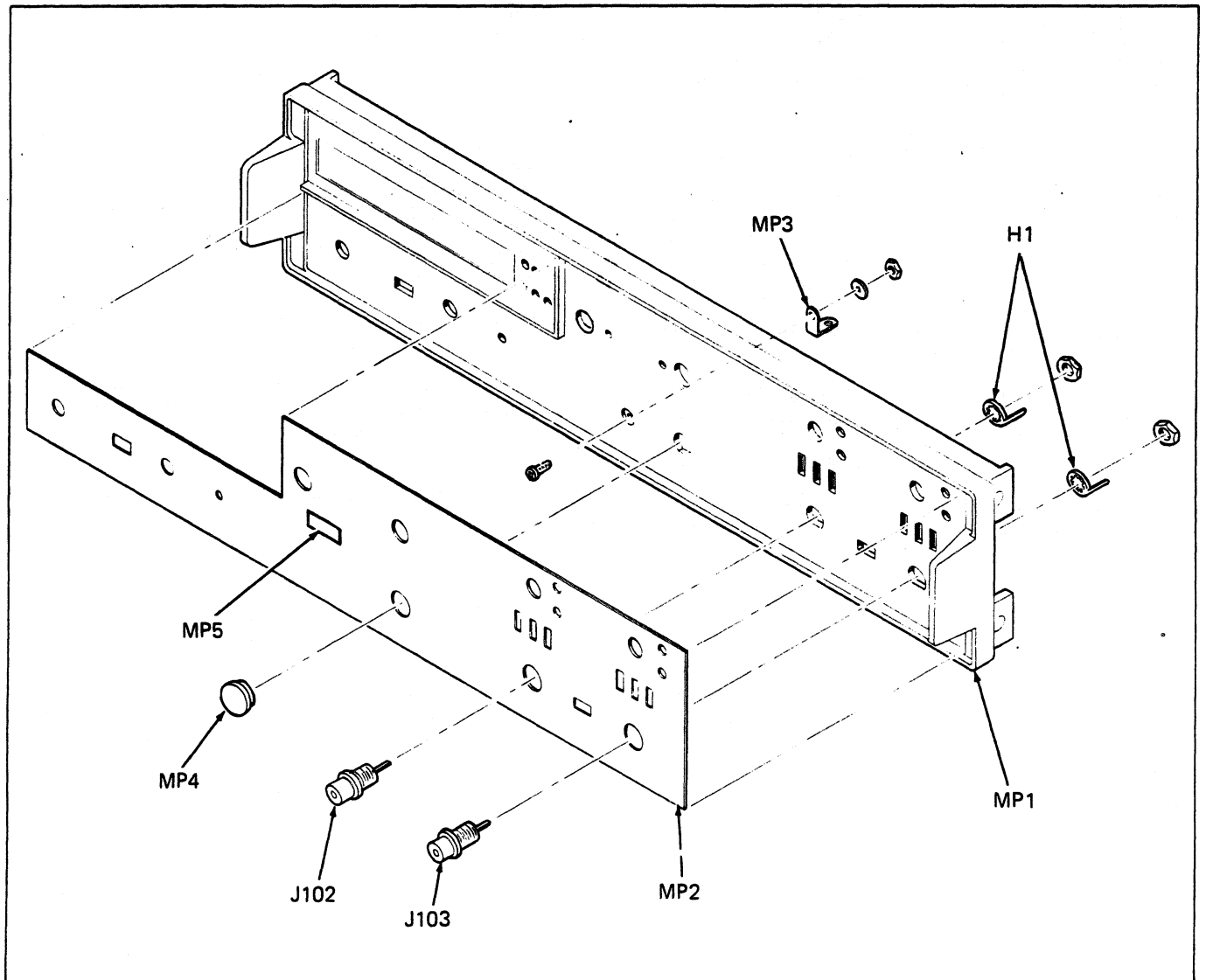

Figure 5-6. A2 Front Panel Assembly

Table 5-7. A3 Display PCB Assembly

ITEM NO.	DESCRIPTION	FLUKE STOCK NO.	MFG SPLY CODE	MFG PART NO. OR TYPE	TOT QTY	REC QTY	USE CDE
A3	DISPLAY PCB ASSEMBLY (1953A-4002T) FIGURE 5-7	396218	89536	396218	REF		
DS101	LIGHT EMITTING DIODE	385898	28480	5082-4887	8	3	
DS102	LIGHT EMITTING DIODE	385898	28480	5082-4887	REF		
DS103	LIGHT EMITTING DIODE	385898	28480	5082-4887	REF		
DS104	LIGHT EMITTING DIODE	385898	28480	5082-4887	REF		
DS105	LIGHT EMITTING DIODE	385898	28480	5082-4887	REF		
DS106	LIGHT EMITTING DIODE	385898	28480	5082-4887	REF		
DS107	LIGHT EMITTING DIODE	385898	28480	5082-4887	REF		
DS108	LIGHT EMITTING DIODE	385898	28480	5082-4887	REF		
J4	CONNECTOR PINS, FEMALE, SMALL PINS, FEMALE, LARGE	375329 149112	00779 74970	85863-3 105-0753	12 2		
J84	FLAT CABLE ASSEMBLY	393520	08261	5142-006	1		
Q1	XSTR, SI, PNP	218396	04713	2N3904	1	1	
R102	RES, VAR, 25K WITH DPST SWITCH	379446	89536	379446	1	1	
R103	RES, COMP, 10K +/-5%, 1/4W	148106	01121	CB1035	1		
R104	RES, COMP, 110 +/-5%, 1/4W	193474	01121	CB1115	1		
R105	RES, COMP, 3.3K +/-5%, 1/4W	148056	01121	CB3325	1		
S101	RES, VAR, 25K WITH DPST SWITCH	379446	89536	379446	REF		
S102	SWITCH, SLIDE	380113	79727	GF-124-SPDT	1	1	
S103	SWITCH, PUSHBUTTON	370353	08353	8532	1	1	
S131	RES, VAR, 25K WITH DPST SWITCH	379446	89536	379446	REF		
U101	LED, DISPLAY SEVEN-SEGMENT, ORANGE	429985	28480	5082-7728	9	3	
U102	LED, DISPLAY SEVEN-SEGMENT, ORANGE	429985	28480	5082-7728	REF		
U103	LED, DISPLAY SEVEN-SEGMENT, ORANGE	429985	28480	5082-7728	REF		
U104	LED, DISPLAY SEVEN-SEGMENT, ORANGE	429985	28480	5082-7728	REF		
U105	LED, DISPLAY SEVEN-SEGMENT, ORANGE	429985	28480	5082-7728	REF		
U106	LED, DISPLAY SEVEN-SEGMENT, ORANGE	429985	28480	5082-7728	REF		
U107	LED, DISPLAY SEVEN-SEGMENT, ORANGE	429985	28480	5082-7728	REF		
U108	LED, DISPLAY SEVEN-SEGMENT, ORANGE	429985	28480	5082-7728	REF		
U109	LED, DISPLAY SEVEN-SEGMENT, ORANGE	429985	28480	5082-7728	REF		
U113	RES, NETWORK, 110 +/-5%, 1/4W (OR 7 DISCRETE RESISTORS, P/N 147926)	386938	89536	386938	1	1	

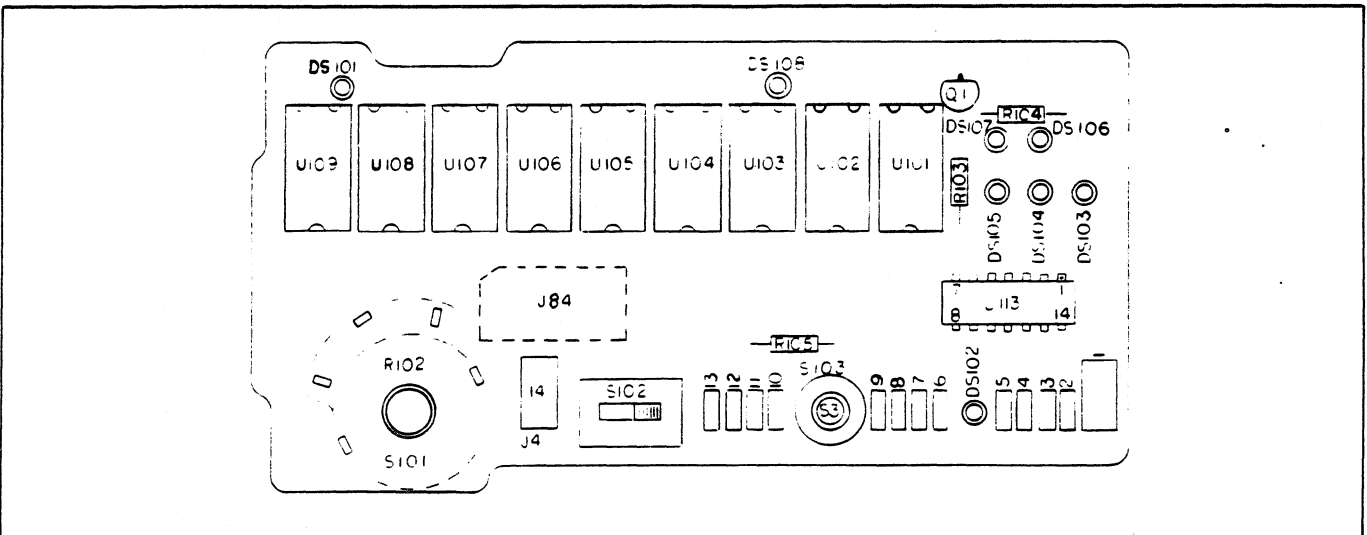

Figure 5-7. A3 Display PCB Assembly



Table 5-8. A4 Switch PCB Assembly

ITEM NO.	DESCRIPTION	FLUKE STOCK NO.	MFG SPLY CODE	MFG PART NO. OR TYPE	TOT QTY	REC QTY	USE CDE
A4	SWITCH PCB ASSEMBLY (1953A-4003) FIGURE 5-8	396119	89536	396119	REF		
J3	CONNECTOR PINS, FEMALE, SMALL PIN, FEMALE, LARGE	375329 149112	00779 74970	85863-3 105-0753	14 2		
S104	SWITCH, ROTARY, TIME BASE	376988	89536	376988	1		
S105	SWITCH, ROTARY, FUNCTION	376970	89536	376970	1		
U301	RESISTOR NETWORK, 13 RES, 6K +/-5%, 1/4W (OR 13 DISCRETE RESISTORS, P/N 148080)	355131	71450	760-1	1		1

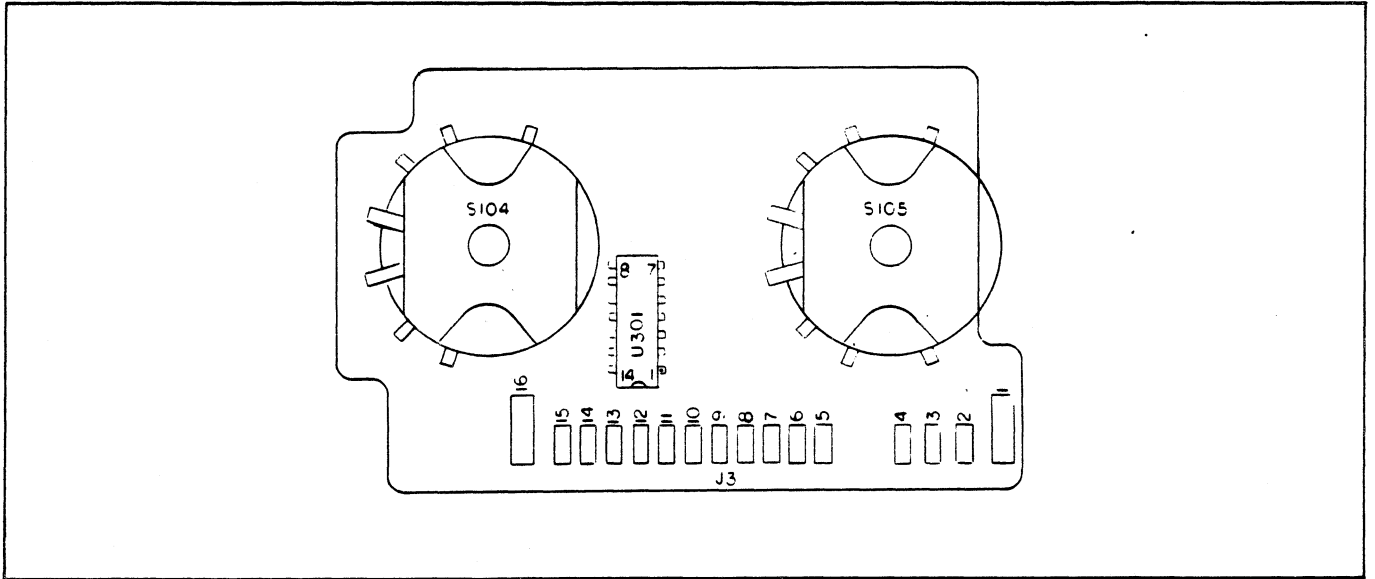
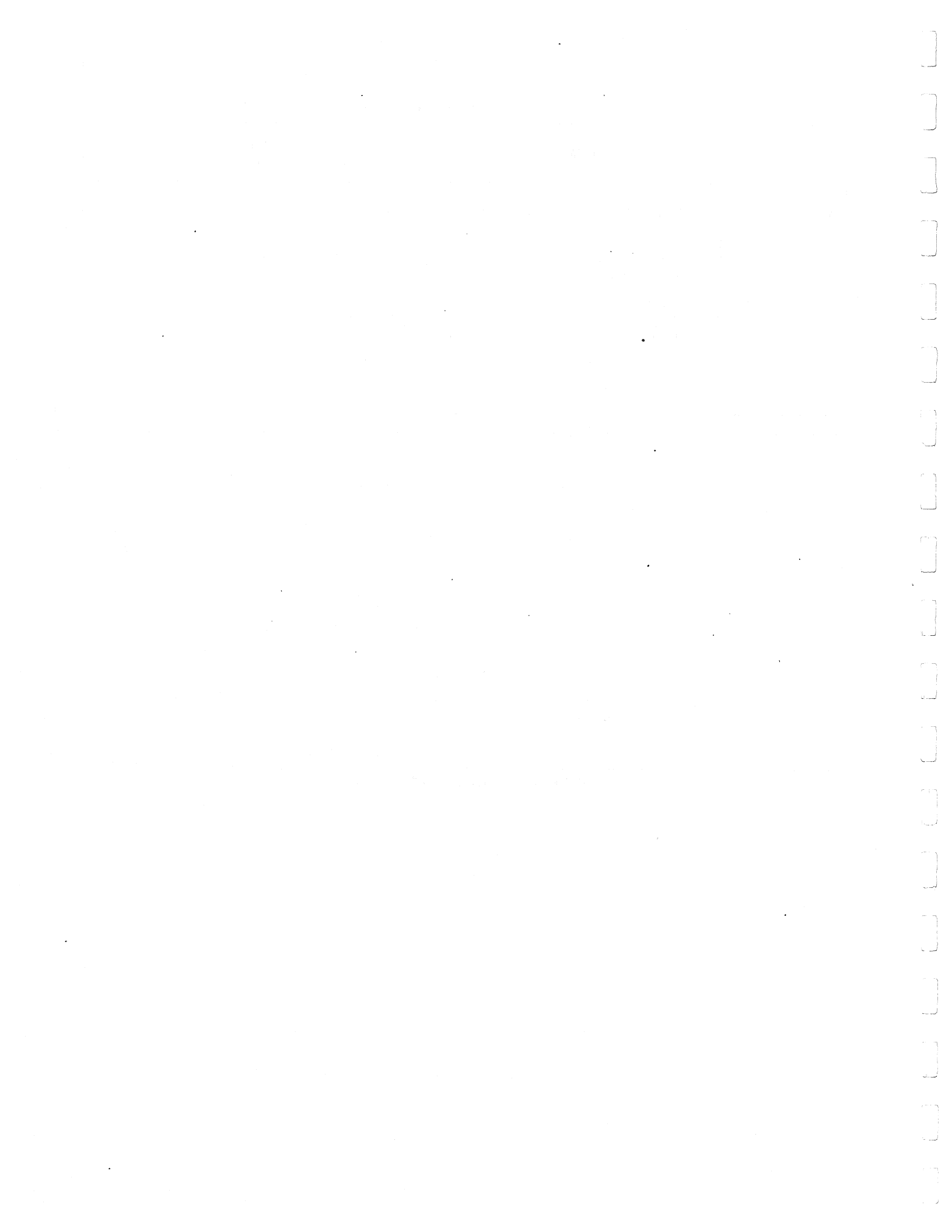

Figure 5-8. A4 Switch PCB Assembly



## Section 6

# Option & Accessory Information

### TABLE OF CONTENTS

OPTION/FL MODEL NO.	DESCRIPTION	PAGE
ACCESSORIES		
M00-200-622	Rack Mounting Kit .....	600-1
M00-200-626	Rack Slide Kit .....	600-1
Y7201	Attenuator/Low Pass Filter .....	600-1
OPTIONS		
-02	Data Output Unit .....	602-1
-04	Temperature Compensated Crystal Oscillator (TCXO) .....	604-1
-05	External Time Base Multiplier .....	605-1
-07	520 MHz Prescaler .....	607-1
-10	Oven-Stabilized Time Base .....	610-1
-11	Basic Remote Control Unit .....	611-1
-12	Full Remote Control Unit .....	612-1
-13	1000 MHz Prescaler .....	613-1
-14	1250 MHz Prescaler .....	614-1
-15	IEEE-488 Standard Interface .....	615-1
-16	Rear Panel Inputs .....	616-1
-20	Superior Oven-Stabilized Time Base .....	620-1

## 6-1. INTRODUCTION

6-2. This section of the manual contains information concerning the options and accessories available for use with the Model 1953A. It consists of a series of subsections that include introduction, accessories, and options. Each option and accessory is listed by Model or Option number in the table of contents on page 6-2.

6-3. Accessories include rack mounting kits, an extender cable, and an input attenuator/filter. Each is discussed in the Accessories subsection.

6-4. Each option of the 1953A is documented in an individual subsection. All of the information necessary to install, operate, and maintain an option is included in its subsection. This includes a list of replaceable parts. The detailed schematic for each option is included in Section 8.

6-5. Each subsection is uniquely identified by page and paragraph numbering that relates to the accessories or a particular option. For example, a 600-X series identifies the accessories subsection, and a 602-X series identifies the subsection for the -02 Option (where X is a sequential page or paragraph number).

## Accessories

### 600-1. INTRODUCTION

600-2. The 1953A can be rack-mounted in a standard 19-inch equipment rack by using Rack Mounting Kit M00-200-622. Use the following procedure to install the kit.

- a. Peel off the 1953A handle trim and side trim decals.
- b. Remove the handles and the feet from the 1953A.
- c. Fasten side brackets (2) to the 1953A using six 8-32 x 1/2" machine screws. See Figure 600-1.
- d. Secure the front panel plate (1) to the brackets. Use eight 6-32 nuts supplied with kit.

### 600-3. RACK SLIDE KIT

600-4. The 1953A can be rack-mounted in a 24-inch deep equipment rack by using Rack Slide Kit M00-200-626. Use the following procedure to install the kit.

- a. Peel off the 1953A handle trim and side trim decals.
- b. Remove the handles and feet from the 1953A.
- c. Disassemble the rack slides into sections A, B, and C as shown in Figure 600-2. (Press release buttons.)
- d. Fasten the four mounting brackets (1) to the inside of the equipment rack (console).
- e. Anchor slide section C to the brackets (1) mounted in the console. Use eight 10-32 x 1 1/2" machine screws.

f. Fasten section A of the rack slide and the rack ear (4) to the side of the 1953A. Use eight 10-32 x 1/2" machine screws. See Detail 1 of Figure 600-2.

g. Attach front panel plate (3) to the rack ears (4) using eight 6-32 nuts.

h. Slide rack sections B into section C as shown in Figure 600-2.

i. Slide the 1953A (and rack section A) into section B in the equipment console.

### 600-5. ATTENUATOR/LOW PASS FILTER

#### 600-6. Introduction

600-7. The Model Y7201, as shown in Figure 600-3, is a combination variable attenuator and selectable low-pass filter intended for use as an input signal noise suppressor for Fluke counters. It features a continuously variable X5 to X100 attenuator and a set of three switch-selectable frequency filters; DC to 1 kHz, DC to 20 kHz, or DC to 100 kHz. A BNC connector is provided for convenient attachment to the counter input and a set of 0.75" spaced banana jacks serve as the input signal connections.

600-8. In operation the Y7201 attenuates and/or filters unwanted noise/transients from the input signal. This isolates the counter from the noise levels and, thereby, eliminates the possibility of measurement errors. See Measurement Errors in Section 2 of this manual for a detailed discussion of the problem.

#### 600-9. Specifications

**Input Impedance:** 47 k $\Omega$

**Attenuation Range:** X5 to X100 continuously variable

**Low Pass Filter:** 1 kHz, 20 kHz, or 100 kHz switch-selectable

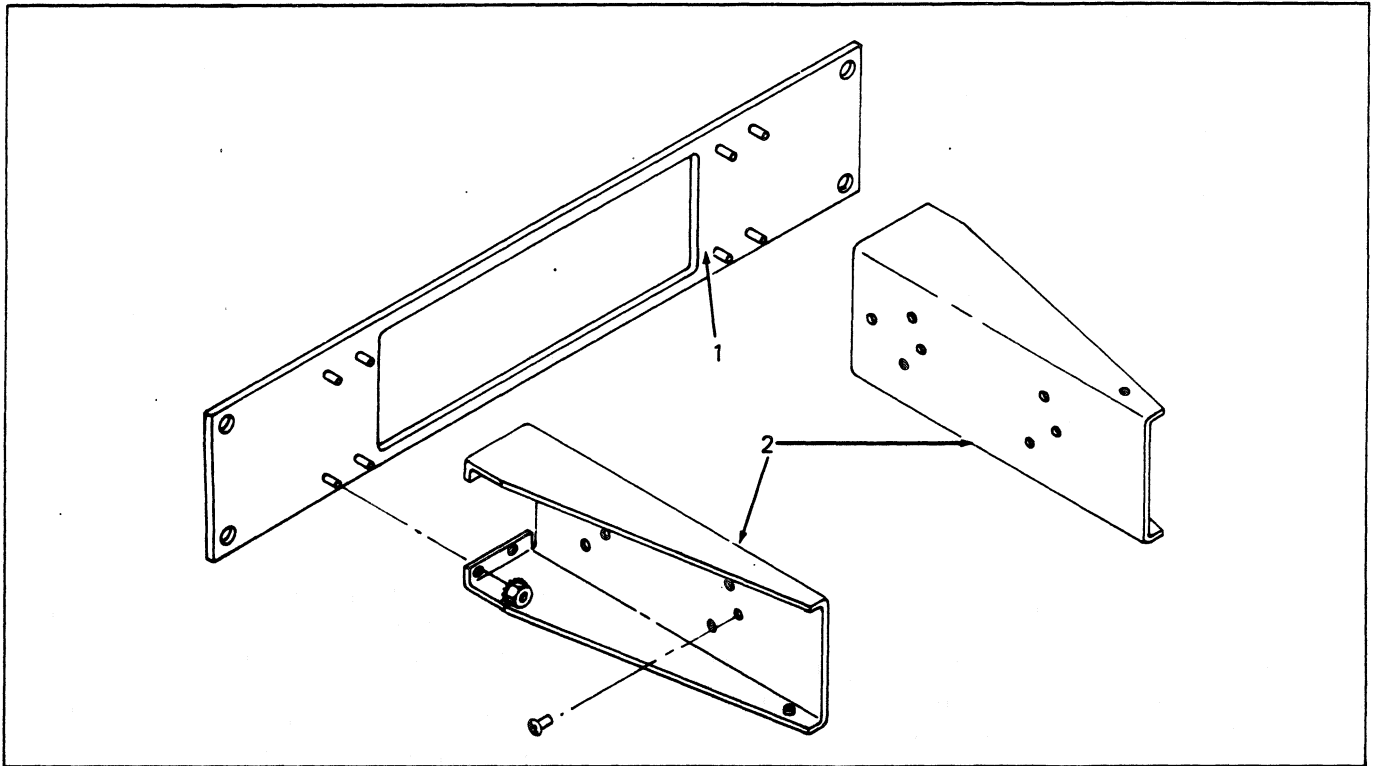

Figure 600-1. Rack Mounting Kit

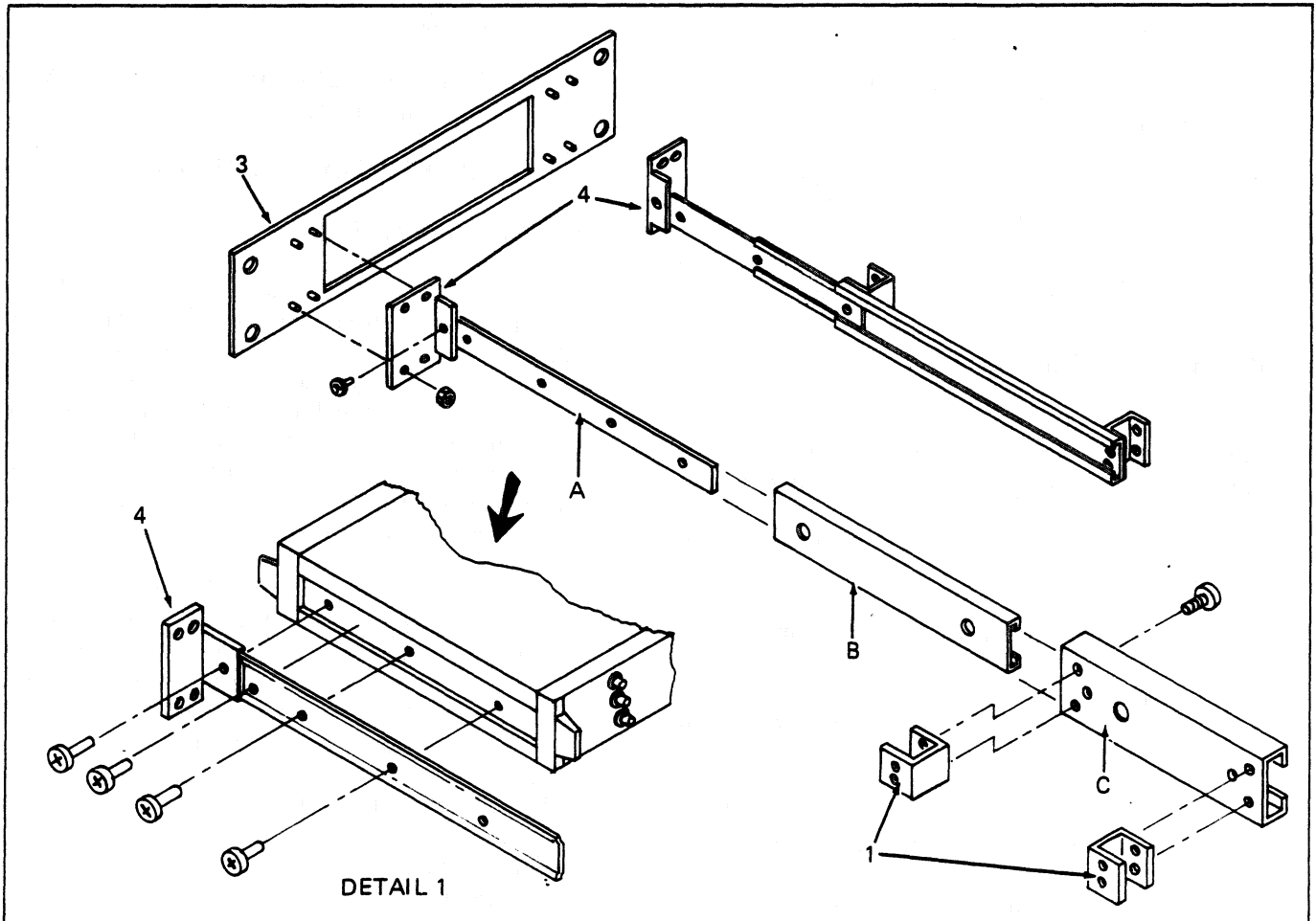

Figure 600-2. Rack Slide Kit

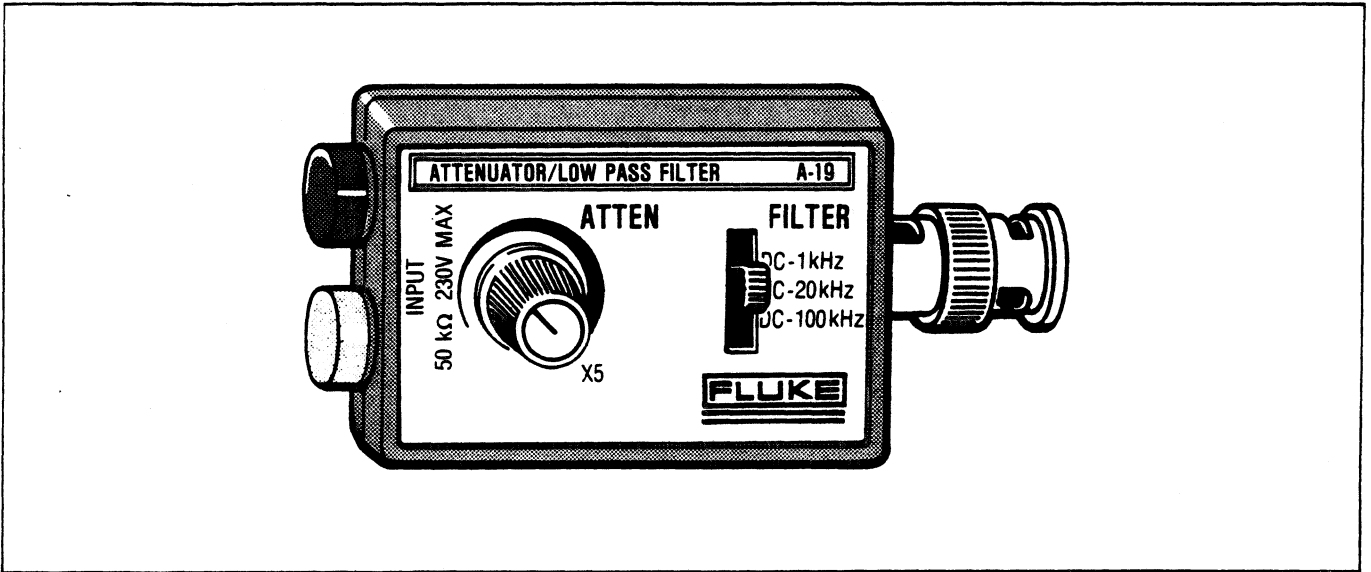

Figure 600-3. Y7201 Attenuator/Low Pass Filter





## Option -02 Data Output Unit

### 602-1. INTRODUCTION

602-2. The data output unit (DOU) permits the Model 1953A to operate in a systems environment where digital acquisition of the measurement data is necessary. The option comprises a single pcb assembly which mounts within the 1953A case and provides all nine digits of measurement data (in BCD format), units indication, decimal point, position, and control signals to the external system by a rear panel pcb connector. The DOU option may be ordered at the time of purchase or at a later date and field-installed. The model number of the DOU when ordered as a field-installable kit is 1953A-02K.

### 602-3. INSTALLATION

602-4. The 1953A-02K DOU kit comprises the following items:

- a. DOU PCB Assembly.
- b. Set of four stand-offs.
- c. Mounting hardware.

602-5. Install the DOU as follows:

- a. Remove the top and bottom dust covers. Remove the upper cover plate from the rear panel.
- b. Attach the four stand-offs to the underside (non-component side) of the DOU PCB.
- c. Position the DOU down on the Main PCB in the position shown in Figure 602-1 so that the stand-offs align with the matching holes in the Main PCB.
- d. Secure the DOU stand-offs to the Main PCB from the underside.

- e. Connect the DOU cable assemblies to the Main PCB so that J83 connects to J83 and J85 connects to J85 as shown in Figure 602-1.

### 602-6. DATA OUTPUT FORMAT

602-7. The DOU output is available via the upper rear panel connector, labeled BCD OUTPUT. The output data is in positive-true BCD format, TTL compatible and is transferred to the external device by means of an interconnecting cable used with the Fluke Model 2010A Digital Printer. The cable is called the Model 2010A-7000 and is available from the factory.

602-8. To fabricate a cable assembly for any other application, use a 50-pin connector made up of the following items:

- a. Connector body, AMP part no. 1-583717-1.
- b. Connector pins (50), AMP part no. 585616-5.
- c. Connector backshell, Fluke part no. 398005.
- d. 50-conductor cable.

602-9. The type and length of cable used is not critical since the measurement data is static. However, loading of the signals at the recording device must be TTL compatible, with fan-in less than 2. Refer to Table 602-1 for the particular pin assignments at the DOU output. The DOU output connector is numbered/lettered from A to C from left to right (as viewed from the rear) on the top side of the pcb, and from 1 to 25 from left to right on the underside of the pcb. All data is positive-true TTL compatible. The decimal point information is binary-coded to permit the six different decimal point positions to be indicated on the three available output lines (i.e. pins 1, 2, and A). Refer to Table 602-2 for the decimal point decoding.

602-10. The DOU connector also provides an external reset input at pin 24. A logic low (ground) signal on this line resets all counter functions except the DOU itself. The DOU ready command is a low-true pulse having a duration of 1.5 milliseconds, and signifies that the measurement data is stored in the DOU and ready for transfer. (When connected back to the external reset input, the DOU ready command causes the 1953A to operate in a continuous mode, and at optimum speed, to drive a printing device.) The print command is a positive (or high)-true signal of 1 millisecond duration to activate the printing or data logging device.

### 602-11. LIST OF REPLACEABLE PARTS

602-12. Table 602-3 is a list of replaceable parts for Data Output Unit. Refer to Section 5 for ordering information.

#### CAUTION

Indicated devices are subject to damage by static discharge.

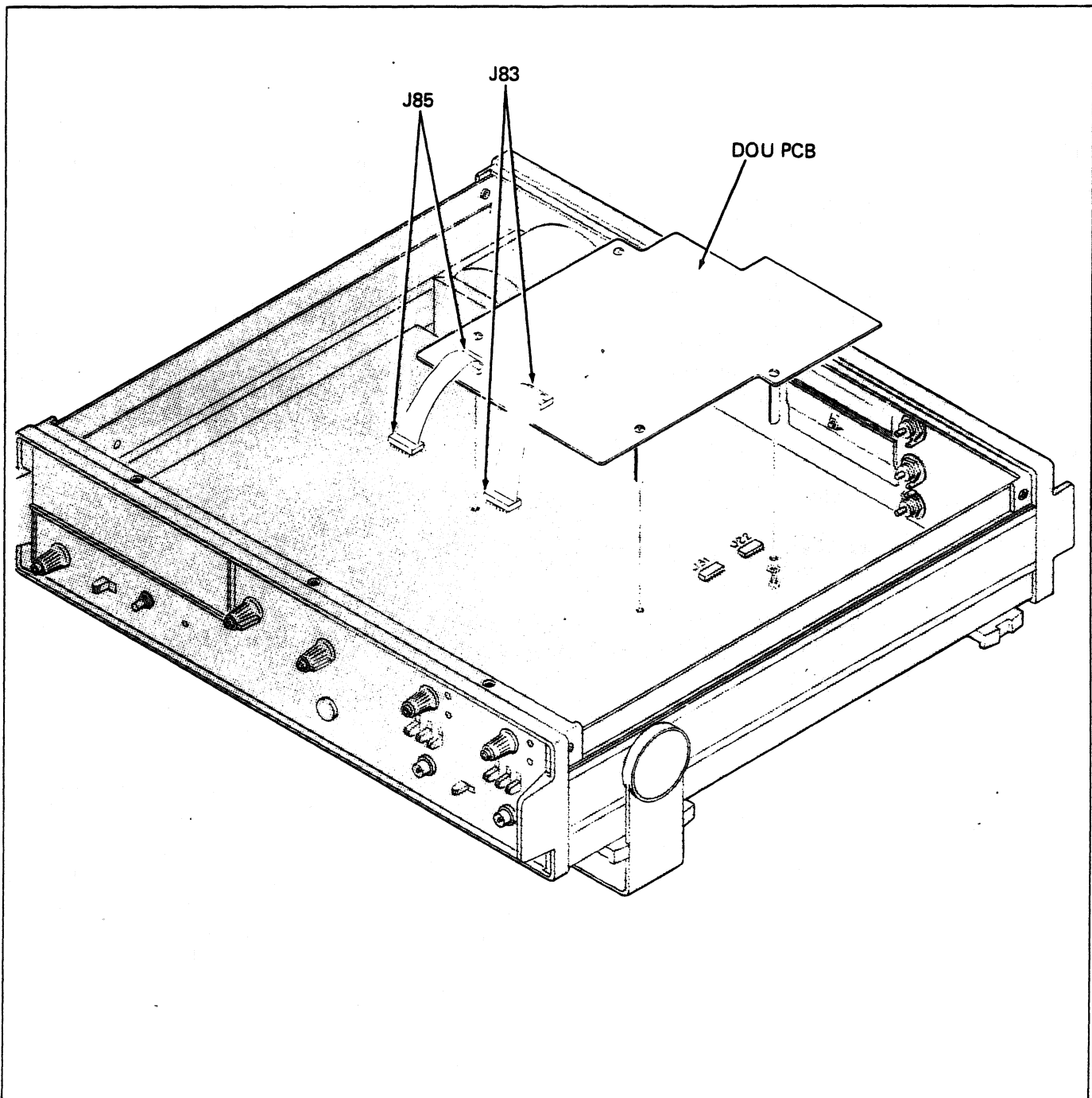

Figure 602-1. DOU Option Location

Table 602-1. DOU Output Pin Assignments

PIN NO.	FUNCTION	PIN NO.	FUNCTION				
A	Decimal Point 3	1	Blank	R	5SD-BCD 4	14	5SD-BCD 2
B	Decimal Point 1	2	Decimal Point 2	S	5SD-BCD 4	15	5SD-BCD 8
C	MHz Units	3	Print	T	6SD-BCD 1	16	6SD-BCD 2
D	Milliseconds	4	kHz Units	U	6SD-BCD 4	17	6SD-BCD 2
E	Seconds	5	Microseconds	V	7SD-BCD 1	18	7SD-BCD 2
F	MSD-BCD 1	6	MSD-BCD 2	W	7SD-BCD 4	19	7SD-BCD 8
H	MSD-BCD 4	7	MSD-BCD 8	X	8SD-BCD 1	20	8SD-BCD 2
J	2SD-BCD 1	8	2SD-BCD 2	Y	8SD-BCD 4	21	8SD-BCD 8
K	2SD-BCD 4	9	2SD-BCD 8	Z	LSD-BCD 1	22	LSD-BCD 2
L	3SD-BCD 1	10	3SD-BCD 8	a	LSD-BCD 4	23	LSD-BCD 9
M	3SD-BCD 4	11	3SD-BCD 8	b	Overflow	24	External Reset
N	4SD-BCD 1	12	4SD-BCD 2	c	Ground	25	DOU Ready
P	4SD-BCD 4	13	4SD-BCD 8				

Table 602-2. Decimal Point Position Coding

DECIMAL POINT POSITION ON DISPLAY			
	(PIN A)	(PIN 2)	(PIN B)
XXXXXXXXXX	1	1	1
XXXXXXXXX.X	1	1	0
XXXXXXXX.XX	1	0	1
XXXXXX.XXX	1	0	0
XXXXX.XXXX	0	1	1
XXXX.XXXXX	0	1	0
XXX.XXXXXX	0	0	1

Goes high in FREQ (A/B), A GTD By B, and SELF-CHECK functions.

Table 602-3. -02 Option, Data Output Unit

ITEM NO.	DESCRIPTION	FLUKE STOCK NO.	MFG SPLY CODE	MFG PART NO. OR TYPE	TOT QTY	REC QTY	USE CDE
-02	DATA OUTPUT UNIT, OPTION -02 FIGURE 602-2						
A6	DOU PCB ASSY	396283	89536	396283			
MP1	COVER, CONNECTOR, PORT, REAR PANEL	398016	89536	398016			
MP2	CONNECTOR KIT (NOT SHOWN)	410241	89536	410241			

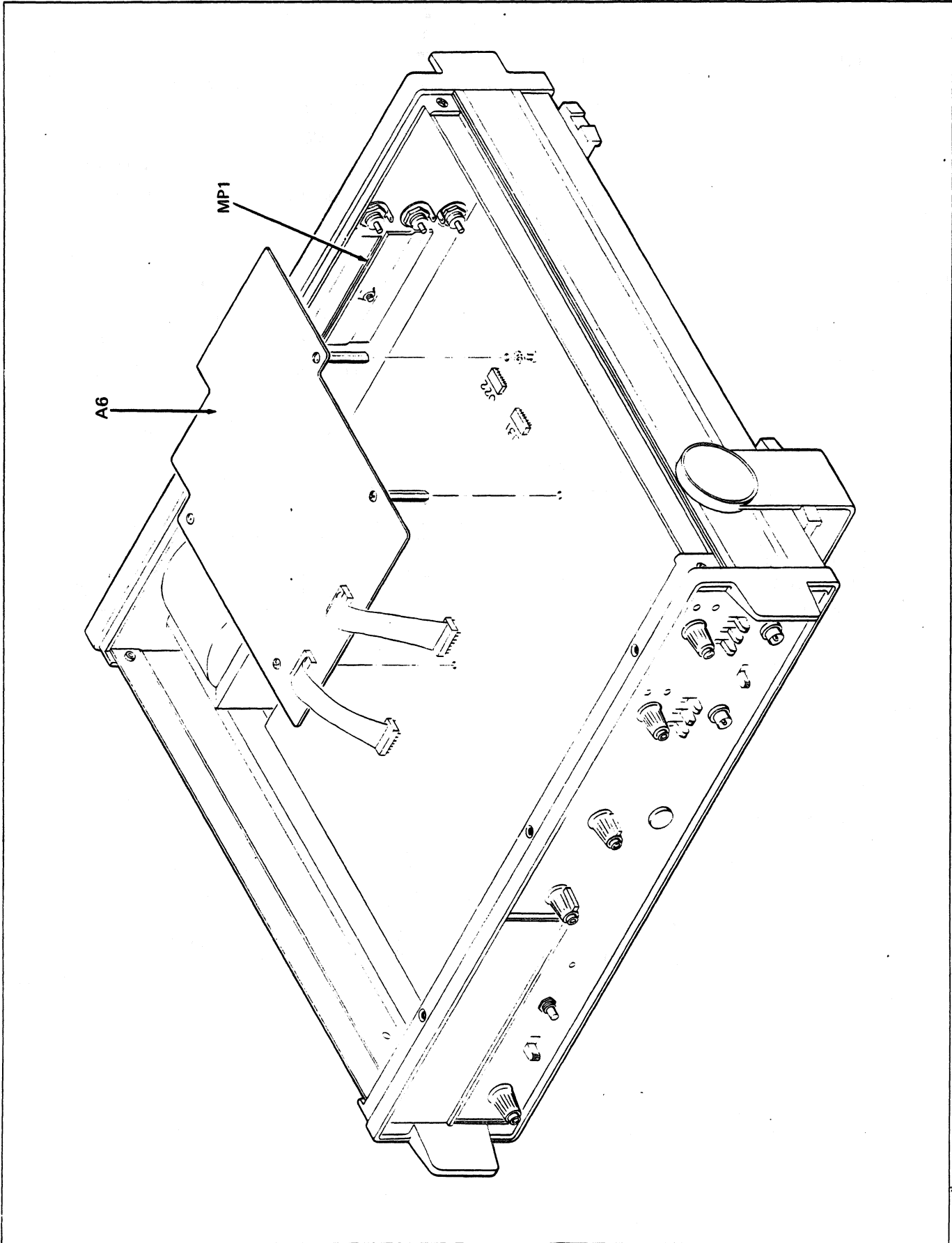

Figure 602-2. -02 Option, Data Output Unit

Table 602-4. A6 Data Output Unit PCB Assembly

ITEM NO.	DESCRIPTION	FLUKE STOCK NO.	MFG SPLY CODE	MFG PART NO. OR TYPE	TOT QTY	REC QTY	USE CDE
A6	⊗ DATA OUTPUT UNIT PCB ASSY (1953A-4025T) FIGURE 602-3	396283	89536	396283			REF
C801	CAP, TA, 10 UF +/-20%	193623	56289	196D106X0015JA1	1		
C802	CAP, CER DISC 100 PF +/-10%, 1 KV	105593	71590	DD-101	1		
C803	CAP, CER DISC, 0.01 UF +80/-20%, 16V	368639	71590	UK-16-103	1		
C804	CAP, CER DISC, 0.1 UF, GMV, 25V	369199	71590	UK-25-104	3		
C805	CAP, CER DISC, 0.1 UF, GMV, 25V	369199	71590	UK-25-104			REF
C806	CAP, CER DISC, 0.1 UF, GMV, 25V	369199	71590	UK-25-104			REF
H1	STAND OFF	436493	89536	436493	4		
J83	FLAT CABLE ASSEMBLY	393520	08261	5142-006	2		
J85	FLAT CABLE ASSEMBLY	393520	08261	5142-006			REF
R801	RES, COMP, 47K +/-5%, 1/4W	148163	01121	CB4735	1		
R802	RES, COMP, 33K +/-5%, 1/4W	148155	01121	CB3335	1		
U801	⊗ IC, CMOS, TRIPLE 3-INPUT NAND GATE	375147	95303	CD4023AE	1		
U802	IC, TTL, TRIPLE 3-INPUT NOR GATE	392951	01295	SN7427	1		
U803	⊗ IC, CMOS, QUAD D-LATCH	355149	95303	CD4042AE	9		
U804	⊗ IC, CMOS, QUAD D-LATCH	355149	95303	CD4042AE			REF
U805	⊗ IC, CMOS, QUAD D-LATCH	355149	95303	CD4042AE			REF
U806	IC, TTL, DUAL MONOSTABLE MULTIVIBRATOR	310235	01295	SN74123N	1		
U807	⊗ IC, CMOS, HEX BUFF/INVERTER	381848	95303	CD4049AE	2		
U808	⊗ IC, CMOS, HEX BUFF/INVERTER	381848	95303	CD4049AE			REF
U809	⊗ IC, CMOS, QUAD D-LATCH	355149	95303	CD4042AE			REF
U810	⊗ IC, CMOS, QUAD D-LATCH	355149	95303	CD4042AE			REF
U811	⊗ IC, CMOS, QUAD D-LATCH	355149	95303	CD4042AE			REF
U812	⊗ IC, CMOS, QUAD D-LATCH	355149	95303	CD4042AE			REF
U813	⊗ IC, CMOS, QUAD D-LATCH	355149	95303	CD4042AE			REF
U814	⊗ IC, CMOS, QUAD D-LATCH	355149	95303	CD4042AE			REF
U815	IC, TTL, HEX INVERTER	352039	01295	SN74L04	6		
U816	IC, TTL, HEX INVERTER	352039	01295	SN74L04			REF
U817	IC, TTL, HEX INVERTER	352039	01295	SN74L04			REF
U818	IC, TTL, HEX INVERTER	352039	01295	SN74L04			REF
U819	IC, TTL, HEX INVERTER	352039	01295	SN74L04			REF
U820	IC, TTL, HEX INVERTER	352039	01295	SN74L04			REF

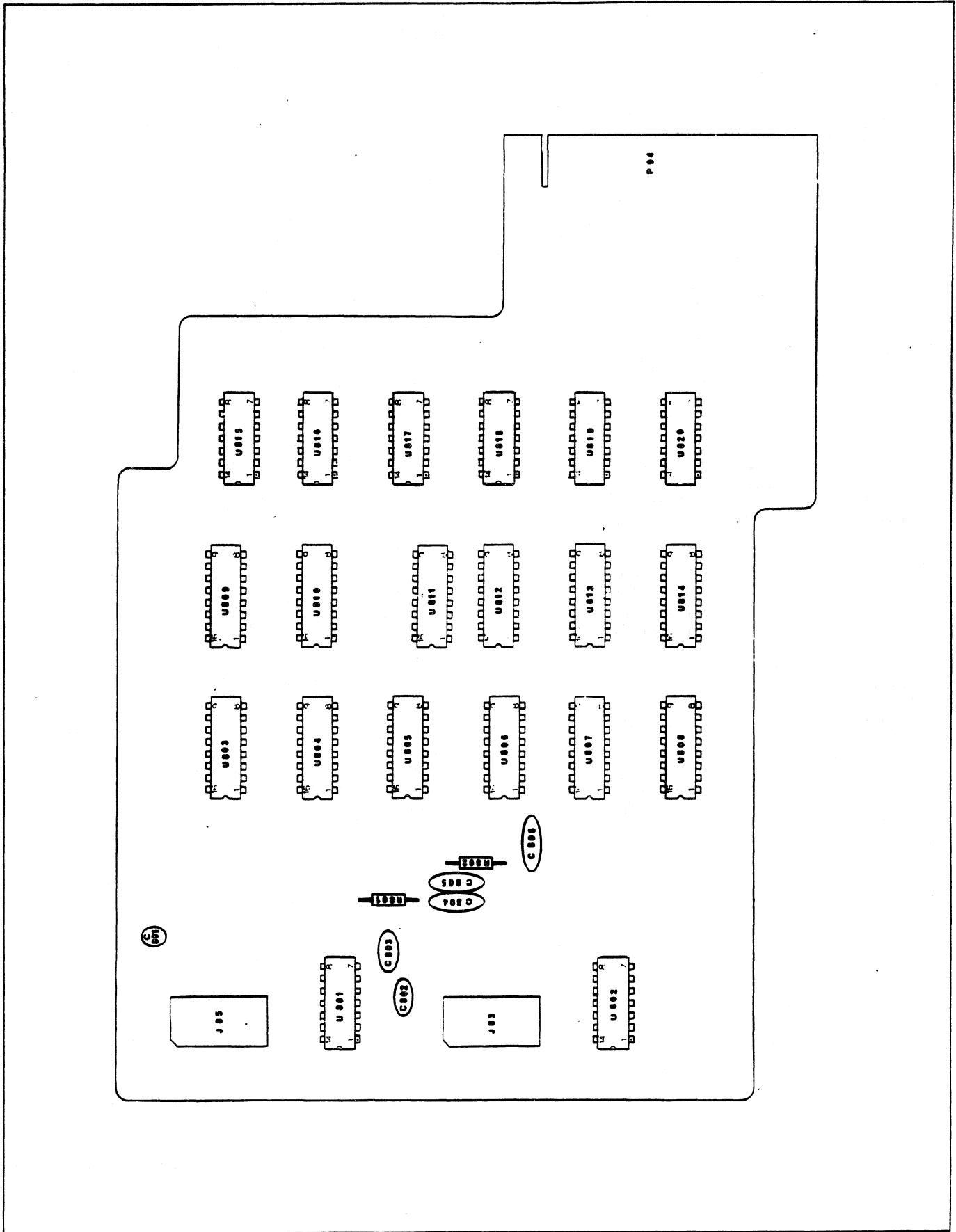

Figure 602-3. A6 Data Output Unit PCB Assembly

## Option -04 Temperature Compensated Crystal Oscillator

### 604-1. INTRODUCTION

604-2. Option -04 is a Temperature Compensated Crystal Oscillator (TCXO) which exhibits stability and temperature dependent characteristics superior to the oscillator normally installed in the standard unit. The specifications for the -04 Option are included in Section 1 of this manual.

### 604-3. LIST OF REPLACEABLE PARTS

604-4. Parts for Option -04 consist only of the TCXO which replaces the standard oscillator U7. Replacements can be ordered using the Fluke Part No. 461855. The manufacturing Federal Supply Code is 89536 and the manufacturer's part no. also 461855. See Figure 604-1.

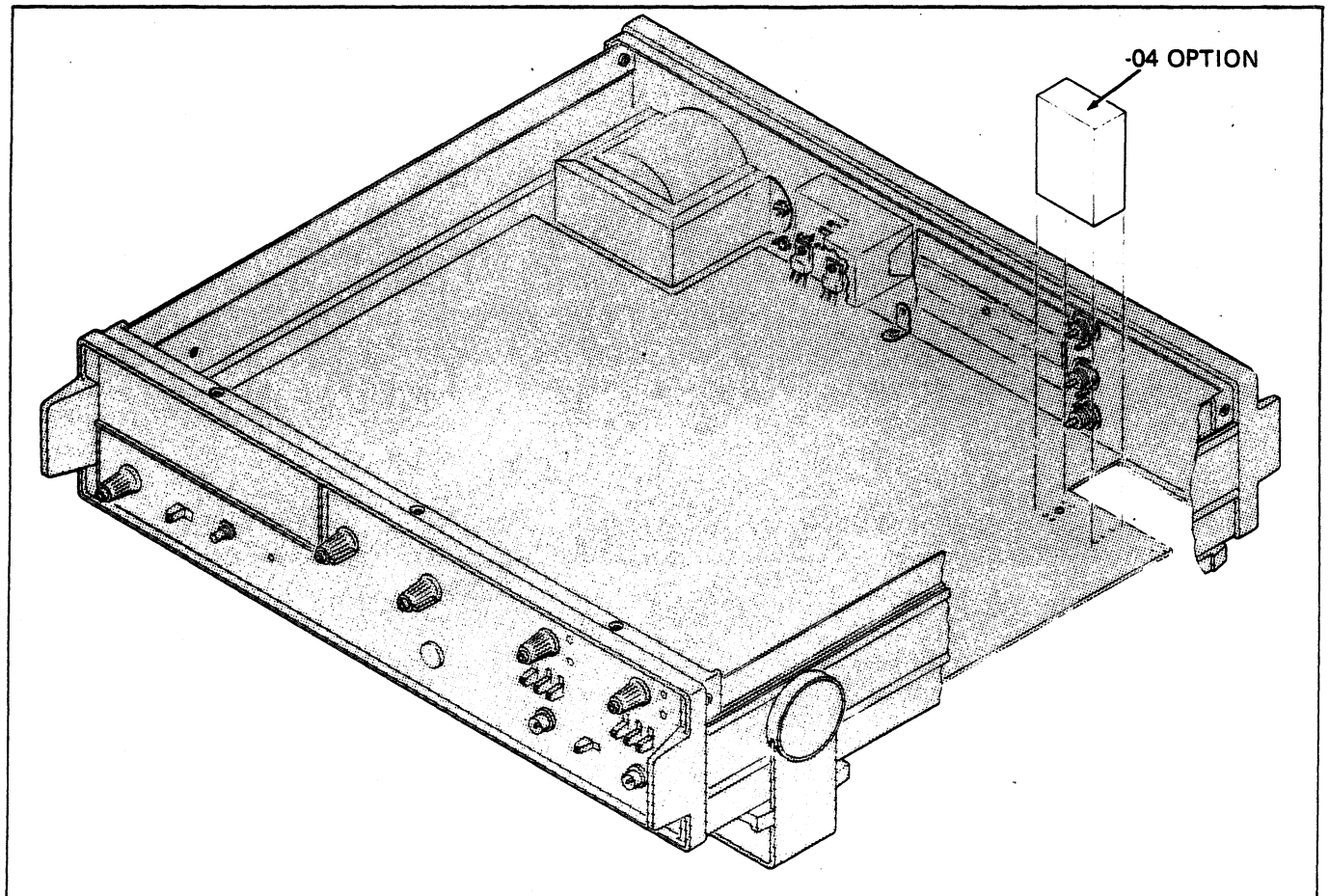
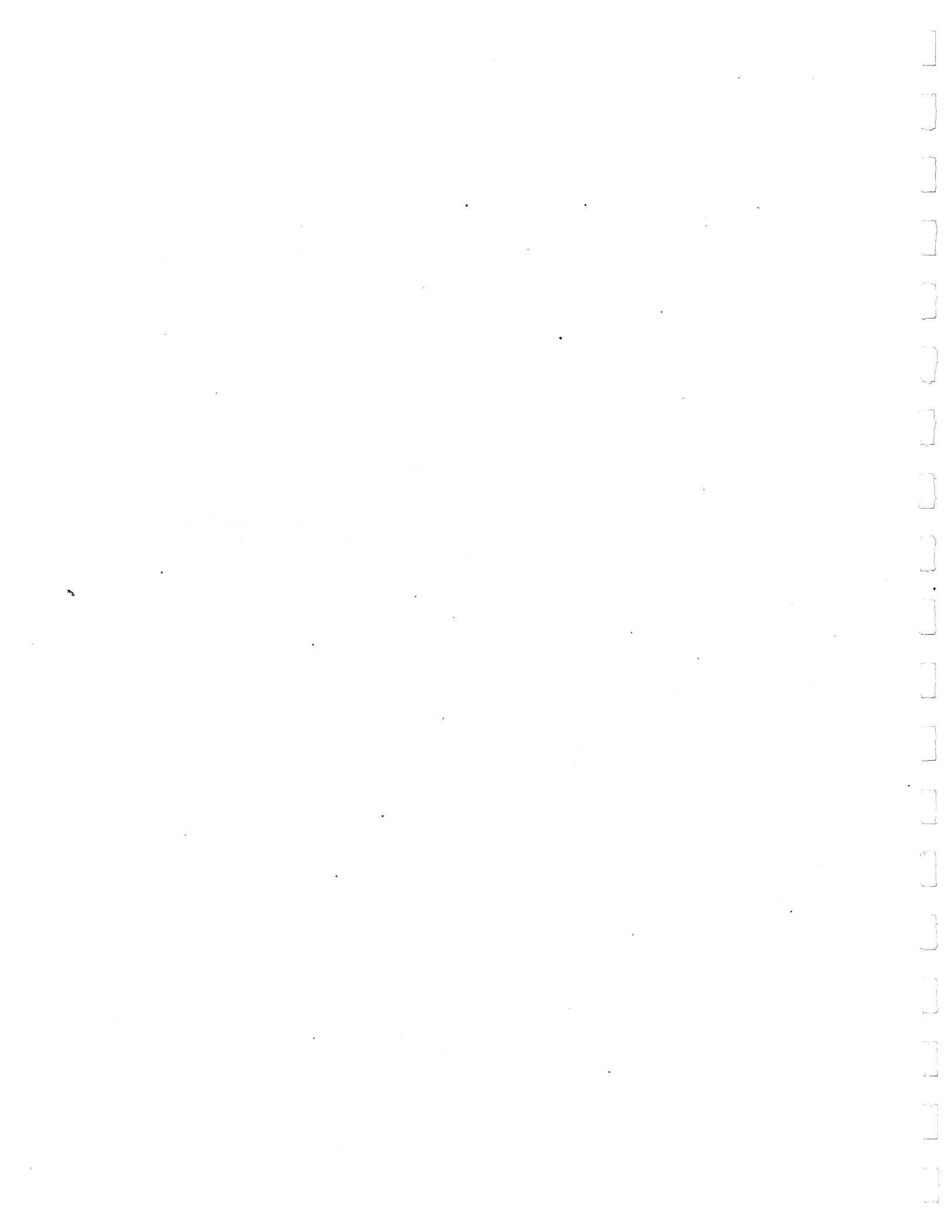

Figure 604-1. Temperature Compensated Crystal Oscillator





## Option -05 External Time Base Multiplier

### 605-1. INTRODUCTION

605-2. The External Time Base Multiplier Option adds two operating features to the 1953A Counter-Timer. External reference inputs of 1, 5, or 10 MHz, having a minimum amplitude of 250 mV rms, may be substituted for the internal time base reference of the instrument. Burst (pulsed oscillator) measurements may be made using control circuitry on the -05 Option.

605-3. The original External Time Base Multiplier Option has been superceded by an updated design, both of which will be covered in this section of the manual. The original version is contained on a single pcb. The later design consists of two pcbs, one mounted on the other, and is installed in instruments with serial numbers 615000 or greater (main pcb revision letter R-1 and on). The later design (two pcb version) is covered first. This information is applicable to the original version (single pcb) with the exceptions of the Time Base Multiplier theory of operation, parts list, and component location drawing, which will be covered second. Schematic diagrams for both versions are contained in Section 8.

### 605-4. OPERATING NOTES

#### 605-5. External Time Base

605-6. To substitute an external reference frequency for the internal time base, the desired input frequency (1, 5, or 10 MHz) must be selected with a three-position slide switch located on the External Multiplexer PCB. Refer to Section 4 for internal access information. Apply the reference signal to the CLOCK IN connector. The EXT INT switch controls which time base is used in the instrument: EXT for external, INT for internal.

#### 605-7. Burst Measurement

605-8. The burst measurement feature allows measurement of the frequency of pulsed oscillator signals within the frequency measurement capability of the

instrument. Burst frequency measurements are made by selecting a gate time for the counter of shorter duration than the pulse width of the signal to be measured. The gate time is initiated or triggered by a transition on channel B. If this transition is due to the start of the burst, and the gate time is shorter than the burst pulse width, the frequency developed during the burst is measured or counted. Burst frequency measurement made in this manner are accurate only if the pulsed oscillator being measured is not "pulled" in frequency by the start of the pulse.

605-9. There are three procedures for using the 1953A with the -05 Option to measure burst frequencies. Select one of the following procedures according to the frequency range of the unknown burst frequency.

605-10. Unknown burst frequency less than 25 MHz.

- a. Select the **FREQ A** function and apply the unknown burst frequency to channel A.
- b. Select **BURST** on the rear panel switch.
- c. Select a gate time less than the width of the burst.
- d. Select **COM** on the **SEP COM** front panel switch.
- e. Adjust channel A and channel B trigger levels for satisfactory triggering, i.e., a stable display.
- f. The counter displays the burst frequency.

605-11. Unknown burst frequency between 25 MHz and 125 MHz.

- a. Select the **FREQ A** function and apply the unknown burst frequency to channel A.
- b. Select **BURST** on the rear panel switch.
- c. Select a gate time less than the width of the burst.
- d. Apply a trigger signal at the burst repetition rate to channel B. The trigger should coincide with the start of the burst but not start before the burst. The pulse width of the trigger does not need to be as wide as the burst, only wide enough to trigger channel B.
- e. Adjust channel A and channel B trigger levels for satisfactory triggering, i.e., a stable display. The slope adjustment on channel B must be set at the polarity of the trigger, e.g., + slope for a positive trigger.
- f. The counter displays the burst frequency.

605-12. Unknown burst frequency greater than 125 MHz.

- a. Select the **FREQ C** function and apply the unknown burst frequency to channel C.
- b. Perform steps b through f in paragraph 605-11 above.

### 605-13. THEORY OF OPERATION

605-14. Time base frequency inputs to the multiplier as shown in Figure 605-1, are switch selectable between internal (10 MHz) or external (1, 5, or 10 MHz). The time base frequency is applied through U3 to a decade counter, U2 (board 1), wired for 5 and 10. The undivided input and the 5 and 10 outputs from U2 are applied to a data selector/multiplexer, U1 (board 1), which is programmed by three sections of U3 (board 1) for a 1 MHz output. The three NOR gate of U3 (board 1) used to program U1 are controlled by S1 (board 1) and SW + 12 (J6 pin 8). SW + 12 is grounded for EXT (rear panel EXT-INT switch) and is at +12V for INT. When INT is

selected, the three outputs from U3 go low, programming U1 for the D0 input which is the 10 output of U2. When EXT is selected, S1 controls which of the three outputs will be high to program U1 for either the D1 input (1), the D2 input (5), or the D4 input (10) so there will always be a 1 MHz output from U1 (board 1).

605-15. On board 2, the 1 MHz output from U1 (board 1) is multiplied to 10 MHz using a phase-locked oscillator. U3 is a phase comparator with the 1 MHz from board 1 applied to the reference input. The output of U3 controls the frequency of oscillation of U1. U1 oscillates at 10 MHz which is divided by a decade divider, U2, for application to the variable input of U3. The output of U1 (board 2) is used as the reference time base for the counter. Inside U3 are three operational blocks: a digital phase detector, a charge pump, and an amplifier. Pins 2 and 11 connect the output of the phase detector, D1 (1 MHz pulses), to the input of the charge pump, PD. The output of the charge pump, DF, is a pulse train whose average value increases or decreases to increase or decrease the frequency of the oscillator, U1. DF is connected to the input of the amplifier, A, through R4. The output of the amplifier is applied to the VTUNE input of U1. R4, R2, C4 and R5 make the amplifier an active integrator to average the output of the charge pump. R1 and C3 provide additional filtering. R3 sets the phase detector pulse width to a finite value to maintain loop gain.

605-16. Burst measurement operations are controlled by a D flip-flop, U4 and four NAND gates, U5, located on board 1. When normal operation is selected with the **BURST/NORMAL** rear panel switch, a low is applied to one input of U5-11 through J6 pin 9. U5-11 goes high and U5-8 goes low putting U4 in the preset condition (U4-5 high) enabling U5-3 to pass the 10 MHz reference frequency. When **BURST** is selected, J6 pin 9 is high and either channel A or C must be selected producing a high at J6 pin 5 (A + C). U5-11 goes low and U5-8 goes high removing the preset condition from U4. At the end of a measurement, **READY** (J6 pin 2) goes low, clearing U4. U4-5 goes low inhibiting the reference frequency by placing a low on one input of U5-3. When the 1953A is ready for another measurement, **READY** goes high. The first negative transition on XB (derived from the channel B input) clocks U4-5 high enabling U5-3 to pass the reference frequency. When the measurement is complete, **READY** goes low, inhibiting the reference frequency.

### 605-17. PARTS LIST

605-18. Table 605-1 gives a parts breakdown for the updated version (2 pcbs) of the External Time Base Multiplier. Refer to Section 5 for ordering information,

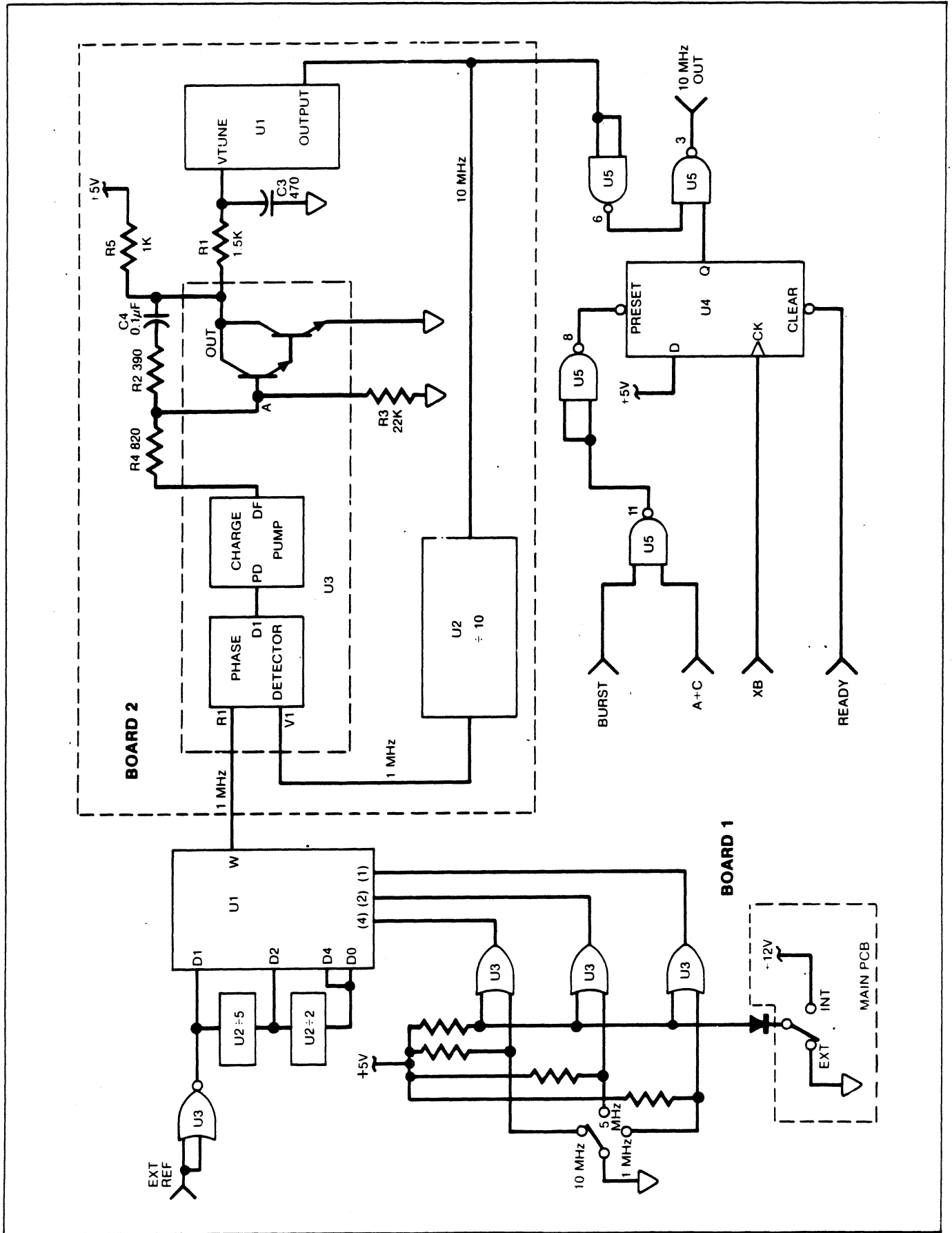

Figure 605-1. External Time Base Multiplier Simplified Schematic

Table 605-1. -05 Option, External Time Base Multiplier

ITEM NO.	DESCRIPTION	FLUKE STOCK NO.	MFG SPLY CODE	MFG PART NO. OR TYPE	TOT QTY	REC QTY	USE CDE
-05	EXTERNAL TIME BASE MULTIPLIER OPTION 05 FIGURE 605-2						
A7	MULTIPLIER PCB ASSEMBLY #1	467811	89536	467811	1		
A8	MULTIPLIER PCB ASSEMBLY #2	467621	89536	467621	1		

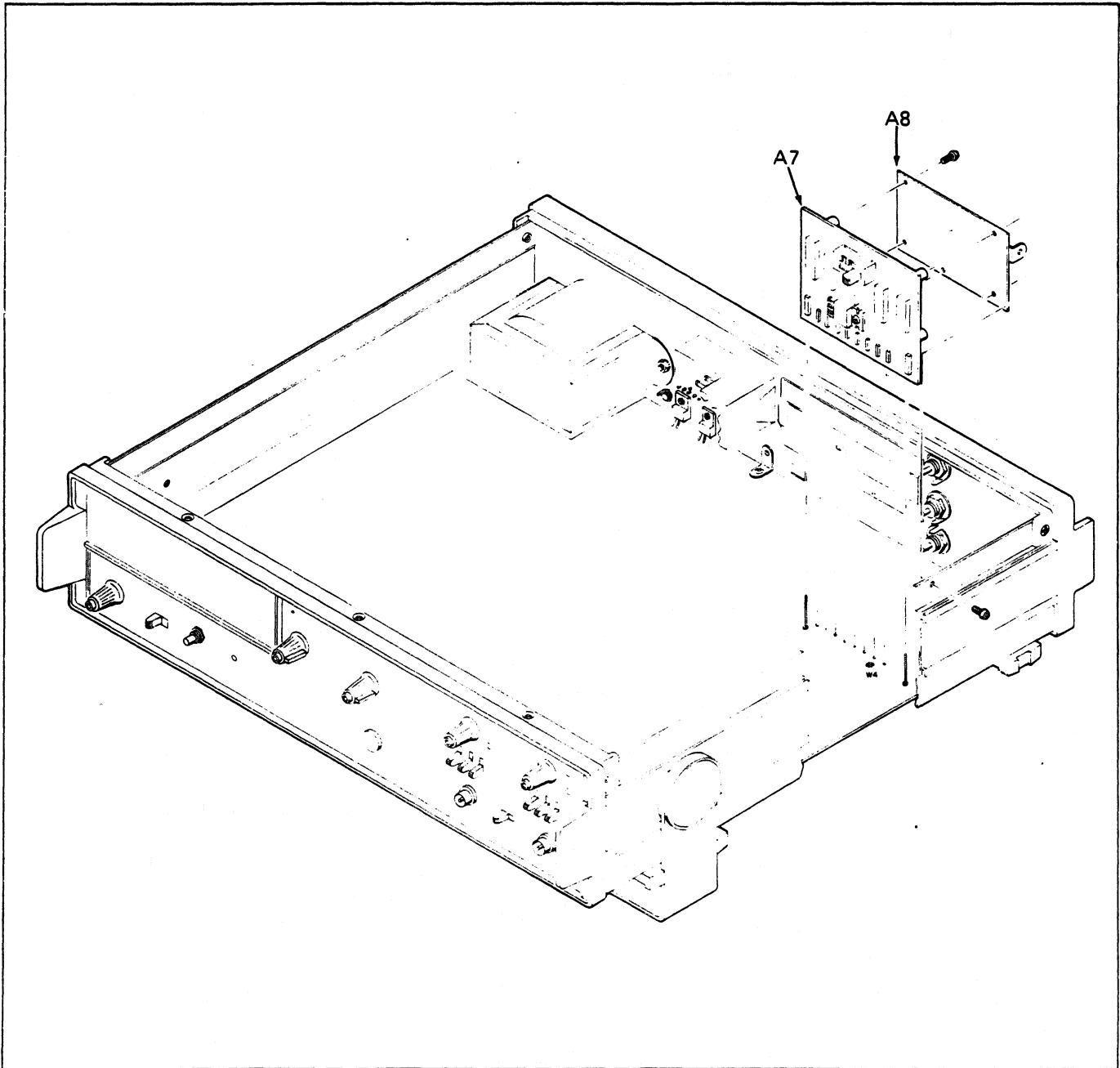

Figure 605-2. -05 Option, External Time Base Multiplier

Table 605-2. A7 and A8 Multiplier PCB Assembly

ITEM NO.	DESCRIPTION	FLUKE STOCK NO.	MFG SPLY CODE	MFG PART NO. OR TYPE	TOT QTY	REC QTY	USE CDE
A7	MULTIPLIER PCB ASSEMBLY #1 (1953A-4034) FIGURE 605-3	467811	89536	467811			REF
C1	CAP, TA, 10 UF +/-20%, 15V	193623	56289	196D106X0015KA1	3		
C2	CAP, TA, 10 UF +/-20%, 15V	193623	56289	196D106X0015KA1			REF
C3	CAP, TA, 10 UF +/-20%, 15V	193623	56289	196D106X0015KA1			REF
CR1	DIODE, SI HI-SWITCH	203323	07910	1N4448	1	1	
J6	CONNECTOR PIN, FEMALE, LARGE	149112	74970	105-0753	2		
	PIN, FEMALE, SMALL	375329	00779	85863-3	8		
L1	INDUCTOR, BEAD, 6-TURN	320911	89536	320911	2		
L2	INDUCTOR, BEAD, 6-TURN	320911	89536	320911			REF
R1	RES, COMP, 4.7K +/-5%, 1/4W	148072	01121	CB4725	4		
R2	RES, COMP, 4.7K +/-5%, 1/4W	148072	01121	CB4725			REF
R3	RES, COMP, 4.7K +/-5%, 1/4W	148072	01121	CB4725			REF
R4	RES, COMP, 4.7K +/-5%, 1/4W	148072	01121	CB4725			REF
S1	SWITCH, SLIDE	453183	34828	G-128-L	1		
U1	IC, TTL, DATA SELECTOR/MULTIPLEXER	393173	01295	SN74LS151	1	1	
U2	IC, TTL, DECADE COUNTER	402545	01295	SN74LS90N	1	1	
U3	IC, TTL, QUAD 2-INPUT NOT GATE	393041	01295	SN74LS02N	1	1	
U4	IC, TTL, DUAL D-TYPE EDGE-TRIGGERED F-F	310227	01295	SN7474N	1	1	
U5	IC, TTL, QUAD 2-INPUT NAND GATE	393033	01295	SN74LS00N	1	1	
U6	IC, LINEAR, VOLTAGE REGULATOR, +5V	355107	04713	MC7805PC	1	1	
A8	MULTIPLIER PCB ASSEMBLY #2 (1953A-4035) FIGURE 605-3	467621	89536	467621			REF
C1	CAP, TA, 10 UF +/-10%, 15V	193623	56289	196D106X0015KA1	3	1	
C2	CAP, CER 27 PF +/-2%, 100V	362749	72982	8121-A100-COG-270G	1		
C3	CAP, CER, 470 PF +/-10%, 1000V	368613	71590	DD471	1		
C4	CAP, POLYESTER FILM, 0.1 UF +/-10%, 100V	393439	73449	C280MAH/A100K	1		
C5	CAP, TA, 10 UF +/-10%, 15V	193623	56289	196D106X0015KA1			REF
C6	CAP, TA, 10 UF +/-10%, 15V	193623	56289	196D106X0015KA1			REF
L1	INDUCTOR, BEAD, 6-TURN	320911	89536	320911	3		
L2	INDUCTOR, BEAD, 6-TURN	320911	89536	320911			REF
L3	INDUCTOR, BEAD, 6-TURN	320911	89536	320911			REF
R1	RES, COMP, 1.5K +/-5%, 1/4W	148031	01121	CB1525	1		
R2	RES, COMP, 390 +/-5%, 1/4W	147975	01121	CB3915	1		
R3	RES, COMP 22K +/-5%, 1/4W	148130	01121	CB2235	1		
R4	RES, COMP, 820 +/-5%, 1/4W	148015	01121	CB8215	1		
R5	RES, COMP, 1K +/-5%, 1/4W	148023	01121	CB1025	1		
U1	IC, TTL, DUAL VOLT-CONTROLLED MV	320713	04713	MC4024P	1	1	
U2	IC, TTL, DECADE COUNTER	402545	01295	SN74LS90N	1	1	
U3	IC, TTL, PHASE-FREQUENCY DETECTOR	320721	04713	MC4044P	1	1	

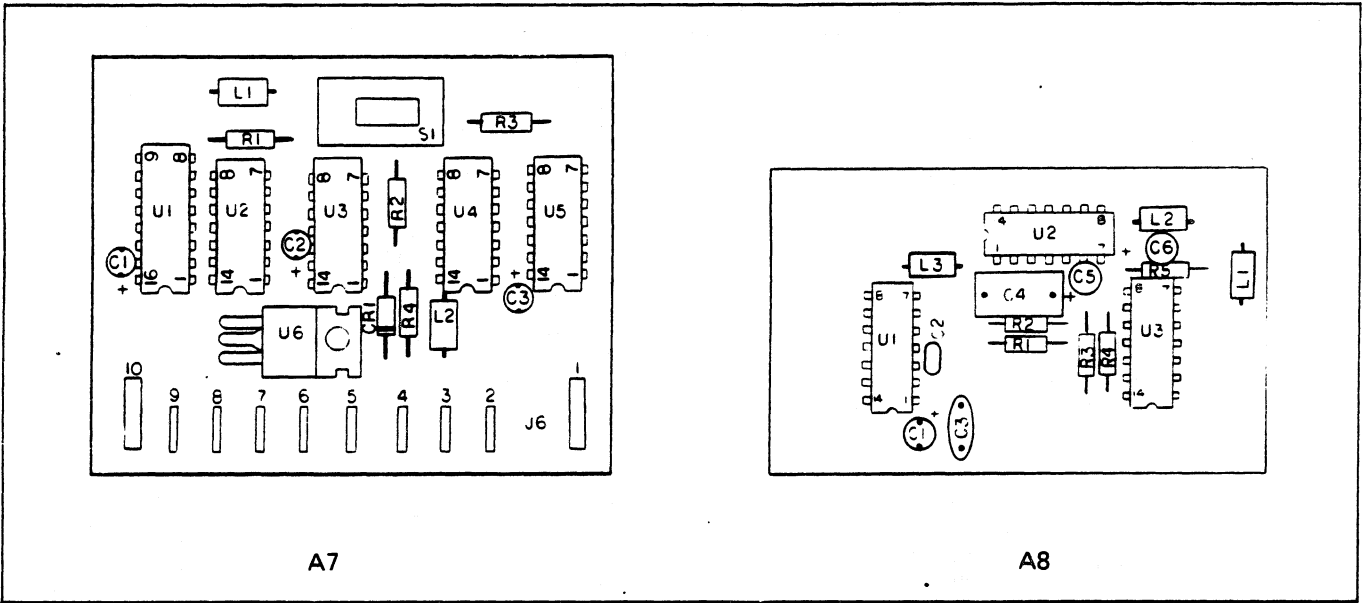

Figure 605-3. A7 and A8 Multiplier PCB Assembly

## Option -07 520 MHz Prescaler

### 607-1. INTRODUCTION

607-2. The channel C input, of the Model 1953A is intended for use with an optional frequency-prescaler. Option -07 is a prescaler which extends the operating range of the counter to 520 MHz. This prescaler has a frequency range extending from 50 MHz to 520 MHz with a specified sensitivity of 15 mV rms throughout the range. The option comprises a plug-in PCB assembly, a front panel mounted BNC connector, and the related components required both to adjust the power supply for correct operating voltages and to compensate the counter circuitry for the prescaling divisor. Option -07 must be ordered factory installed in the 1953A. It is not field installable.

### 607-3. THEORY OF OPERATION

607-4. The main function of the prescaler is to reduce the frequency of the input signal to below 130 MHz for application to the main gate and decade counter. The prescaler also provides the necessary conditioning of the input signal to provide sufficient gain and the proper waveshaping. The frequency division factor for the prescaler is four.

607-5. As shown in Figure 607-1, the input signal is fed through an input protection fuse, F1, to the input of the first amplifier. Input limiting is provided by CR1 and CR2. The output of the second amplifier is applied to the input of a divider circuit which divides by a factor of four to reduce the input frequency to below 130 MHz. The prescaled signal, amplified by U1 and U2, divided and shaped by U3, is then fed to the Main PCB Assembly for application to the main gate and decade counter.

607-6. The output of the second amplifier is also fed to an AGC circuit where it is rectified by CR7, filtered by C11 R12 and amplified by U4. The dc output of U4 is the AGC signal and controls the overall input signal level by

means of CR5 and C4. Diode CR5 is a PIN-type diode whose impedance varies with the amount of bias applied. When AGC signal decreases due to a reduced input signal level the bias across CR5 is reduced causing an increase in impedance. This action results in a reduced shunting action of the input signal by CR5 and C4.

607-8. The AGC signal is also used to block the output of the prescaler when the input is below minimum acceptable amplitude. When this occurs, Q1 turns off and Q4 turns on to clamp the output to +5 volts.

### 607-9. PERFORMANCE CHECKS

607-10. The performance check for the 520 MHz prescaler is actually a sensitivity check made at the upper and lower frequency limits. Proceed as follows:

- a. Connect a 1 GHz RF generator, terminated into 50 ohms, to a T-connector on the CHANNEL C input. Set the generator output for 50 MHz at approximately 15 mV rms.
- b. Connect the RF millivoltmeter (refer to Table 4-1) to the T-connector on the input of the prescaler.
- c. Adjust the generator output for a reading of 15 mV rms on the RF millivoltmeter.
- d. Confirm that the counter reads 50 MHz  $\pm$  generator accuracy.
- e. Change the generator output to 520 MHz and adjust the output for 15 mV rms on the RF millivoltmeter.
- f. Confirm that the counter reads 520 MHz  $\pm$  generator accuracy.

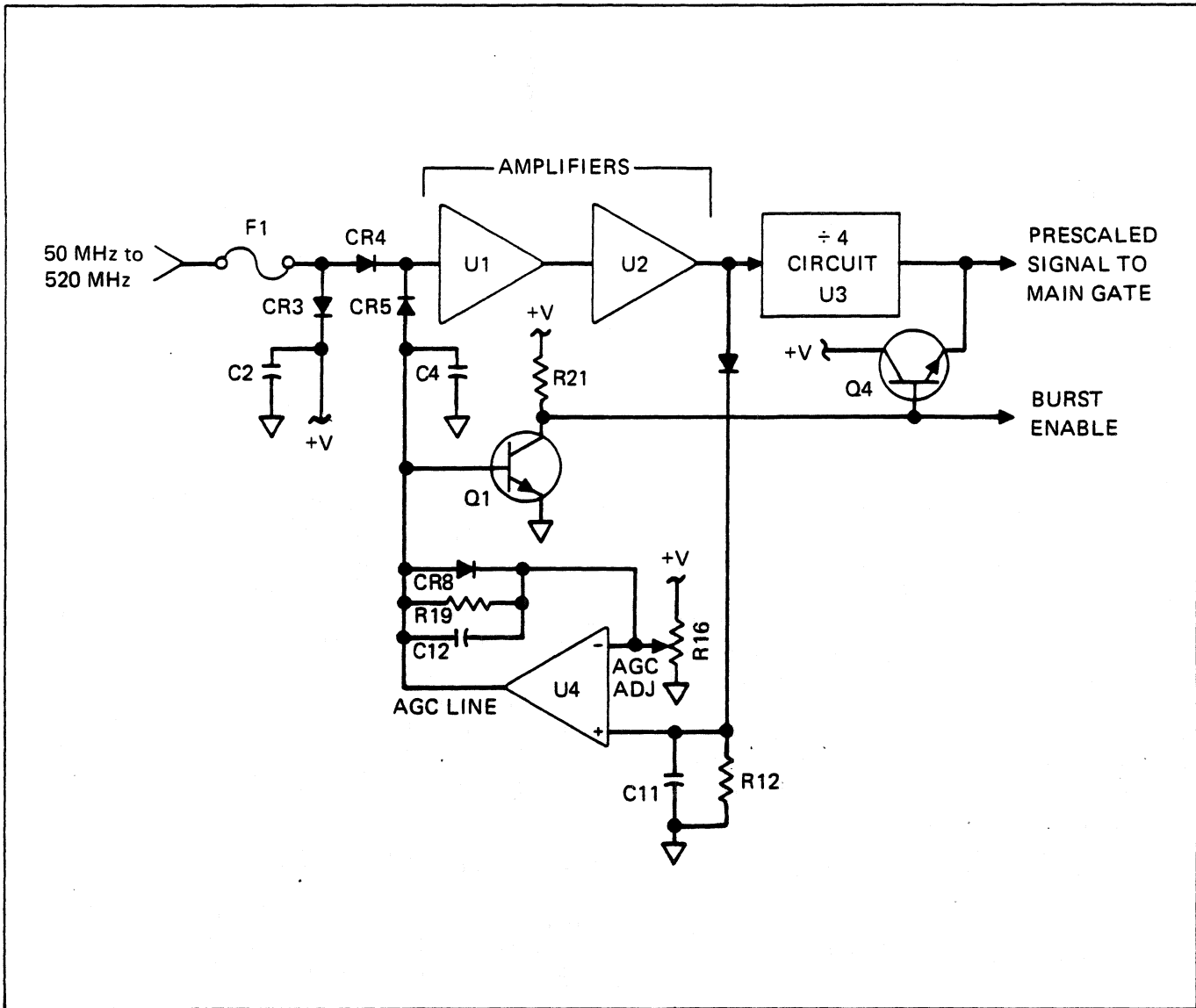

Figure 605-1. 520 MHz Prescaler Block Diagram

### 607-11. CALIBRATION

607-12. Calibration of the prescaler amounts to adjustment of the AGC level control located on the top edge of the Prescaler PCB assembly. Proceed as follows:

- a. Remove the top dust cover from the instrument.
- b. Energize the counter and connect the RF generator to the CHANNEL C input connector. Select an output of 100 MHz at approximately 15 mV rms.
- c. On the counter, adjust the AGC control (R15) to a midpoint which produces a stable display.

d. Reduce the input signal level until the display becomes unstable.

e. Readjust the AGC control until the display is again stable.

f. Repeat steps d and e until no additional sensitivity can be achieved.

### 607-13. LIST OF REPLACEABLE PARTS

607-14. Table 607-1 is a list of replaceable parts for the 520 MHz Prescaler. Option -07. Refer to Section 5 for an explanation of the column entries.



Table 607-1. -07 Option, 520 MHz Prescaler

ITEM NO.	DESCRIPTION	FLUKE STOCK NO.	MFG SPLY CODE	MFG PART NO. OR TYPE	TOT QTY	REC QTY	USE CDE
-07	520 MHZ PRESCALER, OPTION -07 FIGURE 607-2						
A9	520 MHZ PRESCALER PCB ASSEMBLY	396291	89536	396291	1		
C91	CAP, ELECT, 470 UF $\pm 10/+100\%$ , 40V	403030	99392	39CS50FJ52	1	1	
H1	GROUND CLIP	462101	89536	462101	1		
U13	IC, TTL, 4-BIT BINARY COUNTER	320739	01295	SN7493N	1		
U91	DIODE BRIDGE	296509	09423	FB200	1		
U93	IC, LINEAR, VOL REG	429225	07263	F7817UC	1	1	
W1	CABLE ASSEMBLY (FRONT PANEL TO PCB)	406942	89536	406942	1		

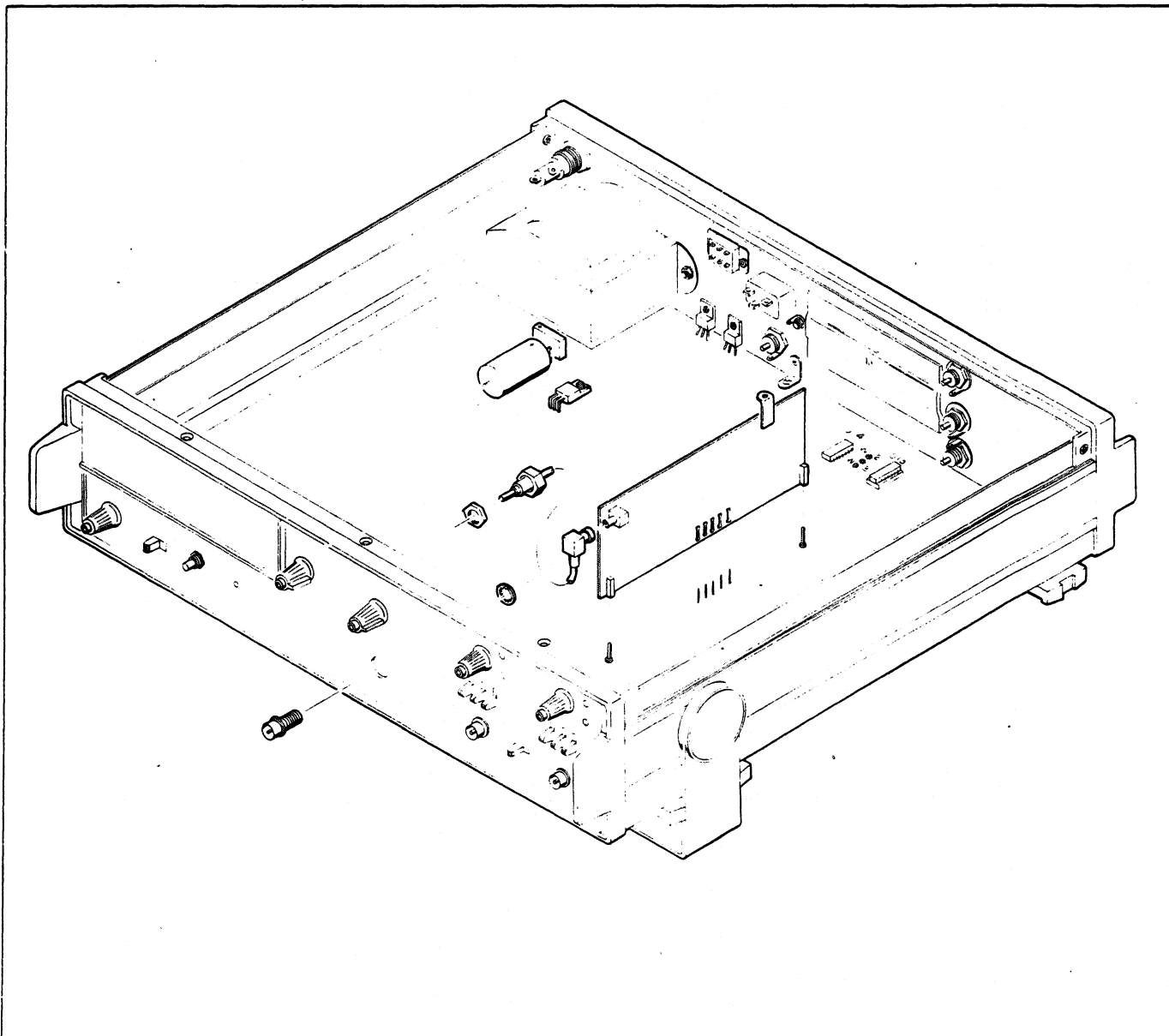

Figure 607-2. -07 Option, 520 MHz Prescaler

Table 607-2. A9 520 MHz Prescaler PCB Assembly

ITEM NO.	DESCRIPTION	FLUKE STOCK NO.	MFG SPLY CODE	MFG PART NO. OR TYPE	TOT QTY	REC QTY	USE CDE
A9	520 MHZ PRESCALER PCB ASSEMBLY (1953A-4026T) FIGURE 607-3	396291	89536	396291			REF
C1	CAP, CER, .001 UF +/-20%, 100V	402966	72982	8121-A100-W5R102M	6		
C2	CAP, CER, .001 UF +/-20%, 100V	402966	72982	8121-A100-W5R102M			REF
C3	CAP, CER, 1000 PF +/-10%, 500V	357806	71590	CF102	3		
C4	CAP, CER, .001 UF +/-20%, 100V	402966	72982	8121-A100-W5R102M			REF
C5	CAP, CER, 0.01 UF +/-20%, 100V	407361	72982	8121-A100-W5R-103M	2		
C6	CAP, CER, .001 UF +/-20%, 100V	402966	72982	8121-A100-W5R102M			REF
C7	CAP, CER, .001 UF +/-20%, 100V	402966	72982	8121-A100-W5R102M			REF
C8	CAP, CER, 22 PF +/-20%, 500V	369157	72982	831-000-C060-220M	1		
C9	CAP, CER, .001 UF +/-20%, 100V	402966	72982	8121-A100-W5R102M			REF
C10	CAP, CER, 0.01 UF +/-20%, 100V	407361	72982	8121-A100-W5R-103M			REF
C11	CAP, CER, 1000 PF +/-10%, 500V	357806	71590	CF102			REF
C12	CAP, CER, 1000 PF +/-10%, 500V	357806	71590	CF102			REF
C13	CAP, CER, 0.01 UF +/-20%, 100V	149153	56289	C023B101F103M	2		
C14	CAP, CER, 0.01 UF +/-20%, 100V	149153	56289	C023B101F103M			REF
C15	CAP, CER, 2700 PF +/-20%, 100V	362889	80031	2222-630-01-272	1		
C16	CAP, TA, 10 UF +/-20%, 15V	193623	56289	196D106X0015KA1	1		
CR1	DIODE, SI	203323	07919	1N4448	2		
CR3	DIODE, SI	402776	28480	HP5082-3379	3		
CR4	DIODE, SI	402776	28480	HP5082-3379			REF
CR5	DIODE, SI	402776	28480	HP5082-3379			REF
CR6	DIODE, HOT CARRIER	369595	07263	FH1100	2		
CR7	DIODE, HOT CARRIER	369595	07263	FH1100			REF
CR8	DIODE, SI	203323	07919	1N4448			REF
CR9	DIODE, ZENER	159798	07263	1N751A	1		
F1	FUSE, .2 AMP	370577	75915	273200	2		
F2	FUSE, .2 AMP	370577	75915	273200			REF
J5	CONNECTOR						
	PIN, FEMALE, LARGE	149112	74270	105-0753	2		
	PIN, FEMALE, SMALL	375329	00779	85863-3	6		
J20	CONNECTOR, COAXIAL	353243	98291	51-053-000	1		
Q1	XSTR, SI, NPN	177105	07263	2N3565	2		
Q2	XSTR, SI, PNP	352369	07263	2N4403	1		1
Q3	XSTR, SI, NPN	177105	07263	2N3565			REF
Q4	XSTR, SI, NPN	369645	07263	2N4274	1		
R1	RES, COMP, 82 OHMS +/-5%, 1/4W	149484	01121	CB8205	2		
R2	RES, COMP, 22 OHMS +/-5%, 1/4W	147884	01121	CB2205	1		
R3	RES, COMP, 470 OHMS +/-5%, 1/4W	147983	01121	CB4715	2		
R4	RES, COMP, 680 OHMS +/-5%, 1/4W	148007	01121	CB6815	1		
R5	RES, COMP, 1K +/-5%, 1/4W	148023	01121	CB1025	4		
R6	RES, COMP, 1K +/-5%, 1/4W	148023	01121	CB1025			REF
R7	RES, COMP, 2.7K +/-5%, 1/4W	170720	01121	CB2725	4		
R8	RES, COMP, 68 +/-5%, 1/4W	147918	01121	CB6805	1		
R9	RES, 10K +/-5%, 1/4W	148106	01121	CB1035	3		
R10	RES, COMP, 2.7K +/-5%, 1/4W	170720	01121	CB2725			REF
R11	RES, COMP, 470 OHMS +/-5%, 1/4W	147983	01121	CB4715			REF
R12	RES, COMP, 2.7K +/-5%, 1/4W	170720	01121	CB2725			REF
R13	RES, COMP, 2.7K +/-5%, 1/4W	170720	01121	CB2725			REF

Table 607-2. A9 520 MHz Prescaler PCB Assembly (cont)

ITEM NO.	DESCRIPTION	FLUKE STOCK NO.	MFG SPLY CODE	MFG PART NO. OR TYPE	TOT QTY	REC QTY	USE CDE
R14	RES, COMP, 82 OHMS +/-5%, 1/4W	149484	01121	CB8205	REF		
R15	RES, 10K +/-5%, 1/4W	148106	01121	CB1035	REF		
R16	RES, VAR, COMP, 10K +/-20%, 20W	385393	54869	PT10(25)10K	1	1	
R17	RES, COMP, 1K +/-5%, 1/4W	148023	01121	CB1025	REF		
R18	RES, COMP, 1M +/-5%, 1/4W	182204	01121	CB1055	1		
R19	RES, COMP, 330K +/-5%, 1/4W	192948	01121	CB3345	1		
R20	RES, 10K +/-5%, 1/4W	148106	01121	CB1035	REF		
R21	RES, COMP, 1K +/-5%, 1/4W	148023	01121	CB1025	REF		
R22	RES, COMP, 100K +/-5%, 1/4W	148149	01121	CB1045	1		
U1	IC, LINEAR, VHF/UHF, WIDE BAND AMPLIFIER	392977	35784	OM185	1	1	
U2	IC, LINEAR, 5-400 MHZ AMPLIFIER	402594	24539	GPD402	1	1	
U3	IC, ECL, DIVIDE BY 4 COUNTER	444034	07263	F11C05PC	1	1	
U4	IC, OP AMP	402750	07263	741TC	1	1	
XF1	FUSE SOCKET, SPRING TYPE	403642	00779	50863-8	4		
XF2	FUSE SOCKET, SPRING TYPE	403642	00779	50863-8	REF		
XU3	SOCKET, IC, 14-PIN DIP	291542	00779	583527	1		

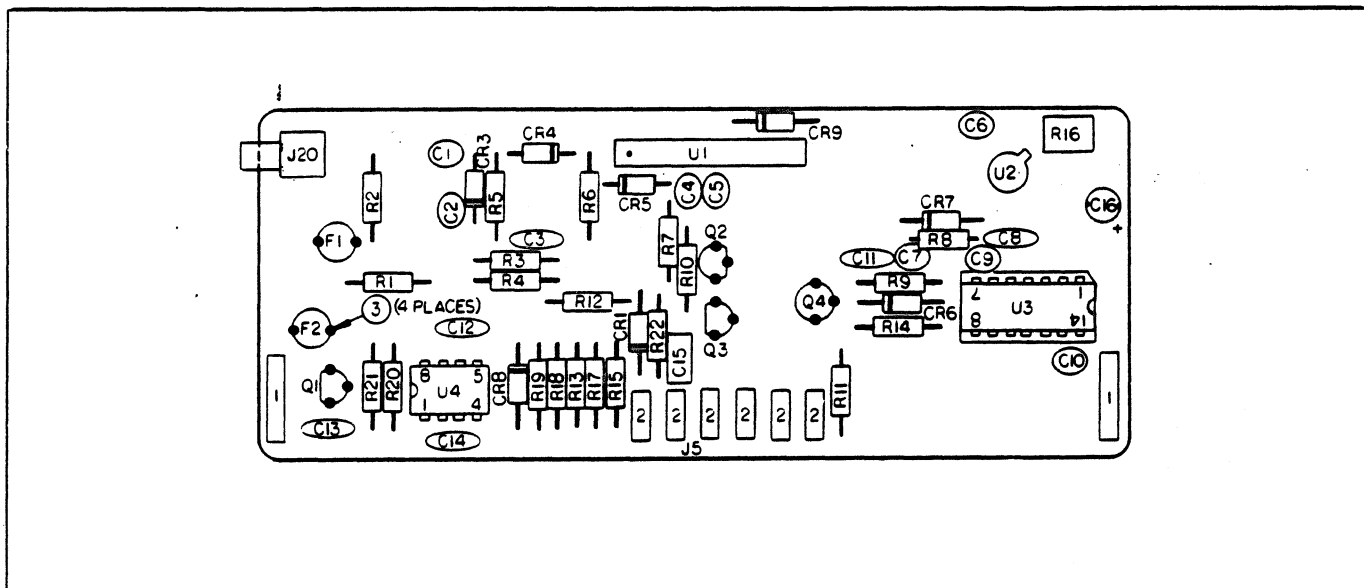
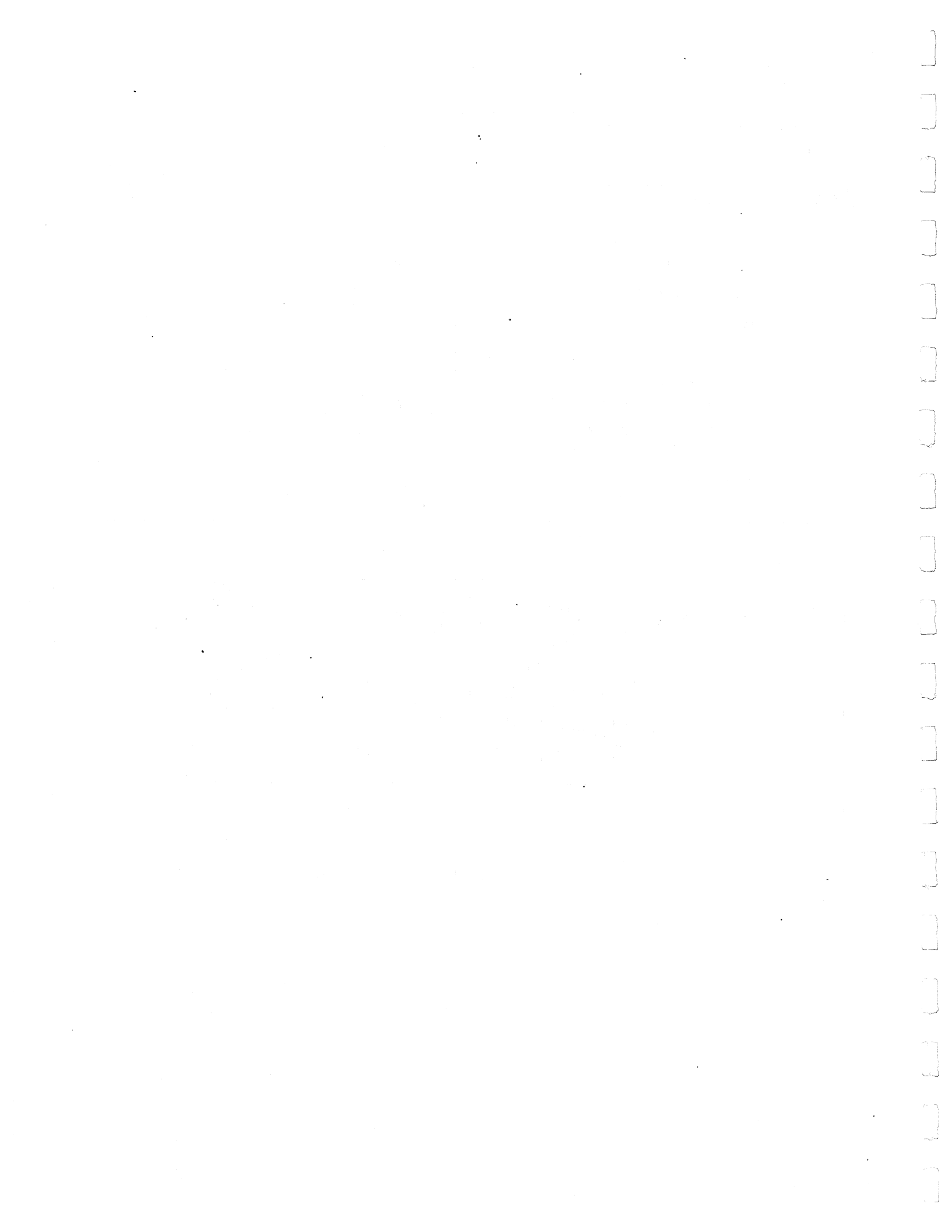

Figure 607-3. A9 520 MHz Prescaler PCB Assembly



## Option -10 Oven-Stabilized Time Base

### 610-1. INTRODUCTION

610-2. The Option -10 Oven-Stabilized Time Base affords a higher degree of time base stability to the Model 1953A than either of the TCXO's available. The specifications for Option -10 are given in Section 1. The unit is installed on the inside of the rear panel of the 1953A and requires re-arrangement of the instrument's power switching. A switch installed on the rear panel of the 1953A is used to activate the heaters independently of

the power switch for the instrument itself. The option must be ordered factory-installed in the 1953A when the instrument is purchased; it is not field installable.

### 610-3. LIST OF REPLACEABLE PARTS

610-4. A list of replaceable parts for the Oven-Stabilized Time Base is given in Table 610-1. Refer to Section 5 for ordering information.

Table 610-1. -10 Option, Oven-Stabilized Time Base

ITEM NO.	DESCRIPTION	FLUKE STOCK NO.	MFG SPLY CODE	MFG PART NO. OR TYPE	TOT QTY	REC QTY	USE CDE
-10	OVEN-STABILIZED TIME BASE, OPTION -10 FIGURE 610-1						
C91	CAP, ELECT, 2100 UF -10/+100%, 35V	370742	80031	3050JJ12U035	1	1	
C122	CAP, TA, 10 UF +/-20%, 15V	193623	56289	196D106X0015KA4	1		
C123	CAP, TA 10 UF +/-20%, 35V	417683	56289	196D106X0035PE4	1		
K1	RELAY, REED, 12V	352658	71707	UF-40063	1		
MP1	DECAL (NOT USED WITH -11 OR -12 OPTIONS)	428052	89536	428052	1		
R121	RES, VAR, 10K +/-20%, 1/2W	267880	11236	190PC103B	1	1	
S121	SWITCH, TOGGLE, DPDT	327734	09353	7201LHPZG1	1		
U7	OSCILLATOR	441170	12020	73-43	1		
U91	RECTIFIER BRIDGE	296509	09423	FB200	1		
U101	VOLTAGE REGULATOR, +18V	443713	89536	443713	1		
W1	CABLE ASSEMBLY	443705	89536	443705	1		

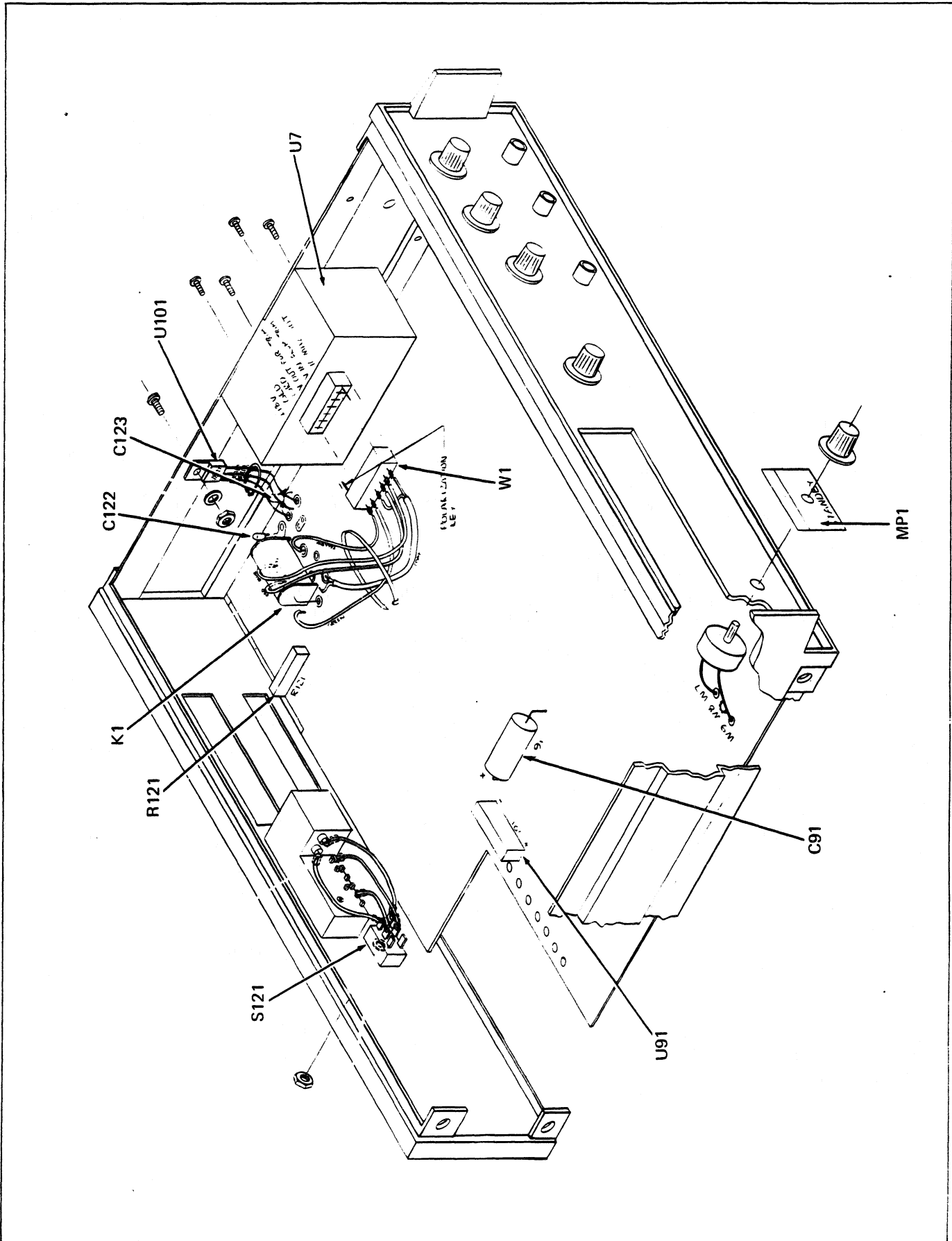

Figure 610-1. -10 Option, Oven-Stabilized Time Base

## Option -11 Basic Remote Control Unit

### 611-1. INTRODUCTION

611-2. Option -11 is a remote control unit allowing remote operation of the 1953A. Option -11 is the Basic Remote Control Unit, permitting control of the essential functions required for remote operation of the 1953A.

### 611-3. BASIC REMOTE CONTROL UNIT

611-4. Option -11 is the basic remote programming option. It consists of a single pcb and ribbon-cable assembly. When installed it allows the 1953A to be operated from a remote station. The option allows full Range and Function selection; control of the trigger edge selectors Slope A and Slope B, and a "Front panel lockout" command (low true) which disables the manual front panel controls corresponding to these functions and places the functions under remote control. In addition, this option provides for remote analog control of the channel A and B trigger levels. When under remote control the 1953A always operates in a single-shot mode, and the Cycle Rate and CONT TRIG controls are disabled. All inputs are TTL compatible, low true commands that can also be controlled by contact-closure to ground.

### 611-5. INSTALLATION

611-6. Remote control Option -11 can be installed at the factory upon request when ordering the 1953A, it is not field installable.

### 611-7. OPERATION

611-8. The following lists and Table 611-1 give the relevant data for operating the 1953A in the Basic Remote Control mode.

#### a. Function (One line of 7 to be low)

FREQ A	(A)	fan-in = 1
FREQ C	(C)	fan-in = 1
FREQ A/B	(A/B)	fan-in = 1
PERIOD A	(PA)	fan-in = 1
TIME INTERVAL	(TI)	fan-in = 1
A GTD BY B	(A x B)	fan-in = 1
CHECK	(CH)	fan-in = 1

#### b. Range (One line of 6 to be low)

0.1 ms	10 <sup>0</sup>	0.1 $\mu$ s	(1)	fan-in = 1
1 ms	10 <sup>1</sup>	1 $\mu$ s	(2)	fan-in = 1
10 ms	10 <sup>2</sup>	10 $\mu$ s	(3)	fan-in = 1
0.1s	10 <sup>3</sup>	0.1 ms	(4)	fan-in = 1
1s	10 <sup>4</sup>	1 ms	(5)	fan-in = 1
10s	10 <sup>5</sup>	10 ms	(6)	fan-in = 1

#### c. Slope (One line per channel)

Slope A (EXT SA) low = positive fan-in = 3

Slope B (EXT SB) low = positive fan-in = 1

#### d. Reset (One line, low true)

When the reset line is brought low and released, a new measurement sequence will start without resetting the display. This same line is used on DOU option.

- e. The following outputs are provided:
1. Power Sense (SP) high (on) A+5 Volt level indicates that the instrument is on.
  2. Overflow Status (OVFL) high trueOutputs a high level when an overflow condition exists.
  3. System Ready low true signals the completion of a measurement cycle. (Note that the System Ready appears about 3 ms before the DOU ready.)
  4. Channels A and B signal outputs (SMA; SMB) TTL. These are not normally connected, except by special request. To connect these outputs, jumper both W5 and W6 on the Main PCB.

#### CAUTION

**These outputs should be connected only in applications where the maximum channel A or B count frequency is below 25 MHz. Exposed wiring external to the unit should be kept to a minimum to prevent signal feedback.**

- f. Also provided are two Analog Trigger Level input/outputs (ATL-A and ATL-B) which can be used for measuring the internally-generated trigger levels with an external voltmeter, or for defining the

trigger levels from an external dc source. The input impedance is 20k, and the response time is 2 ms. The usable range is  $\pm 1$  volt, and the maximum safe level is  $\pm 5$  volts. Operation with X10 attenuation extends the apparent range to  $\pm 10V$ .

- g. Although the counter will operate in a single-shot mode when under remote control, automatic measurement cycling can be established by connecting the System Ready output into the Reset input. The cycle rate will be the maximum attainable with the instrument and will be equal to the gate time plus the conversion time (50  $\mu s$ ).

### 611-9. EXTERNAL CONNECTIONS

611-10. The input commands needed to operate the Remote Control Unit are provided in Table 611-1. The pin numbers identified in the table correspond to the pin numbers on the 50 pin connector supplied with the option.

### 611-11. LIST OF REPLACEABLE PARTS

611-12. Table 611-2 is a list of replaceable parts for the Remote Control Unit, Option -11. Refer to Section 5 for an explanation of the column entries.

Table 611-1. RCU I/O Connections

PIN	SIGNAL	DESCRIPTION		FAN IN*
		LOW LOGIC EQUALS	HIGH LOGIC EQUALS	
B	ATL A	} Analog Tigger Level A Input / Trigger Level Monitor Output		
C	ATL B			
P	SA	+ Slope	- Slope	1
R	SYSTEM READY	System Ready	System Not Ready	
U	PA	Period A Function		1
V	4	0.1 ms Range		1
W	2	1.0 ms Range		1
X	AXB	A GTD by B Function		1
Z	6	10s Range		1
a	OVFL		Overflow Output	
b	A	FREQ A Function		1
c	SR	Sense Remote		
3	SP		Positive (Down on)	



Table 611-1. RCU I/O Connections (cont)

PIN	SIGNAL	DESCRIPTION		FAN IN
		LOW LOGIC EQUALS	HIGH LOGIC EQUALS	
12	SMA	TTL Output Equal to CHL-A Input	Not Normally Connected	
13	SMB	TTL Output Equal to CHL-B Input	Connected	
14	SB	+ Slope	- Slope	1
17	C	FREQ C Function		1
18	TI	T.I. A-B Function		1
19	1	0.1 ms Range		1
20	Remote EXT	Front Panel Lockout		5
21	A/B	FREQ A/B Function		1
22	5	1.0s Range		1
23	EXT-RESET	Resets Counter		
24	3	10 ms Range		1
25	Ground			

\* TTL fan-ins are given where relevant. The remaining inputs are CMOS compatible with internal 100 k $\Omega$  pull-up to +5 volts.

Table 611-2. -11 Option, Basic Remote Control Unit

ITEM NO.	DESCRIPTION	FLUKE STOCK NO.	MFG SPLY CODE	MFG PART NO. OR TYPE	TOT QTY	REC QTY	USE CDE
	BASIC REMOTE CONTROL UNIT, OPTION -11						
	FIGURE 611-1						
A10	BASIC RCU PCB ASSEMBLY	405563	89536	405563	1		
MP1	COVER, CONNECTOR PORT, REAR PANEL	398016	89536	398016	1		
MP2	CONNECTOR KIT (NOT SHOWN)	410241	89536	410241	1		
MP3	REMOTE DECAL	408617	89536	408617	1		
S121	SWITCH, TOGGLE, DPDT (INSTALLED ON REAR PANEL)	327734	09353	7201LHP2G1	1	1	

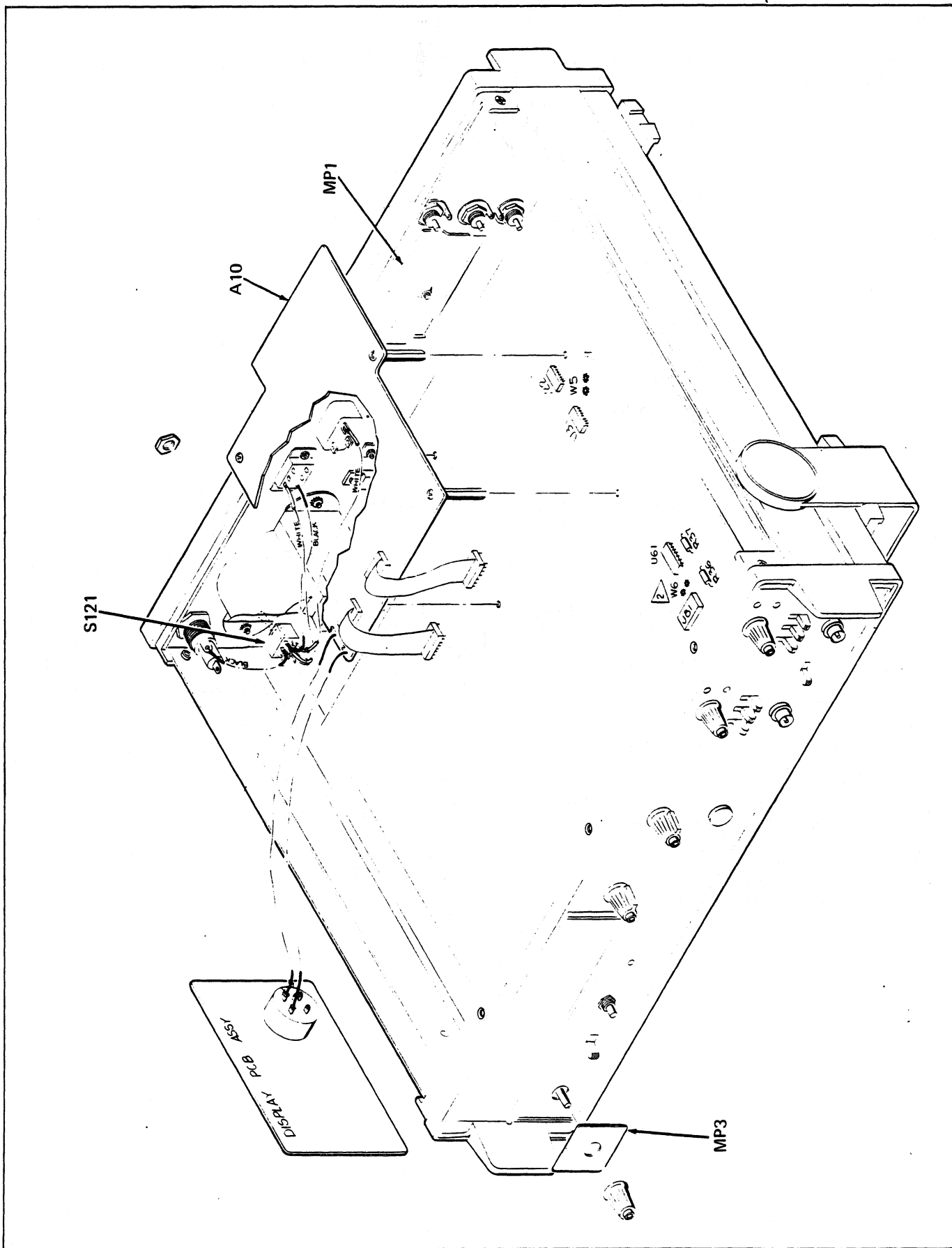

Figure 611-1. -11 Option, Basic Remote Control Unit

Table 611-3. A10 Basic Remote Control Unit PCB Assembly

ITEM NO.	DESCRIPTION	FLUKE STOCK NO.	MFG SPLY CODE	MFG PART NO. OR TYPE	TOT QTY	REC QTY	USE CDE
A10	BASIC REMOTE CONTROL UNIT PCB ASSEMBLY (1953A-4029T) FIGURE 611-2	405563	89536	405563	REF		
C711	CAP, TA, 10 UF +/-20%, 15V	193623	56289	196D106X0015KA4	1		
C712	CAP, CER, 0.002 UF +/-GMV, 1 KV	105569	71590	DA140-139CB	1		
CR702	DIODE, SI	203323	07919	1N4448	4	1	
CR703	DIODE, SI	203323	07919	1N4448	REF		
CR704	DIODE, SI	203323	07919	1N4448	REF		
CR705	DIODE, SI	203323	07919	1N4448	REF		
J81	FLAT CABLE ASSEMBLY	393520	08261	5142-006	2		
J82	FLAT CABLE ASSEMBLY	393520	08261	5142-006	REF		
R751	RES, COMP, 100 OHMS +/-5%, 1/4W	147926	01121	CB1015	2		
R752	RES, COMP, 82 OHMS +/-5%, 1/4W	149484	01121	CB8205	2		
R753	RES, COMP, 82 OHMS +/-5%, 1/4W	149484	01121	CB8205	REF		
R758	RES, COMP, 390 +/-5%, 1/4W	147975	01121	CB3915	1		
R759	RES, COMP, 4.7K +/-5%, 1/4W	148072	01121	CB4725	3		
R760	RES, COMP, 4.7K +/-5%, 1/4W	148072	01121	CB4725	REF		
R762	RES, COMP, 4.7K +/-5%, 1/4W	148072	01121	CB4725	REF		
R763	RES, COMP, 100 OHMS +/-5%, 1/4W	147926	01121	CB1015	REF		
U711	IC, TTL, TRI-STATE, HEX BUFFER	408146	12040	DM8095N	3	1	

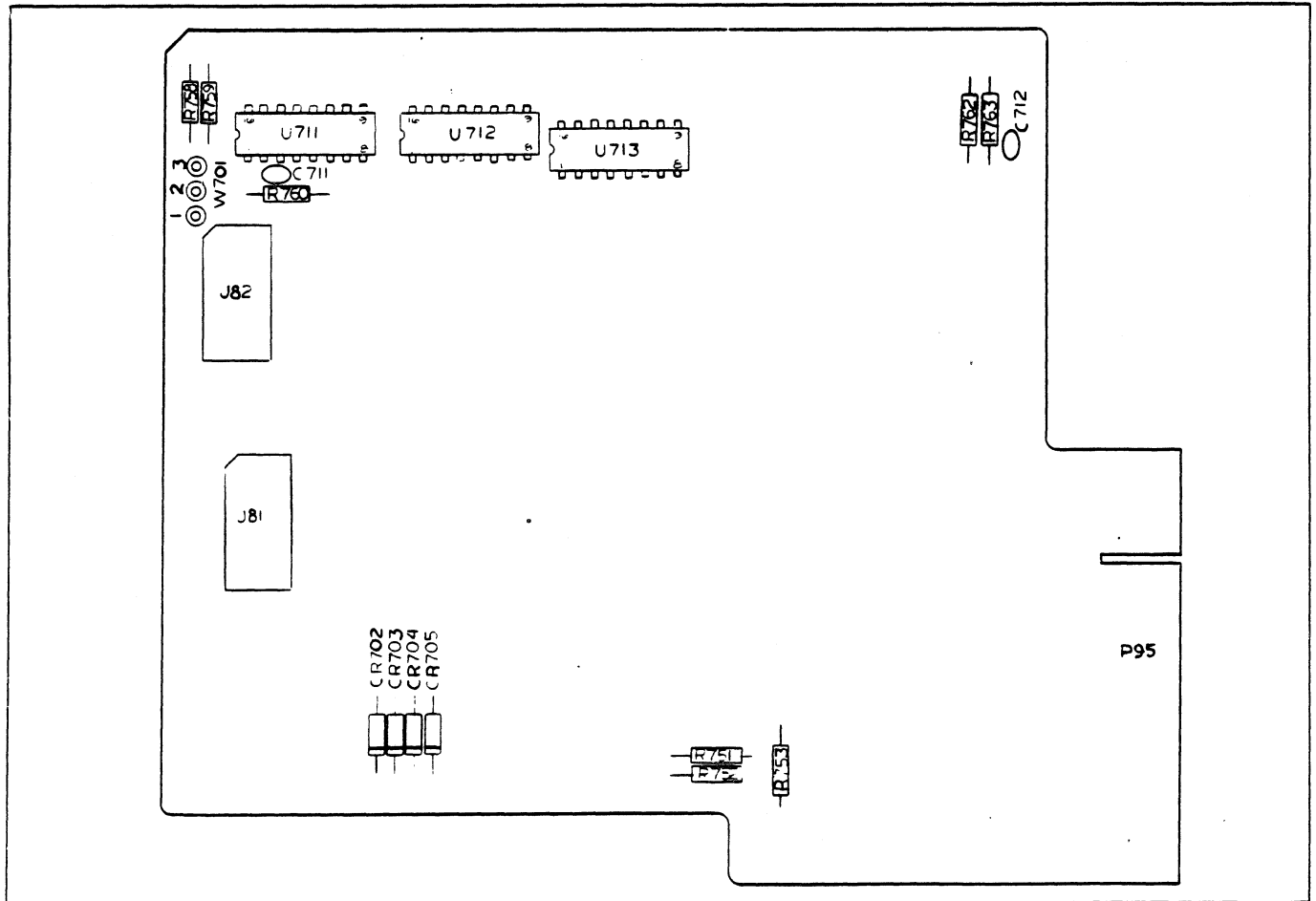
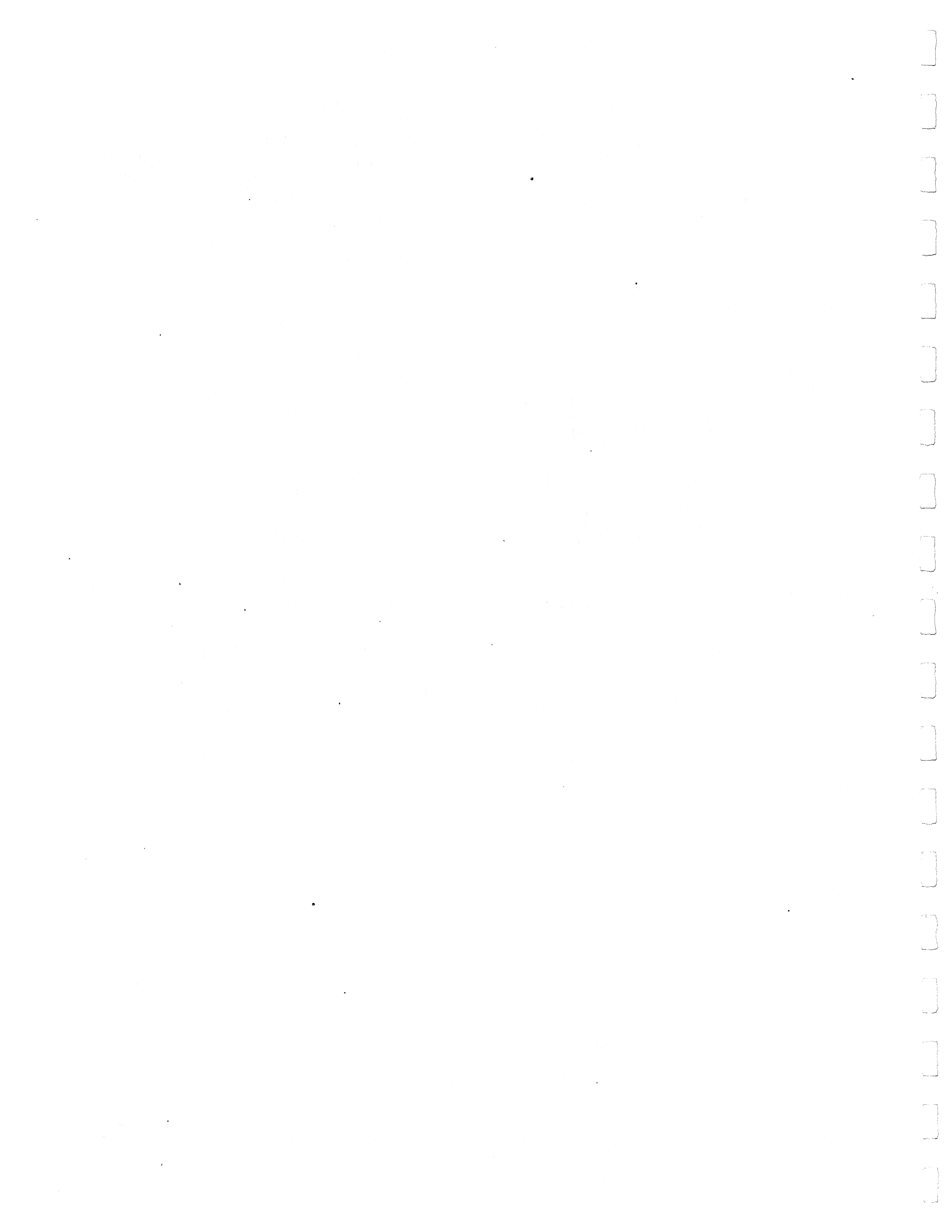

Figure 611-2. A10 Basic Remote Control Unit PCB Assembly



## Option -12 Full Remote Control Unit

### 612-1. INTRODUCTION

612-2. Option -12 is a remote control unit allowing remote operation of the 1953A. Option -12 is the Full Remote Control Unit, comprising the same features as the -11 Option including, in addition, the remaining functions necessary for complete remote digital control of the 1953A.

### 612-3. FULL REMOTE CONTROL UNIT

612-4. Option -12 includes all of the programming features of the Option -11 plus remote control of the AC/DC coupling, attenuation selectors, separate/common input status between channels A and B, and the trigger levels of channel A and B. The Basic configuration allows full range and function selection, control of trigger edge selectors Slope A and Slope B, and a "Front Panel Lockout" command to disable the manual front panel controls corresponding to those functions to place them under exclusive remote control. Under remote control, the 1953A operates in a single-shot mode and the Cycle Rate and CONT/TRIG controls are disabled.

612-5. Two internal D/A converters are used for programming the trigger levels over a -1 to +1 volt range in 10 mV steps. A separate local trigger disable allows control of the local trigger under remote control operations. Two BCD digits, plus a sign, are provided for each channel (A and B). All analog function switches are operated by means of relays working from TTL or contact level closures. No inputs should be forced low when the system is used in the local operating mode.

### 612-6. INSTALLATION

612-7. Option -12 requires installation at the factory. The option includes three PCB assemblies, RCU 1, RCU 2 and RCU 3.

### 612-8. OPERATION

612-9. The following lists and Table 612-1 give the relevant data for operating the 1953A in the Full Remote Control mode.

#### a. Function (One line of 7 to be low)

FREQ A	(A)	fan-in = 1
FREQ C	(C)	fan-in = 1
FREQ A/B	(A/B)	fan-in = 1
PERIOD A	(PA)	fan-in = 1
TIME INTERVAL	(TI)	fan-in = 1
A GTD BY B	(A x B)	fan-in = 1
CHECK	(CH)	fan-in = 1

#### b. Range (One line of 6 to be low)

0.1 ms	$10^0$	0.1 $\mu$ s	(1)	fan-in = 1
1 ms	$10^1$	1 $\mu$ s	(2)	fan-in = 1
10 ms	$10^2$	10 $\mu$ s	(3)	fan-in = 1
0.1s	$10^3$	0.1 ms	(4)	fan-in = 1
1s	$10^4$	1 ms	(5)	fan-in = 1
10s	$10^5$	10 ms	(6)	fan-in = 1

#### c. Slope (One line per channel)

Slope A (EXT SA) low = positive fan-in = 3

Slope B (EXT SB) low = positive fan-in = 1

#### d. D/A Converters:

Resolution = 1%  
 Accuracy =  $\pm 5\%$  of setting +2 mV  
 Temperature Stability = 200  $\mu$ V/ $^{\circ}$ C

All inputs are high true

The x10 attenuator extends the apparent range to  $\pm 10$ V in 100 mV steps.

## e. AC/DC Coupling (One line per channel)

Channel A (DA) low = AC Coupling fan-in = 1

Channel B (DB) low = AC Coupling fan-in = 1

## f. Attenuator (One line per channel)

Channel A (TA) low = x1 fan-in = 1

Channel B (TB) low = x1 fan-in = 1

## g. Separate/Common (One line)

(SC) low = separate fan-in = 1

h. The two Analog Trigger lines are also provided for checking the operation of the internal D/A's or analog programming the trigger levels whenever the D/A's are disabled.

## i. Reset (One line, low true)

When the reset line is brought low and released, a new measurement sequence will start without resetting the display.

Note: This same line is used on DOU option.

## j. The following outputs are provided:

1. Power Sense (SP) High = on

A +5 Volt level indicates that the instrument is on.

2. Overflow Status (OVFL) high true

Outputs a high level when an overflow condition exists.

3. SYSTEM READY Low true

Signals the completion of a measurement cycle. (Note that the System Ready appears about 3 ms before the DOU Ready.)

4. Channels A and B signal outputs (SMA; SMB) TTL.

These are not normally connected, except by special request. To connect these outputs, jumper both W5 and W6 on the Main PCB.

**CAUTION**

**These outputs should be connected only in applications where the maximum channel A or B count frequency is below 25 MHz. Exposed wiring external to the unit should be kept to a minimum to prevent signal feedback.**

k. Also provided are two Analog Trigger Level input outputs (ATL-A and ATL-B) which can be used for measuring the internally-generated trigger levels with an external voltmeter, or for defining the trigger levels from an external dc source. The input impedance is 20k and the response time is 2 ms. Usable range is  $\pm 1$  volt, and the maximum safe level is  $\pm 5$  volts. Operation with X10 attenuation extends the apparent range to  $\pm 10V$ .

l. Although the counter will operate in a single-shot mode when under remote control, automatic measurement cycling can be established by connecting the System Ready output into the Reset input. The cycle rate will be the maximum attainable with the instrument and will be equal to the gate time plus the conversion time (50  $\mu s$ ).

m. Whenever Option -12 is installed, the overall 1953A specifications are changed in two areas:

1. Input capacity increases to 45 pF max.
2. Overload capability becomes:

DC + Peak AC must not exceed 250 volts, when in steady state condition, this decreases to 100 volts maximum whenever any of the following lines are switched:

DA	Channel A Coupling
DB	Channel B Coupling
TA	Attenuation, Channel A
TB	Attenuation, Channel B
SC	Separate/Common

**612-10. EXTERNAL CONNECTIONS**

612-11. The input commands needed to operate the Remote Control Unit are provided in Table 612-1. The pin numbers identified in the table correspond to the pin numbers on the 50 pin connector supplied with the option.

**612-12. THEORY OF OPERATION OF THE DIGITAL-TO-ANALOG CONVERTER**

612-13. The Full Remote Control Unit, Option -12, provides the remote operating station with the ability to digitally program the trigger level. Figure 612-1 is a basic illustration of the remote trigger level control circuit.

612-14. The digital inputs for channel A and channel B are applied to two Digital to Analog Converters each containing current sourcing amplifiers connected to resistors of selected value. The resistor values are selected to provide a trigger level output, in 10 mV steps, up to  $\pm 1$  volt in the x1 ATTEN setting. When the x10 ATTEN setting is selected the trigger level output is in 100 mV steps up to  $\pm 10$  volts.

Table 612-1. RCU I/O Connections

PIN	SIGNAL	DESCRIPTION		FAN IN
		LOW LOGIC EQUALS	HIGH LOGIC EQUALS	
A	Sign A	Negative	Positive	
B	ATL A	} Analog Trigger Level A Input/Trigger Level Monitor Output		
C	ATL B			
D	A "1"		True	
E	A "4"		True	
F	A "10"		True	
H	A "40"		True	
J	B "1"		True	
K	B "4"		True	
L	B "10"		True	
M	B "40"		True	
N	SC	A, B Inputs SEP	A, B Input COM	
P	$\overline{SA}$	+ Slope	- Slope	
R	<u>SYSTEM READY</u>	System Ready	System Not Ready	
S	$\overline{DB}$	CH-B AC Coupled	CH-B DC Coupled	1
T	$\overline{DA}$	CH-A AC Coupled	CH-A DC Coupled	1
U	$\overline{PA}$	Period A Function		1
V	$\overline{4}$	0.1s Range		1
W	$\overline{2}$	1.0 ms Range		1
X	$\overline{AXB}$	A GTD by B Function		1
Y	$\overline{CH}$	Self-check Function		1
Z	$\overline{6}$	10s Range		1
a	$\overline{OVFL}$		Overflow Output	
b	$\overline{A}$	FREQ A Function		1
c	$\overline{SR}$	Sense Remote		
1	$\overline{EXT-T}$	Local Trigger Disable	Local Trigger Enable	
2	Sign B	Negative	Positive	
3	SP		Positive (Down on)	
4	A "2"		True	
5	A "8"		True	
6	A "20"		True	
7	A "80"		True	
8	B "2"		True	
9	B "8"		True	
10	B "20"		True	
11	B "80"		True	
12	$\overline{SMA}$	TTL Output Equal CHL-A Input	Not Normally Connected	
13	$\overline{SMB}$	TTL Output Equal to CHL-B Input	Connected	
14	$\overline{SB}$	+ Slope	- Slope	1

Table 612-1. RCU I/O Connections (cont)

PIN	SIGNAL			FAN IN
		LOW LOGIC EQUALS	HIGH LOGIC EQUALS	
15	$\overline{TB}$	CH-B Atten X1	CH-B Atten X10	1
16	$\overline{TA}$	CH-A Atten X1	CH-A Atten X10	1
17	$\overline{C}$	FREQ C Function		1
18	$\overline{TI}$	T.I. A-B Function		1
19	$\overline{T}$	0.1 ms Range		1
20	$\overline{EXT}$	Front Panel Lockout		5
21	$\overline{A/B}$	FREQ A/B Function		1
22	$\overline{5}$	1.0s Range		1
23	$\overline{EXT-RESET}$	Reset Counter		
24	$\overline{3}$	10 ms Range		1
25	Ground			

**NOTES ON RCU CONNECTIONS TABLE**

- (1) Pins D through M and 4 through 11, as per the table, represent the binary coded decimal inputs for the trigger level controls of channels A and B. The trigger level is divided into 10 mV steps, requiring two sets of binary coded decades, one for units and one for tens. The trigger level signs are provided by pins A and 2. Pins B and C, named ATL-A and ATL-B respectively, can be used as either analog inputs for an externally applied dc trigger level, or as output terminals for external measurement of the trigger level when that level stems from either the D/A converter of the front panel trigger level adjustments.
- (2) TTL fan-ins are given where relevant. The remaining inputs are CMOS compatible with internal 100k ohm pull-up to +5 volts.

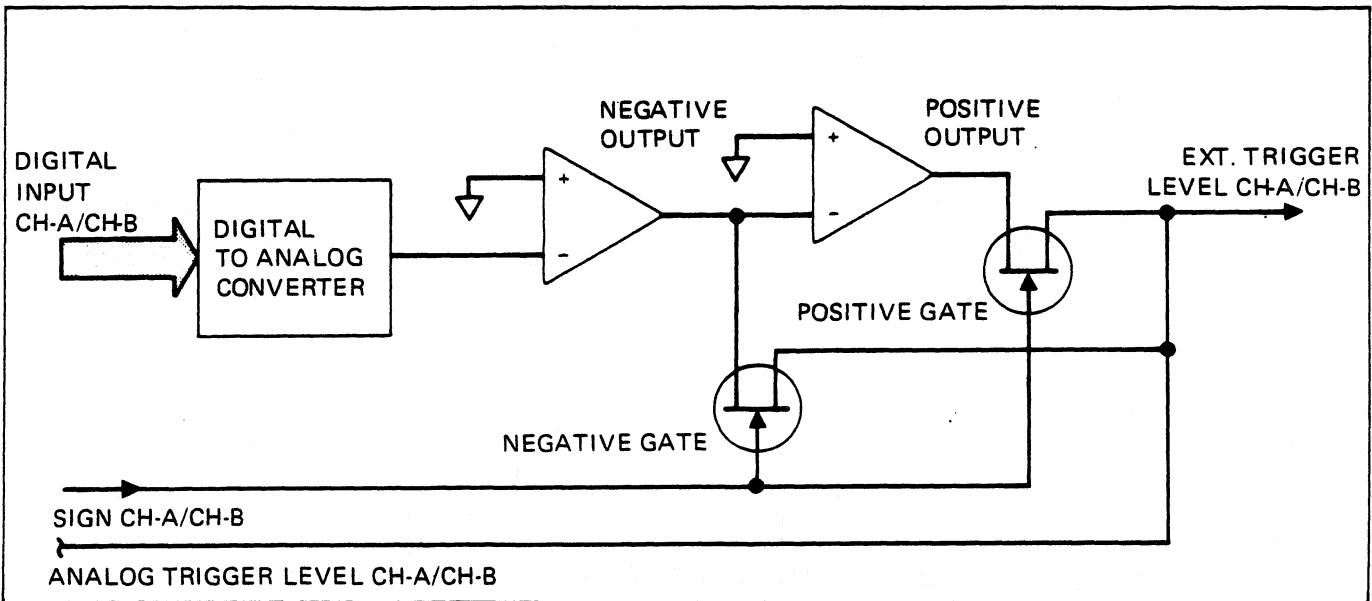

Figure 612-1. Trigger Level Control Block Diagram



612-15. For both channels A and B the SIGN input controls switching FET's that select either a positive output or a negative output for the trigger level control. The external trigger level control is enabled by a LOW input to the EXT-T pin on the RCU rear panel connector.

**612-16. CALIBRATION PROCEDURE FOR DIGITAL TRIGGER LEVEL CONTROL**

612-17. The calibration requires use of a DVM. See Table 4-1 for recommended type. Make reference to Table 612-1 as necessary for pin designations on P95, and reference desigatior Figure 612-4 (RCU 3 PCB Assembly) for location of trimpots R701, R704, R705, R708.

612-18. Calibrate Digital Trigger Level Controls of Channels A and B as follows:

- a. Connect 1953A to line power.
- b. Rotate Cycle Rate control cw, off the OFF detent.
- c. Channel A calibration
  - 1. Connect EXT-T to ground. This enables the digital trigger.
  - 2. Connect Digital Input pins, D, E, F, H, 4, 5, 6, 7) of channel A to ground (0 state).
  - 3. Connect DVM to pin B (ATL-A) of P95 (RCU input).
  - 4. Set SIGN-A to negative (ground pin A).

- 5. Adjust timpot R708 until DVM reads zero  $\pm 0.1$  mV.
- 6. Set SIGN-A to positive (open pin A).
- 7. Adjust trimpot R705 until DVM reads zero  $\pm 0.1$  mV.

d. Channel B calibration

- 1. Connect EXT-T to ground. This enables the digital trigger.
- 2. Connect Digital Input pins (J, K, L, M, 8, 9, 10, 11) of channel B to ground (0 state).
- 3. Connect DVM to pin C (ATL-B) of P95 (RCU input).
- 4. Set SIGN-B to negative (ground pin 2).
- 5. Adjust trimpot R704 until DVM reads zero  $\pm 0.1$  mV.
- 6. Set SIGN-B to positive (open pin 2).
- 7. Adjust trimpot R701 until DVM reads zero  $\pm 0.1$  mV.





**612-19. LIST OF REPLACEABLE PARTS**

612-20. Table 612-2 is a list of replaceable parts for the Full Remote Control Unit. Refer to Section 5 for an explanation of the column entries.



**CAUTION**  
Indicated devices are subject to damage by static discharge.

Table 612-2. -12 Option, Full Remote Control Unit Assembly

ITEM NO.	DESCRIPTION	FLUKE STOCK NO.	MFG SPLY CODE	MFG PART NO. OR TYPE	TOT QTY	REC QTY	USE CDE
FULL REMOTE CONTROL UNIT, OPTION 12							
FIGURE 612-2							
A11	RCU 1 PCB ASSY 	396242	89536	396242	1		
A12	RCU 2 PCB ASSY 	396259	89536	396259	1		
A13	RCU 3 PCB ASSY	396150	89536	396150	1		
MP1	DECAL, REMOTE	408617	89536	408617	1		
MP2	COVER, CONNECTOR, PORT, OPTIONAL 	398016	89536	398016	1		
MP3	CONNECTOR KIT (NOT SHOWN)	410241	89536	410241	1		
S121	SWITCH, TOGGLE DPDT (INSTALLED ON REAR PANEL)	327734	09353	7201LPZGI	1	1	
	REPLACES INPUT PCB ASSY A1A3						
	REPLACES COVER CONNECTOR PORT P/N 398024						

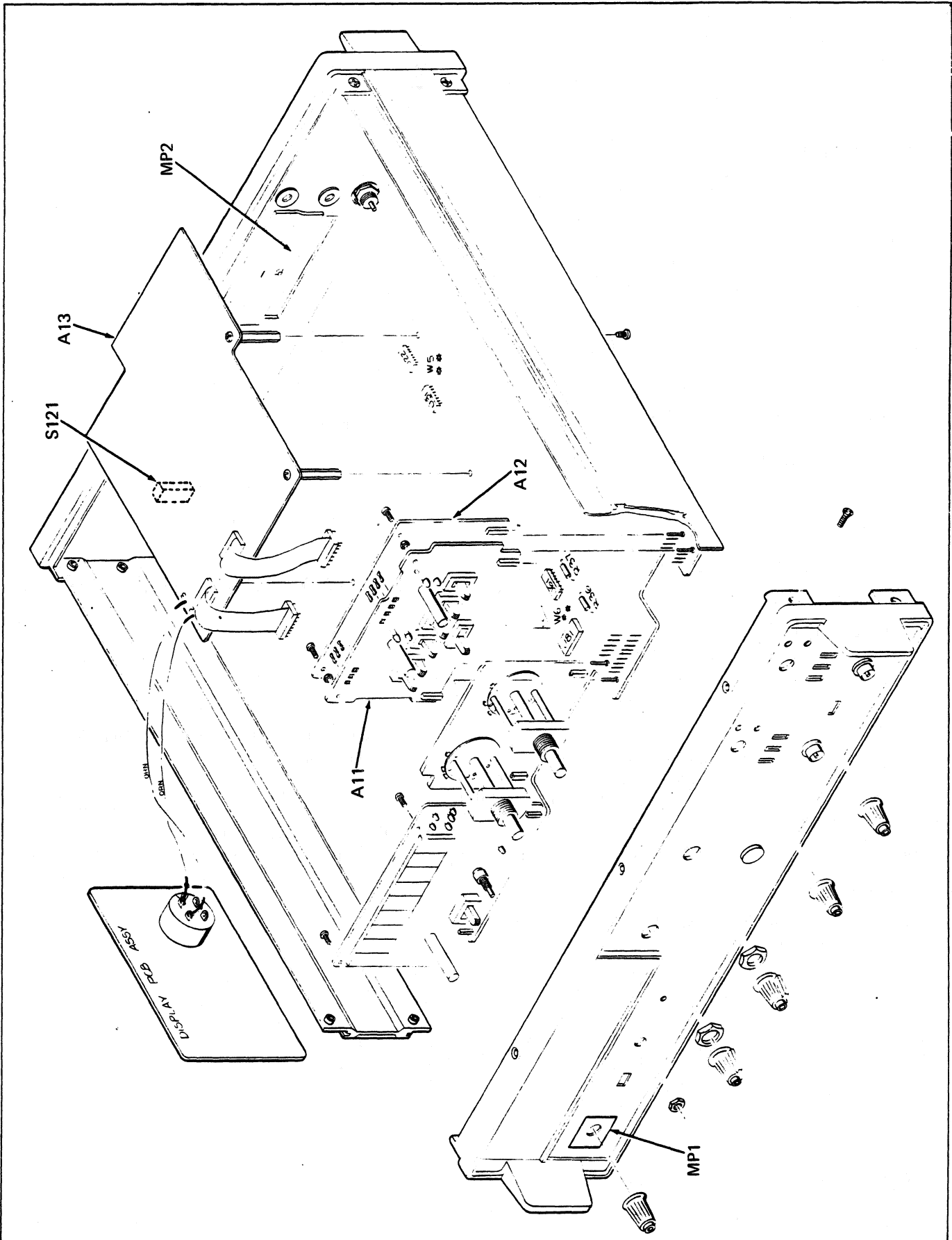

Figure 612-2. -12 Option, Full Remote Control Unit Assembly

Table 612-3. A11 RCU #1 PCB Assembly

ITEM NO.	DESCRIPTION	FLUKE STOCK NO.	MFG SPLY CODE	MFG PART NO. OR TYPE	TOT QTY	REC QTY	USE CDE
A11	REMOTE CONTROL UNIT 1 (1953A-4021) FIGURE 612-3	396242	89536	396242	REF		
DS401	INDICATOR, LED	385898	28480	5082-4487	4	1	
DS402	INDICATOR, LED	385898	28480	5082-4487	REF		
DS403	INDICATOR, LED	385898	28480	5082-4487	REF		
DS404	INDICATOR, LED	385898	28480	5082-4487	REF		
J1	CONNECTOR PIN, FEMALE, LARGE	149112	74970	105-0753	2		
	PIN, FEMALE, SMALL	375329	00779	85863-3	12		
P10	CONNECTOR PINS, MALE	376574	00779	5166-333-68	7		
R410	RES, COMP, 47 +/-5%, 1/4W	147892	01121	CB4705	4		
R411	RES, COMP, 47 +/-5%, 1/4W	147892	01121	CB4705	REF		
R412	RES, COMP, 47 +/-5%, 1/4W	147892	01121	CB4705	REF		
R413	RES, COMP, 47 +/-5%, 1/4W	147892	01121	CB4705	REF		
S108	SWITCH, SLIDE, SPDT	380113	79727	GF-124-SPDT	7	2	
S109	SWITCH, SLIDE, SPDT	380113	79727	GF-124-SPDT	REF		
S110	SWITCH, SLIDE, SPDT	380113	79727	GF-124-SPDT	REF		
S111	SWITCH, SLIDE, SPDT	380113	79727	GF-124-SPDT	REF		
S112	SWITCH, SLIDE, SPDT	380113	79727	GF-124-SPDT	REF		
S113	SWITCH, SLIDE, SPDT	380113	79727	GF-124-SPDT	REF		
S114	SWITCH, SLIDE, SPDT	380113	79727	GF-124-SPDT	REF		
U401	RES, NETWORK, SEVEN 10K +/-5%, 1.5W (OR 7 DISCRETE RESISTORS, P/N 148106)	364000	71450	760-1	1	1	
U402	IC, TTL, HEX INVERTER, OPEN COLLECTOR	379305	01295	SN7405N	1	1	

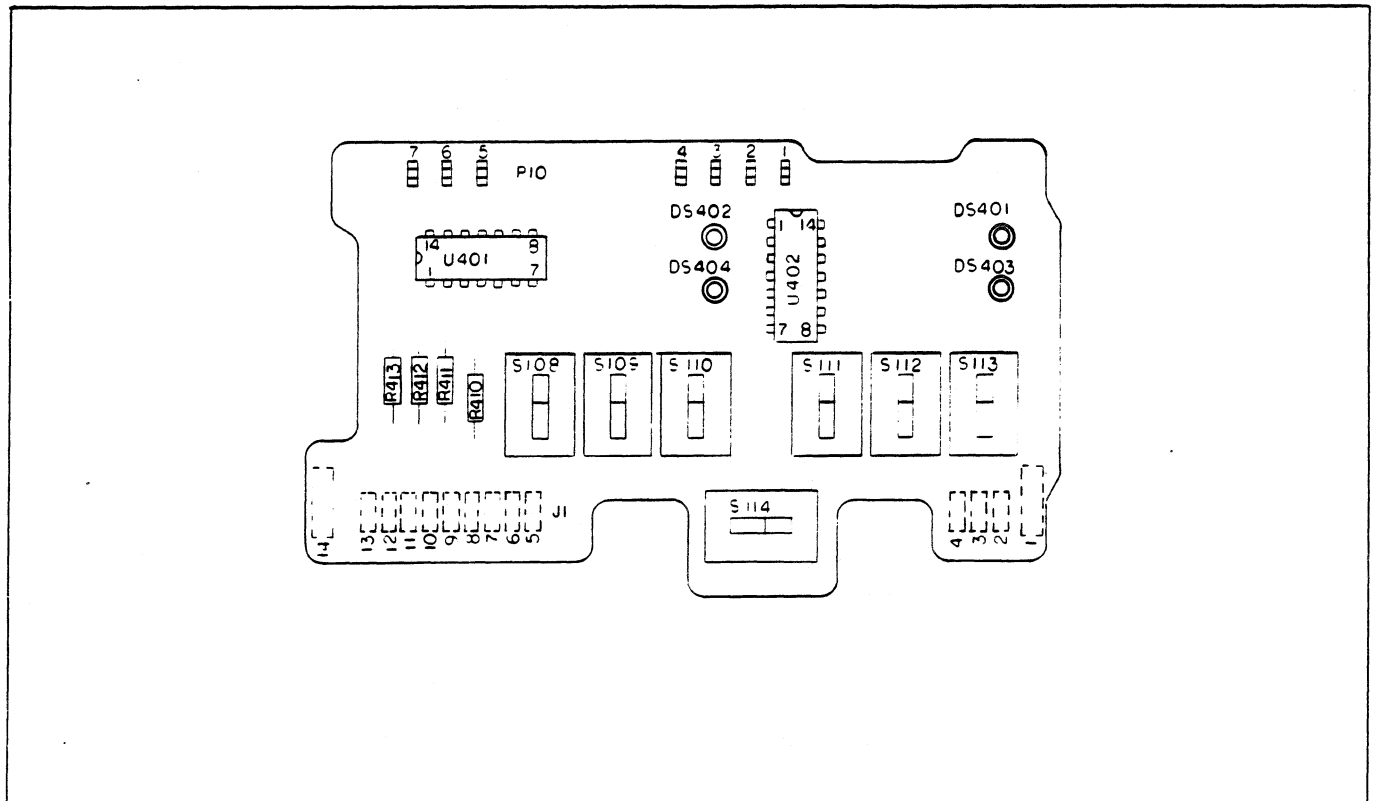

Figure 612-3. A11 RCU #1 PCB Assembly

Table 612-4. A12 RCU #2 PCB Assembly

ITEM NO.	DESCRIPTION	FLUKE STOCK NO.	MFG SPLY CODE	MFG PART NO. OR TYPE	TOT QTY	REC QTY	USE CDE
A12	REMOTE CONTROL UNIT 2 (1953A-4022) FIGURE 612-4	396259	89536	396259			REF
A12A10	RELAY, DRY REED, SPST	334920	24211	GB-831A-4E			REF
A12A11	RELAY, DRY REED, SPST	334920	24211	GB-831A-4E			REF
A12A4	RELAY, DRY REED, SPST	334920	24211	GB-831A-4E		8	
A12A5	RELAY, DRY REED, SPST	334920	24211	GB-831A-4E			REF
A12A6	RELAY, DRY REED, SPST	334920	24211	GB-831A-4E			REF
A12A7	RELAY, DRY REED, SPST	334920	24211	GB-831A-4E			REF
A12A8	RELAY, DRY REED, SPST	334920	24211	GB-831A-4E			REF
A12A9	RELAY, DRY REED, SPST	334920	24211	GB-831A-4E			REF
C1	CAP, MYLAR, 0.1 UF +/-10%, 400V	447573	73445	C280MF/A100K		2	
C2	CAP, MYLAR, 0.1 UF +/-10%, 400V	447573	73445	C280MF/A100K			REF
C3	CAP, CER, 1.5 PF +/-0.25 PF, 1 KV	178475	56289	10TCCV15-NPO		2	
C4	CAP, CER, 1.5 PF +/-0.25 PF, 1 KV	178475	56289	10TCCV15-NPO			REF
J2	CONNECTOR						
	PIN, FEMALE, LARGE	149112	74970	105-0753		2	
	PIN, FEMALE, SMALL	375329	00779	85863-3		9	
R1	RES, COMP, 910K +/-5%, 1/4W	285338	01121	CB9145		2	
R2	RES, COMP, 910K +/-5%, 1/4W	285338	01121	CB9145			REF
R3	RES, COMP, 100K +/-5%, 1/4W	148189	01121	CB1045		2	
R4	RES, COMP, 100K +/-5%, 1/4W	148189	01121	CB1045			REF
R5	RES, VAR, 10K +/-30%, 1/2W	385880	89536	385880		2	
R6	RES, VAR, 10K +/-30%, 1/2W	385880	89536	385880			REF
U3	IC, TTL, HEX INVERTER, OPEN COLLECTOR	379305	01295	SN7405N		1	1

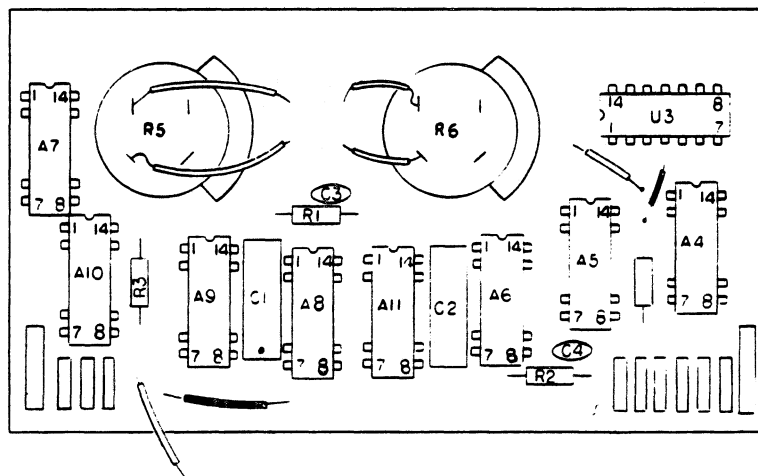

Figure 612-4. A12 RCU #2 PCB Assembly

Table 612-5. A13 RCU #3 PCB Assembly

ITEM NO.	DESCRIPTION	FLUKE STOCK NO.	MFG SPLY CODE	MFG PART NO. OR TYPE	TOT QTY	REC QTY	USE CODE
A13	⊗ REMOTE CONTROL UNIT 3 PCB ASSEMBLY (1953A-4023) FIGURE 612-5	396150	89536	396150			REF
C701	CAP, TA, 10 UF +/-20%, 15V	193623	56289	196D106X0015-5KA4	3		
C702	CAP, DISC, 100 PF +/-10%, 50V	105593	71590	DD101	4		
C703	CAP, DISC, 0.1 UF +/-20%, 50 VDC W	149146	56289	33C41B6	2		
C704	CAP, DISC, 100 PF +/-10%, 50V	105593	71590	DD101			REF
C705	CAP, TA, 10 UF +/-20%, 15V	193623	56289	196D106X0015-5KA4			REF
C706	CAP, DISC, 100 PF +/-10%, 50V	105593	71590	DD101			REF
C708	CAP, DISC, 0.1 UF +/-20%, 50 VDC W	149146	56289	33C41B6			REF
C709	CAP, DISC, 100 PF +/-10%, 50V	105593	71590	DD101			REF
C711	CAP, TA, 10 UF +/-20%, 15V	193623	56289	196D106X0015-5KA4			REF
C712	CAP, CER, 0.002 UF, GMV, 1 KV	105569	56289	DA140-139CB	1		
CR701	DIODE, ZENER, 12V, 400 MW	110726	07910	1N964B	3		1
CR702	DIODE, SI	203323	07919	1N4448	4		1
CR703	DIODE, SI	203323	07919	1N4448			REF
CR704	DIODE, SI	203323	07919	1N4448			REF
CR705	DIODE, SI	203323	07919	1N4448			REF
CR706	DIODE, ZENER, 12V, 400 MW	110726	07910	1N964B			REF
CR707	DIODE, ZENER, 12V, 400 MW	110726	07910	1N964B			REF
J81	FLAT CABLE ASSEMBLY	393520	08261	5142-006	2		
J82	FLAT CABLE ASSEMBLY	393520	08261	5142-006			REF
Q701	XSTR, FET, N-CHANNEL	404277	01295	TIS73	4		
Q702	XSTR, FET, N-CHANNEL	404277	01295	TIS73			REF
Q703	XSTR, FET, N-CHANNEL	404277	01295	TIS73			REF
Q704	XSTR, FET, N-CHANNEL	404277	01295	TIS73			REF
R701	RES, VAR, 10K	369553	54869	PT10V-10K	4		
R702	RES, COMP, 2.2M +/-5%, 1/4W	198390	01121	CB2255	4		
R703	RES, COMP, 2.2M +/-5%, 1/4W	198390	01121	CB2255			REF
R704	RES, VAR, 10K	369553	54869	PT10V-10K			REF
R705	RES, VAR, 10K	369553	54869	PT10V-10K			REF
R706	RES, COMP, 2.2M +/-5%, 1/4W	198390	01121	CB2255			REF
R707	RES, COMP, 2.2M +/-5%, 1/4W	198390	01121	CB2255			REF
R708	RES, VAR, 10K	369553	54869	PT10V-10K			REF
R709	RES, MF, 95.3K +/-0.1%, 1/8W	346858	91637	MFF1-89532B	2		
R710	RES, MF, 4.32K +/-1%, 1/8W	294819	91637	MFF1-84321F	2		
R711	RES, MF, 47.5K +/-0.1%, 1/8W	344523	91637	MFF1-84752B	2		
R712	RES, MF, 2.32K +/-1%, 1/8W	260315	91637	MFF1-82321F	2		
R713	RES, MF, 10K +/-0.1%, 1/8W	343459	91637	MFF1-81002B	4		
R714	RES, MF, 10K +/-0.1%, 1/8W	343459	91637	MFF1-81002B			REF
R715	RES, COMP, 27K +/-5%, 1/4W	148148	01121	CB2735	4		
R716	RES, COMP, 27K +/-5%, 1/4W	148148	01121	CB2735			REF
R717	RES, COMP, 10K +/-5%, 1/4W	148106	01121	CB1035	2		
R718	RES, COMP, 4.7K +/-5%, 1/4W	148072	01121	CB4725	7		
R719	RES, MF, 10K +/-0.1%, 1/8W	343459	91637	MFF1-81002B			REF
R720	RES, COMP, 47K +/-5%, 1/4W	148163	01121	CB4735	3		
R721	RES, MF, 8.06K +/-1%, 1/8W	294942	91637	MFF1-8061F	2		
R722	RES, COMP, 1K +/-5%, 1/4W	148023	01121	CB1025	4		
R723	RES, COMP, 1K +/-5%, 1/4W	148023	01121	CB1025			REF
R724	RES, COMP, 1K +/-5%, 1/4W	148023	01121	CB1025			REF

Table 612-5. A13 RCU #3 PCB Assembly (cont)

ITEM NO.	DESCRIPTION	FLUKE STOCK NO.	MFG SPLY CODE	MFG PART NO. OR TYPE	TOT QTY	REC QTY	USE CDE
R725	RES, COMP, 1K +/-5%, 1/4W	148023	01121	CB1025	REF		
R726	RES, MF, 10K +/-0.1%, 1/8W	343459	91637	MFF1-81002B	REF		
R727	RES, COMP, 27K +/-5%, 1/4W	148148	01121	CB2735	REF		
R728	RES, COMP, 27K +/-5%, 1/4W	148148	01121	CB2735	REF		
R729	RES, COMP, 10K +/-5%, 1/4W	148106	01121	CB1035	REF		
R730	RES, COMP, 4.7K +/-5%, 1/4W	148072	01121	CB4725	REF		
R731	RES, COMP, 4.7K +/-5%, 1/4W	148072	01121	CB4725	REF		
R732	RES, COMP, 47K +/-5%, 1/4W	148163	01121	CB4735	REF		
R733	RES, COMP, 47K +/-5%, 1/4W	148163	01121	CB4735	REF		
R734	RES, MF, 8.06K +/-1%, 1/8W	294942	91637	MFF1-8061F	REF		
R735	RES, MF, 402K +/-1%, 1/8W	348391	91637	MFF1-84023F		2	
R736	RES, MF, 200K +/-1%, 1/8W	261701	91637	MFF1-82003F		2	
R737	RES, MF, 1M +/-1%, 1/8W	268797	91637	MFF1-81004F		2	
R738	RES, MF, 499K +/-1%, 1/8W	349191	91637	MFF1-84993F		2	
R739	RES, COMP, 2M +/-5%, 1/4W	268771	01121	CB2055		2	
R740	RES, COMP, 3.9M +/-5%, 1/4W	188417	01121	CB3955		2	
R741	RES, MF, 47.5K +/-0.1%, 1/8W	344523	91637	MFF1-84752B	REF		
R743	RES, MF, 4.32K +/-1%, 1/8W	294819	91637	MFF1-84321F	REF		
R744	RES, MF, 499K +/-1%, 1/8W	349191	91637	MFF1-84993F	REF		
R745	RES, MF, 402K +/-1%, 1/8W	348391	91637	MFF1-84023F	REF		
R746	RES, MF, 200K +/-1%, 1/8W	261701	91637	MFF1-82003F	REF		
R747	RES, MF, 95.3K +/-0.1%, 1/8W	346858	91637	MFF1-89532B	REF		
R748	RES, MF, 1M +/-1%, 1/8W	268797	91637	MFF1-81004F	REF		
R749	RES, COMP, 2M +/-5%, 1/4W	268771	01121	CB2055	REF		
R750	RES, COMP, 3.9M +/-5%, 1/4W	188417	01121	CB3955	REF		
R751	RES, COMP, 100 +/-5%, 1/4W	147926	01121	CB1015		2	
R752	RES, COMP, 82 +/-5%, 1/4W	149484	01121	CB8205		2	
R753	RES, COMP, 82 +/-5%, 1/4W	149484	01121	CB8205	REF		
R754	RES, COMP, 100K +/-5%, 1/4W	148189	01121	CB1045		3	
R756	RES, COMP, 100K +/-5%, 1/4W	148189	01121	CB1045	REF		
R757	RES, COMP, 100K +/-5%, 1/4W	148189	01121	CB1045	REF		
R758	RES, COMP, 390 +/-5%, 1/4W	147975	01121	CB3915		1	
R759	RES, COMP, 4.7K +/-5%, 1/4W	148072	01121	CB4725	REF		
R760	RES, COMP, 4.7K +/-5%, 1/4W	148072	01121	CB4725	REF		
R761	RES, COMP, 4.7K +/-5%, 1/4W	148072	01121	CB4725	REF		
R762	RES, COMP, 4.7K +/-5%, 1/4W	148072	01121	CB4725	REF		
R763	RES, COMP, 100 +/-5%, 1/4W	147926	01121	CB1015	REF		
R764	RES, COMP, 4.7M +/-5%, 1/4W	220046	01121	CB4755		4	
R765	RES, COMP, 4.7M +/-5%, 1/4W	220046	01121	CB4755	REF		
R766	RES, COMP, 4.7M +/-5%, 1/4W	220046	01121	CB4755	REF		
R767	RES, COMP, 4.7M +/-5%, 1/4W	220046	01121	CB4755	REF		
U701	IC, 5-XSTR, ARRAY, SI, NPN	248906	86684	CA3046		2	1
U702	IC, LIN OP AMP	363515	07263	LM301AN		4	1
U703	IC, LIN OP AMP	363515	07263	LM301AN	REF		
U704	⊗ IC, CMOS, HEX BUFFER/INVERTER	381830	95303	CD4050AE		3	1
U705	IC, 5-XSTR, SI, NPN	248906	86684	CA3046	REF		
U706	IC, LIN OP AMP	363515	07263	LM301AN	REF		
U707	IC, LIN OP AMP	363515	07263	LM301AN	REF		
U708	⊗ IC, CMOS, HEX BUFFER/INVERTER	381830	95303	CD4050AE	REF		
U709	⊗ IC, CMOS, HEX BUFFER/INVERTER	381830	95303	CD4050AE	REF		

Table 612-5. A13 RCU #3 PCB Assembly (cont)

ITEM NO.	DESCRIPTION	FLUKE STOCK NO.	MFG SPLY CODE	MFG PART NO. OR TYPE	TOT QTY	REC QTY	USE CDE
U710	RES, NETWORK, THIRTEEN 100K +/-5%, 1/4W	404624	89536	404624	1		
U711	IC, TTL, TRI-STATE HEX BUFFER	408146	07263	DM8095N	4		
U712	IC, TTL, TRI-STATE HEX BUFFER	408146	07263	DM8095N	REF		
U713	IC, TTL, TRI-STATE HEX BUFFER	408146	07263	DM8095N	REF		
U714	IC, TTL, TRI-STATE HEX BUFFER	408146	07263	DM8095N	REF		

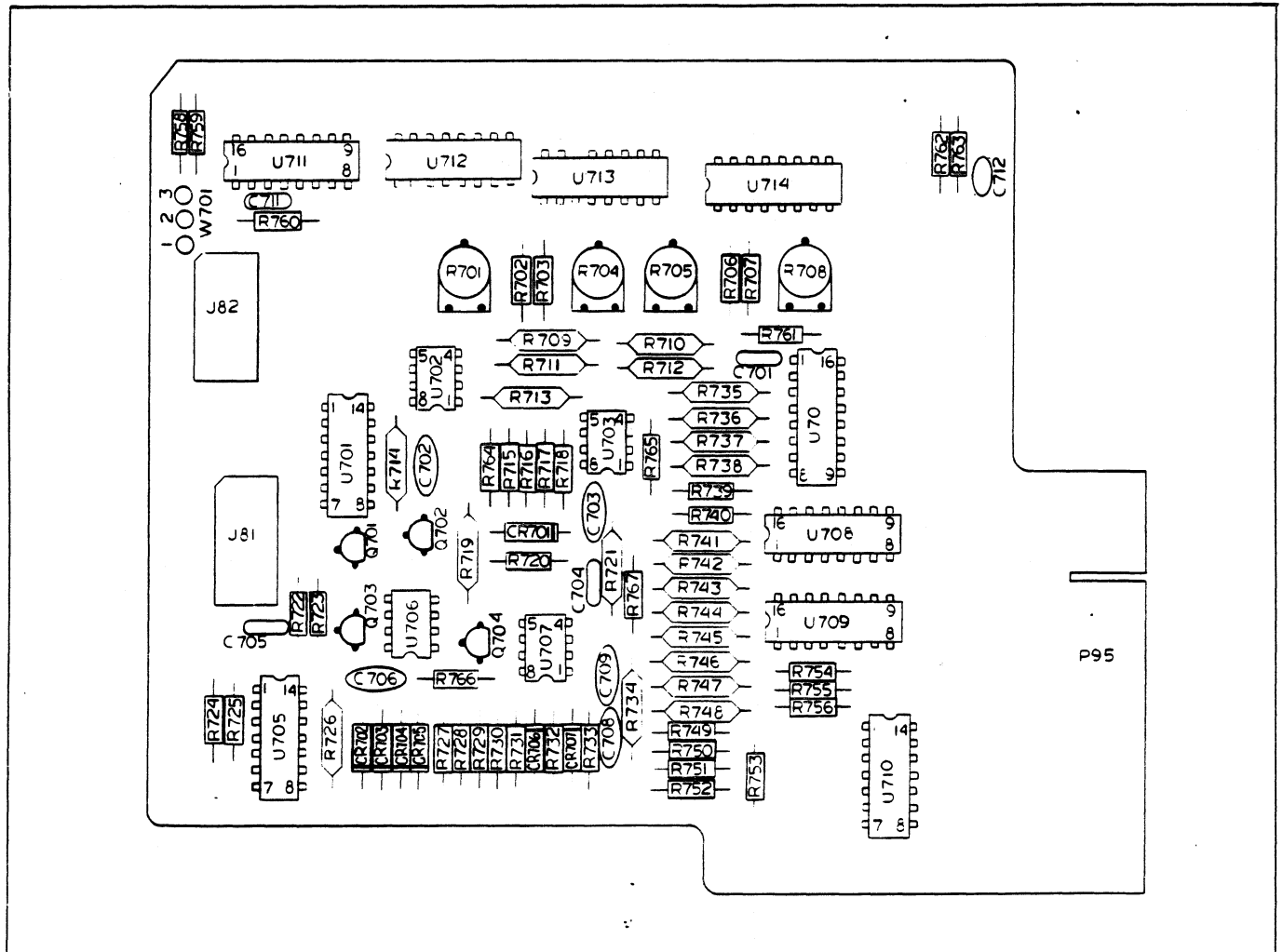
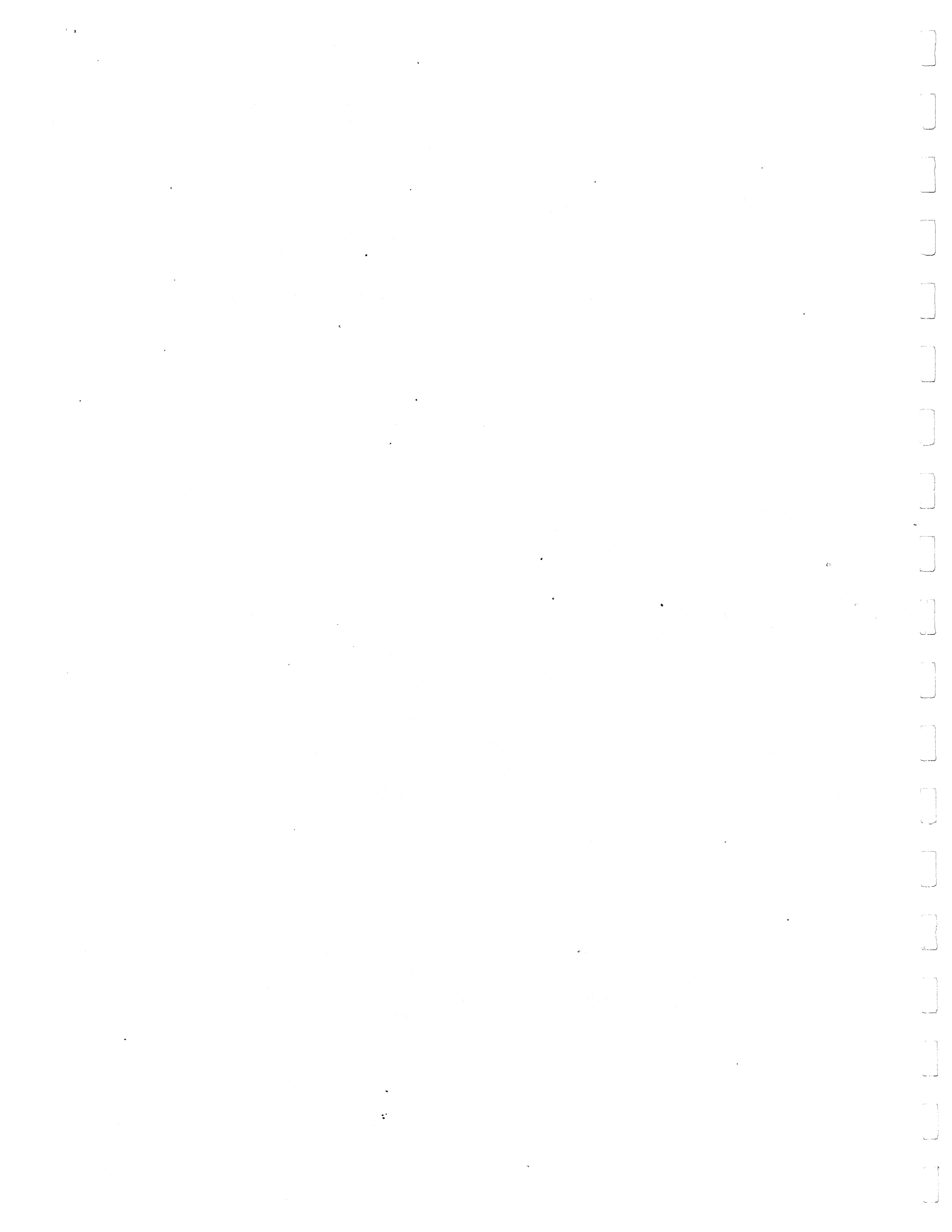

Figure 612-5. A13 RCU #3 PCB Assembly





## Option -13 1000 MHz Prescaler

### 613-1. INTRODUCTION

613-2. The channel C input of the Model 1953A is intended for use with an optional frequency-prescaler. Option -13 is a prescaler which extends the operating range of the counter to 1000 MHz. This prescaler has a frequency range extending from 50 MHz to 1000 MHz with a specified sensitivity of 15 mV rms.

613-3. The option comprises a plug-in pcb assembly, a front panel mounted BNC connector, and the related components required both to adjust the power supply for correct operating voltages and to compensate the counter circuitry for the prescaling divisor. The option must be ordered factory-installed in the 1953A when the instrument is purchased, it is not field installable.

### 613-4. OPERATION

613-5. Operation of the 1953A in the prescaler mode is established by rotating the FUNCTION switch to the FREQ C position.

### 613-6. THEORY OF OPERATION

613-7. The main function of the prescaler is to reduce the frequency of the input signal to below 130 MHz for application to the main gate and decade counters. The prescaler also provides the necessary conditioning of the input signal to provide sufficient gain and the proper waveshaping. The frequency division factor of the 1000 MHz prescaler is eight.

613-8. As shown in Figure 613-1, the input signal is fed through an input protection fuse, F1, to the input of the amplifier, which contains input limiting. The output of the amplifier, which is also internally limited, is applied to a divider circuit which divides by a factor of eight to reduce the input frequency to below 130 MHz. The prescaled signal, amplified by U1 and divided by U2 and U3 is fed to the Main PCB Assembly for application to the main gate and decade counters.

613-9. The output of the amplifier is sensed via CR1/U5, to detect signals whose level is too low to reliably clock the divider circuit. When a low signal level is detected, the divider output is disabled causing the display to read zero.

### 613-10. PERFORMANCE CHECKS

613-11. The performance check for the 1000 MHz Prescaler is actually a sensitivity check made at the upper and lower frequency limits. Proceed as follows:

- a. Connect a 1000 MHz RF generator, terminated into 50 ohms, to a T-connector on the CHANNEL C input. Set the generator output for 25 MHz at approximately 15 mV rms.
- b. Connect the RF millivoltmeter (refer to Table 4-1) to the T-connector on the input of the prescaler.
- c. Adjust the generator output for a reading of 15 mV rms on the RF millivoltmeter.
- d. Confirm that the counter reads 25 MHz  $\pm$  generator accuracy.
- e. Change the generator output to 1000 MHz and adjust the output of 15 mV on the RF millivoltmeter.

### 613-12. CALIBRATION

613-13. Calibration of the prescaler amounts to adjustment of the low level sense control located on the top edge of the Prescaler PCB Assembly. Proceed as follows:

- a. Remove the top dust cover from the instrument.

- b. Energize the counter and connect the RF generator to the CHANNEL C input connector. Select an output of 100 MHz at approximately 15 mV rms.
- c. On the counter, adjust the level control (R15) to a midpoint which produces a stable display.
- d. Reduce the input signal level until the display becomes unstable.

- e. Readjust the level control until the display is again stable.
- f. Repeat steps d and e until no additional sensitivity can be achieved.

**613-14. LIST OF REPLACEABLE PARTS**

613-15. Table 613-1 is a list of replaceable parts for the 1000 MHz Prescaler. Refer to Section 5 for an explanation of the column entries.

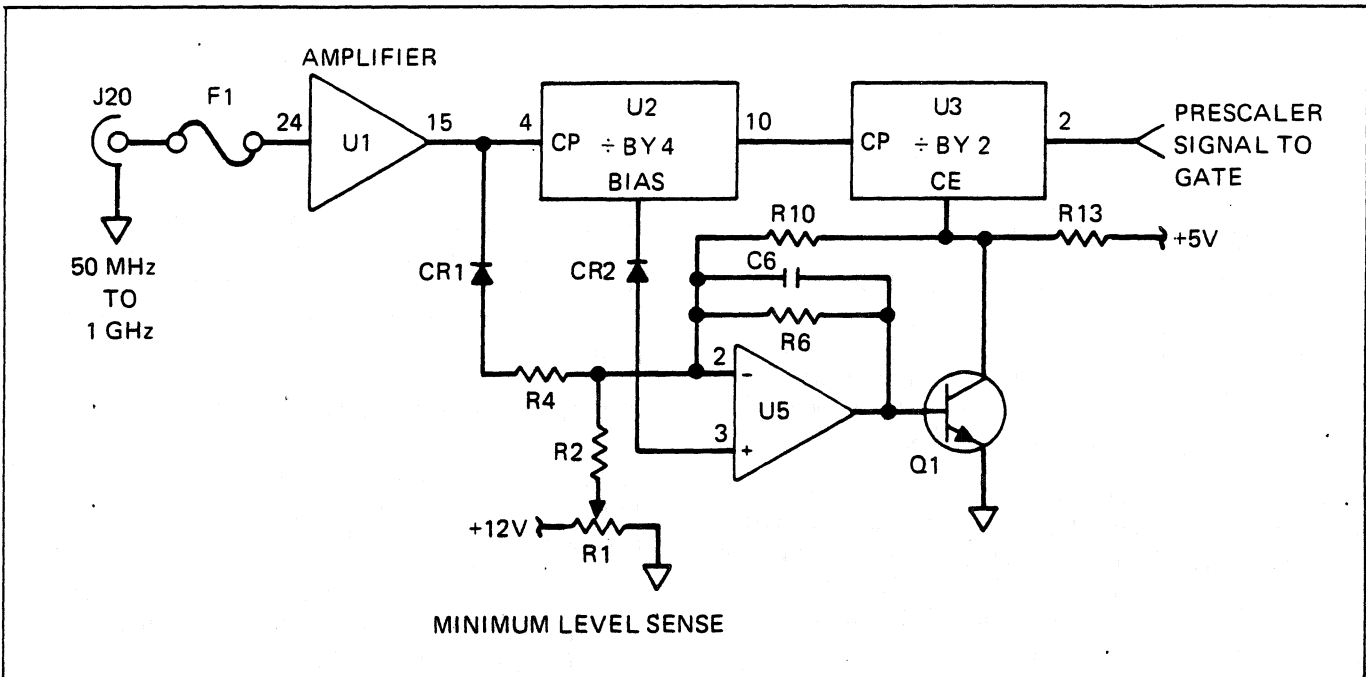

Figure 613-1. 1000 MHz Prescaler Block Diagram

Table 613-1. -13 Option, 1000 MHz Prescaler PCB Assembly

ITEM NO.	DESCRIPTION	FLUKE STOCK NO.	MFG SPLY CODE	MFG PART NO. OR TYPE	TOT QTY	REC QTY	USE CDE
	1000 MHZ PRESCALER, OPTION -13 FIGURE 613-2						
A14	1000 MHZ PRESCALER PCB ASSEMBLY	396309	89536	3963909	1		
H1	GROUND CLIP	462101	89536	462101	1		
MP1	1000 MHZ DECAL	428037	89536	428037	1		
U13	IC, TTL, 4-BIT BINARY COUNTER	320739	01295	SN7493N	1	1	
W1	CABLE ASSY (FRONT PANEL TO PCB)	406942	89536	406942	1		

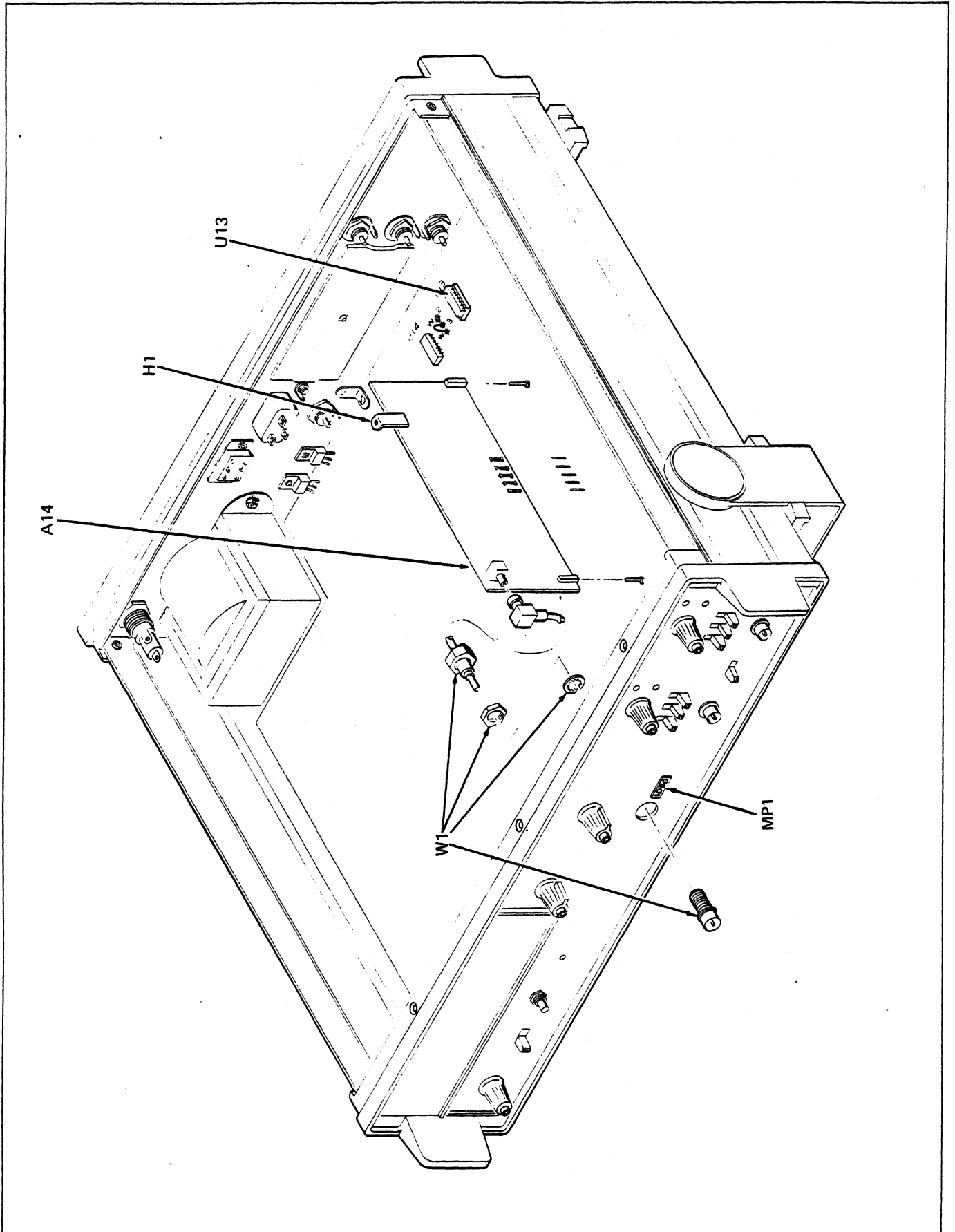

Figure 613-2. -13 Option, 1000 MHz Prescaler PCB Assembly

Table 613-2. A14 1000 MHz Prescaler PCB Assembly

ITEM NO.	DESCRIPTION	FLUKE STOCK NO.	MFG SPLY CODE	MFG PART NO. OR TYPE	TOT QTY	REC QTY	USE CDE
A14	1000 MHZ PRESCALER PCB ASSEMBLY (1953A-4027T) FIGURE 613-3	396309	89536	396309	REF		
C1	CAP, CER, 0.001 UF	402966	71590	8121-A100-W5-R-102M	7		
C3	CAP, CER, 0.001 UF	402966	71590	8121-A100-W5-R-102M	REF		
C4	CAP, CER, 0.001 UF	402966	71590	8121-A100-W5-R-102M	REF		
C5	CAP, CER, 0.001 UF	402966	71590	8121-A100-W5-R-102M	REF		
C6	CAP, CER, 0.001 UF	402966	71590	8121-A100-W5-R-102M	REF		
C7	CAP, CER, 0.001 UF +/-10%, 500V	357806	71590	CB102	2		
C8	CAP, CER, 0.001 UF	402966	71590	8121-A100-W5-R-102M	REF		
C9	CAP, CER, 0.001 UF	402966	71590	8121-A100-W5-R-102M	REF		
C10	CAP, CER, 0.001 UF +/-10%, 500V	357806	71590	CB102	REF		
C11	CAP, TA, 10 UF +/-20%, 16V	193623	56289	196D106X00015KA1	1		
CR1	DIODE, HOT CARRIER	369595	07263	GH1100	2	1	
CR2	DIODE, HOT CARRIER	369595	07263	GH1100	REF		
F1	FUSE, 0.2A	370577	75915	273.200	2		
F2	FUSE, 0.2A	370577	75915	273.200	REF		
J5	CONNECTOR PIN, FEMALE. LARGE	149112	74970	105-0753	2		
	PIN, FEMALE. SMALL	375329	00779	85863-3	6		
J20	CONNECTOR, COAX	353243	98291	51.053.000	1		
L1	FERRITE BEAD	321182	02114	56-590-65-4B	1		
Q1	XSTR, SI, NPN	218396	04713	2N3904	2	1	
Q2	XSTR, SI, PNP	352369	07263	2N4403	1	1	
Q3	XSTR, SI, NPN	218396	04713	2N3904	REF		
R1	RES, VAR, 10K +/-20%	385393	54869	PT-10H-10K	1		
R2	RES, COMP, 330K +/-5%, 1/4W	192948	01121	CB3345	2		
R3	RES, COMP 2.7K +/-5%, 1/4W	170720	01121	CB2725	4		
R4	RES, COMP 10K +/-5%, 1/4W	148106	01121	CB1035	2		
R5	RES, COMP 2.7K +/-5%, 1/4W	170720	01121	CB2725	REF		
R6	RES, COMP, 330K +/-5%, 1/4W	192948	01121	CB3345	REF		
R7	RES, COMP, 470 +/-5%, 1/4W	147983	01121	CB4715	1		
R8	RES, COMP, 470 +/-5%, 1/4W	147983	01121	CB4715	REF		
R9	RES, COMP, 4.7K +/-5%, 1/4W	148072	01121	CB4725	1		
R10	RES, COMP, 1K +/-5%, 1/4W	148023	01121	CB1025	3		
R11	RES, COMP 10K +/-5%, 1/4W	148106	01121	CB1035	REF		
R13	RES, COMP 2.7K +/-5%, 1/4W	170720	01121	CB2725	REF		
R14	RES, COMP, 1K +/-5%, 1/4W	148023	01121	CB1025	REF		
R15	RES, COMP, 470 +/-5%, 1/4W	147983	01121	CB4715	REF		
R17	RES, COMP 2.7K +/-5%, 1/4W	170720	01121	CB2725	REF		
R18	RES, COMP, 1K +/-5%, 1/4W	148023	01121	CB1025	REF		
R19	RES, DEP. CAR, 1.5M +/-5%, 1/4W	349001	80031	CR251-4-5P1M5	1		
U1	IC, LINEAR, BROAD BAND AMPL	428797	31091	CA1044	1	1	
U2	IC, ECL, SELECTED	444034	89536	444034	1	1	
U3	IC, TTL, D-TYPE FLIP-FLOP	404574	07263	F11C06DC	1	1	
U4	IC, OP AMP	402750	07263	LM741CN	1	1	
XU2	SOCKET, IC, 14-PIN, DIP	291542	00779	583527-1	1		
XU3	SOCKET, IC, 16-PIN, DIP	370312	01295	C931602	1		
ZZ	SOCKET, PIN (FOR XU1, XF1, XF2)	403642	00779	50863-B	28		

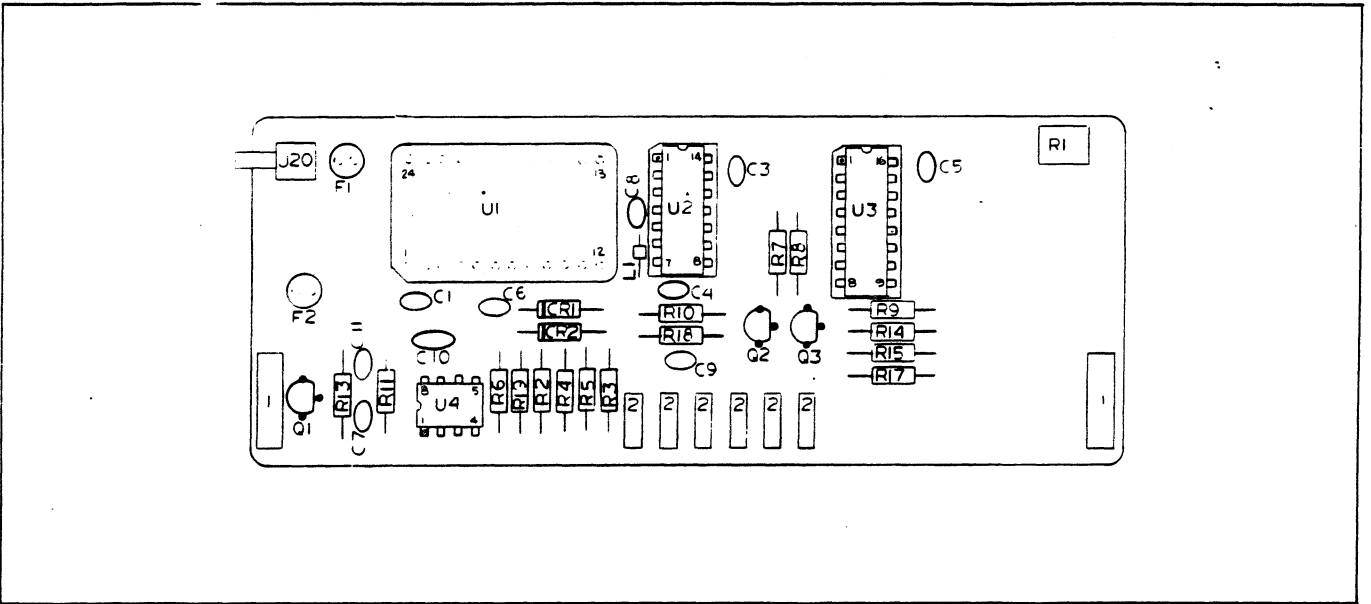
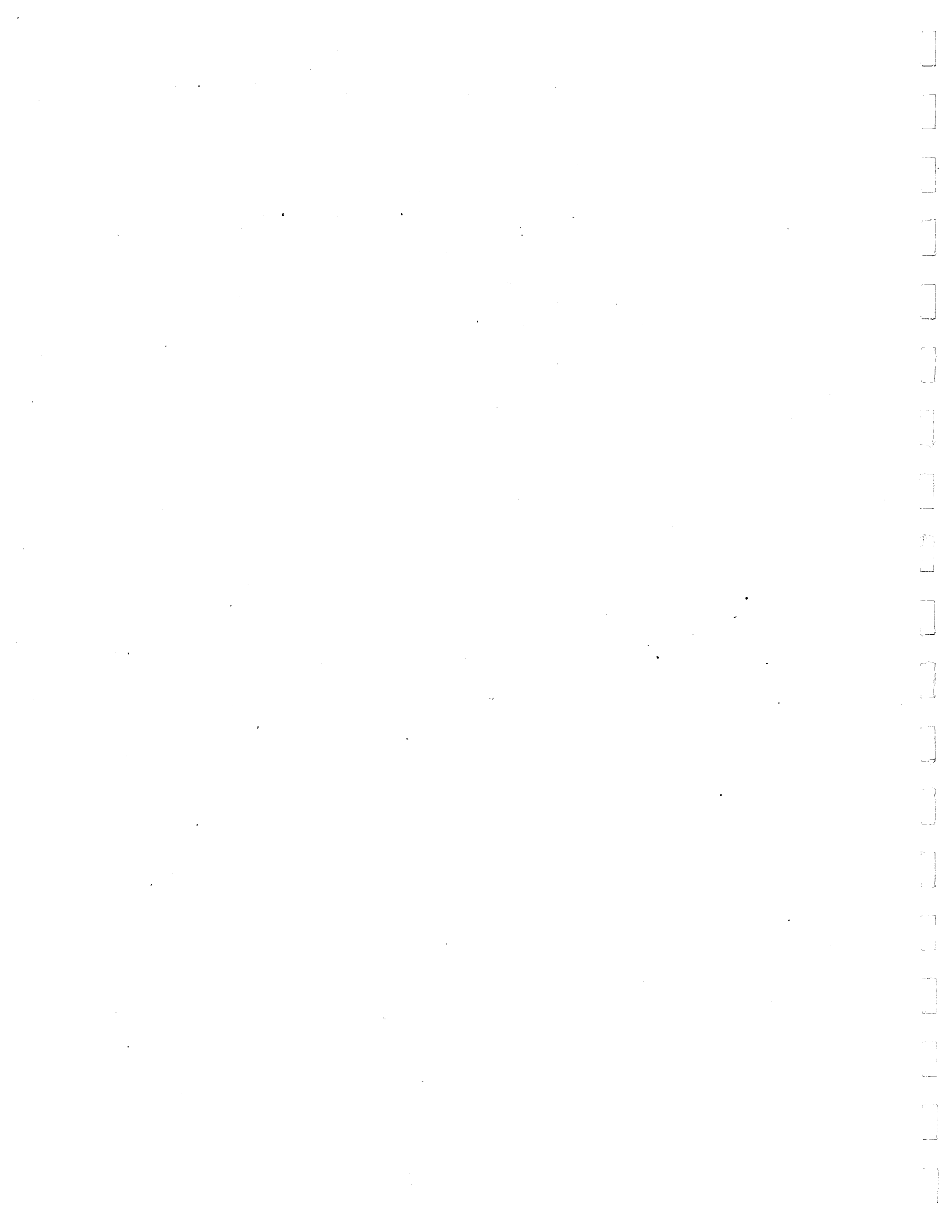

Figure 613-3. A14 1000 MHz Prescaler PCB Assembly



## Option -14 1250 MHz Prescaler

### 614-1. INTRODUCTION

614-2. The channel C input of the Model 1953A is intended for use with an optional frequency prescaler. Option -14 is a prescaler which extends the operating range of the counter to 1250 MHz. This prescaler has a frequency range extending from 50 MHz to 1250 MHz with a specified sensitivity of 15 mV rms, from 50 MHz to 1000 MHz decreasing to 30 mV rms between 1000 MHz and 1250 MHz.

614-3. The option comprises a plug-in pcb assembly, a front panel mounted BNC connector, and the related components required both to adjust the power supply for correct operating voltages and to compensate the counter circuitry for the prescaling divisor. The option must be ordered factory-installed in the 1953A when the instrument is purchased, it is not field installable.

### 614-4. OPERATION

614-5. Operation of the 1953A in the prescaler mode is established by rotating the FUNCTION switch to the FREQ C position.

### 614-6. THEORY OF OPERATION

614-7. The main function of the prescaler is to reduce the frequency of the input signal to below 165 MHz for application to the main gate and decade counters. The prescaler also provides the necessary conditioning of the input signal to provide sufficient gain and the proper waveshaping. The frequency division factor for the 1250 MHz Prescaler is eight.

614-8. As shown in Figure 614-1, the input signal is fed through an input protection fuse, F1, to the input of the amplifier. The output of the amplifier, which is internally limited, is applied to a divider circuit which divides by a factor of eight to reduce the input frequency to below 165

MHz. The prescaled signal, amplified by U1 and divided by U2 and U3 is fed to the Main PCB Assembly for application to the main gate and decade counters.

614-9. The output of the amplifier is sensed via CR1 and U5, to detect signals whose level is too low to reliably clock the divider circuit. When a low signal level is detected, the divider output is disabled causing the display to read zero.

### 614-10. PERFORMANCE CHECKS

614-11. The performance check for the 1250 MHz Prescaler is actually a sensitivity check made at the upper and lower frequency limits. Proceed as follows:

- a. Connect a 1.3 GHz RF generator, terminated into 50 ohms, to a T-connector on the CHANNEL C input. Set the generator output for 50 MHz at approximately 15 mV rms.
- b. Connect the RF millivoltmeter (refer to Table 4-1) to the T-connector on the input of the prescaler.
- c. Adjust the generator output for a reading of 15 mV rms on the RF millivoltmeter.
- d. Confirm that the counter reads 50 MHz  $\pm$  generator accuracy.
- e. Change the generator output to 1250 MHz and adjust the output for 30 mV rms on the RF millivoltmeter.
- f. Confirm that the counter reads 1250 MHz  $\pm$  generator accuracy.

### 614-12. CALIBRATION

614-13. Calibration of the prescaler amounts to adjustment of the sense control located on the top edge of the Prescaler PCB Assembly. Proceed as follows:

- a. Remove the the top dust cover from the instrument.
- b. Energize the counter and connect the RF generator to the CHANNEL C input connector. Select an output of 100 MHz approximately 15 mV rms.
- c. On the counter, adjust the level control (R15) to a midpoint which produces a stable display.

d. Reduce the input signal level until the display becomes unstable.

e. Readjust the level control until the display is again stable.

f. Repeat steps d and e until no additional sensitivity can be achieved.

### 614-14. LIST OF REPLACEABLE PARTS

614-15. Table 614-1 is a list of replaceable parts for the 1250 MHz Prescaler. Refer to Section 5 for an explanation of the column entries.

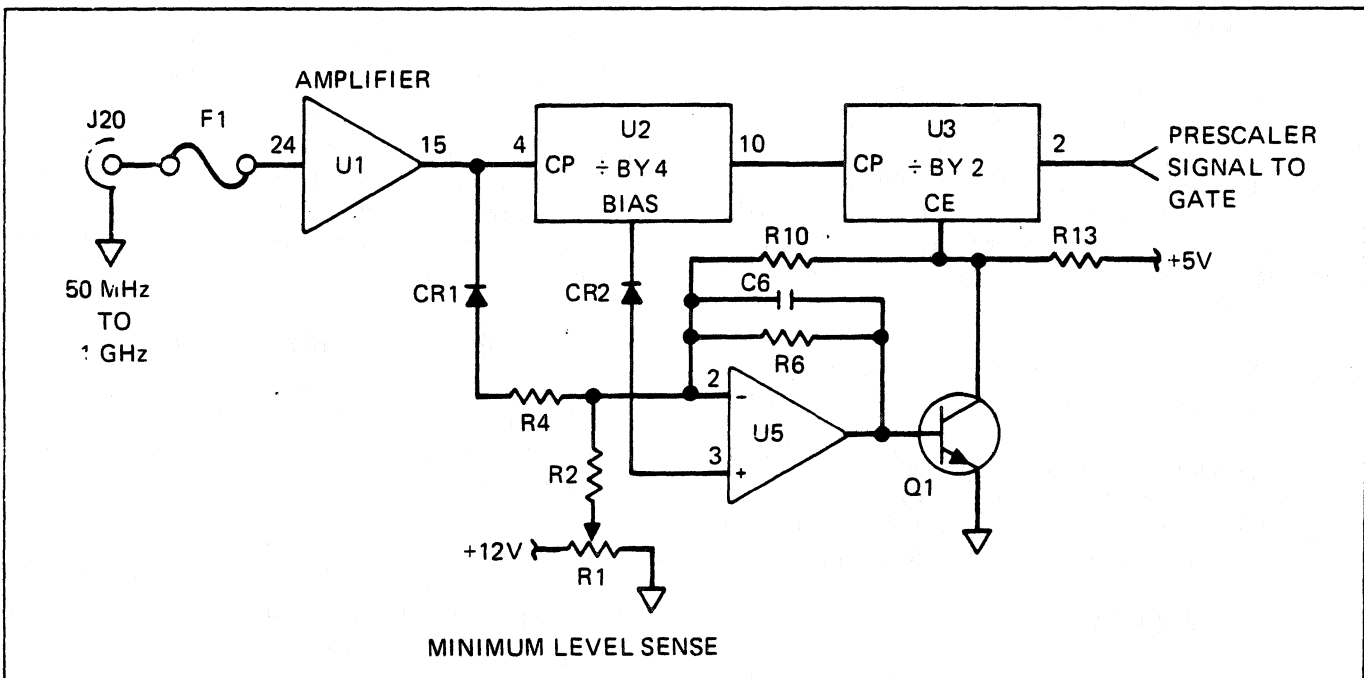

Figure 614-1. 1250 MHz Prescaler Block Diagram

Table 614-1. -14 Option, 1250 MHz Prescaler Assembly

ITEM NO.	DESCRIPTION	FLUKE STOCK NO.	MFG SPLY CODE	MFG PART NO. OR TYPE	TOT QTY	REC QTY	USE CDE
1250 MHZ PRESCALER, OPTION -14 FIGURE 614-2							
A15	1250 MHZ PRESCALER PCB ASSY	405597	89536	405597	1		
H1	GROUND CLIP	462101	89536	462101	1		
MP1	1250 MHZ DECAL	428045	89536	428045	1		
U13	IC, TTL, 4-BIT BINARY COUNTER (INSTALLED ON COUNTER MAIN PCB)	320739	01295	SN7493N	1	1	
W1	CABLE ASSY (FRONT PANEL TO PCB)	406942	89536	406942	1		



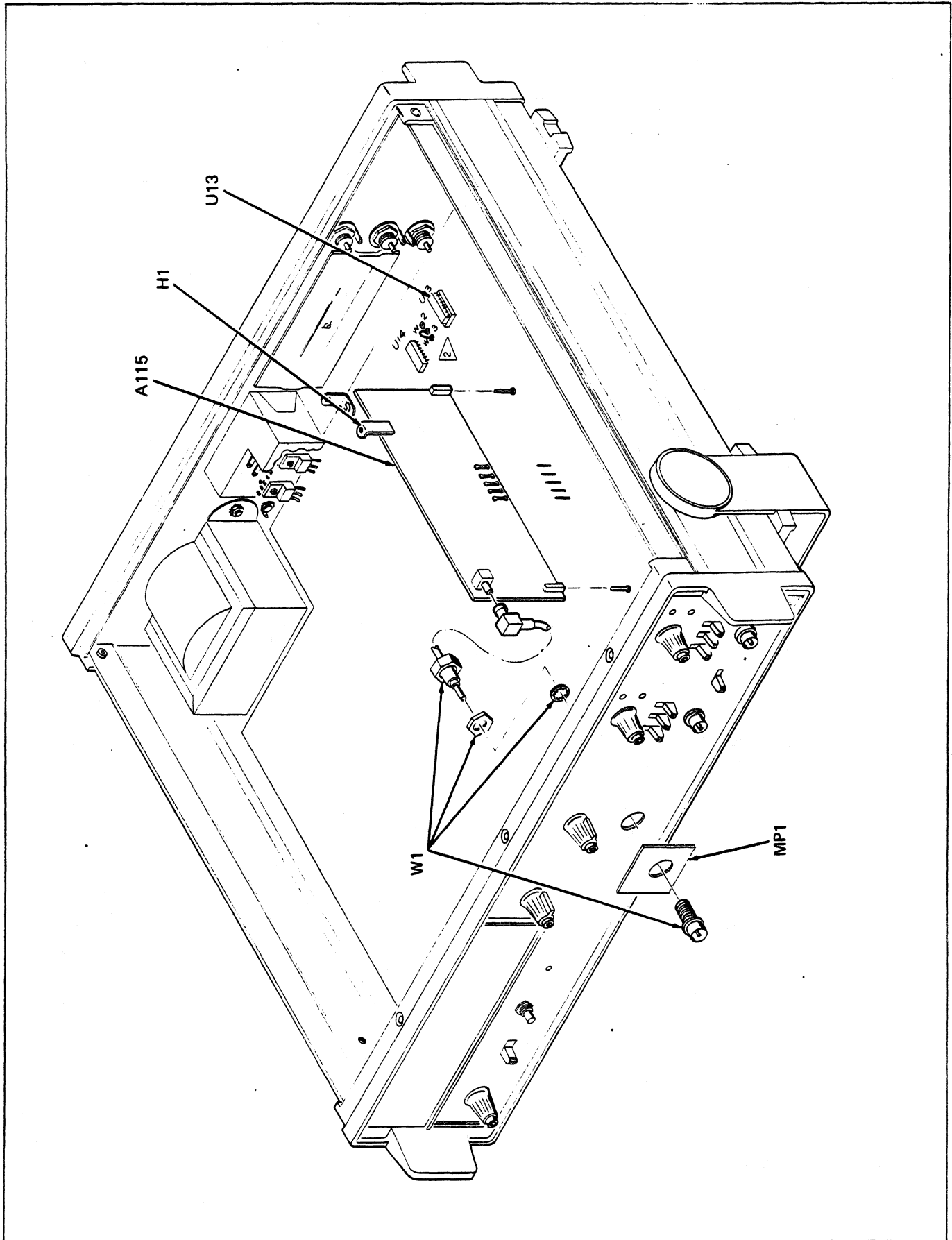

Figure 614-2. -14 Option, 1250 MHz Prescaler Assembly

Table 614-2. A15 1250 MHz Prescaler PCB Assembly

ITEM NO.	DESCRIPTION	FLUKE STOCK NO.	MFG SPLY CODE	MFG PART NO. OR TYPE	TOT QTY	REC QTY	USE CODE
A15	1250 MHZ PRESCALER PCB ASSY (1953A-4028T) FIGURE 614-3	405589	89536	405589	REF		
C1	CAP, CER, 0.001 UF	402966	71590	8121-A100-W5R-102M	7		
C3	CAP, CER, 0.001 UF	402966	71590	8121-A100-W5R-102M	REF		
C4	CAP, CER, 0.001 UF	402966	71590	8121-A100-W5R-102M	REF		
C5	CAP, CER, 0.001 UF	402966	71590	8121-A100-W5R-102M	REF		
C6	CAP, CER, 0.001 UF	402966	71590	8121-A100-W5R-102M	REF		
C7	CAP, CER, 0.001 UF +/-10%, 500V	357806	71590	CB102	2		
C8	CAP, CER, 0.001 UF	402966	71590	8121-A100-W5R-102M	REF		
C9	CAP, CER, 0.001 UF	402966	71590	8121-A100-W5R-102M	REF		
C10	CAP, CER, 0.001 UF +/-10%, 500V	357806	71590	CB102	REF		
C11	CAP, TA, 10 UF +/-20%, 16V	193623	56289	196D106X00015KA1	1		
CR1	DIODE, HOT CARRIER	369595	07263	DH1100	2	1	
CR2	DIODE, HOT CARRIER	369595	07263	DH1100	REF		
F1	FUSE, 0.2A	370577	75915	273.200	2		
F2	FUSE, 0.2A	370577	75915	273.200	REF		
J5	CONNECTOR PIN, FEMALE, LARGE	149112	74970	105-0753	2		
	PIN, FEMALE, SMALL	375329	00779	85863-3	6		
J20	CONNECTOR, COAX	353243	98291	51-053-000	1		
L1	FERRITE BEAD	321182	02114	56-590-65-4B	1		
Q1	XSTR, SI, NPN	218396	04713	2N3904	2	1	
Q2	XSTR, SI, PNP	352369	07263	2N4403	1	1	
Q3	XSTR, SI, NPN	218396	04713	2N3904	REF		
R1	RES, VAR, 10K +/-20%	385393	54869	PT-10H-10K	1		
R2	RES, COMP, 330K +/-5%, 1/4W	192948	01121	CB3345	2		
R3	RES, COMP, 2.7K +/-5%, 1/4W	170720	01121	CB2725	4		
R4	RES, COMP, 10K +/-5%, 1/4W	148106	01121	CB1035	2		
R5	RES, COMP, 2.7K +/-5%, 1/4W	170720	01121	CB2725	REF		
R6	RES, COMP, 330K +/-5%, 1/4W	192948	01121	CB3345	REF		
R7	RES, COMP, 470 +/-5%, 1/4W	147983	01121	CB4715	3		
R8	RES, COMP, 470 +/-5%, 1/4W	147983	01121	CB4715	REF		
R9	RES, COMP, 4.7K +/-5%, 1/4W	148072	01121	CB4725	1		
R10	RES, COMP, 1K +/-5%, 1/4W	148023	01121	CB1025	3		
R11	RES, COMP, 10K +/-5%, 1/4W	148106	01121	CB1035	REF		
R13	RES, COMP, 2.7K +/-5%, 1/4W	170720	01121	CB2725	REF		
R14	RES, COMP, 1K +/-5%, 1/4W	148023	01121	CB1025	REF		
R15	RES, COMP, 4.0 +/-5%, 1/4W	147983	01121	CB4715	REF		
R17	RES, COMP, 2.7K +/-5%, 1/4W	170720	01121	CB2725	REF		
R18	RES, COMP, 1K +/-5%, 1/4W	148023	01121	CB1025	REF		
R19	RES, COMP, 1.5M +/-5%, 1/4W	349001	01121	CB1555	1		
U1	IC, LINEAR, BROAD BAND AMPL	428797	31091	CA1044	1		
U2	IC, ECL, SELECTED	418186	89536	418186	1	1	
U3	IC, TTL, D-TYPE FLIP-FLOP	404574	07263	F11C06DC	1	1	
U4	IC, OP AMP	402750	07263	LM741CN	1	1	
XU2	SOCKET, IC, 14-PIN DIP	291542	00779	582527-1	1		
XU3	SOCKET, IC, 16-PIN DIP	370312	01295	C931602	1		
ZZ	SOCKET, PIN (FOR XU1, XF1, XF2)	403642	00779	50863-B	28		

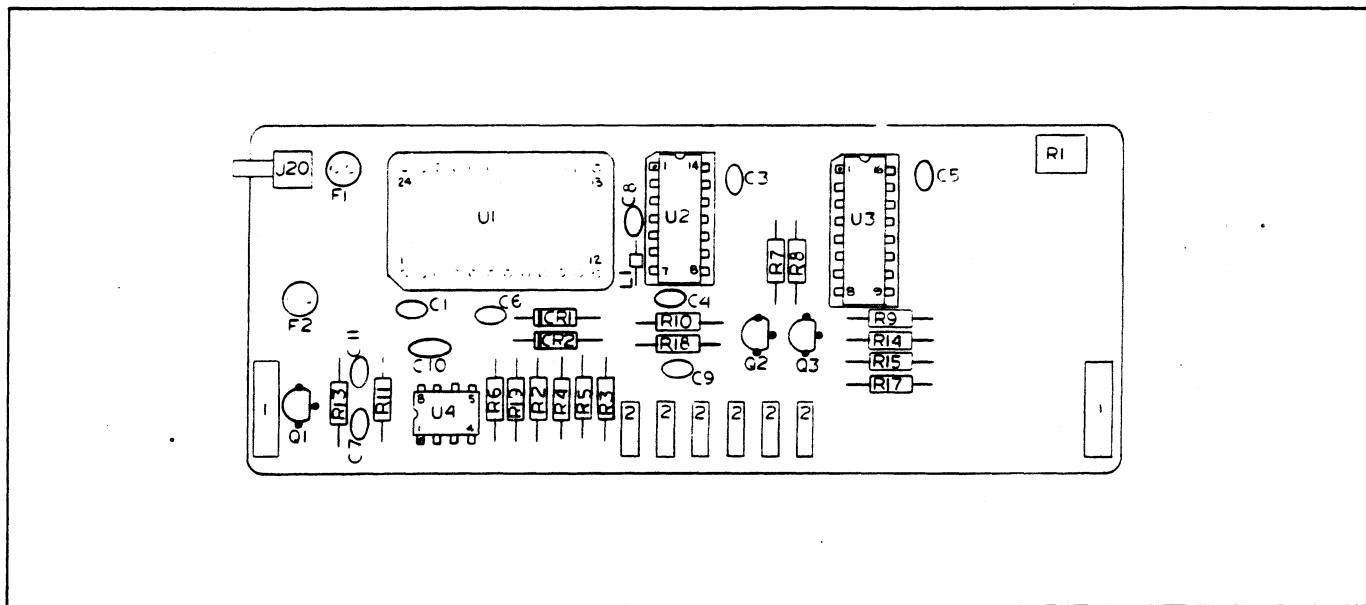
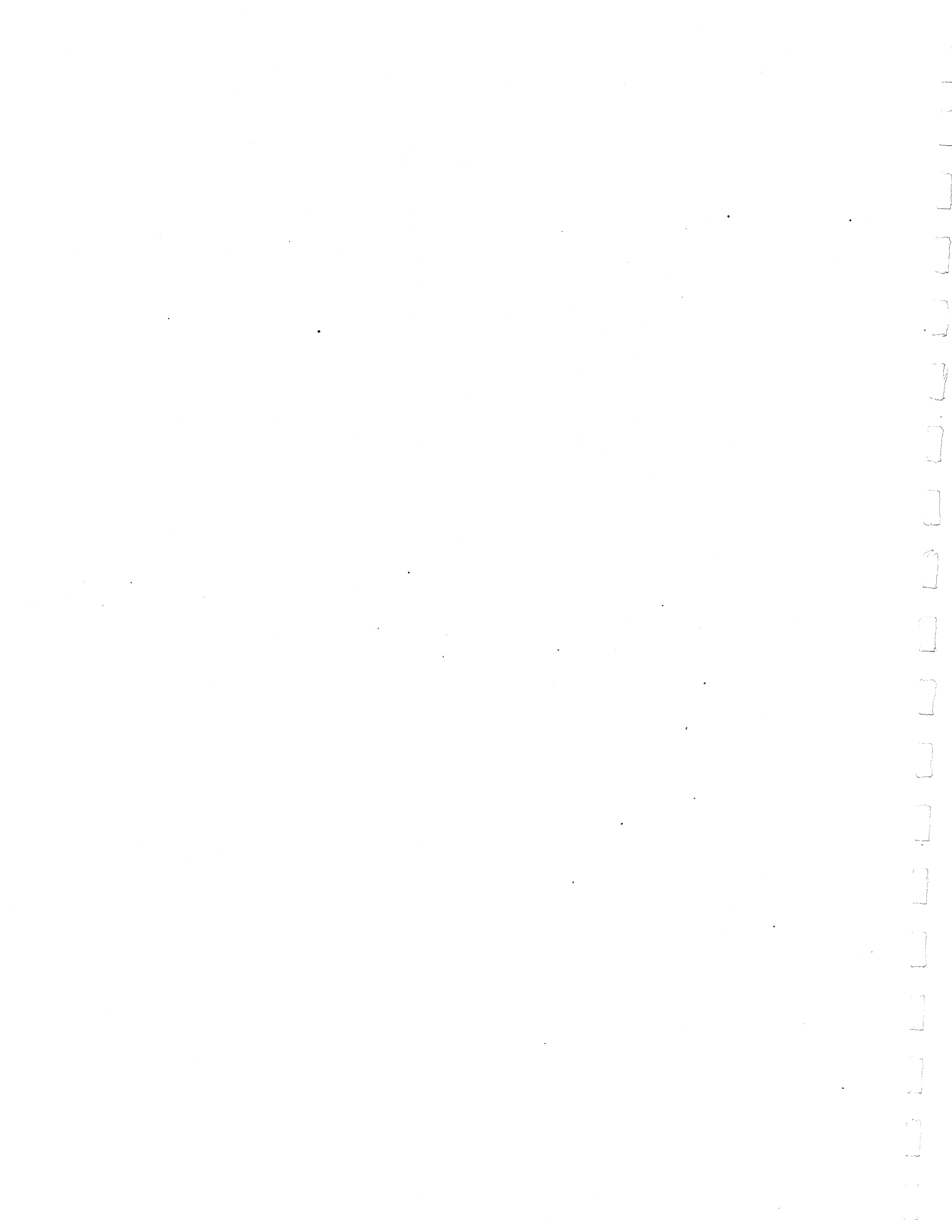

Figure 614-3. A15 1250 MHz Prescaler PCB Assembly



## Option -15 IEEE-488 Standard Interface

### 615-1. INTRODUCTION

615-2. Option -15 is an IEEE-488 Standard Interface. All programming of the counter is based on a character-serial, seven bit ASCII code, using 26 characters of the character set. All other characters are ignored by the interface.

615-3. By entering commands from a control device a measurement response can be obtained, either continuously or on command. The measurement response includes nine digits of data, with an embedded decimal point and an exponent. An overflow indication is included when the response exceeds the numeric display of the instrument. The status of the counter can be obtained by requesting a Status Response Message from the interface. The reply is a single character, in an alphanumeric code.

### 615-4. SPECIFICATIONS

615-5. The specifications for the IEEE Interface are: full remote programming of function, range, and all signal conditioning controls including trigger levels,

directly compatible with IEEE Interface Standard. Data output includes nine digits of display information, decimal point and exponent for time or frequency units. Front panel lockout is provided. An application bulletin covering the programming of this option is available upon request.

### 615-6. INSTALLATION

615-7. If the IEEE-488 Standard Interface, Option -15 is desired, it must be installed at the factory. The option is not field installable.

### 615-8. OPERATING FEATURES

615-9. Installation of Option -15 in the instrument adds the operator switches shown in Figure 615-1. A1 through A5 are used to control the local address of the counter. They may be set to the binary equivalent of the any number, 0 through 30. The number 31 (11111) is not a legal address setting. The A1 through A5 switches are placed toward the top for a binary 1. Set the address of the counter using the codes in Table 615-1.

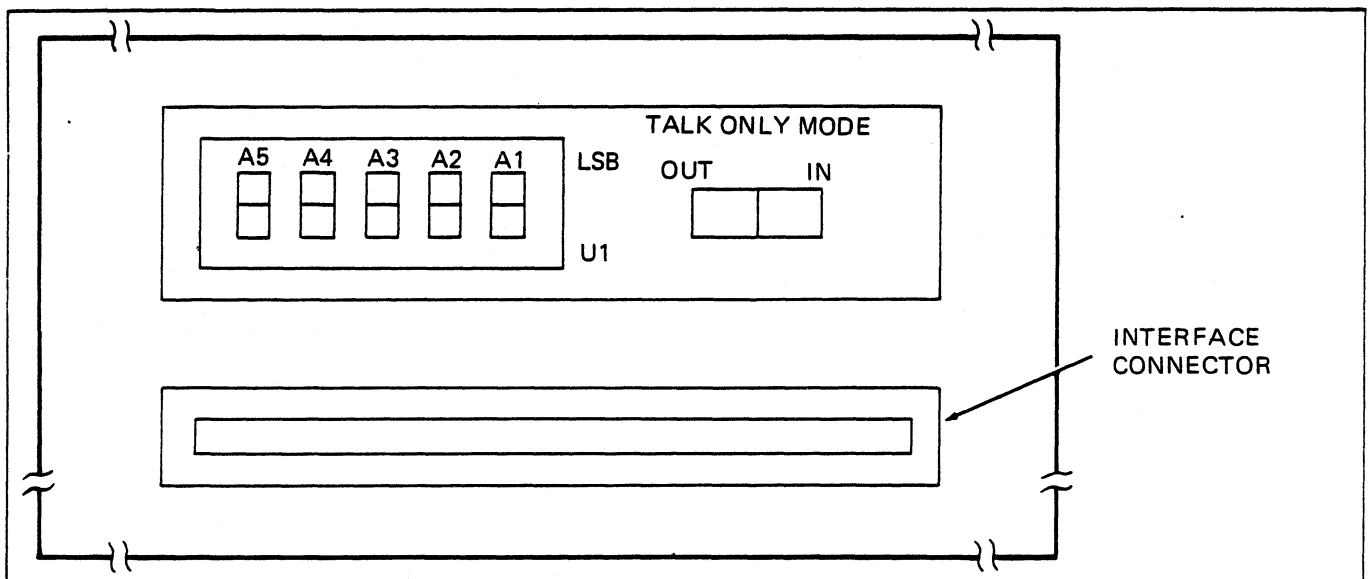

Figure 615-1. IEEE Address Switches

615-10. The TALK ONLY MODE switch controls whether the counter will operate as a "talker" only or as both a "talker" and "listener". With the switch to the right (IN), the counter only "talks".

615-11. Differentiation on the bus between "talk", "listen" and commands is made by the controller as it manipulates the two high order bits of the seven data lines.

Table 612-2. Listen and Talk Addresses

DECIMAL	5 4 3 2 1 BINARY	ASCII CHARACTER	
		LISTEN	TALK
0	0 0 0 0 0	SP	@
1	0 0 0 0 1	!	A
2	0 0 0 1 0	"	B
3	0 0 0 1 1	#	C
4	0 0 1 0 0	\$	D
5	0 0 1 0 1	%	E
6	0 0 1 1 0	&	F
7	0 0 1 1 1	'	G
8	0 1 0 1 0	*	H
9	0 1 0 0 1	(	I
10	0 1 0 1 0	)	J
11	0 1 0 1 1	+	K
12	0 1 1 0 0	,	L
13	0 1 1 0 1	-	M
14	0 1 1 1 0	.	N
15	0 1 1 1 1	/	O
16	1 0 0 0 0	0	P
17	1 0 0 0 1	1	Q
18	1 0 0 1 0	2	R
19	1 0 0 1 1	3	S
20	1 0 1 0 0	4	T
21	1 0 1 0 1	5	U
22	1 0 1 1 0	6	V
23	1 0 1 1 1	7	W
24	1 1 0 0 0	8	X
25	1 1 0 0 1	9	Y
26	1 1 0 1 0	:	Z
27	1 1 0 1 1	;	[
28	1 1 1 0 1	<	\
29	1 1 1 0 1	=	]
30	1 1 1 1 0	>	

## 615-12. OPERATING NOTES

### 615-13. Commands

615-14. The commands can be subdivided into Operating Functions, Range, Trigger Instructions, Coupling, Output Functions, Sampling, Status and Clear. An explanation and breakdown of these commands and their respective codes are given in the following sub-paragraphs.

### 615-15. Operating Function Commands

615-16. This group of commands provide for the selection of the operating function. The commands correspond to the positions of the FUNCTION switch on the front panel. The commands and their applicable codes are listed in Table 615-2.

Table 615-2. Operating Features

CODE	FUNCTION
F0	FREQ A
F1	FREQ C
F2	FREQ (A/B)
F3	Period A
F4	T.I. A-B
F5	A GTD by B
F6	Self-Check

### 615-17. Range Commands

615-18. The Range Commands are listed in Table 615-3. Each code corresponds to a switch position on the front panel RANGE switch.

Table 615-3. Range Commands

CODE	RANGE		
	GATE T.	PER AVGD	T.I. RES
R0	0.1 ms	10 <sup>0</sup>	0.1 $\mu$ s
R1	1.0 ms	10 <sup>1</sup>	1.0 $\mu$ s
R2	10 ms	10 <sup>2</sup>	10 $\mu$ s
R3	0.1s	10 <sup>3</sup>	0.1 ms
R4	1.0s	10 <sup>4</sup>	1.0 ms
R5	10s	10 <sup>5</sup>	10 ms

**615-19. Trigger Instructions**

615-20. The trigger for channel A and channel B can be programmed for both level and function. The function includes positive or negative slope and AC or DC coupling. The trigger levels are variable with either a positive or negative reference between 0.01 and 0.99 volts with 0.01 volt resolution and between 0.1 and 9.9 volts with 0.1 resolution. The commands correspond to the switches in the applicable channel Trigger controls and Signal conditioners. Table 615-4 contains the Trigger Codes and their instructions.

**Table 615-4. Trigger Instructions**

CODE		INSTRUCTION
CHANNEL A	CHANNEL B	
A+	B+	Positive Slope
A-	B-	Negative Slope
A0	B0	AC Coupled
A1	B1	DC Coupled
A+0	B+0	Positive Slope and AC Coupled
A+1	B+1	Positive Slope and DC Coupled
A-0	B-0	Negative Slope and AC Coupled
A-1	B-1	Negative Slope and DC Coupled
LA+X.X	LB+X.X	Trigger Level of +X.X Volts
LA-X.X	LB-X.X	Trigger Level of -X.X Volts
LA+.XX	LB+.XX	Trigger Level of +.XX Volts
LA-.XX	LB-.XX	Trigger Level of -.XX Volts

X = numeric digit 0 through 9. If only the first digit is substituted for the "X" character, the second must be replaced with a termination character.

**615-21. Coupling**

615-22. To couple channel A and channel B, program the instruction S1. Programming the instruction S0 separates channel A and B. The front panel equivalent is the SEP-COM switch between the two channel areas.

**615-23. Sampling Instructions**

615-24. The sample rate can be programmed with either the H0 or H1 code. The data is sampled continuously with H0 programmed; while with H1 it is sampled only on request. The code required to trigger a sample with H1 programmed is the character T.

**615-25. Output Functions**

615-26. The Output Modes are programmed using a code of M0 or M1. When programmed with an M0 code, the 1953A outputs the last frequency measured when it is addressed and then resumes taking measurements at the rate set by the Sampling Instructions, either H0 or H1. For the M1 code, the 1953A outputs a service request (SRQ) on the bus after it has taken a measurement, then waits until it is addressed to transmit that measurement. After transmission of the measurement, the 1953A resumes sampling at the rate programmed by the Sampling Instruction.

615-27. When both the H1 and M1 codes are programmed, the code X causes the retransmission of the last reading.

**615-28. Status Instruction**

615-29. With the code character G programmed and the Interface addressed as a "Talker", the 1953A outputs a status response. the format of the responses is detailed in a later paragraph.

**615-30. Clear Command**

615-31. Programming the code character C initializes the instrument to the following:

F0 R0 A+0 B+0 LA.00 S0 M0 H0.

This is the equivalent of: Frequency A at the 0.1 ms range; channel A positive slope, ac coupled; channel A trigger level of +.00 Volts; channel B trigger level of +.00 Volts; channel A and B separated; output when addressed; and sample continuously.

**615-32. Programming Example**

615-33. A typical command and an explanation of each section is given in Table 615-5.

**Table 615-5. Programming Example**

Example: F4 R1 LA-2.7 LB.85 A-1 B1 S0	
CODE	INSTRUCTION
F4	Time Interval Function
R1	1 μsec Resolution
LA-2.7	A Trigger Level at -2.7 Volts
LB.85	B Trigger Level at .85 Volts
A-1	Channel A, Negative Slope, Direct Coupling
B1	Channel B, Positive Slope, Direct Coupling
S0	Channels A and B Separate

**615-34. INTERFACE RESPONSES**

**615-35. Measurement Response**

615-36. The format of the measurement response is shown in Figure 615-2. The response is transmitted when the interface is addressed while in the proper mode.

**615-37. Status Response**

615-38. A request for status brings a response of a one-digit status message, followed by the carriage return and line feed termination characters. Refer to the applicable columns of Table 615-6 for the status of the Gate, Overflow and Busy Signals.

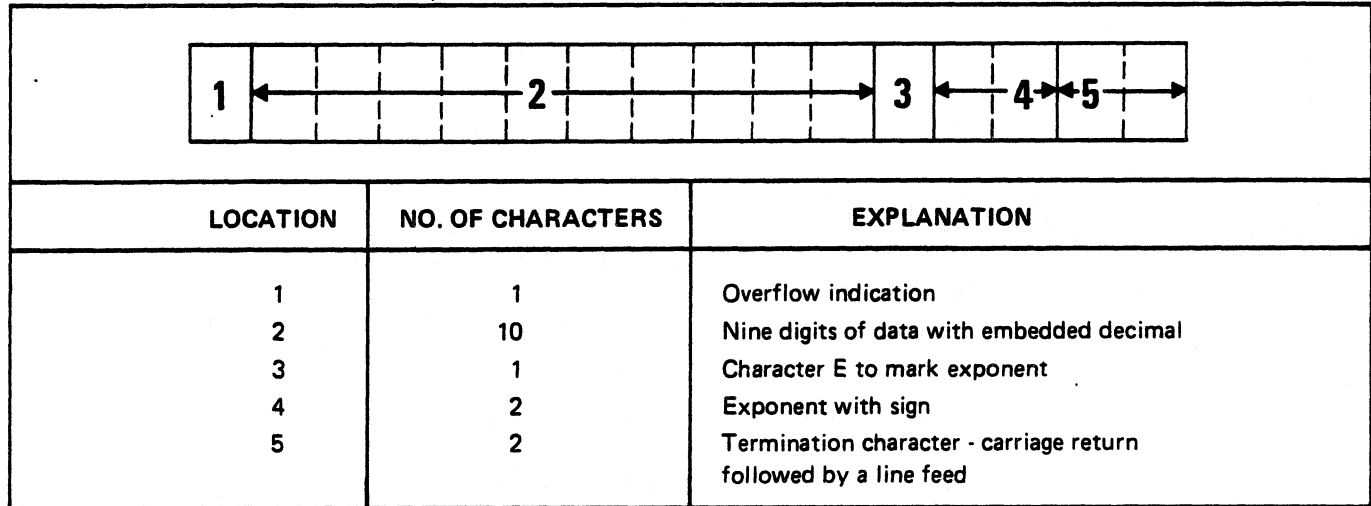

Figure 615-2. Measurement Response Format

Table 615-6. Response Codes

These Columns Are Applicable To Status Response.					
STATUS	GATE OPEN	OVERFLOW	COUNTER BUSY	SERVICE REQUEST	SERIAL-POLL STATUS
0	NO	NO	NO	NO	!
0	NO	NO	NO	YES	a
1	NO	NO	YES	NO	#
1	NO	NO	YES	YES	c
2	NO	YES	NO	NO	%
2	NO	YES	NO	NO	e
3	NO	YES	YES	NO	,
3	NO	YES	YES	YES	g
4	YES	NO	NO	NO	)
4	YES	NO	NO	YES	i
5	YES	NO	YES	NO	+
5	YES	NO	YES	YES	k
6	YES	YES	NO	NO	-
6	YES	YES	NO	YES	m
7	YES	YES	YES	NO	/
7	YES	YES	YES	YES	0
These Columns Are Applicable To Status Response in Serial Poll Mode.					



### 615-39. Status Response In Serial Poll Mode

615-40. A request for a status response in the Serial Poll mode results in a single character reply without any termination characters. Refer to the applicable columns to Table 615-6 for the status of the Gate, Overflow, Busy and Service Request Signals.

615-41. The Serial Poll status request instruction is dependent upon the controlling device and the IEEE bus. Refer to the standard and the sub-set used for this information.

### 615-42. THEORY OF OPERATION

615-43. The theory of operation for the IEEE-488 Interface is given in the following paragraphs on a block diagram level. The description includes an explanation of the operation of the interface in both the listen and talk modes since the counter is capable of both listening (accepting commands to change range, status, function, etc.) and talking (transmitting measurement or status information) to the bus. The counter is assigned a binary address code on the Interface PCB. The address is set on five switches which determine the five low-order bits of an ASCII character. The two high-order bits determine whether it is to be a talk or listen address. Refer to Table 615-6 for the addresses available. The address 11111 is reserved for the "unlisten" and "untalk" commands which prevent the counter from misunderstanding the information on the bus and talking or listening to itself. The block diagram of the interface used in the discussion is found in Figure 615-3.

### 615-44. Listen Mode

615-45. To operate in the Listen Mode, the pre-selected address must be on the Data Lines and the REN and ATN command lines active. This action, followed by active DAV and RFD signals, sets control flip-flops in the Data Decoders and Control Storage, preparing the interface microprocessor to accept instructions from the controller. After the data has been accepted, the DAC lines becomes active, inactivating ATN and DAV. The last action results in the DAC signal returning to inactive so that the interface is now ready to accept instructions.

615-46. Starting an instruction requires the ASCII code for the desired instruction on the data lines with ATN inactive and RFD active. The Controller drives DAV active to start the Handshake sequence. Once the data has been accepted in the microprocessor, the DAC signal goes active to complete the Handshake sequence. The microprocessor acts on the instruction, transforms it into the digital format required and outputs the instruction to the counter.

### 615-47. Talk Mode

615-48. The Talk Mode requires the ATN signal active and the correct address, just as the Listen Mode, to differentiate between it and an instruction. The start of the Handshake sequence latches the command into the Data Decoders and Control Storage for transfer to the microprocessor. Once the Handshake sequence is complete, the interface is in the Talk Mode and can begin transmitting data to the Controller.

615-49. After the addressing has been completed, the microprocessor accepts the data on the lines from the counter and outputs it through Data Storage to the Data I/F Transceivers and Controller. After completion, depending upon the mode selected, the microprocessor will either continue to transmit the outputs from the counter or, after the single sample, be reset by the controller to hold until addressed again.

### 615-50. Talk Only Mode

615-51. The I/F Switchboard assembly has a switch that allows the operator to place the instrument in the Talk Only Mode. In this configuration, the interface outputs the data from the counter, either measurement or status, as determined by a previous mode instruction or by the default configurations.

### 615-52. TROUBLESHOOTING

615-53. The use of microprocessor control in the IEEE-488 Option increases the speed and efficiency of the interface but at the same time increases the complexity and difficulty of troubleshooting. The two significant pcbs in the interface are layered parallel to the counter main pcb. As a result, if any checks are required on the Interface PCB, the I/F Processor PCB must be removed from the counter and reconnected back into the circuit using the extender cables available in the optional extender cable accessory kit 1953A-7020K. For this reason check point locations are given on the I/F Processor PCB, whenever feasible, to preclude removal of the pcb until required.

615-54. Troubleshooting for the 1953A Option -15 IEEE Interface consists of the Tabular Flow Chart in Table 615-7. When a step on the flow chart is completed, check for a decision transfer. If no decision is required, perform the next step of the table in sequence.

### 615-55. LIST OF REPLACEABLE PARTS

615-56. Table 615-9 is a list of replaceable parts for the IEEE-488 Interface Option. Refer to Section 5 for an explanation of the column entries.

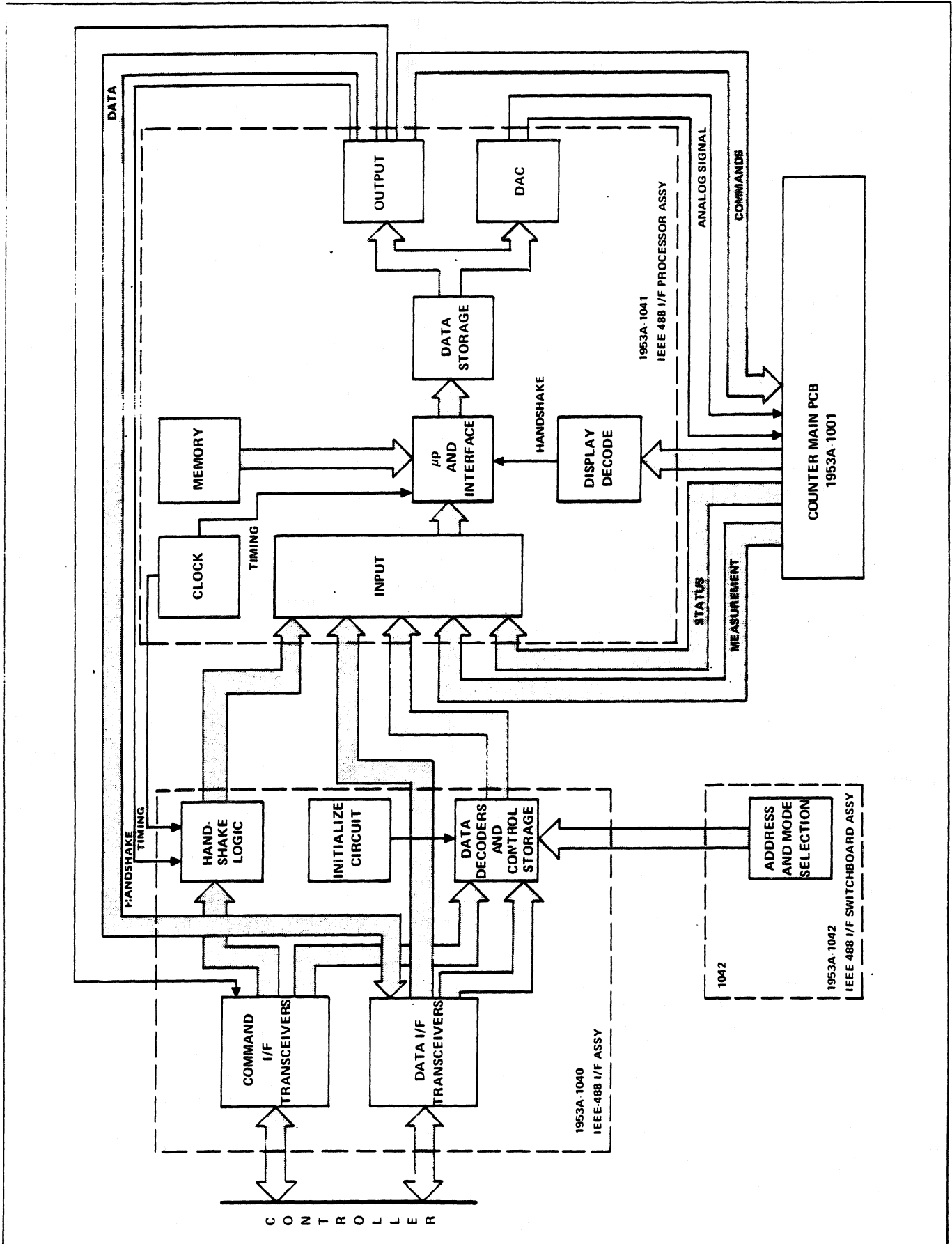

Figure 615-3. IEEE Interface Block Diagram

**CAUTION**

Indicated devices are subject to damage by static discharge.

The 1953A can be ordered with three factory-installed BNC connectors on the rear panel which serve as inputs

to channels A, B, and C. When this option is ordered, no front panel connector is installed for the channel C input. The channels A and B inputs are in parallel with the corresponding front panel inputs. The addition of the rear panel input terminals for channels A and B increases the input capacity of these channels to 85 pF.

**Table 615-7. IEEE-488 Troubleshooting**

STEP NO.	INSTRUCTION	YES	NO	GOTO
	<i>NOTE</i>			
	<i>The Microprocessor group called out in this procedure consists of the Clock U28, the 404 Microprocessor U22, the ROM U23, the Memory Interface U17 and the Multiplexers U8, U13, U18 and U24. Due to the speed and complexity of these components, the recommended solution for troubleshooting is substitution.</i>			
1	Address the counter with the assigned Listen address.			
2	Check MLA at U18-1 with a Scope (Logic Tester).			
3	Is the signal HIGH?	5	4	
4	Check the circuits on the Interface PCB. Verify that the ATN is low at the input, then check the handshake circuits and the listen flip-flop. Repair as required; then restart at step 1.			
5	If the controller will allow it, alter the listen address to ensure the data transceivers will respond to both signal levels, e.g., if the normal listen address as shown in Table 615-1 is "/" for a binary code of 0111, change the address to "0" for a binary code of 10000, forcing the transceivers to go both high and low. Repeat steps 1 through 4 with the new address, then return to the normal address and proceed to step 6. If the address is not alterable, proceed to step 6.			
6	Perform the test in Table 615-8, checking for the applicable logic level with a scope.			
7	Were all readings satisfactory?	9	8	
8	If the output of either U25 or U26 is incorrect, decode and check the signal input from U9, U10, U14 and U15. The data for U32 should be latched into U9, U10, U14 and U15 also. Check the applicable latch and controls if only the signals from that latch are affected. If these areas are satisfactory, check the microprocessor group. Repair as required, then repeat the applicable portions in step 6.			
9	Enter the instruction LA9.9 LB9.9.			
10	With a DVM or scope check at U12-4 (channel A) and U11-4 (channel B) for a voltage approaching 1V dc.			
11	Enter the instruction LA.00 LB.00.			
12	Check U12-4 and U11-4 for a voltage approaching 0V dc.			
13	Are the readings in steps 10 and 12 correct?	15	14	
14	If the problem is in channel A, check the binary coded input to U3 from U14-9, U15-9, U9-9, U10-9 (first four bits) and U14-10, U15-10, U9-10, U10-10 (last four bits). For channel B, check the binary coded input to U5 from pins 11 and 12 of U14, U15, U9 and U10 for the first and last four bits, respectively. U14-9 and U14-11 are high for positive entries and low for negative. The remaining seven bits will start with all low for positive entries and increment for each count. Negative numbers will start with all high except the MSB at zero and decrement one bit for each negative count. If these areas are satisfactory, check the microprocessor group. Repair as required, then repeat the test starting at step 9.			
15	Enter the instruction H0 M0.			

Table 615-7. IEEE-488 Troubleshooting (cont)

STEP NO.	INSTRUCTION	YES	NO	GO TO
16	Observe U20-13 with a scope for a pulse train.			
17	Leave the scope connected to U20-13 and observe the display while entering the instruction H1.			
18	The pulse train should cease with the completion of the entry.			
19	Enter the instruction T.			
20	One pulse should occur concurrent with the entry.			
21	Enter the instruction H0.			
22	The pulse train should resume with the completion of the instruction.			
23	Are the indications in steps 16 through 22 correct?	25	24	
24	Verify the operation of U20 and the microprocessor group. Repair as required, then restart the test at step 16.			
25	Enter the talk address.			
26	Does the counter respond with measurement data to the controller?	31	27	
27	Monitor U21-10/U29-13 with a scope while entering the talk address.			
28	Does the point pulse to a logic level?	30	29	
29	Check at U18-1 for a High MTA. If MTA is not correct, check the circuits on the Interface PCB; ATN, the transceivers, addressing gates, handshake circuitry and the talk flip-flop. Repair as required, then repeat starting at step 25.			
30	Check the microprocessor group and U21/U29 with their associated circuitry. Repair as required, then repeat starting at step 25.			
31	Enter the Listen address and the instruction H1 M1.			
32	Address the instrument as a talker.			
33	Record the transmitted measurement, if not done automatically by the controller.			
34	Enter the Listen address and the instruction X.			
35	Address the instrument as a talker.			
36	Is the response the same as obtained in step 33?	38	37	
37	Check the microprocessor group. The remaining circuits have been verified by previous tests. Repair as required, then restart at step 31.			
38	Enter the Listen address and the instruction G.			
39	Address the instrument as a talker.			
40	Is the one-digit status response correct?	42	41	
41	Check the microprocessor group and the gate and overflow inputs from the Main PCB. The remaining circuits have been verified by previous tests. Repair as required, then restart at step 39.			
42	Troubleshooting of the IEEE-488 Interface is complete.			

Table 615-8. Instruction Logic Levels

INSTRUCTION MNEMONIC		LOGIC LEVEL HIGH AT	LOGIC LEVEL LOW AT	COMMENTS
Clear (C)	F0	U26 Group	U26-2	A high logic level for the U26 group infers that from the designated pins U26-2 through U26-7 and U26-9, all are high except the one specifically designated low. The same hold true for the U25 group which are pins U25-2 through U25-7.
	R0	U25 Group	U25-2	
	$\overline{SC}$		U32-11	
	$\overline{SA}$		U32-13	
	$\overline{DA}$		U32-3	
	$\overline{SB}$		U32-15	
	$\overline{DB}$		U32-7	
	$\overline{TA}$		U35-5	
	$\overline{TB}$		U32-9	
	Freq C (F1)	$\overline{C}$	U26 Group	
Freq A/B (F2)	A/B	"	U26-4	
Period A (F3)	$\overline{PA}$	"	U26-5	
Time Interval (F4)	$\overline{TI}$	"	U26-6	
A Gated By B (F5)	$\overline{AXB}$	"	U26-7	
Self-Check (F6)	$\overline{CH}$	"	U26-9	
Freq A (F0)	$\overline{A}$	"	U26-2	
1.0 ms (R1)	$\overline{2}$	U25 Group	U25-3	
10.0 ms (R2)	$\overline{3}$	"	U25-4	
0.1s (R3)	$\overline{4}$	"	U25-5	
1.0s	$\overline{5}$	"	U25-6	
10.0s (R5)	$\overline{6}$	"	U25-7	
0.1 ms (R0)	$\overline{7}$	"	U25-2	
Com (S1)	$\overline{SC}$	U32-11		
Sep (S0)	$\overline{SC}$		U32-11	
Slope A(A-1)	$\overline{SA}$		U32-13	
Neg DC Coupled	$\overline{DA}$		U32-3	
Slope A Pos AC Coupled (A+0)	$\overline{SA}$	U32-13		
Slope B Neg DC Coupled (B-1)	$\overline{SB}$	U32-3	U32-15	
Slope B Pos AC Coupled (A+0)	$\overline{SB}$	U32-15		
Ch AX10 (LA 0.0).	$\overline{DB}$	U32-7		
Ch AX1 (LA.00)	$\overline{TA}$		U32-5	
Ch BX10 (LB0.0)	$\overline{TB}$		U32-9	
Ch BX1 (LB.00)	$\overline{TB}$	U32-9		

Table 615-9. -15 Option, IEEE-488 Interface Assembly

ITEM NO.	DESCRIPTION	FLUKE STOCK NO.	MFG SPLY CODE	MFG PART NO. OR TYPE	TOT QTY	REC QTY	USE CDE
⊙IEEE-488 INTERFACE, OPTION -15							
FIGURE 615-4							
A11	RCU 1 PCB ASSY	396242	89536	396242	1		
A12	RCU 2 PCB ASSY	396259	89536	396259	1		
A16	BUS INTERFACE PCB ASSY	440214	89536	440214	1		
A17	PROCESSOR PCB ASSY	440222	89536	440222	1		
A18	SWITCH PCB ASSY	440230	89536	440230	1		
H1	SCREW, CONNECTOR MOUNTING	423472	89536	423472	2		
MP1	SUPPORT, CONNECTOR	439190	89536	439190	1		
U17	⊙IC, MOS, STANDARD MEMORY INTERFACE	404434	34649	P4289	1		
U22	⊙IC, MOS, CENTRAL PROCESSOR UNIT	404418	34649	C4040	1		
U23	⊙IC, MOS, ROM	486506	89536	486506	1		

▶	REPLACES A1A3 INPUT PCB ASSY P/N 396127
---	---

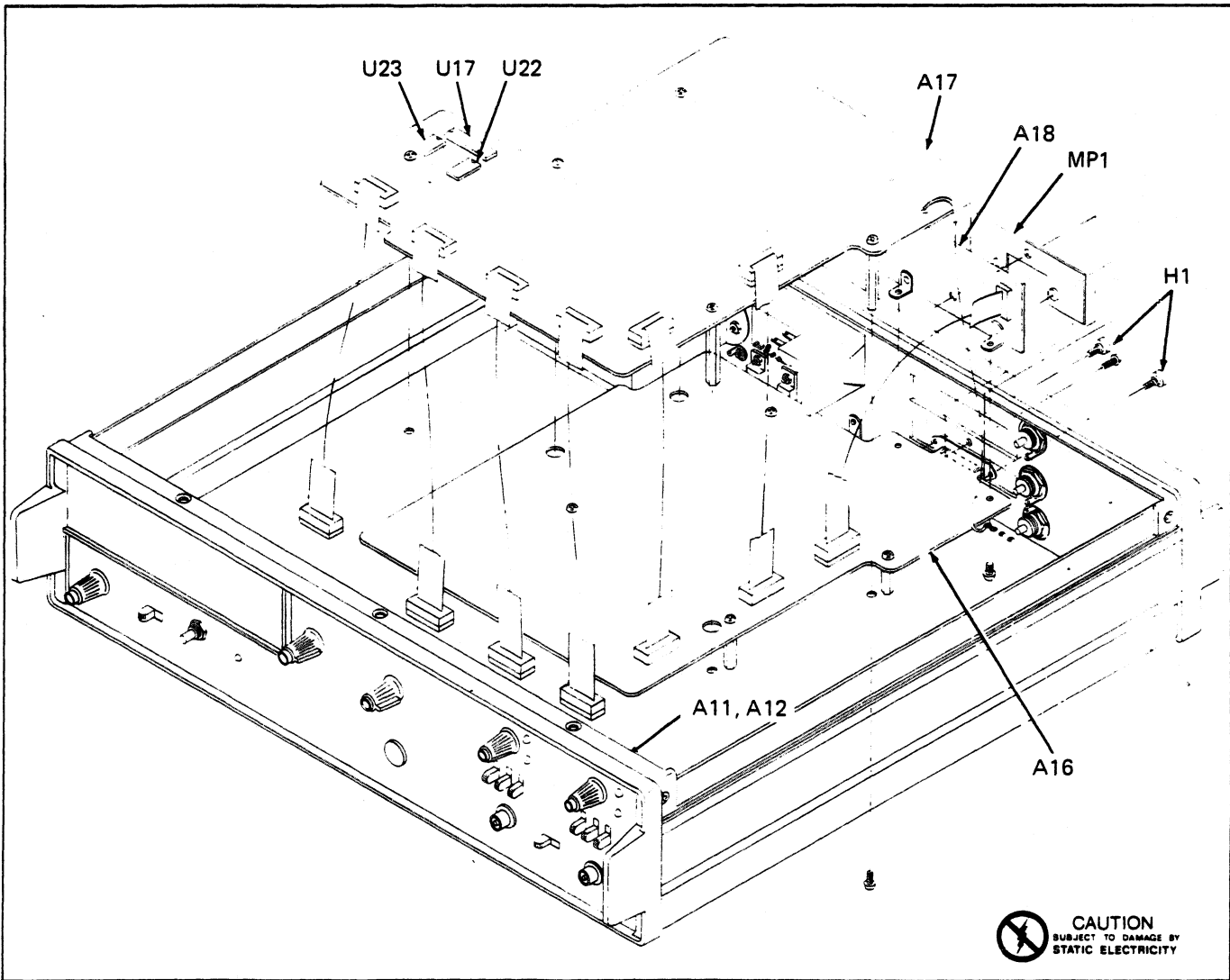

**CAUTION**  
SUBJECT TO DAMAGE BY  
STATIC ELECTRICITY

Figure 615-4. -15 Option, IEEE-488 Interface Assembly

Table 615-10. A11 Remote Control Unit =1 PCB Assembly

ITEM NO.	DESCRIPTION	FLUKE STOCK NO.	MFG SPLY CODE	MFG PART NO. OR TYPE	TOT QTY	REC QTY	USE CDE
A11	REMOTE CONTROL UNIT 1 PCB ASSY (1953A-4021) FIGURE 615-5	396242	89536	396242	REF		
DS401	INDICATOR, LED	385898	28480	5082-4487	4	1	
DS402	INDICATOR, LED	385898	28480	5082-4487	REF		
DS403	INDICATOR, LED	385898	28480	5082-4487	REF		
DS404	INDICATOR, LED	385898	28480	5082-4487	REF		
J1	CONNECTOR PIN, FEMALE, LARGE	149112	74970	105-0753	2		
	PIN, FEMALE, SMALL	375329	00779	85863-3	12		
P10	CONNECTOR POST UNINSULATED	376574	00779	5166-333-68	7		
R410	RES, COMP, 47 +/-5%, 1/4W	147892	01121	CB4705	4		
R411	RES, COMP, 47 +/-5%, 1/4W	147892	01121	CB4705	REF		
R412	RES, COMP, 47 +/-5%, 1/4W	147892	01121	CB4705	REF		
R413	RES, COMP, 47 +/-5%, 1/4W	147892	01121	CB4705	REF		
S108	SWITCH, SLIDE, SPDT	380113	79727	GF-124-SPDT	7	2	
S109	SWITCH, SLIDE, SPDT	380113	79727	GF-124-SPDT	REF		
S110	SWITCH, SLIDE, SPDT	380113	79727	GF-124-SPDT	REF		
S111	SWITCH, SLIDE, SPDT	380113	79727	GF-124-SPDT	REF		
S112	SWITCH, SLIDE, SPDT	380113	79727	GF-124-SPDT	REF		
S113	SWITCH, SLIDE, SPDT	380113	79727	GF-124-SPDT	REF		
S114	SWITCH, SLIDE, SPDT	380113	79727	GF-124-SPDT	REF		
U401	RES, NETWORK, SEVEN 10K +/-5%, 1.5W (OR 7 DISCRETE RESISTORS, P/N 148106)	364000	71450	760-1	1	1	
U402	IC, TTL, HEX INVERTER, OPEN COLLECTOR	379305	01295	SN7405N	1	1	

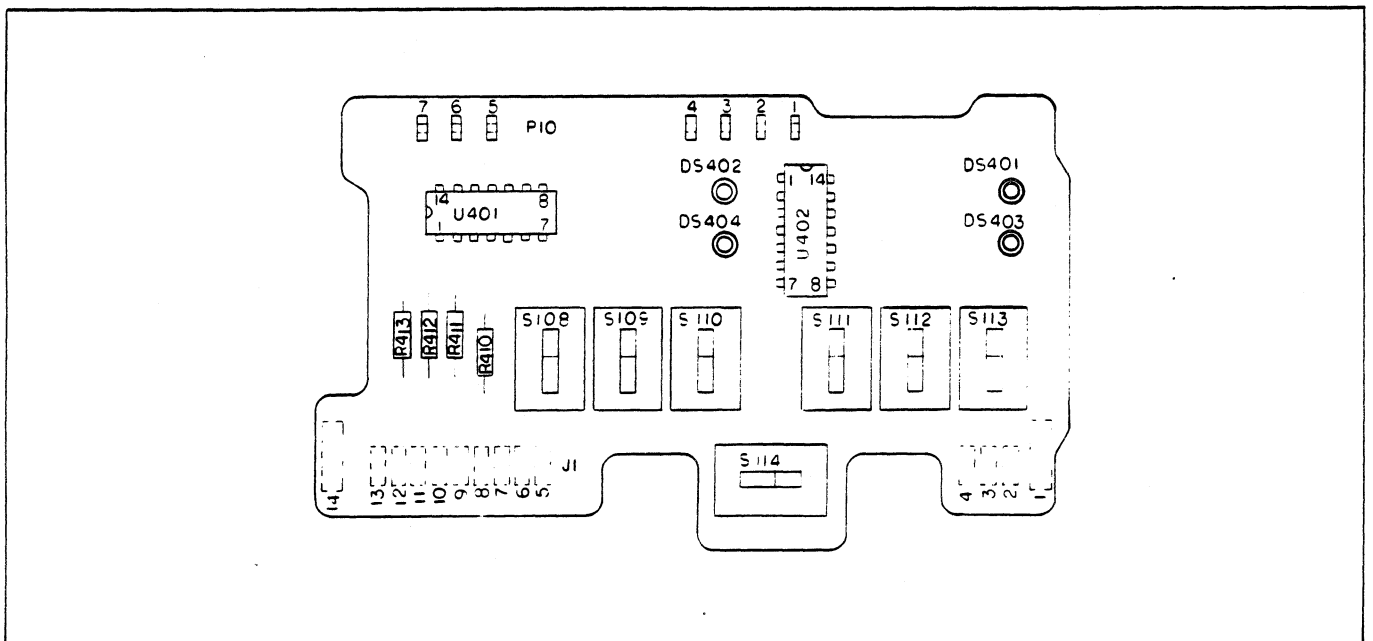

Figure 615-5. A11 Remote Control Unit =1 PCB Assembly

Table 615-11. A12 Remote Control Unit #2 PCB Assembly

ITEM NO.	DESCRIPTION	FLUKE STOCK NO.	MFG SPLY CODE	MFG PART NO. OR TYPE	TOT QTY	REC QTY	USE CDE
A12	REMOTE CONTROL UNIT 2 PCB ASSEMBLY (1953A-4022) FIGURE 615-6	396259	89536	396259		REF	
C1	CAP, MYLAR, 0.1 UF +/-10%, 400V	447573	73445	C280MF/A100K	2		
C2	CAP, MYLAR, 0.1 UF +/-10%, 400V	447573	73445	C280MF/A100K	REF		
C3	CAP, CER, 1.5 PF +/-0.25 PF, 1 KV	178475	56289	10TCCV15-NPO	2		
C4	CAP, CER, 1.5 PF +/-0.25 PF, 1 KV	178475	56289	10TCCV15-NPO	REF		
J2	CONNECTOR PIN, FEMALE, LARGE	149112	74970	105-0753	2		
	PIN, FEMALE, SMALL	375329	00779	85863-3	9		
R1	RES, COMP, 910K +/-5%, 1/4W	285338	01121	CB9145	2		
R2	RES, COMP, 910K +/-5%, 1/4W	285338	01121	CB9145	REF		
R3	RES, COMP, 100K +/-5%, 1/4W	148189	01121	CB1045	2		
R4	RES, COMP, 100K +/-5%, 1/4W	148189	01121	CB1045	REF		
R5	RES, VAR, 10K +/-30%, 1/2W	385880	89536	385880	2		
R6	RES, VAR, 10K +/-30%, 1/2W	385880	89536	385880	REF		
U3	IC, TTL, HEX INVERTER, OPEN COLLECTOR	379305	01295	SN7405N	1	1	

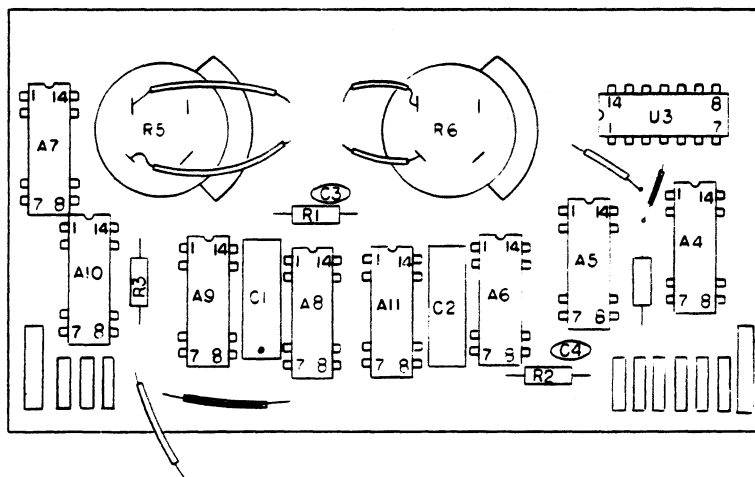

Figure 615-6. A12 Remote Control Unit #2 PCB Assembly



Table 615-12. A16 IEEE-488 1975 Interface PCB Assembly

ITEM NO.	DESCRIPTION	FLUKE STOCK NO.	MFG SPLY CODE	MFG PART NO. OR TYPE	TOT QTY	REC QTY	USE CDE
A16	IEEE-488-1975 BUS INTERFACE PCB ASSY (1953A-4040) FIGURE 615-7						
C1	CAP, TA, 0.22 UF +/-20%, 35V	161331	56289	196D224X0035HA1	4		
C2	CAP, TA, 0.22 UF +/-20%, 35V	161331	56289	196D224X0035HA1	REF		
C3	CAP, TA, 0.22 UF +/-20%, 35V	161331	56289	196D224X0035HA1	REF		
C4	CAP, TA, 0.22 UF +/-20%, 35V	161331	56289	196D224X0035HA1	REF		
C5	CAP, ELECT, 10 UF +/-20%, 15V	193623	56289	196D106X0015KA1	1	1	
J1	CONNECTOR, FEMALE, 24-PIN	408898	13511	57-20240-2 (323)	1		
J2	CABLE ASSEMBLY	380576	89536	380576	2		
J3	CABLE ASSEMBLY	380576	89536	380576	REF		
J6	SOCKET, IC, 16-PIN	370312	01295	C931602	1		
R1	RES, FXD, COMP, 390 +/-5%, 1/4W	147975	01121	CB3905	1		
R2	RES, COMP, 3K +/-5%, 1/4W	193508	01121	CB3025	1		
U1	IC, QUAD INTERFACE BUS TRANSCEIVER	428649	04713	MC3446P	4	1	
U2	IC, QUAD INTERFACE BUS TRANSCEIVER	428649	04713	MC3446P	REF		
U3	IC, QUAD INTERFACE BUS TRANSCEIVER	428649	04713	MC3446P	REF		
U4	IC, QUAD INTERFACE BUS TRANSCEIVER	428649	04713	MC3446P	REF		
U5	IC, TTL, HEX INVERTER	393058	01295	SN74LS04N	2	1	
U6	IC, TTL, HEX INVERTER	393058	01295	SN74LS04N	REF		
U7	IC, TTL, DUAL J-K FLIP-FLOP	393157	01295	SN74LS107N	3	1	
U8	IC, TTL, DUAL J-K FLIP-FLOP	393157	01295	SN74LS107N	REF		
U9	IC, TTL, 8-INPUT NAND GATE	404889	01295	SN74LS30N	4	1	
U10	IC, TTL, 8-INPUT NAND GATE	404889	01295	SN74LS30N	REF		
U11	IC, TTL, QUAD 2-INPUT NOR GATE	393041	01295	SN74SL02N	3	1	
U12	IC, TTL, QUAD 2-INPUT AND GATE	393066	01295	SN74LS08N	1	1	
U13	IC, TTL, DUAL J-K FLIP-FLOP	393157	01295	SN74LS107N	REF		
U14	IC, TTL, QUAD 2-INPUT NOR GATE	393041	01295	SN74SL02N	REF		
U15	IC, TTL, 8-INPUT NAND GATE	404889	01295	SN74LS30N	REF		
U16	IC, TTL, DUAL J-K FLIP-FLOP	414029	01295	SN74LS112N	1	1	
U17	IC, TTL, QUAD 2-INPUT NOR GATE	393041	01295	SN74SL02N	REF		
U18	IC, TTL, DUAL D-TYPE FLIP-FLOP	393124	01295	SN74LS74N	1	1	
U19	IC, TTL, 8-INPUT NAND GATE	404889	01295	SN74LS30N	REF		
U20	IC, TTL, QUAD 2-INPUT NAND GATE	393033	01295	SN74LS00N	1		
U21	IC, TTL, QUAD 2-INPUT OR GATE	393108	01295	SN74LS32N	1	1	

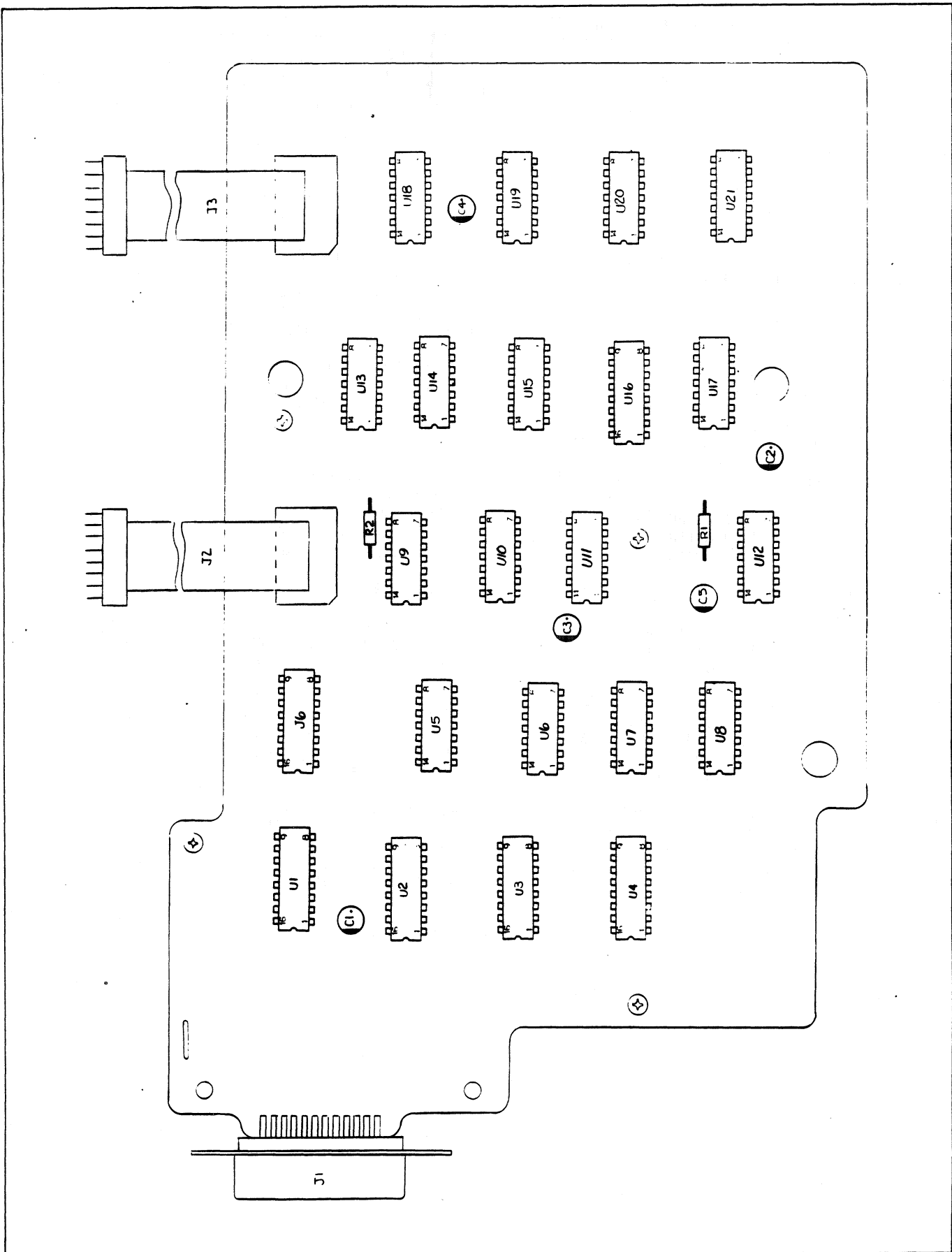

Figure 615-7. A16 IEEE-488-1975 Bus Interface PCB Assembly

Table 615-13. A17 Processor PCB Assembly

ITEM NO.	DESCRIPTION	FLUKE STOCK NO.	MFG SPLY CODE	MFG PART NO. OR TYPE	TOT QTY	REC QTY	USE CDE
A17	⊕IEEE-488-1975 PROCESSOR PCB ASSEMBLY (1953A-4041) (FIGURE 615-8)						
C1	CAP, ELECT, 10 UF +50/-10%, 25V	170266	73445	ET100X25A2	4		1
C2	CAP, ELECT, 10 UF +50/-10%, 25V	170266	73445	ET100X25A2	REF		
C3	CAP, ELECT, 10 UF +50/-10%, 25V	170266	73445	ET100X25A2	REF		
C4	CAP, ELECT, 10 UF +50/-10%, 25V	170266	73445	ET100X25A2	REF		
C5	CAP, TA, 0.47 UF +/-20%, 250V	161349	56289	196D474X0035HA1	1		
C6	CAP, MICA, 22 PF +/-5%, 500V	148551	72136	DM15C220J	2		
C7	CAP, MICA, 22 PF +/-5%, 500V	148551	72136	DM15C220J	REF		
C8	CAP, TA, 1 UF +/-20%, 35V	161919	56289	196D105X0035JA1	2		
C9	CAP, TA, 1 UF +/-20%, 35V	161919	56289	196D105X0035JA1	REF		
C10	CAP, MICA, 100 PF +/-5%, 500V	148494	72136	DM15F101J	2		
C11	CAP, MICA, 100 PF +/-5%, 500V	148494	72136	DM15F101J	REF		
C12	CAP, POLYESTER, 0.01 UF +/-10%, 250V	325548	73445	C280MAEA10K	2		
C13	CAP, POLYESTER, 0.01 UF +/-10%, 250V	325548	73445	C280MAEA10K	REF		
C14	CAP, TA, 0.22 UF +/-20%, 35V	161331	56289	196D224X0035HA1	5		
C15	CAP, TA, 0.22 UF +/-20%, 35V	161331	56289	196D224X0035HA1	REF		
C16	CAP, TA, 0.22 UF +/-20%, 35V	161331	56289	196D224X0035HA1	REF		
C17	CAP, TA, 0.22 UF +/-20%, 35V	161331	56289	196D224X0035HA1	REF		
C18	CAP, TA, 0.22 UF +/-20%, 35V	161331	56289	196D224X0035HA1	REF		
C19	CAP, TA, 5.6 UF +/-20%, 25V	368969	56289	196D565X0025KA1	3		
C20	CAP, TA, 10 UF +/-20%, 35V	417683	56289	196D106X0035PE4	2		
C21	CAP, TA, 10 UF +/-20%, 35V	417683	56289	196D106X0035PE4	REF		
C24	CAP, TA, 5.6 UF +/-20%, 25V	368969	56289	196D565X0025KA1	REF		
C25	CAP, TA, 5.6 UF +/-20%, 25V	368969	56289	196D565X0025KA1	REF		
CR1	DIODE, SI	203323	07910	1N4448	3		
CR2	DIODE, SI	203323	07910	1N4448	REF		
CR3	DIODE, SI	203323	07910	1N4448	REF		
CR4	DIODE, ZENER, 7V	260695	07910	1N754A	1		1
J1	CABLE	380576	08261	5122-003.5	4		
J2	CABLE	380576	08261	5122-003.5	REF		
J3	CABLE	380576	08261	5122-003.5	REF		
J4	SOCKET, IC, 16-PIN	387324	71765	133-59-02-062	3		
J5	CABLE	380576	08261	5122-003.5	REF		
J6	SOCKET, IC, 16-PIN	387324	71765	133-59-02-062	REF		
L1	CHOKER, 6 TURN	320911	89536	320911	3		
L2	CHOKER, 6 TURN	320911	89536	320911	REF		
L3	CHOKER, 6 TURN	320911	89536	320911	REF		
R1	RES, COMP, 51 +/-5%, 1/4W	221879	01121	CB5105	1		
R2	RES, COMP, 680K +/-5%, 1/4W	188433	01121	CB6845	1		
R3	RES, COMP, 100 +/-5%, 1/4W	147926	01121	CB1015	1		
R4	RES, COMP, 20K +/-5%, 1/4W	221614	01121	CB2035	1		
R5	RES, COMP, 3K +/-5%, 1/4W	193508	01121	CB3025	1		
R6	RES, NETWORK, 10K	414003	89536	414003	1		
R7	RES, COMP, 5.6K +/-5%, 1/4W	148080	01121	CB5625	4		
R8	RES, COMP, 5.6K +/-5%, 1/4W	148080	01121	CB5625	REF		
R9	RES, COMP, 5.6K +/-5%, 1/4W	148080	01121	CB5625	REF		
R10	RES, COMP, 5.6K +/-5%, 1/4W	148080	01121	CB5625	REF		
R11	RES, MF, 5.11K +/-1%, 1/8W	294868	91637	MFF1-85111F	4		

Table 615-13. A17 Processor PCB Assembly (cont)

ITEM NO.	DESCRIPTION	FLUKE STOCK NO.	MFG SPLY CODE	MFG PART NO. OR TYPE	TOT QTY	REC QTY	USE CDE
R12	RES, MF, 5.11K +/-1%, 1/8W	294868	91637	MFF1-85111F	REF		
R13	RES, MF, 562 +/-1%, 1/8W	340828	91637	MFF1-85620F	2		
R14	RES, MF, 66.5 +/-1%, 1/8W	289082	91637	MFF1-86652F	2		
R15	RES, MF, 549 +/-1%, 1/8W	436469	91637	MFF1-85490F	2		
R16	RES, VA, 10K +/-10%, 1/2W	309674	89536	309674	2		
R17	RES, MF, 5.11K +/-1%, 1/8W	294868	91637	MFF1-85111F	REF		
R18	RES, MF, 549 +/-1%, 1/8W	436469	91637	MFF1-85490F	REF		
R19	RES, MF, 5.11K +/-1%, 1/8W	294868	91637	MFF1-85111F	REF		
R20	RES, MF, 562 +/-1%, 1/8W	340828	91637	MFF1-85620F	REF		
R21	RES, MF, 66.5 +/-1%, 1/8W	289082	91637	MFF1-86652F	REF		
R22	RES, VA, 10K +/-10%, 1/2W	309674	89536	309674	REF		
R23	RES, COMP, 10K +/-5%, 1/4W	148106	01121	CB1035	1		
U1	IC, TTL, 8-BIT BISTABLE LATCH	408377	01295	SN74LS75N	2		
U2	IC, TTL, HEX INVERTER	393058	01295	SN74LS04N	1		
U3	IC, 8-BIT D/A CONVERTER	419226	06665	DAC08CZ	2		
U4	IC, OP AMP	363515	12040	LM301AN	2	1	
U5	IC, 8-BIT D/A CONVERTER	419226	06665	DAC08CZ	REF		
U6	IC, OP AMP	363515	12040	LM301AN	REF		
U7	IC, TTL, 8-BIT BISTABLE LATCH	408377	01295	SN74LS75N	REF		
U8	IC, TTL, 8-BIT DATA SELECTOR/MULTIPLEXER	407577	01295	SN74LS251	4	1	
U9	IC, TTL, 8-BIT ADDRESSABLE LATCH	419242	01295	SN74LS259N	4	1	
U10	IC, TTL, 8-BIT ADDRESSABLE LATCH	419242	01295	SN74LS259N	REF		
U11	⊗ IC, CMOS, TRIPLE 2-CHANNEL MULTIPLEXER	375808	95303	CD4053AE	2	1	
U12	⊗ IC, CMOS, TRIPLE 2-CHANNEL MULTIPLEXER	375808	95303	CD4053AE	REF		
U13	IC, TTL, 8-BIT DATA SELECTOR/MULTIPLEXER	407577	01295	SN74LS251	REF		
U14	IC, TTL, 8-BIT ADDRESSABLE LATCH	419242	01295	SN74LS259N	REF		
U15	IC, TTL, 8-BIT ADDRESSABLE LATCH	419242	01295	SN74LS259N	REF		
U16	IC, TTL, QUAD 2-INPUT OR GATE	393108	01285	SN74LS32N	1		
U17	SEE OPTION -15 FINAL ASSEMBLY						
U18	IC, TTL, 8-BIT DATA SELECTOR/MULTIPLEXER	407577	01295	SN74LS251	REF		
U19	IC, TTL, QUAD 2-INPUT NAND GATE	393033	01295	SN74LS00N	1	1	
U20	IC, TTL, 3-TO-8 LINE DECODER	407585	01295	SN74LS138N	1	1	
U21	IC, TTL, DUAL J-K FLIP-FLOP	393157	01295	SN74LS107N	2	1	
U22	SEE OPTION -15 FINAL ASSEMBLY				REF		
U23	SEE OPTION -15 FINAL ASSEMBLY				REF		
U24	IC, TTL, 8-BIT DATA SELECTOR/MULTIPLIER	407577	01295	SN74LS251	REF		
U25	IC, TTL, BCD-TO-DECIMAL DECODER/DRIVER	419192	01295	SN74LS145N	2	1	
U26	IC, TTL, BCD-TO-DECIMAL DECODER/DRIVER	419192	01295	SN74LS145N	REF		
U27	IC, TTL, TRIPLE, 3-INPUT NOR GATE	393090	01295	SN74LS27N	1	1	
U28	IC, CLOCK GENERATOR, MICRO-COMPUTER SET	404459	34649	C4201	1	1	
U29	IC, TTL, DUAL J-K FLIP-FLOP	393157	01295	SN74LS107N	REF		
U30	⊗ IC, CMOS, QUAD 2-INPUT NAND GATE	355198	04713	MC14011CP	1	1	
U31	⊗ IC, CMOS, 8-INPUT NOR GATE	408781	95303	CD4078B	1	1	
U32	IC, TTL, TRI-STATE BUFFER	429902	12040	DM81LS95N	1	1	
XU17	SOCKET, IC, 40-PIN DIP	376244	01295	C934002	1		
XU22	SOCKET, IC, 24-PIN DIP	376236	01295	C932402	2		
XU23	SOCKET, IC, 24-PIN DIP	376236	01295	C932402	REF		
XU28	SOCKET, IC, 16-PIN	387324	71765	133-59-02-062	REF		
Y1	CRYSTAL, 5.185 MHZ	408518	89536	408518	1		

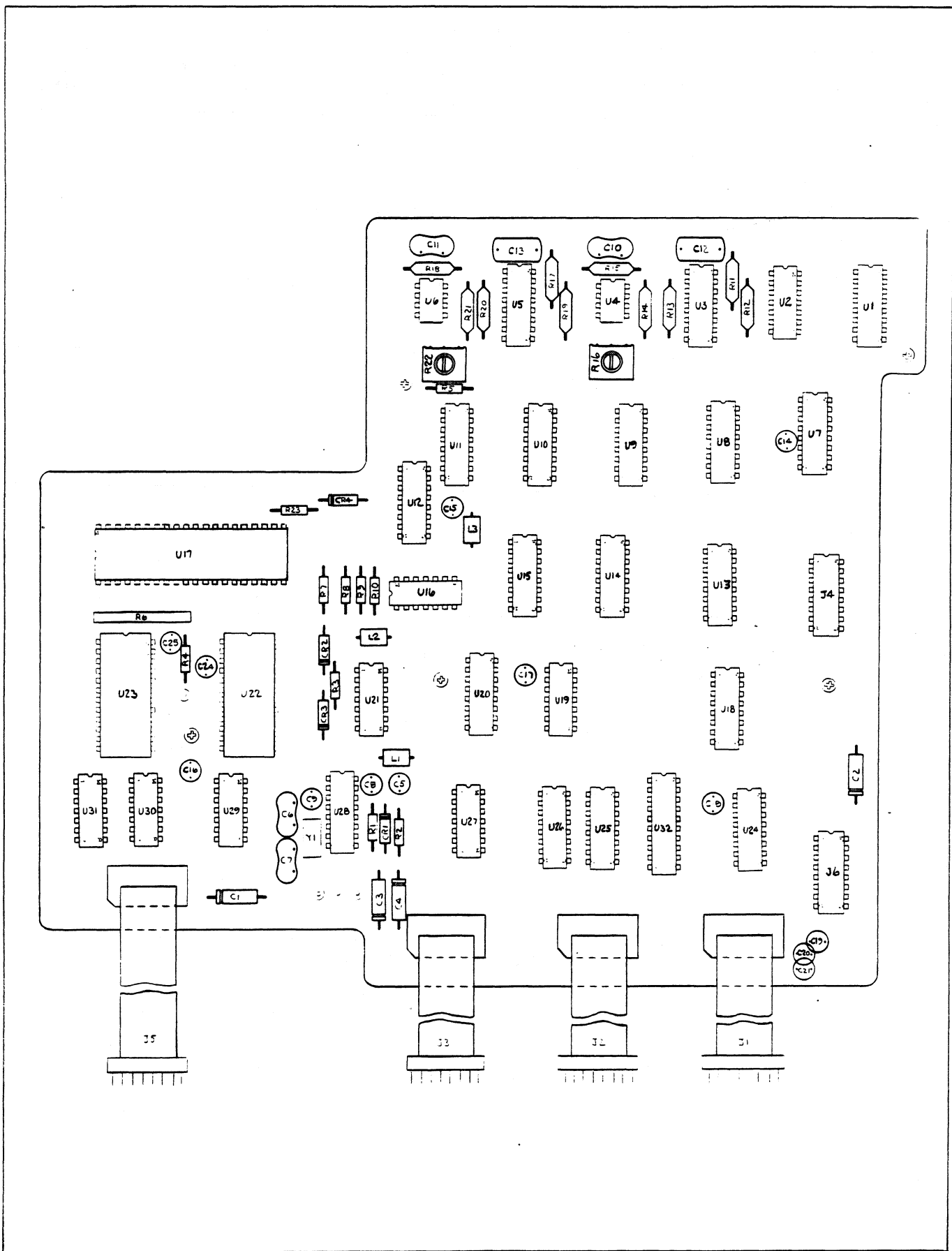

Figure 615-8. A17 Processor PCB Assembly

Table 615-14. A18 IEEE-488-1975 Switch PCB Assembly

ITEM NO.	DESCRIPTION	FLUKE STOCK NO.	MFG SPLY CODE	MFG PART NO. OR TYPE	TOT QTY	REC QTY	USE CDE
A18	IEEE-488-1975 SWITCH PCB ASSEMBLY (1953A-4042) FIGURE 615-9						
H1	BRACKET, ANGLE	306225	73734	36-515	2		
J1	CABLE	393520	08261	5142-006	1		
S1	SWITCH	393629	10389	23-021-114	1	1	
U1	SWITCH, DIP, 5 SPDT	477414	11236	206-125MOD	1	1	

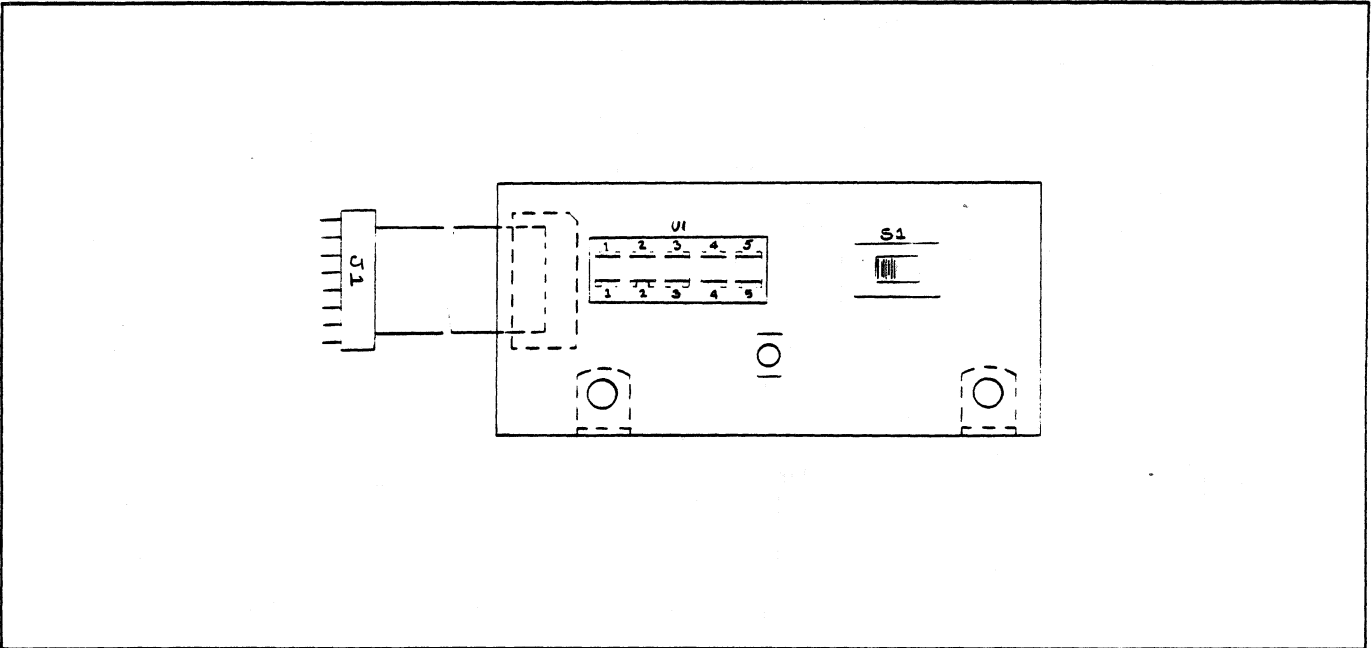

Figure 615-9. A18 IEEE-488-1975 Switch PCB Assembly

## Option -16 Rear Panel Inputs

The 1953A can be ordered with three factory-installed BNC connectors on the rear panel which serve as inputs to channels A, B and C. When this option is ordered, no front panel connector is installed for the channel C input. The channels A and B inputs are in parallel with the corresponding front panel inputs. The addition of the rear panel input terminals for channels A and B increases the input capacity of these channels to 85 pF.

### NOTE

*Sensitivity on the A channel is reduced to 75 mV at 100 MHz, decreasing to 150 mV at 125 MHz, as measured from the rear connector. When using the rear "A" connector at frequencies above 75 MHz a 50 ohm termination is recommended at the front "A" connector to reduce effects of standing waves. See measurement error discussion in Section 2 of this manual.*

Table 616-1. -16 Option, Rear Panel Inputs

ITEM NO.	DESCRIPTION	FLUKE STOCK NO.	MFG SPLY CODE	MFG PART NO. OR TYPE	TOT QTY	REC QTY	USE CDE
REAR PANEL INPUTS OPTION -16 FIGURE 616-1							
H1	SOLDER LUG	167015	73734	118100	2		
J122	CONNECTOR, BNC	152033	95712	30355-1	2		
J123	CONNECTOR, BNC	152033	95712	30355-1	REF		
W1	COAX CABLE ASSY (CHANNEL A & B)	433391	89536	433391	2		
W2	CABLE ASSY (CHANNEL C)	406934	89536	406934	1		

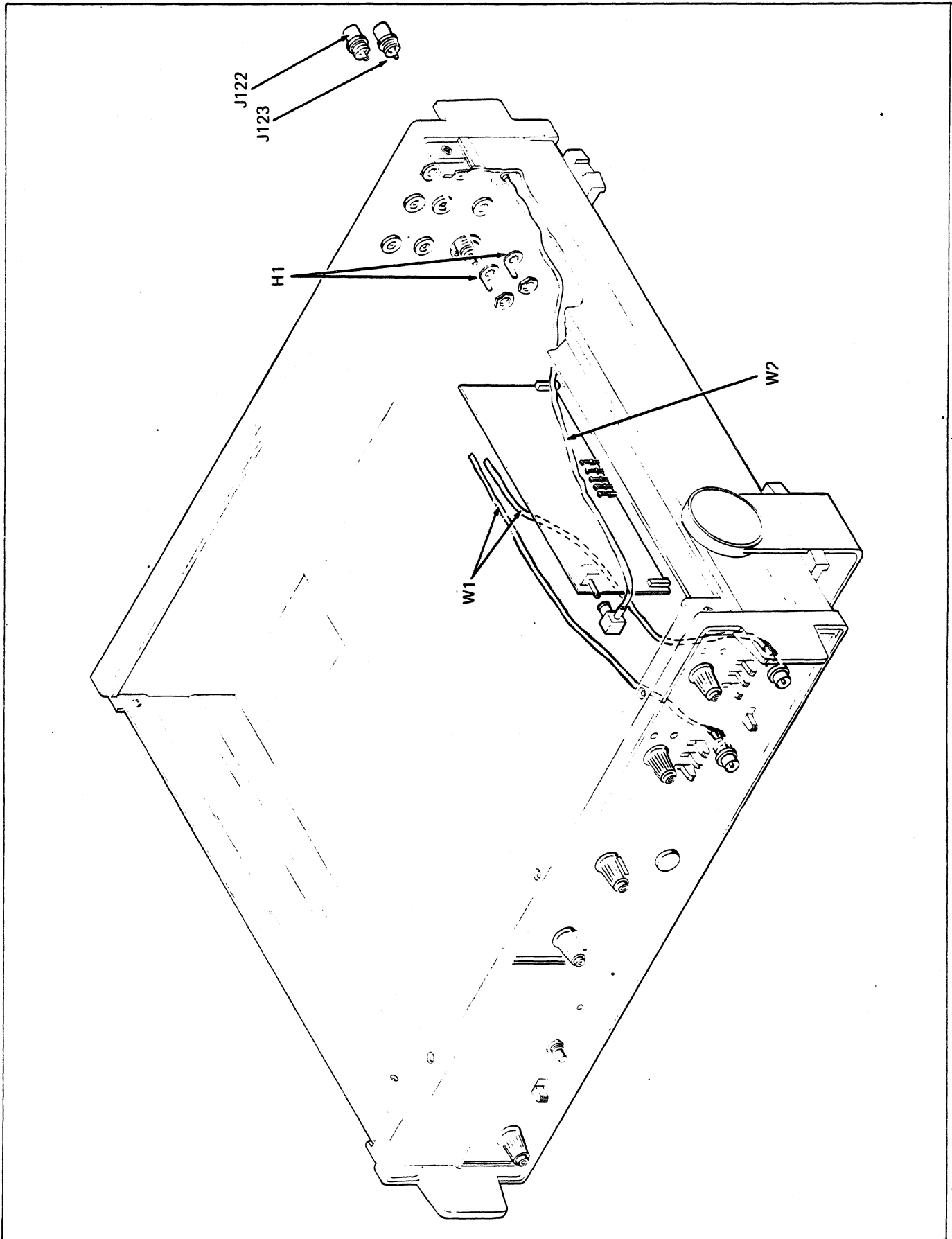

Figure 616-1. -16 Option, Rear Panel Inputs Assembly



## Option -20 Superior Oven-Stabilized Time Base

### 620-1. INTRODUCTION

620-2. The Superior Oven-Stabilized Time Base affords the highest degree of time base available to the Model 1953A. The specifications for Option -20 are given in Section 1. The unit is installed on the inside of the 1953A, and requires re-arrangement of the instrument's power switching. A switch installed on the rear panel of the 1953A is used to activate the oven independently of the power switch for the instrument itself. The option must be ordered factory installed in the 1953A when the instrument is purchased, it is not field installable.

### 620-3. CALIBRATION

620-4. Calibration of the Ovenized Oscillator is similar to that of the other time bases. Proceed as follows:

- a. Connect 1953A to ac line power.
- b. Turn CYCLE RATE control cw, off the OFF detent.
- c. Set FUNCTION switch to FREQ A.
- d. Set CONT/TRIG switch to TRIG.
- e. Connect 10 MHz frequency standard to CHANNEL A connector.
- f. Adjust Channel A TRIGGER LEVEL control to establish proper input signal triggering.
- g. Set RANGE switch to 10s (GATE 4).
- h. Momentarily press RESET button. After 10 seconds 1953A display should indicate: 100000.0000 kHz.
- i. If display is incorrect, locate the adjustment screw access hole on the rear panel. Using an insulated tuning tool, turn the adjustment slightly.
- j. Momentarily press RESET button. Observe the display for a change in the readout.
- k. Repeat steps h, i and j until the display reads 10000.00 kHz.

Table 620-1. -20 Option, Superior Oven-Stabilized Time Base

ITEM NO.	DESCRIPTION	FLUKE STOCK NO.	MFG SPLY CODE	MFG PART NO. OR TYPE	TOT QTY	REC QTY	USE CDE
	SUPERIOR OVEN-STABILIZED TIME BASE OPTION -20 FIGURE 620-1						
C91	CAP, ELECT, 2100 UF, -10/+100%, 35V	370742	80031	3050JJ212U035	1	1	
C122	CAP, TA, 10 UF +/-20%, 15V	193623	56289	196D106X0015KA1	1		
C123	CAP, TA, 10 UF +/-20%, 35V	417683	56289	196D106X0035PE4	1		
K1	RELAY, REED	352658	71707	UF-40063	1		
MP1	DECAL	428052	89536	428052	1		
R121	RES, VAR, CER, 10K +/-20%, 1/2W	267880	11236	190PC103B	1	1	
S121	SWITCH, TOGGLE	327734	09353	7201LHPZG1	1		
U7	OSCILLATOR	416826	12020	48-65B	1		
U91	RECT, BRIDGE	296509	09423	FB200	1		
U101	REG ASSY +18V	443713	89536	443713	1		
W1	CABLE ASSY	443721	89536	443721	1		

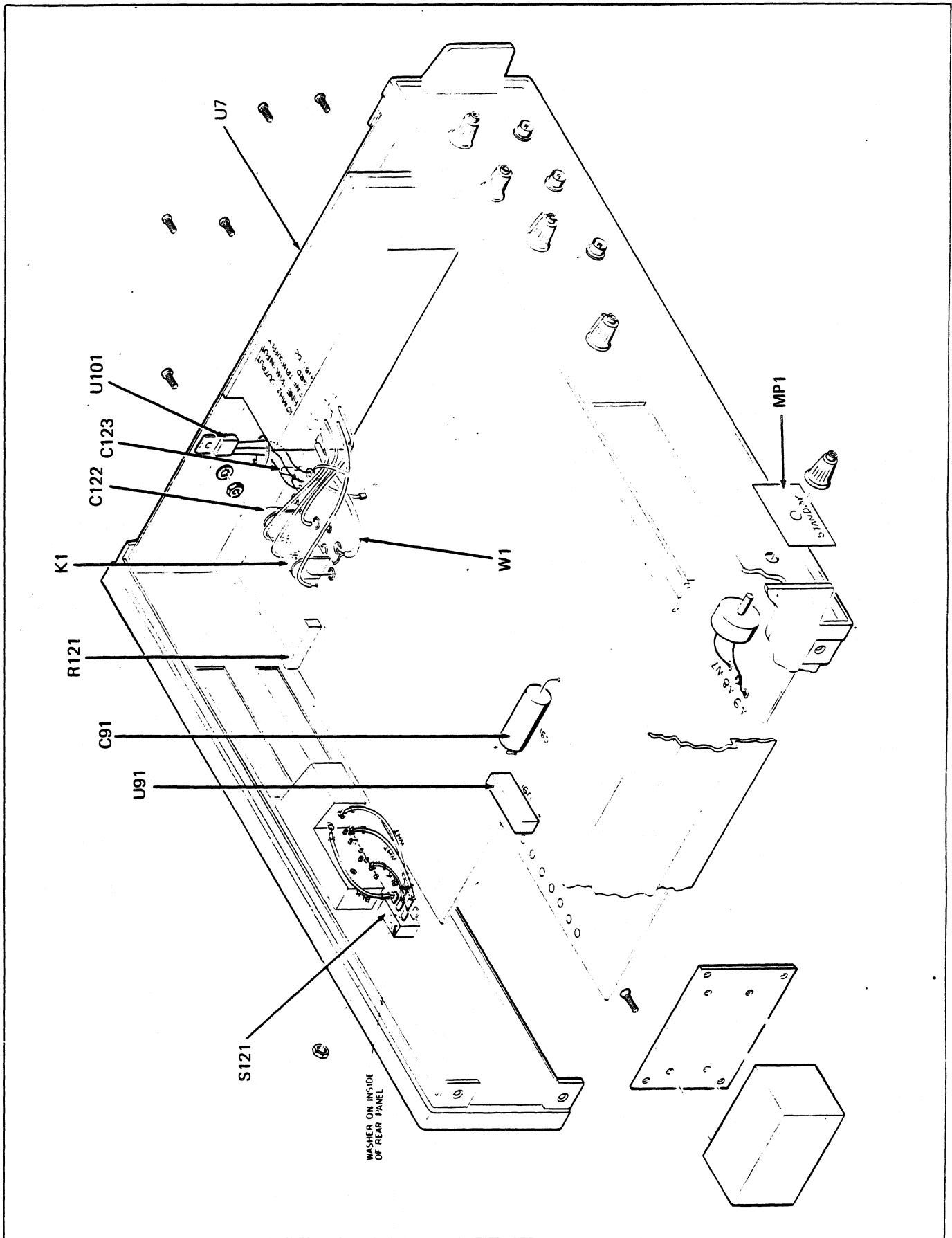

Figure 620-1. -20 Option, Superior Oven-Stabilized Time Base

## Section 7

# General Information

7-1. This section of the manual contains generalized user information as well as supplemental information to the List of Replaceable Parts contained in Section 5.

## Federal Supply Codes for Manufacturers

<p>D9816 Westermann Wilhelm Augusta-Anlage Mannheim-Nackarau Germany</p>	<p>01101 Wabash Inc (Formerly Wabash Magnetics) Wabash, IN</p>	<p>02697 Parker-Hannifin Corp. O-Ring Div Lexington, KY</p>	<p>04423 Telonic Berkley Inc. Laguna Beach, CA</p>
<p>S0482 Sony Corp. Tokyo, Japan</p>	<p>01121 Allen Bradley Co. Milwaukee, WI</p>	<p>02735 RCA-Solid State Div. Somerville, NJ</p>	<p>04713 Motorola Inc. Semiconductor Group Phoenix, AZ</p>
<p>S3774 Oshino Electric Lamp Works Tokoyo, Japan</p>	<p>01281 TRW Electronics &amp; Defense Sector R F Devices Lawndale, CA</p>	<p>02768 ITW (IL Tool Works) Fastex Division Des Plaines, IL</p>	<p>04946 Standard Wire and Cable Rancho Dominguez, CA</p>
<p>0AD86 IN General El Paso, TX</p>	<p>01295 TX Instruments Inc. Semiconductor Group Dallas, TX</p>	<p>02799 Arco Electronics Inc. Chatsworth, CA</p>	<p>05173 General Radio NY,NY. Replaced by:</p>
<p>0AE89 Autosplice Inc. Woodside, NY</p>	<p>01526 Genicom Waynesboro, VA</p>	<p>03296 Nylon Molding Corp. Monrovia, CA</p>	<p>24655 Genrad,INC. Concord, MA</p>
<p>0BW21 Noritake Co. Inc. Burlington, MA</p>	<p>01537 Motorola Communications &amp; Electronics Inc. Franklin Park, IL</p>	<p>03445 Lercon Electronics Inc Burbank, CA</p>	<p>05236 Jonathan Mfg. Co. Fullerton, CA</p>
<p>0ANF0 Topaz Semiconductor Inc San Jose, CA</p>	<p>01686 RCL Electronics/Shallcross Inc. Electro Components Div. Manchester, NH</p>	<p>03508 General Electric Co. Semiconductor Products &amp; Batteries Auburn, NY</p>	<p>05245 Corcom Inc. Libertyville, IL</p>
<p>0DSM7 Conductive (Pkg) Containers Inc. Brookfield, WI</p>	<p>01884 Sprague Electric Co. (Now 56289)</p>	<p>03797 Genisco Technology Corp. Eltronics Div. Rancho Dominguez, CA</p>	<p>05276 ITT Pomona Electronics Div. Pomona, CA</p>
<p>0CLN7 Emhart Fastening Group Shelton, CT</p>	<p>01961 Varian Associates Inc. Pulse Engineering Div. Convoy, CT</p>	<p>03877 Gilbert Engineering Co.Inc Incon Sub of Transistron Electronic Corp. Glendale, AZ</p>	<p>05277 Westinghouse Elec. Corp. Semiconductor Div. Youngwood, PA</p>
<p>0FB81 S-Mos Systems Inc. San Jose, CA</p>	<p>01963 Cherry Electrical Products Corp Waukegan, IL</p>	<p>03888 KDI Electronics Inc. Pyrofilm Div. Whippany, NJ</p>	<p>05347 Ultronix Inc Grand Junction, CO</p>
<p>0FFP1 Eveready LTD Ever Ready Special Battery Div. Dawley Telford Salop UK</p>	<p>02111 Spectrol Electronics Corp. City of Industry, CA</p>	<p>03911 Clairex Corp. Clairex Electronics Div. Mount Vernon, NY</p>	<p>05397 Union Carbide Corp. Materials Systems Div. Cleveland, OH</p>
<p>00199 Marcon Electronics Corp Keamy, NJ</p>	<p>02114 Amperex Electronic Corp. Ferrox Cube Div. Saugerties, NY</p>	<p>03980 Muirhead Inc. Mountainside, NJ</p>	<p>05571 Sprague Electric Co. (Now 56289)</p>
<p>00213 Nytronics Comp. Group Inc. Darrington, NC</p>	<p>02131 General Instrument Corp. Government Systems Div. Westwood, MA</p>	<p>04009 Cooper Industries, Inc. Arrow Hart Div. Hartford, CT</p>	<p>05574 Viking Connectors Inc Sub of Criton Corp. Chatsworth, CA</p>
<p>00327 Welwyn International Inc. Westlake, OH</p>	<p>02395 Sonar Radio Corp. Hollywood, FL</p>	<p>04217 Essex International Inc. Wire &amp; Cable Div. Anaheim, CA</p>	<p>05791 LYN-TRON Burbank, CA</p>
<p>00656 Aerovox Corp. New Bedford, MA</p>	<p>02533 Leigh Instruments Ltd. Frequency Control Div. Don Mills, Ontario, Canada</p>	<p>04221 Midland-Ross Corp. Midtex Div. N. Mankato, MN</p>	<p>05820 EG &amp; G Wakefield Engineering Wakefield, MA</p>
<p>00686 Film Capacitors Inc. Passaic, NJ</p>	<p>02606 Fenwal Labs Division of Travenal Labs Morton Grove, IL</p>	<p>04222 AVX Corp. AVX Ceramics Div. Myrtle Beach, SC</p>	<p>05839 Advance Electrical Chicago, IL</p>
<p>00779 AMP, Inc. Harrisburg, Pennsylvania</p>	<p>02660 Bunker Ramo-Eltra Corp. Amphenol NA Div. Broadview, IL</p>	<p>05972 Loctite Corp. Newington, CT</p>	
<p>00853 Sangamo Weston Inc Components Div Pickens, NC</p>			
<p>01091 Allied Plastics Co. Los Angeles, CA</p>			

## Federal Supply Codes for Manufacturers (cont)

06001 General Electric Co. Electric Capacitor Product Section Columbia, SC	07047 Ross Milton Co., The Southampton, PA	08111 MF Electronics New Rochelle, NY	1B715 (United Shoe & Nylock Corp) -Nylock Fastener Corp.- Paramus, NJ
06141 Fairchild Weston Systems Inc. Data Systems Div. Sarasota, FL	07138 Westinghouse Electric Corp. Industrial & Government Tube Div. Horseheads, NY	08235 Industro Transistor Corp. Long Island City, NY	10059 Barker Engineering Corp. Kenilworth, NJ
06192 La Deau Mfg. Co. Glendale, CA	07233 Benchmark Technology Inc. City of Industry, CA	08261 Spectra-Strip An Eltra Co. Garden Grove, CA	10389 IL Tool Works Inc. Licon Div. Chicago, IL
06229 Electrovert Inc. Elmsford, NY	07239 Biddle Instruments Blue Bell, PA	08445 Electri-Cord Mfg., Inc Westfield, PA	11236 CTS Corp. Resistor Products Div. Beme, IN
06383 Panduit Corp. Tinley Park, IL	07256 Silicon Transistor Corp. Sub of BBF Inc. Chelmsford, MA	08530 Reliance Mica Corp. Brooklyn, NY	11237 CTS Corp of CA Electro Mechanical Div. Paso Robles, CA
06473 Bunker Ramo Corp. Amphenol NA Div. SAMS Operation Chatsworth, CA	07261 Avnet Corp. Culver City, CA	08718 ITT Cannon Electric Phoenix Div. Phoenix, AZ	11295 ECM Motor Co. Schaumburg, IL
06540 Mite Corp Anatom-Electrical Div	07263 Fairchild Semiconductor North American Sales Ridgeview, CT	08806 General Electric Co. Miniature Lamp Products Cleveland, OH	11358 Columbia Broadcasting System CBS Electronic Div. Newburyport, MA
06555 Beede Electrical Instrument Pensacook, NH	07344 Bircher Co. Inc., The Rochester, NY	08863 Nylomatic Fallsington, PA	11403 Vacuum Can Co. Best Coffee Maker Div. Chicago, IL
06665 Precision Monolithics Sub of Boums Inc. Santa Clara, CA	07374 Optron Corp Woodbridge, CT	08988 Skottie Electronics Inc. Archbald, PA	11502 (can also use 35009) TRW Inc. TRW Resistive Products Div. Boone, NC
06666 General Devices Co. Inc. INpolis, IN	07557 Campion Co. Inc. Philadelphia, PA	09021 Airoo Inc. Airoo Electronics Bradford, PA	11503 Keystone Columbia Inc. Freemont, IN
06739 Electron Corp. Littleton, CO	07597 Bumdy Corp. Tape/Cable Div. Rochester, NY	09023 Cornell-Dublier Electronics Fuquay-Varina, NC	11532 Teledyne Relays Teledyne Industries Inc. Hawthorne, CA
06743 Gould Inc. Foil Div. Eastlake, OH	07716 TRW Inc. (Can use 11502) IRC Fixed Resistors/ Burlington Burlington, VT	09214 General Electric Co. Semiconductor Products Dept. Auburn, NY	11711 General Instrument Corp. Rectifier Div. Hicksville, NY
06751 Components Inc. Sencor Div. Phoenix, AZ	07792 Lerma Engineering Corp. Northampton, MA	09353 C and K Components Inc. Newton, MA	11726 Qualidyne Corp. Santa Clara, CA
06776 Robinson Nugent Inc. New Albany, IN	07810 Bock Corp. Madison, WI	09423 Scientific Components Inc. Santa Barbara, CA	12014 Chicago Rivet & Machine Co. Naperville, IL
06915 Richco Plastic Co. Chicago, IL	07910 Teledyne Semiconductor Mtn. View, CA	09922 Bumdy Corp. Norwalk, CT	12020 Ovenaire Div. of Electronic Technologies Charlottesville, VA
06961 Vermtron Corp. Piezo Electric Div. Bedford, OH	07933 Raytheon Co. Semiconductor Div. Mountain View, CA	09969 Dale Electronics Inc. Yankton, SD	12038 Simco (Div of Ransburg Corp) Hatfield, PA
06980 EIMAC (See Varian) San Carlos, CA	08FG6 Calmos Systems Inc. Kanata, Ont. Canada	09975 Burroughs Corp. Electronics Components Detroit, MI	12040 National Semiconductor Corp. Danbury, CT
	080A9 Dallas Semiconductor Dallas, TX	1A791 LFE Electronics Danvers, MA	

Federal Supply Codes for Manufacturers (cont)

12060 Diodes Inc. Northridge, CA	13050 Potter Co. Wesson, MS	14704 Crydom Controls (Division of Int Rectifier) El Segundo, CA	16473 Cambridge Scientific Industries Div. of Chemed Corp. Cambridge, MD
12136 PHC Industries Inc. Formerly Philadelphia Handle Co. Camden, NJ	13103 Thermalloy Co., Inc. Dallas, TX	14752 Electro Cube Inc. San Gabriel, CA	16733 Cablewave Systems Inc. North Haven, CT
12300 AMF Canada Ltd. Potter-Brunfield Guelph, Ontario, Canada	13327 Solitron Devices Inc. Tappan, NY	14936 General Instrument Corp. Discrete Semi Conductor Div. Hicksville, NY	16742 Paramount Plastics Fabricators Inc. Downey, CA
12323 Practical Automation Inc. Shelton, CT	13511 Bunker-Ramo Corp. Amphenol Cadre Div. Los Gatos, CA	14949 Trompeter Electronics Chatsworth, CA	16758 General Motors Corp. Delco Electronics Div. Kokomo, IN
12327 Freeway Corp. Cleveland, OH	13606 Sprague Electric Co. (Use 56289)	15412 Amtron Midlothian, IL	17069 Circuit Structures Lab Burbank, CA
12406 Elpac Electronics Inc. Santa Ana, CA	13689 SPS Technologies Inc. Hatfield, NJ	15542 Scientific Components Corp. Mini-Circuits Laboratory Div. Brooklyn, NY	17117 Electronic Molding Corp. Woonsocket, RI
12443 Budd Co.,The Plastics Products Div. Phoenixville, PA	13764 Micro Plastics Flippin, AZ	15636 Elec-Trol Inc. Saugus, CA	17338 High Pressure Eng. Co. Inc. OK City, OK
12581 Hitachi Metals International Ltd. Hitachi Magna-Lock Div. Big Rapids, MO	13919 Burr-Brown Research Corp. Tucson, AZ	15782 Bausch & Lomb Inc. Graphics & Control Div. Austin, TX	17504 Aluminum Filter Co. Carpinteria, CA
12615 US Terminals Inc. Cincinnati, OH	14099 Semtech Corp. Newbury Park, CA	15801 Fenwal Electronics Inc. Div. of Kidde Inc. Framingham, MA	17545 Atlantic Semiconductors Inc. Asbury Park, NJ
12617 Hamlin Inc. LaKe Mills, WI	14140 McGray-Edison Co. Commercial Development Div. Manchester, NH	15818 Teledyne Inc. Co. Teledyne Semiconductor Div. Mountain View, CA	17745 Angstrom Precision, Inc. Hagerstown, MD
12673 Wesco Electrical Greenfield, MA	14189 Ortronics, Inc. Orlando, FL	15849 Useco Inc. (Now 88245)	17856 Siliconix Inc. Santa Clara, CA
12697 Clarostat Mfg. Co. Inc. Dover, NH	14193 Cal-R-Inc. Santa Monica, CA	15898 International Business Machines Corp. Essex Junction, VT	18178 E G & Gvactee Inc. St. Louis, MO
12749 James Electronic Inc. Chicago, IL	14301 Anderson Electronics Hollidaysburg, PA	16068 International Diode Div. Harrison, NJ	18235 KRL/Bantry Components Inc. Manchester, NH
12856 MicroMetals Inc. Anaheim, CA	14329 Wells Electronics Inc. South Bend, IN	16162 MMI Southfield, MI	18310 Concord Electronics New York, NY
12881 Metex Corp. Edison, NJ	14482 Watkins-Johnson Co. Palo Alto, CA	16245 Conap Inc. Olean, NY	18324 Signetics Corp. Sacramento, CA
12895 Cleveland Electric Motor Co. Cleveland, OH	14552 Microsemi Corp. (Formerly Micro-Semiconductor) Santa Ana, CA	16258 Space-Lok Inc. Burbank, CA	18377 Parlex Corp. Methuen, MA
12954 Microsemi Corp. Components Group Scottsdale, AZ	14604 Elmwood Sensors, Inc Pawtucket, RI	16352 Codi Corp. Linden, NJ	18520 Sharp Electronics Corp. Paramus, NJ
12969 Unitrode Corp. Lexington, MA	14655 Cornell-Dublier Electronics Div. of Federal Pacific Electric Co. Govt Cont Dept. Newark, NJ	16469 MCL Inc. LaGrange, IL	18542 Wabash Inc. Wabash Relay & Electronics Div. Wabash, IN

## Federal Supply Codes for Manufacturers (cont)

18565 Chomerics Inc. Woburn, MA	2Y384 North American Philips Lighting Corp. Van Wert, OH	23732 Tracor Applied Sciences Inc. Rockville, MD	26402 Lumex, Inc. Bayshore, NY
18612 Vishay Intertechnology Inc. Vishay Resistor Products Group Malvern, PA	20584 Enochs Mfg. Inc. INpolis, IN	23880 Stanford Applied Engineering Santa Clara, CA	26629 Frequency Sources Inc. Sources Div. Chelmsford, MA
18632 Norton-Chemplast Santa Monica, CA	20891 Cosar Corp. Dallas, TX	23936 William J. Purdy Co. Pamotor Div. Burlingame, CA	26806 American Zetler Inc. Irvine, CA
18677 Scanbe Mfg. Co. Div. of Zero Corp. El Monte, CA	21317 Electronics Applications Co. El Monte, CA	24347 Penn Engineering Co. S. El Monte, CA	27014 National Semiconductor Corp. Santa Clara, CA
18736 Voltronics Corp. East Hanover, NJ	21604 Buckeye Stamping Co. Columbus, OH	24355 Analog Devices Inc. Norwood, MA	27167 Corning Glass Works Corning Electronics Wilmington, NC
18786 Micro-Power Long Island City, NY	21845 Solitron Devices Inc. Semiconductor Group Riviera Beach, FL	24444 General Semiconductor Industries, Inc. Tempe, AZ	27264 Molex Inc. Lisle, IL
18927 GTE Products Corp. Precision Material Products Business Parts Div. Titusville, PA	21847 Aertech Now TRW Microwave Inc. Sunnyvale, CA	24546 Bradford Electronics Bradford, PA	27440 Industrial Screw Products Los Angeles, CA
19080 Robinson Electronics Inc. San Luis Obispo, CA	21962 Vectron Corp. Replaced by: S.W. Electronics	24618 Transcon Mfg. Now: D.J. Associates Inc.	27494 Staffall, Inc. Providence, RI
19112 Garry Corp. Langhorne, PA	22526 DuPont, EI DeNemours & Co. Inc. DuPont Connector Systems Advanced Products Div. New Cumberland, PA	24655 Genrad Inc. (Replaced General Radio 05173) Concord, MA	27745 Associated Spring Bames Group Inc. Syracuse, NY
19315 Bendix Corp., The Navigation & Control Group Terboro, NJ	22626 Micro Semiconductor (Now 14552)	24759 Lenox-Fugle Electronics Inc. South Plainfield, NJ	27918 Component Parts Corp. Bellmore, NY
19451 Perine Machine Tool Corp. Kent, WA	22670 GM Nameplate Seattle, WA	24796 AMF Inc. Potter & Brumfield Div. San Juan Capistrano, CA	27956 Relcom (Now 14482)
19482 Delta Electronics Alexandria, VA	22767 ITT Semiconductors Palo Alto, CA	24931 Specialty Connector Co. Greenwood, IN	28175 Alpha Metals Chicago, IL
19613 MN Mining & Mfg. Co. Textool Products Dept. Electronic Product Div. Irving, TX	22784 Palmer Inc. Cleveland, OH	24995 ECS Grants Pass, OR	28198 Positronic Industries Springfield, MO
19647 Caddock Electronics Inc. Riverside, CA	23050 Product Comp. Corp. Mount Vernon, NY	25088 Siemen Corp. Isilen, NJ	28213 MN Mining & Mfg. Co. Consumer Products Div. 3M Center Saint Paul, MN
19701 Mepco/Centralab Inc. A N. American Philips Co. Mineral Wells, TX	23223 CTS Microelectronics Lafayette, NY	25099 Cascade Gasket Kent, WA	28309 Kaiser Minette, AL
2B178 Wire Products Cleveland, OH	23237 I.R.C., Inc. Microcircuits Division Philadelphia, PA	25403 Amperex Electronic Corp. Semiconductor & Micro-Circuit Div. Slatersville, RI	28425 Serv-O-Link Eules, TX
2K262 Boyd Corporation Portland, OR	23302 S.W. Electronics & Mfg. Corp. Cherry Hill, NJ	25435 Moldtronics, Inc Downers Grove, IL	28478 Deltrol Corporation Deltrol Controls Div. Milwaukee, WI
	23730 Mark Eyelet and Stamping Inc. Wolcott, CT	25706 Daburn Electronic & Cable Corp. Norwood, NJ	28480 Hewlett Packard Co. Corporate HQ Palo Alto, CA

## Federal Supply Codes for Manufacturers (cont)

28484 Emerson Electric Co. Gearmaster Div. McHenry, IL	31433 Kemet Electronics Corp. Simpsonville, NC	33246 Epoxy Technology Inc. Billerica, MA	36701 Van Waters & Rogers Valley Field, Quebec, Canada
28520 Heyco Molded Products Kenilworth, NJ	31448 Army Safeguard Logistics Command Huntsville, AL	33292 Pioneer Sterilized Wiping Cloth Co. Portland, OR	37942 Mallory Capacitor Corp. Sub of Emhart Industries INpolis, IN
28932 Lumax Industrials, Inc Altoona, PA	31471 Gould Inc Semiconductor Div Santa Clara, CA	33297 NEC Electronics USA Inc. Electronic Arrays Inc. Div. Mountain View, CA	39003 Maxim Industries Middleboro, MA
29083 Monsanto Co. Santa Clara, CA	31522 Metal Masters Inc. Baldwin, MS	33919 Nortek Inc. Cranston, RI	4F434 Plastic Sales Los Angeles, CA
29604 Stackpole Components Co. Raleigh, NC	31746 Cannon Electric Woodbury, TN	34114 Oak Industries Rancho Bernardo, CA	40402 Roderstein Electronics Inc. Statesville, NC
29907 Omega Engineering Inc. Stamford, CT	31827 Budwig Ramona, CA	34263 CTS Electronics Corp. Brownsville, TX	42498 National Radio Melrose, MA
3D536 Aimsco Inc. Seattle, WA	31918 ITT-Schadow Eden Prairie, MN	34333 Silicon General Inc. Garden Grove, CA	43543 Nytronics Inc.(Now 53342)
30035 Jolo Industries Inc. Garden Grove, CA	32293 Intersil Cupertino, CA	34335 Advanced Micro Devices (AMD) Sunnyvale, CA	43744 Panasonic Industrial Co. San Antonio, TX
30045 Solid Power Corp. Farmingdale, NY	32539 Mura Corp. Westbury, Long Island, N.Y.	34359 MN Mining & Mfg. Co. Commercial Office Supply Div. Saint Paul, MN	43791 Datron Systems Wilkes Barre, PA
30146 Symbex Corp. Painesville, OH	32559 Bivar Santa Ana, CA	34371 Harris Corp. Harris Semiconductor Products Group Melbourne, FL	44655 Ohmite Mfg. Co. Skokie, IL
30148 AB Enterprise Inc. Ahoskie, NC	32719 Siltronics Santa Ana, CA	34576 Rockwell International Corp. Newport Beach, CA	47001 Lumberg Inc. Richmond, VA
30161 Aavid Engineering Inc. Laconia, NH	32767 Griffith Plastics Corp. Burlingame, CA	34641 Instrument Specialties Eules, TX	47379 ISOCOM Campbell, CA
30315 Itron Corp. San Diego, CA	32879 Advanced Mechanical Components Northridge, CA	34649 Intel Corp. Santa Clara, CA	49569 IDT (International Development & Trade) Dallas, TX
30323 IL Tool Works Inc. Chicago, IL	32897 Murata Erie North America Inc. Carlisle Operations Carlisle, Pennsylvania	34802 Electromotive Inc. Kenilworth, NJ	49671 RCA Corp. New York, NY
30800 General Instrument Corp. Capacitor Div. Hicksville, NY	32997 Boums Inc. Trimpot Div. Riverside, CA	34848 Hartwell Special Products Placentia, CA	49956 Raytheon Company Executive Offices Lexington, MA
30838 Fastec Chicago, ILL	33025 M/A ComOmni Spectra, Inc. (Replacing Omni Spectra) Microwave Subsystems Div. Tempe, AZ	35009 Renfrew Electric Co. Ltd. IRC Div. Toronto, Ontario, Canada	5D590 Mostek Corp. Replaced by: SGS Thompson Microelec- tronics
31019 Solid State Scientific Inc. Willow Grove, PA	33096 CO Crystal Corp. Loveland, CO	35986 Amrad Melrose Park, IL	5F520 Panel Components Corp. Santa Rosa, CA
31091 Alpha Industries Inc. Microelectronics Div. Hatfield, PA	33173 General Electric Co. Owensboro, KY	36665 Mitel Corp. Kanata, Ontario, Canada	5P575 Nobel Electronics Suffem, NY
31323 Metro Supply Company Sacramento, CA			5W664 NDK Div. of Nihon Dempa Kogyo LTD Lynchburg, VA



## Federal Supply Codes for Manufacturers (cont)

5U802 Dennison Mfg. Co. Framingham, MA	51499 Amtron Corp. Boston, MA	52840 Western Digital Corp. Costa Mesa, CA	54937 DeYoung Mfg. Bellevue, WA
50088 SGS - Thomson Microelectronics Inc. Carrollton, TX	51506 Accurate Screw Machine Co. (ASMC) Nutley, NJ	53021 Sangamo Weston Inc. (See 06141)	54590 RCA Corp. Electronic Components Div. Cherry Hill, NJ
50120 Eagle-Picher Industries Inc. Electronics Div. CO Springs, CO	51605 CODI Semiconductor Inc. Kenilworth, NJ	53036 Textool Co. Houston, TX	55026 American Gage & Machine Co. Simpson Electric Co. Div. Elgin, IL
50157 Midwest Components Inc. Muskegon, MS	51642 Centre Engineering Inc. State College, PA	53184 Xciton Corp. Lathan, NY	55112 Plessey Capacitors Inc. (Now 60935)
50356 Teac Corp. of America Industrial Products Div Montebello, CA	51705 ICO/Rally Palo alto, CA	53217 Technical Wire Products Inc. Santa Barbara, CA	55261 LSI Computer Systems Inc. Melville, NY
50364 MMI, Inc. (Monolithic Memories Inc) Military Products Div. Santa Clara, CA	51791 Statek Corp. Orange, CA	53342 Opt Industries Inc. Phillipsburg, NJ	55285 Bercquist Co. Minneapolis, MN
50472 Metal Masters, Inc. City of Industry, CA	51984 NEC America Inc. Falls Church, VA	53673 Thompson CSF Components Corp. (Semiconductor Div) Conaga Park, CA	55322 Samtech Inc. New Albany, IN
50541 Hypertronics Corp. Hudson, MA	52063 Exar Integrated Systems Sunnyvale, CA	53718 Airmold/W. R. Grese & Co. Roanoke Rapids, NC	55408 STI-CO Industries Co Buffalo, NY
50558 Electronic Concepts, Inc. Eatontown, NJ	52072 Circuit Assembly Corp. Irvine, CA	53848 Standard Microsystems Hauppauge, NY	55464 Central Semiconductor Corp. Hauppauge, NY
50579 Litronix Inc. Cupertino, CA	52152 MN Mining & Mfg. Saint Paul, MN	53894 AHAM Inc. RanchoCA, CA	55557 Microwave Diode Corp. W. Stewartown, NH
50891 Semiconductor Technology Stuart, FL	52333 API Electronics Haugpauge, Long Island, NY	53944 Glow-Lite Pauls Valley, OK	55566 R A F Electronic Hardware Inc. Seymour, CT
50934 Tran-Tec Corp Columbus, NE	52361 Communication Systems Piscataway, NJ	54178 Plasmetex Industries Inc. San Marcos, CA	55576 Synetek Santa Clara, CA
51167 Aries Electronics Inc. Frenchtown, NJ	52500 Amphenol, RF Operations Burlington, MA	54294 Shallcross Inc. Smithfield, NC	55680 Nichicon/America/Corp. Schaumburg, IL
51284 Mos Technology Norristown, PA	52525 Space-Lok Inc. Leroo Div. Burbank, CA	54453 Sullins Electronic Corp. San Marcos, CA	55943 D J Associates, Inc (Replaced Transcon Mfg.-24618) Fort Smith, AZ
51249 Heyman Mfg. Co. Cleveland, OH	52531 Hitachi Magnetics Edmore, MO	54473 Matsushita Electric Corp. (Panasonic) Secaucus, NJ	56282 Utek Systems Inc. Olathe, KS
51372 Verbatim Corp. Sunnyvale, CA	52745 Timco Los Angeles, CA	54492 Cinch Clamp Co., Inc. Santa Rosa, CA	56289 Sprague Electric Co. North Adams, MA
51398 MUPAC Corp. Brockton, MA	52763 Stettner-Electronics Inc. Chattanooga, TN	54583 TDK Garden City, NY	56365 Square D Co. Corporate Offices Palatine, IL
51406 Murata Erie, No. America Inc. (Also see 72982) Marietta, GA	52769 Sprague-Goodman Electronics Inc. Garden City Park, NY	54590 RCA Corp Distribution & Special Products Cherry Hill, NY	56375 WESCORP Div. Dal Industries Inc Mountain View, CA
	52771 Moniterm Corp. Amatrom Div. Santa Clara, CA	54869 Pifer International Corp. Arlington Heights, IL	

## Federal Supply Codes for Manufacturers (cont)

56481 Shugart Associates Sub of Xerox Corp. Sunnyvale, CA	59610 Souriau Inc Valencia, CA	60911 Inmos Corp. CO Springs, CO	64537 KDI Electronics Whippany, NJ
56637 RCD Components Inc. Manchester, NH	59635 HV Component Associates Howell, NJ	60935 Westlake Capacitor Inc. Tantalum Div. Greencastle, IN	64782 Precision Control Mfg. Inc. Bellevue, WA
56708 Zilog Inc. Campbell, CA	59640 Supertex Inc. Sunnyvale, CA	60958 ACIC Intercomp Wire & Cable Div. Hayesville, NC	64834 West M G Co. San Francisco, CA
56856 Vamistor Corp. of TN Sevierville, TN	59660 Tusonix Inc. Tucson, AZ	61271 Fujitsu Microelectronics Inc San Jose, CA	64961 Electronic Hardware LTD North Hollywood, CA
56880 Magnetics Inc. Baltimore, MD	59730 Thomas and Betts Corp. IA City, IA	61394 SEEQ Technology Inc. San Jose, CA	65092 Sangamo Weston Inc. Weston Instruments Div. Newark, NJ
57026 Endicott Coil Co. Inc. Binghamton, NY	59831 Semtronics Corp. Watchung, NJ	61429 Fox Electronics Cape Coral, FL	65786 Cypress Semi San Jose, CA
57053 Gates Energy Products Denver, CO	61053: American Components Inc. an Insilco Co. RPC Div. Hayesville, NC	61529 Aromat Corp. New Providence, NJ	65940 Rohm Corp & Whatney Irvine, CA
57170 Cambridge Thermionic Cambridge, MA Replaced by: 71279 Interconnection Products Inc.	6L611 Allen, Robert G. Inc. Van Nuys, CA	61752 IR-ONICS Inc Warwick, RI	65964 Evox Inc. Bannockburn, IL
57668 R-ohm Corp Irvine, CA	6U850 Burgess Switch Co., Inc Northbrook, IL	61772 Integrated Device Technology Santa Clara, CA	66150 Entron Inc. Winslow Teltronics Div. Glendale, NY
57962 SGS - Thomson Microelectronics Inc Montgomeryville, PA	6U095 AMD Enterprises, Inc. Roswell, GA	61802 Toshiba Houston, TX	66302 VLSI Technology Inc. San Jose, CA
58014 Hitachi Magnalock Corp. (Now 12581)	6X403 SGS/ATES Semiconductor Corp. INpolis, IN	61857 SAN-O Industrial Corp. Bohemia, Long Island, NY	66419 Exel San Jose, CA
58104 Simco Atlanta, GA	6Y440 Micron Technology Inc. Boise, ID	61935 Schurter Inc. Petaluma, CA	66450 Dyna-Tech Electronics, Inc Walled Lake, MI
58364 BYCAP Inc. Chicago, IL	60046 Power Dynamics Inc West Orange, NJ	62351 Apple Rubber Lancaster, NY	66608 Bering Industries Freemont, CA
58451 Precision Lamp Cotat, CA	60197 Precicontact Inc. Langhorne, PA	62643 United Chemicon Rosemont, IL	66891 BKC International Electronics Lawrence, MA
58474 Superior Electric Co. Bristol, CT	60386 Squires Electronics Inc Comelius, OR	62712 Seiko Instruments Torrance, CA	66958 SGS Semiconductor Corp. Phoenix, AZ
58614 Communications Instruments Inc. Fairview, NC	60395 Xicor Inc. Milpitas, CA	62793 Lear Siegler Inc. Energy Products Div. Santa Ana, CA	66967 Powerex Inc Auburn, NY
59124 KOA-Speer Electronics Inc. Bradford, PA	60399 Torin Engineered Blowers Div. of Clevepak Corp. Torrington, CT	63743 Ward Leonard Electric Co.Inc. Mount Vernon, NY	67183 Altera Santa Clara, CA
59422 Holmberg Electronics Irvine, CA	60496 Micrel Inc. Sunnyvale, CA	64154 Lamb Industries Portland, OR	68919 WIMA % Harry Levinson Co. Seattle, WA
	60705 Cera-Mite Corp. (formerly Sprague) Grafton, WI	64155 Linear Technology Milpitas, CA	

Federal Supply Codes for Manufacturers (cont)

7F361 Richmond-Division of Dixico % Zellerbach Paper Co. Seattle, WA	71468 ITT Cannon Div. of ITT Fountain Valley, CA	73138 Beckman Industrial corp. Helipot Div. Fullerton, CA	75042 TRW Inc. IRC Fixed Resistors Philadelphia, PA
7F844 Moore Business Forms, Inc Seattle, WA	71482 General Instrument Corp. Clare Div. Chicago, IL	73168 Fenwal Inc. Ashland, MA	75297 Kester Solder Div. Litton Systems, Inc Des Plaines, IL
7G902 Textron Inc. Camcar Div. Rockford, IL	71590 Mecco/Centralab A North American Philips Co. Fort Dodge, IA	73293 Hughes Aircraft Co. Electron Dynamics Div. Torrance, CA	75376 Kurz-Kasch Inc. Dayton, OH
7J395 Universal Plastics Welshpool, WA	71707 Coto Corp. Providence, RI	73445 Amperex Electronic Corp. Hicksville, NY	75378 CTS Knights Inc. Sandwich, IL
7J696 AMD Plastics East Lake, OH	71744 General Instrument Corp. Lamp Div/Worldwide Chicago, IL	73559 Carlingswitch Inc. Hartford, CT	75382 Kulka Electric Corp. (Now 83330) Mount Vernon, NY
7K354 Omni Spectra Inc Los Altos, CA	71785 TRW Inc. Cinch Connector Div. Elk Grove Village, IL	73586 Circle F Industries Trenton, NJ	75569 Performance Semiconductor Corp. Sunnyvale, CA
7Z884 ALPS Seattle, WA	71984 Dow Coming Corp. Midland, MI	73734 Federal Screw Products Inc. Chicago, IL	75915 Littelfuse Tracor (Formerly: Tracor-Littelfuse) Des Plaines, IL
7X634 Duracell USA Div. of Dart & Kraft Inc. Valdese, NC	72005 AMAX Specialty Metals Corp. Newark, NJ	73743 Fischer Special Mfg. Co. Cold Spring, KY	76854 Oak Switch Systems Inc. Crystal Lake, IL
70290 Almetal Universal Joint Co. Cleveland, OH	72136 Electro Motive Mfg. Corp. Florence, NC	73893 Microdot Mt. Clemens, MS	77122 TRW Assemblies & Fasteners Group Fastener Div. Moutainside, NJ
70485 Atlantic India Rubber Works Inc. Chicago, IL	72228 AMCA International Corp. Continental Screw Div. New Bedford, MA	73899 JFD Electronic Components Div. of Murata Erie Oceanside, NY	77342 AMF Inc. Potter & Brumfield Div. Princeton, IN
70563 Amperite Company Union City, NJ	72259 Nytronics Inc. New York, NY	73905 FL Industries Inc. San Jose, CA	77542 Ray-O-Vac Corp Madison, WI
70903 Cooper-Belden Corp. Geneva, IL	72619 Amperex Electronic Corp. Dialight Div. Brooklyn, NY	73949 Guardian Electric Mfg. Co. Chicago, IL	77638 General Instrument Corp. Rectifier Div. Brooklyn, NY
71002 Bimbach Co. Inc. Farmingdale, NY	72653 G C Electronics Co. Div. of Hydrometals Inc. Rockford, IL	74217 Radio Switch Co. Marlboro, NJ	77900 Shakeproof Lock Washer Co. (Now 78189)
71034 Bliley Electric Co. Erie, PA	72794 Dzus Fastner Co. Inc. West Islip, NY	74306 Piezo Crystal Co. Div. of PPA Industries Inc. Carlisle, PA	77969 Rubbercraft Corp. of CA Ltd. Torrance, CA
71183 Westinghouse Electric Corp. Bryant Div. Bridgeport, CT	72928 Gulton Industries Inc. Gudeman Div. Chicago, IL	74445 Holo-Krome Co. Elmwood, CT	78189 IL Tool Works Inc. Shakeproof Div. Elgin, IL
71279 Interconnection Products Inc. Formerly Midland-Ross Cambion Div. Santa Ana, CA	72962 Elastic Stop Nut Div. of Harnard Industries Union, NJ	74542 Hoyt Elect.Instr. Works Inc. Penacook, NH	78277 Sigma Instruments Inc. South Braintree, MA
71400 Bussman Manufacturing Div. McGraw-Edison Co. St. Louis, MO	72982 Erie Specialty Products, Inc Formerly: Murata Erie Erie, PA	74840 IL Capacitor Inc. Lincolnwood, IL	78290 Struthers Dunn Inc. Pitman, NJ
71450 CTS Corp. Elkhart, IN		74970 Johnson EF Co. Waseca, MN	78553 Eaton Corp. Engineered Fastener Div. Cleveland, OH

**Federal Supply Codes for Manufacturers (cont)**

78592 Stoeger Industries South Hackensack, NJ	81439 Therm-O-Disc Inc. Mansfield, OH	83315 Hubbell Corp. Mundelein, IL	87034 Illuminated Products Inc. (Now 76854)
79497 Western Rubber Co. Goshen, IN	81483 International Rectifier Corp. Los Angeles, CA	83330 Kulka Smith Inc. A North American Philips Co. Manasquan, NJ	87516 Standard Crystal KS City, KS
79727 C - W Industries Southampton, PA	81590 Korry Electronics Inc. Seattle, WA	83478 Rubbercraft Corp. of America West Haven, CT	88044 Aeronautical Standards Group Dept. of Navy & Air Force
79963 Zierick Mfg. Corp. Mount Kisco, NY	81741 Chicago Lock Co. Chicago, IL	83553 Associated Spring Barnes Group Gardena, CA	88219 GNB Inc. Industrial Battery Div. Langhorne, PA
8C798 Ken-Tronics, Inc. Milan, IL	82227 Aipax Corp. Cheshire Div. Cheshire, CT	83740 Union Carbide Corp. Battery Products Div. Danbury, CT	88245 Winchester Electronics Litton Systems-Useco Div. Van Nuys, CA
8D528 Baumgartens Atlanta, GA	82240 Simmons Fastner Corp. Albany, NY	84171 Arco Electronics Commack, NY	88486 Triangle PWC Inc. Jewitt City, CT
8F330 Eaton Corp. Cutler Hammer Product Sales Office Mountain View, CA	82305 Palmer Electronics Corp. South Gate, CA	84411 American Shizuki TRW Capacitors Div. Ogallala, NE	88690 Essex Group Inc. Wire Assembly Div. Dearborn, MI
8T100 Tellabs Inc. Naperville, IL	82389 Switchcraft Inc. Sub of Raytheon Co. Chicago, IL	84613 FIC Corp. Rockville, MD	88786 Atlantic India Rubber Co. Goshen, IN
80009 Tektronix Beaverton, OR	82415 Aipax Corp Frederick Div. Frederick, MD	84682 Essex Group Inc. Peabody, MA	88978 Phillips (Now Fluke) Mahwah, NJ
80031 Mepco/Electra Inc. Morristown, NJ	82872 Roanwell Corp. New York, NY	84830 Lee Spring Co. Inc Brooklyn, NY	89020 Amerace Corp. Buchanan Cromptool Products Div. Union, NJ
80032 Ford Aerospace & Communications Corp. Western Development Laboratories Div. Palo Alto, CA	82877 Rotron Inc. Custom Div. Woodstock, NY	85367 Bearing Distributing Co. San Fransisco, CA	89265 Potter-Brumfield (See 77342)
80145 LFE Corp. Process Control Div. Clinton, OH	82879 IIT Royal Electric Div. Pawtucket, RI	85372 Bearing Sales Co. Los Angeles, CA	89462 Waldes Truarc, Inc. Long Island, NY
80183 Sprague Products (Now 56289)	83003 Varo Inc. Garland, TX	85480 W. H. Brady Co. Industrial Product Milwaukee, WI	89536 John Fluke Mfg. Co., Inc. Everett, WA
80294 Boums Instruments Inc. Riverside, CA	83014 Hartwell Corp. Placentia, CA	85840 Brady WH Co Industrial Products Div Milwaukee, WI	89597 Fredericks Co. Huntingdon Valley, PA
80583 Hammerlund Mfg. Co. Inc. Paramus, NJ	83055 Signalite Fuse Co. (Now 71744)	85932 Electro Film Inc. Valencia, CA	89709 Bunker Ramo-Eltra Corp. Amphenol Div. Broadview, IL
80640 Computer Products Inc. Stevens-Arnold Div. South Boston, MA	83058 TRW Assemblies & Fasteners Group Fasteners Div. Cambridge, MA	86577 Precision Metal Products Co. Peabody, MA	89730 General Electric Lamp Div. Newark, NJ
81073 Grayhill Inc. La Grange, IL	83259 Parker-Hannifin Corp. O-Seal Div. Culver City, CA	86684 Radio Corp. of America (Now 54590)	9R216 Data Composition Svc, Inc Laurel, MD
81312 Litton Systems Inc. Winchester Electronics Div. Watertown, CT	83298 Bendix Corp. Electric & Fluid Power Div. Eatonville, NJ	86928 Seastrom Mfg. Co. Inc. Glendale, CA	9S171 Port Plastics Tukwila, WA

## Federal Supply Codes for Manufacturers (cont)

9W423 Amatom El Mont, CA	91934 Miller Electric Co. Woonsocket, RI	95573 Campion Laboratories Inc. Detroit, MI	98278 Malco A Microdot Co. South Pasadena, CA
90201 Mallory Capacitor Co. Sub of Emhart Industries Inc. Indianapolis, IN	91967 National Tel-Tronics Div. of electro Audio Dynamics Inc Meadville, PA	95712 Bendix Corp. Electrical Comp. Div. Franklin, IN	98291 Sealectro Corp. BICC Electronics Trumbull, CT
90215 Best Stamp & Mfg. Co. KS City, MO	91984 Maida Development Co. Hampton, VA	95987 Weckesser Co. Inc. (Now 85480)	98372 Royal Industries Inc. (Now 62793)
90303 Duracell Inc. Technical Sales & Marketing Bethel, CT	91985 Norwalk Valve Co. S. Norwalk, CT	96733 SFE Technologies San Fernando, CA	98388 Lear Siegler Inc. Accurate Products Div. San Deigo, CA
91094 Essex Group Inc. Suflex/IWP Div. Newmarket, NH	92218 Wakefield Corp., The Wakefield, ME	96853 Gulton Industries Inc. Measurement & Controls Div. Manchester, NH	98978 IERC (International Electronic Research Corp.) Burbank, CA
91247 IL Transformer Co. Chicago, IL	92527 VTC Inc. Bloomington, MN	96881 Thomson Industries Inc. Port WA, NY	99120 Plastic Capacitors Inc. Chicago, IL
91293 Johanson Mfg. Co. Boonton, NJ	92607 Tensolite Co. Div. of Carlisle Corp. Buchanan, NY	97464 Industrial Retainer Ring Irvington, NJ	99217 Bell Industries Inc. Elect. Distributor Div. Sunnyvale, CA
91462 Alpha Industries Inc. Logansport, IN	92914 Alpha Wire Corp. Elizabeth, NJ	97525 EECO Inc. Santa Ana, CA	99378 ATLEE of DE Inc. N. Andover, MA
91502 Associated Machine Santa Clara, CA	93332 Sylvania Electric Products Semiconductor Products Div. Wobum, MA	97540 Whitehall Electronics Corp. Master Mobile Mounts Div. Fort Meyers, FL	99392 Mepco/Electra Inc. Roxboro Div. Roxboro, NC
91506 Augat Alcoswitch N. Andover, MA	94144 Raytheon Co. Microwave & Power Tube Div. Quincy, MA	97913 Industrial Electronic Hardware Corp. NY, NY	99515 Electron Products Inc. Div. of American Capacitors Duarte, CA
91507 Froeliger Machine Tool Co. Stockton, CA	94222 Southco Inc. Concordville, PA	97945 Pennwalt Corp. SS White Industrial Products Piscataway, NJ	99779 Bunker Ramo- Eltra Corp. Bames Div. Lansdown, PA
91637 Dale Electronics Inc. Columbus, NE	94988 Wagner Electric Corp. Sub of McGraw-Edison Co. Whippany, NJ	97966 CBS Electronic Div. Danvers, MA	99800 American Precision Industries Delevan Div. East Aurora, NY
91662 Elco Corp. A Gulf Western Mfg. Co. Connector Div. Huntingdon, PA	95146 Alco Electronic Products Inc. Switch Div. North Andover, MA	98094 Machlett Laboratories Inc. Santa Barbara, CA	99942 Mepco/Centralab A North American Philips Co. Milwaukee, WI
91737 ITT Cannon/Gremar (Now 08718)	95263 Leecraft Mfg. Co. Long Island City, NY	98159 Rubber-Teck Inc. Gardena, CA	
91802 Industrial Devices Inc. Edgewater, NJ	95275 Vitramon Inc. Bridgeport, CT		
91833 Keystone Electronics Corp. NY, NY	95303 RCA Corp. Receiving Tube Div. Cincinnati, OH		
91836 King's Electronics Co. Inc. Tuckahoe, NY	95348 Gordo's Corp. Bloomfield, NJ		
91929 Honeywell Inc. Micro Switch Div. Freeport, IL	95354 Methode Mfg. Corp. Rolling Meadows, IL		

## TECHNICAL SERVICE CENTERS

### U.S. Service Locations

#### California

Fluke Technical Center  
16969 Von Karman Avenue  
Suite 100  
Irvine, CA 92714  
Tel: (714) 863-9031

Fluke Technical Center  
46610 Landing Parkway  
Fremont, CA 94538  
Tel: (415) 651-5112

#### Colorado

Fluke Technical Center  
14180 East Evans Avenue  
Aurora, CO 80014  
Tel: (303) 695-1171

#### Florida

Fluke Technical Center  
940 N. Fern Creek Avenue  
Orlando, FL 32803  
Tel: (407) 896-4881

#### Illinois

Fluke Technical Center  
1150 W. Euclid Ave.  
Palatine, IL 60067  
Tel: (312) 705-0500

#### Maryland

Fluke Technical Center  
5640 Fishers Lane  
Rockville, MD 20852  
Tel: (301) 770-1576

#### New Jersey

Fluke Technical Center  
East 66 Midland Avenue  
Paramus, NJ 07652-0930  
Tel: (201) 599-9500

#### Texas

Fluke Technical Center  
1801 Royal Lane, Suite 307  
Dallas, TX 75229  
Tel: (214) 869-2848

#### Washington

Fluke Technical Center  
John Fluke Mfg. Co., Inc.  
1420 75th St. S.W.  
MS 6-30  
Everett, WA 98203  
Tel: (206) 356-5560

### International

#### Argentina

Coasin S.A.  
Virrey del Pino 4071 DPTO E-65  
1430 CAP FED  
Buenos Aires  
Tel: 54 1 522-5248

#### Australia

Philips Customer Support  
Scientific and Industrial  
23 Lakeside Drive  
Tally Ho Technology Park  
East Burwood  
Victoria 3151

#### Australia

Philips Customer Support  
Scientific & Industrial  
25-27 Paul St. North  
North Ryde N.S.W. 2113  
Tel: 61 02 888 8222

#### Austria

Oesterreichische Philips Industrie  
Unternehmensbereich Prof. Systeme  
Triesterstrasse 66  
Postfach 217  
A-1101 Wein  
Tel: 43 222-60101, x1388

#### Belgium

Philips & MBLE Associated S.A.  
Scientific & Industrial Equip. Div  
Service Department.  
80 Rue des deux Gares B-1070  
Brussels  
Tel: 32 2 525 6111

#### Brazil

Hi-Tek Electronica Ltda.  
Al. Amazonas 422, Alphaville  
CEP 06400 Barueri  
Sao Paulo  
Tel: 55 11 421-5477

#### Canada

Fluke Electronics Canada Inc.  
400 Britannia Rd. East, Unit #1  
Mississauga  
Ontario L4Z 1X9  
Tel: 416-890-7600

#### Chile

Intronica Chile Ltda.  
Casilla 16228  
Santiago 9  
Tel: 56 2 2321886, 2324308

#### China

Fluke International Corp.  
P.O. Box 9085  
Beijing  
Tel: 86 01 512-3436

#### Colombia

Sistemas E Instrumentacion, Ltda.  
Carrera 13, No. 37-43, Of. 401  
Ap. Aereo 29583  
Bogota DE  
Tel: 57 232-4532

#### Denmark

Philips A/S  
Technical Service I & E  
Strandlodsvej 1A  
PO Box 1919  
DK-2300  
Copenhagen S  
Tel: 45 1 572222

#### Ecuador

Proteco Coasin Cia., Ltda.  
P.O. Box 228-A  
Ave. 12 de Octubre  
2285 y Orellana  
Quito  
Tel: 593 2 529684

#### Egypt

Philips Egypt  
10, Abdel Rahman el Rafei st.  
el. Mohandessin  
P.O. Box 242  
Dokki Cairo  
Tel: 20-2-490922

#### England

Philips Scientific  
Test & Measuring Division  
Colonial Way  
Watford  
Hertfordshire WD2 4TT  
Tel: 44 923-40511

#### Finland

Oy Philips AB  
Central Service  
Sinikalliontie 1-3  
P.O. Box 11  
SF-02630 ESPOO  
Tel: 358-0-52572

#### France

S.A. Philips Industrielle  
et Commerciale,  
Science et Industrie  
105 Rue de Paris Bp 62  
93002 Bobigny, Cedex  
Tel: 33-1-4942-8040

#### Germany (F.R.G.)

Philips GmbH  
Service fuer FLUKE - Produkte  
Department VSF  
Oskar-Messter-Strasse 18  
D-8045 Ismaning/Munich,  
West Germany  
Tel: 49 089 9605-239

#### Greece

Philips S.A. Hellenique  
15, 25th March Street  
177 78 Tavros  
10210 Athens  
Tel: 30 1 4894911

#### Hong Kong

Schmidt & Co (H.K.) Ltd.  
18/FL., Great Eagle Centre  
23 Harbour Road  
Wanchai  
Tel: 852 5 8330222

#### India

Hinditron Services Pvt. Ltd  
1st Floor, 17-B,  
Mahal Industrial Estate  
Mahakali Road, Andheri East  
Bombay 400 093  
Tel: 91 22 6300043

Hinditron Services Pvt. Inc.  
33/44A Raj Mahal Villas Extn.  
8th Main Road  
Bangalore 560 080  
Tel: 91 812 363139

#### Hinditron Services Pvt. Ltd.

Field Service Center  
Emerald Complex 1-7-264  
5th Floor  
114 Sarojini Devi Road  
Secunderabad 500 003  
Tel: 08 42-821117

#### Hinditron Services Pvt. Ltd.

15 Community Centre  
Panchshila Park  
New Delhi 110 017  
Tel: 011-6433675

#### Indonesia

P.T. Lamda Triguna  
P.O. Box 6/JATJG  
Jakarta 13001  
Tel: (021) 8195365

#### Israeli

R.D.T. Electronics Engineering, Ltd.  
P.O. Box 43137  
Tel Aviv 61430  
Tel: 972 3 483211

#### Italy

Philips S.p.A.  
Sezione I&E / T&M  
Viale Elvezia 2  
2005 Monza  
Tel: 39 39 3635342

#### Japan

John Fluke Mfg. Co., Inc.  
Japan Branch  
Sumitomo Higashi Shinbashi Bldg.  
1-1-11 Hamamatsucho  
Minato-ku  
Tokyo 105  
Tel: 81 3 434-0181

#### Korea

Myoung Corporation  
Yeo Eui Do P.O. Box 14  
Seoul 150  
Tel: 82 2 784-9942

#### Malaysia

Mecomb Malaysia Sdn. Bhd.  
P.O. Box 24  
46700 Petaling Jaya  
Selangor  
Tel: 60 3 774-3422

#### Mexico

Mexel Servicios en Computacion  
Instrumentacion y Perifericos  
Blvd. Adolfo Lopez Mateos No. 163  
Col. Mixcoac  
Mexico D.F.  
Tel: 52-5-563-5411

#### Netherlands

Philips Nederland  
Test & Meetapparaten Div.  
Postbus 115  
5000 AC Tilburg  
Tel: 31-13-352445

**New Zealand**

Philips Customer Support  
Scientific & Industrial Division  
2 Wagener Place  
Mt. Albert  
Auckland  
Tel: 64 9 894-160

**Norway**

Morgenstjerne & Co. A/S  
Konghellegate 3  
P.O. Box 6688, Rodelokka  
Oslo 5  
Tel: 47 2 356110

**Pakistan**

International Operations (PAK) Ltd.  
505 Muhammadi House  
I.I. Chundrigar Road  
P.O. Box 5323  
Karachi  
Tel: 92 21 221127, 239052

**Peru**

Importaciones & Representaciones  
Electronicas S.A.  
Avad Franklin D. Roosevelt 105  
Lima 1  
Tel: 51 14 288650

**Philippines**

Spark Radio & ElectronicS Inc.  
Greenhills, P.O. Box 610  
San Juan, Metro-Manila Zip 3113  
Tel: 63-2-775192

**Portugal**

Decada Espectral  
Equipmentos de Elec. e Cientificos  
Av. Bomberos Voluntarios  
Lote 102B, Miraflores/Alges  
1495 Lisboa  
Tel: 351 1 410-3420

**Singapore**

Rank O'Connor's Singapore (PTE) Ltd.  
98 Pasir Panjang Road  
Singapore 0511  
Tel: 65 4737944

**South Africa**

South African Philips (Pty) Ltd.  
Service Department  
195 Main Rd  
Martindale, Johannesburg, 2092  
Tel: 27 11 470-5255

**Spain**

Philips Iberica S.A.E.  
Depto. Tecnico Instrumentacion  
c/Martinez Villergas 2  
28027 Madrid  
Tel: 34 1 4042200

**Sweden**

Philips Kistaindustrier AB  
Customer Support  
Borgarfjordsgatan 16  
S-16493 Kista

**Switzerland**

Philips A.G.  
Technischer Kundendienst  
Postfach 670  
Allmendstrasse 140  
CH-8027 Zurich  
Tel: 41 1 482211

**Taiwan**

Schmidt Electronics Corp.  
5th Floor, Cathay Min Sheng  
Commercial Building,  
344 Min Sheng East Road  
Taipei  
Tel: 886 2501-3468

**Thailand**

Measuretronix Ltd.  
2102/63 Ramkamhaeng Rd.  
Bangkok 10240  
Tel: 66 2 374-2516, 374-1632

**Turkey**

Turk Philips Ticaret A.S.  
Inonu Caddesi 78/80  
Posta Kutusu 504-Beyoglu  
Istanbul  
Tel: 90 1 1435891

**Uruguay**

Coasin Uruguay S.A  
Casilla de Correo 1400  
Libertad 2525  
Montevideo  
Tel: 598-2-789015

**Venezuela**

Coasin C.A.  
Calle 9 Con Calle 4, Edif. Edinurbi  
Apartado de Correos Nr-70-136  
Los Ruices  
Caracas 1070-A  
Tel: 58 2 241-0309, 241-1248

**West Germany**

Philips GmbH  
Department VSF  
Service fuer FLUKE - Produkte  
Oskar - Messter - Strasse 18  
D-8045 Ismaning / Munich  
Tel: 49 089 9605-260









## Section 8

# Schematic Diagrams

FIGURE NO.	NAME	PAGE
8-1	1953A Block Diagram .....	8-3
8-2	A1A1 Main PCB Assembly .....	8-4
8-3	A3 Display Switch PCB Assembly .....	8-14
8-4	A4 Switch PCB Assembly .....	8-16
8-5	A1A3 Input PCB Assembly .....	8-18
8-6	A6 Data Output Unit PCB Assembly, Option -02 .....	8-20
8-7	A7/A8 External Time Base Multiplier Assembly, Option -05 .....	8-22
8-8	A9 520 MHz Prescaler PCB Assembly, Option -07 .....	8-24
8-9	A14/A15 1000 MHz and 1250 MHz Prescaler PCB Assembly, Option -13 and -14 .....	8-26
8-10	A10 Basic Remote Control Unit PCB Assembly, Option -11 .....	8-28
8-11	A16 IEEE-488 1975 Bus Interface PCB Assembly, Option -15 .....	8-30
8-12	A17 IEEE-488 1975 Processor PCB Assembly, Option -15 .....	8-32
8-13	A18 IEEE-488 1975 Switch PCB Assembly, Option -15 .....	8-35
8-14	A11/A12 Remote Control 1 and 2 Unit PCB Assemblies, Option -12 and -15 .....	8-36
8-15	A13 Remote Control Unit 3 PCB Assembly, Options -12 and -15 .....	8-38

This page intentionally left blank.

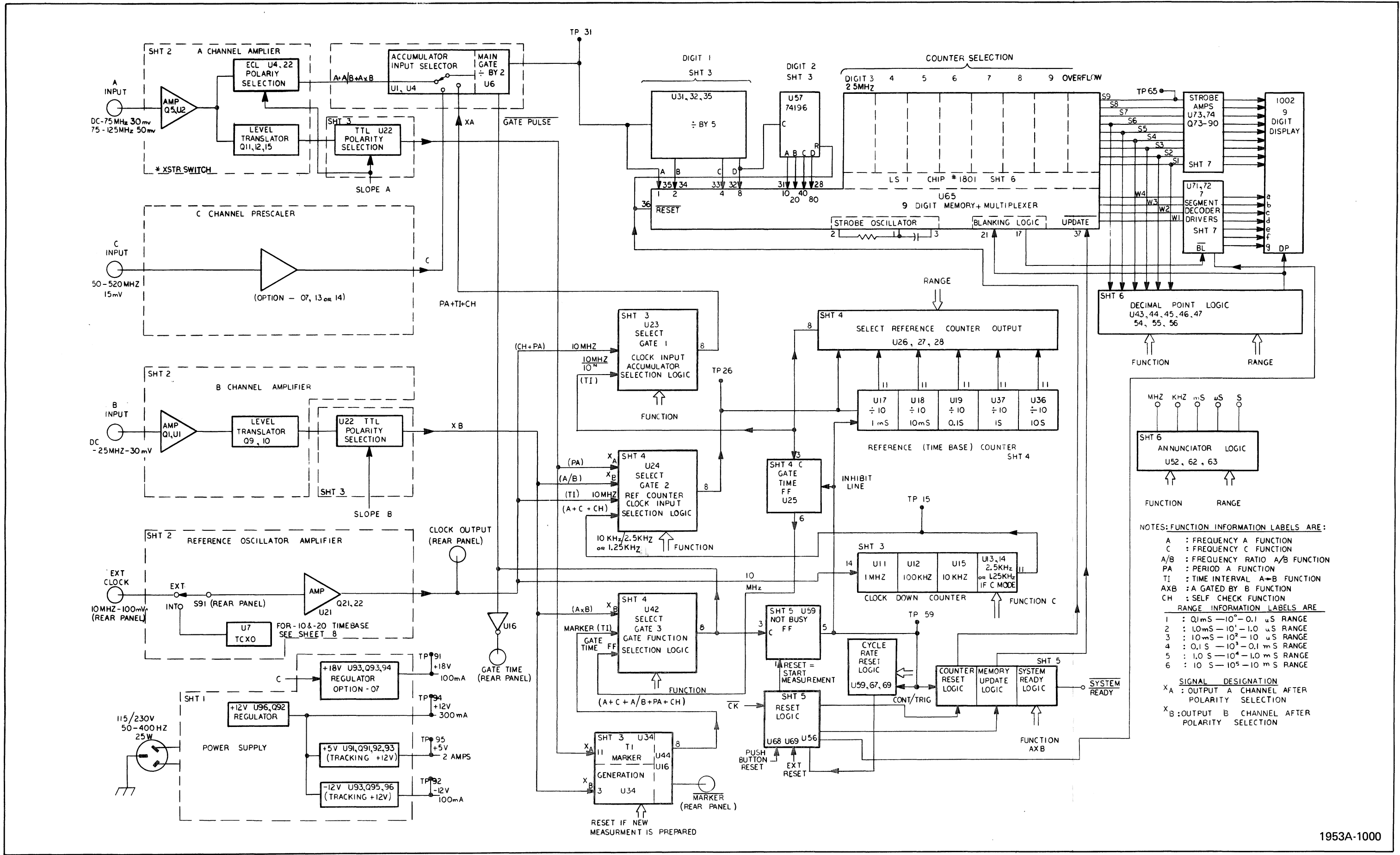

NOTES: FUNCTION INFORMATION LABELS ARE:

- A : FREQUENCY A FUNCTION
- C : FREQUENCY C FUNCTION
- A/B : FREQUENCY RATIO A/B FUNCTION
- PA : PERIOD A FUNCTION
- TI : TIME INTERVAL A→B FUNCTION
- AXB : A GATED BY B FUNCTION
- CH : SELF CHECK FUNCTION

RANGE INFORMATION LABELS ARE

- 1 : 0.1mS — 10<sup>2</sup> — 0.1 μS RANGE
- 2 : 1.0mS — 10<sup>1</sup> — 1.0 μS RANGE
- 3 : 10mS — 10<sup>2</sup> — 10 μS RANGE
- 4 : 0.1 S — 10<sup>3</sup> — 0.1 mS RANGE
- 5 : 1.0 S — 10<sup>4</sup> — 1.0 mS RANGE
- 6 : 10 S — 10<sup>5</sup> — 10 mS RANGE

SIGNAL DESIGNATION

- X<sub>A</sub> : OUTPUT A CHANNEL AFTER POLARITY SELECTION
- X<sub>B</sub> : OUTPUT B CHANNEL AFTER POLARITY SELECTION

Figure 8-1. 1953A Block Diagram

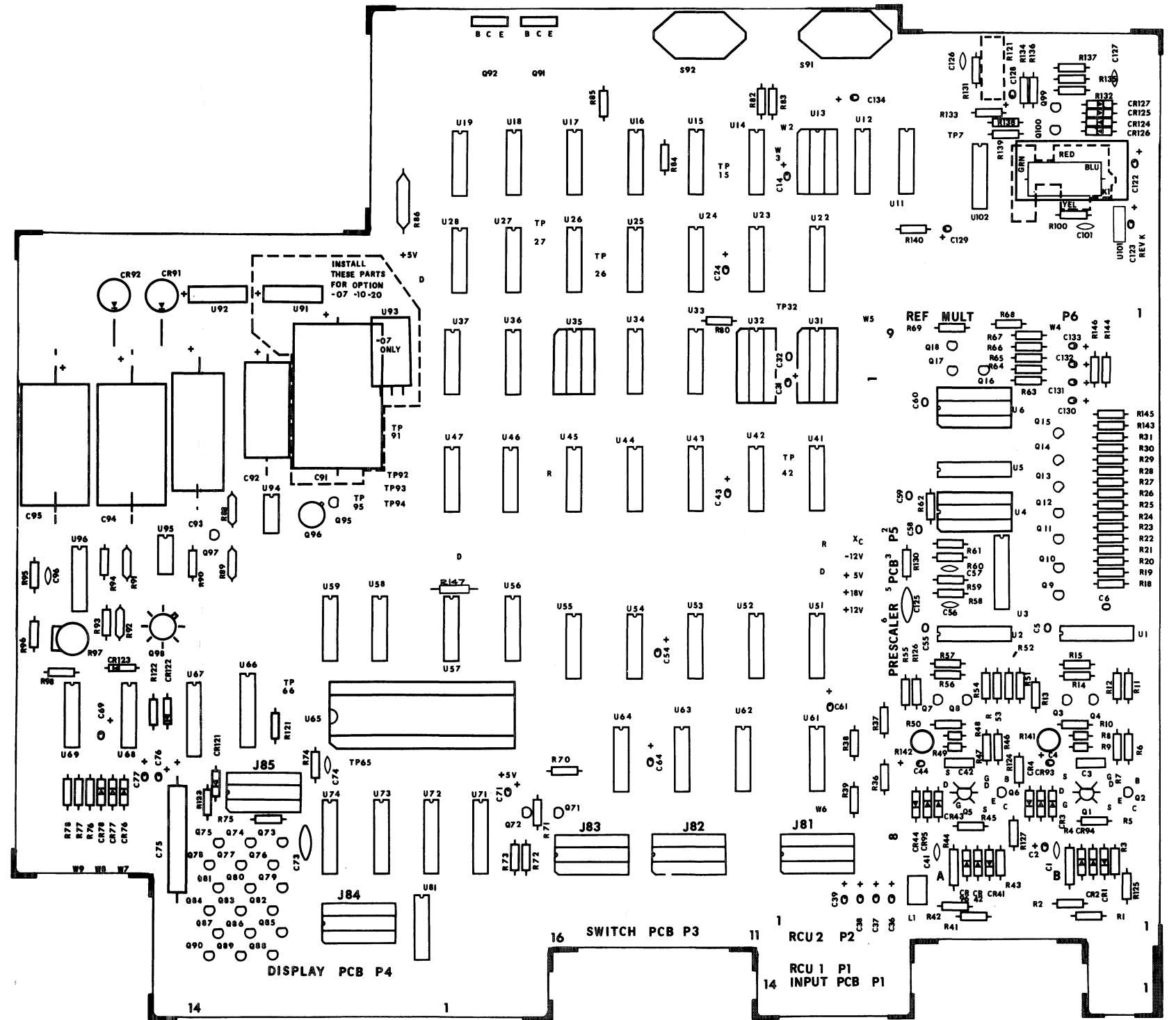
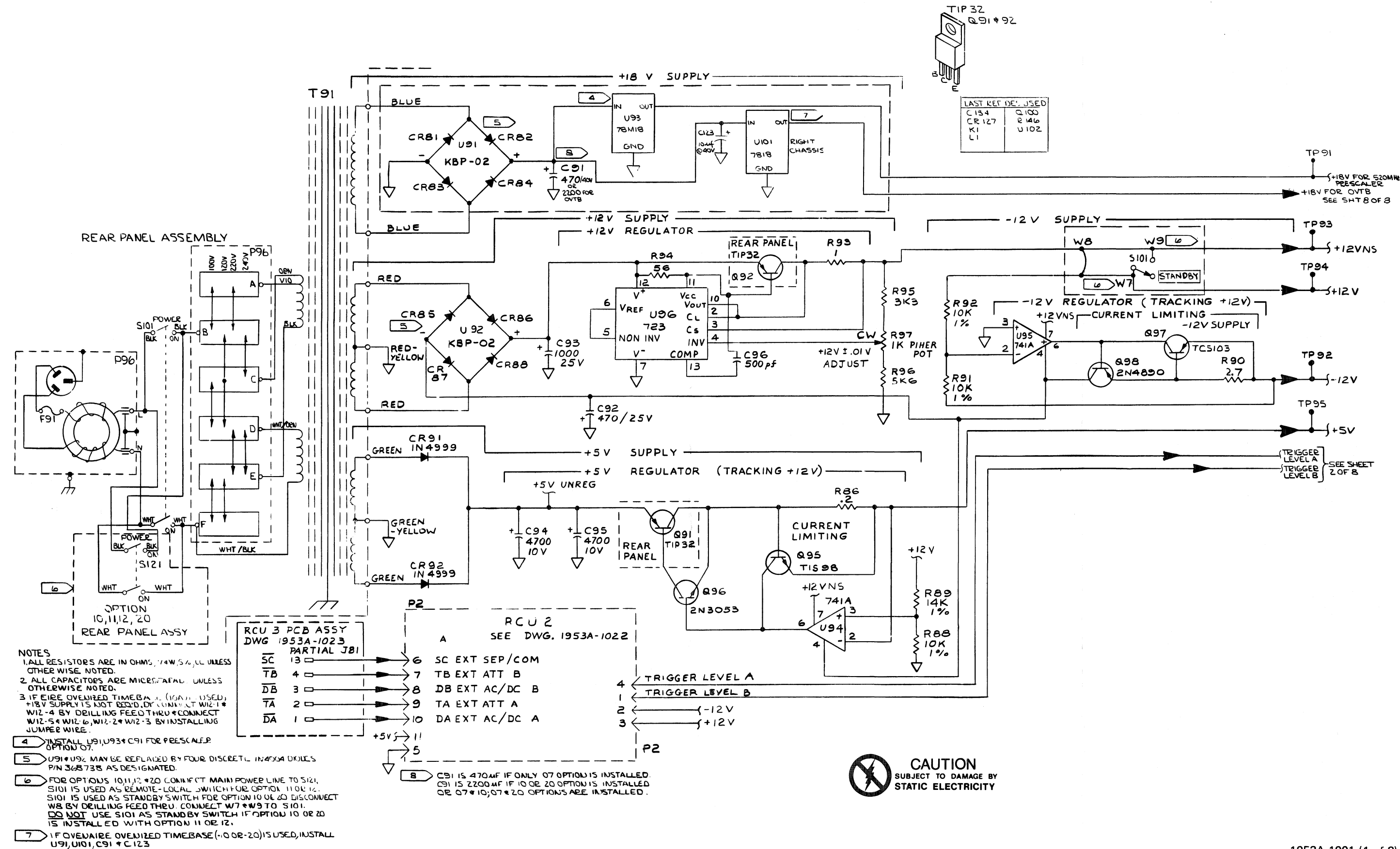
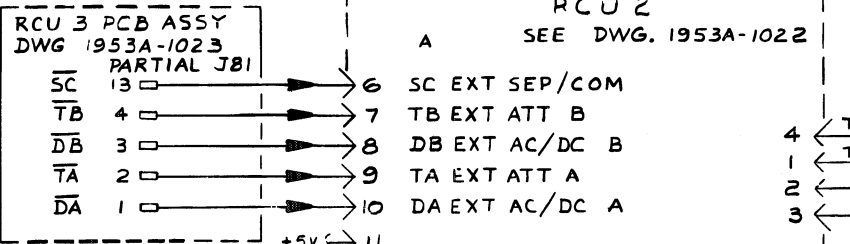

Figure 8-2. A1A1 Main PCB Assembly



LAST REF. DE. USED	
C134	Q100
CR127	R146
K1	U102
L1	

- NOTES**
1. ALL RESISTORS ARE IN OHMS, 1/4W, 5%, UNLESS OTHERWISE NOTED.
  2. ALL CAPACITORS ARE MICROFARAD, UNLESS OTHERWISE NOTED.
  3. IF EIRE OVERVISED TIMEBASE (10 OR 20) IS USED, +18V SUPPLY IS NOT REQ'D. DRILL AND CONNECT W12-1 & W12-4 BY DRILLING FEED THRU & CONNECT W12-5 & W12-6, W12-2 & W12-3 BY INSTALLING JUMPER WIRE.
- 4 INSTALL U91, U93 & C91 FOR PRESCALER OPTION 07.
- 5 U91 & U92 MAY BE REPLACED BY FOUR DISCRETE 1N4004 DIODES P/N 368738 AS DESIGNATED.
- 6 FOR OPTIONS 10, 11, 12 & 20 CONNECT MAIN POWER LINE TO S121. S101 IS USED AS REMOTE-LOCAL SWITCH FOR OPTION 11 OR 12. S101 IS USED AS STANDBY SWITCH FOR OPTION 10 OR 20. DISCONNECT W8 BY DRILLING FEED THRU. CONNECT W7 & W9 TO S101. **DO NOT** USE S101 AS STANDBY SWITCH IF OPTION 10 OR 20 IS INSTALLED WITH OPTION 11 OR 12.
- 7 IF OVERVISED OVERVISED TIMEBASE (10 OR 20) IS USED, INSTALL U91, U101, C91 & C123



8 C91 IS 470µF IF ONLY 07 OPTION IS INSTALLED. C91 IS 2200µF IF 10 OR 20 OPTION IS INSTALLED OR 07 & 10, 07 & 20 OPTION'S ARE INSTALLED.



Figure 8-2. A1A1 Main PCB Assembly (cont)

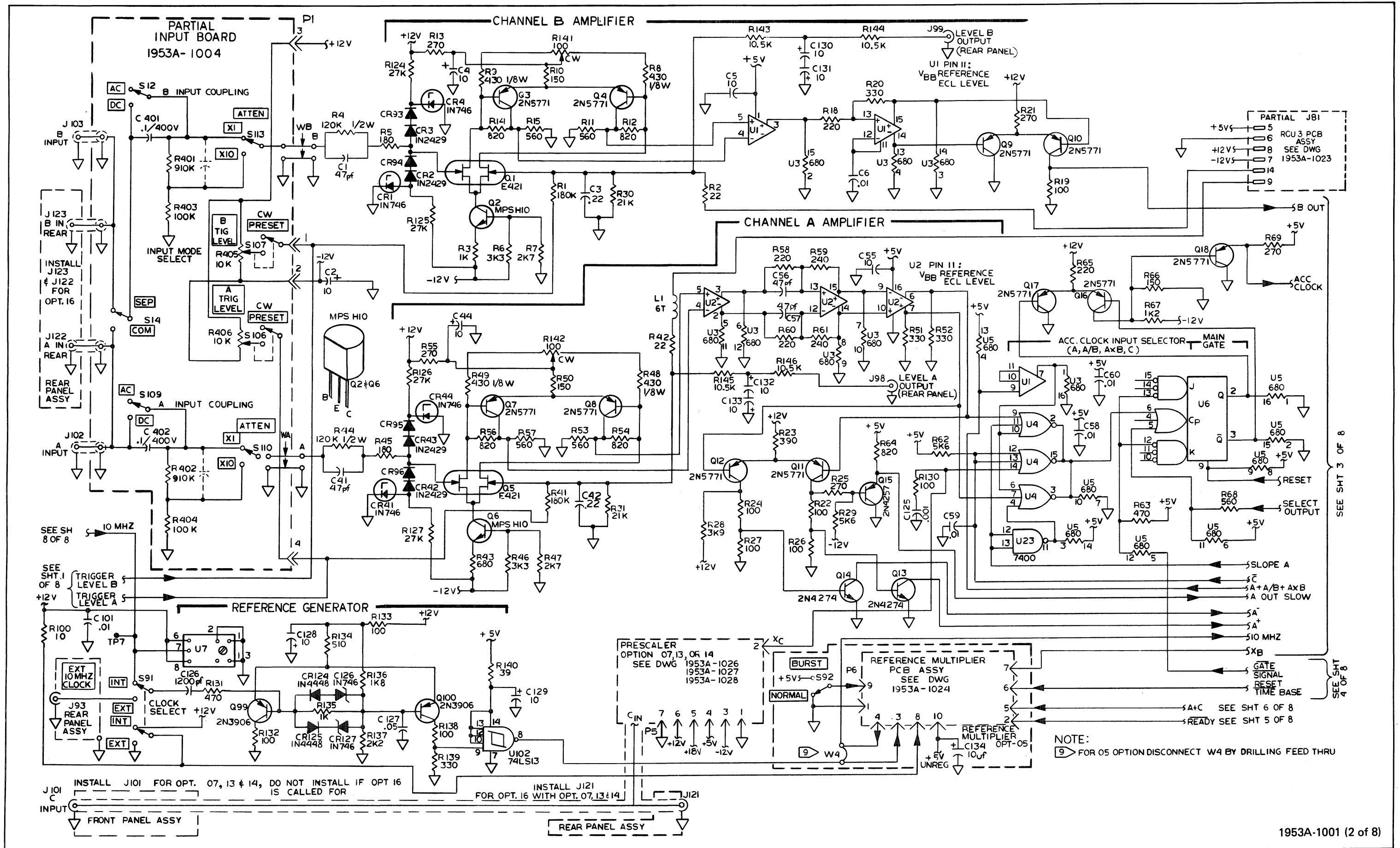

NOTE:  
 9) FOR 05 OPTION DISCONNECT W4 BY DRILLING FEED THRU

Figure 8-2. A1A1 Main PCB Assembly (cont)



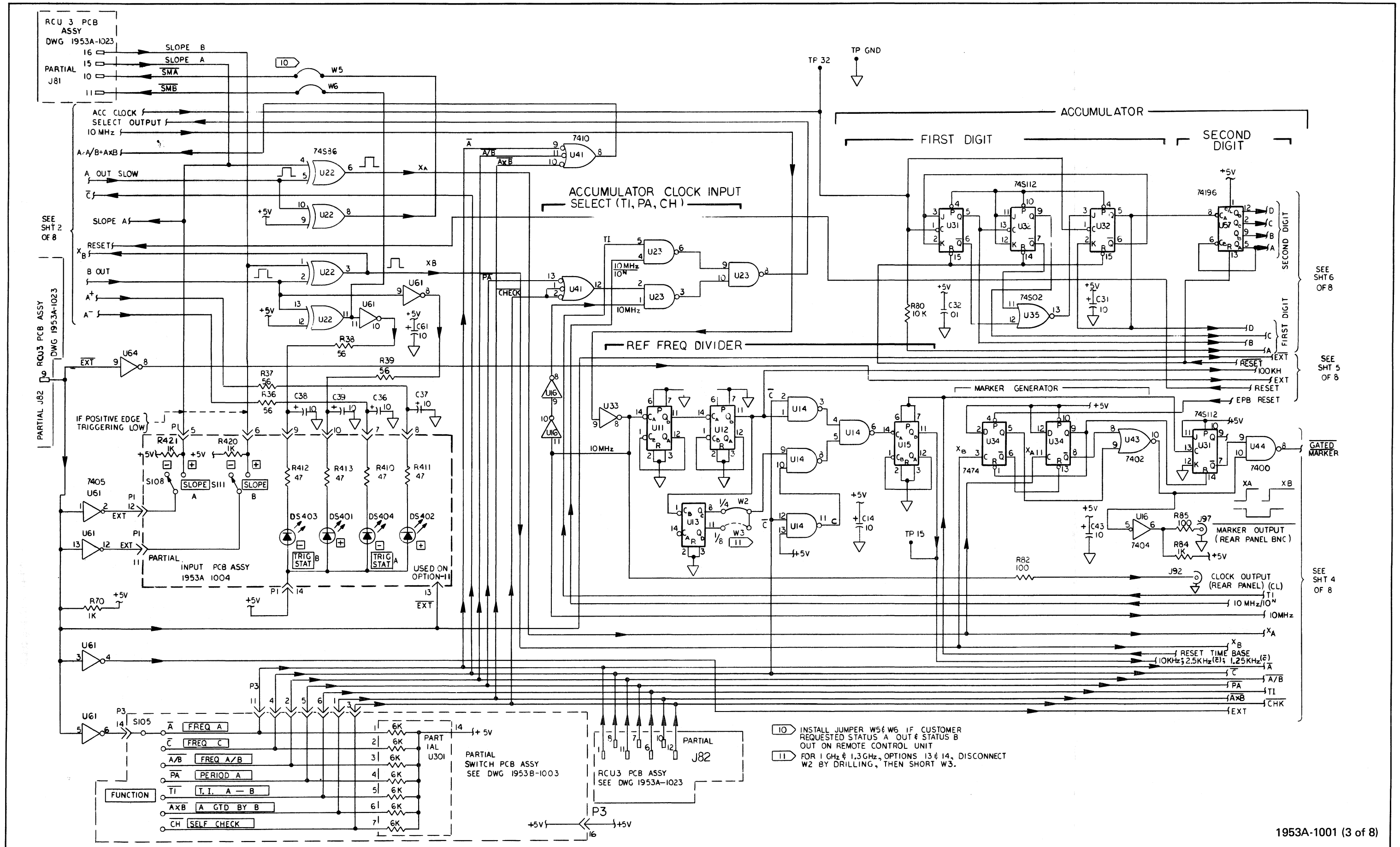

- 10 INSTALL JUMPER W5 & W6 IF CUSTOMER REQUESTED STATUS A OUT & STATUS B OUT ON REMOTE CONTROL UNIT
- 11 FOR 1 GHz & 1.3 GHz, OPTIONS 13 & 14, DISCONNECT W2 BY DRILLING, THEN SHORT W3.

Figure 8-2. A1A1 Main PCB Assembly (cont)

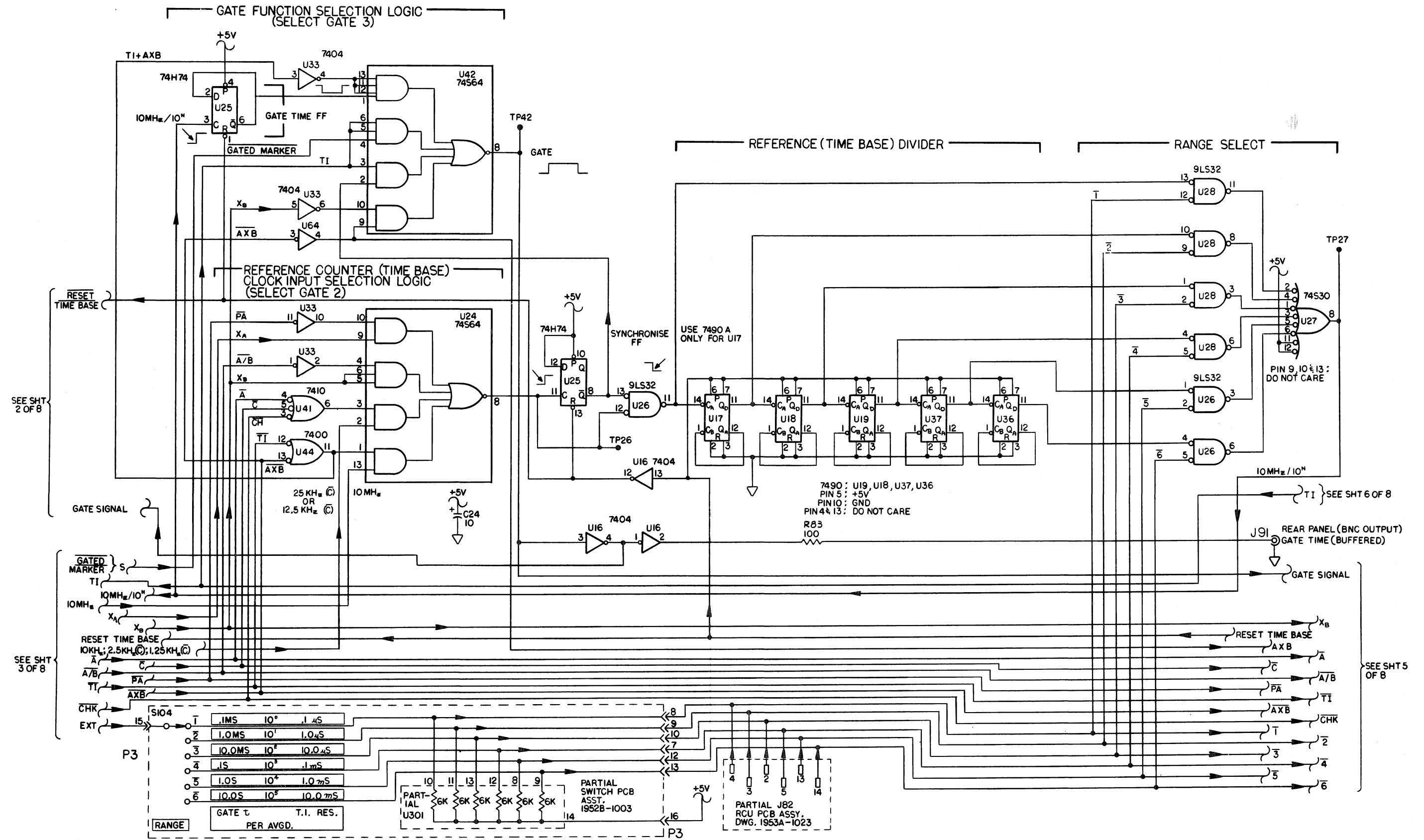
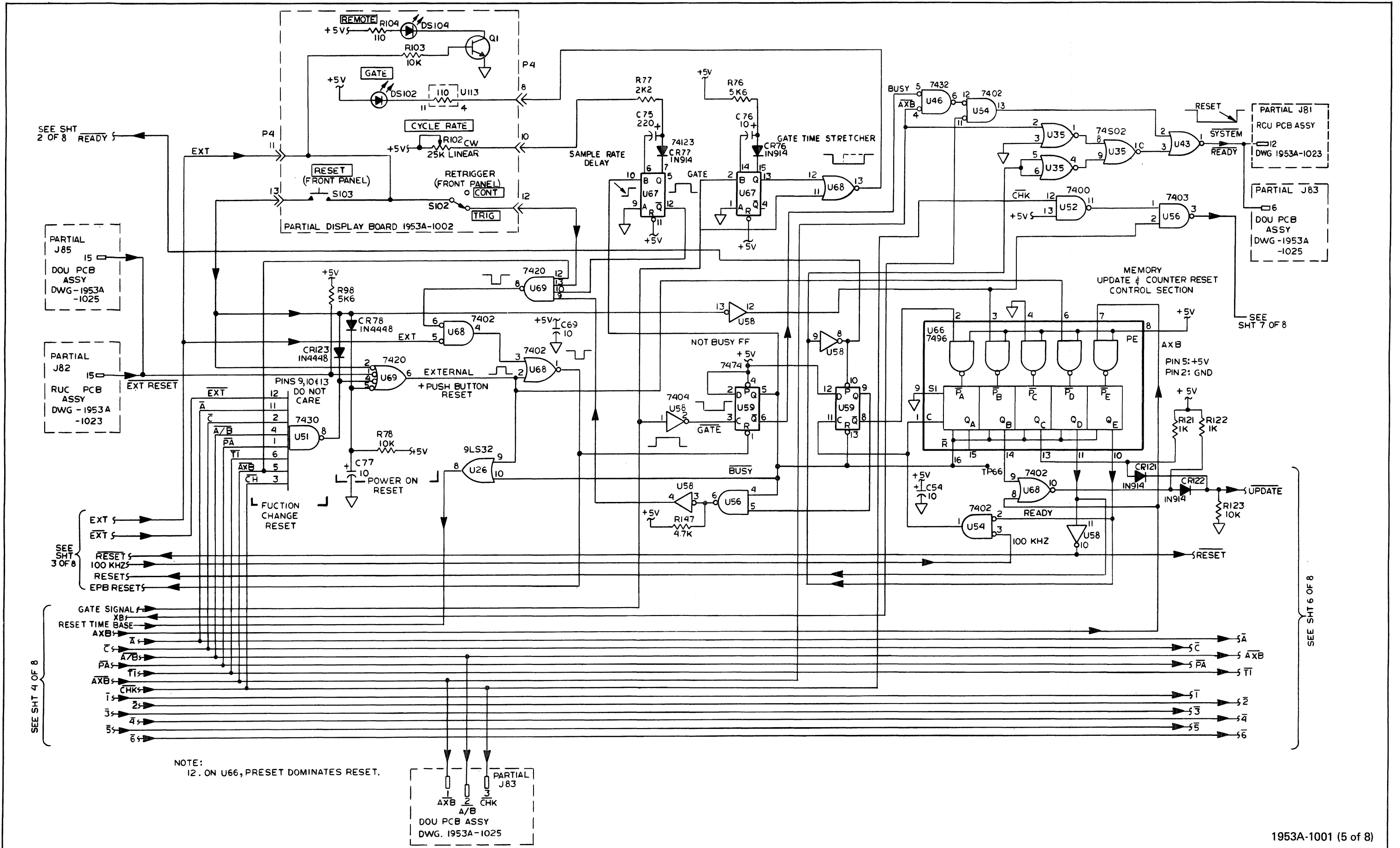

Figure 8-2. A1A1 Main PCB Assembly (cont)



NOTE:  
12. ON U66, PRESET DOMINATES RESET.

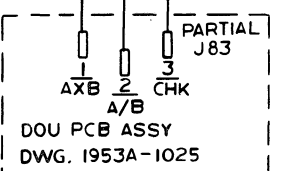
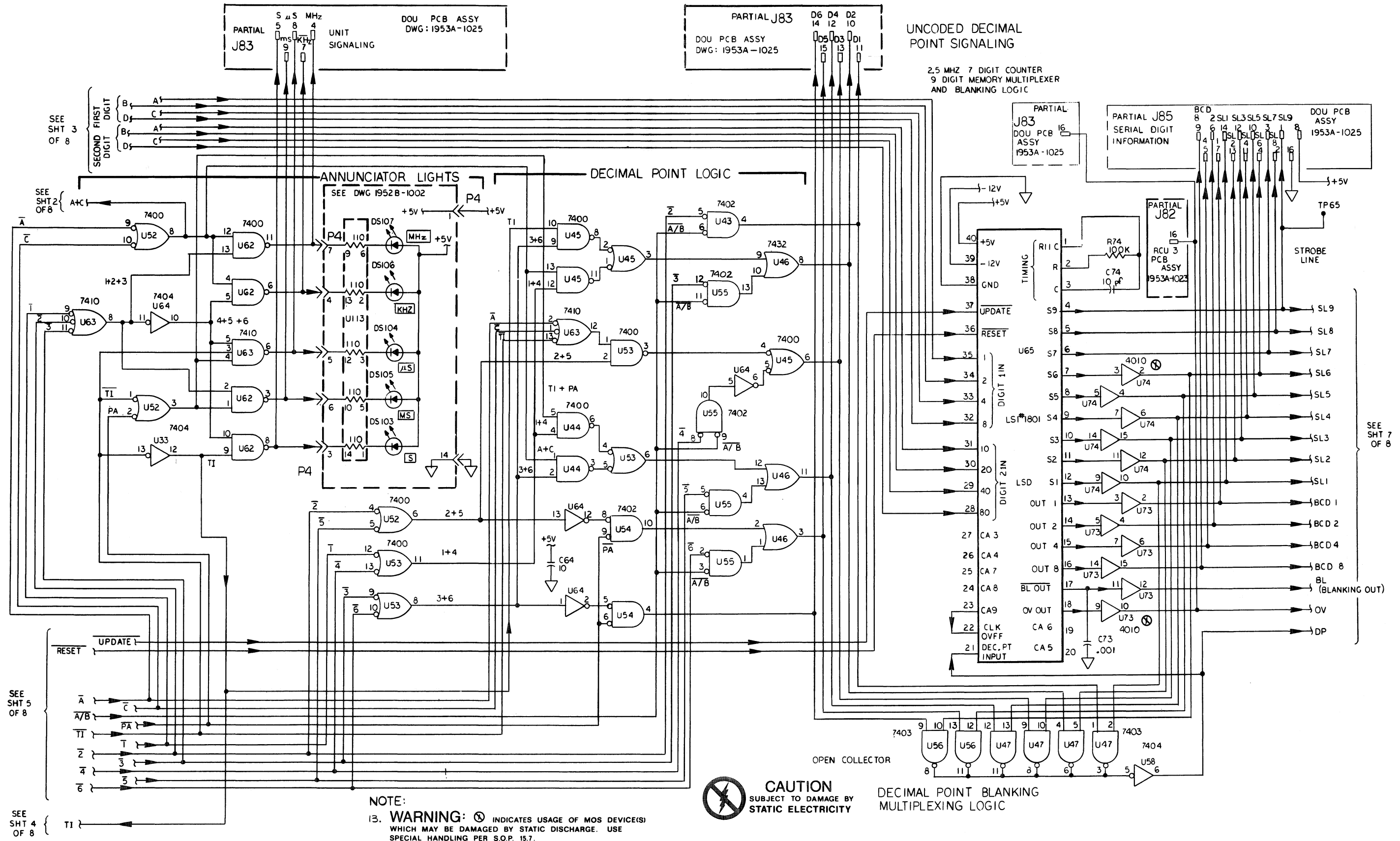

Figure 8-2. A1A1 Main PCB Assembly (cont)



SEE SHT 3 OF 8

SEE SHT 2 OF 8

SEE SHT 5 OF 8

SEE SHT 4 OF 8

SEE SHT 7 OF 8

NOTE:  
 13. **WARNING:** INDICATES USAGE OF MOS DEVICE(S) WHICH MAY BE DAMAGED BY STATIC DISCHARGE. USE SPECIAL HANDLING PER S.O.P. 15.7.

**CAUTION**  
 SUBJECT TO DAMAGE BY STATIC ELECTRICITY

DECIMAL POINT BLANKING MULTIPLEXING LOGIC

Figure 8-2. A1A1 Main PCB Assembly (cont)

SEE SHEET 5 OF 8

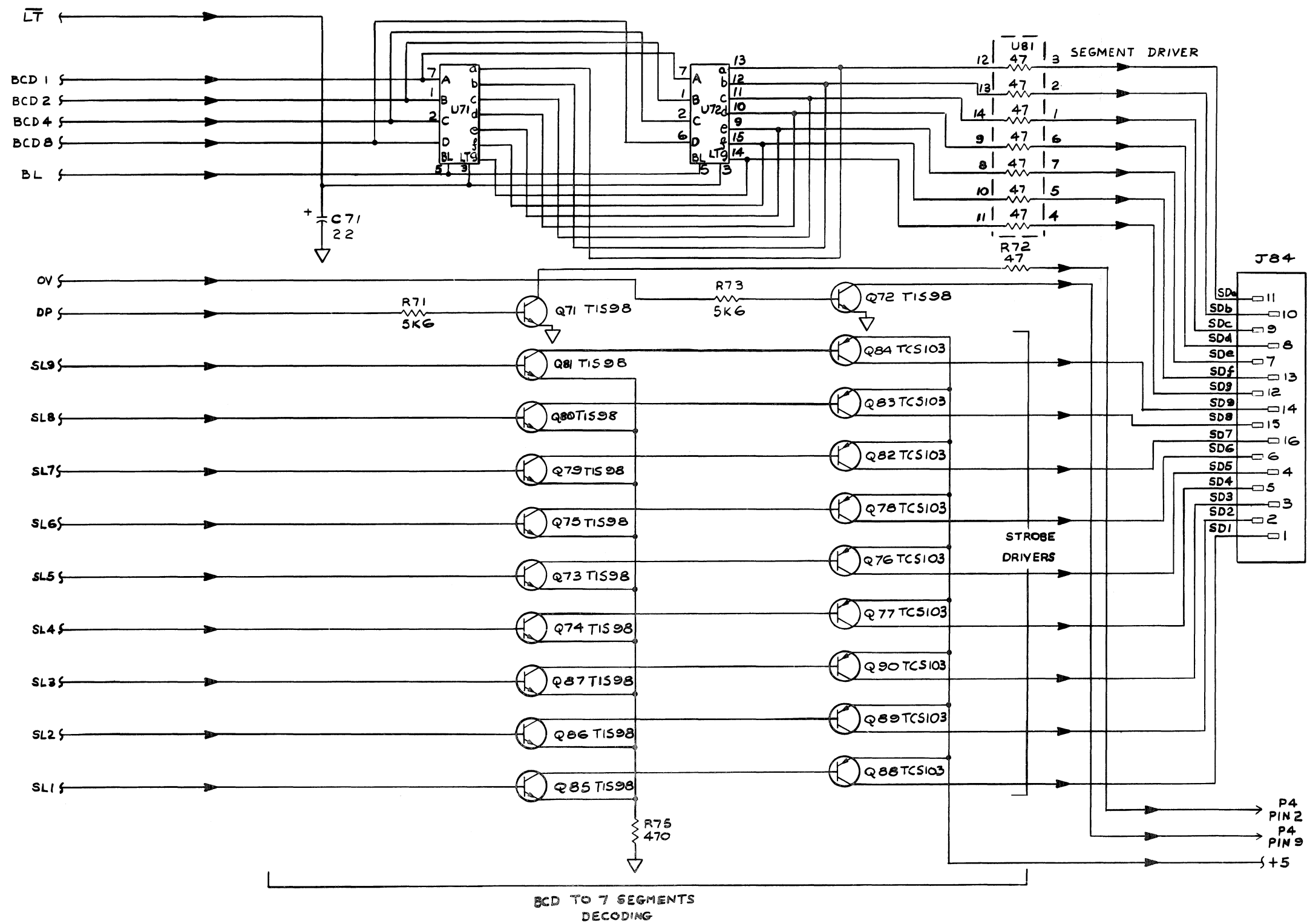

SEE SHT 6 OF 8

STROBE LINE

TO DISPLAY PCB ASSY DWG 1953A -1002

BCD TO 7 SEGMENTS DECODING

Figure 8-2. A1A1 Main PCB Assembly (cont)

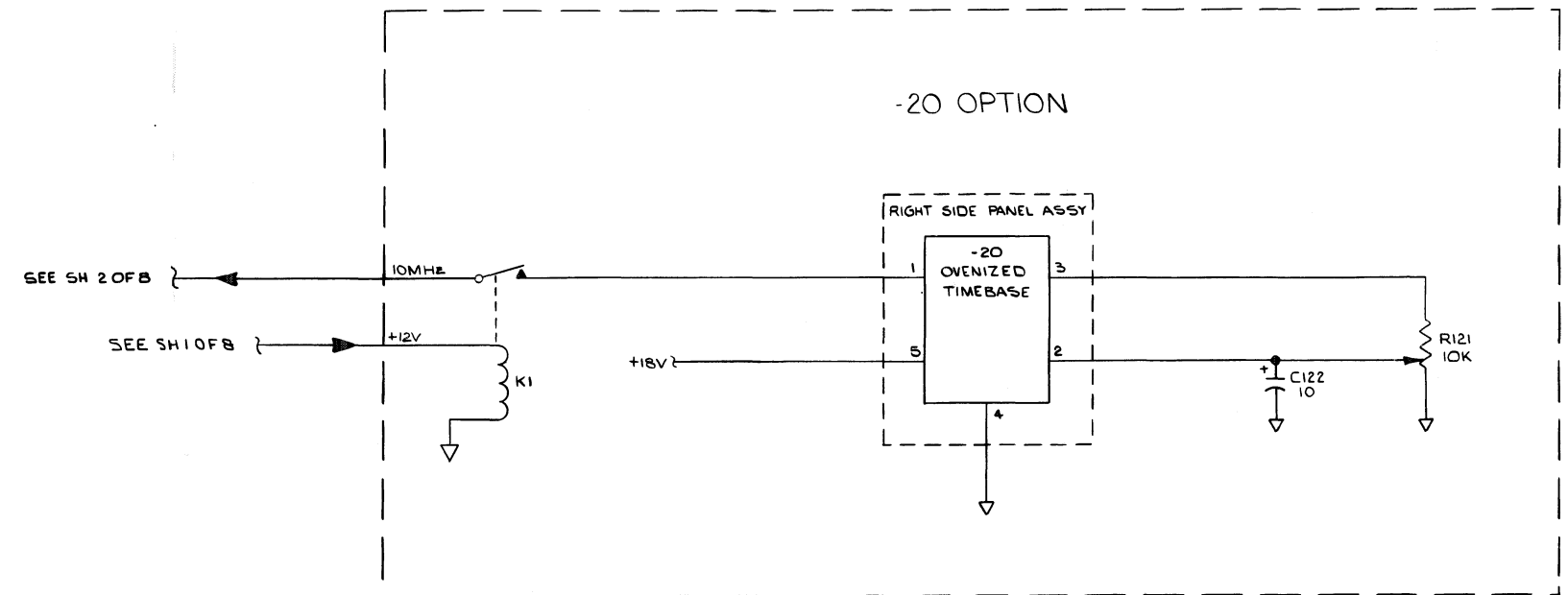
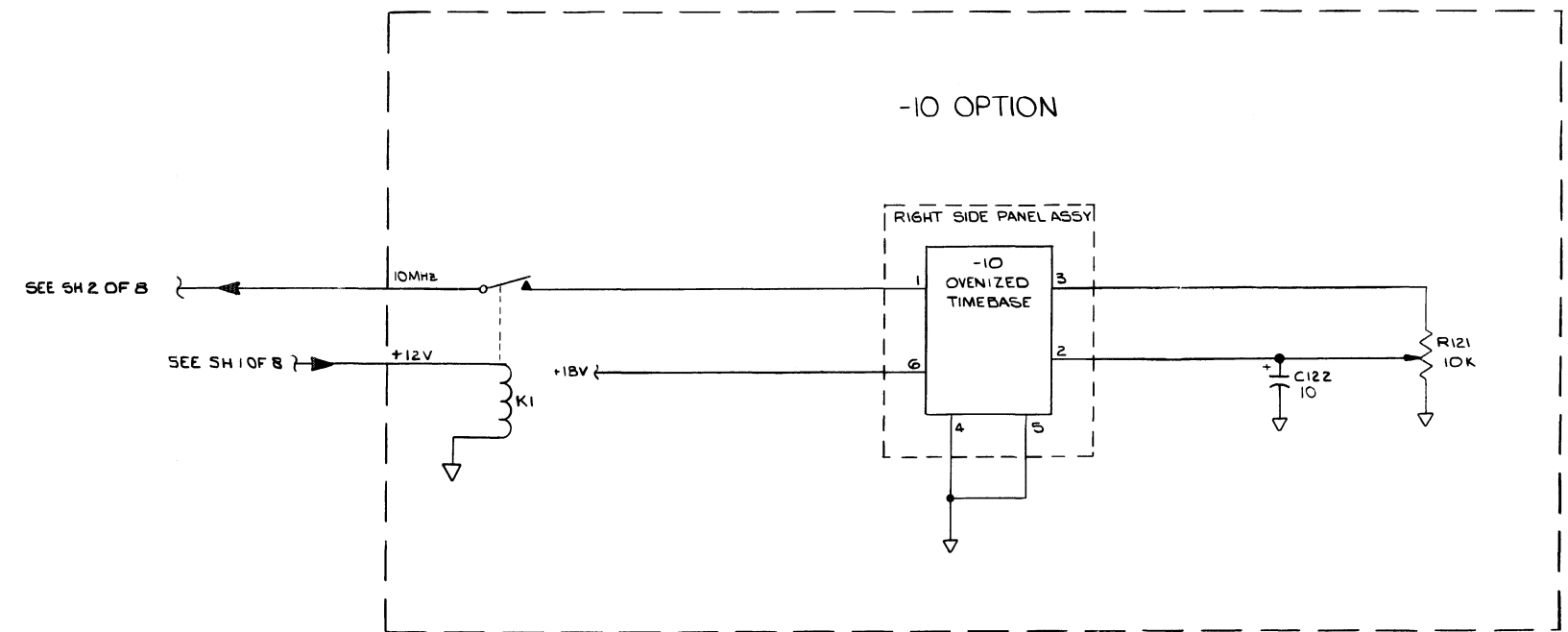

NOTES  
 14 FOR OPTION 10 OR 20 INSTALL R121  
 K1 \* C122 ON MAIN BOARD

Figure 8-2. A1A1 Main PCB Assembly (cont)

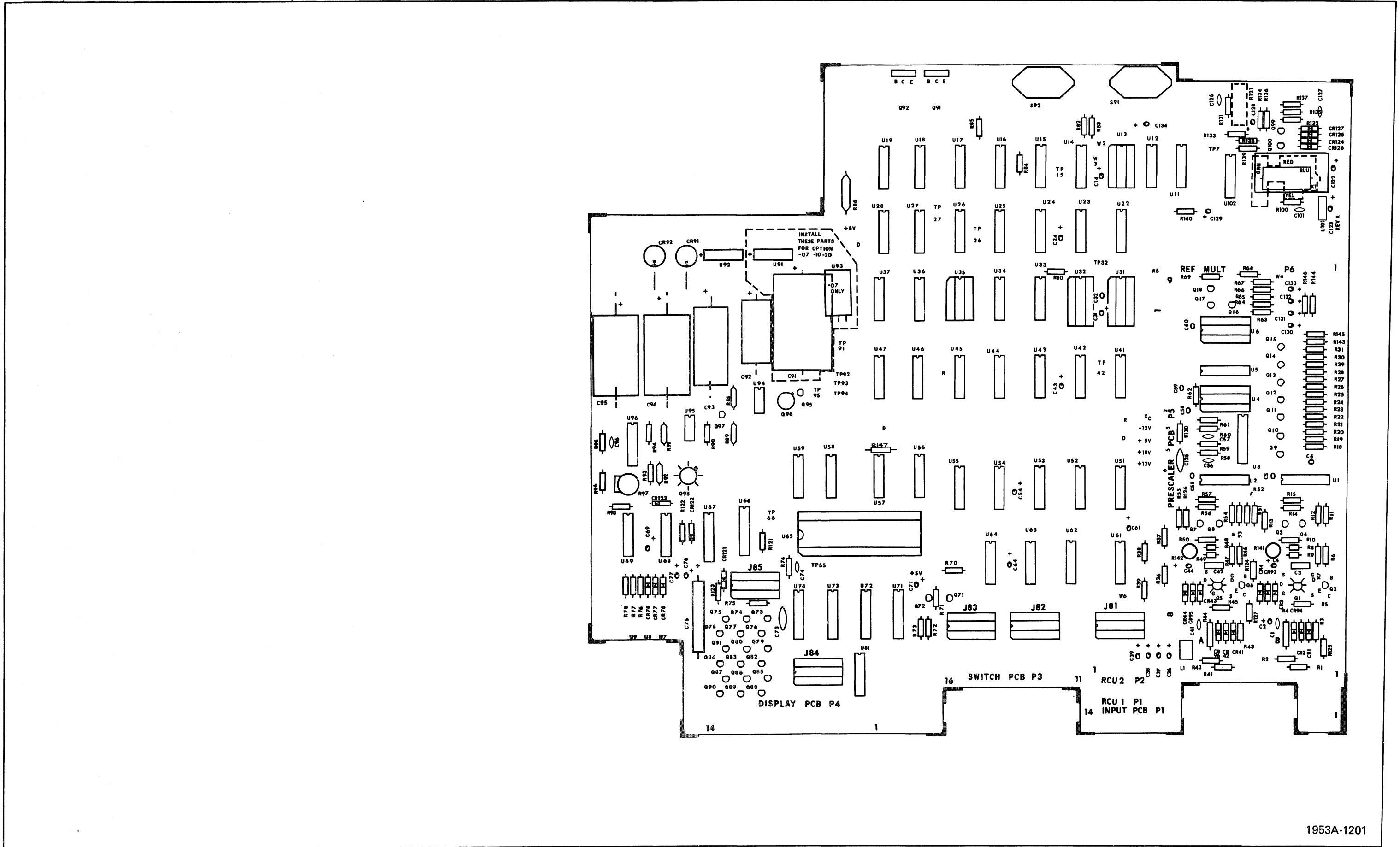

Figure 8-2. A1A1 Main PCB Assembly (cont)

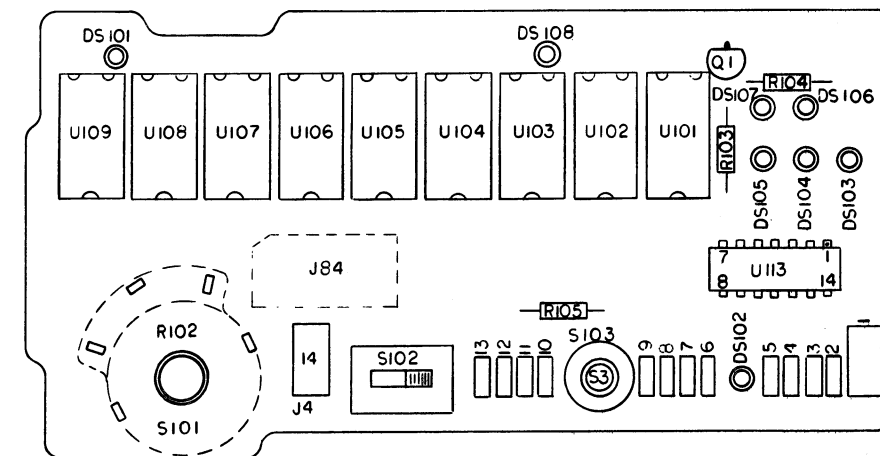
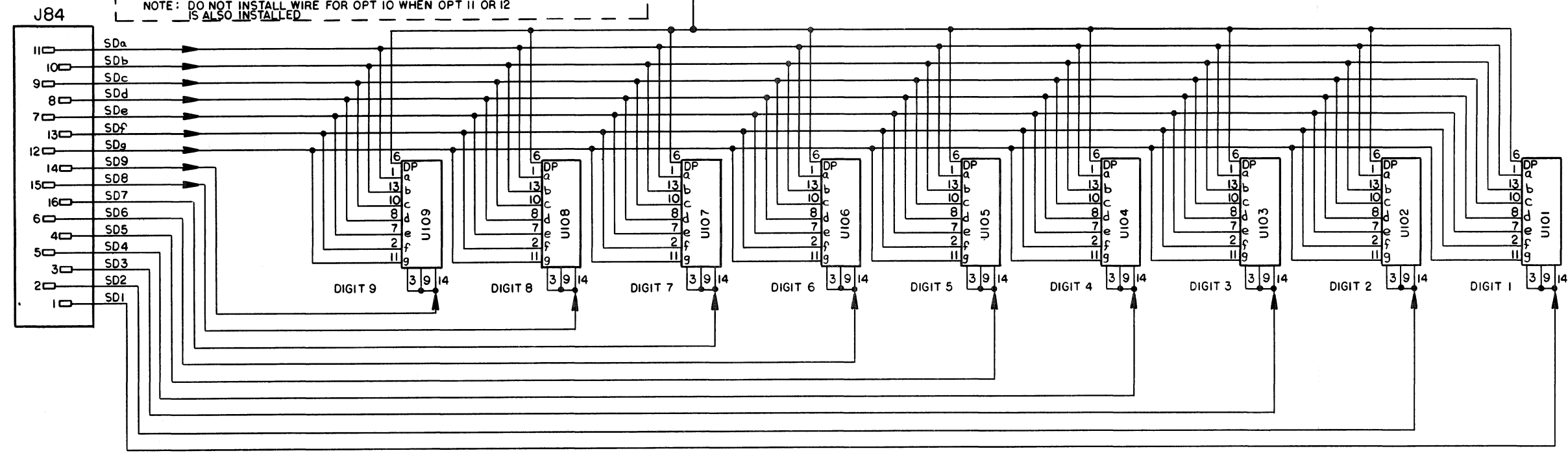
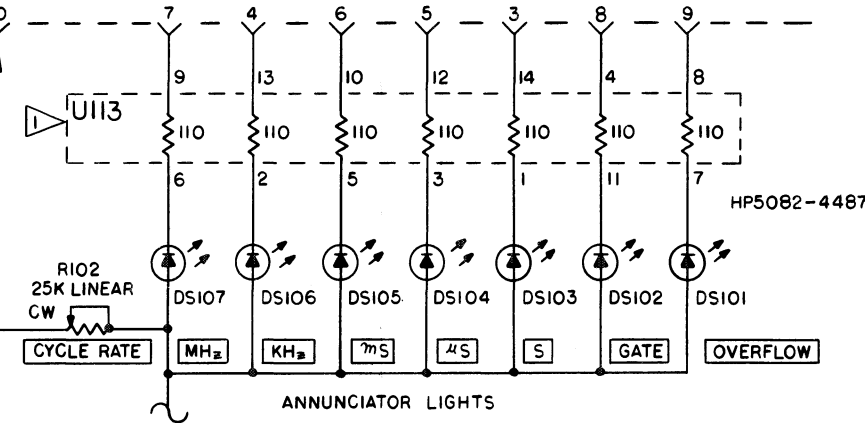
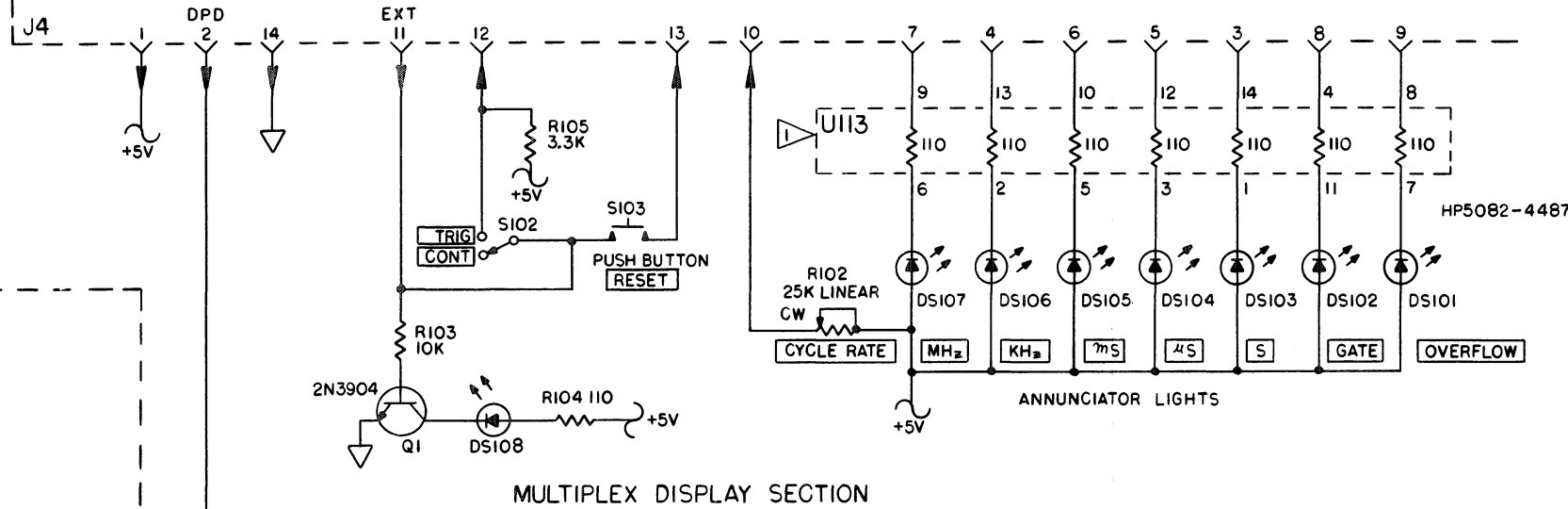
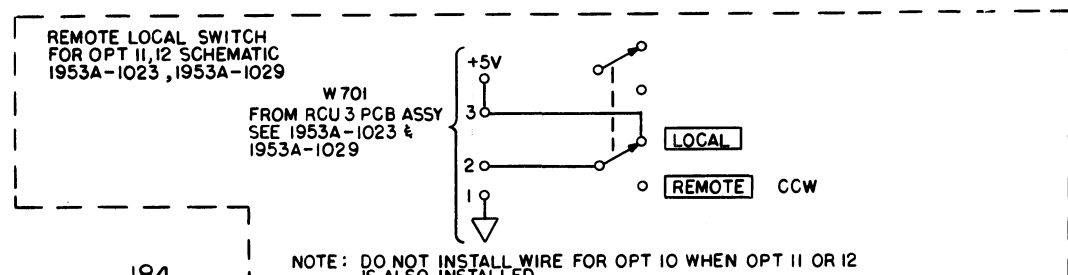
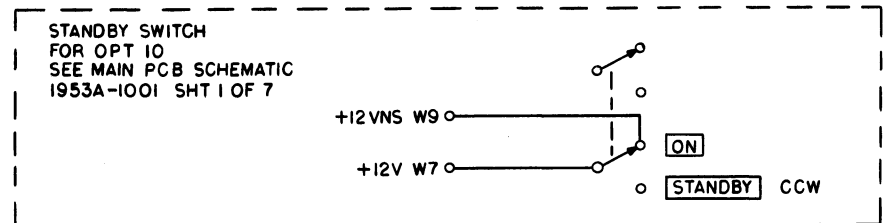
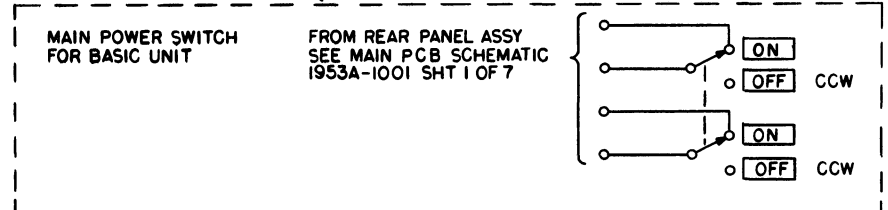

Figure 8-3. A3 Display PCB Assembly



CONNECTIONS FOR SIO1 (PART OF RIO2)



- NOTES:
- U113 MAY BE REPLACED BY SEVEN 100 Ω 1/4W, 5% G.C., DISCRETE RESISTORS P/N 147926
  - SEGMENT INDICATION
- 

Figure 8-3. A3 Display PCB Assembly (cont)

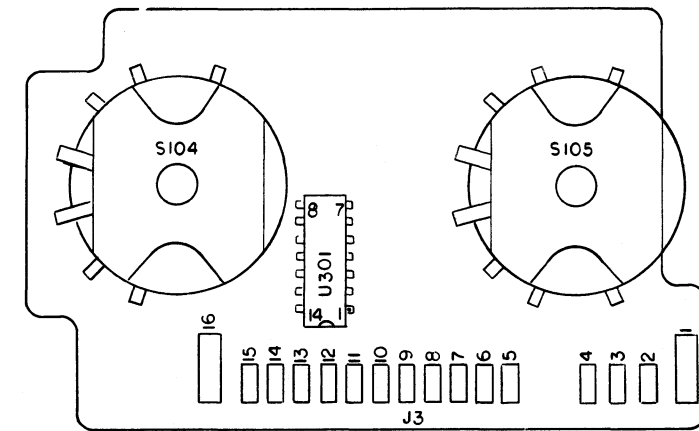
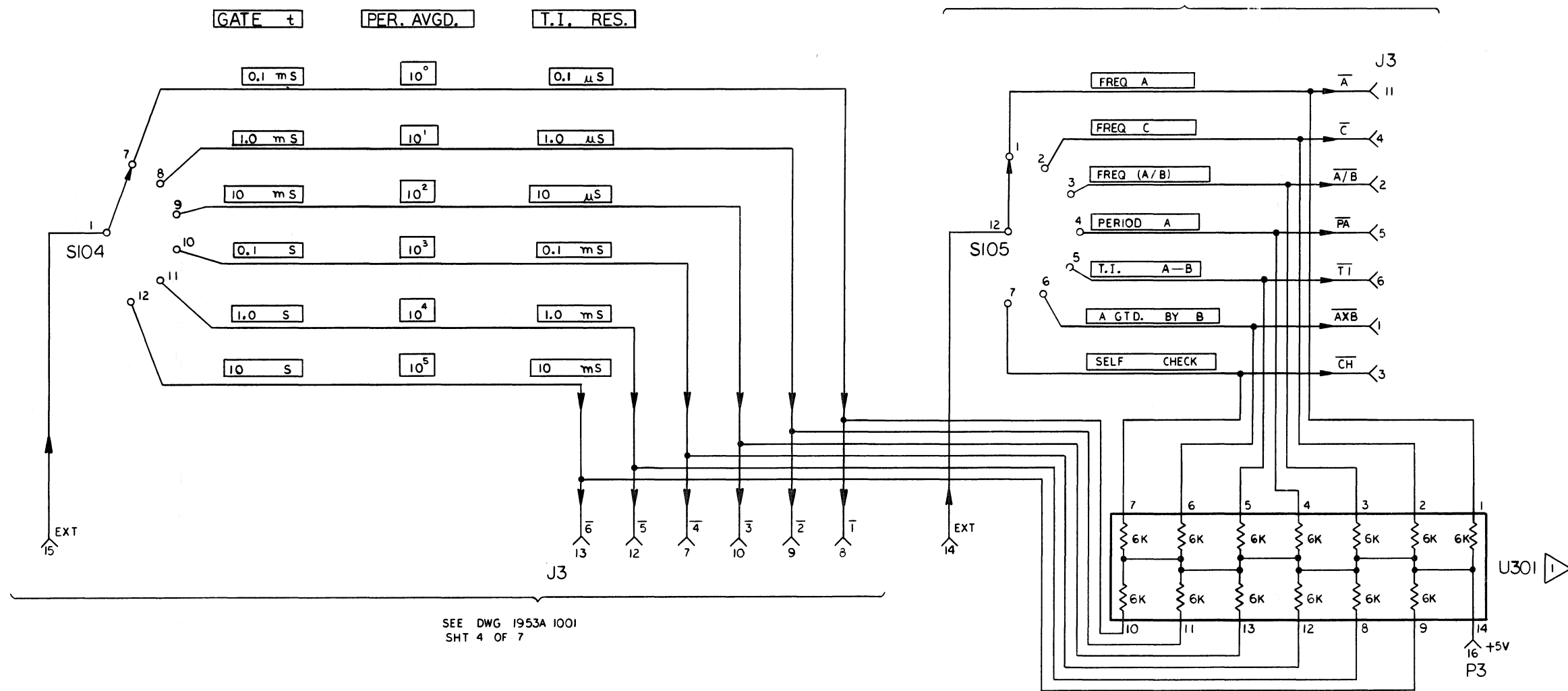

Figure 8-4. A4 Switch PCB Assembly

RANGE SWITCH

FUNCTION SWITCH



SEE DWG 1953A-1001  
SHT 3 OF 7

SEE DWG 1953A 1001  
SHT 4 OF 7

NOTE  
U301 MAY BE REPLACED BY 13 5K6 DISCRETE RESISTORS

Figure 8-4. A4 Switch PCB Assembly (cont)

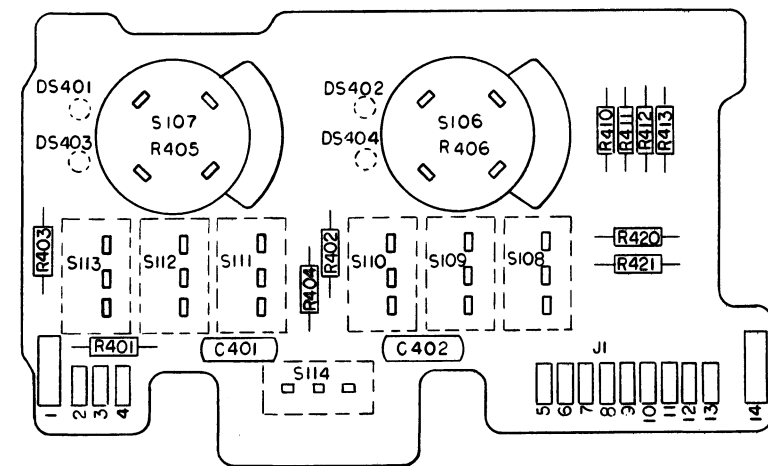

Figure 8-5. A1A3 Input PCB Assembly

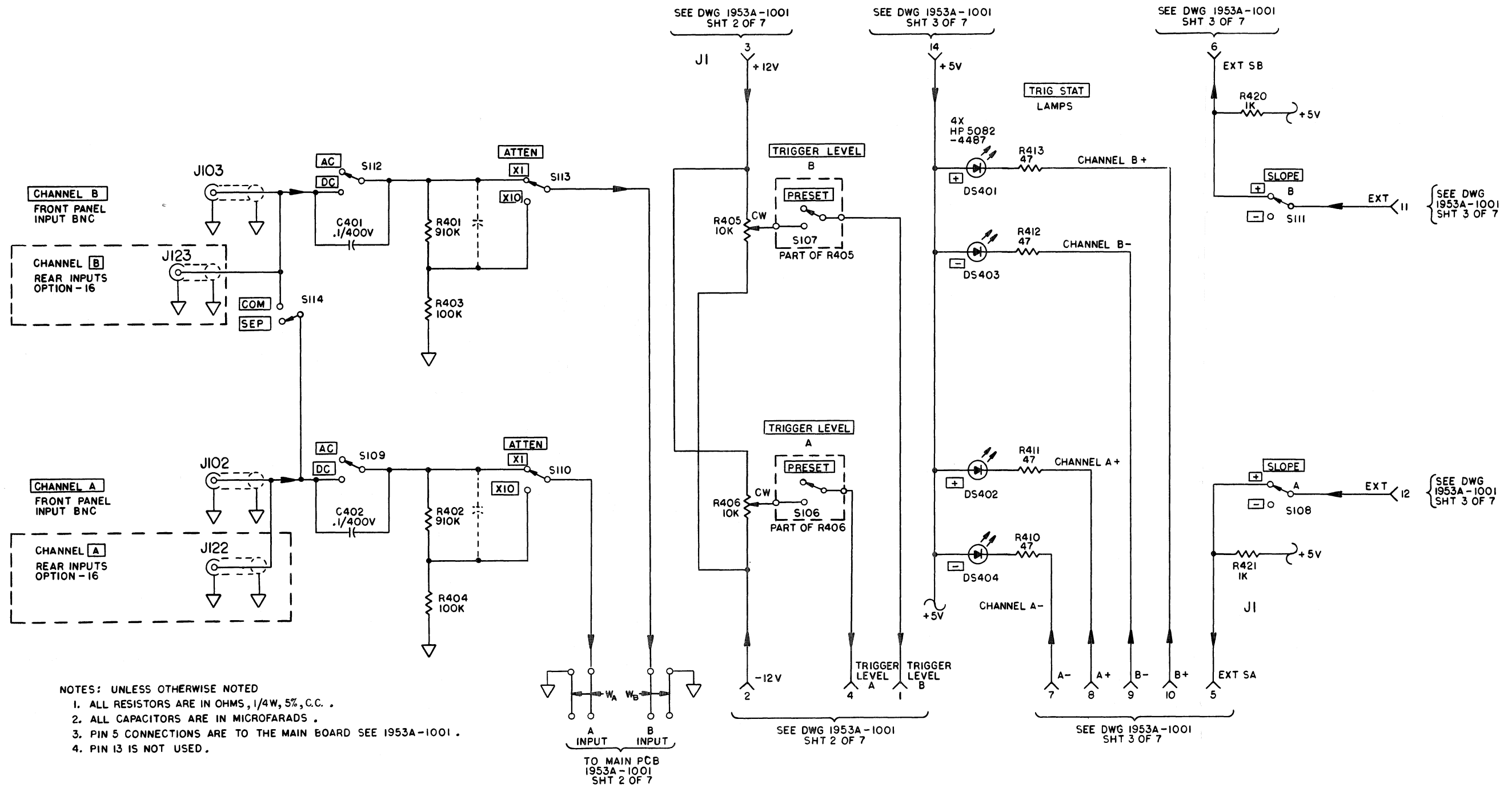

Figure 8-5. A1A3 Input PCB Assembly (cont)

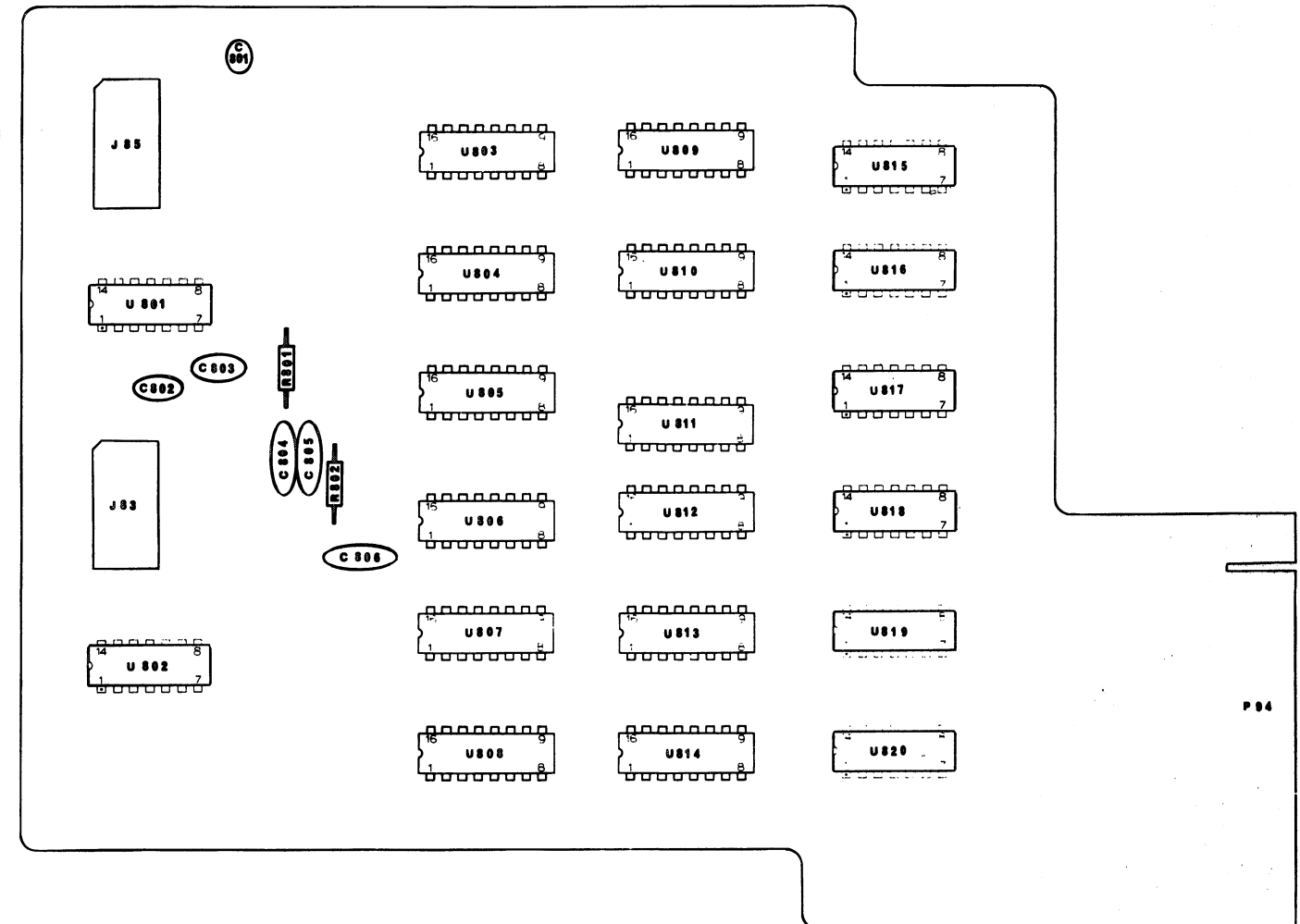
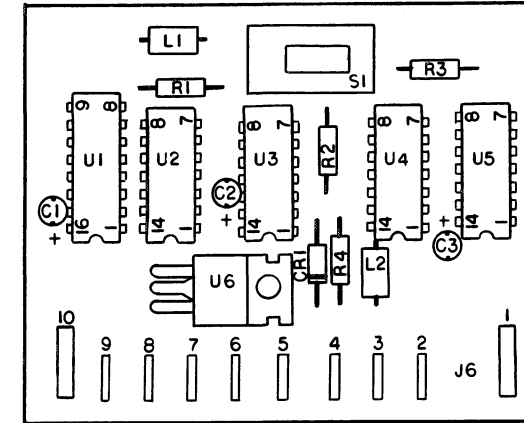
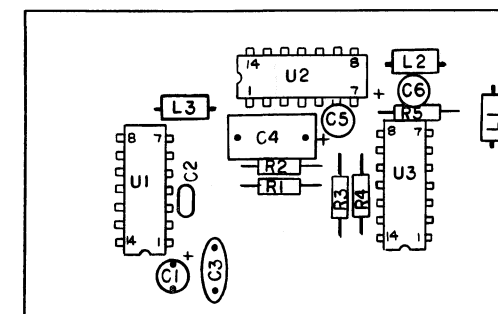

Figure 8-6. A6 Data Output Unit PCB Assembly , -02 Option





A7 External Time Base Multiplier 1  
1953A-1234



A8 External Time Base Multiplier 2  
1953A-1235

Figure 8-7. A7/A8 External Time Base Multiplier PCB Assemblies, -05 Option



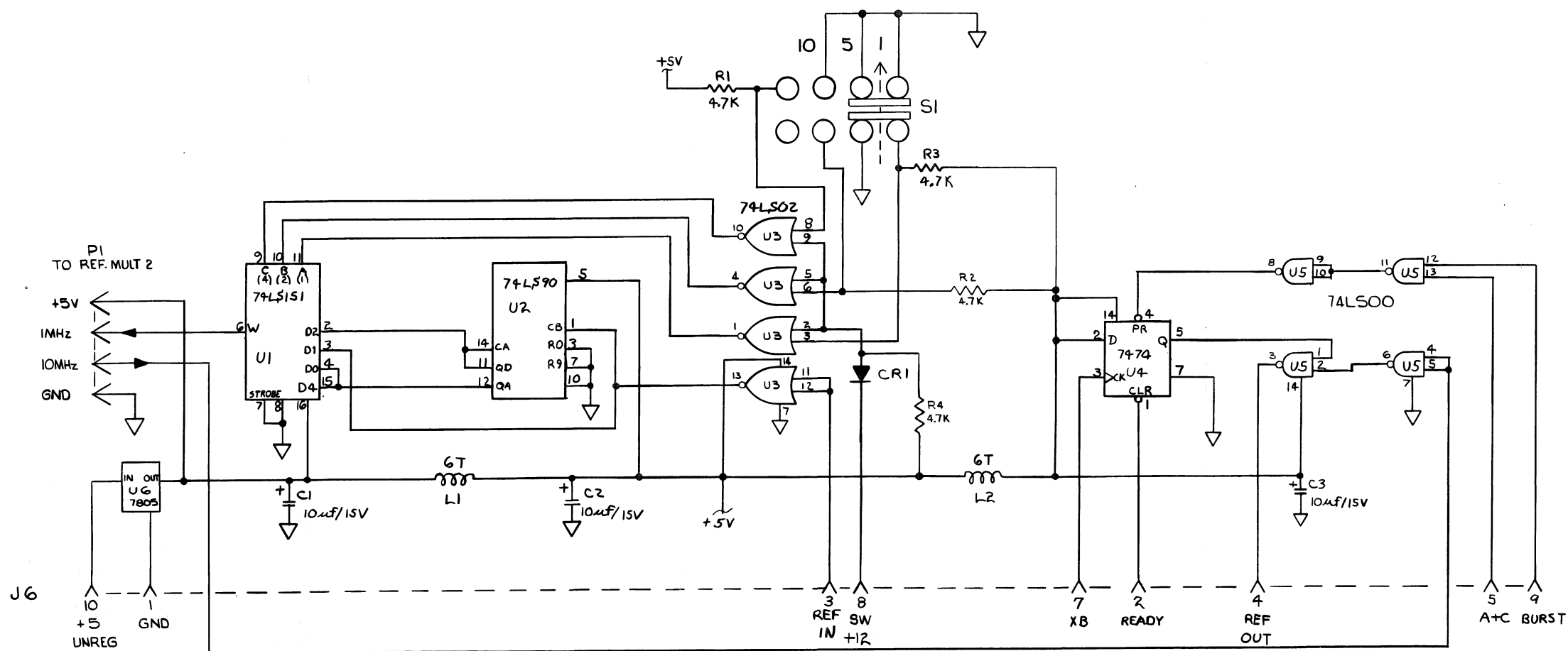

A7 External Time Base Multiplier 1  
1953A-1034

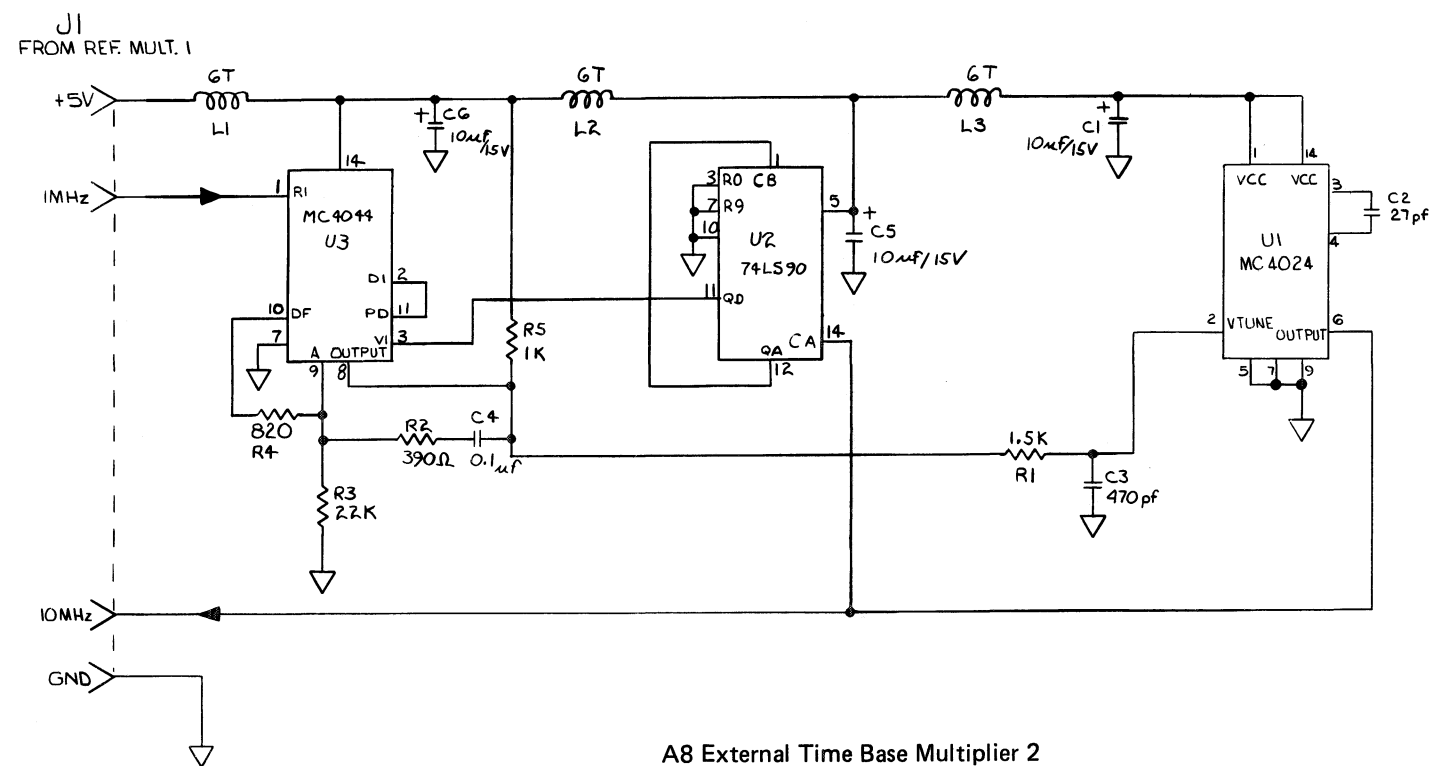

A8 External Time Base Multiplier 2  
1953A-1035

Figure 8-7. A7/A8 External Time Base Multiplier PCB Assemblies, -05 Option (cont)

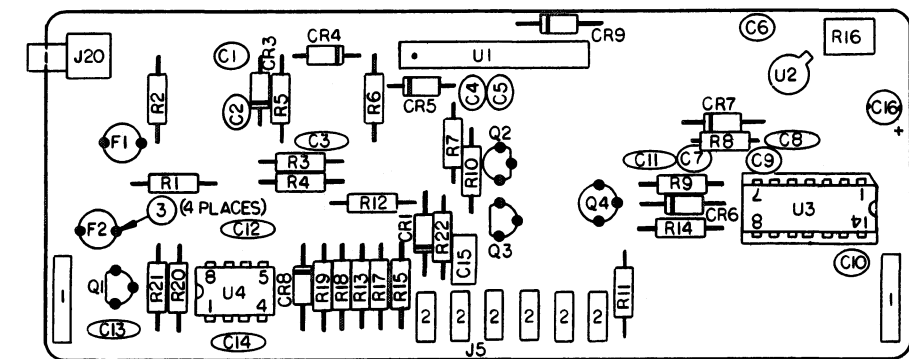
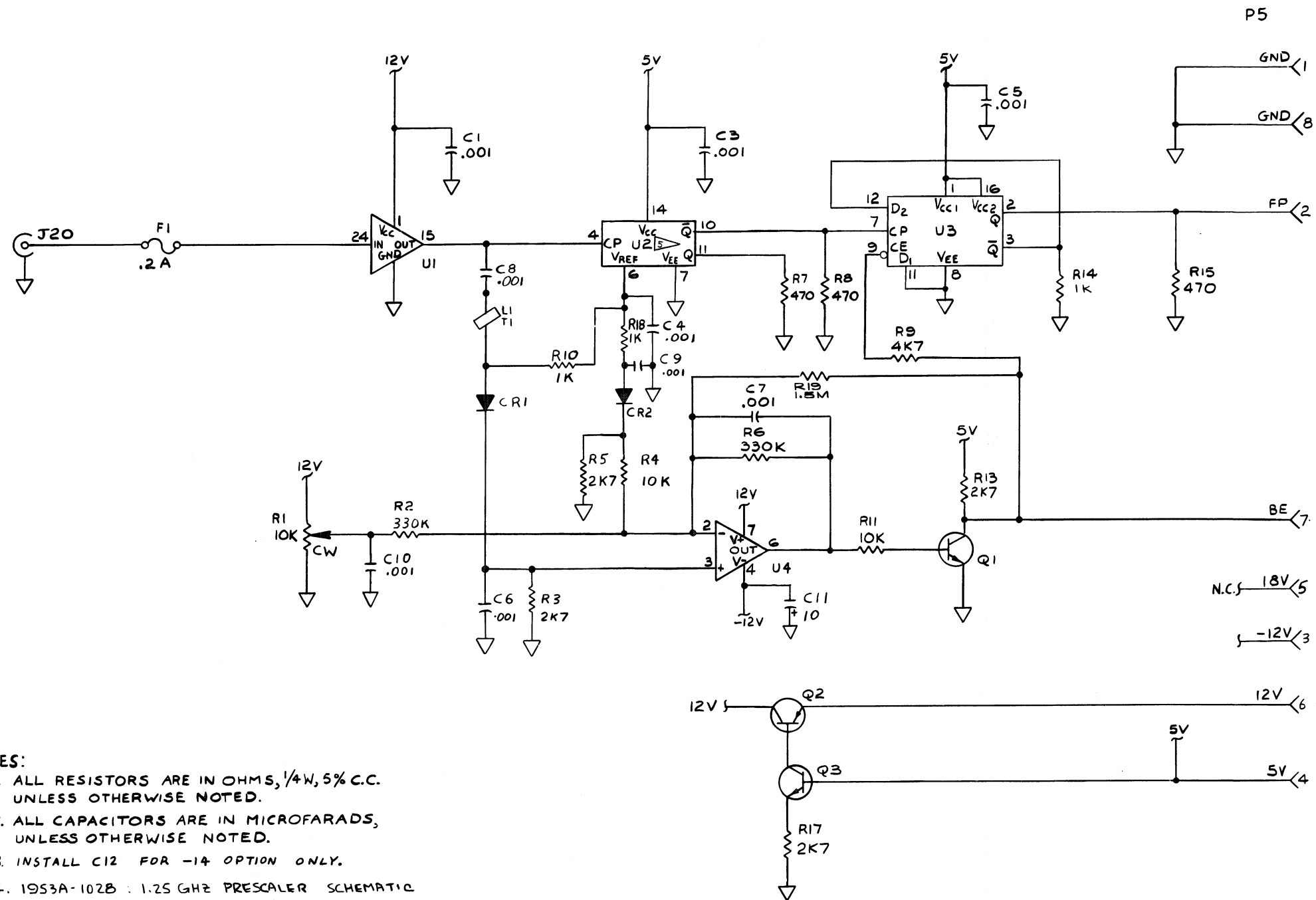

Figure 8-8. A9 520 MHz Prescaler PCB Assembly , -07 Option







- NOTES:
1. ALL RESISTORS ARE IN OHMS, 1/4W, 5% C.C. UNLESS OTHERWISE NOTED.
  2. ALL CAPACITORS ARE IN MICROFARADS, UNLESS OTHERWISE NOTED.
  3. INSTALL C12 FOR -14 OPTION ONLY.
  4. 1953A-102B : 1.25 GHZ PRESCALER SCHEMATIC
  5. U2 SELECTED FOR 1.25 GHZ PRESCALER

SEE DWG 1920A-1001 SHT 2 OF 3

1953A-1027  
1953A-1028

Figure 8-9. A14/A15 Prescaler PCB Assemblies, -13 & -14 Options (cont)

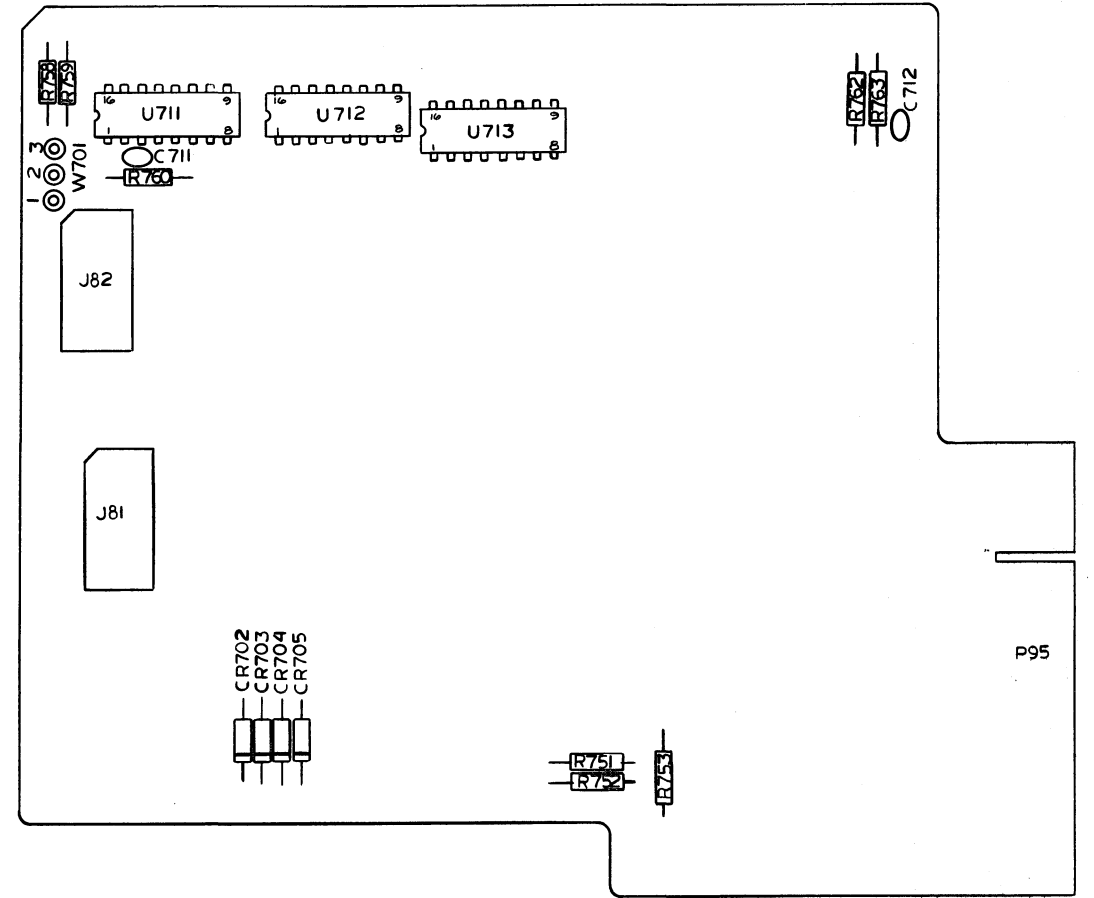
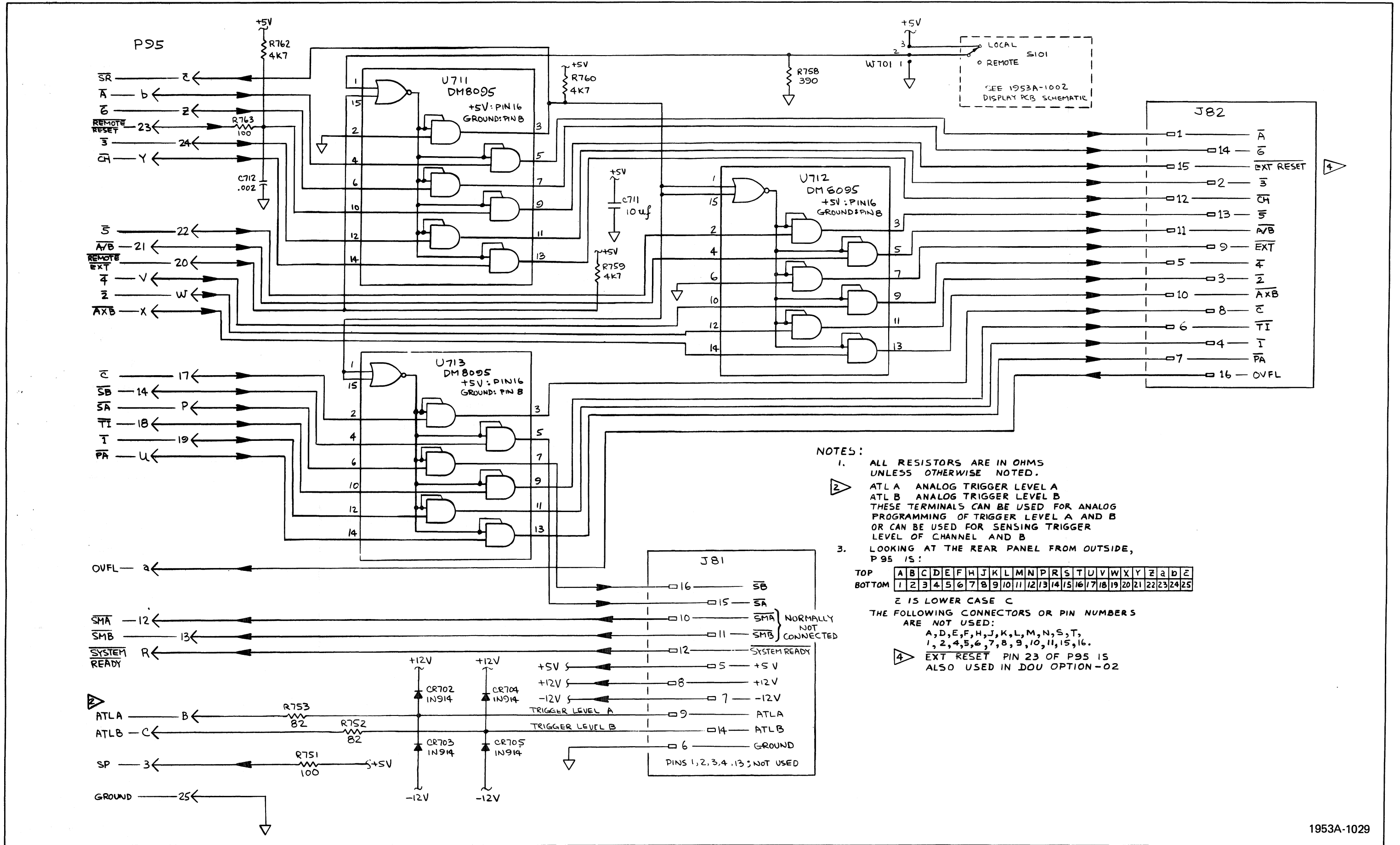

Figure 8-10. A10 Basic Remote Control Unit PCB Assembly , -11 Option



NOTES:

1. ALL RESISTORS ARE IN OHMS UNLESS OTHERWISE NOTED.
2. ATL A ANALOG TRIGGER LEVEL A  
ATL B ANALOG TRIGGER LEVEL B  
THESE TERMINALS CAN BE USED FOR ANALOG PROGRAMMING OF TRIGGER LEVEL A AND B OR CAN BE USED FOR SENSING TRIGGER LEVEL OF CHANNEL AND B
3. LOOKING AT THE REAR PANEL FROM OUTSIDE, P95 IS:  

TOP	A	B	C	D	E	F	H	J	K	L	M	N	P	R	S	T	U	V	W	X	Y	Z	a	b	c
BOTTOM	1	2	3	4	5	6	7	8	9	10	11	12	13	14	15	16	17	18	19	20	21	22	23	24	25

Z IS LOWER CASE C  
THE FOLLOWING CONNECTORS OR PIN NUMBERS ARE NOT USED:  
A, D, E, F, H, J, K, L, M, N, S, T,  
1, 2, 4, 5, 6, 7, 8, 9, 10, 11, 15, 16.
4. EXT RESET PIN 23 OF P95 IS ALSO USED IN DOU OPTION-02

Figure 8-10. A10 Basic Remote Control Unit PCB Assembly, -11 Option (cont)

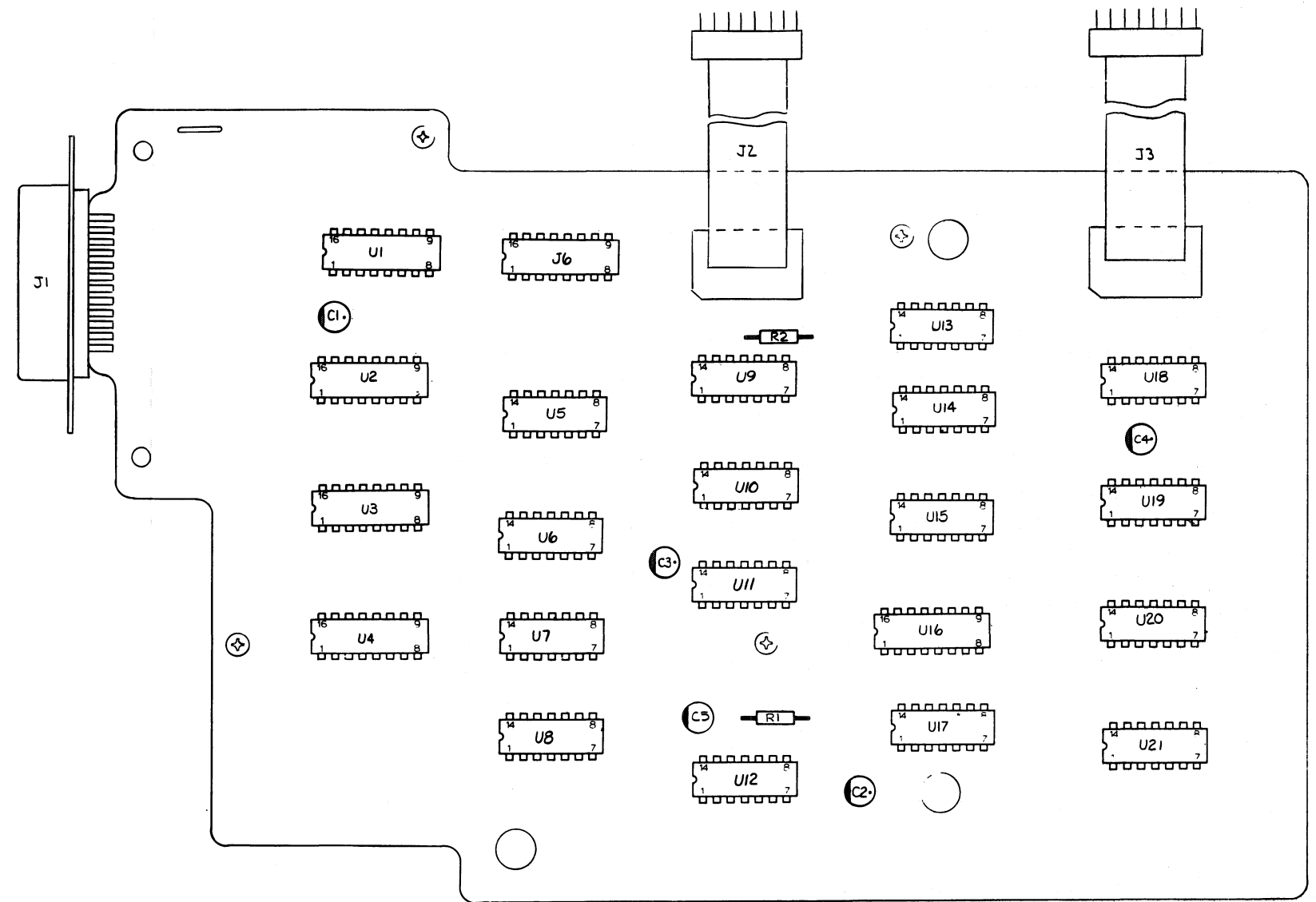

Figure 8-11. A16 IEEE-488 Bus Interface PCB Assembly, -15 Option



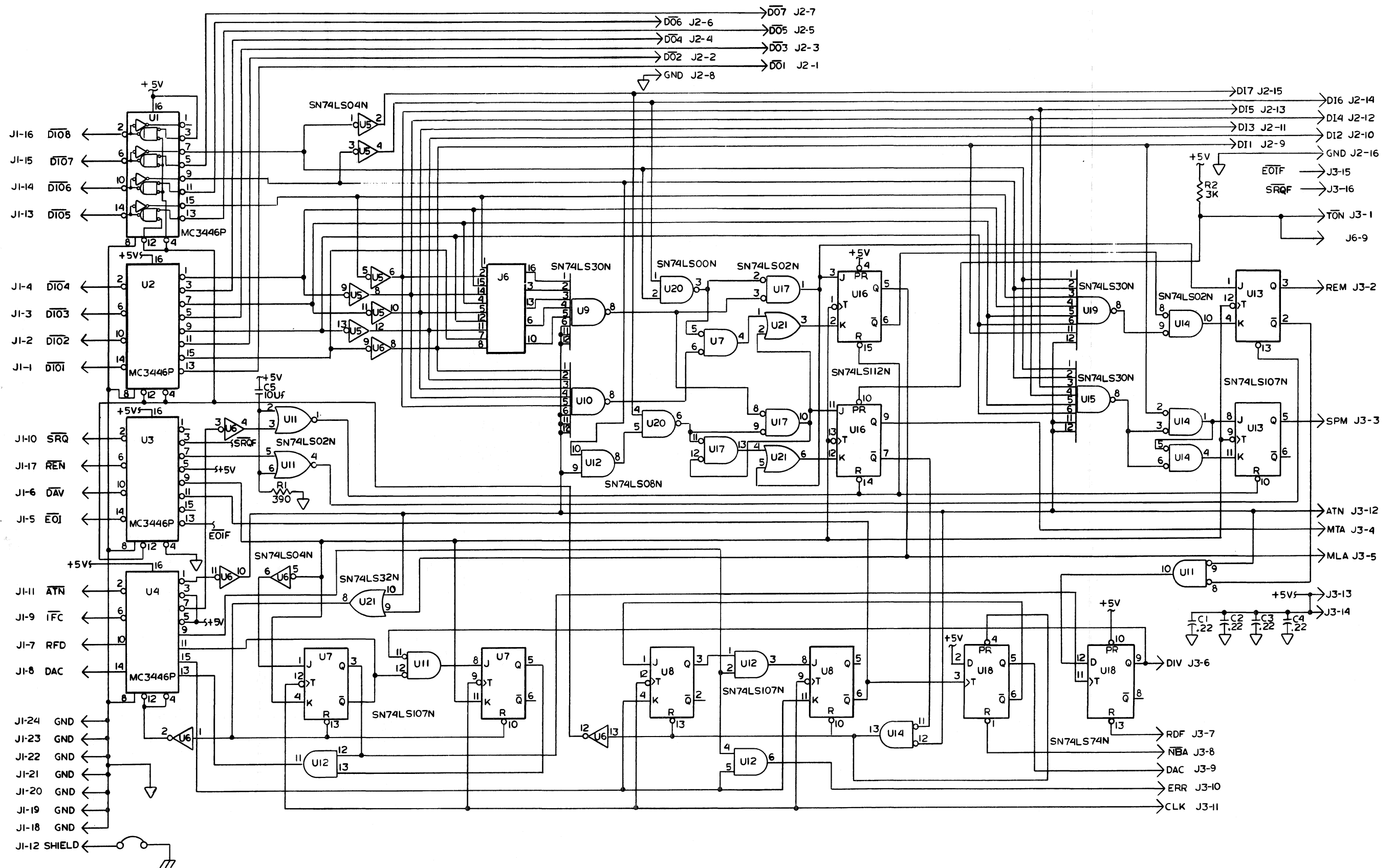

Figure 8-11. A16 IEEE-488 Bus Interface PCB Assembly, -15 Option (cont)

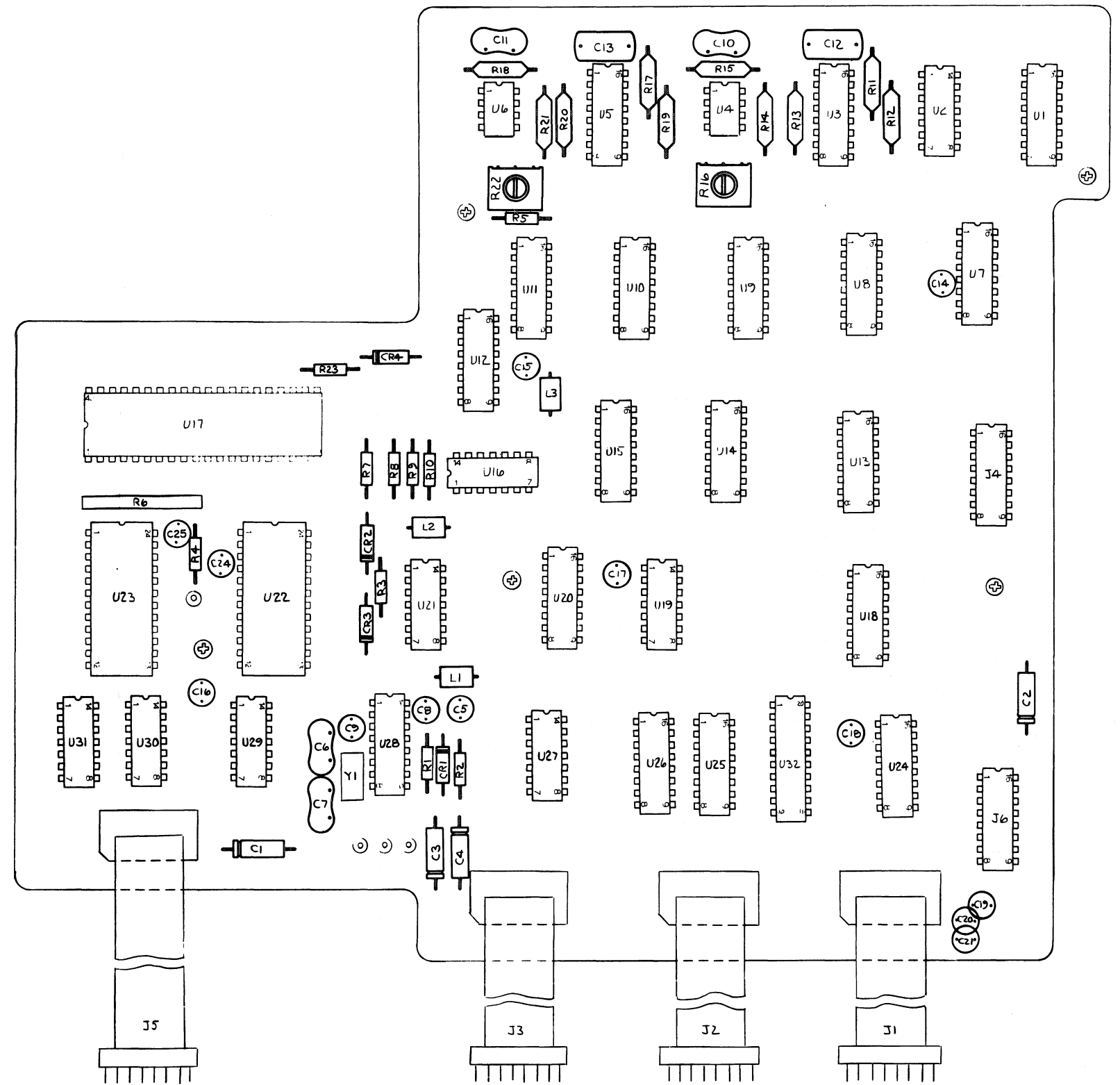

Figure 8-12. A17 IEEE-488-1975 Processor PCB Assembly, -15 Option



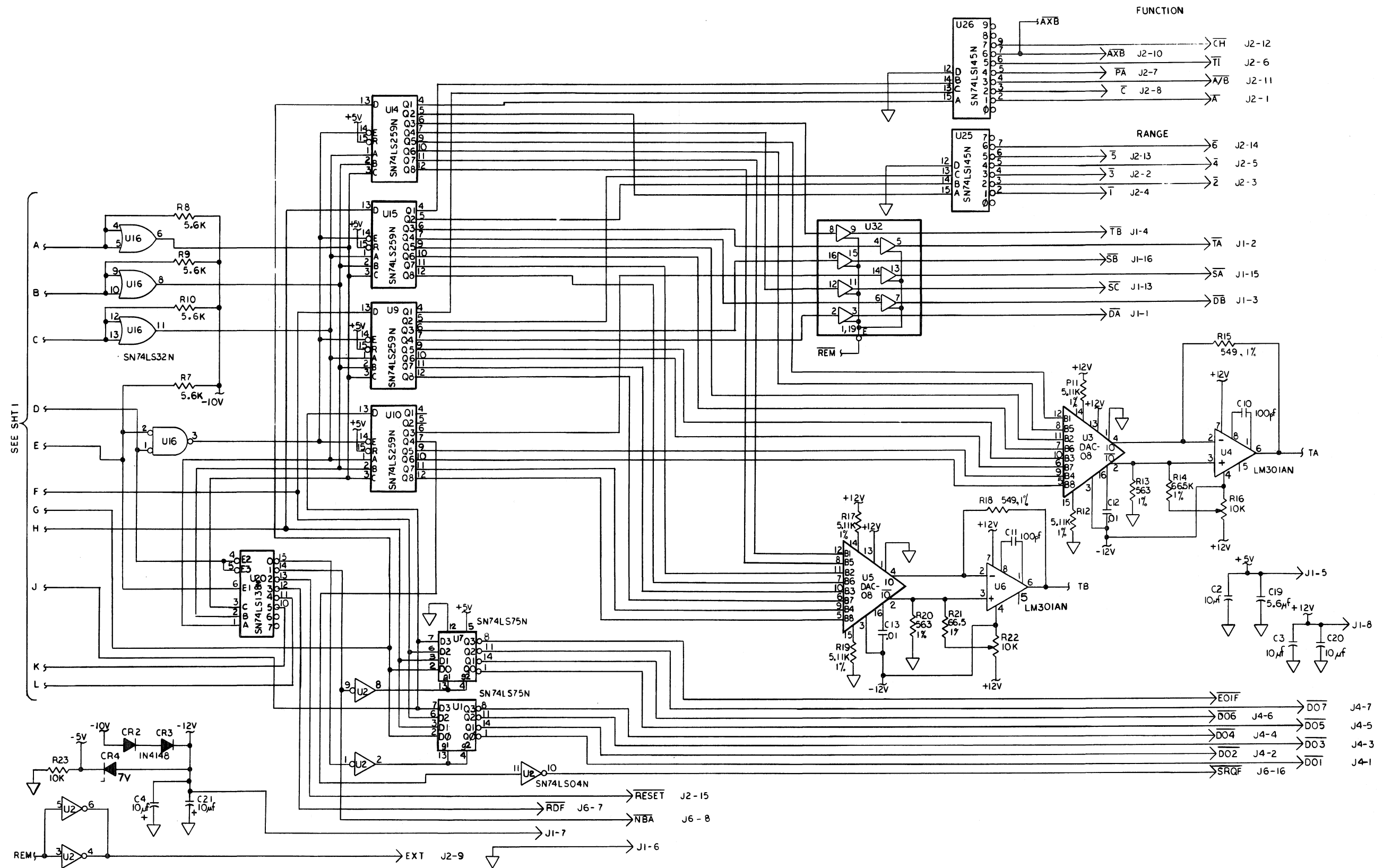

Figure 8-12. A17 IEEE-488-1975 Processor PCB Assembly, -15 Option (cont)

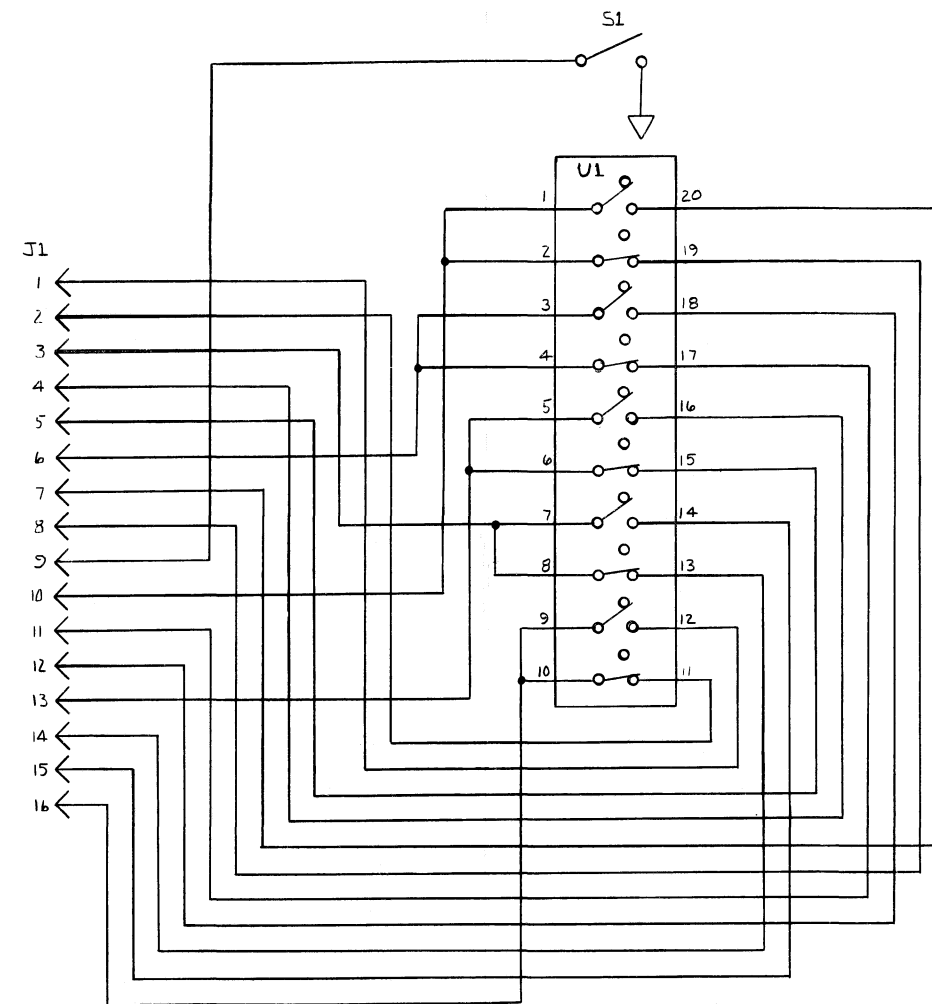
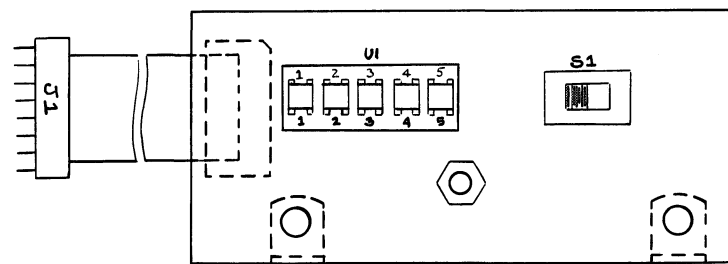
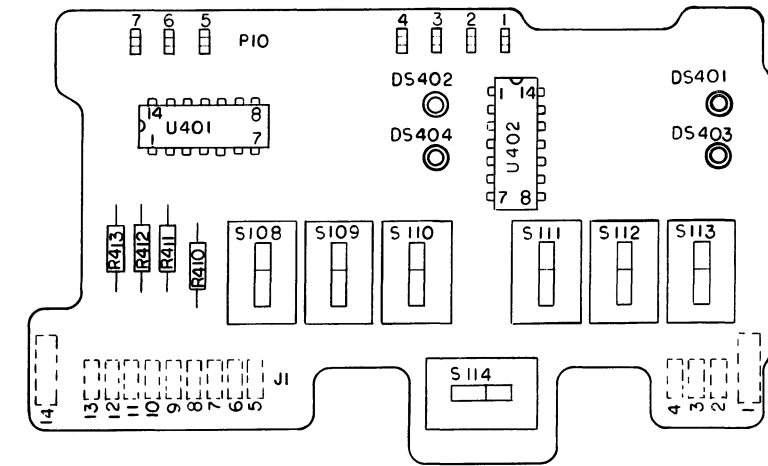
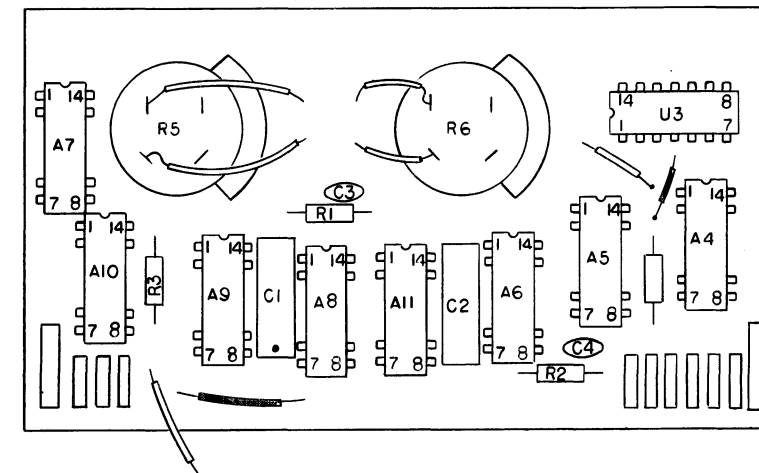

Figure 8-13. A18 IEEE-488-1975 Switch PCB Assembly, -15 Option



A11 (RCU 1)

1953A-1221



A12 (RCU 2)

1953A-1222

Figure 8-14. A11/A12 Remote Control Unit PCB Assemblies 1 and 2, -12 & -15 Options

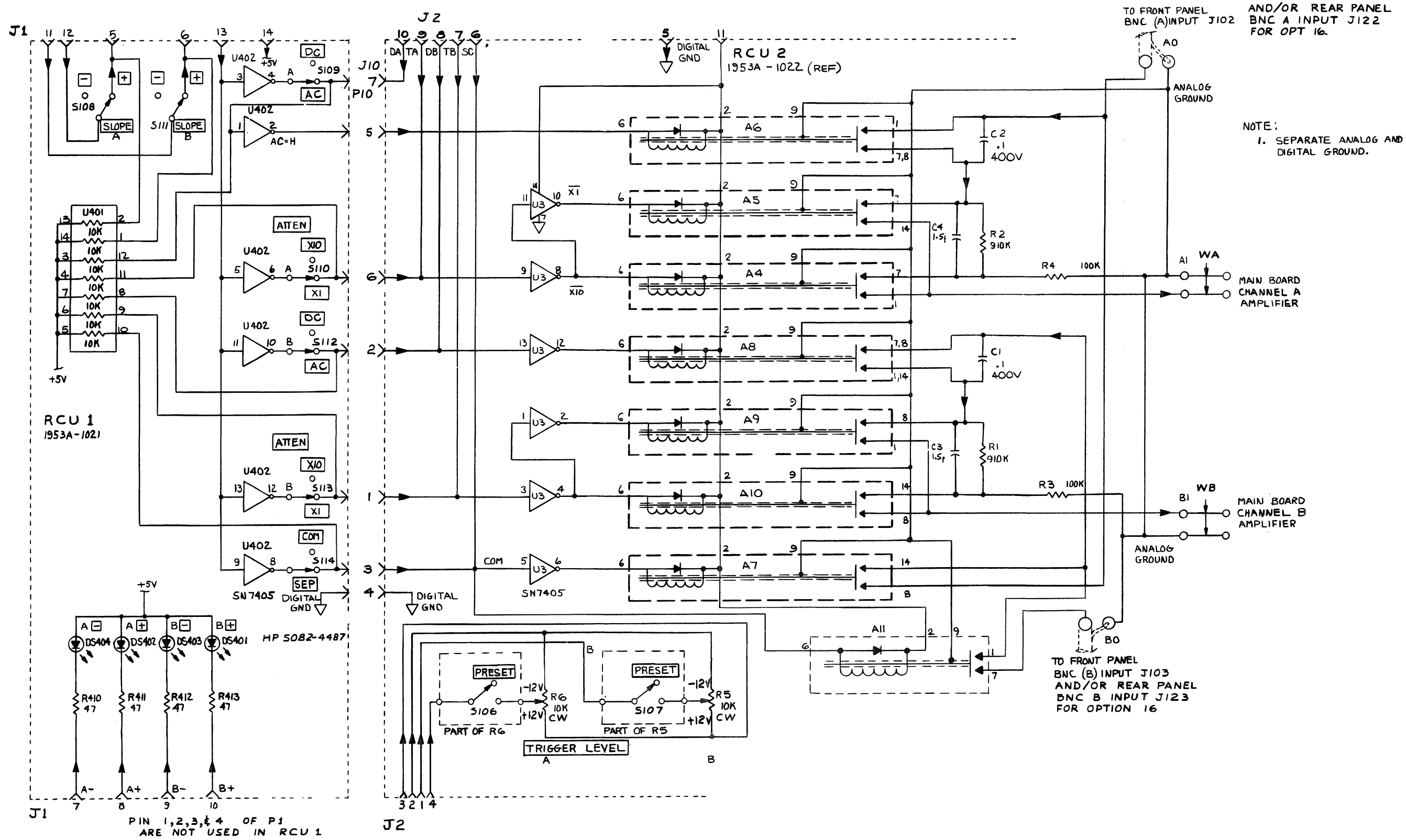

Figure 8-14. A11/A12 Remote Control Unit PCB Assemblies 1 and 2, -12 & -15 Options (cont)

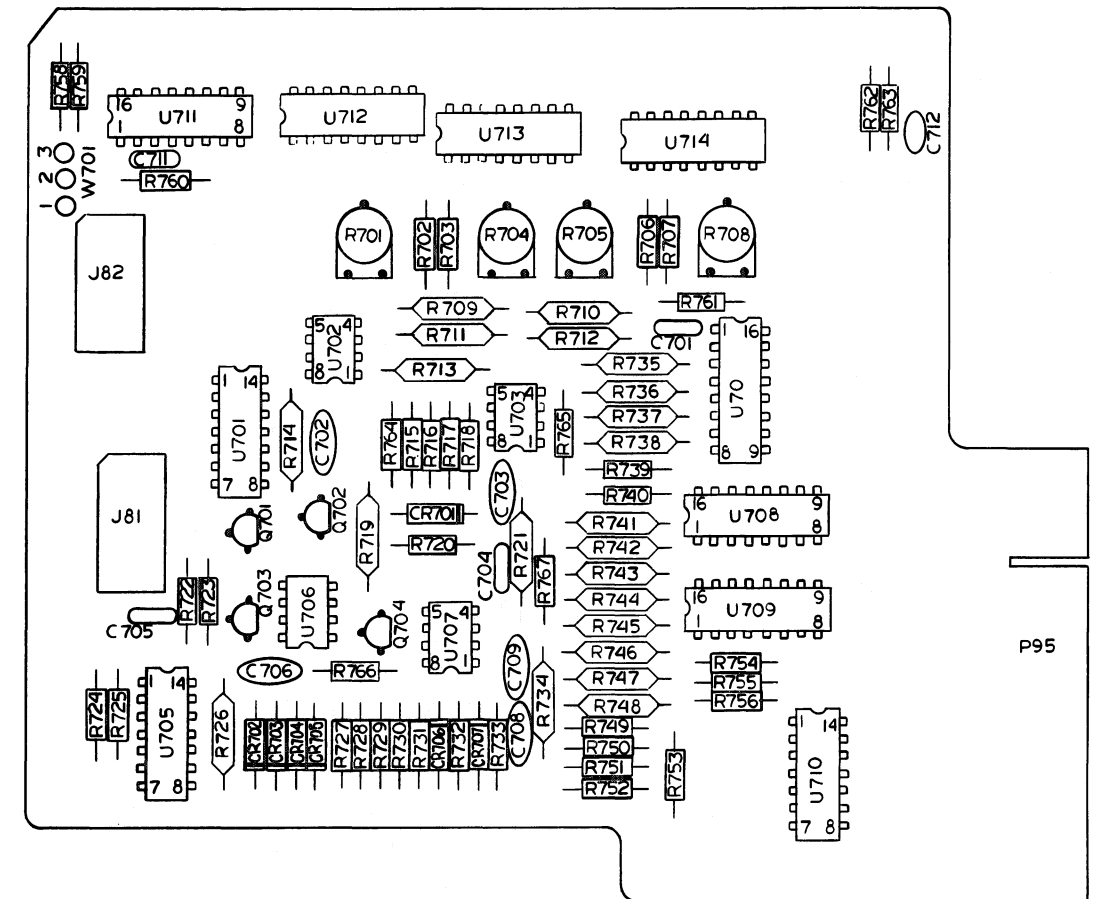
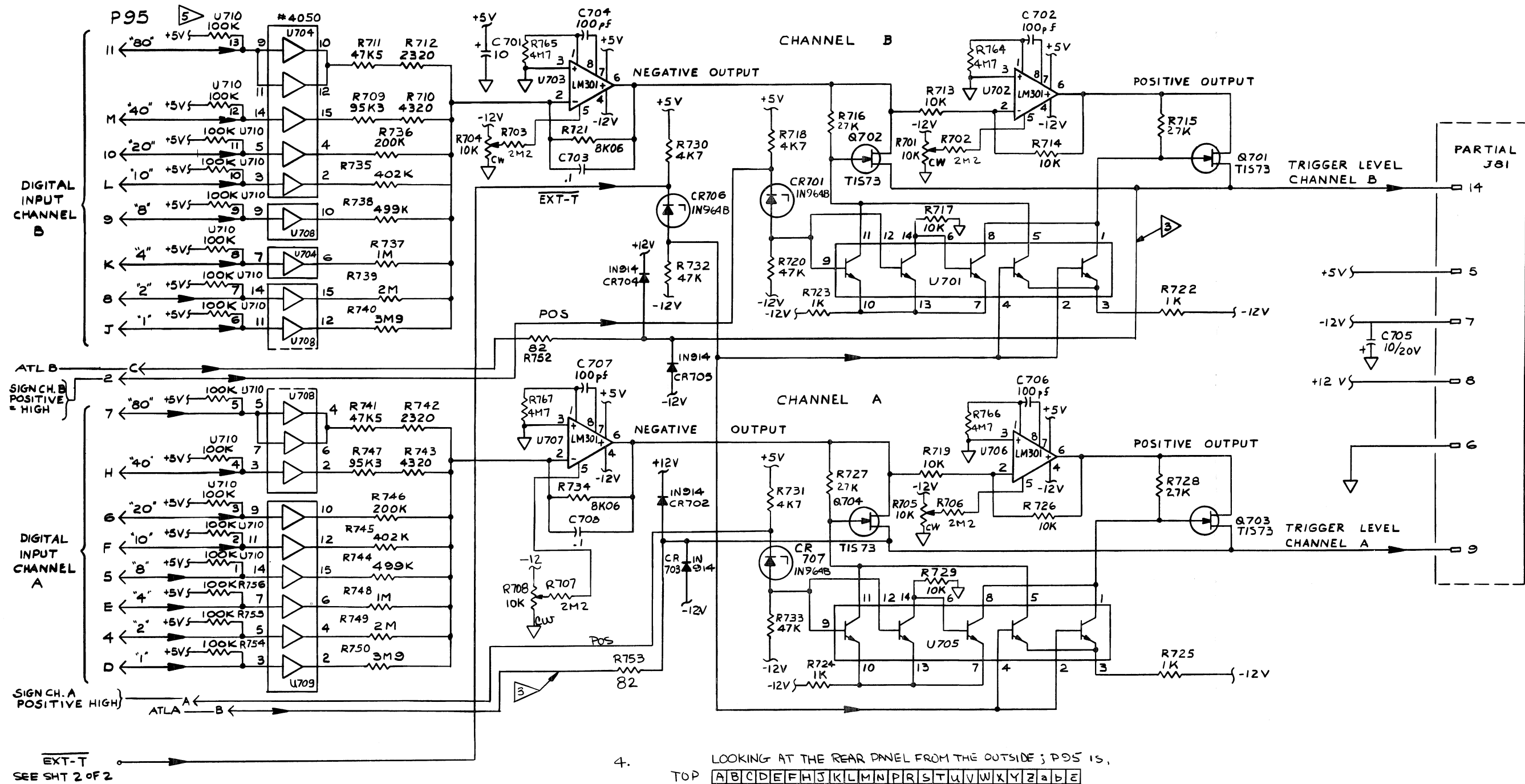

Figure 8-15. A13 Remote Control Unit PCB Assembly 3, -12 & -15 Options





EXT-T  
SEE SH2 2 OF 2

- NOTES:
1. ALL RESISTORS ARE IN OHMS UNLESS OTHERWISE NOTED.
  2. ALL CAPACITORS ARE IN MICROFARADS UNLESS OTHERWISE NOTED.
  3. ATLA (ANALOG TRIGGER LEVEL A) ATLB (ANALOG TRIGGER LEVEL B) THESE TERMINALS CAN BE USED FOR ANALOG PROGRAMMING OF TRIGGER LEVEL A AND B OR CAN BE USED FOR SENSING TRIGGER LEVEL OF CHANNELS A AND B.

4. LOOKING AT THE REAR PANEL FROM THE OUTSIDE ; P95 IS,
- |        |   |   |   |   |   |   |   |   |   |    |    |    |    |    |    |    |    |    |    |    |    |    |    |    |    |   |
|--------|---|---|---|---|---|---|---|---|---|----|----|----|----|----|----|----|----|----|----|----|----|----|----|----|----|---|
| TOP    | A | B | C | D | E | F | H | J | K | L  | M  | N  | P  | R  | S  | T  | U  | V  | W  | X  | Y  | Z  | a  | b  | c  | e |
| BOTTOM | 1 | 2 | 3 | 4 | 5 | 6 | 7 | 8 | 9 | 10 | 11 | 12 | 13 | 14 | 15 | 16 | 17 | 18 | 19 | 20 | 21 | 22 | 23 | 24 | 25 |   |
- c IS LOWER CASE C
5. U710 CAN BE SUBSTITUTED BY 13 DISCRETE 100K 1/4W 5% RESISTORS.
  6. EXT RESET PIN 23 OF P95 IS ALSO USED IN DOU OPTION-02. (SEE SH2 2 OF 2)

Figure 8-15. A13 Remote Control Unit PCB Assembly 3, -12 & -15 Options (cont)

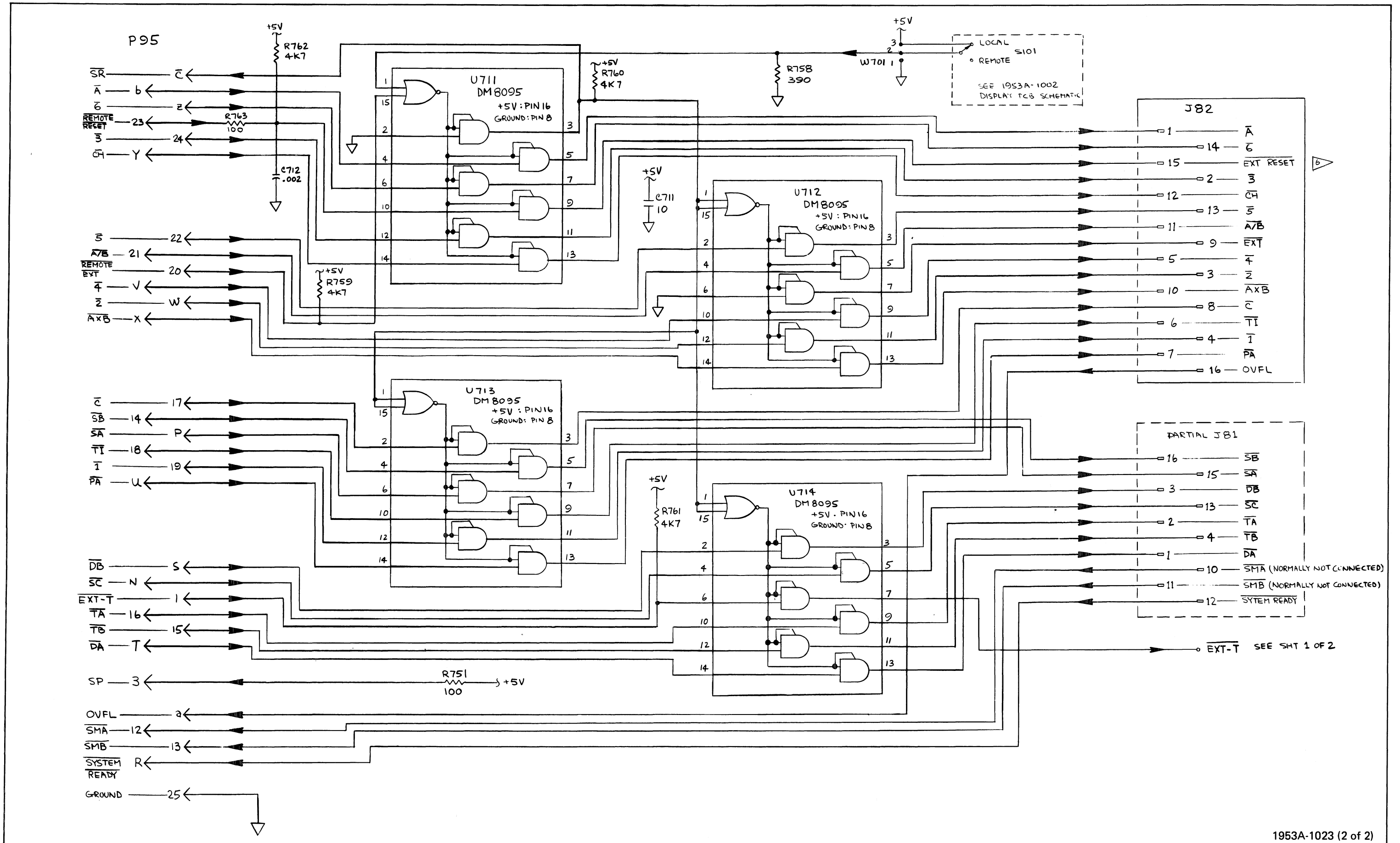

Figure 8-15. A13 Remote Control Unit PCB Assembly 3, -12 & -15 Options (cont)