

LM199/LM299/LM399 Precision Reference

Check for Samples: [LM199](#), [LM299](#), [LM399](#), [LM3999](#)

FEATURES

- **0.0001%/°C Temperature Coefficient**
- **Low Dynamic Impedance — 0.5Ω**
- **Initial Tolerance on Breakdown Voltage — 2%**
- **Sharp Breakdown at 400 μA**
- **Wide Operating Current — 500 μA to 10 mA**
- **Wide Supply Range for Temperature Stabilizer**
- **Low Noise**
- **Low Power for Stabilization — 300 mW at 25°C**
- **Proven Reliability, Low-Stress Packaging in TO-46 Integrated-Circuit Hermetic Package, for Low Hysteresis after Thermal Cycling. 33 Million Hours MTBF at T_A = +25°C (T_J = +86°C)**

DESCRIPTION

The LM199 series are precision, temperature-stabilized monolithic zeners offering temperature coefficients a factor of ten better than high quality reference zeners. Constructed on a single monolithic chip is a temperature stabilizer circuit and an active reference zener. The active circuitry reduces the dynamic impedance of the zener to about 0.5Ω and allows the zener to operate over 0.5 mA to 10 mA current range with essentially no change in voltage or temperature coefficient. Further, a new subsurface zener structure gives low noise and excellent long term stability compared to ordinary monolithic zeners. The package is supplied with a thermal shield to minimize heater power and improve temperature regulation.

The LM199 series references are exceptionally easy to use and free of the problems that are often experienced with ordinary zeners. There is virtually no hysteresis in reference voltage with temperature cycling. Also, the LM199 is free of voltage shifts due to stress on the leads. Finally, since the unit is temperature stabilized, warm up time is fast.

The LM199 can be used in almost any application in place of ordinary zeners with improved performance. Some ideal applications are analog to digital converters, calibration standards, precision voltage or current sources or precision power supplies. Further in many cases the LM199 can replace references in existing equipment with a minimum of wiring changes.

The LM199 series devices are packaged in a standard hermetic TO-46 package inside a thermal shield. The LM199 is rated for operation from -55°C to +125°C while the LM299 is rated for operation from -25°C to +85°C and the LM399 is rated from 0°C to +70°C.

Connection Diagram

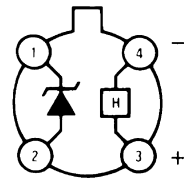

**Figure 1. Metal Can Package (TO-46) Top View
Package Number NER0004D**



Please be aware that an important notice concerning availability, standard warranty, and use in critical applications of Texas Instruments semiconductor products and disclaimers thereto appears at the end of this data sheet.

All trademarks are the property of their respective owners.



These devices have limited built-in ESD protection. The leads should be shorted together or the device placed in conductive foam during storage or handling to prevent electrostatic damage to the MOS gates.

Absolute Maximum Ratings⁽¹⁾⁽²⁾

Temperature Stabilizer Voltage	LM199/LM299/LM399	40V
Reverse Breakdown Current		20 mA
Forward Current, LM199/LM299/LM399		1 mA
Reference to Substrate Voltage $V_{(RS)}$ ⁽³⁾		40V -0.1V
Operating Temperature Range	LM199	-55°C to +125°C
	LM299	-25°C to +85°C
	LM399	-0°C to +70°C
Storage Temperature Range		-55°C to +150°C
Soldering Information, TO-46 package (10 sec.)		+300°C

- (1) "Absolute Maximum Ratings" indicate limits beyond which damage to the device may occur. Operating Ratings indicate conditions for which the device is functional, but do not ensure specific performance limits.
- (2) Specifications for Military/Aerospace products are not contained in this datasheet. Refer to the following Reliability Electrical Test Specifications documents: MNLM199A-X and SMD#5962-88561.
- (3) The substrate is electrically connected to the negative terminal of the temperature stabilizer. The voltage that can be applied to either terminal of the reference is 40V more positive or 0.1V more negative than the substrate.

Electrical Characteristics⁽¹⁾⁽²⁾

Parameter	Conditions	LM299H			LM399H			Units
		Min	Typ	Max	Min	Typ	Max	
Reverse Breakdown Voltage	$0.5 \text{ mA} \leq I_R \leq 10 \text{ mA}$	6.8	6.95	7.1	6.6	6.95	7.3	V
Reverse Breakdown Voltage Change with Current	$0.5 \text{ mA} \leq I_R \leq 10 \text{ mA}$		6	9		6	12	mV
Reverse Dynamic Impedance	$I_R = 1 \text{ mA}$		0.5	1		0.5	1.5	Ω
Reverse Btreakdown Temperature Coefficient RMS Noise	$-25^\circ\text{C} \leq T_A \leq 85^\circ\text{C}$	LM299	0.00003	0.0001				%/°C
	$0^\circ\text{C} \leq T_A \leq 70^\circ\text{C}$	LM399				0.00003	0.0002	%/°C
	$10 \text{ Hz} \leq f \leq 10 \text{ kHz}$		7	20		7	50	μV
Long Term Stability	Stabilized, $22^\circ\text{C} \leq T_A \leq 28^\circ\text{C}$, 1000 Hours, $I_R = 1 \text{ mA} \pm 0.1\%$		20			20		ppm
Temperature Stabilizer	$T_A = 25^\circ\text{C}$, Still Air, $V_S = 30\text{V}$		8.5	14		8.5	15	mA
Supply Current	$T_A = -55^\circ\text{C}$		22	28				
Temperature Stabilizer Supply Voltage		9		40	9		40	V
Warm-Up Time to 0.05%	$V_S = 30\text{V}$, $T_A = 25^\circ\text{C}$		3			3		sec.
Initial Turn-on Current	$9 \leq V_S \leq 40$, $T_A = +25^\circ\text{C}$ ⁽³⁾		140	200		140	200	mA

- (1) These specifications apply for 30V applied to the temperature stabilizer and $-55^\circ\text{C} \leq T_A \leq +125^\circ\text{C}$ for the LM199; $-25^\circ\text{C} \leq T_A \leq +85^\circ\text{C}$ for the LM299 and $0^\circ\text{C} \leq T_A \leq +70^\circ\text{C}$ for the LM399.
- (2) A military data sheet is available for the LM199AH/833 and LM199AH-SMD (SMD#5962-88561) upon request.
- (3) This initial current can be reduced by adding an appropriate resistor and capacitor to the heater circuit. See the performance characteristic graphs to determine values.

Electrical Characteristics⁽¹⁾⁽²⁾

Parameter	Conditions	LM199AH			LM399AH			Units
		Min	Typ	Max	Min	Typ	Max	
Reverse Breakdown Voltage	$0.5 \text{ mA} \leq I_R \leq 10 \text{ mA}$	6.8	6.95	7.1	6.6	6.95	7.3	V
Reverse Breakdown Voltage	$0.5 \text{ mA} \leq I_R \leq 10 \text{ mA}$		6	9		6	12	mV
Change with Current								
Reverse Dynamic Impedance	$I_R = 1 \text{ mA}$		0.5	1		0.5	1.5	Ω
Reverse Breakdown Temperature Coefficient	$-55^\circ\text{C} \leq T_A \leq +85^\circ\text{C}$	LM199A ⁽³⁾	0.00002	0.00005				%/°C
	$+85^\circ\text{C} \leq T_A \leq +125^\circ\text{C}$		0.0005	0.0010				%/°C
	$0^\circ\text{C} \leq T_A \leq +70^\circ\text{C}$	LM399A				0.00003	0.0001	%/°C
RMS Noise	$10 \text{ Hz} \leq f \leq 10 \text{ kHz}$		7	20		7	50	μV
Long Term Stability	Stabilized, $22^\circ\text{C} \leq T_A \leq 28^\circ\text{C}$, 1000 Hours, $I_R = 1 \text{ mA} \pm 0.1\%$		20			20		ppm
Temperature Stabilizer Supply Current	$T_A = 25^\circ\text{C}$, Still Air, $V_S = 30\text{V}$ $T_A = -55^\circ\text{C}$		8.5	14		8.5	15	mA
			22	28				
Temperature Stabilizer Supply Voltage		9		40	9		40	V
Warm-Up Time to 0.05%	$V_S = 30\text{V}$, $T_A = 25^\circ\text{C}$		3			3		sec.
Initial Turn-on Current	$9 \leq V_S \leq 40$, $T_A = +25^\circ\text{C}$, ⁽⁴⁾		140	200		140	200	mA

- (1) These specifications apply for 30V applied to the temperature stabilizer and $-55^\circ\text{C} \leq T_A \leq +125^\circ\text{C}$ for the LM199; $-25^\circ\text{C} \leq T_A \leq +85^\circ\text{C}$ for the LM299 and $0^\circ\text{C} \leq T_A \leq +70^\circ\text{C}$ for the LM399.
- (2) A military data sheet is available for the LM199AH/833 and LM199AH-SMD (SMD#5962-88561) upon request.
- (3) Do not wash the LM199 with its polysulfone thermal shield in TCE.
- (4) This initial current can be reduced by adding an appropriate resistor and capacitor to the heater circuit. See the performance characteristic graphs to determine values.

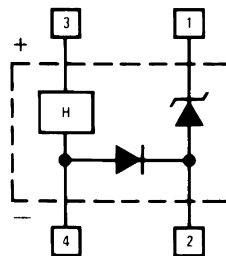
Functional Block Diagram

Figure 2. LM199/LM299/LM399

Typical Performance Characteristics

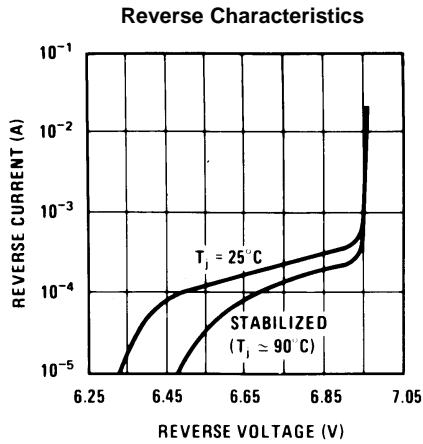

Figure 3.

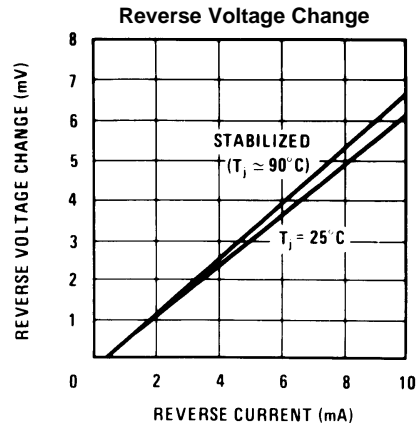

Figure 4.

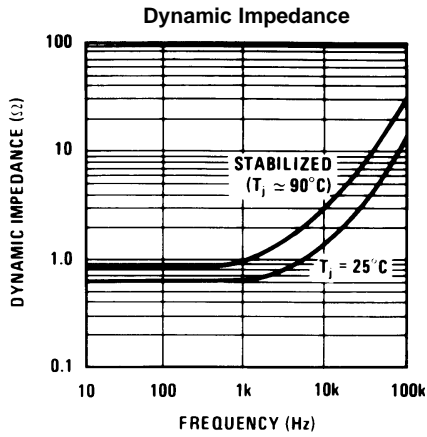

Figure 5.

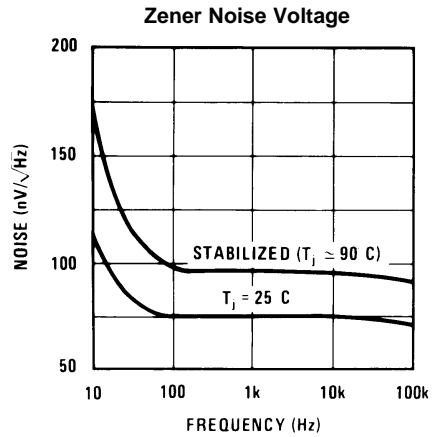

Figure 6.

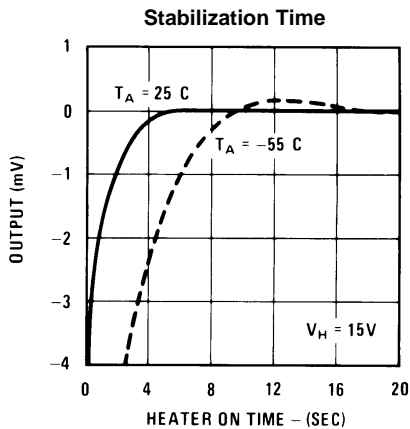

Figure 7.

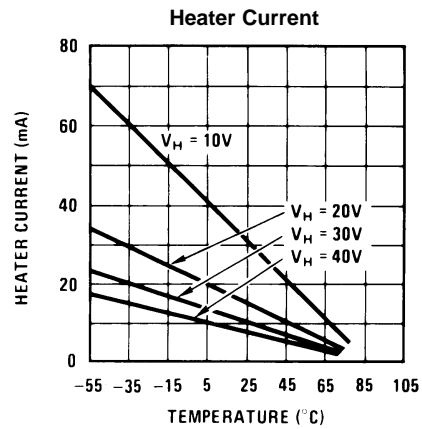

Figure 8.

Typical Performance Characteristics (continued)

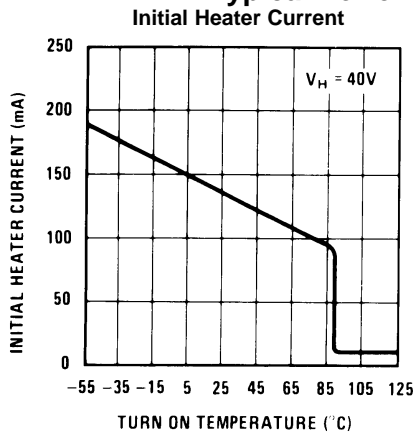

Figure 9.

Heater Current (To Limit This Surge, See Next Graph)

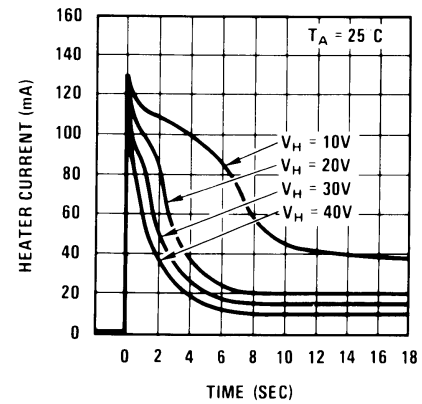

Figure 10.

Heater Surge Limit Resistor vs Minimum Supply Voltage at Various Minimum Temperatures

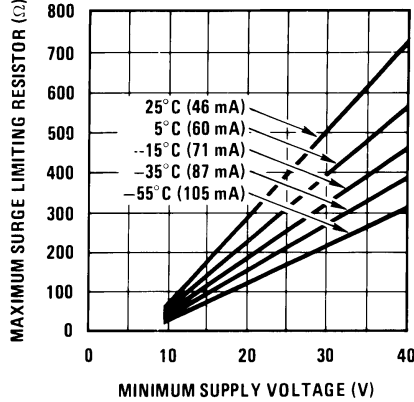

Figure 11.

Response Time

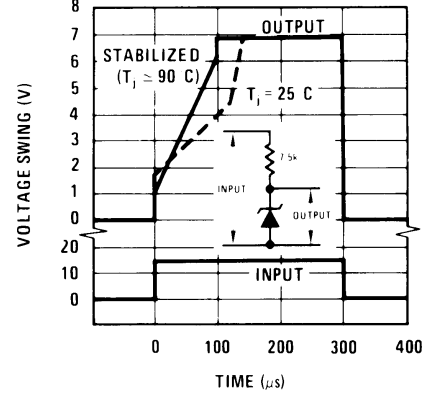

Figure 12.

*Heater must be bypassed with a 2 μF or larger tantalum capacitor if resistors are used.

Low Frequency Noise Voltage

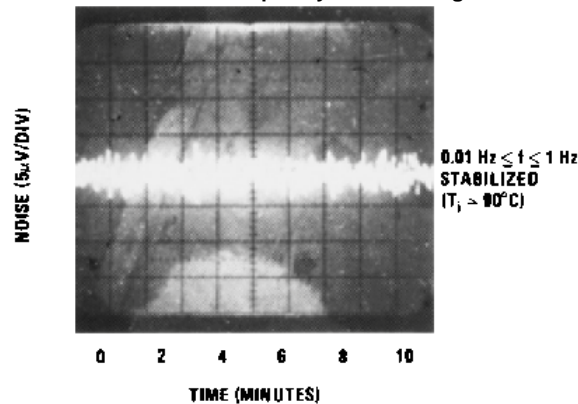

Figure 13.

TYPICAL APPLICATIONS

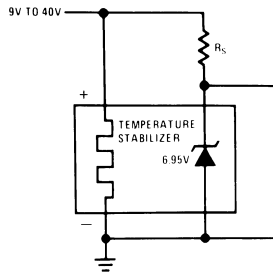

Figure 14. Single Supply Operation

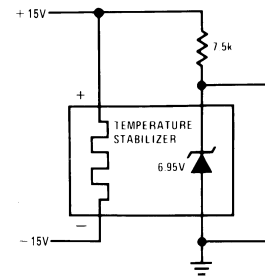

Figure 15. Split Supply Operation

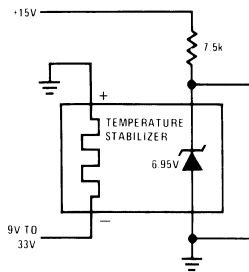

Figure 16. Negative Heater Supply with Positive Reference

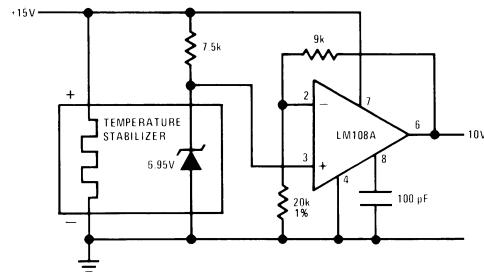

Figure 17. Buffered Reference With Single Supply

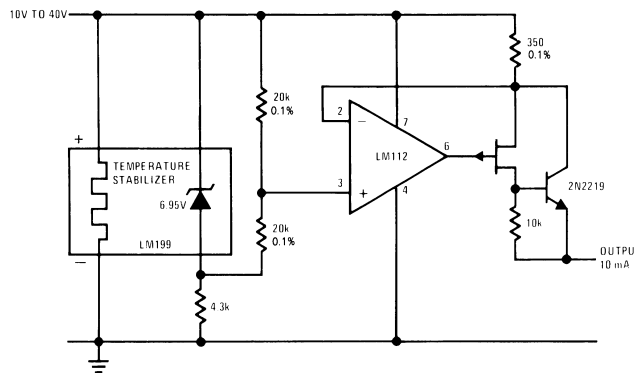

Figure 18. Positive Current Source

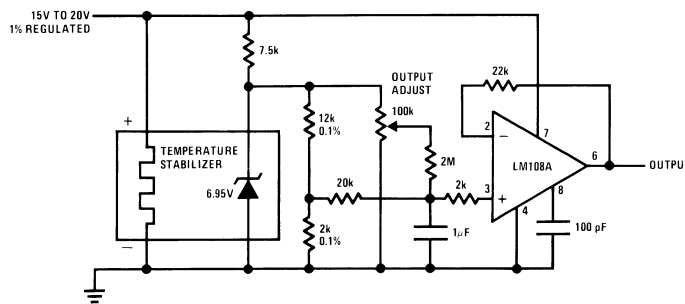

Figure 19. Standard Cell Replacement

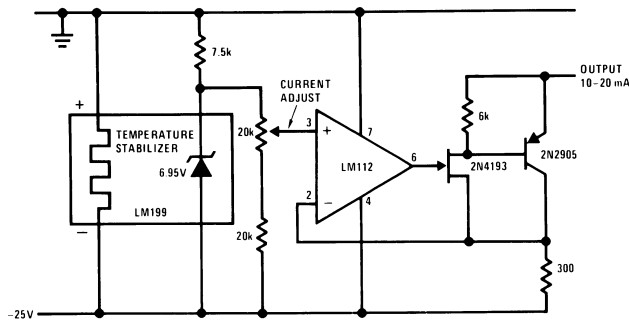

Figure 20. Negative Current Source

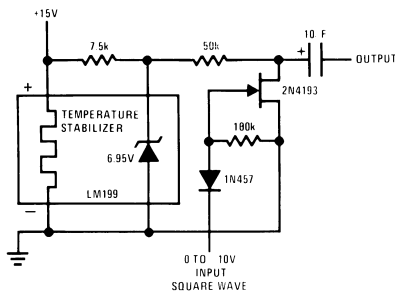
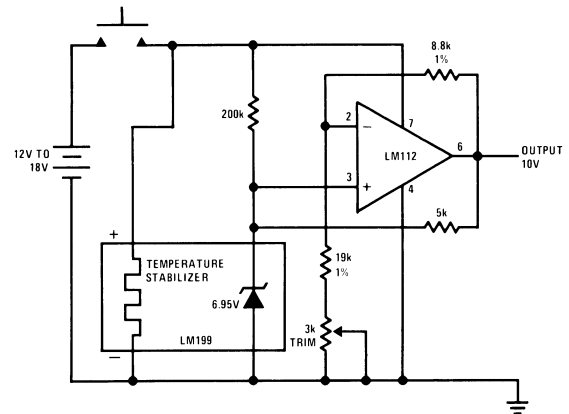

Figure 21. Square Wave Voltage Reference



*Warm-up time 10 seconds; intermittent operation does not degrade long term stability.

Figure 22. Portable Calibrator*

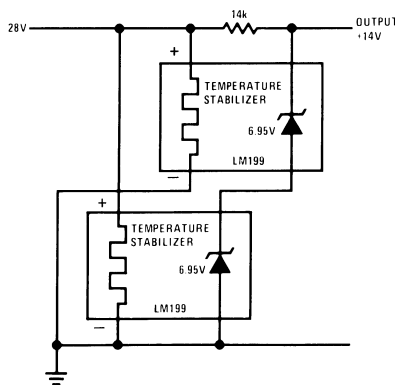
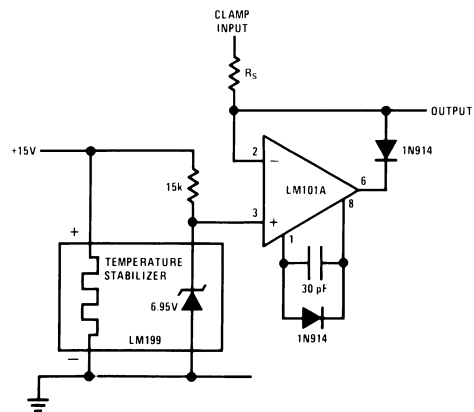

Figure 23. 14V Reference



*Clamp will sink 5 mA when input goes more positive than reference

Figure 24. Precision Clamp*

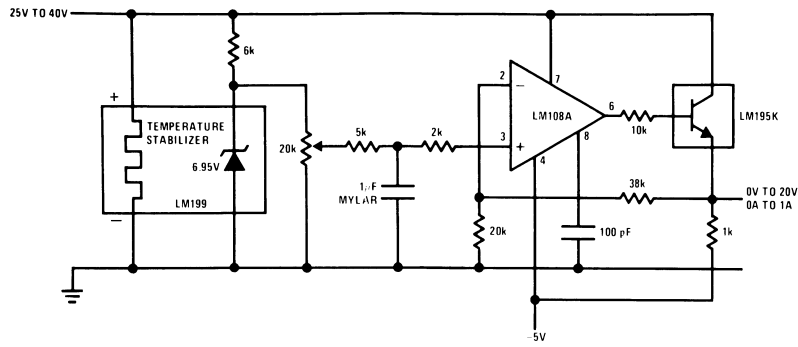

Figure 25. 0V to 20V Power Reference

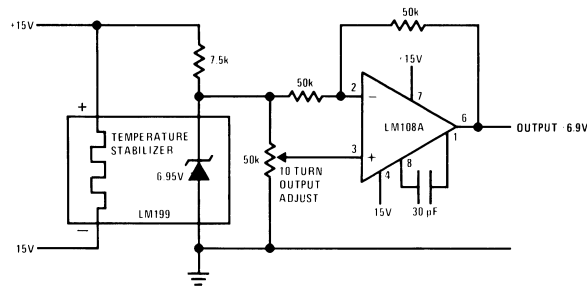

Figure 26. Bipolar Output Reference

Schematic Diagrams

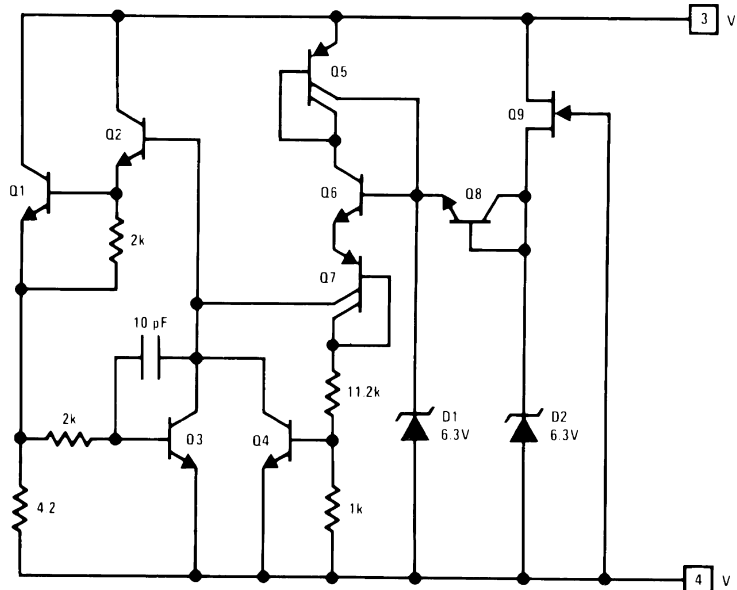

Figure 27. Temperature Stabilizer

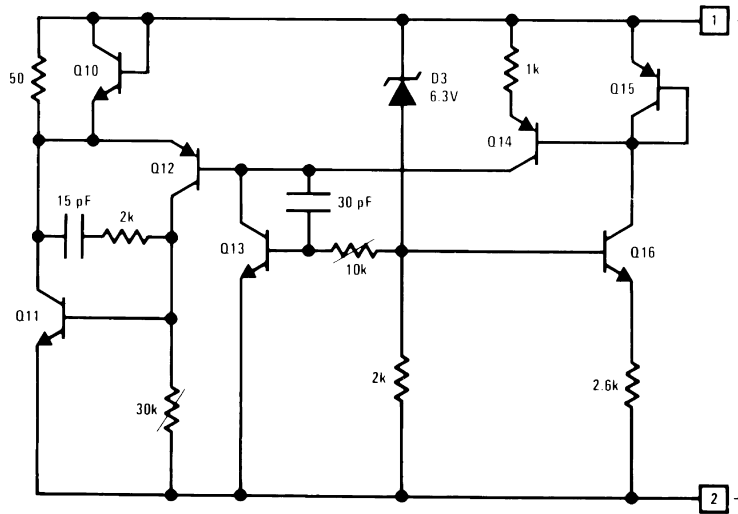

Figure 28. Reference

IMPORTANT NOTICE

Texas Instruments Incorporated and its subsidiaries (TI) reserve the right to make corrections, enhancements, improvements and other changes to its semiconductor products and services per JESD46, latest issue, and to discontinue any product or service per JESD48, latest issue. Buyers should obtain the latest relevant information before placing orders and should verify that such information is current and complete. All semiconductor products (also referred to herein as "components") are sold subject to TI's terms and conditions of sale supplied at the time of order acknowledgment.

TI warrants performance of its components to the specifications applicable at the time of sale, in accordance with the warranty in TI's terms and conditions of sale of semiconductor products. Testing and other quality control techniques are used to the extent TI deems necessary to support this warranty. Except where mandated by applicable law, testing of all parameters of each component is not necessarily performed.

TI assumes no liability for applications assistance or the design of Buyers' products. Buyers are responsible for their products and applications using TI components. To minimize the risks associated with Buyers' products and applications, Buyers should provide adequate design and operating safeguards.

TI does not warrant or represent that any license, either express or implied, is granted under any patent right, copyright, mask work right, or other intellectual property right relating to any combination, machine, or process in which TI components or services are used. Information published by TI regarding third-party products or services does not constitute a license to use such products or services or a warranty or endorsement thereof. Use of such information may require a license from a third party under the patents or other intellectual property of the third party, or a license from TI under the patents or other intellectual property of TI.

Reproduction of significant portions of TI information in TI data books or data sheets is permissible only if reproduction is without alteration and is accompanied by all associated warranties, conditions, limitations, and notices. TI is not responsible or liable for such altered documentation. Information of third parties may be subject to additional restrictions.

Resale of TI components or services with statements different from or beyond the parameters stated by TI for that component or service voids all express and any implied warranties for the associated TI component or service and is an unfair and deceptive business practice. TI is not responsible or liable for any such statements.

Buyer acknowledges and agrees that it is solely responsible for compliance with all legal, regulatory and safety-related requirements concerning its products, and any use of TI components in its applications, notwithstanding any applications-related information or support that may be provided by TI. Buyer represents and agrees that it has all the necessary expertise to create and implement safeguards which anticipate dangerous consequences of failures, monitor failures and their consequences, lessen the likelihood of failures that might cause harm and take appropriate remedial actions. Buyer will fully indemnify TI and its representatives against any damages arising out of the use of any TI components in safety-critical applications.

In some cases, TI components may be promoted specifically to facilitate safety-related applications. With such components, TI's goal is to help enable customers to design and create their own end-product solutions that meet applicable functional safety standards and requirements. Nonetheless, such components are subject to these terms.

No TI components are authorized for use in FDA Class III (or similar life-critical medical equipment) unless authorized officers of the parties have executed a special agreement specifically governing such use.

Only those TI components which TI has specifically designated as military grade or "enhanced plastic" are designed and intended for use in military/aerospace applications or environments. Buyer acknowledges and agrees that any military or aerospace use of TI components which have **not** been so designated is solely at the Buyer's risk, and that Buyer is solely responsible for compliance with all legal and regulatory requirements in connection with such use.

TI has specifically designated certain components as meeting ISO/TS16949 requirements, mainly for automotive use. In any case of use of non-designated products, TI will not be responsible for any failure to meet ISO/TS16949.

Products

Audio	www.ti.com/audio
Amplifiers	amplifier.ti.com
Data Converters	dataconverter.ti.com
DLP® Products	www.dlp.com
DSP	dsp.ti.com
Clocks and Timers	www.ti.com/clocks
Interface	interface.ti.com
Logic	logic.ti.com
Power Mgmt	power.ti.com
Microcontrollers	microcontroller.ti.com
RFID	www.ti-rfid.com
OMAP Applications Processors	www.ti.com/omap
Wireless Connectivity	www.ti.com/wirelessconnectivity

Applications

Automotive and Transportation	www.ti.com/automotive
Communications and Telecom	www.ti.com/communications
Computers and Peripherals	www.ti.com/computers
Consumer Electronics	www.ti.com/consumer-apps
Energy and Lighting	www.ti.com/energy
Industrial	www.ti.com/industrial
Medical	www.ti.com/medical
Security	www.ti.com/security
Space, Avionics and Defense	www.ti.com/space-avionics-defense
Video and Imaging	www.ti.com/video

TI E2E Community

e2e.ti.com