

TO 33K8-4-41-1

TECHNICAL MANUAL

CALIBRATION PROCEDURE

FOR

PORTABLE CALIBRATOR

515A

(FLUKE)



Distribution Statement - Distribution authorized to U.S. Government agencies and their contractors for official use or for administrative or operational purposes only, 30 November 1988. Other requests for this document shall be referred to AGMC/MLEP, Newark AFB OH 43057-0001.

Destruction Notice - For unclassified, limited documents, destroy by any method that will prevent disclosure of the contents or reconstruction of the document.

Published under Authority of the Secretary of the Air Force

REPRINT

30 APRIL 1992
CHANGE 2 - 30 SEPTEMBER 1993

LIST OF EFFECTIVE PAGES

NOTE: The portion of the text affected by the changes is indicated by a vertical line in the outer margins of the page. Changes to illustrations are indicated by miniature pointing hands. Changes to wiring diagrams are indicated by shaded areas.

Dates of issue for original and changed pages are:

Original 0..... 30 April 1992
Change..... 1..... 15 January 1993
Change..... 2..... 30 September 1993

TOTAL NUMBER OF PAGES IN THIS PUBLICATION IS 16, CONSISTING OF THE FOLLOWING:

| Page No. | *Change No. | Page No. | *Change No. | Page No. | *Change No. |
|---------------|-------------|----------|-------------|----------|-------------|
| Title | | | | | 2 |
| A | | | | | 2 |
| 1 - 2 | | | | | 0 |
| 3 - 4 | | | | | 2 |
| 5 | | | | | 1 |
| 6 | | | | | 0 |
| 7 | | | | | 1 |
| 8 | | | | | 0 |
| 9 | | | | | 1 |
| 10 - 14 | | | | | 0 |

*Zero in this column indicates an original page

**PORTABLE CALIBRATOR
515A
(FLUKE)**

1 CALIBRATION DESCRIPTION:

Table 1.

| Test Instrument (TI) Characteristics | Performance Specifications | Test Method |
|---|---|--|
| DC Voltage | Range: 0 to 999 μ V Accuracy: $\pm 2 \mu$ V Range: 1, 10 & 100 VDC Accuracy: $\pm 0.003\%$ setting or 30 μ V, whichever is greater | Checked with a DC Voltage Standard and DC Voltage Divider |
| AC Voltage | Range: 1 V at 400 Hz Accuracy: $\pm 0.05\%$ Range: 10 V at 400 Hz, 4 kHz & 50 kHz Accuracy: $\pm 0.04\%$, 400 Hz & 4 kHz; $\pm 0.1\%$ at 50 kHz Range: 100 V at 400 Hz Accuracy: $\pm 0.06\%$ | Checked with an AC Voltage Standard with Thermal Transfer Standard and DC Voltage Standard |
| Frequency | Range: 400 Hz & 4 kHz Accuracy: $\pm 1\%$ Range: 50 kHz Accuracy: $\pm 5\%$ | Checked with a Standard Frequency Counter |
| Resistance | Range: 10 & 100 Ω Accuracy: $\pm 0.06\%$ + zero tolerance Range: 1 k, 10 k, 100 k & 1 M Ω Accuracy: $\pm 0.015\%$ + zero tolerance | Checked with Standard Decade Resistance and Null Detector |

Table 1. (Cont)

| Test Instrument (TI) Characteristics | Performance Specifications | Test Method |
|---|--|---|
| Line Regulation | Range: 10 M Ω Accuracy: $\pm 0.075\%$ + zero tolerance AC Mode $\pm 100 \mu\text{V}$ for $\pm 10\%$ Line change | Checked with a Variac and Load Resistor |
| Load Regulation No Load to Full Load | AC Mode ± 40 ppm at 400 Hz, 4 kHz; ± 80 ppm at 50 kHz; ± 150 ppm at 400 Hz on 100 V range DC Mode ± 5 ppm (100 V range) | |
| Distortion | Less than 0.03% 400 Hz & 4 kHz Less than 0.05% at 50 kHz | Checked with a Distortion Analyzer |

2 EQUIPMENT REQUIREMENTS:

| Noun | Minimum Use Specifications | Calibration Equipment | Sub- Item |
|-------------------------------------|--|--------------------------|--------------|
| 2.1 STANDARD CELL | Accuracy: 5 ppm | Guildline 9152R | |
| 2.2 NULL DETECTOR | Sensitivity: 10 μV FS | Fluke 845AB | |
| 2.3 DC VOLTAGE STANDARD | Range: 0 to 100 V Accuracy: 0.01% | Fluke 332B | |
| 2.4 AUTO TRANSFORMER | Range: 0 to 125 V at 60 Hz Accuracy: N/A | General Radio W5MT | |
| 2.5 AC/DC DIFFERENTIAL VOLTMETER | Range: 0 to 10 V Accuracy: $\pm 0.4\%$ | Fluke 887AB | |
| 2.6 AC VOLTAGE STANDARD | Range: 0 to 100 V Accuracy: $\pm 0.025\%$ | Hewlett-Packard 745A | |

| | Noun | Minimum Use Specifications | Calibration Equipment | Sub-Item |
|------|---------------------------|---|---|-----------------|
| 2.7 | DC VOLTAGE DIVIDER | Ratio: 1:000000 Linearity: ± 100 ppm | Leeds & Northrup 4397M | |
| 2.8 | THERMAL TRANSFER STD | Range: 1 through 100 V Accuracy: $\pm 0.01\%$ | Fluke 540B | |
| 2.9 | SWITCH | SPDT | | |
| 2.10 | DC GENERATOR/ DETECTOR | Range: 1000-0-1000 V Accuracy: 5% FS | Electro Scientific Industries 800R | |
| 2.11 | KELVIN RATIO BRIDGE | Deviation: -6000 to +6000 ppm Accuracy: ± 1 ppm Multiplier: X0.01, X0.1, X10 & X100 Accuracy: $\pm 0.005\%$ Multiplier: X1 Accuracy: $\pm 0.002\%$ | Electro Scientific Industries 240R | |
| 2.12 | ELECTRONIC COUNTER | Range: 0 through 50 kHz Accuracy: $\pm 0.25\%$ | Hewlett-Packard 5245L | 5345A |
| 2.13 | DECADE RESISTOR | Range: 0 to 1 M Accuracy: $\pm 0.005\%$ +0.002 Ω | Electro Scientific Industries RS-925R | |
| 2.14 | RESISTORS | Range: 1 k Ω $\pm 5\%$, 931 k Ω $\pm 1\%$ and 200 k Ω $\pm 1\%$ 1/2 W | Local Purchase | |
| 2.15 | DISTORTION ANALYZER | Range: 100% Accuracy: $\pm 0.01\%$ | Hewlett-Packard 331A | |

3 PRELIMINARY OPERATIONS:

3.1 Review and become familiar with entire procedure before beginning calibration process.

| |
|----------------|
| WARNING |
|----------------|

Unless otherwise designated, and prior to beginning the Calibration Process, ensure that all test equipment voltage and/or current outputs are set to zero (0) or turned off, where applicable. Ensure that all equipment switches are set to the proper position before making connections or applying power.

T.O. 33K8-4-41-1

- 3.2 Set TI to 115 V position (switch located on side panel) and connect power cord to Autotransformer OUTPUT terminals. Connect AC Voltmeter to monitor the Autotransformer output.
 - 3.3 Adjust Autotransformer for a 115 V output as monitored with an AC Voltmeter and allow for a 30 minute warm-up.
 - 3.4 Measure the Standard Cell Enclosure temperature before use and intercompare the Standard Cell EMF before and after use in accordance with TO 33K8-3-1.
 - 3.5 Connect appropriate test equipment to 115 V/60 Hz power source, set POWER switches to ON and allow a 30 minute warm-up.
- 4 CALIBRATION PROCESS:

NOTE

Unless otherwise specified, verify the results of each test and take corrective action whenever the test requirement is not met, before proceeding.

4.1 LINE AND LOAD REGULATION CALIBRATION:

CAUTION

To avoid damage to the meter movement return the AC/DC Differential Voltmeter to the TVM MODE after nulling.

- 4.1.1 Connect 1 k Ω load across TI HI and LO terminals.
- 4.1.2 Connect an AC/DC Differential Voltmeter set for 10 VAC across TI HI and LO terminals.
- 4.1.3 Depress TI 10 V/400 Hz switch and record the AC/DC Differential Voltmeter indication.
- 4.1.4 Vary the Autotransformer OUTPUT control from 102 to 128 V as observed on the AC Voltmeter. Record the AC/DC Differential Voltmeter indication at both Autotransformer settings.
- 4.1.5 The AC/DC Differential Voltmeter must indicate the value of step 4.1.3, $\pm 100 \mu\text{V}$ as the line voltage is varied.
- 4.1.6 Return Autotransformer OUTPUT to 115 V.
- 4.1.7 Set the TI MULTIPLIER switch to X0 and depress the 1 VDC range switch.
- 4.1.8 Disconnect the 1 k Ω load, depress TI 10 V/400 Hz switch and record the AC/DC Differential Voltmeter indication.
- 4.1.9 Set the TI MULTIPLIER switch to X0 and depress the 1 VDC range switch.
- 4.1.10 Reconnect the 1 k Ω load, depress TI 10 V/400 Hz switch and record the AC/DC Differential Voltmeter indication.
- 4.1.11 The AC/DC Differential Voltmeter must indicate within $\pm 0.004\%$ of step 4.1.8 (400 Hz).
- 4.1.12 Repeat steps 4.1.7 through 4.1.10 for 10 V, 4 kHz.
- 4.1.13 The AC/DC Differential Voltmeter must indicate within $\pm 0.004\%$ of step 4.1.8 (4 kHz).
- 4.1.14 Repeat steps 4.1.7 through 4.1.10 for 10 V, 50 kHz.
- 4.1.15 The AC/DC Differential Voltmeter must indicate within $\pm 0.008\%$ of step 4.1.8 (50 kHz).
- 4.1.16 Set the TI MULTIPLIER switch to X0 and depress the 1 VDC range switch.
- 4.1.17 Remove the 1 k Ω load and connect a 931 k Ω in its place.
- 4.1.18 Set the AC/DC Differential Voltmeter RANGE switch to 100 VAC. Set the AC/DC Differential Voltmeter RANGE switch to 100 VAC.

- 4.1.19 Depress TI 100 V/400 Hz switch and record the AC/DC Differential Voltmeter indication.
- 4.1.20 Set the TI MULTIPLIER switch to X0 and depress the 1 VDC range switch.
- 4.1.21 Disconnect the 931 k Ω load.
- 4.1.22 Depress TI 100 V/400 Hz switch and the AC/DC Differential Voltmeter must indicate the recorded value of step 4.1.19, $\pm 0.015\%$.
- 4.1.23 Set the AC/DC Differential Voltmeter to DC and RANGE to 100 VDC.
- 4.1.24 Depress TI 100 VDC switch and record the AC/DC Differential Voltmeter indication.
- 4.1.25 Set the TI MULTIPLIER switch to X0 and depress the 1 VDC range switch.
- 4.1.26 Connect a 200 k Ω load to TI HI and LO terminals.
- 4.1.27 Depress TI 100 VDC and the AC/DC Differential Voltmeter must indicate the recorded value of step 4.1.24, $\pm 0.0005\%$.
- 4.1.28 Set the TI MULTIPLIER switch to X0 and depress the 1 VDC range switch.
- 4.1.29 Disconnect the load and AC/DC Differential Voltmeter from TI.

4.2 DC MICROVOLT AND 1 VOLT CALIBRATION:

- 4.2.1 Connect equipment as shown in Figure 1.
- 4.2.2 Divide Standard Cell Voltage by 2 and set quotient obtained on the DC Voltage Divider dials.
- 4.2.3 Set up DC Voltage Standard to produce 2 V and set POWER switch to OPERATE.
- 4.2.4 Set DC Null Detector ZERO-OPERATE switch to OPERATE.
- 4.2.5 Set Switch S1 to Position C and while setting the DC Null Detector SENSITIVITY switch to 10 μ V position with less than full scale deflection, adjust DC Voltage Standard OUTPUT dials for a minimum indication. Return SENSITIVITY switch to 1000 V position.

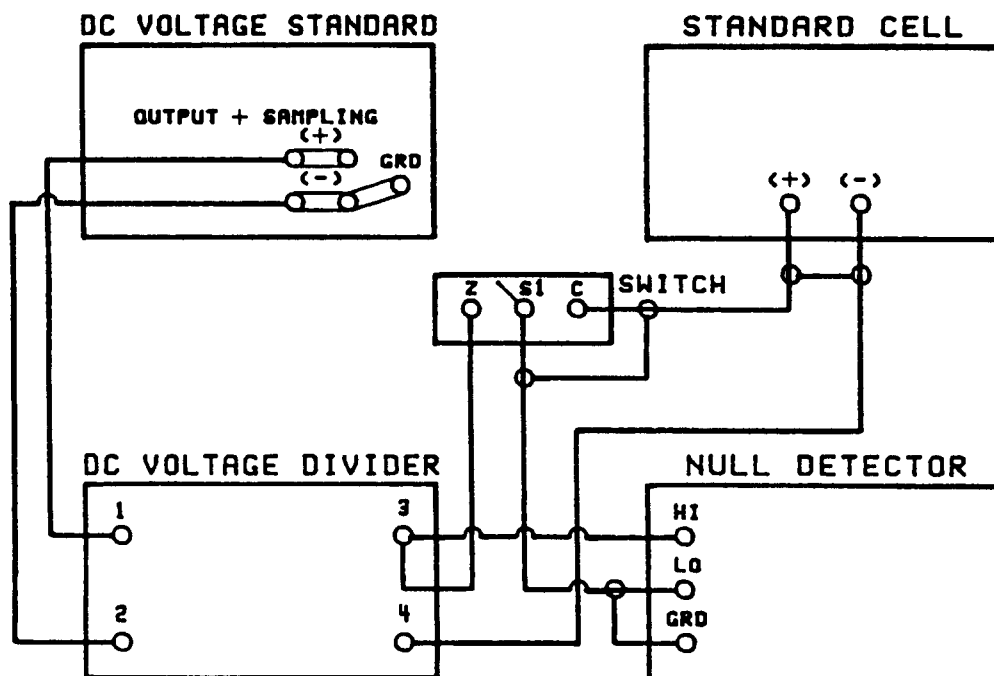

Figure 1.

- 4.2.6 Remove the Standard Cell and substitute TI in its place.

T.O. 33K8-4-41-1

4.2.7 Set the DC Voltage Divider dials to 0.0004950, depress TI μ V switch and set output for 990 μ V.

4.2.8 While setting DC Null Detector SENSITIVITY switch to 10 μ V position with less than full scale deflection, adjust DC Voltage Divider for a minimum indication. Return SENSITIVITY switch to 1000 V position.

4.2.9 DC Voltage Divider must indicate within 0.0004940 to 0.0004960.

4.2.10 Repeat step 4.2.8 for each new output value of TI listed in Table 2.

4.2.11 The DC Voltage Divider must indicate the values listed in Limits column of Table 2.

Table 2.

| Test Instrument μV Dial Settings | DC Voltage Divider Settings | DC Voltage Divider Limits |
|--|--|--------------------------------------|
| 990 | 0.0004950 | 0.0004940 to 0.0004960 |
| 888 | 0.0004440 | 0.0004430 to 0.0004450 |
| 777 | 0.0003885 | 0.0003875 to 0.0003895 |
| 666 | 0.0003330 | 0.0003320 to 0.0003340 |
| 555 | 0.0002775 | 0.0002765 to 0.0002785 |
| 444 | 0.0002220 | 0.0002210 to 0.0002230 |
| 333 | 0.0001665 | 0.0001655 to 0.0001675 |
| 222 | 0.0001110 | 0.0001100 to 0.0001120 |
| 111 | 0.0000555 | 0.0000545 to 0.0000565 |

4.2.12 Set DC Voltage Divider to 0.5000000 and depress TI 1 VDC switch.

4.2.13 Set TI MULTIPLIER switch to X1 and repeat step 4.2.8.

4.2.14 The DC Voltage Divider must indicate within 0.4999850 to 0.5000150. Set DC Voltage Standard POWER switch to STDBY.

4.3 10 VOLTS RANGE LINEARITY CALIBRATION:

4.3.1 Reconnect the equipment as shown in Figure 1.

4.3.2 Divide Standard Cell voltage by 10 and set quotient obtained on the DC Voltage Divider dials.

4.3.3 Set DC Voltage Standard to produce 10 V and set POWER switch to OPERATE.

4.3.4 Set Switch S1 to Position C and while setting the DC Null Detector SENSITIVITY switch to 10 μ V position with less than full scale deflection, adjust DC Voltage Standard OUTPUT dials for a minimum indication. Return SENSITIVITY switch to 1000 V position.

4.3.5 Set DC Voltage Standard POWER switch to STDBY.

4.3.6 Remove Standard Cell and substitute with TI.

4.3.7 Depress TI 10 VDC switch and set MULTIPLIER switch to each setting listed in Table 3.

4.3.8 Set DC Voltage Standard POWER switch to OPERATE.

4.3.9 Set DC Voltage Divider dials to each value listed in Table 3 and set Null Detector SENSITIVITY switch to the range position necessary to produce the values listed in Limits column of Table 3.

4.3.10 The Null Detector must indicate within the values listed in Limits column of Table 3. Return SENSITIVITY switch to 1000 V position.

Table 3.

| Test Instrument Multiplier Switch Setting | Voltage Divider Setting | Null Detector Reading |
|---|-------------------------|----------------------------|
| X1 | 0.999999X | Null $\pm 300 \mu\text{V}$ |
| X.9 | 0.9000000 | Null $\pm 270 \mu\text{V}$ |
| X.8 | 0.8000000 | Null $\pm 240 \mu\text{V}$ |
| X.7 | 0.7000000 | Null $\pm 210 \mu\text{V}$ |
| X.6 | 0.6000000 | Null $\pm 180 \mu\text{V}$ |
| X.5 | 0.5000000 | Null $\pm 150 \mu\text{V}$ |
| X.4 | 0.4000000 | Null $\pm 120 \mu\text{V}$ |
| X.3 | 0.3000000 | Null $\pm 90 \mu\text{V}$ |
| X.2 | 0.2000000 | Null $\pm 60 \mu\text{V}$ |
| X.1 | 0.1000000 | Null $\pm 30 \mu\text{V}$ |

4.3.11 Set the DC Voltage Standard POWER switch to STDBY and reconnect the equipment as shown in Figure 1.

4.4 100 VOLT DC RANGE CALIBRATION:

4.4.1 Divide Standard Cell voltage by 100 and set quotient obtained on the DC Voltage Divider dials.

4.4.2 Set up the DC Voltage Standard to produce 100 V and set POWER switch to OPR.

4.4.3 Repeat step 4.2.5.

4.4.4 Set DC Voltage Standard POWER switch to STDBY and remove the Standard Cell and substitute TI in its place.

4.4.5 Set the DC Voltage Divider dials to 0.999999X.

4.4.6 Set the DC Voltage Standard POWER switch to OPR and depress the TI 100 VDC switch.

4.4.7 Set DC Null Detector SENSITIVITY switch to 10 mV position.

4.4.8 The DC Null Detector must indicate a null $\pm 3 \text{ mV}$.

4.4.9 Set the DC Voltage Standard and TI DC outputs to OFF and disconnect the equipment of Figure 1.

4.5 FREQUENCY CALIBRATION:

4.5.1 Connect the INPUT terminals of the Frequency Counter to TI OUTPUT terminals. Use the period mode if maximum resolution is desired.

4.5.2 Select the 10 VAC/50 kHz function on TI.

4.5.3 The Electronic Counter must indicate within 47.5 to 52.5 kHz (19 to 21 μs for period measurement).

T.O. 33K8-4-41-1

4.5.4 Select the 10 VAC/4 kHz function on TI.

4.5.5 The Electronic Counter must indicate within 3.96 to 4.04 kHz (247.5 to 252.5 μ s for period measurement).

4.5.6 Select the 10 VAC/400 Hz function on TI.

4.5.7 The Electronic Counter must indicate within 396 to 404 Hz (2.475 to 2.525 ms for period measurement).

4.5.8 Disconnect the Electronic Counter from TI.

4.6 AC VOLTAGE CALIBRATION:

4.6.1 Connect equipment as shown in Figure 2.

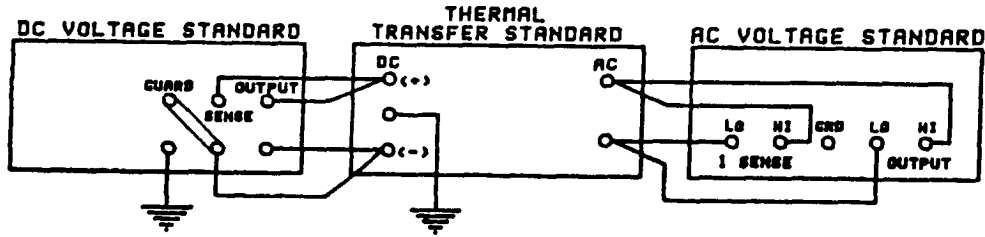

Figure 2.

4.6.2 Set the Transfer Standard RANGE switch to 1 V and AC Voltage Standard RANGE switch to 1 V/400 Hz.

4.6.3 Set the output of the DC Voltage Standard for 1 V and set POWER switch to OPR.

4.6.4 Set Transfer Standard MODE switch to DC Search and then to DC Transfer.

4.6.5 Adjust Transfer Standard Coarse-Medium-Fine Sensitivity controls for a null indication on the Null Meter.

4.6.6 Set Transfer Standard MODE switch to AC Search and then to AC Transfer.

4.6.7 Adjust output of AC Voltage Standard for a null indication on the Transfer Standard Null Meter. Do not change the setting of the AC Voltage Standard output dials until transfer function is completed.

4.6.8 Set DC Voltage Standard outputs to OFF and connect equipment as shown in Figure 3.

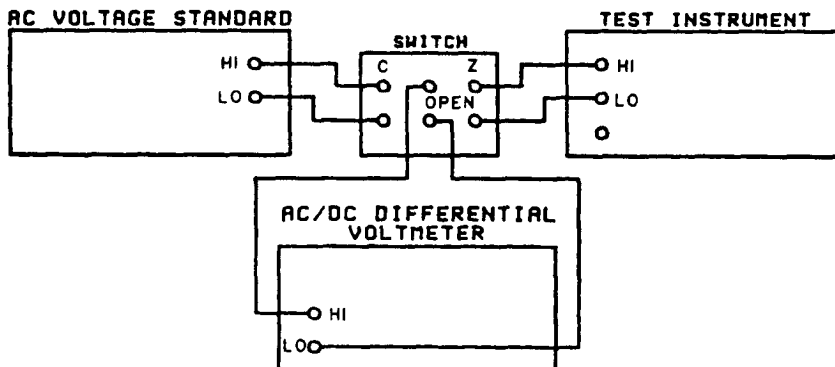

Figure 3.

4.6.9 Set switch S1 to OPEN position.

- 4.6.10 Set FUNCTION switch of AC/DC Differential Voltmeter to AC, RANGE switch to 1 and NULL switch to TVM.
- 4.6.11 Set the switch of Figure 3 to Position C and adjust AC/DC Differential Voltmeter dials for a minimum indication on the Null Meter. Record the AC/DC Differential Voltmeter indication and return to the TVM Mode.
- 4.6.12 Set switch S1 to OPEN position.
- 4.6.13 Set TI for 1 V/400 Hz.
- 4.6.14 Set the switch S1 to Position Z and adjust AC/DC Differential Voltmeter for a minimum indication on Null Meter. Record the AC/DC Differential Voltmeter indication and return to the TVM Mode.
- 4.6.15 Subtract the smaller of the two values obtained in steps 4.6.11 and 4.6.14 from the larger. The difference should not be greater than 0.0005 V.
- 4.6.16 Reconnect equipment as shown in Figure 2.
- 4.6.17 Repeat steps 4.6.2 through 4.6.14 using 100 VDC in place of 1 VDC and 100 VAC in place of 1 VAC.
- 4.6.18 Subtract the smaller of the two values obtained in steps 4.6.11 and 4.6.14 from the larger. The difference should not be greater than 0.06 V.
- 4.6.19 Connect the equipment as shown in Figure 4.

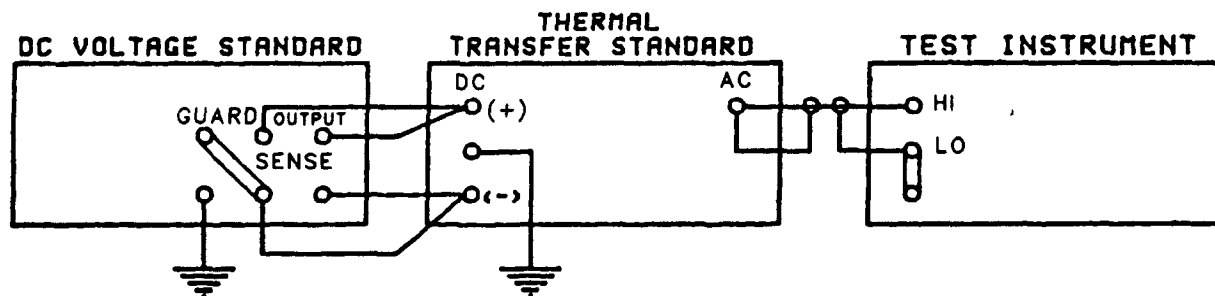

Figure 4.

NOTE

Because of current or loading limitations TI 1 VAC and 100 VAC ranges cannot be verified by the Thermal Transfer Method.

- 4.6.20 Set Thermal Transfer Standard RANGE switch to 10 V.
- 4.6.21 Depress TI 10 V/400 Hz pushbutton.
- 4.6.22 Set Thermal Transfer Standard MODE switch to AC Search, then to AC Transfer.
- 4.6.23 Adjust Thermal Transfer Standard Coarse-Medium-Fine Sensitivity controls for a null indication on the Null Meter.
- 4.6.24 Set the Thermal Transfer Standard MODE switch to DC Search.
- 4.6.25 Set the output of the DC Voltage Standard to 10 V and POWER switch to OPR.
- 4.6.26 Set the Thermal Transfer Standard MODE switch to DC Transfer and adjust DC Voltage Standard output dials for a null indication on the Null Meter.
- 4.6.27 The DC Voltage Standard must indicate within 9.996 to 10.004 V. Set POWER switch to STDBY.
- 4.6.28 Set the Thermal Transfer Standard MODE switch to OFF.
- 4.6.29 Depress TI 10 V/4 kHz pushbutton and repeat steps 4.6.22 through 4.6.28.

- 4.6.30 Depress TI 10 V/50 kHz pushbutton and repeat steps 4.6.22 through 4.6.28 , except in step 4.6.27 the DC Voltage Standard must indicate within 9.99 to 10.01 VDC.
- 4.6.31 Set all DC and AC outputs to OFF and disconnect the equipment of Figure 4.
- 4.6.32 Connect TI OUTPUT terminals to the Distortion Analyzer INPUT terminals.
- 4.6.33 Depress TI 1 V/400 Hz pushbutton.
- 4.6.34 Set the Distortion Analyzer Meter RANGE switch to 100% and set FUNCTION switch to Set Level, FREQUENCY range to X10 and FREQUENCY dial to 40.
- 4.6.35 Adjust Distortion Analyzer SENSITIVITY controls to obtain a full scale or 100% indication on the meter.
- 4.6.36 Set Distortion Analyzer FUNCTION switch to Distortion and adjust FREQUENCY dial Vernier and Balance controls for a minimum meter indication. Set Meter RANGE switch down scale as necessary to keep meter indication on scale.
- 4.6.37 The Distortion Analyzer must indicate less than 0.03%.
- 4.6.38 Depress TI 10 V/400 Hz and repeat steps 4.6.34 through 4.6.37.
- 4.6.39 Depress TI 100 V/400 Hz pushbutton and repeat steps 4.6.34 through 4.6.37.
- 4.6.40 Depress TI 10 V/4 kHz pushbutton and repeat steps 4.6.34 through 4.6.37, with output frequency of the Distortion Analyzer set to 4 kHz.
- 4.6.41 Depress TI 10 V/50 kHz pushbutton and repeat steps 4.6.34 through 4.6.37, with the output frequency of the Distortion Analyzer set to 50 kHz.
- 4.6.42 The Distortion Analyzer must indicate less than 0.05%.
- 4.6.43 Set TI 10 V/50 kHz pushbutton switch to OFF and disconnect the Distortion Analyzer from TI.

4.7 RESISTANCE CALIBRATION:

- 4.7.1 Connect the equipment as shown in Figure 5.
- 4.7.2 Set DC Generator/Detector controls as follows:

| | |
|----------------------|------------|
| GENERATOR POWER | 1000 mW |
| GENERATOR RESISTANCE | 1 Ω |
| POLARITY | +(PLUS) |

- 4.7.3 Connect KELVIN KLIPS to Kelvin Ratio Bridge coax connectors.
- 4.7.4 Connect KELVIN KLIPS to Kelvin Ratio Bridge #3 UNKNOWN terminal.
- 4.7.5 Set Kelvin Ratio Bridge NORMAL-LEAD ADJ switch to LEAD ADJ, and rotate LEAD SELECTOR switch to COAX. Set DC Generator/Detector GEN switch to ON.
- 4.7.6 While adjusting DC Generator/Detector DETECTOR controls for maximum sensitivity with less than full scale meter deflection, adjust Kelvin Ratio Bridge LEAD ADJ control for zero meter indication.

NOTE

A proper null is obtained when there is no change in meter deflection when DC Generator/Detector POLARITY switch is switched back and forth between + (plus) and - (minus).

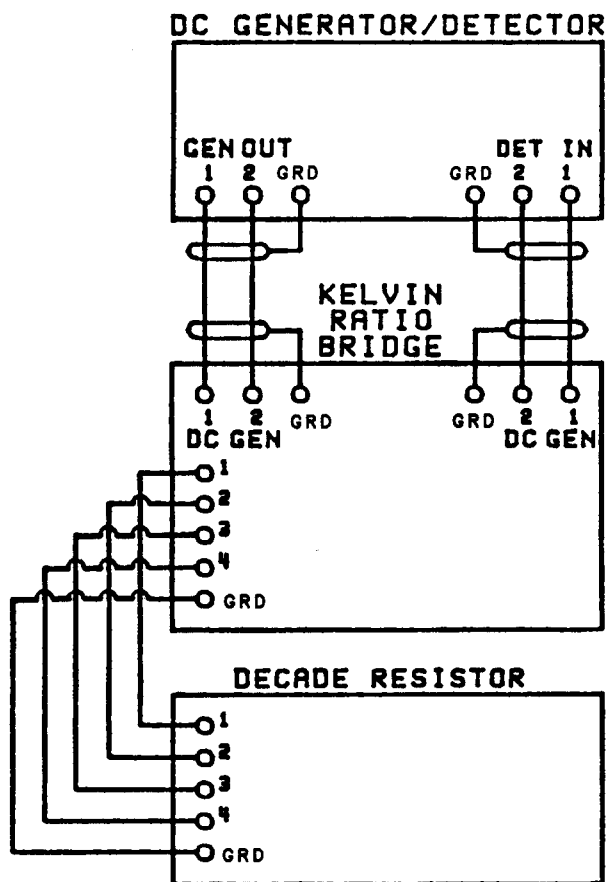

Figure 5.

- 4.7.7 Set DC Generator/Detector GEN switch to OFF and set Kelvin Ratio Bridge NORMAL-LEAD ADJ switch to NORMAL.
- 4.7.8 Connect KELVIN KLIPS to TI OUTPUT terminals, depress switch and set MULTIPLIER switch to 0 Ω .
- 4.7.9 Set DC Generator/Detector GEN POWER control to 250 mW and rotate GEN/RESISTANCE switch to 1 Ω .
- 4.7.10 Set Kelvin Ratio Bridge dials to 0.01X STANDARD + 1 ppm X 0.
- 4.7.11 Set DC Generator/Detector GEN switch to ON.
- 4.7.12 While adjusting DC Generator/Detector DETECTOR controls for maximum sensitivity with less than full scale meter deflection, adjust Decade Resistor dials for zero meter deflection. Set DC Generator/Detector GEN switch to OFF.
- 4.7.13 Multiply Decade Resistor indication by 0.01 and record the product obtained.
- 4.7.14 Rotate TI MULTIPLIER switch to 10 Ω .
- 4.7.15 Set DC Generator/Detector GEN POWER control to 100 mW and rotate GEN RESISTANCE switch to 100 Ω .
- 4.7.16 Set Kelvin Ratio Bridge dials to 0.1 X STANDARD + 1 ppm X 0.
- 4.7.17 Repeat steps 4.7.11 and 4.7.12 and multiply Decade Resistor indication by 0.1.

T.O. 33K8-4-41-1

- 4.7.18 The product obtained in step 4.7.17 minus the value recorded in step 4.7.13 must be within 9.994 to 10.006 Ω .
- 4.7.19 Rotate TI MULTIPLIER switch to 100 and set GEN RESISTANCE switch to 1 k Ω .
- 4.7.20 Set Kelvin Ratio Bridge dial to 1 X STANDARD + 1 ppm X 0.
- 4.7.21 Repeat steps 4.7.11 and 4.7.12.
- 4.7.22 The Decade Resistor indication, minus the value recorded in step 4.7.13 must be within 99.94 to 100.06 Ω .
- 4.7.23 Set DC Generator/Detector GEN POWER control to 250 mW and rotate TI MULTIPLIER switch to 1 k.
- 4.7.24 Set the Kelvin Ratio Bridge dials to 1 X STANDARD + .001% X 0.
- 4.7.25 Rotate Decade Resistor dials to 1000 Ω .
- 4.7.26 Set GEN switch to ON.
- 4.7.27 While adjusting DC Generator/Detector DETECTOR controls for maximum sensitivity with less than full scale deflection, adjust deviation dial for zero meter indication.
- 4.7.28 Set DC Generator/Detector GEN switch to OFF. The Kelvin Ratio Bridge deviation dial must not indicate more than ± 15 .
- 4.7.29 Set TI MULTIPLIER switch to 10 k Ω and set Decade Resistor dials to 10,000 Ω .
- 4.7.30 Set DC Generator/Detector GEN POWER control to 1000 mW and set DC Generator/Detector GEN switch to ON.
- 4.7.31 Repeat step 4.7.27. The deviation dial must not indicate more than ± 15 . Set GEN switch to OFF.
- 4.7.32 Set TI MULTIPLIER switch to 100 k and the Decade Resistor dials to 100,000 Ω .
- 4.7.33 Set the DC Generator/Detector GEN switch to ON and repeat step 4.7.27.
- 4.7.34 The Kelvin Ratio Bridge deviation dial must not indicate more than ± 15 . Set the GEN switch to OFF.
- 4.7.35 Set TI MULTIPLIER switch to 1 M and the Decade Resistor dials to 1,000,000 Ω .
- 4.7.36 Set DC Generator/Detector GENERATOR POWER control to 250 mW and rotate GENERATOR RESISTANCE to 10 k.
- 4.7.37 Set DC Generator/Detector GEN switch to ON and repeat step 4.7.27.
- 4.7.38 The Kelvin Ratio Bridge deviation dial must not indicate more than ± 15 . Set DC Generator/Detector GEN switch to OFF.
- 4.7.39 Set TI MULTIPLIER switch to 10 M and the Decade Resistor dials to 100,000 Ω .
- 4.7.40 Set Kelvin Ratio Bridge dials to 100 X STANDARD + 0.01% X 0.
- 4.7.41 Set DC Generator/Detector GEN switch to ON and repeat step 4.7.27.
- 4.7.42 The Kelvin Ratio Bridge deviation dial must not indicate more than ± 7.5 .
- 4.7.43 Set DC Generator/Detector GEN switch to OFF and disconnect and secure all equipment.

CALIBRATION PERFORMANCE TABLE

LINE AND LOAD REGULATION CALIBRATION:

Line Regulation: AC Mode $\pm 100 \mu\text{V}$

Load Regulation: AC: 40 ppm, 80 ppm, 150 ppm

DC: ± 5 ppmDC μV CALIBRATION:

| <u>TI μV Dial Settings</u> | <u>DC Voltage Divider Settings</u> | <u>DC Voltage Divider Limits</u> |
|--|--|--------------------------------------|
| 990 | 0.0004950 | 0.0004940 to 0.0004960 |
| 888 | 0.0004440 | 0.0004430 to 0.0004450 |
| 777 | 0.0003885 | 0.0003875 to 0.0003895 |
| 666 | 0.0003330 | 0.0003320 to 0.0003340 |
| 555 | 0.0002775 | 0.0002765 to 0.0002785 |
| 444 | 0.0002220 | 0.0002210 to 0.0002230 |
| 333 | 0.0001665 | 0.0001655 to 0.0001675 |
| 222 | 0.0001110 | 0.0001100 to 0.0001120 |
| 111 | 0.0000555 | 0.0000545 to 0.0000565 |

1 VOLT CALIBRATION:

| <u>Range</u> | <u>Divider Setting</u> | <u>Limits (ratio)</u> |
|--------------|------------------------|------------------------|
| 1 V | 0.5000000 | 0.4999850 to 0.5000150 |

10 VOLT DC RANGE LINEARITY CALIBRATION:

| <u>TI Multiplier Switch Setting</u> | <u>Voltage Divider Setting</u> | <u>Null Detector Reading</u> |
|---|------------------------------------|----------------------------------|
| X1 | 0.999999X | Null $\pm 300 \mu\text{V}$ |
| X.9 | 0.9000000 | Null $\pm 270 \mu\text{V}$ |
| X.8 | 0.8000000 | Null $\pm 240 \mu\text{V}$ |
| X.7 | 0.7000000 | Null $\pm 210 \mu\text{V}$ |
| X.6 | 0.6000000 | Null $\pm 180 \mu\text{V}$ |
| X.5 | 0.5000000 | Null $\pm 150 \mu\text{V}$ |
| X.4 | 0.4000000 | Null $\pm 120 \mu\text{V}$ |
| X.3 | 0.3000000 | Null $\pm 90 \mu\text{V}$ |
| X.2 | 0.2000000 | Null $\pm 60 \mu\text{V}$ |
| X.1 | 0.1000000 | Null $\pm 30 \mu\text{V}$ |

T.O. 33K8-4-41-1

100 VOLT DC RANGE CALIBRATION:

| <u>Applied</u> | <u>Limits</u> |
|----------------|---------------------|
| 100 V | 99.997 to 100.003 V |

AC VOLTAGE CALIBRATION:

| <u>Range</u> | <u>Applied</u> | <u>Limits (ACV)</u> |
|--------------|----------------|---------------------|
| 1 VAC 400 Hz | 1 VAC 400 Hz | 0.9995 to 1.0005 |
| 10 V 400 Hz | 10 V 400 Hz | 9.996 to 10.004 |
| 10 V 4 kHz | 10 V 4 kHz | 9.996 to 10.004 |
| 10 V 50 kHz | 10 V 50 kHz | 9.99 to 10.01 |
| 100 V 400 Hz | 100 V 400 Hz | 99.94 to 100.06 |

DISTORTION CALIBRATION:

| <u>Range</u> | <u>Applied</u> | <u>Limits</u> |
|--------------|----------------|---------------|
| 1 V | 1 V 400 Hz | <0.03% |
| 10 V | 10 V 400 Hz | <0.03% |
| 10 V | 10 V 4 kHz | <0.03% |
| 10 V | 10 V 50 kHz | <0.05% |

RESISTANCE CALIBRATION:

| <u>Applied</u> | <u>Limits (Ω)</u> |
|----------------|-------------------------------------|
| 10 Ω | 9.994 to 10.006 |
| 100 Ω | 99.94 to 100.06 |
| 1000 Ω | 999.85 to 1000.15 |
| 10 k Ω | 9998.5 to 10001.5 |
| 100 k Ω | 99.985 to 100.015 k |
| 1 M Ω | 0.99985 to 1.00015 M |
| 10 M Ω | 9.9925 to 10.0075 M |