



540B REFERENCE BATTERY MODIFICATION KIT P/N 897215 INSTALLATION INSTRUCTIONS

ITEM NO.	DESCRIPTION	P/N	QUANTITY
1.	Regulator PCB	926667	1
2.	Resistor, MF, 2.49K, 1%, .125W	226209	1
3.	Spacer, .312 Hex., 6-32, .750	103218	1
4.	Screw, Ph., Lock, 6-32, .312	152157	1
5.	Holder, Battery	928267	1
6.	Battery, Lithium, 1.5V	928270	2
7.	Wire, Red, 22 AWG	115576	3 inch
8.	Wire, Black, 22 AWG	115774	4 inch
9.	Heat Shrink Sleeveing	113852	1 inch
10.	Installation Instruction Sheet	933171	1

These installation instructions are for modification kit P/N 897215

OVERVIEW

The high energy mercury battery, P/N 103226 is being discontinued by battery manufacturers because it is no longer considered environmentally safe due to its mercury content.

PURPOSE

This kit replaces the mercury battery with environmentally safe lithium batteries and a regulator circuit which provides improved stability of the reference voltage resulting in less drift at null.

COMPATIBILITY

This kit is compatible with all 540Bs which have the rechargeable battery pack.

The kit includes all parts listed above.

The following is an overview of the steps required for installation:

- Remove old battery clip and install item 5.
- Replace R457.
- Install Regulator PCB, Item 1.
- Calibrate Reference Battery Check.

This kit can be customer installed.

EQUIPMENT NEEDED

In addition to the Upgrade Kit (listed above), the following equipment is needed to install this option:

- Drill motor and drill set.
- Soldering iron.
- Screwdriver.
- Digital Voltmeter.

INSTALLATION INSTRUCTIONS

1. Place the Battery Check switch in the "OFF" position and remove power from the 540B.
2. Remove the six screws holding the battery module and remove. Due to the drilling required, it is best to mark and unsolder all the wires connecting the battery module to the 540B mainframe.

CAUTION

Care must be taken in step 3 to avoid getting metal chips in the existing Ni-Cad battery holder.

3. With a .187" drill, remove the four rivets holding the old battery clip to the battery module. This is best accomplished by drilling out the knurled portion of the rivet and removing the battery clip. Then knock the remaining portion of the rivet out with a center punch.

4. Clean the battery bracket surface with alcohol, remove the protective paper from the battery holder, Item 5, and install to bracket as shown in Figure 1. Press battery holder firmly into place.
5. Solder the two wires from the old battery clip to the new battery holder, green wire to positive, violet wire to negative, see Figure 1. Place the heat shrink sleeving, Item 9, over the terminals, cut to length, and shrink with heat. **DO NOT** install the lithium batteries at this time.
6. Remove the four screws holding the left hand front panel from the 540B.
7. Remove R457 and replace with Item 2, 2.49K ohm resistor. See Figure 2 for location.
8. Locate and remove the 6-32 nut holding the cable tie, located at the lower left side adjacent to the Battery Check switch. Install the hex spacer, Item 3, on the existing 6-32 stud.
9. Remove the white/red wire from the lower switch clip, rear wafer of the Battery Check switch, Figure 2, and connect it to the center pad marked "O" on the regulator pcb, Item 1. Connect the red wire, Item 7, to the pad marked "I" on the regulator pcb. Connect the black wire, Item 8, to the pad marked "C" on the regulator pcb. Mount the regulator pcb on the hex spacer using the 6-32 screw, Item 4.
10. Connect the red wire to the switch clip vacated by the white/red wire. Connect the black wire to the right hand terminal of the Fine Reference adjust pot. A yellow wire is also connected to this terminal. See Figure 2 for illustrations.
11. Reconnect all the wires from the 540B mainframe to the battery module.

The kit is now installed.

TESTING KIT INSTALLATION

1. Connect an external power supply set to supply 2.8V to the terminals of the new reference battery holder. Place the Battery Check switch in the "REFERENCE" position. Adjust R462 so the meter reads at the lower end of the Battery OK window. Place Battery Check switch to "OFF" and remove the external power supply.
2. Install the two lithium batteries, Item 6, in the battery holder.
3. Connect the positive lead of a DMM to the center terminal of the regulator pcb and the negative lead to the left terminal of the Fine Reference adjust pot. Place Battery Check switch in the "REFERENCE" position and observe the panel meter deflects to the Battery OK window. Place Battery Check switch in the "ON" position, DMM should read 1.3V to 1.4V DC. Place Battery Check switch to the "OFF" position, remove the DMM test leads.
4. With existing screws replace the front panel and the battery module.
5. Place all documentation for this kit in the 540B manual for future reference.

This completes installation test of the kit.

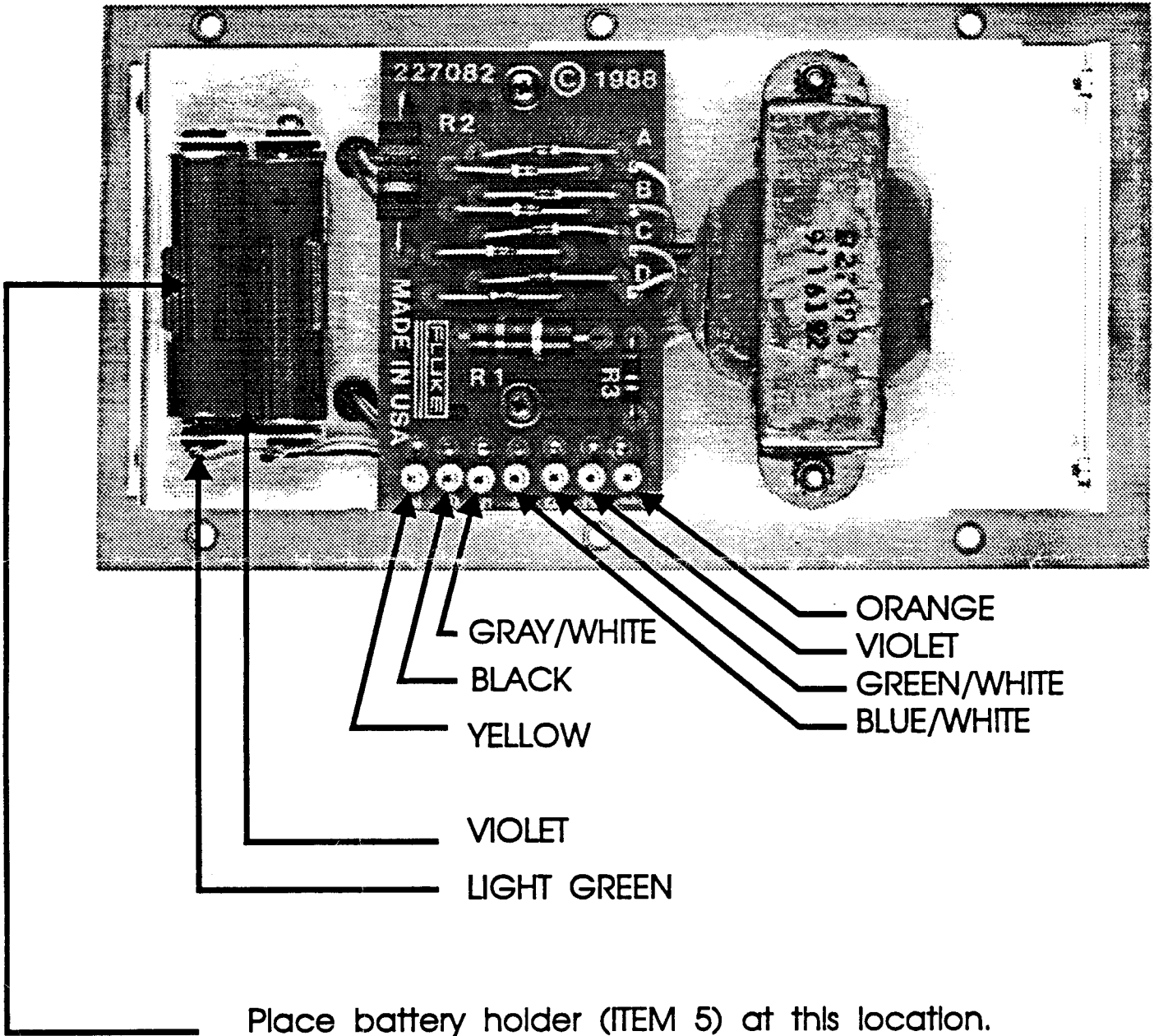

Figure 1

BACK SIDE OF
FRONT PANEL ASSEMBLY

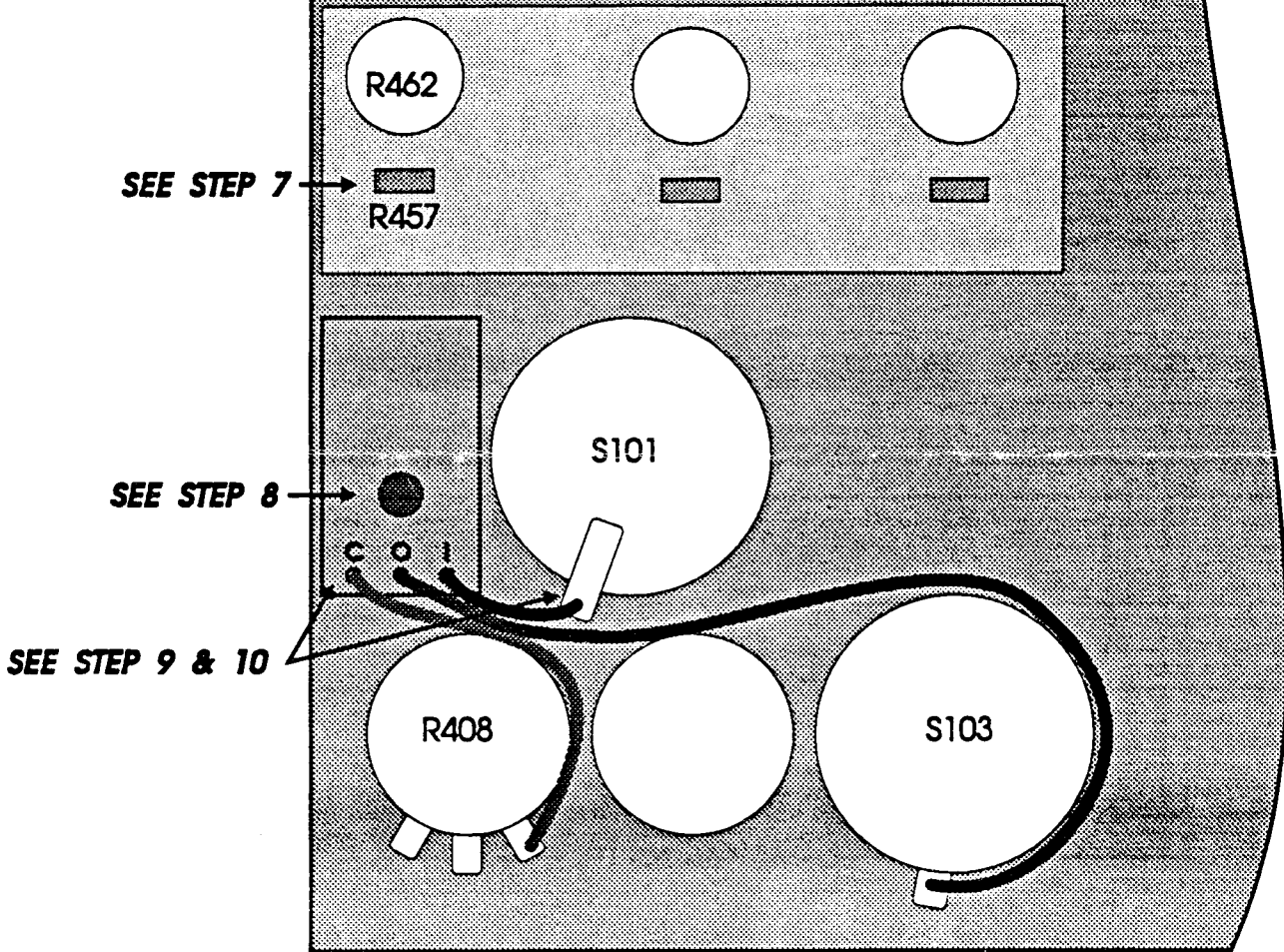

Figure 2

REGULATOR PCB PARTS LIST

LW317T

U1	P/N	460410	VOLTAGE REGULATOR
R1	P/N	441394	RESISTOR, MF, 1.3k Ω
R2	P/N	348771	RESISTOR, MF, 100 Ω
C1	P/N	816843	CAPACITOR, 10 μ F

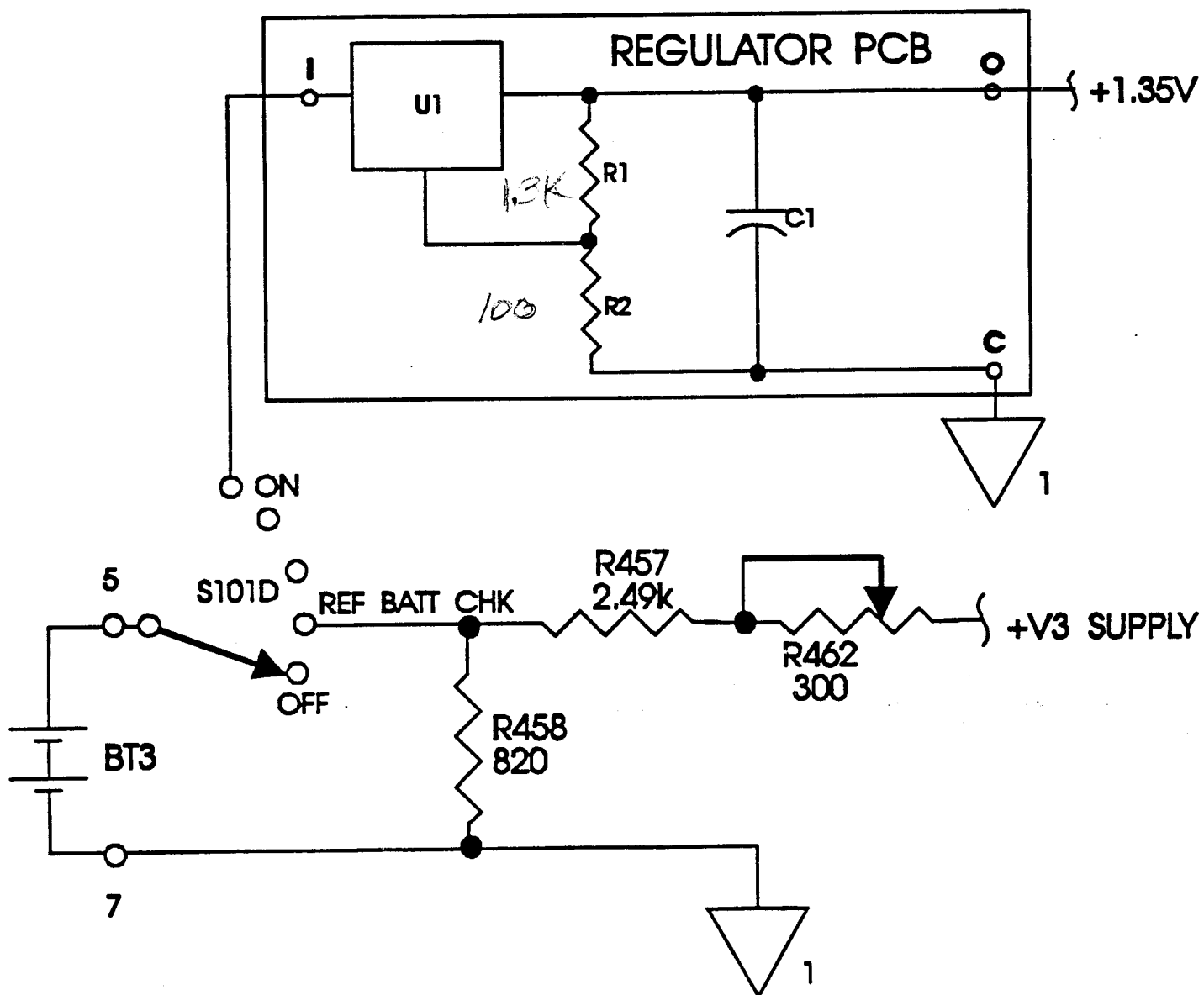

Figure 3