

See discussions, stats, and author profiles for this publication at: <https://www.researchgate.net/publication/321267468>

AN IMPROVED THERMAL VOLTAGE CONVERTER FOR ACCURATE AC VOLTAGE MEASUREMENTS AT NIS, EGYPT

Conference Paper · November 2003

CITATIONS

0

READS

646

1 author:



[Mamdouh Halawa](#)

National Institute of Standards (Egypt)

53 PUBLICATIONS 67 CITATIONS

[SEE PROFILE](#)

Some of the authors of this publication are also working on these related projects:



NIS Capabilities [View project](#)



Assurance Methods [View project](#)

AN IMPROVED THERMAL VOLTAGE CONVERTER FOR ACCURATE AC VOLTAGE MEASUREMENTS AT NIS, EGYPT

Mamdouh M. Halawa

Department of electrical measurements, National Institute for Standards (NIS), Egypt

يقدم البحث دراسة مستفيضة حول طريقة حديثة ومحسنة لقياس الجهد الكهربائي المتردد قياسا بالذقة تصل درجة دقته ومستويات صحته إلى الحدود المطلوبة لمعامل القياس والمعايرة و المنوط بها إجراء القياسات الدقيقة للكميات الكهربائية المختلفة ، فقد تم بناء ناقل حراري مرجعي من خلال دراسة مشتركة مع المعهد القومي للمعايير و التكنولوجيا بالولايات المتحدة الأمريكية حيث يستخدم هذا الناقل الحراري المرجعي في قياس الجهد الكهربائي المتردد في المدى من 300 مللي فولت إلى 1000 فولت تحت ترددات تبدأ من 10 هرتز وحتى 1 ميغا هرتز وذلك عن طريق إرجاعه و إسناده إلى جهد مستمر عياري و مرجعي ، وقد تم تنفيذ مجموعة من الاختبارات لتحديد خصائص هذا المرجع الجديد و مقارنتها بالناقل الحراري المرجعي الحالي و الذي مازال منتشر عبر العديد من معامل القياس المرجعية وهو من طراز Fluke 540B و قد أظهرت هذه المقارنات تميزا واضحا في المميزات والخصائص التي تجعل الناقل الحراري المرجعي الجديد جديرا بأن يحل محل الناقل المرجعي الحالي كمرجع بالذقة في مجال القياس الدقيق للجهد المتردد في مدى الجهود والترددات المذكورة ، و البحث يقدم وصفا تفصيليا لمكونات النظام المحسن و يحدد خصائصه و طريقة ونتائج معايرته أتوماتيكيا بالإضافة إلى مجموعة مقارنات مع النظام القديم لإظهار نقاط تميز النظام الجديد و التي جاءت إيجابية من مختلف الوجوه.

ABSTRACT

This paper describes a new 4-range set of thermal voltage converter (TVC), which was developed to make AC voltage measurements at high accuracy. The improved TVC was completely installed, tested, and calibrated at the National Institute for Standard and Technology (NIST), USA in August 1999. This device was fabricated to measure ac-dc difference, and ac voltages relative to external dc standards from 0.3 V to 1000 V, with a few ppm (parts per million) accuracy at 10 Hz to 1 MHz. A complete set of experiments for comparing the transfer errors and characteristics of the new TVC and the present system (Fluke 540B) of the National Institute for Standards (NIS), Egypt has been developed. An automated calibration system for the two devices are also described.

KEYWORDS

AC-DC Difference; Thermoelement; Thermal Voltage Converter; Accurate AC Voltage Measurement.

1. INTRODUCTION

The AC voltage measurements and the calibration of alternating voltages and currents embrace a wide range of equipment and topics. To meet these demands, much of the equipment and many of the methods in current use were developed in the 1960's [1]. Special instruments have been developed in the Metrology field for the measurement of current and voltage over rather wide ranges.

Therefore, alternating currents and voltages are measured most accurately when they are compared with nominally equal and known DC currents and voltages. The comparisons are usually made with thermal transfer devices, which respond nearly, equally to AC and DC signals. These devices make use of thermal converters (often called thermoelements) like those incorporated in ordinary thermocouple instruments, but differ in the manner of reading and use [2]. They may be used either directly to measure the ac-dc differences of ammeters and voltmeters, or with a suitable potentiometer and accessories to measure alternating currents and voltages.

Now, a new generation of a voltage transfer standard is being introduced. A large number of Fluke 540B Thermal Transfer Standards, TTS, are still in use. Many national institutes such as the National Institute for Standard (NIS) in Egypt, still use the 540B Thermal Transfer Standard in AC calibration and measurements of alternating voltages and currents at level of accuracy about (200 to 2000 parts per million, ppm).

This model of the 540B, **Fig. 1**, is a vacuum thermocouple based AC/DC voltage transfer standard, which incorporates the following in a single instrument:

- Thermocouple
- Resistor network
- Stable power supply
- Null detector
- Range switch

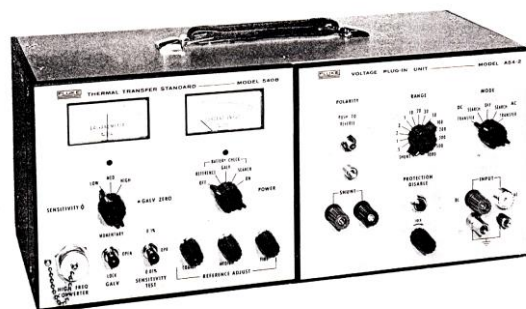

Fig.1 A Photo of Fluke 540B

The 540B operate over the frequency range of a 5 Hz to 1 MHz and a voltage range of 0.25V to 1000V. For higher frequencies up to 50 MHz, model A55 Thermal Voltage Converters are available. The 540B's basic range is its 0.5 V range. In the case of the 540B, 40% of the 0.5V range, or 0.2 volts, is the lowest input specified to be accurately measured. The other ranges have the same consideration. The 540B-ranges follow the sequence 0.5, 1.0, 2.5, 5.0 up to 1000V maximum.

In general, AC and DC voltages are alternately applied. Depending on the category of transfer being made, the 540B's built-in Lindeck potentiometer is adjusted to provide a null on its galvanometer against the thermocouple output produced by either the ac voltage or dc voltage input. The other voltage is adjusted to provide a null without changing the setting of the Lindeck potentiometer. In either case, the value of the ac voltage is taken to be the measured value of the dc voltage. The Lindeck potentiometer is completely shielded. The advantages of this potentiometer are its low thermal emf (less than 1 microvolt) and its freedom from drift (much less than 0.01%/minute under ordinary laboratory conditions) [3].

Due to the long thermal time constant inherent in the thermal element, the dc reference voltage may need to be applied continuously for up to 30 minutes to assure that the element has reached thermal stabilization. Typically, the thermocouple heater has a resistance of 90 ohm. The resistance of thermocouple heater has a temperature coefficient of approximately 0.1%, with a fairly long time constant.

Unfortunately, these types of thermal transfer standards (540B) suffer from several drawbacks that affect their applications in the national and calibration laboratories. Practically, these drawbacks are reflected on the calibration process, which requires high experience of the metrologist. These drawbacks are mainly the following:

- High sensitivity to external temperature.
- Typical transfer time for each measurement is long ≈ 20 Min.
- Difficulty in measuring low level nonlinear output.
- No voltage measurement capability below 250 mV.
- Susceptibility to damage from even moderate overloads.
- Its internal source (Rechargeable Mercury Battery) is not commercially available.
- Low Accuracy (200 - 2000 ppm).
- Pointer error of internal root mean square (rms) indicating galvanometer (about $\pm 1\%$).
- The need to external null detector with Lindeck potentiometers to measure the output dc of its thermocouple.
- Aging may affects the characteristics of internal reference thermocouple.
- Manual operation only; not automated; programmable.
- Low short term stability (due to thermal drift).
- Long stabilizing times for its thermoelement.

This paper describes an improved thermal transfer device, which was developed to make AC voltage measurements at higher accuracies than this stated above.

2. AN IMPROVED THERMAL VOLTAGE CONVERTER

2.1 Design and Construction

The new Thermal Voltage Converter, TVC, (schematic in **Fig. 2**) consists simply of a series resistor and a Thermoement (TE) mounted coaxially in tubular casing, usually a plated brass tube, with input and output connectors. In practice, 7 mV is the typical output voltage of a signal element thermal converter with a full-scale input voltage. The output voltage is proportional to the square of the input voltage.

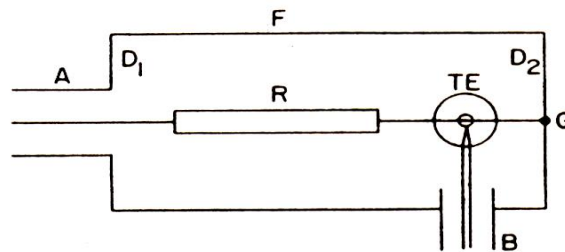

Fig. 2 Schematic of single element thermal transfer converter (TVC)
 TE = Thermoement
 B = Two-pin output connector
 F = Cylindrical brass shield
 A = Coaxial input connector
 D1, D2 = Circular brass disks
 G = Cross wire at center of D2

The new 4-range set of TVCs consists of 3 resistors units and one TE, and extends from 0.3 to 1000V. The TE is rated at 5 mA, and may be attached to any of the resistors by a coaxial connector to make a TVC with the desired voltage range [4]. The output emf of the TE is ordinarily monitored with a null detector and a balance circuit, which may be a Lindeck potentiometer or very accurate digital voltmeter. A balance circuit and a null detector are included in most commercial multirange models [5].

The Thermoement (TE) is mounted in 5.6 cm. brass container (**fig. 3**) with coaxial connectors for attaching to a resistor. The 5 mA-TE has a 124-ohm heater. The TE has a special heater material to reduce thermoelectric effects in the heater. This type of material also has small reverse dc differences, high bead resistance (over 1 G ohm), and small ac-dc differences.

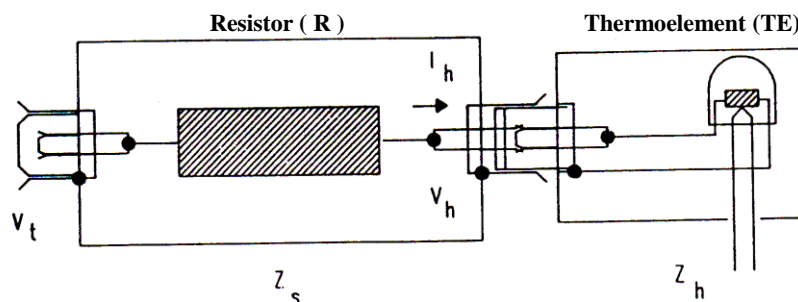

Fig. 3 TE enclosure and low voltage unit with resistor R

Each of resistor elements R in range of (0.6 – 100 V) is a 1/3-Watt metal-film resistor mounted coaxially in a 5 cm. diameter brass cylinder 10.4 cm in long with coaxial connectors at each end. The simple symmetrical geometry of these units permits approximate calculations of their reactances [5]. The calculations are inexact because of the necessary assumptions as to end-effects, and they neglect any small residual reactances of the resistors themselves. They do indicate however, that the frequency error of each resistor unit (without the TE) should be less than few ppm at 50 kHz, even for tubes smaller than 5 cm. in diameter (The 7.5 cm. tube was chosen for the higher ranges where more space is necessary and was therefore used for the middle ranges also). Additional information on the voltage converter is given in **Table 1**.

Table 1
Additional Information for the new Voltage Converter

Rated Voltage, V	Rated Current, MA	Heater Resistance, Ohms	Series Resistor, Kiloohms
0.5	5	124	-
10	5	124	2
100	5	124	20
1000	5	124	200

The low-frequency performance of a TVC depends on the TE it self since the reactance of the resistor is entirely negligible even at a few kilohertz. The accuracy of a TE at low frequency is mainly dependent on the length of the heater. A very short heater permits heat to flow more steadily to the support stems of the TVC. However most commercial TEs have errors less than 10 ppm at 20 Hz and some have errors less than 10 ppm even at 5 Hz [5].

The surfaces of the resistor of the higher voltage ranges are large to avoid excessive temperature rise. A small voltage coefficient was anticipated in these resistors, but measurements have shown to be negligible. In fact, the errors in these ranges are caused mainly by capacitance between the resistor assembly and the outer casing, which permits alternating current to bypass the TE to ground. Therefore more AC than DC voltage is required for a given TE output. Frequency compensation could be provided by placing relatively small capacitors in parallel with part of the resistance. However, such capacitors probably would not be sufficiently stable over a long period of time and might be affected by temperature changes that occur in the resistor enclosure.

Compensation was therefore provided with an inner shield, which is connected to the input and surrounds the high or input end of the resistor (**Fig. 4**). The

shield is positioned, relative to the resistor, to control the capacitance currents and provide optimum high-frequency compensation; perfect compensation is possible only at one frequency.

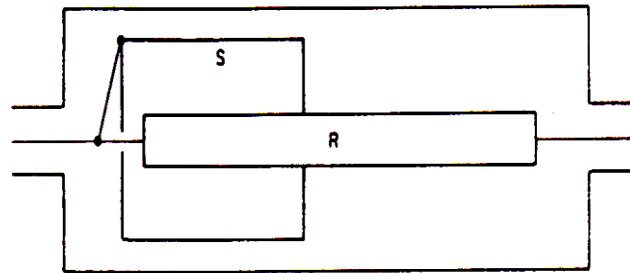

Fig. 4 High voltage unit (200 to 1000 V) with resistor (R) and frequency compensation shield (S)

2.2 High-Voltage TVC (HV-TVC)

High-Voltage thermal converter (HV-TVC) as shown in **Fig. 5** is used as working standards of ac-dc difference up to 1000 V and above 10 kHz. But it is necessary that the ac-dc difference of all ranges be unaffected by voltage level. The voltage effect is rare in low and middle ranges, but it can be troublesome at higher ranges where the heat generated by the resistor is considerable [5]. The highest range then presents a special problem. For this reason, the 1000-V TVC is designed differently. Self-heating of a TVC may affect either the frequency compensation or the resistor itself. Apparently the dielectric losses in the insulation between conductors can be affected by heating and change the impedance of the resistor. This change occurs within a few minutes after a voltage increase or decrease across the resistor.

The high-voltage TVC consists of a Thermoelement (TE) whose heater is in series with an external multiplier resistor module to form the desired voltage range. The resistor module is typically constructed as illustrated in **fig. 5**. The internal shield may be used to compensate the reactance of the structure at frequencies above 10 kHz [6]. The distributed capacitance between the shield and range resistor flattens the frequency response by applying more AC current into the TE than if the shield were absent, reducing the ac-dc difference at higher frequencies.

The frequency-compensating shield may be moved, relative to the resistor, by thermal expansion of mounting parts and cause a change in ac-dc difference. Later shields were therefore mounted very rigidly since a small displacement will have a large effect on the frequency influence. The shield therefore, is in two parts. A brass cylinder, with one end closed, is mounted firmly against the outer end piece (input end) with a polystyrene insulator one-half inch thick (**Fig. 5**). A movable tube fits tightly inside this cylinder and the shield length

adjustment is made by pushing this piece forward with a small rod inserted through the end piece and the insulator. The rod is removed after each adjustment.

The shield is most effective at the leading edge where the voltage difference is greatest between the resistor and the shield. Therefore the movable part of the shield is cut at an angle, so that only part of it extends outside the fixed cylinder. The shield length adjustment is made in small steps, and tests are made after each adjustment. When optimum compensation is achieved, the unit is opened and the shield parts are locked together.

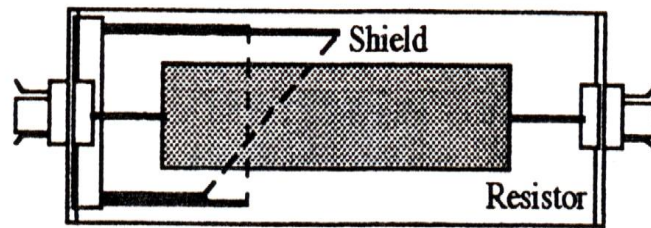

Fig. 5 Cross-section of high voltage TVC

Since the power applied to a HV-TVC at 1000 V is four times that applied at 500 V, the working temperature of the resistor may be much greater for the higher voltage [6]. For this reason, the ac-dc difference may be considerably different at 1000 V than at 500 V. This is a primary cause of voltage coefficients (percentage change in ac-dc difference for a voltage change of 1 volt with constant frequency) of ac-dc difference in compensated HV-TVC and of variations in ac-dc difference with respect to warm-up time and aging.

Another possible source of a voltage coefficient is the variation of the value of the resistor with temperature for different applied voltage [6]. If an internal shield is used to compensate the ac-dc difference to nearly zero, however, the voltage coefficient will also be compensated to nearly zero. So, the effect on ac-dc difference from thermal expansion of the resistor and surrounding structure will tend to be negligible, providing that all of the elements comprising the structure are rigid [6].

The ac-dc differences (transfer error) at 500 V and 1000 V were measured under various forms of conditioning, including the effect of internal shield and the effect of warming up times, and the results are given in **Table 2**. According to the experimental results in **Table 2**, an internal shield in the resistor module can not only improve the frequency dependence of an HV-TVC, but can also reduce the voltage coefficients of the HV-TVC because the ac voltage across some of the strayed capacitances are smaller. To check the effects of heating, the HV-

TVC was tested against a reference standard TVC at NIST according to various conditions as listed in the **Table 2**.

The results in **Table 2** show that for good-quality HV-TVC, the adjustable internal shield (the adjustment was performed 8 times) is very important for the high voltage measurements at frequencies above 10 kHz. In addition, the ac-dc difference at high frequencies may be greatly improved by thermally conditioning the resistors and adding the internal shield at the high-voltage end of the resistor module, which reduces the capacitive effect. Long warm up period may also improve the ac-dc differences of HV-TVC at frequencies from 10 kHz to 100 kHz. It is recommended to be one hour or more.

Table 2
Effect of various forms of conditioning on the ac-dc differences of HV-TVC at high frequencies for 500V and 1000V.

Various forms Of Conditioning	500 V				1000 V			
	AC-DC Differences, (ppm)				AC-DC Differences, (ppm)			
	10 kHz	20 kHz	50 kHz	100 kHz	10 kHz	20 kHz	50 kHz	100 kHz
Without internal shielding	162	610	3503	13295	148	607	3647	14011
With internal shielding (Before adjustment)	- 74	- 32	300	1560	- 107	- 312	-1584	- 5634
With internal shielding (After adjustment)	-72	-113	-102	345	- 96	- 166	- 241	66
After 5 minutes warming-up (Without shielding)	-	-	-	-	-	-	-	14215
After 45 minutes warming-up (Without shielding)	-	-	-	-	-	-	-	14069
After 1.5 hours warming-up (without shielding)	-	-	-	-	-	-	-	14011
After 5 minutes warming-up (With shielding)	- 74	-	-	- 3935	-	-	-	- 5748
After 1 hour warming-up (With shielding)	- 52	-	-	3850	-	-	-	- 5651

3. CHARACTERISTICS OF THE NEW TVC

Few tests were performed involving a variety of experiments to determine the parameters and characteristics of the new TVC and to compare its facilities against the present type of Fluke 540B.

3.1 Temperature Coefficient

The temperature coefficient of most TEs (percentage change in the output for a temperature change of 1 °C) is relatively a considerable source of AC-DC Difference. Elements should therefore be mounted in a thermally lagged enclosure to minimize the effect of ambient temperature changes. In practice, the output of a TE can be very stable at a fixed temperature if the heater is carrying a constant current for several hours [4]. However, if the device is switched back and forth between AC and DC after a brief warm up, as it is in most measurements, the output will usually drift. This drift may be negligible during the short time required for a measurement, especially at low voltage [4]. In contrast, on many ranges where there is some self-heating effect, the drift rate tends to be quite constant but significant. For this reason, accurate measurement of AC and current must be performed by special procedure, which consists in taking every measurement in the sequence AC, +DC, -DC, AC, at equal time intervals.

The temperature coefficient of the TE of 540B and the new TVC were determined practically at rated applied current (5 mA). The two TEs were immersed inside controlled thermal oil container. The output emf of them was measured accurately at two different values of temperature. The collected results in **Table 3** give the temperature coefficients of the new TVC and 540B. These values of temperature coefficients mean that the ambient temperature of the laboratory should be fixed or under control. Consequently, for accurate and consistent AC measurements, it is recommended that the ambient temperature be kept at 23 ± 0.1 °C.

Table 3
Results of the temperature coefficients

Ambient Temperature (°C)	Output emf of 540B (mV)	Output emf of new TVC (mV)
23	3.29003	3.84087
29	3.2710	3.825
Temperature Coefficient (% / °C)	For 540B	For new TVC
	0.096%/ °C	0.069%/ °C

3.2 Short and Long Time Stability of new TVC

Although long-time stability is not required for these converters, fluctuations and drifts in emf for the short time between the applied ac and dc must be less than the desired accuracy [3]. Such changes can arise from self-heating effects and ambient temperature changes and also from thermal emfs and other changes in the circuit elements. Since the measurements of ac-dc difference can be made within 3 minutes for the new TVC (or within about 15 Min. for the 540B), tests

have shown that the error due to short time stability of 540B is about 30 ppm, while this error of new TVC is only about 7 ppm. This self-heating error is not significant in ac-dc transfer tests if a reasonable warm-up period is allowed. So, it is recommended to allow about 1-hour warming-up before the use of both thermal transfer devices. Above all, this error is almost eliminated by the special sequence used for ac-dc transfer tests (AC, DC+, DC-, AC).

By similar manner, the error in ppm due to long time stability was evaluated for the two thermal transfer devices. The output of both devices were measured each 10 minutes for a period of 3 hours after 1 hour warming-up. The error due to this long time was about 3200 ppm for 540B while it was only about 2350 ppm for new TVC. The results of errors due to short and long time stability are given in **Table 4**.

Table 4
Errors due to short and long-time stability of 540B and new TVC

540B		TVC	
Error due to short time stability (ppm)	Error due to long time stability (ppm)	Error due to short time stability (ppm)	Error due to long time stability (ppm)
30	3200	7	2350

3.3 Electromagnetic Interference Immunity

The frequency response of thermoelements extends up to 100 MHz or more. Therefore measurements, which are made by them, can be affected by local electromagnetic fields [7] which are induced in the laboratory by its general purpose equipment such as PCs, fans, motors, florescent light, etc. Interference from television stations can also be troublesome with low-current TEs, because the length of leads used in calibration laboratories often makes them an effective antenna. In general, the sources of Electromagnetic Interference (EMI) or Radio Frequency Interference (RFI) include:

- Radio and TV broadcast transmitters.
- Communications transmitters, including cellular phones and handheld radios.
- Devices incorporating microprocessors and high-speed digital circuits.
- Impulse sources as in the case of arcing in high-voltage environments.

The instrument, measurement leads, and other cables should be kept as far away as possible from any EMI sources. Additional shielding of the test fixture, signal

leads, sources, and measuring instruments will often reduce EMI to an acceptable level. In extreme cases, a specially constructed screen room may be required to sufficiently attenuate these interference signals. To insure accurate measurement, the two thermal transfer devices were tested through a workday to assure that they are exposed to nearly the same interference level.

Practically, the energy picked up by a measurement circuit can usually be detected by shorting the TVC input terminals with all connections in place as in normal use, but with the power supplies off [4]. Any change, (ΔE), in the indication of a detector in the TVC output circuit (referred to rated emf) as the short is opened and closed will indicate a pick up problem and EMI error. The results of this test were collected in **Table 5** and graphed in **Fig. 6**.

Table 5
Results of interference effect on 540B and new TVC

Time	Fluke 540B		New TVC	
	Change in o/p emf, ΔE (μV)	Error due to EMI (ppm)	Change in o/p emf, ΔE (μV)	Error due to EMI (ppm)
11.00 AM	0.03	4.7	0.027	2.5
12.00 AM	0.03	4.7	0.043	3.9
1.00 PM	0.15	21	0.09	8
2.00 PM	0.11	15	0.06	5.3
3.00 PM	0.17	15.7	0.08	7

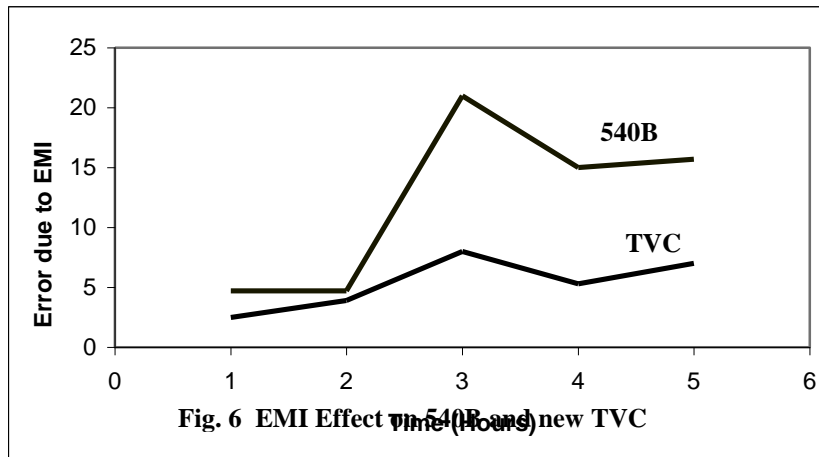

Fig. 6 shows that the level of interference of new TVC is slightly lower than that of the 540B. Therefore, the new TVC can be used in the usual calibration environment for high sensitivity AC/DC transfer. So, the need of elaborate and expensive EMI/RFI suppression and complicated shielding procedures are not necessary.

3.4 Aging Effect

The new TVC was tested two times to explain the effect of aging on its output emf. First time was in September 1999 at the National Institute for Standards and Technology (NIST), USA. The second time was in September 2001 at the National Institute for Standards (NIS), Egypt. The instruments (DC Sources and Digital voltmeters), which was used in the measurements, were nearly having the same accuracy. The difference between its accuracies is very small so that it can be neglected. The laboratory environments and conditions were also nearly similar. The output emfs of the two devices were tested at a range from 50% to 100% of the rated voltage. **Table 6** and **Fig. 7** show comparison of the two results, which performed at Sept. 1999 and Sept. 2001.

Table 6
Results of aging effect on output emf of the new TVC

Applied Voltage (V)	Output emf of new TVC (mV)		
	At Sept. 1999	At Sept. 2001	Difference (μ V)
0.3	2.924	2.973848	49.84837
0.35	3.906	3.964434	58.43432
0.4	4.994	5.05189	57.89037
0.45	6.171	6.219971	48.97149
0.5	7.423	7.467351	44.3506
0.55	8.736	8.783424	47.42394
0.6	10.097	10.18387	86.8651

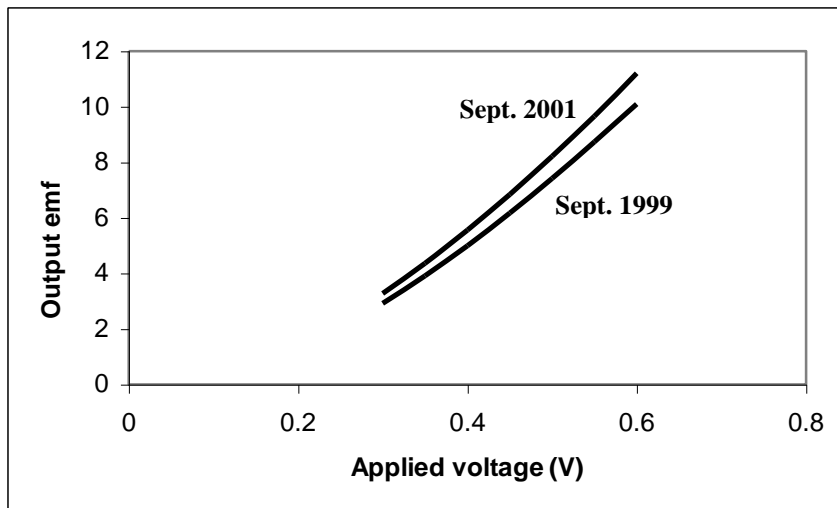

Fig. 7 Comparison of output emf of the new TVC after two years

Referring to **Fig.7**, the new TVC has a significant deviation due to the aging effect. After two years it tends to deviate from its nominal output emf by a deviation ranging from 50 to 87 microvolts. Therefore, this type of TVC should be recalibrating, at least every two years to determine its new ac-dc differences.

4. AUTOMATED CALIBRATION OF NEW TVC

The new TVC was completely tested and calibrated using the automated system shown in **Fig. 8**. This system is established at the National Institute for Standard and Technology (NIST), USA. The results of calibration were determined by the author during his scientific visit to the NIST in September 1999.

4.1 AC-DC Difference Measurement

Thermoelements, as well as the new TVC, usually have a significant ac-dc difference, δ , at high frequencies. It is defined as [4]:

$$\delta = \frac{V_a - V_d}{V_d} \quad (1)$$

Where V_a and V_d are the ac voltage and the average of the two directions of the dc voltage required for equal response, or output emf. The ac-dc difference, δ , in TVC is nearly all due to reactance in the range resistors, and other connections in the ac-dc circuit [4]. Series inductance will impede the ac current, so that more ac than dc voltage is required for equal TE current and thermocouple output. As a result of this phenomena, a certain difference between ac and dc responses, δ , is existing.

The low-range thermoelements used in TVCs (2.5 to 10 mA) rarely add significantly to the ac-dc difference of the transfer devices. In contrast, δ in higher-range vacuum TEs is larger due to skin effect in the current conductors leading to the heater [4]. Practically, all low-frequency range (below 60Hz) ac-dc differences in thermoelectric transfer devices are due to the Thermoelement itself. At most frequencies the heater temperature, and therefore the TE output, are essentially constant. However, at low frequencies the heater is cooled slightly between peaks of ac current by conduction through the heater supports and the thermocouple wires [4]. This effect is greater in high-current TEs and may be detected up to about 60 Hz on some ampere-range TEs. However, in 2.5 to 10 mA TEs used in TVCs the effect usually occurs below 5 or 10 Hz. It also decreases sharply as the heater current is reduced on all current ranges [4].

AC-DC Difference corrections to the new TVC (device under test), δ_t , are determined relative to a similar standard whose corrections, δ_s , are known and determined accurately at the National Institute for Standard and Technology (NIST), USA. These similar TVC are a set of working standards of the coaxial single-range type. Two types (JRL-TNB102 and HOLT-20) were used to calibrate the new TVC using established automated system. This automated calibration was performed over a frequency range from 10 Hz to 1 MHz, covering the voltage range from 0.3V to 1000V.

4.2 Automated Calibration System

The automated ac-dc difference calibration system is shown in block diagram form in **Fig. 8**. The system contains programmable ac and dc voltage sources, a high-voltage relay for switching between ac and dc, digital voltmeters and frequency counters, and a desktop computer to provide IEEE-488 bus control.

The measurement procedure is as follow: The metrologist provides ranges of voltages, frequencies, and record-keeping information to the controller interactively. The ac and dc supplies are then programmed to the appropriate values. AC and DC voltages are then applied to both TVC's in the test sequence (ac, dc+, dc-, ac), and the output of standard TVC and under test TVC are measured by the digital voltmeters. Using **eq. (1)**, the correction of the test TVC, δ_t , was computed against the standard TVC, δ_s .

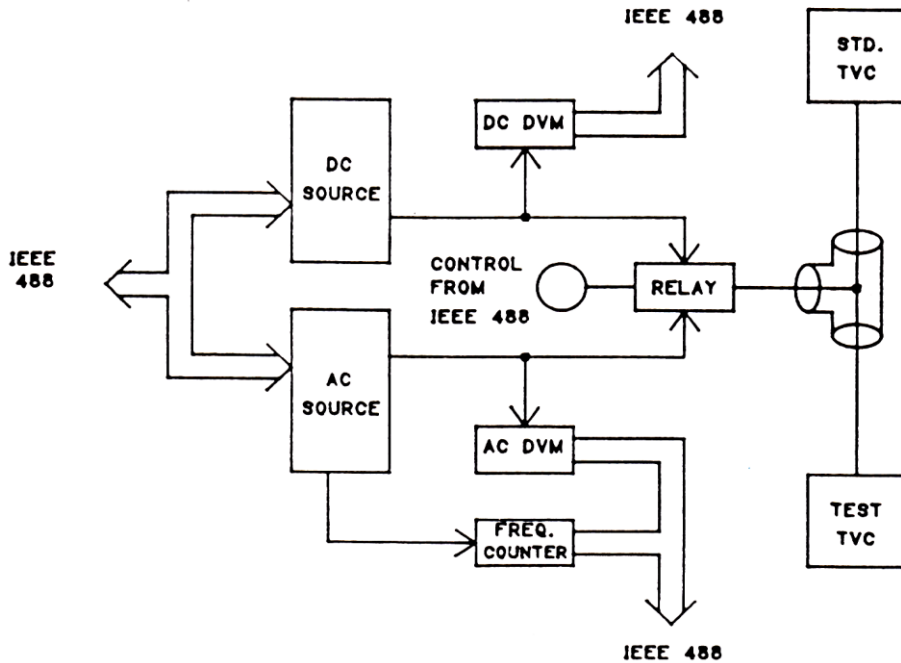

Fig. 8 Block diagram of automated ac-dc difference calibration system

4.3 Results

Final results of the new TVC calibration to determine the correction factors in its ac-dc difference were computed and printed along with other test parameters. This calibration covers the ranges of voltages from 0.3V to 1000V over frequencies from 10 Hz to 1 MHz as shown in **Fig. 9**. **Table 7** contains a model of these results (10V at low and high frequencies ranges).

Table 7
A Model of Calibration Results of New TVC

i) At low frequency ranges

		AC-DC Difference (ppm)					
Range (V)	Applied (V)	10 Hz	20 Hz	50 Hz	100 Hz	400 Hz	1000 Hz
10	10	- 5.2	- 4.1	- 5.4	- 4.1	- 2.9	- 1.9

ii) At high frequency ranges

		AC- DC Difference (ppm)							
Range (V)	Applied (V)	10 kHz	20 kHz	50 kHz	100 kHz	300 kHz	500 kHz	700 kHz	1 MHz
10	10	- 1.1	- 1.6	1.8	6.5	8.3	4.3	13.8	16.9

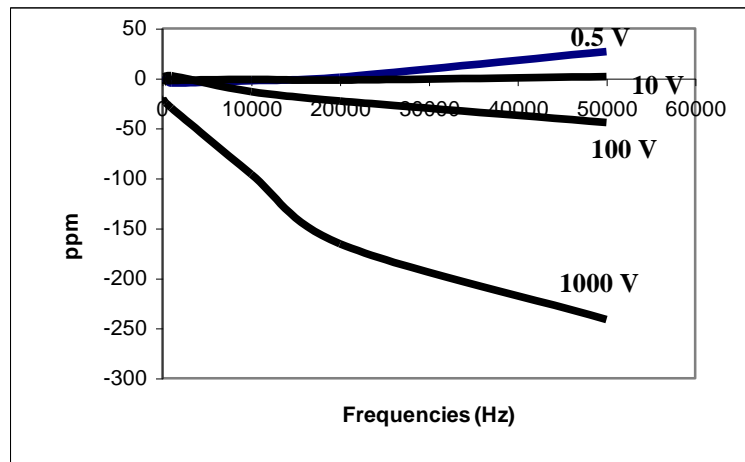

Fig. 9 Calibration results of the new TVC

In the same manner, a Fluke 540B was also tested and calibrated at NIST with same conditions using same automated calibration system, covering voltage ranges from 1V to 100 V over frequencies from 10 Hz to 1 MHz as shown in **Fig. 10**. **Table 8** contains also a model of these results (20V at low and high frequencies ranges).

Table 8
A model calibration result of Fluke 540B

i) At low frequency ranges

		AC-DC Difference (ppm)				
Range (V)	Applied (V)	10 Hz	20 Hz	50 Hz	400 Hz	1000 Hz
20	20	- 85.3	- 42.3	- 29.5	- 16.9	-12.5

ii) At high frequency ranges

		AC- DC Difference (ppm)					
Range	Applied	20 kHz	50 kHz	100 kHz	300 kHz	500 kHz	700 kHz
20	20	- 10.5	0.2	34.4	173.3	373.4	721.8

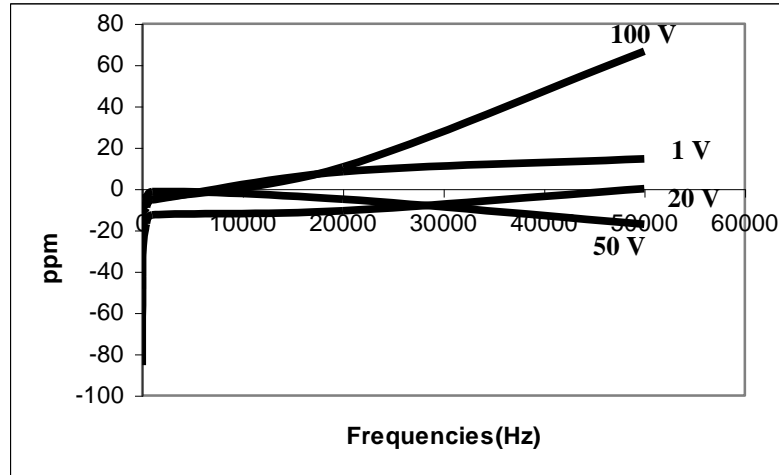

Fig. 10: Calibration results of 540B

Fig. 11 compares, for example, between the ac-dc differences of 540B and the new TVC at range of 100V. It is clear that the ac-dc difference of 540B is larger than ac-dc difference of new TVC with about 2 to 20 times. This important note means that the response of new TVC for the ac and dc signals is nearly equal or better than the response of 540B. This point is the major advantage of the new TVC.

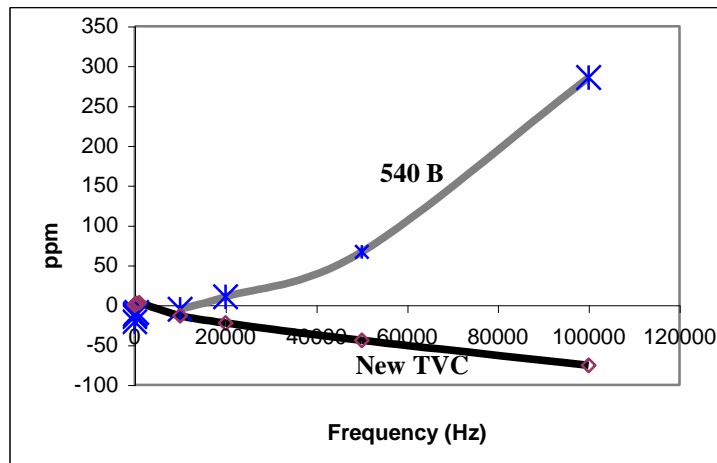

Fig. 11 Comparison of ac-dc difference between 540B and new TVC

5. CONCLUSIONS

The AC-DC Thermal Transfer Standard such as Fluke 540B is an instrument which precisely measures the RMS value of ac voltage (or current when equipped with shunt) by employing a thermocouple to compare the heating effect of a known dc voltage to the unknown ac voltage. As shown in this thesis, these models suffer from several drawbacks that affect their applications in the national and calibration laboratories such as high sensitive to external temperature, longer time to stability, low accuracy, thermal drift,etc.

To improve these drawbacks, a new 4-range set of Thermal Voltage Converter (TVC) has been fabricated in the National Institute for Standard and Technology (NIST), USA to measure AC voltage from 300mV to 1000V at 10kHz to 1MHz. The accuracy and stability of the new TVC set have been verified through few experimental tests. In general, the average Transfer error, δ , of this set is between 10 ppm to 400 ppm depending on the levels of voltage and frequency.

For voltage above 200 V, the transfer error at high frequency may be greatly improved by thermally conditioning the resistors and adding the internal shield at the high-voltage end of the resistor module, which reduces the capacitive effect. After 8 times of the shielding adjustment, the transfer error of the 1000 V range is only 66 ppm.

It was found that the average transfer error of the 100 V new TVC is less than 10 ppm at below 1 kHz and less than 90 ppm up to 100 kHz. While for the 1000 V, this transfer error is less than 30 ppm at below 1 kHz and less than 350 ppm up to 100 kHz. As a result, an average improved by about 85% has been achieved in the transfer error. According to these improvements, these new TVC's now serve as the primary AC-DC transfer standards for AC voltage measurements at National Institute for Standard (NIS, Egypt).

ACKNOWLEDGEMENT

The author wishes to acknowledge the greatest helps of Mr. Joseph R. Kinard of National Institute for Standards and Technology (NIST), USA who not only suggested the main idea of this paper but also guided me during the experimental part. My honest acknowledgment also to T.E. Lipe, C. B. Childers, and Andrew Kofman of NIST for their helps in fabricating and calibrating the improved device.

REFERENCES

1. Fluke Corporation, Legal Department, Everett, WA 98206-9090" Calibration: Philosophy in Practice", Second Edition, April 1992.
2. F. L. Hermach, "Thermal converters as ac-dc transfer standards for current and voltage measurements at audio frequencies," J. Res. Nat. Bur. Stand., vol. 48, Feb. 1952.
3. Hermach, F. L. and Williams, E. S. "Thermal Voltage Converters for accurate voltage measurements to 30 megacycles per second," Trans. AIEE (Communication and Electronics), 79, Pt. I, 200-206, (July 1960).
4. Earl S. Williams "The Practical Uses of AC-DC Transfer Instruments", NBS TECHNICAL NOTE 1166, October 1982.
5. E.S. Williams, "Thermal voltage converters and comparators for very accurate ac voltage measurements," J. Res. Nat. Bur. Stand., vol. 75C, nos. 3 and 4, July-Dec. 1971.
6. D. X. Huang, Thomas E. Lipe, Joseph R. Kinard, and Clifton B. Childers, "AC-DC Difference Characteristics of High-Voltage Thermal Converters," IEEE Transactions on Instrumentation and Measurement, vol. 44, No. 2, April 1995.
7. Earl S. Williams and Joseph R. Kinard, "A Dual-Channel Automated Comparator for AC-DC Difference Measurements," IEEE Transaction on Instrumentation and Measurement, Vol. IM-34 NO. 2, June 1985.