

FLUKE- 6060B

NOTE

This manual documents the Model 6060B and its assemblies at the revision levels identified in Section 7A. If your instrument contains assemblies with different revision letters, it will be necessary for you to either update or backdate this manual. Refer to the supplemental change/errata sheet for newer assemblies, or to the backdating information in Section 7A for older assemblies.

6060B

SYNTHESIZED RF SIGNAL GENERATOR

Instruction Manual

P/N 792697

February 1986

©1986, John Fluke Mfg. Co., Inc. All Rights Reserved. Litho in U.S.A.



Table of Contents

SECTION	TITLE	PAGE
1	INTRODUCTION AND SPECIFICATIONS	1-1
1-1.	INTRODUCTION	1-1
1-2.	UNPACKING THE GENERATOR	1-1
1-3.	SAFETY	1-1
1-4.	OPERATOR INFORMATION CARD	1-2
1-5.	GENERATOR DESCRIPTION	1-2
1-6.	Controller Functions	1-2
1-10.	Frequency	1-3
1-11.	Reference	1-3
1-12.	Amplitude	1-3
1-13.	Modulation	1-3
1-14.	OPTIONS AND ACCESSORIES	1-4
1-15.	RECOMMENDED TEST EQUIPMENT	1-4
1-16.	MNEMONICS	1-4
1-17.	SIGNAL GENERATOR SPECIFICATIONS	1-4
2	INSTALLATION AND OPERATION	2-1
2-1.	INTRODUCTION	2-1
2-2.	INITIAL INSPECTION	2-1
2-3.	SETTING UP THE GENERATOR	2-1
2-4.	Line Power Requirements	2-1
2-5.	Line Voltage and Fuse Selection	2-1
2-6.	IEEE-488 Address	2-2
2-7.	RACK OR BENCH MOUNTING THE GENERATOR	2-2
2-8.	GENERAL OPERATING INFORMATION	2-3
2-9.	Familiarization	2-3
2-10.	Local Versus Remote Operation	2-3
2-11.	Power-On Sequence	2-3
2-12.	Changing Output Parameters	2-3
2-13.	Function Entry	2-9
2-14.	Bright-Digit Edit Operation	2-11
2-15.	Step Operation	2-11
2-16.	Status and Clear Entries	2-12
2-17.	RF Output On/Off	2-12
2-18.	Modulation On/Off and Rate	2-12
2-19.	Memory	2-12
2-20.	Special Function	2-13

TABLE OF CONTENTS, *continued*

SECTION	TITLE	PAGE
2-21.	OPERATING REFERENCE MATERIAL	2-13
2-22.	Amplitude and Frequency Entry	2-13
2-23.	Amplitude Fixed Range	2-16
2-24.	Amplitude Units Conversion	2-17
2-25.	Bright-Digit Edit Entry	2-17
2-26.	Memory Entry	2-19
2-27.	Modulation Entry	2-20
2-28.	Relative Function	2-22
2-29.	RF Output On/Off Entry	2-23
2-30.	Special Function Entry	2-24
2-31.	Status and Clear Entry	2-24
2-32.	Step Entry	2-26
2-33.	REMOTE OPERATION (IEEE-488 INTERFACE)	2-27
2-34.	Setting Up The IEEE-488 Interface	2-28
2-35.	Programming Commands	2-29
2-36.	Programming Examples	2-29
2-40.	Interface Functions	2-38
2-41.	Address Mode	2-38
2-46.	Talk-Only Mode	2-41
2-47.	Listen-Only Mode	2-42
2-48.	Command Syntax	2-42
2-52.	Command Descriptions	2-44
2-60.	Command Processing	2-60
2-63.	Timing Data	2-61
2-69.	Power-on Conditions	2-63
3	THEORY OF OPERATION	3-1
3-1.	INTRODUCTION	3-1
3-2.	GENERAL DESCRIPTION	3-1
3-3.	Front Section	3-1
3-4.	Module Section	3-1
3-5.	Rear Section	3-1
3-6.	FUNCTIONAL DESCRIPTION	3-2
3-7.	Level	3-2
3-8.	Amplitude Modulation	3-2
3-9.	Frequency	3-3
3-10.	Frequency Modulation	3-3
3-11.	SOFTWARE OPERATION	3-3
3-12.	User Interface	3-4
3-13.	Amplitude Control	3-4
3-14.	Attenuators	3-4
3-15.	Level DAC	3-4
3-16.	Temperature Compensation	3-5
3-17.	Reverse Power Protector	3-5
3-18.	Frequency Reference Control	3-5
3-19.	Frequency Control	3-5
3-20.	Modulation On/Off	3-5
3-21.	Modulation Frequency	3-5
3-22.	Amplitude Modulation	3-6
3-23.	Frequency Modulation	3-6
3-24.	FM Deviation	3-6
3-25.	Self Test	3-6
3-26.	Service Special Functions	3-7

SECTION	TITLE	PAGE
3-27.	Status Signals	3-7
3-28.	DETAILED CIRCUIT DESCRIPTIONS	3-8
3-29.	FRONT SECTION, A1	3-8
3-30.	Display PCA, A1A1	3-9
3-37.	Switch PCB, A1A2	3-9
3-38.	MODULE SECTION, A2	3-10
3-39.	Synthesizer PCA, A2A1	3-10
3-50.	VCO PCA, A2A2	3-18
3-51.	Output PCA, A2A4	3-19
3-57.	Attenuator PCA, A2A5	3-22
3-58.	Controller PCA, A2A7	3-23
3-67.	REAR SECTION, A3	3-25
3-68.	Power Supply PCA, A3A1	3-25
3-69.	Sub-Harmonic Reference (Part of A2A1)	3-26
3-70.	NON VOLATILE MEMORY A2A8	3-26
3-71.	Power Circuit	3-26
3-72.	Memory Control	3-26
4	MAINTENANCE	4-1
4-1.	INTRODUCTION	4-1
4-2.	SERVICE METHODS	4-1
4-3.	Fluke Service	4-1
4-4.	Module Replacement	4-1
4-5.	Parts Replacement	4-1
4A	PERFORMANCE TESTS	4A-1
4A-1.	INTRODUCTION	4A-1
4A-2.	TEST EQUIPMENT	4A-1
4A-3.	POWER-ON TEST	4A-3
4A-4.	SYNTHESIS TEST	4A-3
4A-5.	HIGH-LEVEL ACCURACY TEST	4A-4
4A-6.	MID-LEVEL ACCURACY TEST	4A-6
4A-7.	LOW-LEVEL ACCURACY TEST	4A-7
4A-8.	ALTERNATE-LEVEL ACCURACY TEST	4A-8
4A-9.	OUTPUT LEAKAGE TEST	4A-9
4A-10.	ALTERNATE OUTPUT LEAKAGE TEST	4A-10
4A-11.	HARMONIC AND SPURIOUS TEST	4A-11
4A-12.	MODULATION TESTS	4A-12
4A-13.	SWR TESTS	4A-17
4B	ACCESS PROCEDURES	4B-1
4B-1.	INTRODUCTION	4B-1
4B-2.	LOCATION OF MAJOR ASSEMBLIES	4B-1
4B-3.	ACCESS INSTRUCTIONS	4B-1
4B-4.	Removing the Front Section Assembly, A1	4B-1
4B-5.	Removing the Rear Section Assembly, A3	4B-2
4B-6.	Removing the Synthesizer Board, A2A1	4B-2
4B-7.	Removing the Output Board, A2A4	4B-2
4B-8.	Removing the Attenuator/RPP A2A5 Assembly	4B-2
4B-9.	Removing the VCO Board, A2A1	4B-2

TABLE OF CONTENTS, *continued*

SECTION	TITLE	PAGE
4C	CALIBRATION ADJUSTMENTS	4C-1
4C-1.	INTRODUCTION	4C-1
4C-2.	SAFETY	4C-1
4C-3.	POWER SUPPLY, A3A1, ADJUSTMENT	4C-1
4C-4.	DISPLAY ASSEMBLY, A1A1, ADJUSTMENT PROCEDURE	4C-2
4C-5.	OUTPUT ASSEMBLY, A2A4, ADJUSTMENT	4C-4
4C-6.	SYNTHESIZER ASSEMBLY, A2A1 ADJUSTMENT	4C-10
4D	TROUBLESHOOTING AND REPAIR	4D-1
4D-1.	INTRODUCTION	4D-1
4D-2.	MODULE REPLACEMENT	4D-1
4D-3.	Power Supply PCA, A3A1	4D-2
4D-5.	Synthesizer PCA, A2A1	4D-2
4D-6.	VCO PCA, A2A2	4D-3
4D-7.	Output PCA, A2A4	4D-3
4D-8.	Controller PCA, A2A7	4D-3
4D-9.	Display PCA, A1A1	4D-3
4D-10.	Attenuator/RPP PCA A2A5	4D-3
4D-11.	IEEE-488 PCA, A3A3	4D-3
4D-12.	Non-Volatile Memory PCA, A2A8	4D-3
4D-13.	PARTS REPLACEMENT	4D-3
4D-14.	TROUBLESHOOTING	4D-4
4D-15.	Service Special Functions	4D-4
4D-16.	UNCAL Conditions	4D-5
4D-17.	Self Test Description	4D-5
4D-22.	Check Output Signal	4D-8
4D-23.	Auxiliary Power Supply, PCA, A3A2	4D-8
4D-24.	Check Power Supply Voltages	4D-9
4D-25.	DIGITAL AND CONTROL TROUBLESHOOTING	4D-10
4D-26.	Control Activity	4D-10
4D-27.	Latch Control	4D-10
4D-28.	Microprocessor Kernel	4D-10
4D-29.	Power Reset	4D-11
4D-30.	Microprocessor Inputs	4D-11
4D-31.	IEEE-488 Interrupt	4D-11
4D-32.	Microprocessor Bus	4D-11
4D-33.	Address Decoder	4D-11
4D-34.	Display and Controls	4D-11
4D-35.	SYNTHESIZER TROUBLESHOOTING	4D-13
4D-36.	Reference Circuitry Check	4D-13
4D-37.	Main Phase Lock Loop	4D-13
4D-38.	Sub-Synthesizer and HET (800 MHz), 40-MHz Loop	4D-16
4D-39.	FM Circuitry	4D-16
4D-40.	LEVEL TROUBLESHOOTING	4D-17
4D-41.	Output Assembly Test Point Signal Information	4D-17
4D-42.	ATTENUATOR LEVEL CONTROL	4D-17
4D-43.	Attenuator Check	4D-17
4D-44.	Unleveled Condition	4D-19
4D-45.	AM TROUBLESHOOTING	4D-20
4D-46.	Internal/External AM	4D-20
4D-47.	ALC Loop Control Voltage	4D-21
4D-48.	Detector Linearity	4D-21
4D-49.	RPP Control	4D-21

TABLE OF CONTENTS, *continued*

SECTION	TITLE	PAGE
5	LIST OF REPLACEABLE PARTS	5-1
	TABLE OF CONTENTS	5-1
5-1.	INTRODUCTION	5-2
5-2.	Parts List Information	5-2
5-3.	HOW TO OBTAIN PARTS	5-2
5-4.	Recommended Spare Parts Kit	5-3
6	OPTIONS	6-1
	TABLE OF CONTENTS	6-1
7	GENERAL INFORMATION	7-1
7-1.	FEDERAL SUPPLY CODES FOR MANUFACTURERS	7-2
7-2.	U.S. SALES AREAS FOR ALL FLUKE PRODUCTS	7-3
7-3.	INTERNATIONAL SALES OFFICES	7-5
7-4.	TECHNICAL SERVICE CENTERS	7-6
7A	MANUAL CHANGE INFORMATION	7A-1
8	SCHEMATIC DIAGRAMS	8-1
	TABLE OF CONTENTS	8-1

List of Tables

TABLE	TITLE	PAGE
1-1.	Signal Generator Specifications	1-5
2-1.	Front Panel Controls, Indicators, and Connectors	2-5
2-2.	Rear Panel Controls, Connectors, and Switches	2-10
2-3.	Instrument Preset State	2-11
2-4.	Special Functions	2-14
2-5.	UNCAL Error Codes	2-25
2-6.	REJect ENTRY Codes	2-25
2-7.	Index of IEEE-488 Commands	2-29
2-8.	IEEE-488 Commands	2-30
2-9.	IEEE-488 Interface Functions List	2-38
2-10.	IEEE-488 Address Mode Message Descriptions	2-39
2-11.	Suffix Types	2-45
2-12.	Learn Character to Hexadecimal Conversion	2-53
2-13.	Interface Mode Commands	2-54
2-14.	Self-Test Error Codes	2-56
2-15.	Input/Output Monitor Commands	2-58
2-16.	Read/Write Monitor Commands	2-59
2-17.	Hardware Control Monitor Commands	2-59
2-18.	SRQ Mask and Status Values	2-60
2-19.	Command-Parsing Time	2-62
2-20.	Typical Programming Time of the Generator Functions	2-62
2-21.	IEEE-488 Power-On State	2-63
3-1.	Power Supply Rectifier Configurations	3-25
4A-1.	Recommended Test Equipment	4A-2
4A-2.	Modulation Tests Requirements	4A-12
4A-3.	AM Test Conditions	4A-15
4A-4.	AM Depth Range	4A-15
4D-1.	Module Exchange Assemblies	4D-2
4D-2.	Self Test Display Field	4D-5
4D-3.	AAA Field AM and FM Tests	4D-6
4D-4.	BBB Field Test Results	4D-7
4D-5.	CCC Field Test Results	4D-7
4D-6.	DDD Field Test Results	4D-7
4D-7.	Band, Filter, and Frequency Programming Data	4D-8
4D-8.	Power Supply Characteristics	4D-9
4D-9.	Address Codes for the Front Panel Keys	4D-12
4D-10.	Synthesizer PCA Test Points	4D-14
4D-11.	Frequency Reference Control	4D-15
4D-12.	FM Ranges	4D-17

LIST OF TABLES, *continued*

TABLE	TITLE	PAGE
4D-13.	FM DAC Control	4D-17
4D-14.	Output PCA Test Points	4D-18
4D-15.	Attenuator Level Control	4D-19
4D-16.	Attenuator Levels	4D-19
4D-17.	Modulation On/Off Control	4D-20
4D-18.	Modulation Frequency Control	4D-20

List of Illustrations

FIGURE	TITLE	PAGE
Frontispiece	6060B Signal Generator	x
2-1.	Fuse/Filter/Line Voltage Selection Assembly	2-2
2-2.	6060B Outside Dimensions	2-4
2-3.	Front Panel Controls, Indicators, and Connectors	2-5
2-4.	Rear Panel Controls, Connectors, and Switches	2-10
2-5.	6060B Signal Generator Connected to a 1722A	2-28
2-6.	6060B IEEE-488 Bus Connected to a 6060B IEEE-488 Bus	2-42
2-7.	Learn String Example	2-47
3-1.	Triple-Modulus Prescaler Operation	3-12
3-2.	N-Divider Operation	3-13
3-3.	N-Divider Timing Diagram	3-15
4A-1.	Two-Turn Loop	4A-1
4A-2.	High-Level Accuracy Test Conditions	4A-5
4A-3.	High-Level Accuracy Test Conditions	4A-7
4C-1.	Power Supply Test Points	4C-3
4C-2.	Module Plate, Bottom View	4C-5
4C-3.	Module Plate, Top View	4C-12

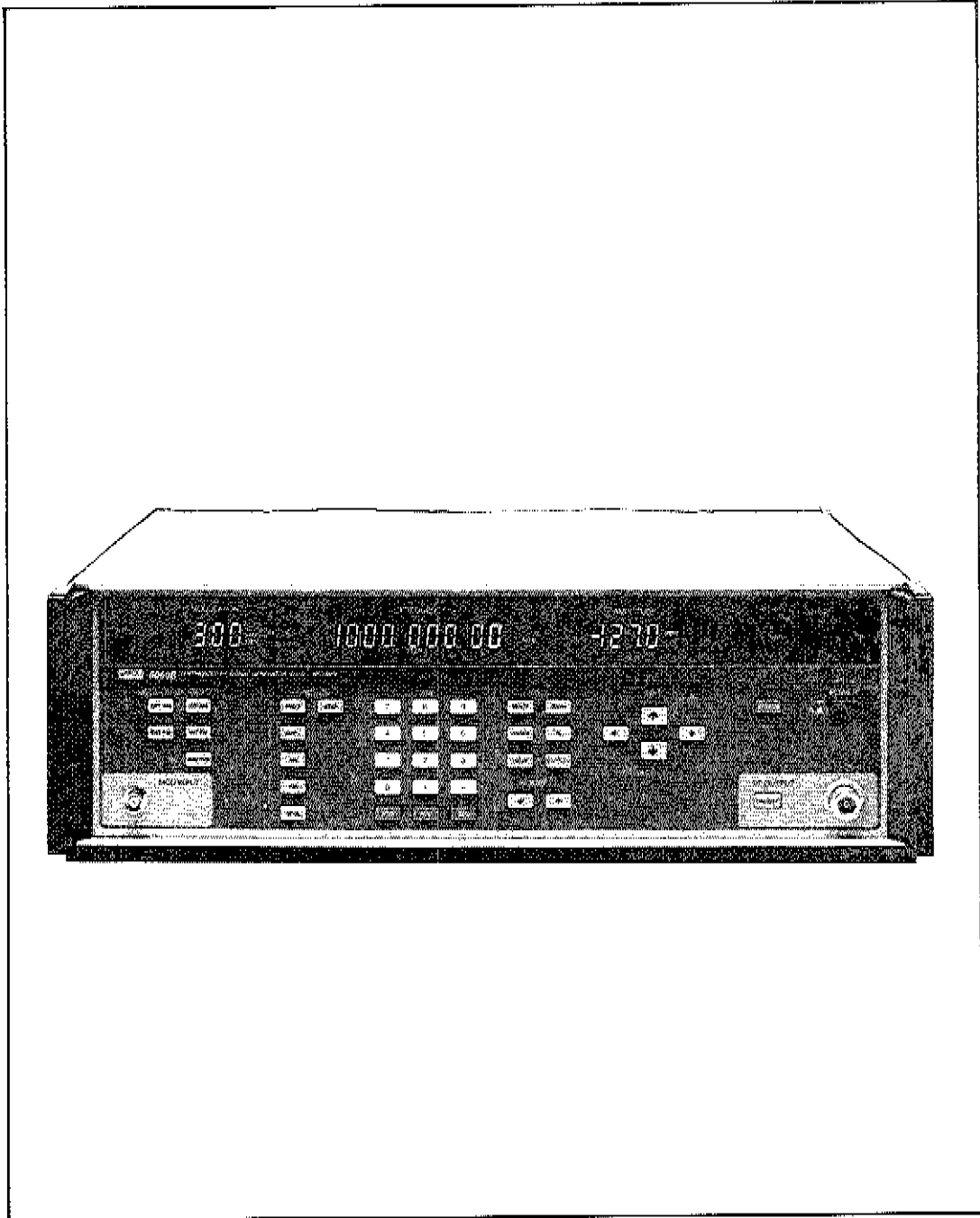

6060B Synthesized Signal Generator

Section 1

Introduction and Specifications

1-1. INTRODUCTION

The 6060B Synthesized Signal Generator (referred to as the Generator or instrument) is a fully-programmable, precision, synthesized signal generator. The Generator is designed for applications that require good modulation, frequency accuracy, and output level performance with moderate spectral purity. It is well suited for testing a wide variety of RF components and systems including filters, amplifiers, mixers, and radios, particularly on-channel radio testing.

1-2. UNPACKING THE GENERATOR

This shipping container should include a 6060B Signal Generator, an Operator Information Card, a Getting Started Manual, an Instruction Manual, and a line power cord. Any accessories ordered for the Generator are shipped in a separate container.

Section 2, Installation and Operation, gives instructions on inspecting your new Generator, and what to do if the instrument arrives with shipping damage. Reshipment information is also included.

1-3. SAFETY

This instruction manual contains information, warnings, and cautions that should be followed to ensure safe operation and to maintain the Generator in a safe condition.

The Generator is designed primarily for indoor use, and it may be operated in temperatures from 0°C to and 50°C without degradation of its safety.

WARNING

TO AVOID ELECTRIC SHOCK, USE A POWER CORD THAT HAS A THREE-PRONG PLUG. IF YOU DO NOT USE A PROPER POWER CORD, THE 6060B CASE CAN DEVELOP AN ELECTRICAL POTENTIAL ABOVE EARTH GROUND.

CAUTION

To avoid damage to the 6060B, check that the rear panel line voltage selection card and fuse are correct for the line voltage in your area. The correct line voltage and fuse combinations are:

LINE VOLTAGE	FUSE
100/120V ac, $\pm 10\%$, 47 Hz to 63 Hz	1.5 AMP
220/240V ac, $\pm 10\%$, 47 Hz to 63 Hz	.75 AMP

INTRODUCTION AND SPECIFICATIONS

1-4. OPERATOR INFORMATION CARD

The Operator Information Card has an adhesive backing so it may be affixed to the top of the Generator in bench applications or to the operator console in remote applications. A copy of the card is located at the end of Section 8 of this manual as a convenient reference or for duplication.

1-5. GENERATOR DESCRIPTION

Fundamental features of the Generator are as follows:

0.01-MHz to 1050-MHz frequency range in 10-Hz steps

+13-dB to -127-dBm level range in 0.1-dB steps

AM and FM, internal or external

Internal 400-Hz and 1000-Hz modulation oscillator

Relative frequency and amplitude

Volts/dBm conversion

Store/recall memory

Master/slave for frequency, amplitude, and modulation step (IEEE-488 Interface controlled.)

Fluorescent display

5 1/4-inches high, rack mountable

1-6. Controller Functions

The Controller microprocessor controls all operator interface functions, performs background operations such as status checks, and updates (strokes) the front panel displays. Whether you are using local control with the front panel, or remote control with the IEEE-488 Interface option, the microprocessor provides self test and diagnostic capability. Economical instrument performance is achieved by using software compensation EPROMs and accuracy-enhancement circuitry.

1-7. LOCAL CONTROL

The value of the basic output parameters of the Generator, i.e., amplitude, frequency, or modulation can be controlled in three ways:

Direct numeric entry

Incrementing or decrementing the bright digit

Step-up or step-down entry where the step size can be operator programmed

Other controls provide selection of the POWER ON/OFF, RF OUTPUT ON/OFF, MODULATION ON/OFF, internal/external frequency reference, and STATUS.

1-8. DISPLAY FIELD

The programmed values of modulation, frequency, and amplitude are displayed in the three display fields.

1-9. REMOTE-CONTROL PROGRAMMING

The Option -488 IEEE-488 Interface allows the Generator to be remotely controlled with any IEEE-488 bus controller. The instrument can also be used on the IEEE-488 bus without a controller in a listen-only or talk-only mode by selecting the appropriate Generator rear panel IEEE-488 switch settings.

All instrument controls can be remotely controlled except the POWER ON/OFF and the rear panel REF INT/EXT switches. The Option -488 IEEE-488 Interface provides additional commands not available with local control, such as data transfer and individual control of internal I/O control bits.

The Option -488 IEEE-488 Interface allows two Generators to track amplitude, frequency, or modulation in a master/slave configuration when using the front panel step-up and step-down entries on one of the instruments. For instance, frequency tracking is convenient for tests involving mixers, and amplitude tracking is useful for two-tone intermodulation testing.

1-10. Frequency

The specified frequency range is 0.01 to 1050 MHz. The frequency is synthesized from a 10-MHz reference and provides an output resolution of 10 Hz over the entire frequency range. The relative frequency mode allows the frequency to be programmed in relation to a center frequency or an offset frequency. This is convenient for testing filters and mixers. The output frequency stability and accuracy depends on the reference, whether that reference is internal or external.

1-11. Reference

The internal frequency reference is a 10-MHz ambient crystal oscillator. If Option -130 High Stability Reference or the option -132 Medium Stability Reference is installed, that oscillator is locked to the internal crystal oscillator. With the rear panel REF INT/EXT switch set to INT, the Generator output frequency is synthesized from the internal 10-MHz crystal oscillator reference, and the internal oscillator (timebase) signal is available at the 10 MHz OUT connector.

The Generator can be operated from an external 10-MHz timebase by setting the rear panel REF INT/EXT switch to EXT and applying a timebase signal to the REF IN connector.

With the REF INT/EXT switch set to EXT, the Generator can be operated from an external 1-, 2-, 2.5-, 5-, or 10-MHz, 0.3V to 4V peak-to-peak sine or square-wave reference applied to the REF IN connector. In either position of the INT/EXT switch, the selected reference is available as a 10-MHz signal at the rear panel 10 MHz OUT connector.

1-12. Amplitude

The Generator has a specified signal level range from +13 to -127 dBm with programming limits of +19 and -147.4 dBm. This corresponds to specified terminated voltages of 1V to 0.1 μ V and limits of 2V to 0.01 μ V, respectively. The maximum usable signal level is approximately +15 dBm. The level entry can be in dBm or volts, or it can be converted from one to the other. In addition, the relative amplitude mode allows you to account for cascaded gain or loss, or to display the level (in dB) relative to 1 μ V or 1 mV.

1-13. Modulation

Both internal and external amplitude modulation and frequency modulation capability is available. The internal modulation oscillator is selectable between 400 Hz and 1000 Hz.

INTRODUCTION AND SPECIFICATIONS

AM depths of 0% to 99% are available in 1% steps. FM deviation ranges of 1 kHz, 10 kHz, and 100 kHz are available in steps of 1 Hz, 10 Hz, and 100 Hz, respectively.

1-14. OPTIONS AND ACCESSORIES

The following options are available for the Generator:

- Option -130 High-Stability (Ovened) Reference
- Option -132 Medium-Stability Reference
- Option -488 IEEE Interface
- Option -651 Low-Rate FM (External only)
- Option -830 Rear RF OUT and MOD IN Connectors

Section 6 provides more detailed information on the options.

The following accessories are included with each Generator:

The following accessories are available for the Generator:

DESCRIPTION	ACCESSORY NO.
Rack Mount Kit. Includes M05-205-600 (5 1/4-inch Rack Mount Ears) and M00-280-610 (24-inch Rack Slides)	Y6001
IEEE-488 Shielded Cable, 1 meter	Y8021
IEEE-488 Shielded Cable, 2 meters	Y8022
IEEE-488 Shielded Cable, 4 meters	Y8023
Coaxial Cable, 50 ohms, 3 feet, BNC (m) both ends	Y9111
Coaxial Cable, 50 ohms, 6 feet, BNC (m) both ends	Y9112

1-15. RECOMMENDED TEST EQUIPMENT

The test equipment recommended for the performance tests, calibration adjustments, and troubleshooting are listed in Table 4A-1. This equipment is assumed to be calibrated to the manufacturer's specifications. If the recommended test equipment is not available, equivalent test equipment can be substituted.

1-16. MNEMONICS

The mnemonics used on the schematics, block diagrams, wiring diagrams, truth tables, and in the text, are listed in Figure 8-1.

1-17. SIGNAL GENERATOR SPECIFICATIONS

Unless otherwise noted, the following performance is guaranteed over the specified environmental and ac power line conditions 20 minutes after turn-on. Table 1-1 lists the Generator specifications.

Table 1-1. Signal Generator Specifications

Warranted performance, 20 minutes after turn-on within operating temperature range.

FREQUENCY (8 1/2-Digit Display)

- RANGE 0.01 MHz to 1050.0 MHz in 3 bands:
0.01 MHz to 244.99999 MHz,
245 MHz to 511.99999 MHz,
512 MHz to 1050 MHz.
- RESOLUTION 10 Hz.
- ACCURACY Same as reference (See REFERENCE).
- REFERENCE (Internal) The unit operates on an internal free-air 10-MHz crystal oscillator, aging $\leq \pm 0.5$ ppm/month and $\leq \pm 5$ ppm for 25°C , $\pm 25^{\circ}\text{C}$. Internal reference signal (10 MHz) available at rear connector, level > 0 dBm, terminated in 50 ohms.
- REFERENCE (External) Accepts 1, 2, 2.5, 5, or 10-MHz signal. Level of 0.3V to 4.0V p-p into 50 ohm termination.

AMPLITUDE (3 1/2-Digit Display)

- RANGE (Indicated) +13 (+13 peak on AM) to -127 dBm; (Autoranging 6-dB step attenuator).
- RESOLUTION 0.1 dB ($< 1\%$ or 1 nV in volts).
- ACCURACY ± 1.0 dB ($20^{\circ}\text{C} \pm 5^{\circ}\text{C}$) at and above 0.4 MHz; below 0.4 MHz ± 2 dB at or above -100 dBm and ± 3 dB below -100 dBm.
- SOURCE SWR < 1.5 below 1 dBm and at or above 0.4 MHz; < 2.0 elsewhere.

SPECTRAL PURITY (CW ONLY)

- SPURIOUS < -60 dBc for offsets greater than 10 kHz. Fixed frequency spurs are < -60 dBc or < -140 dBm whichever is larger. < -55 dBc for frequencies < 100 kHz.

NOTE

"dBc" refers to decibels relative to the carrier frequency, or in this case, relative to the signal level.

- HARMONICS < -30 dBc from 0.1 MHz to 1050 MHz.
 < -26 dBc from 0.01 MHz to 0.1 MHz.

INTRODUCTION AND SPECIFICATIONS

Table 1-1. Signal Generator Specifications (cont)

RESIDUAL FM (rms in 0.3-kHz to 3-kHz Band)	<10 Hz for 245 MHz to 512 MHz; <20 Hz elsewhere (20°C ±5°C).
RESIDUAL FM (rms in 0.05-kHz to 15-kHz Band)	<22 Hz for 245 MHz to 512 MHz; <44 Hz elsewhere (20°C ±5°C).
RESIDUAL AM (in 0.05-kHz to 15-kHz Band)	<-60 dBc.
AMPLITUDE MODULATION (2-Digit Display)	
DEPTH RANGE	0% to 99%.
RESOLUTION	1%.
ACCURACY	±(2% + 4% of setting) for internal rates, for depths 90% or less and peak amplitude of +13 dBm or less.
DISTORTION	<1.5% total harmonic distortion (THD) to 30% AM, <3% to 70% AM, <5% to 90% AM at internal rates, except for frequency >950 MHz and carrier power >+8 dBm, where specified performance is <3% THD to 70% AM, <5% THD to 90% AM.
BANDWIDTH (3 dB)	20 Hz to 30 kHz.
INCIDENTAL FM	<0.3f _m for internal rates and 30% AM.
FREQUENCY MODULATION (3-Digit Display)	
DEVIATION RANGES	100 Hz to 999 Hz, 1 kHz to 9.99 kHz, and 10 kHz to 99.9 kHz.
MAXIMUM DEVIATION	Lesser of 99.9 kHz and 2f _o above 245 MHz, or 2f _o (f _o +800) below 245 MHz, where f _o is in MHz; (f _o -100)/3 kHz, below 0.4 MHz (f _o in kHz).
RESOLUTION	3 digits.
ACCURACY	±7% for rates of 0.3 kHz to 20 kHz (0.3 to 1 kHz for f _o <0.4 MHz) and >100-Hz deviation.
DISTORTION	<1% THD for rates of 0.3 kHz to 20 kHz (0.3 to 1 kHz for f _o <0.4 MHz) and >100-Hz deviation.
BANDWIDTH (3dB)	0.02 kHz to 100 kHz; unspecified for f _o <0.4 MHz.
INCIDENTAL AM	<1% AM at 1-kHz rate, for the maximum deviation or 50 kHz, whichever is less.

Table 1-1. Signal Generator Specifications (cont)

MODULATION SOURCE			
INTERNAL	0.4 kHz or 1 kHz, $\pm 3\%$ for 20°C to 30°C; add $\pm 0.1\%/^{\circ}\text{C}$ outside this range.		
EXTERNAL	$\pm 5\text{V}$ max.; 1V peak provides indicated modulation index. Nominal input impedance is 600 ohms.		
MODES	Any combination of internal AM, internal FM, external AM, and external FM. Modulation may also be disabled. The nominal input impedance with both external AM and external FM enabled is 560 ohms.		
GENERAL			
TEMPERATURE			
Operating	0°C to 50°C (32°F to 122°F).		
Non-Operating	-40°C to 75°C (-40°F to 167°F).		
HUMIDITY RANGE			
Operating	95% to 30°C, 75% to 40°C, 45% to 50°C.		
ALTITUDE			
Operating	Up to 10,000 ft.		
VIBRATION			
Non-Operating	5 Hz to 15 Hz at 0.06 inch, 15 Hz to 25 Hz at 0.04 inch, and 25 Hz to 55 Hz at 0.02 inch, double amplitude (DA).		
SHOCK			
Non-Operating	Bench handling per MIL T 28800C Class 5, Style E.		
ELECTROMAGNETIC COMPATIBILITY			
COMPATIBILITY	The radiated emissions induce $< 3\ \mu\text{V}$ ($< 1\ \mu\text{V}$ of the Generator's output signal) into a 1-inch diameter, 2-turn loop, 1-inch from any surface as measured into a 50-ohm receiver.		
Also complies with the following standards:			
CE03 of MIL-STD-461B (Power and interconnecting leads), 0.015 MHz to 50 MHz.			
RE02 of MIL-STD-461B (14 kHz to 10 GHz).			
FCC Part 15 (j), class A.			
CISPR 11.			
SIZE	Width	Height	Depth
	43 cm	13.3 cm	50.8 cm
	17 in	5.25 in	20 in

INTRODUCTION AND SPECIFICATIONS

Table 1-1. Signal Generator Specifications (cont)

POWER	100, 120, 220, 240V ac $\pm 10\%$, 47 to 63 Hz, <180 VA (<15 VA, with Option -130 installed, and the Generator turned off (standby)).
WEIGHT	<15.7 kg (35 lbs).
NON-VOLATILE MEMORY	
	50 instrument states are retained for 2 years (typically), even without ac line power applied.
REVERSE POWER PROTECTION	
PROTECTION LEVEL	Up to 50 watts from a 50-ohm source, 0.01 MHz to 1050 MHz. Withstands up to 50V dc. Protection is not provided when the Generator is off.
6060B OPTION -130 HIGH STABILITY REFERENCE	
AGING RATE	< $\pm 5 \times 10^{-10}$ /day, after 21 days continuous operation.
TEMPERATURE STABILITY	< $\pm 2 \times 10^{-10}$ / $^{\circ}\text{C}$ (oven remains powered in standby).
6060B OPTION -132 MEDIUM STABILITY REFERENCE	
AGING RATE	< $\pm 1 \times 10^{-7}$ /month after 5 days continuous operation.
TEMPERATURE STABILITY	< $\pm 1 \times 10^{-7}$ / $^{\circ}\text{C}$ (0 to 50 $^{\circ}\text{C}$) (no powered standby).
6060B OPTION -488 IEEE-488 INTERFACE (IEEE Std 488-1978)	
INTERFACE FUNCTIONS	SH1, AH1, T5, TE0, L3, LE0, SR1, RL1, PPO, DC1, DT1, CO, and E1.
6060B OPTION -651 LOW RATE EXTERNAL FM	
MAXIMUM DEVIATION	9.99 kHz.
DROOP	<15% on a 10-Hz square wave.
BANDWIDTH (3dB)	0.5 Hz to 100 kHz (typical).
MAX DC INPUT	± 10 mV.
INCIDENTAL AM	<1% AM at 1-kHz rate and deviation <10 kHz.
SUPPLEMENTAL CHARACTERISTICS	
	The following characteristics are provided to assist in the application of the Generator and to describe the typical performance that can be expected.
FREQUENCY SWITCHING SPEED	<100 ms to be within 100 Hz.

Table 1-1. Signal Generator Specifications (cont)

AMPLITUDE SWITCHING SPEED	<100 ms to be within 0.1 dB.
AMPLITUDE RANGE	Programmable to +19 dBm and -147.4 dBm, usable to +15 dBm. Fixed-range, selected by special function, allows for more than 12 dB of vernier without switching the attenuator.
NOISE (at 20-kHz offset)	<-113 dBc/Hz (except <-107 dBc/Hz below 245 MHz and above 512 MHz).
RESIDUAL FM (rms in 0.3 to 3 kHz)	Approximately a linear function of output frequency between the following typical band-edge values: 15 Hz at 0.1 MHz to 17 Hz at 244.99999 MHz. 6 Hz at 245 MHz to 8 Hz at 511.99999 MHz. 12 Hz at 512 MHz to 17 Hz at 1050 MHz.
EXTERNAL MODULATION	Annunciators indicate when a 1V peak signal is applied, $\pm 2\%$, over a 0.02-kHz to 100-kHz band.
IEEE	All controls except the power switch and the internal/external reference switch are remotely programmable via IEEE-488 Interface (Std 488-1978). All status including the option complement are available remotely. The Store/Recall memory data may be transferred via an external controller. In talk-only, the appropriate commands are generated when the front panel step-up and step-down entries are made to control another 6060B, a 6060A, a 6070A, or a 6071A. (The 6070A and 6071A only have FREQUENCY STEP.)
FREQUENCY DRIFT	<1 ppm/hr after 1-hour warmup at constant ambient temperature using internal free-air crystal.



static awareness



A Message From
John Fluke Mfg. Co., Inc.

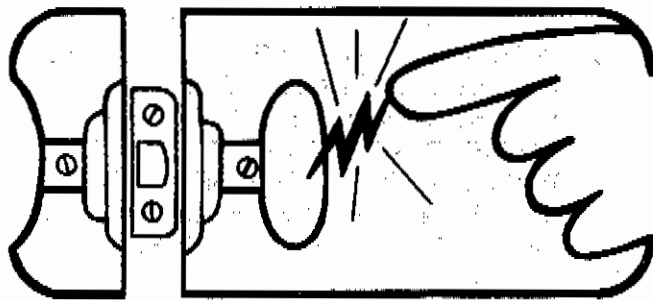

Some semiconductors and custom IC's can be damaged by electrostatic discharge during handling. This notice explains how you can minimize the chances of destroying such devices by:

1. Knowing that there is a problem.
2. Learning the guidelines for handling them.
3. Using the procedures, and packaging and bench techniques that are recommended.

The Static Sensitive (S.S.) devices are identified in the Fluke technical manual parts list with the symbol



The following practices should be followed to minimize damage to S.S. devices.

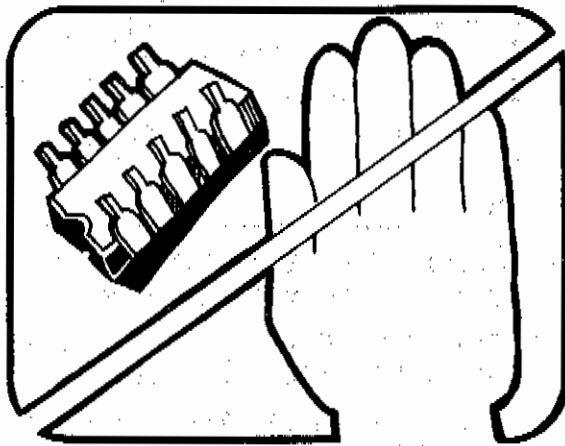

1. MINIMIZE HANDLING

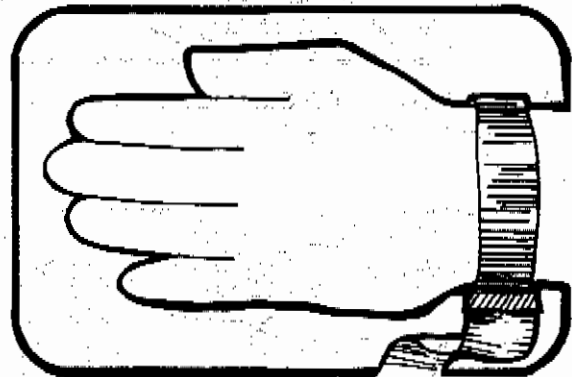

3. DISCHARGE PERSONAL STATIC BEFORE HANDLING DEVICES. USE A HIGH RESISTANCE GROUNDING WRIST STRAP.

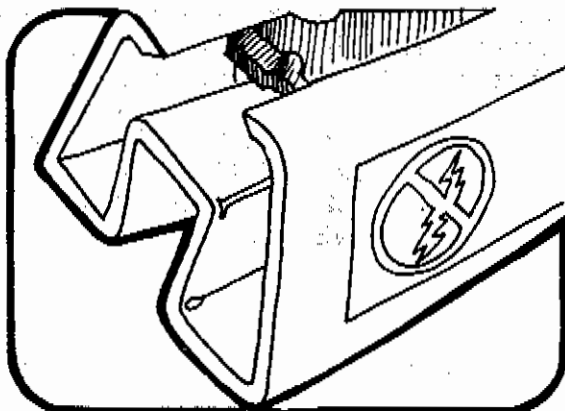

2. KEEP PARTS IN ORIGINAL CONTAINERS UNTIL READY FOR USE.

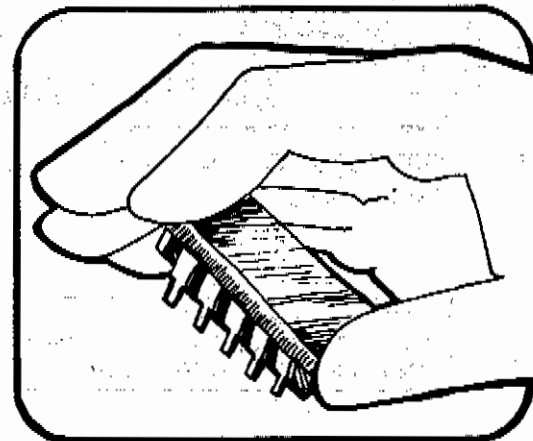

4. HANDLE S.S. DEVICES BY THE BODY

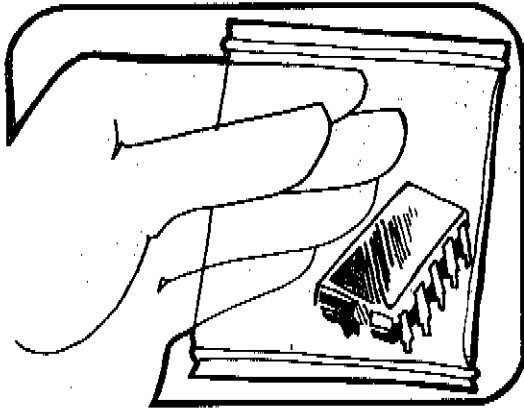

5. USE STATIC SHIELDING CONTAINERS FOR HANDLING AND TRANSPORT

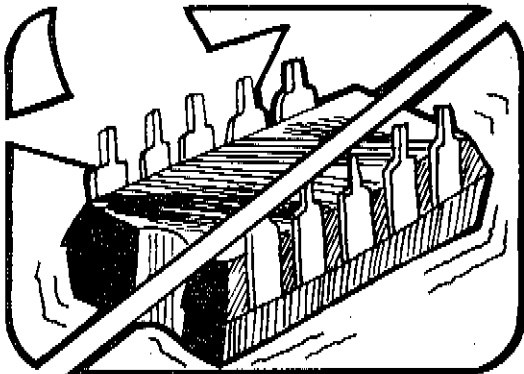

6. DO NOT SLIDE S.S. DEVICES OVER ANY SURFACE

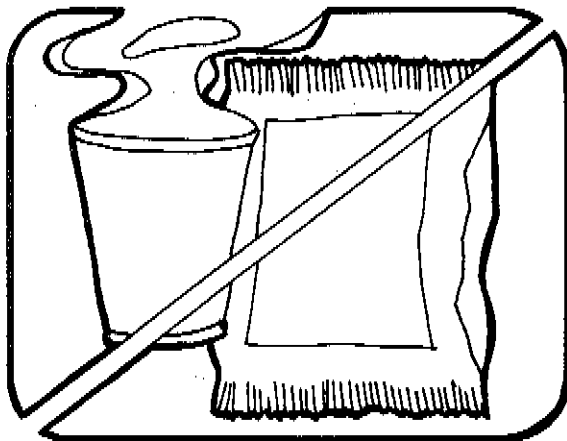

7. AVOID PLASTIC, VINYL AND STYROFOAM® IN WORK AREA

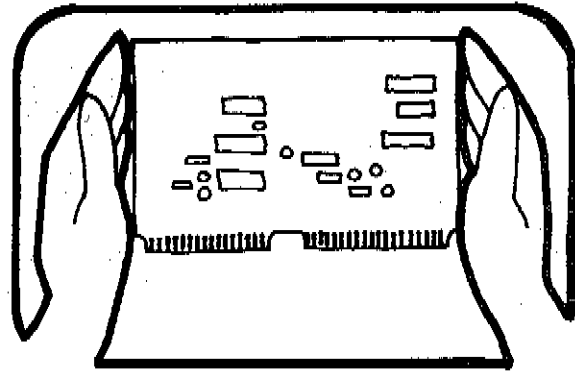

8. WHEN REMOVING PLUG-IN ASSEMBLIES, HANDLE ONLY BY NON-CONDUCTIVE EDGES AND NEVER TOUCH OPEN EDGE CONNECTOR EXCEPT AT STATIC-FREE WORK STATION. PLACING SHORTING STRIPS ON EDGE CONNECTOR HELPS TO PROTECT INSTALLED SS DEVICES.

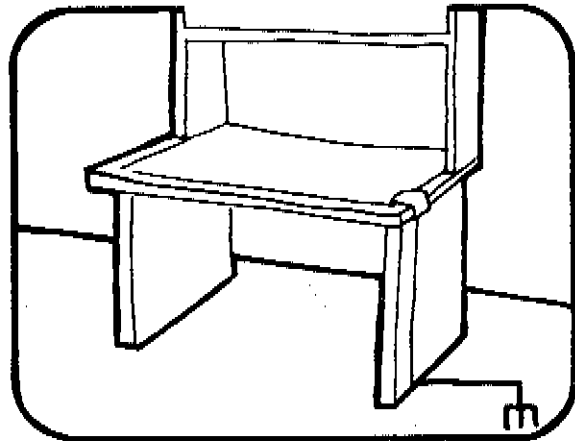

- 9. HANDLE S.S. DEVICES ONLY AT A STATIC-FREE WORK STATION
- 10. ONLY ANTI-STATIC TYPE SOLDER-SUCKERS SHOULD BE USED.
- 11. ONLY GROUNDED TIP SOLDERING IRONS SHOULD BE USED.

A complete line of static shielding bags and accessories is available from Fluke Parts Department, Telephone 800-526-4731 or write to:

JOHN FLUKE MFG. CO., INC.
 PARTS DEPT. M/S 86
 9028 EVERGREEN WAY
 EVERETT, WA 98204

PORTIONS REPRINTED
 WITH PERMISSION FROM TEKTRONIX, INC.
 AND GENERAL DYNAMICS, POMONA DIV.

Section 2

Installation and Operation

2-1. INTRODUCTION

This section describes how to install and operate the Generator. This section contains information for an initial inspection, setting up the instrument, and local and remote operation.

2-2. INITIAL INSPECTION

The Generator is shipped in a special protective container that should prevent damage during shipment. Check the shipping order against the contents of the container, and report any damage or short shipment to the place of purchase or the nearest Fluke Technical Service Center. Instructions for inspection and claims are included on the shipping container.

If reshipment of the Generator is necessary, please use the original shipping container. If the original container is not available, use a container that provides adequate protection during shipment. It is recommended that the Generator be surrounded by at least three inches of shock-absorbing material on all sides of the container. Do not use loose fill to pad the shipping container. Loose fill allows the Generator to settle to one corner of the shipping container, which could result in the Generator being damaged during shipment.

2-3. SETTING UP THE GENERATOR

The following paragraphs describe how to set up the Generator for operation. This information includes: line power requirements, line voltage selection procedures, fuse replacement procedures, and rack mounting instructions.

2-4. Line Power Requirements

The Generator uses a line voltage of 100 or 120V ac rms ($\pm 10\%$) with a 1.5A fuse; or 220V or 240V ac ($\pm 10\%$) with a 0.75A fuse. The line frequency must be between 48 to 63 Hz. The power consumption of the instrument is <180 VA with a full option complement.

2-5. Line Voltage and Fuse Selection

CAUTION

Verify that the intended line power source matches the line voltage setting of your Generator before plugging in the line power cord.

Refer to Figure 2-1 to set the line voltage of the Generator to match your available source. Figure 2-1 also shows how to replace the line fuse of the Generator. The correct fuse value for each of the four line voltages is listed on a plate attached to the rear panel of the Generator.

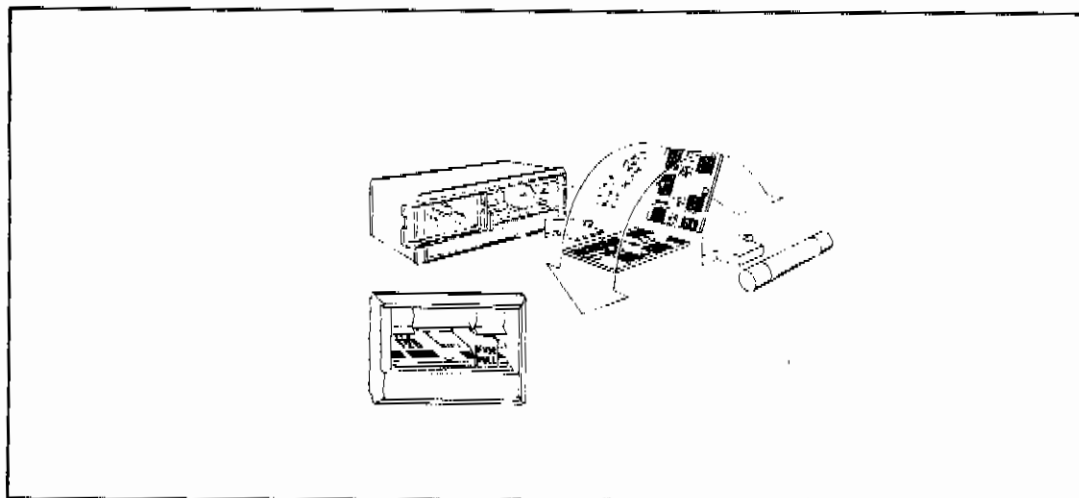

Figure 2-1. Fuse/Filter/Line Voltage Selection Assembly

2-6. IEEE-488 Address

If the IEEE-488 Interface option is installed, the IEEE-488 address can be selected using the switches located next to the IEEE-488 connector on the rear panel. Talk-only and listen-only modes can also be selected on this switch.

2-7. RACK OR BENCH MOUNTING THE GENERATOR

CAUTION

Allow at least 3 inches of clearance behind and on each side of the Generator to ensure proper air circulation.

To meet the specified radiated emissions, the IEEE-488 connector must be terminated with a shielded IEEE-488 cable, such as a Fluke Y8021.

The Generator normally operates on an internal reference oscillator. However, if desired, the Generator can be operated on an external reference by setting the rear panel REF INT/EXT switch to EXT and connecting the external reference to the REF IN connector.

CAUTION

When operating on the internal reference, a 10-MHz signal is present at the 10 MHz OUT connector on the rear panel. To meet the specified radiated emissions, this connector must be terminated with a BNC non-shorting dust cap. A dust cap, JF 478982, is supplied with the Generator. If a cable is connected, it must be a double-shielded coaxial cable such as RG-223 terminated in a 50 Ω load.

CAUTION

Output spectral degradation occurs if the Generator is operated on internal reference with an external reference signal applied.

The Generator may be placed directly on a work bench or mounted in a standard (24-inch deep) equipment rack. Use the Fluke Y6001 Rack Mount Kit for mounting the Generator on an equipment track. Instructions for installing the Generator with the Rack

Mount Kit are provided in the kit. The outside dimensions of the Generator are shown in Figure 2-2. The Rack Mount Kit is composed of the following parts:

- 5-1/4-inch Rack Adapter, P/N M05-205-600
- 24-inch Rack Slides, P/N M00-280-610

2-8. GENERAL OPERATING INFORMATION

The following paragraphs contain general information on the operation of the Generator. This includes all the information required to familiarize the you with the instrument and the differences between local and remote operation.

2-9. Familiarization

Figure 2-3 shows the front panel controls, indicator, and connectors and Table 2-1 describes the features.

Figure 2-4 shows the rear panel controls, connectors, and switches and Table 2-2 describes the features.

2-10. Local Verses Remote Operation

There are two modes of controlling the output of the Generator. One mode uses the keys on the front panel; this is called local operation. The other mode is available when the IEEE-488 Interface option has been installed, and an IEEE-488 controller is used to control the Generator. This is referred to as remote operation. An overview of local control is presented first. The next heading, Operating Reference Material, is divided into two parts. The first part covers local and remote control operations that have similar entry methods. The second part, Remote Operation, contains information on commands or descriptions that pertain only to remote operations.

2-11. Power-On Sequence

When the Generator is turned on, a power-on sequence is started. During the power-on sequence, the microprocessor tests the analog circuitry, the program ROM, the scratch-pad RAM, and the front panel displays. The front panel displays are tested by lighting all segments for a brief period at the same time the rest of the self tests are performed.

If any of the self tests fail, an error code is displayed. If the operator initiates any front panel entry before the power-on sequence is completed, the self test is aborted, and the Generator is set to the state it was in when turned off. In addition, the RF output is turned on. Table 2-3 lists the Instrument Preset State. Power-on instrument settings that relate to the optional IEEE-488 Interface are described in the Remote Operation paragraphs in this section.

2-12. Changing Output Parameters

The four parameters of the Generator (i.e., frequency, amplitude, amplitude modulation (AM), and frequency modulation (FM)) may be changed by one of three methods:

- FUNCTION-DATA-UNIT
- Bright-Digit Edit
- Step Entry

These different methods all accomplish the same result but use different approaches. The reason for this apparent redundancy is to reduce the chance of error during complex test procedures that require continuously resetting parameters or in those cases when a test is partly under remote control and only some of the parameters require changes.

INSTALLATION AND OPERATION

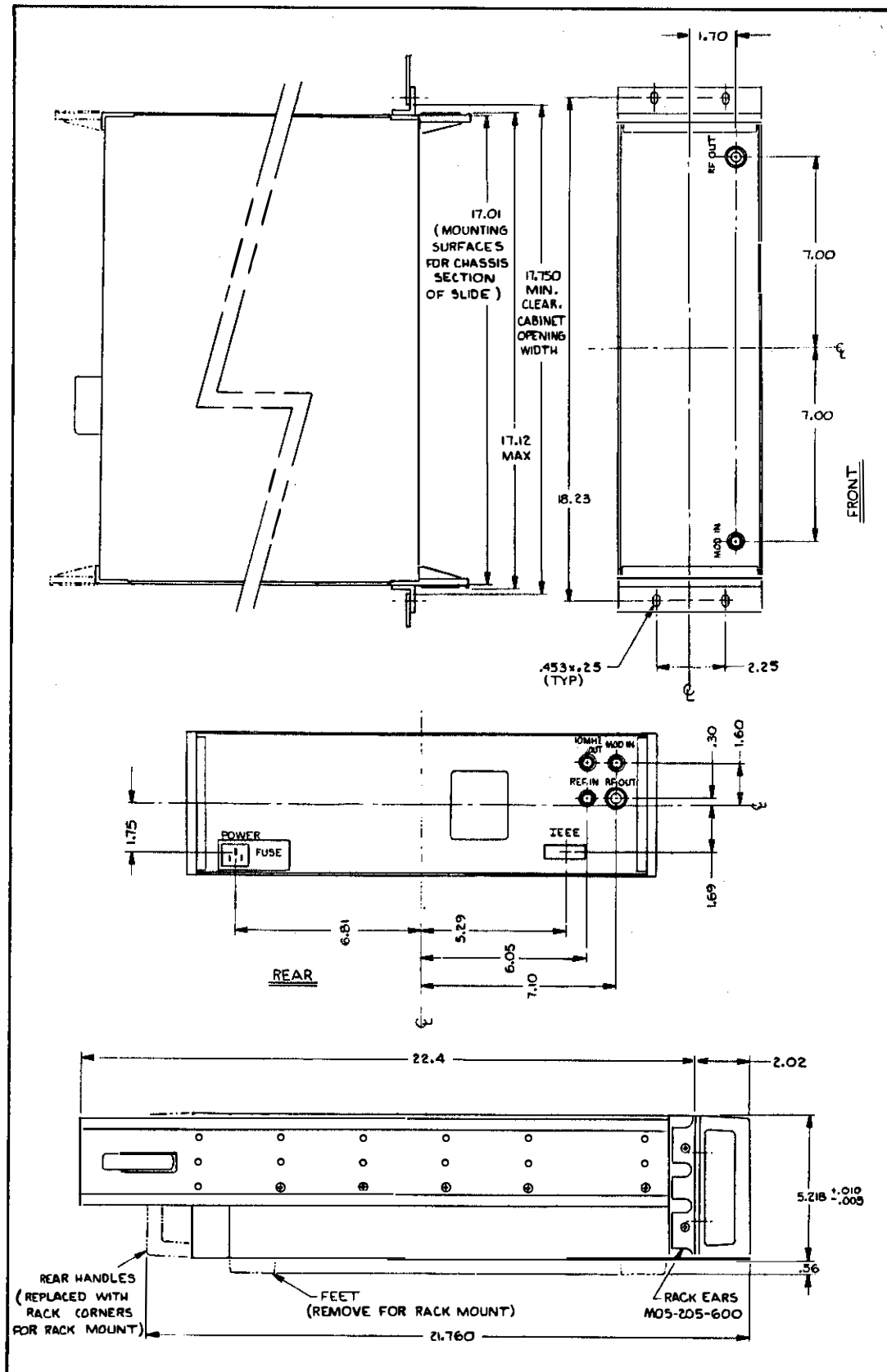

Figure 2-2. 6060B Outside Dimensions

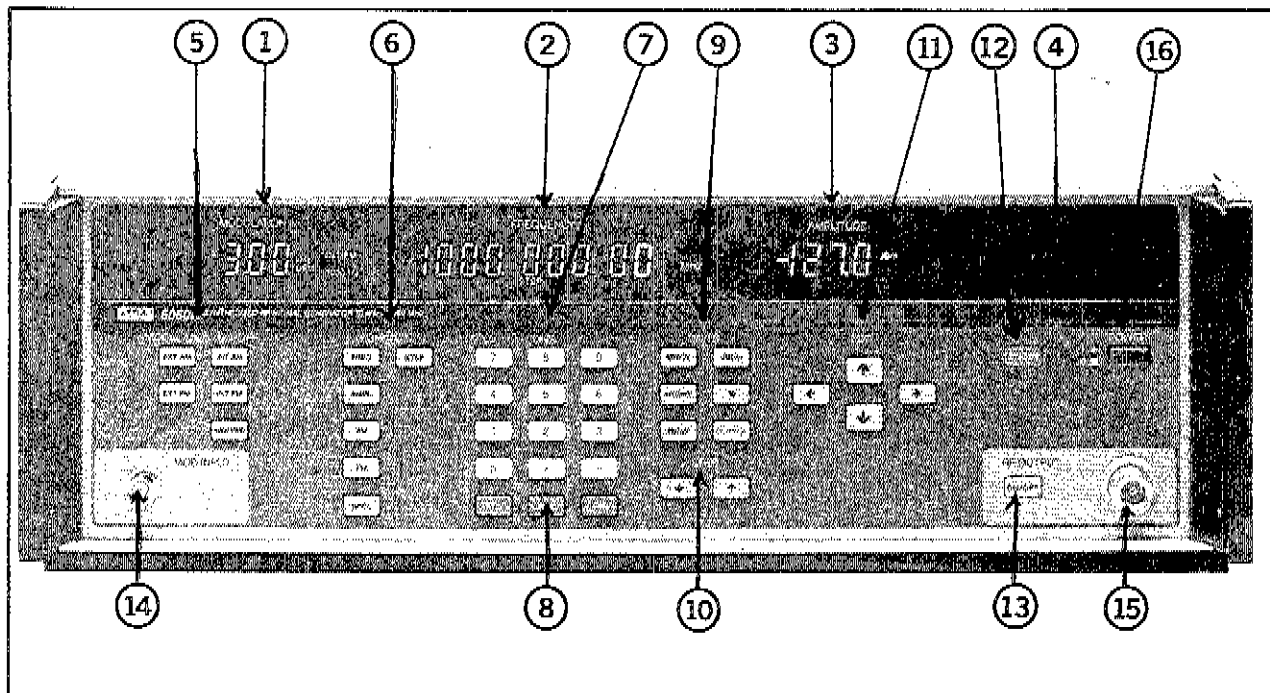

Figure 2-3. Front Panel Controls, Indicators, and Connectors

Table 2-1. Front Panel Controls, Indicators, and Connectors

① MODULATION DISPLAY FIELD	A three-digit display, with associated indicators used to display the AM depth, FM deviation, source of modulation signal, and modulation frequency.
INT AM	Indicates that the internal modulation oscillator signal is amplitude modulating the Generator.
EXT AM	Indicates that the Generator is amplitude modulated by the signal connected to the MOD INPUT connector.
INT FM	Indicates that the internal modulation oscillator signal is frequency modulating the Generator.
EXT FM	Indicates that the Generator is frequency modulated by the signal connected to the MOD INPUT connector.
STEP	Indicates that the Step [\uparrow] or [\downarrow] keys (Step Entry) affect the current Modulation display value.
%	Indicates that the value displayed is the AM Depth in percent.
kHz DEV	Indicates that the value displayed is the FM Deviation in kHz.
400 Hz	Indicates that the internal modulating frequency is 400 Hz.
1000 Hz	Indicates that the internal modulating frequency is 1000 Hz.
EXT HI	Indicates that the external modulation signal is more than 2% above the nominal 1V peak requirement for calibrated operation.
EXT LO	Indicates that the external modulation signal is more than 2% below the nominal 1V peak input requirement.

INSTALLATION AND OPERATION

Table 2-1. Front Panel Controls, Indicators, and Connectors (cont)

②	FREQUENCY DISPLAY FIELD	An 8 1/2-digit display, with two indicators used to display the output frequency of the Generator. Also used to display the special function code, status error codes, or the memory location being stored or recalled, as well as relative and actual frequency, when 'REL' is lit, and step frequency.
	STEP	Indicates that the Step [\uparrow] or [\downarrow] keys (Step Entry) affect the output frequency.
	REL	Indicates that the displayed frequency is relative to a reference frequency.
③	AMPLITUDE DISPLAY FIELD	A 3 1/2-digit (and sign) display, with six indicators, used to display the output amplitude of the Generator into a 50-ohm load.
	STEP	Indicates that the Step [\uparrow] or [\downarrow] keys (Step Entry) affect the output amplitude.
	REL	Indicates that the displayed amplitude is relative to a reference amplitude.
	dBm	Indicates that the output amplitude is in decibels relative to one milliwatt.
	V	Indicates that the output amplitude is in volts.
	uV	Indicates that the output amplitude is in microvolts.
	mV	Indicates that the output amplitude is in millivolts.
④	STATUS DISPLAY FIELD	(Shown unlit.) The status display field is composed of 11 indicators used to denote the current status of the Generator or instrument entry.
	EXT REF	Indicates that the rear panel REF switch is in the EXT (external) position.
	REJ ENTRY	Lights when an invalid entry is made.
	UNCAL	Lights when a parameter entry is outside its specified range. This indicator flashes when any of the internal DACs have over- or under-flowed or when any abnormal operation is detected.
	RF OFF	Lights when the RF OUTPUT is disabled.
	REMOTE	Lights when the Generator is in the remote (IEEE-488 Interface) mode of operation.
	ADDR	Lights when the Generator is addressed to listen or talk.
	SRQ	Lights when the Generator has asserted the IEEE-488 SRQ signal.
⑤	MODULATION ON/OFF	Used to select type, source, and frequency of modulation. With the exception of the [400/1000] key, these keys operate as independent push-on/push-off switches for the given function. Any combination is allowed.
	INT AM	Enables internal amplitude modulation at the frequency annunciated by the '400/1000' Hz indicator.

Table 2-1. Front Panel Controls, Indicators, and Connectors (cont)

INT FM	Enables internal frequency modulation at the frequency annunciated by the '400/1000' Hz indicator.
EXT AM	Enables external amplitude modulation using the signal applied to the MOD INPUT connector.
EXT FM	Enables external frequency modulation using the signal applied to the MOD INPUT connector.
400/1000	Alternately sets the internal modulation oscillator's frequency to 400 or 1000 Hz. The selected frequency is displayed only when INT AM or INT FM is enabled.
⑥ FUNCTION	With the exception of the [STEP] and [SPCL] keys, these keys operate as interlocked switches that select the parameter to be entered or edited. For the [FREQ], [AMPL], [AM], and [FM] FUNCTION keys, the bright digit appears in the corresponding display of the selected function.
FREQ	Selects the frequency parameter of the Generator to be programmed by using the DATA, EDIT, or STEP entry keys.
AMPL	Selects the amplitude parameter of the Generator to be programmed by using the DATA, EDIT, or STEP entry keys.
AM	Selects the amplitude modulation (AM) parameter of the Generator to be programmed by using the DATA, EDIT, or STEP entry keys.
FM	Selects the frequency modulation (FM) parameter of the Generator to be programmed by using the DATA, EDIT, or STEP entry keys.
SPCL	Enables the special function mode. Special functions are called up by a two-digit code, that is entered by using the DATA keys. Refer to the paragraphs on Special Function in this section for a detailed description and a list of the special functions.
STEP	After one of the four parameter functions has been selected for programming, pressing this key allows you to program a step-wise change to that parameter. The step increase or decrease is then performed every time the STEP [+] or [-] keys are pressed.
⑦ DATA	A ten-digit (plus sign and decimal key) keypad used for entering a parameter's value, the special function code, or a memory recall/store location.
⑧ Memory	
STO	Used with the DATA keys to store the current instrument state in a memory location. Memory locations 01 through 50 are available.
RCL	Used with the DATA keys to recall an instrument state from a memory location. Memory locations 01 through 50 are available for operator-stored states; memory location 98 contains the Instrument Preset State (see Table 2-3.)

Table 2-1. Front Panel Controls, Indicators, and Connectors (cont)

SEQ	Sequentially recalls, in increasing location order, the instrument states stored in memory. While the [SEQ] key is pressed, successive memory locations are displayed. When the key is released, the location last displayed is recalled.
⑨ UNITS	These keys, with the exception of [CLR/LCL], serve as the terminating keystroke of a function entry, thereby causing the Generator to be programmed. The amplitude units keys are also used during Amplitude Units Conversion entries.
MHz/V	Used with the [FREQ], [FM], and [AMPL] function keys to program the numerical DATA entries in terms of megahertz (frequency or frequency modulation) or volts (amplitude).
dB(m)	Used with the [AMPL] function key to program the numerical DATA entries in terms of decibels per milliwatt.
KHz/mV	Used with the [FREQ], [FM], and [AMPL] function keys to program the numerical DATA in terms of kilohertz (frequency or frequency modulation) or millivolts (amplitude).
%	Used with the [AM] function key to program the numerical DATA entries in terms of percentage AM depth.
Hz/ μ V	Used with the [FREQ], [FM], and [AMPL] function keys to program the numerical DATA in terms of hertz (frequency or frequency modulation) or microvolts (amplitude).
CLR/LCL	When the Generator is in Local operation, this key is used to clear the current entry and returns the Generator to the previous state. When the instrument is in remote operation, this key is used to return local control.
⑩ STEP	These two keys work in conjunction with the STEP Function key. These keys repeat while they remain pressed.
[↑]	After a parameter is set to the step function mode, and the 'STEP' indicator appears in the display field, this key increments the parameter by the step value previously programmed.
[↓]	After a parameter is set to the step function mode, and the 'STEP' indicator appears in the display field, this key decrements the parameter by the step value previously programmed.
⑪ EDIT	These keys are used to position the bright digit within a display field and to increase or decrease the bright digit value. All four keys repeat while they remain pressed. The function keys are used to move the bright digit to the desired display field.
[+]	Increases the bright-digit value.
[←]	Moves the bright digit one digit to the left.
[-]	Decreases the bright-digit value.
[→]	Moves the bright digit one digit to the right.

Table 2-1. Front Panel Controls, Indicators, and Connectors (cont)

⑫	STATUS	A push-and-hold key that displays the Uncal and Reject Entry status codes in the MODULATION, FREQUENCY, and AMPLITUDE display fields.
⑬	ON/OFF	A push-on/push-off key (with a corresponding 'RF OFF' indicator in the STATUS display field) that enables or disables the output of the Generator.
⑭	Connector	A BNC connector for input of a 1V peak, external modulation signal.
⑮	Connector	A standard RF connector at the output of the Generator.
⑯	POWER	A push-on/push-off detent switch that applies line power to the Generator.

2-13. Function Entry

Changing an instrument parameter with the FUNCTION-DATA-UNIT entry method of consists of:

- Selecting the Function to be changed
- Entering the new numerical value of the parameter
- Selecting the Units of the numerical value (megahertz, millivolts, etc).

The command syntax for function entries is:

Select Function -- Enter Data -- Select Unit

1. Select one of the four parameters using the FUNCTION keys. The bright digit appears in the corresponding display field. The presence of the bright digit in the display field indicates that the value of the selected parameter is ready to be programmed or changed.
2. Enter the data with the DATA keys. The numerics appear in the appropriate display field.
3. Select a UNIT key. This gives the data its absolute value, and causes the microprocessor to internally program the Generator to the new state.

For the amplitude and frequency functions, the entered data programs the displayed value. If the relative mode is enabled, the displayed value may be different from the actual output value.

Once a function is selected, that parameter or feature remains in the active programming mode until a new function is selected. Data for a selected parameter must be followed by a unit value and must be within the range specified for the function. The display field flashes and, the 'REJ ENTRY' status indicator flashes if the entered data is not within the specified range. A rejected entry does not affect the output of the Signal Generator. The output of the Generator remains at its previous values until a new value is accepted.

A function entry may be terminated at any time by the [CLR|LCL] key or by selecting another function.

INSTALLATION AND OPERATION

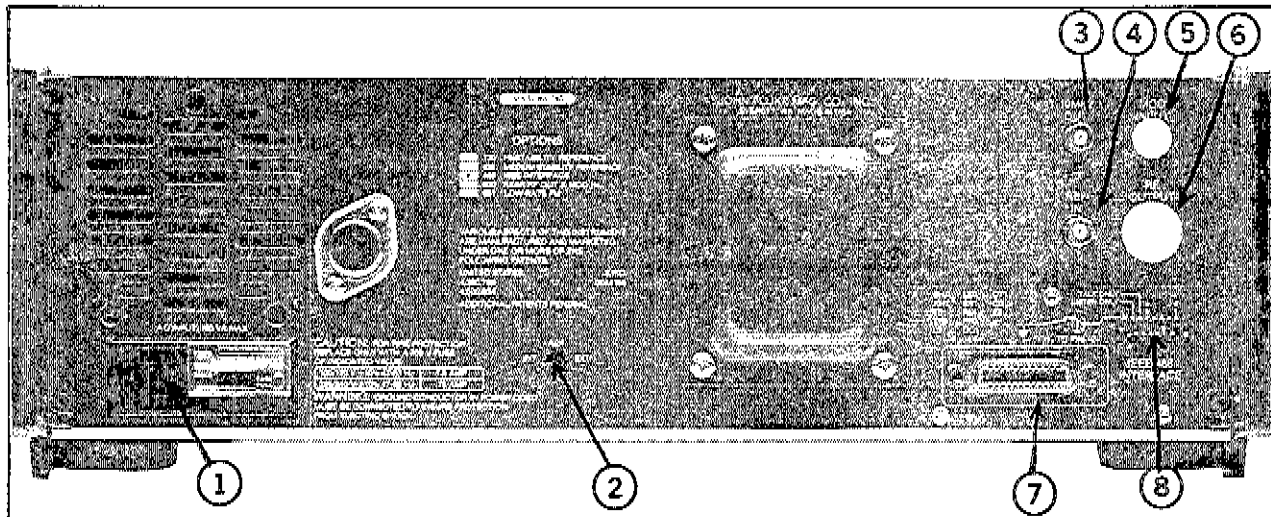

Figure 2-4. Rear Panel Controls, Connectors, and Switches

Table 2-2. Rear Panel Controls, Connectors, and Switches

① AC INPUT	Permits operation from 100, 120, 220, or 240V ac. The number visible through the window on the selector card indicates the nominal line voltage to which the Generator must be connected. The line voltage is selected by orienting the selector card appropriately. A 1 1/2-ampere fuse is required for 100/120V operation; a 3/4-ampere fuse is required for 220/240V operation.
② REF INT/EXT	Permits selection of the Generator frequency reference. When set to INT, the Generator operates on the internal reference, which is either the standard oscillator or the high-stability oscillator if either of the High-Stability References is installed. In either case, the internal 10-MHz reference signal is available at the 10 MHz OUT connector. When set to EXT, the Generator reference is a 1, 2, 2.5, 5, or 10-MHz signal applied to the external REF IN connector.
③ 10 MHz OUT	10-MHz sine wave, >0 dBm level when terminated in 50 ohms.
④ REF IN	Accepts a 1, 2, 2.5, 5, or 10-MHz, 0.3V to 4V p-p sine wave or square wave signal into nominally 50 ohms.
⑤ MOD INPUT	Connector (BNC) is present only with the REAR RF OUT and MOD IN option to accept a 1V peak external modulation signal.
⑥ RF OUTPUT	Connector (type N) is present only with the REAR RF OUT and MOD IN option to provide the Generator output signal.
⑦ IEEE CONNECTOR	Present only with the IEEE-488 Interface option to allow remote operation of the Generator via the IEEE-488 bus.
⑧ IEEE ADDRESS SWITCH	Present only with the IEEE-488 Interface option and allows the selection of the Generator bus address.

Table 2-3. Instrument Preset State

FUNCTION	SETTING
Frequency	300.00000 MHz
Frequency Step	1.00000 MHz
Amplitude	-10.0 dBm
Amplitude Step	1 dB
Modulation Rate	1000 Hz
AM Depth	30%
AM Depth Step	1 %
FM Deviation without/with Option -651	5.0/.5 kHz
FM Deviation Step without/with Option -651	100/10 Hz
Modulation Display	AM Depth
Bright-Digit Location	Frequency Bright Digit
Frequency Bright-Digit Position	1 MHz
Amplitude Bright-Digit Position	1 dBm
AM Bright-Digit Position	1 %
FM Bright-Digit Position without/with Option -651	10/1 Hz
Special Functions	20,30,70,80,90
INT AM	Off
EXT AM	Off
INT FM	Off
EXT FM	Off
Step Function	Frequency Step

2-14. Bright-Digit Edit Operation

Changing an instrument parameter by the edit entry method is the fastest way to make vernier (incremental) changes to one of the four parameters. The EDIT keys are used with the four parameter FUNCTION keys to position the bright digit in the desired display field and then increase or decrease the bright-digit value.

The command syntax for bright-digit edit entries is:

Select Display Field -- Position Bright Digit -- Change Bright-Digit Value

1. Use one of the four FUNCTION keys to position the bright digit in the appropriate display field.
2. Use the [→] or [←] EDIT keys to position the bright digit to the desired resolution, and use the [+] or [-] EDIT keys to increase or decrease the value of the bright digit.

The position of the bright digit within a display field is maintained when the bright digit is moved from one display field to another.

The repeat rate of the [+] or [-] EDIT keys may be changed to a faster or slower rate (a medium repeat rate is the default) with a special function code. Refer to the paragraphs on Special Function and the reference pages in this section for the method and code.

2-15. Step Operation

Changing parameters by the Step Entry method allows you to preset step-wise increments of a parameter then change that parameter (by the amount programmed in the step function) [+] or [-] with a single keystroke.

The command syntax for step entries is:

INSTALLATION AND OPERATION

Select Step Function -- Enter Data -- Select Units -- Change Parameter

1. Select the parameter to be changed step-wise using one of the FUNCTION key.
2. Press the [STEP] key to enable the Step function.
3. Program the step amount using the DATA and UNIT keys.
4. The parameter value can now be changed, up or down by the programmed step amount by using the [▲] or [▼] STEP keys.

While the [STEP] key is pressed, the display field of the selected parameter shows the step amount. The 'STEP' indicator is lit in the display field currently affected by the [STEP] key.

The repeat rate of the [▲] or [▼] STEP keys may be changed to a faster or slower rate (a medium repeat rate is the default) with a Special Function code. Refer to the paragraphs on Special Functions and the reference material for the method and code.

A step entry is ignored when the result of that step entry would cause the value of the parameter to exceed its programmable limit.

2-16. Status and Clear Entries

The Status entry allows you to interrogate the Generator for an explanation of uncalibrated or rejected entry operation ('UNCAL' or 'REJ ENTRY') indicator is lit. Refer to the paragraphs on Status and Clear Entry in the reference section for a complete list of status codes.

The [CLR|LCL] key may be used to clear a partial DATA entry or clear the flashing 'REJ ENTRY' indicator.

2-17. RF Output On/Off

The RF OUTPUT [ON/OFF] key allows the operator to enable or disable the RF output of the Generator. This feature is useful in zeroing a power meter, finding the noise floor of a system, or determining the presence or source of an unknown signal.

On power-up, the RF output of the Generator assumes the state it was in when the Generator was turned off. Pressing the RF OUTPUT [ON/OFF] key disables the output of the Generator and causes the 'RF OFF' indicator (in the STATUS display field) to light. If the RF ON/OFF was off at power-on, pressing the [ON/OFF] key will enable output.

2-18. Modulation On/Off and Rate

The MODULATION ON/OFF keys allow you to select any combination of modulation or no modulation. The MODULATION display field indicates what combination of modulation has been selected. Each modulation key is a push-on push-off type (except the [400/1000] key).

The [400/1000] key toggles the internal modulation oscillator between 400 and 1000 Hz. The '400 Hz' and '1000 Hz' indicators are lit only when INT AM or FM modulation is enabled.

2-19. Memory

Memory entry using the [STO] key allows you to save up to 50 complete front panel settings for later recall.

The command syntax for memory operations follows. No memory location needs to be specified for the sequence operation.

Select Memory Function -- Enter Memory Location

To store the current front panel setting, press the [STO] key (located below the DATA keys). The last memory location stored or recalled is displayed in the FREQUENCY display field. Next, use the DATA keys to enter the two-digit memory location code. The location code must contain both digits (e.g., 01, 02, ...50). The two-digit code appears in the FREQUENCY display field as it is entered.

To recall a front panel setting, press the [RCL] key (located below the DATA keys). The last memory location stored or recalled is displayed in the FREQUENCY display field. Next, use the DATA keys to enter the memory location code of the desired front panel setting. Remember, the location code must contain both digits of the memory location code.

Memory location 98 contains the Instrument Preset State that can be recalled at any time.

The [SEQ] key allows the front panel settings stored in memory to be sequentially recalled. This process is activated by pressing the [SEQ] key at any time. When the [SEQ] key is pressed, the memory location code of the currently recalled setting appears in the FREQUENCY display field, and the location is recalled. When the last memory location is reached (50), the [SEQ] key starts over at 01. The [SEQ] key repeats while pressed.

2-20. Special Function

Special Function Entries allow the operator to enable several special operating functions in the Generator. For example, special functions allow the operator to change the repeat rate of the STEP and EDIT keys, start the self tests, display the results of the power-up self tests, display the IEEE-488 address, enable relative and fixed-range features, and disable or enable special attenuation features. A complete list of the special functions available is presented in Table 2-4.

The command syntax for special function entries is as follows:

Select Special Function -- Enter Special Function Code

The special function is selected by pressing the [SPCL] key. The special function code is entered using the DATA keys.

2-21. OPERATING REFERENCE MATERIAL

This reference section describes local and remote operation for each Generator function. The functions are arranged in alphabetical order. For each function, the syntax of the command, allowable data ranges, and other information is presented.

2-22. Amplitude and Frequency Entry

The following information describes how to control the carrier frequency and amplitude by the FUNCTION-DATA-UNIT entry sequence. This method applies to both normal and relative operations. The frequency display is a fixed-point display in MHz. The amplitude display is fixed point while displaying dBm but is floating point when displaying voltage units.

The RF OUTPUT [ON/OFF] must be enabled for the Generator to produce an output (see the reference material on RF OUTPUT ON/OFF Entry).

INSTALLATION AND OPERATION

Table 2-4. Special Functions

SPECIAL FUNCTION	OPERATION
00	Clears all currently set special functions.
02	Initiates self tests.
03	Display test. This test is detailed in Section 3.
04	Key test. This test is detailed in Section 3.
07	Set SRQ if IEEE-488 Interface option is installed.
08	Reset SRQ if IEEE-488 Interface option is installed.
09	Display instrument software revision level. Information appears in the MODULATION and FREQUENCY display fields for approximately 3 seconds or until another key is pressed.
10	Display IEEE-488 mode and address in decimal form if the IEEE-488 Interface option is installed.
11	Display self-test results. Zeros in the display fields indicate that the self tests have passed. See Section 4 for details of the self-test display.
12	Turn on displays.
13	Turn off all displays. All other functions still operate.
14	Initialize memory locations to Instrument Preset State. 'Sto' appears in the FREQUENCY display field for 3 seconds. If during this time, the [STO] key is pressed, all memory locations are initialized.
15	Latch test. This test is detailed in Section 4.
16	Display option loading. See "Interrogate Commands" in Section 2 for details.
20	Disable Relative Frequency. See reference page on Relative Function.
21	Enable Relative Frequency. See reference page on Relative Function.
30	Disable Relative Amplitude. See reference page on Relative Function.
31	Enable Relative Amplitude. See reference page on Relative Function.
70	Set repeat rate for EDIT and STEP keys to medium.
71	Set repeat rate for EDIT and STEP keys to fast.
72	Set repeat rate for EDIT and STEP keys to slow.
80	Enable Amplitude correction. Normal operation.
81	Disable Amplitude correction. If level accuracy is not critical, level correction circuitry can be disabled for improved programming speed. Level accuracy may be up to 7 dB low.
82	Disable attenuator correction. Useful as a troubleshooting tool. RF input to attenuator is flat.
83	Program alternate 24 dB attenuation. See Section 4.
84	Program alternate 24 dB attenuation. See Section 4.
85	Program alternate 24 dB attenuation. See Section 4.
86	Program alternate 24 dB attenuation. See Section 4.
90	Disable Amplitude Fixed Range. See reference material on Amplitude Fixed Range.
91	Enable Amplitude Fixed Range. See reference material on Amplitude Fixed Range.

Command Syntax

Select Function -- Enter Data -- Select Unit

Summary

	COMMAND	RANGE	RESOLUTION	NOTES
Set Frequency				
Local:	[FREQ] -- DATA -- [MHz V] [kHz mV] [Hz uV]	0.01 to 1050 MHz	10 Hz	1,2
Remote:	"FR" -- float -- "GZ" "MZ" "KZ" "HZ"	0.01 to 1050 MHz	10 Hz	1,3
Set Amplitude				
Local:	[AMPL] -- DATA -- [dB(m)] [MHz V] [kHz mV] [Hz uV]	-127 to +13 dBm 0.1 uV to 1 V	0.1 dBm 3 digits	2,4,5
Remote:	"AP" -- float -- "dB" "V" "MV" "UV" "NV"	-127 to +13 dBm 0.1 uV to 1 V	0.1 dBm 3 digits	3,4,5

Example

Set Frequency to 10.7 MHz and Amplitude to -7.5 dBm.

Local: [FREQ] [1] [0] [.] [7] [MHz|V]
[AMPL] [-] [7] [.] [5] [dB(m)]

Remote: "FR10.7MHz,AP-7.5dB"

Notes

1. Frequency ranging occurs at 245 and 512 MHz.
2. FUNCTION ([FREQ] or [AMPL]) remains selected until another FUNCTION or [STEP], [STO], [RCL], or [SPCL] is pressed.
3. float equals floating-point number.
4. Amplitude uncalibrated range from -147.4 to -127.1 dBm and from +13.1 to +19 dBm.
5. Amplitude ranging occurs at 1/2V, 1/4V, 1/8V, ... 1/2²³ V with AM off and 1/4V, 1/8V, 1/16V, ... 1/2²⁴ V with AM on.

INSTALLATION AND OPERATION

Related Operations

Amplitude Fixed Range
Bright-Digit Edit Entry
Relative Function
Step Entry

2-23. Amplitude Fixed Range

The following information describes how to use the Fixed-Range special function. This special function fixes the current amplitude range (holds the currently selected step of the Step Attenuator). This function allows monotonic and nontransient level control over a limited range around those levels where the Step Attenuator normally autoranges. This level control may be accomplished with the Bright-Digit Edit Entry only.

The level vernier in fixed range has at least 12 dB of range.

Command Syntax

Select Fixed Range -- Enable or Disable

Summary

	COMMAND	NOTES
Enable Fixed Range		
Local:	[SPCL] [9] -- [1]	1
Remote:	"SP" "9" -- "1"	
Disable Fixed Range		
Local:	[SPCL] [9] -- [0]	2
Remote:	"SP" "9" -- "0"	

Example

Set the Generator for monotonic and nontransient amplitude control (Bright-Digit Edit only) over the range of the vernier level control below 0.25V.

Local: [AMPL] [.] [2] [5] [MHz|V] [SPCL] [9] [1]
Remote: "AP.25V,SP91"

Notes

1. The amplitude range is fixed only for Bright-Digit Edit operations. Other methods of changing the amplitude cause the step attenuator to autorange if necessary.
2. With amplitude fixed range disabled, amplitude ranging occurs at 1/2V, 1/4V, 1/8V, ... 1/2²³ V with AM off and 1/4V, 1/8V, 1/16V, ... 1/2²⁴ V with AM on.

Related Operations

Bright-Digit Edit Entry
Relative Function

2-24. Amplitude Units Conversion

The following information describes how to convert the displayed amplitude level from dBm to volts and volts to dBm. The output of the Generator does not change during these operations.

Command Syntax

Select Amplitude Function -- Select Unit

Summary

	COMMAND	NOTE
Convert dBm to volts		
Local:	[AMPL] -- [MHz V] [kHz mV] [Hz uV]	1
Remote:	"AP" -- "V" "mV" "uV" "nV"	1
Convert volts to dBm		
Local:	[AMPL] -- [dB(m)]	
Remote:	"AP" -- "dB"	

Example

Change the displayed amplitude of -10.0 dBm to its voltage equivalent.

Local: [AMPL] [MHz|V]
Remote: "APV"

Note

1. Any voltage unit is accepted since the microprocessor automatically selects the units appropriate for the value being displayed.

Related Operations

Relative Function

2-25. Bright-Digit Edit Entry

The following information describes how to use a Bright-Digit Edit Entry to change an instrument parameter. The output frequency, amplitude and the modulation indices can be modified with this entry method.

The RF OUTPUT [ON/OFF] must be enabled for the Generator to produce an output. (See the reference material on RF OUTPUT [ON/OFF] Entry.)

Command Syntax

Select Display Field -- Position Bright Digit -- Change Bright-Digit Value

INSTALLATION AND OPERATION

Summary

	COMMAND	NOTES
Edit Frequency		
Local:	[FREQ] — EDIT [←]/[→] — EDIT [↑]/[↓]	1,2
Remote:	"FB" — float "GZ" — "KF" float "MZ" "KZ" "HZ"	3,4,5
Edit Amplitude		
Local:	[AMPL] — EDIT [←]/[→] — EDIT [↑]/[↓]	1,2
Remote:	"AB" — float "DB" — "KA" float "V" "MV" "UV" "NV"	3,4,5
Edit FM Deviation		
Local:	[FM] — EDIT [←]/[→] — EDIT [↑]/[↓]	1,2
Remote:	"DB" — float "GZ" — "KD" float "MZ" "KZ" "HZ"	3,4,5
Edit AM Depth		
Local:	[AM] — EDIT [←]/[→] — EDIT [↑]/[↓]	1,2
Remote:	"PB" — float "PC" — "KP" float	3,4,5

Example 1

Edit the displayed amplitude of 9.7 dBm to 10.0 dBm.

Local: Put the bright digit in the amplitude display by pressing [AMPL]. Select the least significant digit in that display by pressing EDIT [→] until the bright digit is on that digit. Increase the value of that digit by pressing EDIT [↑] three times.

Remote: "AB.1DB,KA3"

Example 2

Edit the displayed FM Deviation from 5.0 kHz to 3.0 kHz.

Local: Put the bright digit in the FM display by pressing [FM]. Select the 1-kHz digit by pressing the EDIT [→] or EDIT [←] until the bright digit is on that digit. Decrease the value of that digit by pressing EDIT [↓] twice.

Remote: "DB1KZ,KD-2"

Notes

1. The bright-digit field remains selected until another display field is selected.
2. The bright-digit position is maintained for each of the four functions so that the bright digit can be moved from one display to another and back without losing its position in that previous display field.
3. float equals floating-point number.
4. In remote, the bright digit is positioned within a display field using a decade value and associated unit. Minus signs are ignored.
5. In remote, the bright digit is moved to the corresponding field and is increased or decreased by the signed integer following the "KF,KA,KD,KP" messages. The generic edit command "KB" may also be used to edit up or down the current bright-digit position. Positive integers do not require a sign.

Related Operations

Relative Function
Amplitude Fixed Range

2-26. Memory Entry

The following information describes how to use the memory function to store and recall front panel settings. The Generator has 50 memory locations that are retained for 2 years with the power off.

The sequence feature allows the operator to recall successive memory locations.

Command Syntax

Select Memory Function -- Enter Memory Location

Summary

	COMMAND	NOTES
Store		
Local:	[ST0] -- [n] [n]	1,2,3
Remote:	"ST" -- int	1,4
Recall		
Local:	[RCL] -- [n] [n]	1,2,3
Remote:	"RC" -- int	1,4
Sequence		
Local:	[SEQ]	5,6
Remote:	"SQ"	5

INTRODUCTION AND SPECIFICATIONS

Example

Recall the Instrument Preset State (located in memory location 98). Change the frequency parameter to 302 MHz, then store the new front panel setting in memory location 06.

```
Local: [RCL] [9][8]  EDIT [ + ] [ + ]  [STO] [0][6]
```

```
Remote: "RC98,KF2,ST6"
```

Notes

1. The memory locations available for operator use are 01 through 50. Additionally, the following special memory locations are available:

Memory location 00 contains a backup-memory location. After a recall (or sequence) operation it contains the last front panel setting. After a store operation, it contains the data in the stored memory location before the store operation. Thus, a recall operation can be reversed by recalling location 00.

Memory location 98 contains the Instrument Preset State.

Memory location 99 contains the present instrument state.

2. In local control, two data digits must be entered to specify the memory location. The recall or store is performed when the second digit is released.
3. The last memory location specified (used for sequence operations) is displayed while the [STO] or [RCL] button is pressed.
4. int equals unsigned integer.
5. The sequence operation recalls the next higher memory location, starting from the last memory location stored or recalled. No memory location need to be specified. When the highest location is reached, the sequence starts over again at location 01.
6. While [SEQ] is pressed, the next memory location number is displayed and the memory location is recalled. This key is repeating.

2-27. Modulation Entry

The following information describes how to preset the modulation index (AM depth or FM deviation), internal modulation rate (400 or 1000 Hz), and how to select the modulation source (internal and/or external).

The FUNCTION-DATA-UNIT method of selecting the modulation index is summarized in the following command syntax. The indices may also be modified using Bright-Digit Edit or Step Entry. Since there is only one modulation display, the modulation index displayed is determined by the last modulation FUNCTION key pressed.

Command Syntax

Select Function -- Enter Data -- Select Unit

Summary

	COMMAND	RANGE	RESOLUTION	NOTES
Set AM Depth				
	Local: [AM] -- DATA -- [%]	0 to 99%	1%	1,2
	Remote: "AM" -- float -- "PC"	0 to 99%	1%	1,3
Set FM Deviation				
	Local: [FM] -- DATA -- [MHz V] [kHz mV] [Hz uV]	0.1 to 99.9 kHz	3 digits	1,4
	Remote: "FM" -- float -- "GZ" "MZ" "KZ" "HZ"	0.1 to 99.9 kHz	3 digits	1,3,4

Summary

	COMMAND	NOTES
Select Modulation Rate		
	Local: [400/1000]	5
	Remote: "MR" "0" or "1"	6

Summary

	COMMAND	NOTES
Enable or Disable Modulation		
	Local: [INT AM] [INT FM] [EXT AM] [EXT FM]	7,8
	Remote: "AI" "0" or "1" "FI" "0" or "1" "AE" "0" or "1" "FE" "0" or "1"	9

Example

Set the FM deviation to 5 kHz, the modulation rate to 400 Hz, and internally modulate the carrier.

Local: [FM] [5] [kHz] [INT FM] [400/1000]
Remote: "FM5KZ,MRO,FI1"

INSTALLATION AND OPERATION

Notes

1. This operation does not change the Generator output unless the corresponding modulation is enabled.
2. Uncalibrated if peak amplitude exceeds +13 dBm or if AM depth exceeds 90% and AM is enabled.
3. float equals floating-point number.
4. Uncalibrated if FM is enabled and FM deviation is below 100 Hz or above (frequency -100 kHz)/3.
5. Toggles between 400 or 1000 Hz only. An indicator shows selected rate only if internal modulation is on.
6. "0" selects a modulation rate of 400 Hz; "1" selects 1000 Hz.
7. These are ON/OFF operations; any combination is allowed.
8. Two indicators 'EXT HI' and 'EXT LO' are lit when external modulation is on to indicate that the external modulation signal is 2% above or 2% below the nominal IV peak input requirement.
9. "0" turns the modulation source off; "1" turns it on.

Related Operations

Bright-Digit Edit Entry
Step Entry

2-28. Relative Function

The following paragraphs describe how to change frequency and amplitude using the Relative mode. There are two steps:

1. Setting the reference
2. Changing the parameter relative to that reference

Setting the reference is done by setting the parameter to the desired value and then enabling the relative mode for that parameter. This causes the 'REL' indicator to light and the displayed value to be zero in the corresponding display. The Generator output does not change during these operations. In the relative mode, the usual means of changing the parameter may be used; i.e., FUNCTION-DATA-UNIT, Step, or Bright-Digit Edit Entry.

In the relative frequency mode, the actual frequency is the sum of the reference and the displayed frequency. The actual frequency may be displayed by pressing the [FREQ] key.

In the relative amplitude mode, the actual amplitude is the sum of the reference and the displayed amplitude when the reference and the displayed quantities have the same units. However, with mixed units (volts and dB), the actual amplitude is the voltage value scaled by the dB value. The actual amplitude may be displayed by pressing the [AMPL] key.

Command Syntax

Select Relative Function -- Enable or Disable

Summary

	COMMAND	NOTE
Frequency		
Local:	[SPCL] [2] -- [0] or [1]	1
Remote:	"SP" "2" -- "0" or "1"	1
Amplitude		
Local:	[SPCL] [3] -- [0] or [1]	1
Remote:	"SP" "3" -- "0" or "1"	1

Example

Set the amplitude to -15 dB μ V; i.e., 15 dB below 1 microvolt.

Local: [AMPL] [1] [Hz| μ V] [SPCL] [3] [1] [AMPL] [-] [1] [5] [dB(m)]
 Remote: "AP1UV,SP31,AP-15DB"

Note

1. 1 enables the relative function; 0 disables the relative function.

Related Operations

Amplitude and Frequency Entry
 Bright-Digit Edit Entry
 Step Entry

2-29. RF OUTPUT ON/OFF Entry

The following information describes how to enable the output of the Generator using the RF OUTPUT [ON/OFF] key and the corresponding remote code.

Command Syntax

RF Output On/Off

Summary

	COMMAND	NOTE
RF Output On		
Local:	RF OUTPUT [ON/OFF] when 'RF OFF' is on	1
Remote:	"R01"	1
RF Output Off		
Local:	RF OUTPUT [ON/OFF] when 'RF OFF' is off	
Remote:	"R00"	

INSTALLATION AND OPERATION

Notes

1. Turning the RF Output on resets the RPP circuitry if it has tripped.

2-30. Special Function Entry

The following information describes how to use the Special Function Entry to use the special operating functions of the Signal Generator. Table 2-4 lists the special functions available.

The special function code is a two-digit number. The first digit indicates the classification of the special function, and the second digit specifies the particular special function.

The special function is executed when the second special function code digit is entered. There are ten classes of special functions. The special functions in the 0(n) and 1(n) class cause an action to be performed. Classes 2(n) through 9(n) cause an instrument state to change. The status of classes 2(n) through 9(n) appears (left to right) in the frequency display field when the [SPCL] key is pressed.

Command Syntax

Select Special Function -- Enter Special Function Code

	COMMAND	NOTE
Local:	[SPCL] -- [n] [n]	
Remote:	"SP" -- int	1

Example

Change the repeat rate of the EDIT and STEP keys to slow.

Local: [SPCL] [7] [2]
Remote: "SP72"

Note

1. int equals unsigned integer.

Related Operations

Fixed Range
Relative Function

2-31. Status and Clear Entry

The Status entry allows you to interrogate the Generator for an explanation of either uncalibrated operation ('UNCAL' indicator is lit) or rejected entry operation (the 'REJ ENTRY' indicator is lit).

When either the 'UNCAL' or 'REJ ENTRY' indicator is lit, press and hold the [STATUS] key to display the Uncalibrated or Rejected Entry Error Code Message. These messages provide detailed information on the nature of the uncalibrated or rejected entry

condition. Table 2-5 contains a list and explanation of all the Uncalibrated Error Code Messages. Table 2-6 contains a list and explanation of all the Rejected Entry Error Code messages.

Table 2-5. UNCAL Error Codes

CODE	DESCRIPTION
000 000 000	= Indicates no UNCAL conditions
001 000 000	= FM deviation < 100 Hz (<10 Hz with Option -651)
002 000 000	= FM deviation > (freq -100 kHz)/3
*004 000 000	= Excess FM deviation, main or reference PLL unlocked
020 000 000	= AM depth > 90%
*000 010 000	= Main or reference PLL unlocked
000 000 001	= Level vernier below calibrated range or Level < -127 dBm
000 000 002	= Peak (AM) amplitude > +13 dBm
*000 000 004	= Amplitude unlevelled
*000 000 010	= Fixed-range level vernier at 0
*000 000 020	= Fixed-range level vernier at full scale
*000 000 040	= RPP tripped
000 000 100	= Level below -127 dBm
000 000 200	= Level correction disabled
*000 000 400	= RF output off

Table 2-6. REJECT ENTRY Codes

CODE	DESCRIPTION
001 000 000	= FM deviation not between 0 and 99.9 kHz (9.99 kHz with Option -651)
002 000 000	= FM deviation Step not between 0 and 99.9 kHz (9.99 kHz with Option -651)
004 000 000	= AM depth not between 0 and 99%
010 000 000	= AM depth step not between 0 and 99%
020 000 000	= IEEE-488 command syntax error
040 000 000	= IEEE-488 input value out of range
100 000 000	= Special function requires IEEE option
200 000 000	= IEEE edit or step operation beyond allowed range
000 001 000	= Frequency not between 0.01 and 1050 MHz
000 004 000	= Frequency step not between 0 and 1050 MHz
000 040 000	= Invalid memory location
000 100 000	= Invalid data in memory
000 200 000	= Special function not allowed
000 000 001	= Output amplitude not between 10 nV and 2V
000 000 002	= Insufficient resolution for units conversion
000 000 004	= Units conversion to volts not allowed with reference in volts
000 000 010	= Units conversion to dB not allowed with reference in volts
000 000 020	= Amplitude step not between 0 and 166 dB or 0 and 1999V
000 000 040	= Units conversion on amplitude step not allowed
000 000 100	= Amplitude step and current amplitude display not in same units

INSTALLATION AND OPERATION

The [CLR LCL] key may be used to clear a partial DATA entry or clear the flashing 'REJ ENTRY' indicator. Press the [STATUS] key while an 'UNCAL' indication exists to display the Uncal Error Codes in three fields:

Flashing codes (denoted by *) indicate abnormal operation or aberrated output. Non-flashing codes indicate operation outside specified range.

Press the [STATUS] key while the 'REJ ENTRY' indication exists to display the Reject Entry error codes:

2-32. Step Entry

The following information describes how to use the Step Entry function to change an instrument parameter. The RF OUTPUT [ON/OFF] must be enabled for the Generator to produce an output. (See the reference material on RF OUTPUT [ON/OFF] Entry.)

Command Syntax

Select Step Function -- Enter Data -- Select Units -- Change Parameter

Summary

COMMAND	RANGE	RESOLUTION	NOTES
Frequency			
Local: [FREQ][STEP]--DATA --[MHz V] --STEP [+]/[+] [kHz mV] [Hz uV]	0 to 1050 MHz	10 Hz	
Remote: "FS" --float--"GZ" "MZ" "KZ" "HZ"	0 to 1050 MHz	10 Hz	1,2
Amplitude			
Local: [AMPL][STEP]--DATA --[dB(m)] -- STEP [+]/[+] [MHz V] [kHz mV] [Hz uv]	0 to 166 dB 0 nV to 1999 V	0.1 dB 3 digits	
Remote: "LS" --float--"DB" "v" "MV" "UV" "NV"	0 to 166 dB 0 nV to 1999V	0.1 dB 3 digits	1,2
FM deviation			
Local: [FM][STEP] --DATA --[MHz V] -- STEP [+]/[+] [kHz mV] [Hz uV]	0 to 99.9kHz	3 digits	3

Remote: "DS"	--float--	"GZ" "MZ" "KZ" "HZ"	--"DU"/"DD"	
		0 to 99.9kHz	3 digits	1,2,3
AM depth				
Local: [AM][STEP]	--DATA --[X]		-- STEP [+]/[+]	
	0 to 99%		1%	
Remote: "PS"	--float--	"PC"	--"PU"/"PD"	
	0 to 99%		1%	1,2

Example

Recall the Instrument Preset State: [RCL] [9] [8]. Step the displayed frequency of 300 MHz, in 10-MHz steps, to 270 MHz.

Local: [FREQ] [STEP] [1] [0] [MHz|V] [+] [+] [+]STEP
 Remote: "FS10MZ,FD,FD,FD"

Notes

1. float equals floating-point number.
2. Entering the step size from IEEE-488 does not select the step function. For example, "FS10MZ" does not select the step function; "FD" or "FU" must be used to select the frequency step function. The generic step up/down commands "SU" and "SD" may be used to step the current step function.
3. If the Low-Rate FM option is installed, the range of FM deviation steps is 0 to 9.99 kHz.

Related Operations

Relative Function

2-33. REMOTE OPERATION (IEEE-488 INTERFACE)

The following paragraphs describe how to operate the Generator using the IEEE-488 Interface option. This option allows you to program the Generator and operate instrument functions via the IEEE-488 bus (with the exception of the front panel POWER switch and the rear panel REF INT/EXT switch). The IEEE-488 Interface option also provides additional programming features not accessible from the front panel.

The rest of this section is divided into two parts: the first part describes how to set up the Generator for operation on the IEEE-488 bus and gives some typical programming examples. The first part also includes a complete list of the programming commands recognized by the Generator software.

The second part describes the implementation of the IEEE-488 interface and programming features that are accessible only from the IEEE-488 Interface. The second

INSTALLATION AND OPERATION

part includes typical timing data, provided as an aid to system programmers. This information can assist in writing programs that have greater speed and efficiency.

The Generator can be used with any IEEE-488 controller in the normal addressed mode. The following two additional modes are available for operation without a controller:

Listen-only mode
Talk-only mode

In the listen-only mode, the Generator responds to all data messages on the IEEE-488 bus. In the talk-only mode, the Generator sends commands on the IEEE-488 bus to program another 6060B Generator (or a 607xA with some restrictions).

2-34. Setting Up the IEEE-488 Interface

Figure 2-5 shows a 6060B Signal Generator connected to a 1722A via the IEEE-488 bus.

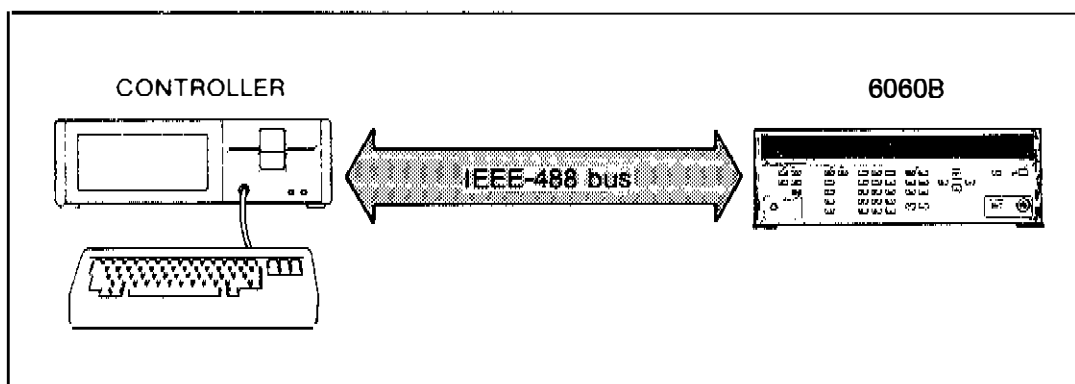

Figure 2-5. 6060B Signal Generator Connected to a 1722A

Use the following procedure to set up the Generator with the IEEE-488 Interface option:

1. Connect a standard IEEE-488 cable between the Generator and the IEEE-488 device.

NOTE

The IEEE-488 Interface signal SHIELD (pin 12) can be disconnected (when using an IEEE-488 cable with a metallic hood) from instrument ground. To do this, use the left most address switch (as viewed from the rear panel).

2. Select the IEEE-488 address and mode as follows:
 - a. For control of the Generator with a controller, set both the LISTEN ONLY and TALK ONLY switches to 0 (down). Set switches a1 through a5 to the desired address 0 through 30. For example, for an address of 1, set switches a2, a3, a4, and a5 to 0 (down), and set switch a1 to 1 (up).
 - b. For talk-only operation, set the TALK ONLY switch to 1 (up).
 - c. For listen-only operation, set the LISTEN ONLY switch to 1 (up) and the TALK ONLY switch to 0 (down).
3. Verify the address and mode:

- a. Press the [SPCL] and the [1][0] keys. Verify that the selected address appears in decimal in the Frequency display field.
- b. If the talk-only mode or listen-only mode has been selected, "to" or "lo" appears to the left of the address in the Frequency display field.

NOTE

The address switches are continuously monitored except when in remote. The TALK ONLY and LISTEN ONLY switches are only read when the Generator is powered on.

2-35. Programming Commands

After the address and mode have been set, the Generator can be programmed by an IEEE-488 controller or from another Generator. Tables 2-7 and 2-8 and the programming examples following them provide the basic information on how to program the Generator.

More details about the commands can be found in two places. Commands that are available from the front panel are described in the first part of this section. Those commands that are only available from the IEEE-488 Interface are described in the Commands Descriptions paragraphs later in this section of the manual.

Table 2-7 is an index for the IEEE-488 Commands used in Table 2-8. This index is a list of the command headers according to function. Table 2-8 lists all the remote commands that are recognized by the Generator. The commands are listed alphabetically by function.

2-36. Programming Examples

The following three examples show how to use the IEEE-488 bus and use a variety of controllers to program the Generator. In the first example, a Fluke 1722A Controller is used to program the Generator. In the second example, two Generators are configured to track each other in frequency. In the third example, a 1722A is used to program the Generator with the frequency step up controlled by the trigger command.

Table 2-7. Index of IEEE-488 Commands

FUNCTION	COMMAND HEADERS
Amplitude Entry	AP, SP3x, RA, SP8x, SP9x
Binary Learn Commands	LI, LM
Clear Commands	CB, CE, CL
Edit Entry	AB, DB, FB, PB, KB, KA, KD, KF, KP
Frequency Entry	FR, SP2x, RF
Interface Mode Commands	EM, RM, TM, VM, UM, @
Interrogate Commands	ID, IE, II, IO, IR, IT, IU, IV
Memory Entry	RC, ST, SQ
Modulation Entry	AM, AE, AI, FM, FE, FI, MR, MF
Monitor Commands	IB, OB, OD, RB, RW, DW, WB, WW, XA, XB, XD, XR
RF ON/OFF Entry	RO
Special Function Entry	SP
SRQ Commands	IM, SM, XF
Step Entry	FS, LS, PS, DS, SU, SD, FU, FD, LU, LD, PU, PD, DU, DD
Trigger Commands	CT, TR

INSTALLATION AND OPERATION

Table 2-8. IEEE-488 Commands

COMMAND USE	COMMAND			COMMENTS
	HEADER	NUMERIC	SUFFIX	
AMPLITUDE ENTRY				
Program Amplitude	AP	float	V MV UV NV DB	Program displayed amplitude in units of: volts millivolts microvolts nanovolts dB or dBm
Convert Amplitude Units	AP	none	V MV UV NV DB	Change amplitude units to: volts volts volts volts dB or dBm
Relative Amplitude	SP	30/31	none	Disable/enable relative amplitude operation
Relative Amplitude	RA	0/1		Alternate programming command for disable/enable relative amplitude operation.
Level Correction	SP	80 81 82	none	Enable all level correction. Disable all level correction. Disable attenuator correction.
Amplitude Fixed Range	SP	90/91	none	Disable/enable amplitude fixed-range operation.
BINARY LEARN COMMANDS				
Store a Front Panel Setup	LI	int	string	The Generator stores the string into the memory location specified by int. See the Command Descriptions paragraph for decoding the learn string.
Send a Front Panel Setup	LM	int	none	The Generator responds with the contents of the memory location specified by int. See the Command Descriptions paragraph for decoding the learn string.
CLEAR COMMANDS				
Clear IEEE-488 Output Buffer	CB	none	none	Clears IEEE-488 output buffer.
Clear error	CE	none	none	Clears the IEEE-488 rejected entry status.
Device Clear	CL	none	none	Clears the instrument state.
EDIT ENTRY				
Position Amplitude	AB	float	V MV	Position the bright digit in the AMPLITUDE display with

Table 2-8. IEEE-488 Commands (cont)

Bright Digit			UV NV DB	the stated resolution. For example, enter "AB10MV" for 10-mV resolution.
Position FM Bright Digit	DB	float	GZ MZ KZ HZ	Position the bright digit in the FM display with the stated resolution. For example, enter "DB1KZ" for 1-kHz resolution.
Position Frequency Bright Digit	FB	float	GZ MZ KZ HZ	Position the bright digit in the FREQUENCY display with the stated resolution. For example, enter "FB1MZ" for 1-MHz resolution.
Position AM Bright Digit	PB	float	PC	Position the bright digit in the AM display with the stated resolution. For example, enter "PB1PC" for 1% resolution.
Edit	KB	float	none	Edit the current bright digit by float counts.
Edit Amplitude	KA	float	none	Move the bright digit to the AMPLITUDE display and edit amplitude by float counts.
Edit FM	KD	float	none	Move the bright digit to the FM display and edit FM by float counts.
Edit Frequency	KF	float	none	Move the bright digit to the FREQUENCY display and edit frequency by float counts.
Edit AM	KP	float	none	Move the bright digit to the AM display and edit AM by float counts.
FREQUENCY ENTRY				
Frequency Programming	FR	float	GZ MZ KZ HZ	Program displayed frequency in units of: gigahertz megahertz kilohertz hertz
Relative Frequency	SP	20/21	none	Disable/enable relative frequency operation.
Relative Frequency	RF	0/1	none	Alternate programming command for disable/enable relative frequency operation.
INTERFACE MODE COMMANDS				
Error Mode	EM	0/1	none	Disable/enable the clear error mode. If disabled, the IEEE-488 error status is cleared only when interrogated. If enabled, the error status is cleared when a new message is processed.

Modulator attenuation is thus approximately proportional to the modulator control voltage at the emitter of Q103. Proportionality is required to maintain constant leveling loop bandwidth as modulator attenuation varies. Minimum attenuation is obtained with a modulator control voltage of 10V, while maximum attenuation is obtained with 0V.

Comparator U310A and associated components form an unlevelled indicator circuit. The comparator senses the modulator control voltage at the emitter of Q103. This voltage is normally less than +11V, and the comparator output is high. If the modulator control voltage exceeds +11V, the modulator attenuation is at a minimum, and the leveling loop becomes inoperative (unlevelled). This condition could be due to a fault or some abnormal operation such as over-modulation. In this case, the comparator output (UNLVLL) goes low. The Controller senses this low and causes the front panel 'UNCAL' indicator to flash and displays an unlevelled status if interrogated.

3-54. LEVEL CONTROL

The instrument output level is set by the level-control circuit. Inputs to this audio signal processing circuit are the internal and external modulation signals, a dc reference voltage, and the digital control commands. The circuit output is the leveling loop control voltage that provides vernier level control of the Generator output. Digitally encoded level, modulation depth, and temperature-compensation information are provided by the Controller.

Selection of the internal or external modulating signal, or no modulation, is made by analog switches U401C, U401D, and Op-amp U402B. The selected, buffered modulation signal at U402B pin 1 is applied to pin 4 of U301, a dual 8-bit DAC. U301, with U302D, acts as a digitally programmed variable attenuator and is labeled AM DAC.

Binary AM depth control information from the Controller is applied to DAC U301. The output at U302D pin 14 is the modulation signal scaled to the programmed AM depth. This ac signal is summed by op-amp U302B with a dc reference voltage provided by CR403. The output at U302B pin 7 is called the 1+AM signal. This signal provides the desired AM depth when scaled by the LVL DAC and applied to the leveling loop. AM depth adjustment is provided by potentiometer R421.

The instrument RF output amplitude is temperature compensated in a frequency-dependent manner as follows. The 1+AM signal is applied to pin 18 of dual 8-bit DAC U301, the DAC B reference input. The DAC output, at U405D pin 14, is the 1+AM signal attenuated by an RF frequency-dependent factor provided by the Controller using constants stored in the Generator firmware. This voltage is applied to a resistor/thermistor network that includes R303, R305, R306, and RT301.

The network output is the 1+AM signal attenuated by an RF frequency and temperature-dependent factor, and is applied to summing op-amp U302C. The 1+AM signal is also applied to this summing amplifier. Thus, the voltage at U302C pin 8 is the temperature-compensated and scaled 1+AM signal.

This signal is applied to the reference input of Level DAC U303. This 12-bit DAC, with op-amp U302A, latches U304, U305, controls the Output assembly RF output amplitude. The DAC output voltage, at U302A pin 1, is the temperature-compensated 1+AM signal multiplied by a factor proportional to the 12-bit level control number provided by the Controller. This voltage is the leveling loop control voltage. The Generator RF output level adjustment is provided by potentiometer R311, and DAC offset voltage adjustment is provided by potentiometer R309.

Table 2-8. IEEE-488 Commands (cont)

UNCAL	IU	none	none	Interrogates the uncalibrated output error codes. The Generator responds with three octal fields: "AAAAA,BBBBB,CCCCC". See Table 2-5 for a list of uncal error codes.
Software Version	IV	none	none	Interrogate the software version. The Generator responds with the status message: "Vxx.x" where x's are decimal digits representing the current software revision level.
MEMORY ENTRY				
Recall	RC	int	none	Recall the front panel setup stored at the memory location specified by int.
Store	ST	int	none	Store the current front panel setup at the memory location specified by int.
Sequence	SQ	none	none	Sequence (recall) to the next higher memory location.
MODULATION ENTRY				
Program AM	AM	float	PC	Program AM depth in percent.
External AM	AE	0/1	none	Disable/enable external AM modulation.
Internal AM	AI	0/1	none	Disable/enable internal AM modulation.
Program FM	FM	float	GZ MZ KZ HZ	Program FM deviation in units of: gigahertz megahertz kilohertz hertz
External FM	FE	0/1	none	Disable/enable external FM modulation.
Internal FM	FI	0/1	none	Disable/enable internal FM modulation.
Program Mod Freq	MR	0/1	none	Program modulation frequency to 400 Hz/1000 Hz.
Program Mod Freq	MF	float	GZ MZ KZ HZ	Program modulation frequency in units of: gigahertz megahertz kilohertz hertz
MONITOR COMMANDS				
Input Bit	IB	none	BIT Designator	Respond with the value of the designated hardware bit.
Output Bit	OB	0/1	BIT Designator	Set the designated hardware bit to 0 or 1.

INSTALLATION AND OPERATION

Table 2-8. IEEE-488 Commands (cont)

Output Dac	OD	int	DAC Designator	Set the value of the designated hardware DAC to the value specified by int.
Read Byte	RB	int	none	Read the value of the addressed byte. The Generator responds with an unsigned integer.
Read Word	RW	int	none	Read the value of the addressed word. The Generator responds with an unsigned integer.
Define Write Address	DW	int	none	Defines the address to be used by the write byte/word commands.
Write Byte	WB	int	none	Write int into the address specified with the define write address command.
Write Word	WW	int	none	Write int into the address specified with the define write address command.
Read Attenuation	XA	none	none	Read the current attenuation. The Generator responds with an unsigned integer.
Write Attenuation	XB	none	none	Change attenuation to 6dB times the unsigned integer. The integer can be 0 to 23.
Set Frequency Direct	XD	float	GZ MZ KZ HZ	Set the frequency hardware directly to the specified synthesizer frequency.
RF Output	XR	0/1	none	"XR0" programs all attenuation. "XR1" restores attenuation to its previous state.
RF ON/OFF ENTRY				
RF Output	RO	0/1	none	Turn RF output off/on.
SPECIAL FUNCTION ENTRY				
Special Functions	SP	00 02 03 04 07/08 09 10 11 12/13 14 15 20/21 30/31 70 71 72 80 81 82 83-86 90/91		Clears all special functions Initiates self test Display check Key check Set/reset SRQ Display S/W rev and instr ID Display IEEE-488 address Display self-test results Turn on/off display Initialize memory Latch test Disable/enable relative frequency Disable/enable relative amplitude Medium key repeat rate Fast key repeat rate Slow key repeat rate Enable all level correction Disable all level correction Disable attenuator correction Program alternate 24dB attenuations Disable/enable amplitude fixed ring

Table 2-8. IEEE-488 Commands (cont)

SRQ COMMANDS				
Interrogate SRQ Mask	IM	none	none	Interrogate the SRQ mask. The Generator responds with the decimal value of the SRQ mask.
Set SRQ	SM	int	none	The SRQ mask is set to int.
Local Operation Alert Mode	XF	0/1	none	Disable/enable a mode to set SRQ each time a local entry is made. This SRQ is enabled by setting the front panel bit in the SRQ mask.
STEP ENTRY				
Program FREQ STEP Size	FS	float	GZ MZ KZ HZ	Program frequency step size in units of: gigahertz megahertz kilohertz hertz
Program AMPL STEP Size	LS	float	V MV UV NV DB	Program amplitude step size in units of: volts millivolts microvolts nanovolts dB or dBm
Program AM STEP Size	PS	float	PC	Program AM step size in percent.
Program FM STEP Size	DS	float	GZ MZ KZ HZ	Program FM step size in units of: gigahertz megahertz kilohertz hertz
Step Up/Down	SU/SD	none	none	Step the currently selected step function up/down one step.
Step Up/Down Frequency	FU/FD	none	none	Change the current step function to frequency and step frequency up/down one step.
Step Up/Down Amplitude	LU/LD	none	none	Change the current step function to amplitude and step amplitude up/down one step.
Step Up/Down AM	PU/PD	none	none	Change the current step function to AM and step AM up/down one step.
Step Up/Down FM	DU/DD	none	none	Change the current step function to FM and step FM up/down one step.
TRIGGER COMMANDS				
Configure Trigger	CT	string	none	Configures the trigger. Each time a trigger command or a group execute trigger interface message is received, the Generator executes the string of commands. The string record must end with a record terminator.

INSTALLATION AND OPERATION

Table 2-8. IEEE-488 Commands (cont)

Trigger	TR	none	none	Trigger command. Equivalent to the group execute interface message. Upon processing the trigger command, the Generator executes the string, which has been preprogrammed with the configure trigger command.
---------	----	------	------	--

2-37. PROGRAMMING EXAMPLE 1

Use the following procedure to program the Generator with a Fluke 1722A Instrument Controller to this state:

```

Frequency      210 MHz
Amplitude      6 dBm
Modulation Freq. 1000 Hz
FM             5 kHz
Internal FM    ON
AM            15%
External AM    ON
    
```

1. Connect the Generator to the Controller with an IEEE-488 cable.
2. Set the address switch of the Generator as follows (as viewed from the rear of the instrument):

00000010

3. Enter the following program into the Controller:

```

1  ! Fluke 1722A BASIC program to control a 6060B.
2  ! The Address of the 6060B is 2.
3  AX = 2X
10 ! Clear the 6060B so that it is in a known state.
15 INIT PORT 0
20 REMOTE @AX \ CLEAR @AX
100 ! SET THE 6060B.
110 PRINT @AX, "FR210MZ, AP6DB, MR1, FM5KZ, F11, AM15PC, AE1"
999 END
    
```

4. Run the program by typing on the Controller "RUN (RETURN)".

2-38. PROGRAMMING EXAMPLE 2

The 6060B Signal Generator can be connected to an other 6060B Signal Generator in a master-slave configuration. In the following example, two Generators are configured to track each other in frequency. This configuration may be used to track frequency, amplitude, AM, or FM.

1. Connect two 6060B Signal Generators together with an IEEE-488 cable.
2. Set the rear panel address switch of the first Generator (talker) as follows:

00100000

3. Set the rear panel address switch of the second Generator (listener) as follows:

01000000

4. Manually program the talker Generator as follows:

FUNCTION	VALUE	KEY SEQUENCE
Frequency	210 MHz	[FREQ] [2] [1] [0] [MHz] [V]
Step Function	Frequency	[FREQ] [STEP]
Frequency Step	1.25 kHz	[1] [.] [2] [5] [kHz] [mV]

5. Manually program the listener Generator as follows:

FUNCTION	VALUE	KEY SEQUENCE
Frequency	195 MHz	[FREQ] [1] [9] [5] [MHz] [V]
Step Function	Frequency	[FREQ] [STEP]
Frequency Step	1.25 kHz	[1] [.] [2] [5] [kHz] [mV]

6. On the talker Generator, press the [+] STEP or [-] STEP keys. Each time the key is pressed, the frequency of both Generators increases or decreases by 1.25 kHz (the Frequency Step) at frequencies 15 MHz apart.

Different functions on each Generator can be programmed to track in the master-slave configuration. In other words, while the master Generator can be programmed to step increase 25 kHz FM, the Slave Generator can be programmed to step 25% AM.

NOTE

To use the step function feature for other functions, change the step function on the Generators to the desired functions.

2-39. PROGRAMMING EXAMPLE 3

In the following example, the Generator is programmed by a Fluke 1722A Controller (via the IEEE-488 bus) to the same state as in Programming Example 1. Additionally, the frequency step size is set to 1.25 kHz, and the trigger buffer is programmed to execute the step up command when the trigger command is received. The SRQ mask of the Generator is set to generate an SRQ when the RF output has settled and the Generator is ready for more input from the bus.

The program then enters a loop where it waits for the ready SRQ, sends the GET (group execute trigger) interface message to step up the frequency, and waits again. At this time you should do the following:

1. Connect the Generator to the Controller with an IEEE-488 cable.
2. Set the rear panel address switch of the Generator as follows:

00000111

3. Enter the following program into the Controller:

```

1  ! Fluke 1722A BASIC program to control a 6060B.
2  ! The address of the 6060B is 7.
3  AX = 7%
10 ! Clear the 6060B so that it is in a known state.
15 INIT PORT 0
20 REMOTE @AX \ CLEAR @AX
100 ! Set the 6060B.
110 PRINT @AX, "FR210MZ, AP6DB, MR1, FM5KZ, F11, AM15PC, AE1"
120 ! Set the frequency step, output valid mode.
121 ! and configure the trigger buffer.
130 PRINT @AX, "FS1, 25KZ, VM1, CTSU"
140 ! Set the SRQ mask to enable "output valid" SRQ
150 PRINT @AX, "SM16"
160 ! Wait for above commands to finish processing
170 WAIT 1000 \ SZ = SPL (AX)
180 ! Trigger the first step up
190 TRIG @AX
300 ! Wait for SRQ
310 ON SRQ GOTO 800
320 WAIT FOR SRQ
800 OFF SRQ
810 ! Check the serial poll response
820 SZ = SPL (AX)
830 IF (SZ AND 64%+16%) (> 80% THEN PRINT sz; " Bad Serial Poll Response"
840 ! Trigger the next step up
890 TRIG @AX
860 ! Resume operation-- waiting for next SRQ
870 RESUME 300
999 END

```

INSTALLATION AND OPERATION

4. Run the program by typing on the Controller "RUN (RETURN)".

2-40. Interface Functions

The Generator implements a subset of interface functions defined by the IEEE Standard 488-1978. Table 2-9 summarizes the interface functions implemented. This section describes the operation of the Generator in response to interface messages associated with each interface function.

Table 2-9. IEEE-488 Interface Functions List

FUNCTION	DESCRIPTION
SH1	Complete source handshake capability
AH1	Complete acceptor handshake capability
T5	Basic talker, Talk only, Serial poll, Unaddressed if MLA
TE0	No extended talker capability
L3	Basic listener, Listen only, Unaddressed if MTA
LE0	No extended listener capability
SR1	Complete service request capability
RL1	Complete remote/local capability
PP0	No parallel poll capability
DC1	Complete device clear capability
DT1	Complete device trigger capability
CO	No controller capability
E1	Open-collector drivers

2-41. Address Mode

In the address mode, the Generator may be operated from local (using the Front Panel keys) or from remote (using the IEEE-488 Interface). The following paragraphs describe the operation of the Generator in both states and transitions between the states.

The available IEEE-488 messages and their descriptions for the address mode of operation are presented in Table 2-10.

2-42. LOCAL OPERATION

The Generator powers up in the local mode. When in local mode, the following conditions are present:

The front panel indicator REM, is not lit.

Device trigger (GET), device clear (DCL), and selected device clear (SDC) interface messages are ignored.

All device dependent messages are ignored.

If the data output was requested while the Generator was in the remote mode, the data output of a talker may be sent.

2-43. GOING FROM LOCAL TO REMOTE

The Generator switches from local to remote when the "my listen address message" (MLA) is received, and the Remote Enable (REN) signal is true.

Table 2-10. IEEE-488 Address Mode Message Descriptions

MESSAGE	DESCRIPTION
<p>pon Power-On</p> <p>Talker Operation</p> <p>Listener Operation</p> <p>Service Request Operation</p>	<p>When powered up, the Generator generates a Power-On message (pon) and clears its output buffer. The Generator is not addressed to talk when powered up.</p> <p>The Generator is not addressed to listen when the power is turned on.</p> <p>The state of the Service Request (SRQ) signal on pon is determined by the SRQ mask. Because of the non-volatile memory, the SRQ mask is the same as when the power was removed. Therefore, if the SRQ mask enables the power on, output valid, or ready SRQs, the SRQ signal will be true during pon.</p>
<p>MTA My Talk Address</p> <p>Talker Operation</p> <p>Listener Operation</p>	<p>The Generator is addressed to talk upon receipt of the MTA message. The front panel 'ADDR' indicator is lit while the Generator is addressed to talk.</p> <p>The Generator unlistens when the MTA message is received.</p>
<p>MLA My Listen Address</p> <p>Talker Operation</p> <p>Listener Operation</p>	<p>The Generator untalks when the MLA message is received.</p> <p>The Generator is addressed to listen when the MLA message is received. The front panel 'ADDR' indicator of the Generator is lit while the Generator is addressed to listen.</p>
<p>Data</p> <p>Talker Operation</p> <p>Listener Operation</p>	<p>The Generator sends data to the IEEE-488 bus only when requested by a programming data message. Message formats are described in the Command Description paragraphs. An End of Record (EOR) character is sent with EOI asserted following all outputs. The EOR character is either a carriage return or a line feed, depending on the setting of the terminator mode. The parity bit is always zero. Multiple output requests are buffered until the buffer is full. Processing of programming data messages is stopped until the buffer is no longer full. The buffer can be cleared with the Clear Buffer command ("CB"), The buffer is also cleared on power up (pon), with a Clear Command ("CL"), or with a Device Clear interface message (DCL or SDC).</p> <p>Command syntax, error processing, and input buffer overflow are described in the paragraphs on Command Processing. Refer to Table 2-8 for a List of IEEE-488 commands that are recognized by the Generator.</p>

INSTALLATION AND OPERATION

Table 2-10. IEEE-488 Address Mode Message Descriptions (cont)

MESSAGE	DESCRIPTION
IFC Interface Clear	
Talker Operation	The Generator untalks and unlistens when the IFC message is received.
Listener Operation	The Generator unlistens and untalks when the IFC message is received.
OTA Other Talk Address	
Talker Operation	The Generator untalks when the OTA message is received.
SPE Serial Poll Enable	
Talker Operation	After receiving the SPE message, the Generator responds with the serial poll status byte, if addressed to talk.
SPD Serial Poll Disable	
Talker Operation	After receiving the SPD message, the Generator resumes normal talk operation.
ULA Unlisten Address	
Listener Operation	The Generator unlistens when the ULA message is received.
RSV Request Service	
Service Operation	The front panel SRQ indicator is lit when the rsv message is sent. The Generator may request service for several reasons. Each reason for service request can be individually masked with the set mask command ("SM"). The service request mask can be interrogated with the interrogate mask command ("IM").
DCL Device Clear	
Clear Operation	The DCL message is ignored when in local. When the DCL message is received (during remote operation) the Generator is cleared. Any characters in the input buffer are cleared followed by the same operation as the clear command ("CL"). The operation of the DCL message is identical to the operation of the selected device clear (SDC) message. The cleared state of the Generator is described in the paragraphs on Power-On Conditions.

Table 2-10. IEEE-488 Address Mode Message Descriptions (cont)

MESSAGE	DESCRIPTION
SDC Selected Device Clear	The SDC message is ignored during local operation. When the SDC message is received (during remote operation), the Generator is cleared. Any characters in the input buffer are cleared followed by the same operation as the clear command ("CL"). The operation of the SDC message is identical to the operation of the device clear (DCL) message. The cleared state of the Generator is described in the paragraphs on Power-On Conditions.
Clear Operation	
GET Group Execute Trigger	The GET message is ignored during local operation. When the GET message is received (during remote operation), the Generator executes a command string that has been preprogrammed with the Configure Trigger command ("CT"). The operation of the GET message is identical to the operation of the Trigger ("TR") command.
Trigger Operation	
Undefined IEEE-488 Commands	All undefined IEEE-488 commands are acknowledged by the Generator handshake sequence, but no action is taken.

2-44. REMOTE OPERATION

When in the remote mode, the following conditions are present:

The front panel REM indicator is lit.

Device trigger (GET), device clear (DCL), and selected device clear (SDC) interface messages are processed.

All device-dependent messages are processed during the remote mode.

2-45. GOING FROM REMOTE TO LOCAL

The Generator switches from remote to local mode in one of the following ways: The IEEE-488 Go To Local (GTL) message is received, the remote enable signal REN is false, or a Return To Local (rtl) message is generated by pressing the front panel [CLR/LCL] key (if the Generator is not in the local lockout mode).

The Generator enters the local lockout mode when the Local Lockout message (LLO) is received. The Generator exits the local lockout mode to the local mode when REN is false.

When switching from remote to local, unprocessed commands in the input buffer are processed until the input buffer is cleared or a front panel entry is made. Switching to local has no effect on the contents of the output buffer.

2-46. Talk-Only Mode

Figure 2-6 shows two 6060B connected together with the IEEE-488 Bus.

INSTALLATION AND OPERATION

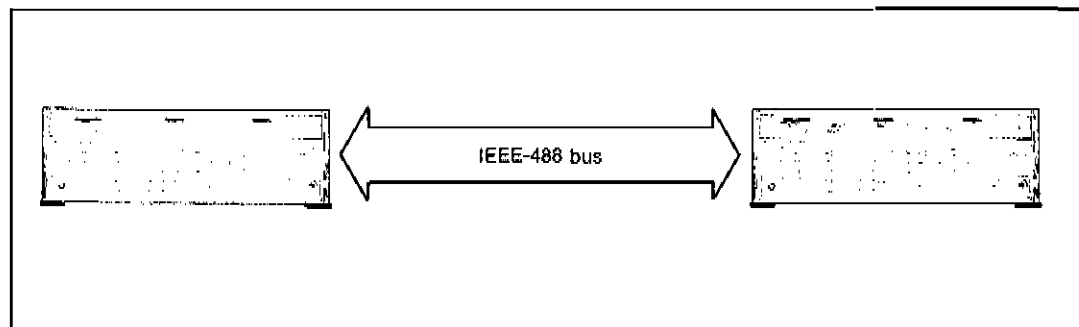

Figure 2-6. 6060B IEEE-488 Bus Connected to a 6060B IEEE-488 Bus

To select the talk-only mode, set the TALK ONLY address switch to 1 (up). If the talk-only address switch and the listen-only address switch are set to 1, the talk-only mode is selected.

In the talk-only mode, the listener, remote/local, service request, device clear, and device trigger interface functions do not apply.

If the talk-only mode is selected, the Generator is always addressed to talk and the front panel ADDR indicator is always lit. The Step Up ("SU") or Step Down ("SD") message is sent when the [+]STEP or [-]STEP front panel keys are pressed. This output is not buffered and if no listener is connected to the IEEE-488 Interface, no output will be sent. A carriage return followed by line feed (with the EOI signal true) are always sent as the end of record.

2-47. Listen-Only Mode

To select the listen-only mode, set the LISTEN ONLY address switch to 1 (up). If the talk-only address switch and the listen-only address switch are set to 1, the talk-only mode is selected.

If the listen-only mode is selected, the Generator is always addressed to listen, and the front panel ADDR indicator is always lit. The Generator listens and responds to all data messages on the IEEE-488 Interface. The response to data messages is the same as in the addressed mode of operation except that requests for talker output are ignored.

In the listen-only mode, the talker, remote/local, service request, device clear, and device trigger interface functions do not apply.

2-48. Command Syntax

The Generator IEEE-488 bus commands alphabet consists of the letters A through Z (upper and lower case letters are treated equally), digits 0 through 9, and the following special characters:

@ . , ; + - CR LF

Spaces, tabs characters, and the parity bit are ignored.

The IEEE-488 commands for the Generator consist of the following three parts:

Header
Numeric
Suffix

The header is always required, but the numeric and suffix may be optional. This rule gives the following four possible combinations:

- (HEADER)
- (HEADER) (NUMERIC)
- (HEADER) (NUMERIC) SUFFIX)
- (HEADER) (SUFFIX)

Multiple commands may be separated with one of the end of string (EOS) characters ";" or ",". Use of EOS characters facilitates recovery in the event of a syntax error and will also enhance readability.

2-49. COMMAND HEADER SYNTAX

The command header is a two alpha-character string. A list of the IEEE-488 command headers used on the Generator is presented in Table 2-8. The header determines the syntax of the numeric and suffix as listed in the table.

2-50. NUMERIC DATA SYNTAX

There are four types of numeric data: Boolean, unsigned integer, floating point, and trigger string. The following paragraphs describes each of the four numeric data formats. A syntax diagram is included for each format.

1. Boolean

Boolean numeric data must be either a "0" or a "1". All other characters will result in a syntax error.

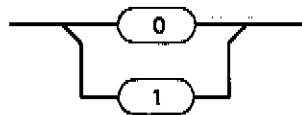

2. Unsigned Integer

Unsigned integers may be specified in decimal or in hexadecimal. Any number of decimal digits are accepted. However, values greater than 65,535 are rejected. Hexadecimal numbers are preceded by an "X". Only 4 hexadecimal digits are accepted. Specifying a number in hexadecimal for the read word and read byte commands causes the response to be sent in hexadecimal. Decimal digits may be the numerals 0 through 9. Hexadecimal digits may be the hexadecimal digits 0 through F.

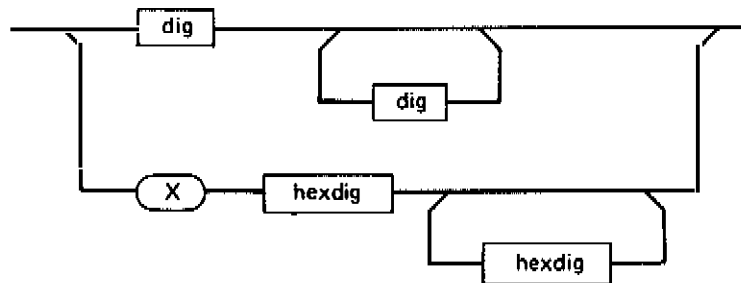

INSTALLATION AND OPERATION

3. Floating Point

The floating-point numeric data format is the most flexible format. Digits may be the numerals 0 through 9. Any number of digits are accepted for both the number and the exponent. However, numbers greater than 2,147,483,629 are truncated, and exponents greater than 32,749 are rejected.

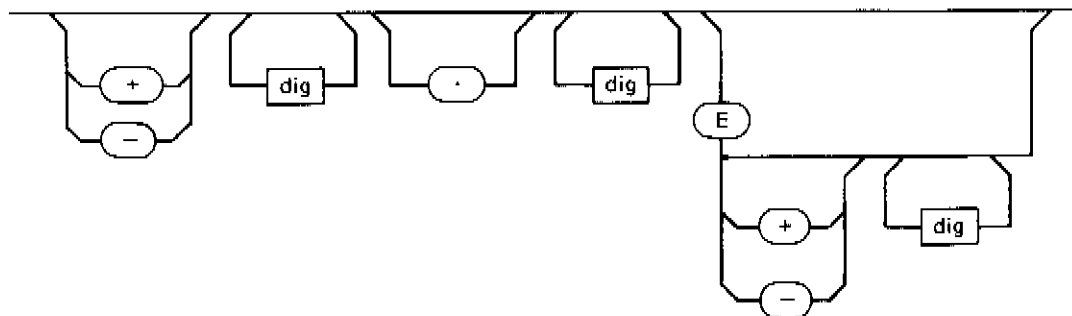

4. Trigger String

The trigger string numeric data is a string of Generator commands terminated with an EOR. The string may be up to 71 characters not including the EOR. Commands in the string are not checked for validity until the trigger string is executed with the trigger command.

EOR is the end of record character. This character is selectable with the terminator mode command. "TM0" selects the linefeed character. "TM1" selects the carriage return character. The IEEE-488 interface signal EOI asserted with any other character is also considered an end of record.

EOS is an end of string character, use either ";" or ":",

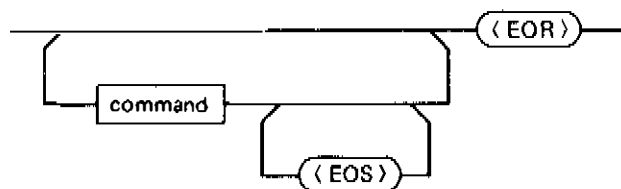

2-51. SUFFIX SYNTAX

Suffixes are always one or two alpha-characters. Certain suffixes are used to scale the numeric (the same as the front panel UNITS keys). Other suffixes mnemonically designate hardware components. The five types of suffixes are described in Table 2-11.

2-52. Command Descriptions

The following paragraphs describe the remote IEEE-488 Interface operating commands that are not accessible from the front panel of the Generator. IEEE-488 Interface commands that are accessible from the front panel of the Generator are described earlier in this section.

Table 2-11. Suffix Types

SUFFIX TYPE	SUFFIX	MNEMONIC	EQUIVALENT EXPONENT
Frequency and FM	GZ	gigahertz	9
	MZ	megahertz	6
	KZ	kilohertz	3
	HZ	hertz	0
Amplitude	V	volts	0
	MV	millivolts	-3
	UV	microvolts	-6
	NV	nanovolts	-9
	DB	dBm or dB	0
AM	PC	percent	0
DAC/BIT Designators	DAC and BIT designators are two alpha-character mnemonics that refer to hardware DACs and bits. Refer to the paragraphs on Monitor Commands for a complete list of designators.		
Learn Suffix	A learn suffix is a string of ASCII characters that contain coded memory location contents. Refer to the paragraphs on Binary Learn Commands for decoding of the learn string.		

2-53. BINARY LEARN COMMANDS

Front panel setups are stored in the memory of the Generator in a packed binary format. The binary learn commands are used to transfer this binary data between an IEEE-488 controller and the Generator. These commands allow you to minimize the amount of programming commands needed to program the entire instrument state. The binary learn commands are:

- “LM” Learn Memory
- “LI” Learn Interface

The syntax for the Learn Memory (“LM”) command is as follows:

“LM” Memory Location Code

The Generator responds to the “LM” command with a string of 64 ASCII characters followed by an (EOR) (end of record character). This string represents the front panel settings (in a packed binary format) that were stored in the memory location specified.

NOTE

The (EOR), end of record character, is sent with EOI asserted. “TM0” selects the linefeed character, and “TM1” selects the carriage return character.

INSTALLATION AND OPERATION

Example

IEEE-488 Command: "LM98"

Response:

"BOABAAAAPPJMAAAKAAAAAAAAABBOKKAAAAPECEAA
BPEAAABDAEEBBAGBLKKMPAC"(EOR)

Refer to Figure 2-7 for information on how to decode this learn string.

The syntax for the Learn Interface "LI" Command is as follows:

"LI" Memory Location Code: Learn String

The Generator stores the learn string in the memory location designated by the memory location code. If the memory location specified is 99, the instrument is programmed to the data sent in the learn string.

Example

To program the Generator to the Instrument Preset State:

"LI99BOABAAAAPPJMAAAKAAAAAAAAABBOKKAAAAPECEAAABPE
AAABDAEEBBAGBLKKMPAC"

Note that the binary learn string in this example is the same as the learn string returned from memory location 98 which contains a record of the Instrument Preset State.

Instructions:

1. Convert the hexadecimal number to a signed decimal number as follows:
 - a. Multiply the most significant hexadecimal digit by 16.
 - b. Add the next significant digit to the value obtained in Step a.
 - c. Multiply the sum of Step b by 16, and add in the next hexadecimal digit until the least significant hexadecimal digit has been added.

NOTE

If the hexadecimal number started with an 8 through F, the number is negative. Perform Step d for negative numbers.

- d. Subtract, 16 from the number raised to the power of the number of digits.

Example of Instruction 1:

To convert hexadecimal number 1E:

$$(1 * 16) + 14 = 30$$

(Since the most significant digit is 1, the number is not negative.)

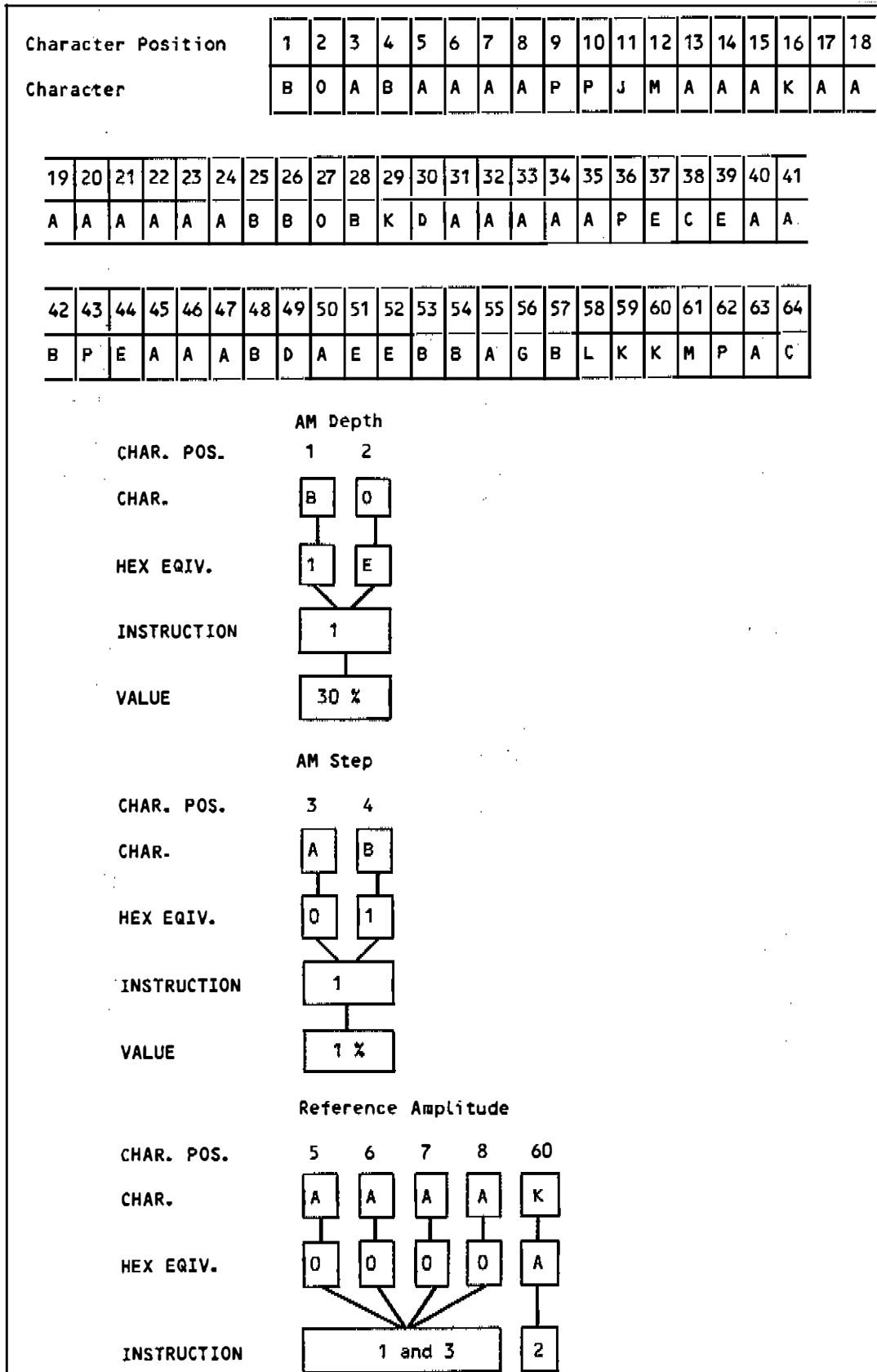

Figure 2-7. Learn String Example

INSTALLATION AND OPERATION

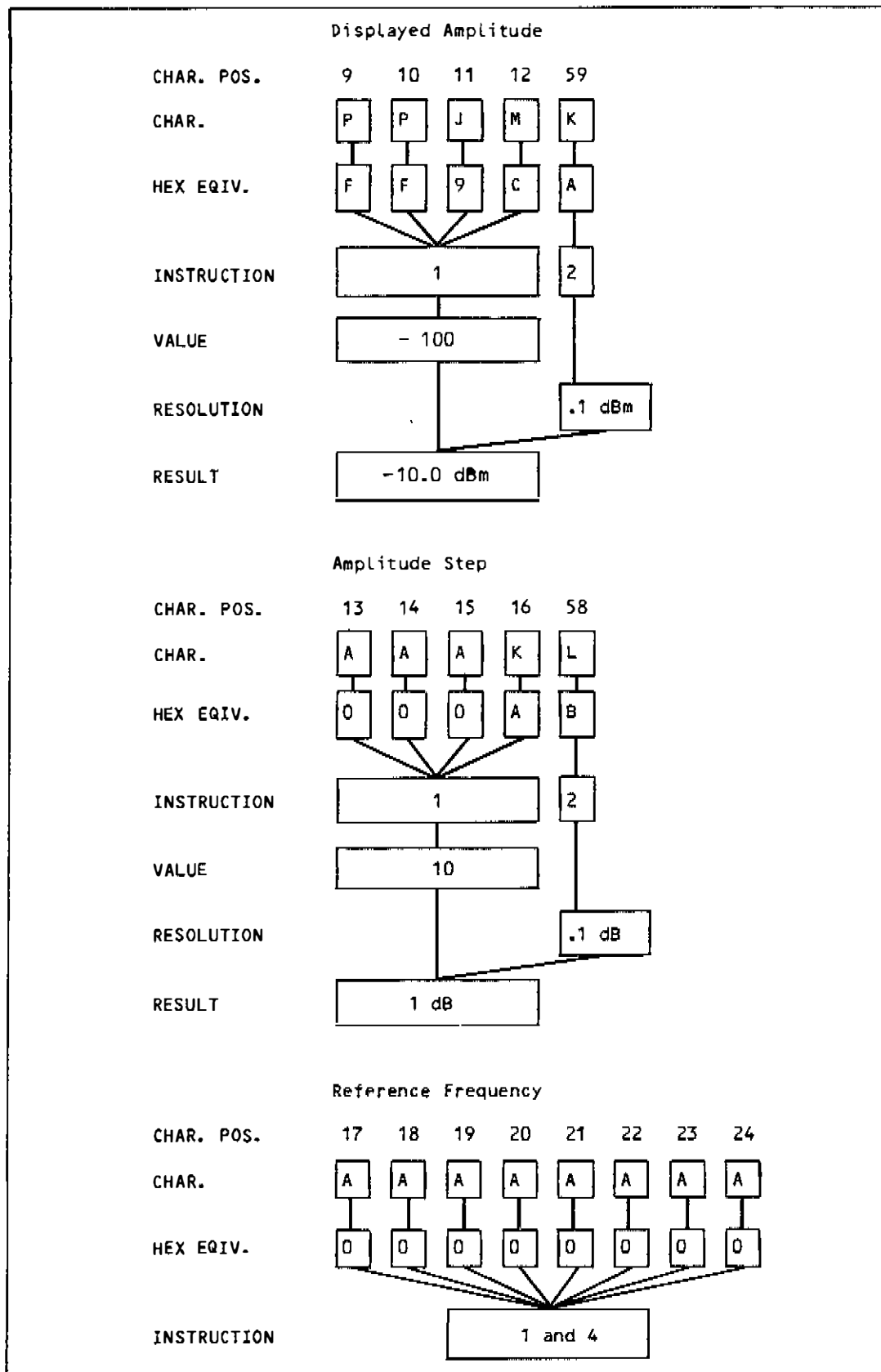

Figure 2-7. Learn String Example (cont)

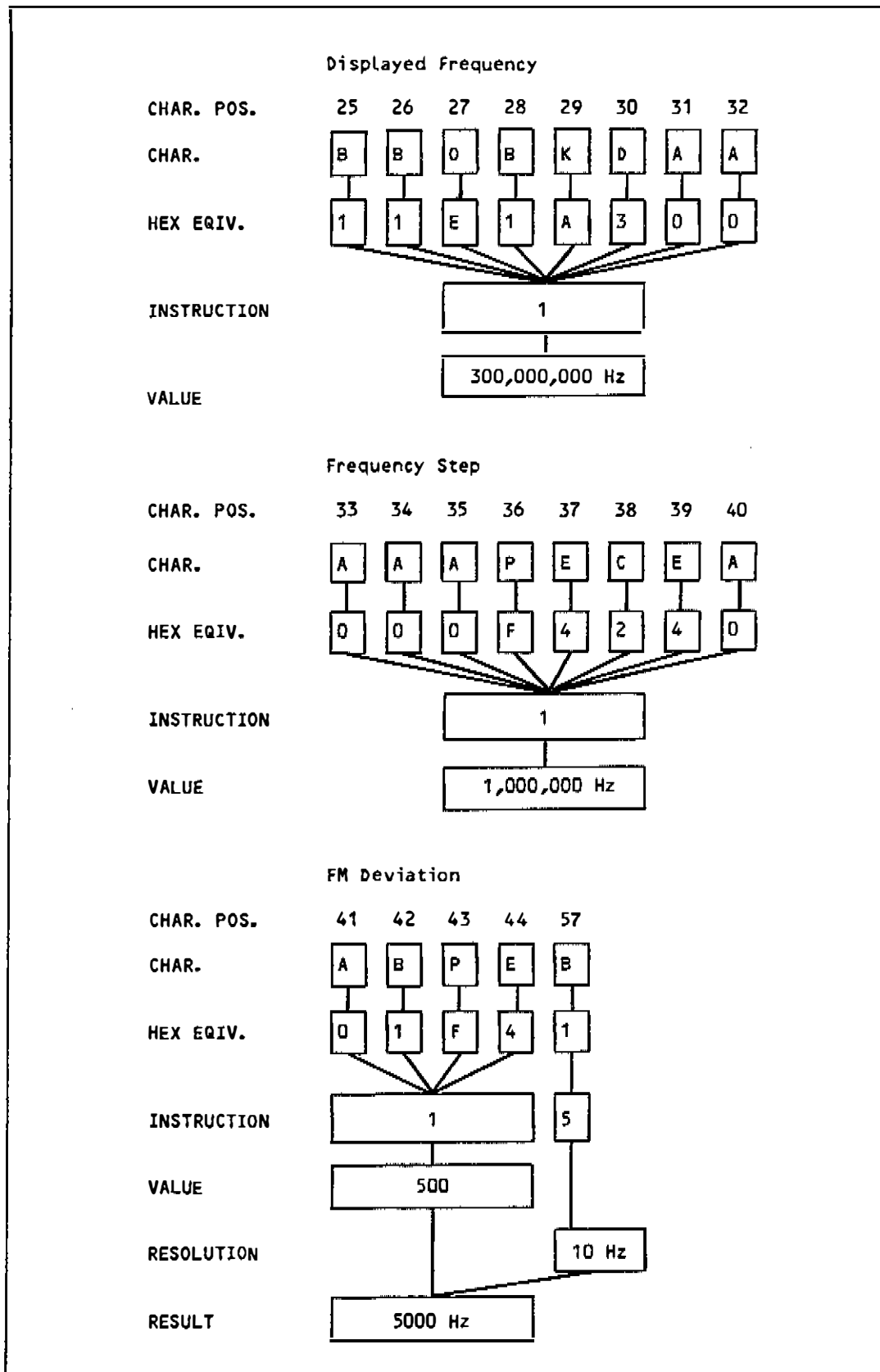

Figure 2-7. Learn String Example (cont)

INSTALLATION AND OPERATION

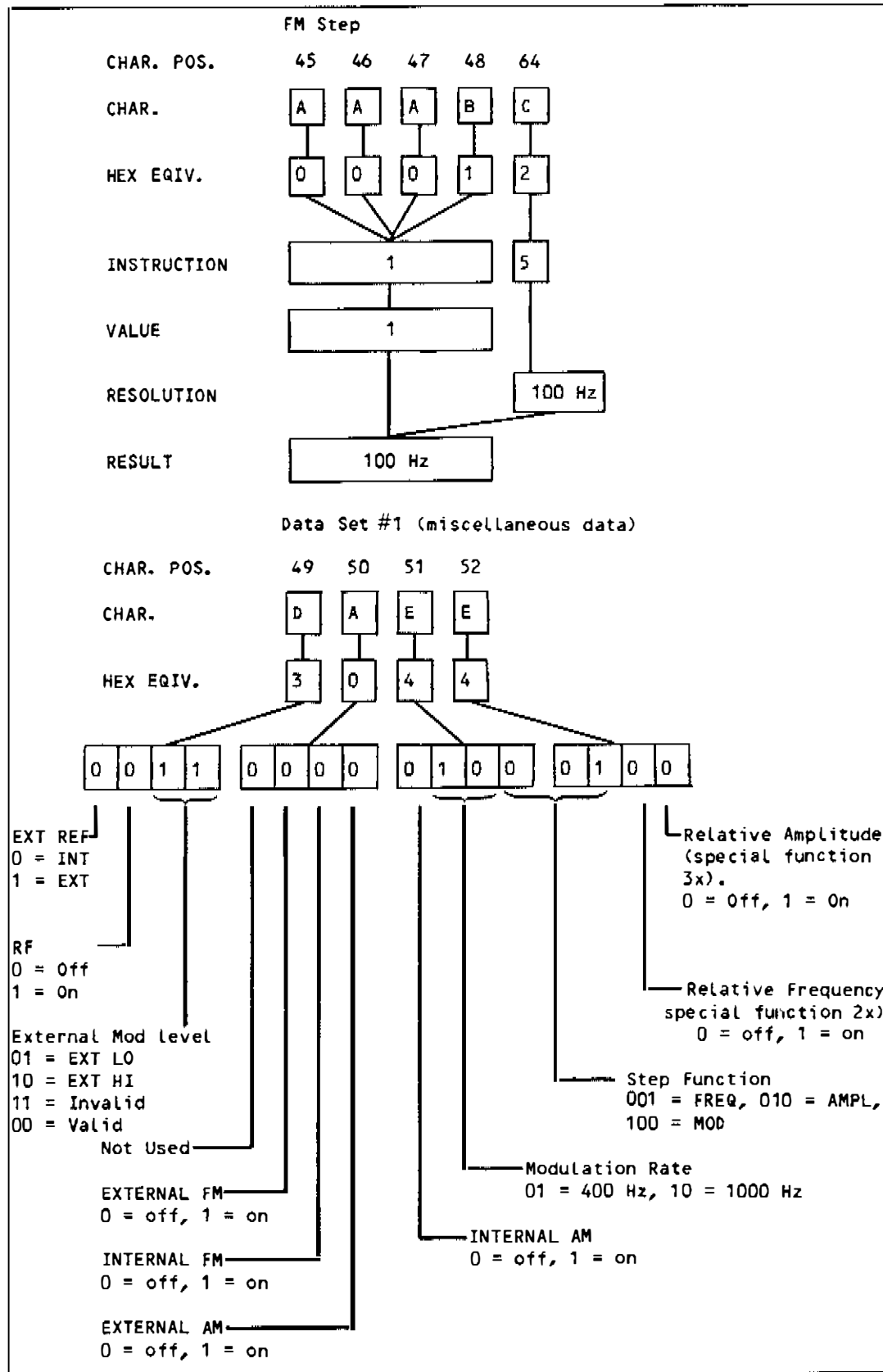

Figure 2-7. Learn String Example (cont)

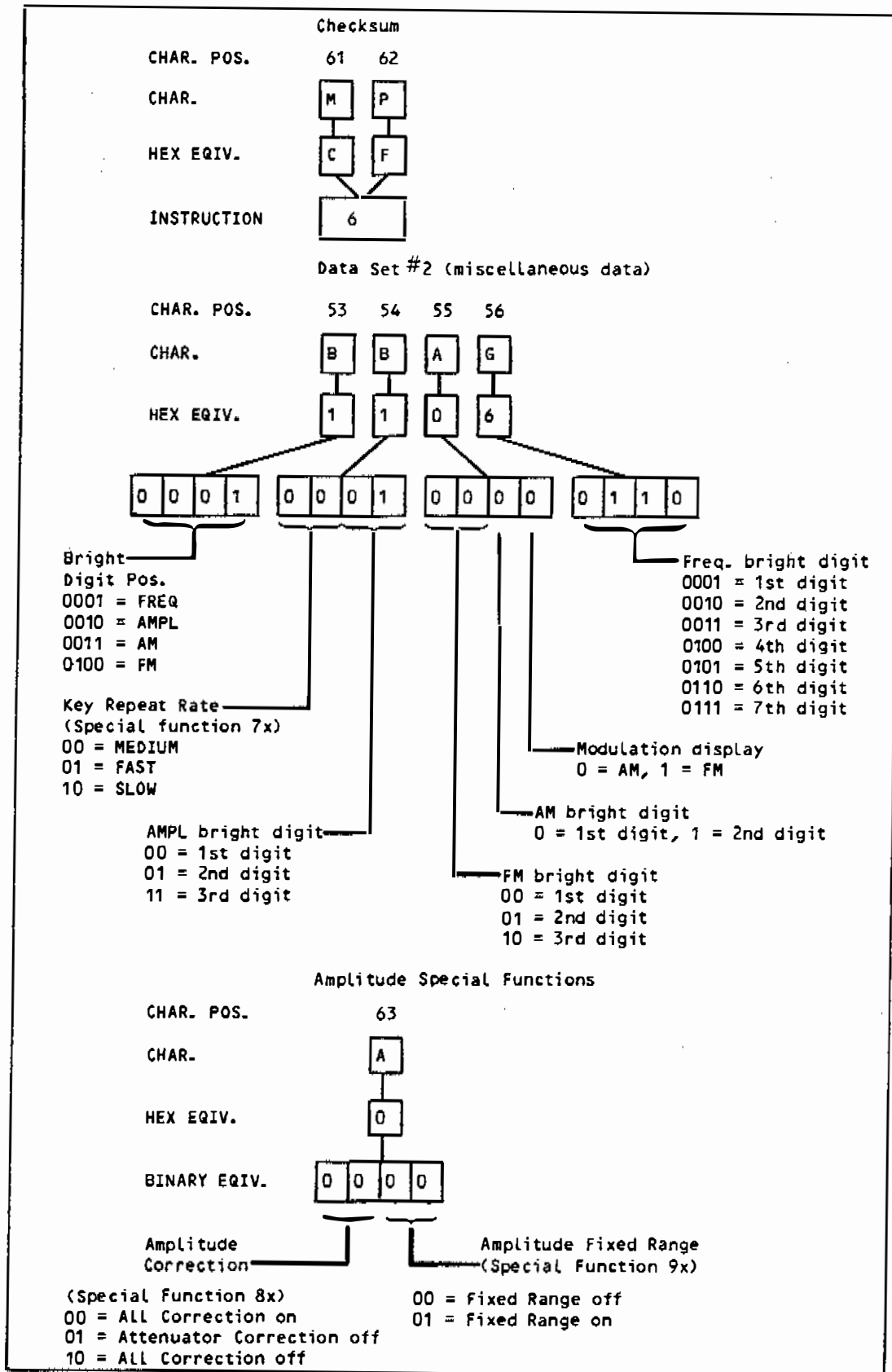

Figure 2-7. Learn String Example (cont)

INSTALLATION AND OPERATION

To convert hexadecimal number FF9C:

$$((((15 * 16) + 15) * 16) + 9) * 16 + 12 = 65436$$

(Since the most significant digit is F, the number is negative.)

Using Step d; $16^4 = 65536$, $65436 - 65536 = -100$. The signed decimal equivalent to FF9C is -100.

2. Amplitude quantities have a number and a resolution associated with them. This applies to the Displayed Amplitude, Reference Amplitude, and Amplitude Step.

Use the following procedure to identify the resolution of an amplitude quantity:

- a. If the resolution is A or B (hexadecimal), the resolution of the number is 0.1 dBm or 0.1 dB units.

Example:

The Displayed Amplitude (in this figure) is -100 with a resolution of A.

- a. The actual displayed amplitude is -10.0 dBm.
- b. If the stored resolution is 0 through 9 (hexadecimal), the amplitude quantity is in volts. To convert the number to the actual amplitude in nanovolts, multiply the amplitude number by the power of ten represented by the resolution.

Example: An Amplitude Step of 12, with a resolution of 6 would be an actual amplitude step of 12,000,000 nV or 12 mV.

3. If the Relative Amplitude mode is off, the data stored in the reference amplitude location is not used.
4. If the Relative Frequency mode is off, the data stored in the reference frequency location is not used.
5. FM and FM Step quantities have a number and a resolution associated with them. To convert the number to the FM quantity in Hz, multiply the number by the power of ten represented by the resolution. If the Low-Rate FM option is installed, the FM quantity, adjusted by the resolution, has a resolution of 0.1 Hz.

Example: The FM number (in this figure) is 500, with a resolution of 10 Hz. The actual FM deviation is 5000 Hz.

6. The checksum data is calculated by adding the data in the learn string, two hexadecimal digits at a time. The total, including the checksum, should add up to a number whose least significant two hexadecimal digits are 01.

NOTE

The memory location code must be an unsigned integer indicating the memory location to be learned. Memory location 99 refers to the current instrument settings. Memory location 98 refers to the Instrument Preset State as listed in Table 2-3.

The characters in the learn string correspond to each Generator function. A description of how to interpret the characters in the learn string is given in Figure 2-7. Table 2-12 shows the conversion from the learn string to the hexadecimal character.

Table 2-12. Learn Character to Hexadecimal Conversion

LEARN CHARACTER	HEXADECIMAL EQUIVALENT	DECIMAL EQUIVALENT
A	0	0
B	1	1
C	2	2
D	3	3
E	4	4
F	5	5
G	6	6
H	7	7
I	8	8
J	9	9
K	A	10
L	B	11
M	C	12
N	D	13
O	E	14
P	F	15

2-54. CLEAR COMMANDS

The following IEEE-488 clear commands are recognized by the Generator:

- “CB” Clear IEEE-488 input buffer
- “CE” Clear IEEE-488 rejected entry error status
- “CL” Clear instrument

The “CB” command can be used to clear the Generator output buffer. The output buffer should be cleared at the beginning of any remote program to synchronize data output. The output buffer is also cleared on power up, with the “CL” clear Generator command, or by the SDC and DCL clear interface messages.

The “CE” command can be used to explicitly clear the error status. The error status is also cleared when it is interrogated with the “IR” command, or the “CL” clear Generator command, or the SDC and DCL clear.

The “CL” command is used to clear the instrument state. The same actions are performed with the SDC and DCL clear interface messages. (In addition, the input buffer is cleared with the clear interface messages.) The following IEEE-488 commands are performed with the clear Generator command: “RC98, RO1, CE, CB, RM0, TM0, EM0, VM0, UM0, SM192, SP08, XF0, DW0, CT”(EOR).

2-55. INTERFACE MODE COMMANDS

Interface Mode commands are used to configure the Generator for different modes of IEEE-488 interface operation. Since the Generator knows when its RF output has settled, it can be configured to synchronize itself with the Controller. This eliminates WAIT statements in the program, which are normally used to allow time for the output of the controlled device to settle. Table 2-13 lists the Interface Mode Commands.

INSTALLATION AND OPERATION

Table 2-13. Interface Mode Commands

COMMAND	DESCRIPTION	COMMAND STATUS
"EM"	Error Mode	1 = on, 0 = off
"RM"	Record Mode	1 = on, 0 = off
"TM"	Select Terminator	1 = CR, 0 = LF
"UM"	Unbuffered Mode	1 = on, 0 = off
"VM"	Valid Mode	1 = on, 0 = off

The error mode selects when the IEEE-488 rejected entry status is cleared. If turned on, the error status is cleared when a new message is processed. If turned off, the status is cleared only when interrogated with the "IR" (interrogate rejected entry) command or when explicitly cleared with the "CE" (clear error command).

The record mode selects whether the message unit is a record or a command. When turned on, the message unit is a record. When turned off, the message unit is a command.

The terminator mode selects the character used as the record terminator. The terminator character is not used for command processing unless the record mode is enabled. When turned on, the record terminator CR (carriage return) is used. If turned off, the record terminator LF (line feed) is used. The record terminator character is the last character in all IEEE-488 messages sent from the Generator.

The unbuffered mode selects when messages from the IEEE-488 interface are processed. When turned on, messages are read from the IEEE-488 interface only when the microprocessor is ready to process them. In this mode, the input buffer will contain a maximum of one message. (A message may be one command or one record, depending on the setting of the record mode.) When turned off, messages are read from the IEEE-488 interface to the input buffer of the Generator at the fastest rate. In this mode, the input buffer may contain up to 80 characters.

The valid mode selects when messages are processed by the Generator microprocessor. When turned on, processing of a new message is begun only after the RF output has settled and become valid. When turned off, a new message is processed immediately after the completion of the previous message.

The interface modes can also be programmed using the command, "@n" (where n is an integer). The interface modes are set to the value of n where n is the sum of the codes for the desired modes. The integer codes for the interface modes that can be programmed using the "@n" commands are as follows:

Terminator Mode = 1
Record Mode = 2
Valid Mode = 4
Unbuffered Mode = 8
Error Mode = 16

For example, to select the record mode and valid mode, the command is "@6".

Interface Mode Example

In this example, the RF output of Generator is connected to a circuit that is being measured by a voltmeter. The output of the Generator must be settled before the voltmeter is given its command to make a measurement.

A Fluke 1722A program might look something like:

```

PRINT @1, "CL, TM1, RM1, VM1, UM1"  ! initialize the 6060, select modes
PRINT @1, "FR100M2, AP-25DB"      ! program the 6060
PRINT @2, "7"                      ! trigger the voltmeter
INPUT @2, R$                       ! get the reading
    
```

The entire record is transferred into the Generator before processing begins. In this example, processing begins when the record terminator CR is received. The following character (LF in this case) will not be received into the Generator until the entire record is processed and the output has settled. No wait statement is needed between setting up the Generator and taking the measurement because the Generator will not handshake the LF character until its output has settled.

NOTE

A record is a string of characters separated by <EOR>. A message is the smallest group of characters that the Generator can process when programmed from the IEEE-488 interface.

NOTE

The output valid state of the Generator occurs 45 ms after any hardware has been changed.

2-56. INTERROGATE COMMANDS

Interrogate commands allow the status of the Generator to be given over the IEEE-488 interface. These commands consist of headers only. The interrogate commands available on the IEEE-488 interface are:

- "ID" Give Instrument ID
- "IE" Elapsed Time Indicator
- "II" Interface Mode Status
- "IO" Option Loading
- "IR" IEEE-488 Rejected Entry Status
- "IT" Self-Test Results
- "IU" UNCAL (uncalibrated) Status
- "IV" Software Revision Level

When the "ID" command is sent, the Generator responds with its instrument model number (and end of record character) as in "6060B"<EOR>.

When the "IE" command is sent, the Generator responds with the time the instrument has been in operation since it was manufactured. The time is 9 digits, a decimal point, a 10th digit and the <EOR> character. The time is in .1 hour units. For example, "000003459.3"<EOR> indicates 3459.3 hours of operation since manufacture.

The "II" command interrogates the current selection of interface modes. A 5-digit integer followed by the <EOR> character is the sum of the modes selected as follows:

- Terminator mode= 1
- Record mode = 2
- Valid mode = 4
- Unbuffered mode= 8
- Error Mode = 16

INSTALLATION AND OPERATION

The "IO" command interrogates the Generator for its option complement. The returned record contains three integers, separated by commas, that indicates configuration of options. For the 6060B, the first number is always 6, which indicates that the Generator being interrogated is in fact a 6060B. The two remaining numbers are the sum of the option related numbers as follows:

2nd Number

- 4 = -130 High-Stability Reference Option
- 8 = -651 Low-Rate FM Option
- 16 = -132 Medium-Stability Option

3rd Number

- 2 = -830 Rear Output Option

For example, "6,12,2" would indicate a 6060B with options -651, -130, and -830.

The "IR" command interrogates the Generator for rejected entry error status. (See Table 2-6 for a list of rejected entry codes.) The returned record is the sum of errors that have been detected while processing IEEE-488 commands. The status is cleared when interrogated with the "IR" command. The status can also be explicitly cleared with the "CE" command and is also cleared on the "CL" command and the clear interface messages DCL and SDC.

The "IT" command interrogates the Generator for the self-test results. Table 2-14. lists the self-test error codes. The self tests are performed on the Generator power-up and can also be initiated with special function 02.

The self-test results are reported in four fields which are explained in the table. Any non-zero code indicates that some tests failed. Further details of the self-test results are listed in the Service Section. Table 2-14. shows the self-test error codes.

The "IU" command interrogates the Generator for the UNCAL entry status. (See Table 2-5 for a list of the UNCAL Error Codes.)

The "IV" command interrogates the Generator for its current software revision level. The returned record is similar to the following:

"V1.0" (EOR).

This means that the software revision level is Version 1.0.

Table 2-14. Self-Test Error Codes

MOD	FREQ	AMPL
aa	-bbb ccc	ddd

aa = Modulation (AM and FM) test results
- = If displayed, indicates the self test did not complete
bbb = Frequency test results
ccc = Digital test results
ddd = Amplitude test results

2-57. MONITOR COMMANDS

The Generator monitor commands are intended for troubleshooting and maintenance procedures. They allow the instrument hardware to be programmed to states not normally possible with the regular programming commands.

CAUTION

The output of the Generator is not guaranteed if the Generator hardware has been changed with these monitor commands.

There are three types of monitor commands: Input/Output, Read/Write, and Hardware Control. Table 2-15 lists the Input/Output types of monitor commands. Table 2-16 lists the Read/Write types of monitor commands. Table 2-17 lists the Hardware Control types of monitor commands.

2-58. SRQ COMMANDS

The Generator asserts the SRQ bus management line on the IEEE-488 interface bus whenever the Generator requires service. The Controller can then perform a serial poll to determine the need for service. The set mask command is used to designate those needs that require service. The SRQ commands are as follows:

- “SM” Set SRQ Mask
- “IM” Interrogate SRQ Mask
- “XF” Local Operation Alert Mode

The SRQ mask is set to the sum of the reason values listed in Table 2-18. These reason values correspond to the allowable reasons that will be requiring service. The SRQ Mask is set by the following command sequence:

“SM” Sum of Reasons

The Generator asserts SRQ when one of the allowed reasons becomes true. The serial poll response is the sum of those values for reasons that are currently true, independent of the setting of the SRQ mask. For example, if the rejected entry SRQ is enabled with “SM2” and a rejected entry occurs, the serial poll response will indicate that the Generator generated the SRQ (value of 64) and that a rejected entry occurred (value of 2). In addition, other values may be set. The default SRQ mask is 192.

The “IM” command interrogates the current SRQ mask, and an integer is returned.

The “XF” command enables a mode that causes an SRQ to be generated any time the Generator processes an entry. In this mode, a front panel SRQ is generated (i.e., the serial poll response indicates that a front panel SRQ is the cause of the SRQ). This mode is enabled and disabled with its own command, not through the Set SRQ Mask commands (as are all other SRQs). The Alert Mode is enabled/disabled as follows:

“XF0” = Alert Mode off, “XF1” = Alert Mode on.

2-59. TRIGGER COMMANDS

The Generator has the ability to preprogram a command string of arbitrary Generator programming commands. This command string is executed whenever the trigger command “TR” or the IEEE-488 group execute trigger interface message (GET) is received. This method of programming the Generator can be used when a long string of commands is to be sent to the Generator over and over. The programming time is shortened by the time required to transmit the string of characters from the controller to the Generator.

INSTALLATION AND OPERATION

Table 2-15. Input/Output Monitor Commands

COMMAND NAME	COMMAND	VALUE	DESIGNATOR NAME	LOCATION		
Read Input Bit	"IB"		"EX"	exrefl	A2A7, U11-13	
			"HS"	hsoptl	A2A7, U11-14	
			"IE"	ieinl	A2A7, U11-7	
			"LF"	lrfm	A2A7, U40-13	
			"MH"	mlevhi	A2A7, U40-8	
			"ML"	mlevlo	A2A7, U40-3	
			"NV"	nvinl	A2A7, U11-8	
			"RO"	roptl	A2A7, U40-17	
			"RP"	rppl	A2A7, U11-3	
			"RT"	rptrpl	A2A7, U11-4	
			"SR"	shrefl	A2A7, U40-18	
			"TQ"	trseql	A2A7, U40-4	
			"UK"	unlok	A2A7, U11-17	
			"UV"	unlvl	A2A7, U11-18	
			"XA"	msoptl	A2A7, U40-14	
			"XB"	extra-b	A2A7, U40-7	
Set Output Bit	"OB"	0 or 1	"CL"	clr	A2A7, U17-16	
			"EA"	extam	A2A4, U308-19	
			"EF"	extfm	A2A4, U308-16	
			"FE"	fmen	A2A1, U19-19	
			"FP"	front-panel	A2A7, U17-9	
			"HO"	haocth	A2A4, U305-5	
			"HT"	het	A2A4, U305-9	
			"IA"	intam	A2A4, U308-15	
			"IF"	intfm	A2A4, U308-12	
			"LP"	mid	A2A4, U305-6	
			"MA"	rmux0	A2A1, U32-5	
			"MB"	rmux1	A2A1, U32-2	
			"MF"	mf400L	A2A4, U308-9	
			"MG"	module-gate	A2A7, U17-6	
			"MS"	trmodl	A2A1, U32-15	
			"NE"	nven	A2A7, U17-5	
			"PU"	pulse	A2A4, U308-6	
			"RI"	rinh	A2A1, U32-9	
			"RR"	rprst	A2A7, U17-2	
			"SE"	shen	A2A1, U32-12	
			"SH"	shet	A2A1, U32-16	
			"XO"	xoentl	A2A1, U32-6	
			"YA"	extra-a	A2A7, U17-19	
			"YB"	extra-b	A2A7, U17-15	
"YC"	extra-c	A2A7, U17-12				
Set Output DAC	"OD" (integer value)	(DAC Location)	0-255	"AM"	AM dac	n.a.
			0-127	"AT"	attenuator	A2A7, U27-5, 6, 9, 12, 15, 16, 19
			0-1023	"FM"	FM dac	A2A4, U403-6 through 13
			0-7	"FR"	FM range	A2A1, U19-12, 15, 16
			0-1023	"KN"	kn dac	A2A1, U27-4 through 13
			0-1023	"KV"	kv dac	A2A1, U29-4 through 13
			0-4095	"LE"	level dac	A2A4, U303-4 through 15
			0-255	"TC"	temp.comp.dac	n.a.

Table 2-16. Read/Write Monitor Commands

COMMAND NAME	COMMAND SYNTAX	NOTES
Read byte	"RB" memory location	1
Read word	"RW" memory location	1
Define write address	"DW" memory location	2
Write byte	"WB" value	2
Write word	"WW" value	2

Notes

1. The Generator responds to these commands with the value of the byte or word in the memory location addressed. The memory location must be an unsigned integer. The value returned is followed by an <EOR>. If the memory location is specified in hexadecimal, then the value is returned in hexadecimal preceded by an "X".
2. The Define Write Address command specifies the write address used with the Write Byte and Write Word commands. When the Write Byte and Write Word commands are used, the specified data will be written to that write address.

Table 2-17. Hardware Control Monitor Commands

COMMAND NAME	COMMAND SYNTAX	NOTES
Read attenuation	"XA"	1
Set attenuation	"XB" integer	1
Set synthesizer frequency	"XD" floating point decimal "MZ"	2
RF on/off	"XR" "0" or "1"	3

Notes

1. The current settings of the Attenuator can be read or set. The attenuation is a number from 0 to 23 where the number specifies the multiple of 6-dB attenuation. Zero indicates no attenuation, and 23 is the maximum attenuation. Only the attenuators are changed with the "XB" command. The value of the attenuation will be output on the "XA" command as an unsigned integer followed by <EOR>.
2. The "XD" command can be used to program the Generator to the specified frequency. Only the synthesizer circuits on the Synthesizer PCB is programmed. No offset is added, no filters are programmed, no VCO compensation is calculated, and no level correction is calculated.
3. "XR0" programs all attenuation, and "XR1" restores the attenuator to its previous state.

The trigger commands are as follows:

- "CT" Configure Trigger
- "TR" Execute Trigger Buffer

The configure trigger command is followed by a string of any Generator programming commands up to 71 characters in length. The validity of the programming commands is not checked until the trigger buffer is executed. The power-on value of the trigger string is null (nothing).

Table 2-18. SRQ Mask and Status Values

VALUE	REASON	TRUE	FALSE
1	Ready	Input buffer is empty and no commands are being processed.	Input buffer is not empty or commands are being processed.
2	Rejected Entry	IEEE-488 rejected entry; error code is not zero.	IEEE-488 rejected entry error; code is zero.
4	Uncalibrated	RF output is not calibrated. (Front panel 'UNCAL' indicator is lit.)	RF output is calibrated. (Front panel 'UNCAL' indicator is not lit.)
8	Power on	Instrument has powered up.	Special function 08.
16	Output valid	RF output is settled.	RF output is not settled.
32	Not Used		
64	RQS	SRQ mask ANDed with currently set values is not zero.	Reason for SRQ goes away or serial poll is performed.
128	Front panel	Special function 07.	Special function 08.

The trigger command causes execution of the trigger buffer, which has been preprogrammed with the configure trigger command "CT". The trigger buffer can also be executed by sending the IEEE-488 group execute trigger interface message (GET).

2-60. Command Processing

The following paragraphs describe how IEEE-488 commands are processed by the Generator. Command processing is a term for how commands are executed and how errors are handled.

2-61. COMMAND EXECUTION

The execution of the IEEE-488 commands depends on the selection of interface modes with one exception: if an IEEE-488 input is buffered and the buffer becomes full, command execution starts and no further input is accepted until there is room in the input buffer. For more details, refer to the paragraphs on Interface Modes.

2-62. ERROR HANDLING

The Generator detects two types of errors while processing IEEE-488 commands: syntax errors and processing errors. All errors are accumulated until the error status is interrogated or is explicitly cleared. The IEEE-488 rejected entry status is interrogated with the "IR" command. The error status is cleared with one of the following commands:

- "CE" Clear Error Command
- "CL" Clear Command
- DCL or SDC Clear Interface Messages

The error status is also cleared on power-up.

The SRQ mask can be set to assert SRQ when an error is detected. The SRQ is unasserted when the error status is cleared.

Syntax errors are commands that do not have the correct syntax for the specified header. For example, "FE5" is a syntax error because the external FM command requires a Boolean numeric field. Unrecognized headers are also syntax errors. An IEEE-488 syntax error causes all commands from the point of the error up to the next string terminator or record terminator to be ignored.

Processing errors are commands that are syntactically valid, but the requested value is outside the range of programmable values. For example, "FR99GZ" is syntactically correct, but the Generator cannot be programmed to a frequency of 99 gigahertz. Command processing continues with the next command.

2-63. Timing Data

The programming time can be broken down into four groups: transfer of commands to Generator, command parsing time, software programming time, and instrument settling time.

The total programming time depends on the selection of the interface modes. In some modes, programming steps are performed in parallel and can increase throughput. This section gives some typical timing data for the above four programming steps and describes how the interface modes affect their relative timing.

2-64. TRANSFER OF COMMANDS TO GENERATOR

The maximum rate of transfer is 0.4 to 0.5 ms per character. With most IEEE-488 controllers, all characters sent with a single output or print statement is transferred together at the maximum rate. The total time to transfer commands to the Generator is obtained by multiplying the number of characters by the rate of transfer.

2-65. COMMAND-PARSING TIME

Command-parsing time is the sum of the time required to process the header, the numeric, and the suffix. Some commands do not have numerics or suffixes. Table 2-19 gives the typical time it takes to process the different components of a command.

2-66. SOFTWARE PROGRAMMING TIME

The minimum time required to process a command is 20 ms. Most of the commands that do not program the hardware (such as storing step values) are programmed in 20 ms. Table 2-20 gives the typical time value for programming the different functions in the Generator.

2-67. INSTRUMENT-SETTLING TIME

Commands that do not change the state of the hardware (such as programming step values) have no settling time after the software-processing time.

For all other Generator parameters, except frequency and recall, the instrument has settled by the time the software-programming time is up, so no additional instrument-settling time is required.

Worst case frequency changes (including recalls) typically settle within 35 ms after the software-programming time. If level correction is disabled, this settling time is increased to 45 ms. Small frequency changes (not crossing a band) typically settle by the time the software-programming time is up, so no additional instrument-settling time is required.

INSTALLATION AND OPERATION

Table 2-19. Command-Parsing Time

COMMAND COMPONENT	TIME
Header	2 ms
Boolean Numeric	1 ms
Unsigned Integer Numeric	2 ms + 1 ms per character
Floating-Point Numeric	2 ms + 1 ms per character
Trigger-String Numeric	10 ms + 0.5 ms per character
Suffix	1 to 1.5 ms
Learn-Interface Suffix	35 ms

Table 2-20. Typical Programming Time of the Generator Functions

FUNCTION	TIME (IN ms)	NOTES
Frequency	55	1, 2, 3, 4
Amplitude in Volts	50	1, 2, 4, 5
Amplitude in dBm	90	1, 2, 4, 5
AM Depth	45	2, 4
FM Deviation	30	4
Modulation Frequency	25	
Enable/Disable AM	55	2.
Enable/Disable FM	25	
Recall 98	185	6, 5
RF Output On	45	2
RF Output Off	30	
Notes		
<ol style="list-style-type: none"> 1. May take up to 5 ms longer if the relative mode is enabled. 2. Can save 10 ms if all level correction is disabled with special function 81. 3. Add 20 ms when frequency changes from greater than or equal to 245 MHz to less than 245 MHz. Subtract 20 ms from frequency hardware-settling time in this case. 4. Edits and steps may take up to 5 ms longer than the programming function directly. 5. Add 5 ms when the Attenuator settings change. 6. Recalls vary considerably depending on the stored data. Maximum is approximately 250 ms. 		

2-68. TIMING OPTIMIZATION

Timing depends upon the interface modes selected. Read the paragraphs on Interface Mode Commands for a complete description of the interface modes.

The transfer of commands from the IEEE-488 controller to the Generator can never be processed in parallel with anything else. The transfer of commands usually happens simultaneously, regardless of which interface mode is selected.

The parsing of the command and programming the new instrument state is performed one message unit at a time. The record mode selects a command or a record as the

message unit. The record mode off ("RM0") is slower since there is extra processing between message units, and the message unit is smaller.

If the valid mode is enabled, the processing of message units is delayed until the Generator has settled from the previous message. If the output of the Generator does not need to be settled between programming strings, the valid mode should be turned off to speed up processing. If the output does not need to be settled between commands, but needs to be settled between records, enable the valid mode and the record mode. The instrument processes commands within the record as fast as possible and wait for the output to settle only between records.

2-69. Power-on Conditions

The power-on conditions of the Generator depend on whether or not the IEEE-488 Interface Option is installed. Table 2-21 lists the instrument parameters at power-on with the IEEE-488 Option installed. The remote clear commands can be used to reset all parameters except the last memory location and the remote/local state.

Table 2-21. IEEE-488 Power-On State

INSTRUMENT PARAMETER	STATE	NOTES
Memory location parameters	Same as power off	1
RF on/off	Same as power off	
Last memory location	Same as power off	2
Remote/local state	Local	
IEEE-488 output buffer	Cleared	
IEEE-488 input buffer	Cleared	
Valid mode	Same as power off	
Record terminator	Same as power off	
Unbuffered mode	Same as power off	
Record mode	Same as power off	
SRQ mask	Same as power off	
Trigger configuration	Same as power off	
SRQ interface signal	May be asserted	3
<p>Notes</p> <ol style="list-style-type: none"> 1. The contents of memory location 98 (Instrument Preset State) is listed in Table 2-3. 2. The last memory location is used for sequence operations. 3. If the SRQ mask has the power on, output valid, or ready SRQ enabled, the SRQ interface signal is asserted on power-on. 		

Section 3

Theory of Operation

3-1. INTRODUCTION

This section of the manual describes the theory of operation for the Generator. There are four major headings:

- General Description
- Functional Description
- Software Operation
- Detailed Circuit Descriptions

The General Description briefly explains the functions and components of the three major modules of the Generator. The Functional Description covers the main output parameters, amplitude, frequency, and modulation. The Software Operation section describes the software and how it affects the hardware. The Circuit Description is a comprehensive explanation of the operation of each circuit assembly.

3-2. GENERAL DESCRIPTION

The Generator has three major sections. The front section includes the keyboard and display for local control. The module section includes the frequency, level, modulation, and control circuits. The rear section includes the power supply, cooling fan, and assorted external connectors.

3-3. Front Section

The front section of the Generator provides the operator interface. It includes the primary controls, connectors, and indicators of the Generator. All front panel keys and displays (except the power switch that controls the power supply directly) are monitored and handled by the Controller in the module section.

3-4. Module Section

The module section is a multi-compartmented, shielded enclosure that includes the circuits that generate the instrument stimulus functions: frequency, modulation, and amplitude. The Controller is also located here. The Controller governs the Generator operation and at power-on determines if any options are installed by checking the option status bits. The optional Low-Rate FM, is also located in this section of the instrument.

3-5. Rear Section

The rear section includes the power supply, the cooling fan, various external connectors, the IEEE-488 Interface and the High-Stability Reference Options.

THEORY OF OPERATION

The power supply is a linear design providing two +15V, -15V, +5V, +37V, +18V, and 6V ac to the Generator. All the power supplies are series-pass regulated except the 6V ac filament supply and the +18V supply, which provides power to the Attenuator relays and Reverse Power Protector (RPP) relays. A fuse/filter/line-voltage selector allows the Generator to operate from any common supply voltage.

The dc fan is powered from the unregulated +5V supply. The fan operates only when line power is available and the front panel POWER switch is ON.

The Option -130 High-Stability Reference operates whenever the instrument is plugged into an active ac outlet, regardless of the position of the instrument POWER switch.

3-6. FUNCTIONAL DESCRIPTION

The following paragraphs describe the key output parameters of the Generator: level, amplitude modulation, frequency, and frequency modulation.

3-7. Level

Level control is provided by two separate circuits, a step attenuator and a vernier level DAC. The 6.02 dB per step Attenuator/RPP, (A2A5) provides coarse control. Fine level control is provided by a vernier level DAC that varies the automatic level control voltage (ALC). The microprocessor automatically controls the step attenuator and the vernier level DAC. The microprocessor also applies level correction to compensate for the Generator frequency response.

Each Generator has level correction data for the Output and Attenuator assemblies, stored in the Output and Attenuator calibration EPROMs. The EPROMs are located on the Controller assembly. The correction data is based on measurements of each assembly during calibration of the Generator at the factory.

This microprocessor level correction data is applied only to the vernier level DAC; it does not affect the coarse level control provided by the Attenuator. In other words, all Generators have the same attenuator pads inserted at a selected level even though the correction data is different for each Generator.

To improve level accuracy in relation to temperature, the Generator uses a software temperature compensation technique. This technique uses data that is the same for all Generators regardless of the options installed.

3-8. Amplitude Modulation

The output of the level DAC is the ALC loop control voltage. The Generator output signal is amplitude modulated by varying this control voltage with the modulating signal. A 1V peak modulating signal from the internal modulation oscillator or from the external MOD INPUT connector is applied to the AM DAC, a multiplying D-to-A Converter. The multiplying factor of this DAC, corresponding to the programmed percentage of modulation, is factored by the Controller.

The modulation signal from the AM DAC is summed with a fixed dc reference voltage. The composite signal (dc plus modulation) is applied to the LEVEL DAC, a level control-multiplying DAC. The multiplying factor for this DAC is also handled by the Controller and corresponds to the programmed signal level. The multiplying factor also includes the level correction information stored in the calibration EPROMs.

The operation of the ALC loop causes the amplitude of the RF signal to conform to this varying control voltage, thus amplitude modulating the Generator output.

3-9. Frequency

The 0.01-MHz to 1050-MHz frequency coverage is divided into the following three bands:

Low-band	0.01 MHz to 245 MHz
Mid-band	245 MHz to 512 MHz
High-band	512 MHz to 1050 MHz

The high and mid bands are derived directly from a voltage-controlled oscillator (VCO) followed by a binary divider that is part of the main phase-locked loop (PLL).

This PLL synthesizes the 245- to 512-MHz band using a modified N-divider loop with a single-sideband mixer (SSB) in the feedback path. The reference frequency for the loop is 1 MHz, which would normally provide 1-MHz steps in a conventional N-divider loop. However, this Generator provides 0.02-MHz steps by using a modified N-divider circuit with pulse deletion controlled by a rate multiplier.

Additional resolution is gained by introducing a signal from the sub-synthesizer circuit into the main PLL through the SSB mixer in the feedback path. This signal provides internal frequency steps of 5 Hz. The sub-synthesizer consists of a 14-bit rate multiplier followed by a divide-by-1000.

Since the main PLL bandwidth varies with the programmed frequency (due to N changing and variations in the VCO tuning coefficient), the Controller uses compensation to program the phase detector gain via the KN DAC to maintain constant loop bandwidth. By keeping the loop bandwidth constant, loop stability and modulation transfer is controlled, thus ensuring accurate, wideband FM.

3-10. Frequency Modulation

Frequency modulation is achieved by applying the modulation signal simultaneously to the PLL VCO and the Phase Detector. Both are necessary because modulating either the VCO or the Phase Detector alone results in FM with a high-pass filter characteristic, or phase modulation with a low-pass filter characteristic. The filter characteristic cutoff frequencies are equal to the PLL bandwidth.

The modulating signal applied to the VCO and the Phase Detector is adjusted in amplitude by the KV DAC to compensate for variations in the VCO tuning coefficient. This compensation is done automatically by the Controller using factory calibration data measured on the VCO in each Generator. This compensation data is stored in the VCO Calibration EPROM.

By integrating the modulation signal applied to the Phase Detector and simultaneously applying the modulation signal to the VCO, the two effects are complementary and result in a flat FM response.

3-11. SOFTWARE OPERATION

The Generator software is executed on a Texas Instruments TMS 9995 microprocessor in the A2A7 Controller assembly. The instrument program is stored in 48K-bytes of ROM, two scratch pad RAM, 2K-bytes off-chip and 250-bytes on-chip RAM. Three 2K-byte EPROMs contain the individual Generator calibration data. The software provides the following general functions:

- Interfaces with the front panel keys and the IEEE-488 Interface to provide access to the Generator functions.

THEORY OF OPERATION

- Configures the Generator functional blocks to produce the required output and then applies linearization and compensation data to optimize the instrument performance and resolution.
- Implements a set of self test and diagnostic functions.

3-12. User Interface

The Generator software is implemented with a simple operating system that allows several tasks to operate in a round-robin fashion on an equal priority basis. Input and output to the front panel and to the IEEE-488 Interface option, however, execute at a higher priority and are handled as interrupt routines.

At power-on, the software performs an instrument self test and initializes both the RAM and the Generator hardware. Three tasks are continuously in operation:

Service task
Key task
IEEE-488 task

The service task checks the status signals. The key task and IEEE-488 task process user input. A fourth task is activated only when needed to process certain UNCAL (uncalibrated) or REJ ENTRY (rejected entry) conditions that cause the instrument STATUS display to flash.

3-13. Amplitude Control

Amplitude is programmed using a 23-step (6.02 dB per step) attenuator assembly and a 12-bit vernier level DAC. The level DAC settings depend on a combination of the programmed output level and amplitude correction data.

The amplitude correction data compensates for level inaccuracies and is a function of the Generator frequency. Correction factors are stored in the Output and the Attenuator Calibration EPROMs. Each Output and Attenuator assembly comes with a matched calibration EPROM. The assemblies may be replaced under the Module Exchange Program with only minor adjustments needed after installing the replacements.

3-14. Attenuators

One 6-dB, one 12-dB, and five 24-dB sections of the Attenuator are programmed in combination to provide course level control. The indicated voltages at which the Attenuator changes ranges are 2^{-m} volts, where

$m = 1, 2, 3, \dots, 23$ for non-AM, or

$m = 2, 3, 4, \dots, 24$ for AM operation

Table 4D-15 lists the Attenuator sections programmed for various displayed levels.

3-15. Level DAC

The level DAC setting (LEV 0 through 9) is calculated from the Generator output level. If level correction is enabled, the level DAC setting is further modified by the data stored in the Output and Attenuator calibration EPROMs.

To minimize level transients that could damage external circuitry, the following sequence is used in programming the Attenuators and the level DAC when the Attenuator setting is changed:

1. The LEVEL DAC is programmed to zero.
2. The new Attenuators are programmed in addition to the old Attenuators.
3. After a 5-ms wait to allow the Attenuators to settle, the new Attenuator and LEVEL DAC settings are programmed.

3-16. Temperature Compensation

The temperature compensation DAC (TC DAC) data is stored in the Generator software as a function of the output frequency (F_o). This data is the same for each Generator.

3-17. Reverse Power Protector

The Reverse Power Protector (RPP) A2A5 protects the Generator from damaging voltages applied to the RF OUTPUT connector. The status line RPTRPL indicates whether the RPP circuitry has tripped. If the RPP trips, the RF output is programmed off, and the RF OFF indicator flashes. The RPP circuitry is reset by the operator turning the RF OUTPUT on. This causes the Controller to reset the RPP by toggling RPRSTL, and programming the RF on.

3-18. Frequency Reference Control

Programming of the frequency reference control bits depends on the setting of the INT/EXT reference switch as well as whether the High-Stability Reference or the Medium-Stability Reference option is installed.

3-19. Frequency Control

The output frequency (F_o) is programmable with 10-Hz resolution. The minimum calibrated output frequency is 0.01 MHz, and the maximum calibrated output frequency is 1050 MHz. The filter and band control bits are programmed in five bands and are determined by the output frequency (F_o). For each band, a synthesizer frequency is determined.

The programming data of the KV and KN DACs are calculated from the synthesizer frequency and the instrument-specific VCO Calibration EPROM data. The KV DAC settings on the high and low bands are one half the settings on the mid-band to compensate for the effective doubling of the FM deviation that occurs on the high and low bands.

3-20. Modulation On/Off

The four modulation modes are:

- Internal AM
- External AM
- Internal FM
- External FM

The modulation modes can be programmed separately or in any combination. The AM depth and FM deviation DACs are always programmed regardless of whether or not modulation is enabled. When enabling or disabling modulation, only the modulation control bits are programmed. Table 4D-17, Modulation ON/OFF Control, lists the control states for each modulation choice.

3-21. Modulation Frequency

The two internal modulation frequencies of 400 Hz and 1000 Hz are programmed with a single control bit MF400L. Table 4D-18 Modulation Frequency Control lists the MF400L control states.

THEORY OF OPERATION

3-22. Amplitude Modulation

The Generator allows amplitude modulation depth programming from 0 to 99% with 1% resolution. However, the maximum calibrated AM depth is 90%. Programming an AM depth greater than 90% causes the 'UNCAL' indicator to light. When the combination of signal amplitude and programmed AM depth exceeds +13 dBm peak, the 'UNCAL' indicator lights to warn you the output level is no longer guaranteed. Amplitude modulation depth is programmed using the 8-bit AM DAC, with a setting of 200 on the AM DAC corresponding to 100% AM modulation of the output frequency.

3-23. Frequency Modulation

Frequency modulation (FM) is programmable with three digits of resolution in the three decade ranges. Table 4D-12, FM Ranges, lists the three ranges.

3-24. FM Deviation

The FM DAC is a 10-bit DAC programmed to the FM deviation in Hz divided by the resolution. Table 4D-13 lists the settings of the FM DAC.

3-25. Self Test

At power-on, the Generator automatically self tests its digital and analog circuits. If the Generator fails any self test, the test results are automatically displayed as error codes. Several special functions are available for additional tests. (See section 4D-16.) Also, the Generator microprocessor continuously monitors two status signals, UNLVL (unleveled) and UNLOK (unlocked).

The self tests can also be invoked by using the [SPCL] [0][2] keys. The results of the self test can be displayed in the four display fields with [SPCL] [1][1] keys and can also be transmitted using the optional IEEE-488 Interface.

Self tests 1 through 5 are digital checks that indicate the general functionality of the Controller assembly. Self tests 6 through 10 use the two status signals UNLVL and UNLOK to test the general functionality of the RF circuitry.

During the self-test sequence all attenuators are programmed ON (maximum attenuation) to prevent unwanted signals at the output. In addition, the Generator is programmed to the internal frequency reference because the self tests fail if there is no reference supplied.

The self-test error codes and descriptions are listed in Section 4D. A brief description of the different Generator self tests are described in the following:

- Test 1. The Generator RAM is verified by writing data to each memory location and checking that the same data can be read back. Both the off-chip RAM and the on-chip RAM are tested in this way.
- Test 2. The data in each word of the two instrument software EPROMs is successively summed and rotated by two. The result of this procedure is compared with a checksum for each EPROM.
- Test 3. The data in each of the three calibration EPROMs (VCO, Output, and Attenuator) is summed and compared with a checksum.
- Test 4. The IEEE-488 (if installed) is verified by the microprocessor writing data to the IEEE-488 chip and then by reading it back to see if the response is the one expected. The operator is given a report only if the test fails.

- Test 5. Each memory location of the Non-Volatile RAM is checked with a checksum.
- Test 6. The low-pass filters on the Output assembly are tested by setting the frequency at the top of each of the four half-octave non-HET bands and verifying that the output is leveled. Then, the frequency is set above the cutoff frequency, and the output is checked to see if the output is unlevelled.
- Test 7. The synthesizer operation is verified by programming the Generator to a normal operating frequency and checking to see that the instrument is locked. The Generator is then programmed to a synthesizer frequency below 225 MHz and then above 550 MHz and is checked to see that the instrument becomes unlocked. Finally, all frequency reference circuitry is turned off and checked to see that the Generator becomes unlocked.
- Test 8. The Generator PLL operation is verified by forcing a large change in frequency. When this is done, the Generator should become unlocked and then lock again.
- Test 9. Frequency modulation is verified by overmodulating the carrier and then checking the unlocked indicator. This is done by programming internal FM on and programming the KV DAC to a higher than normal value.
- Test 10. Amplitude modulation is verified by overmodulating the carrier and then checking the unlevelled indicator. This is done by programming a high output level and programming INT AM on with a high AM depth.

3-26. Service Special Functions

There are two special function self tests for the front panel indicators and keys. These special function self tests are described in the following:

1. The front panel displays are checked any time by pressing the [SPCL] [0][3] keys. When this is done the microprocessor lights all display segments. This test is terminated by pressing any key on the instrument.
2. Check the normally open front panel keys by pressing the [SPCL] [0][4] keys. Now, each key pressed has its row and column address displayed in the center of the FREQUENCY display field. The special function is exited by pressing the [CLR/LCL] key.

3-27. Status Signals

Five status signals indicate the Generator option complement, and these status bits are interrogated at power-on self test as follows:

HSOPTL	= 0 indicates Option -130 High-Stability Reference is installed.
MSREFL	= 0 indicates Option -132 Medium-Stability Reference is installed.
IEINL	= 0 indicates Option -488 IEEE-488 Interface is installed.
LRFML	= 0 indicates the Option -651 Low-Rate FM is installed.

THEORY OF OPERATION

ROPTL = 0 indicates Option -830 rear panel RF OUTPUT and MOD IN connectors is installed.

The status of the rear panel REF EXT/INT reference switch is continuously monitored with the EXREFL bit. The state of this bit is used by the Controller to display the 'EXTREF' indicator on the front panel and to program the reference source.

The RF output of the Generator is considered calibrated whenever the 'UNCAL' indicator is off. The 'UNCAL' indicator is lit, but not flashing, whenever the calibrated limit of the Generator is exceeded. However, the RF output is still considered usable.

The 'UNCAL' indicator flashes when the output of the instrument is considered unusable. This is the result of a severe overrange condition or when one of the following analog status signals becomes active.

RPTRPL = 0 indicates that the RPP circuitry has tripped. If this occurs, the RF output is programmed off to provide additional protection to the instrument. The 'RF OFF' and 'UNCAL' indicators flash to indicate that RPP has tripped.

UNLOKL = 0 indicates one of several conditions. The Synthesizer or the reference circuits could be out-of-lock. If FM is on, it could indicate FM over-modulation. The 'UNCAL' indicator flashes for any of these circumstances.

UNLVLL = 0 indicates that the output is unlevelled. This could also be the result of amplitude over-modulation. With this condition, the 'UNCAL' indicator flashes.

3-28. DETAILED CIRCUIT DESCRIPTIONS

This section contains the detailed circuit descriptions for the following assemblies:

A1 Front Section

A1A1 Display Assembly
A1A2 Switch Assembly

A2 Module Section

A2A1 Synthesizer Assembly
A2A2 VCO Assembly
A2A4 Output Assembly
A2A5 Attenuator/RPP Assembly
A2A7 Controller Assembly
A2A8 Non Volatile Memory Assembly

A3 Rear Section

A3A1 Power Supply Assembly

3-29. FRONT SECTION, A1

The Generator front section, A1, consists of the Display PCA A1A1, the Switch PCA A1A2, and the Elastomer switches mounted in a sheet metal housing. The front section also includes the display lens, the POWER ON/OFF switch, and the MOD INPUT connector.

3-30. Display PCA, A1A1

The Display PCA A1A1 provides a readout of the programmed modulation, frequency, amplitude parameters, and status information. This displayed information and the bright digit are controlled by the Controller, A2A7, under the direction of the instrument software. The display is comprised of two vacuum fluorescent displays and their associated control circuitry. The two displays are refreshed as four groups of eight display fields (usually a digit) each. The four groups share the digit (grid) strobes but have individual segment (anode) strobes.

3-31. DATA COMMUNICATIONS

Display data is sent through a byte-wide bidirectional data bus from the Controller A2A7 and is latched by U1 through U5 on the display board. Latch select signals DIGL, SEG1L, SEG2L, SEG3L, and SEG9L determine which latch receives the data. Level shifting buffer drivers U6 through U10 interface the TTL latches directly to the +37V anodes of the vacuum fluorescent displays.

3-32. DISPLAY FILAMENT VOLTAGE

The 6.0V ac filament voltage for the display is derived from a center-tapped winding on the power supply transformer, T1. The ac filament voltage is biased at +6.2V above ground by circuitry on the power supply board A3A1, to provide a cutoff potential for the displays.

3-33. BRIGHT-DIGIT EFFECT

The bright-digit effect is achieved by providing three extra refresh cycles (strobes) to the specified digit. Grid current-limiting resistor R3 provides uniform digit brightness by controlling electron depletion from the display cathode filaments.

3-34. SWITCHBOARD INTERFACE

The digit strobe data latched by U1 is buffered by open collector inverters U13 and U15, and strobes the front panel switch matrix. The switch columns are strobed in unison with the eight display fields. The switch matrix status is read by the tri-state buffer U14.

3-35. DISPLAY BLANKING

Monostable U11 and NOR gate U12 clear the display if new field or segment strobes are not received. This protects the display if the microprocessor stops refreshing. The display can be blanked manually by pressing [SPCL][1][3] which sets the signal CLRL and the output of U11 low, thus clearing latches U2 through U5. To restore the display, press [SPCL][1][2].

3-36. MODULATION-LEVEL INDICATOR

The external modulation-level indicator warns the operator when the modulation signal is not set to 1V peak ($\pm 2\%$ typically). The external modulation signal is compared in the dual-comparator, U16, with internal references of 0.98 and 1.02V. Two status bits, MLEVLO and MLEVHI, are at the output of the 0.5 second dual one-shot, U17. If either of these reference voltages are exceeded, the two status bits are sensed by the Generator Controller that controls the 'EXT HI' and 'EXT LO' indicators in the MODULATION display field.

3-37. Switch PCB, A1A2

All the front panel control keys, except the POWER ON/OFF switch, consist of an Elastomer membrane sandwiched between the Switch PCB A1A2 and the front panel sheet metal housing. The Switch PCB consists of a 6-by-8 matrix of open switch contact pads. When a key is pressed, a conductive pad on the back of the Elastomer membrane connects a set of contact pads. The Controller software senses what row and column of the matrix are connected when a key is pressed.

THEORY OF OPERATION

3-38. MODULE SECTION, A2

The module section consists of a cast module frame with gasketed covers and includes the following electrical assemblies:

- A2A1, Synthesizer
- A2A2, VCO
- A2A4, Output
- A2A5, Attenuator/RPP
- A2A7, Controller
- A2A8, Non Volatile Memory

3-39. Synthesizer PCA, A2A1

The Synthesizer PCA provides frequency control and modulation of the Signal Generator output. The Synthesizer assembly is located on the top side of the Module Section A2. Together with VCO A2A2 and a 10-MHz reference frequency, the Synthesizer assembly simultaneously generates a high-band signal that spans 490 to 1050 MHz and a mid-band signal that spans 245 to 512 MHz.

The high-band and mid-band signals are coupled to the Output A2A4. Here, heterodyning extends the Generator frequency coverage down to 0.01 MHz.

The Synthesizer assembly consists of the following functional circuits that are described in the following paragraphs:

- 10-MHz Reference
- Main PLL
- FM Processing
- 800/40 MHz PLL
- Sub-Synthesizer

3-40. 10-MHZ REFERENCE

The Generator reference is the internal 10-MHz crystal oscillator. If Option -130 High-Stability Oscillator or Option -132 Medium-Stability Oscillator is installed, that oscillator is locked to the internal crystal oscillator. An external reference of 1, 2, 5, or 10 MHz can also be locked to this oscillator.

The internal 10-MHz crystal oscillator(XO) is a crystal, Y1, and an FET transistor, Q39. The frequency is adjusted by C240 and R230. The oscillator signal from Q39 is buffered by Q40, converted to TTL by U55-B, and sent to the sub-harmonic phase detector, U68, and the rear output through a 10-MHz band-pass filter, C247, L73. The 10-MHz reference is also sent to the 800/40-MHz loop-phase detector, the main loop-phase detector via divide-by-10, U58.

3-41. MAIN PHASE-LOCK LOOP

The main phase-lock loop (PLL) is a fractional divider PLL with a single-sideband mixer (SSB) in the feedback path. The oscillator for this loop is a separate PCA, the A2A2 VCO. All the remaining PLL circuitry is on the synthesizer PCA A2A1.

The key signals to the main PLL are the 1-MHz reference signal from the 10-MHz Reference circuit, the 245-MHz to 512-MHz signal from the binary divider, and the 20-kHz to 40-kHz signal from the sub-synthesizer circuit. The fractional division technique provides 20-kHz frequency resolution.

The SSB mixer, in conjunction with the sub-synthesizer, provides additional 5-Hz resolution at the Synthesizer frequency. This corresponds to 10-Hz resolution on the high band.

The main PLL consists of the VCO, the binary divider, the SSB mixer, the triple-modulus prescaler, the N-Divider, the phase detector, and the loop amplifier. All but the VCO are described in the following paragraphs. The VCO is discussed in paragraphs 3-48.

3-42. Binary Divider And Single-Sideband Mixer

The 490-MHz to 1050-MHz signal from the VCO via J107 is coupled to the binary divider, U1. Regulator Q1 provides +5V for the divider. One output of U1 is coupled to the Output PCA, A2A4 through J104. The other output is amplified by Q2 and Q3. This signal is split into two quadrature (90° phase difference) signals by 3-dB coupler, U6.

This signal, and two other audio quadrature signals from U10, are summed in the double-balanced mixers U7 and U8 to produce two double-sideband suppressed-carrier signals. Because of the phase relationship of the outputs of the mixers, the summing of the two composite signals (in resistor network R21 and R22) results in the upper-sideband component being suppressed. The predominate remaining signal is the lower-sideband signal.

The lower-sideband signal, spanning 245 MHz to 512 MHz in 20-kHz steps, is amplified by U9 and applied to the N-Divider where it is divided down to 1 MHz.

3-43. N-Divider

The main components of the N-Divider are:

Triple-Modulus Prescaler (divide by 20/21/22) U18, U19, and U20
N-Divider Custom Gate Array U17

The triple-modulus prescaler, Figure 3-1, consists of a divide by 10/11 (U20), divide by 2 (U18A), synchronizing flip-flop (U18B), and quad NOR gates (U19). If all the inputs (E1, E2, E3, E4, and E5) to the 10/11 divider are low, the prescaler divides by 11, and the total division to the output (U20 pin 7) is 22. If any of the inputs are high, it divides by 10, and the total division is 20.

If inputs E1 and E3 are low, the modulus of the 10/11 divider is controlled by the output of the following divide by 2 (U18A). Consequently, the prescaler divides by 10 half the time and by 11 the other half, resulting in a divide by 21. U20 contains the ECL to TTL converter. U18B synchronizes the changing of the modulus with the clocking of the subsequent stages. The N-divider is clocked by the composite prescaler output U18A.

The operation of the triple-modulus prescaler is shown in Figure 3-1. The prescaler operates in conjunction with the N-divider gate array shown in Figure 3-2.

THEORY OF OPERATION

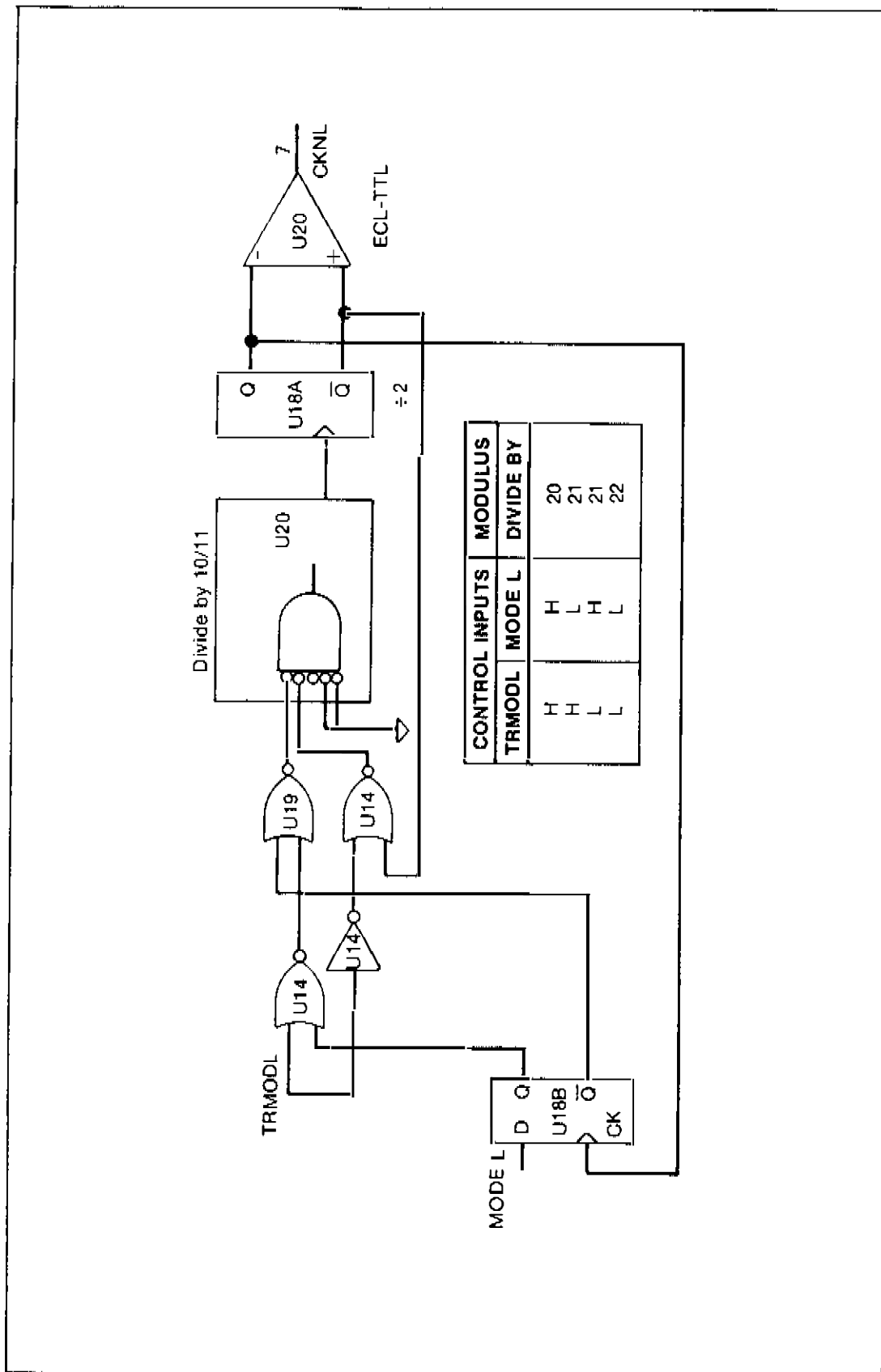
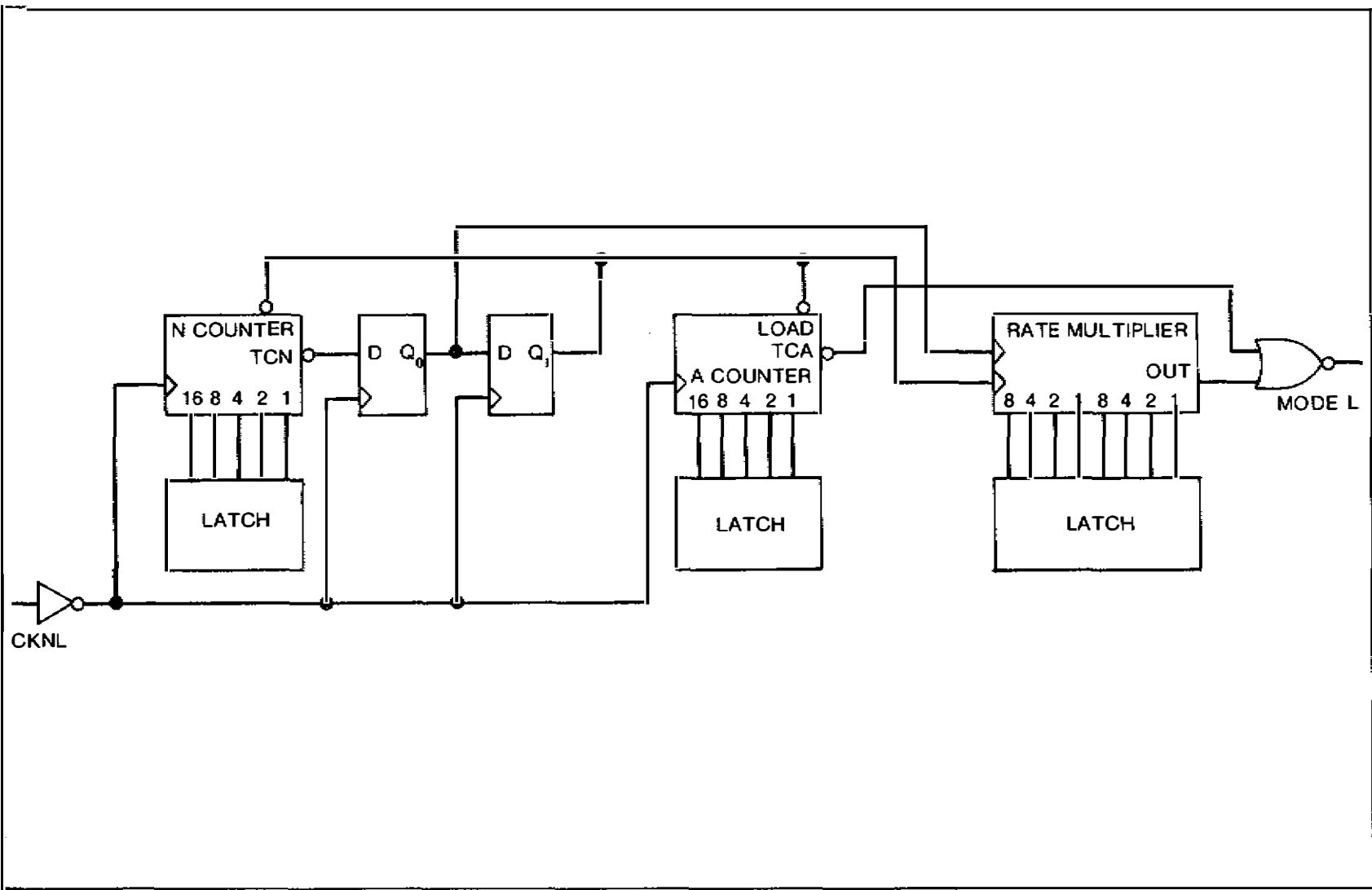

Figure 3-1. Triple-Modulus Prescaler Operation

Figure 3-2. N-Divider Operation



THEORY OF OPERATION

The N-Divider gate-array contains two 5-bit binary counters (A and N), a BCD two-decade rate multiplier, and latches to interface to the microprocessor. The operation of the N and A counters is as follows:

At the beginning of a count cycle, a number is loaded into the A and N counters. The A counter is not at its terminal count, so the output is high, and the mode line (MODE L) is low. This causes the prescaler to divide by 21 (or 22, TRMODL = low). The mode line stays low for 31-A counts, where A is the programmed number. The mode line goes high, and the prescaler divides by 20 (or 21, TRMODL = low) for 31-N counts.

The total division is:

$$(P+1)*(31-A) + P*((31-N)-(31-A)) \text{ or } P*(31-N) + (31-A)$$

On the 31st count, the counters are reinitialized. Figure 3-3 shows the timing for the A-counter programmed to 26, and the N-counter programmed to 18. Only the CKNI, and MODE L signals shown in Figure 3-2 are accessible at U17, pin 6, and 22, respectively. Figure 3-3 show the N-Divider timing diagram.

The N-Divider gate array includes a two-decade rate multiplier that produces the fractional part of the division. It produces a pulse train with a programmed number of pulses for a 100-cycle frame of the 1-MHz N-divider output.

The programmed number ranges between zero and 98 in steps of two, corresponding to 20-kHz steps at the mid-band output frequency. The flip-flops in the rate multiplier get setup on count 29, and on count 30, a pulse may or may not be present depending on the programming of the rate multiplier. This is the shaded pulse in the timing diagram, Figure 3-3.

Irregularly spaced rate-multiplier pulses cause the mode line to go low, and the prescaler divides by P+1 at a rate equal to the rate multiplier programming. At a division of 255, the N and A counters are normally programmed to 15. This means the divider is always dividing by 21; consequently, there is no place to slip in the rate-multiplier pulses.

It might be noted that a 20/21 dual-modulus prescaler will not allow division from 245 to 525 without holes. For example 252 is 0 frames of 20 and 12 frames of 21. Consequently, there is no place to slip in the rate-multiplier pulses. It is not possible to divide by 253.

By using a triple-modulus prescaler, these problems are solved. Continuing with the previous example 252 is 12 frames of 21 and 0 frames of 22. The deleter functions by allowing the prescaler to divide by 22 at a rate equal to the rate-multiplier frequency. Number 253 is 11 frames of 21 and 1 frame of 22. A software algorithm determines whether to operate in the 20/21 mode (TRMODL =1) or 21/22 mode (TRMODL =0).

The frequency at the output of the N-divider gate array, is $(F_o/2 - F_s - F_d)/N$; where F_o is the VCO output frequency, F_s is the sub-synthesizer frequency, and F_d is the fractional-division frequency.

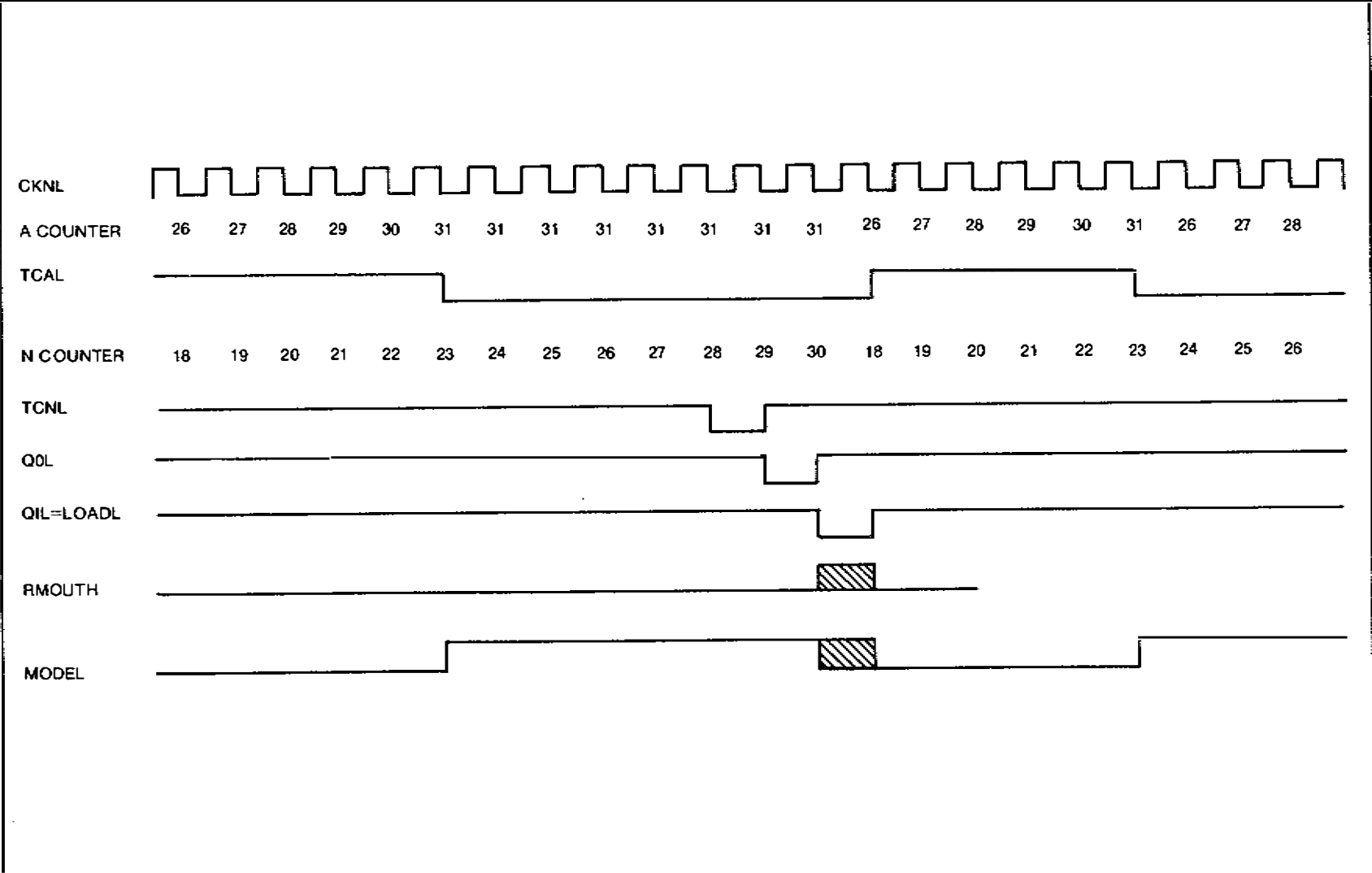

Figure 3-3. N-Divider Timing Diagram

THEORY OF OPERATION

3-44. Phase Detector

The 1-MHz reference signal from divide-by-10 U58, and the 1-MHz signal from the N-divider U17 are connected to a digital phase-frequency detector (U43, U44, U45). If the N-divider output is greater than the reference frequency, the level at TP38 is high. When the output of the level shifter Q16 is above ground, then CR12 is turned off. This allows current from Q19 to flow through CR13 into the integrator, decreasing the voltage at the integrator output, U48 Pin 6, which then lowers the frequency of the VCO until the reference and the N-divider output are the same frequency.

Similarly, if the N-divider output frequency is below the reference, TP39 is low, and the voltage at the output of level shifter Q17 is below ground, turning off CR15 and allowing current from R108 to flow through CR14 out of the integrator. This raises the voltage at the output of the integrator, which raises the VCO frequency. The phase-frequency detector is designed so that if the phase between the reference and N-Divider output slips more than two cycles in either direction, the corresponding phase-detector output is high or low. This provides twice the integrator current during acquisition as a conventional phase-frequency detector.

R107 provides a small bias current to the integrator to bias the phase detector at approximately 2.5 radians; consequently, the down-pump is normally always on. If the up-pump comes on, indicating an over-modulation condition, the pulses are detected by the one-shot, U47 that produces the UNLOCK status that is then sensed by the Controller.

For flat FM response, it is necessary for the PLL bandwidth to be constant at all VCO frequencies. Two factors cause the loop bandwidth to change: the VCO tuning coefficient (K_v) and the divider ratio (N).

During calibration of the VCO, the K_v is measured at many frequencies across the band, and compensation data is stored in the VCO Calibration EPROM. The instrument software uses this data along with N to control the PLL bandwidth in a compensating manner. The PLL bandwidth is controlled by changing the current to the down-pump via the KN DAC, U27, and the voltage-to-current converter, U46, Q18, and Q19.

3-45. Loop Amplifier

The loop amplifier-integrator consists of operational amplifier U48, C118 and R91. Capacitors C121 and C119 filter the 1-MHz reference. The output of the integrator is connected to a multi-pole LC filter (R92, C123, C99, C124, C125, L49, L50, and R93) that attenuates the delete rate (20 and 40 kHz) and reference 1-MHz spurs.

Diodes CR9 and CR10 stabilize the loop during switching. The filter is buffered by the Darlington emitter-follower Q20, which is biased at 10 mA by Q21. Additional lead/lag compensation is provided by R99, R101, and C131. Proper termination for the filter is provided by R93 and Q22. The voltage for the loop amplifier is regulated to approximately +30V by Q15.

Amplifier U49 is a precision clamp to keep the VCO frequency above a minimum value for oscillation, and below a maximum above which the N-divider would not divide correctly. The photoisolator U50 detects when the clamp is active, indicating an out-of-lock condition. This signal is ORed with the signal from one-shot U47 and sent to the microprocessor as the UNLOCK status.

3-46. FM PROCESSING

To provide FM accuracy, the FM signal FMV from the Output board is first processed by the KV DAC (U28, and U29) to compensate for the VCO tuning coefficient. The KV DAC setting is proportional to $1/K_v$, where K_v is the tuning coefficient. This correction

is stored in the VCO Calibration EPROM on the Controller board. For output frequencies above 512 MHz and below 245 MHz, the KV DAC setting is halved to account for the effective frequency doubling that occurs on these bands.

Range switching is provided by resistors R77, R78, R79, and FETs Q10, Q11, and Q12. Comparator U42 converts TTL levels to 0V (on), and -15V (off) required by the FETs. U41A buffers the range switch, and in conjunction with R82, provides an overall FM adjustment. At this point, the audio signal splits into two paths. The path that connects to the integrator, U41, is for modulation frequencies inside the loop bandwidth.

The path that sums with the VCO control voltage at J103 is for frequencies outside the loop bandwidth. U41D is an active high-pass filter that compensates for the non-ideal integrator and the ac coupling to the VCO tuning port.

The output of U41D is summed with the VCO control voltage via R88 and C117. FET Q13 allows the FM to be turned off. The audio signal is also processed by integrator U41A, R85, R86, and C115. The audio signal is ac coupled into the phase-detector integrator via R89, R90, C116, and FET Q14. (Resistor R90 adjusts the low frequency FM gain). This integrator makes the phase modulation produced at the Phase Detector appear as FM.

3-47. 800/40 MHz PLL

When the Signal Generator is operated in the low-band, the 800-MHz oscillator is locked to the 10-MHz Reference and provides a local oscillator for the heterodyne circuit on the Output PCA. It also provides a 40-MHz signal to the sub-synthesizer clock generator.

The 800-MHz VCO is connected to the divide-by-four, U61, followed by a divide-by-five, U62 and U63, providing 40 MHz to the sub-synthesizer clock generator through selector U64. When the Signal Generator is not in the low-band, the 800-MHz oscillator and the first divide-by-four are disabled by turning off Q28 (HET).

The 40-MHz Oscillator consisting of U64, L66, and CR24, is selected by U64. The 40-MHz balanced ECL signal from U64 drives the two-phase clock generator. A self-biased gate, U65, converts ECL to TTL. U66 divides the 40-MHz signal by four to produce a 10-MHz signal that is compared against the 10-MHz reference in the phase detector U59 and U65.

Op-amp U60, resistor network Z9, and C181, C185, C186, and C201 integrate the phase detector pulses to produce a dc control voltage for the 800-MHz VCO and the 40-MHz VCO.

3-48. 800-MHz VCO

The 800-MHz VCO is a low noise, limited range, voltage-controlled oscillator for the 800-MHz PLL. The basic oscillator uses two active devices operating as negative resistance elements, coupled symmetrically to a resonator made up of a varactor and an adjustable capacitor. Each device is followed by an amplifier and isolation pad. This provides two coherent outputs of +5 dBm to the PLL and 0 dBm to the output A2A4 assembly.

The oscillator transistors Q32 and Q35 are biased at 13 mA by R182 and R191. The voltage at the collectors of Q32 and Q35 is typically +2.5V. The two 6-dB amplifiers Q33 and Q37 are biased so that the voltage at their emitters is about +0.3V, and the voltage at their bases is about +1V with the collectors at +6.5V.

The PLL control voltage from U60 provides the tuning voltage for the varactor CR27. The adjustable capacitor C206 is set to provide +16V on the varactor to optimize the VCO noise characteristic. The output attenuators consisting of R186, R187, R189, R197,

THEORY OF OPERATION

R198, and R200 provide isolation between the outputs. The VCO signal is coupled to the output assembly A2A4 by a through-the-plate coaxial connector P108 at the 0 dBm level. The other VCO signal is connected to the divider U61 to provide the feedback for the PLL.

3-49. SUB-SYNTHESIZER

The sub-synthesizer consists of the clock generator, U34, Q4, Q5, the gate-array, U33, the divide by 500, U15, and U16, and the low-pass filter L11 and L17. Internal to the sub-synthesizer gate-array, U33, are a divide-by-two, a 3 1/2 decade-rate multiplier, and associated latches.

The balanced 40-MHz ECL clock signal is converted to TTL in Q4 and Q5, and converted to a two-phase 20-MHz clock in U34, U35.

An enable output of each section allows multiple sections to be cascaded. The input frequency to the rate-multiplier is 20-MHz. The output frequency can be programmed from zero to 19.995 MHz in 5-kHz steps. This signal is ORed with the other phase of the 20-MHz clock to produce 20 MHz to 39.995 MHz at U33 pin 1. This is divided by two in the gate-array, by ten in U15, and again by 50 in U16 to produce 20 kHz to 39.995 kHz in 5-Hz steps. This TTL signal at TP11 is filtered by L11, L17, and C41, C42, C48, C50, and C51. Op-amp, U10 forms an active quadrature generator, and the output pins 14 and 8 are offset by 90°. These two signals are the 20-kHz to 40-kHz inputs for the Main PLL single-sideband mixer.

3-50. VCO PCA, A2A2

The VCO PCA A2A2 is the heart of the main PLL. It produces the signal that is further processed to become the Signal Generator output. The VCO assembly is located in a bottom side compartment of the Module section A2.

The VCO tunes over a frequency range of 490 MHz to 1050 MHz with a control voltage range of +2V to +18V. The basic oscillator circuit uses two active devices operating as negative resistance elements. Coupled symmetrically to a resonator, each active device is followed by a 6-dB amplifier and a 15-dB isolator pad that provides two coherent but isolated signals at about 0 dBm.

One signal is sent to the Output A2A4 assembly, and the other to the Synthesizer A2A1 assembly. To suppress harmonics, two tuned trap filters are placed between the negative resistance devices and amplifiers Q2 and Q4.

The oscillator transistors Q1 and Q3 are biased at 13 mA by the FET current sources Q5 and Q6. The voltage at the collectors of Q1 and Q3 are typically set at +6V. The two 6-dB amplifiers Q2 and Q4 are biased so that the voltage at their emitters is about +0.3V and at their bases about +1V, with the collectors at about +6.5V.

The PLL control voltage from the Synthesizer assembly A2A1 at P102 provides the tuning voltage for varactors CR1 and CR2. This voltage also controls varactors CR3 and CR4 with resistors R6, R4, R18, R19, and R20. These varactors, in conjunction with their lead inductance and C1 and C32, make up a shunt trap filter at twice the VCO frequency to suppress the in-band second harmonic at both VCO outputs to typically less than -10 dBc.

The output attenuators consisting of R13, R14, R15, R27, R28, and R29 provide the isolation between the two VCO outputs at P103 and P104. C23 and C30, in series with the printed board inductors, form out-of-band trap filters for approximately 1.4 GHz. These filters further suppress the out-of-band harmonics.

C23 couples the VCO signal to the Synthesizer assembly by a through-the-plate coaxial connector P104. The other VCO signal is connected to the Output assembly A2A4 by a plug-in capacitor, A2C1. This plug-in capacitor allows either VCO or the Output PCA to be removed independently from the module A2 assembly without the use of a soldering iron.

3-51. Output PCA, A2A4

The Output PCA accepts RF signals from the Synthesizer and the VCO circuits and command signals from the Controller. The output circuit provides a 0.01-MHz to 1050-MHz RF signal to the Attenuator.

The Output assembly reduces harmonic distortion components in the RF signal, controls RF signal amplitude, introduces AM, and generates the low (heterodyne) frequency band 0.01 MHz to 245 MHz through mixing. It also generates a modulation signal to provide internal AM and FM, and provides a digital interconnect path between the Controller and Synthesizer.

3-52. RF PATH

The RF path begins with the two RF signals from the VCO and the Synthesizer assemblies. The SPDT bandswitch circuit selects between the 512-MHz to 1050-MHz signal at P106 and the 245-MHz to 512-MHz signal at P107. The selected signal is applied to buffer amplifier Q101 and Q102.

The 245-to 512-MHz signal directly generates the 245-to 512-MHz mid-band output signal. The 512-MHz to 1050-MHz signal generates the 512-MHz to 1050-MHz high-band output signal directly and the 0.01-MHz to 245-MHz low-band output signal by mixing with an 800-MHz LO signal.

The buffer amplifier Q101 and Q102 is a common-base, common-emitter cascade circuit with 7-dB gain. The three cascaded filter circuits that follow the buffer amplifier consist of combinations of discrete components and printed filters that suppress harmonics in the Generator RF output signal.

The first section of the circuit is a printed 1100-MHz low-pass filter. The second section is switched into the RF path via PIN diodes CR106 through CR110 by asserting MIDL when the Generator is operated in the mid-band (245 to 512 MHz). PIN diodes CR114 through CR116 select capacitors C119, C121, and C123 whenever HAOCTH is asserted to change the section cutoff frequency from 512 to 350 MHz. The third section provides harmonic filtering for the two higher bands, 512 MHz to 730 MHz, and 730 MHz to 1050 MHz. PIN diodes CR111 through CR113 select capacitors C112 through C114 to change the cutoff frequency from 1050 MHz to 730 MHz whenever HAOCTH is not asserted.

The amplitude modulator consists of PIN diodes CR117 through CR120 and associated components and follows the switchable filters in the signal path. The modulator is a voltage-controlled variable attenuator that provides AM and output level control. Modulator control voltage is determined by the leveling-loop circuitry. The leveling loop is described later in this section.

Q209, Q211, Q213, and associated components follow the modulator in the signal path and form a three-stage, 20-dB gain, 245-MHz to 1050-MHz amplifier. This amplifier drives a 3-dB power splitter that consists of resistors R253 through R255 and associated printed transmission lines.

One power splitter output drives the leveling-loop detector diode CR202. The other output goes to the HET band switch that includes PIN diodes CR203 through CR210 and

THEORY OF OPERATION

biasing components. In the 245-MHz to 1050-MHz position, the signal passes through diodes CR204 through CR209 to the output amplifier Q215. This low-distortion output amplifier has 6-dB gain and output capability of 15 dBm.

For low-band operation (0.01 MHz to 245 MHz), the signal from the power splitter is routed through CR203 to an adjustable attenuator, R224 through R229, and then to the RF port of U201 (a double-balanced mixer). The signal frequency at the mixer RF port varies from 800.1 MHz to 1045 MHz. The 800-MHz local oscillator (LO) signal for the mixer comes from the Synthesizer assembly through P108 and is amplified by Q207. This fixed-tuned amplifier has 13 dB of gain and provides a 10-dBm signal at the mixer LO port.

The mixer 0.01-MHz to 245-MHz output signal is passed through a diplexing low-pass filter (C219 through C230, R230, R231) that suppresses unwanted mixer spurious products while maintaining a 50-ohm load at the mixer IF port. The filtered IF signal is amplified by a three-stage IF amplifier Q202, Q204, Q206 and associated components.

The IF amplifier gain increases with frequency and is nominally 35 dB at 0.01 MHz and 37 dB at 245 MHz. This gain characteristic compensates for the increasing loss with frequency of the mixer and the diplexing low-pass filter. The output of the IF amplifier passes through a 245-MHz low-pass filter (C216, C217, C218 and printed inductors) and PIN diode CR210 to the output amplifier. The +15V power supply for the LO and IF amplifiers is switched off by Q301 when the instrument is operating in the 245-MHz to 1050-MHz band to avoid introducing spurious products in the instrument output.

3-53. LEVELING LOOP

The leveling loop accepts the unlevelled 245-MHz to 1050-MHz signal from the switchable low-pass filters and generates a leveled signal at the power splitter output that feeds the HET band switch. The leveled signal is proportional to the leveling loop control voltage that is generated by the level-control circuit. The signal amplitude at the other output of the power splitter is detected by a Schottky detector diode, CR202.

This diode generates a temperature-dependent dc voltage, which is a non-linear function of the applied RF voltage, so temperature compensation and linearization are necessary. The detector diode signal is low-pass filtered by L217 and C253, and is offset by the voltage across temperature-compensating diode CR126. Q104, Q105 and associated components form a current source circuit that provides bias current for CR126 and CR202.

The offset detector diode voltage at U101B pin 3 is linearized by amplifier U101B and its associated feedback components. Potentiometer R144 provides detector linearity adjustment. Thus, the voltage at U101B pin 1 is proportional to the RF voltage at detector diode CR202.

This voltage is divided and applied to the loop integrator amplifier at U101A pin 6. This amplifier drives the modulator through emitter follower Q103 and through the action of the ALC loop, maintaining the voltage level at U101A pin 6 equal to that on pin 5. Pin 5 voltage is a function of the leveling loop control voltage applied to R140. R140, R141, CR127, and CR128 form an additional detector linearizing network that is active for low RF levels. Amplitude modulation is achieved by summing an appropriately scaled modulation signal with the dc leveling loop control voltage applied to R140.

The amplitude modulator consists of PIN diodes CR117 through CR120, resistors R121, R122, and capacitors C137 and C138. Attenuation through the modulator is a function of bias current through the PIN diodes. This current is provided by the modulator linearizer circuit (R123 through R129, R148, R149, C139 through C143, and CR121).

Modulator attenuation is thus approximately proportional to the modulator control voltage at the emitter of Q103. Proportionality is required to maintain constant leveling loop bandwidth as modulator attenuation varies. Minimum attenuation is obtained with a modulator control voltage of 10V, while maximum attenuation is obtained with 0V.

Comparator U310A and associated components form an unlevelled indicator circuit. The comparator senses the modulator control voltage at the emitter of Q103. This voltage is normally less than +11V, and the comparator output is high. If the modulator control voltage exceeds +11V, the modulator attenuation is at a minimum, and the leveling loop becomes inoperative (unleveled). This condition could be due to a fault or some abnormal operation such as over-modulation. In this case, the comparator output (UNLVLL) goes low. The Controller senses this low and causes the front panel 'UNCAL' indicator to flash and displays an unlevelled status if interrogated.

3-54. LEVEL CONTROL

The instrument output level is set by the level-control circuit. Inputs to this audio signal processing circuit are the internal and external modulation signals, a dc reference voltage, and the digital control commands. The circuit output is the leveling loop control voltage that provides vernier level control of the Generator output. Digitally encoded level, modulation depth, and temperature-compensation information are provided by the Controller.

Selection of the internal or external modulating signal, or no modulation, is made by analog switches U401C, U401D, and Op-amp U402B. The selected, buffered modulation signal at U402B pin 1 is applied to pin 4 of U301, a dual 8-bit DAC. U301, with U302D, acts as a digitally programmed variable attenuator and is labeled AM DAC.

Binary AM depth control information from the Controller is applied to DAC U301. The output at U302D pin 14 is the modulation signal scaled to the programmed AM depth. This ac signal is summed by op-amp U302B with a dc reference voltage provided by CR403. The output at U302B pin 7 is called the 1+AM signal. This signal provides the desired AM depth when scaled by the LVL DAC and applied to the leveling loop. AM depth adjustment is provided by potentiometer R421.

The instrument RF output amplitude is temperature compensated in a frequency-dependent manner as follows. The 1+AM signal is applied to pin 18 of dual 8-bit DAC U301, the DAC B reference input. The DAC output, at U405D pin 14, is the 1+AM signal attenuated by an RF frequency-dependent factor provided by the Controller using constants stored in the Generator firmware. This voltage is applied to a resistor/thermistor network that includes R303, R305, R306, and RT301.

The network output is the 1+AM signal attenuated by an RF frequency and temperature-dependent factor, and is applied to summing op-amp U302C. The 1+AM signal is also applied to this summing amplifier. Thus, the voltage at U302C pin 8 is the temperature-compensated and scaled 1+AM signal.

This signal is applied to the reference input of Level DAC U303. This 12-bit DAC, with op-amp U302A, latches U304, U305, controls the Output assembly RF output amplitude. The DAC output voltage, at U302A pin 1, is the temperature-compensated 1+AM signal multiplied by a factor proportional to the 12-bit level control number provided by the Controller. This voltage is the leveling loop control voltage. The Generator RF output level adjustment is provided by potentiometer R311, and DAC offset voltage adjustment is provided by potentiometer R309.

THEORY OF OPERATION

3-55. MODULATION OSCILLATOR

The modulation oscillator generates a leveled sine wave of 400 Hz or 1 kHz and is the modulation source for the internal AM and FM functions. The oscillator is a level-controlled Wien-Bridge type and consists of op-amps U405A, U405B. Frequency is determined by the series RC time constant of the components between pins 5 and 7 of U405B and by the parallel RC time constant of the components from U405 pin 5 to ground. The modulation frequency control line, MF400L, originating at the latch U308, selects either 400-Hz or 1-kHz operation, and is selected by switching resistors with JFETs Q401 and Q403.

The amplitude of oscillation is controlled by an ALC loop that varies the resistance on U405B pin 6 to ground. This resistance comprised of R412 and the drain resistance of Q402, is nominally 2K ohms. The oscillator signal amplitude is sensed by rectifier CR401. The average current through CR401 is made equal to the reference current in R416 by integrator-amplifier U405A. Level adjustment is set by potentiometer R419. Temperature compensation is provided by R417, R418, and CR402.

3-56. FM DEVIATION CONTROL

The FM modulation signal source and deviation control circuits are on the Output assembly. Analog switches U401A, U401B, and op-amp U402A select the internal or external modulating signal, or no modulation. The selected and buffered modulating signal at U402A pin 7 is applied to FM DAC U403. This DAC provides fine control of the FM deviation. (The coarse control FM circuitry is part of the Synthesizer assembly). The output of the DAC, at U405C pin 8, is the modulation signal multiplied by a factor proportional to the 8-bit FM deviation control provided by the Controller.

3-57. Attenuator/RPP, A2A5

The Attenuator/RPP Assembly, A2A5, consists of an Attenuator/RPP PCA, A2A5A4, in a metal housing mounted on the top side of the A2 module section to form a shielded enclosure. The Relay Driver /RPP PCA, A2A5A5, is included in this assembly.

The Attenuator assembly controlled by the microprocessor provides coarse control of the Signal Generator output level. The high-level signal from the Output PC assembly, A2A4, is applied to the Attenuator which provides 0 dB to 138 dB of attenuation, in 6-dB steps, to this signal before it goes to the Generator RF OUTPUT connector.

Compensation data for the attenuator in each Generator is stored in the Attenuator calibration EPROM located on the Controller PCA, A2A7. The instrument program uses this data to correct for the combined deviations of the attenuator sections in use. For more details on level correction, refer to paragraph 3-13, Amplitude Control.

The Attenuator/RPP Assembly provides an attenuation range from 0 dB to 138 dB in 6-dB steps and consists of seven independently cascaded 50-ohm attenuation sections, a 6-dB, a 12-dB, and five 24-dB sections. Each section consists of a DPDT relay and a three-resistor attenuator pad.

One relay position (when power is applied to the relay provides a straight path for the RF signal, and the other position (no power applied to the relay) inserts the attenuator pad into the RF signal path. All seven relays are inside individual shielded compartments in the Attenuator housing.

The control of the Attenuator relays is latched via U27, the open-collector drivers U30 and U31 on the Controller PCA A2A7 and transistor drivers on the A2A5A5 Relay Driver/RPP control PCA. For calibration and troubleshooting purposes, special

functions 83 through 86 allow the direct selection of four of the five 24-dB attenuators. The other 24-dB attenuator is selected by programming the appropriate level (-12 dBm).

Coupling capacitors C6 and C7 protect against dc or low-frequency power. The diode limiter, consisting of CR2 through CR9, provides protection against medium RF Power levels and short-term (fast acting) protection against high RF power levels. Long-term (latched) protection is provided by relay K8 whenever the reverse RF power exceeds a preset level.

RF power detected by CR1 is compared with the preset voltage in one section of comparator U1. When the detected voltage exceeds the set value, the output of UI pin 1 goes positive, turning on Q1 and Q2. This actuates K8 to the protect position. In the protect position, the output connector is shorted to ground and the Generator output is disconnected from the output connector.

CR15 and R6 form a latching network such that K8 remains in the protect position until the Generator RF Output is reset by an RF ON entry. The output of the comparator is buffered and sent as RPTRPL to interrupt the Controller signal that annunciates the RPP trip condition by flashing the UNCAL and RF OFF indicators.

3-58. Controller PCA, A2A7

The Controller, under the direction of the instrument software, handles the data interface between the front panel, remote interface, and Generator functions. The Controller is located in a top side compartment of the module section, A2.

The Controller printed circuit assembly consists of the following functional groups:

- Microprocessor and its interface circuitry
- Attenuator control interface
- Front panel interface
- IEEE-488 Interface
- Memory ICs and addressing circuitry
- Module I/O circuitry
- Reset circuit
- Status and control latches

3-59. MICROPROCESSOR

The heart of the Controller assembly is U1, a TMS9995 16/8 bit microprocessor. The digital system clock signal is generated by an oscillator comprised of gates from U5 and crystal U41. When enabled, bidirectional buffer U4 provides additional drive current to the data bus operation; when it is disabled, it isolates the microprocessor from the system data bus. Buffers U33, U34, and U10 provide extra drive current to the microprocessor address and control signals.

3-60. ATTENUATOR CONTROL INTERFACE

The attenuator control signals are latched by U27. Darlington drivers U30 and U31 control the Relay Drivers A2A5A5 PCA.

3-61. FRONT PANEL INTERFACE

Data is transferred to and from the front panel circuitry through tri-state bidirectional data buffer U18. This buffer is active when a front panel latch is addressed and the buffer control signal from U17 is low; otherwise, it is in the high-impedance state. The front panel latch select lines are decoded by U36. To reduce RF emissions from the Generator, low-pass filters comprised of the following components are used on the following signals:

THEORY OF OPERATION

SIGNALS	COMPONENTS
Signal CLRL	R6 and C51
Latch select SEG1L	R7 and C53
Latch select SEG2L	R8 and C54
Latch select SEG3L	R9 and C55
Latch select SEG9L	R10 and C56
Latch select DIGL	R11 and C57

In addition, capacitors C58 and C59 bypass the display filament supplies. LC filters comprised of L1 and C50, and L2 and C52 are used on the +5 volt and +37 volt supplies to the front panel circuitry.

3-62. IEEE-488 INTERFACE

Tri-state bidirectional buffer U2 buffers the data bus to the optional IEEE-488 assembly, A3A3. Address and control lines to the option are buffered by tri-state buffer U3. These buffers are in the high-impedance state when the option is not addressed.

The active low interrupt signal IEINTL from the IEEE-488 option is connected to the level four interrupt on the microprocessor. When the option is not present, IEINTL is pulled up to the inactive state. R1 and C22 form a low-pass filter to suppress digital emissions from the Generator.

3-63. MEMORY

The microprocessor uses a 2K-byte RAM (U25) to store program variables. A 32K- and an 16K-byte EPROM (U21 and U22) contain the microprocessor instructions and constant data. Three 2K-byte Calibration EPROMs (U23, U24, U26) contain calibration data for the VCO, Output, and Attenuator/RPP assemblies, respectively. Decoders U20 and U14 decode the individual chip selects for the memory ICs.

3-64. MODULE I/O

Control data is transferred to the RF circuitry (located in the Module Section, A2) through a byte wide unidirectional data bus. This data is retained on the RF circuit boards in latches. Select lines BSEL0L, BSEL1L, and address lines BAB2 through BAB0 are decoded into individual latch enables on the various RF circuit boards. Tri-state buffers U15 and U16 on the data and address lines provide extra drive current and allow these signals to float when inactive.

Flip-flop U42 gates the module I/O select pulse from U8 with the system clock to delay the leading edges of BSEL0L and BSEL1L to provide adequate latch setup times. D-flip-flop U9 latches address lines BAB2 through BAB0 to provide adequate latch hold times.

3-65. RESET

Comparator U7 and its associated circuitry generate the active low reset signal to the TMS9995. The reset signal is generated on power-up or if the +5V supply drops below +5V.

At power-up, R5 and C4 provide a slow-rising reset signal to the microprocessor, and the output of U7 is ignored. When the +5V supply is up, a reference voltage is set at U7 pin 2, the negative terminal. This reference voltage is one diode drop below the voltage at the positive terminal (pin 3). When power is lost, the voltage at the positive terminal falls below the reference voltage held by C3, and the output of U7 is immediately pulled low.

3-66. STATUS AND CONTROL

Tri-state buffers U11 and U40 read the three hardware fault detector status signals, UNLVL, UNLOKL and RPTRPL, the five option status signals HSOPTL, MSREFL, IEINL, LRFML, and ROPTL, and the status of the REF INT/EXT switch. Control and buffer enable signals are latched by U17.

3-67. REAR SECTION, A3

The rear panel section consists of a fuse/filter/line-voltage selector switch A3FL1, a transformer A3T1, a Power Supply PCA A3A1, and a fan, A3B1. The line-selector switch accommodates four line voltages, 100/120/220/240 volts, selected by the orientation of a pullout PCB.

The transformer A3T1, with its two primary windings, accepts these four voltages and produces the necessary five secondary voltages. The power supply PCA A3A1 rectifies, filters, and regulates these secondary voltages to produce the dc voltages required by the Generator. The dc fan A3B1 is connected to the unregulated +5V supply.

NOTE

The power supply for Option -130 High-Stability Reference is separate. It has an automatic change over switch for different input line voltages.

3-68. Power Supply PCA, A3A1

The bridge rectifiers in the power supply are used in either a bridge or full-wave center-tapped configuration with capacitor input filters. Table 3-1 lists the rectifier configurations as well as the component designations for the various supplies.

The two +15V, the -15V, and the +5V supplies use conventional three-terminal IC regulators with internal current-limiting and temperature protection. All three 15V regulators have reverse voltage protection diodes CR3, 4, and 8.

The +37V regulator voltage is adjustable via R3. A 6.2V supply is developed from the +37V supply through resistor R4 and zener diode CR7 and is applied to the center tap of the 6V ac filament supply. This provides grid bias for the front panel displays. All regulators (except +37V) have their common reference terminals brought out to an external ground point on module A2 to reduce power supply ripple (P2).

Triac U6 is a voltage surge protector to protect against line voltage surges as well as overvoltage in case of a wrong setting of the selector switch.

Switch S1 is the REF INT/EXT reference selection switch and is not functionally part of the power supply.

Table 3-1. Power Supply Rectifier Configurations

SUPPLY	RECT.	CONFIG.	CAP	REGULATOR	REMARKS
+37	CR6	Bridge	C11	A3A1 U4	Adjustable
+15	CR2	CT/FW	C2	" U5	Fixed
+15	CR2	CT/FW	C2	" U1	Fixed
-15	CR2	CT/FW	C5	" U2	Fixed
+5	CR5	CT/FW	C8	A3 U3	Fixed
+18	CR1	Bridge	C1		Unregulated relay supply
FIL	6V ac with center-tap biased at 6.2V dc.				

THEORY OF OPERATION

3-69. Sub-Harmonic Reference (Part of A2A1)

Comparator U67 forms an ac-to-TTL converter. Diode CR20 and CR21 precondition the REF IN signal to protect the comparator. Resistors R148, R149, R153, and R217 provide hysteresis, preventing oscillation when there is no input.

MOS switch U70 connects the control voltage of the 10-MHz crystal oscillator to a bias network R229, R230, and R231, or to the loop amplifier, thus closing a phase-locked loop.

The phase detector and loop amplifier are made up of U68, Q26, Q27, Q28, and U69. The signal from the external reference input through the ac-to-TTL converter or the enhanced stability options is applied to the flip-flop clock input, U68-3, via U54. The 10-MHz signal from the crystal oscillator goes to the other flip-flop clock input, U68-11. The flip-flops are connected, so the width of the pulse that switches Q38 is the difference in time of these two signals (U68-3 and U68-11). The phase-detector operating point is set by R223 and R224.

The output of the loop amplifier is applied as the control signal to the frequency control input of the 10-MHz crystal oscillator through the control switch U70. The control switch, U70, is controlled by the Generator Controller through the control line SHENL. This line is enabled when rear panel REF INT/EXT switch is set to EXT or when the enhanced stability options are present.

An out-of-lock detector is formed with one-shot U71. The out-of-lock detector provides a status output to the Controller that indicates the 10-MHz oscillator is not locked. An out-of-lock condition causes the loop amplifier to have a low-frequency beat note which triggers the one-shot to act as a pulse stretcher.

The output of the one-shot is an active-low signal and is combined through diode CR29 with other signals to form the UNLOCK status signal.

3-70. NON VOLATILE MEMORY A2A8

3-71. Power Circuit

There are two sources of power for the Non-Volatile Memory RAM IC. These are the battery and the regulated +5V Signal Generator supply. Diodes CR1 and CR2 form a basic diode switching circuit that allows the power source with the higher voltage to provide current to the CMOS RAM and isolate the other power source.

Q1 and Q4 are turned on by Q2 and Q3 when the +5V supply is above the threshold voltage set by VR1, R2, and R3. Q1 has a low collector saturation voltage. When it is turned on, the supply voltage to the CMOS RAM is very close to +5V. The output of Q4 is the power valid signal. The CMOS RAM cannot be accessed until the output of Q4 goes high.

3-72. Memory Control

All address, data, and control lines to the CMOS RAM are buffered. The enable signals WEL, DBINL, and the CMOS RAM are buffered with open-collector gates. These signals are held at the same potential as the CMOS RAM supply when the +5V supply goes down, ensuring the CMOS RAM draws the minimum standby current.

The presence of the Non-Volatile Memory is detected by the microprocessor when the option is plugged into the Controller board. The signal NVMENL, normally at +5V, is pulled to ground when the option is installed.

Section 4 Maintenance

4-1. INTRODUCTION

This section of the manual presents warranty information and service methods. Performance test procedures are presented in Section 4A, access procedures in 4B, calibration adjustment procedures in Section 4C, and troubleshooting and repair information in Section 4D.

Each Signal Generator is warranted for a period of one year following delivery to the original purchaser. The warranty is located in front of Section 1 of this manual.

4-2. SERVICE METHODS

The Signal Generator is designed to be easily and economically serviced. You may return your instrument to Fluke for service, or you may service it yourself, and repair it, if necessary, by module replacement or component replacement.

4-3. Fluke Service

Fluke Service is probably the easiest for you. To ship a Signal Generator to the Fluke Technical Service Center nearest you, see Section 2 for shipping requirements and Section 7 for a list of repair centers. A cost estimate will be provided if you request one and if your instrument purchase date is beyond the warranty period.

4-4. Module Replacement

If your Generator develops a problem, see the Troubleshooting Section 4D for information on identifying the faulty module. With a modest amount of technical knowledge and test equipment, you can identify the faulty module and replace it using the Module Exchange Program. This method takes only a day or two to restore the Generator to proper working order. Very little or no calibration is required depending on the module replaced.

Module exchange is used if it is necessary to completely recalibrate any of the three modules in your Generator that have an associated calibration EPROM.

4-5. Parts Replacement

Parts replacement requires more equipment and service capability but usually offers the best economy and quickest turnaround. It involves part replacement at the customer's facility.

Most faults are detected by the built-in self tests or the UNCAL status circuits. By noting the self-test error code and interrogating the UNCAL status code, the service technician learns where the problem is. By applying normal signal tracing and troubleshooting procedures (see Troubleshooting in Section 4D of the manual), the fault can be quickly identified.

MAINTENANCE

The faulty component is replaced, and then the instrument is recalibrated using Calibration Adjustments in Section 4C of this manual (if necessary). The Performance Tests explained in Section 4A of this manual are used to verify the Generator performance after repair or recalibration of the Generator.

Some assemblies have some non-field-replaceable parts. These parts, if replaced, would invalidate the calibration EPROM associated with that assembly. They are the Output (A2A4), the VCO (A2A2), and the Attenuator/RPP (A2A5) assemblies. Non-field-replaceable parts are listed in the appropriate parts lists at the bottom of that list.

In the event that a non-field-replaceable part is defective (about 10% of the parts are not field-replaceable), it is necessary for the module to be replaced using the Module Exchange Program in order to realize a complete recalibration of that module and its associated EPROM. Section 7 lists the national and international Sales Representatives and Service Centers.

Section 4A Performance Tests

4A-1. INTRODUCTION

The information in the following paragraphs describes the performance tests for the key parameters of the Signal Generator, using the instrument specifications as the performance standard. These covers-on performance tests may be used as an acceptance test upon receipt of the instrument, as an indication that repair and/or calibration is required, or as a performance verification after completing repairs or calibration of the instrument. Individual performance tests can be used as troubleshooting aids.

The Signal Generator being tested (UUT) must be warmed up with all covers in place for at least 20 minutes before starting the performance tests.

Periodic calibration is recommended once a year.

4A-2. TEST EQUIPMENT

Table 4A-1 gives a list of the recommended test equipment for the performance tests, adjustment procedures, and for troubleshooting the Generator. Figure 4A-1 shows a Two-Turn Loop.

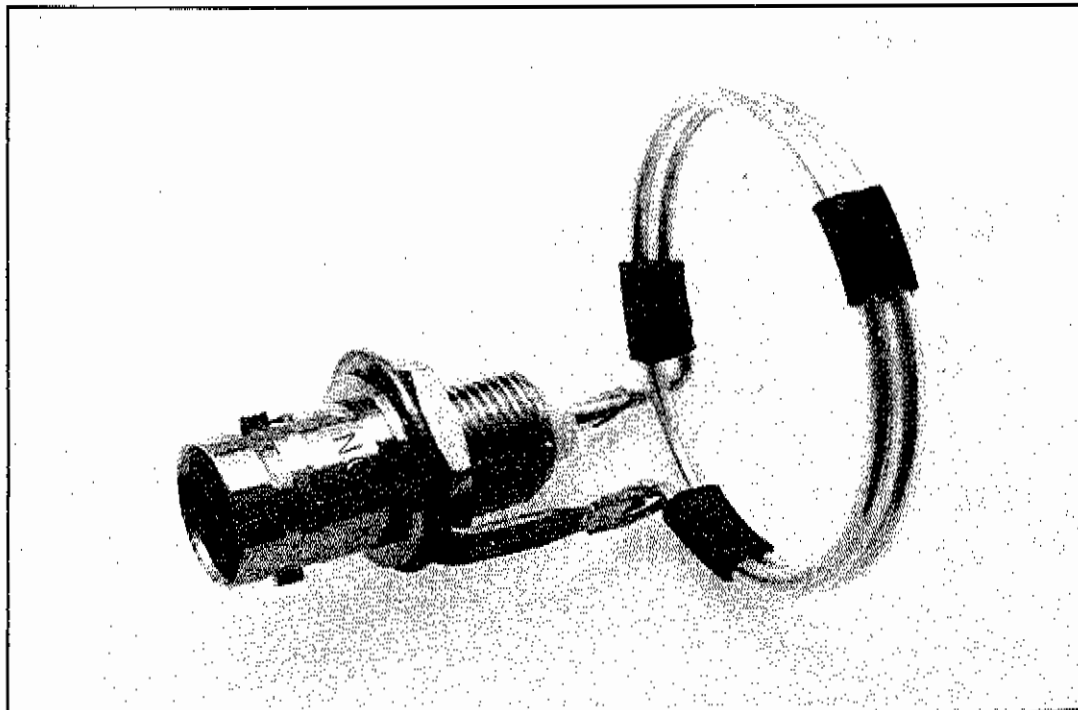

Figure 4A-1. Two-Turn Loop

**MAINTENANCE
PERFORMANCE TESTS**

Table 4A-1. Recommended Test Equipment

INSTRUMENT NAME	MINIMUM REQUIREMENT	MANUFACTURER DESIGNATION	NOTES (1)
DVM	5 1/2-Digit, 0.3% DC-20 kHz	JF 8840A-09	A,P
DMM	3 1/2-Digit, 1% DC and 1 kHz	JF 8020B	A,P,T
Wideband Amplifier	>25-dB gain, 0.4 to 1050 MHz NF <9 dB	HP 8447D-010	P
RF-Spectrum Analyzer	0.1 to 1.5 GHz, 1-kHz BW	HP 8558B/182T	P,T
Oscilloscope	Four-trace 300 MHz, 5-mV/Div	TEK 2465-11	T
FET Probe	DC-900 MHz	TEK 6201	T
RF Voltmeter	0.01 to 700 MHz, 0.01 to 3V $\pm 10\%$	HI RF 801	T, 2
Frequency Counter	0.4-1050 MHz; 10 Hz res; 0.1V	JF 7220A	A,P,T
Modulation Analyzer	Input: 0.4 to 1050 MHz, 0 to +20 dBm AM: 10 to 90%, $\pm 1\%$, FM: 0.1 to 100 kHz dev $\pm 1\%$	HP 8901A	A,P,T,4
Distortion Analyzer	1 to 10% rmg, ± 1 dB, 0.4 and 1 kHz	HP 339B	A,P,T,4
Power Meter	Instrumentation accuracy < $\pm 1\%$	HP 435B	A,P,T,4
Sensor	-30 to 20 dBm; SWR < 1.2 for 0.4 to 1 MHz, < 1.1 for 1 to 1050 MHz	HP 8482A (4)	
Low-Level Sensor	-67 to -20 dBm; SWR < 1.4 for 10 to 30 MHz < 1.15 for 30 to 1050 MHz	HP 8484A	4
Attenuator, 60 dB	0.4 to 1050 MHz SWR < 1.1	Narda 777C	P,5
LF Synthesized Sig- Gen	10 Hz to 11 MHz, 10 Hz steps, Spurs and Harm < -50dB,	1V pk JF 6011A	A,P
Frequency Standard	House Standard, 10 MHz	---	A,P
Test Cable	Dual pin to BNC	JF 732891	A,T
Adapter, Coax	50-ohm, Type-N(m) to BNC(f)	JF Y9308	A,P,T
Adapter, Service	50-ohm, Module output to SMA	JF 744177	T
Two-Turn Loop	For Leakage test (See Figure 4A-1.)	Homebuilt	P,T,3
SWR Bridge	10 MHz to 1000 MHz	Wiltron 62N50	P
Type-N Termination	50-ohm	JF Y9317	P
Coaxial Cable, 50 ohm	3 ft, BNC both ends	Y9111	A,P,T
Coaxial Cable, 50 ohm	6 ft, BNC both ends	Y9112	A,P,T
Screwdriver, electric	Set to 7 inch-pounds torque	Jergens- Cl.6500/CLT50	A,T
Power Supply, Variable	0 to 30V dc		T

Table 4A-1. Recommended Test Equipment (cont)

Notes

1. A = Adjustment; P = Performance Test; T = Troubleshooting.
2. Helper Instruments.
3. Two-Turn, 1-inch diameter Loop made of #18 enamel wire soldered to a BNC connector. Figure 4A-1 shows a two-turn loop.
4. The HP8902A/11722A Measuring Receiver may be used in place of the wideband amplifier, 60-dB Attenuator, HP8901A, HP339B, and the HP435B/8482A/8484A for the alternate performance test.
5. SWR verified and actual attenuation calibrated to ± 0.2 dB by the operator at application frequencies.

4A-3. POWER-ON TEST

This performance test is the built-in self test that performs a simple functional check of the instrument.

REQUIREMENT

The Generator successfully passes the self test.

REMARKS

The test is begun each time the Signal Generator is turned on. Press any of the FUNCTION keys or the [CLR/LCL] key to abort the test.

PROCEDURE

- a. Start the test with the POWER switch off.
- b. Turn the POWER switch on.
- c. The Signal Generator automatically starts the self tests, which include turning on all indicators, indicators, and every segment of the display. This test takes five seconds.
- d. If the instrument fails any of the self tests, the results are shown in the four display fields. See paragraph 4D-17 for the interpretation of the test failure codes.

If the Generator passes the self test, it programs the Generator to the same front panel condition that existed when the Generator was previously turned off. The IEEE-488 Interface (if installed) is programmed to local control.

4A-4. SYNTHESIS TEST

Using a Frequency Counter operating on a common reference with the Generator, the Generator output frequency is measured at several programmed frequencies.

**MAINTENANCE
PERFORMANCE TESTS**

REQUIREMENT

The Generator's measured and programmed frequencies agree within \pm one count.

TEST EQUIPMENT

Frequency Counter

REMARKS

Failing this test indicates the need to repair and/or recalibrate the Synthesizer A2A1 assembly.

PROCEDURE

- a. Connect the UUT 10 MHz OUT to the Frequency Counter 10-MHz reference input, and connect the UUT RF OUTPUT to the Counter input.
- b. Set the UUT REF INT/EXT Switch to INT.
- c. Program the UUT to [RCL] [9][8].
- d. Program the UUT frequency to 111.1111 MHz.
- e. Program the UUT frequency step to 111.1111 MHz.
- f. As the frequency is stepped from 111.1111 MHz, 222.2222 MHz, etc., to 999.9999 MHz, verify that the Counter reading agrees with the UUT frequency \pm one count.

4A-5. HIGH-LEVEL ACCURACY TEST

The output power is measured with a power meter at various frequencies, first with the step attenuator set for zero attenuation, then with each attenuator section individually programmed, the output level accuracy and attenuator section errors are computed.

REQUIREMENT

The output level accuracy, the attenuator section errors, and the sum of the attenuator section errors at each test frequency are less than \pm 1.0 dB, frequency $>$ 0.4MHz.

TEST EQUIPMENT

Power Meter with a Sensor

REMARKS

Failing this performance test indicates the need to replace the Output (A2A4) and/ or the Attenuator/RPP A2A5 assemblies. To determine which assembly is at fault, use Section 4D in this manual for Troubleshooting procedures.

The test frequencies of this procedure provide reasonable confidence of the amplitude accuracy of the UUT. However, additional test frequencies may be included in this test.

This test verifies the high-level accuracy of the Generator and also verifies that the amplitude correction factors for the individual Attenuator sections are correct. This test, in conjunction with the mid-level accuracy and low-level accuracy tests, verifies the overall level performance of the UUT.

PROCEDURE

- a. Calibrate and zero the Power Meter.
- b. Program the UUT to [RCL] [9][8].
- c. Connect the Power Sensor to the UUT RF OUTPUT.
- d. Program the UUT frequency to 0.4 MHz.
- e. Select each attenuator section by programming the UUT amplitude to the levels shown in Figure 4A-2 High-Level Accuracy test conditions, and record the measured power at each level.
- f. For each programmed level of Figure 4A-2, compute the output power error (subtract the programmed power in dBm from the measured power in dBm). These errors must not exceed ± 1.0 dB.
- g. For attenuator sections 1 through 7, subtract the measured power for section zero from the sum of the measured power for that section and the nominal attenuation for that section, e.g., $(-M0+M1+6)$ for section 1. The eight section errors and their sum must not exceed ± 1.0 dB.

Figure 4A-2 shows the parameters of the high-level accuracy test.

ATTENUATION		OUTPUT POWER				
		PROGRAM (dBm)	MEASURED (dBm)	ERROR (dB)	SECTION ERROR (dB)	LIMIT (dB)
SECTION	NOMINAL					
0	0	+12	M0	M0-12	M0-12	± 1.0
1	6	+ 6	M1	M1-6	$-M0+M1+6$	"
2	12	0	M2	M2-0	$-M0+M2+12$	"
3	24	-12	M3	M3-12	$-M0+M3+24$	"
4	24	-12 [SPCL] [8][3]	M4	M4-12	$-M0+M4+24$	"
5	24	-12 [SPCL] [8][4]	M5	M5-12	$-M0+M5+24$	"
6	24	-12 [SPCL] [8][5]	M6	M6-12	$-M0+M6+24$	"
7	24	-12 [SPCL] [8][6]	M7	M7-12	$-M0+M7+24$	"
					Sum of Errors	± 1.0

Figure 4A-2. High-Level Accuracy Test Conditions

**MAINTENANCE
PERFORMANCE TESTS**

NOTE

To test Attenuator sections 4 through 7, program the Signal Generator to -12 dBm, and key in [SPCL][8][3] through [8][6], respectively.

- h. Repeat steps d through g with the UUT programmed to each of the following frequencies:

120 MHz, 244 MHz, 245 MHz, 850, and 1050 MHz.

To illustrate the procedure, Figure 4A-3 is an example in which the measured power and the error calculations are shown. This example is for one frequency, and these measurements and calculations are repeated at other frequencies. In this case, the section errors and the sum of the section errors are within the test limits and, therefore, the unit passed.

4A-6. MID-LEVEL ACCURACY TEST

The level accuracy is verified, from -24 to -66 dBm at frequencies of 120, 244, 245, 850, and 1050 MHz, using the Power Meter with a Low-Level Sensor.

REQUIREMENT

Amplitude accuracy is ± 1.0 dB from +13 to -127dBm.

TEST EQUIPMENT

Power Meter with a Low-Level Sensor

REMARKS

This test, in conjunction with the High-Level Accuracy Test and the Low-Level Accuracy Test, verifies the overall level performance of the UUT.

It is convenient to use the UUT RF ON/OFF control when zeroing the Power Meter.

PROCEDURE

- a. Program the UUT to the Instrument Preset State [RCL] [9][8], and then program 30 MHz and -24 dBm.
- b. Calibrate the Power Meter.
- c. Connect the Power Meter with a Low-Level Sensor to the UUT RF OUTPUT.
- d. Zero the Power Meter.
- e. With the Power Meter, measure the UUT output power (in dBm). It should agree with the programmed level within ± 1.0 dB.
- f. Repeat steps c and f for levels of -30, -36, -42, -48, -54, -60, and -66 dBm.
- g. Repeat steps d to g for frequencies of 244, 245, 850, and 1050 MHz.

ATTENUATION		OUTPUT POWER				
SECTION	NOMINAL	PROGRAM (dBm)	MEASURED (dBm)	ERROR (dB)	SECTION ERROR (dB)	LIMIT (dB)
0	0	+12	+12.2	+0.2	+12.2-12.0	= +0.2
1	6	+ 6	+05.9	-0.1	-12.2+5.9+6	= +0.3
2	12	0	-00.2	-0.2	-12.2-0.2+12	= -0.4
3	24	-12	-12.1	-0.1	-12.2-12.1+24	= -0.3
4	24	-12 [SPCL][8][3]	-11.8	+0.2	-12.2-11.8+24	= +0.0
5	24	-12 [SPCL][8][4]	-12.0	+0.0	-12.2-12.0+24	= -0.2
6	24	-12 [SPCL][8][5]	-12.3	-0.3	-12.2-12.3+24	= -0.5
7	24	-12 [SPCL][8][6]	-11.9	+0.1	-12.2-11.9+24	= -0.1
					Sum of Errors	= -1.0

Figure 4A-3. High-Level Accuracy Test Conditions

4A-7. LOW-LEVEL ACCURACY TEST

The Power Meter with a Low-Level Sensor and the calibrated 60-dB Attenuator are used to verify the UUT level accuracy at -127 dBm and at frequencies of 120, 244, 245, 850, and 1050 MHz, by using the Spectrum Analyzer as an indicator.

REQUIREMENT

Amplitude accuracy is ± 1.0 dB from +13 to -127 dBm.

TEST EQUIPMENT

- Wideband Amplifier
- 60-dB Attenuator
- RF Spectrum Analyzer
- Power Meter with a Low-Level Sensor

REMARKS

This test, in conjunction with the Mid-Level Accuracy and High-Level Accuracy Test, verifies the overall level performance of the UUT.

Failing this test, but passing the High-Level Accuracy Test, probably indicates a leak-around problem in the UUT attenuator. Service tip:

Check for a broken feed-through filter or improper mechanical assembly, i.e., loose screws and/or damaged or misplaced gaskets.

It is convenient to use the UUT RF ON/OFF control when zeroing the Power Meter.

**MAINTENANCE
PERFORMANCE TESTS**

PROCEDURE

- a. Program the UUT to the Instrument Preset State [RCL][9][8], then program 30 MHz and -67 dBm.
- b. Calibrate and then connect the Power Meter with a Low-Level Sensor to the UUT RF OUTPUT.
- c. Program the UUT to -67 dBm.
- d. Zero the Power Meter.
- e. With the Power Meter, measure the UUT output power (in dBm) and record the measurement as the variable P.
- f. Connect UUT RF OUTPUT through the 60-dB Attenuator and the Wideband Amplifier to the input of the RF Spectrum Analyzer. Use well shielded cables to avoid leakage that could affect the measurement.
- g. Adjust the Analyzer to display the signal, using a resolution bandwidth of 1 kHz and a vertical display of 1 dB/Div. Adjust the reference level so that the response is at a convenient reference point on the display, e.g., 2 dB below top scale. This signal response corresponds to a level of (P-A) dBm, where A is the value of the 60 dB Attenuator.
- h. Program the UUT to a level of -127 dBm, remove the 60-dB Attenuator, and note the difference in the resulting response on the Spectrum Analyzer from the previous response (P-A). The actual UUT output level is (P-A) plus this difference and should agree with the programmed level to within ± 1.0 dB.
- i. Repeat steps c through h for frequencies of 244, 245, 850, and 1050 MHz.

4A-8. ALTERNATE-LEVEL ACCURACY TEST

The Measuring Receiver is used to verify the UUT level accuracy from +11 dBm to -127 dBm, and at various amplitude and frequency settings that test all level ranges of the UUT on all RF bands.

REQUIREMENTS

Amplitude accuracy is ± 1.0 dB from +13 dBm to -127 dBm, frequency > 0.4 MHz.

TEST EQUIPMENT

Measuring Receiver

REMARKS

This one test is a more comprehensive test than the High-Level, Mid-Level, and Low-Level Accuracy tests.

Failing this test at levels above approximately -50 dBm indicates the need to replace the A2A4 Output and/or A2A5 Attenuator/RPP assembly.

Failing this test at lower levels probably indicates a leak-around problem with the Attenuator. Check for loose connectors, loose screws, improper gasketing, or a broken feed-through filter.

It is convenient to use the UUT RF ON/OFF control when zeroing the power meter function of the Measuring Receiver.

PROCEDURE

- a. Connect the UUT 10 MHz OUT to the 10 MHz timebase input of the Measuring Receiver.
- b. Set the UUT REF INT/EXT switch to INT.
- c. Program the UUT to [RCL][9][8], and then program the UUT to 0.4 MHz, +11 dBm and program the Amplitude Step to 6 dB.
- d. Calibrate the Measuring Receiver and connect it to the UUT RF OUTPUT.
- e. Verify that the level measured with the Measuring Receiver agrees with the UUT programmed level to within ± 1.0 dB, as the UUT level is stepped down from +11 dbm to -127 dBm in six dB steps at each of the following frequencies:

0.4 MHz, 120 MHz, 244 MHz, 245 MHz, 850 MHz, and 1050 MHz.

4A-9. OUTPUT LEAKAGE TEST

The output signal leakage is verified with a two-turn loop by measuring the induced signal with a spectrum analyzer and comparing it to a $1 \mu\text{V}$ reference established at each frequency from the UUT.

REQUIREMENT

The radiated emissions induce less than $1 \mu\text{V}$ of the Generator's output signal into a 1-inch diameter, two-turn loop, 1 inch away from any surface of the Generator as measured into a 50-ohm receiver.

TEST EQUIPMENT

Wideband Amplifier
RF Spectrum Analyzer
Two-Turn Loop
Type-N Termination

A screen room may be required depending on the RF environment.

REMARKS

Failing this test probably indicates a broken feed-through filter or improper mechanical assembly, i.e.; loose screws and/or damaged or misplaced gaskets.

PROCEDURE

- a. Connect the UUT RF OUTPUT to the Wideband Amplifier input, and connect the Amplifier output to the Spectrum Analyzer input. Use well shielded cables to avoid leakage which could affect the measurement.
- b. Program the UUT to the Instrument Preset State, [RCL][9][8].
- c. Program the UUT to -107 dBm.

**MAINTENANCE
PERFORMANCE TESTS**

- d. Adjust the Spectrum Analyzer to display the UUT signal for a convenient reference, using a vertical scale of 10 dB/division, a resolution bandwidth of 3 kHz, and a span/division of 5 kHz/division.
- e. Disconnect the Amplifier from UUT and terminate UUT OUTPUT with type-N Termination.
- f. Connect the two-turn loop to the Amplifier input.
- g. Program the UUT to +13 dBm.
- h. Verify that the leakage is less than -107dBm (1 μ V), as indicated by the Spectrum Analyzer by moving the two-turn loop over the UUT surface at a distance of 1 inch.
- i. Repeat steps c through h at 550, 850, and 1050 MHz.

4A-10. ALTERNATE OUTPUT LEAKAGE TEST

RF leakage is verified by measuring the induced signal in a two-turn loop with the Measuring Receiver.

REQUIREMENTS

The output signal leakage must induce less than 1 μ V into a 1-inch diameter two-turn loop, 1 inch away from any surface of the generator as measured into a 50-ohm receiver.

TEST EQUIPMENT

Measuring Receiver

Two-Turn Loop

Type-N Termination

A screen room may be required depending on the RF environment.

REMARKS

This test is an alternative to the Output Leakage test.

Failing this test indicates a problem feed-through filter or improper mechanical assembly, i.e., loose screws, and/or damaged or misplaced gaskets.

The Measuring Receiver is used to measure the UUT leakage relative to a 1 μ V reference established at each frequency.

PROCEDURE

- a. Connect the UUT 10 MHz OUT to the 10-MHz timebase input of the Measuring Receiver.
- b. Set the UUT REF INT/EXT switch to INT.
- c. Program the UUT to the Instrument Preset State, [RCL] [98].
- d. Program the UUT to -107 dBm.
- e. Connect the Measuring Receiver sensor to the UUT RF OUTPUT.

- f. Set the Measuring Receiver to make relative level measurements to the -107 dBm signal applied.
- g. Disconnect the sensor from the UUT, and terminate the UUT RF OUTPUT with the Type-N Termination.
- h. Connect the two-turn loop to the Measuring Receiver sensor.
- i. Program the UUT to +13 dBm.
- j. Verify the instrument leakage is less than -107 dBm ($1 \mu\text{V}$) as indicated by the Measuring Receiver by moving the Two-Turn Loop over the UUT surface at a distance of one inch from the UUT.
- k. Repeat steps d through j at 550 MHz, 850 MHz, and 1050 MHz.

4A-11. HARMONIC AND SPURIOUS TEST

Using a spectrum Analyzer, the level of the harmonic and spurious signals are compared to the desired signal at various programmed frequencies.

REQUIREMENTS

RF harmonics < -30 dBc; spurious (non-harmonic) < -60 dBc for offsets > 10 kHz, frequency > 0.1 MHz.

TEST EQUIPMENT

RF Spectrum Analyzer

PROCEDURE

- a. Connect the UUT RF OUTPUT to the Spectrum Analyzer input.
- b. Program the UUT to [RCL] [9][8]. Then program the Generator to +13 dBm.
- c. Program the UUT to 0.4 MHz.
- d. Set the Spectrum Analyzer controls to display the UUT output signal and its harmonics (at least three harmonics wherever possible). Be careful not to overload the Analyzer input. Overloading the Analyzer causes it to generate harmonics, thus invalidating the test.
- e. Verify that all the harmonics are more than 30 dB below the fundamental signal.
- f. Repeat steps c through e for UUT frequencies of 50 MHz, 240 MHz, 300 MHz, 500 MHz, and 750 MHz.
- g. Program the UUT to 185 MHz.
- h. Verify the spur at 245 MHz is < -60 dBc.
- i. Program the UUT to 244 MHz.
- j. Verify the spur at 312 MHz is < -60 dBc.
- k. Program the UUT to 244.99 MHz, 0 dBm.

**MAINTENANCE
PERFORMANCE TESTS**

1. Set the Spectrum Analyzer controls for the appropriate reference level, center frequency, span, and resolution to display the UUT signals and spurs frequencies with appropriate noise floor and signal resolution for the following steps.
 1. Verify the spurs at the offsets of 20 kHz, 30 kHz, 35 kHz, and 40 kHz are < -60 dBc.
 2. Verify the spurs at the offsets of 1 MHz and 10 MHz are < -60 dBc.
 3. Program the UUT level to 1 dBm with the EXT AM on at 30% modulation (no external modulation input is applied).
 4. Verify the spurs at 10 MHz, 20 MHz, and 30 MHz are < -60 dBc.
 5. Verify the spurs at 800 MHz, and 1044.99 MHz are < -60 dBc.
 6. Program the UUT to 600 MHz, 0 dBm, EXT AM modulation off.
 7. Verify the spur at 300 MHz is < -60 dBc.

4A-12. MODULATION TESTS

These tests use the Modulation Analyzer to verify modulation accuracy and residual and incidental modulation of the UUT. The modulation distortion is verified by measuring the demodulated output of the Modulation Analyzer with a Distortion Analyzer. The internal modulation oscillator frequency is measured using the Frequency Counter on the demodulated output of the Modulation Analyzer. Table 4A-2 lists the requirements for the modulation tests.

REMARKS

Failing this performance test indicates the need for repair and/or recalibration of the associated circuitry.

Where residual noise affects the Modulation Analyzer measurements accuracy, apply correction methods provided by the Modulation Analyzer manufacturer.

Table 4A-2. Modulation Tests Requirements

REQUIREMENTS PARAMETER	SPECIFICATION
MOD FREQ	$< \pm 3\%$ at 0.4 or 1 kHz for 20 to 305°C; add $\pm 0.1\%/5^\circ\text{C}$ outside this range.
AM ACCURACY	$< \pm(2\% + 4\%$ of setting) for internal rates and depths of 99% or less, and peak amplitudes of +13 dBm or less.
AM DISTORTION	$< 1.5\%$ THD up to 30% AM, $< 3\%$ to 70%, $< 5\%$ to 90%, at internal rates. $< 3\%$ to 70% AM, $< 5\%$ to 90% AM frequency > 950 MHz, level $> +8$ dbm.
RESIDUAL AM	$< 0.1\%$ rms (-60 dBc) in a 0.05-kHz to 15-kHz bandwidth.
INCIDENTAL FM	< 0.3 fm for internal rates and $< 30\%$ AM.
FM ACCURACY	$< \pm 7\%$ for rates of 0.3 kHz to 20 kHz, and > 100 Hz deviation.
FM DISTORTION	$< 1\%$ THD for rates of 0.3 kHz to 20 kHz, and > 100 Hz deviation.
RESIDUAL FM	rms in a 0.3-kHz to 3-kHz band: < 10 Hz for 245 MHz to 512 MHz and < 20 Hz elsewhere. rms in a 0.05-kHz to 15-kHz band: < 22 Hz for 245 MHz to 512 MHz and < 40 Hz elsewhere.
INCIDENTAL AM	$< 1\%$ AM at 1-kHz rate and for deviation < 50 kHz.

The UUT settings in this procedure are chosen to provide a strong confidence of the modulation performance of the UUT throughout its range. However, performance also may be checked at other instrument settings if desired.

The FM deviation accuracy depends upon software correction data stored in the VCO Calibration EPROM that is derived from the measured data of the particular VCO assembly installed in the Generator.

TEST EQUIPMENT

Modulation Analyzer
Distortion Analyzer
Frequency Counter
Low-Frequency Synthesized Signal Generator (LFSSG)
DVM

PROCEDURE

1. Internal Modulation Oscillator Frequency Test
 - a. Connect the UUT RF OUTPUT to the Modulation Analyzer input.
 - b. Connect the Modulation Analyzer modulation output to the Frequency Counter input.
 - c. Program the Modulation Analyzer to measure AM depth in a 0.05-kHz to 15-kHz bandwidth.
 - d. Program the UUT to [RCL][9][8]. Program the UUT for 90% INT AM at a 1-kHz rate and a level of +1 dBm.
 - e. Verify that the Counter reads between 970 and 1030 kHz.
 - f. Program that the UUT to a modulation frequency of 400 Hz.
 - g. Verify the Counter reads between 388 Hz and 412 Hz.
2. Internal AM Accuracy Test
 - a. Measure the mean AM depth, $(+PEAK \text{ plus } -PEAK)/2$, with the Modulation Analyzer.
 - b. Verify that the mean AM depth is between 84.4% and 95.6%.
 - c. Program the UUT to a modulation frequency of 1 kHz.
 - d. Verify that the mean AM depth is between 84.4% and 95.6%.
3. AM Accuracy and Distortion Test
 - a. Connect the output of the LFSSG to the UUT MOD INPUT and the DVM (use a BNC T connector).
 - b. Program the UUT for a frequency of 0.4 MHz, 1 dBm level, and EXT AM at 30% AM depth.

**MAINTENANCE
PERFORMANCE TESTS**

- c. Program the LFSSG for 1 kHz at 0.7071V rms as measured by the DVM.
 - d. Connect the modulation output of the Modulation Analyzer to the input of the Distortion Analyzer.
 - e. Set the Distortion Analyzer to measure the THD of the 1-kHz modulation signal.
 - f. Verify that the mean AM depth $(+PEAK \text{ plus } -PEAK)/2$, is between 26.8% and 33.2%.
 - g. Verify that the THD is less than 1.5%.
 - h. Program the remaining combinations of RF frequency, level, and AM depth listed in Table 4A-3. For each combination, verify that the mean AM depth is between the allowed limits and that the THD is less than the allowed limit, which depends on programmed depth, as shown in Table 4A-4:
 - i. Disconnect the LFSSG from the UUT.
4. Incidental FM Test
- a. Program the UUT for 30% INT AM at 1 kHz, at 1050 MHz, and 10 dBm.
 - b. Program the Modulation Analyzer to measure peak FM deviation in a 0.3- to 3-kHz bandwidth.
 - c. Verify the incidental FM is less than 300 Hz.

NOTE

It may be necessary to compensate for residual noise effects using the procedure presented in the Modulation Analyzer manual.

5. Residual AM Test
- a. Program the UUT to 100 MHz, +7 dBm, and no modulation.
 - b. Program the Modulation Analyzer to measure rms (or average) AM in a 0.05-kHz to 15-kHz bandwidth.
 - c. Verify the residual AM is less than 0.1% rms (or 0.09% average).
6. FM Accuracy and Distortion Test
- a. Connect the output of the LFSSG to the UUT MODINPUT connector and the DVM (use a BNC T connector).
 - b. Program the Modulation Analyzer to measure peak FM in a 0.05-kHz to 20-kHz bandwidth.
 - c. Program the UUT frequency to 245 MHz, 7 dBm, 99.9 kHz (9.99 kHz if the Generator has Option -651) deviation, and EXT FM.
 - d. Set the LFSSG to 10 kHz and adjust its level so the DVM reads 707.1 mV rms.

Table 4A-3. AM Test Conditions

FREQUENCY (MHz)	LEVEL (dBm)	AM (%)
0.4	1	30
		70
		90
	7	30
		70
		90
244.9	1	70
		90
		70
	7	70
		90
		70
245	1	70
		90
		70
	7	70
		90
		70
512	1	70
		90
		70
	7	70
		90
		70
1050	1	70
		90
		70
	7	70
		90
		70

Table 4A-4. AM Depth Range

PROGRAMMED DEPTH (%)	MEAN AM DEPTH(%)		MAXIMUM THD(%)
	MIN.	MAX.	
30	26.8	33.2	1.5
70	65.2	74.8	3
90	84.4	95.6	5

- e. Set the Distortion Analyzer to measure distortion at 10 kHz.
- f. Verify that the Modulation Analyzer reading is between 93 kHz to 107 kHz, (9.99 kHz if the Generator has Option -651 installed) and the THD is less than 1% as the UUT frequency is stepped up to 1045 MHz in 50-MHz steps. (Tip: use the instrument FREQ STEP feature.)
- g. Set the LFSSG to 0.4 kHz and adjust its level so the DVM reads 707.1 mV rms.
- h. Program the Modulation Analyzer to measure FM in a 0.05-kHz to 3-kHz bandwidth.
- i. Set the Distortion Analyzer to measure distortion at 0.4 kHz.
- j. Verify that the Modulation Analyzer reading is between 93 kHz to 107 kHz (9.99 kHz if the Generator has Option -651 installed), and the THD is less than 1% as the UUT frequency is stepped down to 245 MHz in 50-MHz steps.

**MAINTENANCE
PERFORMANCE TESTS**

- k. Program the UUT to 9.99 kHz deviation. (Skip to step m if the UUT has Option -651 installed.)
- l. Verify that the Modulation Analyzer reading is between 9.3 kHz and 10.7 kHz.
- m. Program the UUT to 0.999 kHz deviation.
- n. Verify that the Modulation Analyzer reading is between 0.93 kHz and 1.07 kHz.

NOTE

It may be necessary to compensate for residual noise effects using the procedure presented in the Modulation Analyzer manual.

- o. Disconnect the LFSSG from the UUT.
7. Incidental AM Test
- a. Program the UUT for 50-kHz deviation, INT FM only, at 1 kHz, a level of 7 dBm and a frequency of 11 MHz.
 - b. Program the Modulation Analyzer to measure peak AM in a 0.3-kHz to 3-kHz bandwidth.
 - c. Verify that the incidental AM is less than 1%.
8. Residual FM Test
- a. Program the UUT for a frequency of 4 MHz and no modulation.
 - b. Program the Modulation Analyzer to measure rms (or average) FM in 0.3-kHz to 3-kHz bandwidth.
 - c. Verify that the Modulation Analyzer reading is less than 20-Hz rms (or 18-Hz average) at the following UUT frequencies:
10, 50, 100, 200, and 244 MHz
 - d. Verify that the Modulation Analyzer reading is less than 10-Hz rms (or 9-Hz average) at the following UUT frequencies:
250, 385, 450, and 510 MHz
 - e. Verify that the Modulation Analyzer reading is less than 20-Hz rms (or 18-Hz average) at the following UUT frequencies:
512.03999, 750.03999, 850.03999, 900.03999, 950.03999, 1000.03999, 1025.03999, and 1049.03999 MHz
 - f. Change the Modulation Analyzer bandwidth from 0.05 kHz to 15 kHz.

- g. Verify that the Modulation Analyzer reading is less than 44-Hz rms (or 40-Hz average) at the UUT frequencies listed in step e.
- h. Verify that the Modulation Analyzer reading is less than 22-Hz rms (or 20-Hz average) at the UUT frequencies listed in step d.
- i. Verify that the Modulation Analyzer reading is less than 44-Hz rms (or 40-Hz average) at the UUT frequencies listed in step c.

4A-13. SWR TESTS

These tests use a VSWR bridge and a Spectrum Analyzer to verify SWR of the UUT.

REQUIREMENTS

The output VSWR is less than 1.5:1 for output levels $< +1\text{dBm}$; < 2.0 elsewhere.

TEST EQUIPMENT REQUIRED

SWR bridge (Wiltron 62N50 or equivalent) High-Frequency Spectrum Analyzer
HFSSG (Fluke 6060B or equivalent)

REMARKS

The UUT settings in this procedure are chosen to provide confidence in the SWR performance of the UUT throughout its range. However, performance also may be checked at other levels $< -10\text{ dBm}$.

PROCEDURE

- a. Connect the HFSSG to the VSWR Bridge RF IN.
- b. Connect the Spectrum Analyzer to the VSWR Bridge RF OUT.
- c. Connect the UUT to the VSWR Device Under Test.
- d. Program UUT to 1 MHz, $+1\text{dBm}$.
- e. Program the HFSSG to 10 MHz, 13 dBm.
- f. Set the Spectrum Analyzer controls to display approximately 10 to 520 MHz. Set Reference Level to $+10\text{ dBm}$.
- g. Step HFSSG from 10 MHz to 1050 MHz in 5 MHz-steps and note frequency and level where the level is a maximum.
- h. Program HFSSG to the frequency found in step g.
- i. Disconnect UUT from VSWR bridge.
- j. Note Spectrum Analyzer level.
- k. The difference between the levels in steps i and g should be greater than 18 dB.
- l. Repeat step e through k with UUT set to 1MHz, $+13\text{dBm}$.
- m. The difference between levels in step i and g should be greater than 9.5dB.

Section 4B

Access Procedures

4B-1. INTRODUCTION

The information in this section describes the general access procedures for the following major module assemblies.

- Front Section Assembly, A1
- Rear Section Assembly, A3
- Synthesizer Board, A2A1
- Output Board, A2A4
- Attenuator/RPP Assembly, A2A5
- VCO Board, A2A2

Access to other assemblies is straightforward; and therefore, other assemblies are not detailed in this manual.

4B-2. LOCATION OF MAJOR ASSEMBLIES

The location of the major assemblies of the Signal Generator is illustrated in Section 8.

Information on exchanging modules is presented in Section 4D.

4B-3. ACCESS INSTRUCTIONS

Access instructions for each module of the Signal Generator are provided in the following paragraphs. Before performing any disassembly of the Signal Generator, remove the power cord from the rear panel power receptacle and remove the exterior top and bottom instrument covers.

To install the assemblies, reverse the disassembly steps. Be certain the pin connectors and filter sockets are straight when replacing the boards.

4B-4. Removing the Front Section Assembly, A1

1. Disconnect the MOD INPUT wire W1 at the module connector located at the front of the Attenuator module.
2. Disconnect the front panel display ribbon cable at the controller.
3. Remove the decals from both front panel handles. Removing the decals ruins them; new decals should be installed to maintain a proper instrument appearance.

The part number for the decal is listed in Section 5.

4. Remove the five flathead screws from each front panel handle.

**MAINTENANCE
ACCESS PROCEDURES**

4B-5. Removing the Rear Section Assembly, A3

1. Disconnect the Synthesizer, Controller, and Attenuator power cable at the power supply.
2. If the High-Stability Reference option is installed, disconnect the oscillator power cable from the Auxiliary power supply
3. Remove the IEEE-488 Interface assembly (if present) from the back of the instrument rear panel.
4. Remove the inside part of the 10 MHz OUT and the REF IN BNC connectors.
5. Remove the decals for both rear panel handles. Removing the decals ruins them; replace with new decals to maintain a proper instrument appearance. The part number for the decal is listed in Section 5.
6. Remove the five flathead screws from each handle and swing the rear panel assembly out from the Signal Generator.
7. If you need to completely detach the rear panel assembly from the Generator, unfasten the front panel power switch.

4B-6. Removing the Synthesizer Board, A2A1

1. Remove the number 6 screws holding the top module (A2) cover. (The number 10 screws are adjustment access screws and need not be removed.) Remove the module cover.
2. Remove the number 6 screws holding the board, and then carefully remove the board.

4B-7. Removing the Output Board, A2A4

1. Remove the number 6 screws holding the bottom module (A1) cover. (The number 10 screws are adjustment-access screws and need not be removed.) Remove the module cover.
2. Remove the plug-in coupling capacitor between the Output and the VCO boards.
3. Remove the number 6 screws holding the board, and then carefully remove the board.

4B-8. Removing the Attenuator/RPP A2A5 Assembly

1. Disconnect the SMA connector at the Attenuator that leads to the RF output.
2. Disconnect the control harness from the Relay Driver PCA.

4B-9. Removing the VCO Board, A2A1

1. Remove the number 6 screws holding the bottom module (A) cover. (The number 10 screws are adjustment-access screws and need not be removed.) Remove the cover.

2. Remove the plug-in capacitor that couples the Output board to the VCO.
3. Remove the number 6 screws holding the assembly, and remove the board.

Section 4C

Calibration Adjustments

4C-1. INTRODUCTION

The adjustment procedures for the Generator are described in the following paragraphs. The recommended test equipment for calibration is denoted by an A in Table 4A-1.

Adjustment procedures for the Power Supply, Display, Output, Synthesizer, and Attenuator/RPP assemblies are covered in this section. Adjustment procedures for the High-Stability Reference, Medium-Stability Reference, and Low-Rate FM options are given in Section 6.

4C-2. SAFETY

This is a Safety Class I instrument. It is provided with a protective earth terminal. Warnings and cautions are for your protection and to avoid damage to the equipment. Please take them seriously.

WARNING

BECAUSE SOME SERVICE PROCEDURES DESCRIBED HERE ARE DONE WITH POWER APPLIED TO THE SIGNAL GENERATOR AND WITH PROTECTIVE COVERS REMOVED, SERVICE SHOULD BE DONE ONLY BY TRAINED SERVICE PERSONNEL WHO UNDERSTAND THE HAZARDS INVOLVED. WHERE SERVICE CAN BE PERFORMED WITHOUT POWER APPLIED, THE SIGNAL GENERATOR SHOULD BE UNPLUGGED FROM THE LINE POWER.

DO NOT INTERRUPT THE PROTECTIVE GROUNDING CONNECTION. TO DO SO WOULD CREATE A POTENTIAL SHOCK HAZARD THAT COULD RESULT IN PERSONAL INJURY. SECURE THE INSTRUMENT AGAINST UNINTENDED OPERATION IF IT IS LIKELY THAT THIS PROTECTION HAS BEEN IMPAIRED. USE ONLY 250V FUSES OF THE PROPER CURRENT RATING.

CAUTION

To avoid damage to the Generator, unplug the instrument before removing any Printed Circuit Assembly.

4C-3. POWER SUPPLY, A3A1, ADJUSTMENT

This procedure covers the +37V adjustment, R3, on the Power Supply assembly, A3A1. This is the only adjustment on the Power Supply PCB.

**MAINTENANCE
CALIBRATION ADJUSTMENTS**

TEST EQUIPMENT

DMM

REMARKS

This adjustment is accessible through a hole in the bottom lip of the rear panel.

See Figure 4C-1 for the location of the power supply test points.

PROCEDURE

R3 is adjusted for +37V as measured at TP5.

1. Remove the UUT top and bottom instrument covers. Connect the DMM to TP5 with the ground lead (black wire) connected to the power distribution connection point on the module plate.
2. Program the UUT to [RCL] [9][8].
3. Adjust R3 for a DMM reading of $+37.00 \pm 0.05V$.
4. Verify the other supply voltages at the test points listed in the following:

TP	Voltage Limits
11	14.5 to 15.7
3	14.5 to 15.7
2	-14.5 to -15.7
4	4.85 to 5.20
1	17.4 to 22.6

NOTE

The voltage at TP1 depends on the line voltage. The limits shown are for a line voltage exactly equal to the line voltage selector setting, i.e., 100, 120, 220, or 240V ac.

5. Remove the test leads, and reinstall the top and bottom instrument covers.

4C-4. DISPLAY ASSEMBLY, A1A1, ADJUSTMENT PROCEDURE

This procedure covers the adjustment of R16, the external modulation level indicator adjustment.

TEST EQUIPMENT

DVM

REMARKS

This adjustment is independent of other adjustments and assumes proper circuit operation.

Adjustment R16 is located below TP1 on the rear of the Display PCA, just above the POWER switch.

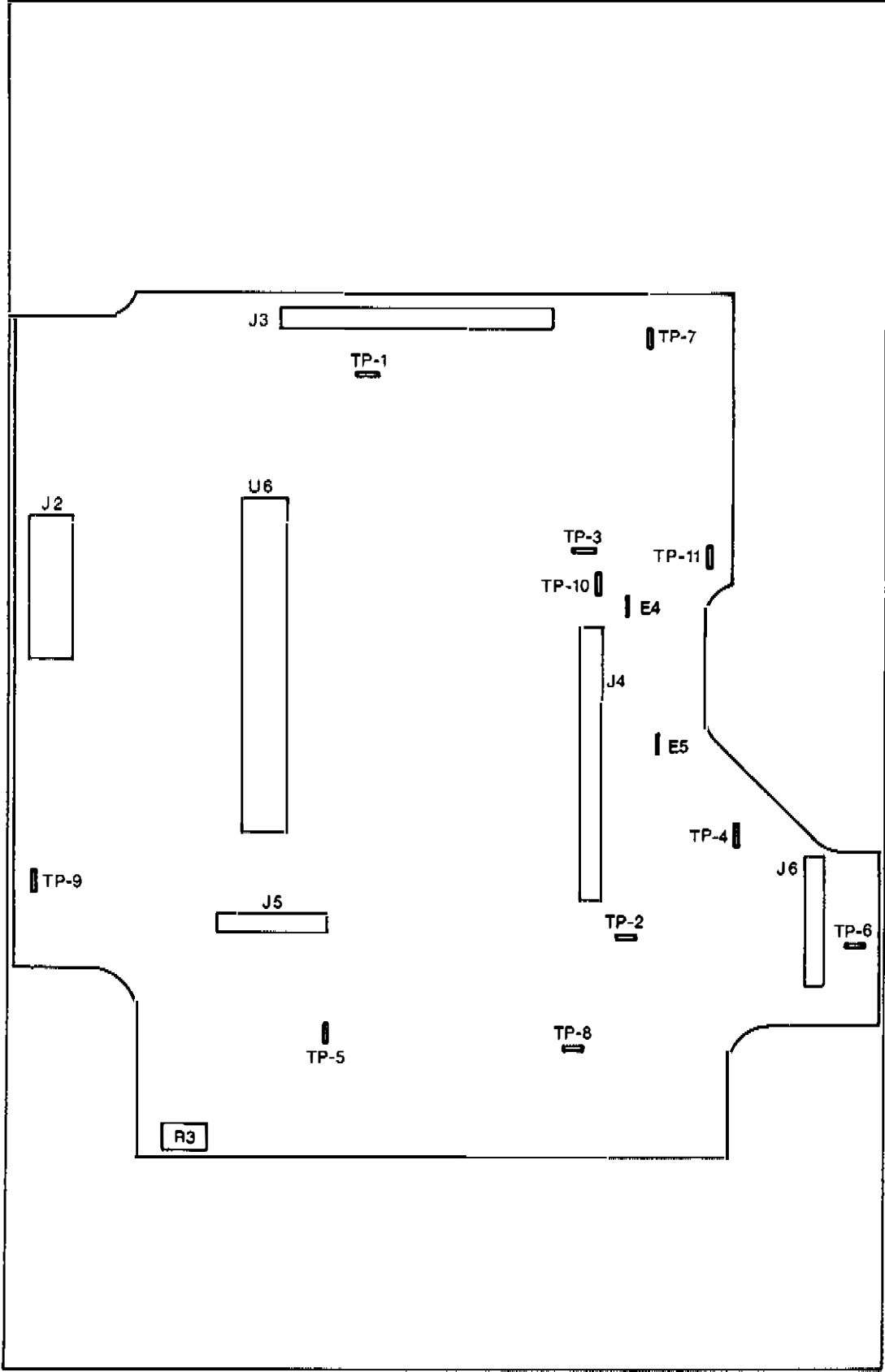

Figure 4C-1. Power Supply Test Points

**MAINTENANCE
CALIBRATION ADJUSTMENTS**

PROCEDURE

Adjust R16 for 0.98V at TP1.

1. Gain access to the rear of the Display PCA by removing the top instrument cover.
2. Connect the DVM to measure the dc voltage at TP1 relative to the chassis.
3. Adjust R16 for $+0.9800 \pm .0005V$ dc.

4C-5. OUTPUT ASSEMBLY, A2A4, ADJUSTMENT

This procedure covers all of the adjustments on the A2A4 Output PCA, as follows:

1. R309, LEVEL DAC offset
2. R419, modulation oscillator level
3. R144, linearizer detector offset
4. R421, AM depth
5. R311, RF level
6. R227, Het level

These adjustments, as well as TP7, are accessible by removing the seven number 10 access screws in the module cover. Refer to Figure 4C-2 to identify the access screw corresponding to a particular adjustment.

Any adjustment can be made independently unless it is noted that it interacts with another adjustment. Interdependent adjustments must be done in the sequence presented. If more than one adjustment is necessary, do them in the sequence presented.

1. Level DAC Offset Adjustment

TEST EQUIPMENT

DVM

REMARKS

This adjustment is normally required only when U302 or any associated components are replaced or when the adjustment has been changed or has shifted.

CAUTION

This adjustment directly affects the output level and should not be adjusted indiscriminately.

PROCEDURE

The LEVEL DAC Offset, R309, is adjusted for 0 ± 0.5 mV at TP7 with the RF OUTPUT turned OFF.

- a. Gain access by removing the bottom instrument cover and removing the access screws for TP7 and R309.
- b. Program the UUT to [RCL][9][8], and program the RF OUTPUT to OFF.
- c. Connect the DVM to measure the voltage between TP7 and the power distribution connection point on the module plate.

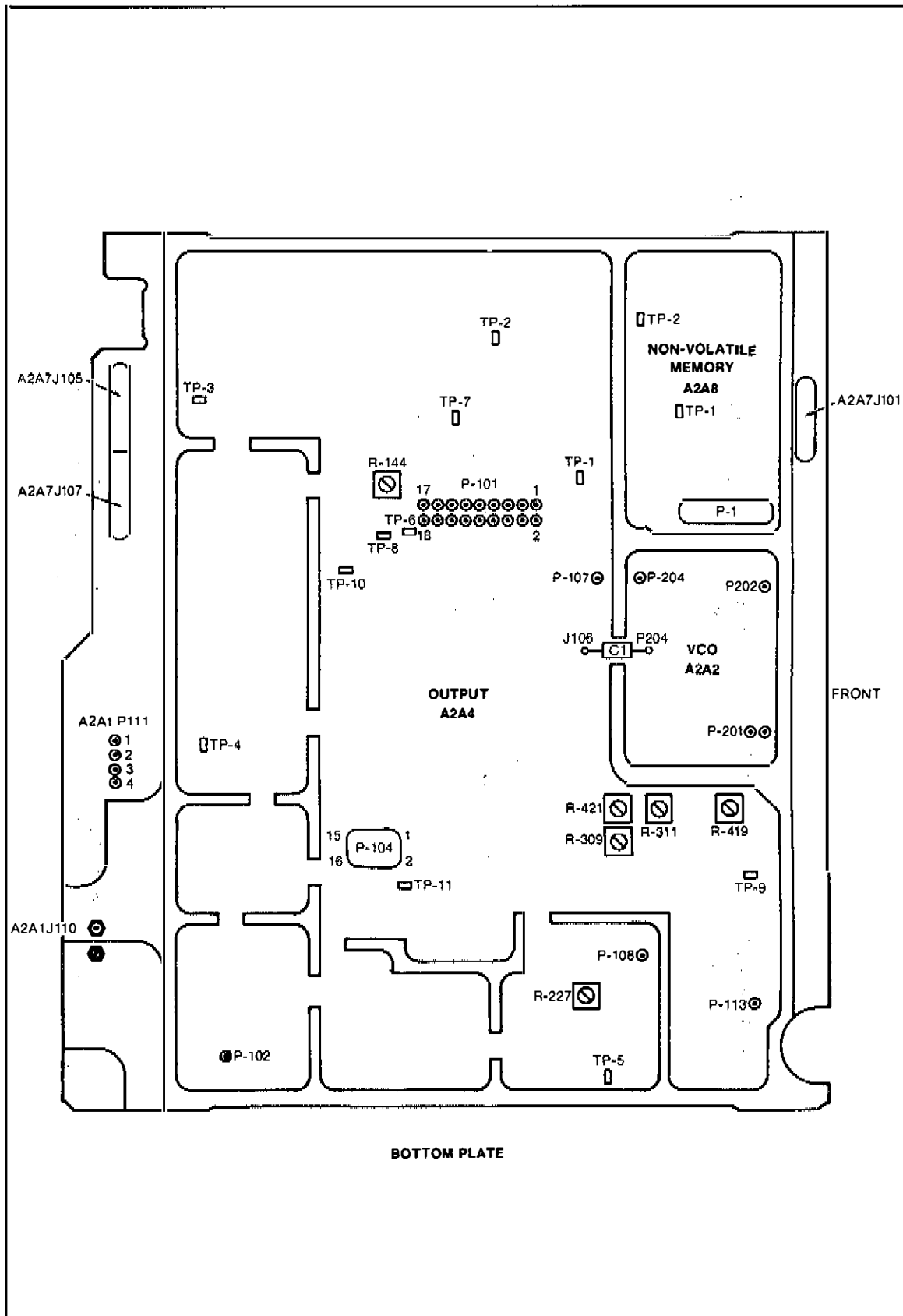

Figure 4C-2. Module Plate, Bottom View

**MAINTENANCE
CALIBRATION ADJUSTMENTS**

- d. Adjust R309 for an indication of $+0 \text{ mV} \pm 0.5 \text{ mV}$.
- e. Program the UUT RF OUTPUT to ON.
- f. Replace the access screws.

2. Modulation Oscillator Level Adjustment

This adjustment sets the modulation oscillator level.

TEST EQUIPMENT

Modulation Analyzer

DVM

Low Frequency Synthesized Signal Generator (LFSSG)

REMARKS

The modulation oscillator adjustment is normally required only when components in the modulation oscillator or modulation switching circuits have been replaced or the adjustment has been changed or has shifted.

PROCEDURE

The AM depth, with internal modulation, is adjusted via R419 to equal the AM depth with a 1-volt peak external modulation signal as measured with the Modulation Analyzer.

- a. Gain access to the access screws for R419 by removing the bottom instrument cover and the access screws for R419.
- b. Connect the output of the LFSSG to the UUT MOD IN connector and the DVM using a BNC tee.
- c. Program the UUT to RCL 98, then program the UUT to 350 MHz, 7 dBm, and EXT AM at 90% AM depth.
- d. Program the LFSSG for 1 kHz and a voltage of 0.7071V rms, as measured by the DVM.
- e. Connect the UUT RF OUTPUT connector to the Modulation Analyzer RF input.
- f. Program the Modulation Analyzer to measure + Peak AM in a 0.3-kHz to 15-kHz bandwidth.
- g. Note the measured AM depth reading with the Modulation Analyzer.
- h. Turn off the UUT EXT AM control and turn on the INT AM control.
- i. Program the UUT for 1000-Hz modulation frequency.
- j. Adjust R419 for an AM depth equal to that noted in step g.
- k. Turn off the UUT INT AM control.

1. Replace the access screw.

3. Detector Offset Adjustment

This adjustment sets the detector offset voltage.

TEST EQUIPMENT

Power Meter and Sensor

REMARKS

The UUT must be operated at room temperature for at least one hour with the module plate cover in place before continuing with this adjustment procedure.

This adjustment is normally required only when components in the detector or detector linearizer circuits have been replaced or when the adjustment has been changed or has shifted. If the Detector Offset is adjusted, perform the AM Depth adjustment.

CAUTION

This adjustment directly affects the output level and should not be adjusted indiscriminately.

PROCEDURE

The Detector Offset adjustment, R144, is adjusted to provide a 20-dB change in output power for a 20-dB change in the LEVEL DAC with level correction disabled, and while operating in fixed range.

- a. Gain access for this adjustment by removing the instrument bottom cover.
- b. Program the UUT to [RCL][9][8], then program the UUT to 350 MHz and 12 dBm.
- c. Program the UUT to [SPCL] [8][1] and [SPCL] [9][1]. These special functions disable all level correction and enable amplitude fixed-range.
- d. Remove the Detector Offset adjustment access screw from the bottom module plate cover.
- e. Zero the Power Meter.
- f. Connect the Power Sensor to the UUT RF OUTPUT connector.
- g. Program the UUT to +12 dBm.
- h. Note the Power Meter reading.
- i. Program the UUT for -8 dBm, using the EDIT keys.
- j. Adjust the Detector Offset adjustment, R144, for a Power Meter reading 20 dB \pm 0.1 dB below the reading obtained in step h.

**MAINTENANCE
CALIBRATION ADJUSTMENTS**

- k. Repeat the previous four steps until the difference between the power measurements is 20 ± 0.1 dBm. This adjustment should require three or fewer iterations.

Program the UUT to +12 dBm, using the EDIT keys. Note the Power Meter reading.

- l. Program the UUT for +2 dBm using the EDIT keys. Verify that the Power Meter reading is $10 \text{ dB} \pm 2 \text{ dB}$ below the previous reading.
- m. Program the UUT for [SPCL] [0][0]. This enables amplitude level correction and disables amplitude fixed range.
- n. Disconnect the Power Sensor from the UUT, and replace the Detector Offset adjustment access screw.

4. AM Depth Adjustment

TEST EQUIPMENT

DVM

Modulation Analyzer LFSSG

REMARKS

The UUT must be operated at room temperature for at least one hour with the module plate covers in place before continuing with this adjustment procedure.

CAUTION

This adjustment directly affects the output level and should not be adjusted indiscriminately.

This adjustment is normally required only when components in the AM signal processing circuits have been replaced, or the adjustment has been changed or shifted. If this adjustment is made, it is necessary to perform the RF level adjustment after the AM depth adjustment has been made.

PROCEDURE

Adjust the AM depth potentiometer R421 for 90% AM depth as measured with the Modulation Analyzer when the UUT is programmed to 90% AM.

- a. Remove the AM depth adjustment access screw from the bottom module plate cover.
- b. Connect the output of the LFSSG to the UUT MOD IN connector and to the DVM using a BNC Tee.
- c. Program the UUT to [RCL] [9][8], then program the UUT for 350 MHz, +1 dBm, and EXT AM at 90% AM depth.
- d. Program the LFSSG for 1 kHz and a voltage of 0.7071 rms, as measured by the DVM.

- e. Connect the UUT RF OUTPUT connector to the Modulation Analyzer input.
- f. Program the Modulation Analyzer to measure AM + Peak, in a 0.05-kHz to 15-kHz bandwidth.
- g. Alternately measure + PEAK and - PEAK and adjust the AM Depth Adjustment, R421, until the readings are symmetrical, about 90%.
- h. Replace the AM Depth adjustment access screw.

5. RF Level Adjustment

TEST EQUIPMENT

Power Meter and Sensor

REMARKS

The UUT must be operated at room temperature for at least one hour with the module plate covers in place before continuing with this adjustment procedure.

This adjustment is required if any of the following events occur:

The Output Assembly, A2A4, or the Attenuator, A2A5 has been replaced.

The AM Depth adjustment is made.

The LEVEL DAC or any associated components are replaced.

The RF level adjustment has been inadvertently changed or shifted.

CAUTION

This adjustment directly affects the output level and should not be adjusted indiscriminately.

PROCEDURE

With the UUT programmed to +9 dBm, adjust the RF Level Adjustment, R311, for +9-dBm output as measured with the Power Meter.

- a. Program the UUT to [RCL][9][8], then program the UUT to 350 MHz, +9 dBm, and turn all modulation OFF.
- b. Zero the Power Meter.
- c. Remove the RF Level Adjustment access screw from the bottom module plate cover.
- d. Connect the Power Sensor to the UUT RF connector.
- e. Adjust RF Level Adjustment, R311, for a reading of exactly +9 dBm on the Power Meter.

**MAINTENANCE
CALIBRATION ADJUSTMENTS**

- f. Replace the RF Level Adjustment access screw.

6. HET Level Adjustment

TEST EQUIPMENT

Power Meter and Sensor

REMARKS

The UUT must be operated at room temperature for at least one hour with the module plate covers in place before continuing with this adjustment procedure.

This adjustment is normally required only when components in the het band circuits have been replaced or when the adjustment has been changed or has shifted.

CAUTION

This adjustment directly affects the output level and should not be adjusted indiscriminately.

PROCEDURE

With the UUT programmed to +9 dBm, adjust the Het Level Adjustment, R227, for equal output power at 100 MHz and 350 MHz.

- a. Program the UUT to [RCL][9][8], then program the UUT to 350 MHz and +9 dBm.
- b. Zero the Power Meter.
- c. Remove the het level adjustment access screw from the bottom module plate cover.
- d. Connect the Power Sensor to the UUT RF OUTPUT connector. Note the Power Meter reading.
- e. Program the UUT to 100 MHz.
- f. Adjust Het Level Adjustment, R227, for a reading equal to that previously noted.
- g. Replace the HET level adjustment access screw.

4C-6. SYNTHESIZER ASSEMBLY, A2A1 ADJUSTMENT

The following are the routine adjustments for the Synthesizer assembly, A2A1.

- 1. R230 10-MHz Adjustment
- 2. R82 FM Cal Adjustment
R90 Low-Rate Deviation Adjustment
R87 FM Flatness Adjustment

The following only need adjustment if the associated circuits are repaired.

3. L49 20-kHz Notch Filter Adjustment
L50 40-kHz Notch Filter Adjustment
4. R104 VCO Upper Clamp Adjustment
5. C206 800-MHz Oscillator Adjustment
6. C240 10-MHz Lock-Range Centering adjustment

Each of the following adjustment procedures is independent; that is, they can be done individually or in any sequence. Figure 4C-3 shows the top view of the module plate.

1. Reference Frequency Adjustment, R230

TEST EQUIPMENT

Frequency Standard
Oscilloscope

REMARKS

The accuracy of this adjustment depends on that of the frequency standard.

The Signal Generator may be equipped with either Option -130 High-Stability Reference, or Option -132 Medium-Stability Reference. The frequency reference operation and adjustment procedure depend on this configuration. That is, the instrument reference may be the 10-MHz crystal oscillator, the High-Stability Reference, the Medium-Stability Reference or an external signal.

Skip this procedure if the UUT is equipped with the High-Stability Reference, or Medium-Stability Reference and use the adjustment procedures in Section 6 of this manual. Also perform the Sub-Harmonic Reference Adjustment described on page 4C-15 of this manual.

PROCEDURE

The UUT reference waveform is viewed on the Oscilloscope while triggering on the Frequency Standard. The 10-MHz adjustment, R230, is adjusted for a stationary display.

- a. Remove the instrument top cover and the 10-MHz adjustment R230 access screw from the module plate cover.
- b. Connect the UUT rear panel 10 MHz OUT to the Oscilloscope vertical input.
- c. Connect the Frequency Standard output to the Oscilloscope external trigger input.
- d. Set the UUT rear panel REF INT/EXT switch to INT, and set the vertical controls of the Oscilloscope to display the UUT 10-MHz signal.
- e. Set the Oscilloscope for external triggering, and adjust the timebase for 0.1 us/div.
- f. Adjust R230 for a drift of less than one cycle per second.

**MAINTENANCE
CALIBRATION ADJUSTMENTS**

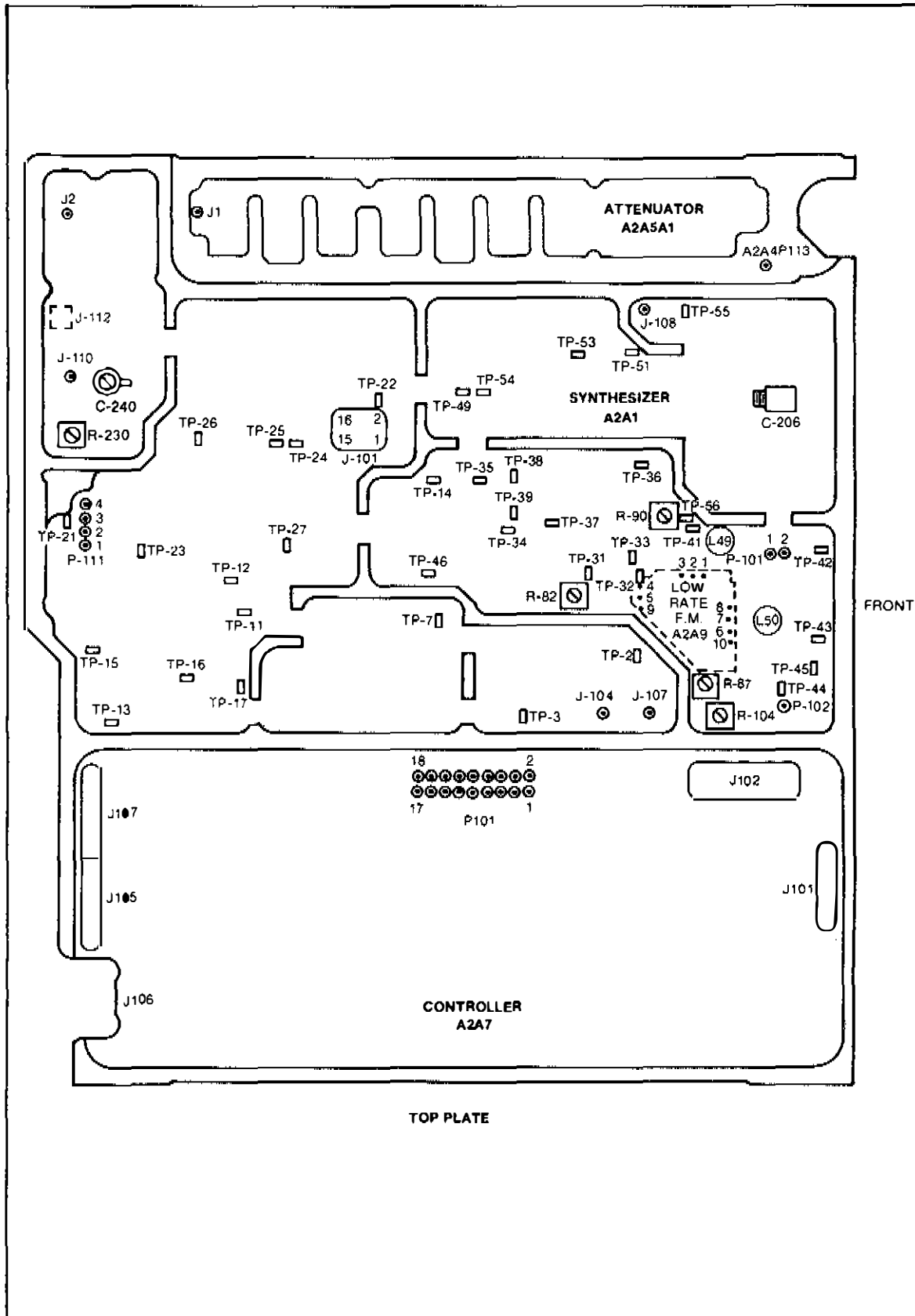

Figure 4C-3. Module Plate, Top View

2. FM Adjustments, R82, R90, AND R87

TEST EQUIPMENT

Modulation Analyzer
LFSSG
DVM

REMARKS

The FM Cal adjustment, R82, sets the overall deviation accuracy, whereas the Low-Rate Deviation Adjustment, R90, equalizes the low and high rate deviation. The FM Flatness Adjustment, R87, equalizes the deviation across the band from 0.4 to 10 kHz.

PROCEDURE

The FM deviation of the UUT, as measured with the Modulation Analyzer, is adjusted to agree with the programmed deviation at 10-kHz and 0.4-kHz rates by adjusting R82, R90, and R87, respectively.

- a. Remove the instrument cover and the FM CAL, FM flatness, and Low-Rate Deviation adjustment access screws from the cover of the module plate.
- b. Connect the output of the LFSSG to the UUT MOD IN connector and to the DVM using a BNC tee.
- c. Connect the UUT RF OUTPUT to the Modulation Analyzer input.
- d. Program the Modulation Analyzer to measure FM + peak in a 0.05-kHz to > 200-kHz bandwidth.
- e. Program the UUT to the [RCL] [9][8]. Then program the UUT to 385.5-MHz, 7 dBm, EXT FM, 99.9-kHz deviation.
- f. Program the LFSSG to 10 kHz and 0.7071V rms as measured by the DVM.
- g. Adjust R82 for 100.0 kHz, as measured by the Modulation Analyzer.
- h. Program the LFSSG to 0.4 kHz and 0.7071V rms, as measured by the DVM.
- i. Adjust R90, the low-rate deviation for 100.0 kHz, as measured on the Modulation Analyzer.
- j. Program the LFSSG to 1 kHz, and adjust R87 for 100.0 kHz as measured on the Modulation Analyzer.
- k. Repeat steps f through j until the deviation flatness is 100.0 kHz \pm 0.3 kHz.
- l. Turn the UUT EXT FM off, and note the Modulation Analyzer peak deviation (noise) reading.
- m. Turn the UUT EXT FM on.

MAINTENANCE
CALIBRATION ADJUSTMENTS

- n. Program the LFSSG to 10 kHz and 0.7071 V rms as measured by the DVM.
- o. With the Modulation Analyzer, alternately measure +peak and -peak FM, and adjust R82 so the readings are symmetrical, about 99.9 kHz plus the noise noted in step l.

3. L49 20-kHz and L50 40-kHz Notch Filter Adjustments

TEST EQUIPMENT

RF Spectrum Analyzer
LFSSG

REMARKS

These adjustments are normally not required unless L49, L50, C123, C99, C124, C126 or C125 are replaced, or unless the Generator has been subjected to severe usage.

PROCEDURE

The 20-kHz and 40-kHz notch adjustments, L49 and L50, are adjusted for sideband level nulls using the RF Spectrum Analyzer.

- a. Remove the instrument and the module plate top covers.
- b. Connect the LFSSG to TP56 (high) and TP36 (low) using clip leads.
- c. Program LFSSG to 20 kHz and 0.2V rms, terminated.
- d. Connect the UUT RF OUTPUT to the RF Spectrum Analyzer input.
- e. Program the UUT to 300 MHz and +13 dBm.
- f. Adjust the RF Spectrum Analyzer to display the signal centered on the display.
- g. Set the span to 10 kHz/division and 1-kHz bandwidth. The 20-kHz sidebands should be visible.
- h. Adjust L49 to minimize the 20-kHz sidebands.
- i. Program the LFSSG to 40 kHz.
- j. Adjust L50 to minimize the 40-kHz sidebands.

4. VCO Upper Clamp Adjustment, R104

TEST EQUIPMENT

Frequency Counter

REMARKS

This adjustment is normally required when the VCO is replaced or when the Generator has been subjected to severe usage.

PROCEDURE

The UUT PLL loop is disabled to cause the VCO frequency to be at the upper limit of its range, then R104 is adjusted for 530 MHz.

- a. Remove the instrument and module plate top covers.
- b. Connect UUT RF OUTPUT to the Frequency Counter input.
- c. Program the UUT to [RCL] [9][8]; then, program the UUT for 500 MHz and +13 dBm.
- d. Using a clip lead, short TP14 to ground to cause the VCO to go to the upper frequency limit.
- e. Adjust R104 for 530 MHz \pm 1 MHz.

5. 800-MHz Oscillator Adjustment, C206

TEST EQUIPMENT

Frequency Counter
DMM

REMARKS

This adjustment is normally not required unless components in the 800-MHz oscillator are replaced or the Generator has been subjected to severe usage.

PROCEDURE

The PLL control voltage operating point is adjusted to 16V while the loop is phase-locked.

- a. Remove the instrument and the module plate top covers.
- b. Program the UUT to [RCL] [9][8]; then, program 200 MHz.
- c. Connect the DMM to measure voltage between TP53 and the chassis.
- d. Adjust C206 for 16.0V \pm 0.5V.

6. 10 MHz Lock-Range Centering Adjustment

TEST EQUIPMENT

Frequency Standard
Low Frequency Synthesized Signal Generator (LFSSG)
Oscilloscope
BNC Tee

REMARKS

The UUT reference output and the LFSSG signal are viewed simultaneously on the oscilloscope for frequencies near the limit of the lock-in range. The 10-MHz crystal

MAINTENANCE
CALIBRATION ADJUSTMENTS

oscillator is adjusted for a stable display on the oscilloscope at both upper and lower limits. The external reference input level to the Generator is reduced to determine sensitivity.

PROCEDURE

- a. Remove the top Generator cover and the 10-MHz adjustment access screw from the the module plate. (See Figure 4C-3 C240 for 10-MHz adjustment location.)
- b. Connect the frequency standard to the reference input of the LFSSG.
- c. Connect the LFSSG output to the oscilloscope vertical input channel 1 using a BNC tee, and then connect the cable to the UUT 10 MHz IN using a cable less than three feet in length.
- d. Connect the UUT rear panel 10 MHz OUT to oscilloscope vertical input channel 2.
- e. Program the LFSSG to 10 MHz and 0 dBm.
- f. Set the UUT rear panel REF INT/EXT switch to EXT.
- g. Set the vertical controls of the oscilloscope to display both the LFSSG output and the UUT 10-MHz signal. Set the triggering to channel 1, and adjust the timebase for 0.1 μ s/div.
- h. Edit the LFSSG to 200 Hz above 10 MHz (10.0002 MHz).
- i. If the signals are unlocked, adjust C240 for a locked condition. Verify the UNCAL indicator is not lit.
- j. Adjust C240 clockwise until the two waveforms are not synchronized (break lock). Verify the UNCAL indicator is flashing. Turn C240 counterclockwise to the first stable, locked point.
- k. Edit the LFSSG to 100 Hz below 10 MHz (9.9999 MHz).
- l. Verify Locked Condition: Two wave forms synchronized and UNCAL indicator is not lit.
- m. Program the LFSSG to 10 MHz.
- n. Reduce the level of LFSSG until the signals displayed on the oscilloscope indicate an unlock condition.
- o. Increase the LFSSG level until the oscilloscope display first indicates the locked-point. Verify that this level is less than 300 mV peak-to-peak as measured with the oscilloscope.
- p. Perform Reference Frequency Adjustment procedure on page 4C-11 of this manual.

Section 4D

Troubleshooting and Repair

4D-1. INTRODUCTION

Usually, the Generator is most easily repaired by identifying the defective module and replacing it through the Module Exchange Program. Alternately, you may wish to troubleshoot down to the component level and replace the defective part. This section of the manual provides the necessary information for both repair methods.

After any module repair or replacement, the Performance Tests should be done to verify the performance of the Generator. Signal Generator problems are generally caused by operator error, out-of-spec performance, or by catastrophic failure. The correction strategy is different in each case.

Although most operator errors are detected and indicated, some are not, and therefore, may be mistaken for an out-of-spec condition. Those operator errors that are detected are indicated with either a steady or flashing 'UNCAL' indicator. Consult the Generator Specifications in Table 1-1 and Section 2 in this manual for more information on Generator operation.

Out-of-spec performance is usually corrected by performing the appropriate adjustment procedure(s). Use the Performance Tests to determine which parameters need adjustment. Refer to adjustment paragraphs in this section for more information.

If the problem is not an operator error and is not corrected by adjustment, the Generator has a catastrophic failure. Then the task is to isolate the fault and make appropriate repairs. The UNCAL and self-test failure codes usually provide a good indication of the cause of the problem. Using the Performance Tests in this situation may help to determine which parameters are not affected.

4D-2. MODULE REPLACEMENT

This repair method involves identifying and replacing the problem module. The replacement module may be obtained using the Module Exchange Program or from your spare module stock, which may then be restored using the Module Exchange Program.

Use the information in the Troubleshooting section to diagnose the problem. To help you identify the problem module, you may call your local Fluke Technical Center for troubleshooting assistance. Once the Fluke service technician believes the problem module is identified, a replacement module can be shipped prepaid by an overnight air carrier.

After the operator verifies that the replacement module corrects the problem, return the defective module using the shipping container and including the prepaid return shipping papers and label.

MAINTENANCE
TROUBLESHOOTING AND REPAIR

NOTE

The Attenuator, Output, and VCO assemblies are individually calibrated, and the correction data are stored in the associated calibration EPROMS.

CAUTION

If any of these assemblies needs calibration or if any non-field replaceable part needs repair, order a replacement using the Module Exchange Program.

To order a replacement module, use the part number for the assembly shown in the List of Parts and specify a Module Exchange part. Table 4D-1 shows a list of replaceable assemblies. To order any new assembly, refer to Section 5 for the part number. (New assemblies are ordered by referring to the same part number). Note that two versions of the Synthesizer assembly are available, one with the Low-Rate FM option and one without the option. The following paragraphs describe the available exchange modules, how to install them, and how to adjust the Generator, if necessary, after installation.

Table 4D-1. Module Exchange Assemblies

A1A1 Display PCA
A2A1 Synthesizer PCA
A2A2 VCO PCA
A2A4 Output PCA
A2A5 Attenuator Assembly
A2A5A4 Attenuator PCA
A2A5A5 Relay Driver PCA
A2A7 Controller PCA
A2A8 Non-Volatile Memory PCA
A3A1 Power Supply PCA

4D-3. Power Supply PCA, A3A1

The Power Supply PCA comes complete with the 5V regulator, A1U3, its socket, and a set of insulated washers for all of the chassis-mounted regulators.

No adjustment is required after installation of the new PCA, but the power supply voltages should be verified, using the last step of the Power Supply Adjustment procedure in this section.

4D-5. Synthesizer PCA, A2A1

Under the Module Exchange Program there are two versions of the A2A1 Synthesizer assembly available. One has the Low-Rate FM option installed on the Synthesizer PCA and the other does not. Therefore, when ordering a replacement Synthesizer module be sure to specify whether or not the Generator being repaired has the Low-Rate FM option.

Also, before replacing the Synthesizer PCA it is important to note what other options are in the Generator and carry out the following instructions pertaining to the option complement of the Generator. If the Low-Rate FM option is present, verify that S1 on the PCB option is set for Low-Rate operation. (See Section 6.)

After the new Synthesizer PCA has been installed, perform the FM CAL, VCO CLAMP, and 10-MHZ adjustments as described in the Synthesizer Adjustment Procedure in Section 4C of this manual. Perform any other adjustments related to the options.

4D-6. VCO PCA, A2A2

The VCO assembly comes with its associated VCO Calibration EPROM. This EPROM replaces the old one installed on the Controller PCB, A2A7. After installing the new VCO assembly, the FM CAL and VCO CLAMP adjustments should be done. These adjustments are presented under the Synthesizer Adjustment Procedure.

A plug-in coupling capacitor is used to interconnect the VCO and Output PCBs, thus eliminating the need for a soldering iron when replacing this assembly.

4D-7. Output PCA, A2A4

The Output assembly comes with its associated Output Calibration EPROM. This EPROM replaces the old one installed on the Controller PCB. After installing the new Output assembly, perform the level DAC offset, the RF Level, the HET level, and the FM CAL adjustment procedures given in the Calibration Adjustment Section of this manual.

A plug-in coupling capacitor is used to interconnect the VCO and Output PCBs, eliminating the need for a soldering iron when replacing this assembly.

If the Generator is equipped with the Low-Rate FM option, then it is necessary to add a jumper around C401 and C402 on the new Output assembly before installing it.

4D-8. Controller PCA, A2A7

The Controller assembly comes without the three calibration EPROMs. Therefore, it is necessary to move these EPROMs from the old to the new Controller. Remember to set the option status switch. No adjustments are required.

4D-9. Display PCA, A1A1

After installing a new Display PCA, the Modulation Indicator adjustment should be done. The procedure is presented under the Display Adjustment Procedure.

4D-10. Attenuator/RPP PCA, A2A5

The Attenuator/RPP PCA comes complete with the housing, Relay Driver PCA and matching Attenuator Calibration EPROM, and comes ready to install. The matching EPROM replaces the Attenuator calibration EPROM on the Controller PCA. After the new Attenuator assembly is installed, perform the RF Level Adjustment procedure on the A2A4 Output PCA in the Calibration Adjustments section of this manual.

4D-11. IEEE-488 PCA, A3A3

The IEEE-488 assembly comes complete with panel, frame, and connector and is ready to plug in. No adjustments are required after installation.

4D-12. Non-Volatile Memory PCA, A2A8

The Non-Volatile Memory assembly comes ready to plug in, and requires no adjustment after installation.

4D-13. PARTS REPLACEMENT

An experienced technician should be able to isolate the defective component and replace it after reading the information presented in Section 3, the Theory of Operation and the troubleshooting information contained in this section. The Schematics are presented in Section 8 (Section 6 for the options) of this manual.

Most parts are replaced using ordinary methods. The parts requiring special attention are the chip components located on the A2A2 VCO PCA. The chip components should be

MAINTENANCE TROUBLESHOOTING AND REPAIR

replaced using a 600°F soldering iron, such as an Ungar 50T7 with a number 76 heater and a number 88 tip, and 2% silver solder paste, such as Electro Science Fabrication SP-37D1 or similar wire solder.

4D-14. TROUBLESHOOTING

To isolate a fault, it is important to note the conditions under which the symptoms are observed and if the symptoms change with different states of the instrument, such as different RF bands or levels, only when FM is on, only under remote control, etc.

If the symptom is a blank front panel or no response to keystrokes, the fault is most likely a digital problem or a power supply problem. If the power supply and cables are good, go to the digital troubleshooting paragraphs in this section.

If the front panel appears to function properly, but the RF output is abnormal or there is a flashing 'UNCAL' indication, the cause is likely an analog circuit problem (although it could be a control problem).

A properly operating front panel indicates that the majority of the Controller circuitry is functional. It is possible, however, that a digital control problem could exist and cause the RF output to be incorrect. If a digital problem is suspected, go to the Digital and Control troubleshooting paragraphs after checking the power supply.

4D-15. Service Special Functions

- Special Function 03, Display check

All display segments are lit until a key is pressed.

- Special Function 04, Key check

For each key pressed, the code is displayed in the FREQUENCY display field. Pressing [CLR|LCL] key exits this check. The test also times out after approximately 8 seconds if no keys are pressed.

- Special Function 15, Latch Test

Special function 15 invokes a built-in latch control test that is useful in verifying that the Controller is sending valid data to the latches of the Output and Synthesizer assemblies. This special function sends an alternating bit pattern (10101010 binary) to each 8-bit latch, and displays "Latch AA". Pressing the EDIT [+] key changes the bit pattern to (01010101 binary), and "Latch 55" is displayed. Pressing the EDIT [+] key changes the pattern back to 10101010. Pressing any other key causes the instrument to exit the test.

CAUTION

This special function is intended as a troubleshooting tool to check the operation of the digital circuitry and the latches on the analog assemblies. Since the Generator is programmed to an abnormal state, its output is turned off by programming full attenuation.

- Special Functions 83 Through 86 Alternate Attenuators

Special functions 83 through 86 program alternate 24-dB Attenuators. The alternate 24-dB attenuators are normally used only when low levels are

programmed too low to be verified with a power meter during service. These special functions allow the alternate attenuators, A242L through A245L, to be programmed one at a time, thus keeping the level high. The first 24-dB attenuator, denoted A241L, is automatically programmed for levels between -17.0 dBm and -11.1 dBm with AM off. These special functions allow the other attenuators, A242L through A245L, to be programmed in the same range.

These special functions also turn off relative amplitude, amplitude fixed range, and all modulation; and turn RF and level correction on. If the level is not in the specified range, -12 dBm will be programmed. Any new entry that normally programs the attenuators causes the default (normal) attenuators to be programmed.

4D-16. UNCAL Conditions

There are two hardware fault detectors, the unlock detector on the Synthesizer PCA, and the unlevel detector on the Output PCA. These two fault detectors are constantly monitored by the Controller, and if asserted, cause a flashing UNCAL indication. The detectors are also used during the self test to check the general operation of the Generator.

It is very important to interrogate and note the UNCAL code if there is an UNCAL indication.

If the unit has a UNCAL condition, interrogate the UNCAL code by pressing the [STATUS] key and interpret the code (see Table 2-5 in this manual). Take note if the code indicates that either UNLOCK or UNLVL conditions have been asserted. Other codes denote overrange or underrange conditions (operator errors) that should be cleared but are not pertinent to troubleshooting.

Usually the unlevel UNCAL code indicates a problem on the Output PCA, whereas a unlocked UNCAL code indicates a problem on the Synthesizer PCA. Be aware that it is possible to have an Unlevelled UNCAL condition due to a problem with the Synthesizer PCA that is not detected by the UNLOCK detector.

It is a good idea to check for a different UNCAL code when other RF bands, levels or functions (FM or AM) are selected for a more complete analysis of the symptoms. For example, if the code indicates that UNLOCK is asserted only with FM on, and not with FM off, it may be indicating an overmodulation condition. See Table 1-1. Signal Generator Specifications, for the FM limitations.

4D-17. Self Test Description

The self test is started whenever the Generator is turned on. It may also be started by [SPCL] [0][2]. If the Generator fails any of the self tests, the self-test failure report is displayed until any key is pressed. The self-test report can also be displayed by [SPCL] [1][1]. The report is presented in four fields as shown in Table 4D-2.

A minus sign in the Frequency Display indicates that the self test was aborted by a front panel entry.

Table 4D-2. Self Test Display Field

MODULATION	FREQUENCY	AMPLITUDE
A A A	- B B B C C C	D D D

**MAINTENANCE
TROUBLESHOOTING AND REPAIR**

The four groups (denoted by the A's, B's, C's and D's) in the self-test report correspond to different test categories. These tests are described below, including a tabulation of the Generator instrument state and the test codes that result if any test fails to achieve the expected result. Understanding how these tests are done can provide more meaning to the results and can assist in understanding how they relate to other symptoms. A successful self test is reported with all zeros.

During the self test, the step attenuator is programmed to maximum attenuation and the internal frequency reference is selected. The analog circuit tests make use of the unlevelled (UNLVL) and unlocked (UNLOK) status detectors, whereas the digital circuit tests make use of write/read techniques.

4D-18. AAA FIELD

AAA is the result of the AM and FM tests. During these tests, level correction is applied. During the four AM tests, a normal AM depth, which should produce a leveled condition, and an abnormally high AM depth, which should provide an unlevelled condition, is set for each modulation frequency. During the two FM tests, a normal FM deviation is set, which should produce a locked condition, and then an abnormally high deviation is set, which should produce an unlocked condition. The two FM tests are not performed if the Option -651 Low-Rate FM is installed. Table 4D-3 shows the AAA Field AM and FM tests.

4D-19. BBB FIELD

BBB is the result of the synthesizer tests. In the first three test steps, the Synthesizer assembly's main PLL operation is verified by programming a large change in frequency. This should cause a momentary unlocked condition that should clear as the frequency settles to the new frequency.

Table 4D-3. AAA Field AM and FM Tests

AAA (CODE)	FREQ (MHZ)	LEVEL (DBM)	AM (%)	MOD FREQ (HZ)	KV DAC	FM DAC	FM RANGE	EXPECTED RESULT
001	1050	10.7	30	400	n/a	n/a	n/a	Leveled
002	1050	14	127	400	n/a	n/a	n/a	Unleveled
004	1050	10.7	30	1000	n/a	n/a	n/a	Leveled
010	1050	14	127	1000	n/a	n/a	n/a	Unleveled
020	280	-10	n/a	400	Normal	1023	4	Locked
040	280	-10	n/a	400	1023	1023	4	Unlocked

In the next three steps, the synthesizer is checked by programming 225 MHz, which is outside the normal operating frequency range, and should result in an unlocked condition. Then 385 MHz is programmed, which should result in a locked condition. Next 550 MHz is programmed, which is again outside the normal range, and should result in unlocked condition.

Finally, all frequency reference circuitry is turned off, which should produce an unlocked condition, and then turned on, which should produce a locked condition. Table 4D-4 shows the BBB Field test results.

4D-20. CCC FIELD

CCC is the result of the digital tests. The IEEE-488 option (if installed) is verified by writing data to the IEEE-488 chip, A3A3U1, then by reading it back and checking for the expected response. Each memory location of the Non-Volatile RAM is checked with a checksum.

Table 4D-4. BBB Field Test Results

BBB (CODE)	SYNTH. FREQ. (MHZ)	MAX. WAIT (MS)	XOENL BIT	EXPECTED RESULT
001	245	120	0	Locked
002	525	5	0	Unlocked
004	525	95	0	Locked
010	225	120	0	Unlocked
020	385	120	0	Locked
040	550	120	0	Unlocked
100	385	120	1	Unlocked
200	385	200	0	Locked

The Generator RAM is verified by writing data to each memory location and checking that the same data can be read back. Both the off-chip RAM (U25) and the on-chip RAM (U1) are tested in this manner. The RAM test is only done during the power-on self test. The data in each of the three calibration EPROMs; VCO (U23), Output (U24), and Attenuator (U26), are summed and compared with a checksum.

The data in each word of the two program EPROMs (U21, 22) are successively summed and rotated by two. The result of this procedure is compared with a checksum for each EPROM. Table 4D-5 shows the CCC field results.

4D-21. DDD FIELD

DDD is the result of the Output filter tests. During these tests, the level is programmed to +13.0 dBm with level correction applied. The low-pass filters on the A2A4 Output assembly are tested by setting the frequency near the high end of each of the four half-octave non-hot bands and checking for a leveled condition. Then, the frequency is set above the cutoff frequencies of two of the filters, and the output is checked for an unlevelled condition. Table 4D-6 shows the DDD field Results.

Table 4D-5. CCC Field Test Results

CCC (CODE)	DIGITAL TEST
001	IEEE-488 option test
002	Non-volatile memory test
004	RAM test
010	Attenuator calibration EPROM checksum
020	Output calibration EPROM checksum
040	Synthesizer calibration EPROM checksum
100	Lower program EPROM checksum
200	Upper program EPROM checksum

Table 4D-6. DDD Field Test Results

DDD (CODE)	FREQ (MHZ)	MIDL	HAOCTH	EXPECTED RESULT
001	349.99999	0	1	Leveled
002	511.99999	0	0	Leveled
004	729.99999	1	0	Leveled
010	1050.00000	1	1	Leveled
020	490.00000	0	1	unleveled
040	1024.00000	1	0	unleveled

MAINTENANCE
TROUBLESHOOTING AND REPAIR

Table 4D-7. Band, Filter, and Frequency Programming Data

OUTPUT FREQUENCY (F_o)	MIDL	HAOCTH	HETL	SHETH	SYNTH. FREQ (F_s)
0.01 - 244.99999 MHz	1	1	0	1	$(800 + F_o) / 2$
245 - 349.99999 MHz	0	1	1	0	F_o
350 - 511.99999 MHz	0	0	1	0	F_o
512 - 729.99999 MHz	1	0	1	0	$F_o / 2$
730 - 1050.00000 MHz	1	1	1	0	$F_o / 2$
1 = TTL High 0 = TTL Low					

4D-22. Check Output Signal

At this point, check the Generator output signal with a Spectrum Analyzer or a Counter at various frequencies on each of the three RF bands and at the state where an UNCAL condition exists. If the frequency is incorrect or erratic, check the power supply first. Go to the Synthesizer troubleshooting paragraphs if the power supply functions properly. Table 4D-7 shows the band, filter, and frequency programming data for the output frequency (at the source).

4D-23. Auxiliary Power Supply PCA, A3A2

The Auxiliary Power Supply consists of the A3A2A1 PCB and the A3A2T1 transformer mounted together with a bracket. The power supply is electrically preadjusted and needs no adjustment after installation.

The Spectrum Analyzer can also be used to check to see if the modulation functions are generally working. If a modulation problem exists, go to the appropriate AM or FM troubleshooting paragraphs after checking the power supply.

If the frequency is stable and correct, but the output level is abnormal, the problem is most likely in the Output PCB. Check the power supply; then go to the Level Troubleshooting paragraphs in this section of the manual.

Armed with a clear knowledge of the symptoms and the conditions under which the UUT fails, the next task is to isolate the problem. Remove the top and bottom instrument covers and visually inspect the interior for loose cables, connectors, etc. Also be alert for the characteristic odor of burned resistors, etc.

WARNING

DO NOT INTERRUPT THE PROTECTIVE GROUNDING CONNECTION. TO DO SO WOULD CREATE A POTENTIAL SHOCK HAZARD THAT COULD RESULT IN PERSONAL INJURY. SECURE THE INSTRUMENT AGAINST UNINTENDED OPERATION IF IT IS LIKELY THAT THIS PROTECTION HAS BEEN IMPAIRED. USE ONLY 250V FUSES OF THE PROPER CURRENT RATING.

WARNING

BECAUSE THE PROCEDURES DESCRIBED HERE ARE DONE WITH POWER APPLIED TO THE SIGNAL GENERATOR AND WITH PROTECTIVE COVERS REMOVED, TESTING SHOULD BE DONE ONLY BY TRAINED SERVICE PERSONNEL WHO UNDERSTAND THE HAZARDS INVOLVED.

CAUTION

To prevent damage to the Generator, turn off the Instrument before removing any PCAs.

4D-24. Check Power Supply Voltages

CAUTION

To prevent damage to the Generator, turn off the Instrument before disconnecting any power distribution cables.

Check all power supply voltages. Table 4D-8 gives the expected dc and ripple voltages at key test points. If one supply voltage is unusually low, this could indicate an abnormal load on that supply due to a fault. To isolate the fault, check the abnormal voltage before and after disconnecting (one at a time) the power cable to the Controller, Synthesizer, Attenuator, and the cable from the Controller to the front panel.

Table 4D-8 lists the typically dc and ripple voltages (relative to ground connection on the module plate) at the key test points of the Power Supply, A3A1, PCB. These characteristics apply for [RCL] [9][8].

The unregulated dc and ripple voltages are those expected with a line voltage of 120V ac at 60 Hz. The dc voltages are expected values as measured with a digital voltmeter with respect to the power supply ground connection on the module plate.

The ripple voltages are expected values as measured with an oscilloscope with respect to the power supply ground connection on the module plate, and are the peak-to-peak values of the 120-Hz waveform.

The characteristics of the unregulated +18V relay supply depend directly on the line voltage and the load (the state of the instrument). For example; at 120V ac:

- At 50 MHz and 13 dBm, Vdc is typically 19.0V with .25V (peak-to-peak) ripple.
- At 50 MHz and RF off, Vdc is typically 20.0V with 0V ripple.

Table 4D-8. Power Supply Characteristics

SUPPLY	UNREGULATED VOLTAGES			REGULATED VOLTAGES		
	@TP	V dc	Ripple(Vpp)	@TP	V dc	Ripple(mVpp)
+37	9	47	0.5	5	36.9 to 37.1	2
+15 Syn	7	22	0.5	11	14.5 to 15.7	0.5
+15 Out				3	" "	"
-15	8	-23	0.2	2	-14.5 to -15.7	"
+5	10	9	1	4	4.75 to 5.25	1
+18	1	23	0.35	None	None	None

4D-25. DIGITAL AND CONTROL TROUBLESHOOTING

If the symptoms indicate a digital or control problem, the following suggestions may help you isolate the fault to a particular functional circuit. In this manual, refer to the schematic diagrams in Section 8, and refer to Section 3 for the Theory of Operation.

First, verify that all assemblies are receiving the correct voltages from the power supply.

The most obvious symptom of failure in the Controller assembly is a blank front panel. A properly operating front panel indicates that most of the Controller circuitry is functional. If the front panel is totally blank or unresponsive to any keystrokes, the microprocessor kernel should be checked first. See the paragraphs entitled Microprocessor Kernel in this section.

If the front panel is operating correctly but the RF output is incorrect, determine if the fault is on the Controller side of connector P101. The control to most of the audio and RF analog circuitry passes through P101 via buffers U15 and U16 on the Controller PCB, A2A7.

4D-26. Control Activity

This can be checked by verifying data activity on the data and address lines of P101. Program the bright digit for 100-Hz resolution in the FREQUENCY display. While pressing the EDIT [+] key, observe with an oscilloscope the activity on P101. Pressing one of the EDIT keys sends bursts of frequency and level control data through the buffers.

Although it is difficult to determine if the data, (BD0-7) and address (BAB0-2) signals on P101 are valid at any given time, the most common failures seen at this point are totally inactive signals. Between bursts, the data and address signals are in the high impedance state (tri-stated). Be careful not to confuse this high impedance state with total inactivity. Observing these signals on a known good unit may be helpful.

If signals are found to be totally inactive, inspect the buffer control signals on U15 (pin 1), and U16 (pins 1 and 19) of the Controller, A2A7. If the buffer control signals are active, check the buffer inputs that correspond to the inactive outputs. If the inputs show activity, replace the buffer and again check the signals. If, however, the inputs to the buffers are also inactive, trace the signals back and determine the fault location.

If all data and address signals show activity and their timing roughly corresponds to the select signals BSEL0L and BSEL1L, assume for now that the Controller is sending the correct data and continue on.

4D-27. Latch Control

Use the [SPCL][1][5] keys to check each available latch on the RF circuit boards to verify that the correct data is reaching them. Passing this test is a good indication that the fault is not in the Controller.

If the IEEE-488 option is present, and an IEEE-488 Bus Controller is available, additional bit-level control of the hardware is available by using the monitor commands (see Section 2). These commands allow you to directly program the DACs, or read and write data to any desired location.

4D-28. Microprocessor Kernel

Connect an oscilloscope probe to the external clock input of A2A7 U1 pin 2. There should be a symmetrical 10-MHz square wave with an adequate TTL logic level. If the

signal deviates from this description, refer to Section 3, Theory of Operation, in this manual to assist you in troubleshooting the clock oscillator circuit.

4D-29. Power Reset

Connect an oscilloscope probe to the RESET input (pin 22) of U1. The signal should generate a low to high transition on power-up and remain high during normal operation. Turning the power on and off generates active low reset pulses to U1. If a problem with the reset circuit is suspected, refer to Section 3, Theory of Operation, and troubleshoot the reset circuitry.

4D-30. Microprocessor Inputs

Input pins to U1, CRUIN (pin 13), INT1 (pin 15), HOLD (pin 18), NMI (pin 21), and READY (pin 23), should all be high. If any of these signals are not high, correct the fault before continuing on.

4D-31. IEEE-488 Interrupt

Verify that the IEEE-488 Interface interrupt signal, IEINTL, is in the inactive (high) state. If IEINTL is active, either troubleshoot the interface to the IEEE-488 Interface option, or temporarily bend out pin 14 of U1 and tie it to +5V.

After completing the above steps, there should be activity on the address, data, and control lines as the microprocessor executes instructions.

4D-32. Microprocessor Bus

The dynamic nature of microprocessor bus circuitry makes it very difficult to verify the data transmitted at any given time. However, most common bus faults show recognizable symptoms. Look at each of the data (D0 to D7), address (A0 to A15), and bus control (CLKOUT, DBINL, WEL, MEML) signals with an oscilloscope.

Suspect inactive signals or signals that enter invalid logic states. Also compare the driver inputs and outputs of buffered signals. A combination of observation and experience is helpful here. An ohmmeter or a pulse generator may be useful in further investigating suspected signals.

4D-33. Address Decoder

Several levels of address decoding are used to select all the memory and I/O devices. The inputs to the address decoders come from the buses and present challenges similar to troubleshooting the buses. A suggested approach is to first choose a decoding path to a particular device or group of devices. Start at the highest level of decoding, and one at a time verify that each part in the path is good.

4D-34. Display and Controls

If the display shows signs of activity, but has missing or bright digits or segments, the problem is most likely in U18 on the A2A7 Controller or on one of the data latches or drivers on the A1A1 Display PCB. If the display is blank and the Controller is operational, check the various power supplies and the display blanking circuitry on the Display PCB.

Two special function-service tests are available to test the front panel indicators and keys. [SPCL] [0][3] keys check the front panel displays by lighting all segments. This test is aborted by pressing any key on the Generator.

The [SPCL] [0][4] keys allow all normally open keys to be checked. As each key is pressed, its row and column address is displayed in the center of the FREQUENCY display field. See Table 4D-9 for the address codes for each key. This test is exited by a clear entry.

MAINTENANCE
TROUBLESHOOTING AND REPAIR

Table 4D-9. Address Codes for the Front Panel Keys

KEY	CODE
[EXTAM]	1
[EXTFM]	2
[INTAM]	4
[INTFM]	5
[400/1000]	6
[FREQ]	9
[AMPL]	10
[AM]	11
[FM]	12
[SPCL]	13
[STEP]	14
[7]	15
[4]	16
[1]	17
[0]	18
[ST0]	19
[8]	20
[5]	21
[2]	22
[.]	23
[RCL]	24
[9]	25
[6]	26
[3]	27
[-]	28
[SEQ]	29
[MHz V]	30
[kHz V]	31
[Hz uV]	32
STEP[v]	33
[dB(m)]	34
[%]	35
[CLR LCL]	(Exit Test)
STEP[↕]	37
EDIT[↕]	38
EDIT[↕]	40
EDIT[↕]	41
EDIT[↕]	43
[STATUS]	45
R[ON/OFF]	46

4D-35. SYNTHESIZER TROUBLESHOOTING

NOTE

All frequencies mentioned are synthesized; hence they are exact (coherent with the 10-MHz reference), unless noted as approximate.

If the Generator has the Low-Rate FM (Option -651), set A2A9S1 for normal operation (See Table 651-1) while troubleshooting. If the Generator level is inaccurate or an unlevelled condition exists, then the A2A4 Output assembly is probably at fault. If an unlock condition exists, the problem is in the synthesizer. If the output frequency is in error or erratic, there is likely a problem with the Synthesizer assembly. However, if the unlocked condition only occurs when using an external reference, the problem is probably in the Sub-Harmonic Reference circuitry.

If the unlocked condition exists with REF INT/EXT set to INT, be sure no signal is applied to the REF IN connector. An external signal applied (while operating on internal reference) can cause the main loop to unlock.

Next, check to see if the Generator frequency is stuck high or low. A good way to do this is to check the dc voltage at TP44. If it is around 2V, go to the Reference Circuitry Check in the following paragraphs.

If the voltage is around 25V, the problem is associated with the main PLL, i.e., VCO, UHF binary divider, buffer amplifier, SSB mixer, triple-modulus prescaler, or N-Divider.

Table 4D-10 shows the characteristics of the signals at the various test points on the Synthesizer PCA. The range of the signal and the expected value for a typical instrument state are given. The values in the TYPICAL column are for the UUT programmed to 160.11999 MHz, INT FM on at 1 kHz, and 99.9 kHz deviation.

4D-36. Reference Circuitry Check

There should be a 10-MHz square wave at U55 pin 12. If there is no signal at this point, the problem is in the internal 10-MHz crystal oscillator. The frequency should change as R230 is adjusted. The DC voltage at TP 57 should vary from 4 to 6 volts as R230 is adjusted. If there is an external signal connected, with the switch set to EXT, there should be a TTL signal at U67 pin 11. The same signal should appear at U68 pin 3. If either of the enhanced stability options is present, with the switch set to INT, there should also be a 10 MHz TTL signal at U68 pin 3. If the loop is locked, there should be a stable DC voltage at the output of the loop amp, U69 pin 6.

Table 4D-11 shows the relationship between various reference frequency configurations and the control of the reference circuitry.

4D-37. Main Phase Lock Loop

If the voltage at TP44 is around 25V, connect a variable power supply to TP41. This allows the frequency of the VCO to be controlled directly. Use a Spectrum Analyzer or Counter to monitor the Generator output.

Program the UUT to 640 MHz. If the power supply can be adjusted to obtain an output frequency of about 640 MHz, the VCO is probably OK; proceed to the next paragraph. If the power supply cannot be adjusted to obtain about 640 MHz output frequency, troubleshoot the VCO or the circuitry between TP41 and TP44.

MAINTENANCE
TROUBLESHOOTING AND REPAIR

Table 4D-10. Synthesizer PCA Test Points

TEST POINT	SIGNAL TYPE	RANGE	TYPICAL	FUNCTION
TP1	RF	245 to 525 MHz	480.059995 MHz; -7 dBm	All frequency digits
TP2	GROUND			
TP3	RF	245 to 525 MHz	480.059995 MHz; +4 dBm	All frequency digits
TP7	GROUND			
TP11	TTL	20 to 39.995 kHz	39.995 kHz	10-K, 1-K, 100-, and 10-Hz Digits
TP12	TTL	1 to 1.99975 MHz	1.99975 MHz	10-K, 1-K, 100-, and 10-Hz Digits
TP13	GROUND			
TP14	TTL	1 MHz (AL)	1 MHz	1-MHz and lower digits
TP15	TTL	0.02 to 1 MHz	20 kHz	
TP16	TTL	12 to 26 MHz	24 MHz	All frequency digits
TP17	RF	245 to 525 MHz	480.02 MHz; -17 dBm	All frequency digits
TP22	AUDIO	0 to 0.7V rms	0.68V rms	FM Deviation
TP23	GROUND			
TP24	TTL	20 MHz, 12.5 ns (AH)	20 MHz	
TP25	TTL	20 MHz, 12.5 ns (AH)	20 MHz	
TP26	GROUND			
TP27	TTL	10 to 19.9975 MHz	19.9975 MHz	10-K, 1-K, 100- and 10-Hz Digits
TP31	GROUND			
TP32	AUDIO	0 to 0.8V rms	0.18V rms	FM Deviation, and Frequency
TP33	AUDIO	0 to 0.8V rms	0.18V rms	FM Deviation, and Frequency
TP34	DC	30 ±0.5V	30V dc	
TP35	TTL	1 MHz	1 MHz	1-MHz Reference
TP36	GROUND			
TP37	DC	-1 to -6v	-2.7V dc	Frequency
TP38	TTL	1 MHz 200 ns (AH)	1 MHz 200 ns	
TP39	TTL	1 MHz 10 ns (AL)	1 MHz 10 ns	
TP40	DC	2 to 22V	17.7V dc	Frequency
TP41	DC	2 to 22V	17.3V dc	Frequency
TP42	GROUND			
TP43	DC	2 to 22V	17.3V dc	Frequency
TP44	DC	2 to 22V	16.2V dc	Frequency
TP45	GROUND			
TP46	TTL	low = unlocked high = locked	TTL high	
TP49	TTL	10 MHz 20 ns (AL)	10 MHz, 20 nS	
TP50	TTL	10 MHz	10 MHz	
TP51	GROUND			
TP52	TTL	10 MHz 10 ns (AL)	10 MHz, 10 nS	
TP53	DC	7.5 ±1V 16 ±2v	16V dc	Above 245 MHz Below 245 MHz
TP54	TTL	10 MHz	10 MHz	
TP55	RF	800 MHz	800 MHz; -10 dBm	Below 245 MHz
TP56	INPUT			To test low- pass filters

NOTE: AH = active high
AL = active low

Table 4D-11. Frequency Reference Control

OPTION INSTALLED		BIT	
HIGH- OR MEDIUM-STABILITY	INT/EXT	RMUX0H	SHENL
NO	INT	0	1
	EXT	0	0
YES	INT	1	1
	EXT	0	0

1 = TTL High
0 = TTL Low

Program the UUT to 320 MHz. If you can adjust the power supply to obtain about 320 MHz output from the VCO, the VCO and binary divider are probably OK; proceed to paragraph 4D-41. If you cannot change the frequency, the problem is either the VCO, or the UHF binary divider, U1.

Check the signal at TP1. It should be the same as the output frequency. The level after the buffer amplifier, Q3, Q4, at TP3 (use RF test cable) should be approximately +3 dBm. The signal at TP17 should be a signal sideband signal with the lower sideband component (the desired signal) at about -20 dBm. If the only signal is the carrier frequency (same frequency as TP3), check the quadrature generator, and the sub-synthesizer circuitry. The signal out of the triple-modulus pre scalar should be approximately 16 MHz (with the output frequency set to approximately 320 MHz). The output of the N-Divider, TP14, should be approximately 1 MHz.

As the UUT frequency is programmed, the frequency at TP14 should change, since the divide ratio is being changed. If the frequency is not 1 MHz and/or it doesn't change, the problem is probably with the N-Divider gate array, U17, or the interface to the microprocessor.

If both the reference (at TP35) and the N-Divider signals at the phase detector are 1 MHz, the loop should lock when the operator removes the variable power supply. If the loop does not lock, check the KNV voltage at TP37. With the Signal Generator programmed to 320 MHz, TP37 should be approximately 1.0 to 2.0V. If this voltage is not correct, check the DAC U27, latches U26 and U30, and op-amp U28. This voltage should also change as the operator changes the Generator frequency.

If the KN DAC appears to function, the problem is with the phase detector. Reconnect the variable power supply as before, and adjust the voltage for a approximately 1-MHz signal at U44 pin 3. With this frequency slightly above 1 MHz, TP38 should be high and TP39 should be low.

With this frequency slightly below 1 MHz, TP38 should be low and TP39 should be high. The only remaining circuitry is the loop amp U48 and the current source, U46, Q18, and Q19.

If the loop is locked, but the 1-MHz, 10-MHz, or 100-MHz digits cannot be programmed, the problem is either the N-divider or the interface to the microprocessor. If the 100-kHz

MAINTENANCE

TROUBLESHOOTING AND REPAIR

or 10-kHz digit is inoperative or the frequency jumps as the 1-MHz digit is programmed, the problem is likely the triple-modulus prescaler. If the lower order (1-kHz, 100-Hz, 10-Hz) digits cannot be programmed, the problem is the sub-synthesizer or single sideband mixer.

4D-38. Sub-Synthesizer and HET (800 MHz), 40-MHz Loop

The frequency at TP24 and TP25 should be 20 MHz. The frequency at U64 pins 14 and 15 should be 40 MHz. If the 40-MHz signal is present, but not the 20 MHz, the problem is most likely with Q4, Q5, U35, or U34. If the 40-MHz signal is in error, the problem is in the 40-MHz loop.

Check the frequency at the 40-MHz VCO, U64 pin 3. It should be 40 MHz. If it is not, lift the op-amp end of R169, and connect it to a variable power supply set to approximately 6V. The signal at U64 pin 3 should be approximately a 40-MHz ECL level (approximately 3.2V to 4.2V) signal. By varying the supply voltage, the frequency should change. A similar signal should be present at U64 pin 2. Check to see if U64 pin 1 is ECL low (approximately 3.2V).

The output of TTL buffer U65 pin 8 should be approximately 40 MHz. The output of the divide-by-4, U66, should be approximately 10 MHz. Once again, if the frequency is greater than 10 MHz, pulses should exist at TP52 and the output of op-amp U60 pin 6 should be low. If the frequency is below 10 MHz, pulses should exist at TP49, and the op-amp should be high (approximately 24V). The loop should lock when the operator reconnects R169.

If the TP checks are all right and the 800-MHz oscillator is not locked when in the HET band, the problem is either with the 800-MHz VCO, the divide-by-4 (U61), the divide-by-5 (U62, U63), or the logic that controls the switched +5V.

Program the UUT to 320 MHz. The frequency at TP27 (the output of the sub-synthesizer gate array U33) should be 10 MHz if the input signals are correct. The frequency at TP12 should be 1 MHz, and TP11 should be 20 kHz. There should be a 20-kHz sine wave at the hot end of R33. The signals at the output of the active quadrature generator, U10 pin 8 and U10 pin 14 should be approximately 300 mv p-p sine waves that are 90° apart in phase. Use a dual-trace Oscilloscope for verification.

The frequency at TP27 should change 500 kHz for a 1-kHz change in the programmed frequency, and 50 kHz for a 100-Hz change, etc.

4D-39. FM Circuitry

Program the UUT to 500 MHz, INT FM, 99.9-kHz deviation, and 1-kHz modulation frequency. There should be a 2V p-p 1-kHz sine wave at TP22. Program 50-kHz deviation, and the level should drop to 1V p-p. Reprogram the deviation to 99.9-kHz. The level of the output of the KV DAC, U28 pin 7 will be approximately 1.5V p-p depending on the FM correction value (KV) in the EPROM.

The signals at TP32 and TP33 should be approximately the same, depending on how R87 is set. The output of the audio integrator should be about 1V p-p. To check the FM range, program the UUT to 9.99-kHz deviation. The ac voltage at TP32 should drop to 10% of the 99.9-kHz value. Program 999-Hz, and the voltage should drop to 1% of the 99.9-kHz value.

The INT/EXT FM selection is done on the A2A4 Output PCA. The controls are listed in Table 4D-17.

Tables 4D-12 and 4D-13 provide FM range and FM DAC (10 bits) control information.

Table 4D-12. FM Ranges

FM DEVIATION (Hz)	FM DEVIATION WITH LOW-RATE FM OPTION (Hz)	FMRN
0 - 999	0 - 99.9	1
1000 - 9990	100 - 999	2
10000 - 99900	1000 - 9,990	4

Table 4D-13. FM DAC Control

FM DEVIATION (Hz)	FM DEVIATION WITH LOW RATE FM OPTION (Hz)	FM 0 - 9 (Bits)
0 - 999	0 - 99.9	FM Deviation /.1
1000 - 9990	100 - 999	FM Deviation
10000 - 99900	1000 - 9,990	FM Deviation /10 FM Deviation /100

4D-40. LEVEL TROUBLESHOOTING

If the Generator level is inaccurate or an unlevelled condition exists, the A2A5 Output assembly or the A2A6 Attenuator assembly is probably at fault. If an unlevelled condition exists, the problem is in the circuitry ahead of the detector. Go to the paragraph in this section entitled Unlevelled Condition.

If there is no unlevelled condition, the problem is likely in the circuitry following the ALC Loop, which includes the Attenuator/RPP, the heterodyne circuit, and the output amplifier, Q215. If the level problem only exists below 245 MHz, then troubleshoot the heterodyne circuitry. If the problem is not frequency dependent and if the level is accurate above +7 dBm but inaccurate below +7 dBm, then the A2A5 Attenuator/RPP is at fault.

4D-41. Output Assembly Test Point Signal Information

Table 4D-14 presents the nominal characteristics of the signals at the various test points on the Output PCA. Not only the range of the signal, but also the expected value for the Instrument Preset State [RCL] [9][8], are given.

4D-42. ATTENUATOR LEVEL CONTROL

Table 4D-14 lists the Attenuator assembly (A2A5) sections that are inserted in the RF output path for the various level ranges of the generator. This information is useful in isolating a faulty section. The sections are labeled by the control line mnemonics at latch U27 on the Controller PCB. Note that the section is inserted in the RF output path when there is no power applied to the relay.

If the Level problem exists above +7 dBm, the through path (0 dB attenuation) of the Attenuator may be faulty.

4D-43. Attenuator Check

Attenuator problems are most likely to be relay contact problems.

To isolate the faulty attenuator section, connect a power meter to the RF OUTPUT connector, and check the nominal levels per Table 4D-16 at both 0.2-MHz and 1050-MHz frequency.

MAINTENANCE
TROUBLESHOOTING AND REPAIR

Table 4D-14. Output PCA Test Points

TEST POINT	SIGNAL TYPE	RANGE	TYPICAL FOR RCL 98	SIGNAL DESCRIPTION
TP1	RF	245 to 1050 MHz -18 to -32 dBm	300 MHz -27 dBm	Output of mid/high bandswitch.
TP2	RF	245 to 1050 MHz -10 to -25 dBm	300 MHz -20 dBm	Output of buffer amplifier.
TP3	RF	245 to 1050 MHz -13 to -28 dBm	300 MHz -22 dBm	Output of switched low-pass filters.
TP4	RF	245 to 1050 MHz -13 to -33 dBm	300 MHz -22 dBm	Power-splitter output.
TP5	RF	800 MHz -8 dBm	No signal	Het mixer LO signal
TP6	dc+audio	-7 to 14V dc nominal	3.1V dc	Modulator control voltage.
TP7	dc+audio	0.04 to 3.0V dc nominal	1.2V dc	Leveling Loop control voltage.
TP8	dc+audio	0 to 2V dc nominal	0.63V dc	Detector diode voltage.
TP9	dc+audio	400 or 1000 Hz, 0.71V rms	400 Hz 0.71V rms	Modulation Oscillator output.
TP10	Ground			
TP11	dc+audio	0 to 0.70V rms	0V	FM modulation signal to Synthesizer.

The through-path operation of the Attenuator/RPP can be roughly checked by removing the instrument and module bottom covers. Program the frequency to 1 MHz and the level to +13 dBm. Measure (with a high-impedance probe and an RF voltmeter or an oscilloscope) the level at PI02 of the A2A4 Output assembly with a power meter connected to the RF OUTPUT connector. If the voltmeter measures a nominal 1V rms, but the power meter does not read +13 dBm, then the signal is not getting through the Attenuator module, and the Attenuator/RPP is at fault.

If the level problem is subtle rather than catastrophic, a more accurate check is required to determine if the fault is the Attenuator or the Output assembly. Such a check is made by removing the Attenuator assembly, attaching an adapter (6060A-4234; P/N 744177) to the interconnect point, and making power meter measurements of the A2A4 Output assembly output. Use [SPCL] [8][2] to disable the Attenuator correction factors. The level at this point should be flat over 0.4 to 1050 MHz within typically 0.2 dB and should agree with the programmed level within 2 dB.

If the problem has been isolated to the Output assembly and there are no self-test errors or flashing UNCAL condition, the problem is probably in the circuits following the ALC loop. If the problem is only in the Het band (frequency < 245 MHz), check the Het band switch and controls, the Het band circuits (mixer, filter, and amplifier), and the local oscillator signal (800 MHz, nominal -10 dBm at TP5). If the problem is at all frequencies, check the output amp, Q215, and the Het/function switch and controls.

Table 4D-15. Attenuator Level Control

AMPLITUDE RANGE IN DBM				ATTENUATOR SECTIONS INSERTED INDICATED BY X						
AM Off		AM On		A6DBL	A12DBL	A241L	A242L	A243L	A244L	A245L
7.0	19.0	1.0	9.0							
1.0	6.9	-5.0	0.9	X						
-5.0	0.9	-11.0	-5.1		X					
-11.0	-5.1	-17.0	-11.1	X	X					
-17.0	-11.1	-23.1	-17.1			X				
-23.1	-17.1	-29.1	-23.2	X		X				
-29.1	-23.2	-35.1	-29.2		X	X				
-35.1	-29.2	-41.1	-35.2	X	X	X				
-41.1	-35.2	-47.1	-41.2			X	X			
-47.1	-41.2	-53.2	-47.2	X		X	X			
-53.2	-47.2	-59.2	-53.3		X	X	X			
-59.2	-53.3	-65.2	-59.3	X	X	X	X			
-65.2	-59.3	-71.2	-65.3			X	X	X		
-71.2	-65.3	-77.2	-71.3	X		X	X	X		
-77.2	-71.3	-83.3	-77.3		X	X	X	X		
-83.3	-77.3	-89.3	-83.4	X	X	X	X	X		
-89.3	-83.4	-95.3	-89.4			X	X	X	X	
-95.3	-89.4	-101.3	-95.4	X		X	X	X	X	
-101.3	-95.4	-107.4	-101.4		X	X	X	X	X	
-107.4	-101.4	-113.4	-107.5	X	X	X	X	X	X	
-113.4	-107.5	-119.4	-113.5			X	X	X	X	X
-119.4	-113.5	-125.4	-119.5	X		X	X	X	X	X
-125.4	-119.5	-131.4	-125.5		X	X	X	X	X	X
-147.0	-125.5	-147.0	-131.5	X	X	X	X	X	X	X

Table 4D-16. Attenuator Levels

ATTENUATOR	PROG LEVEL	SPECIAL FUNCTION	OBSERVED LEVEL (NOMINAL)
6dB	+6dBm	--	+6dBm
12dB	0dBm	--	0dBm
24dB £1	-12dBm	--	-12dBm
24dB £2	-12dBm	83	-12dBm
24dB £3	-12dBm	84	-12dBm
24dB £4	-12dBm	85	-12dBm
24dB £5	-12dBm	86	-12dBm

4D-44. Unleveled Condition

If there are self-test failures and/or unleveled indications, the problem is probably in, or prior to, the ALC loop. If the problem is isolated to a specific frequency band (or bands) and other bands work properly, check signal inputs and controls to the various filters that precede the modulator. See Table 4D-7 Band, Filter, and Frequency Data for band definition. If all frequency bands are affected, the leveling ALC loop or associated controls and inputs are probably at fault.

TP6 (modulator control voltage) is a good place to monitor. With the instrument programmed to +13 dBm, the voltage on TP6 should be between +2V and +8V dc (+4V to +5V dc typical). Another place to monitor is TP7 (ALC control voltage). With the instrument programmed to +13 dBm, and the level correction disabled [SPCL][8][1], the

**MAINTENANCE
TROUBLESHOOTING AND REPAIR**

voltage here should be approximately 1.6V dc. With the RF off, the voltage at TP7 should be 0V dc.

When the problem is isolated to a specific area, use the schematic, Theory of Operation, Test Point Chart, and normal troubleshooting techniques to isolate the fault.

4D-45. AM TROUBLESHOOTING

The following paragraphs provide information that help the operator to trace an AM problem to a specific circuit on the Output assembly.

4D-46. Internal/External AM

If an AM problem exists, determine if the problem occurs with internal AM, external AM or both. This check is done by connecting a 1V peak (2V p-p), 1-kHz signal source to the external MOD INPUT of the UUT and measuring AM depth. Use a Modulation Analyzer. Program the UUT to external AM and then to internal AM at 1-kHz internal modulation rate. The measured AM should agree with the programmed depth within a few percent.

Tables 4D-17 and 4D-18 provide control information for modulation and modulation frequency selection.

If the internal AM does not agree, but external AM is Ok, the Modulation Oscillator is likely at fault. If external AM is bad, but internal AM is Ok, then the problem is somewhere between the external MOD INPUT and the AM DAC.

If both the external and internal AM fail, the problem is likely being caused by either the modulation signal-processing circuit or the leveling loop. To determine which circuit is faulty, perform the following test.

Table 4D-17. Modulation ON/OFF Control

INT AM	EXT AM	INTAML	EXTAML	
Off	Off	1	1	
Off	On	1	0	
On	Off	0	1	
On	On	0	0	
INT FM	EXT FM	INTFML	EXTFML	FMENH
Off	Off	1	1	0
Off	On	1	0	1
On	Off	0	1	1
On	On	0	0	1
1 = TTL High 0 = TTL Low				

Table 4D-18. Modulation Frequency Control

FREQUENCY	MF400L
400 Hz	0
1 kHz	1
1 = TTL High 0 = TTL Low	

4D-47. ALC Loop Control Voltage

PROCEDURE

1. Connect a 1V peak (2V p-p), 1-kHz signal source to the external MOD INPUT.
2. Program the UUT for 350 MHz, 7 dBm, 71% AM depth, and EXT AM ON.
3. Measure the ac and the dc voltage at TP7. The rms voltage should be nominally 50% of the dc voltage.
4. Program the UUT for 35% AM depth. The rms voltage should be nominally 25% of the dc voltage.

If the UUT fails this test, the problem lies somewhere between the EXT MOD input and TP7 (ALC loop-control voltage). To further localize the problem, the same test can be done by measuring the ac voltage at U302 pin 8 (input to level DAC). If the measured ac voltage does not change as programmed AM depth is changed, either the AM DAC or its control is at fault. The AM DAC (A2A4U301) is an 8-bit DAC and is set to twice the programmed AM depth, e.g., 180 for 90% AM.

If the UUT passes this test, then the ALC loop control voltage is correct, and the problem is in the ALC loop. A likely cause of excessive AM depth error and harmonic distortion is detector non-linearity. The following test checks detector linearity.

4D-48. Detector Linearity

PROCEDURE

1. Install the plate covers and let the UUT warm up at room temperature for one hour.
2. Program the UUT for 350 MHz, 12 dBm, modulation OFF.
3. Program [SPCL][8][1] and [SPCL][9][1] to disable level correction and enable amplitude fixed range.
4. Measure power with a power meter at the UUT RF OUTPUT. Note the reading.
5. Program the UUT for 2 dBm using the EDIT keys. The measured power should be 10 dB \pm 0.2 dB below the reading noted in step 4.
6. Program the UUT for -8 dBm using the EDIT keys. The measured power should be 20 dB \pm 0.4 dB below the noted reading.
7. Program the UUT for [SPCL][0][0].

If the UUT fails this test, the problem is likely to be in the detector or detector-linearizer circuit. If the UUT passes the test, the problem is constrained to the other ALC loop elements, and is likely to be a bandwidth problem associated with the loop amplifier or the modulator or modulator-linearizer circuit.

4D-49. RPP Control

When servicing the A2A5A2 Attenuator/RPP Control PCB, use the three dual-pin test points to aid in the troubleshooting of the assembly. The RPP can be tripped (to the protect position) by momentarily shorting the two points of TP1. It can be reset by

MAINTENANCE
TROUBLESHOOTING AND REPAIR

momentarily shorting TP2. Shorting TP3 reduces the level required to trip the Attenuator/ RPP, so it trips on the Generator's own output. This provides a convenient way to verify the operation of the entire trip circuitry, although at a reduced trip level.

To check the trip function with TP3 shorted, it is best to program the Generator to an output level of +10 dBm; then, program it for fixed amplitude range ([SPCL][9][1]). This allows the level to be varied from a low value up to the maximum value without any transients that might otherwise trip the RPP. Then, starting at a low level, such as -10 dBm (with the RPP reset), increase (EDIT) the UUT level in 1 dB steps until the RPP trips. RPP trip normally occurs between +10 and +15 dBm.

Section 5

List of Replaceable Parts

TABLE OF CONTENTS

ASSEMBLY NAME	TABLE		FIGURE	
	NO.	PAGE	NO.	PAGE
6060B Final Assembly	5-1.	5-4	5-1.	5-5
A1 Front Section	5-2.	5-6	5-2.	5-6
A2 Module Section	5-3.	5-7	5-3.	5-7
A3 Rear Section	5-4.	5-8	5-4.	5-9
A1A1 Display PCA	5-5.	5-10	5-5.	5-11
A2A1 Synthesizer PCA	5-6.	5-12	5-6.	5-16
A2A2 VCO PCA	5-7.	5-17	5-7.	5-18
A2A4 Output PCA	5-8.	5-19	5-8.	5-22
A2A5 Attenuator/RPP Assembly	5-9.	5-23	-	-
A2A5A4 Attenuator/RPP PCA	5-10.	5-24	5-9.	5-24
A2A5A5 Relay Driver/RPP PCA	5-11.	5-25	5-10.	5-25
A2A7 Controller PCA	5-12.	5-26	5-11.	5-27
A2A8 Non Volatile Memory PCA	5-13.	5-28	5-12.	5-28
A3A1 Power Supply PCA	5-14.	5-29	5-13.	5-30

LIST OF REPLACEABLE PARTS

5-1. INTRODUCTION

This section contains an illustrated parts breakdown of the instrument. A similar parts list is included in the Options Section for each of the options. Components are listed alphanumerically by assembly. Both electrical and mechanical components are listed by reference designation. Each listed part is shown in an accompanying illustration.

5-2. Parts List Information

Parts lists include the following information:

1. Reference Designation
2. Description of Each Part
3. FLUKE Stock Number
4. Federal Supply Code for Manufacturers
5. Manufacturer's Part Number
6. Total Quantity of Components Per Assembly
7. Recommended quantity: This entry indicates the recommended number of spare parts necessary to support one to five instruments for a period of 2 years. This list presumes an availability of common electronic parts at the maintenance site. For maintenance for 1 year or more at an isolated site, it is recommended that at least one of each assembly in the instrument be stocked. In the case of optional subassemblies, plug-ins, etc., that are not always part of the instrument or are deviations from the basic instrument model, the REC QTY column lists the recommended spares quantity for the items in that particular assembly.

5-3. HOW TO OBTAIN PARTS

Components may be ordered directly from the manufacturer's part number, or from the John Fluke Mfg. Co., Inc. or an authorized representative by using the FLUKE STOCK NUMBER. In the event the part ordered has been replaced by a new or improved part, the replacement will be accompanied by an explanatory note and installation instructions if necessary.

To ensure prompt and efficient handling of your order, include the following information:

1. Quantity
2. FLUKE Stock Number
3. Description
4. Reference Designation
5. Printed Circuit Board Part Number and Revision Letter
6. Instrument Model and Serial number

5-4. Recommended Spare Parts Kit

A Recommended Spare Parts Kit for your basic instrument is available from the factory. This kit contains those items listed in the REC QTY column for the parts lists in the quantities recommended.

Parts price information is available from the John Fluke Mfg. Co., Inc., or its representative. Prices are also available in a Fluke Replacement Parts Catalog, which is available upon request.

CAUTION

*

Indicated devices are subject to damage by static

LIST OF REPLACEABLE PARTS

TABLE 5-1. 6060B FINAL ASSEMBLY
(SEE FIGURE 5-1.)

REFERENCE DESIGNATOR A->NUMERICS-->	DESCRIPTION	FLUXE STOCK --NO--	MFRS SPLY CODE	MANUFACTURERS PART NUMBER --OR GENERIC TYPE--	TOT QTY	R S -Q	N O T -E
A1	FRONT SECTION						
A2	MODULE SECTION						
A3	REAR SECTION						
H 1	SCREW, MACH, FHUP, S, STL, 6-32X1/4	320093	89536	320093	20		
H 2	SCREW, MACH, PHP SENS, STL, 6-32X1/2	177030	89536	177030	4		
H 3	SCREW, MACH, PHP, STL, 10-32X1/4	218941	89536	218941	11		
H 4	SCREW, MACH, PHP, S, STL, 6-32X3/8	334450	89536	334450	67		
H 5	SCREW, MACH, PHP, STL, 6-32X1/8	152140	89536	152140	3		
H 6	WASHER, FLAT, S STEEL, #6, 0.014 THK	260471	84920	5710-23-16	3		
H 7	SCREW, MACH, PHP, MAC S-STL, 6-32X9/32	772236	89536	772236	1		
H 8	WASHER, FLAT, STEEL, #6, 0.031 THK	110270	89536	110270	1		
H 9	SCREW, MACH, PHP SENS, STL, 8-32X3/8	436030	89536	436030	4		
H 10	SCREW, MACH, PHP SENS, STL, 6-32X1/4	178533	89536	178533	6		
H 11	SCREW, MACH, PHP SENS, STL, 4-40X1/4	185918	89536	185918	2		
H 12	SCREW, MACH, FHP, STL, 8-32X3/8	114116	89536	114116	20		
MP 1	TOP COVER	704866	89536	704866	1		
MP 2	BOTTOM COVER	704874	89536	704874	1		
MP 3	FOOT, SINGLE BAIL TYPE (DARK UMBER)	653923	89536	653923	4		
MP 4	NAMEPLATE, SERIAL -REAR PANEL-	472795	89536	472795	1		
MP 5	DECAL, FRONT CORNER	659227	89536	659227	2		
MP 6	SIDE TRIM 10"	525998	89536	525998	2		
MP 7	DECAL, REAR CORNER	685214	89536	685214	2		
MP 8	COVER PLATE BLANK, IEEE	731265	89536	731265	1		
MP 9	COVER, OUTPUT, PLATED	731430	89536	731430	1		
MP 10	COVER, SYNTHESIZER, PLATED	792671	89536	792671	1		
MP 11	COVER, CAL-FROM	774570	89536	774570	1		
MP 12	GASKET, SHIELDING, MONEL MESH	520320	89536	520320	5		
MP 13	DECAL, OPERATION	774620	89536	774620	1		
MP 14	SHIPPING BOX	752758	89536	752758	1		
MP 15	SHIPPING END CAPS	752766	89536	752766	2		
MP 16	CONN ACC, COAX, BNC, CAP (DUST CAP)	478982	89536	478982	1		
MP 17	CHASSIS SIDE	657627	89536	657627	2		
MP 18	CABLE TIE, ANCHOR, ADHSV, 0.122" TIE	407908	89536	407908	2		
MP 19	CABLE CLAMP	103796	95990	5/16-3NA	1		
MP 20	CABLE TIE, 4"L, 0.100" W, 0.75 DIA	172080	89536	172080	8		
MP 21	BRACKET, POWER SWITCH	774489	89536	774489	1		
MP 22	PUSHBUTTON, LG RECT. GREEN CL REPL	420893	89536	420893	1		
P 1	PLUG/JACK	101774	89536	101774	2		
TM 1	6060B INSTRUCTION MANUAL	792697	89536	792697	1		
TM 2	6060B GETTING STARTED MANUAL	794834	89536	794834	1		
U 23, 24	* IC, 2K X 8 EPROM	454403	01295	THS2516JL	2		
W 1	CABLE ASSEMBLY, SEMI-RIGID W 1	731380	89536	731380	1		
W 2	CORD, LINE, 5-15/IEC, 3-10AWG, SVT	284174	89536	284174	1		
W 3	CABLE ASSEMBLY, CONTROLLER-POWER	738534	89536	738534	1		

1 UNPROGRAMMED PART

LIST OF REPLACEABLE PARTS

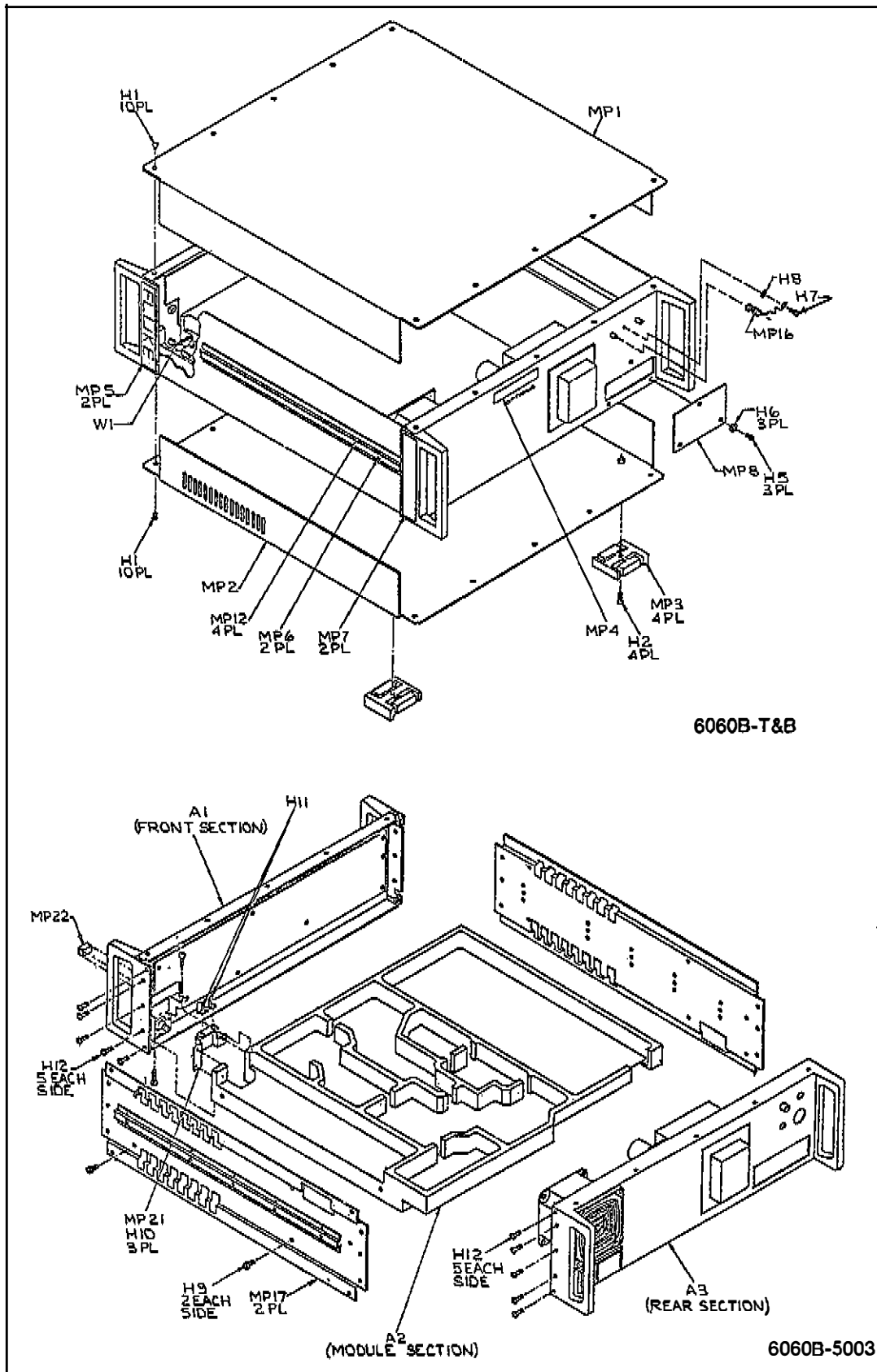
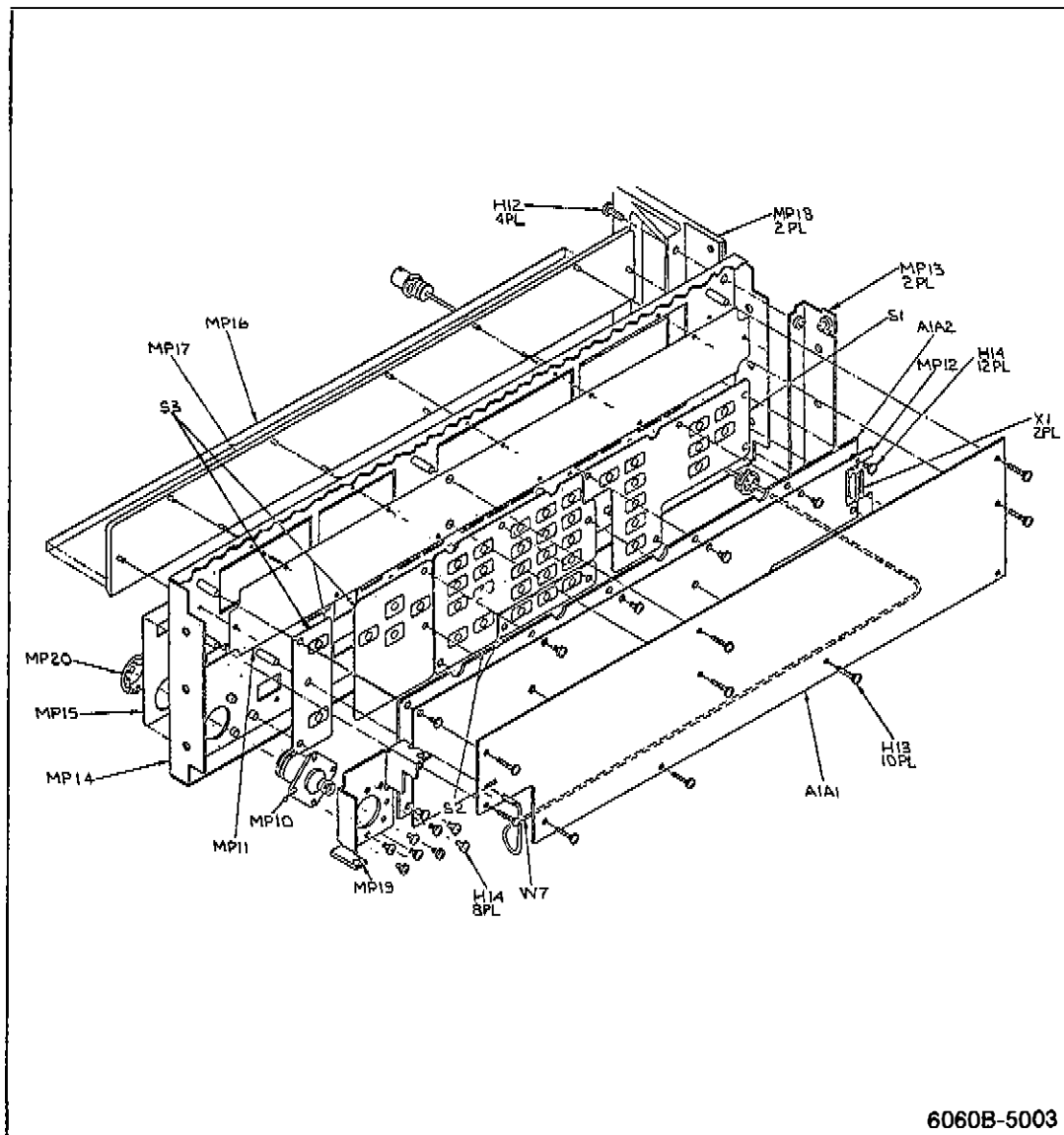

Figure 5-1. 6060B Final Assembly

LIST OF REPLACEABLE PARTS

TABLE 5-2. A1 FRONT SECTION
(SEE FIGURE 5-2.)

REFERENCE DESIGNATOR A-(NUMERIC) S	DESCRIPTION	FLUKE STOCK NO	MFRS SPLY CODE	MANUFACTURERS PART NUMBER OR GENERIC TYPE	TOT QTY	R S T	M O T
A 1	• DISPLAY PCA	738609	89536	738609	1		
A 2	SWITCH PWB	738591	89536	738591	1		
C 2	CAP,CER,270PF,+5%,100V,COG	614586	89536	614586	1		
E 1	TERM,RING,3/8 & 7/64,SOLDR	441972	79963	761	1		
H 12	SCREW,CAP,SECT,STL,8-32X3/8	295105	89536	295105	4		
H 13	SCREW,MACH,PHP SEMS,STL,4-40X1/2	353060	89536	353060	10		
H 14	SCREW,MACH,PHP SEMS,STL,4-40X3/16	732750	89536	732750	20		
HP 10	ADAPTOR,COAX,SMACH),N(H)	516963	89536	516963	1		
MP 11	SHIELD, DISPLAY	731257	89536	731257	1		
MP 12	SHIELD, SWITCH RF	716852	89536	716852	1		
MP 13	CORNER BRACKET	657601	89536	657601	2		
MP 14	FRONT PANEL SM	657593	89536	657593	1		
MP 15	DECAL, FRONT PANEL	774042	89536	774042	1		
MP 16	DECAL, LENS, 10KHZ	774604	89536	774604	1		
MP 17	LENS DISPLAY	657710	89536	657710	1		
MP 18	CORNER HANDLE, FRONT 5.25 INCH	656173	89536	656173	2		
MP 19	BRACKET, RF OUTPUT, PLATED	774471	89536	774471	1		
MP 20	BUSHING INSULATION R.F. OUTPUT	537803	89536	537803	1		
MP 21	SLEEV,POLYOL,SHRINK,.093-.046ID,BLACK	149443	89536	149443	1		
S 1	SWITCH, LEFT CONDUCTIVE ELASTOMERIC	698597	89536	698597	1		
S 2	SWITCH,CENTER CONDUCTIVE ELASTOMERIC	731349	89536	731349	1		
S 3	SWITCH,RIGHT CONDUCTIVE ELASTOMERIC	731356	89536	731356	1		
U 7	CABLE ASSY MOD INPUT FRONT	738506	89536	738500	1		
X 1	SOCKET,1 ROW,PWB,0.100CTR,7 POS	520809	30035	SS-109-1-07	2		



6060B-5003

Figure 5-2. A1 Front Section

LIST OF REPLACEABLE PARTS

TABLE 3-4. A3 REAR SECTION
(SEE FIGURE 3-4.)

REFERENCE DESIGNATOR A-1 NUMERIC(S)-->	S	DESCRIPTION	FLUKE STOCK --NO--	MFRS SPLY CODE	MANUFACTURERS PART NUMBER --OR GENERIC TYPE--	TOT QTY	R S	N T E
A	1	* POWER SUPPLY PCA	744052	89536	744052	1		
B	1	FAN, 12VDC, 34CFM, 3.15" SQ	706598	89536	706598	1		
E	1	TERM. RING #6, 3/32 - 2 PLACES, SOLDR	132399	70189	2104-06-00	1	5	
F	1	FUSE, 1/4 X 1-1/4, FAST, 1.5A, 250V	109320	71400	AGC1-1/2	1		
H	15	NUT, ELAST. STOP, HEX, STL, 8-32	306308	89536	306308	4		
H	16	SCREW, CAP, SCKT, STL, 8-32X3/8	295105	89536	295105	4		
H	17	WASHER, SHLDR, NYLON, #3	485417	89536	485417	4		
H	18	NUT, LOCK, S, STL, 4-40	558866	89536	558866	4		
H	19	SCREW, MACH, PHP SEMS, STL, 6-32X5/8	272591	89536	272591	4		
H	20	SCREW, MACH, STL, PHP, 8-32X2-1/2	772376	89536	772376	4		
H	21	WASHER, FLAT, S STEEL, #8, 0.032 THK	176743	86928	5710-31-32	0		
H	22	WASHER, FLAT, FIBER, #8, 0.063 THK	110753	73734	1472	4		
H	23	SCREW, MACH, FHUP, S, STL, 6-32X1/4	320093	89536	320093	1	1	
H	24	SCREW, MACH, PHP SEMS, STL, 4-32X1/4	178533	89536	178533	3		
H	25	WASHER, SPRING, STL, 0.130X0.281X0.020	571968	89536	571968	2		
H	26	WASHER, SHLDR, FIBER, #6	110387	86928	5604-47	2		
H	27	NUT, ELAST. STOP, HEX, STL, 6-32	110841	89536	110841	8		
H	28	WASHER, LOCK, INTRNL, STEEL, 0.267 ID	110817	89536	110817	3		
H	29	WASHER, FLAT, ALUM, 0.125 ID, 0.062 THK	381749	89536	381749	4		
HP	22	PANEL, REAR	774638	89536	774638	1		
HP	23	CORNER BRACKET	657601	89536	657601	2		
HP	24	CORNER HANDLE, FRONT 5.25 INCH	656173	89536	656173	2		
HP	25	SHOCK MOUNT, P, S, 7116	732941	89536	732941	3		
HP	26	PLUG, BUTTON	740231	89536	740231	2		
HP	27	BUSHING COVER RF OUTPUT	538256	89536	538256	1		
HP	28	INSUL PART, TRANS, SILICONE, POWER	534453	89536	534453	4		
HP	29	INSUL PART, TRANS, SILICONE, TO-3	473165	55285	7403-08-FR-05	1	1	
HP	30	SLEEV, POLYOL, SHRINK, .187-.093ID, BLACK	113852	89536	113852	1		
HP	31	TRANSFORMER COVER, PAINTED	731307	89536	731307	1		
HP	32	CABLE TIE, 4"L, 0.100"W, 0.75 DIA	172080	89536	172080	2		
HP	33	CABLE, ETHYL CELLULOSE, TYPE 1/2-4R	100974	89536	100974	2		
HP	34	CABLE TIE, ANCHOR, ADHSV, 0.122" TIE	407908	89536	407908	2		
HP	35	FAN SKIRT	792721	89536	792721	1		
HP	36	RETAINER, AUX PWR SUPPLY CONN	748640	89536	748640	1		
HP	37	HEAT DIS, TRANSISTOR, SNGL TO3, ALUM	740738	89536	740738	1		
T	1	TRANSFORMER, POWER	717959	89536	717959	1		
U	1	* IC, VOLT REG, FIXED, +15 VOLTS, 1.5 AMPS	413187	04713	MC7815CT	1	1	2
U	1	* IC, VOLT REG, FIXED, +5 VOLTS, 3 AMP, TO-3	453944	12040	LH223K	1		
U	2	* IC, VOLT REG, FIXED, -15 VOLTS, 1.5 AMPS	413179	04713	MC7915CP	1	1	2
U	4	* IC, VOLT REG, ADJ, 1.2 TO 37 V, 1.5 AMPS	460410	12040	LH317T	1		
U	5	* IC, VOLT REG, FIXED 15VOLTS, 1.5A	772830	89536	772830	1		2
W	2	CABLE ASSY, RF, REF IN/OUT	748681	89536	748681	1		
W	15	CABLE, LINE FILTER	774588	89536	774588	1		
W	18	CABLE ASSY AUX TRANSFORMER	748798	89536	748798	1		

1 REFERRED TO THROUGHOUT MANUAL AS A3U1
2 PART OF A3A1

LIST OF REPLACEABLE PARTS

TABLE 5-3. A2 MODULE SECTION
(SEE FIGURE 5-3.)

REFERENCE DESIGNATOR	DESCRIPTION	FLUKE STOCK NO	MFRS SPLY CODE	MANUFACTURERS PART NUMBER OR GENERIC TYPE	TOT QTY	R S T	N O T
A 1	SYNTHESIZER PCA	792812	89536	792812	1		
A 2	MAIN VCO PCA	748780	89536	748780	1	1	
A 4	OUTPUT PCA	774521	89536	774521	1	1	
A 5	ATTENUATOR/RFP ASSEMBLY	752667	89536	752667	1		1
A 7	CONTROLLER PCA	792655	89536	792655	1		
A 8	NON-VOLATILE (STORE/RECALL)MEMORY PCA	744094	89536	744094	1		
BT 1	BATTERY, LITHIUM, 3.7V, 0.85AH	458474	89536	458474	1		
C 1	CAP. CER. 1000PF, +-5%, 50V, COG	520539	51406	RPE113	1		
H 3	SCREW, MACH, PHP, S. STL, 6-32X9/32	541122	89536	541122	5		
H 6	SCREW, MACH, PHP SEMS, STL, 6-32X1/4	178533	89536	178533	3		
H 7	WASHER, FLAT, STEEL, #6, 0.031 THK	110270	89536	110270	4		
H 8	SCREW, MACH, PHP, MAG S-STL, 6-32X9/32	772236	89536	772236	93		
H 9	SCREW, MACH, PHP, STL, 10-32X1/4	218941	89536	218941	3		
H 10	NUT, CAP. EXT. LOCK, STL, 10-32	559237	89536	559237	1		
H 11	SCREW, MACH, PHP SEMS, STL, 6-32X5/16	530287	89536	530287	4		
MP 7	AIDE, PCB FULL	541730	89536	541730	14		
MP 8	AIDE, PCB FULL	541730	89536	541730	2		
MP 9	COMPONENT HOLDER	422865	98159	2829-75-2	1		
MP 10	GASKET, SHIELDING, MONEL MESH, CIRCULAR	720664	89536	720664	11		
MP 11	CABLE TIE, ANCHOR, ADHSV, 0.122" TIE	407908	89536	407908	1		
MP 12	CABLE TIE, 4"L, 0.100"W, 0.75 DIA	172080	89536	172080	1		
W 4	CABLE ASSY, MOD INPUT, MODULE	738542	89536	738542	1		
W 10	CABLE ASSEMBLY, SYNTHESIZER-POWER	738524	89536	738524	1		

1 ASSEMBLY INCLUDES ASSOCIATED CALIBRATED EPROM

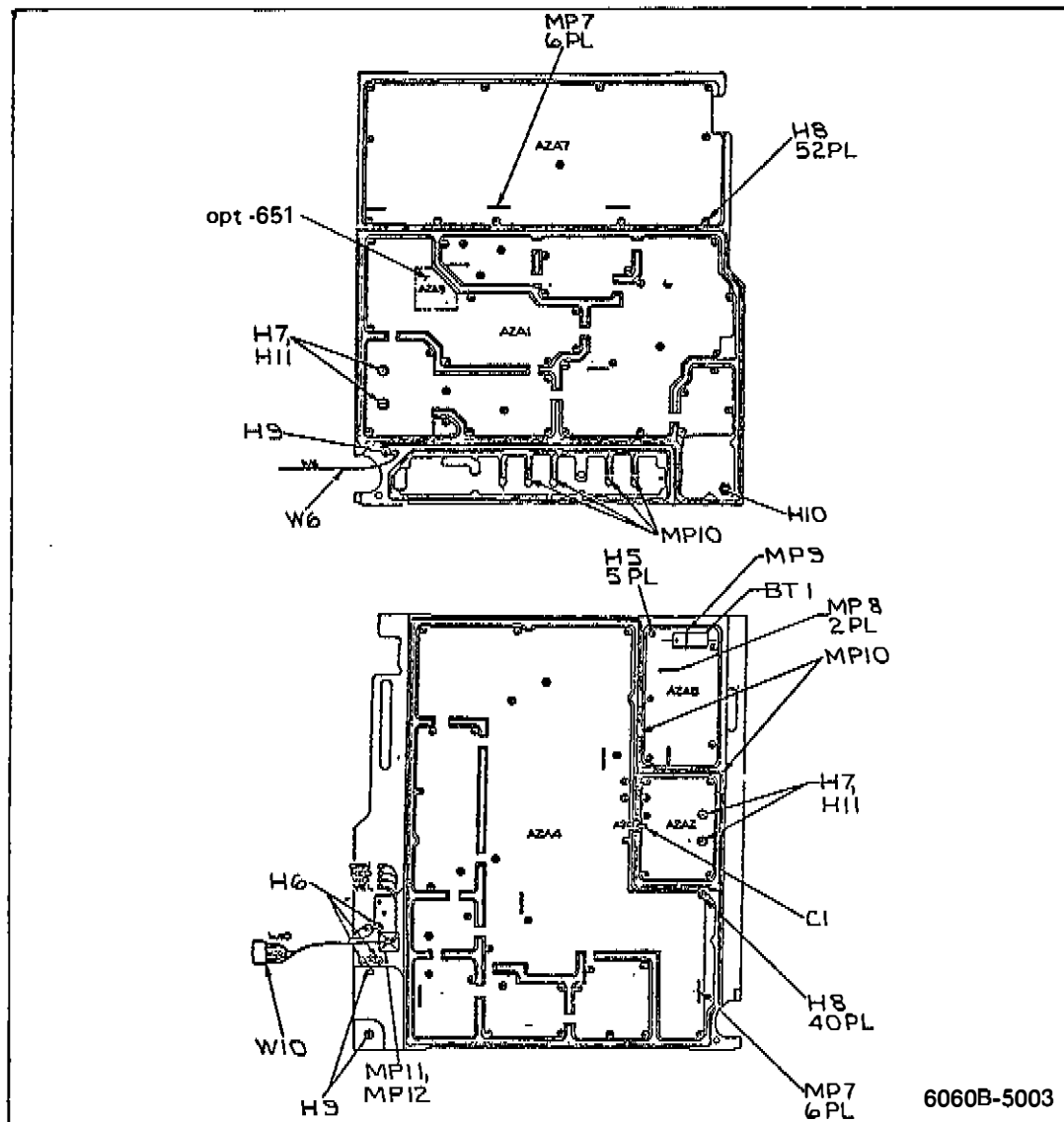
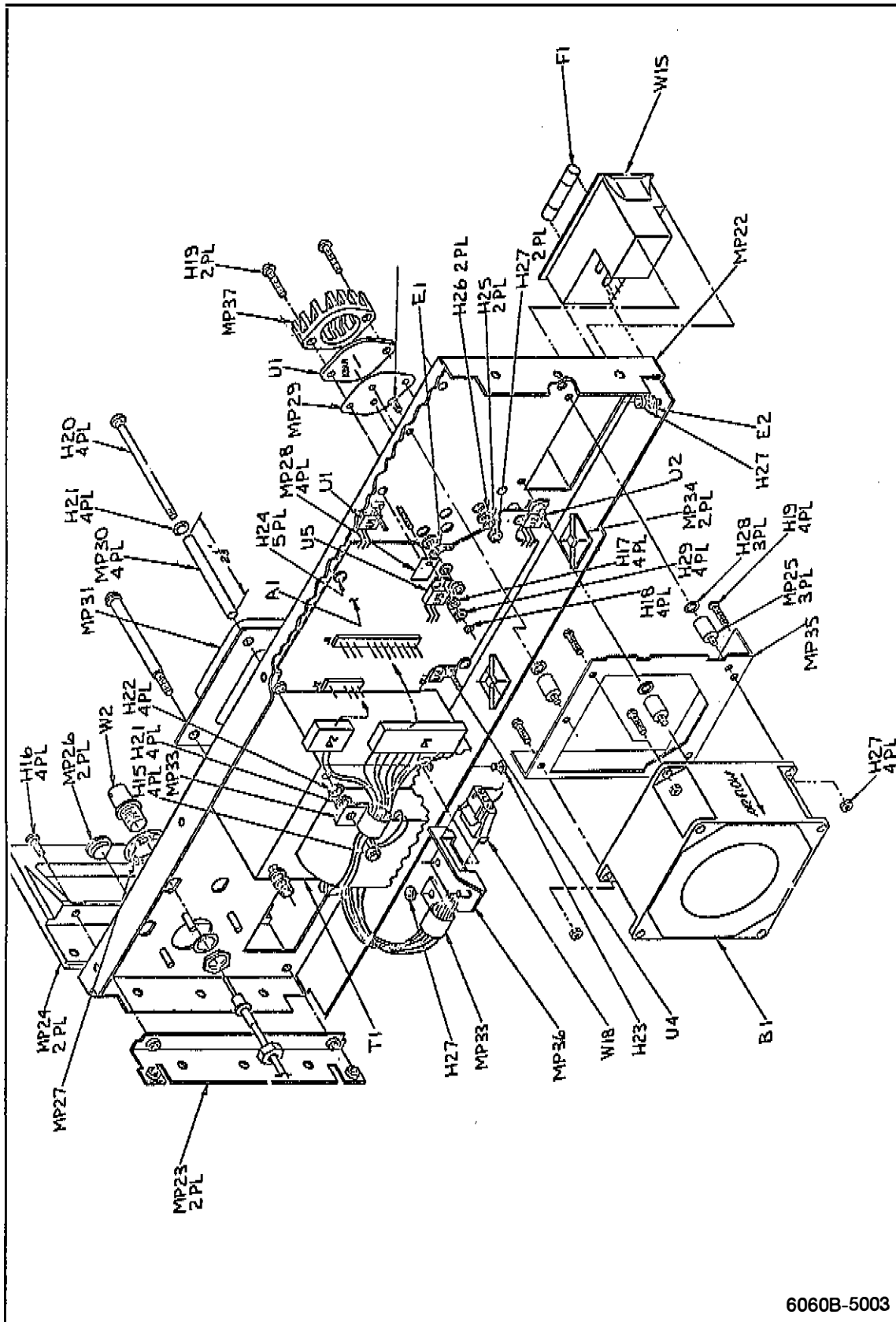

Figure 5-3. A2 Module Section



6060B-5003

Figure 5-4. A3 Rear Section

LIST OF REPLACEABLE PARTS

TABLE 5-5. A1A1 DISPLAY PCA
(SEE FIGURE 5-5.)

REFERENCE DESIGNATOR A->NUMERICS-->	S	DESCRIPTION	FLUKE STOCK --NO--	MFRS SPLY CODE-	MANUFACTURERS PART NUMBER --OR GENERIC TYPE--	TOT QTY	R S T -R -E
C 1		CAP, YA, 4.7UF, +-20%, 50V	363721	56289	196D475X9015HA1	1	
C 2, 27, 28,		CAP, TA, 10UF, +-20%, 10V	176214	56289	196D106X0010KA1	4	
C 30			176214				
C 3- 10		CAP, POLYES, 0.1UF, +-10%, 50V	696484	89536	696484	16	
C 23, 24		CAP, TA, 10UF, +-20%, 20V	330662	56289	196D106X0020KA1	2	
C 25, 26		CAP, TA, 39UF, +-20%, 6V	163915	56289	196D394X0020KA1	2	
C 29		CAP, CER, 0.001UF, +-20%, 100V, X7R	402966	72982	8121-A100-W5R-102M	1	
DS 1		DISPLAY VACUUM FLUORESCENT FREQUENCY	698456	89536	698456	1	
DS 2		DISPLAY VACUUM FLUORESCENT AMPLITUDE	698464	89536	698464	1	1
J 101		CONN, POST, PWB, .025SQ, NON-INSUL, SELECT	267500	80779	87022-1	14	
J 103		CONN, PWB, PIN, CRIMP, 0.058 DIA	233411	80779	68599-3	2	
R 1, 2		RES, CF, 100K, +-5%, 0.25W	348920	80031	CR251-4-5P100K	2	
R 3		RES, CF, 620, +-5%, 0.25W	442319	80031	CR251-4-5P620E	1	
R 4		RES, MF, 9.09K, +-1%, 0.125W, 100PPM	221663	91637	CHF559091F	1	
R 5		RES, MF, 31.6K, +-1%, 0.125W, 100PPM	261610	91637	CHF553162F	1	
R 6		RES, MF, 8.06K, +-1%, 0.125W, 100PPM	294942	91637	CHF558061F	1	
R 7		RES, MF, 2K, +-1%, 0.125W, 100PPM	233226	91637	CHF552001F	1	
R 8		RES, MF, 48.7K, +-1%, 0.125W, 100PPM	267385	89536	267385	1	
R 9, 10		RES, CF, 30K, +-5%, 0.25W	368753	80031	CR251-4-5P30K	2	
R 11- 14		RES, CC, 10K, +-10%, 0.125W	246975	01121	BR1031	4	
R 15		RES, CC, 560, +-10%, 0.125W	115303	89536	115303	1	
R 16		RES, VAR, CERM, 5K, +-10%, 0.5W	288282	75378	360T052A2	1	
TF 1		CONN, TAB, FASTON, PRESS-IN, 0.110 WIDE	512889	02660	62395	1	
U 1- 5		* IC, LSTTL, OCTAL D F/F, +EDG TRG, W/CLEAR	454892	01295	SN74LS273N	5	1
U 6- 10		* IC, BIPLR, 8CHNL FLOURESCNT DISPLY DRVR	535799	56289	UDN6118A	5	
U 11, 17		* IC, LSTTL, RETRC MONOSTAB MULTIVR W/CLR	404186	01295	SN74LS123N	2	1
U 12		* IC, LSTTL, DUAL 4 INPUT AND GATE	408708	01295	SN74LS21N	1	1
U 13, 15		* IC, TTL, HEX INVERTER W/OPEN COLLECTOR	288605	01295	SN7416N	2	1
U 14		* IC, LSTTL, HEX BUFFER W/NOR ENABLE	483800	01295	SN74LS367N	1	1
U 16		* IC, COMPARATOR, DUAL, LO-PWR, 8 PIN DIP	478354	12040	LH393N	1	1
U 18		* IC, 1.22V, 25 PPM T.C., BANDGAP REF	634154	32293	ITS6935-2	1	1
W 8		CABLE ASSEMBLY, CONTROLLER-DISPLAY	738476	89536	738476	1	
XU 1- 5		SOCKET, DIP, 0.100 CTR, 20 PIN	454421	09922	DILB20P-108	5	
XU 6- 10		SOCKET, DIP, 0.100 CTR, 18 PIN	418228	91506	318-AG39D	5	
XU 11, 14, 17		SOCKET, DIP, 0.100 CTR, 16 PIN	276535	91506	316-AG39D	3	
XU 12, 13, 15		SOCKET, DIP, 0.100 CTR, 14 PIN	276527	09922	DILB14P-108	3	
XU 16		SOCKET, DIP, 0.100 CTR, 8 PIN	478016	91506	308-AG39D	1	
Z 1		RES, NET, SIP, 10 PIN, 9 RES, 100K, +-2%	461038	80031	95081002CL	1	
Z 2		RES, NET, SIP, 10 PIN, 9 RES, 10K, +-2%	414003	80031	95081002CL	1	

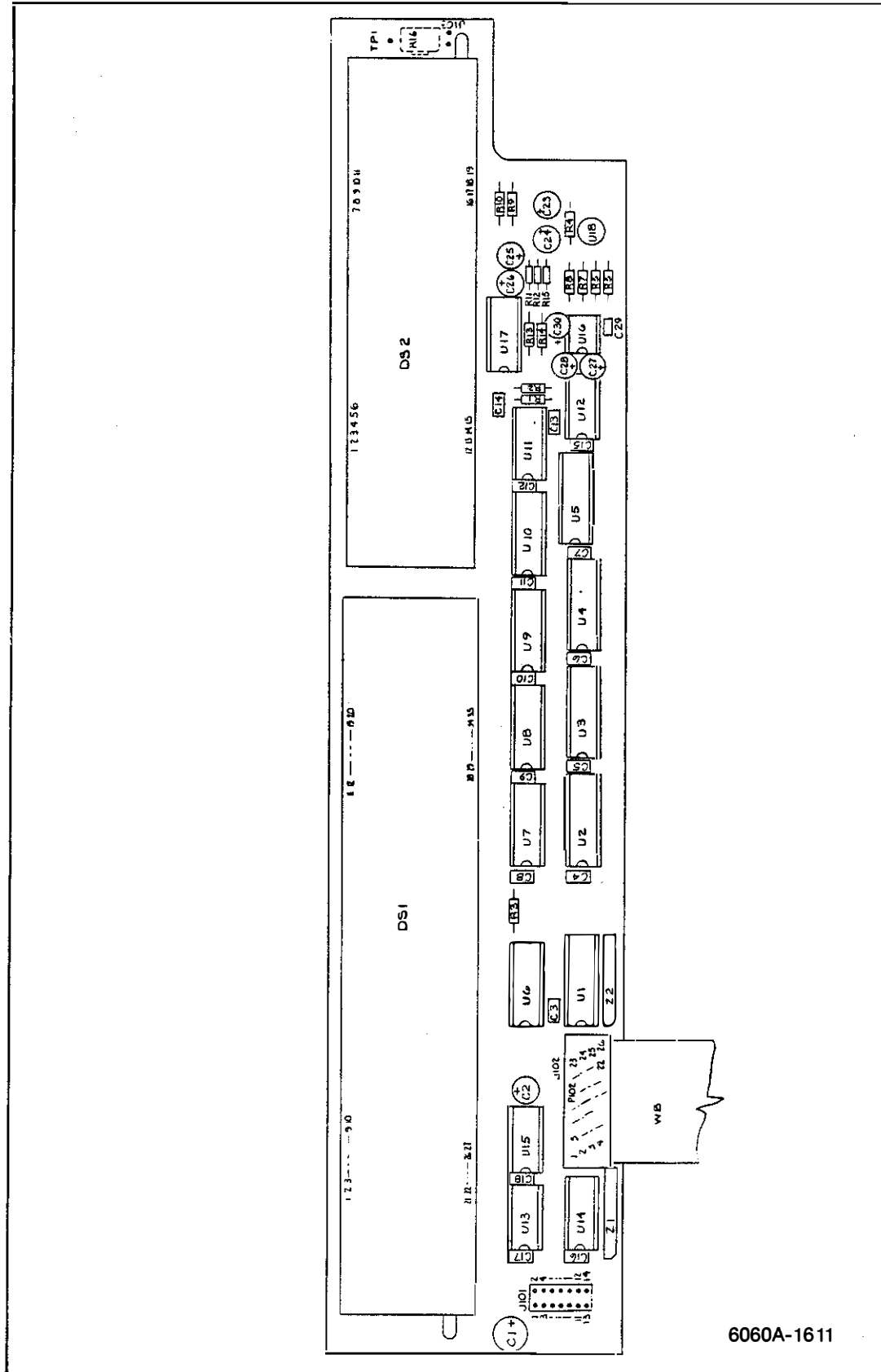

Figure 5-5. A1A1 Display PCA

6060A-1611

LIST OF REPLACEABLE PARTS

TABLE 5-6. A2A1 SYNTHESIZER PCA
(SEE FIGURE 5-6.)

REFERENCE DESIGNATOR A->NUMERICS-->	S	DESCRIPTION	FLUKE STOCK --NO--	MFRS SPLY CODE	MANUFACTURERS PART NUMBER --OR GENERIC TYPE--	TOT QTY	R S	D T	N E
C 1, 2		CAP, CER, 2.7PF, +-0.25PF, 100V, COJ	363705	89536	363705	2			
C 3, 4, 62,		CAP, CER, 0.001UF, +-20%, 100V, X7R	402966	72982	8121-A100-W5R-102M	16			
C 98, 100, 181,			402966						
C 182, 185, 186,			402966						
C 189, 190, 193,			402966						
C 196, 198, 199,			402966						
C 215			402966						
C 5, 7, 10-		CAP, CER, 470PF, +-20%, 100V, X7R	358275	72982	8111-A100-W5R-471M	17			
C 13, 20, 39,			358275						
C 40, 43, 52,			358275						
C 53, 205, 231-			358275						
C 234			358275						
C 8		CAP, CER, 6, 8PF, +-0.25PF, 100V, COH	512327	89536	512327	1			
C 9, 15, 18,		CAP, CER, 100PF, +-2%, 100V, COG	512848	51406	RPE121	11			
C 26, 28, 64,			512848						
C 89, 137, 139,			512848						
C 146, 152			512848						
C 14, 27, 30,		CAP, POLYES, 0.1UF, +-20%, 50V	732883	89536	732883	73			
C 31, 36, 37,			732883						
C 49, 55, 59-			732883						
C 61, 63, 65,			732883						
C 69, 70, 72-			732883						
C 74, 76- 81,			732883						
C 83, 84, 87,			732883						
C 88, 101-106,			732883						
C 108, 110, 112,			732883						
C 120, 122, 132,			732883						
C 133, 135, 138,			732883						
C 140-145, 151,			732883						
C 152, 157, 158,			732883						
C 164, 165, 168,			732883						
C 169, 174, 175,			732883						
C 180, 184, 188,			732883						
C 191, 192, 194,			732883						
C 195, 200, 244-			732883						
C 246, 250, 251,			732883						
C 253			732883						
C 16, 17, 247		CAP, CER, 12PF, +-2%, 100V, COG	376871	89536	376871	3			
C 19		CAP, CER, 4.7PF, +-0.25PF, 100V, COH	362772	89536	362772	1			
C 24		CAP, POLYST, 330PF, +-1%, 63V	528364	12954	831063/330/1/63	1			
C 25		CAP, CER, 10PF, +-5%, 50V, COG	494781	89536	494781	1			
C 29, 38, 202		CAP, CER, 47PF, +-2%, 100V, COG	512368	89536	512368	3			
C 32		CAP, POLYST, 470PF, +-1%, 63V	528356	12954	831063/470/1/63	1			
C 33		CAP, POLYST, 100PF, +-1%, 63V	528372	12954	831063/100/1/63	1			
C 35		CAP, POLYST, 1000PF, +-1%, 63V	528380	12954	831063/1000/1/63	1			
C 41, 42		CAP, POLYES, 0.047UF, +-10%, 50V	714709	89536	714709	2			
C 48		CAP, POLYES, 0.015UF, +-10%, 50V	714691	89536	714691	1			
C 50, 207		CAP, POLYES, 0.082UF, +-10%, 50V	714717	89536	714717	2			
C 51		CAP, POLYES, 0.1UF, +-10%, 50V	696484	89536	696484	1			
C 54, 71, 91,		CAP, TA, 10UF, +-20%, 10V	176214	56289	196D106X0010KA1	5			
C 127, 166			176214						
C 58, 82, 107,		CAP, TA, 39UF, +-20%, 6V	163915	56289	196D394X0020KA1	4			
C 150			163915						
C 75, 85, 86,		CAP, CER, 22PF, +-2%, 100V, COG	512871	89536	512871	6			
C 95, 242, 243			512871						
C 92- 94, 128		CAP, TA, 10UF, +-20%, 35V	417683	56289	196D106X0035KA1	4			
C 99		CAP, POLYST, 0.0075UF, 2%, 100V	484121	89536	484121	1			
C 109, 111		CAP, TA, 15UF, +-20%, 20V	519686	56289	196D156X0020KE4	2			
C 113, 114		CAP, POLYES, 0.22UF, +-10%, 50V	696492	89536	696492	2			
C 115		CAP, POLYPR, 0.0786UF, +-1%, 50V	422998	89536	422998	1			
C 116, 117		CAP, TA, 3.3UF, +-20%, 20V	436071	01884	196D335X0020KA1	2			
C 118, 183, 187		CAP, POLYES, 0.47UF, +-10%, 50V	714725	89536	714725	3			
C 119, 121		CAP, CER, 1000PF, +-5%, 50V, COG	528539	51406	RPE113	2			
C 123		CAP, POLYST, 0.022UF, +-5%, 100V	484147	89536	484147	1			
C 124		CAP, POLYST, 0.056UF, +-5%, 100V	284877	89536	284877	1			
C 125		CAP, POLYST, 0.027UF, +-5%, 100V	484154	89536	484154	1			
C 126		CAP, POLYST, 0.0015UF, +-2%, 100V	484113	89536	484113	1			
C 129, 130		CAP, TA, 82UF, +-20%, 20V	357392	12954	DB2G.12D20H	2			
C 131		CAP, POLYCA, 5UF, +-10%, 50V	313254	84411	X463UM5.0UF-10P-50	1			
C 134		CAP, TA, 15UF, +-20%, 6V	161935	56289	196D156X0006-KA1	1			
C 136		CAP, TA, 2.2UF, +-10%, 15V	364216	56289	196D225X0015HA1	1			
C 153, 154, 160,		CAP, CER, 4700PF, +-20%, 100V, X7R	362871	72982	8121-A100-W5R-472M	4			
C 254			362871						
C 155, 156, 159,		CAP, TA, 10UF, +-20%, 20V	330662	56289	196D106X0020KA1	7			
C 161, 162, 167,			330662						
C 248			330662						
C 163		CAP, POLYES, 0.022UF, +-10%, 50V	715268	89536	715268	1			
C 170		CAP, CER, 27PF, +-2%, 100V, COG	362749	51406	RPE121	1			
C 171		CAP, CER, 1800PF, +-5%, 50V, COG	528547	89536	528547	1			
C 172, 210, 211,		CAP, CER, 180PF, +-5%, 100V, COG	603506	56289	C0235501E181M	11			
C 214, 216, 218,			603506						
C 224, 225, 226,			603506						
C 228, 230			603506						
C 173, 208, 209		CAP, AL, 220UF, +-50-20%, 16V	435990	57640	SM/VB	3			
C 176		CAP, POLYES, 0.27UF, +-10%, 50V	733576	89536	733576	1			
C 177		CAP, POLYES, 0.15UF, +-10%, 50V	682955	89536	682955	1			
C 178		CAP, TA, 6.8UF, +-20%, 35V	363713	56289	196D685X0035KA1	1			
C 179		CAP, CER, 2200PF, +-20%, 100V, X7R	358291	89536	358291	1			
C 197, 219, 227		CAP, CER, 10PF, +-2%, 100V, COG	512343	89536	512343	3			
C 201		CAP, CER, 68PF, +-2%, 100V, COG	362756	89536	362756	1			
C 204		CAP, CER, 330PF, +-5%, 100V, COG	528620	51406	RPE121	1			
C 206		CAP, VAK, 0.8-10PF, 250V, AIR	229930	91293	5201	1			
C 212, 222		CAP, CER, 1000PF, +-10%, 50V, X7R	484378	89536	484378	2			
C 213, 223		CAP, CER, 6.8PF, +-0.5PF, 50, COG	479196	89536	479196	2			

LIST OF REPLACEABLE PARTS

TABLE 5-6. ARAI SYNTHESIZER PCA (CONT.)
(SEE FIGURE 5-6.)

REFERENCE DESIGNATOR	DESCRIPTION	FLUKE STOCK NO	MFRS SPLY CODE	MANUFACTURERS PART NUMBER OR GENERIC TYPE	TOT QTY	R S	N O T
A- (NUMERIC)	S					-Q	-E
C 217	CAP, CER, 4.3PF, +/-0.5PF, 50V, COG	514216	89536	514216	1		
C 220	CAP, CER, 3.9PF, +/-0.25PF, 100V, COJ	512947	89536	512947	1		
C 221	CAP, AL, 470UF, +/-20%, 16V	772855	89536	772855	1		
C 240	CAP, VAR, 1 TO 10PF, 250V, AIR	733212	89536	733212	1		
C 241	CAP, CER, 1.8PF, +/-0.25PF, 100V, COK	512897	89536	512897	1		
C 249	CAP, AL, 47UF, +/-20%, 16V	643304	89536	643304	1		
CR 5- 8, 17, 18, 20, 21	* DIODE, SI, BV= 75.0V, IO=150MA, 500 MW	203323		97910 1N4448	8	1	
CR 9, 10, 12- 15, 29	* DIODE, SI, SCHOTTKY BARRIER, SMALL SIGNAL	313247	28484	HP5082-6264	7	2	
CR 24- 28	* DIODE, SI, VARACTOR, PIV= 30V, HYPER ABRU TERM, FASTON, TAB, SOLDR, 0.110 WIDE	313247					
E 2, 7, 11, 12, 14- 16, 22- 25, 27, 31- 46, 49- 54, 56- 58		722140	89536	722140	4	1	
J 1, 3, 14, 17, 35, 55	PIN, SINGLE, PWB, 0.025 SQ	512889	62660	62395	37		
J 2, 112	* CONN, COAX, SMB(M), PWB DR PANEL	247500	00779	87022-1	12		
J 101	* SOCKET, 1 ROW, PWB, 0.100CTR, 9 POS	247500					
J 110	* SOCKET, SINGLE PWB FOR 0.034-0.037 PIN CHOKE, 6TURN	512095	16733	702033	2		
J 104, 107, 108, 1, 10, 21, 23, 29- 32, 34, 65		436774	30035	33-109-1-09	2		
L 2, 3, 71, 72	INDUCTOR, 0.10 UH, +/-10%, 400MHZ, SHLDED	732826	89536	732826	4		
L 4, 19, 20, 40- 42, 44, 56- 58	INDUCTOR, 0.60 UH, +/-10%, 221MHZ, SHLDED	320911	89536	320911	10		
L 5, 10, 63, 64	CORE, TOROID, FERRITE, .047X.130X.110	320911					
L 11	INDUCTOR, 150 UH, +/-5%, 10.5 MHZ, SHLDED	257154	24759	MR0R10	4		
L 17	INDUCTOR, 220 UH, +/-5%, 9.4 MHZ, SHLDED	257154					
L 43	INDUCTOR, 10 UH, +/-10%, 53 MHZ, SHLDED	320937	24759	MR0.60	10		
L 45	INDUCTOR, 4 TURN	320937					
L 49	* INDUCTOR ADJ 8.4MH	321102	89536	321102	4		
L 50	* INDUCTOR ADJ 11.1MH	174763	72259	WEE150	1		
L 54	INDUCTOR, 270 UH, +/-5%, 8 MHZ, SHLDED	147835	72259	WEE220	1		
L 59	* INDUCTOR, 125UH	249078	24759	MR10	1		
L 62	INDUCTOR, 470 UH, +/-5%, 6.5 MHZ, SHLDED	755314	89536	755314	1		
L 66	INDUCTOR, 0.82UH, +/-10%, 200MHZ, SHLDED	704999	89536	704999	1		
L 67, 68	CORE, TOROID, FERRITE, .079X.185X.291	705004	89536	705004	1		
L 70	INDUCTOR, 0.044UH, +/-15%, 500MHZ, SHLDED	186270	72259	WEE270	1		
L 73	INDUCTOR, 22 UH, +/-10%, 38 MHZ, SHLDED	738484	89536	738484	1		
MP 40	* COMPONENT HOLDER	147827	72259	WEE470	1		
P 101, 102, 111	* SOCKET, SINGLE, PWB FOR .042-.049 PIN	320945	89536	320945	1		
Q 2, 33, 37	* TRANSISTOR, NPN, HI-FREQ, SMALL SIGNAL	219535	25088	B62110A5030X025C	2		
Q 3	* TRANSISTOR, SI, NPN, HI-FREQ, SMALL SIGNAL	249110	72259	WEE0044	1		
Q 4, 5	* TRANSISTOR, SI, PNP, HI-SPEED SWITCH	147843	72259	WEE22	1		
Q 10- 12	* TRANSISTOR, SI, N-JFET, TO-92	422865	98159	2829-75-2	1		
Q 13, 14	* TRANSISTOR, SI, M-DMD5 FET, TO-72	544056	89536	544056	7		
Q 15, 21, 23	* TRANSISTOR, SI, NPN, SMALL SIGNAL	535013	04713	BFR91	3	1	
Q 16, 17	* TRANSISTOR, SI, NPN, SMALL SIGNAL	723379	89536	723379	1	1	
Q 18, 19	* TRANSISTOR, SI, PNP, SMALL SIGNAL	369629	07263	543576	2	1	
Q 20	* TRANSISTOR, SI, PNP, DARLINGTON	604678	17856	J2464	3	1	
Q 22	* TRANSISTOR, SI, PNP, SMALL SIGNAL	477729	18324	SD213EE	2	1	
Q 24, 27, 30	* TRANSISTOR, SI, NPN, SMALL SIGNAL	218396	04713	2N3904	3	1	
Q 28	* TRANSISTOR, SI, PNP, SMALL SIGNAL	248351	04713	MP5918	2	1	
Q 32, 35	* TRANSISTOR, SI, NPN, SMALL SIGNAL	225599	07263	2N4250	2	1	
Q 37, 40	* TRANSISTOR, SI, N-JFET, UHF/VHF USE	381798	04713	MP3A-13	1	1	
R 1	RES, CC, 120, +/-10%, 0.5W	195974	04713	2N3906	1	1	
R 2, 159, 201, 209	RES, CF, 0.51, +/-5%, 0.25W	218081	04714	MF56520	3	1	
R 3, 25, 32	RES, CC, 51, +/-5%, 0.125W	418707	04713	MF56562	1	1	
R 4	RES, CF, 430, +/-5%, 0.25W	483156	89536	483156	2	1	
R 5	RES, CC, 24, +/-5%, 0.125W	403634	12040	J310	2	1	
R 6, 56- 58, 66- 69, 124, 127, 133-139, 210, 212, 215, 216	RES, CC, 100, +/-5%, 0.125W	108696	01121	EB1211	1		
R 7, 44, 94, 154, 169, 170	RES, CF, 1K, +/-5%, 0.25W	381954	80031	CR251-4-5P0R5E	4		
R 8, 152	RES, CF, 470, +/-5%, 0.25W	381954					
R 9, 39	RES, CF, 200, +/-5%, 0.25W	266262	01121	BB5105	3		
R 10	RES, CC, 33, +/-5%, 0.125W	441568	80031	CR251-4-5P430E	1		
R 11, 74, 100	RES, CF, 1.5K, +/-5%, 0.25W	681932	89536	681932	1		
R 12, 46, 165, 167, 171, 172, 177, 211	RES, CC, 510, +/-5%, 0.125W	714469	89536	714469	21		
R 13	RES, CC, 150, +/-5%, 0.5W	714469					
R 14, 15, 198, 241	RES, CC, 30, +/-5%, 0.125W	714469					
R 20	RES, CC, 47, +/-5%, 0.125W	343426	80031	CR251-4-5P1K	6		
R 21, 22	RES, CC, 15, +/-10%, 0.125W	343426					
R 23, 24, 40	RES, CF, 56, +/-5%, 0.25W	343434	80031	CR251-4-5P470E	2		
R 24, 31, 63, 101	RES, HF, 100, +/-1%, 0.125W, 100PPH	441451	80031	CR251-4-5P200E	2		
R 27	RES, HF, 10, +/-1%, 0.125W, 100PPH	720920	89536	720920	1		
R 28	RES, HF, 10.7K, +/-1%, 0.125W, 100PPH	343418	80031	CR251-4-5P1K5	3		
R 29	RES, HF, 11.5K, +/-1%, 0.125W, 100PPH	715383	89536	715383	8		
R 30	RES, HF, 20.7K, +/-1%, 0.125W, 100PPH	715383					
R 33, 161	RES, CF, 51, +/-5%, 0.25W	186056	89536	186056	1		
R 41	RES, CF, 270, +/-5%, 0.25W	512723	01121	BB3005	4		

LIST OF REPLACEABLE PARTS

TABLE 5-6. A2A1 SYNTHESIZER PCA (CON'T.)
(SEE FIGURE 5-6.)

REFERENCE DESIGNATOR A-NUMERIC(S)	DESCRIPTION	FLUKE STOCK NO	MFRS SPLY CODE	MANUFACTURERS PART NUMBER --OR GENERIC TYPE--	TOT QTY	R S Y -Q -E
R 42	RES,CF,180,+5%,0.25W	411436	80031	CR251-4-3P180E	1	
R 43	RES,CF,91,+5%,0.25W	441683	80031	CR251-4-3P91E	1	
R 55	RES,CF,2.7K,+5%,0.25W	386498	80031	CR251-4-3P2K7	1	
R 72	RES,CF,51K,+5%,0.25W	376434	80031	CR251-4-3P51K	1	
R 73	RES,CF,3.3K,+5%,0.25W	318813	80031	CR251-4-3P3K3	1	
R 75, 76	RES,MF,10K,+1%,0.125W,100PPH	168260	91637	CHF551002F	2	
R 77	RES,MF,90K,+1%,0.125W,50PPH	225763	89536	225763	1	
R 78	RES,MF,9K,+0.1%,0.25W,50PPH	236695	89536	236695	1	
R 79	RES,MF,1K,+0.1%,0.25W,50PPH	225813	89536	225813	1	
R 80, 88, 91	RES,MF,4.99K,+1%,0.125W,100PPH	168252	91637	MFF1-B4991	3	
R 81,182,191	RES,MF,1K,+1%,0.125W,100PPH	168229	91637	CHF551001F	3	
R 82	RES,VAR,CERM,5K,+10%,0.5W	288282	75378	360T052A2	1	
R 83	RES,CF,75K,+5%,0.25W	394130	80031	CR251-4-3P75K	1	
R 84, 85	RES,MF,3.01K,+1%,0.125W,100PPH	312643	91637	CHF553011F	2	
R 86	RES,CF,200K,+5%,0.25W	441485	80031	CR251-4-5P200K	1	
R 87	RES,VAR,CERM,2K,+10%,0.5W	309466	89536	309466	1	
R 89,231	RES,MF,4.02K,+1%,0.125W,100PPH	235325	91637	CHF554021F	2	
R 90	RES,VAR,CERM,1K,+10%,0.5W	275750	11236	360T-102A	1	
R 92, 93,113-115	RES,MF,499,+1%,0.125W,100PPH	168211	91637	CHF554990F	5	
R 95	RES,CF,9.1K,+5%,0.25W	441691	80031	CR251-4-3P9K1	1	
R 96	RES,CF,820,+5%,0.25W	442327	80031	CR251-4-3P820E	1	
R 97	RES,CF,6.8K,+5%,0.25W	368761	80031	CR251-4-3P6K8	1	
R 98,121	RES,CF,100,+5%,0.25W	348771	80031	CR251-4-5P100E	2	
R 99	RES,MF,1.5K,+1%,0.125W,100PPH	313098	91637	CHF551501F	1	
R 102,119,129	RES,CF,10K,+5%,0.25W	348839	80031	CR251-4-5P10K	3	
R 103	RES,CF,4.7K,+5%,0.25W	348821	01121	CB4725	1	
R 104	RES,VAR,CERM,10K,+10%,0.5W	309674	75378	360T103A	1	
R 105	RES,CF,18K,+5%,0.25W	348862	80031	CR251-4-5P18K	1	
R 106	RES,CF,2K,+5%,0.25W	441469	80031	CR251-4-5P2K	1	
R 107	RES,MF,3.48K,+1%,0.125W,100PPH	260687	91637	CHF553481F	1	
R 108,116	RES,MF,1.27K,+1%,0.125W,100PPH	267369	91637	CHF551271F	2	
R 109,111	RES,CC,510,+5%,0.5W	108951	01121	RC020GF511JS	2	
R 110,112	RES,CF,36,+5%,0.25W	442236	80031	CR251-4-5P36E	2	
R 117,118	RES,CF,220,+5%,0.25W	342626	80031	CR251-4-5P220E	2	
R 120,163	RES,CF,4.7K,+5%,0.25W	348821	01121	CB4725	2	
R 122	RES,CF,8.2K,+5%,0.25W	441675	80031	CR251-4-5P8K2	1	
R 123	RES,CF,33K,+5%,0.25W	348888	80031	CR251-4-5P33K	1	
R 145	RES,CC,300,+5%,0.125W	512772	01121	BB3015	1	
R 146	RES,CC,18,+5%,0.125W	500397	01121	BB1805	1	
R 147,186,218,219	RES,CC,47,+5%,0.125W	512061	01121	BB4705	4	
R 148,153,162,225,226	RES,CC,10K,+5%,0.125W	643940	01121	BB1035	5	
R 149,217,240	RES,CC,330,+5%,0.125W	613965	01121	BB3315	3	
R 150	RES,CC,1.2K,+10%,0.125W	115329	89536	115329	1	
R 151,222	RES,CC,1K,+5%,0.125W	643932	01121	BB1025	2	
R 160	RES,CF,750,+5%,0.25W	441659	80031	CR251-4-5P750E	1	
R 164	RES,CF,300,+5%,0.25W	441519	80031	CR251-4-5P300E	1	
R 178,179	RES,CF,5.6,+5%,0.25W	441618	80031	CR251-4-5P5R6	2	
R 180,192	RES,MF,178,+1%,0.125W,100PPH	442996	89536	442996	2	
R 181,193	RES,MF,1.05K,+1%,0.125W,100PPH	293530	91637	CHF551051F	2	
R 183,194	RES,MF,3.24K,+1%,0.125W,100PPH	233578	91637	CHF553241F	2	
R 184,195,197,200	RES,CC,180,+5%,0.125W	512756	01121	BB1815	4	
R 185,199	RES,MF,249,+1%,0.125W,100PPH	168203	91637	CHF55249F	2	
R 187,189	RES,CC,120,+5%,0.125W	513978	01121	BB1215	2	
R 188,196	RES,CC,12,+5%,0.125W	714451	89536	714451	2	
R 190	RES,CF,5.1,+5%,0.25W	441287	80031	CR251-4-5P5R1	1	
R 213,214	RES,CC,200,+5%,0.125W	713917	89536	713917	2	
R 220	RES,CC,270,+5%,0.125W	512764	01121	BB2715	1	
R 221	RES,CF,10K,+5%,0.25W	573394	80031	CR251-4-5P10K	1	
R 223	RES,MF,6.04K,+1%,0.125W,100PPH	285189	91637	CHF556041F	1	
R 224	RES,MF,15K,+1%,0.125W,100PPH	285296	91637	CHF551502F	1	
R 227	RES,MF,100K,+1%,0.125W,100PPH	248807	91637	CHF551003F	1	
R 228	RES,CF,56,+5%,0.25W	441068	89536	441068	1	
R 229	RES,MF,9.09K,+1%,0.125W,100PPH	221663	91637	CHF559091F	1	
R 230	RES,VAR,CERM,2K,+20%,0.5W	226076	80294	3329H1202	1	
R 232	RES,CF,1.3K,+5%,0.25W	441394	80031	CR251-4-5P1K3	1	
R 233	RES,CC,680,+5%,0.125W	512798	01121	BB6815	1	
R 234	RES,CC,15K,+5%,0.25W	148114	01121	CB1535	1	
R 235	RES,CF,1M,+5%,0.25W	348987	80031	CR251-4-5P1M	1	
R 236	RES,CC,560,+5%,0.125W	782839	89536	782839	1	
R 237,242	RES,CC,100,+10%,0.125W	261026	01121	BB1011	2	
R 238,239	RES,CC,390,+5%,0.125W	782821	89536	782821	2	
U 1	* IC,VOLT REG, FIXED,+5 VOLTS,0.1 AMPS	429910	07263	uA78L05AWC	1	1
U 1	* IC,ECL,1.3 CHZ DIVIDE BY 2	707943	89536	707943	1	1
U 6	3DB COUPLER	784965	89536	784965	1	1
U 6	* IC,STTL, 360 CELL GATE ARRAY	723700	89536	723700	1	1
U 7, 8	MIXER, DOUBLE BALANCED, 1 - 500 MHZ	733105	89536	733105	2	1
U 9, 25	* IC,DPLR, MONOLITHIC VHF-UHF AMPLIFIER	423387	89536	423387	1	1
U 10	* IC,OP AMP, QUAD, JFET INPUT, TO-5 CASE	483438	89536	483438	1	1
U 15, 58	* IC,TTL, 100MHZ DIV BY 2, DIV BY 3 CNTR	473835	01295	SN74LS194N	2	1
U 16	* IC,LSTTL, DUAL DIV BY 2, DIV BY 3 CNTR	483194	01295	SN74LS390N	1	1
U 17	* IC,STTL, 360 CELL GATE ARRAY	723718	89536	723718	1	1
U 18	* IC,ECL, DUAL D M/S F/F, W/SET&RESET	454959	04713	MC10131P	1	1
U 19	* IC,ECL, QUAD 2 INPUT NOR GATE	388881	04713	MC10102P	1	1
U 20	* IC,ECL, DIV BY 10, DIV BY 14 COUNTER	454900	89536	454900	1	1
U 26, 30-32	* IC,LSTTL, OCTAL D F/F, +EDG TRC, W/CLEAR	454892	01295	SN74LS273N	4	1
U 27, 29	* IC,CMOS, 10BIT DAC, 10BIT ACCUR, CUR OUT	587566	24355	AD7533LN	2	1
U 28	* IC,OP AMP, DUAL, JFET INPUT, 8 PIN DIP	495192	12040	LF353BN	1	1
U 34	* IC,FTTL, QUAD 2 INPUT NAND GATE	654640	07263	74F00PC	1	1
U 35, 66	* IC,FTTL, DUAL D F/F, +EDG TRC, W/CLEAR	659508	07263	74F74PC	2	1

LIST OF REPLACEABLE PARTS

TABLE 5-6. A2A1 SYNTHESIZER PCA
(SEE FIGURE 5-6.)

REFERENCE DESIGNATOR	S	DESCRIPTION	FLUKE STOCK --NO--	MFRS SFLY CODE	MANUFACTURERS PART NUMBER --OR GENERIC TYPE--	TOT QTY	R S T -Q	N O T -E
U 37		* IC, I, STTL, 3-B LINE DCVR W/ENABLE	407585	01295	SN74LS138N	1	1	
U 38		* IC, LSTTL, OCTL LINE DRVR W/3-STATE OUT	429035	01295	SN74LS244N	1	1	
U 41		* IC, OP AMP, QUAD JFET INPUT, 14 PIN DIP	659748	89536	659748	1	1	
U 42		* IC, COMPARTOR, QUAD, 14 PIN DIP	387233	12040	LM339N	1	1	
U 43, 44, 59		* IC, STTL, DUAL D F/F, +EDG TRG, W/SET&CLR	418269	01295	SN74S74N	3	1	
U 45, 65		* IC, STTL, QUAD 2 INPUT NAND GATE	363580	01295	SN7400SN	2	1	
U 46		* IC, ARRAY, 5 TRANS, 5 ISD: 2-PNP, 3-NPN	418954	02735	CA3096E	1	1	
U 47		* IC, LSTTL, RETRG MONOSTAB MULTIVB W/CLR	412734	01295	SN74LS122N	1	1	
U 48, 60		* IC, OP AMP, JFET INPUT, 8 PIN DIP	472779	12040	LF386N	2	1	
U 49		* IC, OP AMP, SELECTED GBW 600KHZ	418566	12040	LM358N	1	1	
U 50		* ISOLATOR, OPTO, LED TO TRANSISTOR, DUAL	454330	07263	MCT-6	1	1	
U 54		* IC, STTL, QUAD 2 INPUT NAND GATE	363580	01295	SN7400SN	1	1	
U 55		* IC, STTL, HEX INVERTER	418004	01295	SN74S04N	1	1	
U 61		* IC, ECL, DIVIDE BY 4 PRESCALER	722157	89536	722157	1	1	
U 63, 64		* IC, ECL, DUAL D M/S F/F, +EDG TRG	525345	04713	MC10231L	2	1	
U 64		* IC, ECL, TRIPLE 2/3 INPUT OR/NOR GATE	723437	89536	723437	1	1	
U 67		* IC, COMPARTOR, HI-SPEED, 14 PIN DIP	386920	18324	NE529A	1	1	
U 68		* IC, STTL, DUAL D F/F, +EDG TRG, W/SET&CLR	418269	01295	SN74S74N	1	1	
U 69		* IC, OP AMP, JFET INPUT, 8 PIN DIP	472779	12040	LF386N	1	1	
U 70		* IC, CMOS, S/PDT ANALOG SWITCH	723742	89536	723742	1	1	
U 71		* IC, I, STTL, RETRG MONOSTAB MULTIVB W/CLR	412734	01295	SN74LS122N	1	1	
VR 2		* ZENER, COMF, 6.4V, 3%, 1 PPM TC, 2.0MA	357848	04713	SZG20118	1	2	
VR 11		* ZENER, UNCOMP, 10.0V, 10%, 12.5MA, 0.4W	113324	07910	1N961A	1	1	
VR 14		* ZENER, UNCOMP, 0.2V, 5%, 20.0MA, 0.4W	386771	04713	1N756A	1	1	
W 1, 2		* CABLE ASSY, RF JUMPER	716985	89536	716985	2	1	
XU 10, 15, 34-		SOCKET, IC, 14 PIN	276527	09922	DILB8P-108	14		
XU 36, 41- 45,			276527					
XU 47, 58, 59,			276527					
XU 65			276527					
XU 16, 18, 19,		SOCKET, IC, 16 PIN	276535	91506	316-AG39D	10		
XU 27, 29, 37,			276535					
XU 46, 62- 64			276535					
XU 17		SOCKET, IC, 28 PIN	448217	91506	320-AG39D	1		
XU 26, 30- 32,		SOCKET, IC, 20 PIN	454421	09922	DILB20P-108	5		
XU 38			454421					
XU 28, 48- 50,		SOCKET, IC, 8 PIN	478016	91506	308-AG39D	5		
XU 60			478016					
XU 33		SOCKET, IC, 24 PIN	376236	91506	324-AG39D	1		
Y 1		* CRYSTAL, 10MHZ, +-0.001%, HC-35/U	536565	33096	PB1360	1		
Z 1		RES, NET, CERM, CUSTOM	501841	89536	501841	1		
Z 5		RES, NET, SIP, 10 PIN, 9 RES, 510, +-2%	478800	89536	478800	1		
Z 6		RES, NET, SIP, 6 PIN, 5 RES, 100K, +-2%	412726	89536	412726	1		
Z 9		RES, NET, DIP, 16 PIN, 8 RES, 1K, +-5%	358119	01121	314	1		
Z 10		RES, NET, SIP, 6 PIN, 5 RES, 510, +-2%	459974	89536	459974	1		

LIST OF REPLACEABLE PARTS

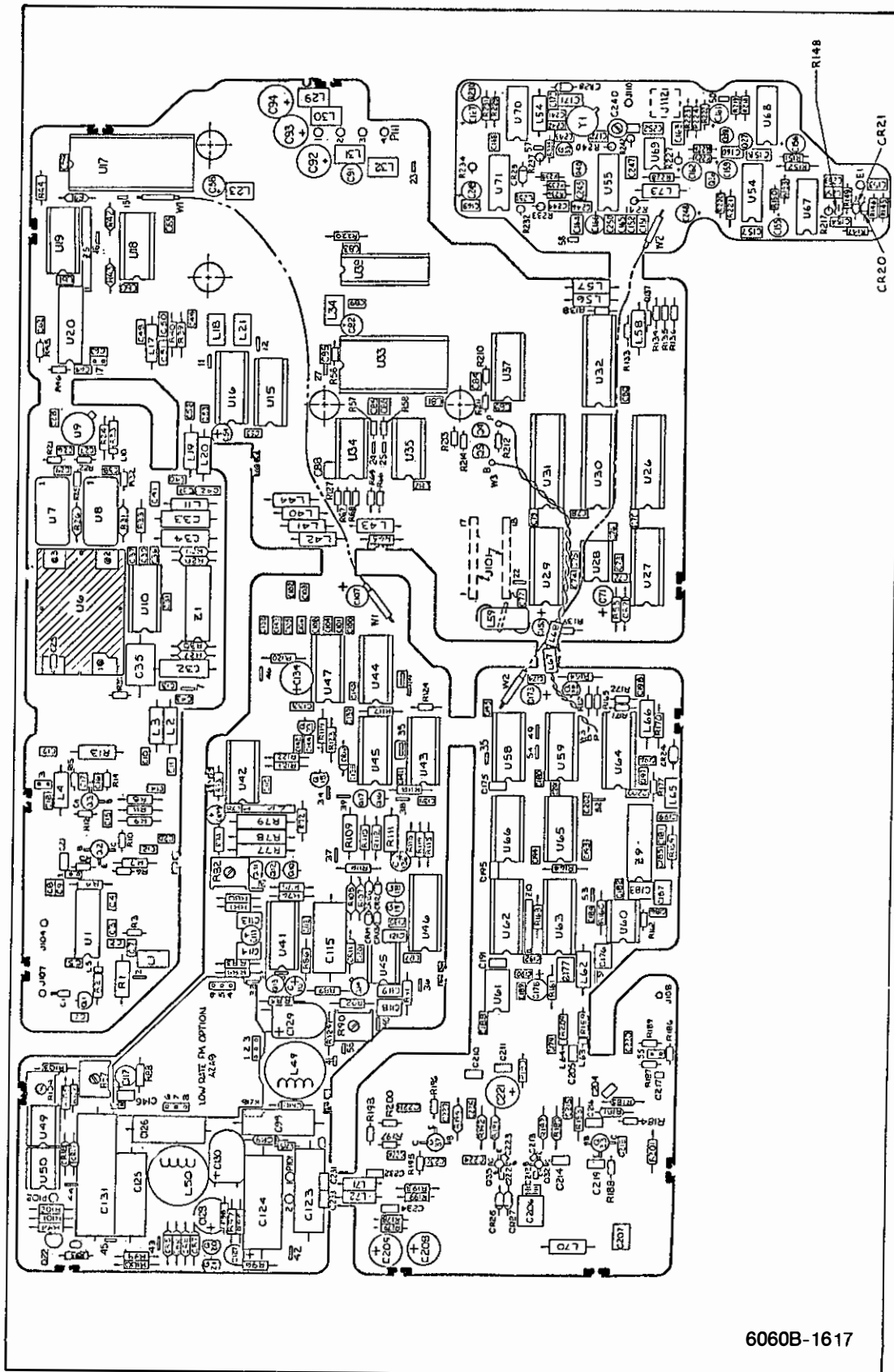

Figure 5-6. A2A1 Synthesizer PCA

LIST OF REPLACEABLE PARTS

TABLE 5-7. A2A2 VCO PCA
(SEE FIGURE 5-7.)

REFERENCE DESIGNATOR A->NUMERICS->>>>	S	DESCRIPTION	FLUKE STOCK --NO--	MFRS SPLY CODE	MANUFACTURERS PART NUMBER --OR GENERIC TYPE--	TOT QTY	R S T -Q -E	N O
C 1, 4, 6,		CAP,CER,330PF,+20%,50V,X7R	450093	89536	650093	11		
C 10, 13, 14,			450093					
C 20, 28, 32,			450093					
C 33, 38			450093					
C 2		CAP,CER,1800PF,+5%,50V,COG	528547	89536	528547	1		
C 3, 30		CAP,CER,1.5PF,+0.5PF,50V,COG	514166	89536	514166	2		
C 5, 15		CAP,CER,4.3PF,+0.5PF,50V,COG	514216	89536	514216	2		
C 7- 9, 12,		CAP,CER,180PF,+5%,100V,COG	603506	56289	C023R501E181M	12		
C 16- 19, 22,			603506					
C 23, 26, 27			603506					
C 11, 21		CAP,CER,10PF,+5%,50V,COG	494781	89536	494781	2		
C 24, 25		CAP,AL,220UF,+50-20%,16V	435990	57640	SM/V8	2		
C 29, 31		CAP,CER,3.3PF,+0.5PF,50V,COG	514208	89536	514208	2		
C 34		CAP,CER,100PF,+5%,50V,COG	514133	89536	514133	1		
C 35		CAP,CER,2.7PF,+0.5PF,50V,COG	519793	89536	519793	1		
C 36, 37		CAP,CER,22PF,+2%,100V,COG	512871	89536	512871	2		
CR 1, 2		DIODE,SI,VARACTOR,P1V= 28V	741504	89536	741504	2	1	
CR 3, 4		* DIODE,SI,VARACTOR,P1V= 30V,HYPER ABKU	722140	89536	722140	2	1	
L 1		CHDKE,6TURN	320911	89536	320911	1		
MP 2		SPACER,RND,SOLUBLE	334797	32559	T0-35-15-E	4		
P 201,202		CONN,SOCKET,PWB,0.049 DIAMETER	544056	89536	544056	3		
P 203		CONN,SOCKET,PWB,0.022 DIAMETER	376418	22526	75060-005	1		
P 204		PIN TEST BASE	698472	89536	698472	1		
Q 1, 3		* TRANSISTOR,SI,NPN,SMALL SIG,MICROWAVE	483164	89536	483164	2		
Q 2, 4, 5		* TRANSISTOR,SI,NPN,HI-FREQ,SMALL SIGNL	535013	04713	BFR91	3	1	
R 1, 9, 23		RES CHIP CERMET 180 +-5% 0.125W	720649	89536	720649	3		
R 2, 16		RES,CC,360,+5%,0.125W	721761	89536	721761	2		
R 3, 17		RES,CC,680,+5%,0.125W	512798	01121	BB6815	2		
R 4, 19		RES,CC,1.6M,+5%,0.125W	740316	89536	740316	2		
R 5, 11		RES,CF,5.6,+5%,0.25W	441618	80031	CR251-4-5P5R6	2		
R 6, 18		RES,CF,1.5M,+5%,0.25W	349001	80031	CR251-4-5P1M5	2		
R 7, 21		RES,MF,3.24K,+1%,0.125W,100PPH	223578	71637	CHF553241F	2		
R 8, 22		RES,MF,1.05K,+1%,0.125W,100PPH	293530	71637	CHF551051F	2		
R 10, 24		RES,MF,249,+1%,0.125W,100PPH	168203	71637	CHF55249F	2		
R 12, 26		RES CHIP CERMET 12 +-5% 0.125W	715102	89536	715102	2		
R 13		RES,CHIP,CERM,68,+5%,0.125W	747675	89536	747675	1	1	
R 14		RES,CHIP,CERM,120,+5%,0.125W	747683	89536	747683	1		
R 15		RES,CC,100,+5%,0.125W	714469	89536	714469	1		
R 20		RES,CF,10K,+5%,0.25W	348839	80031	CR251-4-5P10K	1		
R 25, 30		RES,MF,649,+1%,0.125W,100PPH	309955	71637	CHF556490F	2		
R 27, 29		RES CHIP CERMET 130 +-5% 0.125W	720623	89536	720623	2		
R 28		RES CHIP CERMET 47 +-5% 0.125W	720631	89536	720631	1		
R 31		RES,CC,15,+5%,0.125W	512715	01121	BB1505	1		
R 32		RES,CC,200,+5%,0.125W	713917	89536	713917	1		
R 33		RES,CC,390,+5%,0.5W	109082	89536	109082	1		
W 2		UT-85 MINIATUR,TOTAL SHIELDED	267567	89536	267567	1		

THE FOLLOWING COMPONENTS ARE NON FIELD REPLACEABLE:

- C1,3,4,5,6,8,10,11,14,15,18,19,21,24,27,29,31,32,36,37
- CR1,2,3,4
- Q1,2,3,4
- R1,2,3,4,16,17,18,19,25,30

LIST OF REPLACEABLE PARTS

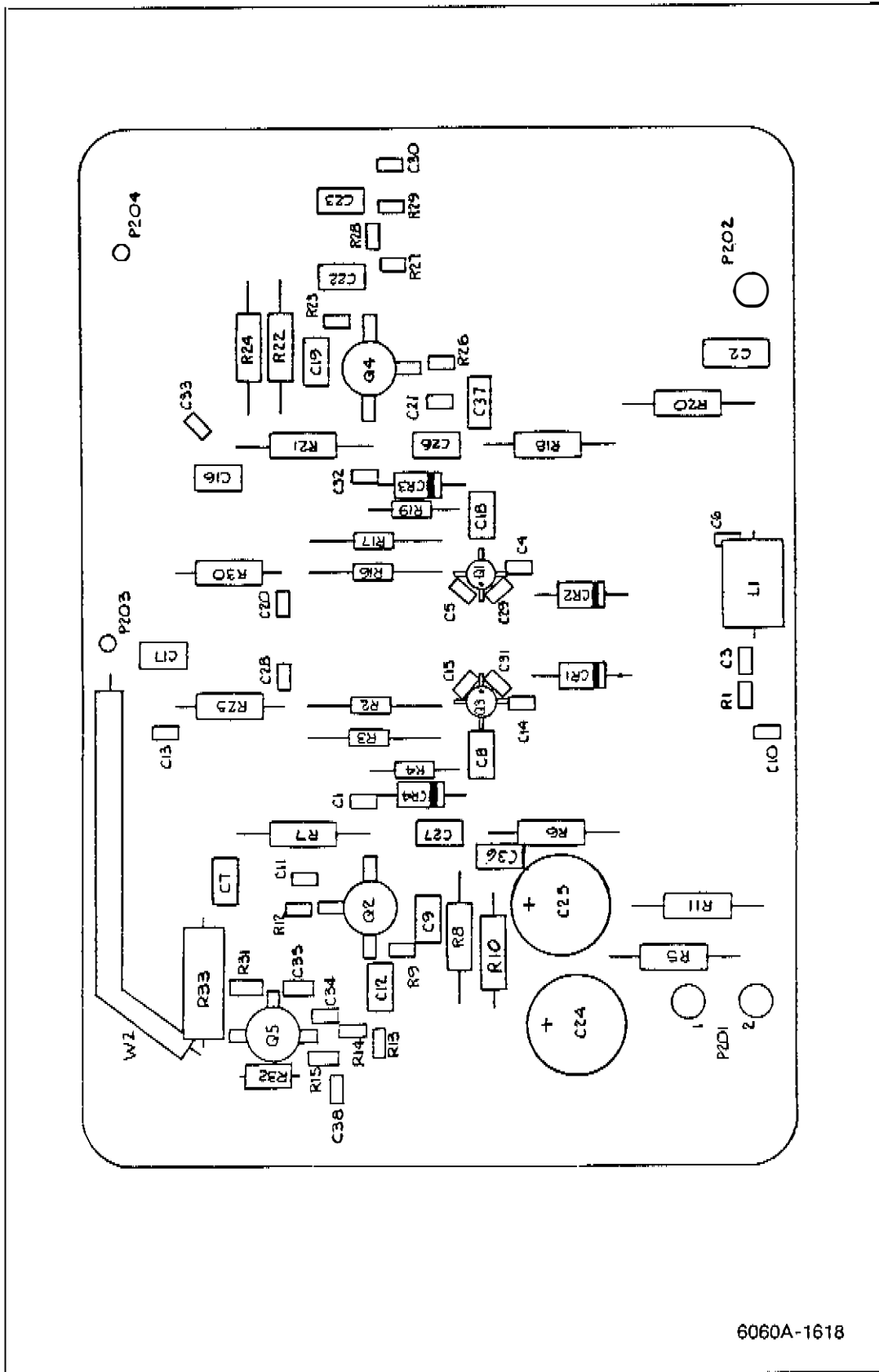

6060A-1618

Figure 5-7. A2A2 VCO PCA

LIST OF REPLACEABLE PARTS

TABLE 5-8. A2A4 OUTPUT PCA
(SEE FIGURE 5-8.)

REFERENCE DESIGNATOR	DESCRIPTION	FLUKE STOCK	MFRS SPLY CODE	MANUFACTURERS PART NUMBER	TOT QTY	R S T	N O I
A-7 NUMERICS	S	--NO--		--OR GENERIC TYPE--		-Q-	-E-
C 101, 104, 106, 115-117, 137, 138, 144, 151, 152, 154-156, 231, 238-240, 243, 246, 247, 250, 253, 301, 303, 305, 307-314, 317-321, 416	CAP, CER, 100PF, +-2X, 100V, COG	512848	51406	RPE121	46		
C 103, 145, 148, 201, 207, 210, 213, 214, 235, 245, 249, 260, 265, 266, 272-274, 302, 304, 306, 403, 404, 406, 412, 421, 422	CAP, POLYES, 0.1UF, +-20X, 50V	732883	89536	732883	26		
C 107, 124, 147, 157, 242, 254-256, 259, 269, 270	CAP, CER, 0.001UF, +-20X, 100V, X7R	402966	72982	8121-A100-W5R-102M	11		
C 108, 119, 121-123	CAP, CER, 5.6PF, +-0.25PF, 100V, COH	512954	89536	512954	3		
C 109, 110, 118	CAP, CER, 3.9PF, +-0.25PF, 100V, COJ	512947	89536	512947	3		
C 111, 236, 237	CAP, CER, 3.3PF, +-0.25PF, 100V, COJ	319330	89536	519330	3		
C 112, 113	CAP, CER, 2.2PF, +-0.25PF, 100V, COG	362731	89536	362731	2		
C 114, 244, 248, 243	CAP, CER, 1.8PF, +-0.25PF, 100V, COK	512897	89536	512897	4		
C 120, 224, 275	CAP, CER, 2.7PF, +-0.25PF, 100V, COJ	363705	89536	363705	3		
C 125, 127, 129, 131, 133, 135, 149	CAP, CER, 0.01UF, +-20X, 50V, Z5U	614214	72982	8121-050-651-10NFM	7		
C 126	CAP, AL, 22UF, +-20X, 16V	614750	89536	614750	1		
C 130, 134	CAP, AL, 15UF, +-20X, 35V	614024	89536	614024	2		
C 139	CAP, CER, 1200PF, +-20X, 100V, X7R	358283	72982	8121-A100-W5R-122M	1		
C 140	CAP, CER, 1000PF, +-3X, 50V, COG	528547	89536	528547	1		
C 142	CAP, CER, 4700PF, +-20X, 100V, X7R	362871	72982	8121-A100-W5R-472M	1		
C 146	CAP, CER, 220PF, +-2X, 100V, COG	512111	31406	RPE121	1		
C 202, 204, 206, 208, 211, 241	CAP, AL, 2.2UF, +-20X, 50V	614875	89536	614875	10		
C 264, 271, 274		614875					
C 285	CAP, CER, 39PF, +-2X, 100V, COG	512962	89536	512962	1		
C 209, 212, 230	CAP, CER, 27PF, +-3X, 100V, COG	362749	51406	RPE121	3		
C 216, 218, 220, 223	CAP, CER, 8.2PF, +-0.25PF, 100V, COH	715359	89536	715359	4		
C 217	CAP, CER, 18PF, +-2X, 100V, COG	715359			1		
C 219, 226-229, 277	CAP, CER, 4.7PF, +-0.25PF, 100V, COH	512335	51406	89870-100V	1		
C 221	CAP, CER, 10PF, +-2X, 100V, COG	362772	89536	362772	6		
C 222	CAP, CER, 12PF, +-2X, 100V, COG	512343	89536	512343	1		
C 225, 252	CAP, CER, 12PF, +-2X, 100V, COG	376871	89536	376871	1		
C 251, 405	CAP, CER, 6.8PF, +-0.25PF, 100V, COH	512327	89536	512327	2		
C 262	CAP, CER, 47PF, +-2X, 100V, COG	512360	89536	512360	2		
C 247, 411	CAP, TA, 2.2UF, +-20X, 35V	772848	89536	772848	1		
C 280	CAP, CER, 1.5PF, +-0.25PF, 100V, COK	485185	56289	196225X0035KAI	2		
C 322, 409	CAP, TA, 0.47UF, +-20X, 35V	529909	89536	529909	1		
C 401, 402	CAP, AL, 47UF, +50-20X, 16V	161349	56349	196D474X0035HAI	2		
C 407, 408	CAP, POLYPR, 0.0786UF, +-1X, 50V	436006	62643	5H/VB	2		
C 410	CAP, TA, 4.7UF, +-20X, 25V	422998	89536	422998	2		
C 420	CAP, TA, 4.7UF, +-20X, 25V	161943	56289	196D475X0025KAI	1		
CR 101, 105, 111-114, 118, 120	* DIODE, SI, PIN, LO-FREQ, BV=100.0V	512145	89536	512145	1		
CR 203, 210	* DIODE, SI, PIN, RF ATTENUATING	402776	28480	HP3379	12	1	
CR 102-104, 106-110, 129, 204-209	* DIODE, SI, PIN, RF ATTENUATING	508077	26629	KS8379	15	1	
CR 117, 119	* DIODE, SI, PIN, RF CUR CONT RESIST DIODE	508077					
CR 121, 301	* ZENER, UNCOMP, 5.1V, 5%, 20.0MA, 0.4W	742296	89536	742296	2	2	
CR 125	* ZENER, UNCOMP, 4.3V, 5%, 20.0MA, 0.4W	159798	04713	1N751A	2	1	
CR 126, 202	* DIODE, SI, SCHOTTKY, MATCHED SET OF 2	180455	07910	1N749A	1	1	
CR 123, 124	* DIODE, SI, BV= 50.0V, IO=150MA, SELCTD VF	722470	89536	722470	1	3	
CR 127, 128	* DIODE, SI, SCHOTTKY BARRIER, SMALL SIGNAL	234468	07910	1D9039	2	1	
CR 130, 201	* DIODE, SI, BV= 75.0V, IO=150MA, 500 MW	533195	28480	5082-2800	2	1	
CR 302	* ZENER, UNCOMP, 15.0V, 5%, 8.5MA, 0.4W	203323	07910	1N4448	2	1	
CR 401, 402	* DIODE, SI, SCHOTTKY BARRIER, SMALL SIGNAL	266601	04713	1N955B	1	1	
CR 403	* ZENER, COMP, 6.3V, 2X, 50 PPM TC, 7.5MA	313247	28484	HP5082-6264	2	1	
J 104	CONNECTOR, 4 PIN	172148	89536	172148	1	1	
L 102, 106, 108, 110, 115, 230	CNOKE, 6TURN	417329	89536	417329	1		
L 103-105, 225	INDUCTOR, 0.68 UH, +/-10X, 221MHZ, SHLDED	320911	89536	320911	6		
L 113, 116, 209, 210, 214-218, 220, 224, 227, 201-203, 228, 221	INDUCTOR, 10 TURNS	320937	24759	MR0.68	4		
MP 1	INDUCTOR, 6800 UH, +/-10X, 1.3MHZ, SHLDED	463448	89536	463448	12		
MP 40	INDUCTOR, 1500 UH, +/-10X, 2.5MHZ, SHLDED	463448					
P 101, 113	HET SHIELD	343184	24759	MR-6800	4		
P 102, 107, 108	CONIFUMENI HOLDER	343863	24759	MR-1500	1		
P 104	CONN, SOCKET, PWB, 0.049 DIAMETER	774190	89536	774190	1		
P 106	PIN TEST BASE	422057	90159	2829-75-1	1		
	HEADER, 1 ROW, 0.100CTK, 10 PIN	544056	89536	544056	19		
	SOCKET, SINGLE, PWB, FOR 0.012-0.022 PIN	698472	89536	698472	3		
		478693	89536	478693	1		
		376418	22526	75060-005	1		

LIST OF REPLACEABLE PARTS

TABLE 5-B. A244 OUTPUT PCA (CONT.)
(SEE FIGURE 5-8.)

REFERENCE DESIGNATOR A->NUMERICS-->	DESCRIPTION	FLUKE STOCK	MFRS SPLY CODE	MANUFACTURERS PART NUMBER --OR GENERIC TYPE--	TOT QTY	R S T	N O T
						-Q	-E
Q 101, 102, 202	* TRANSISTOR, SI, NPN, HI-FREQ, SMALL SIGNAL	535013	04713	8FR91	3		
Q 103, 302, 304, 306	* TRANSISTOR, SI, NPN, SMALL SIGNAL	330103	07243	MFS2560	4	1	
Q 104, 201, 203, 205, 208, 210, 212, 214	* TRANSISTOR, SI, PNP, SMALL SIGNAL	195974	64713	2N3906	8		
Q 105, 106	* TRANSISTOR, SI, NPN, SMALL SIGNAL	195974					
Q 204, 206, 209, 211	* TRANSISTOR, SI, NPN, HI-FREQ, SMALL SIGNAL	210196	04713	2N3904	2	2	
Q 207	* TRANSISTOR, SI, NPN, SMALL SIG, MICROWAVE	720379	09536	721379	4	1	
Q 213, 215	* TRANSISTOR, SI, NPN, HI-FREQ, SMALL SIGNAL	483172	09536	403172	1	1	
Q 301, 303, 305, 307	* TRANSISTOR, SI, NPN, SMALL SIGNAL	722256	09536	722256	2	1	
Q 401, 403	* TRANSISTOR, SI, NPN, HI-FREQ, SMALL SIGNAL	410707	04713	MFS256A2	4	1	
Q 402	* TRANSISTOR, SI, NPN, HI-FREQ, TO-92, SWITCH	261570	15010	02366J	2	1	
R 101, 102, 104, 114, 120, 151, 156, 269, 271, 314, 318, 320	RES, CF, 1K, +-5%, 0.25W	374475	15010	02110J	1	1	
R 103, 121, 122	RES, CC, 39, +-5%, 0.125W	343426	00031	CR251-4-5PIK	19		
R 104	RES, CF, 470, +-5%, 0.25W	343426					
R 107	RES, CF, 200, +-5%, 0.25W	343426					
R 108, 124, 125	RES, HF, 2.15K, +-1%, 0.125W, 100PPM	713909	09536	713909	3		
R 109	RES, CC, 510, +-5%, 0.125W	343434	00031	CR251-4-5P470E	1		
R 110	RES, CC, 270, +-5%, 0.5W	441451	00031	CR251-4-5P200E	1		
R 111, 112, 159, 243-245	RES, CC, 31, +-5%, 0.125W	293712	91637	CMF552151F	3		
R 113	RES, CC, 18, +-5%, 0.125W	715303	09536	715303	1		
R 123, 238	RES, HF, 2.67K, +-1%, 0.125W, 100PPM	159416	01121	ERR715	1		
R 126	RES, HF, 1.65K, +-1%, 0.125W, 100PPM	264262	01121	ERR105	4		
R 127	RES, HF, 465, +-1%, 0.125W, 100PPM	500397	01121	IM1805	1		
R 128, 129	RES, HF, 1.24K, +-1%, 0.125W, 100PPM	209507	91637	CMF552671F	2		
R 130	RES, HF, 1.54K, +-1%, 0.125W, 100PPM	293662	91637	CMF551631	1		
R 131	RES, HF, 3.40K, +-1%, 0.125W, 100PPM	320028	91637	CMF556650F	1		
R 132	RES, HF, 24.3K, +-1%, 0.125W, 100PPM	200407	91637	CMF551243F	2		
R 133	RES, HF, 6.04K, +-1%, 0.125W, 100PPM	209066	91637	CMF551541F	1		
R 134	RES, HF, 21.5K, +-1%, 0.125W, 100PPM	260607	91637	CMF553481F	1		
R 135, 304, 413, 414	RES, HF, 10K, +-1%, 0.125W, 100PPM	237475	91637	CMF55	1		
R 136, 266	RES, HF, 2.55K, +-1%, 0.125W, 100PPM	205109	91637	CMF556041F	1		
R 137	RES, HF, 499, +-1%, 0.125W, 100PPM	160270	09536	160270	1		
R 138	RES, HF, 16.9K, +-1%, 0.125W, 100PPM	160260	91637	CMF551002F	4		
R 139	RES, HF, 34.8K, +-1%, 0.125W, 100PPM	325498	91637	CMF552531F	2		
R 140, 141, 149	RES, HF, 1K, +-1%, 0.125W, 100PPM	160211	91637	CMF554990F	1		
R 141	RES, HF, 37.4K, +-1%, 0.125W, 100PPM	267146	91637	CMF551692F	1		
R 142	RES, HF, 100K, +-1%, 0.125W, 100PPM	261407	09536	261407	1		
R 143, 147	RES, HF, 20K, +-1%, 0.125W, 100PPM	160219	91637	CMF551001F	3		
R 144	RES, VAR, CER, 2K, +-10%, 0.5W	226241	91637	CMF553742F	1		
R 145	RES, HF, 66.5K, +-1%, 0.125W, 100PPM	240007	91637	CMF551003F	1		
R 146, 422	RES, HF, 49.9K, +-1%, 0.125W, 100PPM	291072	91637	CMF552002F	2		
R 150, 233, 242	RES, CC, 180, +-5%, 0.125W	309666	09536	309666	1		1
R 152	RES, CF, 4.7K, +-5%, 0.25W	209082	91637	CMF556432F	1		
R 153, 158, 314, 319	RES, CF, 4.7K, +-5%, 0.25W	260021	91637	CMF554992F	2		
R 154	RES, CC, 22, +-5%, 0.125W	512756	01121	BH1815	3		
R 155	RES, CF, 1K, +-5%, 0.25W	340709	00031	CR251-4-5P270E	1		
R 157, 272	RES, CC, 1K, +-5%, 0.125W	340021	01121	CM1725	4		
R 201, 207, 213, 232, 240, 248, 249	RES, CC, 22, +-5%, 0.125W	474767	01121	BH1-02205	1		
R 202	RES, CF, 10, +-5%, 0.125W	357665	00031	CR251-4-5P1E	1		
R 203, 209, 214	RES, CF, 360, +-5%, 0.25W	443932	01121	BH1025	2		
R 204, 205	RES, CF, 15, +-5%, 0.125W	441449	00031	CR251-4-5P2K	7		
R 206, 212, 217	RES, CF, 11, +-5%, 0.125W	441469					
R 208, 220, 234, 241	RES, CF, 360, +-5%, 0.25W	352706	00031	CR251-4-5P360E	1		
R 210, 211, 215, 216	RES, CF, 18, +-5%, 0.125W	443002	09536	443002	3		
R 218, 239	RES, HF, 6.45K, +-1%, 0.125W, 100PPM	740027	09536	740027	2		
R 219	RES, HF, 1.21K, +-1%, 0.125W, 100PPM	740019	09536	740019	3		
R 221	RES, HF, 5.34K, +-1%, 0.125W, 100PPM	016056	09536	016056	4		
R 222	RES, CC, 300, +-5%, 0.5W	186056					
R 223	RES, CF, 160, +-5%, 0.125W	740035	09536	740035	4		
R 224, 262	RES, CF, 75, +-5%, 0.125W	740035					
R 225, 229	RES, CF, 51, +-5%, 0.125W	275735	11236	361-101A	1		
R 226	RES, VAR, CER, 100, +-10%, 0.5W	740076	09536	740076	1		
R 227	RES, CC, 110, +-5%, 0.125W	714469	09536	714469	2		
R 228	RES, CC, 100, +-5%, 0.125W	512061	01121	BH14705	1		
R 230, 231	RES, CC, 47, +-5%, 0.125W	512723	01121	BH3005	2		
R 233	RES, CC, 30, +-5%, 0.125W	260349	91637	CMF553761F	1		
R 236, 237	RES, HF, 5.74K, +-1%, 0.125W, 100PPM	155101	09536	155101	1		
R 246	RES, HF, 63.4, +-1%, 0.5W, 100PPM	721027	09536	721027	1		
R 249	RES, CC, 160, +-5%, 0.125W	601932	09536	601932	2		
R 250	RES, CC, 24, +-5%, 0.125W	500903	01121	BH1115	1		
R 251, 252	RES, CC, 110, +-5%, 0.125W	721159	09536	721159	1		
R 253	RES, CC, 220, +-5%, 0.125W	512772	01121	BH3015	1		
R 254	RES, CF, 300, +-5%, 0.125W	740084	09536	740084	1		
R 256	RES, CF, 120, +-5%, 0.125W	261000	09536	261000	1		
R 257	RES, CC, 15, +-10%, 0.125W	441370	00031	CR251-4-5P1K2	1		
R 258	RES, CF, 1.2K, +-5%, 0.25W	109082	09536	109082	1		
R 259	RES, CC, 390, +-5%, 0.5W	108936	09536	108936	1		
R 261	RES, CC, 330, +-5%, 0.5W	740043	09536	740043	2		
R 263, 264	RES, CF, 24, +-5%, 0.125W	320010	91637	CMF554750F	1		
R 267	RES, HF, 475, +-1%, 0.125W, 100PPM						

LIST OF REPLACEABLE PARTS

TABLE 5-8. A2A4 OUTPUT PCA (CONT.)
(SEE FIGURE 5-8.)

REFERENCE DESIGNATOR	DESCRIPTION	FLUKE STOCK	MFRS SPLY CODE	MANUFACTURERS PART NUMBER OR GENERIC TYPE	TOT QTY	R S T	M O T
A- NUMERICS	S	--NO--				-Q-	-E-
R 268	RES, MF, 22.1, +1%, 0.5W, 100PPM	151472	89536	151472	1		
R 302	RES, MF, 3.4K, +1%, 0.125W, 100PPM	260323	91637	CHF553401F	1		
R 303	RES, MF, 715, +1%, 0.125W, 100PPM	313080	91637	CHF557150F	1		
R 305	RES, MF, 392, +1%, 0.125W, 100PPM	260299	91637	CHF553920F	1		
R 306	RES, MF, 39.2K, +1%, 0.125W, 100PPM	236414	91637	CHF553922F	1		
R 307	RES, CF, 47, +5%, 0.25W	441592	80031	CR251-4-5P47E	1		
R 308	RES, CF, 56K, +5%, 0.25W	441626	80031	CR251-4-5P56K	1		
R 309	RES, VAR, CERH, 10K, +10%, 0.5W	309674	75378	360T103A	1		
R 310	RES, MF, 523, +1%, 0.125W, 100PPM	294835	91637	CHF555230D	1		
R 311	RES, VAR, CERH, 200, +10%, 0.5W	275743	89536	275743	1		
R 312	RES, MF, 294, +1%, 0.125W, 100PPM	288472	91637	CHF55294F	1		
R 313	RES, CF, 33K, +5%, 0.25W	348888	80031	CR251-4-5P33K	1		
R 315	RES, CF, 620, +5%, 0.25W	442319	80031	CR251-4-5P620E	1		
R 324	RES, CF, 62K, +5%, 0.25W	348904	80031	CR251-4-5P62K	1		
R 401	RES, MF, 601, +1%, 0.125W, 100PPM	543785	91637	CHF556810F	1		
R 402	RES, CF, 1M, +5%, 0.25W	348987	80031	CR251-4-5P1M	1		
R 403, 408	RES, MF, 3.32K, +1%, 0.125W, 100PPM	312652	91637	CHF553321F	2		
R 404, 407	RES, MF, 34.8, +1%, 0.125W, 100PPM	343897	89536	343897	2		
R 405, 409	RES, MF, 4.99K, +1%, 0.125W, 100PPM	168252	91637	MFF1-84991	2		
R 406, 410	RES, MF, 71.5, +1%, 0.125W, 100PPM	393603	91637	CHF5571R5F	2		
R 411	RES, MF, 4.02K, +1%, 0.125W, 100PPM	235325	91637	CHF554021F	1		
R 412	RES, MF, 1.69K, +1%, 0.125W, 100PPM	321414	91637	CHF551691F	1		
R 415	RES, MF, 6.34K, +1%, 0.125W, 100PPM	267344	91637	CHF556341F	1		
R 416	RES, MF, 147K, +1%, 0.125W, 100PPM	291344	91637	CHF551473F	1		
R 417	RES, MF, 23.2K, +1%, 0.125W, 100PPM	291351	91637	CHF552322F	1		
R 418	RES, MF, 301K, +1%, 0.125W, 100PPM	289488	91637	CHF5530102F	1		
R 419	RES, VAR, CERH, 100K, +10%, 0.5W	369510	11236	360T-104A	1		
R 420	RES, CF, 4.3K, +5%, 0.25W	441576	80031	CR251-4-5P4K3	1		
R 421	RES, VAR, CERH, 20K, +10%, 0.5W	335760	11236	360T-203A	1		
RT 301	THERMISTOR, DISC, NEG., 10K, +10%, 25C	104596	73168	JA41J1	1		
TP 1- 5	PIN, SINGLE, PWB, 0.025 SQ	267500	00779	87022-1	10		
TP 6- 11	TEST POINT	512889	02660	62395	6		
U 101, 402	IC, OP AMP, DUAL, JFET INPUT, 8 PIN DIP	495192	12040	LF3538N	2		
U 201	MIXER, DOUBLE BALANCED, 1 - 1000 MHZ	525493	89536	525493	1		
U 301	IC, CMOS, DUAL 8 BIT DAC, CURRENT OUTPUT	722272	89536	722272	1		1
U 302, 311, 405	IC, OP AMP, QUAD JFET INPUT, 14 PIN DIP	659748	89536	659748	3		1
U 303	IC, CMOS, 12 BIT MULTIPLYING DAC	722264	89536	722264	1		1
U 304, 305, 308,	IC, LSTTL, OCTAL D F/F, +EDG TRG, W/CLEAR	454892	01295	SN74LS273N	4		1
U 404		454892					
U 306	IC, LSTTL, QUAD 2 INPUT NAND GATE	393033	01295	SN74LS00N	1		1
U 307	IC, LSTTL, 3-0 LINE DCDR W/ENABLE	407585	01295	SN74LS138N	1		1
U 309, 310	IC, COMPARATOR, QUAD, 14 PIN DIP	387233	12040	LM339N	2		1
U 401	IC, CMOS, QUAD BILATERAL SWITCH	401042	89536	408062	1		1
U 403	IC, CMOS, 10BIT DAC, 10BIT ACCUR, CUR OUT	507566	24355	AD7533LN	1		1
W 1	CABLE ASSY, RF JUMPER	716993	89536	716993	1		
XU 101, 402	SOCKET, IC, 8 PIN	478016	91506	308-AC39D	2		2
XU 301, 304, 305,	SOCKET, IC, 20 PIN	454421	09922	DIL B20P-108	5		
XU 308, 404		454421					
XU 302, 306, 309,	SOCKET, IC, 14 PIN	276527	09922	DIL B14P-108	7		
XU 310, 311, 401,		276527					
XU 405		276527					
XU 303	SOCKET, IC, 18 PIN	410228	91506	318-AC39D	1		
XU 307, 403	SOCKET, IC, 16 PIN	276535	91506	316-AC39D	2		1
Z 301	RES, NET, SIF, 8 PIN, 7 RES, 10K, +2%	412924	80031	95081002CL	1		
Z 401	RES, NET, CERH, CUSTOM	501841	89536	501841	1		

NOTE 1= ALSO INCLUDES XZ401
NOTE 2= ALSO INCLUDES XR144

THE FOLLOWING COMPONENTS ARE NON-FIELD REPLACEABLE:

- C202-206, 208, 209, 211, 212, 216-222, 224, 225, 252, 254, 263, 264, 271, 277
- CR126, 202-210
- L217, 220
- Q202, 204, 206, 215
- R203-206, 209-212, 214-217, 224-228, 253-256, 262-264
- U201

LIST OF REPLACEABLE PARTS

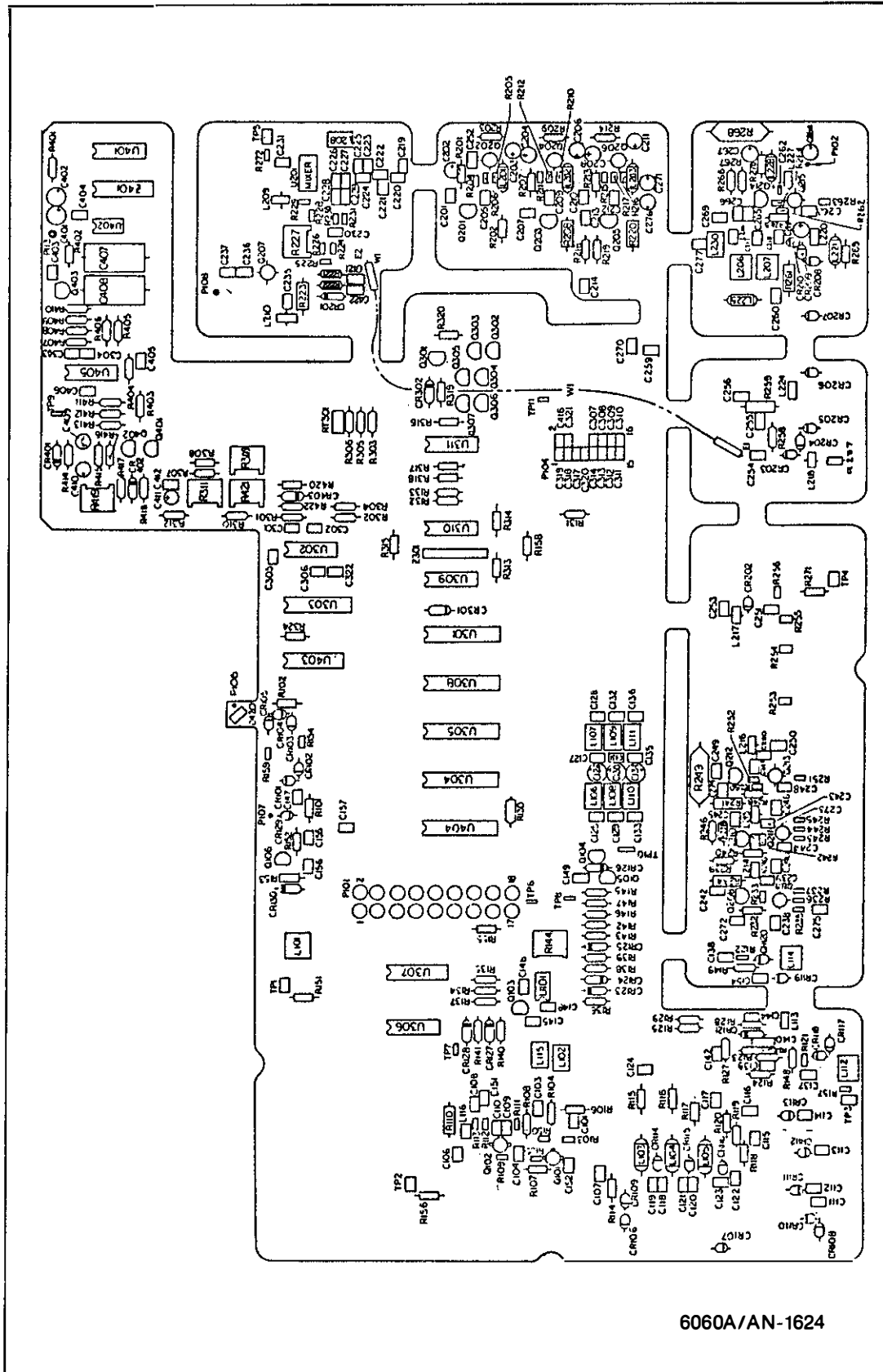

Figure 5-8. A2A4 Output PCA

LIST OF REPLACEABLE PARTS

TABLE 5-9. A2A5 ATTENUATOR/RPP ASSEMBLY

REFERENCE DESIGNATOR A- NUMERICS	S	DESCRIPTION	FLUKE STOCK --NO--	MFRS SPLY CODE	MANUFACTURERS PART NUMBER --OR GENERIC TYPE--	TOT QTY	R S	N O T E
A	4	ATTENUATOR/RPP PCA	752667	89536	752667	1		
A	5	RELAY DRIVER/RPP PCA	752816	89536	752816	1		
FL	1	FILTER, RF, EYELET STYLE, 2000PF, BL	529495	89536	529495	11		
H	1	SCREW, MACH, PHP, STL, 6-32X1/4	152140	89536	152140	1		
H	2	SCREW, MACH, PHP, STL, 6-32X1/2	152173	89536	152173	7		
H	3	SCREW, MACH, PHP, STL, 6-32X7/8	114868	89536	114868	11		
H	4	SCREW, MACH, PHP, STL, 6-32X1/2	152173	89536	152173	2		
HP	1	HOUSING, PLATED, ATTENUATOR, RELAYVERSN	717017	89536	717017	1	1	
U	26	* IC, 2K X 8 EPROM	454603	81295	TMS2516JL	1		
W	24	CABLE ASSEMBLY, ATTENUATOR	752725	89536	752725	1		

FOR MODULE EXCHANGE, ORDER P/N 750414 (INCLUDES CALIBRATED EPROM)

LIST OF REPLACEABLE PARTS

TABLE 5-10. A2A5A4 ATTENUATOR/RPP PCA
(SEE FIGURE 5-9.)

REFERENCE DESIGNATOR A->NUMERICS-->	S	DESCRIPTION	FLUKE STOCK --NO--	MFRS SPLY CODE	MANUFACTURERS PART NUMBER --OR GENERIC TYPE--	TOT QTY	R S -Q	N O T -E
C 1, 2, 4		CAP,CER,1000PF,+20%,50V,X7R	514059	89536	514059	3		
C 3, 5		CAP,AL,4.7UF,+10%,15V	519363	56289	193D475X9015C2	2		
C 6, 7		CAP,POLYES,0.1UF,+20%,50V	732883	89536	732883	2		
CR 1	*	DIODE,SI,SCHOTTKY BARRIER,SMALL SIGNAL	535195	28480	5082-2800	1	2	
CR 2- 9	*	DIODE,SI,BV= 70.0V,500 MW	454181	03508	1N4606	8		
H 1		WASHER,SPRNG,COPPER,0.316 ID	544239	89536	544239	8		
J 2		CONN,COAX,SMA,REC,PWB OR BLKHD	512087	16733	705147-001	1		
J 3		CONN,SOCKET,SPRING TYPE,.0690D,.143L	732826	89536	732826	1		
K 1- 8		RELAY,ARMATURE,2 FORM C,26.5VDC	528638	11532	712-26	8		
P 1- 8		CONN,SOCKET,PWB,0.049 DIAMETER	544056	89536	544056	8		
P 9- 11		CONN,SOCKET,PWB,0.038 DIAMETER	386141	89536	386144	3		
R 1, 7, 10,		RES,MF,402,+0.5%,0.125W,50PPM	461632	89536	461632	5		
R 16, 19			461632					
R 2, 3, 8,		RES,MF,56.9,+0.5%,0.125W,50PPM	461590	89536	461590	10		
R 9, 11, 12,			461590					
R 17, 18, 20,			461590					
R 21			461590					
R 4		RES,MF,94.2,+0.5%,0.125W,50PPM	461616	89536	461616	1		
R 5 6		RES,MF,83.5,+0.5%,0.125W,50PPM	461608	89536	461608	2		
R 13		RES,MF,37.4,+0.5%,0.125W,50PPM	461079	89536	461079	1	1	
R 14, 15		RES,MF,150,+0.5%,0.125W,50PPM	461624	89536	461624	2		
R 22		RES,CC,10K,+5%,0.125W	643940	01121	BB1035	1		

ALL COMPONENTS NON FIELD REPLACEABLE

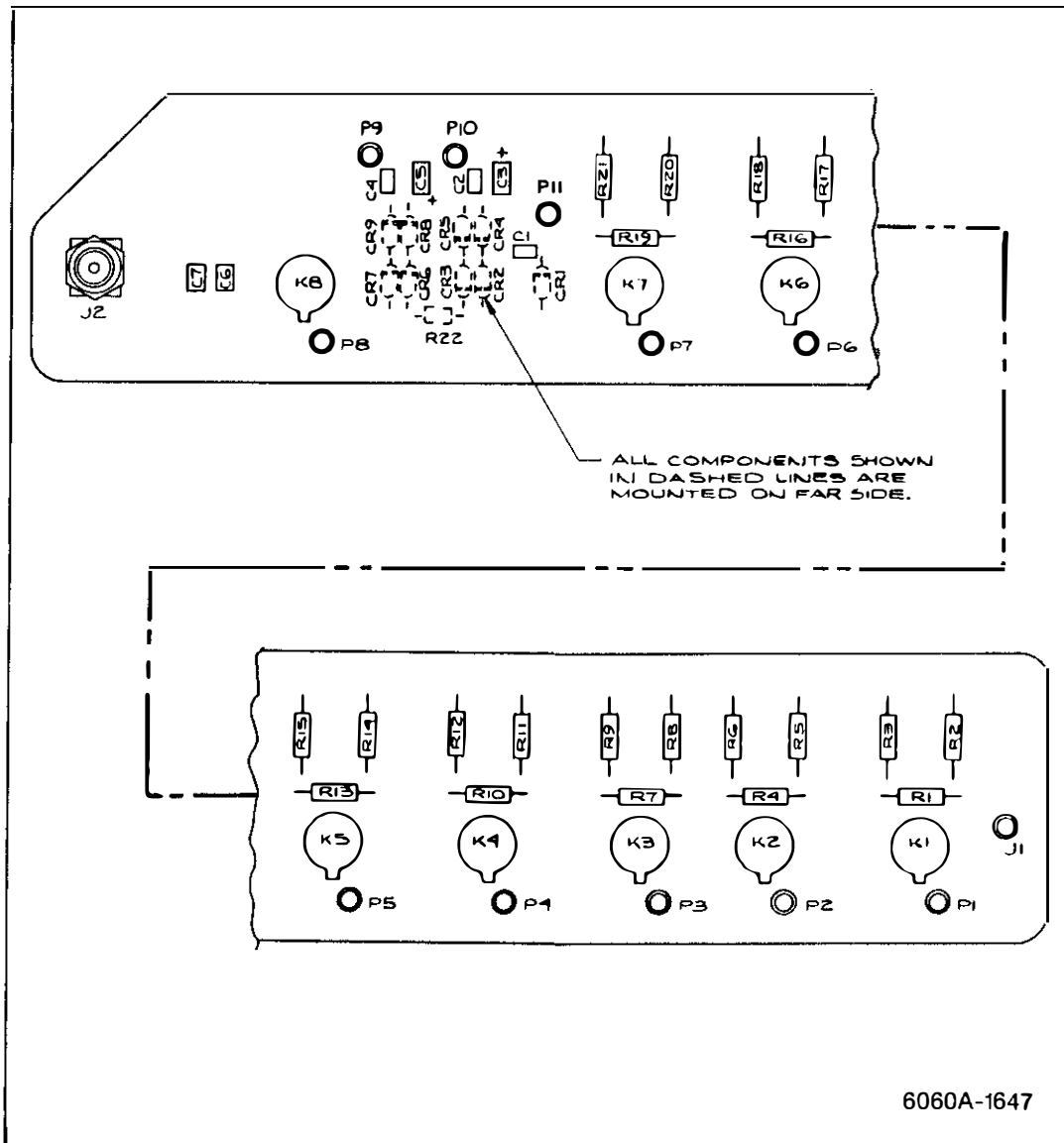

Figure 5-9. A2A5A4 Attenuator/RPP PCA

LIST OF REPLACEABLE PARTS

TABLE 5-11. A2A5A5 RELAY DRIVER/RPP PCA
(SEE FIGURE 5-10.)

REFERENCE DESIGNATOR	DESCRIPTION	FLUKE STOCK	MFRS SPLY --NO--	MANUFACTURERS PART NUMBER --OR GENERIC TYPE--	TOT QTY	R S -Q	N O T -E
C 1- 7, 11	CAP,POLYES,0.1UF,+20%,50V	732883	89536	732883	8		
C 8, 9, 12, 13	CAP,CER,0.01UF,+20%,100V,X7R	487361	72982	8121-A100-W5R-103M	4		
C 10, 16	CAP,CER,0.22UF,+20%,50V,Z5U	519157	51406	RPE111Z5U224M50V	2		
C 14, 15	ELECTRO, MIN,L0 LEAK, 4.7MF, 35V	603993	89536	463993	2		
CR 11- 14, 16, 17	* DIODE,SI,BV= 75.0V,I0=150MA,500 MW	263323	07910	1N4448	6	1	
J 2	* SOCKET,DIP,0.100 CTR,24 PIN	376236	91506	324-AG39D	1		
L 1- 10	CHOKE,6TURN	320911	89536	320911	10		
L 11	INDUCTOR,470 UH,+/-5%,6.5 MHZ,SHLDED	147827	72259	WEE470	1		
L 12, 13	INDUCTOR,47 UH,+/-5%,26.5 MHZ,SHLDED	147850	72259	WEE47	2	2	
P 1- 11	CONN,SOCKET,PWB,0.049 DIAMETER	544056	89536	544056	11		
Q 1- 7, 9	* TRANSISTOR,SI,PNP,SMALL SIGNAL	418707	04713	MPS56562	8	1	
Q 8	* TRANSISTOR,SI,NPN,SMALL SIGNAL	330803	07263	MPS6560	1	1	
R 1, 4, 7, 10, 13, 16, 19, 38	RES,CF,510,+5%,0.25W	441600	80031	CR251-4-5P510E	8	1	
R 2, 5, 8, 11, 14, 17, 20, 39, 41	RES,CF,4.7K,+5%,0.25W	441600	01121	CB4725	9		
R 3, 6, 9, 12, 15, 18, 21, 40	RES,CF,100,+5%,0.25W	348821	80031	CR251-4-5P100E	8		
R 22, 23, 29, 35, 36, 42, 45	RES,CF,1K,+5%,0.25W	348771	80031	CR251-4-5P1K	7		
R 24	RES,CF,30K,+5%,0.25W	343426	80031	CR251-4-5P30K	1		
R 25, 30, 31, 37	RES,CF,10K,+5%,0.25W	368753	80031	CR251-4-5P10K	4		
R 27	RES,MF,1.07K,+1%,0.125W,100PPM	348839	89536	344325	1		
R 28	RES,MF,422,+1%,0.125W,100PPM	344325	91637	CMF554220F	1		
R 32	RES,MF,1.5K,+1%,0.125W,100PPM	288506	91637	CMF551501F	1		
R 33	RES,CF,56,+5%,0.25W	313098	80031	CR251-4-5P56E	1		
R 34	RES,CF,100K,+5%,0.25W	342618	80031	CR251-4-5P100K	1		
R 43	RES,CF,13K,+5%,0.25W	348920	80031	CR251-4-5P13K	1		
R 44	RES,CF,2K,+5%,0.25W	441402	80031	CR251-4-5P2K	1		
R 46	RES,CF,470,+5%,0.25W	441469	80031	CR251-4-5P2K	1		
R 47	RES,CF,12K,+5%,0.25W	343434	80031	CR251-4-5P470E	1		
R 48	RES,CF,4.3K,+5%,0.25W	348847	80031	CR251-4-5P12K	1		
TP 1- 11	CONN,POST,PWB,.025SQ,NON-INSUL,SELECT	415176	80031	CR251-4-5P4K3	20	1	
U 1	* IC,OP AMP,QUAD,JFET INPUT,TO-5 CASE	267500	00779	87022-1	1		
VR 1- 7, 15	* ZENER,UNCOMP, 30.0V,10%, 4.2MA, 0.4W	483438	89536	483438	8		
VR 8, 9, 18	* ZENER,UNCOMP, 4.7V, 5%, 20.0MA, 0.4W	272633	04713	1N972A	3	2	
VR 10	* ZENER,COMP, 6.4V, 5%, 1 PPM TC, 2.0MA	524058	14552	1N751	1	2	
		381988	89536	381988	1		

1 ALSO INCLUDES J1.

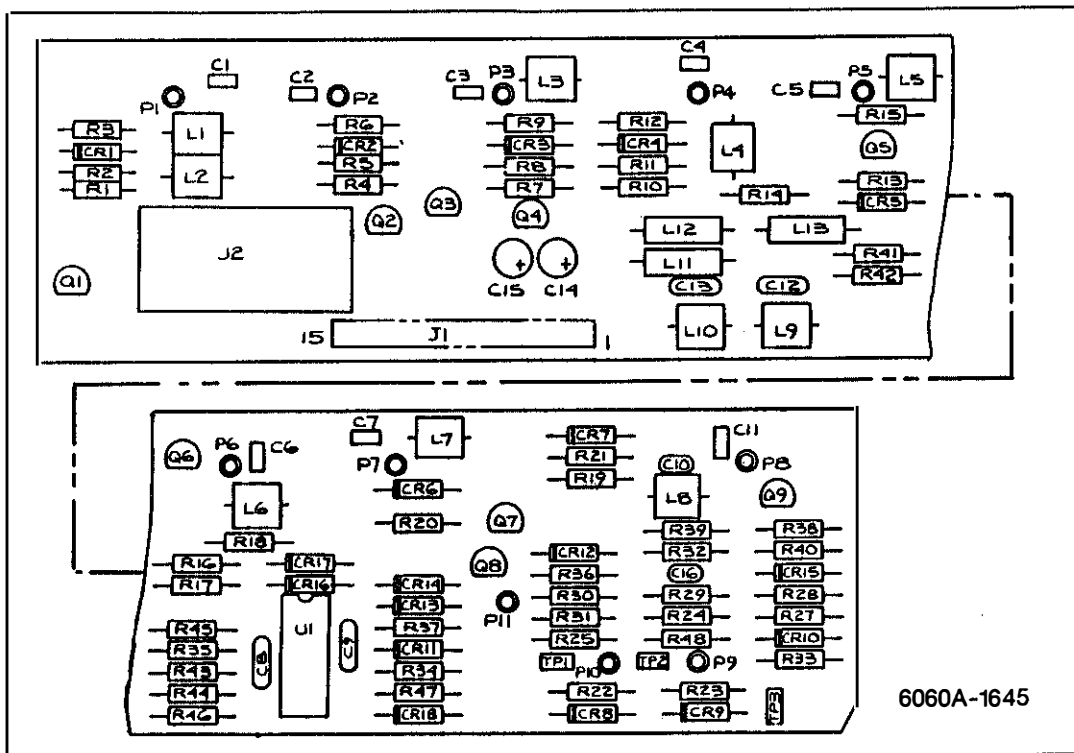

Figure 5-10. A2A5A5 Relay Driver/RPP PCA

LIST OF REPLACEABLE PARTS

TABLE 5-12. A2A7 CONTROLLER PCA
(SEE FIGURE 5-11.)

REFERENCE DESIGNATOR A)-NUMERICS-->	S	DESCRIPTION	FLUKE STOCK --NO--	MFRS SPLY CODE--	MANUFACTURERS PART NUMBER --OR GENERIC TYPE---	TOT QTY	R S	N O T -E
C 1		CAP, AL, 47UF, +50-20%, 16V	436006	62643	SM/VB	1		
C 2, 6, 7,		CAP, POLYES, 0.22UF, +-10%, 50V	696492	89536	696492	26		
C 10- 13, 16,			696492					
C 18, 19, 21,			696492					
C 23- 25, 28-			696492					
C 31, 34, 35,			696492					
C 39- 42, 44,			696492					
C 45			696492					
C 3		CAP, TA, 0.47UF, +-20%, 35V	161349	56349	196D474X0035HA1	1		
C 4, 5		CAP, TA, 10UF, +-20%, 20V	330662	56289	196D106X0020KA1	2		
C 22, 51, 53-		CAP, CER, 220PF, +-10%, 1000V, Z5F	368605	89536	368605	7		
C 57			368605					
C 50, 52, 58,		CAP, CER, 2000PF, +100-0%, 1000V, Z5U	105569	71590	DA140-139CB	4		
C 59			105569					
C 60		CAP, CER, 100PF, +-10%, 1000V, S3N	105593	71590	DD-101	1		
C 61		CAP, CER, 22PF, +-2%, 100V, COG	512871	89536	512871	1		
CR 1	*	DIODE, S1, BV= 75.0V, IO=150MA, 500 MW	203323	07910	1N4448	1	1	
J 101, 105, 107		CONN, POST, PWB, .025SQ, NON-INSUL, SELECT	267500	00779	87022-1	53		
J 102		SOCKET, SIP, 0.100 CTR, 16 PIN	485037	30035	SS-109-1-16C	2		
J 106		CONN, PWB, HEADER, DIP, 90, 0.100, 26 PIN	512590	89536	512590	1		
L 1, 2		CHOKO, 6TURN	320911	89536	320911	2	1	
P 101		CONN, SOCKET, PWB, 0.049 DIAMETER	544056	89536	544056	18		
R 1, 6- 11		RES, CF, 180, +-5%, 0.25W	441436	80031	CR251-4-5P180E	7		
R 2, 13		RES, CF, 4.7K, +-5%, 0.25W	348821	01121	CB4725	2		
R 3		RES, CF, 20K, +-5%, 0.25W	441477	80031	CR251-4-5P20K	1		
R 4		RES, CF, 390K, +-5%, 0.25W	442475	80031	CR251-4-5P390K	1		
R 5		RES, CF, 100K, +-5%, 0.25W	348920	80031	CR251-4-5P100K	1		
R 12		RES, CF, 100, +-5%, 0.25W	348771	80031	CR251-4-5P100E	1		
R 14, 15		RES, CF, 1.3K, +-5%, 0.25W	441394	80031	CR251-4-5P1K3	2		
S 1		SWITCH, DIL, 6-POS, SPST, ASSY	454124	00779	435166-4	1		
U 1	*	IC, NMOS, 16 BIT MICROCOMPUTER	640417	01295	TMS995N	1		
U 2	*	IC, LSTTL, HEX BUFFER W/NOR ENABLE	483800	01295	SN74LS367N	1	1	
U 3, 4, 18	*	IC, LSTTL, OCTAL BUS TRNSCVR W/3-ST OUT	477406	01295	SN74LS245N	3	1	
U 5, 44	*	IC, LSTTL, HEX INVERTER	393058	01295	SN74LS04N	2	1	
U 7	*	IC, COMPARATOR, DUAL, LD-PWR, 8 PIN DIP	478354	12040	LM393N	1	1	
U 8	*	IC, LSTTL, TRIPLE 3 INPUT NAND GATE	393074	01295	SN74LS10N	1	1	
U 9	*	IC, LSTTL, HEX D F/F, +EDG TRG, W/CLEAR	393207	01295	SN74LS174N	1	1	
U 10	*	IC, STTL, QUAD 2 INPUT OR GATE	604629	01295	SN74S32N	1	1	
U 11, 40	*	IC, LSTTL, OCTAL D TRANSPARENT LATCHES	504514	01295	SN74LS373N	2	1	
U 14	*	IC, LSTTL, 2-4 LINE DEMUX	393165	01295	SN74LS139N	1	1	
U 15, 16, 33,	*	IC, LSTTL, OCTAL LINE DRVR W/3-STATE OUT	429035	01295	SN74LS244N	4	1	
U 34	*		429035					
U 17, 27	*	IC, LSTTL, OCTAL D F/F, +EDG TRG, W/CLEAR	454892	01295	SN74LS273N	2	1	
U 20, 35, 36,	*	IC, LSTTL, 3-8 LINE DCDR W/ENABLE	407585	01295	SN74LS138N	4	1	
U 38	*		407585					
U 21		EPROM, PROGRAMMED 2764 (FOR 100KHZ)	792767	89536	792767	1		
U 22		EPROM, PROGRAMMED 27256 (FOR 100KHZ)	792754	89536	792754	1	1	
U 25	*	IC, 2K X 8 STAT RAM	584144	33297	uPD4016C-2	1		
U 30, 31	*	IC, ARRAY, 7 TRANS, NPN, DARLINGTON PAIRS	454116	01295	U1N2003	2	1	
U 37	*	IC, LSTTL, QUAD 2 INPUT OR GATE	393108	01295	SN74LS32N	1	1	
U 42	*	IC, LSTTL, DUAL JK F/F, -EDG TRIG	414029	01295	SN74LS112N	1	1	
XU 1		SOCKET, DIP, 0.100 CTR, 40 PIN	429282	09922	DILB40P-108	1		
XU 2, 9, 14,		SOCKET, DIP, 0.100 CTR, 16 PIN	276535	91506	316-AG39D	10		
XU 20, 30, 31,			276535					
XU 35, 36, 38,			276535					
XU 42			276535					
XU 3, 4, 11,		SOCKET, DIP, 0.100 CTR, 20 PIN	454421	09922	DILB20P-108	11		
XU 15- 18, 27,			454421					
XU 33, 34, 40			454421					
XU 5, 8, 10,		SOCKET, DIP, 0.100 CTR, 14 PIN	276527	09922	DILB8P-108	5		
XU 37, 44			276527					
XU 7		SOCKET, DIP, 0.100 CTR, 8 PIN	478016	91506	308-AG39D	1		
XU 21, 22		SOCKET, DIP, 0.100 CTR, 28 PIN	448217	91506	328-AG39D	2		
XU 23- 26		SOCKET, DIP, 0.100 CTR, 24 PIN	376236	91506	324-AG39D	4		
Y 41	*	CRYSTAL, 10MHZ, +-0.01%, HC-18/U	520239	89536	520239	1	1	
Z 1		RES, NET, SIP, 10 PIN, 9 RES, 4.7K, +-2%	484063	80031	95081002CL	1		
Z 2- 5		RES, NET, SIP, 10 PIN, 9 RES, 10K, +-2%	414003	80031	95081002CL	4		

NOTE

- U23 EPROM PART OF A2A2
- U24 EPROM PART OF A2A4
- U26 EPROM PART OF A2A5

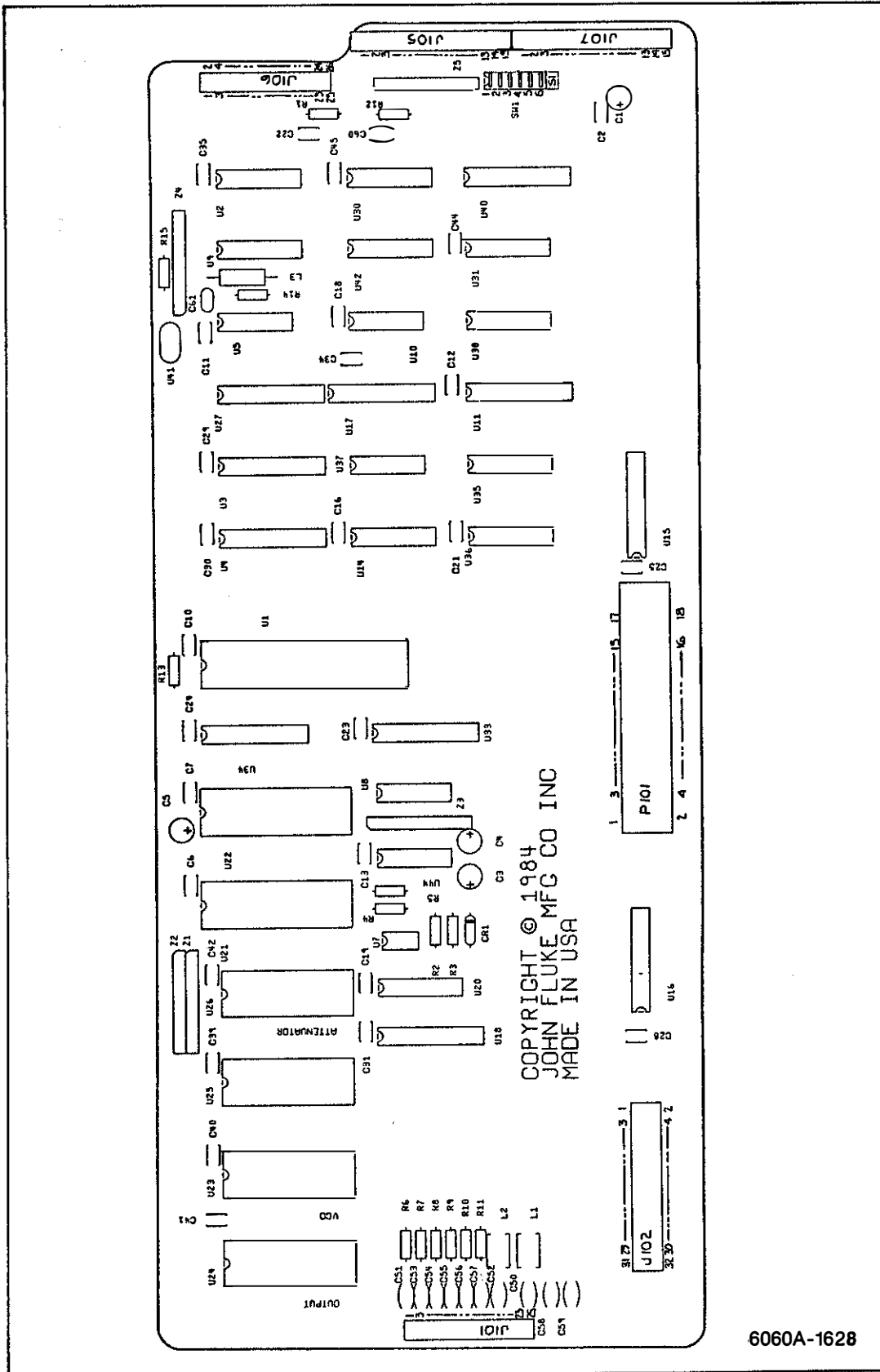

Figure 5-11. A2A7 Controller PCA

LIST OF REPLACEABLE PARTS

TABLE 5-13. A2A8 NON-VOLATILE (STORE/RECALL) MEMORY PCA
(SEE FIGURE 5-12.)

REFERENCE DESIGNATOR	A->NUMERICS-->	S	DESCRIPTION	FLUKE STOCK	MFRS SPLY CODE	MANUFACTURERS PART NUMBER OR GENERIC TYPE	TOT QTY	R S -Q	N O T -E
C	1		CAP, TA, 10UF, +-20%, 20V	330662	56289	196D106X0020KA1	1		
C	2-6		CAP, POLYES, 0.22UF, +-10%, 50V	696492	89536	696492	5	1	
CR	1, 2	*	DIODE, SI, BV= 75.0V, IO=150MA, 500 MW	203323	07910	1N4448	2		
CR	3	*	ZENER, UNCOMP, 3.3V, 10%, 20.0MA, 0.4W	309799	04713	1N746	1	1	
P	1		CONN, POST, PWB, .025SQ, NON-INSUL, SELECT	267500	00779	87022-1	32		
Q	1	*	TRANSISTOR, SI, PNP, SMALL SIG, SELECTED	380394	89536	380394	1	1	
Q	2, 3	*	TRANSISTOR, SI, NPN, SMALL SIGNAL	218396	04713	2N3904	2	1	
Q	4	*	TRANSISTOR, SI, N-DMOS FET, TO-72	477229	18324	SD213EE	1	1	
R	1		RES, MF, 432, +-1%, 0.125W, 100PPM	326397	91637	CMF554320F	1		
R	2		RES, MF, 33.2, +-1%, 0.125W, 100PPM	296681	91637	CMF553320F	1	1	
R	3		RES, MF, 100, +-1%, 0.125W, 100PPM	168195	91637	CMF551000F	1		
R	4		RES, MF, 562, +-1%, 0.125W, 100PPM	340828	91637	CMF555620F	1		
R	5		RES, CF, 100K, +-5%, 0.25W	348920	80031	CR251-4-5P100K	1		
R	6		RES, CF, 10K, +-5%, 0.25W	348839	80031	CR251-4-5P10K	1		
TP	1, 2		CONN, TAB, FASTON, PRESS-IN, 0.110 WIDE	512889	02660	62395	2		
U	1	*	IC, 2K X 8 STAT RAM	647222	51157	HM6116P-3	1		
U	2	*	IC, LSTTL, OCTL BUS TRNSVR W/3-STATE OUT	477406	01295	SN74LS245N	1	1	
U	3	*	IC, LSTTL, OCTL LINE DRVR W/3-STATE OUT	429035	01295	SN74LS244N	1	1	
U	4	*	IC, LSTTL, QUAD BUS BUF W/3-STATE OUT	472746	01295	SN74LS125N	1	1	
U	5	*	IC, TTL, TRIPLE 3 INPUT NAND GATE	363465	01295	SN7412N	1	1	
U	6	*	IC, LSTTL, HEX INVERTER	393058	01295	SN74LS04N	1	1	
XU	1		SOCKET, DIP, 0.100 CTR, 24 PIN	376236	91506	324-AG39D	1		
XU	2, 3		SOCKET, DIP, 0.100 CTR, 20 PIN	454421	09922	DIL820P-108	2		
XU	4-6		SOCKET, DIP, 0.100 CTR, 14 PIN	276527	09922	DIL88P-108	3		
Z	1		RES, NET, SIP, 6 PIN, 5 RES, 10K, +-2X	500876	80031	95081002CL	1		

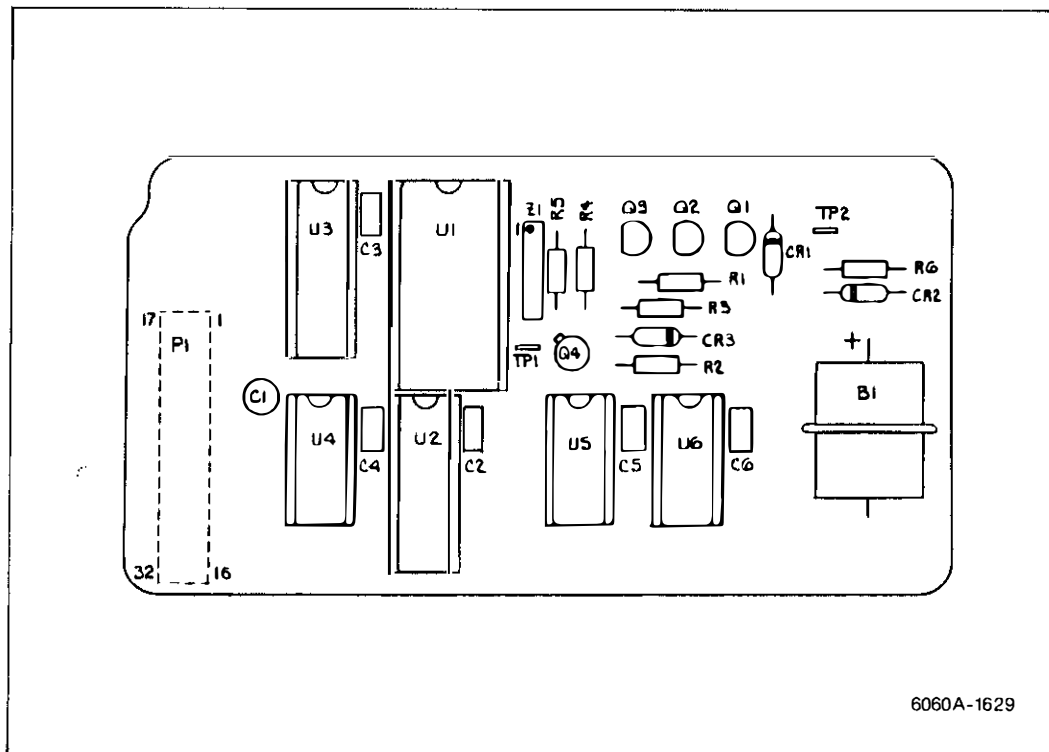

Figure 5-12. A2A8 Non-Volatile (Store/Recall) Memory PCA

LIST OF REPLACEABLE PARTS

TABLE 5-14. A3A1 POWER SUPPLY PCA
(SEE FIGURE 5-13.)

REFERENCE DESIGNATOR A->NUMERICS-->	S	DESCRIPTION	FLUKE STOCK --N0--	MFRS SPLY CODE-	MANUFACTURERS PART NUMBER --OR GENERIC TYPE--	TOT QTY	R S T -Q -E
C 1		CAP,AL,2200UF,+30-10%,35V	715334	89536	715334	1	
C 2, 5		CAP,AL,10000UF,+30-20%,35V	614990	89536	614990	2	
C 3, 6, 12		CAP,CER,0.1UF,+20%,50V,X7R	573808	72892	8131-050-W5R100NFM	3	
C 4, 7, 15,		CAP,TA,6.8UF,+20%,35V	363713	56289	196D685X0035KA1	4	
C 20			363713				
C 8		CAP,AL,15000UF,+30-10%,25V	732958	89536	732958	1	
C 9, 21, 22		CAP,TA,2.2UF,+20%,20V	161927	56289	196D225X0020HA1	3	
C 10		CAP,TA,22UF,+20%,15V	423012	56289	196D226X0015KA1	1	
C 11		CAP,AL,470UF,+30-20%,80V	574160	62643	NH	1	
C 13, 14		CAP,TA,4.7UF,+20%,50V	363721	56289	196D475X9015HA1	2	
C 16-19		CAP,POLYES,0.22UF,+20%,100V	436113	73445	C280MAH1A220K	4	1
CR 1, 2, 6	*	DIODE,SI,RECT,BRIDGE,BV=200V,IO=1.0A	296509	09423	FR200	3	1
CR 3, 4, 8	*	DIODE,SI,100 PIV, 1.0 AMP	343491	01295	1N4002	3	1
CR 5		DIODE,SI,45PIV,7.5A,DUAL SCHOTTKY	741322	89536	741322	1	1
CR 6	*	THYRISTOR,SI,TRIAC,VBO=200V,8.0A	413013	02735	T2800B	1	
CR 9, 10	*	ZENER,UNCOMP,62.0V,5%,20MA,5.0W	559567	89536	559567	2	1
H 1		SCREW,HACH,PHP SEHS,STL,4-40X1/4	185918	89536	185918	1	
H 2		NUT,HACH,HEX,STL,4-40	110635	89536	110635	1	
J 1		CONN,PWB,HEADER,SIP,0.156,12 PIN	512160	27264	09-80-1123	1	
J 2		CONN,PWB,HEADER,SIP,0.156,5 PIN	512186	27264	09-80-1053	1	1
J 3-6		CONN,POST,PWB,.025SQ,NON-INSUL,SELECT	267500	00779	87022-1	39	
HP 1		HEATSINK, TO-220	524934	13103	6025B-TT	1	
R 1		RES,MF,249,+1%,0.125W,100PPM	168203	91637	CHF55249F	1	
R 2		RES,MF,6.65K,+1%,0.125W,100PPM	294918	91637	CHF551272F	1	
R 3		RES,VAR,CERM,1K,+10%,0.5W	285155	71450	360S102A	1	
R 4		RES,CF,10K,+5%,0.25W	348839	80031	CR251-4-5P10K	1	
R 6-9		RES,CF,5.1,+5%,0.25W	441287	80031	CR251-4-5P5R1	4	
R 10, 13		RES,CF,220,+5%,0.25W	342626	80031	CR251-4-5P220E	2	
R 11		RES,CF,1,+5%,0.25W	357665	80031	CR251-4-5P1E	1	
R 12		RES,CF,0.51,+5%,0.25W	381954	80031	CR251-4-5P05E	1	
S 1		SLIDE SWITCH,DPDT SWIDGET JR.	452862	89536	452862	1	1
TP 1-11		CONN,TAR,FASTON,PRESS-IN,0.110 WIDE	512889	02660	62395	11	
VR 7	*	ZENER,UNCOMP, 6.2V, 5%, 20.0MA, 0.4W	325811	07910	1N753A	1	1

U1,2,4,5 AND A3U1 LISTED IN TABLE 5-4 (A3).

LIST OF REPLACEABLE PARTS

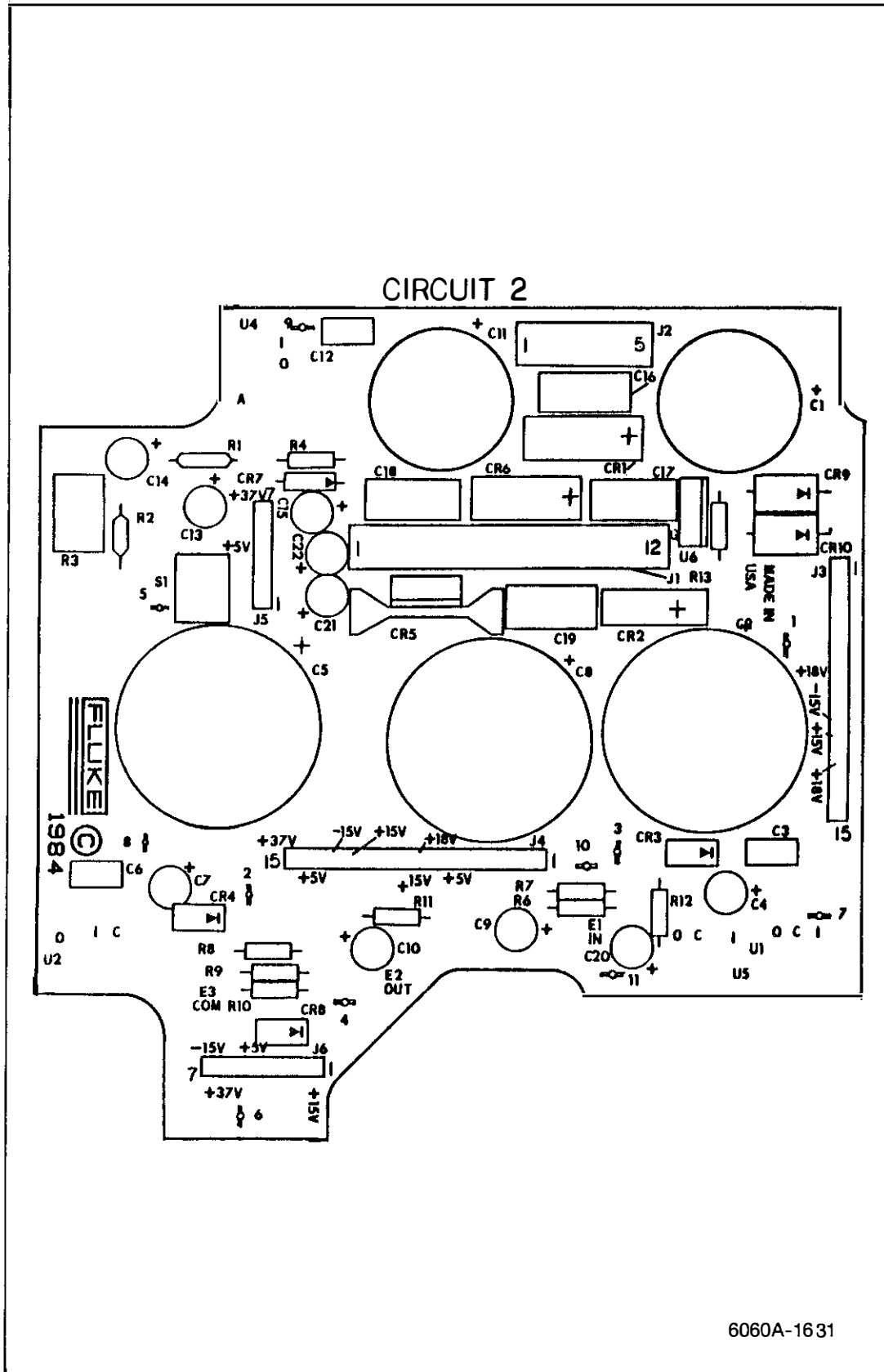

Figure 5-13. A3A1 Power Supply PCA

Section 6 Options

OPTION NO.	TITLE	PAGE
-130	High-Stability Reference	130-1
-132	Medium-Stability Reference	132-1
-488	IEEE-488 Interface	488-1
-651	Low-Rate Fm	651-1
-830	Rear Panel RF Output and Mod Input	830-1

OPTIONS

6-1. INTRODUCTION

This section includes the theory of operation, a circuit description, and maintenance instructions for each option. The IEEE-488 Interface option Theory of operation is covered in Section 2.

Option -130 High-Stability Reference

130-1. INTRODUCTION

Option -130 the High-Stability Reference, with the rear panel REF INT/EXT switch set to INT, configures the Generator's reference to be supplied by the High-Stability Reference.

130-2. OPERATION

The High-Stability Reference consists of the Auxiliary Power Supply (A3A2), and an Ovened Oscillator (Y1). The Auxiliary Power Supply is mounted inside the Generator on the rear panel, and the Ovened Oscillator is mounted inside the instrument on the side rail. Only the Auxiliary Power Supply is field repairable, and it is described here. The Auxiliary Power Supply is also available under the Module Exchange program.

130-3. CIRCUIT DESCRIPTION

The Auxiliary Power Supply is connected directly to the line power on the fuse/filter/line-voltage selector assembly to supply power to the Ovened Oscillator even when the Generator POWER switch is off. The Auxiliary Power Supply PCB (A3A2A1) includes a linear-regulated supply and an automatic line-voltage selector circuit.

The linear-regulated supply consists of a diode rectifier bridge CR1, filter capacitor C1, voltage regulator U1, and associated resistors R2, R3, and R4. The circuit associated with CR3, Q1 and U2, provides automatic line voltage selection between two line-voltage ranges. This is implemented by configuring the rectifier circuit as a bridge rectifier for the lower line voltages or as a center-tapped, full-wave rectifier for the higher line voltages.

At low line voltages (less than approximately 150V ac), transistor Q1 is conducting, thus grounding the minus terminal of rectifier CR1 and causing diode CR3 to be reverse biased. This causes the full secondary voltage of T1 to be rectified by the bridge rectifier, CR1.

When the line voltage is greater than 180V ac, (there is approximately 30V hysteresis), the comparator U2 turns off transistor Q1. Diode CR3 becomes forward biased, and the transformer center tap is effectively grounded. The voltage applied to the rectifier CR1 is then half the secondary voltage.

The comparator U2 input voltages are set by resistors R1, R6, R9, and zenerdiode CR4. U2 controls the base of transistor Q1. The comparator switching point is set between the low and high line voltages, with sufficient hysteresis to accommodate variations in input loading. At very low line voltages, the resistor diode combination R10 and CR5, from the 37V output of the main power supply, augment the Auxiliary Power Supply.

OPTION -130
HIGH STABILITY REFERENCE

The Ovened Oscillator output is disabled when the control line EXREFL is set low, i.e., when the REF INT/EXT switch is set to EXT during external reference operation. The status line HSOPTL, normally at +5V, is pulled to ground when the High-Stability Reference option is installed.

130-4. ADJUSTMENTS

TEST EQUIPMENT

Frequency Standard
Oscilloscope
Two 3-ft. 50- Ω coaxial cables, Y9111

REMARKS

The voltage adjustment (A3A2A1-R4) should be made after the first half hour of the three-hour Generator warmup period has begun. For the best results in the frequency accuracy adjustment, the Generator should be operated at room temperature for at least three hours before continuing with the adjustment procedures.

PROCEDURE

The High-Stability Reference Power supply voltage is first adjusted. Then the UUT reference and the Frequency Standard waveforms are viewed on the oscilloscope while triggering on the Frequency Standard. The ovened oscillator FREQ ADJ, COARSE, and then FINE are adjusted for a stationary display.

Voltage Adjustment

1. Remove the Generator top cover.
2. Connect the DMM to the UUT. Connect the positive lead to TP1 and the negative lead to TP3.
3. Adjust R4 for $23.4 \pm 0.1V$.
4. Remove the DMM connections from the UUT and replace the top cover (temporarily). Wait the remaining Generator warmup time, and perform the frequency accuracy adjustment.

Frequency Adjustment

1. Remove the top Generator cover and the two FREQ ADJ access screws from the top of the ovened oscillator.
2. Connect the Frequency Standard signal to the oscilloscope vertical input channel 1, 50 Ohms termination. Connect the UUT rear panel 10 MHz OUT to the oscilloscope vertical input channel 2, 50 Ohms termination.
3. Set the UUT rear panel UUT REF INT/EXT switch to INT.
4. Set the vertical controls of the oscilloscope to display the UUT 10-MHz signal and the Frequency Standard 10-MHz signal. Set for internal triggering on channel 1, and adjust timebase for $0.1\mu\text{sec/div}$.

5. Adjust the oscilloscope COARSE, and then adjust the FINE controls for a drift of less than one cycle in 10 seconds (for 0.01 ppm or better if desired).

130-5. LIST OF REPLACEABLE PARTS

Table 130-1 lists replaceable parts for the 6060A-130. Figure 130-1 is the component location diagrams for the 6060-130.

**OPTION -130
HIGH STABILITY REFERENCE**

TABLE 130-1. A3A2A1 HIGH-STABILITY (OVENED) REFERENCE PCA
(SEE FIGURE 130-1.)

REFERENCE DESIGNATOR	A->NUMERICS-->	S	DESCRIPTION	FLUKE STOCK	MFRS SPLY --NO--	MANUFACTURERS PART NUMBER --OR GENERIC TYPE--	TOT QTY	R S	N D
								-Q	-E
C	1		CAP, AL, 470UF, +50-20%, 50V	470792	89536	478792	1		
C	2, 6		CAP, TA, 4.7UF, +-20%, 50V	363721	56289	196D475X*015MA1	2		
C	3, 4		CAP, TA, 10UF, +-20%, 35V	417683	56289	196D104X0035KA1	2		
C	5		CAP, AL, 100UF, +50-20%, 50V	649731	89536	649731	1		
C	7		CAP, POLYES, 0.1UF, +-10%, 50V	696484	89536	696484	1		
C	8		CAP, POLYES, 0.1UF, +-10%, 100V	393439	80031	719A1	1		
CR	1	*	DIODE, SI, RECT, BRIDGE, BV=200V, IO=1.0A	296509	09423	FB200	1	1	
CR	2, 3, 5	*	DIODE, SI, 100 FIV, 1.0 AMP	343491	01295	1N4002	3	1	
CR	6	*	DIODE, SI, BV= 75.0V, IO=150MA, 500 MW	203323	07910	1N4448	1	1	
J	2, 3		CONN, POST, PWB, .025SQ, NON-INSUL, SELECT	267500	00779	87022-1	10		
Q	1		TRANSISTOR, SI, BV=60V, 65W, TO-220	386128	89536	386128	1		
R	1		RES, MF, 49.9K, +-1%, 0.125W, 100PPM	268821	91637	CHF554992F	1		
R	2		RES, MF, 249, +-1%, 0.125W, 100PPM	168203	91637	CHF55249F	1		
R	3		RES, MF, 4.02K, +-1%, 0.125W, 100PPM	233325	91637	CHF554021F	1		
R	4		RES, VAR, CERM, 500, +-10%, 0.5W	325613	89536	325613	1	1	
R	5		RES, CC, 2.7, +-5%, 0.5W	218743	89536	218743	1		
R	6, 9		RES, MF, 6.34K, +-1%, 0.125W, 100PPM	267344	91637	CHF556341F	2		
R	7		RES, CF, 4.7K, +-5%, 0.25W	340021	01121	CB4725	1		
R	8		RES, CF, 10K, +-5%, 0.25W	348839	80031	CR251-4--5F10K	1		
R	10		RES, CC, 100, +-10%, 2W	109934	01121	HB1011	1		
T	1		TRANSFORMER, AUXILIARY	731281	89536	731281	1		
TP	1-4		CONN, TAB, FASTON, PRESS-IN, 0.110 WIDE	512889	02660	62395	4		
U	1		IC, VOLT REG, ADJ, 1.2 TO 37V, 1.5 AMPS	460410	89536	460410	1		
U	2	*	IC, COMPARATOR, DUAL, LO-PWR, 8 PIN DIP	478354	12040	LM393N	1		
VR	4	*	ZENER, UNCOMP, 6.2, 2%, 20.0MA, 0.4W	325803	89536	325803	1	1	
Y	1		OSCILLATOR, 10 MMZ	512079	89536	512079	1		

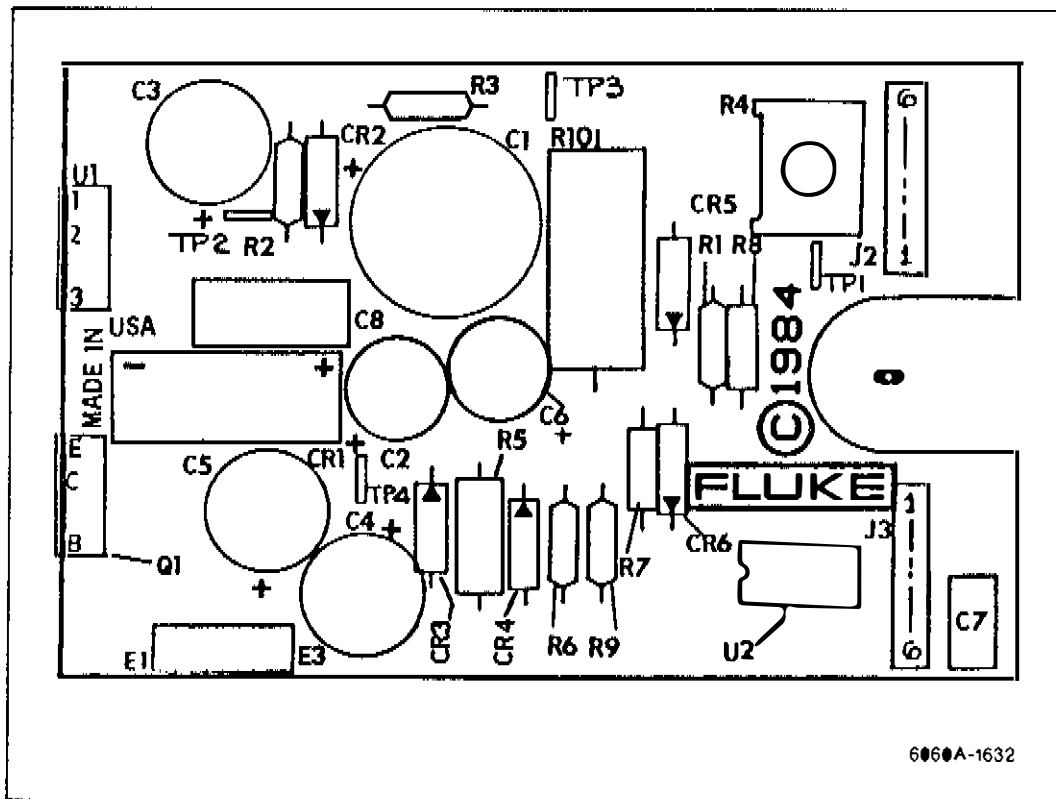

Figure 130-1. A3A2A1 High Stability (Ovened) Reference PCA

Option -132 Medium-Stability Reference

132-1. INTRODUCTION

The Medium-Stability Reference, Option -132, provides the Generator with a medium-stability frequency reference.

132-2. OPERATION

The Medium-Stability Reference is selected as the Generator's reference when the Generator's rear panel REF INT/EXT switch is set to INT.

NOTE

The Medium-Stability Reference does not have standby power nor is its oven kept warm during external reference operation. Therefore, each time the Medium-Stability Reference is selected, a warm-up time is required to meet specifications. The warm-up time is typically 5 to 10 minutes. (See the specifications for details.)

132-3. CIRCUIT DESCRIPTION

The Medium-Stability Reference printed circuit assembly (PCA A5A1) consists of an ovened oscillator (Y1) and an ac-to-TTL converter. The PCA is field repairable and is also available under the Module Exchange Program. The ovened oscillator (Y1) is not field repairable and is not described here.

The PCA is mounted on the left side rail. The PCA is connected to the +5V power supply and to control signals via cable W25. The output is connected to the Synthesizer PCA (A2A1) through cable W24.

Two NAND gates of U1 are used to convert the oscillator's ac-coupled output to a TTL signal. Another NAND gate of U1 and transistor Q1 control the power for the oven and oscillator circuit of Y1.

When the REF INT/EXT switch is set to EXT for external reference operation, the control line EXREFL is set low. This disables the oven and oscillator circuit of Y1 and also disables the ac-to-TTL converter to prevent it from oscillating spuriously.

132-4. ADJUSTMENT

This procedure is used to adjust the frequency of the Medium-Stability Reference. For the best results, the Generator should be warmed up at room temperature before proceeding with the adjustment procedure (see step 1, below).

OPTION -132
MEDIUM STABILITY REFERENCE

The following test equipment is required:

Frequency Standard
Oscilloscope
Two 3-ft, 50-ohm coaxial cables (Fluke Accessory Y9111)

In this procedure, the waveforms of the Unit Under Test (UUT) and the Frequency Standard are viewed on the oscilloscope while triggering on the Frequency Standard. The ovened oscillator's **FREQ ADJ** control is then adjusted for a stationary display.

NOTE

An alternate method of adjustment is to count the 10-MHz reference signal at the 10 MHz OUT connector with a counter that has a suitably stable and accurate reference.

To perform the procedure, proceed as follows:

1. Turn the Generator on, set the REF INT/EXT switch to INT, and then wait 1 hour. (If the Generator has already warmed up for at least 40 minutes, it is sufficient to wait an additional 20 minutes after the the REF INT/ EXT switch is set to INT.)
2. Remove the top Generator cover. The frequency adjustment control is accessed through the upper rear left side.
3. Connect the Frequency Standard's output signal to the oscilloscope's vertical input channel 1, with 50 ohms termination. Connect the UUT's rear panel 10-MHz OUT to the oscilloscope's vertical input channel 2, with 50 ohms termination.
4. Set the vertical controls of the oscilloscope to display the UUT's 10-MHz signal and the Frequency Standard's 10-MHz signal. Set the oscilloscope for internal triggering on channel 1 and adjust the timebase for 0.1 usec/division.
5. Adjust the oscillator **FREQ** for a drift of less than one cycle in 10 seconds (or a counter frequency within 0.1 Hz of 10 MHz) for 0.01 ppm or better if desired.

132-5. LIST OF REPLACEABLE PARTS

A list of replaceable parts for Option -132 is shown in Table 132-1. A component location diagram for Option -132 is shown in Figure 132-1.

Fig 8-11
Sht 1 of 2

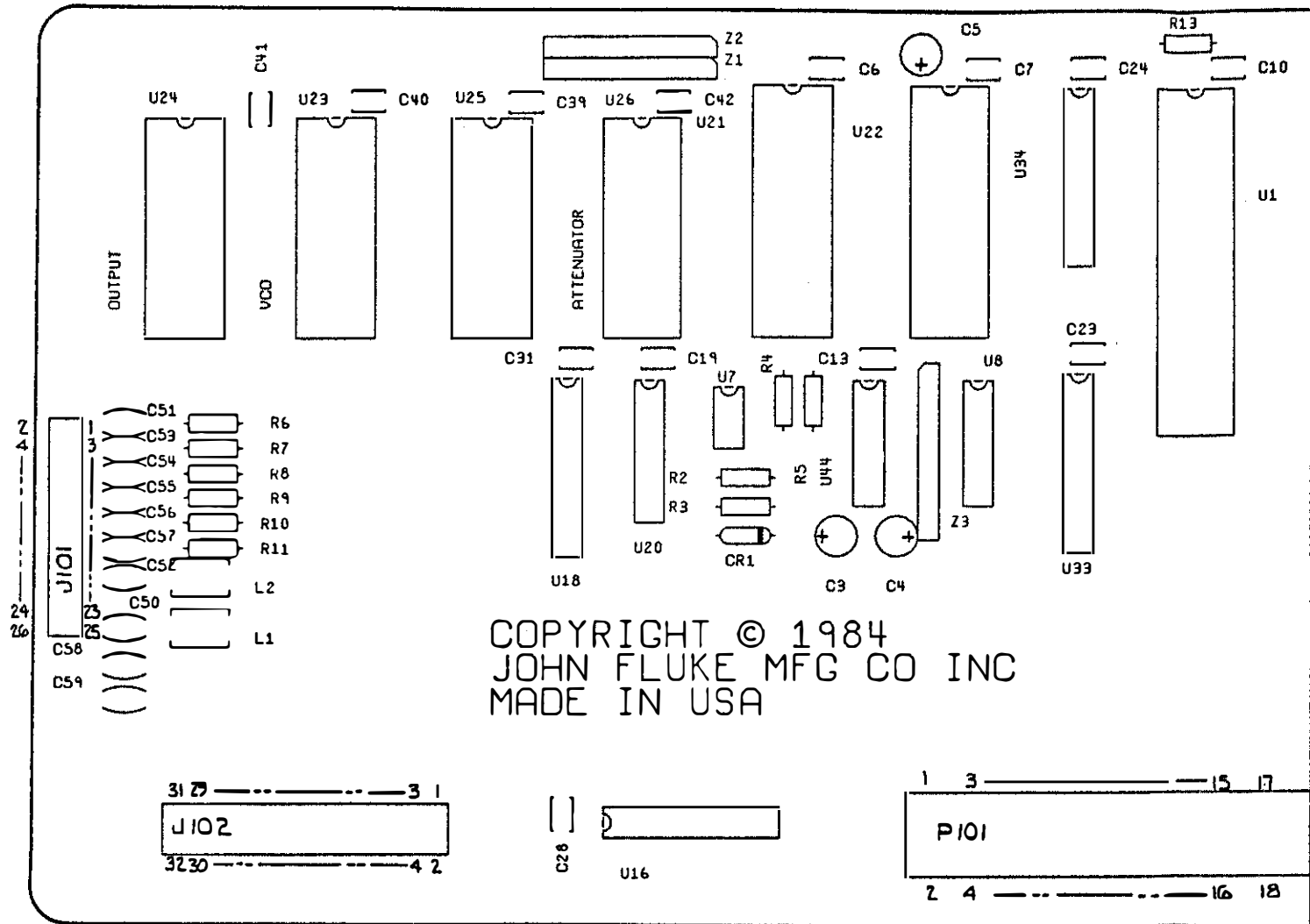

Option -488

IEEE-488 Interface

488-1. INTRODUCTION

The IEEE-488 Interface (Option -488), consists of the IEEE-488 printed circuit assembly (A3A3A1) mounted in a metal frame on the Generator rear panel. It is interfaced directly with the Controller assembly A2A7.

488-2. OPERATION

The operation of this option is covered in Section 2 of this manual.

488-3. CIRCUIT DESCRIPTION

The IEEE-488 Interface uses an NEC μ PD7210 Talker/Listener IC (U1) to handle all IEEE-488 standard communications protocol. All data, address, and control lines to the 7210 are buffered on the Controller. Two MC3447 bus drivers (U3 and U4) interface the 7210 directly to the IEEE-488 bus.

The presence of the optional IEEE-488 Interface is detected by the microprocessor when the option is plugged into the Controller board. The signal IEINL, normally at +5V, is pulled to circuit ground when the option is installed.

488-4. Address Switches

Tri-state buffer U6 provides the status of the IEEE-488 rear panel address switches when the Generator is interrogated. These switches determine the IEEE-488 bus address and talk-only (to) or listen-only (lo) modes. When opened, the switch just to the left of the IEEE-488 bus connector disconnects the bus shield ground from the system ground.

488-5. MAINTENANCE

This option does not change the performance test or calibration adjustments of the Generator. Troubleshooting information for this option is in Section 4D under Digital and Control troubleshooting.

488-6. LIST OF REPLACEABLE PARTS

Table 488-1 lists replaceable parts for the 6060A-488. Figure 488-1 is the component location diagrams for the 6060A-488.

**OPTION -488
IEEE INTERFACE**

**TABLE 488-1. A3A3A1 IEEE-488 INTERFACE PCA
(SEE FIGURE 488-1.)**

REFERENCE DESIGNATOR	A--NUMERIC-->	DESCRIPTION	FLUKE STOCK NO	MFRS SPLY CODE	MANUFACTURERS PART NUMBER OR GENERIC TYPE	TOT QTY	R S Q	N O T E
C	1- 4, 6,	CAP, POLYES, 0.22UF, +-10%, 50V	696492	89536	696492	9		
C	7, 9- 11		696492					
J	1	CONN, PWB, RIBBON, 90, 24 POS, STD ORIENT	658039	89536	658039	1		
L	1- 3	CHOKE, 6TURN	320911	89536	320911	3		
P	1	CONN, PWB, SCKT, HOUSING, DIP, 26	543512	00779	86063-9	1		
R	1	RES, CF, 1K, +-5%, 0.25W	343426	80031	CR251-4-5PIK	1		
S	1	PIANO MULTI-POLE, ST, SIDE ACTUATED	658567	89536	658567	1		
U	1	* IC, NMOS, GPIB TALKER/LISTENER	773143	34649	P8291A	1	1	
U	3, 4	* IC, LSTTL, OCTAL IEEE-488 BUS TRNSCVR	524835	04713	MC3447P	2		
U	6	* IC, LSTTL, OCTAL D TRANSPARENT LATCHES	504514	01295	SN74LS373N	1	1	
U	7	* IC, LSTTL, OCTAL BUS TRNSCVR W/3-ST OUT	477406	01295	SN74LS245N	1	1	
U	8	* IC, TTL, QUAD 2 INPUT AND GATE	393066	01295	SN74LS08N	1		
XU	1	SOCKET, DIP, 0.100 CTR, 40 PIN	429282	09922	DILB40P-108	1		
XU	3, 4	SOCKET, DIP, 0.100 CTR, 16 PIN	274535	91506	316-AC39D	2		
XU	3, 4	SOCKET, DIP, 0.100 CTR, 8 PIN	478016	91506	308-AC39D	2		
XU	6, 7	SOCKET, DIP, 0.100 CTR, 20 PIN	454421	09922	DILB20P-108	2		
XU	8	SOCKET, DIP, 0.100 CTR, 14 PIN	274527	09922	DILB8P-108	1		
Z	1- 4	RES, NET, SIP, 10 PIN, 9 RES, 10K, +-2%	414003	80031	95081002CL	4	1	

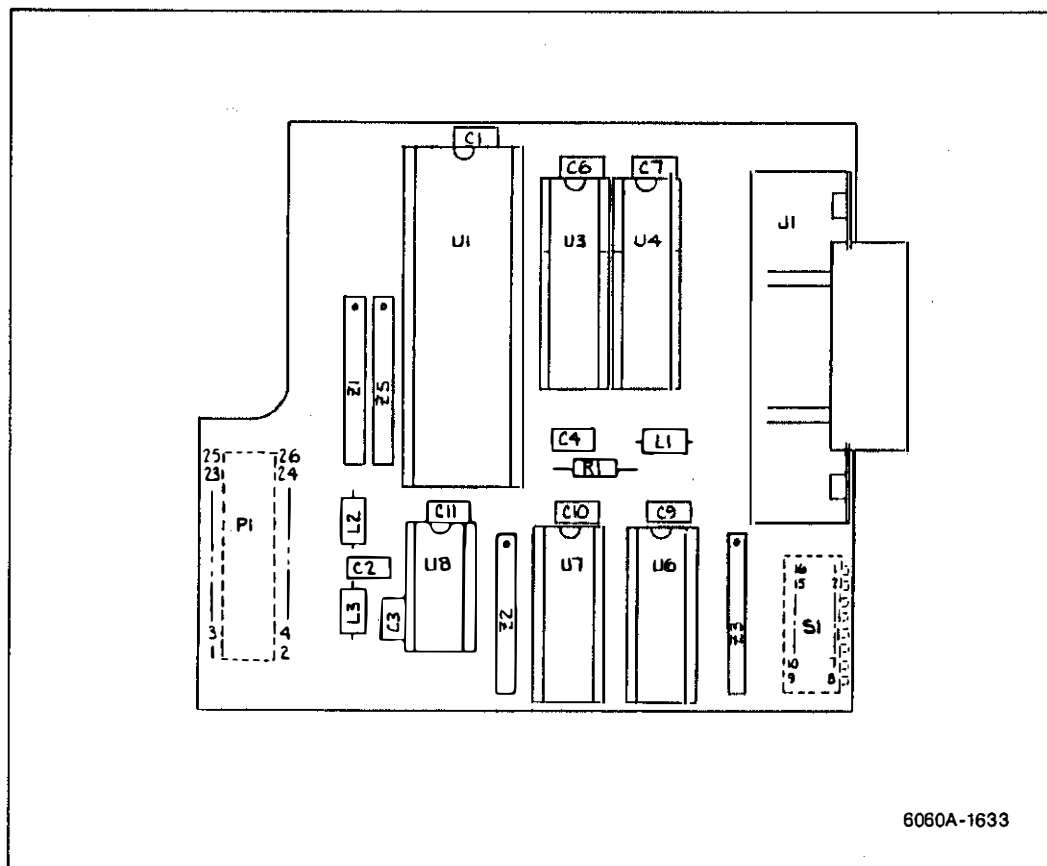

Figure 488-1. A3A3A1 IEEE-488 Interface PCA

Option -651 Low-Rate Fm

651-1. INTRODUCTION

The Low-Rate FM (Option -651), extends the FM 3-dB bandwidth to a lower frequency (approximately 0.5 Hz instead of 20 Hz). This option makes the Generator useful for testing FM radios that use sub-audio tones or low-rate digital techniques.

The option consists of a small printed circuit assembly A2A9 mounted atop the Synthesizer PCB. When installed, certain components are removed from the Synthesizer PCB, the option switch is set on the Controller, and a coupling capacitor is shorted on the Output PCB. A DIP switch on the Low-Rate FM PCB allows the Generator to be configured for Low-Rate FM or standard (normal) operation (except that the coupling capacitor on the Output PCB is shorted in both states). The DIP switch settings are listed in Table 651-1.

651-2. OPERATION

Operation of the Generator with the Low-Rate FM option is the same as operation of a standard instrument except that the maximum FM deviation is limited to 9.99 kHz.

651-3. CIRCUIT DESCRIPTION

The Low-Rate FM option allows frequency modulation at very low rates for use in digital modulation testing. In the low-rate mode, ac coupling capacitor A2A1 C16 is shorted to prevent any dc current from entering the loop amplifier (A2A1 U27) and changing the phase-detector operating point. The voltage at the output of the audio integrator (A2A1 U41-1) is kept at zero volts.

Keeping the voltage at the output of A2A1 U41 at zero volts is accomplished with a voltage-zeroing loop consisting of A2A9 U1. The positive terminal of this op-amp monitors the output voltage of the audio integrator through A2A9 R8. The negative terminal is connected to ground at A2A9 R9. By feeding current through A2A9 R7 back to the negative input of the audio integrator (A2A1 U41), its output voltage is kept at 0V. This is a lead-lag circuit with a low frequency break of approximately 0.3 Hz.

Potentiometer A2A9 R4 adjusts the compliance of the voltage-zeroing loop. Part of the active high-pass filter (A2A9 U41) is disabled by connecting the previous stage directly to A2A1 C114. Since the maximum deviation is limited to 9.99 kHz, the gain of the audio integrator and the VCO summing network (A2A1 R88, C117, C146) is decreased by a factor of ten. The Generator can be reconfigured back to the normal mode by programming the DIP switches on the option board (See Table 651-1).

651-4. PERFORMANCE TEST

The Generator is externally frequency modulated with a low-frequency square wave signal. The droop of the demodulated signal is measured using a spectrum analyzer as an FM demodulator (slope detection is used).

REQUIREMENT

FM Droop is less than 15% with 10 Hz external square wave modulation.

REMARKS

When using the RF Spectrum Analyzer as an FM demodulator using slope detection, it is important to operate the RF Spectrum Analyzer detector in a linear range. This can be checked by stepping the UUT frequency up 5 kHz and then down 5 kHz from the operating point and noting that the display moves equal amounts. If it doesn't, tune the RF Spectrum Analyzer slightly and check for linearity again.

TEST EQUIPMENT

Low-Frequency Synthesized Signal Generator (LFSSG)
RF Spectrum Analyzer

PROCEDURE

1. Remove the Generator top and the Synthesizer module plate covers.
2. Connect the LFSSG TTL output through a 604-ohm resistor and a 320 uF, 6V capacitor to the UUT MOD INPUT. This provides a square wave approximately 2V p-p at the Generator's MOD input.
3. Program the LFSSG to 10 Hz and any level around IV.
4. Program the UUT to the [RCL][9][8] and 3-kHz deviation. This provides a 300-MHz signal at -10 dBm.
5. Connect the input of the RF Spectrum Analyzer to the UUT RF OUTPUT. Set the RF Spectrum Analyzer so that the signal response is at the top of the display using linear detection.
6. Program UUT for EXT FM.
7. Using a 10-kHz Resolution Bandwidth and zero Span/Div, adjust either the Generator frequency or the RF Spectrum Analyzer tuning for slope detection to obtain a square-wave display. Adjust Time/Div and Trigger as necessary to obtain a stable square-wave display.
8. Verify that the droop of the demodulated FM is less than 15%. For example, if the displayed square-wave amplitude (vertical edge) is 3.4 divisions, then the droop should be less than 0.51 divisions (0.15 x 3.4).

651-5. ADJUSTMENT

TEST EQUIPMENT

DMM

PROCEDURE

The Offset adjustment (A2A9 R4) is set to 0V.

1. Program UUT to [RCL][9][8] and 9.99 kHz deviation, and set the rear panel EXT/INT FM switch to EXT, with no external modulation signal applied.

2. With the DMM, measure the dc voltage at A2A9 UI-6. Adjust R4 for $0V \pm 0.1V$.

651-6. LIST OF REPLACEABLE PARTS

Table 651-2 lists replaceable parts for the 6060A-651. Figure 651-1 is the component location diagrams for the 6060A-651.

Table 651-1. Low-Rate FM DIP Switch

NORMAL	LOW-RATE FM
1. Closed	Open
2. Open	Closed
3. Closed	Open
4. Closed	Open
5. Not Applicable	Not Applicable
6. Open	Closed

**OPTION -651
LOW-RATE Fm**

TABLE 651-2. A2A9 LOW-RATE FM PCA
(SEE FIGURE 651-1.)

REFERENCE DESIGNATOR	QTY	DESCRIPTION	FLUKE STOCK NO.	MFRS SPLY CODE	MANUFACTURER'S PART NUMBER --OR GENERIC TYPE--	TOT QTY	R S T	N O T
C 1, 2	2	CAP. POLYES, 0.1UF, +-20%, 50V	732883	89536	732883	2		
C 3	1	CAP. POLYES, 0.47UF, +-10%, 50V	714725	89536	714725	1		
C 4	1	CAP. YA, 3.3UF, +-20%, 20V	436071	81884	196D335X0020KA1	1		
C 6	1	CAP. CER, 100PF, +-2%, 100V, COG	512848	51406	RPE121	1		
C 7	1	CAP. CER, 100PF, +-2%, 100V, COC	512343	89536	512343	1		
R 1	1	RES. MF, 30.1K, +-1%, 0.125W, 100PPM	148286	91637	MFF1-83012F	1		
R 2	1	RES. MF, 24.3, +-1%, 0.125W, 100PPM	281816	91637	CHF5324R2F	1		
R 3	1	RES. MF, 3.32K, +-1%, 0.125W, 100PPM	312652	91637	CHF53321F	1		
R 4	1	RES. VAR. CERM, 100K, +-10%, 0.5W	369520	11236	360T-104A	1		
R 5, 7	2	RES. CC, 6.8M, +-5%, 0.25W	394064	01121	CB	2		
R 6	1	RES. CF, 200K, +-5%, 0.25W	441485	80031	CR251-4-5P200K	1		
R 8, 9	2	RES. CF, 1.2M, +-5%, 0.25W	348995	80031	CR251-4-5P1M2	2		
R 11	1	RES. MF, 4.99K, +-1%, 0.125W, 100PPM	148252	91637	MFF1-81991	1		
R 13	1	RES. MF, 49.9K, +-1%, 0.125W, 100PPM	268821	91637	CHF534992F	1		
S 1	1	SWITCH, DIL, 6-POS, SPST, ASSY	454124	00779	435166-4	1		
U 1	1	* IC, OP AMP, JFET INPUT, 8 PIN DIP	472779	12040	LF384N	1		
XU 1	1	SOCKET, DIP, 0.100 CTR, 8 PIN	478016	91506	308-AC39D	1		

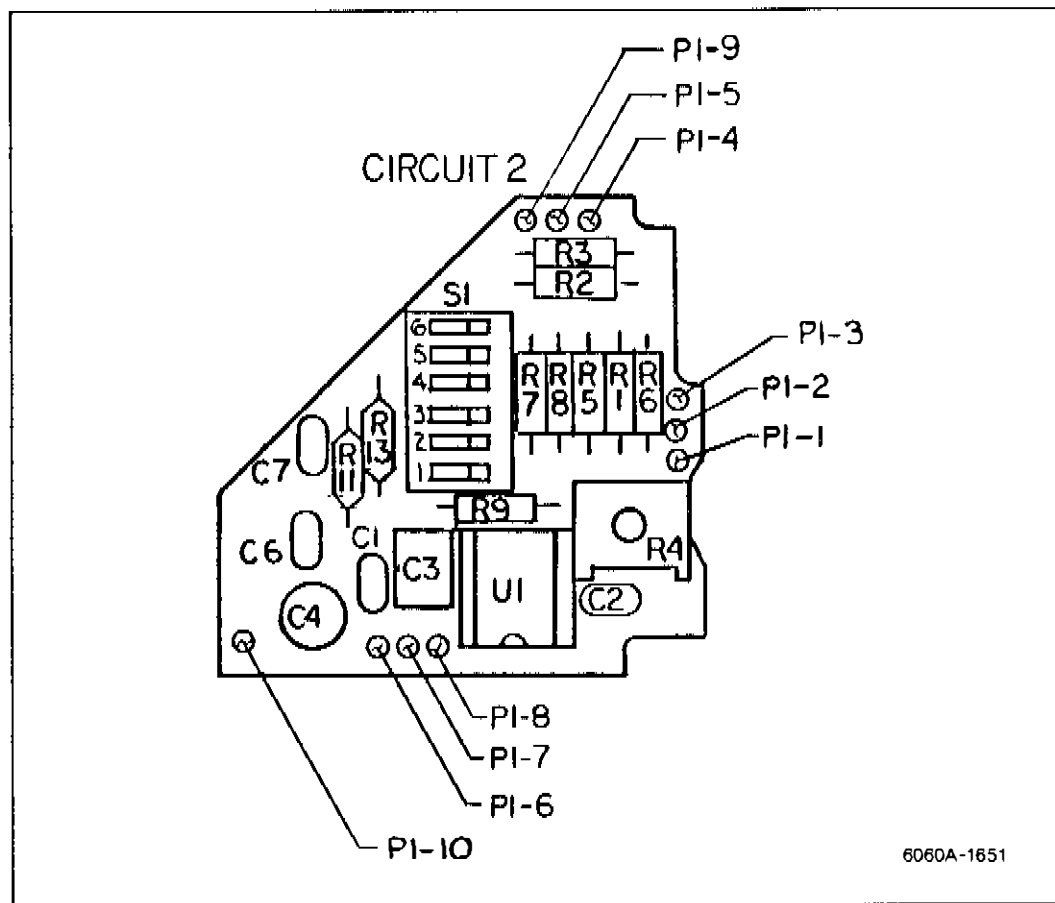

Figure 651-1. A2A9 Low-Rate FM PCA

Option -830

Rear Panel RF Output and Mod Input

830-1. INTRODUCTION

The Rear Panel RF Output and MOD Input (Option -830), moves the RF OUTPUT and MOD INPUT connectors from the front panel to the rear panel of the Generator. An insulating spacer is used when the RF OUTPUT connector is mounted on the rear panel to reduce ground loops. A longer semi-rigid coaxial SMA cable assembly (W17) replaces the standard cable (W1). The option switch on the Controller is set to indicate that the option is installed.

830-2. OPERATION

The additional signal loss of this longer cable is compensated using instrument-independent correction data stored in the Output Calibration EPROM. The Controller applies this correction data only when the rear panel RF Output and MOD Input option jumper is installed on the Controller PCB.

830-3. CIRCUIT DESCRIPTION

This option does not change the operation or specifications of the Generator.

830-4. MAINTENANCE

This option does not change the performance tests, calibration, adjustment, or service of the Generator.

Section 7
General Information

7-1. This section of the manual contains generalized user information as well as supplemental information to the List of Replaceable Parts contained in Section 5.

List of Abbreviations and Symbols

A or amp	ampere	hf	high frequency	(+) or pos	positive
ac	alternating current	Hz	hertz	pot	potentiometer
af	audio frequency	IC	integrated circuit	p-p	peak-to-peak
a/d	analog-to-digital	if	intermediate frequency	ppm	parts per million
assy	assembly	in	inch(es)	PROM	programmable read-only memory
AWG	american wire gauge	intl	internal	psi	pound-force per square inch
B	bel	I/O	input/output	RAM	random-access memory
bcd	binary coded decimal	k	kilo (10 ³)	rf	radio frequency
°C	Celsius	kHz	kilohertz	rms	root mean square
cap	capacitor	kΩ	kilohm(s)	ROM	read-only memory
ccw	counterclockwise	kV	kilovolt(s)	s or sec	second (time)
cer	ceramic	lf	low frequency	scope	oscilloscope
cermet	ceramic to metal(seal)	LED	light-emitting diode	SH	shield
ckt	circuit	LSB	least significant bit	Si	silicon
cm	centimeter	LSD	least significant digit	serno	serial number
cmrr	common mode rejection ratio	M	mega (10 ⁶)	sr	shift register
comp	composition	m	milli (10 ⁻³)	Ta	tantalum
cont	continue	mA	milliampere(s)	tb	terminal board
crt	cathode-ray tube	max	maximum	tc	temperature coefficient or temperature compensating
cw	clockwise	mf	metal film	tcxo	temperature compensated crystal oscillator
d/a	digital-to-analog	MHz	megahertz	tp	test point
dac	digital-to-analog converter	min	minimum	u or μ	micro (10 ⁻⁶)
dB	decibel	mm	millimeter	uhf	ultra high frequency
dc	direct current	ms	millisecond	us or μs	microsecond(s) (10 ⁻⁶)
dmm	digital multimeter	MSB	most significant bit	uut	unit under test
dvm	digital voltmeter	MSD	most significant digit	V	volt
elect	electrolytic	MTBF	mean time between failures	v	voltage
ext	external	MTTR	mean time to repair	var	variable
F	farad	mV	millivolt(s)	vco	voltage controlled oscillator
*F	Fahrenheit	mv	multivibrator	vhf	very high frequency
FEY	Field-effect transistor	MΩ	megohm(s)	vlf	very low frequency
fl	flip-flop	n	nano (10 ⁻⁹)	W	watt(s)
freq	frequency	na	not applicable	ww	wire wound
FSN	federal stock number	NC	normally closed	xfmr	transformer
g	gram	(-) or neg	negative	xtr	transistor
G	giga (10 ⁹)	NO	normally open	xtal	crystal
gd	guard	ns	nanosecond	xtlo	crystal oscillator
Ge	germanium	opnl ampli	operational amplifier	Ω	ohm(s)
GHz	gigahertz	p	pico (10 ⁻¹²)	μ	micro (10 ⁻⁶)
gmV	guaranteed minimum value	para	paragraph		
gnd	ground	pcb	printed circuit board		
H	henry	pF	picofarad		
hd	heavy duty	pn	part number		

Federal Supply Codes for Manufacturers

D9816 Westermann Wilhelm Augusta-Anlage Mannheim-Nackarau Germany	02533 Leigh Instruments Ltd. Frequency Control Div. Don Mills, Ontario, Canada	04713 Motorola Inc. Semiconductor Group Phoenix, Arizona	06665 Precision Monolithics Sub of Bourns Inc. Santa Clara, California
00199 Marcon Electronics Corp Kearny, New Jersey	02606 Fenwal Labs Division of Travenal Labs Morton Grove, Illinois	05236 Jonathan Mfg. Co. Fullerton, California	06666 General Devices Co. Inc. Indianapolis, Indiana
00213 Nytronics Comp. Group Inc. Darlington, South Carolina	02666 Bunker Ramo-Eltra Corp. Amphenol NA Div. Broadview, Illinois	05245 Corecom Inc. Libertyville, Illinois	06739 Electron Corp. Littleton, Colorado
00327 Welwyn International Inc. Westlake, Ohio	02735 RCA-Solid State Div. Somerville, New Jersey	05276 ITT Pomona Electronics Div. Pomona, California	06743 Gould Inc. Foil Div. Eastlake, Ohio
00656 Aerovox Corp. New Bedford, Massachusetts	02799 Arco Electronics Inc. Chatsworth, California	05277 Westinghouse Elec. Corp. Semiconductor Div. Youngwood, Pennsylvania	06751 Components Inc. Semcor Div. Phoenix, Arizona
00686 Film Capacitors Inc. Passaic, New Jersey	03508 General Electric Co. Semiconductor Products & Batteries Auburn, New York	05397 Union Carbide Corp. Materials Systems Div. Cleveland, Ohio	06776 Robinson Nugent Inc. New Albany, Indiana
00779 AMP, Inc. Harrisburg, Pennsylvania	03797 Geniseo Technology Corp. Electronics Div. Rancho Dominguez, Calif.	05571 Sprague Electric Co. (Now 56289)	06915 Richco Plastic Co. Chicago, Illinois
01121 Allen Bradley Co. Milwaukee, Wisconsin	03877 Gilbert Engineering Co. Inc. Incon Sub of Transiron Electronic Corp. Glendale, Arizona	05574 Viking Connectors Inc Sub of Cliton Corp. Chatsworth, Calif.	06961 Vernitron Corp. Piezo Electric Div. Bedford, Ohio
01281 TRW Electronics & Defense Sector Lawndale, California	03888 KDI Electronics Inc. Pyrofilm Div. Whippany, New Jersey	05820 EG & G Wakefield Engineering Wakefield, Massachusetts	06980 Varian Associates Inc. Eimac Div. San Carlos, California
01295 Texas Instruments Inc. Semiconductor Group Dallas, Texas	03911 Clairex Corp. Clairex Electronics Div. Mount Vernon, New York	05972 Loctite Corp. Newington, Connecticut	07047 Ross Milton Co., The Southampton, Penna.
01537 Motorola Communications & Electronics Inc. Franklin Park, Illinois	03980 Muirhead Inc. Mountainside, New Jersey	06001 General Electric Co. Electric Capacitor Product Section Columbia, S. Carolina	07138 Westinghouse Electric Corp. Industrial & Government Tubes Div. Horseneheads, New York
01686 RCL Electronics/Shalleross Inc. Electro Components Div. Manchester, New Hampshire	04009 Cooper Industries, Inc. Arrow Hart Div. Hartford, Connecticut	06141 Fairchild Weston Systems Inc. Data Systems Div. Sarasota, Florida	07233 Benchmark Technology Inc. City of Industry, Calif.
01884 Sprague Electric Co. (Now 56289)	04217 Essex International Inc. Wire & Cable Div. Anaheim, California	06192 La Deau Mfg. Co. Glendale, California	07239 Biddle Instruments Blue Bell, Penna.
01961 Varian Associates Inc. Pulse Engineering Div. Convoy, Connecticut	04221 Midland-Ross Corp. Midtex Div. N. Mankato, Minnesota	06229 Electrovert Inc. Elmsford, New York	07256 Silicon Transistor Corp. Sub of BBF Inc. Chalmersford, Massachusetts
02111 Special Electronics Corp. City of Industry, California	04222 AVX Corp. AVX Ceramics Div. Myrtle Beach, S. Carolina	06383 Panduit Corp. Tinley Park, Illinois	07261 Avnet Corp. Culver City, California
02114 Amperex Electronic Corp. Ferrox Cube Div. Saugerties, New York	04423 Telonic Berkley Inc. Laguna Beach, California	06473 Bunker Ramo Corp. Amphenol NA Div. SAMS Operation Chatsworth, California	07263 Fairchild Camera & Instrument Semiconductor Div. Mountain View, California
02131 General Instrument Corp. Government Systems Div. Westwood, Massachusetts		06555 Beede Electrical Instrument Pensacook, New Hampshire	07344 Bircher Co. Inc., The Rochester, New York
02395 Sonar Radio Corp. Hollywood, Florida			

Federal Supply Codes for Manufacturers (cont)

07557 Campion Co. Inc. Philadelphia, Penna.	09423 Scientific Components Inc. Santa Barbara, California	11711 General Instrument Corp. Rectifier Div. Hicksville, New York	12954 Microsemi Corp. Components Group Scottsdale, Arizona
07597 Burndy Corp. Tape/Cable Div. Rochester, New York	09579 CFS of Canada, Ltd Streetsville, Ontario	11726 Qualidyne Corp. Santa Clara, California	12969 Unitrode Corp. Lexington, Massachusetts
07716 TRW Inc. (Can use 11502) IRC Fixed Resistors/ Burlington Burlington, Iowa	09922 Burndy Corp. Norwalk, Connecticut	12014 Chicago Rivet & Machine Co. Naperville, Illinois	13050 Potter Co. Wesson, Mississippi
07792 Lecma Engineering Corp. Northampton, Massachusetts	09969 Dale Electronics Inc. Yankton, South Dakota	12040 National Semiconductor Corp. Danbury, Connecticut	13103 Thermalloy Co., Inc. Dallas, Texas
07810 Bock Corp. Madison, Wisconsin	09975 Burroughs Corp. Electronics Components Detroit, Michigan	12060 Diodes Inc. Northridge, California	13327 Solitron Devices Inc. Tappan, New York
07933 Raytheon Co. Semiconductor Div. Mountain View, Calif.	10059 Barker Engineering Corp. Kenilworth, New Jersey	12136 PHC Industries Inc. Formerly Philadelphia Handle Co. Camden, New Jersey	13511 Bunker-Ramo Corp. Amphenol Cadex Div. Los Gatos, California
08235 Industro Transistor Corp. Long Island City, New York	10389 Illinois Tool Works Inc. Lison Div. Chicago, Illinois	12300 AMP Canada Ltd. Potter-Brunfield Guelph, Ontario, Canada	13606 Sprague Electric Co. (Use 56289)
08261 Specura-Strip Anfiltra Co. Garden Grove, Calif.	10582 CTS of Asheville Skyland, N. Carolina	12323 Practical Automation Inc. Shelton, Connecticut	13689 SPS Technologies Inc. Hatfield, Pennsylvania
08530 Reliance Mica Corp. Brooklyn, New York	11236 CTS Corp. Beme Div. Beme, Indiana	12327 Freeway Corp. Cleveland, Ohio	13919 Burr-Brown Research Corp. Tucson, Arizona
08718 ITT Cannon Electric Phoenix Div. Phoenix, Arizona	11237 CTS Corp of California Paso Robles Div. Paso Robles, California	12443 Budd Co., The Plastics Products Div. Phoenixville, Pennsylvania	14099 Semtech Corp. Newbury Park, California
08806 General Electric Co. Miniature Lamp Products Cleveland, Ohio	11295 ECM Motor Co. Schaumburg, Illinois	12581 Hitachi Metals International Ltd. Hitachi Magna-Lock Div. Big Rapids, Missouri	14140 McGray-Edison Co. Commercial Development Div. Manchester, New Hampshire
08863 Nylomatic Fallsington, Penna.	11358 Columbia Broadcasting System CBS Electronic Div. Newburyport, Massachusetts	12615 US Terminals Inc. Cincinnati, Ohio	14193 Cal-R-Inc. Santa Monica, California
08988 Skottic Electronics Inc. Archbald, Pennsylvania	11403 Vacuum Can Co. Best Coffee Maker Div. Chicago, Illinois	12617 Hamlin Inc. Lake Mills, Wisconsin	14298 American Components Inc. an Insilco Co. RPC Div. Conshohocken, Pennsylvania
09021 Aircor Inc. Aircor Electronics Bradford, Penna.	11502 TRW Inc. TRW Resistive Products Div. Boone, North Carolina	12697 Clarostat Mfg. Co. Inc. Dover, New Hampshire	14298 ACIC Inc. Sub of Insilco Corp. Research Triangle Park, NC
09023 Cornell-Dublier Electronics Fuquay-Varina, N. Carolina	11503 Keystone Columbia Inc. Fremont, Indiana	12749 James Electronic Inc. Chicago, Illinois	14329 Wells Electronics Inc. South Bend, Indiana
09214 General Electric Co. Semiconductor Products Dept. Auburn, New York	11532 Teledyne Relays Teledyne Industries Inc. Hawthorne, California	12856 MicroMetals Inc. Anaheim, California	14482 Watkins-Johnson Co. Palo Alto, California
09353 C and K Components Inc. Newton, Massachusetts		12881 Metex Corp. Edison, New Jersey	14552 Microsemi Corp. Santa Ana, California
		12895 Cleveland Electric Motor Co. Cleveland, Ohio	14655 Cornell-Dublier Electronics Div. of Federal Pacific Electric Co. Govt Cont Dept. Newark, New Jersey

Federal Supply Codes for Manufacturers (cont)

14704 Crydom Controls (Division of Int Rectifier) El Segundo, California	16733 Cablewave Systems Inc. North Haven, Connecticut	18927 GTE Products Corp. Precision Material Products Business Parts Div. Titusville, Pennsylvania	23936 William J. Pundy Co. Pamotor Div. Burlingame, California
14752 ElectroCubes Inc. San Gabriel, California	16742 Paramount Plastics Fabricators Inc. Downey, California	19315 Bendix Corp., The Navigation & Control Group Texboro, New Jersey	24347 Penn Engineering Co. S. M. Monte, California
14936 General Instrument Corp. Discrete Semi Conductor Div. Hicksville, New York	16758 General Motors Corp. Delco Electronics Div. Kokomo, Indiana	19451 Perine Machinery & Supply Co. Kent, Washington	24355 Analog Devices Inc. Norwood, Massachusetts
14949 Trompeter Electronics Chatsworth, California	17069 Circuit Structures Lab Burbank, California	19613 Minnesota Mining & Mfg. Co. Textool Products Dept. Electronic Product Div. Irving, Texas	24444 General Semiconductor Industries, Inc. Tempe, Arizona
15412 Amtron Midlothian, Illinois	17117 Electronic Molding Corp. Woonsocket, Rhode Island	19647 Caddock Electronics Inc. Riverside, California	24655 Genrad Inc. Concord, Massachusetts
15542 Scientific Components Corp. Mini-Circuits Laboratory Div. Brooklyn, New York	17338 High Pressure Eng. Co. Inc. Oklahoma City, Oklahoma	19701 Mepco/Centralab Inc. A. N. American Philips Co. Mineral Wells, Texas	24759 Lenox-Fugle Electronics Inc. South Plainfield, New Jersey
15636 Elec-Trol Inc. Saugus, California	17545 Atlantic Semiconductors Inc. Asbury Park, New Jersey	20584 Enochs Mfg. Inc. Indianapolis, Indiana	24796 A.M.F. Inc. Potter & Brumfield Div. San Juan Capistrano, Calif.
15782 Bausch & Lomb Inc. Graphics & Control Div. Austin, Texas	17745 Angstrom Precision, Inc. Hagerstown, Maryland	20891 Cosar Corp. Dallas, Texas	24931 Specialty Connector Co. Greenwood, Indiana
15801 Fenwal Electronics Inc. Div. of Kidd Inc. Framingham, Massachusetts	17856 Siliconix Inc. Santa Clara, California	21317 Electronics Applications Co. El Monte, California	25088 Siemens Corp. Islet, New Jersey
15818 Teledyne Inc. Co. Teledyne Semiconductor Div. Mountain View, California	18178 E G & G vacotec Inc. St. Louis, Missouri	21604 Buckeye Stamping Co. Columbus, Ohio	25099 Cascade Gasket Kent, Washington
15849 Useco Inc. (Now 88245)	18324 Signetics Corp. Sacramento, California	21845 Solitron Devices Inc. Semiconductor Group Rivers Beach, Florida	25403 Amperex Electronic Corp. Semiconductor & Micro-Circuit Div. Slatersville, Rhode Island
15898 International Business Machines Corp. Essex Junction, Vermont	18520 Sharp Electronics Corp. Paramus, New Jersey	22526 DuPont, El DeNemours & Co. Inc. DuPont Connector Systems Advanced Products Div. New Cumberland, Pennsylvania	25706 Daburn Electronic & Cable Corp. Norwood, New Jersey
16245 Conap Inc. Olean, New York	18542 Wabash Inc. Wabash Relay & Electronics Div. Wabash, Indiana	22767 ITT Semiconductors Palo Alto, California	26629 Frequency Sources Inc. Sources Div. Chelmsford, Massachusetts
16258 Space-Lok Inc. Burbank, California	18565 Chomerics Inc. Woburn, Massachusetts	22784 Palmer Inc. Cleveland, Ohio	26806 American Zettler Inc. Irvine, California
16352 Codi Corp. Linden, New Jersey	18612 Vishay Intertechnology Inc. Vishay Resistor Products Group Malvern, Pennsylvania	23050 Product Comp. Corp. Mount Vernon, New York	27014 National Semiconductor Corp. Santa Clara, California
16469 MCL Inc. LaGrange, Illinois	18632 Norton-Chemplast Santa Monica, California	23732 Tracor Applied Sciences Inc. Rockville, Maryland	27167 Corning Glass Works Corning Electronics Wilmington, North Carolina
16473 Cambridge Scientific Industries Div. of Chemed Corp. Cambridge, Maryland	18677 Scambe Mfg. Co. Div. of Zero Corp. El Monte, California	23880 Stanford Applied Engineering Santa Clara, California	27264 Molex Inc. Lisle, Illinois
	18736 Voltronics Corp. East Hanover, New Jersey		27440 Industrial Screw Products Los Angeles, California

Federal Supply Codes for Manufacturers (cont)

27745 Associated Spring Barnes Group Inc. Syracuse, New York	30800 General Instrument Corp. Capacitor Div. Hicksville, New York	33297 NEC Electronics USA Inc. Electronic Arrays Inc. Div. Mountain View, California	49956 Raytheon Company Executive Offices Lexington, Massachusetts
27956 Relcom (Now 14482)	31019 Solid State Scientific Inc. Willow Grove, Pennsylvania	33919 Nortek Inc. Cranston, Rhode Island	50088 Thomson Components-Mostek Corp. Carrollton, Texas
28198 Positronic Industries Springfield, Missouri	31091 Alpha Industries Inc. Microelectronics Div. Hatfield, Pennsylvania	34333 Silicon General Inc. Garden Grove, California	50120 Eagle-Picher Industries Inc. Electronics Div. Colorado Springs, Colorado
28213 Minnesota Mining & Mfg. Co. Consumer Products Div. 3M Center Saint Paul, Minnesota	31323 Metro Supply Company Sacramento, California	34225 Advanced Micro Devices Sunnyvale, California	50157 Midwest Components Inc. Muskegon, Mississippi
28425 Serv-O-Link Eules, Texas	31448 Army Safeguard Logistics Command Huntsville, Alabama	34359 Minnesota Mining & Mfg. Co. Commercial Office Supply Div. Saint Paul, Minnesota	50541 Hypertronics Corp. Hudson, Massachusetts
28478 Deltrol Corporation Deltrol Controls Div. Milwaukee, Wisconsin	31746 Cannon Electric Woodbury, Tennessee	34371 Harris Corp. Harris Semiconductor Products Group Malbourne, Florida	50579 Litronix Inc. Cupertino, California
28480 Hewlett Packard Co. Corporate HQ Palo Alto, California	31827 Budwig Ramona, California	34649 Intel Corp. Santa Clara, California	51167 Aries Electronics Inc. Frenchtown, New Jersey
28484 Emerson Electric Co. Guarmaster Div. McHenry, Illinois	31918 ITT-Schadow Eden Prairie, Minnesota	34802 Electromotive Inc. Kenilworth, New Jersey	51372 Vembatim Corp. Sunnyvale, California
28520 Hayco Molded Products Kenilworth, New Jersey	32293 Intersil Cupertino, California	34848 Hartwell Special Products Placentia, California	51406 Murata Erie, No. America Inc. (Also see 72982) Marietta, Georgia
29083 Monsanto Co. Santa Clara, California	32539 Mura Corp. Westbury, Long Island, N.Y.	35009 Renfrew Electric Co. Ltd. I.R.C. Div. Toronto, Ontario, Canada	51499 Amtron Corp. Boston, Massachusetts
29604 Stackpole Components Co. Raleigh, North Carolina	32559 Bivar Santa Ana, California	36665 Mitel Corp. Kanata, Ontario, Canada	51605 CODI Semiconductor Inc. Kenilworth, New Jersey
29907 Omega Engineering Inc. Stamford, Connecticut	32767 Griffith Plastics Corp. Burlingame, California	37942 Mallory Capacitor Corp. Sub of Emhart Industries Indianapolis, Indiana	51642 Centre Engineering Inc. State College, Pennsylvania
30035 Jolo Industries Inc. Garden Grove, California	32879 Advanced Mechanical Components Northridge, California	39003 Maxim Industries Middleboro, Massachusetts	51791 Stack Corp. Orange, California
30146 Symbex Corp. Painesville, Ohio	32897 Murata Erie North America Inc. Cardinal Operations Cardale, Pennsylvania	40402 Rodeman Electronics Inc. Statesville, North Carolina	51984 NEC America Inc. Falls Church, Virginia
30148 A B Enterprise Inc. Ahoskie, North Carolina	32997 Bourns Inc. Trimpot Div. Riverside, California	42498 National Radio Melrose, Massachusetts	52063 Exar Integrated Systems Sunnyvale, California
30161 Aavid Engineering Inc. Laconia, New Hampshire	33096 Colorado Crystal Corp. Loveland, Colorado	43543 Nytronics Inc. (Now 53342)	52072 Circuit Assembly Corp. Irvine, California
30315 Iron Corp. San Diego, California	33173 General Electric Co. Owensboro, Kentucky	44655 Ohmite Mfg. Co. Skokie, Illinois	52152 Minnesota Mining & Mfg. Saint Paul, Minnesota
30323 Illinois Tool Works Inc. Chicago, Illinois	33246 Epoxy Technology Inc. Billerica, Massachusetts	49671 RCA Corp. New York, New York	52333 API Electronics Hauppauge, Long Island, New York

Federal Supply Codes for Manufacturers (cont)

52361 Communication Systems Piscataway, New Jersey	54590 RCA Corp. Electronic Components Div. Cherry Hill, New Jersey	58104 Simco Atlanta, Georgia	64155 Linear Technology Milpitas, California
52525 Space-Lok Inc. Lercio Div. Burbank, California	55026 American Gage & Machine Co. Simpson Electric Co. Div. Elgin, Illinois	58474 Superior Electric Co. Bristol, Connecticut	64834 West M G Co. San Francisco, Calif.
52531 Hitachi Magnetics Edmore, Missouri	55112 Plessey Capacitors Inc. (Now 60935)	59124 KOA-Speer Electronics Inc. Bradford, Pennsylvania	65092 Sangamo Weston Inc. Weston Instruments Div. Newark, New Jersey
52745 Timco Los Angeles, California	55261 LSI Computer Systems Inc. Melville, New York	59640 Supertex Inc. Sunnyvale, California	65940 Rohm Corp & Whatney Irvine, California
52763 Stettner-Electronics Inc. Chattanooga, Tennessee	55285 Bercquist Co. Minneapolis, Minnesota	59660 Tusconix Inc. Tucson, Arizona	65964 Evox Inc. Bannockburn, Illinois
52769 Sprague-Goodman Electronics Inc. Garden City Park, New York	55576 Synetick Santa Clara, California	59730 Thomas and Betts Corp. Iowa City, Iowa	66150 Entron Inc. Winslow Teltronics Div. Glendale, New York
52771 Monitern Corp. Amatrom Div. Santa Clara, California	55680 Michicon/America/Corp. Schmaburg, Illinois	59831 Semtronics Corp. Watchung, New Jersey	66608 Bering Industries Fremont, California
52840 Western Digital Corp. Costa Mesa, California	56282 Utek Systems Inc. Olathe, Kansas	60395 Xicor Inc. Milpitas, California	70290 Almetal Universal Joint Co. Cleveland, Ohio
53021 Sangamo Weston Inc. (See 06141)	56289 Sprague Electric Co. North Adams, Massachusetts	60399 Torin Engineered Blowers Div. of Clevepak Corp. Torrington, Connecticut	70485 Atlantic India Rubber Works Inc. Chicago, Illinois
53217 Technical Wire Products Inc. Santa Barbara, California	56365 Square D Co. Corporate Offices Palatine, Illinois	60705 Cera-Mite Corp. (formerly Sprague) Grafton, Wisconsin	70563 Amperite Company Union City, New Jersey
53342 Opt Industries Inc. Phillipsburg, New Jersey	56375 DAL Industries Inc. Wescorp Div. Mountain View, California	60935 Westlake Capacitor Inc. Tantalum Div. Greencastle, Indiana	70903 Belden Corp. Geneva, Illinois
53944 Glow-Lite Pauls Valley, Oklahoma	56481 Shugart Associates Sub of Xerox Corp. Sunnyvale, California	61804 M/A Com Inc. Burlington, Massachusetts	71002 Bimbach Co. Inc. Farmingdale, New York
54294 Shalkcross Inc. Smithfield, North Carolina	56708 Zilog Inc. Campbell, California	61857 SAN-O Industrial Corp. Bohemia, Long Island, NY	71034 Bibley Electric Co. Erie, Pennsylvania
54453 Sullins Electronic Corp. San Marcos, California	56856 Vanister Corp. of Tennessee Sevierville, Tennessee	61935 Schuster Inc. Petaluma, California	71193 Westinghouse Electric Corp. Bryant Div. Bridgeport, Connecticut
54473 Matsushita Electric Corp. (Panasonic) Secaucus, New Jersey	56880 Magnetics Inc. Baltimore, Maryland	62351 Apple Rubber Lancaster, New York	71400 Bussman Manufacturing Div. McGraw-Edison Co. St. Louis, Missouri
54583 TDK Garden City, New York	57026 Endicott Coil Co. Inc. Binghamton, New York	62793 Lear Siegler Inc. Energy Products Div. Santa Ana, California	71450 CTS Corp. Elkhart, Indiana
54869 Pihler International Corp. Arlington Heights, Illinois	57053 Gates Energy Products Denver, Ohio	63743 Ward Leonard Electric Co. Inc. Mount Vernon, New York	71468 ITT Cannon Div. of IIT Fountain Valley, California
54937 DeYoung Mfg. Bellevue, Washington	58014 Hitachi Magnalock Corp. (Now 12581)	64154 Lamb Industries Portland, Oregon	71482 General Instrument Corp. Clare Div. Chicago, Illinois

Federal Supply Codes for Manufacturers (cont)

71590 Mepco/Centralab A North American Philips Co. Furt Dodge, Iowa	73445 Amperex Electronic Corp. Hicksville, New York	75378 CTS Knights Inc. Sandwich, Illinois	79727 C - W Industries Southampton, Pennsylvania
71707 CotoCorp. Providence, Rhode Island	73559 Carlingswitch Inc. Hartford, Connecticut	75382 Kulka Electric Corp. (Now 83330) Mount Vernon, New York	79963 Ziemick Mfg. Corp. Mount Kisco, New York
71744 General Instrument Corp. Lamp Div/Worldwide Chicago, Illinois	73586 Circle F Industries Trenton, New Jersey	75915 Tracor Littlefuse Des Plaines, Illinois	80009 Tektronix Beaverton, Oregon
71785 TRW Inc. Cinch Connector Div. Elk Grove Village, Illinois	73734 Federal Screw Products Inc. Chicago, Illinois	76854 Oak Switch Systems Inc. Crystal Lake, Illinois	80031 Mepco/Electra Inc. Morristown, New Jersey
71984 Dow Corning Corp. Midland, Michigan	73743 Fischer Special Mfg. Co. Cold Spring, Kentucky	77122 TRW Assemblies & Fasteners Group Fastener Div. Mountainside, New Jersey	80032 Ford Aerospace & Communications Corp. Western Development Laboratories Div. Palo Alto, California
72005 AMAX Specialty Metals Corp. Newark, New Jersey	73893 Microdot Mt. Clemens, Mississippi	77342 AMF Inc. Potter & Brunfield Div. Princeton, Indiana	80145 LFE Corp. Process Control Div. Clinton, Ohio
72136 Electro Motive Mfg. Corp. Florence, South Carolina	73899 JFD Electronic Components Div. of Murata Eric Oceanside, New York	77542 Ray-O-Vac Corp Madison, Wisconsin	80183 Sprague Products (Now 56289)
72228 AMCA International Corp. Continental Screw Div. New Bedford, Massachusetts	73905 FI Industries Inc. San Jose, California	77638 General Instrument Corp. Rectifier Div. Brooklyn, New York	80294 Bouns Instruments Inc. Riverside, California
72259 Nytromics Inc. New York, New York	73949 Guardian Electric Mfg. Co. Chicago, Illinois	77900 Shakeproof Lock Washer Co. (Now 78189)	80583 Hammett Mfg. Co. Inc. Paramus, New Jersey
72619 Amperex Electronic Corp. Dialight Div. Brooklyn, New York	74199 Quam Nichols Co. Chicago, Illinois	77969 Rubbercraft Corp. of CA Ltd. Torrance, California	80640 Computer Products Inc. Stevens-Arnold Div. South Boston, Mass.
72653 G C Electronics Co. Div. of Hydrometals Inc. Rockford, Illinois	74217 Radio Switch Co. Marlboro, New Jersey	78189 Illinois Tool Works Inc. Shakeproof Div. Elgin, Illinois	81073 Grayhill Inc. La Grange, Illinois
72794 Dzus Fastener Co. Inc. West Islip, New York	74306 Piezo Crystal Co. Div. of PPA Industries Inc. CardisLe, Pennsylvania	78277 Sigma Instruments Inc. South Braintree, Mass.	81312 Liton Systems Inc. Winchester Electronics Div. Watertown, Connecticut
72928 Gulton Industries Inc. Gudeman Div. Chicago, Illinois	74542 Hoyt Elect. Instr. Works Inc. Penacook, New Hampshire	78290 Stuthers Dunn Inc. Pitman, New Jersey	81439 Therm-O-Disc Inc. Mansfield, Ohio
72982 Murata Erie N. America Inc. Erie, Pennsylvania	74840 Illinois Capacitor Inc. Lincolnwood, Illinois	78553 Eaton Corp. Engineered Fastener Div. Cleveland, Ohio	81483 International Rectifier Corp. Los Angeles, California
73138 Beckman Industrial corp. Helipot Div. Fullerton, California	74970 Johnson EF Co. Waseca, Minnesota	78592 Stoeger Industries South Hackensack, New Jersey	81590 Korry Electronics Inc. Seattle, Washington
73168 Fenwal Inc. Ashland, Massachusetts	75042 TRW Inc. IRC Fixed Resistors Philadelphia, Pennsylvania	79136 Waldes Kohinor Inc. Long Island City, New York	81741 Chicago Lock Co. Chicago, Illinois
73293 Hughes Aircraft Co. Electron Dynamics Div. Torrance, California	75297 Liton Systems Kester Solder Div. Chicago, Illinois	79497 Western Rubber Co. Garben, Indiana	82227 Aipax Corp. Cheshire Div. Cheshire, Connecticut
			82240 Simmons Fastener Corp. Albany, New York

Federal Supply Codes for Manufacturers (cont)

82305 Palmer Electronics Corp. South Gate, California	84171 Aero Electronics Commack, New York	89536 John Fluke Mfg. Co., Inc. Everett, Washington	91802 Industrial Devices Inc. Edgewater, New Jersey
82389 Switchcraft Inc. Sub of Raytheon Co. Chicago, Illinois	84411 American Suzuki TRW Capacitors Div. Ogallala, Nebraska	89597 Fredericks Co. Huntingdon Valley, Penna.	91833 Keystone Electronics Corp. New York, New York
82415 Airtax Corp. Frederick Div. Frederick, Maryland	84613 FIC Corp. Rockville, Maryland	89709 Bunker Ramo-Eltra Corp. Amphenol Div. Broadview, Illinois	91836 King's Electronics Co. Inc. Tuckahoe, New York
82872 Roanwell Corp. New York, New York	84682 Essex Group Inc. Peabody, Massachusetts	89730 General Electric Lamp Div. Newark, New Jersey	91929 Honeywell Inc. Micro Switch Div. Freeport, Illinois
82877 Rouon Inc. Custom Div. Woodstock, New York	85367 Bearing Distributing Co. San Francisco, California	90201 Mallory Capacitor Co. Sub of Emhart Industries Inc. Indianapolis, Indiana	91934 Miller Electric Co. Woonsocket, Rhode Island
82879 ITT Royal Electric Div. Pawtucket, Rhode Island	85372 Bearing Sales Co. Los Angeles, California	90215 Best Stamp & Mfg. Co. Kansas City, Missouri	91984 Maida Development Co. Hampton, Virginia
83003 Varo Inc. Garland, Texas	85480 W. H. Brady Co. Industrial Product Milwaukee, Wisconsin	90303 Duracell Inc. Technical Sales & Marketing Bethel, Connecticut	91985 Norwalk Valve Co. S. Norwalk, Connecticut
83014 Hanwell Corp. Placentia, California	85932 Electro Film Inc. Valencia, California	91094 Essex Group Inc. Suflux/TWPDiv. Newmarket, New Hampshire	92914 Alpha Wire Corp. Elizabeth, New Jersey
83055 Signalito Fuse Co. (Now 71744)	86577 Precision Metal Products Co. Peabody, Massachusetts	91247 Illinois Transformer Co. Chicago, Illinois	93332 Sylvania Electric Products Semiconductor Products Div. Woburn, Massachusetts
83068 TRW Assemblies & Fasteners Group Fasteners Div. Cambridge, Massachusetts	86684 Radio Corp. of America (Now 54590)	91293 Johnson Mfg. Co. Boonton, New Jersey	94144 Raytheon Co. Microwave & Power Tube Div. Quincy, Massachusetts
83259 Parker-Hannifin Corp. O-Seal Div. Culver City, California	86928 Searsom Mfg. Co. Inc. Glendale, California	91462 Alpha Industries Inc. Logansport, Indiana	94988 Wagner Electric Corp. Sub of McGraw-Edison Co. Whippany, New Jersey
83298 Bendix Corp. Electric & Fluid Power Div. Eatonville, New Jersey	87034 Illuminated Products Inc. (Now 76854)	91502 Associated Machine Santa Clara, California	95146 Aloo Electronic Products Inc. Switch Div. North Andover, Massachusetts
83315 Hubbell Corp. Mundelein, Illinois	88219 GNB Inc. Industrial Battery Div. Langhorne, Pennsylvania	91506 Augat Inc. Attleboro, Massachusetts	95263 Lacraft Mfg. Co. Long Island City, New York
83330 Kulka Smith Inc. A North American Philips Co. Manasquan, New Jersey	88245 Winchester Electronics Litton Systems-Useco Div. Van Nuys, California	91507 Froeliger Machine Tool Co. Stockton, California	95275 Vitramon Inc. Bridgeport, Connecticut
83478 Rubbercraft Corp. of America West Haven, Connecticut	88486 Triangle PWC Inc. Jewitt City, Connecticut	91637 Dale Electronics Inc. Columbus, Nebraska	95309 RCA Corp. Receiving Tube Div. Cincinnati, Ohio
83553 Associated Spring Bames Group Gardena, California	88690 Essex Group Inc. Wire Assembly Div. Dearborn, Michigan	91662 Elco Corp. A Gulf Western Mfg. Co. Connector Div. Huntingdon, Pennsylvania	95348 Gordo's Corp. Bloomfield, New Jersey
83740 Union Carbide Corp. Battery Products Div. Danbury, Connecticut	89020 Amerasee Corp. Buchanan Chimpool Products Div. Union, New Jersey	91737 ITT Cannon/Greder (Now 08718)	95354 Methode Mfg. Corp. Rolling Meadows, Illinois

Federal Supply Codes for Manufacturers (cont)

95573 Campion Laboratories Inc. Detroit, Michigan	97540 Whitehall Electronics Corp. Master Mobile Mounts Div. Fort Meyers, Florida	98278 Malco A Microdot Co. South Pasadena, California	99378 ATLEE of Delaware Inc. N. Andover, Massachusetts
95712 Bendix Corp. Electrical Comp. Div. Franklin, Indiana	97913 Industrial Electronic Hardware Corp. New York, New York	98291 Senlectro Corp. BICC Electronics Trumbull, Connecticut	99392 Mepco/Electra Inc. Roxboro Div. Roxboro, North Carolina
95987 Weckesser Co. Inc. (Now 85480)	97945 Permwal Corp. SS White Industrial Products Piscataway, New Jersey	98372 Royal Industries Inc.(Now 62793)	99515 Electron Products Inc. Div. of American Capacitors Duarte, California
96733 SFE Technologies San Fernando, California	97966 CBS Electronic Div. Danvers, Massachusetts	98388 Lear Siegler Inc. Accurate Products Div. San Diego, California	99779 Bunker Ramo Eltra Corp. Barnes Div. Lansdown, Pennsylvania
96853 Gulton Industries Inc. Measurement & Controls Div. Manchester, New Hampshire	98094 Machlett Laboratories Inc. Santa Barbara, California	99120 Plastic Capacitors Inc. Chicago, Illinois	99800 American Precision Industries Delevan Div. East Aurora, New York
96881 Thomson Industries Inc. Port Washington, New York	98159 Rubber-Teck Inc. Gardena, California	99217 Bell Industries Inc. Elect. Distributor Div. Sunnyvale, California	99942 Mepco/Centralab A North American Philips Co. Milwaukee, Wisconsin
97525 EECO Inc. Santa Ana, California			

Appendix 7A

Manual Change Information

7A-1. INTRODUCTION

This appendix contains information necessary to backdate the manual to conform with the earlier PCB configurations. To identify the configuration of the PCBs used in your instrument, refer to the revision letter (marked in ink) on the component side of each PCB assembly. Table 7A-1 defines the assembly revision levels documented in this manual.

As changes and improvements are made to the instrument, they are identified by incrementing the revision letter marked on the affected PCA. These changes are documented on a supplemental change/errata sheet which, when applicable, is inserted at the front of the manual. To identify the configuration the PCAs used in your Generator, refer to the revision letter on the component side of each PCA.

7A-2. BACKDATING INSTRUCTIONS

To backdate this manual to conform with an earlier assembly revision level, perform the changes indicated in Table 7A-1. If this manual documents all PCAs at their original level, no changes are necessary, and no changes will be indicated in Table 7A-1.

MANUAL CHANGE INFORMATION

Table 7A-1. Manual Status and Backdating Information

REF OR OPTION NO.	ASSEMBLY NAME	FLUKE PART NO.	*To adapt manual to earlier rev configurations perform changes in descending order (by no.), ending with change under desired rev letter																
			-	A	B	C	D	E	F	G	H	J	K	L	M	N	P		
A1A1	Display PCA	738609	X																
A2A1	Synthesizer PCA	792812	X																
A2A2	VCO PCA	748780	X																
A2A4	Output PCA	774521	X																
A2A5 A4	Attenuator/ RPP PCA	752667	X																
A2A5 A5	Relay Driver/ RPP Control PCA	752816	X																
A2A7	Controller PCA	798082	X																
A2A8	Non-Volatile Memory PCA	744094	X																
A3A1	Power Supply PCA	744052	X																
-130	High Stability Reference PCA	744102	X																
-132	Medium Stability Reference PCA	792788	X																
-488	IEEE-488 PCA	738617	X																
-651	Low-Rate FM PCA	716969	X																
			* X	The PCB revision levels documented in this manual.															
			•	These revision letters were never used in the instrument.															
			-	No revision letter on the PCB.															
			·	Change did not affect manual.															

Section 8

Schematic Diagrams

FIGURE	TITLE	PAGE
8-1.	Mnemonics	8-2
8-2.	Schematic Symbols	8-3
8-3.	Synthesizer Block Diagram	8-5
8-4.	Output Block Diagram	8-6
8-5.	A1A1 Display PCA	8-7
8-6.	A2A1 Synthesizer PCA	8-10
8-7.	A2A2 VCO PCA	8-16
8-8.	A2A4 Output PCA	8-17
8-9.	A2A5A4 Attenuator/RPP PCA	8-22
8-10.	A2A5A5 Relay Driver/RPP PCA	8-23
8-11.	A2A7 Controller PCA	8-25
8-12.	A2A8 Non-Volatile (Store/Recall) Memory PCA	8-29
8-13.	A3A1 Power Supply PCA	8-30
8-14.	A3A2A1 High-Stability (Ovened) Reference PCA (Option -130)	8-31
8-15.	A5A1 Medium-Stability Reference PCA (Option -132)	8-32
8-16.	A3A3A1 IEEE-488 Interface PCA (Option -488)	8-33
8-17.	A2A9 Low-Rate FM PCA (Option -651)	8-34

SCHEMATIC DIAGRAMS

MNEMONIC	DESCRIPTION	SIGNAL TYPE *
A 0-15	Address	B
A12DB	Attenuator 12-dB Section Control	L
A24(1-5)	Attenuator 24-dB Section Controls	L
A6DB	Attenuator 6-dB Section Control	L
BAB 0-3	Module Section Address	H
Bd 0-7	Module Section Data	B
BSEL 0.1	Module Section Select	L
CKN	N-Divider Clock	L
CLR	Display Clear	L
D 0-7	Data	B
DBIN	Read Enable	L
DD 0-7	Display Data	B
DIG	Display Digit Select	L
EXREF	External Reference Control	L
EXTAM	External AM Control	L
EXTFM	External FM Control	L
FIL 1.2	Display Filament Supply	AC+DC
FM 0-9	FM Deviation DAC Control	H
FMEN	FM Enable	H
FMRNG 0-2	FM Range Control	H
FMV	FM Audio	AF
HAOCT	Half-Octave Control	H
HET	Het (Low) Band Control	L
HSOPT	High-Stability Option Installed	L
IEA 13-15	IEEE Address Bus	B
IEADR	IEEE Address Latch Enable	L
IECS	IEEE Chip Enable	L
IED 0-7	IEEE Data Bus	B
IEDB	IEEE Read Enable	L
IEIN	IEEE Option Installed	L
IEINT	IEEE Interrupt	L
IEW	IEEE Write Enable	L
INTAM	Internal AM Control	L
INTFM	Internal FM Control	L
KBIN	Keyboard Input Select	H
KN 0-9	PLL Gain Compensation DAC	H
KNV	Main PLL Gain Compensation Voltage	DC
KV 0-9	VCO Compensation DAC Control	H
LEV 0-11	RF Level DAC Control	H
LRFM	Low-Rate FM Option Installed	L
MF400	Modulation Frequency Control	L
MID	Mid Band Control	L
MLEVHI	External Modulation High-Level Status	H
MLEVLO	External Modulation Low-Level Status	H
MODE	Triple-Modulus Prescaler	L
NVCS	NVM RAM Chip Select	L
NVEN	NVM Enable	L
NVIN	NVM Installed	L
RIN	10-MHz Output Buffer Enable	H
RMUXD.1	Reference Multiplexer Select	H
ROPT	Rear Output Option Installed	L
RPP	RPP Option Installed	L
RPRST	RPP Reset Control	H
RPTRP	RPP Tripped Status	L
SEG 1-3.9	Display Segment Select	L
SHEN	Sub-Harmonic Reference Control	L
SHEY	Synthesizer Heterodyne Control	L
SHREF	Sub-Harmonic Ref Option Installed	L
SHTUNE	Sub-Harmonic Ref Tuning Voltage	DC
TBOUT	Output Test Bit	H
TBSYN	Synthesizer Test Bit	H
TRMOD	Triple-Modulus Prescaler Select	L
TRSEQ	Remote Sequence Trigger	L
TUNE	Main PLL Tuning Voltage	DC
UNLOCK	PLL Unlocked or Overmodulated Status	L
UNLVL	ALC Loop Unleveled Status	L
WE	Write Enable	L
XOEN	10-MHz Crystal Oscillator Control	L

* Six SIGNAL types are listed in the following:

DC= DC Control
AC= Line Frequency
AF= Audio (modulation) Signal
L = Logic (binary) signal, active low at the source
H = Logic (binary) signal, active high at the source
B = Dynamic bus

Figure 8-1. Mnemonics

Multipath Interconnection	Printed Capacitor
Dual-Pin Connector Service Aide	Feed-Through Capacitor
Dual-Pin Connector Test Point	Diode, General
Test Point 4	Diode, Varactor
Test Point 5, no post	Diode, Pin
Microstrip Transmission Line	Diode, Zener
Stripline Transmission Line	Diode, Schottky
Printed Inductor	Factor Selected Value
	*

Figure 8-2. Schematic Symbols (cont)

SCHEMATIC DIAGRAMS

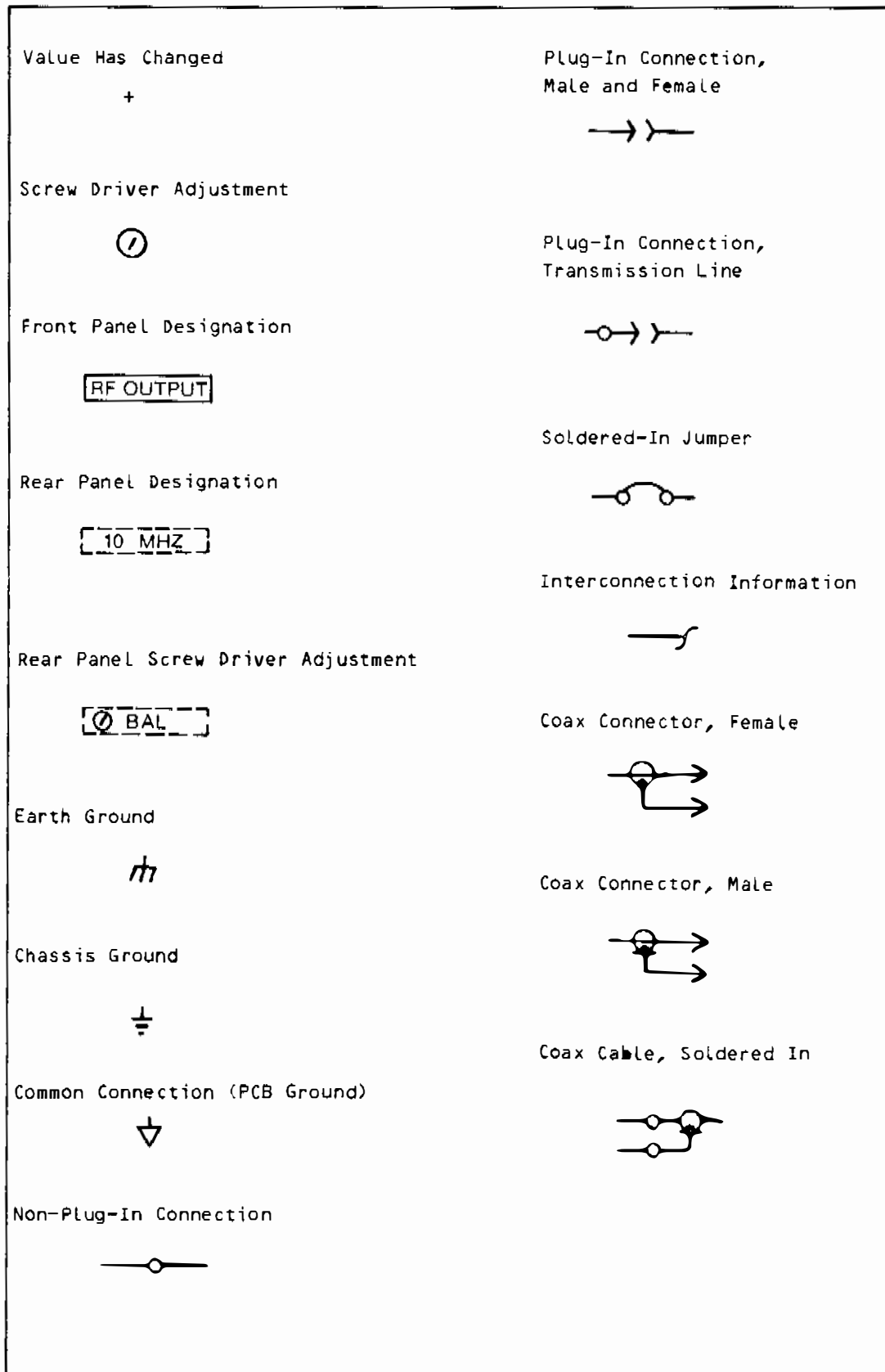

Figure 8-2. Schematic Symbols (cont)

Fig 8-3
 Sht 1 of 3

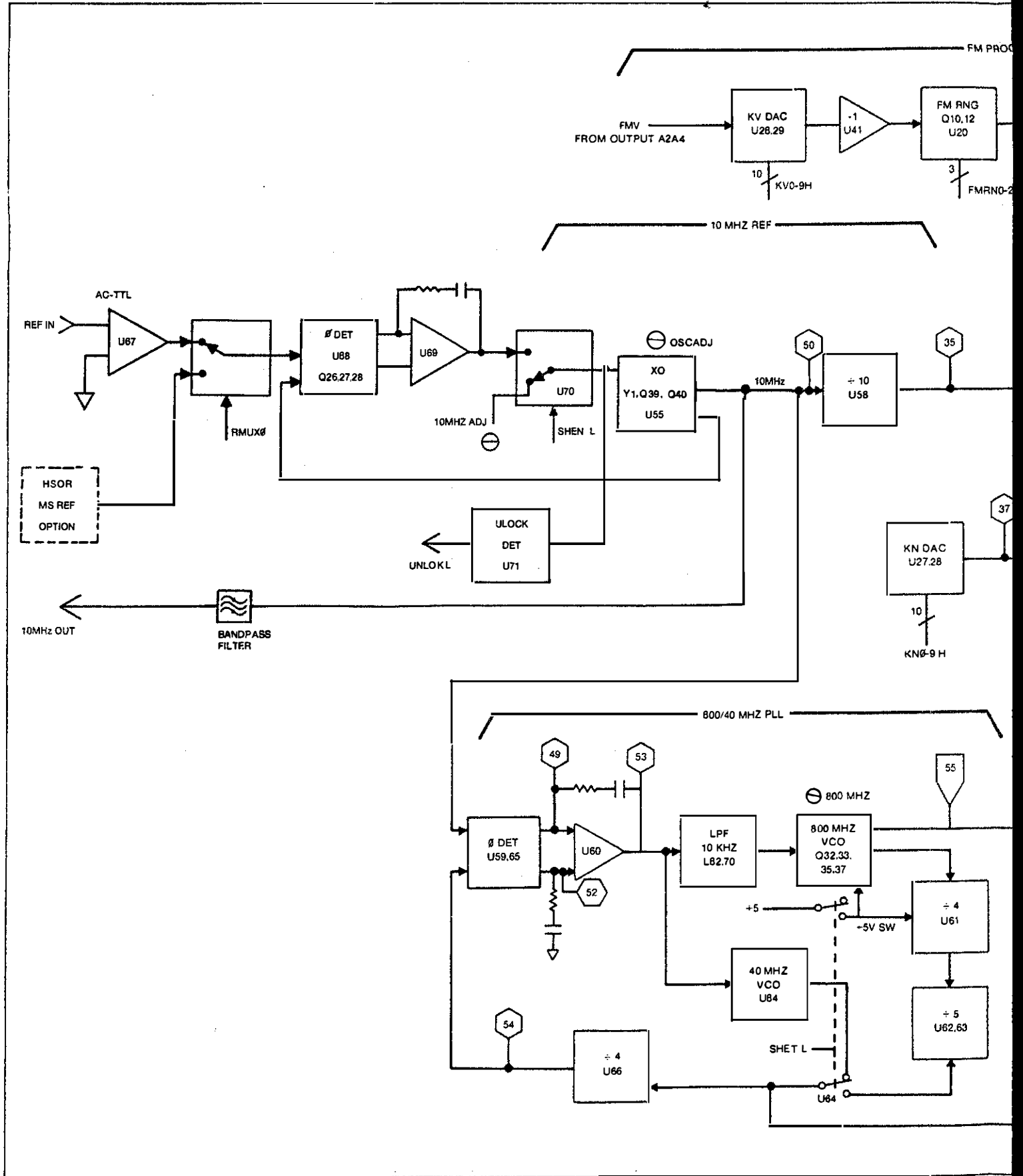

Fig 8-3
 Sht 2 of 3

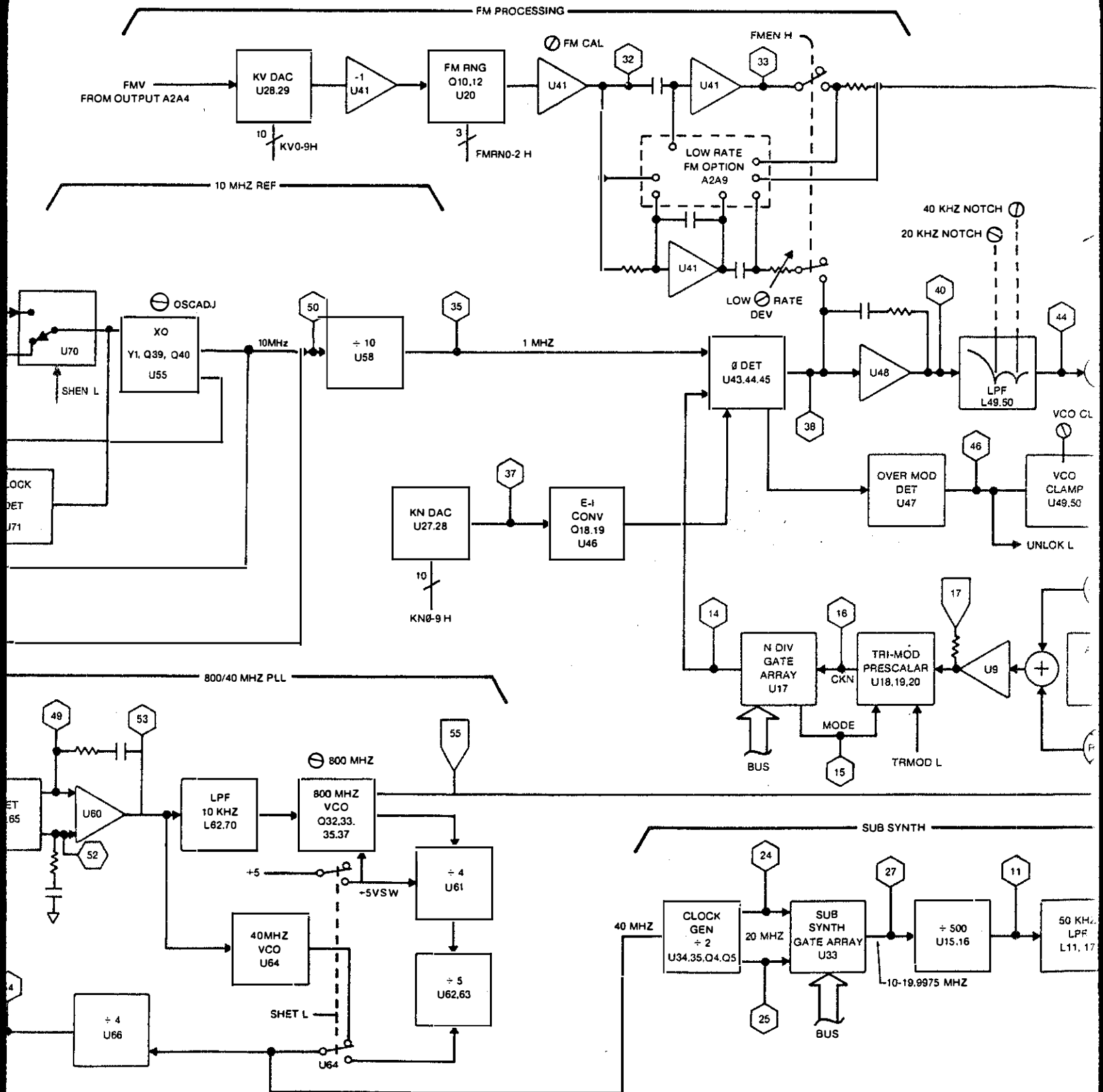

Fig 8-3
 Sht 3 of 3

SCHEMATIC DIAGRAMS

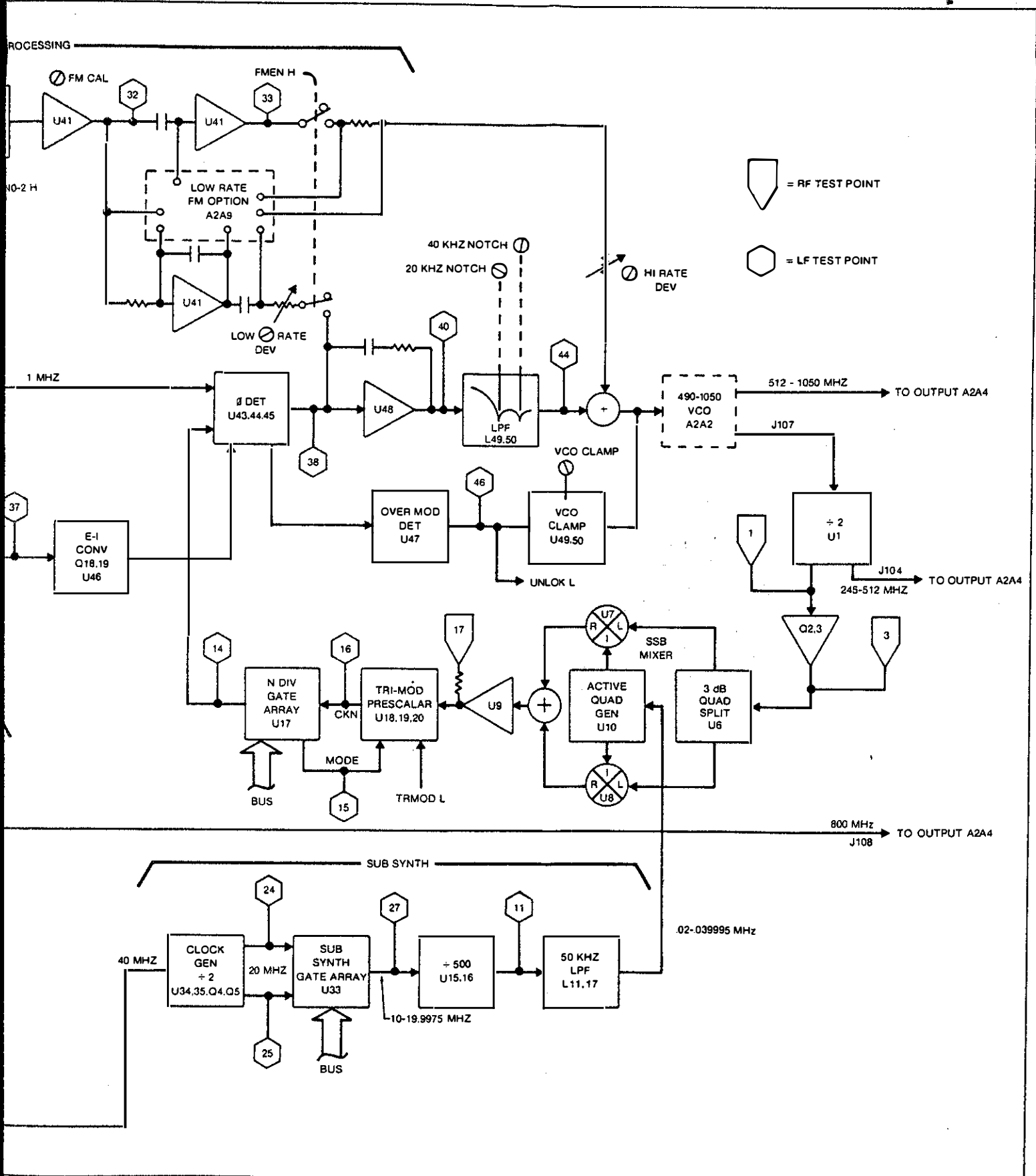

Figure 8-3. Synthesizer Block Diagram

Fig 8-4
Sht 1 of 2

SCHEMATIC DIAGRAMS

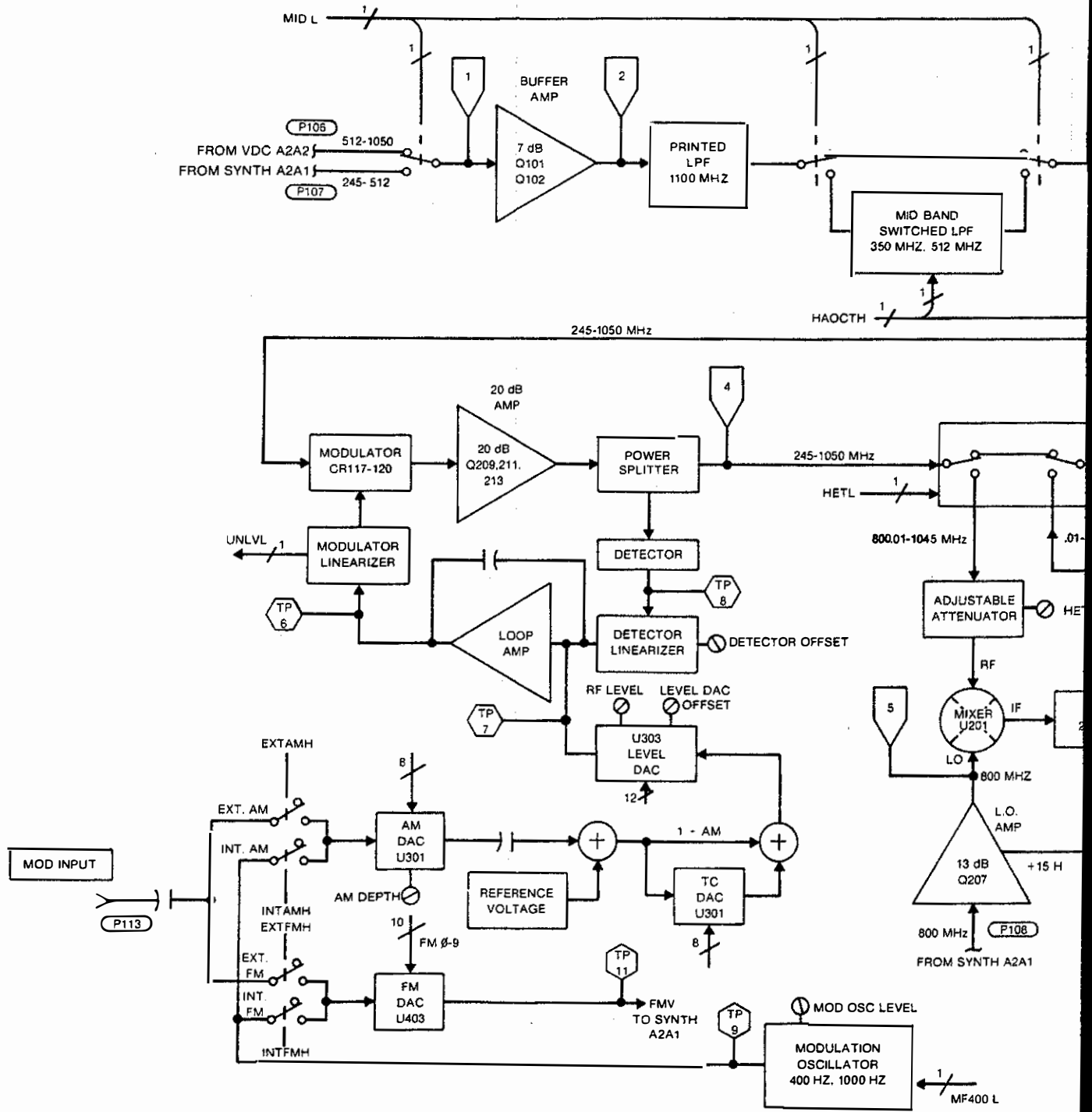

Figure 8-4. Output Block Diagram

Fig 8-4
Sketch 2
SCHEMATIC DIAGRAMS

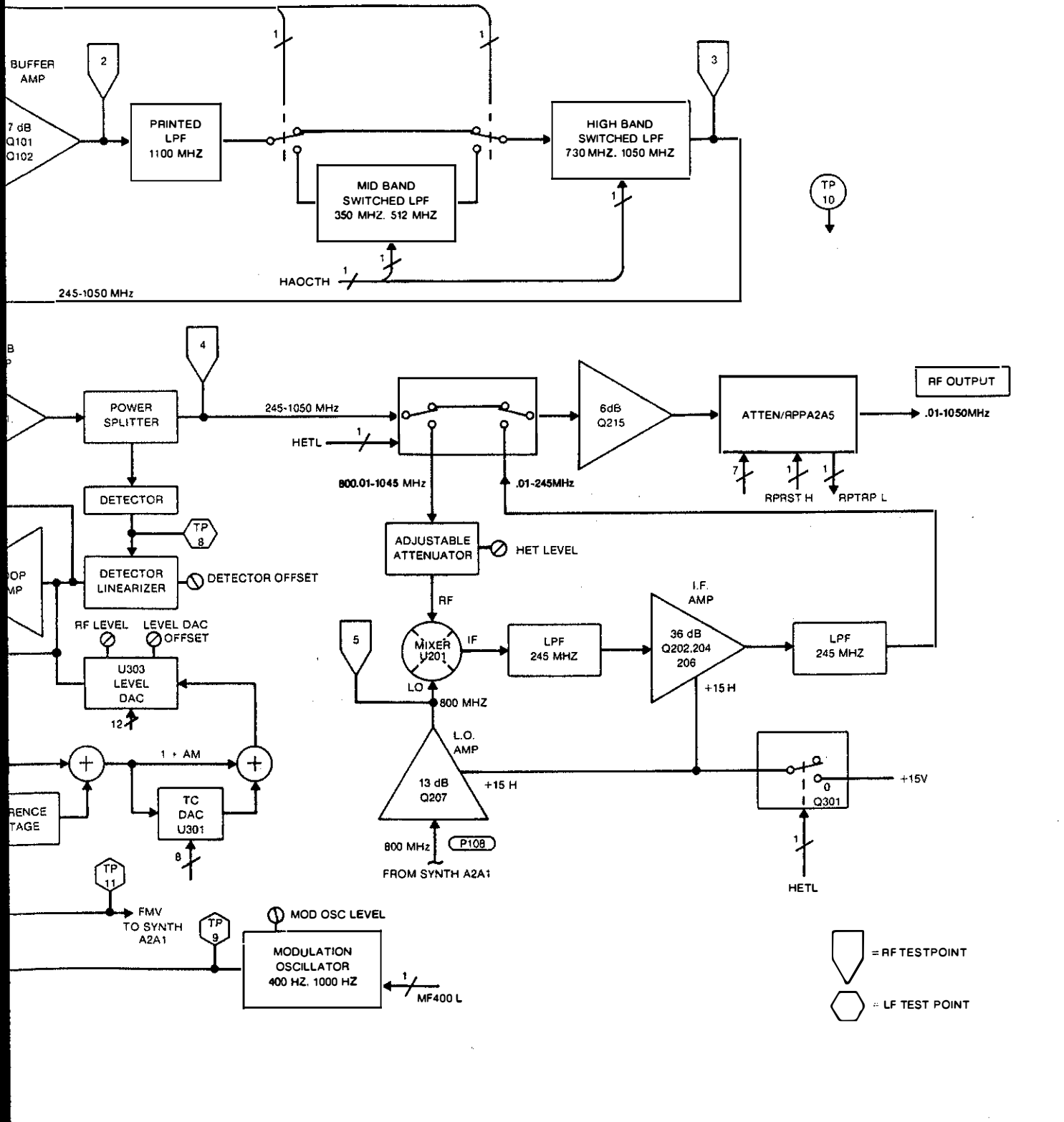

Figure 8-4. Output Block Diagram

Fig 8-5
Sht 1 of 3

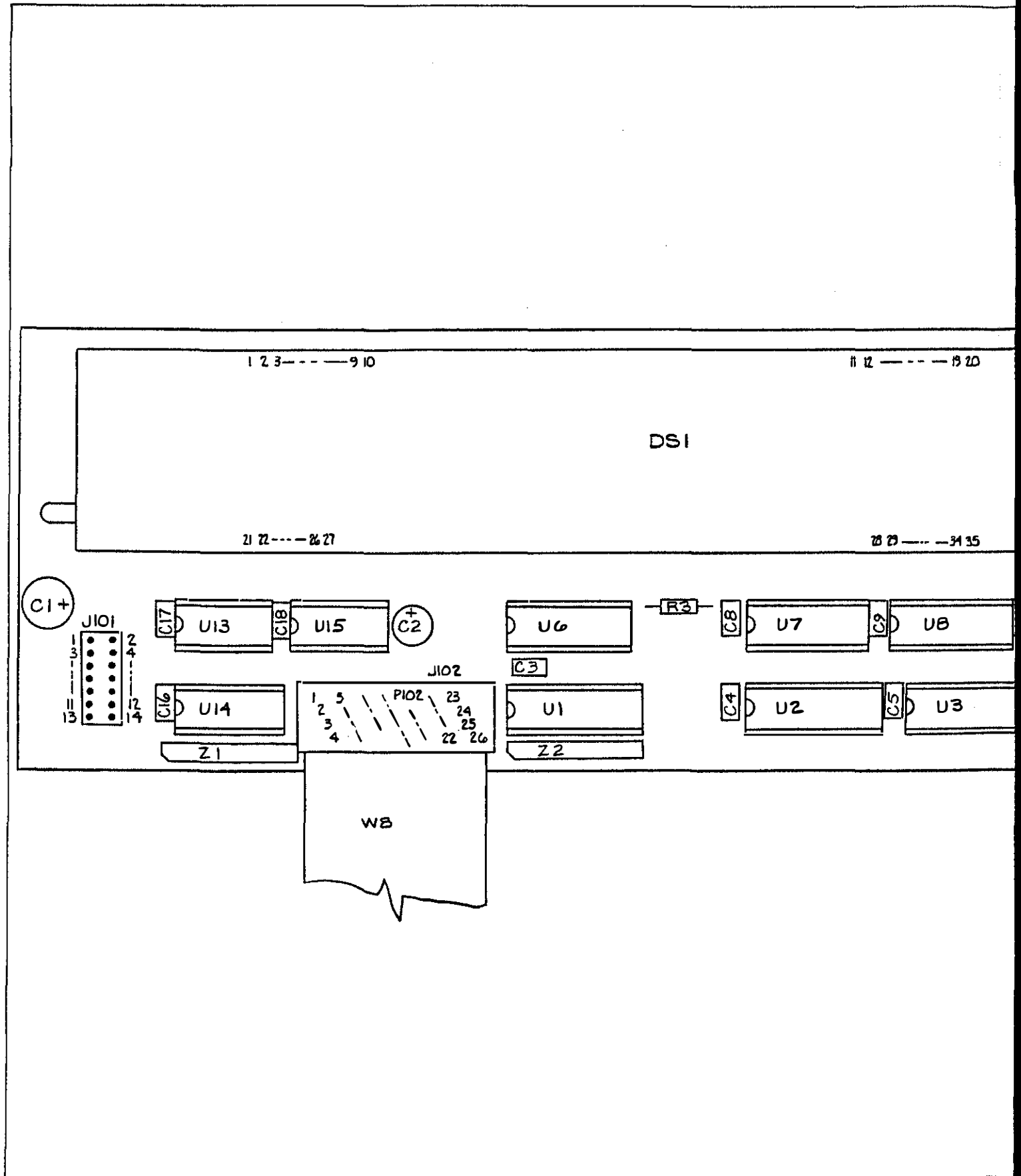

Fig 8-5
Sht 2 of 3

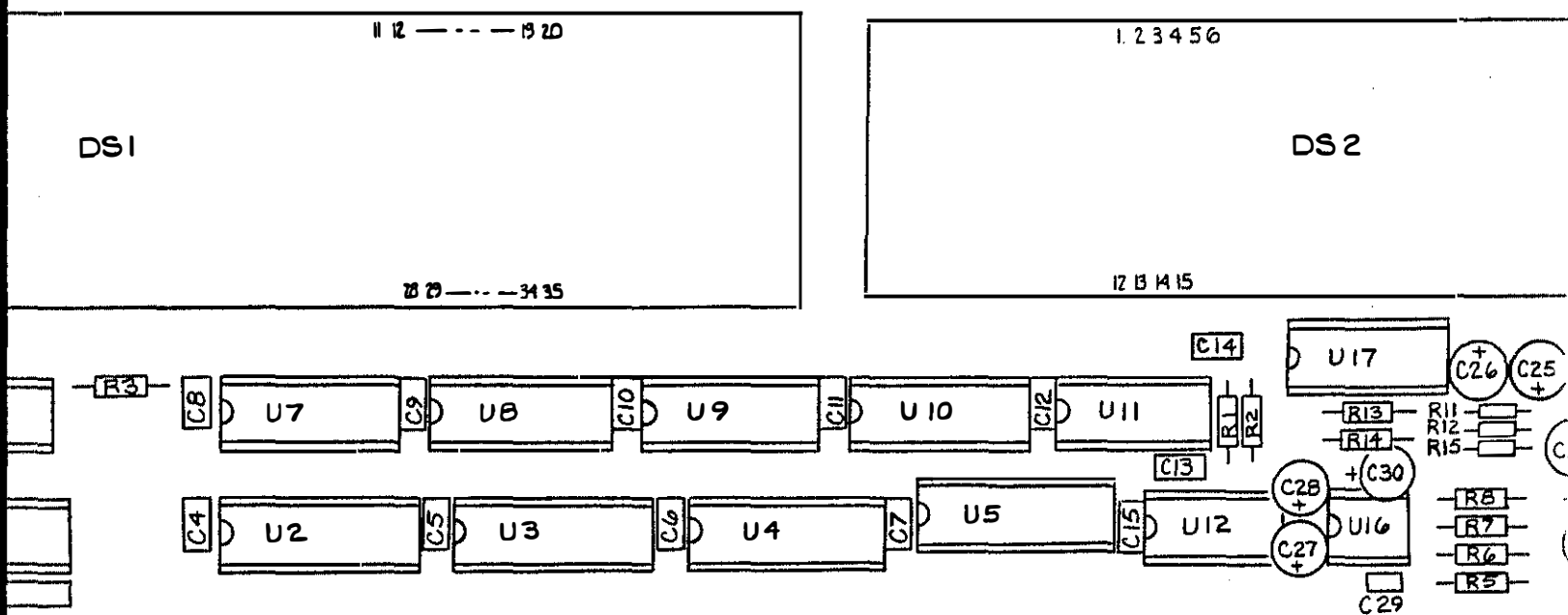
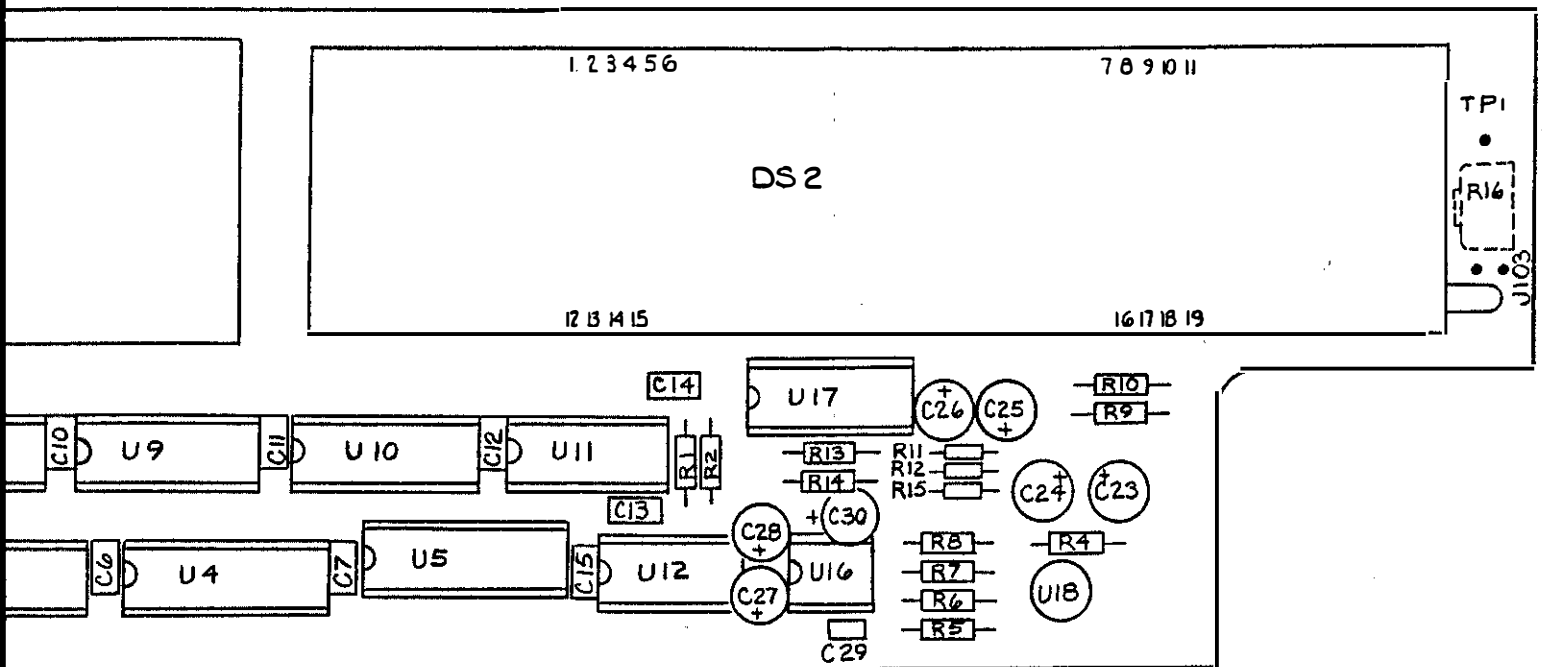

Fig 8-5
Sht 3 of 3

SCHEMATIC DIAGRAMS



6060A-1611

Figure 8-5. A1A1 Display PCA

Fig 8-5 (cont)
Skt 183

MODULATION FREQUENCY DISPLAY

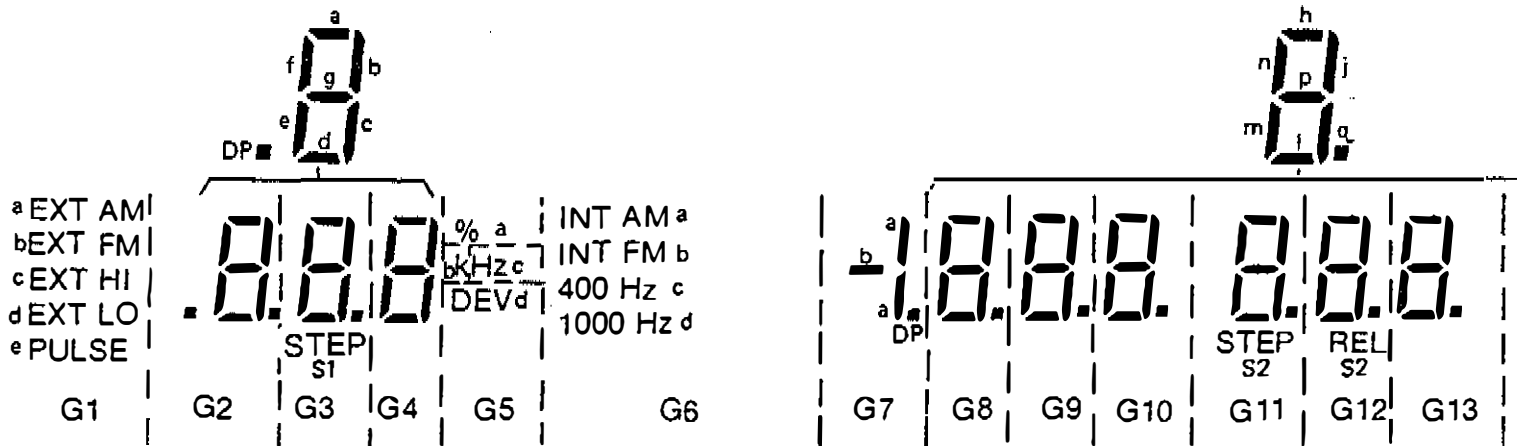
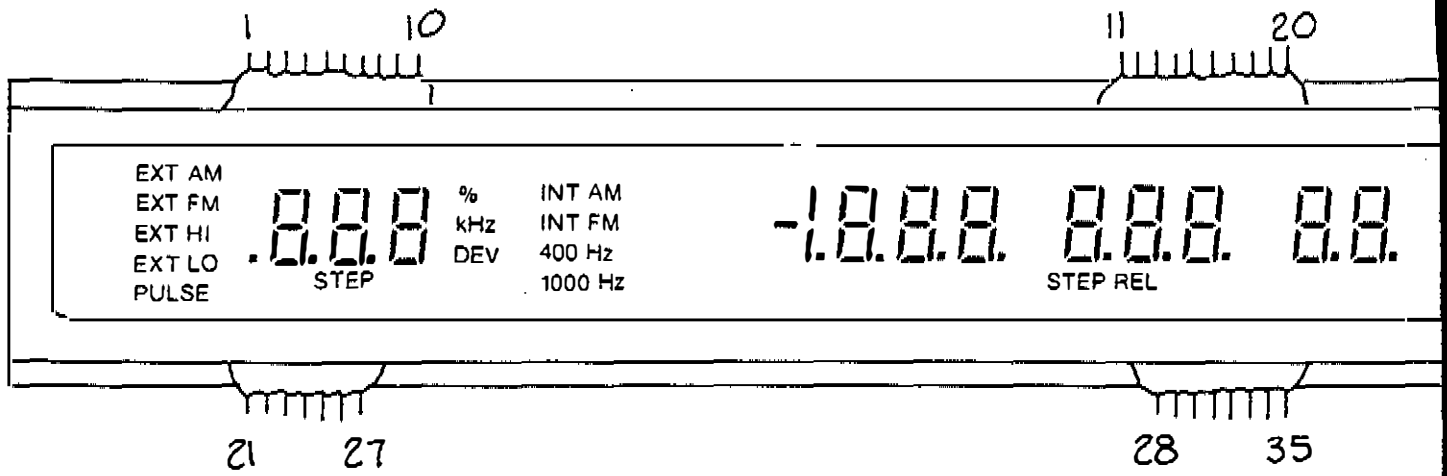

PIN NO	1	2	3	4	5	6	7	8	9	10	11	12	13	14	15	16	17	18	19	20
CONNECTION	F	P _{S1}	P _{DP}	P _d	P _c	P _e	P _g	P _f	P _b	P _a	P _h	P _j	P _n	P _p	P _m	P _n	P _L	P _q	P _{S2}	F
	21	22	23	24	25	26	27	28	29	30	31	32	33	34	35					
	G1	G2	G3	G4	G5	G6	G7	G8	G9	G10	G11	G12	G13	G14	G15					

- NOTES:
- F Denotes Filament
 - G Denotes Grid (numeric suffix identifies display field)
 - P Denotes Plate (subscript identifies display segment)

Fig 8-5 (Cont)
Sht 2 of 3

SCHMATIC DIAGRAMS

FUNCTION FREQUENCY DISPLAY

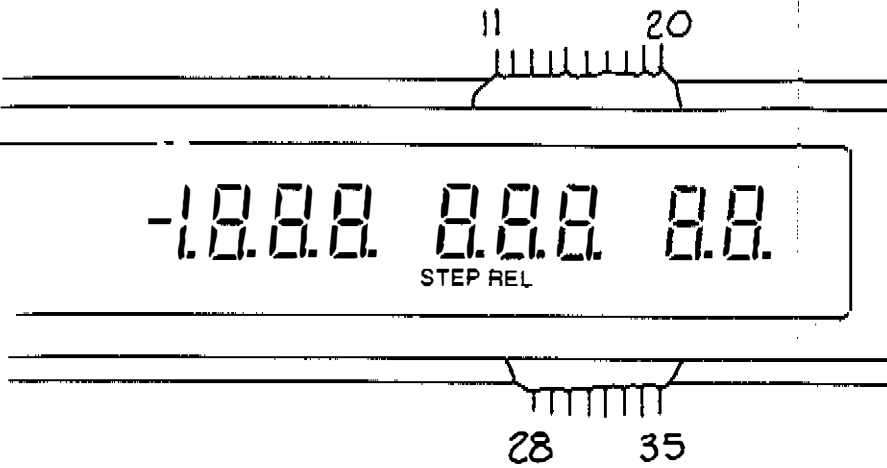

AMPLITUDE

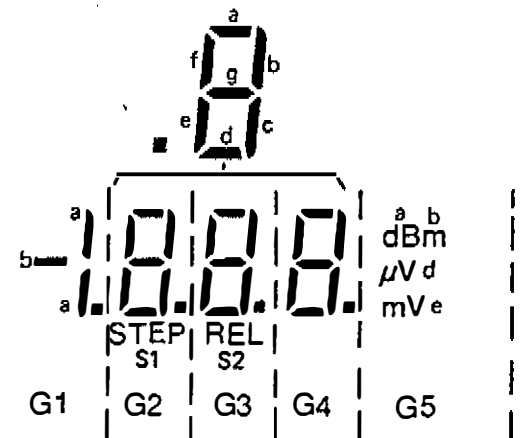
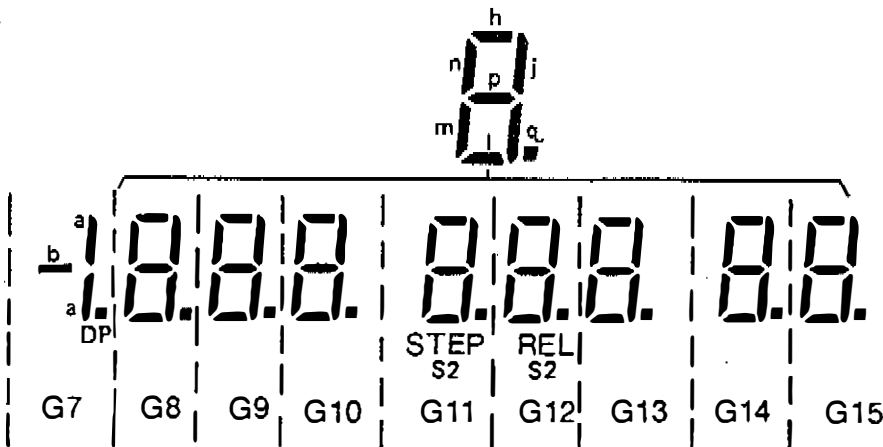
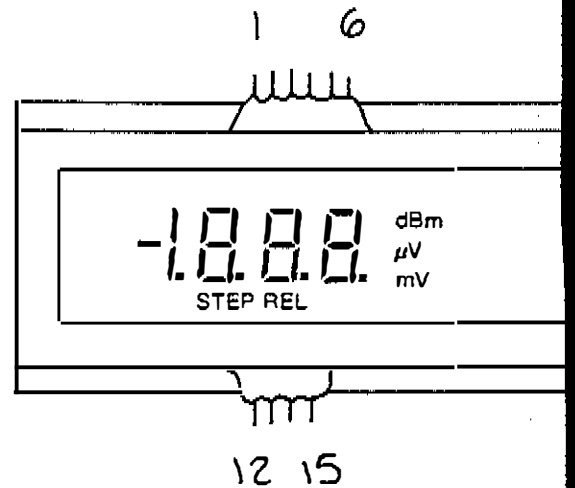

7	8	9	10	11	12	13	14	15	16	17	18	19	20
P _f	P _b	P _a	P _n	P _j	P _n	P _p	P _m	P _n	P _L	P _q	P _{S2}	F	
27	28	29	30	31	32	33	34	35					
G7	G8	G9	G10	G11	G12	G13	G14	G15					

PIN NO	1	2	3	4	5	6	7	8
CONNECTION	F	P _{S1}	P _{np}	P _c	P _g	P _a	P _b	P _f

DISPLAY CONNECTION INFO

(numeric suffix identifies display field)
(subscript identifies display segment)

Figure 8-5. A1A1 Display PCA (cont)

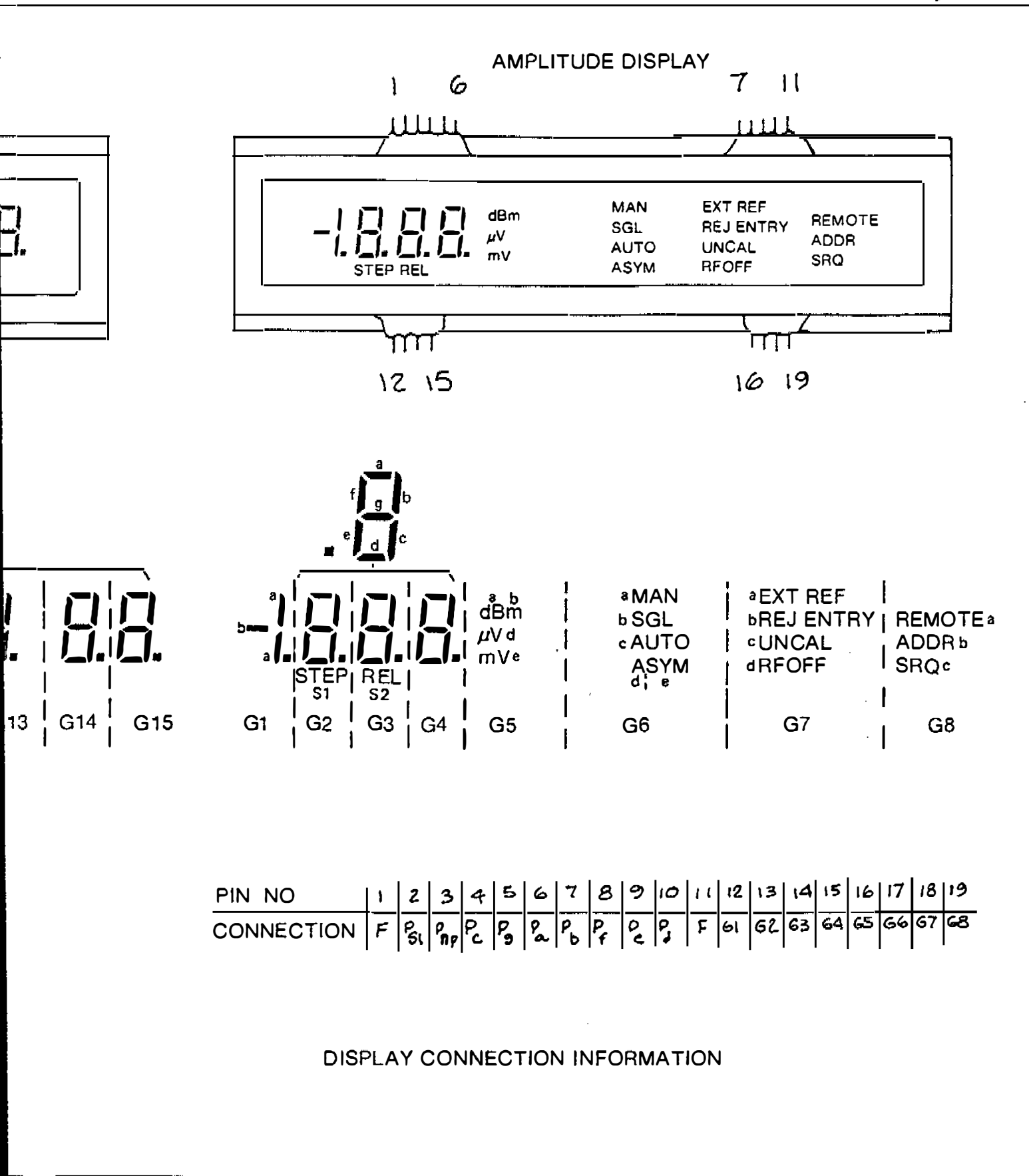

Figure 8-5. A1A1 Display PCA (cont)

Fig 85 (cont)
 Sht 1 of 3

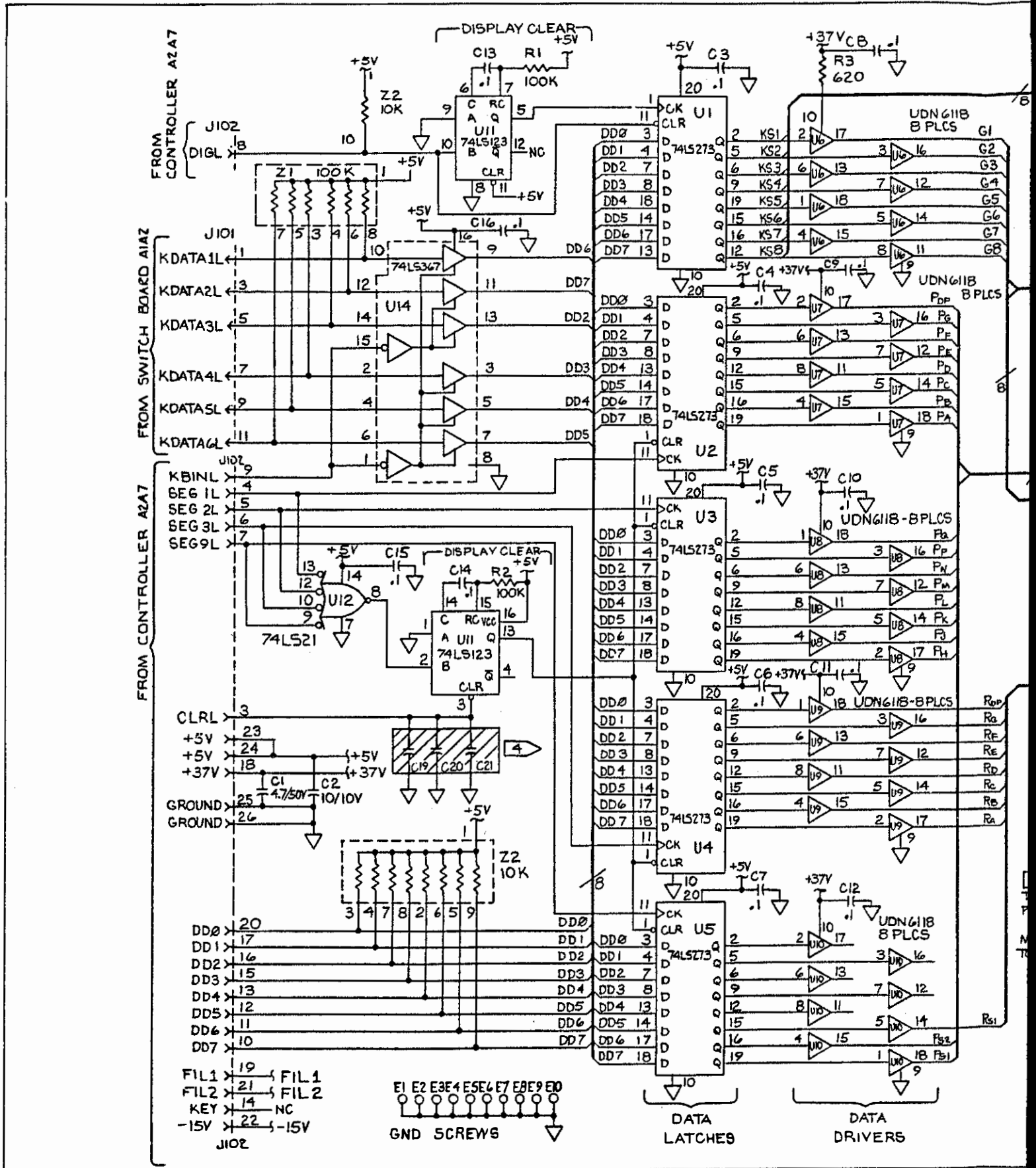

Fig 8-5 (Cont)
Skt 2 of 3

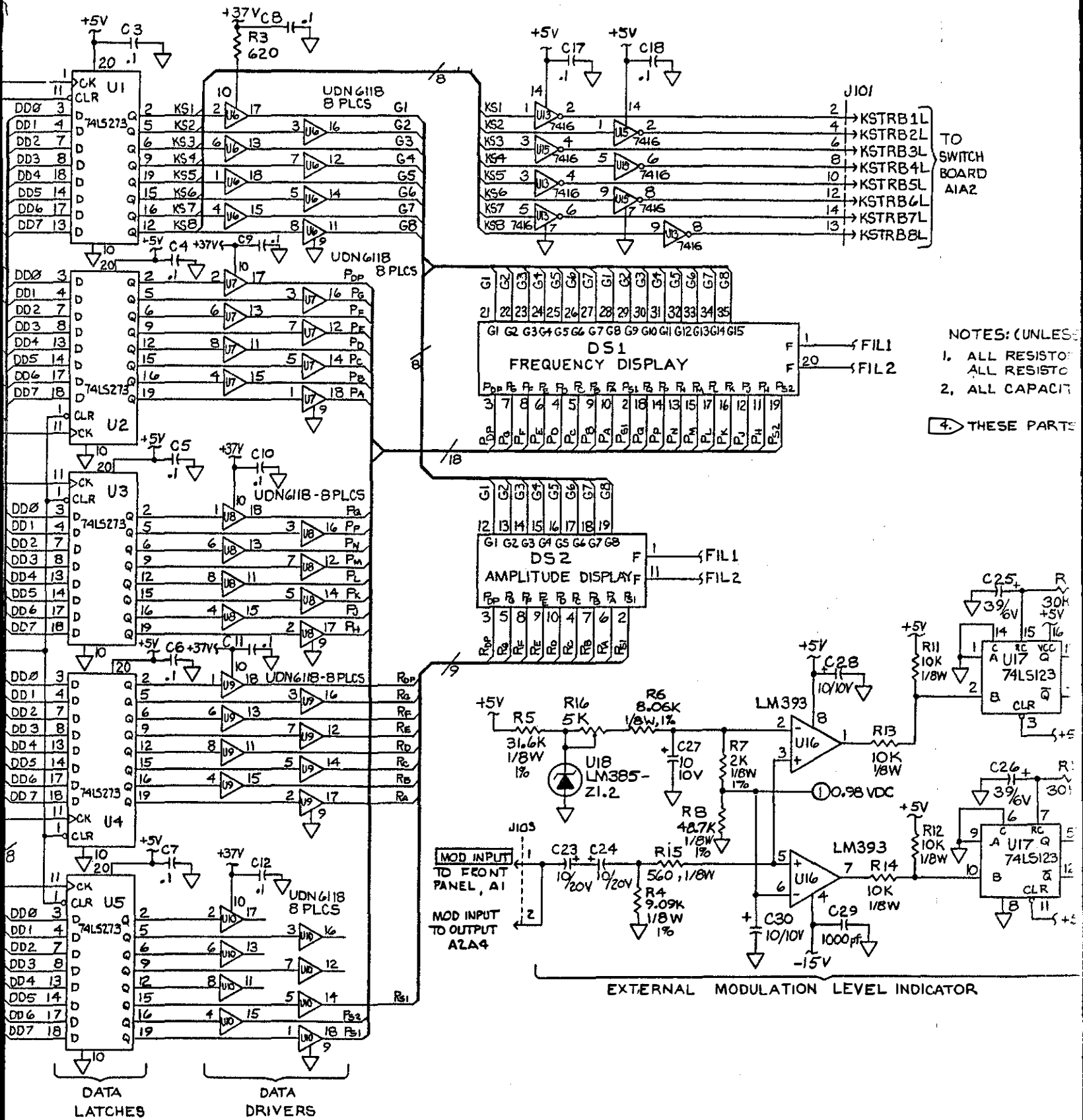
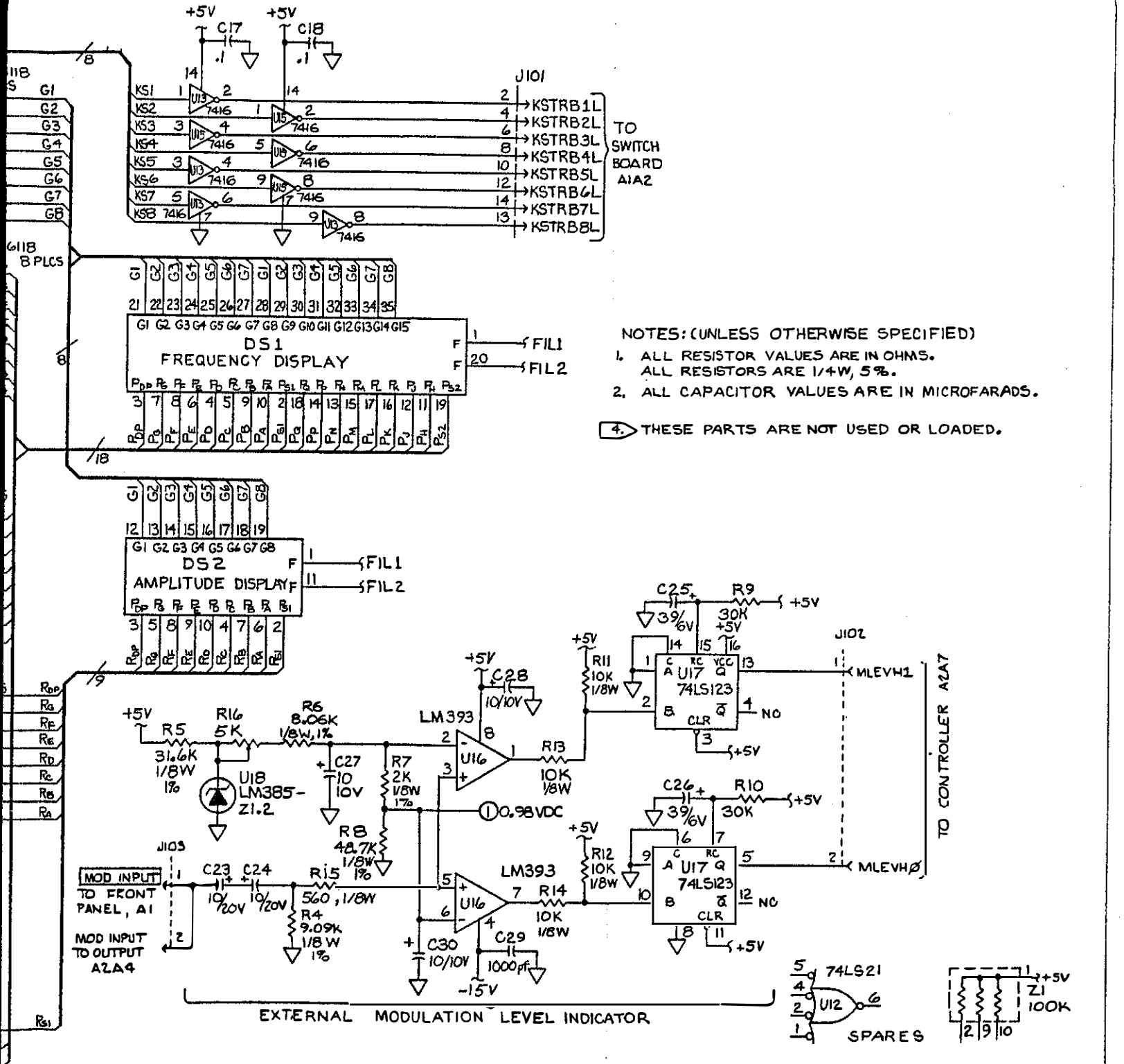

Fig 8-5 (cont)
 SHE 3 of 3

SCHMATIC DIAGRAMS



- NOTES: (UNLESS OTHERWISE SPECIFIED)
1. ALL RESISTOR VALUES ARE IN OHMS. ALL RESISTORS ARE 1/4W, 5%.
 2. ALL CAPACITOR VALUES ARE IN MICROFARADS.
 4. THESE PARTS ARE NOT USED OR LOADED.

6060A-1011

Figure 8-5. A1A1 Display PCA (cont)

Fig 8-6
Skt 1 of 2

SCHE

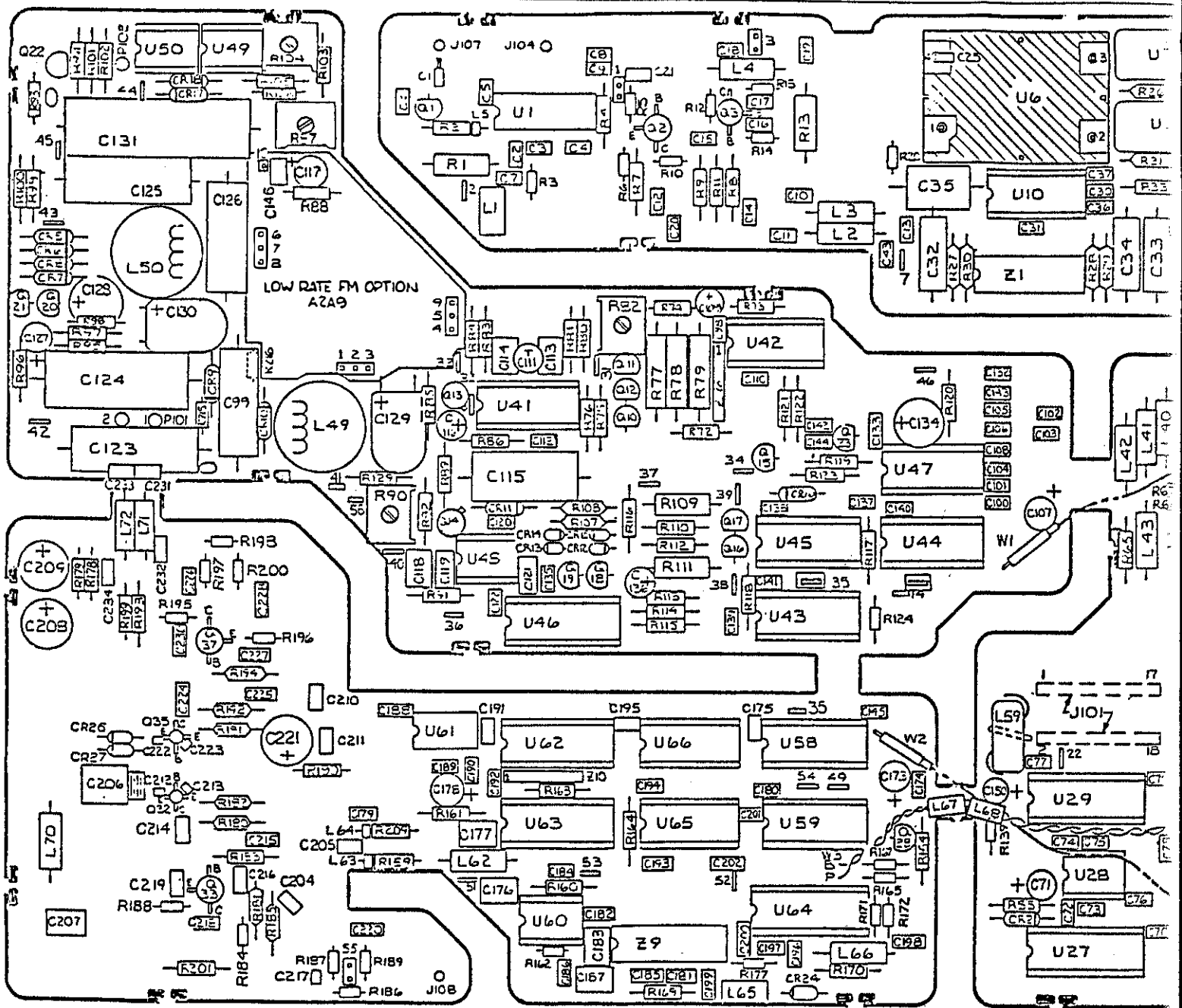

Fig 8-6
 Sht 2 of 2
 SCHEMATIC DIAGRAMS

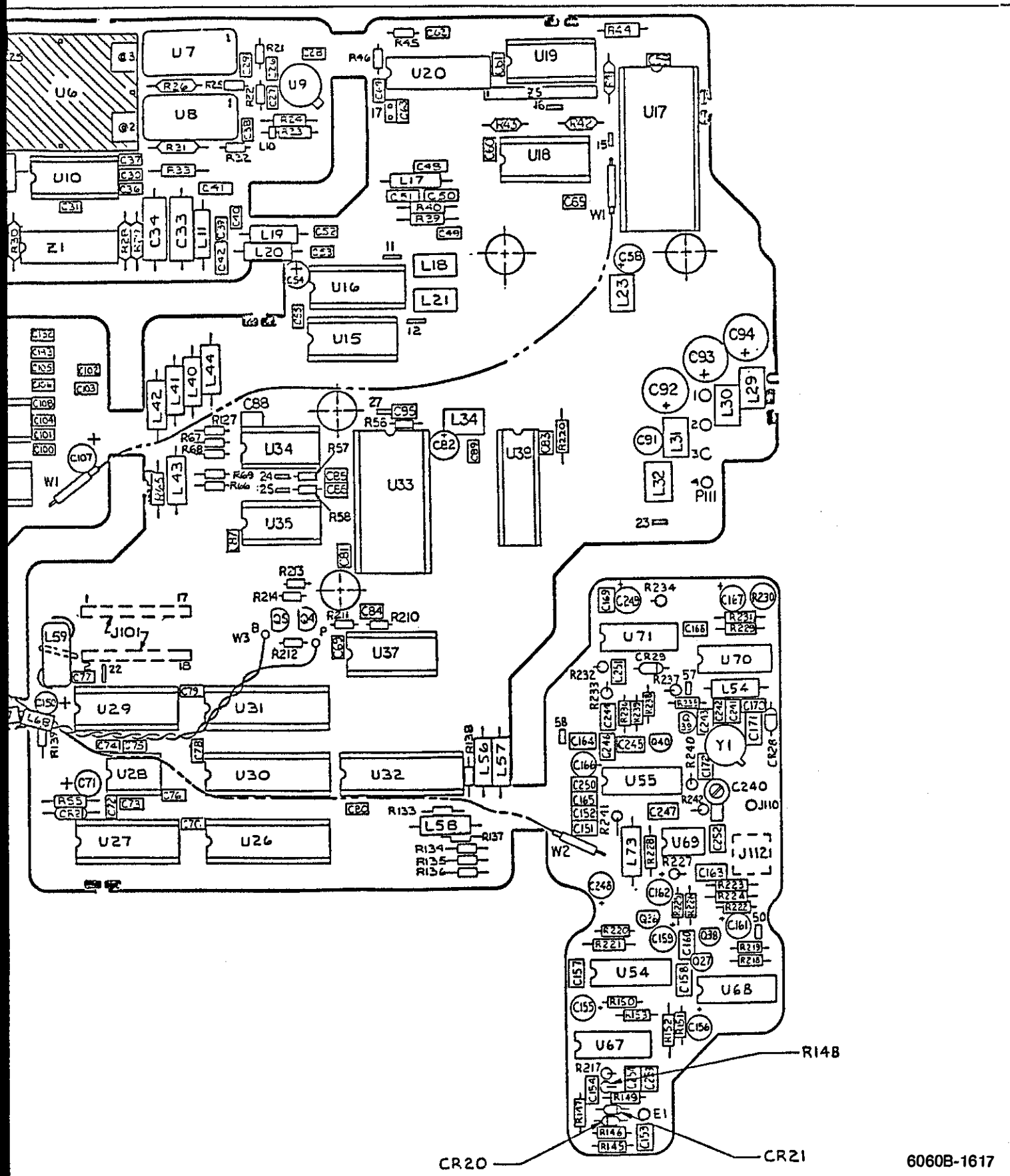
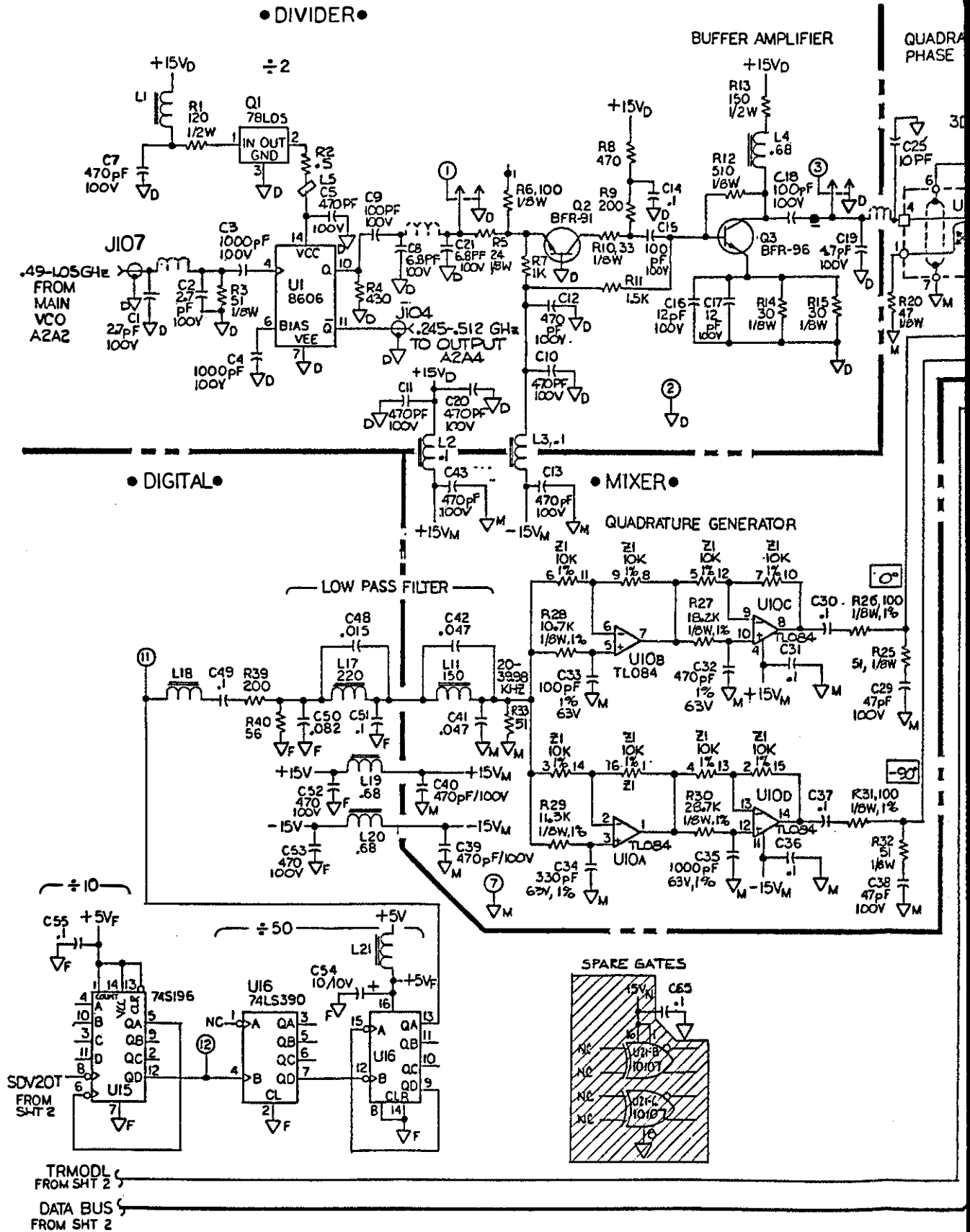

Figure 8-6. A2A1 Synthesizer PCA

6060B-1617

Fig 8-6 (1065)
Sht 1 of 2



TRMODL
FROM SHT 2

DATA BUS
FROM SHT 2

Fig 8-6 (185)
Sht 2 of 2

SCHMATIC DIAGRAMS

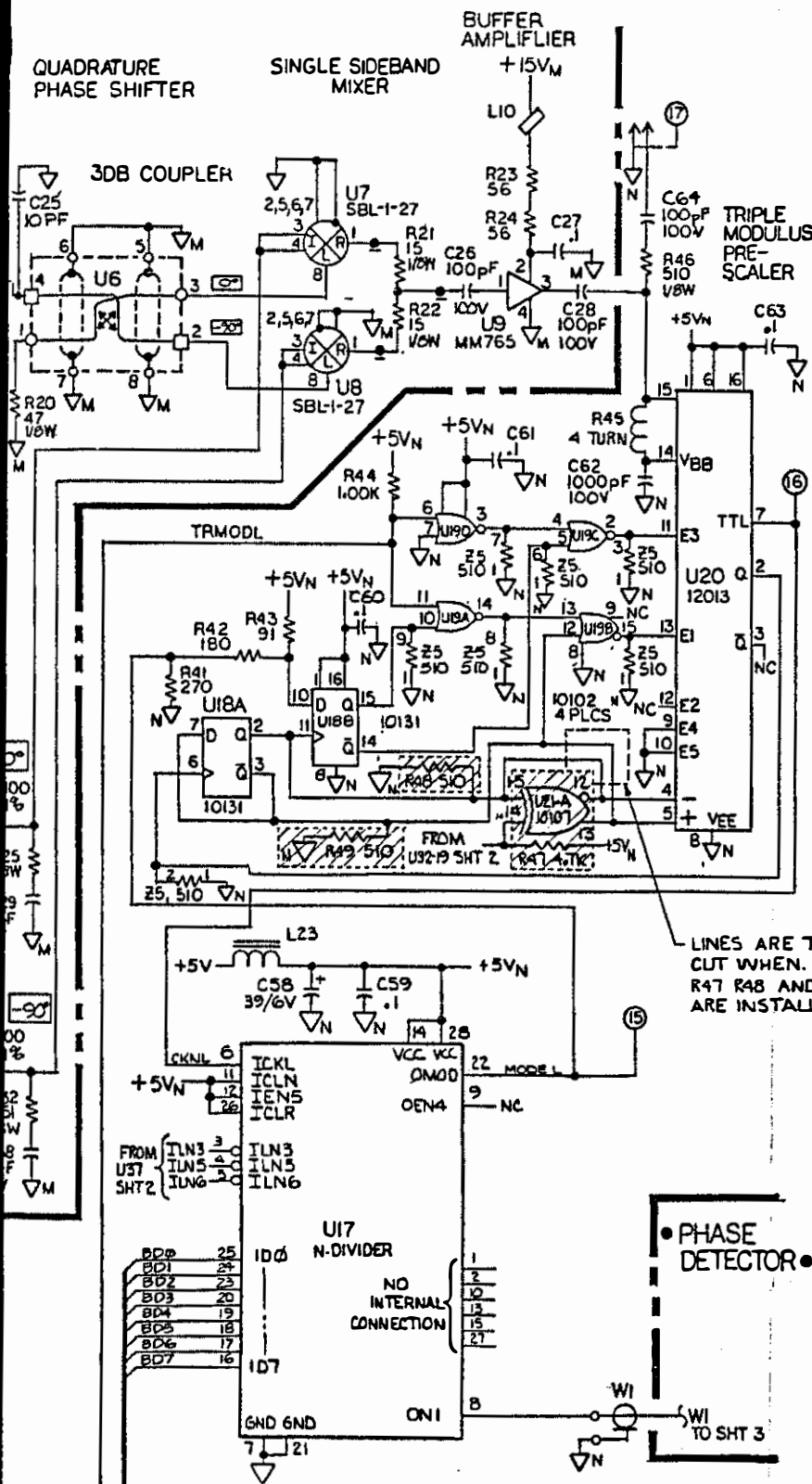

- NOTES: (UNLESS OTHERWISE SPECIFIED),
1. ALL RESISTANCES ARE IN OHMS. ALL RESISTORS ARE 1/4W. ALL RESISTORS ARE 5%.
 2. ALL CAPACITANCES ARE IN MICROFARADS. ALL CAPACITORS ARE 50V.
 3. ALL CHOKES ARE 6-TURN BRADS.
 4. ALL DIODES ARE 1N4448.
 5. ALL INDUCTOR VALUES ARE IN MICROHENRIES.
 6. SYMBOLS DRAWN WITH DASHED LINES INDICATE COMPONENTS PRINTED ON CIRCUIT BOARD.
 7. THE SYMBOL '—●—' INDICATES TRANSMISSION LINES OF OTHER THAN 50 OHM IMPEDANCE WHICH CONSTITUTE CIRCUIT ELEMENTS. 50 OHM TRANSMISSION PATHS ARE NOT INDICATED.
 10. PARTS IN SHADED AREA ARE OPTIONAL AND ARE NOT TO BE INSTALLED.
- ① FACTORY SELECTED COMPONENT.

REFERENCE DESIGNATIONS	
LAST USED	NOT USED
C234	C6, 22, 23, 24, 44, 45, 46, 47, 66, 67, 68, 90, 96, 97, 147, 148, 149, 170, 172, 203, 229, 56, 57,
CR27	CR1, 19, 22, 23, 25, 1, 3
L72	L6, 7, 8, 9, 12, 13, 14, 15, 16, 24, 25, 26, 27, 28, 35, 36, 37, 38, 39, 45, 46, 47, 48, 51, 52, 53, 55, 60, 61, 69, 22, 33
Q37	Q6, 8, 9, 24, 25, 29, 30, 31, 34, 36, 7
R216	R16, 17, 18, 19, 24, 30, 36, 37, 38, 50, 51, 52, 53, 54, 60, 61, 62, 63, 64, 70, 71, 125, 126, 126, 130, 131, 132, 140, 141, 142, 143, 144, 155, 156, 157, 158, 173, 174, 175, 179, 160, 168, 202, 203, 204, 205, 206, 207, 208
TP56	TP4, 5, 6, 8, 9, 10, 18, 19, 20, 28, 29, 30, 47, 48, 21
U66	U2, 3, 4, 5, 11, 12, 13, 14, 22, 23, 24, 25, 36, 39, 40, 51, 52, 53, 56, 57
W3	—
Y1	—
Z10	Z2, 3, 4, 7, 8

6060B-1017
(1 of 5)

Figure 8-6. A2A1 Synthesizer PCA (cont)

Fig 8-6 (2 of 5)
 Sht 1 of 3

• DIGITAL •

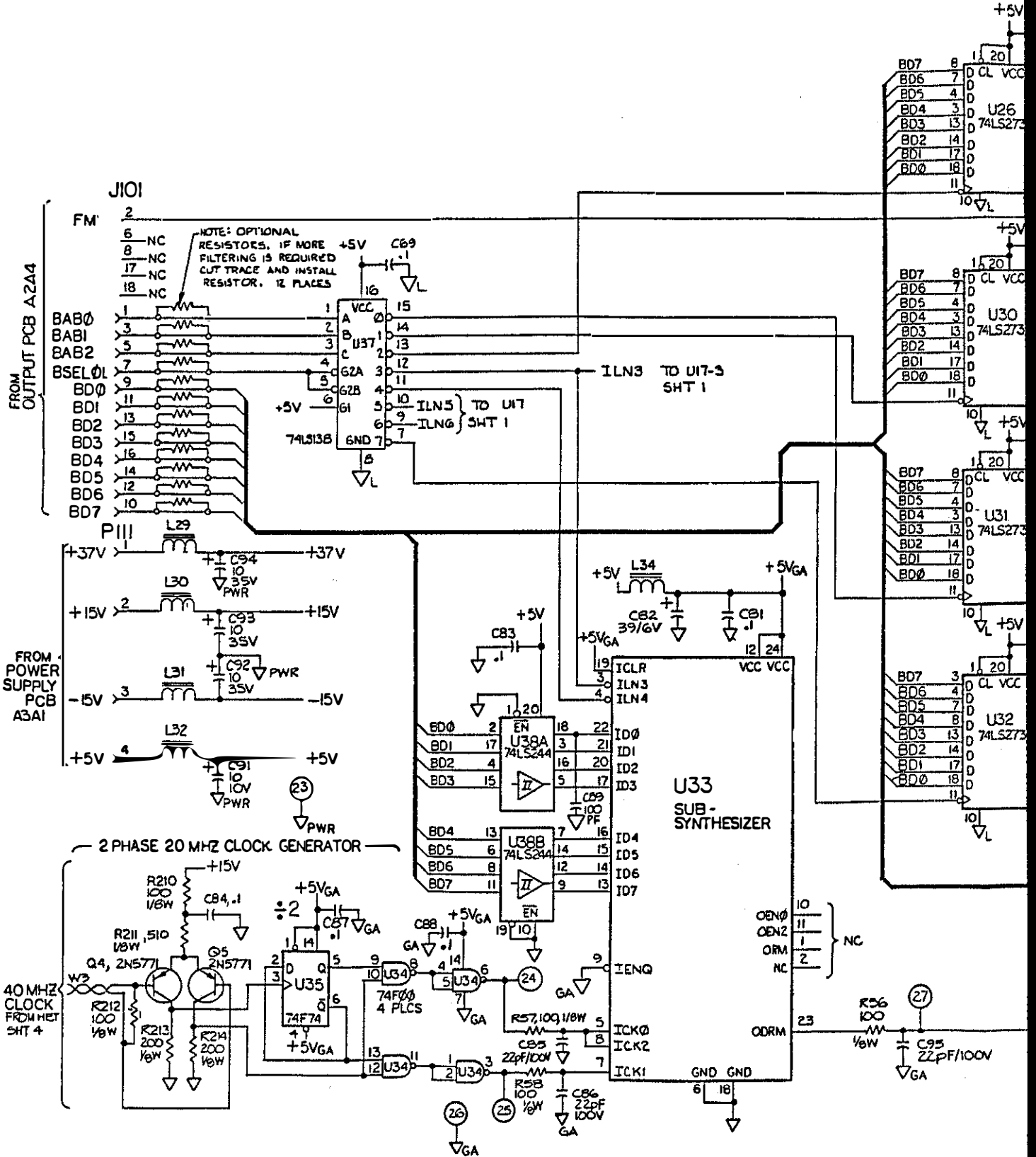

Fig 8-6 (2 of 5)
Sht 2 of 3

SCHMATIC DIAGRAMS

• DIGITAL •

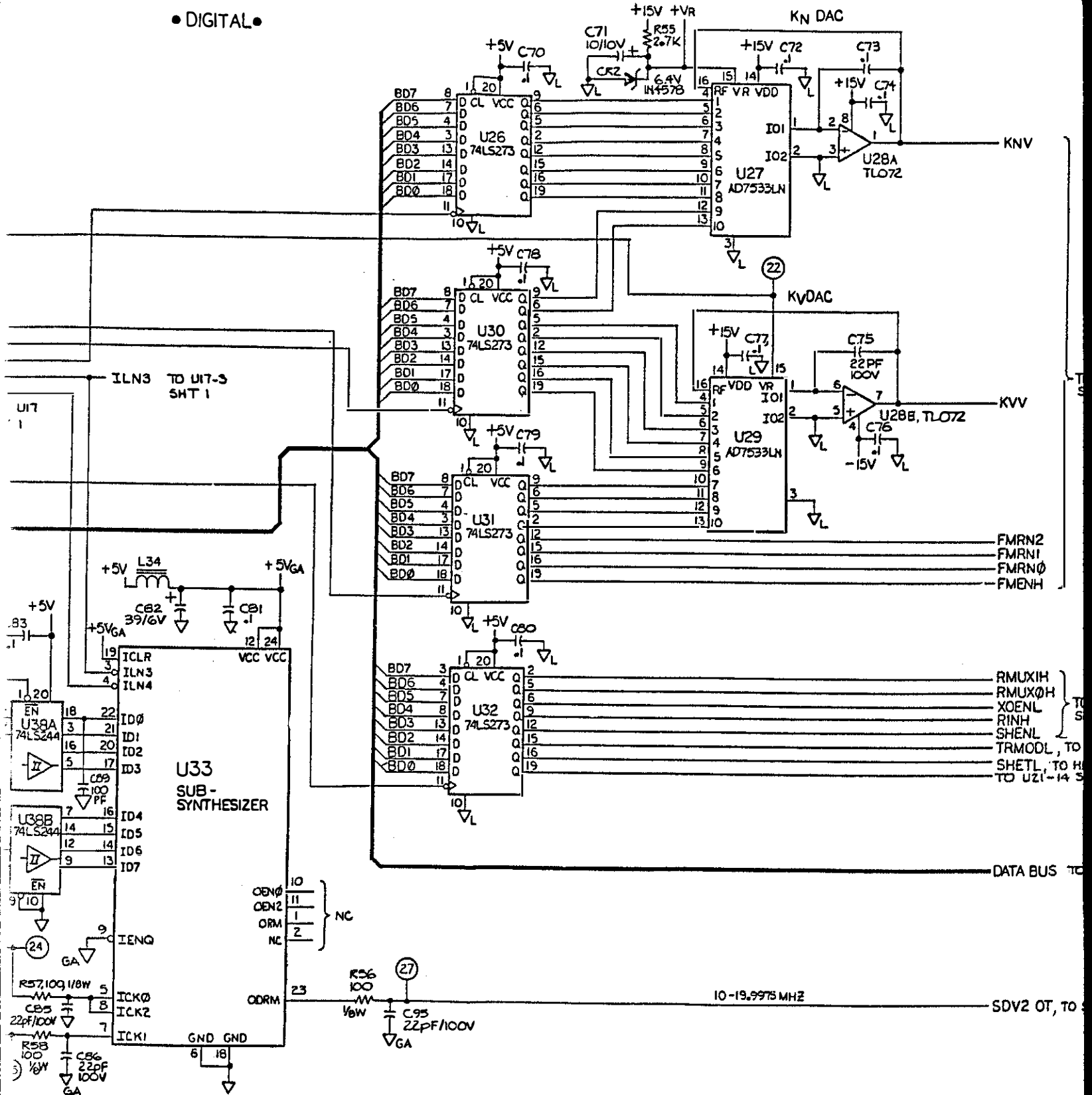
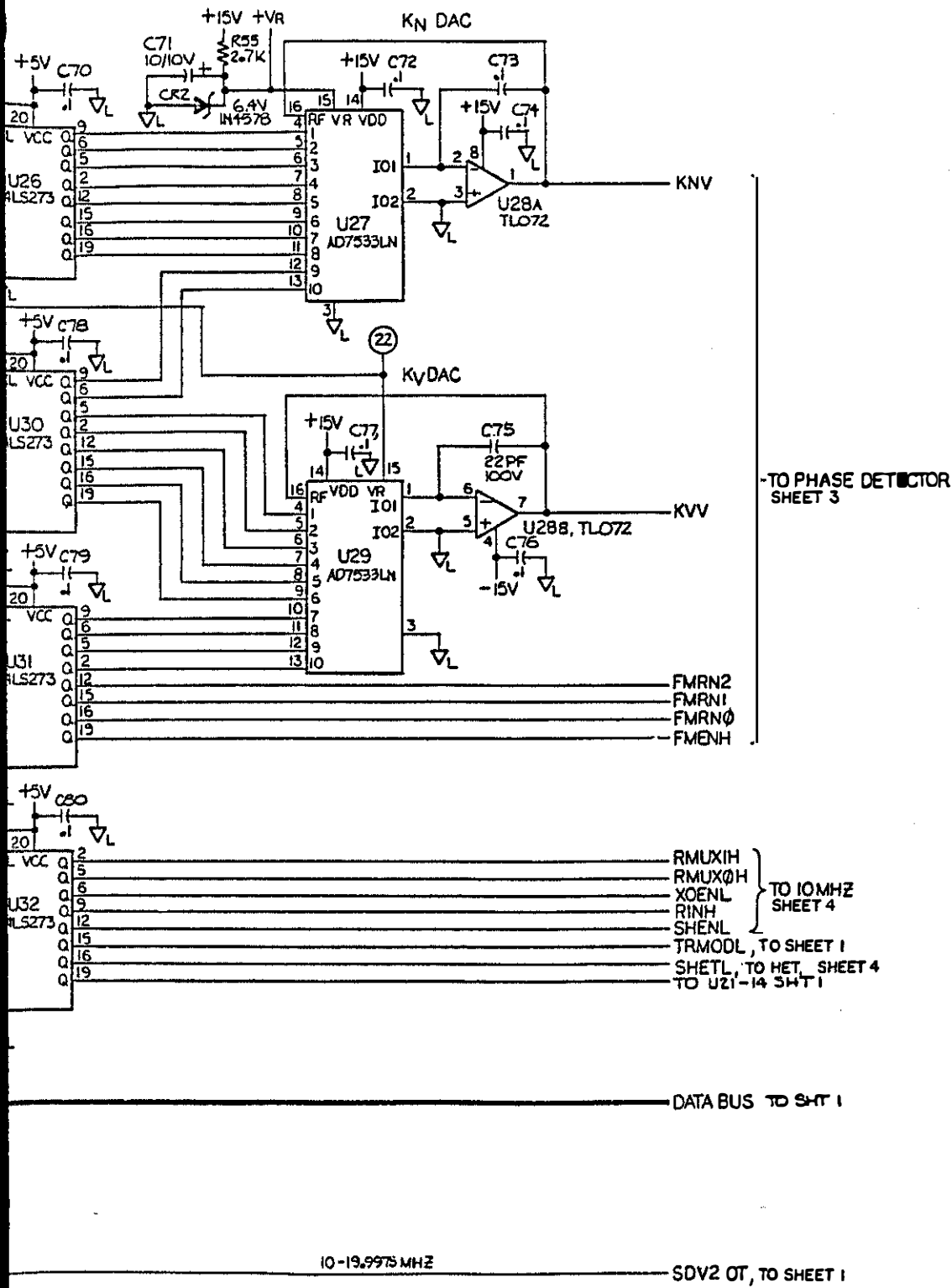

Figure 8-6. A2A1 Synthesizer PCA (cont)

Fig 8-6 (2 of 5)

Schematic Diagrams



6060B-1017
(2 of 5)

Figure 8-6. A2A1 Synthesizer PCA (cont)

Fig 816 (3 of 5)
 Sht 1 of 2

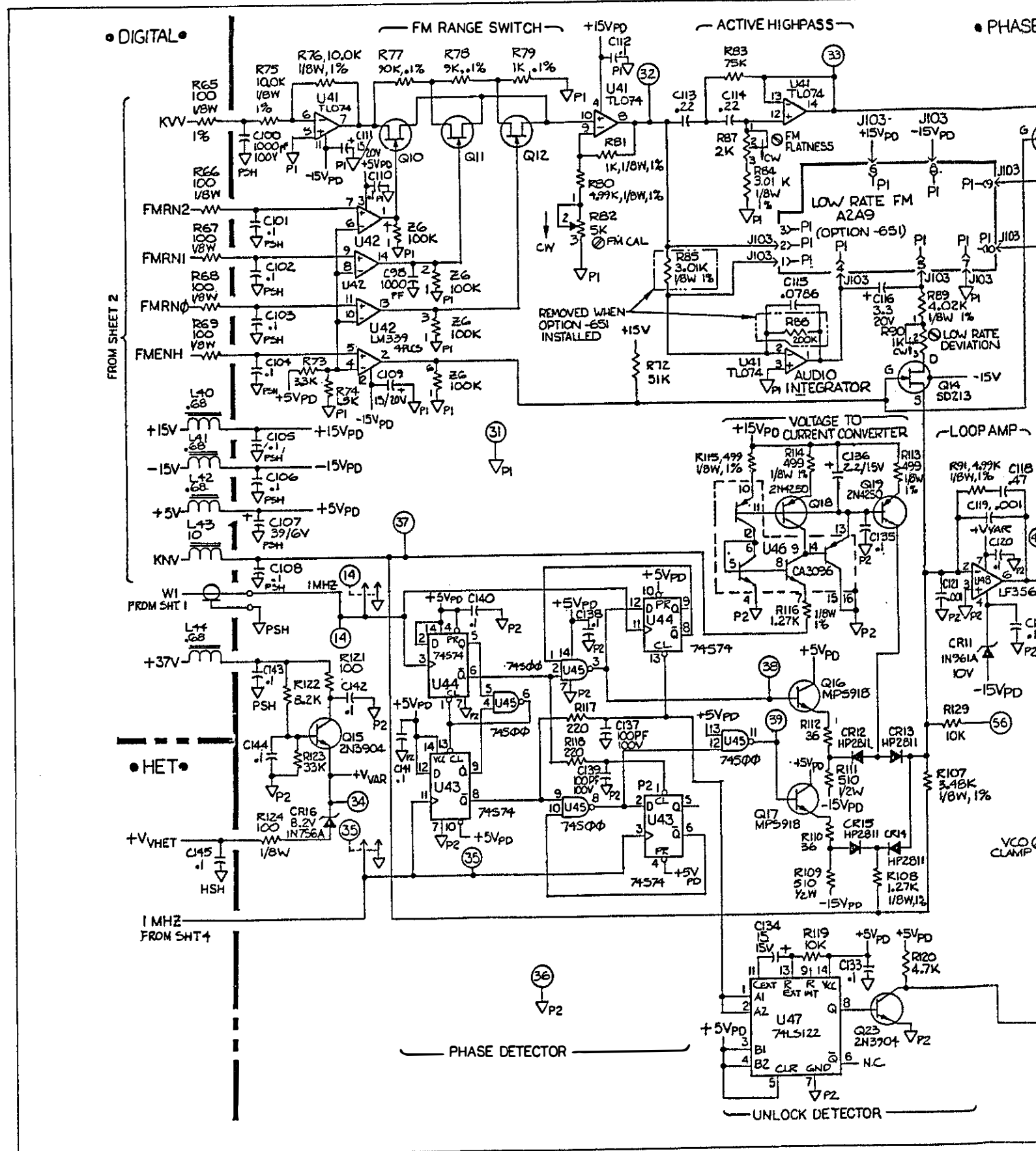
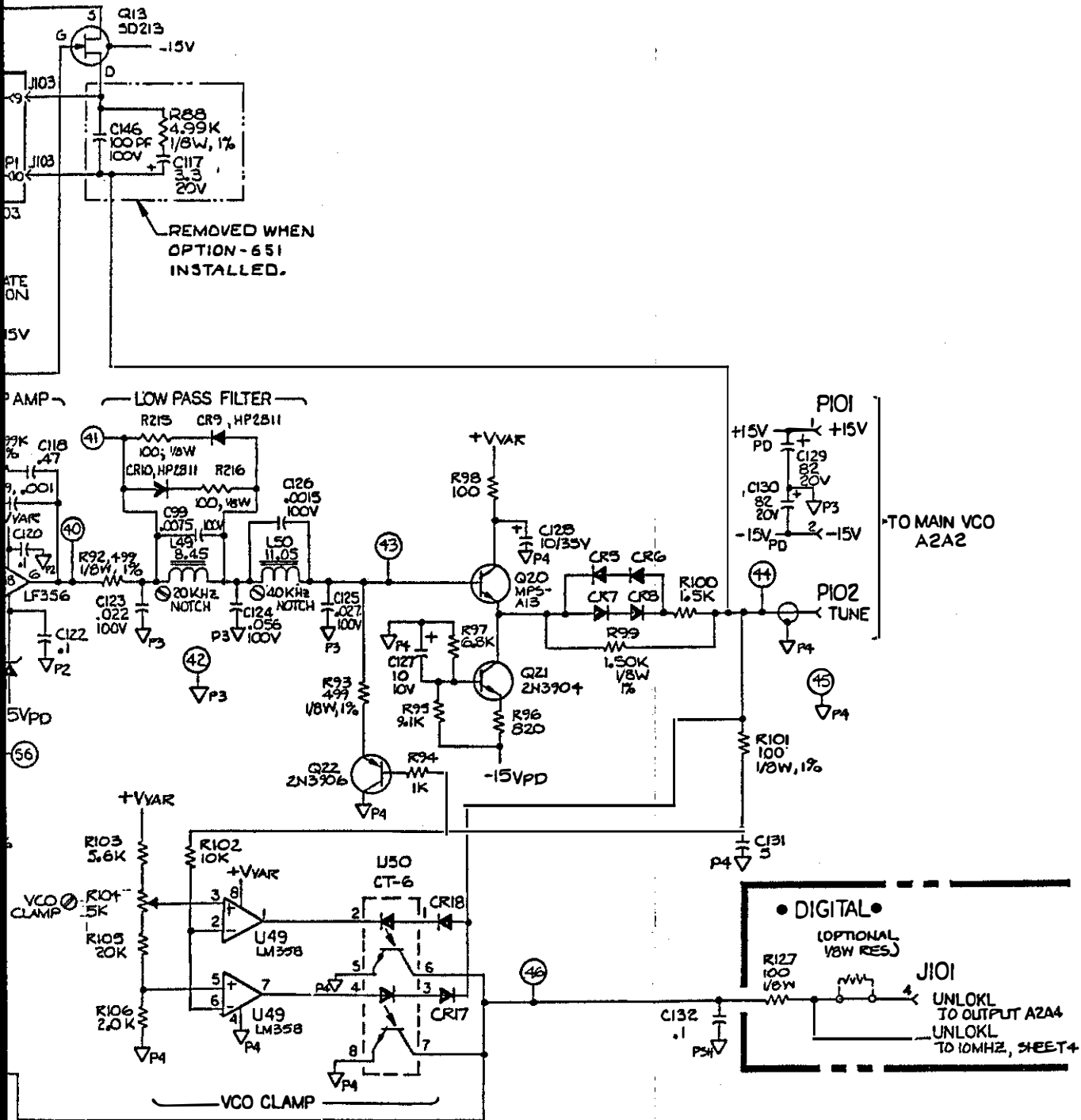

Fig 8-6 (345)
 Sht 2 of 2

SCHMATIC DIAGRAMS

• PHASE DETECTOR •



6060B-1017
 (3 of 5)

Figure 8-6. A2A1 Synthesizer PCA (cont)

Fig 8-6 (4 of 5)
Skt 1 of 2

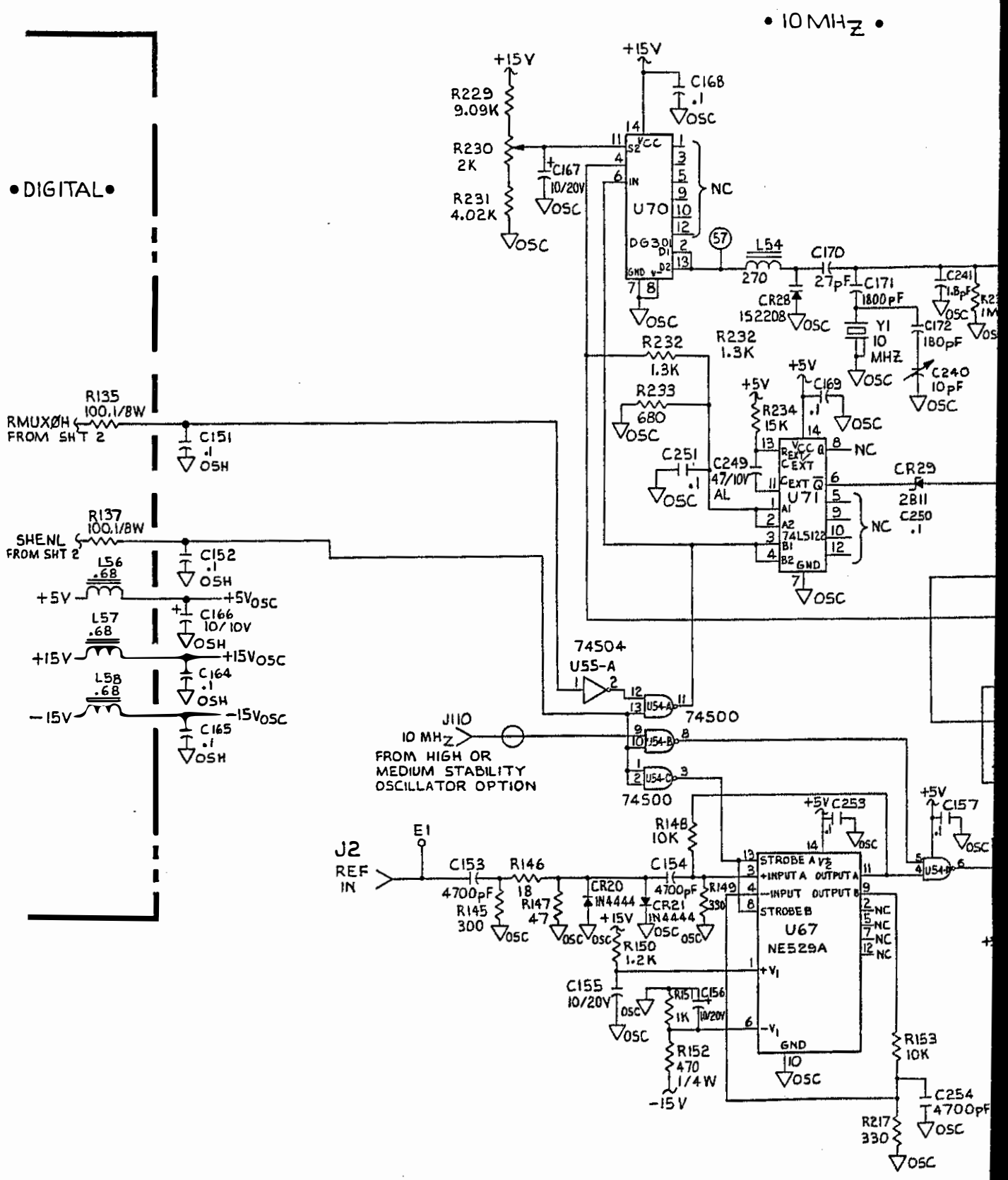
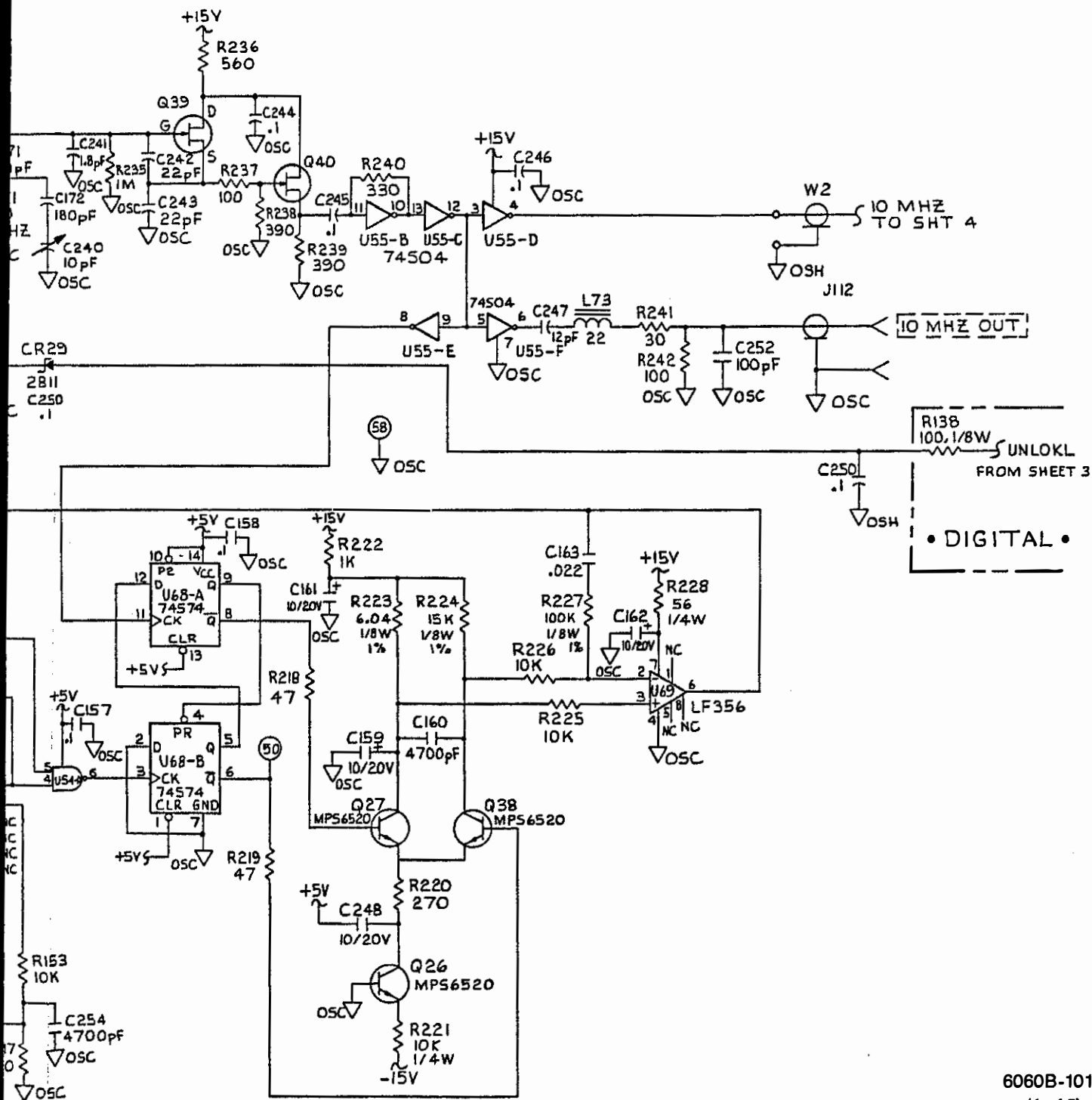

Fig 8-6 (4 of 5)
 Sht 2 of 2 SCHEMATIC DIAGRAMS



6060B-1017
 (4 of 5)

Figure 8-6. A2A1 Synthesizer PCA (cont)

Fig 8-6 (5 of 5)
Sht 1 of 2

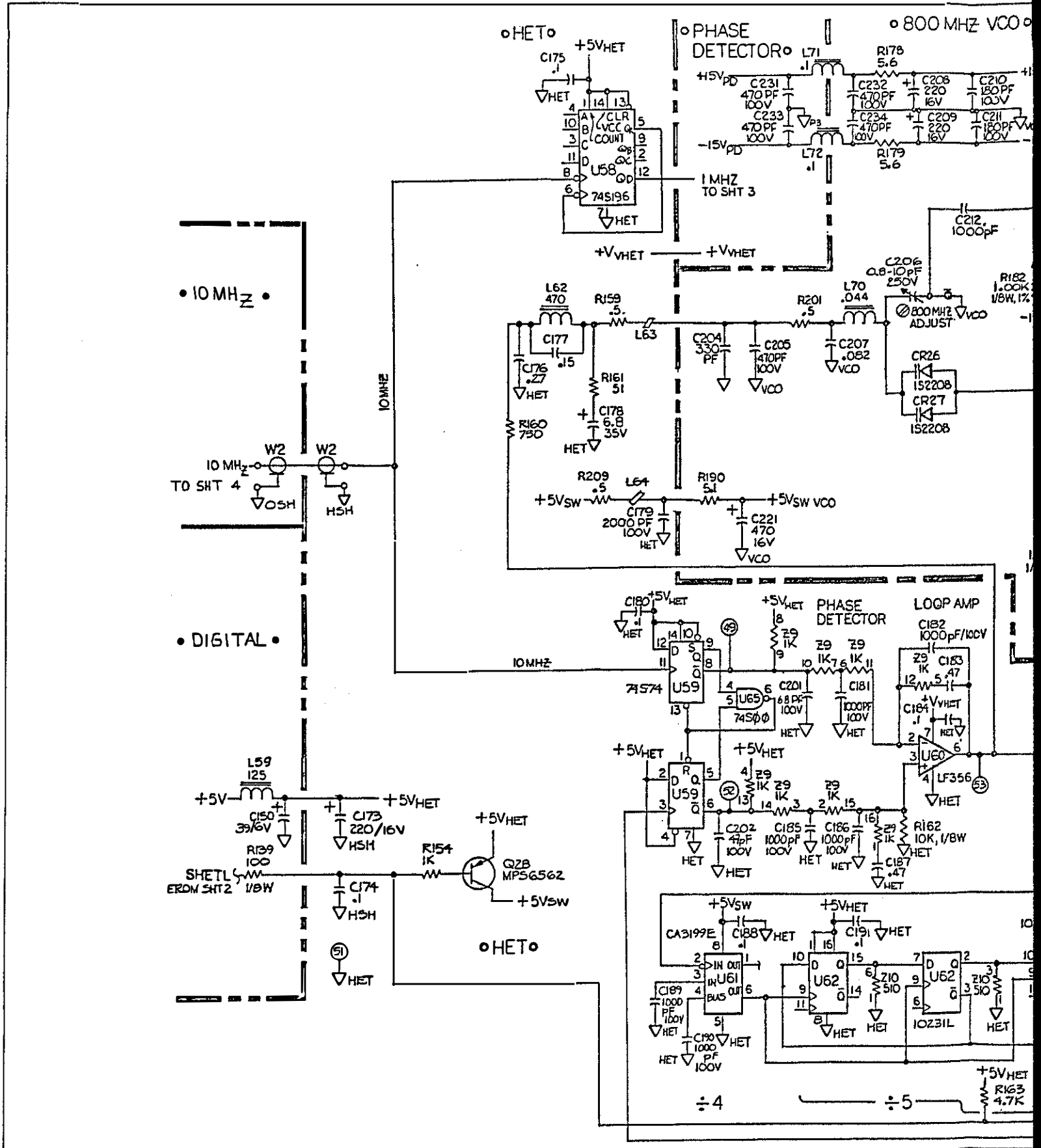
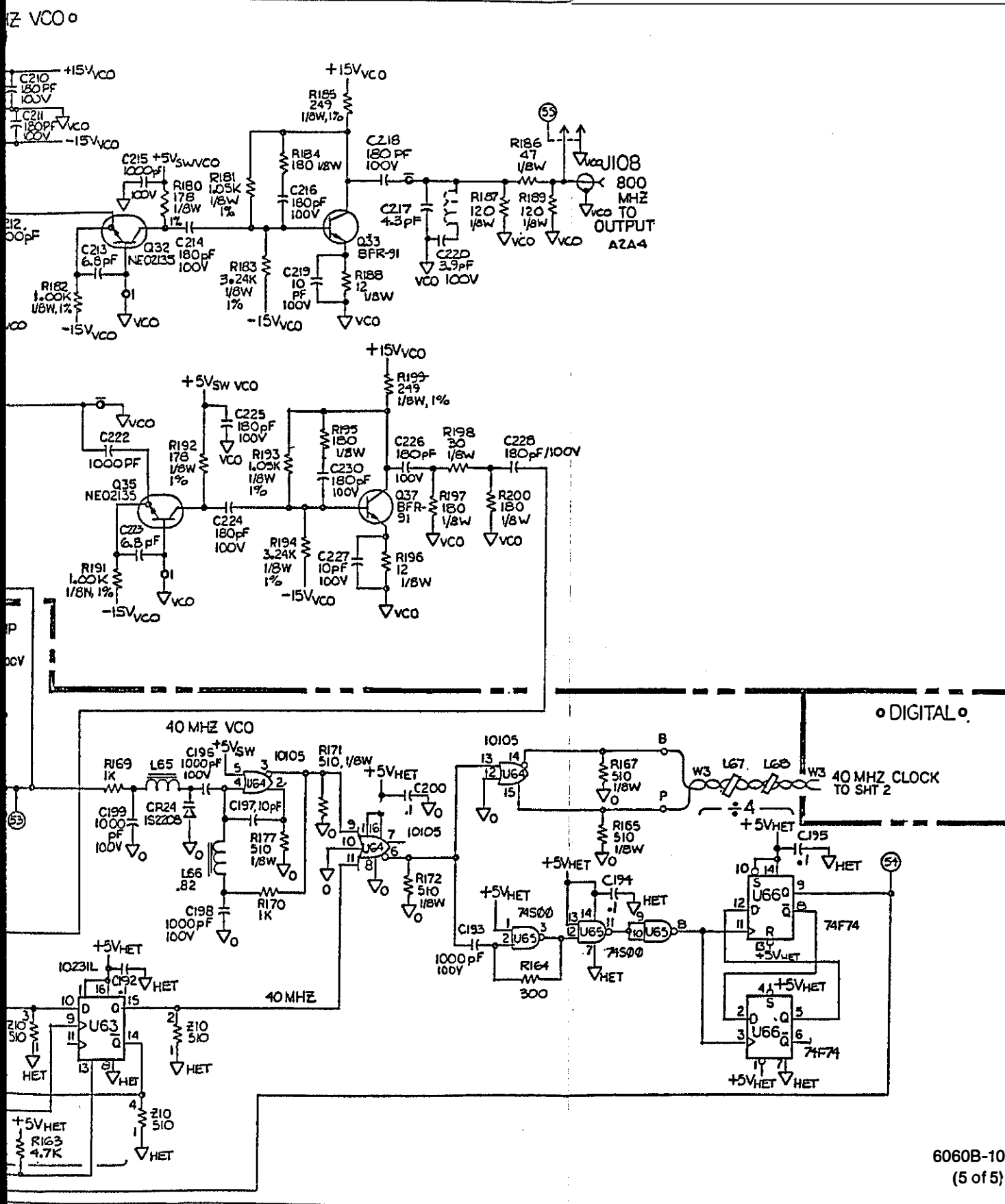

Fig 8-6 (5 of 5)
Sht 2 of 2

SCHMATIC DIAGRAMS



6060B-1017
(5 of 5)

Figure 8-6. A2A1 Synthesizer PCA (cont)

Fig 8-7
Skt 143

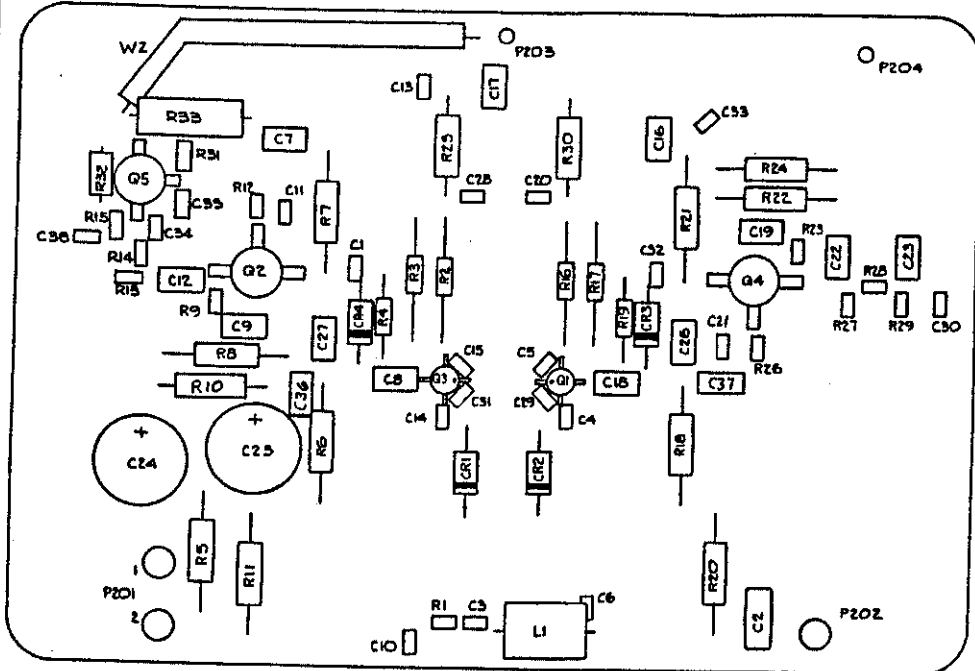

6060A-1618

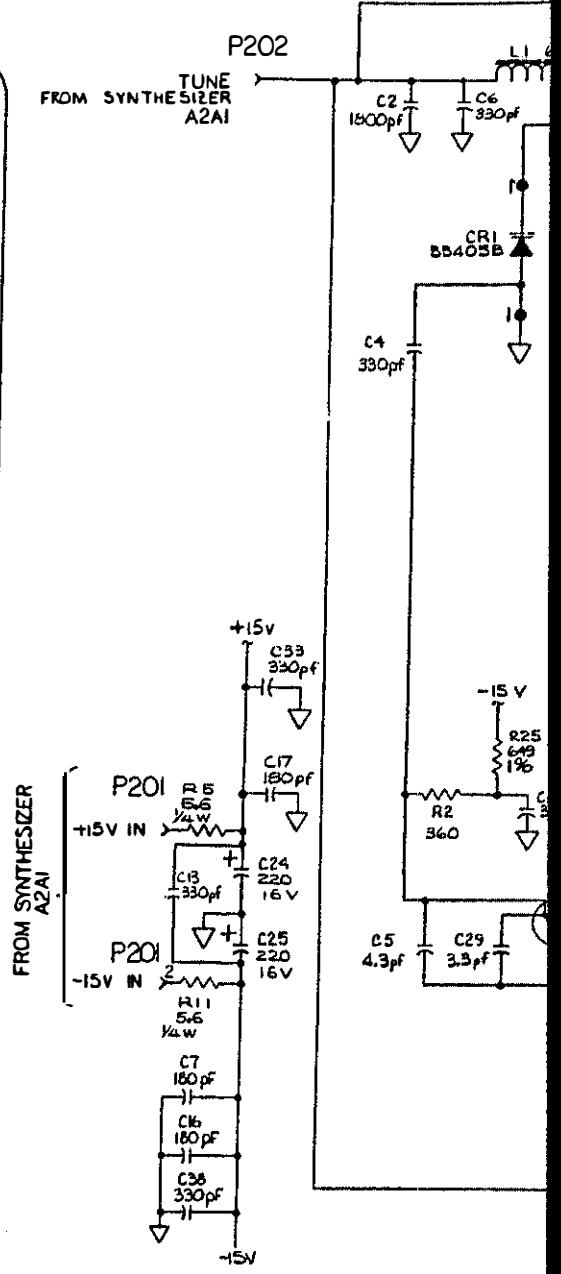
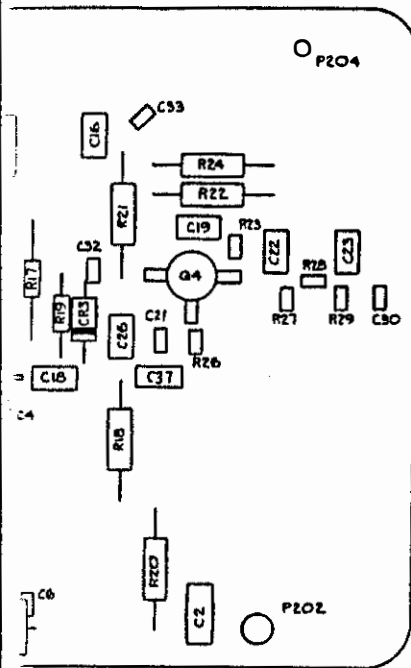
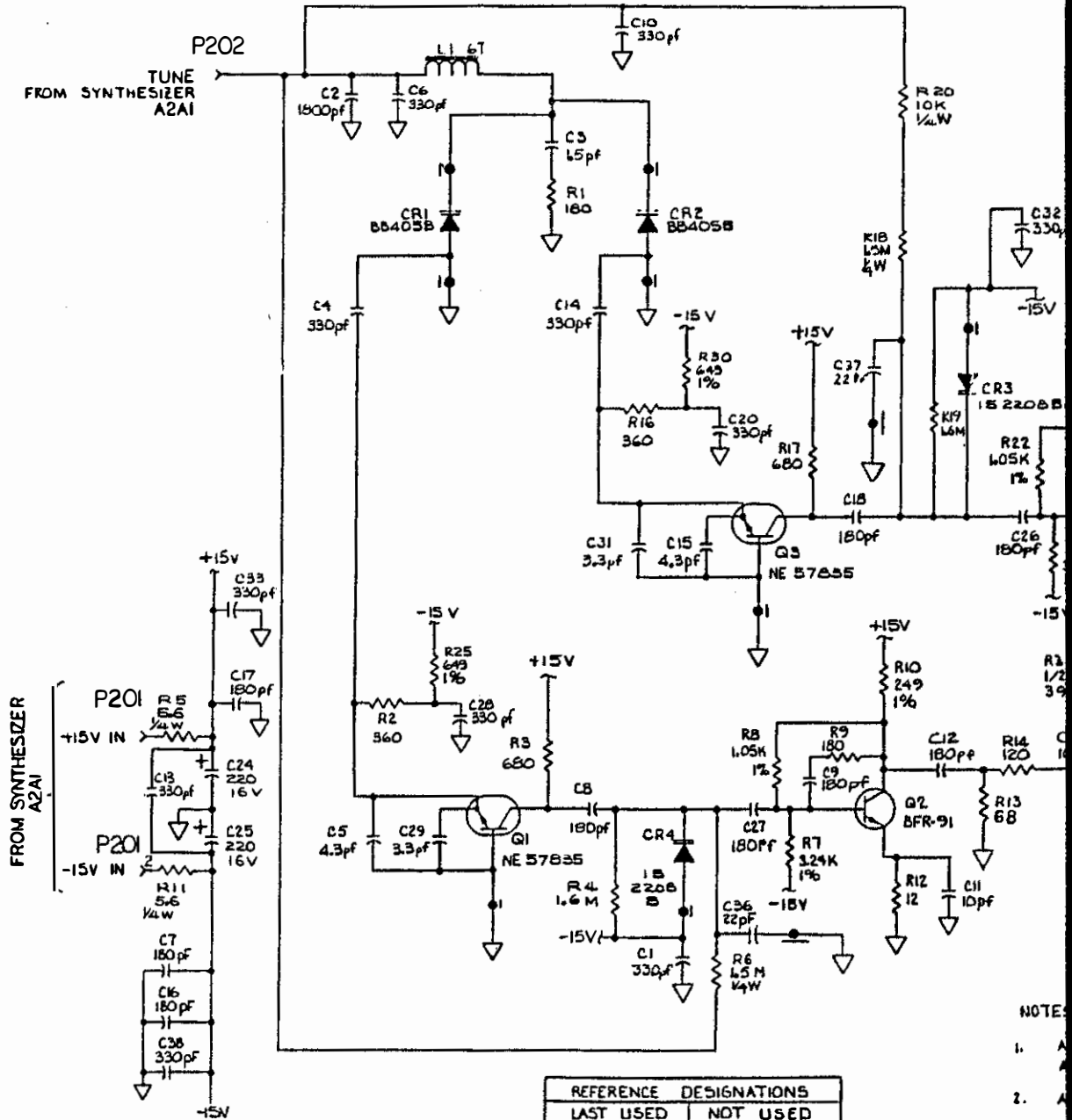

Fig 8-7
 Skt 2 of 3

SCHMATIC DIAGRAMS



6060A-1618



NOTE:
 1. A
 2. A

REFERENCE DESIGNATIONS	
LAST USED	NOT USED
R33	PI-200
C35	
Q5	
CR4	
L1	
P204	
W2	W1

Figure 8-7. A2A2 VCO PCA

Fig 8-7
Sht 3 of 3

SCHMATIC DIAGRAMS

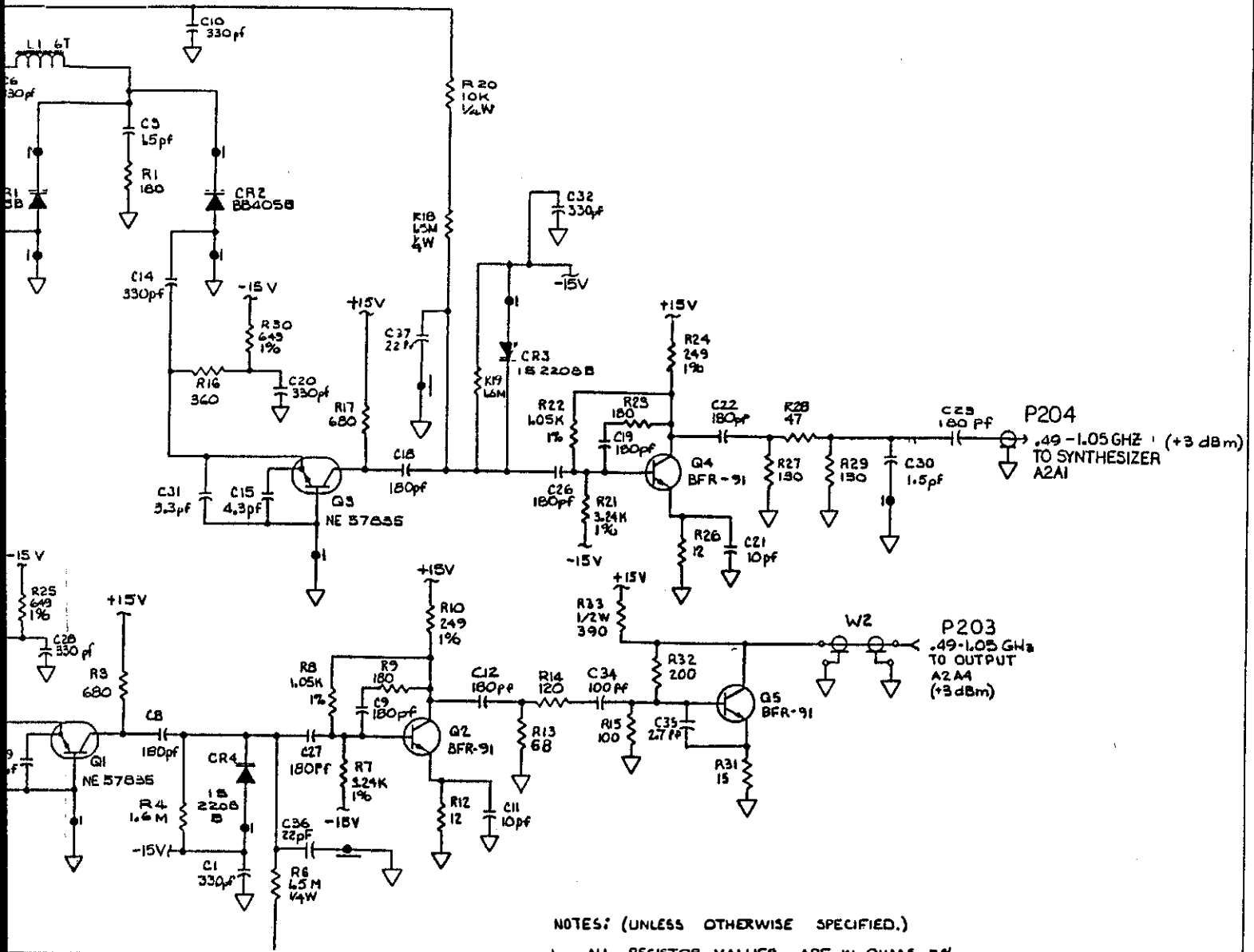

NOTES: (UNLESS OTHERWISE SPECIFIED.)

1. ALL RESISTOR VALUES ARE IN OHMS, 5%
ALL CAPACITOR VALUES ARE IN MICROFARADS.
2. ALL RESISTORS ARE 1/8W.

REFERENCE DESIGNATIONS	
LAST USED	NOT USED
R33	PI-200
C38	
G5	
CR4	
L1	
P204	
W2	W1

6060A-1018

Figure 8-7. A2A2 VCO PCA

Fig 8-8
Skt 1 of 3

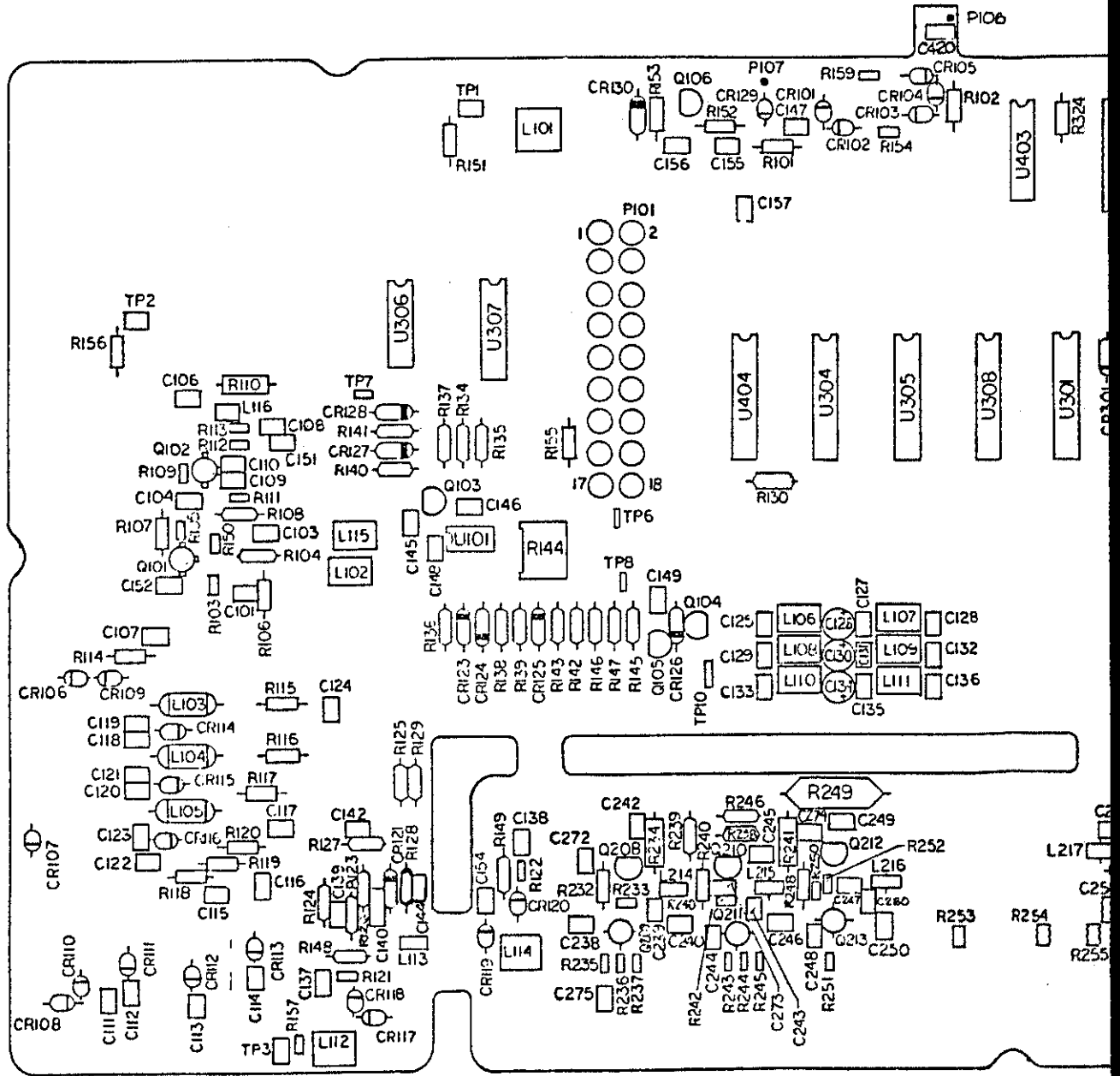

Fig 8-8
Skt 203

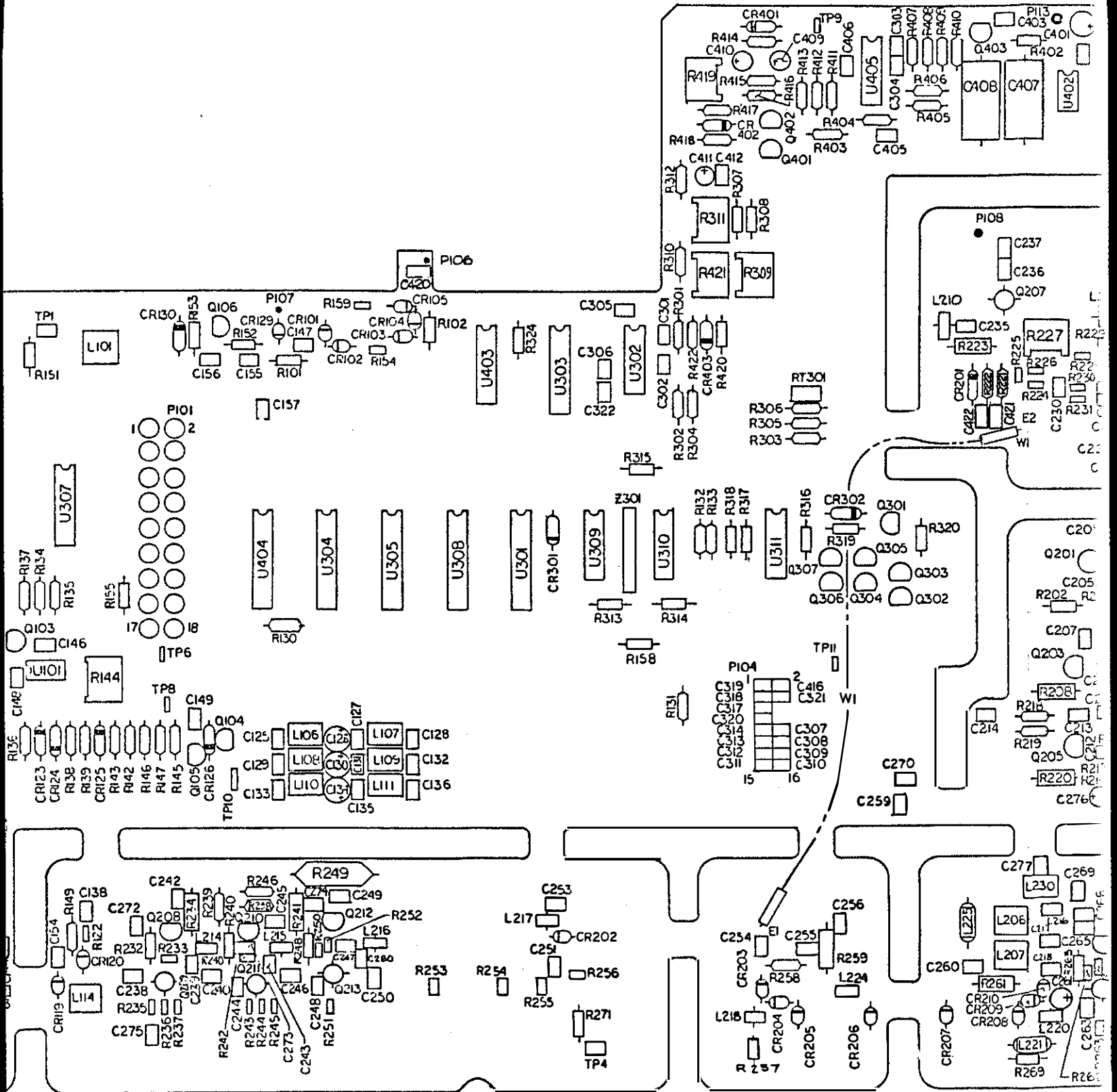
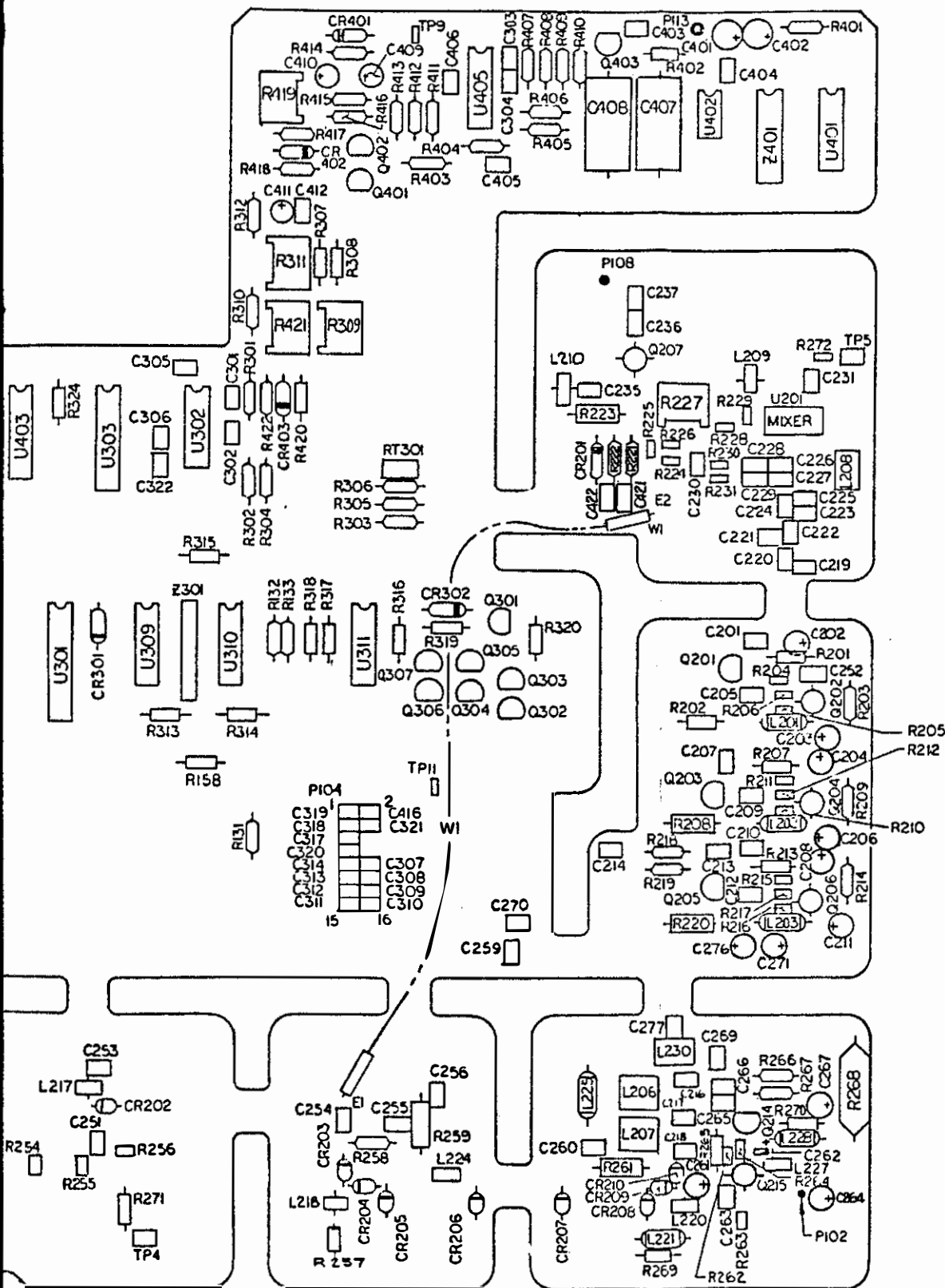

Fig 8-8
Skt 303

SCHMATIC DIAGRAMS



6060A/AN-1624

Figure 8-8. A2A4 Output PCA

Fig 8-8 (184)
Sht 183

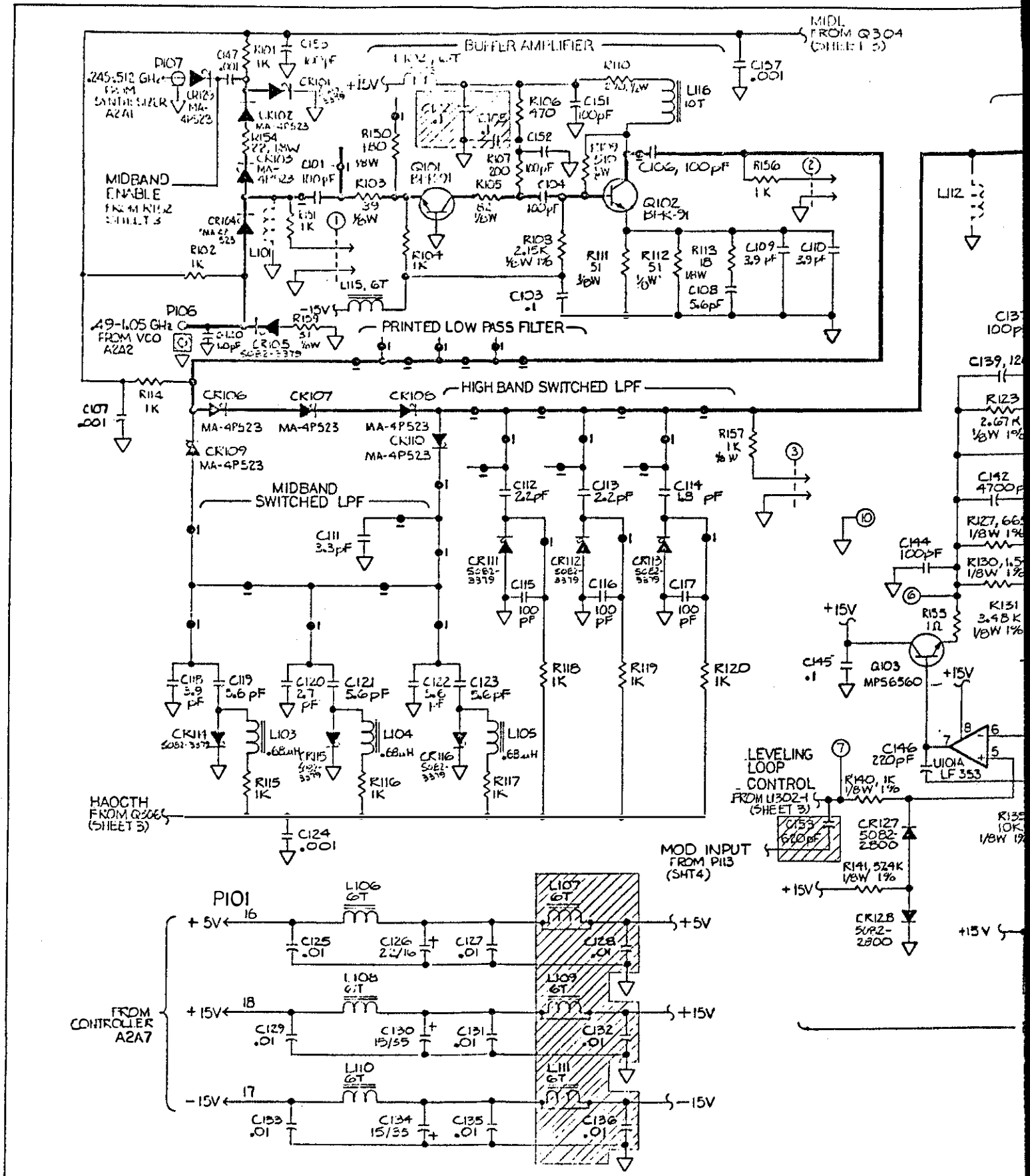

Fig 8-8 (1 of 4)
 Sht 2 of 3

SCHMATIC DIAGRAMS

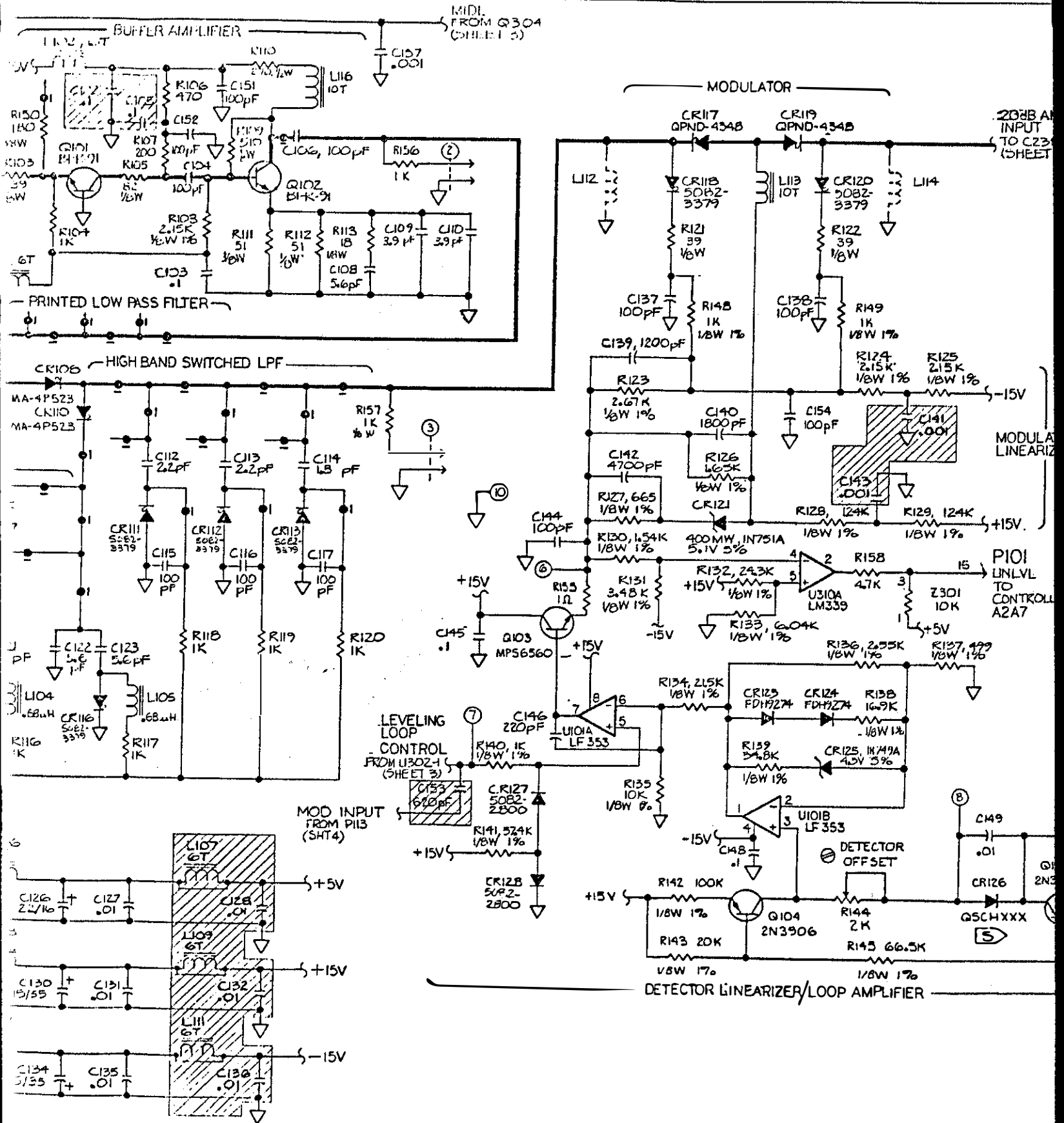
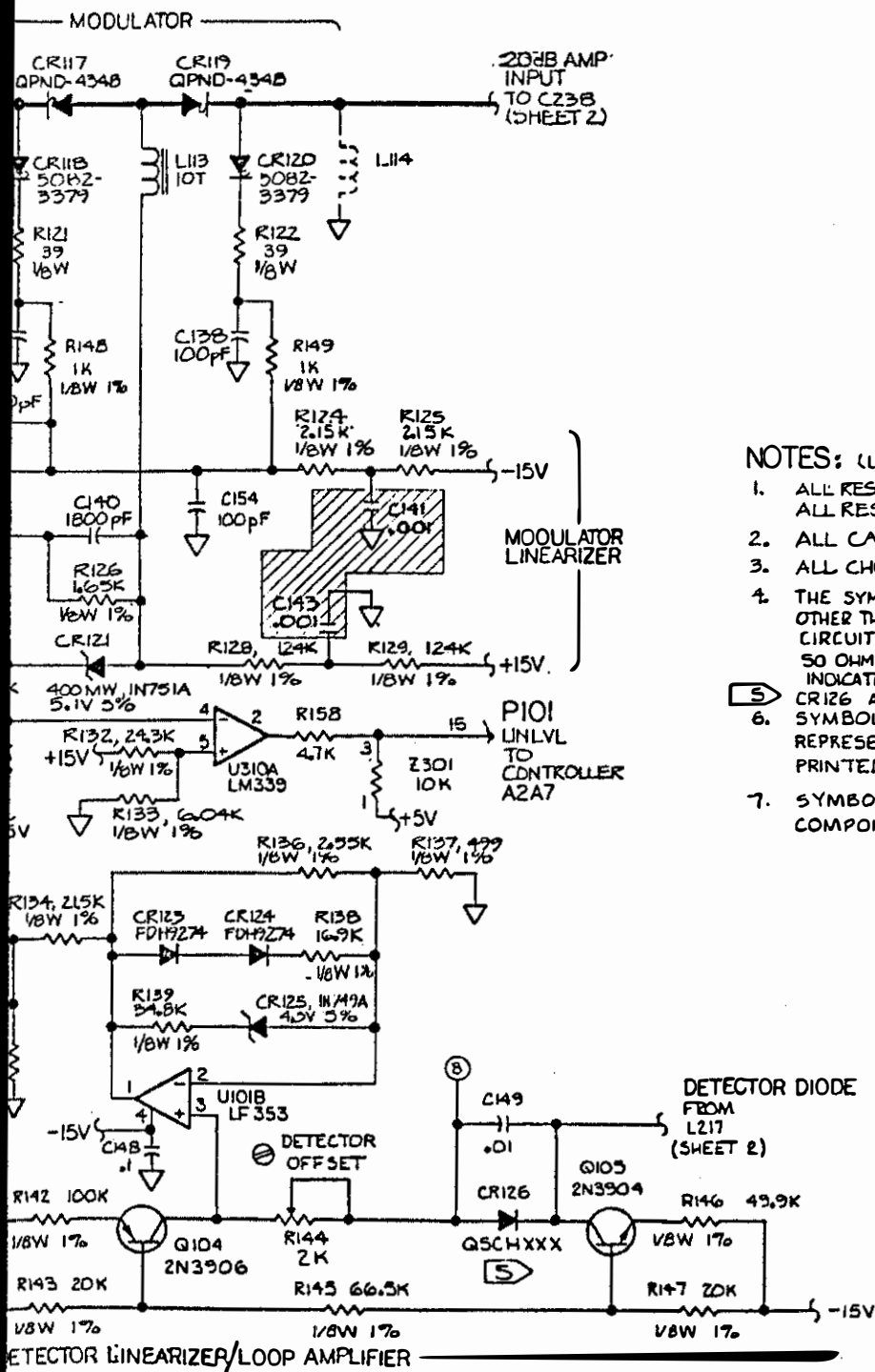



Figure 8-8. A2A4 Output PCA (

Fig 8-8 (1084)
 Slt 383
 SCHEMATIC DIAGRAMS



NOTES: (UNLESS OTHERWISE SPECIFIED)

1. ALL RESISTOR VALUES ARE IN OHMS. ALL RESISTORS ARE 1/4W, 5%.
2. ALL CAPACITOR VALUES ARE IN MICROFARADS.
3. ALL CHOKES ARE 10 TURN BEADS.
4. THE SYMBOL "⚡" INDICATES TRANSMISSION LINES OF OTHER THAN 50 OHM IMPEDANCE WHICH CONSTITUTE CIRCUIT ELEMENTS. 50 OHM TRANSMISSION PATHS ARE NOT INDICATED.
5. CR126 AND CR202 ARE A MATCHED PAIR.
6. SYMBOLS SHOWN IN DOTTED LINES REPRESENT COMPONENTS WHICH ARE PRINTED ON THE CIRCUIT BOARD.
7. SYMBOLS SHOWN IN  ARE OPTIONAL COMPONENTS AND ARE NOT TO BE INSTALLED.

6060A/AN-1024
 (1 of 4)

Figure 8-8. A2A4 Output PCA (cont)

Fig 8.8 (284)
Sht 1 of 3

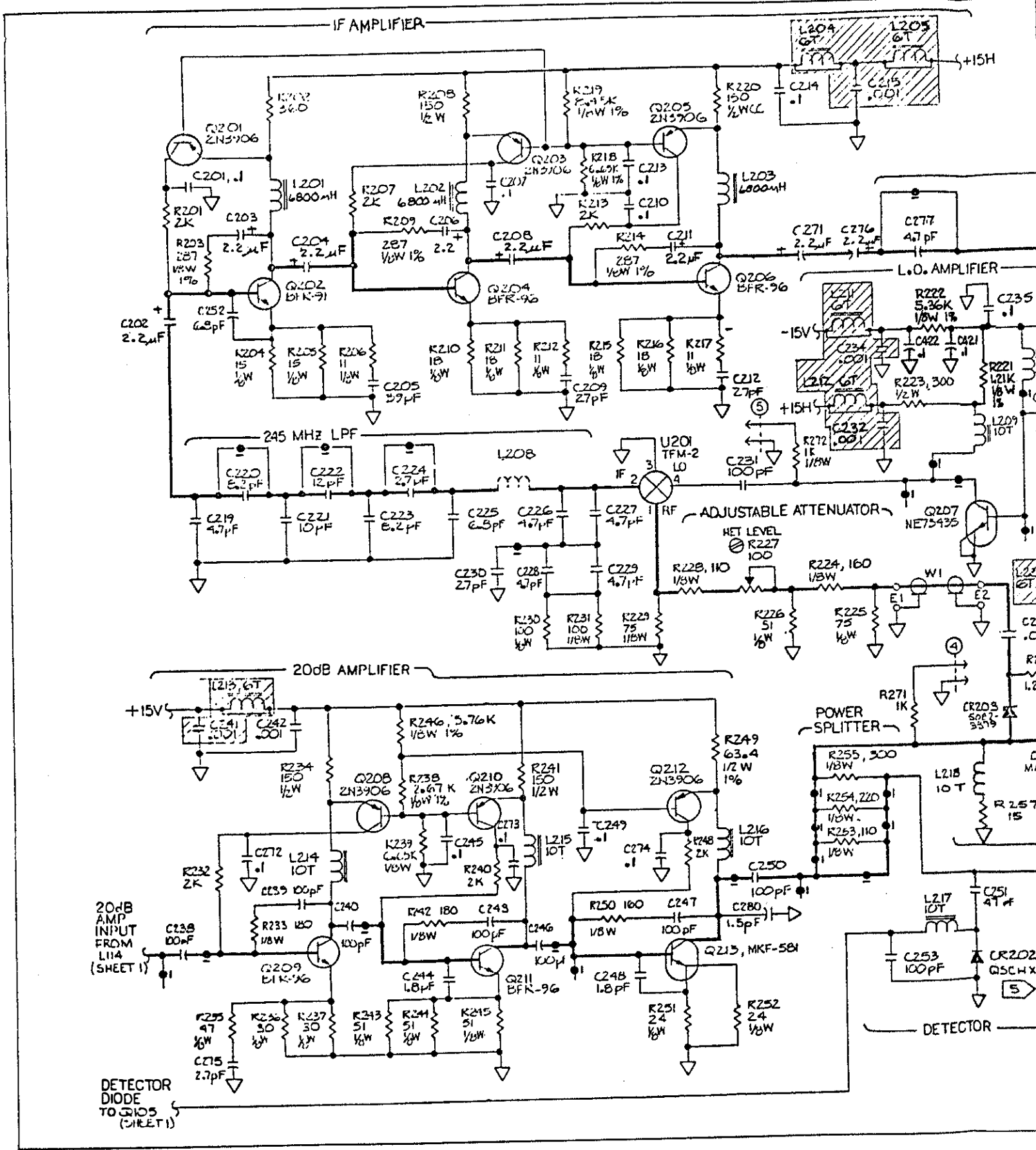
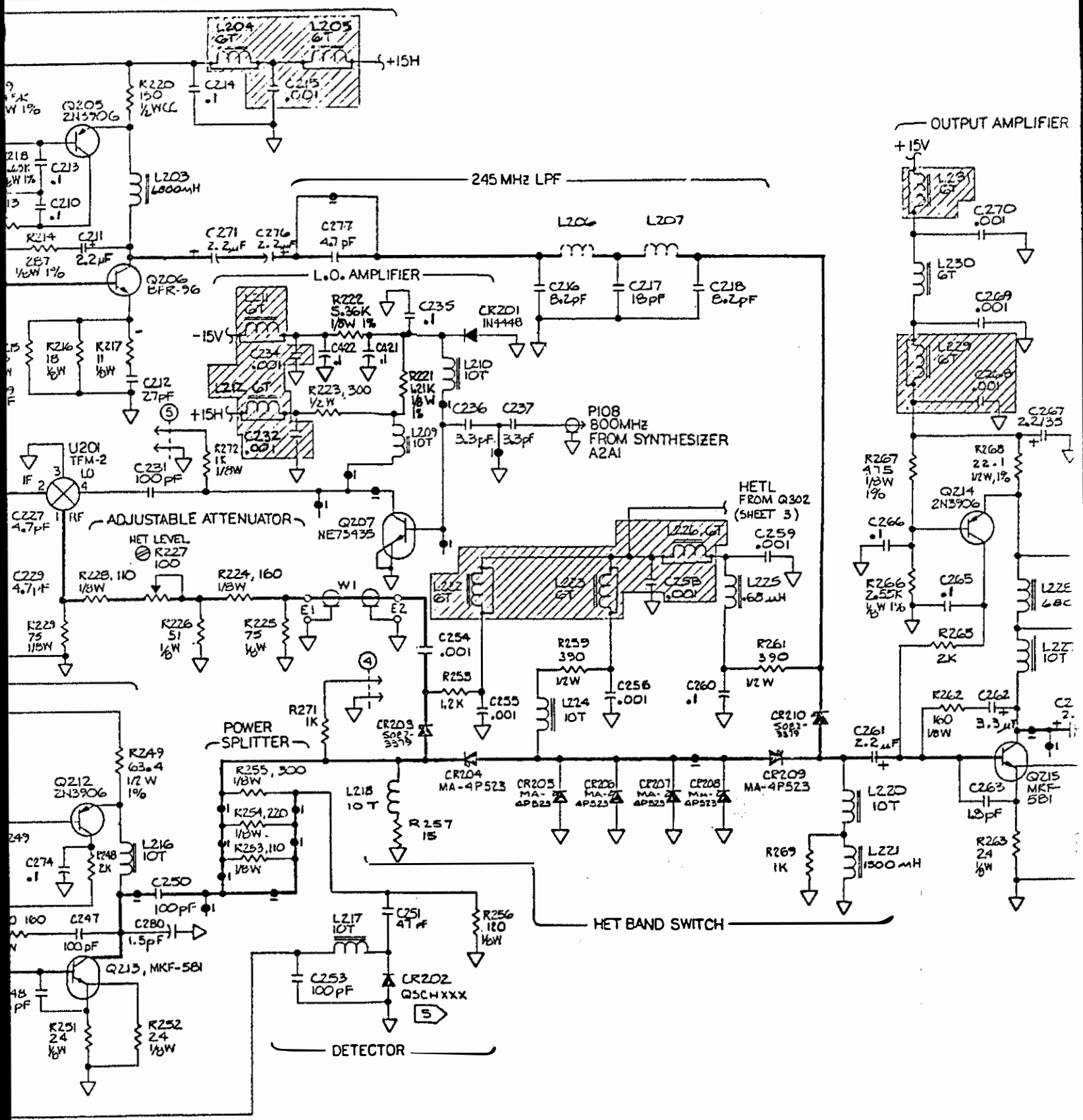

Fig 88 (2 of 4)
 Sht 2 of 3



Fig

Fig 8-8 (2 of 4)
 Sht 3 of 3

SCHEMATIC DIAGRAMS

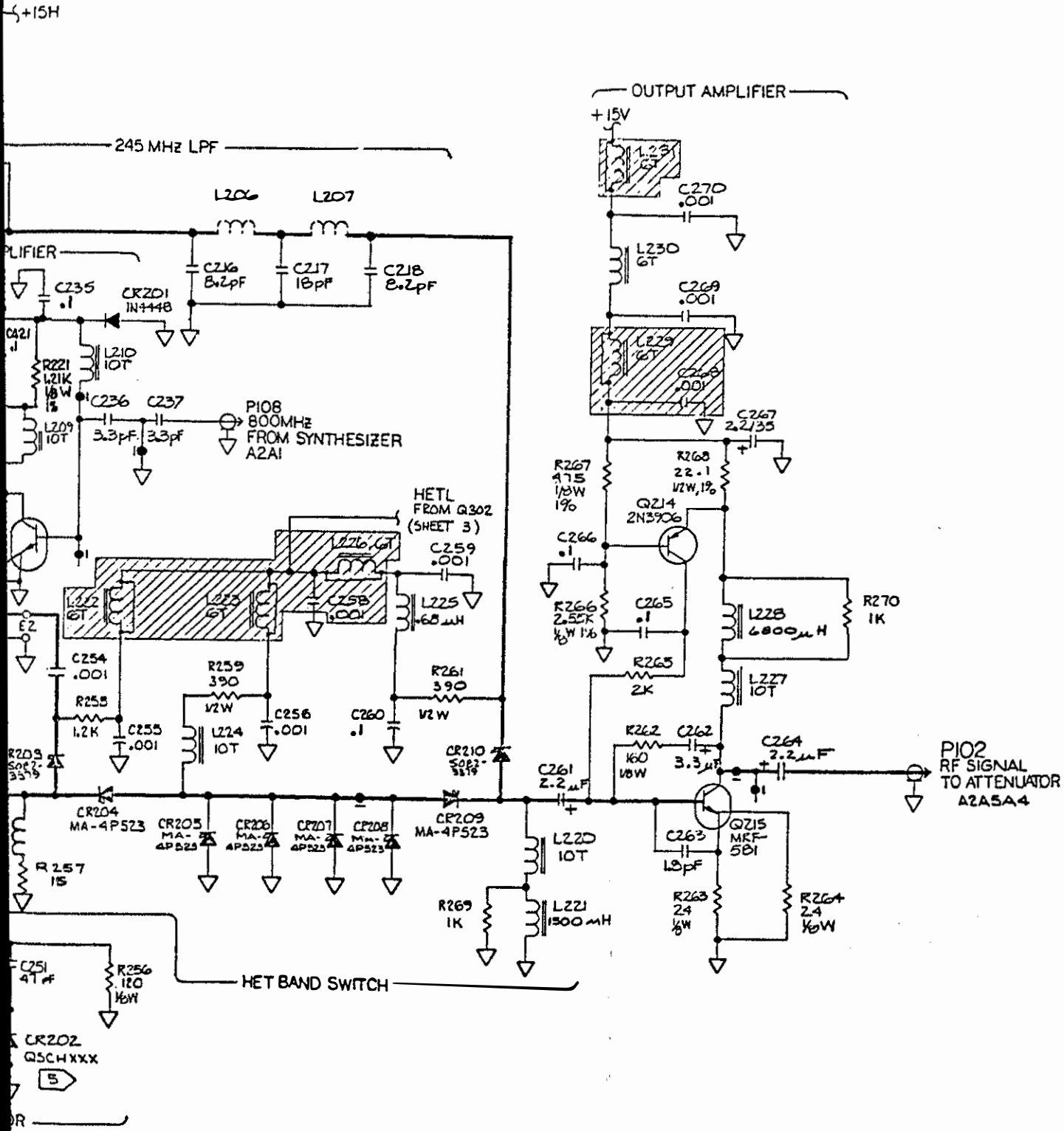

6060A/AN-1024
 (2 of 4)

Figure 8-8. A2A4 Output PCA (cont)

Fig 8-8 (3 of 4)
 Sht 1 of 3

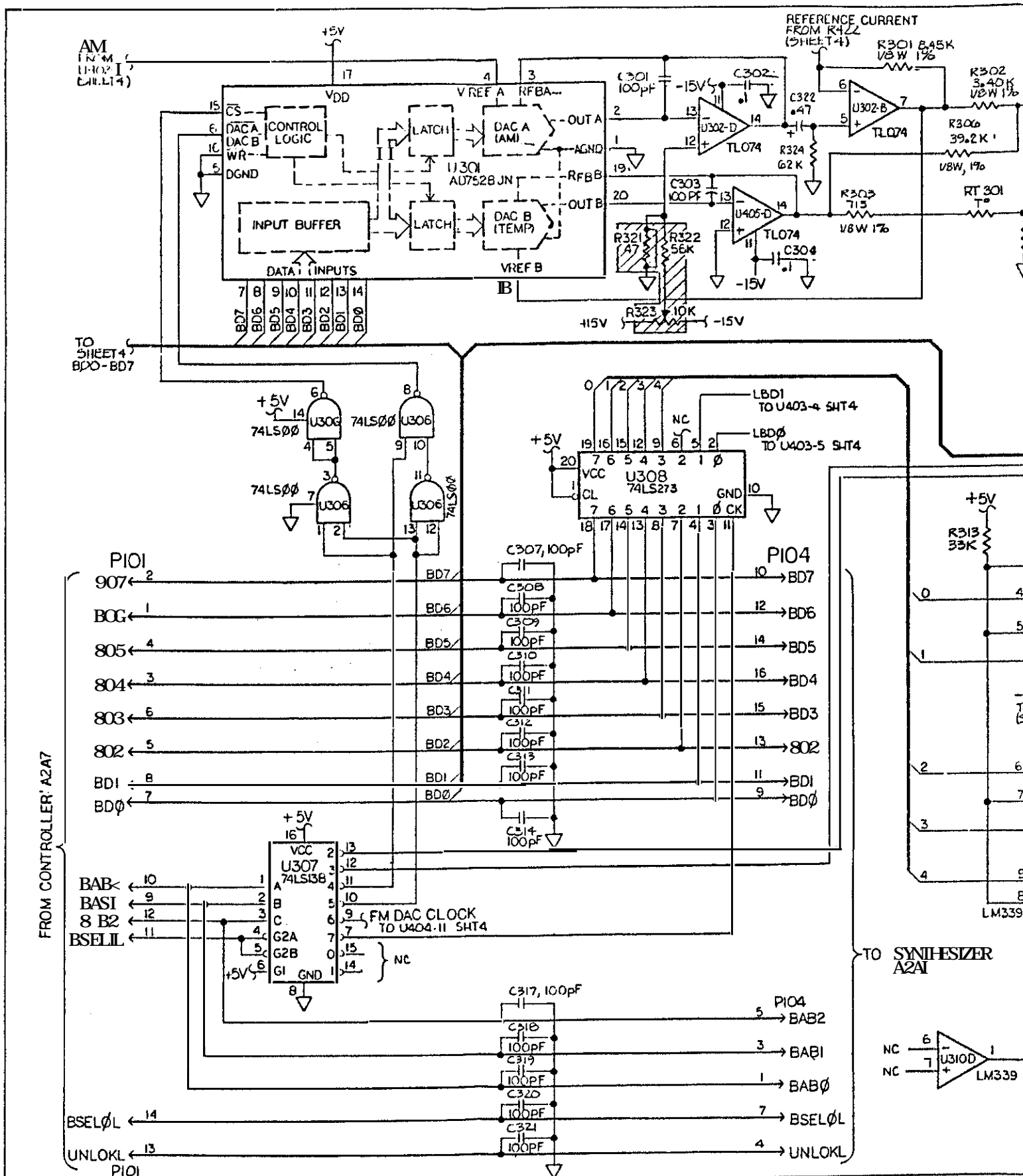

Fig 8-8 (3 of 4)
Sht 2 of 3

SCHEMATIC DIAGRAMS

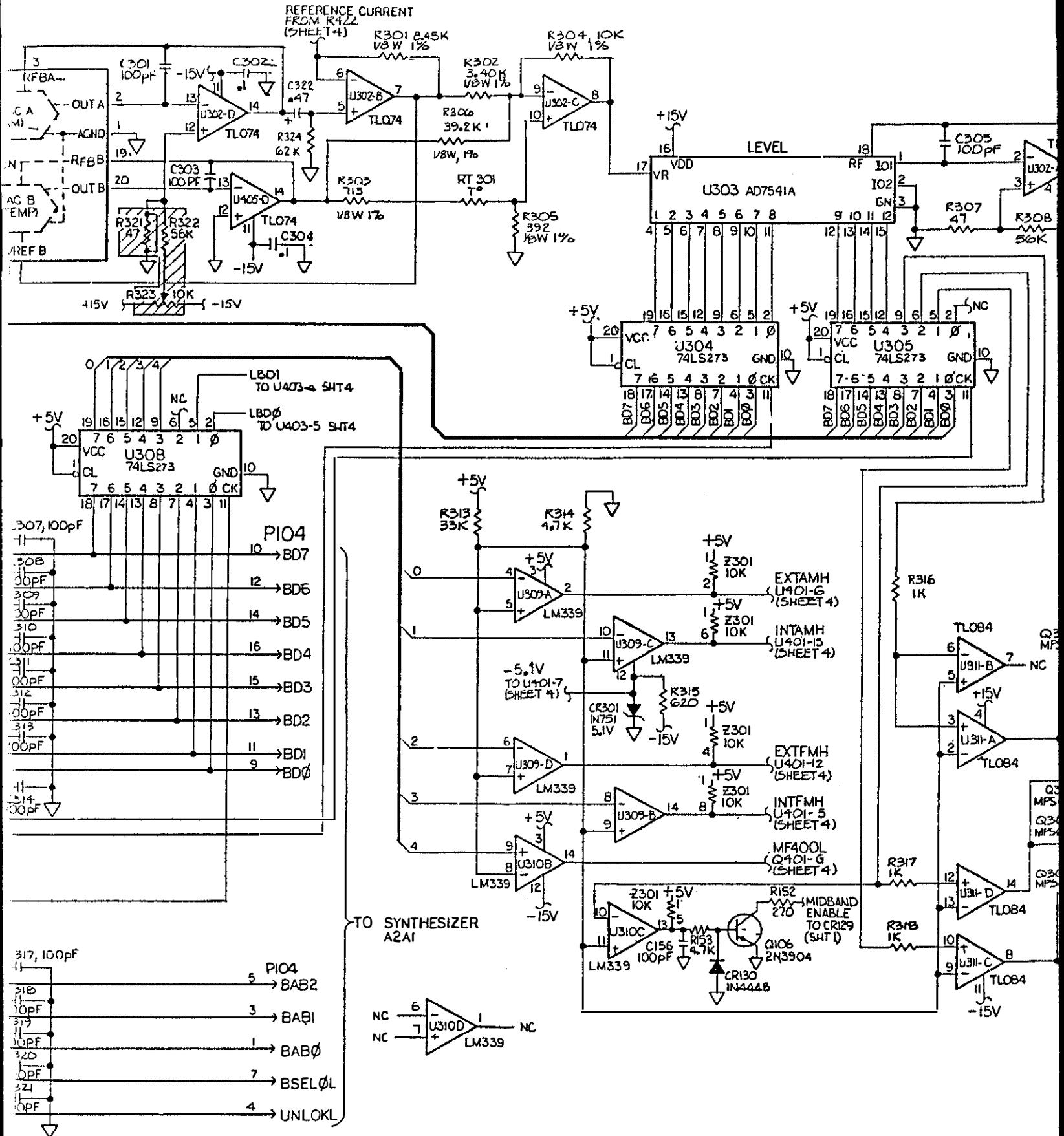
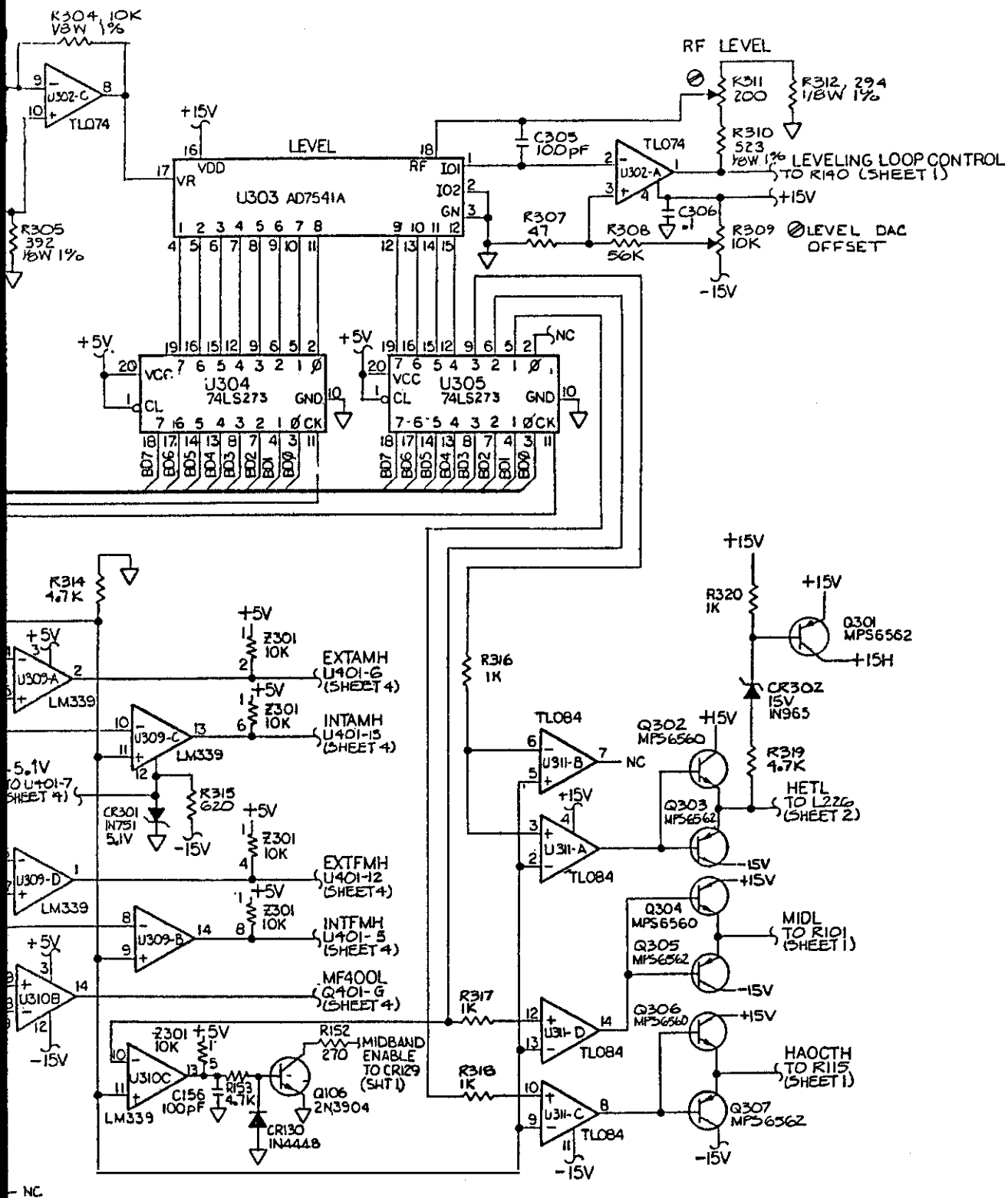

Figure 8-8. A2A4 Output PCA (cont)

Fig 8-8 (3 of 4)
 Sht 3 of 3 SCHEMATIC DIAGRAMS



6060A/AN-1024
 (3 of 4)

Figure 8-8. A2A4 Output PCA (cont)

Fig 8-8 (4 of 4)
 Sht 1 of 3

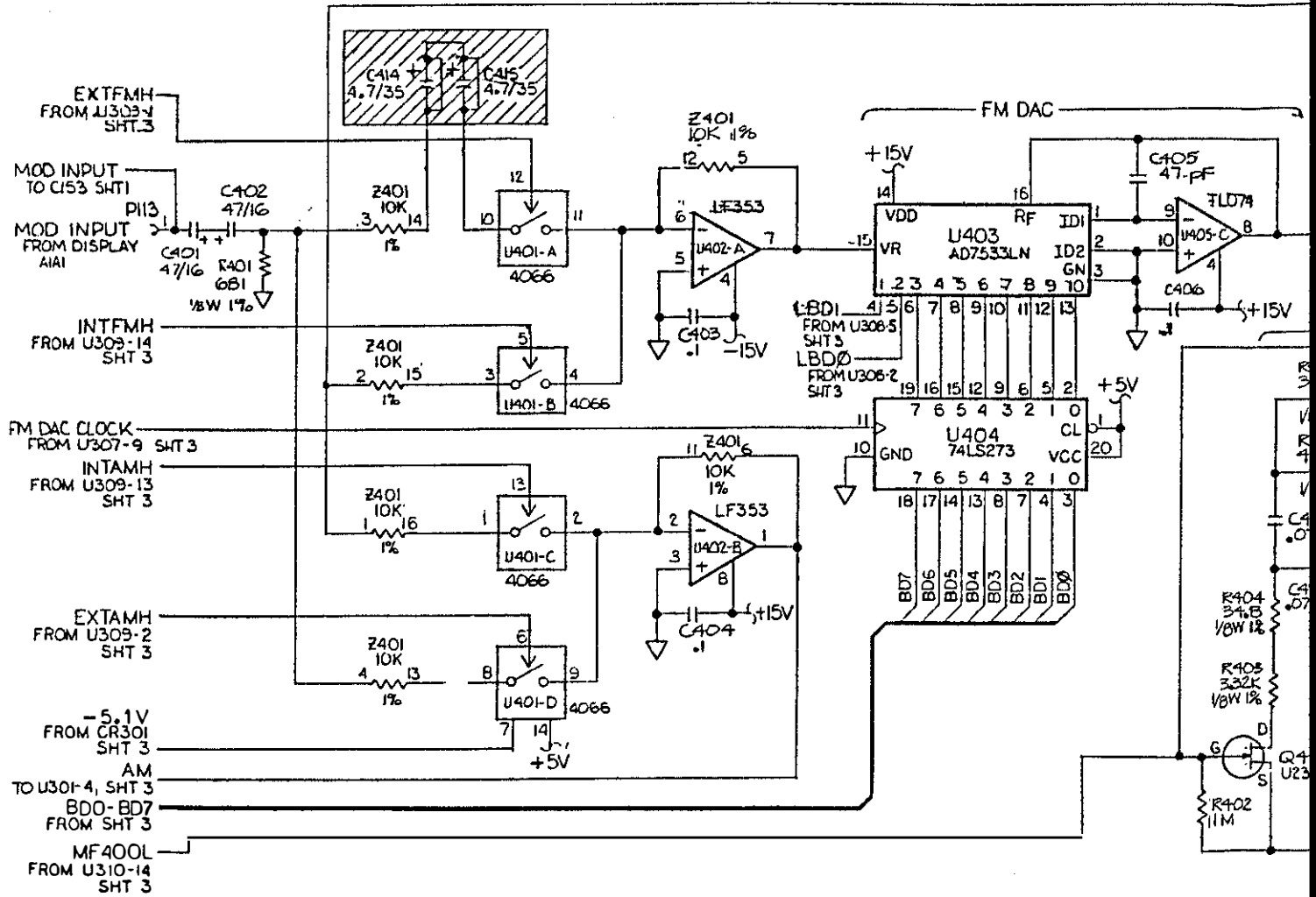
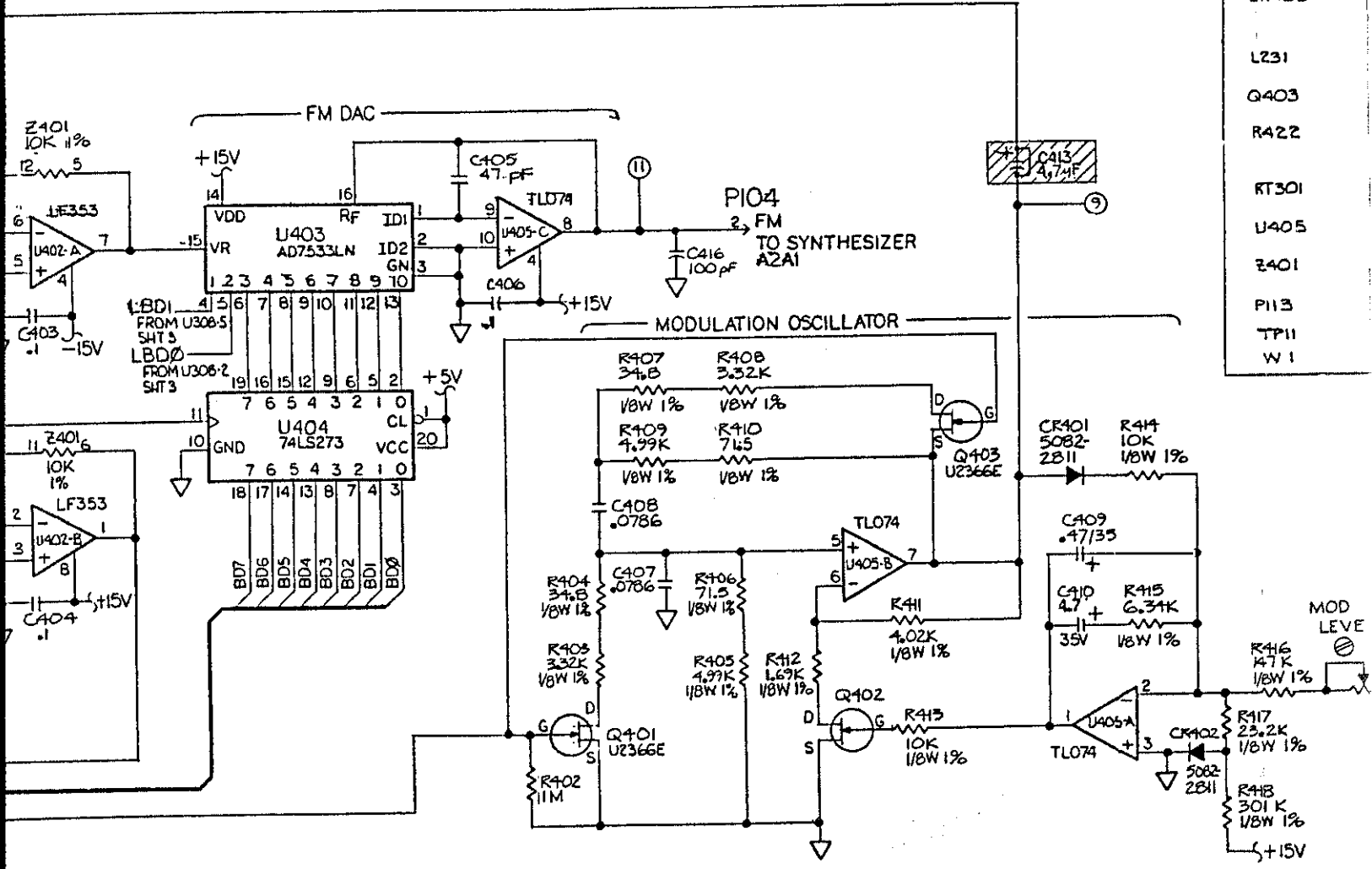

Fig 8-8 (4084)
 Skt 103



LAST USED
C422
CR403
L231
Q403
R422
RT301
U405
Z401
P113
TP11
W1

Fig 8-8 (4 of 4)
 Skt 2 of 3

SCHEMATIC DIAGRAMS

REFERENCE DESIGNATIONS.	
LAST USED	NOT USED
C422	C1-100, C150, C158-C200, C233, C257, C278, 279, 281-300, C315, C316, C323-400, C417-C419.
CR403	CR1-100, CR122, CR131-200, CR211-300, CR303-400.
L231	L1-100, L117-200, L219.
Q403	Q1-100, Q107-200, Q216-300, Q308-400.
R422	R1-100, R160-200, R247, R260, R273-300, R325-400.
RT301	RT1-300
U405	U1-100, U102-200, U202-300, U312-400.
Z401	Z1-300, Z302-400.
P113	P100, P103, P105, P109-112.
TP11	—
W 1	—

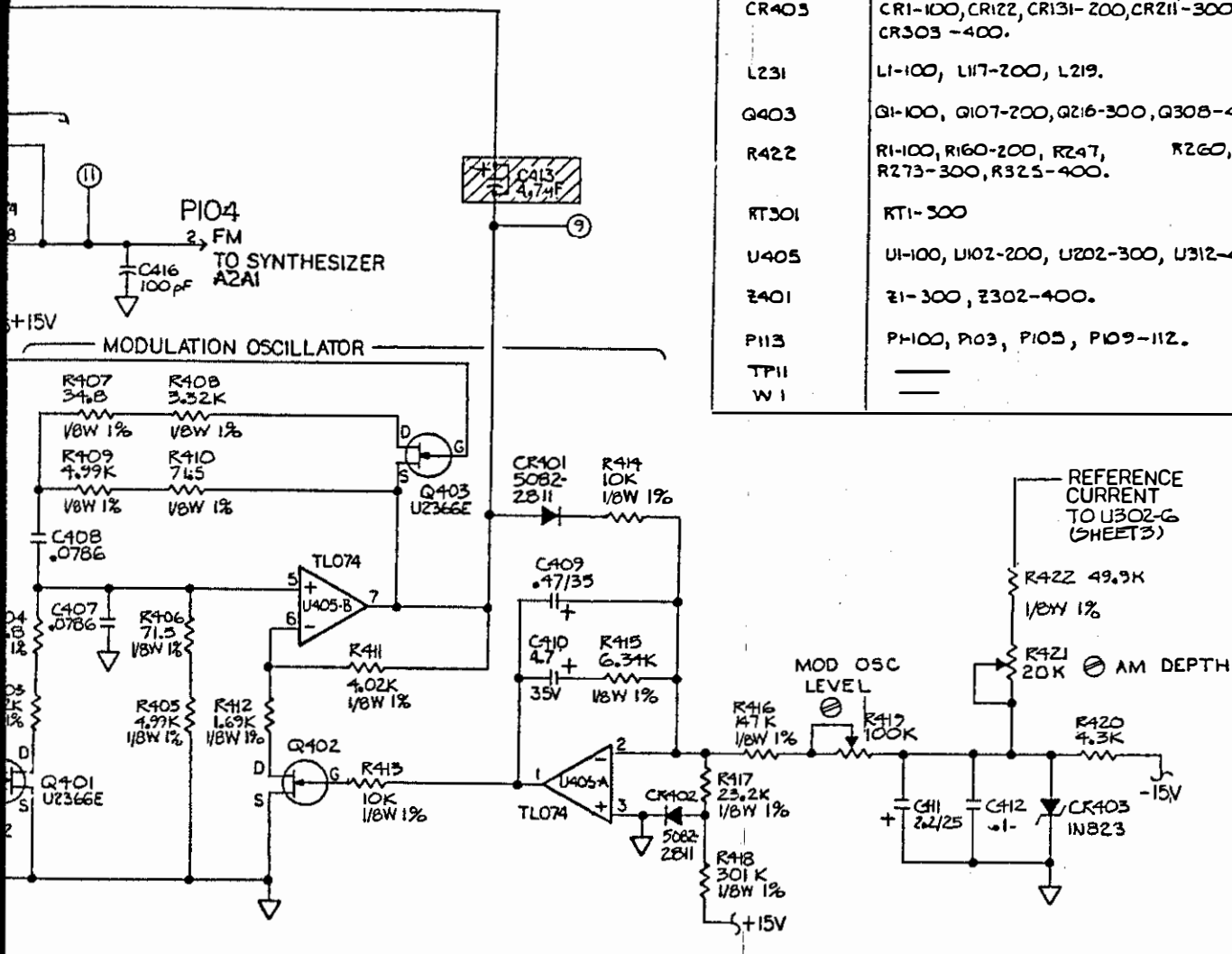

6060A/AN-1024
 (4 of 4)

Figure 8-8. A2A4 Output PCA (cont)

Fig 8-9
 Slt 1q3

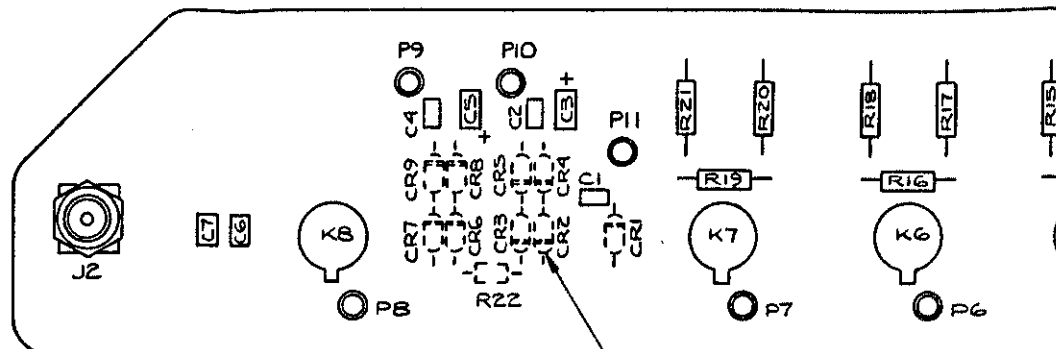

ALL COMPONENTS SHOWN
 IN DASHED LINES ARE
 MOUNTED ON FAR SIDE.

FROM RELAY DRIVER / RPP CONTR
 A2A5A5

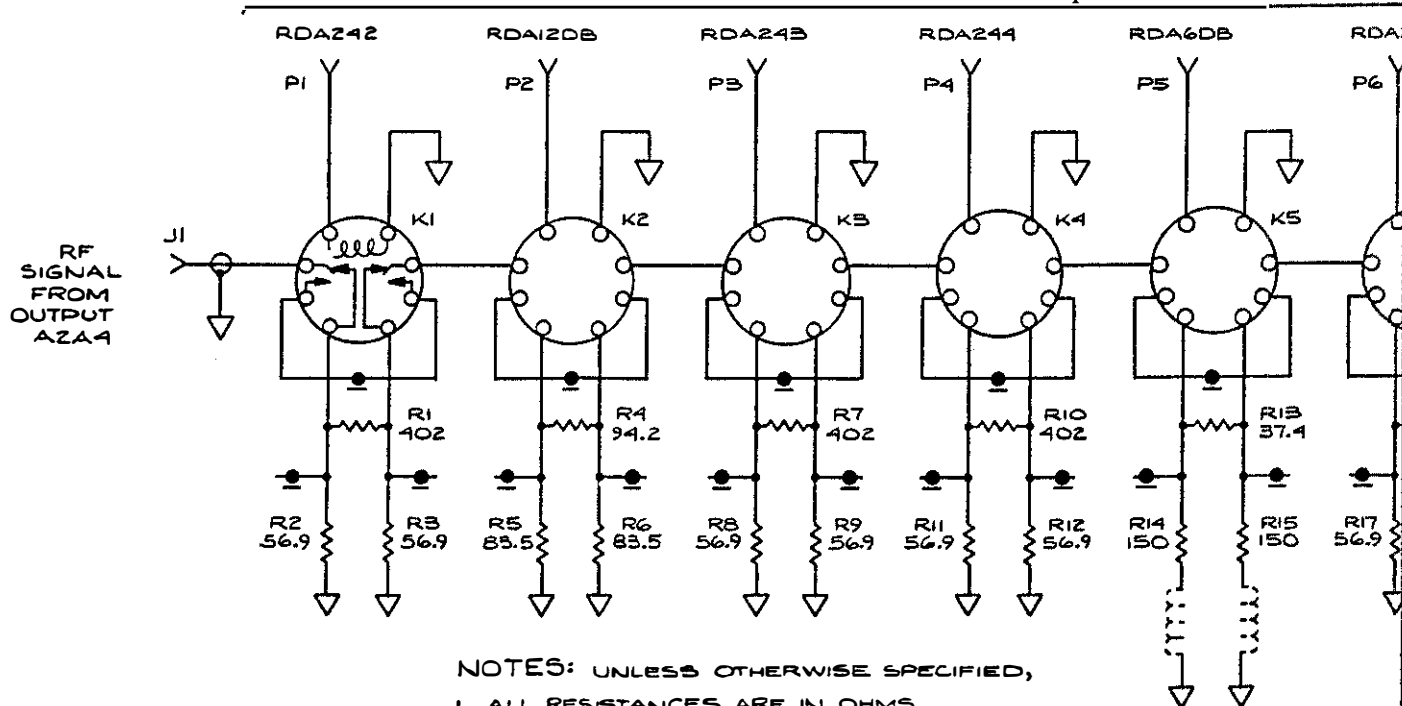

NOTES: UNLESS OTHERWISE SPECIFIED,

1. ALL RESISTANCES ARE IN OHMS.
 ALL RESISTORS ARE 1/8 W, 0.5%.
2. ALL CAPACITANCES ARE IN MICROFARADS.
3. SYMBOLS DRAWN WITH DASHED LINES
 INDICATE COMPONENTS PRINTED ON
 CIRCUIT BOARD.
4. THE SYMBOL  INDICATES TRANSMISSION
 LINES OF OTHER THAN 50 OHM IMPEDANCE
 WHICH CONSTITUTE CIRCUIT ELEMENTS.
 50 OHM TRANSMISSION PATHS ARE NOT
 INDICATED.

REFERENCE DESIGNATIONS	
HIGHEST	NOT USED
P11	
K8	
R22	
C7	
CR9	
J2	

Fig 8-9
Sht 2 of 3

SCHMATIC DIAGRAMS

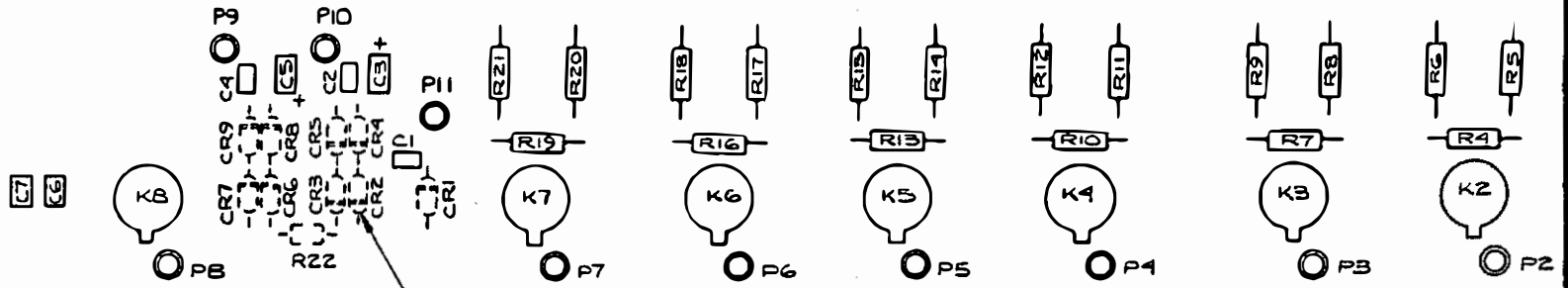

ALL COMPONENTS SHOWN
IN DASHED LINES ARE
MOUNTED ON FAR SIDE.

FROM RELAY DRIVER / RPP CONTROLLER
A2A5A5

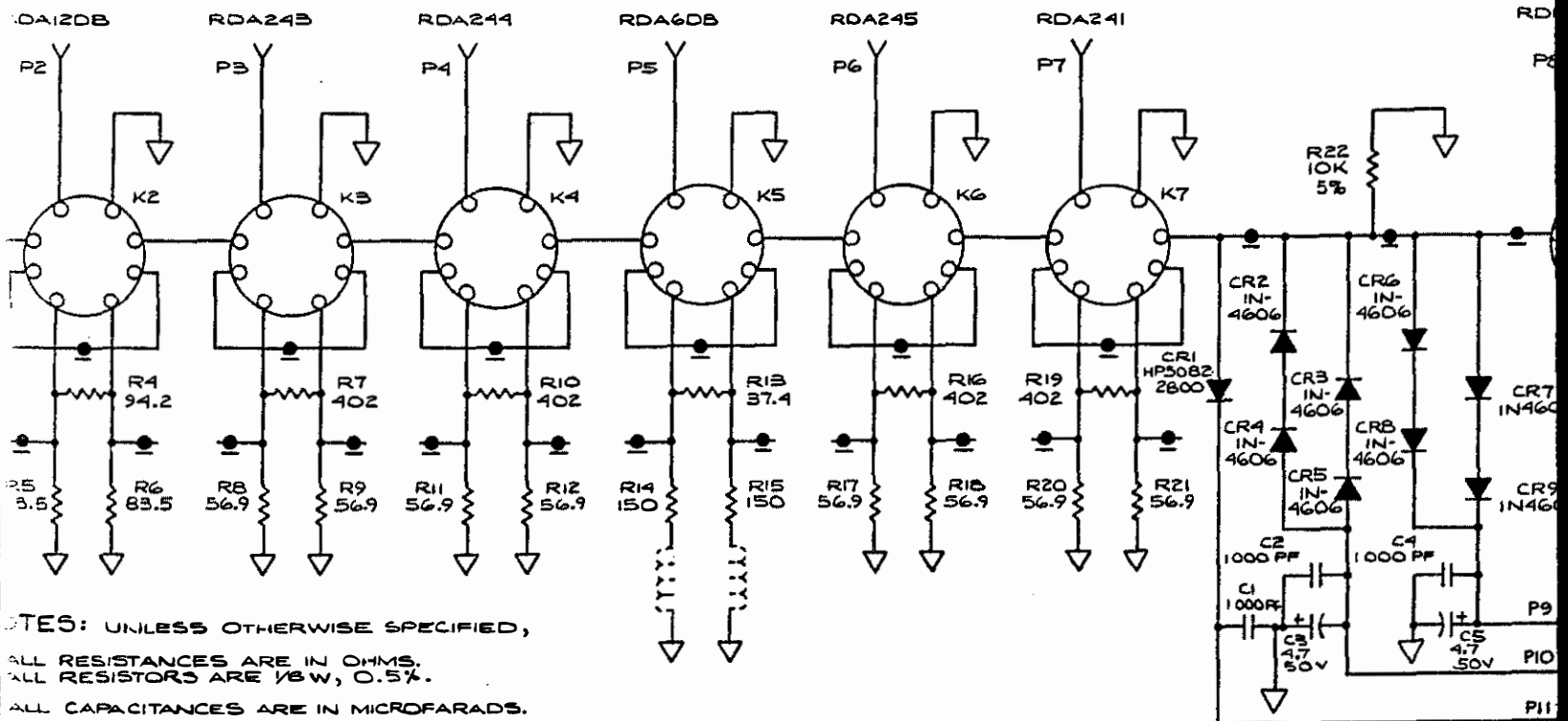

NOTES: UNLESS OTHERWISE SPECIFIED,
ALL RESISTANCES ARE IN OHMS.
ALL RESISTORS ARE 1/8W, 0.5%.
ALL CAPACITANCES ARE IN MICROFARADS.
SYMBOLS DRAWN WITH DASHED LINES
INDICATE COMPONENTS PRINTED ON
REVERSE SIDE OF CIRCUIT BOARD.

THE SYMBOL  INDICATES TRANSMISSION
LINES OF OTHER THAN 50 OHM IMPEDANCE
WHICH CONSTITUTE CIRCUIT ELEMENTS,
50 OHM TRANSMISSION PATHS ARE NOT
INDICATED.

Figure 8-9. A2A5A4 Attenuator/RPP PCA

Fig 8-9
 Skt 3cb 3

SCHMATIC DIAGRAMS

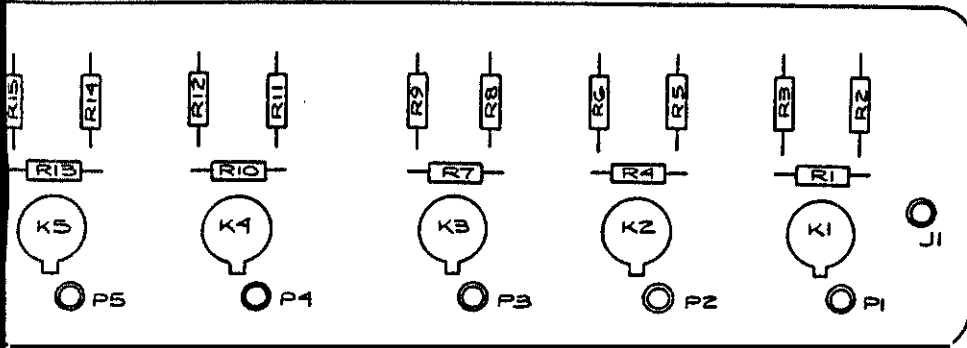

6060A-1647

ROLLER

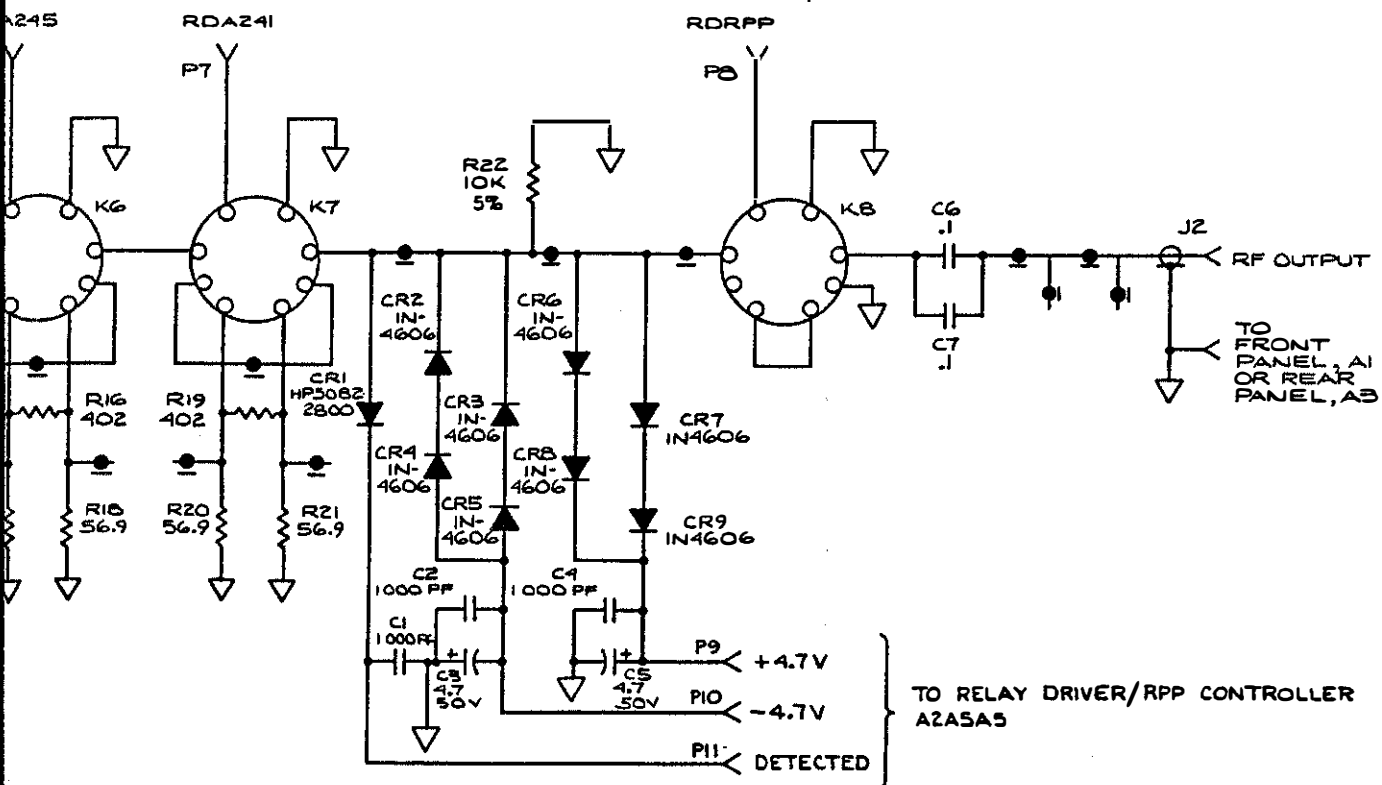

6060A-1047

Figure 8-9. A2A5A4 Attenuator/RPP PCA

Fig 8-10 (102)
 Sht 102

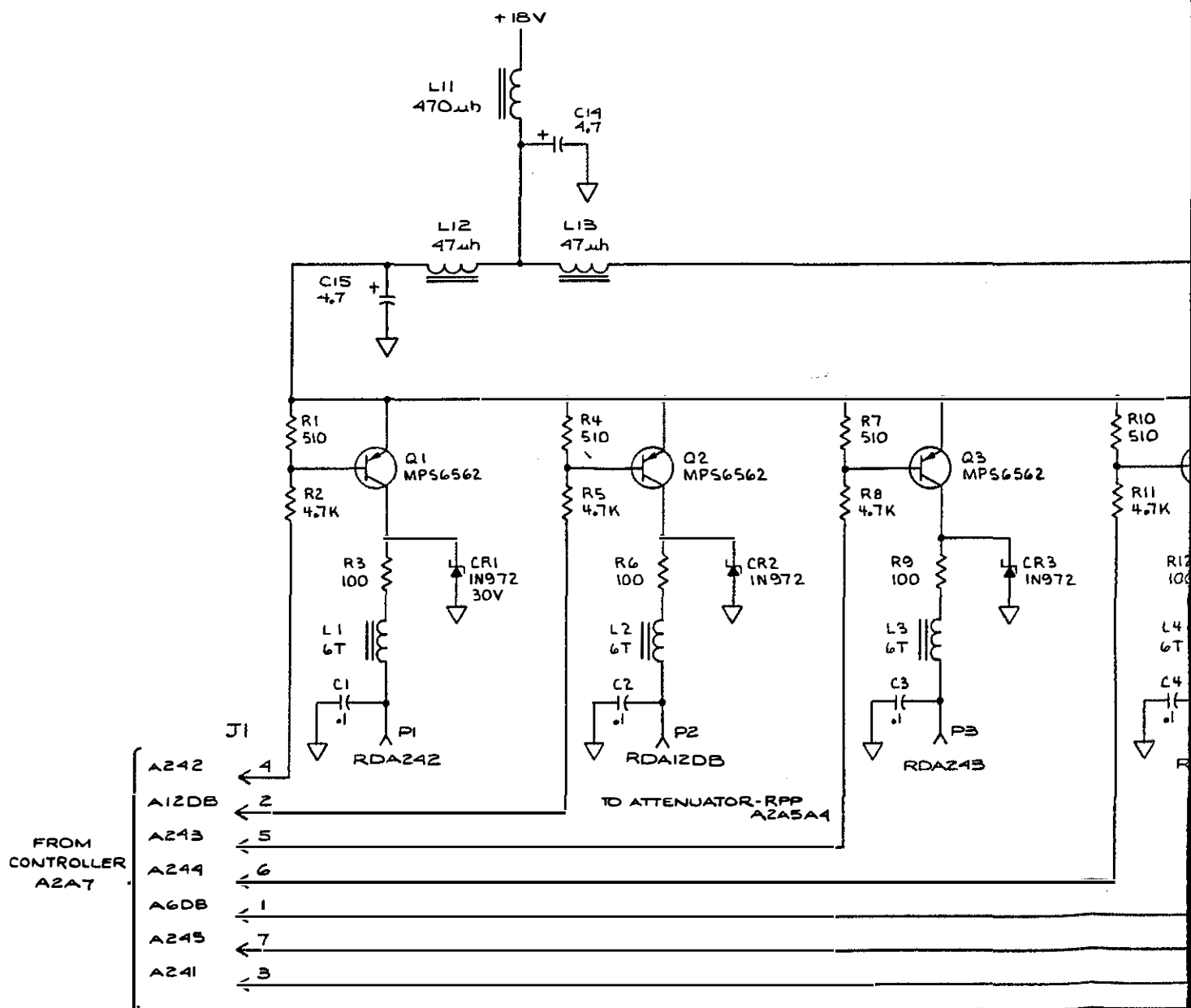
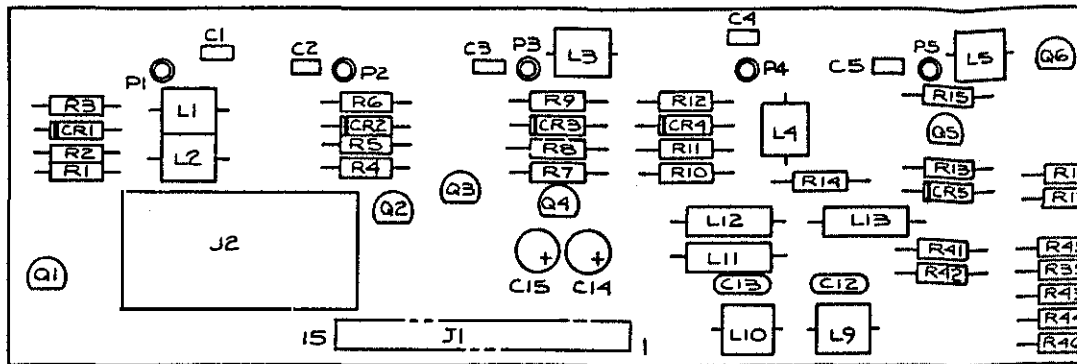
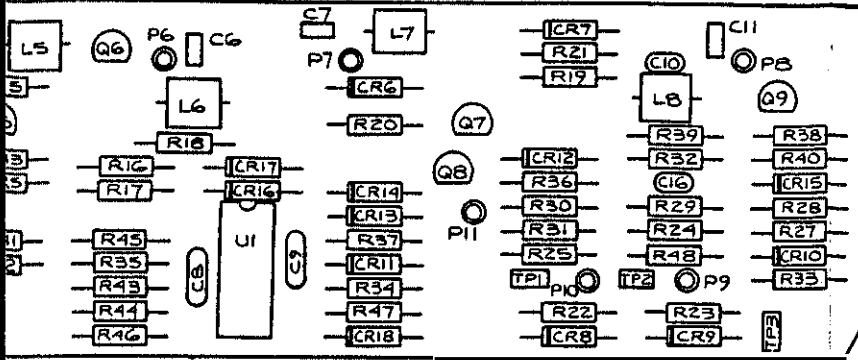

Fig 8-10 (1 of 2)
Sht 2 of 2

SCHMATIC DIAGRAMS



6060A-1645

REFERENCE DESIGNATIONS	
HIGHEST	NOT USED
UI	R26
Q9	
L13	
C16	
CR18	
R48	
TP3	
J2	
P11	

NOTES: (UNLESS OTHERWISE SPECIFIED)

1. ALL RESISTORS ARE 1/4 W 5%
ALL RESISTOR VALUES ARE IN OHMS.
2. ALL CAPACITOR VALUES ARE IN MICROFARADS.

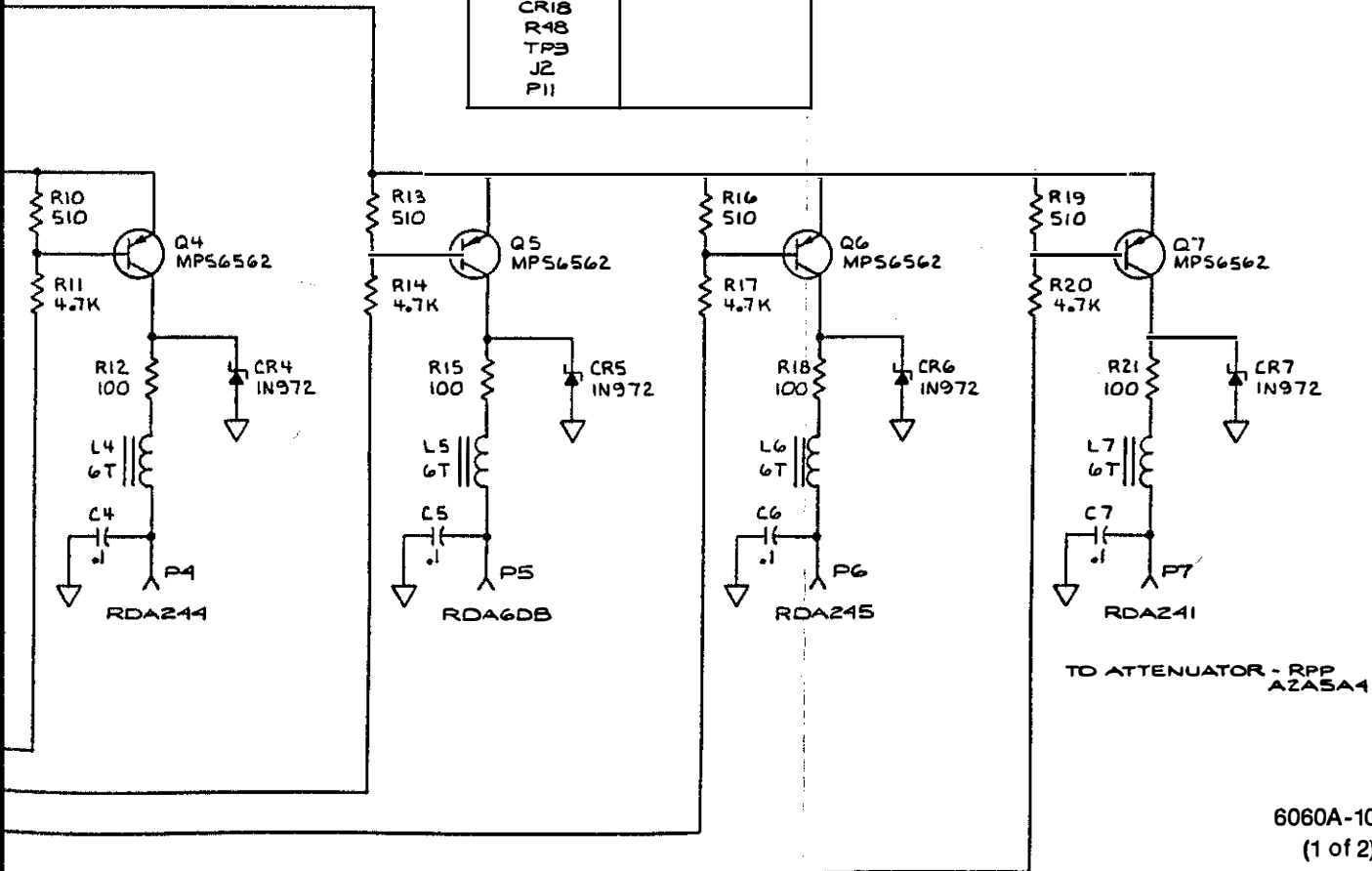

6060A-1045
(1 of 2)

Figure 8-10. A2A5A5 Relay Driver/RPP PCA

Fig 8-10 (2 of 2)
 Sht 1 of 2

SCHMATIC DIAGRAMS

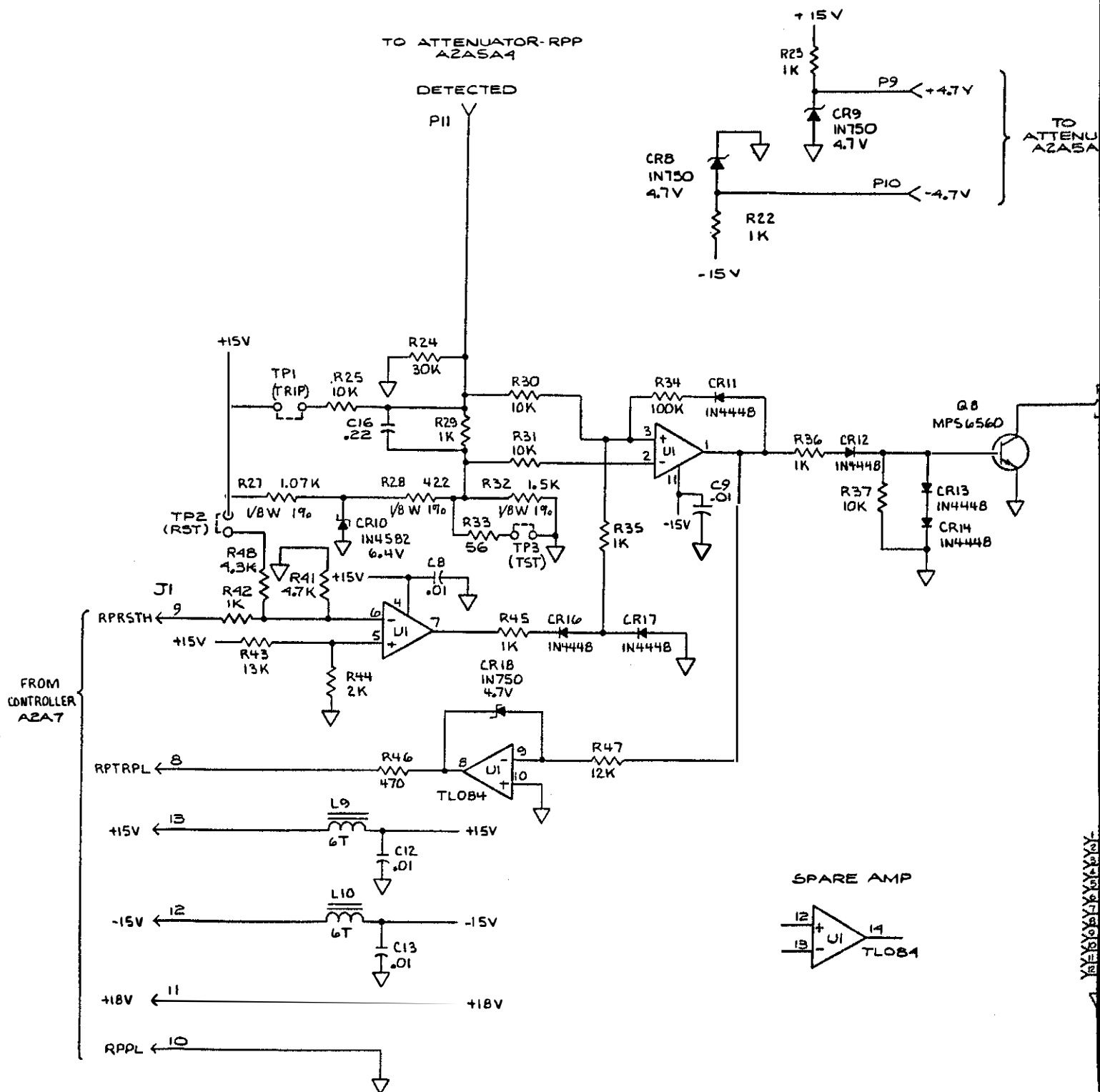
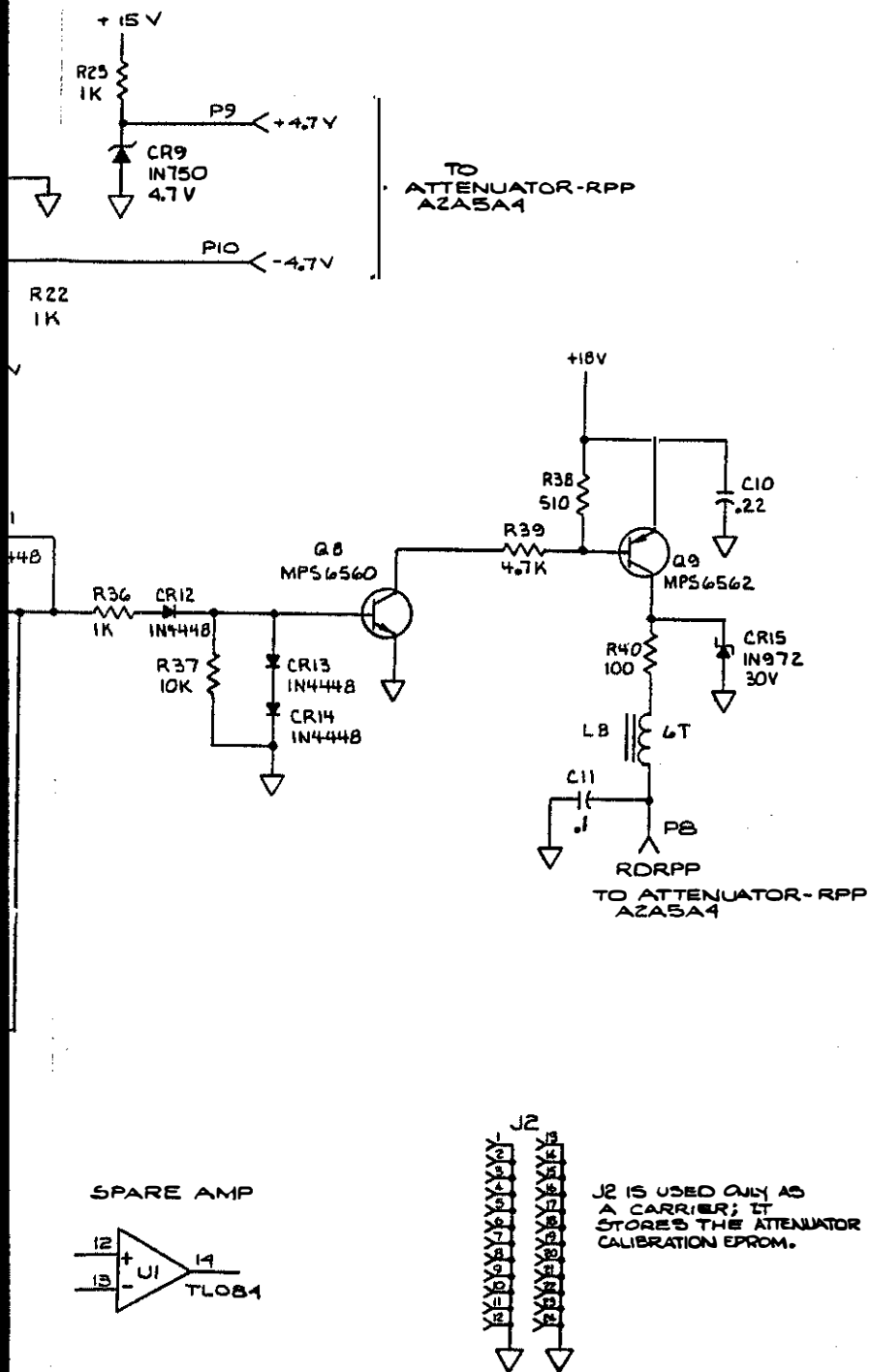

Figure 8-10. A2A5A5 Receiver

Fig 8-10 (2 of 2)
 Set 2 of 2 SCHEMATIC DIAGRAMS



6060A-1045
 (2 of 2)

Figure 8-10. A2A5A5 Relay Driver/RPP PCA (cont)

Fig 8-11
Sht 1 of 2

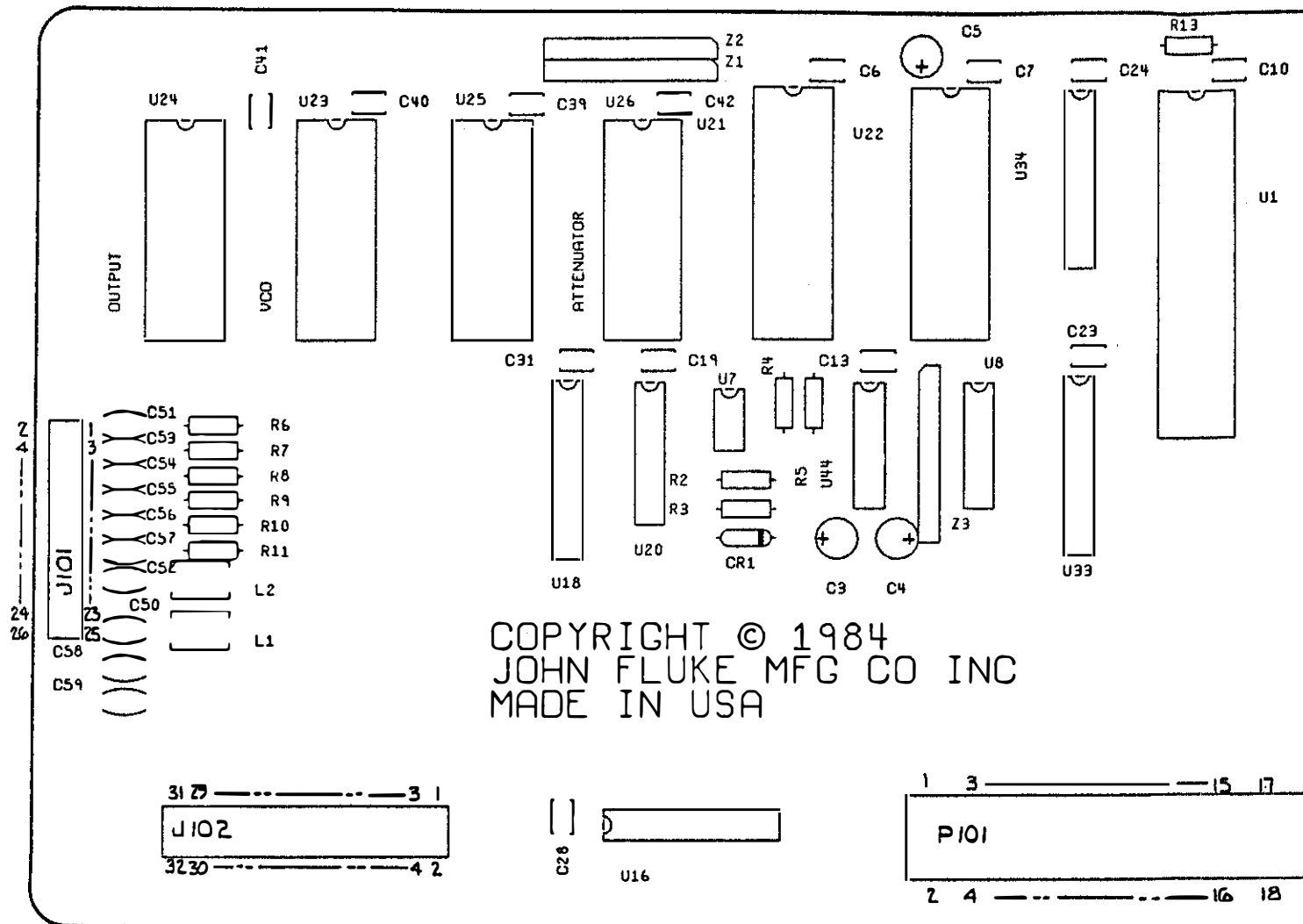
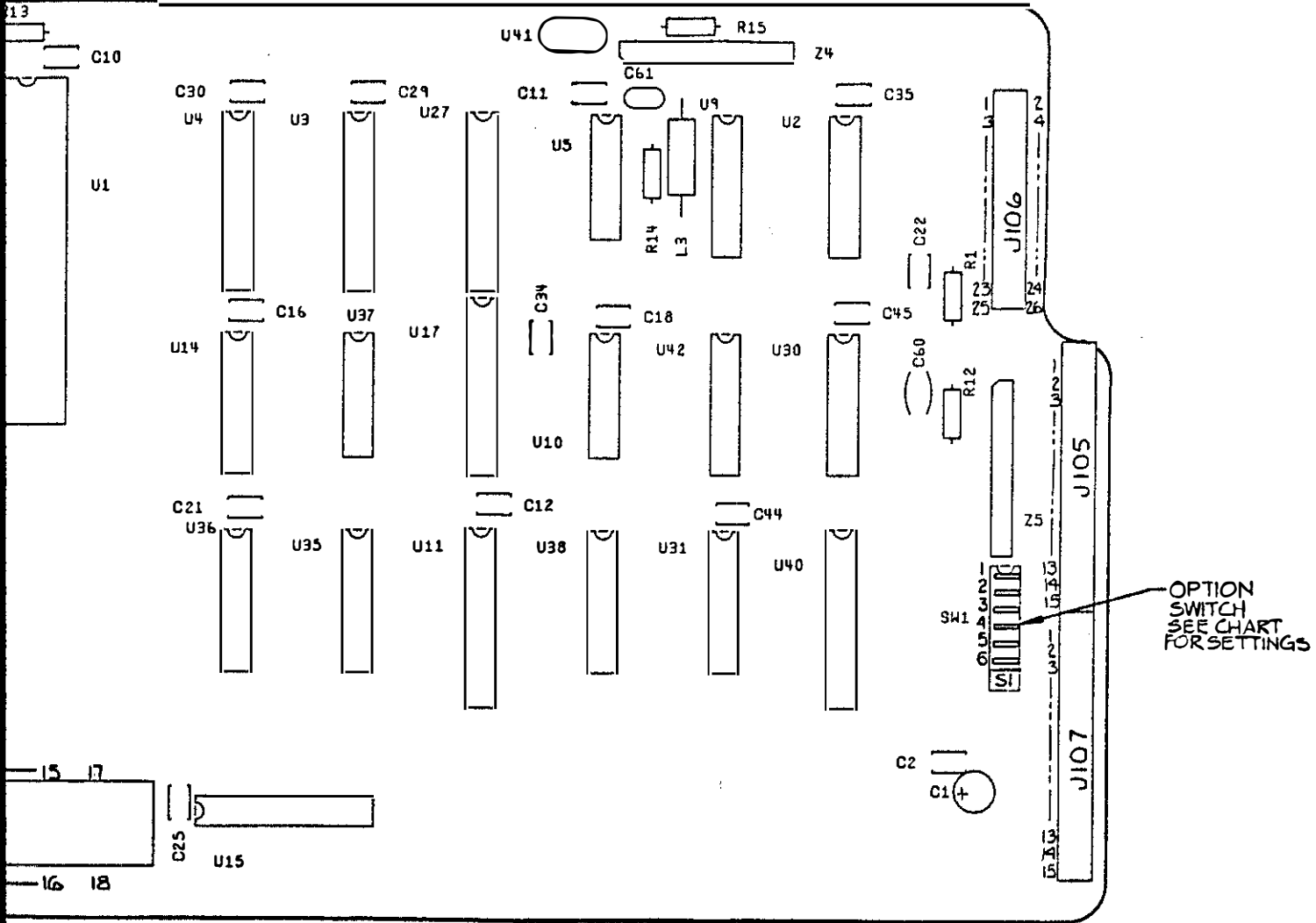

Fig 8-11
Sht 2 of 2

SCHEMATIC DIAGRAMS



OPTION SWITCH SETTINGS (S1)

SWITCH SECTION IN "ON" POSITION	OPTION INSTALLED
1 PECULIAR TO 6060A	SUBHARMONIC REFERENCE OPTION - 131
2 PECULIAR TO 6060B	MEDIUM STABILITY REFERENCE OPTION - 132
3	LOW RATE FM OPTION - 651
4	REAR OUTPUT OPTION - 830

ALL OTHER SWITCH SECTIONS SHALL BE IN "OFF" POSITION

6060A-1628

Figure 8-11. A2A7 Controller PCA

Fig 8-11 (143)
 Sht 142

SCHEMATIC

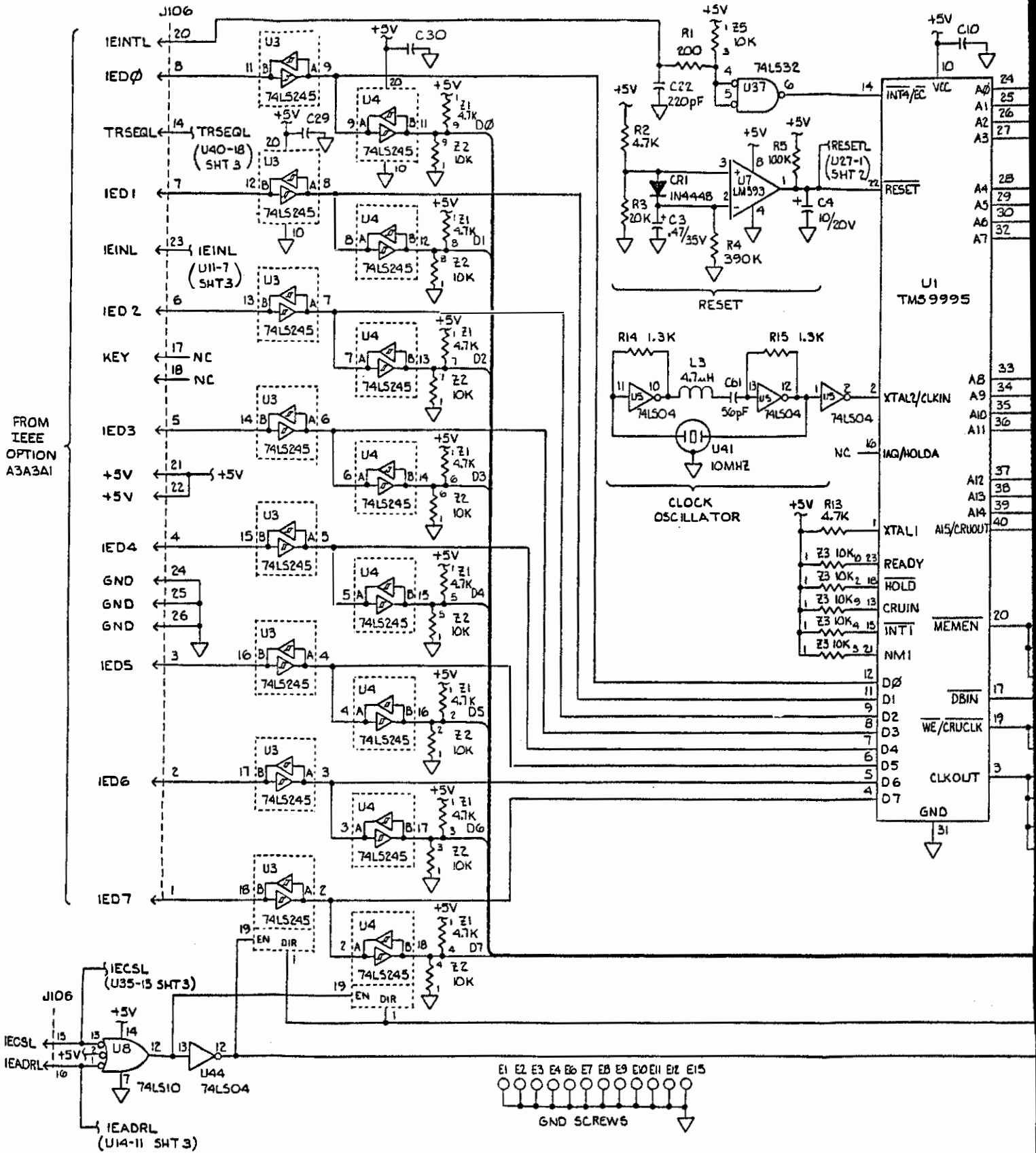
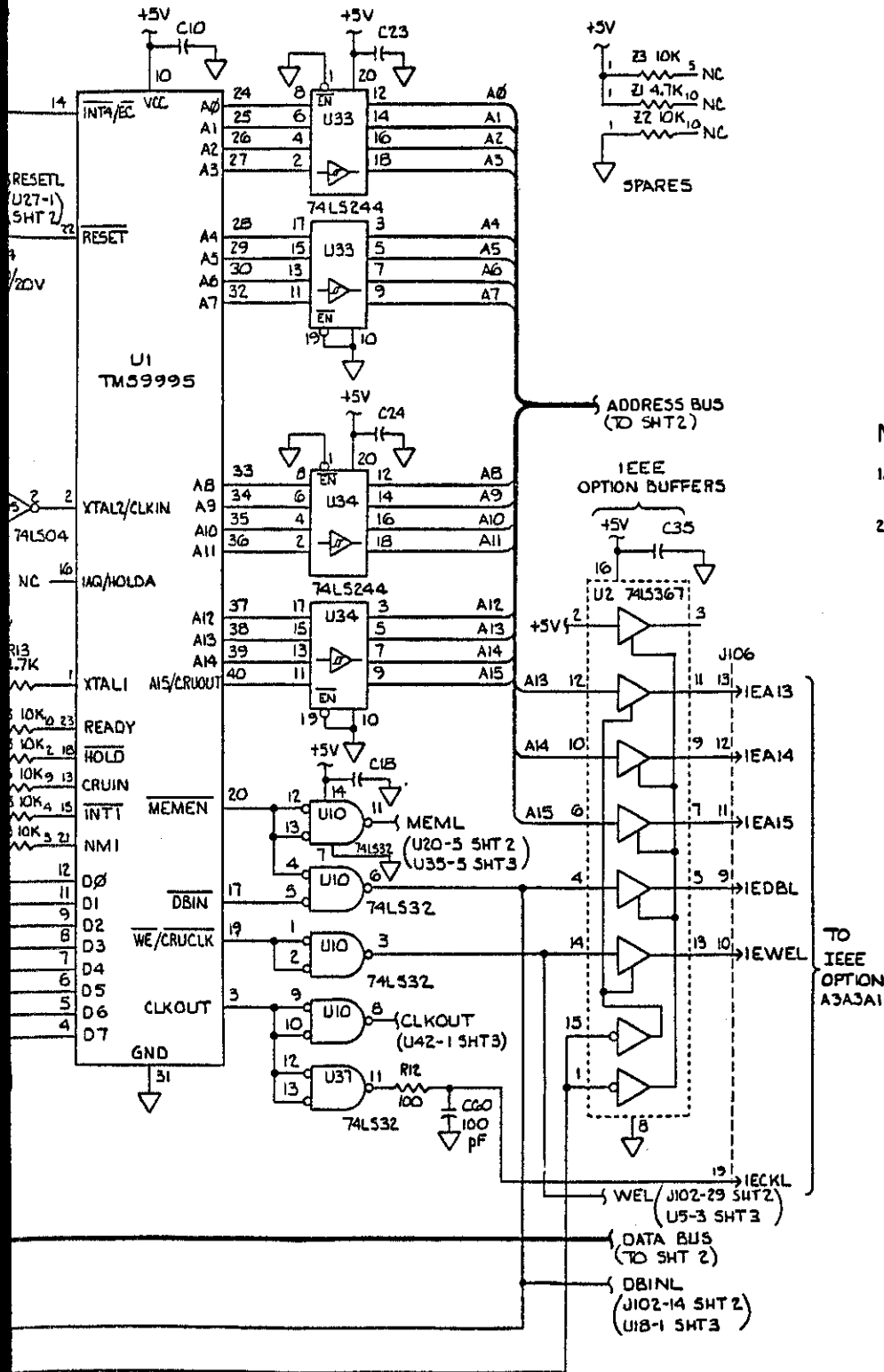

Fig 8-11

Fig 8-11 (1 of 3)
Schematic Diagrams



NOTES:(UNLESS OTHERWISE SPECIFIED.)

1. ALL RESISTOR VALUES ARE IN OHMS.
ALL CAPACITOR VALUES ARE IN MICROFARADS.
2. ALL CAPACITORS ARE .22μF.
ALL RESISTORS ARE 1/4W, 5%.

REFERENCE	DESIGNATIONS
LAST USED	NOT USED
U44	C61 Z5
R15	E15 S1
CRI	L3
	U6 U12 U13 U19 U28
	U29 U32 U39 U43
	C8 C9 C14 C15 C17 C26
	C27 C32 C33 C36-C38
	C43 C46-C49
	E5 E13 E14

6060A-1028
(1 of 3)

Figure 8-11. A2A7 Controller PCA (cont)

Fig 8-11 (243)
Sht 1 of 2

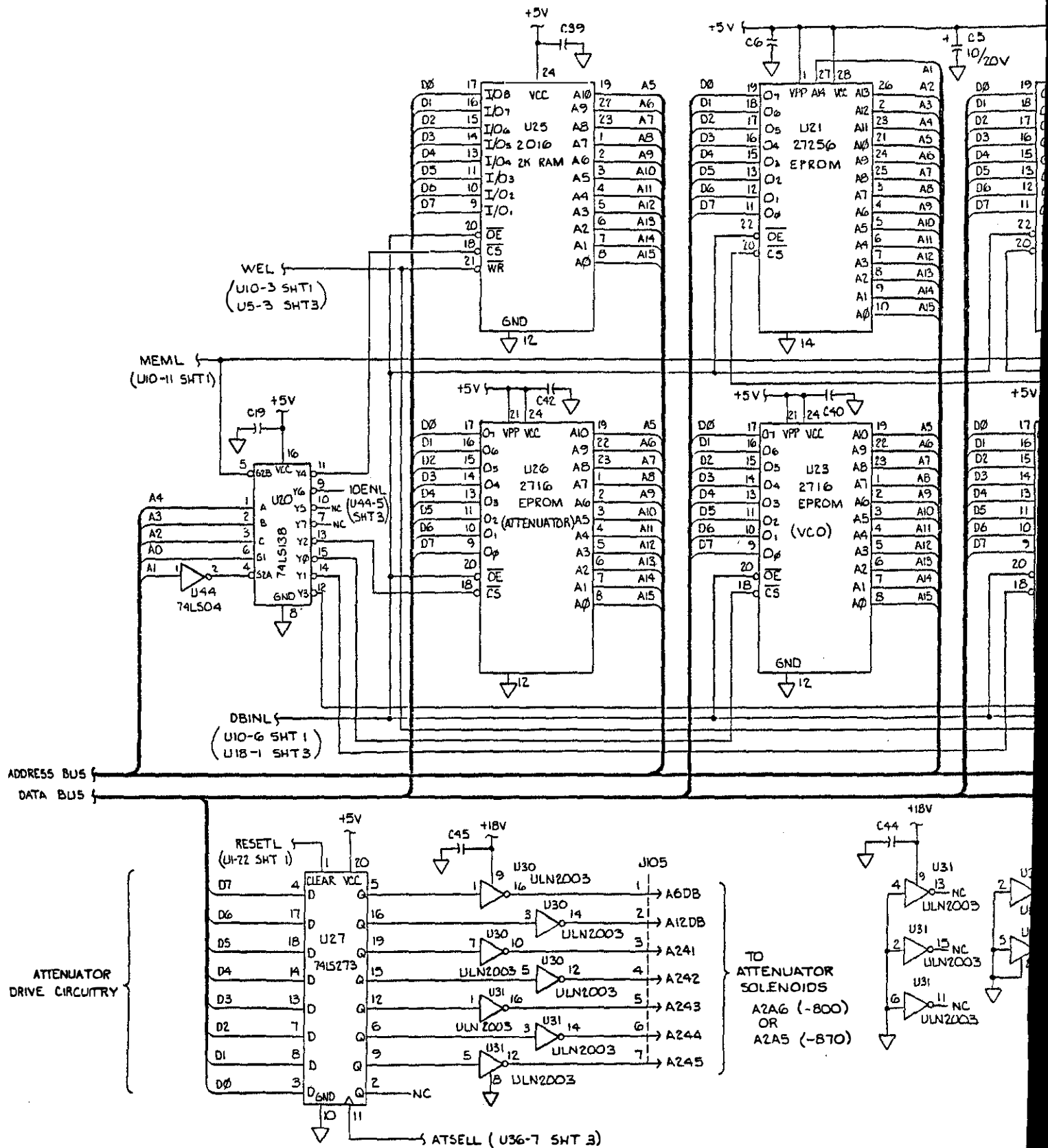
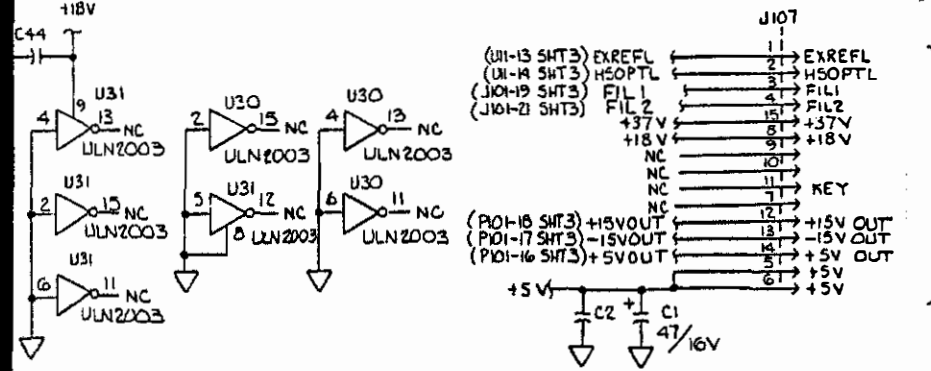
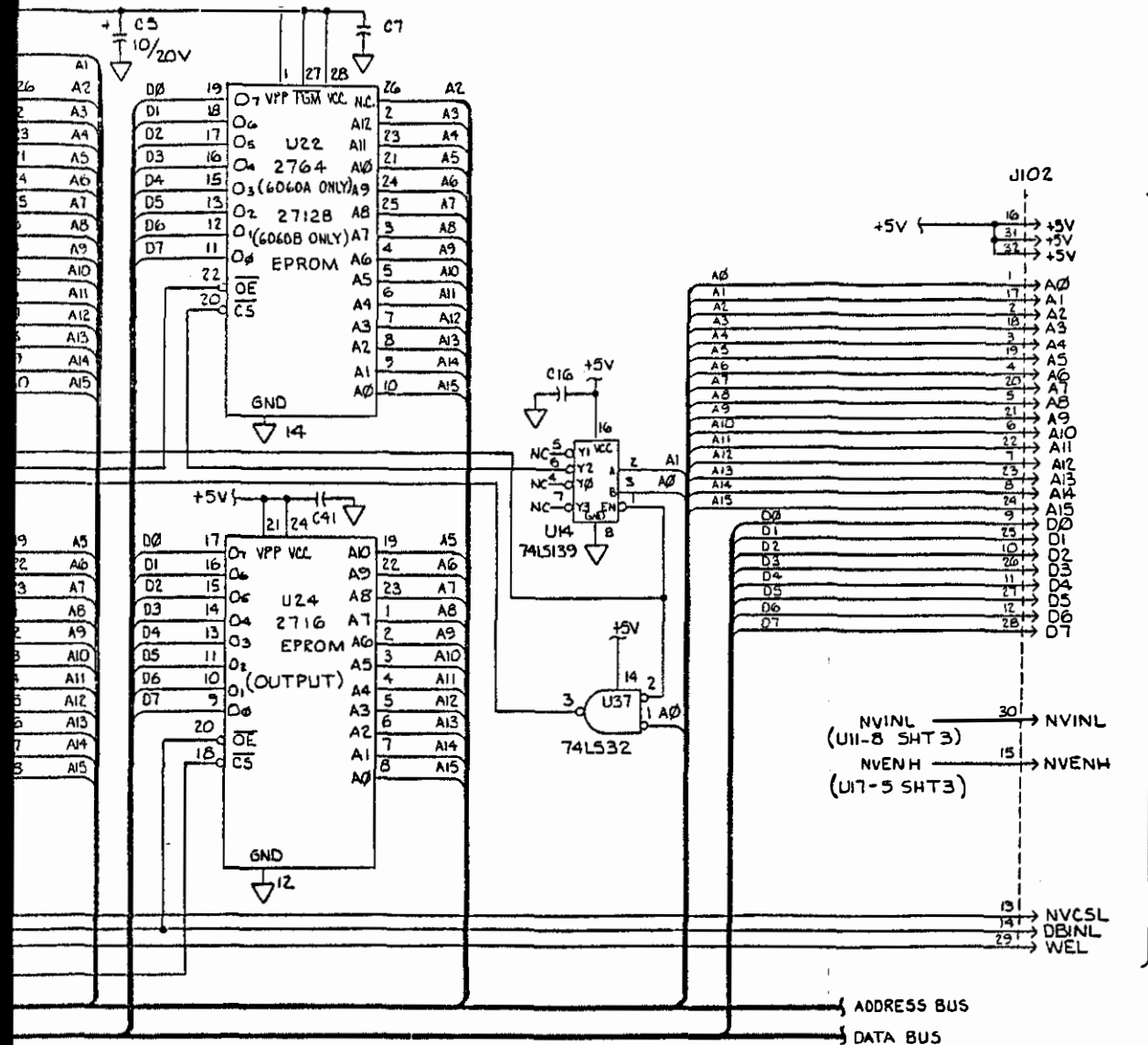

Fig 8-11 (2 of 3)
 Sht 2 of 2

SCHEMATIC DIAGRAMS



6060A-1028
 (2 of 3)

Figure 8-11. A2A7 Controller PCA (cont)

Fig 8-11 (3 of 3)
Sht 1 of 2

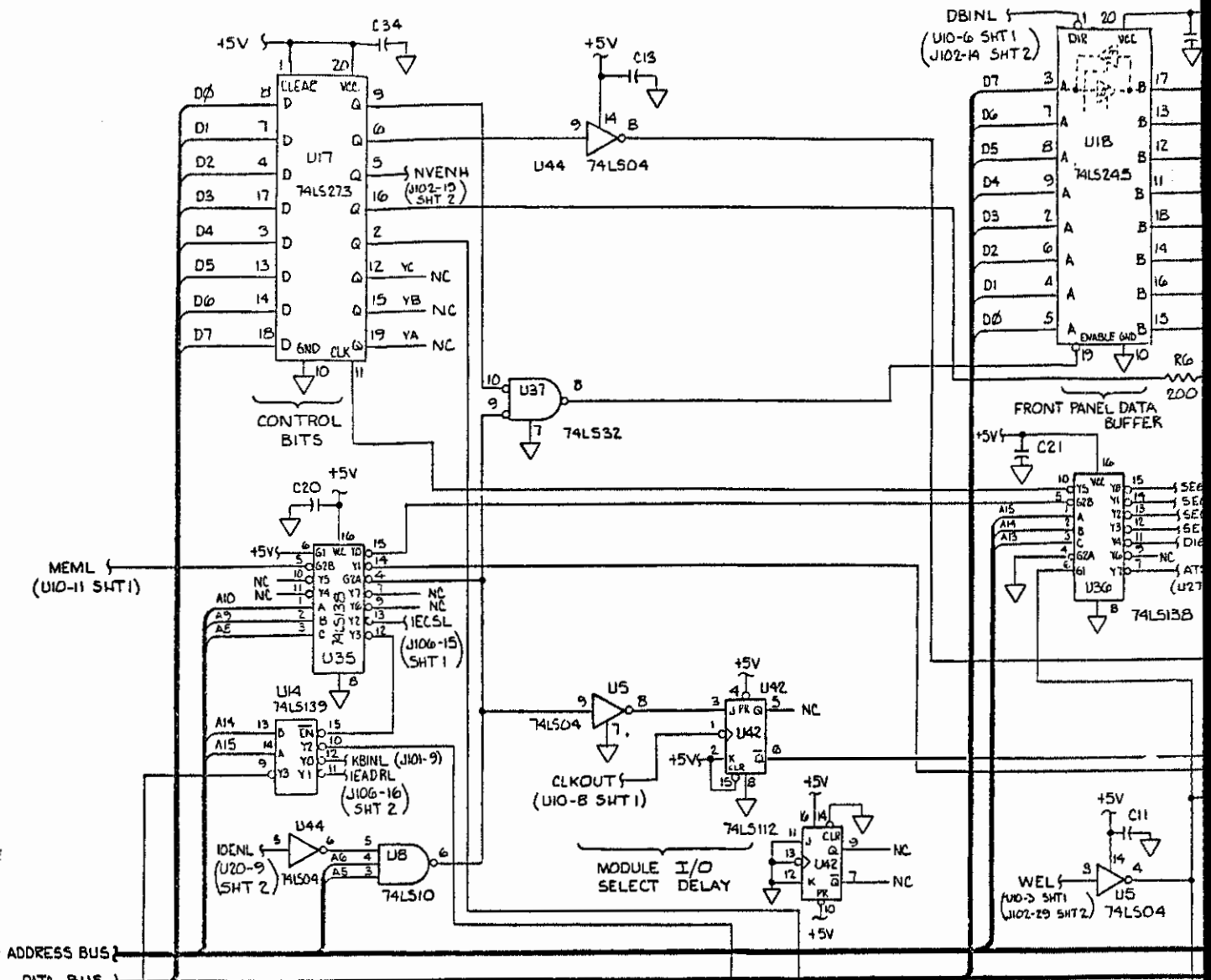

OPTION SWITCH SETTINGS (S1)

SWITCH SECTION IN "ON" POSITION	OPTION INSTALLED
1 PECULIAR TO 6060A	SUBHARMONIC REFERENCE OPTION-131
2	MEDIUM STABILITY REFERENCE TO 6060B OPTION-132
3	LOW RATE FM OPTION-651
4	REAR OUTPUT OPTION-830

ALL OTHER SWITCH SECTIONS SHALL BE IN "OFF" POSITION.

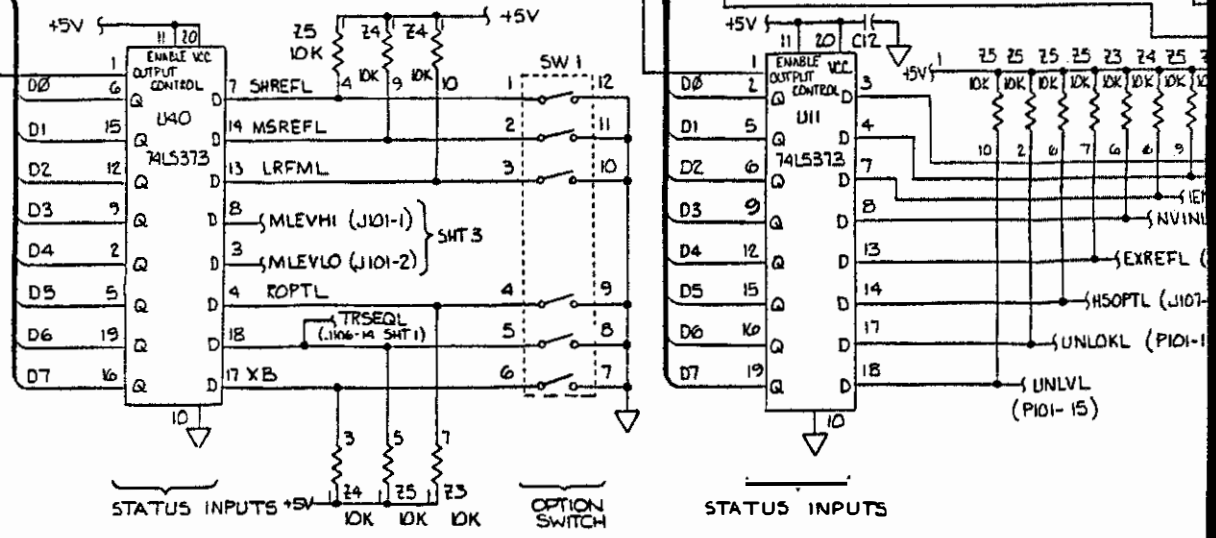
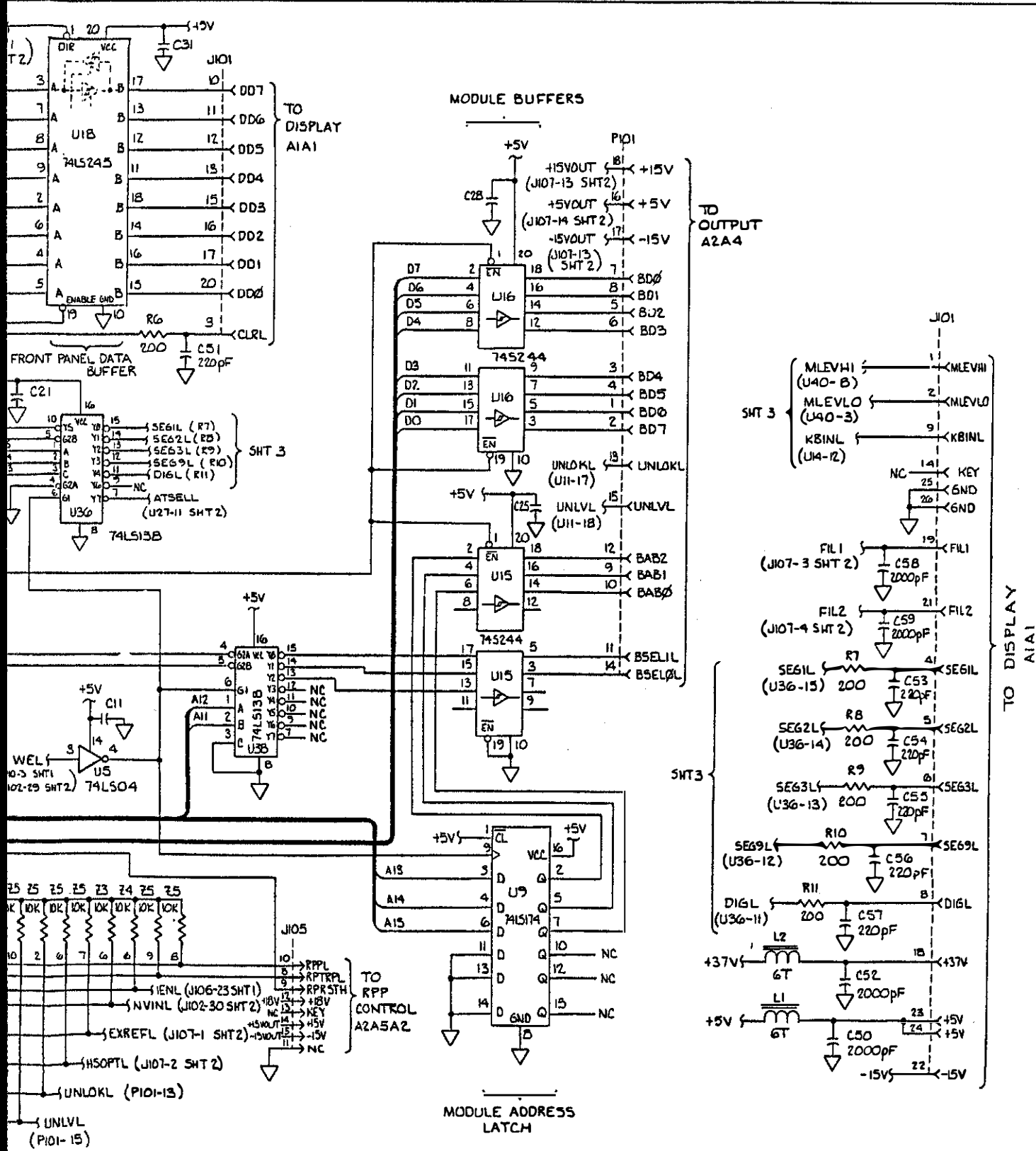

Fig 8-11 (3 of 3)
 Schematic Diagrams



6060A-1028
 (3 of 3)

Figure 8-11. A2A7 Controller PCA (cont)

Fig 8-12
Sht 103

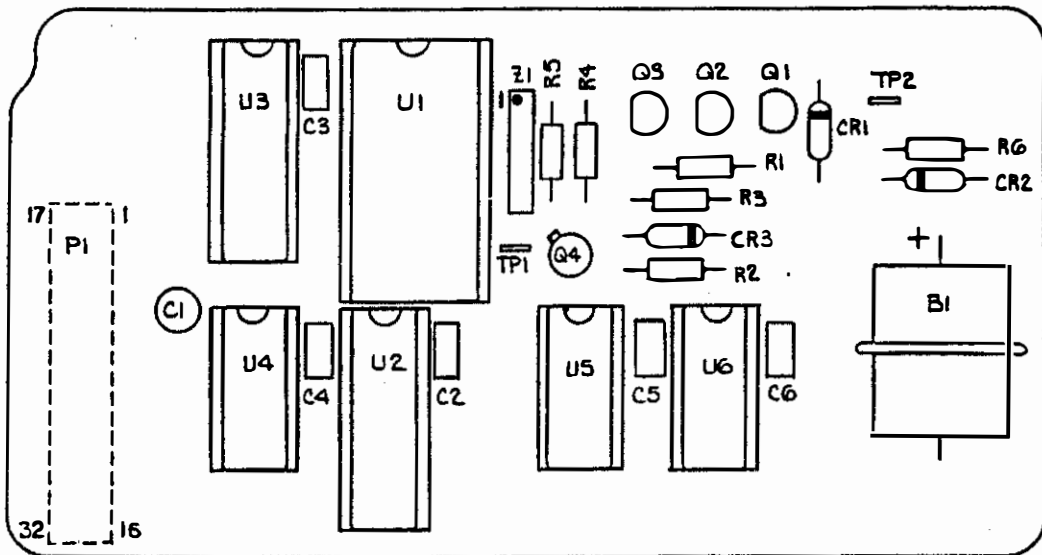

6060A-1629

TO
CONTROLLER
A2A7

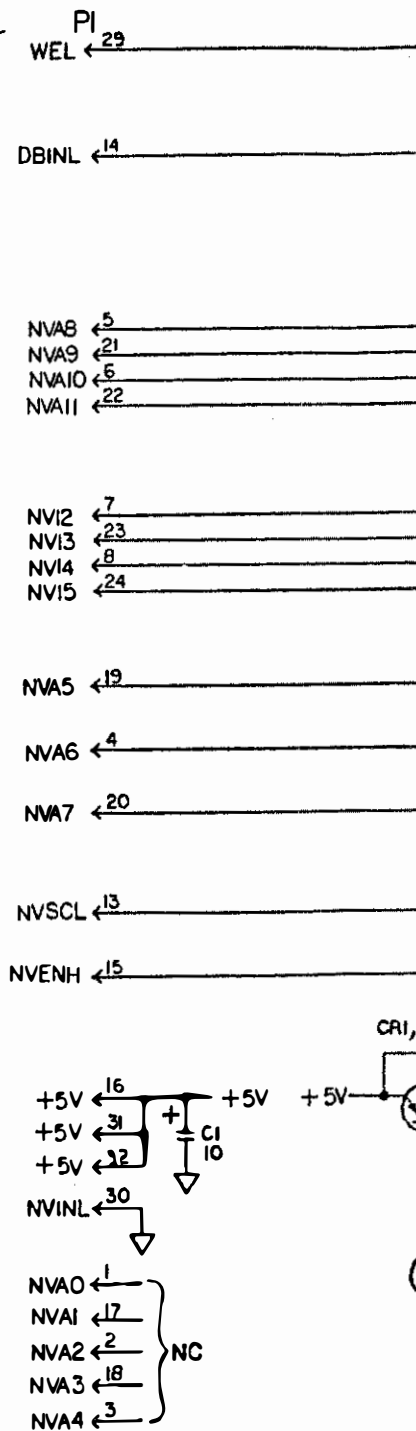

NOTES: (UNLESS OTHERWISE SPECIFIED).

1. ALL RESISTORS ARE 1/4W, 5%.
- ALL RESISTOR VALUES ARE IN OHMS.
2. ALL CAPACITOR VALUES ARE IN MICROFARADS.

Fig 8-12
Sht 2 of 3

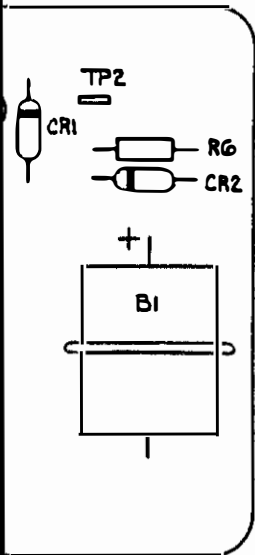

6060A-1629

TO CONTROLLER A2A7

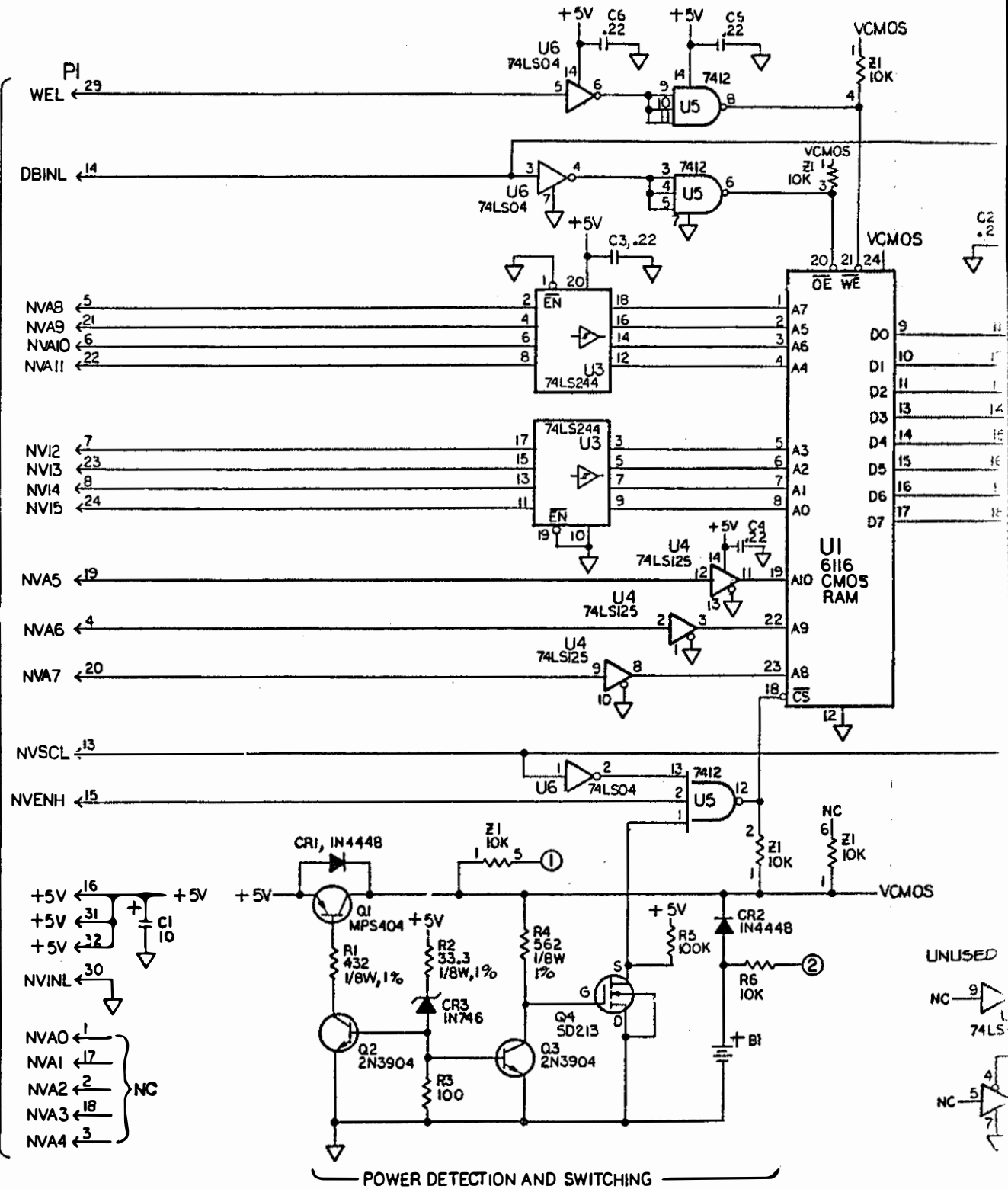

UNSPECIFIED).
%.
IN OHMS.
IN MICROFARADS.

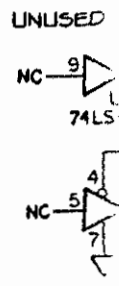

POWER DETECTION AND SWITCHING

Fig 8-12
Std 303

SCHMATIC DIAGRAMS

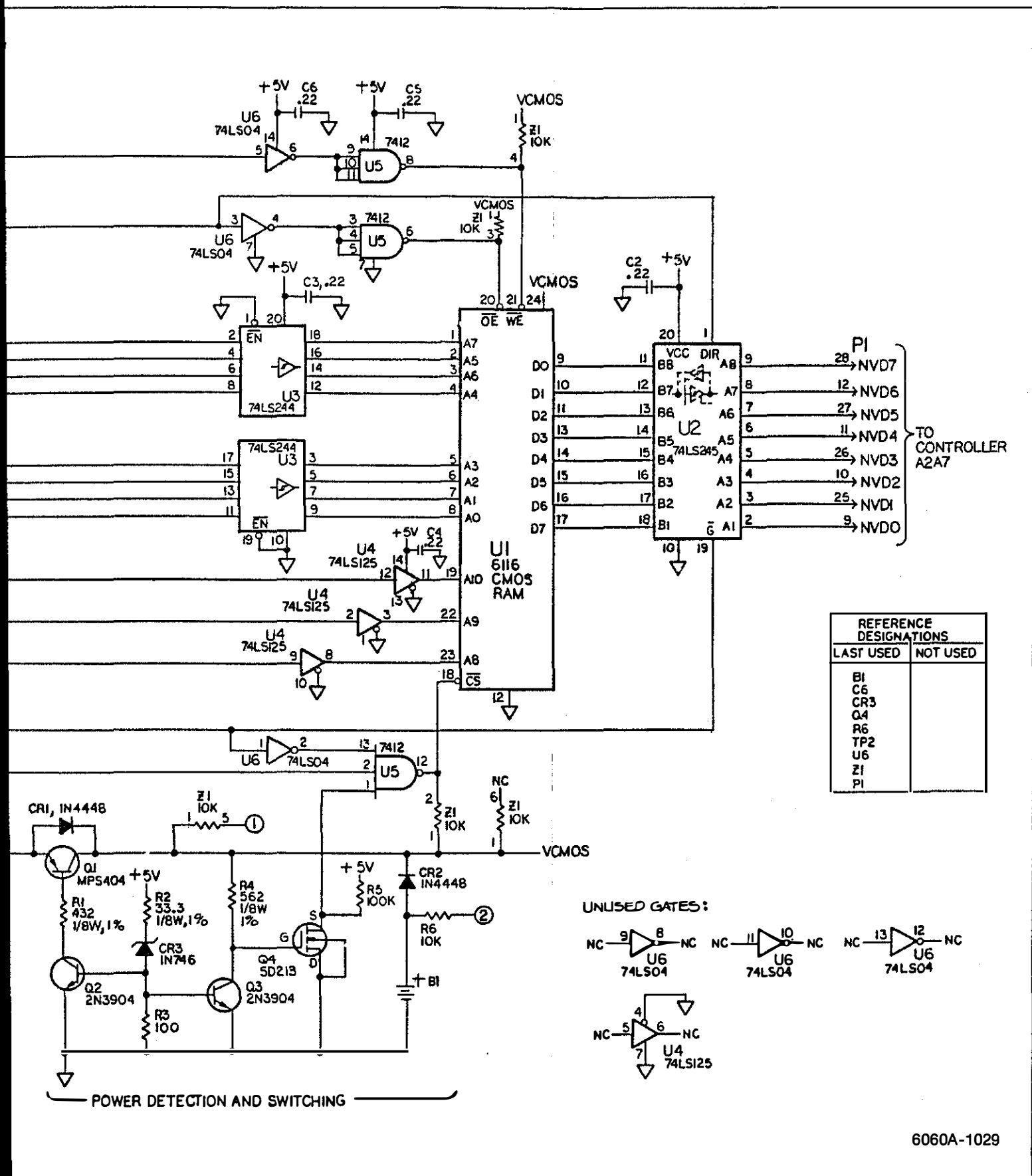

6060A-1029

Figure 8-12. A2A8 Non-Volatile (Store/Recall) Memory PCA

Fig 8-13
 Sht 1 of 3

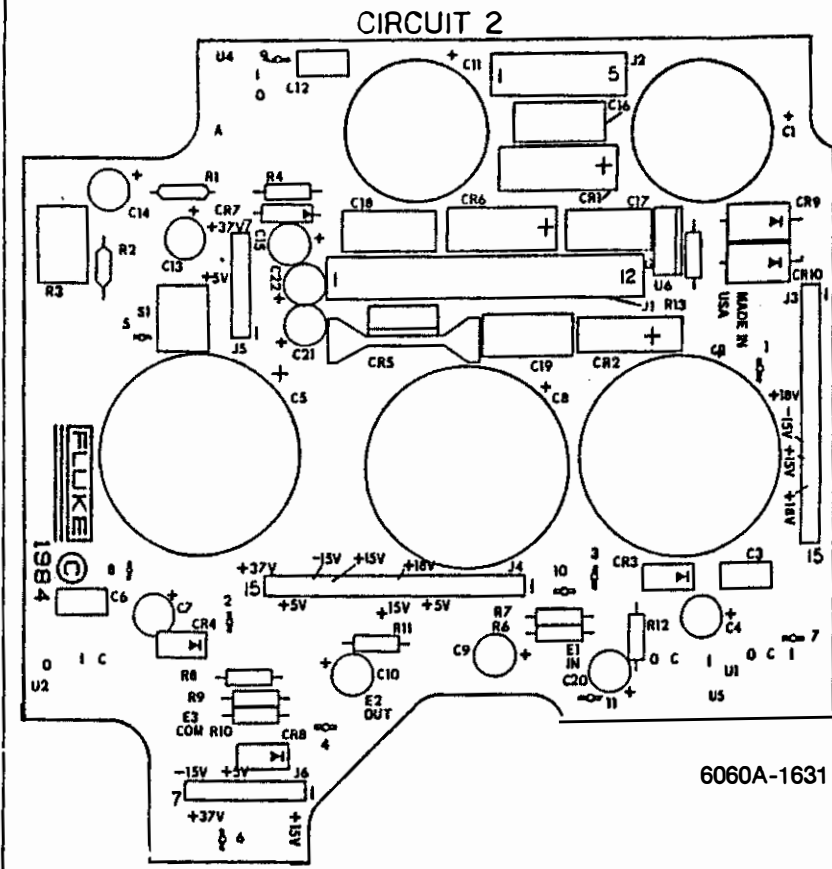

6060A-1631

A3A1 REFERENCE DESIGNATIONS	
LAST USED	UNUSED
R13	R5
C22	U3
CR10	
U6	
S1	
TP11	

NOTES: UNLESS OTHERWISE SPECIFIED.

1. ALL RESISTANCES IN OHMS.
ALL RESISTORS 1/4W, 5%.
2. ALL CAPACITANCES IN MICROFARADS.
3. RATING OF F1:
1.5A WHEN AC INPUT IS 115 VAC.
.75A WHEN AC INPUT IS 230 VAC.
6. THERMAL PROTECTOR INTERNAL TO T1.

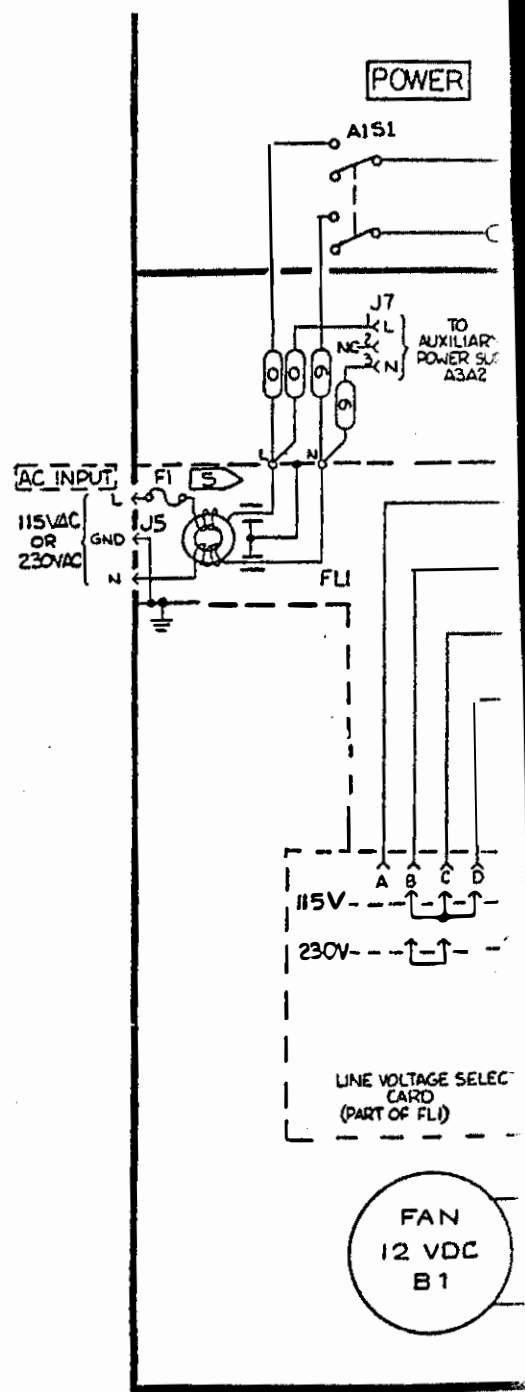
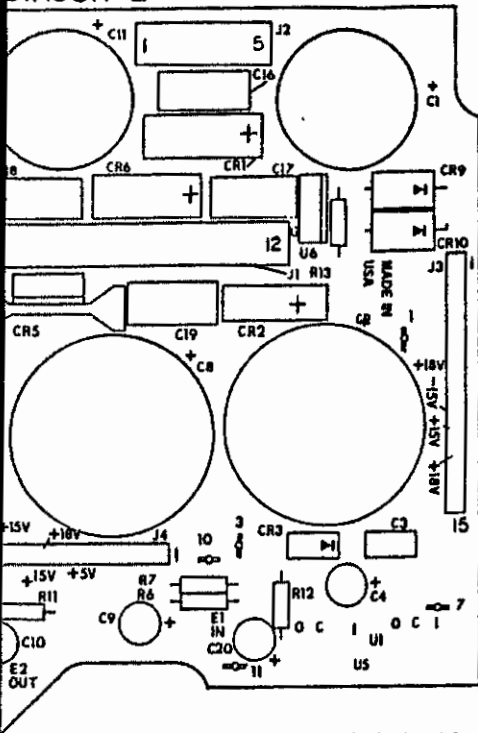

Fig 8-13
Sht 2 of 3

SCHEMATIC DIAGRAM

CIRCUIT 2



6060A-1631

A3A1	
REFERENCE DESIGNATIONS	LAST USED
R13	R5
C22	U3
CR10	
U6	
S1	
TP11	

LESS OTHERWISE SPECIFIED.

RESISTANCES IN OHMS.

CAPACITORS 1/4W, 5%.

INDUCTANCES IN MICROFARADS.

F F13

WHEN AC INPUT IS 115 VAC.

WHEN AC INPUT IS 230 VAC.

FUSE PROTECTOR INTERNAL TO T1.

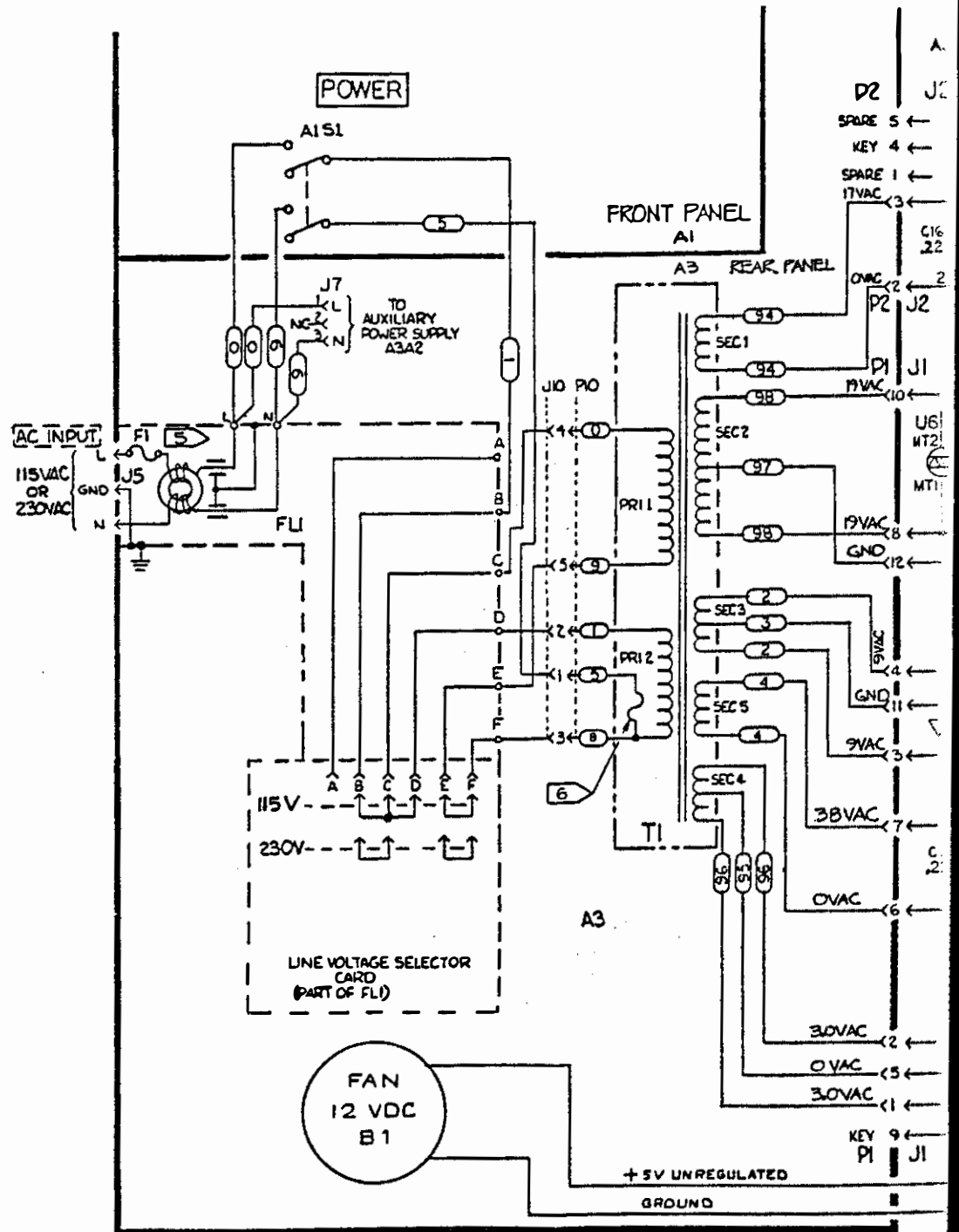

Figure 8-13.

Fig 8-13
 Skt 303
 SCHEMATIC DIAGRAMS

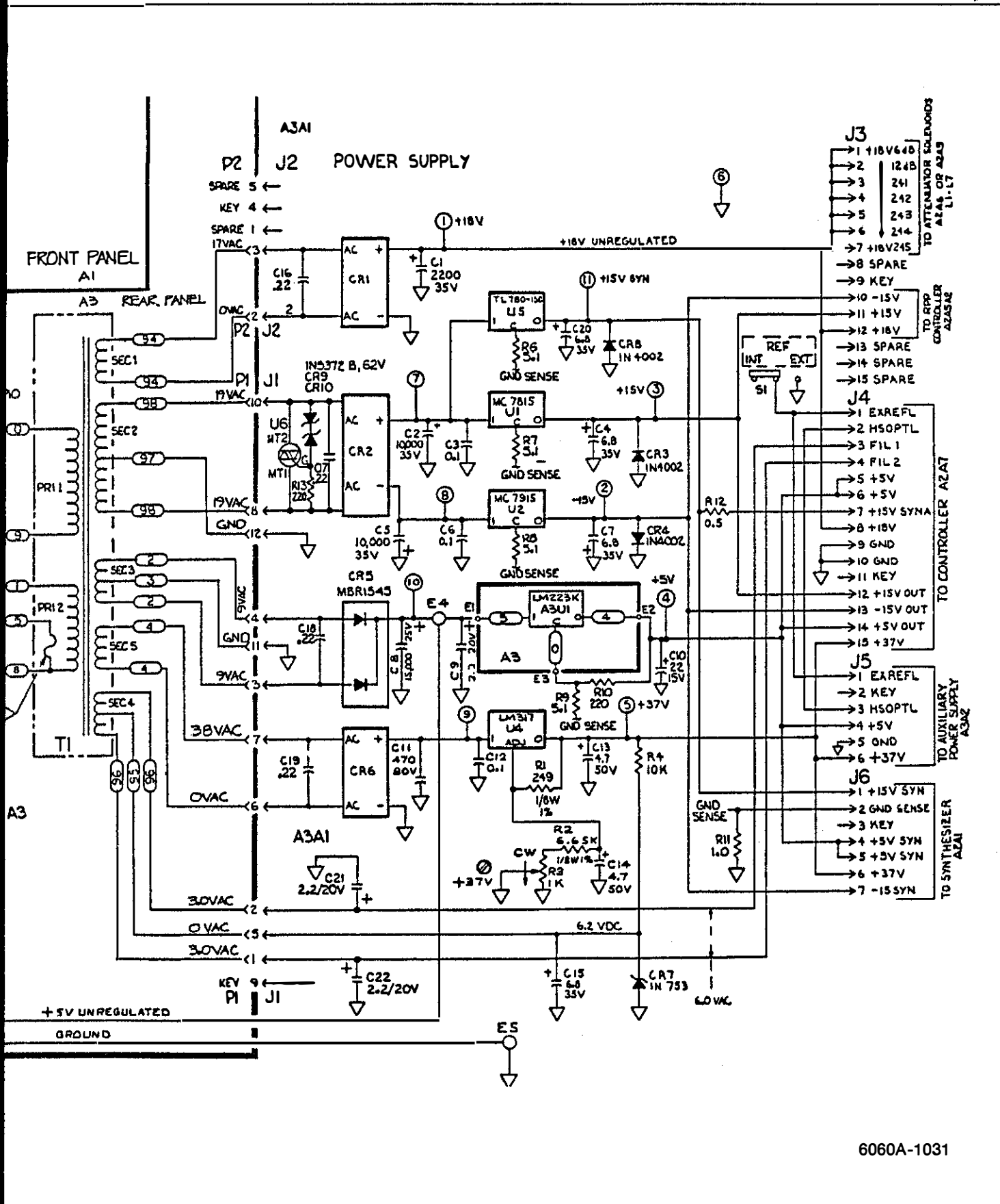
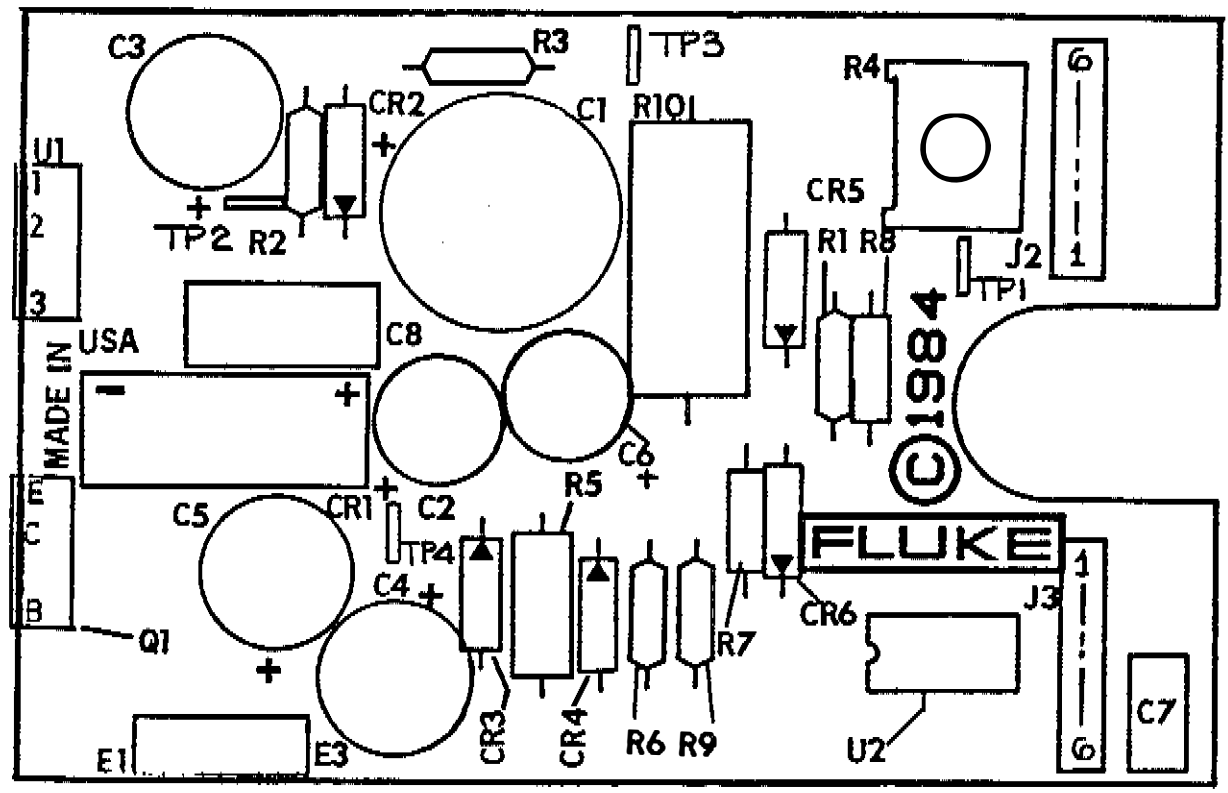
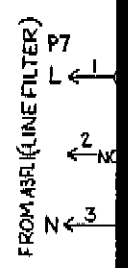

Figure 8-13. A3A1 Power Supply PCA

Fig 8-14
 Sht 1 of 3



6060A-1632



AUX
 BOA
 A3A

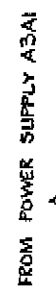
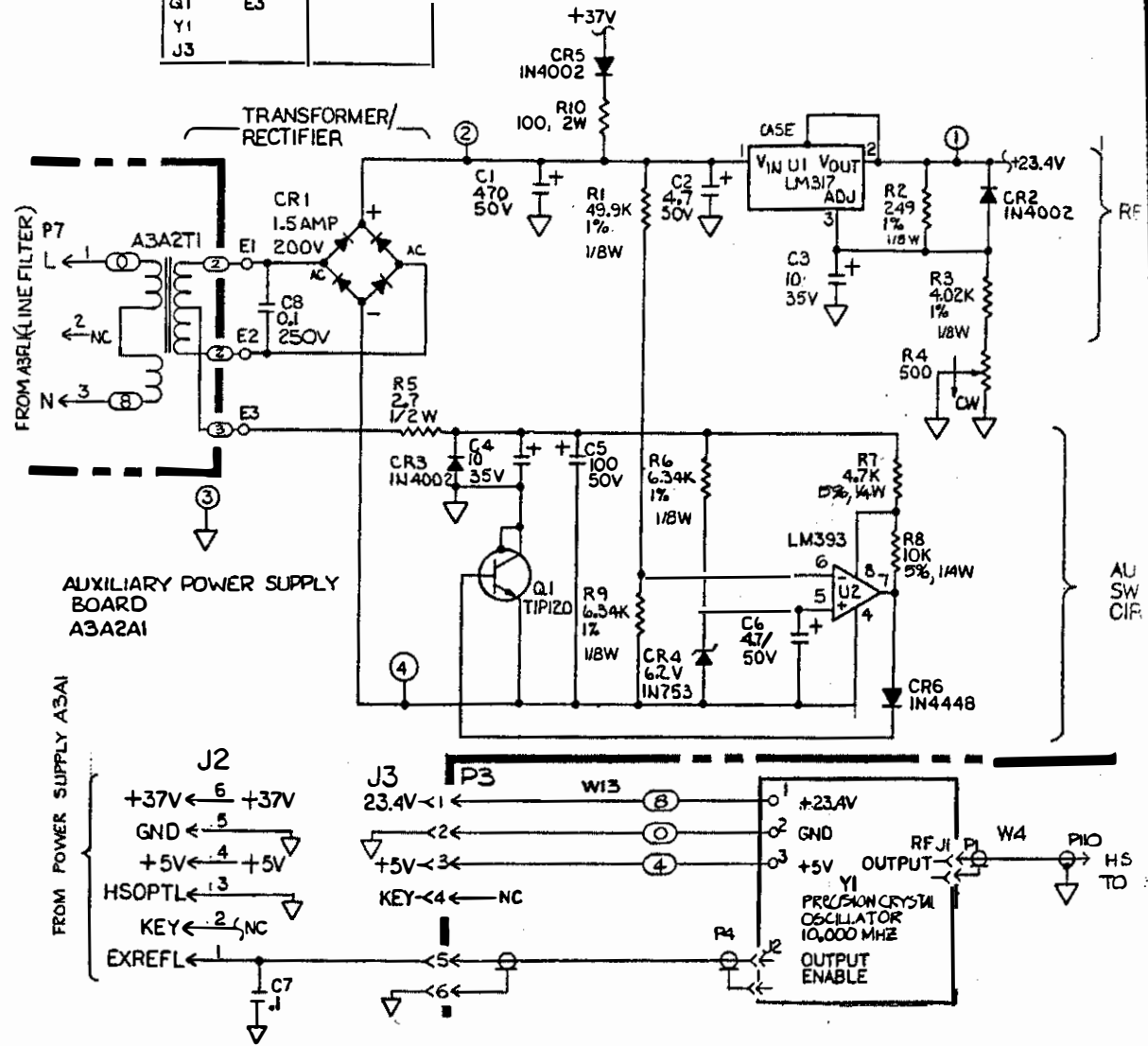

Fig 8-14
Sht 2 of 3

REFERENCE DESIGNATIONS		
HIGHEST USED	NOT USED	
R10	C8	J1
CR6	U2	
Q1	E3	
Y1		
J3		



6060A-1632

NOTES : (UNLESS OTHERWISE SPECIFIED.)

1. ALL RESISTOR VALUES ARE IN OHMS
2. ALL CAPACITOR VALUES ARE IN MICROFARADS

Figure 8-14. A3A2A1
Referer

Fig 8-14
Sht 3 of 3

SCHMATIC DIAGRAMS

REFERENCE DESIGNATIONS		
HIGHEST USED		NOT USED
R10	C8	J1
CR6	U2	
Q1	E3	
Y1		
J3		

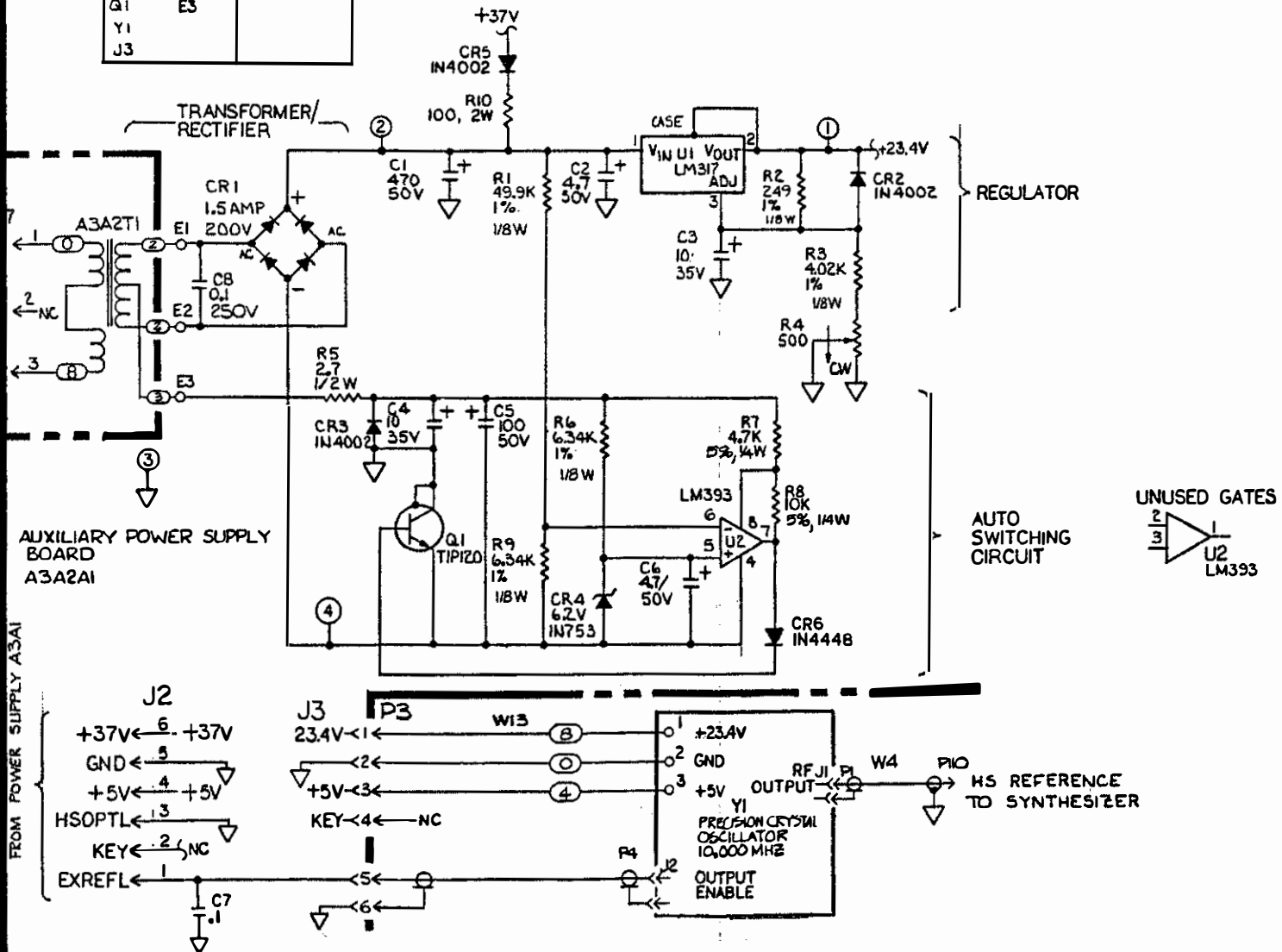

NOTES: (UNLESS OTHERWISE SPECIFIED.)

1. ALL RESISTOR VALUES ARE IN OHMS
2. ALL CAPACITOR VALUES ARE IN MICROFARADS

6060A-1032

Figure 8-14. A3A2A1 High-Stability (Ovened) Reference PCA (Option -130)

Fig 8-15
Swt 1 of 3

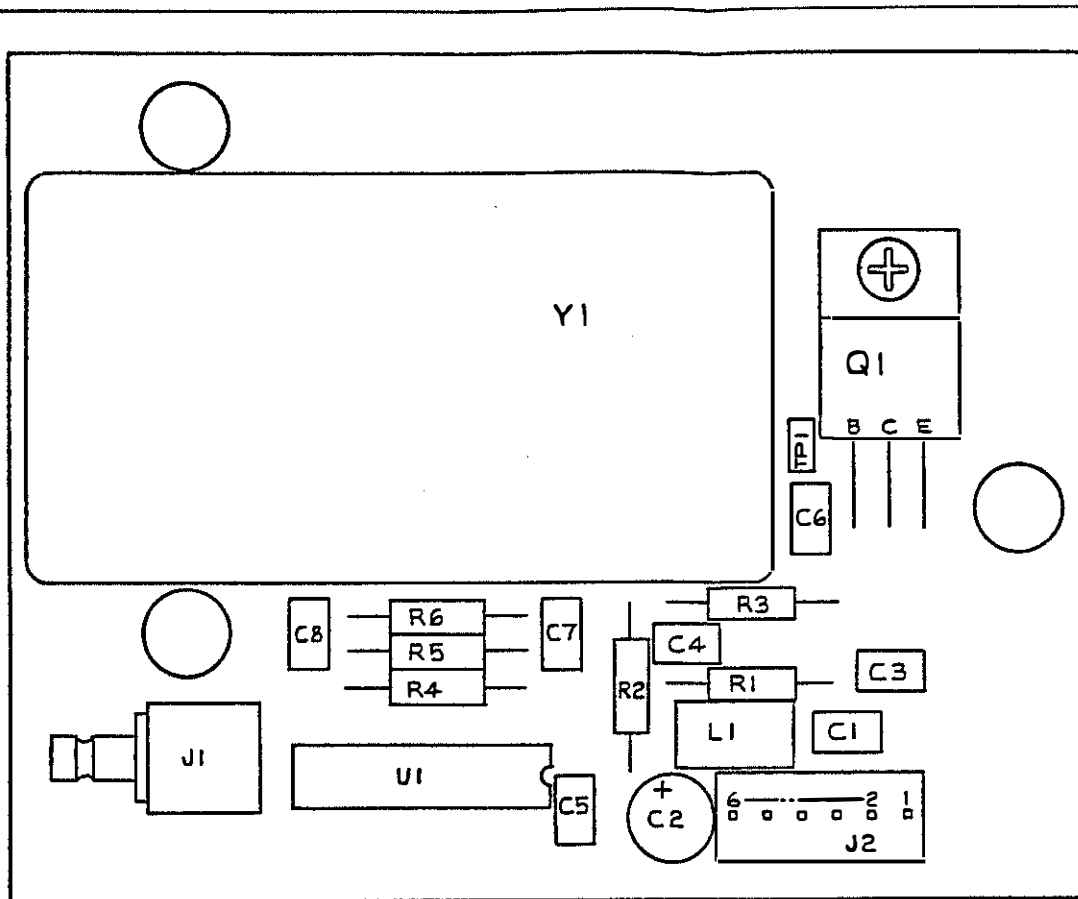

6060B-1634

FROM POWER SUPPLY
A3A1 (W25)

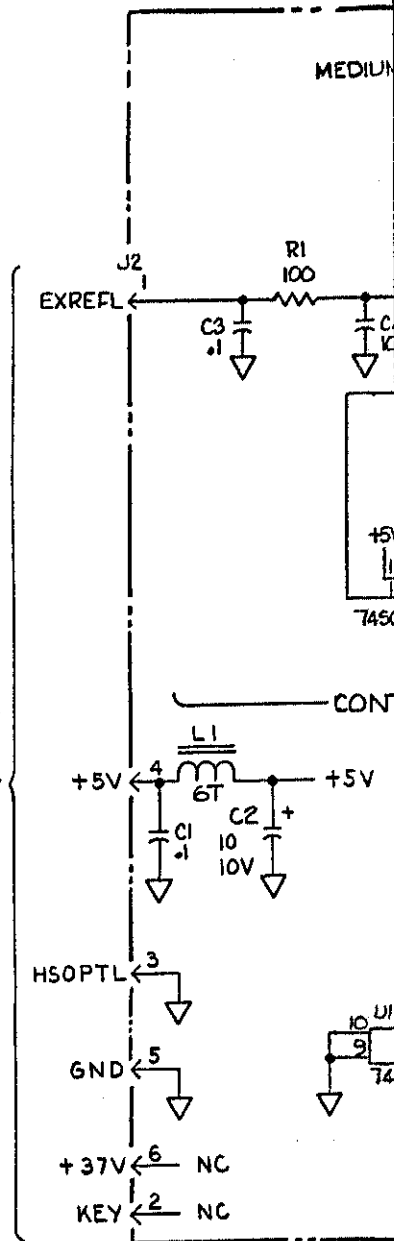
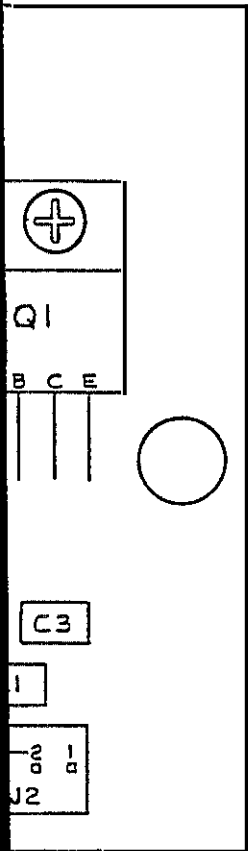

Fig 8-15
Sht 2 of 3

SCHMATIC DIAGRAMS



6060B-1634

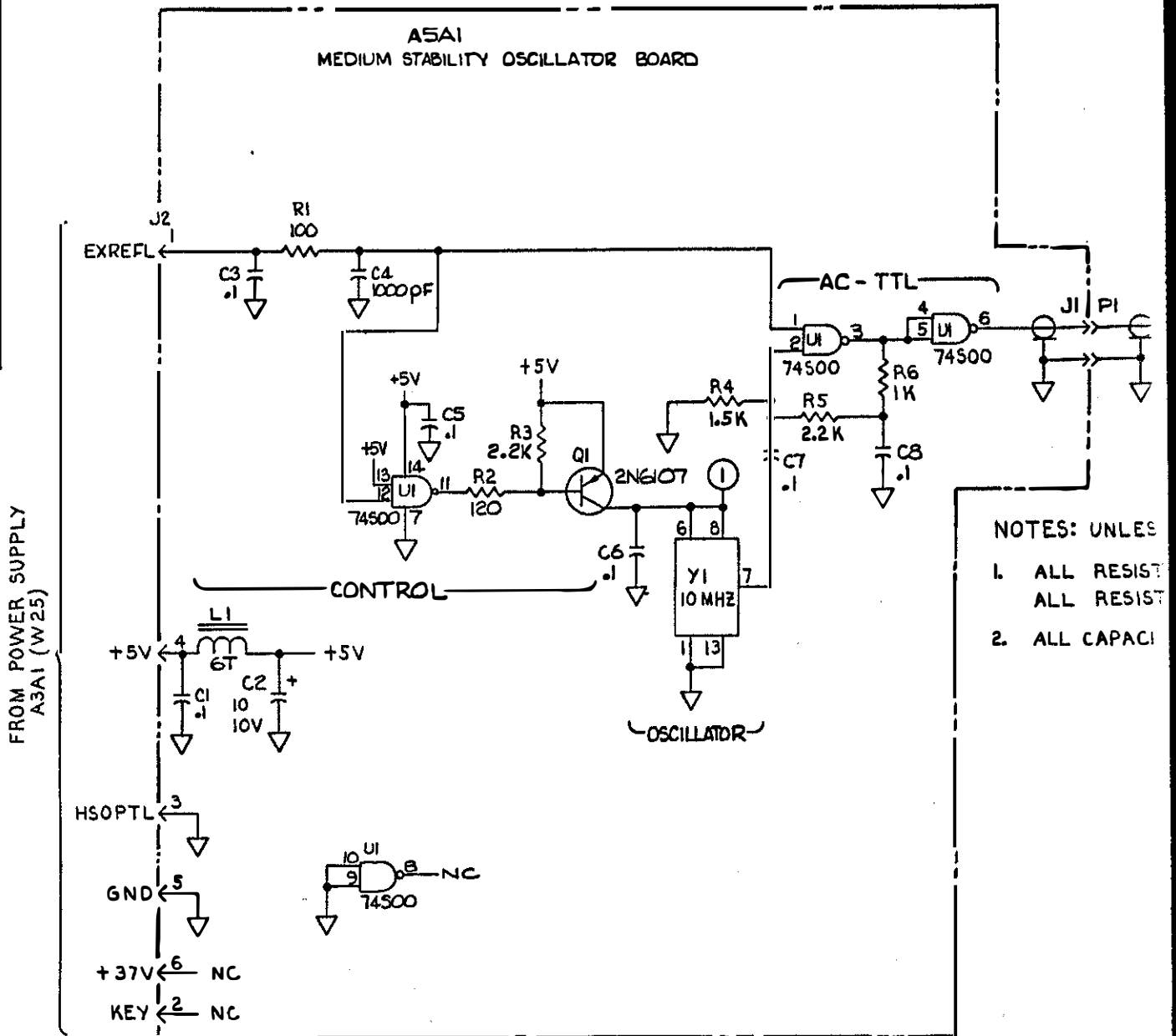
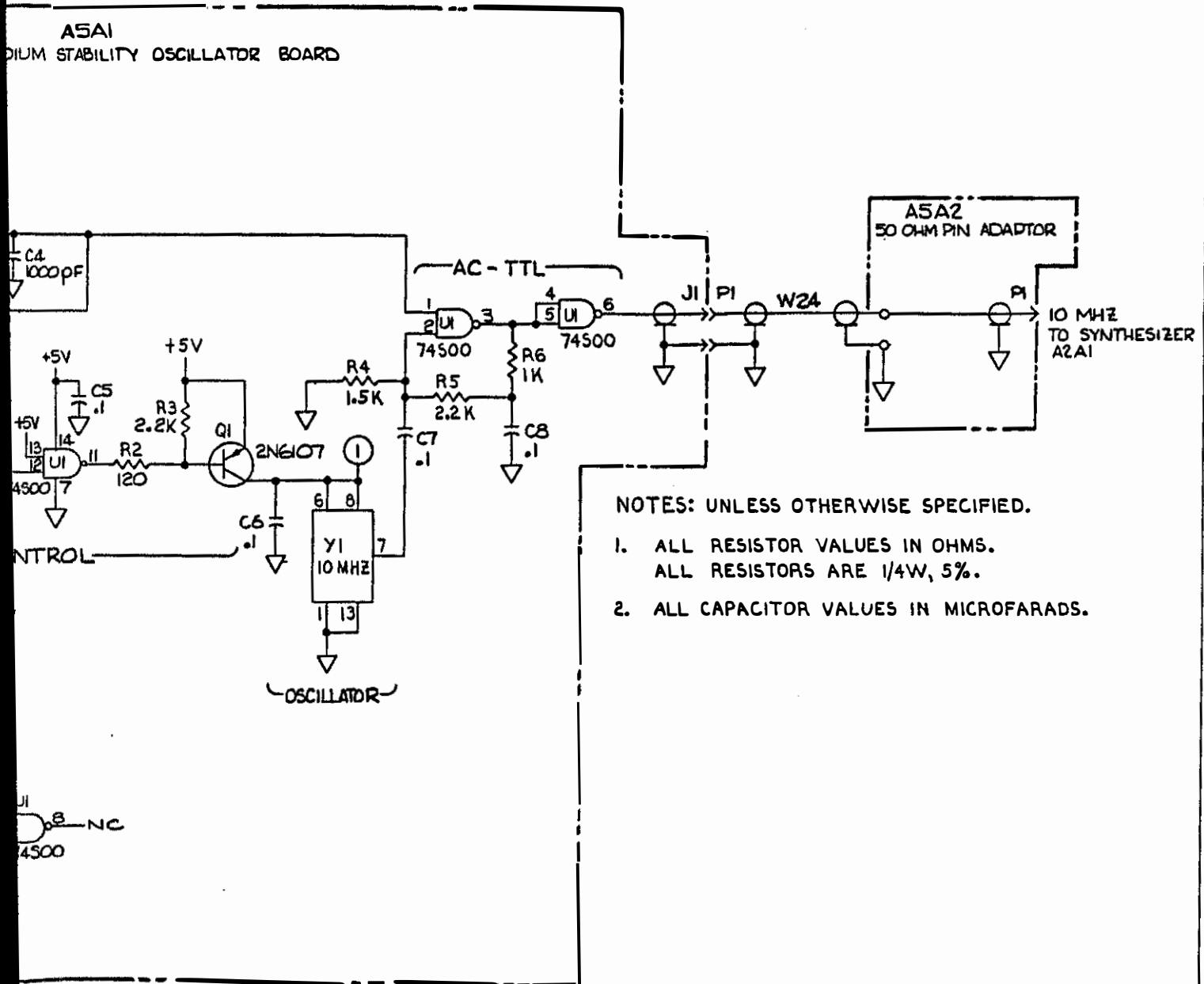

Figure 8-15. A5A1 Medium-Stability Reference PCA
(Option -132)

Fig 8-15
 Sht 3 of 3

SCHMATIC DIAGRAMS



NOTES: UNLESS OTHERWISE SPECIFIED.

1. ALL RESISTOR VALUES IN OHMS.
 ALL RESISTORS ARE 1/4W, 5%.
2. ALL CAPACITOR VALUES IN MICROFARADS.

6060B-1034

Figure 8-15. A5A1 Medium-Stability Reference PCA
 (Option -132)

Fig 8-16
Sht 1 of 3

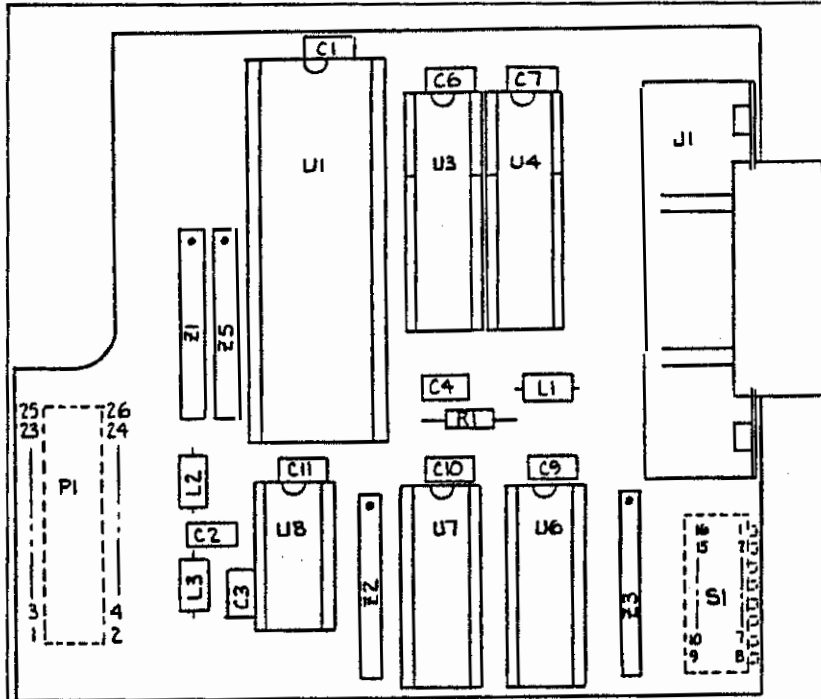

6060A-1633

TO CONTROLLER A2A7

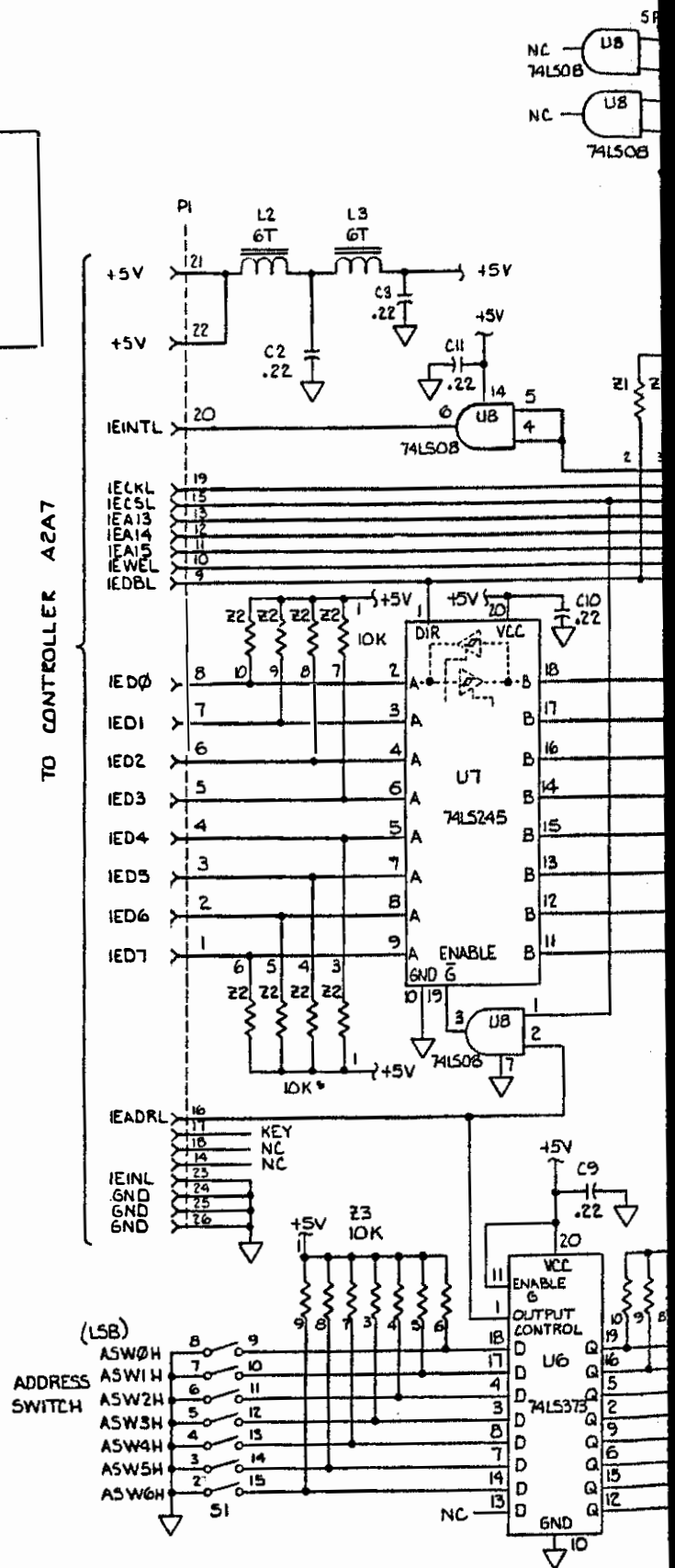

Fig 8-16
 Set 2 of 3

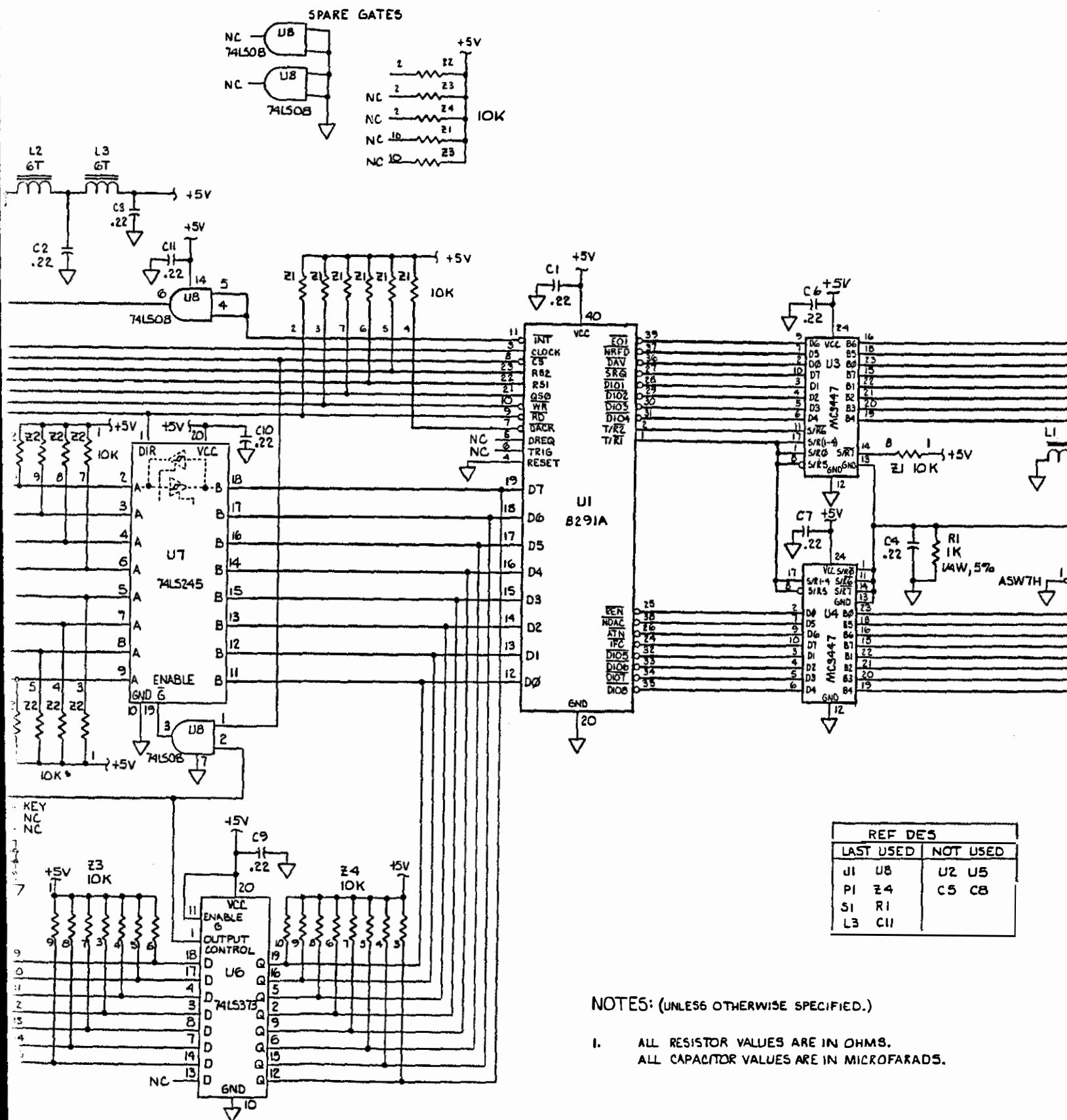
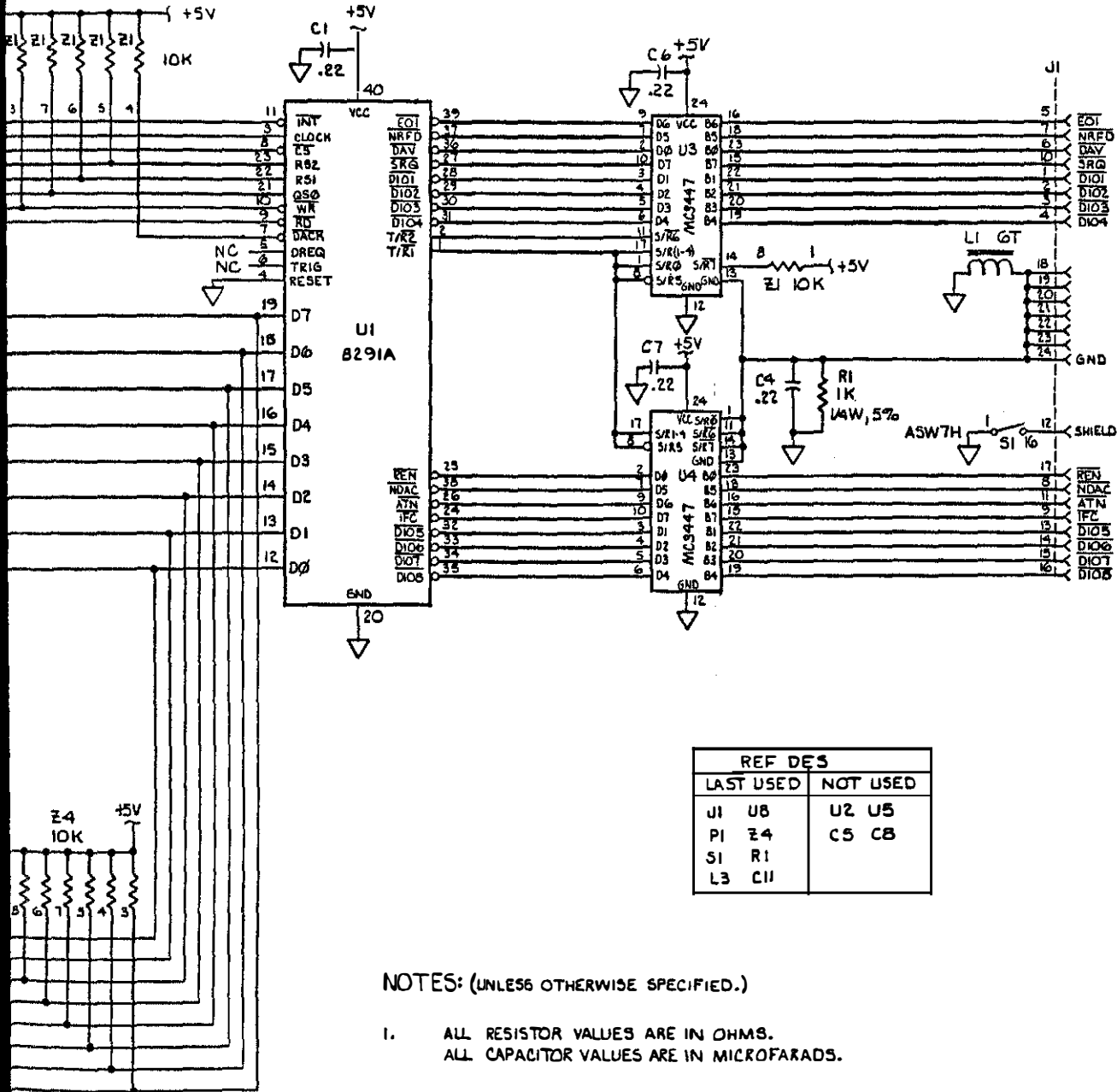
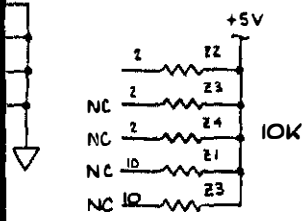

Figure 8-16. A3A3A1 I
 (Option -4)

Fig 8-16
Sht 3 of 3

SCHEMATIC DIAGRAMS

PARE GATES



IEEE-488
INTERFACE

REF DES	
LAST USED	NOT USED
J1 U8	U2 U5
P1 Z4	C5 C8
S1 R1	
L3 C11	

NOTES: (UNLESS OTHERWISE SPECIFIED.)

- ALL RESISTOR VALUES ARE IN OHMS.
ALL CAPACITOR VALUES ARE IN MICROFARADS.

6060A-1033

Figure 8-16. A3A3A1 IEEE-488 Interface PCA
(Option -488)

Fig 8-17
 Sht 1 of 3

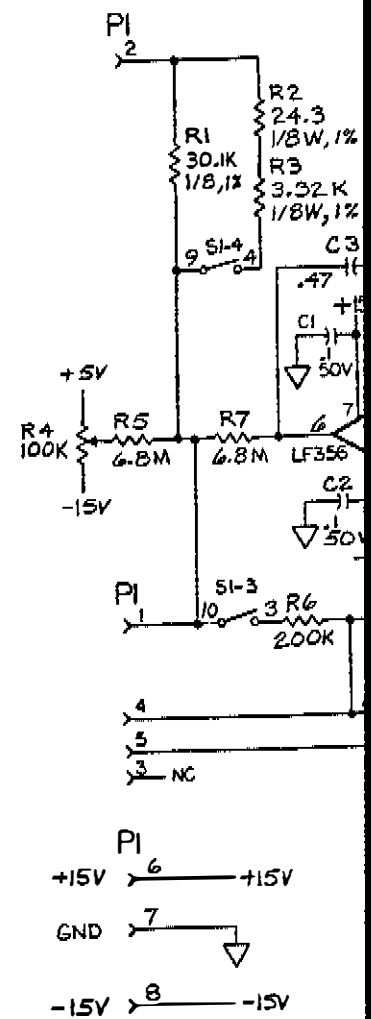
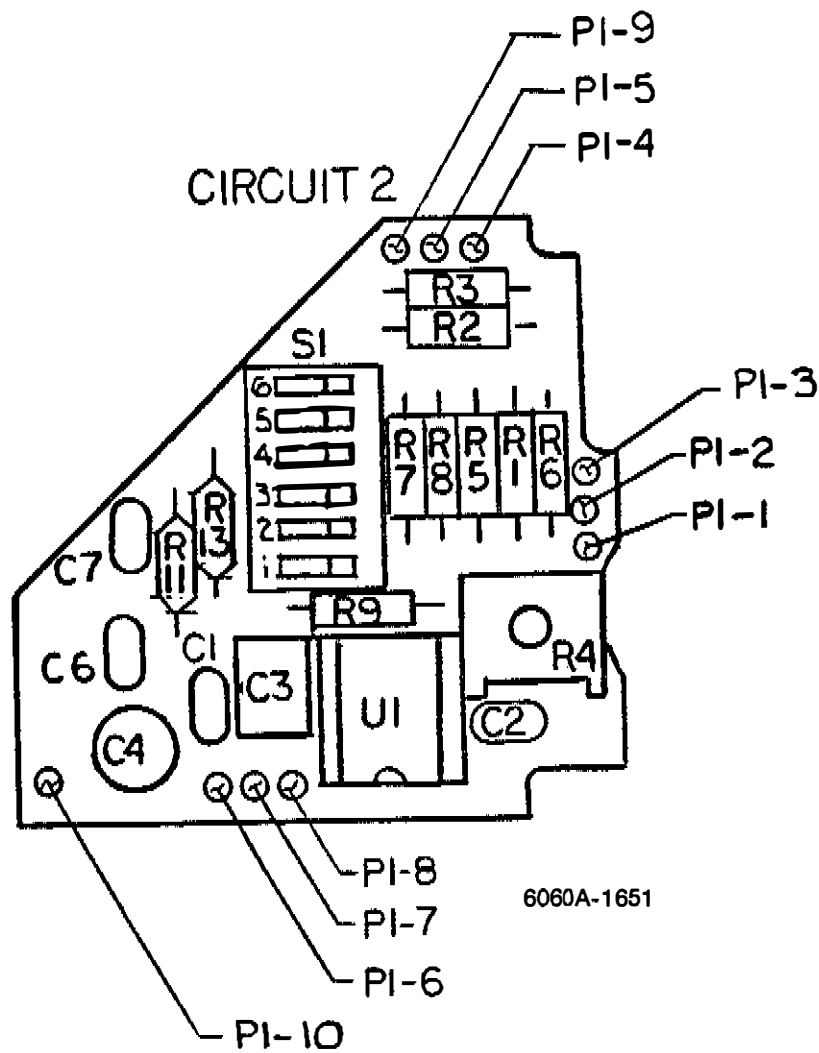
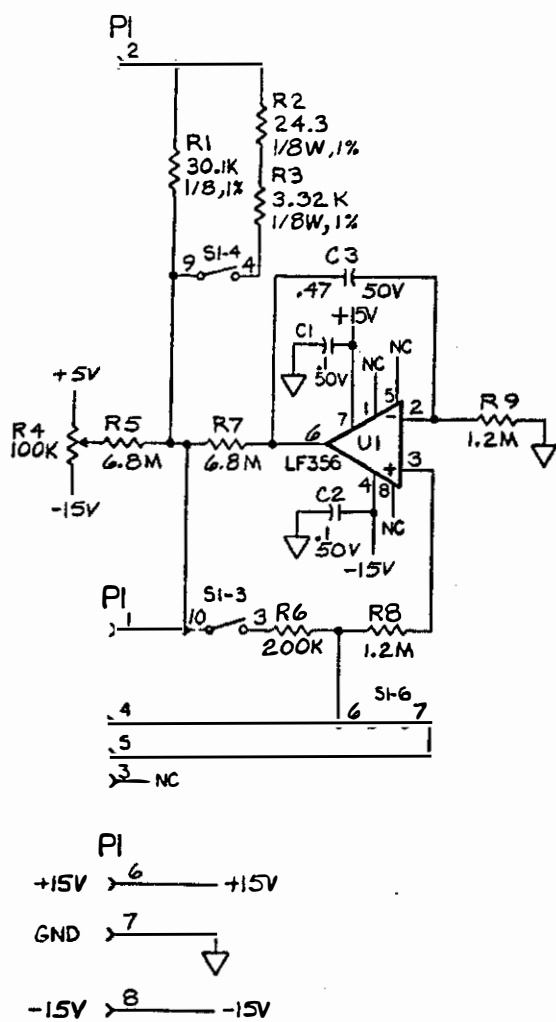

Fig 8-17
Sht 2 of 3

SCHMATIC DIAGRAMS

PI-3
-2
-1



OPTION SWITCH SETTINGS		
SWITCH	NORMAL FM	LOW RATE FM
SI-1	CLOSED	OPEN
SI-2	OPEN	CLOSED
SI-3	CLOSED	OPEN
SI-4	CLOSED	OPEN
SI-5	—	—
SI-6	OPEN	CLOSED

- NOTES
1. ALL
 2. ALL
 3. ALL MIC
 4. SI 1E

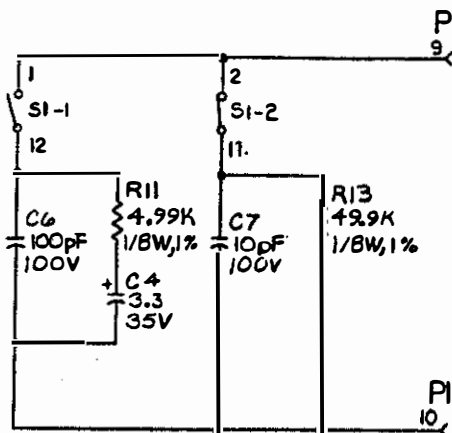

REFERENCE
LAST USED
C7
R13
PI
SI
U1

Figure 8-17. A2A9 Low-Rate FM PCA (Option -651)

Fig 8-17
Sht 3 of 3

SCHMATIC DIAGRAMS

OPTION SWITCH SETTINGS		
SWITCH	NORMAL FM	LOW RATE FM
SI-1	CLOSED	OPEN
SI-2	OPEN	CLOSED
SI-3	CLOSED	OPEN
SI-4	CLOSED	OPEN
SI-5	—————	—————
SI-6	OPEN	CLOSED

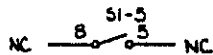
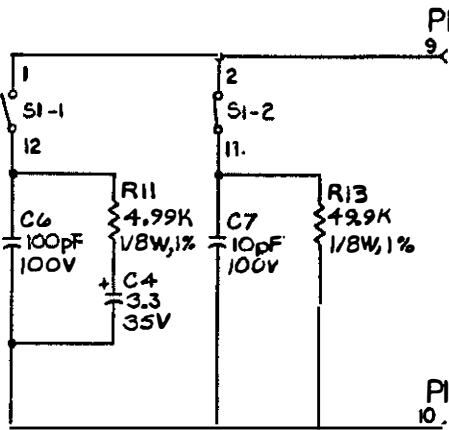
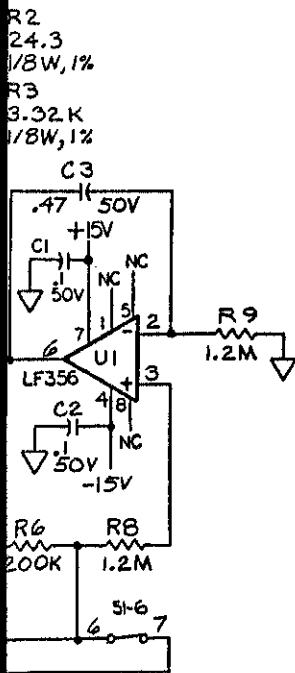

NOTES: (UNLESS OTHERWISE SPECIFIED)

1. ALL RESISTOR VALUES ARE IN OHMS
2. ALL RESISTORS ARE 1/4W, 5%, CF.
3. ALL CAPACITOR VALUES ARE IN MICROFARADS.
4. SI IS SHOWN SET IN LOW RATE FM POSITIONS.

REFERENCE DESIGNATORS	
LAST USED	NOT USED
C7	C5
R13	R10, 12
PI	
SI	
UI	

6060A-1051

Figure 8-17. A2A9 Low-Rate FM PCA (Option -651)

Information Card
Sht 1 of 2

FLUKE 6060B OPERATOR INFORMATION CARD

REJECTED ENTRY CODES (Press the [STATUS] key to display codes)

- 000 000 000 indicates no rejected entries.
- 001 000 000 = FM Deviation not between 0 and 99.9 kHz
(9.99 kHz with option-651)
- 002 000 000 = FM Deviation Step not between 0 and 99.9 kHz
(9.99 kHz with option-651)
- 004 000 000 = AM Depth not between 0 and 99%
- 010 000 000 = AM Depth Step not between 0 and 99%
- 020 000 000 = IEEE-488 command syntax error
- 040 000 000 = IEEE-488 input value out of range
- 100 000 000 = Special function requires IEEE option
- 200 000 000 = IEEE edit or step beyond allowed range
- 000 001 000 = Frequency not between 10 kHz and 1050 MHz
- 000 004 000 = Frequency Step not between 0 and 1050 MHz
- 000 040 000 = Invalid memory location
- 000 100 000 = Invalid data in memory
- 000 200 000 = Special function not allowed
- 000 000 001 = Output amplitude not between 10 nV and 2V
- 000 000 002 = Insufficient resolution for units conversion
- 000 000 004 = Units conversion to volts not allowed with reference in volts
- 000 000 010 = Units conversion to dB not allowed with reference in volts
- 000 000 020 = Amplitude Step not between 0 and 166 dB or 0 and 1999V
- 000 000 040 = Units conversion of Amplitude Step not allowed
- 000 000 100 = Amplitude step and current amplitude display not in same units

UNCAL CODES (Press the [STATUS] key to display codes)

Flashing codes (denoted by *) indicate abnormal operation or aberrated output.
Non-flashing codes indicate operation outside specified range.

- 000 000 000 indicates no UNCAL conditions.
- 001 000 000 = FM Dev < 100 Hz (< 10 Hz with option -651)
- 002 000 000 = Excess FM Deviation for output freq < .4 MHz
- * 004 000 000 = Excess FM Deviation, main or reference PLL unlocked
- 020 000 000 = AM depth > 90%
- * 000 010 000 = Main or reference PLL unlocked
- 000 000 001 = Level vernier below calibrated range
- 000 000 002 = Peak (AM) amplitude > +13 dBm
- * 000 000 004 = Amplitude unlevelled
- * 000 000 010 = Fixed-range level vernier at 0
- * 000 000 020 = Fixed-range level vernier at full scale
- * 000 000 040 = RPP tripped
- 000 000 100 = Level < -127 dBm
- 000 000 200 = Level correction disabled
- * 000 000 400 = RF off

SPECIAL FUNCTION OPERATIONS

The two-digit code consists of the last two digits of the activated modes of class 10000000 field while the [SPCL] key is held. 01000201 indicates that the fixed-range are selected.

Code	Function
00	Clears all special function
02	Initiates self test
03	Display check
04	Key check
07/08	Set/reset SRQ
09	Display S/W reference
10	Display IEEE-488 command
11	Display self test
12/13	Turn on/off Display
14	Initialize Memory
15	Latch test
16	Display Option Loading

SELF TEST RESULTS

The self test results are:

aaa
|
AM/FM Tests

Self Test

000 000 000 000

MEMORY

Instrument settings are stored in memory from Non-Volatile Memory.

ATTENUATOR INFORMATION CARD

SPECIAL FUNCTION OPERATION (Press the [SPCL] key, then press the 2-digit code)

The two-digit code consists of a class numeric followed by a mode numeric. The activated modes of classes 2 through 9 are shown in the FREQUENCY display field while the [SPCL] key is pressed. For example, reading from left to right, 01000201 indicates that relative amplitude, slow key-repeat-rate, and amplitude fixed-range are selected.

Code	Function	Code	Function
00	Clears all special functions	20/21	Disable/enable relative freq.
02	Initiates self test	30/31	Disable/enable relative ampli
03	Display check	40	Not used
04	Key check	50	Not used
07/08	Set/reset SRQ	60	Not used
09	Display S/W rev & instr ID	70/71/72	Medium/fast/slow key-rep-rate
10	Display IEEE-488 address	80	Enable amplitude correction
11	Display self test results	81	Disable all level correction
12/13	Turn on/off Display	82	Disable attenuator correction
14	Initialize Memory	83-86	Program alternate 24 dB atten
15	Latch test	90/91	Disable/enable ampli fixed-rng
16	Display Option Loading		

SELF TEST RESULTS (Press the [SPCL] [1] [1] keys to display the results)

The self test results are reported in the four display fields as follows:

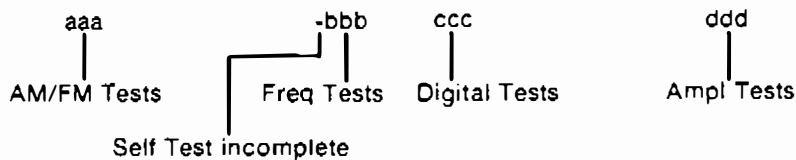

000 000 000 000 indicates all tests passed.

MEMORY

Instrument settings may be stored in locations 01 through 50 and later recalled from Non-Volatile Memory. Location 98 contains the Instrument Preset State.

REV 0 P/N 774260