

Sheet: /  
File: psu.sch

**Title: W7000 PSU Input**

Size: A4 Date: 2021-01-02

KiCad E.D.A. eeschema 5.0.2+dfsg1-1bpo9+1

Rev: 0.1

Id: 1/3

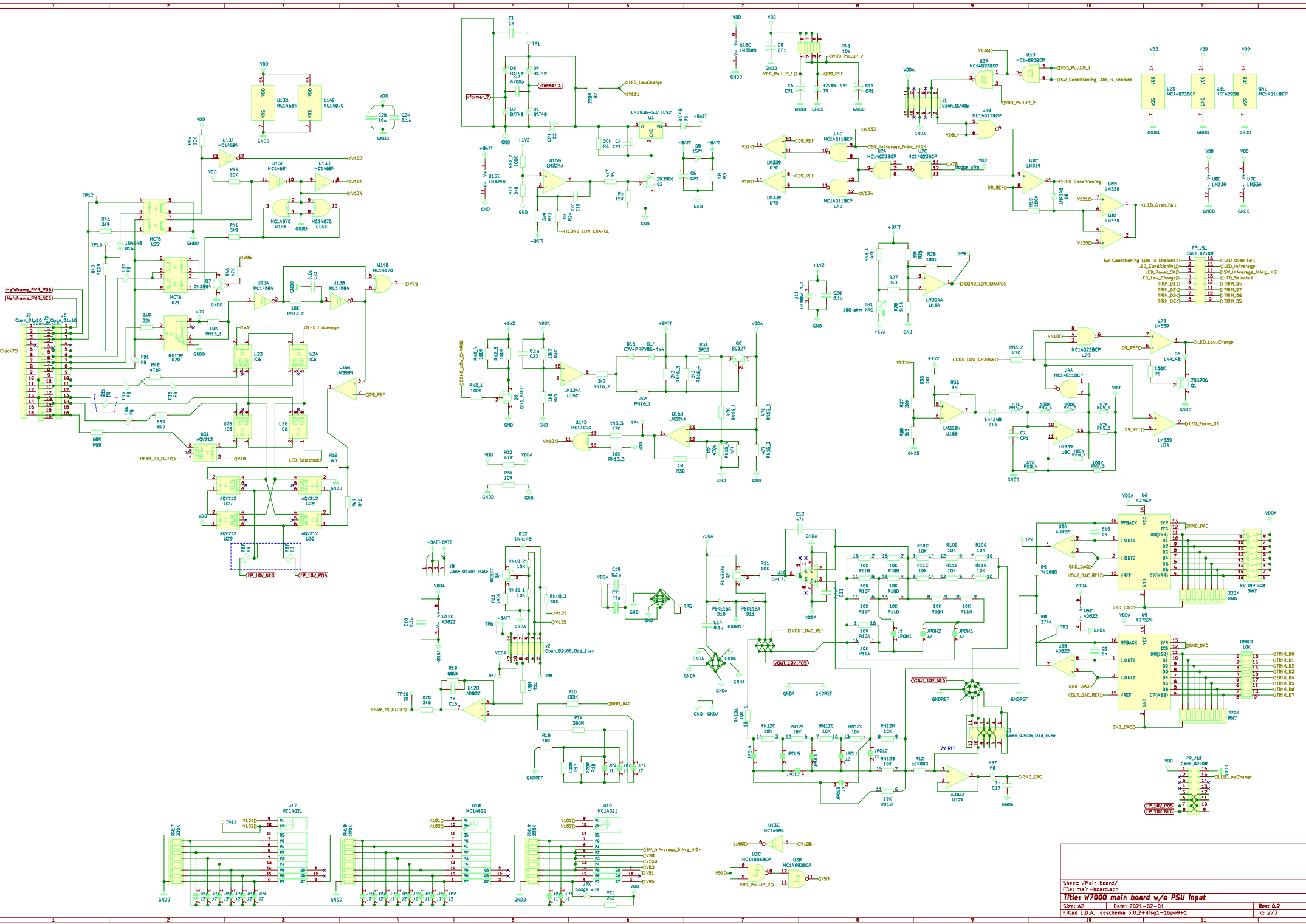

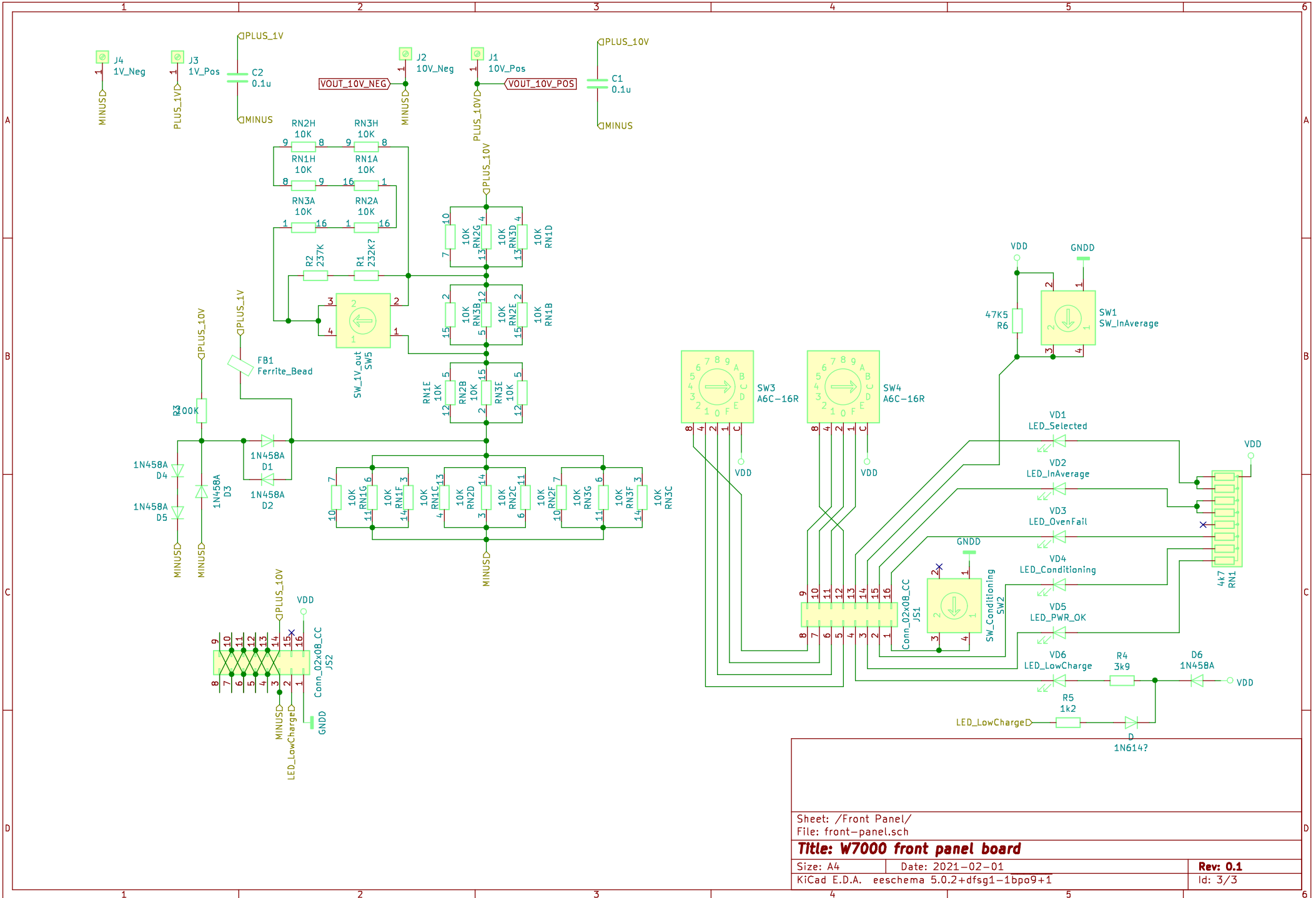

Sheet: /Front Panel/		File: front-panel.sch	
<b>Title: W7000 front panel board</b>			
Size: A4	Date: 2021-02-01		Rev: 0.1
KiCad E.D.A. eeschema 5.0.2+dfsg1-1bpo9+1			Id: 3/3