

FLUKE®

87 V/AN

Digital Multimeter

Service Manual

**Limited permission for the U.S. Government to reproduce Fluke
Item #2153596 is provided pursuant to FAR 52.227.14 Alt. II.**

PN 2153596

July 2004

© 2004 Fluke Corporation, All rights reserved. Printed in USA
All product names are trademarks of their respective companies.

LIMITED WARRANTY AND LIMITATION OF LIABILITY

Each Fluke product is warranted to be free from defects in material and workmanship under normal use and service. The warranty period is one year and begins on the date of shipment. Parts, product repairs, and services are warranted for 90 days. This warranty extends only to the original buyer or end-user customer of a Fluke authorized reseller, and does not apply to fuses, disposable batteries, or to any product which, in Fluke's opinion, has been misused, altered, neglected, contaminated, or damaged by accident or abnormal conditions of operation or handling. Fluke warrants that software will operate substantially in accordance with its functional specifications for 90 days and that it has been properly recorded on non-defective media. Fluke does not warrant that software will be error free or operate without interruption.

Fluke authorized resellers shall extend this warranty on new and unused products to end-user customers only but have no authority to extend a greater or different warranty on behalf of Fluke. Warranty support is available only if product is purchased through a Fluke authorized sales outlet or Buyer has paid the applicable international price. Fluke reserves the right to invoice Buyer for importation costs of repair/replacement parts when product purchased in one country is submitted for repair in another country.

Fluke's warranty obligation is limited, at Fluke's option, to refund of the purchase price, free of charge repair, or replacement of a defective product which is returned to a Fluke authorized service center within the warranty period.

To obtain warranty service, contact your nearest Fluke authorized service center to obtain return authorization information, then send the product to that service center, with a description of the difficulty, postage and insurance prepaid (FOB Destination). Fluke assumes no risk for damage in transit. Following warranty repair, the product will be returned to Buyer, transportation prepaid (FOB Destination). If Fluke determines that failure was caused by neglect, misuse, contamination, alteration, accident, or abnormal condition of operation or handling, including overvoltage failures caused by use outside the product's specified rating, or normal wear and tear of mechanical components, Fluke will provide an estimate of repair costs and obtain authorization before commencing the work. Following repair, the product will be returned to the Buyer transportation prepaid and the Buyer will be billed for the repair and return transportation charges (FOB Shipping Point).

THIS WARRANTY IS BUYER'S SOLE AND EXCLUSIVE REMEDY AND IS IN LIEU OF ALL OTHER WARRANTIES, EXPRESS OR IMPLIED, INCLUDING BUT NOT LIMITED TO ANY IMPLIED WARRANTY OF MERCHANTABILITY OR FITNESS FOR A PARTICULAR PURPOSE. FLUKE SHALL NOT BE LIABLE FOR ANY SPECIAL, INDIRECT, INCIDENTAL, OR CONSEQUENTIAL DAMAGES OR LOSSES, INCLUDING LOSS OF DATA, ARISING FROM ANY CAUSE OR THEORY.

Since some countries or states do not allow limitation of the term of an implied warranty, or exclusion or limitation of incidental or consequential damages, the limitations and exclusions of this warranty may not apply to every buyer. If any provision of this Warranty is held invalid or unenforceable by a court or other decision-maker of competent jurisdiction, such holding will not affect the validity or enforceability of any other provision.

Fluke Corporation
P.O. Box 9090
Everett, WA 98206-9090
U.S.A.

Fluke Europe B.V.
P.O. Box 1186
5602 BD Eindhoven
The Netherlands

11/99

To register your product online, visit register.fluke.com

Table of Contents

Title	Page
Introduction	1
Contacting Fluke	1
Unpacking the Meter.....	2
Inspection.....	2
Inspection Interval	2
Preparations for Use	2
Precautions and Safety Information	2
Electrical Symbols	4
Specifications	5
General Specifications	5
Detailed Specifications	5
Theory of Operation	9
Functional Block Diagram.....	9
Power Supply and Voltage Reference	10
Function Selection and Overload Protection	11
Analog Signal Conditioning	13
VAC.....	13
VDC.....	14
mVDC	14
Temperature.....	14
Ohms Below the 6 M Ω Range.....	14
Ohms in the 6 M Ω & 50 M Ω Range and Siemens in the 60 nS Range....	15
Continuity in all Ohms and the Siemens Ranges.....	15
Capacitance.....	15
Diode Test	15
mA, μ A and AAC.....	15
mA, μ A and ADC.....	16
Active Filter	16
800 Hz Low Pass Filter.....	16
RMS to DC Converter	16
Analog to Digital Converter	17
Secondary Analog Circuits	17
Keypad.....	17
Microprocessor & Support Circuits.....	18
LCD	18

Backlight.....	18
Beeper	18
Troubleshooting	19
Restoration Actions.....	19
Basic Maintenance	19
Cleaning the Meter.....	19
Opening the Meter Case	20
Accessing the PCA and Replacing the LCD.....	21
Reassembling the Meter Case.....	22
Replacing the Battery.....	22
Testing Fuses and Current Circuitry	22
Replacing the Fuses	23
Required Equipment.....	24
Performance Tests	24
Basic Operability Tests	25
Testing the Fuses	25
Testing the Display	25
Testing the Pushbuttons	27
Testing Meter Accuracy.....	27
Calibration Adjustment	29
Calibration Adjustment Counter	29
Calibration Adjustment Password.....	29
Changing the Password	29
Restoring the Default Password	30
Meter Buttons Used in the Calibration Steps.....	31
Calibration Adjustment Procedure.....	31
Service and Parts	33
Schematic Diagrams.....	38

List of Tables

Table	Title	Page
1.	Electrical Symbols.....	4
2.	AC Voltage Function Specifications	6
3.	DC Voltage, Resistance, and Conductance Function Specifications.....	6
4.	Temperature Specifications	6
5.	Current Function Specifications	7
6.	Capacitance and Diode Function Specifications	7
7.	Frequency Counter Specifications.....	7
8.	Frequency Counter Sensitivity and Trigger Levels.....	8
9.	Electrical Characteristics of the Terminals.....	8
10.	MIN MAX Recording Specifications.....	8
11.	Input Path Components	11
12.	Overload Protection Components.....	12
13.	Required Tools and Equipment	24
14.	Display Features	25
15.	Accuracy Tests	27
16.	Calibration Adjustment Steps.....	32
17.	87 V/AN Final Assembly	33
18.	A1 Main PCA.....	35

List of Figures

Figure	Title	Page
1.	87 V/AN Block Diagram.....	10
2.	Opening the Meter, Battery and Fuse Replacement	20
3.	Removing LCD Mask to Access LCD	21
4.	Testing the Current Input Fuses.....	23
5.	Display Features	25
6.	Restoring the Default Password	30
7.	87 V/AN Final Assembly	34
8.	A1 LED PCA.....	39

Introduction

⚠⚠ Warning

To avoid shock or injury:

- Read “Precautions and Safety Information” before performing the verification tests or calibration adjustment procedures documented in this manual.
- Do not perform the verification tests or calibration adjustment procedures described in this manual unless you are qualified to do so.
- The information provided in this manual is for the use of qualified personnel only.

⚠ Caution

- The 87 V/AN Digital Multimeter contains parts that can be damaged by static discharge.
- Follow the standard practices for handling static sensitive devices.

The *87 V/AN Service Manual* provides the following information:

- Safety information
- Specifications
- Theory of operation
- Basic maintenance (cleaning, replacing the battery and fuses)
- Performance test procedures
- Calibration adjustment procedures
- Replaceable parts and schematics

For complete operating instructions, refer to the *87 V/AN Users Manual*.

Contacting Fluke

To contact Fluke or locate the nearest Service Center, call one of the following telephone numbers:

USA: 1-888-44-FLUKE (1-888-443-5853)
Canada: 1-800-36-FLUKE (1-800-363-5853)
Europe: +31 402-675-200
Japan: +81-3-3434-0181
Singapore: +65-738-5655
Anywhere in the world: +1-425-446-5500

Or, visit Fluke's Web site at www.fluke.com.

To register your product, visit register.fluke.com

Unpacking the Meter

Open the Multimeter box. Inside you will find the 87 V/AN Digital Multimeter (hereafter referred to as “the Meter”) the test leads, the *Product Manuals CD*, the printed *87 V/AN User Manual*, and the printed *87 V/AN Service Manual* (this manual). Remove the Meter from its plastic wrapping.

Inspection

Inspect all contents for any visible shipping damage. Look for scratches or any other damage. If the unit is damaged, contact Fluke immediately using the contact information stated previously.

Inspection Interval

Inspect the Meter and test leads before each use.

Warning

To avoid possible electric shock or personal injury, inspect the test leads for damaged insulation or exposed metal. Check the test leads for continuity. Replace damaged test leads before using the Meter.

Preparations for Use

Before using or servicing the Meter, read all associated safety information. Make sure you have complete understanding of all safety issues.

Precautions and Safety Information

In this manual, a **Warning** identifies conditions and actions that pose hazard(s) to the user; a **Caution** identifies conditions and actions that may damage the Meter or the test instruments.

Warning

To avoid possible electric shock or personal injury, follow these guidelines:

- **Use this Meter only as specified in this manual or the protection provided by the Meter might be impaired.**
- **Do not use the Meter if it is damaged. Before using the Meter, inspect the case. Look for cracks or missing plastic. Pay particular attention to the insulation surrounding the connectors.**
- **Make sure the battery door is closed and latched before operating the Meter.**
- **Replace the battery as soon as the battery indicator () appears.**
- **Remove test leads from the Meter before opening the battery door.**
- **Inspect the test leads for damaged insulation or exposed metal. Check the test leads for continuity. Replace damaged test leads before using the Meter.**

- Do not apply more than the rated voltage, as marked on the Meter, between the terminals or between any terminal and earth ground.
- Never operate the Meter with the cover removed or the case open.
- Use caution when working with voltages above 30 V ac rms, 42 V ac peak, or 60 V dc. These voltages pose a shock hazard.
- Use only the replacement fuses specified in this manual.
- Use the proper terminals, function, and range for measurements.
- Avoid working alone.
- When measuring current, turn off circuit power before connecting the Meter in the circuit. Remember to place the Meter in series with the circuit.
- When making electrical connections, connect the common test lead before connecting the live test lead; when disconnecting, disconnect the live test lead before disconnecting the common test lead.
- Do not use the Meter if it operates abnormally. Protection may be impaired. When in doubt, have the Meter serviced.
- Do not operate the Meter around explosive gas, vapor, or dust.
- Use only a single 9 V battery, properly installed in the Meter case, to power the Meter.
- When servicing the Meter, use only specified replacement parts.
- When using probes, keep fingers behind the finger guards on the probes.
- Do not use the Low Pass Filter option to verify the presence of hazardous voltages. Voltages greater than what is indicated may be present. Make a voltage measurement without the filter to detect the possible presence of hazardous voltage, then select the filter function.

⚠ Caution















To avoid possible damage to the Meter or to the equipment under test, follow these guidelines:

- Disconnect circuit power and discharge all high-voltage capacitors before testing resistance, continuity, diodes, or capacitance.
- Before measuring current, check the Meter's fuses. See " Testing Fuses (F1 and F2) ”.

Electrical Symbols

Electrical symbols used on the Meter and in this manual are explained in Table 1.

Table 1. Electrical Symbols

	AC (Alternating Current)		Earth ground
	DC (Direct Current)		Fuse
	Hazardous voltage.		Conforms to European Union directives
	Risk of Danger. Important information. See Manual.		Conforms to relevant Canadian Standards Association directives
	Battery		Double insulated
	Continuity test or continuity beeper tone.		Capacitance
	Underwriters Laboratories		Diode
CAT III	IEC overvoltage category III CAT III equipment is designed to protect against transients in equipment in fixed-equipment installations, such as distribution panels, feeders and short branch circuits, and lighting systems in large buildings.	CAT IV	IEC overvoltage category IV CAT IV equipment is designed to protect against transients from the primary supply level, such as an electricity meter or an overhead or underground utility service.
	Inspected and licensed by TÜV Product Services.		

Specifications

General Specifications

Maximum Voltage between any Terminal and Earth Ground: 1000 V rms

⚠ Fuse Protection for mA or μ A inputs: 44/100 A, 1000 V FAST Fuse

⚠ Fuse Protection for A input: 11 A, 1000 V FAST Fuse

Display: Digital: 6000 counts updates 4/sec. The Meter also has 19,999 counts in high-resolution mode.

Analog Bargraph: 33 segments, updates 40/sec. Frequency: 19,999 counts, updates 3/sec at > 10 Hz.

Temperature: Operating: -20 °C to +55 °C; Storage: -40 °C to +60 °C

Altitude: Operating: 2000 m; Storage: 10,000 m

Temperature Coefficient: 0.05 x (specified accuracy)/ °C (< 18 °C or > 28 °C)

Electromagnetic Compatibility: All ranges unless otherwise noted: In an RF field of 3 V/m total accuracy = specified accuracy + 20 counts

Except: Temperature not specified.

Relative Humidity: 0 % to 90 % (0 °C to 35 °C); 0 % to 70% (35 °C to 55 °C)

Battery Type: 9 V zinc, NEDA 1604 or 6F22 or 006P

Battery Life: 400 hrs typical with alkaline (with backlight off)

Vibration: Per MIL-PRF-28800 for a Class 2 instrument

Shock: 1 Meter drop per IEC 61010-1:2001

Size (HxWxL): 1.25 in x 3.41 in x 7.35 in (3.1 cm x 8.6 cm x 18.6 cm)

Size with Holster and Flex-Stand: 2.06 in x 3.86 in x 7.93 in (5.2 cm x 9.8 cm x 20.1 cm)

Weight: 12.5 oz (355 g)

Weight with Holster and Flex-Stand: 22.0 oz (624 g)

Safety: Complies with ANSI/ISA S82.01-2004, CSA 22.2 No. 1010.1:2004 to 1000 V Overvoltage Category III, IEC 664 to 600 V Overvoltage Category IV. UL listed to UL61010-1. Licensed by TÜV to EN61010-1.

Detailed Specifications

For all detailed specifications:

Accuracy is given as \pm ([% of reading] + [number of least significant digits]) at 18 °C to 28 °C, with relative humidity up to 90 %, for a period of one year after calibration adjustment. In the 4 ½-digit mode, multiply the number of least significant digits (counts) by 10. AC conversions are ac-coupled and valid from 3 % to 100 % of range. The Meter is true rms responding. AC crest factor can be up to 3 at full scale, 6 at half scale. For non-sinusoidal wave forms add -(2 % R_{dg} + 2 % full scale) typical, for a crest factor up to 3.

Tables 2 through 10 list the Meter's detailed specifications.

Table 2. AC Voltage Function Specifications

Function	Range	Resolution	Accuracy					
			45 - 65 Hz	30 - 200 Hz	200 - 440 Hz	440 Hz - 1 kHz	1 - 5 kHz	5 - 20 kHz ¹
\tilde{V} 2,4	600.0 mV	0.1 mV	$\pm (0.7\% + 4)$	$\pm (1.0\% + 4)$	$\pm (1.0\% + 4)$	440 Hz - 1 kHz	$\pm (2.0\% + 4)$	$\pm (2.0\% + 20)$
	6.000 V	0.001 V	$\pm (0.7\% + 2)$				$\pm (2.0\% + 4)^3$	unspecified
	60.00 V	0.01 V					unspecified	unspecified
	600.0 V	0.1 V	unspecified	unspecified	unspecified			
	1000 V	1 V					unspecified	unspecified
	Low pass filter		$\pm (0.7\% + 2)$	$\pm (1.0\% + 4)$	+1 % + 4 -6 % - 4 ⁵	unspecified	unspecified	unspecified

1. Below 10 % of range, add 12 counts.
2. The Meter is a true rms responding meter. When the input leads are shorted together in the ac functions, the Meter may display a residual reading between 1 and 30 counts. A 30 count residual reading will cause only a 2-digit change for readings over 3 % of range. Using REL to offset this reading may produce a much larger constant error in later measurements.
3. Frequency range: 1 kHz to 2.5 kHz.
4. A residual reading of up to 13 digits with leads shorted, will not affect stated accuracy above 3 % of range.
5. Specification increases from -1% at 200 Hz to -6% at 440 Hz when filter is in use.

Table 3. DC Voltage, Resistance, and Conductance Function Specifications

Function	Range	Resolution	Accuracy
\bar{V}	6.000 V	0.001 V	$\pm (0.05\% + 1)$
	60.00 V	0.01 V	$\pm (0.05\% + 1)$
	600.0 V	0.1 V	$\pm (0.05\% + 1)$
	1000 V	1 V	$\pm (0.05\% + 1)$
\bar{mV}	600.0 mV	0.1 mV	$\pm (0.1\% + 1)$
Ω	600.0 Ω	0.1 Ω	$\pm (0.2\% + 2)^1$
	6.000 k Ω	0.001 k Ω	$\pm (0.2\% + 1)$
	60.00 k Ω	0.01 k Ω	$\pm (0.2\% + 1)$
	600.0 k Ω	0.1 k Ω	$\pm (0.6\% + 1)$
	6.000 M Ω	0.001 M Ω	$\pm (0.6\% + 1)$
nS	50.00 M Ω	0.01 M Ω	$\pm (1.0\% + 3)^2$
	60.00 nS	0.01 nS	$\pm (1.0\% + 10)^1$

1. When using the REL Δ function to compensate for offsets.
2. Add 0.5 % of reading when measuring above 30 M Ω in the 50 M Ω range.

Table 4. Temperature Specifications

Temperature	Resolution	Accuracy ^{1,2}
-200 °C to +1090 °C	0.1 °C	1 % + 10
-328 °F to +1994 °F	0.1 °F	1 % + 18



1. Does not include error of the thermocouple probe.
2. Accuracy specification assumes ambient temperature stable to ± 1 °C. For ambient temperature changes of ± 5 °C, rated accuracy applies after 1 hour.

Table 5. Current Function Specifications

Function	Range	Resolution	Accuracy ^{1, 2}	Burden Voltage (typical)
mA A~ (45 Hz to 2 kHz)	60.00 mA	0.01 mA	± (1.0 % + 2)	1.8 mV/mA
	400.0 mA ⁴	0.1 mA	± (1.0 % + 2)	1.8 mV/mA
	6.000 A	0.001 A	± (1.0 % + 2)	0.03 V/A
	10.00 A ³	0.01 A	± (1.0 % + 2)	0.03 V/A
mA A=	60.00 mA	0.01 mA	± (0.2 % + 4)	1.8 mV/mA
	400.0 mA ⁴	0.1 mA	± (0.2 % + 2)	1.8 mV/mA
	6.000 A	0.001 A	± (0.2 % + 4)	0.03 V/A
	10.00 A ³	0.01 A	± (0.2 % + 2)	0.03 V/A
μA ~ (45 Hz to 2 kHz)	600.0 μA	0.1 μA	± (1.0 % + 2)	100 μV/μA
	6000 μA	1 μA	± (1.0 % + 2)	100 μV/μA
μA=	600.0 μA	0.1 μA	± (0.2 % + 4)	100 μV/μA
	6000 μA	1 μA	± (0.2 % + 2)	100 μV/μA

1. AC conversions are ac coupled, true rms responding, and valid from 3 % to 100 % of range, except 400 mA range (5 % to 100 % of range) and 10 A range (15 % to 100 % of range).
2. The Meter is a true rms responding meter. When the input leads are shorted together in the ac functions, the Meter may display a residual reading between 1 and 30 counts. A 30 count residual reading will cause only a 2 digit change for readings over 3 % of range. Using REL to offset this reading may produce a much larger constant error in later measurements
3. Δ 10 A continuous up to 35 °C; < 20 minutes on, 5 minutes off at 35 °C to 55 °C. 20 A for 30 seconds maximum; > 10 A unspecified.
4. 400 mA continuous; 600 mA for 18 hrs maximum.

Table 6. Capacitance and Diode Function Specifications

Function	Range	Resolution	Accuracy
	10.00 nF	0.01 nF	± (1 % + 2) ¹
	100.0 nF	0.1 nF	± (1 % + 2) ¹
	1.000 μF	0.001 μF	± (1 % + 2)
	10.00 μF	0.01 μF	± (1 % + 2)
	100.0 μF	0.1 μF	± (1 % + 2)
	9999 μF	1 μF	± (1 % + 2)
	3.000 V	0.001 V	± (2 % + 1)

1. With a film capacitor or better, using Relative mode to zero residual.

Table 7. Frequency Counter Specifications

Function	Range	Resolution	Accuracy
Frequency (0.5 Hz to 200 kHz, pulse width > 2 μs)	199.99	0.01 Hz	± (0.005 % + 1)
	1999.9	0.1 Hz	± (0.005 % + 1)
	19.999 kHz	0.001 kHz	± (0.005 % + 1)
	199.99 kHz	0.01 kHz	± (0.005 % + 1)
	> 200 kHz	0.1 kHz	unspecified

Table 8. Frequency Counter Sensitivity and Trigger Levels

Input Range ¹	Minimum Sensitivity (RMS Sine wave)		Approximate Trigger Level (DC Voltage Function)
	5 Hz - 20 kHz	0.5 Hz - 200 kHz	
600 mV dc	70 mV (to 400 Hz)	70 mV (to 400 Hz)	40 mV
600 mV ac	150 mV	150 mV	—
6 V	0.3 V	0.7 V	1.7 V
60 V	3 V	7 V (≤ 140 kHz)	4 V
600 V	30 V	70 V (≤ 14.0 kHz)	40 V
1000 V	100 V	200 V (≤ 1.4 kHz)	100 V
Duty Cycle Range	Accuracy		
0.0 to 99.9 %	Within $\pm (0.2\%$ per kHz + 0.1 %) for rise times < 1 μ s.		
1. Maximum input for specified accuracy = 10X Range or 1000 V.			

Table 9. Electrical Characteristics of the Terminals

Function	Overload Protection ¹	Input Impedance (nominal)	Common Mode Rejection Ratio (1 k Ω unbalance)		Normal Mode Rejection					
\bar{V}	1000 V rms	10 M Ω < 100 pF	> 120 dB at dc, 50 Hz or 60 Hz		> 60 dB at 50 Hz or 60 Hz					
\bar{mV}	1000 V rms	10 M Ω < 100 pF	> 120 dB at dc, 50 Hz or 60 Hz		> 60 dB at 50 Hz or 60 Hz					
\tilde{V}	1000 V rms	10 M Ω < 100 pF (ac-coupled)	> 60 dB, dc to 60 Hz							
		Open Circuit Test Voltage	Full Scale Voltage			Typical Short Circuit Current				
	To 6.0 M Ω		50 M Ω or 60 nS		600 Ω	6 k	60 k	600 k	6 M	50 M
Ω	1000 V rms	< 7.5 V dc	< 4.1 V dc	< 4.5 V dc	1 mA	100 μ A	10 μ A	1 μ A	1 μ A	0.5 μ A
\rightarrow	1000 V rms	< 3.9 V dc	3.000 V dc		0.6 mA typical					
1. 10^6 V Hz max										

Table 10. MIN MAX Recording Specifications

Nominal Response	Accuracy
100 ms to 80 % (dc functions)	Specified accuracy ± 12 counts for changes > 200 ms in duration
120 ms to 80 % (ac functions)	Specified accuracy ± 40 counts for changes > 350 ms and inputs > 25 % of range
250 μ s (peak) ¹	Specified accuracy ± 100 counts for changes > 250 μ s in duration (add ± 100 counts for readings over 6000 counts) (add ± 100 counts for readings in Low Pass mode)
1. For repetitive peaks: 1 ms for single events.	

Theory of Operation

This section provides the theory of operation for the 87 V/AN Digital Multimeter to a depth that is required for troubleshooting to the component level. The functional block diagram provides an overview for the description. The schematic diagrams included in the manual are referred to during the following detailed circuit descriptions.

Functional Block Diagram

Figure 1 shows the top-level function block diagram for the Meter. Each of the blocks in this diagram is discussed in detail in the following paragraphs.

The parameter to be measured is connected with test leads to the appropriate two input terminals shown at the left of the block diagram. After the Meter is set to the desired function, the signal is routed to the signal conditioning circuit. Either automatically or manually, a range is selected that puts the signal to be measured within the dynamic range of the analog-to-digital converter (ADC) or other signal conditioning circuits like the RMS-to-DC converter discussed in “RMS to DC Converter”. A scaled AC signal voltage is routed directly, or via an 800-Hz low-pass filter, to the RMS-to-DC converter circuit. A DC input signal or DC output of the RMS-to-DC converter (for AC functions) is routed to a low-pass, 6-Hz, 2-pole active filter to prepare it for ADC measurement. The conditioned analog input signal voltage is converted to a digital value by the ADC and sent to the microprocessor. The microprocessor converts this digital value for display on the LCD based on the function, range and keypad entered options. The output of the signal-conditioning block is also routed to the secondary analog circuits block to be further conditioned for input to the fast ADC contained within the microprocessor block. Other analog circuits that control the behavior of the Meter are located in the secondary analog circuits block and are discussed later.

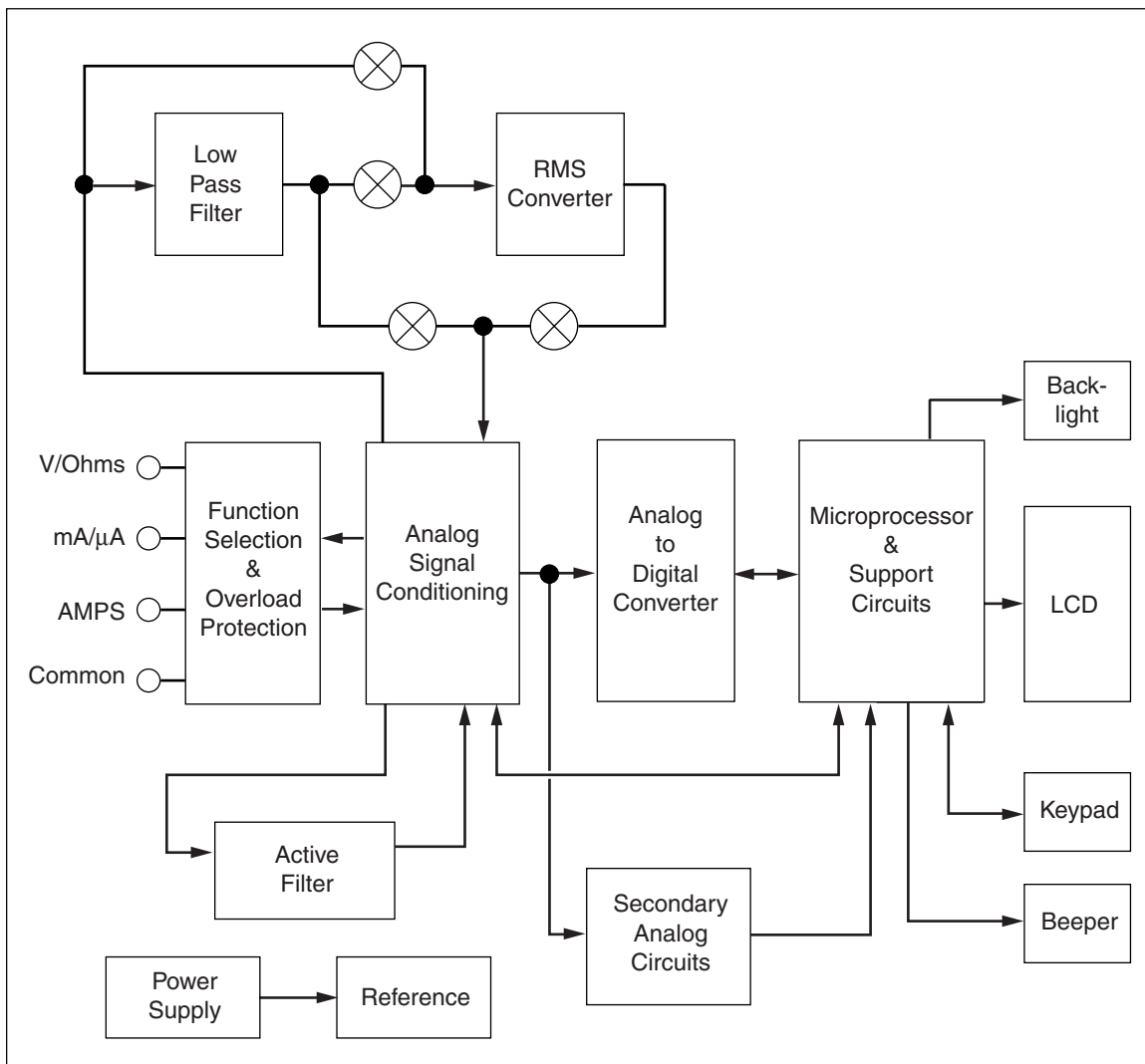

Figure 1. 87 V/AN Block Diagram

Power Supply and Voltage Reference

A 9-V alkaline battery supplies power to the Meter and is connected via a cable assembly to J3 on the A1 printed circuit assembly (PCA). Diode CR3 protects the Meter from damage due to accidental polarity reversal at J3.

Q13 is used as a remote power switch that connects the battery to the power supply regulators when the Meter is turned on. When S1 is in the OFF position, Q14 is off to allow the battery voltage to turn off Q13 via R73. When the Meter is turned on, S1 makes a momentary contact to the battery voltage via R80, turning on Q14, which turns on Q13, which connects the battery voltage to R74, which holds Q14 until S1 is returned to the OFF position.

When Q13 is on, battery voltage is applied to regulators U6 and U10, bypass capacitors C12 and C14 and the low battery detect divider resistors R15 & R16. Note that since the power supply levels are referenced to the COMMON input terminal of the Meter, the negative end of the battery is the -2.5 V power supply.

U6 is a 3.3-V regulator that generates the +0.8-V (-2.5 V + 3.3 V) power supply. U10 is a 5.0-V regulator that generates the +2.5-V (-2.5 V + 5.0 V) power supply. U10 is











enabled and disabled via control line V5* from microprocessor U2. C15 bypasses the output of U10.

When U10 is enabled, 5 V is supplied to the voltage reference U8 input. U8 is a 2.5-V reference with a buffered output and accurately holds the COMMON input 2.5 V above the -2.5 V power supply or at 0 V. The triangular ground symbol represents this reference level throughout the Meter schematic. C16, C57, C50 and R109 bypass the output of U8 keeping the voltage between COMMON and the -2.5 V power supply noise free and stable. C50 and R109 form a low Q bypass that is directed at electromagnetic interference (EMI).

Function Selection and Overload Protection

Sections of rotary switch S1 connect the V/Ohms and mA/μA input jacks to the signal conditioning circuit as required for the respective Meter functions. The Meter schematic symbols for each of the sections of S1 have the functions that correspond to the closed positions listed next to them. Table 11 indicates the components that complete normal operation signal path/paths from input jacks to the required signal conditioning circuit/circuits for each Meter function.

Table 11. Input Path Components

Function	Components
 VAC	RT1, R1, R2, C1, Z1(9.997 M), C43, R94
 VDC	RT1, R1, S1(1,3), Z1(9.997 M)
 mV dc	RT1, R1, S1(1,3), Z1(9.997 M), S1(29,5), R85
 mV dc – HiZ	RT1, R1, S1(29,5), R85
 Temperature	RT1, R1, S1(1,2), R3, S1(29,5), R85, S1(1,3) Z1(9.997M)
 Ohms (Below 6 MΩ)	RT1, R1, S1(1,2), R3, Z2, S1(4,5), R85
 Ohms (6 MΩ, 50 MΩ, nS)	RT1, R1, S1(1,2), R3, S1(1,3), Z1(9.99 7M)
 Continuity (below 6 MΩ)	RT1, R1, S1(1,2), R3, Z2, S1(4,5) R85
 Continuity (6 MΩ, 50 MΩ)	RT1, R1, S1(1,2), R3, S1(1,3), Z1(9.997 M)
 Capacitance	RT1, R1, S1(1,2), R3, Z2, S1(4,5) R85
 Diode Test	RT1, R1, S1(1,2), R3, Z2, S1(4,5), R85

The Meter uses diode clamps, a positive temperature coefficient thermistor, metal oxide varistors (MOVs) and fuses for protection when inadvertent overload conditions are applied across the input terminals. Table 12 shows the components that limit and direct overload currents to prevent damage to the Meter.

Table 12. Overload Protection Components

Function	Components Protected	Protection Components
\tilde{V} VAC	U1 pin 3	Z1(9.997 M), U1-3 clamps
	S1(1,2)(1,3)(29,5)(4,5), Z1(9.997 M)	RT1, R1, RV1, RV2, Z2, RV3
\bar{V} VDC	U1 pin 3	Z1(9.997 M), U1-3 clamps
	S1(1,2)(29,5)(4,5), Z1(9.997 M)	RT1, R1, RV1, RV2, Z2, RV3
$m\bar{V}$, \downarrow mV dc, Temperature	U1 pin 36	RT1, R1, CR10, VR1, CR8, CR9, R3, U1-36 clamps
	U1 pin 3	RT1, R1, CR10, VR1, CR8, CR9, Z1(9.997 M), U1-3 clamps
	U1 pin 1	RT1, R1, CR10, VR1, CR8, CR9, R85, U1-1 clamps
	S1(4,5)	Z2, RV3, RV2, RT1, R1, CR10, VR1, CR8, CR9
Ω , \dashv , \parallel Ohms, Capacitance, Continuity	U1 pin 36	RT1, R1, CR10, VR1, CR8, CR9, R3, U1-36 clamps
	U1 pin 3	RT1, R1, CR10, VR1, CR8, CR9, Z1(9.997 M), U1-3 clamps
	U1 pin 1	Z2, R85, U1-1 clamps
	S1(29,5)	RT1, R1, CR10, VR1, CR8, CR9
\rightarrow Diode Test	U1 pin 36	RT1, R1, CR10, VR1, CR8, CR9, R3, U1-36 clamps
	U1 pin 3	RT1, R1, CR10, VR1, CR8, CR9, R2, C1, Z1(9.997 M), U1-3 clamps
	U1 pin 1	Z2, R85, U1-1 clamps
	S1(1,3)(29,5)	RT1, R1, CR10, VR1, CR8, CR9
Voltage applied to mA/ μ A input jack in any of the above functions or OFF	S1(7,8)(7,6)	F1, CR1, CR2
	U2 pin 3 after F1 opens	R7, CR5
mA/A	R5	F1, CR1, CR2, R6
	U2 pin 3 after F1 opens	R7, CR5
μ A	R4	F1, CR1, CR2
	U2 pin 3 after F1 opens	R7, CR5
Voltage applied to A input jack in any function including OFF	R6	F2 (assuming enough current is available)
	U2 pin 2 after F2 opens	R10, CR6

Internal diodes on each pin of U1 clamp the voltage to a diode drop above or below the power supply levels. Further, U1 power supplies are internally clamped together to prevent overvoltage damage to circuits within U1. U1 pins 1 & 36 have the positive clamp tied to the voltage at CPH (U1 pin 32), which is approximately 5 V above the 2.5-V power supply when the charge pump and current source in U1 are enabled. When an overload voltage is present on the V/Ohms input jack with respect to the COMMON input jack, clamp diodes in U1 conduct enough to drop the offending voltage on resistors that handle the resulting overload current. Additional clamps, CR8, CR9, CR10 and VR1, are used to keep currents from large overload voltages out of U1 pin 36 by safely clamping the voltage at TP6 to approximately +8.9 V and -2.1 V with respect to COMMON. Positive temperature coefficient thermistor, RT1, will aid the safe handling of the overload by increasing in resistance and thereby reducing the overload current being handled by these additional clamps. R1 is a high voltage resistor that drops the overload voltage until RT1 can catch up.

During voltage overload conditions exceeding approximately ± 2 kV at the V/Ohms input jack, the open contacts of S1 need to have the voltage across them kept below the arc-over level. RV1, RV2 & RV3 MOVs will conduct and limit the voltage at TP5 and TP11 to a magnitude of less than 2 kV unless TP5 is connected to TP6 by S1(1,2). The voltage at TP6 will be held by clamps CR8, CR9, CR10 and VR1 as described above with RT1 and the high voltage resistor R1 safely dropping the overload voltage.

During voltage or current overload conditions at the mA/ μ A input jack with the mA/A or μ A Meter function selected, current shunts R4, R5 & R6 and the closed contacts of S1 are protected by F1 opening. CR1 & CR2 limit the voltage at the mA/ μ A input to approximately ± 2.1 V regardless of the Meter function selected, thereby protecting the open or closed contacts of S1 (and the current shunts, if connected) while allowing time for F1 to open.

During voltage or current overload conditions at the A input jack current shunt R6 is protected by F2 opening.

C43 and R94, which are in parallel with Z1 (9.997 M Ω), are used in conjunction with components in the signal conditioning circuit for frequency compensation. C3 reduces input noise in the signal path. R100, R101 & R103 provide a current limited connection to voltages that will minimize the leakage current of CR8, CR9 and CR10, which combines with the input signal creating a temperature-dependent error in the reading.

Inductors L1, L2, L4 & L5 attenuate electromagnetic interference (EMI) and capacitive coupled noise that is picked up by the input circuit and test leads that is passed to the signal conditioning circuit.

The operation of R7, R10, R11, R48, C26, C31, CR5 and CR6 is described in “Secondary Analog Circuits”.

Analog Signal Conditioning

U1 provides the switching that is necessary for range selection, the operational amplifiers that are used for buffering and filtering, various current source values and various voltage comparator functions, which are required to transform the input signal to a representation that can be measured and quantified.

VAC

The V/Ohms input is connected, as described in Table 11, to DIV_A (U1 pin 3) and routed by U1 internal switches to the inverting input of an internal operational amplifier. The overall gain to ACAMP_O (U1 pin 22) is set by the total resistance to the inverting input from the V/Ohms input, the selected range resistor in Z1, R105, R12 and R8. U1 works in conjunction with C43 & R94 to compensate the frequency response of this path. The signal at ACAMP_O is, therefore, a scaled representation of the AC input signal

within the band pass specification of the Meter. The signal at ACAMP_O is routed to the Low-Pass Filter and/or the RMS Converter using multiplexer U12. The output of Low-Pass Filter or the RMS Converter is routed back into CONV_IN (U1 pin13), filtered, buffered and passed to FE_O (U1 pin 19) ready for measurement. If the Hz function is selected, the scaled voltage at ACAMP_O is also routed within U1 to comparators that will produce a digital signal at COMP_O (U1 pin 24) ready for frequency measurement.

VDC

The V/Ohms input is connected, as described in Table 11, to DIV_A (U1 pin 3) and routed by U1 internal switches to one of the other resistors in the Z1 network to be divided. The divided voltage is filtered, buffered and passed to FE_O (U1 pin19) ready for measurement. If the operator selects the Hz function, the signal is routed within U1 to comparators that will produce a digital signal at COMP_O (U1 pin 24) ready for frequency or duty cycle measurement.

mVDC

The V/Ohms input is connected, as described in Table 11, to SENSE_HI (U1 pin 1) and routed by U1 internal switches to be filtered, buffered and passed to FE_O (U1 pin19) ready for measurement. The resistor Z1 (9.997 M Ω), is used to provide a 10 M Ω impedance across the Meter V/Ohms to COMMON input jacks by connecting DIV_A (U1 pin 3) to R3 (U1 pin 9), which in turn is connected to COMMON by Z1 (440.4 Ω) and R8. This connection is opened by U1 when the HiZ input power up option is selected. If the operator selects the Hz function, the signal is routed within U1 to comparators that will produce a digital signal at COMP_O (U1 pin 24) ready for frequency or duty cycle measurement.

Temperature

The V/Ohms input is connected the same as in mVDC to FE_O (U1 pin 19) with the exception that U1 provides a gain of 10 to the signal. Another measurement of the temperature of the input terminals where the thermocouple wire transitions to copper is required to calculate the actual temperature sensed by a thermocouple. Since U1 is controlled by the microprocessor, this measurement is done by routing two different values of current from the U1 current source via RJT_I (U1 pin 35) to Q3 and the resulting VBE is routed, buffered and passed to the FE_O (U1 pin 19) ready for measurement. The reference junction temperature is calculated from these measurements. Inductor L2 and capacitor C2 keep noise out of the measurement circuitry. Since thermocouples are easily broken and give incorrect readings, a periodic test of the thermocouple is required. A current from the U1 current source is routed to ISRC (U1 pin36) and on to the thermocouple that is connected from V/Ohms to COMMON. The resulting voltage drop across the thermocouple is connected to the U1 internal comparators and converted to a digital signal at COMP_O (U1 pin 24) ready for evaluation by the microprocessor.

Ohms Below the 6 M Ω Range

The U1 current source is enabled and routed to ISRC (U1 pin 36) and on to the V/Ohms input jack, which is also connected to SENSE_HI (U1 pin 1) via the components indicated in Table 11. SENSE_HI is routed by U1 internal switches, filtered, buffered and passed to FE_O (U1 pin19) ready for measurement. Resistor R51 sets the reference for the 1 mA and 100 μ A U1 current-source currents. Resistor R52 sets the reference for the 10 μ A, 1 μ A and 0.5 μ A U1 current source currents. Capacitors C4 and C5 are used by the U1 current source charge pump to set the available compliance voltage at ISRC to 7.5 V with respect to COMMON. The 0.5- μ A current source is not used for resistor measurements in these ranges. If the operator selects the Hz function, the signal is

routed within U1 to comparators that will produce a digital signal at COMP_O (U1 pin 24) ready for frequency or duty cycle measurement.

Ohms in the 6 MΩ & 50 MΩ Range and Siemens in the 60 nS Range

The U1 current source is enabled and routed to ISRC (U1 pin 36) and on to the V/Ohms input jack, which is also connected to DIV_A (U1 pin 3) via the components indicated in Table 11. DIV_A is routed by U1 internal switches to R0 (U1 pin 5) and on to Z1 (1.106 MΩ) to divide the sensed voltage by 10. The divided voltage is filtered, buffered with a gain of two, and passed to FE_O (U1 pin19) ready for measurement. Only the 1 μA and 0.5 μA current sources are used in these ranges. If the operator selects the Hz function, the signal is routed within U1 to comparators that will produce a digital signal at COMP_O (U1 pin 24) ready for frequency or duty cycle measurement.

Continuity in all Ohms and the Siemens Ranges

The same measurement paths discussed above apply with the exception that the filtering is turned off to speed up the circuit response and the signal at FE_O (U1 pin 19) is routed to U1 comparators, which convert it to a digital signal at CONT_O (U1 pin 24) ready for evaluation by the microprocessor.

Capacitance

The U1 current source is enabled and internally routed to COMMON. ISRC (U1 pin 36) is routed to the V/Ohms input, which is also connected to SENSE_HI (U1 pin 1) via the components indicated in Table 11. The voltage signal at SENSE_HI is internally routed in U1 to the comparators converted to a digital signal at COMP_O (U1 pin 24) ready for evaluation by the microprocessor, buffered and passed on to FE_O (U1 pin 19) ready for measurement. The capacitor is discharged to below a value set on the comparator via ISRC (U1 pin 36), which is connected to COMMON or the negative voltage rail depending on how much voltage is on the capacitor being measured. Once the capacitor is discharged sufficiently, current is applied to it in accurately measured packets until the U1 comparator signals that the capacitor under test has been sufficiently charged. By measuring the voltage at discharge and after charge the value of the capacitor is calculated by the microprocessor.

Diode Test

The U1 1-mA current source is enabled and routed to ISRC (U1 pin 36) and on to the V/Ohms input, which is also connected to SENSE_HI (U1 pin 1) via the components indicated in Table 11. SENSE_HI is routed by U1 internal switches to R1 (U1 pin 7) and on to Z1 (110.01 kΩ) & R8 which form 10-to-1 divider with Z2. The divided voltage signal is filtered, buffered with a gain of two and passed to FE_O (U1 pin19) ready for measurement.

mA, μA and AAC

The mA/μA input and the A input are connected to R4 (U1 pin 10) as described in Table 11. The voltage at R4 is proportional to the product of the current being measured and the shunt resistance that is in use. The voltage at R4 is routed by U1 internal switches to the inverting input of an internal operational amplifier. The overall gain to ACAMP_O (U1 pin 22) is set by the total resistance from the shunt in use to the inverting input, either resistor Z1(1.106 MΩ) or Z1(110.01 kΩ), R105, R12 & R8. The signal at ACAMP_O is, therefore, a scaled representation of the AC current input signal. The signal at ACAMP_O is routed to either the Low-Pass Filter or the RMS Converter or both using multiplexer U12. The output of the Low-Pass Filter or the RMS Converter is routed back into CONV_IN (U1 pin13), filtered, buffered with a gain of two and passed to FE_O (U1 pin 19) ready for measurement. If the operator selects the Hz function, the

scaled voltage at ACAMP_O is also routed within U1 to comparators that will produce a digital signal at COMP_O (U1 pin 24) ready for frequency measurement.

mA, μ A and ADC

The mA/ μ A input and the A input are connected to R4 (U1 pin 10) as described in Table 11. The voltage at R4 is proportional to the product of the current being measured and the shunt resistance that is in use. The voltage at R4 is routed by U1 internal switches, filtered, buffered with a gain of 1 or 10 depending upon the range selected and passed to FE_O (U1 pin 19) ready for measurement. If the Hz function is selected, the signal at FE_O is also routed within U1 to comparators that will produce a digital signal at COMP_O (U1 pin 24) ready for frequency or duty-cycle measurement.

The U1 buffer amplifier connected to FE_O (U1 pin 19) is zeroed digitally by the microprocessor. The voltage at ZERO_IN (U1 pin 14) is routed by U1, buffered with the selected gain and passed on to FE_O ready for measurement.

Active Filter

C9, C10, R17 & R18 are used in conjunction with an operational amplifier internal to U1 to form a low-pass active filter. This configuration produces the equivalent of two cascaded filters, each at approximately 6 Hz. R18 is bypassed by switches in U1 when the input impedance of the range voltage divider is above 1 M Ω .

800 Hz Low Pass Filter

R86, R87, R88, C36, C37, C38 & U4 form an 800-Hz low-pass filter (three pole Butterworth) that can be selected in the VAC function. This filter is used to stop high frequency noise such as that encountered in motor drive controllers from passing on to the measurement circuits. The A switch of multiplexer U12 is used to select between either the input or output of this filter as an input to the RMS Converter. The B switch of multiplexer U12 can select the output of this filter for input to CONV_IN (U1 pin 13) and bypass the RMS Converter when the Frequency function or **PEAK MIN MAX** option is selected.

RMS to DC Converter

C6, U7 & C7 form the RMS-to-DC conversion circuit. C33 & C35 are RF-bypass capacitors. C32 & C34 are power-supply bypass capacitors for U7. R29, R30, R32, R33, Q6 & Q7 form the power-control circuit for U7.

The selected AC signal at the A output of U12 is passed to U7 pin 1 via DC-blocking capacitor C6. U7, with the aid of the averaging capacitor C7 on pin 5, produces a DC output at pin 6 that is proportional to the RMS of the input.

U7 is powered on and off as needed for the selected Meter function by the microprocessor controlling the AC* signal. When AC* is driven to a logic high (+0.8 V), Q6 is turned on, turning on Q7, which connects the positive end of the battery (6 V minimum) to the pin 3 of U7, thereby powering it down. When AC* is driven to a logic low (-2.5 V), transistor Q6 is turned off, turning off Q7, which allows U7 pin 3 to be pulled to +0.8 V through R33, thereby allowing Q7 to power on.

Analog to Digital Converter

U3 is a 20-bit $\Sigma\Delta$ analog-to-digital converter (ADC). C21 & C22 are power-supply bypass capacitors. The DC signal at FE_O (U1 pin 19) provides the signal input for U3. The reference for conversion is supplied by U8 as described in 1.3 to the REF and VIN* (compliment of VIN) inputs. Since REF* (compliment of REF) is tied to -2.5 V and both pairs of inputs to U3 are handled differentially, the dynamic range of the VIN is ± 1.25 V around COMMOM. The microprocessor U2 uses three digital lines to communicate with U3. U3 signals the microprocessor U2 that a conversion is completed by pulling the SDO signal line to logic low (-2.5 V), which is coupled through current limiting resistor R31 to DOUT. When U2 is ready for the reading, it pulls ADCS* of U3 to a logic low and clocks the data serially out of SDO with the signal ADSCK applied to SCK. Connecting F0 of U3 to -2.5 V sets the internal clock so that the normal mode rejection ratio (NMRR) of the digital filter will provide adequate rejection of both 50 Hz and 60 Hz.

Secondary Analog Circuits

Several secondary analog circuits are used to provide signals to a 12-bit, 200 kilo samples per second (ksps) (8000 sps is the highest rate used) analog to digital converter (ADC) with eight multiplexed-inputs in U2.

R7, R48 C31 & CR5 form a circuit that determines whether a plug is inserted into the mA/ μ A input jack. The signal MAJACK is held at -2.5 V via R48 if the split-jack J1 is not shorted by a plug. When a plug shorts split-jack J1, current will flow through R7 and the MAJACK signal is pulled to near COMMON via R28 or R4 and/or R5. MAJACK is measured by U2 to determine if the function selected by the rotary switch S1 is in conflict with the Meter inputs. C31 suppresses high frequency noise. Diode CR5 provides protection in case F1 is open. R10, R11, C26 & CR6 provide the same function for the **A** input with the COMMON connection via R6.

R97 & R98 allow the Meter model and possible revision number to be read by the microprocessor U2 as an analog signal over the single signal path MODEL.

R34, R35, R36, R37, C56 & U4 form a buffer and analog level shifter for allowing the ADIN signal to be sampled by the faster U2 ADC. This ADC is used for auto-ranging, for bar graph readings and **PEAK MIN MAX**. R34 and R35 set the DC gain at the output of U4 to 2. Since the dynamic range of ADIN is ± 1.25 , the signal at the U4 output is ± 2.5 V. Since R36 and R37 form a voltage divider referenced to -2.5V, the signal at FASTADIN has a dynamic range of -2.5V to 0 V with respect to COMMON. C56 provides a band-limited response to the higher frequencies contained in signals that are being evaluated for **PEAK MIN MAX**. C39 bypasses U4 power supplies.

S1, R22, R53, R54, R55, R58, R59, R60, R61, R84 & C20 allow the position of the rotary switch S1 to be read by the microprocessor U2 as an analog signal over the signal path SWPOS. U2 reads the position of S1 by pulling the SWPWR signal to logic high (+0.8V) and reading the signal at SWPOS. The voltage divider formed by R61, R60, R59, R58, R55, R54, R53 & R84 creates a signature voltage for each switch position of S1. R22 will pull this voltage down slightly when the divider taps are connected, but will pull the SWPOS voltage to -2.5 V when S1 is between switch positions. C20 suppresses noise.

R15 & R16 form a voltage divider to allow the battery voltage to be monitored via signal LOWBATT. C28 suppresses noise.

Keypad

R40, R43, R68, S3, S4, S5, S6, S7, S8, S9, S10 & S11 form the buttons that allow access to Meter functions that are not selected by rotary switch S1. The microprocessor U2 is connected to 9 switches with three strobe lines PB4, PB5 & PB6 to three switches each. The other end of each switch is pulled to +0.8 V by R40, R43 or R68 and connected to