

A40B

Precision AC Current Shunt Set

Instruction Manual

LIMITED WARRANTY AND LIMITATION OF LIABILITY

Each Fluke product is warranted to be free from defects in material and workmanship under normal use and service. The warranty period is one year and begins on the date of shipment. Parts, product repairs, and services are warranted for 90 days. This warranty extends only to the original buyer or end-user customer of a Fluke authorized reseller, and does not apply to fuses, disposable batteries, or to any product which, in Fluke's opinion, has been misused, altered, neglected, contaminated, or damaged by accident or abnormal conditions of operation or handling. Fluke warrants that software will operate substantially in accordance with its functional specifications for 90 days and that it has been properly recorded on non-defective media. Fluke does not warrant that software will be error free or operate without interruption.

Fluke authorized resellers shall extend this warranty on new and unused products to end-user customers only but have no authority to extend a greater or different warranty on behalf of Fluke. Warranty support is available only if product is purchased through a Fluke authorized sales outlet or Buyer has paid the applicable international price. Fluke reserves the right to invoice Buyer for importation costs of repair/replacement parts when product purchased in one country is submitted for repair in another country.

Fluke's warranty obligation is limited, at Fluke's option, to refund of the purchase price, free of charge repair, or replacement of a defective product which is returned to a Fluke authorized service center within the warranty period.

To obtain warranty service, contact your nearest Fluke authorized service center to obtain return authorization information, then send the product to that service center, with a description of the difficulty, postage and insurance prepaid (FOB Destination). Fluke assumes no risk for damage in transit. Following warranty repair, the product will be returned to Buyer, transportation prepaid (FOB Destination). If Fluke determines that failure was caused by neglect, misuse, contamination, alteration, accident, or abnormal condition of operation or handling, including overvoltage failures caused by use outside the product's specified rating, or normal wear and tear of mechanical components, Fluke will provide an estimate of repair costs and obtain authorization before commencing the work. Following repair, the product will be returned to the Buyer transportation prepaid and the Buyer will be billed for the repair and return transportation charges (FOB Shipping Point).

THIS WARRANTY IS BUYER'S SOLE AND EXCLUSIVE REMEDY AND IS IN LIEU OF ALL OTHER WARRANTIES, EXPRESS OR IMPLIED, INCLUDING BUT NOT LIMITED TO ANY IMPLIED WARRANTY OF MERCHANTABILITY OR FITNESS FOR A PARTICULAR PURPOSE. FLUKE SHALL NOT BE LIABLE FOR ANY SPECIAL, INDIRECT, INCIDENTAL, OR CONSEQUENTIAL DAMAGES OR LOSSES, INCLUDING LOSS OF DATA, ARISING FROM ANY CAUSE OR THEORY.

Since some countries or states do not allow limitation of the term of an implied warranty, or exclusion or limitation of incidental or consequential damages, the limitations and exclusions of this warranty may not apply to every buyer. If any provision of this Warranty is held invalid or unenforceable by a court or other decision-maker of competent jurisdiction, such holding will not affect the validity or enforceability of any other provision.

Fluke Corporation
P.O. Box 9090
Everett, WA 98206-9090
U.S.A.

Fluke Europe B.V.
P.O. Box 1186
5602 BD Eindhoven
The Netherlands

11/99

To register your product online, visit <http://register.fluke.com>

Table of Contents

Title	Page
Introduction and Specifications	1
About the Manual	1
Safety Information	1
General Safety Summary	1
Symbols	3
Product Description	4
Electrical Specifications.....	5
Current Shunt Basic Specification	5
Resistance Specifications.....	6
Maximum AC-DC Difference at time of Manufacture	7
Maximum Overload Current	7
Typical Phase Displacement	7
General Specifications	8
Dimensions (maximum).....	8
Physical/Mechanical Parameters	8
Operating Environment.....	8
Safety	8
Storage and Transit Environments (for models other than the 1 mA Current Shunt).....	8
Additional 1 mA Current Shunt Specifications.....	8
Preparing for Operation	9
Unpacking and Inspecting the Shunts	9
Accessories	9
Table.....	9
How to Contact Fluke Calibration	10
Shipping Information.....	10
Storage Information	10
Acceptance Test.....	10
General Maintenance/Cleaning	11
Operating Information.....	11
Feature Descriptions	11
Input/Output Connectors	13
Maximum Current	14
Operating Environment.....	14
Correcting for Current Shunt Error Contributions	14
Output Voltage Measurement Using a Fluke Calibration 5790B	15

Output Voltage Measurement – Loading Effect.....	15
Output Voltage Measurement Using a Fluke Calibration 5790A	16
Output Voltage Measurement Using a Fluke Calibration 8508A	17
Operating Instructions	18
Introduction.....	18
Measuring Current.....	18
Direct Read-out When Measuring Current	20
Theory of Operation	20
Coaxial Shunts	21
Boxed Shunts	22
Introduction.....	22
An Overview of Calibration Methods	22
Potential Voltage Measurement Devices.....	23
DC Considerations	24
AC Considerations.....	25
The Fluke Calibration Method	26
Recommended Tools and Equipment	27
System Calibration for AC-DC Difference	27
TVC Sensitivity Characterization	28
UUT AC-DC Difference Measurement Sequence and Calculations	29
Current Source DC Noise	30
UUT DC Resistance Measurement	30
Repair Procedures Including Disassembly and Reassembly	31
Repair Limits.....	31
List of Tools Required for Repair.....	32
End Plates and Guard Binding Post Replacement (Coaxial Shunts)	32
Input N-type Connector Replacement (Coaxial Shunts).....	33
Output N-Type Connector Replacement (Coaxial Shunts).....	35
Verification of Operation after Repair	35
List of Replaceable Parts	36

List of Tables

Table	Title	Page
1.	Contents of the Current Shunt Set Packaging	9
2.	A40B Accessories	9
3.	Features and Connectors	13
4.	Typical Loading Effect of a 5790B, 2.2 V Range.....	15
5.	Typical Loading Effect of a 5790A, 2.2 V Range.....	16
6.	Typical Loading Effect of an 8508A 2 V ACV Range	17
7.	Estimating the Uncertainty of a 5790B Measurement	19
8.	Sample Calculation of Measured Current	20
9.	Single Junction Thermal Voltage Converters	23
10.	Fluke Calibration 792A AC/DC Transfer Standard.....	23
11.	Fluke Calibration 5790A/B Measurement Standard	24
12.	Other Error Sources and Solutions	25
13.	List of Recommended Equipment	27
14.	Final Assembly	36

List of Figures

Figure	Title	Page
1.	Current Shunt Configurations	4
2.	Features and Connectors	12
3.	Loading Effect of the Measurement Device	16
4.	Current Shunt - Simplified Electrical Diagram	21
5.	Circuit Using a Reference Shunt Resistor to Determine Source Current ..	22
6.	Sources of Error in AC Measurements.....	25
7.	The Fluke Calibration System	26
8.	Calibrating Gain Difference	27
9.	Characterizing Sensitivity	28
10.	AC/DC Difference Sequence.....	29
11.	Exploded View of a Shunt	33
12.	N Type Input Current Connector	34
13.	Output Voltage Connector	35
14.	Final Assembly – Typical Current Shunt from the Set.....	36

Introduction and Specifications

About the Manual

This is the Instruction Manual for the A40B Precision AC Current Shunt Set (hereafter referred to as the Current Shunt, Current Shunts, or Product). It contains all of the information a Calibration Technician needs to operate and maintain the Current Shunts. The manual is divided into the following sections:

- Introduction and Specifications
- Preparing for Operation
- Operation Instructions
- Theory of Operation
- Service Instructions

Safety Information

This section addresses safety considerations and describes symbols that may appear either in this manual or on the Current Shunts.

A **Warning** identifies conditions and procedures that are dangerous to the user. A **Caution** identifies conditions and procedures that can cause damage to the Product or the equipment under test.

Warning

To prevent electrical shock, personal injury, or death, carefully read the information under *General Safety Summary* before attempting to install, use, or service the Current Shunts.

General Safety Summary

This manual contains information and warnings that must be observed to keep the Current Shunts in a safe condition and ensure safe operation. Using or servicing the Current Shunts in conditions other than as specified in the Instruction Manual could compromise your safety.

To use the Current Shunts correctly and safely, read and follow the precautions on the next few pages, as well as, the safety instructions or warnings given throughout this manual. In addition, follow all generally accepted safety practices and procedures when working with and around electricity.

⚠⚠ Warning













To prevent possible electrical shock, fire, or personal injury, or death:

- Read all safety information before you use the Product.
- Use the Current Shunts only as specified in this manual.
- To avoid damage to eyes, skin, and the respiratory system, do not significantly exceed the maximum current rating of a shunt. Doing so may cause tracks on the printed circuit boards to vaporize. (See Maximum Overload Current in the Electrical Specifications.)
- Do not use the Product around explosive gas, vapor, or in damp or wet environments.
- Examine the case before you use the Product. Look for cracks or missing plastic. Carefully look at the insulation around the terminals.
- Do not use the Product if it is damaged.
- Do not use the Product if it operates incorrectly.
- Do not use test leads if they are damaged. Examine the test leads for damaged insulation and measure a known voltage.
- Use Product-approved measurement category (CAT), voltage, and amperage rated accessories (probes, test leads, and adapters) for all measurements.
- Do not connect directly to mains.
- Limit operation to the specified measurement category, voltage, or amperage ratings.
- Have the Current Shunts serviced only by qualified service personnel.
- When servicing the Current Shunts, use only specified replacement parts.
- Do not touch voltages > 30 V ac rms, 42 V ac peak, or 60 V dc.
- Only use probes, test leads, and accessories that have the same measurement category, voltage, and amperage ratings as the Product.
- Do not put battery cells and battery packs near heat or fire. Do not put in sunlight.
- Remove the batteries if the Product is not used for an extended period of time, or if stored in temperatures above 50 °C. If the batteries are not removed, battery leakage can damage the Product.

- If batteries are removed from the Shunt, ensure they are re-inserted with the correct polarity.
- Use only the battery charger provided to charge the 1 mA active shunt.
- Always connect the Battery Charger / Power Adapter to the AC outlet before connecting it to the shunt.
- When replacing the batteries, replace them all together. Use only Nickel Metal Hydride (NiMH) batteries.
- Do not operate the batteries together with other types of batteries, or batteries with different charge levels.
- The batteries in the 1 mA Current Shunt are always connected to the charging socket, even when the Current Shunt is turned off.

Symbols

The following safety and electrical symbols may appear on the Current Shunt or in this manual.

Symbol	Description	Symbol	Description
	WARNING. RISK OF DANGER.		Consult user documentation.
	WARNING. HAZARDOUS VOLTAGE. Risk of electric shock.		DC (Direct Current)
	Power Off setting		WARNING. HOT SURFACE. Risk of burns.
	Power on setting		Earth
	Conforms to European Union directives.		Chassis ground
	This product complies with the WEEE Directive marking requirements. The affixed label indicates that you must not discard this electrical/electronic product in domestic household waste. Product Category: With reference to the equipment types in the WEEE Directive Annex I, this product is classed as category 9 "Monitoring and Control Instrumentation" product. Do not dispose of this product as unsorted municipal waste.		Recycle

Product Description

The A40B Precision AC Current Shunt Set consists of 14 Current Shunts, adapters, and a rugged transit/storage case. The Current Shunts are designed for laboratory use in making AC-DC current measurements or absolute AC or DC current measurements. They exhibit outstanding resistance value stability, excellent self-heating power coefficient, and a low temperature coefficient. Five configurations of Current Shunts comprise the set. They are as follows:

- One boxed *active* shunt 1 mA
- Three boxed passive shunts 10 mA, 20 mA 50 mA
- Five small size coaxial shunts 100 mA, 200 mA, 500 mA, 1 A, 2 A
- Three medium size coaxial shunts 5A, 10 A, 20 A
- Two large size coaxial shunts 50 A, 100 A

The physical construction and the components used in the Current Shunts ensure that amplitude displacement (error relative to DC resistance) and phase displacement at 100 kHz are small enough to be neglected in all but the highest accuracy measurements.

Voltage output is nominally 0.8 V for full-scale current input. The sizes of the current shunts vary depending on the current range. A few examples of the different current shunts are shown in Figure 1.

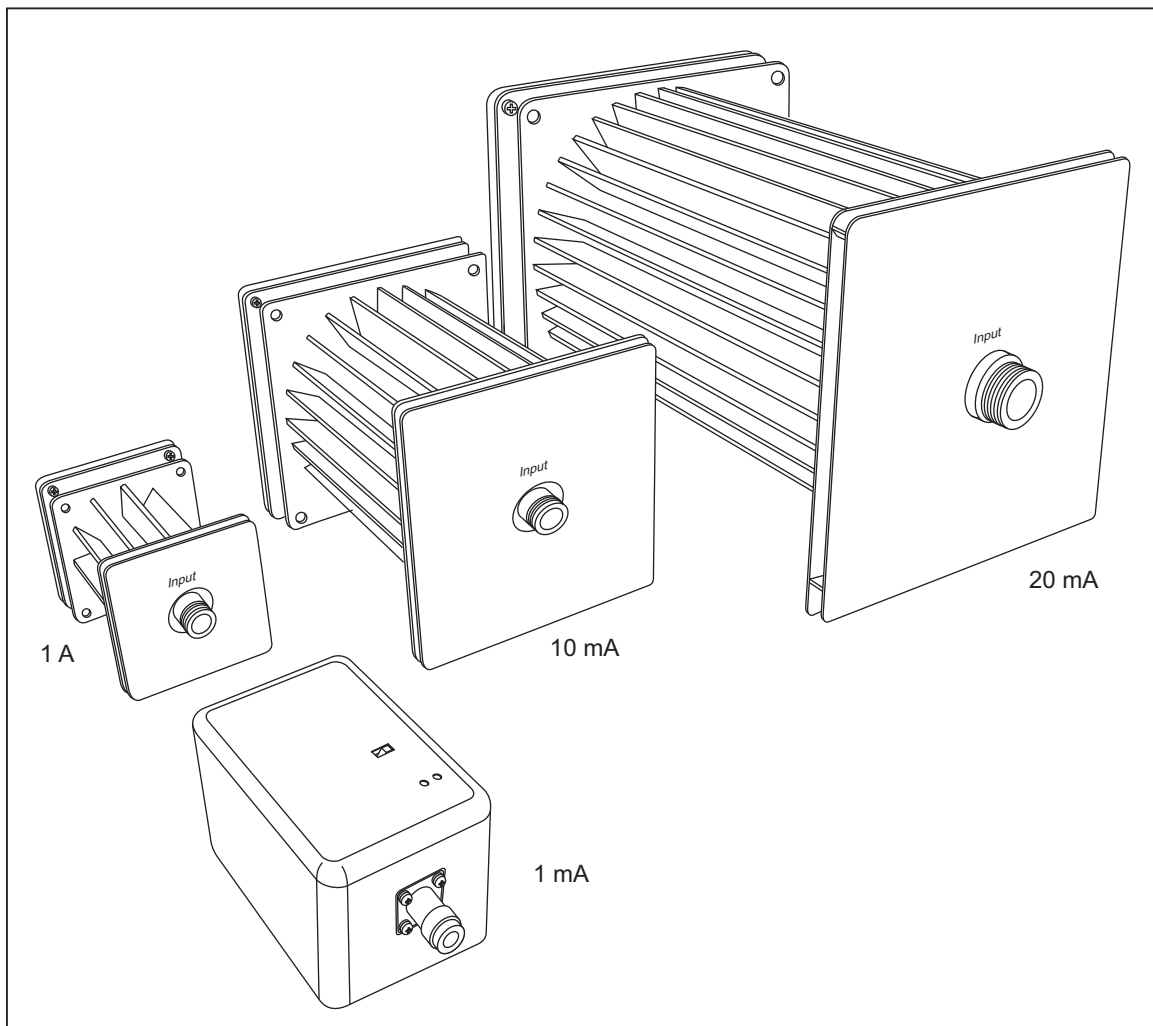

Figure 1. Current Shunt Configurations

fim002.eps

Electrical Specifications

Current Shunt Basic Specification

These devices are precision calibration reference standards. In order to attain the best performance of the product, the end-user should develop an uncertainty analysis based on their particular use. The uncertainty analysis should include stability of the device over time (usually much better than the specification), humidity and temperature effects for the laboratory, measurement uncertainty of the calibrated value at DC and the uncertainty of the AC-DC difference correction

When the best performance of the product is not needed, the following table provides an approximate uncertainty stated at k=2, approximately 95 % confidence for the calibrated value. The approximate uncertainty includes 1 year stability, temperature effects over TCal ± 1 °C, and the measurement uncertainty of the calibrated value.

Shunt Nominal Current	Nominal Resistance (Ohms)	Basic Specification ±μA/A, TCal ±1 °C, ≤50 % RH ^{[1][2][3][5]}				
		DC	1 kHz	10 kHz	30 kHz	100 kHz
1 mA ^[4]	800	20	55	75	75	150
10 mA	80	20	26	26	26	26
20 mA	40	20	26	26	26	26
50 mA	16	20	23	23	23	23
100 mA	8	20	24	24	24	24
200 mA	4	20	26	26	26	26
500 mA	1.6	21	27	27	27	28
1 A	0.8	21	27	28	28	31
2 A	0.4	21	27	30	30	48
5 A	0.16	21	31	32	40	71
10 A	0.08	26	37	60	61	92
20 A	0.04	26	43	52	70	113
50 A	0.016	32	55	80	81	144
100 A	0.008	35	65	90	98	174

[1] The measured current is determined from:
 $I = (V/R_{\text{calibrated}}) \times (1 + (\text{AC-DC}_{\text{calibrated}} / 1,000,000))$; where AC-DC_{calibrated} is expressed in μA/A

[2] Above 1 kHz interpolate the specification (s) between frequencies f_{upper} and f_{lower} using:

$$S_i = S_{\text{lower}} + (f_i - f_{\text{lower}}) \times (S_{\text{upper}} - S_{\text{lower}}) \div (f_{\text{upper}} - f_{\text{lower}})$$

[3] Add 20 μA/A if relative humidity is outside specification limits.

[4] 1 mA specifications apply with the battery charger disconnected.

[5] Specifications assume no loading effects due to the voltage-sensing device. See *Output Voltage Measurement - Loading Effects* in the operating information.

Resistance Specifications

Shunt Nominal Current	Nominal Resistance (Ohms)	Maximum Deviation from Nominal Resistance ($\pm\mu\Omega/\Omega$) ^[2]	Approximate Uncertainty of Calibrated Value at 95 % Confidence ($\pm\mu\Omega/\Omega$) TCal $\pm 1^\circ\text{C}$	12 Month Stability ($\pm\mu\Omega/\Omega$) ^{[1][2]}	Temperature Coefficient ($\pm\mu\Omega/\Omega/^\circ\text{C}$) ^[2]	Power Coefficient Multiplier ($\pm\mu\Omega/\Omega$) ^{[2][3]}
1 mA	800	250	8.2	18	5	1
10 mA	80	250	6.8	18	2.5	1
20 mA	40	250	8.2	18	4.5	1
50 mA	16	250	8.3	18	4.5	1
100 mA	8	250	8.3	18	2.5	2
200 mA	4	250	8.6	18	3.5	4
500 mA	1.6	250	9.6	18	4.5	13
1 A	0.8	250	9.3	18	4.5	26
2 A	0.4	250	9.4	18	4.5	26
5 A	0.16	250	9.9	18	4.5	30
10 A	0.08	250	15	18	4.5	65
20 A	0.04	250	14	18	4.5	78
50 A	0.016	250	24	18	4.5	105
100 A	0.008	250	28	18	4.5	105

[1] Stability specification combines long term change due to aging (permanent) and short term fluctuation due to humidity changes when shunts are used and stored within specified humidity limits. Add 20 ($\pm\mu\Omega/\Omega$) if humidity is >50 % RH).

[2] Assume rectangular distribution when combining with other uncertainty contributions.

[3] Calibrated resistance values include the effects of power coefficient at the nominal current. For currents other than nominal, apply an additional uncertainty for the power coefficient from:

$$Adder = Power_Coefficient_Multiplier \times \left[1 - \left(\frac{I_{Applied}}{I_{Nominal}} \right)^2 \right]$$

Maximum AC-DC Difference at time of Manufacture

Shunt Nominal Current	Maximum AC-DC Difference ($\pm\mu\text{A/A}$) ^{[1][2]}			
	1 kHz	10 kHz	30 kHz	100 kHz
1 mA ^[3]	53	72	72	150
10 mA	20	20	20	40
20 mA	18	18	19	30
50 mA	13	13	14	25
100 mA	14	15	17	37
200 mA	17	17	18	35
500 mA	17	17	17	25
1 A	17	19	19	23
2 A	17	22	22	47
5 A	23	24	34	69
10 A	28	55	58	110
20 A	37	51	80	170
50 A	47	75	79	180
100 A	60	90	120	300

[1] Specifications indicate the maximum flatness deviation from DC, and include both measured AC-DC difference and the uncertainty of measurement. They are stated at k=2, approximately 95 % confidence.
 [2] Includes 1-year stability of the AC-DC difference.
 [3] Specifications for the 1 mA Current Shunt are for ambient temperature equal to TCal ± 1 °C.

Maximum Overload Current

Shunt Nominal Current	Maximum Current <5 Seconds ^[1]	Maximum Sustained Current ^[2]	Shunt Nominal Current	Maximum Current <5 Seconds ^[1]	Maximum Sustained Current ^[2]
1 mA	3 mA	2 mA ^[3]	1 A	3.9 A	1.3 A
10 mA	150 mA	20 mA	2 A	5.5 A	2.2 A
20 mA	250 mA	40 mA	5 A	17 A	5.5 A
50 mA	450 mA	100 mA	10 A	24 A	11 A
100 mA	1.2 A	200 mA	20 A	42 A	22 A
200 mA	1.7 A	400 mA	50 A	95 A	55 A
500 mA	2.7 A	1 A	100 A	190 A	110 A

[1] Longer than 5 seconds may cause permanent damage to the shunt. The output voltage may be considerably higher than 0.8 V.
 [2] Exceeding maximum sustained current may cause a resistance value step change.
 [3] 1 mA shunt batteries should be fully charged to ensure performance at 2 mA.

Typical Phase Displacement

Typical Phase Displacement			
Shunt Nominal Current	1 kHz	10 kHz	100 kHz
1 mA to 200 mA	< 0.001 °	< 0.006 °	< 0.060 °
500 mA to 2 A	< 0.003 °	< 0.030 °	< 0.300 °
2 A to 20 A	< 0.008 °	< 0.075 °	< 0.750 °
20 A to 100 A	< 0.013 °	< 0.125 °	< 1.250 °

General Specifications

Dimensions (maximum)

Shunt Value	Height mm (inches)	Width mm (inches)	Overall Length ^[1] mm (inches)
1 mA to 2 A	70 (2.75)	70 (2.75)	124 (4.9)
5 A to 20 A	130 (5)	130 (5)	210 (8.25)
50 A and 100 A	200 (7.9)	200 (7.9)	343 (13.5)

[1] Includes input and output connectors; subject to change by component vendor.

Physical/Mechanical Parameters

Shunt Value	Weight (maximum) kg (lb)	Input Connector	Output Connector
1 mA to 20 A	0.7 (1.6)	Type-N (female)	Type-N (female)
50 A and 100 A	3.4 (7.5)	Type-LC (female)	Type-N (female)

Operating Environment

Temperature 13 °C to 33 °C
 Calibration Temperature (TCal) Range..... 18 °C to 28 °C
 Humidity Range for best specification^{[1][2]} ≤50 % RH
 Altitude 0 m to 3,000 m

[1] Resistance stability is affected by humidity, but changes are reversible.

[2] If the shunts are calibrated outside this RH, stability specifications will be met as long as the shunts are stored and used at the same relative humidity ±10% RH.

Safety

General IEC 61010-1: Pollution Degree 2

Storage and Transit Environments (for models other than the 1 mA Current Shunt)

Temperature to avoid damage.....-20 °C to 140 °C
 Temperature and Humidity to maintain
 performance^[1] 5 °C to 45 °C; 15% to 80 % RH
 Non-operating Altitude 0 m to 12,000 m

[1] Storage at extremes of temperature or humidity will cause a temporary change of shunt resistance by up to ±20 ppm. When subsequently stored or used within the limits of the operating environment, the shunts will recover to their original resistance value within 30 days.

Additional 1 mA Current Shunt Specifications

Battery Charger Specifications

Input..... 100 V to 240 V, 50 Hz / 60 Hz. Output 4.8 V dc to 12 V dc, 800 mA
 Output Resistance 8 mΩ
 Maximum Safe Output Current 11 mA (e.g., 1 V output into 90 Ω)
 Maximum Capacitive Load 800 pF
 Output Voltage Regulation 15 ppm / 100 pF
 Maximum Output DCV Offset ±100 μV (typical ± 25 μV)
 Typical Error @ 1 MHz..... <2 %

Battery Specifications

Battery Size AAA (44.5 x 10.5 mm)
 Battery Technology Nickel-Metal Hydride (NiMH)
 Number of Batteries Required 8 (in 2 groups of 4)
 Nominal Battery Voltage 1.2 V (4.8 V per group of 4)
 Typical Battery Capacity 800 mAh
 Storage and Transit Environment to preserve the batteries
 Less Than 90 days -20 °C to 40 °C
 Less Than 1 year -20 °C to 30 °C
 Charging Time (from fully discharged) 100 minutes

Maximum Operating Time Between Charges:
 Maximum Output Load (11 mA) 18 hours
 High Impedance Load 24 hours
 Recommended cooling period 100 minutes
 To prevent loss of battery capacity recharge at least twice per year.

Preparing for Operation

This section of the manual describes how to unpack and prepare the Current Shunts for operation.

Unpacking and Inspecting the Shunts

Note

The coaxial Current Shunts are robust when handled correctly by their ends. Take care not to damage the horizontal struts of the coaxial shunts.

Upon receiving the Current Shunts from the carrier, carefully unpack and inspect them for damage. If there is any sign of physical damage, notify the carrier immediately.

As part of the inspection process, check the contents against the list shown in Table 1. Report any shortages to the nearest Fluke Calibration Technical Service Center. See *How to Contact Fluke Calibration*.

Save the container and any packing material for future use in storing or shipping the Current Shunts

Table 1. Contents of the Current Shunt Set Packaging

Description	Quantity
A40B-Case Transit/storage case for the A40B Current Shunts	1
Packing List of Items Includes the serial number of the Current Shunts	1
Current Shunts	14
one boxed <i>active</i> shunt with battery charger 1 mA	
three boxed passive shunts 10 mA, 20 mA 50 mA	
five small size coaxial shunts 100 mA, 200 mA, 500 mA, 1 A, 2 A	
three medium size coaxial shunts 5A, 10 A, 20 A	
two large size coaxial shunts 50 A, 100 A	
Connector Adapters	
A40B-ADAPT/LC LC Male to LC Male adapter	1
A40B-ADAPT/LCN LC Female to N Male inter-series adapter	1
A40B-LEAD/N N Male to N Male lead	1
A40B-LEAD/4mm N to 4 mm double banana connector	2
Battery charger for 1 mA active shunt	1
CD containing the Instruction Manual (PDF)	1

Accessories

The LC and N adapters described in Table 2 are available as accessories:

Table 2. A40B Accessories

Accessory	Description
A40B-CAL/LC	High current adapter to connect two shunts in series for measurement (LC to LC)
A40B-CAL/N	Low current adapter to connect two shunts in series for measurement (N to N)

How to Contact Fluke Calibration

To contact Fluke Calibration, call one of the following telephone numbers:

- Technical Support USA: 1-877-355-3225
- Calibration/Repair USA: 1-877-355-3225
- Canada: 1-800-36-FLUKE (1-800-363-5853)
- Europe: +31-40-2675-200
- Japan: +81-3-6714-3114
- Singapore: +65-6799-5566
- China: +86-400-810-3435
- Brazil: +55-11-3759-7600
- Anywhere in the world: +1-425-446-6110

To see product information and download the latest manual supplements, visit Fluke Calibration's website at www.flukecal.com.

To register your product, visit <http://flukecal.com/register-product>.

Shipping Information

To prepare the Current Shunt Set for shipping, place them in the appropriate pre-cut foam insert positions in the transit/storage case and secure the lid.

When shipping individual Current Shunts, completely enclose them within at least 5 cm (2 inches) of polyurethane foam cushioning and pack them in a crush-proof container.

Storage Information

To prepare the Current Shunts for storage, place them in their transit/storage case, and secure the lid. Then, store the container in a location that complies with the environmental specifications described earlier in the *General Specifications*. Storage outside these conditions may reduce the battery life of the 1 mA shunt or cause a temporary change in the resistance of the Current Shunts by up to ± 20 ppm. When returned to an acceptable operating environment, the Current Shunts will recover to their original resistance value within 30 days.

Acceptance Test

Upon initial receipt of the Current Shunts, perform the following acceptance test to ensure that they are functional:

1. Inspect the physical condition of the Current Shunts for obvious physical damage, including connector damage as described under *General Maintenance/Cleaning*. Repair any damage before proceeding.

Instructions for contacting Fluke Calibration are provided earlier in this manual.

2. Functionally test each Current Shunt by applying the nominal current to its input. At nominal current, the output voltage for each Current Shunt should be approximately 0.8 volts.

Note

Each Current Shunt produces 0.8 volts output for an input at nominal operating current. The highest current shunts (10 A and above) get warm when operating at full current. The 50 A and 100 A shunts may become uncomfortable to touch; their operating temperature can be as high as 70 °C (158 °F).

General Maintenance/Cleaning

For General Cleaning, wipe the Carrying Case and Current Shunts with a damp cloth and mild detergent. Do not use abrasives, isopropyl alcohol, or solvents.

⚠ Caution

To prevent damage to the instrument:

- **Do not use aromatic hydrocarbons or chlorinated solvents for cleaning the Current Shunts.**
- **Do not spray liquid on or immerse the Current Shunts.**

Other than calibration, the only maintenance the Current Shunts require is inspection of the input and output connectors for wear or damage. The LC-type input connectors of the 50 A and 100 A shunts are robust, but the N-type connectors on the medium and small shunts are easily damaged by misuse or mating with out-of-tolerance N-type male connectors. The center pins of male N-type connectors are prone to moving, particularly when assembled onto cables. If a center pin on an N-type connector protrudes too much, the female connector on the shunt will be damaged by splaying the inner connector. If there is any doubt about connector condition, gauge the connectors (see MIL-C-39012 for details). Defective connectors can be replaced but it is recommended the work be performed at a Fluke Calibration Service Center.

Operating Information

This section of the manual contains practical information the user needs to know before and after making a current measurement. The material is intended to help the user make high quality precision measurements.

Feature Descriptions

The features and connectors of the Current Shunts are shown in Figure 2 and described in Table 3.

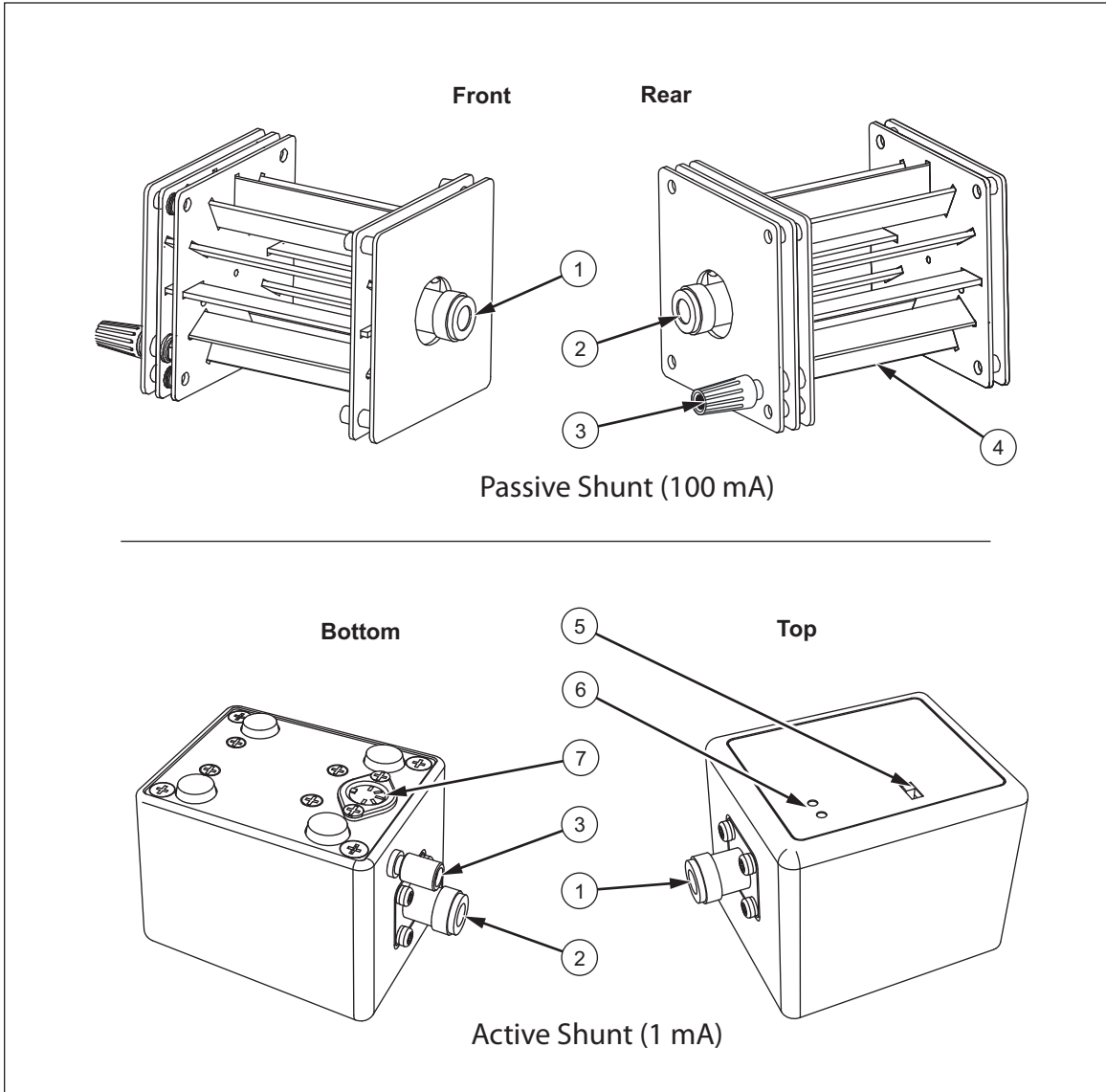

Figure 2. Features and Connectors

fim005.eps

Table 3. Features and Connectors

Item	Feature	Description
①	Current Input Connector	Connector for applying current to the shunt. All of the shunts use the N-type female connectors except the 50 A and 100 A versions which use type LC female Connectors.
②	Voltage Output Connector	Connector for measuring voltage drop across the shunt. The output connectors are all N-type female.
③	Guard Connection	Binding post terminal for making a guard connection to Shunt Lo.
④	PCB Struts	Low inductance connections carrying current to and from the shunt resistors.
⑤	Power on/off switch	Switches power for the current Shunt on or off.
⑥	LED indicators	Green indicates power on. Red indicates low battery.
⑦	Battery charger connector	Input connector for the external battery charger.

Input/Output Connectors

Warning

To avoid skin burns and possible damage to the 50 A and 100 A Current Shunts, make sure the current-carrying input connectors are undamaged and fully tightened before applying current to them.

The input connectors on the 50 A and 100 A shunts are of the LC-type. Under full current conditions, the connectors will get hot to the touch. This is normal because of contact resistance. If the connectors are not fully tightened, they will get hot enough to burn skin and damage the shunt.

Caution

To avoid pin damage to N-Type connectors on the Current Shunts, make sure the male pin of a mating connector is in tolerance and does not protrude.

All other coaxial connectors on the Current Shunts are 50 Ω , female, N-type. These connectors are especially vulnerable to damage while being connected to a male N-type connector. If the male connector is out-of-tolerance or its center pin protrudes too far, it will splay the center pin of the female connector and lead to a poor connection. If there is any doubt about the condition of the center pin in a female N-type connector, gauge the connector (see MIL-C-39012 for details).

In extreme cases of connector damage, the connection resistance may be high enough to prevent some current sources from driving the additional compliance voltage, particularly at higher frequencies.

Another potential compliance voltage problem occurs when a Current Shunt is in series with an inductance. The inductance can also burden current sources beyond their capability. To help counter the effect, make sure the current connections are coaxial and as short as possible.

A defective connector on a Current Shunt is replaceable. However, Fluke Calibration recommends the work be done at a Fluke Calibration Service Center.

Maximum Current

Each Current Shunt is marked at the input connector with its nominal (rated) current. Similarly, markings at the voltage output connector indicate the nominal voltage out for nominal current in. A table in the specifications section provides maximum currents to maintain performance and to avoid irreversible damage.

⚠⚠ Warning

To prevent possible electrical shock, fire, or personal injury do not touch voltages >30 V ac rms, 42 V ac peak, or 60 V dc.

⚠ Warning

To prevent personal injury, do not significantly exceed the maximum overload current rating of a Current Shunt. Doing so may cause traces on the printed circuit boards to vaporize. (See Maximum Overload Current in the Electrical Specifications.)

⚠ Caution

To avoid irreversible damage to the sense shunt resistors, do not exceed the maximum sustained current for a Current Shunt as shown earlier in the Electrical Specifications. (See Maximum Overload Current.)

Operating Environment

The Current Shunts are designed to operate in a controlled environment such as calibration and measurement laboratories. Temperature and humidity outside specified storage and transit environment may affect their performance and, in the extreme case, damage them.

The *open* coaxial shunts rely on natural convection for cooling. Adverse performance will result if airflow is restricted.

Correcting for Current Shunt Error Contributions

The Current Shunts are designed for use with a voltage-measuring device to measure current. When making a measurement, both instruments contribute known measurement errors and usually require a measurement correction to achieve the best accuracy. The Current Shunt can be used to directly measure current without the need to make AC-DC difference comparisons to a DC current reference. The Current Measurement Specifications table gives the specification for a measurement where the calibrated DC resistance value and AC-DC difference are corrected for and allowance is made for the shunt's 12-month stability.

Use the following formula to determine a measured current, I , from voltage, and calibrated resistance ($R_{\text{calibrated}}$) and AC-DC difference ($\text{AC-DC}_{\text{calibrated}}$) values:

Where: $\text{AC-DC}_{\text{calibrated}}$ is expressed in ppm.

$$I = \left(\frac{V}{R_{\text{calibrated}}} \right) \times \left(1 + \frac{\text{AC-DC}_{\text{calibrated}}}{1,000,000} \right)$$

The formula above is based on the assumption that the voltmeter has infinite input impedance at the frequency of interest.

Output Voltage Measurement Using a Fluke Calibration 5790B

The typical input impedance of a 5790B (input 1 or 2) is a 10 MΩ in parallel with 100 pF. For lower-value shunts, the loading error is comparable with or exceeds the shunt error when used to measure current directly.

Table 4 shows the loading effects of the 5790B on Current Shunts in the range of the 1 mA to 200 mA.

Table 4. Typical Loading Effect of a 5790B, 2.2 V Range

Current (mA)	DC	1 kHz		10 kHz		30 kHz		100 kHz	
	Loading Error (ppm)	Loading Error (ppm)	AC-DC Diff. (ppm)	Loading Error (ppm)	AC-DC Diff. (ppm)	Loading Error (ppm)	AC-DC Diff. (ppm)	Loading Error (ppm)	AC-DC Diff. (ppm)
1	0	0	0	-1	+1	-4	+3	-16	+11
10	-8	-8	0	-8	+2	-9	+10	-21	+49
20	-4	-4	0	-4	+1	-4	+5	-7	+23
50	-2	-2	0	-2	0	-2	+2	-2	+9
100	-1	-1	0	-1	0	-1	+1	-1	+4
200	0	0	0	0	0	0	0	0	+2

Note

The 5790B is optimized for use with the A40B shunts. For convenience, these loading values are preprogrammed into the Loading Error tables located in the shunt properties. Refer to the 5790B Operators Manual for more information.

Output Voltage Measurement – Loading Effect

The published specifications for a Current Shunt represent its performance under ideal conditions. In practical use, placing the input of the voltage measurement device in parallel with the Current Shunt introduces an additional impedance (loading effect) which will result in a measurement error. See Figure 3. The 1 mA boxed Current Shunt has less than 8 mΩ output resistance, so resistive loading effects are negligible. The capacitive loading effect is less than 15 ppm per 100 pF at 100 kHz. For the non-active Current Shunts, the loading effect becomes more significant as the resistance value of the Current Shunt increases, that is, as the nominal current value decreases. For the most accurate measurements, the error due to this loading effect must be calculated and used as a measurement correction.

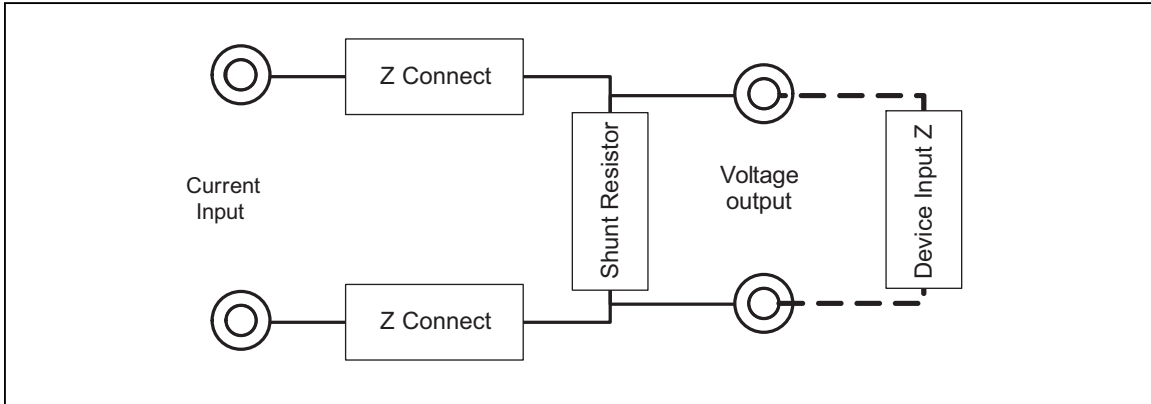

Figure 3. Loading Effect of the Measurement Device

feh004.eps

Output Voltage Measurement Using a Fluke Calibration 5790A

The typical input impedance of a 5790A (input 1 or 2) is $>10\text{ M}\Omega$ (dc) in parallel with 70 pF . The $10\text{ M}\Omega$ in parallel with the shunt resistance has a small effect on the lowest current value Current Shunts at DC. The 5790A impedance typically decreases to approximately $1.5\text{ M}\Omega$ in parallel with 70 pF at 100 kHz , and, at this frequency, the loading effect is more pronounced. For the lower value shunts, the loading error is comparable with or exceeds the shunt error when used to measure current directly.

Table 5 shows the loading effect of the 5790A on Current Shunts in the range of 10 mA to 200 mA .

Table 5. Typical Loading Effect of a 5790A, 2.2 V Range

Current (mA)	DC	1 kHz		10 kHz		30 kHz		100 kHz	
	Loading Error (ppm)	Loading Error (ppm)	AC-DC Diff. (ppm)	Loading Error (ppm)	AC-DC Diff. (ppm)	Loading Error (ppm)	AC-DC Diff. (ppm)	Loading Error (ppm)	AC-DC Diff. (ppm)
1	0	0	0	-1	+1	-3	+3	-11	+11
10	-6	-6	0	-8	+2	-16	+10	-56	+49
20	-3	-3	0	-4	+1	-8	+5	-26	+23
50	-1	-1	0	-2	0	-3	+2	-10	+9
100	-1	-1	0	-1	0	-2	+1	-5	+4
200	0	0	0	0	0	-1	0	-2	+2

Output Voltage Measurement Using a Fluke Calibration 8508A

The input impedance of an 8508A on its DC function is >10 GΩ and the loading effect for measuring DC current with any Current Shunt is negligible. The typical AC function (DC coupled) low frequency input impedance of an 8508A is 1 MΩ in parallel with 135 pF. The impedance reduces with frequency to typically 550 kΩ || 135 pF at 100 kHz. For the lower-current Current Shunts, the loading error is comparable with or exceeds the shunt error when used to measure current directly.

Table 6 shows the loading effect of the 8508A on Current Shunts in the range of 1 mA to 1000 mA.

Table 6. Typical Loading Effect of an 8508A 2 V ACV Range

Current (mA)	DC	1 kHz		10 kHz		30 kHz		100 kHz	
	Loading Error (ppm)	Loading Error (ppm)	AC-DC Diff. (ppm)	Loading Error (ppm)	AC-DC Diff. (ppm)	Loading Error (ppm)	AC-DC Diff. (ppm)	Loading Error (ppm)	AC-DC Diff. (ppm)
1	0	0	0	-2	+2	-6	+6	-20	+20
10	-80	-80	0	-82	+2	-92	+12	-172	+92
20	-40	-40	0	-41	+1	-45	+5	-80	+40
50	-16	-16	0	-16	0	-18	+2	-31	+15
100	-8	-8	0	-8	0	-9	+1	-15	+7
200	-4	-4	0	-4	0	-4	0	-8	+4
500	-2	-2	0	-2	0	-2	0	-3	+1
1000	-1	-1	0	-1	0	-1	0	-1	0

Use the following formula correct for the loading effect:

Where: AC-DC_{calibrated} and Loading error are expressed in ppm.

$$I = \left(\frac{V}{R_{\text{calibrated}}} \right) \times \left(1 + \frac{\text{AC-DC}_{\text{calibrated}}}{1,000,000} \right) \times \left(1 - \frac{\text{Loading error}}{1,000,000} \right)$$

Operating Instructions

Warning

To prevent possible electrical shock, fire, or personal injury, remove circuit power before you connect the Product in the circuit when you measure current. Connect the Product in series with the circuit.

Introduction

This section of the manual describes how to measure both AC and DC current using any one of the Current Shunts. The procedures are based on the assumption that the user is familiar with the *Operating Information* and *Specifications* presented earlier in this manual.

Measuring Current

Use the following procedure to measure current using one of the Current Shunts:

1. Analyze the circuit being tested and determine the following:
 - a. The approximate value of the current that flows in the circuit.
 - b. The frequency of the current to be measured (DC to 100 kHz).
2. Select a Current Shunt capable of safely handling the estimated current.
3. If using the 1 mA Current Shunt, switch it to On and verify that the battery low (red) indicator is off. If the 1 mA Current Shunt has been charging, disconnect the charger. The charging process creates heat in the battery so for the best accuracy allows the shunt temperature to stabilize for 100 minutes after charging completes.
4. Remove power from the circuit under test and connect the input of the Current Shunt in series with the circuit.
5. Connect an appropriate voltage measuring device to the output of the Current Shunt, and select the correct range. The output voltage of the Current Shunt is proportional to the input current; 0.8 V for nominal rated current.

It is generally appropriate to set the measuring device to remote guard and connect its guard terminal to the guard on the Current Shunt. Refer to the measuring device documentation.

6. Apply current to the circuit and measure the resulting output voltage. This output voltage is directly proportional to the current flowing in the circuit.
7. Use the voltage measurement and the *Operating Information* in the previous section of this manual to accurately determine the current level.

Determine the current using the following formula:

Where: AC-DC calibrated and Loading error are expressed in ppm.

$$I = \left(\frac{V}{R_{\text{calibrated}}} \right) \times \left(1 + \frac{\text{AC - DC calibrated}}{1,000,000} \right) \times \left(1 - \frac{\text{Loading error}}{1,000,000} \right)$$

Example: Estimating the Uncertainty of a 5790B Measurement

The following example shows how to estimate the measurement uncertainty of a calibration measurement (ambient temperature 23 °C). It illustrates one of the performance verification tests for the Fluke Calibration 5730A calibrator. Specifically it tests 200 mA at 1 kHz, as documented in the 5730A's full verification procedure.

Source: Fluke Calibration 5730A – 200 mA output at 1 kHz.

Measurement Equipment: Fluke Calibration Current Shunt, 200 mA (calibrated at 23 °C) and a Fluke Calibration 5790B.

Make the measurement and estimate the uncertainty using the information given in Table 7. A sample calculation of Measured Current using arbitrary values is shown in Table 8.

As described in the 5730A full verification procedure, evaluating the measured current uses limits based on the specification at 200 mA, 1 kHz of ± 135 ppm; calculated by the 5730A's 1 year, 99 % confidence specification of $\pm(120$ ppm of output + 3 μ A). As shown, the expanded measurement uncertainty is very adequate to reliably confirm this level of performance.

Note

Cables in the measurement path can add error to the current measurement. In the above example, cable error is not included in the analysis. To ensure best performance, use either the A40B-Lead/4mm cable or A40B-Lead/N cable.

Table 7. Estimating the Uncertainty of a 5790B Measurement

Error Component	Value (ppm)	Distribution	Divisor	Value at k=1	Squared Value
Standard deviation of measurement noise ^[1]	5	normal	1	5	25
Shunt current measurement specification (95 %)	26	normal	2	13	169
Shunt temperature coefficient	0	rectangular	1.73	0	0
Shunt power coefficient ^[2]	0	rectangular	1.73	0	0
5790B loading effect uncertainty ^[3]	1	normal	2	0.5	0.25
5790B specification (2.2 V range)	22	normal	2.58	8.53	72.71
Sum of squared value					266.96
Std uncertainty = square root of the sum					16.34
Expanded, rounded uncertainty in ppm (k = 2)					33
Expanded Uncertainty					± 0.000066 A
Notes: [1] Value arbitrarily chosen for this example [2] Power Coefficient = 0 as shunt is used at nominal current value [3] Typical uncertainty at 1 kHz					

Table 8. Sample Calculation of Measured Current (Arbitrary Values)

Givens/Calculations	Values	Units
5790B reading	0.799977	V
Calibrated resistance value	3.999770	Ω
Uncorrected calculated 5730A current output (V/R)	0.2000058	A
Add A40B AC-DC difference error (ppm)	+1	ppm
Subtract 5790B loading error (ppm)	0	ppm
Total measurement error	+1	ppm
Corrected measurement result	0.2000060	A
Measurement uncertainty in Amperes	± 0.0000066	A

Direct Read-out When Measuring Current

When using a Current Shunt with a meter that allows the displayed value to be manipulated using math functions, the meter can be configured to give a direct reading of current. For Example:

In the following scenario, a current source operating at a given frequency is measured with a 100 mA Current Shunt and a Fluke Calibration 8508A.

Assumptions:

- Calibrated DC resistance of the Current Shunt (z) = 7.999600
- Calibrated AC-DC difference of the Current Shunt at this frequency = +7 ppm
- Loading effect at this frequency = -9 ppm

1. Combine the AC-DC difference and loading effect numbers:

$$\text{Combined ppm errors} = -(+7) - 9 = -16 \text{ ppm}$$

Note

AC-DC difference error is the amount the AC value would have to be changed to make it the same as the DC value. To change this into a frequency flatness error, reverse the sign.

2. Convert the combined ppm errors into a multiplier (m)

$$m = 1 - \left(\frac{-16}{1,000,000} \right) = 1.000016$$

3. Enter the z value (7.99960) into the z store of the 8508A
4. Enter the m value (1.000016) into the m store of the 8508
5. Activate **divide by z** and **multiply by m** on the 8508A

The 8508A now gives a direct reading of the current being measured.

To measure the same current level at a different frequency; calculate a new value for m and enter the new value into the 8508A m store. The z value remains the same.

Theory of Operation

The Current Shunts are ideally a pure resistance through which a current is passed to develop a voltage. They are intended for precision AC-DC current measurements in the range 1 mA to 100 A at frequencies DC to 100 kHz. Inductance tends to make accurate measurement difficult as current and frequency increases.

Coaxial Shunts

The coaxial shunts are especially designed for low-inductance. The design is similar to that developed by Mendeleyev Institute, St Petersburg. The key components of the coaxial shunts are the printed circuit board (PCB) construction and the precision resistive elements. The design provides several parallel current paths (struts) each with its own resistive element. Each current path is symmetrical to minimize mutual inductance. Resistive elements comprise 1 to 8 discrete high precision bulk foil resistors per strut depending on the current rating of the Current Shunt.

Individual PCB struts, collected in a cylindrical construction to reduce external magnetic fields, form the path through the shunt. Figure 4 shows the current path through one of the strut/resistor elements.

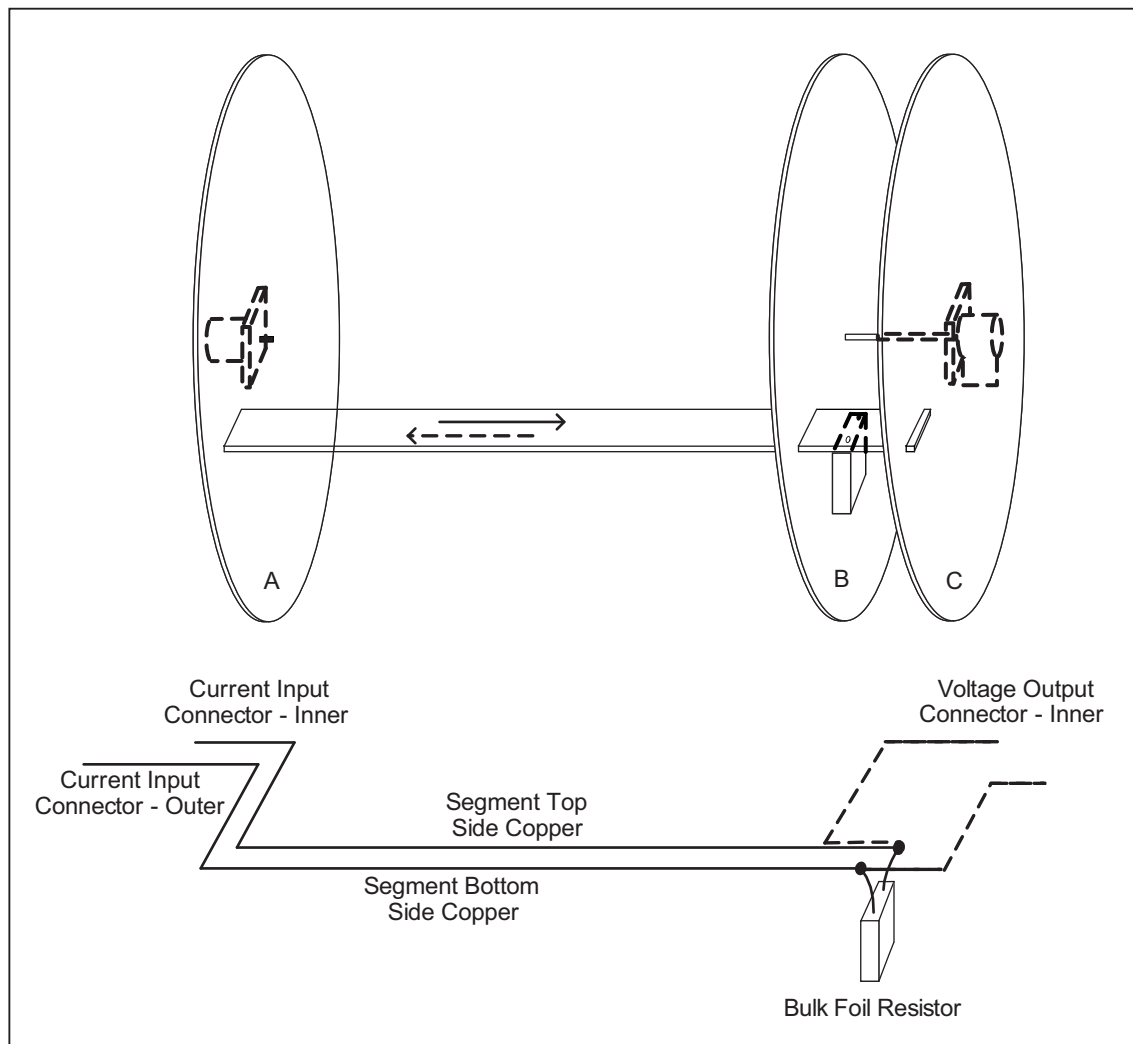

Figure 4. Current Shunt - Simplified Electrical Diagram

feh006.png

The PCB designated **A** in Figure 4 is copper clad on both sides. PCBs **B** and **C** are single sided. Current flows into the shunt through the input connector, through one side of the PCB **A**, along one side of the struts to the resistor. The current return is through the resistor and along the other side of the struts and end PCB to the input connector. The voltage across the resistor is carried by the strut to the dual PCB end (**B** and **C** in Figure 4) and to the output connector.

The parallel current paths provided by the PCB struts and ends minimize mutual inductance. Using numerous bulk foil resistors reduces skin effect in the resistive element and provides excellent stability.

Boxed Shunts

With the exception of the 1 mA Current Shunt, the boxed Current Shunts are electrically simpler than the coaxial versions. Inductance and self heating become less of a problem so the resistive elements can be enclosed to reduce external influences. The 1 mA Current Shunt includes a battery powered amplifier to buffer the shunt resistance from loading effects.

Calibration

Introduction

This section of the manual describes the calibration of the Current Shunts. The description is presented in two parts:

1. An overview/discussion of the considerations for calibration of Current Shunts.
2. A description of the Fluke Calibration Method.

Neither of the descriptions contains detailed step by step procedures for calibrating the Current Shunts. Rather, the descriptions are meant to provide a foundation for the seasoned calibration technician to work with and use the Fluke Calibration method of calibrating Current Shunts.

An Overview of Calibration Methods

Current Shunts can be used in AC-DC difference or absolute AC or DC measurements. This requires that both AC flatness and DC resistance performance are calibrated. Both AC and DC calibration involves passing a known current through the device being calibrated (UUT) and measuring the voltage output.

The calibration method for the Current Shunts is to transfer calibration against reference shunts. This eliminates the need for a calibrated current source. However, the source current must be stable and able to provide the necessary voltage compliance levels. Figure 5 shows the basic configuration.

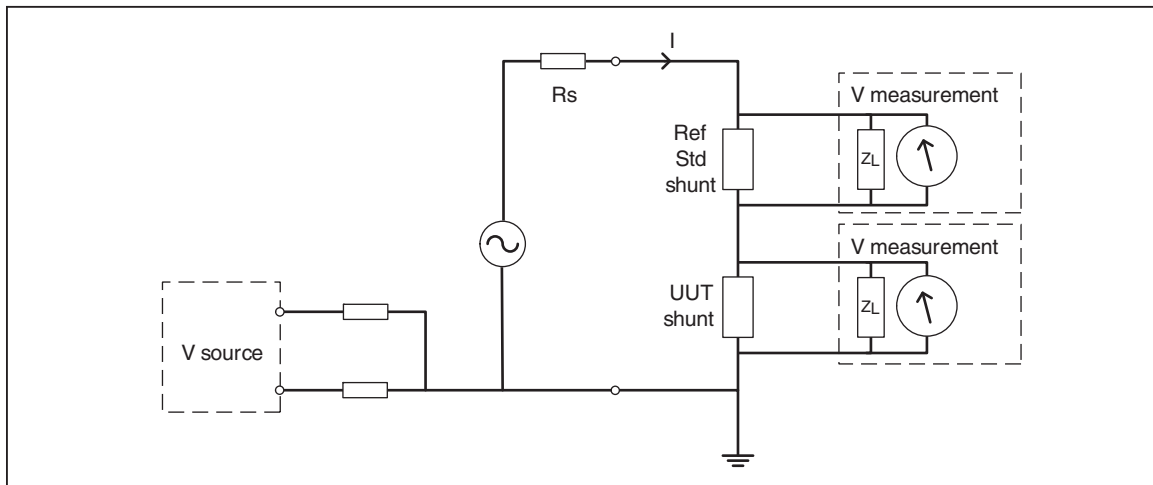

Figure 5. Circuit Using a Reference Shunt Resistor to Determine Source Current

feh014.eps

Potential Voltage Measurement Devices

TVC

The system could use thermal voltage converters (TVC) in conjunction with a DC voltmeter to measure the voltage output from a Current Shunt. The TVC produces a dc output voltage proportional to the ac or dc voltage applied and is intrinsically flat across the entire frequency range required for this application. The TVC can only be used to compare two signals and does not provide an absolute measurement; hence its main use is AC-DC difference measurements. There are various forms of TVC; Table 9 lists advantages and disadvantages of the simplest: the single junction TVC (SJTVC).

Table 9. Single Junction Thermal Voltage Converters

Advantage	Disadvantage
Frequency flatness errors are generally very small.	Slow to reach thermal stability
Input impedance is mainly resistive	Low input resistance (90 Ω)
Very good output / input isolation. Negligible errors due to common-mode current	Maximum input voltage is 0.45 V. Appropriate series resistor is required to increase input voltage capability
	Square law response offers poor amplitude linearity
	Nanovoltmeter or potentiometer /null detector required to resolve mV output levels
	Susceptible to small changes in local environment (draughts, heat source)

Fluke Calibration 792A AC-DC Transfer Standard

The Fluke Calibration 792A can be used to make AC-DC difference measurements and has many advantages over the SJTVC. See Table 10. It does, however, have one disadvantage that reduces its usefulness for this application. Unlike the single junction TVC, the 792A is subject to common-mode interference, particularly when used as the measurement device for the Reference Standard shunt.

Table 10. Fluke Calibration 792A AC-DC Transfer Standard

Advantage	Disadvantage
Frequency flatness errors are generally very small.	Common-mode errors ^[1]
Solid state TVC with 2 V output.	Requires DC voltmeter to resolve output
Faster to settle than SJTVC	Input impedance varies with frequency
Smaller DC reversal error	
Linear response	
High input impedance	
[1] Common-mode errors are the biggest source of error for mains powered devices.	

DMM / Measurement Standard

The output voltage of the Current Shunts is nominally 0.8 V making them ideal for use with instruments such as the Fluke Calibration 5790A/B and Fluke Calibration 8508A. The obvious advantages of this type of instrument are fast settling time and absolute measurement capability. See Table 11. The 5790A/B provides AC-DC difference measurement capability although the Current Shunts allow direct AC measurements with accuracy adequate for many applications. Instruments like the Fluke Calibration 5790B and 8508A have math functions that allow the resistance value of the Current Shunt to be entered into memory so that the reading displayed is the measured current.

Table 11. Fluke Calibration 5790A/B Measurement Standard

Advantage	Disadvantage
Fast settling	Common-mode errors ^[1]
Absolute (not comparative) measurements	Overall accuracy lower than TVC / DC meter
Fast readings	Input impedance varies with frequency
Good accuracy over a wide bandwidth	Frequency flatness errors must be corrected
No additional equipment required	
Two inputs; ratio measurements	
Very good linearity	
Not as sensitive to local environment as TVC	
Can do AC-DC difference transfer	
[1] Common-mode errors are the biggest source of error for mains powered devices.	

DC Considerations

Note that the impedance of the measuring device is in parallel with the shunt, causing a loading effect. Generally, the loading becomes more significant as the resistance value of the Current Shunt increases, that is, as the nominal current value decreases.

Example

Assume the UUT is the 10 mA Current Shunt with a resistance of 80 Ω. The measuring device across the UUT is a 0.8 V, 5 mA SJTVC. Its input impedance is typically 160 Ω. The Reference Shunt is also a 10 mA Current Shunt, but its voltage is measured with a Fluke Calibration 792A, 700 mV range – input impedance more than 10 MΩ. The entire 10 mA current generated by the source passes through the Reference Shunt. Because of the shunting effect of the SJTVC, 6.7 mA flows in the UUT and 3.3 mA flows in the SJTVC; the UUT Current Shunt is operating at 66 % of nominal value. This would be unacceptable for an absolute level measurement of DC (or AC). However, for an AC-DC difference measurement, half current has long been the norm as this is how shunts are traditionally used. Table 12 lists other potential sources of error and recommended solutions.

Table 12. Other Error Sources and Solutions

Potential Error Source	Solution
Is the current stable, i.e., the same for both measurements?	Careful selection of equipment.
Is the loading effect of the measuring device the same for each measurement? It will not be if the Reference Shunt and the UUT have significantly different resistance values resulting in a change of the current in the circuit between measurements. The value of the source resistance (R_s in Figure 5) influences the magnitude of the error.	
How significant is the difference between different measurement devices? Switching would allow the same device to measure both the UUT and the Reference Shunt, but switch impedance repeatability may introduce more problems than it solves.	
All Current Shunts experience I^2R self-heating to some extent. The temperature coefficient of the Current Shunt causes a change in its resistance value.	Careful selection of equipment. Allow all elements in the system to stabilize at normal operating temperature before measurements are started.
How will DC zero errors be compensated?	Take the average of positive and negative DC measurements (DC reversal).
How will the measurement overcome thermal emf?	

AC Considerations

Most of the DC considerations also apply to AC measurements. Figure 6 shows the measurement device input impedance as a resistance and capacitance to indicate that impedance changes with frequency. The low input resistance value of SJTVC (160 Ω) is beneficial in this respect; it swamps the capacitance. Devices with active input circuits generally have high input resistance and capacitance becomes more influential on frequency flatness. Tables 5, 6, and 7 provide typical values and errors for Fluke Calibration 5790A, 5790B, and 8508A.

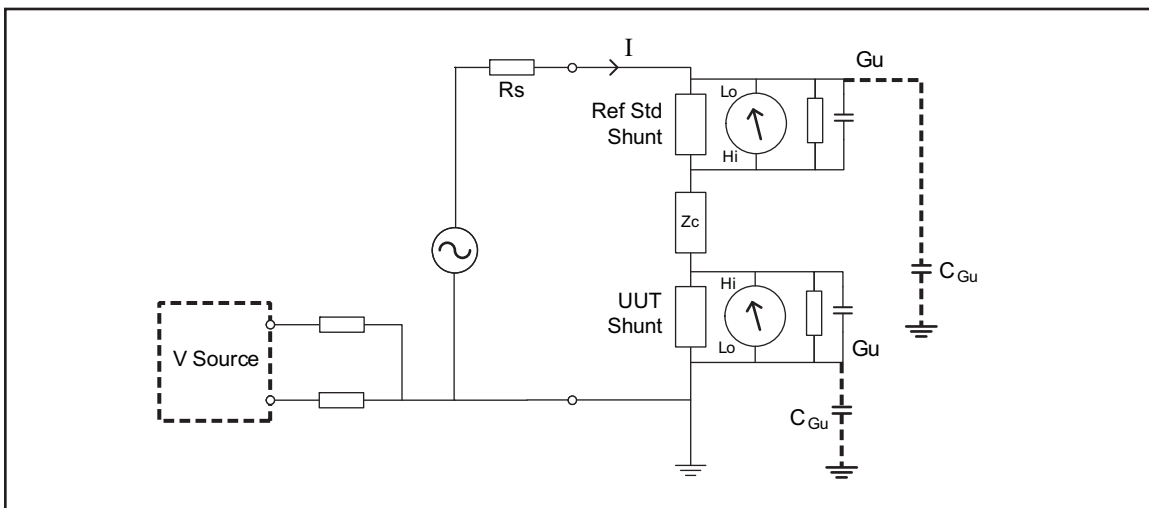

Figure 6. Sources of Error in AC Measurements

feh016.eps

Common-mode current can be very significant in Current Shunt measurements especially when one or more of the voltage measuring devices is mains (line) powered. The main cause of common-mode current is capacitance between the measurement circuits and ground. Careful guarding can reduce, but not eliminate, the effect. In Figure 6. G_u represents instrument guards and C_{G_u} the capacitance to ground. Notice that C_{G_u} in the lower measurement circuit is almost shorted out by the G_u / ground connections. The voltage drop caused by connection impedances means that G_u in the lower circuit is not exactly at ground and the difference changes with frequency. As a result, common-mode current will cause small UUT measurement errors. Common-mode current errors usually increase with frequency.

The errors caused by common-mode current in the Reference Standard measurement circuit are potentially much greater. Z_c in Figure 6 is the impedance of the connection between the shunts. It can immediately be seen that the G_u / ground potential difference in the upper circuit is higher so more common-mode current flows in C_{G_u} of the Reference Standard measurement circuit than in the UUT circuit. Note the connection of the detector in the upper circuit. In this configuration C_{G_u} is driven by the source current reducing the effect of common-mode errors associated with the Reference Standard shunt. The voltage across the UUT, Z_c and the Reference Standard will increase with frequency because of inductance. This compounds the frequency dependence of common-mode current errors. Careful design of this connection to minimize inductance is essential.

Common-mode chokes are often used in the input of measuring devices to reduce common-mode effects. However, care must be taken to avoid resonances with C_{G_u} within the frequency range of interest.

The Fluke Calibration Method

This calibration method makes automated AC-DC difference and DC Resistance measurements. See Figure 7. The voltage outputs from the reference and UUT shunts are each detected with a 0.8 V, 5 mA SJTVC and a Keithley 2182A nanovoltmeter. A single manual intervention during the calibration disconnects the TVC assemblies and connects the shunt outputs to the nanovoltmeter secondary inputs. A comparative measurement is made to calibrate resistance at nominal current.

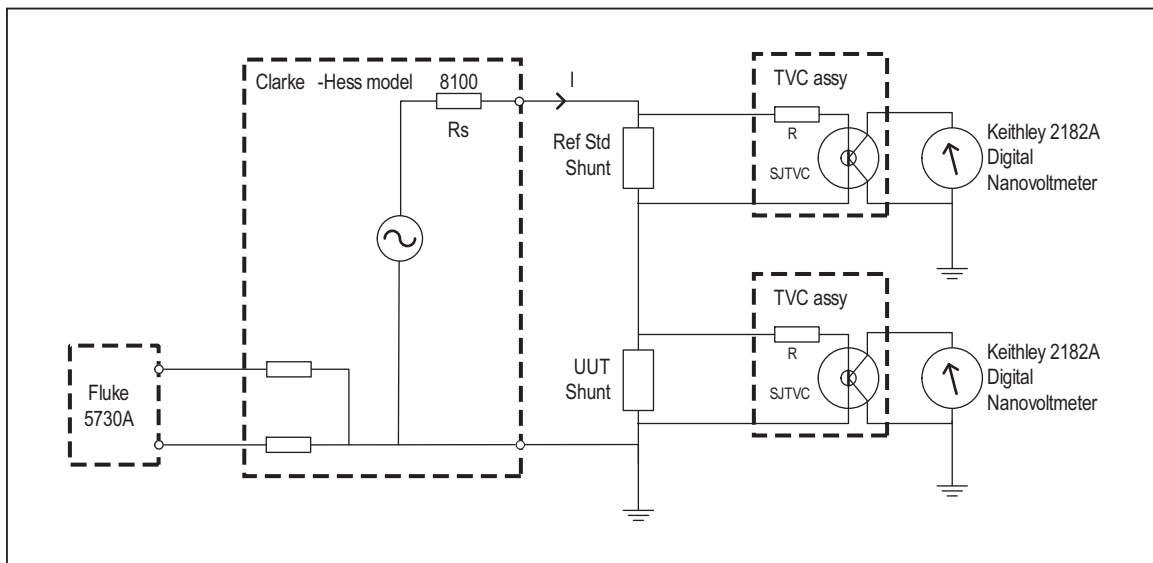

Figure 7. The Fluke Calibration System

feh018.eps

The TVC assembly comprises a 5 mA SJTVC and a 70 Ω precision series resistor to drop the 0.8 V output of the Reference Standard shunt to the 0.45 V maximum of the SJTVC. The components of the TVC assembly are packed in expanded polystyrene in a metal box to provide thermal stability. Construction is coaxial. The TVC assembly input connector is an N-type plug (male) which mates directly with the Reference Standard output connector.

Recommended Tools and Equipment

Table 13 provides a list of recommended equipment for using the Fluke Calibration Method to calibrate the Current Shunts. When using substitutes for the recommended models, make sure they meet or exceed the minimum use specifications shown in the table.

Table 13. List of Recommended Equipment

Nomenclature	Recommended Model	Minimum Use Specifications
Multifunction Calibrator	Fluke Calibration 5730A	0 to 10 volts, DC to 100 kHz
Transconductance Amplifier	Clarke-Hess 8100	100 A, 100 kHz
Precision AC Current Shunt Set	A40B	Calibrated at a National Measurement Institute or a Fluke Calibration Service Center
TVC Assembly (two required)	A UHF, 5 mA Single Junction thermocouple device or thermal voltage convertor such as the Fluke Model A55, Ballantine 1394A, or Measuretech EL1200; A 70 Ω resistor.	0.8V, 5 mA DC to 100 kHz
Nanovoltmeter (two required)	Keithley 2182A	10 mV DC, 1 nV resolution

System Calibration for AC-DC Difference

Periodic system calibration is required to compensate for the gain difference between the two TVC assemblies. Figure 8 shows how this is achieved.

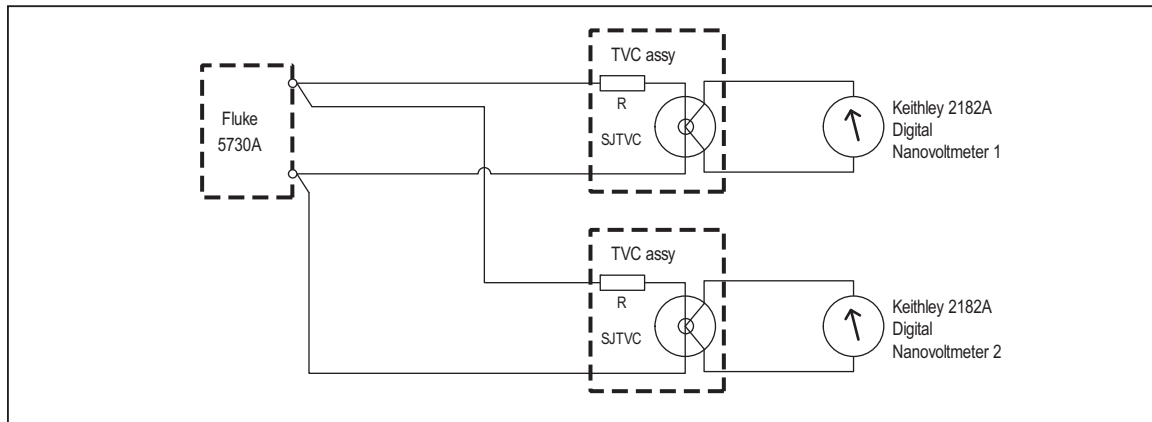

Figure 8. Calibrating Gain Difference

feh020.eps

The Fluke Calibration 5730A produces an output of 0.8 V. The relative AC-DC difference of the SJTVC assemblies is measured and applied as a correction.

TVC Sensitivity Characterization

The voltage output of a SJTVC output is proportional to the square of the applied voltage. Thus the device is inherently non-linear and transresistance gain or sensitivity changes with input current. Sensitivity characterization minimizes the resulting errors by determining mean sensitivity in a narrow band ± 500 ppm from the nominal current. Sensitivity characterization is performed before UUT calibration with the system configured as for UUT measurement (Figure 7). Figure 9 shows the characterization sequence where:

V_{in} is the setting on the 5730A

V_{in_1} = nominal + 500 ppm

V_{in_2} = nominal - 500 ppm

V_{in_3} = nominal + 500 ppm

V_{out_1} , 2 and 3 are the voltages reported by the measuring devices.

The gain factor η is a measure of the sensitivity of the device used to measure the output voltage

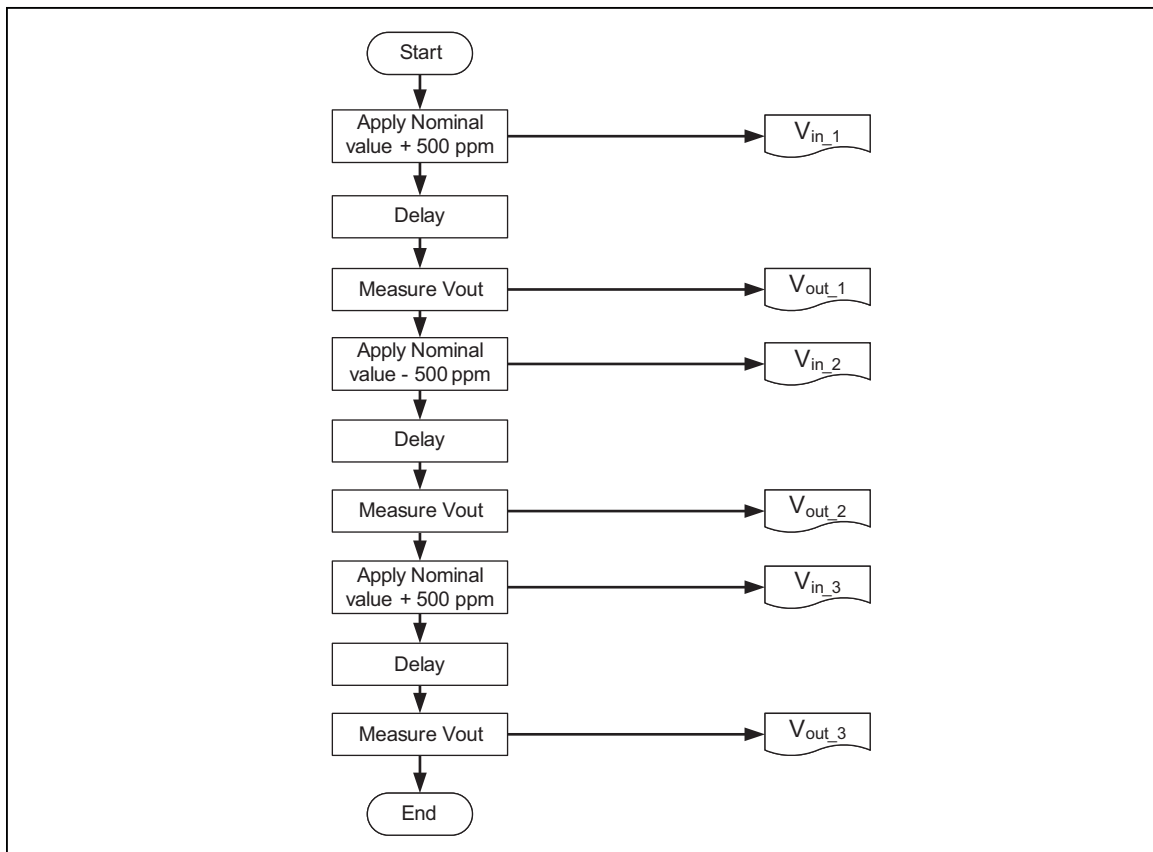

Figure 9. Characterizing Sensitivity

feh022.eps

$$\text{Gain factor } \eta = \frac{\Delta V_{out} (\text{inppm})}{\Delta V_{in} (\text{inppm})} = \frac{\frac{V_{OUT_1} + V_{OUT_3}}{2} - 1}{\frac{V_{IN_1} + V_{IN_3}}{2} - 1}$$

The +500 ppm measurement is performed twice to counter drift in the measurement.

UUT AC-DC Difference Measurement Sequence and Calculations

In order to minimise the effects of drift, the measurement sequence is symmetrical in the form AC1, +DC, -DC, AC2. The \pm DC measurements cancel thermal emf and zero offset. The two AC measurements compensate for drift during the measurement. Figure 10 shows the sequence where:

V_{DCUUT} = average of magnitude of V_{DC+UUT} and V_{DC-UUT}

V_{DCSTD} = average of magnitude of V_{DC+STD} and V_{DC-STD}

V_{ACUUT} = average of $V_{ACUUT-1}$ and $V_{ACUUT-2}$

V_{ACSTD} = average of $V_{ACSTD-1}$ and $V_{ACSTD-2}$

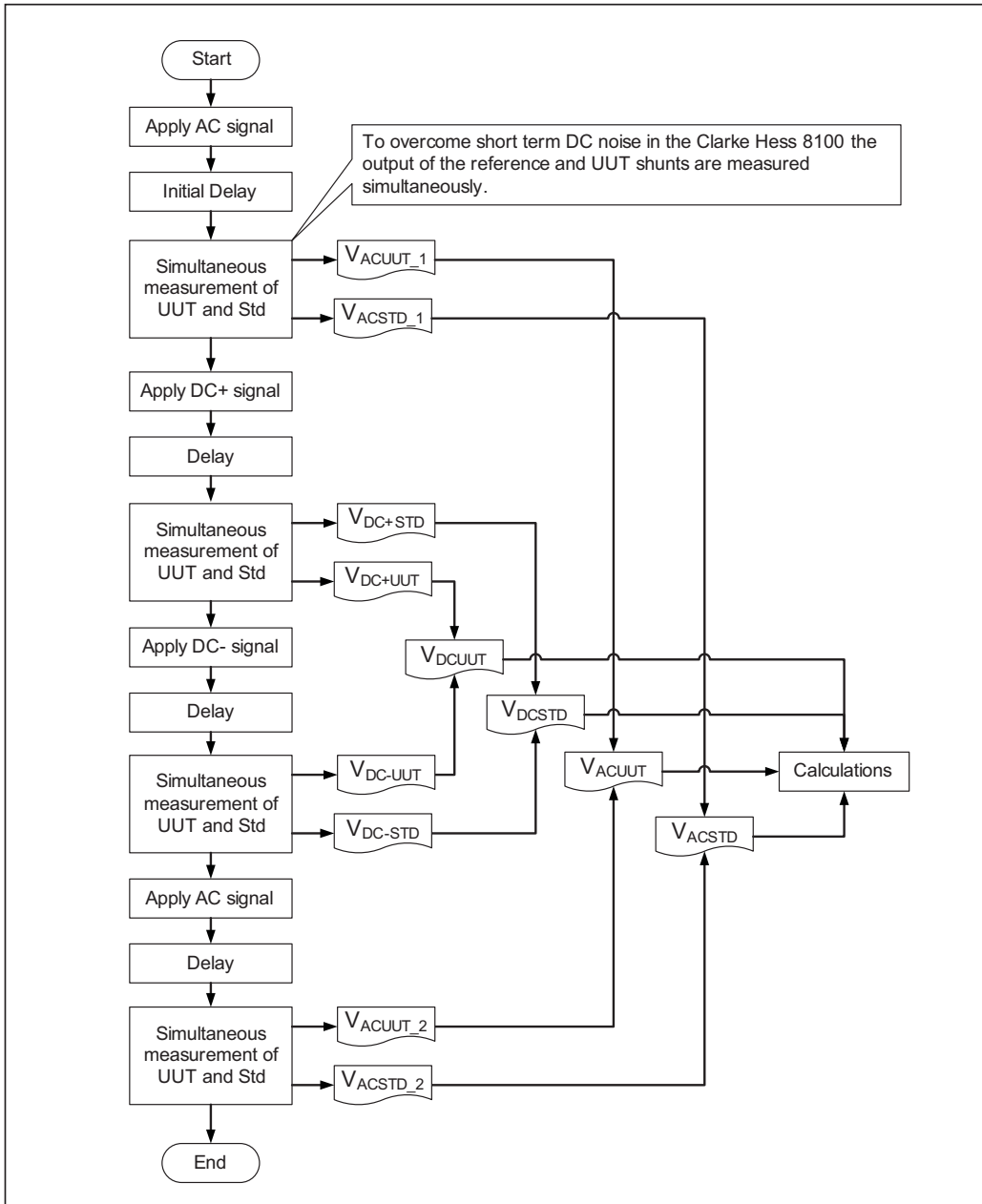

Figure 10. AC-DC Difference Sequence

feh024.eps

The AC-DC difference of the UUT shunt in ppm is determined from:

$$\delta_{UUT} = \delta_{STD} + \frac{(V_{ACSTD} - V_{DCSTD}) * 10^6}{\eta_{STD} \times V_{DCSTD}} - \frac{(V_{ACUUT} - V_{DCUUT}) * 10^6}{\eta_{UUT} \times V_{DCUUT}} + \delta_{USTD:TVC} - \delta_{UUT:TVC}$$

Where:

- δ_{UUT} = AC-DC Difference of UUT in ppm
- $\delta_{UUT:TVC}$ = AC-DC Difference of UUT SJTVC at the test frequency in ppm
- δ_{STD} = AC-DC Difference of reference Shunt in ppm
- $\delta_{STD:TVC}$ = AC-DC Difference of STD SJTVC at the test frequency in ppm
- V_{ACSTD} = Reference shunt voltage with AC current
- V_{DCSTD} = Reference shunt voltage, average of forward and reverse DC current
- V_{ACUUT} = UUT shunt voltage with AC current
- V_{DCUUT} = UUT shunt voltage, average of forward and reverse DC current
- η_{UUT} = Gain sensitivity of the UUT measurement system
- η_{STD} = Gain sensitivity of the Reference Standard measurement system

Current Source DC Noise

From some transconductance amplifiers, noise on DC can be problematic. The Fluke Calibration system addresses this problem by triggering the two nanovoltmeters at the same time so they integrate simultaneously to maximize noise immunity.

UUT DC Resistance Measurement

The DC resistance of the UUT is determined by Ratio measurement against the Reference Standard shunt. See Figure 7. The TVC assemblies are disconnected and the outputs of the Reference Standard and UUT shunts are each connected to the second input of their nanovoltmeter. DC reversal is employed to minimize thermal emf and DC zero offset errors.

Repair Procedures Including Disassembly and Reassembly

Warning

For safe operation and maintenance of the product:

- Repair the Product before use if the battery leaks.
- Batteries contain hazardous chemicals that can cause burns or explode. If exposure to chemicals occurs, clean with water and get medical aid.
- Do not disassemble or crush battery cells and battery packs.
- Do not put battery cells and battery packs near heat or fire. Do not put in sunlight.
- Do not short the battery terminals together.
- Do not keep cells or batteries in a container where the terminals can be shorted.
- Remove the input signals before you clean the Product.
- Use only specified replacement fuses.
- Remove circuit power before you connect the Product in the circuit when you measure current. Connect the Product in series with the circuit.
- Do not put metal objects into connectors.

Repair Limits

This section of the manual provides procedures for making minor repairs to the Current Shunts. These procedures are limited to the following replaceable parts as shown in Table 12 and Figure 14:

- Coaxial shunt guard Binding Post
- Coaxial shunt end plates
- N-Type Connectors

The N-type connectors of the 10 mA, 20 mA and 50 mA boxed Current Shunts can be replaced after removing the cover plate on the underside, but it is recommended the Current Shunts be returned to a Fluke Calibration Service Center for repair. Other than battery replacement, do not attempt to service the 1 mA Current Shunt.

Replacement batteries for the 1 mA Current Shunt must be NiHM. See the *Battery Specifications* earlier in the *General Specification* section of this manual. A NiMH battery replacement kit is available from Fluke Calibration; see Table 14. Read the Safety Information earlier in this manual before replacing the batteries.

All other repair and/or parts replacement should be performed at a Fluke Calibration Service Center. See *How to Contact Fluke Calibration* earlier in this manual to find the location nearest you.

Note

A replacement procedure for the N-type connectors is included in this manual. However, Fluke Calibration highly recommends having the work performed at a Fluke Calibration Service Center.

The LC-type connectors (50 A and 100 A shunts) cannot be repaired or replaced in the field. These connectors are very robust and do not need to be replaced unless they are damaged or worn. (Excessive heat buildup under load may indicate damage or wear.) If replacement of an LC connector is necessary, have the work performed at a Fluke Calibration Service Center.

List of Tools Required for Repair

A list of the tools required for disassembly, repair, and reassembly follows:

- 2.5 mm Allen wrench for Current Shunts rated at 20 A or less
- T25 Torx driver for Current Shunts rated at 50 A and 100 A
- 7 mm wrench (output end plate only)
- No. 10 Torx driver
- Magnetized slim line 5.5 mm wrench
- 50 W Soldering iron thin enough to work between the PCB struts
- Solder removal copper braid
- Solder suction tool
- T20 Torx driver for replacing the batteries in the 1 mA Current Shunt

End Plates and Guard Binding Post Replacement (Coaxial Shunts)

Note

The end plates have a small effect on the magnetic fields in the Current Shunt and should always be in place during operation of the Current Shunt. The magnetic effect increases with the current rating of the Current Shunt and can change AC-DC difference by around 80 ppm at 100 A, 100 kHz.

Use the following procedure to replace the binding post and the Aluminum end plates; see Figure 11.

1. To remove the binding post ①:
 - a. Remove the nut and washers from the back of the post ②, and
 - b. Pull the post out and away from the end plate.
 - c. Catch and save the spacer ③ as the post is removed.
2. To remove the output end plate ④:
 - a. Remove the binding post as described in step 1.
 - b. Remove the four Allen head screws ⑤.
 - c. Pull the end plate off and away from the body of the Current Shunt.
3. To remove the input end plate ⑥:
 - a. Remove the four Allen head screws ⑦.
 - b. Pull the end plate off and away from the body of the Current Shunt.

To remount or replace the removed components, logically reverse the removal procedure.

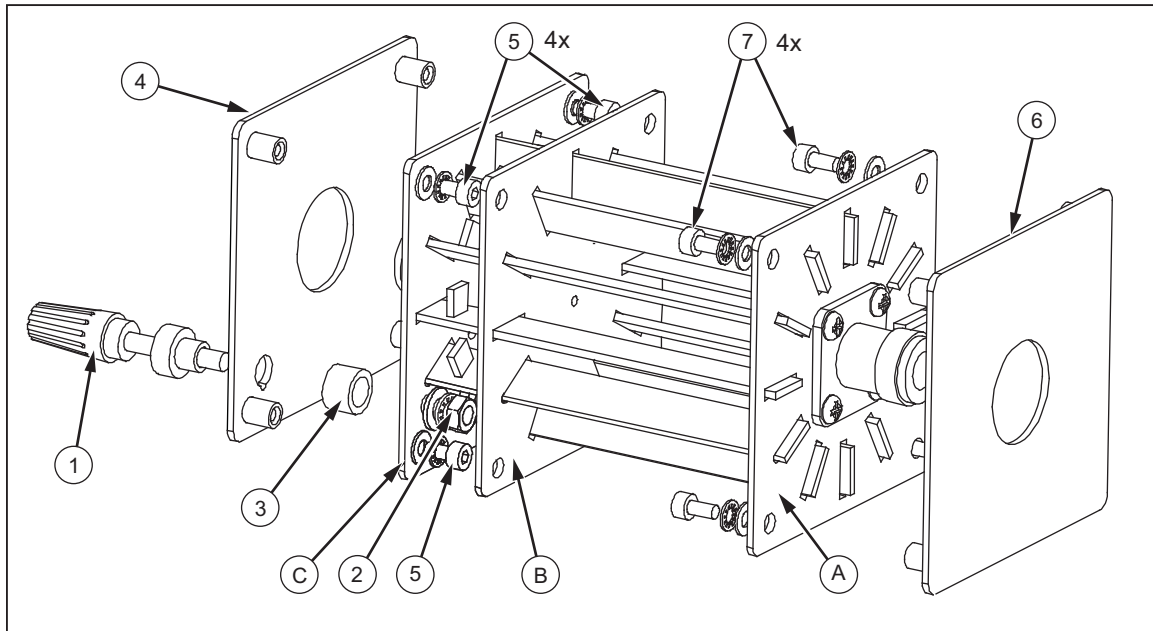

Figure 11. Exploded View of a Shunt

feh008.eps

Input N-type Connector Replacement (Coaxial Shunts)

Use the following procedure to replace the type-N input connector:

1. Remove the input end plate (Figure 11- ⑥).
2. Remove the 3 mm screws, nuts and washers shown in Figure 11.
3. Using solder braid and the solder suction tool, remove the solder from the N-type connector base plate/PCB joint.
4. Working between and taking care not to damage the PCB struts, melt the solder attaching the N-type center pin from the back of PCB **A** and withdraw the N-type connector. It may be necessary to repeat both solder removal steps until both the base and the center pin are free.
5. Remove excess solder from the connector pad on PCB **A**.
6. Mount the new connector to the Current shunt with the original screws and washers.
7. Position the nuts with the magnetized wrench and tighten the screws until the connector is securely positioned. Do not fully tighten the screws as the N-type connector may settle when residual solder melts.
8. Solder the N-type connector base to PCB **B**.
9. Working between the PCB struts, solder the center pin of N-type connector to the back of the end PCB.
10. Fully tighten the 3 mm screws securing the connector.
11. Clean any flux residue from the soldered areas. Be careful not to get cleaning fluids on the shunt resistors.
12. Replace the end plate.

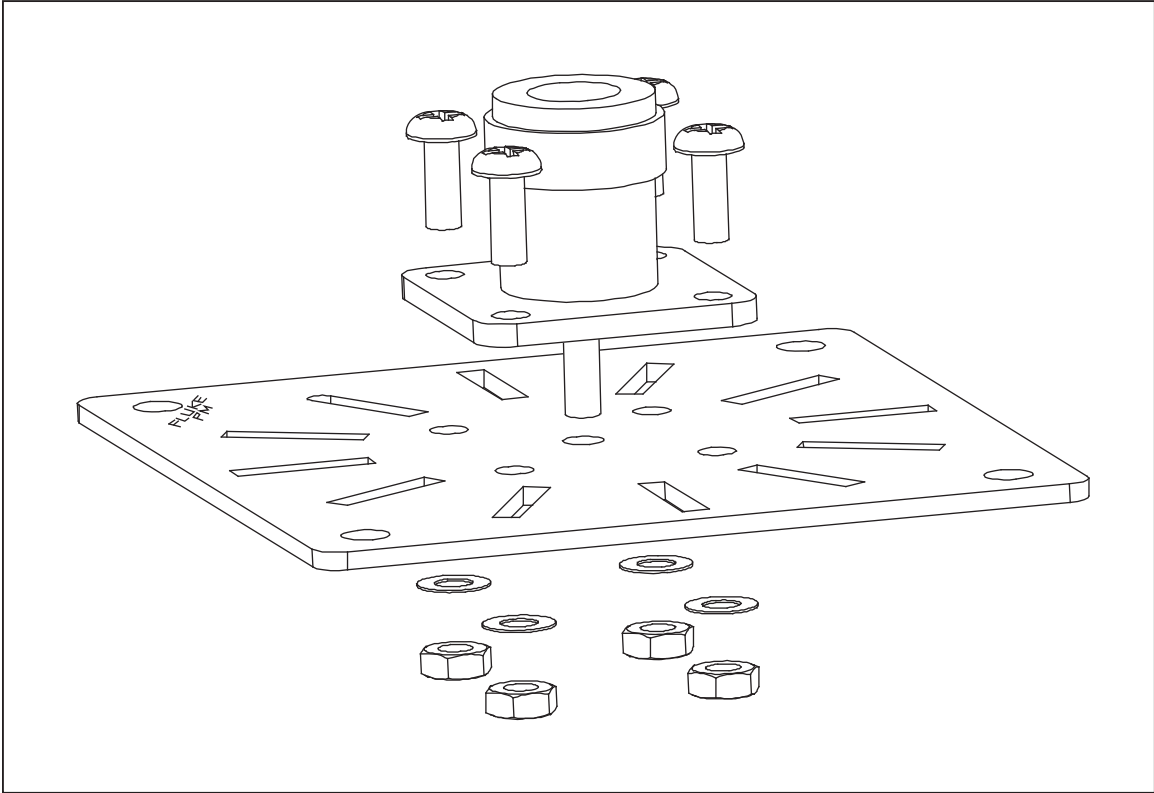

Figure 12. N-Type Input Current Connector

feh010f.eps

Output N-Type Connector Replacement (Coaxial Shunts)

Use the following procedure to replace the N-type output connector:

1. Remove the output end plate (Figure 11- (4)).
2. Remove the 3 mm screws, nuts and washers from the N-type connector.
3. Using solder braid and the solder suction tool, remove the solder from the N-type connector base plate, PCB **C**.
4. The inner pin of the N-type connector is connected by 18 mm (0.71 inches) of 20 SWG tinned copper wire to PCB **B**. See Figure 13. Working between and taking care not to damage the PCB struts, melt the solder attaching the wire from the back of PCB **B** and withdraw the N-type connector. It may be necessary to repeat both solder removal steps until both the base and the center pin are free.
5. Remove excess solder from the connector pad on PCB **B** and **C**.
6. Mount the new connector to the Current Shunt with the original screws and washers. Take care that the 20 SWD wire is correctly located through PCB **B**.
7. Position the nuts with the magnetized wrench and tighten the screws until the connector is securely positioned. Do not fully tighten the screws as the N-type connector may settle when residual solder melts.
8. Solder the N-type connector base to the end PCB. Then, working between the PCB struts, solder the connector wire to PCB **B**.
9. Fully tighten the 3 mm screws securing the connector.
10. Clean any flux residue from the soldered areas taking care not to get cleaning fluids on the shunt resistors.
11. Replace the end plate and binding post.

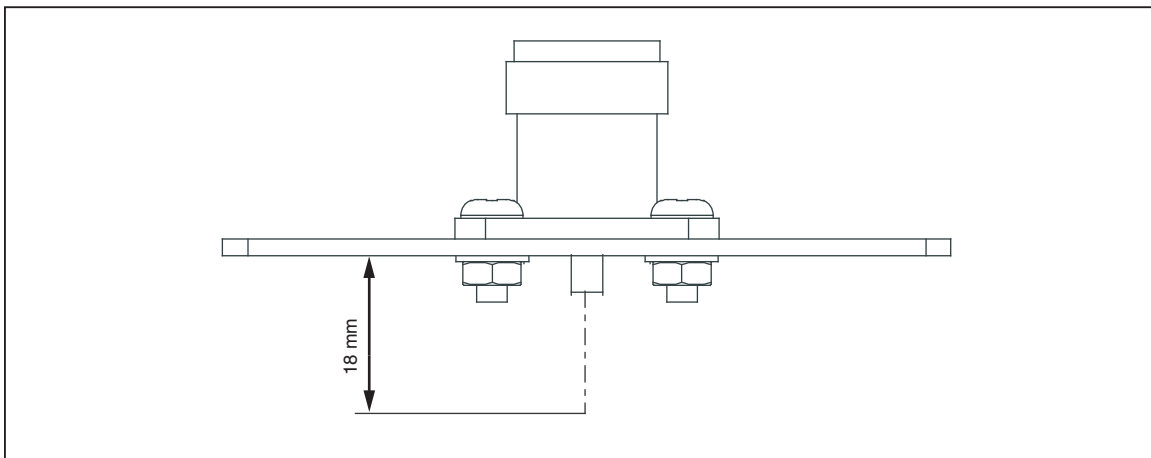

Figure 13. Output Voltage Connector

feh012.eps

Verification of Operation after Repair

Apply limited input current within specifications of product and verify the correct output.

Check to see that the ground connection is still connected to the chassis by resistance measurement.

List of Replaceable Parts

User service is limited to replacing the parts identified in Figure 14 and listed in Table 14. To order replacement parts refer to *How to Contact Fluke Calibration* earlier in this manual.

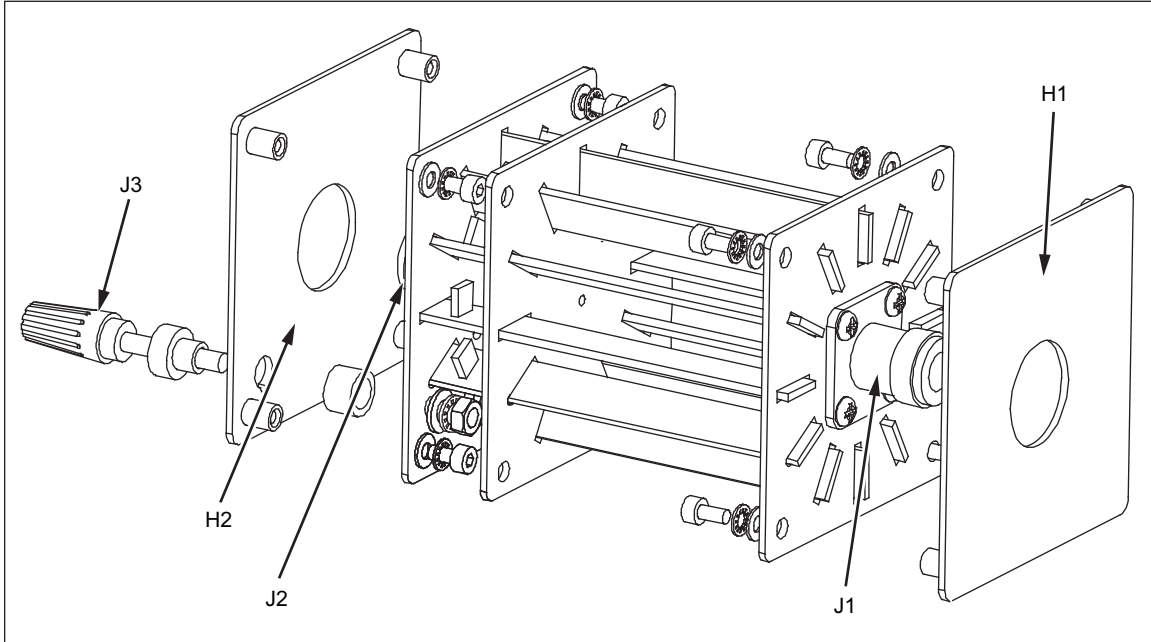

Figure 14. Final Assembly – Typical Current Shunt from the Set

Table 14. Final Assembly – Current Shunt Set

Ref Des	Description	Fluke Calibration Part No.	Qty
H1	End Plate, Front		
	100 mA Shunt	3275992	1
	200 mA Shunt	3276007	1
	500 mA Shunt	3276018	1
	1 A Shunt	3276029	1
	2 A Shunt	3276034	1
	5 A Shunt	3276041	1
	10 A Shunt	3276052	1
	20 A Shunt	3276065	1
	50 A Shunt	3276076	1
	100 A Shunt	3276083	1
H2	End Plate, Rear		
	100 mA, 200 mA, 500 mA, 1 A, 2 A Shunts	3276090	1
	5A, 10 A, 20 A Shunts	3276104	1
	50 A, 100 A Shunts	3276119	1
J1, J2	N-Type Connector, Female <i>(J2 on the 50 A and 100 A shunts use an LC-type connector, not replaceable in the field)</i>	875435	2
J3	Binding Post, Black (coaxial shunts)	3276128	1
--	Battery Charger for the 1 mA Current Shunt (not shown)	3359506	1
--	Replacement Battery Kit (not shown)	3359499	1
--	CD containing the manuals for the A40B Precision AC Current Shunt Set (not shown)	3356284	1