

NOTE

This manual documents the Model 2205A and its assemblies at the revision levels shown in Section 8. If your instrument contains assemblies with different revision letters, it will be necessary for you to either update or backdate this manual. Refer to the supplemental change/errata sheet for newer assemblies or to the backdating sheet in Section 8 for older assemblies.

2205A

Switch Controller

Instruction Manual

P/N 633644
JANUARY 1982

©1982, John Fluke Mfg. Co., Inc., all rights reserved. Litho in U.S.A.



WARRANTY

Notwithstanding any provision of any agreement the following warranty is exclusive:

The JOHN FLUKE MFG. CO., INC., warrants each instrument it manufactures to be free from defects in material and workmanship under normal use and service for the period of 1-year from date of purchase. This warranty extends only to the original purchaser. This warranty shall not apply to fuses, disposable batteries (rechargeable type batteries are warranted for 90-days), or any product or parts which have been subject to misuse, neglect, accident, or abnormal conditions of operations.

In the event of failure of a product covered by this warranty, John Fluke Mfg. Co., Inc., will repair and calibrate an instrument returned to an authorized Service Facility within 1 year of the original purchase; provided the warrantor's examination discloses to its satisfaction that the product was defective. The warrantor may, at its option, replace the product in lieu of repair. With regard to any instrument returned within 1 year of the original purchase, said repairs or replacement will be made without charge. If the failure has been caused by misuse, neglect, accident, or abnormal conditions of operations, repairs will be billed at a nominal cost. In such case, an estimate will be submitted before work is started, if requested.

THE FOREGOING WARRANTY IS IN LIEU OF ALL OTHER WARRANTIES, EXPRESS OR IMPLIED, INCLUDING BUT NOT LIMITED TO ANY IMPLIED WARRANTY OF MERCHANTABILITY, FITNESS, OR ADEQUACY FOR ANY PARTICULAR PURPOSE OR USE. JOHN FLUKE MFG. CO., INC., SHALL NOT BE LIABLE FOR ANY SPECIAL, INCIDENTAL, OR CONSEQUENTIAL DAMAGES, WHETHER IN CONTRACT, TORT, OR OTHERWISE.

If any failure occurs, the following steps should be taken:

1. Notify the JOHN FLUKE MFG. CO., INC., or nearest Service facility, giving full details of the difficulty, and include the model number, type number, and serial number. On receipt of this information, service data, or shipping instructions will be forwarded to you.
2. On receipt of the shipping instructions, forward the instrument, transportation prepaid. Repairs will be made at the Service Facility and the instrument returned, transportation prepaid.

SHIPPING TO MANUFACTURER FOR REPAIR OR ADJUSTMENT

All shipments of JOHN FLUKE MFG. CO., INC., instruments should be made via United Parcel Service or "Best Way" prepaid. The instrument should be shipped in the original packing carton; or if it is not available, use any suitable container that is rigid and of adequate size. If a substitute container is used, the instrument should be wrapped in paper and surrounded with at least four inches of excelsior or similar shock-absorbing material.

CLAIM FOR DAMAGE IN SHIPMENT TO ORIGINAL PURCHASER

The instrument should be thoroughly inspected immediately upon original delivery to purchaser. All material in the container should be checked against the enclosed packing list. The manufacturer will not be responsible for shortages against the packing sheet unless notified immediately. If the instrument is damaged in any way, a claim should be filed with the carrier immediately. (To obtain a quotation to repair shipment damage, contact the nearest Fluke Technical Center.) Final claim and negotiations with the carrier must be completed by the customer.

The JOHN FLUKE MFG. CO., INC., will be happy to answer all applications or use questions, which will enhance your use of this instrument. Please address your requests or correspondence to: JOHN FLUKE MFG. CO., INC., P.O. BOX C9090, EVERETT, WASHINGTON 98206, ATTN: Sales Dept. For European Customers: Fluke (Holland) B.V., P.O. Box 5053, 5004 EB, Tilburg, The Netherlands.

*For European customers, Air Freight prepaid.

John Fluke Mfg. Co., Inc., P.O. Box C9090, Everett, Washington 98206

Table of Contents

SECTION	TITLE	PAGE
1	INTRODUCTION AND SPECIFICATIONS	1-1
	1-1. INTRODUCTION	1-1
	1-8. SPECIFICATIONS	1-1
2	INSTALLATION	2-1
	2-1. INTRODUCTION	2-1
	2-3. SHIPPING INFORMATION	2-1
	2-6. INPUT POWER	2-1
	2-9. FUSE REPLACEMENT	2-1
	2-11. INSTALLATION NOTES	2-2
	2-12. Introduction	2-2
	2-14. Switch Modules	2-2
	2-17. Analog Signal Cable	2-2
	2-19. Internal Scanner Buses	2-2
	2-23. INTERNAL SWITCHES	2-3
	2-24. Access Procedure	2-3
	2-26. Two-/Four-wire Bus Selection	2-3
	2-28. Auto Increment Rate Selection	2-4
	2-30. Trigger Output	2-4
	2-33. Baud Rate Selection	2-5
	2-35. IEEE Address Selection	2-6
	2-37. RACK INSTALLATION	2-6
	2-39. SCANNER EXTENTION	2-6
3	OPERATING INSTRUCTIONS	3-1
	3-1. INTRODUCTIONS	3-1
	3-3. OPERATING FEATURES	3-1
	3-5. OPERATING NOTES	3-1
	3-6. Introduction	3-1
	3-8. Internal Scanner Buses	3-1
	3-12. Local Operation	3-1
	3-14. Auto Increment Operation	3-4
	3-17. Remote Operation	3-4
	3-69. Operating Conditions	3-8
	3-71. OPERATION	3-8
4	THEORY OF OPERATION	4-1
	4-1. INTRODUCTION	4-1
	4-3. OVERALL FUNCTIONAL DESCRIPTION	4-1

TABLE OF CONTENTS, *continued*

SECTION	TITLE	PAGE
4-6.	BLOCK DIAGRAM ANALYSIS	4-2
4-7.	Front Panel Display PCB	4-2
4-11.	Extended Bus PCB	4-3
4-16.	Power Supply	4-4
4-21.	Remote Interface Options	4-4
5	MAINTENANCE	5-1
5-1.	INTRODUCTION	5-1
5-3.	SERVICE INFORMATION	5-1
5-6.	GENERAL MAINTENANCE	5-1
5-7.	Cleaning	5-1
5-9.	PERFORMANCE TEST	5-2
5-11.	Set-up Procedure	5-2
5-13.	Manual Test Procedure	5-2
5-15.	Baud Rate/IEEE Address	5-3
5-17.	Remote Interface Test Procedure	5-3
5-19.	CALIBRATION ADJUSTMENT	5-3
5-21.	TROUBLESHOOTING	5-3
6	LIST OF REPLACEABLE PARTS	6-1
6-1.	INTRODUCTION	6-2
6-4.	HOW TO OBTAIN PARTS	6-2
7	OPTIONS AND ACCESSORIES	7-1
	TABLE OF CONTENTS	7-1
8	MANUAL CHANGE INFORMATION	8-1
9	SCHEMATIC DIAGRAMS	9-1
	TABLE OF CONTENTS	9-1

List of Tables

TABLE	TITLE	PAGE
1-1.	Options and Accessories	1-2
1-2.	2205A Specifications	1-2
2-1.	Auto Scan Rate Selection	2-4
2-2.	Trigger Delay Selection	2-5
2-3.	Baud Rate Selection	2-6
2-4.	IEEE Address Selection	2-6
3-1.	Front Panel Control Functions	3-4
3-2.	Channel Display Indications	3-4
3-3.	Remote Control Characters	3-5
3-4.	Actuator Module Commands	3-6
3-5.	Latching Module Commands	3-6
3-6.	General Purpose and Low Level Scanner Module Commands	3-7
3-7.	Four-Wire Resistance Scanner Module Commands	3-8
5-1.	Required Test Equipment	5-1
5-2.	Troubleshooting Guide	5-4

1
2
3
4
5
6
7
8
9
10
11
12
13
14
15
16
17
18
19
20
21
22
23
24

List of Illustrations

FIGURE	TITLE	PAGE
Frontispiece	2205A Switch Controller	vi
1-1.	Outline Drawing	1-4
2-1.	Line Voltage Selection Details	2-2
2-2.	Analog Signal Connector Jumpers	2-3
2-3.	Internal Switch and Adjustment Locations	2-4
2-4.	Trigger Delay Patterns	2-5
2-5.	Typical 2205A System Interconnects	2-7
3-1.	2205A Controls, Indicators, Connectors	3-2
4-1.	2205A Functional Block Diagram	4-1
4-2.	Front Panel Display PCB	4-2
4-3.	Extended Bus PCB	4-3
5-1.	Test Cable	5-2

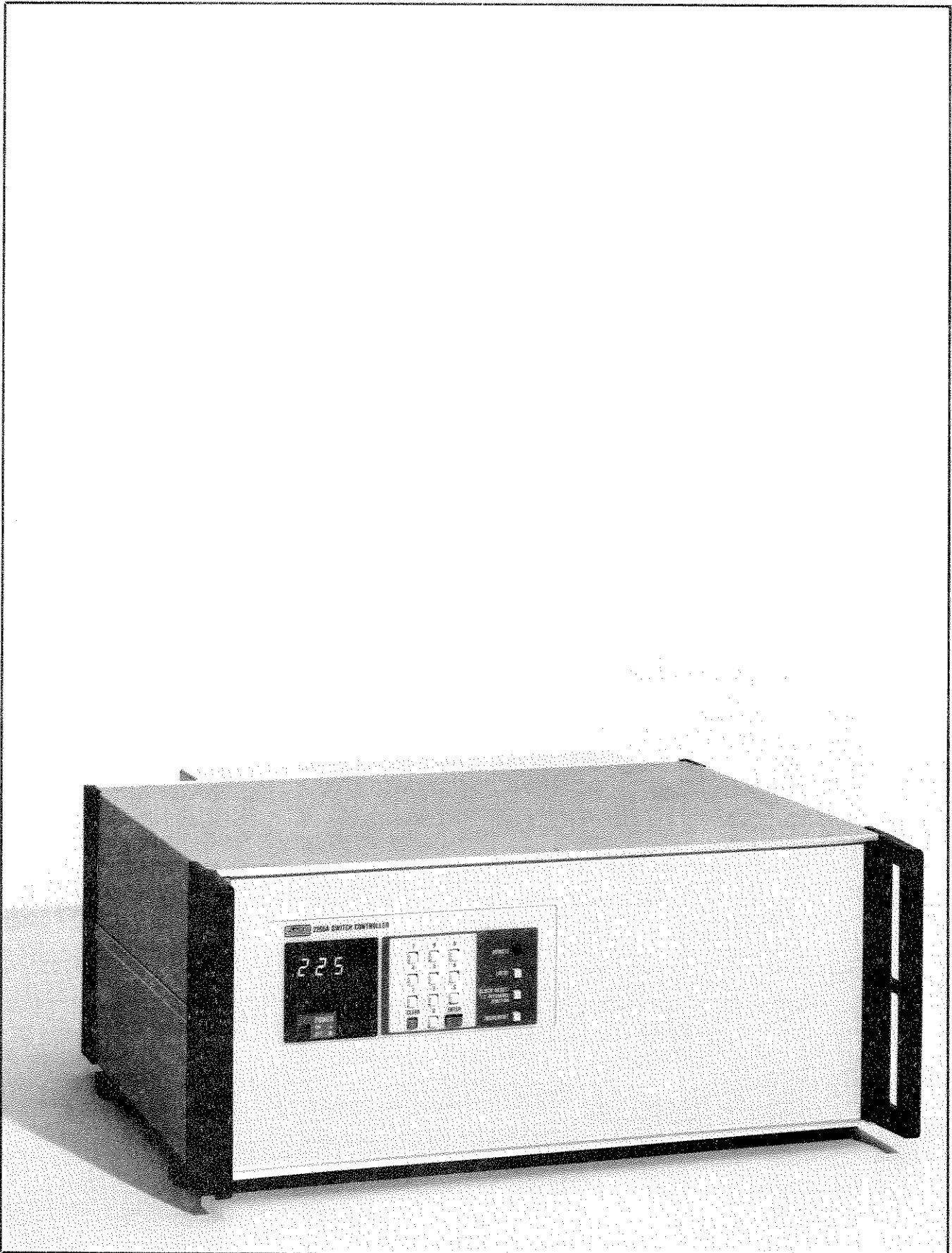

2205A Switch Controller

Section 1

Introduction and Specifications

1-1. INTRODUCTION

1-2. The Fluke Model 2205A Switch Controller is an instrument mainframe which accepts plug-in options for multi-function switching of analog signals. The 2205A is designed for automatic test equipment (ATE) and data acquisition system use. The switch modules functionally accommodate the three fundamental requirements for switching in instrumentation systems: signal acquisition, distribution, and control.

1-3. The key feature of the 2205A is its modular configuration which supports concurrent multi-function switching. Other important features include: low thermal design for low level measurement applications, dual guarded internal scanner bus for precision resistance measurements or parallel scanning, and expansion capability. In its basic form, the 2205A is capable of physically housing up to 10 switch modules and can be expanded to electrically control up to 100 switch modules. The 2205A is also compatible with companion instruments for system application.

1-4. The front panel of the 2205A features the controls and indicators necessary for manual (local) control of the switch modules. Commands are entered on a calculator-type keyboard (0-9) and are displayed on a three-digit LED display. Three control buttons (BLOCK RESET/T.C. REF. JUNCTION, LOCAL, and INCREMENT) are provided for commanding thermocouple reference junction measurements or module resets (depending on type of module addressed), local recall (remote-to-local), and channel increment.

1-5. The rear panel of the 2205A includes a remote interface connector (for use on IEEE-488 or RS-232-C Standard buses), an extender connector to add extension mainframes, an analog connector for connecting the internal scanner buses to an external instrument such as a digital multimeter (DMM), and a trigger output connector for initiating a DMM reading. An analog output cable for connection between the 2205A and a system type DMM is supplied with the 2205A. The remote interface cable, the trigger output cable (coax with BNC connectors), and an extender cable (which is required when adding an extension chassis) are options and are not included with the unit. Extender cables are available as accessories and are fabricated by the factory to meet particular cable length requirements. Cable lengths from 3 to 1500 feet may be used depending upon the extension mainframe employed.

1-6. The slots for the switch modules are also located at the rear of the 2205A. They consist of a series of 10 pcb slots (blocks) numbered from 0 through 9. Each slot will accommodate a plug-in relay pcb and an input connector for supplying analog data to the 2205A. The relay pcbs and the input connectors make-up a module are available as options.

1-7. All options and accessories available for use with the 2205A are listed in Table 1-1. Details necessary for specification, installation, operation, and maintenance are given in Section 7 of this manual.

1-8. SPECIFICATIONS

1-9. The specifications for the Model 2205A Switch Controller are listed in Table 1-2.

Table 1-1. Options and Accessories

OPTION/ MODEL NO.	DESCRIPTION	OPTION/ MODEL NO.	DESCRIPTION
2201A	Extender Scanner Chassis and Cable	2205A-300	General Purpose Scanner Module
2202A	Remote Scanner Chassis and Cable	2205A-400	Four-wire Resistance Scanner Module (requires 2 slots)
2200A-7001	Remote Scanner Connector Kit	2205A-600	Low Level Scanner Module
2200A-7002	Remote Scanner Cable	M07-205-600	Rack Mounting Kit
2205A-050	IEEE-488 Compatible Interface	M00-280-610	Rack Slide Kit
2205A-060	RS-232-C Interface	Y8001	1 Meter IEEE-488 Compatible I/F Cable
2205A-100	Actuator Module	Y8004	3 Meter RS-232 I/F Cable
2205A-200	Latching Module	Y8013	Delay Trigger Cable
		Y8076	Analog Signal Cable

Table 1-2. 2205A Specifications

ELECTRICAL CHANNEL CAPACITY	
Mainframe	Any combination of ten switch modules. Up to 100 channels of scanning capacity, 80 latching relays, 50 actuator relays, or 50 channels of four wire switching.
System	Up to nine extender chassis can be serially added to the 2205A for a maximum of 100 switch modules. This provides up to 1000 channels of scanning, 800 latching channels, or 500 actuator relays. A system with one 2205A and no 2202A is power limited to 100 latching closures, or 50 actuator closures, or any equivalent combination at any one time.
CHANNEL SWITCHING RATE	
On Delay	2 ms or 4 ms
Off Delay	2, 4, 6 or 8 ms
Logic Delay	2 ms maximum
	Use 2 + 4 ms for general purpose scanning modules. Use 4 + 8 ms for low level scanning modules.
TRIGGER OUTPUT	A negative going TTL compatible pulse of 15 μ s, referenced to logic common.
SCANNER BUS SPECIFICATIONS	
Isolation	Signal lines to power ground, $>10^{10} \Omega$.
Cross Talk	Less than 30 dB below applied signal from dc to 1 MHz when terminated with 1 M Ω .
Noise	General purpose and low level scanning modules only.

Table 1-2. 2205A Specifications (cont)

COMMON MODE REJECTION			
(50 to 60 Hz)	-90 dB for 1 k Ω unbalanced. See extender chassis manuals for specifications of CMR with added external chassis.		
BROADBAND	Less than 1 μ V rms for a source resistance < 2 k Ω and a dc to 3 kHz bandwidth.		
THERMAL	Low level modules; less than 1 μ V offset. General purpose modules; less than 10 μ V offset.		
Leakage Resistance	High-to-low; > 10 ¹⁰ Ω .		
Channel Capacitance	2205A with two like scanner modules on the internal scanner bus.		
	OPEN	CLOSED	EACH ADDED SCANNER
LOW LEVEL, HI TO LO	4 pF	30 pF	2 pF
GENERAL PURPOSE, HI TO LO	8 pF	70 pF	8 pF
INTERCHANNEL	3 pF	5 pF	
Common Mode Voltage	Guard to chassis; 170V dc or peak ac (50 to 60 Hz) maximum. Logic common to chassis; 30V dc or peak ac maximum.		
ENVIRONMENTAL SPECIFICATIONS			
Operating Temperature	0 to +50°C		
Storage Temperature	-55 to +75°C		
Relative Humidity	0 to 80% up to +40°C		
GENERAL SPECIFICATIONS			
Display	A 3-digit LED display is used to indicate the selected channel. Also provides remote interface identification when the unit is initially turned on.		
Remote Interfaces	IEEE-488 or RS-232 Compatible Interfaces are available as options.		
Power	Selectable 100, 120, 220, or 240V \pm 10%, 50 to 60 Hz, 15 VA maximum.		
Dimensions	17.8 cm H x 43.2 cm W x 44.2 cm D 7 in H x 17 in W x 17.4 in D (See Figure 1-1)		
Weight	7.1 kg (15.6 lbs) without options.		

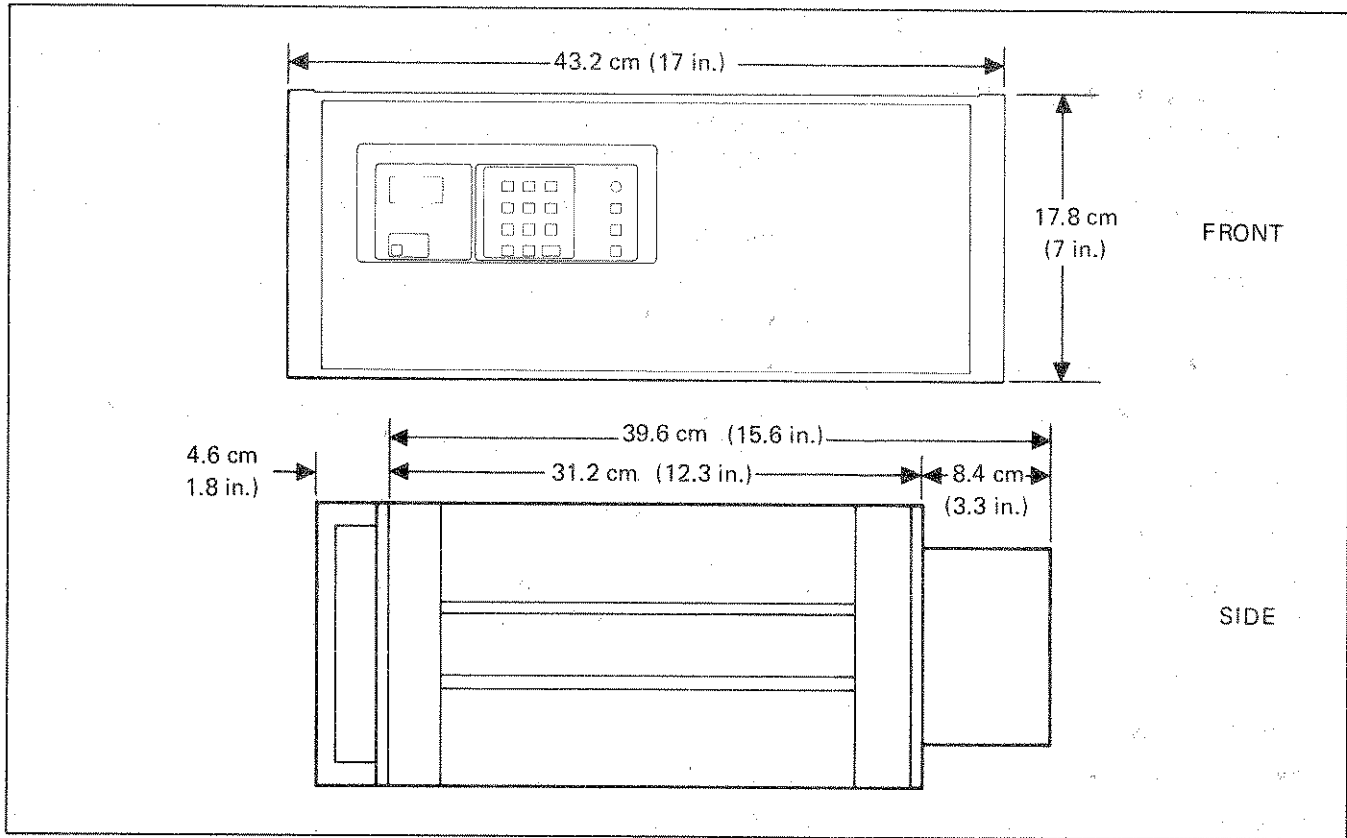

Figure 1-1. Outline Drawing



static awareness



A Message From
John Fluke Mfg. Co., Inc.

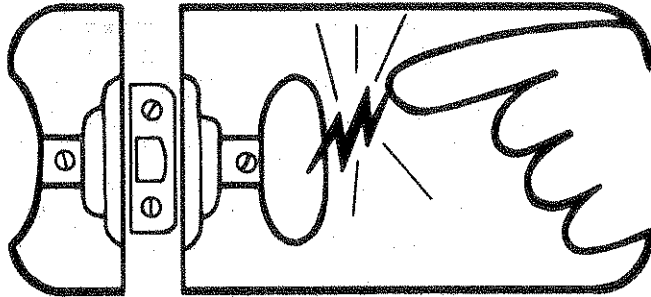

Some semiconductors and custom IC's can be damaged by electrostatic discharge during handling. This notice explains how you can minimize the chances of destroying such devices by:

1. Knowing that there is a problem.
2. Learning the guidelines for handling them.
3. Using the procedures, and packaging and bench techniques that are recommended.

The Static Sensitive (S.S.) devices are identified in the Fluke technical manual parts list with the symbol "⊗"

The following practices should be followed to minimize damage to S.S. devices.

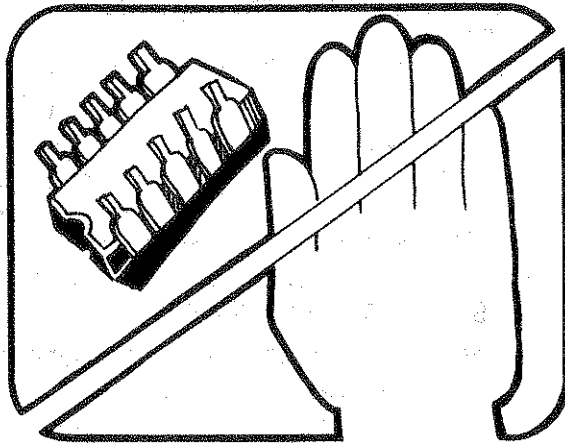

1. MINIMIZE HANDLING

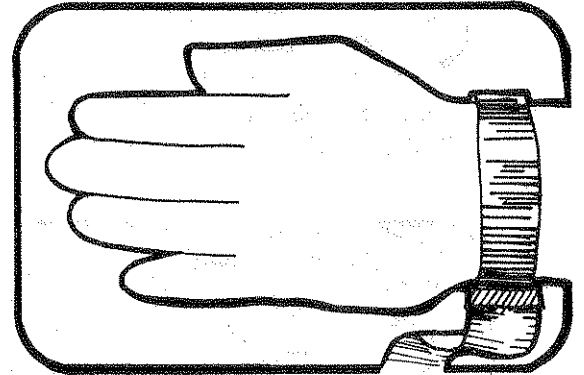

3. DISCHARGE PERSONAL STATIC BEFORE HANDLING DEVICES

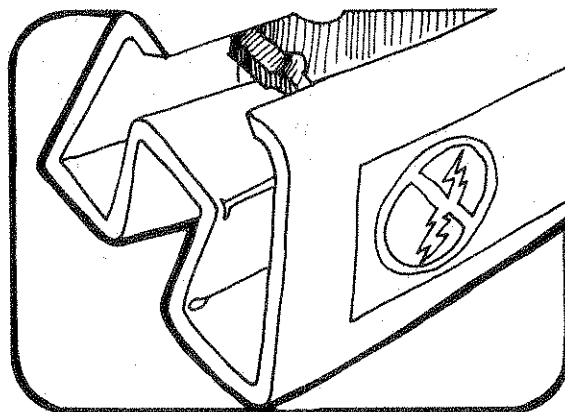

2. KEEP PARTS IN ORIGINAL CONTAINERS UNTIL READY FOR USE.

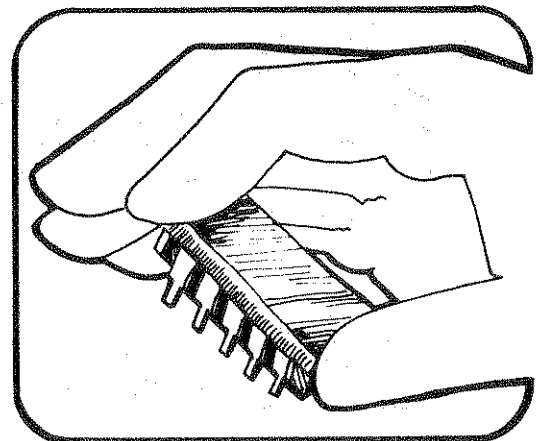

4. HANDLE S.S. DEVICES BY THE BODY

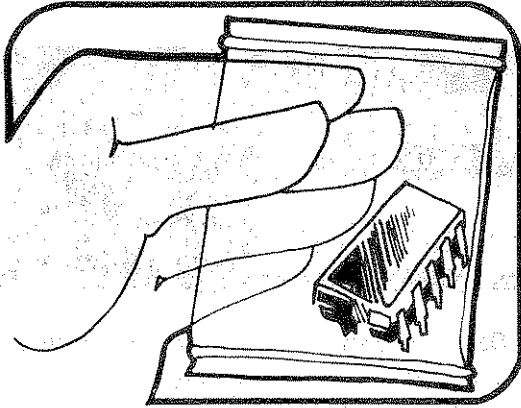

5. USE ANTI-STATIC CONTAINERS FOR HANDLING AND TRANSPORT

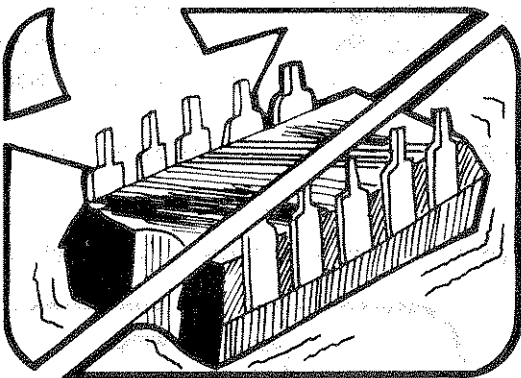

6. DO NOT SLIDE S.S. DEVICES OVER ANY SURFACE

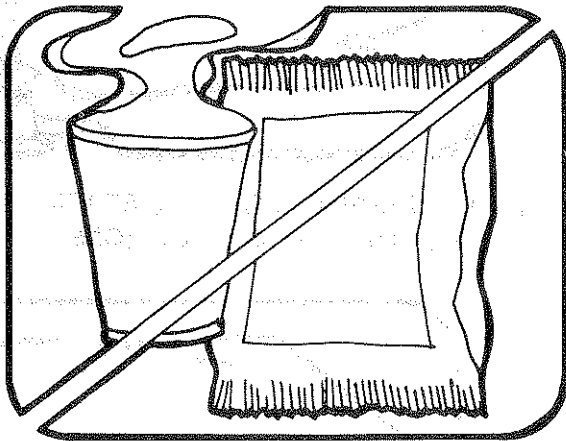

7. AVOID PLASTIC, VINYL AND STYROFOAM® IN WORK AREA

PORTIONS REPRINTED
WITH PERMISSION FROM TEKTRONIX, INC.
AND GENERAL DYNAMICS, POMONA DIV.

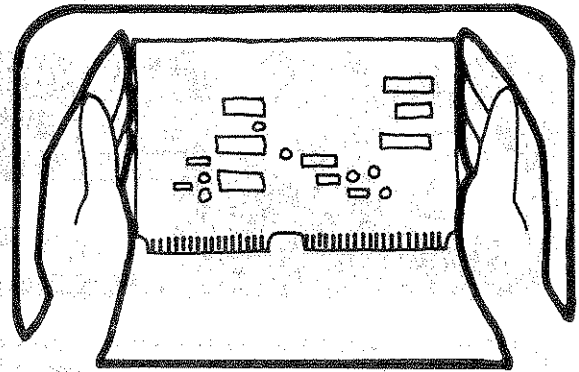

8. WHEN REMOVING PLUG-IN ASSEMBLIES, HANDLE ONLY BY NON-CONDUCTIVE EDGES AND NEVER TOUCH OPEN EDGE CONNECTOR EXCEPT AT STATIC-FREE WORK STATION. PLACING SHORTING STRIPS ON EDGE CONNECTOR USUALLY PROVIDES COMPLETE PROTECTION TO INSTALLED SS DEVICES.

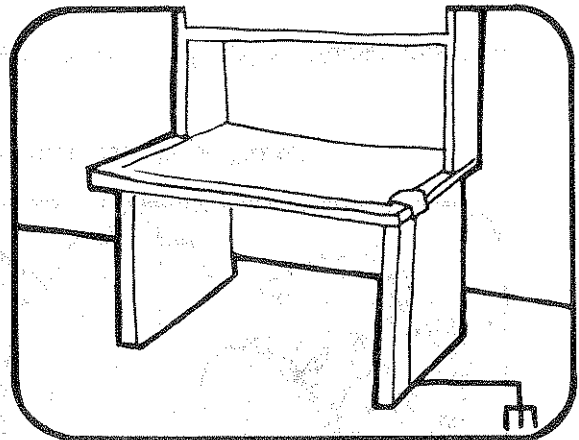

9. HANDLE S.S. DEVICES ONLY AT A STATIC-FREE WORK STATION
10. ONLY ANTI-STATIC TYPE SOLDER-SUCKERS SHOULD BE USED.
11. ONLY GROUNDED TIP SOLDERING IRONS SHOULD BE USED.

Anti-static bags, for storing S.S. devices or pcbs with these devices on them, can be ordered from the John Fluke Mfg. Co., Inc.. See section 5 in any Fluke technical manual for ordering instructions. Use the following part numbers when ordering these special bags.

John Fluke Part No.	Description
453522	6" X 8" Bag
453530	8" X 12" Bag
453548	16" X 24" Bag
454025	12" X 15" Bag
Pink Poly Sheet	Wrist Strap
30"x60"x60 Mil	P/N TL6-60
P/N RC-AS-1200	\$7.00
\$20.00	

Section 2 Installation

WARNING

THESE INSTALLATION INSTRUCTIONS ARE FOR USE BY QUALIFIED PERSONNEL ONLY. TO AVOID ELECTRIC SHOCK, DO NOT PERFORM ANY PROCEDURES OTHER THAN THOSE CONTAINED IN THE OPERATING INSTRUCTIONS UNLESS YOU ARE QUALIFIED TO DO SO.

2-1. INTRODUCTION

2-2. This section provides the information for the installation and set-up of the 2205A Switch Controller. The following also covers operating features that should be taken into consideration before operating the 2205A.

2-3. SHIPPING INFORMATION

2-4. The 2205A is packaged and shipped in a foam-packed container. Upon receipt of the instrument, a thorough inspection should be made to reveal any possible shipping damage. Special instructions for inspection and claims are included in the shipping carton.

2-5. If reshipment of the instrument is necessary, the original container should be used. If the original container is not available, a new container can be obtained from the John Fluke Mfg. Co., Inc. Please reference the instrument's model number when requesting a new shipping container.

2-6. INPUT POWER

2-7. The 2205A can be configured to operate from any one of the following voltages: 100, 120, 220, or 240V ac $\pm 10\%$, 50 to 60 Hz. A rear panel decal identifies the line voltage selected prior to shipment. Figure 2-1 gives the complete procedure for changing to one of the other voltage configurations if a different one is required.

2-8. The three-prong, line-power connector (on the rear panel) permits the 2205A to be connected through the power cord to the local line power. The offset prong on this connector is connected to the 2205A chassis and

should be connected, via the power cord, to a high quality earth ground.

2-9. FUSE REPLACEMENT

2-10. The line fuse is safely accessible from the rear of the 2205A and can be easily replaced. Check and/or replace the fuse as follows:

1. Set the power switch to OFF and disconnect the power cord from line power.
2. Disconnect the power cord from the 2205A. The fuse compartment is located just below the power connector.
3. Open the fuse compartment by sliding the see-thru fuse cover toward the power connector.
4. Locate the fuse tab (next to fuse) and gently lift it up. This releases and lifts one end of the fuse.
5. Remove and inspect the fuse. If replacement is required, use MDL 1/4 amp fuse for 100/120V ac operations and MDL 1/8 amp fuse for 220/240V ac operation.
6. Lower the fuse tab and press a good fuse into the fuse holder.
7. Close the fuse compartment and connect the power cord.

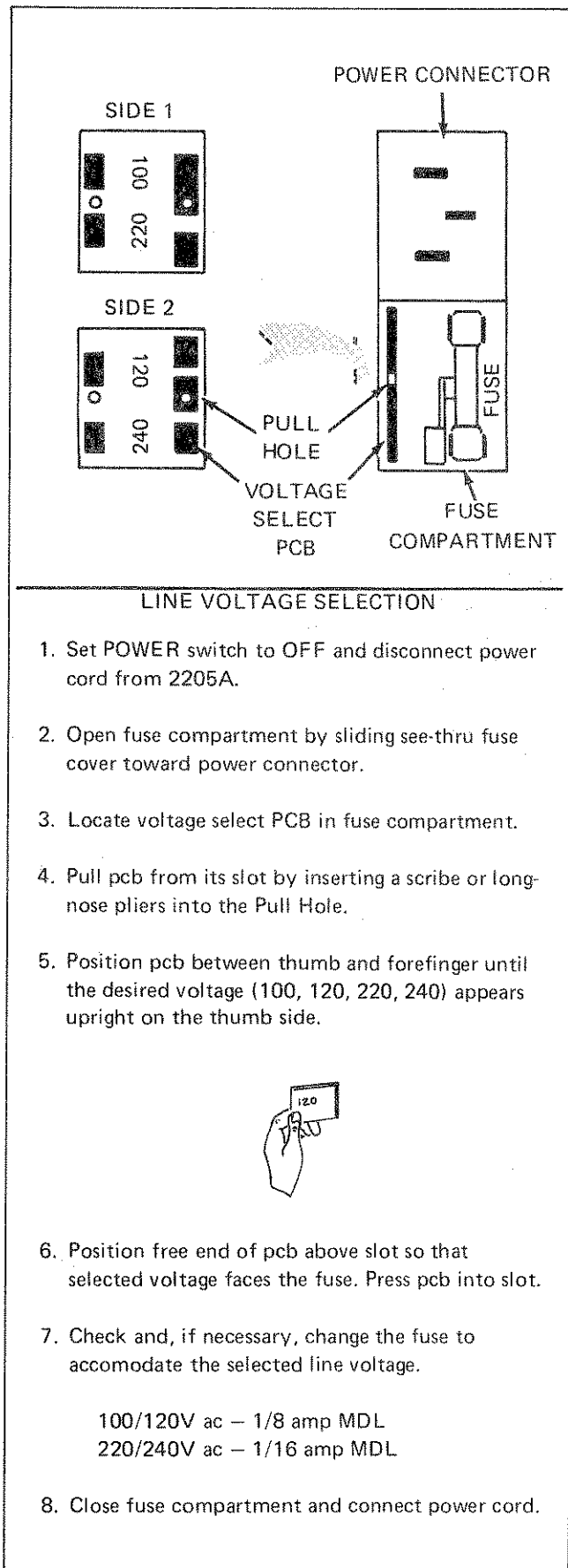

Figure 2-1. Line Voltage Selection Details

2-11. INSTALLATION NOTES

2-12. Introduction

2-13. The following paragraphs describe various conditions which should be considered before installing the 2205A.

2-14. Switch Modules

2-15. The 2205A is designed to accommodate any combination of up to 10 of either type switch module. The scanning modules provide 10 channels of analog signals using a common output bus. That is, when any one of the 10 channels is selected, that channel (high, low, and guard) is connected to one of the 2205A internal scanner buses for measurement (or stimulus) purposes. The switching modules provide programmable switching of external stimulus or signal lines under the control of the 2205A. These modules provide relays of various ratings and configurations for latching, external scanning, matrices, and other isolated switching functions.

2-16. Due to the wide variety of functions, review the descriptions of each module in Section 7 to ensure compatibility between the module and the intended application. Descriptions include specifications and the necessary information for installation, operation, and maintenance of the module.

2-17. Analog Signal Cable

2-18. An Analog Signal Cable (Y8076) is provided with the 2205A. The cable connects the internal scanner buses to the terminals of a system type DMM. Jumpers are installed on the connector to tie the buses together for two-wire operation. If four-wire operation is preferred, the high and low jumpers should be removed from the 2205A end of the cable (Figure 2-2). These jumpers parallel the two analog buses and make them appear as a single bus.

2-19. Internal Scanner Buses

2-20. The 2205A is equipped with two internal analog buses (bus 1 and bus 2) for use in conjunction with the relay scanning modules. Bus 1 is associated with the even numbered slots (0, 2, 4, 6, 8,) and bus 2 is associated with the odd numbered slots (1, 3, 5, 7, 9,). Each bus consists of three lines; high, low, and guard. When a channel relay is selected on a given scanning module, that channel and its input signal are connected to the appropriate internal scanner bus.

2-21. Channel relays may be closed singly or in pairs. If closed singly, the analog buses should be connected in parallel at the Analog Signal Cable so that a single bus is formed. This configuration is called two-wire operation. That is, a single two-wire bus (high, low, guard) is common to all channels. If the relays are closed in pairs, the buses should remain electrically isolated so that two separate buses (bus 1 and bus 2) are available at the Analog Cable Output connector. This configuration, is

called four-wire operation. That is, a four-wire bus (high 1, high 2, low 1, low 2, guard, and shield 2) is common to all channel pairs. Guard and shield 2 are generally connected together at the Analog Signal Cable to form a single instrument guard. The desired bus operation is manually selected, and applies to all channels in the 2205A.

2-22. In the four-wire operation, relay pairs are closed by selecting a channel in one of the even numbered slots (0, 2, 4, 6, 8). The selected channel relay in the even numbered slot plus the corresponding channel relay in the next higher odd numbered slot are closed together. Thus, slots 0 and 1, 2 and 3, 4 and 5, 6 and 7, 8 and 9 operate as pairs. Selecting a channel in an odd numbered slot closes only that channel, not the pair.

NOTE

Four-wire operation is possible only in the 2205A. Extender chassis are configured for two-wire operation.

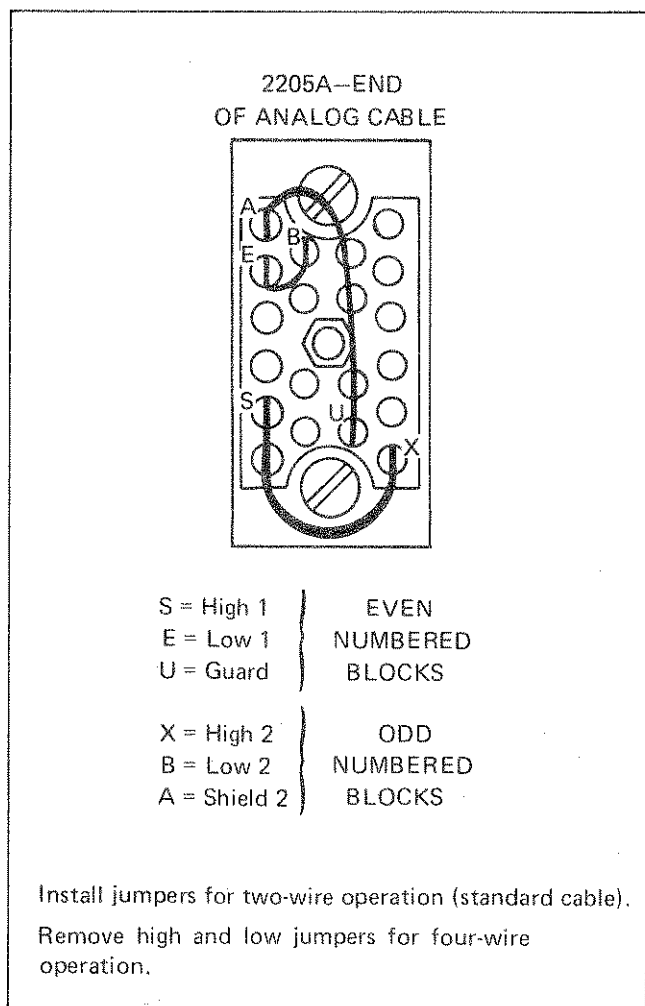

Figure 2-2. Analog Signal Cable Jumpers

2-23. INTERNAL SWITCHES

2-24. Access Procedure

2-25. All internal switches can be accessed by removing the top cover from the 2205A. The locations of the applicable switches are shown in Figure 2-3. Switch setting procedures are given later in this section of the manual. Complete the following procedure to remove the top cover:

WARNING

TO AVOID ELECTRICAL SHOCK HAZARD REMOVE LINE POWER AND THE MODULE INPUT CONNECTORS FROM THE 2205A BEFORE REMOVING THE TOP COVER. LETHAL VOLTAGES MAY BE PRESENT AT THE LINE POWER INPUT CONNECTOR AND THE POWER SUPPLY PCB ASSEMBLY WHEN THE 2205A IS CONNECTED TO LINE POWER. LETHAL COMMON MODE VOLTAGES MAY ALSO BE PRESENT AT THE MODULE INPUT CONNECTORS, EXTENDER CHASSIS AND MODULE PCBs EVEN THOUGH THE LINE POWER CORD IS DISCONNECTED.

1. Disconnect the controller mainframe from line power.
2. Disconnect and remove all of the switch module input connectors.
3. Remove the six screws on the top of the unit.
4. Remove the top cover.
5. Reverse the procedure to re-install the top cover.

2-26. Two-/Four-wire Bus Selection

2-27. The internal slide switch S1 on the Extended Bus PCB Assembly allows selection of either a two-wire or a four-wire bus operation of the internal scanner bus. The procedure for accessing and setting the switch follows:

1. Use the Access Procedure to remove the 2205A top cover and locate the two-/four-wire switch (S1) on the Extended Bus PCB (Figure 2-3).
2. Set the switch to the desired bus operation; toward the rear of the unit for four-wire, forward for two-wire.
3. Use the Access Procedure to install the top cover.

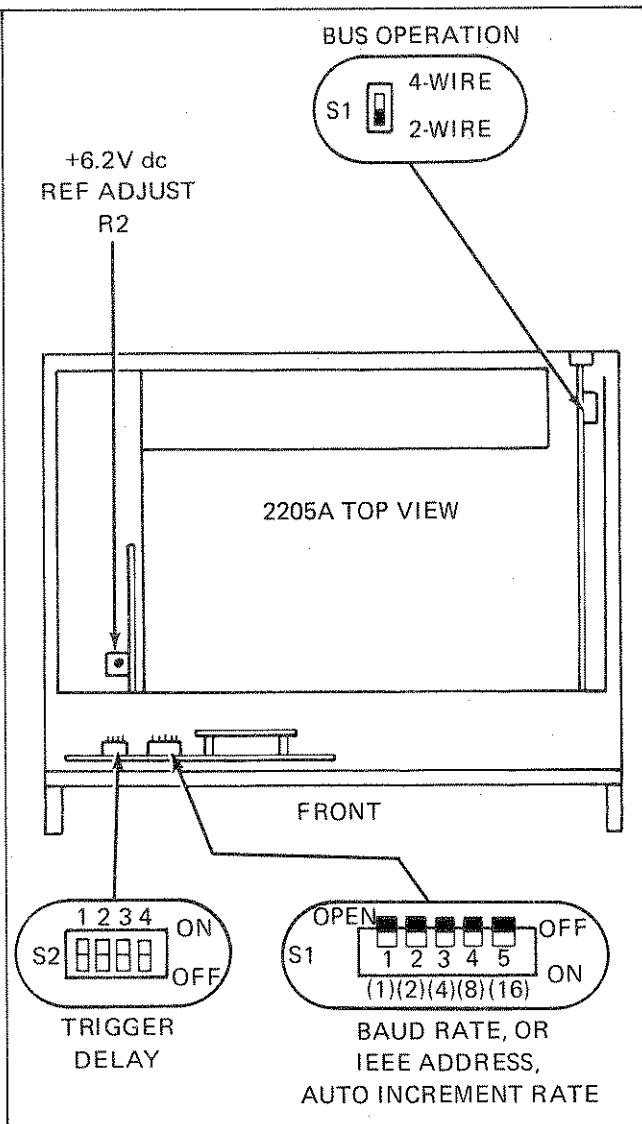

Figure 2-3. Internal Switch and Adjustments Location

2-28. Auto Increment Rate Selection

2-29. The auto increment rate for the 2205A is selectable using the five-lever switch S1 located on the back of the Front Panel Display PCB. Normally, during remote operation switch S1 defines the baud rate or IEEE address of the remote interface. However, when the auto increment mode is enabled S1 defines the auto increment rate. The procedure for accessing and setting the auto increment switches follows:

1. Use the Access Procedure to remove the 2205A top cover and locate S1 on the Front Panel Display PCB (Figure 2-3).
2. Refer to the list of increment rate codes in Table 2-1 and set the S1 switch levers to match the desired rate.
3. Use the Access Procedure to install the top cover.

Table 2-1. Auto Scan Rate Selection

RATE IN SEC/CHANNEL	SWITCH S1				
	1	2	3	4	5
0.2	0	0	0	0	0
0.3	1	0	0	0	0
0.4	0	1	0	0	0
0.5	1	1	0	0	0
0.6	0	0	1	0	0
0.7	1	0	1	0	0
0.8	0	1	1	0	0
0.9	1	1	1	0	0
1.0	0	0	0	1	0
1.1	1	0	0	1	0
1.2	0	1	0	1	0
1.3	1	1	0	1	0
1.4	0	0	1	1	0
1.5	1	0	1	1	0
1.6	0	1	1	1	0
1.7	1	1	1	1	0
1.8	0	0	0	0	1
1.9	1	0	0	0	1
2.0	0	1	0	0	1
2.1	1	1	0	0	1
2.2	0	0	1	0	1
2.3	1	0	1	0	1
2.4	0	1	1	0	1
2.5	1	1	1	0	1
2.6	0	0	0	1	1
2.7	1	0	0	1	1
2.8	0	1	0	1	1
2.9	1	1	0	1	1
3.0	0	0	1	1	1
3.1	1	0	1	1	1
3.2	0	1	1	1	1
3.3*	1	1	1	1	1

* = Err displayed on turn on
 1 = OFF (OPEN) 0 = ON (CLOSED)

2-30. Trigger Output

CAUTION

The low side of the TRIGGER OUTPUT connector is connected to Logic Common, not chassis ground. Do not connect the low side of the connector to a potential more than 30V above chassis ground.

2-31. A trigger pulse is available from the rear panel of the 2205A at the BNC connector marked TRIGGER OUTPUT. The function of the trigger pulse is to serve as a measurement command to externally trigger a system type DMM. The trigger pulse is TTL compatible and occurs as a 15 microsecond negative-going pulse (+5V dc to Logic Common). The elapsed time between channel

selection and the Trigger Output pulse can be selected to ensure that the channel relays operate in a break-before-make pattern. Eight patterns are available. Two of these are recommended for use with particular types of switch modules. The possible delay patterns are defined in Figure 2-4. The times listed are fixed and are cumulative. When a channel is selected the affected relays operate in a break-before-make pattern and settle within the allotted time period.

2-32. The elapsed time between a channel selection and the trigger output pulse can be manually selected by switch S2 on the Front Panel Display PCB. The procedure for accessing and setting this switch is as follows:

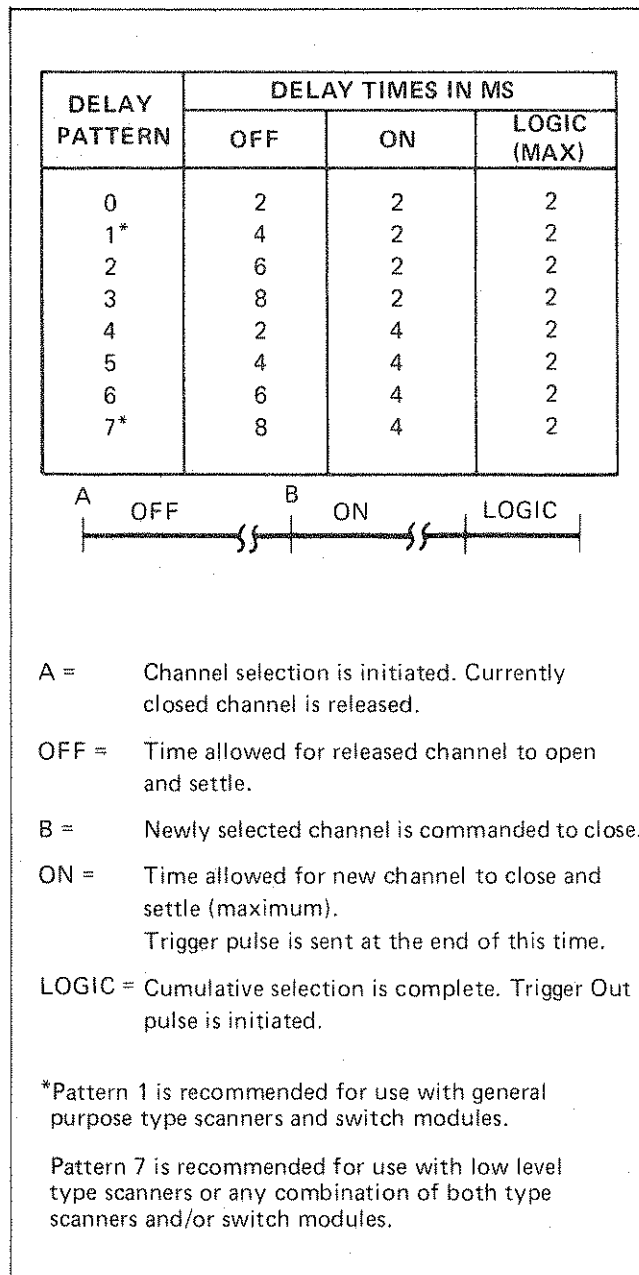

Figure 2-4. Trigger Delay Patterns

1. Use the Access Procedure to remove the 2205A top cover and locate switch S2 on the Front Panel Display PCB (Figure 2-3).

2. Refer to the list of delay patterns given in Table 2-2. Set S2 to match the desired delay. Pattern 7 is recommended for use with the Low Level Scanner Module (Option -600), and pattern 1 is recommended for use with the General Purpose Scanner Module (Option -300). If a combination of both scanning modules is used, pattern 7 is recommended.

3. Use the Access Procedure to install the top cover.

Table 2-2. Trigger Delay Selection

DELAY PATTERN	SWITCH S2*				DELAY IN ms		
	1	2	3	4	OFF	ON	LOGIC
0	0	0	0	x	2	2	2
1	1	0	0	x	4	2	2
2	0	1	0	x	6	2	2
3	1	1	0	x	8	2	2
4	0	0	1	x	2	4	2
5	1	0	1	x	4	4	2
6	0	1	1	x	6	4	2
7	1	1	1	x	8	4	2

*0 = ON
1 = OFF
x = DON'T CARE

2-33. Baud Rate Selection

2-34. Baud rates for the RS-232-C Interface are selectable using the five-lever switch S1 located on the back of the Front Panel Display PCB. The procedure for accessing and setting this switch is as follows:

1. Use the Access Procedure to remove the 2205A top cover and locate switch S1 on the Front Panel Display PCB (Figure 2-3).

2. Refer to the baud rate codes in Table 2-3. Set the S1 switch levers to the code that corresponds to the desired baud rate.

3. Use the Access Procedure to install the top cover and energize the unit. The display should read 'b' followed by the assigned baud rate code (0-7).

Table 2-3. Baud Rate Selection

BAUD RATE	SWITCH S1					DISPLAY CODE
	1	2	3	4	5	
110	0	0	0	x	x	b-0
134.5	1	0	0	x	x	b-1
150	0	1	0	x	x	b-2
300	1	1	0	x	x	b-3
600	0	0	1	x	x	b-4
1200	1	0	1	x	x	b-5
2400	0	1	1	x	x	b-6
4800	1	1	1	x	x	b-7

1 = OFF (OPEN)
0 = ON (CLOSED)
x = DON'T CARE

During normal TTY operation, all baud rates are useable. If a controller is used at a baud rate of 1200, 2400 or 4800; commands may be missed if consecutive channel selections are made at a rate that is faster than the relays can switch. See Figure 2-4, for relay switching times.

2-35. IEEE Address Selection

2-36. The listen address for the IEEE-488 Compatible Interface is selectable using the five-lever switch S1 located on the back of the Front Panel Display PCB. The procedure for accessing and setting this switch is as follows:

1. Use the Access Procedure to remove the 2205A top cover and locate switch S1 on the Front Panel Display PCB (Figure 2-3).
2. Refer to the list of address codes in Table 2-4. Set the S1 switch levers to match the desired IEEE address.
3. Use the Access Procedure to install the top cover and energize the unit. The display should read 'A' followed by the assigned address code (0-30).

2-37. RACK INSTALLATION

2-38. The 2205A is designed for either bench-top use or for installation in a standard 19-inch equipment rack. If rack mounting is desired, two rack mounting kits are available; a standard Rack Mount Kit (Model no. M07-205-600) and a Rack Slide Kit (Model no. M00-208-610). Installation instructions for both models are given in Section 7, Option and Accessory Information.

2-39. SCANNER EXTENSION

2-40. The capacity of the 2205A can be extended from 100 channels up to 1000 channels. The extension is

accomplished through the use of one or more of the Models 2201A or 2202A Extender Chassis. Figure 2-5 shows the interconnection of extenders in a typical 2205A system. Each extension chassis is capable of housing and controlling either 10 (2202A) or 12 (2201A) modules. The chassis interconnect in a daisy-chain fashion, and the first unit in the chain connects to the EXTENDER CABLE I/O connector on the rear of the 2205A. These chassis are available as accessories (see Section 7). The 2201A and 2202A chassis are documented in separate stand-alone manuals.

Table 2-4. IEEE Address Selection

IEEE ADDRESS	SWITCH S1					DISPLAY CODE
	1	2	4	3	5	
0	0	0	0	0	0	A-0
1	1	0	0	0	0	A-1
2	0	1	0	0	0	A-2
3	1	1	0	0	0	A-3
4	0	0	1	0	0	A-4
5	1	0	1	0	0	A-5
6	0	1	1	0	0	A-6
7	1	1	1	0	0	A-7
8	0	0	0	1	0	A-8
9	1	0	0	1	0	A-9
10	0	1	0	1	0	A10
11	1	1	0	1	0	A11
12	0	0	1	1	0	A12
13	1	0	1	1	0	A13
14	0	1	1	1	0	A14
15	1	1	1	1	0	A15
16	0	0	0	0	1	A16
17	1	0	0	0	1	A17
18	0	1	0	0	1	A18
19	1	1	0	0	1	A19
20	0	0	1	0	1	A20
21	1	0	1	0	1	A21
22	0	1	1	0	1	A22
23	1	1	1	0	1	A23
24	0	0	0	1	1	A24
25	1	0	0	1	1	A25
26	0	1	0	1	1	A26
27	1	1	0	1	1	A27
28	0	0	1	1	1	A28
29	1	0	1	1	1	A29
30	0	1	1	1	1	A30
31 *	1	1	1	1	1	Err

* = Illegal address, Err = error
0 = ON (CLOSED)
1 = OFF (OPEN) x = DON'T CARE

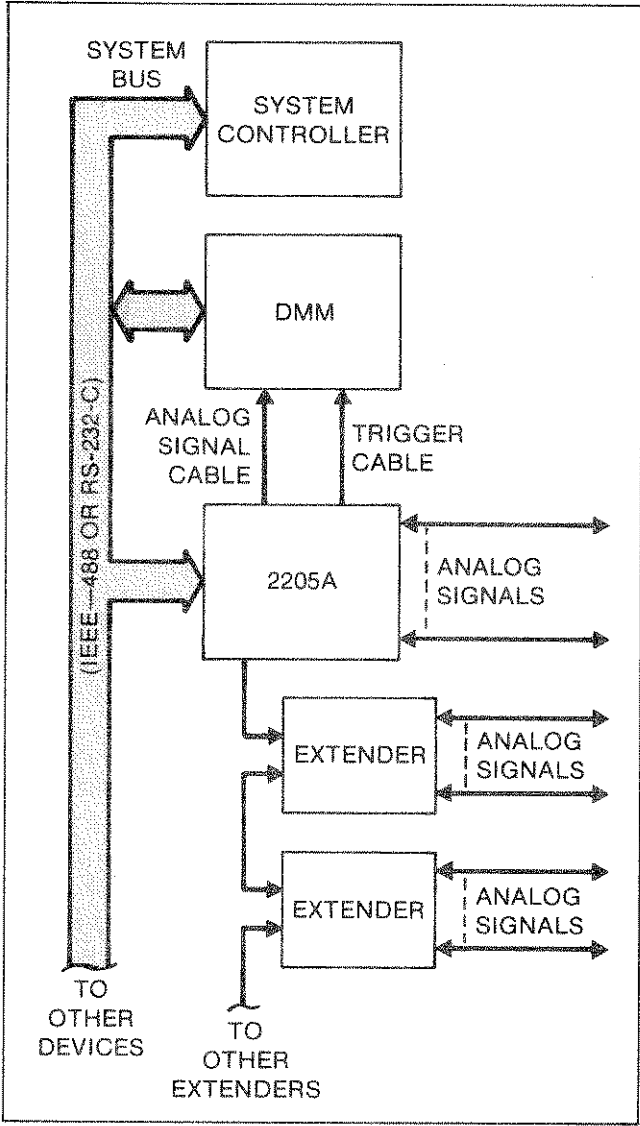
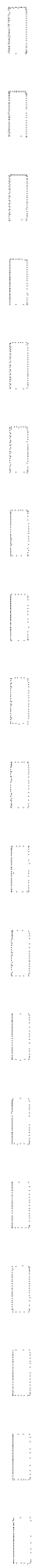

Figure 2-5. Typical 2205A System Interconnects



Section 3

Operating Instructions

3-1. INTRODUCTION

3-2. This section of the manual contains information concerning the operation of the Model 2205A Switch Controller. It is recommended that the contents of this section be read and understood before any attempt is made to operate the instrument. Should any difficulties arise during operation, contact your nearest John Fluke Sales Representative, or the John Fluke Mfg. Co., Inc., P.O.Box C9090, Everett, Washington, 98206. A list of sales representatives is given in the rear of this manual.

3-3. OPERATING FEATURES

3-4. All controls, indicators, and connectors for the 2205A are described in Figure 3-1.

3-5. OPERATING NOTES

3-6. Introduction

3-7. The following paragraphs describe various conditions which should be considered before operating the 2205A. This section assumes that the 2205A has been equipped with the desired switch modules and any other desired option or accessory. It also assumes that the unit has been incorporated into its normal operating environment and is connected to line power.

3-8. Internal Scanner Buses

3-9. The 2205A is equipped with two internal analog buses (bus 1 and bus 2) for use in conjunction with the relay scanning modules. Bus 1 is associated with the even numbered slots (0, 2, 4, 6, 8) and bus 2 is associated with the odd numbered slots (1, 3, 5, 7, 9). Each bus consists of three lines; high, low, and guard. When a channel relay is selected on a given scanning module, that channel and its input signal are connected to the appropriate internal scanner bus.

3-10. Channel relays may be closed singly or in pairs. If closed singly, the analog buses should be connected in parallel at the Analog Signal Cable so that a single bus is

formed. This configuration is called two-wire operation. That is, a single two-wire bus (high, low, guard) is common to all channels. If the relays are closed in pairs, the buses should remain electrically isolated so that two separate buses (bus 1 and bus 2) are available at the Analog Cable Output connector. This configuration is called four-wire operation. That is, a four-wire bus (high 1, high 2, low 1, low 2, guard, and shield 2) is common to all channel pairs. Guard and shield 2 are generally connected together at the Analog Signal Cable to form a single instrument guard. The desired bus operation is manually selected by an internal switch, and applies to channels in the 2205A only.

3-11. In the four-wire operation, relay pairs are closed by selecting a channel in one of the even numbered slots (0, 2, 4, 6, 8). The selected channel relay in the even numbered slot plus the corresponding channel relay in the next higher odd numbered slot are closed together. Thus, slots 0 and 1, 2 and 3, 4 and 5, 6 and 7, 8 and 9 operate as pairs. Selecting a channel in an odd numbered slot closes only that channel relay, not the pair.

NOTE

Four-wire operation is possible only in the 2205A. Extender chassis are configured for two-wire operation.

3-12. Local Operation

3-13. The scanning and switching functions of the 2205A can be manually controlled using the front panel switches. Table 3-1 lists the functions that can be performed and their respective control sequences. When a sequence is properly entered, the selected channel appears on the display. Other indications that can appear are defined in Table 3-2. Refer to the Operating Conditions information for important considerations before operating the unit.

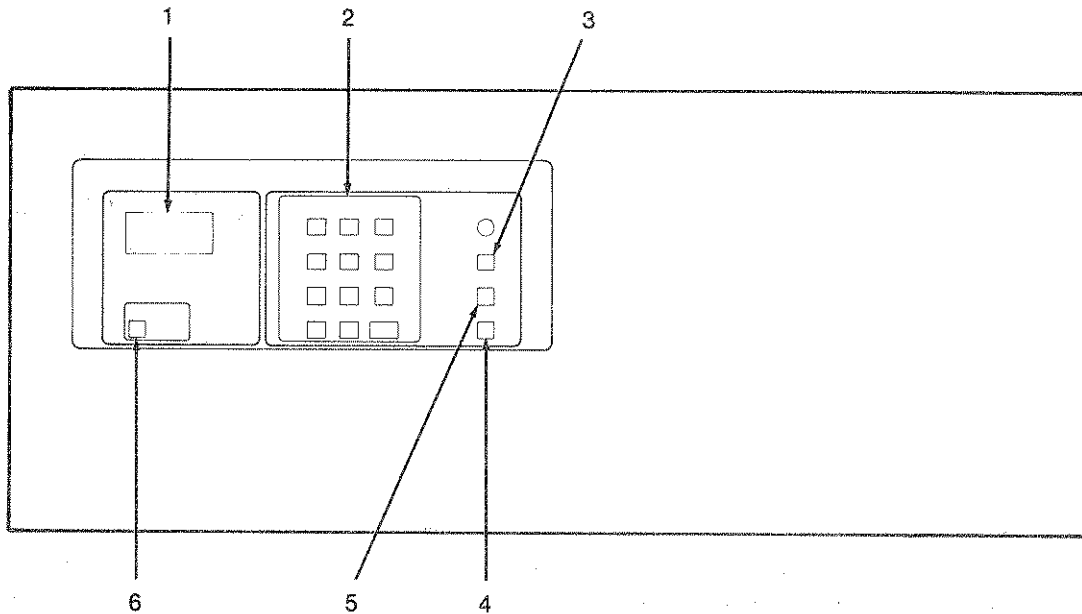

REF NO.	NAME	FUNCTION
1	CHANNEL DISPLAY	Three seven-segment LEDs used to indicate the displayed or selected channel (000 through 999). Also indicates baud rate address for remote interface and data entry messages.
2	DATA Keyboard	Calculator type keyboard, with CLEAR and ENTER switches, used for manual entry of channel control data.
3	LOCAL Switch, REMOTE LED	A pushbutton switch used to recall local (manual) operating mode if unit is in remote. REMOTE LED is lit in the remote mode.
4	INCREMENT Switch	A pushbutton switch used to manually increment the displayed channel.
5	BLOCK RESET/T.C. REFERENCE JUNCTION Switch	A pushbutton switch to reset switch modules to their normal normal condition. Also used to manually select (for measurement the reference voltage of a displayed channel, 0 through 999. An r is displayed to indicate that a reference voltage is selected.
6	POWER Switch	A green pushbutton switch used to turn the instrument on and off.

Figure 3-1. 2205A Controls, Indicators and Connectors

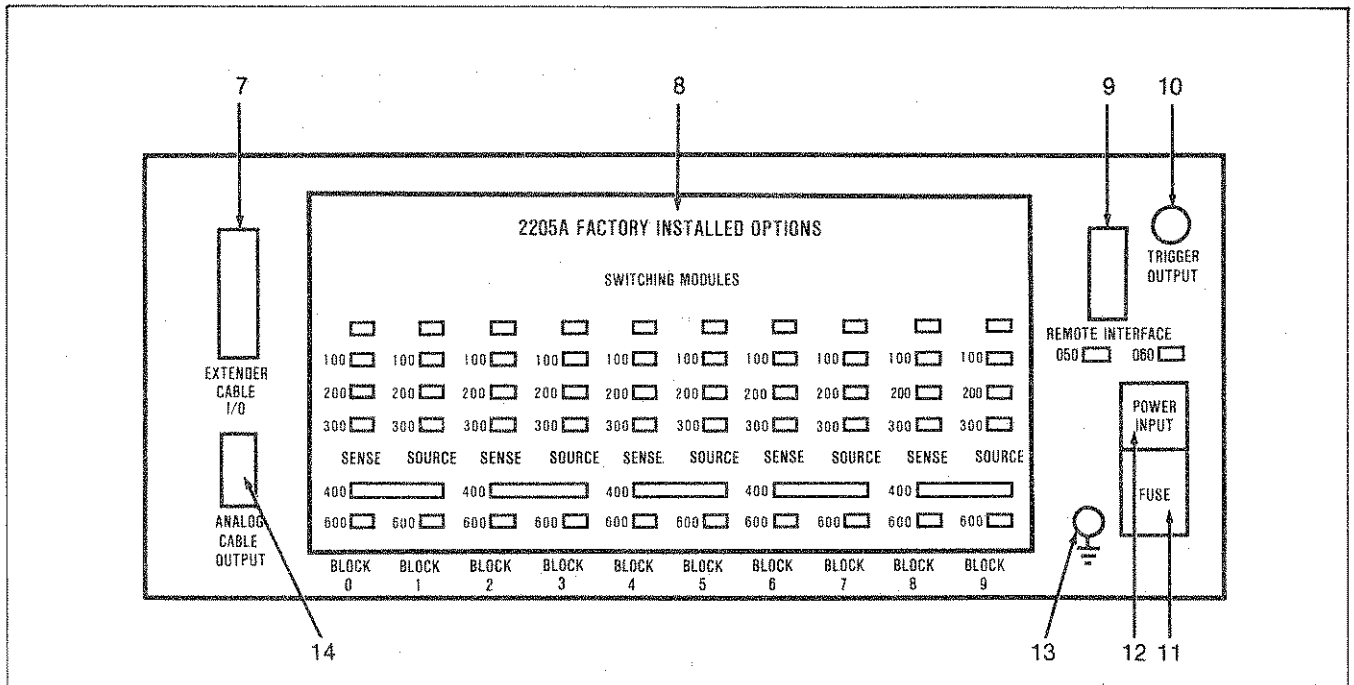

REF. NO.	NAME	FUNCTION
7	EXTENDER CABLE I/O CONNECTOR EXTENDER	This 36-pin connector is used as a data I/O port for controlling the operation of chassis. Up to nine such chassis can be added in a serial fashion for a total of 100 switch modules.
8	SWITCH MODULE SLOTS	Access to the switch modules (Block 0 through 9) is provided when the snap-on rear cover is removed.
9	REMOTE INTERFACE	A connector used as a control port for receiving remote control data. The data format is RS-232-C (-060) or IEEE-488 ---050) compatible depending upon the installed option.
10	TRIGGER OUTPUT CONNECTOR	This BNC Connector provides electrical access to the Trigger Output pulse; a 15 μ sec pulse used to trigger a measurement. The pulse is negative-going, TTL compatible, and is generated after each channel selection is complete. The pulse is referenced to logic common, not chassis ground.
11	Fuse Holder	The line power fuse and the voltage-select pcb are housed in this compartment. The line cord must be removed before the compartment can be opened.
12	POWER INPUT Connector	A 3-prong connector used to connect the instrument (via the line cord) to line power.
13	Ground Connector	This binding post provides a convenient connection to chassis ground.
14	ANALOG CABLE OUTPUT Connector	Both analog buses are electrically accessible for measurement purposes via this connector. An analog cable supplied with the 2205A completes the connection between the buses and the DMM analog input.

Figure 3-1. 2205A Controls, Indicators and Connectors (cont)

Table 3-1. Front Panel Control Functions

FUNCTION	FRONT PANEL CONTROL SEQUENCE
Select a channel.	[DIGIT] [DIGIT] [DIGIT] [ENTER]
Clear the display.	[CLEAR]
Open all channels.	[CLEAR] [ENTER]
Reset boundaries to 0 and 99.	[CLEAR] [ENTER] [ENTER]
Set a lower scan boundary channel.	[DIGIT] [DIGIT] [DIGIT] [ENTER] [ENTER] 0
Set an upper scan boundary channel.	[DIGIT] [DIGIT] [DIGIT] [ENTER] [ENTER] 1
Select next higher channel.	[INCREMENT]
Initiate the auto increment mode.	[INCREMENT] and [LOCAL] Simultaneously
Exit the auto increment mode (last channel is still selected).	[CLEAR]
Exit the auto increment mode and clear all channels	[CLEAR] [ENTER]
Select isothermal block of displayed channel or reset displayed switch modules.	[BLOCK RESET/T.C. REF JUNCTION]
Go to local. Remote light will go out.	[LOCAL]
Clear error condition.	[CLEAR]

Table 3-2. Channel Display Indications

DISPLAY READING	DEFINITION
— — — —	All channels reset
—	Clear entry
Err	Function or control sequence is in error, try again. (Does not effect present status)
Axx	Address for IEEE Compatible Interface. (xx = 0 through 30)
b-x	Baud rate for RS-232-C Interface (x = 0 through 7)
xr	Block reset or temperature reference selected. (x = block 0-99)

3-14. Auto Increment Operation

3-15. The auto increment mode is a free-run scanning condition that can be initiated (only in local operation) via the front panel controls. Upper and lower channel boundaries can be assigned so that the scanning cycle includes only the channels of interest. For example, if 3 and 5 are assigned as lower and upper boundaries respectively, the auto increment mode, when initiated, will continuously cycle from channel 3 through channel 5.

NOTE

The 2205A does not respond to any remote commands while scanning in auto increment mode.

3-16. The timing for the relay switching and the Trigger Output are given in the Installation section of this manual. The auto increment rates range from 0.2 to 3.3 seconds per channel in 0.1 second increments.

NOTE

The 2205A will generate an external rear trigger pulse each time a module command to close a relay occurs.

3-17. Remote Operation

3-18. INTRODUCTION

3-19. In a systems configuration, the 2205A can be remotely programmed via the rear panel REMOTE INTERFACE connector. The 2205A automatically enters the remote mode when data is received from the system controller. Data format is determined by the type of interface option installed in the 2205A, the RS-232-C Interface (Option -060) or the IEEE-488-compatible Interface (Option -050). To positively identify the option installed in a given unit, watch the channel display when the 2205A is turned on. If the IEEE option is installed, the instrument displays 'A' followed by a numeric listen

address code (0 through 30). If the RS-232-C option is installed, a 'b' followed by a numeric baud rate code (0 through 7) is displayed. If the interface option must be changed, refer to Section 7 for the installation and interface instructions. Refer to the Programming Conditions information for important considerations before operating.

3-20. PROGRAMMING FORMAT

3-21. Command strings are used to control the 2205A. A command string is a sequence of ASCII characters sent over the IEEE-488 or RS-232C remote interface. The 2205A will respond only to those upper case characters which are within its control character vocabulary. All other characters are ignored. Table 3-3 lists the Remote Control Characters recognized by the 2205A. Remote Control Characters are enclosed within quotes in the test to facilitate character identification.

3-22. If the Increment character "+" and the Reference Junction character "R" are sent without a channel being selected, an error will be generated. The message (Err) will be displayed on the front panel, and the command will be ignored. Note that the 2205A cannot generate a remote error message because it is a listener only.

3-23. Do not use autoscan from the front panel while operating via a remote interface (IEEE-488 or RS-232C). When the 2205A is in autoscan mode, it effectively ignores remote devices by not completing handshakes.

3-24. GENERAL COMMANDS

3-25. The following remote control commands can be used by both the IEEE-488 and RS-232C remote interface options.

3-26. Enter - The Comma (,) Command

3-27. The "," is the remote equivalent to the front panel ENTER key. It is used as a delimiter to terminate each numerical entry.

3-28. Reset - The \$ and * Commands

3-29. The 2205A can be reset on three levels. The first level, sending a "\$", only clears the display. The second level, sending a "*" or "\$", clears the display and resets all of the modules to power up condition. The third level, sending a "**", or "\$,," clears the display, resets all of the modules, and sets the lower and upper scanning boundaries to 0 and 99.

3-30. MODULE COMMANDS

3-31. Every module installed in the 2205A or extender chassis has a unique block address/ Also, each type of module has a set of module commands associated with it. Depending upon the module, the command can correspond to a specific channel, a relay position in a specific channel, or a block or relays on one module.

3-32. The Module Command Format is "bbc". The "bb" represents the block address, which ranges from 00 to 99. (If no block address is entered, the default address is 00.) The "c" represents the module command, a number between 0 and 9.

Table 3-3. Remote Control Characters

EQUIVALENT REMOTE CONTROL CHARACTER SEQUENCE (ASCII)	REMARKS	KEYBOARD CONTROL SEQUENCE
0 through 9	Numeric data	0 through 9
,	Select displayed channel	ENTER
+	Increment displayed channel by one	INCREMENT
\$	Clear display	CLEAR
R	Select reference junction of the displayed channel, or reset displayed block	T.C. REF JUNCTION/ BLOCK RESET
* or \$,	Open all channels	CLEAR ENTER
B0	Set lower boundary	ENTER ENTER 0
B1	Set upper boundary	ENTER ENTER 1
*, or \$,,	Reset boundaries to 0 and 99	CLEAR ENTER ENTER
L	Set local lockout (RS-232-C only)	NONE
L0	Reset local lockout (RS-232-C only)	NONE

3-33. To select a channel under remote control, enter the numerical value of the channel using the "bbc" format, then enter the Entry command ",". This is the same format used for front panel entry.

3-34. The Block Reset/Reference Junction Selection command, "R", operates in the same manner as the front panel BLOCK RESET/T.C. REFERENCE JUNCTION key. When using the Isothermal Block Connector, the reference junction voltage can be measured and used to calculate thermocouple temperatures. The "R" command connects the reference junction of the Block being addressed to the scanning bus. If "R" is sent to a block other than an Isothermal Block, it acts as a Block Reset. If no channel is addressed, (Err) appears on the front panel and the command is ignored.

3-35. 2205A-100 Actuator Module Commands

3-36. The -100 module has 5 SPDT relays with contacts identified as Common, Normally Open (N.O.), and Normally Closed (N.C.). Upon power up or module reset each relay defaults to the position with common connected to Normally Closed. Even numbered module commands (0, 2, 4, 6, 8) correspond with a set position where the Normally Open contact is connected to Common. Each of the 5 relays responds to a unique even or odd module command number pair. Table 3-4 lists the module commands.

3-37. 2205A-200 Latching Module Commands

3-38. The -200 module has 8 DPST relays. The 8 relays are interconnected in 2 groups of 4 each. The interconnected contacts are labeled Bus A and Bus B. Bus A interconnects relays 0, 1, 2, and 3 and Bus B interconnects relays 4, 5, 6, and 7. Each group of relays function independently. Each group also has a common unswitched guard. All jumpering for matrix configurations is done on the connector card which is factory-wired as two IX4 matrices. Jumpers may be cut or relocated for custom configurations.

Table 3-4. Actuator Module Commands

MODULE COMMAND	RELAY AFFECTED	RELAY POSITION
0	0	RESET (N.C.)*
1	0	SET (N.O.)**
2	1	RESET (N.C.)
3	1	SET (N.O.)
4	2	RESET (N.C.)
5	2	SET (N.O.)
6	3	RESET (N.C.)
7	3	SET (N.O.)
8	4	RESET (N.C.)
9	4	SET (N.O.)

*N.C. — Normally Closed
**N.O. — Normally Open

3-39. Module commands 0 through 7 latch the respective relays. Use module commands 8 and 9 to open relays once latched. Module command 8 will open relays 0, 1, 2, and 3. Module command 9 will open relays 4, 5, 6, and 7. A block Reset, "R", will open all latched relays on the addressed module. Table 3-5 lists the module commands.

3-40. 2205A-300 General Purpose Scanner Module Commands

3-41. The -300 module has 10 two wire channels. Each channel is connected to the mainframe scanning bus by the module command corresponding to that channel, 0 to 9. When a channel is closed any other scanner channel on that card or any other in that system will open. Only one scanner channel may be closed at any one time. A reset will open any closed scanning channel.

3-42. 2205A-600 Low Level Scanner Module Commands

3-43. The -600 module provides 10 channels of 3 wire switching which are programmed in the same way as the -300 General Purpose Scanner Module. Table 3-6 lists the commands for both the -300 and the -100.

3-44. 2205A-400 Four-wire Resistance Scanner Module Commands

3-45. The -400 option consists of a source module and a sense module with 10 channels each. The SENSE module is in an even numbered block address. The SOURCE module is in an odd numbered block address. The 2205A needs to be configured to 4 wire mode by manually switching the 2/4 wire switch. In 4 wire mode with each even block command 2 relays close, one per card. Odd Block commands only close the relay being called.

3-46. Scanning in 4 wire mode is achieved by programming the EVEN blocks (Sense modules) only. Programming ODD blocks (Source modules) will not result in 4 wire operation. Table 3-7 lists the module commands.

Table 3-5. Latching Module Commands

MODULE COMMAND	RELAY AFFECTED	RELAY POSITION
0	0	LATCHED
1	1	LATCHED
2	2	LATCHED
3	3	LATCHED
4	4	LATCHED
5	5	LATCHED
6	6	LATCHED
7	7	LATCHED
8	0, 1, 2, 3	OPEN/RESET
9	4, 5, 6, 7	OPEN/RESET

Table 3-6. General Purpose and Low Level Scanner Module Commands

MODULE COMMAND	CHANNEL AFFECTED	CHANNEL CONNECTED
0	0	0
1	1	1
2	2	2
3	3	3
4	4	4
5	5	5
6	6	6
7	7	7
8	8	8
9	9	9

3-47. SPECIAL SCANNING COMMANDS

3-48. The 2205A can be programmed to set upper and lower boundaries for a sequential scanning loop. The default boundaries are 0 and 99. The manual auto scan mode cannot be remotely programmed. When configured for 4 wire mode the scanning boundaries must be set within an even block address.

3-49. Three commands set the upper and lower boundaries, and increment through the addresses:

1. "mB0" sets the lower boundary. Where m is a number between 0 and 999, representing the lower address.
2. "nB1" sets the upper boundary. Where n is a number between 0 and 999, representing the upper address.
3. Each time a "+" is received, the 2205A increments to the next sequential address. If an address is not selected, (Err) is displayed and the command is ignored.

3-50. When the 2205A has been incremented to the upper boundary, on the next increment command the 2205A steps the address equal to the lower boundary. It steps to the lower boundary, counts up to address 999, loops to 0, and increments up until it reaches the upper boundary, then steps to the lower boundary again.

3-51. IEEE-488 COMPATIBLE INTERFACE (Option -050)

3-52. The IEEE-488 Compatible Interface is designed to meet the intent and requirements of the IEEE-488 1978 Standard. Once installed, it requires no operator attention other than identification of the IEEE-488 listen address code. Table 3-3 lists the 2205A control sequences and their corresponding ASCII control characters. After the interface is addressed, the 2205A will respond to subsequent control characters. Section 7 includes a

detailed description of the IEEE-488 Compatible Interface Option. The commands are described below.

3-53. IEEE-488 UNIVERSAL COMMANDS

3-54. The 2205A is a listen only device. It will never output any data to the bus. The 2205A responds only to the following Universal Bus Commands. All other commands are ignored.

3-55. MLA - My Listen Address

3-56. When the 2205A detects its listen address (0 to 30 set by the IEEE address switch) it goes into remote (the front panel remote indicator turns on). Note that the 2205A will not handshake data if it is in the manual auto scan mode.

3-57. UNL - Unlisten

3-58. The 2205A stops listening when it receives the unlisten command. It will not respond to data until it has been addressed as a listener again.

3-59. LLO - Local Lockout

3-60. When it receives the Local Lockout command, the 2205A locks out (disables) the front keyboard including the LOCAL key.

3-61. DCL - Device Clear

3-62. The 2205A resets all modules and clear the display when it receives the Device Clear command. This has the same effect as the "*" or "\$" commands.

3-63. SDC - Selected Device Clear

3-64. The 2205A resets in response to the SDC only when it has been addressed as a listener. It resets all modules and clear the display. This has the same effect as the "*" or "\$" commands.

3-65. RS-232-C INTERFACE OPTION -060

3-66. The RS-232-C Interface is designed to meet the intent and requirements of the Electronic Industries Association Standard RS-232-C. Once installed, it requires no operator attention other than verification of the baud rate. This appears on the display when the 2205A is initially energized. Section 2-33 discusses display indications for the various baud rates. Section 7 includes a detailed description of the RS-232-C Interface Option. The RS-232-C commands are described below.

3-67. RS-232-C SERIAL DATA COMMANDS

3-68. When the 2205A receives data via the RS-232C interface it goes into remote and the front panel remote indicator turns on. There are two additional commands which are used only with the RS-232C interface to provide local lockout capability: L and L0. The 2205A locks out (disables) the front panel, including the LOCAL key, when it receives the "L" via the RS-232C interface. The 2205A unlocks the front panel when a "L0" is received. To resume local control press the LOCAL key.

Table 3-7. Four-Wire Resistance Scanner Module Commands.

BLOCK #	MODULE COMMAND	CHANNEL #	SENSE	SOURCE
EVEN	0	0	CLOSED	CLOSED
EVEN	1	1	CLOSED	CLOSED
EVEN	2	2	CLOSED	CLOSED
EVEN	3	3	CLOSED	CLOSED
EVEN	4	4	CLOSED	CLOSED
EVEN	5	5	CLOSED	CLOSED
EVEN	6	6	CLOSED	CLOSED
EVEN	7	7	CLOSED	CLOSED
EVEN	8	8	CLOSED	CLOSED
EVEN	9	9	CLOSED	CLOSED
ODD	0	0	OPEN	CLOSED
ODD	1	1	OPEN	CLOSED
ODD	2	2	OPEN	CLOSED
ODD	3	3	OPEN	CLOSED
ODD	4	4	OPEN	CLOSED
ODD	5	5	OPEN	CLOSED
ODD	6	6	OPEN	CLOSED
ODD	7	7	OPEN	CLOSED
ODD	8	8	OPEN	CLOSED
ODD	9	9	OPEN	CLOSED

3-69. Operating Conditions

3-70. There are eight conditions that should be taken into consideration when operating the 2205A:

1. Rapid successive power-on/power-off switching can cause the 2205A to lockup. A slow power-off/power-on sequence clears the lockup condition.
2. Multiple ENTER commands should be used with care. An even number of enter commands followed by a digit sets a boundary. An odd number of enter commands followed by a digit causes the digit to be displayed.
3. The data that appears on the CHANNEL DISPLAY is dim until the ENTER button is pressed. This indicates a standby condition.
4. When selecting an upper boundary, any digit other than 0 (zero) should be used.
5. A channel within the auto increment range must be selected to start the auto increment sequence. If a channel higher than the range is selected, scanning begins at that channel and increments up to channel 999, rolls over to channel 0, and increments up to the upper boundary. If a channel lower than the range is selected, scanning begins at that channel and increments up to the upper boundary.

6. With the exception of entering the auto increment mode, simultaneous keyboard entries are undefined.

7. IEEE-488 data will not be recognized while the 2205A is in auto increment operation. The 2205A does not handshake the information sent, and does not act on it.

8. If a remote interface is not installed in the 2205A, and the auto increment rate is set to 3.3 seconds (slowest rate), the unit displays Err (error) on power up. Ignore the error message.

3-71. OPERATION

3-72. Use the following procedure to operate the 2205A:

1. Energize the 2205A by pressing the POWER switch.
2. Observe the CHANNEL DISPLAY and verify the displayed baud rate (RS-232-C) or listen address (IEEE-488).
3. Enter control data using either local or remote input. If local control is desired after a remote control sequence, press the LOCAL switch before attempting to enter data. See Table 3-1 for a complete list of manual control functions. See Table 3-3 for equivalent remote control sequences.

Section 4 Theory of Operation

4-1. INTRODUCTION

4-2. This section of the manual contains an overall functional description followed by a block diagram analysis of the Model 2205A Switch Controller. Simplified diagrams are used to support the block diagram analysis. Detailed schematics of individual pcb assemblies are given in Section 9.

4-3. OVERALL FUNCTIONAL DESCRIPTION

4-4. The 2205A, as shown in Figure 4-1, is a controller mainframe complete with power supply, room for up to 10 switching modules (10 channels per module), the logic necessary for local operation, and the front panel controls and indicators necessary for a man/machine interface. It is designed to provide controlled sequential or random access to external analog data (via the rear connector terminals) for measurement purposes and/or a variety of switching functions.

4-5. Functionally, the 2205A is a programmable, 100 channel controller (when a total of 10 optional scanner or switch modules are installed) that is electrically capable of being expanded up to 1000 channels, using a series of (up to nine) Extender Chassis (Models 2201A or 2202A). Internal microprocessor based logic allows a scan sequence to be either manually or remotely defined, displayed, and incremented on manual, automatic, or remote command. Analog data to a selected scanner channel is presented to a common internal scanner bus which is electrically accessible via a rear panel connector. Normally, the bus is connected to a system type DMM input (Model 8520A is recommended). After a channel is selected, the 2205A generates a Trigger Output pulse. This externally accessible pulse is used to command the DMM to read the analog bus, and thus, the selected analog input channel.

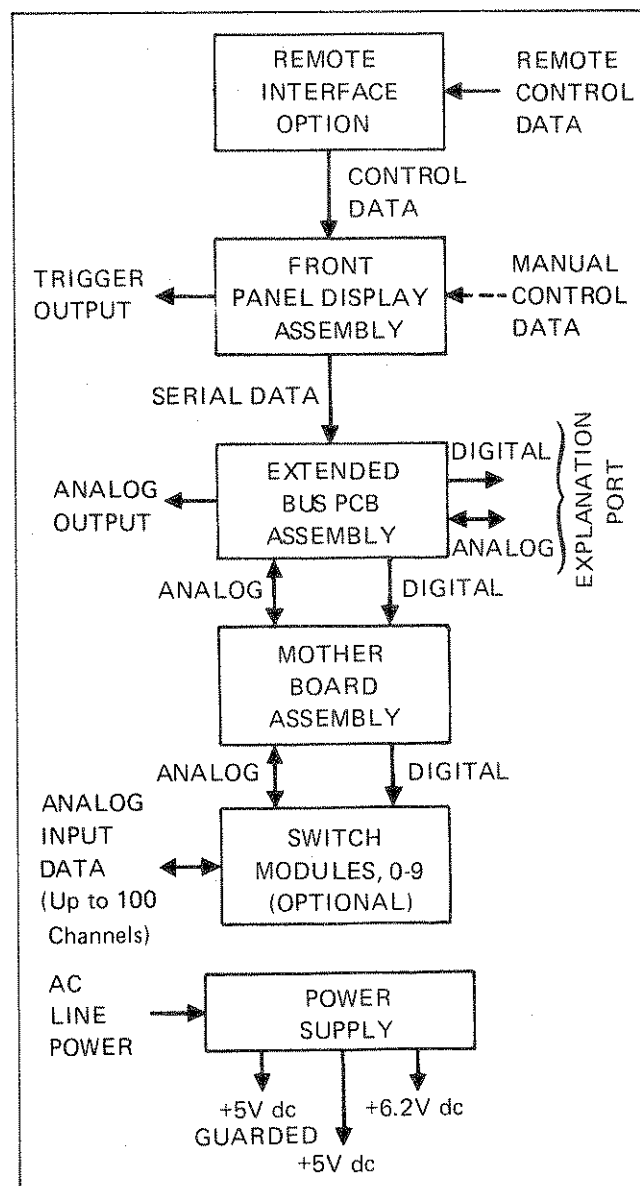

Figure 4-1. 2205A Functional Block Diagram

4-6. BLOCK DIAGRAM ANALYSIS

4-7. Front Panel Display PCB

4-8. The Front Panel Display PCB (Figure 4-2) functions as the data processor for the 2205A. It consists of an 8-bit microcomputer, a system oscillator, an onboard keyboard, a 3-digit display, an output trigger driver, and a set of switches to define the output trigger delay time and remote interface requirements. Program data can be entered manually using the keyboard or remotely by way of the data bus and an interface option (RS-232-C or IEEE-488). Updated channel select

information is presented to the display via an 8-bit register and serially output to the Extended Bus PCB as control data.

4-9. The microcomputer used in the 2205A is a single component device complete with an 8-bit CPU, RAM, and two I/O ports. All switch controller activity is under control of the microcomputer. This includes local and remote data entry, data display, trigger delay, auto increment control and remote interface programming (baud rate, IEEE address, or auto increment rate).

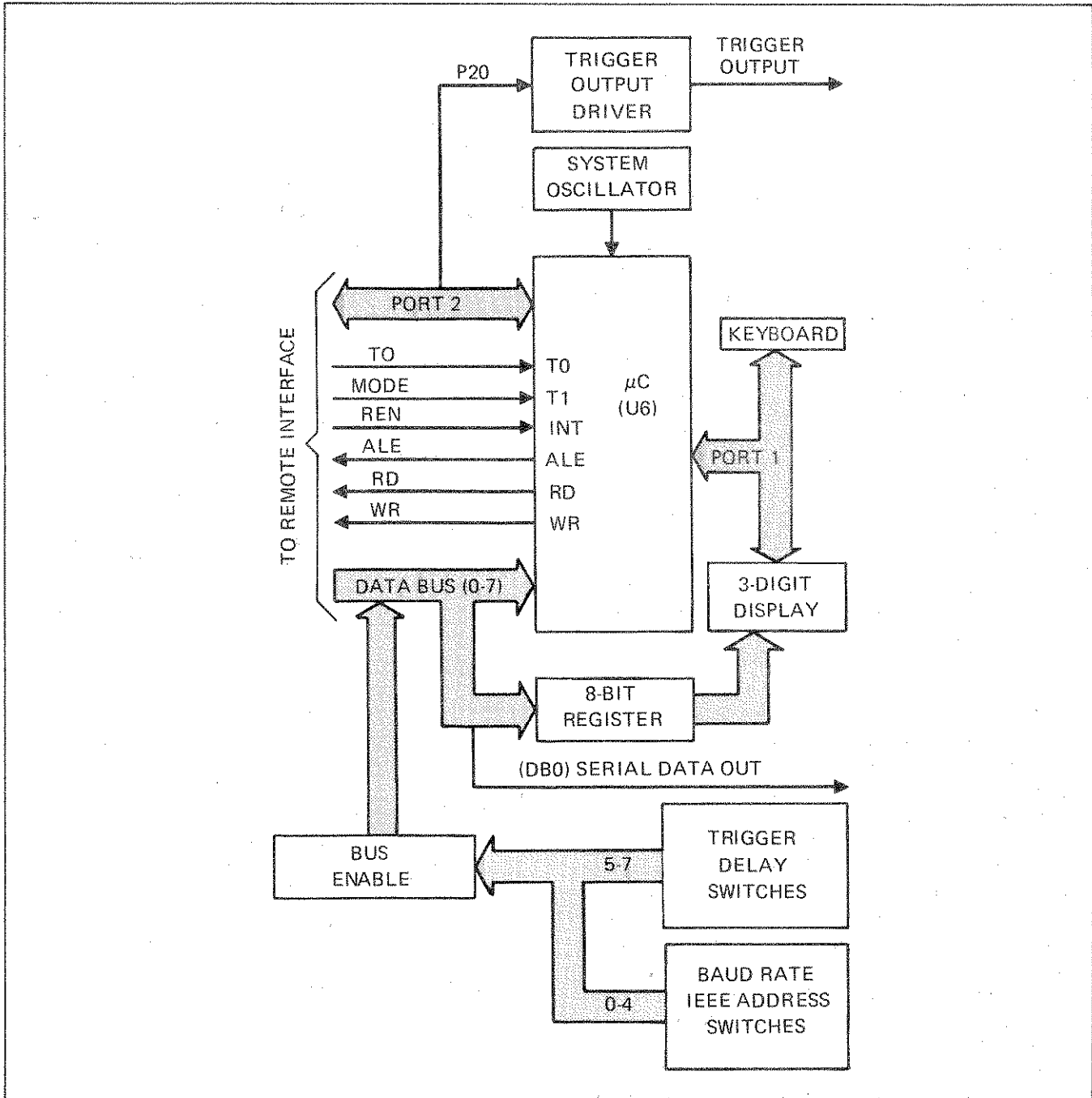

Figure 4-2. Front Panel Display PCB

4-10. System control data leaving the Front Panel Display PCB is limited to bit-serial channel selection data (14 characters) and an output trigger. Channel selection data is stored as a 12-bit parallel word on the Extended Bus PCB where it is used to energize the selected channel (000-999). A predetermined (switch selected) delay is initiated when a channel selection is made. At the end of the delay (i.e., after the break-before-make switching is complete), an output trigger is generated to enable the DMM to make a measurement of the analog signal from the selected channel.

4-11. Extended Bus PCB

4-12. The Extended Bus PCB (Figure 4-3) is designed to store, decode, and distribute the digital channel select

data received from the Front Panel Display PCB. The extended bus consists of a pair of dual shift registers, three 4-bit latches, a 1-of-10 decoder, a 4-bit multiplexer, and a pair of analog switching relays. Incoming serial data is entered into the serial data register as a 12-bit data word preceded by two fixed start bits (1 and 0). When the first bit (1) is shifted into the fourteenth position a transfer command is generated to load the 12 parallel data outputs of the serial registers into the parallel data register. The parallel data output is used to provide channel select commands to both the local switch modules and the extender chassis. This dual register technique is known as double buffering. It is used to prevent the switch modules from responding while new data is being entered into the serial register.

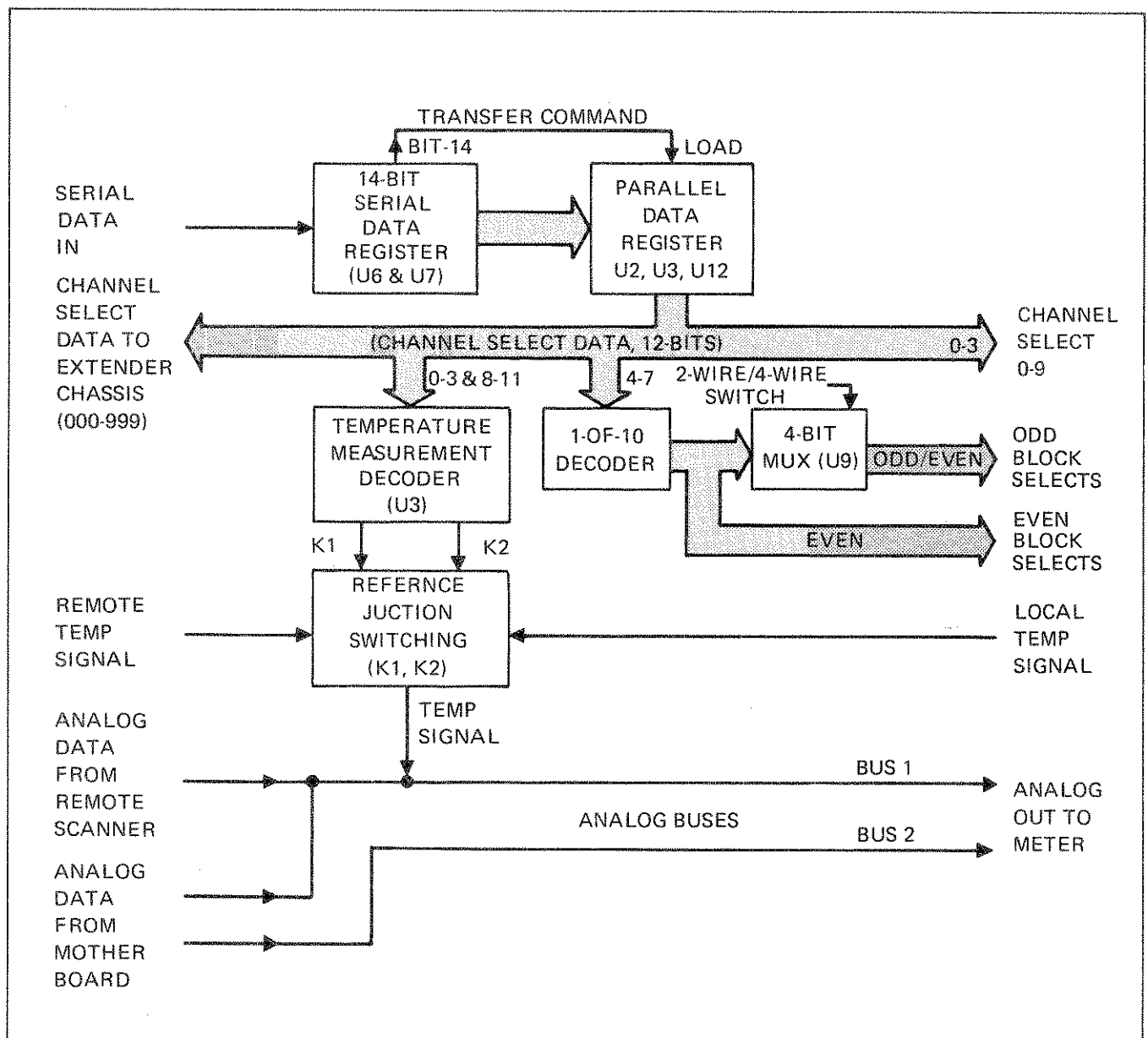

Figure 4-3. Extended Bus PCB

4-13. The 12-bits of channel select data are divided into three bcd command groups; units, tens, and hundreds. These lines are buffered and output to the Extender Cable I/O connector for use in commanding external channels (100 to 999). Internally, the channel select lines are used to control channels 0 through 99. Lines 0 through 4 are buffered and used as bcd channel select commands 0 through 9. Lines 5 through 9 are decoded into 10 discrete controls lines (Block Select 0-9) for selecting one of the 10 possible internal switch modules. When four-wire operation is required one of the even numbered slots (0, 2, 4, 6, 8) and the next higher odd numbered slot are enabled simultaneously. This is accomplished by a four bit multiplexer which supplies either even or odd commands to the odd numbered switch module blocks. An internal switch setting (two-wire/four-wire) controls the multiplexer's operation.

4-14. Thermocouple temperature measurements are made using special low level scanner modules. The modules are equipped with the ability to sample a reference junction plus the standard 10-channel scanning capability. To make an accurate temperature determination both the thermocouple output and the temperature at the thermocouple connections (reference junction) must be measured. The controls needed to accomplish this two step measurement are included on the Extender Bus PCB in the form of the temperature measurement decoder and two reference junction relays. Relay K1 selects between local (within the 2205A) or remote (within the extender chassis) reference temperature signals. Relay K2 is closed when the microcomputer determines the need for a reference junction measurement. This places the local or remote reference as selected by K1 onto the analog bus for measurement purposes. Relay K2 is always open for channel data measurements.

4-15. Measurement data from the selected switch module input channel or reference junction (local or remote) is presented to the analog bus on the Extended Bus PCB. Measurement connections for the external measurement device (DMM) are taken directly from the bus and made available at the ANALOG CABLE OUTPUT connector.

4-16. Power Supply

4-17. The power supply provides the operating voltages for the 2205A with a full complement of switch modules.

Voltages include +5V for the guarded logic (GL+5V), +5V for the unguarded logic (UL+5V), and the 6.2V reference voltage required for thermocouple temperature measurements.

4-18. Input power for the power supply is derived from a 100/120/220/240V ac transformer with three secondary windings. Transformer line requirements are selectable by changing the position of a plug-in pcb located in the rear panel fuse compartment. A transformer shield isolates two of the output windings. This shield is extended to the power supply pcb and the 2205A mainframe where it is used for signal isolation (guard). Guarded voltages includes GL+5V and +6.2V reference.

4-19. Logic Common for the guarded +5V supply is 15 volts below analog common and guard. This allows the FETs on the scanning modules to be switched directly. The +6.2V supply uses Reference Common as its ground return. Reference Common is tied directly to A/D Common. The unguarded +5V supply has a floating ground that is referenced to the 2205A chassis when a system controller is used. If a system controller is not used, internal zener diodes keep the common from floating. The unguarded common is also accessible at the shell of the Trigger Output connector on the rear of the 2205A. When the Trigger Output is used, the shell (unguarded common) should not be floated more than 30 volts above chassis.

4-20. Conventional regulating techniques are used in both sections of the power supply. Three terminal IC regulators are used for both +5V supplies and no adjustments are provided. The +6.2V supply is adjustable. It uses a unity gain op-amp whose adjustable input is derived from a regulated zener reference.

4-21. Remote Interface Options

4-22. Two remote interface options are available for use with 2205A; the IEEE-488 Compatible Interface (Option -050) and the RS-232-C Interface (Option -060). Both interfaces are receive-only devices. The IEEE-488 Interface conforms to the IEEE-488, 1978 Standard and is used to receive character-serial control data. The RS-232-C Interface is used to receive bit-serial input data conforming to the EIA RS-232-C Standard. Theory for each interface assembly is given in Section 7 of this manual.

Section 5 Maintenance

WARNING

THESE SERVICING INSTRUCTIONS ARE FOR USE BY QUALIFIED PERSONNEL ONLY. TO AVOID ELECTRIC SHOCK, DO NOT PERFORM ANY SERVICING OTHER THAN THAT CONTAINED IN THE OPERATING INSTRUCTIONS UNLESS YOU ARE QUALIFIED TO DO SO.

5-1. INTRODUCTION

5-2. This section of the manual contains maintenance information for the Model 2205A Switch Controller including general maintenance and a performance test. The performance test is recommended as an acceptance test when the instrument is first received and later, as a calibration procedure to periodically verify specifications. The 2205A does require one calibration adjustment. Table 5-1 lists the equipment required for servicing the instrument. If the recommended model is not available, a substitute meeting the minimum use specifications may be used.

5-3. SERVICE INFORMATION

5-4. The 2205A is warranted for a period of 1-year upon delivery to the original purchaser. The WARRANTY is located on the back of the title page located in the front of this manual.

5-5. Factory Authorized calibration and service for each Fluke product is available at various worldwide locations. A complete list of these service centers is included at the rear of this manual. If requested, an estimate will be provided to the customer before work is begun on instruments that are beyond the warranty period.

5-6. GENERAL MAINTENANCE

5-7. Cleaning

5-8. Clean the 2205A periodically to remove dust, grease and other contamination. Use the following procedure:

CAUTION

Do not use aromatic hydrocarbons or chlorinated solvents to clean the 2205A. They will react with the plastic materials used in the instrument.

Table 5-1. Required Test Equipment

INSTRUMENT TYPE	REQUIRED CHARACTERISTICS	RECOMMENDED MODEL
DMM	20V dc range $\pm 0.1\%$ accuracy	Fluke 8520A
SCANNING MODULE	10-channel	Fluke 2205A-610K
TEST CABLE	See Set-up Procedure	Fabricate

1. Clean the front panel and case with a soft cloth dampened with a mild solution of detergent and water.
2. Clean the surface of the pcbs using clean, dry air at low pressure (<20 psi). If grease is encountered, spray with Freon T.F. Degreaser and remove grime with dry, low-pressure air.

5-9. PERFORMANCE TEST

5-10. The performance test is designed to verify the overall operation of the 2205A, and is intended for use as an acceptance test and/or periodic maintenance check. The equipment used in the test is specified in Table 5-1. If the 2205A fails any part of the performance test, corrective action is required.

5-11. Set-Up Procedure

5-12. Before attempting to execute any of the performance test procedures complete the following set-up procedure:

1. Fabricate a test cable using a isothermal block input connector (2205A-008); two 24-inch lengths of 20-gauge insulated copper wire (red, black); ten 1/4 watt, 1% resistors; and a 36-pin male connector (Fluke Part Number 417378). Assemble the cable as shown in Figure 5-1.

2. Disconnect the 2205A from the line power.

3. Remove the top cover, the rear panel enclosure, and the guard chamber top for the duration of the performance test.

4. Install a scanning pcb in slot 0 (channels 0-9) of the 2205A.

5. Remove all other modules and input connectors from the remaining slots.

6. Attach the test cable to the scanning module in slot 0. Connect the male cable connector end to the rear panel EXTENDER CABLE I/O connector.

7. Select the two-wire configuration by setting the S1 switch on the Extender Bus PCB to the 2-wire position.

8. Connect a DMM to the 2205A (use a two-wire bus) by way of the rear panel ANALOG CABLE OUTPUT connector.

9. Set the DMM to the 20V dc range.

10. Connect the 2205A to line power and press the POWER switch to ON. The channel display should indicate the assigned baud rate (b0-b7) or the assigned IEEE-488 address (A0 thru A31), as applicable.

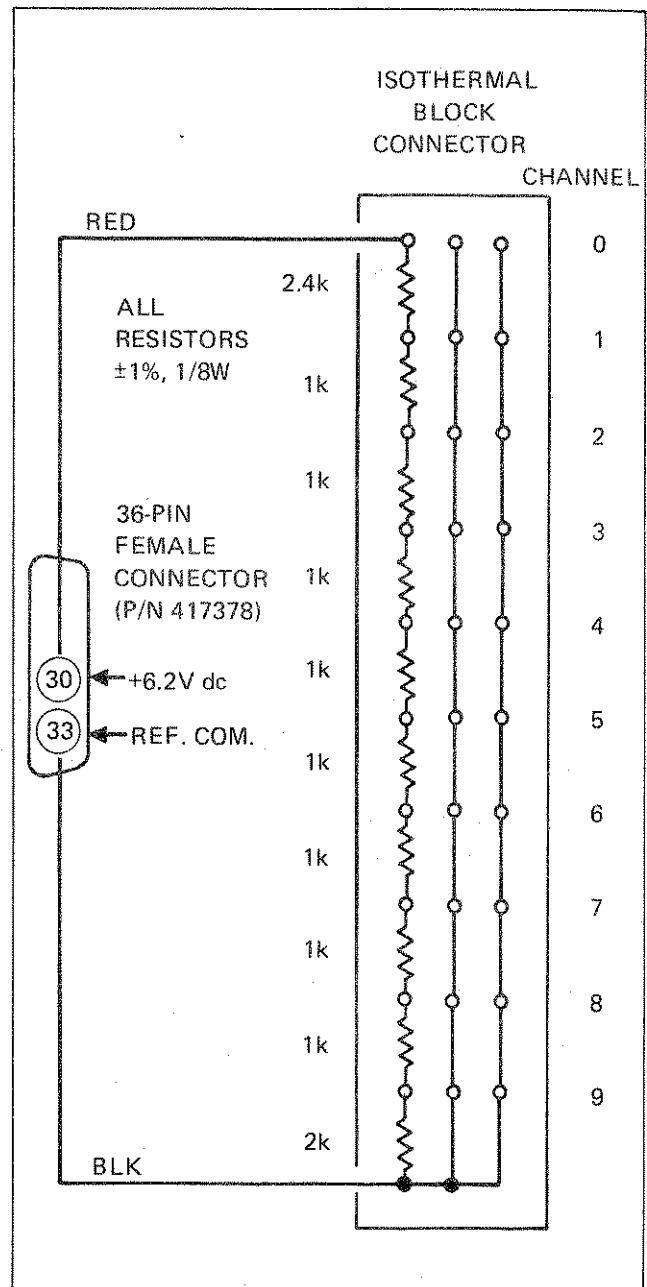

Figure 5-1. Test Cable

5-13. Manual Test Procedure

5-14. Manually test the overall operation of the 2205A using the following procedure:

1. Using the front panel keyboard, manually call channel 9 (press 9 and ENTER). The DMM display should read $6.200 \pm 0.001V$ dc. If the voltage is out of tolerance, the supply must be adjusted. See CALIBRATIONADJUSTMENTS later in this section.

2. Select channel 0. The DMM should read $1.50 \pm 0.03V$ dc.

3. Scan channels 0 through 9 using the INCREMENT switch. The DMM reading at each channel should be as follows:

Channel	Vdc Reading
0	1.00 \pm 0.03
1	1.50 \pm 0.03
2	2.00 \pm 0.03
3	2.50 \pm 0.03
4	3.00 \pm 0.03
5	3.50 \pm 0.04
6	4.00 \pm 0.04
7	4.50 \pm 0.05
8	5.00 \pm 0.05
9	6.200 \pm 0.001

4. Set the POWER switch to OFF and move the test cable and scanning module to slot 1.

5. Energize the 2205A and manually scan channels 10 through 19. The DMM readings should agree with those shown in step 3 of this procedure.

6. Using steps 3, 4, and 5 of this procedure, check the operation of slots 2 through 9.

7. With the module in slot 9, press 90 followed by T.C. REF JUNCTION. The DMM should read between 0.4 and 0.6V dc at an ambient room temperature of 25°C.

5-15. Baud Rate/IEEE Address

5-16. The following procedure tests the operation of the baud rate/IEEE address switch (S1 on the Front Panel Display PCB). Switch S1 is a set of five switches located on the Front Panel Display PCB. The switch is accessible when the 2205A's top dust cover is removed. Conduct the test as follows:

1. Set the 2205A POWER switch to OFF.
2. Set all five S1 switches to the ON (closed) position.
3. Set the POWER switch the ON. The display should read A0 if the IEEE Compatible Interface is installed or b0 for the RS-232-C Interface.
4. Verify the remaining switch positions as follows:
 - a. If the IEEE Compatible Interface is installed, sequentially set switches 1 through 5 to the open position. Switch power off and on at each setting and observe the display. The reading for each setting should agree with the following list:

Switch:	1	2	3	4	5
Display:	A1	A2	A4	A8	A16

b. If the RS-232-C Interface is installed, sequentially set switches 1 through 3 (4 and 5 are not used) to the open position. Switch power off and on at each setting and observe the display. The reading for each setting should agree with the following list:

Switch:	1	2	3
Display:	b1	b2	b4

5-17. Remote Interface Test Procedure

5-18. The following procedure is used to test the remote interface portion of the 2205A. Refer to Section 3 of this manual for programming information. See Section 7 for interface requirements of the IEEE-488 Compatible and RS-232-C Interface options.

1. Perform the set-up procedure given earlier in this section.
2. Select the appropriate baud-rate/IEEE address using the procedure described in the Installation section of this manual.
3. Refer to the Manual Test Procedure given earlier in this section and execute it using remote commands.

5-19. CALIBRATION ADJUSTMENT

5-20. The 2205A is equipped with a calibration adjustment (R2) on the Power Supply PCB. This potentiometer is used to adjust the +6.2V dc reference voltage used in making thermocouple temperature measurements. Use the following procedure to adjust R2:

1. Complete the set-up procedure given earlier in this section under Performance Test.
2. Remove the top cover using the Access Procedure given earlier in Section 2.
3. Using the front panel keyboard, manually call channel 9 (press 9 and ENTER). The DMM should read 6.200 0.001V dc. If the voltage is out of tolerance, adjust R2 for a reading of 6.200V dc.
4. Re-install the top cover.

5-21. TROUBLESHOOTING

CAUTION



Static discharge can damage MOS components contained in the 2205A.

5-22. When troubleshooting or repairing the 2205A use the following precautions to prevent damage from static discharge:

1. Never remove, install or otherwise connect or

disconnect components or pcbs without first setting the 2205A POWER switch to OFF.

2. Perform all repairs at a static-free work station.
3. Do not handle IC's or pcbs by their connectors.
4. Use static ground straps to discharge repair personnel.
5. Use conductive foam to store replacement or removed IC's.
6. Remove all plastic, vinyl and styrofoam products from the work area.

7. Use a grounded soldering iron.

5-23. A troubleshooting guide for the 2205A is given in Table 5-2. To properly use the guide, complete the performance test given earlier in this section and note any discrepancies. Then locate the heading of the procedure in question in the Test and Symptom column. Under that heading isolate the symptom that approximates the observed malfunction. Possible causes are listed to the right of the selected symptom. Details necessary to isolate a particular cause can be derived from the theory of operation in Section 4 and the schematic diagrams in Section 9 of this manual.

Table 5-2. Troubleshooting Guide

TEST AND SYMPTOM	POSSIBLE CAUSE
<p>SET-UP PROCEDURE Display Blank</p> <p>MANUAL TEST PROCEDURE Channels 0 through 9 No +6.2V reading</p> <p>+6.2V reads OK; one or more of other voltages are incorrect</p> <p>Some block slots are OK others are not</p> <p>Baud Rate/IEEE-Address</p>	<p>Fuse, power supply, power supply cable and connections, system clock, microcomputer U6.</p> <p>Power Supply, Extender PCB Assembly, Motherboard.</p> <p>Extender PCB channel select logic, Motherboard.</p> <p>Extender Bus PCB block select logic, Motherboard.</p> <p>All baud rate/IEEE address malfunctions can be isolated to the Front Panel Display PCB Assembly.</p>

Section 6

List of Replaceable Parts

TABLE OF CONTENTS

ASSEMBLY NAME	TABLE		FIGURE	
	NO.	PAGE	NO.	PAGE
6070A/6071A Final Assembly	6-1	6-3	6-1	6-5
A1 Front Panel Display PCB Assembly	6-2	6-8	6-2	6-10
A2 Motherboard PBC Assembly	6-3	6-11	6-3	6-11
A3 Power Supply PCB Assembly	6-4	6-12	6-4	6-13
A4 Extender Bus PCB Assembly	6-5	6-14	6-5	6-15

6-1. INTRODUCTION

6-2. This section contains an illustrated parts breakdown of the instrument. A similar parts list is included in the Options and Accessories Section for each of the options. Components are listed alphanumerically by assembly. Both electrical and mechanical components are listed by reference designation. Each listed part is shown in an accompanying illustration.

6-3. Parts lists include the following information:

1. Reference Designation.
2. Description of Each Part.
3. FLUKE Stock Number.
4. Federal Supply Code for Manufacturers.
5. Manufacturer's Part Number.
6. Total Quantity of Components Per Assembly.
7. Recommended quantity: This entry indicates the recommended number of spare parts necessary to support one to five instruments for a period of 2 years. This list presumes an availability of common electronic parts at the maintenance site. For maintenance for 1 year or more at an isolated site, it is recommended that at least one of each assembly in the instrument be stocked. In the case of optional subassemblies, plug-ins, etc., that are not always part of the instrument or are deviations from the basic instrument model, the REC QTY column lists the recommended spares quantity for the items in that particular assembly.

6-4. HOW TO OBTAIN PARTS

6-5. Components may be ordered directly from the manufacturer's part number, or from the John Fluke Mfg. Co., Inc. or an authorized representative by using the FLUKE STOCK NUMBER. In the event the part ordered has been replaced by a new or improved part, the replacement will be accompanied by an explanatory note and installation instructions if necessary.

6-6. To ensure prompt and efficient handling of your order, include the following information.

1. Quantity.
2. FLUKE Stock Number.
3. Description.
4. Reference Designation.
5. Printed Circuit Board Part Number and Revision Letter.
6. Instrument Model and Serial Number.

6-7. A Recommended Spare Parts Kit for your basic instrument is available from the factory. This kit contains those items listed in the REC QTY column for the parts lists in the quantities recommended.

6-8. Parts price information is available from the John Fluke Mfg. Co., Inc. or its representative. Prices are also available in a Fluke Replacement Parts Catalog, which is available upon request.

CAUTION

Indicated devices are subject to damage by static discharge.

Table 6-1. 6070A/6071A Final Assembly

REF DES	DESCRIPTION	FLUKE STOCK NO.	MFG SPLY CODE	MFG PART NO.	TOT QTY	REC QTY	NOTE
	FINAL ASSEMBLY, MODEL 2205A FIGURE 6-1 (2205A-5001, T&B)						
A1⊗	FRONT PANEL DISPLAY ASSEMBLY	639708	89536	611061	1		
A2	MOTHER BOARD PCB ASSEMBLY	468132	89536	468132	1		
A3	POWER SUPPLY PCB ASSEMBLY	639690	89536	611897	1		
A4⊗	EXTENDED BUS PCB ASSEMBLY	639716	89536	611087	1		
F1	FUSE, SLO-BLO, 1/4 AMP	166306	71400	MDL1-4	1		
F2	FUSE, 1/2 AMP, 125V (NOT SHOWN)	603274	71400	GFA	8		
H1	NUT, HEX 2-56	110668	89536	110668	4		
H2	NUT, HEX 28-1/4	110619	89536	110619	1		
H3	SCREW, 2-56 X 5/8	370270	89536	370270	4		
H4	SCREW, PHP 4-40 X 1/4	185918	89536	185918	19		
H5	SCREW, SEMS 4-40 X 3/8	281196	89536	281196	2		
H6	SCREW, PHP 6-32 X 1/4	385401	89536	385401	11		
H7	SCREW, FH, UC, 6-32 X 1/4	320093	89536	320093	6		
H8	SCREW, PHP 6-32 X 1/2	177022	89536	177022	4		
H9	SCREW, FH, UC 6-32 X 1/2	320093	89536	320093	10		
H10	SCREW W/LOCKWASHER, 6-32 X 3/8	177022	89536	177022	22		
H11	SCREW, PHP, 6-32 X 3/8	334458	89536	334458	5		
H12	SCREW, CAP 8-32 X .375	295105	89536	295105	4		
H13	SCREW, PHP 8-32 X 1/4	228890	89536	228890	4		
H14	SCREW, FHP 8-32 X 1/2	114355	89536	114355	6		
H15	SCREW, FHP 8-32 X 3/8	114116	89536	114116	12		
H16	LOCKWASHER #2	110676	89536	110676	4		
MP1	BAIL, STANDFOOT	292870	89536	292870	4		
MP2	BRACKET, GUARD	468686	89536	468686	1		
MP3	BRACKET, POWER SUPPLY	467886	89536	467886	1		
MP4	BRACKET, GUARD	467944	89536	467944	1		
MP5	BRACKET, SUPPORT, ISOTHERMAL	440529	89536	440529	1		
MP6	BINDING POST, BRASS	225623	20584	3576	1		
MP7	BINDING POST	225615	20584	3575	1		
MP8	BUSHING, NYLON	339978	89536	339978	1		
MP9	GUIDE, CARD 4 1/2 X .312	256461	23880	1450F	11		
MP10	GUIDE, CARD	298836	89536	298836	31		
MP11	BUTTON, POWER SWITCH	401646	89536	401646			
MP12	BUMPER, RUBBER	423442	70485	1178-2	4		
MP13	GUARD, BOTTOM CHAMBER	467951	89536	467951	1		
MP14	GUIDE, CARD 2 1/2 X .312	295022	23880	1250F	1		
MP15	CHANNEL, BLK RUBBER	404665	77969	539	1		
MP16	CONNECTOR, LINE CORD	461269	05245	6J1	1		
MP17	COVER, EXTENDER I/O	632117	89536	632117	1		
MP18	COVER, TOP	526814	89536	526814	1		
MP19	COVER, REAR	632125	89536	632125	1		
MP20	CORNER, MODIFIED	471375	89536	471375	2		
MP21	COVER, BOTTOM GRAY	526882	89536	526882	1		

Table 6-1. 6070A/6071A Final Assembly (cont)

REF DES	DESCRIPTION	FLUKE STOCK NO.	MFG SPLY CODE	MFG PART NO.	TOT QTY	REC QTY	NOTE
MP22	DECAL, REAR PANEL	629147	89536	629147	1		
MP23	DECAL, FRONT PNL	605022	89536	605022	1		
MP24	HANDLE, FRONT CORNER	394320	89536	394320	2		
MP25	INSULATOR, FASTENER	372342	89536	372342	25		
MP26	LUG, SOLDER	102566	79963	813	1		
MP27	NAMEPLATE, S/N	472522	89536	472522	1		
MP28	FRONT PANEL ASSEMBLY	468892	89536	468892	1		
MP29	PANEL, REAR	467878	89536	467878	1		
MP30	RETAINER, CARD	468660	89536	468660	1		
MP31	BUTTON, POWER SHAFT	467910	89536	467910	1		
MP32	CHASSIS, LEFT SIDE	618819	89536	618819	1		
MP33	CHASSIS, RIGHT SIDE	419580	89536	419580	1		
MP34	SPACER, INSULATED	372334	89536	372334	25		
MP35	GUARD CHAMBER, TOP	467894	89536	467894	1		
MP36	DECAL, HANDLE	394403	89536	394403	4		
T1	TRANSFORMER, POWER	618884	89536	618884	1		
TM1	INSTRUCTION MANUAL, 2205A	633644	89536	633644			
W1	CABLE, TRIGGER	612945	89536	612945	1		
W2	CABLE, ANALOG OUTPUT	612960	89536	612960	1		
W3	CABLE, LINE CORD	611103	89536	611103	1		
W4	CABLE, EXTENDER BUS	612952	89536	612952	1		
W5	CABLE, POWER	611111	89536	611111	1		
W6	CABLE, INTERCONNECT (NOT SHOWN)	468611	89536	468611	1		
W7	LINE CORD SET (NOT SHOWN)	284174	89536	284174	1		
	RECOMMENDED SPARE PARTS KIT	641787	89536	641787			

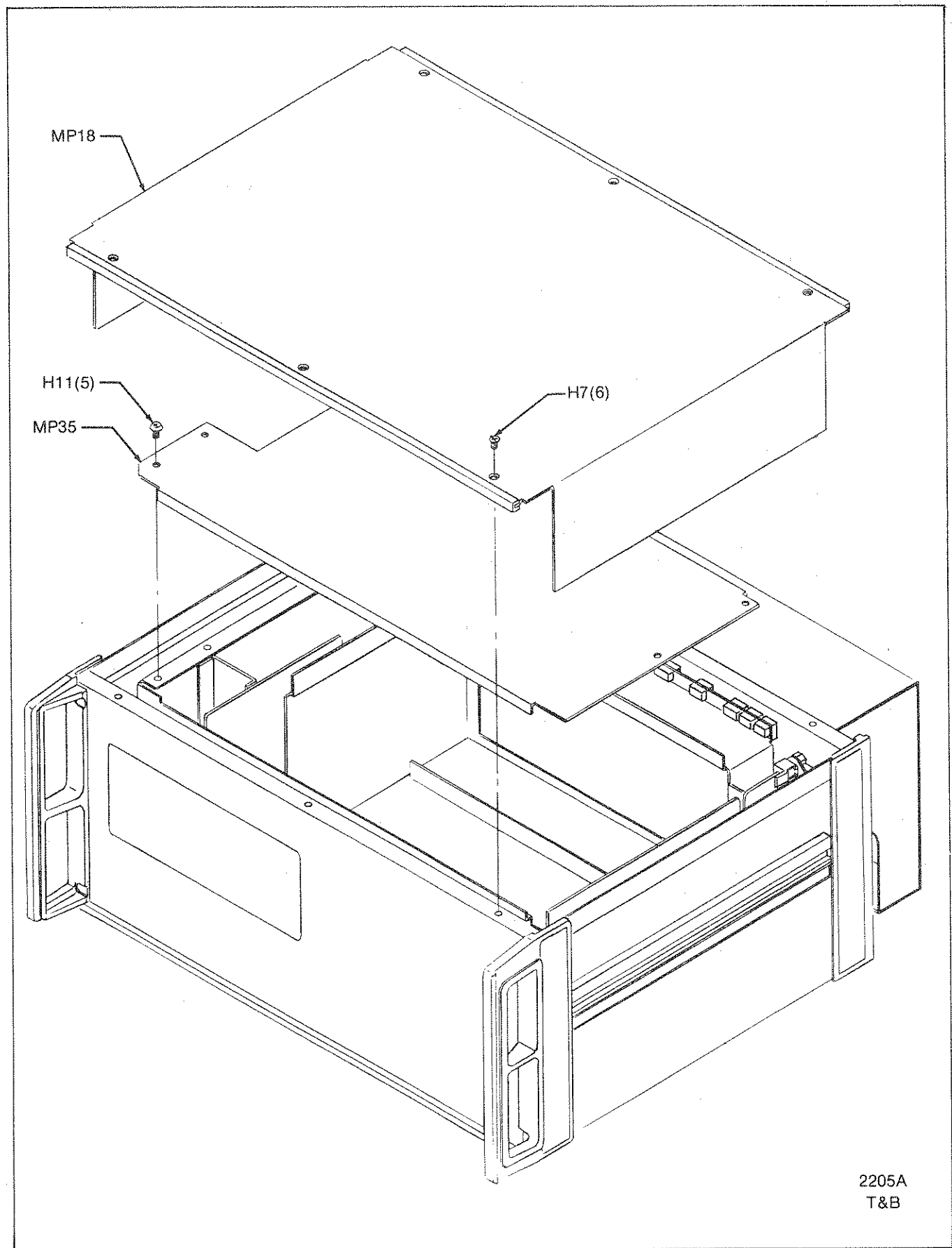
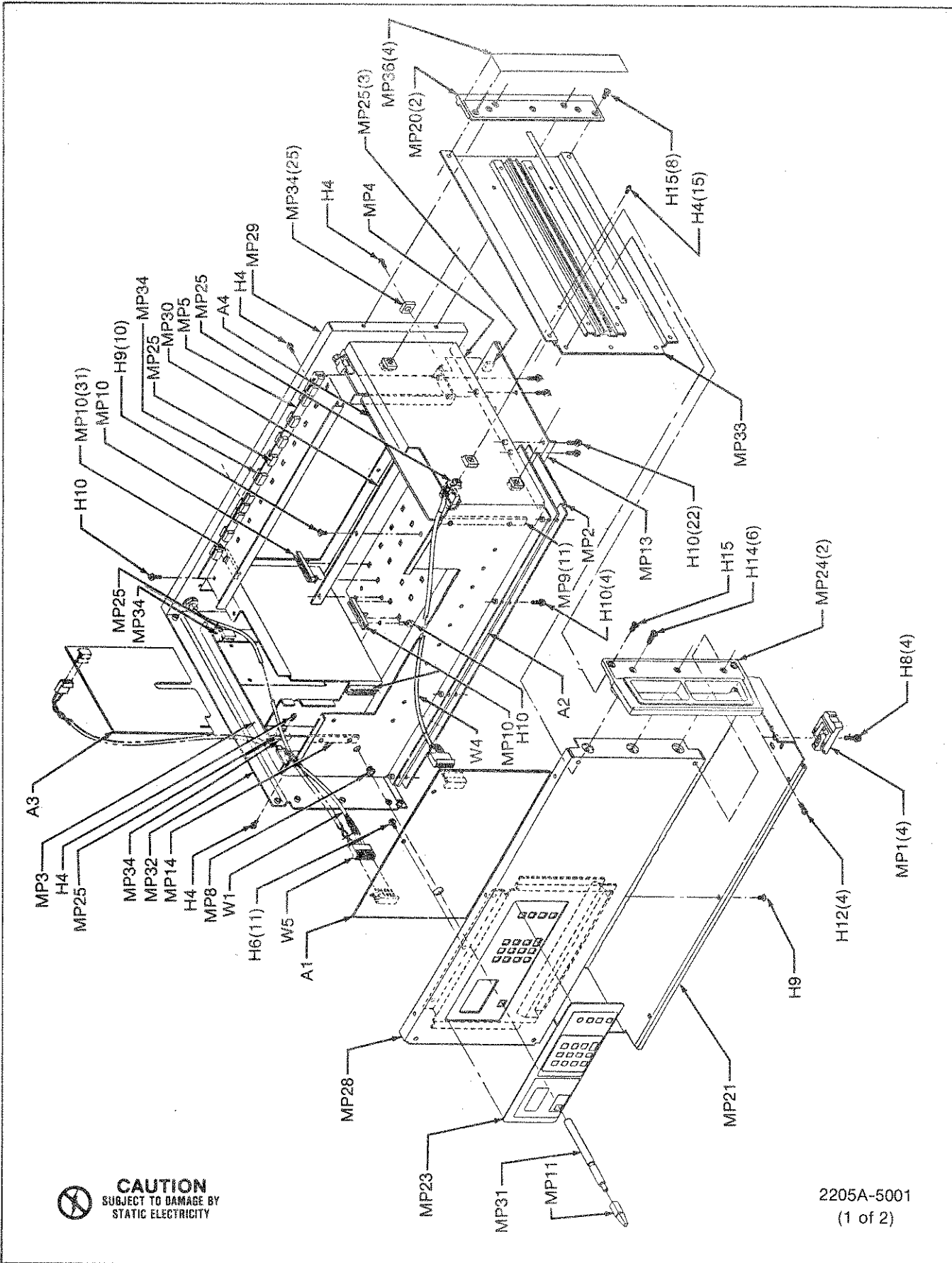

Figure 6-1. 6070A/6071A Final Assembly



 **CAUTION**
SUBJECT TO DAMAGE BY
STATIC ELECTRICITY

2205A-5001
(1 of 2)

Figure 6-1. 6070A/6071A Final Assembly (cont)

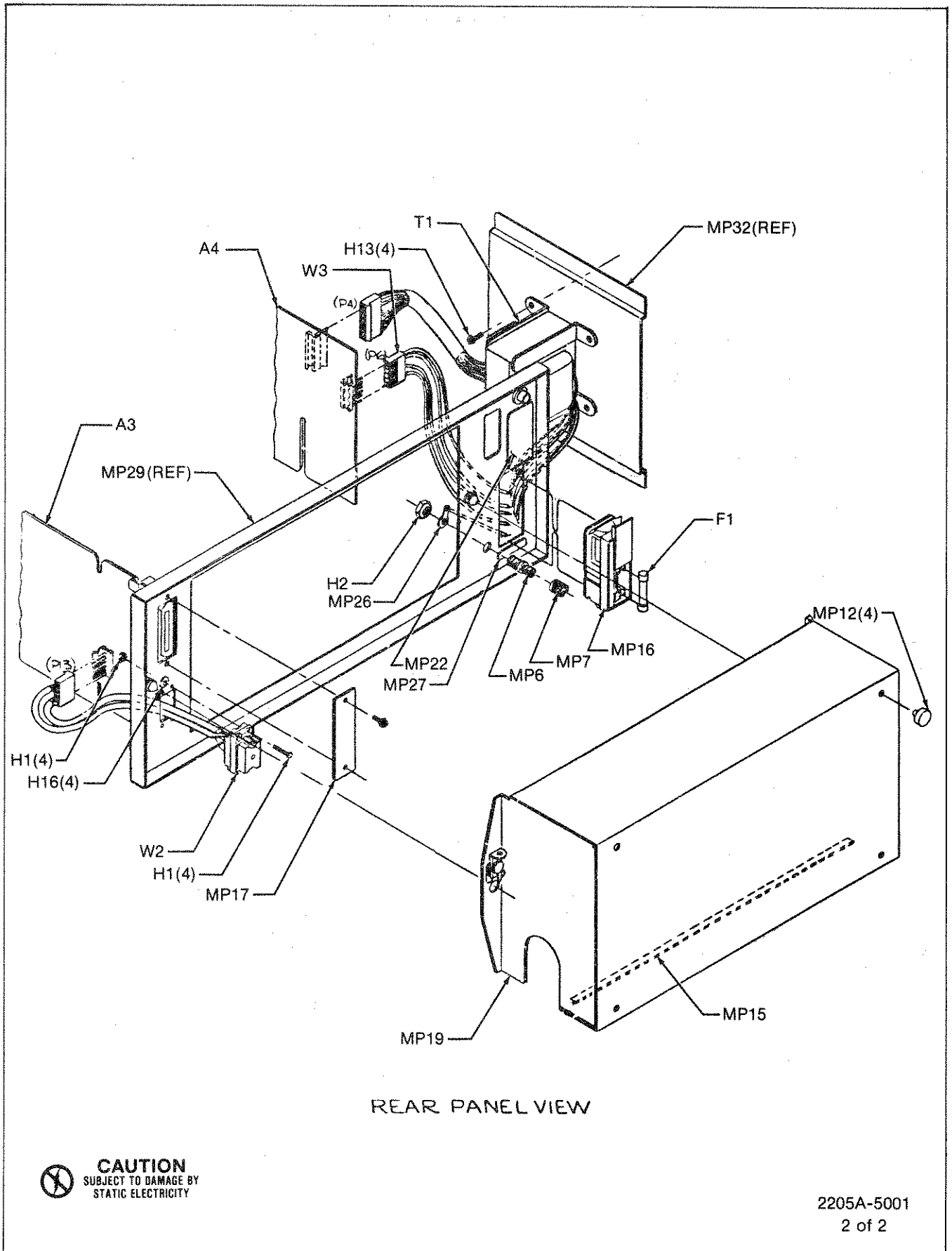

Figure 6-1. 6070A/6071A Final Assembly (cont)

Table 6-2. A1 Front Panel Display PCB Assembly

REF DES	DESCRIPTION	FLUKE STOCK NO.	MFG SPLY CODE	MFG PART NO.	TOT QTY	REC QTY	NOTE
A1①	FRONT PANEL DISPLAY PCB ASSY FIGURE 6-2 (2204A-4010T-PH2)	639708	89536	611061	REF		
C1	CAP, TA, 10 UF +/-20%, 20V	330662	56289	196D106X0025KA1	4		
C2	CAP, TA, 10 UF +/-20%, 20V	330662	56289	196D106X0025KA1	REF		
C3	CAP, TA, 10 UF +/-20%, 20V	330662	56289	196D106X0025KA1	REF		
C4	CAP, TA, 10 UF +/-20%, 20V	330662	56289	196D106X0025KA1	REF		
C5	CAP, MICA, 22 PF +/-5%, 500V	148551	72136	DM15C220J	2		
C6	CAP, MICA, 22 PF +/-5%, 500V	148551	72136	DM15C220J	REF		
C7	CAP, TA, 1 UF +/-20%, 35V	161919	56289	196D105X0035JA1	1		
C8	CAP, CER, 0.22 UF +/-20%, 50V	309849	71590	CW30C224K	1		
CR1	DIODE, SI, HI-SPEED SWITCH	203323	07910	1N4448	5	1	
CR2	DIODE, SI, HI-SPEED SWITCH	203323	07910	1N4448	REF		
CR3	DIODE, SI, HI-SPEED SWITCH	203323	07910	1N4448	REF		
CR4	DIODE, INDICATOR, LED	413831	29083	MV5153	1	1	
CR5	DIODE, SI, HI-SPEED SWITCH	203323	07910	1N4448	REF		
CR6	DIODE, SI, HI-SPEED SWITCH	203323	07910	1N4448	REF		
CR7	DIODE, ZENER, 36V	186163	07910	1N974B	2	1	
CR8	DIODE, ZENER, 36V	186163	07910	1N974B	REF		
DS1	DIODE, LED, 7-SEGMENT	468124	89536	468124	3	1	
DS2	DIODE, LED, 7-SEGMENT	468124	89536	468124	REF		
DS3	DIODE, LED, 7-SEGMENT	468124	89536	468124	REF		
MP1	COVER, SWITCH	401299	89536	401299	15		
MP2	CONTACT, FIXED	416875	00779	62313	15		
MP3	SPRING	414516	00779	63212	15		
MP4	ACTUATOR, SWITCH	412106	89536	412106	15		
MP5	POST, CONNECTOR (TYPICAL)	267500	00779	87022-1	30		
P7	CONNECTOR, 6-PIN	380378	89536	380378	2		
P9	CONNECTOR, 6-PIN	380378	89536	380378	REF		
P10	CONNECTOR, FEMALE, 12-PIN	447813	22526	65501-136	2		
Q1	XSTR, SI, PNP	195974	04713	2N3906	3	1	
Q2	XSTR, SI, PNP	195974	04713	2N3906	REF		
Q3	XSTR, SI, PNP	195974	04713	2N3906	REF		
Q4	XSTR, SI, NPN	218396	04713	2N3904	1	1	
R1	RES, DEP. CAR, 390 +/-5%, 1/4W	441543	80031	CR251-4-5P390E	2		
R2	RES, DEP. CAR, 390 +/-5%, 1/4W	441543	80031	CR251-4-5P390E	REF		
R3	RES, DEP. CAR, 5.6K +/-5%, 1/4W	442350	80031	CR251-4-5P5K6	4		
R4	RES, DEP. CAR, 5.6K +/-5%, 1/4W	442350	80031	CR251-4-5P5K6	REF		
R5	RES, DEP. CAR, 5.6K +/-5%, 1/4W	442350	80031	CR251-4-5P5K6	REF		
R6	RES, COMP, 4.7K +/-5%, 1/4W	148072	01121	CB4725	3		
R7	RES, COMP, 4.7K +/-5%, 1/4W	148072	01121	CB4725	REF		
R8	RES, COMP, 4.7K +/-5%, 1/4W	148072	01121	CB4725	REF		
R9	RES, DEP. CAR, 2K +/-5%, 1/4W	441469	80031	CR251-4-5P2K	1		
R10	RES, DEP. CAR, 5.6K +/-5%, 1/4W	442350	80031	CR251-4-5P5K6	REF		
R11	RES, DEP. CAR, 24 +/-5%, 1/4W	442210	80031	CR251-4-5P24E	1		
R12	RES, DEP. CAR, 10 +/-5%, 1/4W	340075	80031	CR251-4-5P10E	1		
S1	SWITCH, PIANO, 5 PST	454769	00779	435802-4	1		
S2	SWITCH, DIP, 4 PST	408559	00779	435166-2	1		
S3	SWITCH ASSY, PUSHBUTTONS PUSHBUTTON, BLUE (0)	406736	89536	406736	1		

Table 6-2. A1 Front Panel Display PCB Assembly (cont)

REF DES	DESCRIPTION	FLUKE STOCK NO.	MFG SPLY CODE	MFG PART NO.	TOT QTY	REC QTY	NO TE
S3-2	PUSHBUTTON, WHITE (1 THRU 9, 14)	406744	89536	406744	10		
S3-3	PUSHBUTTON, GREY (10 THRU 12)	401307	89536	401307	3		
S3-4	PUSHBUTTON, ORANGE (13)	420620	89536	420620	1		
U1	IC, 8-RESISTOR NETWORK, 180	424531	89536	424531	1		1
U2	IC, TTL, BUFFERS, INTERFACE GATES	407593	01295	SN7406N	2		1
U3	IC, TTL, BUFFERS, INTERFACE GATES	407593	01295	SN7406N		REF	
U4⊗	IC, TTL, SCHOTTKY "D" TYPE, FLIP-FLOP	454892	01295	SN74LS273N	1		1
U5⊗	IC, TTL SCHOTTKY TRI-STATE, OCTAL BUFFER	429902	12040	DM81LS95N	1		1
U7⊗	ISOLATOR, OPT-CPLD, DUAL, HI-SPEED	429894	28480	5082-4355	1		1
U8⊗	IC, TTL, HEX INVERTER	393058	01295	SN74LS04N	1		1
U9	IC, TTL, QUAD, 2-INPUT, POS OR GATES	393108	01295	SN74LS32N	1		1
U10	IC, TTL SCHOTTKY DUAL "D" CLEAR & PRESET	393124	01295	SN74LS74N	1		1
U11	RES. NETWORK, 1K, DUAL IN LINE	358119	89536	358119	1		1
XDS1	SOCKET, IC, DIP, 14-PIN	453514	23880	T3800-14B	3		
XDS2	SOCKET, IC, DIP, 14-PIN	453514	23880	T3800-14E		REF	
XDS3	SOCKET, IC, DIP, 14-PIN	453514	23880	T3800-14E		REF	
XU6	SOCKET, IC, DIP, 40-PIN	418988	91506	340-AG39E	1		
XU7	SOCKET, IC, DIP, 8-PIN	478016	91506	308-AG39D	1		
Y1	CRYSTAL, 6 MHZ +/-0.015%	461665	89536	461665	1		1

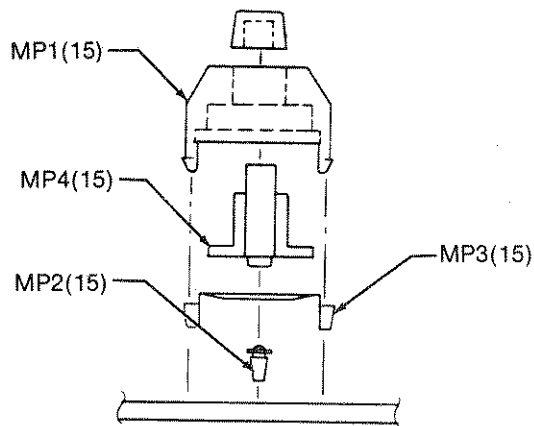
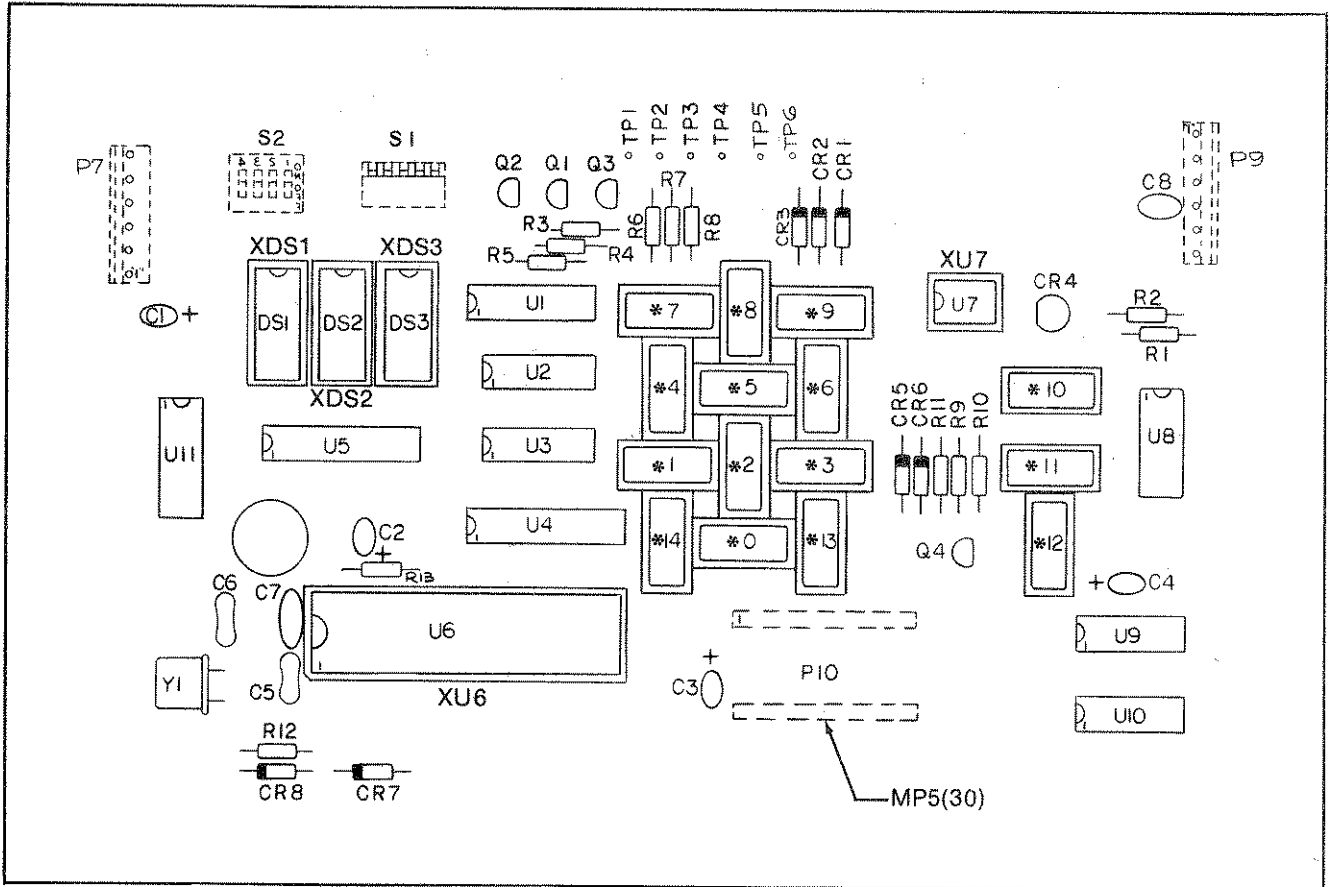

DETAIL A
*S3 SWITCH ASSEMBLY

CAUTION
SUBJECT TO DAMAGE BY
STATIC ELECTRICITY

2204A-1710

Figure 6-2. A1 Front Panel Display PCB Assembly

Table 6-3. A2 Mother Board PCB Assembly

REF DES	DESCRIPTION	FLUKE STOCK NO.	MFG SPLY CODE	MFG PART NO.	TOT QTY	REC QTY	NOTE
A2	MOTHER BOARD PCB ASSY FIGURE 6-3 (2204A-4001T)	468132	89536	468132			REF
C1	CAP, CER, 1000 PF +/-20%, 250VAC	485680	52763	RY11-2500		1	
J1	CONNECTOR, CARD EDGE, 8-PIN	354951	00779	583407-5		1	
J2	CONNECTOR, CARD EDGE, 24-PIN	295352	00779	583650-9		1	
J3	CONNECTOR, 6-PIN	291625	00779	583650-1		11	
J4	CONNECTOR, 12-PIN	291898	00779	583650-2		10	
MP1	KEY, POLARIZING, CONNECTOR	424572	89536	424572		33	
R1	RES, COMP, 1.5M +/-5%, 1/2W	108175	01121	EB1555		1	

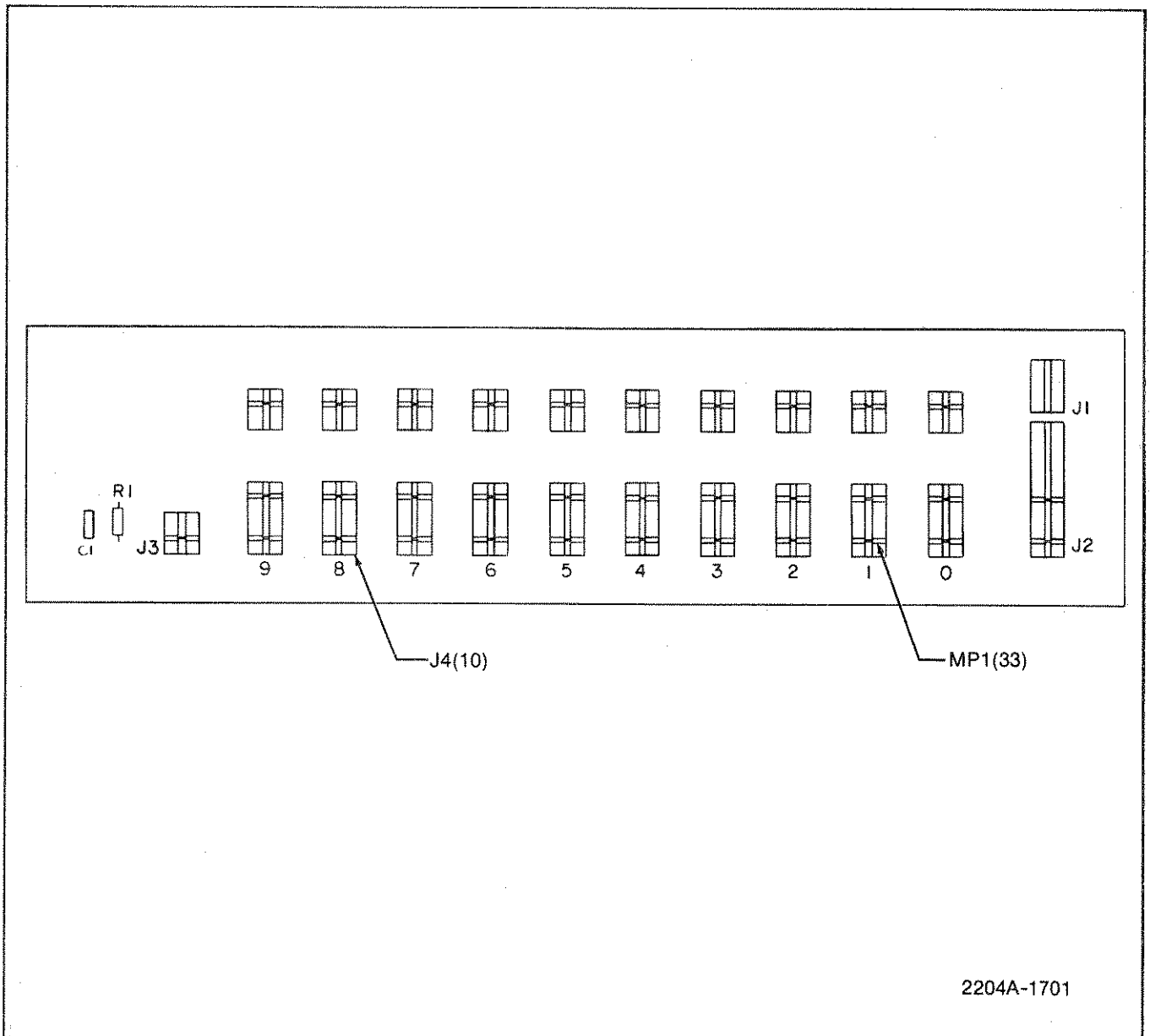
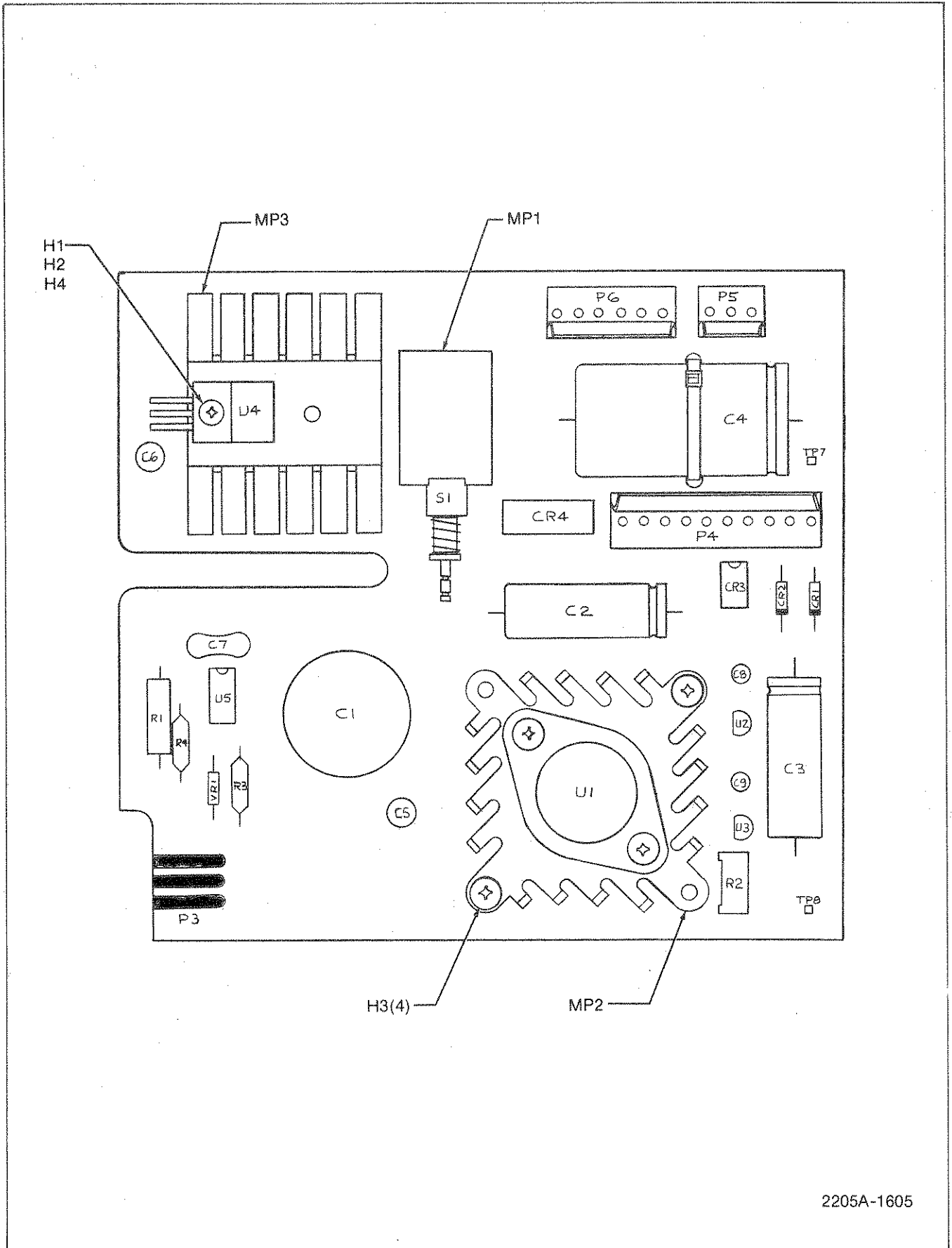

Figure 6-3. A2 Mother Board PCB Assembly

Table 6-4. A3 Power Supply PCB Assembly

REF DES	DESCRIPTION	FLUKE STOCK NO.	MFG SPLY CODE	MFG PART NO.	TOT QTY	REC QTY	NO TE
A3	POWER SUPPLY PCB ASSY FIGURE 6-4 (2205A-4005T)	639690	89536	611897	REF		
C1	CAP, ELECT, 10,000 UF -10/+30%, 16V	603290	89536	603290	1		
C2	CAP, ELECT, 220 UF -10/+50%, 40V	178616	80031	ET221X040A01	2		
C3	CAP, ELECT, 220 UF -10/+50%, 40V	178616	80031	ET221X040A01	REF		
C4	CAP, ELECT, 2200 UF -10/+100%, 25V	392720	80031	3050HJ222U025	1		
C5	CAP, ELECT, 15 UF +/-20%, 35V	614024	89536	614024	2		
C6	CAP, TA, 10 UF +/-20%, 20V	330662	56289	196D106X0025KA1	REF		
C7	CAP, MICA, 33 PF +/-5%, 500V	160317	72136	DM15E330J	1		
C8	CAP, TA, 1 UF +/-20%, 35V	161919	56289	196D105X0035JA1	2		
C9	CAP, TA, 1 UF +/-20%, 35V	161919	56289	196D105X0035JA1	REF		
CR1	DIODE, SI, PWR RECTIFIER	483701	14099	5FF10	2	1	
CR2	DIODE, SI, PWR RECTIFIER	483701	14099	5FF10	REF		
CR3	RECTIFIER, BRIDGE, 1 AMP	418582	83003	VM08	1	1	
CR4	RECTIFIER, BRIDGE	296509	09423	FB200	1	1	
H1	NUT, HEX, 4-40	147611	89536	147611	1		
H2	SCREW, PHP, 4-40 X 3/8	152124	89536	152124	1		
H3	SCREW, PHP, 6-32 X 1/4	152140	89536	152140	4		
H4	WASHER, LOCK, 4-40	110403	89536	110403	1		
MP1	COVER, AC SWITCH	475681	89536	475681	1		
MP2	HEATSINK, w/U1	342675	89536	342675	1		
MP3	HEATSINK, w/U4	473686	89536	473686	1		
MP4	NYLON STRAP, w/C4	172080	89536	172080	1		
P4	CONNECTOR, 10-PIN	446724	27264	09-65-1101	1		
P5	CONNECTOR, 3-PIN	380022	89536	380022	1		
P6	CONNECTOR, 6-PIN	267500	00779	87022-1	REF		
R1	RESISTOR, SELECTED SET	377283	89536	377283	1		
R2	RES, VAR, 500 +/-10%, 1/2W	291120	89536	291120	1		
R3	RESISTOR, SELECTED SET, SEE R1						
R4	RES, MTL. FILM, 61.9K +/-1%, 1/8W	237230	91637	CMF556192F	1		
S1	SWITCH, PUSH-PUSH, DPDT	453605	89536	453605	1		
U1	IC, LIN, VOLTAGE REGULATOR, +5V DC	453944	12040	LM223K	1	1	
U2	IC, LIN, VOLTAGE REGULATOR, +15V DC	453035	04713	MC78L15ACP	1	1	
U3	IC, LIN, VOLTAGE REGULATOR, -15V DC	454801	04713	MC79L15ACP	1	1	
U4	IC, LIN, VOLTAGE REGULATOR, +5V DC	355107	12040	F7805UC	1	1	
U5	IC, LINEAR, OP AMP	363515	12040	LM301	1	1	
VR1	VOLTAGE REG, SELECTED SET, SEE R1						



2205A-1605

Figure 6-4. A3 Power Supply PCB Assembly

Table 6-5. Extender Bus PCB Assembly

REF DES	DESCRIPTION	FLUKE STOCK NO.	MFG SPLY CODE	MFG PART NO.	TOT QTY	REC QTY	NOTE
A4⊗	EXTENDER BUS PCB ASSY FIGURE 6-5 (2204A-4015T-PH 2)	639716	89536	611087	REF		
C1	CAP, TA, 2.2 UF +/-20%, 20V	161927	56289	196D225X0020HA1	6		
C2	CAP, TA, 2.2 UF +/-20%, 20V	161927	56289	196D225X0020HA1	REF		
C3	CAP, TA, 2.2 UF +/-20%, 20V	161927	56289	196D225X0020HA1	REF		
C4	CAP, TA, 2.2 UF +/-20%, 20V	161927	56289	196D225X0020HA1	REF		
C5	CAP, TA, 2.2 UF +/-20%, 20V	161927	56289	196D225X0020HA1	REF		
C6	CAP, TA, 2.2 UF +/-20%, 20V	161927	56289	196D225X0020HA1	REF		
CR1	DIODE, SI	203323	07910	1N4448	2	1	
CR2	DIODE, SI	203323	07910	1N4448	REF		
H1	SCREW, 4-40 X 3/8	152124	73734	19024	2		
H2	WASHER, LOCK, #4	110395	89536	110395	2		
H3	NUT, HEX, 4-40	147611	89536	147611	2		
H4	LUG, SOLDER	151431	79963	329	1		
H5	KIT, CONNECTOR	448563	89536	448563	1		
J12	CONNECTOR, FEMALE, 36-PIN	414409	00779	552241-1	1		
K1	RELAY, DRY REED, DPST	442921	21317	052A5*300BAA	2		
K2	RELAY, DRY REED, DPST	442921	21317	052A5*300BAA	REF		
P11	PINS, CONNECTOR, MALE	380378	89536	380378	2		
P13	PINS, CONNECTOR, MALE	380378	89536	380378	REF		
Q1	XSTR, SI, NPN	218396	04713	2N3904	2	1	
Q2	XSTR, SI, NPN	218396	04713	2N3904	REF		
R1	RES, DEP. CAR, 3.3K +/-5%, 1/4W	348813	80031	CR251-4-5P3K3	2		
R2	RES, DEP. CAR, 3.3K +/-5%, 1/4W	348813	80031	CR251-4-5P3K3	REF		
R3	RES, DEP. CAR, 2.2K +/-5%, 1/4W	343400	80031	CR251-4-5P2K2	2		
R4	RES, DEP. CAR, 2.2K +/-5%, 1/4W	343400	80031	CR251-4-5P2K2	REF		
R5	RES, DEP. CAR, 10K +/-5%, 1/4W	348839	80031	CR251-4-5P10K	1		
S1	SWITCH, SLIDE, SPDT	453365	79727	G1-116-0001G20-52	1		
U1⊗	IC, MOS, HEX INVERTER	381848	02735	CD4049AE	1	1	
U2⊗	IC, TTL, QUAD, D-TYPE FLIP-FLOP	452912	12040	MM74C175N	3	1	
U3⊗	IC, TTL, QUAD, D-TYPE FLIP-FLOP	452912	12040	MM74C175N	REF		
U4⊗	IC, MOS, HEX BUFFER	381830	02735	CD4050AE	4	1	
U5⊗	IC, MOS, QUAD, 2-INPUT AND GATE	408401	02735	CD4081AE	1	1	
U6⊗	IC, MOS, DUAL 4-STAGE SHIFT REGISTER	340125	04713	MC14015BCP	2	1	
U7⊗	IC, MOS, DUAL 4-STAGE SHIFT REGISTER	340125	04713	MC14015BCP	REF		
U8⊗	IC, MOS, HEX BUFFER	381830	02735	CD4050AE	REF		
U9⊗	IC, MOS, QUAD, AND/OR SELECT GATE	419010	02735	CD4019AE	1	1	
U10⊗	IC, MOS, BCD-TO-DECIMAL DECODER	473769	04713	MC14028B	1	1	
U11⊗	IC, MOS, QUAD, 2-INPUT OR GATE	408393	02735	CD4071BE	1	1	
U12⊗	IC, TTL, QUAD, D-TYPE FLIP-FLOP	452912	12040	MM74C175N	REF		
U13⊗	IC, MOS, DUAL, 4-INPUT NOR GATE	363820	02735	CD4002AE	1	1	
U14⊗	IC, MOS, HEX BUFFER	381830	02735	CD4050AE	REF		
U15⊗	IC, MOS, HEX BUFFER	381830	02735	CD4050AE	REF		

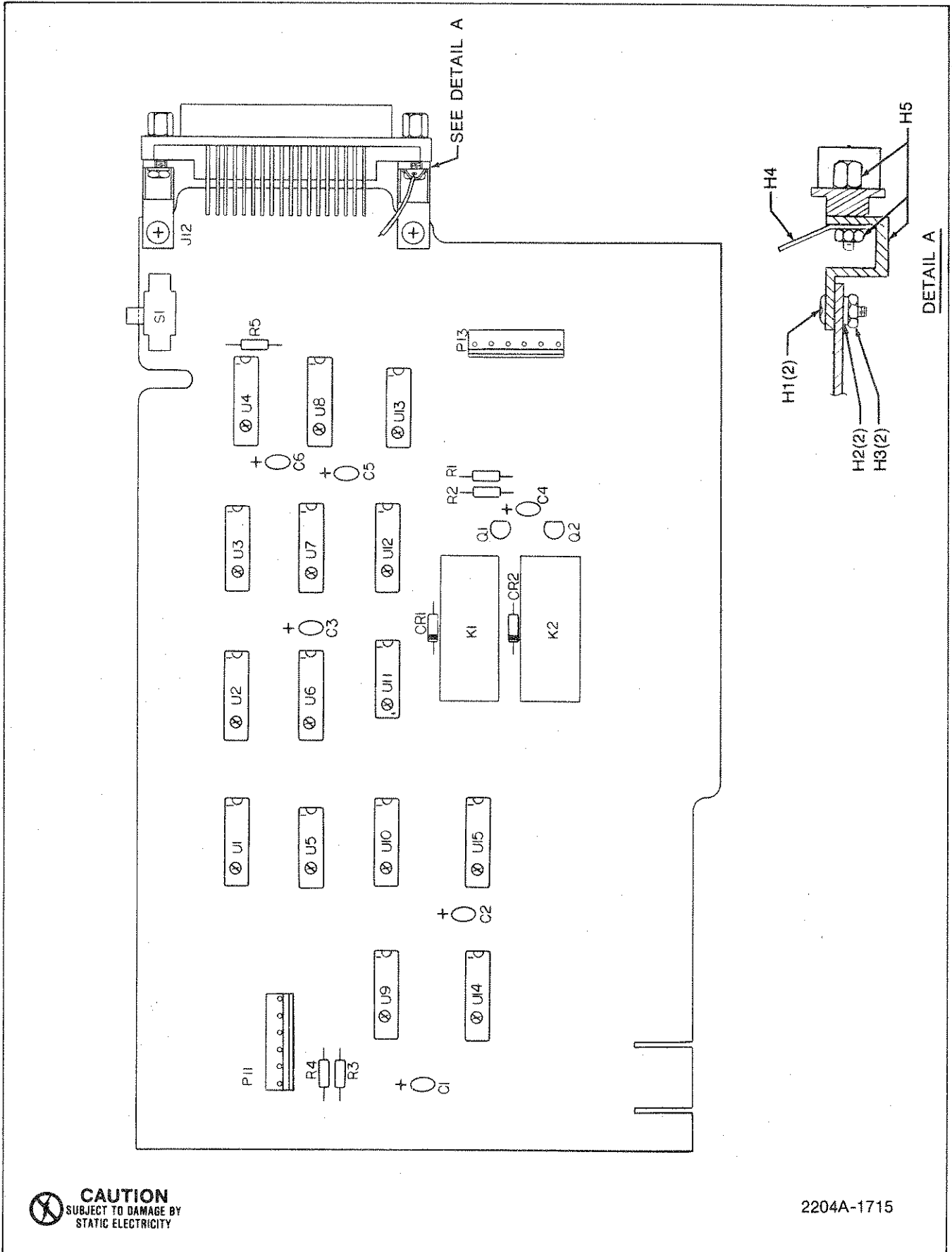
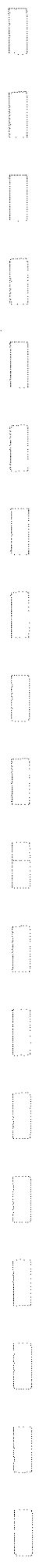

Figure 6-5. Extender Bus PCB Assembly



Section 7

Options and Accessories

TABLE OF CONTENTS

OPTION/ MODEL NO.	DESCRIPTION	PAGE
2205A-050	IEEE-488 Interface	050-1
2205A-060	RS-232-C Interface	060-1
2205A-100	Actuator Module	100-1
2205A-200	Latching Module	200-1
2205A-300	General Purpose Scanner Module	300-1
2205A-400	Four-wire Resistance Scanner Module	400-1
2205A-600	Low Level Scanner Module	600-1

7-1. INTRODUCTION

7-2. This section of the manual contains information concerning the options and accessories available for use with the Model 2205A Switch Controller. Each option and accessory is listed by model or option number in the table of contents on page 7-1.

7-3. Each option for the 2205A is documented as an individual subsection. All of the information necessary for installation, operation, and maintenance of the option is included in a its own subsection. This includes a list of replaceable parts. Schematics are included in Section 9 of this manual.

7-4. Each subsection is uniquely identified by page and paragraph numbering that relates to that particular option. For example, a 600-X series identifies the subsection for the -600 option, where X is a sequential page or paragraph number.

7-5. ACCESSORIES

7-6. Introduction

7-7. Accessories include a series of rack mounting kits, remote interface cables/connectors, and scanner extender chassis. The rack mount kits are designed for use in standard 19-inch equipment racks. The cables/connectors are used for I/O connection between the 2205A and the extender chassis.

7-8. Rack Mounting Kit

7-9. The 2205A can be rack mounted in a standard 19-inch equipment rack using Rack Mounting Kit, M07-205-600. Use the following procedure to install the kit:

1. Peel off the nameplate decals from the front side-corners of the unit.
2. Remove the front corner screws which match the hole pattern in the rack mounting ears (see Figure 7-1).
3. Attach the rack mounting ears to the front corners of the unit using the screws supplied in the rack mounting kit.

7-10. Rack Slide Kit

7-11. The 2205A can be rack mounted in a 24-inch deep equipment rack using the Rack Slide Kit, M00-280-610. Use the following procedure to install the kit:

1. Remove the horizontal side trim decal from both sides of the unit.
2. Refer to Figure 7-2, and, using the screws supplied with the kit, attach the Chassis Section (B) of the slide kit to each side of the unit. Use the center row of mounting holes.

3. Install the Cabinet Section (D) and the Center Section (C) in the equipment rack.

4. Pull the Center Section of the slide out through the front of the equipment rack until it locks in the extended position.

5. Depress the spring locks on the Chassis Section (B) and join Section B and C.

6. Push the unit into the equipment rack and then pull it out to the extended position. The spring locks should limit the rack slide travel.

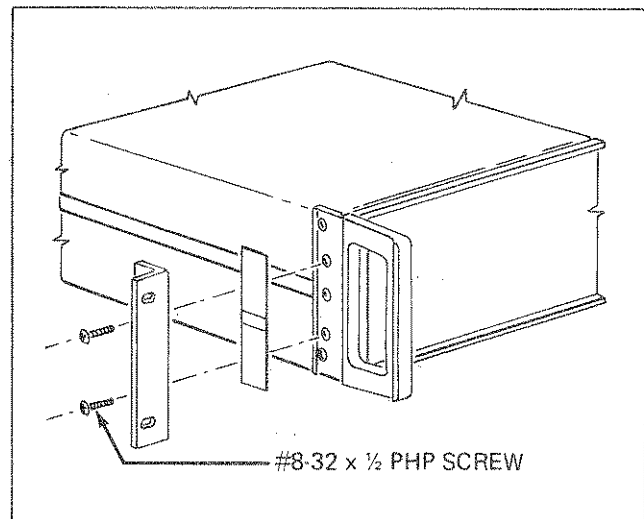

Figure 7-1. Rack Mounting Kit

7-12. Remote Scanner Cables

7-13. The cable assemblies necessary to add a series of extender chassis are fabricated by the factory on a custom basis. This allows the user to determine the cable lengths necessary for a particular application. The components required to complete a cable are available as two kits; a connector kit 2200A-7001 (two connector assemblies), and a length of cable 2200A-7002. When ordering the cable specify the length in feet. An assembled cable is shown in Figure 7-3.

7-14. IEEE-488 Compatible Interface Cables

7-15. A series of three interface cables are available for use with the IEEE-488 Compatible Interface (Option -050). The cables are available in 1, 2, and 4 meter lengths. (Y8001, Y8002, and Y8003 respectively). As shown in Figure 7-3, the cables are equipped with double-ended connectors so that they may be interconnected in serial and/or star patterns.

7-16. RS-232 Interface Cable

7-17. A 3-meter interface cable is available for use with the RS-232-C Interface (Option -060). Specify Model Y8004 when ordering.

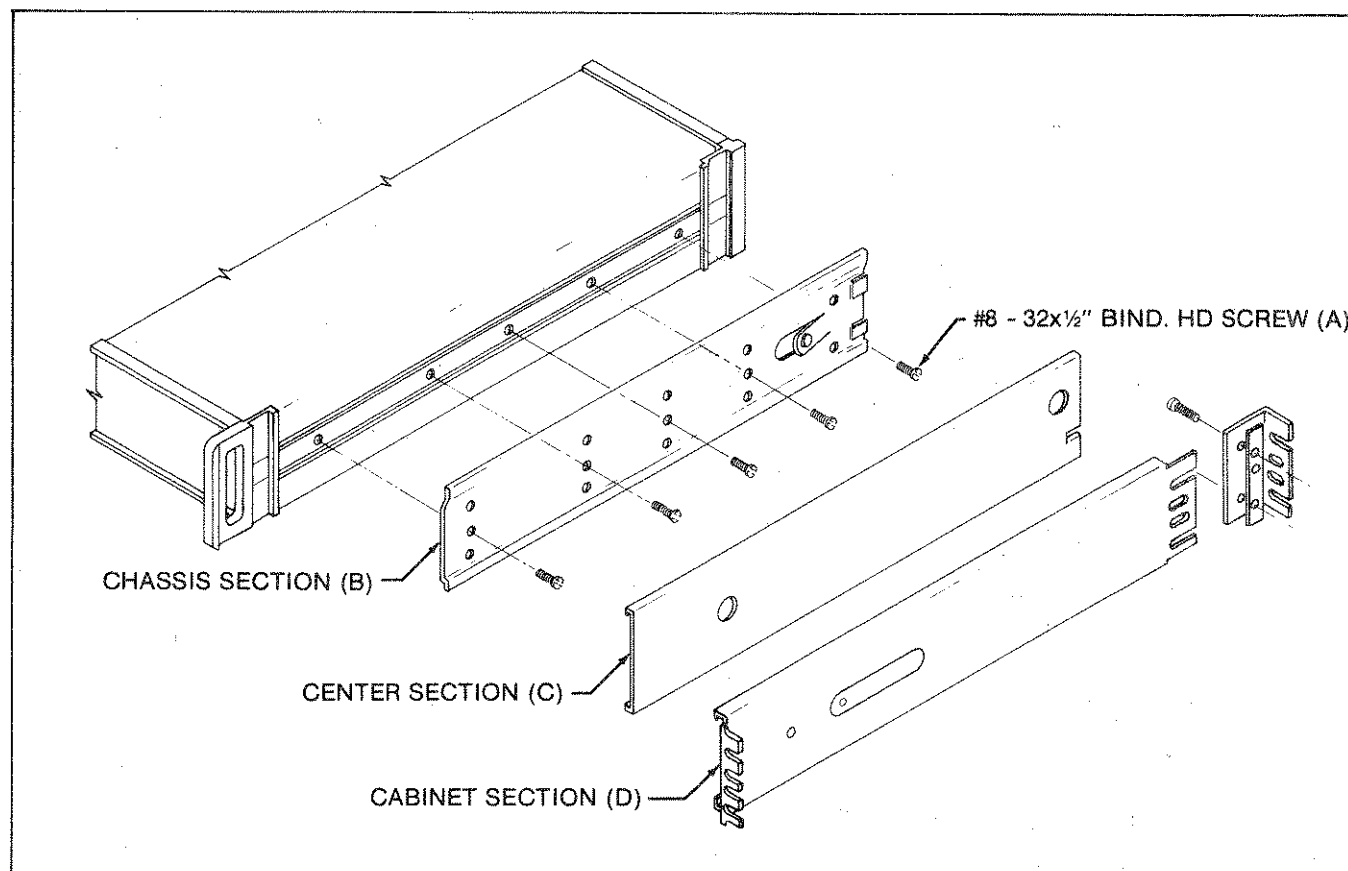

Figure 7-2. Rack Slide Kit

7-18. Analog Signal Cable

7-19. A 1-meter analog signal cable (Figure 7-3) connects the 2205A to a DMM. Specify the Model Y8076 Analog Signal Cable (one cable is included with the 2205A) when ordering.

7-20. Delay Trigger Cable

7-21. A 0.9 meter coax cable (see Figure 7-3) with male BNC connectors is available for use as a 2205A delay trigger cable to trigger a DMM reading. Specify Model Y8013 when ordering.

7-22. Extender Chassis

7-23. The channel capacity of the 2205A can be expanded from 100 up to 1000 by adding a series of extender chassis. Two units are available for this purpose; the Model 2201A (120 channels) and the Model 2202A (100 channels). Both units function as a physical extension of the 2205A logic. The Model 2201A is recommended for applications not more than 50 feet away from the 2205A. Locations from 51 to 1500 feet from the 2205A should use the 2202A.

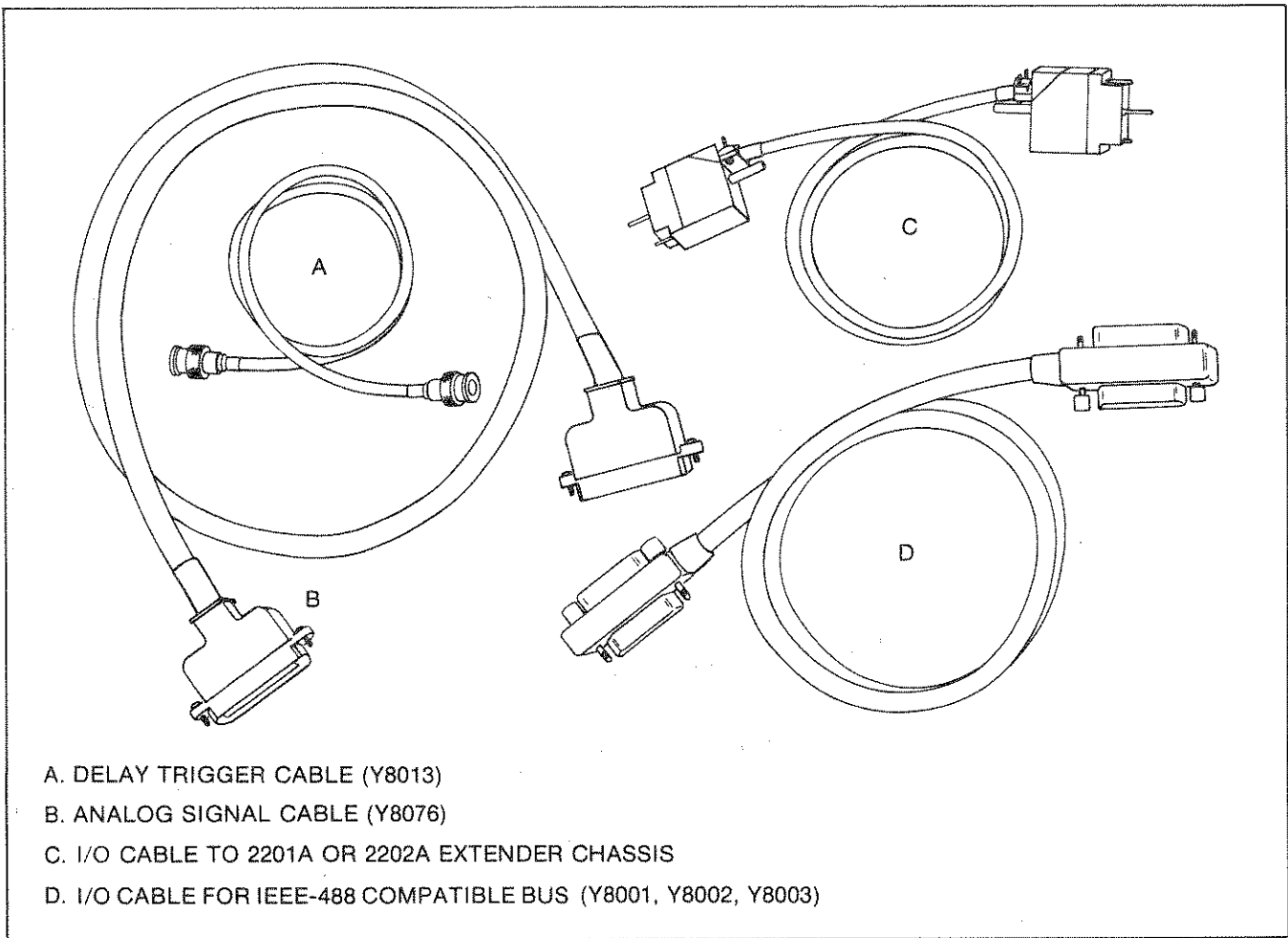

Figure 7-3. Rear Panel Cables

Option 2205A-050 IEEE-488 Compatible Interface

050-1. INTRODUCTION

050-2. The IEEE-488 Compatible Interface (Option -050) provides the controller mainframe with a remote control interface capable of responding to the asynchronous transfer of character-serial ASCII control data by way of an IEEE-488, 1978 Standard bus. This bus is bidirectional and can be driven by a variety of program sources, such as, a computer or a system controller. Since the controller mainframe responds to (listens), but does not issue control data (talk), it is defined as a listen-only device. A unique address code (0 through 30) is assigned (by the user) to the interface so that all control data on the

bus is ignored by the controller mainframe unless it is preceded by the proper listen address. A series of handshake lines ensure the asynchronous transfer of data regardless of data speed.

050-3. Connection of the controller mainframe to the system data bus is made with a 24-pin connector that conforms to the IEEE-488 standard.

050-4. SPECIFICATIONS

050-5. The specifications for the IEEE-488 Compatible Interface are listed in Table 050-1.

Table 050-1. Option -050 Specifications

Functions	This option provides the following functions of the IEEE-488, 1978 Standard Compatible Bus.		
	SUBSET	FUNCTION	REMARKS
	SH0	Source Handshake	No Capability
	AH1	Acceptor Handshake	Complete Capability
	T0	Talker	No Capability
	TE0	Extended Talker	No Capability
	L2	Listener	Listen Only
	LE	Extended Listener	
	SRO	Service Request	No Capability
	RL1	Remote Local	Complete Capability
	PP0	Parallel Poll	No Capability
	DCI	Device Clear	Complete Capability
	DT0	Device Trigger	
	C0	Controller	No Capability
Messages	The -050 will handshake all messages on the bus. However only those listed above will affect the instrument's operation.		
Address	Any address from 0 to 30 may be user selected. Factory installed option has address set at 3. Instrument shows address at power up as 'Axx'.		

050-6. INSTALLATION

050-7. A controller mainframe can be equipped with either an IEEE-488 Compatible Interface (Option -050) or an RS-232-C Interface (Option -060). If an IEEE-488 Compatible Interface is to be installed, it may or may not replace an existing interface pcb. The IEEE-488 Compatible Interface PCB installs as follows:

1. Remove the 2205A from line power.
2. Remove the top cover.
3. Remove the three screws along the top side of the Front Panel Display PCB.
4. Push the pcb away from the front panel (the switch buttons must clear the front panel) and pull the pcb upward.
5. Unplug the attached cables.
6. Remove the four screws that hold the existing interface pcb to the Front Panel Display PCB.
7. Carefully separate the two pcbs at connectors J10 and P10.
8. Remove the rear panel screws that anchor the interface connector to the rear panel.
9. Plug the IEEE-488 Interface PCB into the Front Panel Display PCB at J10 and P10.
10. Thread the interface cable along side of the guard housing so that the cable won't interfere with the installation of the top cover.
11. Position the 24-pin connector in the REMOTE INTERFACE hole in the rear panel and anchor it in place using the screws removed earlier.
12. Set switch S1 on the Front Panel Display PCB for the desired IEEE-488 address. See Section 2 of this manual for the instructions necessary to select an address.
13. Install the Front Panel Display PCB and the top dust cover.

050-8. INTERFACE INFORMATION**050-9. System Connection**

050-10. Connection of the controller mainframe to the IEEE-488 compatible system bus is made using a 24-wire cable. The cable is available as an accessory and comes in three standard lengths; 1, 2, and 4 meters. See the Accessories section for cable descriptions and model numbers.

050-2

050-11. Cables may be interconnected in any manner deemed suitable by the user; i.e., star, linear or combinations thereof. Before a cable is ordered, the system bus should be analyzed to ensure that adding the controller mainframe will not cause an excessive load. IEEE-488 compatible system connections must not exceed the following limits:

1. No more than 15 bus loads may be connected in a single IEEE-488 compatible system bus.
2. The total length of cable used in one IEEE-488 compatible system bus must not exceed 20 meters.
3. The length of cable must also not exceed 2 meters times the number of devices in the system.

050-12. Each cable added to the IEEE-488 compatible bus connects all 26 lines of the added interface in parallel with all other devices on the bus. As a result, the cable not only connects the added device, it also physically and electrically extends the bus. Sixteen of the lines are signal lines. The remaining lines are used for signal support, i.e., logic common, signal return and shield. The 16 signal lines are separated into 8 data lines, the data byte transfer (handshake) lines and 5 general interface management lines. The data lines normally carry ASCII control characters and data. Data transfer is asynchronous and is directly controlled by the handshake lines. Thus, data transfer speed varies to accommodate the speed of the sending and receiving devices. Cable pin assignments and signal definitions are given in Table 050-2.

050-13. Basic Listener

050-14. All devices connected to the IEEE-488 compatible bus can be functionally categorized as controllers, talkers, and listeners. The 2205A qualifies as a listener. A brief description of each function follows:

1. Controller
A controller is a device that assigns which device will transmit data (talk) and which device(s) will receive data (listen). There may be only one controller. It services all interrupts. A controller may be a listener or talker.
2. Talker
A talker is a device that outputs data to the bus on command. Only one talker can be assigned (addressed) at any one time.
3. Listener
A listener is a device that, when properly addressed, accepts data from the bus. Up to 14 listeners can participate in any simultaneous bus operation.

Table 050-2. IEEE-488 Compatible Interface Pin Assignments

PIN	MNEMONIC	FUNCTION	COMMENTS
1	DIO1	DATA	Data input/output lines. Message bytes are carried on the DIO lines in a bit-parallel byte-serial form, asynchronous, and generally in a bidirectional manner.
2	DIO2	DATA	
3	DIO3	DATA	
4	DIO4	DATA	
13	DIO5	DATA	
14	DIO6	DATA	
15	DIO7	DATA	
16	DIO8	DATA	
5	EOI	End of Identify	Used to indicate the end of a multiple byte message.
6	DAV	Data Available	Is asserted TRUE by the sender of data when NRFD goes TRUE, remains TRUE until NDAC is sent TRUE by the data receiver.
7	NRFD	Not Ready For Data	When all devices are ready to receive data this line goes high. Remains high until DAV is sent TRUE.
8	NDAC	No Data Accepted	When all receiving devices are through with the data on the bus, this line goes high, indicating that the sender may remove the data and set DAV low. When DAV goes to the receiving devices then pull NDAC low again.
9	IFC	Interface Clear	Sent high by the controller. It places all device interfaces in a known quiescent state.
10	SRQ	Service Request	This line is used by some devices to get the attention of the controller.
11	ATN	Attention	Used by the controller to notify all other devices what type of message (interface versus device dependent) is on the data bus. When ATN is TRUE, messages sent are interface messages and all devices capable of receiving messages must handshake the transfer. When false, device dependent messages are sent and only devices that have been addressed remain active.
12		Shield*	Surrounds all conductors.
17	REN	Remote Enable	Must be TRUE to place instruments into remote. Once in Remote, if REN goes false all instruments must go to local.
18	GND	Return to DAV	
19	GND	Return to NRFD	
20	GND	Return to NDAC	
21	GND	Return to IFC	
22	GND	Return to SRQ	
23	GND	Return to ATN	
24	GND	Logic common for DIO1-DIO8, EOI and REN	

*The cable shield is internally routed to a banana jack on the rear of the 2205A adjacent to the line connector.

050-15. Interface Address

050-16. Any address from 0 through 30 may be assigned to the controller mainframe. The address is determined by the position of the sections of switch S1 on the Front Panel Display PCB. The selected address is displayed when the controller mainframe is turned on. Instructions for setting the switch are given in Section 2 of this manual.

050-17. Interface Messages

050-18. The interface handshakes all messages on the bus. The interface messages for the IEEE-488 Compatible Interface are listed in Table 050-3.

050-19. OPERATION

050-20. Once installed, the IEEE-488 Interface does not require attention from the operator. Programming information is given in Section 3 of this manual.

050-21. THEORY OF OPERATION

050-22. The IEEE-488 Interface, as shown in Figure 050-1, consists of a series of four, 4-bit data buffers and an 8-bit tri-state inverter. Two of the inverters receive ASCII character-serial data (DIO1-DIO8) and present it to the input of the tri-state inverter. The inverter is normally in the high impedance state. When the microcomputer is ready to read input data, it issues a Port 0 Enable and a

read (RD) command. This enables the tri-state buffer causing the 8-bit character to be placed onto the microcomputer's data bus. The IEEE-488 handshake lines (three) and general interface management lines (five) control input/output to and from the microcomputer through the data buffers. Buffered input lines includes: REN, DAV, ATN, and IFC. Buffered output lines include: RFD, DAC, EOI, and SRQ. All handshake and management routines are handled by the microcomputer.

050-23. MAINTENANCE

050-24. Calibration and/or adjustment of the IEEE-488 Interface PCB is not required. The performance of the interface can be checked using the Remote Test Procedure given in Section 5 of this manual.

050-25. LIST OF REPLACEABLE PARTS

050-26. A list of replaceable parts for the IEEE-488 Compatible Interface is given in Table 050-4. Refer to Section 6 of this manual for ordering information.

CAUTION



Indicated devices are subject to damage by static discharge.

Table 050-3. Interface Messages

MESSAGE	MNEMONICS	MESSAGE CODING	NOTES
My Listen Address	MLA	00 through IE	2, 3, 4
Unlisten	UNL	3F	1
Local Lockout	LLO	11	1, 3
Go To Local	GTL	01	3
Device Clear	DCL	14	1
Selected Device Clear	SDC	04	2

1 = Universal Command
 2 = Address Command
 3 = Messages that affect the interface while in local
 4 = Receiving MLA will address the interface or a listener and place the interface (and 2205A) into remote if REN is sent true.

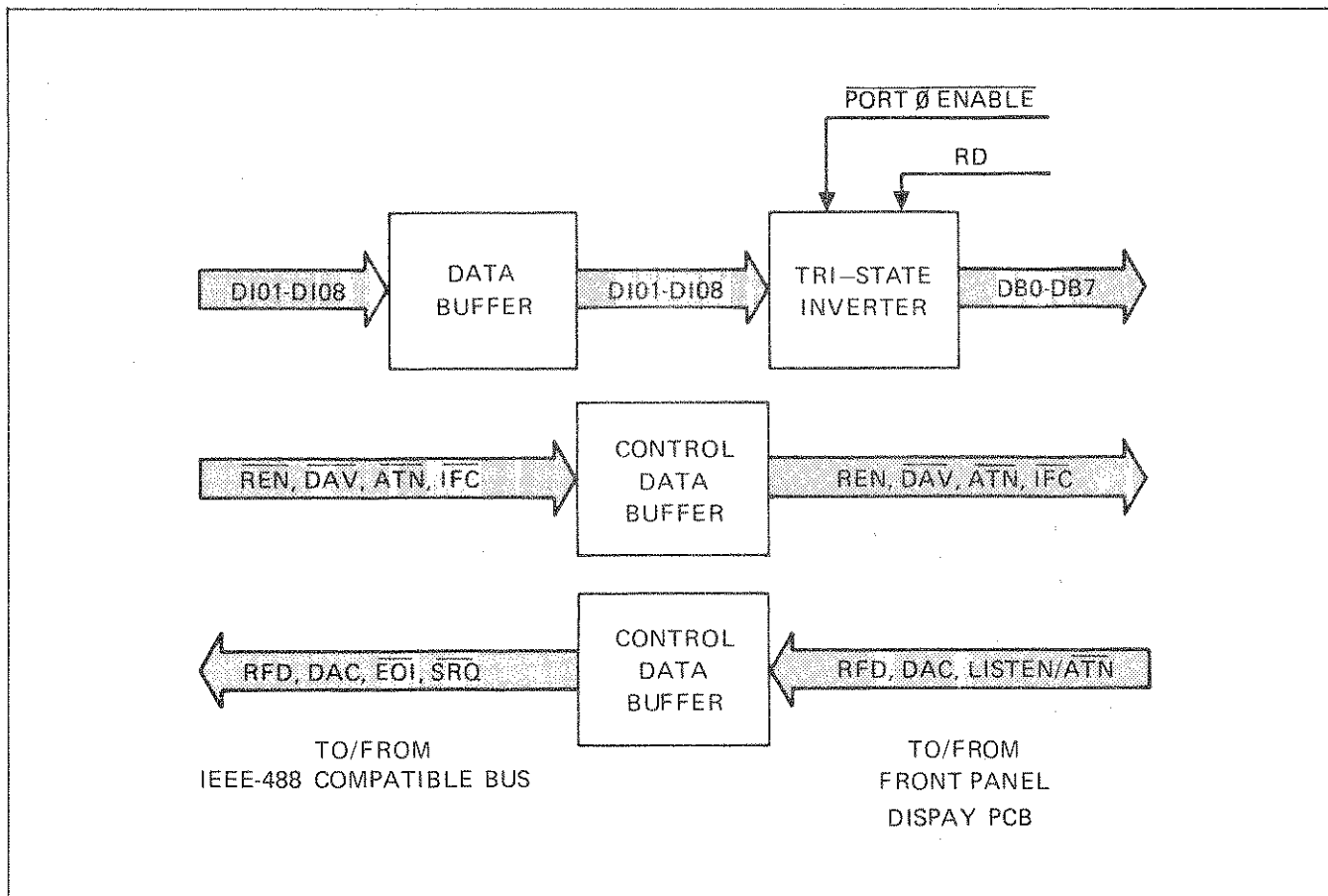
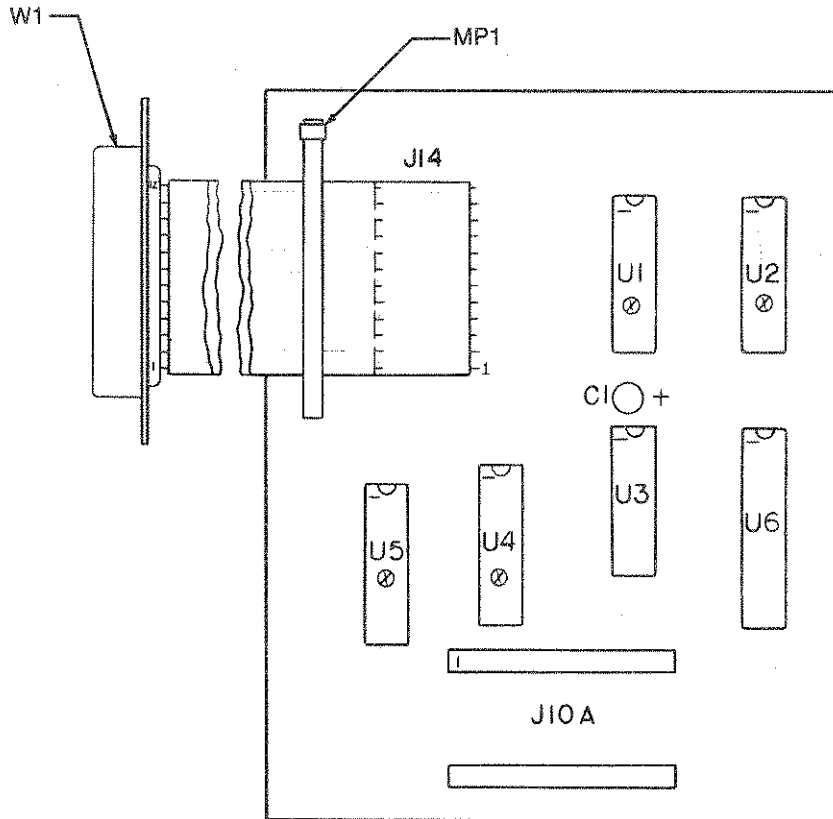

Figure 050-1. IEEE-488 Compatible Interface Block Diagram

Table 050-4. IEEE-488 Interface PCB Assembly

REF DES	DESCRIPTION	FLUKE STOCK NO.	MFG SPLY CODE	MFG PART NO.	TOT QTY	REC QTY	NOTE
-050	IEEE-488 INTERFACE PCB ASSY FIGURE 050-2 (2204A-4012T)	639765	89536	469254	1		
C1	CAP, TA, 10 UF +/-20%, 20V	330662	56289	196D106X0025KA1	1		
J10A	CONNECTOR, FEMALE, 12-PIN	417733	30035	SS-109-1-12	2		
MP1	STRAP, NYLON	172080	06383	SST-1M	1		
U1	IC, MOS, QUAD, INTERFACE BUS TRANSCEIVER	428649	04713	MC3446P	4	1	
U2	IC, MOS, QUAD, INTERFACE BUS TRANSCEIVER	428649	04713	MC3446P	REF		
U3	IC, TTL, QUAD, 2-INPUT, NOR GATE	393041	01295	SN74LS02N	1	1	
U4	IC, MOS, QUAD, INTERFACE BUS TRANSCEIVER	428649	04713	MC3446P	REF		
U5	IC, MOS, QUAD, INTERFACE BUS TRANSCEIVER	428649	04713	MC3446P	REF		
U6	IC, SCHOTTKY	453308	12040	DM81LS96N	1	1	
W1	CABLE ASSEMBLY, IEEE 488	468629	89536	468629	1		



 **CAUTION**
SUBJECT TO DAMAGE BY
STATIC ELECTRICITY

2204A-1712

Figure 050-2. IEEE-488 Interface PCB Assembly

Option 2205-060 RS-232-C Interface

060-1. GENERAL

060-2. EIA Standard RS-232-C provides the electronics industry with the ground rules necessary for independent manufacturers to design and produce both data terminal and data communication equipment that conforms to a common interface requirement. As a result, a data communications system can be formed by connecting an RS-232-C data terminal (such as, a controller mainframe) to an RS-232-C data communication peripheral (such as, a TTY, MODEM, computer, etc.). This works fine on paper. However, in practice, the user must be aware of the subtleties of serial binary data interchange to ensure that any two pieces of RS-232-C equipment will be compatible. For example, the two instruments must share at least one of the features from each of the following characteristics:

1. Timing Format - Synchronous or Asynchronous.
2. Transmission Mode - Simplex, half-duplex or full duplex.
3. Baud Rate (bits per second) - 110, 150, 300, 600, 1200, 1800, 2400, 4800, 9600.
4. Bits per character - 5, 6, 7, 8.
5. Parity Bit - Odd, even, hi, low, not used.
6. Data Interface Levels - EIA or 20 mA current loop.

060-3. Timing formats conforming to both synchronous and asynchronous operation are shown in Figure 060-1. In asynchronous operation each character is bracketed by both start and stop bits. These bits separate the characters and synchronize both the transmission and receipt of data. When data is not being sent the data line is held high. In synchronous operation a

sync character is sent prior to each data stream (a data stream usually consists of a block of characters). When the line is idle a fill or sync character is continuously transmitted.

060-4. Transmission mode is an overall system requirement. It defines the communication ability of both instruments in the system configuration. Simplex indicates data transmission in one direction only. Half-duplex permits two way communication, but not simultaneously. Simultaneous transmission of data in both directions defines a full duplex system. Obviously, an instrument capable of full-duplex operation can be down graded to simplex operation. However, the reverse is not possible without degrading the system capability.

060-5. Baud rate is usually selectable on a RS-232-C Interface. If it is not, the manufacturer usually offers a choice when the instrument is purchased.

060-6. Character format (bits per character and parity) is somewhat flexible between instruments. Investigate the requirements of both instruments before committing either to a system configuration.

060-7. Data interface levels can occur as either EIA voltage levels or as a 20 mA current loop. At times an interface offers both simultaneously. The 20 mA current loop is used almost exclusively for teletypewriter, or paper tape punch/reader interface. EIA voltage levels are: 1 or OFF = -15 to -3V dc, 0 or ON = +3 to +15V dc.

060-8. INTRODUCTION

060-9. The RS-232-C Interface (Option 2205A-060) is designed to interface the controller mainframe with an external RS-232-C data communication instrument, such as a TTY, modem, computer, CRT, etc. It features asynchronous timing, simplex operation, selectable baud rate, and EIA voltage levels. The interface is not addressable and, therefore, responds to all input data.

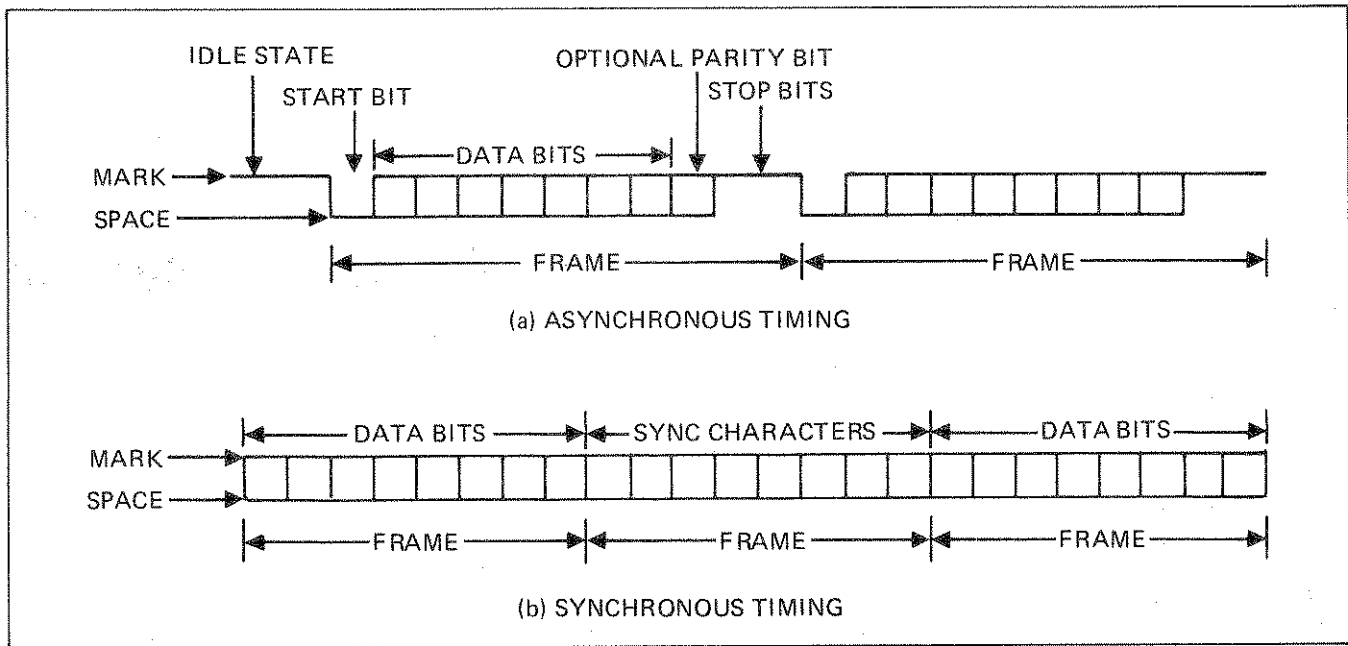

Figure 060-1. RS-232-C Timing Formats

060-10. Interface connection to the remote data communication instrument is made by way of a rear-panel, 25-pin connector labeled REMOTE INTERFACE. The connector is RS-232-C compatible. A mating connector is supplied with the option for use in fabricating an interface cable.

060-11. SPECIFICATIONS

060-12. Specifications for the RS-232-C Interface Option are listed in Table 060-1.

060-13. INSTALLATION

060-14. A controller mainframe can be equipped with either an IEEE-488 (Option -050) or an RS-232-C (Option -060) Interface PCB. If an RS-232-C interface is to be installed, it may or may not replace an existing interface pcb. The RS-232-C Interface PCB installs as follows:

1. Remove the 2205A from line power.
2. Remove the top cover.
3. Remove the three screws along the top side of the Front Panel Display PCB.
4. Push the pcb away from the front panel (the switch buttons must clear the front panel) and pull the pcb upward.
5. Unplug the attached cables.
6. Remove the four screws that hold the existing interface pcb to the Front Panel Display PCB.
7. Carefully separate the two pcbs at connectors J10 and P10.
8. Remove the rear panel screws that anchor the interface connector to the rear panel.

Table 060-1. Option -060 Specifications

Timing Format	Asynchronous
Input Data Format	Bit-Serial, Seven Level ASCII with two stop bits
Baud Rates	110; 134.5, 150, 300, 600, 1200, 2400, 4800 (switch selectable)
Parity	Not used
Signal Levels	EIA voltage level inputs

9. Plug the RS-232-C Interface PCB into the Front Panel Display PCB at J10 and P10.

10. Thread the interface cable along side of the guard housing so that the cable won't interfere with the installation of the top cover.

11. Position the 25-pin connector in the REMOTE INTERFACE hole in the rear panel and anchor it in place using the screws removed earlier.

12. Set switch S1 on the Front Panel Display PCB for the desired baud rate. See Section 2 of this manual for the instructions necessary to select baud rate.

13. Install the Front Panel Display PCB and the top dust cover.

060-15. INTERFACE INFORMATION

060-16. The input connection to the RS-232-C Interface is made using a 25-pin female connector, type DB25S. The connector is available from Fluke as P/N 312579. A compatible hood is also available as P/N 320184. Connections necessary to complete an interface cable are limited to pins 3 and 7. Pin 3 is Transmitted Data and pin 7 is Signal Ground. Use a twisted pair to form the cable between the bit-serial data source and the interface connector.

060-17. OPERATION

060-18. Once installed, the RS-232-C Interface does not require attention from the operator. Programming information is given in Section 3 of this manual.

060-19. THEORY OF OPERATION

060-20. The RS-232-C Interface is designed to enable a 2205A to be controlled by a remote bit-serial data source such as a computer, CRT, TTY, etc. Input data requirements include EIA voltage levels, 8-bit ASCII control characters, and two stop bits. Data is received in the asynchronous mode, and baud rates from 100 through 4800 are switch selectable. Parity (the eighth bit of each character) is not checked and therefore may be odd, even, high, or low.

060-21. The RS-232-C Interface, as shown in Figure 060-2, consists of a universal asynchronous receiver transmitter (UART), an EIA line receiver, and a programmable bit-rate generator. The UART receives TTL, character-serial data via the EIA line receiver and enters it into memory in synchronous with the baud rate clock. When a complete character is stored, the UART issues a Data Ready pulse to the microcomputer which, in turn, issues read and port 0 enable commands. These commands cause the UART to place the stored ASCII character onto the Data Bus so that it can be read by the microcomputer.

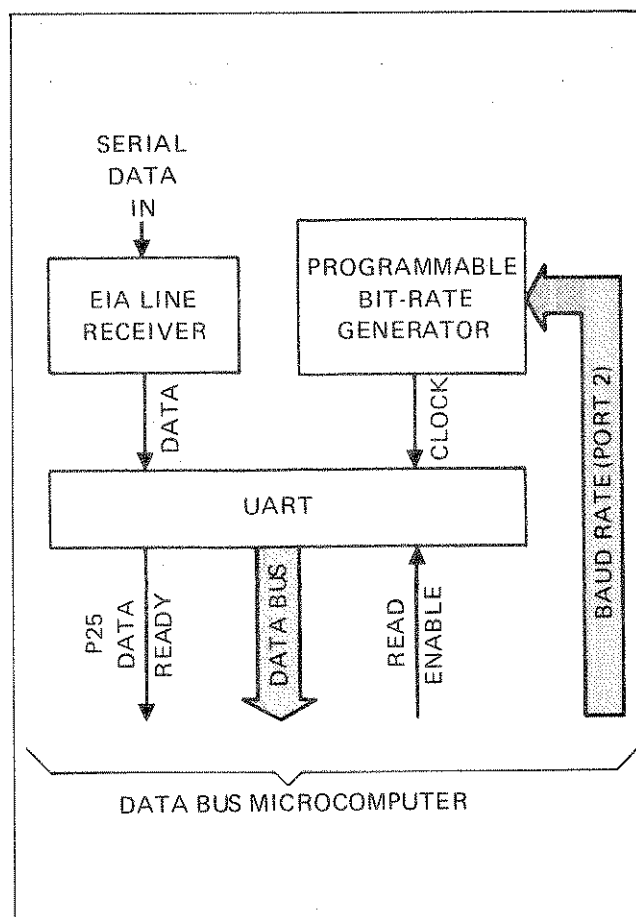

Figure 060-2. RS-232-C Interface Block Diagram

060-22. The bit-serial data rate is controlled by an onboard, programmable bit-rate generator which runs continuously at 16 times the programmed baud rate. This increased frequency is necessary to satisfy the UART which must synchronize incoming data. Program data for the bit-rate generator is received from the microcomputer which, in turn, receives baud-rate information from the baud rate switch on the Front Panel Display PCB.

060-23. MAINTENANCE

060-24. Calibration and/or adjustment of the RS-232-C Interface PCB is not required. The performance of the interface can be checked using the Remote Test Procedure given in Section 5 of this manual.

060-25. LIST OF REPLACEABLE PARTS

060-26. A list of replaceable parts for the RS-232-C Interface is given in Table 060-2. Refer to Section 6 of this manual for ordering information.

CAUTION



Indicated devices are subject to damage by static discharge.

Table 060-2. RS-232C Interface PCB Assembly

REF DES	DESCRIPTION	FLUKE STOCK NO.	MFG SPLY CODE	MFG PART NO.	TOT QTY	REC QTY	NOTE
-060⊗	RS-232-C INTERFACE PCB ASSEMBLY FIGURE 060-3 (2204A-4011T)	639757	89536	469247	1		
C1	CAP, TA, 10 UF +/-20%, 20V	193623	56289	196D106X0020KA1	1		
C2	CAP, MICA, 56 PF +/-5%, 500V	148528	72136	DM15F560J	2		
C3	CAP, MICA, 56 PF +/-5%, 500V	148528	72136	DM15F560J	REF		
J10B	CONNECTOR, FEMALE, 12-PIN	417733	30035	SS-109-1-12	2		
MP1	STRAP, NYLON	172080	06383	SST-1M	2		
R1	RES, COMP, 10M +/-5%, 1/4W	194944	01121	CB1065	1		
R2	RES, DEP. CAR, 1K +/-5%, 1/4W	343426	80031	CR251-4-5P1K	1		
U1⊗	IC, C-MOS, RECEIVER, TRANSMITTER	453464	32293	1M6402CPL	1	1	
U2	IC, TTL, MSI, DUAL COMMUNICATIONS	354704	18324	8T16A	1	1	
U3⊗	IC, C-MOS, PROGRAMABLE, BIT RATE GEN	418731	07263	F4702/34702	1	1	
U4⊗	IC, TTL, QUAD, 2-INPUT OR GATE	393108	01295	SN74LS32N	1	1	
W1	CABLE ASSEMBLY, RS-232-C	468637	89536	468637	1		
XU1	SOCKET, 40-PIN	418988	91506	340-AG39D	1		
Y1	CRYSTAL, 2.4576 MHZ	474825	89536	474825	1		

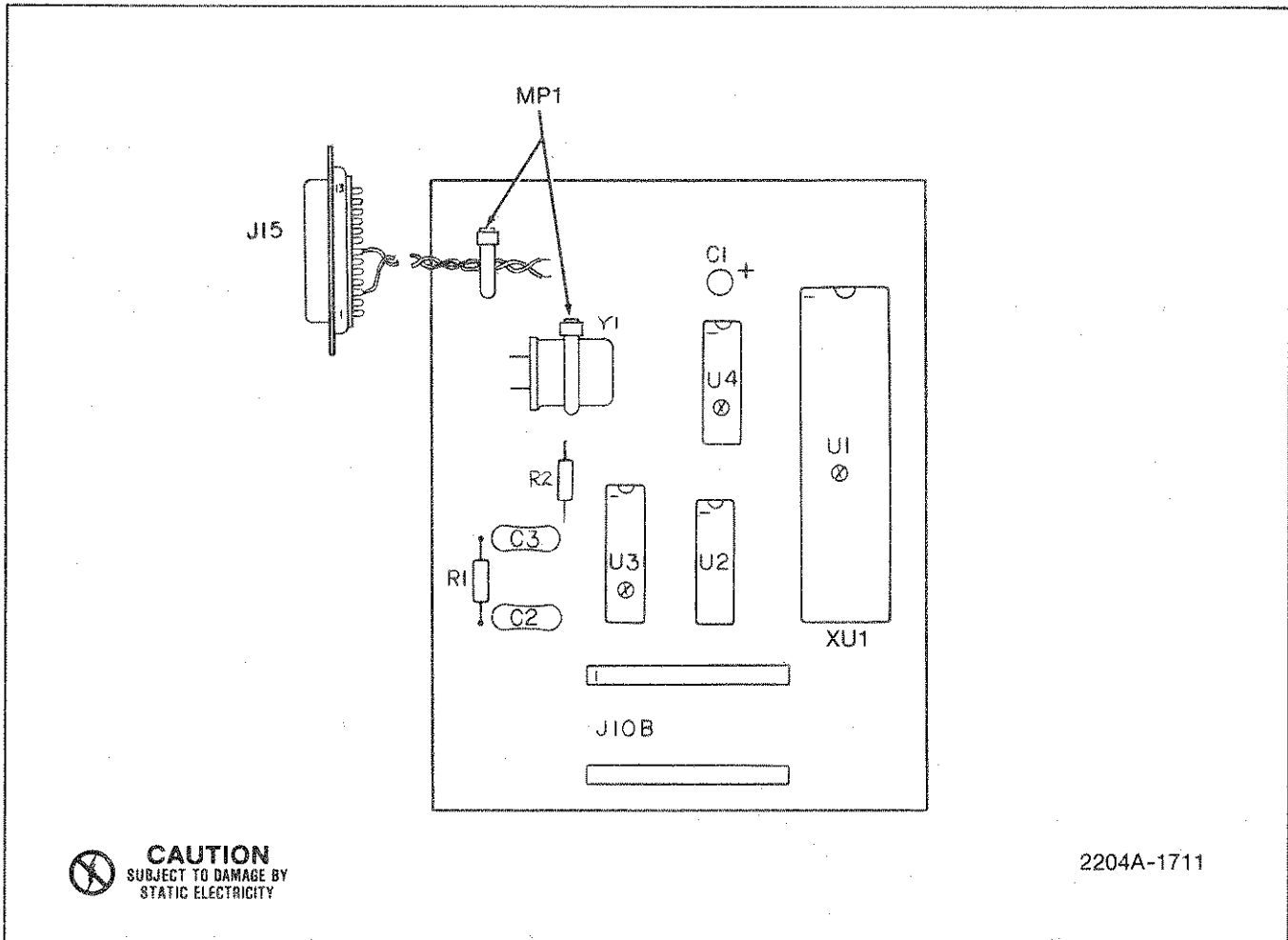

Figure 060-3. RS-232C Interface PCB Assembly

Option 2205A-100 Actuator Module

100-1. INTRODUCTION

100-2. The Actuator Module (Option 2205A-100) is a general purpose relay card design to provide the 2205A control of external switching functions. The five independently controlled relays can control power lines, signal lines, and other control lines in an automatic test equipment environment. The module consists of an actuator pcb and an input connector.

100-3. The Actuator PCB is a plug-in, relay pcb that is used for programmable control of medium-power signal and control lines. The five relays have form C contacts brought out to screw-type terminals on the Actuator Connector. These contacts do not connect to the internal scanner buses of the 2205A.

100-4. SPECIFICATIONS

100-5. The specifications for the Actuator Module are listed in Table 100-1.

100-6. INPUT CONNECTIONS

100-7. Analog interface connections are completed through an input connector with screw-type terminals. Figure 100-1 identifies the relay contacts brought out to five terminal blocks on the input connector. An extra terminal block is provided for additions by the user. Access to the screw-type terminals on the connector pcb is accomplished by removing the four screws from the decal side of the connector enclosure. The normally closed contacts (even numbered channels) refer to the state of the relay when the controller mainframe is powered up or the module is reset. The channel numbering is used for the programming of the Actuator PCB (see Theory of Operation). As connections are made to the terminals, the user can identify the block assignment (the logical location in the system) and the use of each contact on the connector decal.

100-8. INSTALLATION

100-9. The Actuator Module is installed in two parts. First the actuator pcb is installed, followed by the connector.

Table 100-1. Option -100 Specifications

Hardware	One each Actuator PCB and Actuator Connector.
Switching	Any combination of the five relays may be enabled. Each relay is latched on individually until it receives its individual reset command. A common Block Reset can reset all the relays at once.
Switch Life	Less than 2×10^5 operations at rated load.
Contact Resistance	Less than $.15\Omega$, typical.
Contact Current	1 amp maximum.
Input Voltage Limit	60V dc or 30V ac maximum.
Rated Load	1 amp at 26V dc or 30V ac.
Over Current Protection	Fused at 3 amp.

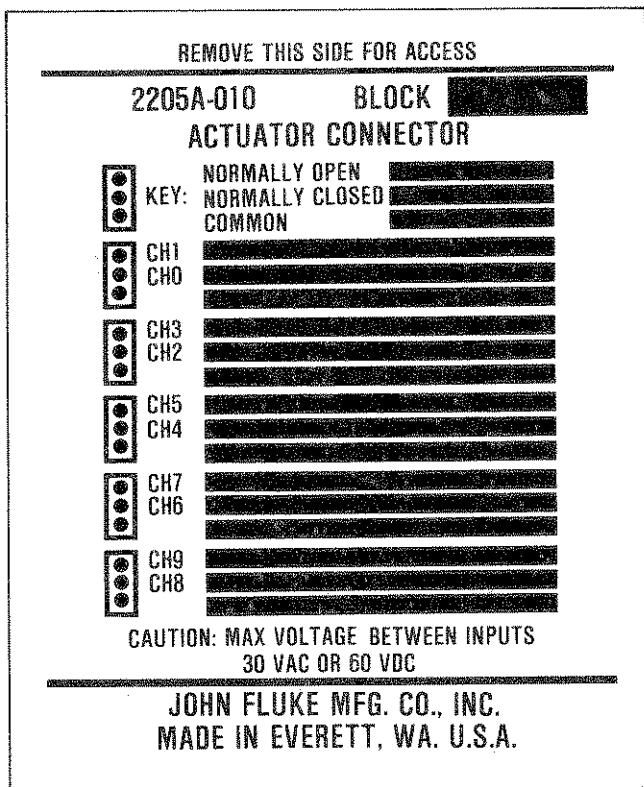

Figure 100-1. Input Connector Terminals

100-10. The Actuator PCB can be installed in any one of the available slots in the controller mainframe. Install the pcb as follows:

WARNING

REMOVE LINE POWER AND ALL OTHER HIGH VOLTAGE INPUTS TO THE CONTROLLER MAINFRAME BEFORE STARTING THIS PROCEDURE.

1. Remove the top dust cover from the controller mainframe.
2. Remove the guard chamber cover.

CAUTION

Handle the actuator pcb by its edges to avoid contaminating the pcb with oil from the hands. The use of gloves is recommended.

3. Select the slot that includes the logical block of channels the actuator pcb is to represent. Align the pcb in the slot so that the 44-pin board-edge connector is toward the rear of the unit, and the small offset board-edge connectors are toward the bottom of the unit. Push the pcb straight down onto the mating connectors.

4. Install the guard chamber cover.
5. Install the top dust cover.

100-11. The Actuator Connector and user cable assembly can be installed in any one of the controller mainframe slots that contain an actuator pcb. Install the connector as follows:

1. Unlatch the slide fasteners located on either side of the protruding enclosure at the rear of the controller mainframe.
2. Remove the enclosure from the rear panel.
3. Locate the desired slot on the rear panel and check to ensure that an actuator pcb is installed in the slot.
4. With the connector key toward the top, position the connector in the guides of the selected slot and mate it with the connector of the actuator pcb.
5. Install the retaining screw and washer that hold the input connector to the controller mainframe.
6. Install the rear panel enclosure.

100-12. OPERATION

100-13. Once installed, the Actuator Module requires no operator attention.

100-14. THEORY OF OPERATION

100-15. The Actuator Module (Figure 100-2) is a plug-in programmable relay card designed to provide latched relay closures under the control of the mainframe. These closures can be used to control external equipment or for switching input and output signal lines. The five form C relays are independently switched and the contacts are brought out on the actuator connector (there is no contact with the internal bus) for connection to external lines. Each relay is set or reset by addressing the proper latch.

100-16. All pcbs installed in the controller mainframe and/or extender chassis receive bcd channel-select information in parallel form on a 4-bit data bus (CS0-CS3). This data is decoded on each actuator pcb into five command lines and individually latched. The command lines are buffered by the relay drivers and connected to the five relay coils. Even though the channel-select data is present, the relay is not energized until the module receives a block-select (BSX) command to latch in the channel-select data.

100-17. Channel select data entered from the front panel of the controller mainframe (or remotely) turns the individual relays on and off. Each relay is toggled by a

particular pair of channel selects. The Actuator Connector decal shows the channel pairs for each relay. Selecting an odd numbered channel energizes the relay. Selecting an even numbered channel de-energizes the relay. The even numbered channels are normally closed on mainframe power up or by a BLOCK RESET.

100-18. The individual latching of each relay makes it possible to have more than one relay energized at a time. When a channel has been selected, that relay is latched. Additional relays may be energized by subsequent channel selects. Pushing the BLOCK RESET button returns all the relays on the pcb to their normal state.

100-19. MAINTENANCE

100-20. Introduction

100-21. The following paragraphs cover the access and performance test information for maintaining the switch module.

100-22. Access Information

100-23. Refer to the installation information given earlier for switch module access information. Remove the

rear panel input connector before attempting to remove the switch module pcb from its slot.

100-24. Performance Test

100-25. The performance test is designed to verify the overall operation of the Actuator Module Assembly, and is intended for use as an acceptance test and/or periodic maintenance check. The equipment used in the test is listed in Table 100-2. If the actuator module fails any part of the test, corrective action is required. The performance test is conducted as follows:

1. Remove the top cover of the Actuator Connector and set it aside during the test.
2. Install the Actuator PCB and Actuator Connector in the channel 0-9 slot of the controller mainframe.
3. Select channel 0.
4. Push the BLOCK RESET button on the controller mainframe to reset all the relays on the pcb.

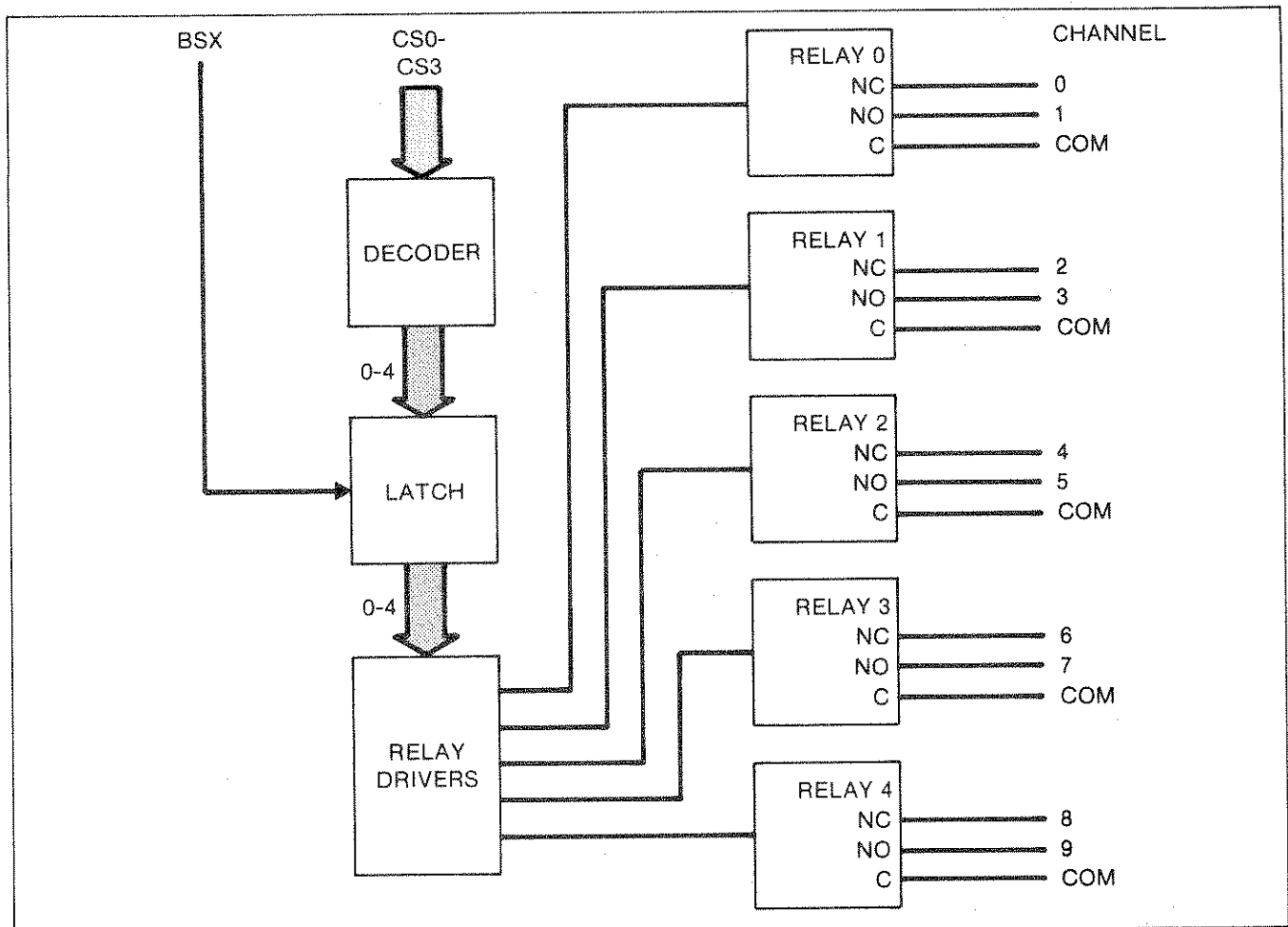

Figure 100-2. Functional Block Diagram

Table 100-2. Required Test Equipment

INSTRUMENT	RECOMMENDED MODEL
DMM	Fluke 8520A
Mainframe	Fluke 2205A

5. Set the DMM to the 2-ohm range.
6. Connect the DMM to the normally closed (even numbered channel) and common contacts on the first terminal block of the connector. The meter should read 2 ohms or less.

7. Repeat Step 6 for all of the even numbered channels on the remaining terminal blocks of the connector.

8. Select all of the odd numbered channels (1, 3, 5, 7, 9).

9. Repeat Step 6 for the odd numbered channels (normally open contacts) on each of the terminal blocks of the connector.

100-26. LIST OF REPLACEABLE PARTS

100-27. The replaceable parts of the Actuator Module Assembly are listed in Table 100-3. Refer to Section 6 of this manual for ordering information.

CAUTION



Indicated devices are subject to damage by static discharge.

Table 100-3. Actuator PCB Assembly

REF DES	DESCRIPTION	FLUKE STOCK NO.	MFG SPLY CODE	MFG PART NO.	TOT QTY	REC QTY	NOTE
-100⊗	ACTUATOR MODULE FIGURE 100-3	ORDER	BY	OPTION -100			
-100A1⊗	ACTUATOR PCB ASSEMBLY	639773	89536	612234	1		
-100A2	SCREW TERMINAL CONNECTOR	618843	89536	618843	1		
H1	SCREW, PHP, 4-40 X 7/8	335133	89536	335133	2		
H2	SCREW, PHP, 6-32 X 1/4	152140	89536	152140	8		
H3	WASHER, FLAT, #4	146225	89536	146225	2		
MP1	DECAL, ACTUATOR CONNECTOR	632141	89536	632141	1		
MP2	ISOTHERMAL CONNECTOR HOUSING	414276	89536	414276	2		

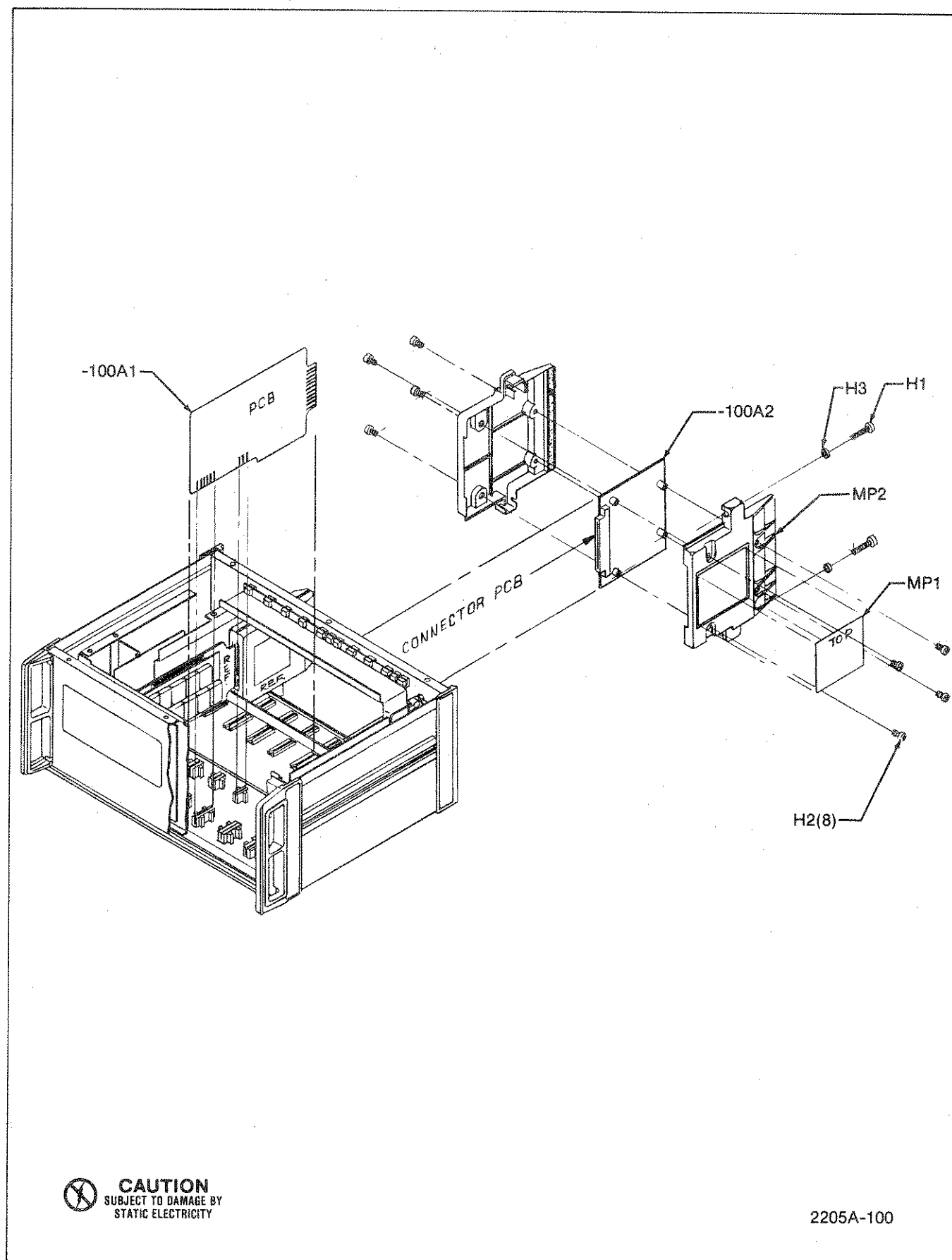

 **CAUTION**
SUBJECT TO DAMAGE BY
STATIC ELECTRICITY

2205A-100

Figure 100-3. Actuator Module

Figure 100-4. Actuator PCB Assembly

REF DES	DESCRIPTION	FLUKE STOCK NO.	MFG SPLY CODE	MFG PART NO.	TOT QTY	REC QTY	NOTE
-100A1⊗	ACTUATOR PCB ASSEMBLY FIGURE 100-4 (2205A-4002T)	639773	89536	612234		REF	
C1	CAP, ELECT, TA, 1 UF +/-5%, 15V	461152	56289	150D106X5015A2	1		
C2	CAP, MICA, 3000 PF +/-5%, 500V	161786	72136	DM19F302J	1		
C3	CAP, MICA, 220 PF +/-5%, 500V	170423	72136	DM15F22J	2		
C4	CAP, MICA, 220 PF +/-5%, 500V	170423	72136	DM15F22J	REF		
C5	CAP, ELECT, 15 UF +/-20%, 35V	614024	89536	614024	2		
C6	CAP, ELECT, 15 UF +/-20%, 35V	614024	89536	614024	REF		
F0	FUSE, PICO, 3A, 125V	460915	71400	GFA3	5		
F1	FUSE, PICO, 3A, 125V	460915	71400	GFA3	REF		
F2	FUSE, PICO, 3A, 125V	460915	71400	GFA3	REF		
F3	FUSE, PICO, 3A, 125V	460915	71400	GFA3	REF		
F4	FUSE, PICO, 3A, 125V	460915	71400	GFA3	REF		
F5	FUSE, PICO, 0.5A, 125V	603274	71400	GFA	1		
K0	RELAY, ULTRA SENSITIVE, SPDT	603282	26806	AZ 2530-08-52	5		
K1	RELAY, ULTRA SENSITIVE, SPDT	603282	26806	AZ 2530-08-52	REF		
K2	RELAY, ULTRA SENSITIVE, SPDT	603282	26806	AZ 2530-08-52	REF		
K3	RELAY, ULTRA SENSITIVE, SPDT	603282	26806	AZ 2530-08-52	REF		
K4	RELAY, ULTRA SENSITIVE, SPDT	603282	26806	AZ 2530-08-52	REF		
R6	RES, MTL. FILM, 953 +/-1%, 1/8W	288563	91637	CMF559530F	1		
R7	RES, MTL. FILM, 681K +/-1%, 1/8W	381517	91637	CMF556813F	1		
R8	RES, COMP, 100K +/-5%, 1/4W	348920	01121	CB1045	2		
R9	RES, COMP, 100K +/-5%, 1/4W	348920	01121	CB1045	REF		
R11	RES, DEP. CAR, 1K +/-5%, 1/4W	343426	80031	CR251-4-5P1K	5		
R12	RES, DEP. CAR, 1K +/-5%, 1/4W	343426	80031	CR251-4-5P1K	REF		
R13	RES, DEP. CAR, 1K +/-5%, 1/4W	343426	80031	CR251-4-5P1K	REF		
R14	RES, DEP. CAR, 1K +/-5%, 1/4W	343426	80031	CR251-4-5P1K	REF		
R15	RES, DEP. CAR, 1K +/-5%, 1/4W	343426	80031	CR251-4-5P1K	REF		
RN1	RES NET, 100K +/-2%, 1/8W	412726	89536	412726	1		
U1⊗	IC, C-MOS, QUAD 2-INPUT NAND GATE	418509	12040	MM74C00N	1		
U2⊗	IC, C-MOS 8-BIT ADDRESSABLE LATCH 16-PIN	453258	02735	CD4099BE	1		
U3⊗	IC, COS/MOS, QUAD, 2-INPUT NOR GATES	355172	02735	CD4001AE	1		
U4⊗	IC, C-MOS, MONOSTABLE MV	454017	04713	MC14538BCP	2		
U5	IC, LINEAR, NPN 5-XSTR ARRAY	418574	02735	CA3083E	1		
U6⊗	IC, C-MOS, MONOSTABLE MV	454017	04713	MC14538BCP	REF		

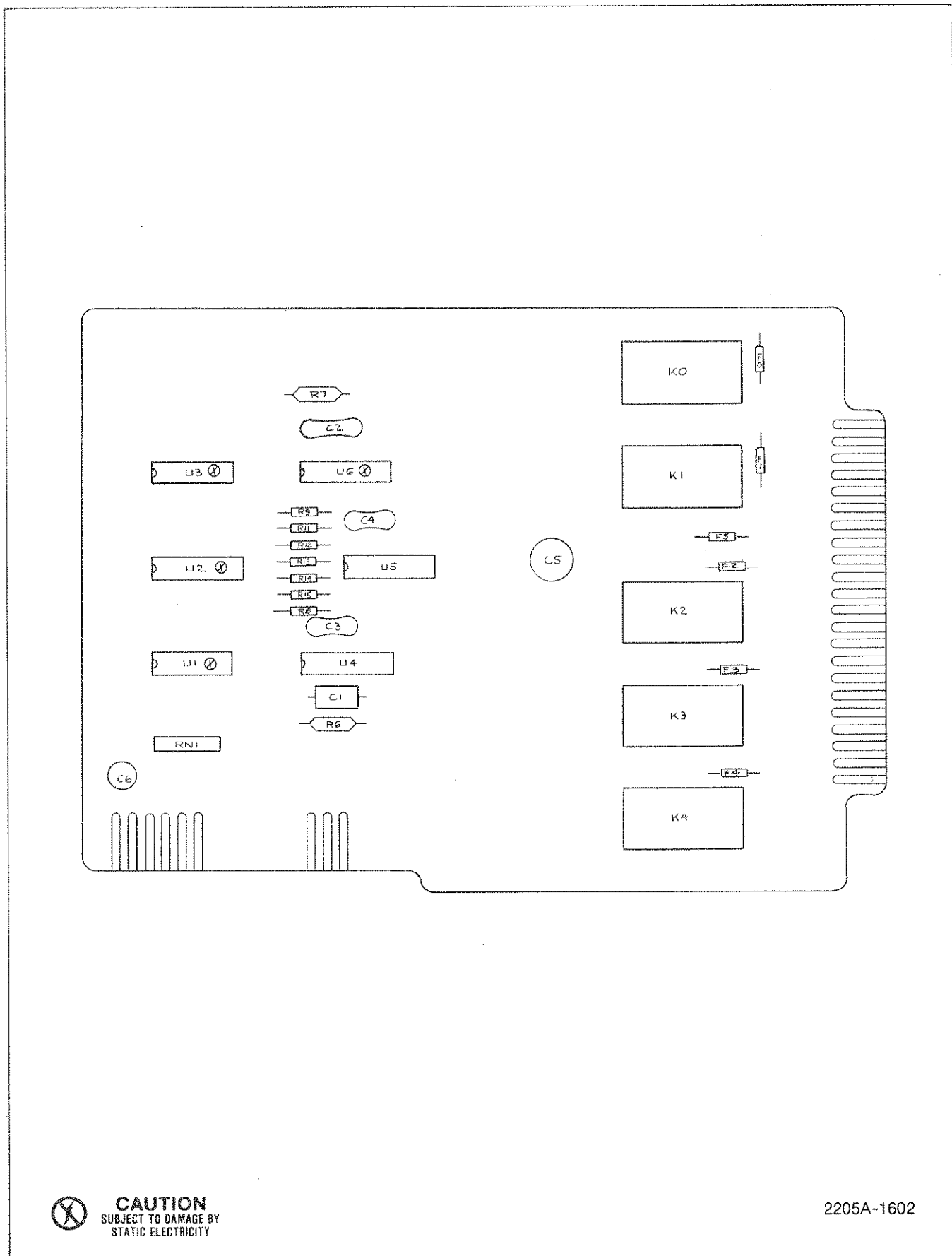

CAUTION
 SUBJECT TO DAMAGE BY
 STATIC ELECTRICITY

2205A-1602

Figure 100-4. Actuator PCB Assembly

Table 100-5. Screw Terminal Connector

REF DES	DESCRIPTION	FLUKE STOCK NO.	MFG SPLY CODE	MFG PART NO.	TOT QTY	REC QTY	NOTE
-100A2	SCREW TERMINAL CONNECTOR FIGURE 100-5 (2205A-4006)	618843	89536	618843		REF	
H1	WASHER, #4	147728	89536	147728	2		
MP1	KEY, POLARIZING	961060	00779	530374-1	1		
P1	CONNECTOR, 44-PIN	602839	54453	EYM-22-DRAS	1		
TB1	TERMINAL STRIP, 3-PIN	615344	89536	615344	6		
TB2	TERMINAL STRIP, 3-PIN	615344	89536	615344		REF	
TB3	TERMINAL STRIP, 3-PIN	615344	89536	615344		REF	
TB4	TERMINAL STRIP, 3-PIN	615344	89536	615344		REF	
TB5	TERMINAL STRIP, 3-PIN	615344	89536	615344		REF	
TB6	TERMINAL STRIP, 3-PIN	615344	89536	615344		REF	

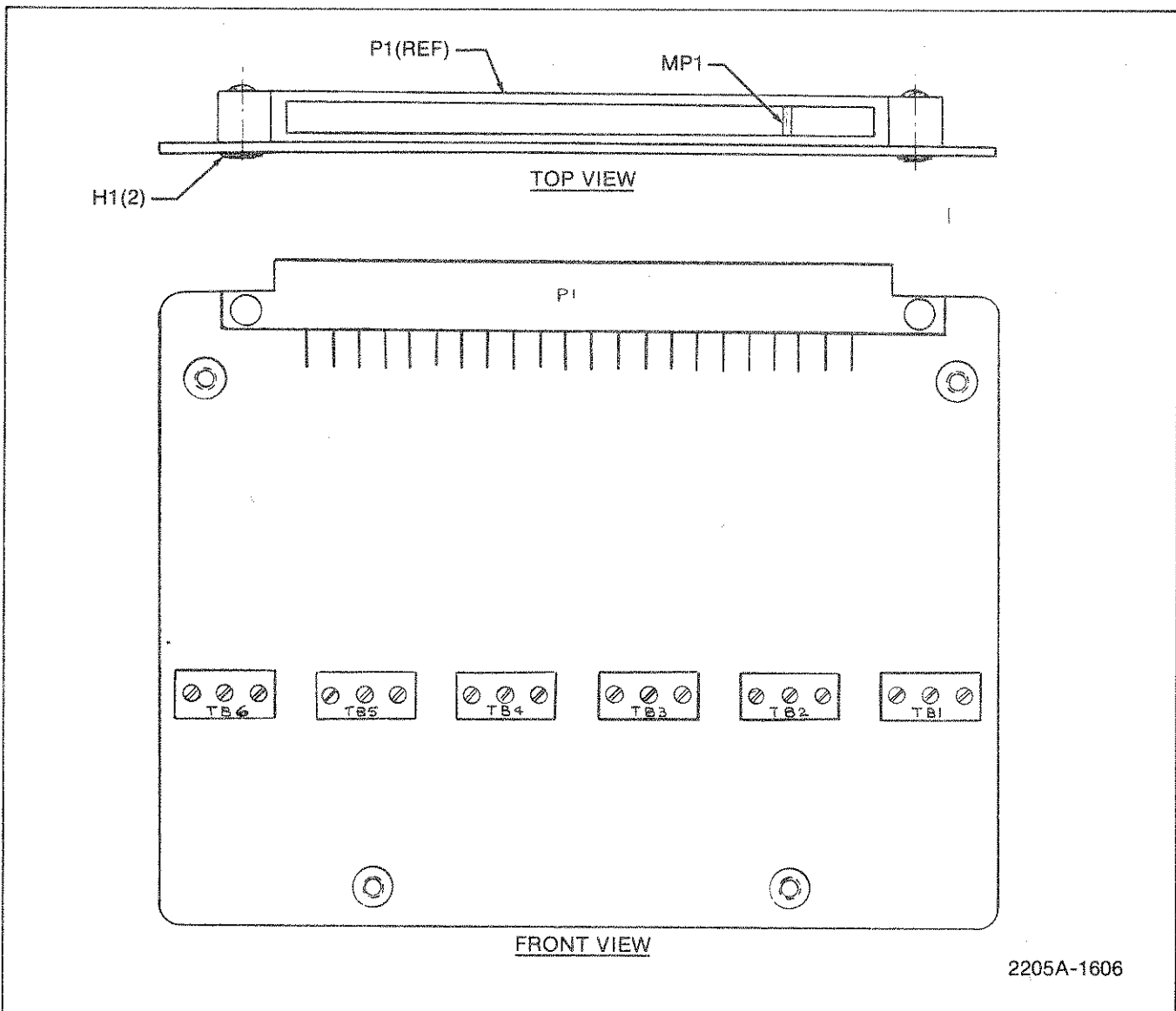

Figure 100-5. Screw Terminal Connector

Option 2205A-200 Latching Module

200-1. INTRODUCTION

200-2. The Latching Module (Option 2205A-200) is a general purpose relay pcb that can be configured into a variety of matrices. The Latching Module, in its basic form, is a dual 1-by-4 matrix with all lines brought out on the General Purpose Connector to allow the user to develop any size matrix externally. The module is isolated from internal scanner bus in the 2205A. The module consists of a latching pcb and a general purpose connector.

200-3. The Latching PCB is a plug-in relay pcb that operates as a basic multiplexer, de-multiplexer, or as a

matrix building block. Eight 2-wire (high and low) relays select which input channel(s) is to be connected to the common bus of the connector (not the internal bus of the controller).

200-4. The General Purpose Connector is a screw-type terminal connector designed for inputting signal lines to the switch module. Jumpers on the connector pcb allow the Latching Module to be configured into different types of matrices.

200-5. SPECIFICATIONS

200-6. The specifications for the Latching Module are listed in Table 200-1.

Table 200-1. Option -200 Specifications

Hardware	One each Latching PCB and General Purpose Connector.
Channels	Two groups of four each 2-wire reed relays. The relays connect each channel to a common bus (brought out on the connector, not the internal scanner bus in the 2205A) to form a dual 1-by-4 matrix. Jumpers allow configuration of 1x4, 2x4, 1x8 matrices.
Switching	Any combination of the eight relays may be enabled. Each relay is latched individually until that group (4 relays) receives a Block Reset command.
Switch Life	Greater than 10 ⁷ operations at 40V, 1 mA load.
Rated Load	10 mA at input voltage limit.
Contact Resistance	Typical 1Ω for high plus low paths.
Contact Current	40 mA maximum.
Bandwidth	±0.1 dB from 600Ω to 1 MΩ. Typical -0.2 dB at 50Ω.
Offset Voltage	Total offset from channel to channel or channel to bus is <10 μV.
Input Voltage Limit	170V dc or peak ac.
Over Current Protection	Fused at 0.5 amp.

200-7. INPUT CONNECTIONS

200-8. The analog interface to the module is completed through a general purpose connector with screw-type terminals. Figure 200-1 identifies the location of the terminals for the 8 latching channels on the left side of each terminal block. Channels 0 through 3 are switched on to and off of bus A, while channels 4 through 7 are switched on to and off of bus B. These buses are isolated from the internal scanner bus. Access to the terminal blocks is accomplished by removing the four screws from the decal side of the connector enclosure. The high, low, and shield connections for each channel are identified next to the terminal blocks on the pcb inside the connector enclosure. Each of the signal lines has a 0.5 amp fuse for current protection.

200-9. Jumpers J1 through J11 are used in making the necessary connections between channels and buses to form the desired matrix. Table 200-2 shows the jumper configuration for the possible matrices.

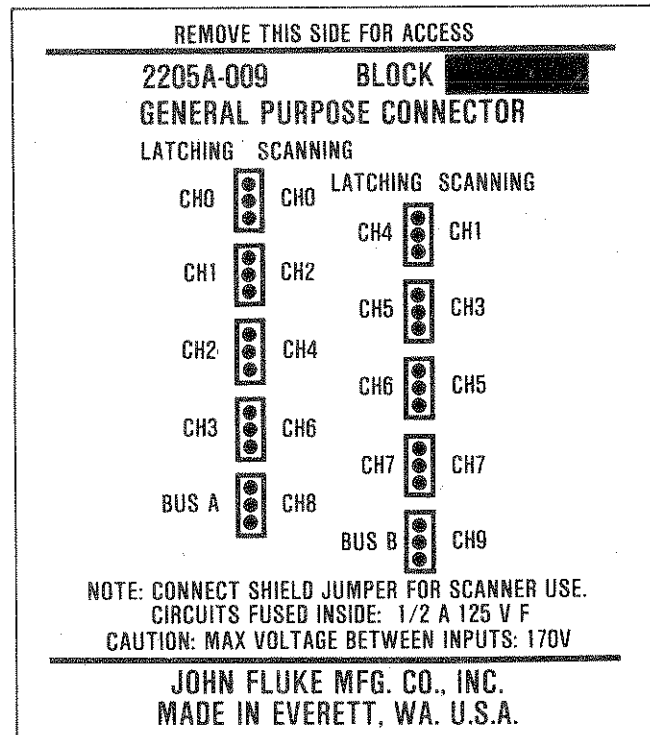

Figure 200-1. Input Connector Terminals

Table 200-2. Matrix Connections

MATRIX SIZE	INSTALL JUMPERS
Dual 1x4	J11
Dual 1x4 (isolated guards)	—
1x8	J9-J11
2x4	J1-J8, J11

200-10. INSTALLATION

200-11. The Latching Module is installed in two parts. The latching pcb is installed first, followed by the connector.

200-12. The Latching PCB can be installed in any one of the available slots in the controller mainframe. Install the latching pcb as follows:

WARNING

REMOVE LINE POWER AND ALL OTHER HIGH VOLTAGE INPUTS TO THE CONTROLLER MAINFRAME BEFORE STARTING THIS PROCEDURE.

1. Remove the top dust cover from the controller mainframe.
2. Remove the guard chamber cover.

CAUTION

Handle the latching pcb by its edges to avoid contaminating the pcb with oil from the hands. The use of gloves is recommended.

3. Select the slot that includes the logical block of channels that the latching pcb is to represent. Align the pcb in the slot so that the 44-pin board-edge connector is toward the rear of the unit, and the small offset board-edge connectors are toward the bottom of the unit. Push the pcb straight down onto the mating connectors.

4. Install the guard chamber cover.
5. Install the top dust cover.

200-13. The General Purpose Connector and user cable assembly can be installed in any one of the controller mainframe slots that contain a latching pcb. Install the connector as follows:

1. Unlatch the slide fasteners located on either side of the protruding enclosure at the rear of the controller mainframe.

2. Remove the enclosure from the rear panel.

3. Locate the desired slot on the rear panel and check to ensure that a latching pcb is installed in the slot.

4. With the connector key toward the top, position the connector in the guides of the selected slot and mate it with the connector on the latching pcb.

5. Install the retaining screw and washer that hold the input connector to the controller mainframe.
6. Install the rear panel enclosure.

200-14. OPERATION

200-15. Once installed, the Latching Module requires no operator attention.

200-16. THEORY OF OPERATION

200-17. The Latching Module (Figure 200-2) is a programmable, dual 1-by-4 relay matrix. The matrix is made up of two groups of four relays each. The relays are addressable, 2-wire, form-A, reed relays that switch each of the channel inputs (or outputs) onto their associated bus. The shield of channels 0 through 3 are tied to the shield of bus A and the shield of channels 4 through 7 are tied to the shield of bus B. Jumper J11 on the input connector must be cut if the shields of bus A need to be isolated from the shields of bus B. The remaining jumpers (J1 through J10) on the input connector are used for connecting channels and buses of the latching module in a matrix of X-by-Y channels. See the Input Connections information presented earlier in this section for more information on matrix configurations.

200-18. All pcbs installed in the controller mainframe and/or extender chassis receive bcd channel select information in parallel form on a 4-bit data bus (CS0 through CS3). This data is decoded on each latching pcb by two 1-of-4 decoders into eight channel commands. Each command line is then individually latched, buffered, and connected to one of the relay coils. Even though the channel select data is present, the relay is not energized unless the latching module receives a block-select (BSX) command to latch the channel select data.

200-19. The individual latching of each relay makes it possible to have more than one relay energized at a time. When a channel has been selected, that relay is latch on. Additional relays may be energized by subsequent channel selects. The latch must be reset to de-energize any relay. Selecting channel 8 of that block resets latches 0-3. Selecting channel 9 of that block resets latches 4-7. All channels are reset by the BLOCK RESET button on the mainframe. If two channels are selected on the same bus, and only one is to be de-energized, then a reset followed by a channel select must occur. For example, when channel 0 and channel 1 are both on, selecting channel 8 turns both relays off. If only channel 0 was to be turned off, a channel 1 select must be entered next.

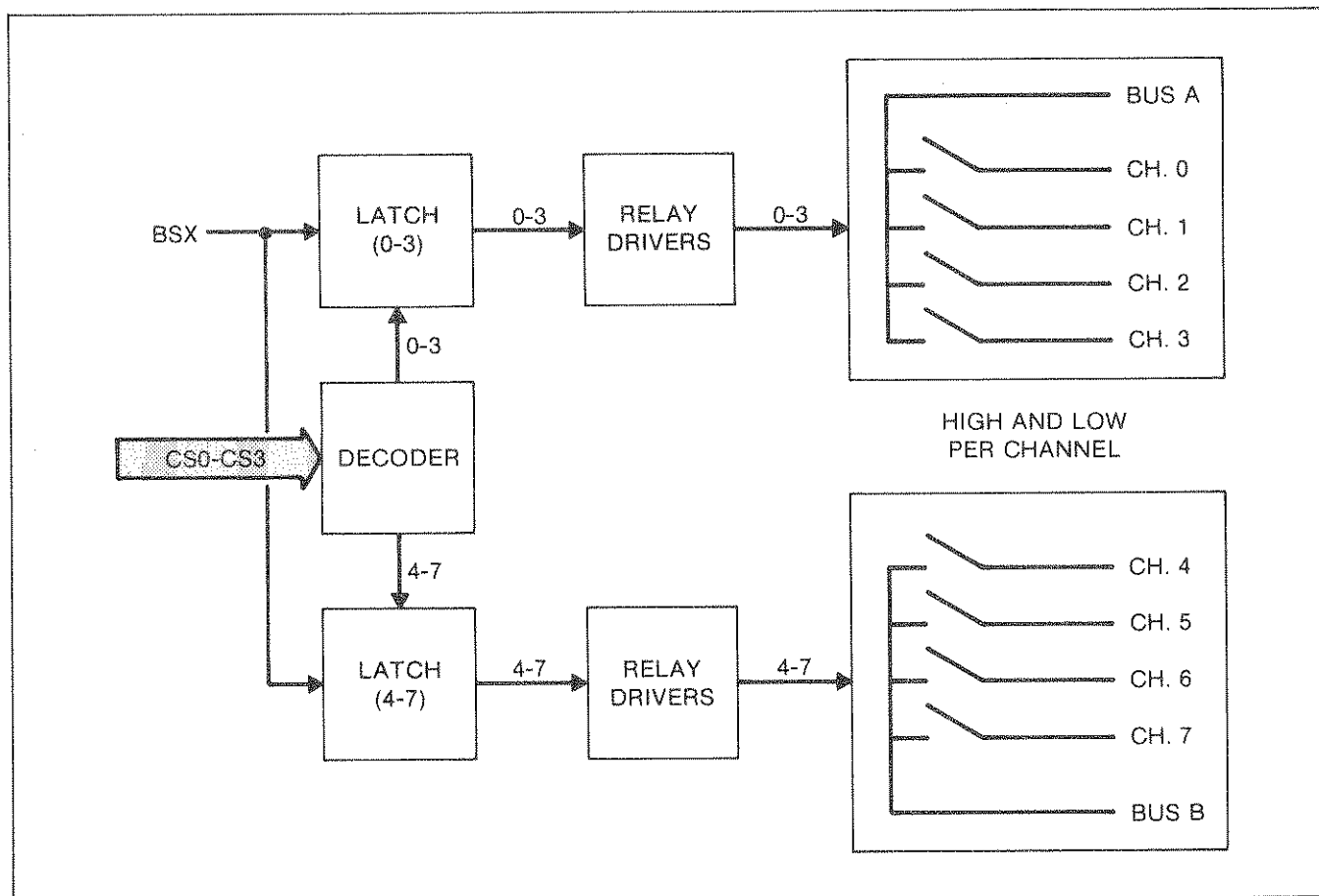

Figure 200-2. Functional Block Diagram

200-20. MAINTENANCE

200-21. Introduction

200-22. The following paragraphs cover the access and performance test information for maintaining the switch module.

200-23. Access Information

200-24. Refer to the Installation information given earlier in this section for switch module access information. Remove the rear panel input connector before attempting to remove the switch module pcb from its slot.

200-25. Performance Test

200-26. The performance test is designed to verify the overall operation of the Latching Module Assembly, and is intended for use as an acceptance test and/or periodic maintenance check. The equipment used in the test is listed in Table 200-3. If the latching module fails any part of the test, corrective action is required. The performance test is conducted as follows:

1. Fabricate a test cable and connector as shown in Figure 200-3.

NOTE

Jumpers J1 thru J8 must be installed and jumpers J9 and J10 must be cut.

2. Install the Latching Module and the test cable in the channel 0-9 slot of the controller mainframe.
3. Set the DMM to the 2 ohm range.
4. Connect the test cable leads to the DMM.
5. Push the BLOCK RESET button to reset all the relays on the pcb.
6. Manually select channel 0 and channel 4. The DMM should read 2 ohms or less.
7. Manually select the remaining channels by first pushing the BLOCK RESET button and then selecting the next channel pair (1 & 5, 2 & 6, 3 & 7). A reading of 2 ohms or less should be observed on each of the channel pairs. Any deviation in this pattern indicates a defective pcb.

Table 200-3. Required Test Equipment

INSTRUMENT	RECOMMENDED MODEL
DMM	Fluke 8520A
Mainframe	Fluke 2205A

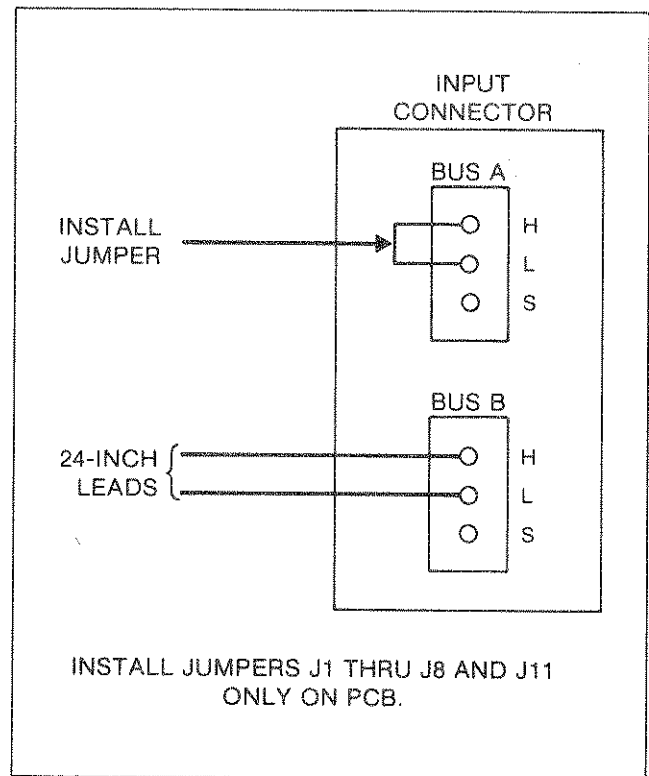

Figure 200-3. Test Cable

200-27. LIST OF REPLACEABLE PARTS

200-28. The replaceable parts of the Latching Module Assembly are listed in Table 200-4. Refer to Section 6 of this manual for ordering information.

CAUTION



Indicated devices are subject to damage by static discharge.

Table 200-4. Latching Module

REF DES	DESCRIPTION	FLUKE STOCK NO.	MFG SPLY CODE	MFG PART NO.	TOT QTY	REC QTY	NOTE
-200⊕	LATCHING MODULE FIGURE 200-4)	ORDER	BY	OPTION -200			
-200A1⊕	LATCHING PCB ASSEMBLY	639781	89536	612242	1		
-200A2	FUSED TERMINAL CONNECTOR	618876	89536	618876	1		
H1	SCREW, PHP, 4-40 X 7/8	335133	89536	335133	2		
H2	SCREW, PHP, 6-32 X 1/4	152140	89536	152140	8		
H3	WASHER, FLAT	146225	89536	146225	2		
MP1	DECAL, GENERAL PURPOSE CONN.	632133	89536	632133	1		
MP2	ISOTHERMAL CONNECTOR HOUSING	414127	89536	414127	2		

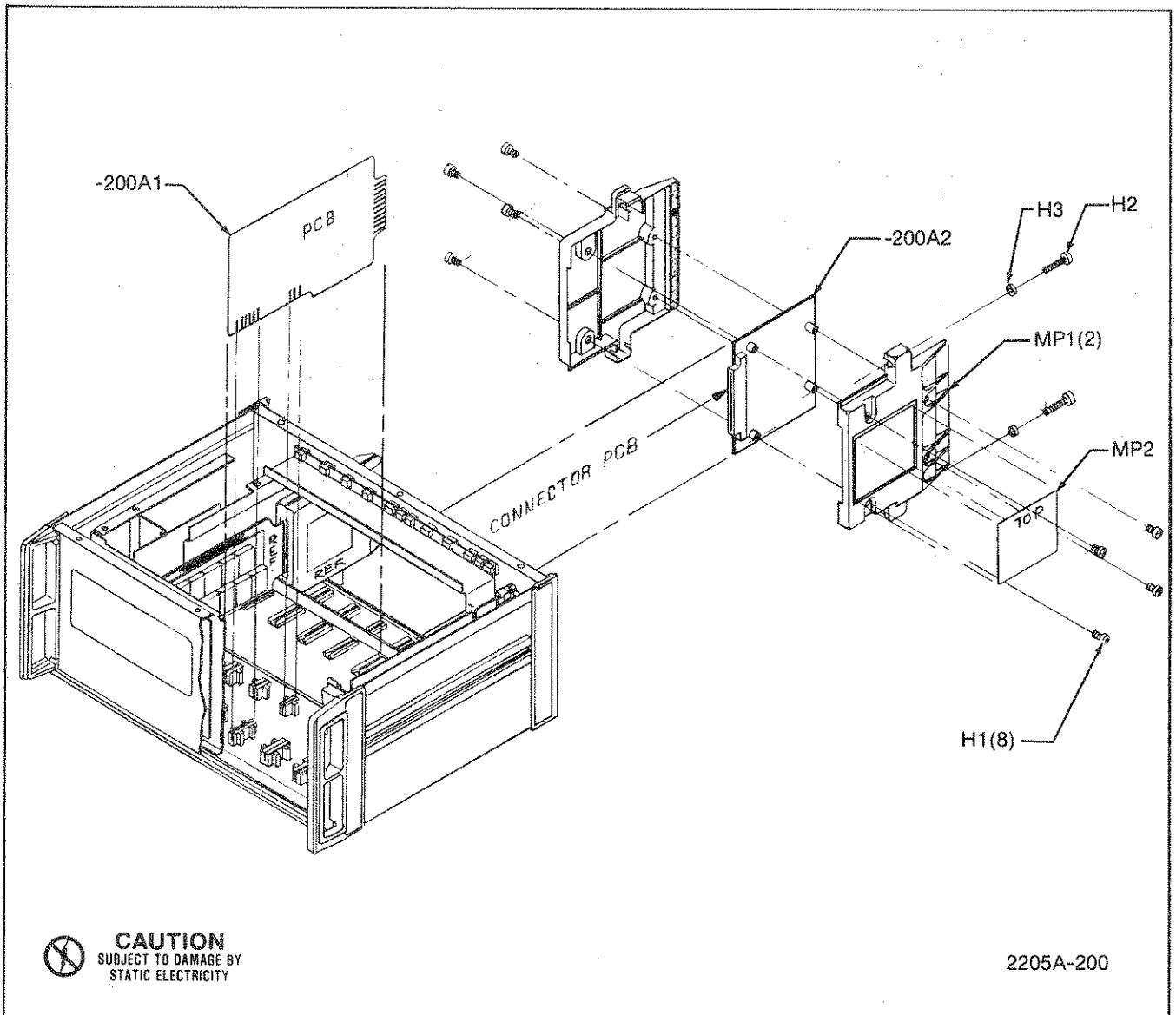
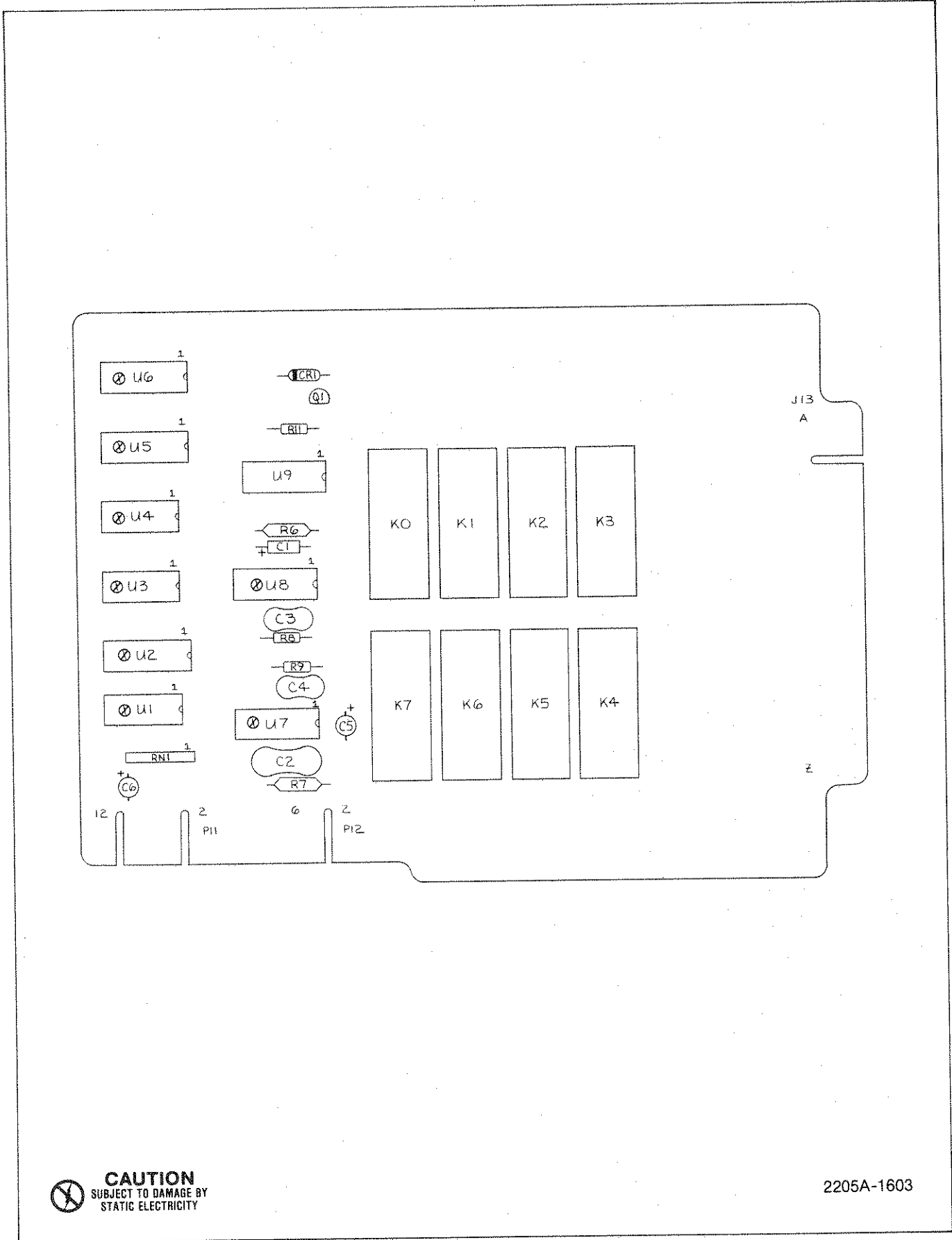

Figure 200-4. Latching Module

Table 200-5. Latching PCB Assembly

REF DES	DESCRIPTION	FLUKE STOCK NO.	MFG SPLY CODE	MFG PART NO.	TOT QTY	REC QTY	NOTE
-200A1⑩	LATCHING PCB ASSEMBLY FIGURE 200-5 (2205A-4003T)	639781	89536	612242	REF		
C1	CAP, ELECT, TA, 1 UF +/-5%, 15V	461152	56289	150D106X5015A2	1		
C2	CAP, MICA, 3000 PF +/-5%, 500V	161786	72136	DM19F302J	1		
C3	CAP, MICA, 220 PF +/-5%, 500V	170423	72136	DM15F221J	2		
C4	CAP, MICA, 220 PF +/-5%, 500V	170423	72136	DM15F221J	REF		
C5	CAP, ELECT, 15 UF +/-20%, 35V	614024	89536	614024	2		
C6	CAP, ELECT, 15 UF +/-20%, 35V	614024	89536	614024	REF		
CR1	DIODE, HI-SPEED SWITCHING	203323	04713	1N4448	1	1	
K0	RELAY, DRY REED, DPST	442921	21317	052A5300BAA	8		
K1	RELAY, DRY REED, DPST	442921	21317	052A5300BAA	REF		
K2	RELAY, DRY REED, DPST	442921	21317	052A5300BAA	REF		
K3	RELAY, DRY REED, DPST	442921	21317	052A5300BAA	REF		
K4	RELAY, DRY REED, DPST	442921	21317	052A5300BAA	REF		
K5	RELAY, DRY REED, DPST	442921	21317	052A5300BAA	REF		
K6	RELAY, DRY REED, DPST	442921	21317	052A5300BAA	REF		
K7	RELAY, DRY REED, DPST	442921	21317	052A5300BAA	REF		
Q1	TRANSISTOR, SI, NPN	218396	04713	2N3904	1		
R6	RES, MTL. FLM, 9.53K +/-1%, 1/8W	288563	91637	CMF559531F	1		
R7	RES, MTL. FLM, 681K +/-1%, 1/8W	381517	91637	CMF556813F	1		
R8	RES, COMP, 100K +/-5%, 1/4W	348920	01121	CB1045	2		
R9	RES, COMP, 100K +/-5%, 1/4W	348920	01121	CB1045	REF		
R11	RES, DEP. CAR, 3.3K +/-5%, 1/4W	348813	80031	CR251-4-5P3K3	1		
RN1	RESISTOR NETWORK, 100K	412726	89536	412726	1	1	
U1⑩	IC, C-MOS, QUAD 2-INPUT NAND GATE	418509	12040	MM74C00N	2	1	
U2⑩	IC, C-MOS, DCDR/MULTIPLEXER	408369	04713	MC14556CP	1	1	
U3⑩	IC, COS/MOS, QUAD, 2-INPUT NOR GATES	355172	02735	CD4001AE	1	1	
U4⑩	IC, C-MOS, QUAD 2-INPUT NAND GATE	418509	12040	MM74C00N	REF		
U5⑩	IC, C-MOS 8-BIT ADDRESSABLE LATCH 16-PIN	453258	02735	CD4099BE	2	1	
U6⑩	IC, C-MOS 8-BIT ADDRESSABLE LATCH 16-PIN	453258	02735	CD4099BE	REF		
U7⑩	IC, C-MOS, MONOSTABLE MV	454017	04713	MC14538BCP	2	1	
U8⑩	IC, C-MOS, MONOSTABLE MV	454017	04713	MC14538BCP	REF		
U9	IC, TRANSISTOR ARRAY	454116	01295	ULN2003	1	1	



CAUTION
SUBJECT TO DAMAGE BY
STATIC ELECTRICITY

2205A-1603

Figure 200-5. Latching PCB Assembly

Table 200-6. Fused Terminal Connector

REF DES	DESCRIPTION	FLUKE STOCK NO.	MFG SPLY CODE	MFG PART NO.	TOT QTY	REC QTY	NOTE
-200A2	FUSED TERMINAL CONNECTOR FIGURE 200-6 (2205A-4007)	618876	89536	618876	REF		
F1	FUSE, PICO, 0.5A, 125V	603274	71400	GFA	22	5	
F2	FUSE, PICO, 0.5A, 125V	603274	71400	GFA	REF		
F3	FUSE, PICO, 0.5A, 125V	603274	71400	GFA	REF		
F4	FUSE, PICO, 0.5A, 125V	603274	71400	GFA	REF		
F5	FUSE, PICO, 0.5A, 125V	603274	71400	GFA	REF		
F6	FUSE, PICO, 0.5A, 125V	603274	71400	GFA	REF		
F7	FUSE, PICO, 0.5A, 125V	603274	71400	GFA	REF		
F8	FUSE, PICO, 0.5A, 125V	603274	71400	GFA	REF		
F9	FUSE, PICO, 0.5A, 125V	603274	71400	GFA	REF		
F10	FUSE, PICO, 0.5A, 125V	603274	71400	GFA	REF		
F11	FUSE, PICO, 0.5A, 125V	603274	71400	GFA	REF		
F12	FUSE, PICO, 0.5A, 125V	603274	71400	GFA	REF		
F13	FUSE, PICO, 0.5A, 125V	603274	71400	GFA	REF		
F14	FUSE, PICO, 0.5A, 125V	603274	71400	GFA	REF		
F15	FUSE, PICO, 0.5A, 125V	603274	71400	GFA	REF		
F16	FUSE, PICO, 0.5A, 125V	603274	71400	GFA	REF		
F17	FUSE, PICO, 0.5A, 125V	603274	71400	GFA	REF		
F18	FUSE, PICO, 0.5A, 125V	603274	71400	GFA	REF		
F19	FUSE, PICO, 0.5A, 125V	603274	71400	GFA	REF		
F20	FUSE, PICO, 0.5A, 125V	603274	71400	GFA	REF		
F21	FUSE, PICO, 0.5A, 125V	603274	71400	GFA	REF		
F22	FUSE, PICO, 0.5A, 125V	603274	71400	GFA	REF		
H1	WASHER, FLAT, #4	147728	89536	147728	2		
MP1	KEY, POLARIZING	961060	00779	530374-1	1		
P1	CONNECTOR, 44-PIN	602839	54453	KSM-22-DRA5	1		
TB1	TERMINAL STRIP, 3-PIN	615344	06229	25.102.0353	10		
TB2	TERMINAL STRIP, 3-PIN	615344	06229	25.102.0353	REF		
TB3	TERMINAL STRIP, 3-PIN	615344	06229	25.102.0353	REF		
TB4	TERMINAL STRIP, 3-PIN	615344	06229	25.102.0353	REF		
TB5	TERMINAL STRIP, 3-PIN	615344	06229	25.102.0353	REF		
TB6	TERMINAL STRIP, 3-PIN	615344	06229	25.102.0353	REF		
TB7	TERMINAL STRIP, 3-PIN	615344	06229	25.102.0353	REF		
TB8	TERMINAL STRIP, 3-PIN	615344	06229	25.102.0353	REF		
TB9	TERMINAL STRIP, 3-PIN	615344	06229	25.102.0353	REF		
TB10	TERMINAL STRIP, 3-PIN	615344	06229	25.102.0353	REF		
W1	WIRE, JUMPER	529206	89536	529206	9		
W2	WIRE, JUMPER	529206	89536	529206	REF		
W3	WIRE, JUMPER	529206	89536	529206	REF		
W4	WIRE, JUMPER	529206	89536	529206	REF		
W5	WIRE, JUMPER	529206	89536	529206	REF		
W6	WIRE, JUMPER	529206	89536	529206	REF		
W7	WIRE, JUMPER	529206	89536	529206	REF		
W8	WIRE, JUMPER	529206	89536	529206	REF		
W9	WIRE, JUMPER	529206	89536	529206	REF		

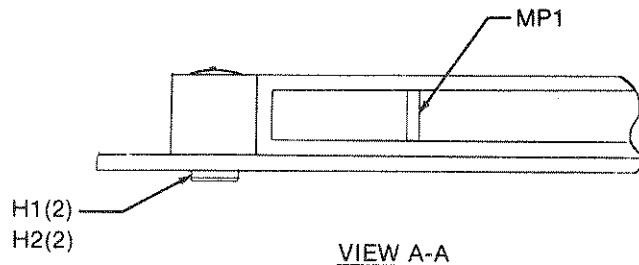
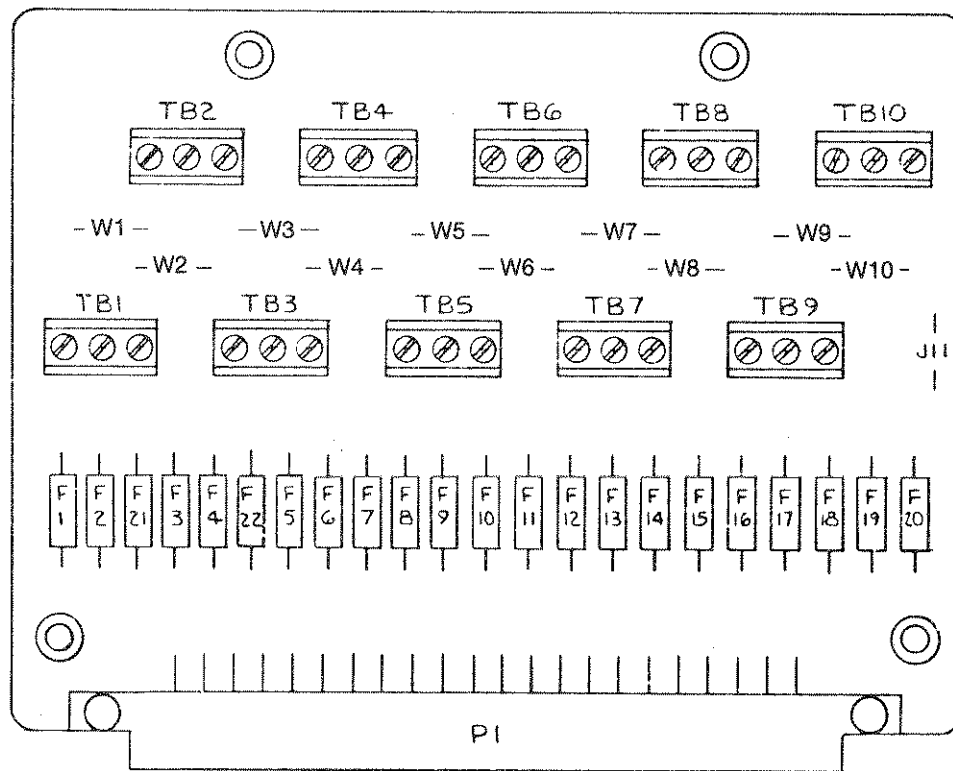

2205A-1607

Figure 200-6. Fused Terminal Connector



Option 2205A-300 General Purpose Scanner Module

300-1. INTRODUCTION

300-2. The General Purpose Scanner Module (Option 2205A-300) is a plug-in relay scanner designed to operate as a general purpose analog data multiplexer. The scanner option consists of a relay scanner pcb and an input connector.

300-3. The General Purpose Scanner PCB is a plug-in, 10-channel, 2-wire relay scanner that operates as an analog data multiplexer. Switched high and low inputs are provided for each of the 10 channels and a common (unswitched) shield is provided for all 10 channels. A decoupling relay is used to isolate the high, low and shield buses from the common connections to the internal

scanner bus of the 2205A when a channel relay is not activated. Activating any one of the 10 channel relays also energizes the decoupling relay.

300-4. The General Purpose Connector is a connector assembly with screw-type terminals. The connector mounts in the rear of a controller mainframe and provides electrical contact and fused protection for both the scanning and latching type modules. Use the connector to fabricate a custom interface cable from external analog signal sources to a scanner pcb.

300-5. SPECIFICATIONS

300-6. Specifications for the General Purpose Scanner Module are listed in Table 300-1.

Table 300-1. Option -300 Specifications

Hardware	One each Latching PCB and General Purpose Connector.
Channels	Ten 2-wire, reed relays (high and low). One each common shield and output bus decoupling relay.
Thermal Offset	Less than 10 μ V.
Bandwidth	\pm 0.2 dB to 1 MHz with 1 M Ω termination.
Switch Life	Greater than 10 ⁷ operations.
Contact Current	40 mA maximum.
Input Voltage Limit*	170V dc or peak ac.
Common Mode Voltage Limit (Voltage between chassis and any input)	170V dc or peak ac maximum provided the Input Voltage Limit is not exceeded.
Over Current Protection	0.5 amp fuse in series with each input line.

* Maximum voltage between any two terminals in the system including normal mode as well as common mode voltages.

300-7. INPUT CONNECTIONS

300-8. The analog interface is completed through a general purpose connector. Figure 300-1 identifies the location of the terminals for the 10 scanning channels on the right side of each terminal block. Access to the terminal blocks is accomplished by removing the four screws from the decal side of the connector enclosure. The high, low, and shield connections for each channel are identified inside the connector enclosure next to the terminal blocks on the pcb. Each of the signal lines has a 0.5 amp fuse for current protection. Only jumper J11 should be installed in the connector pcb to use the input connector with a scanner pcb.

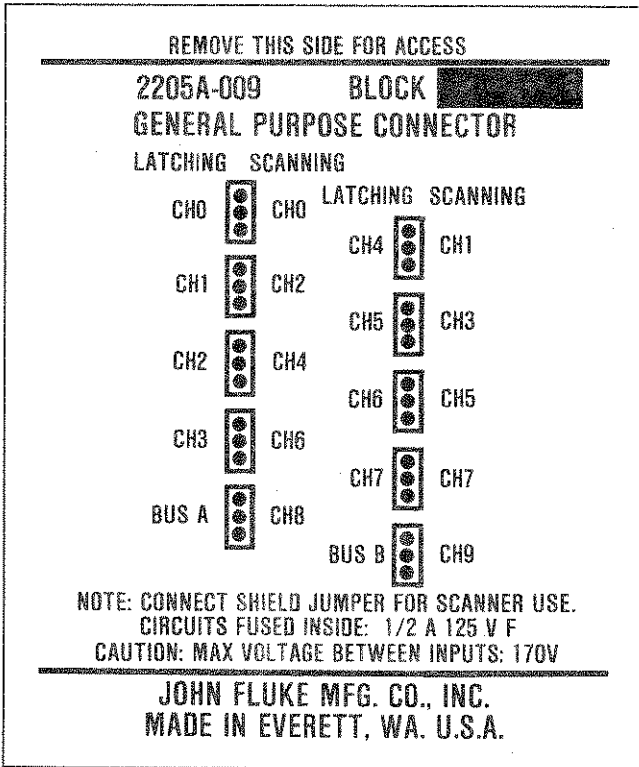

Figure 300-1. Input Connector Terminals

300-9. INSTALLATION

300-10. The General Purpose Scanner Module is installed in two parts. The scanner pcb is installed first, followed by the connector.

300-11. The General Purpose Scanner PCB can be installed in any one of the available slots in the controller mainframe. Install the scanner pcb as follows:

WARNING

REMOVE LINE POWER AND ALL OTHER HIGH VOLTAGE INPUTS TO THE MAINFRAME BEFORE STARTING THIS PROCEDURE.

1. Remove the top dust cover from the controller mainframe.
2. Remove the guard chamber cover.

CAUTION

Handle the scanner pcb by its edges to avoid contaminating the pcb with oil from the hands. The use of gloves is recommended.

3. Select the slot that includes the logical block of channels the scanner pcb is to represent. Align the scanner in the slot so that the 44-pin board edge connector is toward the rear of the unit, and the small offset board-edge connectors are toward the bottom of the unit. Push the scanner pcb straight down onto the mating connectors.

4. Install the guard chamber cover.
5. Install the top dust cover.

300-12. The General Purpose Connector and user cable assembly can be installed in any one of the controller mainframe slots which contain a scanner pcb. Install the connector as follows:

1. Unlatch the slide fasteners located on either side of the protruding enclosure at the rear of the controller mainframe.
2. Remove the enclosure from the rear panel.
3. Locate the desired slot on the rear panel and check to ensure that a scanner pcb is installed in the slot.
4. With the connector key toward the top, position the connector in the guides of the selected slot and mate it to the connector on the scanner pcb.
5. Install the retaining screw and washer that hold the connector to the controller mainframe.
6. Install the rear panel enclosure.

300-13. OPERATION

300-14. Once installed, the General Purpose Scanner Module requires no operator attention.

300-15. THEORY OF OPERATION

300-16. The General Purpose Scanner Module (Figure 300-2) is a programmable, 10-channel relay scanner designed to operate as a plug-in option in any one of the slots in a controller mainframe. Channel scanning or multiplexing is accomplished by a series of 12 form-A reed relays, 11 double-pole and 1 single-pole. Ten of the

double-pole relays serve as two-wire input channel switches to a common high/low output bus. The eleventh two-pole relay also contacts the two-wire bus; however, the function of the eleventh relay is to isolate or decouple the bus from the actual output connections. When any one of the channel relays are energized the decoupling relay is also activated to complete the two-wire input/output circuit. The single-pole relay operates in parallel with the decoupling relay. When closed, the relay connects a common channel-input shield to the output shield connection. Thus, the scanner actually provides a three-wire output (high, low, and shield).

300-17. All scanner pcbs installed in a controller mainframe and/or extender chassis receive bcd channel-select information from a 4-bit data bus (CS0 through CS3). This data is decoded on each scanner pcb into 10 separate channel commands (0-9). Each channel line is first buffered and then connected to one of the 10 channel relay coils. Even though these commands are present the relays will not be energized unless the scanner receives a block select (BSX) command. This command is actually an address or enable signal which applies voltage to the low sides of the relay coils. When the coil voltage is present the decoupling relay, the shield relay and the selected channel relay are energized. At that time the analog input data on the selected channel appears at the scanner output terminals.

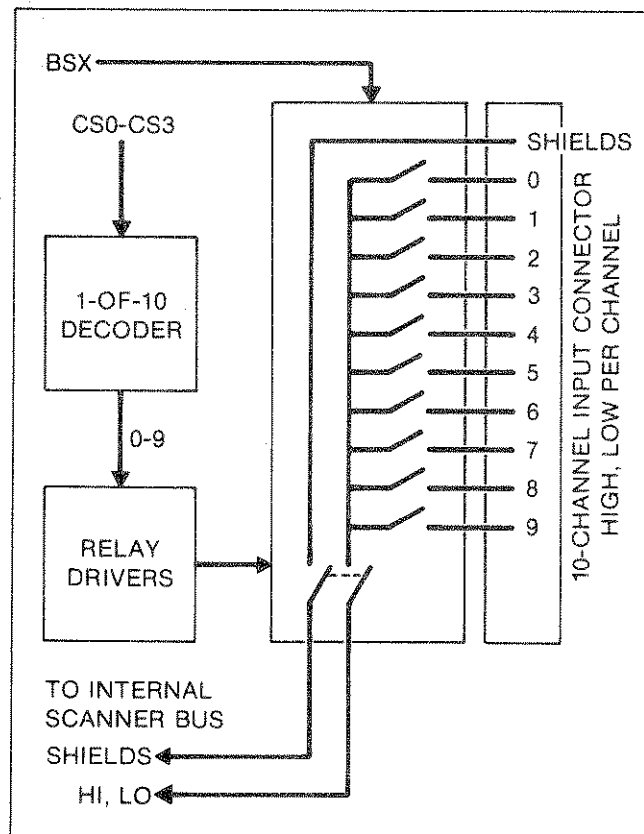

Figure 300-2. Functional Block Diagram

300-18. MAINTENANCE

300-19. Introduction

300-20. The following paragraphs cover the access and performance test information for maintaining the scanner module.

300-21. Access Information

300-22. Refer to the Installation information given earlier in this section for scanner pcb access information. Remove the rear panel input connector before attempting to remove the scanner pcb from its slot.

300-23. Performance Test

300-24. The performance test is designed to verify the overall operation for the General Purpose Scanner Module and is intended for use as an acceptance test and/or periodic maintenance check. The equipment used in the test is listed in Table 300-2. If the module fails any part of the performance test, corrective action is required. The performance test is conducted as follows:

1. Fabricate a scanner test cable as shown in Figure 300-3, using the test equipment and resistors specified in Table 300-2.

Table 300-2. Required Test Equipment

INSTRUMENT	RECOMMENDED MODEL
DC Voltage Calibrator	Fluke 515A
Mainframe	Fluke 2205A
Resistors (10 each)	Metal Film, 1K \pm 1%, 1/4W
DMM	Fluke 8520A

NOTE

Jumpers J1 thru J10 must be removed on the input connector for this test.

2. Install the General Purpose Scanner Module and the test cable in the channel 0-9 slot of the mainframe.
3. Set the calibrator output to 0V dc.
4. Connect the test cable leads to the calibrator's voltage output terminals (red to positive, black and white to negative).
5. Set the calibrator output to +1.000V dc.
6. Manually program the mainframe as follows:
 - a. Lower channel boundary to 0.

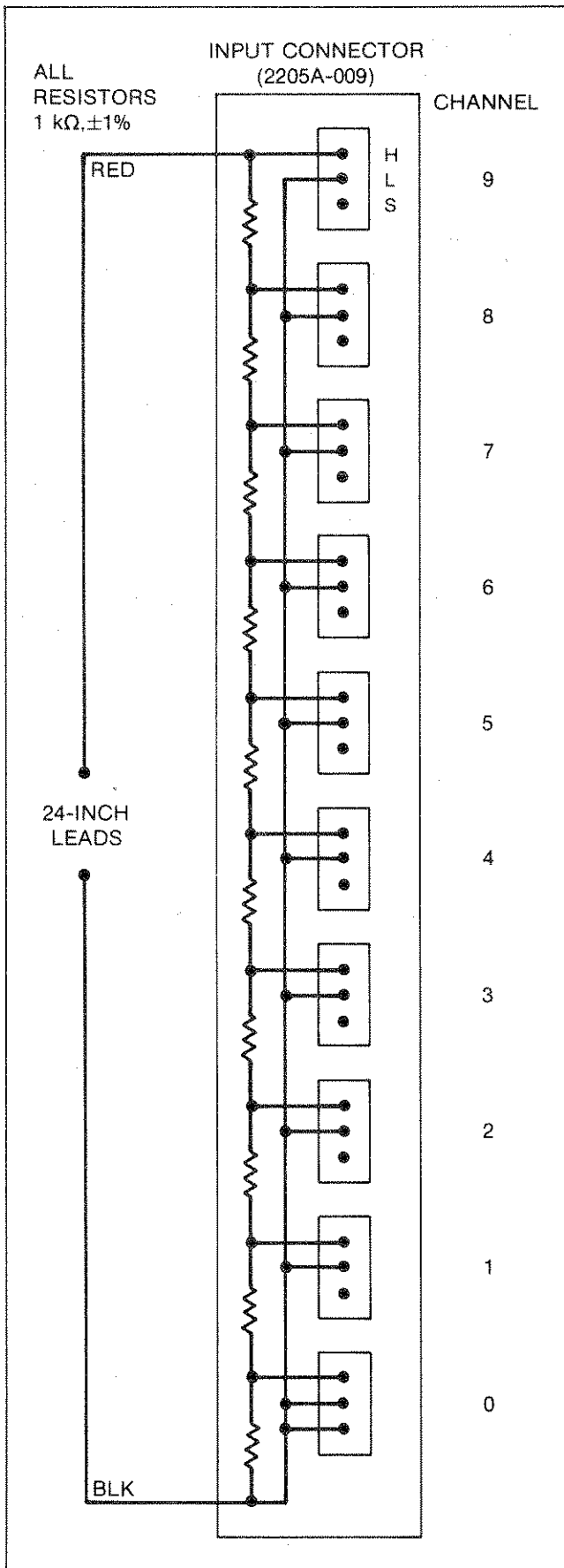

Figure 300-3. Scanner Test Cable

b. Upper channel boundary to 9.

7. Manually scan channels 0 through 9. Channels 0 should read +0.100V dc. A cumulative +0.1V increase should be observed on each of the remaining channels (channel 9 should read +1.000V dc ±1%). Any deviation in this pattern indicates a defective pcb assembly.

300-25. LIST OF REPLACEABLE PARTS

300-26. The replaceable parts of the General Purpose Scanner Module are listed in Table 300-3. Refer to Section 6 of this manual for ordering information.

CAUTION



Indicated devices are subject to damage by static discharge.

Table 300-3. General Purpose Scanner Module

REF DES	DESCRIPTION	FLUKE STOCK NO.	MFG SPLY CODE	MFG PART NO.	TOT QTY	REC QTY	NOTE
-300⊗	GENERAL PURPOSE SCANNER MODULE FIGURE 300-4	ORDER	BY	OPTION -300			
-300A1⊗	GENERAL PURPOSE SCANNER PCB ASSEMBLY	639799	89536	471409	1		
-300A2⊗	FUSED TERMINAL CONNECTOR SEE OPTION -200 FIGURE 200-6	618868	89536	618876	REF		
H1	SCREW, PHP, 4-40 X 7/8	335133	89536	335133	2		
H2	SCREW, PHP, 6-32 X 1/4	152140	89536	152140	8		
H3	WASHER, FLAT, #4	146225	89536	146225	2		
MP1	DECAL, GENERAL PURPOSE CONN.	632133	89536	632133	1		
MP2	ISOTHERMAL CONNECTOR HOUSING	414276	89536	414276	2		

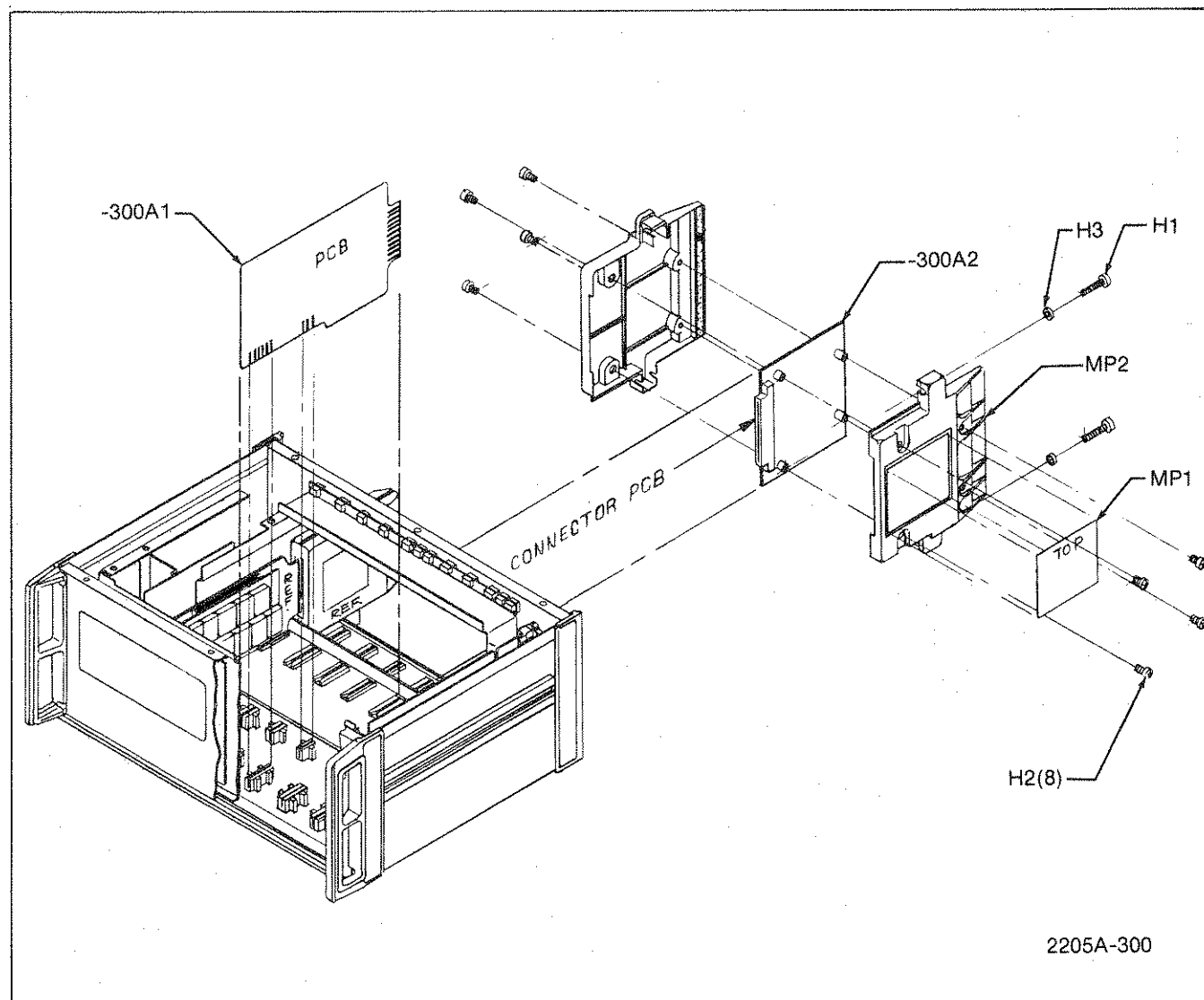
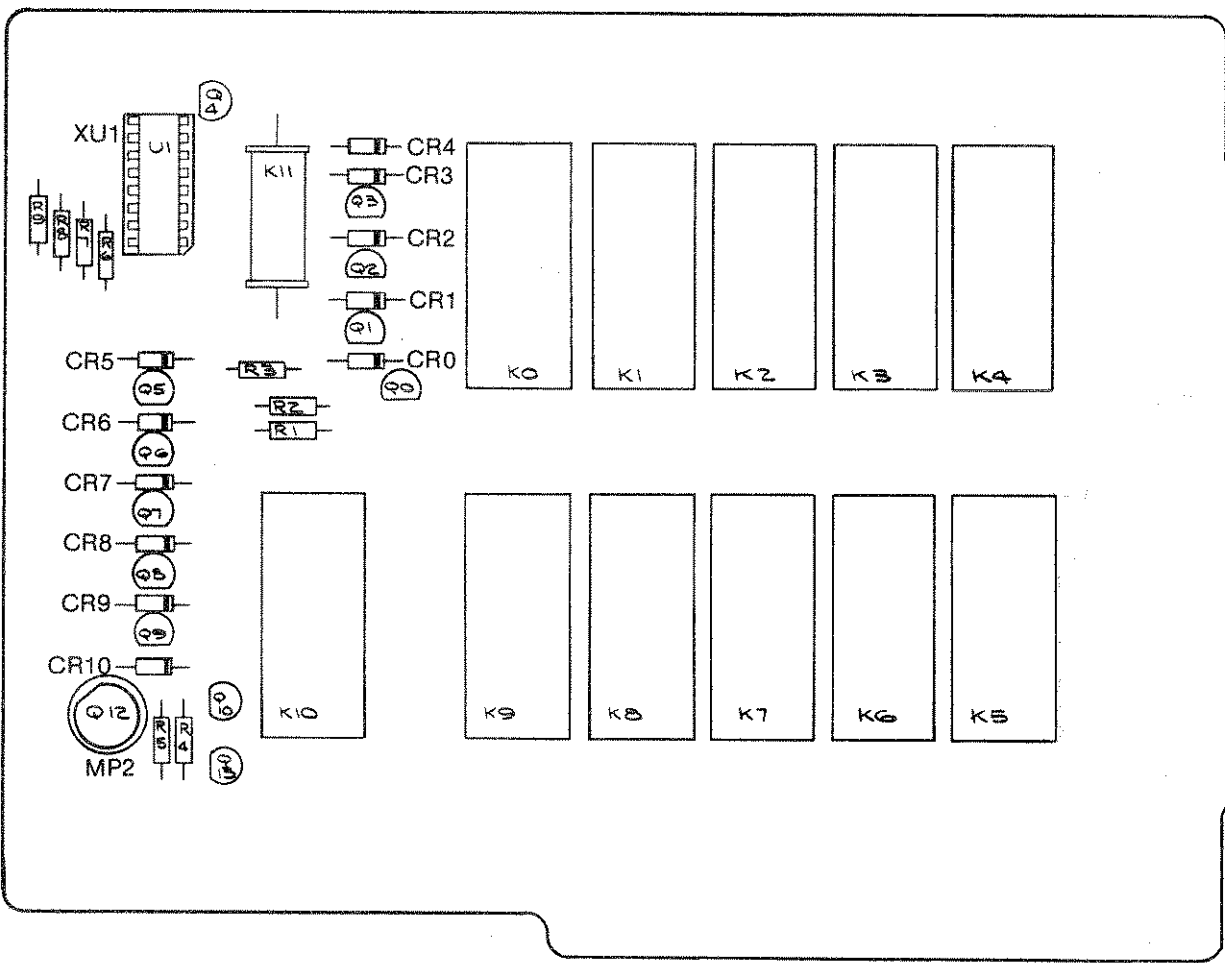

Figure 300-4. General Purpose Scanner Module

Table 300-4. General Purpose Scanner PCB Assembly

REF DES	DESCRIPTION	FLUKE STOCK NO.	MFG SPLY CODE	MFG PART NO.	TOT QTY	REC QTY	NOTE
-300A1⊗	GENERAL PURPOSE SCANNER PCB ASSEMBLY FIGURE 300-5 (2200A-4037T)	639799	89536	471409	REF		
CR0	DIODE, SI	203323	07910	1N4448	11	3	
CR1	DIODE, SI	203323	07910	1N4448	REF		
CR2	DIODE, SI	203323	07910	1N4448	REF		
CR3	DIODE, SI	203323	07910	1N4448	REF		
CR4	DIODE, SI	203323	07910	1N4448	REF		
CR5	DIODE, SI	203323	07910	1N4448	REF		
CR6	DIODE, SI	203323	07910	1N4448	REF		
CR7	DIODE, SI	203323	07910	1N4448	REF		
CR8	DIODE, SI	203323	07910	1N4448	REF		
CR9	DIODE, SI	203323	07910	1N4448	REF		
CR10	DIODE, SI	203323	07910	1N4448	REF		
K0	RELAY, DRY REED, DPST	442921	21317	052A5300BAA	11		
K1	RELAY, DRY REED, DPST	442921	21317	052A5300BAA	REF		
K2	RELAY, DRY REED, DPST	442921	21317	052A5300BAA	REF		
K3	RELAY, DRY REED, DPST	442921	21317	052A5300BAA	REF		
K4	RELAY, DRY REED, DPST	442921	21317	052A5300BAA	REF		
K5	RELAY, DRY REED, DPST	442921	21317	052A5300BAA	REF		
K6	RELAY, DRY REED, DPST	442921	21317	052A5300BAA	REF		
K7	RELAY, DRY REED, DPST	442921	21317	052A5300BAA	REF		
K8	RELAY, DRY REED, DPST	442921	21317	052A5300BAA	REF		
K9	RELAY, DRY REED, DPST	442921	21317	052A5300BAA	REF		
K10	RELAY, DRY REED, DPST	442921	21317	052A5300BAA	REF		
K11	COIL, REED RELAY	269019	71707	U-6-P	1		
MP1	DECAL, PART NO. (NOT SHOWN)	475517	89536	475517	1		
MP2	SPACER, XSTR MOUNT W/Q12	152207	07047	10123-DAP	1		
Q0	XSTR, SI, PNP	195974	04713	2N3906	10	2	
Q1	XSTR, SI, PNP	195974	04713	2N3906	REF		
Q2	XSTR, SI, PNP	195974	04713	2N3906	REF		
Q3	XSTR, SI, PNP	195974	04713	2N3906	REF		
Q4	XSTR, SI, PNP	195974	04713	2N3906	REF		
Q5	XSTR, SI, PNP	195974	04713	2N3906	REF		
Q6	XSTR, SI, PNP	195974	04713	2N3906	REF		
Q7	XSTR, SI, PNP	195974	04713	2N3906	REF		
Q8	XSTR, SI, PNP	195974	04713	2N3906	REF		
Q9	XSTR, SI, PNP	195974	04713	2N3906	REF		
Q10	XSTR, J-FET, N-CHANNEL	352112	07910	U26106	1	1	
Q12	XSTR, SI, NPN	182196	07263	2N3643	1	1	
Q13	XSTR, SI, NPN	218396	04713	2N3904	1	1	
R1	RES, MTL. FILM, 40.2 +/-1%, 1/8W	484014	91637	CMF5540R2F	3		
R2	RES, MTL. FILM, 40.2 +/-1%, 1/8W	484014	91637	CMF5540R2F	REF		
R3	RES, MTL. FILM, 40.2 +/-1%, 1/8W	484014	91637	CMF5540R2F	REF		
R4	RES, DEP. CAR, 470 +/-5%, 1/4W	343434	80031	CR251-4-5P470E	1		
R5	RES, DEP. CAR, 10K +/-5%, 1/4W	348839	80031	CR251-4-5P10K	1		
R6	RES, DEP. CAR, 100K +/-5%, 1/4W	348920	80031	CR251-4-5P100K	4		
R7	RES, DEP. CAR, 100K +/-5%, 1/4W	348920	80031	CR251-4-5P100K	REF		
R8	RES, DEP. CAR, 100K +/-5%, 1/4W	348920	80031	CR251-4-5P100K	REF		
R9	RES, DEP. CAR, 100K +/-5%, 1/4W	348920	80031	CR251-4-5P100K	REF		
S1	SWITCH, REED (NOT SHOWN)	414300	95348	MR5830-7	1		
U1⊗	IC, MOS, DECODER (INSTALLED IN TEST)	407981	12040	MM74C42N	1	1	
XU1	SCCKET, IC, 16-PIN DIP	276535	91506	316AG39D	1		



2200A-1637

Figure 300-5. General Purpose Scanner PCB Assembly

Option 2205A-400

Four-wire Resistance Scanner Module

400-1. INTRODUCTION

400-2. The Four-wire Resistance Scanner Module (Option 2205A-400) is a plug-in, relay scanner module designed to provide the source and sense connections for accurate 4-wire resistance measurements. The 4-wire scanner option consists of four major components; a general purpose scanner pcb for sourcing, a low level scanner pcb for sensing and two types of input connectors.

400-3. The General Purpose Scanner PCB is a plug-in, 10-channel, 2-wire relay scanner that operates as an analog data multiplexer. Switched high and low inputs are provided for each of the 10 channels and a common (unswitched) shield is provided for all 10 channels. A decoupling relay is used to isolate the high, low, and shield buses from the common output connections when a channel relay is not activated. Activating any one of the 10 channel relays also energizes the decoupling relay.

400-4. The Low Level Scanner PCB is a plug-in, 10-channel, relay scanner designed to operate as a low-level, analog data multiplexer. Each relay is a 3-wire, low-thermal-offset reed relay. Switched high, low, and shield inputs are provided for each of the 10 channels. A decoupling relay is used to isolate the high, low, and shield buses from the common output connections when a channel relay is not activated. Activating any one of the 10 channel relays also energizes the decoupling relay.

400-5. The General Purpose Connector is a connector assembly with screw-type terminals which mounts in the rear of a controller mainframe and provides electrical contact and fused protection for scanning pcbs. The connector is designed for use in fabricating a custom interface cable from external analog signals to the scanner pcbs.

400-6. The Isothermal Block Connector is an input connector assembly designed for inputting low level

thermocouple voltages and/or general purpose voltages to the Low Level Scanner PCB. Screw-type terminals provide the connections for input cables. These terminals are thermally intergrated into a isothermal block which is allowed to drift with ambient temperature. A temperature measuring circuit monitors the block temperature and returns a proportional voltage to the controller mainframe. This voltage is used by a remote controller to calculate the temperature represented by each of up to 10 thermocouple generated voltages (i.e., one per channel). The temperature measuring feature does not interfere with ordinary voltage measurements.

400-7. SPECIFICATIONS

400-8. Specifications for the Four-wire Resistance Scanner Module are listed in Table 400-1.

400-9. INPUT CONNECTIONS

400-10. All of the source connections are made at the General Purpose Connector and all of the sense connections are made at the Isothermal Block Connector. Figure 400-1 identifies the locations of the terminals for the 10 scanning channels of each connector. Access to the terminal blocks is accomplished by removing the four screws from the decal sides of the connector enclosures. The high, low, and shield connections for each channel are identified next to the terminal blocks on the general purpose connector pcb and on the decal of the isothermal connector. Only jumper J11 should be installed in the connector pcb to use the input connector with a scanner pcb.

400-11. INSTALLATION

400-12. The Four-wire Resistance Scanner Module is installed in two parts. First the scanner pcbs are installed, then the connectors are installed. The two scanner pcbs are installed in the same way. However, the Low Level Scanner PCB (sense) is installed in an even numbered slot and the General Purpose Scanner PCB (source) is installed in the next higher odd numbered slot.

Table 400-1. Option -400 Specifications

Hardware	One each General Purpose Scanner PCB, Low Level Scanner PCB, General Purpose Connector, and Isothermal Connector.
Channels	10 channels of four-wire resistance measurement.
Voltage Offset	Less than 1 μ V.
Switch Life	Greater than 10 ⁷ operations.
Over-Current Protection	0.5 amp fuse in series with each source input line. 470 ohm resistor in series with each sense input line.

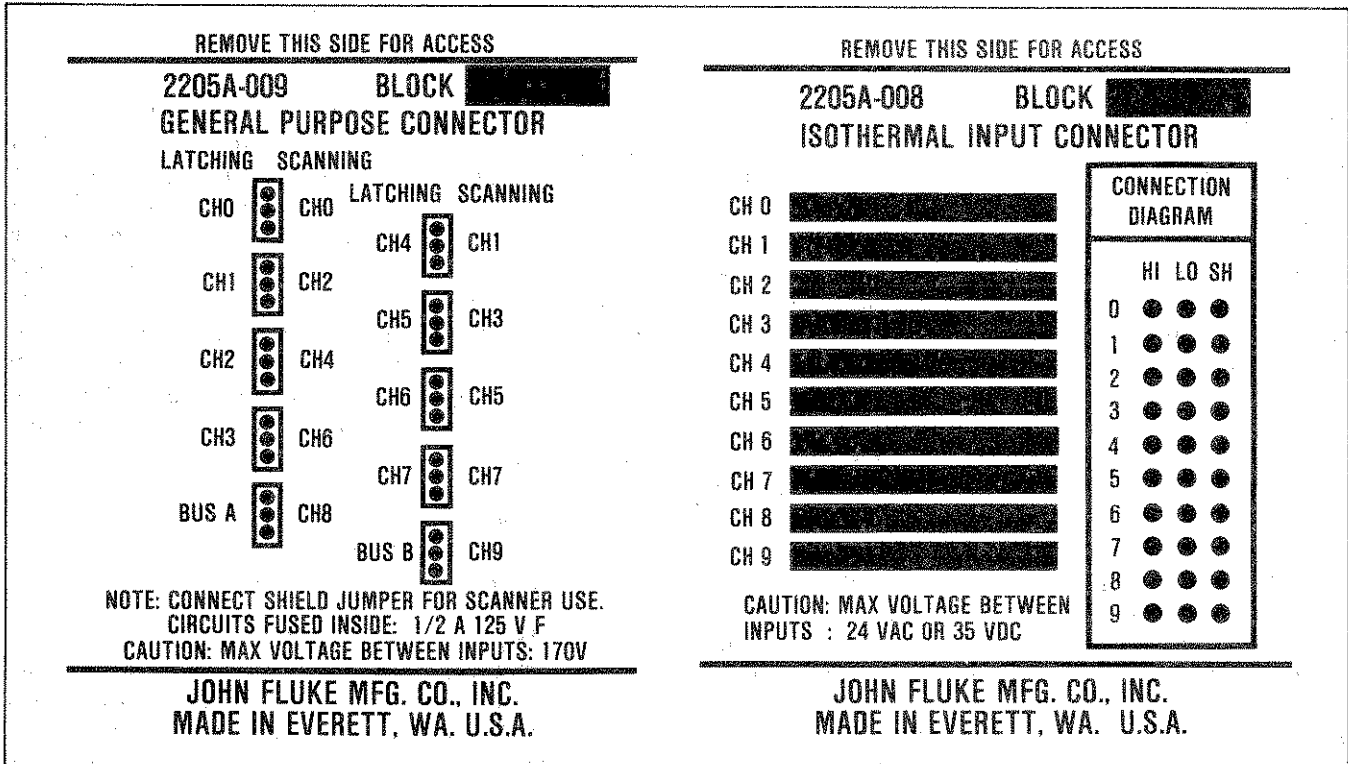

Figure 400-1. Input Connector Terminals

400-13. The scanner pcbs can be installed in any one of the available slots in the controller mainframe. Install the scanners as follows:

WARNING

REMOVE LINE POWER AND ALL OTHER HIGH VOLTAGE INPUTS TO THE MAINFRAME BEFORE STARTING THIS PROCEDURE.

1. Remove the top dust cover from the controller mainframe.
2. Set switch S1 (on the Extended Bus PCB) to the 4-wire position (toward the rear of the unit). The

controller mainframe must be in the 4-wire mode for this option to function properly.

3. Remove the guard chamber cover.

CAUTION

Handle the scanner pcbs by their edges to avoid contaminating the pcb with oil from the hands. The use of gloves is recommended.

4. Select the slot that includes the logical block of channels the scanner pcb is to represent. Align the scanner in the slot so that the 44-pin board edge connector is toward the rear of the unit, and the small offset board-edge connectors are toward the

bottom of the unit. Push the scanner pcb straight down onto the mating connectors.

5. After both of the scanner pcbs are installed, install the guard chamber cover.
6. Install the top dust cover.
7. Remove the high and low jumpers on the Analog Signal Cable (Y8076) at the controller mainframe end.

400-14. Use the following procedure to install the connectors on the appropriate scanner pcbs:

1. Unlatch the slide fasteners located on either side of the protruding enclosure at the rear of the controller mainframe.
2. Remove the enclosure from the rear panel.
3. Locate the desired slot on the rear panel and check to ensure that the proper scanner pcb is installed in the slot.

NOTE

Be sure to mate the connector with source inputs to the General Purpose PCB (odd numbered slot) and the connector with sense inputs to the Low Level PCB (even numbered slot).

4. With the connector key toward the top, position each connector in the guides of the selected slot and mate it to the connector on the scanner pcb.
5. Install the retaining screws and washers that hold the connectors to the controller mainframe.
6. After both of the input connectors are installed, install the rear panel enclosure.

400-15. OPERATION

400-16. Once installed, the Four-wire Resistance Scanner Module requires no operator attention.

400-17. THEORY OF OPERATION

400-18. The Four-wire Resistance Scanner Module (Figure 400-2) is a scanner module made up of two scanner pcbs and two input connectors. The module is designed to provide all the source and sense connections to operate as a 10 channel 4-wire resistance measurement scanner. A general purpose scanner pcb (in an odd numbered slot) provides the 10 source lines and a low level scanner pcb (in an even numbered slot) provides the 10 sense lines.

400-19. The General Purpose Scanner PCB is a programmable, 10-channel relay scanner designed to provide the source lines for 4-wire resistance measurements. Channel scanning or multiplexing is accomplished by a series of 12 form-A reed relays: 11 double-pole and one single-pole. Ten of the double-pole relays serve as two-wire input channel switches to a common high/low output bus. The eleventh two-pole relay also contacts the two-wire bus; however, the function of the eleventh relay is to isolate or decouple the bus from the actual output connections. When any one of the channel relays is energized, the decoupling relay is also activated to complete the two-wire input/output circuit. The single-pole relay operates in parallel with the decoupling relay. When closed, the single pole relay connects a common channel-input shield to the output shield connection to provide a three-wire output (Bus 1 - high, low and shield).

400-20. The Low Level Scanner PCB is a programmable, 10-channel relay scanner designed to provide the sense lines for 4-wire resistance measurements. Channel scanning or multiplexing is accomplished by a series of 11 three-pole, form-A, reed relays. Ten of the relays serve as three-wire input channel switches to a common (high, low and shield) output bus. The eleventh relay also contacts the three-wire output bus. However, the function of the eleventh relay is to isolate or decouple the bus from the actual output connections. When any one of the channel relays are energized the decoupling relay is also activated to complete the three-wire output (Bus 2 - high, low and shield).

400-21. All scanner pcbs installed in a controller mainframe and/or extender chassis receive bcd channel-select information from a 4-bit data bus (CS0 through CS3). The 2-/4-wire switch (on the Extended Bus PCB) puts the controller mainframe in 4-wire operation so both scanner pcbs receive the same channel-select data. This data is decoded on each scanner pcb into 10 separate channel commands (0-9). Each channel line is first buffered and then connected to one of the 10 channel relay coils. Even though these commands are present the relays will not be energized unless the module receives an even numbered block select (BSX) command. This command is actually an address or enable signal which applies voltage to the low side of the relay coils. When the coil voltage is present the decoupling relay, the shield relay and the selected channel relay are energized. At that time the 4-wire circuit is complete from the source line (Bus 2) to the selected measurement channel and back to the sense line (Bus 1).

400-22. MAINTENANCE

400-23. Introduction

400-24. The following paragraphs cover the access and performance test information for maintaining the switch module.

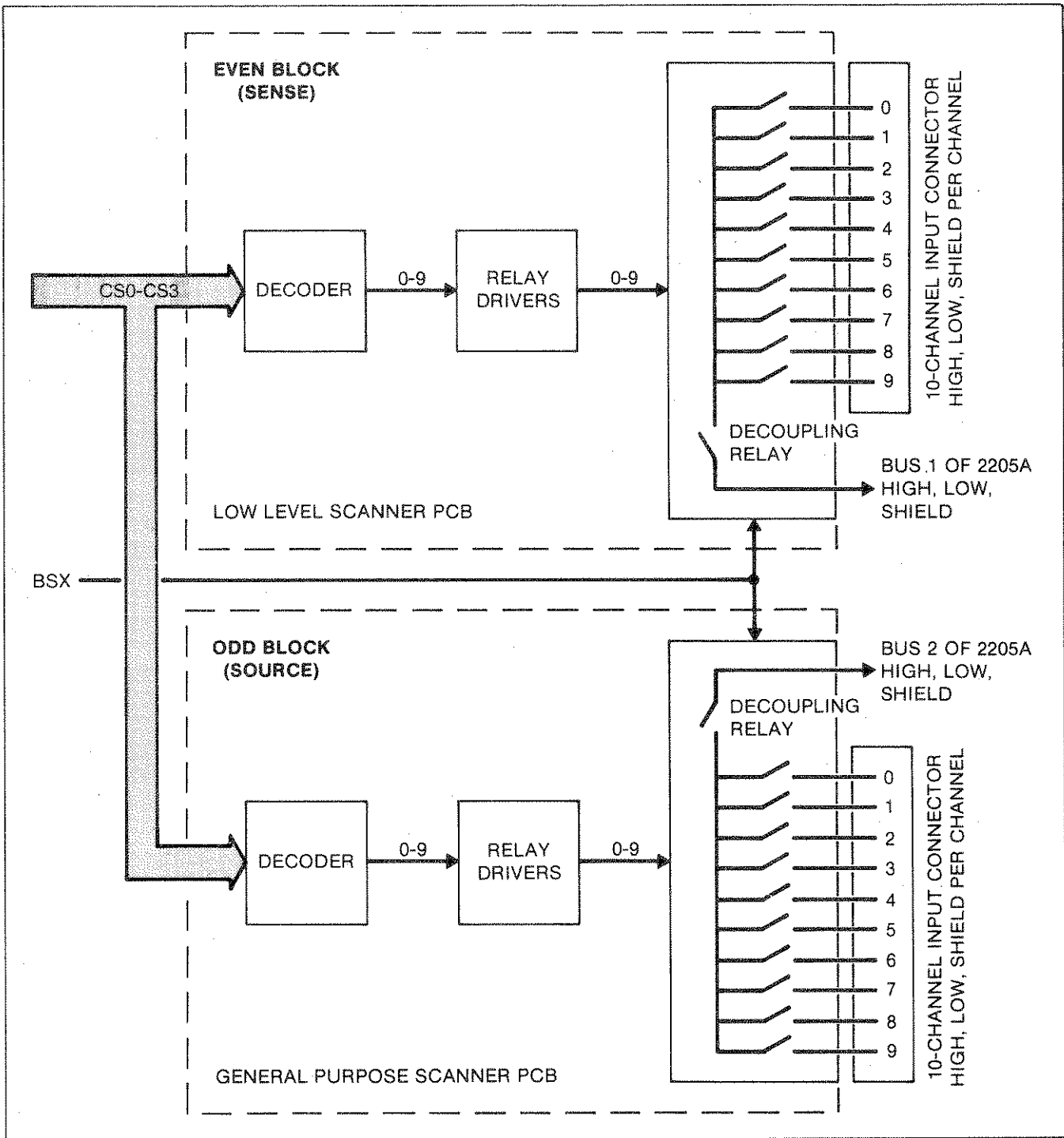

Figure 400-2. Functional Block Diagram

400-25. Access Information

400-26. Refer to the Installation information given earlier in this section for scanner pcb access information. Remove the rear panel input connector before attempting to remove a scanner pcb from its slot.

400-27. Performance Test

400-28. The performance test is designed to verify the

overall operation for the Four-wire Resistance Scanner Module and is intended for use as an acceptance test and/or periodic maintenance check. The following procedure is used to test both the Low Level and the General PurposeScanner PCBs. The equipment used in the test is listed in Table 400-2. If either of the scanner pcbs fail any part of the performance test, corrective action is required. The performance test is conducted as follows:

1. Fabricate a scanner test cable as shown in Figure 400-3 using the resistors specified in Table 400-2.

NOTE

Jumpers J1 thru J10 must be cut and jumper J11 must be installed on the General Purpose Connector for this test.

2. Install the Low Level Scanner PCB in slot 0 and the General Purpose PCB in slot 1.
3. Install the input connectors and test cable.
4. Set the DMM to the 10 ohm range.
5. Connect the DMM to the controller mainframe through the Analog Signal Cable (Bus 1 to sense; Bus 2 to source).
6. Manually program the controller mainframe as follows:
 - a. Lower channel boundary to 0.
 - b. Upper channel boundary to 9.
7. Manually scan channels 0 through 9. All of the channels should read 10 ohms $\pm 1\%$. Any deviation in this pattern indicates a defective pcb assembly.

Table 400-2. Required Test Equipment

INSTRUMENT	RECOMMENDED MODEL
DMM (with 4-wire resistance)	Fluke 8502A
Mainframe	Fluke 2205A
Resistors (10 each)	Metal Film, 10 Ω , $\pm 1\%$

400-29. LIST OF REPLACEABLE PARTS

400-30. The replaceable parts of the Four-wire Resistance Scanner Module Assembly are listed in Table 400-3. Refer to Section 6 of this manual for ordering information.

CAUTION



Indicated devices are subject to damage by static discharge.

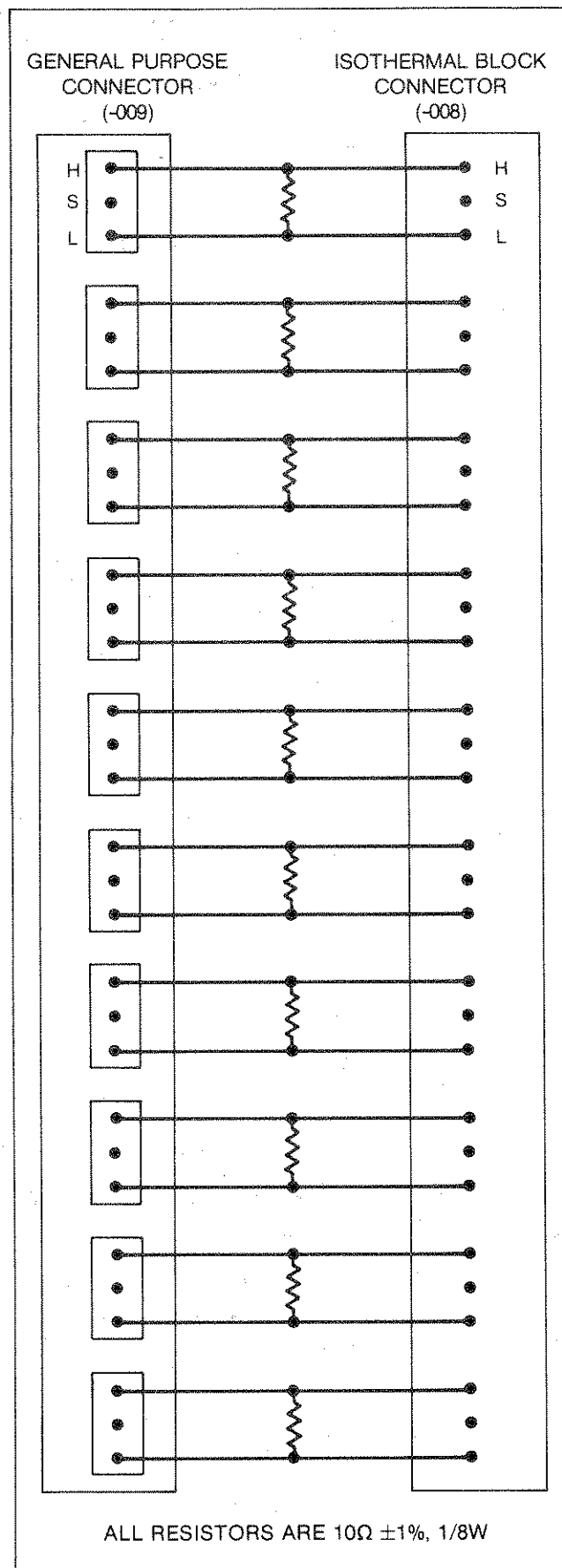

Figure 400-3. Scanner Test Cable

Table 400-3. Four-wire Resistance Scanner

REF DES	DESCRIPTION	FLUKE STOCK NO.	MFG SPLY CODE	MFG PART NO.	TOT QTY	REC QTY	NOTE
-400⊗	FOUR-WIRE RESISTANCE SCANNER - FIGURE 400-4	ORDER	BY	OPTION -400			
	GENERAL PURPOSE SCANNER PCB ASSY SEE OPTION -300 FIGURE 300-5	639779	89536	471409		REF	
	FUSED TERMINAL CONNECTOR SEE OPTION -200 FIGURE 200-6	618868	89536	618868		REF	
	LOW LEVEL SCANNER PCB ASSEMBLY SEE OPTION -600 FIGURE 600-5	409607	89536	409607		REF	
	ISOTHERMAL INPUT CONNECTOR SEE OPTION -600 FIGURE 600-6	409573	89536	409573		REF	
H1	SCREW, PHP, S/S, 4-40 X 7/8	335133	89536	335133		4	
H2	SCREW, PHP, 6-32 X 1/4	152140	89536	152140		16	
H3	WASHER, FLAT, #4	146225	89536	146225		4	
MP1	DECAL, GENERAL PURPOSE CONN.	632133	89536	632133		1	
MP2	DECAL, ISOTHERMAL INPUT CONN.	629899	89536	629899		1	
MP3	ISOTHERMAL CONNECTOR HOUSING	414276	89536	414276		4	

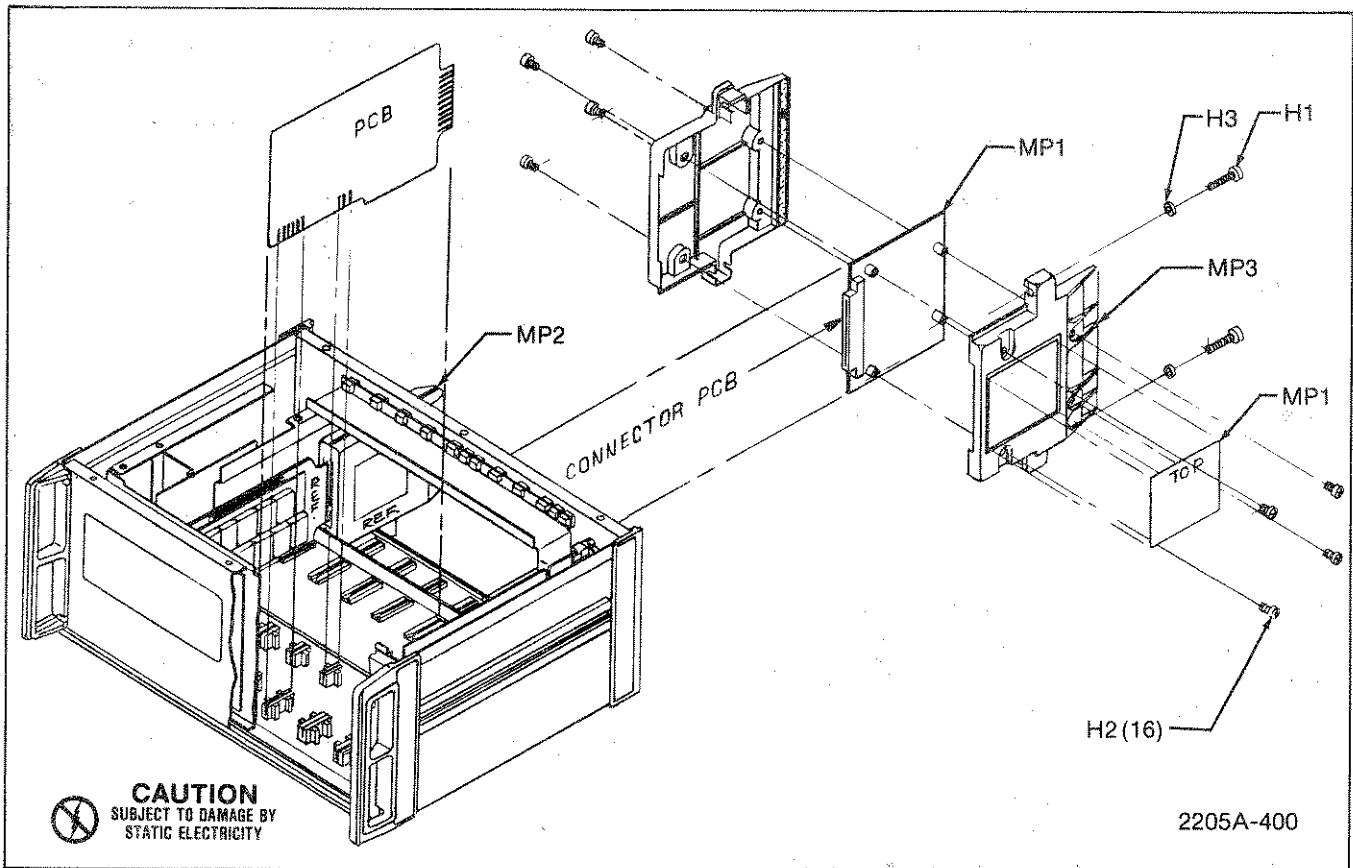

Figure 400-4. Four-wire Resistance Scanner

Option 2205A-600 Low Level Scanner Module

600-1. INTRODUCTION

600-2. The Low Level Scanner Module (Option 2205A-600) is a plug-in relay scanner module designed for use with thermocouples or other low level analog signal sources. The module consists of a Low Level Scanner PCB and an Isothermal Block Connector.

600-3. The Low Level Scanner PCB is a plug-in 10-channel, relay scanner that operates as a low-level analog data multiplexer. Each relay is a 3-wire, low-thermal-offset reed relay. Switched high, low, and shield inputs are provided for each of the 10 channels. A decoupling relay is used to isolate the high, low, and shield buses from the common output connections when a channel relay is not activated. Activating any one of the 10 channel relays also energizes the decoupling relay.

600-4. The Isothermal Block Connector is an input connector assembly designed for inputting low level thermocouple voltages and/or general purpose voltages to the Low Level Scanner PCB. Screw-type terminals provide the connections for input cables. These terminals are thermally integrated into an isothermal block which is allowed to drift with ambient temperature. A temperature measuring circuit monitors the block temperature and returns a proportional voltage to the mainframe. This voltage is used by a system controller to calculate the temperature represented by each of up to 10 thermocouple generated voltages (i.e., one per channel). The temperature measuring feature does not interfere with ordinary voltage measurements.

600-5. SPECIFICATIONS

600-6. The specifications for the Low Level Scanner Module are listed in Table 600-1.

Table 600-1. Option -600 Specifications

Hardware	One each Low Level Scanner PCB and Isothermal Block Connector.
Channels	Ten 3-wire channels using low thermal offset reed relays. High, low, and shield are switched. Contacts are brought out to an isothermal block input connector with screw-type terminals and monitored reference junction temperature.
Voltage Offset	Less than 1 μ V.
Switch Life	Greater than 10 ⁷ operations.
Contact Current	15 mA maximum.
Input Voltage Limit*	24V ac or 35V dc.
Common Mode Voltage Limit (Voltage between chassis and any input)	24V ac or 35V dc provided the input voltage limit is not exceeded.
Over Current Protection	100 ohm resistor in series with each input line.

* Maximum voltage between any two terminals in the system including normal mode as well as common mode voltages.

600-7. INPUT CONNECTIONS

600-8. The analog interface is completed through an Isothermal Block Connector with screw-type terminals. Figure 600-1 identifies the location of the high, low, and shield input terminals for each of the 10 channels. Access to the terminals is accomplished by removing the four cover screws from the decal side of the connector enclosure. As input connections are completed, use the space provided on the connector decal to identify the connector's logical block assignment and each of its input signals.

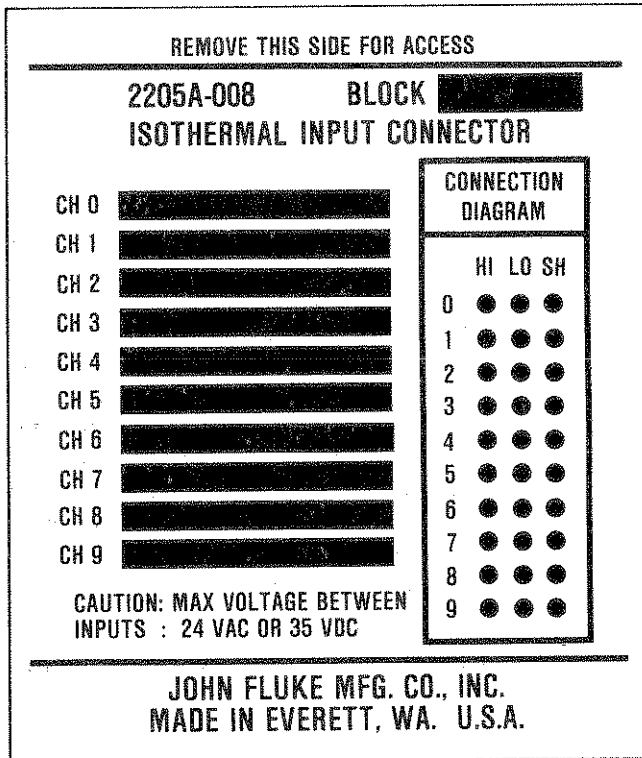

Figure 600-1. Input Connector Terminals

600-9. INSTALLATION

600-10. The Low Level Scanner Module is installed in two parts. First the Low Level Scanner PCB is installed, then the Isothermal Block Connector is installed.

600-11. The Low Level Scanner PCB can be installed in any slot available in the controller mainframe. Install the scanner pcb as follows:

WARNING

REMOVE LINE POWER AND ALL OTHER HIGH VOLTAGE INPUTS TO THE MAINFRAME BEFORE STARTING THIS PROCEDURE.

1. Remove the top dust cover from the controller mainframe.

2. Remove the guard chamber cover.

CAUTION

Handle the scanner pcb by its edges to avoid contaminating the pcb with oil from the hands. The use of gloves is recommended.

3. Select the slot that includes the logical block of channels the scanner pcb is to represent. Align the scanner in the slot so that the 44-pin board-edge connector is toward the rear of the unit, and the small offset board-edge connectors are toward the bottom of the unit. Push the scanner pcb straight down onto the mating connectors.

4. Install the guard chamber cover.
5. Install the top dust cover.

600-12. The Isothermal Block Connector can be installed in any one of the controller mainframe slots which contain a relay scanner pcb. Install the connector as follows:

1. Unlatch the slide fasteners located on either side of the protruding enclosure at the rear of the controller mainframe.
2. Remove the enclosure from the rear panel.
3. Locate the desired slot on the rear panel and check to ensure that a scanner pcb is installed in the slot.
4. With the connector key toward the top, position the connector in the guides of the selected slot and mate it with the connector on the scanner pcb.
5. Install the retaining screw and washer that hold the input connector to the controller mainframe.
6. Install the rear panel enclosure.

600-13. OPERATION

600-14. Once installed, the Low Level Scanner Module requires no operator attention.

600-15. THEORY OF OPERATION

600-16. The Low Level Scanner Module (Figure 600-2) is a 10-channel relay multiplexer that provides the selection of input analog signals to the output bus of the mainframe. An Isothermal Block Connector provides the reference junction temperature for use with thermocouples.

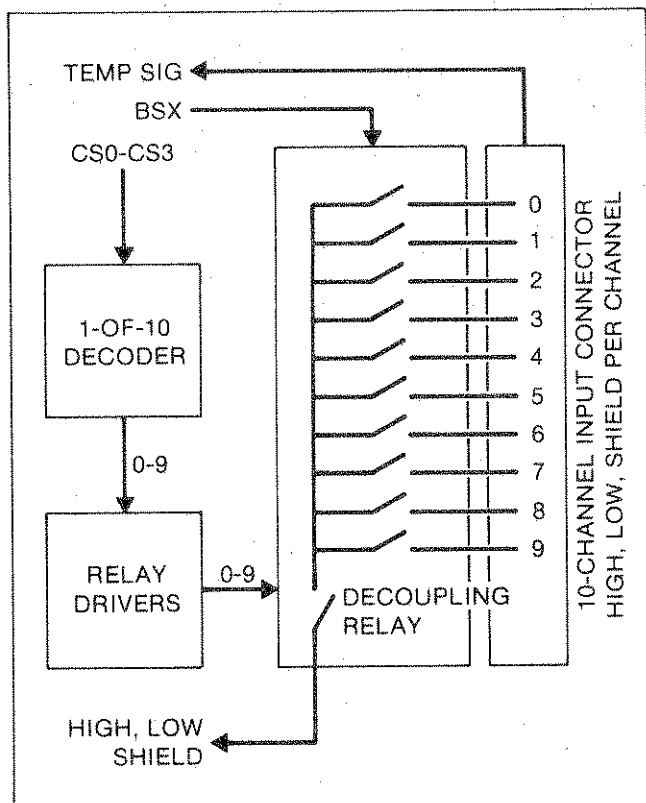

Figure 600-2. Functional Block Diagram

600-17. The Low Level Scanner PCB is a programmable 10-channel relay scanner designed to operate as a plug-in option in any one of the slots in a controller mainframe. Channel scanning or multiplexing is accomplished by a series of 11 three-pole, form-A, reed switches. Ten of the relays serve as three-wire input channel switches to a common (high/low/shield) output bus. The eleventh relay also contacts the three-wire output bus; however, the function of the eleventh relay is to isolate or decouple the bus from the actual output connections. When any one of the channel relays is energized the decoupling relay is also activated to complete the three-wire input/output circuit.

600-18. All scanner pcbs installed in the controller mainframe and/or extender chassis receive bcd channel-select information in parallel from a 4-bit data bus (CS0 through CS3). This data is decoded on each scanner pcb into 10 separate channel commands (0-9). Each command line is first buffered and then connected to one of the 10 channel relay coils. Even though these commands are present, the relays will not be energized unless the scanner pcb receives a block select (BSX) command. This command is actually an address or enable signal which applies a control command to the low side of the relay coils. When this signal is present, the decoupling relay and the selected channel relay are energized. At that time the analog input data on the selected channel appears at the scanner output terminals.

600-19. The Isothermal Block Connector provides the connections necessary for supplying voltage and/or thermocouple temperature inputs to any of the 10 scanner channels. Input connections are in the form of 10 sets of 3-screw terminals (high, low, and shield). The input signals at any given channel are measured in terms of voltage. When thermocouple inputs are used, temperature is calculated using both the thermocouple voltage and the reference voltage. The voltage of the junction is normally 539.2 mV at 25°C. To convert the reference junction voltage to a temperature use the formula:

$$T (^{\circ}\text{C}) = 250.17 - (417.54 \times V_{\text{ref}})$$

600-20. Assuming that a thermocouple is providing the input signal to a channel when the temperature function is programmed, the isothermal connector provides a remote measurement device with information necessary to compute the actual temperature at the thermocouple probe. This information includes the thermocouple voltage at the input terminals and a voltage indicative of the thermocouple input terminal temperature. The thermocouple input voltage is a direct result of the probe temperature versus the input terminal temperature. The input terminal temperature is measured by a separate sensing circuit and is electrically isolated from the thermocouple connections.

600-21. The mass and temperature response of the isothermal block is such that the input terminal temperature and the semiconductor sensor are held to within less than +0.05°C of each other. Actual block temperature is allowed to vary with ambient temperature.

600-22. When a relay scanner is addressed, the temperature sensing circuit provides the remote measurement device with a voltage proportional to the temperature of the isothermal block. This method of compensating a thermocouple reference junction is accurate over a temperature range of 0 to 50°C.

600-23. MAINTENANCE

600-24. Introduction

600-25. The following paragraphs cover the access and performance test information for maintaining the module.

600-26. Access Information

600-27. Refer to the installation information given earlier for scanner pcb access information. Remove the input connector before attempting to remove the scanner pcb from its slot.

600-28. Performance Test

600-29. The performance test is designed to verify the overall operation of the Low Level Scanner Module and is intended for use as an acceptance test and/or periodic maintenance check. The equipment used in the test is

specified in Table 600-2. If the scanner pcb fails any part of the performance test, corrective action is required. The performance test is conducted as follows:

1. Fabricate a scanner test cable as shown in Figure 600-3 using the resistors specified in Table 600-2.
2. Install the Low Level Scanner Module and the test cable in the channel 0-9 slot of the controller mainframe.
3. Set the calibrator output to 0V dc.
4. Connect the test cable leads to the calibrator's voltage output terminals (red to positive, black and white to negative).
5. Set the calibrator output to +1.000V dc.
6. Manually program the mainframe as follows:
 - a. Lower channel boundary to 0.
 - b. Upper channel boundary to 9.
7. Manually scan channels 0 through 9. Channels 0 should read +0.1V dc. A cumulative +0.1V increase should be observed on each of the remaining channels (channel 9 should read +1.000V dc $\pm 1\%$). Any deviation in this pattern indicates a defective pcb assembly.

Table 600-2. Required Test Equipment

INSTRUMENT	RECOMMENDED MODEL
DC Voltage Calibrator	Fluke 515A
Mainframe	Fluke 2205A
Resistors (10 each)	Metal Film, 1K $\pm 1\%$, 1/4W
DMM	Fluke 8520A

600-30. LIST OF REPLACEABLE PARTS

600-31. The replaceable parts of the Low Level Scanner Module are listed in Table 600-3. Refer to Section 6 of this manual for ordering information.

CAUTION



Indicated devices are subject to damage by static discharge.

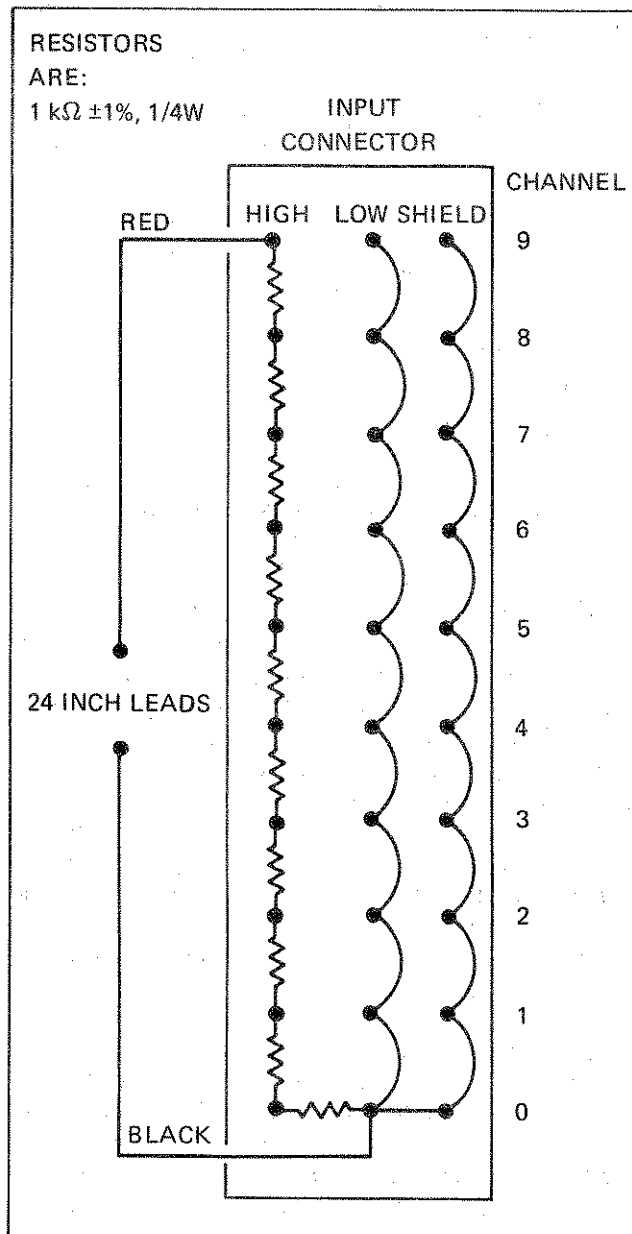

Figure 600-3. Scanner Test Cable

Table 600-3. Thermocouple Scanner Module

REF DES	DESCRIPTION	FLUKE STOCK NO.	MFG SPLY CODE	MFG PART NO.	TOT QTY	REC QTY	NOTE
-600⊕	THERMOCOUPLE SCANNING MODULE (SEE FIGURE 600-4)	ORDER	BY	OPTION -600			
-600A1⊕	LOW LEVEL SCANNER PCB ASSEMBLY	639740	89536	409607	1		
-600A2	ISOTHERMAL INPUT CONNECTOR	409573	89536	409573	1		
H1	SCREW, PHP, 4-40 X 7/8	335133	89536	335133	2		
H2	SCREW, PHP, 6-32 X 1/4	152140	89536	152140	8		
H3	WASHER, FLAT, #4	146225	89536	146225	2		
MP1	DECAL, ISOTHERMAL INPUT CONN.	629899	89536	629899	1		
MP2	ISOTHERMAL CONNECTOR HOUSING	414276	89536	414276	2		

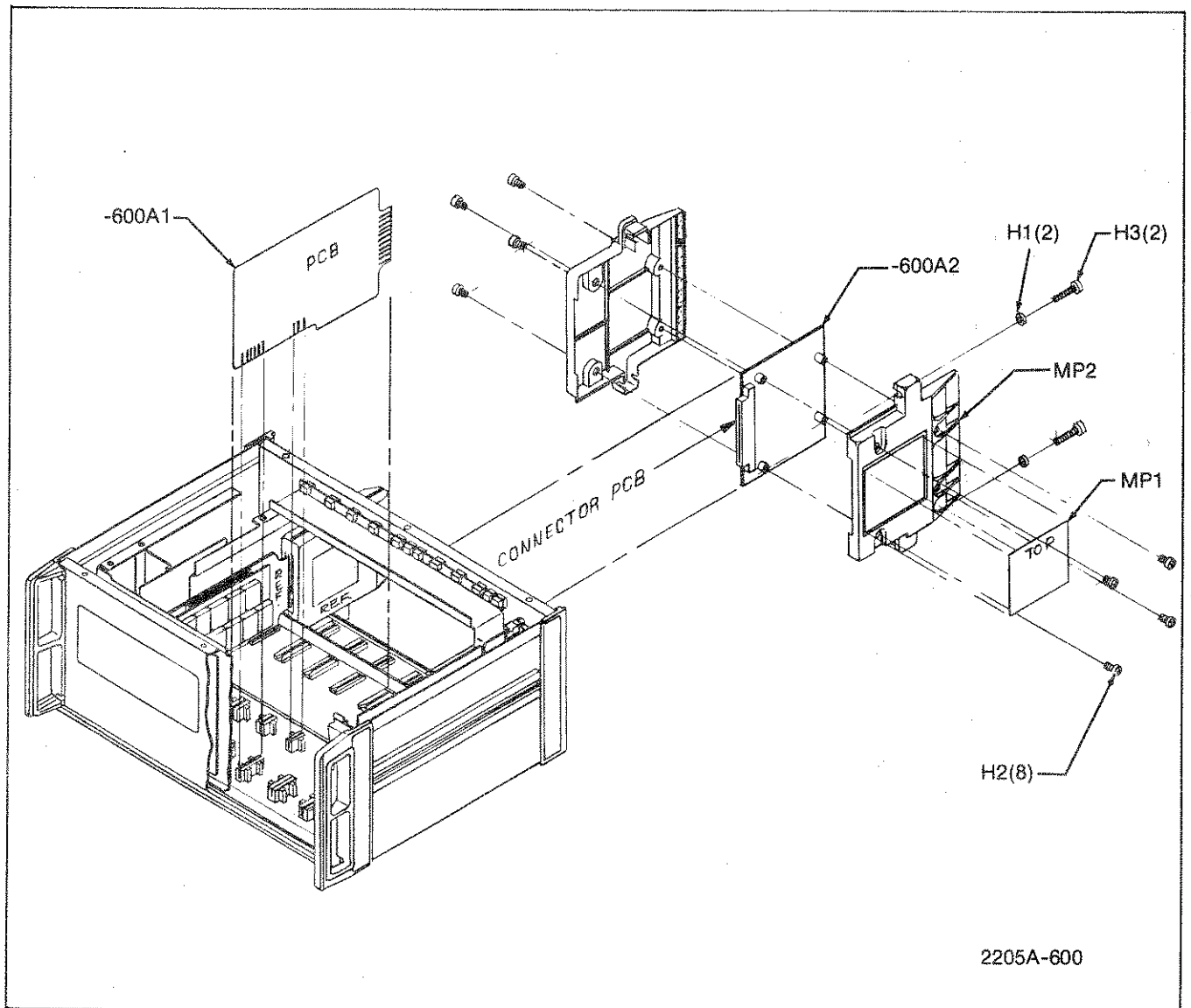

Figure 600-4. Thermocouple Scanner Module

Table 600-4. Low Level Scanner PCB Assembly

REF DES	DESCRIPTION	FLUKE STOCK NO.	MFG SPLY CODE	MFG PART NO.	TOT QTY	REC QTY	NOTE
-600A10	LOW LEVEL SCANNER PCB ASSEMBLY FIGURE 600-5 (2200A-4029T)	639740	89536	409607	REF		
CR0	DIODE, HI-SPEED SWITCHING	203323	07910	1N4448	11	3	
CR1	DIODE, HI-SPEED SWITCHING	203323	07910	1N4448	REF		
CR2	DIODE, HI-SPEED SWITCHING	203323	07910	1N4448	REF		
CR3	DIODE, HI-SPEED SWITCHING	203323	07910	1N4448	REF		
CR4	DIODE, HI-SPEED SWITCHING	203323	07910	1N4448	REF		
CR5	DIODE, HI-SPEED SWITCHING	203323	07910	1N4448	REF		
CR6	DIODE, HI-SPEED SWITCHING	203323	07910	1N4448	REF		
CR7	DIODE, HI-SPEED SWITCHING	203323	07910	1N4448	REF		
CR8	DIODE, HI-SPEED SWITCHING	203323	07910	1N4448	REF		
CR9	DIODE, HI-SPEED SWITCHING	203323	07910	1N4448	REF		
CR10	DIODE, HI-SPEED SWITCHING	203323	07910	1N4448	REF		
H1	SCREW, S/S, 6-32 X 3/8	572537	89536	572537	5		
J14	CONNECTOR, MALE, 12-PIN	380683	27264	A2402-09-64-1121	1		
KO-K10	RELAY COIL ASSEMBLY						
KO-K11	COIL, REED RELAY, 135 +/-10%, 5V	380709	71707	E8206	11		
KO-K12	CORE, METAL, RELAY COIL	380451	89536	380451	11		
MP1	SHIELD, BOTTOM	526830	89536	526830	1		
MP2	SHIELD, TOP	526863	89536	526863	1		
MP3	SPACER, SHIELD, BOTTOM	412320	89536	412320	1		
MP4	SPACER, SHIELD, TOP	412312	89536	412312	1		
MP5	SPACER, XSTR MOUNT W/Q11	152207	07047	10123-DAP	1		
MP6	COIL PCB	409334	89536	409334	1		
MP7	1 MICROVOLT REED PCB	409276	89536	409276	1		
P14	CONNECTOR, FEMALE, 12-PIN	380691	27264	2145B09-52-3122	1		
Q0	XSTR, SI, PNP	195974	04713	2N3906	10	2	
Q1	XSTR, SI, PNP	195974	04713	2N3906	REF		
Q2	XSTR, SI, PNP	195974	04713	2N3906	REF		
Q3	XSTR, SI, PNP	195974	04713	2N3906	REF		
Q4	XSTR, SI, PNP	195974	04713	2N3906	REF		
Q5	XSTR, SI, PNP	195974	04713	2N3906	REF		
Q6	XSTR, SI, PNP	195974	04713	2N3906	REF		
Q7	XSTR, SI, PNP	195974	04713	2N3906	REF		
Q8	XSTR, SI, PNP	195974	04713	2N3906	REF		
Q9	XSTR, SI, PNP	195974	04713	2N3906	REF		
Q10	XSTR, SI, NPN	218396	04713	2N3904	1	1	
Q11	XSTR, SI, NPN	182196	07263	2N3643	1	1	
Q12	XSTR, FET, N-CHANNEL	429977	89536	429977	1	1	
R0	RES, DEP. CAR, 470 +/-5%, 1/4W	343434	80031	CR251-4-5P470E	31		
R1	RES, DEP. CAR, 470 +/-5%, 1/4W	343434	80031	CR251-4-5P470E	REF		
R2	RES, DEP. CAR, 470 +/-5%, 1/4W	343434	80031	CR251-4-5P470E	REF		
R3	RES, DEP. CAR, 470 +/-5%, 1/4W	343434	80031	CR251-4-5P470E	REF		
R4	RES, DEP. CAR, 470 +/-5%, 1/4W	343434	80031	CR251-4-5P470E	REF		
R5	RES, DEP. CAR, 470 +/-5%, 1/4W	343434	80031	CR251-4-5P470E	REF		
R6	RES, DEP. CAR, 470 +/-5%, 1/4W	343434	80031	CR251-4-5P470E	REF		
R7	RES, DEP. CAR, 470 +/-5%, 1/4W	343434	80031	CR251-4-5P470E	REF		
R8	RES, DEP. CAR, 470 +/-5%, 1/4W	343434	80031	CR251-4-5P470E	REF		
R9	RES, DEP. CAR, 470 +/-5%, 1/4W	343434	80031	CR251-4-5P470E	REF		

Table 600-4. Low Level Scanner PCB Assembly (cont)

REF DES	DESCRIPTION	FLUKE STOCK NO.	MFG SPLY CODE	MFG PART NO.	TOT QTY	REC QTY	NOTE
R10	RES, DEP. CAR, 470 +/-5%, 1/4W	343434	80031	CR251-4-5P470E	REF		
R11	RES, DEP. CAR, 470 +/-5%, 1/4W	343434	80031	CR251-4-5P470E	REF		
R12	RES, DEP. CAR, 470 +/-5%, 1/4W	343434	80031	CR251-4-5P470E	REF		
R13	RES, DEP. CAR, 470 +/-5%, 1/4W	343434	80031	CR251-4-5P470E	REF		
R14	RES, DEP. CAR, 470 +/-5%, 1/4W	343434	80031	CR251-4-5P470E	REF		
R15	RES, DEP. CAR, 470 +/-5%, 1/4W	343434	80031	CR251-4-5P470E	REF		
R16	RES, DEP. CAR, 470 +/-5%, 1/4W	343434	80031	CR251-4-5P470E	REF		
R17	RES, DEP. CAR, 470 +/-5%, 1/4W	343434	80031	CR251-4-5P470E	REF		
R18	RES, DEP. CAR, 470 +/-5%, 1/4W	343434	80031	CR251-4-5P470E	REF		
R19	RES, DEP. CAR, 470 +/-5%, 1/4W	343434	80031	CR251-4-5P470E	REF		
R20	RES, DEP. CAR, 470 +/-5%, 1/4W	343434	80031	CR251-4-5P470E	REF		
R21	RES, DEP. CAR, 470 +/-5%, 1/4W	343434	80031	CR251-4-5P470E	REF		
R22	RES, DEP. CAR, 470 +/-5%, 1/4W	343434	80031	CR251-4-5P470E	REF		
R23	RES, DEP. CAR, 470 +/-5%, 1/4W	343434	80031	CR251-4-5P470E	REF		
R24	RES, DEP. CAR, 470 +/-5%, 1/4W	343434	80031	CR251-4-5P470E	REF		
R25	RES, DEP. CAR, 470 +/-5%, 1/4W	343434	80031	CR251-4-5P470E	REF		
R26	RES, DEP. CAR, 470 +/-5%, 1/4W	343434	80031	CR251-4-5P470E	REF		
R27	RES, DEP. CAR, 470 +/-5%, 1/4W	343434	80031	CR251-4-5P470E	REF		
R28	RES, DEP. CAR, 470 +/-5%, 1/4W	343434	80031	CR251-4-5P470E	REF		
R29	RES, DEP. CAR, 470 +/-5%, 1/4W	343434	80031	CR251-4-5P470E	REF		
R33	RES, COMP, 10K +/-5%, 1/2W	109165	01121	EB1035		1	
R34	RES, DEP. CAR, 470 +/-5%, 1/4W	343434	80031	CR251-4-5P470E	REF		
S0	SWITCH, DRY REED, SPST, 3W, 40V	450627	89536	450627		33	
S1	SWITCH, DRY REED, SPST, 3W, 40V	450627	89536	450627	REF		
S2	SWITCH, DRY REED, SPST, 3W, 40V	450627	89536	450627	REF		
S3	SWITCH, DRY REED, SPST, 3W, 40V	380717	95348	MR-0780-3	REF		
S4	SWITCH, DRY REED, SPST, 3W, 40V	450627	89536	450627	REF		
S5	SWITCH, DRY REED, SPST, 3W, 40V	450627	89536	450627	REF		
S6	SWITCH, DRY REED, SPST, 3W, 40V	450627	89536	450627	REF		
S7	SWITCH, DRY REED, SPST, 3W, 40V	450627	89536	450627	REF		
S8	SWITCH, DRY REED, SPST, 3W, 40V	450627	89536	450627	REF		
S9	SWITCH, DRY REED, SPST, 3W, 40V	380717	95348	MR-0780-3	REF		
S10	SWITCH, DRY REED, SPST, 3W, 40V	450627	89536	450627	REF		
S11	SWITCH, DRY REED, SPST, 3W, 40V	450627	89536	450627	REF		
S12	SWITCH, DRY REED, SPST, 3W, 40V	450627	89536	450627	REF		
S13	SWITCH, DRY REED, SPST, 3W, 40V	450627	89536	450627	REF		
S14	SWITCH, DRY REED, SPST, 3W, 40V	450627	89536	450627	REF		
S15	SWITCH, DRY REED, SPST, 3W, 40V	450627	89536	450627	REF		
S16	SWITCH, DRY REED, SPST, 3W, 40V	450627	89536	450627	REF		
S17	SWITCH, DRY REED, SPST, 3W, 40V	450627	89536	450627	REF		
S18	SWITCH, DRY REED, SPST, 3W, 40V	450627	89536	450627	REF		
S19	SWITCH, DRY REED, SPST, 3W, 40V	450627	89536	450627	REF		
S20	SWITCH, DRY REED, SPST, 3W, 40V	450627	89536	450627	REF		
S21	SWITCH, DRY REED, SPST, 3W, 40V	450627	89536	450627	REF		
S22	SWITCH, DRY REED, SPST, 3W, 40V	450627	89536	450627	REF		
S23	SWITCH, DRY REED, SPST, 3W, 40V	450627	89536	450627	REF		
S24	SWITCH, DRY REED, SPST, 3W, 40V	450627	89536	450627	REF		
S25	SWITCH, DRY REED, SPST, 3W, 40V	450627	89536	450627	REF		
S26	SWITCH, DRY REED, SPST, 3W, 40V	450627	89536	450627	REF		
S27	SWITCH, DRY REED, SPST, 3W, 40V	450627	89536	450627	REF		

Table 600-4. Low Level Scanner PCB Assembly (cont)

REF DES	DESCRIPTION	FLUKE STOCK NO.	MFG SPLY CODE	MFG PART NO.	TOT QTY	REC QTY	NOTE
S28	SWITCH, DRY REED, SPST, 3W, 40V	450627	89536	450627	REF		
S29	SWITCH, DRY REED, SPST, 3W, 40V	450627	89536	450627	REF		
S30	SWITCH, DRY REED, SPST, 3W, 40V	450627	89536	450627	REF		
S31	SWITCH, DRY REED, SPST, 3W, 40V	450627	89536	450627	REF		
S32	SWITCH, DRY REED, SPST, 3W, 40V	450627	89536	450627	REF		
U1⊗	IC, C-MOS, 1-OF-10 DECODER	407981	12040	MM74C42	1	1	
XU1	SOCKET, IC, 16-PIN	276535	91506	316AG39D	1		

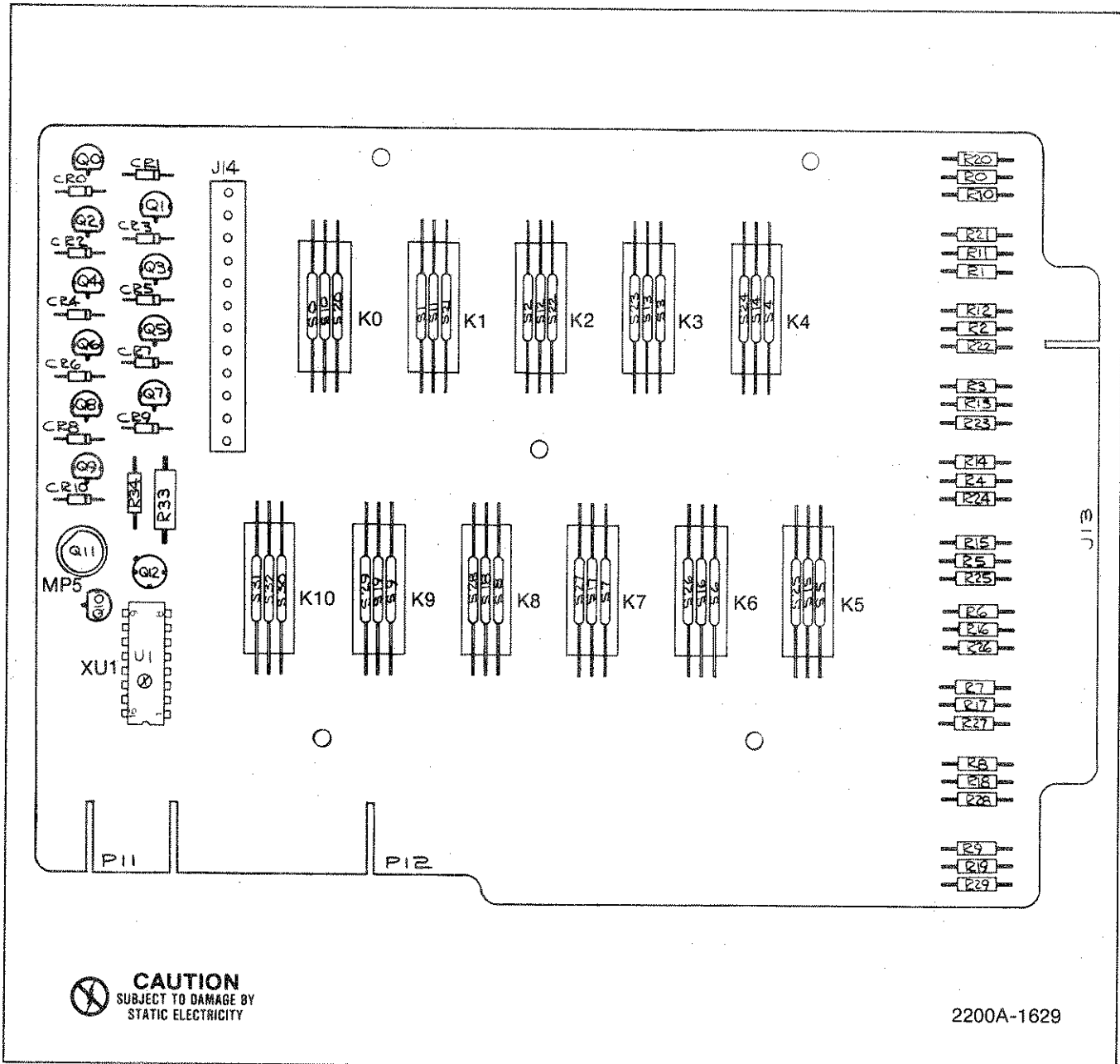
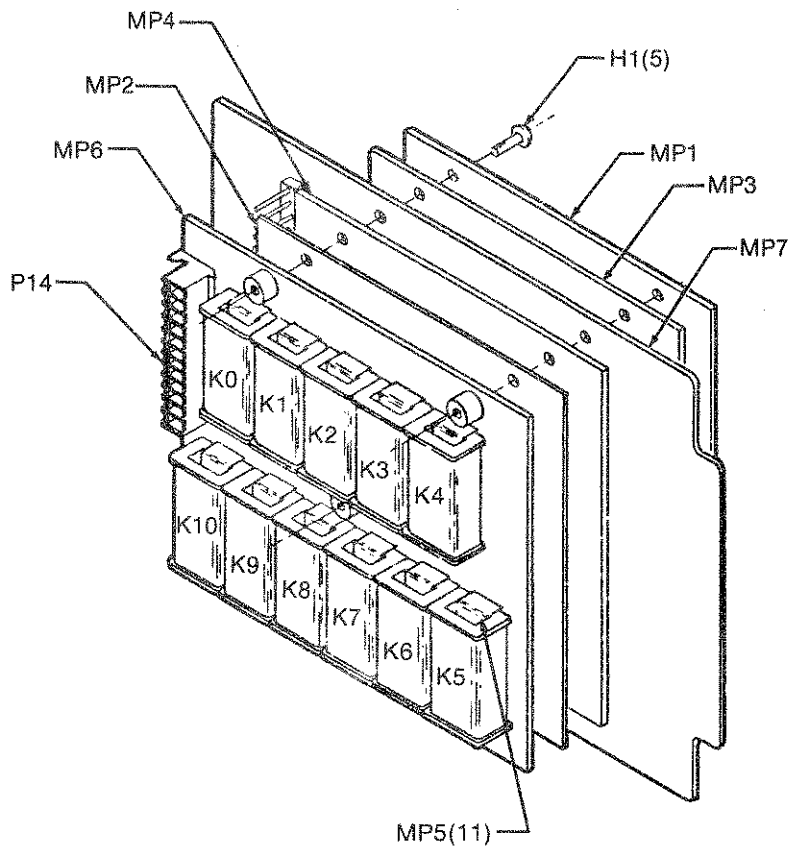

Figure 600-5. Low Level Scanner PCB Assembly



2200A-4029

Figure 600-5. Low Level Scanner PCB Assembly (cont)

Table 600-5. Isothermal Input Connector

REF DES	DESCRIPTION	FLUKE STOCK NO.	MFG SPLY CODE	MFG PART NO.	TOT QTY	REC QTY	NOTE
-600A2	ISOTHERMAL INPUT CONNECTOR FIGURE 600-6 (2200A-4023T)	409573	89536	409573		REF	
C1	CAP, CER 0.05 UF +/-20%, 50V	149161	56289	55C23A1	1		
H1	SCREW, FHP, S/S, 4-40 X 3/8	256024	89536	256024	3		
H2	SCREW, PHP, 4-40 X 1/2	152132	89536	152132	4		
H3	SCREW, PHP, 6-32 X 1/4	385401	89536	385401	30		
H4	RIVET, #4 X .500	276493	89536	276493	2		
H5	WASHER, FLAT #4	147728	89536	147728	2		
MP1	INSULATOR, ISOTHERMAL BLOCK	373340	89536	373340	1		
MP2	ISOTHERMAL BLOCK	412379	89536	412379	1		
MP3	KEY, POLARIZING	961060	00779	530374-1	1		
MP4	SOCKET, COMPONENT LEAD	343285	00779	2-331272-6	2		
P13	CONNECTOR, BOARD-EDGE, 44-PIN	385674	13511	225-22221-105	1		
Q1	XSTR, SI, PNP (SELECTED)	380394	89536	380394	1	1	
Q2	XSTR, FET, N-CHANNEL	429977	89536	429977	1	1	
R1	RES, DEP. CAR, 330K, +/-5%, 1/4W	376640	80031	CR251-4-5P330K	1		
R2	RES, COMP, 4.7K +/-5%, 1/4W	348821	01121	CB4725	1		
R3	RES, MTL. FILM, 130K +/-1%, 1/8W	221648	91637	MFF1-81303F	1		
R4	RES, FACTORY SELECTED						
	(76.8K, 100K, 147K, 287K OR OPEN)						
R5	RES, VAR, CERMET, 150K +/-10%	414102	11236	360T151A	1	1	

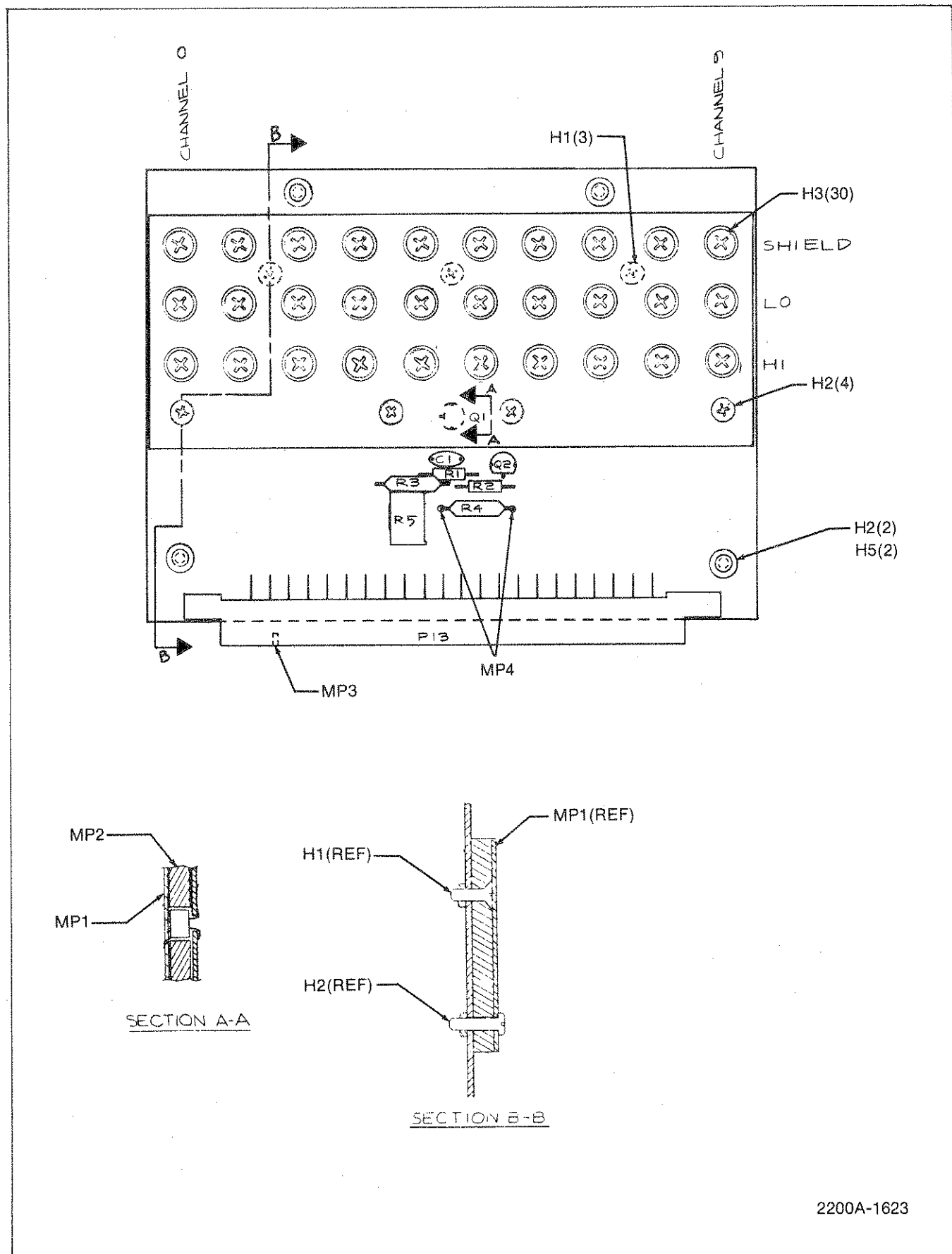

2200A-1623

Figure 600-6. Isothermal Input Connector



Section 8

Manual Change Information

INTRODUCTION

This section contains information necessary to backdate the manual to conform with earlier pcb configurations. To identify the configuration of the pcb's used in your instrument, refer to the revision letter (marked in ink) on the component side of each pcb assembly. Table 8-1 defines the assembly revision levels documented in this manual.

NEWER INSTRUMENTS

As changes and improvements are made to the instrument, they are identified by incrementing the revision letter marked on the affected pcb assembly. These changes are documented on a supplemental change/errata sheet which, when applicable, is inserted at the front of the manual.

OLDER INSTRUMENTS

To backdate this manual to conform with earlier revision levels, perform the changes indicated in Table 7A-1.

CHANGES

The following design changes, unless otherwise noted, affect only Section 6 and Section 9 of this manual:

- Section 6, parts list and component location drawings.
- Section 9, schematics and component location drawings.

The material affected within these sections is easily determined by the type of change. See Table 8-2.

Table 8-1. Manual Status and Backdating Information

Ref Or Option No.	Assembly Name	Fluke Part No.	* To adapt manual to earlier rev configurations perform changes in descending order (by no.), ending with change under desired rev letter																			
			-	A	B	C	D	E	F	G	H	J	K	L	M	N	P					
A1	FRONT PANEL DISPLAY PCB ASSY	611061	-																			
A2	MOTHER BOARD PCB ASSY	468132				X																
A3	POWER SUPPLY PCB ASSY	611897			X																	
A4	EXTENDER BUS PCB ASSY	611087	-																			
<p>* X = The PCB revision levels documented in this manual. ● = These revision letters were never used in the instrument. -- = No revision letter on the PCB.</p>																						

Table 8-2. Material Affected By a Change

TYPE OF CHANGE	MATERIAL AFFECTED = •		
	Parts List	Schematic	Component Location
Electrical Value	•	•	
Part Number	•		
Hardware	•		•
Size/Location (physical)			•
Addition/Deletion (electrical)	•	•	•

U.S. SALES AREAS for all Fluke products

AL, Huntsville

John Fluke Mfg. Co., Inc.
3322 S. Memorial Parkway
Suite 96
Huntsville, AL 35801
(205) 881-8220

AZ, Tempe

John Fluke Mfg. Co., Inc.
2211 S. 48th Street
Suite B
Tempe, AZ 85282
(602) 438-8314

Tucson

(602) 790-9881

CA, Los Angeles

John Fluke Mfg. Co., Inc.
20902 South Bonita St.
Carson, CA 90746
(213) 538-3900

San Diego

John Fluke Mfg. Co., Inc.
4540 Kearny Villa Rd., Suite 115
San Diego, CA 92123
(619) 292-7656

Santa Clara

John Fluke Mfg. Co., Inc.
2300 Walsh Ave., Bldg. K
Santa Clara, CA 95051
(408) 727-0513

Tustin

John Fluke Mfg. Co., Inc.
15445 Red Hill Ave., Suite F
Tustin, CA 92680
(714) 838-8863

CO, Denver

John Fluke Mfg. Co., Inc.
1980 South Quebec St. #4
Denver, CO 80231
(303) 750-1222

CT, Hartford

John Fluke Mfg. Co., Inc.
Glen Lochen East
41-C New London Turnpike
Glastonbury, CT 06033
(203) 659-3541

FL, Orlando

John Fluke Mfg. Co., Inc.
940 N. Fern Creek Ave.
Orlando, FL 32803
(305) 896-4881

GA, Atlanta

John Fluke Mfg. Co., Inc.
2700 Delk Rd., Suite 250
Marietta, GA 30067
(404) 953-4747

IA, Iowa City

(319) 354-2811

IL, Chicago

John Fluke Mfg. Co., Inc.
3740 Industrial Ave.
Rolling Meadows, IL 60008
(312) 398-0850

IN, Indianapolis

John Fluke Mfg. Co., Inc.
8777 Purdue Road
Suite 101
Indianapolis, IN 46268
(317) 875-7870

KS, Kansas City

(913) 381-9800

LA, New Orleans

(504) 455-0814

MA, Burlington

John Fluke Mfg. Co., Inc.
25 "B" Street
Burlington MA 01803
(617) 273-4674

MD, Baltimore

(301) 792-7060

Rockville

John Fluke Mfg. Co., Inc.
5640 Fishers Lane
Rockville, MD 20852
(301) 770-1570

MI, Detroit

John Fluke Mfg. Co., Inc.
33031 Schoolcraft
Livonia, MI 48150
(313) 522-9140

MN, Bloomington

John Fluke Mfg. Co., Inc.
1801 E. 79th St., Suite 9
Bloomington, MN 55420
(612) 854-5526

MO, St. Louis

John Fluke Mfg. Co., Inc.
2029 Woodland Parkway
Suite 105
St. Louis, MO 63141
(314) 993-3805

NC, Greensboro

John Fluke Mfg. Co., Inc.
1310 Beaman Place
Greensboro, NC 27408
(919) 273-1918

NJ, Paramus

John Fluke Mfg. Co., Inc.
P.O. Box 930
West 75 Century Road
Paramus, NJ 07652
(201) 262-9550

NM, Albuquerque

John Fluke Mfg. Co., Inc.
1108 Alvarado Drive N.E.
Albuquerque, NM 87110
(505) 881-3550

NY, Rochester

John Fluke Mfg. Co., Inc.
4515 Culver Road
Rochester, NY 14622
(716) 323-1400

OH, Cleveland

John Fluke Mfg. Co., Inc.
7830 Freeway Circle
Middleburg Heights, OH 44130
(216) 234-4540

Columbus

(614) 889-5715

Dayton

John Fluke Mfg. Co., Inc.
4756 Fishburg Rd.
Dayton, OH 45424
(513) 233-2238

OR, Portland

John Fluke Mfg. Co., Inc.
2700 NW 185th
Suite 2080
Portland, OR 97229
(503) 629-5928

PA, Philadelphia

John Fluke Mfg. Co., Inc.
1010 West 8th Ave., Suite H
King of Prussia, PA 19406
(215) 265-4040

Pittsburgh

(412) 261-5171

TX, Dallas

John Fluke Mfg. Co., Inc.
14400 Midway Road
Dallas, TX 75234
(214) 233-9990

Houston

John Fluke Mfg. Co., Inc.
4240 Blue Bonnet Dr.
Stafford, TX 77477
(713) 491-5995

San Antonio

John Fluke Mfg. Co., Inc.
10417 Gulfdale
San Antonio, TX 78216
(512) 340-2621

UT, Salt Lake City

(801) 268-9331

WA, Seattle

John Fluke Mfg. Co., Inc.
5020 148th Ave. N.E.
Suite 110
Redmond, WA 98052
(206) 881-6966

Service Center Areas

CA, Burbank (213) 849-4641
CA, Santa Clara (408) 727-8121
CO, Denver (303) 750-1228
FL, Orlando (305) 896-2296
IL, Chicago (312) 398-5880
MA, Burlington (617) 273-4678
MD, Rockville (301) 770-1576
NJ, Paramus (201) 262-9550
TX, Dallas (214) 233-9945
WA, Everett (206) 356-5560

For more information on Fluke products or Sales Offices you may dial (800) 426-0361 toll-free in most of the U.S.A. From Alaska, Hawaii, or Washington phone (206) 356-5400. From Canada and other countries phone (206) 356-5500.



John Fluke Mfg. Co., Inc., P.O. Box C9090, Everett, WA 98206
Fluke (Holland) B.V., P.O. Box 5053, 5004 EB, Tilburg, The Netherlands. Phone (013) 673973
Litho in U.S.A. 4/84

INTERNATIONAL SALES OFFICES

Argentina *

Coasin S.A.
Virrey del Pino 4071
Buenos Aires, Argentina
Tel: 552-5248, TLX: 22284

Australia *

Elmeasco Instruments Pty Ltd.
P.O. Box 30, Concord, N.S.W.
Australia 2137
Tel: (2) 736-2888, TLX: (790) 25887

Elmeasco Instruments Pty Ltd.
21-23 Anthony Drive
Mt. Waverly, VIC 3149
Australia
Tel: 233-4044, TLX: (790) 36206

Elmeasco Instruments Pty Ltd.
Professional Suites Bldg.
G.P.O. Box 2360
Brisbane, 4001, Australia
Tel: (07) 369-8688

Elmeasco Instruments Pty Ltd.
G.P.O. Box 1240, Adelaide
South Australia 5001
Tel: (08) 271-1839

Elmeasco Instruments Pty Ltd.
P.O. Box 95, Gosnells
West Australia 6110
Tel: (09) 398-3362

Austria *

Walter Rekersch
Elektronische Gerate GmbH & Co.
Vertrieb KG
Obachgasse 28
1220 Vienna, Austria
Tel: (0222) 235555, TLX: 134759

Bangladesh *

Motherland Corporation
24 Haikholia Rd., Tikatuli
Dacca 3, Bangladesh
Tel: 257249 or 255776

Belgium *

Fluke (Belgium) S.A./N.V.
6, Rue de Geneve
1140 Brussels, Belgium
Tel: (2) 2164090, TLX: 26312

Bolivia *

Coasin Bolivia S.R.L.
Casilla 7295, La Paz, Bolivia
Tel: 40962, TLX: 3233

Brazil *

Fluke Brasil-Industria E
Comercio LTDA
Al. Amazonas 422,
Alphaville, Barueri,
CEP 06400 Sao Paulo, Brazil
Tel: (011) 421-5477, TLX: 01135589

Fluke Brasil-Industria E
Comercio LTDA
Av. Henrique Valadares, 23/401
Rio de Janeiro, Brazil
Tel: 252-1297

Brunei *

Rank O'Connor's (PTE) Limited
No. 8, Bk. D
Sufri Shop House Complex
Mile 1, Jalong Tutong
Bandar Seri Begawan, Brunei
Tel: 26680

Bulgaria *

Amtest Associates Ltd.
Clarence House, 31, Clarence St.
Staines, Middlesex TW18 4SY
United Kingdom
Tel: (784) 63555, TLX: 928855

Canada *

Allan Crawford Assoc., Ltd.
#14 1935 30th Ave. N.E.
Calgary, Alberta T2E 6Z5
Tel: (403) 230-1341, TLX: 03-821186

Allan Crawford Assoc., Ltd.
P.O. Bag 3967
Postal Station "D"
15043A - 118 Ave.
Edmonton, Alberta T5L 4K1
Tel: (403) 451-4893

Allan Crawford Assoc., Ltd.
3795 William Street
Burnaby, British Columbia V5C 3H3
Tel: (604) 294-1326, TLX: 04-54247

Allan Crawford Assoc., Ltd.
881 Lady Ellen Place
Ottawa, Ontario K1Z 5L3

Tel: (613) 722-7682, TLX: 0533600

Allan Crawford Assoc., Ltd.
6503 Northam Drive
Mississauga, Ontario L4V 1J2
Tel: (416) 678-1500, TLX: 06968769

Allan Crawford Assoc., Ltd.
7918 Cote de Liesse
St. Laurent, Quebec H4T 1E7
Tel: (514) 731-8564, TLX: 05824944

Chad *

Fluke (Holland) B.V.
P.O. Box 5053, 5004 EB Tilburg
Zevenheuvelenweg 53, 5048 AN Tilburg
The Netherlands
Tel: (013) 673973, TLX: 52237

Chile *

Intronica Chile Ltda.
Manuel Montt 024 - Of. D
Casilla 16228, Santiago 9, Chile
Tel: 44940, TLX: 240301
Attn: Intronica Chile

China, People's Republic of *

Fluke International Corporation
P.O. Box C9090
Everett, WA 98206, U.S.A.
Tel: (206) 356-6511
TLX: 152662 JOHN FLUKE EVT

Colombia *

Sistemas E Instrumentacion, Ltda.
Carrera 13, No. 37-43, Of. 401
Ap. Aereo 29583
Bogota DE, Colombia SA
Tel: 232-45-32, TLX: 45787

Cyprus *

Chris Radiovision Ltd.
P.O. Box 1989, Nicosia, Cyprus
Tel: 66121, TLX: 8262395

Czechoslovakia *

Amtest Associates Ltd.
Clarence House, 31, Clarence St.
Staines, Middlesex TW18 4SY
United Kingdom
Tel: (784) 63555, TLX: 928855

Denmark *

Tage Olsen A/S
Ballerup Byvej 222
DK - 2750 Ballerup, Denmark
Tel: (2) 658111, TLX: (855) 35293

Ecuador *

Protoco Coasin Cia., Ltda.
Edificio "Jerico"
Ave. 12 de Octubre #2285 y
Ave. Orellana (Planta Baja)
Quito, Ecuador
Tel: 529684, TLX: (393) 2865

Protoco Coasin Cia., Ltda.
Calderon 103 y Malecon
Casilla #9733
Guayaquil, Ecuador
Tel: 526093

Egypt and Sudan *

Electronic Engineering Liaison Office
P.O. Box 2891 Horreya
Heliopolis, Cairo, Egypt
Tel: 691588, TLX: (927) 92502

England *

Fluke (G.B.) Ltd.
Colonial Way
Watford, Herts, WD2 4TT
United Kingdom
Tel: (0923) 40511, TLX: (851) 934583
Rapifax: (0923) 25067

Ethiopia *

Fluke (Holland) B.V.
P.O. Box 5053, 5004 EB Tilburg
Zevenheuvelenweg 53, 5048 AN Tilburg
The Netherlands
Tel: (013) 673973, TLX: 52237

Fiji *

AWA Fiji
47 Forster Road, Walu Bay
Suva, Fiji
Tel: 312079, TLX: FJ2347

Finland *

Findip-Havulinna Instr. Oy
PL 64 - Vitikka 1
02631 Espoo 63
Finland
Tel: 5281, TLX: 124426

France *

M.B. Electronique S.A.
Rue Fourny 606
78530 BUC
B.P. No. 31
78530 BUC, France
Tel: (3) 9568131, TLX: (842) 695414

German Democratic Republic *

Amtest Associates Ltd.
Clarence House, 31, Clarence St.
Staines, Middlesex TW18 4SY
United Kingdom
Tel: (784) 63555, TLX: 928855

German Federal Republic *

Fluke (Deutschland) GmbH
Oskar-Messter-Strasse 18
8045 Ismaning, West Germany
Tel: (089) 96050, TLX: 522472
Rapifax: (089) 9605166

Fluke (Deutschland) GmbH
Meineckestrasse 53
4000 Dusseldorf 30, West Germany
Tel: (0211) 450831, TLX: (841) 8685576

Greece *

Hellenic Scientific Representations Ltd.
11, Vrasside Street
Athens 612, Greece
Tel: (1) 711140, TLX: (863) 219330

Hong Kong *

Schmidt & Co Ltd
18th Fl, Great Eagle Centre
23 Harbour Road
Wanchai, Hong Kong
Tel: 5-833-0222, TLX: 74766

Hungary *

Amtest Associates Ltd.
Clarence House, 31, Clarence St.
Staines, Middlesex TW18 4SY
United Kingdom
Tel: (784) 63555, TLX: 928855

Iceland *

Kristjan O. Skagfjord Ltd.
P.O. Box 906
Reykjavik, Iceland
Tel: 24120, TLX: 2133

India *

Hinditron Services Pvt. Ltd.
69/A.L. Jagmohandas Marg
Bombay 400 006, India
Tel: 812-1316, TLX: 112326

Hinditron Services Pvt. Ltd.
8th Main Road
33/44-A Raj Mahal Vilas Extension
Bangalore 560 080, India
Tel: 33139, TLX: (953) 0845741

Hinditron Services Pvt. Ltd.
Shantiniketan, Office No. 6
6th Floor, 8 Camac Street
Calcutta 700 017, India
Tel: 434032, 447541

Hinditron Services Pvt. Ltd.
204-206 Hemkunt Tower
98 Nehru Place
New Delhi, 110019, India
Tel: 640380, TLX: (95) 314890

Hinditron Services Pvt. Ltd.
Srinath Complex, 5th Floor
1-1-58/1 to 1-1-58/11
Sarojini Devi Road
Secunderabad 500 003, India
Tel: 821117, TLX: (953) 0155 575

Indonesia *

P.T. Dwi Tunggal Jaya Sakti
Jln Panglima Polim Raya #29
Kebayoran Baru
Jakarta Selatan, Indonesia
Tel: 716374, TLX: 47308

Iraq *

Fluke (Holland) B.V.
P.O. Box 5053, 5004 EB Tilburg
Zevenheuvelenweg 53, 5048 AN Tilburg
The Netherlands
Tel: (013) 673973, TLX: 52237

Ireland *

Euro Instruments and
Electronics Ltd.
Euro House, Swords Road
Santry, Dublin 9
Tel: (01) 425666, TLX: 31821

Israel *

R.D.T. Electronics Engineering Ltd.
P.O. Box 75
46, Sokolov Street
Ramat Hasharon 47235, Israel
Tel: (3) 483216, TLX: (922) 32143

Italy *

Sistrel S.p.A.
Via Pelizza da Volpedo 59
20092 Cinisello Balsamo
Milan, Italy
Tel: (2) 6181893, TLX: (843) 334643

Sistrel S.p.A.

Via Giuseppe Armellini No. 39
00143 Rome, Italy
Tel: (6) 5915551, TLX: (843) 68356

Sistrel S.p.A.

Via Cintia
Parco S. Paolo 35
80126 Naples, Italy
Tel: (81) 7679700

Japan *

John Fluke Mfg. Co., Inc.
Japan Branch
Sumitomo Higashi
Shinbashi Bldg.
1-1-11 Hamamatsucho
Minato-ku, Tokyo, Japan
Tel: (03) 434-0181, TLX: 2424331



John Fluke Mfg. Co., Inc. / PO Box C9090 / Everett, WA 98206 / (206) 356 5400

Litho in U.S.A. 4/84

Kenya ●
ADCOM Ltd.
P.O. Box 30070
Nairobi, Kenya, East Africa
Tel: 331955, TLX: 22639

Korea ●
Electro Science
201 Hyunjin Bldg
251-19 Bangbae
Gangnam-Ku
Seoul, Korea
Tel: 583-7703, TLX: K25381

Kuwait ■
Al-Bahar Int. Group
P.O. Box 26672 Safat
Kuwait, Arabian Gulf
Tel: 450108, TLX: 44822

Lebanon and Jordan ■
Mabek (Electronics Division)
P.O. Box 11-3823
Beirut, Lebanon
Tel: 812523, TLX: (923) 22889

Libya ■
Fluke (Holland) B.V.
P.O. Box 5053, 5004 EB Tilburg
Zevenheuvelenweg 53, 5048 AN Tilburg
The Netherlands
Tel: (013) 673973, TLX: 52237

Malaysia ●
Mecomb Malaysia SDN BHD
Lot 20, Jalan 225
Petaling Jaya, Malaysia
Tel: 743422, TLX: MA37764

Mexico ●
Electronica y Tecnologia
Avanzada S.A. de C.V.
Pafnucio Padilla 53
Circuito Comercial Satellite
Naucalpan Edo. De Mexico
Tel: 393 0902, TLX: (383) 017 2697

Nepal ●
Associated Enterprises
GPO Box 790, Pyaphai Tole
Kathmandu, Nepal
Tel: 13868

Netherlands ■
Fluke (Nederland) B.V.
Gasthuisring 14
5041 DS Tilburg
The Netherlands
P.O. Box 115
5000 AC Tilburg
The Netherlands
Tel: (013) 352455, TLX: 52683

New Zealand ●
McLean Information Technology, Ltd.
P.O. Box 9464, Newmarket
Auckland 1, New Zealand
Tel: 501-801; TLX: (791) NZ 215 70
McLean Information Technology, Ltd.
P.O. Box 496
Wellington, New Zealand
Tel: 851-450 or 844-424

Nigeria ●
Mofat Engineering Co., Ltd.
P.O. Box 8369
Lagos, Nigeria
Tel: 21353,
Cable: MOFATENG LAGOS

Norway ■
Morgenstjerne & Co A/S
P.O. Box 6688, Rodelokka
Oslo 5, Norway
Tel: (2) 356110, TLX: (856) 71719

Oman ■
OHI Telecommunications
P.O. Box 889
Muscat
Sultanate of Oman
Tel: 702866 or 703862
TLX: 3160

Pakistan ●
International Operations (PAK)
505 Muhammadi House
I.I. Chundrigar Road
P.O. Box 5323, Karachi, Pakistan
Tel: 221127, TLX: (952) 24494

PDR Yemen ■
Fluke (Holland) B.V.
P.O. Box 5053, 5004 EB Tilburg
Zevenheuvelenweg 53, 5048 AN Tilburg
The Netherlands
Tel: (013) 673973, TLX: 52237

Peru ●
Importaciones Y Representaciones
Electronicas S.A.
Avda. Franklin D. Roosevelt 105
Lima 1, Peru
Tel: 288650, TLX: (394) 25663

Philippines ●
Spark Radio & Electronics, Inc.
Greenhills P.O. Box 610
Metro-Manila, Philippines 3113
Tel: 704096, TLX: 27901

Poland ■
Amtest Associates Ltd.
Clarence House, 31, Clarence St.
Staines, Middlesex TW18 4SY
United Kingdom
Tel: (784) 63555, TLX: 928855

Portugal ■
Decada Espectral
Equipamentos de Electronica e
Cientificos, Sari
Av. Bombeiros Voluntarios
Lote 102, B
Miraflores/Alges
1495 Lisboa, Portugal
Tel: (01) 2103426, TLX: 15515

Qatar ■
Technology Organisation
P.O. Box 5549, Doha, Qatar
Tel: 321431, TLX: (957) 4581

Romania ■
Amtest Associates Ltd.
Clarence House, 31, Clarence St.
Staines, Middlesex TW18 4SY
United Kingdom
Tel: (784) 63555, TLX: 928855

Saudi Arabia ■
Electronic Equipment Marketing Co.
P.O. Box 3750
Riyadh, Saudi Arabia
Tel: (1) 477-165001
TLX: 201120

Singapore ●
Rank O'Connor's (PTE) Ltd.
98 Pasir Panjang Road
Singapore 0511
Republic of Singapore
Tel: 637944
TLX: RS21023

Somalia ■
Fluke (Holland) B.V.
P.O. Box 5053, 5004 EB Tilburg
Zevenheuvelenweg 53, 5048 AN Tilburg
The Netherlands
Tel: (013) 673973, TLX: 52237

South Africa ●
Fluke S.A. (Pty) Ltd.
P.O. Box 39797, Bramley 2018
Republic of South Africa
Tel: (011) 786-3170, TLX: 4-24328SA

Fluke S.A. (Pty) Ltd.
P.O. Box 7135
Roggebaai 8012
Cape Town
Republic of South Africa
Tel: (021) 21-1819, TLX: 57-21898

Spain ■
ESSA
(Equipos y Sistemas S.A.)
Apolonio Morales 13-b
Madrid 16 - Spain
Tel. 4580150

Sri Lanka ●
Jay-Es Electronics
160 Poorvarama Mawatha
Colombo 5, Sri Lanka
Tel: 073-2393

Sweden ■
Teleinstrument AB
P.O. Box 4490
162 04 Vallingby, Sweden
Tel: (8) 380370, TLX: (854) 15770

Switzerland ■
Traco Electronic AG
Jenatschstrasse 1
8002 Zurich, Switzerland
Tel: (1) 2010711, TLX: (845) 54318

Syria ■
Mabek (Electronics Division)
P.O. Box 4238
Damascus, Syria

Taiwan ●
Schmidt Electronics Corp.
6th Fl Cathay Min-Sheng
Commercial Bldg, 344
Min-Sheng East Road
Taipei 104, Taiwan
Tel: 501-3468, TLX: (785) 11111

Thailand ●
Measuretronix Ltd.
2102/63 Ramkhamhaeng Rd.
Huamark, Bangkok 24, Thailand
Tel: 3782516, TLX: 81143

Tunesia ■
Selep S.A.R.L.
6, Rue de Sparte
Tunis - 1000 RP, Tunesia
Tel: (1) 248093, TLX: (934) 13030

Turkey ■
Erkman Elektronik Aletler
Ticaret Anonim Sirketi
Necatib Cad 92/3
Karakoy, Istanbul, Turkey
Tel: 441546, TLX: (821) 23353

United Arab Emirates ■
Al Sanani Trad. Est.
P.O. Box 7187
Abu-Dhabi, United Arab Emirates
Tel: 821370 or 821371
TLX: 23966

United Kingdom ■
Fluke (Great Britain) Ltd.
Colonial Way
Watford, Herts, WD2 4TT
United Kingdom
Tel: (0923) 40511, TLX: 934583
Rapifax: (0923) 25067

Uruguay ●
Coasin Uruguay S.R.L.
Casilla de Correo 1400
Correo Central
Montevideo, Uruguay
Tel: 29-31-95, TLX: UY6571

U.S.S.R. ■
Amtest Associates Ltd.
Clarence House, 31, Clarence St.
Staines, Middlesex TW18 4SY
United Kingdom
Tel: (784) 63555, TLX: 928855

Venezuela ●
Coasin C.A.
Calle 9 Con Calle 4, Edif. Edinurbi
Apartado De Correos
NR-70.136 Los Ruices
Caracas 1070A, Venezuela
Tel: 239-0967, TLX: (395) 21027

Yemen ■
Fluke (Holland) B.V.
P.O. Box 5053, 5004 EB Tilburg
Zevenheuvelenweg 53, 5048 AN Tilburg
The Netherlands
Tel: (013) 673973, TLX: 52237

Yugoslavia ■
Amtest Associates Ltd.
Clarence House, 31, Clarence St.
Staines, Middlesex TW18 4SY
United Kingdom
Tel: (784) 63555, TLX: 928855

■ **Supplied and Supported by —**
Fluke (Holland) B.V.
P.O. Box 5053, 5004 EB Tilburg
Zevenheuvelenweg 53, 5048 AN Tilburg
The Netherlands
Tel: (013) 673973, TLX: 52237

● **Supplied and Supported by —**
Fluke International Corporation
P.O. Box C9090
Everett, WA 98206 U.S.A.
Tel: (206) 356-5500
TLX: 152662 JOHN FLUKE EVT



TECHNICAL SERVICE CENTERS

U.S.A.

CA, Burbank
John Fluke Mfg. Co., Inc.
(213) 849-4641

CA, Santa Clara
John Fluke Mfg. Co., Inc.
(408) 727-8121

CO, Denver
John Fluke Mfg. Co., Inc.
(303) 750-1228

FL, Orlando
John Fluke Mfg. Co., Inc.
(305) 896-2296

IL, Rolling Meadows
John Fluke Mfg. Co., Inc.
(312) 398-5800

MA, Burlington
John Fluke Mfg. Co., Inc.
(617) 273-4678

MD, Rockville
John Fluke Mfg. Co., Inc.
(301) 770-1576

NJ, Paramus
John Fluke Mfg. Co., Inc.
(201) 262-9550

TX, Dallas
John Fluke Mfg. Co., Inc.
(214) 233-9945

WA, Everett
John Fluke Mfg. Co., Inc.
(206) 356-5560

Other Countries

Argentina, Buenos Aires
Coasin S.A.
Tel: 552-5248/3485
TLX: 122284 COASN AR

Australia, Concord
Elmeasco Instruments Pty Ltd.
Tel: (02) 736-2888
TLX: (790) 25887

Australia, Mount Waverley
Elmeasco Instruments Pty Ltd.
Tel: 03-233-4044
TLX: 36206

Australia, Brisbane
Elmeasco Instruments Pty Ltd.
Tel: (07) 229-3161

Austria, Vienna
Walter Rekirsch Electronische Gerate
GmbH & Co.
Tel: (0222) 235555
TLX: 134759

Belgium, Brussels
Fluke (Belgium) SA/NA
Tel: (02) 2164090
TLX: 26312

Brazil, Sao Paulo
Fluke Brasil-Industria E Comercio Ltda.
Tel: (011) 421-3603
TLX: 01135589 FLKE BR

Canada, Calgary, AB
Allan Crawford Associates Ltd.
Tel: (403) 230-1341

Canada, Burnaby, BC
Allan Crawford Associates Ltd.
Tel: (604) 294-1326

Canada, Mississauga, ON
Allan Crawford Associates Ltd.
Tel: (416) 678-1500

Canada, St. Laurent, PQ
Allan Crawford Associates Ltd.
Tel: (514) 731-8564

Chile, Santiago
Intronica Chile Ltda.
Tel: 44940
TLX: 240301

China, Beijing
Beijing Radio Research Institute
Tel: 445612

Colombia, Bogota
Sistemas E Instrumentacion, Ltda.
Tel: 232-45-32
TLX: 45787 COASN CO

Denmark, Bailerup
Tage Olsen A/S
Tel: (02) 658111
TLX: 35293 TOAS SK

Ecuador, Quito
Edificio "Jerico"
Tel: 529684, 526759
TLX: 2865 Protec Ed

Egypt, Cairo
Electronic Engineering Liaison Office
Tel: 691588
TLX: (927) 92502

England, Watford, Herts
Fluke (Great Britain) LTD
Tel: 44-923-40511
TLX: 934583

Finland, Kaunialainen
Oy Findip AB
Tel: (0) 5052255
TLX: 123129

France, BUC
M.B. Electronique S.A.
Tel: (01) 9568131
TLX: 695414

Greece, Athens
Hellenic Scientific Representations
Tel: (01) 711140
TLX: 219330

Hong Kong, Hong Kong
Schmidt & Co. (H.K.) Ltd.
Tel: 5-456644
TLX: 74766 SCHMC HX

India, Bombay
Hinditron Services Pvt. Ltd.
Tel: 811316, 815344
TLX: 953-112326 HSPL IN

India, Bangalore
Hinditron Services Pvt. Ltd.
Tel: 33139
TLX: 0845741

India, New Delhi
Hinditron Services Pvt. Ltd.
Tel: 619118
TLX: 031 4890 SRMP IN

Indonesia, Jakarta Selatan
P.T. Dwi Tunggal Jaya Sakti
Tel: 716374
TLX: 47308 DIJS IA

Israel, Ramat Hasharon
R.D.T. Electronics Engineering Ltd.
Tel: (03) 483216
TLX: 32143

Italy, Milan
Sistrel S.p.A.
Tel: (02) 6181893
TLX: 334643

Italy, Rome
Sistrel S.p.A.
Tel: (06) 5915551
TLX: 68356

Japan, Tokyo
John Fluke Mfg. Co., Inc.
Japan Branch
Tel: (03) 434-0181
TLX: (781) 2424331 (FLUKJPJ)

Korea, Seoul
Electro-Science Korea Co.
Tel: 261-7702, 260-1908
TLX: K25381

Malaysia, Petaling Jaya
Mecomb Malaysia SDN BHD
Tel: 573455
TLX: MA37605

Mexico, Mexico D.F.
Electronica y Tecnologia
Avanzada S.A. de C.V. (ETA)
Tel: 393 09 02 or 393 57 62
TLX: 0172697 BLOSME

Netherlands, Maarssen
Fluke (Nederland) B.V.
Tel: (030) 436514
TLX: 47128

Netherlands, Tilburg
Fluke (Holland) B.V.
Tel: (013) 673973
TLX: 52237

New Zealand, Auckland
McLean Information Technology, Ltd.
Tel: 501-801, 501-219, 587-037
TLX: NZ21570 THERMAL

Norway, Oslo
Morgenstjerne & Co A/S
Tel: (02) 356110
TLX: 71719

Pakistan, Karachi
Pak International Operations
Tel: 221127, 239052
TLX: 24494 PIO PK

Peru, Lima
Importaciones Y Representaciones
Electronicas S.A.
Tel: 288650
TLX: 37425663

Philippines, Metro Manila
Spark Radio & Electronics Corp.
Tel: 78-78-16
TLX: 27901 RLA PH

Portugal, Lisboa
Decada-Equipamentos de
Electronica, Lda.
Tel: (19) 574984
TLX: 18469

Republic of Singapore, Singapore
Rank O'Connor's (PTE) Limited
Tel: 637944, 239052
TLX: OCONSIN RS21023

Republic of South Africa, Bramley
Fluke S.A. (Pty) Ltd.
Tel: (011) 786-3170
TLX: 424328

Spain, Alcorcon (Madrid)
Hispano Electronics S.A.
Tel: (01) 6194108
TLX: 22404/42634

Sweden, Vallingby
Teleinstrument AB
Tel: (08) 360370
TLX: 15770

Switzerland, Zurich
Traco Electronic AG
Tel: (01) 2010711
TLX: 54318

Taiwan, Taipei
Schmidt Scientific Far East Ltd.
Tel: 5414600
TLX: 11111 Schmidt

Thailand, Bangkok
Measuretronix Ltd.
Tel: 3143369, 3143430
TLX: 81143 DEJOBKK TH

Turkey, Istanbul
Erkman Elektronik Aletler
Tel: (01) 5461
TLX: 23363

Uruguay, Montevideo
Coasin Uruguay S.R.L.
Tel: 29-31-952
TLX: UY 6571 OROCUER

Venezuela, Caracas
Coasin, C.A.
Tel: 38-78-42, 38-78-86
TLX: 21027 EMVEN VE

West Germany, Ismaning
Fluke (Deutschland) GmbH
Tel: (089) 96050
TLX: 0522472



John Fluke Mfg. Co., Inc., P.O. Box C9090, Everett, WA 98206
Fluke (Holland) B.V., P.O. Box 5053, 5004 EB, Tilburg, The Netherlands. Phone (013) 673973
Litho in U.S.A. 4/84

Section 9

Schematic Diagrams

TABLE OF CONTENTS

FIGURE	TITLE	PAGE
9-1.	Mnemonics	9-2
9-2.	2205A Interconnect Diagram	9-3
9-3.	A2 Motherboard PCB Assembly	9-4
9-4.	A1 Front Panel Display PCB Assembly	9-6
9-5.	A4 Extender Bus PCB assembly	9-8
9-6.	A3 Power Supply PCB Assembly	9-10
9-7.	Option -050, IEEE-488 Compatible Interface PCB Assembly	9-12
9-8.	Option -060, RS-232-C Interface PCB Assembly	9-13
9-9.	Option -100, Actuator Module	
	Actuator PCB Assembly	9-14
	Screw Terminal Connector	9-16
9-10.	Option -200, Latching Module	
	Fused Terminal Connector	9-17
	Latching PCB Assembly	9-18
9-11.	Option -300, General Purpose Scanner Module	
	Fused Terminal Connector	9-20
	General Purpose Scanner PCB Assembly	9-22
9-12.	Option -400, Four-Wire Resistance Scanner Module	
	General Purpose Scanner PCB Assembly	9-24
	Low Level Scanner PCB Assembly	9-26
	Isothermal Input Connector	9-28
	Fused Terminal Connector	9-30
9-13.	Option -600, Low Level Scanner Module	
	Isothermal Input Connector	9-32
	Low Level Scanner PCB Assembly	9-34

UL	Unguarded Logic
GL	Guarded Logic
D80-D87	Data Bus (7-Bit)
REN	Remote Enable
WR	Write
TO	Clock Output
ALE	Address Latch Enable
RD	Read
PORT 0 EN	Port 0 (Zero) Enable
IFC	Interface Clear
WR DIS	Write Disabled
SD	Serial Data
SC	Serial Clock (BCD)
CS0 thru CS3	Channel Select (BCD)
DS0 thru DS3	Decade Select (BCD)
HS0 thru HS3	Hundreds Select
REF COM	Reference Common
HIGH	Analog High
LO	Analog Low
A/D COM	Analog-to-Digital Common
BS0 thru BS9	Block Select 0 thru 9
A COM	Analog Common
DIO	Data Input/Output
DAV	Data Valid
ATN	Attention
RFD	Ready For Data
DAC	Data Accepted
EOI	End Or Identify
SRQ	Service Request

Figure 9-1. Mnemonics

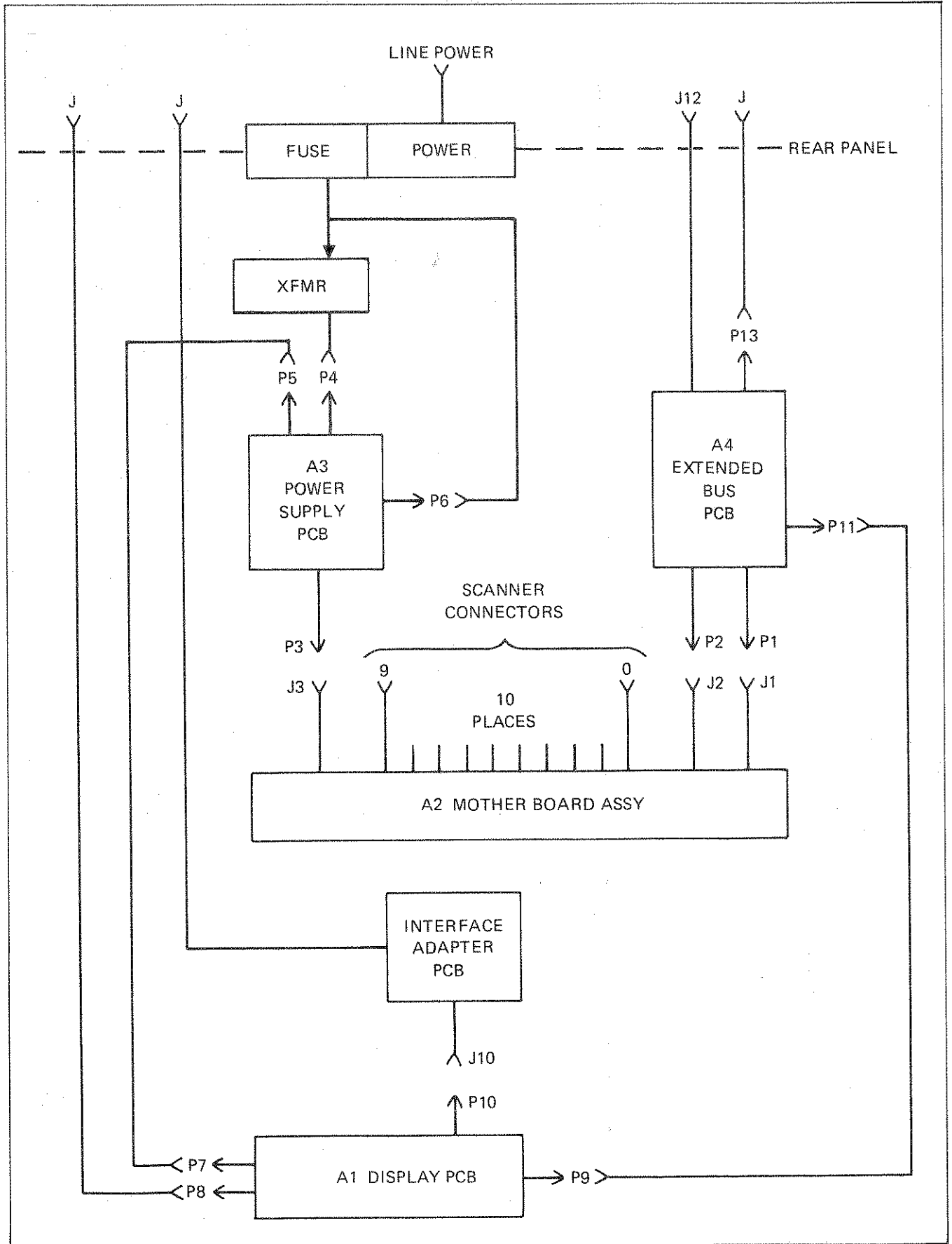
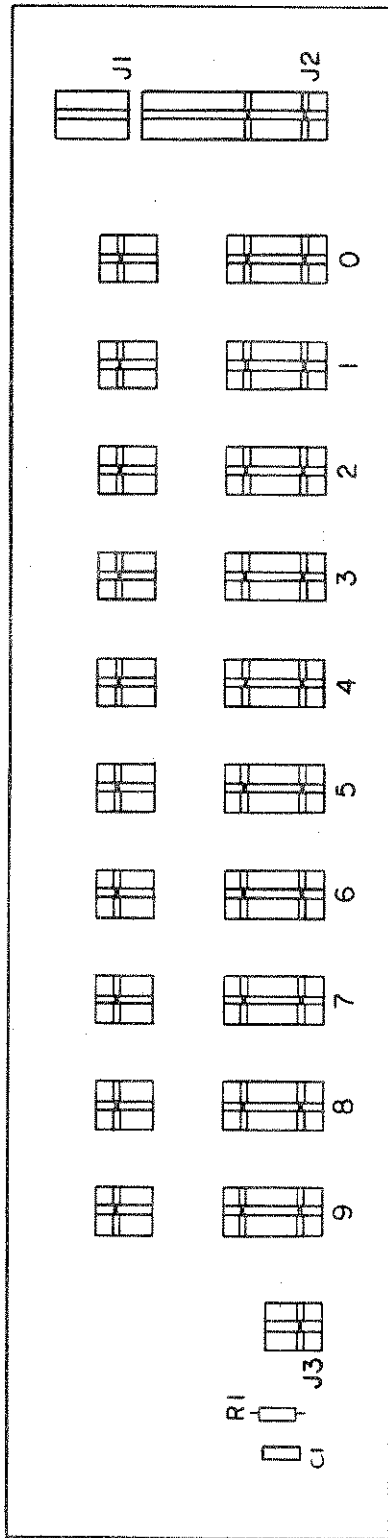
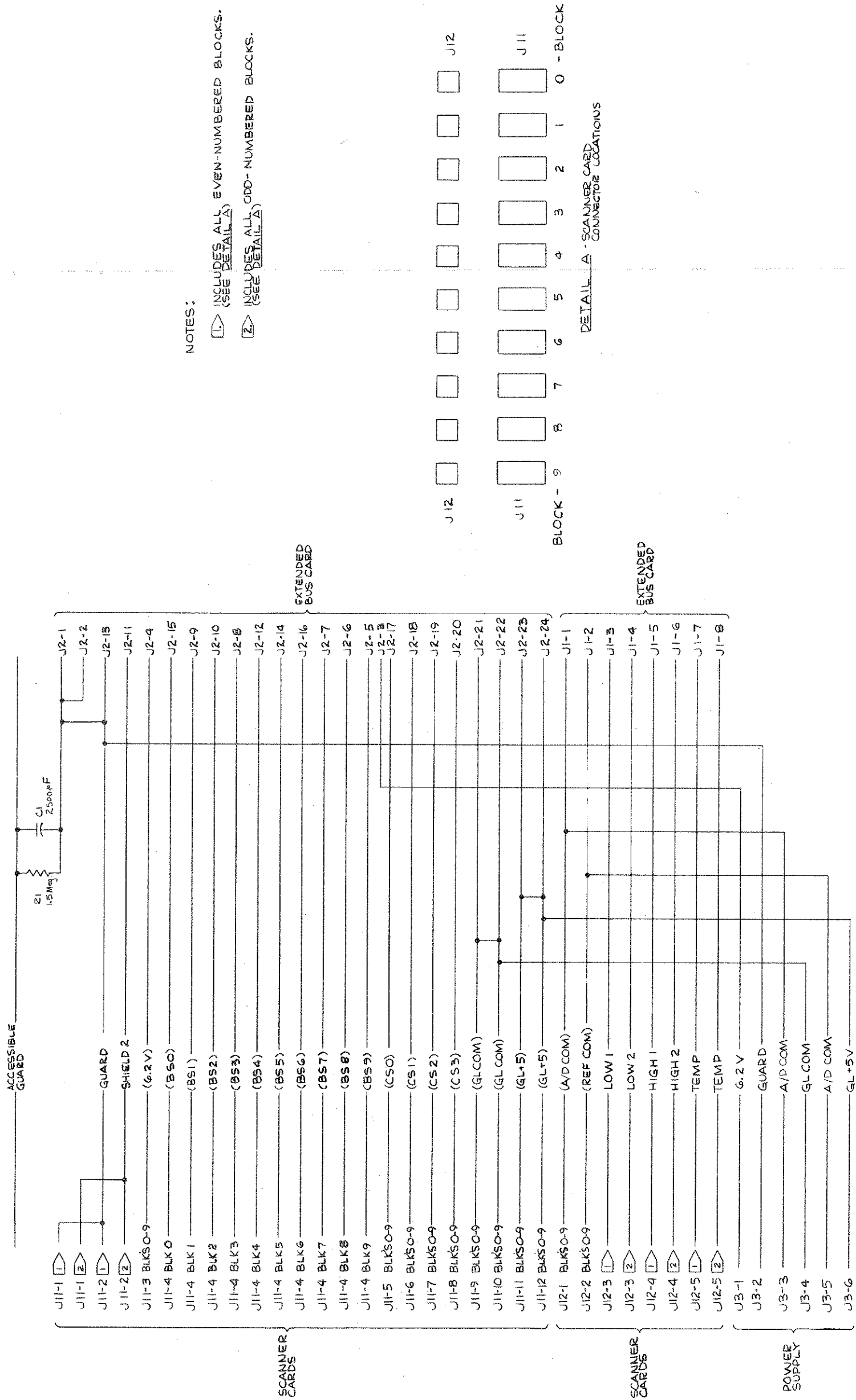

Figure 9-2. 2205A Interconnect Diagram



2204A-1701

Figure 9-3. A2 Mother Board PCB Assembly



NOTES:

- 1. INCLUDES ALL EVEN-NUMBERED BLOCKS. (SEE DETAIL A)
- 2. INCLUDES ALL ODD-NUMBERED BLOCKS. (SEE DETAIL A)

EXTENDED BUS CARD

EXTENDED BUS CARD

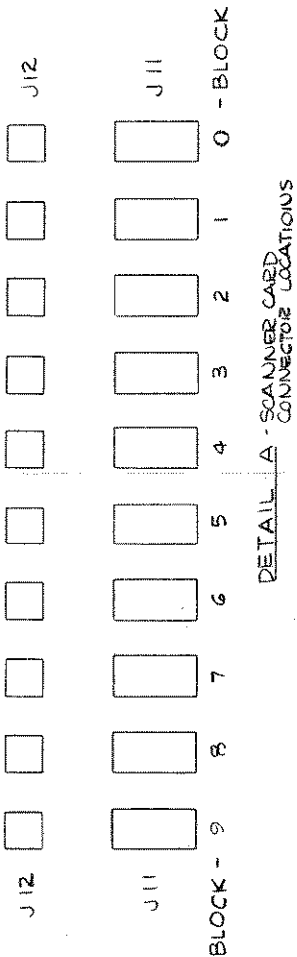

Figure 9-3. A2 Mother Board PCB Assembly (cont)

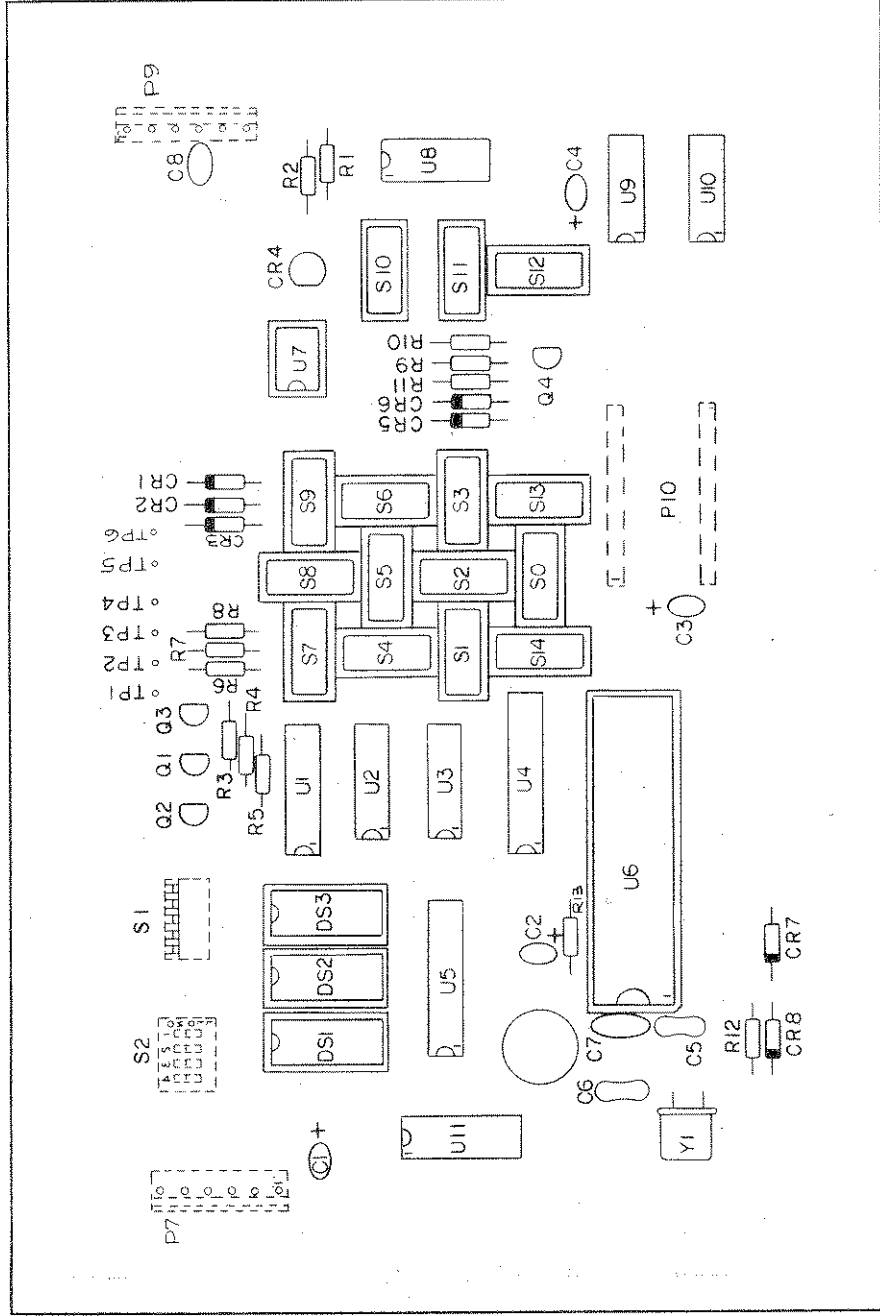
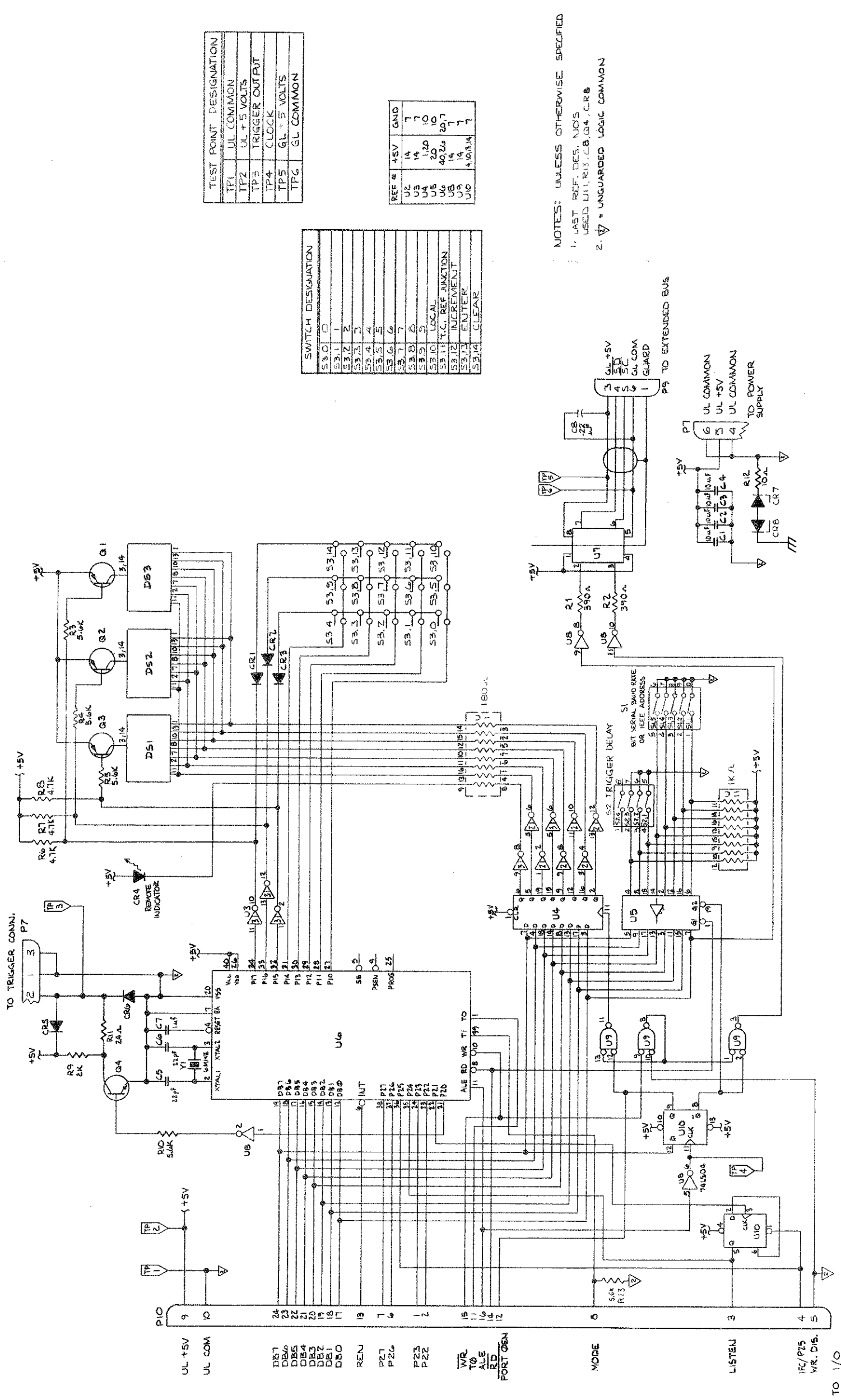

Figure 9-4. A1 Front Panel Display PCB Assembly



TEST POINT DESIGNATION	
TP1	UL COMMON
TP2	UL +5 VOLTS
TP3	TRIGGER OUTPUT
TP4	CLOCK
TP5	GL +5 VOLTS
TP6	GL COMMON

SWITCH DESIGNATION	
S3.0	0
S3.1	1
S3.2	2
S3.3	3
S3.4	4
S3.5	5
S3.6	6
S3.7	7
S3.8	8
S3.9	9
S3.10	LOCAL
S3.11	T.G. REF. JUNCTION
S3.12	INCREMENT
S3.13	ENTER/E
S3.14	CLEAR

REF #	+5V	GND
U2	14	7
U3	14	7
U4	14	10
U5	20	10
U6	40, 26	20, 7
U8	14	7
U9	14	7
U10	4, 10, 14	7

NOTES: UNLESS OTHERWISE SPECIFIED
 1. LAST REF. DES. NOS. USED U11, R13, C8, C9, C.R8
 2. ▽ = UNGUARDED LOGIC COMMON

2204A-1010

Figure 9-4. A1 Front Panel Display PCB Assembly (cont)

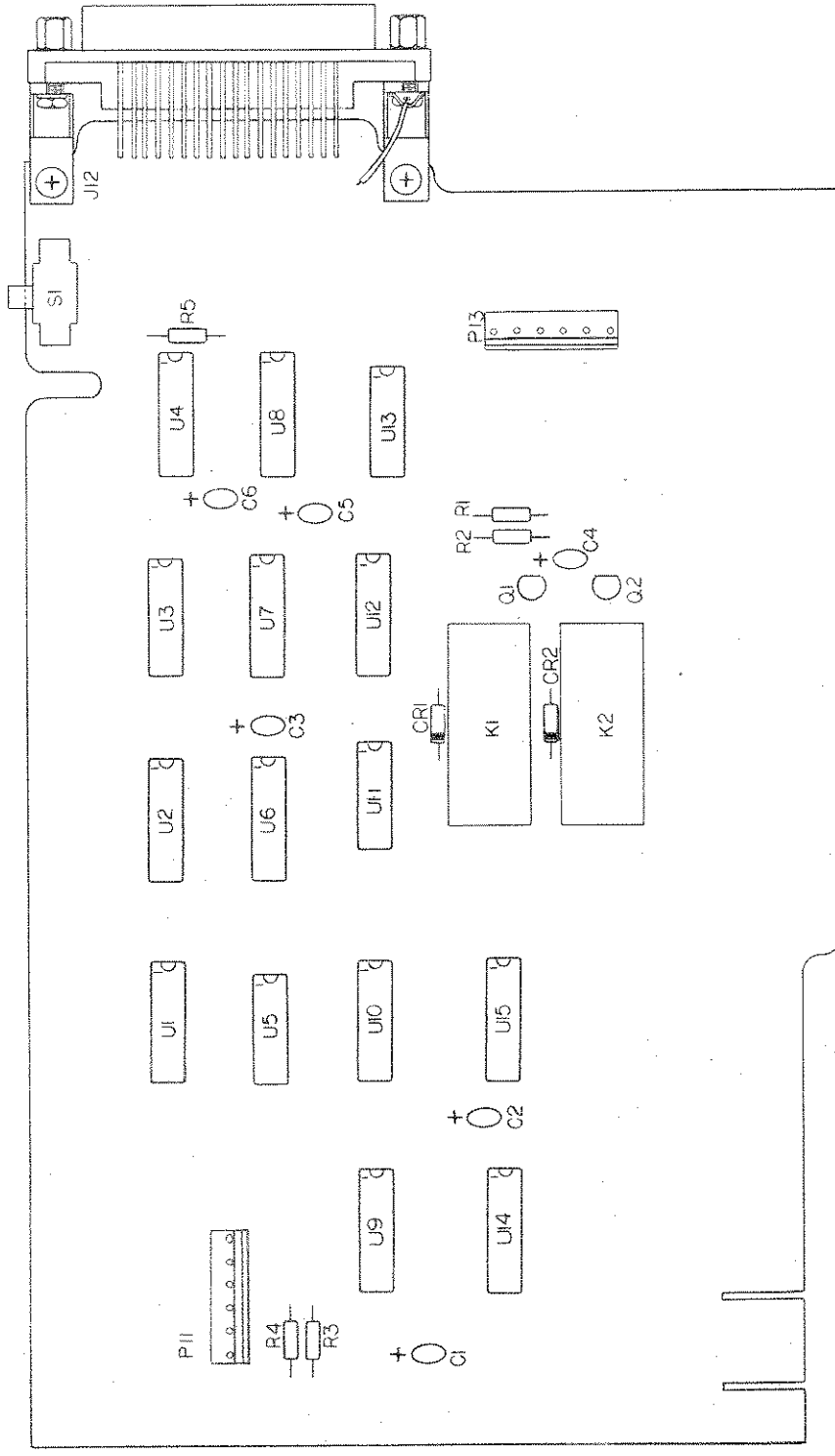
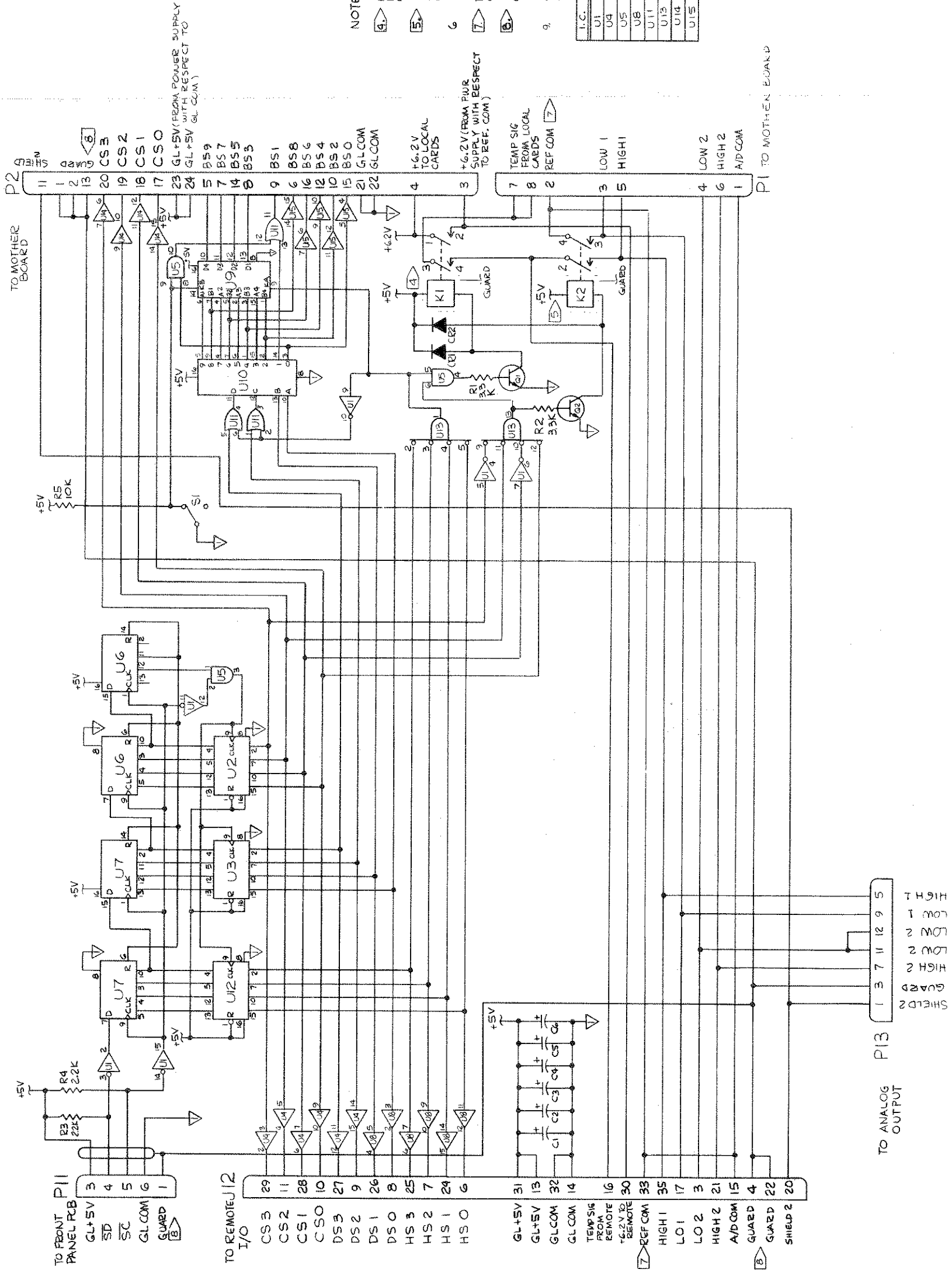

Figure 9-5. A4 Extender Bus PCB Assembly



- NOTES: UNLESS OTHERWISE SPECIFIED
- 4. K1 IS ON FOR ALL RESIDENT CHANNEL TEMP. MEASUREMENT, OFF FOR ALL EXPANDER CHANNEL TEMP. MEASUREMENTS.
 - 5. K2 IS ON FOR ALL TEMP. MEASUREMENT, OFF FOR ALL CHANNEL MEASUREMENTS.
 - 6. GUARDED LOGIC COMMON
 - 7. REF COMMON IS +5VOLTS ABOVE GLCOMMON.
 - 8. GUARD IS CONNECTED TO EXPOSED GUARD BY RC NETWORK ON THE MOTHER BOARD.
 - 9. GUARD IS TIED TO SHIELD 2 ON REAR ANALOG CONNECTOR.

I.C.	GND	+5V
U1	8	1, 16
U4	8	1
U5	8	14
U8	8	1, 16
U11	7	14
U13	8	16
U14	8	1, 16
U15	8	1, 16

2204A-1015

Figure 9-5. A4 Extender Bus PCB Assembly (cont)

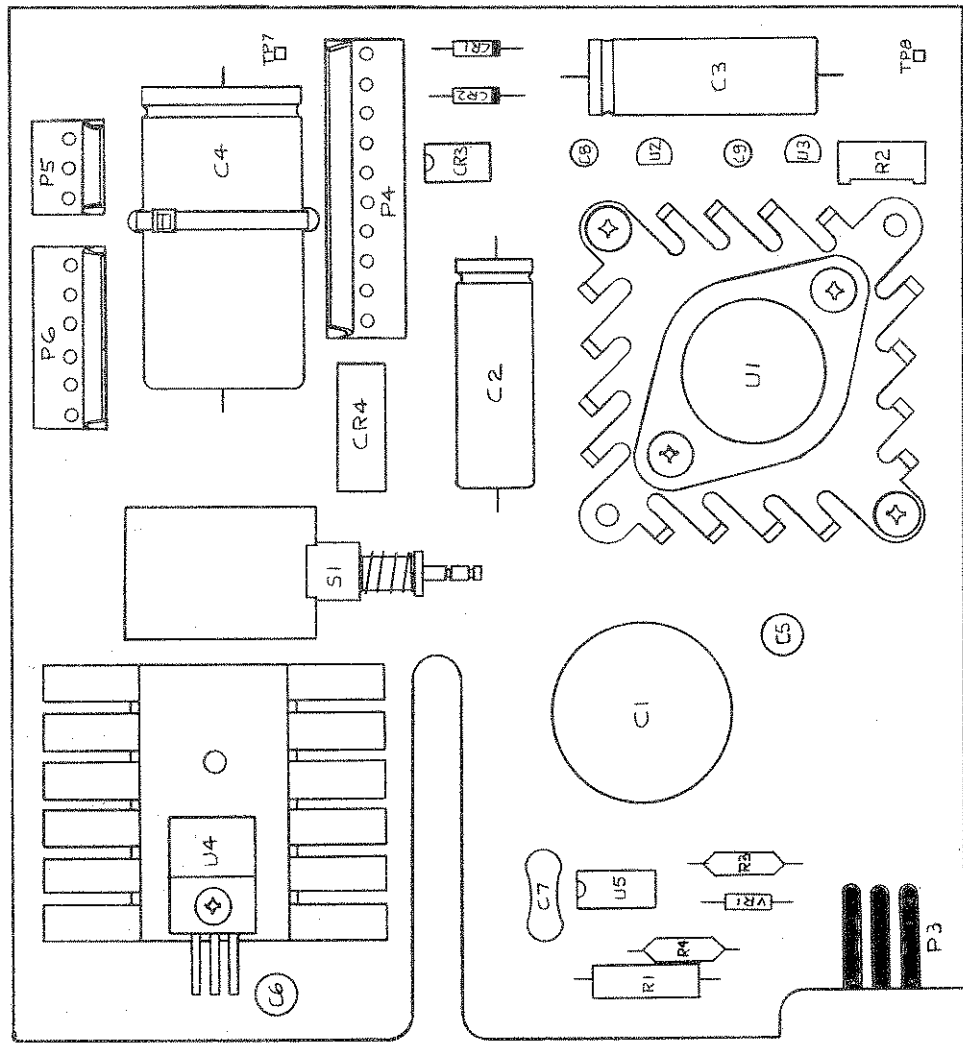

2205A-1605

Figure 9-6. A3 Power Supply PCB Assembly

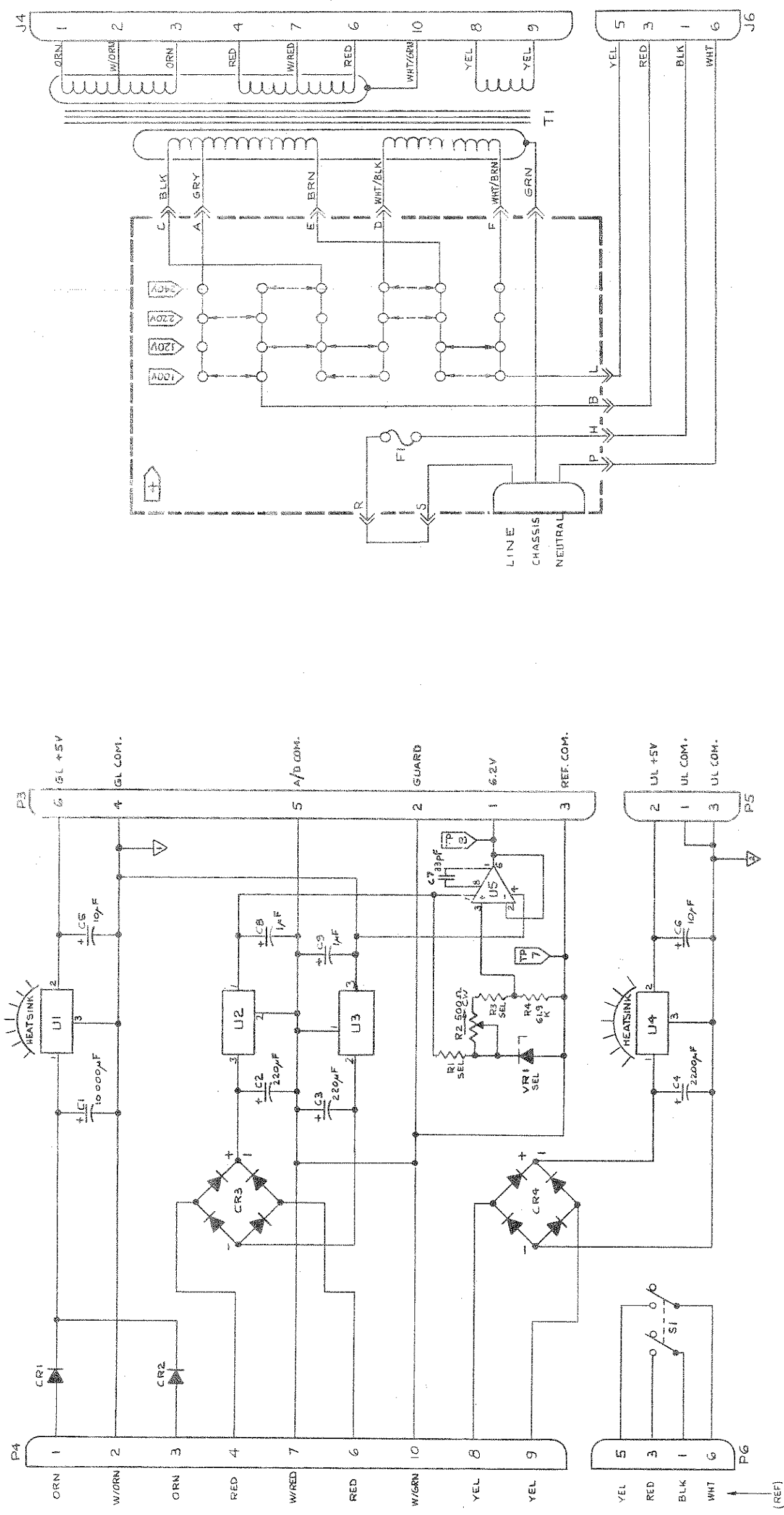
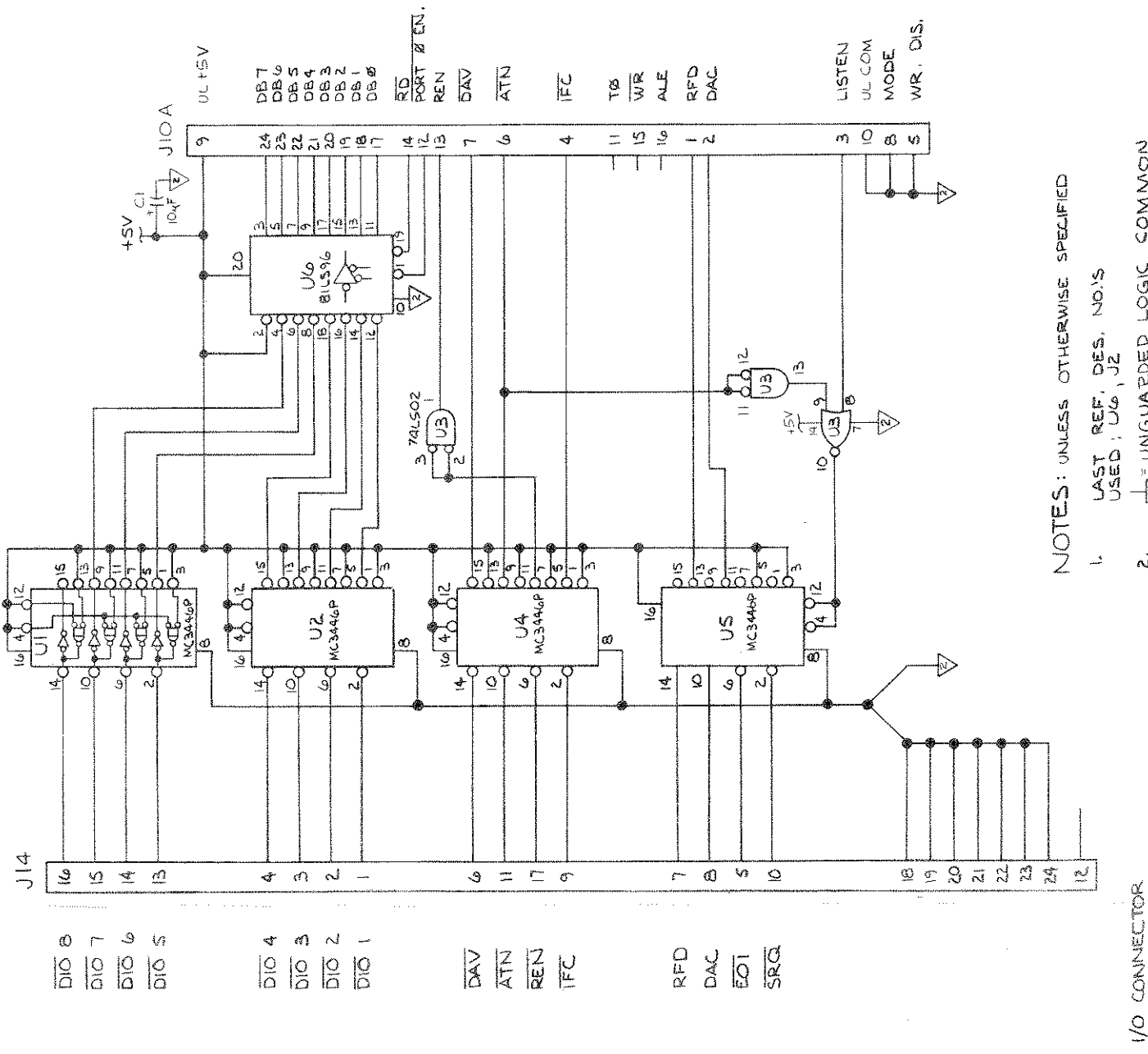

Figure 9-6. A3 Power Supply PCB Assembly (cont)



NOTES: UNLESS OTHERWISE SPECIFIED

1. LAST REF. DES. NO.'S USED: U6, J2
2. UNQUARDED LOGIC COMMON
3. CORRESPONDING IEEE-488 PCB IS CONFIGURED AS -CSD OPTION FOR THE 2204A.

I/O CONNECTOR

2204A-1712

2204A-1012

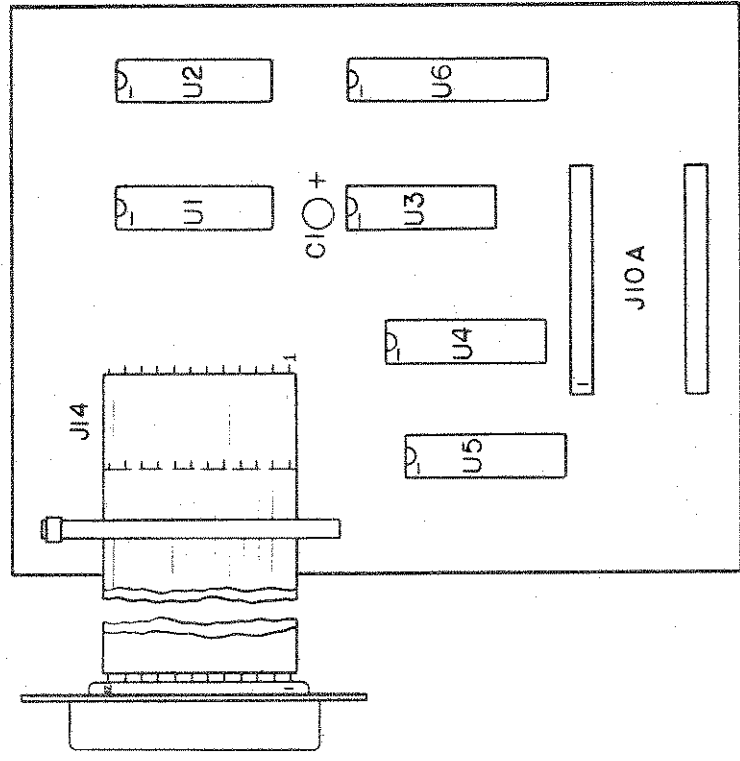
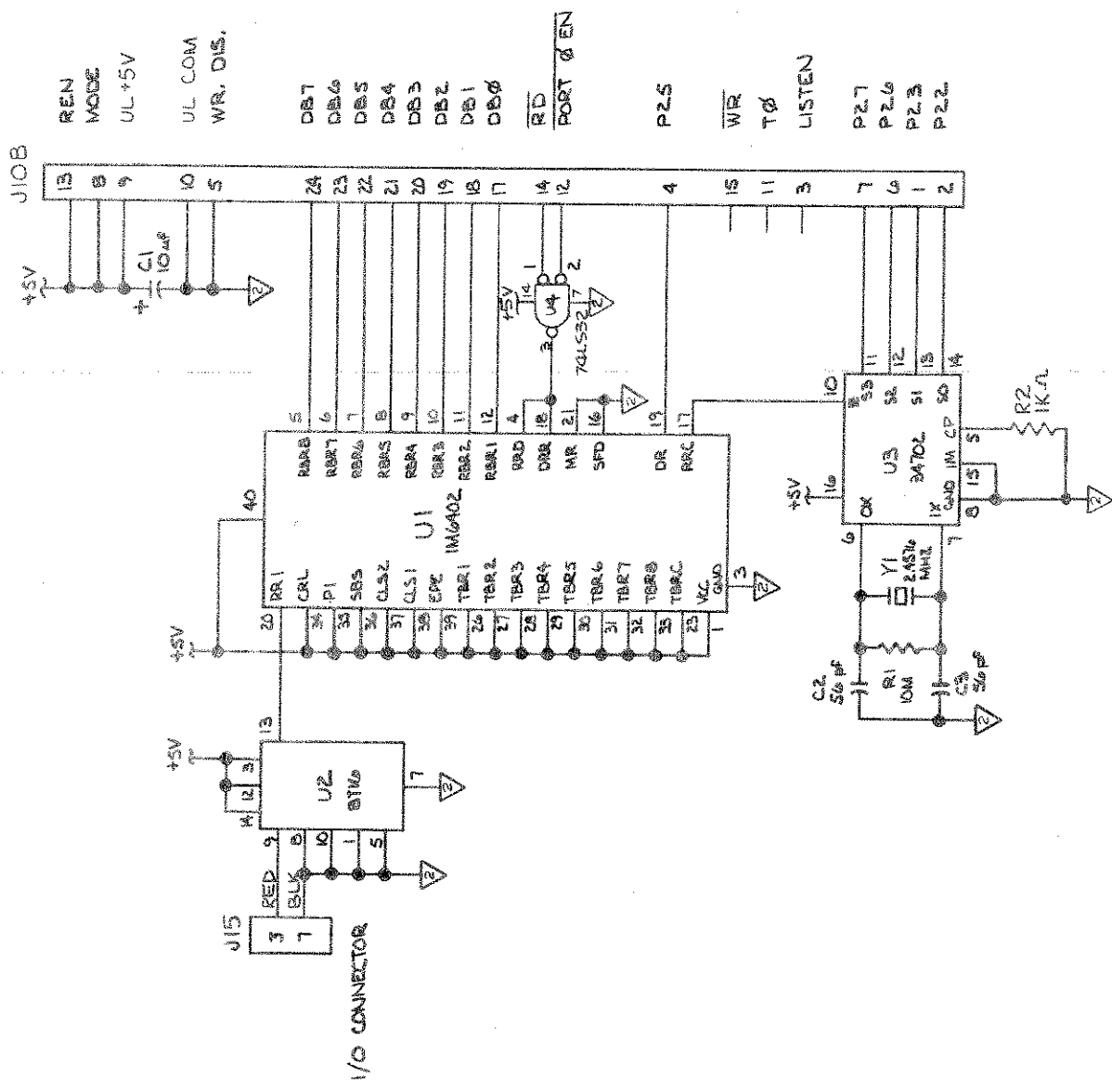
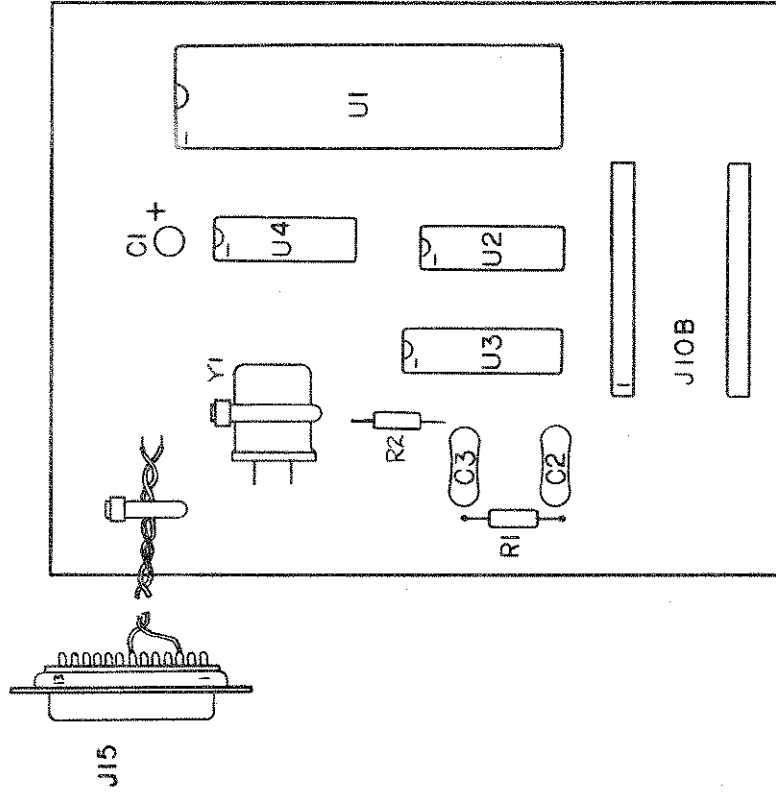

Figure 9-7. Option -050, IEEE-488 Compatible Interface PCB Assembly



NOTES: UNLESS OTHERWISE SPECIFIED
 1. LAST REF. DES. NO.'S USED:
 U1, R1, C3, Y1.
 2. △ = UNGUARDED LOGIC COMMON

2204A-1711

2204A-1011

Figure 9-8. Option -060, RS-232-C Interface PCB Assembly

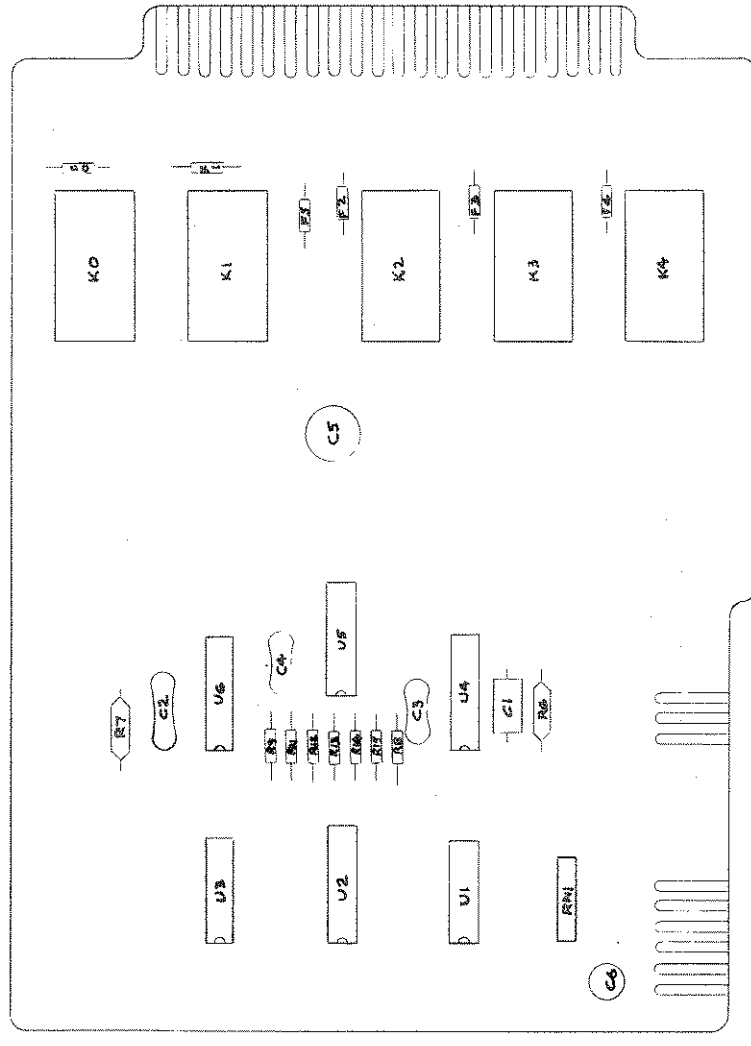

2205A-1602
Actuator PCB Assembly

Figure 9-9. Option -100, Actuator Module

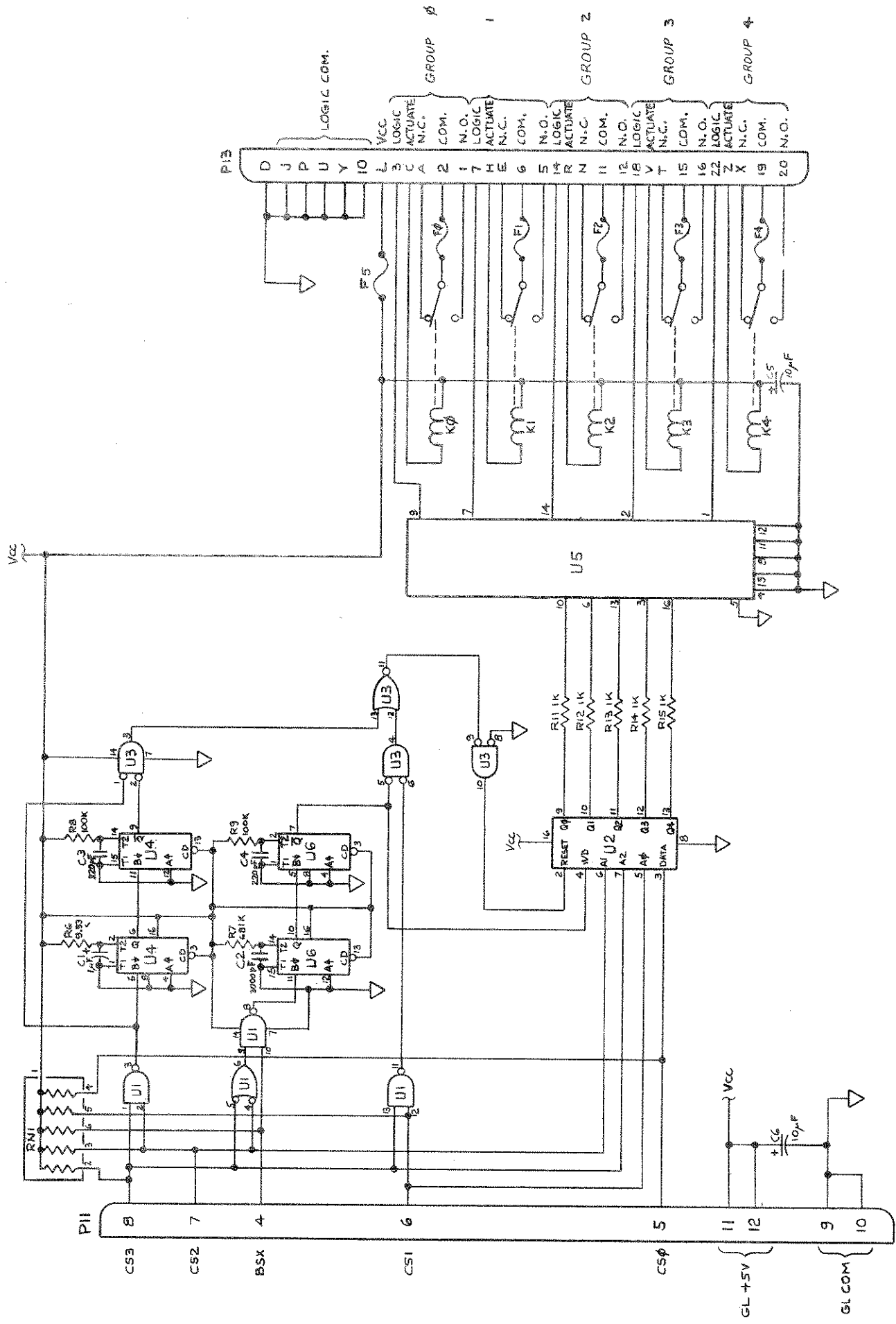

2205A-1002
Actuator PCB Assembly

Figure 9-9. Option -100, Actuator Module (cont)

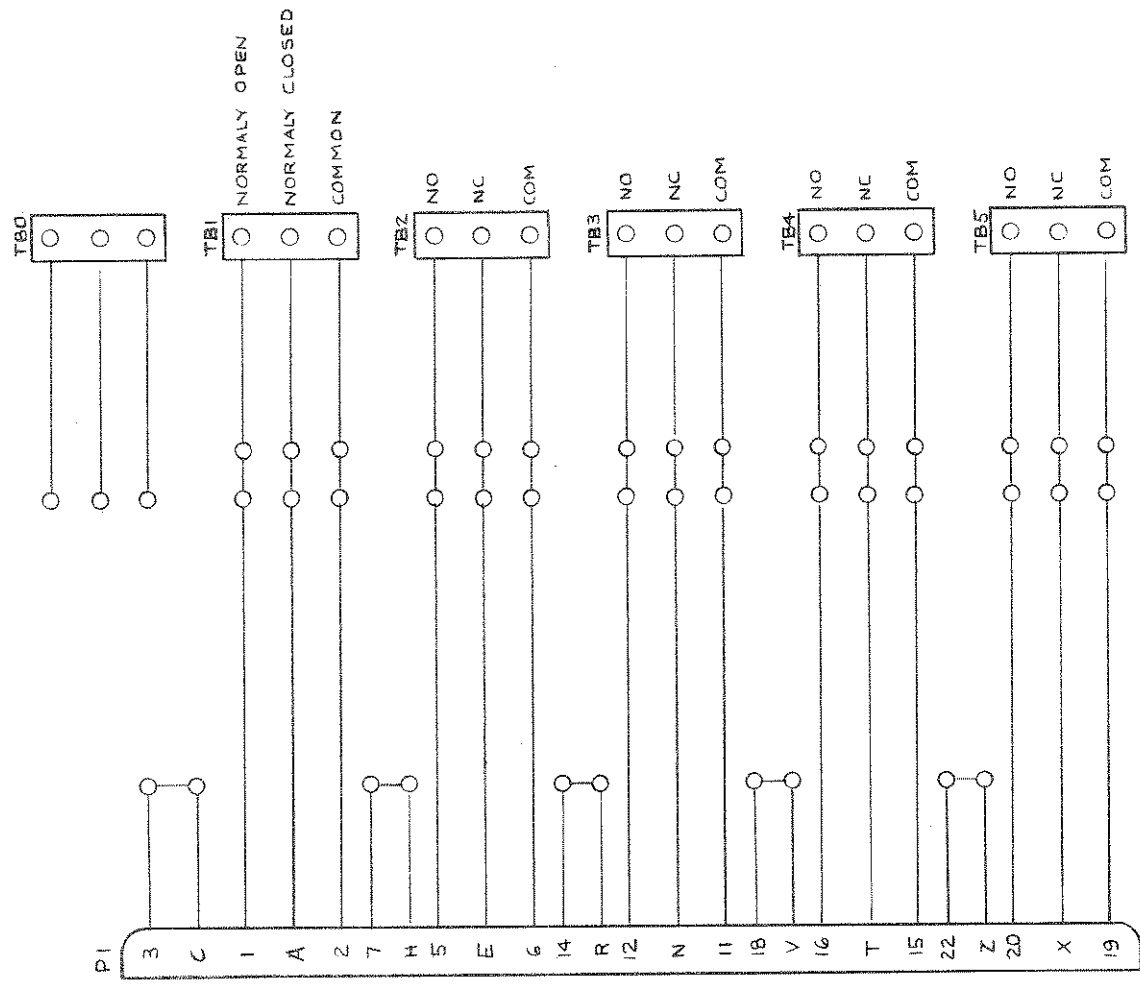

2205A-1006
Screw Terminal Connector

Figure 9-9. Option -100, Actuator Module (cont)

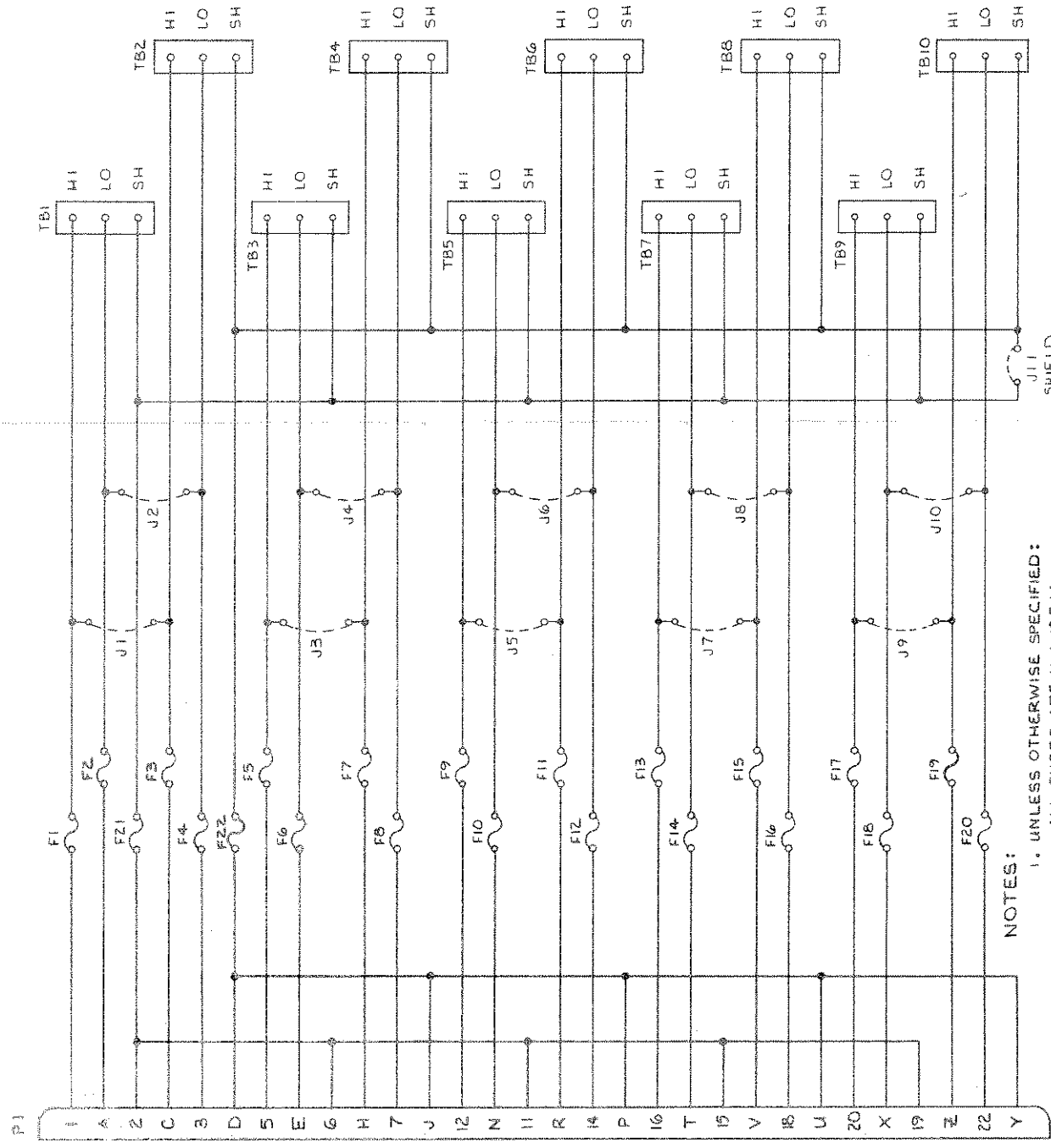

NOTES:

1. UNLESS OTHERWISE SPECIFIED:
ALL FUSES ARE 1/2 A, 125 V.
2. DESIGNATIONS OF TERMINAL STRIPS WHEN
USED WITH GENERAL PURPOSE SCANNING
& LATCHING CARDS SHOWN IN TABLE BELOW:

TERMINAL STRIP	LATCHING	SCANNING
TB1	CHO	CHO
TB2	CH4	CH1
TB3	CH1	CH2
TB4	CH5	CH3
TB5	CH2	CH4
TB6	CH6	CH5
TB7	CH3	CH6
TB8	CH7	CH8
TB9	BUS A	CH8
TB10	BUS B	CH9

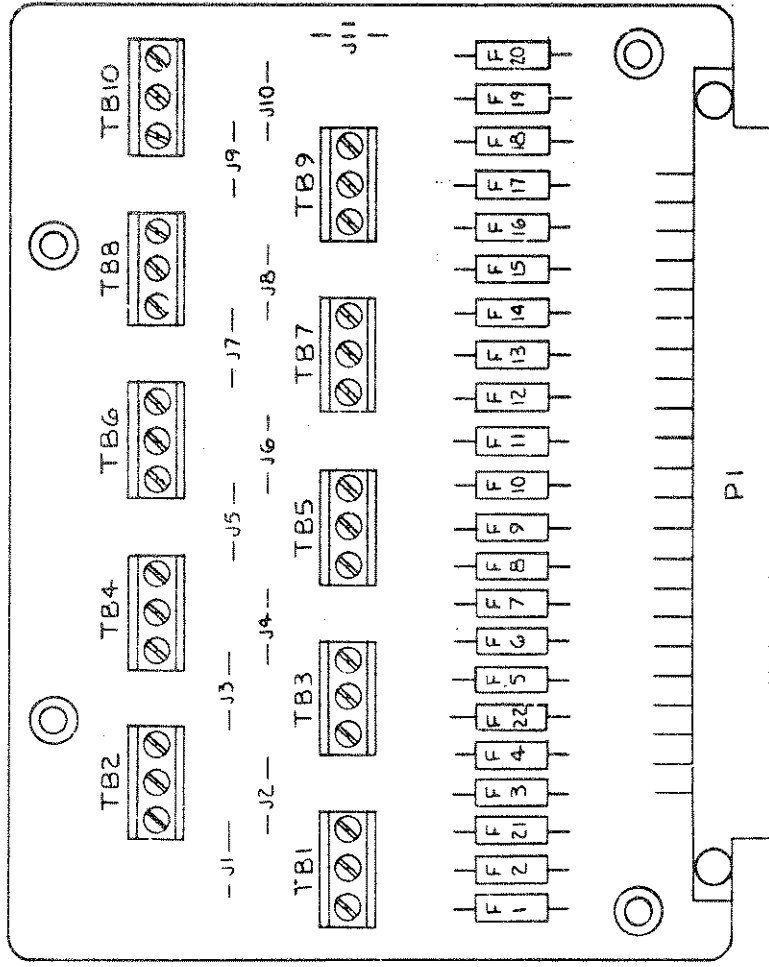

2205A-4007

Fused Terminal PCB Assembly

2205A-1007

Fused Terminal Connector

Figure 9-10. Option -200, Latching Module

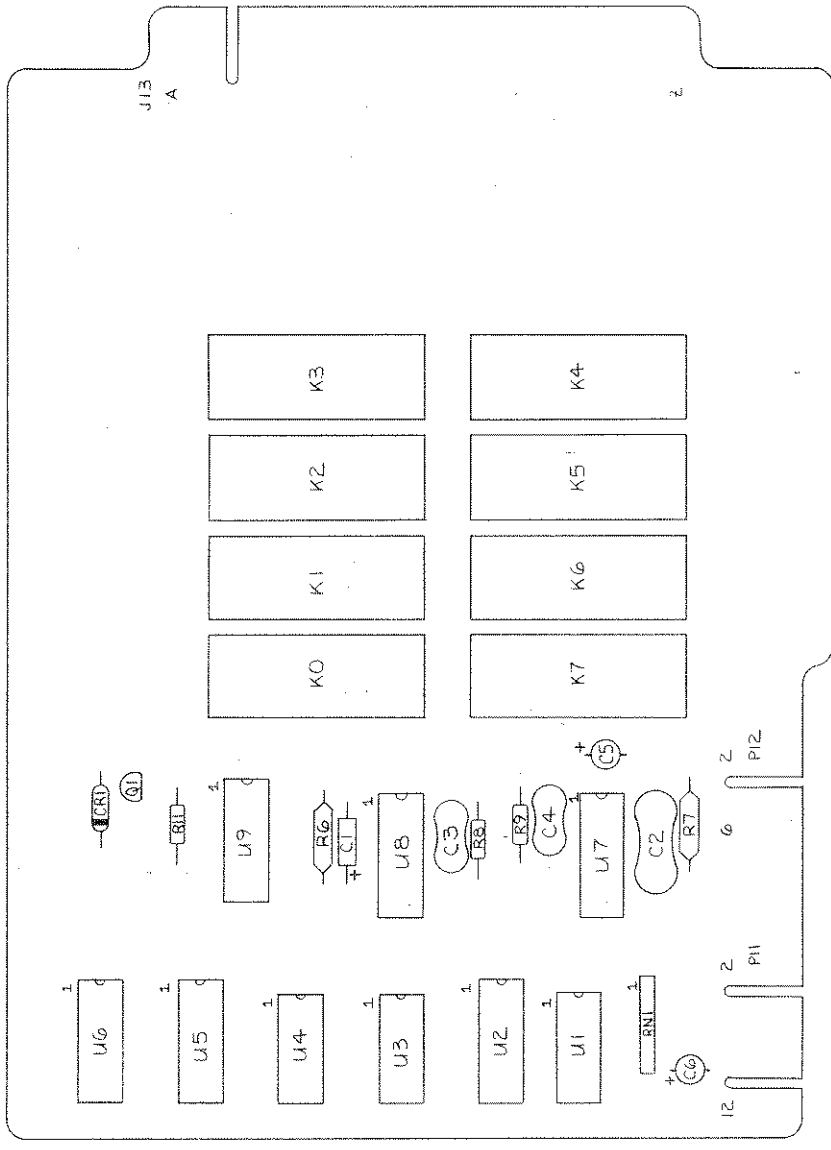

2205A-1603
Latching PCB Assembly

Figure 9-10. Option -200, Latching Module (cont)

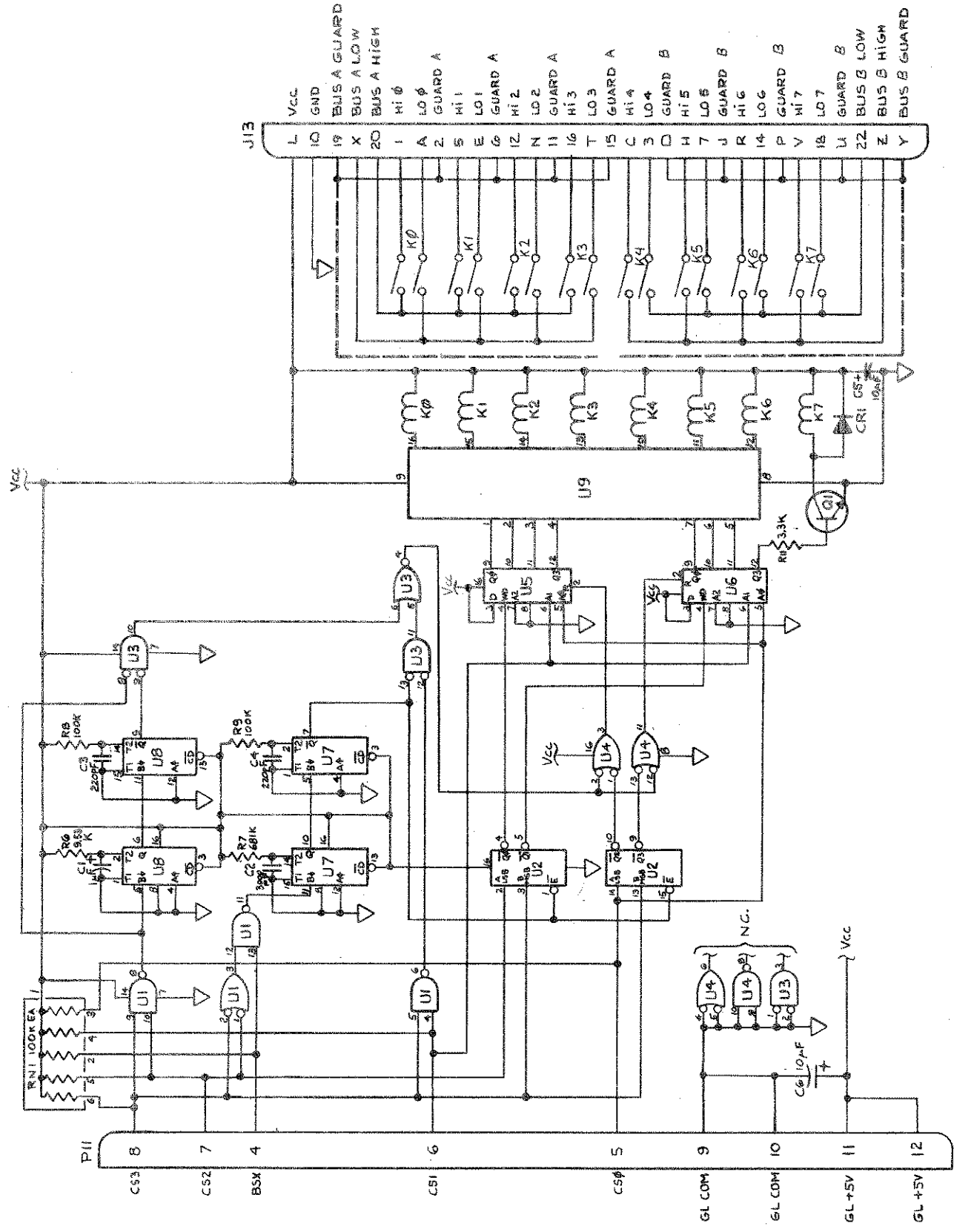

2205A-1003
Latching PCB Assembly

Figure 9-10. Option -200, Latching Module (cont)

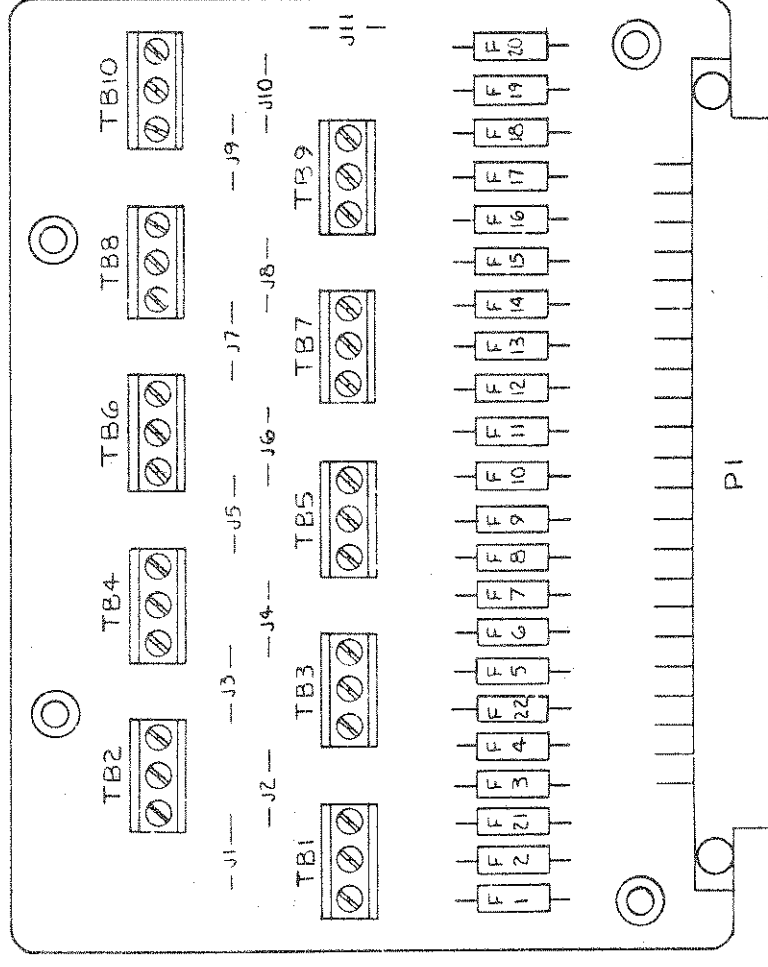

2205A-1607
Fused Terminal Connector

Figure 9-11. Option -300, General Purpose Scanner
Module

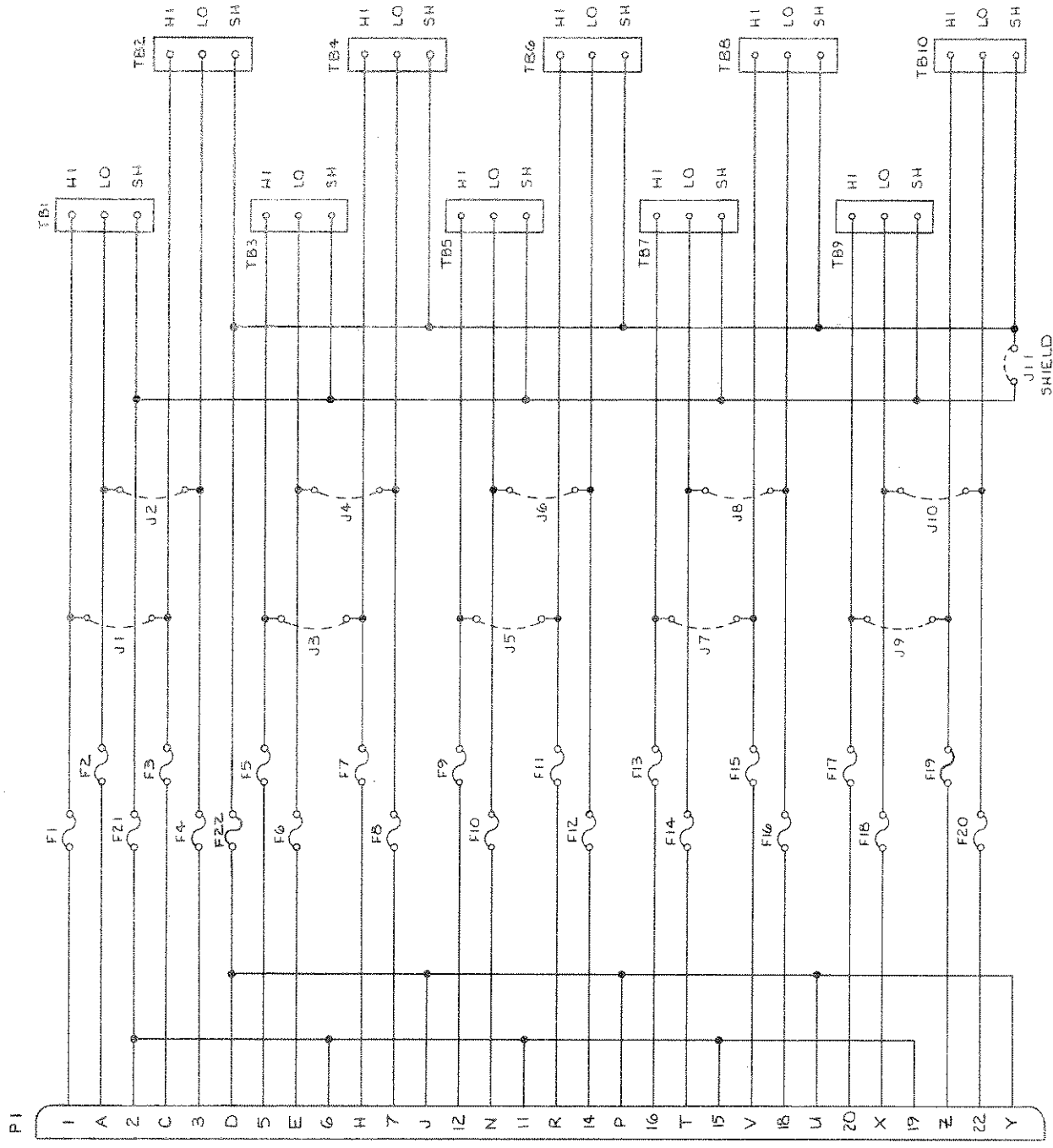

NOTES:
 1. UNLESS OTHERWISE SPECIFIED:
 ALL FUSES ARE 1/2 A, 125 V.
 2. DESIGNATIONS OF TERMINAL STRIPS WHEN
 USED WITH GENERAL PURPOSE SCANNING
 & LATCHING CARDS SHOWN IN TABLE BELOW:

TERMINAL STRIP	LATCHING	SCANNING
TB1	CHO	CHO
TB2	CH4	CH1
TB3	CH1	CH2
TB4	CH5	CH3
TB5	CH2	CH4
TB6	CH6	CH5
TB7	CH3	CH6
TB8	CH7	CH7
TB9	BUS A	CH8
TB10	BUS B	CH9

Figure 9-11. Option -300, General Purpose Scanner Module (cont)

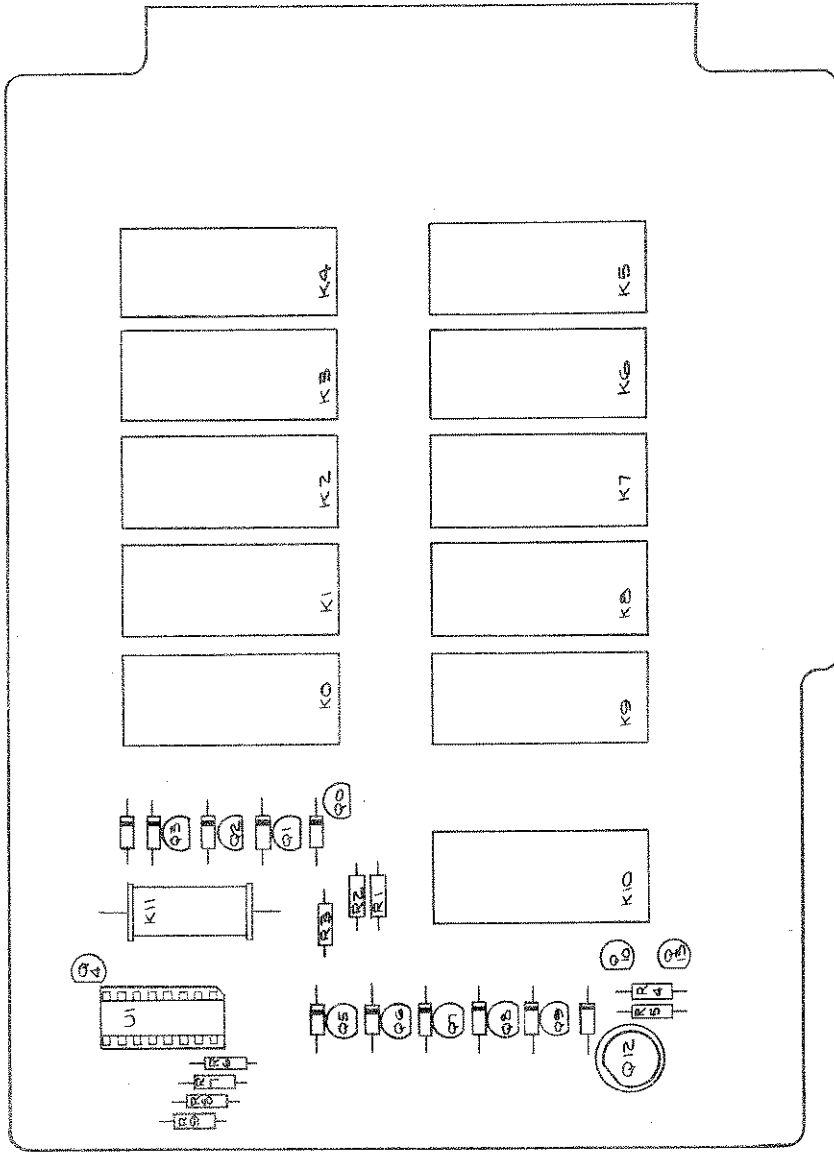

2200A-1637
General Purpose Scanner PCB Assembly

Figure 9-11. Option -300, General Purpose Scanner Module (cont)

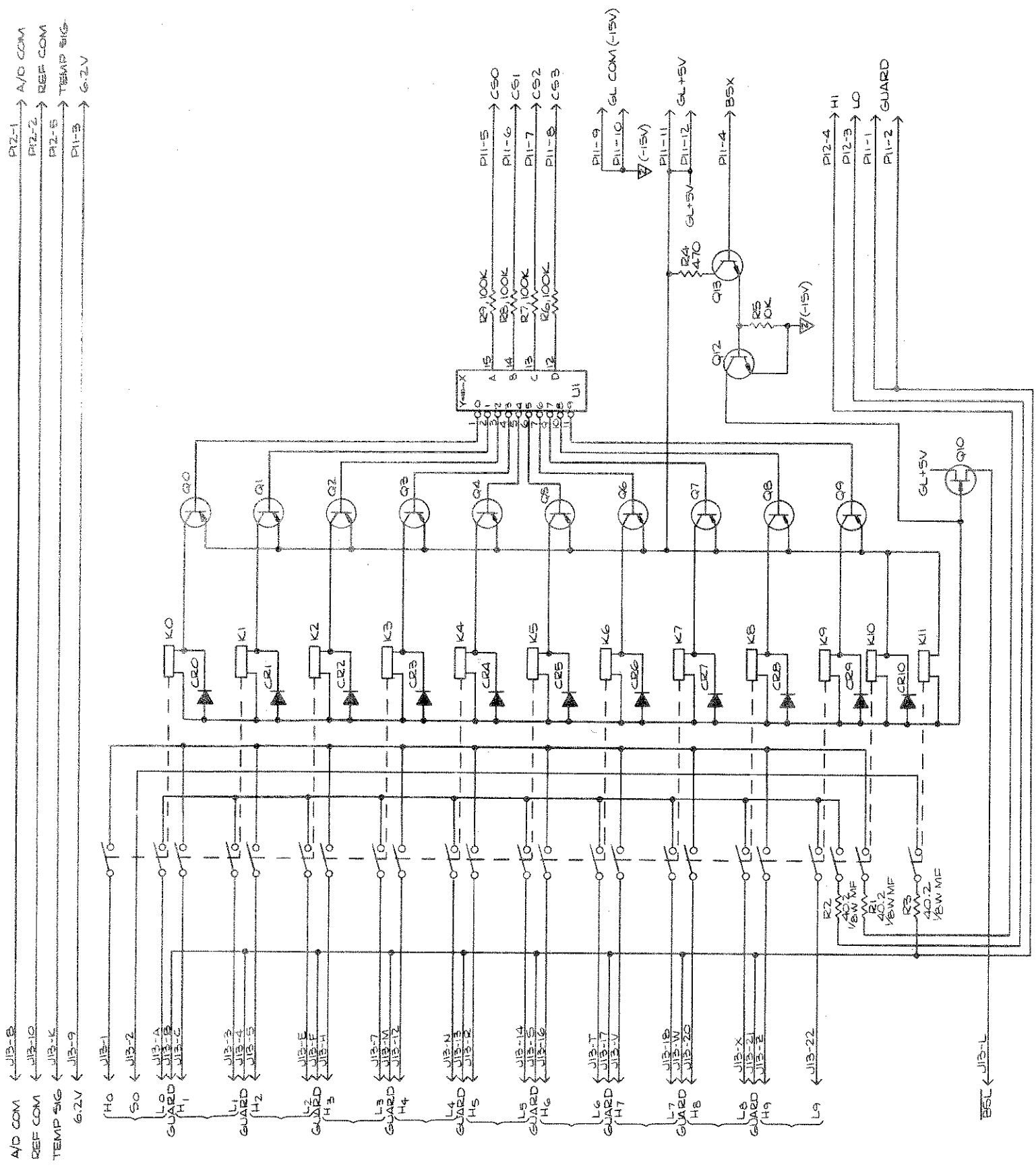

- NOTES:
1. UNLESS OTHERWISE SPECIFIED ALL RESISTANCES ARE IN OHMS AND ALL CAPACITANCES ARE IN MICROFARADS.
 2. ∇ (-15V) DENOTES GUARDED LOGIC COMMON (GL COM (-15V)) WHICH IS -15V WITH RESPECT TO A/D COM.
 3. ALL RESISTORS ARE 1/4W, 5% UNLESS OTHERWISE NOTED.
 4. ALL VOLTAGES NOTED ARE WITH RESPECT TO A/D COM.

REF DES	PIN NO	REFERENCE DESIGNATIONS LAST USED	NOT USED
U1	16	CR10	U1
		K11	Q11
		C29	
		R29	

2200A-1037
General Purpose PCB Assembly

Figure 9-11. Option -300, General Purpose Scanner Module (cont)

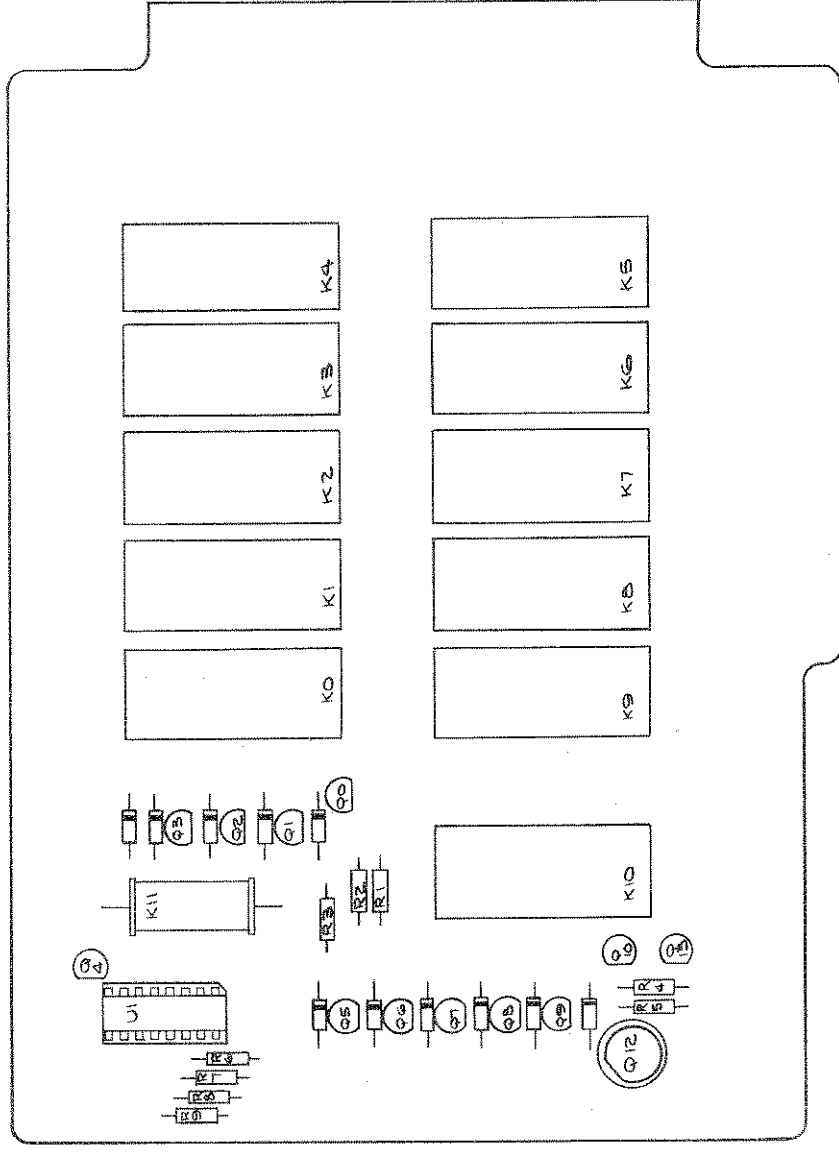

2200A-1637
General Purpose Scanner PCB Assembly

Figure 9-12. Option -400, Four-Wire Resistance Scanner Module

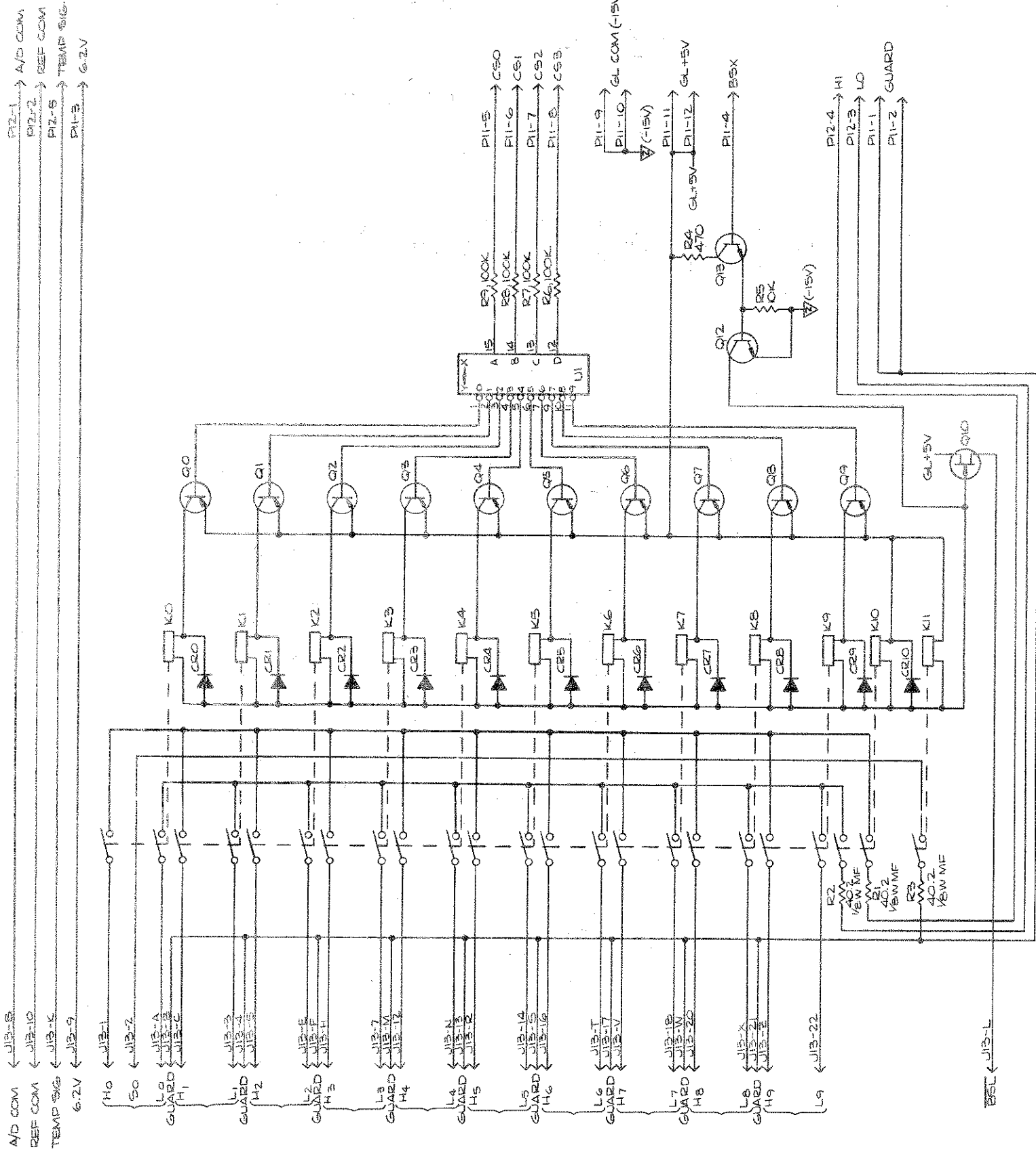

- NOTES:
1. UNLESS OTHERWISE SPECIFIED ALL RESISTANCES ARE IN OHMS AND ALL CAPACITANCES ARE IN MICROFARADS.
 2. ∇ (-15V) DENOTES GUARDED LOGIC COMMON (GL COM (-15V)) WHICH IS -15V WITH RESPECT TO A/D COM.
 3. ALL RESISTORS ARE 1/4W, 5% UNLESS OTHERWISE NOTED.
 4. ALL VOLTAGES NOTED ARE WITH RESPECT TO A/D COM.

REF DES	PIN NO.	GL+5V	GL COM	REFERENCE DESIGNATIONS
U1	16	5		
				CR10
				Q13
				Q14
				Q15
				Q16
				Q17
				Q18
				Q19
				Q20

2200A-1037
General Purpose PCB Assembly

Figure 9-12. Option -400, Four-Wire Resistance Scanner Module (cont)

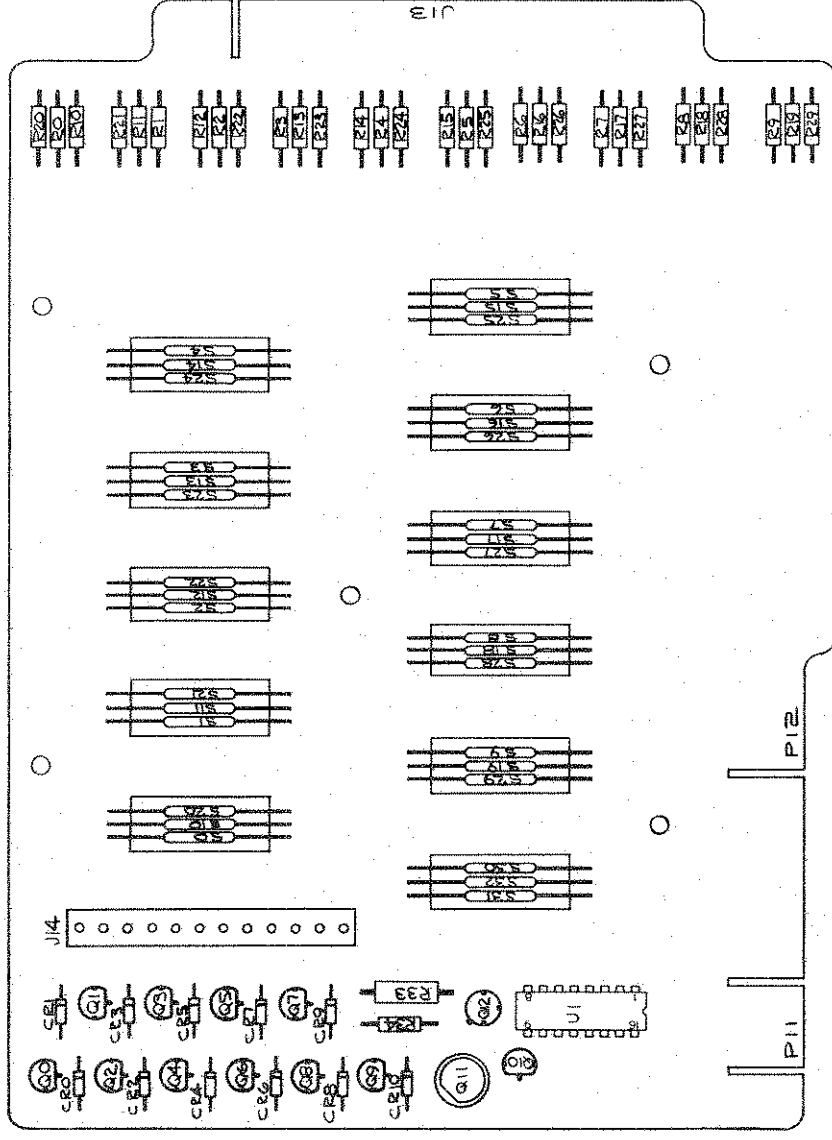
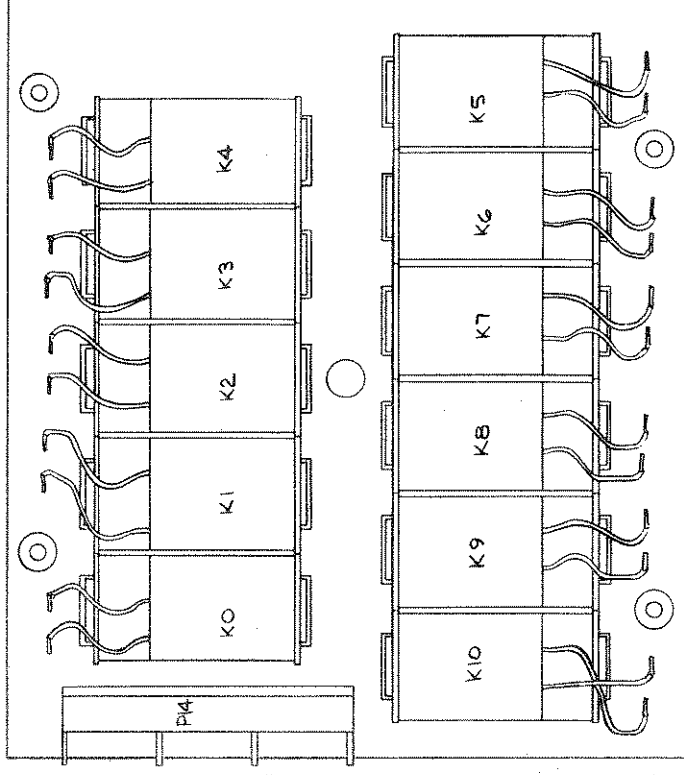
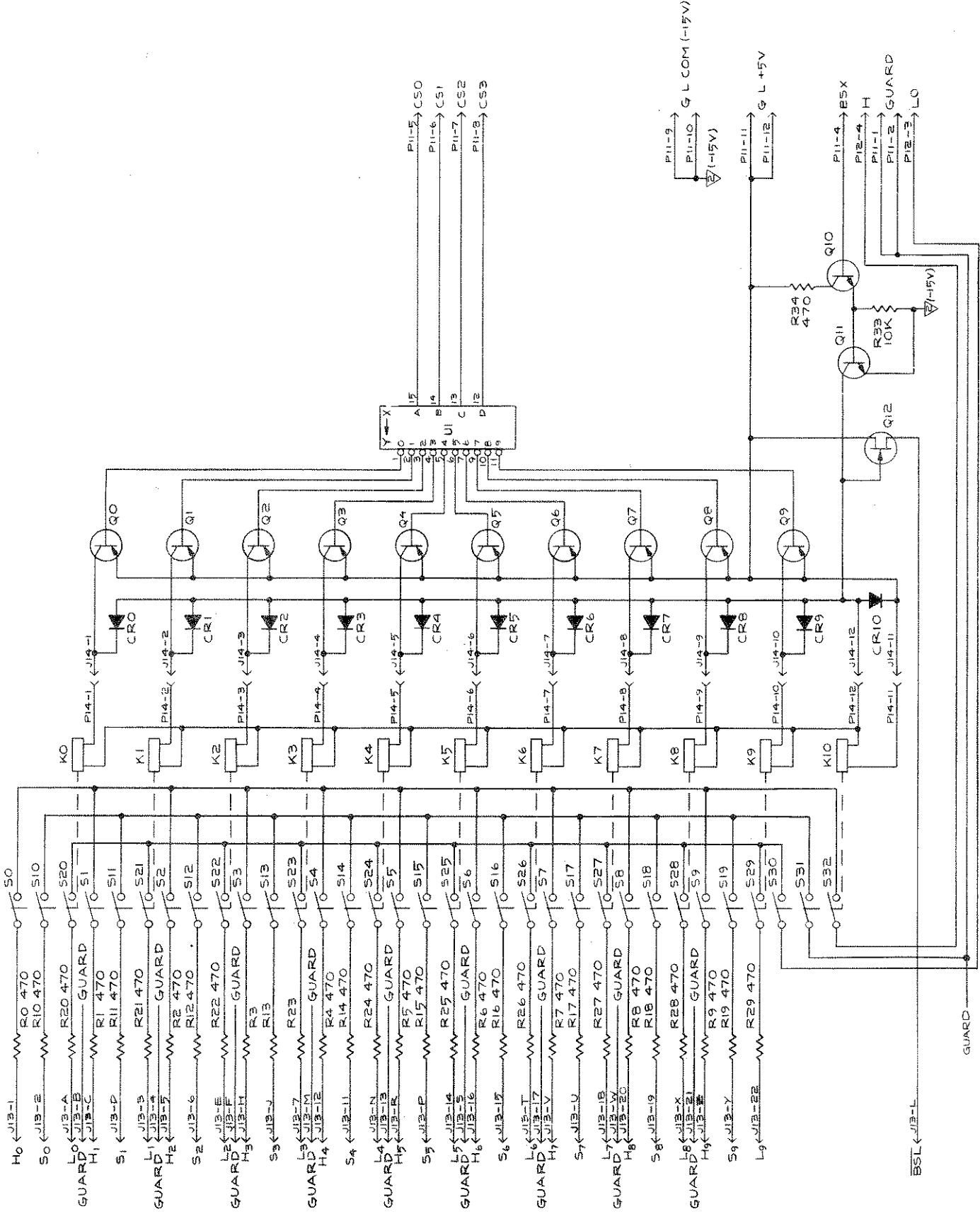
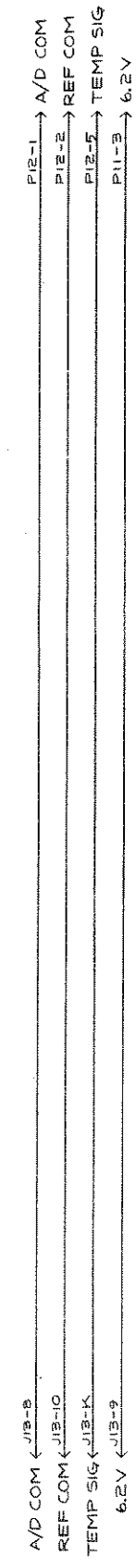

Figure 9-12. Option -400, Four-Wire Resistance Scanner Module (cont)



- NOTES:
1. UNLESS OTHERWISE SPECIFIED ALL RESISTANCES ARE IN OHMS AND ALL CAPACITANCES ARE IN MICROFARADS.
 2. ○ DENOTES CALIBRATION ADJ POINTS. ALL POINTS ARE SCREWDRIVER ADJUST.
 3. ALL RESISTORS ARE 1/4W, 5% UNLESS OTHERWISE NOTED.
 4. ALL GRAPHIC SYMBOLS IN ACCORDANCE WITH ANST Y32.2 AND Y32.14.
 5. ⚡ (-15V) DENOTES GUARDED LOGIC COMMON [G L COM (-15V)] WHICH IS -15V WITH RESPECT TO A/D COM.
 6. ALL VOLTAGES NOTED ARE WITH RESPECT TO A/D COM.

IC REF DES	PIN NO.
U1	16
	8

REFERENCE DESIGNATIONS	LAST USED	NOT USED
CR10	S32	
K10	U1	
Q12		
R34		R.30-32

2200A-1029
Low Level Scanner PCB Assembly

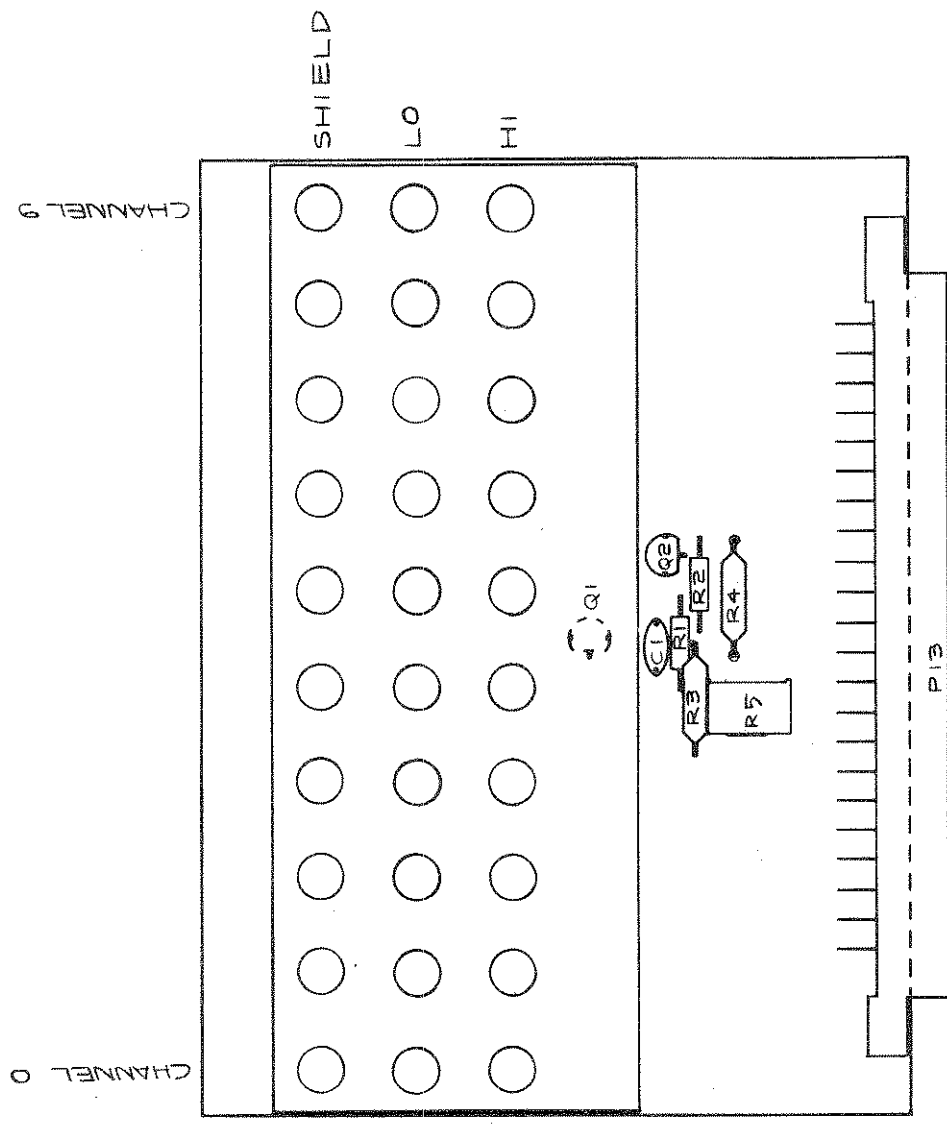

Figure 9-12. Option -400, Four-Wire Resistance Scanner Module (cont)



2200A-1623
Isothermal Input Connector

Figure 9-12. Option -400, Four-Wire Resistance Scanner Module (cont)

NOTES:

1. UNLESS OTHERWISE SPECIFIED ALL RESISTANCES ARE IN OHMS AND ALL CAPACITANCES ARE IN MICROGRADS.
 2.  DENOTES CALIBRATION ADJ POINTS. ALL POINTS ARE SCREWDRIVER ADJUST.
 3. ALL RESISTORS ARE 1/4W, 5% UNLESS OTHERWISE NOTED.
 4. ALL GRAPHIC SYMBOLS IN ACCORDANCE WITH ANSI Y32.2.
-  RA IS FACTORY SELECTED AND IS ONE OF THE LISTED VALUES:
 OPEN 100K
 287K 700K
 147K

A	1
B	2
C	3
D	4
E	5
F	5
G	6
H	7
J	8
K	9
L	10
M	11
N	12
P	13
R	14
S	15
T	16
U	17
V	18
W	19
X	20
Y	21
Z	22

REAR VIEW OF P13

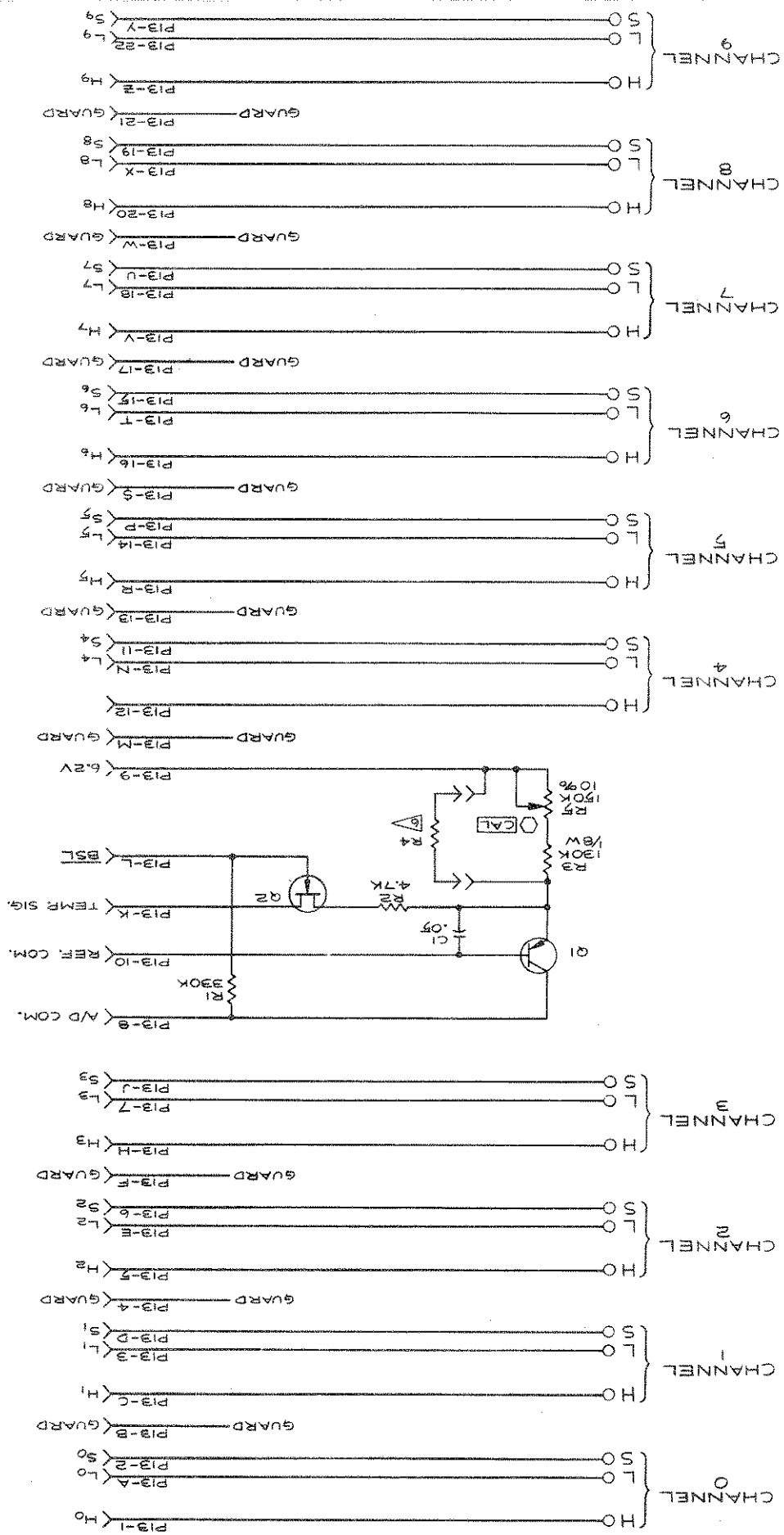

2200A-1023
 Isothermal Input Connector

Figure 9-12. Oplon -400, Four-Wire Resistance Scanner Module (cont)

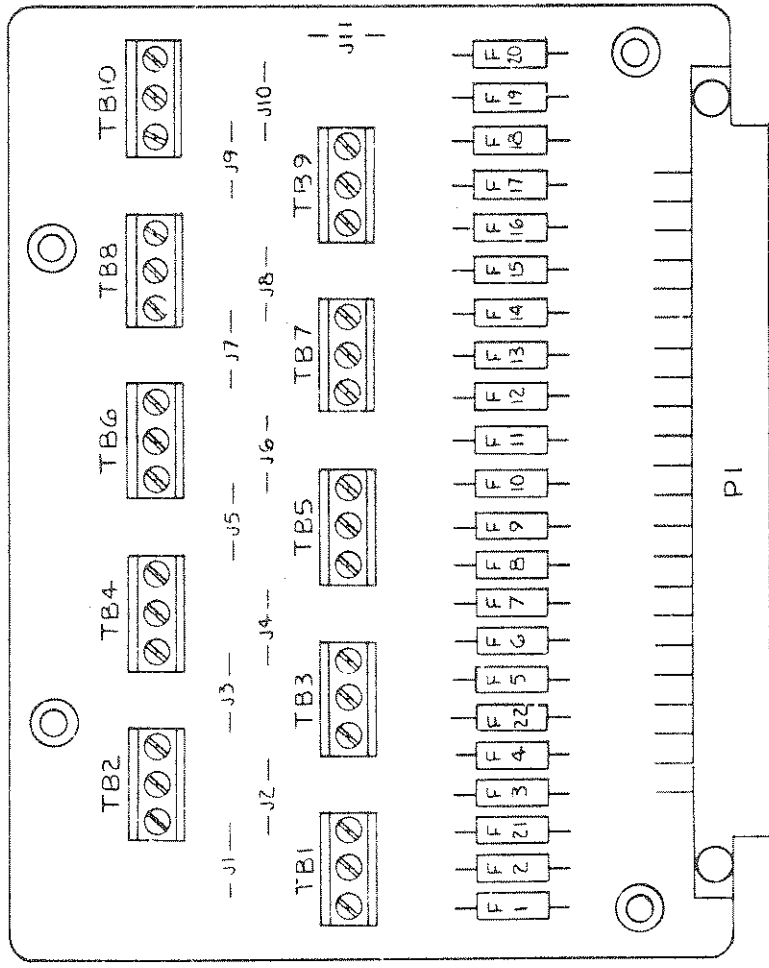

2205A-1607
Fused Terminal Connector

Figure 9-12. Option -400, Four-Wire Resistance
Scanner Module (cont)

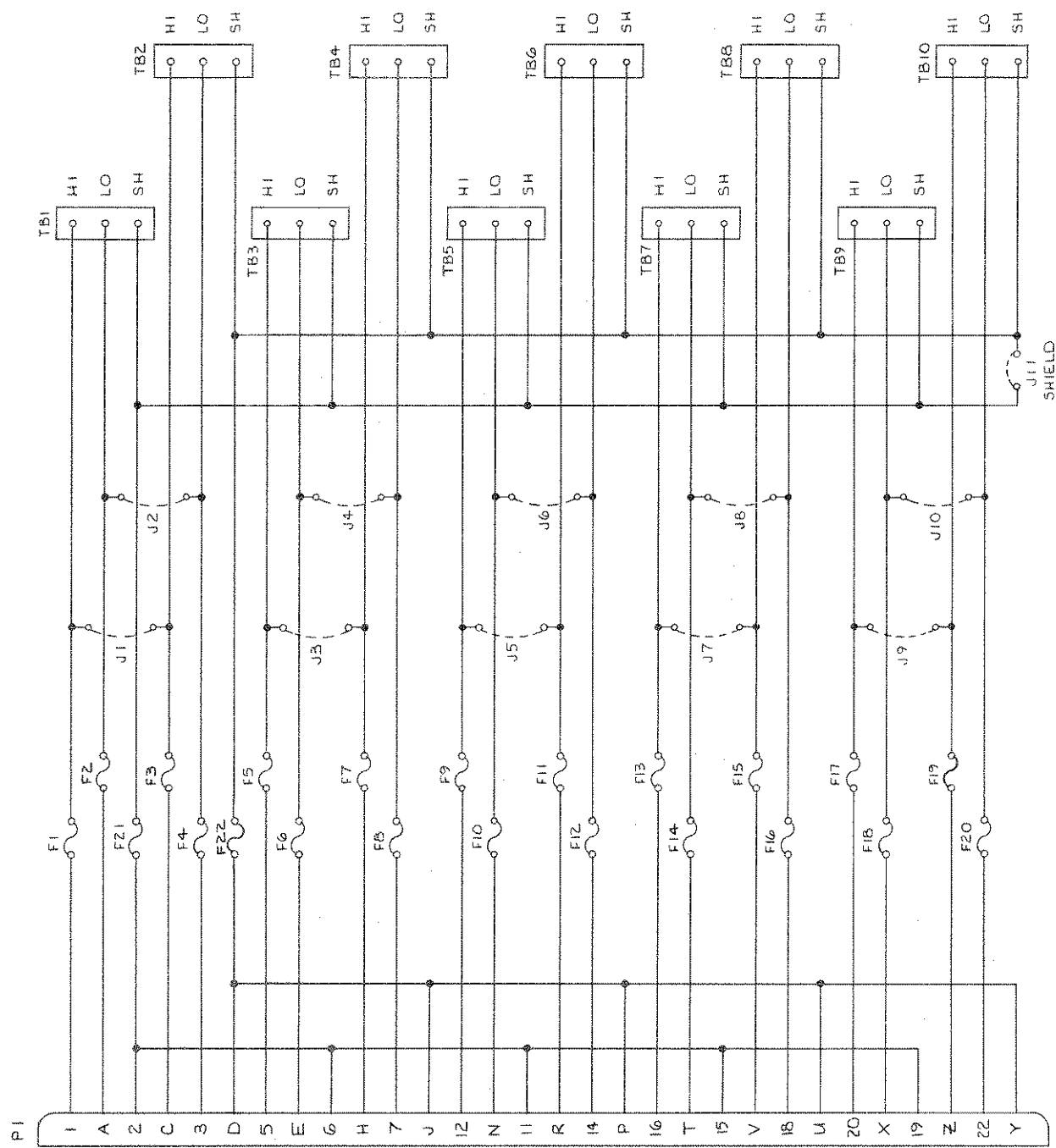

NOTES:
 1. UNLESS OTHERWISE SPECIFIED:
 ALL FUSES ARE 1/2 A, 125 V.
 2. DESIGNATIONS OF TERMINAL STRIPS WHEN
 USED WITH GENERAL PURPOSE SCANNING
 & LATCHING CARDS SHOWN IN TABLE BELOW:

TERMINAL STRIP	LATCHING	SCANNING
TB1	CHO	CHO
TB2	CH4	CH1
TB3	CH1	CH2
TB4	CH5	CH3
TB5	CH2	CH4
TB6	CH6	CH5
TB7	CH3	CH6
TB8	CH7	CH7
TB9	BUS A	CH8
TB10	BUS B	CH9

Figure 9-12. Option -400, Four-Wire Resistance Scanner Module (cont)

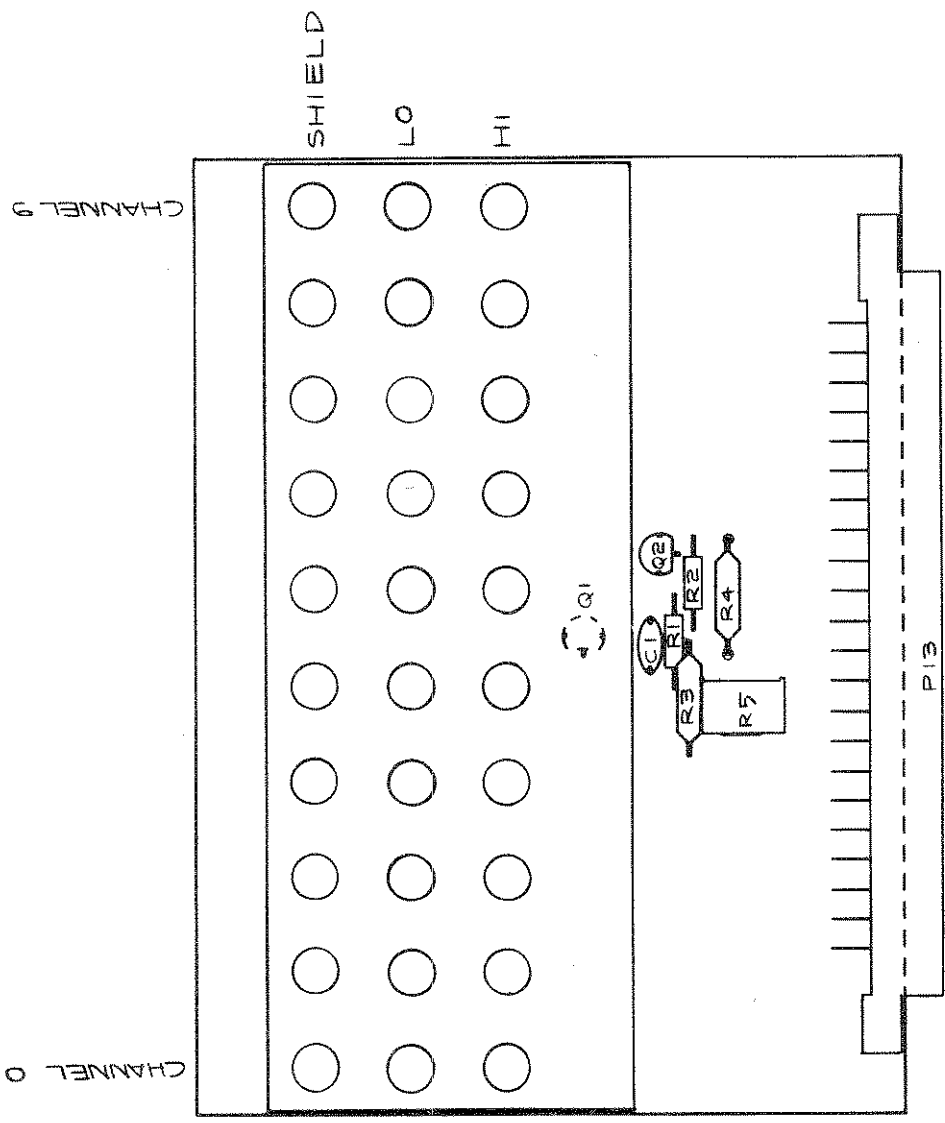

2200A-1623
Isothermal Input Connector

Figure 9-13. Option -600, Low Level Scanner Module

- NOTES:
1. UNLESS OTHERWISE SPECIFIED ALL RESISTANCES ARE IN OHMS AND ALL CAPACITANCES ARE IN MICROFARADS.
 2. \bigcirc DENOTES CALIBRATION ADJ. POINTS. ALL POINTS ARE SCREWDRIVER ADJUST.
 3. ALL RESISTORS ARE 1/4W, 5% UNLESS OTHERWISE NOTED.
 4. ALL GRAPHIC SYMBOLS IN ACCORDANCE WITH ANSI Y22.2.

\triangle R4 IS FACTORY SELECTED AND IS ONE OF THE LISTED VALUES:
 OPEN 100K
 287K 76.8K
 147K

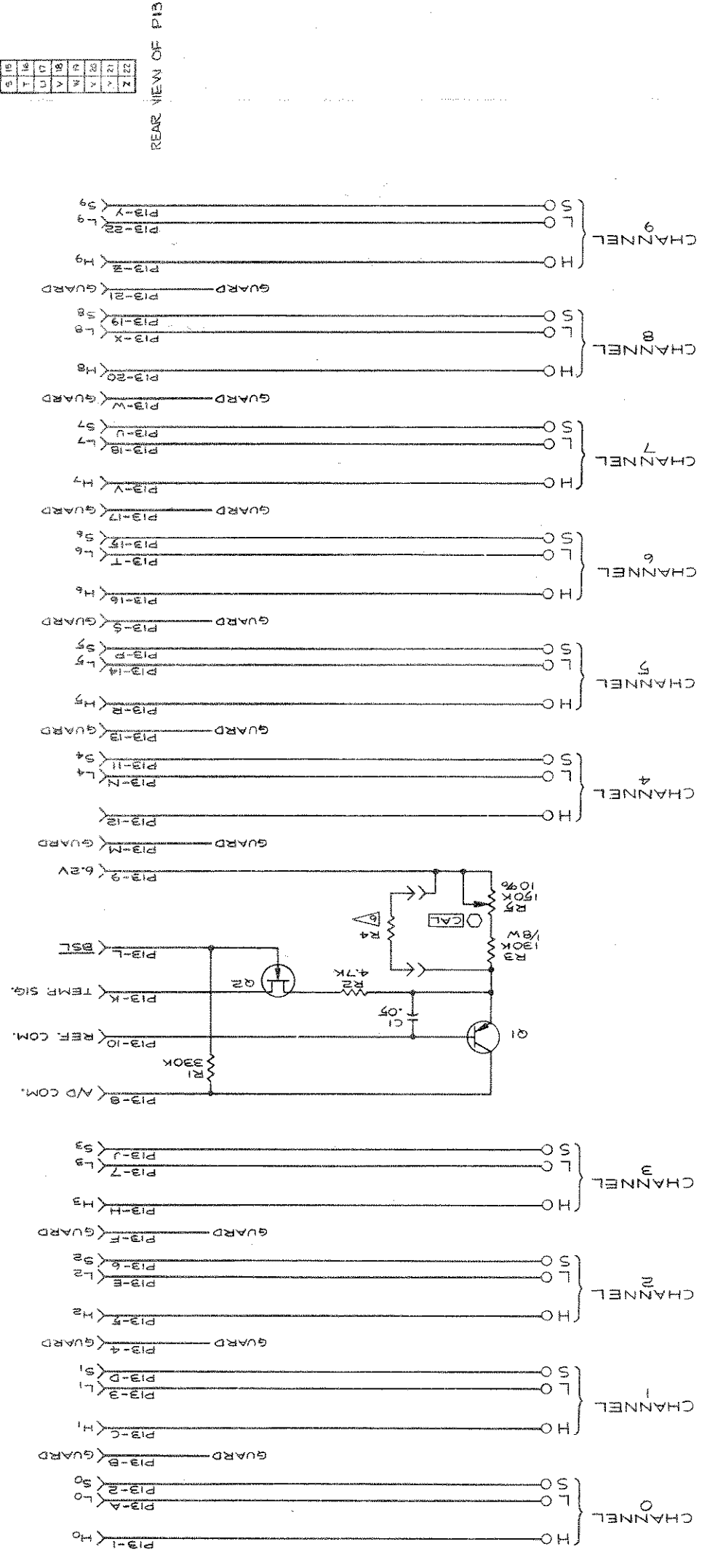

REAR VIEW OF P13

2200A-1623
 Isothermal Input Connector

Figure 9-13. Option -600, Low Level Scanner Module (cont)

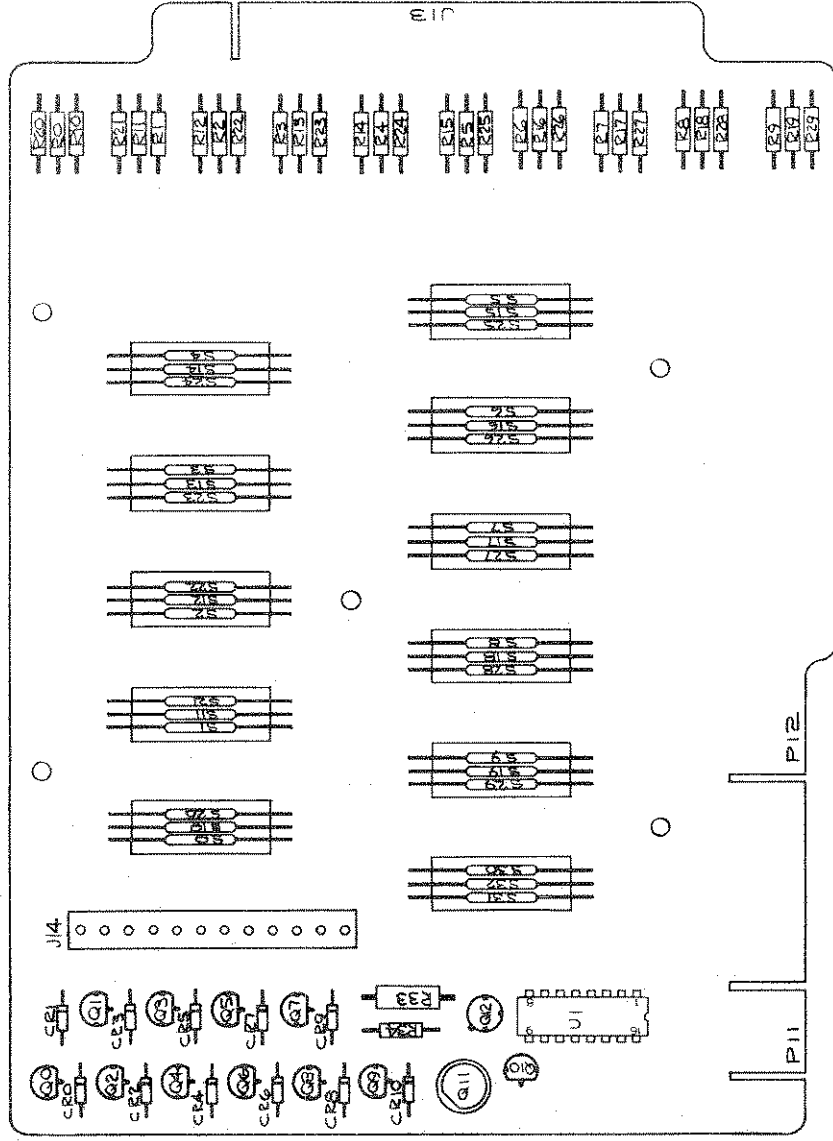
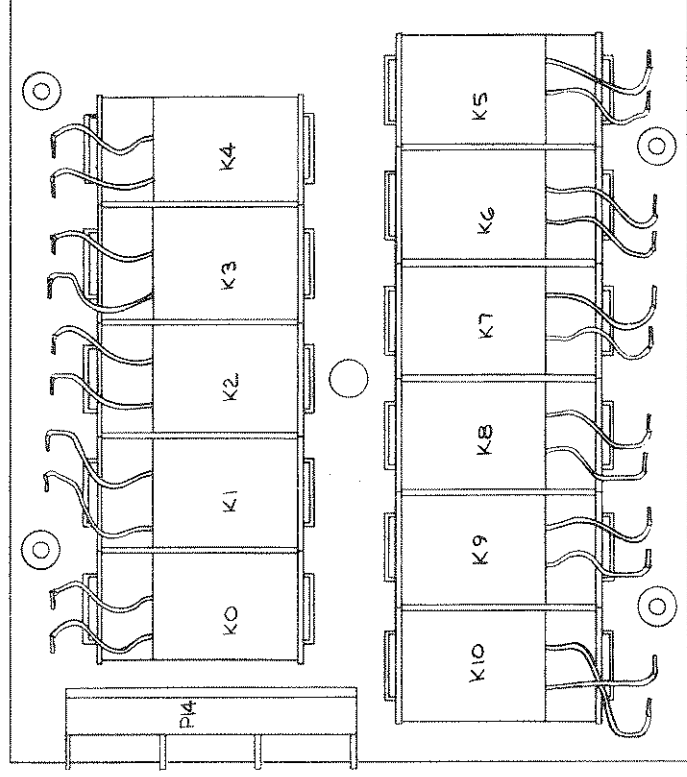
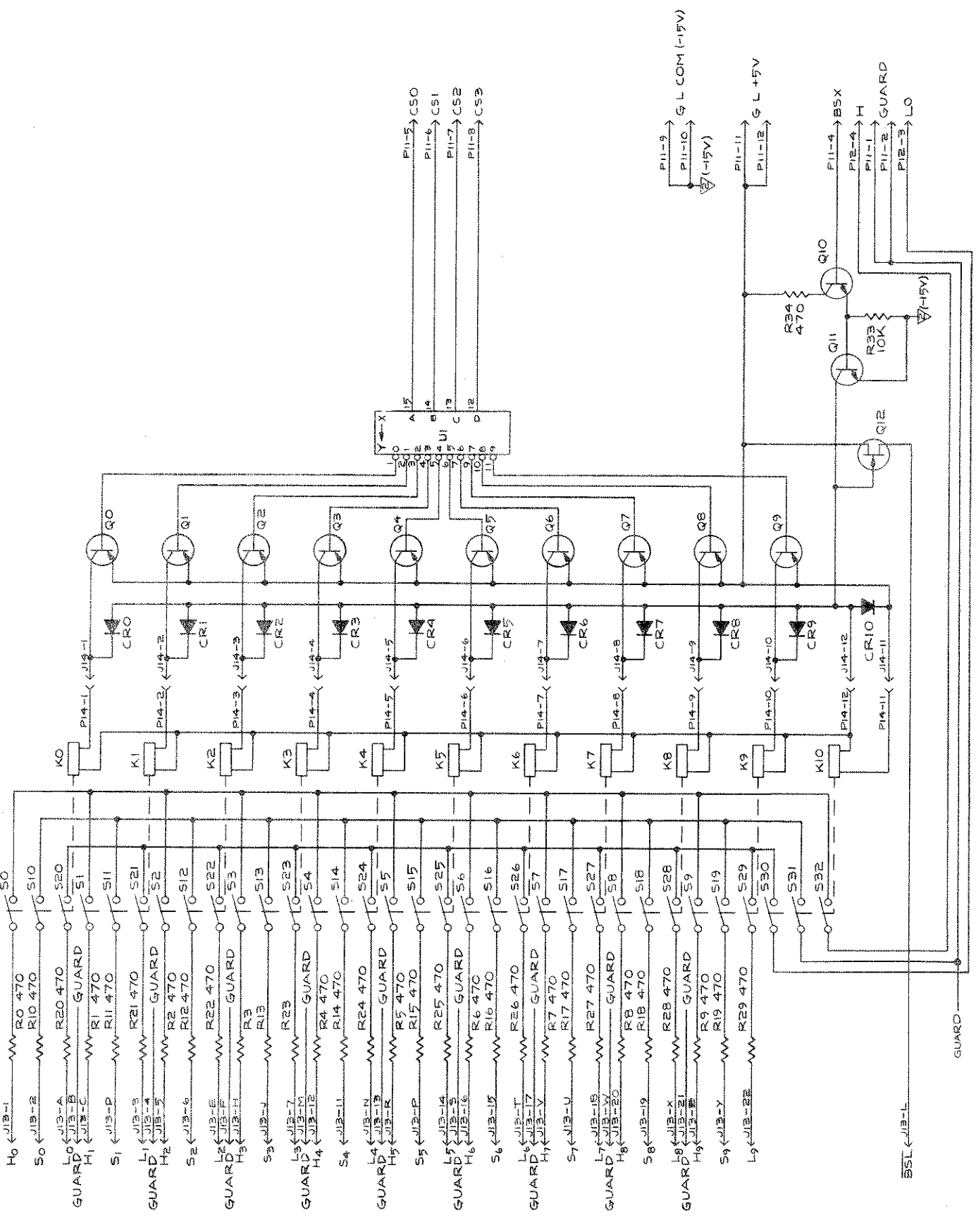
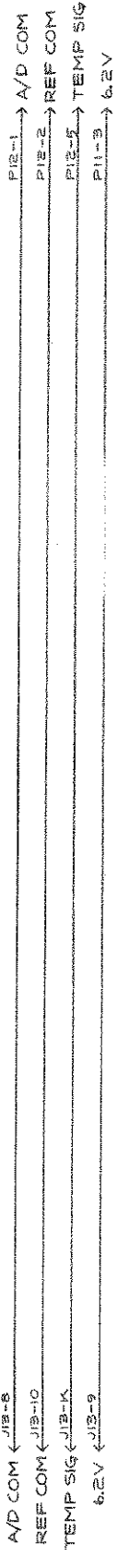

Figure 9-13. Option -600, Low Level Scanner Module
(cont)

- NOTES:
1. UNLESS OTHERWISE SPECIFIED ALL RESISTANCES ARE IN OHMS AND ALL CAPACITANCES ARE IN MICROFARADS.
 2. ○ DENOTES CALIBRATION ADJ. POINTS. ALL POINTS ARE SCREWDRIVER ADJUST.
 3. ALL RESISTORS ARE 1/4W, 5% UNLESS OTHERWISE NOTED.
 4. ∇(-15V) DENOTES GUARDED LOGIC COMMON (G L COM (-15V)) WHICH IS -15V WITH RESPECT TO A/D COM.
 5. ALL VOLTAGES NOTED ARE WITH RESPECT TO A/D COM.



IC REF. DES.	PIN NO.	FUNCTION
U1	16	B

REFERENCE DESIGNATIONS	
LAST USED	NOT USED
CR10	S22
K10	U1
Q12	
R34	R30-32

2200A-1029
 Low Level Scanner PCB Assembly

Figure 9-13. Option -600, Low Level Scanner Module (cont)

