

# 2240C Data Logger

Instruction Manual

P/N 581348  
February 1981

©1980, John Fluke Mfg. Co., Inc., all rights reserved Litho in U.S.A.



2240C  
Table of Contents

SECTION	TITLE	PAGE
1	INTRODUCTION AND SPECIFICATIONS.....	1-1
	INTRODUCTION.....	1-1
	Front Panel.....	1-1
	Display.....	1-2
	Printer.....	1-3
	Power Supply.....	1-3
	Control Logic.....	1-3
	A/D Converter.....	1-3
	Options and Accessories.....	1-3
	SPECIFICATIONS.....	1-4
2	OPERATING INSTRUCTIONS.....	2-1
	INTRODUCTION.....	2-1
	SHIPPING INFORMATION.....	2-1
	INPUT POWER.....	2-1
	RACK INSTALLATION.....	2-1
	OPERATING FEATURES.....	2-1
	OPERATING NOTES.....	2-1
	AC Line Connection.....	2-2
	Printer Paper Installation.....	2-2
	Printer Ribbon Installation.....	2-3
	Option Information.....	2-3
	Scanner Extension.....	2-4
	Internal Switch Settings.....	2-4
	A/D Converter Speed.....	2-4
	Program Memory.....	2-4
	Individual/Block Mode.....	2-5
	Remote Control.....	2-5
	Power Failure.....	2-6
	Output Control.....	2-6
	Scan Control.....	2-7
	Display Control.....	2-8
	Print/Record Format.....	2-9
	Fixed Data.....	2-9
	Improper Program Data.....	2-9
	Programmable Limits.....	2-9
	Program List.....	2-10
	Audio-Tone Keyboard.....	2-10
	OPERATION.....	2-11
	Turn-on Procedure.....	2-11
	Turn-Off Procedure.....	2-11
	Entering Program Data.....	2-11
3	THEORY OF OPERATION.....	3-1
	INTRODUCTION.....	3-1
	OVERALL FUNCTIONAL DESCRIPTION.....	3-1
	BLOCK DIAGRAM DESCRIPTION.....	3-2
	Introduction.....	3-2

	Controller PCB Assembly.....	3-3
	Keyboard Switch and Keyboard	
	Logic Assemblies.....	3-5
	Keyboard Memory PCB Assemblies.....	3-7
	Mode Switch PCB Assemblies.....	3-7
	Display PCB Assembly.....	3-9
	Printer Drive PCB Assembly.....	3-10
	Power Supply PCB Assembly.....	3-11
	Range and Function Memory PCB Assembly	3-12
	Guard Crossing PCB Assembly.....	3-13
	A/D Converter.....	3-14
4	MAINTENANCE.....	4-1
	INTRODUCTION.....	4-1
	SERVICE INFORMATION.....	4-1
	GENERAL MAINTENANCE.....	4-1
	Access Information.....	4-1
	Cleaning.....	4-3
	Lubrication.....	4-3
	Internal Switch Settings.....	4-4
	Fuse Replacement.....	4-5
	Service Tools.....	4-6
	PERFORMANCE TEST.....	4-6
	Set-up Procedure.....	4-6
	Display and Data Entry Test.....	4-7
	Data and Time Test.....	4-8
	Scan Format Test.....	4-9
	Channel Programming Test.....	4-11
	Scan Control Test.....	4-13
	Output Control Test.....	4-14
	Display Control Test.....	4-15
	Limits Test.....	4-15
	A/D Converter Accuracy Test.....	4-16
	mx+b Scaling Test.....	4-17
	CALIBRATION.....	4-18
	Initial Procedure.....	4-19
	Power Supply.....	4-19
	A/D Converter.....	4-19
	Temperature and Scaling Option.....	4-22
	Isothermal Block Connectors.....	4-22
	TROUBLESHOOTING.....	4-22
5	LIST OF REPLACEABLE PARTS.....	5-1
	INTRODUCTION.....	5-2
	HOW TO OBTAIN PARTS.....	5-3
6	OPTIONS AND ACCESSORIES.....	6-1
	INTRODUCTION.....	6-1
	ACCESSORIES.....	6-1
	OPTIONS.....	6-1
	TABLE OF CONTENTS.....	6-2
7	GENERAL INFORMATION.....	7-1





## List of Illustrations

FIGURE	TITLE	PAGE
	Frontispiece.....	v
1-1.	Outline Drawing.....	1-4h
2-1.	2240C Front Panel Controls and Indicators....	2-1a
2-2.	Properly Installed Ribbon.....	2-3a
2-3.	Threading Direction for Ribbon Spools.....	2-3a
2-4.	2240C Option Installation Locations.....	2-4a
2-5.	Remote Control Configurations.....	2-5a
2-6.	Typical Format of Printed Measurement Data...	2-9a
2-7.	Typical Format of Program List Data.....	2-10a
2-8.	Program Form, Recommended Format.....	2-17a
2-9.	Programming Guide.....	2-17c
3-1.	2240C Data Logger, Simplified Block Diagram..	3-1a
3-2.	2240C Data Logger, Detailed Block Diagram....	3-3a
3-3.	Two Phase Clock Timing Diagram.....	3-4a
3-4.	Keyboard Switch and Keyboard Logic, Simplified Block Diagram.....	3-5a
3-5.	Keyboard Memory, Simplified Block Diagram....	3-7a
3-6.	Mode Switch, Simplified Block Diagram.....	3-7b
3-7.	Display, Simplified Block Diagram.....	3-9a
3-8.	Printer Drive, Simplified Block Diagram.....	3-10a
3-9.	Power Supply, Simplified Block Diagram.....	3-11a
3-10.	Range and Function Memory PCB Block Diagram..	3-12a
3-11.	Guard Crossing, Simplified Block Diagram.....	3-13a
3-12.	General Purpose A/D Converter PCB Assembly Functional Block Diagram.....	3-15a
3-13.	A/D Converter Timing Diagram.....	3-16a
4-1.	Lubrication Chart.....	4-3a
4-2.	Internal Switch Locations.....	4-4a
4-3.	2240C Test Cable.....	4-6a
4-4.	Power Supply Test Point and Adjustment Locations.....	4-19a
4-5.	A/D Converter Test Point and Adjustment Locations.....	4-19b
4-6.	Measurement Point Locations for Troubleshooting (Bottom View).....	4-23a

## List of Tables

TABLE	TITLE	PAGE
1-1.	2240C Option Information.....	1-3a
1-2.	Description of -12, -13, -14, and -17 Series Options.....	1-3b
1-3.	2240C Accessories.....	1-3c
1-4.	2240C Specifications.....	1-4a
1-5.	System Speed (Channels/Second).....	1-4g
2-1.	2240C Front Panel Controls and Indicators....	2-1b
2-2.	Internal Switch Information.....	2-4b
2-3.	Data Recorded By Various Scan Control and Output Control Modes.....	2-6a
3-1.	Control Bus Address Codes.....	3-1b
3-2.	Display LED Addresses and Functions.....	3-9b
3-3.	Guard Crossing Signal Descriptions.....	3-16b
4-1.	Recommended Test Equipment.....	4-1a
4-2.	A/D Converter Accuracy Test Specifications...	4-16a
4-3.	Troubleshooting.....	4-23b

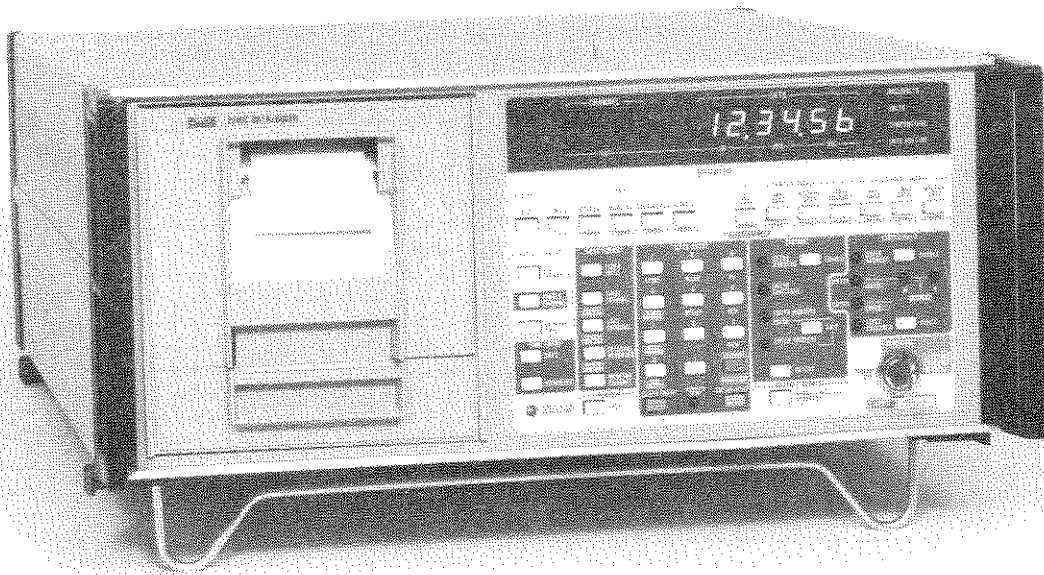

2240C Data Logger Frontispiece

*Multi  
channels.  
with all data*

## Section 1 Introduction and Specifications

### 1-1. INTRODUCTION

1-2. The Fluke Model 2240C Data Logger in its basic form is a processor and recorder which, through the use of optional plug-in modules, is expandable into a user-designed data acquisition system capable of servicing up to 1000 channels of guarded analog data. The basic unit is contained within a mechanical housing and consists of a front-mounted control panel, a digital display, a digital printer, a power supply, the control logic required to interface the basic unit with a full complement of options, an A/D converter and guard crossing, and a series of pcb and module slots designed to accommodate a number of plug-in options. To form an operational data acquisition system, the 2240C must be equipped with at least one each of the two following options: a scanner (Option -05, -06 or -33) and a scanner input connector (Option -03, -07 or -08).

### 1-3. Front Panel

1-4. The front panel of the 2240C features all of the controls necessary to operate the unit with a full complement of options. The controls consist primarily of pushbutton switches which are separated into 10 unique groups. Five groups perform control functions and five groups are dedicated to programming the 2240C. The control group includes: Power, OUTPUT CONTROL, PROGRAM LIST, SCAN CONTROL, and DISPLAY CONTROL. The program groups include: TIME ENTRY, SCAN FORMAT, PROGRAMMING (CHANNEL, AVERAGING,  $mx + b$ , and LIMITS), ADVANCE ADDRESS, and DATA ENTRY.

1-5. The 2240C is energized when the power switch is set to POWER ON or KEYBOARD PROGRAM DISABLE. In the POWER ON position, all control functions are enabled. In KEYBOARD PROGRAM DISABLE, all control functions except OUTPUT CONTROL and SCAN CONTROL are enabled. If channel programming data has been previously entered into memory (via the front panel programming switches), any one of four unique scan modes (single, interval, monitor, or continuous) can be started and/or stopped using the SCAN CONTROL switches. During a scan sequence, analog data present at program-selected channels is measured and displayed at the 2240C front panel. When desired, this measurement data can also be recorded on either the internal printer and/or an external recording device. The recording devices to be used and the type of data to be recorded are selected by the OUTPUT CONTROL and the SCAN CONTROL switch groups. While measurement data is being recorded, alternate forms of data (date and time or single channels) can be selected and displayed by depressing the appropriate switches in the DISPLAY CONTROL group. Similarly, an alternate form of data, program list, can be recorded when the SCAN CONTROL switches are reset and the internal printer is enabled to print all data. When the PROGRAM LIST switch is depressed under these conditions, the contents of the keyboard

controlled program memory are recorded on the internal printer. If a Remote Program Option (-15 or -17) is installed, a program list can be requested and output via the option.

1-6. The programming switch groups are enabled when the POWER switch is set to POWER ON. Program data is manually entered via the DATA ENTRY keyboard and the specific kind of data to be entered is determined by selecting it from either the TIME ENTRY, SCAN FORMAT, or PROGRAMMING (CHANNEL, AVERAGING,  $mx + b$  and LIMITS) switch groups. Time is entered in days, hours, minutes, and seconds, and is easily synchronized to the true time-of-day. The scan format can be randomly programmed to define: 6 digits of fixed data, first and last channel in a scan sequence, time interval between the start of scan sequences when the interval scan control mode is initiated, and the single channel to be monitored when the monitor scan control mode is initiated. Channel programming switches enable unique measurement functions and measurement limits to be assigned to each channel in the scan format. If one or more channels in the scan format are not to be used, a skip function can be programmed. Limits programming (Option -41) switches enable up to 60 unique 5-digit limit values (including HI/LO sense and polarity) to be programmed. Each limit is assigned a unique address code from 1 to 60, and any one of the limit values assigned to codes 1 through 15, 16 through 30, 31 through 45, and/or 46 through 60 can be assigned to any channel by entering the appropriate address codes while programming channel data.

1-7. In addition, 30 user-programmable math scaling functions are available with Option 2240C-40 installed. The scaling functions use the formula  $mx + b$ , and engineering units notation is also programmable. The Data Averaging Option (2240C-42) provides individual-channel time averaging and multi-channel group averaging. Up to 30 individual channels may be averaged over a selectable period from 2 to 99 readings. Also, up to 30 groups of channels may be averaged, with a maximum of 99 channels per group. A second averaging interval may be programmed by pressing the SECOND FUNCTION switch, then selecting the second interval.

#### 1-8. Display

1-9. The digital display is functionally two separate displays which are used for visually presenting the current measurement channel (three digits) and the current measurement data for that channel (polarity, plus five digits and a decimal point). During a normal scan sequence (first channel to last channel), the measurement channel is incrementally advanced as each channel measurement is completed, and continues to advance after each measurement until the last selected channel, (000 up to 999) is scanned. A series of annunciators complement the display and indicate the selected measurement function (volts, millivolts, or temperature) for the channel indicated. The display is also used during the scan intervals to present the

current date and time, and during programming sequences to display program data.

1-10. Printer

1-11. The printer employed in the 2240C is the Seiko Model 102. It is medium-speed, ink-impression line printer, capable of recording data at a maximum rate of 2.5 lines per second. Sixteen data columns are available. However, the print format for a scan sequence is fixed, as described in Section 2. Ordinary 2-1/4 inch fan-fold adding machine paper is used as the recording medium. A front-panel drawer is provided for both housing and take up of the self-stacking fan-fold paper.

1-12. Power Supply

1-13. The power supply provided with the 2240C is capable of servicing both the basic unit and a full complement of options. Input power requirements are 100, 115, or 230V ac  $\pm 10\%$ , 50 to 60 Hz, 50 watts maximum. The desired combination of line voltage and frequency should be specified at the time of purchase.

1-14. Control Logic

1-15. The control logic of the 2240C includes all of the circuitry necessary to accommodate a full complement of 2240C options. Two important features of the control logic are the program memory and the guard crossing. The program memory is impervious to line power interruption and can be maintained for several years after the 2240C is switched off. The memory is sustained by a lithium battery which is switched into operation when the line power is removed. The guard-crossing circuit electrically isolates the operation of the scanner blocks (Option -05 or -06 or -33) and the analog portion of the measurement circuit (A/D Converter) from the digital control and external equipment interface section of the 2240C.

1-16. A/D Converter

1-17. The A/D Converter and Guard Crossing pcbs operate in conjunction to form a programmable, four-range (40 mV, 400 mV, 4V, and 40V), dual-slope A/D Converter. All four ranges can be programmed via the Guard Crossing, and include a 40,000 count full-scale output capability. As a result, 1 uV can be accurately resolved on the 40 mV range.

1-18. Options and Accessories

1-19. Several options and accessories are available for use with the 2240C. The options, their quantity limitations and their installation requirements (factory or field) are listed in Table 1-1. Table 1-2 provides a description of the sub-options included in the -12, -13, -14, -15 and -17 series of options, and Table 1-3 describes the available 2240C accessories. Descriptions of

Table 1-1. 2240C Option Information

FUNCTION	OPTION NO.	DESCRIPTION	QUANTITY USED		CUSTOMER INSTALLED?
			MAX	MIN	
Input Connectors	-03	RTD Connector	6	1	Yes
	-07	Solder Pin Connector			
	-08	Isothermal Block Connector			
	-28	Current Transmitter 1-5 mA			
	-29	Current Transmitter 4-20 mA			
	-30	Current Transmitter 10-50 mA			
Scanners	-05	General Purpose Scanner	6	1	Yes
	-06	Low Level Scanner			
	-33	Eight Channel RTD Scanner			
Linearization	-43 ✓	Temperature ✓ Measurement	*1	0	No
	-44				
	-45				
Alarms	-41 ↖	Limits Option ✓	1	0	No
	-23	Alarm Set Point Output	2	0	Yes
Digital Input	-16	Digital Input Interface	3	0	Yes
Digital I/O	-15	Remote Programming Interface	*1	0	Yes
	-17				
Digital Output	-12	TTY RS-232-C	3	0	Yes
	-13	Paper Punch/Cassette Interface	3	0	Yes
	-14	Magnetic Tape Interface	3	0	Yes
Second Interval	-32	Dual Interval	1	0	No
Scaling	-40 ↗	mx + b Scaling and Engineering Units	1	0	No
Averaging	-42 ↗	Data Averaging	1	0	No

\*One per system

NOTE:

These options are subject to change. Please consult a Fluke Sales Representative for an up to date listing.

Table 1-2. Description of -12, -13, -14, -15 and -17 Series Options

OPTION NO.	DESCRIPTION	RECORDER TYPE	OPTION CONFIGURATION		
			RECORDER	CABLE	INTERFACE
12B	ASR33 Interface	Teleprinter		•	•
12C	T1733 KSR RO Interface			•	•
12L	RS-232C Data Terminal Interface			•	•
12M	RS-232C Modem Interface	Modem		•	•
12N	Tektronix 4923 and Interface	Cartridge, Mag Tape	•	•	•
13A	Facit 4070 (benchtop) and Interface	Paper Tape	•	•	•
13B	Facit 4070 (rackmount) and Interface	Punch	•	•	•
13C	Facit 4070 Interface			•	•
13D	Facit 4203 0005 and Interface	Cassette	•	•	•
13E	Facit 4203 0005 Interface			•	•
14A	Kennedy 1600/5 and Interface	Magnetic Tape	•	•	•
14B	Kennedy 1610/5 and Interface		•	•	•
14C	Kennedy 1600/360 and Interface		•	•	•
14D	Kennedy 1610/360 and Interface		•	•	•
14E	Kennedy 1600/5 or 1610/5 Interface		•	•	•
14G	Kennedy 1600/360 or 1610/360 Interface		•	•	•
14J	Kennedy 9853-9 and Interface		•	•	•
14K	Kennedy 9852-9 Interface		•	•	
15	IEEE Interface	Remote Programming			•
17A	Data Communication Interface			•	•
17B	Data Terminal Interface			•	•
17C	Current Loop (20mA) Interface			•	•
17G	Remote Interface PCB				•
17J	Columbia 300c Reader and Interface-115 Vac		•	•	•
17K	Columbia 300c Reader and Interface-100, 200, or 230 Vac		•	•	•



Table 1-3. 2240C Accessories

MODEL NO.	DESCRIPTION	FUNCTION
2201A	Scanner Chassis	Houses up to twelve -05, -06 or -33 scanners; operates up to 50 ft. from 2240C.
2202A	Remote Scanner Chassis	Houses up to ten -05,-06 or -33 scanners; operates up to 1500 ft. from 2240C.
2203A	RTD Scanner Chassis	Houses up to ten -04,-05,-06 or -33 scanners; operates up to 1500 ft. from 2240C.
2200A-7007	Interface Connector, Blank	I/O connector for use with option -16 or -23.
2200-7006	General Purpose Interface Cable (6-foot)	I/O connector and cable for use with option -16 or -23.
2200-7005	Service Extender Cable Set	Extends most 2240C PCBs for servicing.
A22-46	Maintenance Cable Set	Extends 2240C Keyboard Front Panel Assembly for servicing.
M07-205-600	Rack Mounting Kit	Rack-mounts 2240C in 19" wide console.
M00-280-610	Rack Slide Kit, 24" Cabinet	Slide-mounts 2240C in 19" wide X 24" deep cabinet.
2010A-7013	Fan-Fold Printer Paper (1 dozen)	Replacement printer paper.
2010A-7014	Printer Ribbon (1 dozen)	Replacement printer ribbon.

the options and accessories (all except 2201A, 2202A, and 2203A) are included in Section 6 of this manual. The 2201A, 2202A, and 2203A series of scanner chassis are documented in separate stand-alone instruction manuals.

1-20. SPECIFICATIONS

1-21. Specifications for the Model 2240C Data Logger are contained in Table 1-4. Specifications for the options are supplied in the appropriate option subsection in Section 6, Options and Accessories.

Table 1-4. 2240C Specifications

OPERATIONAL SPECIFICATIONS

Channel Capacity.....	60 Channels, expandable to 1000 channels using 2201A, 2202A, and/or 2203A Scanner Chassis
System Speed..... (Channels/Sec)	Refer to Table 1-5 for both 50 and 60 Hz system speeds.
Channel Display.....	3 digits
Data Display	
Numeric.....	Polarity plus 5 digits
Annunciator.....	mV, V, temperature, date and time
Scan Controls.....	Push button switches initiate the following sequences:
	SINGLE                                      CONTINUOUS
	INTERVAL                                      REMOTE
	MONITOR                                      STOP/RESET
Output Controls.....	Push button switches control internal printer and/or external recorder operation.
	PRINTER ENABLE                      EXTERNAL ENABLE
	ALL DATA                              ALL DATA
	LIMIT DATA                              LIMIT DATA
	INTERVAL DATA                      INTERVAL DATA
	PAPER ADVANCE
Display Control.....	Push button switches select one of the following functions for display:
	ALL CHANNELS                      DATE AND TIME
	SINGLE CHANNEL
Time Entry.....	Push button switches enable keyboard entry of 3-digit date (day) or time (HR, MIN, SEC). Clock operates from 50 or 60 Hz line frequency.
Scan Format.....	Push button switches enable keyboard entry of the following scan information:
	FIXED DATA                              INTERVAL-HR, MIN, SEC
	FIRST CHANNEL                              MONITOR CHANNEL
	LAST CHANNEL
Program List.....	Push button switch enables printer to record contents of program memory. This includes: channel number, range and function, limits address, limits value, fixed data, monitor channel, time of year, first interval, second interval, mx+b address and values, and averaging mode.
Programming.....	Push button switches enable keyboard entry of unique program data for each of the channels.
	This includes:
	CHANNEL
	Address.....000-999
	Function.....40 mV, 400 mV, 4V, 40V, T0-T11, and Skip
	Address Limit A..... 1 through 15
	Address Limit B.....16 through 30
	Address Limit C.....31 through 45
	Address Limit D.....46 through 60

Table 1-4. 2240C Specifications (cont)

LIMITS

Address.....1 through 60  
 Sense.....High or Low  
 Polarity.....+ or -  
 Value.....-39990 to +39990 (with  
 mx + b option -99990 to +99990)

MX+B

Address.....1 through 30  
 m.....-9.9999 to +9.9999  
 b.....-99999 to +99999

Decimal Point

location.....0 (xxxxx)  
 1 (xxxx.x)  
 2 (xxx.xx)  
 3 (xx.xxx)  
 4 (x.xxxx)

Engineering

Units.....Selectable, 32

Advance Address..... Push button switch for step advancing channel, limit ,  
 mx+b, monitor channel, or single channel address.

Digital Printer

Print Speed.....2.5 lines/sec.  
 Print Mechanism..... Seiko Model 102  
 Column Capacity..... 16

Program Memory.....Nonvolatile with minimum life of 5 years (program data  
 is retained while power is off).

Options Required for

Operation.....Minimum of one Scanner PCB (Option -05, -06, or -33)  
 and one input connector (Option -03, -07, or -08).

A/D Converter

Compatibility.....Specifications apply when used with Low Level Scanner  
 option (Option -06).  
 Measurement Method.....Dual slope integration over 5 line cycles (slow speed), or  
 1 line cycle (fast speed).  
 Measurement Speed.....3 readings/second with integration over 5 line cycles  
 (slow speed), or 15 readings/second with integration over  
 1 line cycle (fast speed).  
 Dynamic Range..... $\pm 40,000$  counts ( $0 \pm 39,999$ ).  
 Ranges..... $\pm 40$  mV (1 uV resolution).  
 $\pm 400$  mV (10 uV resolution).  
 $\pm 4$  V (100 uV resolution).  
 $\pm 40$  V (1 mV resolution).  
 Input Impedance..... $>200M$  on all ranges except 40V range: input impedance is  
 $10M$  on 40V range. The A/D Converter uses a single-pole  
 R-C input filter. Its input impedance is initially  $39 k \Omega$ ,  
 and increases to  $\geq 200 M \Omega$ , when the filter is settled  
 (fully charged). Since settling time is not an operator  
 controlled function, the source impedance of the circuit  
 being measured must be  $<4 k \Omega$  to achieve the full  $200M$   
 input impedance, and thus, avoid filter settling errors.  
 See Figure 1. Refer to the A/D Converter theory of  
 operation for additional details.

Table 1-4. 2240C Specifications (cont)

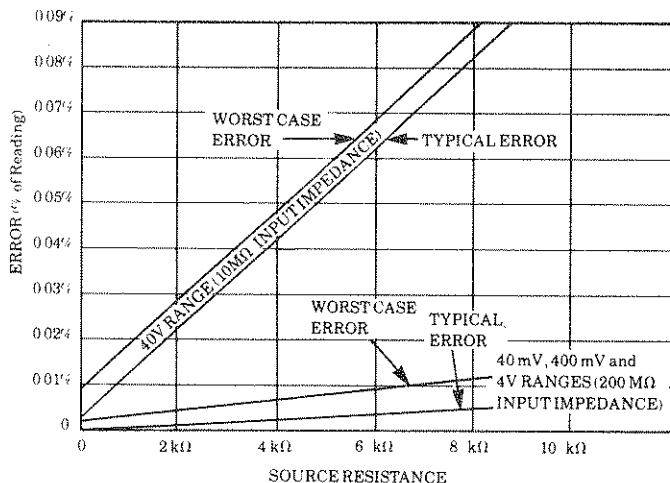

Figure 1. Input Impedance Error

Zero Stability.....	Automatic zero
Overload without Damage.....	170V dc or peak ac any range
Overrange Indication.....	Front panel display, printer and output indicate overrange.
Common Mode Rejection.....	140 dB at 50 and 60 Hz ± 0.1%. 120 dB at dc with 1 kΩ unbalance at slow speed. 110 dB at 50 and 60 Hz ± 0.1%, 120 dB at dc with 1 Ω unbalance at fast speed.
Common Mode Voltage.....	Maximum of 350V dc or peak ac. (see scanner specs for normal mode qualifications).
Normal Mode Rejection.....	70 dB at 50 and 60 Hz ± 0.1% fast speed.
Accuracy (system)	
90 days (20-30°C).....	± (0.01% reading + 0.005% range + 1 uV) slow speed. ± (0.01% reading + 0.008% range + 2 uV) fast speed.
1 Year (15-35°C).....	± (0.02% reading + 0.01% range + 2 uV) slow speed. ± 0.02% reading + 0.015% range + 4 uV) fast speed.
Thermocouples.....	See Table 1
Temperature	
Coefficient.....	± (0.001% reading + 0.001% range) per degree °C. (0-20°C and 30-50°C)
Reference Voltage	
For Self Check.....	Available via 2 jacks at the rear of the instrument.
Reference Voltages.....	2V, 0.02V
Reference Accuracy.....	± 0.002%, 90 days, 20°C-30°C
Reference Stability.....	± 0.003%/°C ± 0.003%/year

GENERAL SPECIFICATIONS

Dimensions.....	17.8 cm H x 43.2 cm W x 57.1 cm D (7 in. x 17 in. x 22.47 in.) Refer to Figure 1-1.
-----------------	---

Table 1-4. 2240C Specifications (cont)

Table 1. Thermocouple Total Instrument Accuracy

TEMPERATURE RANGE	WORST CASE RESOLUTION	NBS CONFORMITY	SYSTEM ACCURACY		
			90 DAYS 77°F ± 9°F 25°C ± 5°C		1 YEAR 77°F ± 18°F 25°C ± 10°C
			** SLOW	*** FAST	** SLOW
J Iron - Constantan					
°F -332 to -200	0.2°	0.15°	1.0°	1.2°	1.2°
-200 to 32	0.1°	0.15°	0.8°	0.9°	1.0°
32 to 1400	0.1°	0.1°	0.7°	0.8°	0.7°
1400 to 2200	0.1°	0.3°	0.8°	0.9°	1.0°
°C -202 to 0	0.1°	0.083°	0.6°	0.7°	0.7°
0 to 760	0.1°	0.055°	0.4°	0.5°	0.5°
760 to 1205	0.1°	0.166°	0.5°	0.6°	0.6°
K Chromel - Alumel					
°F -332 to -300	0.3°	0.175°	1.2°	1.4°	1.5°
-300 to -200	0.2°	0.175°	1.0°	1.2°	1.3°
-200 to 32	0.2°	0.175°	0.8°	1.0°	1.1°
32 to 500	0.1°	0.15°	0.7°	0.8°	0.8°
500 to 2500	0.1°	0.15°	0.8°	0.9°	1.0°
°C -202 to -172	0.2°	0.1°	0.7°	0.8°	0.9°
-172 to -130	0.1°	0.1°	0.6°	0.7°	0.8°
-130 to 0	0.1°	0.1°	0.5°	0.6°	0.6°
0 to 260	0.1°	0.083°	0.4°	0.5°	0.5°
260 to 1370	0.1°	0.083°	0.5°	0.6°	0.6°
T Copper - Constantan					
°F -332 to -300	0.2°	0.1°	1.0°	1.4°	1.5°
-300 to -200	0.1°	0.1°	0.9°	1.2°	1.3°
-200 to 32	0.1°	0.1°	0.8°	1.0°	1.1°
32 to 750	0.1°	0.1°	0.6°	0.7°	0.8°
°C -202 to -130	0.1°	0.055°	0.6°	0.8°	0.8°
-130 to 0	0.1°	0.055°	0.5°	0.6°	0.7°
0 to 400	0.1°	0.055°	0.4°	0.5°	0.5°
E Chromel - Constantan					
°F -332 to -240	0.2°	0.175°	0.9°	1.0°	1.1°
-240 to 32	0.1°	0.175°	0.8°	0.9°	1.0°
32 to 500	0.1°	0.11°	0.6°	0.7°	0.7°
500 to 1830	0.1°	0.11°	0.6°	0.7°	0.7°
°C -202 to 0	0.1°	0.1°	0.5°	0.6°	0.6°
0 to 260	0.1°	0.1°	0.4°	0.5°	0.5°
260 to 960	0.1°	0.07°	0.4°	0.5°	0.5°
R Pt. 13% Rhodium					
°F 32 to 90	0.4°	0.2°	2.8°	3.6°	3.6°
90 to 500	0.3°	0.2°	2.4°	3.2°	3.2°
500 to 3200	0.2°	0.2°	1.6°	2.2°	2.4°
°C 0 to 260	0.2°	0.1°	1.5°	2.2°	2.2°
260 to 350	0.2°	0.1°	1.0°	1.2°	1.4°
350 to 1760	0.1°	0.1°	1.0°	1.4°	1.4°

\* NOT ANSI SYMBOL

\*\* SLOW SPEED = 2.5 READINGS/SEC.

\*\*\* FAST SPEED = 15 READINGS/SEC.

Table 1-4. 2240C Specifications (cont)

Table 1. Thermocouple Total Instrument Accuracy (cont)

TEMPERATURE RANGE	WORST CASE RESOLUTION	NBS CONFORMITY	SYSTEM ACCURACY		
			90 DAYS 77°F ± 9°F 25°C ± 5°C		1 YEAR 77°F ± 18°F 25°C ± 10°C
			** SLOW	*** FAST	** SLOW
S Pt. 10% Rhodium					
°F 32 to 90	0.4°	0.2°	2.8°	3.6°	3.6°
90 to 500	0.3°	0.2°	2.4°	3.2°	3.2°
500 to 3200	0.2°	0.2°	1.6°	2.2°	2.4°
°C 0 to 260	0.2°	0.1°	1.5°	2.2°	2.2°
260 to 550	0.2°	0.1°	1.0°	1.2°	1.4°
550 to 1760	0.1°	0.1°	1.0°	1.4°	1.4°
B Pt. 6% Rhodium vs. Pt. 30% Rhodium					
°F 896 to 1800	0.3°	0.14°	2.8°	3.6°	3.6°
1800 to 3308	0.2°	0.14°	2.0°	2.6°	2.6°
°C 480 to 1000	0.2°	0.08°	1.6°	2.4°	2.4°
1000 to 1820	0.1°	0.08°	1.2°	1.6°	1.6°
C* Tungsten 5% Rhenium vs. Tungsten 26% Rhenium					
°F 32 to 3632	0.2°	0.18°	1.2°	1.6°	1.6°
3632 to 4208	0.2°	13.5°	15.0°	16.0°	16.0°
°C 0 to 2000	0.1°	0.1°	0.7°	1.0°	1.0°
2000 to 2320	0.1°	7.5°	9.0°	9.5°	9.5°
D* (W3)* Tungsten 3% Rhenium vs. Tungsten 25% Rhenium					
°F 32 to 500	0.2°	0.22°	1.4°	1.8°	1.8°
500 to 3632	0.2°	0.22°	1.2°	1.6°	1.6°
3632 to 4208	0.2°	18.4°	20.0°	21.0°	21.0°
°C 0 to 260	0.1°	0.12°	0.8°	1.0°	1.0°
260 to 2000	0.1°	0.12°	0.7°	1.0°	1.0°
2000 to 2320	0.1°	10.2°	12.0°	12.5°	12.5°
G* Tungsten vs. Tungsten 26% Rhenium					
°F 410 to 800	0.2°	0.2°	1.6°	2.2°	2.2°
800 to 3632	0.2°	0.2°	1.4°	1.8°	1.8°
3632 to 4208	0.2°	13.8°	15.0°	16.0°	16.0°
°C 210 to 420	0.2°	0.12°	1.0°	1.4°	1.4°
420 to 2000	0.1°	0.12°	0.8°	1.0°	1.2°
2000 to 2320	0.1°	7.1°	8.0°	8.5°	8.5°
N (Nicrosil vs. Nisil)					
°F 32 to 824	0.2°	0.23°	0.4°	0.6°	0.7°
824 to 2354	0.2°	0.23°	0.5°	0.7°	0.9°
°C 0 to 440	0.1°	0.13°	0.2°	0.3°	0.4°
440 to 1290	0.1°	0.13°	0.3°	0.4°	0.5°

\* NOT ANSI SYMBOL

\*\* SLOW SPEED = 2.5 READINGS/SEC.

\*\*\* FAST SPEED = 15 READINGS/SEC.

Table 1-4. 2240C Specifications (cont)

Table 2. Thermocouple (DIN) Total Instrument Accuracy (cont)

TEMPERATURE RANGE	WORST CASE RESOLUTION	DIN CONFORMITY	SYSTEM ACCURACY		
			90 DAYS 77°F ± 9°F 25°C ± 5°C		1 YEAR 77°F ± 18°F 25°C ± 10°C
			** SLOW	*** FAST	** SLOW
<b>J DIN</b>					
Iron - Constantan					
°F -328 to 32	0.2°	0.15°	0.5°	0.7°	0.8°
32 to 1652	0.1°	0.15°	0.4°	0.5°	0.5°
°C -200 to 0	0.1°	0.08°	0.3°	0.4°	0.5°
0 to 900	0.1°	0.08°	0.3°	0.3°	0.3°
<b>K DIN</b>					
Nickelcrome - Nickel					
°F 32 to 500	0.1°	0.27°	0.4°	0.5°	1.1°
500 to 2372	0.1°	0.27°	0.7°	0.8°	1.0°
°C 0 to 260	0.1°	0.15°	0.3°	0.3°	0.6°
260 to 1300	0.1°	0.15°	0.4°	0.5°	0.6°
<b>T DIN</b>					
Copper - Constantan					
°F -328 to -202	0.2°	0.15°	0.5°	0.7°	0.8°
-202 to 32	0.1°	0.15°	0.5°	0.5°	0.6°
32 to 1112	0.1°	0.15°	0.4°	0.4°	0.5°
°C -200 to -130	0.1°	0.08°	0.3°	0.4°	0.5°
-130 to 0	0.1°	0.08°	0.3°	0.3°	0.3°
0 to 600	0.1°	0.08°	0.2°	0.2°	0.3°
<b>S DIN</b>					
Platinum 10% Rhodium					
°F 32 to 500	0.4°	0.16°	1.3°	1.7°	1.9°
500 to 1022	0.3°	0.16°	1.0°	1.2°	1.4°
1022 to 2882	0.2°	0.16°	1.1°	1.3°	1.5°
°C 0 to 260	0.2°	0.09°	0.7°	0.9°	1.1°
260 to 550	0.2°	0.09°	0.6°	0.7°	0.8°
550 to 1600	0.1°	0.09°	0.6°	0.7°	0.8°

\*\* SLOW SPEED = 2.5 READINGS/SEC.

\*\*\* FAST SPEED = 15 READINGS/SEC.

Weight.....Approximately 18.144 kg. (40 pounds) without options.

Power.....Specify one of the following combinations at time of purchase:

- 100V ac ± 10%, 50 Hz
- 115/230V ac ± 10%, 50 Hz
- 100V ac ± 10%, 60 Hz
- 115/230V ac ± 10%, 60 Hz

Warm-up Time.....One hour for full accuracy. Accuracy is reduced by 0.02% of range at initial power-up.



Table 1-4. 2240C Specifications (cont)

ENVIRONMENTAL SPECIFICATIONS	
Temperature	
Operating.....	0°C to +50°C
Storage.....	-40°C to +60°C
Humidity, Maximum.....	
	80% relative, non-condensing, 0 to +35°C.
	70% relative, non-condensing, +35 to +50°C.
Shock & Vibration.....	Meets MIL-T-288800A, Class 4

Table 1-5. System Speed (Channels/Second)

SCAN CONTROL MODE	A/D SPEED	ENABLED OUTPUT DEVICE									
		INTERNAL PRINTER		-14		-12 (110 BAUD)		-13		-17 (4800 BAUD)	
		VOLTS	TEMP.	VOLTS	TEMP.	VOLTS	TEMP.	VOLTS	TEMP.	VOLTS	TEMP.
Monitor	Fast	2.65	2.65	14.8 (12.3)	13.0 (12.1)	0.65	0.65	4.6	4.6	14.8 (12.3)	12.3 (11.5)
	Slow	2.65 (2.46)	2.65 (2.32)	2.96 (2.46)	2.78 (2.32)	0.65	0.65	2.96 (2.46)	2.78 (2.32)	2.96 (2.46)	2.78 (2.32)
Continuous or Interval	Fast	2.65	2.65	14.7 (12.3)	11.4 (11.0)	0.65	0.65	4.6	4.6	14.7 (12.3)	11.0 (10.7)
	Slow	2.65 (2.46)	2.65 (2.23)	2.96 (2.46)	2.69 (2.23)	0.65	0.65	2.96 (2.46)	2.69 (2.23)	2.96 (2.46)	2.68 (2.23)

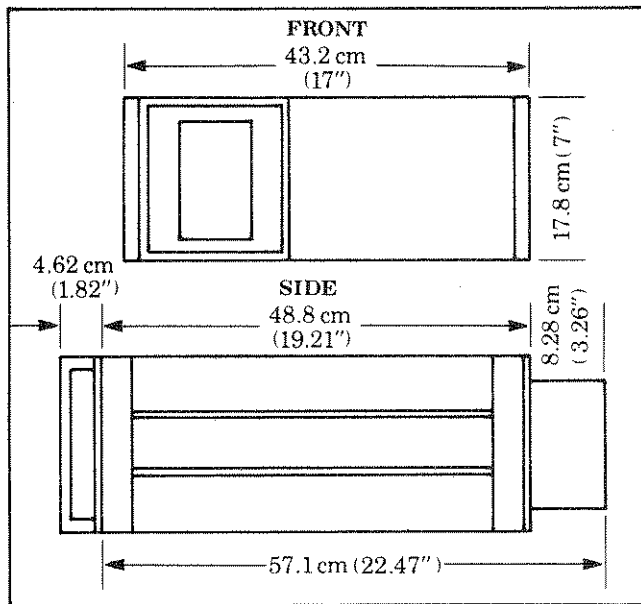

Figure 1-1. Outline Drawing

1  
2  
3  
4  
5  
6  
7  
8  
9  
10  
11  
12  
13  
14  
15  
16  
17  
18  
19  
20  
21  
22  
23  
24  
25  
26  
27  
28  
29  
30  
31  
32  
33  
34  
35  
36  
37  
38  
39  
40  
41  
42  
43  
44  
45  
46  
47  
48  
49  
50  
51  
52  
53  
54  
55  
56  
57  
58  
59  
60  
61  
62  
63  
64  
65  
66  
67  
68  
69  
70  
71  
72  
73  
74  
75  
76  
77  
78  
79  
80  
81  
82  
83  
84  
85  
86  
87  
88  
89  
90  
91  
92  
93  
94  
95  
96  
97  
98  
99  
100



# static awareness



A Message From  
**John Fluke Mfg. Co., Inc.**

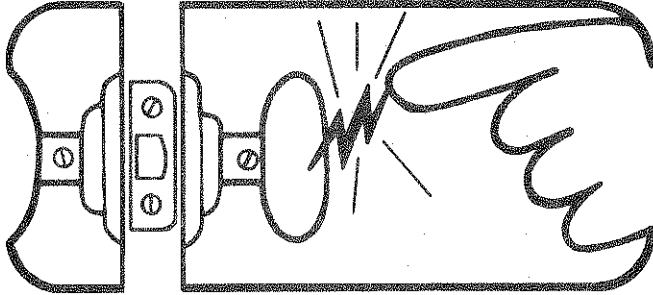

Some semiconductors and custom IC's can be damaged by electrostatic discharge during handling. This notice explains how you can minimize the chances of destroying such devices by:

1. Knowing that there is a problem.
2. Learning the guidelines for handling them.
3. Using the procedures, and packaging and bench techniques that are recommended.

The Static Sensitive (S.S.) devices are identified in the Fluke technical manual parts list with the symbol "⊗"

The following practices should be followed to minimize damage to S.S. devices.

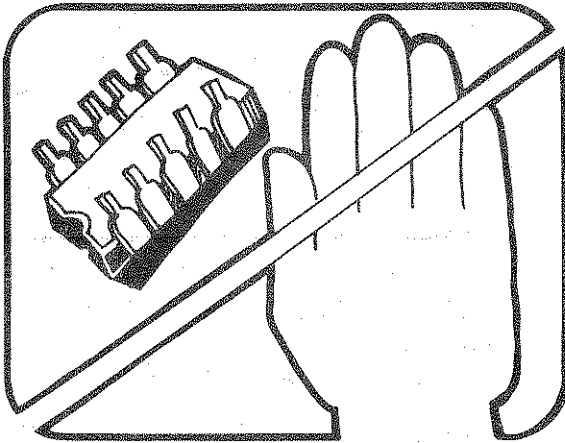

1. MINIMIZE HANDLING

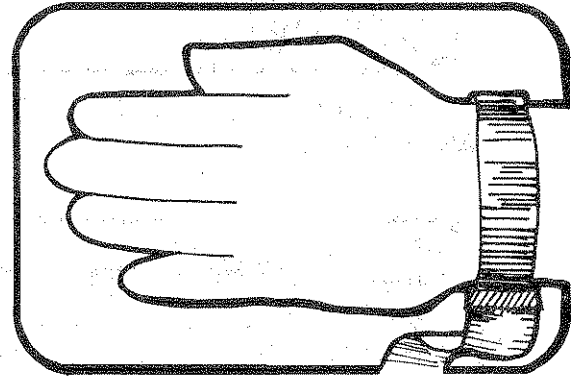

3. DISCHARGE PERSONAL STATIC BEFORE HANDLING DEVICES

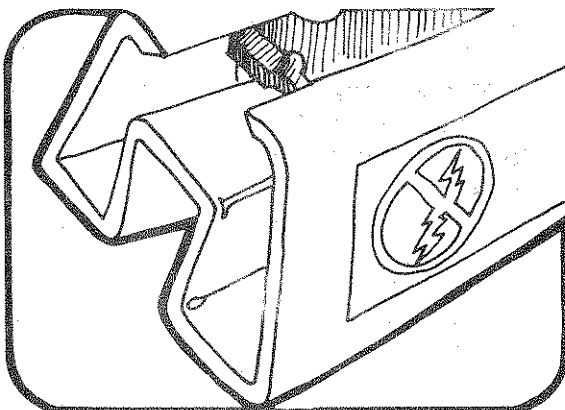

2. KEEP PARTS IN ORIGINAL CONTAINERS UNTIL READY FOR USE.

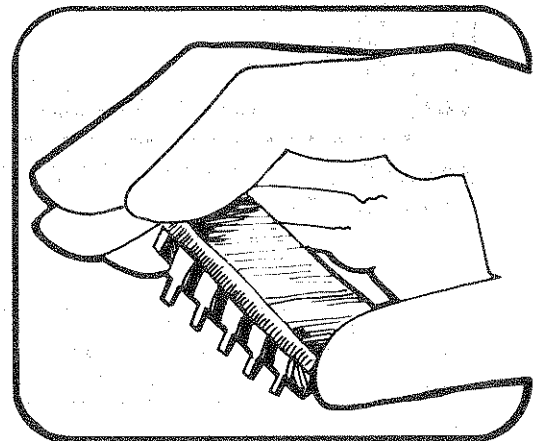

4. HANDLE S.S. DEVICES BY THE BODY

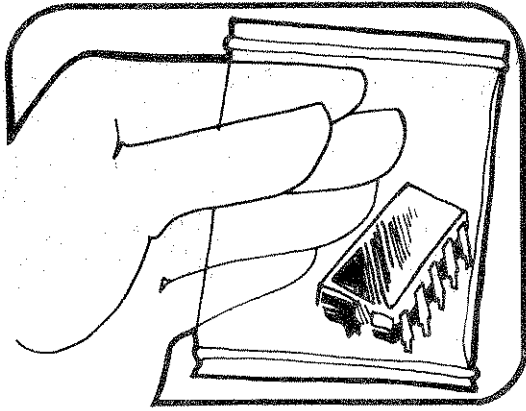

5. USE ANTI-STATIC CONTAINERS FOR HANDLING AND TRANSPORT

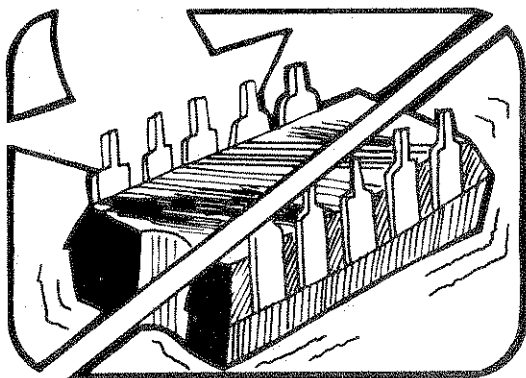

6. DO NOT SLIDE S.S. DEVICES OVER ANY SURFACE

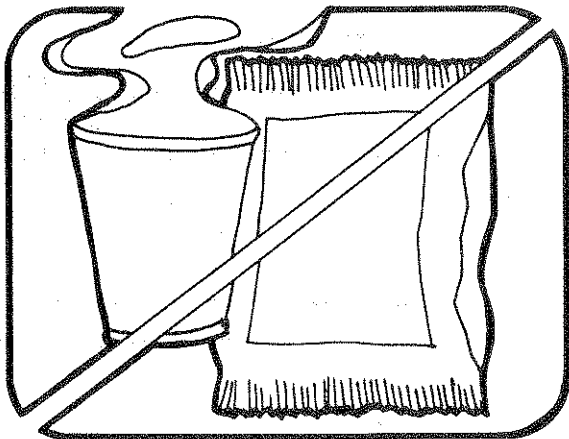

7. AVOID PLASTIC, VINYL AND STYROFOAM® IN WORK AREA

PORTIONS REPRINTED  
WITH PERMISSION FROM TEKTRONIX, INC.  
AND GENERAL DYNAMICS, POMONA DIV.

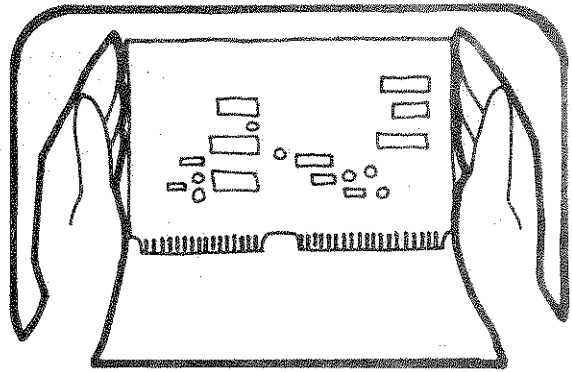

8. WHEN REMOVING PLUG-IN ASSEMBLIES, HANDLE ONLY BY NON-CONDUCTIVE EDGES AND NEVER TOUCH OPEN EDGE CONNECTOR EXCEPT AT STATIC-FREE WORK STATION. PLACING SHORTING STRIPS ON EDGE CONNECTOR USUALLY PROVIDES COMPLETE PROTECTION TO INSTALLED SS DEVICES.

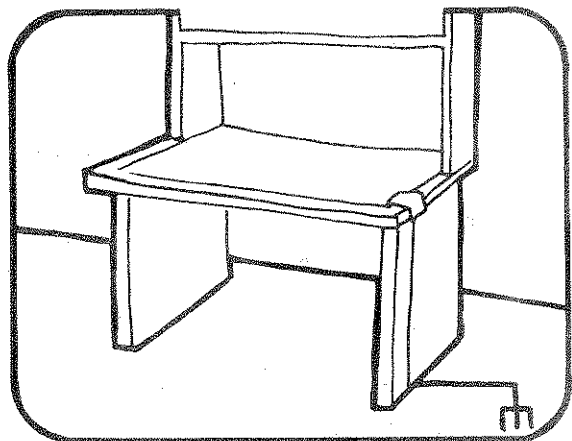

9. HANDLE S.S. DEVICES ONLY AT A STATIC-FREE WORK STATION  
10. ONLY ANTI-STATIC TYPE SOLDER-SUCKERS SHOULD BE USED.  
11. ONLY GROUNDED TIP SOLDERING IRONS SHOULD BE USED.

Anti-static bags, for storing S.S. devices or pcbs with these devices on them, can be ordered from the John Fluke Mfg. Co., Inc.. See section 5 in any Fluke technical manual for ordering instructions. Use the following part numbers when ordering these special bags.

John Fluke Part No.	Description
453522	6" X 8" Bag
453530	8" X 12" Bag
453548	16" X 24" Bag
454025	12" X 15" Bag
Pink Poly Sheet	Wrist Strap
30"x60"x60 Mil	P/N TL6-60
P/N RC-AS-1200	\$7.00
\$20.00	

## Section 2 Operating Instructions

### 2-1. INTRODUCTION

2-2. This section of the manual contains information concerning the installation and operation of the Model 2240C Data Logger. It is recommended that the contents of this section be read and understood before any attempt is made to operate the instrument. Should any difficulties arise during operation, contact your nearest John Fluke Sales Representative, or the John Fluke Mfg. Co., Inc., P.O. Box 43210, Mountlake Terrace, WA 98043; telephone (206) 774-2211. A list of sales representatives is given in Section 7.

### 2-3. SHIPPING INFORMATION

2-4. The 2240C is packaged and shipped in a foam-packed container. Upon receipt of the instrument, a thorough inspection should be made to reveal any possible shipping damage. Special instructions for inspection and claims are included in the shipping carton.

2-5. If reshipment of the instrument is necessary, the original container should be used. If the original container is not available, a new container can be obtained from the John Fluke Mfg. Co., Inc. Please reference the instrument's model number when requesting a new shipping container.

### 2-6. INPUT POWER

2-7. The 2240C can be operated from either 100, 115, or 230V ac, 50 or 60 Hz line power, depending upon the combination specified at the time of purchase. Check the rear panel decal for the voltage and frequency selected prior to shipment. If a change in either is required, refer to Section 4 of the manual for the proper selection procedures.

### 2-8. RACK INSTALLATION

2-9. The 2240C is designed for either bench-top use or for installation in a standard 19-inch equipment rack using the accessory Rack Mounting Kit (John Fluke P/N M07-205-600). Chassis slides (John Fluke P/N M00-208-610) can also be installed to facilitate access to the instrument when it is installed in an equipment rack. Information regarding the installation of the rack-mounting accessories is included in Section 6.

### 2-10. OPERATING FEATURES

2-11. The function and location of all 2240C controls and indicators is shown in Figure 2-1 and described in Table 2-1.

### 2-12. OPERATING NOTES

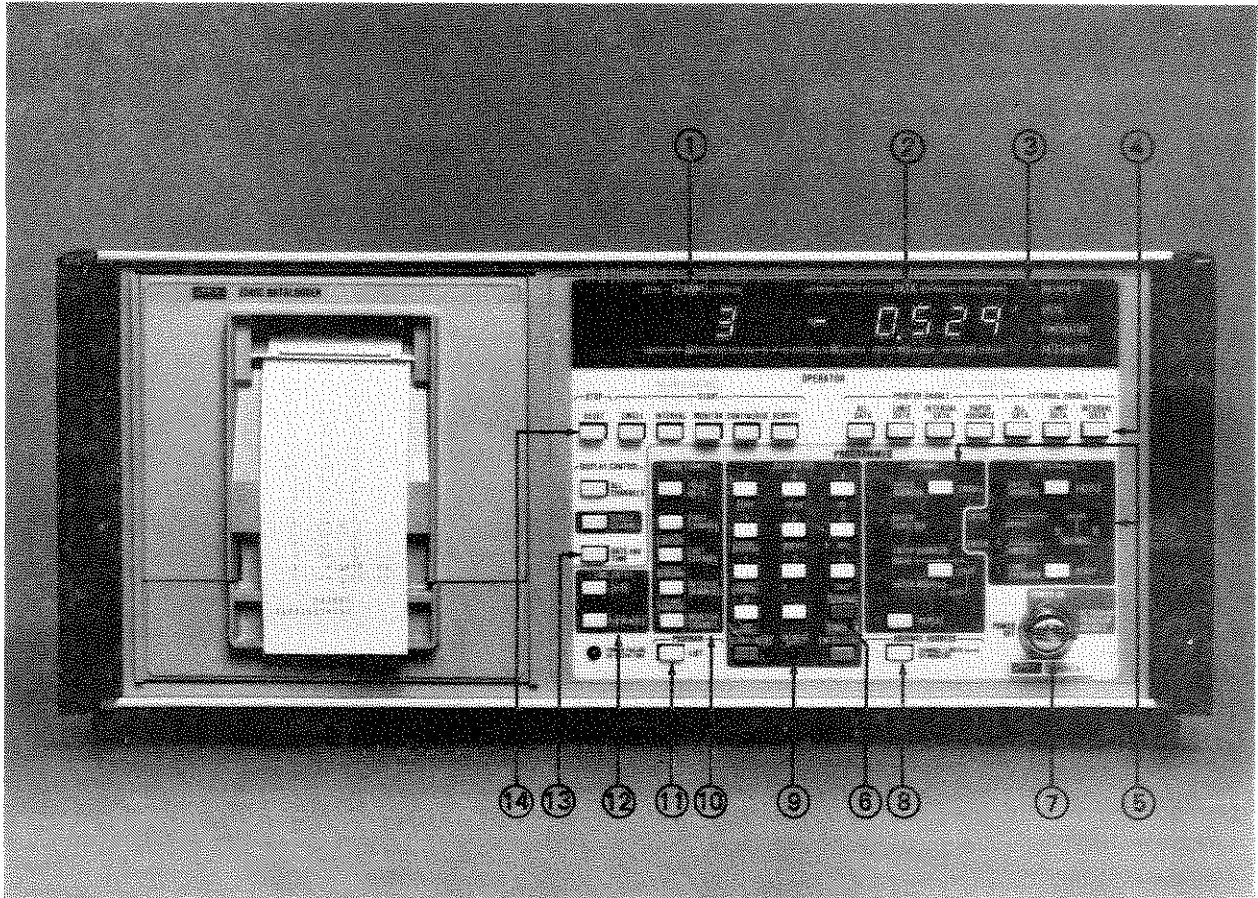

Figure 2-1. 2240C Front Panel Controls and Indicators

Table 2-1. 2240C Front Panel Controls and Indicators

REF. NO.	NAME	FUNCTION
1	CHANNEL/DAY	<p>A three-digit, multi-purpose display which provides any one of the following read-outs: CHANNEL, DAY, or limits address.</p> <p>CHANNEL data is displayed as a three-digit number from 000 to 999.</p> <p>DAY data is displayed as a three-digit date code from 000 to 999, and can be distinguished from CHANNEL data by a lit DATE AND TIME lamp in the display annunciator group.</p> <p>Limits address and mx + b data is displayed as a two-digit code. The left-most digit is blanked to distinguish it from both Channel and Day data.</p>
2	DATA/HR:MIN:SEC Display	<p>Six-digit display for any of the following: measurement data (voltage, temperature, ect.); time-of-day in hours, minutes, and seconds; programmed function; programmed limit value; programmed mx + b function; or Average mode and data.</p>
3	Display Annunciator	<p>Four LEDs which light on a mutually-exclusive basis to indicate the kind of data currently present on the CHANNEL/DATA display, or the limits group selected during programming.</p>
4	OUTPUT CONTROL Switches	<p>Seven push button switches, in two groups (EXTERNAL ENABLE and PRINTER ENABLE), that provide individual control over the type of data to be recorded on the printer and any external recording peripherals. Three switches in each group select ALL DATA, LIMIT DATA, INTERVAL DATA, or all of these. A fourth switch (PAPER ADVANCE) in the PRINTER ENABLE group manually advances the printer paper.</p>
5	PROGRAMMING Switches	<p>Three groups of push button switches (CHANNEL, LIMITS and mx + b) allow function, limit and scaling data to be assigned to each channel. Data is entered through the DATA ENTRY keyboard, and a program sequence for channel, limits or scaling is initiated by pressing the ENABLE switch in the appropriate group. A lamp is lit to prompt data entry. When data entry is completed, press the ENTER/STEP switch in the DATA ENTRY switch group to advance the sequence.</p>
6	SECOND FUNCTION Switch	<p>A push button switch that allows entry of a second interval, an averaging function, or mx + b scaling for each channel.</p>
7	Power Switch	<p>A three-position, key-operated switch controls 2240C power. In either the POWER ON or the KEYBOARD PROGRAM DISABLE position, the 2240C is operational. However, program data can be entered only with the switch in the POWER ON position. Removing the key with the switch in the KEYBOARD PROGRAM DISABLE position prevents tampering with, or accidental destruction of, program data.</p>
8	ADVANCE ADDRESS Switch	<p>A push button switch that sequentially advances the displayed channel, limits address, or mx + b address. It also advances the monitor channel address (when either mode is selected) to allow manual scanning of channels and the single channel address.</p>
9	DATA ENTRY Keyboard	<p>A general purpose, push button keyboard for entering variable program data. It works with the TIME ENTRY, SCAN FORMAT and PROGRAMMING switch groups. CLEAR ENTRY, ENTER/STEP and SECOND FUNCTION switches are also provided. An IMPROPER ENTRY lamp lights if an attempt to enter illegal data has been made.</p>
10	SCAN FORMAT Switches	<p>A series of push button switches that enable programming a scan format sequence through the DATA ENTRY keyboard. A fixed data heading, first and last channels, and first and second time intervals may be entered in the interval scan mode. In the monitor scan control mode, the MONITOR CHANNEL switch allows the monitored channel to be assigned through the keyboard.</p>



Table 2-1. 2240C Front Panel Controls and Indicators (cont)

REF. NO.	NAME	FUNCTION
11	PROGRAM LIST Switch	A push button switch used to initiate a printout of all limits data and the first channel through last channel data in program memory. The RESET switch (in the SCAN CONTROL group) and the ALL DATA switch (in the PRINTER ENABLE group) must be pressed before pressing the PROGRAM LIST switch. See Figure 2-8 for an example of data listed.
12	TIME ENTRY Switch	Push button switches that allow the data and time to be set via the DATA ENTRY keyboard. Separate switches provide for entry of the three-digit date or six-digit time-of-day. A power failure lamp included in this group indicates an interruption of power since the time was set.
13	DISPLAY CONTROL Switches	<p>Push button switches that provide manual selection of displayed data during a scan sequence. The switches will not interrupt the scan sequence or the recorded data.</p> <p>ALL CHANNELS: Selects all channels in a scan sequence for display. In INTERVAL SCAN mode, the day-of-year (3-digits) and time-of-day (6-digits) are displayed between scans.</p> <p>SINGLE CHANNEL: Allows a single channel to be addressed through the Data Entry Keyboard. The single channel is selected for display when ENTER/STOP is pressed. This procedure does not alter the scan sequence.</p> <p>DATE &amp; TIME: Selects the date and time for display.</p>
14	SCAN CONTROL Switches	<p>Six, mutually-exclusive, push button switches which select a scan control mode.</p> <p>STOP/RESET: Terminates any previously selected scan control sequence.</p> <p>SINGLE: Initiates the SINGLE scan control mode; i.e., one scan sequence is executed.</p> <p>INTERVAL: A scan sequence is initiated at programmed time intervals (primary and secondary).</p> <p>MONITOR: Initiates a continuously repeated scan of monitor channel.</p> <p>CONTINUOUS: Initiates a continuously repeated, sequential scan of all channels.</p> <p>REMOTE: In conjunction with any output option (-12, -13, -14), it provides remote start of a scan sequence. If Option -15 or -17 is installed, it enables remote programming of the 2240C.</p>

2-13. The following paragraphs describe various conditions which should be considered before operating the 2240C.

2-14. AC Line Connection

2-15. The rear-panel, three-prong, U-ground connector permits the 2240C to be connected, through a power cord, to either 100, 115, or 230V ac, 50 to 60 Hz line power. The offset prong on this connector is connected to the 2240C chassis and should be connected, via the power cord, to a high quality earth ground.

2-16. Printer Paper Installation

2-17. Standard 2-1/4 inch fan-fold adding machine tape is used as a recording medium for the printer. A package of fan-fold paper is shipped with the 2240C and should be installed before attempting to operate the unit. Use the following procedure for installing the printer paper:

NOTE

The printer is not designed to accommodate rolled paper tape.

1. Fully extend the tape drawer, raise the panel above the drawer to a horizontal position, and pull the paper cutter bar away from the print drum.
2. Pick up the paper pack so that the red marking (visible on one side of the package) is located on the bottom of the stack (some packs may not have the red marking).
3. Remove the band from the paper and fold out the top sheet. This provides a leader for loading the tape into the printer mechanism.
4. Hold the pack with the leader pointing on top and away from the printer. Then slide the pack deep into the tape drawer. When properly positioned, the front of the pack should be just behind the front panel.
5. Turn on the data logger using the procedure given later in this section under Operation.
6. Locate the arrow on the front of the printer mechanism. The arrow points to the paperfeed slot. Hold the paper leader in a horizontal position and insert it as far as possible into the feed slot (5/8 of an inch). Depress and hold the PAPER ADVANCE switch until 8 to 10 inches of leader has been fed through the printer mechanism.

7. Thread the leader through the paper cutter bar and press the bar back into position.
8. Thread the leader through the front panel opening and close the panel. Check to ensure that the paper is still free to advance.
9. The tape drawer should be left in the extended position, and used to store the printed tape expelled from the printer. Guide the first two or three folds into position in the drawer.

#### NOTE

Simplified paper loading instructions are given on a decal located in the bottom of the paper drawer.

#### 2-18. Printer Ribbon Installation

2-19. A printer ribbon is supplied with the 2240C and should be installed before attempting to operate the instrument. The ribbon installation location is accessible by raising the printer's front panel to the horizontal position. If the ribbon is already installed, refer to Figure 2-2 and check to ensure that the ribbon is properly positioned on the feed guides and that the ribbon spools are threaded in the proper direction. Use the following procedure for ribbon installation:

1. Separate the ribbon spools and lay them on a flat surface with their finger-side down.
2. Refer to Figure 2-3 and ensure that the ribbon is properly threaded on the spools.
3. On the printer mechanism, locate and push down the detecting lever of either spool shaft (see Figure 2-2) and with the finger-side of either spool pointer toward the printer mechanism, slide one of the spools onto the shaft.
4. Unwind 6 or 8 inches of ribbon from the remaining spool, if necessary, and position the ribbon over the feed guides as shown in Figure 2-2.
5. Depress the detecting lever on the empty spool shaft and slip the second spool onto the shaft. Make sure there are no twists in the ribbon.

#### 2-20. Option Information

2-21. The front panel operating instructions, given in this

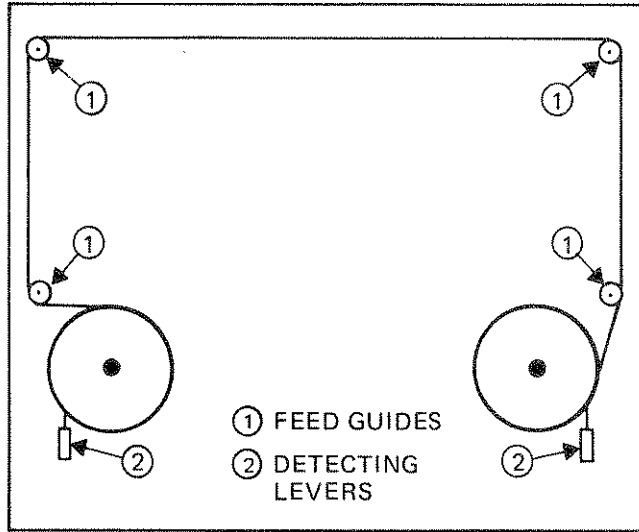

Figure 2-2. Properly Installed Ribbon

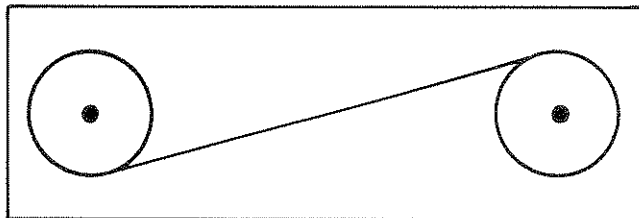

Figure 2-3. Threading Direction for Ribbon Spools

section of the manual, assume that the 2240C contains specific options as shown in Figure 2-4. However, additional operating information which is unique to a particular option, is contained in the appropriate subsection of Section 6, Option and Accessory Information.

#### 2-22. Scanner Extension

2-23. The channel scanning capability of the 2240C can be extended from 60 possible channels up to 1000 channels. The extension is accomplished through the use of one or more of the Model 2201A/2202A/2203A Scanner Chassis which are available as accessories. The units interconnect in a daisy-chain fashion, and the first unit in the chain connects to a rear-panel connector on the A/D Converter PCB (location B in Figure 2-4).

2-24. Each scanner chassis is capable of housing and controlling either 10 (2202A or 2203A) or 12 (2201A) scanner blocks. Since each block contains 10 channels, a total of 100/120 channels can be added with each scanner chassis included in the daisy-chain. The 2201A, 2202A, and 2203A Scanner Chassis are documented in separate stand-alone instruction manuals.

#### 2-25. Internal Switch Settings

##### WARNING

THE INTERNAL SWITCHES ARE FOR USE BY QUALIFIED PERSONNEL ONLY. TO AVOID ELECTRICAL SHOCK, DO NOT ATTEMPT TO SET THESE SWITCHES UNLESS YOU ARE QUALIFIED TO DO SO. SEE SECTION 4 OF THIS MANUAL OR THE APPROPRIATE OPTION, AS DEFINED IN TABLE 2-2.

2-26. Several control- and function-enable switches are contained on the interior of the 2240C. These switches are not intended for use by the operator, and are mentioned at this time for identification purposes only. Each of the switches is named and its location defined in Table 2-2. Instructions for properly setting each switch are also referenced.

#### 2-27. A/D Converter Speed

2-28. The measurement speed of the A/D Converter can be set by the operator for either 3 (slow) or 15 (fast) readings per second. The selection of measurement speed is accomplished by setting a slide switch on the A/D Converter PCB to the fast or slow position. The access procedure, the switch location, and the switch settings are described in Section 4, Maintenance.

#### 2-29. Program Memory

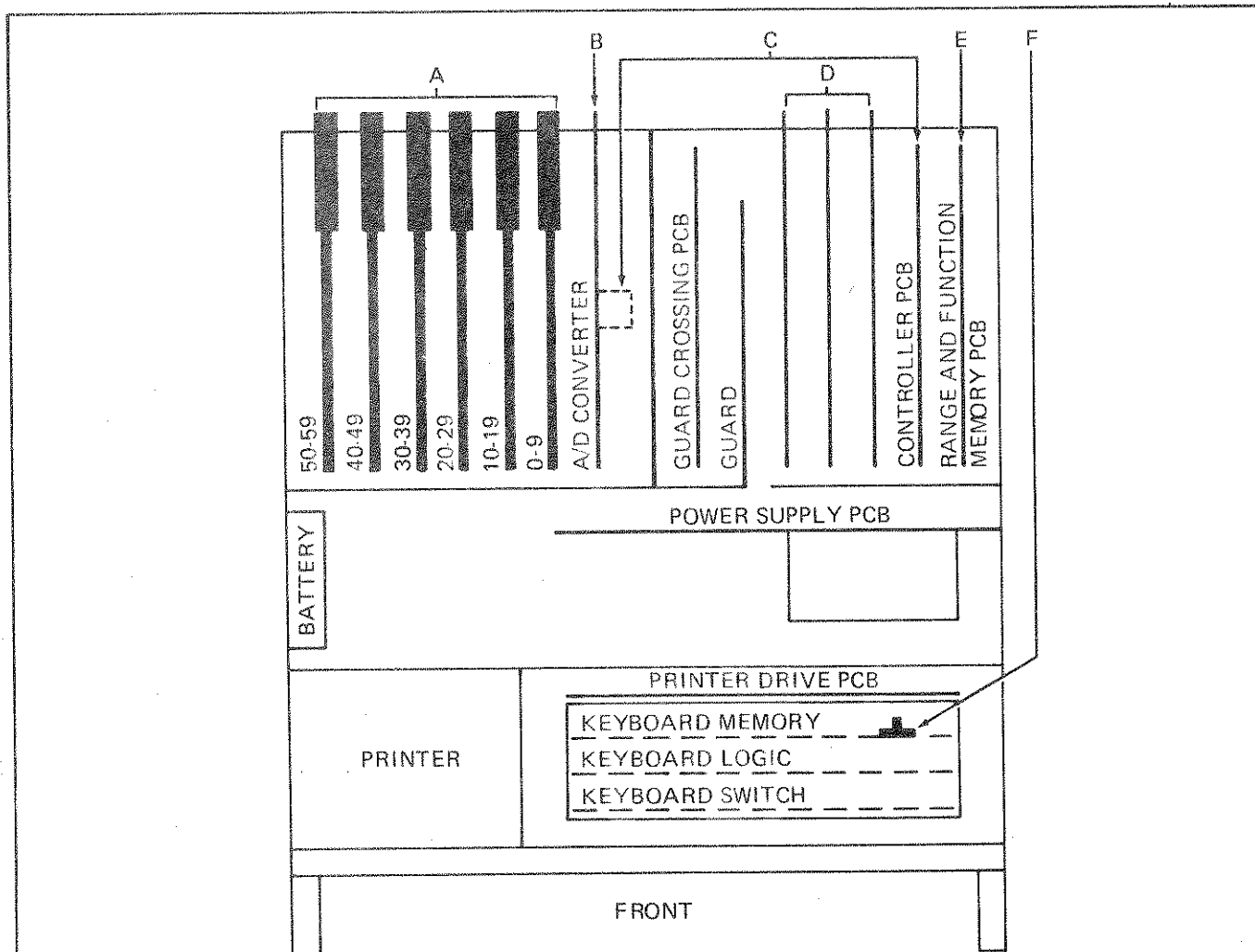

- A = SCANNER PCB'S (-05, -06, -33) AND THEIR INPUT CONNECTORS (-03, -07, -08, -28, -29, -30).
- B = A/D CONVERTER PCB
- C = TEMPERATURE OPTIONS (-43, -44, -45). THIS OPTION ALSO REQUIRES THE INSTALLATION OF LINEARIZING IC'S ON THE CONTROLLER PCB.
- D = I/O INTERFACE PCB'S (-15, -16, -17, -23, AND -12, -13, -14 SERIES).
- E = PROGRAMMABLE LIMITS (-41),  $mx + b$  (-40), IC'S LOCATED ON THE RANGE AND FUNCTION MEMORY PCB.
- F = SECOND INTERVAL OPTION (-32), DATA AVERAGING (-42) IC'S LOCATED ON KEYBOARD MEMORY PCB (UNDER MODE SWITCH PCB).

Figure 2-4. 2240C Option Installation Locations

Table 2-2. Internal Switch Information

SWITCH NAME	LOCATION	POSITION INFORMATION
50/60 Hz 115/230V ac °C/°F Block/Individual Local/Remote Alarms Once/All Fast/Slow	Power Supply PCB Power Supply PCB Controller PCB *3 Controller PCB *4 Controller PCB *1 Controller PCB *2 A/D Converter PCB	Section 4 Section 4 Option 43, 44 or 45 Section 4 Section 4 Section 4 Section 4
<p>*1. Switch 1 selects local (OFF) or remote (ON) when Option 15 or 17 is installed.                      *2. Switch 2 selects alarms once (OFF) or alarms all (ON).                      *3. Switch 3 selects the °C (OFF) or °F (ON) scale when Option 43,44 or 45 is installed.                      *4. Switch 4 selects the block (OFF) or individual (ON) mode of operation.</p>		

2-30. The 2240C is equipped with a nonvolatile memory which is impervious to power interruptions caused by either power failures or switching the instrument to power off. The memory is maintained under these conditions by a lithium battery which is switched into service when the line operated power supply is shut down. This battery will maintain the program memory for a minimum of 5 years.

#### 2-31. Individual/Block Mode

2-32. The basic 2240C contains the memory necessary to program up to 256 individual input channels. If more than 256 channels are required, the 2240C is operated in the block mode. That is, the first 170 channels are individually programmed and the last 830 channels are programmed as 83 blocks of 10 channels each. Thus, a total of 1000 channels (170 + 830) can be programmed when the unit is operated in the block mode.

2-33. The individual or block mode of operation is selected by a switch (#4) located on the Controller PCB Assembly on the interior of the 2240C (see Figure 4-2). The individual mode is selected when the switch is in the ON position; OFF selects the block mode.

#### 2-34. Remote Control

2-35. The 2240C is basically a manually controlled instrument. However, as shown in Figure 2-5, remote operation can be achieved through the addition of options. Currently, one of two remote control configurations is possible: remote start (of scan) or total remote control and programming. Remote start is enabled by the installation of one or more of the -12 through -14 output interface options. The addition of -15 or -17 Remote Programming Options enables remote control capability. It also overrides the remote start capability of Options -12, -13 and -14 and, at the same time, allows switch selection of one of two remote enable modes, local or remote. The local/remote switch (SW1) is located on the Controller PCB and functions as follows:

1. Local (switch 1 set to OFF)  
Allows local or remote control of the 2240C to be selected by the position of the REMOTE switch in the SCAN CONTROL group (IN = remote, OUT = local). All front panel controls with the exception of the REMOTE, PAPER ADVANCE, and DISPLAY CONTROL switches, are disabled when remote control is selected.
2. Remote (Switch 1 set to ON)  
Allows local or remote control to be selected by a remote command. Selecting remote control disables all front panel switches, except DISPLAY CONTROL and PAPER ADVANCE, and enables total remote control



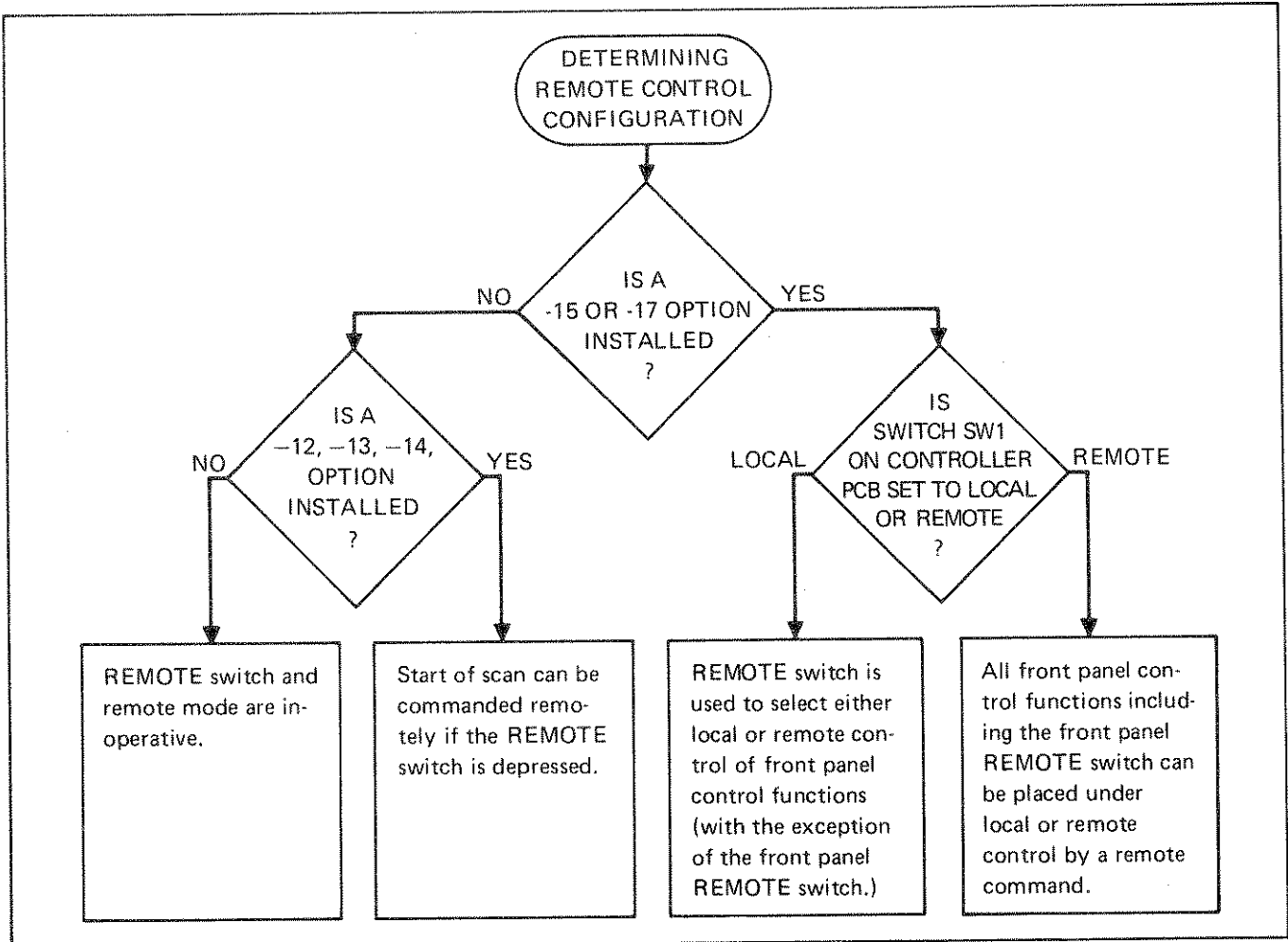

Figure 2-5. Remote Control Configurations

of all front panel functions. The REMOTE switch is disabled for both control modes.

#### 2-36. Power Failure

2-37. The TIME ENTRY switch group contains a lamp which blinks to indicate the occurrence of a line power interruption during normal operation of the 2240C. The lamp begins to blink after power is restored and serves as a visual flag to indicate that the displayed date and time is in error. The restoration of the line power resets the clock to zero, allowing it to operate as an elapsed time counter. Thus, the clock provides a direct readout of the time elapsed since power was restored. Instructions for resetting the clock are given later in this section under Operation.

#### 2-38. Output Control

2-39. The OUTPUT CONTROL switch group provides the operator with manual control over the operation of the data recording devices associated with the 2240C. The switches are divided into two separate groups: PRINTER ENABLE and EXTERNAL ENABLE. The PRINTER ENABLE switches apply only to the operation of the internal printer. The EXTERNAL ENABLE switches affect all external recording devices which are interfaced with the 2240C.

2-40. The function of the switches in both groups, as they apply to their respective recording devices, are identical with the exception of the printer's PAPER ADVANCE (paper feed) switch which is not featured in the EXTERNAL ENABLE group. Therefore, an explanation of the ALL DATA, LIMIT DATA, and INTERVAL DATA switches is sufficient to explain the operation of both switch groups.

2-41. The ALL DATA, LIMIT DATA, and INTERVAL DATA switches are of the push-push type and each is capable of independent operation. When all three switches are in the released or out position, the associated recording devices are inhibited from recording output data from the 2240C. Depressing one or more of the switches allows selected data to be recorded. Table 2-3 lists all of the possible switch combinations, the mode(s) in which data will be recorded, and the kind of data recorded.

#### NOTE

An Alarm Once/Alarm All switch (SW2) is located on the Controller PCB. It operates in conjunction with the LIMIT DATA switches of the OUTPUT CONTROL group to define the output record format under alarm conditions. See Table 2-3 for switch setting information.

Table 2-3. Data Recorded for Various Scan Control and Output Control Modes

OUTPUT CONTROL MODES			DATA RECORDED												
ALL DATA	ALARM DATA	INTERVAL DATA	APPLICABLE SCAN MODES				ALARM SWITCH (SW2) SETTING*	NONE	ALL SCAN SEQUENCE DATA	TIME OF YEAR, CHANNEL, MEASUREMENT DATA	ONCE EACH INTERVAL	ONCE UPON ENTERING & EXITING AN ALARM CONDITION	WHENEVER AN ALARM IS ENCOUNTERED	FOLLOWED BY: (See next line.)	ALARM AT ANY CHANNEL CAUSES ALL DATA IN NEXT SCAN TO BE RECORDED
			MONITOR	SINGLE	INTERVAL	CONTINUOUS									
○	○	○	/	/	/	/	X								
○	○	●	/	/	/	/	X			X					
○	●	●	/	/	/	ONCE			X		X				
○	●	●	/	/	/	ALL			X			X			
○	●	●	/	/	/	ONCE		↪X	X		X		X↪		
○	●	●	/	/	/	ALL		↪X	X			X		X↪	
●	○	○	/	/	/	-		X		X					
●	○	●	/	/	/	-		X							
●	●	○	/	/	/	ONCE		↪X	X		X		X↪		
●	●	○	/	/	/	ALL		X				X			X
●	●	●	/	/	/	ONCE		↪X	X		X		X↪		
								X		X					

NOTES:

- / = Any one may be selected.
- = Don't care
- X = Indicates format and timing of recorded data.
- \* = SW2 on Controller PCB. Alarms one = OFF. Alarms all = ON.
- = Selected
- = Not selected

2-42. Scan Control

2-43. The scan sequence can be manually controlled (when the power switch is set to POWER ON) by pressing one of the following five switches in the SCAN CONTROL group: STOP/RESET, SINGLE, INTERVAL, MONITOR, or CONTINUOUS. STOP/RESET allows termination of a previously selected scan sequence. SINGLE, INTERVAL, MONITOR, and CONTINUOUS allow separate variations of the scan sequence to be initiated. A sixth switch, REMOTE, operates in conjunction with Options -12, -13, -14, -15, and -17 and SW1 on the Controller PCB to enable the remote capabilities of the 2240C. See Remote Control earlier in this section of the manual.

NOTE

To avoid unwanted alteration of the switches in the SCAN CONTROL group, set the Power Switch to KEYBOARD PROGRAM DISABLE and remove the key from the switch.

2-44. The basic scan sequence is initiated by the SINGLE switch and is keyed to manually entered program data. A simplified sequence of events in the single scan mode is as follows:

1. The first channel relay in the program sequence closes and connects an external stimulus to the input of the A/D Converter.
2. The A/D Converter measures the input signal in terms of the programmed function (volts, millivolts, or temperature) and provides a digital display of the results.
3. The displayed value is compared with a programmed high and/or low limit value (Option -41).
4. If a recording device has been enabled, the channel, measurement, and function data are recorded. Also, prior to each scan sequence, the time of year and the fixed heading data are recorded.
5. The first channel relay is opened and the second channel relay in the sequence is closed to connect its external input to the A/D Converter.

NOTE

Channels between the first and last channels can be skipped

under program control. Therefore, the measurement channels may be separated by several skipped channels. For example, the channel sequence might appear as follows: 1, 2, 8, 14, 15, 20, where channel 1 is the first channel and 20 is the last channel.

6. Steps 2, 3, and 4 are repeated.
7. The channel relay is opened and the next programmed channel relay is closed. Its input is measured, compared, and recorded.
8. Step 7 is repeated for each programmed channel until the last channel has been scanned.

2-45. Variations of the single scan mode include interval (standard interval) and continuous. The interval scan mode causes the single scan sequence to be repeated at a programmed time interval. The time interval is the time between the start of one sequence and the start of the next sequence. Interval time can be programmed from a minimum of 1 second, for standard interval, to a maximum of 23 hours, 59 minutes, and 59 seconds (23:59:59). A 1-second resolution can be achieved for any interval time within the 24-hour limit. The continuous mode causes the scan sequence to be continuously repeated with a minimum time between the end of one sequence and the start of the next sequence (typically  $\pm 1$  second). A second interval is available as an option, See Section 6, Option -32.

2-46. The monitor scan mode allows the operator to monitor a single selected channel during a scan sequence. The monitored channel is addressed in conjunction with the MONITOR CHANNEL switch in the SCAN FORMAT group and the DATA ENTRY keyboard. Pressing the ADVANCE ADDRESS switch incrementally advances the monitor address and allows the operator to manually scan and measure the input present at each of the accessible channels. The monitor mode is useful for both program verification and troubleshooting.

2-47. Operation of the remote mode depends upon the combination of options installed in the 2240C. Figure 2-5 defines these option combinations and the remote capabilities of each. Details concerning the remote capabilities of each option purchased are given in Section 6 of this manual.

2-48. Display Control

2-49. The DISPLAY CONTROL switch group contains three switches which allow the operator to manually assign the display to read one of three types of data (All Channels, Single Channel, or Date

and Time). For example, assume that a continuous scan sequence is in progress and the operator initiates and/or executes a change in the scan format. The operator can exit the programming mode at any time and assign the display to read either all channel measurements, selected single channel measurements, or date and time. This is accomplished by pressing the appropriate switch in the DISPLAY CONTROL group and, if SINGLE CHANNEL is selected, entering channel number, and then pressing ENTER/STEP. Reassigning the display in this manner allows the operator to enter or verify program data without interrupting the scan sequence.

#### 2-50. Print/Record Format

2-51. Measurement data generated during a scan sequence can be recorded on the printer and/or any given external recording device interfaced with the 2240C. Examples of the recording format for any given scan sequence are shown in Figure 2-6. The examples assume the printer as the recording device.

#### 2-52. Fixed Data

2-53. Fixed data is a six-digit number which is recorded after the date and time. The number is manually entered by the operator to identify the program, lot, run, project, etc., associated with the scan sequence and can be any number from 000000 to 999999. Once entered, the number will remain fixed until a new one is entered.

#### 2-54. Improper Program Data

2-55. An IMPROPER ENTRY lamp is provided in the DATA ENTRY switch group to indicate that an attempt to enter illegal program data has been made. An operator error in format or data entry causes the lamp and the displayed data to begin flashing. As long as the lamp is flashing, the STEP/ENTER switch is inhibited to prevent the improper data from being entered into memory. The improper entry condition can be cleared by pressing the CLEAR ENTRY switch, or by entering new data. (When the keyboard program senses an error, it prepares itself to accept new data without the aid of the CLEAR ENTRY switch. CLEAR ENTRY is used primarily for correcting (erasing) partial entries and starting again.)

#### 2-56. Programmable Limits

2-57. Programmable measurement limits (Option -41) are available for up to 60 separate and variable values, each of which is addressable for use by all available channels. The limits are split into 4 equal groups, (1 to 15 (LIMIT A)), (16 to 30 (LIMIT B)), (31 to 45 (LIMIT C)), and (46 to 60 (LIMIT D)), and one limit from any or all groups can be assigned to a given channel. However, two limits from the same group cannot be assigned to the same channel. Therefore, when a channel measurement requires two or more limits, each must be taken from

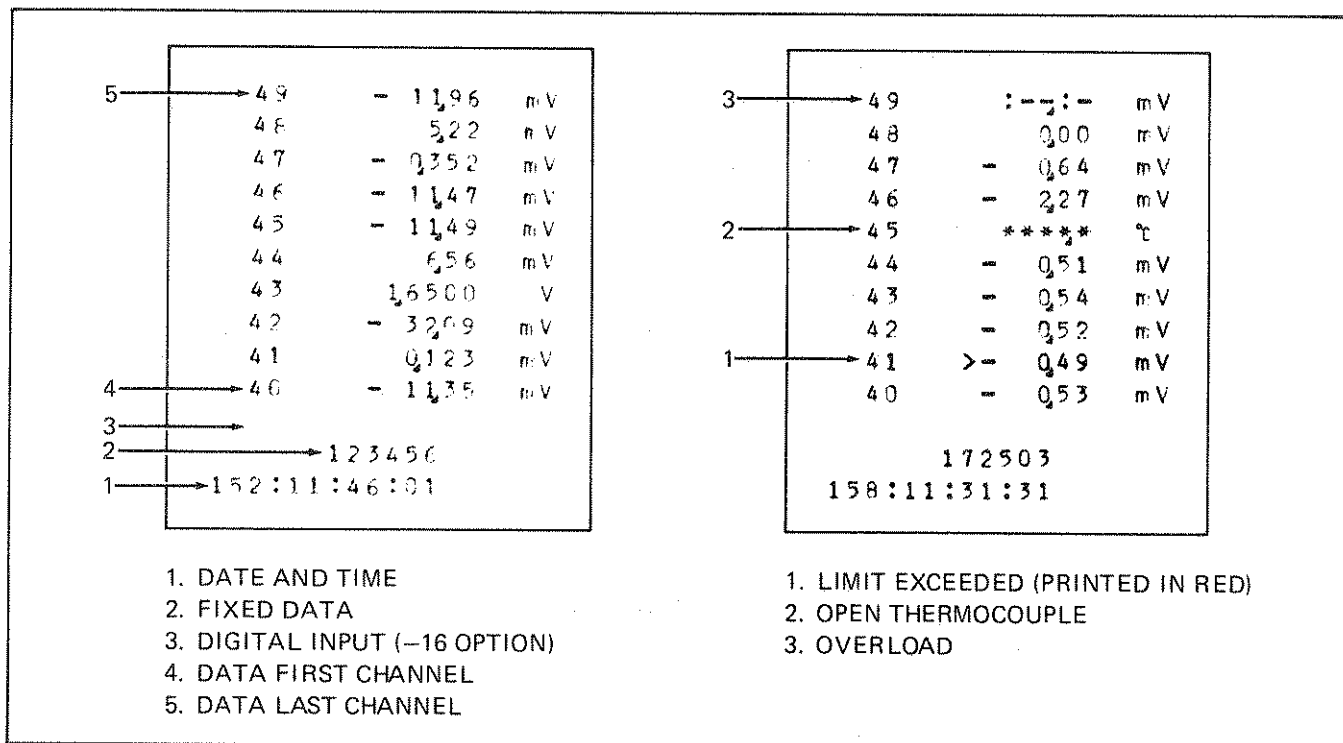

Figure 2-6. Typical Format of Printed Measurement Data

a separate limit group.

2-58. When a limit value is assigned to a channel it is compared directly with the measurement reading. Therefore, care must be taken to ensure that the limit's magnitude is compatible with the selected function and range and vice versa. For example, a limit value of 10000 can represent a limit of 10.000V, 1.0000V, 100.00 mV, 10.000 mV, 1000.00°F or 1000.00°C, depending upon the selected function.

2-59. When a limit is exceeded during a scan sequence, a LIMIT EXCEEDED lamp in the PROGRAMMING switch group begins to blink, and continues to blink until it is reset. The reset is accomplished by pressing the adjacent RESET switch. Recorded limit data is also identified as greater than (>) or less than (<) the specified limit. In addition, the printer records out-of-limits data in red for easy identification. The date and time is also printed prior to each out-of-limits measurement.

#### 2-60. Program List

2-61. The 2240C is equipped with a program list feature which allows the operator to solicit and record the contents of the program memory. The listed information includes date and time; time intervals; fixed data; monitor channel; all available limit addresses (60 maximum) and their respective sense, polarity, and value; and channel from first to last. Channel programming includes function and limit data assigned to each channel. A sample of the program list format is given in Figure 2-7.

2-62. The program list feature should be employed both before and after entering new program data. By listing the old program, the user will know what must be added to or deleted from memory during the reprogramming process. Listing a newly entered program allows the operator to verify its accuracy.

#### NOTE

The program list feature requires that both the ALL DATA switch in the PRINTER ENABLE group and the RESET switch in the SCAN CONTROL switch group be depressed prior to pressing the PROGRAM LIST switch.

#### 2-63. Audio-Tone Keyboard

2-64. As a programming aid, the 2240C includes the capability of rejecting the entry of both invalid and improperly formatted program data. The entry of each valid data character is accompanied by an audio tone when one of the keyboard switches is depressed. The tone indicates that the data is valid and has been accepted by the 2240C. The absence of the audio tone indicates



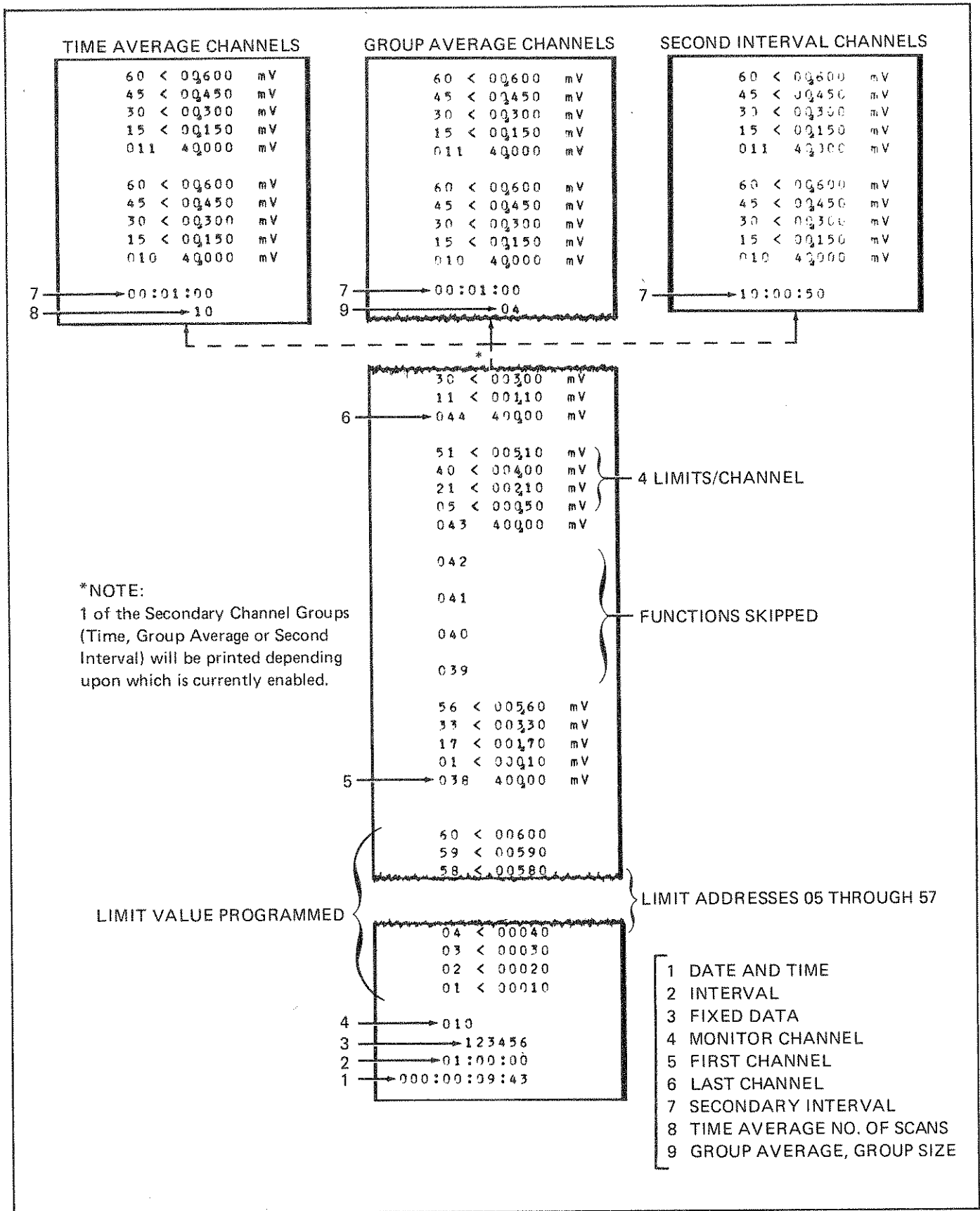

Figure 2-7. Typical Format of Program List Data

that the data is either invalid or improperly formatted and has not been accepted by the 2240C.

2-65. OPERATION

2-66. Turn-On Procedure

2-67. Use of the following procedure is suggested for initial turn-on of the 2240C. With reference to the previous paragraphs turn on the 2240C as follows:

1. Connect the 2240C to line power.
2. Install available options, as required.
3. Connect interface cables, as required.
4. Press the STOP/RESET switch in the SCAN CONTROL group.
5. Insert the key in the Power switch and set it to POWER ON. For approximately 3 seconds after turn-on, the DATA display indicates the model number of the data logger (2240C) followed by the control firmware version installed in the instrument (7 or higher). During this time, CHANNEL display remains blank unless either the -43, -44, or -45 Temperature Option is installed. If one of these options is present, a 43, 44, or 45 appears on the CHANNEL display. After the 3 seconds, the display indicates elapsed time starting at 000 00:00:03 (3 seconds).
6. Press the ALL DATA switch in the PRINTER ENABLE group.
7. Press the PROGRAM LIST switch. The program currently in memory will be printed.

2-68. Turn-Off Procedure

2-69. The turn-off procedure consists of a single step: Insert the key into the Power switch and set it to POWER OFF.

NOTE

The turn-off procedure will not clear or alter the program data present in the 2240C.

2-70. Entering Program Data

2-71. Meaningful operation of the 2240C requires the manual entry of a series of program words to define the variables

associated with a scan sequence. The procedures required to enter each variable are given in the following paragraphs. (Typical programming examples are provided in Figure 2-9.) Completion of the entire series of procedures, in the order given, is recommended to familiarize the inexperienced operator with the programming requirements of the 2240C. However, it is not necessary for the experienced operator to complete the procedures in the order given. Nor, is it necessary to complete an entire procedure. Thus, variables not affected can be omitted from any of the procedures.

NOTE

Generating a written program prior to entry simplifies the programming process and ensures duplication when reentering old programs. A recommended format for a program form is given in Figure 2-8.

NOTE

All programming procedures are summarized in a programming guide at the end of this section. See Figure 2-9.

2-72. INITIAL PROCEDURE

2-73. Perform the following procedure prior to attempting to program the 2240C:

1. Complete the turn-on procedure given earlier in this section.
2. Set the Power switch to POWER ON.
3. Release all switches in the EXTERNAL ENABLE section of the OUTPUT CONTROL group.

NOTE

After the 2240C has been programmed, accidental alteration of the program can be avoided by setting the Power switch to KEYBOARD PROGRAM DISABLE and removing the key from the switch.

2-74. TIME ENTRY

2-75. The date and time must be updated after the turn-on procedure is performed, and after a power interruption has

occurred. The POWER FAILURE/REENTER TIME lamp flashes to indicate that the clock is in error. Use the following procedure to update the date and time:

1. If the DAY display indicates the wrong date, press the DAYS switch in the TIME ENTER group. The HRS: MIN: SEC portion of the display will go blank.
2. On the DATA ENTRY keyboard, serially enter the Julian day of year or an equivalent three-digit date code. As each digit is entered, it will be presented on the DAY portion of the display. If the entry was made incorrectly, press the CLEAR ENTRY switch on the DATA ENTRY keyboard and then reenter the proper day.

NOTE

When using the DATA ENTRY keyboard, it is not necessary to enter leading zeros.

3. After the desired day is displayed, enter it into memory by pressing the ENTER/STEP switch on the DATA ENTRY keyboard. The DATA display should now be illuminated.

NOTE

When the HR, MIN, SEC switch is pressed, the clock is not actually stopped. It continues to run and can be recalled at any time prior to pressing the ENTER/STEP switch by pressing DATE AND TIME.

4. Press the HR MIN SEC switch in the TIME ENTRY group. The DAY portion of the display should go blank.
5. Serially enter the desired time on the DATA ENTRY keyboard, hours first and seconds last. Remember that the clock is to be restarted at some future time and should be synchronized with the true time of day. Therefore, the time entered on the keyboard should agree with the time at which the clock is to be started.
6. Synchronize and start the clock by pressing the ENTER/STEP switch.

2-76. SCAN FORMAT

2-77. The scan format program involves the variables which define the scope of a scan sequence. These include: fixed data, first channel, last channel, time interval, and monitor channel address. Use the following procedure to program the scan format:

1. Press the FIXED DATA switch in the SCAN FORMAT group. The six digits currently in memory will be presented on the DATA display.
2. If the fixed data is incorrect, serially enter the desired data on the DATA ENTRY keyboard (MSD first) and press the ENTER/STEP switch. If the original data is correct, no action is required.
3. Press the FIRST CHANNEL switch in the SCAN FORMAT group. The first channel address currently in memory will appear on the CHANNEL display.
4. If the channel displayed is incorrect, serially enter the desired first channel on the DATA ENTRY keyboard and press the ENTER/STEP switch. If the original channel is correct, no action is required.
5. Press the LAST CHANNEL switch in the SCAN FORMAT group. The last channel currently in memory will appear on the CHANNEL display.
6. If necessary, enter the correct last channel on the DATA ENTRY keyboard and press the ENTER/STEP switch.
7. Press the INTERVAL HR MIN SEC switch in the SCAN FORMAT group. The time interval currently in memory will be displayed in hours, minutes, and seconds on the DATA display. (See Option -32 in Section 6 for second interval operation.)
8. If necessary, enter the desired time interval on the DATA ENTRY keyboard and press the ENTER/STEP switch.
9. Press the MONTIOR CHANNEL switch in the SCAN FORMAT group. The current address of the channel to be monitored will appear on the CHANNEL display.
10. If a new monitor channel is desired, enter it on the DATA ENTRY keyboard and press the ENTER/STEP switch.

#### 2-78. LIMITS PROGRAMMING

2-79. The memory required to program measurement limits is available only when the 2240C is equipped with the set-point limits option. Prior to programing the limits, the operator

should familiarize himself with the limit capabilities available in the 2240C. To simplify programming, the limits assigned to each address should be determined prior to entering limit address data in the Channel Programming procedure. Refer to the Alarms Setpoint option information in Section 6 of this manual.

#### NOTE

When two or more limits are associated with a single measurement, care must be taken to ensure that the limits appear in separate address groups: 1 through 15 for group A, 16 through 30 for group B, 31 through 45 for group C, and 46 through 60 for group D. High or low sense can be assigned to any address in either group. However, two limits within one group cannot be assigned to the same channel.

#### 2-80. CHANNEL PROGRAMMING

2-81. Use the following procedure to assign the appropriate measurement function, limits address(es), and  $mx + b$  addresses to each channel included in a scan sequence; i.e., first channel to last channel as defined in the Scan Format program procedure:

1. Press the CHANNEL ENABLE switch in the PROGRAMMING group. The ENTER ADDRESS lamp will light.
2. Using the DATA ENTRY keyboard, enter the address of the first channel in the scan sequence and press the ENTER/STEP switch. The selected channel and the currently programmed function will be displayed. The ENTER ADDRESS lamp will go out and ENTER FUNCTION will light.
3. On the DATA ENTRY keyboard, press the appropriate voltage/temperature range, from the Temperature Linearizations listed in Figure 2-8, (or SKIP) for the display channel, and then press the ENTER/STEP switch. The ENTER FUNCTION lamp will go out and the ENTER ADDRESS  $mx + b$  lamp will light.

#### NOTE

All measurement functions are available as options. Therefore, prior to attempting to select a function, determine whether or not it is available

in your 2240C. The IMPROPER ENTRY lamp will light when an invalid function is selected. The condition is cleared by pressing the CLEAR ENTRY switch or selecting an available function.

#### NOTE

When the ENTER ADDRESS  $mx + b$  lamp lights, the address of the  $mx + b$  function assigned to that channel is shown on the DATA display. If a  $mx + b$  is not currently assigned, the display will read S S S for skip.

4. Refer to Sections 6-40 and 6-41 for  $mx+b$  and limits programming instructions. If  $mx + b$  scaling is required, enter its address on the DATA ENTRY keyboard and press the ENTER/STEP switch. If scaling is not required, press the SKIP switch adjacent to the ENTER ADDRESS  $mx + b$  switch and press the ENTER/STEP switch. In either case, the ENTER ADDRESS  $mx + b$  lamp will go out and the ENTER ADDRESS LIMIT (A.B.C.D.) will light, as well as the LIMIT A lamp in the upper right portion of the display.
5. If a limit from address group A (1-15) is required, enter its address on the DATA ENTRY keyboard and press the ENTER/STEP switch. If a limit from address group A is not required, press the SKIP switch adjacent to the ENTER ADDRESS LIMIT switch and press the ENTER/STEP switch. In either case, the LIMIT A Lamp in the display will go out and the LIMIT B Lamp will light.
6. Either skip or enter a limit address code from address group B (16-30) and press the ENTER/STEP switch. The LIMIT B lamp in the display will go out and the LIMIT C lamp will light. Repeat this step for group C (31-45) and group D (46-60). After the group D address is entered, the ENTER ADDRESS LIMIT (A.B.C.D) lamp will go out and the ENTER ADDRESS lamp will light.
7. Press the ADVANCE ADDRESS switch. The CHANNEL display will advance to the next channel in the sequence and the ENTER FUNCTION lamp will light.
8. With reference to the following notes, repeat steps

3 through 7 of this procedure for each channel in the scan sequence.

- a. Any combination of channels between the first and last channels can be skipped by sequentially pressing the SKIP and ENTER/STEP switches when the ENTER FUNCTION lamp is lit. When a channel is skipped, the  $mx + b$  address and limit address will be ignored.
- b. When a series of channels require identical function,  $mx + b$ , and limit data, program the first channel in the series using the above procedure. Then alternately press the ADVANCE ADDRESS and the REPEAT switches for each like channel.

2-82. SINGLE CHANNEL PROGRAMMING

2-83. Use the following procedure to address and select the single channel to be displayed:

1. Press the SINGLE CHANNEL switch in the DISPLAY CONTROL group. The current address of the single channel will appear on the CHANNEL display.
2. If a new single channel is desired, enter it on the DATA ENTRY keyboard and press the ENTER/STEP switch.
3. The displayed channel can be advanced by pressing the ADVANCE ADDRESS switch.



# FLUKE 2240C PROGRAMMING FORM

PRIMARY INTERVAL	SECOND INTERVAL	MONITOR CH. _____
INTERVAL _____	INTERVAL _____	FIXED DATA _____
FIRST CH. _____	FIRST CH. _____	DAY _____
LAST CH. _____	LAST CH. _____	

CHANNEL PROGRAM							LIMIT A PROGRAM			LIMIT C PROGRAM		
CHANNEL ADDRESS	FUNCTION OR A/D RANGE	mx+b ADDRESS (1-30)	ADDRESS LIMIT A (1-15)	ADDRESS LIMIT B (16-30)	ADDRESS LIMIT C (31-45)	ADDRESS LIMIT D (46-60)	LIMIT ADDRESS	SENSE HI/LO	VALUE & POLARITY	LIMIT ADDRESS	SENSE HI/LO	VALUE & POLARITY
							1			31		
							2			32		
							3			33		
							4			34		
							5			35		
							6			36		
							7			37		
							8			38		
							9			39		
							10			40		
							11			41		
							12			42		
							13			43		
							14			44		
							15			45		

### TEMPERATURE LINEARIZATION

OPTION	CODE	1	2	3	4	5	6	7	8	9	10	11	0
-43		J	K	T	S	R	B	E	C	385	390	0-100%	REF JUN
-44		J	K	T	S	JDIN	KDIN	TDIN	SDIN	385	392	0-100%	REF JUN
-45		J	K	T	S	N*	D	G	120Ω Nickel	385	10Ω Copper	0-100%	REF JUN

\*Nicrosil/Nisil (NBS)

Figure 2-8. 2240C Program Form, Recommended Format

# 2240C PROGRAMMING FORM

## mx+b SCALING (OPTION -40)

mx+b ADDRESS	SLOPE (m) ±X.XXXX	INTERCEPT (b) ±XXXXX	DECIMAL LOCATION OF SCALED RESULT 0 XXXXX 3 XX.XXX 1 XXXX.X 4 X.XXXX 2 XXX.XX	ENGINEERING UNITS NOTATION (0- 31)		SCALING APPLIED TO CHANNELS NUMBERED:
				UNITS	CODE 0-31	
1						
2						
3						
4						
5						
6						
7						
8						
9						
10						
11						
12						
13						
14						
15						
16						
17						
18						
19						
20						
21						
22						
23						
24						
25						
26						
27						
28						
29						
30						

### ENGINEERING UNITS NOTATION TABLE

PROG. CODE	E/U	PROG. CODE	E/U	PROG. CODE	E/U	PROG. CODE	E/U
01	ACA	11	psi	21	ACW	31	%
02	ACmA	12	s	22	DCW	0	BLANK
03	DCA	13	ms	23	kW		
04	DCmA	14	μs	24	mW		
05	μA	15	ACV	25	μW		
06	dB	16	dBV	26	°C		
07	μF	17	DCV	27	°F		
08	Hz	18	kV	28	Ω		
09	kHz	19	mV	29	kΩ		
10	MHz	20	μV	30	MΩ		

### DATA AVERAGING (OPTION -42)

GROUP AVERAGE

GROUP SIZE \_\_\_\_\_  
 INTERVAL \_\_\_\_\_  
 FIRST CHANNEL \_\_\_\_\_  
 LAST CHANNEL \_\_\_\_\_

TIME AVERAGE

FIRST CHANNEL \_\_\_\_\_  
 LAST CHANNEL \_\_\_\_\_  
 SKIPPED CHANNELS \_\_\_\_\_  
 NUMBER OF SCANS PER AVG. \_\_\_\_\_  
 INTERVAL \_\_\_\_\_

Figure 2-8. 2240C Program Form, Recommended Format (cont)



# 2240C PROGRAMMING GUIDE

The following is a step by step guide through 2240C front panel programming sequences and description of front panel key operations.

□ Indicates a pushbutton to be pressed.  
 (XX) Indicates a pushbutton's reference number-see front panel chart at the end of this guide.  
**Initial Step:** Press **RESET (1)** under **SCAN CONTROL**, turn key to **POWER ON**

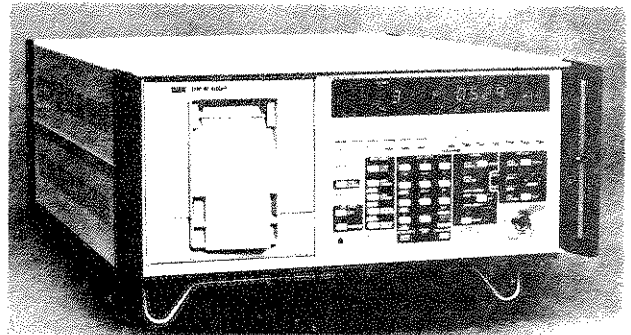

## TIME ENTRY

### Days

(17) **DAYS**

Press **3 Digits**  
 (38) **ENTER/STEP**



(Julian Date) Example: 227

### Time

(18) **HR MIN SEC**

Press **6 Digits** Example: 14:21:36  
 (38) **ENTER/STEP**

## CHANNEL PROGRAMMING

(Temperature Example) (Options -43 or -44 and -41)

**Example:**  
 Channel Number = 24;  
 Function = J Thermocouple;  
 Limits = 2 Hi, 1 Lo Limit

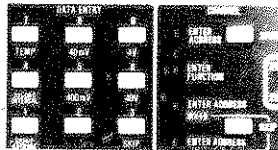

Under CHANNEL press:

- (39) **ENTER ADDRESS**
  - (32) **2**
  - (26) **4**
  - (38) **ENTER/STEP**
  - (25) **TEMP**
  - (27) **1**
  - (38) **ENTER/STEP**
- ENTER CHANNEL ADDRESS 24
- ENTER FUNCTION (J THERMOCOUPLE CODE)

mx+b skip is not required if option -40 is not installed

- (40) **SKIP**
  - (38) **ENTER/STEP**
  - (27) **1**
  - (38) **ENTER/STEP**
  - (27) **1**
  - (35) **6**
  - (38) **ENTER/STEP**
  - (36) **3**
  - (27) **1**
  - (38) **ENTER/STEP**
  - (40) **SKIP**
  - (38) **ENTER/STEP**
- SKIP ADDRESS mx+b
- ENTER LIMIT ADDRESS A
- ENTER LIMIT ADDRESS B
- ENTER LIMIT ADDRESS C
- SKIP LIMIT ADDRESS D

## LIMITS PROGRAMMING

For Example At Left (Option -41)  
 First Hi Limit Address = 1 (100°)  
 Second Hi Limit Address = 16 (90°)  
 Lo Limit Address = 31 (10°)

Under LIMITS/mx + b press:

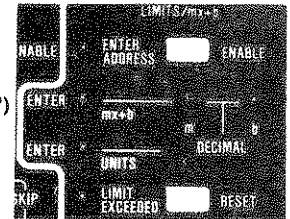

- (43) **ENTER ADDRESS**
  - (27) **1**
  - (38) **ENTER/STEP**
  - (32) **HI LIMIT**
  - (38) **ENTER/STEP**
  - (27) **1**
  - (28) **0**
  - (28) **0**
  - (38) **ENTER/STEP**
  - (27) **1**
  - (35) **6**
  - (38) **ENTER/STEP**
  - (32) **HI LIMIT**
  - (38) **ENTER/STEP**
  - (34) **9**
  - (28) **0**
  - (38) **ENTER/STEP**
  - (36) **3**
  - (27) **1**
  - (38) **ENTER/STEP**
  - (33) **LO LIMIT**
  - (38) **ENTER/STEP**
  - (27) **1**
  - (28) **0**
  - (38) **ENTER/STEP**
- ENTER LIMIT ADDRESS A
- ENTER SENSE LIMIT A
- ENTER VALUE (100°) LIMIT A
- ENTER ADDRESS LIMIT B
- ENTER SENSE LIMIT B
- ENTER VALUE (90°) LIMIT B
- ENTER ADDRESS LIMIT C
- ENTER SENSE LIMIT C
- ENTER VALUE (10°) LIMIT C

## THERMOCOUPLE FUNCTION CODE

OPTION	CODE	1	2	3	4	5	6	7	8	9	10	11	0
-43	J	K	T	S	R	B	E	C	385	390	0-100%	REF JUN	
-44	J	K	T	S	JDIN	KDIN	TDIN	SDIN	385	392	0-100%	REF JUN	
-45	J	K	T	S	N*	D	G	120Ω Nickel	385	10Ω Copper	0-100%	REF JUN	

\*Nicrosil/Nisil (NBS)

Figure 2-9. 2240C Programming Guide

## CHANNEL PROGRAMMING

(mx + b Scaling Example)

### CHANNEL PROGRAMMING APPLICATION:

Pressure Transducer Input = 4 - 20 mA  
 Display = 100 to 200 psi  
 Limits = No Limits Required

### Hardware Required:

Option 40 (mx + b)  
 Option 29 (Current Input Connector)

### Programming Required:

Selected Channel = 8  
 Selected mx + b Address = 5  
 A/D Range Required = 400 mV  
 m calculated = 0.4167  
 b calculated = 7500

Under CHANNEL press:

- (39) **ENTER ADDRESS** } ENTER CHANNEL ADDRESS 8  
 (30) **8**  
 (38) **ENTER/STEP**  
 (31) **400 mV** } ENTER FUNCTION (A/D RANGE)  
 (38) **ENTER/STEP**  
 (31) **5** } ENTER mx + b ADDRESS  
 (38) **ENTER/STEP**  
 (40) **SKIP** } SKIP LIMIT ADDRESS A,B,C,D  
 (38) **ENTER/STEP**  
 (40) **SKIP**  
 (38) **ENTER/STEP**  
 (40) **SKIP**  
 (38) **ENTER/STEP**  
 (40) **SKIP**  
 (38) **ENTER/STEP**

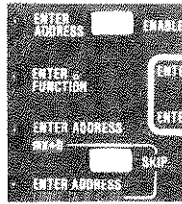

## mx + b PROGRAMMING

For Example At Left (Option -40)

- (37) **SECOND FUNCTION** } ENTER mx + b ADDRESS  
 (43) **ENTER ADDRESS**  
 (31) **5**  
 (38) **ENTER/STEP**  
 (28) **0** } ENTER Slope (m)  
 (26) **4**  
 (27) **1**  
 (35) **6**  
 (25) **7**  
 (38) **ENTER/STEP**  
 (25) **7** } ENTER Intercept (b)  
 (31) **5**  
 (28) **0**  
 (28) **0**  
 (38) **ENTER/STEP**  
 (32) **2** } ENTER DECIMAL Location (# of digits to right of decimal place.) 200 psi would read 200.00 in this case  
 (38) **ENTER/STEP**  
 (27) **1** } ENTER UNITS CODE (psi in this example)  
 (27) **1**  
 (38) **ENTER/STEP**

NOTE: 4 to 20 mA is seen by the data logger (when properly configured with Option -29 Connector) as 60 mV → 300 mV (hence the selection of 400 mV as the A/D range under CHANNEL PROGRAMMING). In analog digital converter counts, 60 mV is 6000 and 300 mV is 30,000. Desired display is chosen as 200.00 → 100.00 psi. This corresponds to 20,000 and 10,000 counts, respectively.

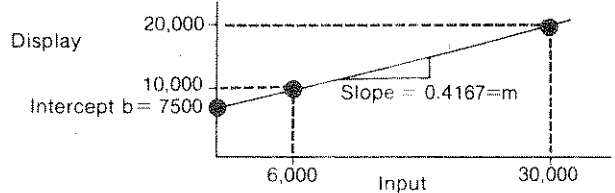

Slope Calculation:  $\frac{20,000 - 10,000}{30,000 - 6,000} = 0.4167 = m$

Intercept Calculation:  $10,000 - (0.4167 \times 6000) = 7500 = b$

## PROGRAMMING PRIMARY INTERVAL:

Example:  
 Want to Scan Channels 50- 300  
 Scan Interval:  
 40 seconds

Under SCAN FORMAT press:

- (20) **FIRST CHANNEL**  
 (31) **5**  
 (28) **0**  
 (38) **ENTER/STEP**  
 (21) **LAST CHANNEL**  
 (36) **3**  
 (28) **0**  
 (28) **0**  
 (38) **ENTER/STEP**  
 (22) **INTERVAL HR MIN SEC**  
 (26) **4**  
 (28) **0**  
 (38) **ENTER/STEP**

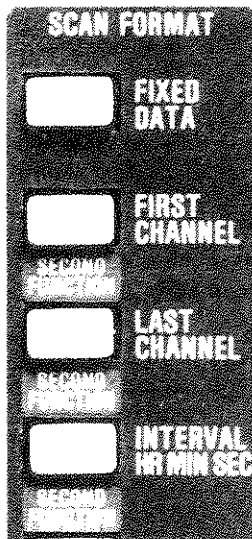

## GENERAL CASE OF COMPUTING SLOPE AND INTERCEPT

A more general set of equations for computing slope and intercept: (Note: display limited to 5 digits.)

\*Values in terms of A/D counts (same as seen on display ignoring decimal.)

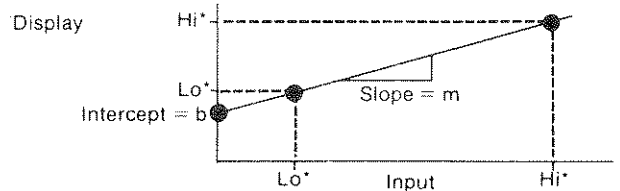

First Calculate:  
 Slope =  $m = \frac{\text{Display Hi}^* - \text{Display Lo}^*}{\text{Input Hi}^* - \text{Input Lo}^*}$

Then Calculate: Intercept =  $b = \text{Display Lo}^* - (m \times \text{Input Lo}^*)$

Figure 2-9. 2240C Programming Guide (cont)

## GROUP AVERAGING PROGRAMMING

Example:

Average 4 groups of 5 channels numbered 0 - 19. Recalculate these averages every minute.

- (37) **SECOND FUNCTION** } Establishes GROUP AVERAGE mode and sets group size=5 channels. A single 6 (simulating a "G" for GROUP AVG.) in the display indicates GROUP AVERAGE mode.
- (27) **GROUP AVERAGE** }
- (31) **5** }
- (38) **ENTER/STEP** }
- (37) **SECOND FUNCTION** }
- (20) **FIRST CHANNEL** }
- (28) **0** }
- (38) **ENTER/STEP** }
- (37) **SECOND FUNCTION** } Sets First and Last Channels Encompassed in GROUP AVERAGING\*
- (21) **LAST CHANNEL** }
- (27) **1** }
- (34) **9** }
- (38) **ENTER/STEP** }
- (37) **SECOND FUNCTION** }
- (22) **INTERVAL HR MIN SEC** } Sets GROUP AVERAGE "SCAN INTERVAL" to one minute.
- (27) **1** }
- (28) **0** }
- (28) **0** }
- (38) **ENTER/STEP** }

(\*See SPECIAL NOTE\*)

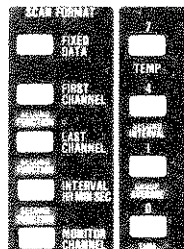

\*Channels contained in GROUP AVERAGE must be numbered consecutively, however, channels programmed to "SKIP" are ignored in the average. In this example channels 0-4 comprise the first GROUP AVERAGE. If channels 2 and 3 are skipped, the first GROUP AVERAGE is computed only on the basis of channels 0, 1, and 4. This technique of skipping channels may be used to average groups of varying size (numbers of channels). Open thermocouples are treated as skipped channels in the GROUP AVERAGE mode.

NOTE: Limits on the Last Channel in each group become the GROUP AVERAGE limits.

### SPECIAL NOTE:

The 2240C will utilize (in operation) only one of GROUP AVERAGE, TIME AVERAGE, and SECOND INTERVAL at any given time. The data logger will automatically operate utilizing the last of these three modes to be programmed. To change mode, simply press SECOND FUNCTION, followed by either GROUP AVERAGE, TIME AVERAGE, or SECOND INTERVAL, then ENTER/STEP. To interrogate the 2240C to determine its present mode, simply press SECOND FUNCTION, then FIRST CHANNEL and observe the display.

t = Time Average    6 = Group Average    tttt = Second Interval

## TIME AVERAGING PROGRAMMING

Example:

Average Channels 3, 4, 5, 7, 8, 9\*\* over 20 scans, scans performed each 30 seconds.

- (37) **SECOND FUNCTION** } Establish TIME AVERAGE mode and set # of scans per avg. at 20. The single "t" appearing in the display indicates TIME AVERAGE mode.
- (28) **TIME AVERAGE** }
- (32) **2** }
- (28) **0** }
- (38) **ENTER/STEP** }
- (37) **SECOND FUNCTION** }
- (20) **FIRST CHANNEL** }
- (36) **3** }
- (38) **ENTER/STEP** }
- (37) **SECOND FUNCTION** } Establish 1st and Last Channels in Average.
- (21) **LAST CHANNEL** }
- (34) **9** }
- (38) **ENTER/STEP** }
- (37) **SECOND FUNCTION** }
- (22) **INTERVAL HR MIN SEC** } Set TIME AVERAGE Scan Interval to 30 Seconds.
- (22) **3** }
- (28) **0** }
- (38) **ENTER/STEP** }

(\*See "SPECIAL NOTE")

\*\*TIME AVERAGE CHANNELS must be consecutively numbered -however, skipped channels are ignored in averaging. So in this example, Channel #6's function should be programmed as "SKIP" to exclude it from the average.

## PROGRAMMING SECOND INTERVAL:

Example:

Scan on SECOND INTERVAL channels 0-100  
Interval: 1 hour

- (37) **SECOND FUNCTION** }
- (26) **SECOND INTERVAL** }
- (38) **ENTER/STEP** }
- (37) **SECOND FUNCTION** }
- (20) **FIRST CHANNEL** }
- (28) **0** }
- (38) **ENTER/STEP** }
- (37) **SECOND FUNCTION** }
- (21) **LAST CHANNEL** }
- (27) **1** }
- (28) **0** }
- (28) **0** }
- (38) **ENTER/STEP** }
- (37) **SECOND FUNCTION** }
- (22) **INTERVAL HR MIN SEC** }
- (27) **1** }
- (28) **0** }
- (28) **0** }
- (28) **0** }
- (28) **0** }
- (38) **ENTER/STEP** }

A string of t's in the display indicates the data logger is in the SECOND INTERVAL mode.

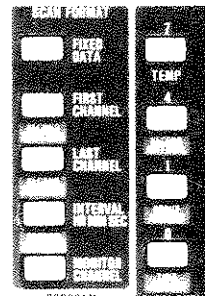

(\*See "SPECIAL NOTE")

Figure 2-9. 2240C Programming Guide (cont)

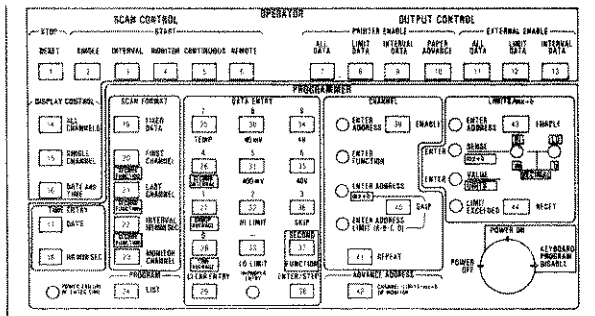

### SCAN MODE

The following scan modes, except **MONITOR**, scan sequentially from **FIRST CHANNEL** to **LAST CHANNEL**.

**SINGLE:** Initiates a single scan.

**INTERVAL:** Initiates a single scan immediately and repeats that scan at a programmed interval. Date and time is displayed between scans.

A delayed interval may be programmed by selecting initial interval (delay period), starting the interval, then programming a new interval (desired eventual interval) during the first interval scan. The new interval will repeat at the end of the delay period.

**MONITOR:** Continuously scans the programmed **MONITOR CHANNEL**. To program the **MONITOR CHANNEL**, press **MONITOR CHANNEL**, 3 digit channel number, and **ENTER/STEP**.

**CONTINUOUS:** Continuously repeats a scan.

**REMOTE:** Allows the remote start of a single scan. (At least one output option is required or Remote Control using Option -17 or -15.)

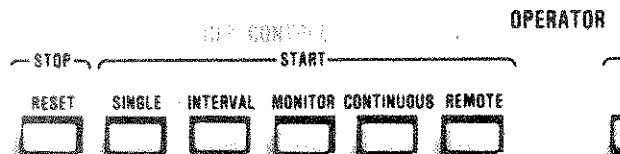

### OUTPUT CONTROL

Two identical control key groups provide individual control of the **PRINTER** and **EXTERNAL** outputs. When more than one output switch is activated the sum of the functions results.

**ALL DATA:** All readings are recorded.

**LIMIT DATA:** Only that data that exceeds limits is recorded.

(Alarms once with internal switch)

**INTERVAL DATA:** One scan is recorded periodically at the programmed interval. The **SCAN CONTROL** may be in **CONTINUOUS**, **MONITOR**, or **INTERVAL** mode.

The display may be used to inspect all keyboard memory (Scan Format, Time of Day and Channel and Limits programming) without affecting in any way the scan sequence in progress. To return the display to the scan sequence the **DISPLAY CONTROL** is used.

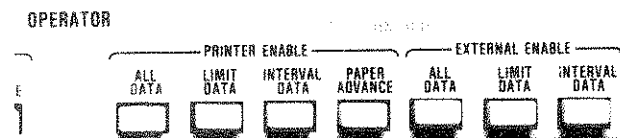

### ENGINEERING UNITS NOTATION TABLE (mx+b scaling)

PROG. CODE	E/U	PROG. CODE	E/U	PROG. CODE	E/U	PROG. CODE	E/U
01	ACA	11	psi	21	ACW	31	%
02	ACmA	12	s	22	DCW	0	BLANK
03	DCA	13	ms	23	kW		
04	DCmA	14	μs	24	mW		
05	μA	15	ACV	25	μW		
06	dB	16	gBV	26	°C		
07	μF	17	DCV	27	°F		
08	Hz	18	kV	28	Ω		
09	kHz	19	mV	29	kΩ		
10	MHz	20	μV	30	MΩ		

### DISPLAY CONTROL

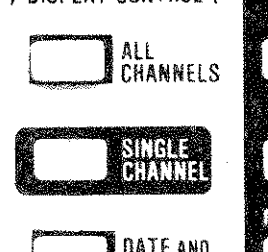

### DISPLAY CONTROL

**ALL CHANNELS:** Returns display to scan sequence. Displays channel number and data for each channel read.

**SINGLE CHANNEL:** Displays a random channel number and data for that channel without affecting the scan sequence. Updates once per scan.

A new **SINGLE CHANNEL** is programmed by pressing **SINGLE CHANNEL**, the desired channel address and **ENTER/STEP**. The **ADDRESS** button will increment **SINGLE CHANNEL** and then **ENTER/STEP** will activate the function if the Data Logger is in an appropriate scan mode.

**DATE AND TIME:** Displays date and time continuously.

### ADVANCE ADDRESS

The **ADVANCE ADDRESS** key may be used while programming to advance by 1 digit the channel address or the limits or mx+b address. It may also be used to advance the Monitor Channel and Single Channel number. When used in this manner it performs the functions of entering a new address one digit higher, and pressing **ENTER/STEP**.

### REPEAT

When programming channels the **REPEAT** key may be used to duplicate the function and limits address programming of the previous channel. When used with **ADVANCE ADDRESS** key it is not necessary to press **ENTER/STEP**.



### ADVANCE ADDRESS



### PROGRAM LIST

To obtain a listing of data in memory place the **Scan Control** to **RESET**, enable the printer **All DATA** key (other printer enable switches must be in **OFF** position) and press **PROGRAM LIST**. The following information is listed on the printer: Time of Day, Interval, Fixed Data, Monitor Channel, all limits programming and all channel programming between First Channel and Last Channel of Primary and Secondary Intervals, Time and Group Average Data.



### John Fluke Mfg. Co., Inc.

P.O. Box 43210, Mountlake Terrace, WA 98043  
800-426-0361 (toll free) in most of U.S.A.  
206-774-2481 from AK, HI, WA and Canada  
206-774-2398 from other countries

### Fluke (Holland) B.V.

P.O. Box 5053, 5004 EB, Tilburg, The Netherlands  
Tel. (013) 673973, TELEX 52237

Phone or write for the name of your local Fluke representative.

Figure 2-9. 2240C Programming Guide (cont)

1  
2  
3  
4  
5  
6  
7  
8  
9  
10  
11  
12  
13  
14  
15  
16  
17  
18  
19  
20  
21  
22  
23  
24  
25  
26  
27  
28  
29  
30  
31  
32  
33  
34  
35  
36  
37  
38  
39  
40  
41  
42  
43  
44  
45  
46  
47  
48  
49  
50  
51  
52  
53  
54  
55  
56  
57  
58  
59  
60  
61  
62  
63  
64  
65  
66  
67  
68  
69  
70  
71  
72  
73  
74  
75  
76  
77  
78  
79  
80  
81  
82  
83  
84  
85  
86  
87  
88  
89  
90  
91  
92  
93  
94  
95  
96  
97  
98  
99  
100

## Section 3 Theory of Operation

### 3-1. INTRODUCTION

3-2. This section contains an overall functional description followed by a Block Diagram Analysis of the Model 2240C Data Logger. Both descriptions are supported by simplified block diagrams. Detailed schematics of the individual pcb assemblies are given in Section 8 of this manual.

### 3-3. OVERALL FUNCTIONAL DESCRIPTION

3-4. The 2240C, as shown in Figure 3-1, is a data processor and recorder which is expandable, through the use of optional plug-in modules, into a user designed data acquisition system capable of servicing up to 1000 channels of guarded analog data. Logically, the 2240C can be divided into two major sections, analog and digital. The analog section comprises the Scanner PCBs and the A/D Converter. The remaining blocks comprise the digital section.

3-5. The analog section of the 2240C is an electrically isolated scanner and A/D converter which is used to interface the individual channels of analog data with the control logic contained in the digital section. Analog data is presented to the analog section through a series of plug-in relay scanner pcbs (up to 100 ten-channel scanner pcbs can be serviced). The individual channels are energized under digital control, and the selected channel data is measured and digitized by a dual-slope A/D Converter (the analog portion of which is contained on the A/D Converter PCB while the digital portion is contained on the Guard Crossing PCB). After each channel measurement is completed, the Guard Crossing PCB transfers the digitized measurement data across an optical isolator to the digital section. All additional processing of measurement data (e.g., display, recording and comparison) is accomplished by the digital section.

3-6. The digital section of the 2240C is a bus oriented system based upon a four-bit-parallel microprocessor (which is an integral part of the controller). Three buses are used to route data within the digital section. Two are unidirectional control buses, and the third is a bidirectional data bus (which is used to exchange data between the microprocessor and the other elements of the digital section).

3-7. The control buses (four lines each) are identified as Control Bus A and Control Bus B, and are mutually exclusive in operation. Both control buses are used by the controller to transmit address data to the various elements (peripherals) of the digital section. When a particular peripheral is addressed, communications between it and the Controller are possible via the bidirectional Data Bus. The address codes and assignments for both Control Bus A and Control Bus B are given in Table 3-1.



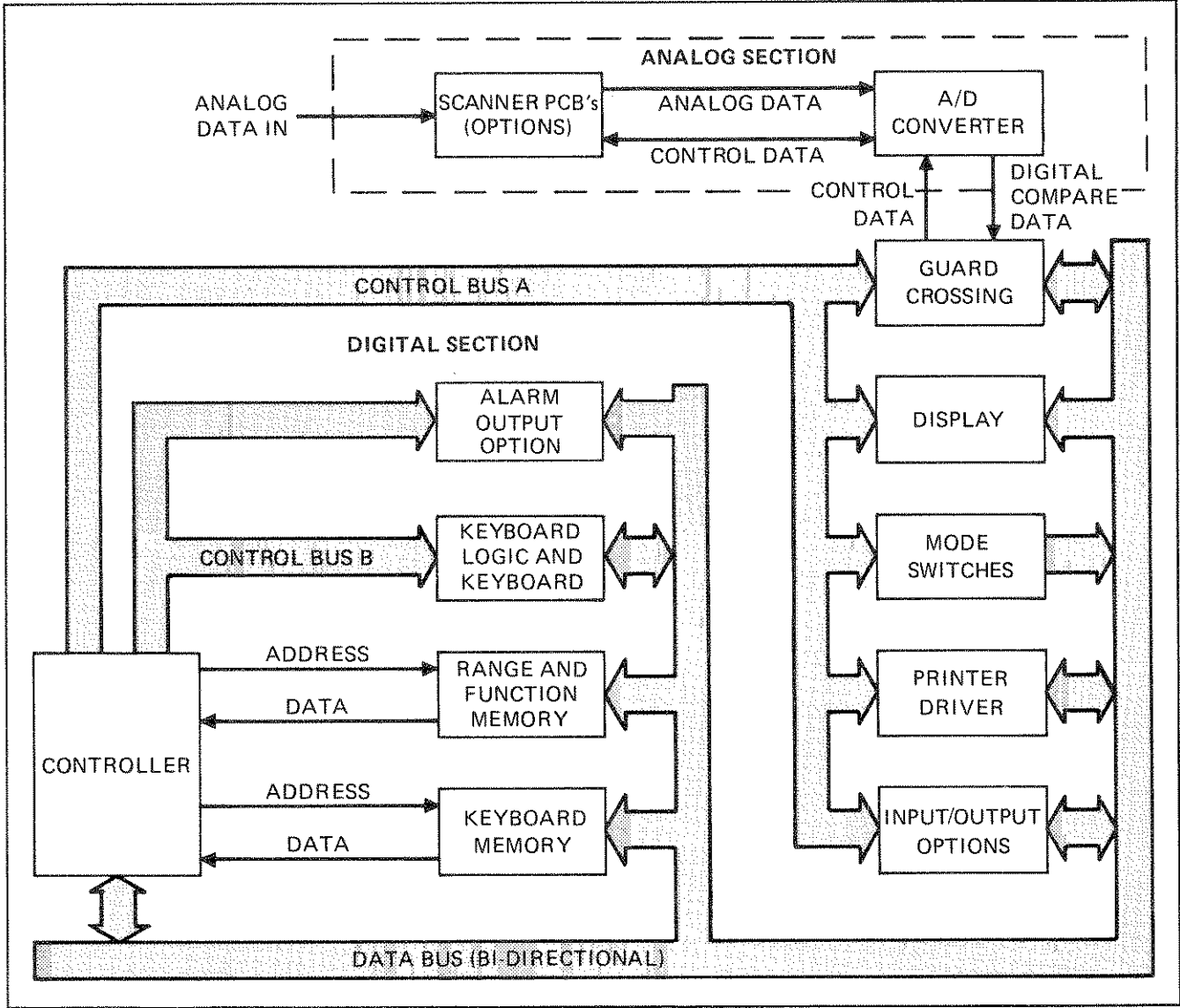

Figure 3-1. 2240C Data Logger, Simplified Block Diagram

Table 3-1. Control Bus Address Codes

CONTROL BUS A		CONTROL BUS B	
CODE	ASSIGNMENT	CODE	ASSIGNMENT
0000	Null Character	0000	Null Character
0001	Guard Crossing Transmit	0001	Not Used
0010	Guard Crossing Receive	0010	Not Used
0011	Guard Crossing Status	0011	Not Used
0100	Output Receive	0100	Alarm Output Receive (31-60)
0101	Printer Receive	0101	Not Used
0110	Remote/Output Status	0110	Not Used
0111	Input Transmit	0111	Not Used
1000	Mode Switch Transmit	1000	Keyboard Receive
1001	Display Receive	1001	Keyboard Transmit
1010	Not Used	1010	Keyboard Status
1011	Remote Received	1011	Not Used
1100	Configuration Transmit	1100	Alarm Output Receive (1-30)
1101	Printer/Interval Status	1101	Not Used
1110	Remote Transmit	1110	Not Used
1111	Not Used	1111	Not Used

3-8. Each address code, in addition to addressing a particular peripheral, also defines the communication function the peripheral is to perform (i.e., transmit or receive). Therefore, peripherals which are capable of both transmitting and receiving data are assigned multiple address codes. Other peripherals, such as the display, are only capable of receiving data, and therefore, require only one address code. Similarly, the Mode switches are assigned a single address code because they are only capable of transmitting data.

3-9. When an address code is placed on either of the control buses (A or B), the corresponding peripheral is enabled to perform the solicited function; transmit or receive. If a transmit function is enabled, (e.g., the Mode switches are addressed to transmit data on the Data Bus when a binary coded 8 (1000) is placed on Control Bus A), the responding peripheral immediately places its first 4-bit character onto the Data Bus. When the controller reads the Data Bus it generates an In strobe. This strobe is used by the addressed peripheral to move the next character for transmission onto the Data Bus. The process is repeated until all of the characters (determined by the controller) have been transmitted. At that time, the controller removes the address code from the Control Bus and replaces it with a Null-Character Code, 0000. If the receiver function is enabled, the process is similar. However, data moves from the controller to the addressed peripheral, and an Out strobe is generated to allow the peripheral to receive each data character.

3-10. Four of the peripherals perform functions which are not normally synchronized by the controller. They are the Power Supply, the Printer, the -15 and -17 Options (Remote Programming), and the Guard Crossing. The power supply generates a 1 Hz clock pulse to maintain the time-of-year clock, the Printer records data supplied via the Data Bus, the -15 and -17 Options enter remote programming data, and the Guard Crossing sends A/D measurement data to the controller via the Data Bus. Since the operation of these peripherals is not synchronized with the controller, each is provided with an interrupt line (IRQ) to notify the controller that they are ready to perform their function. When any one of the units pull the IRQ line, the controller responds by interrupting its normal data processing routine and sequentially requesting the status of each of the four peripherals: Guard Crossing, Printer, -15 or -17 Option, and Power Supply, respectively. The interrupting unit is identified by its status code and serviced as necessary. When multiple interrupts occur, priority is established by the status interrogation sequence. (The interrupt circuit for the Power Supply's 1 Hz output is actually contained on the Controller PCB.)

3-11. BLOCK DIAGRAM DESCRIPTION

3-12. Introduction

3-13. A block diagram description of the 2240C is given in the following paragraphs. The description is keyed to the detailed block diagram shown in Figure 3-2. Each block or group of blocks represents a pcb assembly which is supported by a detailed schematic in Section 8 of this manual.

#### 3-14. Controller PCB Assembly

3-15. The Controller PCB Assembly contains the microprocessor set and its associated program memory and control circuitry. The microprocessor set consists of CPU (U16), Memory Interface (U17) and eight RAMs standard, 12 total with -42 option. ROMs U12, U11, U9, U8, and U14 comprise the program memory. Supporting control circuits include a 2 $\emptyset$  (two phase) Clock Generator, the Interrupt Circuit and the configuration switches.

#### 3-16. MICROPROCESSOR SET

3-17. The microprocessor set solicits and responds to program data stored in four separate locations: the Control Program ROMs, the Range and Function memory, the Temperature ROMs, and the Keyboard Memory (peripheral). The Control Program ROMs contain the program data that determines the basic characteristics of the 2240C. The Temperature ROMs contain alternate temperature measurement programs that can be enabled under program control. The Keyboard Memory (which can be either manually programmed via the front panel keyboard or remotely reprogrammed via the -15 or -17 Option, when installed) provides the microprocessor set with the following data: First Channel, Last Channel, Monitor Channel, Interval, and Fixed Data. Second Interval Time, and First and Last Channels for the second interval are provided when the -32 Option is installed.

3-18. To access data in one of the four program data locations, the CPU (U16) generates a 12-bit address in the form of 3-serial, 4-bit characters. These characters are presented to the Memory Interface (U17) where they are assembled into a 12-bit parallel address word and placed on the ROM Address Bus. The address word is then presented in parallel to each of the four program data locations. To ensure a response from only the desired program data location, an additional location-enable line is required. Control data for this line is derived from program content. RAM U32, 1-of-10 decoder U5, and RS flip-flop U15 generate the enable for the Temperature and the Control Program ROMs. The Range and Function memory and the Keyboard Memory are enabled by RAM U29 and 1-of-10 decoder U6 via the Program Memory (PM) output of U17.

3-19. Program data from the addressed program-data location is placed on the 8-bit ROM Data Output Bus (01 through 08) and read by the Memory Interface. The data is then returned to the CPU for further processing.

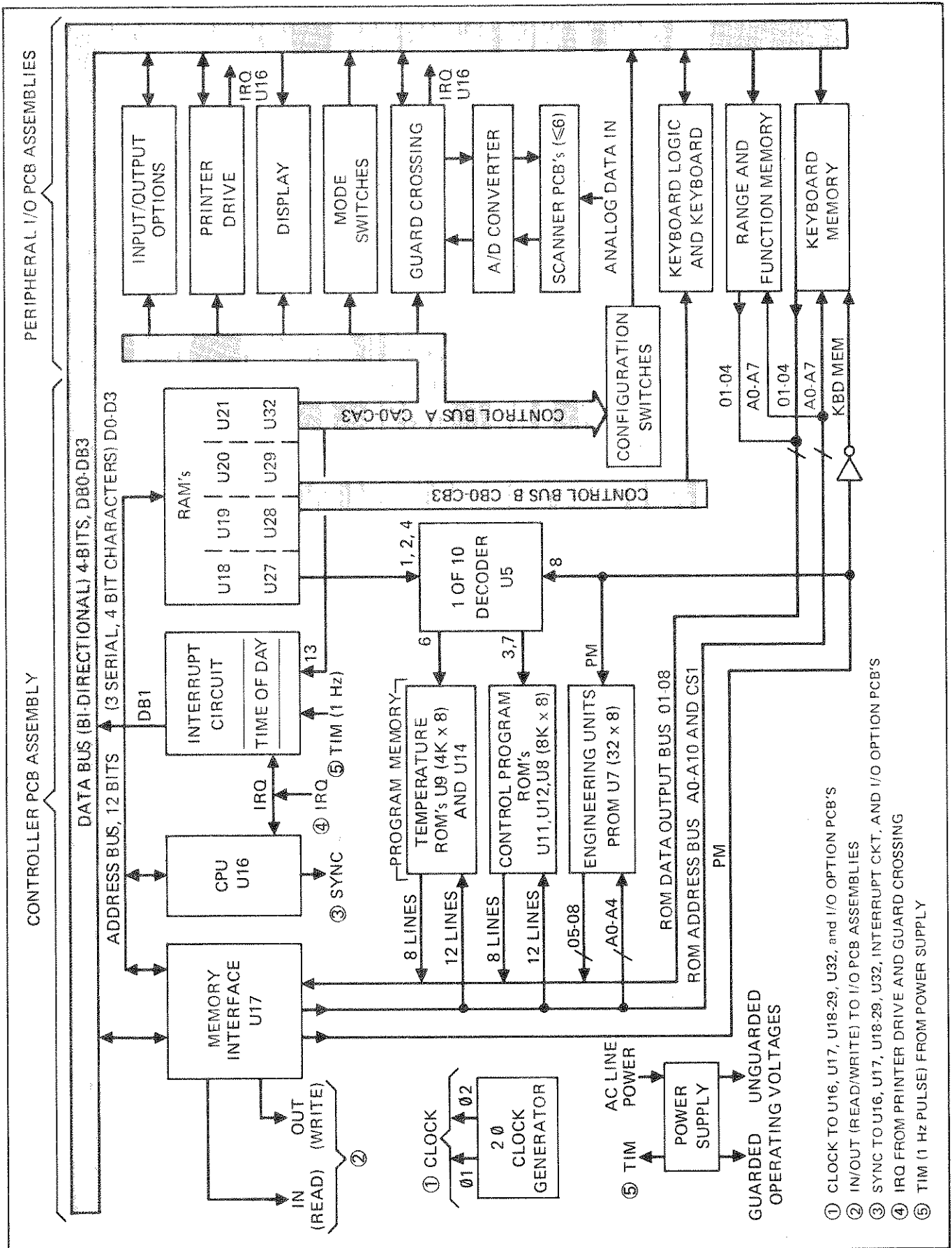

Figure 3-2. 2240C Data Logger, Detailed Block Diagram

3-20. Since the control Program ROMs (U12, U11, and U8) contain the instructions which determine the characteristics of the 2240C, they must be addressed when the unit is initially energized. This is accomplished by forcing U32 to present a binary coded 7 (0111) to the 1-of-10 decoder U5; thereby enabling the Control Program ROMs to respond to the initial 12-bit address on the ROM Address Bus. Subsequent program data locations are accessed under the direction of the Control Program.

3-21. Control and response data to and from the Controller PCB Assembly is routed over the bidirectional Data Bus under the direction of the Control Program ROMs. The appropriate peripheral and the desired response (transmit or receive) are solicited by address codes placed on Control Bus A or Control Bus B. These codes are derived from the control program via RAMs U28 and U27. If the addressed peripheral is to return (transmit) data to the Controller PCB Assembly, the Memory Interface U17 generates an In strobe to retrieve character-serial data via the Data Bus. If the peripheral is to receive data from the Controller PCB Assembly, the Memory Interface generates an Out strobe after it places each character on the Data Bus. This enables the addressed peripheral to synchronize the serial I/O data with the Controller PCB Assembly.

#### 3-22. TWO PHASE CLOCK GENERATOR

3-23. The microprocessor set is synchronized to a 2-phase crystal controlled clock. The clock circuitry consists of a synchronous counter U4, a 5.185 MHz crystal Y1, gates U1 and U3, and a level shifter U2.

3-24. In operation, crystal Y1 provides the time base (1/5.185 MHz) for a free-running oscillator. Counter U4 divides the oscillator output by seven and presents its Q1 (2) and Q2 (4) outputs to gates U3B (Ø1) and U3C (Ø2) for decoding. The decoded outputs are then presented to U2 where the two TTL output signals are shifted to the +5 and -10 volt levels required by the microprocessor set. The timing of the 2-phase clock is shown in Figure 3-3.

#### 3-25. CONFIGURATION SWITCHES

3-26. The positions of the four configuration switches, SW1 through SW4, are read by the microprocessor set when the 2240C is powered up. The switches are used as selectable variables which operate in conjunction with the data stored in program memory. Switch SW2 selects Alarms All or Alarms Once. Switch SW1 selects the Local or Remote control mode. Switch SW3 defines the temperature scale, °C or °F, and SW4 selects the individual or block mode of programming. Switch settings are described in Section 4.

3-27. After the 2240C is energized, the microprocessor Set places a binary coded 12 on Control Bus A. The address is

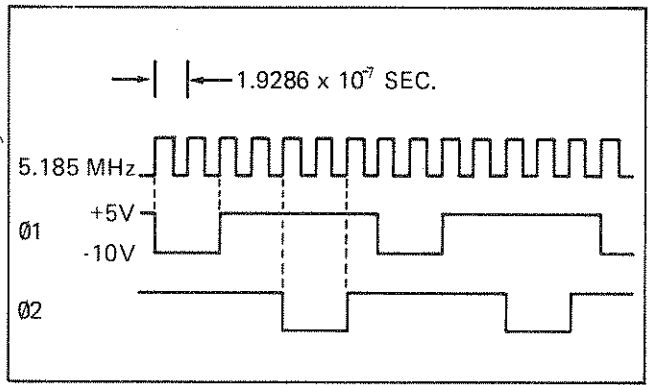

Figure 3-3. Two Phase Clock Timing Diagram

detected by U33B which, in turn, enables the tri-state driver U38. All switch positions are placed on the Data Bus by U38 and read by the CPU when the Memory Interface generates an In strobe. Switch data is assigned to the Data Bus as follows: S1-1 to DB2, S1-2 to DB3, S1-3 to DB1, and S1-4 to DB0. After the switch data is read, the binary coded 12 address is removed from Control Bus A and the tri-state driver U38 reverts to its normal high impedance output state.

### 3-28. INTERRUPT CIRCUIT

3-29. The interrupt circuit comprises flip-flops U35, gates U34, U37, and U33A, tri-state buffer U38 (E2 half), and transistor Q2. The circuit operates in conjunction with the 1 Hz time interval marker (TIM, from the Power Supply) to update the date and time in the CPU. When a TIM pulse is generated (+5V dc), the next CPU Sync pulse sets flip-flop U35B. Subsequently, the IRQ line is pulled low by transistor Q4. As the CPU interrogates the status of the interrupt peripherals (Guard Crossing, Printer and Power Supply), it places a binary coded 13 on Control Bus A. This address is detected by U33A which, in turn, enables U38. The output of U35A is routed through U38 and a binary coded 2 is placed on the Data Bus (DB1). An In strobe is generated by the microprocessor to read the Data Bus and, thereby update the current date and time. As the Data Bus is read, the in strobe sets flip-flop U35 and the IRQ line is cleared. The next Sync pulse clocks flip-flop U35 to remove the data from the Data Bus. When the TIM pulse returns low, the next Sync pulse clocks U35 to the reset state so that the process can be repeated when the next TIM pulse occurs.

### 3-30. Keyboard Switch and Keyboard Logic PCB Assemblies

3-31. The Keyboard Switch and Keyboard Logic PCB Assemblies, as shown in Figure 3-4, are controller peripherals designed to function as a unit and to provide the operator interface necessary for local control and programming of the 2240C. In the local mode, program data is manually presented to the 2240C through a series of momentary-type switches that comprise a portion of the Keyboard Switch PCB Assembly. When any keyboard switch is pressed, it is detected by the Keyboard Logic PCB and analyzed by the controller to determine its validity. In response to a valid input, the controller interrogates the Keyboard Logic, accepts the entered data, and returns a series of keyboard instructions to prompt the subsequent action of the operator. These instructions always include an audio tone to indicate the acceptance of entered data, and may include an illuminated prompting LED if a particular programming sequence is required. Additional prompting LEDs are used to notify the operator of abnormal operating conditions. They are: POWER FAILURE to indicate the interruption of line power, IMPROPER ENTRY to flag the attempted entry of illegal data or format, and LIMIT EXCEEDED to indicate that a measurement value has exceeded its programmed limit value.



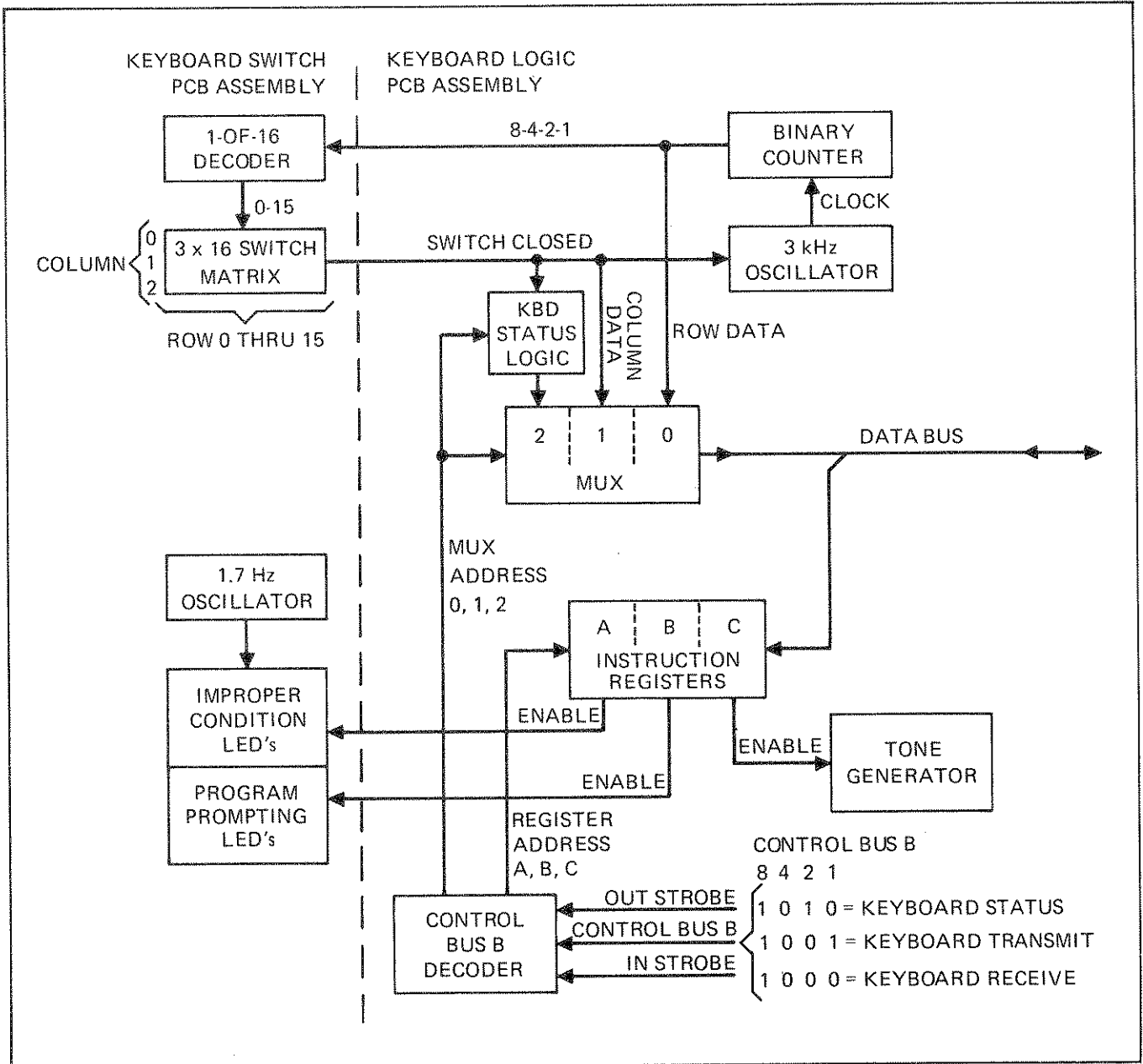

Figure 3-4. Keyboard Switch and Keyboard Logic, Simplified Block Diagram

3-32. Operation begins when power is applied to the circuit. A 3 kHz oscillator free runs to provide a clock input to a 4-bit binary counter which, in turn, drives a 1-of-16 decoder. The decoder outputs are connected to the individual rows of a 3-column by 16-row switch matrix. Since the counter continually scans the matrix rows, a switch depression in any row will cause one of the three columns buses to go low. When this occurs, a switch-closed signal is generated and the 3 kHz oscillator is stopped. As a result, the matrix coordinates of the depressed switch are identified. The counter output defines the matrix row and the low column output defines the matrix column. When the matrix switch is released, the scanning cycle is resumed.

3-33. Periodically, the controller interrogates the status of the Keyboard Logic PCB to see if an attempt to enter program data is being made. The interrogation is initiated when the controller places a binary coded 10 on Control Bus B. A decoder on the Keyboard Logic PCB detects the code and enables channel 2 of three-channel multiplexer (MUX). Channel 2 data is placed on the Data Bus and returned to the controller. If the controller recognizes the following two conditions on the Data Bus (DB0 through DB3) it places a binary coded 9 on Control Bus B as a command for the keyboard to transmit data. If the conditions are not met, the controller ignores the response and resumes its other activities.

DB0 - A keyboard switch must be depressed.

DB3 - The depressed switch must represent new data (i.e., it has not been read since it was last depressed).

3-34. The receipt of a keyboard transmit code (binary 9) causes the Control Bus B Decoder to enable Channel 1 of the three channel multiplexer, and thereby place the closed-switch, column-coordinate data (Column 0, 1, or 2) onto the Data Bus. An In strobe from the Controller reads the Data Bus and then causes the Control Bus Decoder to enable Channel 0 of the 3 channel multiplexer. Channel 0 places the closed-switch row-coordinate data (0 through 15) onto the Data Bus. The controller again reads the Data Bus by generating an In strobe, the trailing edge of which is used to remove the keyboard transmit code from Control Bus B and to set a new-data flip-flop in the keyboard status logic. This flip-flop is reset when the depressed switch is released. However, when set, it inhibits the controller from reading a single switch depression more than once.

3-35. The controller returns response data to the keyboard after every accepted keyboard transmission. A series of instruction registers (A, B, and C) store the response data and drive the appropriate tone generator or front panel LEDs. Response data is presented to the registers via the Data Bus and is loaded into the individual register as a series of three 4-bit characters. Register A is enabled when the Controller places a

keyboard receive code (binary coded 8) on Control Bus B, and is loaded when the Out strobe occurs. On the trailing edge of the Out strobe the Control Bus B Decoder enables Register B and allows it to be loaded on the next Out strobe. Register C is loaded in a similar manner.

3-36. The +5V dc drive for the improper condition LEDs is derived from the output of a 1.7 Hz oscillator located on the Keyboard Switch PCB Assembly. When any one of the LEDs is activated (via register A) the oscillator causes it to flash.

### 3-37. Keyboard Memory PCB Assembly

3-38. The Keyboard Memory PCB Assembly is a controller peripheral designed to function as a nonvolatile memory for storing scan format, scan control, and output control data entered by the keyboard or the -15 or -17 Option if installed. This includes: fixed data, first channel, last channel, interval, single channel, and monitor channel.

3-39. The simplified block diagram shown in Figure 3-5 identifies the functional logic contained on the Keyboard Memory PCB Assembly, and defines the major flow of data to, from, and within the pcb. Prior to initial turn-on, previously entered program data is stored in a series of RAMs and is maintained by a 5.9V lithium battery. The battery is switched into the circuit during the absence of the Power-On-Reset (POR) signal (high during power-on) as derived from the Power Supply PCB. When power is turned on, the RAM memory is switched to operate from the unguarded +5V dc (line powered) power supply.

3-40. Memory is enabled for either read or write applications when both the Power-On-Reset signal from the power supply, and the Keyboard Memory (KBD MEM) signal from the controller are present as Keyboard Memory PCB inputs. These signals are ANDed to enable a series of tri-state drivers which normally isolate the RAM and prevent it from being read or written into.

3-41. After memory is enabled, read/write operations can be executed in a character-serial fashion. An 8-bit Address Bus, A0 through A7, is operated by the controller and used to select a particular location within the RAMs. The upper four bits of this bus, A4 through A7, drive a 1-of-10 decoder to develop the individual IC memory addresses, while the lower four bits, A0 through A3, define the unique character (word) location within the addressed IC. Data present in the addressed memory location is placed onto the Output Bus (O1 through O4) and, if desired, can be read by the controller. If a word is to be written into the addressed location, the controller places the new word onto the Data Bus (DB0 through DB3) and then issues an Out strobe.

### 3-42. Mode Switch PCB Assembly

3-43. The Mode Switch PCB Assembly, as shown in Figure 3-6,

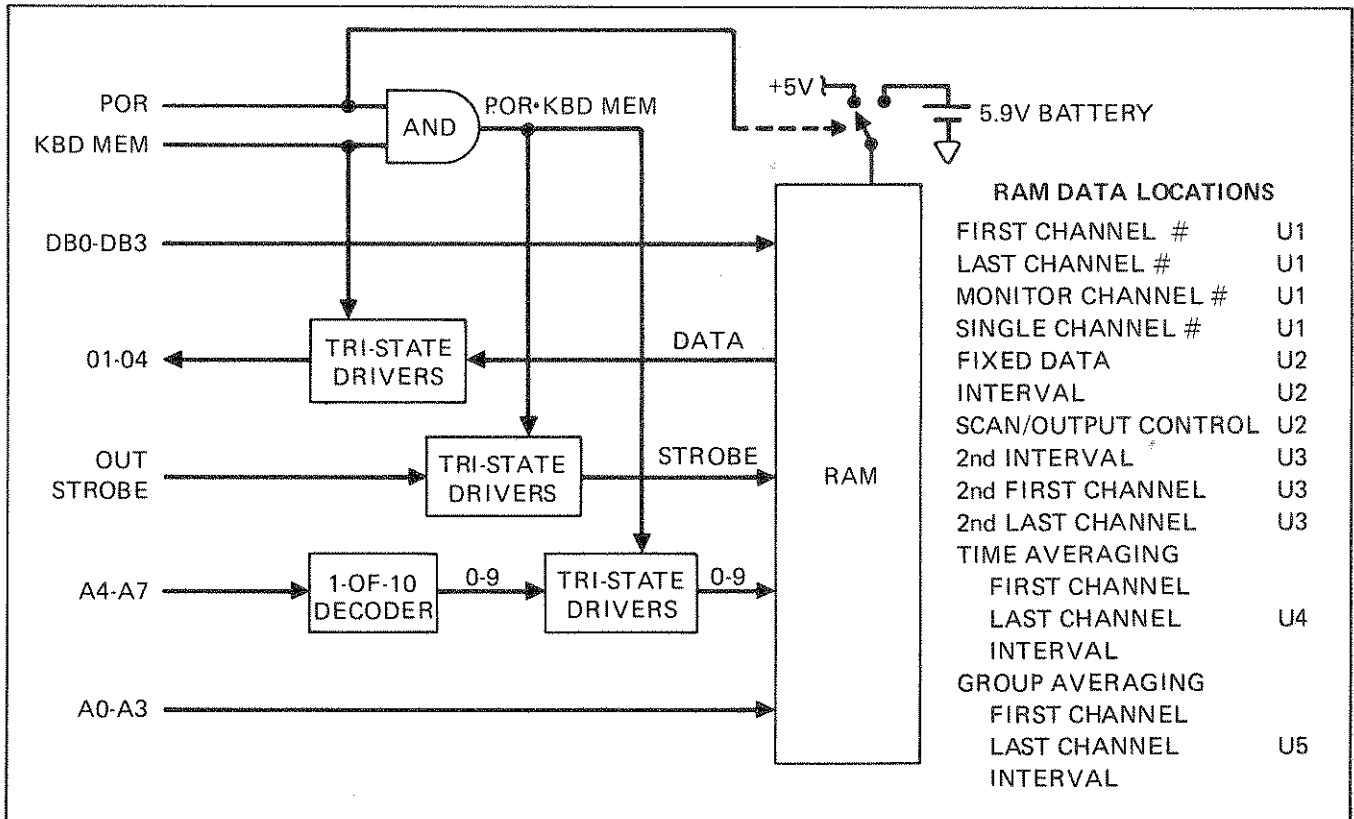

Figure 3-5. Keyboard Memory, Simplified Block Diagram

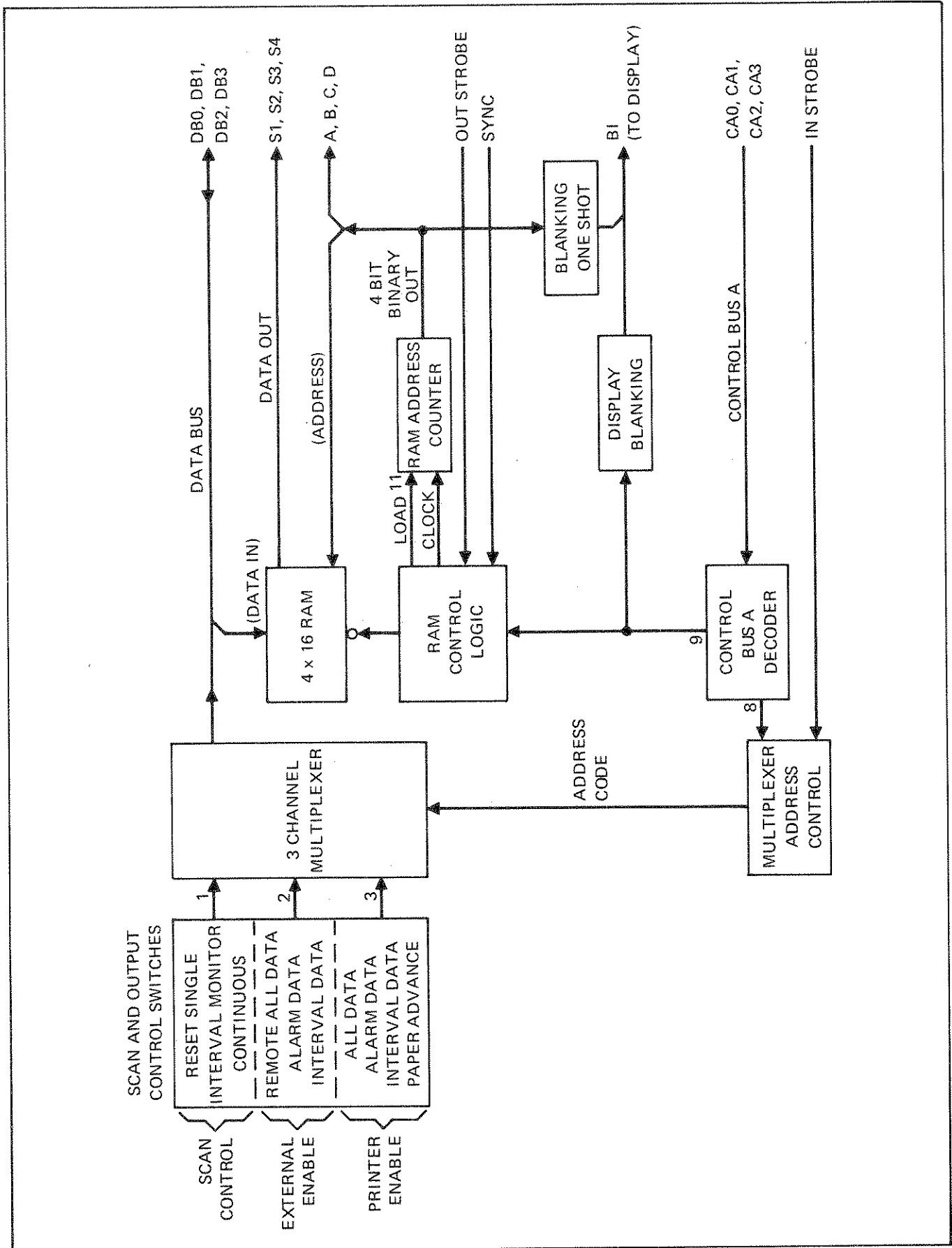

Figure 3-6. Mode Switch, Simplified Block Diagram

operates as a controller peripheral and is capable of both transmitting and receiving data via the Data Bus. In the transmit mode, it provides the controller with SCAN CONTROL and OUTPUT CONTROL switch-setting information. In the receive mode it accepts and stores numeric decade information from the controller for use in driving the front panel display. The required operating mode is enabled via address data placed on Control Bus A and is executed under the direction of control signals received from the controller.

3-44. In the transmit mode of operation the Mode Switch PCB Assembly scans the individual settings of the SCAN CONTROL and OUTPUT CONTROL switches and places the position information (depressed or out) onto the Data Bus for use by the controller. Transmit mode operation begins when the controller places a binary coded 8 on Control Bus A. This code is detected by the Control Bus Decoder on the Mode Switch PCB and is used to enable a 3-bit Multiplexer Address Control counter. The counter is sequenced by subsequent In strobe pulses from the controller, and is used to sequentially address each channel of a three channel (4-bit per channel) multiplexer. Each channel of multiplexed data contains the switch position information for 4 of the 12 CONTROL switch settings. This data is presented to the Data Bus on the leading edge of the In strobe, and is assimilated by the controller on the trailing edge. At the end of the third In stobe all 12 CONTROL switch settings have been transmitted and the controller removes the address code from Control Bus A. This isolates the Mode Switch PCB from the Data Bus and, thus, the controller.

3-45. In the receive mode of operation the Mode Switch PCB receives updated display information from the controller (via the Data Bus) and stores it in a 4 x 16 bit RAM. Receive mode operation begins when the controller places a binary coded 9 on Control Bus A. As a direct result of the address code, the RAM address counter is preset to a binary coded 11 output (via the RAM control logic) and the front panel display is blanked by a high BI level generated by the display blanking circuit. On the trailing edge of the next Sync pulse the RAM control logic is conditioned to respond to the controller generated Out strobe. A valid display character precedes each Out strobe and is placed on the Data Bus by the controller. On the leading edge of the first Out strobe the RAMs write enable input is pulled low and the Data Bus character is entered into the binary coded 11 RAM location as defined by the RAM address counter. On the trailing edge of the Out strobe the counter is decremented to 10 and new data is solicited from the controller. The remaining 11 characters are similarly written into memory by the controller. After all 12 characters of display data have been written, the controller terminates the receive mode by removing the binary coded 9 from Control Bus A.

3-46. When the Mode Switch PCB is not operating in the receive mode the sync pulse causes the RAM control logic to continuously

cycle and, thereby address the RAM locations. As each location is addressed, its stored 4-bit character is presented to the display PCB via data output lines S1, S2, S3, and S4. Since the RAM does not output data via the Data Bus, transmit and RAM read operation are conducted simultaneously. However, receive and RAM read are mutually exclusive operations.

3-47. A blanking one-shot is used to blank the display if the counter stops running. This prevents the display segments (which are normally scanned) from drawing excessive current in a static situation.

### 3-48. Display PCB Assembly

3-49. The Display PCB Assembly, as shown in Figure 3-7, operates as an extension of the Mode Switch PCB Assembly. It provides a digital display of either date and time, measurement, or program data that has been processed by the controller, and stored in the 4 x 16 bit RAM on the Mode Switch PCB Assembly. As the RAM locations are serially addressed and read, both the address and the stored data readings are presented to the Display PCB. Address data is received as inputs A, B, C, and D. Stored data is received as inputs S1, S2, S3, and S4.

3-50. The individual display digits are formed by nine 7-segment LEDs. These LEDs are driven in parallel by the output of a BCD-to-seven segment decoder whose input is taken directly from the mode switch as S1, S2, S3, and S4. Each of the LEDs is individually strobed in serial fashion, and allowed to respond to data present on the seven-line Data Bus. The strobe sequence is derived directly from the mode switch RAM address counter (A, B, C, D), and each strobed LED is allowed to read the addressed character stored in the (Mode Switch PCBs) corresponding RAM location. Since the data is scanned very rapidly (sync pulse frequency divided by 12), the display character appears to be continuously lit.

3-51. In addition to the nine numeric characters, the Data Display PCB also contains provisions for driving the polarity (minus only), annunciator (MILLIVOLTS, VOLTS, TEMPERATURE, and DATE AND TIME), and decimal point LEDs as stored in the RAM on the Mode Switch PCB. Annunciator data is read from the seven-line Data Bus as if it were a numeric character. However, polarity and decimal point data are not. When either of these two RAM locations are addressed (binary coded 9 or 11) the resultant strobe (from display column decoder) disables the BCD-to-seven segment decoder and enables the decimal point position decoder. Under these conditions the seven-line Data Bus is dead and data from the addressed RAM location is decoded by the decimal point position decoder. The appropriate decimal point location(s) and/or minus polarity LEDs are driven by the output of the decimal point position decoder. Table 3-2 lists each of the display strobe lines decoded from the RAM address counter on the Mode Switch PCB, and indicates the data enabled during each

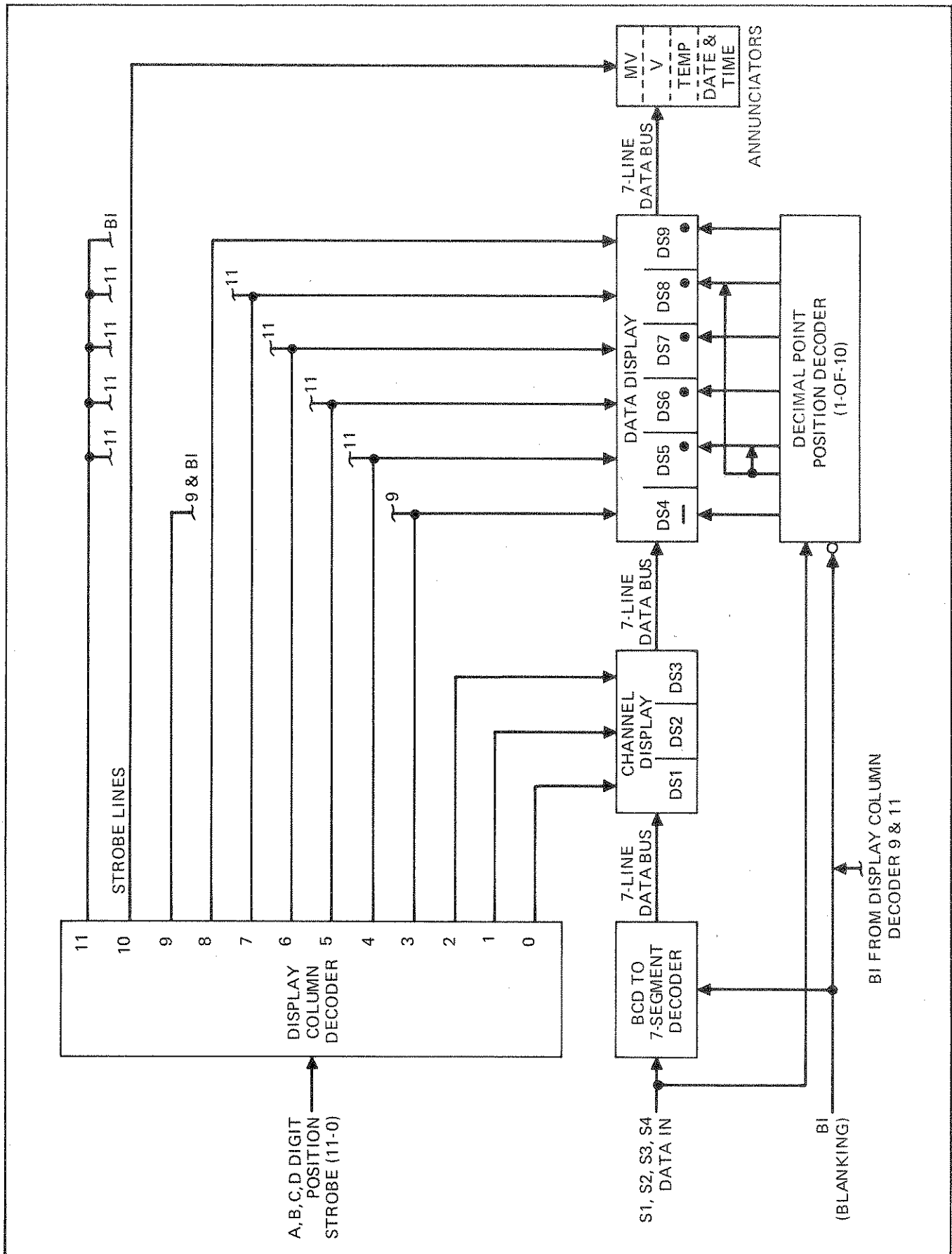

Figure 3-7. Display, Simplified Block Diagram



Table 3-2. Display LED Addresses and Functions

STROBE CODE	LED ENABLE	LED FUNCTION
11 <sub>2</sub>	DS5, DS6, DS7, DS8	DECIMAL POINTS
10 <sub>2</sub>	CR18, CR19 CR20, CR21	ANNUNCIATORS
9 <sub>2</sub>	DS4	MINUS SIGN
8 <sub>2</sub>	DS9	LSD
7 <sub>2</sub>	DS8	5TH DIGIT
6 <sub>2</sub>	DS7	4TH DIGIT
5 <sub>2</sub>	DS6	3RD DIGIT
4 <sub>2</sub>	DS5	2ND DIGIT
3 <sub>2</sub>	DS4	MSD
2 <sub>2</sub>	DS3	LSD
1 <sub>2</sub>	DS2	2ND DIGIT
0 <sub>2</sub>	DS1	MSD

DATA  
DISPLAY

CHANNEL  
DISPLAY

display (strobe) period.

### 3-52. Printer Drive PCB Assembly

3-53. The Printer Drive PCB Assembly, as shown in Figure 3-8, operates as a controller peripheral, to interface the internal Seiko Model 102 printhead with the controller Data Bus. Both transmit and receive operating modes are employed in the printing operation. The transmit mode is used to solicit data from the controller and to synchronize the controller to the printers mechanical rotation. In the receive mode the controller sends printer data to the Printer Drive PCB Assembly via the Data Bus. Data for all 16 columns is printed within the time required for one rotation of the printer drum.

3-54. The printer is a free-running device and (to print properly) requires that input data be synchronized with the mechanical rotation of its print drum. Print drum position information is generated by the printhead in the form of a Reset pulse and a series of 13 TL-TP pulses. Reset is generated once for every print drum revolution and indicates that row 0 is positioned under the 16-column print hammers. TL-TP pulses are generated as each of the 13 possible data rows (0 through 12) are positioned beneath the print hammers. Therefore, for each print drum revolution, 1 Reset pulse is generated and 13 TL-TP pulses are generated.

3-55. The TL-TP pulses from the printer are used by the Printer Drive PCB to synchronize the system clock (Sync) with the print position of the drum. Since the sync pulse frequency is much higher than the TL-TP frequency, synchronization is accomplished by a coincidence detector and does not require a change in the drum rotation or system clock frequency. When either a Reset or a TL-TP pulse is detected, a pulse is generated by the synchronizing logic. This pulse arms the interrupt control logic to enable the next Sync pulse to generate an Interrupt to the controller and, thereby indicate that the print drum is in position to receive data.

3-56. In response to the Interrupt, the controller interrogates the status of the three possible interrupt peripherals to determine which generated the Interrupt signal. When the Printer Drive status is requested (by a binary coded 13 on Control Bus A) it responds by placing the Reset and TL-TP signal levels onto the Data Bus (via status response logic) as bits DB2 and DB3, respectively, thus confirming that it initiated the Interrupt. When the controller generates the next In strobe, it reads the confirming interrupt status code (binary coded 12) and then removes the status interrogation code from Control Bus A. As the status request line from the control bus decoder goes low it resets the interrupt control logic and returns the Interrupt to a high level.

3-57. If the controller is ready to supply data to the Printer

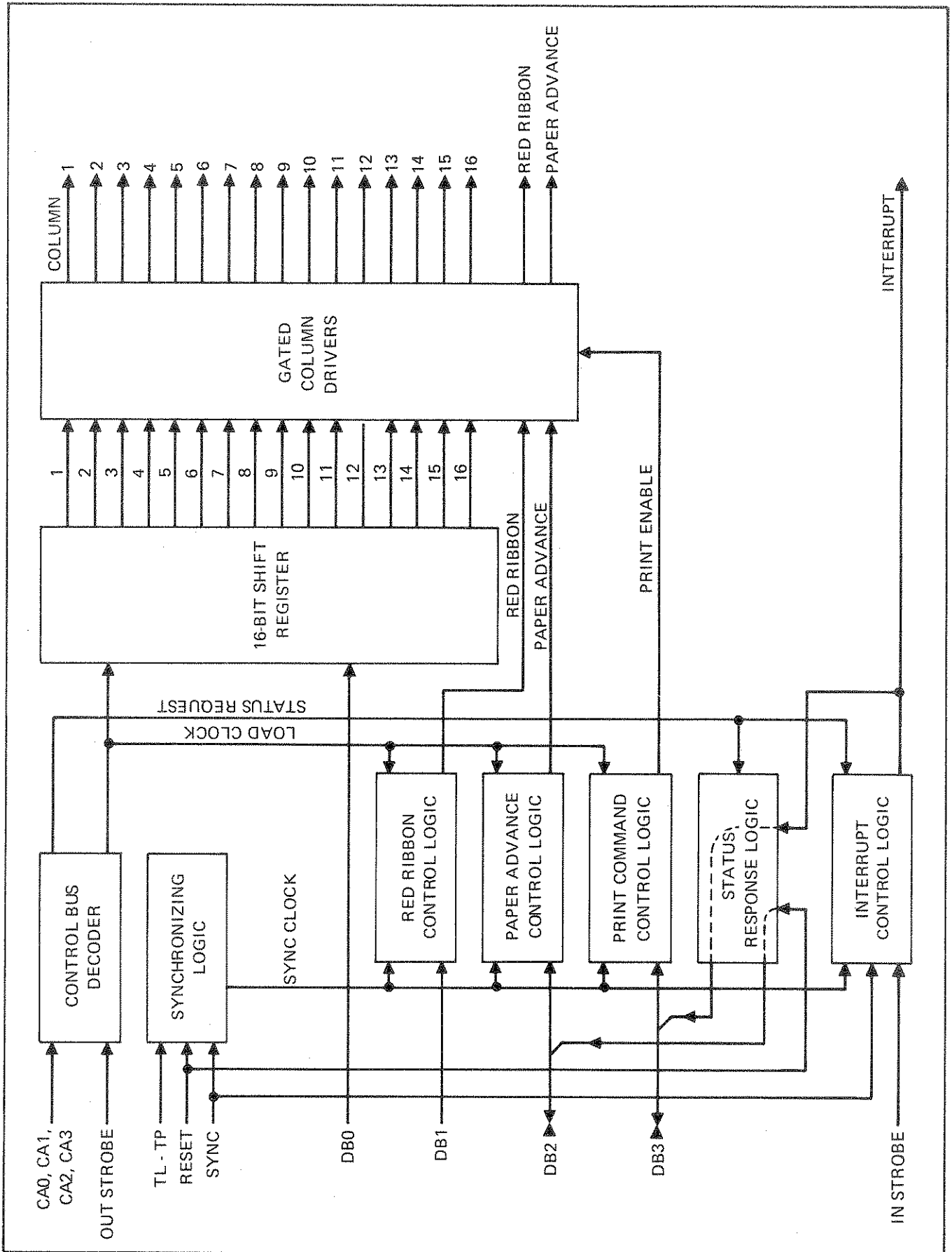

Figure 3-8. Printer Drive, Simplified Block Diagram

Drive PCB when the Interrupt line returns high, it places a binary coded 5 onto Control Bus A. The control bus decoder detects this code and enables the 16 subsequent Out strobes from the controller to be accepted as a series of 16 Load clocks on the Printer Drive Assembly. As each Load clock is accepted, the bit-serial data on DB0 is loaded into a 16-bit shift register. This stored data determines which print hammers, if any, will be activated while row 0 of the printer drum is under the print hammers. As the 16th data bit is presented to the shift register, Red Ribbon, Paper Advance, and Print Command data are received on DB1, DB2, and DB3, respectively. The subsequent Load clock shifts the last data bit into the 16-bit shift register, enters ribbon color data into the red ribbon control logic, and enters paper advance information into the paper advance control logic. On the trailing edge of the Load clock the print command control logic generates a Print Enable signal. This signal enables the gated column drivers (tri-State drivers) to energize the appropriate print hammers and, thereby print row 0 characters in the selected columns. The printer also responds to the red ribbon and paper advance commands, when present.

3-58. As the print drum continues to rotate, row 1 data is loaded into the shift register and the appropriate print hammers are energized. The sequence is performed a total of 13 times (once for each row on the printer drum) to complete a single print sequence. After the 13th Print Enable is derived from the Out strobe, the controller terminates the sequence by removing the printer receive code (binary coded 5) from Control Bus A.

### 3-59. Power Supply PCB Assembly

3-60. The Power Supply PCB Assembly, as shown in Figure 3-9, provides the operating voltages for the data logger and a full complement of options. It also provides the 1-second time interval marker (TIM) and the Power-On-Reset (POR) signal. TIM is used by the controller to update date and time. POR is used to initialize the entire data logger when power is turned on or when a power interruption occurs.

3-61. Input power for the power supply is derived from a 115/230V ac power transformer with four secondary windings. Transformer line power requirements (115/230V ac) are switch selectable through a switch mounted on the Power Supply PCB. Output windings are separated into two pairs by a transformer shield. Isolation between the pairs is maintained on both the Power Supply PCB and the data logger by including the shield as part of the data logger guard circuit. As a result the data logger operating voltages are classified as guarded and unguarded. Guarded voltages include +21 and -21V dc unregulated, and +5V dc regulated. Unguarded supplies include +5V dc, +16V dc, and -10V dc; all of which are regulated and overload protected. The 1-second time base circuitry and the Power-On-Reset circuit are contained in the unguarded section of the power supply.

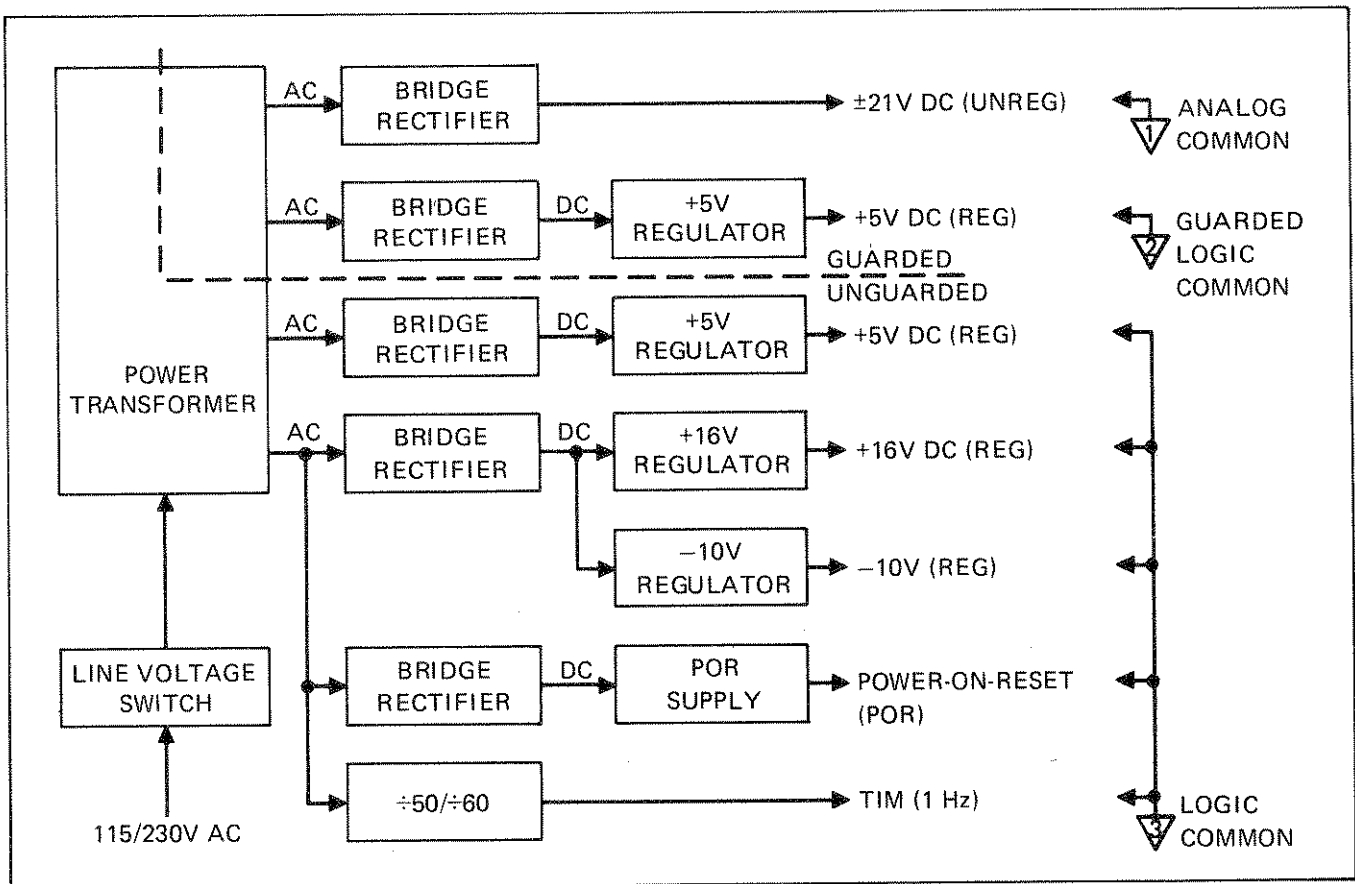

Figure 3-9. Power Supply, Simplified Block Diagram

3-62. Conventional regulating techniques are used in both sections of the power supply. No voltage adjustments are required or included in the guarded section of the supply. In the unguarded section the -10V dc output serves as a reference voltage for both the +5 and +16V dc regulators. As a result, a single adjustment is provided for the -10V dc supply. When the -10V dc is calibrated the +5 and +16V dc supplies are automatically calibrated.

3-63. The 1-second time marker circuit consists of a switch selectable divide-by-50 or divide-by-60 IC whose input clock is derived from the ac voltage present at one of the transformer secondary windings. When the IC is set to divide by the actual line frequency (50 or 60 Hz) it generates a 1 Hz pulse as an output. The pulse is buffered and provided as a power supply output signal (TIM) for use by the controller for updating date and time entries.

3-64. The Power-On-Reset (POR) signal serves as a reset command to initialize the system when power is initially turned-on, or when line power is restored after a power failure. POR is generated by a fast-acting unregulated supply whose output is normally low during power off. When line power is initially applied, POR remains low for approximately 600 ms (reset period) and then goes high (+5V dc). The signal is adequately buffered for use in resetting all data logger logic.

#### 3-65. Range and Function Memory PCB Assembly

3-66. The Range and Function Memory is a nonvolatile memory peripheral for the controller. Channel function data, limits data, mx+b scaling data, and temperature function data are stored in the Range and Function Memory PCB if the limits, scaling, or temperature option is installed. Data entered through the keyboard or through a Remote Programming Option is stored in the Range and Function Memory PCB.

3-67. The simplified block diagram in Figure 3-10 identifies the functional logic contained on the Range and Function Memory PCB Assembly. It also defines the major data flow to, from, and within the pcb. Prior to initial turn-on, previously entered program data is stored in a series of RAMs and is maintained by a 5.9V lithium battery. The battery is switched into the circuit during the absence of the Power-On-Reset (POR) signal (high during power-on) as derived from the Power Supply PCB. When power is turned on, the RAM memory is switched to operate from the unguarded +5V dc (line powered) power supply.

3-68. Memory is enabled for either read or write applications when both the Power-On-Reset signal from the power supply and the Range and Function Memory (R&F MEM) signal from the Controller are present as Range and Function Memory inputs. These signals are ANDed to enable a series of tri-state drivers which normally isolate the RAM and prevent it from being read or written into.

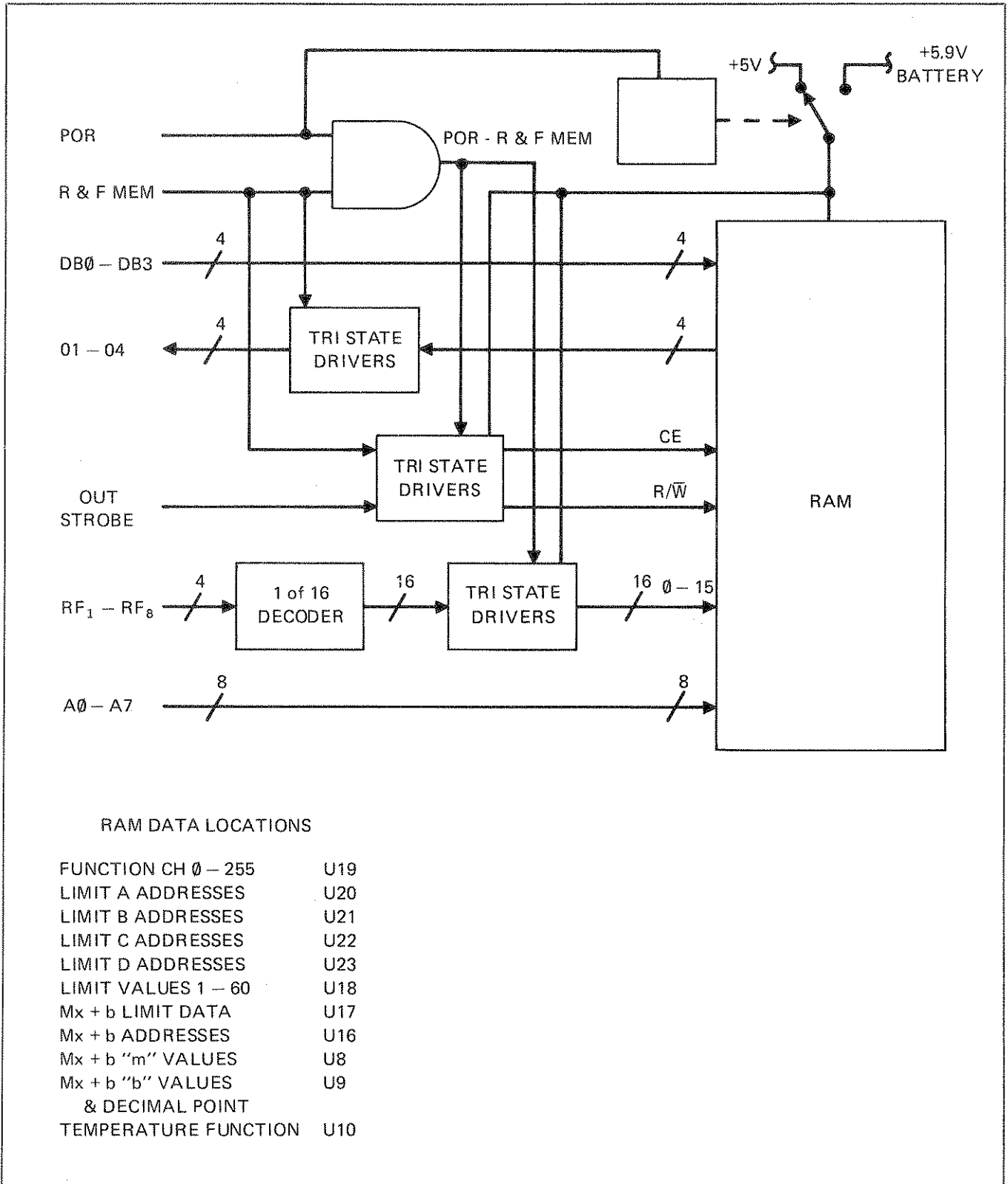

Figure 3-10. Range and Function Memory PCB Block Diagram

3-69. After memory is enabled, read or write operations can be executed in a character-serial fashion. An eight-bit address bus, A0 through A7, is operated by the Controller and used to select a particular location within the RAMs. A four-bit memory select bus (RF1, RF2, RF4, and RF8) drives a 1-of-16 decoder to develop the individual IC memory address, while the eight-bit address bus defines the character (word) within the addressed memory IC.

3-70. Data present in the addressed memory location is placed on the Output Bus (O1 through O4) and, if desired, can be read by the controller. If a word is to be written into the location addressed, the controller places the new word on the Data Bus (DB0 through DB3), then issues an Out Strobe.

### 3-71 Guard Crossing PCB Assembly

3-72. The Guard Crossing PCB Assembly operates in conjunction with the High Performance A/D Converter to provide the data logger with guarded, programmable, A/D voltage-measurement capability. Functions performed by the Guard Crossing PCB in this operation include: electrical isolation of the guarded input section of the data logger from the unguarded digital control section, and digital control for the analog half of the dual-slope A/D converter (i.e., A/D control logic, crystal controlled clock, and main counter string).

3-73. The Guard Crossing PCB Assembly, as shown in Figure 3-11, operates as a Controller peripheral and is capable of both receiving and transmitting data via the Data Bus. In the receive mode, channel and range programming data is accepted from the Controller, transferred across the guard crossing, and presented to the a/d converter. In the transmit mode, status or measurement data from the digital section of the a/d converter is transferred across the guard and presented to the Controller. The required operating mode is enabled when the appropriate address code is present on Control Bus A, and is executed under the direction of control signals received from the Controller.

3-74. The receive mode is enabled when the Controller places a binary coded 2 on Control Bus A. Input data from the Controller is received in character-serial format (four 4-bit characters) on the Data Bus (DB0 through DB3) and temporarily entered into storage in the channel and range latch by the Out Strobe. Once stored, the character is optically transmitted across the guard, buffered, and presented to the a/d converter as channel and range control data. As each character crosses the guard, it is followed by a 10 us Receive clock. The clock is derived from the Out Strobe and is generated by the receive clock logic. On the guarded side of the pcb, the Receive clock increments a four-bit shift register, the output of which addresses range (S1) and channel storage (S2, S3 and S4) locations on the a/d converter. Data entered into these locations define the channel to be measured and the measurement range to be used.



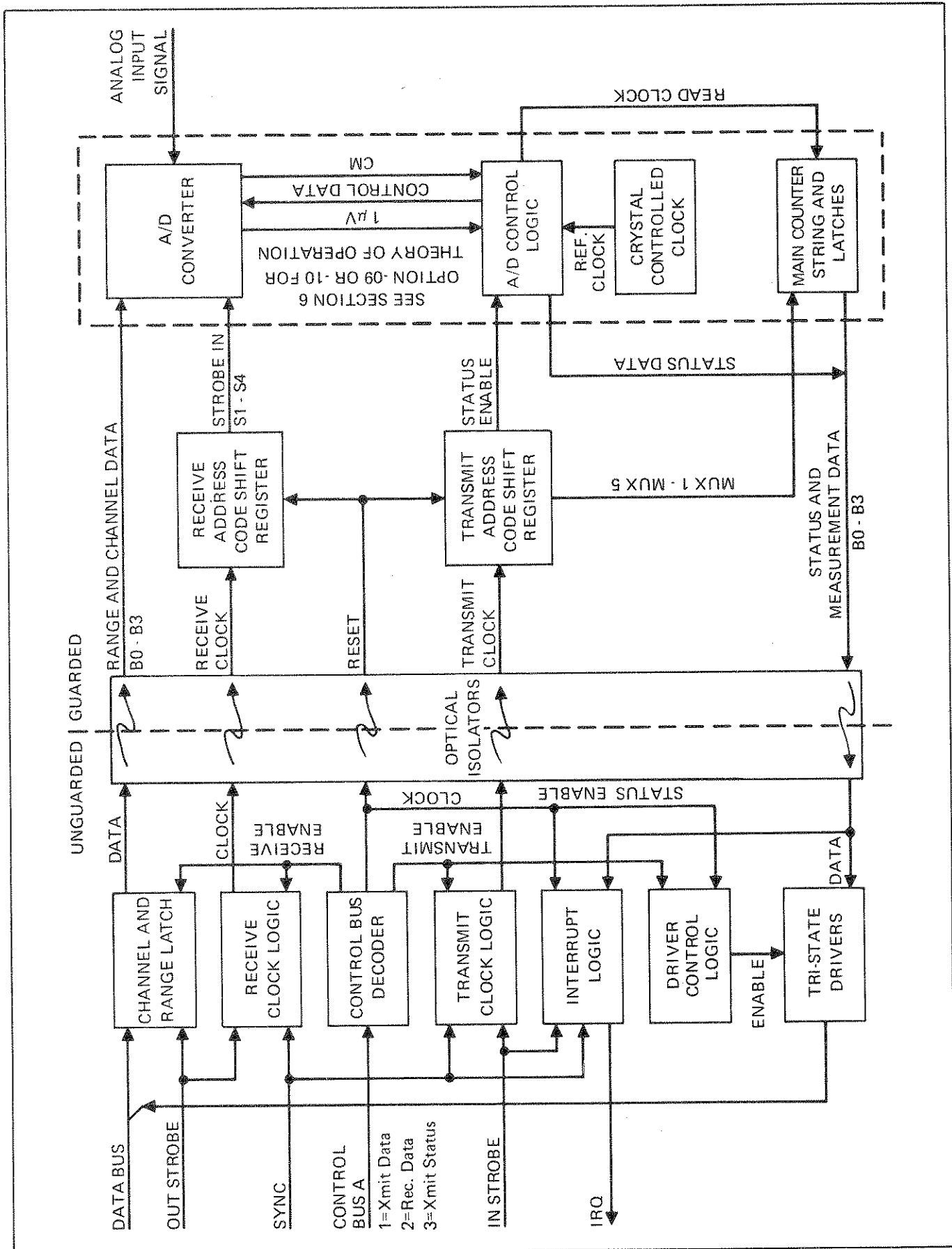

Figure 3-11. Guard Crossing, Simplified Block Diagram

3-75. The transmit status mode is enabled when the Controller places a binary coded 3 on Control Bus A. During the presence of this code, the control bus decoder generates a Status Enable signal which is used to perform three separate functions. First, it is transmitted across the guard where it is used to reset (initialize) both the transmit and receive address code shift registers. Second, it enables the tri-state driver switch, allowing transmitted data to be placed onto the Data Bus. Third, it allows the next In strobe to reset the Interrupt Logic and, thereby, clear the interrupt request line (IRQ).

3-76. When the tri-state drivers are enabled and the two address code registers are reset, status information is allowed to appear on the Data Bus as a single four-bit output character. Three separate characters are employed to indicate each of the following status conditions: measurement data ready, new channel and function data required for next measurement, and a 1 uV flag. All three of these codes are derived from the a/d control logic portion of the Guard Crossing. The new-data-required and data-ready status conditions are keyed to the beginning and end, respectively, of each measurement cycle. The 1 uV flag is transmitted only once (during the initial power-on) and is used to inform the Controller of the type of A/D Converter installed.

3-77. When the a/d converter completes a measurement cycle it notifies the Controller by setting the Interrupt Logic and pulling the IRQ line low. The Controller responds by serially interrogating the status of the Printer Drive, the output options, and the Guard Crossing PCB Assemblies, to determine which of the three random responding units pulled the IRQ line low. When the Guard Crossing PCB is interrogated, it indicates that the measurement data is ready to be transmitted. The Controller responds by terminating the status transmit mode and enabling the transmit data mode.

3-78. The transmit data mode is enabled when the Controller places a binary coded 1 code on Control Bus A. While the code is present on the Control Bus, it causes the control bus decoder to generate a transmit Enable signal. This signal, in turn, enables the tri-state drivers and the transmit clock logic. The next In strobe from the Controller is passed through the transmit clock logic, coupled across the guard and used to set the first position of a five-bit shift register. Each subsequent In strobe is used to advance the shift register position and, thereby, sequentially address a five-channel multiplexer (main counter string and latches) in which measurement data is stored (MUX1-MUX5). As each channel of data is addressed (LSD first, MSD last), it is placed onto the guarded side of the data bus (B0 through B3), transmitted across the guard, and presented to the Data Bus through the enabled tri-state drivers. Each character is read into the Controller on the trailing edge of the In strobe.

3-79. A/D Converter

3-80. The High Performance A/D Converter PCB operates in conjunction with the Guard Crossing PCB to perform the analog functions of a five-range (40 V, 4 V, 400 mV, 80 mV, and 40 mV), dual-slope, integrating DVM capable of resolving 1 uV on the 40 mV range. Digital program and control data necessary to complete a measurement cycle (this includes the read clock) are generated on the Guard Crossing PCB. Similarly, a 40,000 count counter string is included on the Guard Crossing PCB for accumulating the digital equivalent of the measured analog input. After measurement data is accumulated, it is presented to the Data bus in character-serial format when solicited by the controller. A simplified block diagram of the High Performance A/D Converter plus the associated digital logic from the Guard Crossing is given in Figure 3-12.

### 3-81. DIGITAL CONTROL LOGIC

3-82. Digital control logic for the High Performance A/D Converter is contained on both the Guard Crossing PCB and the A/D Converter PCB. A/D conversion logic on the Guard Crossing PCB consists of a two-speed crystal controlled clock, a digital counter with latches and multiplexed tri-state outputs, and dual-slope digital control logic. Digital logic on the High Performance A/D Converter PCB consists of four addressable 4-bit registers and three output decoders. All digital input data utilized by the digital control logic is received from the controller via the Guard Crossing PCB Assembly.

3-83. Operation of the guard crossing logic is synchronized with the output of the crystal controlled clock, which is divided down so that integrate time is an even multiple of a line cycle. The line cycle reference optimizes the common mode and normal mode rejection characteristics of the A/D Converter. The reference is established by either a 2 MHz (for 50 Hz) or 2.4 MHz (for 60 Hz) crystal. Additional clock circuitry in the form of pulse shaping dividers produce the final 2-phase reference clock as received by the dual-slope control logic.

3-84. Clock rate (and, therefore, measurement speed) can be selected manually by positioning a FAST/SLOW slide switch on the A/D Converter PCB. In the fast position a 1.2 MHz (60 Hz), 2-phase clock is supplied directly to the A/D Converter logic. Since a measurement cycle requires 80,000 clock pulses to produce a reading, the A/D converter can accomplish a maximum of 15 readings per second. In the slow switch position the 1.2 MHz clock is divided by five. Thus, the measurement rate is reduced to three readings per second, maximum.

3-85. Overall timing of the dual-slope conversion process is governed directly by the dual-slope control logic. Two control flip-flops (U14B/FAA and U20A/FFB) operate in response to the carry outputs of the various counter stages and the reference clock to determine the next state of the dual-slope control logic

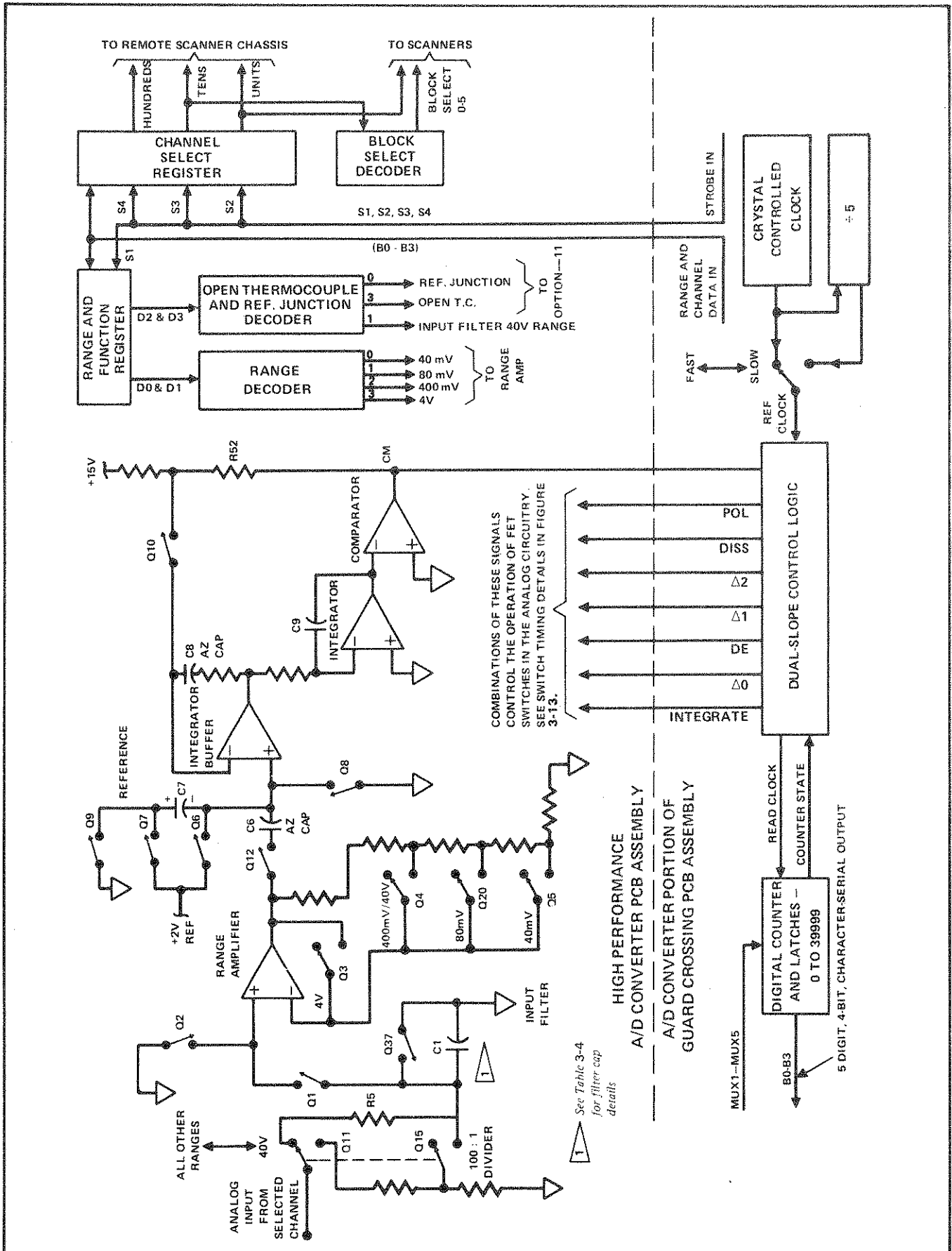

Figure 3-12. General Purpose A/D Converter PCB Assembly Functional Block Diagram

and, therefore, its output control signals. These signals are shown in Figure 3-13 and described in Table 3-3.

3-86. The data accumulated in the digital counter (if  $\leq 39999$ ) is determined to be the digital equivalent of the analog input voltage when the CM (compare) input from the A/D Converter PCB transitions to a state which is the opposite of the POL (Polarity) level. This transition indicates the end of the read period and causes the counter data to be loaded into the output latches. It also initiates a Data Ready signal which is transmitted across the guard as part of the status word.

3-87. When the controller detects the Data Ready status it generates a series of five Strobe In pulses which are converted on the Guard Crossing PCB into a series of five multiplexer pulses, MUX1 through MUX5. As each pulse sequentially occurs, one of the five 4-bit counter characters is solicited and transferred across the guard before the next measurement cycle is allowed to start (i.e., the reference clock is inhibited until MUX5 goes low to indicate that the last digit of measurement data has been solicited).

3-88. Channel select data for measurement purposes is updated once during each A/D conversion (measurement) cycle so that new analog data can be presented to the A/D converter. Updating occurs in response to an interrupt status signal generated by the Guard Crossing PCB. The interrupt causes the controller to specify the next programmed measurement channel and its associated function data to the Guard Crossing PCB. Data is received as a series of four 4-bit characters which are serially transferred across the guard to the A/D Converter PCB. A unique strobe pulse (S1 through S4) accompanies each character and causes it to be entered into a 4-bit register. The first character is entered into a range and function register by strobe pulse S1. The second, third, and fourth characters are similarly entered into a series of three channel select registers by strobe pulses S2, S3, and S4, respectively.

3-89. Range and function data for the next measurement cycle are derived from the first stored character. Its two low-order bits, D0 and D1, are decoded to provide the range command (4V, 400 mV, 80 mV, 40 mV) for the Range Amplifier on the A/D Converter PCB. Similarly, the 40V range, open-thermocouple detect and reference-junction measure commands are decoded from the two high-order bits, D2 and D3.

3-90. Channel select commands (units, tens, and hundreds) are taken directly from the output of the three channel select registers. Tens data is decoded to provide the individual block select commands for the first 60 (0-59) channels in the data logger, while units data activates the appropriate channel relay (0-9) in the selected scanner block-channel. Commands above 59 (60 through 999) are available at a rear-panel connector on the A/D Converter PCB for use in selecting channels maintained in an

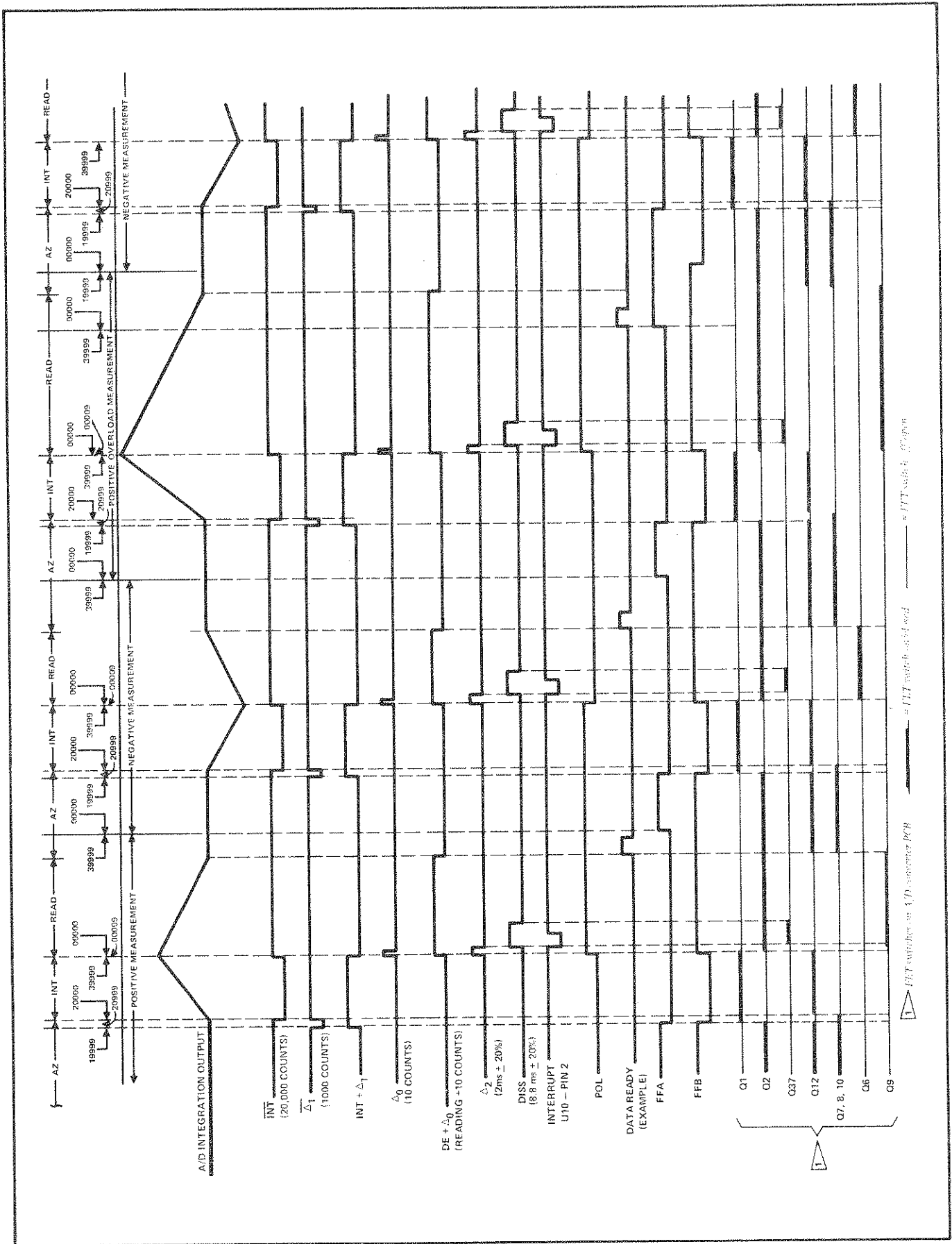

Figure 3-13. A/D Converter Timing Diagram

Table 3-3. Guard Crossing Signal Descriptions

SIGNAL NAME	DESCRIPTION
Int + $\Delta 1$	A 2100 count period derived directly from control flip-flop FFB (U20A). Used for controlling FET switching on the A/D Converter PCB.
$\Delta 1$	A 1000 count period which starts when FAA and FFB are both low and the counter has reached a count of 19999. The period ends when the counter three least-significant stages go through a count of 999. At this time the fourth stage is prevented from clocking so that the clock pulse will change the counter from 20999 to 20000. This signals the beginning of the integrate period.
$\Delta 0$	A 10 count period immediately following the end of the integrate period. During this time the second counter stage is inhibited so that the count goes from 39999 to 00009 and then to 00000. Thus, after a 10 count settling period the read period starts at a count of 00000 and continues on. The count at the end of the read period is proportional to the analog input voltage.
POL	Indicates the polarity of the integrated input signal, and is derived from the level (high or low) of the CM signal at the end of the integrate period.
$\Delta 2$	A 2 ms pulse generated at the end of the integrate period. It is used by the Temperature Options -43, -44 and -45 to trigger an open thermocouple detector.
Diss	An 8.8 ms pulse generated at the end of $\Delta 2$ . It is used to discharge the input filter before the next analog input is applied and to prevent the closing of more than 1 scanner relay at a time.
DE	A variable length read period which begins at the end of the $\Delta 0$ pulse. The end of the read period occurs when the CM pulse transitions to a state that is different from POL or when the counter counts through 19999 after an overload reading of 39999.
$\Phi$ (Overload)	An overload signal (1-bit) which is returned to the controller with the MSD of measurement data. The signal occurs when the counter counts through 39999 before a CM input transition occurs, and prevents the counter MSD from going from 19999 to 20000. Instead, the counter transitions from 19999 to 00000. This allows an extra 20000 count auto-zero period to ensure full recovery from overload condition.

external scanner chassis (2201A, 2202A, and/or 2203A).

### 3-91. ANALOG CIRCUIT

3-92. The analog portion of the dual-slope A/D converter is contained entirely on the High Performance A/D Converter PCB Assembly. It consists of an input filter, a range amplifier, a reference supply, an integrator buffer, a comparator, and a series of FET switches. Digital control signals from the Guard Crossing PCB control the operation of the analog circuit. Figure 3-14 relates the operation of each individual FET switch to the digitally controlled measurement cycle.

3-93. Operation of any given measurement cycle can be logically divided into three measurement periods: auto zero, integrate, and read. Auto zero is used to measure and eliminate any in-circuit errors which might influence the end reading. Integrate allows the input signal to be sampled (integrated) for a known time period. During the read period two separate functions are performed. The next analog input is applied to the input (integrate), and the input voltage is compared (integrated) with a reference voltage. The time required to complete the read period is then translated, by the dual-slope control logic, into a digital equivalent of the analog input voltage.

3-94. The auto zero period begins at the end of the read period, as indicated by the leading edge of the Data Ready pulse. At that time, FET switches Q1, Q37, Q6, and Q9 are open and Q2, Q7, Q8, Q10, and Q12 are closed. Switch Q1 isolates the input of the range amplifier from the analog level present at the input filter. Switches Q2 and Q8 provide zero volt reference levels for charging a series of reference capacitors C6, C7, and C8. Capacitor C6 charges through Q8 and Q12, to a value which is equal to the offset voltage error inherent in the range amplifier. Similarly, capacitor C8 is charged through switch Q10 to a value which is equal to the loop offset voltage of the integrator buffer, integrator, and comparator combination. Finally, capacitor C7 is charged to the +2V reference level through switches Q7 and Q8. The charges on these capacitors will be retained throughout the remainder of the measurement cycle for use in eliminating offset errors (C6 and C8), and providing the choice of selectable reference polarity (C7) which is compatible with the analog input signal.

3-95. Termination of the auto zero period occurs in two steps. First, switches Q2 and Q12 are opened and switch Q1 is closed. This isolates the range amplifier output from the rest of the circuit and allows it to respond to the input voltage applied through switch Q1. Second, switches Q7, Q8, and Q10 are opened and switch Q12 is closed. This connects the output of the range amplifier to the integrator buffer. At this time, the auto zero period is ended and the integrate period begins.

3-96. During the integrate period the integrator buffer



presents the integrator with an offset-corrected dc input voltage which is equivalent to the analog input voltage level. This signal is then integrated for a fixed time which is equal to 20,000 read-clock pulses, as determined by the digital counters on the Guard Crossing PCB. When the time period is satisfied the integrate period is ended and the read period is started.

3-97. At the start of the read period, switches Q1 and Q12 are opened, and Q2 and either Q6 or Q9, are closed. Switches Q1, Q2, and Q12 electrically remove the range amplifier and, therefore, the analog input signal from the input of the integrator buffer. If the input signal was positive, switch Q9 is closed and a -2 volt reference is applied to the integrator buffer via the previously charged reference capacitor C7. However, if the original analog input signal was negative, switch Q6 is closed causing the +2 volt reference to be applied directly to the input of the integrator buffer. In either event, integrator capacitor C9 begins to discharge at a fixed linear rate, and the counter string on the Guard Crossing PCB begins to count and accumulate the reference clock output. The discharge continues until the capacitor reaches a zero-charge level as determined by the previous auto-zero period. When that level is detected by the comparator, a compare (CM) transition is generated to terminate the read period. This stops the counter on the Guard Crossing PCB and returns the analog circuitry to the auto-zero period. (The next measurement cycle starts after data is transferred across the guard to the controller).

3-98. Since the range amplifier and the input filter are isolated from the rest of the analog circuit at the beginning of the read period, both digital range data and the analog input signal for the next measurement channel are entered at that time. This allows both the input filter and the range amplifier to settle before the next measurement cycle begins.

3-99. The input filter is a single pole RC filter designed to suppress noise which accompanies the input signal. On all ranges, except 40V, resistor R5 acts as the primary resistive component. The capacitive component, however, varies as a function of both measurement speed (fast/slow) and selected range. On the 40V range, resistor R5 is switched out of the input circuit by relay, K1, and is replaced by a 100:1 divider. On the 40 mV and 80 mV ranges, separate capacitors, as well as active clamp circuitry (U25), are switched into the circuit. Table 3-4 defines each of the input filter capacitors, as well as which capacitor (s) is (are) selected for any given combination of range and measurement speed.

Section 4  
Maintenance

WARNING

THESE SERVICING INSTRUCTIONS  
ARE FOR USE BY QUALIFIED  
PERSONNEL ONLY. TO AVOID  
ELECTRIC SHOCK, DO NOT PERFORM  
ANY SERVICING OTHER THAN THAT  
CONTAINED IN THE OPERATING  
INSTRUCTIONS UNLESS YOU ARE  
QUALIFIED TO DO SO.

4-1. INTRODUCTION

4-2. This section of the manual contains maintenance information for the Model 2240C Data Logger. This includes service information, general maintenance, and a performance test. The performance test is recommended as an acceptance test when the instrument is first received, and later as a calibration procedure to verify instrument specifications. A calibration cycle of 1 year is recommended to maintain the 2240C within the 1-year specifications. If the 90-day specifications are to be maintained, a 90-day calibration cycle is recommended. Table 4-1 lists the recommended test equipment necessary to execute the performance test and calibration adjustments. If the specified equipment is not available, alternate equipment having equivalent specifications may be substituted.

4-3. SERVICE INFORMATION

4-4. The 2240C is warranted for a period of 1 year upon delivery to the original purchaser. The WARRANTY is given on the back of the title page located in the front of the manual.

4-5. Factory authorized calibration and service for each Fluke product is available at various worldwide locations. A complete list of these service centers is included with the WARRANTY. Shipping information is given in Section 2 of this manual. If requested, an estimate will be provided to the customer before any repair work is begun on instruments that are beyond the warranty period.

4-6. GENERAL MAINTENANCE

4-7. Access Information

WARNING

LETHAL VOLTAGES MAY BE PRESENT  
AT THE LINE POWER INPUT  
CONNECTOR AND THE POWER SUPPLY  
PCB ASSEMBLY WHEN THE 2240C IS

Table 4-1. Recommended Test Equipment

INSTRUMENT	MINIMUM USE SPECIFICATIONS	RECOMMENDED MODEL
DC VOLTAGE CALIBRATOR	0 to 40 VOLTS DC, $\pm 0.002\%$	FLUKE 343A
DVM	20 mV to 20V DC, $\pm 0.03\%$	FLUKE 8050A
LOW LEVEL SCANNER		FLUKE OPTION -06
INPUT CONNECTOR		FLUKE OPTION -07 OR -08

CONNECTED TO LINE POWER. LETHAL  
COMMON MODE VOLTAGES MAY ALSO  
BE PRESENT AT THE SCANNER INPUT  
CONNECTORS AND SCANNER PCB'S  
EVEN THOUGH THE LINE POWER CORD  
IS DISCONNECTED.

4-8. CALIBRATION ADJUSTMENTS

4-9. All calibration adjustments and all plug-in options within the data logger can be accessed for maintenance purposes by removing the top dust cover and the two inner covers located in the top rear of the instrument. Six phillips-head screws hold the top dust cover in place.

4-10. REMOVING THE 102 PRINTER HEAD

4-11. Use the following procedure to remove the printer head from the 2240C:

1. Remove the top dust cover from the 2240C
2. Locate the hinges for the printer's front panel assembly and, with the panel closed, apply pressure, using a thumb or finger, to the rear of one of the hinges. The hinge will snap apart.
3. Using a lateral motion, separate the other hinge and remove the printer's front panel.
4. Disconnect the printer's cable and connector assembly from the Printer Driver PCB. (The cable is located at the bottom of the printer bulkhead.)
5. Remove the four large mounting screws at the rear of the printer bulkhead. Support the printer with one hand while removing these screws. (The use of an offset Phillips-head screwdriver is suggested.)
6. Fully extend the paper drawer and work the top of the printer through the front panel opening. Tilt the printer forward and rest it on the paper drawer.
7. Push the cable through the bulkhead bushing and cable clamp to obtain about 4- to 5-inches of free cable at the printer.
8. Remove the printer's cable clamp and cable bushing from the printer bulkhead.
9. Remove the cable from the bushing slot and slide both the cable and connector past the extended printer drawer.

10. Logically reverse this procedure to install the printer head.

4-12. Cleaning

4-13. Clean the Model 2240C periodically to remove dust, grease, and other contamination. Separate procedures are given below for cleaning the Seiko Model 102 Printer Head, and the 2240C cables and pcbs.

4-14. PRINTER HEAD

4-15. The printer should be cleaned after using 10 packs of paper or every 90-days. Use the following procedure:

1. Remove the printer head from the chassis using the procedure given in previous paragraphs.
2. Use a brush or vacuum cleaner to remove dust and other clinging particles.
3. Clean the face of the print drum using a hard bristle brush.
4. Use alcohol or benzine to remove grease and grime from the printer.

CAUTION

The use of thinner, tri-chloroethelene, ketone, etc., may cause damage to plastic parts on the printer.

4-16. CABLE AND PCBS

4-17. Use the following procedure to clean the interface cables and pcbs used with the data logger.

1. Clean the cables with a soft cloth dampened with a mild solution of detergent and water.
2. Clean the surface of the pcbs using clean, dry air at low pressure ( $\leq 20$  psi). If grease is encountered, spray with Freon T.F. Degreaser and remove grime with clean, dry air at low pressure.

4-18. Lubrication

4-19. The Seiko Model 102 Printer should be lubricated every 6 months under normal use conditions and, if necessary, after cleaning. Refer to Figure 4-1 and apply the specified lubricant, O2 or G2, to the points indicated. Use a syringe for

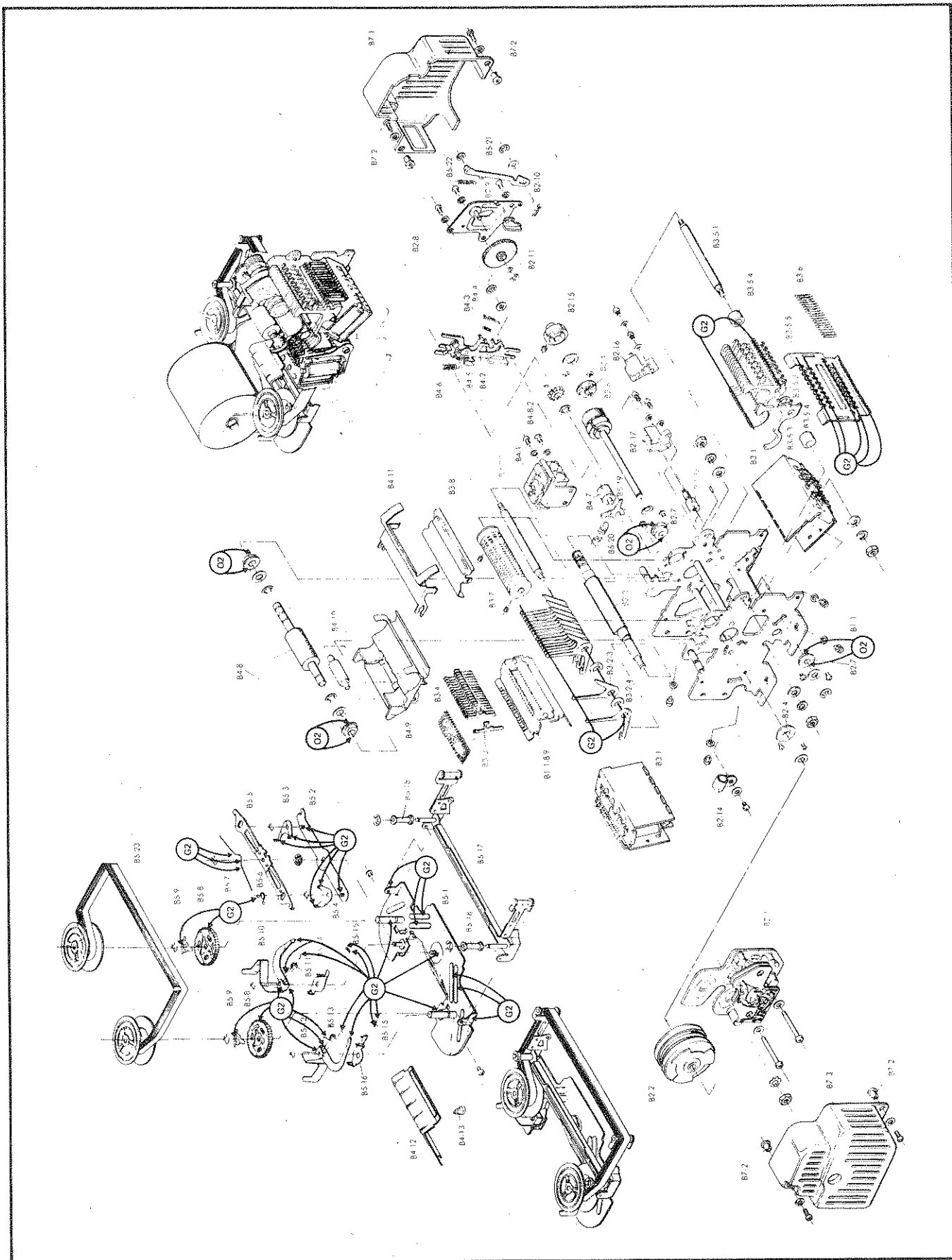

Figure 4-1. Lubrication Chart

hard-to-reach lubrication points.

NOTE

The required lubricants. O2 and G2, can be purchased from: C. Itoh and Co., telephone: (213) 390-7778.

4-20. Internal Switch Settings

4-21. A series of switches on the inside of the 2240C allows the user to select, and thereby, define certain 2240C operating characteristics. These include: Option -43, -44, and -45 temperature scale (C/ F), programming mode (individual/block), format of printed and/or recorded data (alarm all/once), A/D converter measurement speed (fast/slow), line voltage, and frequency. Figure 4-2 identifies each of the switch locations. Procedures for setting the switches are given in the following paragraphs.

NOTE

Changes to these switch settings are not recognized by the 2240C while power is on. Switch the power switch to POWER OFF, then to POWER ON to read in new switch settings.

4-22. INDIVIDUAL/BLOCK PROGRAMMING

4-23. The individual or block programming mode, as described in Section 2 of this manual, can be selected by setting switch 4 on the Controller PCB Assembly; ON selects the individual mode, and OFF selects the block mode. See Figure 4-2.

4-24. PRINT/RECORD FORMAT

4-25. The data formats for recorded data, as described in Section 2 of this manual, can be selected by setting switch 2 on the Controller PCB Assembly. See Figure 4-2. Printed data format is selected by setting switch 2 to ON for alarms all, or to OFF for alarm once.

4-25a. Switch S1 selects local or remote operation. Refer to Section 2 for local/Remote information.

4-26. INPUT POWER SELECTION

WARNING

LETHAL VOLTAGE MAY BE PRESENT  
AT THE LINE POWER INPUT

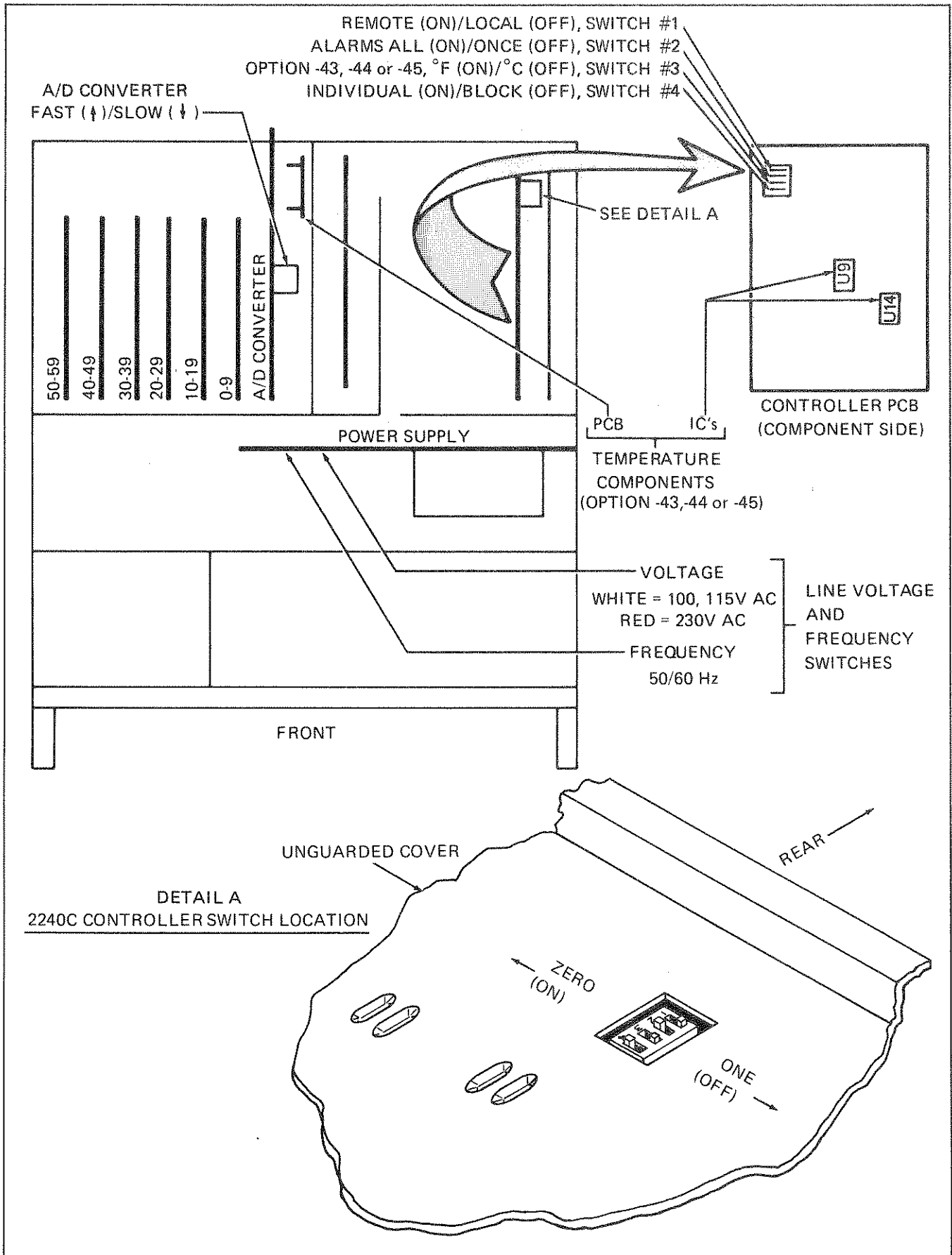

Figure 4-2. Internal Switch Locations



CONNECTOR AND THE POWER SUPPLY PCB ASSEMBLY WHEN THE 2240C IS CONNECTED TO LINE POWER. LETHAL COMMON MODE VOLTAGES MAY ALSO BE PRESENT AT THE SCANNER INPUT CONNECTORS AND SCANNER PCB'S EVEN THOUGH THE LINE POWER CORD IS DISCONNECTED.

4-27. The 2240C can be operated from either 100, 115, 230V ac, 50 or 60 Hz line power depending upon the combination specified at the time of purchase. Before connecting the 2240C to line power, check and, if necessary, set the line voltage and the line frequency switches on the Power Supply PCB as follows:

1. Remove the top dust cover from the instrument.
2. Locate the line voltage switch shown in Figure 4-2.
3. Refer to the rear panel decal and use a screwdriver to set the slide switch so that the specified voltage (100/115 [white] or 230V ac [red]) appears in the slide aperture.
4. Locate the line frequency switch shown in Figure 4-2.
5. Set the switch to the line frequency (50 or 60 Hz) specified on the rear panel decal.

NOTE

If it becomes necessary to change the line frequency from that originally specified, a crystal on the guard crossing must be changed. Contact your nearest Fluke Representative or the John Fluke Mfg. Co., Inc.

6. Install the proper fuse in the rear panel fuse holder. See Fuse Replacement procedure in the following paragraph.
7. Install the top dust cover.

4-28. Fuse Replacement

WARNING

DISCONNECT THE UNIT FROM LINE POWER BEFORE ATTEMPTING FUSE REPLACEMENT.

4-29. The power fuse is located on the rear panel of the data logger. If replacement is necessary, select the fuse rating according to the local line voltage as listed below:

1. 100v ac - 3/4A Slo-Blo
2. 115V ac - 3/4A Slo-Blo
3. 230V ac - 3/8A Slo-Blo

#### NOTE

The fuse holder cap can be replaced with a metric cap (John Fluke P/N 424440) which will accept 5 mm x 20 mm fuses.

#### 4-30. Service Tools

4-31. A special interface cable is required to execute the Performance Test given later in this section. The cable is fabricated using either of the available input connectors, (Option -07 or -08) and a length of 20 gauge insulated wire. The instructions necessary to fabricate the cable are given in Figure 4-3.

4-32. A set of PCB Extender Cables is available for servicing the plug-in pcb's contained in the data logger. The Extender Cables are available as accessories and are described in Section 6, Option and Accessory Information.

#### 4-33. PERFORMANCE TEST

4-34. The performance test is designed to verify the overall operation of the 2240C, and is intended for use as an acceptance test and/or periodic maintenance check. The equipment used in the test is specified in Table 4-1. The entire test should be executed in the sequence given. If the 2240C fails any part of the performance test, corrective action is indicated. Troubleshooting information is given at the end of the section.

#### 4-35. Set-Up Procedure

4-36. Prior to executing the performance test complete the following set-up procedure:

1. Install a Low Level Scanner (Option -06) in slot 0 (Channel 0-9) of the 2240C. The dust cover and the left-rear inner guard should be removed for the duration of the performance test.
2. Set switch #2 on the A3 Controller PCB to OFF (Alarms Once).

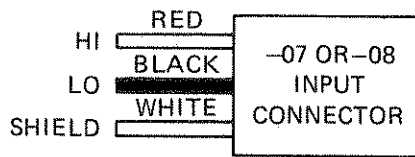

Use the following procedure to prepare the above test cable:

1. Cut a 24-inch length of each of the following wires. Use insulated, 20 guage, standard wire:
  - a. RED
  - b. BLACK
  - c. WHITE
2. Refer to the connector decal for pin locations and connect the wires from step 1 to the following connector inputs:
  - a. RED wire to HI-0, HI-4, and HI-5
  - b. BLACK wire to LO-0, LO-4, and LO-5
  - c. WHITE wire to SH-0, SH-4, and SH-5
3. Strip  $\frac{1}{2}$  inch of insulation from the free ends of the red, black and white wires, and tin the exposed wire.
4. Install the following jumpers on the input connector. Use bare copper hook-up wire:
 

a. LO-1 to HI-1	e. LO-7 to HI-7
b. LO-2 to HI-2	f. LO-8 to HI-8
c. LO-3 to HI-3	g. LO-9 to HI-9
d. LO-6 to HI-6	

Figure 4-3. 2240C Test Cable

3. Attach the test cable described earlier under Service Tools to the scanner in slot 0.
4. Connect the free end of the test cable to the output of the DC Voltage Calibrator (red to +, black to -, and white to ground).
5. Set the DC Voltage Calibrator for a 0V dc output.
6. Energize the DC Voltage Calibrator.
7. Press the RESET switch in the 2240C's SCAN CONTROL group.
8. Press the ALL DATA switch in the PRINTER ENABLE group. Release all other switches in the OUTPUT CONTROL group.
9. Connect the 2240C to line power and set the Power switch to POWER ON. The DATA display should read 2240C 7 or higher, determined by the software version installed for approximately 3 seconds and then begin to read elapsed time. If a temperature option is installed, the initial display will include either 43, 44, or 45 in the CHANNEL display. The POWER FAILURE RE-ENTER TIME lamp in the TIME ENTRY group should begin to flash.

NOTE

The initial display identifies the 2240C and the control firmware version installed in the instrument.

4-37. Display and Data Entry Test

4-38. Use the following procedure to check the operation of the 2240C display and data entry switches:

1. Complete the Set-Up procedure.
2. Press the FIXED DATA switch in the SCAN FORMAT group. All annunciators and the CHANNEL display should be out. The fixed data currently in memory should appear at the DATA display.
3. Using the DATA ENTRY keyboard, enter a series of six 1's. The DATA display should read 111111.
4. Press CLEAR ENTRY switch and enter six 2's on the keyboard. The DATA display should read 222222.
5. Press CLEAR ENTRY switch and repeat the previous

step using a series of 3's, 4's, 5's, 6's, 7's, 8's, 9's, and 0's. The entered data should appear on the DATA display.

6. Press the MONITOR CHANNEL switch in the SCAN FORMAT group. The monitor channel currently in memory should appear at the CHANNEL display.
7. Using the DATA ENTRY keyboard enter a series of the three 1's. The CHANNEL display should read 111.
8. Press CLEAR ENTRY switch and enter three 2's on the keyboard. The CHANNEL display should read 222.
9. Press CLEAR ENTRY switch and repeat the previous step using a series of 3's, 4's, 5's, 6's, 7's, 8's, 9's, and 0's. The entered data should appear on the CHANNEL display.

#### 4-39. Date and Time Test

4-40. Use the following procedure to check the operation of the time-of-year clock.

1. Press the DAYS switch in the TIME ENTRY group. All annunciators and the DATA display should be out. The day code currently in memory should appear on the DAY (CHANNEL) display (000 if day code has not been entered since power was turned on).
2. Using the DATA ENTRY keyboard, enter 222 and press the ENTER/STEP switch. The DAY display should read 222 along with hours, minutes, and seconds on the DATA display. The power failure LED should no longer flash.
3. Press the HR:MIN:SEC switch in the TIME ENTRY group. The DAY display should go out and the DATA display should read the time-of-day currently in memory.
4. Using the DATA ENTRY keyboard, enter 235950. The entered data should appear on the DATA display as 23 hours, 59 minutes and 50 seconds.
5. Press the ENTER/STEP switch and observe the display. The clock should start running the instant the ENTER/STEP switch is pressed. When the clock makes the transition from 23:59:59 to 00:00:00 ensure that the DAY display changes from 222 to 223.
6. Press HR:MIN:SEC in the TIME ENTRY group and enter 489999 on the DATA ENTRY keyboard.

7. Press the ENTER/STEP switch while observing the display. The reading should change to 225 01:40:40 and begin counting.

4-41. Scan Format Test

4-42. Use the following procedure to check the operation of the SCAN FORMAT switches and the associated memory.

1. Press the FIXED DATA switch in the SCAN FORMAT group.
2. Using the DATA ENTRY keyboard, enter 123456 and press the ENTER/STEP switch.
3. Press the FIRST CHANNEL switch in the SCAN FORMAT group. the first channel currently in memory will be displayed.
4. Enter 0 on the DATA ENTRY keyboard and press the ENTER/STEP switch. The CHANNEL DISPLAY should read 000.
5. Press the LAST CHANNEL switch in the SCAN FORMAT group. The last channel currently in memory will be displayed.
6. Enter 59 on the DATA ENTRY keyboard and press the ENTER/STEP switch. The CHANNEL DISPLAY should read 059.
7. Press the INTERVAL HR:MIN:SEC switch in the SCAN FORMAT group. The time interval currently in memory will be displayed in HR:MIN:SEC on the DATA display.
8. Enter 10 on the DATA ENTRY keyboard and press the ENTER/STEP switch. The DATA DISPLAY should read 00.00.10.
9. Press the SECOND FUNCTION switch, then press the SECOND INTERVAL switch, followed by the ENTER/STEP switch. The display will contain a string of t's, indicating the data logger is in the SECOND INTERVAL mode.
10. Press the SECOND FUNCTION switch, followed by the FIRST CHANNEL switch. Press 5, then press the ENTER/STEP switch. The CHANNEL DISPLAY should read 005, the first channel to be scanned at the second interval.
11. Press the SECOND FUNCTION switch, then the LAST

CHANNEL switch. Press 1, then press 0 twice, then press the ENTER/STEP switch. The channel display should read 100; the last channel to be scanned at the second interval.

12. Press the SECOND FUNCTION switch, then press the INTERVAL HR MIN SEC switch. Press 1, then press 0 four times to shift the 1 into the hours position. Press the ENTER/STEP switch to enter a second interval of 1 hour.
13. To check the TIME AVERAGE function, press the SECOND FUNCTION switch, then the TIME AVERAGE switch, followed by a 2 and a 0. This establishes the time average mode and sets the number of scans at 20. A single "t" will appear in the display to indicate the TIME AVERAGE mode.
14. Press the SECOND FUNCTION switch, then the FIRST CHANNEL switch, followed by a 3 and ENTER/STEP switch to establish channel 3 as the first channel to be averaged.
15. Press the SECOND FUNCTION switch, then the LAST CHANNEL switch, followed by a 9 and the ENTER/STEP switch to establish channel 9 as the last channel to be averaged.
16. To establish a 30-second scan interval, press SECOND FUNCTION, then INTERVAL HR MIN SEC, then 3 and 0, followed by ENTER/STEP. Channels 3 through 9 will be scanned and averaged every 30 seconds.
17. To check the GROUP AVERAGE function, press the SECOND FUNCTION switch, then the GROUP AVERAGE switch, followed by 5 and ENTER/STEP. This establishes the group average mode and sets the group size to 5 channels. A single 6 in the display simulates a "G" for group average mode.
18. Press the SECOND FUNCTION switch, the FIRST CHANNEL switch, the 0, then ENTER/STEP. Press the SECOND FUNCTION switch, the LAST CHANNEL switch, a 1 and a 9, then ENTER/STEP. This sets the first channel (0) and the last channel (19) encompassed in group averaging.
19. Press the SECOND FUNCTION switch, then the INTERVAL HR MIN SEC switch, then 1, 0, 0, followed by ENTER/STEP. This establishes a group average scan interval of one minute. Four groups, each consisting of five channels, will be scanned and averaged once each minute.

20. Press the MONITOR CHANNEL switch in the SCAN FORMAT group. The CHANNEL displays should read the monitor channel currently in memory.
21. Enter 5 on the DATA ENTRY keyboard and press ENTER/STEP. The CHANNEL display should read 005.
22. Press the SINGLE CHANNEL switch in the DISPLAY CONTROL group. The single channel currently in memory will be displayed.
23. Enter 4 on the DATA ENTRY keyboard and then press ENTER/STEP. The CHANNEL display should read 004.
24. Starting with FIXED DATA, sequentially press each switch in the SCAN FORMAT group and ensure that the previously entered data is displayed.
25. Press the SINGLE CHANNEL switch in the DISPLAY CONTROL group and verify the presence of previously entered data.
26. Set the Power switch to POWER OFF for at least 1-minute and then set it to POWER ON. The POWER FAILURE RE-ENTER TIME lamp should begin to flash.
27. Repeat steps 13 and 14.
28. Reset the POWER FAILURE RE-ENTER TIME lamp by pressing the DAY or HR:MIN:SEC switch in the TIME ENTRY group and the ENTER/STEP switch on the DATA ENTRY keyboard.

4-43. Channel Programming Test

4-44. Use the following procedure to check the operation of the channel programming circuits:

1. Press RESET in the SCAN CONTROL group.
2. Press ALL DATA in the PRINTER ENABLE group.
3. Press the PROGRAM LIST switch. The printer should print the date and time; interval in hours, minutes, and seconds; fixed data; the monitor channel; and all available limit addresses (60 maximum) and their assigned values. This data is then followed by a list of all channels within the limits defined by the scan format, primary channels first followed by secondary (time/group average, second interval) channels (if installed). The assigned measurement function and scale is printed on the channel line. If limits data has been assigned to the channel, the limit address, HI (>)



or LO (<) sense, and the limit value is printed on the line following the channel data. If a channel is programmed to skip, function, scale, and limits data will not accompany the channel number.

4. Press the ENABLE switch in the CHANNEL PROGRAMMING group and enter the number of the first channel listed by the printer. Press the ENTER/STEP switch. The ENTER FUNCTION lamp should light.
5. Press the SKIP switch on the DATA ENTRY keyboard and then press the ENTER/STEP switch.
6. Identify the next channel printed on the program list and enter it on the DATA ENTRY keyboard.

#### NOTE

When practical, use the ADVANCE ADDRESS switch to call up the next applicable channel.

7. Press the REPEAT switch in the CHANNEL PROGRAMMING switch group.
8. Repeat step 6 and 7 of this procedure for all remaining channels listed by the printer.
9. Press the PROGRAM LIST switch. Heading data, limits data, and channel numbers will be printed. However, channel function data for primary channels will not be printed.
10. Press the ENABLE switch in the CHANNEL PROGRAMMING group and enter an address of 0.
11. Press the ENTER/STEP switch. The ENTER FUNCTION lamp should light.
12. Select the 4V function on the DATA ENTRY keyboard and press the ENTER/STEP switch.
13. If the scaling option (-40) is installed, press the SKIP and ENTER/STEP switches.
14. If the Limit Option (-41) is installed, press the SKIP and ENTER/STEP switches for LIMIT A, LIMIT B, LIMIT C, and LIMIT D. The CHANNEL ENTER ADDRESS lamp should light.
15. Enter an address of 4 using the DATA ENTRY keyboard and press the ENTER/STEP switch.
16. Sequentially press the REPEAT, ADVANCE ADDRESS, and

the REPEAT switches.

17. Call the following channel addresses using the DATA ENTRY and ENTER/STEP switches, and press the REPEAT switch after each is entered: 10, 15, 20, 25, 30, 35, 40, 45, 50, 55.
18. Press the PROGRAM LIST switch. The standard heading and each of the programmed channels and their function should be printed.
19. Set the Power switch to POWER OFF for 1 minute and then set it to POWER ON.
20. Repeat step 18. Program data should not change.

#### 4-45. Scan Control Test

4-46. The following procedure checks the operation of the 2240C scan control logic and measurement circuitry:

1. Adjust the calibrator for an output of 1.0000V dc.
2. Press the SINGLE switch in the SCAN CONTROL group. The printer should record inputs of 1.0000V dc at channels 0, 4, and 5; and 0V dc at all channels that have not been skipped.
3. Press the STOP/RESET switch in the SCAN CONTROL group.
4. Press LAST CHANNEL in the SCAN FORMAT group, then press 9 and ENTER/STEP on the DATA ENTRY keyboard.
5. Press the SECOND FUNCTION switch, then press the SECOND INTERVAL switch, followed by the ENTER/STEP switch. The display will contain a string of t's, indicating data logger is in the SECOND INTERVAL mode.
6. Press the SECOND FUNCTION switch, then the INTERVAL HR MIN SEC switch. Press 0 to set the second interval time to 0, then press ENTER STEP. A scan will not occur at the second interval.
7. Set the DC Voltage Calibrator for an output of 2.0000V dc.
8. Press the INTERVAL switch in the SCAN CONTROL group. The printer should record a 2.0000V dc reading for channels 0, 4, and 5. The scan cycle should repeat itself at the programmed interval (10 sec).

9. Press the MONITOR switch in the SCAN CONTROL group. The display should indicate a 2.0000V dc input to channel 5.
10. Increase the calibrator output to 5.0V dc. The DATA display should read uuuuu to indicate the presence of an overrange voltage.
11. Press the CONTINUOUS switch in the SCAN CONTROL group, and the ALL DATA switch in the PRINTER ENABLE group. The printer should print :--:-V for channels 0, 4, and 5 to indicate the presence of an overrange voltage. The scan cycle should continue to repeat with a minimum time between the end of one cycle and the start of the next.
12. Decrease the calibrator output to 3.0V dc.
13. Press the SINGLE CHANNEL switch in the DISPLAY CONTROL group followed by ENTER/STEP. The display should indicate a 3.0000V dc input at channel 4.
14. Press the STOP/RESET switch in the SCAN CONTROL group.

4-47. Output Control Test

4-48. Use the following procedure to check the operation of the OUTPUT CONTROL logic:

1. Press the LIMIT DATA switch in the PRINTER ENABLE group and release the ALL DATA switch. Set the calibrator output to 5.0V dc.
2. Press the INTERVAL switch in the SCAN CONTROL group. The display should indicate an overrange for channels 0, 4, and 5, but the printer should not record data.
3. Reduce the output of the voltage calibrator to 3.9000V dc. After 10 seconds, the display should indicate 3.9000 volts for channels 0, 4, and 5, and the printer should not record data for either channel.
4. Press the INTERVAL DATA switch in the PRINTER ENABLE section of the OUTPUT CONTROL group. The printer should record the displayed data for channels 0, 4, and 5 each time a scan sequence occurs.
5. Press the CONTINUOUS switch in the SCAN CONTROL group. The scan sequence should be continuously repeated, and data should be printed on the initial

scan and every 10 seconds thereafter.

6. Press the RESET switch in the SCAN CONTROL group.

4-49. Display Control Test

4-50. Use the following procedure to check the operation of the DISPLAY CONTROL group:

1. Release all switches in the PRINTER ENABLE section of the OUTPUT CONTROL group.
2. Press the CONTINUOUS switch in the SCAN CONTROL group. The data logger should alternately display channels 0, 4, and 5, and their associated voltage readings.
3. Press the DATE AND TIME switch in the DISPLAY CONTROL group. The display should read date and time. The clock should be running.

4-51. Limits Test

4-52. If the LIMIT Option (-41) is installed, use the following procedure to perform a functional limits check:

1. Set the calibrator output to 0V dc.
2. Program and recall each of the available limits (1-60 using the following sense and value combinations: HI-1111, HI-2222, LO-0444, and LO-0888.
3. Program channel 5 as follows:
  - a. Channel Address = 5
  - b. Function = 4V
  - c.  $mx + b$  scaling = SKIP (if installed) (option 40)
  - d. Limit Address A = 1
  - e. Limit Address B = 16
  - f. Limit Address C = SKIP
  - g. Limit Address D = SKIP
4. Program limit address 1 as follows:
  - a. Limit Address = 1

- b. Enter Sense = HI
- c. Enter Value = 1248
5. Program limit address 16 as follows:
  - a. Limit Address = 16
  - b. Enter Sense = LO
  - c. Enter Value = 1244
6. Set the calibrator output for +1.246V dc.
7. Press MONITOR in SCAN CONTROL group. The display should indicate a voltage of approximately +1.246V on channel 5.
8. Increase the calibrator output until the display reads 1.248 VOLTS. At that time the LIMIT EXCEEDED indicator should start blinking.
9. Reduce the calibrator output for a display of 1.246 VOLTS and press the limit RESET switch. The LIMIT EXCEEDED indicator should be off.
10. Reduce the calibrator output for a display of 1.244 VOLTS. At that time the LIMIT EXCEEDED indicator should start blinking.
11. Increase the calibrator output for a display of 1.246 VOLTS and press the limit RESET switch. The LIMIT EXCEEDED indicator should be off.
12. Press the RESET switch in the SCAN CONTROL group.

4-53. A/D Converter Accuracy Test

4-54. Use the following procedure to check the operation of the A/D Converter.

1. Set the calibrator output to 0V dc.
2. Press the MONITOR switch in the SCAN CONTROL switch group.
3. Set the A/D Converter FAST/SLOW switch to SLOW.
4. Refer to Table 4-2 and sequentially enter each of the input voltage and data logger range combinations for channel 5 (monitor channel). As each entry is completed, check the data logger display against the indicated display readings.

Table 4-2. A/D Converter Accuracy Test Specifications

INPUT VOLTAGE	RANGE (FUNCTION)	DISPLAY READING (90-DAY SPECIFICATION, 20°C - 30°C AMBIENT) LOW LEVEL SCANNER (SLOW SPEED)
0.0V	40 mV	-0.03 to 0.003
0.0V	400 mV	-0.02 to 0.02
0.0V	4V	-0.0002 to 0.0002
0.0V	40V	-0.002 to 0.002
39.9 mV	40 mV	39.893 to 39.907
399 mV	400 mV	398.94 to 399.06
3.99V	4V	3.9894 to 3.9906
39.9V	40V	39.984 to 39.906

5. Disconnect the calibrator, and remove the test cable and the scanner from the 2240C.
6. Install the inner guard cover and the top dust cover.
7. Set 2240C POWER switch to OFF and disconnect the line power.

4-55. mx + b Scaling Test

4-56. Use the following procedure to check the operation of the mx + b Scaling Option (Option -40).

#### NOTE

The values used in the following test are based on the programming example given in the mx + b Scaling Option (-40) part of Section 6. These values represent a pressure transducer input, through a Current Transmitter Connector (Option -29).

1. Adjust the calibrator output to 60 mV.
2. Press the SECOND FUNCTION button located in the DATA ENTRY section of the front panel, then press the ENTER ADDRESS button in the LIMITS/mx+b programming section.
3. Press one or two digits (1-30) in the DATA ENTRY front panel section to select a mx+b address, then press the ENTER/STEP button. Example: press 4, then ENTER/STEP to assign an address of 4 to the scaling function. After pressing ENTER/STEP, both the SENSE/mx + b light and the HI/m light will be on, indicating that the slope value (m) should be entered next.
4. To enter the slope value, press the appropriate digits in the DATA ENTRY group, then press the ENTER/STEP button. Example: press 0, 4, 1, 6, 7, then ENTER/STEP to enter a slope of 0.4167. After pressing ENTER/STEP, both the SENSE/mx+b light and the LO/b light will be on, indicating that an intercept value (b) should be entered next.
5. To enter an intercept value, press the appropriate digit switches in the front panel DATA ENTRY group, then press ENTER/STEP. Example: press 7, 5, 0, 0, and ENTER/STEP to enter an intercept value of 7500.

After ENTER/STEP is pressed, the DECIMAL lights will be on, indicating a decimal point location may be entered next.

6. To enter a decimal point position, press the digit in the DATA ENTRY group that represents the number of digits to the right of the decimal point, then press ENTER/STEP. Example: press 2 then ENTER/STEP. In this case, the DISPLAY would read 200.00 to indicate 200 psi. After ENTER/STEP is pressed, the UNITS lamp will be on, indicating that engineering units notation may be programmed next.
7. To program engineering units notation, enter the appropriate 2-digit code (refer to Table 640-1) for the units desired, then press 1, 1, and ENTER/STEP. Engineering Units notation psi is programmed to appear on the printer.
8. Press the ENTER ADDRESS button in the CHANNEL programming group.
9. Press the appropriate digits in the DATA ENTRY front panel section to select the channel address. Example: Press 5 to select channel 5.
10. Press the ENTER/STEP button in the DATA ENTRY front panel section to enter the channel address. After the ENTER/STEP switch is pressed, the ENTER FUNCTION light in the CHANNEL section of the front panel will light.
11. Press the 400 mV button in the DATA ENTRY section of the front panel, then the ENTER/STEP switch, to enter a 400 mV A/D converter range. After the ENTER/STEP switch is pressed, the ENTER mx+b ADDRESS light in the CHANNEL section will light.
12. Press the required digits in the DATA ENTRY front panel section necessary to enter the appropriate scaling function. Example: To enter scaling function address number 4, press 4, then ENTER/STEP.
13. Press the MONITOR button in the SCAN CONTROL front panel section. The DATA display should be: 100.00. The printer output should be: 100.00 psi.
14. Increase the calibrator output to 300 mV. The DATA display should be: 200.00. The printer output should be: 200.00 psi.

4-57. CALIBRATION



4-58. The 2240C should be calibrated once every year or 90-days (as required to maintain desired accuracy) or whenever repairs have been made in the Power Supply or the A/D Converter. Calibration should be accomplished at an ambient room temperature of +22°C to +25 °C and a relative humidity of less than 70%. Table 4-1 lists the required equipment.

4-59. Initial Procedure

1. Remove the top dust cover from the 2240C.
2. Press the RESET switch in the SCAN CONTROL group.
3. Connect the 2240C to line power and set the Power switch to ON.
4. Allow the 2240C to stabilize for a period of not less than 1-hour.

4-60. Power Supply

4-61. Use the following procedure to calibrate the Power Supply PCB:

1. Connect the DVM to TP1 (common) and TP2 (-10.2V dc) on the Power Supply PCB. See Figure 4-4.
2. Adjust pot R17 to obtain a reading of  $-10.20 \pm 0.05V$  dc.
3. Move the DVM input from TP2 to TP3. The DVM should read  $+5.1 \pm 0.2V$  dc.
4. Move the DVM input from TP3 to TP4. The DVM should read  $+16 \pm 1.0V$  dc.

4-62. A/D Converter

4-63. Use the following procedure to calibrate the High Performance A/D Converter. Adjustment locations are shown in Figure 4-5.

CAUTION

Turn power off before removing  
or installing pcb's.

1. De-energize the data logger and press the STOP/RESET switch in the SCAN CONTROL group.
2. Install a Low Level Scanner (Option -06) in scanner slot 0 of the data logger.
3. Set the output of the DC Calibrator to 0V, and,

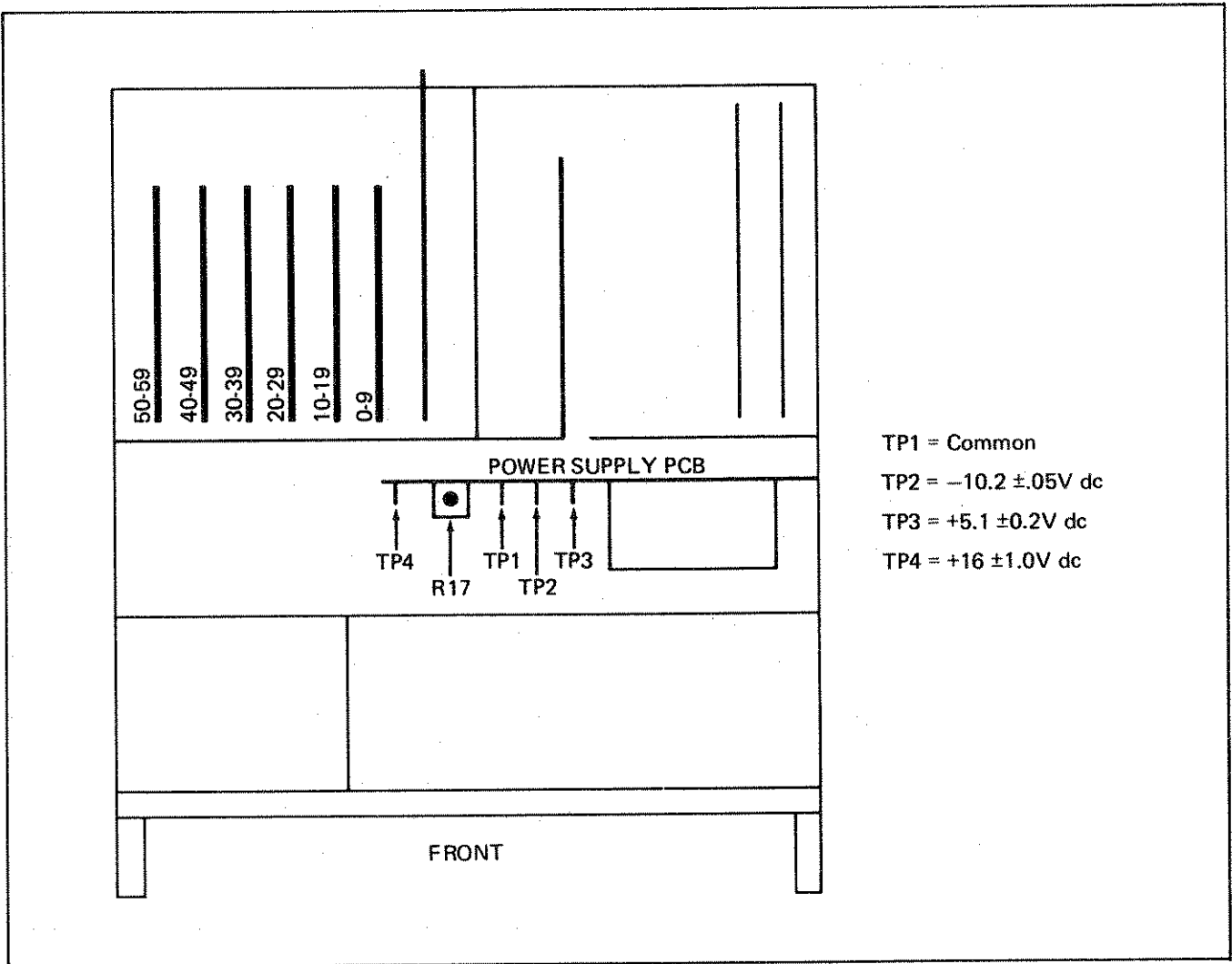

Figure 4-4. Power Supply Test Point and Adjustment Locations

NOTES:

1. TP1, TP2, TP3 ARE ACCESSIBLE FROM THE REAR OF THE INSTRUMENT.
2. TP5, 6 AND 7 ARE PROVIDED FOR CONVENIENCE IN TROUBLESHOOTING AND ARE NOT USED IN THE CALIBRATION PROCEDURE.
3. SHADED ADJUSTMENTS ARE LOCATED BELOW THE TOP EDGE OF THE PCB.

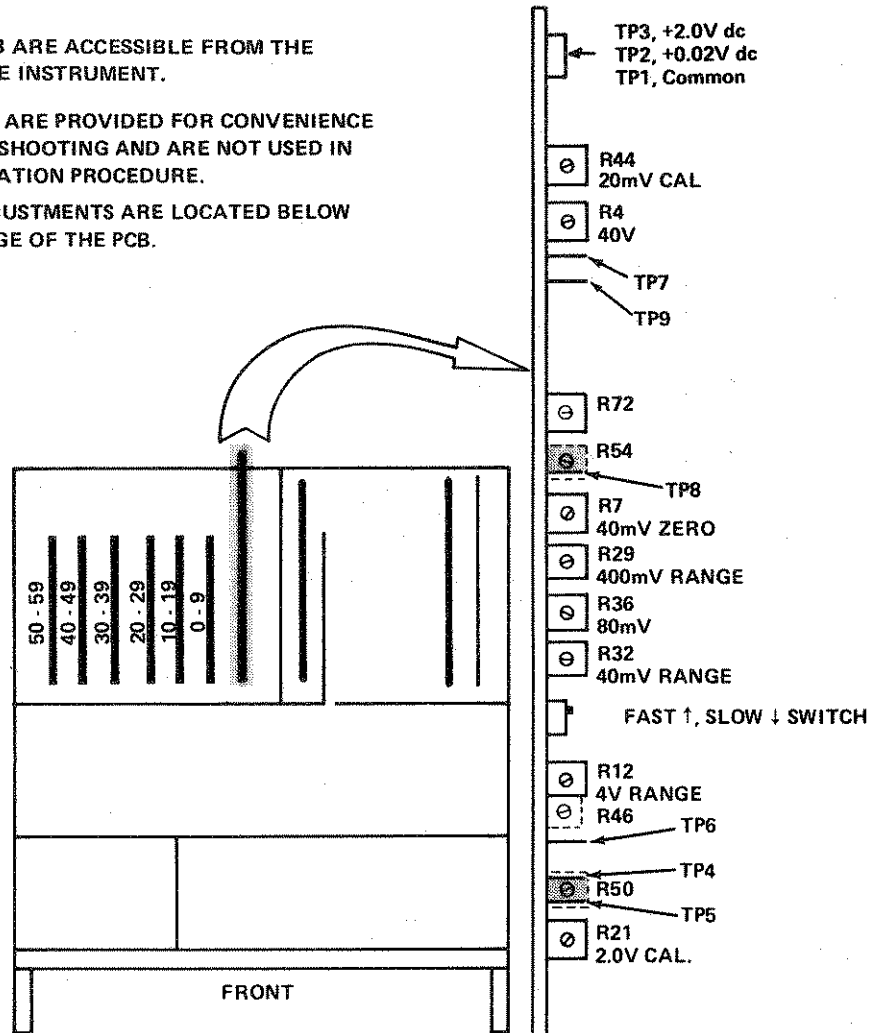

Figure 4-5. A/D Converter Test Point and Adjustment Locations

using a Solder Pin Connector (Option -07), connect the output of the dc calibrator to channel 0 of the scanner in slot 0.

4. Energize the data logger and program it to perform the following scan sequence:
  - a. Monitor Channel 00.
  - b. Function = 40 mV.
5. Set the Fast/Slow switch on the A/D Converter to Slow. See Figure 4-5.
6. Press the MONITOR switch and adjust the 40 mV ZERO pot (R7) for a zero indication i.e., the display alternates between a + and - polarity indication. Ignore the digital display.

#### NOTE

Under normal conditions steps 7 through 14 may be omitted from the calibration procedure. However, if the A/D Converter has been repaired prior to calibration, component parts have been replaced, or potentiometers, R46, R50, or R55, have been inadvertently adjusted, the steps must be executed.

7. Remove the inner guard cover.
8. Connect a DVM between TP4 (common) and TP8. Adjust R54 for a reading of 0  $\pm$ 20 mV dc.
9. Program the data logger for the 4V function and set the DC Calibrator for a +1 mV output.
10. Adjust R50 for the data logger display of 0.0010V.
11. Reverse the polarity of the DC Calibrator output. The display should be -0.0010V.
12. Set the Fast/Slow switch to Fast and adjust R46 for a display of -0.0010V.
13. Reverse the polarity of the DC Calibrator output. The display should read 0.0010V.
14. Set the Fast/Slow switch to Slow.

15. Set the output of the DC Calibrator to 0V.
16. Connect the DVM between TP4 and TP9.
17. Adjust R72 for a DVM reading of  $0 \pm 5$  mV dc.
18. Install the inner guard cover. Allow the A/D Converter to stabilize for 30-minutes before proceeding.
19. Set the output of the DC Calibrator to -3.0000 volts and adjust R12 for a display of -3.000V.
20. Reverse the polarity of the DC Calibrator output. The reading should be  $-3.0000 \pm 0.0002$ V.
21. Set the DC Calibrator output to +300 mV.
22. Program the data logger function to 400 mV and adjust R29 for a display of 300.00 mV.
23. Set the DC Calibrator output to +60 mV.
24. Program the data logger function to 80 mV and adjust R36 for a display of 30000.

NOTE

The 80 mV function is programmed using the HI LIMIT switch on the 2240C.

25. Set the DC Calibrator output to +30 mV.
26. Program the data logger function to 40 mV and adjust R32 for a reading of +30.000 mV.
27. Program the data logger to the 40V function and set the DC Calibrator output to 0 volts. The display should read 0.000V.
28. Set the DC Calibrator output to +30V and adjust R4 for a display of 30.000V.
29. Connect the DVM between TP1 (common) and TP3 on the A/D Converter PCB. Adjust R21 for a DVM display of +2.0000V dc.
30. Connect a DVM between TP1 and TP2. Adjust R44 for a DVM display of +20.000 mV.
31. Set the DC Calibrator to 0 volts and program the data logger function to 40 mV. The data logger display should read 0.000V.

32. Set the Fast/Slow switch to speed at which the A/D Converter is to operate and adjust R7 for a data logger display of 0.000V.

4-64. Temperature Option (Option -43, -44, or -45)

4-65. The Temperature option does not require calibration. However, its accuracy is dependent upon the calibration of the A/D Converter and the Isothermal Block Connectors.

4-66. Isothermal Block Connectors (Option -08)

4-67. The basic 2240C is capable of housing up to six Isothermal Block Connectors (Option -08) for use in conjunction with the Temperature Option (Option -43 or -44). Each Isothermal Block Connector has been calibrated at the factory and does not require periodic calibration. However, if a connector has been repaired or if the seal on the factory adjustment has been broken, calibration is required. Refer to subsection -08 in Section 6, Option and Accessory Information, for the calibration procedure.

4-68. TROUBLESHOOTING

#### CAUTION

Static discharge can damage MOS components contained in the 2240C. To prevent this possibility use the following precautions when troubleshooting and/or repairing the unit.

1. Never remove, install or otherwise connect or disconnect pcb's and/or components without first turning the 2240C Power switch to OFF.
2. Perform all repairs at a static-free work station.
3. Do not handle IC's or pcb's by their connectors.
4. Use static ground straps to discharge repair personnel.
5. Use conductive foam to store replacement or removed IC's.
6. Remove all plastic, vinyl, and Styrofoam products from the work area.
7. Use a grounded soldering iron.

4-69. A troubleshooting guide for the 2240C is given in Table 4-3. The guide is in the form of a tabular flow chart and is recommended for use in isolating a 2240C mainframe malfunction to the pcb (board) level. Details necessary to troubleshoot faulty pcb's to the component level can be derived from the schematic diagrams given in Section 8 and the theory of operation in Section 3.

4-70. When troubleshooting the 2240C in accordance with Table 4-3 the following notes apply.

1. Do not start in the middle of the procedure. Any given step assumes that the previous steps have been completed.
2. All measurements using external test equipment are referenced to logic common (TP1 on Power Supply PCB) unless otherwise specified.
3. All connectors referenced for measurement are accessible from the bottom of the 2240C when the bottom dust cover is removed. See Figure 4-6 for connector and pin identification.

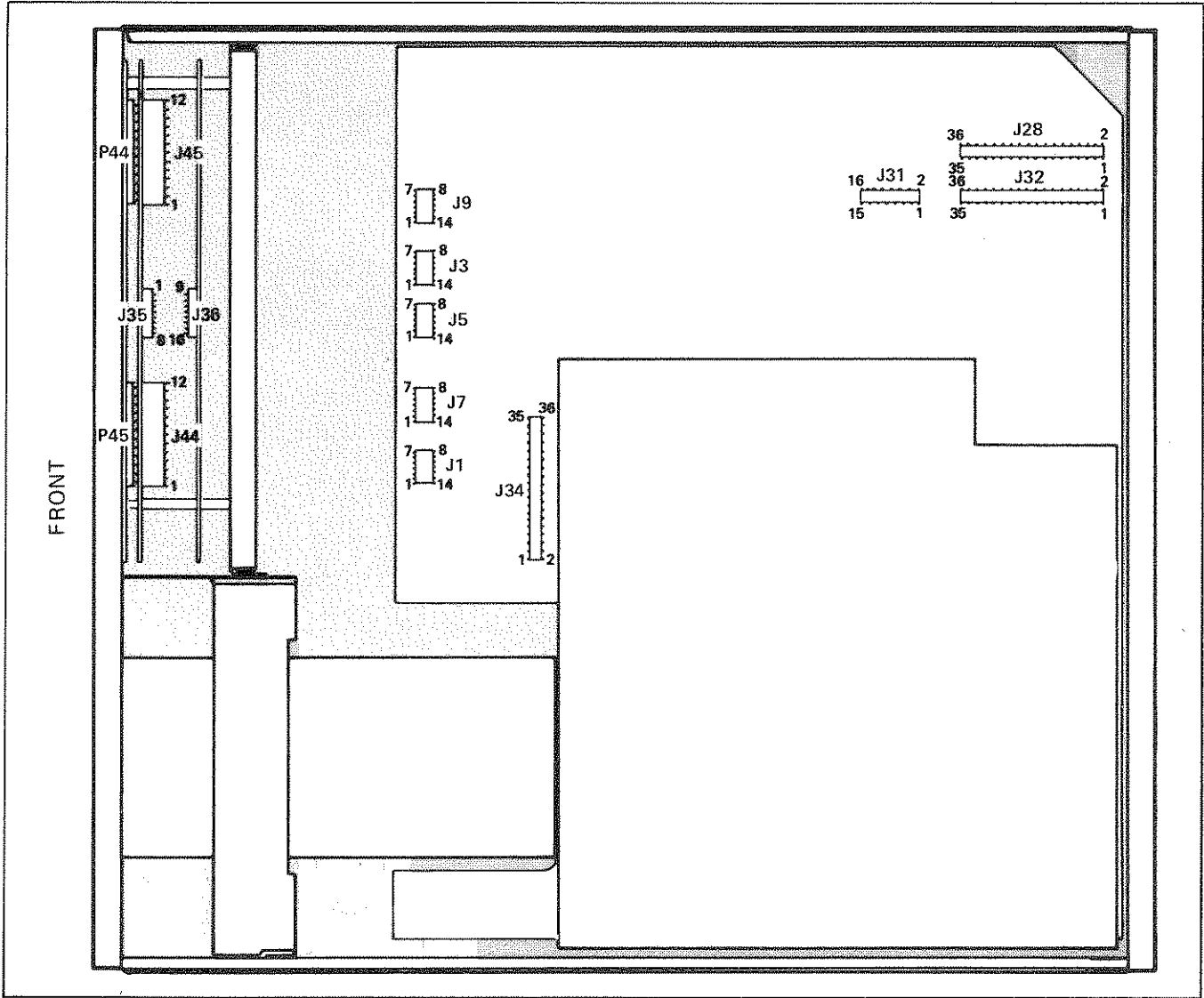

Figure 4-6. Measurement Point Locations for Troubleshooting (Bottom View)



Table 4-3. Troubleshooting

STEP NO.	INSTRUCTION	YES	NO	GOTO
1	Turn 2240C Power switch to OFF and disconnect power cord at rear panel.			2
2	Remove the top and bottom dust covers, and the two inner guard covers from the 2240C.			3
3	Remove all scanner pcb's and input connectors from the scanner section.			4
4	Remove all option pcb's that may be installed in the digital I/O section.			5
5	Remove the A/D Converter PCB and the Guard Crossing PCB.			6
6	Disconnect the printer cable at the Printer Driver PCB.			7
7	Connect the 2240C to line power and set the Power switch to POWER ON.			8
8	Refer to Power Supply Calibration procedure and verify the presence and accuracy of all power supply voltages. If necessary: a. Isolate and relieve any shorted output conditions. b. Repair and/or calibrate the power supply.			9
	<b>INITIAL TURN-ON</b>			
9	Set the 2240C Power switch to POWER OFF, wait 10-seconds, and then to POWER ON. Observe the front panel display. Does it read 2240C 7?	10	19	
10	Does the display change to (000 000003) in approximately 3-seconds and begin to count-up?	11	14	
11	Is the POWER FAILURE LED on or blinking?	12	15	
12	Check the operation of the front panel keyboard. Do all keys appear to be operational?	13	18	
13	Initial turn-on appears normal.			40
14	If display continues to read 2240C 7 check for continuously low outputs on the following lines: Control Bus A – P32-7 (CA2) TIM – P32-31 (1Hz pulse train)			9
15	Is the IMPROPER ENTRY LED blinking?	16	17	
16	Check Control Bus B at P32-12 (CB3) for a continuously low condition.			9
17	Check for presence of In strobe at P32-15.			9
18	Check Control Bus B at P32-9 (CB0) and P32-10 for a continuously low condition.			9
19	Does the display read a series of 1111's (may go blank after initial turn-on)?	20	27	
20	Is the IMPROPER ENTRY LED blinking or on?	21	26	
21	Is the POWER FAILURE LED blinking?	22	25	
22	Does front panel keyboard appear to be operational?	23	24	
23	If all PROGRAMMING LIMITS LED's are lit, check P32-16 for the presence of the Out strobe. Also check for continuously low A0 through A7 outputs of J9 (pins 1 through 4 and 11 through 14).			9
24	Check Mode Switch PCB (U11 and U12).			9
25	If limit program prompting LED's are on, 2φ clock on controller is defective.			9
26	Check Control Bus A for continuously high outputs. P32-5, -6, -7, -8 (CA0, CA1, CA2, and CA3, respectively).			9
27	Is the display blank upon turn-on and remain blank?	28	30	

Table 4-3. Troubleshooting (cont)

STEP NO.	INSTRUCTION	YES	NO	GOTO
28	Does the POWER FAILURE LED blink and is the IMPROPER ENTRY LED off?	29	30	
29	Check U19-3 (B1) on the Mode Switch PCB. If continuously high, check the operation of U4 and U1 and the associated circuitry on the Mode Switch PCB.			9
30	Is the IMPROPER ENTRY LED blinking and the POWER FAIL LED off?	31	32	
31	If the PROGRAMMING LIMITS prompting LED's are lit the Power-On-Reset (POR) signal for the Power Supply PCB (J32-18) is continuously low. If all annunciator LED's (mV, V, Temperature, Date and Time) are lit, check for a continuously low condition at J42-13 (A) on the Mode Switch Assembly.			9
32	Check for the presence of a continuously low Sync pulse at J32-17.			9
33	Does a series of three like-characters appear in the CHANNEL display prior to the 3-second time out?	34	37	
34	Does data display read 888880?	35	36	
35	U9 on the Mode Switch Assembly and/or its associated circuitry is not operating.			9
36	Check the Data Bus at P32-1, -2, -3, and -4 (DB0, DB1, DB2, and DB3, respectively) for the presence of a continuously low output.			9
37	Does a series of three like-characters other than 000 appear in the CHANNEL display after the 3-second time out?	38	39	
38	Check the operation of U5 of the Mode switch.			9
39	If only one or two of the six display digits are lit, check for a continuously low condition at J42-10, -11, and -12 (D, C, B) on the Mode Switch PCB Assembly.			9
	<b>DISPLAY AND DATA ENTRY</b>			
40	Refer to Performance Test and complete the Display and Data Entry Test.			41
41	Does the display and keyboard respond properly?	61	42	
42	Does the keyboard appear to respond?	43	48	
43	Are all digits in a series of entered numbers displayed the same, e.g., 111111, 222222, etc.?	44	46	
44	Are digits displayed as entered on both DATA and CHANNEL displays?	45	47	
45	Defective Mode Switch Assembly, repair as required.			40
46	Some digits are blank or some character segments are not lit. Defective Display Assembly. Check U3 and U6 outputs. Check transistor drivers Q1 through Q11. Check LED elements by interchanging decades.			40
47	Channel Display PCB is defective. Check U1 and U4. Repair as required.			40
48	Make sure Power switch is set to POWER ON. Use scope to check for the presence of a 3 kHz clock at J45-4. Is clock present?	50	49	
49	Keyboard Logic PCB is defective. Check for presence of +5V dc and the operation of oscillator formed by U11. Repair as required.			40
50	Use scope to check for the presence of 1-2-4-8 outputs from binary counter. J45-10, -1, -8, -7 (1-2-4-8, respectively). Are counter outputs correct?	52	51	
51	Defective Keyboard Logic PCB. Check U12 and U16. Repair as required.			40
52	Use scope to monitor 3 kHz clock at P45-4 and individually press all front panel momentary type switches (not PAPER ADVANCE). The clock should stop when any one of the switches is depressed. Ignore order in which switches are pressed.			53

Table 4-3. Troubleshooting (cont)

STEP NO.	INSTRUCTION	YES	NO	GO TO
53	Does clock stop for each switch that is pressed?	54	58	
54	Keyboard Switch Assembly is functional.			55
55	Was a tone generated with any of the switch depressions?	57	56	
56	Check for presence of In and Out strobe pulses at J35-3 and J35-2, respectively. If not present, controller is defective. If present, Control Bus B decoder on Keyboard Logic PCB Assembly is defective. Also check tone generator circuit on Keyboard Logic PCB. Repair as required.			40
57	Check multiplexer operation of U6 and U7 on Keyboard Logic PCB Assembly. If okay, controller is defective. Repair as required.			40
58	Does clock stop for all switch depressions except one or two?	59	60	
59	Switch is defective on Keyboard Switch PCB Assembly.			40
60	If clock does not stop for any switch depression, U1 on Keyboard Switch Assembly is defective. Repair as required.			52
	<b>SCAN FORMAT</b>			
61	Enter the following scan format data and observe the display as the ENTER/STEP switch is pressed for each entry: FIXED DATA – 123456                      INTERVAL – 10-seconds FIRST CHANNEL – 0                              MONITOR CHANNEL – 5 LAST CHANNEL – 10			62
62	Does display data change or shift when the ENTER/STEP switch is pressed? (The addition of leading zeros is not considered a change in data.)	63	64	
63	Check the following IC's on the Keyboard Memory PCB and repair as required: U1 – First, Last, and Monitor Channels U2 – Fixed and Interval Data			61
64	Set Power switch to POWER OFF, wait 1-minute, then return switch to POWER ON. Recall scan format data.			65
65	Is recalled data the same as previously entered?	67	66	
66	If recalled data comprises a series of 69's, the battery on the front-left chassis side is defective.			61
67	Program channels 0 through 10 with the following function and limit address data. Function – 4V **mx + b SCALING ADDRESS – Skip *LIMIT ADDRESS A – Skip *LIMIT ADDRESS B – Skip *LIMIT ADDRESS C – Skip *LIMIT ADDRESS D – Skip  *Applicable only if the 2240C is equipped with limit option (–41). **Applicable only if the 2240C is equipped with mx + b scaling option (–40)			68
68	Did program prompting LED's react normally?	70	69	
69	Defective Keyboard Switch and/or Logic PCB.			67
70	Recall and verify the program data for channels 0 through 10.			71
71	Is recalled data correct?	73	72	

Table 4-3. Troubleshooting (cont)

STEP NO.	INSTRUCTION	YES	NO	GO TO																																	
72	Memory IC's on Range and Function Memory PCB are defective. Try interchanging IC's and reprogramming to verify defect. Function IC           U19 Limit A Address IC    U20 Limit B Address IC    U21 Limit C Address IC    U22 Limit D Address IC    U23			67																																	
73	Sequentially press each of the SCAN CONTROL switches and observe the CHANNEL display to verify proper scanning operation in each mode. Ignore the DATA display characters. However, check the annunciator LED's to ensure that VOLTS is lit during the actual scan sequence (TEMPERATURE and MILLIVOLTS should blink). SINGLE – Single scan should occur. Channel data will stop and remain at 10. INTERVAL – Repeated scan sequences with a 10-second time interval between the start of each scan. Display will read the date and time between scans. MONITOR – Continuously displays channel 5. CONTINUOUS – Continuously scans channel 0-10 with a minimum delay (<1 second) between the end of one scan sequence and the start of the next. REMOTE – Displays date and time, no scan sequence.			74																																	
74	Do all scan sequences react normally?	76	75																																		
75	Check the operation of each Mode switch and its associated driver on the Mode Switch PCB Assembly.			73																																	
76	Press the CONTINUOUS scan mode switch.			77																																	
77	Momentarily press the PAPER ADVANCE switch in the OUTPUT CONTROL switch group.			78																																	
78	Does the scan sequence stop and remain at channel 10?	80	79																																		
79	Defective Printer Drive PCB or Mode Switch PCB. Repair is required.			80																																	
80	Turn Power switch to POWER OFF then to POWER ON. Scan sequence will resume.			81																																	
81	Turn Power switch to POWER OFF.			82																																	
82	Connect Printer cable to Printer Drive PCB and set Power switch to ON.			83																																	
83	Does printer sound like it's running?	85	84																																		
84	Check ±16V dc on Power Supply PCB. If voltage is okay, printer head is defective. Repair as required.			81																																	
85	Press PAPER ADVANCE switch.			86																																	
86	Does printer advance paper?	88	87																																		
87	If scan sequence stops, printer head is defective. Interrupting power will resume scan sequence. Repair or replace printer head.			81																																	
88	Sequentially press the following switches: RESET (SCAN CONTROL) ALL DATA (PRINTER ENABLE) SINGLE (SCAN CONTROL)			89																																	
	<table style="margin-left: 400px;"> <tr><td>10</td><td>⋮--:--</td><td>v</td></tr> <tr><td>9</td><td>⋮--:--</td><td>v</td></tr> <tr><td>8</td><td>⋮--:--</td><td>v</td></tr> <tr><td>7</td><td>⋮--:--</td><td>v</td></tr> <tr><td>6</td><td>⋮--:--</td><td>v</td></tr> <tr><td>5</td><td>⋮--:--</td><td>v</td></tr> <tr><td>4</td><td>⋮--:--</td><td>v</td></tr> <tr><td>3</td><td>⋮--:--</td><td>v</td></tr> <tr><td>2</td><td>⋮--:--</td><td>v</td></tr> <tr><td>1</td><td>⋮--:--</td><td>v</td></tr> <tr><td>0</td><td>⋮--:--</td><td>v</td></tr> </table>	10	⋮--:--	v	9	⋮--:--	v	8	⋮--:--	v	7	⋮--:--	v	6	⋮--:--	v	5	⋮--:--	v	4	⋮--:--	v	3	⋮--:--	v	2	⋮--:--	v	1	⋮--:--	v	0	⋮--:--	v			
10	⋮--:--	v																																			
9	⋮--:--	v																																			
8	⋮--:--	v																																			
7	⋮--:--	v																																			
6	⋮--:--	v																																			
5	⋮--:--	v																																			
4	⋮--:--	v																																			
3	⋮--:--	v																																			
2	⋮--:--	v																																			
1	⋮--:--	v																																			
0	⋮--:--	v																																			
	1 2 3 4 5 6 000:00:04:34																																				

Table 4-3, Troubleshooting (cont)

STEP NO.	INSTRUCTION	YES	NO	GO TO
89	Release the ALL DATA switch and press ALARM DATA (PRINTER ENABLE).			90
90	Does the printer print?	91	92	
91	Note channels printed and verify that Limit addresses for those channels are skipped.			67
92	Release the ALARM DATA switch, press INTERVAL DATA and then press CONTINUOUS (SCAN CONTROL). The printer should print data for channels 0 through 10 once during each interval period. In this case, 10-seconds. The scan continues normally between intervals.			93
93	Release the INTERVAL DATA switch. The scanning sequence should continue, but data will not be printed.			94
94	Does the printer respond normally to the PRINTER ENABLE switch settings?	96	95	
95	Defective Mode Switch, Printer Drive PCB, or printer head. Repair as required.			88
	<b>DISPLAY CONTROL TEST</b>			
96	Press FIRST CHANNEL in the SCAN FORMAT group, and then CHANNEL ENABLE in the PROGRAMMING group. The display should read: 000 4.000 volts			97
97	Press ALL CHANNELS in the DISPLAY CONTROL group. The continuous scan of channels (0 through 10) should be displayed.			98
98	Press SINGLE CHANNEL in the DISPLAY CONTROL group. The CHANNEL display read 004.			100
99	Press DATE AND TIME in the DISPLAY CONTROL group. The time-of-day and date code should be displayed.			
100	Does the display respond normally to the DISPLAY CONTROL settings?	102	101	
101	Defective Keyboard Switch PCB or Keyboard Memory PCB. Repair as required.			96
	<b>PROGRAM LIST</b>			
102	Press RESET in the SCAN CONTROL group and ALL DATA in the PRINTER ENABLE group.			103
103	Press PROGRAM LIST. The printer should record:			104
104	Date and time, interval time, monitor channel, all available limits by address and their assigned values (may read any value at this point), all programmed channels (0-10) by address and their assigned function data, including second interval channels. All channels should show the 4V function (4.0000V).			
105	Missing column data indicates defective printer head. If no list is printed PROGRAM LIST switch or Printer Drive PCB may be defective. Missing digits in LIMIT data only indicates that the limits need programming or the Keyboard Memory PCB is defective. If this is the case, go to the next step. If printed data does not agree with displayed data, check the Printer Drive PCB.			102
	<b>PROGRAMMING LIMITS</b>			
106	If the limits option (-41) is installed, program each available limit (as indicated on the previously printed Program List) to <00000. Observe the display as each limit value is entered with the ENTER/STEP switch.			107

Table 4-3. Troubleshooting (cont)

STEP NO.	INSTRUCTION	YES	NO	GOTO																																																				
107	Does entered data for one or more limits addresses change when the ENTER/STEP switch is pressed?	108	109																																																					
108	U18 on the Range and Function Memory PCB is defective. Repair is required.			106																																																				
109	Program channels 0 through 10 with the following function data, and review after entry.			110																																																				
	<table border="1" style="width: 100%; border-collapse: collapse;"> <thead> <tr> <th colspan="2">PROGRAM DATA</th> <th colspan="2">REVIEW DATA</th> </tr> <tr> <th>CHANNEL</th> <th>FUNCTION</th> <th>CHANNEL DISPLAY</th> <th>DATA DISPLAY</th> </tr> </thead> <tbody> <tr> <td>0</td> <td>T1</td> <td>000</td> <td>1</td> </tr> <tr> <td>1</td> <td>T2</td> <td>001</td> <td>2</td> </tr> <tr> <td>2</td> <td>T3</td> <td>002</td> <td>3</td> </tr> <tr> <td>3</td> <td>T4</td> <td>003</td> <td>4</td> </tr> <tr> <td>4</td> <td>40 mV</td> <td>004</td> <td>40.000 Millivolts</td> </tr> <tr> <td>5</td> <td>400 mV</td> <td>005</td> <td>400.00 Millivolts</td> </tr> <tr> <td>6</td> <td>HI LIMIT</td> <td>006</td> <td>40000</td> </tr> <tr> <td>7</td> <td>4V</td> <td>007</td> <td>4.0000 Volts</td> </tr> <tr> <td>8</td> <td>40V</td> <td>008</td> <td>40.000 Volts</td> </tr> <tr> <td>9</td> <td>SKIP</td> <td>009</td> <td>s s s</td> </tr> <tr> <td>10</td> <td>SKIP</td> <td>010</td> <td>s s s</td> </tr> </tbody> </table>	PROGRAM DATA		REVIEW DATA		CHANNEL	FUNCTION	CHANNEL DISPLAY	DATA DISPLAY	0	T1	000	1	1	T2	001	2	2	T3	002	3	3	T4	003	4	4	40 mV	004	40.000 Millivolts	5	400 mV	005	400.00 Millivolts	6	HI LIMIT	006	40000	7	4V	007	4.0000 Volts	8	40V	008	40.000 Volts	9	SKIP	009	s s s	10	SKIP	010	s s s			
PROGRAM DATA		REVIEW DATA																																																						
CHANNEL	FUNCTION	CHANNEL DISPLAY	DATA DISPLAY																																																					
0	T1	000	1																																																					
1	T2	001	2																																																					
2	T3	002	3																																																					
3	T4	003	4																																																					
4	40 mV	004	40.000 Millivolts																																																					
5	400 mV	005	400.00 Millivolts																																																					
6	HI LIMIT	006	40000																																																					
7	4V	007	4.0000 Volts																																																					
8	40V	008	40.000 Volts																																																					
9	SKIP	009	s s s																																																					
10	SKIP	010	s s s																																																					
110	Program data correctly entered and verified?	112	111																																																					
111	Defective range and function memory. Repair as required.			109																																																				
112	Turn Power switch to POWER OFF, install Guard Crossing PCB and set the Power switch to POWER ON. Review channel data entered earlier in this procedure. The following results should be obtained for the units that display 2240C 7 on initial turn on.			113																																																				
	<table border="1" style="width: 100%; border-collapse: collapse;"> <thead> <tr> <th>PROGRAM CHANNEL</th> <th>CHANNEL DISPLAY</th> <th>DATA DISPLAY</th> </tr> </thead> <tbody> <tr> <td>0</td> <td>000</td> <td>1</td> </tr> <tr> <td>1</td> <td>001</td> <td>2 or s s s</td> </tr> <tr> <td>2</td> <td>002</td> <td>3</td> </tr> <tr> <td>3</td> <td>003</td> <td>4</td> </tr> <tr> <td>4</td> <td>004</td> <td>40.000 Millivolts</td> </tr> <tr> <td>5</td> <td>005</td> <td>400.00 Millivolts</td> </tr> <tr> <td>6</td> <td>006</td> <td>40000</td> </tr> <tr> <td>7</td> <td>007</td> <td>4.0000 Volts</td> </tr> <tr> <td>8</td> <td>008</td> <td>40.000V</td> </tr> <tr> <td>9</td> <td>009</td> <td>s s s</td> </tr> <tr> <td>10</td> <td>010</td> <td>s s s</td> </tr> </tbody> </table>	PROGRAM CHANNEL	CHANNEL DISPLAY	DATA DISPLAY	0	000	1	1	001	2 or s s s	2	002	3	3	003	4	4	004	40.000 Millivolts	5	005	400.00 Millivolts	6	006	40000	7	007	4.0000 Volts	8	008	40.000V	9	009	s s s	10	010	s s s																			
PROGRAM CHANNEL	CHANNEL DISPLAY	DATA DISPLAY																																																						
0	000	1																																																						
1	001	2 or s s s																																																						
2	002	3																																																						
3	003	4																																																						
4	004	40.000 Millivolts																																																						
5	005	400.00 Millivolts																																																						
6	006	40000																																																						
7	007	4.0000 Volts																																																						
8	008	40.000V																																																						
9	009	s s s																																																						
10	010	s s s																																																						
113	Is reviewed channel data correct?	115	114																																																					
114	Guard crossing defective. Repair as required.			109																																																				
115	2240C Mainframe is operational.																																																							

11  
12  
13  
14  
15  
16  
17  
18  
19  
20  
21  
22  
23  
24  
25  
26  
27  
28  
29  
30  
31  
32  
33  
34  
35  
36  
37  
38  
39  
40  
41  
42  
43  
44  
45  
46  
47  
48  
49  
50  
51  
52  
53  
54  
55  
56  
57  
58  
59  
60  
61  
62  
63  
64  
65  
66  
67  
68  
69  
70  
71  
72  
73  
74  
75  
76  
77  
78  
79  
80  
81  
82  
83  
84  
85  
86  
87  
88  
89  
90  
91  
92  
93  
94  
95  
96  
97  
98  
99  
100  
101  
102  
103  
104  
105  
106  
107  
108  
109  
110  
111  
112  
113  
114  
115  
116  
117  
118  
119  
120  
121  
122  
123  
124  
125  
126  
127  
128  
129  
130  
131  
132  
133  
134  
135  
136  
137  
138  
139  
140  
141  
142  
143  
144  
145  
146  
147  
148  
149  
150  
151  
152  
153  
154  
155  
156  
157  
158  
159  
160  
161  
162  
163  
164  
165  
166  
167  
168  
169  
170  
171  
172  
173  
174  
175  
176  
177  
178  
179  
180  
181  
182  
183  
184  
185  
186  
187  
188  
189  
190  
191  
192  
193  
194  
195  
196  
197  
198  
199  
200  
201  
202  
203  
204  
205  
206  
207  
208  
209  
210  
211  
212  
213  
214  
215  
216  
217  
218  
219  
220  
221  
222  
223  
224  
225  
226  
227  
228  
229  
230  
231  
232  
233  
234  
235  
236  
237  
238  
239  
240  
241  
242  
243  
244  
245  
246  
247  
248  
249  
250  
251  
252  
253  
254  
255  
256  
257  
258  
259  
260  
261  
262  
263  
264  
265  
266  
267  
268  
269  
270  
271  
272  
273  
274  
275  
276  
277  
278  
279  
280  
281  
282  
283  
284  
285  
286  
287  
288  
289  
290  
291  
292  
293  
294  
295  
296  
297  
298  
299  
300  
301  
302  
303  
304  
305  
306  
307  
308  
309  
310  
311  
312  
313  
314  
315  
316  
317  
318  
319  
320  
321  
322  
323  
324  
325  
326  
327  
328  
329  
330  
331  
332  
333  
334  
335  
336  
337  
338  
339  
340  
341  
342  
343  
344  
345  
346  
347  
348  
349  
350  
351  
352  
353  
354  
355  
356  
357  
358  
359  
360  
361  
362  
363  
364  
365  
366  
367  
368  
369  
370  
371  
372  
373  
374  
375  
376  
377  
378  
379  
380  
381  
382  
383  
384  
385  
386  
387  
388  
389  
390  
391  
392  
393  
394  
395  
396  
397  
398  
399  
400  
401  
402  
403  
404  
405  
406  
407  
408  
409  
410  
411  
412  
413  
414  
415  
416  
417  
418  
419  
420  
421  
422  
423  
424  
425  
426  
427  
428  
429  
430  
431  
432  
433  
434  
435  
436  
437  
438  
439  
440  
441  
442  
443  
444  
445  
446  
447  
448  
449  
450  
451  
452  
453  
454  
455  
456  
457  
458  
459  
460  
461  
462  
463  
464  
465  
466  
467  
468  
469  
470  
471  
472  
473  
474  
475  
476  
477  
478  
479  
480  
481  
482  
483  
484  
485  
486  
487  
488  
489  
490  
491  
492  
493  
494  
495  
496  
497  
498  
499  
500  
501  
502  
503  
504  
505  
506  
507  
508  
509  
510  
511  
512  
513  
514  
515  
516  
517  
518  
519  
520  
521  
522  
523  
524  
525  
526  
527  
528  
529  
530  
531  
532  
533  
534  
535  
536  
537  
538  
539  
540  
541  
542  
543  
544  
545  
546  
547  
548  
549  
550  
551  
552  
553  
554  
555  
556  
557  
558  
559  
560  
561  
562  
563  
564  
565  
566  
567  
568  
569  
570  
571  
572  
573  
574  
575  
576  
577  
578  
579  
580  
581  
582  
583  
584  
585  
586  
587  
588  
589  
590  
591  
592  
593  
594  
595  
596  
597  
598  
599  
600  
601  
602  
603  
604  
605  
606  
607  
608  
609  
610  
611  
612  
613  
614  
615  
616  
617  
618  
619  
620  
621  
622  
623  
624  
625  
626  
627  
628  
629  
630  
631  
632  
633  
634  
635  
636  
637  
638  
639  
640  
641  
642  
643  
644  
645  
646  
647  
648  
649  
650  
651  
652  
653  
654  
655  
656  
657  
658  
659  
660  
661  
662  
663  
664  
665  
666  
667  
668  
669  
670  
671  
672  
673  
674  
675  
676  
677  
678  
679  
680  
681  
682  
683  
684  
685  
686  
687  
688  
689  
690  
691  
692  
693  
694  
695  
696  
697  
698  
699  
700  
701  
702  
703  
704  
705  
706  
707  
708  
709  
710  
711  
712  
713  
714  
715  
716  
717  
718  
719  
720  
721  
722  
723  
724  
725  
726  
727  
728  
729  
730  
731  
732  
733  
734  
735  
736  
737  
738  
739  
740  
741  
742  
743  
744  
745  
746  
747  
748  
749  
750  
751  
752  
753  
754  
755  
756  
757  
758  
759  
760  
761  
762  
763  
764  
765  
766  
767  
768  
769  
770  
771  
772  
773  
774  
775  
776  
777  
778  
779  
780  
781  
782  
783  
784  
785  
786  
787  
788  
789  
790  
791  
792  
793  
794  
795  
796  
797  
798  
799  
800  
801  
802  
803  
804  
805  
806  
807  
808  
809  
810  
811  
812  
813  
814  
815  
816  
817  
818  
819  
820  
821  
822  
823  
824  
825  
826  
827  
828  
829  
830  
831  
832  
833  
834  
835  
836  
837  
838  
839  
840  
841  
842  
843  
844  
845  
846  
847  
848  
849  
850  
851  
852  
853  
854  
855  
856  
857  
858  
859  
860  
861  
862  
863  
864  
865  
866  
867  
868  
869  
870  
871  
872  
873  
874  
875  
876  
877  
878  
879  
880  
881  
882  
883  
884  
885  
886  
887  
888  
889  
890  
891  
892  
893  
894  
895  
896  
897  
898  
899  
900  
901  
902  
903  
904  
905  
906  
907  
908  
909  
910  
911  
912  
913  
914  
915  
916  
917  
918  
919  
920  
921  
922  
923  
924  
925  
926  
927  
928  
929  
930  
931  
932  
933  
934  
935  
936  
937  
938  
939  
940  
941  
942  
943  
944  
945  
946  
947  
948  
949  
950  
951  
952  
953  
954  
955  
956  
957  
958  
959  
960  
961  
962  
963  
964  
965  
966  
967  
968  
969  
970  
971  
972  
973  
974  
975  
976  
977  
978  
979  
980  
981  
982  
983  
984  
985  
986  
987  
988  
989  
990  
991  
992  
993  
994  
995  
996  
997  
998  
999  
1000

## Section 5

# List of Replaceable Parts

### TABLE OF CONTENTS

ASSEMBLY NAME	DRAWING NO.	TABLE		FIGURE	
		NO.	PAGE	NO.	PAGE
Final Assembly . . . . .	2240C	5-1	5-4	5-1	5-7
A1 Motherboard PCB Assembly . . . . .	2200A-4001	5-2	5-12	5-2	5-13
A2 Power Supply PCB Assembly . . . . .	2200A-4002T 2200A-4018T	5-3	5-14	5-3	5-17
A3 Controller PCB Assembly . . . . .	2240C-4041T	5-4	5-18	5-4	5-21
A4 Guard Crossing PCB Assembly . . . . .	2200A-4004T	5-5	5-22	5-5	5-24
A5 Printer Drive PCB Assembly . . . . .	2200A-4007T	5-6	5-25	5-6	5-27
A6 Display PCB Assembly . . . . .	2240A-4008T	5-7	5-28	5-7	5-30
A7 Switch Mode Assembly . . . . .	2240A-4009T	5-8	5-31	5-8	5-32
A8 Keyboard Switch PCB Assembly . . . . .	2240B-4011T	5-9	5-33	5-9	5-34
A9 Keyboard Memory PCB Assembly . . . . .	2240A-4013T	5-10	5-35	5-10	5-37
A10 Keyboard Logic PCB Assembly . . . . .	2240A-4012T	5-11	5-38	5-11	5-39
A11 Range and Function Memory PCB Assembly . . . . .	2240C-4042T	5-12	5-40	5-12	5-42
A12 High Performance A/D Converter PCB Assembly . . . . .	2200A-4028T	5-13	5-43	5-13	5-47



Section 5  
List of Replaceable Parts

5-1. INTRODUCTION

5-2. This section contains an illustrated parts breakdown of the instrument. Components are listed alpha-numerically by assembly. Electrical components are listed by reference designation and mechanical components are listed by item number. Each listed part is shown in an accompanying illustration.

5-3. Parts lists include the following information:

- a. Reference Designation or Item Number.
- b. Description of each part.
- c. Fluke Stock Number
- d. Federal Supply Code for Manufacturers.
- e. Manufacturer's Part Number or Type.
- f. Total Quantity per assembly or component.
- g. Recommended Quantity: This entry indicates the recommended number of spare parts necessary to support one to five instruments for a period of two years. This list presumes an availability of common electronic parts at the maintenance site. For maintenance for one year or more at an isolated site, it is recommended that at least one of each assembly in the instrument be stocked. In the case of optional subassemblies, plug-ins, etc, that are not always part of the instrument, or are deviations from the basic instrument mode, the REC QTY columns lists the recommended quantity of the item in that particular assembly.
- h. Use Code is provided to identify certain parts that have been added, deleted or modified during production of the instrument. Each part for which a use code has been assigned may be identified with a particular instrument by consulting the Rev. letter printed (in ink) on the assembly.

5-4. HOW TO OBTAIN PARTS

5-5. Components may be ordered directly from the manufacturer by using the manufacturer's part number, or from the John Fluke Mfg. Co., Inc. factory or authorized representative by using the FLUKE STOCK NUMBER. In the event the part you order has been replaced by a new or improved part, the replacement will be accompanied by an explanatory note and installation instructions, if necessary.

5-6. To ensure prompt and efficient handling of your order, include the following information.

- a. Quantity
- b. FLUKE Stock Number
- c. DESCRIPTION
- d. Refernece Designation or Item Number
- e. Printed Circuit Board Part Number and rev. letter (use code) as printed in ink on the PCB.
- f. Instrument model and Serial number.

 CAUTION

Indicated devices are subject  
to damage by static discharge.

Table 5-1. 2240C Final Assembly (cont)

REF DES	DESCRIPTION	FLUKE STOCK NO.	MFG SPLY CODE	MFG. PART NO.	TOT QTY	REC QTY	NOTE
MP45	CARD GUIDE	256461	23880	1450F	17		
MP46	CARD GUIDE	229047	23880	1800F	2		
MP47	INSULATOR, SPACER	372334	89536	372334	9		
MP48	INSULATOR	372342	89536	372342	9		
MP49	BUSHING, NYLON	102988	28520	SB250-2	2		
MP50	GROMMET, PRINTER, RUBBER	135269	83330	2172	4		
MP51	BUSHING, NYLON	104620	28520	SB500-6	1		
MP52	BUSHING, STEEL	375162	73734	32-201	4		
MP53	HEATSINK, XSTR	610436	89536	610436	1		
MP54	LINE CORD, (NOT SHOWN)	343723	89536	343723	1		
MP55	LOCK, TUMBLER	417543	89536	417543	1		
MP56	CLAMP, CABLE	165951	31827	3-4-1	1		
MP57	DECAL, SIDE TRIM	526004	89536	526004	2		
MP58	CRIMP CONTACT	380295	00779	87124-2	2		
MP59	DOUBLE CONTACT	381566	89536	381566	1		
MP60	BATTERY HOLDER ASSY	462804	89536	462804	1		
MP61	FOAM SPACER	462853	89536	462853	1		
MP62	PRIMARY BATTERY	448498	37942	305090	1		
MP63	COMPONENT HOLDER, MOUSETAIL	104794	98159	2829-115-3	3		
MP64	RUBBER BUMPER	423442	70485	1178-2	4		
MP65	DECAL, PAPER LOADING	424119	89536	424119	1		
P1	CONN, CABLE ASSEMBLY	413344	32038	5132-010	5		
P3	CONN, CABLE ASSEMBLY	413344	32038	5132-010		REF	
P5	CONN, CABLE ASSEMBLY	413344	32038	5132-010		REF	
P7	CONN, CABLE ASSEMBLY	413344	32038	5132-010		REF	
P9	CONN, CABLE ASSEMBLY	413344	32038	5132-010		REF	
P36	CONN, CABLE ASSY., 16-PIN	380576	89536	380576	1		
P42	CONN, CABLE ASSY., 14-PIN	380568	89536	380568	1		
S1	SWITCH ROTARY LINE	417204	89536	417204	1		
TM1	INSTRUCTION MANUAL, 2240C	581348	89536	581348	1		
W1	POWER SWITCH/SUPPLY CABLE	374009	89536	374009	1		
W2	POWER SWITCH INPUT CABLE	419952	89536	419952	1		
W3	POWER SWITCH/PLUG CABLE	398115	89536	398115	1		
XF1	FUSEHOLDER	424416	89536	424416	1		
	RECOMMENDED SPARE PARTS KIT (NOT SHOWN)	480798	89536	480798		AR	

1 ONE IS USED TO SECURE THE RED AND  
BLACK WIRES FROM A9 TO MP38.

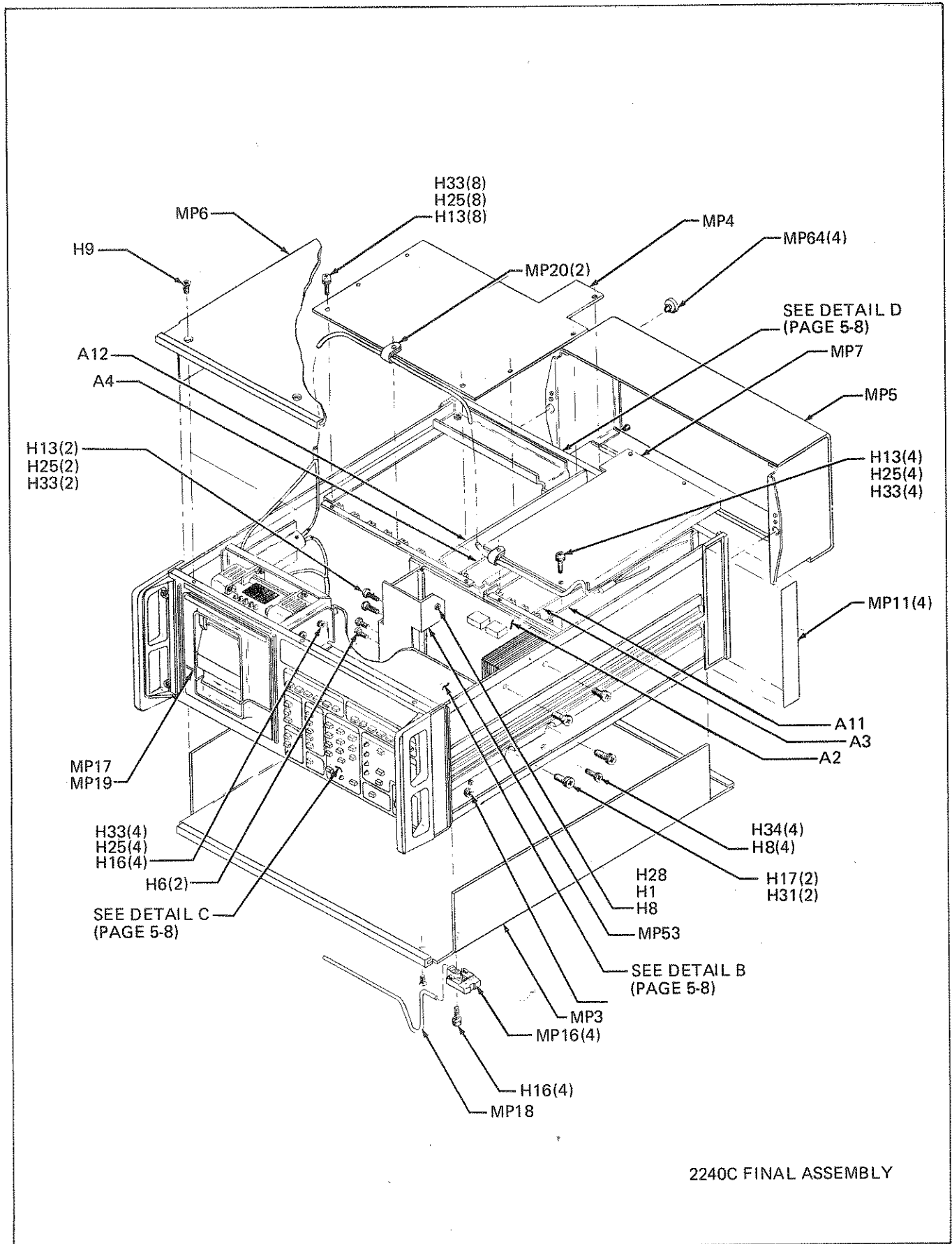
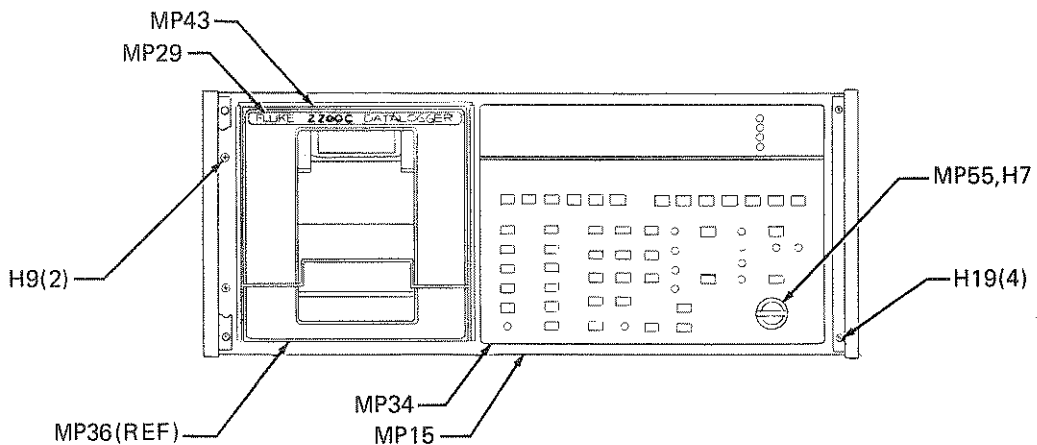
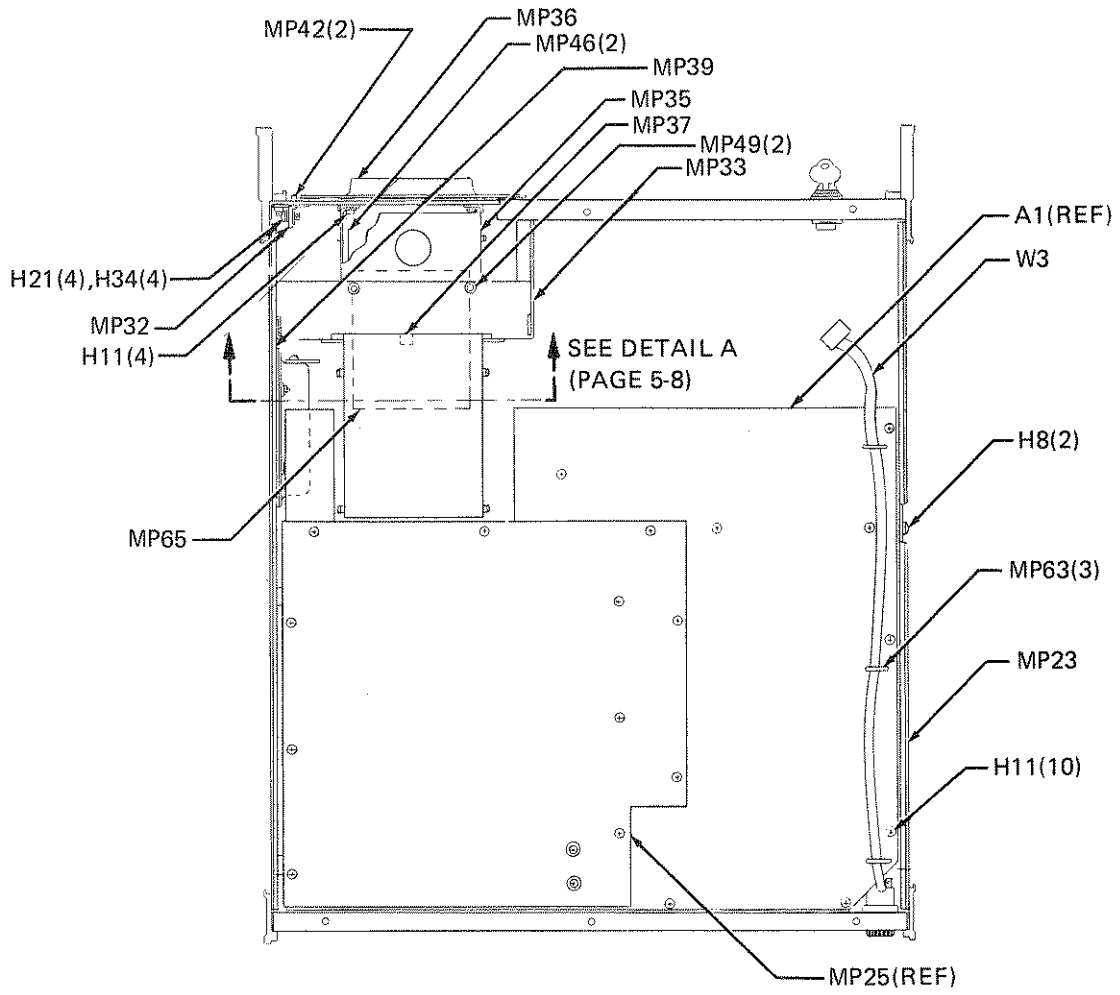

Figure 5-1. 2240C Final Assembly



FRONT VIEW



TOP VIEW

2240C FINAL ASSEMBLY

Figure 5-1. 2240C Final Assembly (cont)

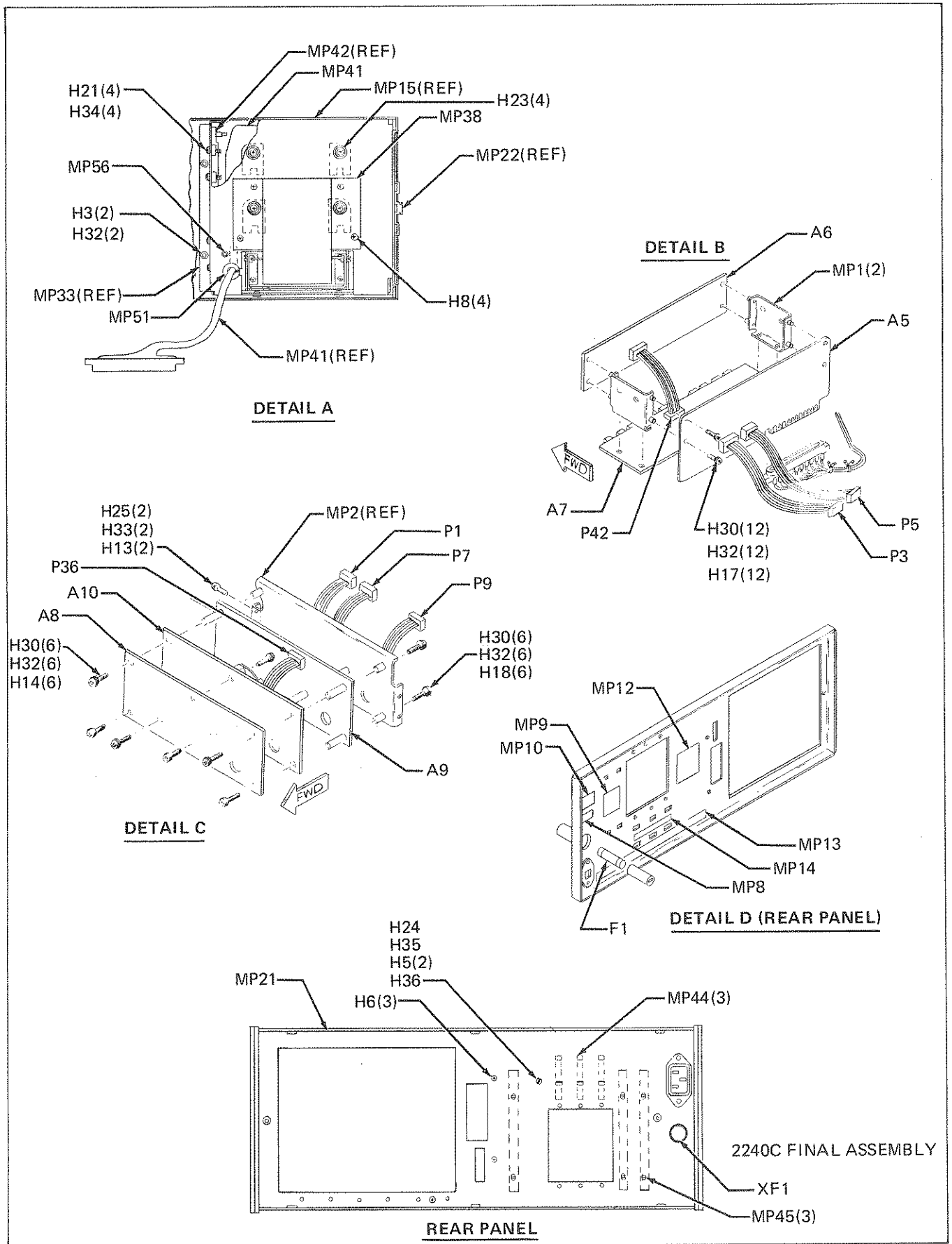
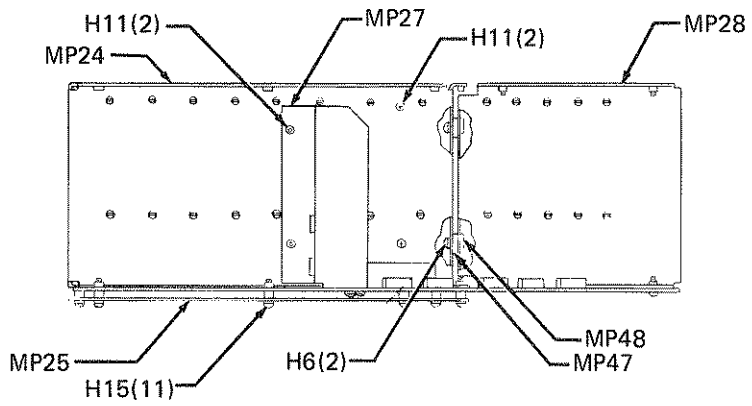
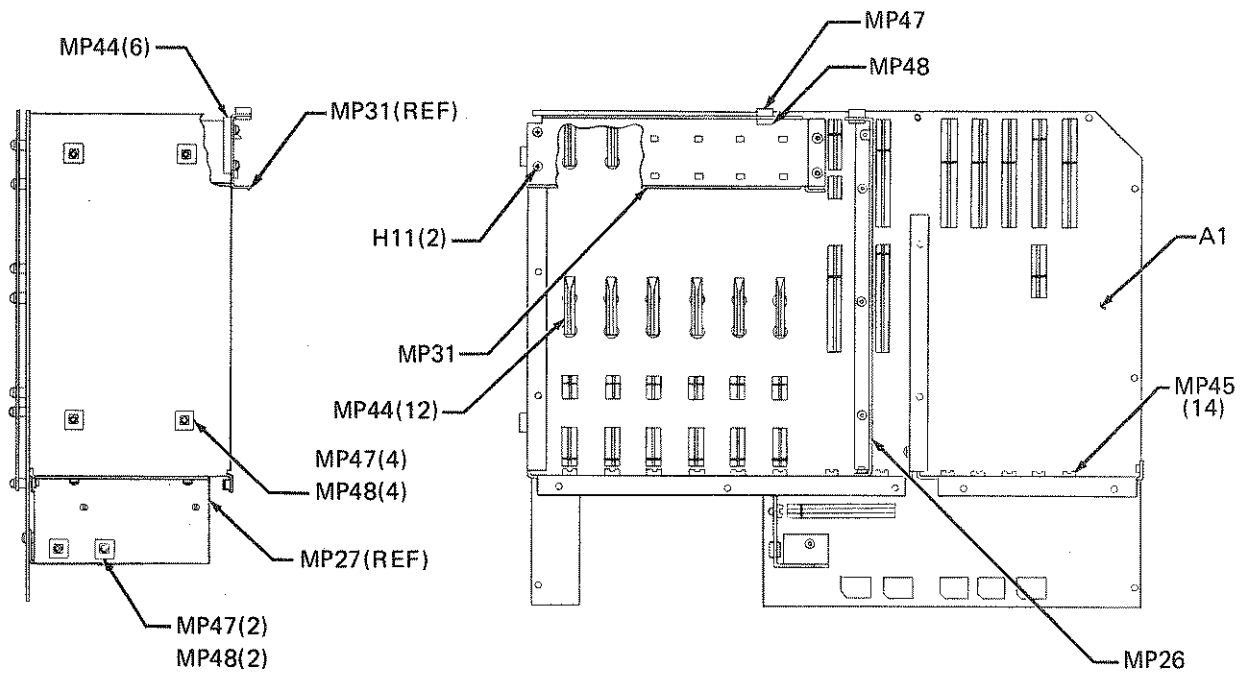

Figure 5-1. 2240C Final Assembly (cont.)



**CHASSIS SECTIONS**

2240C FINAL ASSEMBLY

Figure 5-1. 2240C Final Assembly (cont)

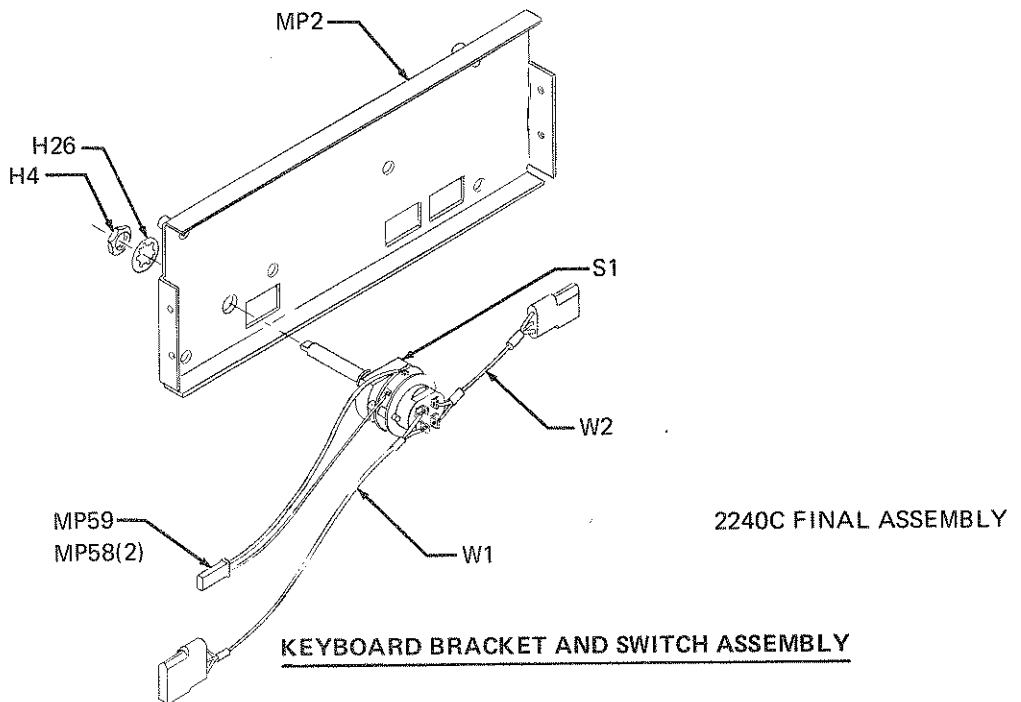
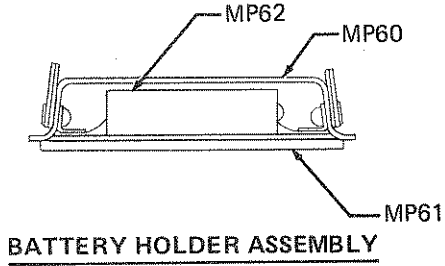
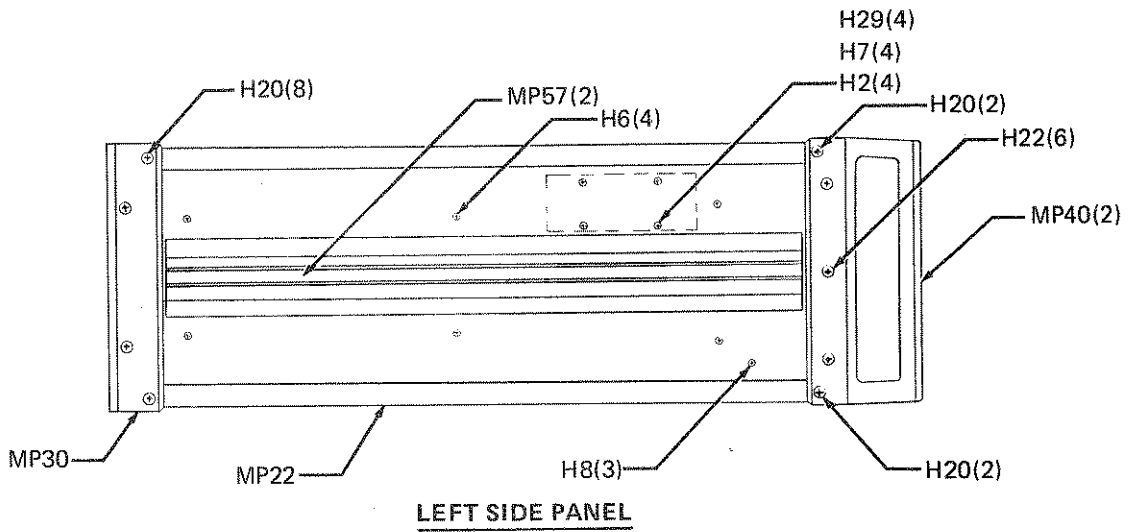
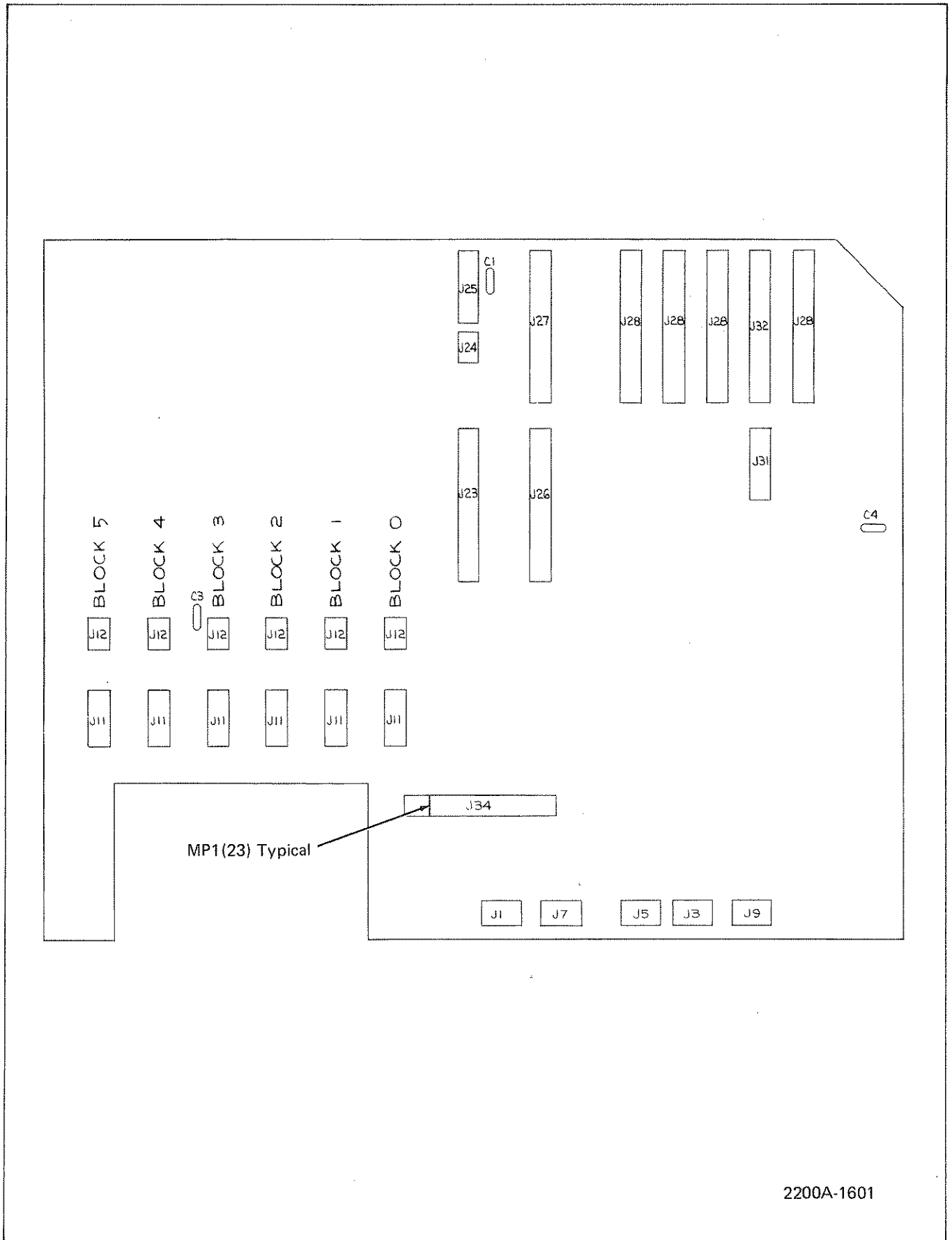

Figure 5-1. 2240C Final Assembly (cont)



Table 5-2. A1 Mother Board PCB Assembly

REF DES	DESCRIPTION	FLUKE STOCK NO.	MFG SPLY CODE	MFG. PART NO.	TOT QTY	REC QTY	NOTE
A1	MOTHER BOARD PCB ASSEMBLY FIGURE 5-2 (2200A-4001)	406306	89536	406306	REF		
C1	CAP, CER, 20,000 PF +/-20%	407403	72982	811-000-Z5U0203M	3		
C3	CAP, CER, 20,000 PF +/-20%	407403	72982	811-000-Z5U0203M	REF		
C4	CAP, CER, 20,000 PF +/-20%	407403	72982	811-000-Z5U0203M	REF		
J1	SOCKET, 14-PIN, DIP	387316	71785	133-59-02-059	5		
J3	SOCKET, 14-PIN, DIP	387316	71785	133-59-02-059	REF		
J5	SOCKET, 14-PIN, DIP	387316	71785	133-59-02-059	REF		
J7	SOCKET, 14-PIN, DIP	387316	71785	133-59-02-059	REF		
J9	SOCKET, 14-PIN, DIP	387316	71785	133-59-02-059	REF		
J11	CONNECTOR, 12-PIN	291898	00779	583650-2	6		
J12	CONNECTOR, 6-PIN	291625	00779	583650-1	7		
J23	CONNECTOR, 36-PIN	404947	00779	1-583407-8	9		
J24	CONNECTOR, 6-PIN	291625	00779	583650-1	REF		
J25	CONNECTOR, 16-PIN	408484	00779	408484	2		
J26	CONNECTOR, 36-PIN	404947	00779	1-583407-8	REF		
J27	CONNECTOR, 36-PIN	404947	00779	1-583407-8	REF		
J28	CONNECTOR, 36-PIN	404947	00779	1-583407-8	REF		
J31	CONNECTOR, 16-PIN	408484	00779	408484	REF		
J32	CONNECTOR, 36-PIN	404947	00779	1-583407-8	REF		
J34	CONNECTOR, 36-PIN	404947	00779	1-583407-8	REF		
MP1	KEY, CONNECTOR POLARIZING	424572	00779	530286-2	23		



2200A-1601

Figure 5-2. A1 Mother Board PCB Assembly

Table 5-3. A2 Power Supply PCB Assembly

REF DES	DESCRIPTION	FLUKE STOCK NO.	MFG SPLY CODE	MFG. PART NO.	TOT QTY	REC QTY	NO TE
A2①	POWER SUPPLY PCB ASSEMBLY FIGURE 5-3	ORDER	FOR	APPLICABLE SOURCE	REF		
	115/230V (2200A-4002T)	409433	89536	409433			
	100V (2200A-4018T)	426676	89536	426676			
C1	CAP, ELECT, 100 UF -10/+50%, 40V	236919	73445	ET101X040A6	2		
C2	CAP, ELECT, 100 UF -10/+50%, 40V	236919	73445	ET101X040A6	REF		
C3	CAP, ELECT, 8000 UF -10/+100%, 15V	309245	12676	61C15AS83	1		
C4	CAP, TA, 10 UF +/-20%, 20V	330662	56289	196D106X0020KA1	4		
C5	CAP, ELECT, 15,000 UF -10/+75%, 15V	310367	06001	86F520	1		
C6	CAP, TA, 10 UF +/-20%, 20V	330662	56289	196D106X0020KA1	REF		
C7	CAP, TA, 1 UF +/-20%, 35V	161919	56289	196D105X0020JA1	1		
C8	CAP, CER, 50,000 PF +/-20%, 100V	149161	56289	55C23A1	3		
C9	CAP, TA, 10 UF +/-20%, 20V	330662	56289	196D106X0020KA1	REF		
C10	CAP, ELECT, 8000 UF -10/+100%, 25V	309971	80031	39C025SL83	1		1
C11	CAP, TA, 10 UF +/-20%, 20V	330662	56289	196D106X0020KA1	REF		
C12	CAP, TA, 4.7 UF +/-20%, 25V	161943	56289	196D475X0025KA1	1		
C13	CAP, CER, 2000 PF GMV, 1 KV	105569	71590	DA140-139CB	1		
C14	CAP, CER, 50,000 PF +/-20%, 100V	149161	56289	55C23A1	REF		
C15	CAP, ELECT, 2100 UF -10/+100%, 35V	370742	80031	33C35JJ212	1		
C16	CAP, CER, 50,000 PF +/-20%, 100V	149161	56289	55C23A1	REF		
CR1	DIODE BRIDGE	296509	09423	FB200	3		1
CR2	DIODE BRIDGE	296509	09423	FB200	REF		
CR3	DIODE, SI, HIGH VOLTAGE	325746	04713	MR751	4		1
CR4	DIODE, SI, HIGH VOLTAGE	325746	04713	MR751	REF		
CR5	DIODE, SI, HIGH VOLTAGE	325746	04713	MR751	REF		
CR6	DIODE, SI, HIGH VOLTAGE	325746	04713	MR751	REF		
CR10	DIODE BRIDGE	296509	09423	FB200	REF		
CR11	DIODE, SI, HI-SPEED SWITCH	203323	07910	1N4448	5		1
CR12	DIODE, SI, HI-SPEED SWITCH	203323	07910	1N4448	REF		
CR14	DIODE, SI, HI-SPEED SWITCH	203323	07910	1N4448	REF		
CR15	DIODE, SI, HI-SPEED SWITCH	203323	07910	1N4448	REF		
CR16	DIODE, SI, HI-SPEED SWITCH	203323	07910	1N4448	REF		
H1	WASHER, FLAT #4 (NOT SHOWN)	110775	73734	97201	1		
H2	SCREW, PHP, 4-40 X 3/8	152124	73734	19024	3		
H3	WASHER, LOCK, SPLIT #4 (W/Q3)	110395	73734	1355	1		
H4	NUT, HEX, 4-40 (W/Q3, Q8)	110635	73734	8003	1		
H5	SCREW, PHP, 10-32 X 1/4	218941	73734	19082	2		
H6	LUG, SOLDER	101030	79963	174	2		
H7	SCREW, PHP, 6-32 X 1/2 (W/MP6)	152173	73734	19046	2		
H8	WASHER, LOCK, SPLIT #6	110692	73734	1358	2		
H9	NUT, HEX, 6-32 NC2B	110551	73734	8006	2		
H10	WASHER, LOCK, INTERNAL TOOTH	110312	73734	1306	2		
J48	CONNECTOR, 3-PIN (W/MP10)	417154	27264	03-09-2032	1		
MP1	HEATSINK, XSTR	411710	89536	411710	1		
MP2	HEATSINK, SEMICONDUCTOR	386235	13103	6032D	1		
MP3	HEATSINK BRACKET	374934	89536	374934	1		
MP4	DECAL, NAMEPLATE (NOT SHOWN)	433862	89536	433862	1		
MP5	INSULATOR, MICA, XSTR MOUNTING	101493	08530	757	1		

Table 5-3. A2 Power Supply PCB Assembly (cont)

REF DES	DESCRIPTION	FLUKE STOCK NO.	MFG SPLY CODE	MFG. PART NO.	TOT QTY	REC QTY	N O T E
MP6	WASHER, INSULATING (W/MP1)	195354	89536	195354	2		
MP7	HOLDER, COMPONENT (RUBBER)	104794	98159	2829-115-3	4		
MP8	XSTR, MTG INSULATOR (W/MP3)	331116	13103	4778A	1		
MP9	WASHER, SHOULDER (W/MP3)	436386	86928	5607-45	1		
MP10	PIN, CONNECTOR (TO J48)	342998	27264	02-09-2133	3		
Q1	XSTR, SI, NPN	418095	95303	2N6383	1		1
Q2	XSTR, SI, NPN	218396	04713	2N3904	4		1
Q3	XSTR, SI, NPN (W/WSHR & MICA INSUL.)	386128	01295	T1P120	1		1
Q4	XSTR, SI, NPN	218396	04713	2N3904		REF	
Q5	XSTR, SI, NPN	218396	04713	2N3904		REF	
Q6	XSTR, SI, PNP	195974	04713	2N3906	3		1
Q7	XSTR, SI, PNP	195974	04713	2N3906		REF	
Q8	XSTR, SI, NPN, (W/SPRING & MICA INSUL.)	325720	04713	MJE3055	1		1
Q9	XSTR, PBT, N-CHAN	261578	07910	U2366E	1		1
Q10	XSTR, SI, NPN	218396	04713	2N3904		REF	
Q11	XSTR, SI, PNP	195974	04713	2N3906		REF	
R1	RES, COMP, 2K +/-5%, 1/4W	202879	01121	CB2025	1		
R2	RES, MTL. FILM, 953 +/-1%, 1/8W	288555	91637	MFF1-89530F	1		
R3	RES, MTL. FILM, 2.37K +/-1%, 1/8W	293720	91637	MFF1-82371F	1		
R4	RES, COMP, 47K +/-5%, 1/4W	148163	01121	CB4735	2		
R5	RES, COMP, 1K +/-5%, 1/4W	148023	01121	CB1025	2		
R6	RES, COMP, 47K +/-5%, 1/4W	148163	01121	CB4735		REF	
R7	RES, COMP, 510 +/-5%, 1/4W	218032	01121	CB5115	1		
R9	RES, WW, 0.62 +/-5%, 2W	219352	75042	BWHR62J	1		1
R10	RES, COMP, 2.7K +/-5%, 1/4W	170720	01121	CB2725	1		
R11	RES, MTL. FILM, 7.50K +/-1%, 1/8W	223529	91637	MFF1-87501F	1		
R12	RES, COMP, 15K +/-5%, 1/4W	148114	01121	CB1535	1		
R13	RES, MTL. FILM, 10K +/-1%, 1/8W	168260	91637	MFF1-81002F	3		
R14	RES, MTL. FILM, 1.15K +/-1%, 1/8W	293597	91637	MFF1-81151F	1		
R15	RES, COMP, 2.4K +/-5%, 1/4W	193443	01121	CB2425	1		
R16	RES, COMP, 100 +/-10%, 1/4W	193185	01121	CB1011	1		
R17	RES, VAR, 2K +/-10%, 1/2W	285163	89536	285163	1		1
R18	RES, MTL. FILM, 4.53K +/-1%, 1/8W	260331	91637	CMF554531F	1		
R19	RES, COMP, 100K +/-5%, 1/4W	148189	01121	CB1045	2		
R20	RES, WW, 1.2 +/-5%, 2W	248658	75042	BWH1R2J	2		1
R21	RES, COMP, 330 +/-5%, 1/4W	147967	01121	CB3315	1		
R22	RES, WW, 1.2 +/-5%, 2W	248658	75042	BWH1R2J		REF	
R23	RES, COMP, 1K +/-5%, 1/4W	148023	01121	CB1025		REF	
R24	RES, MTL. FILM, 5.11K +/-1%, 1/8W	294868	91637	MFF1-85111F	1		
R25	RES, COMP, 22M +/-10%, 2W	108233	01121	EB2261	1		
R26	RES, MTL. FILM, 10K +/-1%, 1/8W	168260	91637	MFF1-81002F		REF	
R27	RES, MTL. FILM, 10K +/-1%, 1/8W	168260	91637	MFF1-81002F		REF	
R28	RES, COMP, 100K +/-5%, 1/4W	148189	01121	CB1045		REF	
S1	SWITCH, SLIDE, DPDT	234278	82389	XW1649	1		1
S2	SWITCH, SLIDE, SPDT	386813	*	GS-111-SPDT	1		
T1	TRANSFORMER, POWER	ORDER	FOR	APPLICABLE SOURCE	1		
	115/230V	409979	89536	409979			
	100V	427765	89536	427765			

Table 5-3. A2 Power Supply PCB Assembly (cont)

REF DES	DESCRIPTION	FLUKE STOCK NO.	MFG SPLY CODE	MFG. PART NO.	TOT QTY	REC QTY	N O T E
U1⊗	IC, C-MOS, HEX BUFFER	381830	04713	MC14050CP	1	1	
U2	IC, LIN, OP AMP	310219	12040	LM304H	1	1	
U3⊗	IC, C-MOS, TIME BASE GENERATOR	404251	04713	MC14566CP	1	1	
VR1	IC, LIN, VOL REGULATOR	355107	07263	F7805UC	1	1	
VR2	DIODE, ZENER	277236	07910	1N752A	1	1	
XU1	SOCKET, IC, 16-PIN	276535	91506	316AG39D	2		
XU3	SOCKET, IC, 16-PIN	276535	91506	316AG39D	REF		
	1 ORIENT DOT AS SHOWN						
	* G.E. INDUSTRIES						

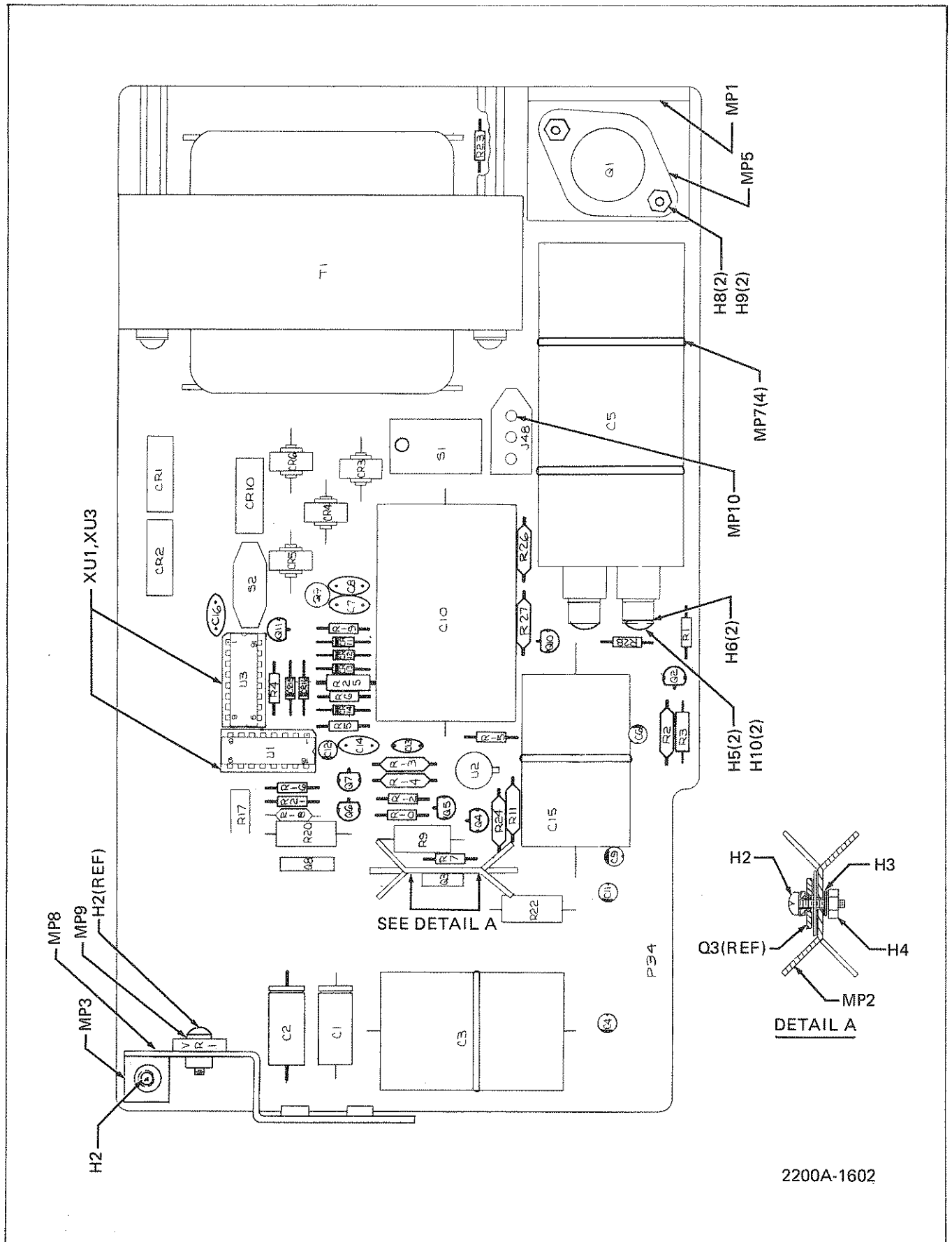

Figure 5-3. A2 Power Supply PCB Assembly

Table 5-4. A3 Controller PCB Assembly

REF DES	DESCRIPTION	FLUKE STOCK NO.	MFG SPLY CODE	MFG. PART NO.	TOT QTY	REC QTY	N O T E
A3④	CONTROLLER PCB ASSEMBLY FIGURE 5-4 (2200A-4041T)	580746	89536	580746		REF	
C1	CAP, MICA, 51 PF +/-5%, 500V	277210	72136	DM15E510J	1		
C2	CAP, CER, 0.025 UF +/-20%, 100V	168435	56289	C023B101H253M	2		
C3	CAP, CER, 10,000 PF -20/+80%, 25V	335786	72982	5835-000Y5-U103Z	3		
C4	CAP, CER, 10,000 PF -20/+80%, 25V	335786	72982	5835-000Y5-U103Z	REF		
C5	CAP, TA, 2.2 UF +/-20%, 15V	364216	56289	196D225X0015HA1	2		
C6	CAP, CER, 10,000 PF -20/+80%, 25V	335786	72982	5835-000Y5-U103Z	REF		
C7	CAP, TA, 2.2 UF +/-20%, 15V	364216	56289	196D225X0015HA1	REF		
C8	CAP, CER, 0.025 UF +/-20%, 100V	168435	56289	C023B101H253M	REF		
C9	CAP, CER, 0.22 UF +/-20%, 50V	519157	51406	RPE111Z5U224M50V	14		
C10	CAP, CER, 0.22 UF +/-20%, 50V	519157	51406	RPE111Z5U224M50V	REF		
C11	CAP, CER, 0.22 UF +/-20%, 50V	519157	51406	RPE111Z5U224M50V	REF		
C12	CAP, CER, 0.22 UF +/-20%, 50V	519157	51406	RPE111Z5U224M50V	REF		
C13	CAP, CER, 0.22 UF +/-20%, 50V	519157	51406	RPE111Z5U224M50V	REF		
C14	CAP, CER, 0.22 UF +/-20%, 50V	519157	51406	RPE111Z5U224M50V	REF		
C15	CAP, CER, 0.22 UF +/-20%, 50V	519157	51406	RPE111Z5U224M50V	REF		
C16	CAP, CER, 0.22 UF +/-20%, 50V	519157	51406	RPE111Z5U224M50V	REF		
C17	CAP, CER, 0.22 UF +/-20%, 50V	519157	51406	RPE111Z5U224M50V	REF		
C18	CAP, CER, 0.22 UF +/-20%, 50V	519157	51406	RPE111Z5U224M50V	REF		
C19	CAP, CER, 0.22 UF +/-20%, 50V	519157	51406	RPE111Z5U224M50V	REF		
C20	CAP, CER, 0.22 UF +/-20%, 50V	519157	51406	RPE111Z5U224M50V	REF		
C21	CAP, CER, 0.22 UF +/-20%, 50V	519157	51406	RPE111Z5U224M50V	REF		
C22	CAP, CER, 0.22 UF +/-20%, 50V	519157	51406	RPE111Z5U224M50V	REF		
C23	CAP, TA, 10 UF +/-20%, 15V	193623	56289	196D106X0015A1	2		
C24	CAP, TA, 10 UF +/-20%, 15V	193623	56289	196D106X0015A1	REF		
H1	SCREW, PHP, 3/8 HI-LO THD/FORM	448456	89536	448456	2		
J54	CONNECTOR, 26-POS, 1A, RIGHT-ANGLE	572289	02660	840-FRC2-C26L11	1		
JM1	JUMPER WIRE	528257	89536	528257	3		
MP1	HOLDER, COMPONENT	422857	98159	2829-75-1	1		
Q1	XSTR, SI, PNP	229898	04713	MPS6522	1		
Q2	XSTR, SI, NPN	218081	04713	MPS6520	1		
R1	RES, DEP. CAR, 820 +/-5%, 1/4W	442327	80031	CR251-4-5P820E	2		
R2	RES, DEP. CAR, 820 +/-5%, 1/4W	442327	80031	CR251-4-5P820E	REF		
R3	RES, DEP. CAR, 10K +/-5%, 1/4W	348839	80031	CR251-4-5P10K	4		
R4	RES, DEP. CAR, 110 +/-5%, 1/4W	442285	80031	CR251-4-5P110E	4		
R5	RES, DEP. CAR, 110 +/-5%, 1/4W	442285	80031	CR251-4-5P110E	REF		
R6	RES, DEP. CAR, 110 +/-5%, 1/4W	442285	80031	CR251-4-5P110E	REF		
R7	RES, DEP. CAR, 1K +/-5%, 1/4W	343426	80031	CR251-4-5P1K	5		
R8	RES, DEP. CAR, 110 +/-5%, 1/4W	442285	80031	CR251-4-5P110E	REF		
R9	RES, DEP. CAR, 5.6K +/-5%, 1/4W	442350	80031	CR251-4-5P5K6	2		
R10	RES, DEP. CAR, 5.6K +/-5%, 1/4W	442350	80031	CR251-4-5P5K6	REF		
R11	RES, DEP. CAR, 10K +/-5%, 1/4W	348839	80031	CR251-4-5P10K	REF		
R12	RES, DEP. CAR, 10K +/-5%, 1/4W	348839	80031	CR251-4-5P10K	REF		
R13	RES, DEP. CAR, 100K +/-5%, 1/4W	348920	80031	CR251-4-5P100K	1		
R14	RES, DEP. CAR, 1K +/-5%, 1/4W	343426	80031	CR251-4-5P1K	REF		
R15	RES, DEP. CAR, 1K +/-5%, 1/4W	343426	80031	CR251-4-5P1K	REF		
R16	RES, DEP. CAR, 1K +/-5%, 1/4W	343426	80031	CR251-4-5P1K	REF		
R17	RES, DEP. CAR, 470 +/-5%, 1/4W	343434	80031	CR251-4-5P470E	4		

Table 5-4. A3 Controller PCB Assembly (cont)

REF DES	DESCRIPTION	FLUKE STOCK NO.	MFG SPLY CODE	MFG. PART NO.	TOT QTY	REC QTY	N O T E
R18	RES, DEP. CAR, 470 +/-5%, 1/4W	343434	80031	CR251-4-5P470E	REF		
R19	RES, DEP. CAR, 470 +/-5%, 1/4W	343434	80031	CR251-4-5P470E	REF		
R20	RES, DEP. CAR, 470 +/-5%, 1/4W	343434	80031	CR251-4-5P470E	REF		
R21	RES, DEP. CAR, 1K +/-5%, 1/4W	343426	80031	CR251-4-5P1K	REF		
R22	RES, DEP. CAR, 10K +/-5%, 1/4W	348839	80031	CR251-4-5P10K	REF		
S1	SWITCH, 4-POS, DIP	495218	00779	435802-3	1		
TP1	CONNECTOR, FATON TAP	512889	02660	62395-1	3		
TP2	CONNECTOR, FATON TAP	512889	02660	62395-1	REF		
TP3	CONNECTOR, FATON TAP	512889	02660	62395-1	REF		
U1	IC, TTL, HEX INVERTER	418004	01295	SN74S04N	1		
U2⊗	IC, C-MOS, CLOCK DRIVER	408567	12040	MH0026CN	1		
U3	IC, TTL SHOTKY, QUAD 2-IN NAND GATE	363580	89536	363580	1		
U4	IC, TTL, 4-BIT COUNTER	340463	01295	SN74163N	1		1
U5	IC, 4-LINE TO 10-LINE DECODER	408716	01295	SN74LS42N	2		1
U6	IC, 4-LINE TO 10-LINE DECODER	408716	01295	SN74LS42N	REF		
U7	IC, PROGRAMMED (SEE -40 OPTION) SEC. 6						
U8	IC, PROGRAMMABLE SET (U8,U9,U11,U12)	610477	89536	610477	1		
U9	IC SET, PART OF U8						
U11	IC SET, PART OF U8						
U12	IC SET, PART OF U8						
U13	IC, TTL, QUAD, 2-INPUT, POS, NAND GATE	393033	01295	SN74LS00N	1		1
U14	IC, PROGRAMMED (SEE -43 OPTION) SEC. 6						
U15⊗	IC, C-MOS, QUAD, 2-INPUT NAND GATE	355198	02735	CD4011AE	1		1
U16⊗	IC, C-MOS, 4-BIT CPU	404418	34649	C4040	1		1
U17⊗	IC, C-MOS, STANDARD MEMORY INTERFACE	404434	34649	P4289CA	1		1
U18⊗	IC, P-MOS, 320-BIT RAM, 4-BIT OUTPUT	404467	34649	P4002-2	4		1
U19⊗	IC, P-MOS, 320-BIT RAM, 4-BIT OUTPUT	404442	34649	P4002-1	4		1
U20⊗	IC, P-MOS, 320-BIT RAM, 4-BIT OUTPUT	404467	34649	P4002-2	REF		
U21⊗	IC, P-MOS, 320-BIT RAM, 4-BIT OUTPUT	404442	34649	P4002-1	REF		
U23,U24	IC, (SEE -42 OPTION) SEC. 6						
U25,U26	IC, (SEE -42 OPTION) SEC. 6						
U27⊗	IC, P-MOS, 320-BIT RAM, 4-BIT OUTPUT	404442	34649	P4002-1	REF		
U28⊗	IC, P-MOS, 320-BIT RAM, 4-BIT OUTPUT	404442	34649	P4002-1	REF		
U29⊗	IC, P-MOS, 320-BIT RAM, 4-BIT OUTPUT	404467	34649	P4002-2	REF		
U30	IC, TTL, HEX INVERTER, OPEN COLLECTOR	394536	01295	SN74LS05N	2		1
U31	IC, TTL, HEX INVERTER, OPEN COLLECTOR	394536	01295	SN74LS05N	REF		
U32⊗	IC, P-MOS, 320-BIT RAM, 4-BIT OUTPUT	404467	34649	P4002-2	REF		
U33⊗	IC, C-MOS, DUAL 4-INPUT POS NAND GATE	355206	04713	MC4012CP	1		1
U34⊗	IC, C-MOS, QUAD 2-INPUT NOR GATES	355172	02735	CD4001AE	1		1
U35⊗	IC, C-MOS, DUAL J-K, F/F	355230	12040	CD4027BCN	1		1
U36⊗	IC, C-MOS, HEX, INVERTER	404681	02735	CD4069BE	1		1
U37⊗	IC, C-MOS, TRIPLE 3-INPUT NOR GATES	355180	02735	CD4025AE	1		1
U38⊗	IC, C-MOS, TRI-STATE, HEX, NONINV BFFRS	407759	12040	MM80C97N	1		1
XU3	SOCKET, IC, 14-PIN	276527	91506	314-AG39D	1		
XU7	SOCKET, IC, USED FOR -40 OPTION	276535	91506	316-AG39D	13		
XU8	SOCKET, IC, 24-PIN	418970	91506	324-AG39D	6		
XU9	SOCKET, IC, 24-PIN	418970	91506	324-AG39D	REF		
XU11	SOCKET, IC, 24-PIN	418970	91506	324-AG39D	REF		
XU12	SOCKET, IC, 24-PIN	418970	91506	324-AG39D	REF		
XU14	SOCKET, IC, USED FOR -43 OPTION	418970	91506	324-AG39D	REF		



Table 5-4. A3 Controller PCB Assembly (cont)

REF DES	DESCRIPTION	FLUKE STOCK NO.	MFG SPLY CODE	MFG. PART NO.	TOT QTY	REC QTY	NOTE
XU16	SOCKET, IC, 24-PIN	418970	91506	324-AG39D	REF		
XU17	SOCKET, IC, 40-PIN	418988	91506	340-AG39D	1		
XU18	SOCKET, IC, 16-PIN	276535	91506	316-AG39D	REF		
XU19	SOCKET, IC, 16-PIN	276535	91506	316-AG39D	REF		
XU20	SOCKET, IC, 16-PIN	276535	91506	316-AG39D	REF		
XU21	SOCKET, IC, 16-PIN	276535	91506	316-AG39D	REF		
XU23	SOCKET, IC, USED FOR -42 OPTION	276535	91506	316-AG39D	REF		
XU24	SOCKET, IC, USED FOR -42 OPTION	276535	91506	316-AG39D	REF		
XU25	SOCKET, IC, USED FOR -42 OPTION	276535	91506	316-AG39D	REF		
XU26	SOCKET, IC, USED FOR -42 OPTION	276535	91506	316-AG39D	REF		
XU27	SOCKET, IC, 16-PIN	276535	91506	316-AG39D	REF		
XU28	SOCKET, IC, 16-PIN	276535	91506	316-AG39D	REF		
XU29	SOCKET, IC, 16-PIN	276535	91506	316-AG39D	REF		
XU32	SOCKET, IC, 16-PIN	276535	91506	316-AG39D	REF		
Y1	CRYSTAL, 5.185 MHZ	408518	89536	408518	1	1	
Z1	RESISTOR NETWORK, 4.7K +/-2%, 1/8W	484063	89536	484063	1	1	
Z2	RESISTOR NETWORK, 2K, 1/4W	446880	89536	446880	1	1	
Z3	RESISTOR NETWORK, 10K +/-5%, 1.5W	364000	89536	364000	1	1	
Z4	RESISTOR NETWORK, 10K +/-5%	414003	89536	414003	1	1	
Z5	RESISTOR NETWORK, 10K	500876	89536	500876	1	1	

NOTE: EMPTY SOCKETS ARE RESERVED FOR OPTIONS

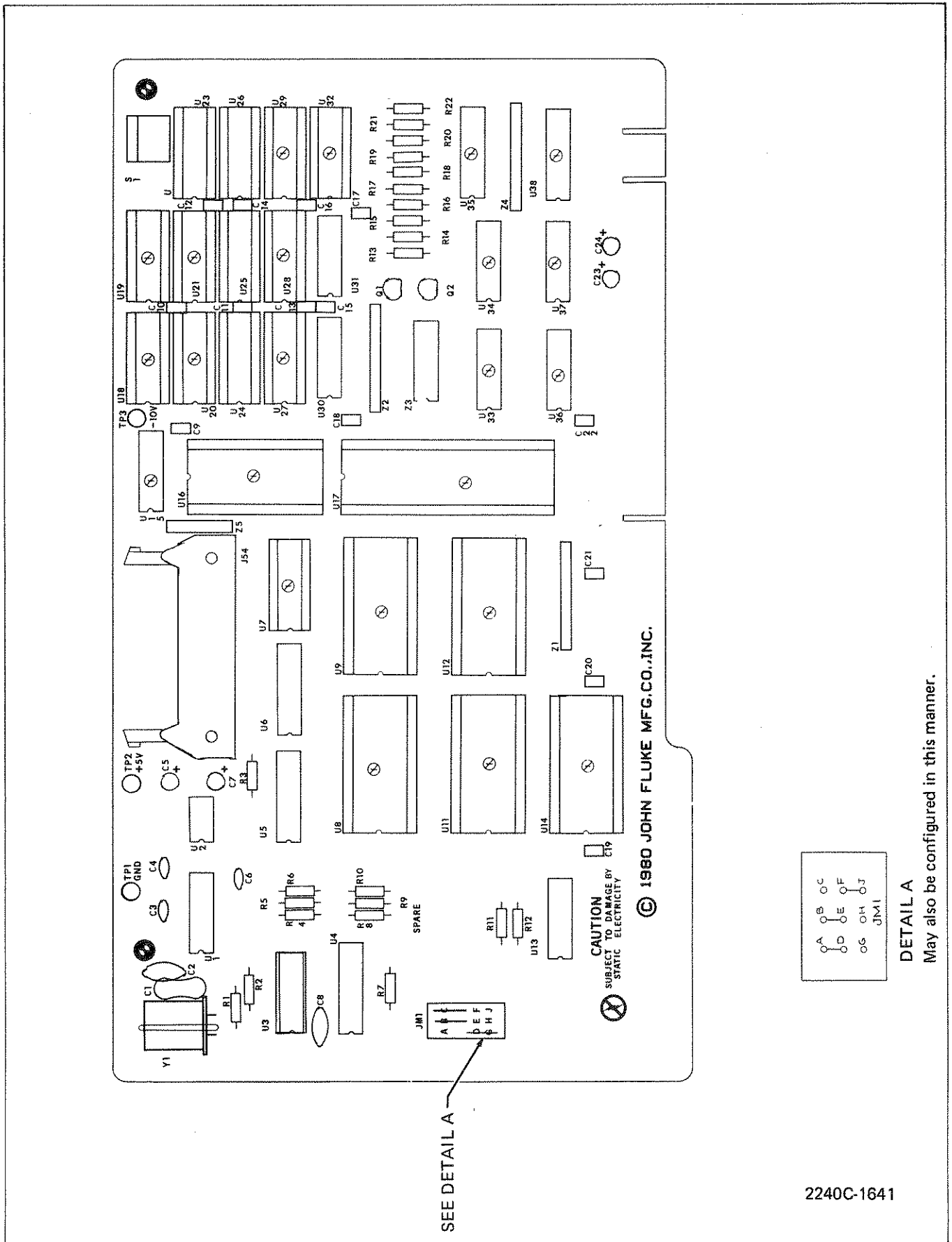

Figure 5-4. A3 Controller PCB Assembly

Table 5-5. A4 Guard Crossing PCB Assembly

REF DES	DESCRIPTION	FLUKE STOCK NO.	MFG SPLY CODE	MFG. PART NO.	TOT QTY	REC QTY	NO TE
A4⊙	GUARD CROSSING PCB ASSEMBLY FIGURE 5-5 (2200A-4004T)	409458	89536	409458		REF	
C1	CAP, CER, 0.22 UF +/-20%, 50V	309849	71590	CW30C224K	9		
C2	CAP, CER, 0.22 UF +/-20%, 50V	309849	71590	CW30C224K		REF	
C3	CAP, CER, 0.22 UF +/-20%, 50V	309849	71590	CW30C224K		REF	
C4	CAP, CER, 0.22 UF +/-20%, 50V	309849	71590	CW30C224K		REF	
C5	CAP, CER, 0.22 UF +/-20%, 50V	309849	71590	CW30C224K		REF	
C6	CAP, CER, 0.22 UF +/-20%, 50V	309849	71590	CW30C224K		REF	
C7	CAP, CER, 0.22 UF +/-20%, 50V	309849	71590	CW30C224K		REF	
C8	CAP, CER, 200 PF +/-10%, 1 KV	272880	71590	DD201	1		
C9	CAP, CER, 5000 PF +/-20%, 100V	175232	56289	C023B101E502M	2		
C10	CAP, CER, 0.22 UF +/-20%, 50V	309849	71590	CW30C224K		REF	
C11	CAP, CER, 0.22 UF +/-20%, 50V	309849	71590	CW30C224K		REF	
C12	CAP, TA, 10 UF +/-20%, 35V	330662	56289	196D106X0035KA1	2		
C13	CAP, CER, 5000 PF +/-20%, 100V	175232	56289	C023B101E502M		REF	
C14	CAP, TA, 10 UF +/-20%, 35V	330662	56289	196D106X0035KA1		REF	
C20	CAP, TA, 0.22 UF +/-20%, 35V	161331	56289	196D224X0035HA1	2		
C21	CAP, TA, 0.22 UF +/-20%, 35V	161331	56289	196D224X0035HA1		REF	
Q1	XSTR, SI, NPN	218396	04713	2N3904	5		1
Q2	XSTR, SI, NPN	218396	04713	2N3904		REF	
Q3	XSTR, SI, NPN	218396	04713	2N3904		REF	
Q4	XSTR, SI, NPN	218396	04713	2N3904		REF	
Q23	XSTR, SI, NPN	218396	04713	2N3904		REF	
R1	RES, COMP, 4.7K +/-5%, 1/4W	148072	01121	CB4725	5		
R2	RES, COMP, 3K +/-5%, 1/4W	193508	01121	CB3025	5		
R3	RES, COMP, 3K +/-5%, 1/4W	193508	01121	CB3025		REF	
R4	RES, COMP, 3K +/-5%, 1/4W	193508	01121	CB3025		REF	
R5	RES, COMP, 3K +/-5%, 1/4W	193508	01121	CB3025		REF	
R7	RES, COMP, 4.7K +/-5%, 1/4W	148072	01121	CB4725		REF	
R8	RES, COMP, 4.7K +/-5%, 1/4W	148072	01121	CB4725		REF	
R11	RES, COMP, 4.7K +/-5%, 1/4W	148072	01121	CB4725		REF	
R12	RES, COMP, 2.2K +/-5%, 1/4W	148049	01121	CB2225	2		
R13	RES, COMP, 2.2K +/-5%, 1/4W	148049	01121	CB2225		REF	
R14	RES, COMP, 4.7K +/-5%, 1/4W	148072	01121	CB4725		REF	
R15	RES, COMP, 330 +/-5%, 1/4W	147967	01121	CB3315	2		
R16	RES, COMP, 330 +/-5%, 1/4W	147967	01121	CB3315		REF	
R20	RES, COMP, 22K +/-5%, 1/4W	348870	01121	CB2235	1		
R21	RES, MTL. FILM, 100K +/-1%, 1/8W	248807	91637	MFF1-81003F	1		
R23	RES, COMP, 3K +/-5%, 1/4W	193508	01121	CB3025		REF	
U1	IC, TTL, TRPL 3-INPUT POS. NAND GATE	393157	01295	SN74LS107N	6		2
U2	IC, TTL, QUAD, 2-INPUT POS. AND GATE	393066	01295	SN74LS08N	1		1
U3	IC, TTL, QUAD, D-TYPE FLIP-FLOP	408203	12040	DM85L51N	1		1
U4	IC, TTL, BCD COUNTER WITH LATCH	408195	12040	DM85L52N	4		1
U5	IC, TTL, BCD COUNTER WITH LATCH	408195	12040	DM85L52N		REF	
U6	IC, TTL, BCD COUNTER WITH LATCH	408195	12040	DM85L52N		REF	
U7	IC, TTL, BCD COUNTER WITH LATCH	408195	12040	DM85L52N		REF	
U8⊙	IC, C-MOS, QUAD, BILATERAL SWITCH	363838	02735	CD4016AE	1		1
U9	IC, OPTO-ISOLATOR	429894	28480	5082-4355	5		
U10	IC, TTL, TRPL 3-INPUT POS. NAND GATE	393157	01295	SN74LS107N		REF	

Table 5-5. A4 Guard Crossing PCB Assembly (cont)

REF DES	DESCRIPTION	FLUKE STOCK NO.	MFG SPLY CODE	MFG. PART NO.	TOT QTY	REC QTY	NOTE
U11	IC, TTL, QUAD, 2-INPUT NAND GATE	393033	01295	SN74LS00N	1	1	
U12	IC, TTL, TRIPLE 3-INPUT NAND GATE	393074	01295	SN74LS10N	2	1	
U13	IC, TTL, QUAD 2-INPUT EXCLUSIVE -OR GATE	408237	01295	SN74LS86N	1	1	
U14	IC, TTL, TRPL 3-INPUT POS. NAND GATE	393157	01295	SN74LS107N	REF		
U15⊗	IC, C-MOS, HEX BUFFER/CONVERTER	381848	02735	CD4049AE	3	1	
U16⊗	IC, C-MOS, DUAL 4-BIT STATIC SHIFT RGSTR	340125	04713	MC14015CP	1	1	
U17⊗	IC, C-MOS, DUAL D-TYPE FLIP-FLOP	340117	04713	MC14013L	5	1	
U18	IC, TTL, TRPL 3-INPUT POS. NAND GATE	393157	01295	SN74LS107N	REF		
U19	IC, TTL DUAL D-TYPE FLIP-FLOP	393124	01295	SN74LS74N	2	1	
U20	IC, TTL, TRPL 3-INPUT POS. NAND GATE	393157	01295	SN74LS107N	REF		
U21	IC, TTL, TRIPLE 3-INPUT NOR GATE	393090	01295	SN74LS27N	1	1	
U22	IC, TTL, QUAD, 2-INPUT NOR GATE	393041	01295	SN74LS02N	2	1	
U23	IC, TTL, HEX INVERTER	393058	01295	SN74LS04N	2	1	
U24⊗	IC, C-MOS, DUAL D-TYPE FLIP-FLOP	340117	04713	MC14013L	REF		
U25	IC, TTL, QUAD, 2-INPUT NOR GATE	393041	01295	SN74LS02N	REF		
U26	IC, TTL, HEX INVERTER	393058	01295	SN74LS04N	REF		
U27	IC, TTL, TRIPLE 3-INPUT NAND GATE	393074	01295	SN74LS10N	REF		
U28	IC, TTL, DUAL ONE-SHOT	404186	01295	SN74LS123N	1	1	
U29	IC, TTL DUAL D-TYPE FLIP-FLOP	393124	01295	SN74LS74N	REF		
U30⊗	IC, C-MOS, HEX BUFFER/CONVERTER	381848	02735	CD4049AE	REF		
U31	RES, NETWORK, 4.7K	494690	89536	494690	2		
U32	OPTO-ISOLATOR	429894	28480	5082-4355	REF		
U34	IC, TTL, DECADE COUNTER	402545	01295	SN74LS90N	1	1	
U35	IC, TTL, TRPL 3-INPUT POS. NAND GATE	393157	01295	SN74LS107N	REF		
U36	RES, NETWORK, 330	408302	89536	408302	2		
U37	OPTO-ISOLATOR	429894	28480	5082-4355	REF		
U38	OPTO-ISOLATOR	407742	28480	HP5082-4351	1		
U39	OPTO-ISOLATOR	429894	28480	5082-4355	REF		
U40	OPTO-ISOLATOR	429894	28480	5082-4355	REF		
U42⊗	IC, C-MOS, QUAD, 2-INPUT NOR GATE	355172	02735	CD4001AC	2	1	
U43⊗	IC, C-MOS, DUAL D-TYPE FLIP-FLOP	340117	04713	MC14013L	REF		
U44	RES, NETWORK, 4.7K	494690	89536	494690	REF		
U45⊗	IC, C-MOS, STROBED HEX INVERTER	408211	04713	MC14502CP	1	1	
U46⊗	IC, C-MOS, DUAL D-TYPE FLIP-FLOP	340117	04713	MC14013L	REF		
U47⊗	IC, C-MOS, DUAL D-TYPE FLIP-FLOP	340117	04713	MC14013L	REF		
U48⊗	IC, DGTL, C-MOS, NAND GATES QUAD 2-INPUT	355198	02735	CD4011AE	1	1	
U49⊗	IC, C-MOS, QUAD, 2-INPUT NOR GATE	355172	02735	CD4001AC	REF		
U50⊗	IC, C-MOS, HEX BUFFER/CONVERTER	381848	02735	CD4049AE	REF		
U51⊗	IC, C-MOS, NOR-GATES DUAL 4-INPUT	363820	02735	CD4002AE	2	1	
U52	RES, NETWORK, 330	408302	89536	408302	REF		
U53⊗	IC, C-MOS QUAD CLOCKED D LATCH TRI-STATE	412742	12040	MM74C173N	1		
U54⊗	IC, C-MOS, NOR-GATES DUAL 4-INPUT	363820	02735	CD4002AE	REF		
U55	TRANSISTOR ARRAY	454116	01295	ULN2003N	1		
XY1	SOCKET CRYSTAL	148668	91506	8000-AG10	1		
Y1	CRYSTAL	ORDER	FOR	APPROPRIATE SOURCE	1	1	
	2.4 MHZ (60 HZ LINE) 100/115V	408153	89536	408153			
	2.0 MHZ (50 HZ LINE) 100/230V	408161	89536	408161			

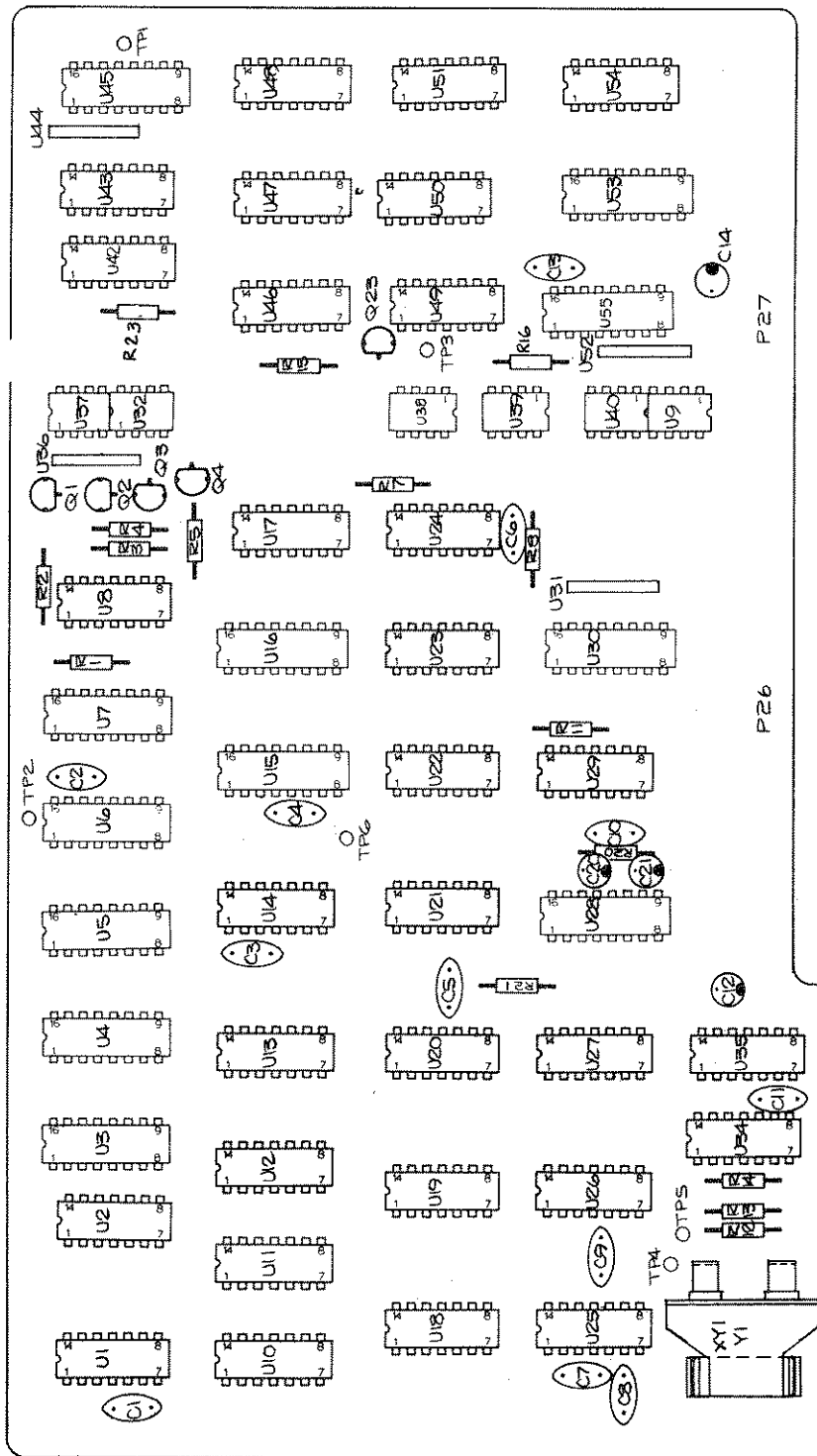

2200A-1604

Figure 5-5. A4 Guard Crossing PCB Assembly

Table 5-6 A5 Printer Drive PCB Assembly

REF DES	DESCRIPTION	FLUKE STOCK NO.	MFG SPLY CODE	MFG PART NO. OR TYPE	TOT QTY	REC QTY	NO TE
A5①	PRINTER DRIVE PCB ASSEMBLY FIGURE 5-6 (2200A-4007T)	409482	89536	409482		REF	
C1	CAP, CER, 50,000 PF +/-20%, 100V	149161	56289	55C23A1	6		
C2	CAP, CER, 50,000 PF +/-20%, 100V	149161	56289	55C23A1		REF	
C3	CAP, CER, 50,000 PF +/-20%, 100V	149161	56289	55C23A1		REF	
C4	CAP, CER, 50,000 PF +/-20%, 100V	149161	56289	55C23A1		REF	
C5	CAP, CER, 10,000 PF +/-20%, 100V	149153	56289	C023B101F103M	2		
C6	CAP, CER, 50,000 PF +/-20%, 100V	149161	56289	55C23A1		REF	
C7	CAP, ELECT, 330 UF -10/+50%, 16V	187765	73445	ET331X016A02	1		1
C8	CAP, CER, 10,000 PF +/-20%, 100V	149153	56289	C023B101F103M		REF	
C9	CAP, CER, 50,000 PF +/-20%, 100V	149161	56289	55C23A1		REF	
C10	CAP, CER, 25,000 PF +/-20%, 100V	168435	56289	C023B101H253M	5		
C11	CAP, CER, 25,000 PF +/-20%, 100V	168435	56289	C023B101H253M		REF	
C12	CAP, CER, 25,000 PF +/-20%, 100V	168435	56289	C023B101H253M		REF	
C13	CAP, CER, 25,000 PF +/-20%, 100V	168435	56289	C023B101H253M		REF	
C14	CAP, CER, 25,000 PF +/-20%, 100V	168435	56289	C023B101H253M		REF	
C15	CAP, TA, 10 UF +/-20%, 20V	330662	56289	196D106X0020KA1	1		
J4	SOCKET, CONNECTOR	387316	71785	133-59-02-059	2		
J6	SOCKET, CONNECTOR	387316	71785	133-59-02-059		REF	
P41	CONTACT, 15-PIN (NOT SHOWN)	424135	27264	09-64-1152	1		
Q1	XSTR, SI, NPN	218396	04713	2N3904	1		1
R1	RES, COMP, 5.1K +/-5%, 1/4W	193342	01121	CB5125	1		
R2	RES, COMP, 1K +/-5%, 1/4W	148023	01121	CB1025	4		
R3	RES, COMP, 1K +/-5%, 1/4W	148023	01121	CB1025		REF	
R4	RES, COMP, 1K +/-5%, 1/4W	148023	01121	CB1025		REF	
R5	RES, COMP, 18K +/-5%, 1/4W	148122	01121	CB1835	2		
R6	RES, COMP, 2K +/-5%, 1/4W	202879	01121	CB2025	2		
R7	RES, COMP, 1K +/-5%, 1/4W	148023	01121	CB1025		REF	
R8	RES, COMP, 18K +/-5%, 1/4W	148122	01121	CB1835		REF	
R9	RES, COMP, 2K +/-5%, 1/4W	202879	01121	CB2025		REF	
R10	RES, COMP, 47K +/-5%, 1/4W	148163	01121	CB4735	2		
R11	RES, COMP, 47K +/-5%, 1/4W	148163	01121	CB4735		REF	
U1	IC, TTL, HEX INVERTER	393058	01295	SN74LS04N	2		1
U2	IC, TTL, DUAL D-TYPE FLIP-FLOP	393124	01295	SN74LS74N	4		1
U3	IC, TTL, DUAL J-K FLIP-FLOP	414029	01295	SN74LS112N	1		1
U4	IC, TTL, TRIPLE 3-INPUT NOR GATE	393090	01295	SN74LS27N	1		1
U5	IC, TTL, DUAL D-TYPE FLIP-FLOP	393124	01295	SN74LS74N		REF	
U6	IC, TTL, QUAD 2-INPUT NOR GATE	393041	01295	SN74LS02N	1		1
U7	IC, TTL, DUAL D-TYPE FLIP-FLOP	393124	01295	SN74LS74N		REF	
U8	IC, TTL 8-BIT PARALLEL OUT SER SHIFT REG	408732	01295	SN74LS164N	2		1
U9	IC, TTL 8-BIT PARALLEL OUT SER SHIFT REG	408732	01295	SN74LS164N		REF	
U10①	IC, C-MOS, HEX BUFFER	355412	02735	CD4010AE	1		1
U11①	IC, C-MOS, HEX INVERTER	355214	02735	CD4009AE	1		1
U12	IC, TTL, TRIPLE 3-INPUT NAND GATE	393074	01295	SN74LS10N	1		1
U13	IC, TTL, QUAD 2-INPUT NAND GATE	393033	01295	SN74LS00N	1		1
U14	IC, TTL, DUAL PERIPHERAL NAND DRIVER	329706	01295	SN75452P	9		2
U15	IC, TTL, DUAL PERIPHERAL NAND DRIVER	329706	01295	SN75452P		REF	
U16	IC, TTL, DUAL PERIPHERAL NAND DRIVER	329706	01295	SN75452P		REF	
U17	IC, TTL, DUAL PERIPHERAL NAND DRIVER	329706	01295	SN75452P		REF	

Table 5-6. A5 Printer Drive PCB Assembly (cont)

REF DES	DESCRIPTION	FLUKE STOCK NO.	MFG SPLY CODE	MFG PART NO. OR TYPE	TOT QTY	REC QTY	NOTE
U18	IC, TTL, DUAL D-TYPE FLIP-FLOP	393124	01295	SN74LS74N	REF		
U19	IC, LIN, COMPARATOR	352195	01295	SN72311P	2	1	
U20	IC, TTL, DUAL PERIPHERAL NAND DRIVER	329706	01295	SN75452P	REF		
U21	IC, TTL, DUAL PERIPHERAL NAND DRIVER	329706	01295	SN75452P	REF		
U22	IC, TTL, DUAL PERIPHERAL NAND DRIVER	329706	01295	SN75452P	REF		
U23	IC, TTL, DUAL PERIPHERAL NAND DRIVER	329706	01295	SN75452P	REF		
U24	IC, TTL, DUAL PERIPHERAL NAND DRIVER	329706	01295	SN75452P	REF		
U25⊙	IC, C-MOS, HEX TRI-STATE BUFFER	407759	04713	MC14503CP	1	1	
U26	IC, TTL, HEX INVERTER	393058	01295	SN74LS04N	REF		
U27	IC, LIN, COMPARATOR	352195	01295	SN72311P	REF		

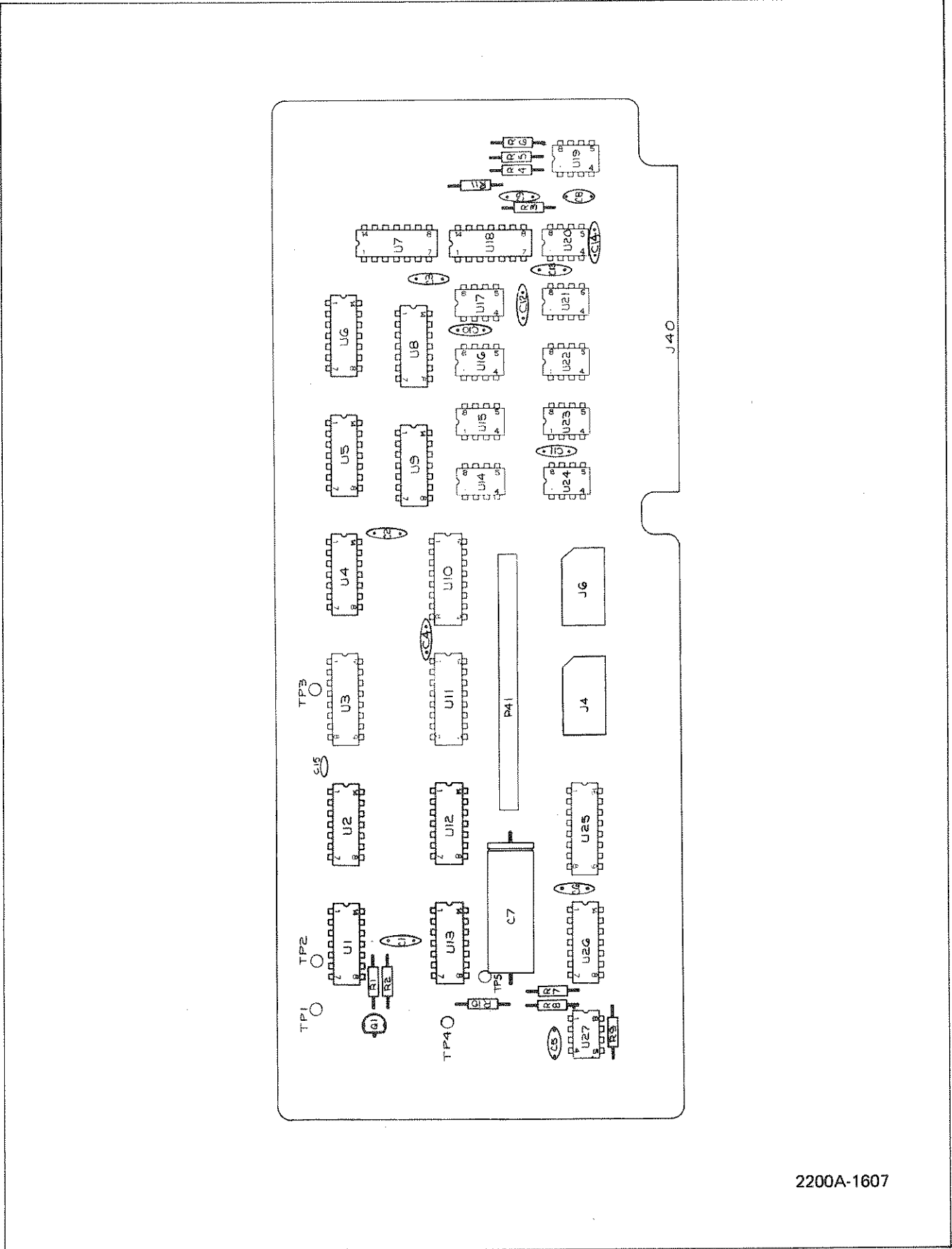

Figure 5-6. A5 Printer Drive PCB Assembly

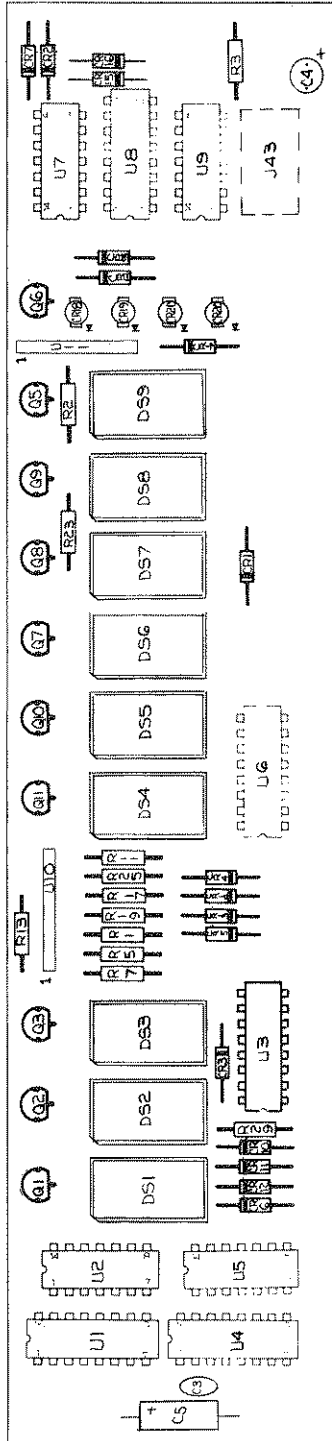

Table 5-7. A6 Display PCB Assembly

REF DES	DESCRIPTION	FLUKE STOCK NO.	MFG SPLY CODE	MFG. PART NO.	TOT QTY	REC QTY	NOTE
A6	DISPLAY PCB ASSEMBLY FIGURE 5-7 (2240A-4008T)	409656	89536	409656	REF		
C3	CAP, CER, 100 PF +/-10%, 1 KV	105593	71590	DD-101	1		
C4	CAP, TA, 39 UF +/-20%, 6V	163915	56287	196D396X0006KA1	1		
C5	CAP, ELECT, TA, 33 UF +/-10%, 10V	182832	56289	150D336X9010B2	1		
CR1	DIODE, SI, SWITCHING	313247	28480	HP5082-6264	5	1	
CR2	DIODE, SI, SWITCHING	313247	28480	HP5082-6264	REF		
CR3	DIODE, SI, SWITCHING	313247	28480	HP5082-6264	REF		
CR4	DIODE, SI, HI-SPEED SWITCHING	203323	07910	1N4448	12	3	
CR5	DIODE, SI, HI-SPEED SWITCHING	203323	07910	1N4448	REF		
CR6	DIODE, SI, HI-SPEED SWITCHING	203323	07910	1N4448	REF		
CR7	DIODE, SI, SWITCHING	313247	28480	HP5082-6264	REF		
CR8	DIODE, SI, HI-SPEED SWITCHING	203323	07910	1N4448	REF		
CR9	DIODE, SI, HI-SPEED SWITCHING	203323	07910	1N4448	REF		
CR10	DIODE, SI, HI-SPEED SWITCHING	203323	07910	1N4448	REF		
CR11	DIODE, SI, HI-SPEED SWITCHING	203323	07910	1N4448	REF		
CR12	DIODE, SI, HI-SPEED SWITCHING	203323	07910	1N4448	REF		
CR13	DIODE, SI, HI-SPEED SWITCHING	203323	07910	1N4448	REF		
CR14	DIODE, SI, HI-SPEED SWITCHING	203323	07910	1N4448	REF		
CR15	DIODE, SI, HI-SPEED SWITCHING	203323	07910	1N4448	REF		
CR16	DIODE, SI, HI-SPEED SWITCHING	203323	07910	1N4448	REF		
CR17	DIODE, SI, SWITCHING	313247	28480	HP5082-6264	REF		
CR18	DIODE, LIGHT-EMITTING (WHITE DOT)	428623	12040	59NSL-5046	4	1	
CR19	DIODE, LIGHT-EMITTING (WHITE DOT)	428623	12040	59NSL-5046	REF		
CR20	DIODE, LIGHT-EMITTING (WHITE DOT)	428623	12040	59NSL-5046	REF		
CR21	DIODE, LIGHT-EMITTING (WHITE DOT)	428623	12040	59NSL-5046	REF		
DS1	LED, DISPLAY, 7-SEGMENT	418012	28480	2N4403	9	2	
DS2	LED, DISPLAY, 7-SEGMENT	418012	28480	5082-7651	REF		
DS3	LED, DISPLAY, 7-SEGMENT	418012	28480	5082-7651	REF		
DS4	LED, DISPLAY, 7-SEGMENT	418012	28480	5082-7651	REF		
DS5	LED, DISPLAY, 7-SEGMENT	418012	28480	5082-7651	REF		
DS6	LED, DISPLAY, 7-SEGMENT	418012	28480	5082-7651	REF		
DS7	LED, DISPLAY, 7-SEGMENT	418012	28480	5082-7651	REF		
DS8	LED, DISPLAY, 7-SEGMENT	418012	28480	5082-7651	REF		
DS9	LED, DISPLAY, 7-SEGMENT	418012	28480	5082-7651	REF		
J43	SOCKET, CONNECTOR	387316	71785	133-59-02-059	1		
Q1	XSTR, SI, PNP	352369	12040	2N4403	10	2	
Q2	XSTR, SI, PNP	352369	12040	2N4403	REF		
Q3	XSTR, SI, PNP	352369	12040	2N4403	REF		
Q5	XSTR, SI, PNP	352369	12040	2N4403	REF		
Q6	XSTR, SI, PNP	352369	12040	2N4403	REF		
Q7	XSTR, SI, PNP	352369	12040	2N4403	REF		
Q8	XSTR, SI, PNP	352369	12040	2N4403	REF		
Q9	XSTR, SI, PNP	352369	12040	2N4403	REF		
Q10	XSTR, SI, PNP	352369	12040	2N4403	REF		
Q11	XSTR, SI, PNP	352369	12040	2N4403	REF		
R1	RES, DEP. CAR, 68 +/-5%, 1/4W	414532	80031	CR251-4-5P68E	5		
R2	RES, DEP. CAR, 68 +/-5%, 1/4W	414532	80031	CR251-4-5P68E	REF		
R3	RES, DEP. CAR, 6.8K +/-5%, 1/4W	368761	80031	CR251-4-5P6K8	1		

Table 5-7. A6 Display PCB Assembly (cont)

REF DES	DESCRIPTION	FLUKE STOCK NO.	MFG SPLY CODE	MFG. PART NO.	TOT QTY	REC QTY	N O T E
R5	RES, DEP. CAR, 68 +/-5%, 1/4W	414532	80031	CR251-4-5P68E	REF		
R7	RES, DEP. CAR, 68 +/-5%, 1/4W	414532	80031	CR251-4-5P68E	REF		
R11	RES, DEP. CAR, 51 +/-5%, 1/4W	414540	80031	CR251-4-5P51E	5		
R13	RES, DEP. CAR, 51 +/-5%, 1/4W	414540	80031	CR251-4-5P51E	REF		
R17	RES, DEP. CAR, 51 +/-5%, 1/4W	414540	80031	CR251-4-5P51E	REF		
R19	RES, DEP. CAR, 51 +/-5%, 1/4W	414540	80031	CR251-4-5P51E	REF		
R23	RES, DEP. CAR, 51 +/-5%, 1/4W	414540	80031	CR251-4-5P51E	REF		
R25	RES, DEP. CAR, 68 +/-5%, 1/4W	414532	80031	CR251-4-5P68E	REF		
R29	RES, DEP. CAR, 33 +/-5%, 1/4W	414524	80031	CR251-4-5P33E	1		
U1	IC, TTL, BCD-TO-7-SEGMENT DECODER/DRIVER	340109	01295	SN7447AN	2	1	
U2	RES, NETWORK, 60	344069	89536	344069	2	1	
U3	IC, TTL, BCD-TO-DECIMAL DECODER/DRIVER	293175	01295	SN74145N	3	1	
U4	IC, TTL, BCD-TO-7-SEGMENT DECODER/DRIVER	340109	01295	SN7447AN	REF		
U5	RES, NETWORK, 60	344069	89536	344069	REF		
U6	IC, TTL, BCD-TO-DECIMAL DECODER/DRIVER	293175	01295	SN74145N	REF		
U7	IC, TTL, QUAD 2-INPUT NOR GATE	393041	01295	SN74LS02N	1	1	
U8	IC, TTL, BCD-TO-DECIMAL DECODER/DRIVER	293175	01295	SN74145N	REF		
U9	RES, NETWORK, 33	364018	89536	364018	1	1	
U10	RES, NETWORK, 1K	414557	89536	414557	2	1	
U11	RES, NETWORK, 1K	414557	89536	414557	REF		
XCR18	SOCKET, ANNUNCIATOR LED (NOT SHOWN)	436055	22526	65358-001	4		
XCR19	SOCKET, ANNUNCIATOR LED (NOT SHOWN)	436055	22526	65358-001	REF		
XCR20	SOCKET, ANNUNCIATOR LED (NOT SHOWN)	436055	22526	65358-001	REF		
XCR21	SOCKET, ANNUNCIATOR LED (NOT SHOWN)	436055	22526	65358-001	REF		
XDS1	SOCKET, DISPLAY LED (NOT SHOWN)	387316	71785	133-59-02-059	9		
XDS2	SOCKET, DISPLAY LED (NOT SHOWN)	387316	71785	133-59-02-059	REF		
XDS3	SOCKET, DISPLAY LED (NOT SHOWN)	387316	71785	133-59-02-059	REF		
XDS4	SOCKET, DISPLAY LED (NOT SHOWN)	387316	71785	133-59-02-059	REF		
XDS5	SOCKET, DISPLAY LED (NOT SHOWN)	387316	71785	133-59-02-059	REF		
XDS6	SOCKET, DISPLAY LED (NOT SHOWN)	387316	71785	133-59-02-059	REF		
XDS7	SOCKET, DISPLAY LED (NOT SHOWN)	387316	71785	133-59-02-059	REF		
XDS8	SOCKET, DISPLAY LED (NOT SHOWN)	387316	71785	133-59-02-059	REF		
XDS9	SOCKET, DISPLAY LED (NOT SHOWN)	387316	71785	133-59-02-059	REF		



2240A-1608

Figure 5-7. A6 Display PCB Assembly

Table 5-8. A7 Mode Switch PCB Assembly

REF DES	DESCRIPTION	FLUKE STOCK NO.	MFG SPLY CODE	MFG. PART NO.	TOT QTY	REC QTY	NOTE
A7①	MODE SWITCH PCB ASSEMBLY FIGURE 5-8 (2240A-4009T)	502229	89536	502229	REF		
C1	CAP, TA, 22 UF +/-20%, 25V	357780	56289	196D226X0025PE4	1		
C2	CAP, MYLAR, 0.0047 UF +/-20%, 200V	106054	56289	192P47202	1		
J41	CONN, PCB MOUNT	414375	27264	09-52-3151	1		
J42	SOCKET, CONNECTOR	387316	71785	133-59-02-059	1		
MP1	PUSHBUTTON, SMALL	412163	89536	412163	13		
MP2	SPACER, SWITCH (NOT SHOWN)	295246	71590	J64286	11		
MP3	SWITCH ASSEMBLY	408526	89536	408526	1		
R1	RES, DEP. CAR, 47K +/-5%, 1/4W	348896	80031	CR251-45P47K	1		
U1	IC, MSI, SYNCHR, 4-BIT UP/DOWN COUNTER	393231	01295	SN74LS193N	1	1	
U2①	IC, C-MOS, DUAL J-K MSTR-SLAVE F/F	355230	04713	MC14027BCP	1	1	
U3①	IC, C-MOS, HEX/BUFFER INVERTERS	381848	04713	MC14049CP	3	1	
U4	IC, MSL, MONOSTBL MULTIVIBRATOR	293134	04713	MC8601P	1	1	
U5	IC, TTL, 64-BIT READ/WRITE MEMORY	408583	01295	SN7489N	1	1	
U6	RES, NETWORK, 15K +/-5%, 1/4W	352054	89536	352054	2		
U7①	IC, C-MOS, DUAL 4-INPUT NOR GATES	363820	04713	MC14002CP	1	1	
U8①	IC, C-MOS, HEX/BUFFER INVERTERS	381848	04713	MC14049CP	REF		
U9①	IC, C-MOS, TRIPLE 3-INPUT OR GATES	408575	02735	CD4075BE	1	1	
U10	RES, NETWORK, 15K +/-5%, 1/4W	352054	89536	352054	REF		
U11	IC, TTL, DUAL J-K NEG-EDGE-TRIG F/F	393157	01295	SN74LS107N	1	1	
U12	IC, TTL, QUAD, 2-INPUT POS NAND GATES	393033	01295	SN74LS00N	2	1	
U13①	IC, C-MOS, HEX/BUFFER INVERTERS	381848	04713	MC14049CP	REF		
U14①	IC, C-MOS, HEX BUFFER INVERTER	381830	04713	MC14050CP	2	1	
U15①	IC, C-MOS, TRI-ST NON-INVRT HEX/BUFFERS	407759	04713	MC14503CP	2	1	
U16①	IC, C-MOS, TRI-ST NON-INVRT HEX/BUFFERS	407759	04713	MC14503CP	REF		
U17①	IC, C-MOS, HEX BUFFER INVERTER	381830	04713	MC14050CP	REF		
U18①	IC, C-MOS, QUAD, 2-INPUT NOR GATES	355172	04713	MC14001CP	1	1	
U19	IC, TTL, QUAD, 2-INPUT POS NAND GATES	393033	01295	SN74LS00N	REF		
U20	RES, NETWORK, 1K	408310	89536	408310	1	1	

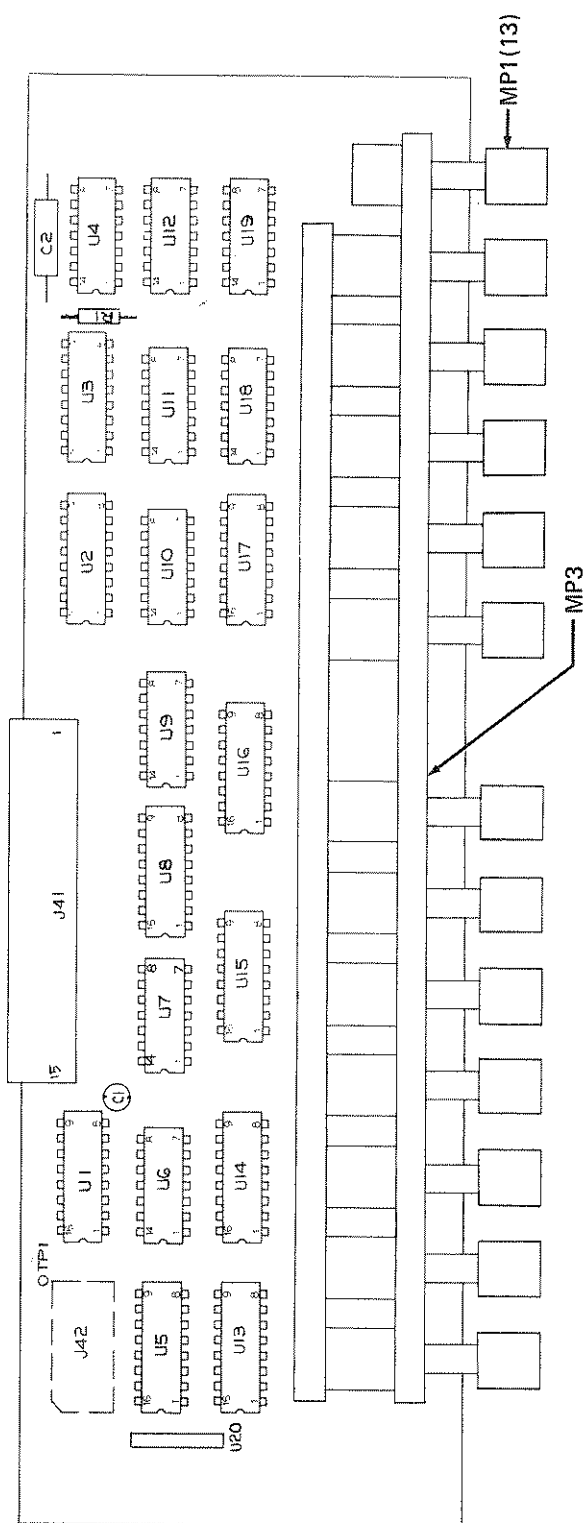

2240A-1609

Figure 5-8. A7 Mode Switch PCB Assembly

Table 5-9. A8 Keyboard Switch PCB Assembly

REF DES	DESCRIPTION	FLUKE STOCK NO.	MFG SPLY CODE	MFG. PART NO.	TOT. QTY	REC QTY	N O T E
A8⊗	KEYBOARD SWITCH PCB ASSEMBLY FIGURE 5-9 (2240C-4011T)	613166	89536	613166	REF		
C1	CAP, PLSTC, 0.10 UF +/-220%, 250V	441345	73445	C281A/A100K	1		
CR1	DIODE, LIGHT-EMITTING	428623	12040	59NSL-5046	12	3	
CR3	DIODE, LIGHT-EMITTING	428623	12040	59NSL-5046	REF		
CR4	DIODE, LIGHT-EMITTING	428623	12040	59NSL-5046	REF		
CR5	DIODE, LIGHT-EMITTING	428623	12040	59NSL-5046	REF		
CR6	DIODE, LIGHT-EMITTING	428623	12040	59NSL-5046	REF		
CR7	DIODE, LIGHT-EMITTING	428623	12040	59NSL-5046	REF		
CR8	DIODE, LIGHT-EMITTING	428623	12040	59NSL-5046	REF		
CR9	DIODE, LIGHT-EMITTING	428623	12040	59NSL-5046	REF		
CR10	DIODE, LIGHT-EMITTING	428623	12040	59NSL-5046	REF		
CR11	DIODE, LIGHT-EMITTING	428623	12040	59NSL-5046	REF		
CR12	DIODE, LIGHT-EMITTING	428623	12040	59NSL-5046	REF		
CR13	DIODE, LIGHT-EMITTING	428623	12040	59NSL-5046	REF		
MP1	ACTUATOR, SWITCH	412106	89536	412106	31		1
MP2	SPRING, SWITCH CONTACT	414516	00779	62353-3	31		
MP3	CONTACT, SWITCH	416875	00779	62380-4	31		
MP4	COVER, SWITCH	401299	89536	401299	31		
MP5	PUSHBUTTON, BLUE	406876	89536	406876	1		
MP6	PUSHBUTTON, RED ORANGE	583799	89536	583799	1		
MP7	PUSHBUTTON, LIGHT GRAY	406819	89536	406819	17		
MP8	PUSHBUTTON, ORANGE	420620	89536	420620	1		
MP9	PUSHBUTTON, WHITE	406884	89536	406884	11		
MP10	SOCKET, LED (W/CR1, CR3-CR13)	436055	22526	65358-001	12		
MP11	SPACER, SWAGED (NOT SHOWN)	380352	89536	380352	7		
MP12	SPACER, XSTR (W/Q1)	152207	07047	10123DAP	1		
P44	PIN, CONTACT	380683	27264	09-64-1121	2		
P45	PIN, CONTACT	380683	27264	09-64-1121	REF		
Q1	XSTR, SI, PNP	203364	07263	S37234	1		1
R1	RES, COMP, 12K +/-5%, 1/4W	159731	01121	CB1235	3		
R2	RES, COMP, 12K +/-5%, 1/4W	159731	01121	CB1235	REF		
R3	RES, COMP, 12K +/-5%, 1/4W	159731	01121	CB1235	REF		
R4	RES, COMP, 100 +/-5%, 1/4W	147926	01121	CB1015	8		
R5	RES, COMP, 680 +/-5%, 1/4W	148007	01121	CB6815	1		
R6	RES, COMP, 100 +/-5%, 1/4W	147926	01121	CB1015	REF		
R7	RES, COMP, 100 +/-5%, 1/4W	147926	01121	CB1015	REF		
R8	RES, COMP, 100 +/-5%, 1/4W	147926	01121	CB1015	REF		
R9	RES, COMP, 100 +/-5%, 1/4W	147926	01121	CB1015	REF		
R10	RES, COMP, 100 +/-5%, 1/4W	147926	01121	CB1015	REF		
R11	RES, COMP, 100 +/-5%, 1/4W	147926	01121	CB1015	REF		
R12	RES, COMP, 100 +/-5%, 1/4W	147926	01121	CB1015	REF		
R13	RES, COMP, 8.2K +/-5%, 1/4W	160796	01121	CB8225	1		
R14	RES, COMP, 10M +/-5%, 1/4W	194944	01121	CB1065	1		
R15	RES, COMP, 2.4M +/-5%, 1/4W	221945	01121	CB2455	1		
U1	IC, TTL, 4-TO-1 LINE DECODER	408351	12040	MM74C154N	1		1
U2	IC, TTL, HEX INVERTER	288605	01295	SN7416N	2		1
U3	IC, TTL, HEX INVERTER	288605	01295	SN7416N	REF		
U4⊗	IC, C-MOS, TRIPLE 3-INPUT NOR GATE	355180	02735	CD4025AE	1		1

1 SWITCH PIECES (MP1 THRU MP4) MUST BE ORDERED INDIVIDUALLY TO PRODUCE THE 31 SWITCHES S1 THRU S13, S15, S19 AND S22 THRU S37.

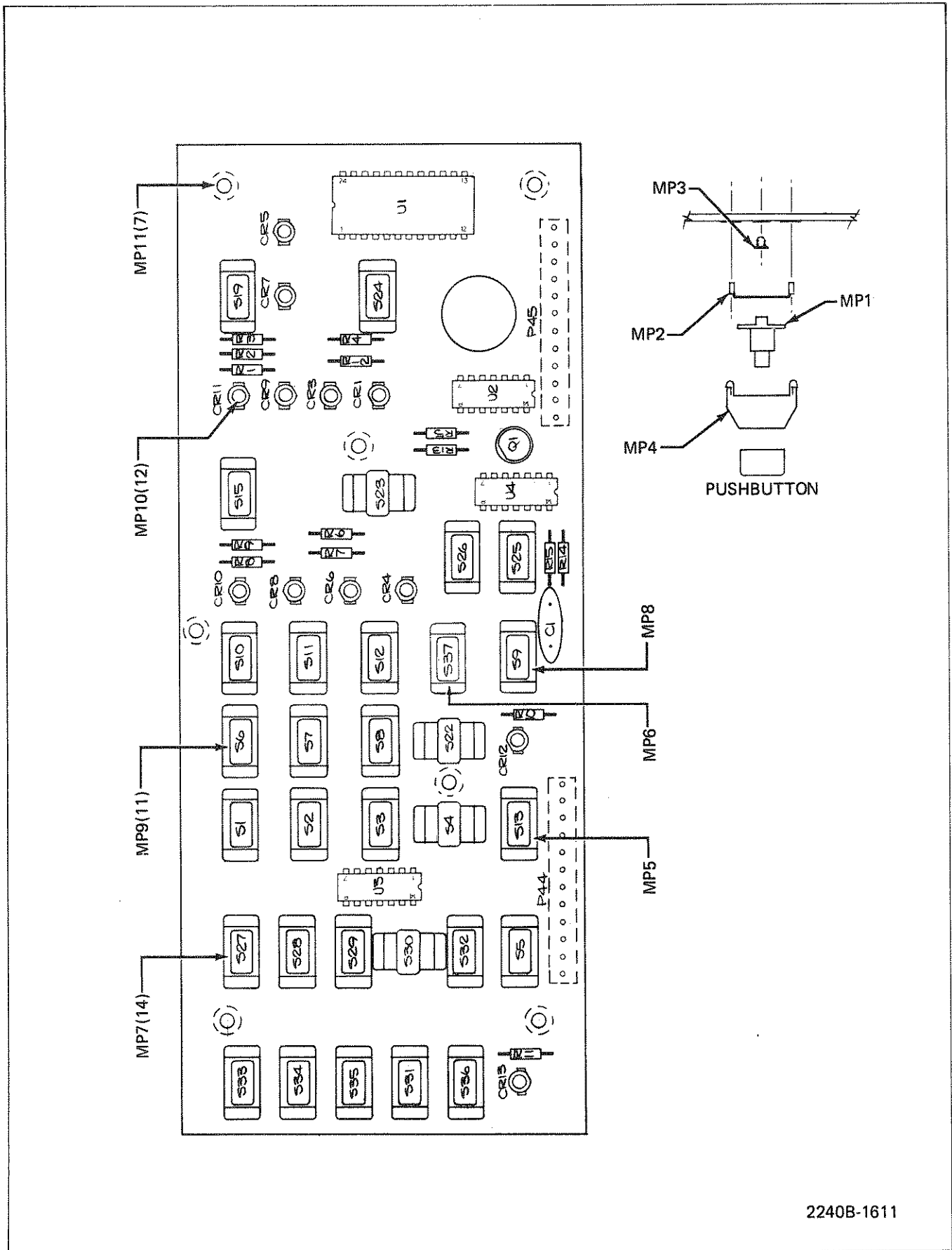

2240B-1611

Figure 5-9. A8 Keyboard Switch PCB Assembly

Table 5-10. A9 Keyboard Memory PCB Assembly

REF DES	DESCRIPTION	FLUKE STOCK NO.	MFG SPLY CODE	MFG. PART NO.	TOT QTY	REC QTY	NOTE
A9④	KEYBOARD MEMORY PCB ASSEMBLY FIGURE 5-10 (2240A-4013T)	409698	89536	409698		REF	
C1	CAP, TA, 10UF +/-20%, 15V	193623	56289	196D106X0015KA1	1		
C2	CAP, CER, 0.05UF +/-20%, 100V	149161	56289	55C23C1	1		
CR1	DIODE, HI-SPEED SWITCHING	203323	07910	1N4448	1		1
J2	SOCKET, 14-PIN	387316	71785	133-59-02-059	3		
J8	SOCKET, 14-PIN	387316	71785	133-59-02-059		REF	
J10	SOCKET, 14-PIN	387316	71785	133-59-02-059		REF	
J36	SOCKET, 16-PIN	276535	91506	316AG39D	11		
MP1	CONN (TO BLK & RED SLEEVED WIRES)	294975	89536	294975	2		
Q1	XSTR, SI, NPN	218081	04713	MPS6520	2		1
Q2	XSTR, SI, NPN	218081	04713	MPS6520		REF	
Q3	XSTR, FET, N-CHANNEL	370072	89536	370072	1		1
R1	RES, COMP, 6.8K +/-5%, 1/4W	148098	01121	CB6825	19		
R2	RES, COMP, 6.8K +/-5%, 1/4W	148098	01121	CB6825		REF	
R3	RES, COMP, 15K +/-5%, 1/4W	148114	01121	CB1535	2		
R4	RES, COMP, 6.8K +/-5%, 1/4W	148098	01121	CB6825		REF	
R5	RES, COMP, 6.8K +/-5%, 1/4W	148098	01121	CB6825		REF	
R6	RES, COMP, 6.8K +/-5%, 1/4W	148098	01121	CB6825		REF	
R7	RES, COMP, 6.8K +/-5%, 1/4W	148098	01121	CB6825		REF	
R8	RES, COMP, 6.8K +/-5%, 1/4W	148098	01121	CB6825		REF	
R9	RES, COMP, 6.8K +/-5%, 1/4W	148098	01121	CB6825		REF	
R10	RES, COMP, 6.8K +/-5%, 1/4W	148098	01121	CB6825		REF	
R11	RES, COMP, 6.8K +/-5%, 1/4W	148098	01121	CB6825		REF	
R12	RES, COMP, 6.8K +/-5%, 1/4W	148098	01121	CB6825		REF	
R13	RES, COMP, 6.8K +/-5%, 1/4W	148098	01121	CB6825		REF	
R14	RES, COMP, 6.8K +/-5%, 1/4W	148098	01121	CB6825		REF	
R15	RES, COMP, 6.8K +/-5%, 1/4W	148098	01121	CB6825		REF	
R16	RES, COMP, 6.8K +/-5%, 1/4W	148098	01121	CB6825		REF	
R17	RES, COMP, 6.8K +/-5%, 1/4W	148098	01121	CB6825		REF	
R18	RES, COMP, 6.8K +/-5%, 1/4W	148098	01121	CB6825		REF	
R19	RES, COMP, 47K +/-5%, 1/4W	148163	01121	CB4735	5		
R20	RES, COMP, 47K +/-5%, 1/4W	148163	01121	CB4735		REF	
R21	RES, COMP, 47K +/-5%, 1/4W	148163	01121	CB4735		REF	
R22	RES, COMP, 47K +/-5%, 1/4W	148163	01121	CB4735		REF	
R23	RES, COMP, 30K +/-5%, 1/4W	193417	01121	CB3035	1		
R24	RES, COMP, 15K +/-5%, 1/4W	148114	01121	CB1535		REF	
R25	RES, COMP, 1K +/-5%, 1/4W	108597	01121	CB1025	1		
R26	RES, COMP, 6.8K +/-5%, 1/4W	148098	01121	CB6825		REF	
R27	RES, COMP, 6.8K +/-5%, 1/4W	148098	01121	CB6825		REF	
R28	RES, COMP, 47K +/-5%, 1/4W	148163	01121	CB4735		REF	
U1④	IC, C-MOS, 16 X 4 RAM	408385	12040	MM74C89N	2		1
U2④	IC, C-MOS, 16 X 4 RAM	408385	12040	MM74C89N		REF	
U9④	IC, C-MOS, TRI-STATE HEX BUFFER	407759	12040	MM80C97N	3		1
U10④	IC, C-MOS, BCD-TO-DECIMAL DECODER	407981	12040	MM74C42N	1		1
U13④	IC, C-MOS, HEX INVERTER	381848	86684	CD4049AE	1		1
U14④	IC, C-MOS, TRI-STATE HEX BUFFER	407759	12040	MM80C97N		REF	
U15④	IC, C-MOS, TRI-STATE HEX BUFFER	407759	12040	MM80C97N		REF	
XU1	SOCKET, 16-PIN	276535	91506	316AG39D		REF	



Table 5-10. A9 Keyboard Memory PCB Assembly (cont)

REF DES	DESCRIPTION	FLUKE STOCK NO.	MFG SPLY CODE	MFG. PART NO.	TOT QTY	REC QTY	N O T E
XU2	SOCKET, 16-PIN	276535	91506	316AG39D	REF		
XU3	SOCKET, 16-PIN	276535	91506	316AG39D	REF		*
XU4	SOCKET, 16-PIN	276535	91506	316AG39D	REF		*
XU5	SOCKET, 16-PIN	276535	91506	316AG39D	REF		*
XU6	SOCKET, 16-PIN	276535	91506	316AG39D	REF		
XU7	SOCKET, 16-PIN	276535	91506	316AG39D	REF		
XU8	SOCKET, 16-PIN	276535	91506	316AG39D	REF		
XU11	SOCKET, 16-PIN	276535	91506	316AG39D	REF		
XU12	SOCKET, 16-PIN	276535	91506	316AG39D	REF		

\*SEE FIGURE 5-10 FOR USAGE,U3,U4,U5.  
SOME SOCKETS MAY OR MAY NOT BE USED.

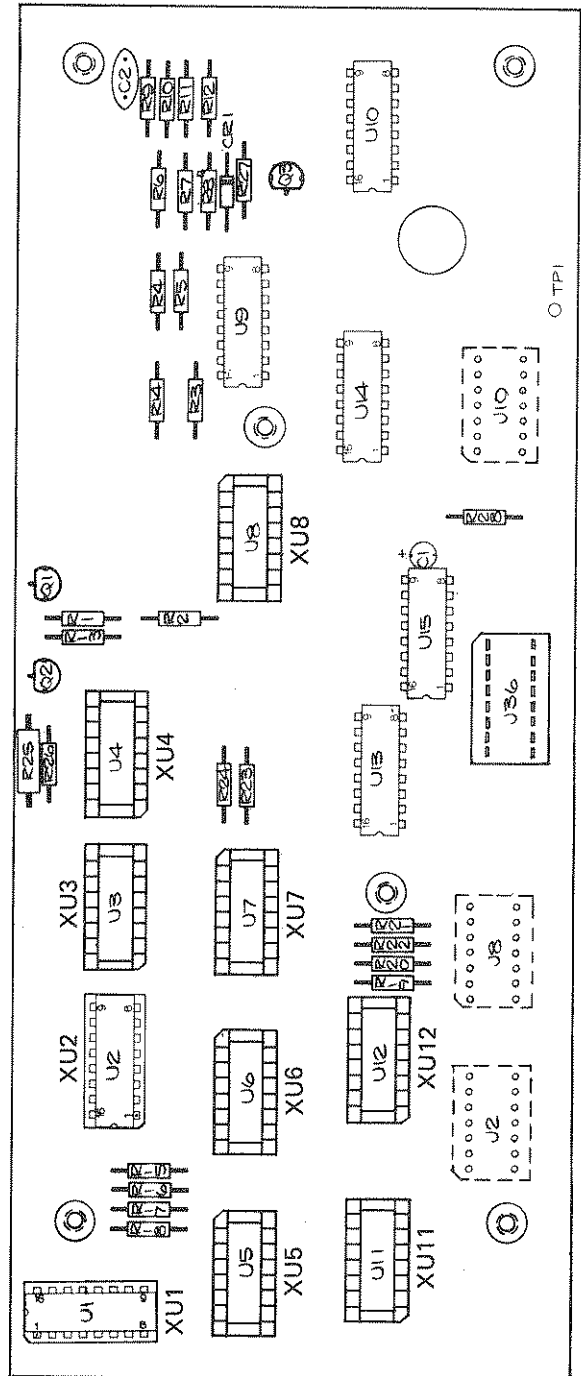

\* NOTE:  
 U3 USED ONLY FOR -32 OPTION.  
 U4,U5 USED ONLY FOR -42 OPTION.

2240A-1613

Figure 5-10. A9 Keyboard Memory PCB Assembly

Table 5-11. A10 Keyboard Logic PCB Assembly

REF DES	DESCRIPTION	FLUKE STOCK NO.	MFG SPLY CODE	MFG. PART NO.	TOT QTY	REC QTY	NOTE
A10⊗	KEYBOARD LOGIC PCB ASSEMBLY FIGURE 5-11 (2240A-4012T)	409680	89536	409680		REF	
C1	CAP, FILM, .022 UF +/-10%, 50V	271577	06001	751R5A223	1		
C2	CAP, TA, 10 UF +/-20%, 10V	176214	56289	196D106X0010KA1	2		
C3	CAP, TA, 2.2 UF +/-10%, 15V	364216	56289	196D222X9015HA1	1		
C4	CAP, CER, 1000 PF +/-10%, 500V	357806	71590	CF-102	1		
C5	CAP, TA, 10 UF +/-20%, 10V	176214	56289	196D106X0010KA1		REF	
C6	CAP, CER, 100 PF +/- 10%, 1KV	105593	71590	DD101	1		
H1	SCREW, PHP, 4-40 X 5/16	152124	89536	152124	2		
H2	WASHER, #4	110403	89536	110403	2		
J35	SOCKET, IC, 16-PIN	276535	91506	316AG39D	1		
J44	CONNECTOR, RECEPT, 12-PIN	380691	27264	09523122	2		
J45	CONNECTOR, RECEPT, 12-PIN	380691	27264	09523122		REF	
J49	CONNECTOR, POST	379438	00779	86144-5	2		
LS1	SPEAKER, MINI	339879	72653	TYPE S2-203	1		
MP1	BRACKET, SPEAKER	415224	89536	415224	1		
MP2	SPACER, XSTR MOUNTING	152207	07047	10123-DAP	2		
Q1	XSTR, SI, PNP	203364	07263	S37234	2		1
Q2	XSTR, SI, PNP	203364	07263	S37234		REF	
Q3	XSTR, SI, NPN	218396	04713	2N3904	2		1
Q4	XSTR, SI, NPN	218396	04713	2N3904		REF	
Q5	XSTR, SI, NPN	381798	04713	MPSA-13	1		1
R1	RES, COMP, 680 +/-5%, 1/4W	148007	01121	CB6815	4		
R2	RES, COMP, 680 +/-5%, 1/4W	148007	01121	CB6815		REF	
R3	RES, COMP, 1M +/-5%, 1/4W	182204	01121	CB1055		A	
R4	RES, COMP, 680 +/-5%, 1/4W	148007	01121	CB6815		REF	
R5	RES, COMP, 62 +/-5%, 1/4W	261842	01121	CB6205	1		
R6	RES, COMP, 39 +/-5%, 1/4W	193391	01121	CB3905	1		
R7	RES, COMP, 47K +/-5%, 1/4W	148163	01121	CB4735	1		
R8	RES, COMP, 16K +/-5%, 1/4W	221606	01121	CB1635	1		
R9	RES, COMP, 150K +/-5%, 1/4W	182212	01121	CB1545	1		
R10	RES, COMP, 100K +/-5%, 1/4W	148189	01121	CB1045	1		
R11	RES, COMP, 200K +/-5%, 1/4W	248781	01121	CB2045	1		
R13	RES, COMP, 8.2K +/-5%, 1/4W	160796	01121	CB8225	4		
R14	RES, COMP, 680 +/-5%, 1/4W	148007	01121	CB6815		REF	
R15	RES, COMP, 8.2K +/-5%, 1/4W	160796	01121	CB8225		REF	
R16	RES, COMP, 8.2K +/-5%, 1/4W	160796	01121	CB8225		REF	
R17	RES, COMP, 8.2K +/-5%, 1/4W	160796	01121	CB8225		REF	
U1⊗	IC, C-MOS, HEX INVERTER	381848	86684	CD4049AE	2		1
U2⊗	IC, C-MOS, QUAD 2-IN OR GATE	408393	86684	CD4071BE	1		1
U3⊗	IC, C-MOS, DUAL-BNRY, 1 OF 4 DECODE	408369	04713	MC14556CP	1		1
U4⊗	IC, C-MOS, QUAD 2-IN AND GATE	408401	86684	CD4081BE	1		1
U5⊗	IC, C-MOS, DUAL D-TYPE F/F	340117	12040	MM5613AN	3		1
U6⊗	IC, C-MOS, HEX BUFFER	407759	12040	MM80C97N	2		1
U7⊗	IC, C-MOS, HEX BUFFER	407759	12040	MM80C97N		REF	
U8	IC, TTL, 4-BIT BISTABLE LATCH	408377	01295	SN74LS75N	3		1
U9	IC, TTL, 4-BIT BISTABLE LATCH	408377	01295	SN74LS75N		REF	
U10⊗	IC, C-MOS, QUAD 2-IN NOR GATE	355172	86684	CD4001AE	1		1
U11⊗	IC, C-MOS, DUAL PAIR PLUS INVERTER	408013	86684	CD4007AE	1		1

Table 5-11. A10 Keyboard Logic PCB Assembly (cont)

REF DES	DESCRIPTION	FLUKE STOCK NO.	MFG SPLY CODE	MFG. PART NO.	TOT QTY	REC QTY	NOTE
U12⊕	IC, C-MOS, DUAL D-TYPE F/F	340117	12040	MM5613AN	REF		
U13⊕	IC, C-MOS, TRIPLE 3-IN NAND GATE	375147	86684	CD4023AE	1	1	
U14⊕	IC, C-MOS, HEX INVERTER	381848	86684	CD4049AE	REF		
U15	IC, TTL, 4-BIT BISTABLE LATCH	408377	01295	SN74LS75N	REF		
U16⊕	IC, C-MOS, DUAL D-TYPE F/F	340117	12040	MM5613AN	REF		
U17	IC, TTL, ONE-SHOT MV	404186	01295	SN74LS123N	1	1	

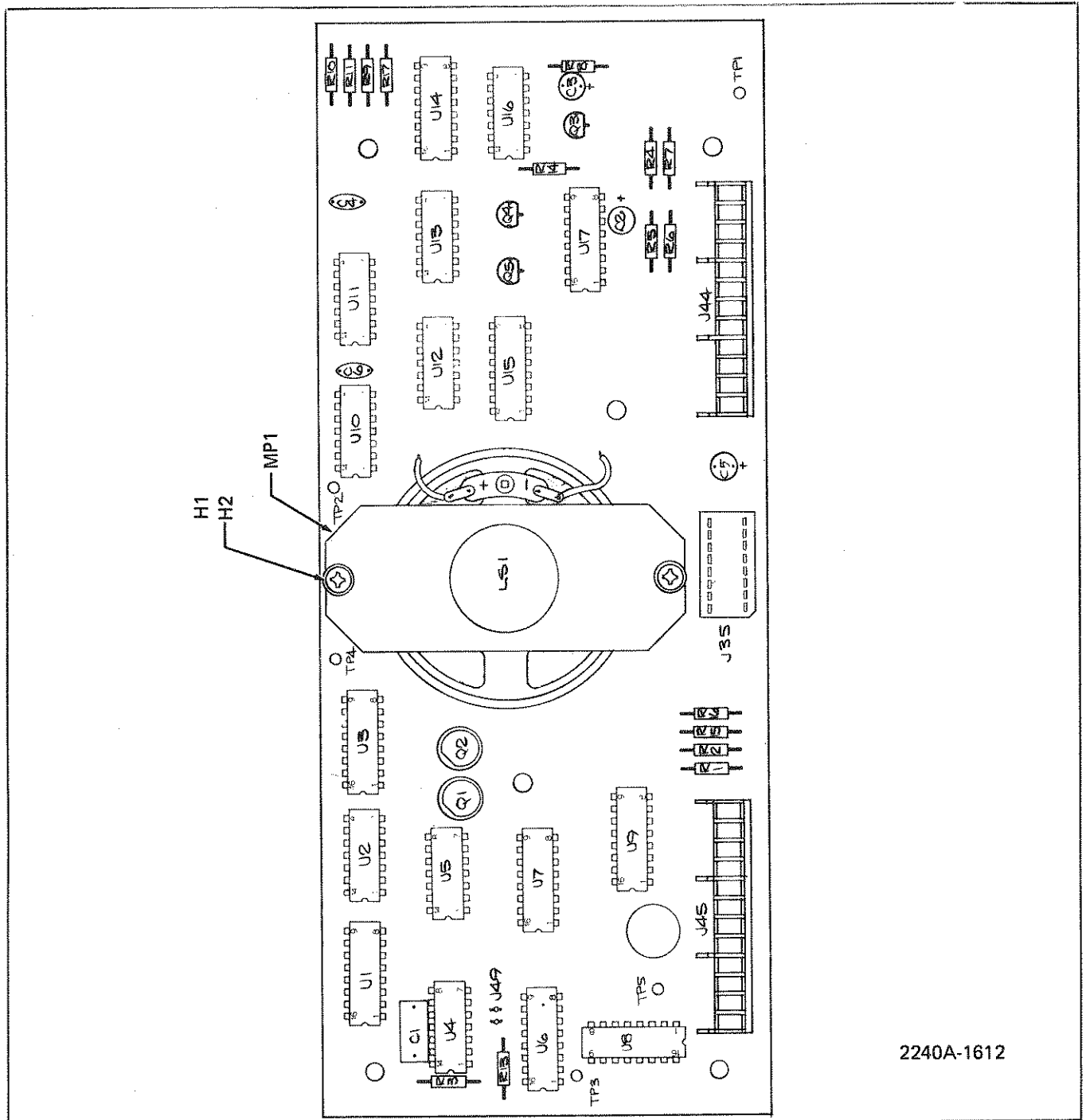

2240A-1612

Figure 5-11. A10 Keyboard Logic PCB Assembly

Table 5-12. A11 Range and Function Memory PCB Assembly

REF DES	DESCRIPTION	FLUKE STOCK NO.	MFG SPLY CODE	MFG. PART NO.	TOT QTY	REC QTY	NO TE
A11⊙	RANGE AND FUNCTION MEMORY PCB ASSEMBLY FIGURE 5-12 (2240C-4042T)	580753	89536	580753		REF	
C1	CAP, CER, 0.05 UF +/-20%, 100V	149161	56289	55C23A1	1		
C2	CAP, TA, 10 UF +/-20%, 15V	193623	56289	196D106X0015A1	1		
C3	CAP, CER, 0.01 UF +/-20%, 100V	407361	72982	8121-A100-W5R-103M	15		
C4	CAP, CER, 0.01 UF +/-20%, 100V	407361	72982	8121-A100-W5R-103M	REF		
C5	CAP, CER, 0.01 UF +/-20%, 100V	407361	72982	8121-A100-W5R-103M	REF		
C6	CAP, CER, 0.01 UF +/-20%, 100V	407361	72982	8121-A100-W5R-103M	REF		
C7	CAP, CER, 0.01 UF +/-20%, 100V	407361	72982	8121-A100-W5R-103M	REF		
C8	CAP, CER, 0.01 UF +/-20%, 100V	407361	72982	8121-A100-W5R-103M	REF		
C9	CAP, CER, 0.01 UF +/-20%, 100V	407361	72982	8121-A100-W5R-103M	REF		
C10	CAP, CER, 0.01 UF +/-20%, 100V	407361	72982	8121-A100-W5R-103M	REF		
C11	CAP, CER, 0.01 UF +/-20%, 100V	407361	72982	8121-A100-W5R-103M	REF		
C12	CAP, CER, 0.01 UF +/-20%, 100V	407361	72982	8121-A100-W5R-103M	REF		
C13	CAP, CER, 0.01 UF +/-20%, 100V	407361	72982	8121-A100-W5R-103M	REF		
C14	CAP, CER, 0.01 UF +/-20%, 100V	407361	72982	8121-A100-W5R-103M	REF		
C15	CAP, CER, 0.01 UF +/-20%, 100V	407361	72982	8121-A100-W5R-103M	REF		
C16	CAP, CER, 0.01 UF +/-20%, 100V	407361	72982	8121-A100-W5R-103M	REF		
C17	CAP, CER, 0.01 UF +/-20%, 100V	407361	72982	8121-A100-W5R-103M	REF		
CR1	DIODE, SI, HI-SPEED SWITCHING	203323	07910	1N4448	1	1	
P54	CONNECTOR, BODY	530154	89536	530154	1		
	CONNECTOR, COVER	530162	89536	530162	1		
Q1	XSTR, SI, NPN	218396	89536	218396	2	1	
Q2	XSTR, SI, NPN	218396	89536	218396	REF		
Q3	XSTR, PET, N-CHANNEL, JUNCTION SWITCHING	370072	89536	370072	1	1	
R1	RES, DEP. CAR, 30K +/-5%, 1/4W	368753	80031	CR251-4-5P30K	1		
R2	RES, DEP. CAR, 15K +/-5%, 1/4W	348854	80031	CR251-4-5P15K	2		
R3	RES, DEP. CAR, 15K +/-5%, 1/4W	348854	80031	CR251-4-5P15K	REF		
R4	RES, DEP. CAR, 6.8K +/-5%, 1/4W	368761	80031	CR251-4-5P6K8	5		
R5	RES, DEP. CAR, 6.8K +/-5%, 1/4W	368761	80031	CR251-4-5P6K8	REF		
R6	RES, DEP. CAR, 1K +/-5%, 1/4W	343426	80031	CR251-4-5P1K	1		
R7	RES, DEP. CAR, 6.8K +/-5%, 1/4W	368761	80031	CR251-4-5P6K8	REF		
R8	RES, DEP. CAR, 6.8K +/-5%, 1/4W	368761	80031	CR251-4-5P6K8	REF		
R9	RES, DEP. CAR, 6.8K +/-5%, 1/4W	368761	80031	CR251-4-5P6K8	REF		
U1	IC, TTL, 4-TO-1 LINE DECODER	408351	12040	MM74C154N	1	1	
U2⊙	IC, C-MOS, HEX BUFFER/INVERTERS	381830	02735	CD4050AE	2	1	
U3⊙	IC, C-MOS, HEX BUFFER/INVERTERS	381830	02735	CD4050AE	REF		
U4⊙	IC, C-MOS, TRI-STATE, HEX, NONINV BFFRS	407759	12040	MM80C97N	4	1	
U5⊙	IC, C-MOS, TRI-STATE, HEX, NONINV BFFRS	407759	12040	MM80C97N	REF		
U6⊙	IC, C-MOS, TRI-STATE, HEX, NONINV BFFRS	407759	12040	MM80C97N	REF		
U7⊙	IC, C-MOS, TRI-STATE, HEX, NONINV BFFRS	407759	12040	MM80C97N	REF		
U19⊙	IC, C-MOS, 1024 BIT, STATIC RAM	429860	34649	PT5101L	1	1	
W1	CABLE ASSY, R/F MEMORY (TO P54, NOT SHOWN)	581595	89536	581595	1		
W2	CABLE, BATTERY (TO P28, NOT SHOWN)	463760	89536	463760	1		
XU8	SOCKET, IC, 22-PIN	453126	91506	322-AG39D	16		
XU9	SOCKET, IC, 22-PIN	453126	91506	322-AG39D	REF		
XU10	SOCKET, IC, 22-PIN	453126	91506	322-AG39D	REF		
XU11	SOCKET, IC, 22-PIN	453126	91506	322-AG39D	REF		

Table 5-12. A11 Range and Function Memory PCB Assembly (cont)

REF DES	DESCRIPTION	FLUKE STOCK NO.	MFG SPLY CODE	MFG. PART NO.	TOT QTY	REC QTY	NOTE
XU12	SOCKET, IC, 22-PIN	453126	91506	322-AG39D	REF		
XU13	SOCKET, IC, 22-PIN	453126	91506	322-AG39D	REF		
XU14	SOCKET, IC, 22-PIN	453126	91506	322-AG39D	REF		
XU15	SOCKET, IC, 22-PIN	453126	91506	322-AG39D	REF		
XU16	SOCKET, IC, 22-PIN	453126	91506	322-AG39D	REF		
XU17	SOCKET, IC, 22-PIN	453126	91506	322-AG39D	REF		
XU18	SOCKET, IC, 22-PIN	453126	91506	322-AG39D	REF		
XU19	SOCKET, IC, 22-PIN	453126	91506	322-AG39D	REF		
XU20	SOCKET, IC, 22-PIN	453126	91506	322-AG39D	REF		
XU21	SOCKET, IC, 22-PIN	453126	91506	322-AG39D	REF		
XU22	SOCKET, IC, 22-PIN	453126	91506	322-AG39D	REF		
XU23	SOCKET, IC, 22-PIN	453126	91506	322-AG39D	REF		
Z1	RESISTOR NETWORK, 100K	412726	89536	412726	1		
Z2	RESISTOR NETWORK, 100K	461038	89536	461038	2		1
Z3	RESISTOR NETWORK, 100K	461038	89536	461038	REF		
Z4	RESISTOR NETWORK, 10K	414003	89536	414003	2		
Z5	RESISTOR NETWORK, 10K	414003	89536	414003	REF		

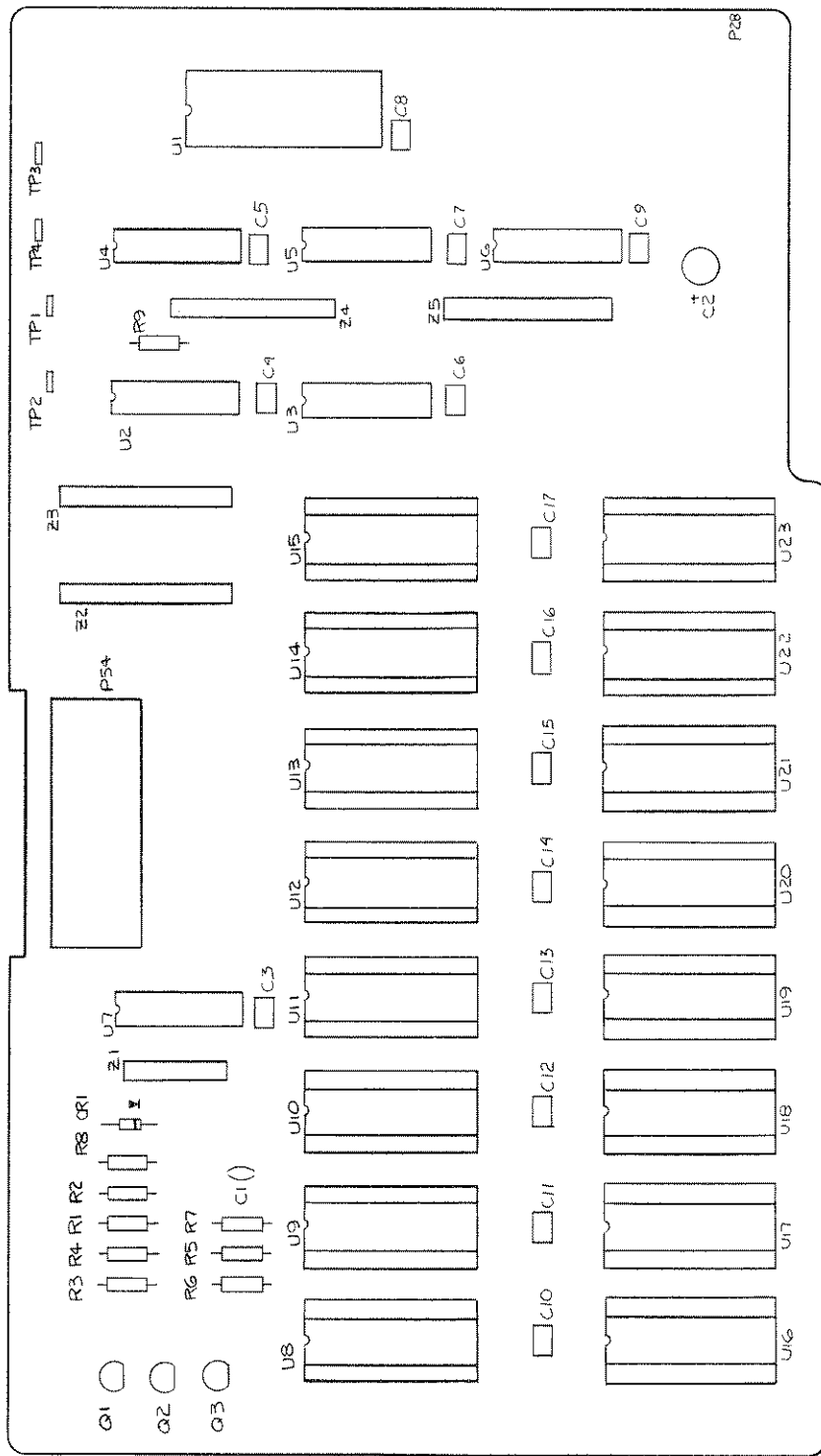

2240C-1642

Figure 5-12. A11 Range and Function Memory PCB Assembly

Table 5-13. A12 High Performance A/D Converter PCB Assembly

REF DES	DESCRIPTION	FLUKE STOCK NO.	MFG SPLY CODE	MFG. PART NO.	TOT QTY	REC QTY	NO TE
A12⊙	HIGH PERFORMANCE A/D CONVERTER PCB ASSY FIGURE 5-13 (2200A-4028T)	409599	89536	409599		REF	
C1	CAP, POLY PROPLYN, 0.033 UF +/-10%, 50V	424218	89536	424218		2	
C2	CAP, POLY PROPLYN, 0.22 UF +/-10%, 50V	423210	89536	423210		2	
C3	CAP, MICA, 4 PF +/-0.5 PF, 500V	190397	72136	DM15C040K		2	
C4	CAP, CER, 500 PF +/-10%, 1KV	105692	71590	2DDH60N501K		3	
C5	CAP, CER, 500 PF +/-10%, 1KV	105692	71590	2DDH60N501K		REF	
C6	CAP, POLY CAR, 2.2 UF +/-10%, 100V	306522	73445	C280MCH/A2M2		3	
C7	CAP, POLY CAR, 2.2 UF +/-10%, 100V	306522	73445	C280MCH/A2M2		REF	
C8	CAP, POLY CAR, 2.2 UF +/-10%, 100V	306522	73445	C280MCH/A2M2		REF	
C9	CAP, POLY PROPLYN, 0.47 UF +/-5%, 50V	364042	89536	346042		1	
C10	CAP, CER, 0.0027 UF +/-GMV, 600V	106211	56289	5GA-D33		1	
C11	CAP, TA, 22 UF +/-20%, 25V	357780	56289	196D226C0020XA1		3	
C12	CAP, TA, 22 UF +/-20%, 25V	357780	56289	196D226C0020XA1		REF	
C13	CAP, TA, 22 UF +/-20%, 25V	357780	56289	196D226C0020XA1		REF	
C14	CAP, POLY PROPLYN, 0.033 UF +/-10%, 50V	424218	89536	424218		REF	
C15	CAP, POLY PROPLYN, 0.22 UF +/-10%, 50V	423210	89536	423210		REF	
C16	CAP, MICA, 33 PF +/-5%, 500V	160317	72136	DM15E330J1		1	
C17	CAP, MICA, 4 PF +/-0.5 PF, 500V	190397	72136	DM15C040K		REF	
C18	CAP, MICA, 120 PF +/-5%, 500V	148486	72136	DM15F121J		1	
C19	CAP, CER, 500 PF +/-10%, 1KV	105692	71590	2DDH60N501K		REF	
C20	CAP, POLY PROPLYN, 0.068 UF +/-10%, 50V	424226	89536	424226		1	
C21	CAP, POLY PROPLYN 0.039 UF +/-10%, 50V	424234	89536	424234		1	
C22	CAP, CER, 0.005 UF +/-20%, 50V	255471	51642	200-050-601-502M		1	
CR2	DIODE, SI, HI-SPEED SWITCH	203323	07910	1N4448		6	2
CR7	DIODE, SI, HI-SPEED SWITCH	203323	07910	1N4448		REF	
CR8	DIODE, SI, HI-SPEED SWITCH	203323	07910	1N4448		REF	
CR9	DIODE, SI, HI-SPEED SWITCH	203323	07910	1N4448		REF	
CR11	DIODE, SI, HI-SPEED SWITCH	203323	07910	1N4448		REF	
CR12	DIODE, SI, HI-SPEED SWITCH	203323	07910	1N4448		REF	
H1	LOCKWASHER, SPLIT #4	110395	89536	110395		2	
H2	NUT, HEX, 4-40	147611	89536	147611		2	
H3	SCREW, PHP, 4-40 X 3/8	152124	73734	19024		2	
J15	CONNECTOR, CABLE	414409	00779	552241-1		1	
J29	CONNECTOR SOCKET, 14-PIN	387316	71785	135-59-02-059		1	
K1	RELAY	404061	71707	CR-3201-5-710		1	
MP1	DECAL, PART NO. (NOT SHOWN)	406405	89536	406405		1	
MP2	HARDWARE, CONNECTOR KIT (W/J15)	448563	00779	552565-2		1	
Q1	XSTR, J-FET, N-CHANNEL	429977	89536	429977		22	5
Q2	XSTR, J-FET, N-CHANNEL	429977	89536	429977		REF	
Q3	XSTR, J-FET, N-CHANNEL	429977	89536	429977		REF	
Q4	XSTR, J-FET, N-CHANNEL	429977	89536	429977		REF	
Q5	XSTR, J-FET, N-CHANNEL	429977	89536	429977		REF	
Q6	XSTR, J-FET, N-CHANNEL	376475	89536	376475		5	1
Q7	XSTR, J-FET, N-CHANNEL	376475	89536	376475		REF	
Q8	XSTR, J-FET, N-CHANNEL	429977	89536	429977		REF	
Q9	XSTR, J-FET, N-CHANNEL	429977	89536	429977		REF	
Q10	XSTR, J-FET, N-CHANNEL	429977	89536	429977		REF	
Q11	XSTR, J-FET, N-CHANNEL	376475	89536	376475		REF	



Table 5-13. A12 High Performance A/D Converter PCB Assembly (cont)

REF DES	DESCRIPTION	FLUKE STOCK NO.	MFG SPLY CODE	MFG. PART NO.	TOT QTY	REC QTY	NOTE
Q12	XSTR, J-FET, N-CHANNEL	429977	89536	429977	REF		
Q13	XSTR, FET, DUAL, N-CHANNEL	376087	89536	376087	1	1	
Q14	XSTR, FET, DUAL, N-CHANNEL	379321	89536	379321	1	1	
Q15	XSTR, J-FET, N-CHANNEL	376475	89536	376475	REF		
Q16	XSTR, J-FET, N-CHANNEL	429977	89536	429977	REF		
Q17	XSTR, J-FET, N-CHANNEL	429977	89536	429977	REF		
Q18	XSTR, J-FET, N-CHANNEL	429977	89536	429977	REF		
Q19	XSTR, SI, NPN	218396	04713	2N3904	1	1	
Q20	XSTR, J-FET, N-CHANNEL	429977	89536	429977	REF		
Q21	XSTR, J-FET, N-CHANNEL	429977	89536	429977	REF		
Q22	XSTR, J-FET, N-CHANNEL	429977	89536	429977	REF		
Q30	XSTR, J-FET, N-CHANNEL	429977	89536	429977	REF		
Q31	XSTR, J-FET, N-CHANNEL	376475	89536	376475	REF		
Q32	XSTR, J-FET, N-CHANNEL	429977	89536	429977	REF		
Q33	XSTR, J-FET, N-CHANNEL	429977	89536	429977	REF		
Q34	XSTR, J-FET, N-CHANNEL	429977	89536	429977	REF		
Q35	XSTR, J-FET, N-CHANNEL	429977	89536	429977	REF		
Q36	XSTR, J-FET, N-CHANNEL	429977	89536	429977	REF		
Q37	XSTR, J-FET, N-CHANNEL	429977	89536	429977	REF		
R1	RES, NETWORK	461202	89536	461202	2	1	
R2	RES, NETWORK	461202	89536	461202	REF		
R3	RES, COMP, 10K +/-5%, 1/4W	148106	01121	CB1035	2		
R4	RES, VAR, 500 +/-10%, 1/2W	291120	89536	291120	3	1	
R5	RES, COMP, 39K +/-5%, 2W	424721	01121	HB3935	1		
R7	RES, VAR, CER, 50K +/-10%, 1/2W	288290	89536	288290	3		
R8	RES, MTL. FILM, 2K +/-0.1%, 1/8W	340174	91637	MFF1-82001B	1		
R9	RES, COMP, 22K +/-5%, 1/4W	148130	01121	CB2235	6		
R10	RES, COMP, 22K +/-5%, 1/4W	148130	01121	CB2235	REF		
R11	RES, PART OF VR5 SET				REF		
R12	RES, VAR, 500 +/-10%, 1/2W	291120	89536	291120	REF		
R13	RES, PART OF VR5 SET				REF		
R14	RES, WW, 40K +/-0.2%, 1/2W	112037	89536	112037	1	1	
R15	RES, COMP, 22K +/-5%, 1/4W	148130	01121	CB2235	REF		
R16	RES, MTL. FILM, 23.7K +/-1%, 1/8W	188367	91637	MFF1-82372F	1		
R17	RES, MTL. FILM, 15K +/-1%, 1/8W	285296	91637	MFF1-81502F	2		
R18	RES, MTL. FILM, 15K +/-1%, 1/8W	285296	91637	MFF1-81502F	REF		
R19	RES, COMP, 22K +/-5%, 1/4W	148130	01121	CB2235	REF		
R20	RES, MTL. FILM, 130K +/-1%, 1/8W	221648	91637	MFF1-81303F	1		
R21	RES, VAR, CER, 50K +/-10%, 1/2W	288290	89536	288290	REF		
R22	RES, MTL. FILM, 1M +/-1%, 1/8W	268797	91637	MFF1-81004F	1		
R23	RES, COMP, 100K +/-5%, 1/4W	148189	01121	CB1045	10		
R24	RES, MTL. FILM, 4.02K +/-1%, 1/8W	235325	91637	MFF1-84021F	1		
R25	RES, COMP, 1.5K +/-5%, 1/4W	148031	01121	CB1525	2		
R27	RES, COMP, 3.3M +/-5%, 1/4W	208389	01121	CB3355	1		
R28	RES, WW, 22.5K +/-0.1%, 1/2W	112045	89536	112045	1	1	
R29	RES, VAR, CER, 5K +/-10%, 1/2W	288282	89536	288282	1	1	
R30	RES, MTL. FILM, 806K +/-1%, 1/8W	217976	91637	MFF1-88063F	1		
R31	RES, WW, 2K +/-1%, 1/2W	171843	89536	171843	1	1	
R32	RES, VAR, 500 +/-10%, 1/2W	291120	89536	291120	REF		
R33	RES, MTL. FILM, 100K +/-1%, 1/8W	248807	91637	MFF1-81003F	2		

Table 5-13. A12 High Performance A/D Converter PCB Assembly (cont)

REF DES	DESCRIPTION	FLUKE STOCK NO.	MFG SPLY CODE	MFG. PART NO.	TOT QTY	REC QTY	N O T E
R34	RES, MTL. FILM, 100K +/-1%, 1/8W	248807	91637	MFF1-81003F	REF		
R35	RES, WW, 250 +/-0.05%, 1/2W	182220	89536	182220	2	1	
R36	RES, VAR, CER, 1K +/-10%, 1/2W	285155	89536	285155	1	1	
R37	RES, WW, 99.975K	178780	89536	178780	1	1	
R38	RES, MTL. FILM, 75K +/-1%, 1/8W	291443	91637	MFF1-87502	2		
R39	RES, WW, 1.022K +/-0.05%, 1/4W	288654	89536	288654	1	1	
R40	RES, WW, 250 +/-0.05%, 1/2W	182220	89536	182220	REF		
R41	RES, COMP, 2.2K +/-5%, 1/4W	148049	01121	CB2225	1		
R42	RES, MTL. FILM, 6.81K +/-1%, 1/8W	268417	91637	MFF1-86811F	2		
R43	RES, MTL. FILM, 6.81K +/-1%, 1/8W	268417	91637	MFF1-86811F	REF		
R44	RES, VAR, CER, 20K +/-10%, 1/2W	291609	89536	291609	2	1	
R45	RES, COMP, 22K +/-5%, 1/4W	148130	01121	CB2235	REF		
R46	RES, VAR, CER, +/-10%, 1/2W	288290	89536	288290	REF		
R47	RES, MTL. FILM, 75K +/-1%, 1/8W	291443	91637	MFF1-87502	REF		
R48	RES, MTL. FILM, 54.9K +/-1%, 1/8W	271353	91637	MFF1-85492F	1		
R49	RES, MTL. FILM, 13.0K +/-1%, 1/8W	335539	91637	MFF1-81302F	1		
R50	RES, VAR, CER, 200 +/-10%, 1/2W	285148	89536	285148	2	1	
R51	RES, COMP, 820K +/-5%, 1/4W	220541	01121	CB8245	1		
R52	RES, COMP, 680K +/-5%, 1/4W	188433	01121	CB6845	1		
R53	RES, COMP, 1.5K +/-5%, 1/4W	148031	01121	CB1525	REF		
R54	RES, VAR, CER, 200 +/-10%, 1/2W	285148	89536	285148	REF		
R55	RES, COMP, 100K +/-5%, 1/4W	148189	01121	CB1045	REF		
R56	RES, WW, 19.991K, 1/4W	277988	89536	277988	1	1	
R57	RES, COMP, 22K +/-5%, 1/4W	148130	01121	CB2235	REF		
R60	RES, COMP, 47K +/-5%, 1/4W	148163	01121	CB4735	2		
R61	RES, COMP, 10K +/-5%, 1/4W	148106	01121	CB1035	REF		
R63	RES, COMP, 1K +/-5%, 1/4W	148023	01121	CB1025	1		
R64	RES, COMP, 470 +/-5%, 1/4W	147983	01121	CB4715	1		
R70	RES, COMP, 100K +/-5%, 1/4W	148189	01121	CB1045	REF		
R71	RES, COMP, 750 +/-5%, 1/4W	218024	01121	CB7515	2		
R72	RES, VAR, CER, 20K +/-10%, 1/2W	291609	89536	291609	REF		
R73	RES, COMP, 100K +/-5%, 1/4W	148189	01121	CB1045	REF		
R74	RES, COMP, 100K +/-5%, 1/4W	148189	01121	CB1045	REF		
R75	RES, COMP, 750 +/-5%, 1/4W	218024	01121	CB7515	REF		
R76	RES, COMP, 100K +/-5%, 1/4W	148189	01121	CB1045	REF		
R77	RES, COMP, 100K +/-5%, 1/4W	148189	01121	CB1045	REF		
R78	RES, COMP, 100K +/-5%, 1/4W	148189	01121	CB1045	REF		
R79	RES, COMP, 100K +/-5%, 1/4W	148189	01121	CB1045	REF		
R80	RES, COMP, 47K +/-5%, 1/4W	148163	01121	CB4735	REF		
R81	RES, COMP, 10M +/-5%, 1/4W	194944	01121	CB1065	2		
R82	RES, COMP, 10M +/-5%, 1/4W	194944	01121	CB1065	REF		
R83	RES, COMP, 100M +/-10%, 1/2W	190520	01121	EB1071	1		
R84	RES, COMP, 100K +/-5%, 1/4W	148189	01121	CB1045	REF		
S1	SWITCH, SLIDE, DPDT SLIDE SWITCH, BOTTOM-A	454777	10389	24-420-020	1		
	SLIDE SWITCH, TOP-B	454835	10389	24-420-020	1		
TP1	CONNECTOR, PLUG-JACK	170480	74970	105-752	3		
TP2	CONNECTOR, PLUG-JACK	170480	74970	105-752	REF		
TP3	CONNECTOR, PLUG-JACK	170480	74970	105-752	REF		
TP4	CONNECTOR, POST	267500	00779	861442	6		

Table 5-13. A12 High Performance A/D Converter PCB Assembly (cont)

REF DES	DESCRIPTION	FLUKE STOCK NO.	MFG SPLY CODE	MFG. PART NO.	TOT QTY	REC QTY	NO TE
TP5	CONNECTOR, POST	267500	00779	86 1442	REF		
TP6	CONNECTOR, POST	267500	00779	86 1442	REF		
TP7	CONNECTOR, POST	267500	00779	86 1442	REF		
TP8	CONNECTOR, POST	267500	00779	86 1442	REF		
TP9	CONNECTOR, POST	267500	00779	86 1442	REF		
U1	IC, LINEAR, DUAL	478032	04713	MC4558NCP1	2		1
U2	IC, LINEAR, DUAL	478032	04713	MC4558NCP1	REF		
U3	IC, LINEAR, COMPARATOR	472894	12040	LM311N	1		1
U4	IC, LINEAR, VOLTAGE REGULATOR	419044	49956	RC4195T	1		1
U5	IC, LINEAR, OP AMP	284760	12040	LM308	1		1
U6	IC, TTL QUAD, 2-INPUT & GATE (SELECTED)	412759	89536	412759	1		1
U7	IC, XSTR, ARRAY (SELECTED)	413237	89536	413237	2		1
U13	IC, TTL, DUAL, J-K FLIP-FLOP	393157	01295	SN74LS107N	1		1
U14	IC, TTL, DECODER/DEMULTIPLEXER	393165	01295	SN74LS139	1		1
U15⊗	IC, C-MOS, 4-BIT REG W/TR-ST OUTPUTS	412742	12040	MM74C173N	4		1
U16⊗	IC, C-MOS, 4-BIT REG W/TR-ST OUTPUTS	412742	12040	MM74C173N	REF		
U17⊗	IC, C-MOS, 4-BIT REG W/TR-ST OUTPUTS	412742	12040	MM74C173N	REF		
U18⊗	IC, C-MOS, 4-BIT REG W/TR-ST OUTPUTS	412742	12040	MM74C173N	REF		
U19⊗	IC, C-MOS, 8-INPUT OR GATE	418798	12040	MM4048AN	1		1
U20⊗	IC, C-MOS, 1-OF-10 DECODER	380741	86684	CD4028AE	1		1
U21⊗	IC, C-MOS, HEX, BUFFER, INVERTER	381830	86684	CD4050AE	1		1
U22	IC, TTL, QUAD, 2-INPUT NAND GATE	393033	01295	SN74LS00N	1		1
U23	RES, NETWORK, 100K	412726	89536	412726	2		1
U24	RES, NETWORK, 100K	412726	89536	412726	REF		
U25	IC, LINEAR, OPNL, AMPL	418566	12040	LM358N	1		1
U26	IC, XSTR, ARRAY (SELECTED)	413237	89536	413237	REF		
VR5	REFERENCE VOLTAGE SET KIT (INCLUDES R11 & R13)	377283	89536	377283	1		1
VR6	DIODE, ZENER, 5.6V	277236	07910	1N752A	2		1
VR10	DIODE, ZENER, 5.6V	277236	07910	1N752A	REF		

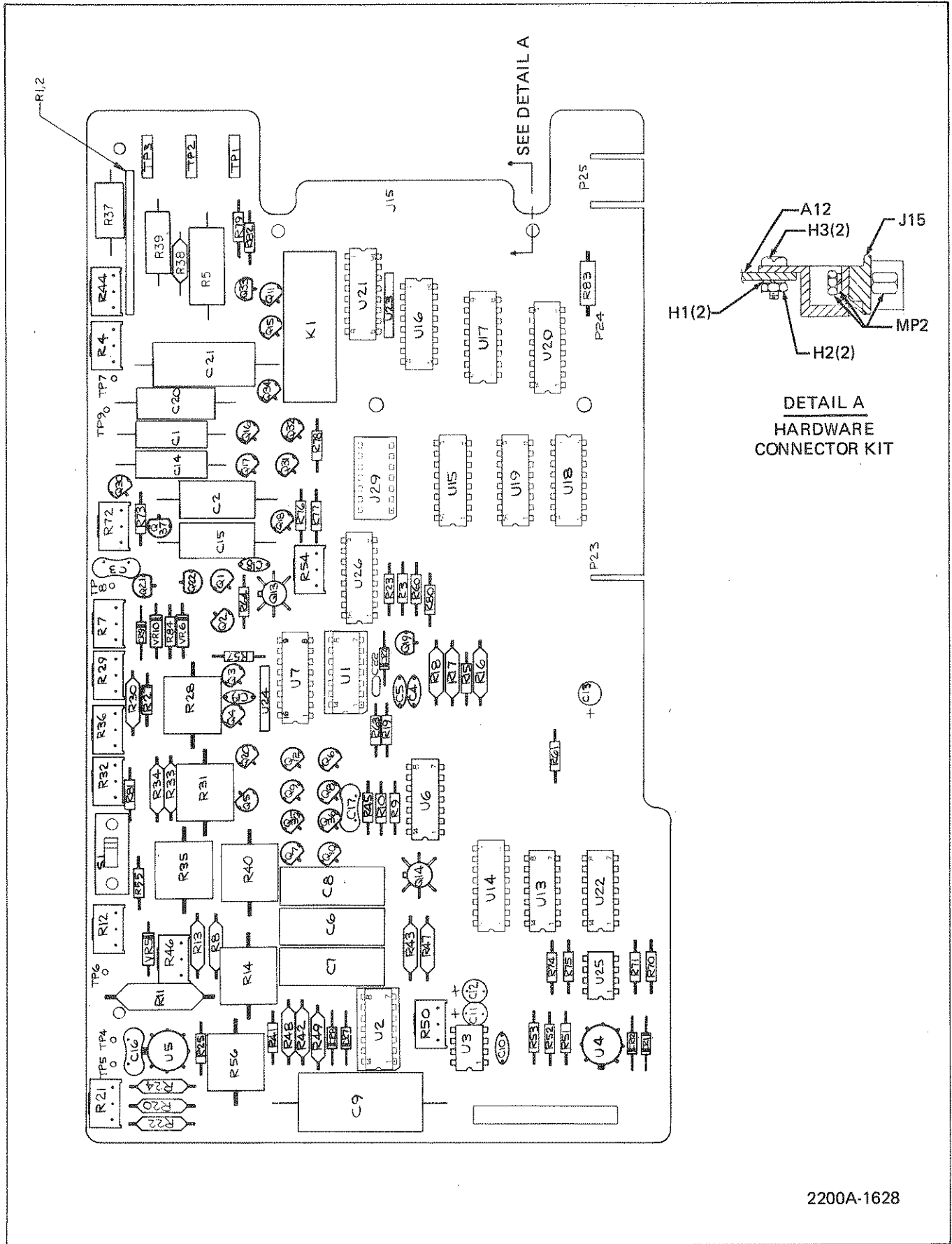

Figure 5-13. A12 High Performance A/D Converter PCB Assembly



Section 6  
Table of Contents

Accessories

OPTION/ MODEL NO.	DESCRIPTION	PAGE
M07-205-600	Rack Mounting Kit.....	600-1
M00-280-610	Rack Slide Kit.....	600-1
2200A-7005	Service Extender Cable Set.....	600-1
2200A-7006	General Purpose Interface Cable.....	600-2
2200A-7007	Interface Connector.....	600-2
2010A-7013	Fan-Fold Printer Paper.....	600-2
2010A-7014	Printer Ribbon.....	600-2
A22-46	Data Logger Maintenance Cable Set.....	600-2
2201A	Scanner Chassis.....	With 2201A
2202A	Remote Scanner Chassis.....	With 2202A
2203A	RTD Scanner Chassis.....	With 2203A

Options

-03	RTD Connector.....	603-1
-04	RTD Scanner.....	With 2203A
-05	General Purpose Scanner.....	605-1
-06	Low Level Scanner.....	606-1
-07	Solder Pin Connector.....	607-1
-08	Isothermal Block Connector.....	608-1
-12 Series	TTY/RS-232C Interface.....	612-1
-13 Series	Paper Tape Puch Interface.....	613-1
-14 Series	Magnetic Tape Interface.....	614-1
-15	IEEE Interface.....	615-1
-16	Digital Input Interface.....	616-1
-17	Remote Programming Interface.....	617-1
-18	Non-Standard Output Format.....	617-1
-23	Alarm Set Point Output.....	623-1
-28	Current Transmitter, 1-5 mA.....	628-1
-29	Current Transmitter, 4-20 mA.....	628-1
-30	Current Transmitter, 10-50 mA.....	628-1
-32	Dual Interval.....	632-1
-33	Eight Channel RTD Scanner.....	633-1
-40	mx+b Scaling Point Option.....	640-1
-41	Alarm Set Point Option.....	641-1
-42	Data Averaging Option.....	642-1
-43	Temperature Option.....	643-1
-44	Temperature Option.....	643-1

Section 6  
Option and Accessories

6-1. INTRODUCTION

6-2. This section of the manual contains information concerning the options and accessories available for use with the Model 2240C. It consists of an introductory section, an accessories subsection and a series of option subsections. All options and accessories are listed by model or option number in the Table of Contents. Corresponding subsection page numbers and other documentation location information are also listed.

6-3. ACCESSORIES

6-4. Hardware type accessories, i.e., rack mounting kits and cables, are documented in the accessories subsection. However, the more complex accessories, (scanner chassis) are documented in stand-alone manuals which are provided with the purchased instrument.

6-5. OPTIONS

6-6. All currently available options are documented herein as individual subsections. Each subsection contains all of the information necessary to install, operate, and maintain the option, including a list of replaceable parts. Schematics are included in Section 8.

6-7. The location of a particular subsection is facilitated by the use of unique page and paragraph numbering which corresponds to the option or accessory in question. For example, a 600-X series identifies the general accessories subsection and a 605-X series identifies the subsection for the -05 Option (where X is the sequential page or paragraph number).

## Accessories

### 600-1. RACK MOUNTING KIT (M07-205-600)

600-2. The data logger can be rack-mounted in a standard 19-inch equipment rack using Rack Mounting Kit M07-205-600. Use the following procedure to install the kit:

1. Peel off the name plate decals from the front side-corners of the data logger.
2. Remove the front corner screws which match the hole pattern in the rack-mounting ears (see Figure 600-1).
3. Attach the rack-mounting ears to the front corners of the unit using the screws supplied in the rack-mounting kit.

### 600-3. RACK SLIDE KIT (M00-280-610)

600-4. The data logger can be rack-mounted in a 24-inch deep equipment rack using the Rack Slide Kit M00-280-610. Use the following procedure to install the kit:

1. Remove the horizontal side trim decal from both sides of the data logger.
2. Refer to Figure 600-2, and, using the screws supplied with the kit, attach the Chassis Section (B) of the slide kit to each side of the unit. Use the center row of mounting holes.
3. Install the cabinet Section (D) and the Center Section (C) in the equipment rack.
4. Pull the center section of the slide out through the front of the equipment rack until it locks in the extended position.
5. Depress the spring locks on the Chassis Section (B) and join Section B and C.
6. Push the instrument into the equipment rack and then pull it out to the extended position. The spring locks should limit the rack slide travel.

### 600-5. SERVICE EXTENDER CABLE SET (2200A-7005)

600-6. A set of three service extender cables is available for use in servicing any one of the data logger's vertical plug-in pcb's. The majority of the pcb's require the use of only one extender. However, some of the pcb's, such as the A/D Converter, require the use of the two cables. The third cable is used to



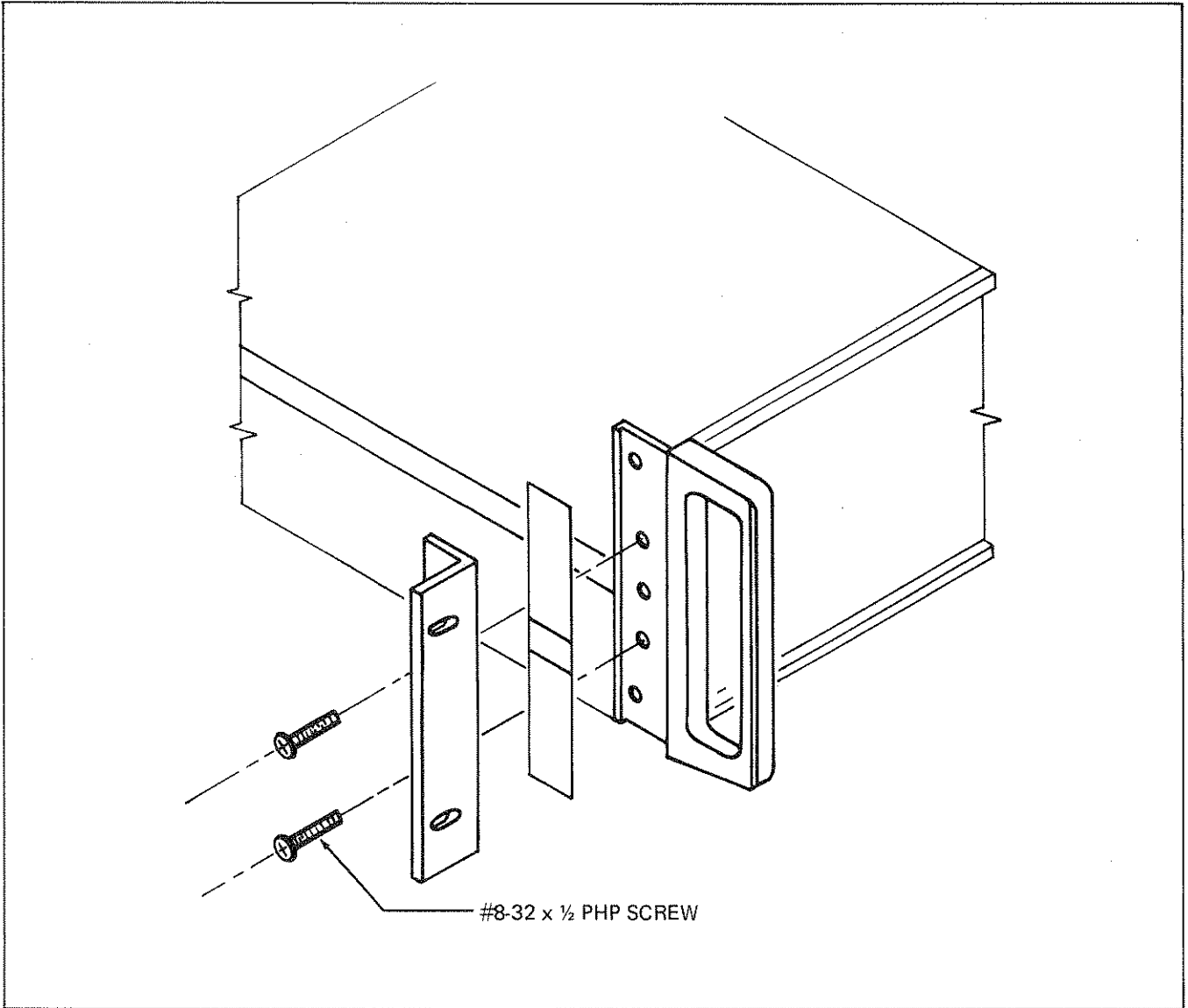

Figure 600-1. Rack Mounting Kit

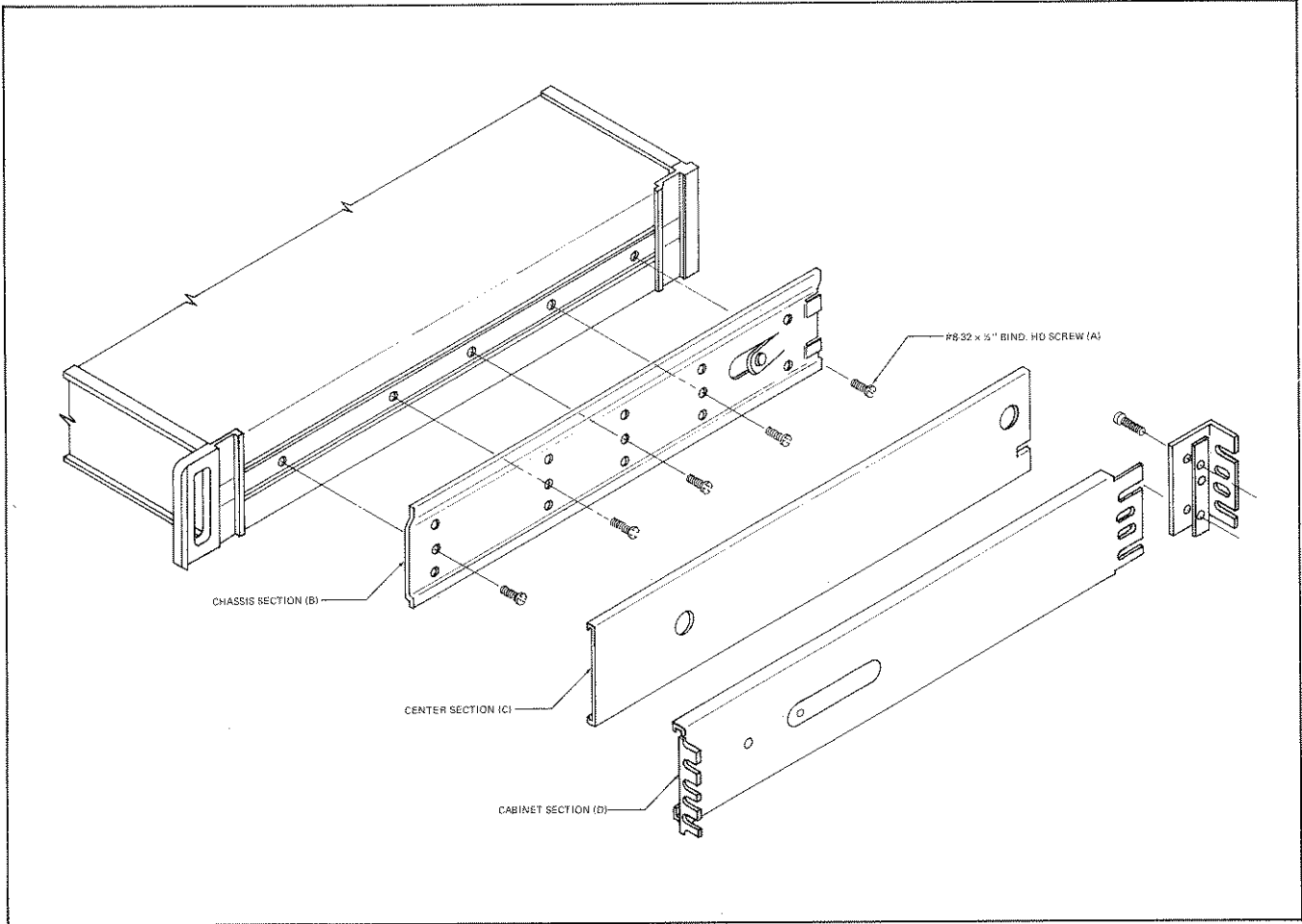

Figure 600-2. Rack Slide Kit

extend the Controller PCB. In addition, a set of six maintenance extender cables (Model A22-46) is available for use in servicing the Keyboard Switch logic and the Memory boards.

600-7. GENERAL PURPOSE INTERFACE CABLE (2200A-7006)

600-8. The General Purpose Interface Cable is designed for use in fabricating custom I/O cables for the Digital Input Option (-16) and the Alarm Set-Point Output Option (-23). The cable assembly consists of a 6-foot, 50-wire cable, and a 50-pin connector. The connector is attached to one end of the cable and is designed to mate with the rear-panel connectors on Options -16 and -23. The user is responsible for completing the connections at the free-end of the cable. Refer to the appropriate option (-16 or -23) in this section of the manual for the necessary connector pin assignments.

600-9. INTERFACE CONNECTOR (2200A-7007)

600-10. The Interface Connector is designed for use in fabricating custom I/O cables for the Digital Input Option (-16) and the Alarm Set-Point Option (-23). The connector assembly consists of a blank 50-pin connector and a hood. The user is responsible for the remainder of the cable. Refer to the appropriate option (-16 or -23) in this section of the manual for the necessary connector pin assignments.

600-11. FAN-FOLD PRINTER PAPER (2010A-7013)

600-12. Fan-fold paper suitable for use with the data logger's internal printer is available from the John Fluke Mfg. Co., Inc. The paper is supplied in packages containing one dozen packets. Therefore, when ordering, specify model number 2010A-7013 and indicate a quantity of 1 for each dozen packets required. (See Section 2 for paper installation instructions.)

600-13. PRINTER RIBBON (2010A-7014)

600-14. Two-color (red and black) printer ribbon suitable for use with the data logger's internal printer is available from the John Fluke Mfg. Co., Inc. The ribbon is supplied in packages containing one dozen spools. Therefore, when ordering, specify model number 2010A-7014 and indicate a quantity of 1 for each dozen spools required. (See Section 2 for printer ribbon installation instructions.)

600-15. DATA LOGGER MAINTENANCE CABLE SET (A22-46)

600-16. The Data Logger Maintenance Cable Set is a set of extender cables which allow various data logger modules to be removed from the data logger mainframe for maintenance or repair. The set includes six cables: two 10-inch cables with a 12-pin male Molex connector on one end and a 12-pin female Molex connector on the other, three 24-inch flat cables with a 14-pin

DIP connector on each end, and a 6-inch flat cable with 16-pin DIP connectors on each end. These cables are helpful in maintaining or repairing the Keyboard Memory, Keyboard Logic and Keyboard Switch components.



Option -03  
RTD Connector

603-1. INTRODUCTION

603-2. The RTD (Resistance Temperature Device) Connector (Option 2200A-03) is a card-edge connector assembly designed to function as the input connector for the 2240A-33 RTD Scanner or the 2200A-04 RTD Scanner. Four screw-type input connectors are provided for introducing either a three- or four-wire RTD input on each of 10 channels, 0 through 9. A separate common shield terminal is also available on the connector. The shield is connected internally to the data logger's measurement guard when 1 of the 10 channels is selected for measurement.

603-3. SPECIFICATIONS

603-4. Specifications for the 2200A-03 RTD Connector are given in Table 603-1.

603-5. INSTALLATION NOTES

603-6. The purpose of the SHIELD connection is to improve rejection of common-mode voltage noise. This is done by connecting the SHIELD lead to the LO lead at the measurement point as shown in Figure 603-1. In the presence of common-mode voltage, this connection provides a path for the current which flows as the capacitance between the A/D Converter and the chassis is being charged or discharged. Since the A/D converter and the Shield (built into the instrument) are forced to track the same voltage, the common-mode current in the HI and LO leads is minimized. It is this current which produces unstable readings. It is important to note that HI, LO and Shield are fully isolated and capable of being safely floated to 350 Volts above ground. The following guidelines should be followed when connecting the RTD Input Connector:

1. If significant RFI (Radio Frequency Interference) or EMI (Electro-Magnetic Interference) is present, the best measurement results will be obtained by connecting SHIELD to LO on the input connector with the shortest path possible.
2. If significant common mode voltage (greater than one volt) is present, connect SHIELD to LO by means of a third wire at the measurement point as shown in Figure 603-1.
3. For Thermocouples, connect SHIELD to the low Thermocouple lead as close to the Thermocouple junction as possible without affecting its temperature.
4. Never tie SHIELD to HI. This may actually amplify

**Table 603-1. Specifications**

Compatibility:	2200/2240 series data loggers
Input Terminals:	41 screw-type connections (HI, LO, +S, -S for each of 10 channels plus common shield).

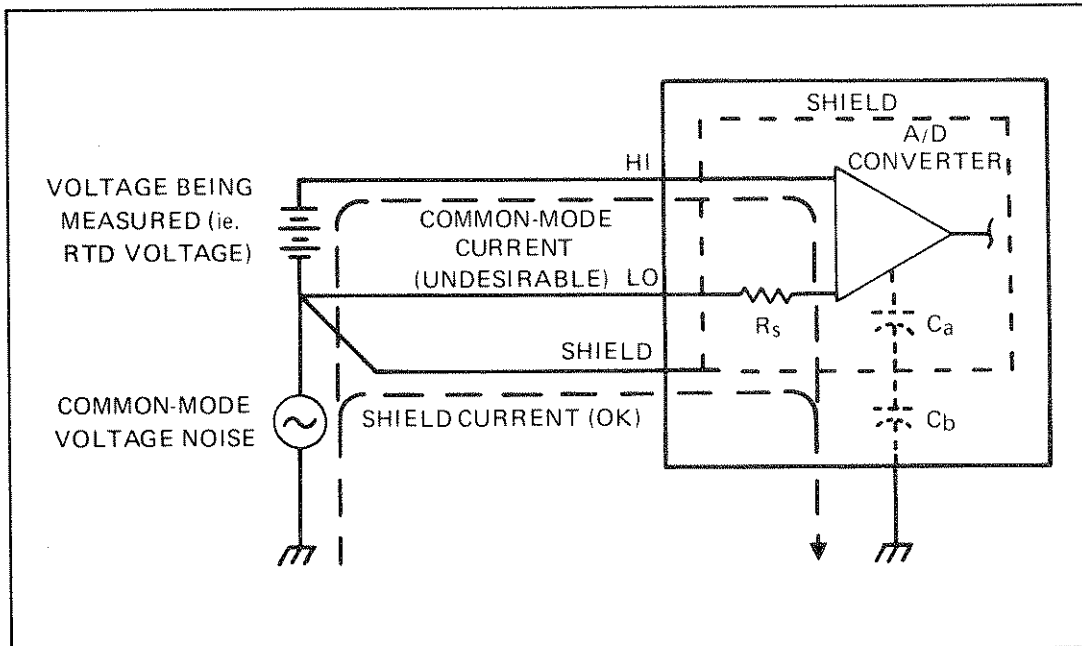

**Figure 603-1. Shield Connection for Optimum Common Mode Rejection**

the effects of noise on the signal, causing a degradation in measurement performance.

5. Never leave SHIELD unconnected. Static charge build-up may cause the maximum SHIELD to LO voltage to be exceeded, resulting in instrument damage.
6. Never connect SHIELD to the chassis ground. This will result in greatly increased common mode currents due to the large value of capacitance between the shield and the A/D Converter.

603-7. For further information on this subject, refer to the Fluke Application Bulletin AB-20 concerning guarded measurements. The Application Bulletin is available from your Fluke Sales Representative.

#### 603-8. INSTALLATION

603-9. The RTD Connector can be mounted in any one of the data logger scanner-block slots which contain an RTD Scanner. Install the connector as follows:

1. Unlatch the slide fasteners located on either side of the protruding enclosure at the rear of the data logger. Remove the enclosure from the rear panel.
2. Locate the desired scanner-block slot on the rear panel and check to ensure that an RTD Scanner is installed in the slot.
3. With the connector key toward the top, position the RTD Connector in the guides of the selected slot and mate it with the scanner's connector.
4. Install the retaining screws and washers that anchor the input connector to the data logger.
5. Install the rear panel enclosure.

#### 603-10. INPUT CONNECTIONS

603-11. Figure 603-2 identifies the screw terminals provided for attaching RTDs to the input connector. Access to the terminals is accomplished by removing the four screws from the decal side of the connector enclosure. Spaces are provided on the decal for the user to record the connector's block and channel assignments for RTD inputs. Refer to the RTD Scanner manual (Option -04 or -33) for instructions concerning three- and four-terminal RTD connections.

#### 603-12. LIST OF REPLACEABLE PARTS

603-13. Table 603-2 contains a list of replaceable parts for the



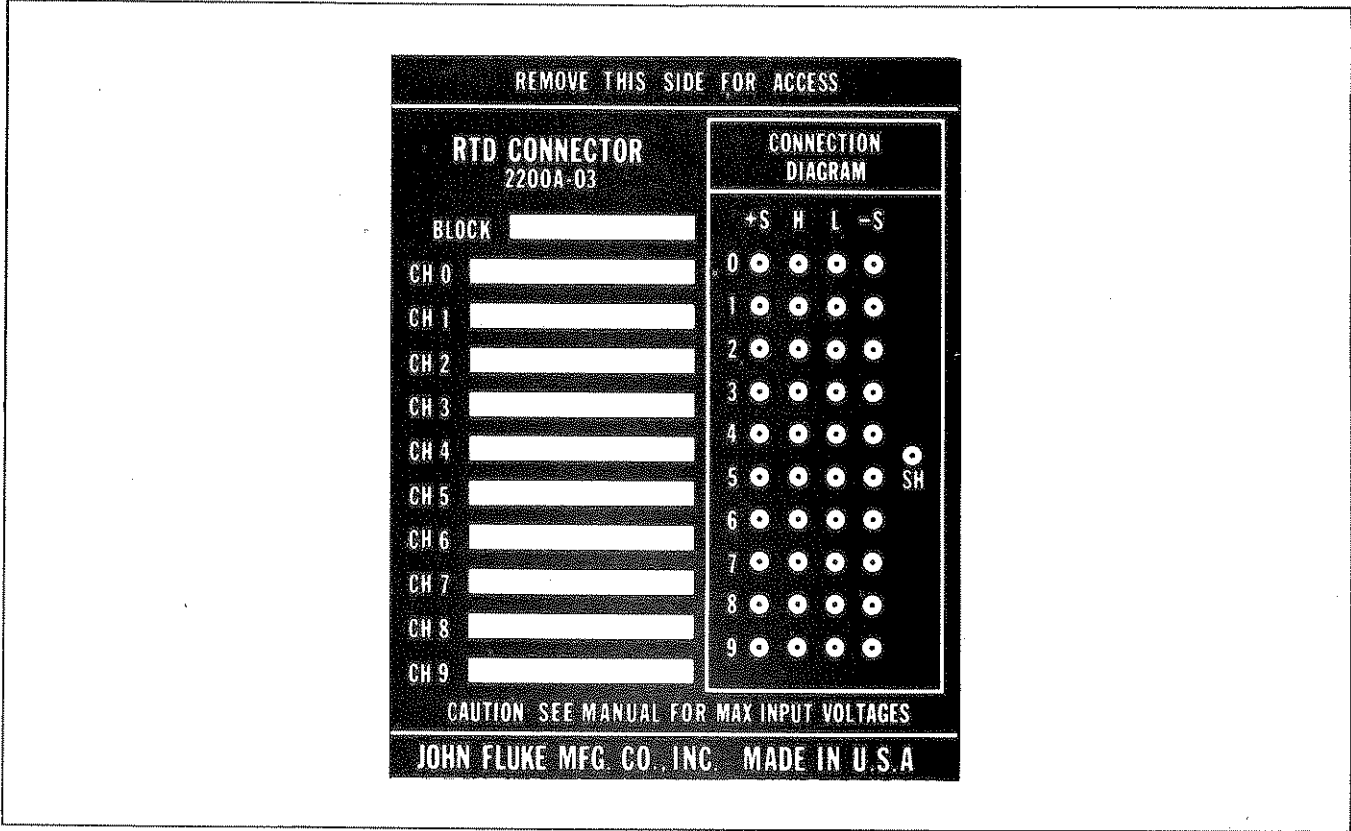
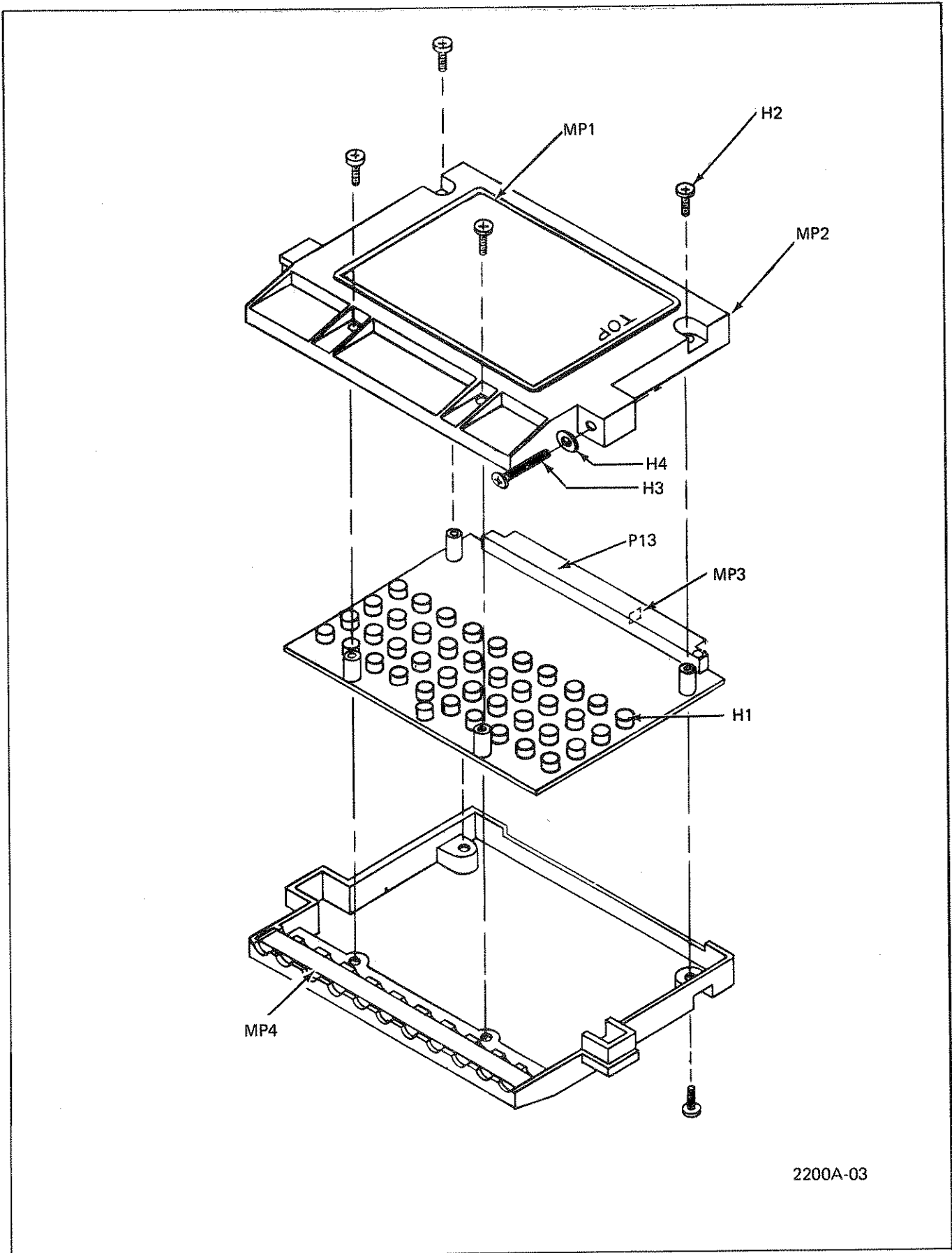

Figure 603-2. RTD Connector Terminal Assignments

RTD Connector. Refer to Section 5 of the data logger manual for ordering information.

Table 603-2. RTD Connector Assembly

REF DES	DESCRIPTION	FLUKE STOCK NO.	MFG SPLY CODE	MFG. PART NO.	TOT QTY	REC QTY	NOTE
-03	RTD CONNECTOR ASSEMBLY FIGURE 603-2 (2200A-03)	ORDER	BY	OPTION -03			
H1	SCREW, PHP, 6-32 X 1/4	385401	89536	385401	41		
H2	SCREW, PHP, 6-32 X 1/4	152140	89536	152140	8		
H3	SCREW, PHP, 4-40 X 7/8	335133	89536	335133	1		
H4	WASHER, FLAT	146225	89536	146225	1		
MP1	DECAL, RTD CONNECTOR	442780	89536	442780	1		
MP2	HOUSING, RTD CONNECTOR	414276	89536	414276	2		
MP3	INSERT, CONNECTOR, POLARIZING	407254	54453	ISM-K1	1		
MP4	TAPE, FOAM	424127	89536	424127	2		
P13	CONNECTOR, CARD-EDGE, 44-PIN	385674	89536	385674	1		



2200A-03

Figure 603-2. RTD Connector Assembly

1  
2  
3  
4  
5  
6  
7  
8  
9  
10  
11  
12  
13  
14  
15  
16  
17  
18  
19  
20  
21  
22  
23  
24  
25  
26  
27  
28  
29  
30  
31  
32  
33  
34  
35  
36  
37  
38  
39  
40  
41  
42  
43  
44  
45  
46  
47  
48  
49  
50  
51  
52  
53  
54  
55  
56  
57  
58  
59  
60  
61  
62  
63  
64  
65  
66  
67  
68  
69  
70  
71  
72  
73  
74  
75  
76  
77  
78  
79  
80  
81  
82  
83  
84  
85  
86  
87  
88  
89  
90  
91  
92  
93  
94  
95  
96  
97  
98  
99  
100

Option -05  
General Purpose Scanner

605-1. INTRODUCTION

605-2. The General Purpose Scanner (Option -05) is a plug-in, 10-channel, 2-wire relay scanner designed to operate as a general purpose, analog data multiplexer in a 2200/2400 series data logger/scanner chassis (hereafter referred to collectively as data logger). Switched high and low inputs are provided for each of the 10 channels and a common (unswitched) shield is provided for all 10 channels. A decoupling relay is used to isolate the high, low, and shield buses from the common output connections when a channel relay is not activated. Activating any one of the 10 channel relays also energizes the decoupling relay.

605-3. SPECIFICATIONS

605-4. Specifications for the General Purpose Scanner are given in Table 605-1.

605-5. INSTALLATION

605-6. The General Purpose Scanner mounts in any one of the available scanner-block slots provided in the data logger, as shown in Figure 605-1. Install the scanner as follows:

WARNING

REMOVE LINE POWER AND ALL OTHER  
HIGH VOLTAGE INPUTS TO THE DATA  
LOGGER BEFORE STARTING THIS  
PROCEDURE.

1. Remove the top dust cover from the data logger.
2. Remove the large top inner cover located in the left rear of the unit (as viewed from the top front).

CAUTION

Handle the Scanner PCB by its  
edges to avoid contaminating  
the pcb with oil from the  
hands. The use of gloves is  
recommended.

3. Select the slot that includes the block of channels the scanner is to represent, and align the scanner in the slot so that the large board-edge connector is toward the rear of the unit, and the small offset board-edge connectors are toward the bottom of the unit. Push the scanner straight down onto

Table 605-1. Option -05 Specifications

Channel Relays . . . . .	10 low thermal-emf reed relays
Poles Per Channel . . . . .	Two (form A)
Shield Switching . . . . .	One switch for 10 channels
Voltage Offset . . . . .	$\leq 10 \mu V$
Input Voltage Limit* . . . . .	170V dc or peak ac max
Common Mode Voltage Limit (Voltage between chassis and any input)	350V dc or peak ac max provided the Input Voltage Limit is not exceeded

*\*Maximum voltage between any two terminals in the system. Includes normal mode as well as common mode voltages.*

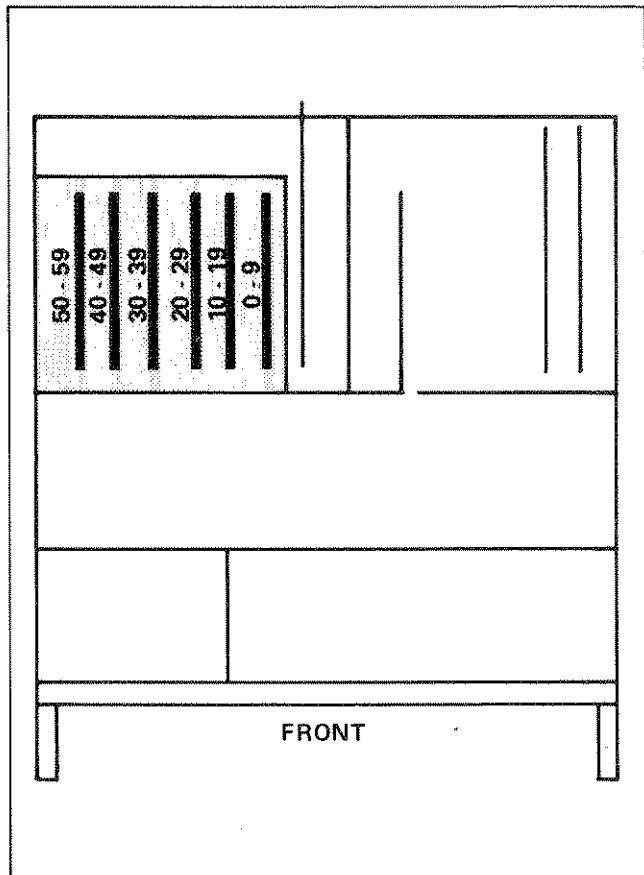

Figure 605-1. Scanner Mounting Locations

the mating connectors.

4. After the desired number of scanners is installed, install the large left rear inner cover.
5. Install the top dust cover.

#### 605-7. OPERATION

605-8. Once installed in the data logger, the General Purpose Scanner requires no operator attention. However, certain considerations are necessary to properly interface the scanner with analog input data. These considerations are covered in the following paragraphs.

#### 605-9. Input Connections

605-10. Analog interface connections with the General Purpose Scanner are completed through either one of two types of connectors, both of which are available as options. They include the Solder Pin Connector (Option -07) and the Isothermal Block Connector (Option -08). The Solder Pin Connector is a general purpose assembly which consists of a 44-pin connector with solder-type cable connections. A clam-shell housing provides strain relief for the cable, and protection of the connector contacts. The Isothermal Block Connector is required of the thermocouple inputs. It features an Isothermal Block with screw-type connections, and a temperature sensing circuit. Refer to the appropriate option subsection for additional information.

#### 605-11. Input Pin Assignments

605-12. The pin assignments for the rear panel connector of the General Purpose Scanner are shown in Figure 605-2. Since contact with these signals is completed through one of two connector assemblies (Option -07 or -08), refer to the appropriate option subsection for pin assignments as available for fabrication interface cables.

#### NOTE

The guard connections shown in Figure 605-2 represent a unique potential within the data logger. Input shields should be connected to the Shield (pin 2), not to the guards.

#### 605-13. THEORY OF OPERATION

605-14. The General Purpose Scanner, as shown in Figure 605-3, is a programmable, 10-channel relay scanner designed to operate as a plug-in option in any one of the scanner-block slots in a 2200/2240 Series Data Logger. Channel scanning or multiplexing is



TOP			
L0	A	1	H0
GUARD	B	2	SHIELD
H1	C	3	L1
-	D	4	GUARD
L2	E	5	H2
GUARD	F	6	-
H3	H	7	L3
-	J	8	A/D COM.
TEMP. SIG.	K	9	6.2V dc (OUT)
BSL	L	10	REF. COM.
GUARD	M	11	-
L4	N	12	H4
-	P	13	GUARD
H5	R	14	L5
GUARD	S	15	-
L6	T	16	H6
-	U	17	GUARD
H7	V	18	L7
GUARD	W	19	-
L8	X	20	H8
-	Y	21	GUARD
H9	Z	22	L9

Lx = Low input to channel x.  
 Hx = High input to channel x.  
 Where: x = Block channel No. (0 - 9)  
 - = Not Used

Figure 605-2. General Purpose Scanner J13 Pin Assignments

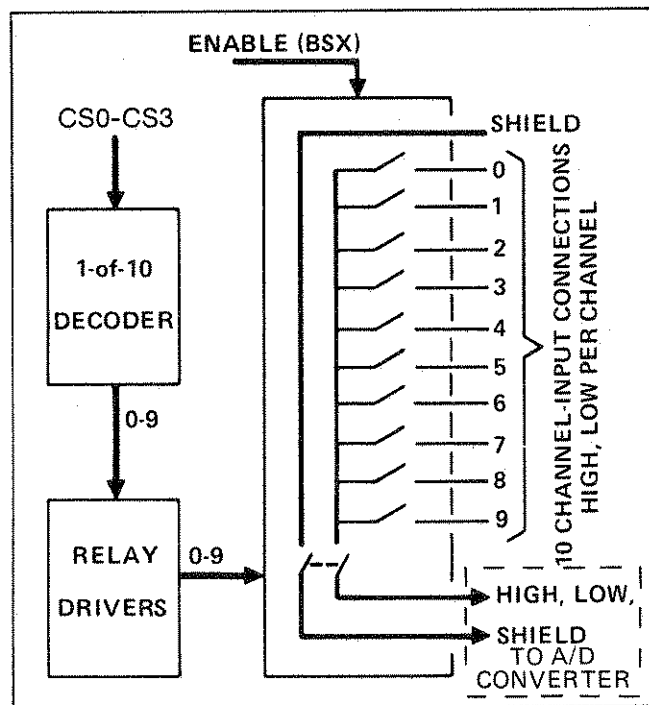

Figure 605-3. General Purpose Scanner, Functional Block Diagram

accomplished by a series of 12 form-A, reed relays; 11 are double-pole and 1 is single-pole. Ten of the double-pole relays serve as two-wire input channel switches of a common high/low output bus. The eleventh two-pole relay also contacts the two-wire bus. However, its function is to isolate or decouple the Scanner Bus from the actual output connections. When any one of the channel relays is energized, the decoupling relay is also activated to complete the two-wire input/output circuit. The single-pole relay operates in parallel with the decoupling relay. When closed, it connects a common channel-input shield to the output shield connection. Thus, the scanner actually provides a three-wire output (high, low, and shield).

605-15. All scanner pcb's installed in a data logger receive bcd channel select information from a single Data Bus (CS0 through CS3). This data is decoded on each scanner pcb into 10 separate channel commands (0-9). Each channel line is first buffered and then connected to one of the 10 channel relay coils. Even though these commands are present, the relay will not be energized unless the scanner receives a scanner-block select (BSX) command. This command is actually an address or enable signal which applies voltage on the low side of the relay's coils. When the coil voltage is present the decoupling relay, the shield relay, and the selected channel relay will be energized. At that time, the analog input data on the selected channel appears at the scanner output terminals.

#### 605-16. MAINTENANCE

#### 605-17. Access Information

605-18. Refer to the installation information given in paragraph 605-6 for scanner access information. Remove the rear panel input connector before attempting to remove the scanner pcb from the data logger.

#### 605-19. Performance Test

605-20. The performance test is designed to verify the overall operation of the General Purpose Scanner PCB Assembly and is intended for use as an acceptance test and/or periodic maintenance check. The equipment used in the test is specified in Table 605-2. If the scanner fails any part of the performance test, corrective action is required.

1. Using the resistors and the input connector specified in Table 605-2, fabricate a scanner test cable as shown in Figure 605-4.
2. Install the Low Level Scanner PCB in the channel 0-9 slot of the data logger.
3. Set the calibrator output to 0V dc.

Table 605-2. Required Test Equipment

INSTRUMENT	RECOMMENDED MODEL
DC Voltage Calibrator	Fluke 343A
Data Logger	Fluke 2200B/2240C
Input Connector	Fluke 2200A-07 or -08
Resistors (10 each)	Metal film, 1k $\pm$ 1%, 1/4W

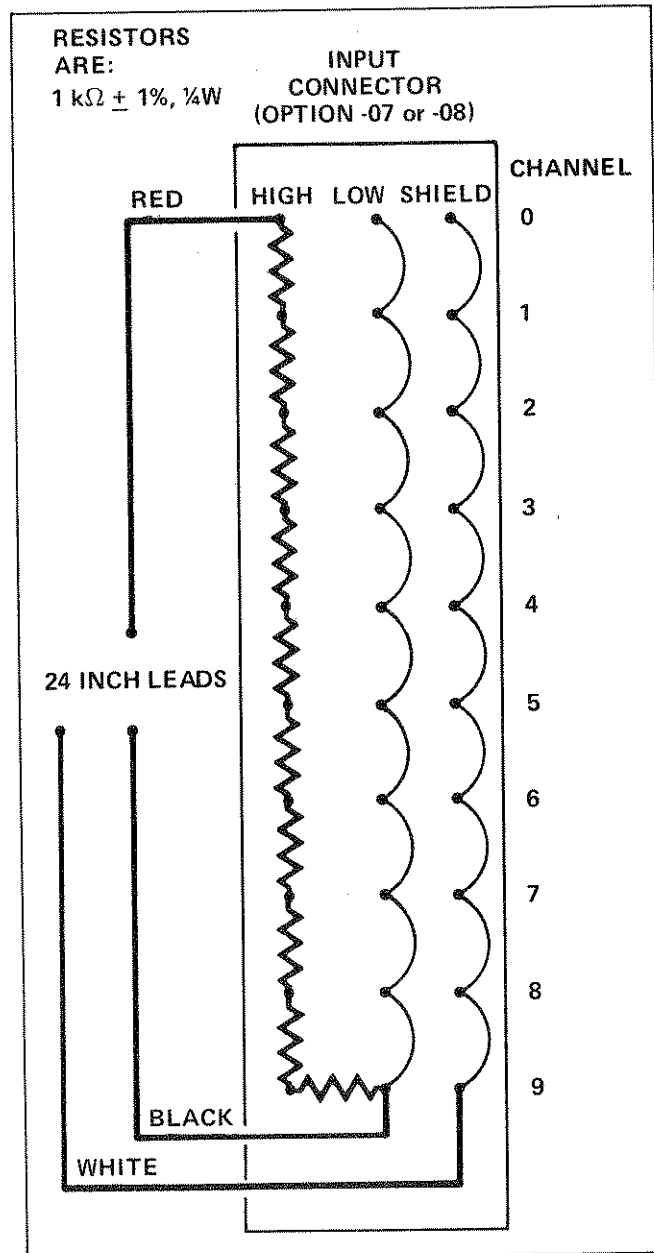

Figure 605-4. Scanner Test Cable

4. Connect the test cable leads to the calibrator's voltage output terminals (red to positive, black and white to negative).
5. Set the calibrator output to 1.000V dc.
6. Program the data logger as follows:
  - a. First channel to 0.
  - b. Last channel to 9.
  - c. Each channel function to 4V.
  - d. Press the ALL DATA (printer) switch in the OUTPUT CONTROL switch group.
7. Press the SINGLE scan switch and observe the printer measurement data. Channel 0 should read +1.000V dc  $\pm 1\%$ . A cumulative +0.1V dc decrease should be observed at each of the remaining channels. (Channel 9 should read +0.1V dc.) Any deviation in this pattern indicates a defective pcb assembly.

#### 605-21. LIST OF REPLACEABLE PARTS

605-22. A list of replaceable parts for the General Purpose Scanner PCB Assembly is given in Table 605-3. Refer to Section 5 of this manual for ordering information.

#### CAUTION

Indicated devices are subject to damage by static discharge.

Table 605-3. General Purpose Scanner PCB Assembly

REF DES	DESCRIPTION	FLUKE STOCK NO.	MFG SPLY CODE	MFG. PART NO.	TOT QTY	REC QTY	N O T E
-05①	GENERAL PURPOSE SCANNER PCB ASSEMBLY FIGURE 605-5 (2200A-4006T)	ORDER	BY	OPTION -05			
CR0	DIODE, SI	203323	07910	1N4448	11		2
CR1	DIODE, SI	203323	07910	1N4448	REF		
CR2	DIODE, SI	203323	07910	1N4448	REF		
CR3	DIODE, SI	203323	07910	1N4448	REF		
CR4	DIODE, SI	203323	07910	1N4448	REF		
CR5	DIODE, SI	203323	07910	1N4448	REF		
CR6	DIODE, SI	203323	07910	1N4448	REF		
CR7	DIODE, SI	203323	07910	1N4448	REF		
CR8	DIODE, SI	203323	07910	1N4448	REF		
CR9	DIODE, SI	203323	07910	1N4448	REF		
CR10	DIODE, SI	203323	07910	1N4448	REF		
K0	RELAY, DRY REED, DPST	442921	21317	052A5300BAA	11		
K1	RELAY, DRY REED, DPST	442921	21317	052A5300BAA	REF		
K2	RELAY, DRY REED, DPST	442921	21317	052A5300BAA	REF		
K3	RELAY, DRY REED, DPST	442921	21317	052A5300BAA	REF		
K4	RELAY, DRY REED, DPST	442921	21317	052A5300BAA	REF		
K5	RELAY, DRY REED, DPST	442921	21317	052A5300BAA	REF		
K6	RELAY, DRY REED, DPST	442921	21317	052A5300BAA	REF		
K7	RELAY, DRY REED, DPST	442921	21317	052A5300BAA	REF		
K8	RELAY, DRY REED, DPST	442921	21317	052A5300BAA	REF		
K9	RELAY, DRY REED, DPST	442921	21317	052A5300BAA	REF		
K10	RELAY, DRY REED, DPST	442921	21317	052A5300BAA	REF		
K11	RELAY ASSEMBLY COIL, EXT. SINGLE SWITCH, INTERNAL REED	ORDER 269019 414300	BY 71707 95348	PIECE PARTS U-6-P MR5830-7		1 1	
MP2	SPACER, XSTR	152207	07047	10123-DAP	1		
Q0	XSTR, SI, PNP	195974	04713	2N3906	10		2
Q1	XSTR, SI, PNP	195974	04713	2N3906	REF		
Q2	XSTR, SI, PNP	195974	04713	2N3906	REF		
Q3	XSTR, SI, PNP	195974	04713	2N3906	REF		
Q4	XSTR, SI, PNP	195974	04713	2N3906	REF		
Q5	XSTR, SI, PNP	195974	04713	2N3906	REF		
Q6	XSTR, SI, PNP	195974	04713	2N3906	REF		
Q7	XSTR, SI, PNP	195974	04713	2N3906	REF		
Q8	XSTR, SI, PNP	195974	04713	2N3906	REF		
Q9	XSTR, SI, PNP	195974	04713	2N3906	REF		
Q10	XSTR, J-FET, N-CHANNEL	352112	89536	352112	1		1
Q12	XSTR, SI, NPN	182196	07263	2N3643	1		1
Q13	XSTR, SI, NPN	218396	04713	2N3904	1		1
R1	RES, COMP, 470 +/-5%, 1/4W	147983	01121	CB4715	4		
R2	RES, COMP, 470 +/-5%, 1/4W	147983	01121	CB4715	REF		
R3	RES, COMP, 470 +/-5%, 1/4W	147983	01121	CB4715	REF		
R4	RES, COMP, 470 +/-5%, 1/4W	147983	01121	CB4715	REF		

Table 605-3. General Purpose Scanner PCB Assembly (cont)

REF DES	DESCRIPTION	FLUKE STOCK NO.	MFG SPLY CODE	MFG. PART NO.	TOT QTY	REC QTY	NOTE
R5	RES, COMP, 10K +/-5%, 1/4W	148106	01121	CB1035	1		
R6	RES, COMP, 100K +/-5%, 1/4W	148189	01121	CB1045	4		
R7	RES, COMP, 100K +/-5%, 1/4W	148189	01121	CB1045	REF		
R8	RES, COMP, 100K +/-5%, 1/4W	148189	01121	CB1045	REF		
R9	RES, COMP, 100K +/-5%, 1/4W	148189	01121	CB1045	REF		
U1Ⓢ	IC, MOS, 1-OF-10 DECODER	407981	12040	MM74C42N	1	1	
XU1	SOCKET, IC, 16-PIN DIP	276535	91506	316AG39D	1		

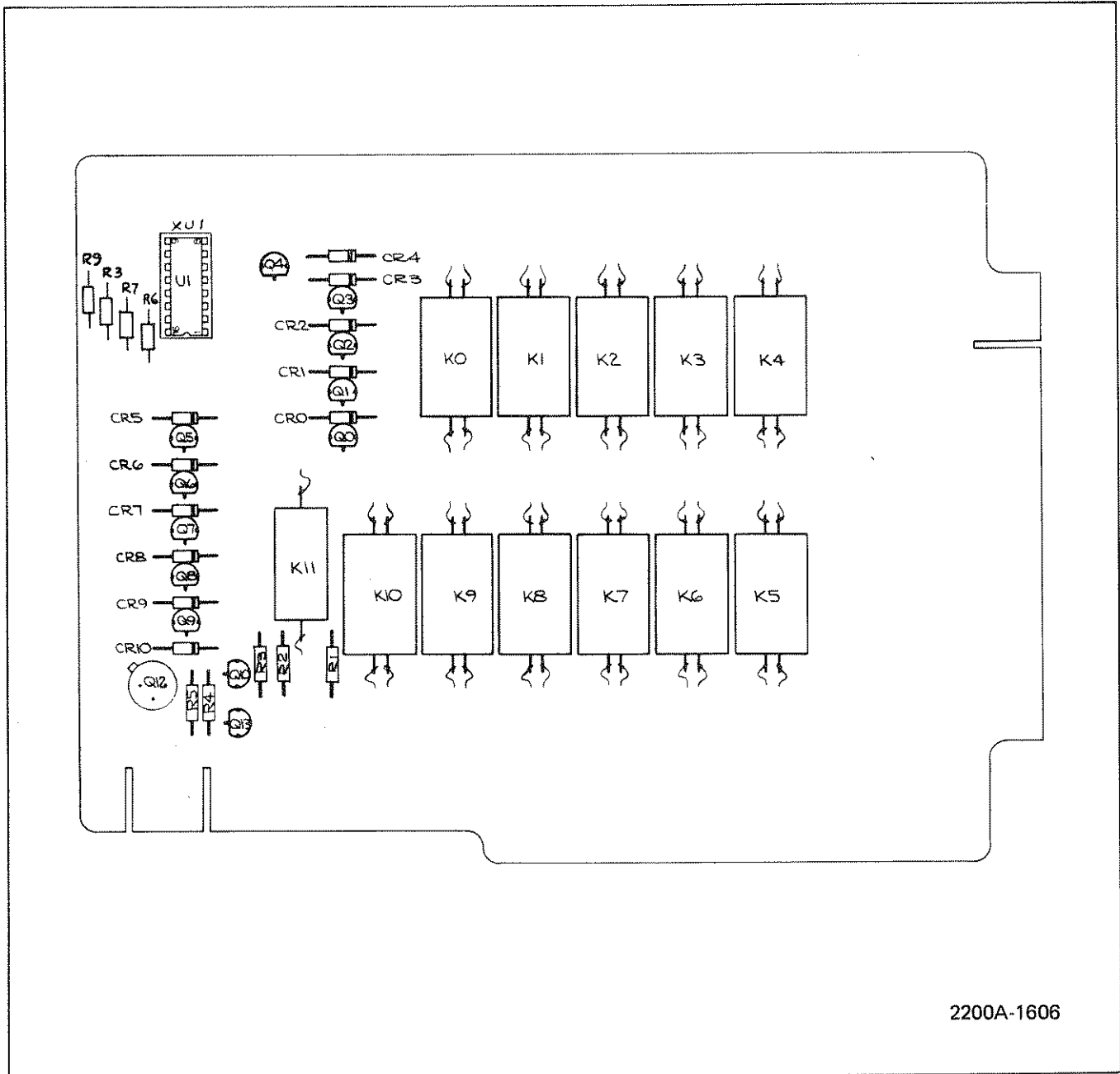

2200A-1606

Figure 605-5. General Purpose Scanner PCB Assembly

Option -06  
Low Level Scanner

606-1. INTRODUCTION

606-2. The Low Level Scanner (Option -06) is a plug-in, 10-channel, 3-wire relay scanner designed to operate as a low-level, analog data multiplexer in a 2200/2240 Series Data Logger/Scanner Chassis (hereafter referred to collectively as data logger). Switched high, low, and shield inputs are provided for each of the 10 channels. A decoupling relay is used to isolate the high, low, and shield buses from the common output connections when a channel relay is not activated. Activating any one of the 10-channel relays also energizes the decoupling relay.

606-3. SPECIFICATIONS

606-4. Specifications for the Low Level Scanner are contained in Table 606-1.

606-5. INSTALLATION

606-6. The Low Level Scanner mounts in any one of the available scanner block slots provided in the data logger, as shown in Figure 606-1. Install the scanner as follows:

WARNING

REMOVE LINE POWER AND ALL OTHER  
HIGH VOLTAGE INPUTS TO THE DATA  
LOGGER BEFORE STARTING THIS  
PROCEDURE.

1. Remove the top dust cover from the data logger.
2. Remove the large top inner cover located in the left rear of the unit (as viewed from the top front).

CAUTION

Handle the scanner pcb by its  
edges to avoid contaminating  
the pcb with oil from the  
hands. The use of gloves is  
recommended.

3. Select the slot that includes the block of channels the scanner is to represent, and align the scanner in the slot so that the 44-pin board-edge connector is toward the rear of the unit, and the small offset board-edge connectors are toward the bottom of the unit. Push the scanner straight down onto the mating connectors.



Table 606-1. Option -06 Specifications

Channel Relays . . . . .	10 low thermal-emf reed relays
Poles per Channel . . . . .	Three (includes shield switch)
Shield Switching . . . . .	One switch per channel
Voltage Offset . . . . .	$\leq 1 \mu\text{V}$
Input Voltage Limit* . . . . .	170V dc or peak ac max
Common Mode Voltage Limits (Voltage between chassis and any input)	350V dc or peak ac provided the Input Voltage Limit is not exceeded
Over-Current Protection . . . . .	470 $\Omega$ resistor in series with each input

*\*Maximum voltage between any two terminals in the system. Includes normal mode as well as common mode voltages.*

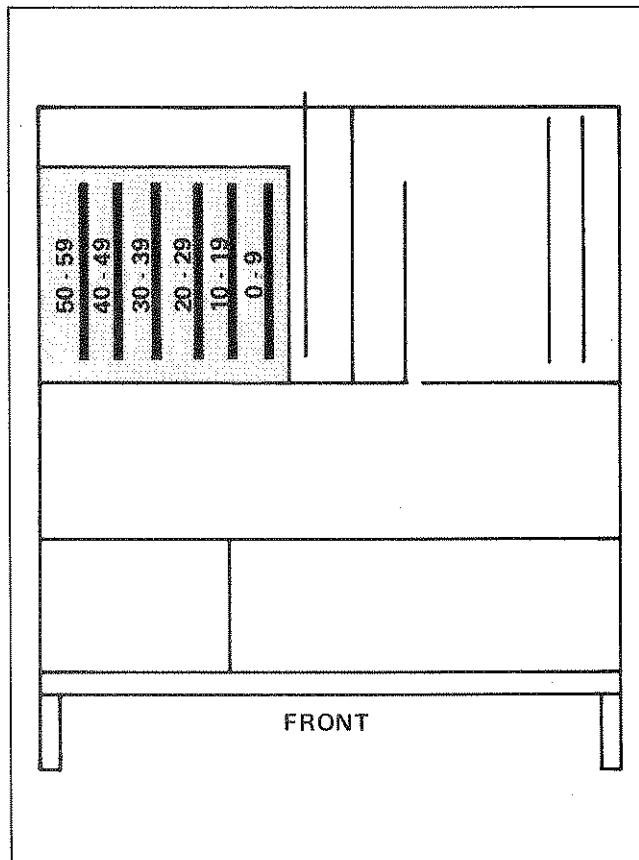

Figure 606-1. Scanner Mounting Locations

4. After the desired number of scanners is installed, install the large left rear inner cover.
5. Install the top dust cover.

#### 606-7. OPERATION

606-8. Once installed in the data logger, the Low Level Scanner requires no operator attention. However, certain considerations are necessary to properly interface the scanner with analog input data. These considerations are covered in the following paragraphs.

#### 606-9. Input Connections

606-10. Analog interface connections with the Low Level Scanner are completed through either one of two types of connectors, both of which are available as options. They include the Solder Pin Connector (Option -07) and the Isothermal Block Connector (Option -08). The Solder Pin Connector is a general purpose assembly which consists of a 44-pin connector mounted on a pcb. Solder-type cable connections are provided. A clam-shell housing provides strain relief for the cable and protection of the connector contacts. The Isothermal Block Connector is required for thermocouple inputs. It features an isothermal block with screw-type connections and a temperature sensing circuit. Refer to the appropriate option subsection for additional information.

#### 606-11. Input Pin Assignments

606-12. The pin assignments for the rear panel connector of the Low Level Scanner are shown in Figure 606-2. Since contact with these signals is completed through one of two optional connectors (Option -07 or -08) refer to the appropriate option subsection for pin assignments as available for fabrication interface cables.

#### NOTE

The guard connections shown in Figure 606-2 represent a unique potential within the data logger. Input shields should be connected to the shield pins, not to the guard pins.

#### 606-13. THEORY OF OPERATION

606-14. The Low Level Scanner, as shown in Figure 606-3, is a programmable, 10-channel relay scanner designed to operate as a plug-in option in any one of the scanner block slots in a 2200/2240 Series Data Logger. Channel scanning or multiplexing is accomplished by a series of 11 three-pole, form-A, reed relays.

TOP			
L0	A	1	H0
GUARD	B	2	S0
H1	C	3	L1
S1	D	4	GUARD
L2	E	5	H2
GUARD	F	6	S2
H3	H	7	L3
S3	J	8	A/D COM.
TEMP. SIG.	K	9	6.2V dc (OUT)
BSL	L	10	REF. COM.
GUARD	M	11	S4
L4	N	12	H4
S5	P	13	GUARD
H5	R	14	L5
GUARD	S	15	S6
L6	T	16	H6
S7	U	17	GUARD
H7	V	18	L7
GUARD	W	19	S8
L8	X	20	H8
S9	Y	21	GUARD
H9	Z	22	L9

Sx = Shield for channel x.  
 Lx = Low input to channel x.  
 Hx = High input to channel x.  
 Where :x = Block channel no. (0-9)

Figure 606-2. Low Level Scanner J13 Pin Assignments

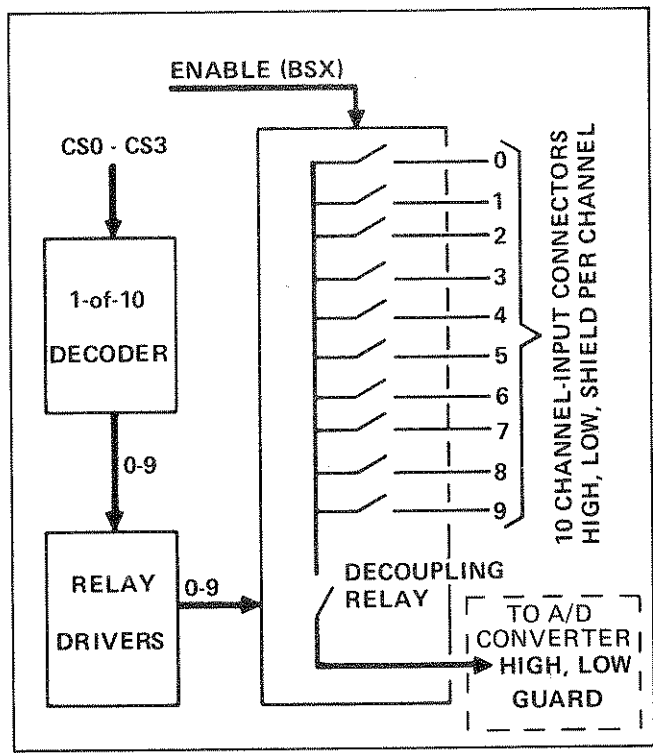

Figure 606-3. Low Level Scanner, Functional Block Diagram

Ten of the relays serve as three-wire input-channel switches to a common (high/low/shield) output bus. The eleventh relay also contacts the three-wire bus. However, its function is to isolate or decouple the Scanner Bus from the actual output connections. When any one of the channel relays is energized the decoupling relay is also activated to complete the three-wire input/output circuit.

606-15. All scanner pcb's installed in a data logger receive bcd channel select information in parallel from a 4-bit Data Bus (CS0 through CS3). This data is decoded on each scanner pcb into 10 separate channel commands (0-9). Each command line is first buffered and then connected to one of the 10 channel-relay coils. Even though these commands are present, the relays will not be energized unless the scanner receives a scanner-block select (BSX) command. This command is actually an address or enable signal which applies a control command to the low side of the relay coils. When this signal is present the decoupling relay and the selected channel relay will be energized. At that time, the analog input data on the selected channel appears at the scanner output terminals.

606-16. MAINTENANCE

606-17. Access Information

606-18. Refer to the installation information given previously for scanner access information. Remove the rear panel input connector before attempting to remove the scanner pcb from the data logger.

606-19. Performance Test

606-20. The performance test is designed to verify the overall operation of the Low Level Scanner PCB Assembly, and is intended for use as an acceptance test and/or periodic maintenance check. The equipment used in the test is specified in Table 606-2. If the scanner fails any part of the performance test, corrective action is required.

1. Using the resistors and the input connector specified in Table 606-2, fabricate a scanner test cable as shown in Figure 606-4.
2. Install the Low Level Scanner PCB in the channel 0-9 slot of the data logger.
3. Set the calibrator output to 0V dc.
4. Connect the test cable leads to the calibrator's voltage output terminals (red to positive, black and white to negative).
5. Set the calibrator output to 1.000V dc.

Table 606-2. Required Test Equipment

INSTRUMENT	RECOMMENDED MODEL
DC Voltage Calibrator	Fluke 343A
Data Logger	Fluke 2200B/2240C
Input Connector	Fluke 2200A-07 or -08
Resistors (10 each)	Metal film 1k $\pm$ 1%, 1/4W

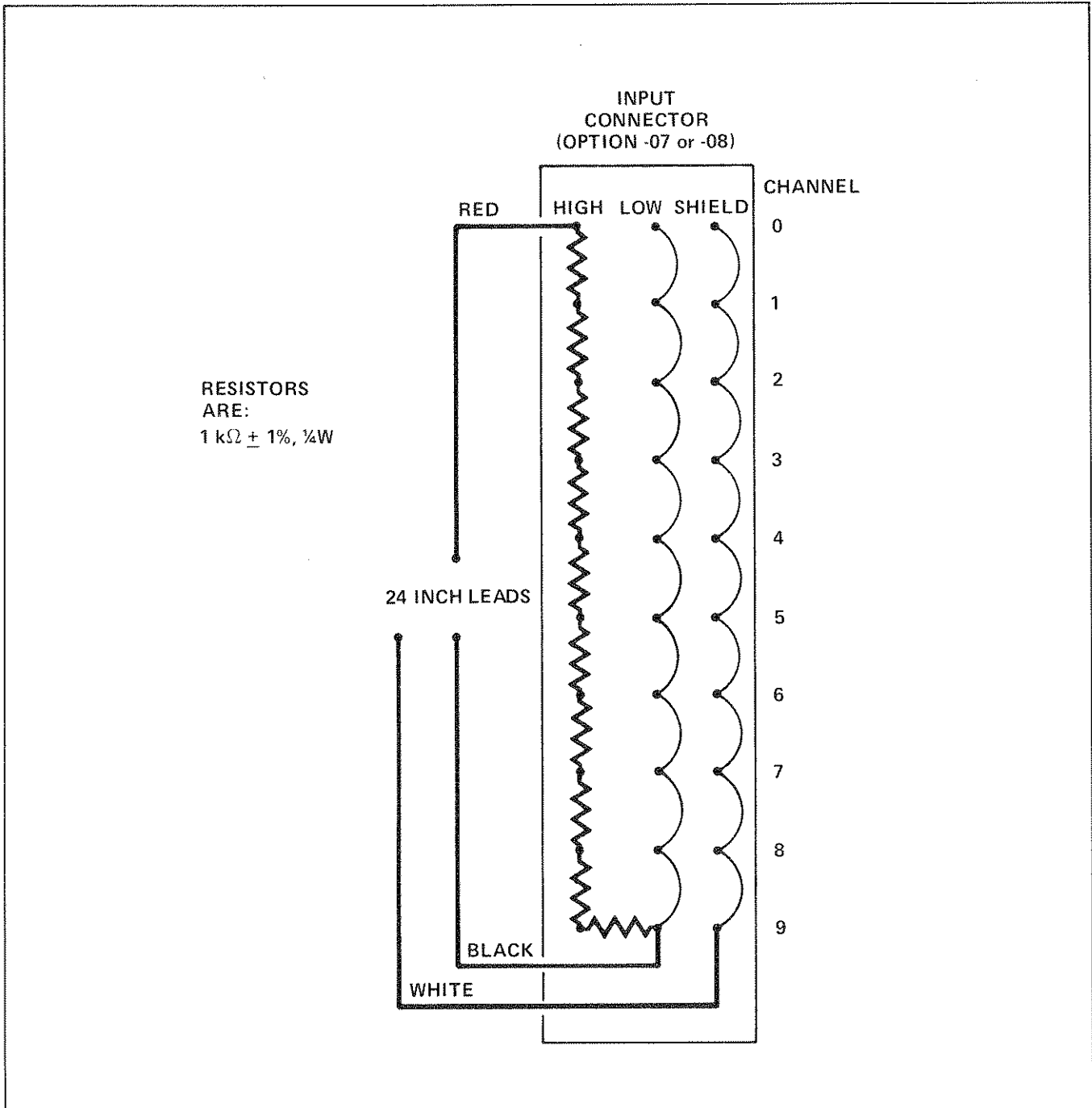

Figure 606-4. Scanner Test Cable

6. Program the data logger as follows:
  - a. First channel to 0.
  - b. Last channel to 9.
  - c. Each channel function to 4V.
  - d. Press the ALL DATA (printer) switch in the OUTPUT CONTROL switch group.
7. Press the SINGLE can switch and observe the printed measurement data. Channel 0 should read +1.000V dc  $\pm 1\%$ . A cumulative +0.1V dc decrease should be observed at each of the remaining channels. (Channel 9 should read +0.1V dc.) Any deviation in this pattern indicates a defective pcb assembly.

#### 606-21. LIST OF REPLACEABLE PARTS

606-22. A list of replaceable parts for the Low Level Scanner PCB Assembly is given in Table 606-3. Refer to Section 5 of this manual for ordering information.

#### ⊗ CAUTION

Indicated devices are subject to damage by static discharge.

Table 606-3. Low Level Scanner Assembly

REF DES	DESCRIPTION	FLUKE STOCK NO.	MFG SPLY CODE	MFG. PART NO.	TOT QTY	REC QTY	N O T E
06②	LOW LEVEL SCANNER ASSEMBLY FIGURE 606-5 (2200A-4029T)	ORDER	BY	OPTION -06			
CR0	DIODE, SI, HI-SPEED SWITCH	203323	07910	1N4448	11		3
CR1	DIODE, SI, HI-SPEED SWITCH	203323	07910	1N4448	REF		
CR2	DIODE, SI, HI-SPEED SWITCH	203323	07910	1N4448	REF		
CR3	DIODE, SI, HI-SPEED SWITCH	203323	07910	1N4448	REF		
CR4	DIODE, SI, HI-SPEED SWITCH	203323	07910	1N4448	REF		
CR5	DIODE, SI, HI-SPEED SWITCH	203323	07910	1N4448	REF		
CR6	DIODE, SI, HI-SPEED SWITCH	203323	07910	1N4448	REF		
CR7	DIODE, SI, HI-SPEED SWITCH	203323	07910	1N4448	REF		
CR8	DIODE, SI, HI-SPEED SWITCH	203323	07910	1N4448	REF		
CR9	DIODE, SI, HI-SPEED SWITCH	203323	07910	1N4448	REF		
CR10	DIODE, SI, HI-SPEED SWITCH	203323	07910	1N4448	REF		
H1	SCREW, PHP, 6-32 X 5/8	572537	89536	572537	5		
J14	CONNECTOR, MALE, 12-PIN	380683	27264	A2402-09-64-1121	1		
J15.							
KO-K10	RELAY COIL ASSEMBLY	ORDER	THE	COIL/CORES SEPARATE			
	COIL, REED RELAY, 135 +/-10%, 5V	380709	71707	E8206	11		
	CORE, METAL	380451	89536	380451	11		
MP1	SHIELD, BOTTOM SCANNER	412296	89536	412296	1		
MP2	SHIELD, TOP SCANNER	412304	89536	412304	1		
MP3	SPACER, BOTTOM	412320	89536	412320	1		
MP4	SPACER, TOP	412312	89536	412312	1		
P14	CONNECTOR, FEMALE, 12-PIN	380691	27264	2145-B09-52-3122	1		
Q0	XSTR, SI, PNP	195974	04713	2N3906	10		2
Q1	XSTR, SI, PNP	195974	04713	2N3906	REF		
Q2	XSTR, SI, PNP	195974	04713	2N3906	REF		
Q3	XSTR, SI, PNP	195974	04713	2N3906	REF		
Q4	XSTR, SI, PNP	195974	04713	2N3906	REF		
Q5	XSTR, SI, PNP	195974	04713	2N3906	REF		
Q6	XSTR, SI, PNP	195974	04713	2N3906	REF		
Q7	XSTR, SI, PNP	195974	04713	2N3906	REF		
Q9	XSTR, SI, PNP	195974	04713	2N3906	REF		
Q10	XSTR, SI, NPN	218396	04713	2N3904	1		1
Q11	XSTR, SI, NPN	182196	07263	2N3643	1		1
Q12	XSTR, FET, N-CHANNEL	357905	89536	357905	1		1
R0	RES, COMP, 470 +/-5%, 1/4W	147983	01121	CB4715	31		
R1	RES, COMP, 470 +/-5%, 1/4W	147983	01121	CB4715	REF		
R2	RES, COMP, 470 +/-5%, 1/4W	147983	01121	CB4715	REF		
R3	RES, COMP, 470 +/-5%, 1/4W	147983	01121	CB4715	REF		
R4	RES, COMP, 470 +/-5%, 1/4W	147983	01121	CB4715	REF		
R5	RES, COMP, 470 +/-5%, 1/4W	147983	01121	CB4715	REF		
R6	RES, COMP, 470 +/-5%, 1/4W	147983	01121	CB4715	REF		
R7	RES, COMP, 470 +/-5%, 1/4W	147983	01121	CB4715	REF		
R8	RES, COMP, 470 +/-5%, 1/4W	147983	01121	CB4715	REF		
R9	RES, COMP, 470 +/-5%, 1/4W	147983	01121	CB4715	REF		
R10	RES, COMP, 470 +/-5%, 1/4W	147983	01121	CB4715	REF		
R11	RES, COMP, 470 +/-5%, 1/4W	147983	01121	CB4715	REF		

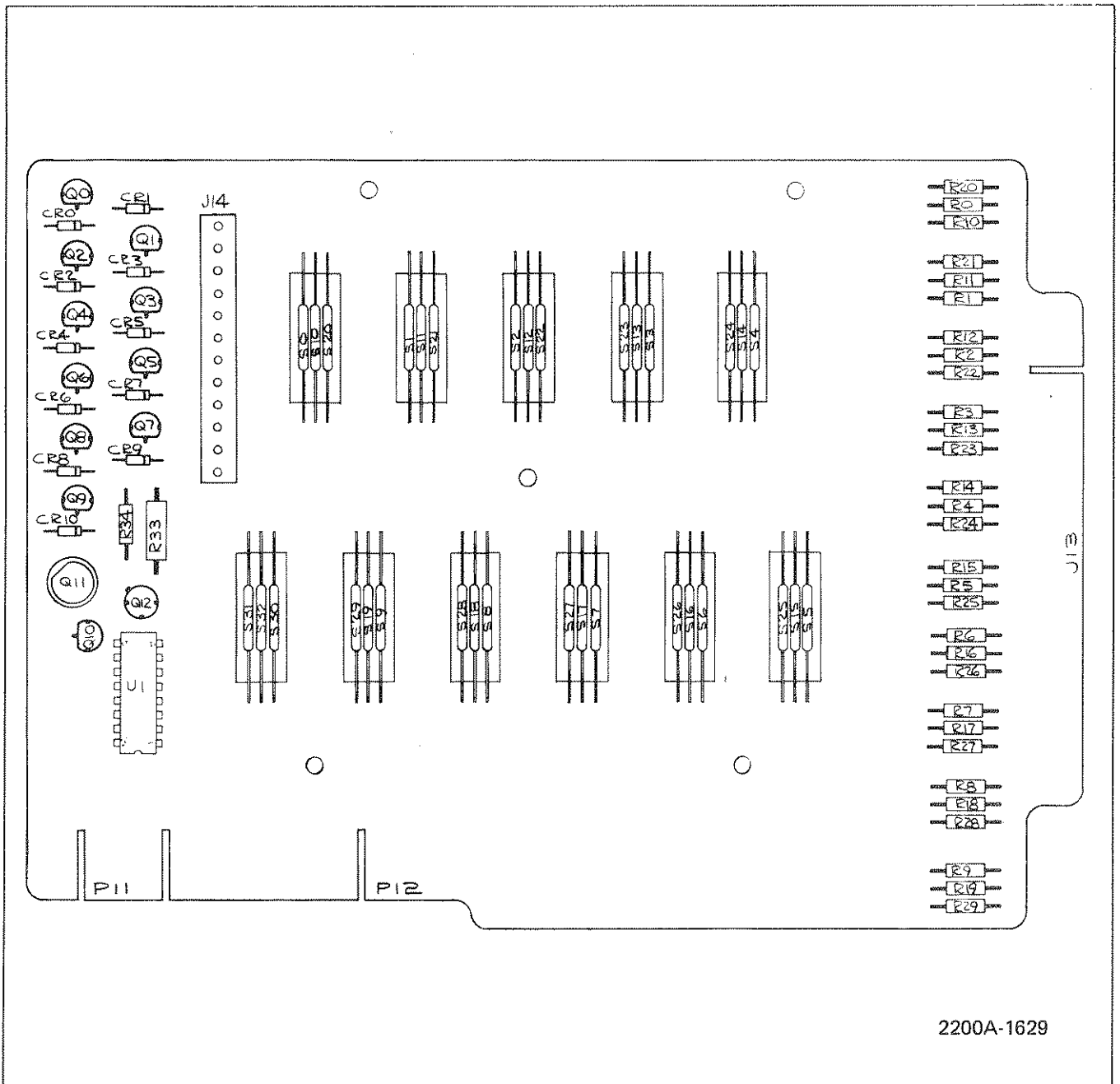

Table 606-3. Low Level Scanner Assembly (cont)

REF DES	DESCRIPTION	FLUKE STOCK NO.	MFG SPLY CODE	MFG. PART NO.	TOT QTY	REC QTY	NOTE
R12	RES, COMP, 470 +/-5%, 1/4W	147983	01121	CB4715		REF	
R13	RES, COMP, 470 +/-5%, 1/4W	147983	01121	CB4715		REF	
R14	RES, COMP, 470 +/-5%, 1/4W	147983	01121	CB4715		REF	
R15	RES, COMP, 470 +/-5%, 1/4W	147983	01121	CB4715		REF	
R16	RES, COMP, 470 +/-5%, 1/4W	147983	01121	CB4715		REF	
R17	RES, COMP, 470 +/-5%, 1/4W	147983	01121	CB4715		REF	
R18	RES, COMP, 470 +/-5%, 1/4W	147983	01121	CB4715		REF	
R19	RES, COMP, 470 +/-5%, 1/4W	147983	01121	CB4715		REF	
R20	RES, COMP, 470 +/-5%, 1/4W	147983	01121	CB4715		REF	
R21	RES, COMP, 470 +/-5%, 1/4W	147983	01121	CB4715		REF	
R22	RES, COMP, 470 +/-5%, 1/4W	147983	01121	CB4715		REF	
R23	RES, COMP, 470 +/-5%, 1/4W	147983	01121	CB4715		REF	
R24	RES, COMP, 470 +/-5%, 1/4W	147983	01121	CB4715		REF	
R25	RES, COMP, 470 +/-5%, 1/4W	147983	01121	CB4715		REF	
R26	RES, COMP, 470 +/-5%, 1/4W	147983	01121	CB4715		REF	
R27	RES, COMP, 470 +/-5%, 1/4W	147983	01121	CB4715		REF	
R28	RES, COMP, 470 +/-5%, 1/4W	147983	01121	CB4715		REF	
R29	RES, COMP, 470 +/-5%, 1/4W	147983	01121	CB4715		REF	
R33	RES, COMP, 10K +/-5%, 1/2W	109165	01121	EB1035		1	
R34	RES, COMP, 470 +/-5%, 1/4W	147983	01121	CB4715		REF	
S0	SWITCH, DRY REED, SPST 3W, 40V	450627	89536	450627		33	
S1	SWITCH, DRY REED, SPST 3W, 40V	450627	89536	450627		REF	
S2	SWITCH, DRY REED, SPST 3W, 40V	450627	89536	450627		REF	
S3	SWITCH, DRY REED, SPST 3W, 40V	450627	89536	450627		REF	
S4	SWITCH, DRY REED, SPST 3W, 40V	450627	89536	450627		REF	
S5	SWITCH, DRY REED, SPST 3W, 40V	450627	89536	450627		REF	
S6	SWITCH, DRY REED, SPST 3W, 40V	450627	89536	450627		REF	
S7	SWITCH, DRY REED, SPST 3W, 40V	450627	89536	450627		REF	
S8	SWITCH, DRY REED, SPST 3W, 40V	450627	89536	450627		REF	
S9	SWITCH, DRY REED, SPST 3W, 40V	450627	89536	450627		REF	
S10	SWITCH, DRY REED, SPST 3W, 40V	450627	89536	450627		REF	
S11	SWITCH, DRY REED, SPST 3W, 40V	450627	89536	450627		REF	
S12	SWITCH, DRY REED, SPST 3W, 40V	450627	89536	450627		REF	
S13	SWITCH, DRY REED, SPST 3W, 40V	450627	89536	450627		REF	
S14	SWITCH, DRY REED, SPST 3W, 40V	450627	89536	450627		REF	
S15	SWITCH, DRY REED, SPST 3W, 40V	450627	89536	450627		REF	
S16	SWITCH, DRY REED, SPST 3W, 40V	450627	89536	450627		REF	
S17	SWITCH, DRY REED, SPST 3W, 40V	450627	89536	450627		REF	
S18	SWITCH, DRY REED, SPST 3W, 40V	450627	89536	450627		REF	
S19	SWITCH, DRY REED, SPST 3W, 40V	450627	89536	450627		REF	
S20	SWITCH, DRY REED, SPST 3W, 40V	450627	89536	450627		REF	
S21	SWITCH, DRY REED, SPST 3W, 40V	450627	89536	450627		REF	
S22	SWITCH, DRY REED, SPST 3W, 40V	450627	89536	450627		REF	
S23	SWITCH, DRY REED, SPST 3W, 40V	450627	89536	450627		REF	
S24	SWITCH, DRY REED, SPST 3W, 40V	450627	89536	450627		REF	
S25	SWITCH, DRY REED, SPST 3W, 40V	450627	89536	450627		REF	
S26	SWITCH, DRY REED, SPST 3W, 40V	450627	89536	450627		REF	
S27	SWITCH, DRY REED, SPST 3W, 40V	450627	89536	450627		REF	
S28	SWITCH, DRY REED, SPST 3W, 40V	450627	89536	450627		REF	
S29	SWITCH, DRY REED, SPST 3W, 40V	450627	89536	450627		REF	

Table 606-3. Low Level Scanner Assembly (cont)

REF DES	DESCRIPTION	FLUKE STOCK NO.	MFG SPLY CODE	MFG PART NO. OR TYPE	TOT QTY	REC QTY	NOTE
S30	SWITCH, DRY REED, SPST 3W, 40V	450627	89536	450627	REF		
S31	SWITCH, DRY REED, SPST 3W, 40V	450627	89536	450627	REF		
S32	SWITCH, DRY REED, SPST 3W, 40V	450627	89536	450627	REF		
U1Ø	IC, C-MOS, 1-OF-10 DECODER	407981	12040	MM74C42	1		
XQ11	SPACER, XSTR MOUNTING, (NOT SHOWN)	152207	07047	10123-DAP	1		
XU1	SOCKET, IC, 16-PIN	276535	91506	316-AG39D	1		



2200A-1629

Figure 606-5. Low Level Scanner Assembly

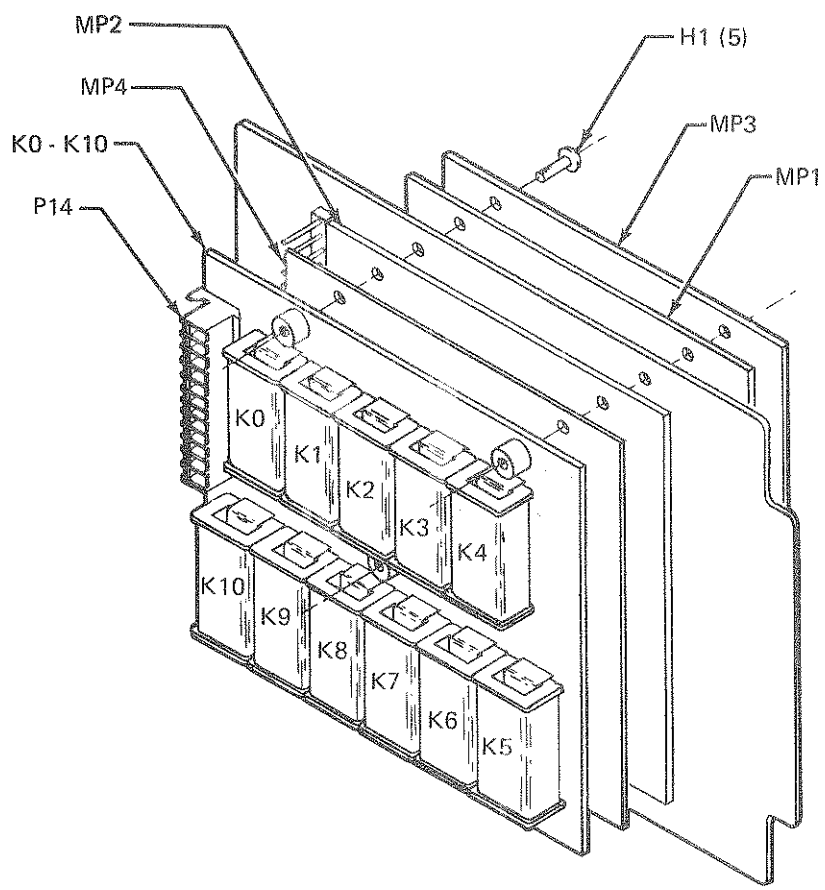

2200A-1629

Figure 606-5. Low Level Scanner Assembly (cont)

Option -07  
Solder Pin Connector

607-1. INTRODUCTION

607-2. The Solder Pin Connector (Option -07) is a general purpose connector assembly which mounts in the rear of the data logger and provides electrical contact with the analog inputs of either the General Purpose Scanner or the Low Level Scanner. The connector is designed for use in fabricating a custom interface cable to provide external analog inputs to a single relay scanner (10 analog channels).

607-3. The connector assembly consists of a 44-pin board-edge connector which is mounted on a pcb housed in a clam-shell enclosure. The enclosure separates from the assembly to provide access to solder-type connections at the rear of the connector. Strain relief for the cable connections is provided by the enclosure.

607-4. SPECIFICATIONS

607-5. Specifications for the Solder Pin Connector are given in Table 607-1.

607-6. INSTALLATION NOTES

607-7. The purpose of the SHIELD connection is to improve rejection of common-mode voltage noise. This is done by connecting the SHIELD lead to the LO lead at the measurement point as shown in Figure 607-1. In the presence of common-mode voltage, this connection provides a path for the current which flows as the capacitance between the A/D Converter and the chassis is being charged or discharged. Since the A/D Converter and the Shield (built into the instrument) are forced to track the same voltage, the common-mode current in the HI and LO leads is minimized. It is this current which produces unstable readings. It is important to note that HI, LO and Shield are fully isolated and capable of being safely floated to 350 Volts above ground. The following guidelines should be followed when connecting the Solder Pin Connector:

1. If significant RFI (Radio Frequency Interference) or EMI (Electro-Magnetic Interference) is present, the best measurement results will be obtained by connecting SHIELD to LO on the input connector with the shortest path possible.
2. If significant common mode voltage (greater than one volt) is present, connect SHIELD to LO by means of a third wire at the measurement point as shown in Figure 607-1.
3. For Thermocouples, connect SHIELD to the low

**Table 607-1. Option -07 Specifications**

Compatibility . . . . .	Mates with either the -05 or -06 scanners
Terminal Style . . . . .	Solder Type
Number of Terminals . . .	30 (High, Low, Shield per channel)

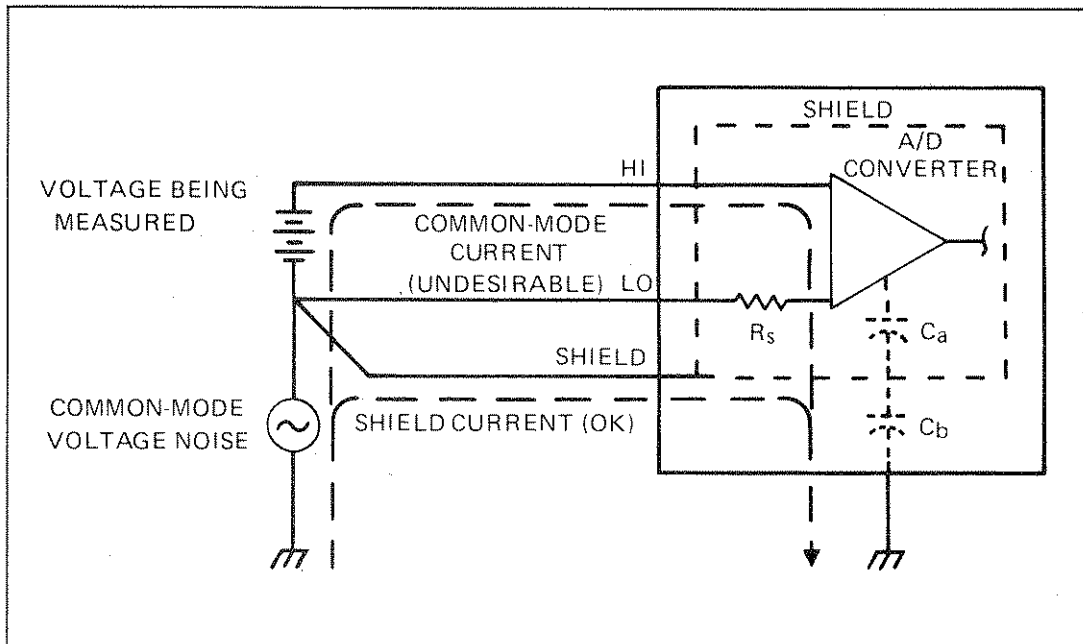

**Figure 607-1. Shield Connection for Optimum Common Mode Rejection**

Thermocouple lead as close to the Thermocouple junction as possible without affecting its temperature.

4. Never tie SHIELD to HI. This may actually amplify the effects of noise on the signal, causing a degradation in measurement performance.
5. Never leave SHIELD unconnected. Static charge build-up may cause the maximum SHIELD to LO voltage to be exceeded, resulting in instrument damage.
6. Never connect SHIELD to chassis ground. This will result in greatly increased common mode currents due to the large value of capacitance between the shield and the A/D Converter.

607-8. For further information on this subject, refer to the Fluke Application Bulletin AB-20 concerning guarded measurements. The Application Bulletin is available from your Fluke Sales Representative.

#### 607-9. CABLE FABRICATION

607-10. Figure 607-2 identifies the connector pins and signals necessary to interface external analog input data with either the General Purpose Scanner or the Low Level Scanner. Access to the solder-type terminals on the connector is accomplished by removing the four screws from the decal side of the connector enclosure. The decal identifies the pin connections and provides spaces for the user to uniquely identify the connector's block assignment and each of its channel inputs.

#### 607-11. INSTALLATION

607-12. The Solder Pin Connector and cable assembly mounts in any one of the available scanner-block slots containing a scanner module. See Figure 607-3. Install the Solder Pin Connector as follows:

1. Using your fingers, unlatch the two slide fasteners located on either side of the protruding enclosure on the rear of the data logger. Remove the enclosure from the rear panel.
2. Locate the desired scanner-block slot on the rear panel and check to ensure that a scanner module is installed in the slot.
3. With the connector key toward the top, position the Solder Pin Connector in the guides of the selected scanner block and mate it with the scanner's connector.

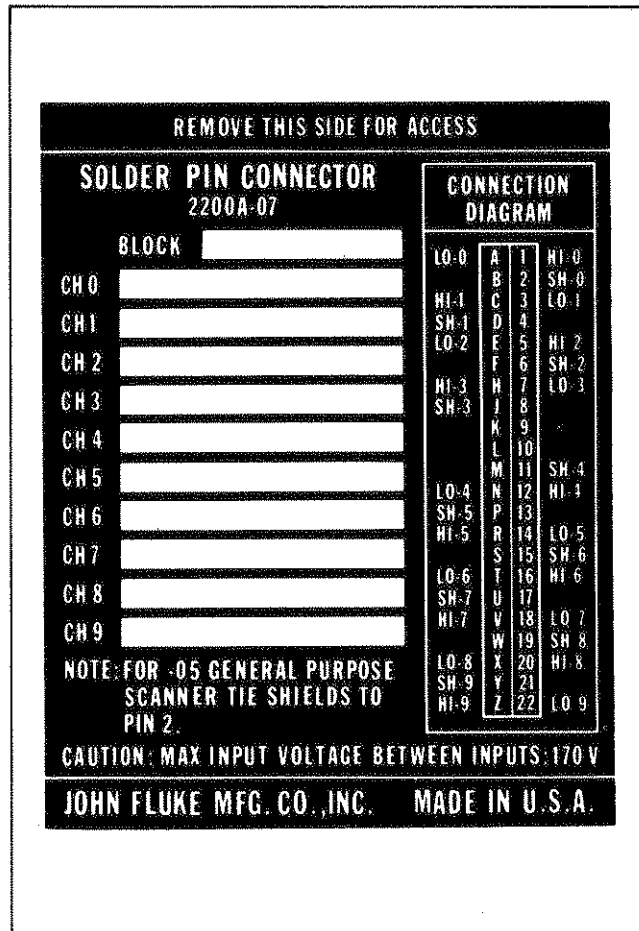

Figure 607-2. Solder Pin Connector  
Pin Assignments

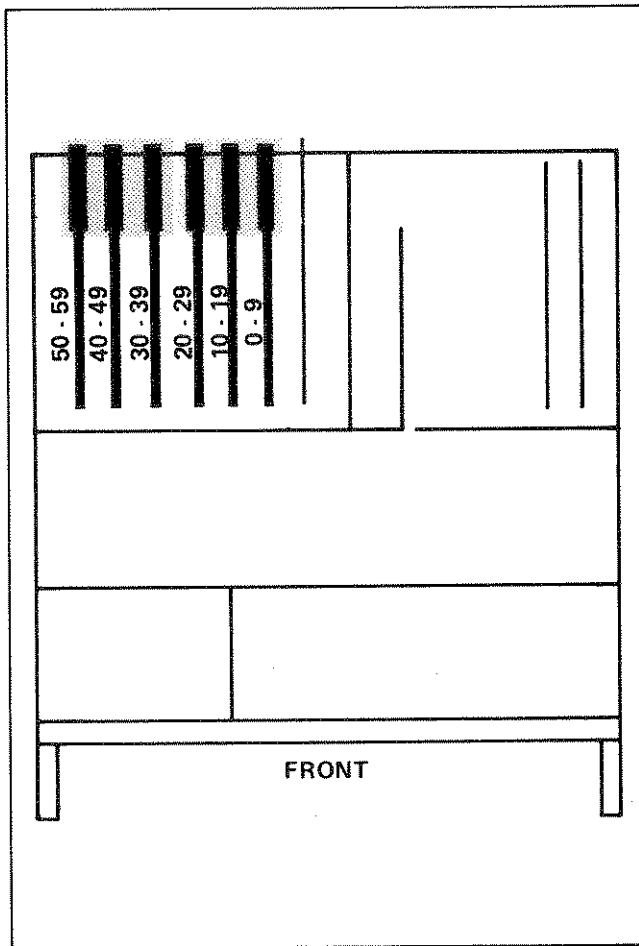

Figure 607-3. Solder Pin Connector  
Mounting Locations



the input connector to the data logger.

5. After the required number of input connectors are installed, install the rear panel enclosure.

#### 607-13. LIST OF REPLACEABLE PARTS

607-14. A list of replaceable parts for the Solder Pin Connector Assembly is given in Table 607-2. Refer to Section 5 of this manual for ordering information.

Table 607-2. Solder Pin Connector Assembly

REF DES	DESCRIPTION	FLUKE STOCK NO.	MFG SPLY CODE	MFG. PART NO.	TOT QTY	REC QTY	N O T E
07	SOLDER PIN CONNECTOR ASSEMBLY FIGURE 607-3 (2200A-07)	ORDER	BY	OPTION -07			
H1	SCREW, PHP, 4-40 X 5/8	145813	89536	145813	2		
H2	SCREW, PHP, S/S, 4-40 X 7/8	335133	89536	335133	2		
H3	SCREW, PHP, 6-32 X 1/4	152140	89536	152140	8		
H4	NUT, 4-40	110635	89536	110635	2		
H5	WASHER, FLAT	110775	89536	110775	2		
H6	WASHER, FLAT #4	146225	89536	146225	2		
H7	WASHER, LOCK #4	110395	89536	110395	2		
MP1	HOUSING, PLASTIC	414276	89536	414276	2		
	CONNECTOR BOARD ASSEMBLY	ORDER	PIECE	PARTS SEPARATELY			
MP2	CONNECTOR PCB	373332	89536	373332	1		
MP3	CONNECTOR, BOARD-EDGE, 44-PIN	385666	13511	225-22221-101	1		
MP4	KEY, CONNECTOR, POLARIZING	407254	13511	225-22221-101-22	1		

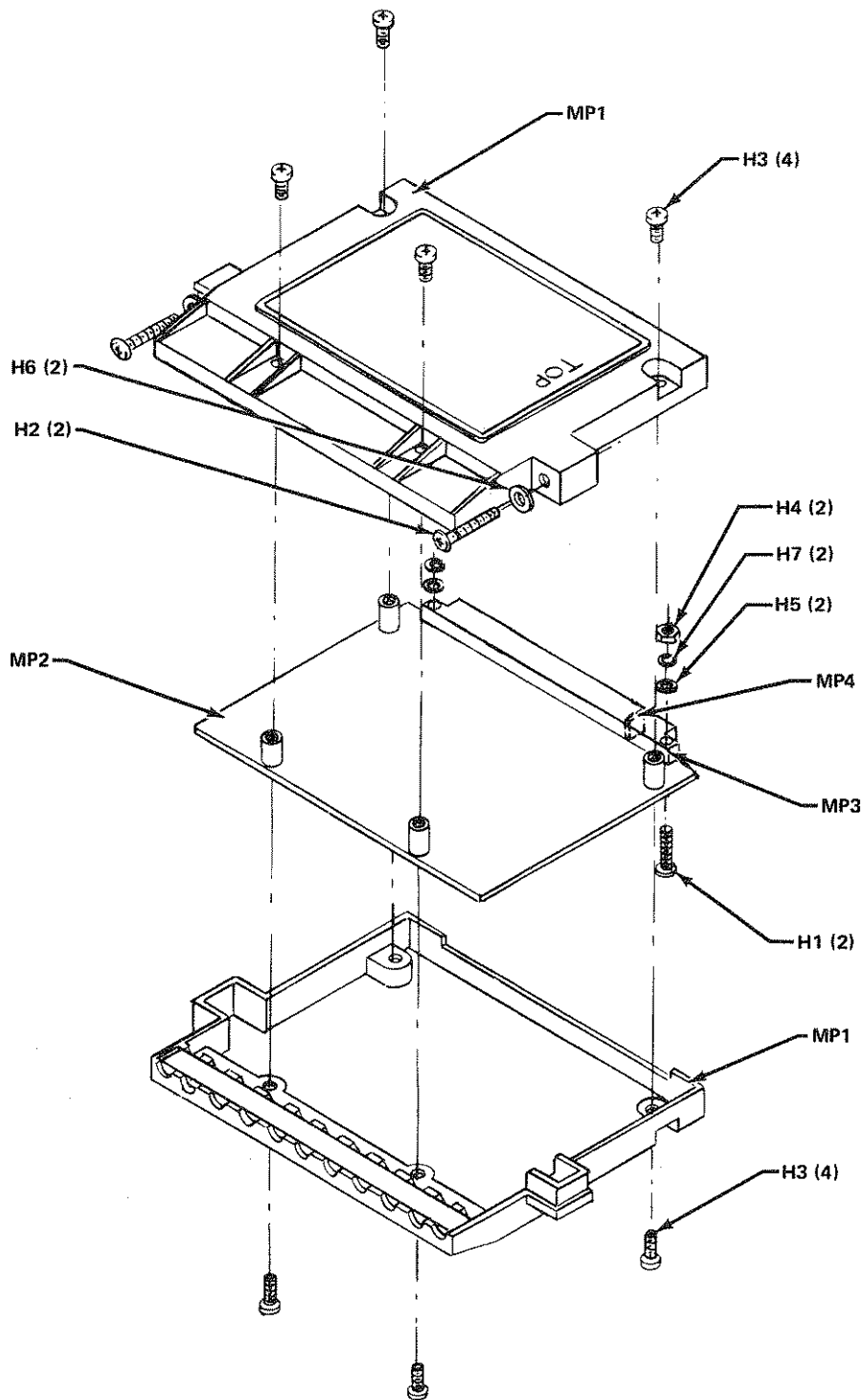

2200A-07

Figure 607-3. Solder Pin Connector

Option -08  
Isothermal Block Connector

608-1. INTRODUCTION

608-2. The Isothermal Block Connector (Option -08) is a 44-pin card-edge connector assembly designed for connecting low level thermocouple voltages and/or general purpose dc voltages to either the General Purpose Scanner (Option -05) or the Low Level Scanner (Option -06). Convenient screw-type input terminals are used to provide a fast and reliable method of completing the input connections. These terminals are thermally integrated into an isothermal block which is allowed to drift with ambient temperature. A temperature measuring circuit monitors the block temperature, and returns a proportional voltage to the data logger. This voltage is used by the data logger to calculate the temperature represented by each of up to 10 thermocouple-generated input voltages (i.e., one per channel). The temperature measuring feature does not interfere with ordinary voltage measurements.

608-3. SPECIFICATIONS

608-4. Specifications for the Isothermal Block Connector are given in Table 608-1.

608-5. INSTALLATION NOTES

608-6. Once installed in the chassis, the Isothermal Block Connector is ready for use. However, certain considerations are necessary to obtain optimal measurement accuracy. These considerations concern the use of the SHIELD terminal on the input connector.

608-7. The purpose of the SHIELD connection is to improve rejection of common-mode voltage noise. This is done by connecting the SHIELD lead to the LO lead at the measurement point as shown in Figure 608-1. In the presence of common-mode voltage, this connection provides a path for the current which flows as the capacitance between the A/D Converter and the chassis is being charged or discharged. Since the A/D Converter and the Shield (built into the instrument) are forced to track the same voltage, the common-mode current in the HI and LO leads is minimized. It is this current which produces unstable readings. It is important to note that HI, LO and Shield are fully isolated and capable of being safely floated to 350 Volts above ground. The following guidelines should be followed when connecting the Isothermal Block Connector:

1. If significant RFI (Radio Frequency Interference) or EMI (Electro-Magnetic Interference) is present, the best measurement results will be obtained by connecting SHIELD to LO on the input connector with the shortest path possible.

**Table 608-1. Option -08 Specifications**

Compatibility . . . . .	Mates with either the -05 or -06 scanners
Terminal Style . . . . .	Screw Type
Number of Terminals . . . . .	30 (High, Low, Shield per channel)
Temperature Gradient . . . . .	$\pm 0.05^{\circ}\text{C}$ maximum between any terminals
Reference Junction Stability . . . . .	$\pm 0.005^{\circ}\text{C}$ per $^{\circ}$ ( $0^{\circ}\text{C}$ to $50^{\circ}\text{C}$ )

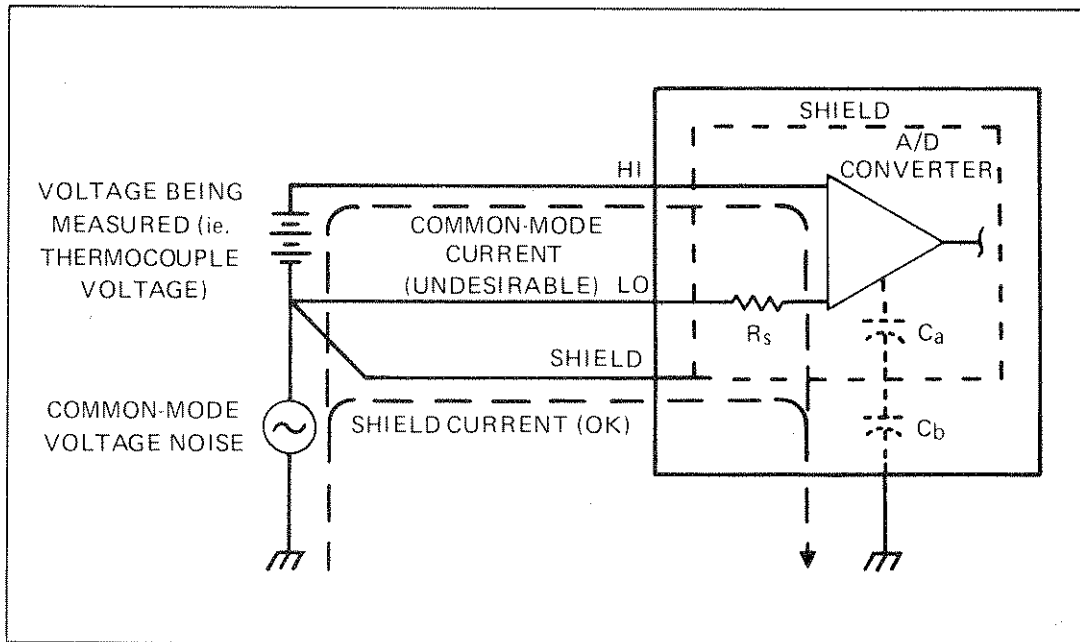

**Figure 608-1. Shield Connection for Optimum Common Mode Rejection**

2. If significant common mode voltage (greater than one volt) is present, connect SHIELD to LO by means of a third wire at the measurement point as shown in Figure 608-1.
3. For Thermocouples, connect SHIELD to the low Thermocouple lead as close to the Thermocouple junction as possible without affecting its temperature.
4. Never tie SHIELD to HI. This may actually amplify the effects of noise on the signal, causing a degradation in measurement performance.
5. Never leave SHIELD unconnected. Static charge build-up may cause the maximum SHIELD to LO voltage to be exceeded, resulting in instrument damage.
6. Never connect SHIELD to chassis ground. This will result in greatly increased common mode currents due to the large value of capacitance between the shield and the A/D Converter.

608-8. For further information on this subject, refer to the Fluke Application Bulletin AB-20 concerning guarded measurements. The Application Bulletin is available from your Fluke Sales Representative.

#### 608-9. INPUT CONNECTIONS

608-10. Figure 608-2 identifies the location of the high, low, and shield input terminals for each of the 10 scanner channels. Access to the terminals is accomplished by removing the four screws from the decal side of the connector enclosure. As input connections are completed, use the spaces provided on the connector decal to uniquely identify the connector's block (slot) assignment and each of its channel input signals.

#### 608-11. INSTALLATION

608-12. The Isothermal Block Connector can be mounted in any one of the data logger scanner-block slots which contain a relay scanner (Option -05 or -06). See Figure 608-3. Install the connector as follows:

1. Using your finger, unlatch the slide fasteners located on either side of the protruding enclosure at the rear of the data logger. Remove the enclosure from the rear panel.
2. Locate the desired scanner-block slot on the rear panel and check to ensure that a scanner module is installed in the slot.

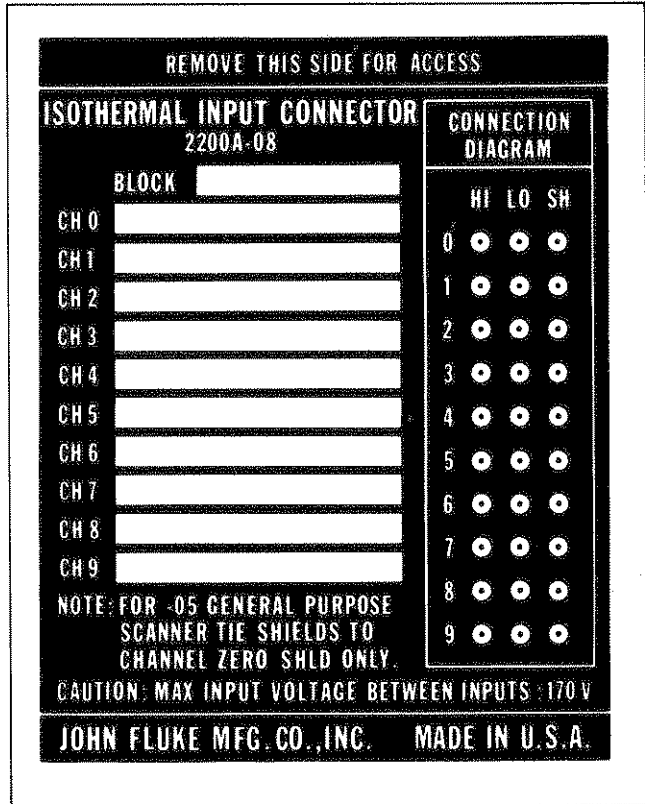

Figure 608-2. Isothermal Block Connector  
Terminal Assignments

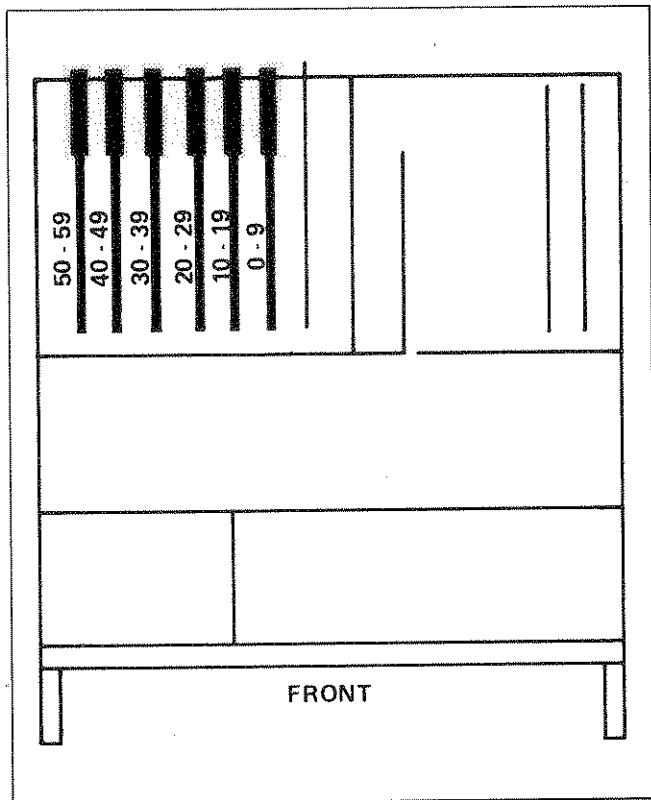

Figure 608-3. Isothermal Block Connector  
Mounting Locations



3. With the connector key toward the top, position the Isothermal Block Connector in the guides of the selected slot and mate it with the scanner's connector.
4. Install the retaining screws and washers that hold the input connector to the data logger.
5. After the required number of input connectors are installed, install the rear panel enclosure.

#### 608-13. OPERATION

608-14. Once installed, the Isothermal Block Connector requires no operator attention other than ensuring that the programmed function and/or range for each channel is compatible with the input signal source. For example, if the channel 0 input signal is derived from a thermocouple and a temperature reading is required, the programmed function must be in terms of temperature and thermocouple probe type. Programming a voltage range in this case would be meaningless.

#### 608-15. THEORY OF OPERATION

608-16. The Isothermal Block Connector provides the connections necessary for supplying voltage and/or (thermocouple) temperature inputs to any 10 scanner channels. Input connections are in the form of 10 sets of 3 screw terminals (high, low, and guard). The input signals at any given channel are measured in terms of voltage when a voltage function is programmed and in terms of temperature when a temperature function is programmed.

608-17. When a temperature function is programmed for a particular channel, it is assumed that a thermocouple probe (compatible with the selected function) is providing the input signal to that channel. Under these conditions the Isothermal Block Connector provides the microprocessor with the information necessary to compute the actual temperature at the thermocouple probe. This information includes the thermocouple voltage at the input terminals and a voltage indicative of the thermocouple input terminal temperature. The thermocouple input voltage is a direct result of the probe temperature versus the input terminal temperature. The input terminal temperature is measured by a separate sensing circuit and is electrically isolated from the thermocouple connections.

608-18. The temperature sensing circuit consists of a forward biased semiconductor junction which is thermally integrated into an anodized aluminum block. This block also surrounds and thermally integrates each of the 30 screw-type input terminals. The mass and temperature response of the block is such that the input terminal temperatures and the semiconductor sensor are held to within less than  $\pm 0.05^{\circ}\text{C}$  of each other. Actual block

temperature is allowed to vary with ambient temperature.

608-19. When a relay scanner is addressed the temperature sensing circuit provides the microprocessor with a voltage input proportional to the temperature of the isothermal block. This method of compensating a thermocouple reference junction is accurate over a temperature range of 0 to 50°C.

#### 608-20. CALIBRATION

608-21. The temperature sensor on the Isothermal Block Connector has been calibrated at the factory and does not require periodic calibration to meet the specifications (Table 608-1). However, calibration is required after the connector undergoes repair, or if the seal on the factory adjustment has been broken. The required equipment is listed in Table 608-2. Use the following procedure to calibrate the reference junction:

1. Calibrate the A/D Converter.
2. Install the Low Level Scanner (Option -06) in block 0 of the data logger.
3. Connect the thermocouple probe to the channel 4 terminals on the Isothermal Block Connector. Leave the terminal side of the connector cover off during the calibration procedure.
4. Attach the Isothermal Block Connector to the scanner in slot 0.
5. Prepare a room-temperature lag bath using the thermos bottle, and insert the thermometer and the thermocouple probe into the bath. (Allow the lag bath at least 15 minutes to stabilize.)
6. Energize the data logger and program it as follows:
  - a. Set Monitor Channel to 4.
  - b. Select temperature function that is compatible with the thermocouple probe.
  - c. Depress the MONITOR scan control switch.
7. The data logger display should read the temperature of the lag bath as indicated by the mercury thermometer. If the display is in error, slowly adjust the pot on the Isothermal Block Connector while observing the display. The adjustment is correct when the display agrees with the thermometer reading and remains constant for at least 30 seconds.

**Table 608-2. Equipment Required for Calibration**

<b>DESCRIPTION</b>	<b>RECOMMENDED MODEL OR TYPE</b>
Data Logger	Fluke 2200B/2240C
Low Level Scanner	Fluke 2200A-06
Thermocouple Probe	Type J, K, or T (select type compatible with data logger being used)
Mercury Thermometer, 0.02°C Resolution	Princo ASTM-56C
Dewar Flask and Cap	1-pint Thermos Bottle

608-22. LIST OF REPLACEABLE PARTS

608-23. A list of replaceable parts for the Isothermal Block Connector is given in Table 608-3. Refer to Section 5 of this manual for ordering information.

Table 608-3. Isothermal Block Connector

REF DES	DESCRIPTION	FLUKE STOCK NO.	MFG SPLY CODE	MFG. PART NO.	TOT QTY	REC QTY	NO TE
08	ISOTHERMAL BLOCK CONNECTOR FIGURE 608-3 (2200A-4023)	ORDER	BY	OPTION -08			
C1	CAP, CER, 0.05 UF +/-20%, 50V	148924	72982	5855-000-Y5U0-5032	1		
H1	SCREW, PHP, 4-40 X 1/2	152132	73734	19026	7		
H2	SCREW, PHP, 4-40 X 7/8	335133	89536	335133	2		
H3	SCREW, PHP, CAD, 6-32 X 1/4	152140	73734	19042	8		
H4	SCREW, PHP, S/S, 6-32 X 1/4	385401	89536	385401	30		
H5	WASHER, FLAT, #4	146225	86928	5710-18-32	2		
H6	WASHER, FLAT #4	147728	89536	147728	2		
H7	SCREW, FHP, SS, 4-40 X 3/8	256024	89536	256024	3		
MP1	INSULATOR, ISOTHERMAL BLOCK	373340	89536	373340	1		
MP2	ISOTHERMAL BLOCK	412379	89536	412379	1		
MP3	INSERT, POLARIZING (CEMENTED)	407254	54453	ISM-K1	1		
MP4	DECAL, ISOTHERMAL	423517	89536	423517	1		
MP5	CONNECTOR, HOUSING	414276	89536	414276	2		
MP6	SOCKET, COMP. LEAD	343285	00779	2-331272-6	2		
P13	CONNECTOR, BOARD-EDGE, 44-PIN	385674	13511	225-22221-105	1		
Q1	XSTR, SI, PNP (SELECTED)	380394	89536	380394	1	1	
Q2	XSTR, PET, N-CHANNEL	357905	89536	357905	1	1	
R1	RES, COMP, 330K +/-5%, 1/4W	192948	01121	CB3345	1		
R2	RES, COMP, 4.7K +/-5%, 1/4W	148072	01121	CB4725	1		
R3	RES, MF, 130K +/-1%, 1/8W	221648	91637	MFF1-81303F	1		
R4	RES, MTL. FILM, 287K +/- 1%, 1/8W	221622	91637	MFF1-82873F	1		1
R5	RES, VAR, CERMET, 150K +/-10%, 300V	414102	11236	360T151A	1	1	
1	R4....FACTORY SELECTED RESISTOR MAY OR MAY NOT BE USED.						

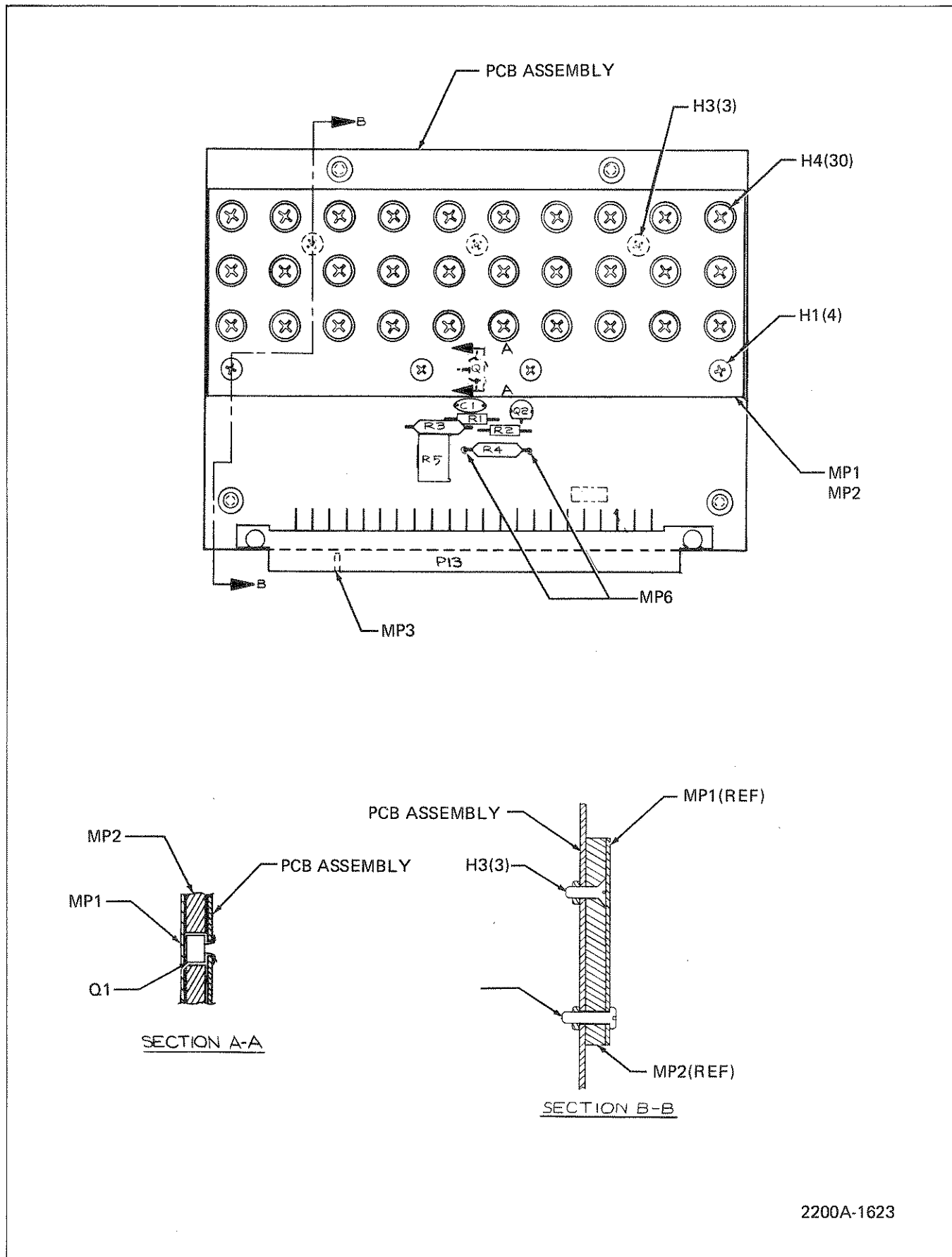

2200A-1623

Figure 608-3. Isothermal Block Connector



-12 Series  
Teleprinter and RS-232-C Interface Options

612-1. SCOPE

612-2. The -12 Series Options include Option -12C, -12L and -12M and most are described in Section 1 of the data logger manual. Only the PROMs installed on the board change from one -12 series option to the next. A -12C option PROM is marked TIS700 P0 (U17) and TIS700 P1 (U8); a -12L or M option PROM is marked VTTY P0 (U17) and VTTY P1 (U8). Each option in the series is compatible with a commercially available teleprinter or RS-232-C compatible recorder. The information contained herein deals with the basic Digital Output PCB used to interface these recorders.

612-3. INTRODUCTION

612-4. The Digital Output PCB is designed to transfer bit-serial-character-serial data from the data logger to an external recording peripheral. This includes: Time-of-Day, Fixed Data, Digital Input Data (Option -16), and measurement data. The appropriate carriage-return and line-feed characters are also generated. Provisions are included for initiating a scan sequence using a remote start input.

612-5. A unique interface cable and a series of 24 switches on the pcb are used to tailor the digital output to the recorder. The cable is included as part of the option. The switches are set by the user to define recorder baud rate and data format.

612-6. The pcb used with the -12 Series Options is capable of operating as either an RS-232-C or a 20 mA current loop interface. For current loop operation a relay on the pcb opens and closes the loop for character transmission. The 20 mA current source must be resident in the teletypewriter.

612-7. Table 612-1 defines the configuration of each available option in the -12 Series, as well as its intended interface type: current loop or RS-232-C. Order by option number and description.

612-8. SPECIFICATIONS

612-9. Specifications for the -12 Series of options are given in Table 612-2.

612-10. INSTALLATION

612-11. Digital Output PCB

612-12. Up to three Digital Output PCB's can be mounted in the data loggers I/O slots, as shown in Figure 612-1. Install each -12 Series pcb as follows:



Table 612-1. Configuration of -12 Series Options

OPTION NO.	DESCRIPTION	OPTION COMPONENTS (INDICATED BY ●)			INTERFACE TYPE	
		PCB	CABLE	RECORDER	20 mA	RS-232C
-12B	ASR-33 Interface	●	●		x	
-12C	TI733 KSR/RO Interface	●	●			x
-12L	RS-232C General Purpose Terminal Interface	●	●			x
-12M	RS-232C General Purpose Modern Interface	●	●			x

Table 612-2. -12 Series Option Specifications

Compatibility.....	Specify at time of purchase, using alphabetic suffix as shown in Table 617-1.
Output Format.....	Bit-serial, 8 bits per character, one start bit
Number of Stop Bits.....	1 for 300 to 4800 Band, 2 for 110 Band
Output Levels.....	20 mA dc current loop (-12B) and EIA Standard RS-232C (-12C, -12L, -12M, -12N)
Output Code.....	ASCII 7-level (no parity bit)
Measurements per Line.....	1 through 16, switch selectable
Word Format.....	Unwanted word blocks may be deleted by switches on pcb. Word order cannot be changed
Record Format.....	CR, LF (Carriage Return, Line Feed) Time-of-Day (days, hrs., min., sec.) CR, LF CR, LF (not in -12C), fixed Data, CR, LF Digital Inputs CR, LF (-16 Option) Channel, limit, sign, data, range, function, CR, LF
Baud Rate	
RS-232-C.....	110, 300, 1200, 2400, 4800 (Switch selectable)
20 mA Current Loop.....	110
-12C.....	110, 300

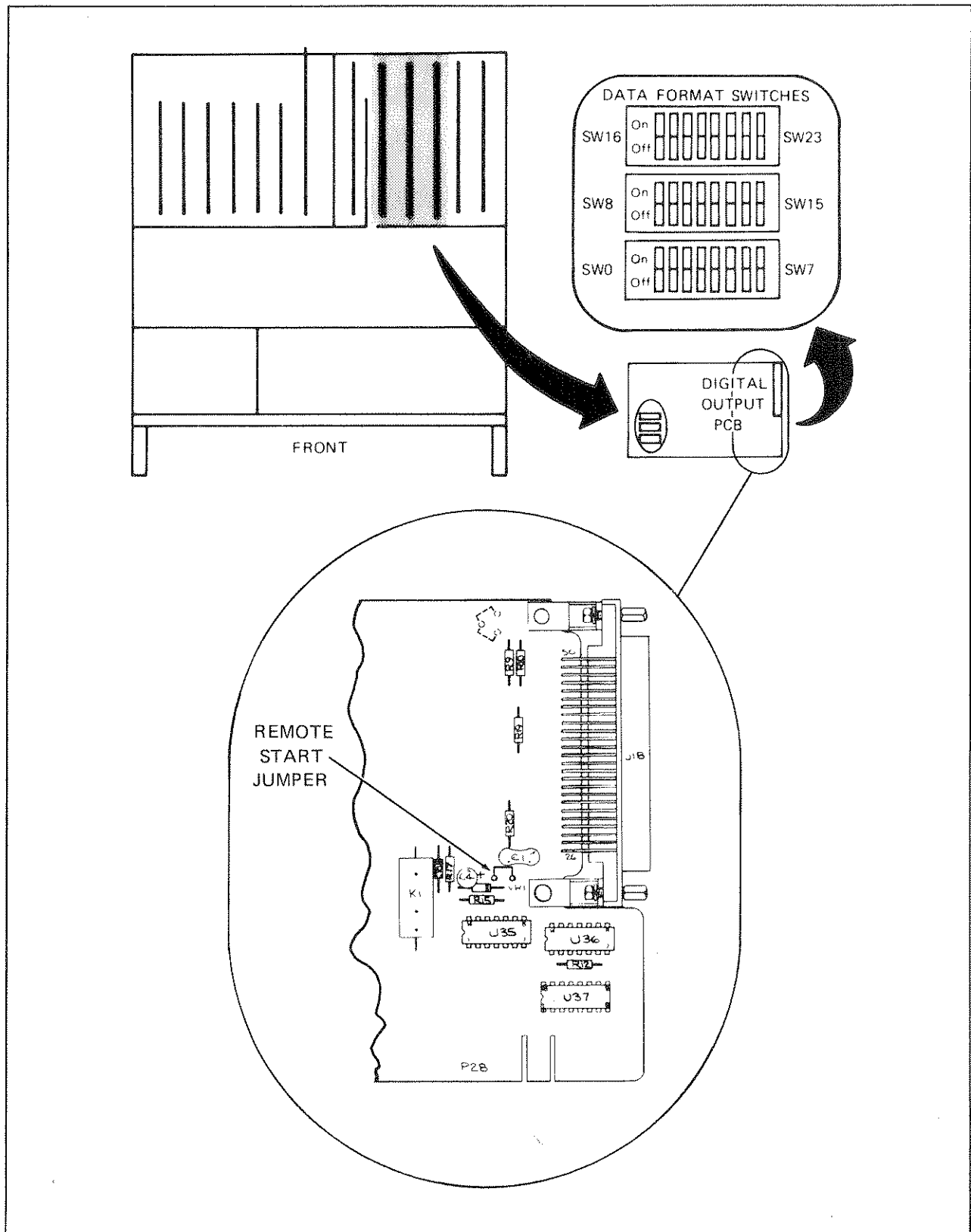

Figure 612-1. Digital Output PCB Installation and Switch Locations

## WARNING

REMOVE LINE POWER AND ALL OTHER HIGH VOLTAGE INPUTS TO THE DATA LOGGER BEFORE STARTING THIS PROCEDURE.

1. Set the data logger POWER switch to OFF.
2. Remove the top dust cover from the data logger.
3. Remove the inner, unguarded cover and locate the Data Format switches on each -12 Series Digital Output PCB, as shown in Figure 612-1.
4. With reference to Figure 612-2, establish the format of recorded data as follows:
  - a. Set switches 0 through 11 to OFF. This establishes the format shown in Figure 612-2.
  - b. Delete any combinations of unwanted character segments by setting the assigned switches to ON.
  - c. Set the desired baud rate using switches 16 through 19.
  - d. If a teletype or CRT is used to record data, set switches 12 through 15 to the desired number of readings per line minus 1. For example, a setting 0000 is equal to 1 reading per recorded line. The total number of characters and space per line cannot exceed the number of columns available on the teletype or CRT (80 typical).

## NOTE

Set unused switches (SW20-SW23) to OFF. If remote start capability is required, insure that the remote start jumper is installed on the pcb (refer to Figure 612-1).

5. Align each Digital Output PCB in its selected I/O slot so that the large female connector is toward the rear of the data logger, and the small board-edge connector is toward the bottom of the unit. Push the pcb straight down onto the mating connector.

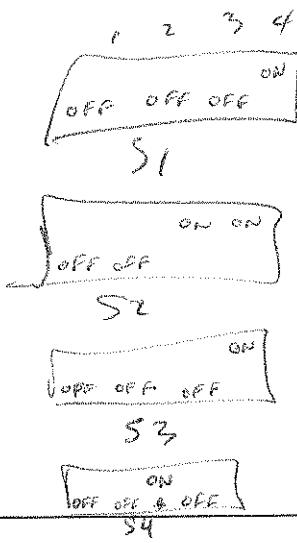

DETAILS OF RECORDED DATA																																																																																
DESCRIPTION	RECORDED DATA FORMAT AND CONTROL SWITCH (0 thru 11) ASSIGNMENTS *																																																																															
START OF SCAN	CR LF																																																																															
TIME OF YEAR (2240C ONLY)	<table border="0"> <tr> <td>D</td><td>D</td><td>D</td><td>:</td><td>H</td><td>H</td><td>:</td><td>M</td><td>M</td><td>:</td><td>S</td><td>S</td><td>CR</td><td>LF</td> </tr> <tr> <td colspan="11" style="text-align: center;">SW 0</td> <td style="text-align: center;">*</td> <td colspan="2" style="text-align: center;">SW 1</td> </tr> </table>	D	D	D	:	H	H	:	M	M	:	S	S	CR	LF	SW 0											*	SW 1																																																				
D	D	D	:	H	H	:	M	M	:	S	S	CR	LF																																																																			
SW 0											*	SW 1																																																																				
FIXED DATA (2240C)	NOT ON -12C <table border="0"> <tr> <td>CR</td><td>LF</td><td>SP</td><td>SP</td><td>FD</td><td>FD</td><td>FD</td><td>FD</td><td>FD</td><td>FD</td><td>CR</td><td>LF</td> </tr> <tr> <td colspan="11" style="text-align: center;">SW 2</td> <td style="text-align: center;">*</td> <td colspan="2" style="text-align: center;">SW 3</td> </tr> </table>	CR	LF	SP	SP	FD	FD	FD	FD	FD	FD	CR	LF	SW 2											*	SW 3																																																						
CR	LF	SP	SP	FD	FD	FD	FD	FD	FD	CR	LF																																																																					
SW 2											*	SW 3																																																																				
DIGITAL INPUT DATA (Option -16)	AC AC SP DD DD DD DD DD DD DD DD DD CR LF																																																																															
MEASUREMENT DATA -NORMAL	<table border="0"> <tr> <td>CH</td><td>CH</td><td>CH</td><td>SP</td><td>±</td><td>AD</td><td>AD</td><td>AD</td><td>AD</td><td>AD</td><td>AD</td><td>AD</td><td>SP</td><td>CR</td><td>LF</td> </tr> <tr> <td colspan="3" style="text-align: center;">SW4</td> <td style="text-align: center;">SW5</td> <td style="text-align: center;">SW6</td> <td style="text-align: center;">SW7</td> <td style="text-align: center;">SW8</td> <td style="text-align: center;">SW9</td> <td colspan="3" style="text-align: center;">SW10</td> <td style="text-align: center;">SW11</td> <td colspan="3"></td> </tr> <tr> <td colspan="11" style="text-align: center;">Floating Decimal Point</td> <td style="text-align: center;">m</td> <td style="text-align: center;">V</td> <td style="text-align: center;">C</td> <td style="text-align: center;">CR</td> <td style="text-align: center;">LF</td> </tr> <tr> <td colspan="11"></td> <td style="text-align: center;">↓</td> <td style="text-align: center;">F</td> <td style="text-align: center;">SP</td> <td style="text-align: center;">SP</td> <td style="text-align: center;">SP</td> </tr> <tr> <td colspan="11"></td> <td colspan="3" style="text-align: center;">MEASUREMENT UNITS</td> <td colspan="3"></td> </tr> </table>	CH	CH	CH	SP	±	AD	AD	AD	AD	AD	AD	AD	SP	CR	LF	SW4			SW5	SW6	SW7	SW8	SW9	SW10			SW11				Floating Decimal Point											m	V	C	CR	LF												↓	F	SP	SP	SP												MEASUREMENT UNITS					
CH	CH	CH	SP	±	AD	AD	AD	AD	AD	AD	AD	SP	CR	LF																																																																		
SW4			SW5	SW6	SW7	SW8	SW9	SW10			SW11																																																																					
Floating Decimal Point											m	V	C	CR	LF																																																																	
											↓	F	SP	SP	SP																																																																	
											MEASUREMENT UNITS																																																																					
MEASUREMENT DATA -ABNORMAL	<table border="0"> <tr> <td>CH</td><td>CH</td><td>CH</td><td>SP</td><td>SP</td><td>SP</td><td>O</td><td>L</td><td>SP</td><td>SP</td><td>SP</td><td>m</td><td>V</td><td>CR</td><td>LF</td> </tr> <tr> <td colspan="7"></td> <td style="text-align: center;">B</td> <td style="text-align: center;">T</td> <td colspan="3"></td> <td style="text-align: center;">C</td> <td style="text-align: center;">F</td> <td style="text-align: center;">SP</td> </tr> <tr> <td colspan="7"></td> <td colspan="2" style="text-align: center;">OVERLOAD</td> <td colspan="3"></td> <td colspan="3" style="text-align: center;">MEASUREMENT UNITS</td> </tr> <tr> <td colspan="7"></td> <td colspan="2" style="text-align: center;">BROKEN THERMOCOUPLE</td> <td colspan="3"></td> <td colspan="3"></td> </tr> </table>	CH	CH	CH	SP	SP	SP	O	L	SP	SP	SP	m	V	CR	LF								B	T				C	F	SP								OVERLOAD					MEASUREMENT UNITS										BROKEN THERMOCOUPLE																										
CH	CH	CH	SP	SP	SP	O	L	SP	SP	SP	m	V	CR	LF																																																																		
							B	T				C	F	SP																																																																		
							OVERLOAD					MEASUREMENT UNITS																																																																				
							BROKEN THERMOCOUPLE																																																																									
<b>BAUD RATE AND LINE LENGTH SWITCHES (12 thru 23)</b> The binary code entered is equivalent to one less than the number of recorded measurements per teleprinter line prior to CR LF, EXAMPLE: 0000=1 measurement per line.										<b>*MNEMONICS</b> AC = Address Code AD = Analog Data CH = Channel Number CR = Carriage Return D = Day Code DD = Digital Input Data FD = Fixed Data H = Hours LF = Line Feed M = Minutes S = Seconds SP = Space																																																																						
NOT USED		BAUD RATE				1=ON				1=ON																																																																						
SWITCHES	20	21	22	23	16	17	18	19	12	13	14	15																																																																				
					110=	1	1	1	1	8	4	2	1																																																																			
					300=	1	1	0	1																																																																							
					1200=	1	0	1	1																																																																							
					2400=	1	0	0	1																																																																							
					4800=	0	1	1	1																																																																							

Figure 612-2. Recorded Data Format and Digital Output PCB Switch Assignments

6. After the Digital Output PCB(s) is (are) installed, install the top covers.

#### 612-13. Interface Cable

612-14. The interface cable supplied with the Digital Output PCB is designed to interface a specific recording device (see Section 1 of the data logger). If data logger scan sequences are to be initiated manually using the front-panel switches, connect the interface cable between the Digital Output PCB's rear-panel connector and the appropriate recorder. If the scan sequences are to be initiated by a remote input, complete the following procedure prior to connecting the interface cable:

1. Remove approximately 2 inches of the sleeving covering the data logger end of the cable, behind the connector.
2. Separate the three wires outside the main cable, under the sleeving.
3. Identify each wire, using an Ohmmeter.
  - a. Pin 31 - Start
  - b. Pin 6 - Scan in Progress
  - c. Pin 48 - Logic Common
4. Install the interface cable and connect the remote control lines to the desired source. The function of each line is described below:
  - a. START - If the REMOTE switch in the data logger's SCAN CONTROL switch group is depressed, a contact closure to Logic Common or a low TTL/DTL logic level will initiate a scan sequence. If a scan is in progress, the Start input is ignored.
  - b. SIP (Scan in Progress) - This TTL output goes low to indicate that a scan is in progress. Start inputs during this period are ignored. SIP also goes low when REMOTE is pressed, and will remain low until an external START is received and the first scan sequence is completed.
  - c. LOGIC COMMON - Logic common for the start input and SIP output signals.

#### NOTE

If a single remote control

source is used and more than one Digital Output PCB is installed, it is sufficient to complete the remote control connections on only one interface cable.

#### 612-15. OPERATION

612-16. Once installed in the data logger, the Digital Output PCB requires no operator attention. Instructions for connecting the remote control lines are given earlier under Installation. Refer to the appropriate teleprinter/cassette-recorder instruction manual for additional recorder information.

612-17. The timing required to initiate a remote start depends upon the data logger's configuration and its current activities. Assuming that the REMOTE SCAN CONTROL switch is depressed and an EXTERNAL ENABLE switch is depressed (Preferably ALL DATA) the following conditions will assure a start of scan.

1. Apply a momentary contact closure to ground or a low logic level to the Start input (31). If SIP (6) is initially low (prior to start input), allow the first scan sequence to complete. SIP will return high at the end of the sequence, and will go low for subsequent scan sequences.
2. While the Scan in Progress output is high (i.e., no keyboard or front panel activity) a negative-going Start pulse with a width of  $\geq 5$  ms will cause a remote start.
3. Under worst case keyboard activity, a Start pulse  $\geq 100$  ms is required to ensure a remote start.
4. If the Start input is held low from the start to finish of a scan sequence, a second scan will be initiated. A continuous scan mode is achieved by holding the Start input low.

#### 612-18. THEORY OF OPERATION

612-19. The Digital Output PCB, as shown in Figure 612-3, is a microprocessor based subsystem which functions as a controller peripheral to provide the interface necessary to transfer data logger time-of-day, digital data, heading, and measurement data (as printed on the internal printer) to an external digital recording device. Any one of several types of recorders can be accommodated by the interface. Among these are: a 20 mA current-loop teleprinter (-12 Options), a paper tape punch (-13 Options), an incremental magnetic tape recorder (-14 Options), or any RS-232-C compatible recording device (-12 Options). Once the recorder is defined, the interface pcb can be tailored to meet

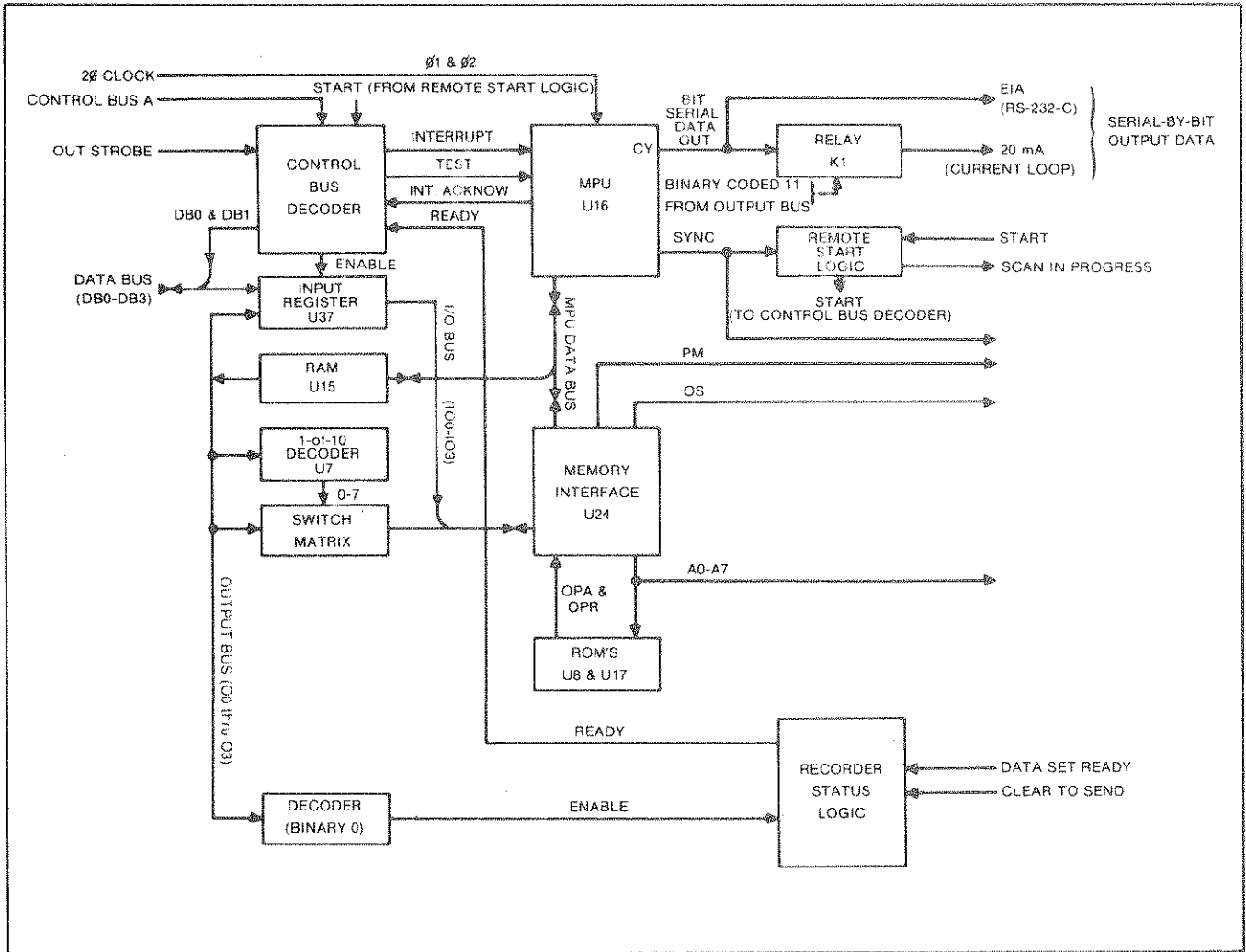

Figure 612-3. Digital Output PCB Simplified Block Diagram

the interface requirements by the addition of two plug-in ROM's and an interface cable (both are supplied as an integral part of the option). Additional formatting and baud rate requirements (when applicable) are manually selected using a series of 24 switches located on the pcb. (See installation instructions for switch settings as they apply to this option.) Provisions are also included which allow a contact closure to ground (or any other low-level input) to serve as a remote start-of-scan signal to the data logger. While a scan is in progress (SIP) an SIP output is generated to indicate that subsequent start inputs will not be accepted until the current scan sequence has been completed.

612-20. Data transfer from the controller to the external recorder is accomplished in two operations: first, an input transfer sequence, and then, an output transfer sequence. The input transfer sequence is executed under the direction of the controller and includes the character-serial transfer of sixteen 4-bit characters from the controller (via the Data Bus) to a storage location (RAM) on the Digital Output PCB. After the input transfer is complete, the microprocessor on the Digital Output PCB directs the execution of the output transfer sequence. That is, the transfer of data from the storage location to the recording device. Appropriate handshaking is employed to ensure the output transfer is synchronized with the recorder.

612-21. When the controller is ready to initiate a data transfer it interrogates the status of the Digital Output PCB by placing a binary coded 6 onto Control Bus A. A decoder on the pcb detects the 6 and initiates an appropriate status response via the Data Bus. Table 612-3 lists the possible responses and their meanings.

612-22. Upon receiving a binary coded 3 (11) as a status response, the controller initiates the data transfer sequence by simultaneously placing a binary coded 4 onto Control Bus A, and the first data character (4-bits) onto the Data Bus. A Control Bus Decoder detects the control character (binary coded 4) and responds by generating an Interrupt to the MPU and an Input-Enable to the 4-bit Input Register. On the rising edge of the accompanying Out Strobe, the Test input to the MPU is driven high and the character on the Data Bus is entered into the Input Register. As a result of the high Interrupt and Test inputs, the MPU generates a low Interrupt Acknowledge output which is used to provide a Busy response. (Busy is used in the event the status of the output pcb is interrogated prior to completing the entire data transfer to the peripheral device, see Table 612-3.) At the same time the MPU causes the output RAM to place a binary coded 8 onto the Output Bus. The presence of this code plus a subsequent IS pluse (generated by the Memory Interface) enables the contents of the Input Register to be read (via the I/O Bus) by the Memory Interface. On the trailing edge of the IS pulse the MPU's Test input is returned low to complete the first character segment of the 16-character input-transfer sequence.



**Table 612-3. Description of Status Response Codes**

Status Response		Meaning of Status Response
DB1	DB0	
0	0	Remote Start commanded but transfer in progress. Wait until not Busy.
0	1	Remote Start. Initiate a scan sequence.
1	0	Busy. Data transfer in progress. No action required.
1	1	Initiate a data transfer sequence.

612-23. Since the binary coded 4 is still present on the Control Bus, the character-serial transfer of data between the controller and the Memory Interface continues, as previously described, until an entire block of 16 characters has been processed. As each character of input data is read by the System Interface it is also transferred through the MPU (via the MPU Data Bus) into the RAM.

612-24. After the controller presents the last input character to the Digital Output PCB it removes the binary coded 4 from Control Bus A. With the control code gone, the Interrupt input to the MPU goes low to inhibit additional data from being entered into the input register. This completes the initial phase (input data transfer) of the data transfer sequence.

612-25. The output transfer sequence begins as the MPU writes a binary coded 0 onto the Output Bus. A decoder detects the zero and issues an Enable input to the Recorder Status Logic. If the external device is ready to receive data, the Recorder Status Logic will provide a low Ready output which drives the MPU's test input high to indicate that an output transfer may commence. Since the Digital Output PCB is capable of transferring output data in a bit-serial-by-character format, as well as a bit-parallel-by-character format, each process will be considered separately.

612-26. Bit parallel output data is stored, one character at a time, in a pair of 4-bit output registers. Data transfer to the registers is enabled by the PM input from the Memory Interface, and is entered on the leading edge of the OS pulse. As PM goes low the first output character, including 4-bits of supplementary data (ASCII, BCDIC, and/or EBCDIC), is placed onto address lines A0 through A7. After the character is entered by the subsequent OS pulse, the PM output is returned high. This PM transition arms the Write Punch Logic to allow the rising edge of the next Sync pulse to initiate a Write/Punch output pulse. An appropriate amount of time later a second OS pulse is issued, and the write/punch output is terminated on the trailing edge of the next Sync pulse. As each bit-parallel character appears on the output lines (D0 through D7) a Parity Generator provides a ninth bit (jumper selectable odd or even) for parity.

612-27. The bit serial output is enabled when the MPU instructs the RAM to place a binary coded 11 onto the Output Bus. Output data is then taken a bit at a time from the MPU's CY output and used to drive an EIA output buffer as well as relay K1. The mercury-wetted contacts of K1 are used to provide a current loop interface (contact closure for a 20 mA current loop).

612-28. The format of output data is established by the setting of 24 rocker switches which comprise a 3 X 8 switch matrix (see Figure 612-3). These switches are scanned at the beginning of each output transfer sequence by the MPU (via the RAM Output Bus) and read into the Memory Interface as six 4-bit characters. To

read each character the MPU causes the RAM to sequentially place binary coded numbers 0 through 5 onto the Output Bus. A 1-of-10 decoder detects each number, and effectively scans the matrix switches in groups of four. Thus, each closed switch within a scanned group causes a low level to be placed onto the normally high I/O Bus. (Isolation diodes are provided with each switch to avoid interaction between the various groups of matrix switches.) As each 4-bit word appears on the I/O Bus, it is read into the Memory Interface (by an IS pulse).

612-29. The transfer of output data, regardless of format, must be synchronized with the interface recorder. This is accomplished by the Recorder Status Logic which detects and reacts to a series of handshaking routines. For example, Ready and Punch input/outputs are used to synchronize the operation to a paper tape punch. Similarly, RS-232-C compatible recorders employ the Data-Set-Ready and Clear-to-Send inputs. Magnetic tape recorders utilize the Ready and Write lines to record data, and the EOR (End-Of-Record) and Gap-in-Progress lines to initiate (EOR) a standard inter-record gap, and to indicate its duration (Gap-in-Progress).

612-30. The Remote Start Logic, upon receipt of an external Start command, alters the Digital Output PCB's status response so as to initiate a data logger scan sequence (see Table 612-3). An acceptable start input is a  $\geq 5$  ms contact closure to ground while the Scan-in-Progress output is high. When the controller interrogates the Status of the Digital Output PCB (binary coded 6 on Control Bus A) the Remote Start Logic provides a start scan response via the Control Bus Decoder. During the following data transfer sequence the controller includes both a start-of-scan (binary coded 8) and an end-of-scan (binary coded 9) character with the normal data transfer characters. These two characters are decoded by the 1-of-10 decoder, and used to initiate and terminate the Scan-in-Progress (SIP) output. While the SIP output is active all start inputs are ignored.

612-31. MAINTENANCE

612-32. Access Information

612-33. Refer to the installation instructions given earlier in Digital Output PCB access information. Remove the rear panel output connector before attempting to remove the pcb from the data logger.

612-34. Performance Test

612-35. The Digital Output PCB Assembly is most easily tested under normal operating conditions. That is, installed in a functional data logger and interfaced with the recording device it normally drives. Output data format and characters can then be checked by comparing data recorded on the internal printer with hard copy data derived from the external recording device.

612-36. LIST OF REPLACEABLE PARTS

612-37. The lists of replaceable parts for the -12 Series of data logger options are given in Tables 612-4, -5, and -6. Refer to Section 5 of the data logger manual for ordering information.

⊗ CAUTION

Indicated devices are subject  
to damage by static discharge.

Table 612-4. -12 Series Options

REF DES	DESCRIPTION	FLUKE STOCK NO.	MFG SPLY CODE	MFG. PART NO.	TOT QTY	REC QTY	NOTE
-12	SERIES -12 OPTIONS						
-12B	OPTION 12B, INTERFACE FOR ASR33 TELETYPE	431148	89536	431148			
	TELETYPE INTERFACE PCB ASSEMBLY (2200A-4014T)	409524	89536	409524	1		
	IC, REPROGRAMMABLE PROM U8,U17 CABLE ASSY., TELETYPE INTERFACE FIGURE 612-5	408591 378349	89536 89536	408591 378349	2 1	1	1
	JUMPER STRIP, 10 PART CARRIER	373316	89536	373316		AR	
-12C	OPTION -12C, INTERFACE (TI 733 KSR/RO)	431155	89536	431155			
	TELETYPE INTERFACE PCB ASSEMBLY (2200A-4014T)	409524	89536	409524	1		
	IC, REPROGRAMMABLE PROM, U8, U17 CABLE ASSY., TI SILENT 700 INTERFACE FIGURE 612-6 (2200A-8039)	408591 477901	89536 89536	408591 477901	2 1		1
	JUMPER STRIP, 10 PART CARRIER	373316	89536	373316		AR	
-12L	OPTION -12L INTERFACE FOR RS232C TERMINAL	451682	89536	451682			
	TELETYPE INTERFACE PCB ASSEMBLY (2200A-4014T)	409524	89536	409524	1		
	IC, REPROGRAMMABLE PROM, U8, U17 CABLE ASSY., TI SILENT 700 INTERFACE SEE FIGURE 612-6	408591 477901	89536 89536	408591 477901	2 1		1
	JUMPER STRIP, 10 PART CARRIER	373316	89536	373316		AR	

Table 612-4. -12 Series Options (cont)

REF DES	DESCRIPTION	FLUKE STOCK NO.	MFG SPLY CODE	MFG. PART NO.	TOT QTY	REC QTY	N O T E
-12M	OPTION -12M INTERFACE FOR RS232C MODEM	451690	89536	451690			
	TELETYPE INTERFACE PCB ASSEMBLY (2200A-4014T)	409524	89536	409524	1		
	IC, REPROGRAMMABLE PROM, U8, U17 CABLE ASSY., RS232 INTERFACE FIGURE 612-7	408591	89536	408591	2		1
	JUMPER STRIP, 10 PART CARRIER	477893	89536	477893	1		
	JUMPER STRIP, 10 PART CARRIER	373316	89536	373316	AR		
	1....TO ORDER, SUBMIT U NUMBER AND OPTION NUMBER AND DESCRIPTION. USED ON FIGURE 612-4 PCB ASSEMBLY.						

WIRE LIST	
FROM	TO
P18-1	
↓ -2	
-3	
-4	
-5	
-6	▷
-7	▷
-8	▷
-9	
-10	
-11	
-12	
-13	
-14	
-15	
-16	
-17	
-18	
-19	
-20	
-21	
-22	
-23	
-24	
-25	
-26	
-27	
-28	
-29	
-30	
-31	▷
-32	
-33	
-34	
-35	
-36	
-37	
-38	
-39	
-40	
-41	
-42	
-43	
-44	
-45	
-46	
-47	
-48	▷
↓ -49	
P18-50	

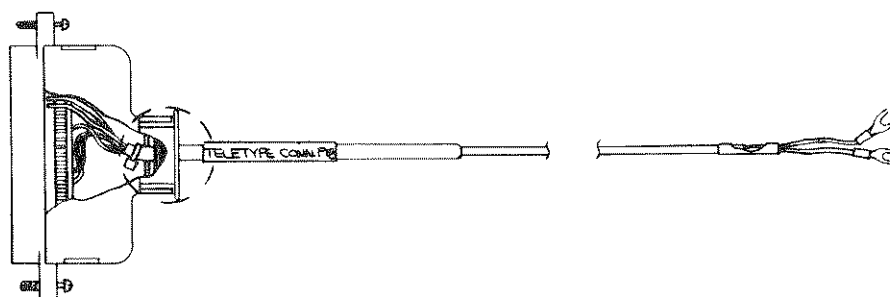

- ▷ Common connections to one I/O wire.
- ▷ Common connections to other I/O wire.

2200A-4406

Figure 612-5. ASR Teletype Interface Cable Assembly

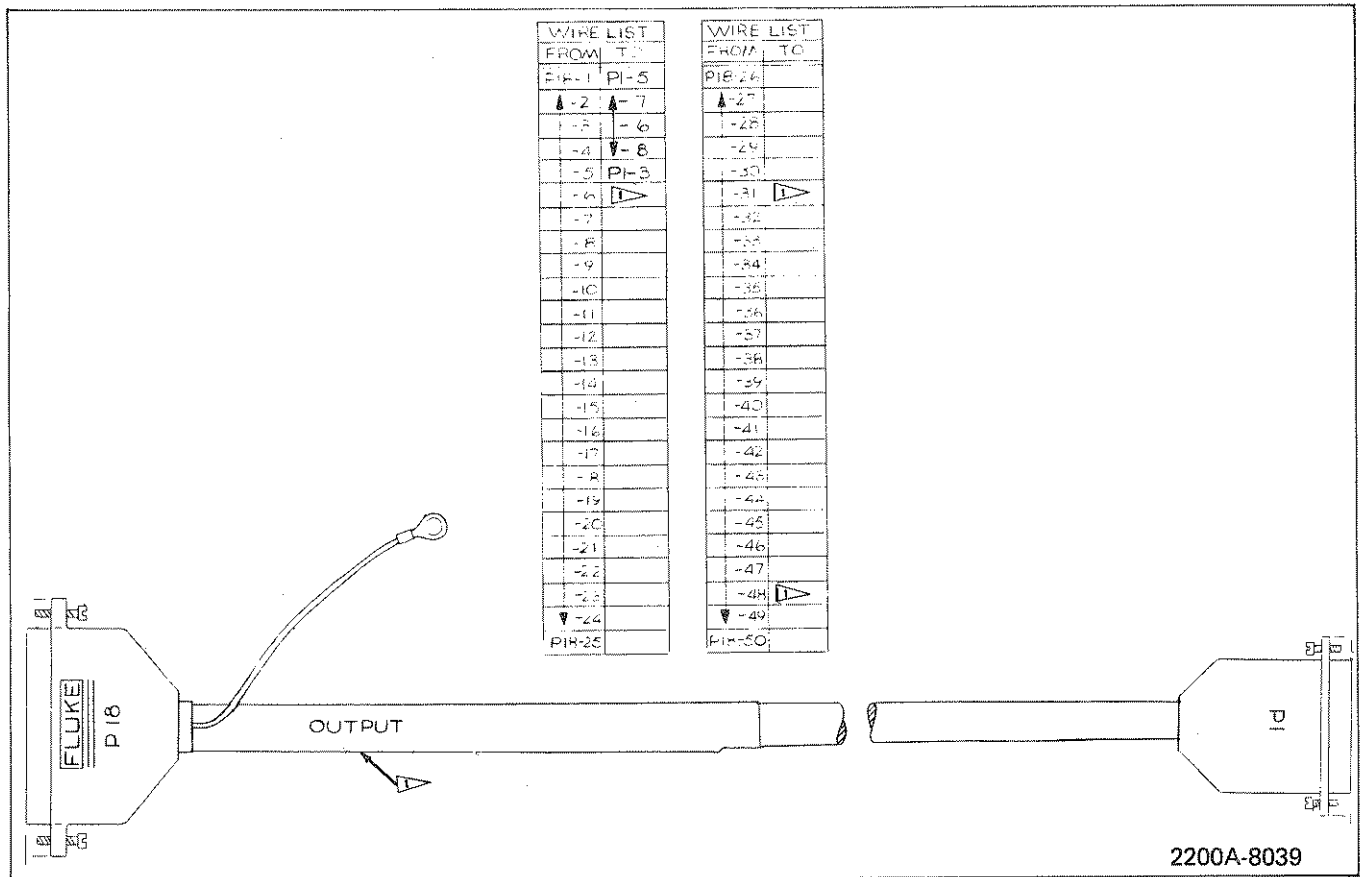

Figure 612-6. TI Silent 700 Interface Cable Assembly

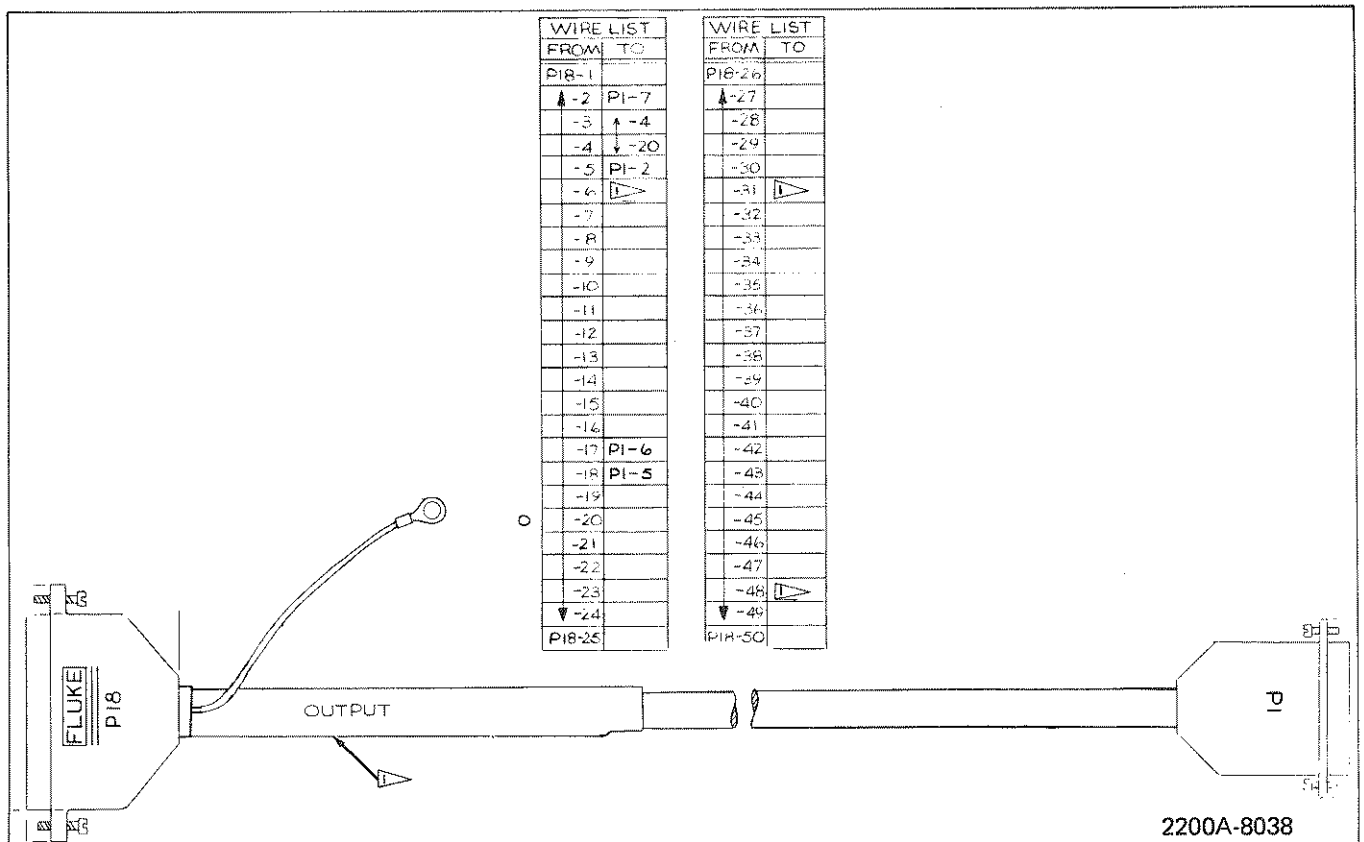

Figure 612-7. RS232 Interface Cable Assembly



Table 612-5. Teletype Interface PCB Assembly

REF DES	DESCRIPTION	FLUKE STOCK NO.	MFG SPLY CODE	MFG. PART NO.	TOT QTY	REC QTY	N O T E
	⊗ TELETYPE INTERFACE PCB ASSEMBLY FIGURE 612-8 (2200A-4014T)	409524	89536	409524		REF	
C1	CAP, MICA, 400 PF +/-1%, 500V	385328	72136	DM15F401F	1		
C2	CAP, CER, 300 PF +/-10%, 500V	105734	71590	BB60301KW7W	2		
C3	CAP, CER, 300 PF +/-10%, 500V	105734	71590	BB60301KW7W	REF		
C4	CAP, TA, 10 UF +/-20%, 20V	330662	56289	196D106X0020KA1	1		
C5	CAP, CER, 0.68 UF -20/+80%, 25V	179077	56289	5C023684D8250B3	1		
CR1	DIODE, SI, SWITCHING	203323	07910	1N4448	27	6	
CR3	DIODE, SI, SWITCHING	203323	07910	1N4448	REF		
CR3	DIODE, SI, SWITCHING	203323	07910	1N4448	REF		
CR4	DIODE, SI, SWITCHING	203323	07910	1N4448	REF		
CR5	DIODE, SI, SWITCHING	203323	07910	1N4448	REF		
CR6	DIODE, SI, SWITCHING	203323	07910	1N4448	REF		
CR7	DIODE, SI, SWITCHING	203323	07910	1N4448	REF		
CR8	DIODE, SI, SWITCHING	203323	07910	1N4448	REF		
CR9	DIODE, SI, SWITCHING	203323	07910	1N4448	REF		
CR10	DIODE, SI, SWITCHING	203323	07910	1N4448	REF		
CR11	DIODE, SI, SWITCHING	203323	07910	1N4448	REF		
CR12	DIODE, SI, SWITCHING	203323	07910	1N4448	REF		
CR13	DIODE, SI, SWITCHING	203323	07910	1N4448	REF		
CR14	DIODE, SI, SWITCHING	203323	07910	1N4448	REF		
CR15	DIODE, SI, SWITCHING	203323	07910	1N4448	REF		
CR16	DIODE, SI, SWITCHING	203323	07910	1N4448	REF		
CR17	DIODE, SI, SWITCHING	203323	07910	1N4448	REF		
CR18	DIODE, SI, SWITCHING	203323	07910	1N4448	REF		
CR19	DIODE, SI, SWITCHING	203323	07910	1N4448	REF		
CR20	DIODE, SI, SWITCHING	203323	07910	1N4448	REF		
CR21	DIODE, SI, SWITCHING	203323	07910	1N4448	REF		
CR22	DIODE, SI, SWITCHING	203323	07910	1N4448	REF		
CR23	DIODE, SI, SWITCHING	203323	07910	1N4448	REF		
CR24	DIODE, SI, SWITCHING	203323	07910	1N4448	REF		
CR25	DIODE, SI, SWITCHING	203323	07910	1N4448	REF		
CR26	DIODE, SI, SWITCHING	203323	07910	1N4448	REF		
CR27	DIODE, SI, SWITCHING	203323	07910	1N4448	REF		
CR28	DIODE, SI, SWITCHING	203323	07910	1N4448	REF		
J18	CONNECTOR, FEMALE, 50-PIN	414417	00779	552130-1	1		
K1	RELAY, REED	357509	71707	UF-40066	1		
MP1	HARDWARE KIT, CONNECTOR (TO J18)	448563	89536	448563	1		
Q1	XSTR, SI, NPN	218396	04713	2N3904	1	1	
R1	RES, COMP, 100K +/-5%, 1/4W	148189	01121	CB1045	1		
R2	RES, COMP, 10K +/-5%, 1/4W	148106	01121	CB1035	6		
R3	RES, COMP, 13K +/-5%, 1/4W	221598	01121	CB1335	3		
R4	RES, COMP, 13K +/-5%, 1/4W	221598	01121	CB1335	REF		
R5	RES, COMP, 1K +/-5%, 1/4W	148023	01121	CB1025	11		
R6	RES, COMP, 1K +/-5%, 1/4W	148023	01121	CB1025	REF		
R7	RES, COMP, 1K +/-5%, 1/4W	148023	01121	CB1025	REF		
R8	RES, COMP, 1K +/-5%, 1/4W	148023	01121	CB1025	REF		
R9	RES, COMP, 1K +/-5%, 1/4W	148023	01121	CB1025	REF		

Table 612-5. Teletype Interface PCB Assembly (cont)

REF DES	DESCRIPTION	FLUKE STOCK NO.	MFG SPLY CODE	MFG PART NO. OR TYPE	TOT QTY	REC QTY	NOTE
R12	RES, COMP, 1K +/-5%, 1/4W	148023	01121	CB1025		REF	
R13	RES, COMP, 10K +/-5%, 1/4W	148106	01121	CB1035		REF	
R14	RES, COMP, 1K +/-5%, 1/4W	148023	01121	CB1025		REF	
R15	RES, COMP, 200 +/-5%, 1/4	193482	01121	CB2015		1	
R16	RES, COMP, 1K +/-5%, 1/4W	148023	01121	CB1025		REF	
R17	RES, COMP, 1K +/-5%, 1/4W	148023	01121	CB1025		REF	
R18	RES, COMP, 1K +/-5%, 1/4W	148023	01121	CB1025		REF	
R19	RES, COMP, 1K +/-5%, 1/4W	148023	01121	CB1025		REF	
R20	RES, COMP, 10K +/-5%, 1/4W	148106	01121	CB1035		REF	
R21	RES, COMP, 5.1K +/-5%, 1/4W	193342	01121	CB5125		1	
R23	RES, COMP, 3.3K +/-5%, 1/4W	148056	01121	CB3325		1	
R24	RES, COMP, 10K +/-5%, 1/4W	148106	01121	CB1035		REF	
R25	RES, COMP, 10K +/-5%, 1/4W	148106	01121	CB1035		REF	
R26	RES, COMP, 13K +/-5%, 1/4W	221598	01121	CB1335		REF	
R27	RES, COMP, 10K +/-5%, 1/4W	148106	01121	CB1035		REF	
U1②	IC, C-MOS, HEX BUFFER	407759	12040	MM80C97N		1	1
U2	RES, NETWORK	376962	89536	376962		1	1
U4	SWITCH ASSEMBLY, DIL, 8-POS, SPDT	414490	00779	435166-5		3	1
U5	SWITCH ASSEMBLY, DIL, 8-POS, SPDT	414490	00779	435166-5		REF	
U6	SWITCH ASSEMBLY, DIL, 8-POS, SPDT	414490	00779	435166-5		REF	
U7②	IC, C-MOS, BCD-TO-DECIMAL DECODER	407981	12040	MM74C42N		1	1
U9②	IC, C-MOS DUAL J-K F/F	355230	04713	MC14027CP		1	1
U10②	IC, C-MOS, QUAD 2-INPUT NAND GATE	355198	04713	MC14011CP		2	1
U11②	IC, C-MOS, DUAL "D" TYPE F/F	340117	04713	MC14013CL		3	1
U12②	IC, C-MOS, QUAD 2-INPUT NOR GATE	355172	04713	MC14001CP		1	1
U13②	IC, C-MOS, DUAL 4-INPUT NOR GATE	363820	04713	MC14002CP		1	1
U14②	IC, C-MOS, HEX BUFFER/CONVERTER	355214	04713	MC14009CP		3	1
U15②	IC, P-MOS, 320 BIT RAM & 4-BIT OTPT PORT	404442	34649	P4002-1		1	1
U16②	IC, MOS, CENTRAL PROCESSOR	404418	34649	C4040		1	1
U18②	IC, C-MOS, HEX BUFFER/CONVERTER	355412	04713	MC14010CP		1	1
U19②	IC, C-MOS, TRIPLE 3-INPUT NAND GATE	375147	04713	MC14023CP		1	1
U20②	IC, C-MOS, HEX BUFFER/CONVERTER	355214	04713	MC14009CP		REF	
U21②	IC, C-MOS, DUAL 4-INPUT NAND GATE	355206	04713	MC14012CP		1	1
U22②	IC, C-MOS, DUAL "D" TYPE F/F	340117	04713	MC14013CL		REF	
U23	IC, TTL, TRI-STATE, QUAD "D" TYPE F/F	408203	12040	DM85L51N		2	1
U24②	IC, C-MOS, STANDARD MEMORY INTERFACE	404434	34649	P4289		1	1
U25②	IC, C-MOS, DUAL "D" TYPE F/F	340117	04713	MC14013CL		REF	
U26②	IC, C-MOS, 12-BIT PARITY TREE	414060	04713	MC14531CP		1	1
U27	IC, QUAD LINE RECEIVER	414045	12040	LM1489		1	1
U28②	IC, C-MOS, QUAD 2-INPUT NAND GATE	355198	04713	MC14011CP		REF	
U29②	IC, C-MOS, HEX BUFFER/CONVERTER	355214	04713	MC14009CP		REF	
U32	RESISTOR NETWORK	358119	89536	358119		1	1
U34	RESISTOR NETWORK	417469	89536	417469		1	1
U35	IC, TTL, QUAD 2-INPUT NOR BUFFER	414037	01295	SN74LS33N		1	1
U36	IC, QUAD LINE DRIVER	414052	12040	LM1488		1	1
U37②	IC, C-MOS, QUAD "D" TYPE LATCH	412742	12040	MM74C173N		1	1
VR1	DIODE, ZENER	340695	12969	UZ8710		1	1
XU8	SOCKET, IC, 24-PIN DIL	418970	91506	324-AG39D		3	
XU15	SOCKET, IC, 16-PIN DIL	276535	91506	316-AG39D		1	
XU16	SOCKET, IC, 24-PIN DIL	418970	91506	324-AG39D		REF	

Table 612-5. Teletype Interface PCB Assembly (cont)

REF DES	DESCRIPTION	FLUKE STOCK NO.	MFG SPLY CODE	MFG. PART NO.	TOT QTY	REC QTY	N O T E
XU17	SOCKET, IC, 24-PIN DIL	418970	91506	324-AG39D	REF		
XU24	SOCKET, IC, 40-PIN DIL	418988	91506	340-AG39D	1		
XU31	SOCKET, IC, 14-PIN DIL	276527	91507	314-AG39D	2		
XU33	SOCKET, IC, 14-PIN DIL	276527	91507	314-AG39D	REF		

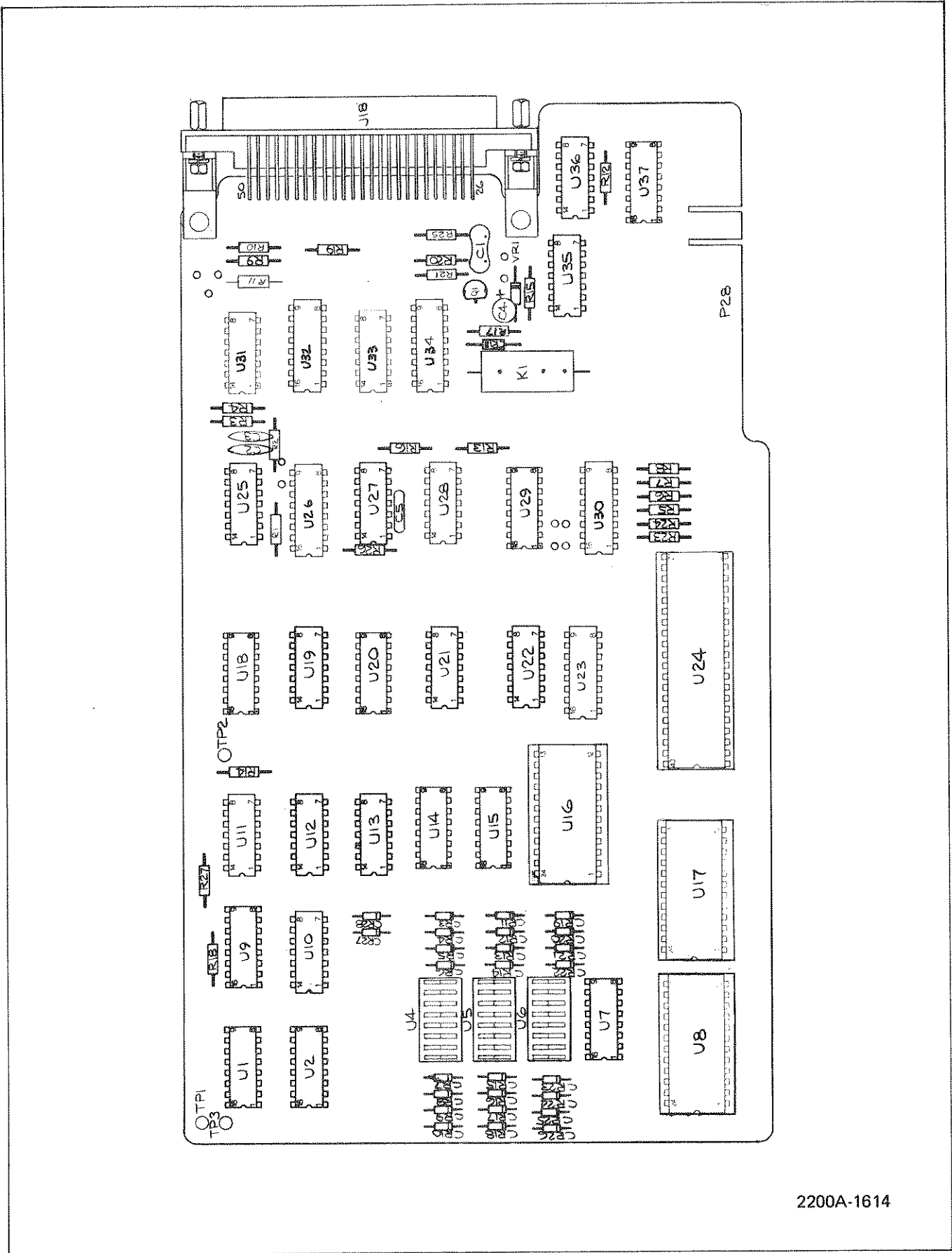

Figure 612-8. Teletype Interface PCB Assembly

T  
E  
R  
M  
I  
N  
A  
L  
E  
X  
I  
S  
T  
E  
N  
C  
E

## -13 Series

### Paper Tape Punch and Cassette Recorder Interface Options

#### 613-1. SCOPE

613-2. The -13 Series Options include Options 13A through 13E, and are described in Section 1 of the data logger manual. Each option in the 13A through 13C series is compatible with the Facit Model 4070 Paper Tape Punch, and the PROMs installed are marked PTAPE P0 (U17) and PTAPE P1 U8. Option 13C and 13D are compatible with Facit Model 4203.0005 Cassette Tape Recorder, and the PROMs installed are marked SP1 P0 (U17) and SP1 P1 (U8). The information contained herein deals with the Digital Output PCB used to interface these recording devices. Option configurations for Series -13 are defined in Table 613-1.

#### 613-3. INTRODUCTION

613-4. The Digital Output PCB is designed to transfer character-serial/bit-parallel data from the data logger to either an external paper tape punch (Facit Model 4070) or an Incremented Interface Recorder. This includes: Time-of-Day, Fixed Data, Digital Input Data (Option -16), and measurement data. The appropriate carriage-return and line-feed characters are also generated. Provisions are included for initiating a scan sequence using a remote start input.

613-5. A special interface cable and a series of 24 switches located on the pcb are used to tailor the pcb's digital output with the external recorder's digital inputs. The cable is included as part of the option and the user manually sets the switches to define the format of the recorded data. Provisions are included on the pcb for selecting either odd or even parity.

#### 613-6. SPECIFICATIONS

613-7. Specifications for the -13 series of options are given in Table 613-2.

#### 613-8. INSTALLATION

#### 613-9. Digital Output PCB

613-10. Up to three Digital Output PCB's can be mounted in the data loggers I/O slots, as shown in Figure 613-1. Install each output pcb as follows:

#### WARNING

REMOVE LINE POWER AND ALL OTHER  
HIGH VOLTAGE INPUTS TO THE DATA  
LOGGER BEFORE STARTING THIS  
PROCEDURE.

**Table 613-1. -13 Series Options Specifications**

<b>Compatibility</b> .....	Designed to interface the data logger output with the Facit Model 4203.0005. Specify requirements at time-of-purchase using alphabetic suffix as shown in Section 1, Table 1-2.
<b>Output Format</b> .....	Bit-parallel/Character-serial
<b>Output Code</b> .....	ASCII 7-level plus jumper selectable parity bit.
<b>Output Level</b> .....	TTL compatible.
<b>Measurements per Line</b> .....	1 through 16, switch selectable. (-13A through -13C)
<b>Characters per Record</b> .....	1 through 256, switch selectable. (-13D through -13E)
<b>Word Format</b> .....	Unwanted word blocks may be deleted by switches on PCB. Word order cannot be changed.
<b>Record Format</b> .....	@, CR, LF (Carriage Return, Line Feed) Time-of-Day (day, hr, min) CR,LF Digital Inputs, CR, LF (-16 Option) Channels, limit, sign, data, range, function, CR, LF

**Table 613-2. Description of Status Response Codes**

Status Response		Meaning of Status Response
DB1	DB0	
0	0	Remote Start commanded but transfer in progress. Wait until not Busy.
0	1	Remote Start. Initiate a scan sequence.
1	0	Busy. Data transfer in progress. No action required.
1	1	Initiate a data transfer sequence.

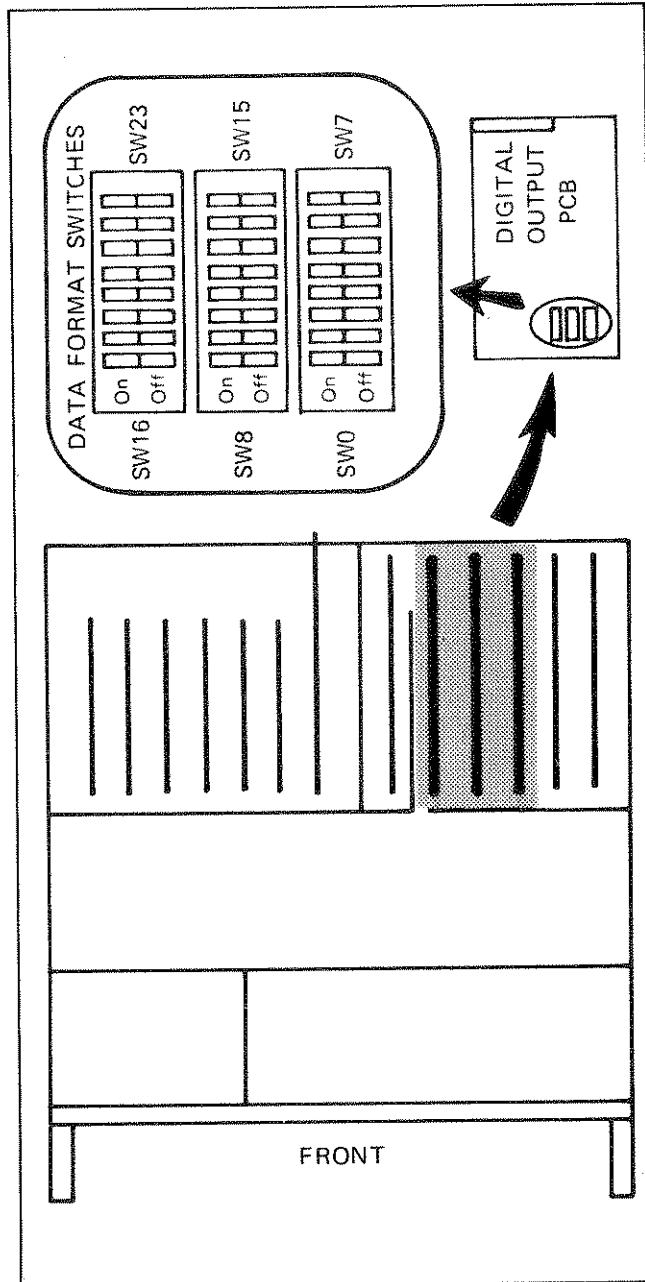

**Figure 613-1. Digital Output PCB, Installation and Switch Locations**



1. Set the data logger POWER switch to OFF.
2. Remove the top cover from the data logger.
3. Locate the Data Format switches on each Digital Output PCB as shown in Figure 613-1.
4. With reference to Figure 613-2, establish the format of recorded data as follows:
  - a. Set switches 0 through 11 to OFF. This establishes the format shown in Figure 613-2.
  - b. Delete any combination of unwanted character segments by setting the appropriate switches to ON.
  - c. Refer to Figure 613-2 and set switches 12 through 15 for either the desired number of readings per line (paper tape punch interface) or the desired number of characters per record (incremental cassette tape recorder).
  - d. Set unused switches (16 through 23 or 20 through 23) to OFF.
5. Refer to Figure 613-3. Position the jumpers for desired odd or even parity and check or install the Remote Start jumper if necessary.
6. Align the Digital Output PCB in the selected I/O slot so that the large female connector is toward the rear of the data logger, and the small board-edge connector is toward the bottom of the unit. Push the pcb straight down onto the mating connector.
7. After the Digital Output PCB(s) is (are) installed, install the top cover.

#### 613-11. Interface Cable

613-12. The interface cable supplied with the -13 Series Option is designed to interface the Digital Output PCB with the specified recorder: Model 4070 Paper Tape Punch or Model 4203.0005 Cassette Tape Recorder. If the data logger scan sequences are to be manually initiated using the front panel SCAN CONTROL switches, connect the interface cable between the Digital Output PCB's rear-panel connector and the appropriate recording device. If the scan sequences are to be initiated by a remote input signal, complete the following procedure prior to connecting the interface cable.

1. Remove approximately 2 inches of the sleeving

### DETAILS OF RECORDED DATA

DESCRIPTION	RECORDED DATA FORMAT AND CONTROL SWITCH (0 thru 11) ASSIGNMENTS*
START OF SCAN	@ CR LF
TIME OF YEAR (2240C ONLY)	D D D : H H : M M : S S CR LF ← SW 0 → * SW 1 →
FIXED DATA (2240C)	CR LF SP SP FD FD FD FD FD FD CR LF ← SW 2 → * SW 3 →
DIGITAL INPUT DATA (Option-16)	AC AC SP DD DD DD DD DD DD DD DD CR LF
MEASUREMENT DATA -NORMAL	CH CH CH SP SP AD AD AD AD AD AD m SP V C CR LF > ± Floating Decimal Point ↓ ← SW 4 →   SW 5   SW 6   SW 7     SW 8     SW 9   ← SW 10 →   ← SW 11 →   MEASUREMENT UNITS OVERLOAD O L B T SP SP SP m SP V C CR LF BROKEN THERMOCOUPLE MEASUREMENT UNITS
MEASUREMENT DATA -ABNORMAL	CH CH CH SP SP SP O L B T SP SP SP m SP V C CR LF BROKEN THERMOCOUPLE MEASUREMENT UNITS

#### OPTIONS -13A thru -13C

#### RECORDED MEASUREMENTS PER LINE SWITCH SETTINGS(12 thru 15)

Set switches to indicate, in binary, one less than the desired maximum number of recorded measurements per teleprinter line prior to CR LF. For example, 0000= one measurement recorded per teleprinter line. 1=ON

	NOT USED								SETTINGS INDICATE MEASUREMENTS PER LINE +1			
SWITCHES	20	21	22	23	16	17	18	19	12	13	14	15
BINARY EQUIVALENT	—	—	—	—	—	—	—	—	2 <sup>3</sup>	2 <sup>2</sup>	2 <sup>1</sup>	2 <sup>0</sup>
DECIMAL EQUIVALENT	—	—	—	—	—	—	—	—	8	4	2	1

#### \*MNEMONICS

AC	=	Address Code
AD	=	Analog Data
CH	=	Channel Number
CR	=	Carriage Return
D	=	Day Code
DD	=	Digital Input Data
FD	=	Fixed Data
H	=	Hours
LF	=	Line Feed
M	=	Minutes
S	=	Seconds
SP	=	Space

#### OPTIONS -13D and -13E

#### CHARACTERS PER RECORD SWITCH SETTINGS(12 thru 19)

Set switches to indicate, in binary, one less than the maximum number of recorded characters per scan sequence. For example, a binary coded 199 is equal to 200 recorded characters per scan sequence 1= ON

	NOT USED				SETTINGS INDICATE CHARACTERS PER RECORD +1							
SWITCHES	20	21	22	23	16	17	18	19	12	13	14	15
BINARY EQUIVALENT	—	—	—	—	2 <sup>7</sup>	2 <sup>6</sup>	2 <sup>5</sup>	2 <sup>4</sup>	2 <sup>3</sup>	2 <sup>2</sup>	2 <sup>1</sup>	2 <sup>0</sup>
DECIMAL EQUIVALENT	—	—	—	—	128	64	32	16	8	4	2	1

Figure 613-2. Recorded Data Format and Digital Output PCB Switch Assignments

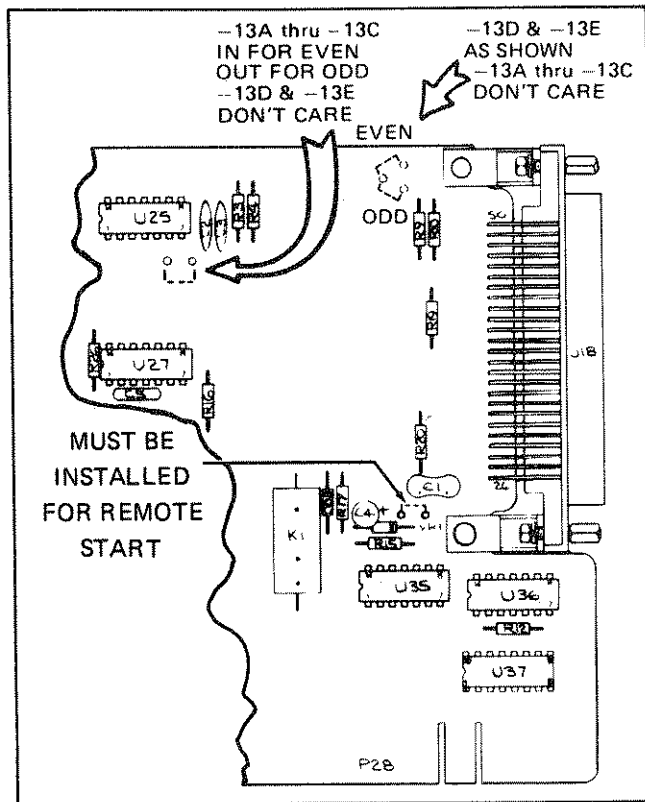

Figure 613-3. Even Parity Jumper Location, -13 Series Options

covering the data logger end of the cable, behind the connector.

2. Separate the three wires outside the main cable, under the sleeving.
3. Identify each wire, using an Ohmmeter.
  - a. Pin 31 - Start
  - b. Pin 6 - Scan in Progress
  - c. Pin 48 - Logic Common
4. Feed the three wires through the cable port in the connector hood and reassemble the connector.
5. Install the interface cable and connect the remote control lines to the desired control source. The function of each line is described below:
  - a. START - If the REMOTE switch in the data logger's SCAN CONTROL switch group is depressed, a contact closure to Logic Common or a low TTL/DTL logic level will initiate a scan sequence. If a scan is in progress, the Start input is ignored.
  - b. SIP - A TTL output that goes low to indicate that a scan is in progress. Start inputs during this period are ignored. SIP also goes low when REMOTE is pressed, and will remain low until an external START is received and the first scan sequence is completed.
  - c. LOGIC COMMON - Logic common for the Start input and the SIP output signals.

#### NOTE

If a single remote control source is used and more than one Digital Output PCB is installed, it is sufficient to complete the remote control connections on only one interface cable.

#### 613-13. OPERATION

613-14. Once installed in the data logger, the Digital Output PCB requires no operator attention. Instructions for connecting the remote control lines are given under Installation. Refer to the Facit Instruction Manual for details concerning the external

recording device.

613-15. The timing required to initiate a remote start depends upon the data logger's configuration and its current activities. Assuming that the REMOTE SCAN CONTROL switch is depressed and an EXTERNAL ENABLE switch is depressed (preferable ALL DATA) the following conditions will assure a start of scan:

1. Apply a contact closure to ground or a low logic level to the Start input (31). If SIP (6) is initially low (prior to start input) allow the first scan sequence to complete. SIP will return high at the end of the sequence, and will go low for subsequent scan sequences.
2. While the Scan in Progress output is high (i.e., no keyboard or front panel activity) a negative-going Start pulse with a width of  $\geq 5$  ms will cause a remote start.
3. Under worst case keyboard activity, a Start pulse,  $\geq 100$  ms is required to ensure a remote start.
4. If the Start input is held low from the start to finish of a scan sequence, a second scan will be initiated. A continuous scan mode is achieved by holding the Start input low.

#### 613-16. THEORY OF OPERATION

613-17. The Digital Output PCB, as shown in Figure 613-4, is a microprocessor based subsystem which functions as a controller peripheral to provide the interface necessary to transfer the data logger time-of-day, digital data, heading, and measurement data (as printed on the internal printer) to an external digital recording device. Any one of several types of recorders can be accommodated by the interface. Among these are: a 20 mA current-loop teleprinter (-12 Options), a paper tape punch (-13 Options), an incremental magnetic tape recorder (-14 Options), or any RS-232-C compatible recording device (-12 Options). Once the recorder is defined, the interface pcb can be tailored to meet the interface requirements by the addition of two plug-in ROM's and an interface cable (both are supplied as an integral part of the option). Additional formatting and baud rate requirements (when applicable) are manually selected using a series of 24 switches located on the pcb. (See Installation instructions for switch settings as they apply to this option.) Provisions are also included which allow a contact closure to ground (or any other low-level input) to serve as a remote start-of-scan signal to the data logger. While a scan is in progress (SIP) and SIP output is generated to indicate that subsequent start inputs will not be accepted until the current scan sequence has been completed.

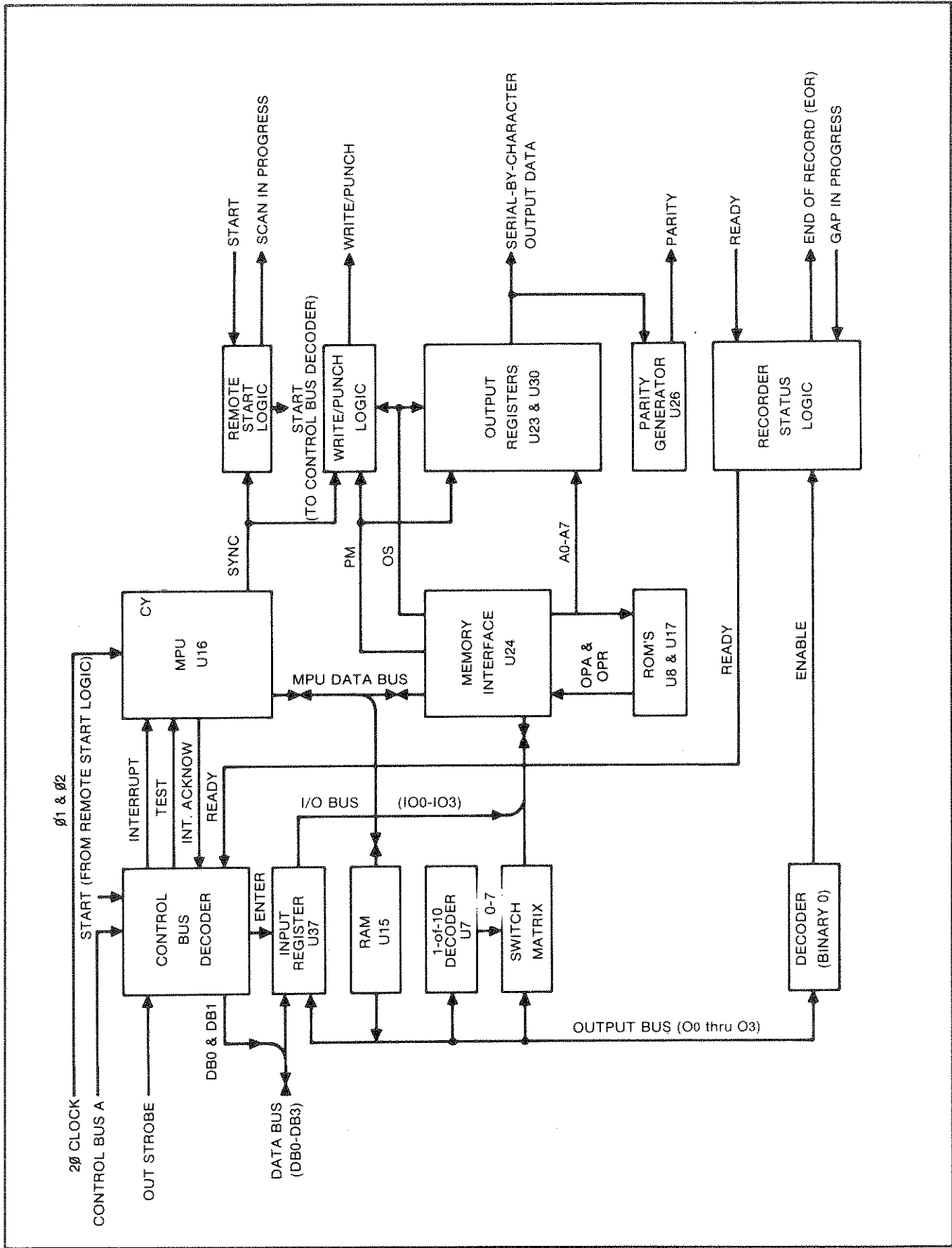

Figure 613-4. Digital Output PCB Simplified Block Diagram

613-18. Data transfer from the controller to the external recorder is accomplished in two operations: first, an input transfer sequence, and then, an output transfer sequence. The input transfer sequence is executed under the direction of the controller and includes the character-serial transfer of 16 four-bit characters from the Controller (via the Data Bus) to a storage location (RAM) on the Digital Output PCB. After the input transfer is complete, the microprocessor on the Digital Output PCB directs the execution of the output transfer sequence. That is, the transfer of data from the storage location to the recording device. Appropriate handshaking is employed to ensure the output transfer is complete, the microprocessor on the Digital Output PCB directs the execution of the output transfer sequence. That is, the transfer of data from the storage location to the recording device. Appropriate handshaking is employed to ensure the output transfer is synchronized with the recorder.

613-19. When the controller is ready to initiate a data transfer, it interrogates the status of the Digital Output PCB by placing a binary coded 6 onto Control Bus A. A decoder on the PCB detects the 6 and initiates an appropriate status response via the Data Bus. Table 613-2 lists the possible responses and their meanings.

613-20. Upon receiving a binary coded 3 (11) as a status response, the controller initiates the data transfer sequence by simultaneously placing a binary coded 4 onto Control Bus A, and the first data character (4 bits) onto the Data Bus. A Control Bus Decoder detects the control character (binary coded 4) and responds by generating an interrupt to the MPU and an input-Enable to the 4-bit Input Register. On the rising edge of the accompanying Out Strobe, the Test input to the MPU is driven high and the character on the Data Bus is entered into the Input Register. As a result of the high interrupt and test inputs the MPU generates a low Interrupt Acknowledge output which is used to provide a Busy response. (Busy is used in the event the status of the output pcb is interrogated prior to completing the entire data transfer to the peripheral devices, see Table 613-2.) At the same time the MPU causes the output RAM to place a binary coded 8 onto the Output Bus. The presence of this code plus a subsequent IS pulse (generated by the Memory Interface) enables the contents of the Input Register to be read (via the I/O Bus) by the Memory Interface. On the trailing edge of the IS pulse the MPU's Test input is returned low to complete the first character segment of the 16-character input-transfer sequence.

613-21. Since the binary coded 4 is still present on the Control Bus, the character-serial transfer of data between the controller and the Memory Interface continues, as previously described, until an entire block of 16 characters has been processed. As each character of input data is read by the System Interface it is also transferred through the MPU (via the MPU Data Bus) into the RAM.

613-22. After the controller presents the last input character to the Digital Output PCB it removes the binary coded 4 from Control Bus A. With the control code gone the Interrupt input to the MPU goes low to inhibit additional data from being entered into the Input Register. This completes the initial phase (input data transfer) of the data transfer sequence.

613-23. The output transfer sequence begins as the MPU writes a binary coded 0 onto the Output Bus. A decoder detects the zero and issues an Enable input to the Recorder Status Logic. If the external device is ready to receive data, the Recorder Status Logic will provide a low Ready output which drives the MPU's test input high to indicate that an output transfer may commence. Since the Digital Output PCB is capable of transferring output data in a bit-serial-by-character format, as well as a bit-parallel-by-character format, each process will be considered separately.

613-24. Bit-parallel output data is stored, one character at a time, in a pair of 4-bit output registers. Data transfer to the registers is enabled by the PM input from the Memory Interface, and is entered on the leading edge of the OS pulse. As PM goes low the first output character, including 4-bits of supplementary data (ASCII, BDCIC, and/or EBCDIC), is placed onto address lines A0 through A7. After the character is entered by the subsequent OS pulse, the PM output is returned high. This PM transition arms the Write/Punch Logic to allow the rising edge of the next Sync pulse to initiate a Write/Punch output pulse. An appropriate amount of time later a second OS pulse is issued, and the write/punch output is terminated on the trailing edge of the next Sync pulse. As each bit-parallel character appears on the output lines (D0 through D7) a Parity Generator provides a ninth bit (jumper selectable odd or even) for parity.

613-25. The bit-serial output is enabled when the MPU instructs the RAM to place a binary coded 11 onto the Output Bus. Output data is then taken, a bit at a time, from the MPU's CY output and used to drive an EIA output buffer as well as relay K1. The mercury-wetted contacts of K1 are used to provide a current loop interface (contact closure for a 20 mA current loop).

613-26. The format of output data is established by the setting of 24 rocker switches which comprise a 3 X 8 switch matrix (see Figure 613-4). These switches are scanned at the beginning of each output transfer sequence by the MPU (via the RAM Output Bus) and read into the Memory Interface as six 4-bit characters. To read each character the MPU causes the RAM to sequentially place binary coded numbers 1 through 5 onto the Output Bus. A 1-of-10 decoder detects each number and effectively scans the matrix switches in groups of four. Thus, each closed switch with a scanned group causes a low level to be placed onto the normally high I/O Bus. (Isolation diodes are provided with each switch to avoid interaction between the various groups of matrix switches.) As each 4-bit word appears on the I/O Bus, it is read into the



Memory Interface (by an IS pulse).

613-27. The transfer of output data, regardless of format, must be synchronized with the interfaced recorder. This is accomplished by the Recorder Status Logic which detects and reacts to a series of handshaking routines. For example, Ready and Punch input/outputs are used to synchronize the operation to a paper tape punch. Similarly, RS-232-C compatible recorders employ the Data-Set-Ready and Clear-to-Send inputs. Magnetic tape recorders utilize the Ready and Write lines to record data, and the EOR (end-of-record) and Gap-in-Progress lines to initiate (EOR) a standard inter-record gap, and to indicate its duration (Gap-in-Progress).

613-28. The Remote Start Logic, upon receipt of an external Start command, alters the Digital Output PCB's status response so as to initiate a data logger scan sequence (see Table 613-2). An acceptable start input is a  $\geq 5$  ms contact closure to ground while the Scan-in-Progress output is high. When the controller interrogates the status of the Digital Output PCB (binary coded 6 on Control Bus A) the Remote Start Logic provides a start scan response via the Control Bus Decoder. During the following data transfer sequence the controller includes both a start-of-scan (binary coded 8) and an end-of-scan (binary coded 9) character with the normal data transfer characters. These two characters are decoded by the 1-of-10 decoder, and used to initiate and terminate the Scan-in-Progress (SIP) output. While the SIP output is active all start inputs are ignored.

613-29. MAINTENANCE

613-30. Access Information

613-31. Refer to the installation instructions given earlier in Digital Output PCB access information. Remove the rear panel output connector before attempting to remove the pcb from the data logger.

613-32. Performance Test

613-33. The Digital Output PCB Assembly is most easily tested under normal operating conditions. That is, installed in a functional data logger and interfaced with the recording device it normally drives. Output data format and characters can then be checked by comparing data recorded on the internal printer with hard copy data derived from the external recording device.

613-34. LIST OF REPLACEABLE PARTS

613-35. The lists of replaceable parts for the -14 series of data logger options are given in Tables 613-3, -4, and -5. Refer to Section 6 of the data logger manual for ordering information.

⊗ CAUTION

Indicated devices are subject  
to damage by static discharge.

Table 613-3. -13 Series Options

REF DES	DESCRIPTION	FLUKE STOCK NO.	MFG SPLY CODE	MFG. PART NO.	TOT QTY	REC QTY	NOTE
-13	-13 SERIES OPTIONS						
-13A	FACIT 4070, BENCH MODEL, INTERFACE	431239	89536	431239			
	TELETYPE INTERFACE PCB ASSEMBLY (2200A-4014T)	409524	89536	409524	1		
	BENCH TAPE PUNCH, FACIT 4070-0004	435453	89536	435453	1		
	JUMPER STRIP	373316	89536	373316			
	RES, COMP, 1K +/-5%, 1/4W, (R10,R11)	148023	01121	CB1025	1		
	IC, REPROGRAMMABLE PROM, (U8,U17)	408591	89536	408591	2		1
	IC, TTL, HEX BUFF/DRIVER, (U31,U32)	328021	89536	328021	2	1	
	CABLE ASSY., PAPER TAPE INTERFACE FIGURE 613-5 (2200A-4403)	377531	89536	377531	1		
-13B	FACIT 4070, RACK MODEL, INTERFACE	431247	89536	431247			
	TELETYPE INTERFACE PCB ASSEMBLY (2200A-4014T)	409524	89536	409524	1		
	RACK TAPE PUNCH, FACIT 4070-0024	435461	89536	435461	1		
	JUMPER STRIP	373316	89536	373316	AR		
	RES, COMP, 1K +/-5%, 1/4W (R10,R11)	148023	01121	CB1025	1		
	IC, REPROGRAMMABLE PROM (U8,U17)	408591	89536	408591	2		1
	IC, TTL, HEX BUFF/DRIV (U31,U32)	328021	89536	328021	2	1	
	CABLE ASSY., PAPER TAPE INTERFACE FIGURE 613-5 (2200A-4403)	377531	89536	377531	1		
-13C	INTERFACE FOR FACIT 4070	431254	89536	431254			
	TELETYPE INTERFACE PCB ASSEMBLY (2200A-4014T)	409524	89536	409524	1		
	JUMPER STRIP	373316	89536	373316	AR		
	RES, COMP, 1K +/-5%, 1/4W, R10,R11	148023	01121	CB1025	1		
	IC, REPROGRAMMABLE PROM, U8,U17	408591	89536	408591	2		1
	IC, TTL, HEX BUFF/DRIV, U31,U32	328021	89536	328021	2	1	
	CABLE ASSY., PAPER TAPE INTERFACE FIGURE 613-5 (2200A-4403)	377531	89536	377531	1		

Table 613-3. -13 Series Options (cont)

REF DES	DESCRIPTION	FLUKE STOCK NO.	MFG SPLY CODE	MFG. PART NO.	TOT QTY	REC QTY	NOTE
-13D	FACIT 4203/0005 RECORDER INTERFACE	455030	89536	455030			
	TELETYPE INTERFACE PCB ASSEMBLY (2200A-4014T)	409524	89536	409524	1		
	RES, COMP, 1K +/-5%, 1/4W R10 OR R11	148023	01121	CB1025	1		
	IC, PROGRAMMABLE PROM U8, U17	408591	89536	408591	2		1
	IC, TTL, HEX BUF/DRIV U31, U32	328021	89536	328021	2	1	
	TAPE RECORDER, 4203/0005	446732	89536	446732	1		
	CABLE ASSY, 4203.0005 INTERFACE FIGURE 613-6 (2200A-8040)	477919	89536	477919	1		
	JUMPER STRIP, 10 PART CARRIER	373316	89536	373316	AR		
-13E	INTERFACE FOR FACIT 4203/0005	455048	89536	455048			
	TELETYPE INTERFACE PCB ASSEMBLY (2200A-4014T)	409524	89536	409524	1		
	RES, COMP, 1K +/-5%, 1/4W (R10 OR R11)	148023	01121	CB1025	1		
	IC, PROGRAMMABLE PROM (U8, U17)	408591	89536	408591	2		1
	IC, TTL, HEX BUF/DRIV (U31, U32)	328021	89536	328021	2	1	
	TAPE RECORDER, 4203/0005	446732	89536	446732	1		
	CABLE ASSEY, 4203.0005 INTERFACE FIGURE 613-6 (2200A-8040)	477919	89536	477919	1		
	JUMPER STRIP, 10 PART CARRIER	373316	89536	373316	AR		
	1....TO ORDER, SUBMIT U NUMBER, OPTION NUMBER AND DESCRIPTION.						

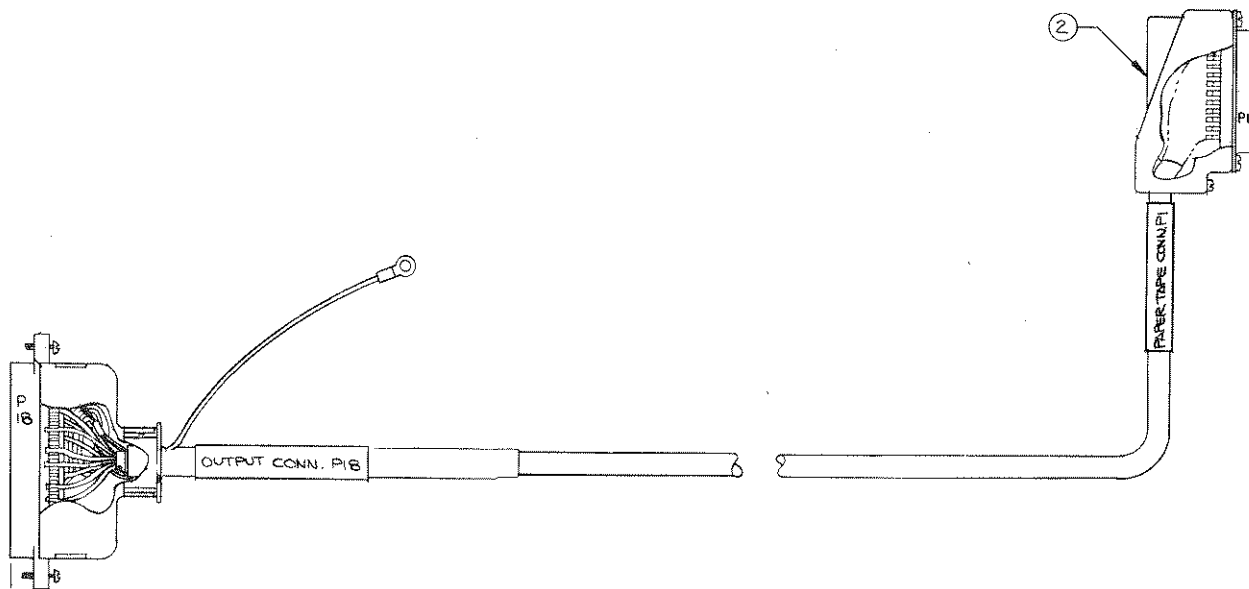

WIRE LIST	
FROM	TO
P18-1	
-2	P1-25
-3	P1-9
-4	
-5	
-6	2
-7	
-8	
-9	
-10	
-11	
-12	
-13	P1-1
-14	P1-4
-15	P1-6
-16	P1-7
-17	
-18	
-19	P1-12
-20	P1-11
-21	
-22	P1-10
-23	
-24	
-25	

WIRE LIST	
FROM	TO
-26	
-27	
-28	
-29	
-30	
-31	2
-32	
-33	
-34	
-35	
-36	
-37	P1-8
-38	P1-2
-39	P1-3
-40	P1-5
-41	
-42	
-43	
-44	
-45	
-46	
-47	
-48	2
-49	
P18-50	

2200A-4403

Figure 613-5. Paper Tape Interface Cable Assembly

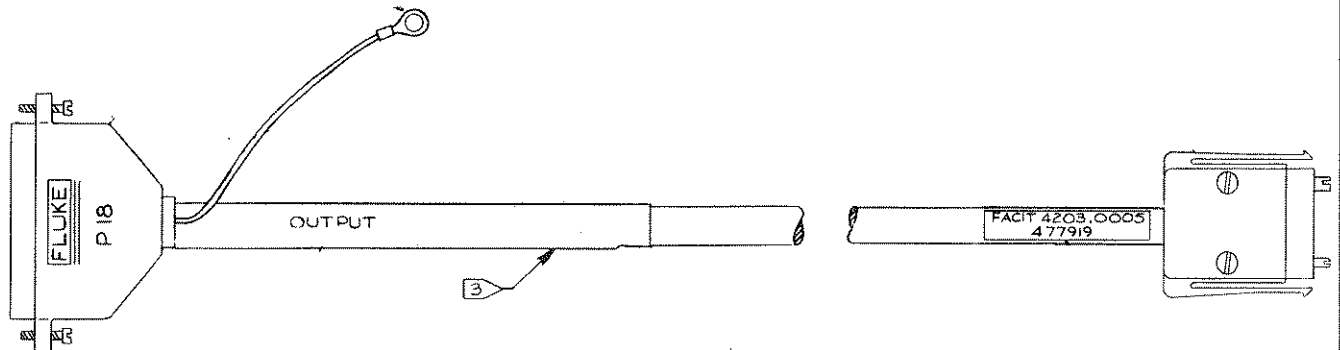

WIRE LIST	
FROM	TO
P18-1	
▲-2	PI-A
-3	PI-D
-4	
-5	
-6	3 >
-7	
-8	
-9	
-10	
-11	
-12	
-13	PI-M
-14	PI-R
-15	PI-T
-16	PI-U
-17	
-18	
-19	PI-E
-20	PI-F
-21	
-22	PI-B
-23	
▼-24	
P18-25	

WIRE LIST	
FROM	TO
P18-26	
▲-27	
-28	
-29	
-30	
-31	3 >
-32	
-33	
-34	
-35	
-36	
-37	PI-L
-38	PI-N
-39	PI-P
-40	PI-S
-41	PI-J
-42	
-43	
-44	
-45	
-46	
-47	PI-V
-48	3 >
▼-49	
P18-50	

2200A-8040

Figure 613-6. 4203.0005 Interface Cable Assembly

Table 613-4. Teletype Interface PCB Assembly

REF DES	DESCRIPTION	FLUKE STOCK NO.	MFG SPLY CODE	MFG. PART NO.	TOT QTY	REC QTY	NOTE
	⊗ TELETYPE INTERFACE PCB ASSEMBLY FIGURE 613-7 (2200A-4014T)	409524	89536	409524	REF		
C1	CAP, MICA, 400 PF +/-1%, 500V	385328	72136	DM15F401F	1		
C2	CAP, CER, 300 PF +/-10%, 500V	105734	71590	BB60301KW7W	2		
C3	CAP, CER, 300 PF +/-10%, 500V	105734	71590	BB60301KW7W	REF		
C4	CAP, TA, 10 UF +/-20%, 20V	330662	56289	196D106X0020KA1	1		
C5	CAP, CER, 0.68 UF -20/+80%, 25V	179077	56289	5C023684D8250B3	1		
CR1	DIODE, SI, SWITCHING	203323	07910	1N4448	27	6	
CR3	DIODE, SI, SWITCHING	203323	07910	1N4448	REF		
CR3	DIODE, SI, SWITCHING	203323	07910	1N4448	REF		
CR4	DIODE, SI, SWITCHING	203323	07910	1N4448	REF		
CR5	DIODE, SI, SWITCHING	203323	07910	1N4448	REF		
CR6	DIODE, SI, SWITCHING	203323	07910	1N4448	REF		
CR7	DIODE, SI, SWITCHING	203323	07910	1N4448	REF		
CR8	DIODE, SI, SWITCHING	203323	07910	1N4448	REF		
CR9	DIODE, SI, SWITCHING	203323	07910	1N4448	REF		
CR10	DIODE, SI, SWITCHING	203323	07910	1N4448	REF		
CR11	DIODE, SI, SWITCHING	203323	07910	1N4448	REF		
CR12	DIODE, SI, SWITCHING	203323	07910	1N4448	REF		
CR13	DIODE, SI, SWITCHING	203323	07910	1N4448	REF		
CR14	DIODE, SI, SWITCHING	203323	07910	1N4448	REF		
CR15	DIODE, SI, SWITCHING	203323	07910	1N4448	REF		
CR16	DIODE, SI, SWITCHING	203323	07910	1N4448	REF		
CR17	DIODE, SI, SWITCHING	203323	07910	1N4448	REF		
CR18	DIODE, SI, SWITCHING	203323	07910	1N4448	REF		
CR19	DIODE, SI, SWITCHING	203323	07910	1N4448	REF		
CR20	DIODE, SI, SWITCHING	203323	07910	1N4448	REF		
CR21	DIODE, SI, SWITCHING	203323	07910	1N4448	REF		
CR22	DIODE, SI, SWITCHING	203323	07910	1N4448	REF		
CR23	DIODE, SI, SWITCHING	203323	07910	1N4448	REF		
CR24	DIODE, SI, SWITCHING	203323	07910	1N4448	REF		
CR25	DIODE, SI, SWITCHING	203323	07910	1N4448	REF		
CR26	DIODE, SI, SWITCHING	203323	07910	1N4448	REF		
CR27	DIODE, SI, SWITCHING	203323	07910	1N4448	REF		
CR28	DIODE, SI, SWITCHING	203323	07910	1N4448	REF		
J18	CONNECTOR, FEMALE, 50-PIN	414417	00779	552130-1	1		
K1	RELAY, REED	357509	71707	UF-40066	1		
MP1	HARDWARE KIT, CONNECTOR (TO J18)	448563	89536	448563	1		
Q1	XSTR, SI, NPN	218396	04713	2N3904	1	1	
R1	RES, COMP, 100K +/-5%, 1/4W	148189	01121	CB1045	1		
R2	RES, COMP, 10K +/-5%, 1/4W	148106	01121	CB1035	6		
R3	RES, COMP, 13K +/-5%, 1/4W	221598	01121	CB1335	3		
R4	RES, COMP, 13K +/-5%, 1/4W	221598	01121	CB1335	REF		
R5	RES, COMP, 1K +/-5%, 1/4W	148023	01121	CB1025	11		
R6	RES, COMP, 1K +/-5%, 1/4W	148023	01121	CB1025	REF		
R7	RES, COMP, 1K +/-5%, 1/4W	148023	01121	CB1025	REF		
R8	RES, COMP, 1K +/-5%, 1/4W	148023	01121	CB1025	REF		
R9	RES, COMP, 1K +/-5%, 1/4W	148023	01121	CB1025	REF		

Table 613-4. Teletype Interface PCB Assembly (cont)

REF DES	DESCRIPTION	FLUKE STOCK NO.	MFG SPLY CODE	MFG. PART NO.	TOT QTY	REC QTY	NOTE
R12	RES, COMP, 1K +/-5%, 1/4W	148023	01121	CB1025	REF		
R13	RES, COMP, 10K +/-5%, 1/4W	148106	01121	CB1035	REF		
R14	RES, COMP, 1K +/-5%, 1/4W	148023	01121	CB1025	REF		
R15	RES, COMP, 200 +/-5%, 1/4	193482	01121	CB2015	1		
R16	RES, COMP, 1K +/-5%, 1/4W	148023	01121	CB1025	REF		
R17	RES, COMP, 1K +/-5%, 1/4W	148023	01121	CB1025	REF		
R18	RES, COMP, 1K +/-5%, 1/4W	148023	01121	CB1025	REF		
R19	RES, COMP, 1K +/-5%, 1/4W	148023	01121	CB1025	REF		
R20	RES, COMP, 10K +/-5%, 1/4W	148106	01121	CB1035	REF		
R21	RES, COMP, 5.1K +/-5%, 1/4W	193342	01121	CB5125	1		
R23	RES, COMP, 3.3K +/-5%, 1/4W	148056	01121	CB3325	1		
R24	RES, COMP, 10K +/-5%, 1/4W	148106	01121	CB1035	REF		
R25	RES, COMP, 10K +/-5%, 1/4W	148106	01121	CB1035	REF		
R26	RES, COMP, 13K +/-5%, 1/4W	221598	01121	CB1335	REF		
R27	RES, COMP, 10K +/-5%, 1/4W	148106	01121	CB1035	REF		
U10	IC, C-MOS, HEX BUFFER	407759	12040	MM80C97N	1		1
U2	RES, NETWORK	376962	89536	376962	1		1
U4	SWITCH ASSEMBLY, DIL, 8-POS, SPDT	414490	00779	435166-5	3		1
U5	SWITCH ASSEMBLY, DIL, 8-POS, SPDT	414490	00779	435166-5	REF		
U6	SWITCH ASSEMBLY, DIL, 8-POS, SPDT	414490	00779	435166-5	REF		
U7	IC, C-MOS, BCD-TO-DECIMAL DECODER	407981	12040	MM74C42N	1		1
U9	IC, C-MOS DUAL J-K F/F	355230	04713	MC14027CP	1		1
U10	IC, C-MOS, QUAD 2-INPUT NAND GATE	355198	04713	MC14011CP	2		1
U11	IC, C-MOS, DUAL "D" TYPE F/F	340117	04713	MC14013CL	3		1
U12	IC, C-MOS, QUAD 2-INPUT NOR GATE	355172	04713	MC14001CP	1		1
U13	IC, C-MOS, DUAL 4-INPUT NOR GATE	363820	04713	MC14002CP	1		1
U14	IC, C-MOS, HEX BUFFER/CONVERTER	355214	04713	MC14009CP	3		1
U15	IC, P-MOS, 320 BIT RAM & 4-BIT OTPT PORT	404442	34649	P4002-1	1		1
U16	IC, MOS, CENTRAL PROCESSOR	404418	34649	C4040	1		1
U18	IC, C-MOS, HEX BUFFER/CONVERTER	355412	04713	MC14010CP	1		1
U19	IC, C-MOS, TRIPLE 3-INPUT NAND GATE	375147	04713	MC14023CP	1		1
U20	IC, C-MOS, HEX BUFFER/CONVERTER	355214	04713	MC14009CP	REF		
U21	IC, C-MOS, DUAL 4-INPUT NAND GATE	355206	04713	MC14012CP	1		1
U22	IC, C-MOS, DUAL "D" TYPE F/F	340117	04713	MC14013CL	REF		
U23	IC, TTL, TRI-STATE, QUAD "D" TYPE F/F	408203	12040	DM85L51N	2		1
U24	IC, C-MOS, STANDARD MEMORY INTERFACE	404434	34649	P4289	1		1
U25	IC, C-MOS, DUAL "D" TYPE F/F	340117	04713	MC14013CL	REF		
U26	IC, C-MOS, 12-BIT PARITY TREE	414060	04713	MC14531CP	1		1
U27	IC, QUAD LINE RECEIVER	414045	12040	LM1489	1		1
U28	IC, C-MOS, QUAD 2-INPUT NAND GATE	355198	04713	MC14011CP	REF		
U29	IC, C-MOS, HEX BUFFER/CONVERTER	355214	04713	MC14009CP	REF		
U32	RESISTOR NETWORK	358119	89536	358119	1		1
U34	RESISTOR NETWORK	417469	89536	417469	1		1
U35	IC, TTL, QUAD 2-INPUT NOR BUFFER	414037	01295	SN74LS33N	1		1
U36	IC, QUAD LINE DRIVER	414052	12040	LM1488	1		1
U37	IC, C-MOS, QUAD "D" TYPE LATCH	412742	12040	MM74C173N	1		1
VR1	DIODE, ZENER	340695	12969	UZ8710	1		1
XU8	SOCKET, IC, 24-PIN DIL	418970	91506	324-AG39D	3		
XU15	SOCKET, IC, 16-PIN DIL	276535	91506	316-AG39D	1		
XU16	SOCKET, IC, 24-PIN DIL	418970	91506	324-AG39D	REF		



Table 613-4. Teletype Interface PCB Assembly (cont)

REF DES	DESCRIPTION	FLUKE STOCK NO.	MFG SPLY CODE	MFG PART NO. OR TYPE	TOT QTY	REC QTY	N O T E
XU17	SOCKET, IC, 24-PIN DIL	418970	91506	324-AG39D	REF		
XU24	SOCKET, IC, 40-PIN DIL	418988	91506	340-AG39D	1		
XU31	SOCKET, IC, 14-PIN DIL	276527	91507	314-AG39D	2		
XU33	SOCKET, IC, 14-PIN DIL	276527	91507	314-AG39D	REF		

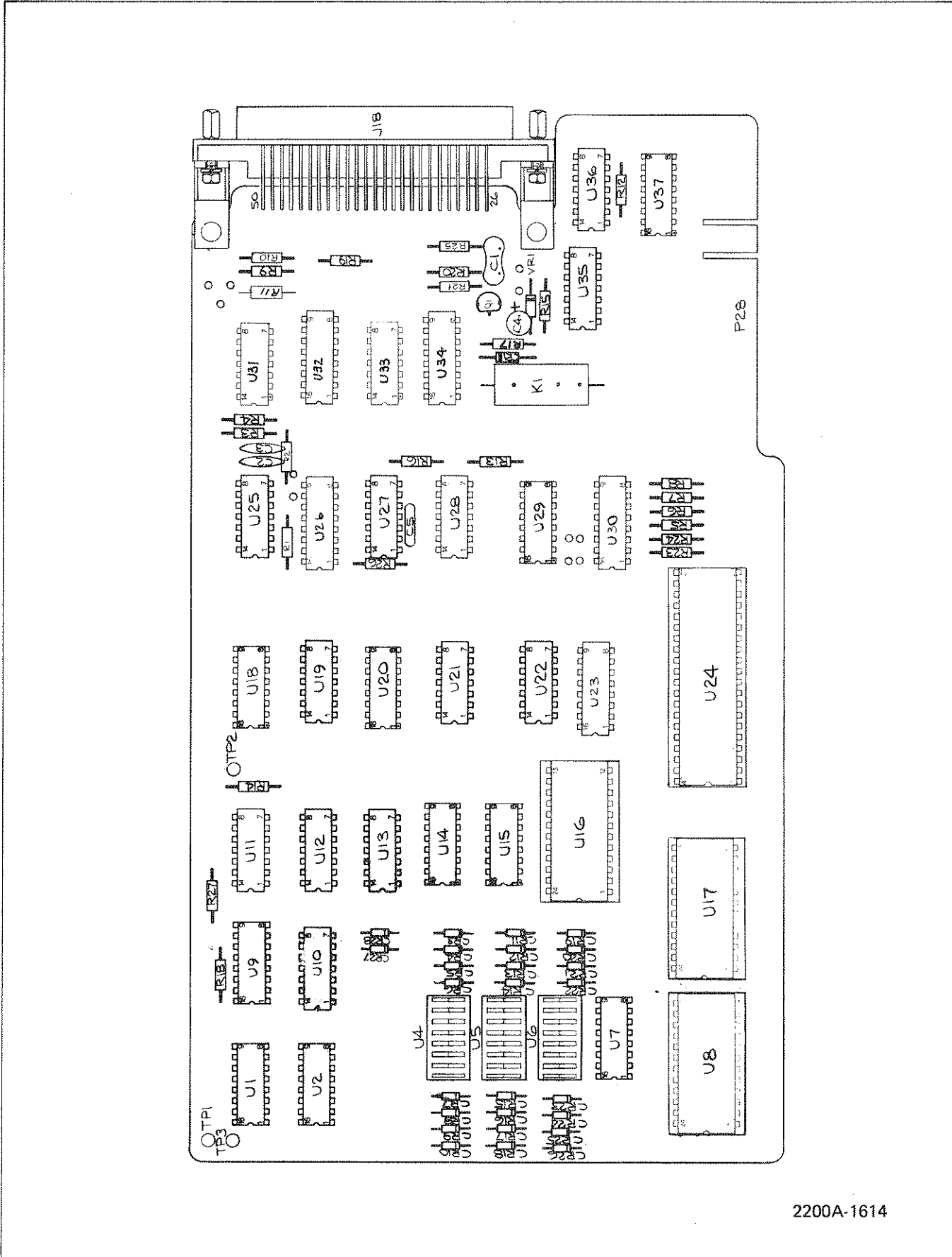

2200A-1614

Figure 613-7. Teletype Interface PCB Assembly

1  
2  
3  
4  
5  
6  
7  
8  
9  
10  
11  
12  
13  
14  
15  
16  
17  
18  
19  
20  
21  
22  
23  
24  
25  
26  
27  
28  
29  
30  
31  
32  
33  
34  
35  
36  
37  
38  
39  
40  
41  
42  
43  
44  
45  
46  
47  
48  
49  
50  
51  
52  
53  
54  
55  
56  
57  
58  
59  
60  
61  
62  
63  
64  
65  
66  
67  
68  
69  
70  
71  
72  
73  
74  
75  
76  
77  
78  
79  
80  
81  
82  
83  
84  
85  
86  
87  
88  
89  
90  
91  
92  
93  
94  
95  
96  
97  
98  
99  
100

-14 series  
Magnetic Tape Interface Options

614-1. SCOPE

614-2. The -14 Series Options include Options -14A through -14K, and are described in Table 614-1. Each option in the series is compatible with a Kennedy Magnetic Tape Recorder. The information contained herein deals with the basic Digital Output PCB used to interface these recorders.

614-3. INTRODUCTION

614-4. The Digital Output PCB is designed to transfer bit-parallel/character-serial data from the data logger to an external Kennedy Magnetic Tape Recorder. This includes, Time-of-Year, Fixed Data, Digital Input Data (Option -16), and measurement data. The appropriate carriage-return and line-feed characters are also generated. Provisions are included for initiating a scan sequence using a remote Start input.

614-5. A unique interface cable and a series of 24 switches on the pcb are used to tailor the digital output with the recorder. The cable is included as part of the option. The switches are set by the user to define characters per record and data format.

614-6. The Digital Output PCB transfers ASCII, BCDIC, and EBCDIC coded characters to the recorder, along with a write pulse. On some units odd or even parity can be selected by positioning a jumper wire on the pcb. On others, it is fixed at odd parity by the recorder. The pcb is shipped from the factory with the odd parity jumper installed.

614-7. After a preset number of characters (switch selectable) have been transferred to the recorder, the Digital Output PCB generates an End-Of-Record (EOR) command. The recorder responds by generating a standard EOR and returning a Gap-In-Progress signal to inhibit a data transfer during the IRG generation. If the scan mode is changed before the specified number of characters have been transferred, the Digital Output PCB will insert a \$ character into the record until the character count is satisfied.

614-8. SPECIFICATIONS

614-9. Specifications for the -14 Series of options are given in Table 614-2.

614-10. INSTALLATION

614-11. Digital Output PCB

614-12. Up to three Digital Output PCB's can be mounted in the data logger's I/O slots, as shown in Figure 614-1. Install each

Table 614-1. Configuration of -14 Option

OPTION NO.	DESCRIPTION	TRACKS*	PARITY (ODD/EVEN)	OPTION COMPONENTS (INDICATED BY ●)		
				PCB	CABLE	RECORDER
-14A	Kennedy 1600/5 and Interface	7	Selectable	●	●	●
-14B	Kennedy 1610/5 and Interface	7	Selectable	●	●	●
-14C	Kennedy 1600/360 and Interface	9	Odd	●	●	●
-14D	Kennedy 1610/360 and Interface	9	Odd	●	●	●
-14E	Kennedy 1600/5 or 1610/5 Interface	7	Selectable	●	●	
-14G	Kennedy 1600/360 or 1610/360 Interface	9	Odd	●	●	
-14J	Kennedy 9832-9 and Interface	9	Odd	●	●	●
-14K	Kennedy 9832-9 Interface	9	Odd	●	●	

\* 7 track = BCDIC or ASCII } IC locations are P0 (U17) and P1 (U8).  
 9 track = EBCDIC or ASCII }

Table 614-2. -14 Series Options Specifications

Compatibility.....	Specify at time-of-purchase using alphabetic suffix as shown in Table 614-1.
Output Format.....	Bit-parallel/character-serial
Output Levels.....	TTL compatible (-14A - -14G Positive-True: -14J & 14K Negative-True)
Output Code.....	BCDIC, EBCDIC or ASCII
Record Format.....	@CR, LF (Carriage Return, Line Feed) Time-of-Day (day, hr., min., s) CR, LF CR, LF, Fixed Data CR, LF Digital Inputs, CR, LF (-16 Option) Channels, limit, sign, data, function, CR, LF
Word Format.....	Unwanted word blocks may be deleted by switches on PCB. Word order cannot be changed.
Physical Record Length.....	Selectable. 1 to 4096 characters, switch selectable on PCB.

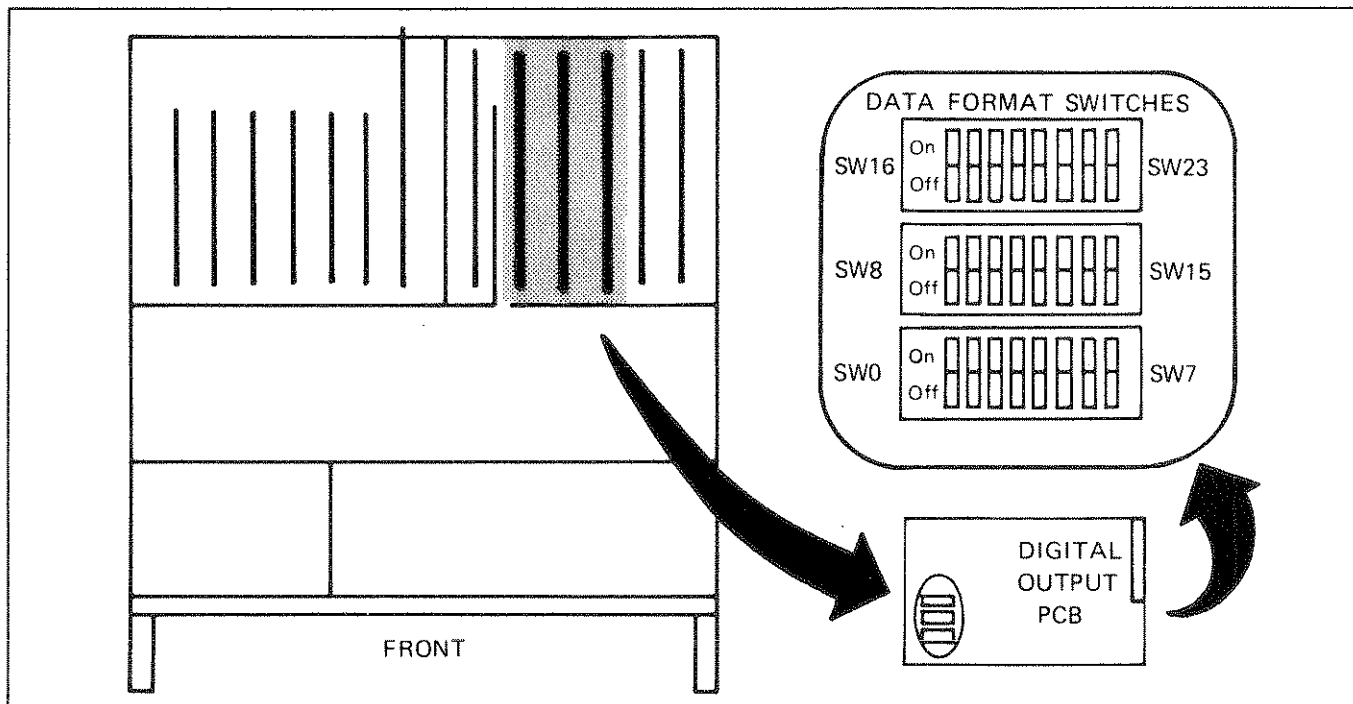

Figure 614-1. Digital Output PCB, Installation and Switch Locations

-14 Series pcb as follows:

WARNING

REMOVE LINE POWER AND ALL OTHER  
HIGH VOLTAGE INPUTS TO THE DATA  
LOGGER BEFORE STARTING THIS  
PROCEDURE.

1. Set the data logger's POWER switch to OFF.
2. Remove the top cover from the data logger.
3. Locate the Data Format switches on each -14 Series Digital Output PCB, as shown in Figure 614-1.
4. With reference to Figure 614-2, establish the format of recorded data as follows:
  - a. Set switches 0 through 11 to OFF. This establishes the format shown in Figure 614-2.
  - b. Delete any combination of unwanted character segments by setting the appropriate switches to ON.
  - c. Set switches 12 through 23 to indicate (in binary) one less than the maximum number of characters to be recorded during a scan sequence. One (binary coded zero) to 4096 (binary coded 4095) characters can be selected (1 = ON).
5. Refer to Figure 614-3 and check to ensure that the parity jumper is properly positioned and the Remote Start jumper is installed if required. If necessary, reposition the jumper to obtain the desired odd or even parity.
6. Align the Digit Output PCB in the selected I/O slot so that the large female connector is toward to rear of the data logger, and the small board-edge connector is toward the bottom of the unit. Push the pcb straight down onto the mating connector.
7. After the Digital Output PCB(s) is (are) installed, install the top cover.

614-13. Interface Cable

614-14. The interface cable supplied with the -14 Series Options is designed to connect the Digital Output PCB to the appropriate Kennedy Magnetic Tape Recorder. If the data logger scan sequences are to be manually initiated using the front-panel switches,

### DETAILS OF RECORDED DATA

DESCRIPTION	RECORDED DATA FORMAT AND CONTROL SWITCH (0 thru 11) ASSIGNMENTS*
START OF SCAN	@   CR   LF
TIME OF YEAR (2240C ONLY)	D   D   D   :   H   H   :   M   M   :   S   S   CR   LF ←———— SW 0 —————→ * SW 1 →
SCAN COUNTER (2200A) FIXED DATA (2240C)	CR   LF   SP   SP   FD   FD   FD   FD   FD   FD   CR   LF ←———— SW 2 —————→ * SW 3 →
DIGITAL INPUT DATA (Option-16)	AC   AC   SP   DD   DD   DD   DD   DD   DD   DD   DD   CR   LF
MEASUREMENT DATA -NORMAL	CH   CH   CH   SP   > < ±   AD   AD   AD   Floating Decimal Point   AD   AD   m   SP   V C F   CR   LF ← SW 4 →   SW 5   SW 6   SW 7       SW 8       SW 9   ← SW 10 →   ← SW 11 →
MEASUREMENT DATA -ABNORMAL	CH   CH   CH   SP   SP   SP   O L   SP   SP   SP   m   V C F   CR   LF BROKEN THERMOCOUPLE      MEASUREMENT UNITS

#### CHARACTERS PER RECORD SWITCH SETTINGS (12 thru 23)

Set switches to indicate, in binary, one less than the maximum number of recorded characters per record. For example a binary coded 499 is equal to 500 recorded characters per record.

SETTINGS INDICATE CHARACTERS PER RECORD +1												
SWITCHES	20	21	22	23	16	17	18	19	12	13	14	15
BINARY	2 <sup>11</sup>	2 <sup>10</sup>	2 <sup>9</sup>	2 <sup>8</sup>	2 <sup>7</sup>	2 <sup>6</sup>	2 <sup>5</sup>	2 <sup>4</sup>	2 <sup>3</sup>	2 <sup>2</sup>	2 <sup>1</sup>	2 <sup>0</sup>
EQUIVALENT												
DECIMAL	2048	1024	512	256	128	64	32	16	8	4	2	1
EQUIVALENT												

#### \*MNEMONICS

AC	=	Address Code
AD	=	Analog Data
CH	=	Channel Number
CR	=	Carriage Return
D	=	Day Code
DD	=	Digital Input Data
FD	=	Fixed Data
H	=	Hours
LF	=	Line Feed
M	=	Minutes
S	=	Seconds
SP	=	Space

**Figure 614-2. Recorded Data Format and Digital Output PCB Switch Assignments**



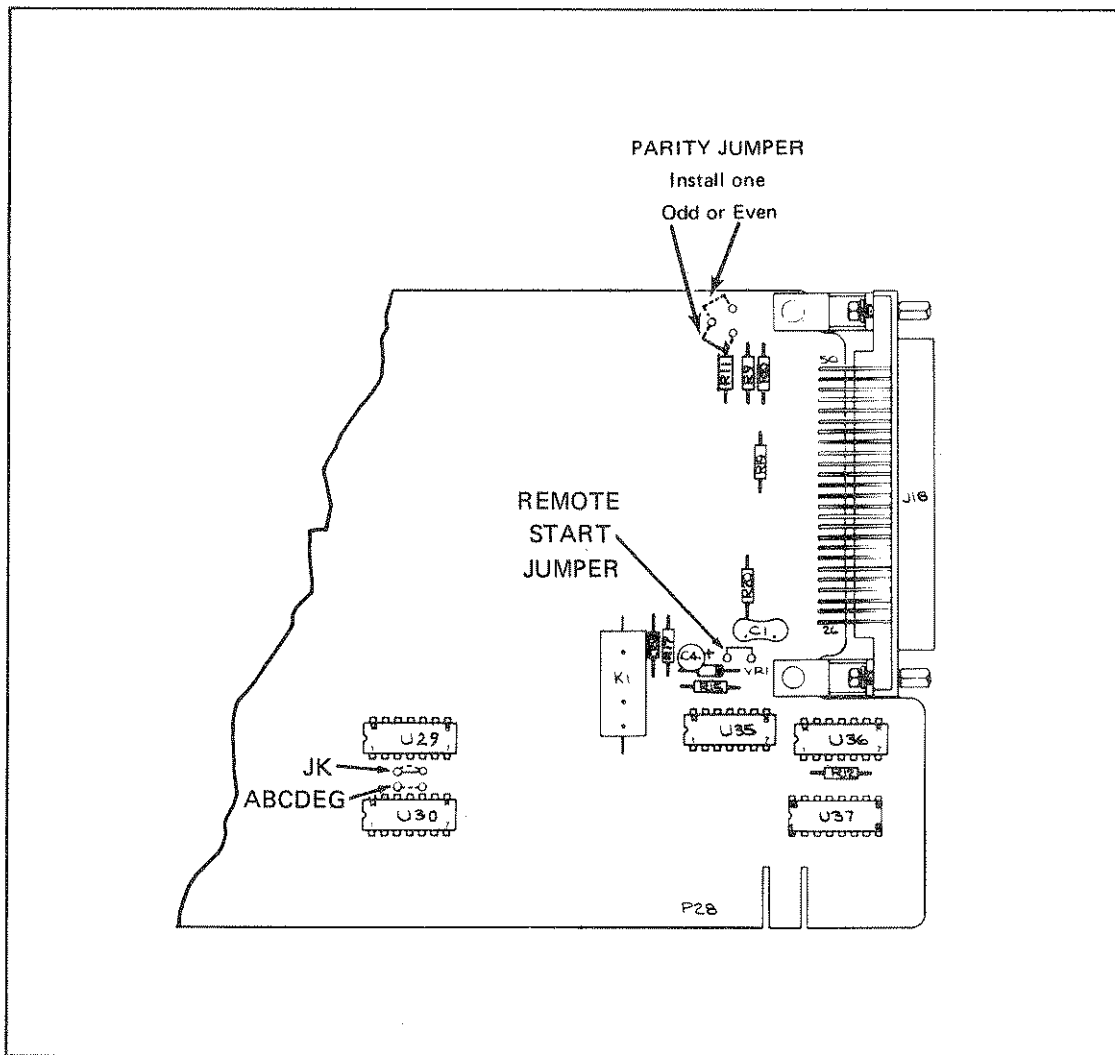

Figure 614-3. Jumper Location, -14 Series Options

connect the interface cable between the Digital Output PCB's rear-panel connector and the tape recorder. If the scan sequence is to be initiated by a remote input, complete the following procedure prior to connecting the interface cable:

1. Remove approximately 2 inches of the sleeving covering the data logger end of the cable, behind the connector.
2. Separate the three wires outside the main cable, under the sleeving.
3. Identify each wire, using an Ohmmeter.
  - a. Pin 31 - Start
  - b. Pin 6 - Scan In Progress
  - c. Pin 48 - Logic Common
4. Install the interface cable and connect the remote control lines to the desired control source. The function of each line is described below:
  - a. START - If the REMOTE switch in the data logger's SCAN CONTROL switch group is depressed, a contact closure to Logic Common or a low TTL/DTL logic level will initiate a scan sequence. If a scan is in progress, the Start input is ignored.
  - b. SIP - A TTL output that goes low to indicate that a scan is in progress. Starts input during this period are ignored. SIP also goes low when REMOTE is pressed, and will remain low until an external START is received and the first scan sequence is completed.
  - c. LOGIC COMMON - Logic common for the Start input and the SIP output signals.

#### NOTE

If a single remote control source is used and more than one Digital Output PCB is installed, it is sufficient to complete the remote control connections on only one interface cable.

614-15. OPERATION

614-16. Once installed in the data logger, the Digital Output

PCB requires no operator attention. Instructions for connecting the remote control lines are given earlier under installation. Refer to the appropriate Kennedy Instruction Manual for details concerning the magnetic tape recorder.

1. Apply a momentary contact closure to ground (48) or a low logic level to the Start input (31). If SIP (6) is initially low (prior to Start input), allow the first scan sequence to complete. SIP will return high at the end of the sequence and will go low for subsequent scan sequences.
2. While the Scan In Progress output is high (i.e., no keyboard or front panel activity) a negative-going Start pulse with a width of  $\geq 5$  ms will cause a remote start.
3. Under worst case keyboard activity, a Start pulse  $\geq 100$  ms is required to ensure a remote start.
4. If the Start input is held low from the start to finish of a scan sequence, a second scan will be initiated. A continuous scan mode is achieved by holding the Start input low.

#### 614-18. THEORY OF OPERATION

614-19. The Digital Output PCB, as shown in Figure 614-4, is a microprocessor based subsystem which functions as a controller peripheral to provide the interface necessary to transfer data logger time-of-day, digital data, heading, and measurement data (as printed on the internal printer) to an external digital recording device. Any one of several types of recorders can be accommodated by the interface. Among these are: a 20 mA current-loop teleprinter (-12 Options), a paper tape punch (-13 Options), an incremental magnetic tape recorder (-14 Options), or any RS-232-C compatible recording device. Once the recorder is defined, the interface pcb can be tailored to meet the interface requirements by the addition of two plug-in ROMs and an interface cable (both are supplied as an integral part of the option). Additional formatting and baud rate requirements (when applicable) are manually selected using a series of 24 switches located on the pcb. (See installation instructions for switch settings as they apply to this option.) Provisions are also included which allow a contact closure to ground (or any other low-level input) to serve as a remote start-of-scan signal to the data logger. While a scan is in progress (SIP), an SIP output is generated to indicate that subsequent start inputs will not be accepted until the current scan sequence has been completed.

614-20. Data transfer from the controller to the external recorder is accomplished in two operations: first, an input transfer sequence, and then, an output transfer sequence. The input transfer sequence is executed under the direction of the

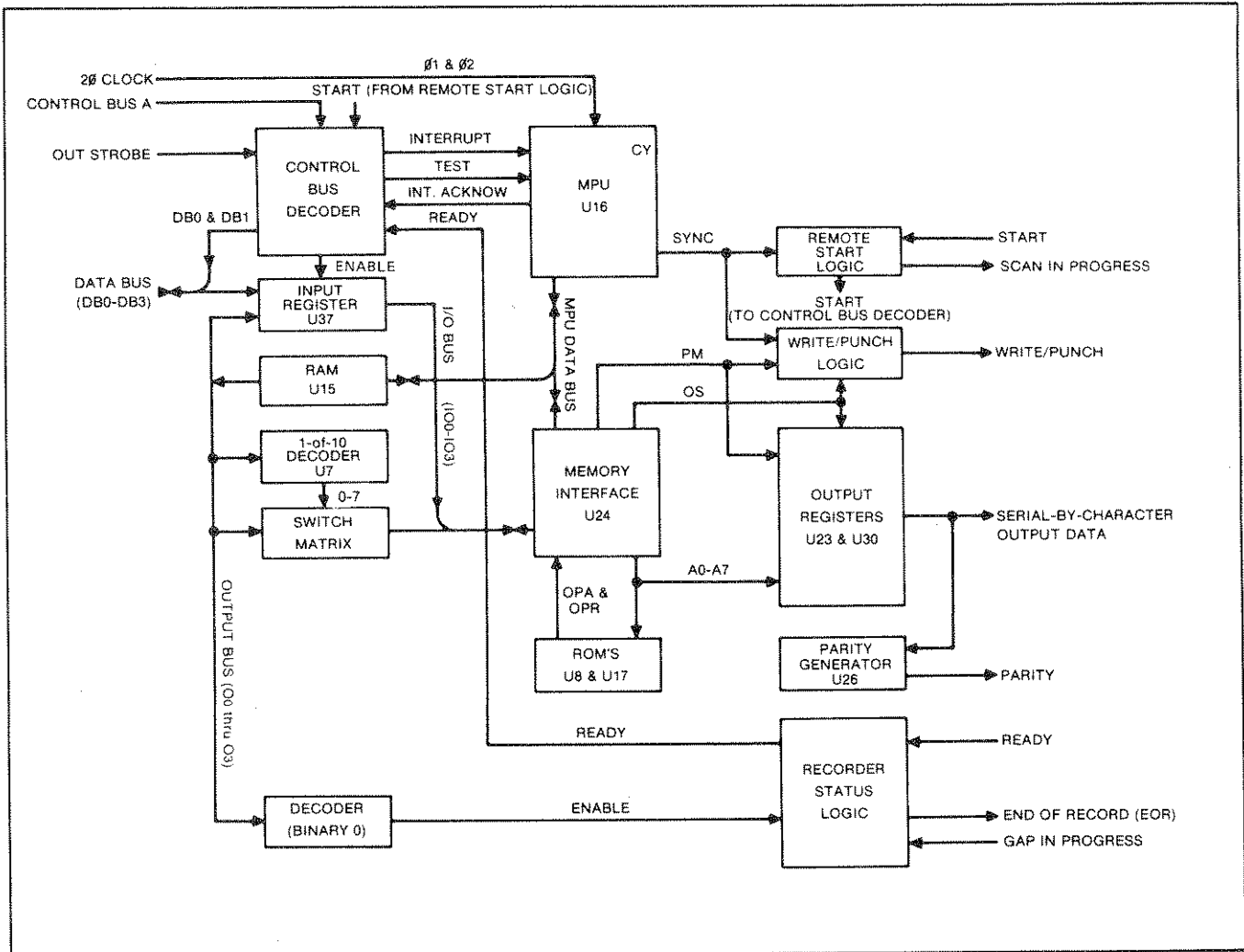

Figure 614-4. Digital Output PCB Simplified Block Diagram

controller and includes the character-serial transfer of 16 four-bit characters from the controller (via the Data Bus) to a storage location (RAM) on the Digital Output PCB. After the input transfer is complete, the microprocessor on the Digital Output PCB directs the execution of the output transfer sequence. That is, the transfer of data from the storage location to the recording device. Appropriate handshaking is employed to ensure the output transfer is synchronized with the recorder.

614-21. When the controller is ready to initiate a data transfer it interrogates the status of the Digital Output PCB by placing a binary coded 6 onto Control Bus A. A decoder on the pcb detects the 6 and initiates an appropriate status response via the Data Bus. Table 614-3 lists the possible responses and their meanings.

614-22. Upon receiving a binary coded 3 (11) as a status response, the controller initiates the data transfer sequence by simultaneously placing a binary coded 4 onto Control Bus A, and the first data character (4-bits) onto the Data Bus. A Control Bus Decoder detects the control character (binary coded 4) and responds by generating an Interrupt to the MPU and an input Enable to the 4-bit Input Register. On the rising edge of the accompanying Out Strobe, the Test input to the MPU is driven high and the character on the Data Bus is entered into the Input Register. As a result of the high Interrupt and Test inputs, the MPU issues a low Interrupt Acknowledge. (Busy is used in the event the status of the Output PCB is interrogated prior to completing the entire data transfer to the peripheral device; see Table 614-3.) At the same time the MPU causes the output RAM to place a binary coded 8 onto the Output Bus. The presence of this code plus a subsequent IS pulse (generated by the Memory Interface) enables the contents of the Input Register to be read (via the I/O Bus) by the Memory Interface. On the trailing edge of the IS pulse, the MPU's test input is returned low to complete the first character segment of the 16-character input-transfer sequence.

614-23. Since the binary coded 4 is still present on the Control Bus, the character-serial transfer of data between the controller and the Memory Interface continues, as previously described, until an entire block of 16 characters has been processed. As each character of input data is read by the System Interface, it is also transferred through the MPU (via the MPU Data Bus) into the RAM.

614-24. After the controller presents the last input character to the Digital Output PCB it removes the binary coded 4 from the Control Bus A. With the Control code gone, the Interrupt input to the MPU goes low to inhibit additional data from being entered into the Input Register. This completes the initial phase (input data transfer) of the data transfer sequence.

614-25. The output transfer sequence begins as the MPU writes a binary coded 0 onto the Output Bus. A decoder detects the zero

**Table 614-3. Description of Status Response Codes**

Status Response		Meaning of Status Response
DB1	DB0	
0	0	Remote Start commanded but transfer in progress. Wait until not Busy.
0	1	Remote Start. Initiate a scan sequence.
1	0	Busy. Data transfer in progress. No action required.
1	1	Initiate a data transfer sequence.

and issues an Enable input to the Recorder Status Logic. If the external device is ready to receive data, the Recorder Status Logic will provide a low Ready output which drives the MPU's test input high to indicate that an output transfer may commence. Since the Digital Output PCB is capable of transferring output data in a bit-serial-by-character format, as well as, a bit-parallel-by-character format, each process will be considered separately.

614-26. Bit-parallel output data is stored, one character at a time, in a pair of 4-bit output registers. Data transfer to the registers is enabled by the PM input from the Memory Interface, and is entered on the leading edge of the OS pulse. As PM goes low the first output character, including four-bits of supplementary data (ASCII, BCDIC, and/or EBCDIC), is placed onto address lines A0 through A7. After the character is entered by the subsequent OS pulse, the PM output is returned high. This PM transition arms the Write/Punch Logic to allow the rising edge of the next Sync pulse to initiate a Write/Punch output pulse. An appropriate amount of time later, a second OS pulse is issued, and the write/punch output is terminated on the trailing edge of the next Sync pulse. As each bit-parallel character appears on the output lines (D0 through D7) a Parity Generator provides a ninth bit (jumper selectable odd or even) for parity.

614-27. The bit-serial output is enabled when the MPU instructs the RAM to place a binary coded 11 onto the Output Bus. Output data is then taken a bit at a time from the MPU's CY output and used to drive an EIA output buffer as well as relay K1. The mercury-wetted contacts of K1 are used to provide a current loop interface (contact closure for a 20 mA current loop).

614-28. The format of output data is established by the setting of 24 rocker switches which comprise a 3 x 8 switch matrix (see Figure 614-4). These switches are scanned at the beginning of each output transfer sequence by the MPU (via the RAM Output Bus) and read into the Memory Interface as six 4-bit characters. To read each character the MPU causes the RAM to sequentially place binary coded numbers 0 through 5 onto the Output Bus. (Isolation diodes are provided with each switch to avoid interaction between the various groups of matrix switches.) As each 4-bit word appears on the I/O Bus, it is read into the Memory Interface (by an IS pulse).

614-29. The transfer of output data, regardless of format, must be synchronized with the interfaced recorder. This is accomplished by the Recorder Status Logic which detects and reacts to a series of handshaking routines. For example, Ready and Punch input/outputs are used to synchronize the operation to a paper tape punch. Similarly, RS-232-C compatible recorders employ the Data-Set-Ready and Clear-To-Send inputs. Magnetic tape recorders utilize the Ready and Write lines to record data, and the EOR (End-Of-Record) and Gap-In-Progress lines to initiate (EOR) a standard inter-record gap, and to indicate its duration

(Gap-In-Progress).

614-30. The Remote Start Logic, upon receipt of an external Start command, alters the Digital Output PCB's status response so as to initiate a data logger scan sequence (see Table 614-3). An acceptable start input is a  $\geq 5$  ms contact closure to ground while the Scan-In-Progress output is high. When the controller interrogates the status of the Digital Output PCB (binary coded 6 on Control Bus A), the Remote Start Logic provides a start scan response via the Control Bus Decoder. During the following data transfer sequence, the controller includes both a start-of-scan (binary coded 8) and end-of-scan (binary coded 9) character with the normal data transfer characters. These two characters are decoded by the 1-of-10 decoder, and used to initiate and terminate the Scan-In-Progress (SIP) output. While the SIP output is active all Start inputs are ignored.

614-31. MAINTENANCE

614-32. Access Information

614-33. Refer to the installation instructions given earlier for Digit Output PCB access information. Remove the rear-panel output connector before attempting to remove the pcb from the data logger.

614-34. Performance Test

614-35. The Digital Output PCB Assembly is most easily tested under normal operating conditions. That is, installed in a functional data logger and interfaced with the recording device it normally drives. Output data format and characters can then be checked by comparing data recorded on the internal printer with hard copy data derived from the external recording device.

614-36. LIST OF REPLACEABLE PARTS

614-37. The lists of replaceable parts for the -14 Series of data logger options are given in Tables 614-4, -5, and -6. Refer to Section 5 of the data logger manual for ordering information.

⊗ CAUTION

Indicated devices are subject  
to damage by static discharge.



Table 614-4. -14 Series Options

REF DES	DESCRIPTION	FLUKE STOCK NO.	MFG SPLY CODE	MFG. PART NO.	TOT QTY	REC QTY	NO TE
-14	SERIES -14 OPTIONS						
-14A	KENNEDY 1600/5 INTERFACE (7 TRACK, 8-1/2 INCH REEL)	431262	89536	431262			
	TELETYPE INTERFACE PCB ASSEMBLY (2200A-4014T)	409524	89536	409524	1		
	RES, COMP, 1K +/-5%, 1/4W, R10,R11	148023	01121	CB1025	1		
	IC, REPROGRAMMABLE PROM, U8,U17	408591	89536	408591	2		1
	IC, TTL, HEX BUF/DRIV, U31,U32	328021	89536	328021	2		1
	TAPE RECORDER, KENNEDY MAGNETIC 1600/5	435479	89536	435479	1		
	CABLE ASSY., MAG TAPE INTERFACE FIGURE 614-5 (2200A-8034)	477885	89536	477885	1		
	JUMPER STRIP, 10 PART CARRIER	373316	89536	373316	AR		
-14B	KENNEDY 1610/5 INTERFACE (7 TRACK, 10-1/2 INCH REEL) (2200A-14B)	431270	89536	431270			
	TELETYPE INTERFACE PCB ASSEMBLY	409524	89536	409524	1		
	RES, COMP, 1K +/-5%, 1/4W, R10,R11	148023	01121	CB1025	1		
	IC, REPROGRAMMABLE PROM, U8,U17	408591	89536	408591	2		1
	IC, TTL, HEX BUF/DRIV, U31,U32	328021	89536	328021	2		1
	TAPE RECORDER, KENNEDY MAGNETIC 1610/5	435487	89536	435487	1		
	CABLE ASSY., MAG TAPE INTERFACE FIGURE 614-5 (2200A-8034)	477885	89536	477885	1		
	JUMPER STRIP, 10 PART CARRIER	373316	89536	373316	AR		
-14C	KENNEDY 1600/360 INTERFACE (9 TRACK, 8-1/2 INCH REEL)	431288	89536	431288			
	TELETYPE INTERFACE PCB ASSEMBLY (2200A-4014T)	409524	89536	409524	1		
	RES, COMP, 1K +/-5%, 1/4W, R10,R11	148023	01121	CB1025	1		
	IC, REPROGRAMMABLE PROM, U8,U17	408591	89536	408591	2		1
	IC, TTL, HEX BUF/DRIV, U31,U32	328021	89536	328021	2		1
	TAPE RECORDER, KENNEDY MAGNETIC 1600/360	435495	89536	435495	1		
	CABLE ASSY., MAG TAPE INTERFACE FIGURE 614-5 (2200A-8034)	477885	89536	477885	1		
	JUMPER STRIP, 10 PART CARRIER	373316	89536	373316	AR		

Table 614-4. -14 Series Options (cont)

REF DES	DESCRIPTION	FLUKE STOCK NO.	MFG SPLY CODE	MFG. PART NO.	TOT QTY	REC QTY	NO TE
-14D	KENNEDY 1610/360 INTERFACE (9 TRACK, 10-1/2 INCH REEL)	431296	89536	431296			
	TELETYPE INTERFACE PCB ASSEMBLY (2200A-4014T)	409524	89536	409524	1		
	RES, COMP, 1K +/-5%, 1/4W, R10,R11	148023	01121	CB1025	1		
	IC, REPROGRAMMABLE PROM, U8,U17	408591	89536	408591	2		1
	IC, TTL, HEX BUF/DRIV, U31,U32	328021	89536	328021	2	1	
	TAPE RECORDER, MAGNETIC CABLE ASSY., MAG TAPE INTERFACE FIGURE 614-5 (2200A-8034)	435503 477885	89536 89536	435503 477885	1 1		
	JUMPER STRIP, 10 PART CARRIER	373316	89536	373316	AR		
-14E	INTERFACE FOR KENNEDY 1600/5 OR 1610/5	431304	89536	431304			
	TELETYPE INTERFACE PCB ASSEMBLY (2200A-4014T)	409524	89536	409524	1		
	RES, COMP, 1K +/-5%, 1/4W, R10,R11	148023	01121	CB1025	1		
	IC, REPROGRAMMABLE PROM, U8,U17	408591	89536	408591	2		1
	IC, TTL, HEX BUF/DRIV, U31,U32	328021	89536	328021	2	1	
	CABLE ASSY., MAG TAPE INTERFACE FIGURE 614-5 (2200A-8034)	477885	89536	477885	1		
	JUMPER STRIP, 10 PART CARRIER	373316	89536	373316	AR		
-14G	INTERFACE FOR KENNEDY 1600 OR 1610/360	431312	89536	431312			
	TELETYPE INTERFACE PCB ASSEMBLY (2200A-4014T)	409524	89536	409524	1		
	RES, COMP, 1K +/-5%, 1/4W, R10,R11	148023	01121	CB1025	1		
	IC, SPECIAL PROGRAMMED PROM, U8,U17	432757	89536	432757	2		1
	IC, TTL, HEX BUF/DRIV, U31,U32	328021	89536	328021	2	1	
	CABLE ASSY., MAG TAPE INTERFACE FIGURE 614-5 (2200A-8034)	477885	89536	477885	1		
	JUMPER STRIP, 10 PART CARRIER	373316	89536	373316	AR		

Table 614-4. -14 Series Options (cont)

REF DES	DESCRIPTION	FLUKE STOCK NO.	MFG SPLY CODE	MFG PART NO. OR TYPE	TOT QTY	REC QTY	NOTE
-14J	KENNEDY 9832-9 AND INTERFACE (9 TRACK, 8-1/2 INCH REEL)	470492	89536	470492			
	TELETYPE INTERFACE PCB ASSEMBLY (2200A-4014T)	409524	89536	409524	1		
	RES, COMP, 1K +/-5%, 1/4W, R10,R11	148023	01121	CB1025	1		
	IC, REPROGRAMMABLE PROM, U8,U17	408591	89536	408591	2		1
	IC, TTL, HEX BUF/DRIV, U31,U32	328021	89536	328021	2	1	
	TAPE RECORDER, KENNEDY CD 9832 CABLE ASSY., 9832-9 INTERFACE	413468	89536	413468	1		
	FIGURE 614-6 (2200A-4412) JUMPER STRIP, 10 PART CARRIER	471359	89536	471359	1		
	373316	89536	373316	AR			
-14K	INTERFACE FOR KENNEDY 9832-9	470500	89536	470500			
	TELETYPE INTERFACE PCB ASSEMBLY (2200A-4014T)	409524	89536	409524	1		
	RES, COMP, 1K +/-5%, 1/4W, R10,R11	148023	01121	CB1025	1		
	IC, REPROGRAMMABLE PROM, U8,U17	408591	89536	408591	2		1
	IC, TTL, HEX BUF/DRIV, U31,U32	328021	89536	328021	2	1	
	CABLE ASSY., 9832-9 INTERFACE FIGURE 614-6 (2200A-4412)	471359	89536	471359	1		
	JUMPER STRIP, 10 PART CARRIER	373316	89536	373316	AR		
1....TO ORDER SUBMIT U NUMBER, OPTION NUMBER AND DESCRIPTION.							

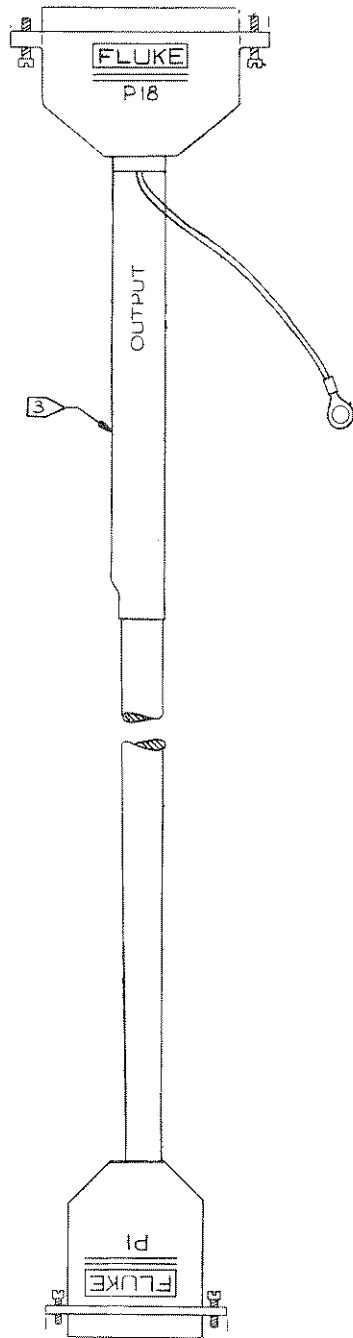

WIRE LIST	
FROM	TO
P18-1	
▲-2	PI-29
-3	PI-1
-4	PI-3
-5	
-6	3 >
-7	
-8	
-9	
-10	
-11	
-12	
-13	PI-18
-14	▲-20
-15	▼-16
-16	PI-22
-17	
-18	
-19	PI-27
-20	▲-14
-21	▼-30
-22	PI-6;7
-23	
▼-24	
P18-25	

90  
/

WIRE LIST	
FROM	TO
P18-26	
▲-27	PI-8;11
-28	PI-10
-29	
-30	
-31	3 >
-32	
-33	
-34	
-35	
-36	PI-28
-37	
-38	PI-19
-39	▲-17
-40	▼-21
-41	PI-23
-42	
-43	
-44	
-45	
-46	PI-13
-47	
-48	3 >
▼-49	
P18-50	

2200A-8034

Figure 614-5. Mag Tape Interface Cable Assembly

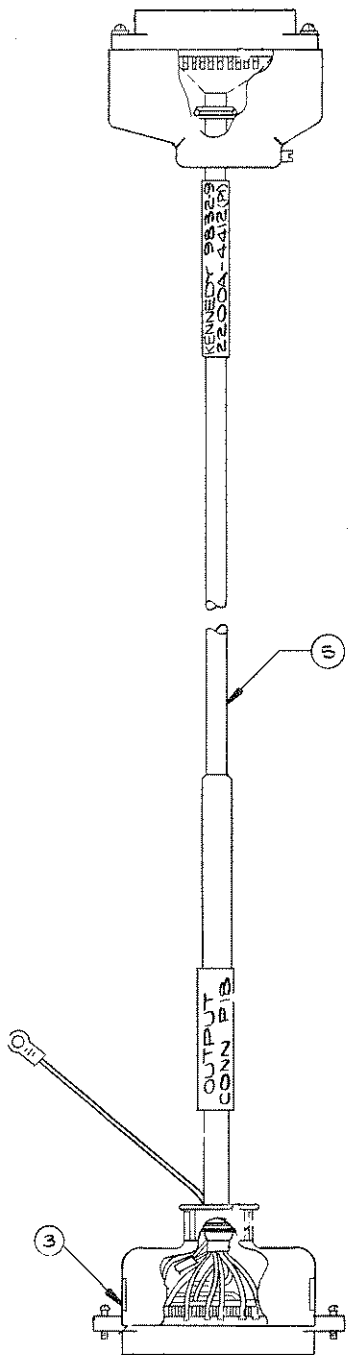

WIRE LIST		
FROM	TO	GROUND
PIB-1		
-2	5	
-3		
-4		
-5		
-6	5	
-7		
-8		
-9		
-10		
-11		
-12		
-13	PI-17	PI-35
-14	PI-14	PI-32
-15	PI-12	PI-30
-16	PI-11	PI-29
-17		
-18		
-19		
-20	PI-6	PI-24
-21	PI-7	PI-25
-22	PI-5	PI-23
-23	5	
-24		
-25		
-26		
-27		
-28		
-29		
-30		
-31	5	
-32		
-33		
-34		
-35		
-36	PI-4	PI-22
-37		
-38	PI-16	PI-34
-39	PI-15	PI-33
-40	PI-13	PI-31
-41	PI-10	PI-28
-42		
-43		
-44		
-45		
-46		
-47		
-48	5	
-49		
PIB-50		

5

2200A-4412

Figure 614-6. 9832-9 Interface Cable Assembly

Table 614-5. Teletype Interface PCB Assembly

REF DES	DESCRIPTION	FLUKE STOCK NO.	MFG SPLY CODE	MFG. PART NO.	TOT QTY	REC QTY	NO TE
	⊗ TELETYPE INTERFACE PCB ASSEMBLY FIGURE 614-7 (2200A-4014T)	409524	89536	409524	REF		
C1	CAP, MICA, 400 PF +/-1%, 500V	385328	72136	DM15F401F	1		
C2	CAP, CER, 300 PF +/-10%, 500V	105734	71590	BB60301KW7W	2		
C3	CAP, CER, 300 PF +/-10%, 500V	105734	71590	BB60301KW7W	REF		
C4	CAP, TA, 10 UF +/-20%, 20V	330662	56289	196D106X0020KA1	1		
C5	CAP, CER, 0.68 UF -20/+80%, 25V	179077	56289	5C023684D8250B3	1		
CR1	DIODE, SI, SWITCHING	203323	07910	1N4448	27	6	
CR3	DIODE, SI, SWITCHING	203323	07910	1N4448	REF		
CR3	DIODE, SI, SWITCHING	203323	07910	1N4448	REF		
CR4	DIODE, SI, SWITCHING	203323	07910	1N4448	REF		
CR5	DIODE, SI, SWITCHING	203323	07910	1N4448	REF		
CR6	DIODE, SI, SWITCHING	203323	07910	1N4448	REF		
CR7	DIODE, SI, SWITCHING	203323	07910	1N4448	REF		
CR8	DIODE, SI, SWITCHING	203323	07910	1N4448	REF		
CR9	DIODE, SI, SWITCHING	203323	07910	1N4448	REF		
CR10	DIODE, SI, SWITCHING	203323	07910	1N4448	REF		
CR11	DIODE, SI, SWITCHING	203323	07910	1N4448	REF		
CR12	DIODE, SI, SWITCHING	203323	07910	1N4448	REF		
CR13	DIODE, SI, SWITCHING	203323	07910	1N4448	REF		
CR14	DIODE, SI, SWITCHING	203323	07910	1N4448	REF		
CR15	DIODE, SI, SWITCHING	203323	07910	1N4448	REF		
CR16	DIODE, SI, SWITCHING	203323	07910	1N4448	REF		
CR17	DIODE, SI, SWITCHING	203323	07910	1N4448	REF		
CR18	DIODE, SI, SWITCHING	203323	07910	1N4448	REF		
CR19	DIODE, SI, SWITCHING	203323	07910	1N4448	REF		
CR20	DIODE, SI, SWITCHING	203323	07910	1N4448	REF		
CR21	DIODE, SI, SWITCHING	203323	07910	1N4448	REF		
CR22	DIODE, SI, SWITCHING	203323	07910	1N4448	REF		
CR23	DIODE, SI, SWITCHING	203323	07910	1N4448	REF		
CR24	DIODE, SI, SWITCHING	203323	07910	1N4448	REF		
CR25	DIODE, SI, SWITCHING	203323	07910	1N4448	REF		
CR26	DIODE, SI, SWITCHING	203323	07910	1N4448	REF		
CR27	DIODE, SI, SWITCHING	203323	07910	1N4448	REF		
CR28	DIODE, SI, SWITCHING	203323	07910	1N4448	REF		
J18	CONNECTOR, FEMALE, 50-PIN	414417	00779	552130-1	1		
K1	RELAY, REED	357509	71707	UF-40066	1		
MP1	HARDWARE KIT, CONNECTOR (TO J18)	448563	89536	448563	1		
Q1	XSTR, SI, NPN	218396	04713	2N3904	1	1	
R1	RES, COMP, 100K +/-5%, 1/4W	148189	01121	CB1045	1		
R2	RES, COMP, 10K +/-5%, 1/4W	148106	01121	CB1035	6		
R3	RES, COMP, 13K +/-5%, 1/4W	221598	01121	CB1335	3		
R4	RES, COMP, 13K +/-5%, 1/4W	221598	01121	CB1335	REF		
R5	RES, COMP, 1K +/-5%, 1/4W	148023	01121	CB1025	11		
R6	RES, COMP, 1K +/-5%, 1/4W	148023	01121	CB1025	REF		
R7	RES, COMP, 1K +/-5%, 1/4W	148023	01121	CB1025	REF		
R8	RES, COMP, 1K +/-5%, 1/4W	148023	01121	CB1025	REF		
R9	RES, COMP, 1K +/-5%, 1/4W	148023	01121	CB1025	REF		

Table 614-5. Teletype Interface PCB Assembly (cont)

REF DES	DESCRIPTION	FLUKE STOCK NO.	MFG SPLY CODE	MFG. PART NO.	TOT QTY	REC QTY	N O T E
R12	RES, COMP, 1K +/-5%, 1/4W	148023	01121	CB1025	REF		
R13	RES, COMP, 10K +/-5%, 1/4W	148106	01121	CB1035	REF		
R14	RES, COMP, 1K +/-5%, 1/4W	148023	01121	CB1025	REF		
R15	RES, COMP, 200 +/-5%, 1/4	193482	01121	CB2015	1		
R16	RES, COMP, 1K +/-5%, 1/4W	148023	01121	CB1025	REF		
R17	RES, COMP, 1K +/-5%, 1/4W	148023	01121	CB1025	REF		
R18	RES, COMP, 1K +/-5%, 1/4W	148023	01121	CB1025	REF		
R19	RES, COMP, 1K +/-5%, 1/4W	148023	01121	CB1025	REF		
R20	RES, COMP, 10K +/-5%, 1/4W	148106	01121	CB1035	REF		
R21	RES, COMP, 5.1K +/-5%, 1/4W	193342	01121	CB5125	1		
R23	RES, COMP, 3.3K +/-5%, 1/4W	148056	01121	CB3325	1		
R24	RES, COMP, 10K +/-5%, 1/4W	148106	01121	CB1035	REF		
R25	RES, COMP, 10K +/-5%, 1/4W	148106	01121	CB1035	REF		
R26	RES, COMP, 13K +/-5%, 1/4W	221598	01121	CB1335	REF		
R27	RES, COMP, 10K +/-5%, 1/4W	148106	01121	CB1035	REF		
U10	IC, C-MOS, HEX BUFFER	407759	12040	MM80C97N	1	1	
U2	RES, NETWORK	376962	89536	376962	1	1	
U4	SWITCH ASSEMBLY, DIL, 8-POS, SPDT	414490	00779	435166-5	3	1	
U5	SWITCH ASSEMBLY, DIL, 8-POS, SPDT	414490	00779	435166-5	REF		
U6	SWITCH ASSEMBLY, DIL, 8-POS, SPDT	414490	00779	435166-5	REF		
U7	IC, C-MOS, BCD-TO-DECIMAL DECODER	407981	12040	MM74C42N	1	1	
U9	IC, C-MOS DUAL J-K F/F	355230	04713	MC14027CP	1	1	
U10	IC, C-MOS, QUAD 2-INPUT NAND GATE	355198	04713	MC14011CP	2	1	
U11	IC, C-MOS, DUAL "D" TYPE F/F	340117	04713	MC14013CL	3	1	
U12	IC, C-MOS, QUAD 2-INPUT NOR GATE	355172	04713	MC14001CP	1	1	
U13	IC, C-MOS, DUAL 4-INPUT NOR GATE	363820	04713	MC14002CP	1	1	
U14	IC, C-MOS, HEX BUFFER/CONVERTER	355214	04713	MC14009CP	3	1	
U15	IC, P-MOS, 320 BIT RAM & 4-BIT OTPT PORT	404442	34649	P4002-1	1	1	
U16	IC, MOS, CENTRAL PROCESSOR	404418	34649	C4040	1	1	
U18	IC, C-MOS, HEX BUFFER/CONVERTER	355412	04713	MC14010CP	1	1	
U19	IC, C-MOS, TRIPLE 3-INPUT NAND GATE	375147	04713	MC14023CP	1	1	
U20	IC, C-MOS, HEX BUFFER/CONVERTER	355214	04713	MC14009CP	REF		
U21	IC, C-MOS, DUAL 4-INPUT NAND GATE	355206	04713	MC14012CP	1	1	
U22	IC, C-MOS, DUAL "D" TYPE F/F	340117	04713	MC14013CL	REF		
U23	IC, TTL, TRI-STATE, QUAD "D" TYPE F/F	408203	12040	DM85L51N	2	1	
U24	IC, C-MOS, STANDARD MEMORY INTERFACE	404434	34649	P4289	1	1	
U25	IC, C-MOS, DUAL "D" TYPE F/F	340117	04713	MC14013CL	REF		
U26	IC, C-MOS, 12-BIT PARITY TREE	414060	04713	MC14531CP	1	1	
U27	IC, QUAD LINE RECEIVER	414045	12040	LM1489	1	1	
U28	IC, C-MOS, QUAD 2-INPUT NAND GATE	355198	04713	MC14011CP	REF		
U29	IC, C-MOS, HEX BUFFER/CONVERTER	355214	04713	MC14009CP	REF		
U32	RESISTOR NETWORK	358119	89536	358119	1	1	
U34	RESISTOR NETWORK	417469	89536	417469	1	1	
U35	IC, TTL, QUAD 2-INPUT NOR BUFFER	414037	01295	SN74LS33N	1	1	
U36	IC, QUAD LINE DRIVER	414052	12040	LM1488	1	1	
U37	IC, C-MOS, QUAD "D" TYPE LATCH	412742	12040	MM74C173N	1	1	
VR1	DIODE, ZENER	340695	12969	UZ8710	1	1	
XU8	SOCKET, IC, 24-PIN DIL	418970	91506	324-AG39D	3		
XU15	SOCKET, IC, 16-PIN DIL	276535	91506	316-AG39D	1		
XU16	SOCKET, IC, 24-PIN DIL	418970	91506	324-AG39D	REF		

Table 614-5. Teletype Interface PCB Assembly (cont)

REF QES	DESCRIPTION	FLUKE STOCK NO.	MFG SPLY CODE	MFG. PART NO.	TOT QTY	REC QTY	NOTE
XU17	SOCKET, IC, 24-PIN DIL	418970	91506	324-AG39D	REF		
XU24	SOCKET, IC, 40-PIN DIL	418988	91506	340-AG39D	1		
XU31	SOCKET, IC, 14-PIN DIL	276527	91507	314-AG39D	2		
XU33	SOCKET, IC, 14-PIN DIL	276527	91507	314-AG39D	REF		

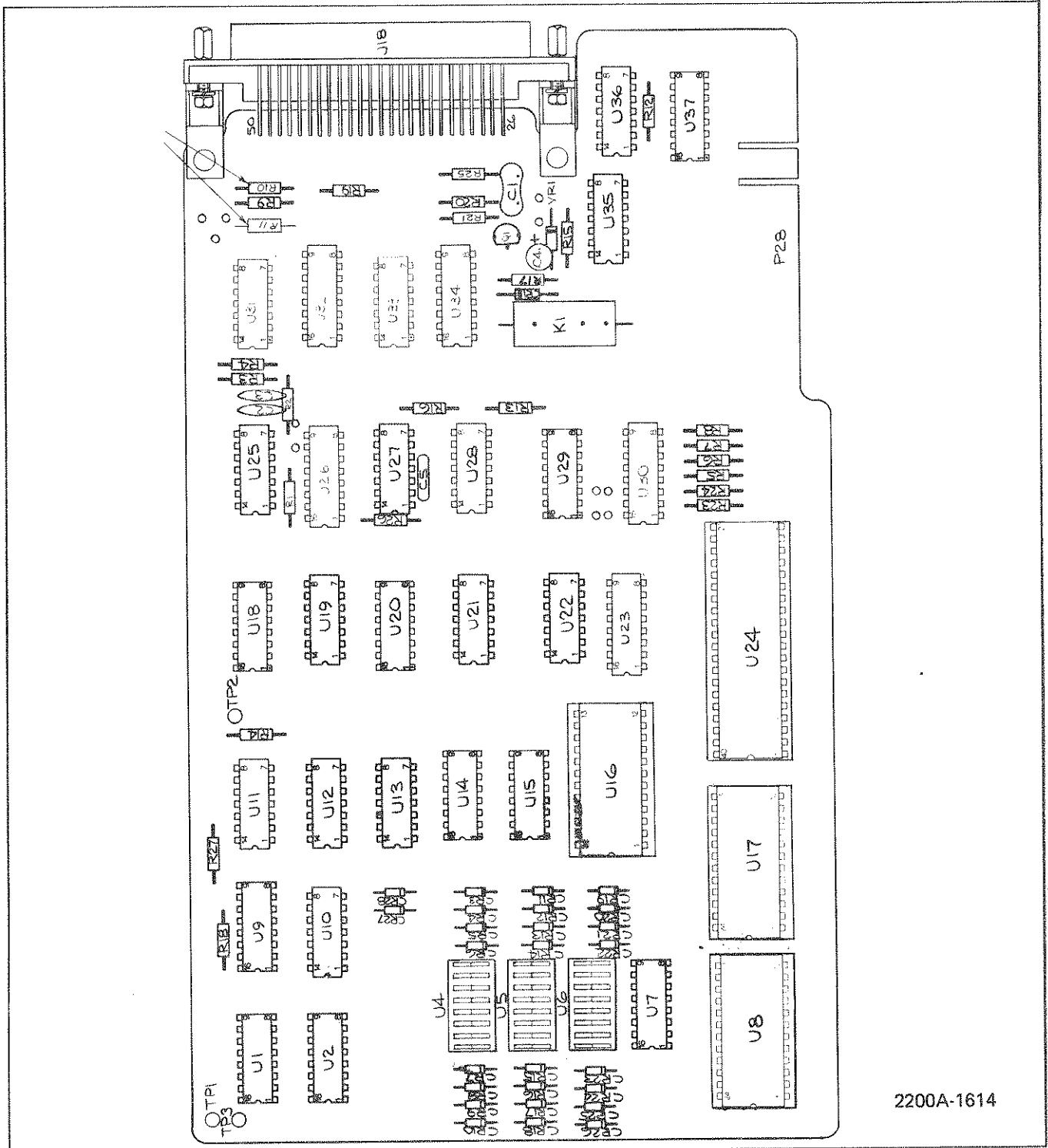

Figure 614-7. Teletype Interface PCB Assembly



1  
2  
3  
4  
5  
6  
7  
8  
9  
10  
11  
12  
13  
14  
15  
16  
17  
18  
19  
20  
21  
22  
23  
24  
25  
26  
27  
28  
29  
30  
31  
32  
33  
34  
35  
36  
37  
38  
39  
40  
41  
42  
43  
44  
45  
46  
47  
48  
49  
50  
51  
52  
53  
54  
55  
56  
57  
58  
59  
60  
61  
62  
63  
64  
65  
66  
67  
68  
69  
70  
71  
72  
73  
74  
75  
76  
77  
78  
79  
80  
81  
82  
83  
84  
85  
86  
87  
88  
89  
90  
91  
92  
93  
94  
95  
96  
97  
98  
99  
100

Option -15  
IEEE Interface

615-1. INTRODUCTION

615-2. The IEEE Interface (Option 2240B-15) is a plug-in pcb designed to provide the interface necessary to transfer programs and output data to and from devices on the IEEE-488 Bus (IEEE Standard 488, Digital Interface for Programmable instrumentation, hereafter referred to as IEEE-488) and a Model 2240C, 2241B, 2242B Data Logger. The option, along with an IEEE-488 Bus Interface Cable (not provided with this option), provides the required interface between the 2242B Data Logger and IEEE-488 Bus controller, such as the Fluke Model 1720A. The card is field installable using procedures given later under Installation.

615-3. Operation of the IEEE Interface can be functionally divided into two sequences: Talk and Listen. The Listen function transfers program information from the IEEE-488 Bus to the A3 controller pcb assembly in the data logger, and the Talk function transfers output data (scan and measurement data) from the data logger to the IEEE-488 Bus.

615-4. The IEEE Interface PCB consists of a single plug-in pcb which can be installed in any one of the three data logger I/O slots. Access to the IEEE-488 Bus is accomplished by a back panel cable and connector. Once the pcb is installed, the Data Logger IEEE-488 Bus address and mode of operation can be set without removing the card from the data logger.

NOTE

2240B-15 and the 2240B-17  
Options (Remote Programming  
Interface) cannot be installed  
in the data logger at the same  
time.

615-5. SHIPPING INFORMATION

615-6. Upon receipt of the IEEE Interface PCB, check carefully for shipping damage. If the pcb is damaged, contact the shipping carrier representative for inspection and request an inspection report. Before returning the pcb to the factory contact the local Fluke Customer Service Center.

615-7. If reshipment is necessary and the original container is not available, a new one can be obtained by writing the John Fluke Mfg. Co., Inc. Please reference the instrument model number, part, and part number when requesting a new shipping container.

615-8. INSTALLATION

615-9. The IEEE Interface PCB can be installed in any one of the data logger I/O slots shown in Figure 615-1. To install the pcb in a data logger, use the following procedure:

**WARNING**

**REMOVE LINE POWER AND ALL OTHER  
HIGH VOLTAGE INPUTS TO THE DATA  
LOGGER BEFORE STARTING THIS  
PROCEDURE.**

1. Set the data logger POWER switch to OFF.
2. Remove the top cover from the data logger.
3. Locate switch S2 on the pcb as shown in Figure 615-1. S2 is used to assign the IEE-488 Bus address code to the pcb.
4. With reference to Table 615-1, set positions 1 through 5 of S2 to assign the desired address character.
5. Locate switch S1 on the pcb as shown on Figure 615-1.
6. Refer to Table 615-2, and set positions 1 through 4 of S1 to define the configuration of the pcb.
7. Align the IEEE Interface PCB in the selected I/O slot, so that the female connector is toward the rear of the data logger, and the small board-edge connector is toward the bottom of the unit. Push the pcb straight down and into the mating connector.
8. After the pcb is installed, install the top cover.

**615-10. IEEE-488 BUS INTERFACE CABLE**

615-11. The IEEE Interface PCB is connected to devices on the IEEE-488 Bus by means of the IEEE-488 Bus Interface cable. The cable conforms to IEEE-488 Bus standards and can be ordered in three different lengths: 1 meter (Y8001), 2 meters (Y8002), and 4 meters (Y8003).

**615-12. OPERATING NOTES**

615-13. The following paragraphs describe various conditions that should be considered before attempting to operate the IEEE Interface PCB.

**615-14. IEEE-488 BUS**

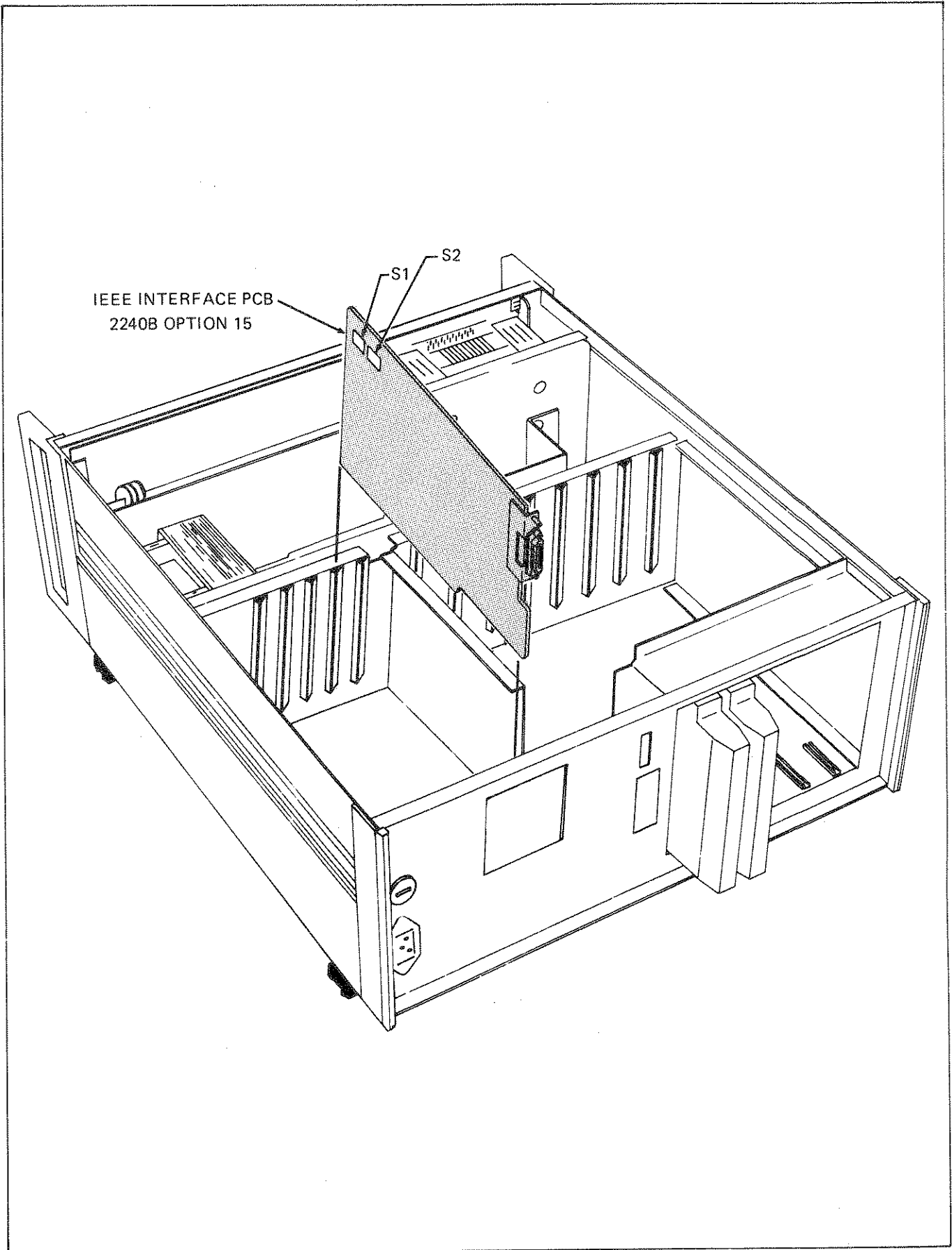

Figure 615-1. Installation and Switch Locations

Table 615-1. Switch S2, IEEE-488 Bus Address Selection

ADDRESS CODES		ADDRESS CHARACTERS		ADDRESS SWITCH SETTINGS				
DECIMAL	OCTAL	LISTEN	TALK	(5)	(4)	(3)	(2)	(1)
0	0	SP	@	0	0	0	0	0
1	1	!	A	0	0	0	0	1
2	2	"	B	0	0	0	1	0
3	3	#	C	0	0	0	1	1
4	4	\$	D	0	0	1	0	0
5	5	%	E	0	0	1	0	1
6	6	&	F	0	0	1	1	0
7	7	'	G	0	0	1	1	1
8	10	(	H	0	1	0	0	0
9	11	)	I	0	1	0	0	1
10	12	*	J	0	1	0	1	0
11	13	+	K	0	1	0	1	1
12	14	,	L	0	1	1	0	0
13	15	-	M	0	1	1	0	1
14	16	.	N	0	1	1	1	0
15	17	/	O	0	1	1	1	1
16	20	0	P	1	0	0	0	0
17	21	1	Q	1	0	0	0	1
18	22	2	R	1	0	0	1	0
19	23	3	S	1	0	0	1	1
20	24	4	T	1	0	1	0	0
21	25	5	U	1	0	1	0	1
22	26	6	V	1	0	1	1	0
23	27	7	W	1	0	1	1	1
24	30	8	X	1	1	0	0	0
25	31	9	Y	1	1	0	0	1
26	32	:	Z	1	1	0	1	0
27	33	;	[	1	1	0	1	1
28	34	<	\	1	1	1	0	0
29	35	=	]	1	1	1	0	1
30	36	>	^	1	1	1	1	0

Table 615-2. Switch S1, Configuration/Interface Selection

SWITCH SLIDE	FUNCTION	ON	OFF
1	Talker Only Mode (ton)	Talker Only	Not enabled
2	Analog readings per line	4 RPL	1 RPL
3	SRQ Enable	Enabled	Not enabled
4	Not implemented	-----	-----
5	Not connected	-----	-----

615-15. IEEE-488 Bus is an interfacing arrangement suited for programmable measurement instrumentation systems. Sixteen bus transmission lines provide for all data and message transfer and control. Bus lines are defined under the following three categories:

1. Eight data bus lines (DI01-DI08) data or address information will be carried on these lines in bit-parallel, byte-serial format. Information transfer on these lines is asynchronous and bidirectional.
2. Three handshake lines:
  - a. DAV (Data Valid): Indicates to a receiver that data is available on the DIO lines.
  - b. NRFD (Not Ready For Data): Indicates whether all devices are ready to accept data.
  - c. NDAC (Not Data Accepted): Indicates the acceptance of data by all devices.
3. Five bus management lines:
  - a. ATN (Attention): When true (low), DI01-DI08 will carry addresses or commands; when false DI01-DI08 carry data.
  - b. IFC (Interface Clear): When true, (low) enables the following states:
    - Talker idle
    - Serial Poll idle
    - Listener idle
  - c. SRQ (Service Request): operates as described by SRQ switch operation (Configuration/Interface Switch (S1) Operation: SRQ, (S1-3)).
  - d. REN (Remote Enable): Not used in the 2240C-15.
  - e. EOI (End or Identify): Set true (low) when the last byte of data is present on the IEEE-488 Bus. The 2240C-15 sets EOI true on each LF (Line Feed).

615-16. A maximum of 15 devices may be interconnected on one contiguous bus structure. These devices may perform any combination of the following functions: talk, listen, or control. Figure 615-2 illustrates typical connections on the IEEE-488 Bus. Table 615-3 defines remote message coding used on the bus.

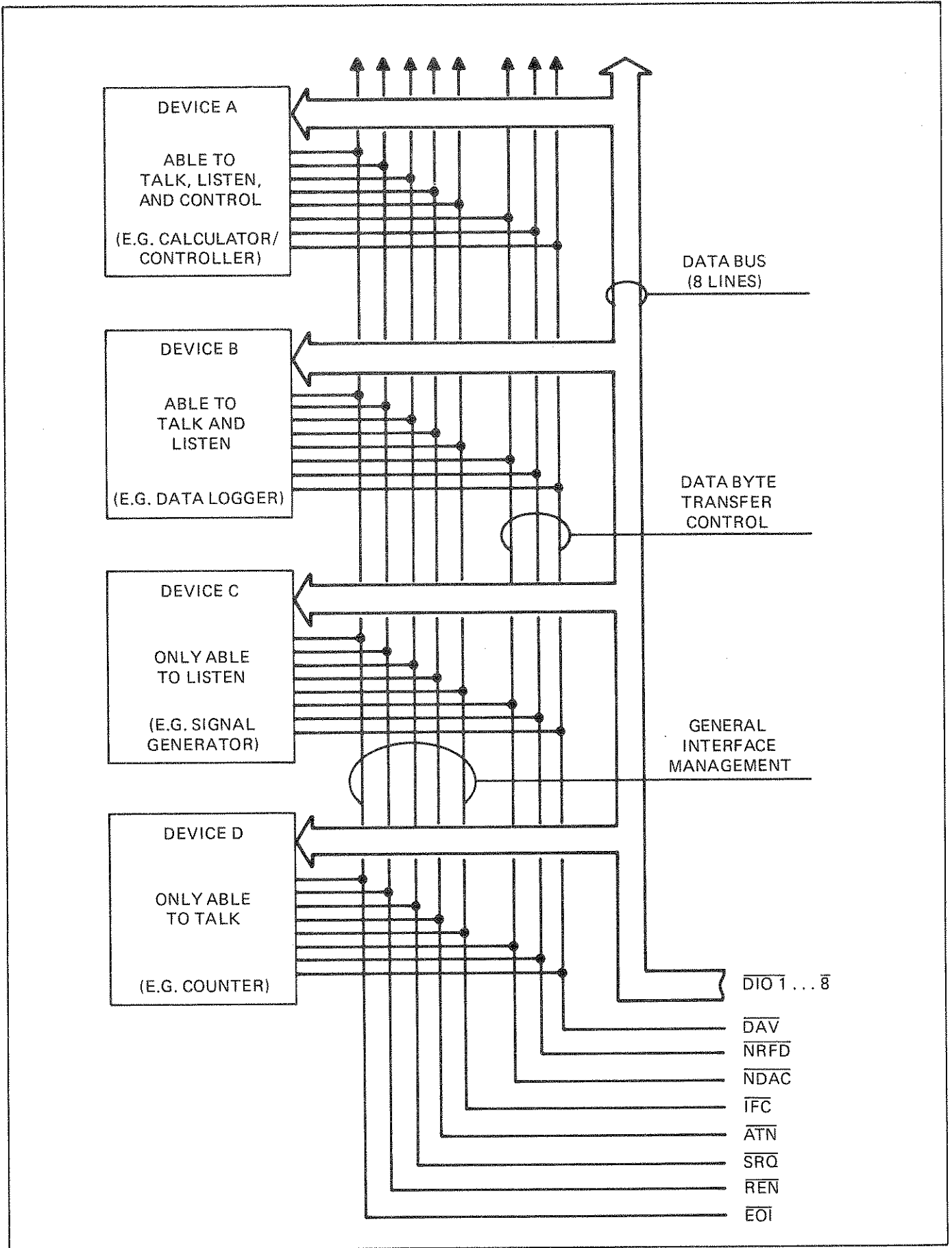

Figure 615-2. IEEE-488 Bus Connections

Table 615-3. Remote Message Coding

MNEMONIC	MESSAGE NAME	BUS SIGNAL LINE(S) AND CODING THAT ASSERT MESSAGE TRUE													MESSAGE TYPE	MESSAGE CLASS	NOTES	
		DATA I/O								BUS MANAGEMENT								
		D108	D107	D106	D105	D104	D103	D102	D101	ATN	EOI	SRQ	IFC	REN				
ACG	Addressed Command Group	X	0	0	0	X	X	X	X	1	X	X	X	X	M	AC		
ATN	Attention	X	X	X	X	X	X	X	X	1	X	X	X	X	U	UC		
DAB	Data Byte	D8	D7	D6	D5	D4	D3	D2	D1	0	X	X	X	X	M	DD	1,6,7	
DCL	Device Clear	X	0	0	1	0	1	0	0	1	X	X	X	X	M	UC		
END	End	X	X	X	X	X	X	X	X	0	1	X	X	X	U	ST	7	
EOS	End of String	E8	E7	E6	E5	E4	E3	E2	E1	0	X	X	X	X	M	DD	2,7	
GET	Group Execute Trigger	X	0	0	0	1	0	0	0	1	X	X	X	X	M	AC		
GTL	Go To Local	X	0	0	0	0	0	0	1	1	X	X	X	X	M	AC		
IDY	Identify	X	X	X	X	X	X	X	X	1	1	X	X	X	U	UC		
IFC	Interface Clear	X	X	X	X	X	X	X	X	X	X	X	1	X	U	UC		
LAG	Listen Address Group	X	0	1	X	X	X	X	X	1	X	X	X	X	M	AD		
LLO	Local Lock Out	X	0	0	1	0	0	0	1	1	X	X	X	X	M	UC		
MLA	My Listen Address	X	0	1	L5	L4	L3	L2	L1	1	X	X	X	X	M	AD	3	
MTA	My Talk Address	X	1	0	T5	T4	T3	T2	T1	1	X	X	X	X	M	AD	4	
MSA	My Secondary Address	X	1	1	S5	S4	S3	S2	S1	1	X	X	X	X	M	SE	5	
NUL	Null Byte	0	0	0	0	0	0	0	0	0	X	X	X	X	M	DD	7	
OSA	Other Secondary Address	(OSA = SCG • MSA)													M	SE		
OTA	Other Talk Address	(OTA = TAG • MTA)													M	AD		
PCG	Primary Command Group	(PCG = ACG + UCG + LAG + TAG)													M	-		
REN	Remote Enable	X	X	X	X	X	X	X	X	X	X	X	X	X	1	U	UC	
RQS	Request Service	X	1	X	X	X	X	X	X	0	X	X	X	X	U	ST	7	
SCG	Secondary Command Group	X	1	1	X	X	X	X	X	1	X	X	X	X	M	SE		
SDC	Selected Device Clear	X	0	0	0	0	1	0	0	1	X	X	X	X	M	AC		
SPD	Serial Poll Disable	X	0	0	1	1	0	0	1	1	X	X	X	X	M	UC		
SPE	Serial Poll Enable	X	0	0	1	1	0	0	0	1	X	X	X	X	M	UC		
SRQ	Service Request	X	X	X	X	X	X	X	X	X	X	1	X	X	U	ST		
STB	Status Byte	S8	X	S6	S5	S4	S3	S2	S1	0	X	X	X	X	M	ST	6,7	
TCT	Take Control	X	0	0	0	1	0	0	1	1	X	X	X	X	M	AC		
TAG	Talk Address Group	X	1	0	X	X	X	X	X	1	X	X	X	X	M	AD		
UCG	Universal Command Group	X	0	0	1	X	X	X	X	1	X	X	X	X	M	UC		
UNL	Unlisten	X	0	1	1	1	1	1	1	1	X	X	X	X	M	AD		
UNT	Untalk	X	1	0	1	1	1	1	1	1	X	X	X	X	M	AD		

**SYMBOLS**

Type           U = Uniline Message  
                   M = Multiline Message

Class           AC = Address Command  
                   AD = Address (Talk or Listen)  
                   DD = Device Dependent  
                   HS = Handshake  
                   UC = Universal Command  
                   SE = Secondary  
                   ST = Status

0 = Logical Zero (HIGH Signal Level)  
 1 = Logical One (LOW Signal Level)  
 X = Don't Care or Not Driven

**NOTES**

- (1) D1-D8 specify the device dependent data bits
- (2) E1-E8 specify the device dependent code used to indicate EOS message
- (3) L1-L5 specify the device dependent bits of the device's listen address
- (4) T1-T5 specify the device dependent bits of the device's talk address
- (5) S1-S5 specify the device dependent bits of the device's secondary address
- (6) S1-S6, S8 specify the device dependent status. (D107 is used for the RQS message)
- (7) The true message value must be ignored when received the LACS is inactive



## 615-17. PROGRAMMING FORMAT

615-18. The IEEE Interface PCB is capable of accepting a series or string of alpha-numeric characters and interpreting them as control/program data. These data command strings when properly formatted, enable the IEEE-488 bus controller to program the following data logger functions:

1. Scan Control
2. Output Control
3. Time
4. Scan Format
5. Channel Programming
6. Limits Programming

615-19. The format of the command string is shown in Table 615-4. It consists of a command character, a numeric data field, and a carriage return terminator. An alphabetic command character defines the function to be programmed (scan control, output control, etc). The commanded function is then programmed by a series of numeric characters. These characters represent a variable length numeric field and may contain a number of delimiters in the form of commas (,). After the numeric field is complete, the command string is both terminated and executed by a carriage return (CR) character.

### NOTE

A delimiter cannot be used for concatenation of command strings. Each string must be individually terminated.

615-20. A complete list of command characters and their associated numeric fields are given in Table 615-5. Proper formatting of a typical programming sequence is shown in Table 615-6.

## 615-21. Output Format

615-22. Output format from the IEEE Interface PCB is recorded at the IEEE-488 talker device in the standard format shown in Table 615-7. A switch (S1-2) on the IEEE Interface PCB allows selection of either one or four measurement data readings per line.

## 615-23. Configuration/Interface Switch (S1) Operation

## 615-24. SRQ (Service Request)

Table 615-5. Definition of Command and Response Codes

COMMAND CHARACTERS		
	Format	Action
P	P	Outputs The Program Currently In Memory
Q	Q	Program List On Internal Printer
A	A00	Sets Alarm Output/Resets All Alarms
	ADD	Resets All Alarm Outputs (-23 Option)
E	ADD	Sets Specified Alarm DD = 01-30
		Enables Local Or Remote Control
		(Must Be Enabled By Switch Internal To 2240B)
	E0	Local Control
	E1	Remote Control Only
D		Command Response* And Error Message Control
	D0	Restores Response* And Message
	D1	Deletes Response* And Message
S		Scan Control, Starts Data Logger
	S0	Resets Data Logger Scan Control
	S1	Single Scan
	S2	Interval Scan
	S3	Monitor Scan
	S4	Continuous Scan
W		Output Control (External Only)
	W0	No Data Output
	W1	Alarm Data Only
	W2	Interval Data Only
	W3	Alarm Data And Interval Data
	W4	All Data
	W5	All Data On Alarm
	W6	All Data And Interval Data
	W7	All Data On Alarm And Interval Data
X		Printer Control
	X0	No Data Output
	X1	Alarm Data Only
	X2	Interval Data Only
	X3	Alarm Data And Interval Data
	X4	All Data
	X5	All Data On Alarm
	X6	All Data And Interval Data
	X7	All Data On Alarm And Interval Data
<b>Scan Format</b>		
F	FXXX	Sets First Channel To XXX (000-999)
L	LYYY	Sets Last Channel To YYY (000-999)
M	MZZZ	Sets Monitor Channel To ZZZ (000-999)
H	HXXXXXX	Sets Fixed Data To XXXXXX (000000-999999)
I	IXX.YY.ZZ	Sets The Interval To XX Hrs., YY Min., ZZ Secs
T	TWWW.XX.YY.ZZ	Sets Time Of Year To WWW Days, XX Hrs., YY Min., ZZ Secs
<b>MEASUREMENT RESPONSE</b>		
Y	123:16:57:30	Time Of Year
X	123456	Fixed Data
D	01 123456789	Digital Input Data
A	0 >+3777.7 mV	Analog Data
A	0 +7777.7 **BT	Broken Thermocouple
A	0 +9999.9 **OL	Overload
		Units Or Fault Message
		Measured Value
		Polarity
		Limits Exceeded Symbol
		Channel Number
		Data Code

Programming		
	Format	Action
V	VXX.Y.ZZZZ	Limits Value Sets Limit Addressed By XX (01-30) To Polarity And Sense Y, And Value ZZZZ Y = 0 - Low Y = 1 + Low Y = 2 - High Y = 3 + High ZZZZ (0000-3999)
C	CWWW.X.YY.ZZ	Channel Programs Channel Number WWW (000-999) To Range And Function X, With Limit A Address YY And Limit B Address ZZ X Range And Function: 0 SKIP 1 40 mV 2 80 mV (Calibration Only) 3 400 mV 4 4V 5 40V 6 T1 7 T2 8 T3 9 T4 YY (01-15) Limit A ZZ (16-30) Limit B
R	RXXX.Y	Random Access Any Channel Channel XXX (000-999) Y = Range And Function Code Same As X Above, Does Not Program Memory
<b>SECOND INTERVAL</b>		
G	GXXX	Sets First Channel To XXX, (000-999)
K	KYYY	Sets Last Channel To YYY, (000-999)
J	JXX.YY	Sets Second Interval Time To XX Hours (00-99) And YY Minutes (00-59)
<b>COMMAND RESPONSE*</b>		
	@ <CR> <LF>	Data Logger Ready To Accept Next Command
<b>ERROR MESSAGES</b>		
ERR01		Data Logger Not In Remote
ERR02		Command String Over 16 Characters
ERR03		Not A Valid Command
ERR04		Memory Error a) Individual Programming Mode, Channel Number > 255 b) Memory Not Available For Channels Above 127 c) Limits Memory Option Not Installed
ERR05		A-D Function Error Random Access Channel Programming a) Function Is Not Available b) Temperature Option Not Installed
ERR06		Remote Command Is Not Enabled

Table 615-6. Typical Programming Sequence

COMMAND STRING	COMMENTS
\$T123,23,50,31 CR	Time of Year
\$W4 CR	Output, All Data
\$F000 CR	First Channel = 0
\$L003 CR	Last Channel = 3
\$M001 CR	Monitor Channel = 1
\$C000,1,00,00 CR	Channel 0, 400 mV, Skip Limits
\$C001,6,01,16 CR	Channel 1, T1, Limits 1 & 16
\$C002,0,00,00 CR	Skip Channel 2
\$C003,4,33,16 CR	Channel 3, 4V, Limit 16
\$V01,3,2000 CR	Limit 1 = HI +2000
\$V16,1,1000 CR	Limit 16 = LO +1000
\$S1 CR	Continuous scan starts on CR.

Table 615-7. Standard Output Format

DESCRIPTION	OUTPUT DATA*																	
Time of Year	<u>Y</u>	<u>DC</u>	<u>DC</u>	<u>DC</u>	:	<u>H</u>	<u>H</u>	<u>:</u>	<u>M</u>	<u>M</u>	<u>:</u>	<u>S</u>	<u>S</u>	<u>CR</u>	<u>LF</u>			
Fixed Data	<u>X</u>	<u>FD</u>	<u>FD</u>	<u>FD</u>	<u>FD</u>	<u>FD</u>	<u>CR</u>	<u>LF</u>										
Digital Input Data (Option -16)	<u>D</u>	<u>AC</u>	<u>AC</u>	<u>SP</u>	<u>DD</u>	<u>DD</u>	<u>DD</u>	<u>DD</u>	<u>DD</u>	<u>DD</u>	<u>DD</u>	<u>DD</u>	<u>DD</u>	<u>CR</u>	<u>FL</u>			
								SP	9	9	9	9	9	*	*	O	L	
								SP	7	7	7	7	7	*	*	B	T	
Measurement Data														SP	C	SP	SP	
					>									SP	F	SP	SP	
					<									M	V	SP	SP	
Data Column ID (For Reference Purposes only- Not Recorded)	<u>A</u>	<u>CH</u>	<u>CH</u>	<u>CH</u>	<u>SP</u>	<u>±</u>	<u>AD</u>	<u>AD</u>	<u>AD</u>	<u>.</u>	<u>AD</u>	<u>AD</u>	<u>SP</u>	<u>V</u>	<u>SP</u>	<u>SP</u>	<u>CR</u>	<u>LF</u>
	<u>0</u>	<u>1</u>	<u>2</u>	<u>3</u>	<u>4</u>	<u>5</u>	<u>6</u>	<u>7</u>	<u>8</u>	<u>9</u>	<u>10</u>	<u>11</u>	<u>12</u>	<u>13</u>	<u>14</u>	<u>15</u>	<u>16</u>	<u>17</u>
<p><b>*MNEMONICS</b></p> <p>A = Measurement Data ID            AC = Address Code            AD = Analog Data            CH = Channel No            CR = Carriage Return            D = Digital Input ID            DC = Day Code</p> <p>DD = Digital Input Data            FD = Fixed Data            H = Hours            LF = Line Feed            M = Minutes            S = Seconds            SP = Space</p> <p>X = Fixed Data ID            Y = Time of Year ID            **OL = Overload            **BT = Broken Bhermocouple            C = Degrees Celsius            F = Degrees Fahrenheit            MV = Millivolts            V = Volts</p>																		

615-25. When SRQ is enabled (switch S1-3 = on) the IEEE Interface PCB requests service from the IEEE-488 Bus controller when it contains a complete "data logger" reading. Service is requested by asserting the SRQ bus management line low. The SRQ line is released by the IEEE Interface PCB when the first data byte is transferred onto the IEEE-488 Bus from the output buffer. The IEEE Interface responds to a serial poll interrogation by a controller on the IEEE-488 Bus. The serial poll response can be a 41 hex code (ASCII "A") if the IEEE Interface has initiated the service request, or a D hex code (ASCII "null") if it had not. If the IEEE Interface has initiated an SRQ and the current reading has not been entirely read (through the terminating CR/LF characters) all data logger scanning stops. Scanning resumes when the complete current reading has been completely read.

615-26. When SRQ is not enabled (S1-3 = OFF), the IEEE Interface PCB continuously updates its output with the current reading until addressed as a talker. When addressed as a talker, the current reading is held. The data logger stops scanning until the full reading has been taken or an untalk signal has been sent to the IEEE Interface PCB.

615-27. TON (Talker Only)

615-28. When TON is enabled, (Switch S1-1 = on) the IEEE Interface PCB automatically enters the Talker Addressed State (TADS). To use this function, three switches must be set. The LOCAL/REMOTE switch (S1) located on the A3 Controller must be set to LOCAL, and the SCAN control and OUTPUT control must be selected on the 2240C front panel (see Section 2 of the 2240C Instruction Manual).

615-29. Analog Readings Per Line

615-30. When switch S1-2 is enabled (ON), a CR/LF character is opened to every fourth analog reading output to the IEEE-488 Bus. The 1st, 2nd, and 3rd analog readings are followed by two spaces.

615-31. OPERATION

615-32. Once installed, the IEEE Interface PCB requires no operator attention other than ensuring that normal turn-on procedures are observed for both the data logger and devices on the IEEE-488 Bus. Select the remote mode of operation either manually or remotely as required by the position of switch S1 on the data logger A3 Controller PCB (see Section 2, Figure 2-6 of the 2240C Instruction Manual). Follow the programming format given earlier to control the operation of the data logger. Each of the remote programming functions correspond to the manual functions described in Section 2 of the 2240C Instruction Manual.

615-33. THEORY OF OPERATION

615-34. The IEEE Interface PCB, as shown in Figure 615-3 is a

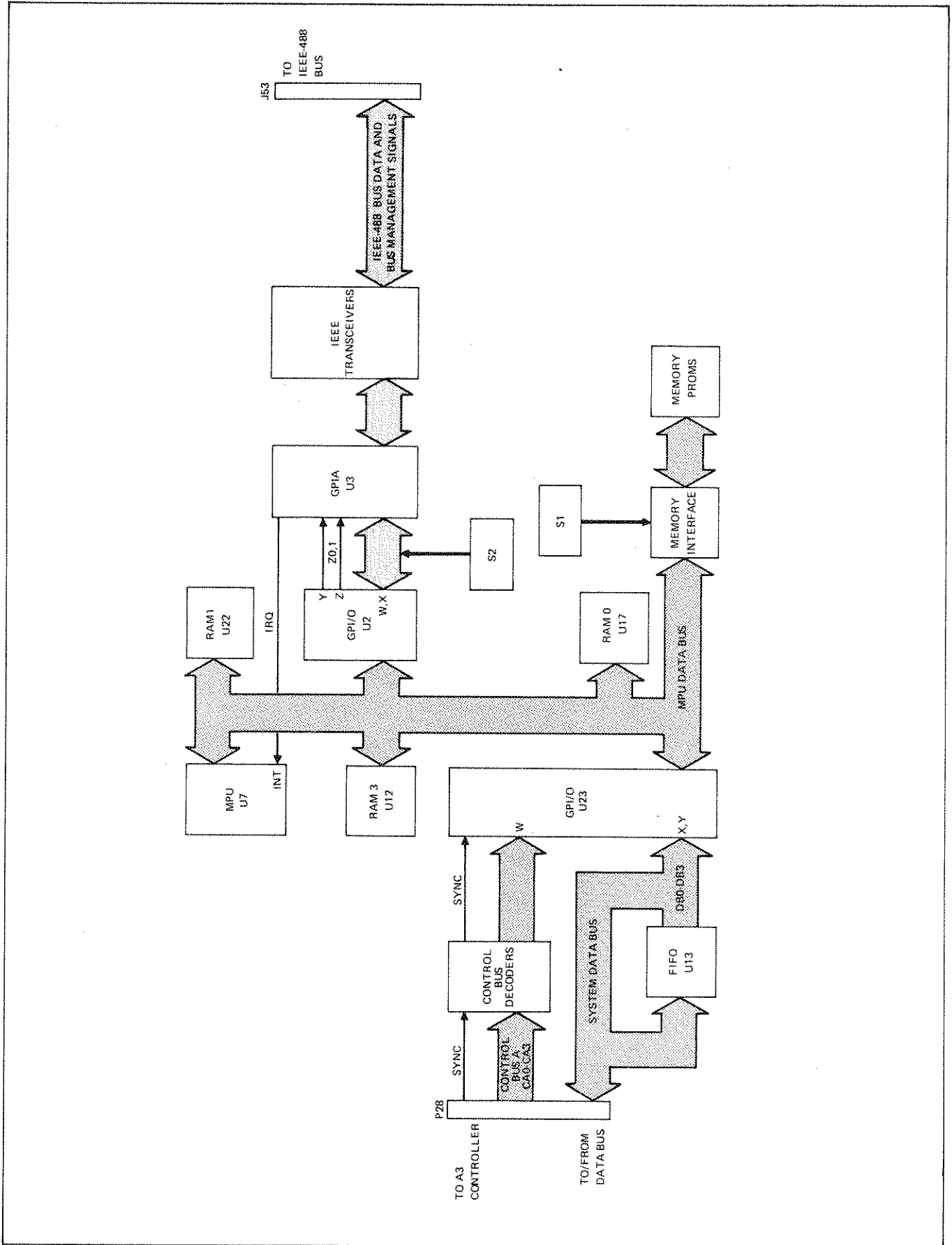

Figure 615-3. IEEE Interface Functional Block Diagram

microprocessor based subsystem which functions as an A3 Controller peripheral to provide the interface necessary to transfer data logger program and output data to and from devices on the IEEE-488 Bus. Once devices on the IEEE-488 Bus have been defined, the IEEE Interface PCB is tailored to meet the interface requirements by setting a series of switches on the pcb. (See installation instructions for switch settings as they apply to this option). These settings are read by the MPU (Microprocessor Unit) and stored in the memory PROMS (Programmable Read Only Memories) U21 and U11 via the memory interface (U6) each time the data logger is turned on.

615-35. Operation of the IEEE Interface PCB can be functionally divided into two sequences: Listen and Talk. The Listen function involves the transfer of program information from the IEEE-488 Bus to the A3 Controller in the data logger. The Talk function involves the transfer of output data (scan and measurement data) from the data logger to the IEEE-488 Bus. For both cases, each I/O word up to 16 characters) is temporarily stored on the IEEE-488 Interface PCB to synchronize its transfer operations with either the A3 Controller PCB or devices on the IEEE-488 Bus as required.

#### 615-36. Listen Function

615-37. Bit-parallel, byte-serial program data from the IEEE-488 Bus is received by the PCB through IEEE-488 compatible transceivers to the GPIA (General Purpose Interface Adapter) U3. When a character byte is received, the GPIA generates an Interrupt Request (IRQ) low (0.0v) output, (IRQ is connected to the INT input on the MPU.) In response to an Interrupt (INT) low input, the MPU reads the 8-bit GPIA data in character byte via GPI/O U2 and the MPU Data Bus. Data characters received by the MPU, are transferred to, and stored in RAM 0 (Random Access Memory). When a complete command (up to 16 characters) has been assembled, the MPU checks it for errors and formats it for use by the data logger's A3 Controller PCB. Then RAM 0 initiates IRQ to notify the A3 Controller PCB that data is ready to be processed.

615-38. In response to the IRQ, the A3 Controller PCB begins to poll the various I/O pcb's to determine which pcb requested the interrupt, and what service, if any, is required. To poll the IEEE Interface PCB, the A3 Controller places a binary coded 6 onto Control Bus A (CA0-CA3). The pcb detects its code and responds with its current status via the System Data Bus. The possible response codes and their meanings are shown in Table 615-8. When the IEEE Interface PCB has initiated an interrupt request (IRQ), it confirms the action by placing a binary coded 7 on the System Data bus as a response code.

615-39. When the A3 Controller PCB is ready to receive data from the IEEE Interface PCB, it places a binary coded 14 onto Control Bus A. The code is detected by the Control Bus Decoders which in turn, enables data from port Y of the GPI/O (U23) to be placed

**Table 615-8. IEEE Interface PCB Response Codes**

<b>BINARY CODED STATUS RESPONSE</b>	<b>DEFINITION</b>
6	Interrupt Request and Busy
7	Interrupt Request (IRQ)
14	Busy
15	Not Busy, No Interrupt

onto the System Data Bus. The decoded transmit code (Binary 14) is latched onto port W of the GPI/O with every Sync pulse. Concurrently, the MPU, on every Sync pulse, reads port D of the GPI/O (U23). When it detects a data request code (Binary 14), it proceeds to transfer 16 characters to the A3 controller via port Y of the GPI/O. At the end of the transfer, the Controller terminates the sequence by removing the binary coded 14 from the Control Bus.

#### 615-40. Talk Function

615-41. When the A3 Controller PCB is ready to put data onto the IEEE-488 Bus, it polls the status of the IEEE Interface PCB by placing a binary coded 6 on Control Bus A. If the PCB is not busy it responds with a binary 15 via the System Data Bus and thereby prompts the controller to output data onto the IEEE-488 Bus. The controller places a binary coded 4 onto Control Bus A. This code is latched into port W of the GPI/O (U23) for later reference by the MPU. Subsequent data characters that appear on the System Data Bus are serially loaded into the FIFO (First-In First-Out) and held until accessed by the MPU. When accessed by the MPU, the 16 data characters are serially loaded into port X of the GPI/O (U23) by pulse Z1. All 16 characters are transferred and stored in RAM 0 for further processing. Processed data is transferred to RAM 1 and 3 to await output to the IEEE-488 Bus. During the remainder of the sequence, the MPU checks the content and format of the received data. Before transfer to the IEEE-488 Bus occurs, the MPU polls the status of the GPIA and IEEE-488 Bus Control lines. If the IEEE Interface PCB is addressed as a talker, NRFD (Not Ready For Data) is false (high) and the data out register of the GPIA is empty. The MPU also checks to see if SRQ is to be sent out. Data is then sent to the data out register of the GPIA for output on the IEEE-488 Bus.

615-42. Each character is transformed into an ASCII seven-level character by the MPU before being presented to the GPIA via ports W and X of the GPI/O (U23). Port Y is used to address the appropriate register in the GPIA. Each character is entered into the GPIA data out register by strobe Z0. The data is then sent to listeners on the IEEE-488 Bus via the handshake process.

#### 615-43. MAINTENANCE

##### 615-44. Access Information

615-45. Refer to the installation instructions given earlier in this subsection for IEEE Interface PCB access information. Remove the rear panel output connector before attempting to remove the pcb from the data logger.

##### 615-46. Performance Test

615-47. The IEEE Interface PCB is most easily tested under normal operating conditions; i.e., installed in a functional data



logger and interfaced with a IEEE-488 Bus Controller. Output data can then be checked by comparing data recorded on the internal printer with hard copy data derived from the external recording device. Similarly, the effects of remote programming can be compared with manual programming to isolate malfunctions to the pcb level.

615-48. If a malfunction has been isolated to the IEEE Interface PCB, replace it and send the malfunctioning pcb back to the manufacturer (see Shipping Information).

#### 615-49. LIST OF REPLACEABLE PARTS

615-50. The lists of replaceable parts for the -15 Option are given in Table 615-9. Refer to Section 5 of the data logger manual for ordering information.

#### ⊗ CAUTION

Indicated devices are subject  
to damage by status discharge.

Table 615-9. IEEE Interface PCB Assembly

REF DES	DESCRIPTION	FLUKE STOCK NO.	MFG SPLY CODE	MFG. PART NO.	TOT QTY	REC QTY	NOTE
-15⊗	IEEE INTERFACE PCB ASSEMBLY FIGURE 615-3 (2240B-4015T)	ORDER	BY	OPTION -15			
C1	CAP, TA, 10 UF, +/-20%, 20V	330662	56289	196D106X0020KA1	2		
C2	CAP, TA, 10 UF, +/-20%, 20V	330662	56289	196D106X0020KA1	REF		
C3	CAP, TA, 1 UF +/-20%, 35V	161919	56289	196D105X0020JA1	2		
C4	CAP, TA, 1 UF +/-20%, 35V	161919	56289	196D105X0020JA1	REF		
C5	CAP, CER, 0.22 UF +/-20%, 50V	309849	71590	CW30C224K	11		
C6	CAP, CER, 0.22 UF +/-20%, 50V	309849	71590	CW30C224K	REF		
C7	CAP, CER, 0.22 UF +/-20%, 50V	309849	71590	CW30C224K	REF		
C8	CAP, CER, 0.22 UF +/-20%, 50V	309849	71590	CW30C224K	REF		
C9	CAP, CER, 0.22 UF +/-20%, 50V	309849	71590	CW30C224K	REF		
C10	CAP, CER, 0.22 UF +/-20%, 50V	309849	71590	CW30C224K	REF		
C11	CAP, CER, 0.22 UF +/-20%, 50V	309849	71590	CW30C224K	REF		
C12	CAP, CER, 0.22 UF +/-20%, 50V	309849	71590	CW30C224K	REF		
C13	CAP, CER, 0.22 UF +/-20%, 50V	309849	71590	CW30C224K	REF		
C14	CAP, CER, 0.22 UF +/-20%, 50V	309849	71590	CW30C224K	REF		
C15	CAP, CER, 0.22 UF +/-20%, 50V	309849	71590	CW30C224K	REF		
CR1	DIODE, SI, HI-SPEED SWITCHING	203323	09214	1N4448	2		
CR3	DIODE, SI, HI-SPEED SWITCHING	203323	09214	1N4448	REF		
H1	SCREW, PHP, 4-40 X 3/8 (NOT SHOWN)	152124	89536	152124	3		
J53	CONNECTORS, IEEE	484220	89536	484220	1		
MP1	BRACKET	526624	89536	526624	1		
MP2	HARDWARE, CONNECTOR MOUNTING (TO J53)	429472	89536	429472	2		
Q1	XSTR, SI, PNP	195974	04713	2N3906	1	1	
Q2	XSTR, SI, NPN	218396	04713	2N3904	2	1	
Q3	XSTR, SI, NPN	218396	04713	2N3904	REF		
R1	RES, DEP. CAR, 30K +/-5%, 1/4W	368753	80031	CR251-4-5P30K	5		
R2	RES, DEP. CAR, 30K +/-5%, 1/4W	368753	80031	CR251-4-5P30K	REF		
R3	RES, DEP. CAR, 30K +/-5%, 1/4W	368753	80031	CR251-4-5P30K	REF		
R4	RES, DEP. CAR, 6.2K +/-5%, 1/4W	442368	80031	CR251-4-5P6.2K	5		
R5	RES, DEP. CAR, 6.2K +/-5%, 1/4W	442368	80031	CR251-4-5P6.2K	REF		
R6	RES, DEP. CAR, 6.2K +/-5%, 1/4W	442368	80031	CR251-4-5P6.2K	REF		
R7	RES, DEP. CAR, 6.2K +/-5%, 1/4W	442368	80031	CR251-4-5P6.2K	REF		
R8	RES, DEP. CAR, 6.2K +/-5%, 1/4W	442368	80031	CR251-4-5P6.2K	REF		
R9	RES, DEP. CAR, 30K +/-5%, 1/4W	368753	80031	CR251-4-5P30K	REF		
R10	RES, DEP. CAR, 100K +/-5%, 1/4W	348920	80031	CR251-4-5P100K	1		
R11	RES, DEP. CAR, 30K +/-5%, 1/4W	368753	80031	CR251-4-5P30K	REF		
S1	SWITCH, DIP	454769	89536	454769	2		
S2	SWITCH, DIP	454769	89536	454769	REF		
TP1-TP7	CONNECTOR, TEST POINT	512889	89536	512889	7		
U1⊗	IC, C-MOS TRI-STATE HEX NON INVRTNG BUFF	407759	12040	MM80C97N	2	1	
U2	IC, PROGRAMABLE, GENERAL PURPOSE	453456	34649	P4265	2		
U3⊗	IC, C-MOS, N-CHANNEL, SILICON GATE	477794	04713	MC68488P	1	1	
U4	IC, QUAD, THREE-STATE BUS TRANSCEIVER	453480	04713	MC3448P	4	1	
U5	IC, QUAD, THREE-STATE BUS TRANSCEIVER	453480	04713	MC3448P	REF		
U6	IC, 4-BIT MICROCOMPUTER	404434	34649	P4289CA	1	1	
U7	IC, 4-BIT MICROCOMPUTER	404418	34649	C4040	1	1	
U8⊗	IC, C-MOS, HEX INVERTER, 14-PIN DIP	404681	02735	CD4069UBE	3	1	
U9	IC, QUAD, THREE-STATE BUS TRANSCEIVER	453480	04713	MC3448P	REF		

Table 615-9. IEEE Interface PCB Assembly (cont)

REF DES	DESCRIPTION	FLUKE STOCK NO.	MFG SPLY CODE	MFG. PART NO.	TOT QTY	REC QTY	N O T E
U10	IC, QUAD, THREE-STATE BUS TRANSCEIVER	453480	04713	MC3448P	REF		
U11	IC, EPROM SET	538835	89536	538835	1		
U12	IC, 4-BIT MICROCOMPUTER	404467	34649	P4002-2	1	1	
U13⊗	IC, C-MOS, FIFO REGISTER	495200	02735	CD40105BE	1	1	
U14⊗	IC, C-MOS, QUAD, 2-INPUT OR GATE	408393	02735	CD4071BE	1	1	
U15⊗	IC, C-MOS, DUAL, 4-INPUT, POS, NAND GATE	355206	04713	MC14012CP	2		1
U16⊗	IC, C-MOS, HEX INVERTER, 14-PIN DIP	404681	02735	CD4069UBE	REF		
U17	IC, 4-BIT MICROCOMPUTER	404442	34649	P4002-1	2	1	
U18⊗	IC, C-MOS TRI-STATE HEX NON INVRTNG BUFF	407759	12040	MM80C97N	REF		
U19⊗	IC, C-MOS, DUAL, 4-INPUT, POS, NAND GATE	355206	04713	MC14012CP	REF		
U20⊗	IC, C-MOS, HEX INVERTER, 14-PIN DIP	404681	02735	CD4069UBE	REF		
U21	IC, EPROM SET	538835	89536	538835	REF		
U22	IC, 4-BIT MICROCOMPUTER	404442	34649	P4002-1	REF		
U23	IC, PROGRAMABLE, GENERAL PURPOSE	453456	34649	P4265	REF		
U24⊗	IC, C-MOS, QUAD 2-INPUT AND GATE	408401	02735	CD4081BE	1	1	
XU2	SOCKET, 28-PIN	448217	89536	448217	2		
XU3	SOCKET, 40-PIN	418988	89536	418988	2		
XU6	SOCKET, 40-PIN	418988	89536	418988	REF		
XU7	SOCKET, 24-PIN	418970	89536	418970	3		
XU11	SOCKET, 24-PIN	418970	89536	418970	REF		
XU12	SOCKET, 16-PIN	276535	89536	276535	3		
XU17	SOCKET, 16-PIN	276535	89536	276535	REF		
XU21	SOCKET, 24-PIN	418970	89536	418970	REF		
XU22	SOCKET, 16-PIN	276535	89536	276535	REF		
XU23	SOCKET, 28-PIN	448217	89536	448217	REF		
Z1	RESISTOR, 10-PIN	461038	89536	461038	3		
Z2	RESISTOR, 10-PIN	461038	89536	461038	REF		
Z3	RESISTOR, 10-PIN	461038	89536	461038	REF		

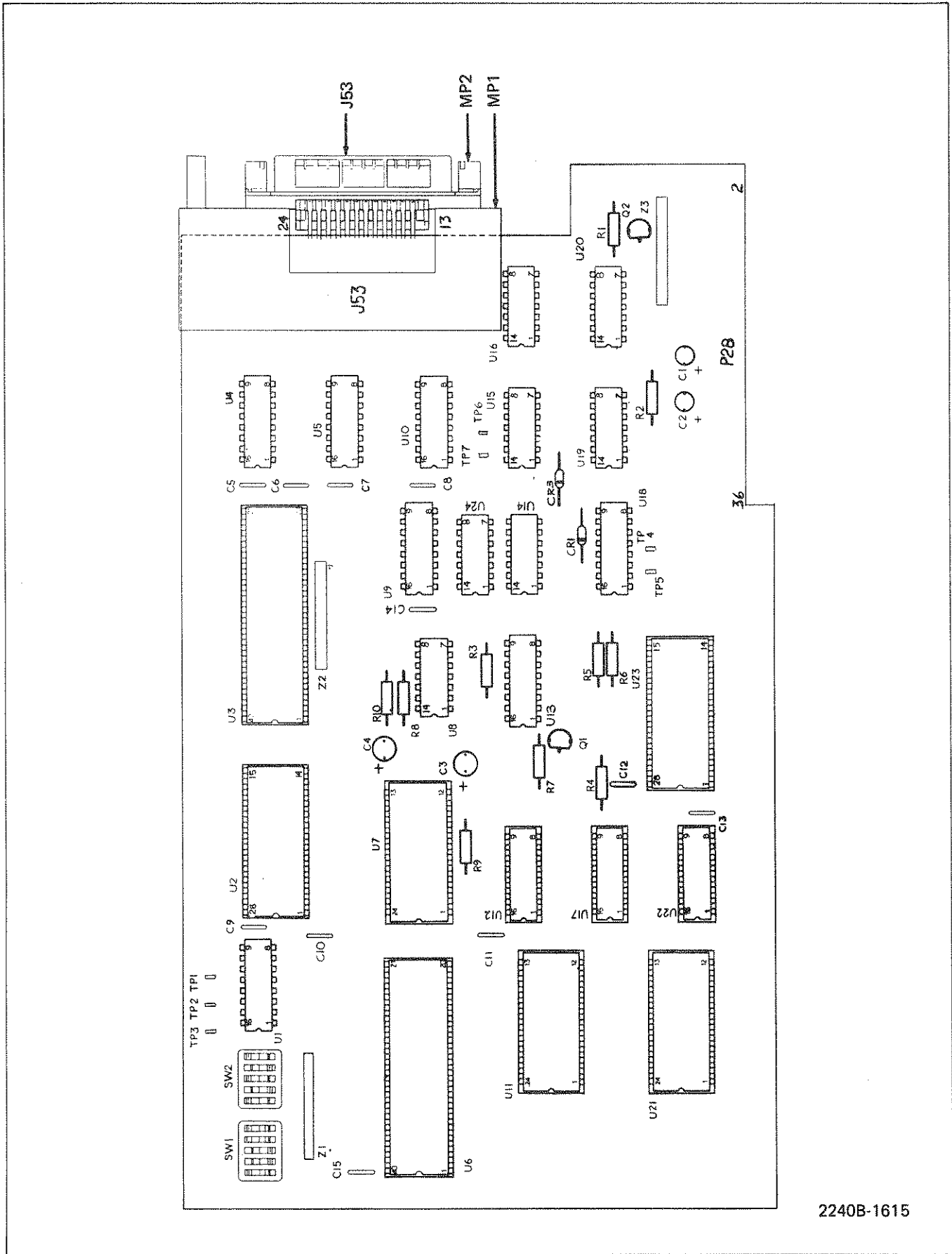

Figure 615-3. IEEE Interface PCB Assembly

1  
2  
3  
4  
5  
6  
7  
8  
9  
10  
11  
12  
13  
14  
15  
16  
17  
18  
19  
20  
21  
22  
23  
24  
25  
26  
27  
28  
29  
30  
31  
32  
33  
34  
35  
36  
37  
38  
39  
40  
41  
42  
43  
44  
45  
46  
47  
48  
49  
50  
51  
52  
53  
54  
55  
56  
57  
58  
59  
60  
61  
62  
63  
64  
65  
66  
67  
68  
69  
70  
71  
72  
73  
74  
75  
76  
77  
78  
79  
80  
81  
82  
83  
84  
85  
86  
87  
88  
89  
90  
91  
92  
93  
94  
95  
96  
97  
98  
99  
100

Option -16  
Digital Input Option

616-1. INTRODUCTION

616-2. The Digital Input Option (-16) is a plug-in pcb assembly designed to provide the printer and external recording devices with up to nine digits of externally generated digital input data. The data is derived from a remote source in bcd character-parallel format (DTL/TTL, positive-true) and loaded into storage by a remote Load Data pulse. Data cannot be loaded while the recorders are reading input data, and Bus Busy output flags are provided to indicate the read period. Read period occurs immediately prior to the first analog data reading.

616-3. The data logger is capable of accommodating up to three Digital Input PCBs. Digital data from the pcbs is read in a sequence determined by the setting of four Address Code Switches located on each pcb. These address codes are assigned by the user so that if the first pcb to be read is coded as address 0, the second is coded 1, and the third is coded 2. The physical order in which the pcbs are installed in the data logger does not influence the order in which data is read.

616-4. SPECIFICATIONS

616-5. Specifications for the Digital Input Option (-16) are given in Table 616-1.

616-6. INSTALLATION

616-7. Up to three Digital Input PCBs can be mounted in the data logger's I/O slots, as shown in Figure 616-1. Install each pcb as follows:

WARNING

REMOVE LINE POWER AND ALL OTHER  
HIGH VOLTAGE INPUTS TO THE DATA  
LOGGER BEFORE STARTING THIS  
PROCEDURE.

1. Set the data logger's POWER switch to OFF.
2. Remove the top cover from the data logger.
3. Locate the Address Code Switches on each Data Input PCB as shown in Figure 616-1, and assign consecutive address codes (starting with 0) to each pcb by setting the switches to the patterns shown in Table 616-2. When Digital Input Data is recorded, address 0 is read first, 1 second, and 2 last.

**Table 616-1. Digital Input Option Specifications**

Number of Digits	... Nine
Input Code	..... BCD, positive-true
Logic Levels	..... DTL/TTL
Control Inputs	..... Load Data, Busy, <u>Busy</u>
Record Location	.... Follows Fixed Data

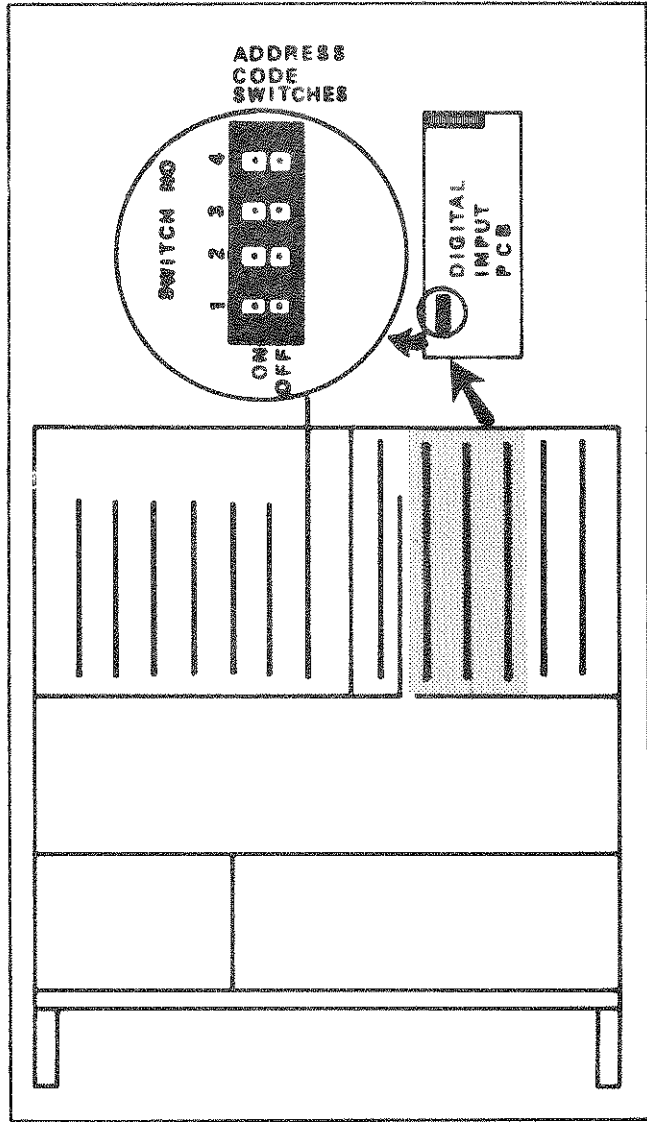

**Figure 616-1. Data Input Option, Installation and Switch Locations**

**Table 616-2. Address Code Switch Settings**

ADDRESS CODE	ADDRESS CODE SWITCH SETTINGS			
	1	2	3	4
0	ON	ON	ON	ON
1	ON	ON	ON	OFF
2	ON	ON	OFF	ON

4. Align each Data Input PCB in its selected I/O slot so that the large female connector is toward the rear of the data logger, and the small board-edge connector is toward the bottom of the unit. Push the pcb straight down onto the mating connector.
5. After the Digital Input PCB(s) is (are) installed, install the top cover.

#### 616-8. OPERATION

616-9. Once installed in the data logger, the Digital Input Option requires no operator attention. However, certain considerations are necessary to properly interface the option with remote input data. These considerations are covered in the following paragraphs.

#### 616-10. Interface Connections

616-11. Remote interface connections to a Digital Input PCB are completed through a General Purpose Interface Cable (2200A-7006) or a blank Interface Connector (2200A-7007 supplied with option) which attaches to the rear of the data logger. The cable assembly and the connector are available as accessories. Descriptions of both are given earlier in this section under accessories.

616-12. The user is responsible for completing the cable connections to the remote data source. The pin assignments for the Digital Input Option rear-panel connector are given in Table 616-3.

#### 616-13. I/O Data Requirements

616-14. The I/O requirements necessary to load data into a Digital Input Option PCB are given in Table 616-4. See Table 616-3 for I/O connector pin assignments.

#### 616-15. Ground Loop Considerations

616-16. Data inputs to the Digital Input PCB are not isolated and therefore, are referenced to the data loggers unguarded +5V dc supply (logic common). To protect both the data logger and the external data source from damage due to ground loops, a fuse is installed on the Digital Input PCB. Fuse replacement details are given later under maintenance.

#### 616-17. THEORY OF OPERATION

616-18. The Digital Input PCB, as shown in Figure 616-2, functions as a remote data interface to provide the controller with up to nine externally-generated digits of input data. Ultimately, the controller presents this data to the printer as supplemental heading information. The input digits are derived from a user supplied data source and are received at the Digital



Table 616-3. Option —16, I/O Connector (J33) Pin Assignments

PIN	SIGNAL	PIN	SIGNAL
1	N/C	26	LOAD
2	DB0	27	DB3
3	DB1	28	DB2
4	DB2	29	DB1
5	DB3	30	DB0
6	BUSY	31	SIGNAL GND.
7	BUSY	32	SIGNAL GND.
8	DB3	33	DB0
9	DB2	34	DB1
10	DB1	35	DB2
11	DB0	36	DB3
12	N/C	37	+5V dc
13	N/C	38	+5V dc
14	DB3	39	DB0
15	DB2	40	DB1
16	DB1	41	DB2
17	DB0	42	DB3
18	N/C	43	DB0
19	N/C	44	DB1
20	DB3	45	DB2
21	DB2	46	DB3
22	DB1	47	DB3
23	DB0	48	DB2
24	N/C	49	DB1
25	N/C	50	DB0

N/C = No Connection

**Table 616-4. I/O Data Requirements**

Logic Levels . . . . .	DTL/TTL compatible, positive true.
Input Data Format.	Up to nine BCD, character-parallel digits.
Load Pulse . . . . .	Input Data is loaded by a negative going pulse at the Load input. The pulse duration must be $\geq 50 \mu\text{s}$ .
Busy/ $\overline{\text{Busy}}$ . . . . .	Input data can be loaded any time the $\overline{\text{Busy}}$ pulse is low or the Busy pulse is high.
Unused Digits . . . .	The inputs for unused digits may be left open. Data will not be recorded in these positions.
+5V dc Output . . . .	A +5V dc output is available to power external circuitry. The total current drain should not exceed 50 mA.

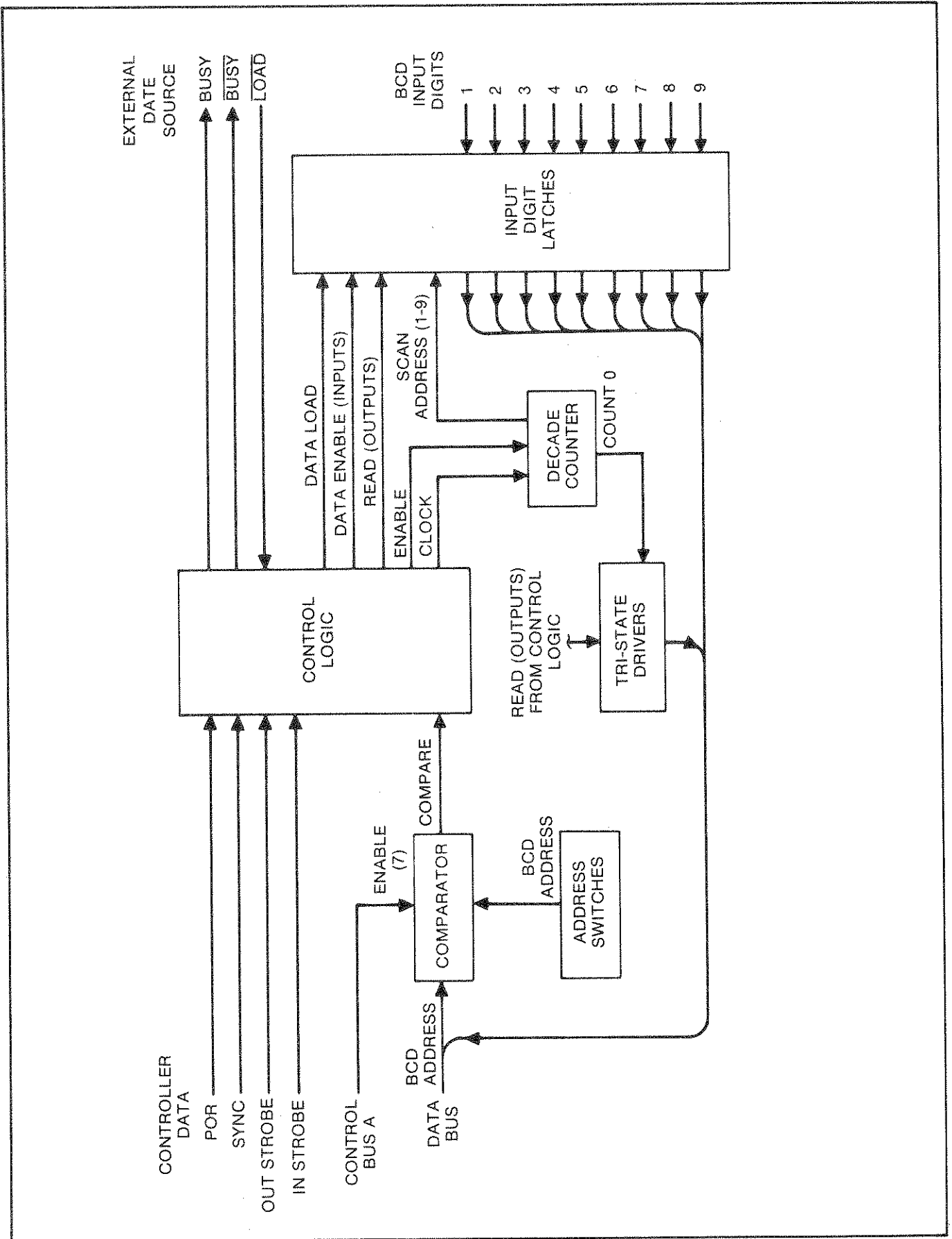

Figure 616-2. Digital Input PCB Simplified Block Diagram

Input PCB in character-parallel format. An externally generated load pulse enters the parallel digits into a series of storage registers on the pcb. This stored data is then solicited via Control Bus A and read into the controller via the Data Bus. While the controller is reading data from the registers, a complementary pair of Busy flags is generated by the Digital Input PCB. These flags indicate the duration of the read period and are intended for use in providing the external data sources with legal load-period timing. This is necessary since the storage registers cannot be updated while they are being read by the controller. All data and control DTL/TTL inputs/outputs to the external data source are positive-true DTL/TTL logic levels.

616-19. Operation can be logically divided into two sequences; load and read. Load sequences are initiated by an externally generated Load command and can be executed any time a read sequence is not in progress. Complementary Busy flags are provided to indicate the legal load periods. Read sequences are initiated under the direction of the controller and include an address verification routine to ensure that the proper output pcb has been addressed. This is necessary since up to three Digital Input PCBs can be installed in a data logger.

616-20. A load sequence is initiated when a low level ( $\geq 50$  us) is applied to the Load input of the Digital Input PCB. If a read sequence is not in progress, the next Sync pulse from the controller sets a pair of flip-flops in the control logic. This generates the leading edge of the data load pulse causing all nine digits of external input data to be loaded into a series of parallel input digit latches. On the next Sync pulse the data load pulse is terminated. When the external Load input returns high the control logic is reset, thereby arming the Input Register for the next load sequence.

616-21. A read sequence is initiated when the controller places a binary coded 7 onto the Control Bus A and the Digital Input PCBs switch address (0, 1, or 2) onto the Data Bus. When the combination of these inputs is present a compare input is presented to the control logic. On the rising edge of the subsequent Out strobe, the control logic accepts the compare input to enable the read sequence. As a result, the decade counter is enabled, an In strobe is enabled to serve as the counter's clock, and a read (outputs) signal is generated. The combination of the read (outputs) and the count 0 outputs enable a set of four tri-state drivers which place a binary coded zero onto the Data Bus. The controller recognizes this code as a valid address reply and responds by generating a series of In strobes. Each strobe advances the decade counter causing each of the nine input digit latches to be sequentially addressed. The controller reads each new character on the leading edge of the In strobe and advances the decade counter on the strobe's trailing edge. After the ninth character has been read the binary coded 7 is removed from Control Bus A. This effectively resets the control logic by clearing the enable and read outputs.

## 616-22. MAINTENANCE

### 616-23. Access Information

616-24. Refer to the installation instructions given earlier in this section for Digital Input Option access information. Remove the rear panel input connector before attempting to remove the pcb from the data logger.

### 616-25. Fuse Replacement

616-26. A 1/4 amp, fast-acting fuse is located on the component side of the Digital Input PCB Assembly. If replacement is necessary, pull the old fuse from the fuse clip and press a new one into place.

### 616-27. Performance Test

616-28. The Digital Input Option is most easily tested under normal operating conditions. That is, installed in a functional data logger, and connected to its input data source (as provided by the user). When any scan sequence is executed and the internal printer is enabled, the digital input data source should be printed following the fixed data entry (2240C) or the time-of-day entry (2200B). If two or three Digital Input Option PCBs are installed in the same unit, input data will be printed in the order assigned by the address switch settings (see Installation instructions). If no data is printed, either the fuse on the pcb is blown, input data is not being loaded correctly, or the board address has not been set correctly. If some, but not all, characters of entered data are printed incorrectly, the Input Registers on the Digital Input PCB are probably defective.

### 616-29. LIST OF REPLACEABLE PARTS

616-30. A list of replaceable parts for the Digital Input Option is given in Table 616-5. Refer to Section 5 of this manual for ordering information.

### ⊗ CAUTION

Indicated devices are subject  
to damage by static discharge.

Table 616-5. Digital Input PCB Assembly

REF DES	DESCRIPTION	FLUKE STOCK NO.	MFG SPLY CODE	MFG. PART NO.	TOT QTY	REC QTY	NO TE
-16⊗	DIGITAL INPUT PCB ASSEMBLY, OPTION -16 FIGURE 616-3 (2200A-4017T)	409557	89536	409557			
C1	CAP, TA, 10 UF +/-20%, 25V	330662	56289	190D106X0020KA1	1		
F1	FUSE, FAST ACTING, 1/4 AMP	109314	71400	AGC1-4	1	5	
H1	NUT, HEX, 4-40	147611	89536	147611	2		
H3	SCREW, PHP, 4-40 X 3/8	152124	89536	152124	2		
H4	WASHER, SPLIT/LK	110395	89536	110395	2		
J33	CONNECTOR, PCB MOUNTING, 64-PIN, FEMALE	414417	00779	552130-1	1		
MP2	CONNECTOR HARDWARE KIT	448563	00779	552565-2	1		
R1	RES, COMP, 10K +/-5%, 1/4 W	148106	01121	CB1035	8		
R2	RES, COMP, 10K +/-5%, 1/4 W	148106	01121	CB1035		REF	
R3	RES, COMP, 10K +/-5%, 1/4 W	148106	01121	CB1035		REF	
R4	RES, COMP, 10K +/-5%, 1/4 W	148106	01121	CB1035		REF	
R5	RES, COMP, 100 +/-5%, 1/4W	147926	01121	CB1015	2		
R6	RES, COMP, 10K +/-5%, 1/4 W	148106	01121	CB1035		REF	
R7	RES, COMP, 10K +/-5%, 1/4 W	148106	01121	CB1035		REF	
R8	RES, COMP, 10K +/-5%, 1/4 W	148106	01121	CB1035		REF	
R9	RES, COMP, 10K +/-5%, 1/4 W	148106	01121	CB1035		REF	
R10	RES, COMP, 10K +/-5%, 1/4 W	148106	01121	CB1035		REF	
U1	SWITCH ASSEMBLY	408559	00779	435166-2	1	1	
U2⊗	IC, COS/MOS, QUAD EXCLUSIVE-OR GATE	355222	18725	CD4030AE	1	1	
U3⊗	IC, COS/MOS, QUAD "D" TYPE LATCH	412742	12040	MM74C173N	9	2	
U4⊗	IC, COS/MOS, QUAD "D" TYPE LATCH	412742	12040	MM74C173N		REF	
U5	RESISTOR NETWORK, 100K (TYPICAL)	380618	89536	380618	5	1	
U6	RES, NETWORK, 47K (TYPICAL)	381996	89536	381996	5	1	
U7⊗	IC, C-MOS, DECADE COUNTER/DIVIDER	403568	18725	CD4017AE	1	1	
U8⊗	IC, COS/MOS, HEX BUFFER/CONVERTER	355214	04713	MC14009CP	4	1	
U9⊗	IC, COS/MOS, QUAD "D" TYPE LATCH	412742	12040	MM74C173N		REF	
U10⊗	IC, COS/MOS, QUAD "D" TYPE LATCH	412742	12040	MM74C173N		REF	
U11	RESISTOR NETWORK, 100K (TYPICAL)	380618	89536	380618		REF	
U12	RES, NETWORK, 47K (TYPICAL)	381996	89536	381996		REF	
U13⊗	IC, C-MOS, TRIPLE 3-INPUT NAND GATE	375147	04713	MC14023CP	1	1	
U14⊗	IC, COS/MOS, HEX BUFFER/CONVERTER	355214	04713	MC14009CP		REF	
U15⊗	IC, COS/MOS, QUAD "D" TYPE LATCH	412742	12040	MM74C173N		REF	
U16⊗	IC, COS/MOS, QUAD "D" TYPE LATCH	412742	12040	MM74C173N		REF	
U17	RESISTOR NETWORK, 100K (TYPICAL)	380618	89536	380618		REF	
U18	RES, NETWORK, 47K (TYPICAL)	381996	89536	381996		REF	
U19⊗	IC, COS/MOS, DUAL J-K F/F	355230	04713	MC14027CP	1	1	
U20⊗	IC, COS/MOS, QUAD 2-INPUT NOR GATE	355172	04713	MC14001CP	2	1	
U21⊗	IC, COS/MOS, QUAD "D" TYPE LATCH	412742	12040	MM74C173N		REF	
U22⊗	IC, COS/MOS, QUAD "D" TYPE LATCH	412742	12040	MM74C173N		REF	
U23	RESISTOR NETWORK, 100K (TYPICAL)	380618	89536	380618		REF	
U24	RES, NETWORK, 47K (TYPICAL)	381996	89536	381996		REF	
U25⊗	IC, C-MOS, QUAD 2-INPUT NAND GATE	355198	04713	MC14011CP	1	1	
U26⊗	IC, COS/MOS, HEX BUFFER/CONVERTER	355214	04713	MC14009CP		REF	
U27⊗	IC, COS/MOS, HEX BUFFER/CONVERTER	355214	04713	MC14009CP		REF	
U28⊗	IC, COS/MOS, QUAD "D" TYPE LATCH	412742	12040	MM74C173N		REF	
U29	RESISTOR NETWORK, 100K (TYPICAL)	380618	89536	380618		REF	
U30	RES, NETWORK, 47K (TYPICAL)	381996	89536	381996		REF	

Table 616-5. Digital Input PCB Assembly (cont)

REF DES	DESCRIPTION	FLUKE STOCK NO.	MFG SPLY CODE	MFG. PART NO.	TOT QTY	REC QTY	NOTE
U31⊗	IC, C-MOS, HEX NON-INVERTING BUFFER	407759	12040	MM80C97N	2	1	
U32⊗	IC, C-MOS, DUAL, "D" TYPE F/F	340117	04713	MC14013CL	1	1	
U33⊗	IC, COS/MOS, QUAD 2-INPUT NOR GATE	355172	04713	MC14001CP	REF		
U34⊗	IC, C-MOS, DUAL 4-INPUT NAND GATE	355206	04713	MC14012CP	1	1	
U35⊗	IC, COS/MOS, HEX BUFFER/CONVERTER	355412	04713	MC14010CP	1	1	
U36⊗	IC, C-MOS, HEX NON-INVERTING BUFFER	407759	12040	MM80C97N	REF		

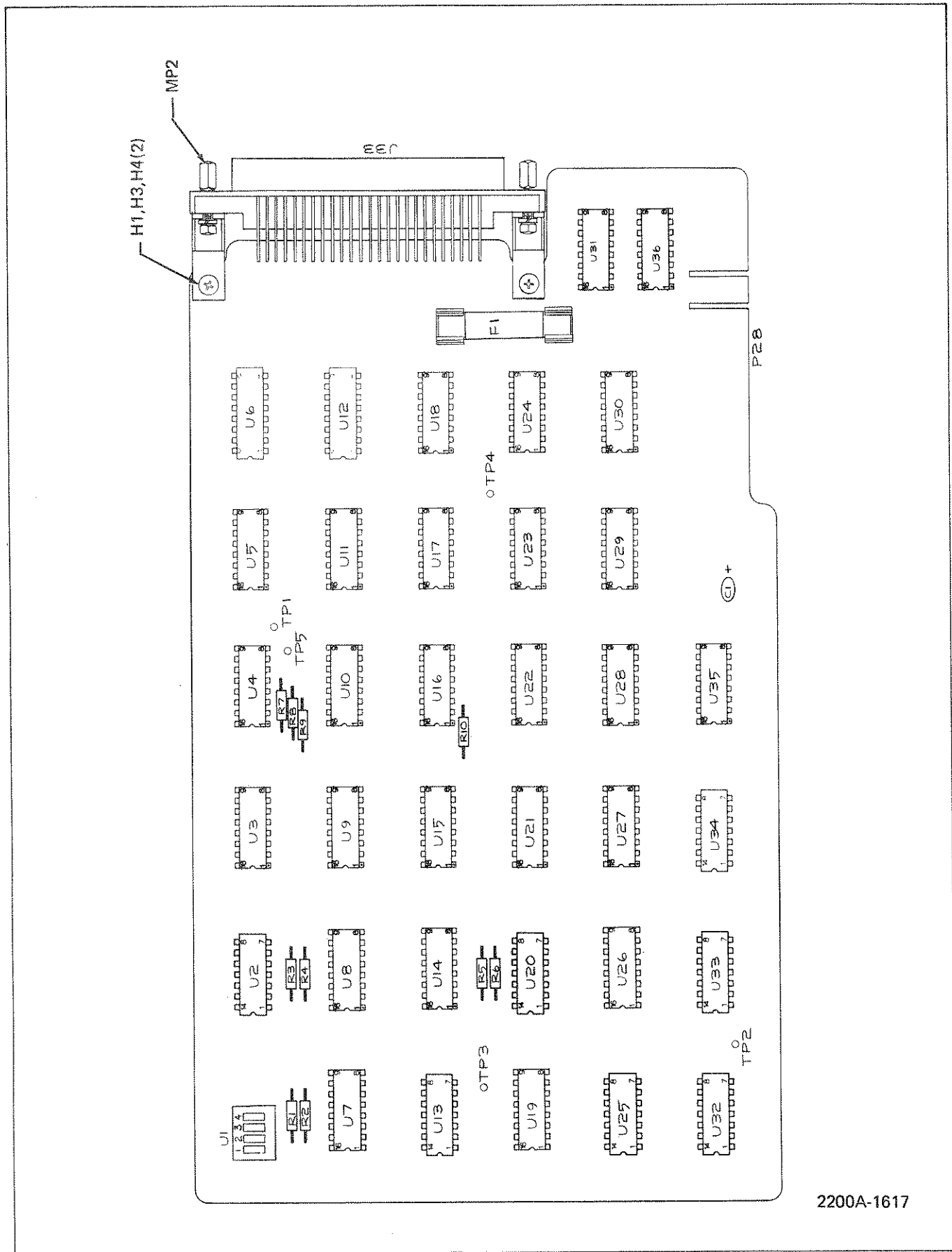

Figure 616-3. Digital Input PCB Assembly



1  
2  
3  
4  
5  
6  
7  
8  
9  
10  
11  
12  
13  
14  
15  
16  
17  
18  
19  
20  
21  
22  
23  
24  
25  
26  
27  
28  
29  
30  
31  
32  
33  
34  
35  
36  
37  
38  
39  
40  
41  
42  
43  
44  
45  
46  
47  
48  
49  
50  
51  
52  
53  
54  
55  
56  
57  
58  
59  
60  
61  
62  
63  
64  
65  
66  
67  
68  
69  
70  
71  
72  
73  
74  
75  
76  
77  
78  
79  
80  
81  
82  
83  
84  
85  
86  
87  
88  
89  
90  
91  
92  
93  
94  
95  
96  
97  
98  
99  
100

Option -17  
Remote Programming Interface

617-1. GENERAL

617-2. EIA Standard RS-232-C provides the electronics industry with the ground rules necessary for independent manufacturers to design and produce both data terminal and data communication equipment that conforms to a common interface requirement. As a result, a data communications system can be formed by connecting an RS-232-C data terminal (such as, the 2240B) to an RS-232-C data communication peripheral (such as, a TTY, MODEM, computer, etc.). This works fine on paper. However, in practice, the user must be aware of the subtleties of binary data interchange to ensure that any two pieces of RS-232-C equipment will be compatible. For example, the two instruments must share at least one of the features from each of the following characteristics:

1. Timing Format - Synchronous or Asynchronous.
2. Transmission Mode - Simplex, Half-duplex, or Full duplex.
3. Baud Rate (bits per second) - 110, 150, 300, 600, 1200, 1800, 2400, 4800, 9600.
4. Bits Per Character - 5, 6, 7, 8.
5. Parity Bit - Odd, Even, High, Low, Not Used.
6. Data Interface Levels - EIA or 20 mA Current Loop.

617-3. Timing formats conforming to both synchronous and asynchronous operation are shown in Figure 617-1. In asynchronous operation each character is bracketed by both start and stop bits. These bits separate the characters and synchronize both the transmission and receipt of data. When data is not being sent the data line is held high. In synchronous operation a sync character is sent prior to each data stream (a data stream usually consists of a block of characters). When the line is idle a fill or sync character is continuously transmitted.

617-4. Transmission mode is an overall system requirement. It defines the communication ability of both instruments in the system configuration. Simplex indicates data transmission in one direction only. Half-duplex permits two way communication, but not simultaneously. Simultaneous transmission of data in both directions defines the full duplex system. Obviously, an instrument capable of full duplex operation can be downgraded to simplex operation. However, the reverse is not possible without degrading the system capability.

617-5. Baud rate is usually selectable on the RS-232-C Interface. If it is not, the manufacturer usually offers a choice

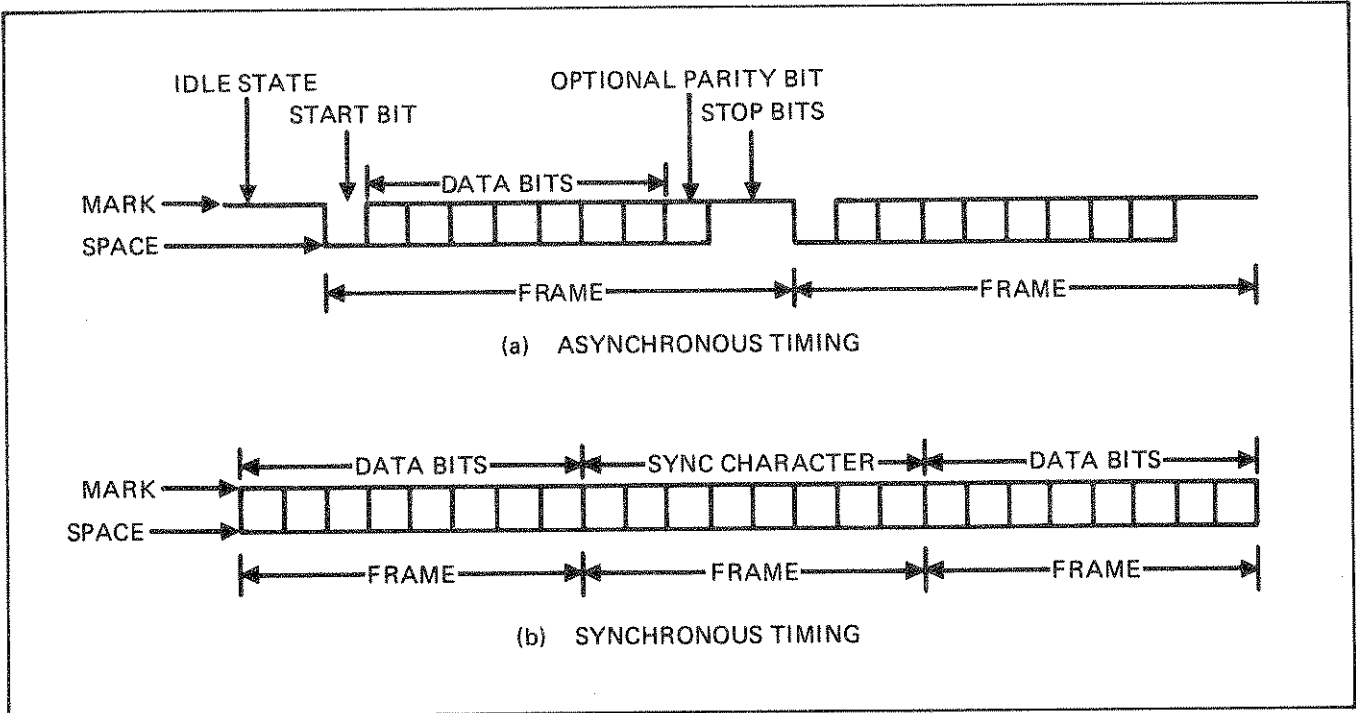

Figure 617-1. RS-232-C Timing Formats

when the instrument is purchased.

617-6. Character format (bits per character and parity) is somewhat flexible between instruments. Investigate the requirement of both instruments before committing either to a system configuration.

617-7. Data interface levels can occur as either EIA voltage levels or as a 20 mA current loop. At times, an interface offers both simultaneously. The 20 mA current loop is used almost exclusively for teletypewriter, or paper tape punch/reader interface. EIA voltage levels are: 1 or OFF = -15 to -3V dc, 0 or ON = +3 to +15V dc.

#### 617-8. INTRODUCTION

617-9. The Remote Programming Option (-17) is designed to interface the Model 2240B Data Logger with an external, RS-232-C/20 mA current loop compatible data communication instrument, such as a TTY, MODEM, computer, CRT, etc. It features asynchronous timing, full duplex capability, selectable baud rate, choice of EIA or 20 mA current loop data levels, selectable parity for both transmit and receive, selectable character format (bits per character) and selectable output data format (lines per record, etc.). In addition, a unique address code can be assigned to the interface pcb. This code allows the interface to ignore all data not preceded by its assigned address character.

617-10. Option -17 is available in a variety of configurations as shown in Table 617-1. Order by model number and description. (Interface cable detail is given later under Operating Notes.)

#### 617-11. SPECIFICATIONS

617-12. Specifications for the -17 Option are as follows:

Timing Format ...	Asynchronous
Output Format ...	Bit-Serial, 5, 6, 7 or 8 bits per character, one start bit.
# of stop bits...	one for 150 to 9600 Baud two for 110 Buad
Output Code .....	Seven level ASCII
Data Buffer .....	16-characters
Baud Rates .....	110, 150, 300, 600, 1200, 1800, 2400, 4500, 9600
Operating Power .	Derived from data logger
Operating Temp ..	0 to 50°C

#### 617-13. INSTALLATION

#### 617-14 Interface PCB

617-15. The Remote Programming PCB Assembly can be installed in

Table 617-1. Option -17 Configurations

MODEL NO.	DESCRIPTION
2240B-17A	Data Communication Interface Kit (PCB and Cable)
2240B-17B	Data Terminal Interface Kit (PCB and Cable)
2240B-17C	Current Loop (20 mA) Interface Kit (PCB and Cable)
2240B-17G	Interface PCB (no cable)
2200A-7008	Interface Cable (-17A), Data Communications
2200A-7009	Interface Cable (-17B), Data Terminal
2200A-7010	Interface Cable (-17C), Current Loop (20 mA)

any one of the data logger I/O slots shown in Figure 617-2. Use the following procedure to install the pcb:

#### WARNING

REMOVE LINE POWER AND ALL OTHER  
HIGH VOLTAGE INPUTS TO THE DATA  
LOGGER BEFORE STARTING THIS  
PROCEDURE.

1. Set the data logger POWER switch to OFF.
2. Remove the top cover from the data logger.
3. Locate S3 on the pcb as shown in Figure 617-2. This switch is used to establish the format of transmitted data.
4. With reference to Table 617-2, set 1 through 4 of S3 to establish the desired format.

#### NOTE

When parity is enabled, the parity bit adds 1 to the number of bits per character, up to a maximum of 8 bits. For example, 6 bits per character plus parity will result in a character length of 7 bits. Because the maximum number of bits is 8, 7 bits per character plus parity will result in the same number of bits as selecting 8 bits per character plus parity.

5. Locate S4 on the pcb as shown in Figure 617-2. This switch is used to establish the baud rate of both transmitted and received data.
6. With reference to Table 617-3, set 1 through 4 of S4 to establish the desired baud rate.
7. Locate S2 on the pcb as shown in Figure 617-2. S2 is used to assign a unique address code to the pcb. This code allows the pcb to ignore all command (data) strings that are not preceded by the code.
8. With reference to Table 617-4, set 2 through 4 of S2 to assign the desired address character.
9. Locate S1 on the pcb as shown in Figure 617-2.

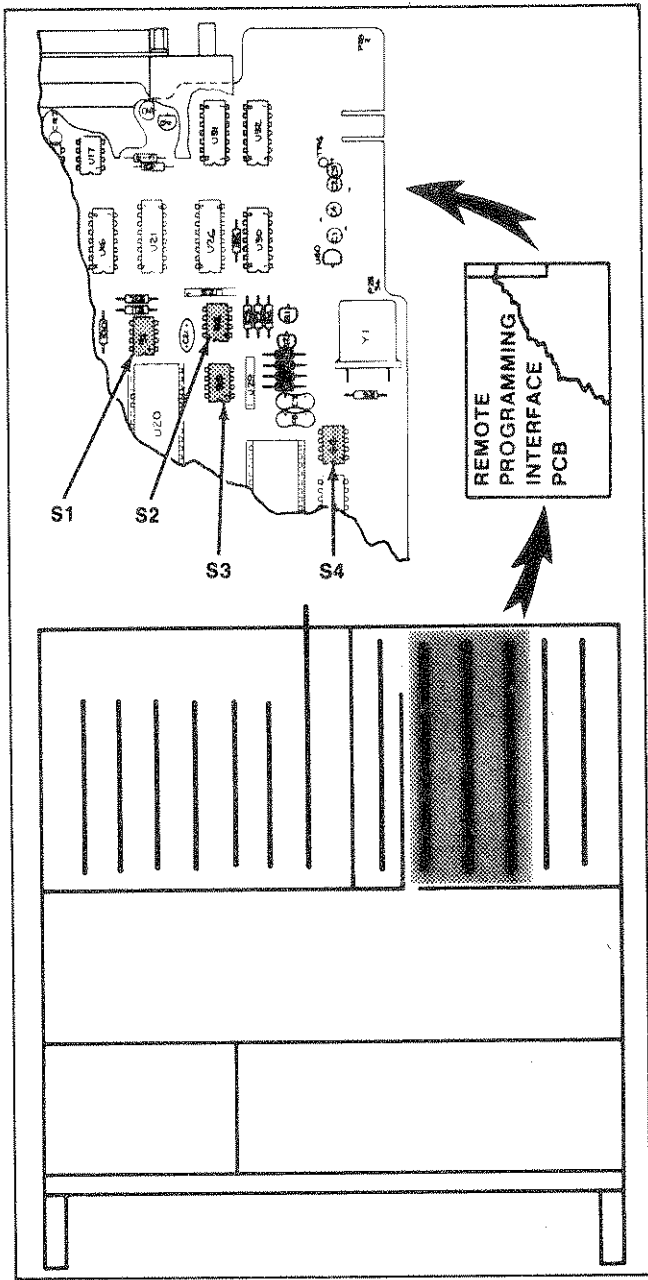

Figure 617-2. Remote Programming Interface PCB, Installation and Switch Locations

Table 617-2. S3 Switch Settings

S3 DEFINES THE FORMAT OF TRANSMITTED DATA CHARACTERS					
CHARACTER FORMAT			PARITY		
Bits Per Character	Position		Function	Position	
	3	2		1	4
5	On	On	Odd	On	On
6	On	Off	Even	Off	On
7	Off	On	None	X	Off
8	Off	Off	X = May be Off or On		



Table 617-3. S4 Switch Settings

S4 DEFINES THE BAUD RATE OF TRANSMITTED AND RECEIVED DATA				
BAUD RATE *	SWITCH POSITIONS			
	1	2	3	4
110	Off	Off	Off	Off
150	Off	Off	Off	On
300	Off	Off	On	Off
600	On	Off	Off	On
1200	Off	On	Off	Off
1800	Off	On	Off	On
2400	On	Off	Off	Off
4800	Off	On	On	Off
9600	Off	On	On	On

\*One stop bit accompanies each character except at 110 baud where 2 stop bits are used.

Table 617-4. S2 Switch Settings

S2 DEFINES ADDRESS CODE ASSIGNED TO REMOTE PROGRAMMING PCB						
ADDRESS CHARACTER		POSITION				S2 CODE (HEX)
ASCII	Hex	4	3	2	1	
	21	Off	Off	Off	See Note	0
"	22	On	Off	Off		1
#	23	Off	On	Off		2
\$	24	On	On	Off		3
%	25	Off	Off	On		4
&	26	On	Off	On		5
No Address	—	Off	On	On		6
Auto Answer	—	On	On	On		7

Note: S2 - P1, when set to ON, will cause a delay of ≈250 ms after each CR LF. When set to OFF no delay will occur.

10. Refer to Table 617-5 and set 1 through 4 of S1 to define the interface and data characteristics of the pcb.
11. Align the Remote Programming PCB in the selected I/O slot so that the female connector is toward the rear of the data logger, and the small board-edge connector is toward the bottom of the unit. Push the pcb straight down onto the mating connector.
12. After the pcb is installed, install the top cover.

#### 617-16. Interface Cable

617-17. The peripheral is connected to the Remote Programming PCB by means of the interface cable. Connector P52 connects to the pcb, and P1 connects to the peripheral. Before actually installing the cable, refer to the interface information given later under Operating Notes and check to ensure that all required signal lines are present in the interface connection. If the 20 mA current loop interface is used, refer to Operating Notes for connection information.

#### 617-18. OPERATING NOTES

617-19. The following paragraphs describe various conditions that should be considered before attempting to operate the Remote Programming Option.

#### 617-20. Interface Cables

617-21. One of three user specified, interface cables may be used with the Remote Programming Interface; i.e., -17A, -17B, or -17C. The 17A and 17B cables are designed for use with an RS-232-C peripheral employing EIA data levels. The -17A cable has a male connector suitable for use with data communication equipment. The -17B cable has a female connector and is compatible with data terminal equipment. Signal and connection details are given in Table 617-6. Notice that all pins relating to the 20 mA current loop interface (\*) are not connected (in cables 17A and 17B). Equipment requiring a 20 mA current loop interface must, therefore, use the -17C cable. Connection details for this cable are given later in this section under Current Loop Interface.

#### 617-22. Control Signals

617-23. All of the control signals specified in RS-232-C which have been implemented in the -17 Option are listed and described in the following paragraphs.

1. CD - Data Terminal Ready - pin 20

Table 617-5. S1 Switch Settings

S1 DEFINES INTERFACE AND DATA CHARACTERISTICS		
POSITION	FUNCTION	SETTING
1	Controls echo of received characters to the peripheral.	On = Echo Off = No Echo
2 *	Selects number of analog readings per line (output data).	On = Four Off = One
3 **	Used in conjunction with U10 and U11 to alter the standard output format.	On = Special Off = Standard
4	Selects I/O data levels. 20mA Current Loop or EIA.	On = EIA Off = 20mA

\*With -18, ON selects number of R.P.L. specified by -18, OFF = 1.  
\*\*Option -18.

Table 617-6. Interface Cable Signals and Connections

Signal	REMOTE PROGRAMMING PCB		INTERFACE CABLE		
	J52	P52	▶	P1	
				17A	17B
Protective Ground (Chassis)	1	1	→	1	1
Transmitted Data	2	2	→	2	3
Received Data	3	3	→	3	2
Request to Send	4	4	→	4	5
Clear to Send	5	5	→	5	4
Data Set Ready	6	6	→	6	20
Signal Ground	7	7	→	7	7
Received Line Signal Detector	8	8	→	8	20
Not Used	9	9	→	9	9
Not Used	10	10	→	10	10
I2 Current Source	11	11	.	11	11
-I <sub>T</sub> Transmit (20mA)	12	12	.	12	12
+I <sub>R</sub> Receive (20mA)	13	13	.	13	13
-I <sub>R</sub> Receive (20mA)	14	14	.	14	14
Not Used	15	15	→	15	15
+I <sub>T</sub> Transmit (20mA)	16	16	.	16	16
Not Used	17	17	→	17	17
-I Current Sink	18	18	.	18	18
-I Current Sink	19	19	.	19	19
Data Terminal Ready	20	20	→	20	6,8
Not Used	21	21	→	21	21
Ring Indicator	22	22	→	22	22
Not Used	23	23	→	23	23
Not Used	24	24	→	24	24
I1 Current Source	25	25	.	25	25

▶ → = Pins connected.

\* = No connection between pins.

2. CA - Request to Send - pin 4
3. CE - Ring Indicator - pin 22
4. CF - Received Line Signal Detector - pin 8
5. CB - Clear to Send - pin 5
6. CC - Data Set Ready - pin 6

617-24. Signals CF, CB, CC must be generated by the peripheral for all pcb address codes (S2) other than 7. If address 7 is assigned to the pcb, the peripheral must also supply signal CE. If CA and CD or CE are not used, they should be left open. When CF, CB, and CC are not required they should be tied to an RS-232-C "ON" state (+3 to +15V dc with respect to signal common).

617-25. The automatic answer or switched service mode of operation is enabled when address code 7 is assigned to the Remote Programming PCB. In this mode the pcb polls Ring Indicator line (CE) for activity. When CE is turned on, the pcb sets its Data Terminal Ready line (CD) to on. Then, after a 4-second delay it checks for both Data Set Ready (CC) and Received Line Signal Detector (CF) to be on, and CE to be off. When this condition is met, the pcb sets the Request to Send line (CA) to on and then checks the Clear to Send Line (CB). If CB is on, a connection is made. Otherwise, no connection is made and the pcb sets CA and CD to off, and returns to polling the Ring Indicator (CE).

617-26. The dedicated line mode of operation is used for all address codes other than 7. In this mode the pcb sets the Data Terminal Ready line (CD) to the on state when power occurs. It then polls for Data Set Ready (CC), and if on, sets the Request to Send line (CA) to on. In order, it then checks the Clear to Send (CB) and Received Line Signal Detector (CF). If both are on, then a data connection is made and the pcb is ready to receive data.

617-27. When a -17 Remote Programming Interface is installed in the 2240C Data Logger, the following control lines must be connected to an RS-232-C logic ON state (+3V to +15V) to insure proper interface operation.

Data Set Ready (CC)	. . . . .	.J52, Pin 6
Clear To Send (CB)	. . . . .	.J52, Pin 5
Received Line Signal Detector (CF)	. . . . .	.J52, Pin 8

617-28. Most peripheral devices provide the proper signals. If the Data Logger is to be operated without a peripheral device, the control lines can be tied to J52, Pin 20, Data Terminal Ready.

Ready.

#### 617-29. Current Loop Interface

617-30. The Remote Programming PCB is designed to transmit/receive data at either EIA voltage levels or 20 mA current loop levels. Switch S1, position 4, is used to select the desired data levels (see Installation Instructions). If the current loop levels are to be used, the -17C version of the interface cable must be employed. The -17 design is somewhat flexible in that it allows the current sources (transmit and receive) to be derived from either the Remote Programming PCB of the peripheral. Figure 617-3 illustrates the current loop I/O capabilities provided on the Remote Programming PCB. An example of current loop interface with a teletypewriter (Model ASR-33) is shown in Figure 617-4. When multiple data loggers are to be interfaced with a single peripheral current loop connections similar to those shown in Figure 617-5 are recommended.

#### 617-31. Programming Format

617-32. The Remote Programming PCB is capable of accepting a series or string of alpha numeric characters and interpreting them as control/program data. These data (command) strings, when properly formatted, enable the remote peripheral to program the following data logger functions:

1. Scan Control
2. Output Control
3. Time
4. Scan Format
5. Channel Programming
6. Limits Programming

617-33. The format of the command string is shown in Figure 617-6. It consists of an address character, a command character, a numeric data field, and a carriage return terminator. The address character must correspond to that assigned (by #S2) to the interfaced Remote Programming PCB. An alphabetic command character follows to define the function to be programmed (scan control, output control, etc.). The commanded function is then programmed by a series of numeric characters. These characters represent a variable length numeric field and may contain a number of delimiters in the form of commas (,). After the numeric field is completed the command string is both terminated and executed by a carriage return (CR) character.

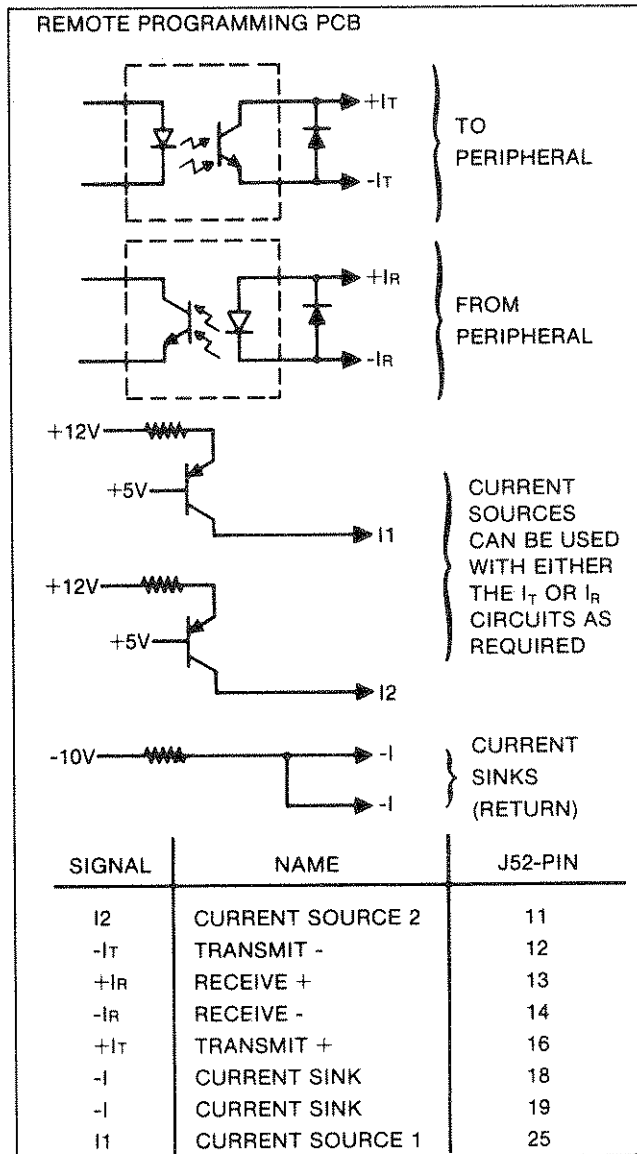

**Figure 617-3. Current Loop Provisions on Remote Programming PCB**

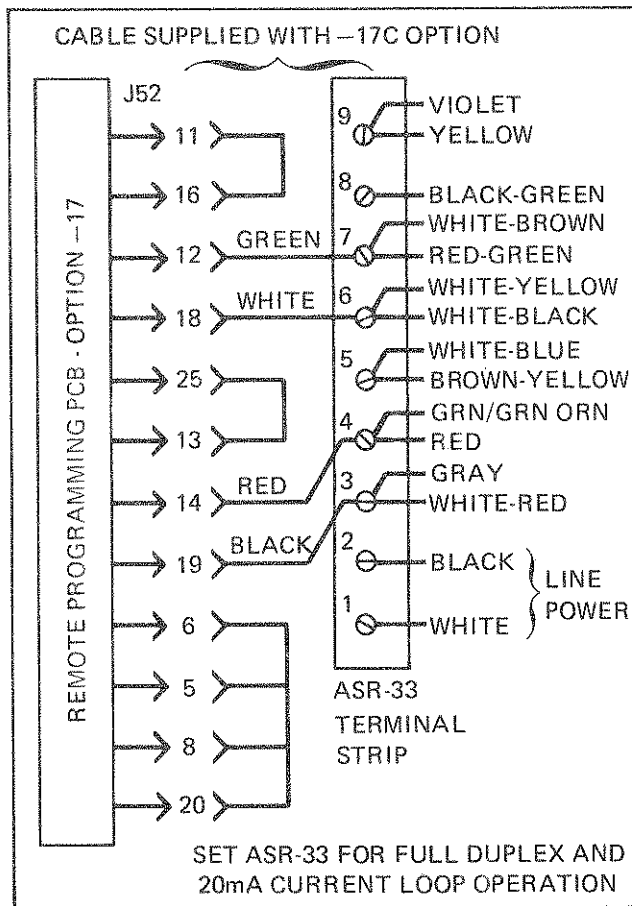

Figure 617-4. Connections Required for 20 mA Current Loop Interface with Model ASR-33 Teletypewriter

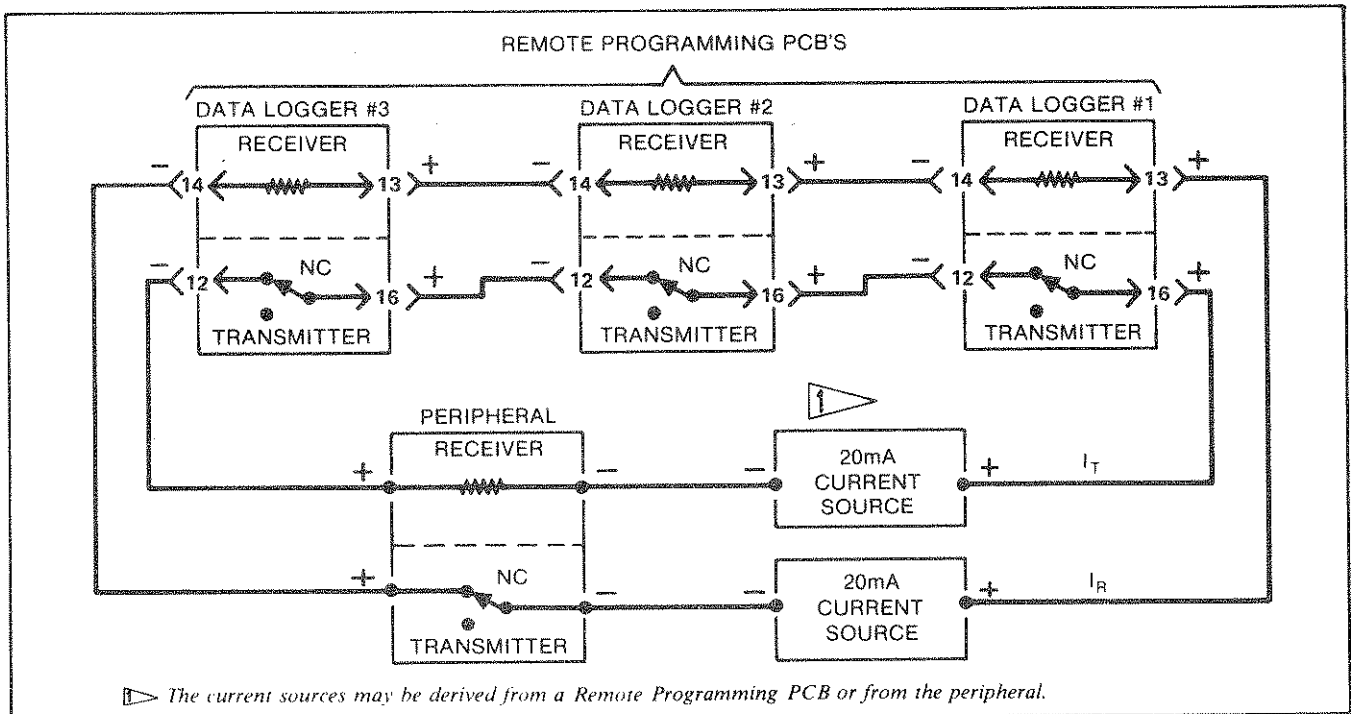

Figure 617-5. Current Loop Connections for Multiple Data Loggers

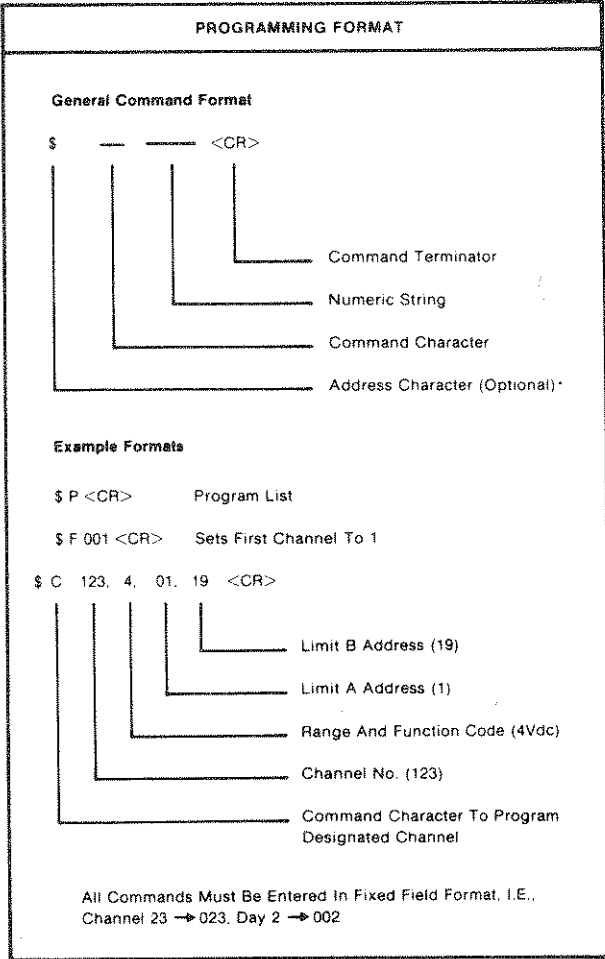

Figure 617-6. Command String Format Example



## NOTE

A delimiter cannot be used for concatenation of command strings. Each string must be individually addressed and terminated.

617-34. A complete list of command characters and their associated numeric fields are given in Table 617-7. Proper formatting of a typical programming sequence is shown in Table 617-8.

### 617-35. Output Format

617-36. Output data from the interface pcb is recorded at the peripheral in the standard format shown in Table 617-9. A switch on the interface pcb (S1 position 2) allows selection (and printing) of either one or four measurement data readings per line.

617-37. Special formats are available on request (2240B-18, Special Output Format Option) and require the use of IC U10 (and depending on the format required by the customer, may include IC U11) with a custom program. The format variations are limited to those listed below. When ordering a special format, specify the variations using a form similar to that in Figure 617-7.

1. Figure 617-7 shows the -17 option standard output format and the characters which may be deleted and/or substituted for using the -18 option. A switch on the -17 board allows selection of the standard or non-standard output format. Shaded areas indicate that a substitute or delete may not be entered at that point.
2. The same letter appearing above a column in more than one section of the format indicates that those columns are interrelated under certain conditions which will be explained individually in 4, and 5, below.
3. To delete a particular character, one must mark the DELETE box below that character, (if it is unshaded). Then another character may be substituted by filling in the SUBSTITUTE box (if it is unshaded) immediately below the character that has been deleted. If a character is deleted, but no substituting character is entered, no character will be output, and the line length will be shortened accordingly.

Table 617-7 Definition of Command and Response Codes

COMMAND CHARACTERS		
	Format	Action
P	P	Outputs The Program Currently In Memory
Q	Q	Program List On Internal Printer
B	B	Automatic Telephone Transmission Terminator*
A	A00	Sets Alarm Output/Resets All Alarms
	ADD	Resets All Alarm Outputs (-23 Option)
E		Sets Specified Alarm DD = 01-30
		Enables Local Or Remote Control (Must Be Enabled By Switch Internal To 2240B)
	E0	Local Control
	E1	Remote Control Only
D		Command Response* And Error Message Control
	D0	Restores Response* And Message
	D1	Deletes Response* And Message
S		Scan Control, Starts Data Logger
	S0	Resets Data Logger Scan Control
	S1	Single Scan
	S2	Interval Scan
	S3	Monitor Scan
	S4	Continuous Scan
W		Output Control (External Only)
	W0	No Data Output
	W1	Alarm Data Only
	W2	Interval Data Only
	W3	Alarm Data And Interval Data
	W4	All Data
	W5	All Data On Alarm
	W6	All Data And Interval Data
	W7	All Data On Alarm And Interval Data
X		Printer Control
	X0	No Data Output
	X1	Alarm Data Only
	X2	Interval Data Only
	X3	Alarm Data And Interval Data
	X4	All Data
	X5	All Data On Alarm
	X6	All Data And Interval Data
	X7	All Data On Alarm And Interval Data
<b>Scan Format</b>		
F	FXXX	Sets First Channel To XXX (000-999)
L	LYYY	Sets Last Channel To YYY (000-999)
M	MZZZ	Sets Monitor Channel To ZZZ (000-999)
H	HXXXXXX	Sets Fixed Data To XXXXXX (000000-999999)
I	IXX,YY,ZZ	Sets The Interval To XX Hrs., YY Min., ZZ Secs
T	TWWW,XX,YY,ZZ	Sets Time Of Year To WWW Days, XX Hrs., YY Min., ZZ Secs
<b>MEASUREMENT RESPONSE</b>		
Y	123:16:57:30	Time Of Year
X	123456	Fixed Data
D	01 123456789	Digital Input Data
A	0 >+3777.7 mV	Analog Data
A	0 +7777.7 **BT	Broken Thermocouple
A	0 +9999.9 **OL	Overload
		Units Or Fault Message
		Measured Value
		Polarity
		Limits Exceeded Symbol
		Channel Number
		Data Code

Programming		
	Format	Action
V	VXX,Y,ZZZZ	Limits Value Sets Limit Addressed By XX (01-30) To Polarity And Sense Y, And Value ZZZZ Y = 0 - Low Y = 1 + Low Y = 2 - High Y = 3 + High ZZZZ (0000-3999)
C	CWWW,X,YY,ZZ	Channel Programs Channel Number WWW (000-999) To Range And Function X, With Limit A Address YY And Limit B Address ZZ X Range And Function: 0 SKIP 1 40 mV 2 80 mV (Calibration Only) 3 400 mV 4 4V 5 40V 6 T1 7 T2 8 T3 9 T4 YY (01-15) Limit A ZZ (16-30) Limit B
R	RXXX,Y	Random Access Any Channel Channel XXX (000-999) Y = Range And Function Code Same As X Above, Does Not Program Memory
<b>SECOND INTERVAL</b>		
G	GXXX	Sets First Channel To XXX, (000-999)
K	KYYY	Sets Last Channel To YYY, (000-999)
J	JXX,YY	Sets Second Interval Time To XX Hours (00-99) And YY Minutes (00-59)
<b>COMMAND RESPONSE*</b>		
	@ <CR> \LF >	Data Logger Ready To Accept Next Command
<b>ERROR MESSAGES</b>		
ERR01		Data Logger Not In Remote
ERR02		Command String Over 16 Characters
ERR03		(Command Aborted With ↑ C Control "C")
ERR04		Not A Valid Command Memory Error a) Individual Programming Mode, Channel Number > 255 b) Memory Not Available For Channels Above 127 c) Limits Memory Option Not Installed
ERR05		A-D Function Error Random Access Channel Programming a) Function Is Not Available b) Temperature Option Not Installed
ERR06		Remote Command Is Not Enabled

Control C - Abort Entry\*

\*RS232 (-17) Only

Table 617-8. Typical Programming Sequence

COMMAND STRING	COMMENTS
\$T123,23,50,31 CR	Time of Year
\$W4 CR	Output, All Data
\$F000 CR	First Channel = 0
\$L003 CR	Last Channel = 3
\$M001 CR	Monitor Channel = 1
\$C000,1,00,00 CR	Channel 0, 400 mV, Skip Limits
\$C001,6,01,16 CR	Channel 1, T1, Limits 1 & 16
\$C002,0,00,00 CR	Skip Channel 2
\$C003,4,33,16 CR	Channel 3, 4V, Limit 16
\$V01,3,2000 CR	Limit 1 = HI +2000
\$V16,1,1000 CR	Limit 16 = LO +1000
\$S1 CR	Continuous scan starts on CR.

Table 617-9. Standard Output Format

DESCRIPTION	OUTPUT DATA *																	
Scan Start Character	<u>DC2</u> <u>CR</u> <u>LF</u>																	
Time of Year	<u>Y</u>	<u>DC</u>	<u>DC</u>	<u>DC</u>	<u>:</u>	<u>H</u>	<u>H</u>	<u>:</u>	<u>M</u>	<u>M</u>	<u>:</u>	<u>S</u>	<u>S</u>	<u>CR</u>	<u>LF</u>			
Fixed Data	<u>X</u>	<u>FD</u>	<u>FD</u>	<u>FD</u>	<u>FD</u>	<u>FD</u>	<u>FD</u>	<u>CR</u>	<u>LF</u>									
Digital Input Data (Option-16)	<u>D</u>	<u>AC</u>	<u>AC</u>	<u>SP</u>	<u>DD</u>	<u>DD</u>	<u>DD</u>	<u>DD</u>	<u>DD</u>	<u>DD</u>	<u>DD</u>	<u>DD</u>	<u>DD</u>	<u>CR</u>				
Measurement Data	<u>A</u>	<u>CH</u>	<u>CH</u>	<u>CH</u>	<u>+</u>	<u>SP</u>	<u>9</u>	<u>9</u>	<u>9</u>	<u>9</u>	<u>9</u>	<u>*</u>	<u>*</u>	<u>O</u>	<u>L</u>	<u>CR</u>	<u>LF</u>	
	<u>A</u>	<u>CH</u>	<u>CH</u>	<u>CH</u>	<u>+</u>	<u>SP</u>	<u>7</u>	<u>7</u>	<u>7</u>	<u>7</u>	<u>7</u>	<u>*</u>	<u>*</u>	<u>B</u>	<u>T</u>	<u>CR</u>	<u>LF</u>	
	<u>A</u>	<u>CH</u>	<u>CH</u>	<u>CH</u>	<u>±</u>	<u>AD</u>	<u>AD</u>	<u>AD</u>	<u>*</u>	<u>AD</u>	<u>AD</u>	<u>SP</u>	<u>C</u>	<u>SP</u>	<u>SP</u>	<u>CR</u>	<u>LF</u>	
	<u>A</u>	<u>CH</u>	<u>CH</u>	<u>CH</u>	<u>&gt;</u>	<u>AD</u>	<u>AD</u>	<u>AD</u>	<u>*</u>	<u>AD</u>	<u>AD</u>	<u>SP</u>	<u>F</u>	<u>SP</u>	<u>SP</u>	<u>CR</u>	<u>LF</u>	
	<u>A</u>	<u>CH</u>	<u>CH</u>	<u>CH</u>	<u>&lt;</u>	<u>AD</u>	<u>AD</u>	<u>AD</u>	<u>*</u>	<u>AD</u>	<u>AD</u>	<u>M</u>	<u>V</u>	<u>SP</u>	<u>SP</u>	<u>CR</u>	<u>LF</u>	
<u>A</u>	<u>CH</u>	<u>CH</u>	<u>CH</u>	<u>SP</u>	<u>±</u>	<u>AD</u>	<u>AD</u>	<u>AD</u>	<u>*</u>	<u>AD</u>	<u>AD</u>	<u>SP</u>	<u>V</u>	<u>SP</u>	<u>SP</u>	<u>CR</u>	<u>LF</u>	
Data Column I.D. (For Reference Purposes Only-Not Recorded)	<u>0</u>	<u>1</u>	<u>2</u>	<u>3</u>	<u>4</u>	<u>5</u>	<u>6</u>	<u>7</u>	<u>8</u>	<u>9</u>	<u>10</u>	<u>11</u>	<u>12</u>	<u>13</u>	<u>14</u>	<u>15</u>	<u>16</u>	<u>17</u>
End of Scan Character	<u>DC4</u> <u>CR</u> <u>LF</u>																	

**\*MNEMONICS:**

A = Measurement Data I.D.  
 AC = Address Code  
 AD = Analog Data  
 CH = Channel No.  
 CR = Carriage Return

D = Digital Input I.D.  
 DC = Day Code  
 DD = Digital Input Data  
 FD = Fixed Data  
 H = Hours  
 LF = Line Feed

M = Minutes  
 S = Seconds  
 SP = Space  
 X = Fixed Data I.D.  
 Y = Time of Year I.D.  
 \*\*OL = Overload

\*\*BT = Broken Thermocouple  
 \_C\_ = Degrees Celsius  
 \_F\_ = Degrees Fahrenheit  
 MV\_ = Millivolts  
 \_V\_ = Volts



4. A, B, and C - Each of these columns has only one substitution possible for the entire output. This means that only one of the SUBSTITUTE boxes in each of these columns may be filled in. A typical example: If a delete and a substitute are performed for one character in column C, but the other (two) characters in column C are left undeleted, they will be output normally. However, if one or both of these other (two) characters are deleted, then the substitution called for earlier will be automatically performed for the character(s) deleted.
5. D, E, F, G, and H columns have the capability of one delete because that will delete all characters in the column. All characters in the column may then be substituted for individually except the asterisks, and the spaces in the columns G and H. Also, any of the original characters which are desired must be substituted back in.
6. Readings per line MUST be specified.

#### 617-38. OPERATION

617-39. Once installed, the Remote Programming Option requires no operator attention other than ensuring that normal turn-on procedures are observed for both the 2240C and its peripheral. Select the remote mode of operation either manually or remotely as required by the position of switch #1 on the 2240C's A3 Controller PCB. (See Section 2, Figure 2-6 of the 2240C Instruction Manual.) Follow the programming format given earlier to control the operation of the 2240C. Each of the remote programming functions correspond to the manual functions described in Section 2 of the 2240C Instruction Manual.

#### 617-40. THEORY OF OPERATION

617-41. The Remote Programming PCB, as shown in Figure 617-8, is a microprocessor based subsystem which functions as an A3 Controller peripheral to provide the interface necessary to transfer 2240C program and output data to and from a remote, digital I/O, data terminal type device. Any one of several types of remote data terminal instruments can be accommodated by the interface. Among these are: a 20 mA current loop teleprinter, paper tape reader/punch, or any RS-232-C compatible device capable of qualifying as a data terminal. Once the data terminal equipment is defined, the interface pcb is tailored to meet the interface requirements by setting a series of switches on the pcb. (See Installation Instructions for switch settings as they apply to this option.) These settings are read and stored by the MPU each time the data logger is turned on.

617-42. Operation of the Remote Programming PCB Assembly can be



functionally divided into two sequences: transmit and receive. The transmit sequence involves the transfer of programming information from the data terminal to the A3 Controller in the 2240C. Conversely, the receive sequence involves the transfer of output data (scan and measurement data) from the data logger to the data terminal equipment. In both cases, each I/O word (up to 16 characters) is temporarily stored on the interface pcb before being transferred to its final destination. This allows the interface pcb to synchronize its transfer operations with either A3 Controller of the data terminal, as required.

#### 617-43. Transmit Sequence

617-44. Character-serial program data from the data terminal is received at the Remote Programming PCB as either 20 mA current levels or EIA (RS-232-C) voltage levels. The data is level shifted and/or buffered, and then used as the data input to a Universal Asynchronous Receiver Transmitter (UART). Data is received at the baud rate defined by switch S4, and in the format defined by switch S3. When a complete character is received, the UART generates a high (+5V dc) DR output. DR is inverted for use as the INT input to the MPU (microprocessor unit). In response to an INT input the MPU reads the parallel UART output character (I/O) via the General Purpose Input/Output (GP I/O) device U20 and the MPU Data Bus. The UART is prompted to output data by a strobe received from the GP I/O (U20). This strobe is initiated by the MPU via the Data Bus. After the character is read by the MPU, the strobe input resets the UART's DR output, and thus removes the INT input from the MPU.

617-45. Transmit data characters received by the MPU are transferred to and stored in RAM0. When a complete command (up to 16 characters) has been assembled, the MPU checks it for errors and formats it for use by the data logger's A3 Controller. Then RAM0 initiates an IRQ (Interrupt Request) to notify the A3 Controller that the data is ready to be processed.

617-46. In response to the IRQ the A3 Controller begins to poll the various I/O pcb's to determine which pcb requested the interrupt and what service, if any, is required. To poll the Remote Programming PCB the A3 Controller places a binary coded 6 onto Control Bus A (CA0-CA3). The pcb detects its code and responds with its current status via the Data Bus. The possible response codes and their meanings are shown in Table 617-10. When the Remote Programming PCB has initiated the interrupt request (IRQ), it confirms its action by placing a binary coded 7 on the Data Bus as a response code.

617-47. When the A3 Controller is ready to receive data from the Remote Programming PCB, it places a binary coded 14 onto Control Bus A. The code is detected by the Control Bus Decoder which, in turn, enables data from port Y of the GP I/O (U19) to be placed onto the Data Bus. Concurrently, the MPU, on every Sync pulse, reads port W of the GP I/O (U19). When it detects a data request

**Table 617-10. Remote Programming PCB  
Response Codes**

<b>BINARY CODED STATUS RESPONSE</b>	<b>DEFINITION</b>
6	Interrupt Request and Busy
7	Interrupt Request (IRQ)
14	Busy
15	Not Busy, No Interrupt



code (binary coded 14), it proceeds to transfer 16 characters to the A3 Controller via port Y of the GP I/O (U19). At the end of the transfer, the Controller terminates the sequence by removing the binary coded 14 from the Control Bus.

#### 617-48. Receive Sequence

617-49. When the A3 Controller is ready for the remote data terminal to receive data, it polls the status of the Remote Programming PCB by placing a binary coded 6 onto Control Bus A. If the pcb is not busy, it responds with a binary coded 15 via the Data Bus, and thereby prompts the controller to initiate a Receive Sequence.

617-50. The controller initiates a receive sequence by placing either a binary coded 4 or 11 onto Control Bus A. These codes are detected by the Control Bus Decoder on the Remote Programming PCB, and are used to indicate to the MPU (by driving its Test input high) that data is about to be received from the controller. As subsequent data characters appear on the Data Bus, they are serially loaded into port X of the GP I/O (U19) by pulse Z1 (Z1 is derived from the Out strobe, and is enabled when binary codes 4 or 11 are on Control Bus A).

617-51. A total of 16 data characters are involved in each Receive Sequence. As they are transferred to the GP I/O (U19) they are also stored in RAM0 for further processing. When the transfer is completed the controller removes the receive code (4 or 11) from Control Bus A to terminate the first phase of the Receive Sequence.

617-52. During the remainder of the Receive Sequence the MPU checks the content and format of the received data, and then, if all conditions at the data terminal are correct, formats the data for transfer to the data terminal. Before the transfer occurs the MPU polls the status of the UART and the data terminal input lines. If the UART is ready (TBRE and TRE output must be high), and the Received Line Signal Detector, the Clear to Send, and the Data Set Ready inputs are on, then data will be accepted by the UART. Each receive-data character is transformed into an ASCII seven-level character by the MPU before being presented to the UART via ports X and W of the GP I/O (U20). Strobe pulse Z0 is used to enter each serial character into the UART buffer. As each character is loaded, the correct parity (as determined by switch setting of S3) is assigned. Then the character is shifted (serial-by-bit, LSB first) out of the UART as output or receive data. Data from the pcb is level-shifted and buffered to provide a choice of RS-232-C voltage levels or 20 mA current levels as the data source to the data terminal.

#### 617-53. MAINTENANCE

#### 617-54. Access Information

617-55. Refer to the Installation Instructions given earlier in the subsection for Remote Programming PCB access information. Remove the rear panel output connector before attempting to remove the pcb from the data logger.

617-56. PERFORMANCE TEST

617-57. The Remote Programming PCB Assembly is most easily tested under normal operating conditions. That is, installed in a functional data logger and interfaced with its normal peripheral. Output data can then be checked by comparing data recorded on the internal printer with hard copy data derived from the external recording device. Similarly, the effects of remote programming can be compared to isolate malfunctions to the pcb level.

617-58. LIST OF REPLACEABLE PARTS

617-59. The lists of replaceable parts for the -17 Option are given in Tables 617-11 through 617-16. Refer to Section 5 of the data logger manual for ordering information.

⊗ CAUTION

Indicated devices are subject  
to damage by static discharge.

Table 617-11. -17 Series Options

REF DES	DESCRIPTION	FLUKE STOCK NO.	MFG SPLY CODE	MFG. PART NO.	TOT QTY	REC QTY	N O T E
-17	SERIES -17 OPTIONS						
-17A	REMOTE CONTROL INTERFACE (RS232C TO MODEM)	452441	89536	452441			
	REMOTE PROGRAMMING PCB ASSEMBLY (2240A-4017T)	456632	89536	456632		REF	
	REMOTE PROGRAMMING CABLE ASSY FIGURE 617-9 (2240A-4403)	457234	89536	457234		1	
U1	IC, E-PROM SET	610428	89536	610428		1	1
U3	PART OF U1 E-PROM SET	610428	89536	610428		REF	1
-17B	REMOTE CONTROL INTERFACE (RS232C TO TERMINAL)	470286	89536	470286			
	REMOTE PROGRAMMING PCB ASSEMBLY (2240A-4017T)	456632	89536	456632		REF	
	TERMINAL REMOTE PROGRAMMING CABLE ASSY. FIGURE 617-10 (2240A-4406)	469239	89536	469239		1	
U1	IC, E-PROM SET	610428	89536	610428		1	1
U3	PART OF U1 E-PROM SET	610428	89536	610428		REF	1
-17C	REMOTE CONTROL INTERFACE (TTY 20mA CURRENT LOOP)	470302	89536	470302		REF	
	REMOTE PROGRAMMING PCB ASSEMBLY (2240A-4017T)	456632	89536	456632		REF	
	TTY REMOTE PROGRAMMING CABLE ASSY. FIGURE 617-11 (2240A-4405)	469221	89536	469221		1	
U1	IC, E-PROM SET	610428	89536	610428		1	1
U3	PART OF U1 E-PROM SET	610428	89536	610428		REF	1

Table 617-11. -17 Series Options (cont)

REF DES	DESCRIPTION	FLUKE STOCK NO.	MFG SPLY CODE	MFG. PART NO.	TOT QTY	REC QTY	NOTE
-17J	COLUMBIA 300C (115VAC CARTRIDGE RECORDER)	511972	89536	511972			
	REMOTE PROGRAMMING PCB ASSEMBLY (2240A-4017T)	456632	89536	456632		REF	
	TERMINAL REMOTE PROGRAMMING CABLE ASSY. FIGURE 617-10 (2240A-4406)	469239	89536	469239		1	
	CASSETTE TAPE	513689	89536	513689		1	
	TAPE RECORDER	513994	89536	513994		1	
U1	IC, E-PROM SET	610428	89536	610428		1	1
U3	PART OF U1 E-PROM SET	610428	89536	610428		REF	1
-17K	COLUMBIA 300C (100, 200, 230VAC CARTRIDGE RECORDER)	511980	89536	511980		REF	
	REMOTE PROGRAMMING PCB ASSEMBLY (2240A-4017T)	456632	89536	456632		REF	
	TERMINAL REMOTE PROGRAMMING CABLE ASSY. FIGURE 617-10 (2240A-4406)	469239	89536	469239		1	
	TAPE RECORDER	514026	89536	514026		1	
	TAPE CASSETTE	513689	89536	513689		1	
U1	IC, E-PROM SET	610428	89536	610428		1	1
U3	PART OF U1 E-PROM SET	610428	89536	610428		REF	1
	1....USED ON FIGURE 617-12 PCB ASSY. PLUG-IN AT U1 AND U3 SOCKETS.						

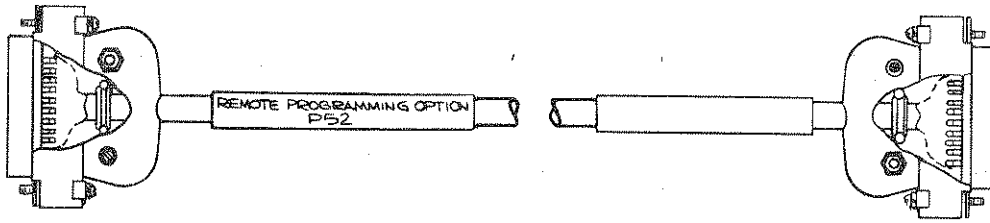

WIRE LIST

FROM	TO
P1-1	P52-1
↑ -2	↑ -2
-3	-3
-4	-4
-5	-5
-6	-6
-7	-7
-8	-8
-9	-9
-10	-10
-15	-15
-17	-17
-20	-20
-21	-21
-22	-22
-23	-23
↓ -24	↓ -24

2240A-4403

Figure 617-9. Remote Programming Cable Assembly

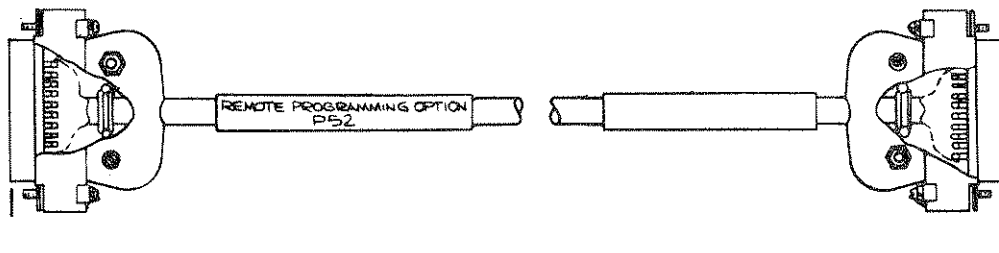

WIRE LIST

FROM	TO
P1-1	P52-1
↑ -2	↑ -3
-3	-2
-4	-5
-5	-4
-6	-20
-7	-7
-8	-20
-9	-9
-10	-10
-15	-15
-17	-17
-20	-6,8
-21	-21
-22	-22
-23	-23
↓ -24	↓ -24

2240A-4406

Figure 617-10. Terminal Remote Programming Cable Assembly

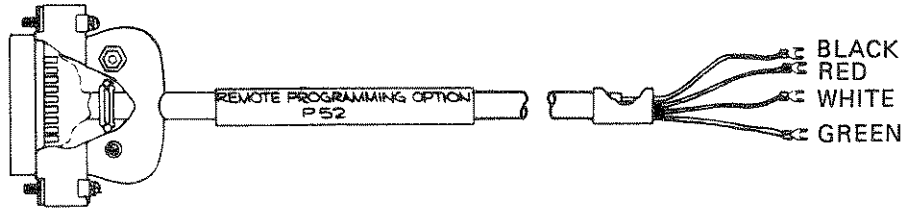

WIRE LIST

FROM	TO
P52-1	SHIELD
↑ -2	
-3	
-4	
-5	1
-6	1
-7	
-8	1
-9	
-10	
-11	P52-16 2
-12	GREEN
-13	P52-25 3
-14	RED
-15	
-16	P52-11 2
-17	
-18	WHITE
-19	BLACK
-20	1
-21	
-22	
-23	
↓ -24	
P52-25	P52-13 3

- 1 Pins 5, 6, 8, & 20 are connected.
- 2 Pins 11 and 16 are connected.
- 3 Pins 13 and 25 are connected.

2240A-4405

Figure 617-11. TTY Remote Programming Cable Assembly

Table 617-12. Remote Programming PCB Assembly

REF DES	DESCRIPTION	FLUKE STOCK NO.	MFG SPLY CODE	MFG. PART NO.	TOT QTY	REC QTY	NOTE
-17⊕	OPTION -17 REMOTE PROGRAMMING PCB ASSY  FIGURE 617-12 (2240A-4017T)						
C1	CAP, TA, .33 UF +/-20%, 35V	408690	56289	196D334X0035H	2		
C2	CAP, TA, 10 UF +/-20%, 20V	330662	56289	196D106X0020K	2		
C3	CAP, TA, .33 UF +/-20%, 35V	408690	56289	196D334X0035H	REF		
C4	CAP, TA, 10 UF +/-20%, 20V	330662	56289	196D106X0020K	REF		
C5	CAP, TA, 1 UF +/-20%, 35V	161919	56289	196D105X0020J	2		
C6	CAP, TA, 1 UF +/-20%, 35V	161919	56289	196D105X0020J	REF		
C7	CAP, MICA, 56 PF +/-5%, 500V	148528	72136	DM15F560J	2		
C8	CAP, MICA, 56 PF +/-5%, 500V	148528	72136	DM15F560J	REF		
C9	CAP, CER, 0.05 -20/+80%, 25V	148924	72982	5855-000-Y5U0-503Z	7		
C12	CAP, CER, 0.05 -20/+80%, 25V	148924	72982	5855-000-Y5U0-503Z	REF		
C13	CAP, CER, 0.05 -20/+80%, 25V	148924	72982	5855-000-Y5U0-503Z	REF		
C14	CAP, CER, 0.05 -20/+80%, 25V	148924	72982	5855-000-Y5U0-503Z	REF		
C19	CAP, CER, 0.05 -20/+80%, 25V	148924	72982	5855-000-Y5U0-503Z	REF		
C21	CAP, CER, 0.05 -20/+80%, 25V	148924	72982	5855-000-Y5U0-503Z	REF		
C22	CAP, CER, 0.05 -20/+80%, 25V	148924	72982	5855-000-Y5U0-503Z	REF		
CR1	DIODE, SI, HI-SPEED SWITCHING	203323	07910	1N4448	6	2	
CR2	DIODE, SI, HI-SPEED SWITCHING	203323	07910	1N4448	REF		
CR3	DIODE, SI, HI-SPEED SWITCHING	203323	07910	1N4448	REF		
CR4	DIODE, SI, HI-SPEED SWITCHING	203323	07910	1N4448	REF		
CR5	DIODE, SI, HI-SPEED SWITCHING	203323	07910	1N4448	REF		
CR6	DIODE, SI, HI-SPEED SWITCHING	203323	07910	1N4448	REF		
CR7	DIODE, LED, RED	385898	28480	5082-4487	1	1	
H1	SCREW, PHP, 4-40 X 3/8 (NOT SHOWN)	152124	89536	152124	2		
H2	WASHER, FLAT #4 (NOT SHOWN)	110775	89536	110775	2		
H3	WASHER, SPLIT/LK #4 (NOT SHOWN)	110395	89536	110395	2		
J52	CONNECTOR, 25-PIN	413112	71785	DB-255V	1		
MP1	CONNECTOR BRACKET (TO J52)	456566	89536	456566	1		
MP2	HARDWARE KIT ASSEMBLY	448092	31746	D-20418-2	2		
MP3	SPACER (TO CR7)	296319	32559	T0806	1		
Q1	XSTR, SI, PNP	195974	04713	2N3906	3	1	
Q2	XSTR, SI, NPN	218396	04713	2N3904	2	1	
Q3	XSTR, SI, NPN	218396	04713	2N3904	REF		
Q4	XSTR, SI, PNP	195974	04713	2N3906	REF		
Q5	XSTR, SI, PNP	195974	04713	2N3906	REF		
R1	RES, DEP. CAR, 30K +/-5%, 1/4W	368753	80031	CR251-4-5P30K	4		
R2	RES, DEP. CAR, 30K +/-5%, 1/4W	368753	80031	CR251-4-5P30K	REF		
R3	RES, DEP. CAR, 6.2K, +/-5%, 1/4W	442368	80031	CR251-4-5P6K2	1		
R4	RES, DEP. CAR, 30K +/-5%, 1/4W	368753	80031	CR251-4-5P30K	REF		
R5	RES, DEP. CAR, 30K +/-5%, 1/4W	368753	80031	CR251-4-5P30K	REF		
R6	RES, COMP, 10M +/-5%, 1/4W	194944	01121	CB1065	1		
R8	RES, DEP. CAR, 560 +/-5%, 1/4W	385948	80031	CR251-4-5P560E	1		
R9	RES, DEP. CAR, 270 +/-5%, 1/4W	348789	80031	CR251-4-5P270E	2		
R10	RES, DEP. CAR, 24 +/-5%, 1/4W	442210	80031	CR251-4-5P24E	1		
R11	RES, DEP. CAR, 100K +/-5%, 1/4W	348920	80031	CR251-4-5P100K	2		
R12	RES, DEP. CAR, 100K +/-5%, 1/4W	348920	80031	CR251-4-5P100K	REF		
R13	RES, DEP. CAR, 270 +/-5%, 1/4W	348789	80031	CR251-4-5P270E	REF		



Table 617-12. Remote Programming PCB Assembly (cont)

REF DES	DESCRIPTION	FLUKE STOCK NO.	MFG SPLY CODE	MFG. PART NO.	TOT QTY	REC QTY	NOTE
S1	SWITCH MODULE, DIL, 4-SPST	408559	00779	435166-2	4		1
S2	SWITCH MODULE, DIL, 4-SPST	408559	00779	435166-2	REF		
S3	SWITCH MODULE, DIL, 4-SPST	408559	00779	435166-2	REF		
S4	SWITCH MODULE, DIL, 4-SPST	408559	00779	435166-2	REF		
U4	IC, 4-LINE TO 10-LINE DECODER	408716	01295	SN74LS42N	2		1
U5	IC, 4-LINE TO 10-LINE DECODER	408716	01295	SN74LS42N	REF		
U9⊗	IC, C-MOS, STANDARD MEMORY INTERFACE	404434	34649	P4289CA	1		1
U12	OPTO-ISOLATOR	407742	28480	HP5082-4351	2		1
U13⊗	IC, P-MOS, 320-BIT RAM, 4-BIT OUTPUT	404442	34649	P4002-1	2		1
U14⊗	IC, P-MOS, 320-BIT RAM, 4-BIT OUTPUT	404442	34649	P4002-1	REF		
U15⊗	IC, P-MOS, 320-BIT RAM, 4-BIT OUTPUT	404467	34649	P4002-2	1		1
U16	IC, QUAD LINE RECEIVER	414045	12040	LM1489	2		1
U17	OPTO-ISOLATOR	407742	28480	HP5082-4351	REF		
U18⊗	IC, C-MOS, 4-BIT CPU	404418	34649	C4040	1		1
U19	IC, PROGRAMMABLE, GENERAL PURPOSE	453456	34649	P4265	2		1
U20	IC, PROGRAMMABLE, GENERAL PURPOSE	453456	34649	P4265	REF		
U21⊗	IC, C-MOS, TRI-STATE, HEX NONINV BFFRS	407759	12040	MM80C97N	3		1
U22⊗	IC, C-MOS, QUAD, 2-INPUT NAND GATE	355198	02735	CD4011AE	1		1
U23⊗	IC, C-MOS, TRI-STATE, HEX NONINV BFFRS	407759	12040	MM80C97N	REF		
U24⊗	IC, C-MOS, ASYNCRNS, REC/ TRANSMITTER	453464	32293	IM6402CPL	1		1
U25	RES, NETWORK, 100K +/-5%, 1/8W	412726	89536	412726	4		1
U26⊗	IC, C-MOS, TRI-STATE, HEX NONINV BFFRS	407759	12040	MM80C97N	REF		
U27⊗	IC, C-MOS, DUAL 4-INPUT POS NAND GATE	355206	04713	MC4012CP	2		1
U28⊗	IC, C-MOS, HEX, INVERTER	404681	02735	CD4069BE	2		1
U29	RES, NETWORK, 100K +/-5%, 1/8W	412726	89536	412726	REF		
U30	IC, TTL, POS NAND GATES, HEX INVERTERS	393058	01295	SN74LS04N	1		1
U31	IC, QUAD LINE RECEIVER	414045	12040	LM1489	REF		
U32	IC, QUAD LINE DRIVER	414052	12040	LM1488	1		1
U33⊗	IC, C-MOS, DUAL 4-INPUT POS NAND GATE	355206	04713	MC4012CP	REF		
U34⊗	IC, C-MOS, HEX, INVERTER	404681	02735	CD4069BE	REF		
U35	RES, NETWORK, 100K +/-5%, 1/8W	412726	89536	412726	REF		
U36	RES, NETWORK, 100K +/-5%, 1/8W	412726	89536	412726	REF		
U37⊗	IC, C-MOS, PROGRAMMABLE BIT RATE GNRTR	418731	07263	F4702/34702	1		1
U39	RES, NETWORK, 10K	414003	89536	414003	1		1
U40	IC, LIN, POSITIVE VOLTAGE REG	408138	07263	A78L12WC	1		1
XU1	SOCKET, IC, 24-PIN	418970	91506	324-AG39D	3		
XU3	SOCKET, IC, 24-PIN	418970	91506	324-AG39D	REF		
XU9	SOCKET, IC, 40-PIN	418988	91506	340-AG39D	2		
XU10	SOCKET, IC, 16-PIN	276535	91506	316-AG39D	5		
XU11	SOCKET, IC, 16-PIN	276535	91506	316-AG39D	REF		
XU13	SOCKET, IC, 16-PIN	276535	91506	316-AG39D	REF		
XU14	SOCKET, IC, 16-PIN	276535	91506	316-AG39D	REF		
XU15	SOCKET, IC, 16-PIN	276535	91506	316-AG39D	REF		
XU18	SOCKET, IC, 24-PIN	418970	91506	324-AG39D	REF		
XU19	SOCKET, IC, 28-PIN	448217	89536	448217	2		
XU20	SOCKET, IC, 28-PIN	448217	89536	448217	REF		
XU24	SOCKET, IC, 40-PIN	418988	91506	340-AG39D	REF		
Y1	CRYSTAL, QUARTZ	435370	89536	435370	1		





Option -23  
Alarm Set Point Output

623-1. INTRODUCTION

623-2. Alarm Set Point Output (Option -23) is a plug-in pcb assembly designed to operate in any one of the data logger's I/O slots. Its function is to provide an external output when a measurement at any channel exceeds an assigned limit value. The output is in the form of 30 separate open-collector transistors. Each output is identified by number (1 through 30) on the pcb.

623-3. When Option -23 is used in the 2240C each of the 30 outputs correspond to 1 of 60 possible limit addresses. With switch S1 in the 1-30 position, the outputs correspond to the first 30 limit addresses. With switch S1 in the 31-60 position, the outputs correspond to the second 30 limit address. Two Alarms Outputs Options are necessary for 60 simultaneous Alarm outputs. An active (turned-on) output transistor indicates that the limit value of the corresponding limit address is assigned to the previously measured channel, and that the measurement exceeded the limit value. Memory included on the pcb maintains all limit-exceeded indications until a reset, either manual or remote, is received. The manual reset is located on the 2240C front panel above the power switch. A front panel LIMIT EXCEEDED lamp, located next to the RESET switch, flashes when one or more limit values have been exceeded.

623-4. When Option -23 is used in a 2200B switch S1 must be in the 1-30 position, and only 14 of the 30 outputs are used. Ten are used to denote a limit exceeded condition on individual channels or on blocks of 10 channels, depending upon the selected programming mode, individual or block. The remaining four outputs identify which of the four limits (assigned to that channel or block ) has been exceeded. Thus, the 14 outputs are capable of identifying a total of 40 unique limits. Memory on the pcb maintains all limit-exceeded indications until a reset, either manual or remote, is received. The manual ALARM RESET switch is located on the 2200B front panel in the SCAN CONTROL switch group.

623-5. SPECIFICATIONS

623-6. Specifications for the Alarm Set Point Output (Option -23) are given in Table 623-1.

623-7. INSTALLATION

623-8. The Alarm Set Point Output PCB can be mounted in any one of the data logger's I/O slots, as shown in Figure 623-1. Install the pcb as follows:

**Table 623-1. Alarm Set Point Output Specifications**

Compatibility	
2240C . . . . .	Used in conjunction with Option -41
2200B . . . . .	Used in conjunction with Option -34 (2200B-34)
Number of Outputs . . . . .	30 open-collector outputs (one output for each limit value)
Uncommitted Relays . . . . .	2 (These relays can be hard wired to any or all of the 30 set point outputs)
Open Collector Output Current . . . . .	30 mA maximum
Relay Contact Rating . . . . .	50V/1A (15 watts maximum)

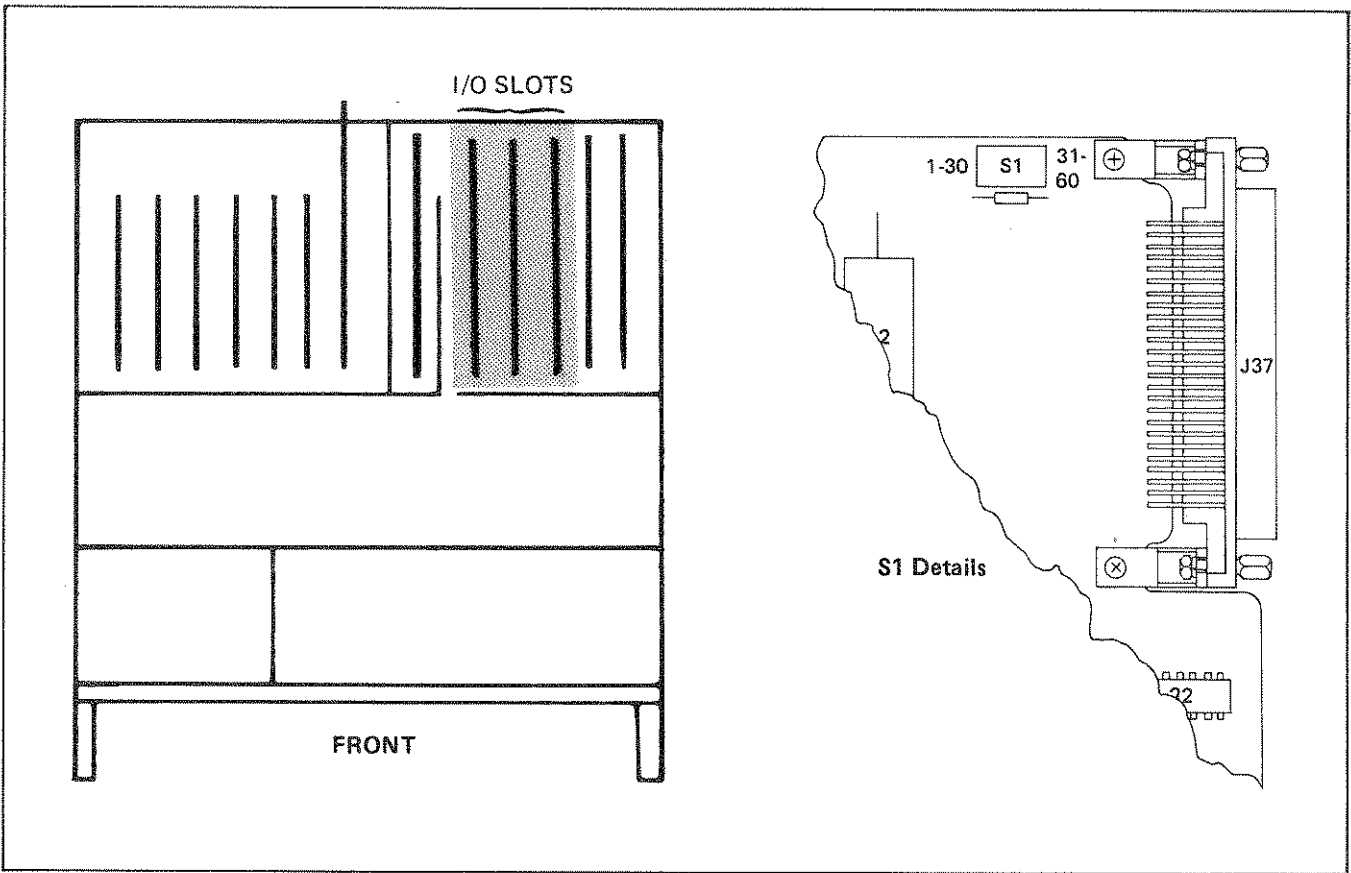

**Figure 623-1. Alarm Set-Point Output, Installation Locations**

## WARNING

REMOVE LINE POWER AND ALL OTHER HIGH VOLTAGE INPUTS TO THE DATA LOGGER BEFORE STARTING THIS PROCEDURE.

1. Set the data logger's POWER switch to OFF.
2. Remove the top cover from the data logger.
3. Refer to the Alarm Relays in later paragraph and ensure that the proper jumpers are installed.
4. Place switch S1 in the desired position (1-30 or 31-60).
5. Align the Alarm Set Point Output PCB in the selected I/O slot so that the large female connector is toward the rear of the data logger, and the small board-edge connector is toward the bottom of the unit. Push the pcb straight down onto the mating connector.
6. After the pcb is installed, install the top cover.

### 623-9. OPERATION

623-10. Once installed in the data logger, the Alarm Set Point Output requires no operator attention. However, certain considerations are necessary to properly access and utilize the alarm outputs. These considerations are covered in the following paragraphs.

### 623-11. Interface Connection

623-12. Remote connections to the Alarm Set Point Output PCB are completed through either General Interface Cable (2240A-7006) or a blank Interface Connector (2240A-7007 supplied with option). Either the cable or the connector attaches to the Alarm Set Output PCB connector at the rear of the data logger. Both the cable and connector are available as accessories and are described in this section (Section 6).

623-13. The user is responsible for completing the cable connections between the output connector and the remote input device. The pin connections of the Alarm Set Point Output's rear panel connector are given in Table 623-2, for both the 2200B and the 2240C.

### 623-14. Alarm Outputs

623-15. The alarm outputs are driven by 30 separate open-collector transistors. When a channel measurement exceeds

Table 623-2. Option -23, I/O Connector Pin Assignments

PIN	SIGNAL			PIN	SIGNAL		
	2240C		2200B		2240C		2200B
1		15		26		30	
2		14		27		29	
3		13		28		28	
4		12	ALARM	29		27	
5		11	CHANNEL or BLOCK	30		26	
6		10	9-99	31		25	
7		9	8	32		24	
8	ALARMS	8	7	33	ALARMS	23	
9		7	6	34		22	
10		6	5	35		21	ALARM
11		5	4	36		20	LIMIT NUMBER
12		4	3	37		19	4
13		3	2	38		18	3
14		2	1	39		17	2
15		1	0	40		16	1
16	Logic Common (Unguarded)			41	Logic Common (unguarded)		
17	N/C			42	N/C		
18	External Reset			43	N/C		
19	Relay 4 (Spare for contact)			44	Relay 4 (Spare for contact)		
20	N/C			45	N/C		
21	Relay 3 (Spare for contact)			46	Relay 3 (Spare for contact)		
22	N/C			47	N/C		
23	Relay 2 (contact)			48	Relay 2 (contact)		
24	N/C			49	N/C		
25	Relay 1 (contact)			50	Relay 1 (contact)		

the value of its assigned limit, the corresponding transistor turns on and pulls the appropriate alarm output to logic common. The output is held low until it is either manually or externally reset. Each open-collector output is capable of sinking a maximum of 30 mA when turned on. The maximum VCE, when off is +25V dc. Power dissipation is 180 mW, maximum.

#### CAUTION

Use an external, isolated power supply to power devices driven by the alarm outputs.

623-16. The open-collector alarm outputs can be used to drive TTL-CMOS logic, LED's and/or relays. The recommended interface for each of these devices is shown in Figure 623-2. Notice that an external voltage supply must be used to drive the interface devices. This source should provide an isolated output so that its low terminal can be referenced to the data logger's logic common (unguarded). Otherwise a ground loop will result. A fuse is provided on the Alarm Set Point Output PCB to prevent possible damage in the event of ground loop currents. Fuse replacement details are given later under maintenance.

#### 623-17. External Reset

623-18. The External Reset input responds to a low input supplied by a contact closure to logic common, or a low TTL logic level. The reset command must be equal to or exceed 2 us. A continuously low reset input holds 30 alarm transistors off regardless of the inputs from the data logger. When the reset is returned high, the alarm transistors are again allowed to respond to alarm data. This function allows a simple control loop to be established as a response to clear the command. The next scan of the data logger will determine if the command needs to be set again.

#### 623-19. Alarm Relays

623-20. Two alarm relays, K1 and K2, are provided on the Alarm Set Point PCB. Normally, the relays are uncommitted. However, they can be assigned by the user to operate with any combination of alarm outputs. The assignments are made by installing a series of jumpers in the spaces provided on the pcb. Figure 623-3 defines the jumper locations. The square land patterns are numbered 1 through 30 and are common to the individual open collector outputs, 1 through 30. The round land patterns are common to the K1 and K2 Control Buses.

623-21. When jumper wires are installed, the collectors are tied to the Relay Buses in a wired OR configuration. See Figure 623-4A. Therefore, when either relay is operated, all alarm outputs common to the Relay Bus go low. If it is desirable to maintain the integrity of the individual alarm outputs while



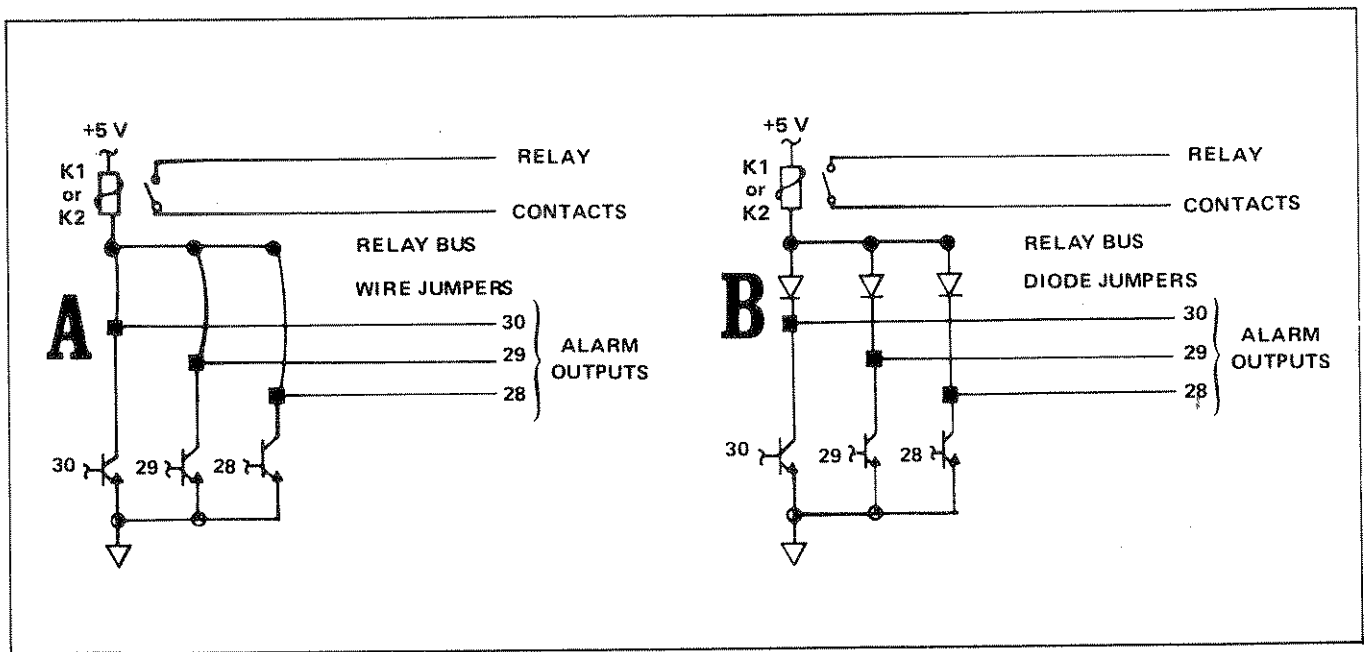

Figure 623-4. Collector-to-Relay-Bus Jumper Configurations

operating the control relays, install diodes in place of jumper wires. See Figure 623-4B.

623-22. Circuitry is included on the Alarm Set Point Output PCB for the addition of two form-A, reed relays (K3 and K4), and their associated suppression diodes (CR3 and CR4). The I/O pin assignments for the K3 and K4 contacts are given in Table 623-2. The details necessary to install both relays are shown in Figure 623-5. The relay coils, reed switches, and suppression diodes are available from the John Fluke Mfg. Co., Inc. Use the following part numbers when ordering:

- |    |                   |        |
|----|-------------------|--------|
| 1. | Relay Coil        | 288357 |
| 2. | Reed Switch       | 413294 |
| 3. | Suppression Diode | 203323 |

### 623-23. THEORY OF OPERATION

623-24. The Alarm Set Point Output PCB, as shown in Figure 623-6, functions as a remote data interface to provide high/low limit information to external indicators/devices. Limit exceeded indications from the pcb are in the form of open-collector transistors and relay contacts. Thirty transistor outputs and two relay outputs are provided. Jumper pads on the pcb allow the user to connect the two relay coils to any combination of the output transistors.

623-25. After the data logger completes each channel measurement, it compares the measured value with the assigned limit values, if any, for that channel. If the measured value falls within the assigned limit values, no action is taken at the Alarm Set Point Output PCB. However, if an out-of-limits indication is detected, the controller addresses the Alarm Set Point Output PCB via the Control Bus and provides it with the failed limit address. If switch S1 is in the 1-30 position, Option -23 is addressed by a binary coded 12 on the Control Bus. If S1 is in the 31-60 position, the Alarms Setpoint Output is addressed by a binary coded 4. A corresponding address register on the pcb stores the limit indication and, thereby turns on the appropriate output transistor as a limit exceeded indication.

623-26. Limit exceeded indications are supplied to the Alarm Set Point Output PCB as a maximum of two successive binary coded characters (0 through 15). The first character represents limit outputs 1 through 15 and the second represents limit outputs 16 through 30. If the exceeded limit is from group 16 through 30 (or 46 through 60 with S1 in the 31-60 position), the first character received on the Data Bus will be a binary zero (0000). A Strobe 1 pulse (derived from the Out strobe) is generated by the control logic causing the zero to be entered into a 4-bit latch and decoder. Prior to the next Out strobe a Sync pulse occurs causing the control logic to generate an Inhibit 1 pulse. This pulse

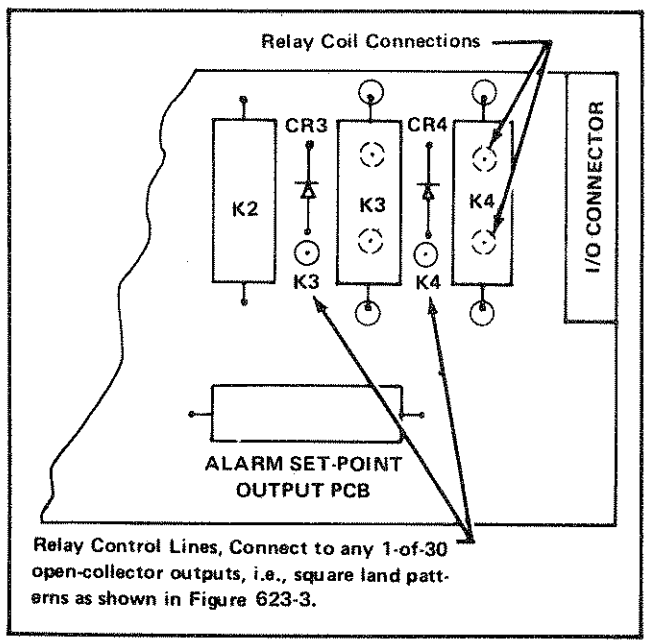

Figure 623-5. Locations for Mounting Reed Relays K3 and K4

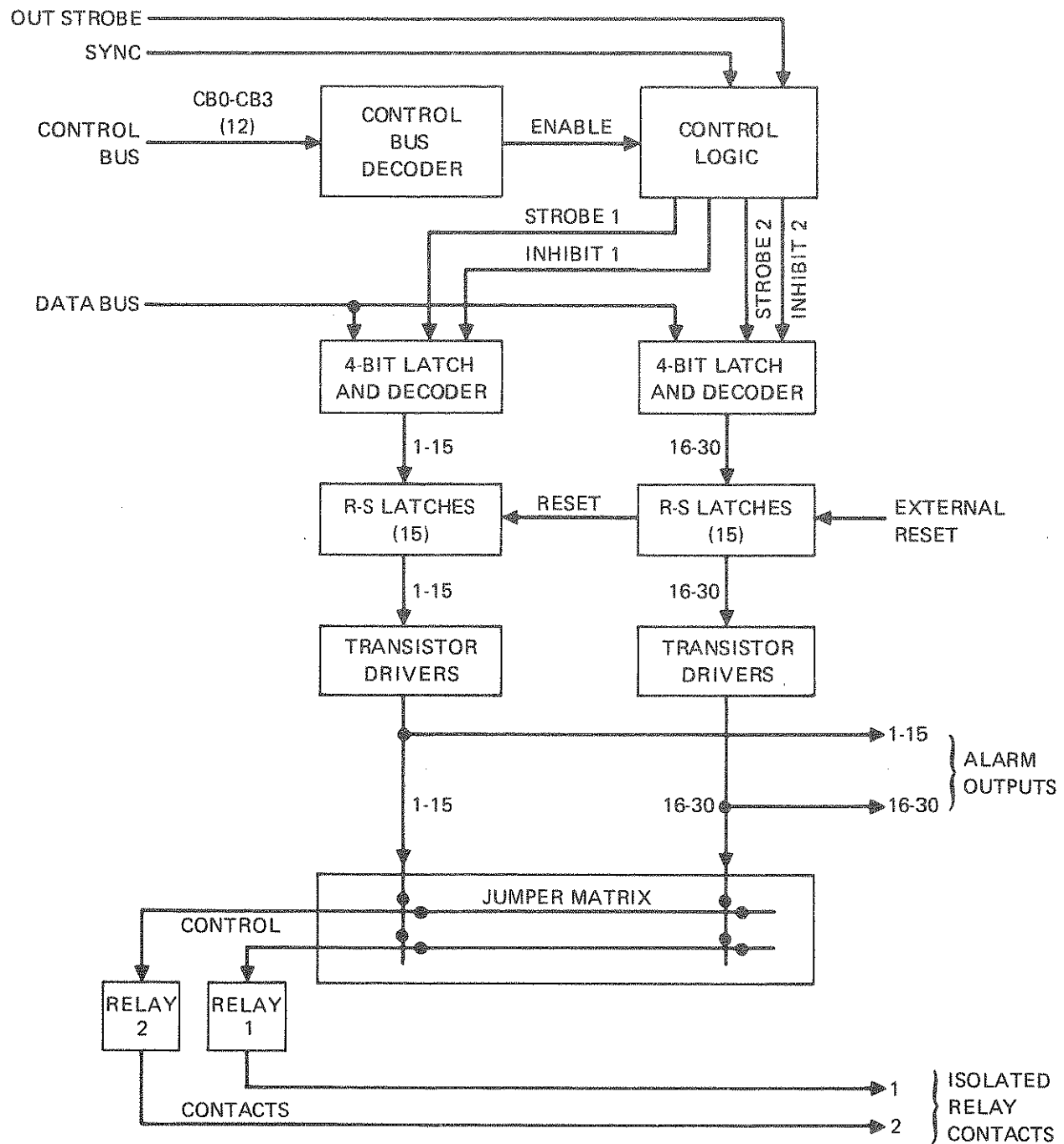

Figure 623-6. Alarm Set Point Output PCB, Simplified Block Diagram

allows the decoder to read the 4-bit latch and enable the appropriate output (1-of-16); in this case 0 (zero). Normally, a decoder output of 1 through 15 would set 1 of the 15 R-S latches assigned to group 1 through 15. However, since the output is 0 (zero), all of the latches remain in their reset state.

623-27. The second address character is placed onto the Data Bus when the next Out strobe occurs. As before, a strobe pulse (Strobe 2) is generated by the control logic and the limit address is entered into a 4-bit latch and decoder. On the following Sync pulse the resulting Inhibit 2 pulse enables the decoded output (representing outputs 16 through 30 or 46 through 60) allowing it to set the corresponding R-S latch. The set-latch turns on the appropriate transistor driver to generate an alarm output.

623-28. When the limit exceeded indication is in the 1 through 15 (or 31-45) output group, the controller supplies only one character rather than two, as previously described. This is necessary since a zero entered into the 16 through 30 output section represents a reset for all 30 R-S latches. Reset occurs when the front panel RESET/ALARM RESET switch is pressed or when an external reset is entered at the Alarm Set Point Output PCB.

#### 623-30. MAINTENANCE

##### 623-30. Access Information

623-31. Refer to the installation instructions given earlier in Alarm Set Point Output PCB access information. Remove the rear panel output connector before attempting to remove the pcb from the data logger.

##### 623-32. Fuse Replacement

623-33. A 1/2 amp, fast-acting fuse is located on the component side of the Alarm Set Point Output PCB Assembly. If replacement is necessary, pull out the old fuse from the fuse clip and press a new one into place.

##### 623-34. Performance Test

623-35. The Alarm Set Point Output PCB Assembly is most easily tested under normal operating conditions, that is, installed in a functional data logger and connected to the output devices it normally drives. Each alarm output can then be checked for pass or fail indications by limit-address and limit-value programming. Use the MONITOR scan control mode to ensure constant observation of the channel to which the limit address in question is assigned. Also be sure to reset the Alarm Output PCB when a limit is exceeded (see Internal Reset earlier in this subsection).

#### 623-36. LIST OF REPLACEABLE PARTS

623-37. A list of replaceable parts for the Alarm Set Point Output Option is given in Table 623-3. Refer to Section 5 of this manual for ordering information.

⊗ CAUTION

Indicated devices are subject  
to damage by static discharge.

Table 623-3. Alarm Set Point Output PCB Assembly

REF DES	DESCRIPTION	FLUKE STOCK NO.	MFG SPLY CODE	MFG. PART NO.	TOT QTY	REC QTY	NOTE
-23⊕	ALARM SET POINT OUTPUT PCB ASSY FIGURE 623-7 (2240C-4031T)	ORDER	BY	OPTION -23			
C1	CAP, TA, 10 UF +/-20%, 10V	176214	56218	196D106X0010KA1	1		
CR1	DIODE, HI-SPEED SWITCHING	203323	07910	1N4448	3	1	
CR2	DIODE, HI-SPEED SWITCHING	203323	07910	1N4448	REF		
CR5	DIODE, HI-SPEED SWITCHING	203323	07910	1N4448	REF		
F1	FUSE, 1/2 AMP	153858	71400	AGC1-2	1	5	
H1	NUT, 4-40	147611	89536	147611	2		
H2	SCREW, PHP, 4-40 X 3/8	152124	89536	152124	2		
H4	WASHER, SPLIT LOCK #4	110395	73734	1355	2		
J37	CONNECTOR, PCB MOUNTING	414417	00779	552130-1	1		
K1-K2	RELAY ASSEMBLY						
K2	COIL, REED RELAY	288357	71707	SP-6-P	2		
	SWITCH, REED	413294	89536	413294	2		
MP2	CONNECTOR, HARDWARE KIT	448563	00779	552565-2	1		
Q1	XSTR, SI, NPN	330803	07263	MPS6560	30	6	
Q2	XSTR, SI, NPN	330803	07263	MPS6560	REF		
Q3	XSTR, SI, NPN	330803	07263	MPS6560	REF		
Q4	XSTR, SI, NPN	330803	07263	MPS6560	REF		
Q5	XSTR, SI, NPN	330803	07263	MPS6560	REF		
Q6	XSTR, SI, NPN	330803	07263	MPS6560	REF		
Q7	XSTR, SI, NPN	330803	07263	MPS6560	REF		
Q8	XSTR, SI, NPN	330803	07263	MPS6560	REF		
Q9	XSTR, SI, NPN	330803	07263	MPS6560	REF		
Q10	XSTR, SI, NPN	330803	07263	MPS6560	REF		
Q11	XSTR, SI, NPN	330803	07263	MPS6560	REF		
Q12	XSTR, SI, NPN	330803	07263	MPS6560	REF		
Q13	XSTR, SI, NPN	330803	07263	MPS6560	REF		
Q14	XSTR, SI, NPN	330803	07263	MPS6560	REF		
Q15	XSTR, SI, NPN	330803	07263	MPS6560	REF		
Q16	XSTR, SI, NPN	330803	07263	MPS6560	REF		
Q17	XSTR, SI, NPN	330803	07263	MPS6560	REF		
Q18	XSTR, SI, NPN	330803	07263	MPS6560	REF		
Q19	XSTR, SI, NPN	330803	07263	MPS6560	REF		
Q20	XSTR, SI, NPN	330803	07263	MPS6560	REF		
Q21	XSTR, SI, NPN	330803	07263	MPS6560	REF		
Q22	XSTR, SI, NPN	330803	07263	MPS6560	REF		
Q23	XSTR, SI, NPN	330803	07263	MPS6560	REF		
Q24	XSTR, SI, NPN	330803	07263	MPS6560	REF		
Q25	XSTR, SI, NPN	330803	07263	MPS6560	REF		
Q26	XSTR, SI, NPN	330803	07263	MPS6560	REF		
Q27	XSTR, SI, NPN	330803	07263	MPS6560	REF		
Q28	XSTR, SI, NPN	330803	07263	MPS6560	REF		
Q29	XSTR, SI, NPN	330803	07263	MPS6560	REF		
Q30	XSTR, SI, NPN	330803	07263	MPS6560	REF		
TP1-TP2	CONNECTOR POST	267500	00779	87022-1	2	1	
U1⊕	IC, C-MOS, DUAL D TYPE FLIP-FLOP	340117	04713	MC14013CL	15	3	
U2⊕	IC, C-MOS, DUAL D TYPE FLIP-FLOP	340117	04713	MC14013CL	REF		
U3⊕	IC, C-MOS, DUAL D TYPE FLIP-FLOP	340117	04713	MC14013CL	REF		

Table 623-3. Alarm Set Point Output PCB Assembly (cont)

REF DES	DESCRIPTION	FLUKE STOCK NO.	MFG SPLY CODE	MFG. PART NO.	TOT QTY	REC QTY	NOTE
U4⊗	IC, C-MOS, DUAL D TYPE FLIP-FLOP	340117	04713	MC14013CL	REF		
U5⊗	IC, C-MOS, DUAL D TYPE FLIP-FLOP	340117	04713	MC14013CL	REF		
U6⊗	IC, C-MOS, DUAL D TYPE FLIP-FLOP	340117	04713	MC14013CL	REF		
U7⊗	IC, C-MOS, 4-BIT LATCH/4-TO-16 LINE DCDR	414342	18725	C04514BE	2	1	
U8⊗	IC, C-MOS, DUAL D TYPE FLIP-FLOP	340117	04713	MC14013CL	REF		
U9⊗	IC, C-MOS, DUAL D TYPE FLIP-FLOP	340117	04713	MC14013CL	REF		
U10⊗	IC, C-MOS, DUAL D TYPE FLIP-FLOP	340117	04713	MC14013CL	REF		
U11⊗	IC, C-MOS, DUAL D TYPE FLIP-FLOP	340117	04713	MC14013CL	REF		
U12⊗	IC, C-MOS, 4-BIT LATCH/4-TO-16 LINE DCDR	414342	18725	C04514BE	REF		
U13⊗	IC, C-MOS, DUAL D TYPE FLIP-FLOP	340117	04713	MC14013CL	REF		
U14⊗	IC, C-MOS, DUAL D TYPE FLIP-FLOP	340117	04713	MC14013CL	REF		
U15⊗	IC, C-MOS, DUAL D TYPE FLIP-FLOP	340117	04713	MC14013CL	REF		
U16⊗	IC, C-MOS, DUAL D TYPE FLIP-FLOP	340117	04713	MC14013CL	REF		
U17⊗	IC, C-MOS, DUAL D TYPE FLIP-FLOP	340117	04713	MC14013CL	REF		
U18⊗	IC, C-MOS, 2-INPUT NOR GATE	355172	04713	MC14001CP	2	1	
U19⊗	IC, C-MOS, DUAL J-K FLIP-FLOP	355230	04713	MC14027BCP	1	1	
U20⊗	IC, C-MOS, QUAD 2-INPUT NAND GATE	355198	04713	MC14011CP	1	1	
U21⊗	IC, C-MOS, 2-INPUT NOR GATE	355172	04713	MC14001CP	REF		
U22⊗	IC, C-MOS, HEX BUFFER/CONVERTER	355412	04713	MC14010CP	1	1	



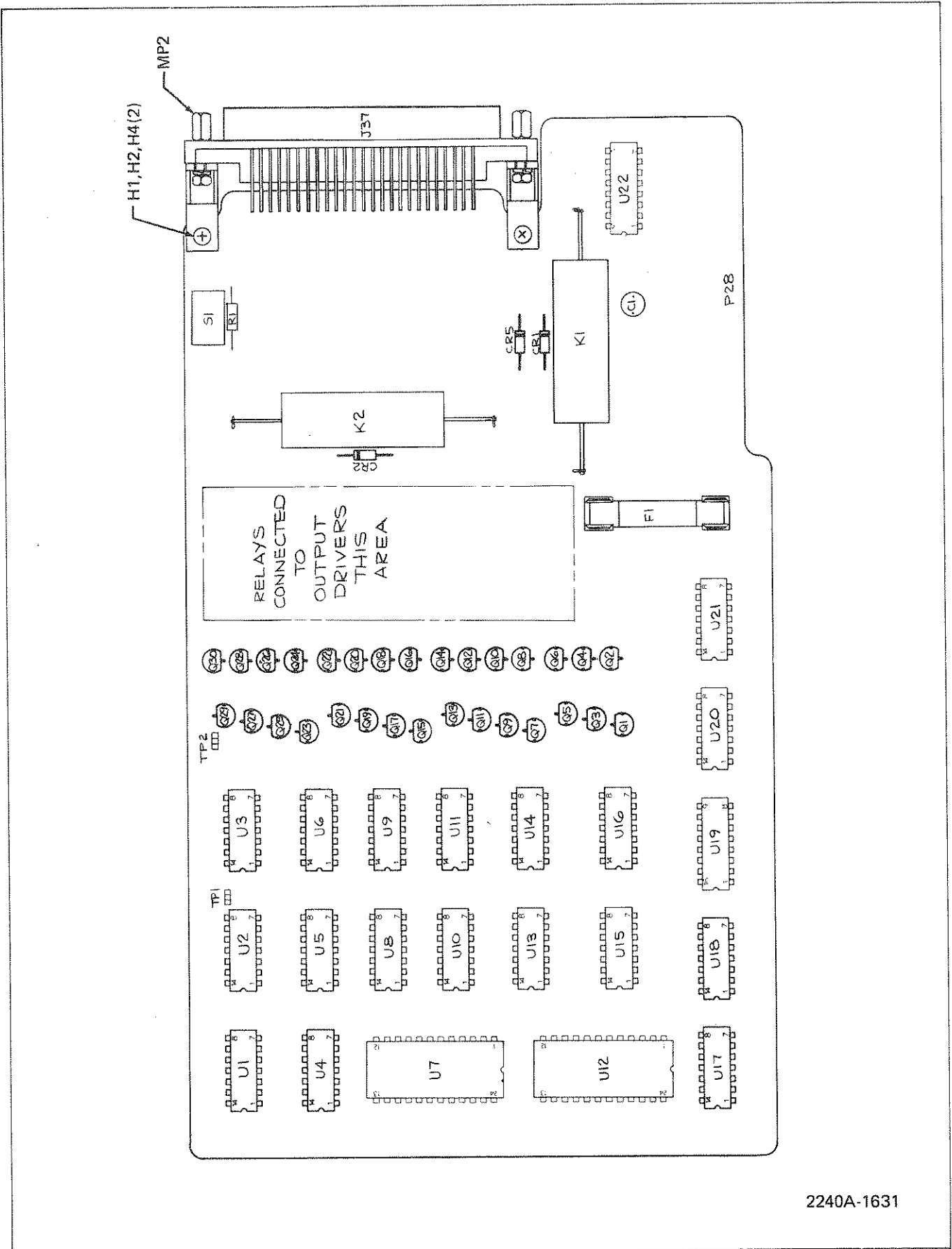

Figure 623-7. Alarm Set Point Output PCB Assembly

Option -28, -29, and -30  
Current Transmitter Connectors

628-1. INTRODUCTION

628-2. The Current Transmitter Connectors are card-edge connector assemblies designed for use in making dc current measurements. The connector assemblies are compatible with the General Purpose Scanner (2200A-05) and Low Level Scanner (2200A-06) and are intended for use with the Model 2240C Data Logger, Model 2201A Scanner Chassis, Model 2202A Remote Chassis, and Model 2203A RTD Scanner Chassis. The connector assemblies mount on the rear of the data logger or scanner chassis and provide input connections in the form of screw terminals.

628-3. DESCRIPTION

628-4. Current Transmitter Inputs

628-5. The Current Transmitter Connectors provide accuracy and convenience in handling the output of current transmitters with dc current ranges of 1 to 15 mA, 4 to 20 mA, and 10 to 50 mA. The Current Transmitter Connectors accept the dc output current to a proportional dc voltage using precision shunt resistors. The dc voltage is then detected and displayed by the data logger. Up to 10 current transmitter inputs can be assigned to each Current Transmitter Connector.

628-6. With the exception of shunt resistor value, the Current Transmitter Connectors are identical in construction and operation. The 1 to 5 mA unit uses 60 Ohm shunt resistors, the 4 to 20 mA unit 15 Ohm shunt resistors, and the 10 to 50 mA unit 6 Ohm resistors. The Current Transmitter Connectors produce the same range of voltage readout on the data logger, i.e., 60 mV to 300 mV for 1 to 5 mA, 4 to 20 mA, and 10 to 50 mA current transmitter inputs.

628-7. General Purpose Current Inputs

628-8. The current handling capability of the Current Transmitter Connectors is not limited to 5 mA, 20 mA, and 50 mA. These values simply designate the appropriate connector for current transmitter use. For general lab or production applications, the current range for each connector is limited only by the maximum power dissipation in the associated shunt resistors. Since the shunt resistors are all 1/4 watt units, the maximum working dc current ranges are as follows:

Current Transmitter Connector	Maximum Current Input	Corresponding Full Scale Data Logger Readout
1 to 5 mA	0 to 64.5 mA	3.87V

4 to 20 mA	0 to 129 mA	1.935V
10 to 50 mA	0 to 204 mA	1.224V

#### 628-9. Current Transmitter Readout Options

628-10. The basic Model 2240C Data Logger measures, records, and displays channel input data in terms of dc voltage. Depending on the range selected, the data is displayed in either millivolts or volts. Analog input signals, however, may represent any physical or electrical parameter such as pressure, temperature, flow, strain, voltage, current, etc. If proper signal conditioning and the appropriate scaling option are used, the data logger will measure, scale, and record data in the proper engineering units, e.g., °C, °F, psi, %, etc. Compatible transducers include thermocouples, thermistors, resistance temperature detectors (RTDs), or any device whose output is a dc voltage (1 uV to 40V) or dc current. Measuring, recording, and displaying data directly in terms of the transducer measurement unit requires one or more of the available scaling options.

#### 628-11. Readout In Voltage

628-12. When the -28, -29, or -30 Current Transmitter Connectors are used in the basic data logger without adding any of the available Measurement and Scaling Options, the data logger will display and print out in dc volts and millivolts corresponding to current transmitter inputs.

#### 628-13 Readout In Percent

628-14. Adding the -43 or -44 Temperature Option provides the data logger with the capability of scaling current transmitter inputs to provide reading in percent. For example, using the -28, -29 or -30 Current Transmitter Connectors, a minimum (1 mA, 4 mA or 10 mA) current transmitter input would be displayed as 0% and a maximum (5 mA, 20 mA, 50 mA) input as 100%. The proper function and range for this application would be called by selecting the assigned front panel function.

#### 628-15. Readout In Other Engineering Units

628-16. If the data logging application requires that current transmitter inputs be presented in measurement units other than percent, the data logger would have to be fitted with the 2240C-40 Scaling Option. The Scaling Option provides the actual scaling necessary for readout in the desired measurement unit. Selections of units, provided by the mx+b Scaling Option, offers the customer's choice of notation. For more information on custom scaling, refer to the scaling option (6-40) section.

#### 628-17. SPECIFICATIONS

628-18. See Table 628-1 for Current Transmitter Connector Specifications.

#### 628-19. INPUT CONNECTIONS

628-20. Figure 628-1 shows the terminal assignments for the Current Transmitter Connectors. Access to the terminals is accomplished by removing the four screws from the decal side of the connector's input terminals which consist of HI, LO and Shield for each of the 10 channels. Best results are usually obtained using a 2-conductor shielded cable for each channel with the shield connected to the appropriate "SH" terminal at the connector and to source "LO" at the measurement source.

#### 628-21. CONNECTION INSTALLATION

#### 628-22. Installation Notes

628-23. Certain considerations are necessary to obtain optimal measurement accuracy. These considerations concern the use of the SHIELD terminal on the input connector.

628-24. The purpose of the SHIELD connection is to improve rejection of common-mode voltage noise. This is done by connecting the SHIELD lead to the LO lead at the measurement point as shown in Figure 628-2. In the presence of common-mode voltage, this connection provides a path for the current which flows as the capacitance between the A/D Converter and the chassis is being charged or discharged. Since the A/D Converter and the Shield (built into the instrument) are forced to track the same voltage, the common-mode current in the HI and LO leads is minimized. It is this current which produces unstable readings. It is important to note that HI, LO and Shield are fully isolated and capable of being safely floated to 350 Volts above ground. The following guidelines should be followed when connecting the Current Transmitter Connector:

1. If significant RFI (Radio Frequency Interference) or EMI (Electro-Magnetic Interference) is present, the best measurement results will be obtained by connecting SHIELD to LO on the input connector with the shortest path possible.
2. If significant common mode voltage (greater than one volt) is present, connect SHIELD to LO by means of a third wire at the measurement point as shown in Figure 628-2.
3. For Thermocouples, connect SHIELD to the low Thermocouple lead as close to the Thermocouple junction as possible without affecting its temperature.
4. Never tie SHIELD to HI. This may actually amplify

**Table 628-1. Current Transmitter Connector Specifications**

<b>Type Connector:</b> .....	Current Transmitter			
<b>Compatibility:</b> .....	Mates with 2200A-05 and 2200A-06 scanners			
<b>Range</b>	<u>Current Transmitter</u>	<u>Maximum Input</u>		
Option 2240A-28: .....	1 to 5 mA dc	0 to 64.5 mA dc		
Option 2240A-29: .....	4 to 20 mA dc	0 to 129 mA dc		
Option 2240A-30: .....	10 to 50 mA dc	0 to 204 mA dc		
<b>Number of Inputs:</b> .....	10			
<b>Number of Terminals:</b> .....	30 (HI, LO, and Shield) with a current shunt resistor connected between each HI and LO terminal.			
<b>Terminal Style:</b> .....	Screw type			
<b>Shunt Resistances</b>				
Option 2240A-28: .....	60Ω			
Option 2240A-29: .....	15Ω			
Option 2240A-30: .....	6Ω			
<b>Maximum Input Power: (each input channel)</b> .....	0.25W			
<b>Accuracy of Measurement: (20°C to 30°C)</b> .....	Add <u>0.1% of reading</u> to all data logger accuracy specifications.			
<b>Temperature Coefficient:</b> (0°C to 20°C, 30°C to 50°C) .....	<table border="1" style="margin-left: auto; margin-right: auto;"> <tr> <td style="text-align: center;"><b>High Performance A-D Converter</b></td> </tr> <tr> <td style="text-align: center;">(0.0015% of reading +0.001% of range)/°C</td> </tr> </table>		<b>High Performance A-D Converter</b>	(0.0015% of reading +0.001% of range)/°C
<b>High Performance A-D Converter</b>				
(0.0015% of reading +0.001% of range)/°C				

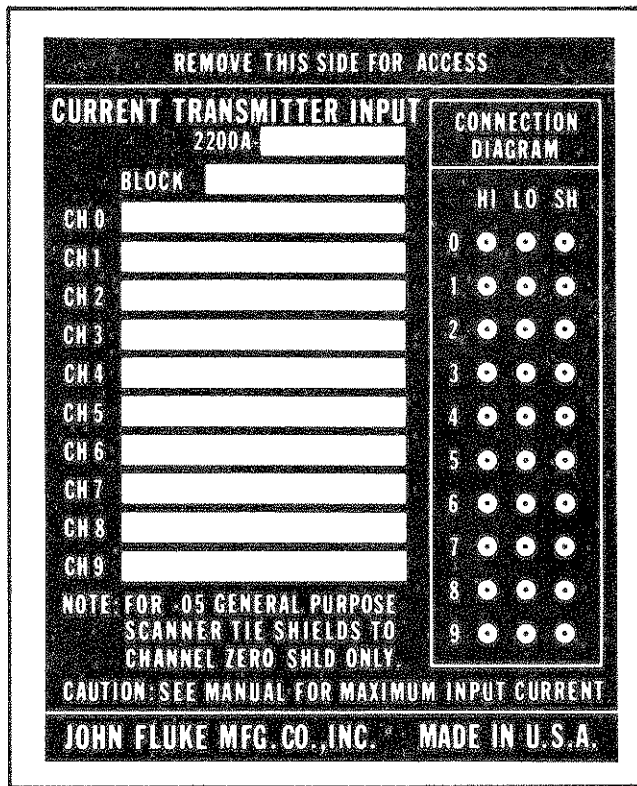

Figure 628-1.  
Current Transmitter Connector Terminal Arrangement

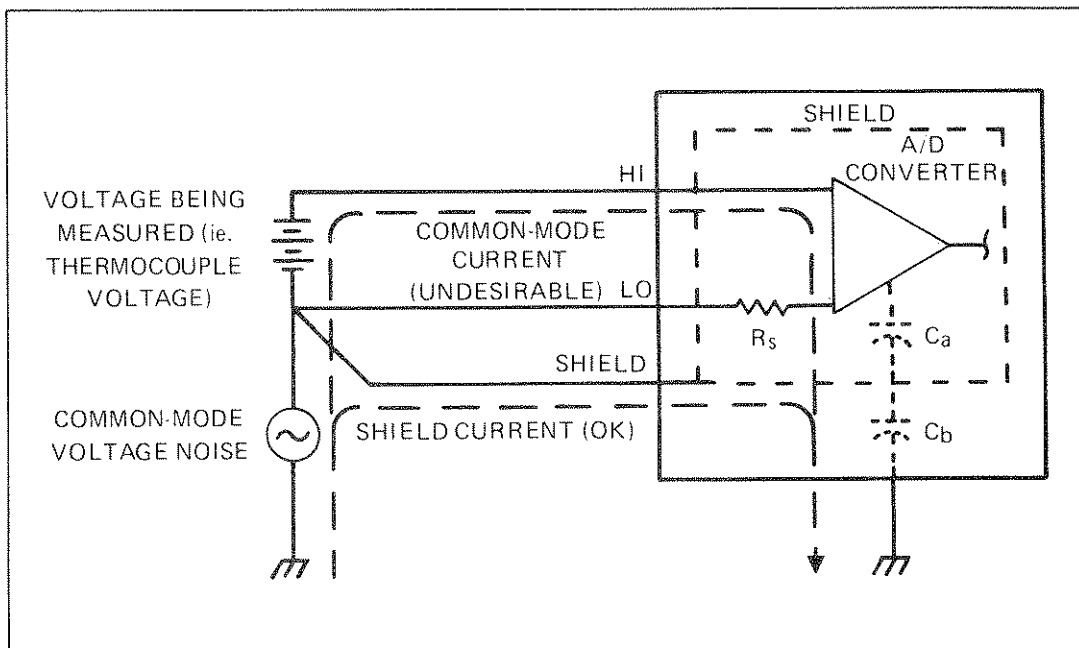

Figure 628-2. Shield Connection For Optimum Common Mode Rejection

the effects of noise on the signal, causing a degradation in measurement performance.

5. Never leave SHIELD unconnected. Static charge build-up may cause the maximum SHIELD to LO voltage to be exceeded, resulting in instrument damage.
6. Never connect SHIELD to chassis ground. This will result in greatly increased common mode currents due to the large value of capacitance between the shield and the A/D Converter.

628-25. For further information on this subject, refer to the Fluke Application Bulletin AB-20 concerning guarded measurements. The Application Bulletin is available from your Fluke Sales Representatives.

628-26. The Current Transmitter Connectors mount in any available scanner-block slot containing either a General Purpose or Lower Level Scanner. Install the connector as follows:

1. Unlatch the slide fasteners located on either side of the protruding enclosure at the rear of the data logger or scanner chassis as appropriate. Remove the enclosure from the rear panel.
2. Locate the desired scanner-block slot on the rear panel and check to ensure that a scanner is installed in the slot. See Figure 628-3 for scanner block arrangement in the 2240C data logger.
3. With the Current Transmitter Connector key positioned at the top, insert the connector in the scanner-block guides until it mates with the scanner connection.
4. Install the two retaining screws and washers that hold the connector to the data logger rear panel.
5. Repeat the procedure for additional connectors and install the rear-panel enclosures, routing the connector input cables out of the slot at the bottom of the enclosure.

#### 628-27. OPERATION

628-28. To set up the data logger for current measurements using the Current Transmitter Connectors, proceed as follows:

1. Turn data logger power OFF.
2. Select the desired connector according to the required current range as follows:  
Option -28 1 to 5 mA (0 to 64.5 mA)

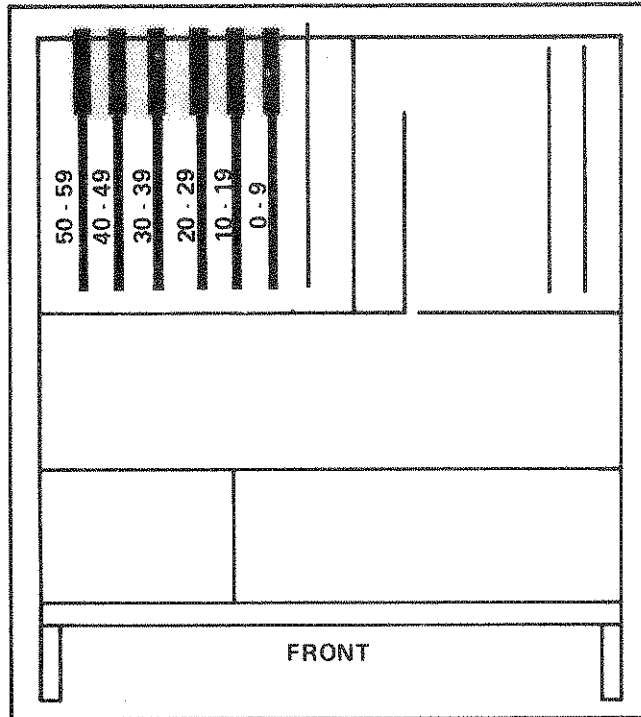

Figure 628-3.  
Scanner Block Locations in the Model 2240C Data Logger

Table 628-2. Data Logger Function and Range Programming for Current Transmitter Connectors

Current Transmitter Connector	Corresponding Voltage Output to Data Logger	Data Logger Function and Range Programming for Optimum Readout
For Current Transmitter Inputs		
Option —28 1 to 5 mA	60 to 300 mV	400 mV *
Option —29 4 to 20 mA	60 to 300 mV	400 mV *
Option —30 10 to 50 mA	60 to 300 mV	400 mV *
For Maximum Range Inputs		
Option —28 0 to 64.5 mA	0 to 3.87V	4V
Option —29 0 to 129 mA	0 to 1.935V	4V
Option —30 0 to 204 mA	0 to 1.224V	4V
*Or Current Transmitter input with -43, -44 or -45 Temperature Options.		



Option -29 4 to 20 mA (0 to 129 mA)  
Option -30 10 to 50 mA (0 to 204 mA)

3. Connect current transmitters or other inputs to the connector.
4. Attach the wired Current Transmitter Connector to the desired scanner.
5. Turn data logger power ON.
6. Program the data logger for current transmitter or maximum range inputs, as shown in Table 628-2, for maximum resolution. Note that for current transmitter inputs, 100 mV of overrange capability is provided or 1.66 mA, 6.6 mA, and 16.6 mA at the input connector for 1 to 5 mA, 4 to 20 mA and 10 to 50 mA inputs, respectively.
7. Refer to Section 2 of the data logger manual for detailed instructions concerning programming of the data logger scan, display, and printout.

#### 628-29. CALIBRATION

628-30. The shunt resistors in the Current Transmitter Connectors have been factory selected and do not require calibration. However, a calibration check is required after repairs or any time it is desired to verify shunt resistor accuracy. The following procedure requires a digital multimeter capable of measuring resistance in true 4-terminal ohms configuration. Required specifications for the digital multimeter are given in Table 628-3.

1. Remove the cover from the Current Transmitter Connector.
2. Connect the digital multimeter OHMS SOURCE leads to CH0 HI and LO terminals as shown in Figure 628-4.
3. Connect the digital multimeter HI and LO OHMS SENSE leads to the terminals of resistor R6. Be sure the HI and LO OHMS SENSE leads are connected to the proper terminal of the resistor as shown in Figure 628-4.
4. Set digital multimeter controls for resistance measurements on the 200 Ohms range.
5. Verify digital multimeter readout as shown in Table 628-4.
6. Repeat steps (2) through (5) for channels CH1 through CH9 with OHMS SENSE leads connected to the

**Table 628-3. Required Test Equipment**

Instrument Type	Minimum Use Specifications	Recommended Model
Digital Multimeter	Range: 0 to 60Ω Resolution: 1 mΩ Accuracy: ±0.01% Configuration: 4-Terminal Ohms	Fluke Model 8860A

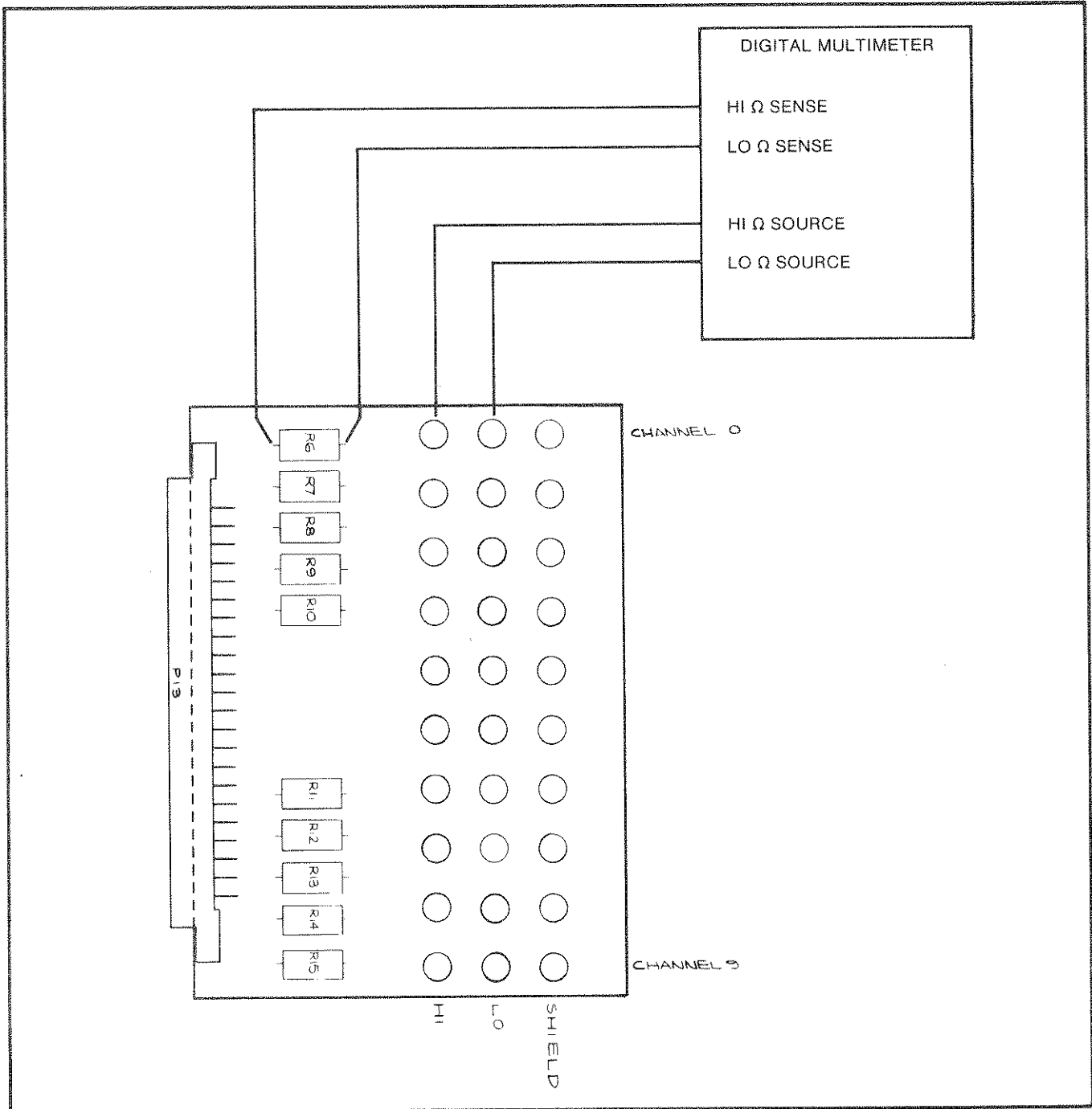

**Figure 628-4. Equipment Connections for Shunt Resistor Accuracy Check**

**Table 628-4. Shunt Resistor Calibration Check**

<b>Current Transmitter Connector</b>	<b>Required DVM Readout Using 4-Terminal Ohms Measurement Connections</b>
Option —28 1 to 5 mA	60.000Ω ±0.024Ω
Option —29 4 to 20 mA	15.000Ω ±0.006Ω
Option —30 10 to 50 mA	6.000Ω ±0.003Ω

corresponding shunt resistor for each channel, R7 through R15, respectively.

7. If the requirements of this test are not met, the associated shunt resistor, R6 through R15, should be replaced.
8. This includes the calibration check of the Current Transmitter Connector.

#### 628-31. LIST OF REPLACEABLE PARTS

628-32. Tables 628-5 through 628-7 contain a list of replaceable parts for the Current Transmitter Connectors. For an explanation of column headings and ordering information, refer to Section 5 of the data logger manual.

Table 628-5. 1-5 MA Transmitter Connector

REF DES	DESCRIPTION	FLUKE STOCK NO.	MFG SPLY CODE	MFG. PART NO.	TOT QTY	REC QTY	NO TE
-28	CONNECTOR, 1-5 MA TRANSMITTER FIGURE 628-4 (2240A-28)	ORDER	BY	OPTION -28			
	1-5 MA TRANSMITTER INPUT PCB ASSY (2200A-4033T)				1		
H1	SCREW, PHP, 4-40 X 7/8 (NOT SHOWN)	335133	89536	335133	2		
H2	SCREW, PHP, 6-32 X 1/4 (NOT SHOWN)	152140	89536	152140	8		
H3	WASHER, FLAT, S/STEEL (NOT SHOWN)	146225	89536	146225	2		
MP1	DECAL, CURRENT TRANSMITTER (NOT SHOWN)	428920	89536	428920	1		
MP2	ISOTHERMAL CONNECTOR HOUSING (NOT SHOWN)	414276	89536	414276	2		
	1-5 MA TRANSMITTER INPUT PCB ASSY FIGURE 628-4 (2200A-4033T)						REF
H4	SCREW, PHP, 6-32 X 1/4	385401	89536	385401	30		
H5	WASHER, FLAT (NOT SHOWN)	147728	89536	147728	2		
MP3	INSERT, POLARIZING, CONNECTOR	407254	89536	407254	1		
P13	CONNECTOR, PCB	385674	02660	225-22221-105	1		
R6	RES, WW, 60 +/-0.04%, 1/3W	459966	89536	459966	10		
R7	RES, WW, 60 +/-0.04%, 1/3W	459966	89536	459966			REF
R8	RES, WW, 60 +/-0.04%, 1/3W	459966	89536	459966			REF
R9	RES, WW, 60 +/-0.04%, 1/3W	459966	89536	459966			REF
R10	RES, WW, 60 +/-0.04%, 1/3W	459966	89536	459966			REF
R11	RES, WW, 60 +/-0.04%, 1/3W	459966	89536	459966			REF
R12	RES, WW, 60 +/-0.04%, 1/3W	459966	89536	459966			REF
R13	RES, WW, 60 +/-0.04%, 1/3W	459966	89536	459966			REF
R14	RES, WW, 60 +/-0.04%, 1/3W	459966	89536	459966			REF
R15	RES, WW, 60 +/-0.04%, 1/3W	459966	89536	459966			REF

Table 628-6. 4-20 MA Transmitter Connector

REF DES	DESCRIPTION	FLUKE STOCK NO.	MFG SPLY CODE	MFG. PART NO.	TOT QTY	REC QTY	NOTE
-29	CONNECTOR, 4-20 MA TRANSMITTER FIGURE 628-4 (2240A-29)	ORDER	BY	OPTION -29			
	4-20 MA TRANSMITTER INPUT PCB ASSY (2200A-4034T)				1		
H1	SCREW, PHP, 4-40 X 7/8 (NOT SHOWN)	335133	89536	335133	2		
H2	SCREW, PHP, 6-32 X 1/4 (NOT SHOWN)	152140	89536	152140	8		
H3	WASHER, FLAT #4, S/STEEL (NOT SHOWN)	146225	89536	146225	2		
MP1	DECAL, CURRENT TRANSMITTER (NOT SHOWN)	428920	89536	428920	1		
MP2	ISOTHERMAL CONNECTOR HOUSING (NOT SHOWN)	414276	89536	414276	2		
	4-20 MA TRANSMITTER INPUT PCB ASSY FIGURE 628-4 (2200A-4034T)					REF	
H4	SCREW, PHP, 6-32 X 1/4	385401	89536	385401	30		
H5	WASHER, FLAT (NOT SHOWN)	147728	89536	147728	2		
MP3	INSERT, POLARIZING, CONNECTOR	407254	89536	407254	1		
P13	CONNECTOR, PCB	385674	02660	225-22221-105	1		
R6	RES, WW, 15 +/-0.04%, 1/3W	459958	89536	459958	10		
R7	RES, WW, 15 +/-0.04%, 1/3W	459958	89536	459958	REF		
R8	RES, WW, 15 +/-0.04%, 1/3W	459958	89536	459958	REF		
R9	RES, WW, 15 +/-0.04%, 1/3W	459958	89536	459958	REF		
R10	RES, WW, 15 +/-0.04%, 1/3W	459958	89536	459958	REF		
R11	RES, WW, 15 +/-0.04%, 1/3W	459958	89536	459958	REF		
R12	RES, WW, 15 +/-0.04%, 1/3W	459958	89536	459958	REF		
R13	RES, WW, 15 +/-0.04%, 1/3W	459958	89536	459958	REF		
R14	RES, WW, 15 +/-0.04%, 1/3W	459958	89536	459958	REF		
R15	RES, WW, 15 +/-0.04%, 1/3W	459958	89536	459958	REF		

Table 628-7. 10-50 MA Transmitter Connector

REF DES	DESCRIPTION	FLUKE STOCK NO.	MFG SPLY CODE	MFG. PART NO.	TOT QTY	REC QTY	NO TE
-30	CONNECTOR, 10-50 MA TRANSMITTER FIGURE 628-4 (2240A-30)	ORDER	BY	OPTION -30			
	10-50 MA TRANSMITTER INPUT PCB ASSY (2200A-4035T)				1		
H1	SCREW, PHP, 4-40 X 7/8 (NOT SHOWN)	335133	89536	335133	2		
H2	SCREW, PHP, 6-32 X 1/4 (NOT SHOWN)	152140	89536	152140	8		
H3	WASHER, FLAT #4, S/STEEL	146225	89536	146225	2		
MP1	DECAL, CURRENT TRANSMITTER	428920	89536	428920	1		
MP2	ISOTHERMAL CONNECTOR HOUSING (NOT SHOWN)	414276	89536	414276	2		
	10-50 MA TRANSMITTER INPUT PCB ASSY FIGURE 628-4 (2200A-4035T)					REF	
H4	SCREW, PHP, 6-32 X 1/4	385401	89536	385401	30		
H5	WASHER, FLAT (NOT SHOWN)	147728	89536	147728	2		
MP3	INSERT, POLARIZING, CONNECTOR	407254	89536	407254	1		
P13	CONNECTOR, PCB	385674	02660	225-22221-105	1		
R6	RES, WW, 6 +/-0.04%, 1/3W	459941	89536	459941	10		
R7	RES, WW, 6 +/-0.04%, 1/3W	459941	89536	459941		REF	
R8	RES, WW, 6 +/-0.04%, 1/3W	459941	89536	459941		REF	
R9	RES, WW, 6 +/-0.04%, 1/3W	459941	89536	459941		REF	
R10	RES, WW, 6 +/-0.04%, 1/3W	459941	89536	459941		REF	
R11	RES, WW, 6 +/-0.04%, 1/3W	459941	89536	459941		REF	
R12	RES, WW, 6 +/-0.04%, 1/3W	459941	89536	459941		REF	
R13	RES, WW, 6 +/-0.04%, 1/3W	459941	89536	459941		REF	
R14	RES, WW, 6 +/-0.04%, 1/3W	459941	89536	459941		REF	
R15	RES, WW, 6 +/-0.04%, 1/3W	459941	89536	459941		REF	

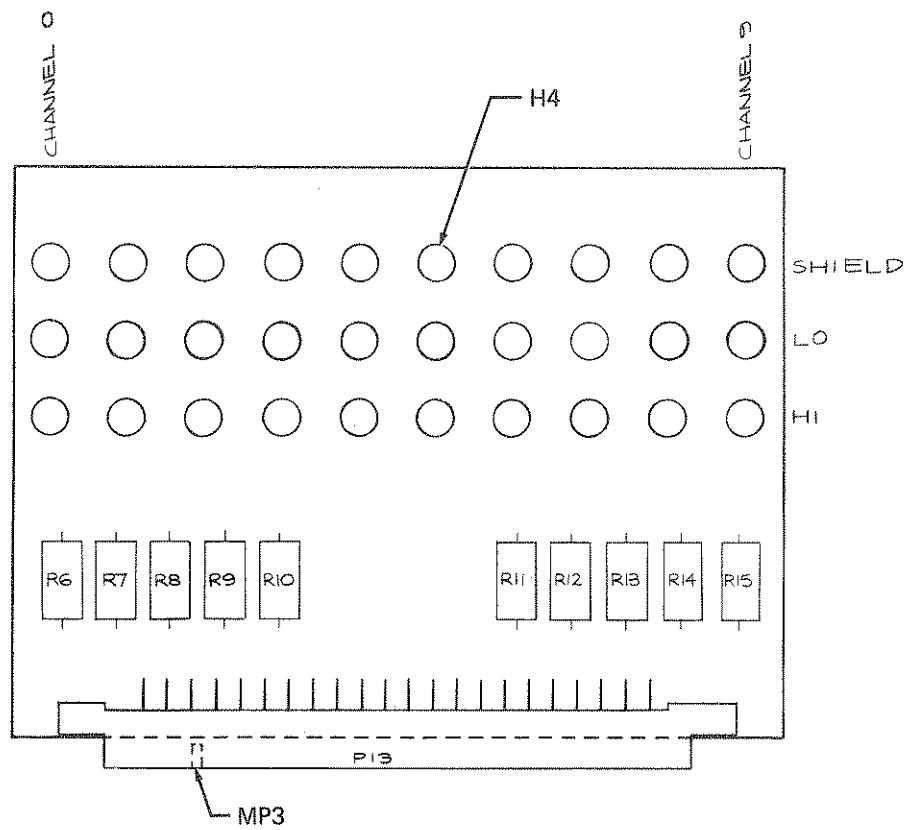

2200A-1633

Figure 628-4. Current Transmitter PCB Assembly





Option -32  
Dual Interval

632-1. INTRODUCTION

632-2. The Dual Interval, Option -32, is a factory installed software addition that provides the data logger with a second programmable scan control interval mode. This second interval can be controlled locally via the front panel keyboard or remotely if a Remote Programming Interface (Option -15 or -17) is installed. It has a range of 1 second, minimum, to 99 hours, 59 minutes, and 59 seconds, maximum. First and last channel assignments are independent of the standard scan format assignments.

632-3. As with the standard interval, the second interval can be enabled or disabled by programming its time. Setting a time of zero disables the interval, and setting a time other than zero enables the interval. When both intervals are enabled the standard interval has priority.

632-4. SPECIFICATIONS

632-5. Specifications for the Dual Interval Option are as follows:

INTERVAL TIME

Minimum: 1 second

Maximum: 99 hours, 59 minutes, and 59 seconds

CHANNEL LIMITS: None (000 to 999)

PROGRAM ENTRY: Manual (front panel) or remote (Option -15 or -17)

632-6. OPERATING NOTES

632-7. When the Dual Interval Option is installed, operation of the data logger is altered from that described in Section 2. These variations are discussed in the following paragraphs.

632-8. Program List

632-9. When a program list is manually solicited, the second interval time is printed after the standard program list is complete. This is followed by a list of first to last channels as assigned to the second interval. The channel format is the same as that of the standard scan.

632-10. When a program list is remotely solicited (via Remote Programming Interface) the second interval time, its first channel, and its last channel are listed after the standard program list format. This is followed by a list of first to last channels assigned to the second interval.

632-11. Program list can be printed on an external recorder or on the interval printer. Program Code P solicits a program list on an external printer. Code Q solicits a program list on the internal printer. See Remote Programming information (later in this subsection) or Option -15 or -17 documentation for additional details. Remember, set SCAN CONTROL to RESET and OUTPUT CONTROL to ALL DATA before attempting to solicit a program list.

#### 632-12. Scan Control Modes

632-13. The effect of the second interval function on each of the scan modes is summarized in Table 632-1. Standard interval operation is not affected.

632-14. In the single and continuous scan modes the standard first and last channel assignments determine the channels to be scanned. In the continuous scan mode with the INTERVAL DATA print switch depressed, the second interval channels are not scanned unless a second interval time has been entered. If both interval programs simultaneously initiate print records, the standard interval data is recorded first and is followed by second interval data. If the standard interval time is less than the time necessary to record the standard interval data, the second interval will not be recorded.

632-15. In the monitor scan mode with the INTERVAL DATA print switch depressed both time intervals will cause a record of the monitor channel. The standard interval has priority when both intervals simultaneously trigger a record.

632-16. In the interval scan mode with either the INTERVAL DATA or the ALL DATA switch depressed, both time intervals will be recorded upon initiation of the scan. This occurs even if one of the interval times is set to zero. The interval that is set to zero will not trigger subsequent scans.

#### 632-17. OPERATION

632-18. The Dual Interval can be programmed manually from the front panel keyboard or remotely through a Remote Programming Interface (Option -15 or -17). Instructions for both methods are given in the following paragraphs.

#### 632-19. Keyboard Entry

632-20. Use the following procedure to enter second interval program data from the front panel keyboard:

1. Press the SECOND FUNCTION switch in the DATA ENTRY switch group. The display will show a series of "E" characters indicating the SECOND FUNCTION keypress.
2. Press the SECOND INTERVAL switch in the DATA ENTRY

Table 632-1. Scan Control vs Second Interval

SCAN CONTROL MODE	SECOND INTERVAL CHANNELS SCANNED AND DISPLAYED	OUTPUT RECORD TRIGGERED BY SECOND INTERVAL
Single	No	No
Interval	Yes	Yes
Monitor	No	Yes
Continuous	No	Yes

switch group. The display will show a series of t's (ttt tttttt).

3. Press the SECOND FUNCTION switch in the DATA ENTRY switch group.
4. Press the INTERVAL switch in the SCAN FORMAT switch group. The interval time in memory will be displayed, e.g., ttt 99.59.59 (99 hours, 59 minutes, 59 seconds).
5. Enter the desired interval time on the DATA ENTRY keyboard and then press ENTER/STEP.
6. Press the SECOND INTERVAL switch followed by the FIRST CHANNEL switch. The display will read the first channel data in memory, e.g., 001 tttttt.
7. Enter the desired first channel on the DATA ENTRY keyboard. When properly displayed, press ENTER/STEP.
8. Enter last channel data by pressing SECOND INTERVAL, LAST CHANNEL, LAST CHANNEL value on keyboard, and then ENTER/STEP.

#### 632-21. Remote Programming

632-22. The Dual Interval function can be remotely programmed when the data logger is equipped with a Remote Programming Interface (Option -15 or -17). Programming information for the Dual Interval Option is given in Table 617-7. Refer to Option -15 or -17 documentation (Section 615 or 617) for additional programming details.

-33 Option  
Eight Channel RTD Scanner

633-1. INTRODUCTION

633-2. The RTD Scanner (Option -33) is an eight-channel, two-wire relay scanner which operates in conjunction with the 2200 Series data logger and an RTD Input Connector (2200A-03) to provide excitation current and multiplex switching for up to eight RTD (resistance-temperature-device) inputs. The scanner can be installed in any one of the available scanner pcb slots in the data logger or an associated scanner chassis. Scanner input connections for the RTDS are accomplished using the 2200A-03 RTD Input Connector. When a channel is selected, reed relays in the scanner connect the RTD input to the data logger's Analog Bus. At the same time an on-board reference supply is energized to supply an adjustable excitation current (1 mA nominal) to the selected RTD. The resultant I-R drop is measured as a voltage and displayed in terms of temperature by the data logger.

633-3. SPECIFICATIONS

633-4. Specifications for the RTD Scanner are given in Table 633-1.

633-5. INSTALLATION

633-6. The Eight Channel RTD Scanner can be installed in any one of the scanner locations in a 2200B/2240C Data Logger. Use the following procedure to install a scanner:

WARNING

REMOVE LINE-POWER AND ALL OTHER  
HIGH VOLTAGE INPUTS TO THE DATA  
LOGGER BEFORE STARTING THIS  
PROCEDURE.

1. Remove the top cover and the inner top-guard cover from the data logger.

CAUTION

Handle the scanner pcb by its  
edges to avoid contaminating  
the pcb with oil from the  
hands. The use of gloves is  
recommended.

2. Select the location that includes the block of channels the scanner is to represent and align the scanner in the slot so that the large board-edge connector is toward the rear of the unit and the small offset board-edge connector is toward the

Table 633-1. RTD Scanner Specifications

Platinum RTDs

- RTD Channels..... 8
- Ice-Point Resistance (standard).....  $100\Omega \pm 0.8\%$
- Temperature Range.....  $-200^{\circ}\text{C}$  to  $+775^{\circ}\text{C}$ ,  $-328^{\circ}\text{F}$  to  $+1,427^{\circ}\text{F}$
- Linearization Conformity.....  $0.035^{\circ}\text{C}$  or  $0.063^{\circ}\text{F}$
- Resolution.....  $0.1^{\circ}\text{C}$  or  $0.1^{\circ}\text{F}$
- Open RTD Indicates.....  $-245.0^{\circ}\text{C}$
- System Accuracy..... NOTE: Specifications do not include sensor error.

TEMPERATURE RANGE	90-DAY $25 \pm 5^{\circ}\text{C}$		1-YEAR $25 \pm 10^{\circ}\text{C}$
	SLOW	FAST	SLOW
$-200^{\circ}\text{C}$ to $-450^{\circ}\text{C}$	$0.3^{\circ}\text{C}$	$0.4^{\circ}\text{C}$	$0.4^{\circ}\text{C}$
$-450^{\circ}\text{C}$ to $+775^{\circ}\text{C}$	$0.3^{\circ}\text{C}$	$0.4^{\circ}\text{C}$	$0.6^{\circ}\text{C}$
$-328^{\circ}\text{F}$ to $+700^{\circ}\text{F}$	$0.6^{\circ}\text{F}$	$0.7^{\circ}\text{F}$	$0.8^{\circ}\text{F}$
$+700^{\circ}\text{F}$ to $+1427^{\circ}\text{F}$	$0.6^{\circ}\text{F}$	$0.8^{\circ}\text{F}$	$1.0^{\circ}\text{F}$

Slow: 2.5 Rdgs/Sec

Fast: 15 Rdgs/Sec

NOTE:

Temperature Accuracy is based on the following RTD characteristics:

385 Platinum RTD

Alpha = 0.00385, delta = 1.52610, A4 = 0.759668E-4, C4 = 0.119619E-12

392 Platinum RTD

Alpha = 0.00392, delta = 1.49885, A4 = 0.59668E-5, C4 = 0.422832E-13

Copper RTDs

- Temperature Range.....  $-75^{\circ}\text{C}$  to  $+150^{\circ}\text{C}$
- Linearization.....  $0.002^{\circ}\text{C}$
- Resolution.....  $0.01^{\circ}\text{C}$

\*System Accuracy

TEMPERATURE RANGE	90 DAY $25 \pm 5^{\circ}\text{C}$		1 YEAR $25 \pm 10^{\circ}\text{C}$
	SLOW	FAST	SLOW
$-75^{\circ}\text{C}$ to $150^{\circ}\text{C}$	$\pm 0.15^{\circ}\text{C}$	$\pm 0.20^{\circ}\text{C}$	$\pm 0.25^{\circ}\text{C}$

Ice Point Resistance ( $R_0$ ) = 9.042 Ohms

R25 = 10.005 Ohms

alpha =  $0.004260\Omega/\Omega/^{\circ}\text{C}$

\*NOTE: Specifications do not include sensor error and are given only for 4 wire connections.

bottom of the unit. Push the scanner straight down onto the mating connectors.

3. Prior to use, test and calibrate the scanner using the procedures given later under maintenance.
4. Install the inner guard cover and the top cover.

#### 633-7. OPERATION

633-8. Once installed in the data logger the Eight Channel RTD Scanner requires no operator attention. However, certain considerations are necessary to properly interface the scanner with the RTDs. These considerations are discussed in the following paragraphs.

#### 633-9. Input Connections

633-10. The 2200/2240 Series data loggers accept three types of input connectors depending on the type of scanner in use. The General Purpose and Low Level Scanners are compatible with both the -07 Solder Pin Connector and -08 Isothermal Connector. Refer to Option -07 and -08 subsections in Section 6 of the data logger manual for instructions covering hookup and installation of these connectors. The RTD Scanner is only compatible with the RTD Connector. Refer to Option -03 subsection in Section 6 of this manual for RTD Connector hookup and installation instructions. Refer to the following paragraphs for applications information concerning three- and four-terminal RTD measurements.

#### 633-11. Input Pin Assignments

633-12. The pin assignments for the rear panel, card-edge connector of the RTD Scanner are shown in Figure 633-1. Since contact with signals on this connector is completed through the -03 RTD Connector, refer to the -03 Option subsection in this manual for pin assignments available for fabricating RTD interface cables.

#### 633-13. Four-Terminal Measurements

633-14. Four-terminal RTDs must be connected to the scanner in true four-terminal configuration to achieve full accuracy from the system. Four-terminal RTDs are supplied by the manufacturer with four leads, usually two of one color and two of another. (Color code and other indentifying marks on RTDs vary with the manufacturer.) The two leads with a common connection at one end of the RTD should be connected to the HI and +S terminals of the RTD Connector and the remaining two leads should be connected to the LO and -S (sense terminals) of the RTD connections to channel 0 (CH0) and channel 1 (CH1) of the RTD Connector with the RTDs having four wires, two red and two white. Additional four-terminal RTDs would be connected in exactly the same manner to HI, LO, +S and -S terminals of any other available channels in



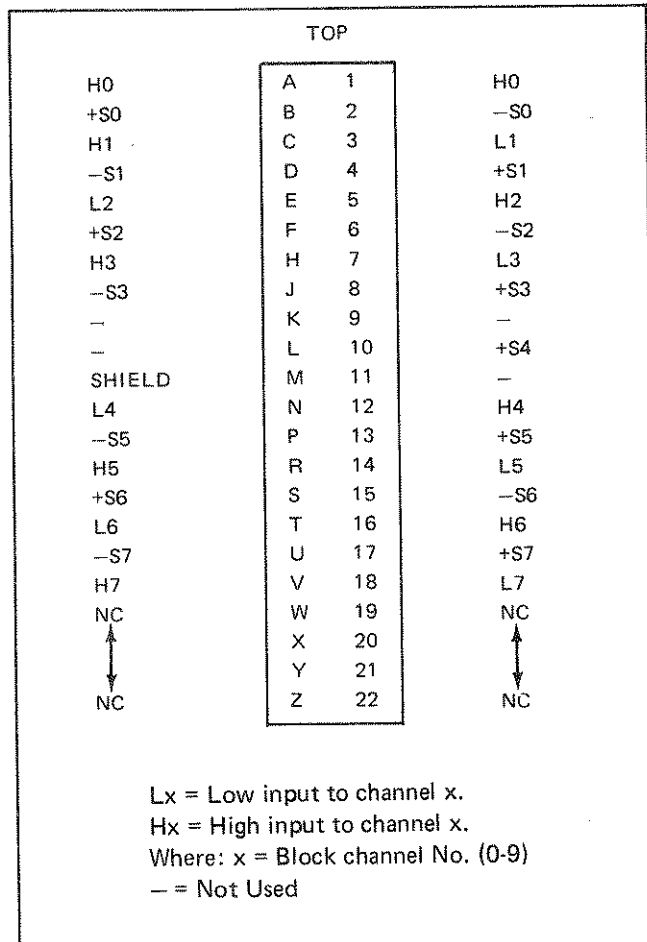

**Figure 633-1. RTD Scanner Rear Panel Connector  
Pin Assignments**

the RTD Connector, up to a maximum of eight per scanner. When shielded input cables are used, best results are usually obtained by connecting all of the shields on the block to the common shield terminal. The best common mode rejection performance is usually obtained by connecting only one of these shields to the LO terminal at the RTD. When no shields are used, connect the shield input to the LO input of one of the channels.

633-15. It is important to note that four individual wires must be brought out from the scanner to connect to each four-terminal RTD, as shown in Figure 633-2 to achieve true four-terminal RTD measurements. Connecting HI to +S and LO to -S at the scanner and extending two wires only for connection to the RTD will not provide a four-terminal measurement because sensing is not taking place at the RTD. Such a two-wire hookup actually comprises a two-terminal measurement configuration, introducing associated lead resistance error into the measurement.

#### 633-16. Three-Terminal Measurement

633-17. Three-terminal RTDs should be connected to the scanner as shown in Figure 633-3. In this hookup, the scanner LO and -S terminals are brought out to the RTD and connected to the common third wire on the RTD. The HI and +S terminals are connected individually to the remaining two RTD wires in the same manner as in the four-terminal hookup.

#### NOTE

Lead wire resistance errors are introduced by the resistance of the common or third wire of the RTD. For this reason the independent connection of -S and LO terminal should be made as close to the RTD sensing element as possible.

#### 633-18. THEORY OF OPERATION

633-19. The RTD Scanner contains 11, form-A, double-pole, reed relays. A contact pair from eight of the relays, K0 through K7, is connected to two separate busses (one pole to each bus) to form a two-pole, eight-channel scanner complete with treeing relay, K10. The treeing relay operates when any one of the channel relays is operated. It is used to connect the scanner busses to the input of the data logger's A/D converter. Relay K11 operates in parallel with K10 to connect the scanner's shield to the data logger's guard. The remaining relay, K9, switches the output of the +10V reference supply onto the Analog Bus for measurement purposes. It is energized whenever channel 8 or 9 is selected on the scanner. A bcd-to-decimal decoder, U1, operates in conjunction with Q7 through Q15 to select the desired channel.

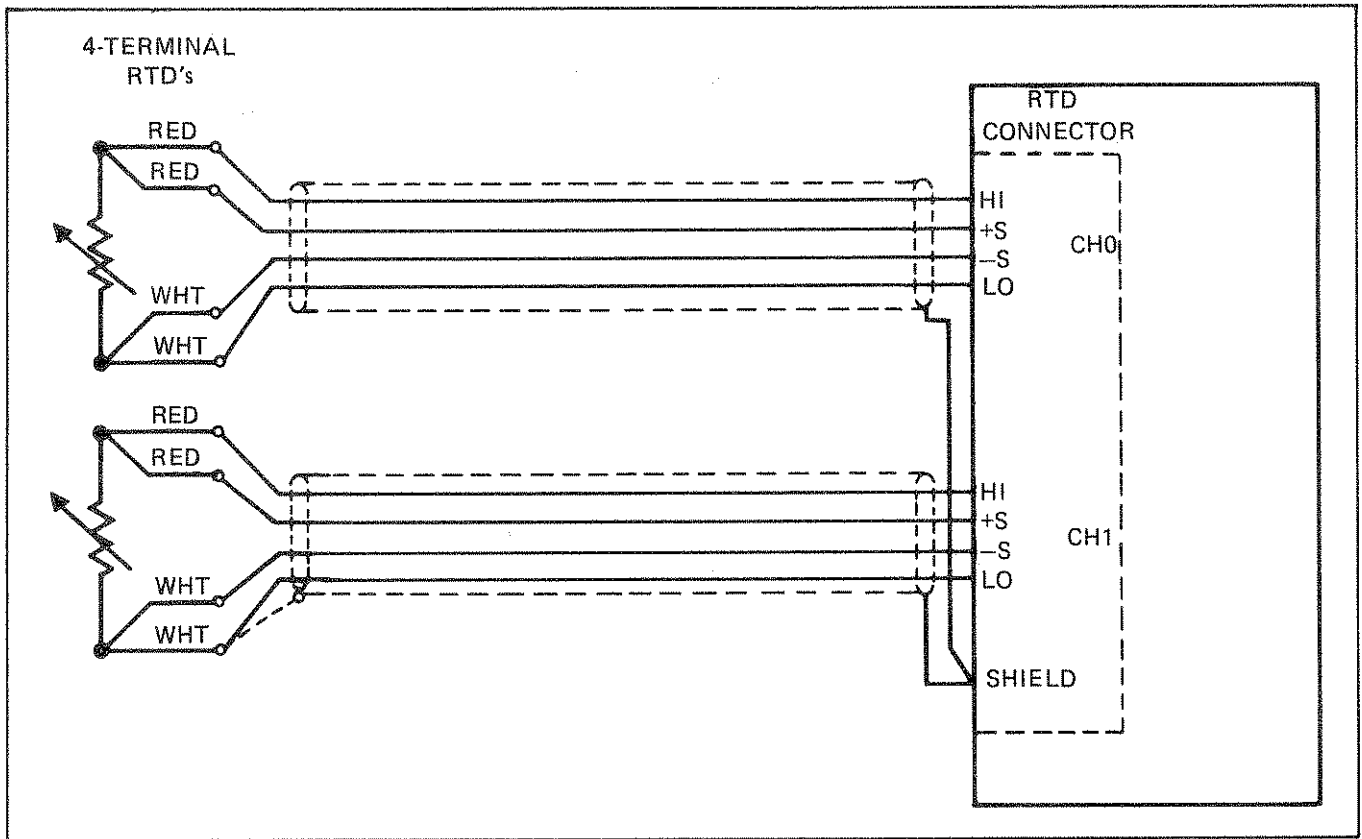

Figure 633-2. Example of Four-Terminal RTD Connections

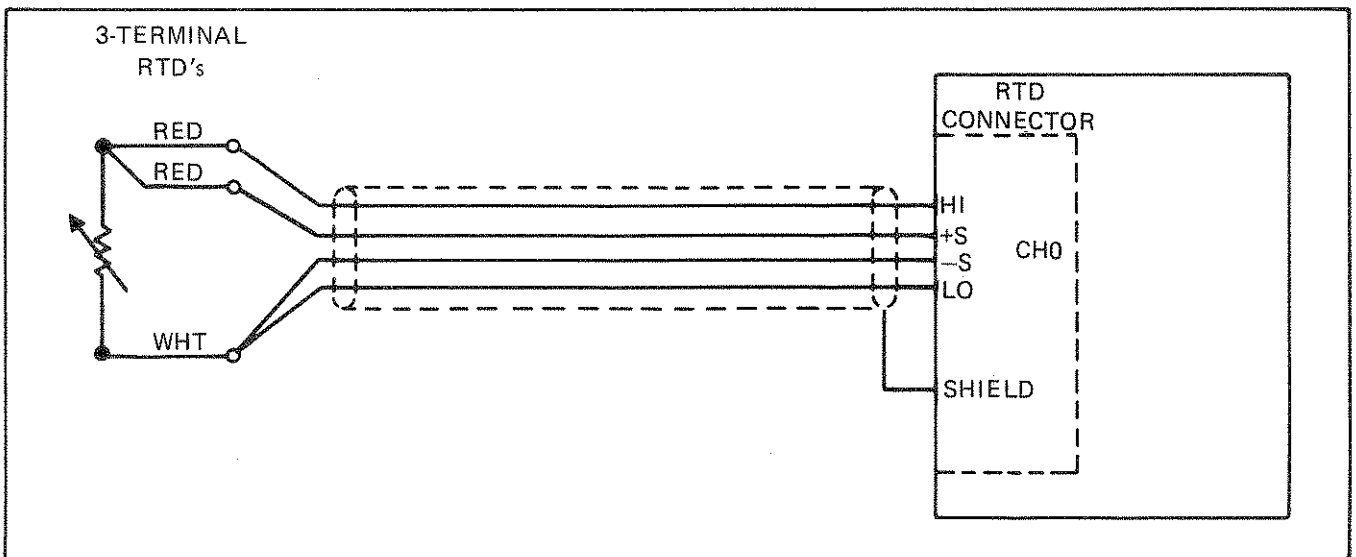

Figure 633-3. Example of Three-Terminal RTD Connections

633-20. Excitation current (1 mA) for the RTDs is supplied on-board 10 volt precision power supply. The supply is powered by the guarded logic +5 volts supply (GL+5L) in the data logger inverter and a regulator on the scanner are used to generate +10V dc output.

633-21. The power supply consists of a high frequency inverter (U2A, Q3, Q4, C1, Q1, Q2, CR1, CR2), a +15V dc regulator (U2B). The supply provides when energized through a channel dc regulator (U2B). This voltage is rectified and a +10V dc regulator is called. The voltage is unregulated by way of a transformer, T1, secondary ac winding. The voltage is unregulated before being presented to the operating dual op amp U2. One half of the power. A conventional series-pass regulator as unregulated dc power. A feedback control the +15V dc regulator. The other half is established a stable supply to provide the +10V dc output. Both of U2 is used as a feedback amplifier to provide the +10V dc output. Both used as a feedback amplifier to provide the +10V dc output. Both the +10 and +15V supplies use CR5 as a voltage reference.

633-22. The output of the +10V supply is applied through a precision wirewound resistor and potentiometer in each RTD input channel to the +S terminal and potentiometer in each RTD input terminal, -S (-Source), HI, and LO operate with the +s terminal to provide true four-terminal ohms measurement with the +s terminal potentiometer on each channel allows the RTD current to be adjusted for calibration purposes.

### 633-23. MAINTENANCE

#### 633-24. Access Information

633-25. Refer to the installation information given in this option subsection for access information. Remove the rear panel input connector before attempting to remove the scanner pcb from the data logger.

#### 633-26. Performance Test

633-27. The following performance test is designed to verify the overall operation of the Eight Channel RTD Scanner and is intended for use as an acceptance test and/or periodic maintenance check. The equipment used in the test is specified in Table 633-2. If the scanner fails any part of the test, corrective action is required.

1. Turn the data logger power off and disconnect the power cord from the ac line.
2. Install the Eight Channel RTD Scanner being tested in block 0 of the data logger.
3. Connect a 100 Ohm  $\pm 0.1\%$  resistor between the +S and -S terminals of each channel (0-7) on the RTD Input Connector (Option -03).

UNCLASSIFIED

Table 633-2. Required Test Equipment

INSTRUMENT	RECOMMENDED MODEL
Data Logger	Fluke 2200B/2240C
Input Connector	Fluke Model 2200A-03
Resistors (8 each) (1)	100Ω ±0.1%, ¼ watt
Thermos Bottle (2)	1 pint for 0°C ice-point bath
RTD's (2)	RTD's that will be used with the -33 Scanner

(1) Used only in Performance Test  
(2) Used only in Calibration Adjustments Procedure

4. Using a bare hookup wire, connect HI to +S and LO to -S on each channel of the RTD Input Connector.
5. Install the modified RTD Input Connector in block 0 of the data logger.
6. Connect the data logger to line power and set the power switch to POWER ON.
7. Program the data logger to read the voltage present at channel 9. Select the 40V range and observe the data logger display. The reading should be 10.000 +0.01.V dc. If the reading is incorrect, complete the power supply calibration adjustment (given later in this subsection) before proceeding.
8. Program the data logger to monitor the voltage at channel 0. The voltage should read approximately +100 mV dc.
9. Refer to Figure 633-4 and verify that the channel 0 potentiometer (R25) can be adjusted over a minimum range of 99.1 to 100.9 mV. Leave the adjustment set for a data logger reading of 100.00 mV.
10. Repeat steps 8 and 9 of this procedure for channel 1 through 7.
11. Program the data logger to scan and record the voltages at channels 0 through 7. Each reading should indicate 100.00  $\pm$ 0.02 mV.
12. Turn the data logger power off and disconnect the power cord from the ac line.
13. Disconnect the modified RTD Input Connector (block 0).
14. Remove the Eight Channel RTD Scanner from Block 0. This completes the performance test.

#### 633-28. Calibration Adjustments

633-29. The Eight Channel RTD Scanner should be calibrated when it is initially installed in a data logger, and whenever the data logger is calibrated. Calibration adjustments for the scanner are shown in Figure 633-4. See Table 633-2 for the required test equipment. The procedure assumes that the data logger and the A/D Converter calibration procedures have been completed and that the scanner is installed in its assigned location.

#### 633-30. +10 VOLT REFERENCE

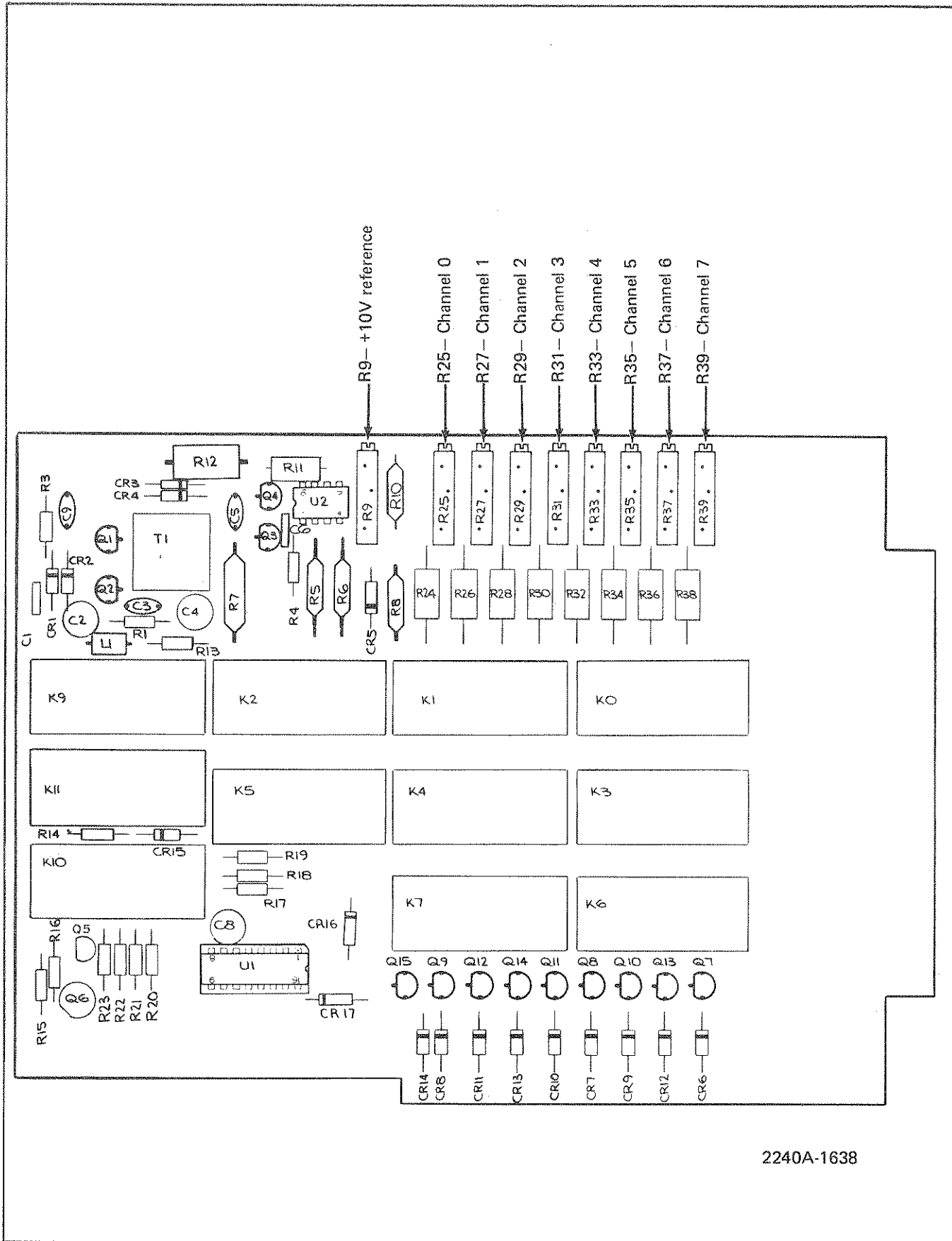

2240A-1638

Figure 633-4. Eight Channel RTD Scanner PCB Assembly

633-31. Use the following procedure to adjust the +10 volt reference supply:

1. Program the data logger to monitor the voltage on channel 9 of the scanner pcb being checked; use the 40V range. The voltage reading should be 10.000  $\pm$ 0.010V dc.
2. If the reading is not within limits, adjust R9 on the scanner pcb for a reading of 10.000  $\pm$ 0.002V dc. Disconnect the DMM.

633-33. Each RTD channel that is equipped with an RTD input must be calibrated when the RTD is connected. Calibration is accomplished by making screwdriver adjustments on the scanner pcb. These adjustments set the RTD excitation current so that a known I-R (voltage) is produced across the RTD at a known temperature (0°C).

1. Determine the location of the scanner to be calibrated and attach its RTDs using the RTD Input Connector.

#### NOTE

RTDs are assumed to have a resistance 100 Ohms  $\pm$ 0.8% at 0°C.

2. Remove the top cover and the inner guard cover from the data logger.
3. Prepare a 0°C (32°F) ice-point bath using 1 pint thermos bottle.
4. Place each RTD to be calibrated in the ice-point bath and allow the RTD temperature to stabilize.
5. Monitor each scanner channel and adjust the appropriate potentiometer (see Figure 633-4) for a reading of 00.0 °C (32.0°F) on the RTD measurement function or 100.00 on the 400 mV range.
6. Install the top and inner guard covers after the calibration adjustments have been completed.

#### 633-35. LIST OF REPLACEABLE PARTS

633-36. A list of replaceable parts for the Eight Channel RTD Scanner is given in Table 633-3. Refer to Section 5 of this manual for ordering information.



⊗ CAUTION

Indicated devices are subject  
to damage by static discharge.

Table 633-3. Eight Channel RTD Scanner

REF DES	DESCRIPTION	FLUKE STOCK NO.	MFG SPLY CODE	MFG. PART NO.	TOT QTY	REC QTY	NO TE
-33⊙	EIGHT CHANNEL RTD SCANNER (2240A-4038) FIGURE 633-5	ORDER	BY	OPTION -33			
C1	CAP, CER, 0.22 UF +/-20%, 50V	309849	71590	CW30C224K	2		
C2	CAP, TA, 10 UF +/-20%, 15V	193623	56289	196D106X0015KA1	2		
C3	CAP, CER, 0.05 -20/+80%, 25V	148924	72982	5855-000-Y5U0-503Z	3		
C4	CAP, TA, 10 UF +/-20%, 35V	417683	56289	196D106X0035PE4	1		
C5	CAP, CER, 0.05 -20/+80%, 25V	148924	72982	5855-000-Y5U0-503Z	REF		
C6	CAP, CER, 0.22 UF +/-20%, 50V	309849	71590	CW30C224K	REF		
C8	CAP, TA, 10 UF +/-20%, 15V	193623	56289	196D106X0015KA1	REF		
C9	CAP, CER, 0.05 -20/+80%, 25V	148924	72982	5855-000-Y5U0-503Z	REF		
CR1	DIODE, SI, HI-SPEED SWITCH	203323	07910	1N4448	16		4
CR2	DIODE, SI, HI-SPEED SWITCH	203323	07910	1N4448	REF		
CR3	DIODE, SI, HI-SPEED SWITCH	203323	07910	1N4448	REF		
CR4	DIODE, SI, HI-SPEED SWITCH	203323	07910	1N4448	REF		
CR5	ZENER REFERENCE SET	377283	89536	377283	1		
CR5A	(INCLUDES RESISTORS R7 AND R8)						
CR6	DIODE, SI, HI-SPEED SWITCH	203323	07910	1N4448	REF		
CR7	DIODE, SI, HI-SPEED SWITCH	203323	07910	1N4448	REF		
CR8	DIODE, SI, HI-SPEED SWITCH	203323	07910	1N4448	REF		
CR9	DIODE, SI, HI-SPEED SWITCH	203323	07910	1N4448	REF		
CR10	DIODE, SI, HI-SPEED SWITCH	203323	07910	1N4448	REF		
CR11	DIODE, SI, HI-SPEED SWITCH	203323	07910	1N4448	REF		
CR12	DIODE, SI, HI-SPEED SWITCH	203323	07910	1N4448	REF		
CR13	DIODE, SI, HI-SPEED SWITCH	203323	07910	1N4448	REF		
CR14	DIODE, SI, HI-SPEED SWITCH	203323	07910	1N4448	REF		
CR15	DIODE, SI, HI-SPEED SWITCH	203323	07910	1N4448	REF		
CR16	DIODE, SI, HI-SPEED SWITCH	203323	07910	1N4448	REF		
CR17	DIODE, SI, HI-SPEED SWITCH	203323	07910	1N4448	REF		
K0	RELAY, REED, 2-POLE, FORM-A	442921	21317	052A5*300BAA	11		
K1	RELAY, REED, 2-POLE, FORM-A	442921	21317	052A5*300BAA	REF		
K2	RELAY, REED, 2-POLE, FORM-A	442921	21317	052A5*300BAA	REF		
K3	RELAY, REED, 2-POLE, FORM-A	442921	21317	052A5*300BAA	REF		
K4	RELAY, REED, 2-POLE, FORM-A	442921	21317	052A5*300BAA	REF		
K5	RELAY, REED, 2-POLE, FORM-A	442921	21317	052A5*300BAA	REF		
K6	RELAY, REED, 2-POLE, FORM-A	442921	21317	052A5*300BAA	REF		
K7	RELAY, REED, 2-POLE, FORM-A	442921	21317	052A5*300BAA	REF		
K9	RELAY, REED, 2-POLE, FORM-A	442921	21317	052A5*300BAA	REF		
K10	RELAY, REED, 2-POLE, FORM-A	442921	21317	052A5*300BAA	REF		
K11	RELAY, REED, 2-POLE, FORM-A	442921	21317	052A5*300BAA	REF		
L1	INDUCTOR, 6-TURN	320911	89536	320911	1		
MP1	TRANS-PAD, SPACER (TO Q6)	152207	07047	10123-DAP	1		
Q1	XSTR, SI, NPN	272237	89536	272237	3		1
Q2	XSTR, SI, NPN	272237	89536	272237	REF		
Q3	XSTR, SI, NPN	272237	89536	272237	REF		
Q4	XSTR, J-FET, N-CHANNEL	261388	89536	261388	1		1
Q5	XSTR, SI, NPN	218396	04713	2N3904	1		1
Q6	XSTR, SI, NPN	182196	89536	182196	1		1
Q7	XSTR, SI, PNP	195974	04713	2N3906	9		2
Q8	XSTR, SI, PNP	195974	04713	2N3906	REF		



Option -40  
mx + b Scaling Option

640-1. INTRODUCTION

640-2. The mx + b Scaling Option (Option -40) provides 30 user-programmable scaling functions and Engineering Units notation for the 2240C. Scaling functions and Engineering Units notation are programmable from the 2240C front panel. It requires factory or Fluke Service Center installation.

640-3. Any of the 30 user-selected scaling functions may be assigned to any channel, or any group of channels within the 2240C system, and a single scaling function may be assigned to more than one channel or group of channels. In addition, decimal point location within the displayed information is programmable, allowing a scaled presentation on the 2240C data display. Engineering units notation is not displayed on the 2240C data display, or on an external recording device, but can be programmed to appear on the printer output.

640-4. SPECIFICATIONS

640-5. Specifications for the Scaling Option are as follows:

Scaling Functions.....30 (30 m and 30 b values)  
Engineering Units.....32 (see Table 640-1.)  
Decimal Positions.....5 (Maximum)

Ranges

Slope (m).....-9.9999 to +9.9999  
Intercept.....-99999 to +99999

In addition, the Scaling Option meets all environmental specifications of the 2240C.

640-6. OPERATING NOTES

640-7. Programming the mx + b Scaling Option is accomplished through 2240C front panel controls. Limits can be set for use with the Scaling function, and any limits established apply to the scaled data, not the original input data. Regarding mx+b limit programming, refer to Option -41.

640-8. mx + b General Equation

640-9. The Scaling expression, mx+b, allows output conditioning to reflect specific user requirements. It defines the data indication on the display. The complete equation is  $Y = mx+b$ , where Y is the displayed data. The element m in the equation is referred to as the slope of the scaling function; the element b is the intercept value; the element x is the input data.

Table 640-1. Engineering Units Codes.

CODE	NOTATION	CODE	NOTATION
01	ACA	17	DCV
02	ACmA	18	KV
03	DCA	19	mV
04	DCmA	20	$\mu$ V
05	$\mu$ A	21	ACW
06	dB	22	DCW
07	$\mu$ F	23	KW
08	Hz	24	mW
09	KHz	25	$\mu$ W
10	MHz	26	$^{\circ}$ C
11	psi	27	$^{\circ}$ F
12	S	28	$\Omega$
13	ms	29	K $\Omega$
14	$\mu$ s	30	M $\Omega$
15	ACV	31	%
16	dBV	$\emptyset$	BLANK

640-10. A general set of equations, represented by Figure 640-1, for determining slope and intercept is:

$$\text{Slope} = m = \frac{\text{Display Hi} - \text{Display Lo}}{\text{Input Hi} - \text{Input Lo}}$$

$$\text{Intercept} = b = \text{Display Lo} - (m \times \text{Input Lo})$$

640-11. All values in these equations are in terms of A/D converter counts (as seen on the display, ignoring the decimal point). The display is limited to five digits.

640-12. mx+b Programming Example

640-13. Assume that input data is being received from a 100 to 200 psi pressure transducer with a 4-20 mA output. The data logger, when properly configured with a Current Transmitter Connector (Option -29), receives a 60mV to 300mV signal from the connector option. In A/D Converter counts, 60mV equals 6000 and 300mV equals 30,000 counts. The desired display is chosen as 200.00->100.00 psi. In terms of A/D counts, this is 20,000 and 10,000 counts, respectively.

640-14. To obtain the desired indication on the display, the input data must be scaled. Applying the general formula for slope, the required slope value is:

$$\text{Slope} = \frac{20,000 - 10,000}{30,000 - 6,000} = 0.4167 = m$$

The required value is:

$$\text{Intercept} = 10,000 - (0.4167 \times 6,000) = 7500 = b$$

The slope intercept values used in this example are illustrated in Figure 640-2.

640-15. OPERATING INSTRUCTIONS

640-16. Two procedures are necessary to operate the Scaling Option. First, the desired slope and intercept values must be established for one of the 30 possible scaling addresses. Then that scaling address and A/D Converter range must be selected and assigned to the channel or channels with which it is to be used. The first procedure outlines establishing the desired slope and intercept values for a particular scaling function. The second procedure outlines programming that scaling function for use with a specific channel.

A. Assign values to an mx+b address.

1. Press the SECOND FUNCTION button located in the DATA ENTRY section of the front panel, then press the ENTER ADDRESS button in the LIMITS/mx+b

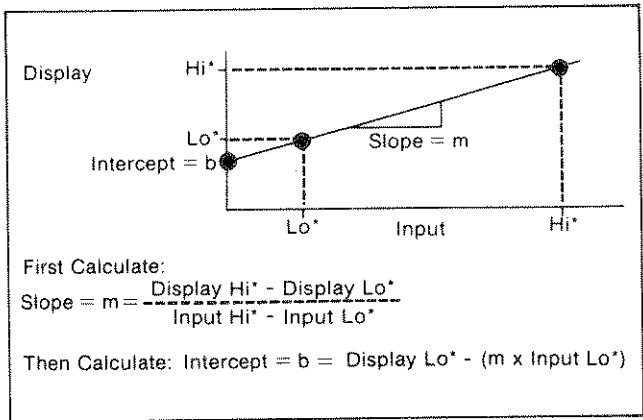

Figure 640-1. General Scaling Equations

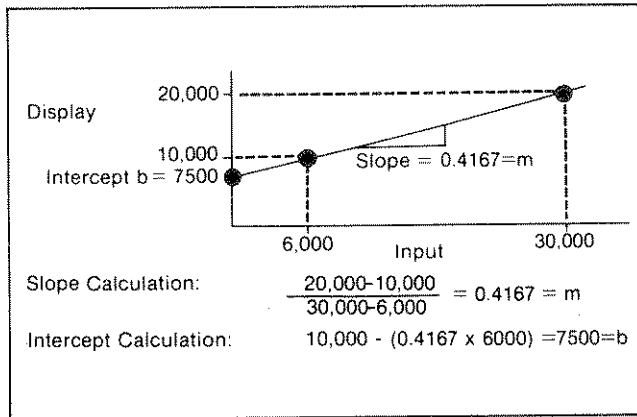

Figure 640-2. Scaling Equation Example

programming section.

2. Press one or two digits (1-30) in the DATA ENTRY front panel section to select a  $mx+b$  address, then press the ENTER/STEP button. Example: press 5, then ENTER/STEP to assign an address number of 5 to the scaling function. After pressing ENTER/STEP, both the SENSE/ $mx+b$  light and the HI/ $m$  light will be on, indicating that the slope value ( $m$ ) should be entered next.
3. To enter the slope value, press the appropriate digits in the DATA ENTRY group, then press the ENTER/STEP button. Example: press 0, 4, 1, 6, 7, then ENTER/STEP to enter a slope of 0.4167. After pressing ENTER/STEP, both the SENSE/ $mx+b$  light and the LO/ $b$  light will be on, indicating that an intercept value ( $b$ ) should be entered next.
4. To enter an intercept value, press the appropriate digit switches in the front panel DATA ENTRY group, then press ENTER/STEP. Example: press 7, 5, 0, 0, and ENTER/STEP is pressed, the both the HI/ $m$  and LO/ $b$  lights will be on, indicating a decimal point location may be entered next.
5. To enter a decimal point position, press the digit in the DATA ENTRY group representing the number of digits to the right of the decimal point, then press ENTER/STEP. Example: press 2 then ENTER/STEP. In this case, the DISPLAY should read 75.00 to indicate our offset of 75 psi. After ENTER/STEP is pressed, the UNITS lamp will be on, indicating that engineering units notation may be programmed next.
6. To program engineering units notation, enter the appropriate 2-digit code (refer to Table 640-1) for the unit desired, then press the ENTER/STEP button. Example: press 1, 1, and ENTER/STEP. Engineering Units notation psi is programmed to appear on the printer.

B. Assign a scaling function to a channel.

1. Press the ENTER ADDRESS button in the CHANNEL programming group.
2. Press the appropriate digits in the DATA ENTRY front panel section to select the channel address. Example: Press 2, then 5 to select channel 25.
3. Press the ENTER/STEP button in the DATA ENTRY front panel section to enter the channel address. After the ENTER/STEP button is pressed, the ENTER



FUNCTION light in the CHANNEL section of the front panel will light.

4. Press the desired button in the DATA ENTRY section of the front panel, then the ENTER/STEP button, to enter an A/D converter range. Example: to enter a 400 mV range, press 400 mV, then ENTER/STEP. After the ENTER/STEP switch is pressed, the ENTER mx+b ADDRESS light in the CHANNEL section will light.
5. Press the required digits in the DATA ENTRY front panel section necessary to enter the appropriate scaling function. Example: To enter scaling function address number 5, press 5, then ENTER/STEP. After ENTER/STEP is pressed, the ENTER LIMIT ADDRESS light in the CHANNEL section of the front panel will light, and the LIMIT A light just to the right of the DATA display will light.
6. To enter a limit address, press the appropriate digits in the DATA ENTRY front panel section, then press the ENTER/STEP button. If limits are not needed, press the SKIP button, then the ENTER/STEP button.

#### NOTE

The ENTER LIMIT ADDRESS light will remain illuminated to indicate that limits, B, C, and D can be entered at this time. Repeat step 6 for each limit.

7. Select SCAN CONTROL and OUTPUT CONTROL functions from the front panel OPERATOR section (Refer to Section 2 of the 2240C Instruction Manual).

#### 640-17. THEORY OF OPERATION

#### 640-18. Introduction

640-19. Option -40, the Scaling Option, consists of one PROM (Programmable Read Only Memory) and four RAMs (Random Access Memory). The PROM is located on the Controller pcb and is designated U7. The RAMs are located on the Range and Function Memory pcb, and are designated U8, U9, U16, and U17.

#### 640-20. Function

640-21. The PROM located on the Controller pcb is a configuration PROM which contains engineering units notation programming. It is structured such that PROM locations correspond to the two-digit code entered for a specific engineering units notation. The four RAMs on the Range and Function Memory pcb

provide memory storage for the 30 user-programmable scaling functions. Refer to Section 3 (Range & Function Memory) of the 2240C mainframe manual for additional information.

#### 640-22. MAINTENANCE

640-23. Option -40 does not require periodic maintenance or calibration. Troubleshooting information and a performance test is given in Section 4 of the mainframe manual.

#### 640-24. LIST OF REPLACEABLE PARTS

640-25. The mx+b Scaling Option consists of only one Integrated Circuit, which is installed by inserting it in the socket provided at location U7 on the Control PCB. It may be ordered by Fluke stock number 587204.



Option 41  
Alarm Setpoint Option

641-1. INTRODUCTION

641-2. The Alarm Setpoint Option Option (Option -41) is a factory or service center installed set of ICs that provide four limits per channel in the 2240C, with maximum of 60 individual limit set points. Limits are divided into 4 distinct groups of 15 limits. Limits group A consists of limit addresses 1 through 15; group B consists of addresses 16 through 30; group C consists of addresses 31 through 45; group D consists of addresses 46 through 60. One limit from each group may be assigned to each channel, which provides a maximum of four limits per channel. Limit values are assigned through the front panel DATA ENTRY keyboard, and each of the 60 limits may be addressed by entering a two-digit limit address through the 2240C front panel controls.

641-3. SPECIFICATIONS

641-4. Specifications for the Alarm Setpoint Option are given in Table 641-1.

641-5. OPERATING NOTES

641-6. All limits within a group may be set as either a HI or LO limit, or any combination of HIs and LOs. Limit values are pure numbers and, as such, assume the same engineering notation and decimal point position as the data from the channel to which they are assigned.

641-7. In addition, one programmed limit value may be applied to any number of channels. For instance, if limit number 5 were initially assigned a value of 20, and all 1000 possible channels needed a low limit of 20, limit number 5 could be assigned to every channel in the system as a low limit. The remaining 59 limit values could be used for other limit requirements or left unassigned.

641-8. Limits can be assigned to channels with an  $mx+b$  Scaling Function also assigned. The limits established apply to the scaled data, not the original input data. When the  $mx+b$  Option (-40) is installed, the range of limit values is increased from 0,  $\pm 39990$  to 0,  $\pm 99990$ .

641-9. The following points relate to limits applications.

1. Limits can be applied to the results of an averaging calculation (Option -42).
2. Limits programmed to a channel are always applied to the results of an average in time average mode.
3. Limits programmed to the last channel in a group

Table 641-1. Specifications

TOTAL LIMITS.....	60 (4 groups of 15)
LIMIT ADDRESSES	
GROUP A.....	1 through 15
GROUP B.....	16 through 30
GROUP C.....	31 through 45
GROUP D.....	46 through 60
MAXIMUM LIMITS/CHANNEL.....	4 (one from each group)
LIMITS VALUE.....	$\pm 39990$ ( $\pm 99990$ w/mx + b)

are always applied to the results of an average in group average mode.

4. Limits are applied to individual channels within an average according to the positions of the OUTPUT CONTROL switches on the 2240C front panel. If no output is enabled (all switches in the out position), no limit evaluation is performed on the individual channels, only on the average result. This is also the case if only the INTERVAL DATA and/or LIMIT DATA switches are pressed. However, if the ALL DATA switch is pressed, limits will be evaluated on all channels as well as on the averages.

#### 641-10. OPERATION

641-11. Operating procedures for the Alarm Setpoint Option (-41) consist of assigning a value to the various limits address to be used, then assigning those limits address to the applicable channels in the 2240C. The following procedures may be used to assign a value to a limit address and assign a limit address to a channel.

- A. Assign a value to a limit address.
  1. Press the ENTER ADDRESS button in the LIMITS/mx+b front panel section.
  2. Press on or two digits (1-60) in the DATA ENTRY front panel section to select a limits address, then press ENTER/STEP. After ENTER/STEP is pressed, the SENSE lamp and either the HI or LO lamp in the LIMITS/mx+b section will light.
  3. If the limit being programmed is already the proper sense (HI limit or LO limit), press ENTER/STEP and proceed to step 4. To establish a limit as HI or LOW, press either HI or LO button in the DATA ENTRY front panel section, followed by the ENTER/STEP button. After ENTER/STEP is pressed, the VALUE lamp in the LIMITS/mx+b section will light to indicate a value must be entered.
  4. To enter a limit value, press the appropriate digits in the DATA ENTRY section, followed by the ENTER/STEP button. Upon pressing the ENTER/STEP button, the ENTER ADDRESS light in the LIMIT/mx+b front panel section will light. The next limit address can be programmed at this time. Repeat steps 1 through 4 program the next limit address.

B. Assign a limit address to a channel.

1. In the channel programming group, press ENTER ADDRESS.
2. Press the required digits in the DATA ENTRY group to select a channel address, then press the ENTRY/STEP button.
3. The ENTER FUNCTION lamp will light in the CHANNEL group after the ENTER/STEP button is pressed. Enter the channel function (see Section 2 of the 2240C Manual) then press the ENTER/STEP button.
4. Next, the ENTER ADDRESS mx+b lamp in the CHANNEL section will light, if Option -40 is installed. Enter a scaling address or press SKIP if no scaling is required, then press the ENTER/STEP button.
5. The ENTER ADDRESS LIMIT (A, B, C, D) lamp in the CHANNEL section will light upon completion of the mx+b programming, along with the lamp marked A, located just to the right of the DATA display.
6. Press the DATA ENTRY group digits required to enter a limits address from limits group A (1-15) then press the ENTER/STEP button. Example: to assign limit address number 5 to the selected channel, press 0, 5, and ENTER/STEP.
7. Upon pressing ENTER/STEP, the lamp marked B, just to the right of the DATA display, will light. Either enter an address from limit from group B (16-30) or press SKIP if no limit from group B is required for that specific channel.
8. Repeat the preceding procedure for limits group C and D.
9. Repeat steps 1 through 8 for each additional channel to which a limit must be assigned.

641-12. THEORY OF OPERATION

641-13. Option -41, the Limit Option consists of five RAM chips installed on the Range and Function Memory pcb. These chips provide memory for the limits functions. Refer to Section 3 of the mainframe manual for additional information.

641-14. MAINTENANCE

641-15. The Limits Option (Option 41) does not require periodic maintenance or calibration. Troubleshooting information is given in Section 4 of the 2240C mainframe manual.

641-16. LIST OF REPLACEABLE PARTS

641-17. The Limits Option consists of five Integrated Circuits which are installed by inserting them into sockets on the Range and Function Memory PCB. They must be installed in the sockets at locations U18, U20, U21, U22, and U23 on the Range and Function Memory PCB. All five Integrated Circuits may be ordered by Fluke stock number 429860.





Option -42  
Data Averaging Option

642-1. INTRODUCTION

642-2. The Data Averaging Option (Option -42) provides data averaging in either of two modes: Time averaging or group averaging. In the time average mode, up to 30 channels may be individually averaged over a user selectable time interval, with a user selectable averaging window of from 1 to 99 scans. A single point may be time averaged using MONITOR scan mode and multiple points may be time averaged using either INTERVAL or CONTINUOUS scan modes.

642-3. The group average mode allows up to 30 groups of channels each containing up to 99 channels to be averaged. All groups must be the same size, and the channels must be sequential in each group, with no channel appearing in more than one group. However, any group may have any number of skipped channels and more channels may be skipped or enabled at any time. SINGLE scan mode will provide a single set of group averages while multiple consecutive group averages are performed using INTERVAL or CONTINUOUS scan modes.

642-4. Time and group average channels are comprised of unique and totally different groups of channels than those used for normal scanning (FIRST, LAST CHANNEL). Therefore, primary channels are also scanned during averaging. Averaging can also be disabled for normal primary channel scanning by setting either the time average count or the group size to zero.

642-5. Averaging may be done on any voltage range, with the exception that all channels within a group average must be programmed to the same range for valid results. Averaging may also be done on channels programmed to a temperature function (Option -43, -44, or -45) or to a channel programmed with an  $mx+b$  scaling (Option -40).

642-6. SPECIFICATIONS

642-7. Specifications for the Data Averaging Option (Option -42) are given in Table 642-1. In addition, the Data Averaging Option meets all environmental specifications given for the 2240C mainframe (see Section 1 of the mainframe manual).

642-8. OPERATING NOTES

642-9. Average values are always displayed as they are calculated. If INTERVAL output is enabled, then the average value will be printed/output along with the averaging channels and primary interval channels at their appropriate intervals. If LIMIT DATA output is enabled, average data is printed/output when its limit is exceeded, the same as an alarm condition on any channel (See Section 2). If ALL DATA output is enabled, the

Table 642-1. Specifications

OPERATING MODES. ....	Time Average and Group Average
<b>TIME AVERAGE</b>	
Maximum Channels. ....	30
Scan Interval. ....	User Selectable
Scans/Average. ....	1 to 99
Limits On Time Average. ....	Standard Limits programming applies.
<b>GROUP AVERAGE</b>	
Number of Groups. ....	1 to 30
Channels/Group. ....	2 to 99
Limits on Group Average. ....	Limits Programmed for last channel in the group apply.

individual channels will be printed/output as well as the averaged value.

642-10. Average data is marked by an '\*' when it is printed on the internal printer to distinguish it from normal data.

#### NOTE

The '\*' character can only be printed on the internal printer. No special character will appear with average data when using any output option with the 2240C.

642-11. If any channel should fail during a scan (open thermocouple), while group averaging, that channel will be excluded from the average and a correct average will be calculated from the remaining valid readings. An overload will be treated as a full scale reading.

642-12. The scan modes will perform as follows:

##### A. Time Average Mode

1. Single scan - no averaging. Will scan only first interval (primary) channels only.
2. Interval scan - will scan time averaged channels once each averaging (secondary) interval and output the time averaged values after the selected number of scans. Primary channels will be scanned once each primary interval.
3. Monitor scan - will average MONITOR channel over the selected number of scans (if the number of scans  $\neq$  0).
4. Continuous scan - will scan time averaged channels followed by primary channels continuously. Time average will be output after the selected number of scans.

##### B. Group Average Mode

1. Single scan - will perform a single set of group averages of group average channels.
2. Interval scan - will perform group averaging at averaging interval time and primary interval scan at primary interval time.
3. Monitor scan - no group averaging. Will scan

monitor channel as normal.

4. Continuous scan - will perform group averaging followed by primary channel scan continuously.

#### 642-13. INSTALLATION AND OPERATION

642-14. Option -42 requires factory or Fluke Service Center installation.

642-15. Operating procedures for group averaging and time averaging are slightly different from each other. The following procedures detail both time averaging and group averaging programming through the 2240C front panel buttons. Channels selected for time averaging or group averaging must be consecutively numbered, but any channel or channels within the group may be excluded using the SKIP button on the front panel. Channels that are programmed for SKIP will not be included in the averaging calculation.

##### A. TIME AVERAGING PROGRAMMING

1. Press the SECOND FUNCTION button in the DATA ENTRY section of the front panel.
2. Press the TIME AVERAGE button, also located in the DATA ENTRY front panel section, to establish the time averaging mode of operation.
3. Press the appropriate digit buttons in the DATA ENTRY keyboard to establish the number of scans per average, then press the ENTER/STEP button. Example: to average readings over a 20-scan period, press 2, 0, then ENTER/STEP.
4. Press the SECOND FUNCTION and TIME AVERAGE button again, followed by the FIRST CHANNEL button in the SCAN FORMAT front panel section.
5. Press the digit buttons required to establish the first channel to be averaged, then press ENTER/STEP.
6. Press SECOND FUNCTION and TIME AVERAGE again, followed by the LAST CHANNEL button in the SCAN FORMAT front panel section, then press the digit buttons necessary to establish the last channel. Press ENTER/STEP.
7. To establish a Time Average scan interval, press the SECOND FUNCTION button, then the INTERVAL/HR MIN SEC button. Press the digit buttons required to establish a scan interval,

then press ENTER/STEP.

#### B. GROUP AVERAGING PROGRAMMING

1. Press the SECOND FUNCTION button, then the GROUP AVERAGE button, both located in the DATA ENTRY front panel section.
2. Press the necessary digit buttons in the DATA ENTRY section of the front panel to establish a group size, then press ENTER/STEP. Example: press 5, then ENTER/STEP to establish a group size of 5 channels.
3. Press the SECOND FUNCTION and GROUP AVERAGE buttons again, then press the FIRST CHANNEL button. Press the digit button (s) required to establish the first channel for group averaging, then press the ENTER/STEP button.
4. Press the SECOND FUNCTION button once again, then the LAST CHANNEL button. Press the required digit buttons to establish a last channel for group averaging, then press the ENTER/STEP button.
5. To establish a group average scan interval, press the SECOND FUNCTION button, then the GROUP AVERAGE button, then the INTERVAL/HR MIN SEC button. Press the digit buttons required to set the desired scan interval, then press the ENTER/STEP button. Example: press SECOND FUNCTION, INTERVAL/HR MIN SEC, 1, 0, 0, and ENTER/STEP to establish a second scan at one minute intervals.

#### 642-18. THEORY OF OPERATION

642-19. Four RAM ICs installed on the Controller PCB and two RAM ICs installed on the Keyboard Memory PCB comprise the Data Averaging Option. Data Averaging Option RAMs on the Controller PCB are U23, U24, U25, and U26. Data Averaging Option RAMs on the Keyboard Memory PCB are U4 and U5.

642-20. The RAM ICs installed on the Controller PCB are used for averaging calculations. Those mounted on the keyboard memory PCB provide memory locations for first and last channel numbers and the averaging interval. The Keyboard Memory PCB RAMs are nonvolatile.

#### 642-21. MAINTENANCE

642-22. The Data Averaging Option does not require periodic maintenance or calibration. Troubleshooting procedures for the

Data Averaging Option are included in the mainframe troubleshooting chart, located in Section 4.

642-23. LIST OF REPLACEABLE PARTS

642-24. A list of replaceable parts for the Data Averaging Option is given in Table 642-2. Refer to Section 5 of this manual for ordering information.

ITEM NO.	DESCRIPTION	FLUKE STOCK NO.	MFG SPLY CODE	MFG PART NO. OR TYPE	TOT QTY	REC QTY	USE CDE
-42	-42 OPTION DATA AVERAGING (TIME & GROUP AVERAGE)						
	IC, C-MOS MEMORY 16 X 4 RAM U4, U5 PLUG-IN ON A9 (KEYBOARD MEMORY ASSEMBLY PCB)	408385	89536	408385	2	1	
	IC, MOS, 320-BIT RAM, 4-BIT OUTPUT U23, U24 PLUG-IN ON A3 (CONTROLLER PCB ASSEMBLY)	404442	89536	404442	2	1	
	<i>4 257 26 same</i>						



1  
2  
3  
4  
5  
6  
7  
8  
9  
10  
11  
12  
13  
14  
15  
16  
17  
18  
19  
20  
21  
22  
23  
24  
25  
26  
27  
28  
29  
30  
31  
32  
33  
34  
35  
36  
37  
38  
39  
40  
41  
42  
43  
44  
45  
46  
47  
48  
49  
50  
51  
52  
53  
54  
55  
56  
57  
58  
59  
60  
61  
62  
63  
64  
65  
66  
67  
68  
69  
70  
71  
72  
73  
74  
75  
76  
77  
78  
79  
80  
81  
82  
83  
84  
85  
86  
87  
88  
89  
90  
91  
92  
93  
94  
95  
96  
97  
98  
99  
100

Options -43, -44 and -45  
Temperature

643-1. INTRODUCTION

643-2. Temperature Scaling options (Option -43, -44 or -45) are factory installed options that provide temperature measurement and linearization capability for the data logger. Measurement readings using 11 different linearizations are available with either of the three options, along with a current transmitter reading, displayed as a percent of scale. Option -43, Option -44, and Option -45 contain linearization programs for different types of input transducers, but they are otherwise identical.

643-3. When using thermocouple inputs, the Temperature Option operates in conjunction with the isothermal connectors to provide direct temperature readouts selectable in °C or °F, with 0.10 resolution. The 2240C can accept one temperature linearization option (-43, -44 or -45). Each option consists of a group of 11 temperature linearizations and one scaling function, selected through front panel programming codes as shown in Table 643-1.

643-4. Current measurements derived from any of 3 types of current transmitter connectors can be scaled by the Temperature Option to provide readings in percent. For example, the 1 to 5 mA current transmitter input would be scaled to read 1 mA as 0% and 5 mA at 100%. If measurement units other than percent are required, the mx+b Scaling Option (Option -40) must be installed.

643-5. SPECIFICATIONS

643-6. Specifications for the Temperature Option are contained in Section 1 of this manual.

643-7. OPERATION

643-8. Once installed in the data logger, the Temperature Option requires no operator attention other than ensuring that the transducers connected at the measurement channels are compatible with the measurement functions selected for those channels. Instructions for assigning temperature functions to specific channels are contained in Section 2 of this manual.

643-9. The temperature measurement scale can be set by the user to provide a direct temperature readout in either °C or °F. A switch located on the controller is used to select the desired scale. Information necessary to properly set the switch is given later under maintenance.

NOTE

Thermocouple temperature  
measurements require the use of  
an Isothermal Block Connector

Table 643-1. Temperature Linearization, Options -43, -44 and -45

OPTION	PROGRAMMING CODE											
	1	2	3	4	5	6	7	8	9	10	11	0
-43	J	K	T	S	R	B	E	C	385	390	0-100%	REF JUN
-44	J	K	T	S	JDIN	KDIN	TDIN	SDIN	385	392	0-100%	REF JUN
-45	J	K	T	S	N*	D	G	120Ω Nickel	385	10Ω Copper	0-100%	REF JUN

\*Nicrosil/Nisil (NBS)

(Option -08).

NOTE

When a series of C's is displayed during a scan sequence, as shown in Figure 643-1, it indicates that the thermocouple input for the channel indicated is open circuited (R source  $>7.5 \pm 2.5$  kilohms).

643-10. THEORY OF OPERATION

643-11. General

643-12. The Temperature Option operates as an extension of the A/D Converter to provide direct-reading temperature measurements using thermocouple or RTD probes. It consists of a Temperature Measurement PCB and two linearization ROMs. The Temperature Measurement PCB mounts on the a/d converter as a plug-in subassembly and provides the analog switching necessary for open thermocouple detection as well as reference junction measurement. Both ROMs plug into sockets provided on the Controller PCB. The linearization ROMs contain the linearization program for the microprocessor and the linearization tables for the selected thermocouple types. Table 643-1 lists the appropriate thermocouple types for each option (-43, -44 and -45).

643-13. When a temperature measurement is made, the processor first calls for a reference junction measurement to determine the temperature of the terminal block on the measurement channel's Isothermal Block Connector (Option -08). Since this temperature is the same for all thermocouples associated with the block connector, only one measurement is required each time the block channels are scanned. Measured reference junction data is then sent to the microprocessor where it is used to derive a voltage offset which is the difference between the voltage generated at the thermocouple termination at ambient temperature and the terminal voltage which would be observed at 0°C. (The difference is due to the thermocouple effect at the terminal block where a transition is made from thermocouple wire alloys to copper.) This voltage is then added to each subsequently measured thermocouple voltage at the Isothermal Block Connector. The result is a thermocouple output relative to a terminal point temperature of 0°C. Finally the corrected thermocouple voltage is converted, via a piecewise linear approximation (linearization ROM), into an equivalent temperature which is subsequently displayed.

643-14. Reference junction temperature from the isothermal connector is represented by a voltage. At an ambient temperature of 25°C, the reference junction voltage is 540 mV. Reference junction voltage changes by -2.395 mV per °C temperature change.

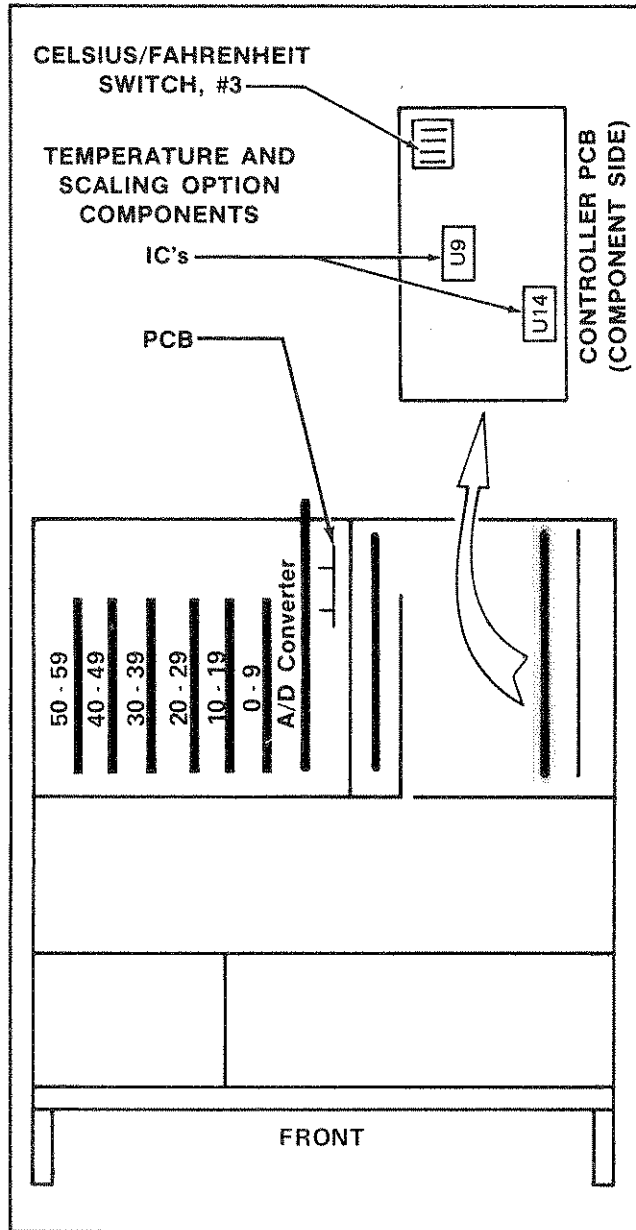

Figure 643-1. Temperature and Scaling Option PCB Assembly, Options -43, -44 and 45 (2200A-1021)

Reference junction temperature may be read directly from the data display if an mx+b Scaling option is installed by entering the scaling values shown in Table 643-2.

#### 643-15. Temperature Measurement PCB Assembly

643-16. The operation of the Temperature Measurement PCB can be divided into three separate functions: open thermocouple detector, reference voltage buffer, and reference junction measurement. Refer to the schematic diagram, Figure 643-2, to supplement the following descriptions.

643-17. Open thermocouple detection is enabled when the measurement function has been programmed for a thermocouple temperature measurement. The enabling program data bit is stored in the function register on the A/D Converter PCB and is delivered to the Temperature Measurement PCB as a low signal via the T (temperature) input. At the end of the a/d converter's integration period (during  $\Delta 2$ ), relay K2 is energized and R-S flip-flop (U1B and U1C) is preset. The closed contacts of K2 allow the flip-flop to observe the condition of the input thermocouple, and reset if a normally low impedance is encountered ( $<7.5 \pm 2.5$  k ohms). Otherwise the flip-flop will remain in the preset condition and generate an open-thermocouple indication (open TC low). At the beginning of the read portion of the measurement cycle the  $\Delta 2$  pulse returns low allowing relay K2 to open. This allows the flip-flop to remain latched in its current position until changed during subsequent temperature measurement cycles.

643-18. The reference voltage used to power the reference junction circuitry on the Isothermal Block Connectors (Option -08) is derived from the 6.2V reference on the A/D Converter PCB. A unity gain amplifier on the Temperature Measurement PCB buffers the reference voltage and drives the 6.2V Bus which supplies operating power to the Isothermal Connectors housed in both the data logger and the extender chassis.

643-19. When the reference junction is to be measured, input RJ (from the function register on the a/d converter) is driven low causing the DPST contacts of relay K1 to close. As a result, the output of the reference voltage amplifier is connected to the 6.2V Reference Bus. A return signal in the form of reference junction temperature from the enabled Isothermal Block Connector (Option -08) is presented to the a/d converter for measurement purposes through the other pair of relay contacts.

#### 643-20. MAINTENANCE

##### 643-21. Access

643-22. The Temperature and Scaling Option comprises one pcb assembly and two IC's. These components are installed on two separate locations in the data logger and can be easily accessed

Table 643-2. Reference Junction Applications

DISPLAY IN DEGREES F	DISPLAY IN DEGREES C
mx + b Function: $m = -7.5160$ $b = 48290$	mx + b Function: $m = -4.1750$ $b = 25050$
Decimal Location $= 2(\text{XXX.XX})$	Decimal Location $= 2(\text{XXX.XX})$
Engineering Units = 27 ( $^{\circ}\text{F}$ )	Engineering Units = 26 ( $^{\circ}\text{C}$ )

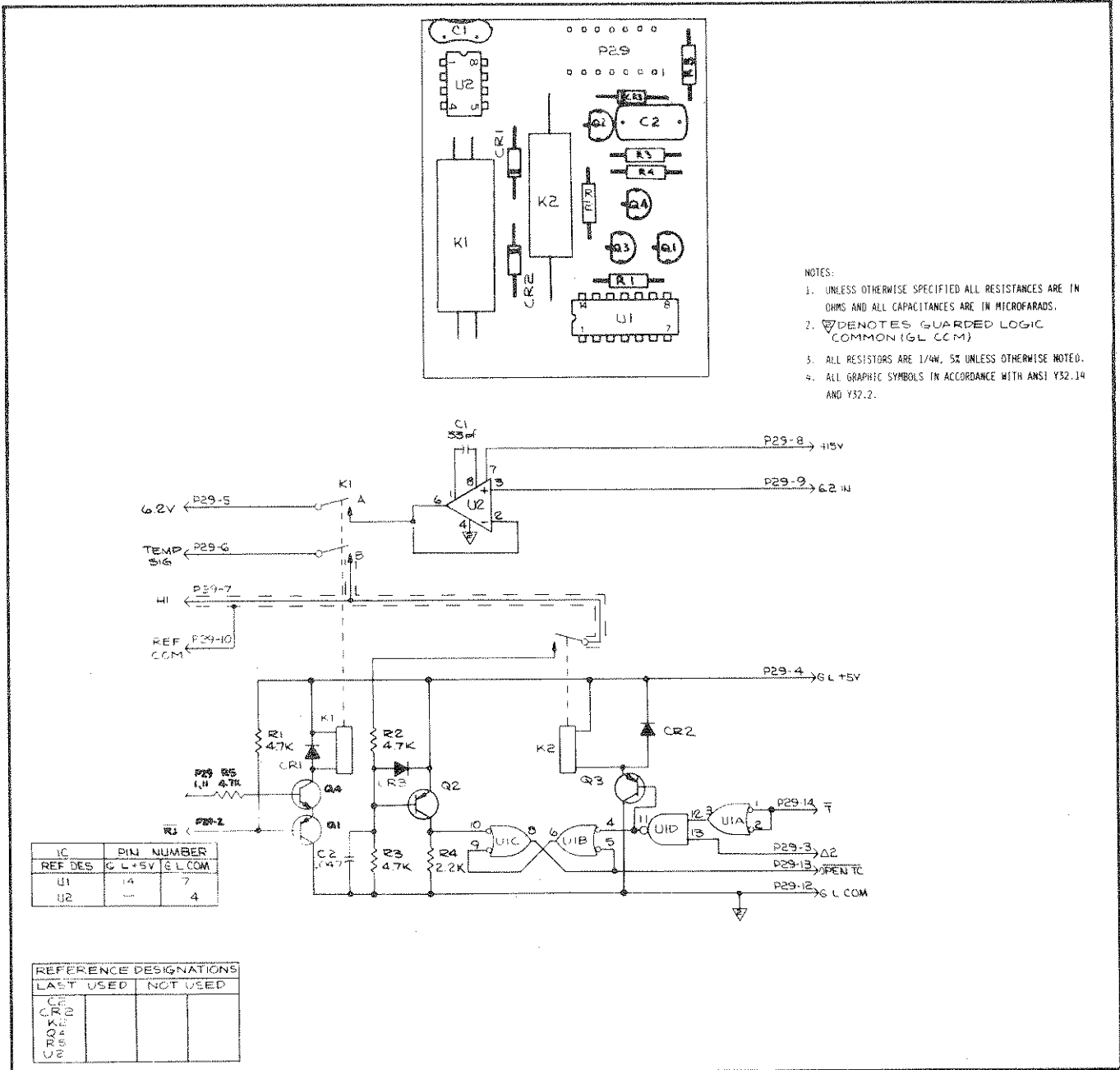

Figure 643-2. Temperature and Scaling Option PCB Assembly, Options -43, -44 and -45 (2200A-1021)



for maintenance purposes. Figure 643-3 defines the individual component locations of both the controller and A/D Converter PCB's. Access to these pcb's is achieved by removing the top cover and the two inner guard covers from the data logger.

#### 643-23. Temperature Scale Switch Settings

643-24. Temperature measurements can be displayed in terms of either OC or OF by properly setting a switch on the Controller PCB Assembly. The switch location is shown in Figure 643-2 (Celsius/Fahrenheit switch, #3). Setting the switch to ON selects the Fahrenheit scale. Conversely, OFF selects the Celsius scale.

#### 643-25. Calibration

643-26. The Temperature Option does not require calibration. However, its accuracy is dependent upon the calibration of the A/D Converter and the reference junction on the Isothermal Block Connector (Option -08).

#### 643-27. LIST OF REPLACEABLE PARTS

643-28. Option -43, -44, and -45 all include the Temperature Option PCB Assembly. However, each of the options (-43, -44, or -45) requires a different linearization Integrated Circuit which is installed as U14 on the Controller PCB. A list of replaceable parts for the Temperature Option PCB Assembly is given in Table 643-3.

643-29. To order a Temperature Option with both the linearization IC and the Temperature Option PCB Assembly, simply order by option number (-43, -44, or -45). To order only an Option -43 linearization IC, use Fluke part number 610816; to order only an Option -44 linearization IC, use Fluke part number 610824; to order only an Option -45 linearization IC, use Fluke part number 613174.

#### CAUTION



Indicated devices are subject  
to damage by static discharge.

Table 643-5. Temperature Option PCB Assembly

REF DES	DESCRIPTION	FLUKE STOCK NO.	MFG SPLY CODE	MFG. PART NO.	TOT QTY	REC QTY	NOTE
	TEMPERATURE OPTION PCB ASSEMBLY FIGURE 643-3 (2200A-4021)					REF	
C1	CAP, MICA, 33 PF +/-5%, 500V	160317	72136	DM15E330J	1		
C2	CAP, PLASTIC, 0.47 UF +/-10%, 50V	271858	06001	75F1R5A474	1		
CR1	DIODE, SI, HI-SPEED-SWITCHING	203323	07910	2N4448	3		1
CR2	DIODE, SI, HI-SPEED-SWITCHING	203323	07910	2N4448	REF		
CR3	DIODE, SI, HI-SPEED-SWITCHING	203323	07910	2N4448	REF		
K1	COIL, REED RELAY	272070	71707	UD-6-P	1		
	REED SWITCH, INTERNAL	414300	95348	MR5830-7	3		
K2	COIL, EXT, SINGLE	269019	71707	U-6-P	1		
P29	CONNECTOR, POST	267633	00779	86144-1	14		
Q1	XSTR, SI, PNP	195974	04713	2N3906	3		1
Q2	XSTR, SI, PNP	195974	04713	2N3906	REF		
Q3	XSTR, SI, PNP	195974	04713	2N3906	REF		
Q4	XSTR, SI, NPN	218396	04713	2N3904	1		1
R1	RES, COMP, 4.7K +/-5%, 1/4W	148072	01121	CB4725	3		
R2	RES, COMP, 4.7K +/-5%, 1/4W	148072	01121	CB4725	REF		
R3	RES, COMP, 4.7K +/-5%, 1/4W	148072	01121	CB4725	REF		
R4	RES, COMP, 2.2K +/-5%, 1/4W	148049	01121	CB2225	1		
U1	IC, TTL, QUAD, 2-INPUT, POS, NAND GATE	393033	01295	SN74LS00N	1		1
U2	IC, LINEAR, OP AMP	363515	12040	LM301AN	1		1

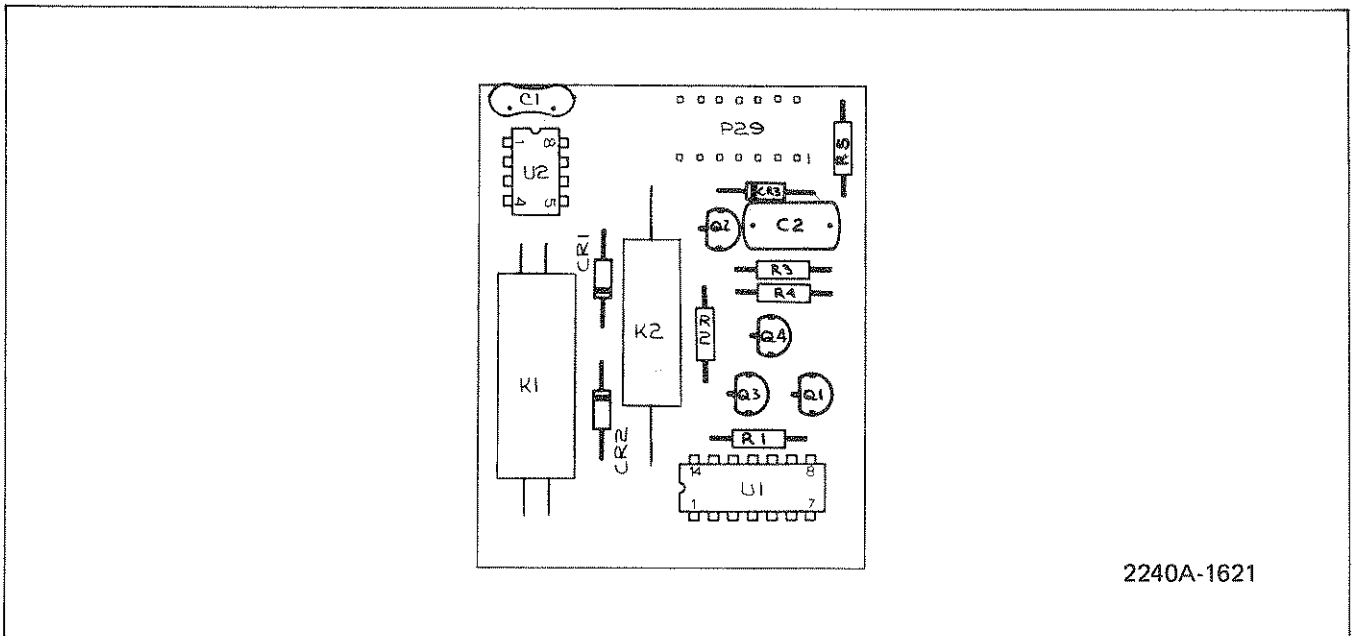

2240A-1621

Figure 643-3. Temperature Option PCB Assembly



## Section 7

# General Information

7-1. This section of the manual contains generalized user information as well as supplemental information to the List of Replaceable Parts contained in Section 5. The following information is presented in this section:

List of Abbreviations

Federal Supply Codes for Manufacturers

Fluke Technical Service Centers - U.S. and Canada

Fluke Technical Service Centers - International

Sales Representatives - U.S. and Canada

Sales Representatives - International

## List of Abbreviations and Symbols

<b>A or amp</b>	ampere	<b>hf</b>	high frequency	<b>(+) or pos</b>	positive
<b>ac</b>	alternating current	<b>Hz</b>	hertz	<b>pot</b>	potentiometer
<b>af</b>	audio frequency	<b>IC</b>	integrated circuit	<b>p-p</b>	peak-to-peak
<b>a/d</b>	analog-to-digital	<b>if</b>	intermediate frequency	<b>ppm</b>	parts per million
<b>assy</b>	assembly	<b>in</b>	inch(es)	<b>PROM</b>	programmable read-only memory
<b>AWG</b>	american wire gauge	<b>intl</b>	internal	<b>psi</b>	pound-force per square inch
<b>B</b>	bel	<b>I/O</b>	input/output	<b>RAM</b>	random-access memory
<b>bcd</b>	binary coded decimal	<b>k</b>	kilo (10 <sup>3</sup> )	<b>rf</b>	radio frequency
<b>°C</b>	Celsius	<b>kHz</b>	kilohertz	<b>rms</b>	root mean square
<b>cap</b>	capacitor	<b>kΩ</b>	kilohm(s)	<b>ROM</b>	read-only memory
<b>ccw</b>	counterclockwise	<b>kV</b>	kilovolt(s)	<b>s or sec</b>	second (time)
<b>cer</b>	ceramic	<b>lf</b>	low frequency	<b>scope</b>	oscilloscope
<b>cermet</b>	ceramic to metal(seal)	<b>LED</b>	light-emitting diode	<b>SH</b>	shield
<b>ckt</b>	circuit	<b>LSB</b>	least significant bit	<b>Si</b>	silicon
<b>cm</b>	centimeter	<b>LSD</b>	least significant digit	<b>serno</b>	serial number
<b>cmrr</b>	common mode rejection ratio	<b>M</b>	mega (10 <sup>6</sup> )	<b>sr</b>	shift register
<b>comp</b>	composition	<b>m</b>	milli (10 <sup>-3</sup> )	<b>Ta</b>	tantalum
<b>cont</b>	continue	<b>mA</b>	milliamper(e)s	<b>tb</b>	terminal board
<b>crt</b>	cathode-ray tube	<b>max</b>	maximum	<b>tc</b>	temperature coefficient or temperature compensating
<b>cw</b>	clockwise	<b>mf</b>	metal film	<b>tcxo</b>	temperature compensated crystal oscillator
<b>d/a</b>	digital-to-analog	<b>MHz</b>	megahertz	<b>tp</b>	test point
<b>dac</b>	digital-to-analog converter	<b>min</b>	minimum	<b>u or μ</b>	micro (10 <sup>-6</sup> )
<b>dB</b>	decibel	<b>mm</b>	millimeter	<b>uhf</b>	ultra high frequency
<b>dc</b>	direct current	<b>ms</b>	millisecond	<b>us or μs</b>	microsecond(s) (10 <sup>-6</sup> )
<b>dmm</b>	digital multimeter	<b>MSB</b>	most significant bit	<b>uut</b>	unit under test
<b>dvm</b>	digital voltmeter,	<b>MSD</b>	most significant digit	<b>V</b>	volt
<b>elect</b>	electrolytic	<b>MTBF</b>	mean time between failures	<b>v</b>	voltage
<b>ext</b>	external	<b>MTTR</b>	mean time to repair	<b>var</b>	variable
<b>F</b>	farad	<b>mV</b>	millivolt(s)	<b>vco</b>	voltage controlled oscillator
<b>°F</b>	Fahrenheit	<b>mv</b>	multivibrator	<b>vhf</b>	very high frequency
<b>FET</b>	Field-effect transistor	<b>MΩ</b>	megohm(s)	<b>vlf</b>	very low frequency
<b>ff</b>	flip-flop	<b>n</b>	nano (10 <sup>-9</sup> )	<b>W</b>	watt(s)
<b>freq</b>	frequency	<b>na</b>	not applicable	<b>ww</b>	wire wound
<b>FSN</b>	federal stock number	<b>NC</b>	normally closed	<b>xfmr</b>	transformer
<b>g</b>	gram	<b>(-) or neg</b>	negative	<b>xstr</b>	transistor
<b>G</b>	giga (10 <sup>9</sup> )	<b>NO</b>	normally open	<b>xtal</b>	crystal
<b>gd</b>	guard	<b>ns</b>	nanosecond	<b>xtlo</b>	crystal oscillator
<b>Ge</b>	germanium	<b>opnl ampl</b>	operational amplifier	<b>Ω</b>	ohm(s)
<b>GHz</b>	gigahertz	<b>p</b>	pico (10 <sup>-12</sup> )	<b>μ</b>	micro (10 <sup>-6</sup> )
<b>gmV</b>	guaranteed minimum value	<b>para</b>	paragraph		
<b>gnd</b>	ground	<b>pcb</b>	printed circuit board		
<b>H</b>	henry	<b>pF</b>	picofarad		
<b>hd</b>	heavy duty	<b>pn</b>	part number		

### Federal Supply Codes for Manufacturers

00213 Nytronics Comp. Group Inc. Subsidiary of Nytronics Inc. Formerly Sage Electronics Rochester, New York	02660 Bunker Ramo Corp., Conn Div. Formerly Amphenol-Borg Electric Corp. Broadview, Illinois	04946 Standard Wire & Cable Los Angeles, California	06751 Components, Inc. Semcor Div. Phoenix, Arizona
00327 Welwyn International, Inc. Westlake, Ohio	02799 Aero Capacitors, Inc. Chatsworth, California	05082 Replaced by 94988	06860 Gould Automotive Div. City of Industry, California
00656 Aerovox Corp. New Bedford, Massachusetts	03508 General Electric Co. Semiconductor Products Syracuse, New York	05236 Jonathan Mfg. Co. Fullerton, California	06961 Vernitron Corp., Piezo Electric Div. Formerly Clevite Corp., Piezo Electric Div. Bedford, Ohio
00686 Film Capacitors, Inc. Passaic, New Jersey	03614 Replaced by 71400	05245 Components Corp. now Corcom, Inc. Chicago, Illinois	06980 Eimac Div. Varian Associates San Carlos, California
00779 AMP Inc. Harrisburg, Pennsylvania	03651 Replaced by 44655	05277 Westinghouse Electric Corp. Semiconductor Div. Youngwood, Pennsylvania	07047 The Ross Milton Co. South Hampton, Pennsylvania
01121 Allen-Bradley Co. Milwaukee, Wisconsin	03797 Eldema Div. Genisco Technology Corp. Compton, California	05278 Replaced by 43543	07115 Replaced by 14674
01281 TRW Electronic Comp. Semiconductor Operations Lawndale, California	03877 Transistron Electronic Corp. Wakefield, Massachusetts	05279 Southwest Machine & Plastic Co. Glendora, California	07138 Westinghouse Electric Corp., Electronic Tube Div. Horsehead, New York
01295 Texas Instruments, Inc. Semiconductor Group Dallas, Texas	03888 KDI Pyrofilm Corp. Whippany, New Jersey	05397 Union Carbide Corp. Materials Systems Div. New York, New York	07233 TRW Electronic Components Cinch Graphic City of Industry, California
01537 Motorola Communications & Electronics Inc. Franklin Park, Illinois	03911 Clairex Electronics Div. Clairex Corp. Mt. Vernon, New York	05571 Use 56289 Sprague Electric Co. Pacific Div. Los Angeles, California	07256 Silicon Transistor Corp. Div. of BBF Group Inc. Chelmsford, Massachusetts
01686 RCL Electronics Inc. Manchester, New Hampshire	03980 Muirhead Inc. Mountainside, New Jersey	05574 Viking Industries Chatsworth, California	07261 Aumet Corp. Culver City, California
01730 Replaced by 73586	04009 Arrow Hart Inc. Hartford, Connecticut	05704 Replaced by 16258	07263 Fairchild Semiconductor Div. of Fairchild Camera & Instrument Corp. Mountain View, California
01864 Use 56289 Sprague Electric Co. Dearborn Electronic Div. Lockwood, Florida	04062 Replaced by 72136	05820 Wakefield Engineering Inc. Wakefield, Massachusetts	07344 Bircher Co., Inc. Rochester, New York
02114 Ferroxcube Corp. Saugerties, New York	04202 Replaced by 81312	06001 General Electric Co. Electronic Capacitor & Battery Products Dept. Columbia, South Carolina	07597 Burndy Corp. Tape/Cable Div. Rochester, New York
02131 General Instrument Corp. Harris ASW Div. Westwood, Maine	04217 Essex International Inc. Wire & Cable Div. Anaheim, California	06136 Replaced by 63743	07792 Lerma Engineering Corp. Northampton, Massachusetts
02395 Rason Mfg. Co. Brooklyn, New York	04221 Aemco, Div. of Midtex Inc. Mankato, Minnesota	06383 Panduit Corp. Tinley Park, Illinois	07910 Teledyne Semiconductor Formerly Continental Device Hawthorne, California
02533 Snelgrove, C.R. Co., Ltd. Don Mills, Ontario, Canada M3B 1M2	04222 AVX Ceramics Div. AVX Corp. Myrtle Beach, Florida	06473 Bunker Ramo Corp. Amphenol SAMS Div. Chatsworth, California	07933 Use 49956 Raytheon Co. Semiconductor Div. HQ Mountain View, California
02606 Fenwal Labs Div. of Travenal Labs. Morton Grove, Illinois	04423 Telonic Industries Laguna Beach, California	06555 Beede Electrical Instrument Co. Penacook, New Hampshire	08225 Industro Transistor Corp. Long Island City, New York
	04645 Replaced by 75376	06739 Electron Corp. Littleton, Colorado	
	04713 Motorola Inc. Semiconductor Products Phoenix, Arizona	06743 Clevite Corp. Cleveland, Ohio	

### Federal Supply Codes for Manufacturers (cont)

08261 Spectra Strip Corp. Garden Grove, California	11726 Qualidyne Corp. Santa Clara, California	13606 Use 56289 Sprague Electric Co. Transistor Div. Concord, New Hampshire	16299 Corning Glass Electronic Components Div. Raleigh, North Carolina
08530 Reliance Mica Corp. Brooklyn, New York	12014 Chicago Rivet & Machine Co. Bellwood, Illinois	13839 Replaced by 23732	16332 Replaced by 28478
08806 General Electric Co. Miniature Lamp Products Dept Cleveland, Ohio	12040 National Semiconductor Corp. Danbury, Connecticut	14099 Semtech Corp. Newbury Park, California	16473 Cambridge Scientific Ind. Div. of Chemed Corporation Cambridge, Maryland
08863 Nylomatic Corp. Norrisville, Pennsylvania	12060 Diodes, Inc. Chatsworth, California	14140 Edison Electronic Div. Mc Gray-Edison Co. Manchester, New Hampshire	16742 Paramount Plastics Fabricators, Inc. Downey, California
08988 Use 53085 Skottie Electronics Inc. Archbald, Pennsylvania	12136 Philadelphia Handle Co. Camden, New Jersey	14193 Cal-R-Inc. formerly California Resistor, Corp. Santa Monica, California	16758 Delco Electronics Div. of General Motors Corp. Kokomo, Indiana
09214 G E. Co. Semi-Conductor Products Dept. Power Semi-Conductor Products OPN Sec. Auburn, New York	12300 Potter-Brumfield Div. AMF Canada LTD. Guelph, Ontario, Canada	14298 American Components, Inc. an Insilco Co. Conshohocken, Pennsylvania	17001 Replaced by 71468
09353 C and K Components Watertown, Massachusetts	12323 Presin Co., Inc. Shelton, Connecticut	14655 Cornell-Dublier Electronics Division of Federal Pacific Electric Co. Govt. Control Dept. Newark, New Jersey	17069 Circuit Structures Lab. Burbank, California
09423 Scientific Components, Inc. Santa Barbara, California	12327 Freeway Corp. formerly Freeway Washer & Stamping Co. Cleveland, Ohio	14752 Electro Cube Inc. San Gabriel, California	17338 High Pressure Eng. Co., Inc. Oklahoma City, Oklahoma
09922 Burndy Corp. Norwalk, Connecticut	12443 The Budd Co. Polychem Products Plastic Products Div. Bridgeport, Pennsylvania	14869 Replaced by 96853	17545 Atlantic Semiconductors, Inc. Asbury Park, New Jersey
09969 Dale Electronics Inc. Yankton, S. Dakota	12615 U.S. Terminals Inc. Cincinnati, Ohio	14936 General Instrument Corp. Semi Conductor Products Group Hicksville, New York	17856 Siliconix, Inc. Santa Clara, California
10059 Barker Engineering Corp. Formerly Amerace, Amerace ESNA Corp. Kenilworth, New Jersey	12617 Hamlin Inc. Lake Mills, Wisconsin	15636 Elec-Trol Inc. Saugus, California	17870 Replaced by 14140
11236 CTS of Berne Berne, Indiana	12697 Clarostat Mfg. Co. Dover, New Hampshire	15801 Fenwal Electronics Inc. Div. of Kidde Walter and Co., Inc. Framingham, Massachusetts	18178 Vactec Inc. Maryland Heights, Missouri
11237 CTS Keene Inc. Paso Robles, California	12749 James Electronics Chicago, Illinois	15818 Teledyne Semiconductors, formerly Amelco Semiconductor Mountain View, California	18324 Signetics Corp. Sunnyvale, California
11358 CBS Electronic Div. Columbia Broadcasting System Newburyport, Minnesota	12856 Micrometals Sierra Madre, California	15849 Litton Systems Inc. Useco Div. formerly Useco Inc. Van Nuys, California	18612 Vishay Resistor Products Div. Vishay Intertechnology Inc. Malvern, Pennsylvania
11403 Best Products Co. Chicago, Illinois	12954 Dickson Electronics Corp. Scottsdale, Arizona	15898 International Business Machines Corp. Essex Junction, Vermont	18736 Voltronics Corp. Hanover, New Jersey
11503 Keystone Columbia Inc. Warren, Michigan	12969 Unitrode Corp. Watertown, Massachusetts	15909 Replaced by 14140	18927 GTE Sylvania Inc. Precision Material Group Parts Division Titusville, Pennsylvania
11532 Teledyne Relays Hawthorne, California	13103 Thermalloy Co., Inc. Dallas, Texas	16258 Space-Lok Inc. Burbank, California	19451 Perine Machinery & Supply Co. Seattle, Washington
11711 General Instrument Corp. Rectifier Division Hicksville, New York	13327 Solitron Devices Inc. Tappan, New York		19701 Electro-Midland Corp. Mepco-Electra Inc. Mineral Wells, Texas
	13511 Amphenol Cadre Div. Bunker-Ramo Corp. Los Gatos, California		20584 Enochs Mfg. Inc. Indianapolis, Indiana

**Federal Supply Codes for Manufacturers (cont)**

20891 Self-Organizing Systems, Inc. Dallas, Texas	28480 Hewlett Packard Co. Corporate HQ Palo Alto, California	43543 Nytronics Inc. Transformer Co. Div. Geneva, New York	70903 Belden Corp. Geneva, Illinois
21604 Bucheye Stamping Co. Columbus, Ohio	28520 Heyman Mfg. Co. Kenilworth, New Jersey	44655 Ohmite Mfg. Co. Skokie, Illinois	71002 Birnback Radio Co., Inc. Freeport, New York
21845 Solitron Devices Inc. Transistor Division Riveria Beach, Florida	29083 Monsanto, Co., Inc. Santa Clara, California	49671 RCA Corp. New York, New York	71400 Bussmann Mfg. Div. of McGraw-Edison Co. Saint Louis, Missouri
22767 ITT Semiconductors Palo Alto, California	29604 Stackpole Components Co. Raleigh, North Carolina	49956 Raytheon Company Lexington, Massachusetts	71450 CTS Corp. Elkhart, Indiana
23050 Product Comp. Corp. Mount Vernon, New York	30148 AB Enterprise Inc. Ahoskie, North Carolina	50088 Mostek Corp. Carrollton, Texas	71468 ITT Cannon Electric Inc. Santa Ana, California
23732 Tracor Inc. Rockville, Maryland	30323 Illinois Tool Works, Inc. Chicago, Illinois	50579 Litronix Inc. Cupertino, California	71482 Clare, C.P. & Co. Chicago, Illinois
23880 Stanford Applied Engrng. Santa Clara, California	31091 Optimax Inc. Colmar, Pennsylvania	51605 Scientific Components Inc. Linden, New Jersey	71590 Centrelab Electronics Div. of Globe Union Inc. Milwaukee, Wisconsin
23936 Pamotor Div., Wm. J. Purdy Co. Burlingame, California	32539 Mura Corp. Great Neck, New York	53021 Sangamo Electric Co. Springfield, Illinois	71707 Coto Coil Co., Inc. Providence, Rhode Island
24248 Replaced by 94222	32767 Griffith Plastic Corp. Burlingame, California	54294 Cutler-Hammer Inc. formerly Shallcross, A Cutter-Hammer Co. Selma, North Carolina	71744 Chicago Miniature Lamp Works Chicago, Illinois
24355 Analog Devices Inc. Norwood, Massachusetts	32879 Advanced Mechanical Components Northridge, California	55026 Simpson Electric Co. Div. of Am. Gage and Mach. Co. Elgin, Illinois	71785 TRW Electronics Components Cinch Connector Operations Div. Elk Grove Village Chicago, Illinois
24655 General Radio Concord, Massachusetts	32897 Erie Technological Products, Inc. Frequency Control Div. Carlisle, Pennsylvania	56289 Sprague Electric Co. North Adams, Massachusetts	72005 Wilber B. Driver Co. Newark, New Jersey
24759 Lenox-Fugle Electronics Inc. South Plainfield, New Jersey	32997 Bourns Inc. Trimpot Products Division Riverside, California	58474 Superior Electric Co. Bristol, Connecticut	72092 Replaced by 06980
25088 Siemen Corp. Isilen, New Jersey	33173 General Electric Co. Products Dept. Owensboro, Kentucky	60399 Torin Corp. formerly Torrington Mfg. Co. Torrington, Connecticut	72136 Electro Motive Mfg. Co. Williamantic, Connecticut
25403 Amperex Electronic Corp. Semiconductor & Micro-Circuits Div. Slatersville, Rhode Island	34333 Silicon General Westminister, California	63743 Ward Leonard Electric Co., Inc. Mount Vernon, New York	72259 Nytronics Inc. Pelham Manor, New Jersey
27014 National Semiconductor Corp. Santa Clara, California	34335 Advanced Micro Devices Sunnyvale, California	64834 West Mfg. Co. San Francisco, California	72619 Dialight Div. Amperex Electronic Corp. Brooklyn, New York
27264 Molex Products Downers Grove, Illinois	34802 Electromotive Inc. Kenilworth, New Jersey	65092 Weston Instruments Inc. Newark, New Jersey	72653 G.C. Electronics Div. of Hydrometals, Inc. Brooklyn, New York
28213 Minnesota Mining & Mfg. Co. Consumer Products Div. St. Paul, Minnesota	37942 P.R. Mallory & Co., Inc. Indianapolis, Indiana	66150 Winslow Tele-Tronics Inc. Eaton Town, New Jersey	72665 Replaced by 90303
28425 Serv--Link formerly Bohannon Industries Fort Worth, Texas	42498 National Radio Melrose, Massachusetts	70485 Atlantic India Rubber Works Chicago, Illinois	72794 Dzus Fastener Co., Inc. West Islip, New York
28478 Deltrol Controls Div. Deltrol Corporation Milwaukee, Wisconsin		70563 Amperite Company Union City, New Jersey	72928 Gulton Ind. Inc. Gudeman Div. Chicago, Illinois



### Federal Supply Codes for Manufacturers (cont)

72982 Erie Tech. Products Inc. Erie, Pennsylvania	75382 Kulka Electric Corp. Mount Vernon, New York	80583 Hammarlund Mfg. Co., Inc. Red Bank, New Jersey	83594 Burrhoughs Corp. Electronic Components Div. Plainfield, New Jersey
73138 Bechman Instrument Inc. Helipot Division Fullerton, California	75915 Littlefuse Inc. Des Plaines, Illinois	80640 Arnold Stevens, Inc. South Boston, Massachusetts	83740 Union Carbide Corp. Battery Products Div. formerly Consumer Products Div. New York, New York
73293 Hughes Aircraft Co. Electron Dynamics Div. Torrance, California	76854 Oak Industries Inc. Switch Div. Crystal Lake, Illinois	81073 Grayhill, Inc. La Grange, Illinois	84171 Arco Electronics Great Neck, New York
73445 Amperex Electronic Corp. Hicksville, New York	77342 AMF Inc. Potter & Brumfield Div. Princeton, Indiana	81312 Winchester Electronics Div. of Litton Industries Inc. Oakville, Connecticut	84411 TRW Electronic Components TRW Capacitors Ogallala, Nebraska
73559 Carling Electric Inc. West Hartford, Connecticut	77638 General Instrument Corp. Rectifier Division Brooklyn, New York	81483 Therm-O-Disc Inc. Mansfield, Ohio	84613 Fuse Indicator Corp. Rockville, Maryland
73586 Circle F Industries Trenton, New Jersey	77969 Rubbercraft Corp. of CA. LTD. Torrance, California	81483 International Rectifier Corp. Los Angeles, California	84682 Essex International Inc. Industrial Wire Div. Peabody, Massachusetts
73734 Federal Screw Products, Inc. Chicago, Illinois	78189 Shakeproof Div. of Illinois Tool Works Inc. Elgin, Illinois	81590 Korry Mfg. Co. Seattle, Washington	86577 Precision Metal Products of Malden Inc. Stoneham, Massachusetts
73743 Fischer Special Mfg. Co. Cincinnati, Ohio	78277 Sigma Instruments, Inc. South Braintree, Massachusetts	81741 Chicago Lock Co. Chicago, Illinois	86684 Radio Corp. of America Electronic Components Div. Harrison, New Jersey
73899 JFD Electronics Co. Components Corp. Brooklyn, New York	78488 Stackpole Carbon Co. Saint Marys, Pennsylvania	82305 Palmer Electronics Corp. South Gate, California	86928 Seastrom Mfg. Co., Inc. Glendale, California
73949 Guardian Electric Mfg. Co. Chicago, Illinois	78553 Eaton Corp. Engineered Fastener Div. Tinnerman Plant Cleveland, Ohio	82369 Switchcraft Inc. Chicago, Illinois	87034 Illuminated Products Inc. Subsidiary of Oak Industries Inc. Anahiem, California
74199 Quan Nichols Co. Chicago, Illinois	79136 Waides Kohinoor Inc. Long Island City, New York	82415 North American Phillips Controls Corp. Frederick, Maryland	88219 Gould Inc. Industrial Div. Trenton, New Jersey
74217 Radio Switch Corp. Marlboro, New Jersey	79497 Western Rubber Company Goshen, Indiana	82872 Roanwell Corp. New York, New York	88245 Litton Systems Inc. Useco Div. Van Nuys, California
74276 Signalite Div. General Instrument Corp. Neptune, New Jersey	79963 Zierick Mfg. Corp. Mt. Kisko, New York	82877 Rotron Inc. Woodstock, New York	88419 Cornell-Dubilier Electronic Div. Federal Pacific Co. Fuquay-Varian, North Carolina
74306 Piezo Crystal Co. Carlisle, Pennsylvania	80031 Electro-Midland Corp. Mepco Div. A North American Phillips Co. Norristown, New Jersey	82879 ITT Royal Electric Div. Pawtucket, Rhode Island	88486 Plastic Wire & Cable Jewitt City, Connecticut
74542 Hoyt Elect. Instr. Works Penacook, New Hampshire	80145 LFE Corp., Process Control Div. formerly API Instrument Co. Chesterland, Ohio	83003 Varo Inc. Garland, Texas	88690 Replaced by 04217
74970 Johnson E.F., Co. Waseca, Minnesota	80183 Use 56289 Sprague Products North Adams, Massachusetts	83058 The Carr Co., United Can Div. of TRW Cambridge, Massachusetts	89536 John Fluke Mfg. Co., Inc. Seattle, Washington
75042 TRW Electronics Components IRC Fixed Resistors Philadelphia, Pennsylvania	80294 Bourns Inc., Instrument Div. Riverside, California	83298 Bendix Corp. Electric Power Div. Eatontown, New Jersey	89730 G.E. Co., Newark Lamp Works Newark, New Jersey
75376 Kurz-Kasch Inc. Dayton, Ohio		83330 Herman H. Smith, Inc. Brooklyn, New York	
75378 CTS Knights Inc. Sandwich, Illinois		83478 Rubbercraft Corp. of America, Inc. West Haven, Connecticut	

**Federal Supply Codes for Manufacturers (cont)**

90201  
Mallory Capacitor Co.  
Div. of P.R. Mallory Co., Inc.  
Indianapolis, Indiana

90211  
Use 56365  
Square D Co.  
Chicago, Illinois

90215  
Best Stamp & Mfg. Co.  
Kansas City, Missouri

90303  
Mallory Battery Co.  
Div. of Mallory Co., Inc.  
Tarrytown, New York

91094  
Essex International Inc.  
Suglex/IWP Div.  
Newmarket, New Hampshire

91293  
Johanson Mfg. Co.  
Boonton, New Jersey

91407  
Replaced by 58474

91502  
Associated Machine  
Santa Clara, California

91506  
Augat Inc.  
Attleboro, Massachusetts

91637  
Dale Electronics Inc.  
Columbus, Nebraska

91662  
Elco Corp.  
Willow Grove, Pennsylvania

91737  
Use 71468  
Gremar Mfg. Co., Inc.  
ITT Cannon/Gremar  
Santa Ana, California

91802  
Industrial Devices, Inc.  
Edgewater, New Jersey

91833  
Keystone Electronics Corp.  
New York, New York

91836  
King's Electronics Co., Inc.  
Tuckahoe, New York

91929  
Honeywell Inc.  
Micro Switch Div.  
Freeport, Illinois

91934  
Miller Electric Co., Inc.  
Div. of Aunet  
Woonsocket, Rhode Island

92194  
Alpha Wire Corp.  
Elizabeth, New Jersey

93332  
Sylvania Electric Products  
Semiconductor Products Div.  
Woburn, Massachusetts

94145  
Replaced by 49956

94154  
Use 94988  
Wagner Electric Corp.  
Tung-Sol Div.  
Newark, New Jersey

94222  
Southco Inc. formerly  
South Chester Corp.  
Lester, Pennsylvania

95146  
Alco Electronic Products Inc.  
Lawrence, Massachusetts

95263  
Leecraft Mfg. Co.  
Long Island City, New York

95264  
Replaced by 98278

95275  
Vitramon Inc.  
Bridgeport, Connecticut

95303  
RCA Corp.  
Receiving Tube Div.  
Cincinnati, Ohio

95348  
Gordo's Corp.  
Bloomfield, New Jersey

95354  
Methode Mfg. Corp.  
Rolling Meadows, Illinois

95712  
Bendix Corp.  
Electrical Components Div.  
Microwave Devices Plant  
Franklin, Indiana

95987  
Weckesser Co. Inc.  
Chicago, Illinois

96733  
San Fernando Electric Mfg. Co.  
San Fernando, California

96853  
Gulton Industries Inc.  
Measurement and Controls Div.  
formerly Rustak Instruments Co.  
Manchester, New Hampshire

96881  
Thomson Industries, Inc.  
Manhasset, New York

97540  
Master Mobile Mounts, Div. of  
Whitehall Electronics Corp.  
Ft. Meyers, Florida

97913  
Industrial Electronic  
Hardware Corp.  
New York, New York

97945  
Penwalt Corp.  
SS White Industrial Products Div.  
Piscataway, New Jersey

97966  
Replaced by 11358

98094  
Replaced by 49956

98159  
Rubber-Teck, Inc.  
Gardena, California

98278  
Malco A Microdot Co., Inc.  
Connector & Cable Div.  
Pasadena, California

98291  
Sealectro Corp.  
Mamaroneck, New York

98388  
Royal Industries  
Products Div.  
San Diego, California

98743  
Replaced by 12749

98925  
Replaced by 14433

99120  
Plastic Capacitors, Inc.  
Chicago, Illinois

99217  
Bell Industries Elect.  
Comp. Div.  
formerly Southern Elect. Div.  
Burbank, California

99392  
STM  
Oakland, California

99515  
ITT Jennings Monrovia Plant  
Div. of ITT Jennings formerly  
Marshall Industries Capacitor Div.  
Monrovia, California

99779  
Use 29587  
Bunker-Ramo Corp.  
Barnes Div.  
Landsdowne, Pennsylvania

99800  
American Precision Industries Inc.  
Delevan Division  
East Aurora, New York

99942  
Centrelab Semiconductor  
Centrelab Electronics Div. of  
Globe-Union Inc.  
El Monte, California

Toyo Electronics  
(R-Ohm Corp.)  
Irvine, California

National Connector  
Minneapolis, Minnesota

## Fluke Technical Service Centers - U.S. and Canada

### UNITED STATES

#### CA, Burbank

Fluke Technical Center  
2020 N. Lincoln Street  
Burbank, CA 91504  
(213) 849-4641

#### CA, Santa Clara

Fluke Technical Center  
2300 Walsh Avenue  
Santa Clara, CA 95050  
(408) 985-1200

#### CO, Denver

Fluke Technical Center  
1980 S. Quebec Street, Unit 4  
Denver, CO 80231  
(303) 750-1228

#### FL, Orlando

Fluke Technical Center  
940 N. Fern Creek Avenue  
Orlando, FL 32803  
(305) 896-2296

### IL, Rolling Meadows

Fluke Technical Center  
1400 Hicks Road  
Rolling Meadows, IL 60008  
(312) 398-5800

### MA, Waltham

Fluke Technical Center  
244 Second Avenue  
Waltham, MA 02154  
(617) 890-1604

### MD, Rockville

Fluke Technical Center  
5640 Fishers Lane  
Rockville, MD 20852  
(301) 770-1576

### MN, Apple Valley

Fluke Technical Center  
7373 West 147th Street, Suite 196  
Apple Valley, MN 55124  
(612) 432-9400

### NC, Greensboro

Fluke Technical Center  
1310 Beaman Place  
Greensboro, NC 27408  
(919) 273-1918

### NJ, Paramus

Fluke Technical Center  
West 75th Century Road  
Paramus, NJ 07652  
(210) 262-9550

### TX, Dallas

Fluke Technical Center  
14400 Midway Road  
Dallas, TX 75240  
(214) 233-9945

### WA, Mountlake Terrace

John Fluke Mfg. Co., Inc.  
21707 66th Avenue W., Suite 1  
Mountlake Terrace, WA 98043  
(206) 774-2206

### CANADA

#### ALB, Calgary

Allan Crawford Assoc., Ltd.  
1935 30th Avenue N.E. #14  
Calgary, ALB T2E 6Z5  
(403) 230-1341

#### ONT, Mississauga

Allan Crawford Assoc., Ltd.  
6503 Northam Drive  
Mississauga, ONT L4V 1J5  
(416) 678-1500

#### QUE, St. Laurent

Allan Crawford Assoc., Ltd.  
7018 Cote de Liesse  
St. Laurent, QUE H4T 1E7  
(514) 731-8564

## Technical Service Centers - International

### ARGENTINA

Fluke Latin American  
Service Headquarters  
Virrey del Pino 4071  
Buenos Aires, Argentina  
Tel: 523185

### AUSTRALIA

Elmeasco Instrument Pty Ltd.  
P.O. Box 30  
Concord, N.S.W.  
Australia 2137  
Tel: (02) 736-2888

### AUSTRIA

Walter Rekirsch  
Elektronische Gerate GmbH & Co.  
Vertriebs-KG.  
Liechtensteinstrasse 97/6  
A-1090 Vienna, Austria  
Tel: 09-43-222-347646

### BELGIUM

Fluke (Belgium) S.A./N.V.  
6, Rue de Geneve  
1140 Brussels, Belgium  
Tel: 09-32-2-2164090

### BRAZIL

Arotec S.A.  
Industria e Comercio  
Av. Pacaembu 811  
01234 Sao Paulo S.P., Brazil  
Tel: 826-2266

### CHILE

Intronica Chile Ltda.  
Casilla 16228  
Santiago 9, Chile  
Tel: 44940

### COLOMBIA

Coasin Ltda.  
Carrera 13, # 37-37, Of. 407  
Ap. Aero 29583  
Bogota DE, Colombia  
Tel: 285-0230

### DENMARK

Tage Olsen A/S  
Ballerup Byvej 222  
DK-2750 Ballerup  
Denmark  
Tel: (01) 2-65 81 11

### ECUADOR

Proteco Coasin Cia., Ltda.  
Edificio "Jerico"  
Ave. 12 de Octubre #2285y  
Ave. Orellana (Planta Baja)  
Quito, Ecuador  
Tel: 526759

### EGYPT

Lotus Engineering Organisation  
P.O. Box 1252  
Cairo, Egypt  
Tel: 71617

### FINLAND

Oy Findip AB  
Teollisuustie 7  
02700 Kauniainen  
Finland  
Tel: 09-358-0-502255

### FRANCE

M.B. Electronique S.A.  
Rue Fourny  
ZAC de BUC  
B.P. #31  
78530 BUC, France  
Tel: 09-33-1-9568131

### GREECE

Hellenic Scientific  
Representations Ltd.  
11, Vrassida Street  
Athens 615, Greece  
Tel: 09-30-1-711140

### HONG KONG

Gilman Industrial Bldg., 9F  
107-109 Wai Yip Street  
Kwun Tong  
Kowloon, Hong Kong  
Tel: 3-427144

### INDIA

Hinditron Services Pvt. Ltd.  
"Hinditron House"  
412 Raj Mahal Vilas Extension  
Bangalore 560 006, India  
Tel: 33139

Hinditron Services Pvt. Ltd.  
69 A.L. Jagmohandas Marg  
Bombay 400 006, India  
Tel: 365344

### INDONESIA

P.T. Dwi Tunggal Jaya Sakti  
Sangga Buana Bldg., 1st Floor  
J1. Senen Raya 44, P.O. Box 4435  
Jakarta, Indonesia  
Tel: 376608

### IRAN

Irantronics Company Ltd.  
20 Salm Road  
Roosevelt Avenue  
Tehran, Iran  
Tel: 828294/831564

### ISRAEL

R.D.T. Electronics Engineering Ltd.  
P.O. Box 75  
46, Sokolov Street  
Ramat Hasharon 47235  
Israel  
Tel: 09-972-3-483211

### ITALY

Sistrel S.p.A.  
Via Timavo 66  
20099 Sesto S. Giovanni (Milan)  
Italy  
Tel: 09-39-2-2476693

Sistrel S.P.A.  
Via Giuseppe Armellini #37  
00143 Rome, Italy  
Tel: 09-39-6-5915551

### JAPAN

John Fluke Mfg. Co., Inc.  
Japan Branch  
1 Higashikata-machi  
Midori-ku  
Yokohama 226, Japan  
Tel: (045) 473-5425

### KOREA

Electro-Science Korea Co.  
C.P.O. Box 8446  
Room 1201 Bowon Bldg.  
490 Chongro - 5 Ka  
Chongro-ku  
Seoul, Korea  
Tel: 261-7702

### MALASIA

O'Connor's (Malaysia) SDN. BHD.  
P.O. Box 91  
Petaling Jaya, Selangor  
West Malaysia  
Tel: 51563

## Technical Service Centers - International (cont)

### MEXICO

C.J. Christensen S.A. De C.V.  
Melchor Ocampo 150-8  
Mexico 4 D.F., Mexico  
Tel: (905) 535-2258

### NETHERLANDS

Fluke (Nederland) B.V.  
P.O. Box 5053  
5004 EB Tilburg  
The Netherlands  
Tel: (013) 673973

### NEW ZEALAND

W & K McLean Ltd.  
P.O. Box 18065  
Glen Innes  
Auchland, New Zealand  
Tel: 587-037

### NORWAY

Morgenstjerne & Co. A/A  
Konghellegate 3  
P.O. Box 6688, Rodelokka  
Oslo 5, Norway  
Tel: 09-47-2-356110

### PAKISTAN

Pak International Operations  
505 Mohammadi House  
1.1. Chundrigar Road  
Katrachi-2 Pakistan  
Tel: 221127/239052

### PERU

Importaciones Y Representaciones  
Electronicas S.A.  
Avda. Franklin D. Roosevelt 105  
Lima 1, Peru  
Tel: 288650

### PORTUGAL

Equipamentos de Laboratorio, Ltda  
P.O. Box 1100  
Lisbon 1002, Portugal  
Tel: 09-351-1-578936/547512

### REPUBLIC OF SINGAPORE

Rank O'Connor's (PTE) Ltd.  
98 Pasir Panjang Road  
Singapore 0511  
Republic of Singapore  
Tel: 637944

### REPUBLIC OF SOUTH AFRICA

Fluke S.A. (Pty) Ltd.  
P.O. Box 39797  
Bramley 2018  
Republic of South Africa  
Tel: (011) 786-3170

### SPAIN

Hispano Electronica S.A.  
Apartado de Correos 48  
Alcorcon (Madrid)  
Spain  
Tel: 09-3416194108

### SWEDEN

Teleinstrument AB  
P.O. Box 490  
S-162 Vallingby 4  
Sweden  
Tel: 09-46-8-380370

### SWITZERLAND

Traco Electronic AG  
Jenatschstrasse 1  
8002 Zurich  
Switzerland  
Tel: 09-41-1-2010711

### TAIWAN

CCT Associates, Inc.  
P.O. Box 24209  
Taipei, Taiwan  
Republic of China  
Tel: 914434/928532

### THAILAND

Dynamic Supply Engineering R.O.P.  
# 56 Ekamai, Sukhumvit 63  
Bangkok-11, Thailand  
Tel: 914434/928532

### TURKEY

Erkman Elektronik Aletler  
Ticaret Anonim Sirketi  
Necatiby Cad 92/3  
Karakoy, Istanbul, Turkey  
Tel: 09-44-1-5461

### UNITED KINGDOM

Fluke International Corp. - UK  
Colonial Way  
Watford, Herts. WD24TT  
United Kingdom  
Tel: 09-4492340511

### URUGUAY

Coasin Uruguay S.R.L.  
Edificio Ciudadela  
Sarandi 690 D. Esc. 109  
Casilla de Correos 1400  
Correo Central  
Montevideo, Uruguay  
Tel: 917978

### VENEZUELA

Coasin C.A.  
Apdo. Postal 50939  
Sabana Grande # 1  
Caracas 105, Venezuela  
Tel: 782-9109

### WEST GERMANY

Fluke (Deutschland) GmbH  
Krausstrasse 32  
8045 Ismaning  
West Germany  
Tel: (089) 96251

Customers in the following countries: Bulgaria, Czechoslovakia, Hungary, Poland, Romania, U.S.S.R., and Yugoslavia, contact: Amtest Associates Ltd., P.O. Box 55, Addlestone, Surrey, KT 15 1DU, England, Tel. (0932) 52121

## Sales Representatives - U.S. and Canada

### UNITED STATES

#### AK, Anchorage

Harry Lang & Associates  
1371 Hillcrest Drive #303  
Anchorage, AK 99503  
(907) 279-5741

#### AL, Huntsville

John Fluke Mfg. Co., Inc.  
3322 Memorial Parkway  
Huntsville, AL 35807  
(205) 881-6220  
(404) 321-0980 (Atlanta)

#### AZ, Tempe

John Fluke Mfg. Co., Inc.  
2125 S. 48th Street, Suite 104  
Tempe, AZ 85285  
(602) 967-8724

#### CA, Los Angeles

John Fluke Mfg. Co., Inc.  
20902 S. Bonita Street  
Carson, CA 90746  
(213) 538-3900

#### CA, Santa Clara

John Fluke Mfg. Co., Inc.  
2300 Walsh Avenue  
Santa Clara, CA 95050  
(408) 244-1505

#### CA, Tustin

John Fluke Mfg. Co., Inc.  
15445 Red Hill Avenue, Suite F  
Tustin, CA 92680  
(714) 838-8863  
(714) 226-1254 (San Diego)

#### CO, Denver

John Fluke Mfg. Co., Inc.  
1980 S. Quebec, #4  
Denver, CO 80231  
(303) 750-1222

#### CT, Hartford

John Fluke Mfg. Co., Inc.  
124 Hebron Avenue  
Glastonbury, CT 06033  
(203) 633-0777

#### FL, Orlando

John Fluke Mfg. Co., Inc.  
940 N. Fern Creek Avenue  
Orlando, FL 32803  
(305) 896-4881

#### HI, Honolulu

EMC Corporation  
2979 Uaiena Street  
Honolulu, HI 96819  
(808) 847-1138

#### IA, Iowa City

John Fluke Mfg. Co., Inc.  
1027 Hollywood Blvd., Suite 309  
Iowa City, IA 52240  
(319) 354-2811

#### IL, Chicago

John Fluke Mfg. Co., Inc.  
4300 Lincoln, Unit K  
Rolling Meadows, IL 60008  
(312) 398-0850

#### IN, Indianapolis

John Fluke Mfg. Co., Inc.  
5610 Crawfordsville Road,  
Suite 802  
Indianapolis, IN 46224  
(317) 244-2456

#### LA, Metairie

John Fluke Mfg. Co., Inc.  
2700 Kingman Street, Suite 103  
Metairie, LA 70002  
(504) 455-0814

#### MA, Waltham

John Fluke Mfg. Co., Inc.  
244 Second Avenue  
Waltham, MA 02154  
(617) 890-1600

#### MD, Baltimore

John Fluke Mfg. Co., Inc.  
5640 Fishers Lane  
Rockville, MD 20852  
(301) 770-1570  
(301) 792-7060 (Baltimore)

#### MI, Detroit

John Fluke Mfg. Co., Inc.  
13955 Farmington Road  
Livonia, MI 48154  
(313) 522-9140

#### MN, Minneapolis

John Fluke Mfg. Co., Inc.  
7373 W. 147th Street, Suite 196  
Apple Valley, MN 55124  
(612) 432-9400

#### MO, Kansas City

John Fluke Mfg. Co., Inc.  
4406 Chouteau Traffic Way  
Kansas City, MO 64117  
(816) 454-5836

#### MO, St. Louis

John Fluke Mfg. Co., Inc.  
300 Brookes Drive, Suite 100  
Hazelwood, MO 63042  
(314) 731-3388

## Sales Representatives - U.S. and Canada (cont)

### NC, Greensboro

John Fluke Mfg. Co., Inc.  
1310 Beaman Place  
Greensboro, NC 27408  
(919) 273-1918

### NJ, Paramus

John Fluke Mfg. Co., Inc.  
West 75 Century Road  
Paramus, NJ 07625  
(201) 262-9550

### NM, Albuquerque

John Fluke Mfg. Co., Inc.  
1108 Alvarado Drive N.E.  
Albuquerque, NM 87110  
(505) 265-8431

### NY, Rochester

John Fluke Mfg. Co., Inc.  
4515 Culver Road  
Rochester, NY 14622  
(716) 266-1400

### OH, Cleveland

John Fluke Mfg. Co., Inc.  
7830 Freeway Circle  
Middleburg Heights, OH 44130  
(216) 234-4540

### OH, Dayton

John Fluke Mfg. Co., Inc.  
4756 Fishburg Road  
Dayton, OH 45424  
(513) 233-2238

### OR, Portland

John Fluke Mfg. Co., Inc.  
18360 S.W. Springfield Lane  
Aloha, OR 97006  
(502) 642-1342

### PA, Philadelphia

John Fluke Mfg. Co., Inc.  
1010 W. 8th Avenue, Suite H  
King of Prussia, PA 19406  
(215) 265-4040  
(412) 261-5171 (Pittsburgh)

### TX, Austin

John Fluke Mfg. Co., Inc.  
111 W. Anderson Lane, Suite 213  
Austin, TX 78752  
(512) 478-9901

### TX, Dallas

John Fluke Mfg. Co., Inc.  
14400 Midway Road  
Dallas, TX 75243  
(214) 233-9990

### TX, Houston

John Fluke Mfg. Co., Inc.  
1014 Wirt Road, Suite 270  
Houston, TX 77055  
(713) 683-7913  
(512) 222-2726 (San Antonio)

### UT, Salt Lake City

John Fluke Mfg. Co., Inc.  
782 E. 8325 South  
Sandy, UT 84070  
(801) 566-4864

### WA, Kennewick

John Fluke Mfg. Co., Inc.  
3613 W. 16th Place #C  
Kennewick, WA 99336

### WA, Seattle

John Fluke Mfg. Co., Inc.  
975 Industry Drive  
Seattle, WA 98188  
(206) 575-3765

### CANADA

#### ALB, Calgary

Allan Crawford Assoc., Ltd.  
1935 30th Avenue N.E., #14  
Calgary, ALB T2E 6Z5  
Tel: (403) 230-1341

### BC, North Vancouver

Allan Crawford Assoc., Ltd  
3795 William Street  
Burnaby, BC Y5C 3H3  
Tel: (604) 294-1326

### NS, Halifax

Allan Crawford Assoc., Ltd  
Townsend Place, Suite 201  
800 Windmill Road  
Burnside Industrial Park  
Dartmouth, NS B3B 1L1  
Tel: (902) 469-7865

### ONT, Ottawa

Allan Crawford Assoc., Ltd  
1299 Richmond Road  
Ottawa, ONT K2B 7Y4  
Tel: (613) 829-9651

### ONT, Toronto

Allan Crawford Assoc., Ltd.  
6503 Northam Drive  
Mississauga, ONT L4V 1J5  
Tel: (416) 678-1500

### QUE, Montreal

Allan Crawford Assoc., Ltd.  
7018 Cote de Liesse  
St. Laurent, QUE H4T 1E7  
Tel: (514) 731-8564

For more information on Fluke products or Sales Offices you may dial (800) 426-0361 toll free in most of U.S.  
From Alaska, Hawaii, Washington, or Canada phone (206) 774-2481. From other countries phone (206) 774-2398.

For Canadian areas not listed, contact the office nearest you or Allan Crawford Assoc. Ltd., Mississauga (Toronto), Ontario.

## Sales Representatives - International

Supplied and Supported by Fluke International Corporation, P.O. Box 43210, Mountlake Terrace, WA 98043, Tel: (206) 774-2398,  
TLX: 152662 JOHNFLUKE MTLT

### ARGENTINA

Coasin S.A.  
Virrey del Pino 4071  
Buenos Aires, Argentina  
Tel: 525130  
TLX: 390122284 COASN AR

### AUSTRALIA

Elmeasco Instruments Pty Ltd.  
P.O. Box 30  
Concord, N.S.W.  
Australia 2137  
Tel: (2) 736-2888  
TLX: 79025887

Elmeasco Instruments Pty Ltd.  
P.O. Box 107  
Mt. Waverly, VIC. 3149  
Australia  
Tel: 233-4044  
TLX: 26206 (ELMVIC)

Elmeasco Instruments Pty Ltd.  
Professional Suite's Bldg.  
B.P.O. Box 2360  
Brisbane, 4001  
Australia  
Tel: (07) 229-3161

Elmeasco Instruments Pty Ltd.  
P.O. Box 1240  
G.P.O. Adelaide 5001  
South Australia

### BOLIVIA

Coasin Bolivia S.R.L.  
Casilla 7295  
La Paz, Bolivia  
Tel: 40962  
TLX: Public Booth # 5377, indicate  
"Para Coasin B.S.R.L., Av 6  
de Agosto 2300 3er Piso, La Paz  
tl 40962"

### BRAZIL

Arotec S.A.  
Industria e Comercio  
Av. Pacaembu 811  
01234 Sao Paulo S.P., Brazil  
Tel: (011) 67-2393  
TLX: 1122207 AROT BR

Arotec S.A.  
Rua Araguari, 1705 s 402  
30.000 Belo Horizonte M.G., Brazil

### Arotec S.A.

Av. Rio Branco 277  
Grupo 1309  
02000 Rio de Janeiro, R.J., Brazil  
Tel: (021) 242-9776

### BRUNEI

O'Connor's Limited  
(Brunei Branch) Chin Kian Bldg.  
P.O. Box 2126  
Bandar Seri Begawan, Brunei  
Tel: 26680

### CHILE

Intronica Chile Ltda.  
Manuel Montt 024 - Of. D  
Casilla 16228  
Santiago 9, Chile  
Tel: 44940  
TLX: 40301 Cab Publ.,  
Attn: Intronica Chile

### CHINA, PEOPLE'S REPUBLIC OF

China National Instrument Import  
& Export Corp.  
P.O. Box 49, Erh-Li-Kou  
Hsi Chi'ao  
Beijing  
People's Republic of China  
TLX: CO 2242 CNIEC

### COLOMBIA

Coasin Ltda.  
Carrera 13, # 37-37, Of. 407  
Ap. Aero 29583  
Bogota DE, Colombia  
Tel: 285-0230/0250  
TLX: 45787 COASN CO

### ECUADOR

Proteco Coasin Cia., Ltda.  
Edificio "Jerico"  
Ave. 12 de Octubre #2285 y  
Ave. Orellana (Planta Baja)  
Quito, Ecuador  
Tel: 529684  
TLX: 2865 Protec Ed

Proteco Coasin Cia., Ltda  
Casilla 9733  
9 de Octubre 424  
Edificio Gran Pasaje, Of. 1012  
Guayaquil, Ecuador

## Sales Representatives - International (cont)

### HONG KONG

Gilman & Co., Ltd.  
P.O. Box 56  
Gilman Ind. Bldg. 9 F  
107-109 Wai Yip Street  
Kwun Tong, Kowloon  
Hong Kong  
Tel: 5-7909633  
TLX: 73358 GILMN HX

### ICELAND

Kristjan O. Skagfjord Ltd.  
P.O. Box 906  
Reykjavik, Iceland  
Tel: 24120  
TLX: 2133 KOS-1S

### INDIA

Hinditron Services Pvt. Ltd.  
69 A.L., Jagmohandas Marg  
Bombay 400 006  
India  
Tel: 811316  
TLX: 953-112326 Hspl In

Hinditron Services Pvt. Ltd.  
"Hinditron House"  
412 Raj Mahal Vilas Extension  
Bangalore 560 006  
India  
Tel: 33139  
TLX: 043741

### INDONESIA

P.T. Dwi Tunggal Jaya Sakti  
Sangga Buana Bldg., 1st Floor  
Jl. Senen Raya 44, P.O. Box 4435  
Jakarta, Indonesia  
Tel: 367390-9  
TLX: 46624 SABUANA 1A

P.T. Dwi Tunggal Jaya Sakti  
Jalan Sasakgantung 45  
Bandung, Indonesia  
Tel: 367390-9  
TLX: 46624 SABUANA 1A

### JAPAN

John Fluke Mfg. Co., Inc.  
Japan Branch  
(PC Board Testers only)  
1 Higashikata-machi  
Midori-ku  
Yokohama 226, Japan  
Tel: (045) 473-5425  
TLX: 3823-666 FLUKJJP

Tokyo Electron Ltd.  
38 Fl. Shinjuku Nomura Bldg.  
1-26-2, Nishi-Shinjuku  
Shinjuku-ku  
Tokoyo 160, Japan  
Tel: 03-343-4411  
TLX: 2322220 LABTEL J

### KENYA

ADCom Limited Inc.  
P.O. Box 30070  
Nairobi, Kenya  
East Africa  
Tel: 331955  
TLX: 22639 ADCOM

### KOREA

Electro-Science Korea Co.  
C.P.O. Box 8446  
Room. 1201 Bowon Bldg.  
490 Chongro - 5 Ka  
Chongro-ku  
Seoul, Korea  
Tel: 261-7702  
TLX: 78723270+

### MALAYSIA

O'Connor's (PTE) Limited  
P.O. Box 91  
Petaling Jaya, Selangor  
West Malaysia  
Tel: 51563  
TLX: OCONNOR MA37649

O'Connor's (PTE) Limited  
Lot # 5 Taman Mesra  
Mile 3, Jalan Penampang  
Kota Kinabalu  
East Malaysia  
Tel: 55322  
TLX: MA80286FL

### MEXICO

C.J. Christensen S.A. De C.V.  
Instrumentos Electronicos  
de Medicion  
Melchor Ocampo 150-8  
Mexico 4 D.F., Mexico  
Tel: (905) 535-2258

### NEW ZEALAND

W & K McLean Ltd.  
P.O. Box 18065  
Glen Innes  
Auckland, New Zealand  
Tel: 587-037  
TLX: N.Z. 7912763

W & K McLean Ltd.  
P.O. Box 2421  
Christchurch, New Zealand

W & K McLean Ltd.  
P.O. Box 496  
Wellington, New Zealand  
Tel: 851-450

### NIGERIA

Mofat Engineering Co., Ltd.  
P.O. Box 6369  
Lagos, Nigeria  
TLX: 21353, Attn: MOFAT

### PAKISTAN

Pak International Operations  
505 Mohammadi House  
- McLeod Road  
P.O. Box 5323  
Karachi, Pakistan  
Tel: 221127  
TLX: 24494 PIO PK

### PERU

Importaciones Y Representaciones  
Electronicas S.A.  
Avda. Franklin D. Roosevelt 105  
Lima 1, Peru  
Tel: 288650  
TLX: 37425663

### PHILIPPINES

Spark Radio and Electric Supply  
P.O. Box 1333  
Manila, Philippines  
Tel: 473183  
TLX: 27901 RLA PH

### SINGAPORE

Rank O'Connor's (PTE) Limited  
98 Pasir Panjang Road  
Singapore 0511  
Republic of Singapore  
Tel: 637944  
TLX: OCONSIN RS21023

### SOUTH AFRICA

Fluke S.A. (Pty) Ltd.  
P.O. Box 39797  
Bramley 2018  
Republic of South Africa  
Tel: (011) 786-3170  
TLX: 82899

### TAIWAN

CCT Associates, Inc.  
P.O. Box 24209  
Taipei, Taiwan  
Republic of China  
Tel: (02) 391-6894  
TLX: 24263 Longgulf

### THAILAND

Dynamic Supply Engineering R.O.P.  
# 56 Ekamai, Sukhumvit 63  
Bangkok-11, Thailand  
Tel: 914434  
TLX: TH 82938 MONTIEN TH

### URUGUAY

Coasin Uruguaya S.R.L.  
Edif. Ciudadela  
Sarandi 690 D. Esc. 109  
Casilla de Correos 1400  
Correo Central  
Montevideo, Uruguay  
Tel: 917978  
TLX: Public Booth UY901 Coasin

### VENEZUELA

Coasin C.A.  
Apdo. Postal 50939  
Sabana Grande # 1  
Caracas 105, Venezuela  
Tel: 782-9109-8741  
TLX: 39531228

Latin America also Supported by -

Sr. Leonardo Cusnir, c/o COASIN A.A., Virrey del Pino 4071, Buenos Aires, Argentina, Tel: 523185, TLX: 390122284 COASN AR  
Sr. Benewaldo Padovani, c/o AROTEC S.A., Industria e Comercio, Av. Pacaembu 811, 01234 Sao Paulo S.P., Brazil, Tel: (011) 67-2393,  
TLX: 1122207 AROT BR

Supplied and Supported by Fluke (Holland) B.V., P.O. Box 5053, Zevenheuvelenweg 53, 5004 EB Tilburg, Netherlands, Tel: (013) 673973,  
TLX: 522337

### AUSTRIA

Walter Rekirsch  
Electronische Gerate GmbH & Co.  
Vertriebs-KG  
Liechtensteinstrasse 97/6  
A-1090 Vienna, Austria  
Tel: (222) 347646  
TLX: 134759

### BELGIUM

Fluke (Belguim) S.A./N.V.  
6 Rue de Geneve  
1140 Brussels, Belgium  
Tel: (2) 2164090  
TLX: 26312

### BULGARIA

Amtest Associates Ltd.  
P.O. Box 55  
Addlestone, Surrey KT15 1DU  
United Kingdom  
Tel: Weybridge (923) 52121  
TLX: 928855

### CHAD

Fluke (Holland) B.V.  
P.O. Box 5053  
Zevenheuvelenweg 53  
5004 EB Tilburg, Netherlands  
Tel: (013) 673973  
TLX: 52237

### CYPRUS

Chris Radiovision Ltd.  
P.O. Box 1989  
Nicosia, Cyprus  
Tel: 66121  
TLX: 2395

### CZECHOSLOVAKIA

Amtest Associates Ltd.  
P.O. Box 55  
Addlestone, Surrey KT15 1DU  
United Kingdom  
Tel: Weybridge (932) 52121  
TLX: 928855

### DENMARK

Tage Olsen A/S  
Ballerup Byvej 222  
DK - 2750 Ballerup, Denmark  
Tel: (2) 658111  
TLX: 35293

### EGYPT AND SUDAN

Lotus Engineering Organisation  
P.O. Box 1252  
22, Kasi El Nil  
Cairo, Egypt  
Tel: 971617  
TLX: 92504

## Sales Representatives - International (cont)

### EIRE (REPUBLIC OF IRELAND)

Euro Electronics  
32 Brews Hill  
Naven. County Meath  
Tel: 46-23577  
TLX: 31821

### ETHIOPIA

Fluke (Holland) B.V.  
P.O. Box 5053  
Zevenheuvelenweg 53  
5004 EB Tilburg, Netherlands  
Tel: (013) 673973  
TLX: 52237

### FINLAND

Oy Findip AB  
Teollisuustie 7  
02700 Kauniainen, Finland  
Tel: (0) 502255  
TLX: 123129

### FRANCE

M.B. Eictronique S.A.  
Rue Fourny  
ZAC de BUC  
B.P. # 31  
78530 BUC, France  
Tel: (1) 9568131  
TLX: 695414

### GERMAN DEMOCRATIC REPUBLIC

Amtest Associates Ltd.  
P.O. Box 55  
Addlestone, Surrey KT15 1DU  
United Kingdom  
Tel: Weybridge (932) 52121  
TLX: 928855

### GERMAN FEDERAL REPUBLIC

Fluke (Deutschland) GmbH  
Krausstrasse 55  
8045 Ismaning  
West Germany  
Tel: (089) 96251  
TLX: 0522472  
Rapitax: (089) 966718

Fluke (Deutschland) GmbH  
Meineckestrasse 53  
4000 Dusseldorf 30  
West Germany  
Tel: (0211)450831  
TLX: 8585576

Fluke (Deutschland) GmbH  
Oberer Kirchhaldenweg 135  
7000 Stuttgart 1  
West Germany  
Tel: (0711) 694091  
TLX: 722518

PK Elektronik  
Lietzenburger Strasse 91  
1000 Berlin 15  
West Germany  
Tel: (030) 8831058

### GREECE

Hellenic Scientific  
Representations Ltd.  
11, Vrasside Street  
Athens 615, Greece  
Tel: (1) 711140  
TLX: 219330

### HUNGARY

Amtest Associates Ltd.  
P.O. Box 55  
Addlestone, Surrey KT15 1DU  
United Kingdom  
Tel: Weybridge (932) 52121  
TLX: 928855

### IRAN

Irantronics Company Ltd.  
20, Salm Road  
Roosevelt Avenue  
Tehran, Iran  
Tel: 828294/831564  
TLX: 212956/212876

### IRAQ

Fluke (Holland) B.V.  
P.O. Box 5053  
Zevenheuvelenweg 53  
5004 EB Tilburg, Netherlands  
Tel: (013) 673973  
TLX: 52237

### IRELAND

Euro Electronics  
32 Brews Hill  
Naven County Meath  
Ireland  
Tel: (46) 23577  
TLX: 3182

### ISRAEL

R.D.T. Electronics Engineering Ltd.  
P.O. Box 75  
46, Sokolov Street  
Ramat Hasharon 47235  
Israel  
Tel: (3) 483211  
TLX: 32143

### ITALY

Sistrel S.p.A.  
Via Giuseppe Armellini # 37  
00143 Rome, Italy  
Tel: (6) 5915551  
TLX: 680356

Sistrel S.p.A.  
Via Timavo 66  
20099 Sesto S. Giovanni (Milan)  
Italy  
Tel: (2) 2476693  
TLX: 320346

Sistrel S.p.A.  
Via Cintia  
Parco S. Paolo 35  
80126 Naples, Italy  
Tel: (81) 7679700

### KUWAIT

Tareq Company  
P.O. Box Safat 20506  
Kuwait, Arabian Gulf  
Tel: 436100/436045  
TLX: 2315

### LEBANON AND JORDAN

Mabek (Electronics Division)  
P.O. Box 11-3823  
Beirut, Lebanon  
Tel: 252631/348728  
TLX: 22889

### LIBYA

Fluke (Holland) B.V.  
P.O. Box 5053  
Zevenheuvelenweg 53  
5004 EB Tilburg, Netherlands  
Tel: (013) 673973  
TLX: 52237

### MOROCCO

Mainvest, Residence Moulay Ismail  
Bat. C Boulevard Moulay Slimane  
Rabat, Morocco  
Tel: (7) 27664  
TLX: 31036

### NETHERLANDS

Fluke (Nederland) B.V.  
P.O. Box 5053  
Zevenheuvelenweg 53  
5004 EB Tilburg, Netherlands  
Tel: (013) 673973  
TLX: 52237

### NORWAY

Morgenstjerne & Co. A/A  
Konghellegate 3  
P.O. Box 6688, Rodelokka  
Oslo 5, Norway  
Tel: (2) 356110  
TLX: 11719

### PDR YEMEN

Fluke (Holland) B.V.  
P.O. Box 5053  
Zevenheuvelenweg 53  
5004 EB Tilburg, Netherlands  
Tel: (013) 673973  
TLX: 52237

### POLAND

Amtest Associates Ltd.  
P.O. Box 55  
Addlestone, Surrey KT15 1DU  
United Kingdom  
Tel: Weybridge (932) 52121  
TLX: 928855

### PORTUGAL

Equipamentos de Laboratorio, Ltda.  
E.P.O. Box 1100  
1002 Lisbon, Portugal  
Tel: (1) 578936/547512  
TLX: 18469

### QATER, OMAN & UNITED ARAB EMIRATES

Technology Organisation  
P.O. Box 5549  
Doha, Qatar  
Tel: 321431  
TLX: 4581

### ROMANIA

Amtest Associates Ltd.  
P.O. Box 55  
Addlestone, Surrey KT15 1DU  
United Kingdom  
Tel: Weybridge (932) 52121  
TLX: 928855

### SAUDI ARABIA

Electronic Equipment  
Marketing Co. Ltd.  
P.O. Box 3750  
Riyadh, Saudi Arabia  
Tel: 32761/32700/37023  
TLX: 201120

### SOMALIA

Fluke (Holland) B.V.  
P.O. Box 5053  
Zevenheuvelenweg 53  
5004 EB Tilburg, Netherlands  
Tel: (013) 673973  
TLX: 52237

### SPAIN

Hispano Electronica S.A.  
Piligono Industrial Urtinsa  
Apartado de Correos 48  
Alcorcon (Madrid)  
Spain  
Tel: (1) 6194108  
TLX: 22404/42634

### SWEDEN

Teleinstrument AB  
P.O. Box 490  
S-162 04 Vallingby 4  
Sweden  
Tel: (8) 380370  
TLX: 11347

### SWITZERLAND

Traco Electronic Company Ltd.  
I. Jenatschstrasse  
Postfach, 8027 Zurich  
Switzerland  
Tel: (1) 2010711  
TXL: 54318

### SYRIA

Mabek (Electronics Division)  
P.O. Box 4238  
Damascus, Syria

### TURKEY

Erkman Elektronik Aletler  
Ticaret Anonim Sirketi  
Necatiby Cad 92/3  
Karakoy, Istanbul, Turkey  
Tel: (1) 5461  
TLX: 23353

### UNITED KINGDOM

Fluke International Corp.-UK  
Colonial Way  
Watford, Herts, WD 24 TT  
United Kingdom  
Tel: (923) 40511

### U.S.S.R.

Amtest Associates Ltd.  
P.O. Box 55  
Addlestone, Surrey KT15 1DU  
United Kingdom  
Tel: Weybridge (932) 52121  
TLX: 928855

### YEMEN

Fluke (Holland) B.V.  
P.O. Box 5053  
Zevenheuvelenweg 53  
5004 EB Tilburg, Netherlands  
Tel: (013) 673973  
TLX: 52237

### YUGOSLAVIA

Amtest Associates Ltd.  
P.O. Box 55  
Addlestone, Surrey KT15 1DU  
United Kingdom  
Tel: Weybridge (932) 52121  
TLX: 928855

Customers in the following countries: Bulgaria, Czechoslovakia, Hungary, Poland, Romania, U.S.S.R., and Yugoslavia, contact:  
Amtest Associates Ltd., P.O. Box 55, Addlestone, Surrey, KT 15 1DU, England, Tel. (0932) 52121

## Section 8

# Schematic Diagrams

### TABLE OF CONTENTS

FIGURE	TITLE	PAGE
8-1	A1 Motherboard PCB Assembly . . . . .	8-2
8-2	A2 Power Supply PCB Assembly . . . . .	8-4
8-3	A3 Controller PCB Assembly . . . . .	8-6
8-4	A4 Guard Crossing PCB Assembly . . . . .	8-9
8-5	A5 Printer Drive PCB Assembly . . . . .	8-12
8-6	A6 Display PCB Assembly . . . . .	8-14
8-7	A7 Switch Mode PCB Assembly . . . . .	8-16
8-8	A8 Keyboard Switch PCB Assembly . . . . .	8-18
8-9	A9 Keyboard Memory PCB Assembly . . . . .	8-20
8-10	A10 Keyboard Logic PCB Assembly . . . . .	8-22
8-11	A11 Range and Function Memory PCB Assembly . . . . .	8-24
8-12	A12 High Performance A/D Converter PCB Assembly . . . . .	8-26
8-13	-03 RTD Connector Assembly . . . . .	8-29
8-14	-05 General Purpose Scanner PCB Assembly . . . . .	8-30
8-15	-06 Low Level Scanner Assembly . . . . .	8-32
8-16	-08 Isothermal Block Connector . . . . .	8-34
8-17	-12 Teletype Interface PCB Assembly, Options -12, -13 and -14 . . . . .	8-36
8-18	-15 IEEE Interface PCB Assembly . . . . .	8-38
8-19	-16 Digital Input PCB Assembly . . . . .	8-41
8-20	-17 Remote Programming PCB Assembly . . . . .	8-44
8-21	-23 Alarm Set Point Output PCB Assembly . . . . .	8-48
8-22	-28 1-5 mA Transmitter Connector . . . . .	8-50
8-23	-29 4-20 mA Transmitter Connector . . . . .	8-52
8-24	-30 10-50 mA Transmitter Connector . . . . .	8-53
8-25	-33 Eight Channel RTD Scanner . . . . .	8-54
8-26	-43 Temperature Option PCB Assembly, Options -43, -44 and -45 . . . . .	8-56



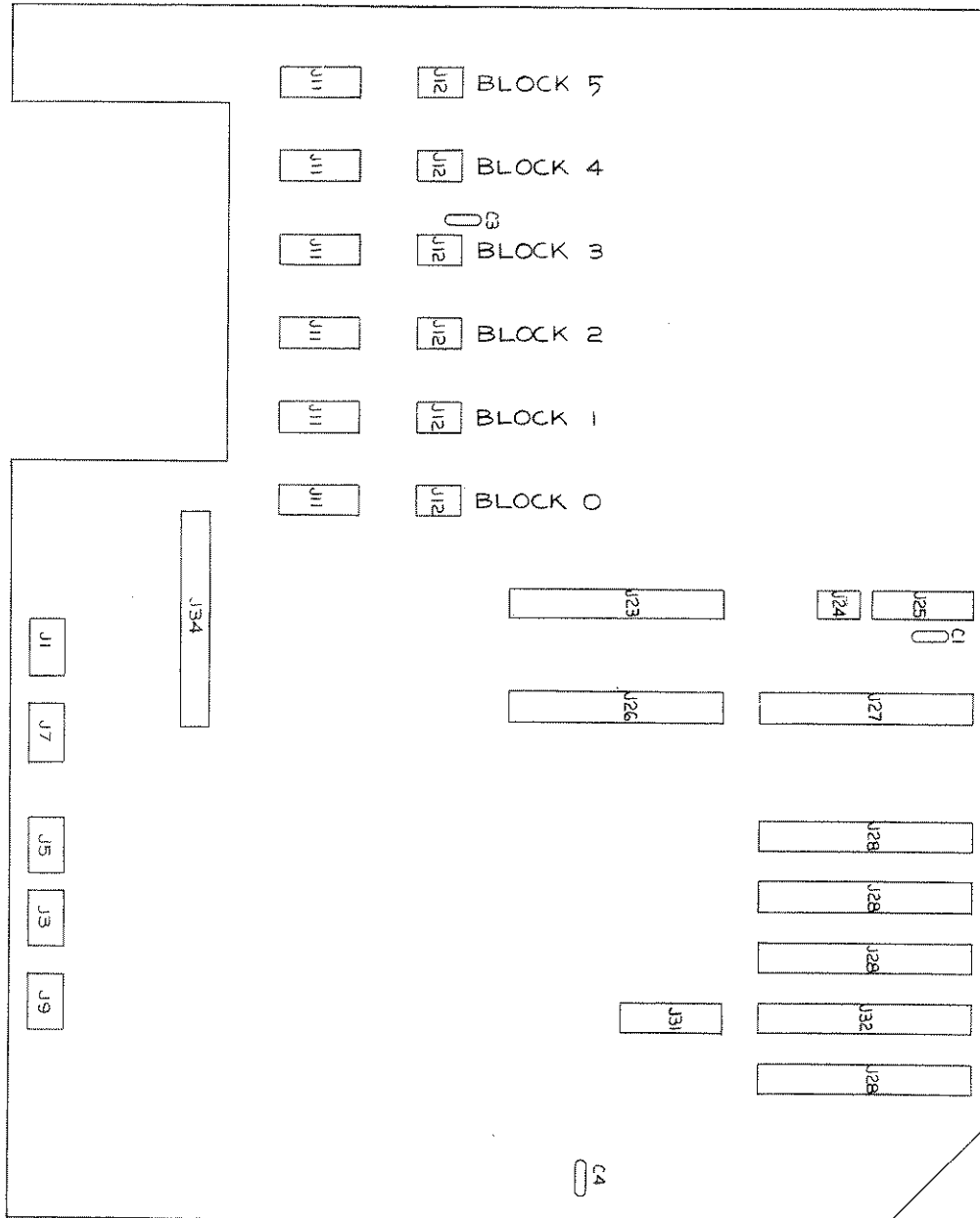

2200A-1601

Figure 8-1. Motherboard PCB Assembly

- J28 4 PLACES:
- TELETYPE INTERFACE (2200A-1014)
- PAPERTAPE INTERFACE (2200A-1015)
- MAGNETIC TAPE INTERFACE (2200A-1016)
- DIGITAL INPUT (2200A-1017)
- PROM (2200A-1027 OR 2240A-1027)
- R/F MEMORY (2240A-1032)
- ALARMS OUTPUT (2240A-1031)
- J32: CONTROLLER (2200A-1003)

UNGUARDED | GUARDED

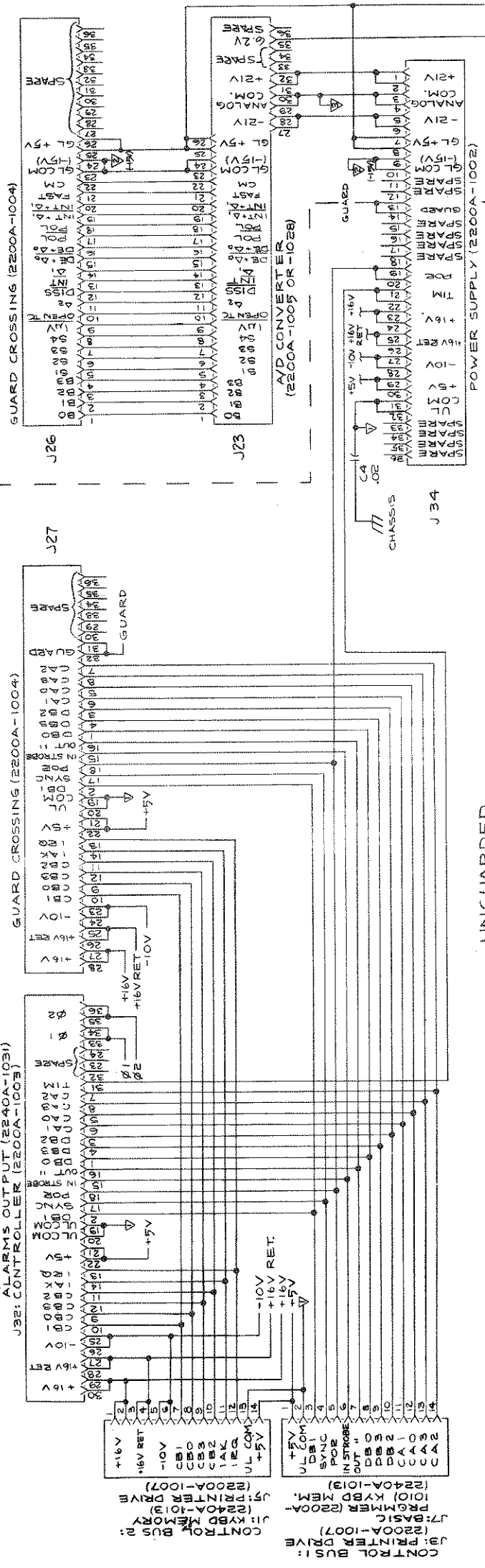

- NOTES:
1. ALL VOLTAGES NOTED WITHIN GUARDED SECTION OF INSTRUMENT ARE WITH RESPECT TO A/D COM.
  2. FOR ASSY DWG. SEE 2200A-4001. FOR REF. DES. DWG. SEE 2200A-1601.
  3. ∇ DENOTES UNGUARDED LOGIC COMMON (UL COM).
  4. ∇(-15V) DENOTES GUARDED LOGIC COMMON [GL COM (-15V)] WHICH IS -15V WITH RESPECT TO A/D COM.
  5. ∇ DENOTES ANALOG COMMON (A COM).
  6. ∇ DENOTES A/D COMMON (A/D COM).
  7. ∇ DENOTES REFERENCE COMMON (REF COM).
  8. ∇ DENOTES CHASSIS COMMON.
  9. UNLESS OTHERWISE SPECIFIED ALL CAPACITANCES ARE IN MICROFARADS

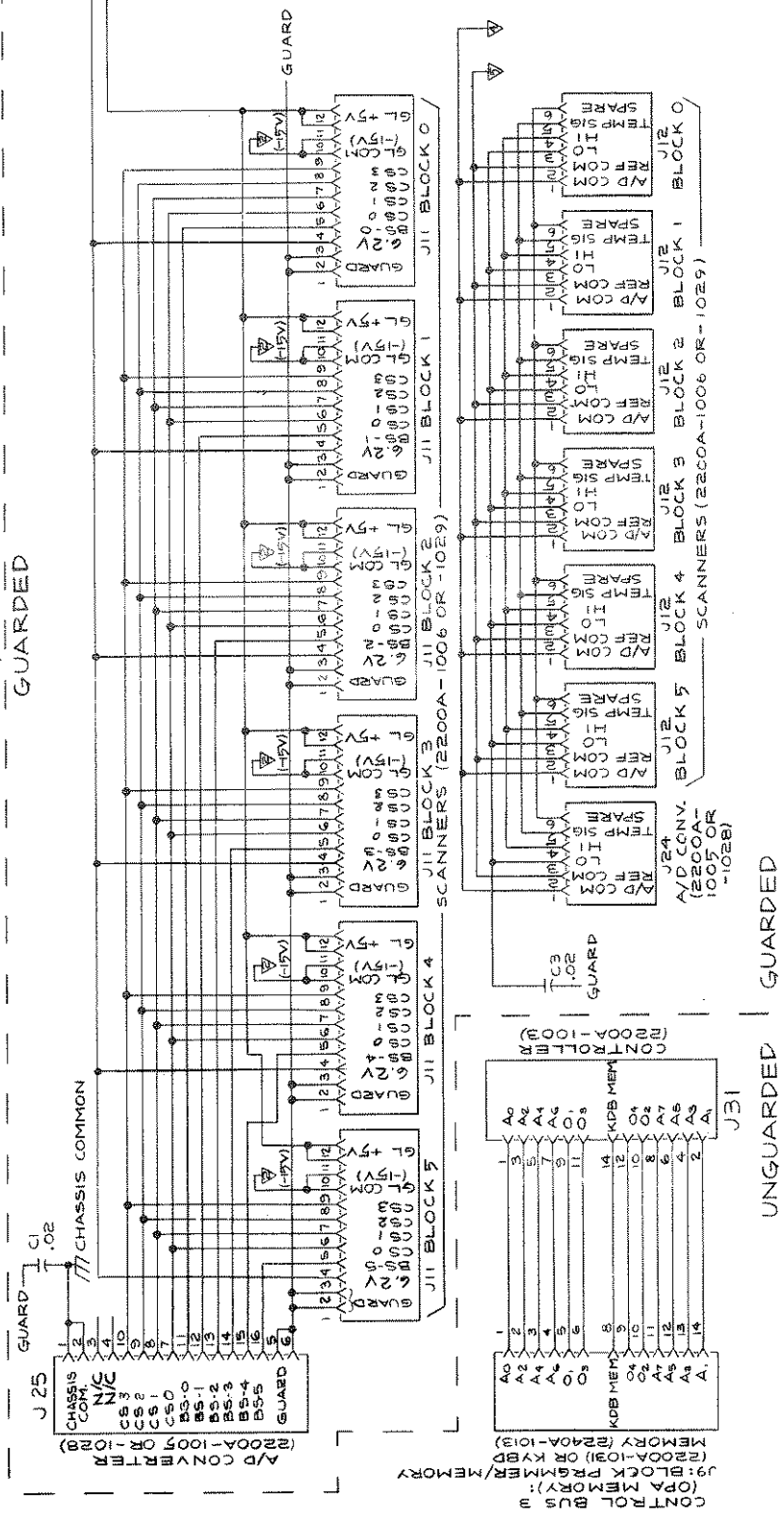

2200A-1001

Figure 8-1. Motherboard PCB Assembly (cont)

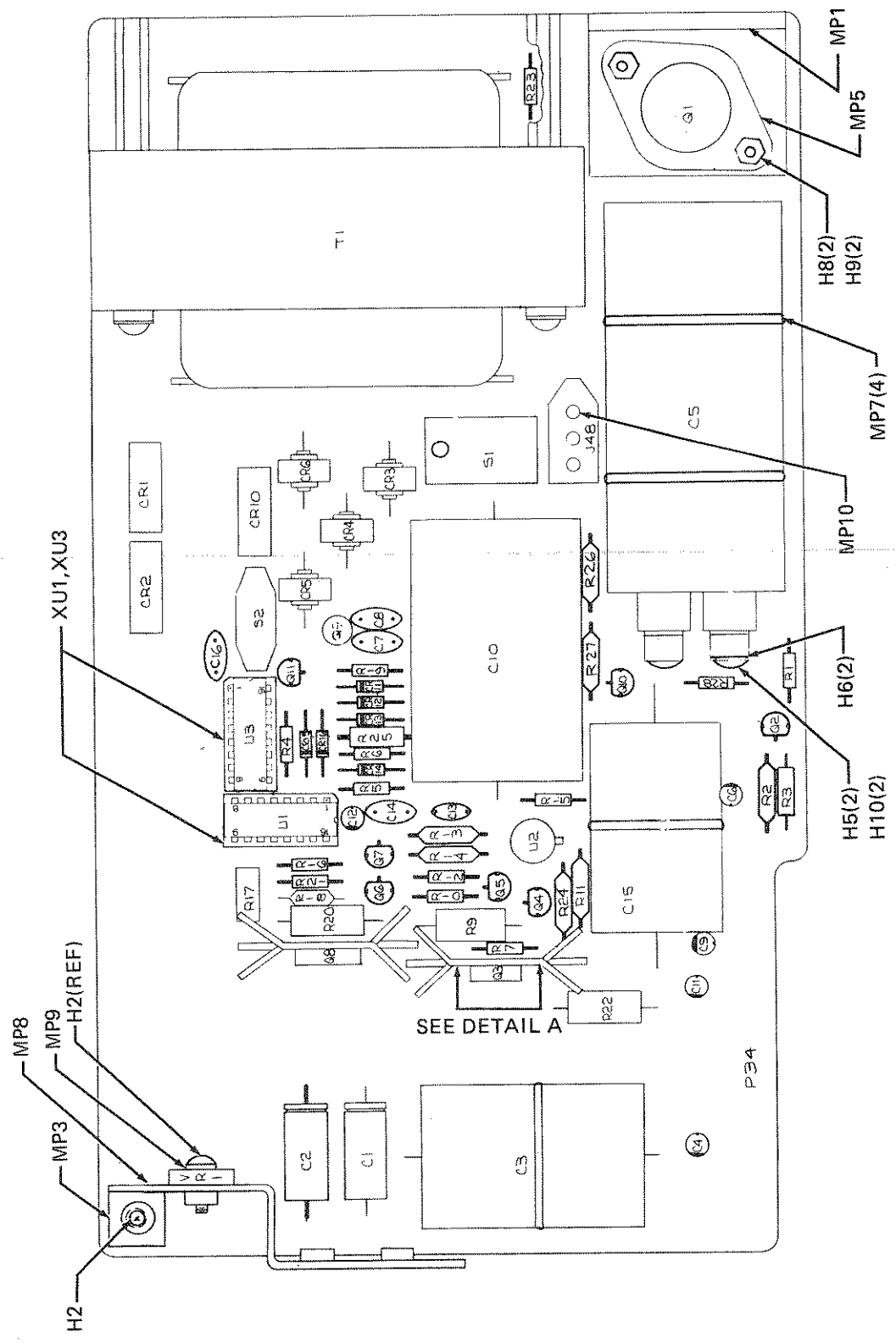
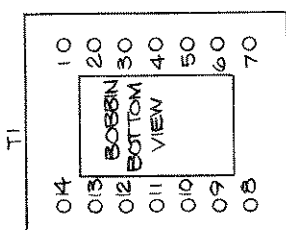
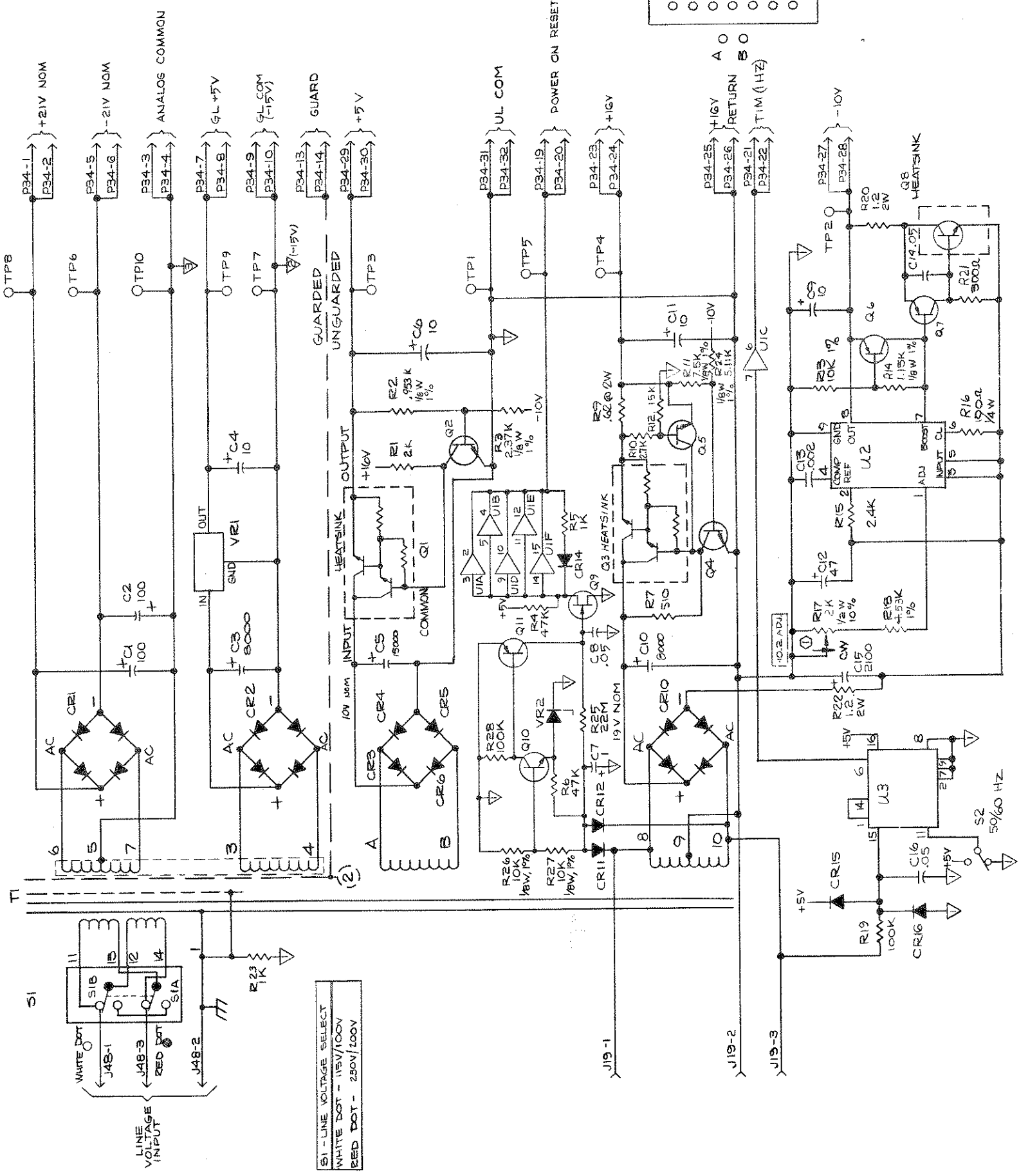

Figure 8-2. Power Supply PCB Assembly

IC REF. DES.	PIN NO.	REFERENCE DESIGNATIONS
U1	1/16	B
C16	U3	CR7-9, CR13
CR16	VR2	RB
Q11	P28	
S2	TI	
TP9		

IC REF. DES.	PIN NO.	REFERENCE DESIGNATIONS
U1	1/16	B



- NOTES:
- UNLESS OTHERWISE SPECIFIED ALL RESISTANCES ARE IN OHMS AND ALL CAPACITANCES ARE IN MICROFARADS.
  - FOR ASSEMBLY DRAWING SEE 2200A-4002.
  - DENOTES CALIBRATION ADJ POINTS. ALL POINTS ARE SCREWDRIVER ADJUST.
  - ALL RESISTORS ARE 1/4 W, 5% UNLESS OTHERWISE SPECIFIED.
  - ALL GRAPHIC SYMBOLS ARE IN ACCORDANCE WITH ANSI Y32.14 AND Y32.2
  - ▽ DENOTES GUARDED LOGIC COMMON [6L COM (-15V) WHICH IS -15V WITH RESPECT TO A/P COM.]
  - ▽ DENOTES ANALOG COMMON.
  - ▽ DENOTES UNGUARDED LOGIC COMMON (UL COM)
  - ALL VOLTAGES NOTED WITHIN GUARDED SECTION OF INSTRUMENT ARE WITH RESPECT TO A/P COM.

2200A-1002

Figure 8-2. Power Supply PCB Assembly (cont)

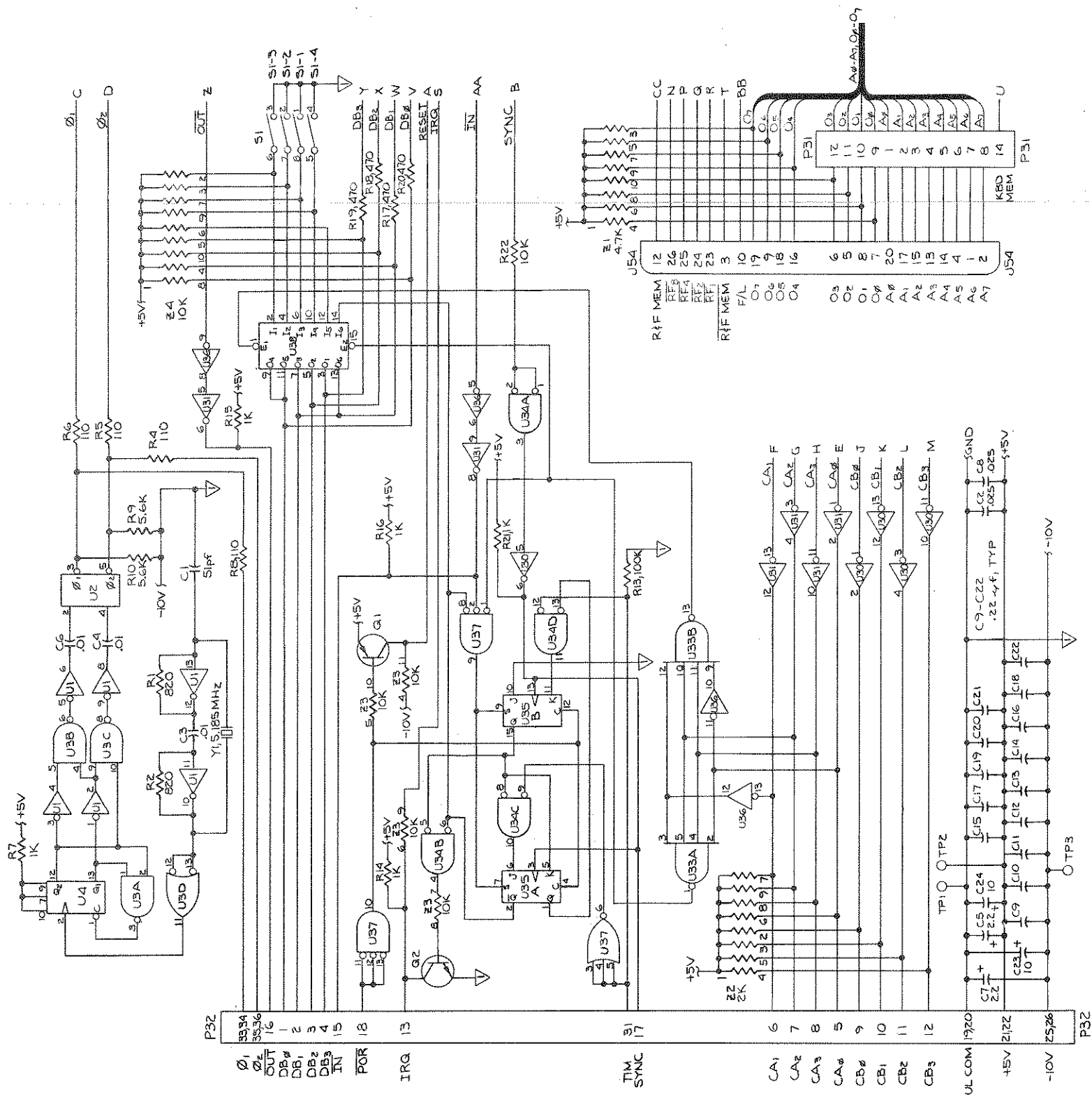

- NOTES:
1. UNLESS OTHERWISE SPECIFIED ALL RESISTANCE ARE IN OHMS AND ALL CAPACITANCES ARE IN MICROFARADS.
  2.  $\nabla$  DENOTES UNGUARDED LOGIC COMMON (OIL COM).
  3. ALL RESISTORS ARE 1/4W, 5% UNLESS OTHERWISE NOTED.
  4. ALL GRAPHIC SYMBOLS ARE IN ACCORDANCE WITH AMS1 Y32.2 AND Y32.14.
  5.  $\nabla$  J1L SHOWS JUMPERS CONFIGURED FOR A "TI 2532" EPROM (PREFERRED PART) INSTALLED IN "U8". IF "U8" IS AN "INTEL 2732" EPROM THEN JUMPERS SHOULD BE CONFIGURED PER DETAIL 1.
  6. FOR ASSY DNG SEE 2240C-4041 FOR REF. DES. DNG. SEE 2240C-1641

REFERENCE DESIGNATOR	NOT USED
U10, U22	
C24, R22, O2	
U39, Z5, J1L	

REF. DES.	+5V	-10V
U1	14	7
U2	6	3
U3	14	7
U4	16	8
U5	16	8
U6	16	8
U7	16	8
U8	24	12
U9	21,24	12
U11	21,24	12
U12	21,24	12
U13	14	7
U14	21,24	12
U15	14	7
U16	9	4,15,21
U17	20	35
U18	5	10,12
U19	5	10,12
U20	5,10	12
U21	5,10	12
U23	5,10	12
U24	5	10,12
U25	5,10	12
U26	5	10,12
U27	5	10,12
U28	5,10	12
U29	5	10,12
U30	9,14	7
U31	14	7
U32	5,10	12
U33	14	7
U34	14	7
U35	16	8,10
U36	14	7
U37	14	7
U38	16	8

2240C-1041 (1 of 2)

Figure 8-3. Controller PCB Assembly

SEE SHT 1

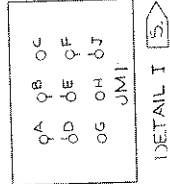
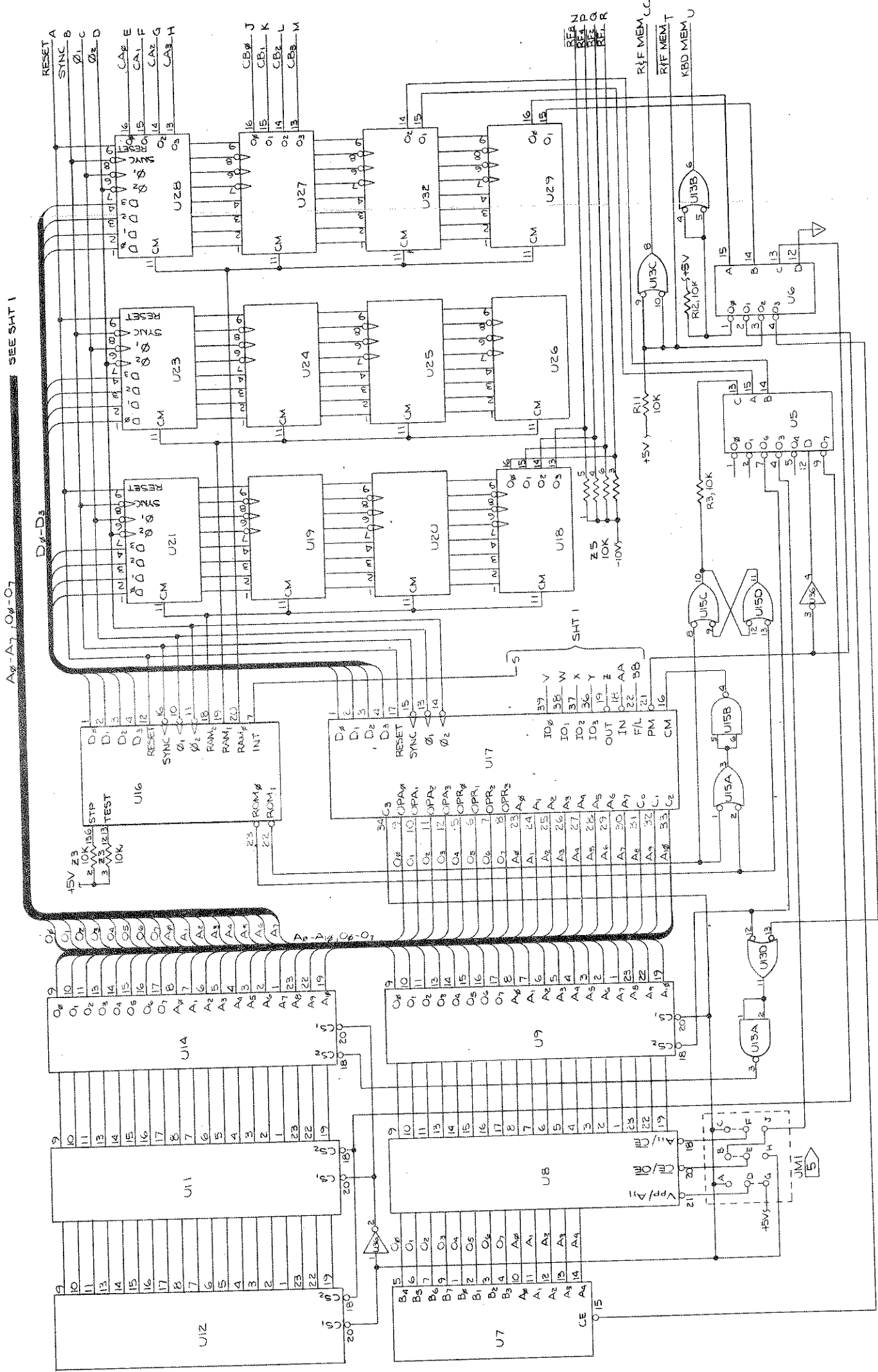

DETAIL I 5

2240C-1041 (2 of 2)

Figure 8-3. Controller PCB Assembly (cont)

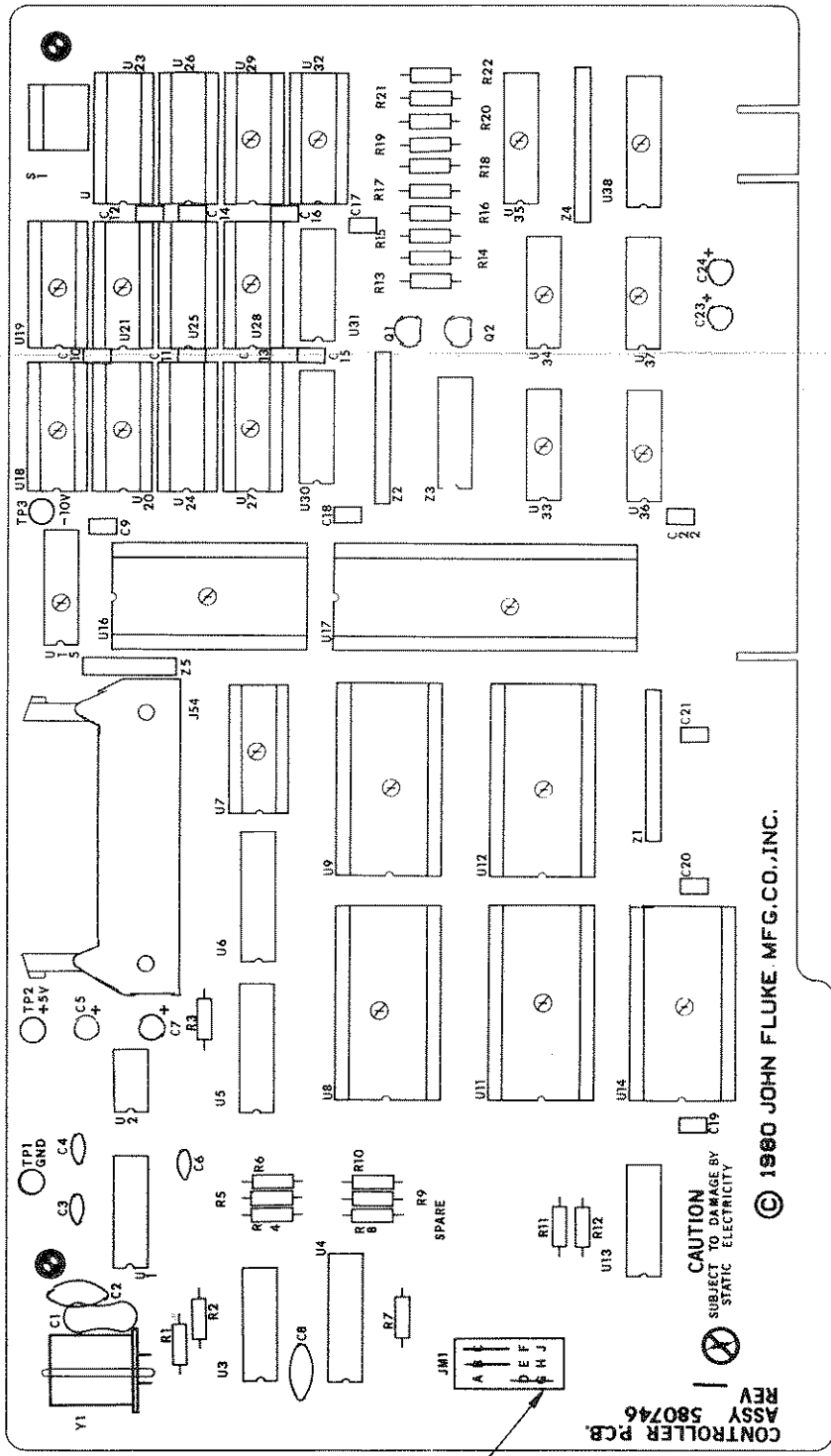

NOTES: UNLESS OTHERWISE SPECIFIED

1. FOR SCHEMATIC DIAGRAM, SEE 2240C-1041.
2. FOR ASSEMBLY DRAWING SEE 2240C-4041.
3. "JMI" SHOWS JUMPERS CONFIGURED FOR A "11 2532" EPROM (PREFERRED PART) INSTALLED IN "U8". IF "U8" IS AN "INTEL 2732" EPROM THEN JUMPERS SHOULD BE CONFIGURED PER DETAIL 1.
4. **WARNING:** ⓧ INDICATES USAGE OF MOS DEVICES WHICH MAY BE DAMAGED BY STATIC DISCHARGE. USE SPECIAL HANDLING PER S.O.P. 13.7.

**CAUTION**  
SUBJECT TO DAMAGE BY  
STATIC ELECTRICITY

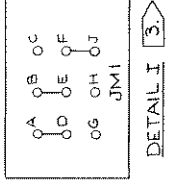

DETAIL I 3

2240C-1641

Figure 8-3. Controller PCB Assembly (cont)

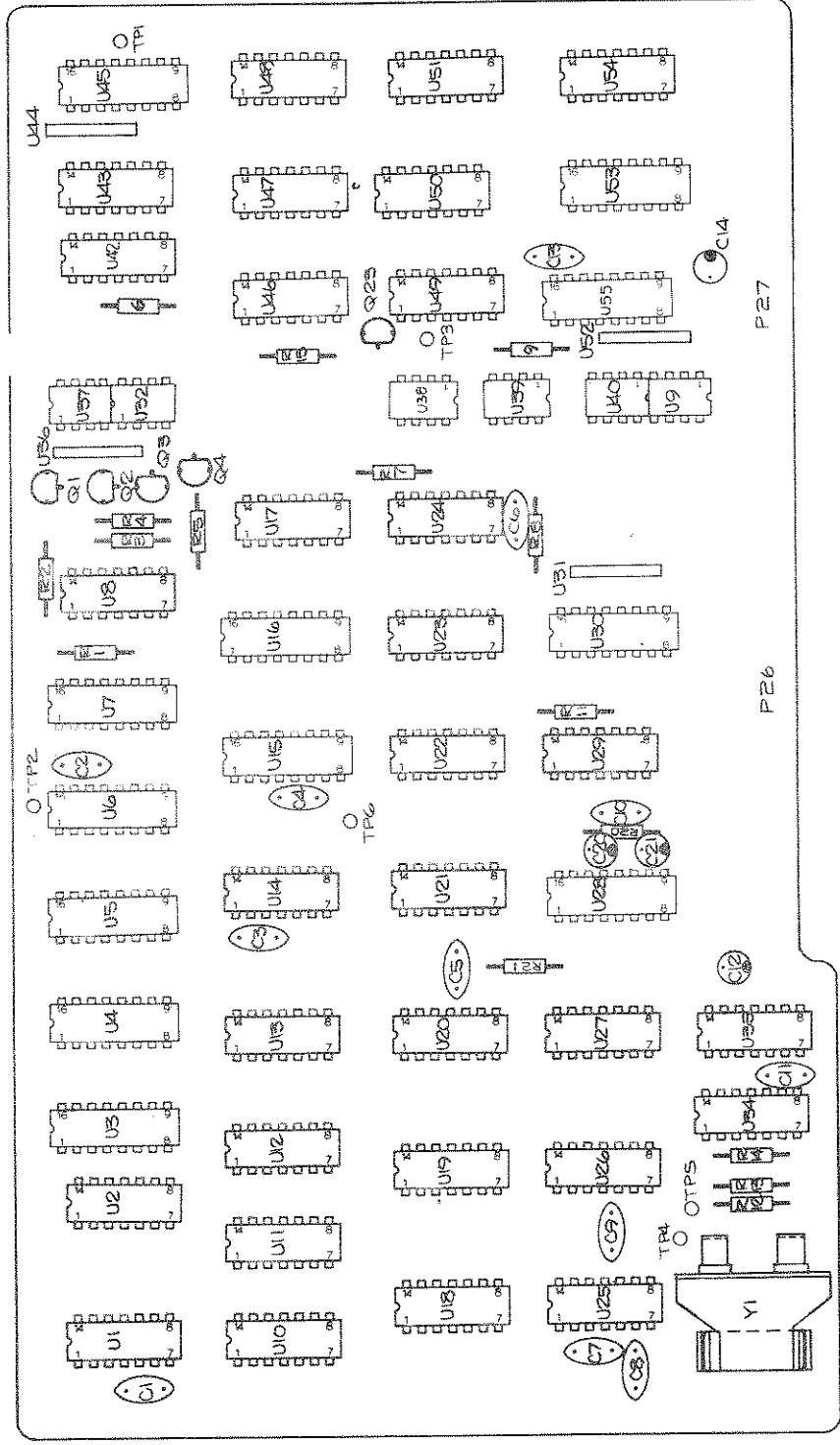

2200A-1604

Figure 8-4. Guard Crossing PCB Assembly



NOTES:  
 1. UNLESS OTHERWISE SPECIFIED ALL RESISTANCES ARE IN OHMS AND ALL CAPACITANCES ARE IN MICROFARADS.

2. ALL RESISTORS ARE 1/4W, 5% UNLESS OTHERWISE NOTED.  
 4. ALL GRAPHIC SYMBOLS IN ACCORDANCE WITH ANSI Y32.14 AND Y32.2.

5. FOR ASSY. DWG. SEE 2200A-4004. FOR REF. DES. DWG. SEE 2200A-1604.

6. ▽ DENOTES UNGUARDED LOGIC COMMON (UL COM).

7. ▽ (-15V) DENOTES GUARDED LOGIC COMMON [GL COM (-15V)] WHICH IS -15V WITH RESPECT TO A/D COM.

8. ALL VOLTAGES NOTED WITHIN GUARDED SECTION OF INSTRUMENT ARE WITH RESPECT TO A/D COM.

IC REF.	PIN NO.	UL	GL	SL	SL	SL
U1	14					
U2	14					
U3	16					
U4	16					
U5	16					
U6	16					
U7	16					
U8	14					
U9	14					
U10	14					
U11	14					
U12	14					
U13	14					
U14	14					
U15	16					
U16	16					
U17	14					
U18	14					
U19	14					
U20	14					
U21	14					
U22	14					
U23	14					
U24	14					
U25	14					
U26	14					
U27	14					
U28	16					
U29	16					
U30	16					
U31	16					
U32	14					
U33	14					
U34	14					
U35	14					

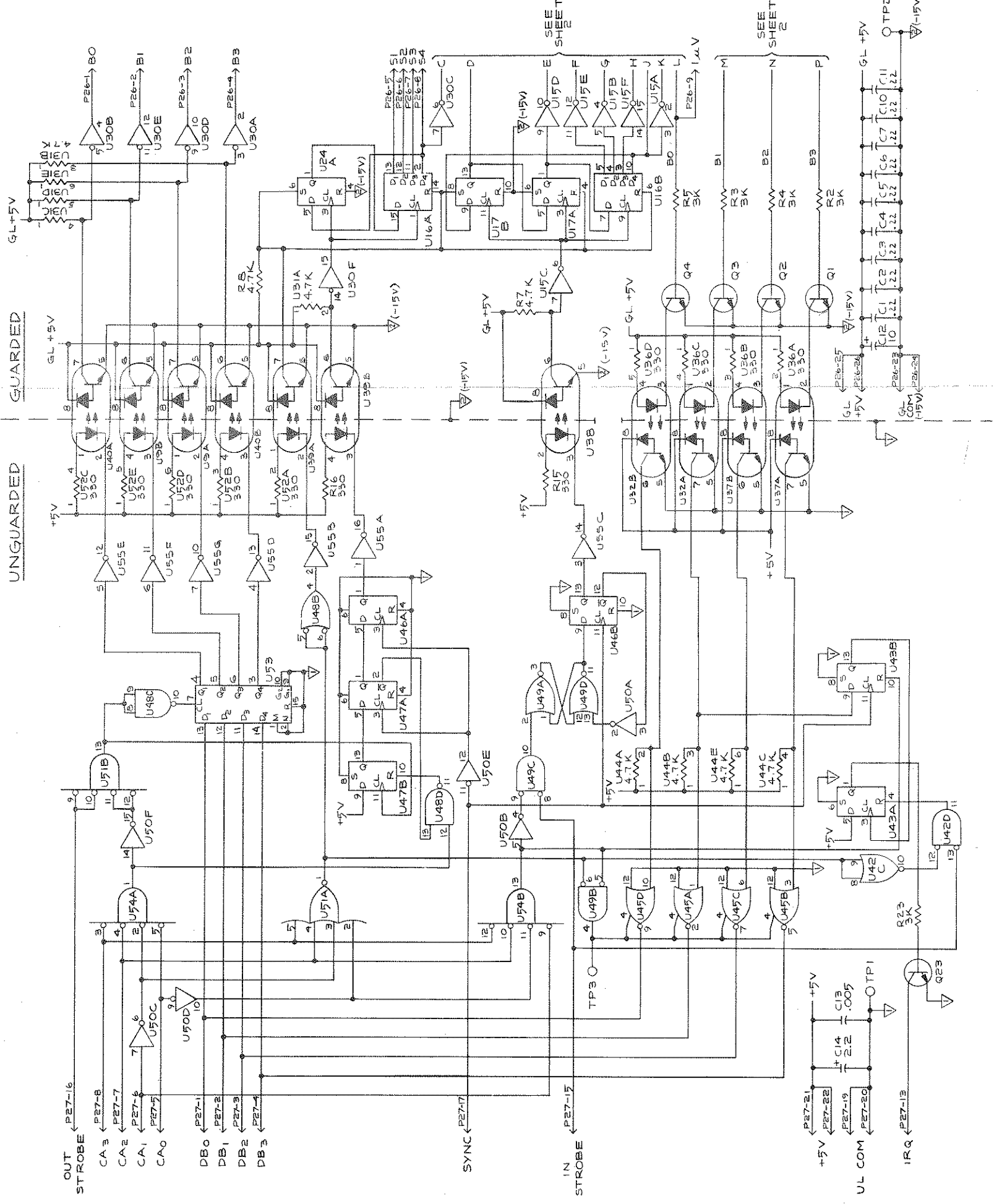
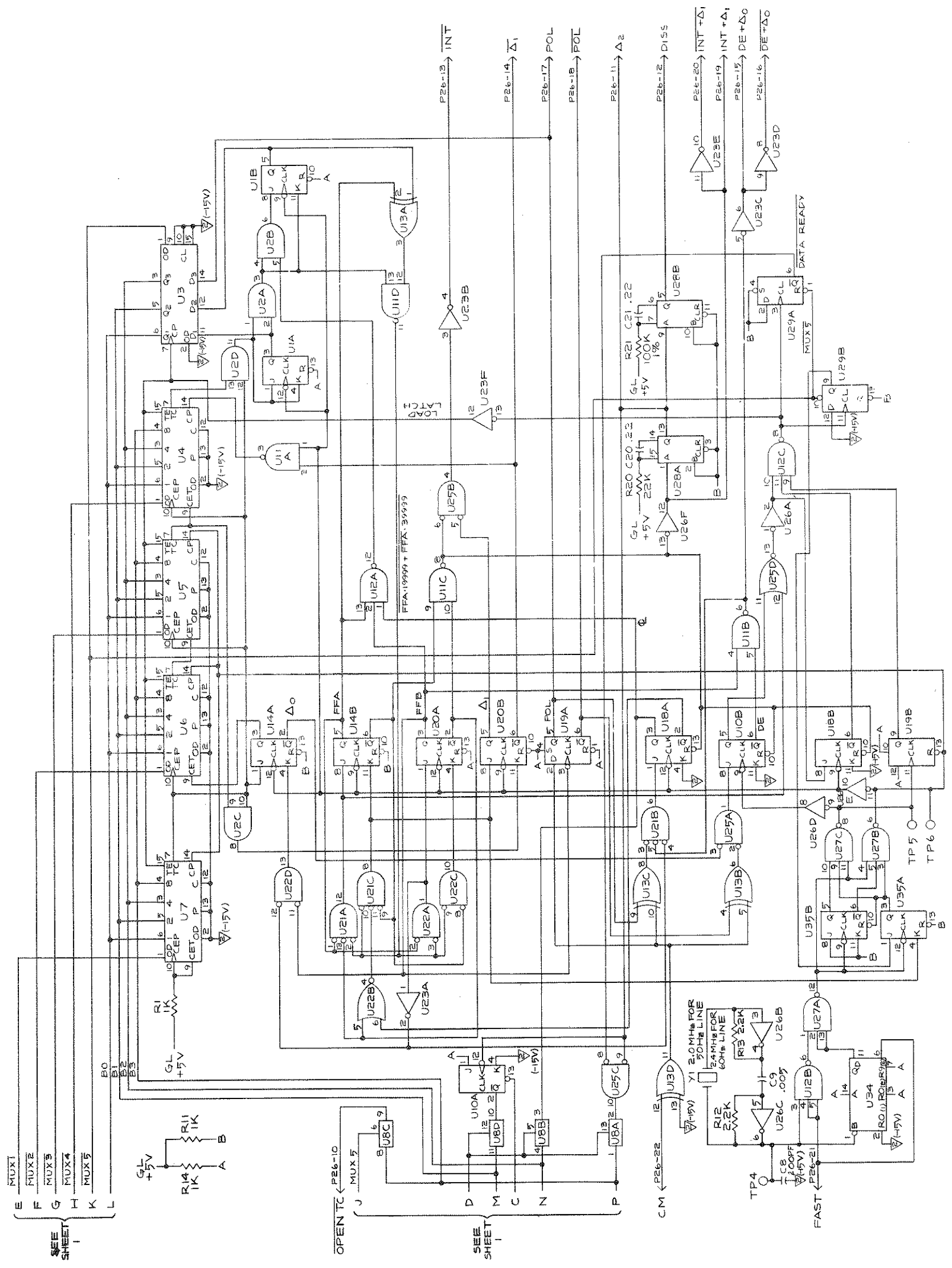

Figure 8-4. Guard Crossing PCB Assembly (cont)



2200A-1004 (2 of 2)

Figure 8-4. Guard Crossing PCB Assembly (cont)

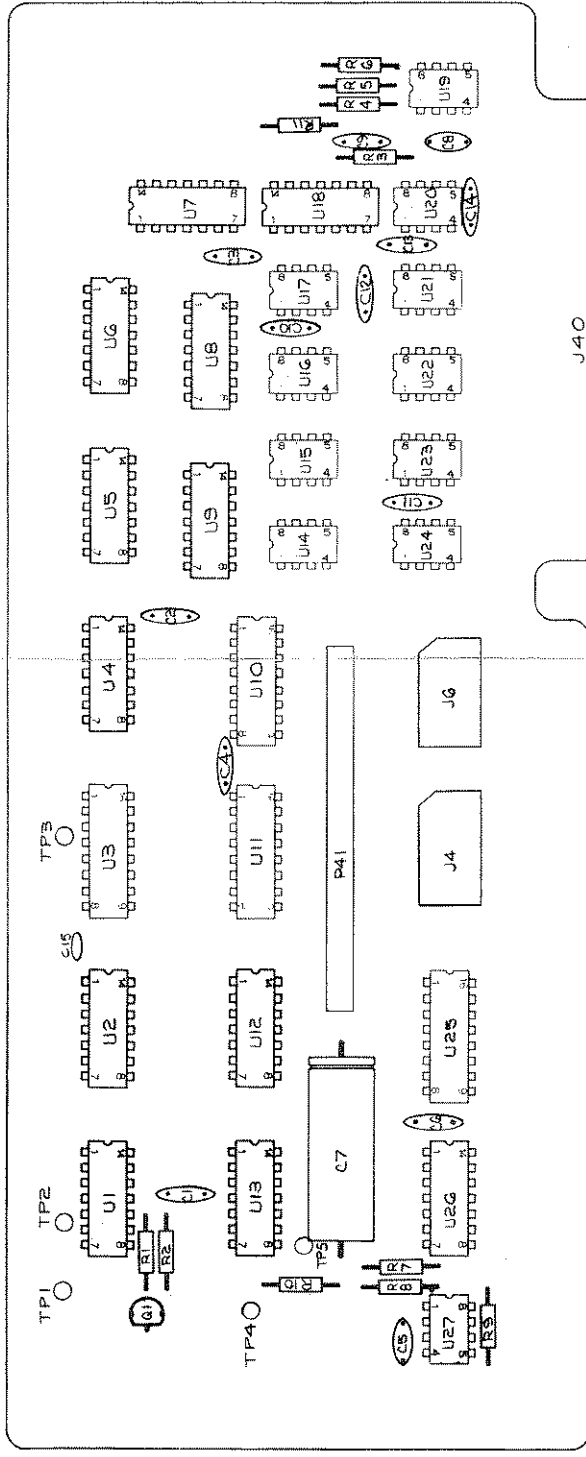
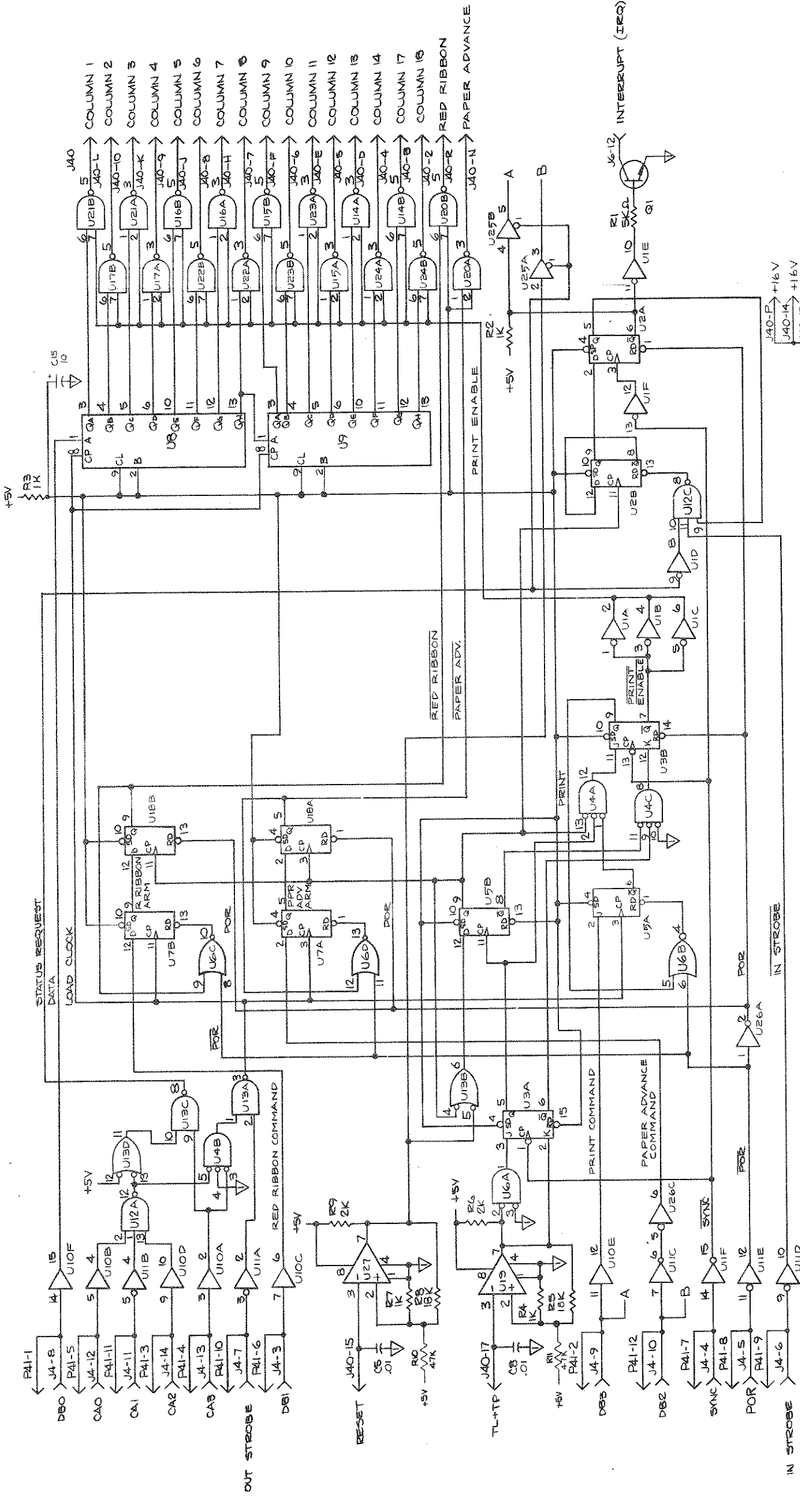

Figure 8-5. Printer Drive PCB Assembly



IC REF.	PIN NO.	I.C. REF. DES.	PIN NO.		REFERENCE DESIGNATIONS	
			+5V	RET	LAST USED	NOT USED
U1	14	U15	8	4	C14	
U2	16	U16	8	4	G1	
U3	14	U17	14	7	R27	
U4	14	U18	8	4		
U5	14	U19	8	4		
U6	14	U20	8	4		
U7	14	U21	8	4		
U8	14	U22	8	4		
U9	14	U23	8	4		
U10	16	U24	8	4		
U11	14	U25	16	14		
U12	14	U26	14	7		
U13	14	U27	14	7		
U14	8					

- NOTES:
1. UNLESS OTHERWISE SPECIFIED ALL RESISTANCES ARE IN OHMS AND ALL CAPACITANCES ARE IN MICROFARADS.
  2. ▽ DENOTES UNGUARDED LOGIC COMMON (V/L COM).
  3. ALL RESISTORS ARE 1/4W, 5% UNLESS OTHERWISE NOTED.
  4. ALL GRAPHIC SYMBOLS IN ACCORDANCE WITH ANSI Y32.2.

2200A-1007

Figure 8-5. Printer Drive PCB Assembly (cont)

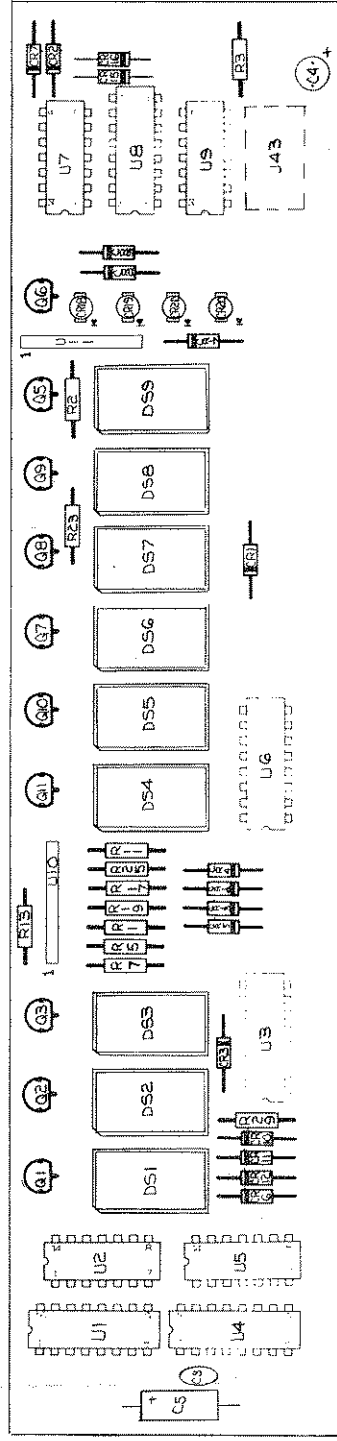

2240A-1608

Figure 8-6. Display PCB Assembly

IC DES	PIN NO. +5V	UL COM
U1	16	8
U3	16	8
U4	16	8
U7	14	7
U8	16	8

NOTES:

1. UNLESS OTHERWISE SPECIFIED ALL RESISTANCES ARE IN OHMS AND ALL CAPACITANCES ARE IN MICROFARADS.
2. ▽ DENOTES UNGUARDED LOGIC COMMON (UL COM).
3. ALL RESISTORS ARE 1/4W, 5% UNLESS OTHERWISE NOTED.
4. ALL GRAPHIC SYMBOLS IN ACCORDANCE WITH ANSI Y32.14 AND Y32.2.
5. FOR ASSY DWG SEE 2240A-4008 FOR REF DES DWG SEE 2240A-1608.

REFERENCE DESIGNATIONS	
LAST USED	NOT USED
C5	C1,2
CR21	Q4
DS9	R4,6,8
Q11	9,10,12
R29	14,15,16
	18,20,21
	22,24,26
	27,28

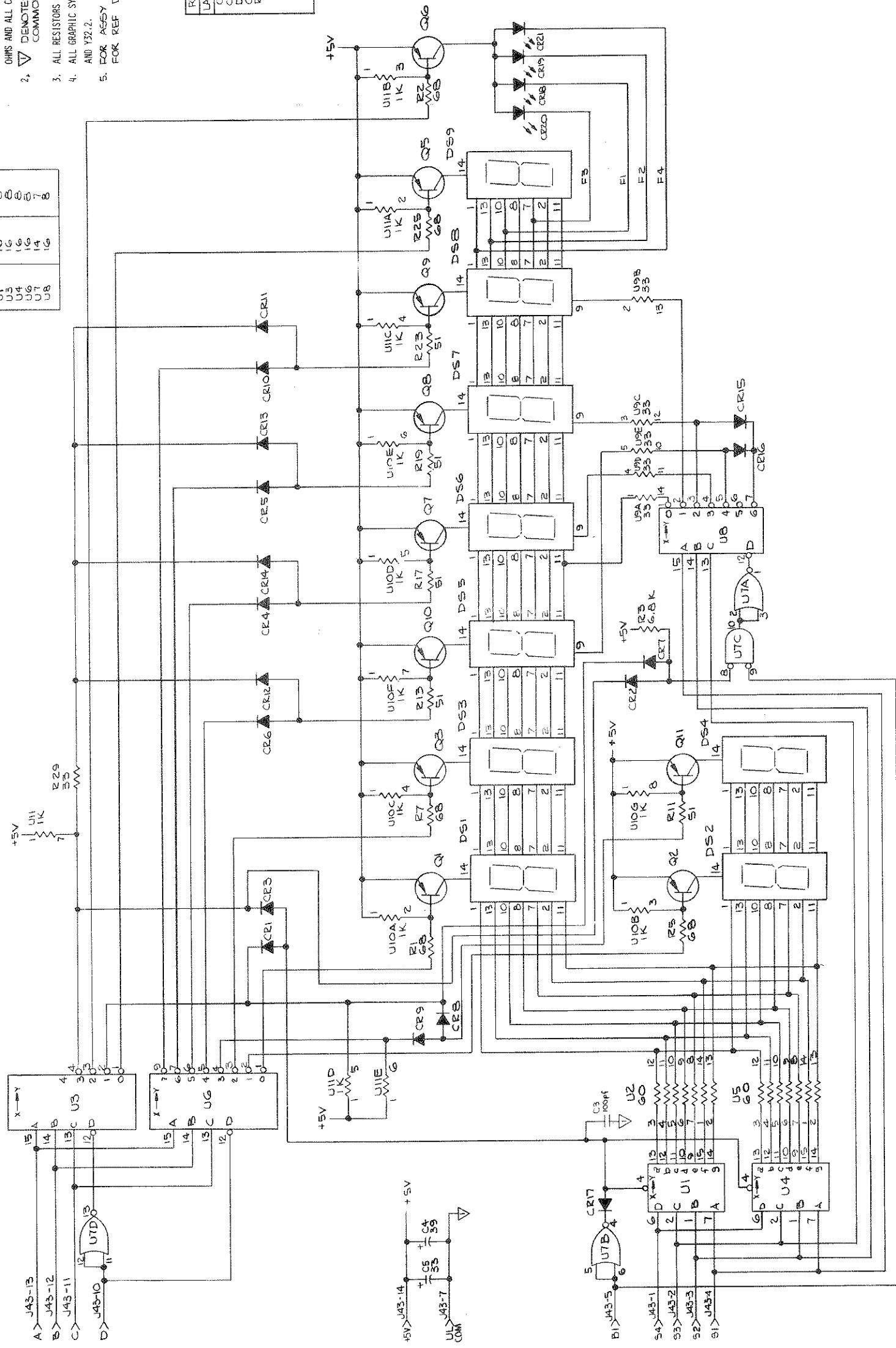

2240A-1008

Figure 8-6. Display PCB Assembly (cont)

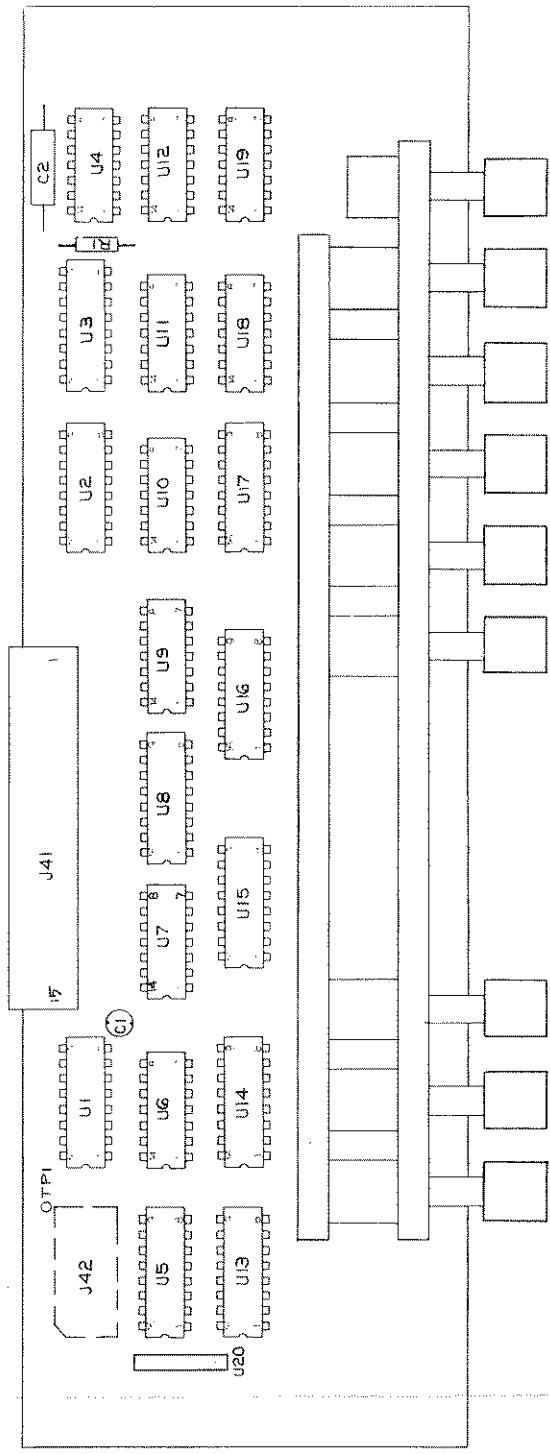

2200A-1609

Figure 8-7. Mode Switch PCB Assembly

NOTES:

1. FOR ASSEMBLY DWG. SEE 2200A-4009.
2. ALL GRAPHIC SYMBOLS ARE IN ACCORDANCE WITH Y32.14 AND Y32.2.
3. ▽ DENOTES UNGUARDED COMMON (UL COM).
4. ALL RESISTANCES ARE IN OHMS AND ALL CAPACITANCES ARE IN MICROFARADE UNLESS OTHERWISE SPECIFIED.

▽ "RESET" SWITCH SHOWN IN DEPRESSED POSITION. ALL OTHER SWITCHES SHOWN IN NONDEPRESSED POSITION.

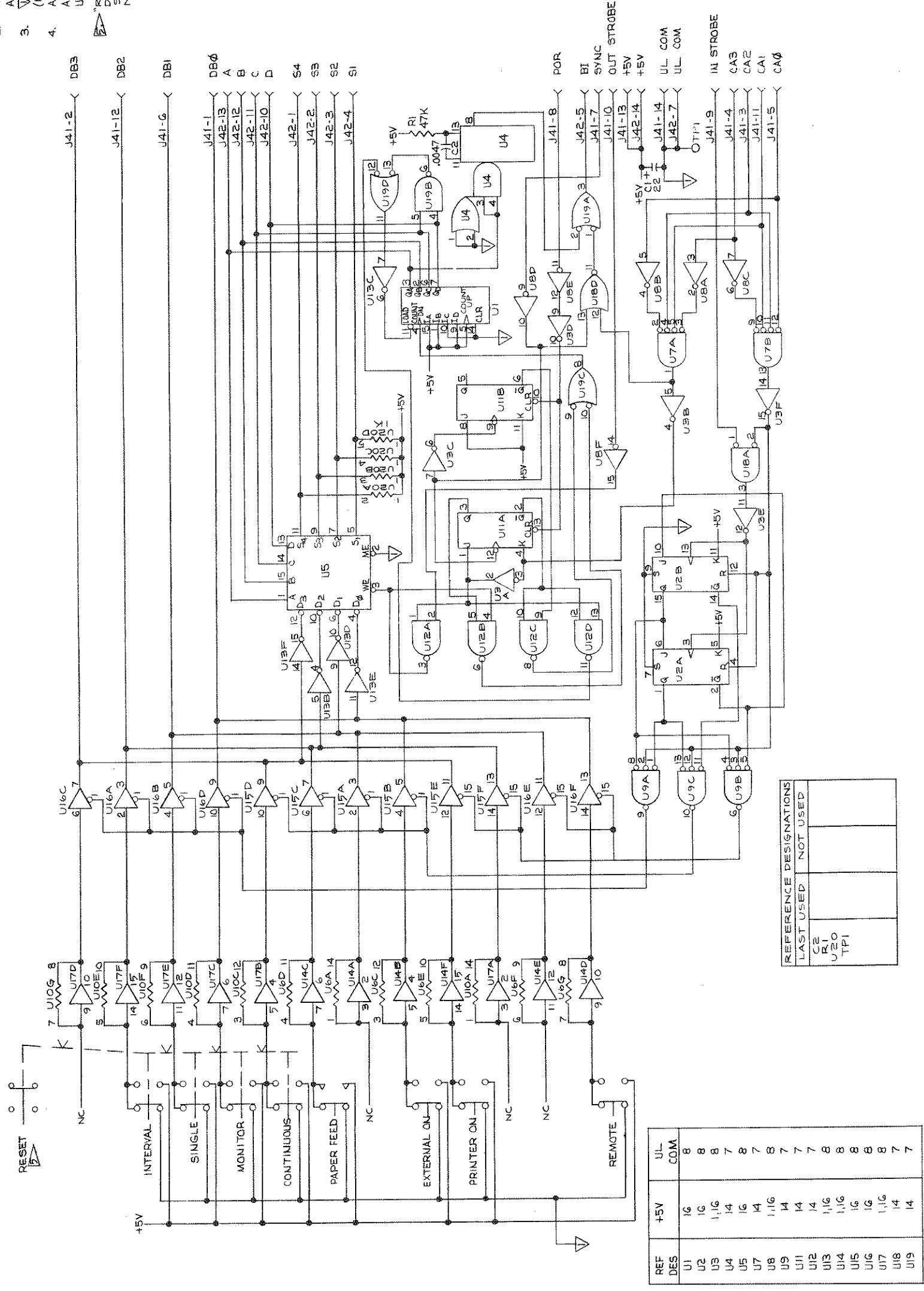

REF DES	+5V	UL COM
U1	1G	8
U2	1G	8
U3	1,1G	8
U4	1G	7
U5	1G	8
U7	1,1G	7
U8	1,1G	8
U9	1,1G	7
U11	1,1G	7
U12	1,1G	7
U13	1,1G	8
U14	1,1G	8
U15	1G	8
U16	1,1G	8
U17	1,1G	8
U18	1,1G	7
U19	1,1G	7

REFERENCE DESIGNATIONS	
LAST USED	NOT USED
C2	
U20	
TPI	

2200A-1009

Figure 8-7. Mode Switch PCB Assembly (cont)



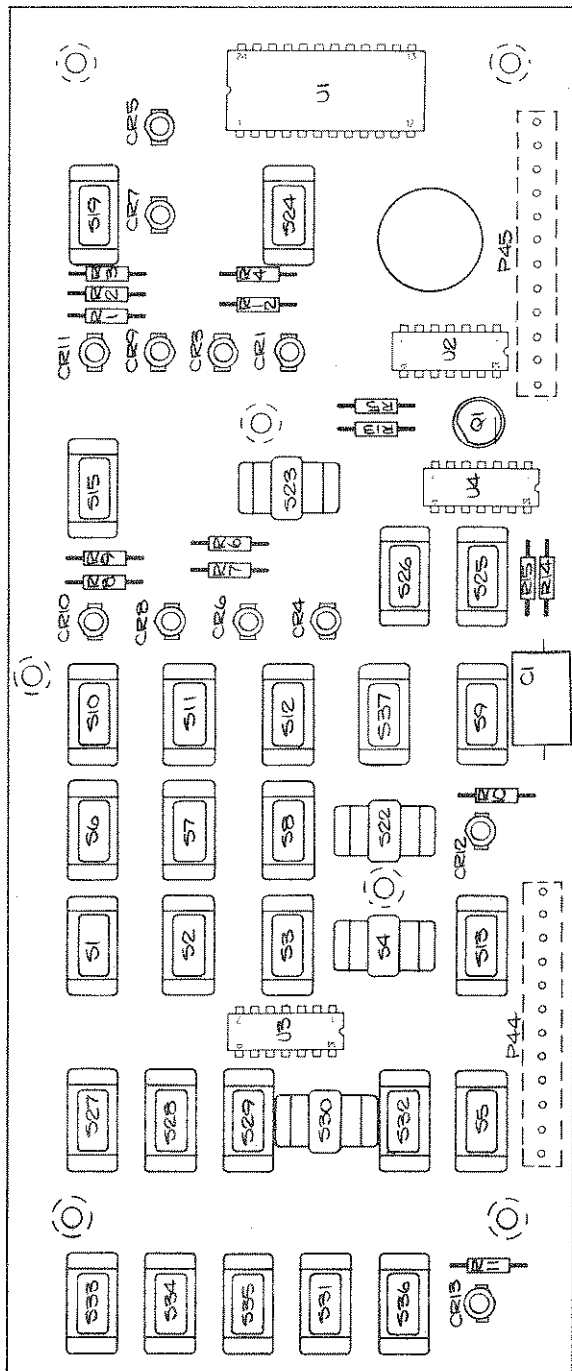

2240B-1611

Figure 8-8. Keyboard Switch PCB Assembly

- NOTES:
1. UNLESS OTHERWISE SPECIFIED ALL RESISTANCES ARE IN OHMS AND ALL CAPACITANCES ARE IN MICROFARADS.
  2. ▽ DENOTES UNGUARDED LOGIC COMMON (ULCOM).
  3. ALL RESISTORS ARE 1/4W, 5% UNLESS OTHERWISE NOTED.
  4. ALL GRAPHIC SYMBOLS IN ACCORDANCE WITH ANSI Y32.14 AND Y32.2.
  5. FOR ASSY DWG. SEE 2240A-4011, FOR REF. DES. DWG. SEE 2240A-1611.

IC. REF. DES.	PIN NO.	UL
U1	24	12,19
U2	14	7
U3	14	7
U4	14	7

REFERENCE DESIGNATIONS	LAST USED	NOT USED
R15	S37	CR2
C1		S416-8
CR13		Q1
Q1		U4

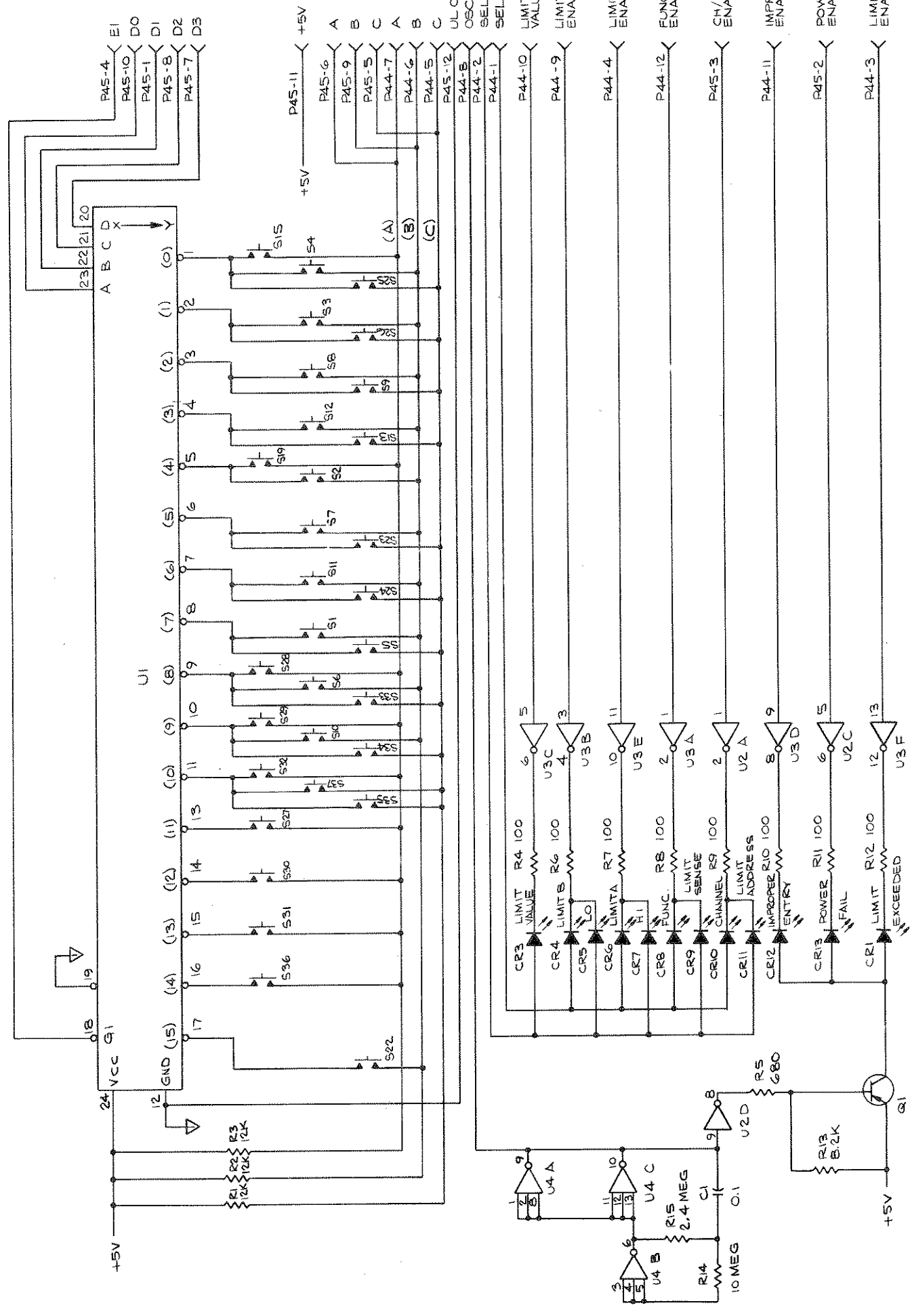

2240B-1011

Figure 8-8. Keyboard Switch PCB Assembly (cont)

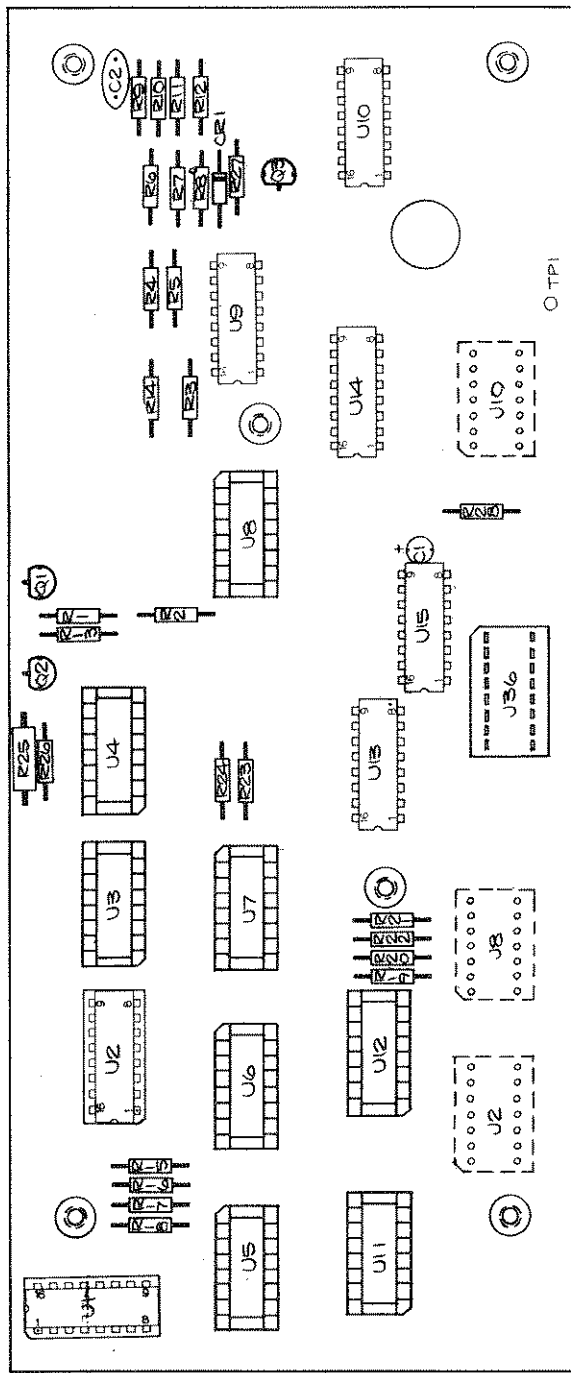

2240A-1613

Figure 8-9. Keyboard Memory PCB Assembly

REFERENCE DESIGNATIONS	
LAST USED	NOT USED
BT1	U15
C2	
CR1	
G3	
R2B	
S1	

ROOM 1013

- NOTES:
- UNLESS OTHERWISE SPECIFIED ALL RESISTANCES ARE IN OHMS AND ALL CAPACITANCES ARE IN MICROFARADS.
  - FOR ASSY DWG. SEE 2240A-4013. FOR REF. DES. DWG. SEE 2240A-1613.
  - ALL RESISTORS ARE 1/4W, 5% UNLESS OTHERWISE NOTED.
  - ALL GRAPHIC SYMBOLS IN ACCORDANCE WITH ANSI Y32.14 AND Y32.2.
  - ▽ DENOTES UNSHARDED LOGIC COMMON (UL COM).

- MEMORY ASSIGNMENTS ARE:
- U1 FIRST LAST, MONITOR CHAN.
  - U2 INTERVAL, HEADER
  - U3 LIMIT A 1-7
  - U4 LIMIT A 8-15
  - U5 LIMIT B 16-22
  - U6,7 LIMIT B 23-30

IC REF. DES.	PIN NUMBERS	BAT	UL COM
U1	16	16	B
U2	16	16	B
U3	16	16	B
U4	16	16	B
U5	16	16	B
U6	16	16	B
U7	16	16	B
U8	16	16	B
U9	16	16	B
U10	16	16	B
U11	16	16	B
U12	1,16	16	B
U13	16	16	B
U14	16	16	B
U15	16	16	B

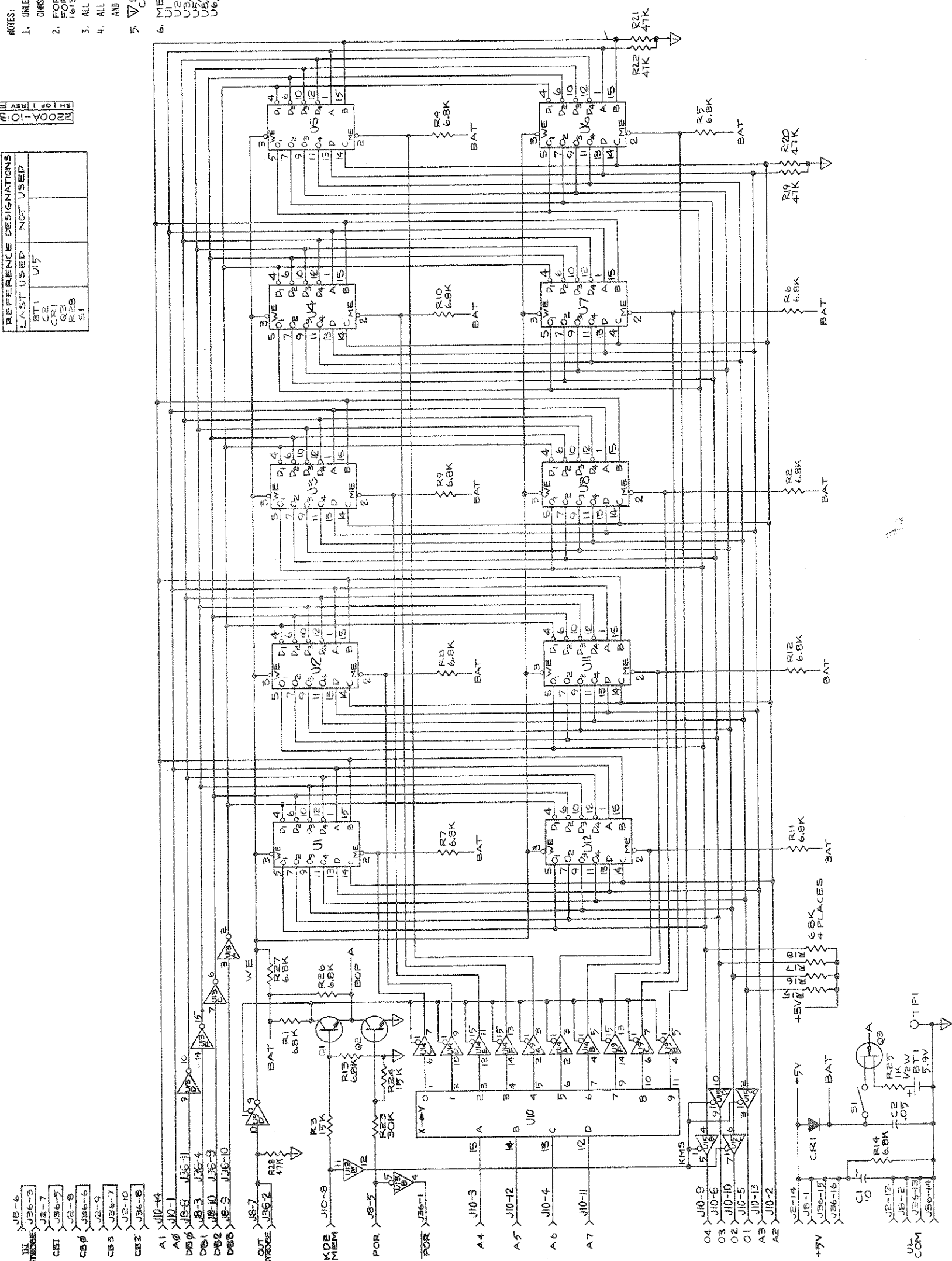

2240A-1013

Figure 8-9. Keyboard Memory PCB Assembly (cont)

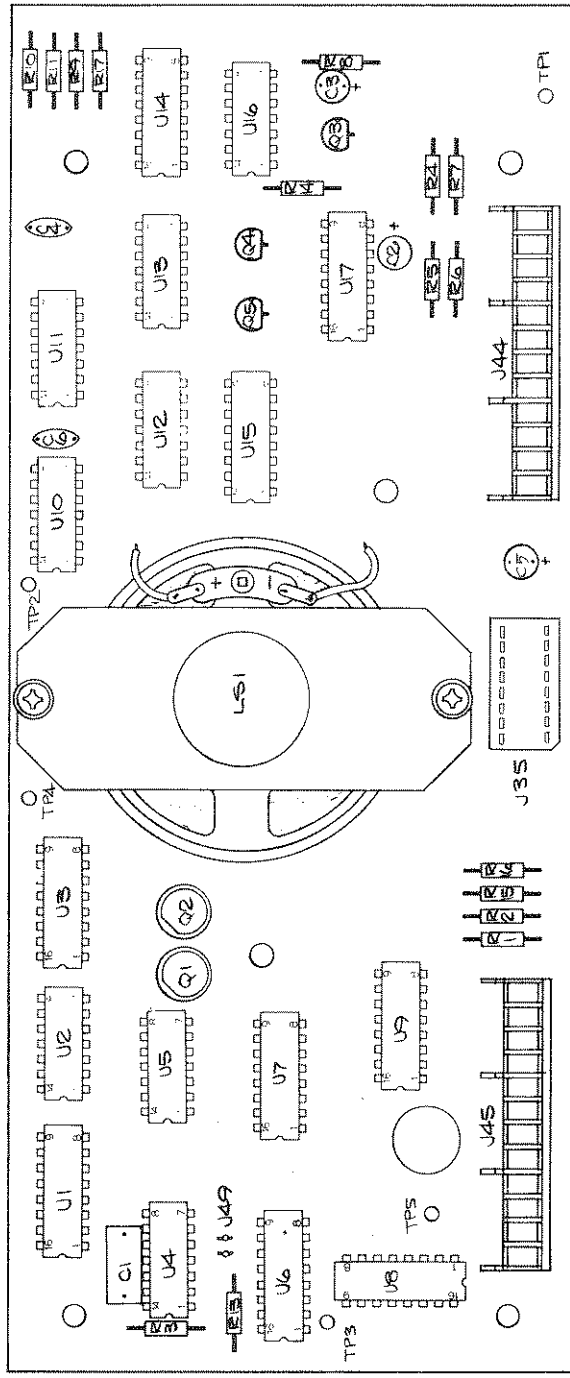

2240A-1612

Figure 8-10. Keyboard Logic PCB Assembly

- NOTES:
1. UNLESS OTHERWISE SPECIFIED ALL RESISTANCES ARE IN OHMS AND ALL CAPACITANCES ARE IN MICROFARADS.
  2. ▽ DENOTES UNGUARDED LOGIC COMMON (UL COM).
  3. ALL RESISTORS ARE 1/4W, 5% UNLESS OTHERWISE NOTED.
  4. ALL GRAPHIC SYMBOLS IN ACCORDANCE WITH ANSI Y32.14 AND Y32.2.
  5. FOR ASSY DWG. SEE 2240A-4012. FOR REF DES. DWG. SEE 2240A-1612.

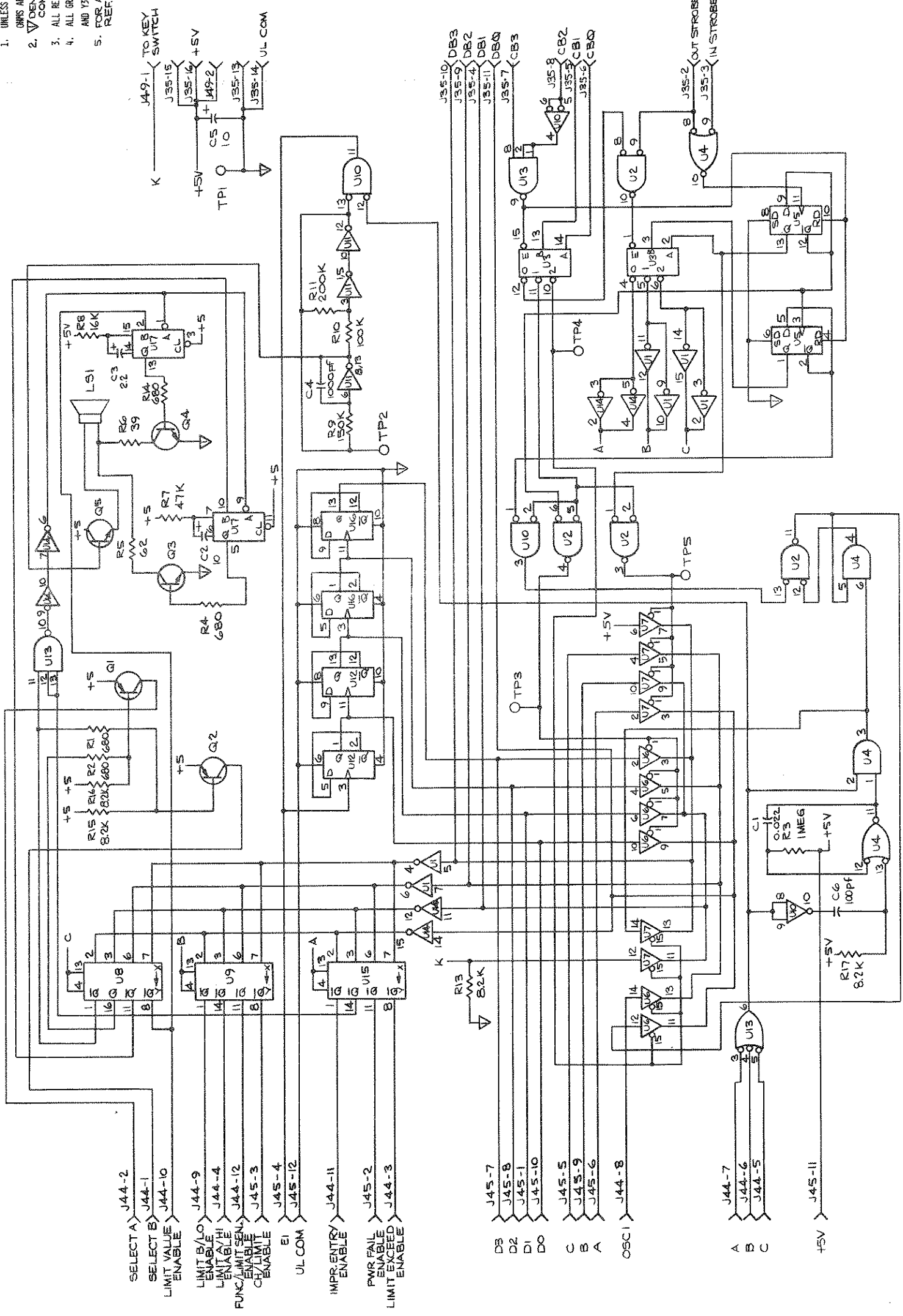

IC REF	PN NO.	HSV	QTY
U1	116	8	
U2	14	7	
U3	16	8	
U4	14	7	
U5	14	6,8	
U6	16	8	
U7	616	8	
U8	5	12	
U9	5	12	
U10	14	7	
U11	2114	4,7,9	
U12	14	7	
U13	14	7	
U14	116	8	
U15	5	12	
U16	14	7	
U17	16	8	

REFERENCE DESIGNATIONS	LAST USED	NOT USED
R17		
C6		
Q5		
U17		
LS1		
TP5		
R12		

2240A-1012

Figure 8-10. Keyboard Logic PCB Assembly (cont)

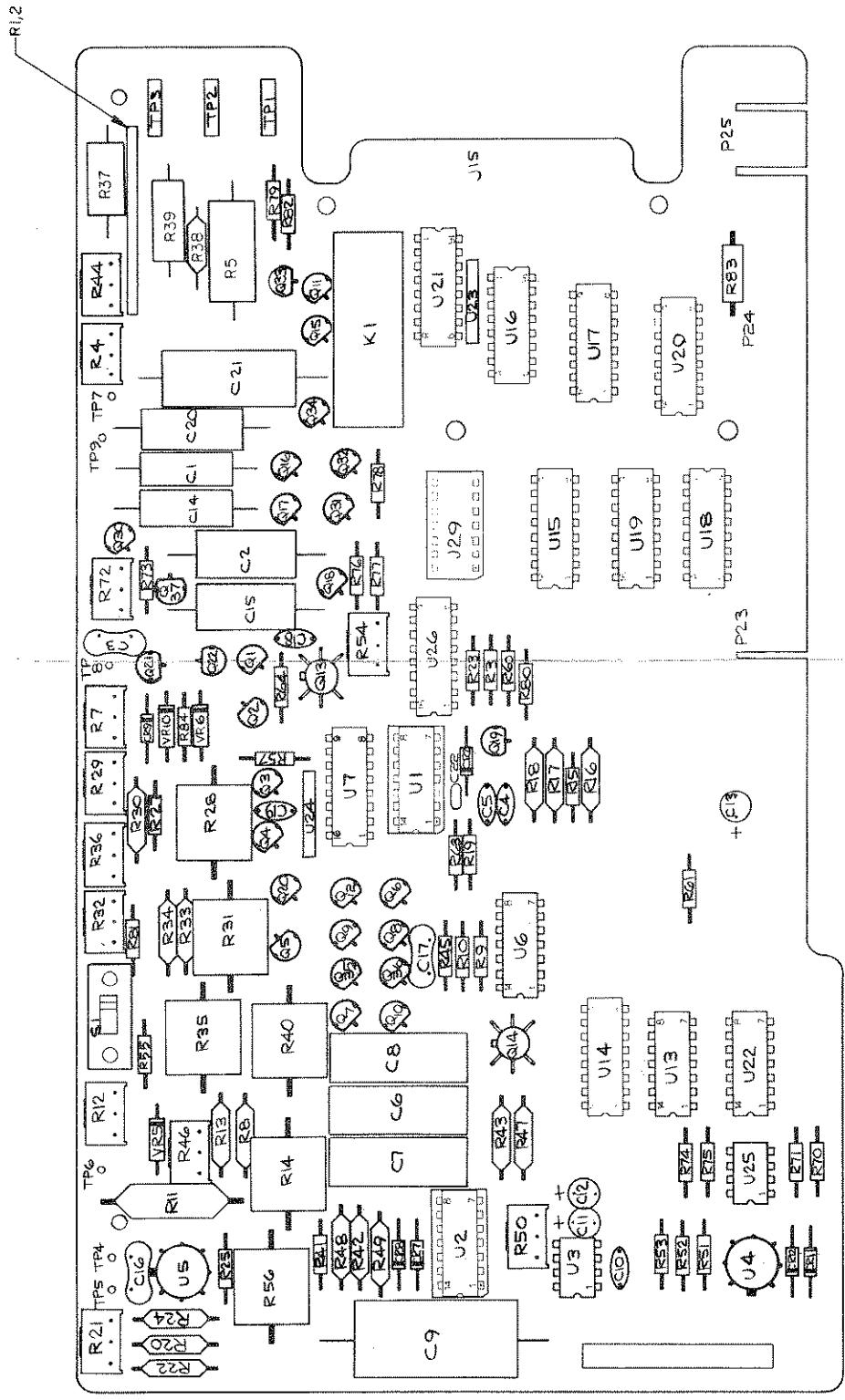

2200A-1628

Figure 8-12. High Performance A/D Converter PCB Assembly

- NOTES:
- UNLESS OTHERWISE SPECIFIED ALL RESISTORS ARE IN OHMS AND ALL CAPACITANCES ARE IN MICROFARADS.
  - FOR REF. DES. DWG. SEE 2200A-1628.
  - DENOTES CALIBRATION ADJ. POINTS. ALL POINTS ARE SCREWDRIER ADJUST.
  - ALL RESISTORS ARE 1/4 W, 5% UNLESS OTHERWISE NOTED.
  - ALL GRAPHIC SYMBOLS IN ACCORDANCE WITH ANSI Y32.14 AND Y32.2.
  - ▽ (-15V) DENOTES GUARDED LOGIC COMMON TO A/D COM. (-15V) WHICH IS -15V WITH RESPECT TO A/D COM.
  - ▽ DENOTES A/D COMMON (A/D COM).
  - ▽ DENOTES REFERENCE COMMON (REF COM).
  - ALL VOLTAGES NOTED ARE WITH RESPECT TO A/D COM.

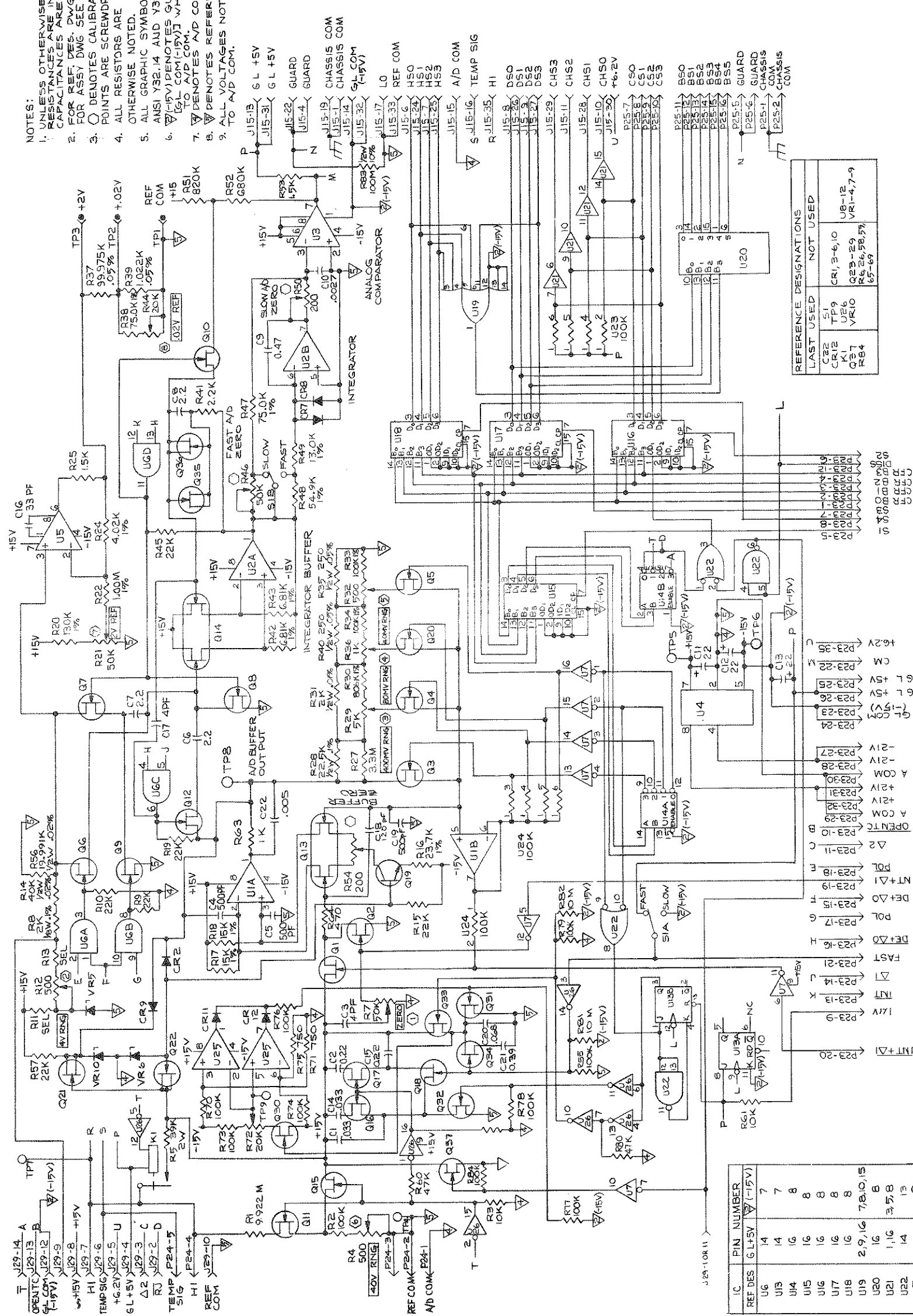

REFERENCE DESIGNATIONS	NOT USED
C22	S1
CR12	CR1, 3-6, 10
U19	U18-12
Q17	VR1-4, 7-9
R54	R5, 26, 58, 57
	65-69

IC	PIN NUMBER
REF DES	G LHV (-15V)
U6	7
U13	14
U14	16
U15	16
U16	8
U17	16
U18	16
U19	2, 9, 16
U20	7, 8, 10, 15
U21	16
U22	8
U7	1, 16
U26	3, 5, 8
	13
	8

2200A-1028

Figure 8-12. High Performance A/D Converter PCB Assembly (cont)



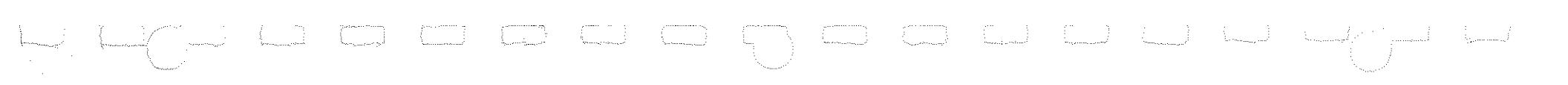

2203A-1004

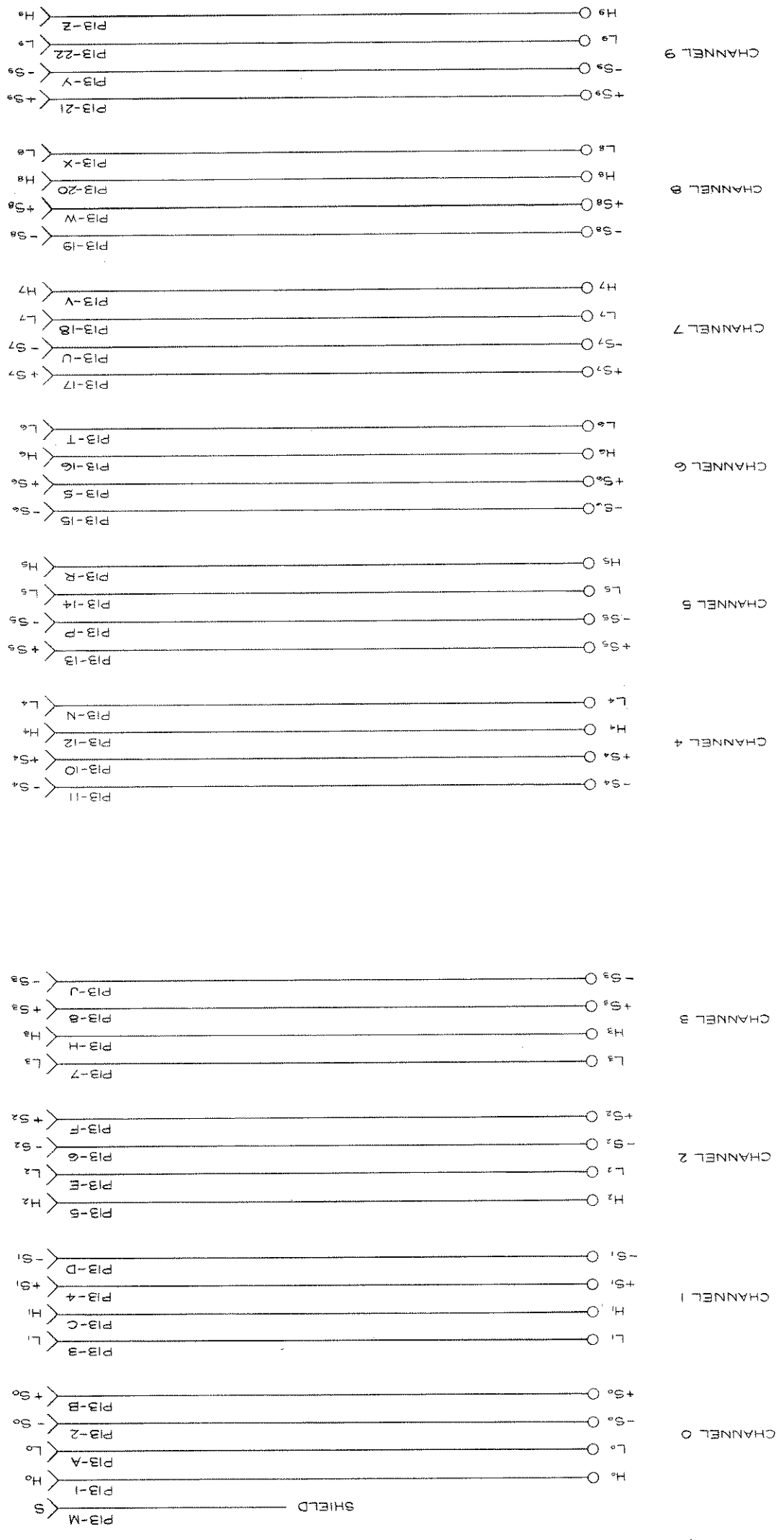
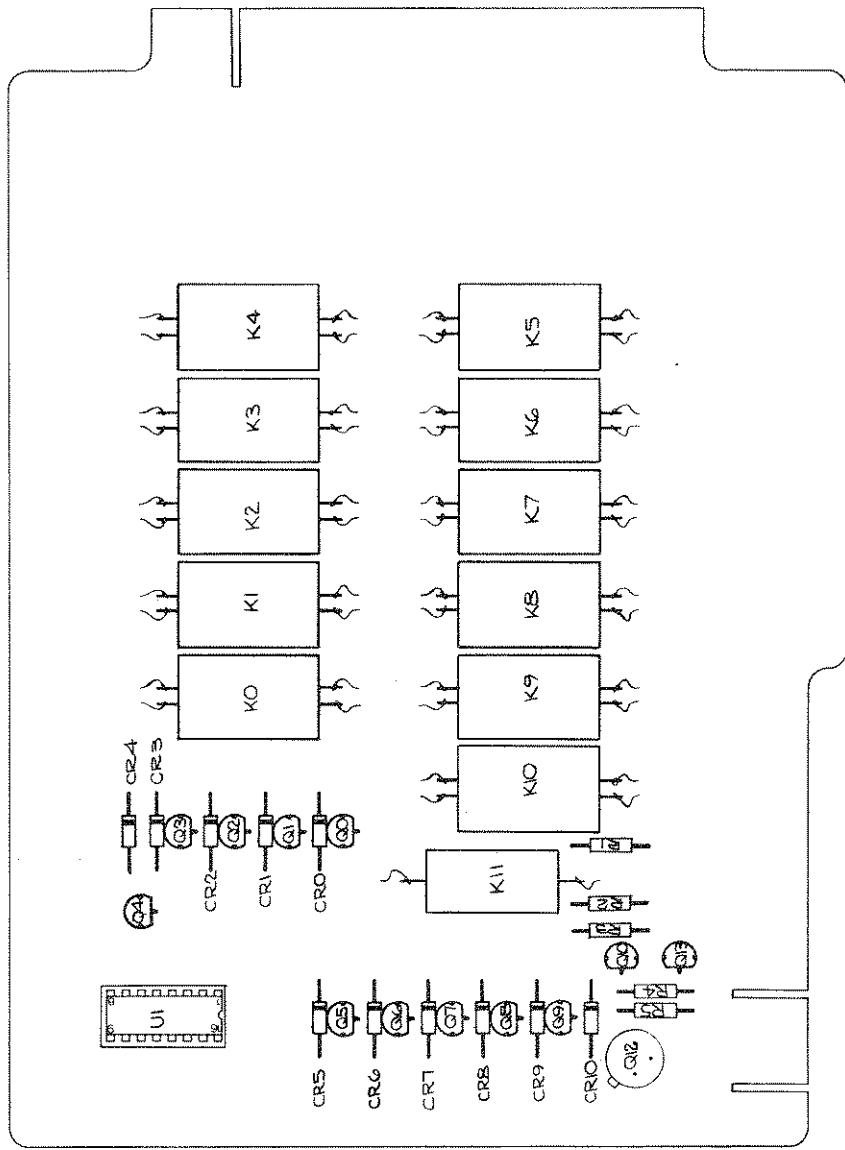

Figure 8-13. RTD Connector Assembly, Option -03



2200A-1606

Figure 8-14. General Purpose Scanner PCB Assembly, Option -05

- NOTES:
1. UNLESS OTHERWISE SPECIFIED ALL RESISTANCES ARE IN OHMS AND ALL CAPACITANCES ARE IN MICROFARADS.
  2. (V) DENOTES GUARDED LOGIC COMMON RESPECT TO A/D COM.
  3. ALL RESISTORS ARE 1/4W, 5% UNLESS OTHERWISE NOTED.
  4. ALL GRAPHIC SYMBOLS IN ACCORDANCE WITH ANSI Y32.14 AND Y32.2.
  5. FOR ASSY. DWG. SEE 2200A-4006. FOR REF. DES. DWG. SEE 2200A-1609.
  6. ALL VOLTAGES NOTED ARE WITH RESPECT TO A/P COM.

K.C. REF. DES. U1		PIN NO. GL+5V GL COM	
		16	8

REFERENCE DESIGNATIONS	
LAST USED	NOT USED
CR10	U1
K11	Q11
Q13	
R9	

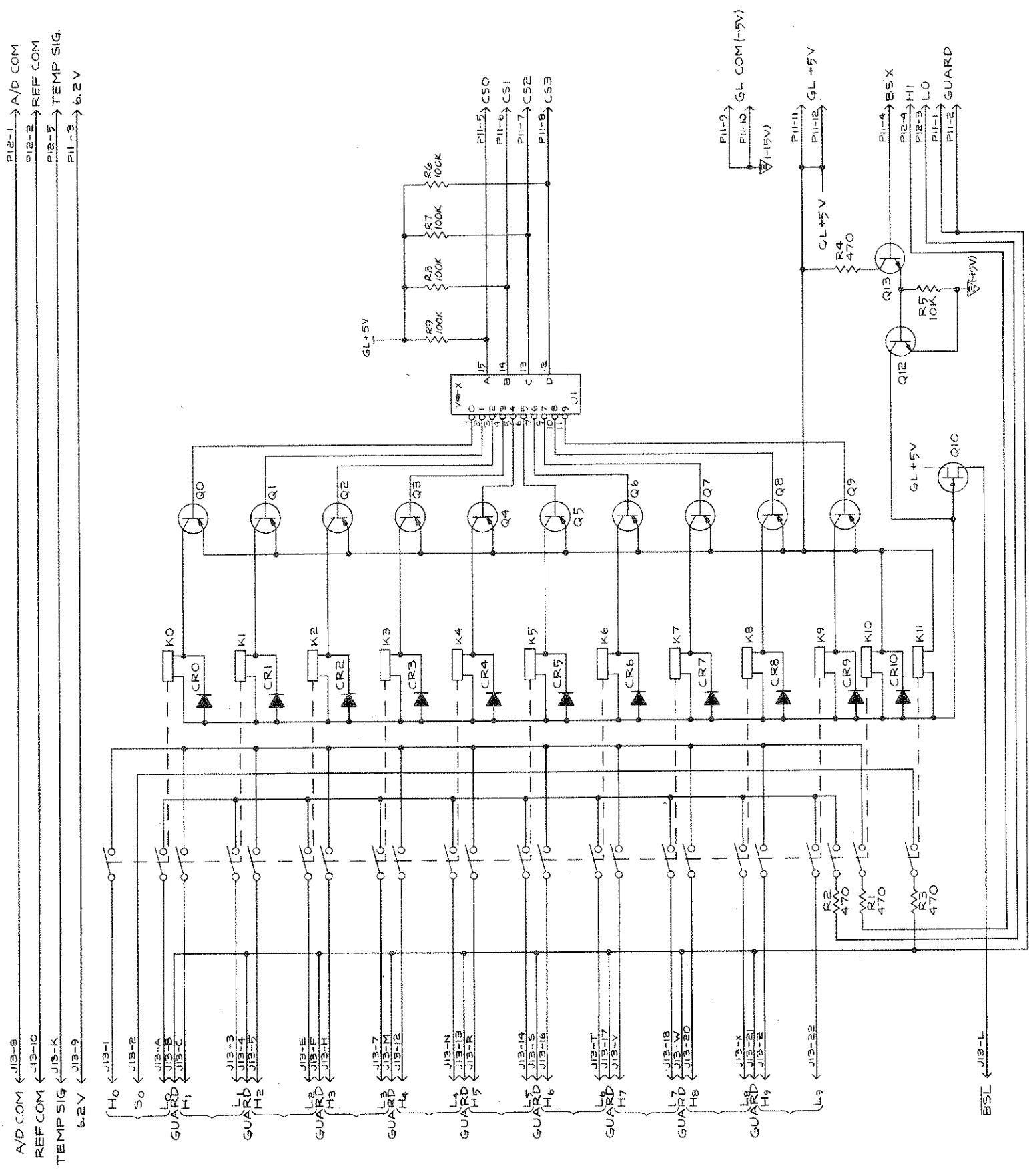

2200A-1006

Figure 8-14. General Purpose Scanner PCB Assembly, Option -05 (cont)

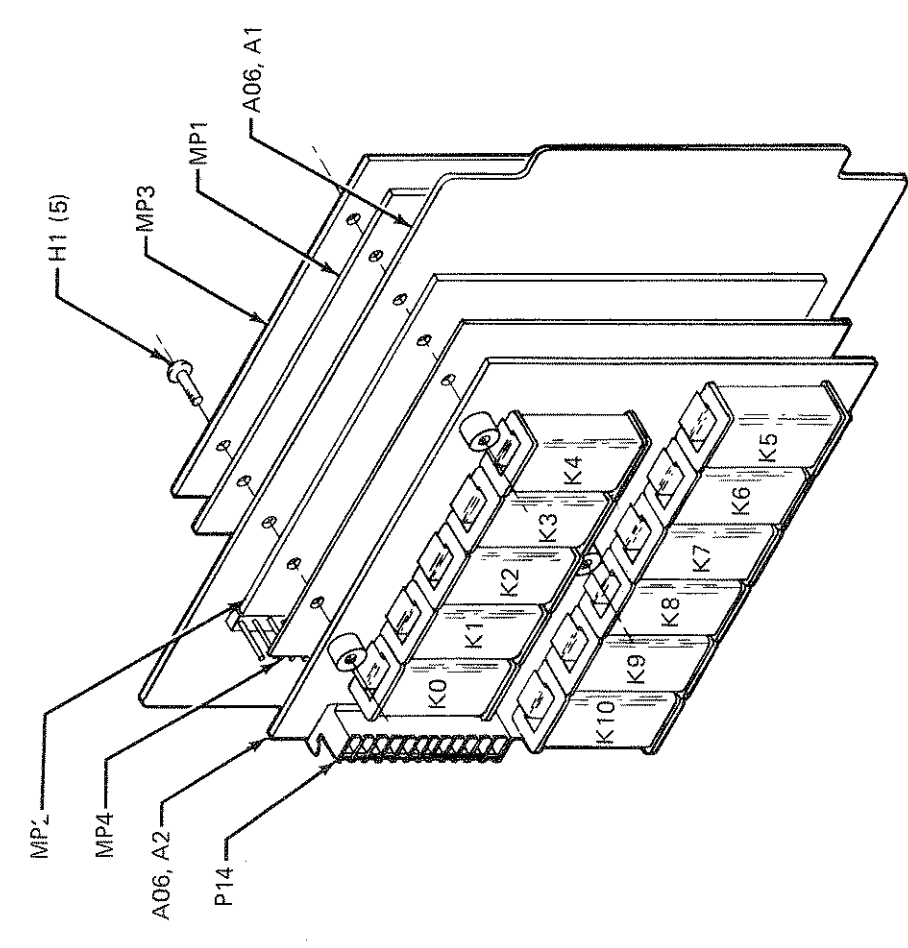
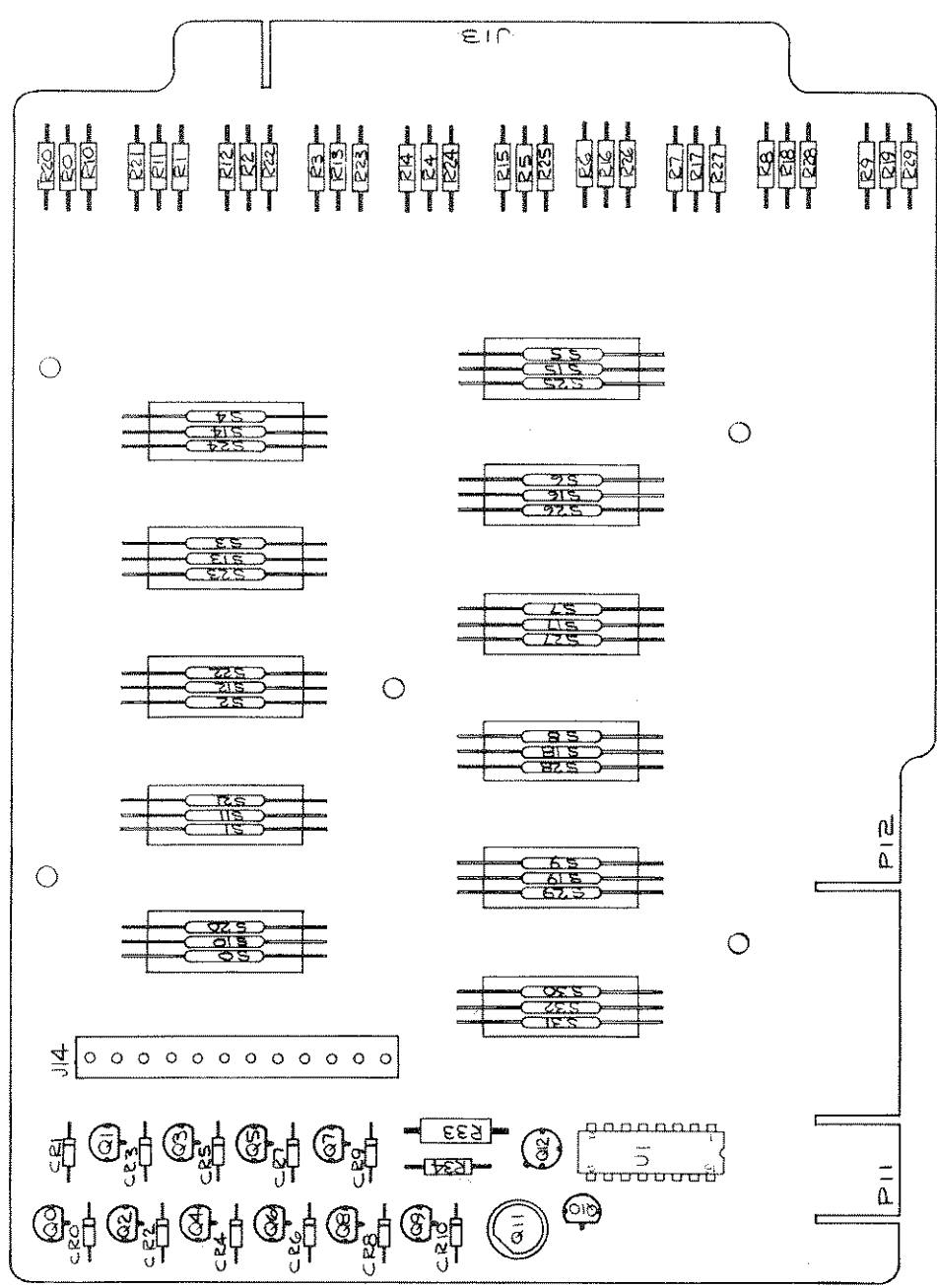

2200A-1629

Figure 8-15. Low Level Scanner Assembly, Option -06

- NOTES:
1. UNLESS OTHERWISE SPECIFIED ALL RESISTANCES ARE IN OHMS AND ALL CAPACITANCES ARE IN MICROFARADS.
  2.  $\odot$  DENOTES CALIBRATION ADJ POINTS. ALL POINTS ARE SCREWDRIVER ADJUST.
  3. ALL RESISTORS ARE 1/4W, 5% UNLESS OTHERWISE NOTED, AND Y 32.14.
  4. ALL GRAPHIC SYMBOLS IN ACCORDANCE WITH ANSII Y32.2.
  5.  $\nabla$  (-15V) DENOTES GUARDED LOGIC COMMON (G L COM (-15V)) WHICH IS -15V WITH RESPECT TO A/D COM. FOR ASSY. DWG. SEE 2200A-4029. FOR REF. DES. DWG. SEE 2200A-1629.
  6. ALL VOLTAGES NOTED ARE WITH RESPECT TO A/D COM.

I.C. REF. DES.	PIN NO.	REFERENCE DESIGNATIONS
U1	6	CR10
	16	Q12
	8	R34
		NOT USED
		R30-32

I.C. REF. DES.	PIN NO.	REFERENCE DESIGNATIONS
U1	6	CR10
	16	Q12
	8	R34
		NOT USED
		R30-32

A/D COM  $\leftarrow$  J13-9  
 REF COM  $\leftarrow$  J13-10  
 TEMP SIG  $\leftarrow$  J13-K  
 6.2V  $\leftarrow$  J13-9

P12-1  $\rightarrow$  A/D COM  
 P12-2  $\rightarrow$  REF COM  
 P12-5  $\rightarrow$  TEMP SIG  
 P11-3  $\rightarrow$  6.2V

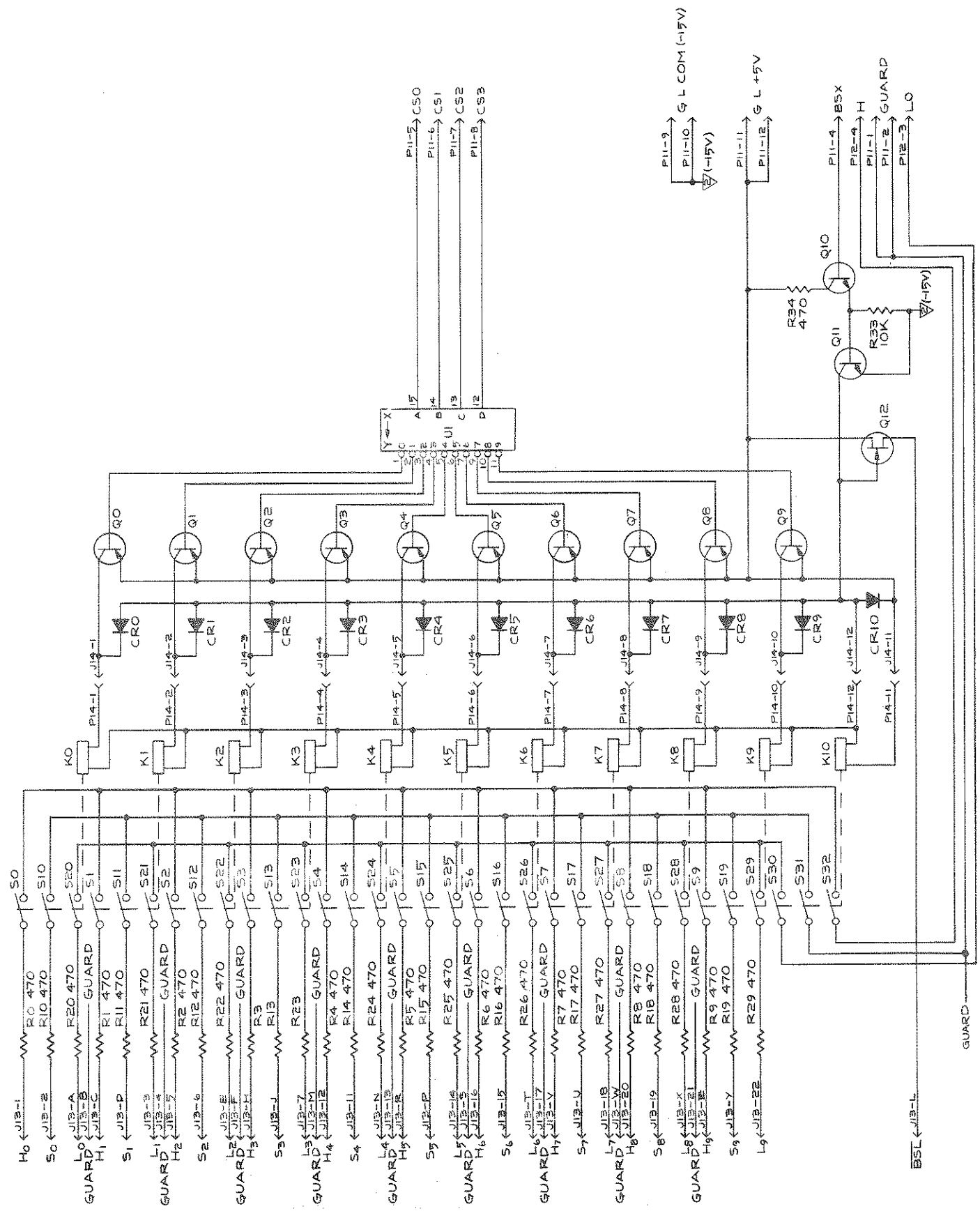

2200A-1029

Figure 8-15. Low Level Scanner Assembly, Option -06 (cont)

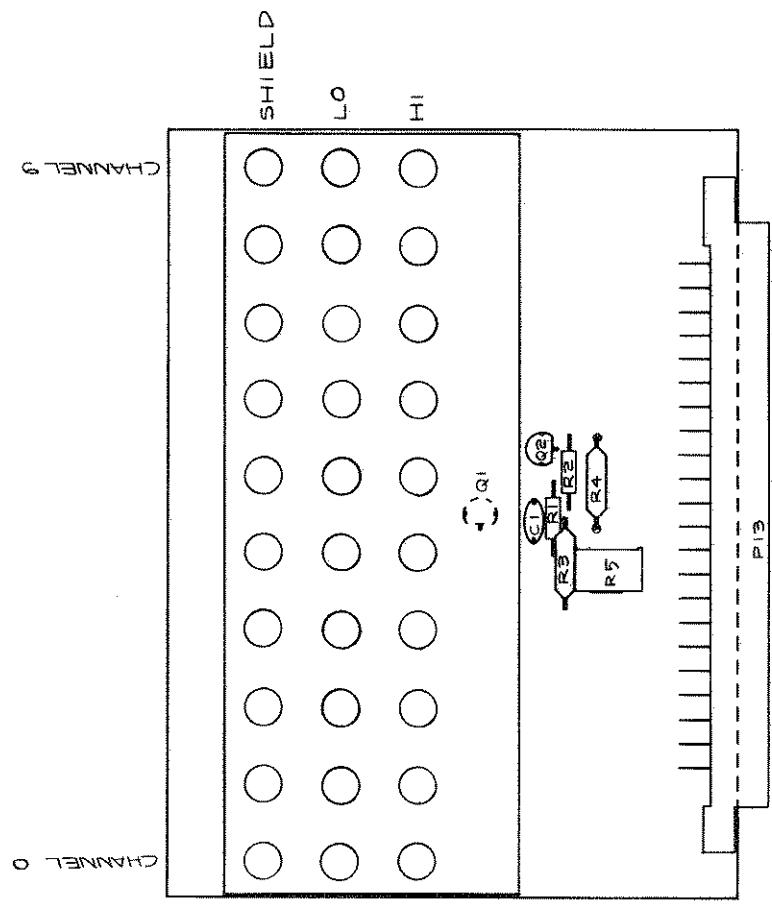

2200A-1623

Figure 8-16. Isothermal Block Connector, Option -08

- NOTES:
1. UNLESS OTHERWISE SPECIFIED ALL RESISTANCES ARE IN OHMS AND ALL CAPACITANCES ARE IN MICROFARADS.
  2. DENOTES CALIBRATION ADJ POINTS. ALL POINTS ARE SCREWDRIVER ADJUST.
  3. ALL RESISTORS ARE 1/4W, 5% UNLESS OTHERWISE NOTED.
  4. ALL GRAPHIC SYMBOLS IN ACCORDANCE WITH ANSI Y32.2.
  5. FOR ASSX DWG. SEE 2200A-1023.
- R4 IS FACTORY SELECTED AND IS ONE OF THE LISTED VALUES:  
 100K  
 257K  
 768K  
 147K

A	1
B	2
C	3
D	4
E	5
F	6
G	7
H	8
J	9
K	10
L	11
M	12
N	13
P	14
R	15
S	16
T	17
V	18
X	19
Y	20
Z	21
	22

REAR VIEW OF P13

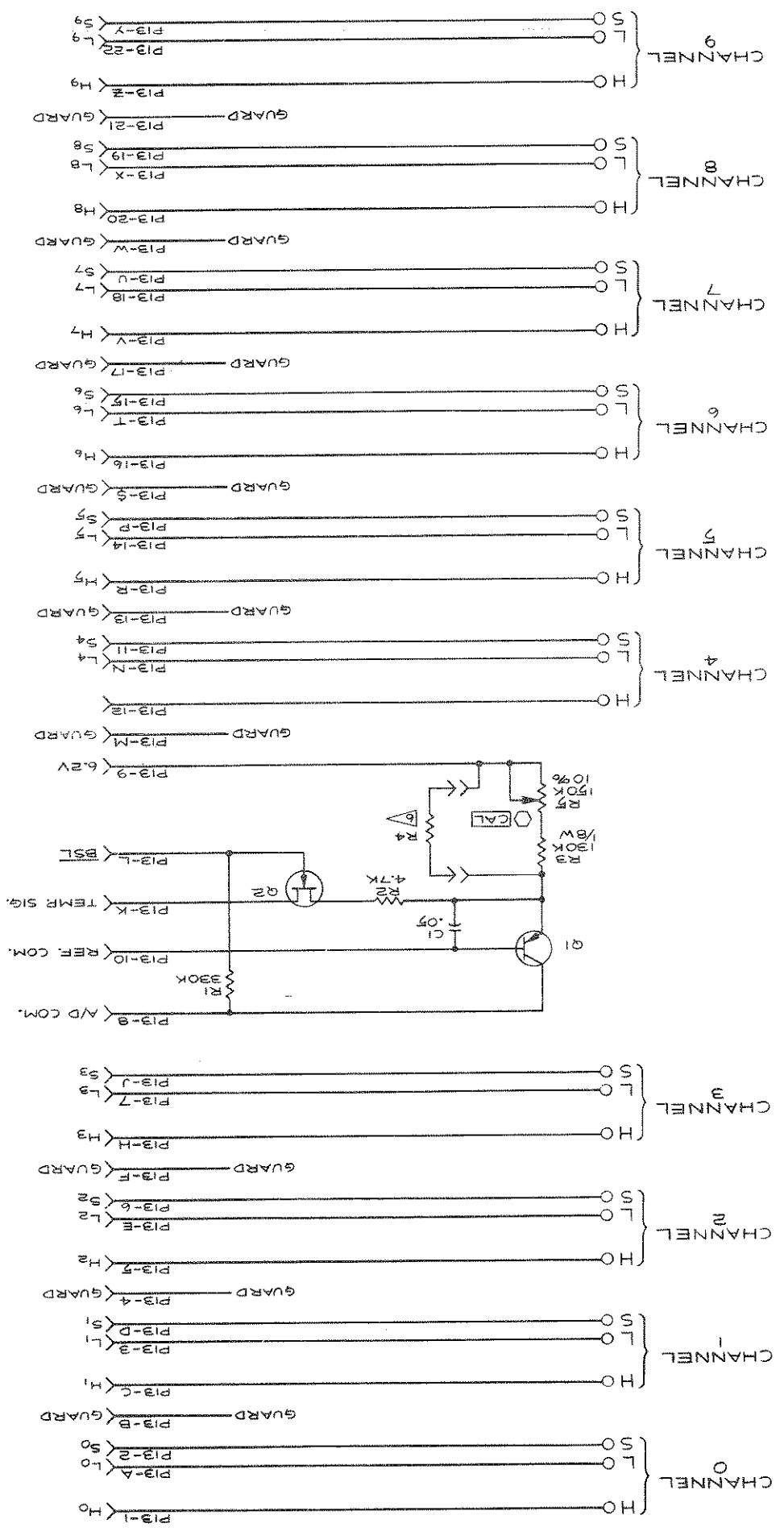

2200A-1023

Figure 8-16. Isothermal Block Connector, Option -08 (cont)



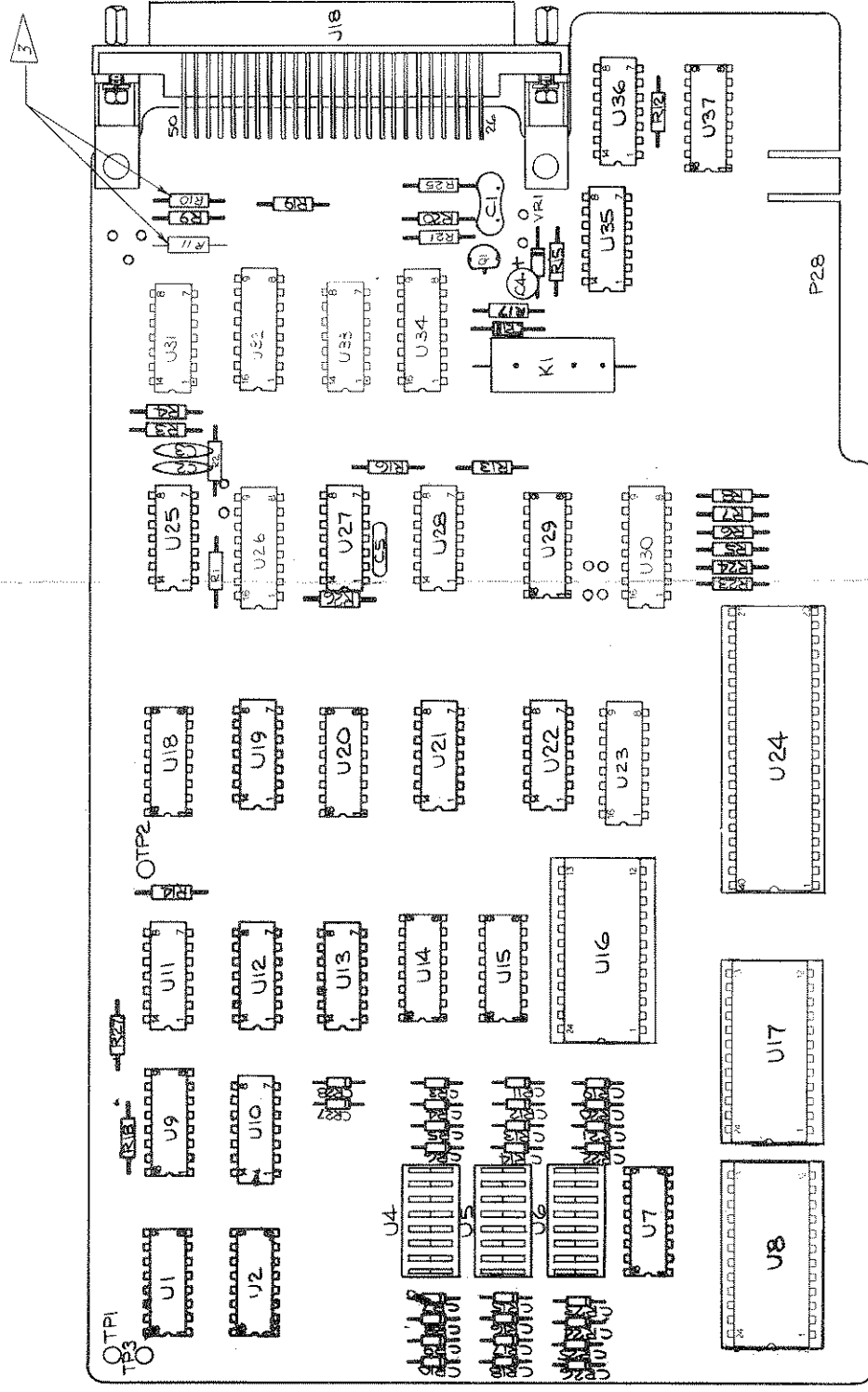

2200A-1614

Figure 8-17. Teletype Interface PCB Assembly, Options -12, -13 and -14

1. UNLESS OTHERWISE NOTED ALL RESISTANCES ARE IN OHMS & MICRORESISTANCES ARE IN MILLI-OHMS.
2. ALL RESISTORS ARE 1/4W 5% UNLESS OTHERWISE NOTED.
3. ALL GRAPHIC SYMBOLS ARE IN ACCORDANCE WITH ANSI Y32.14.
4. FOR 2-LEAD DMS SEE 2200A-1014.
5. FOR REF DESIGNS SEE 2200A-1014.
6. FOR REF DESIGNS SEE 2200A-1014.
7.  $\nabla$  DENOTES UNGUARDED LOGIC COMMON (UL.COM).

IC	DES	FUNCTION	UL
U1	U37	+5V	B
U2	U4	+10V	B
U3	U5	-10V	B
U4	U6	UL.COM	B
U5	U7	U3	B
U6	U8	U3	B
U7	U9	U3	B
U8	U10	U3	B
U9	U11	U3	B
U10	U12	U3	B
U11	U13	U3	B
U12	U14	U3	B
U13	U15	U3	B
U14	U16	U3	B
U15	U17	U3	B
U16	U18	U3	B
U17	U19	U3	B
U18	U20	U3	B
U19	U21	U3	B
U20	U22	U3	B
U21	U23	U3	B
U22	U24	U3	B
U23	U25	U3	B
U24	U26	U3	B
U25	U27	U3	B
U26	U28	U3	B
U27	U29	U3	B
U28	U30	U3	B
U29	U31	U3	B
U30	U32	U3	B
U31	U33	U3	B
U32	U34	U3	B
U33	U35	U3	B
U34	U36	U3	B
U35	U37	U3	B
U36	U38	U3	B
U37	U39	U3	B
U38	U40	U3	B
U39	U41	U3	B
U40	U42	U3	B
U41	U43	U3	B
U42	U44	U3	B
U43	U45	U3	B
U44	U46	U3	B
U45	U47	U3	B
U46	U48	U3	B
U47	U49	U3	B
U48	U50	U3	B
U49	U51	U3	B
U50	U52	U3	B
U51	U53	U3	B
U52	U54	U3	B
U53	U55	U3	B
U54	U56	U3	B
U55	U57	U3	B
U56	U58	U3	B
U57	U59	U3	B
U58	U60	U3	B
U59	U61	U3	B
U60	U62	U3	B
U61	U63	U3	B
U62	U64	U3	B
U63	U65	U3	B
U64	U66	U3	B
U65	U67	U3	B
U66	U68	U3	B
U67	U69	U3	B
U68	U70	U3	B
U69	U71	U3	B
U70	U72	U3	B
U71	U73	U3	B
U72	U74	U3	B
U73	U75	U3	B
U74	U76	U3	B
U75	U77	U3	B
U76	U78	U3	B
U77	U79	U3	B
U78	U80	U3	B
U79	U81	U3	B
U80	U82	U3	B
U81	U83	U3	B
U82	U84	U3	B
U83	U85	U3	B
U84	U86	U3	B
U85	U87	U3	B
U86	U88	U3	B
U87	U89	U3	B
U88	U90	U3	B
U89	U91	U3	B
U90	U92	U3	B
U91	U93	U3	B
U92	U94	U3	B
U93	U95	U3	B
U94	U96	U3	B
U95	U97	U3	B
U96	U98	U3	B
U97	U99	U3	B
U98	U100	U3	B

SEE OPTION FINAL ASSY DWG. THAT DETERMINES THE POSITION OF THIS PART (OPTION 12 CONFIGURATIONS, U31 & U33 ARE INSTALLED AS BUFFERS (7417) FOR ALL OPTION 13 CONFIGURATIONS, U31 & U33 ARE INSTALLED AS BUFFERS (7417) FOR OPTION 14A, B, C, D, E & AS INVERTERS (7416) FOR OPTIONS 14H, J, K.

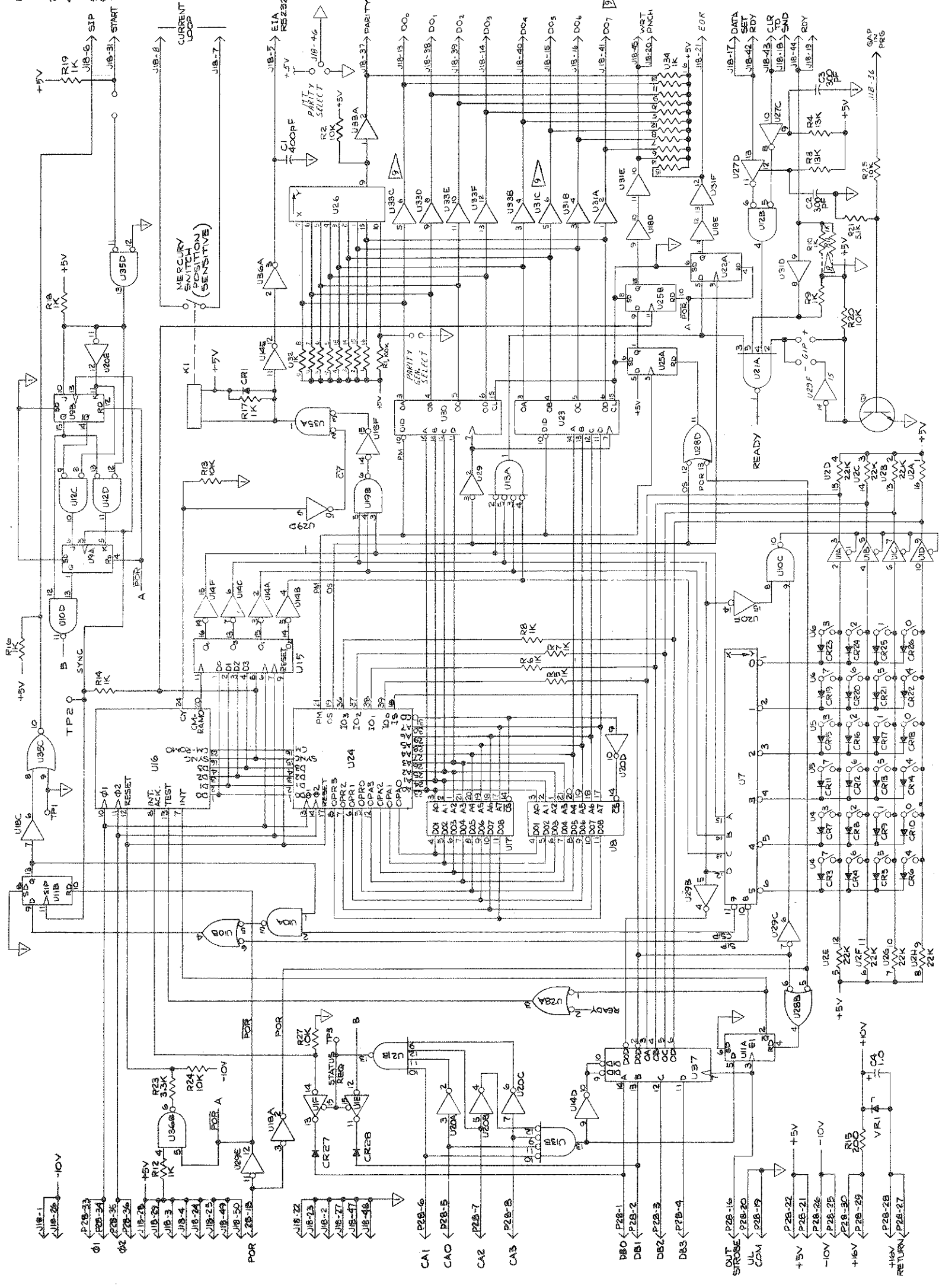

2200A-1014

Figure 8-17. Teletype Interface PCB Assembly, Options -12, -13 and -14 (cont)

REF. DES.	+5V	-10V	▽
U1	16	—	2, 8
U2	1	28	15
U3	20	—	1, 2
U4	16	—	8, 1, 2
U5	16, 4, 1	—	8, 1, 2
U6	20	40	35
U7	9	14, 15, 21	—
U8	14	—	7, 3, 13
U9	16, 7, 12	—	8, 9, 15, 4
U10	16	—	8, 4, 12
U11	2, 1, 2, 4	—	12
U12	5	10, 12	—
U13	16	—	8, 1
U14	14	—	7, 12, 13
U15	14	—	7
U16	14	—	7
U17	5, 10	12	—
U18	16	—	8
U19	14	—	7
U20	14	—	7, 13
U21	2, 1, 2, 4	—	12
U22	5	10, 12	—
U23	1	28	15
U24	14	—	7

NOTES: UNLESS OTHERWISE SPECIFIED

1. ALL RESISTANCES ARE IN OHMS & ALL CAPACITANCES ARE IN MICROFARADS
2. ALL RESISTORS ARE 5%<sub>1/4W</sub>
3. ALL GRAPHIC SYMBOLS ARE IN ACCORDANCE WITH ANSI Y32.2 & Y32.14

REFERENCE DESIGNATOR	
LAST USED	NOT USED
R11 Z3	
C15 Q3	
CRI TPT	
U24	

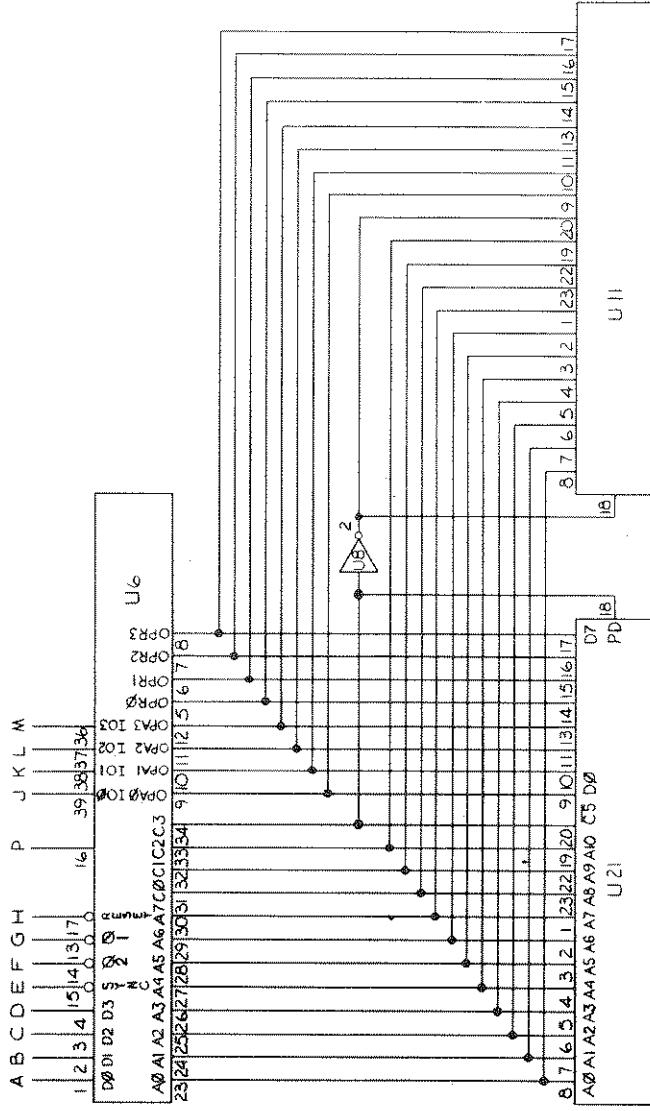
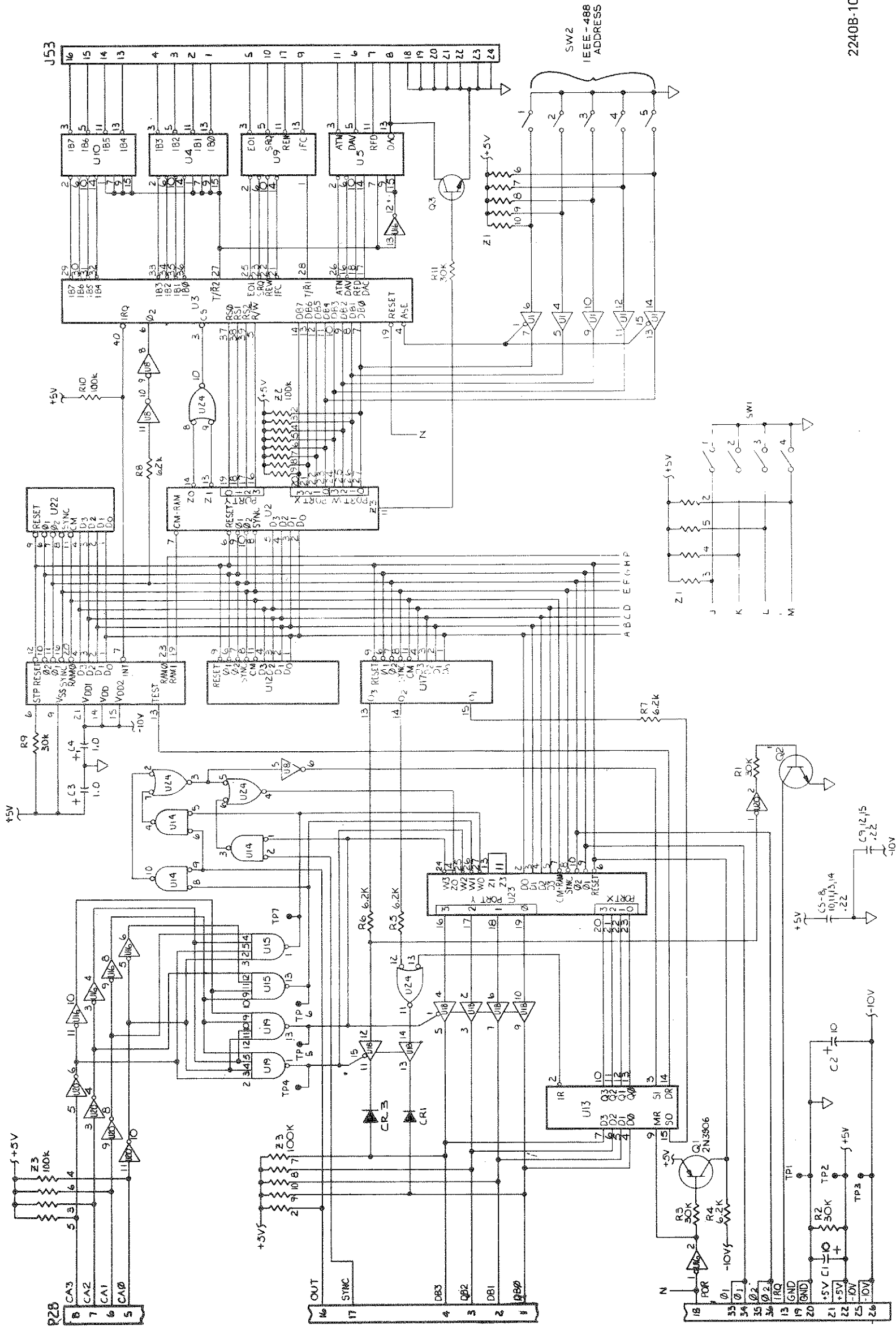

Figure 8-18. IEEE Interface PCB Assembly, Option -15



2240B-1015 (2 of 2)

Figure 8-18. IEEE Interface PCB Assembly, Option -15 (cont)

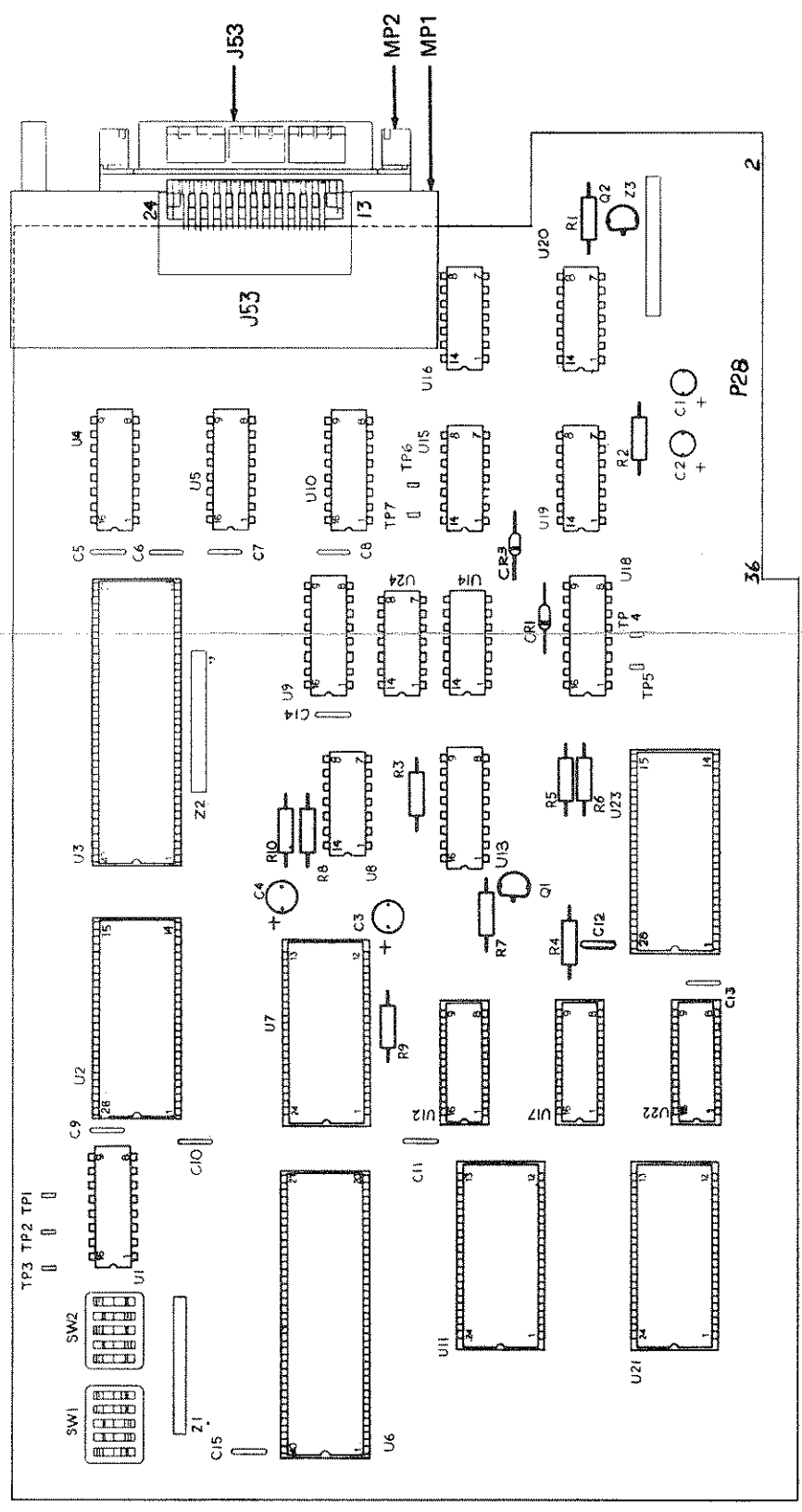
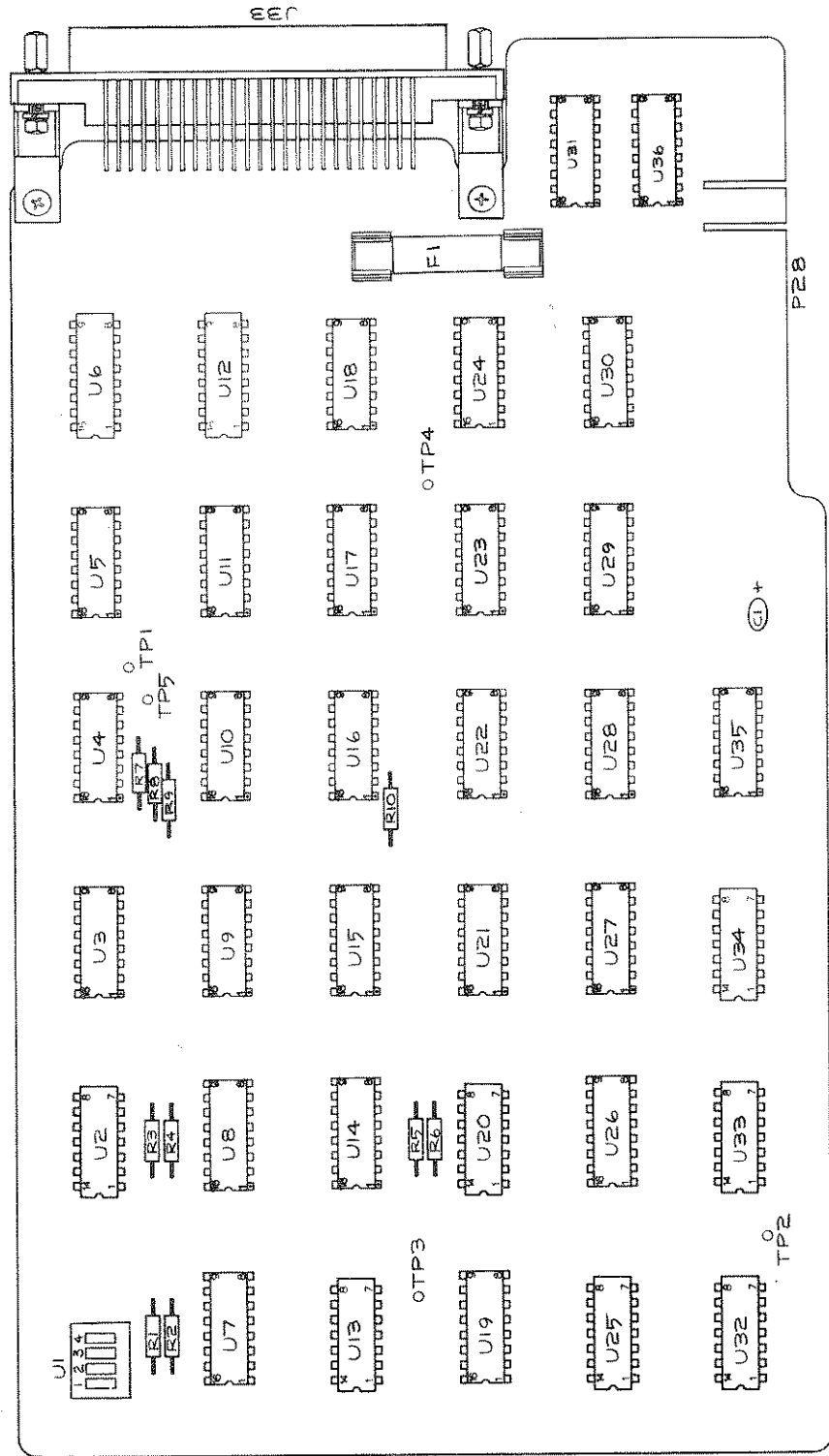

Figure 8-18. IEEE Interface PCB Assembly, Option -15 (cont)



2200A-1617

Figure 8-19. Digital Input PCB Assembly, Option -16

NOTES:

1. UNLESS OTHERWISE SPECIFIED ALL RESISTANCES ARE IN OHMS AND ALL CAPACITANCES ARE IN MICROFARADS.
2. FOR ASSY DWG SEE 2200A-4017.
3. ALL RESISTORS ARE 1/4W, 5% UNLESS OTHERWISE NOTED.
4. ALL GRAPHIC SYMBOLS IN ACCORDANCE WITH ANSI Y32.14 AND Y32.2.
5. ▽ DENOTES UNGUARDED LOGIC COMMON (ULCOM).

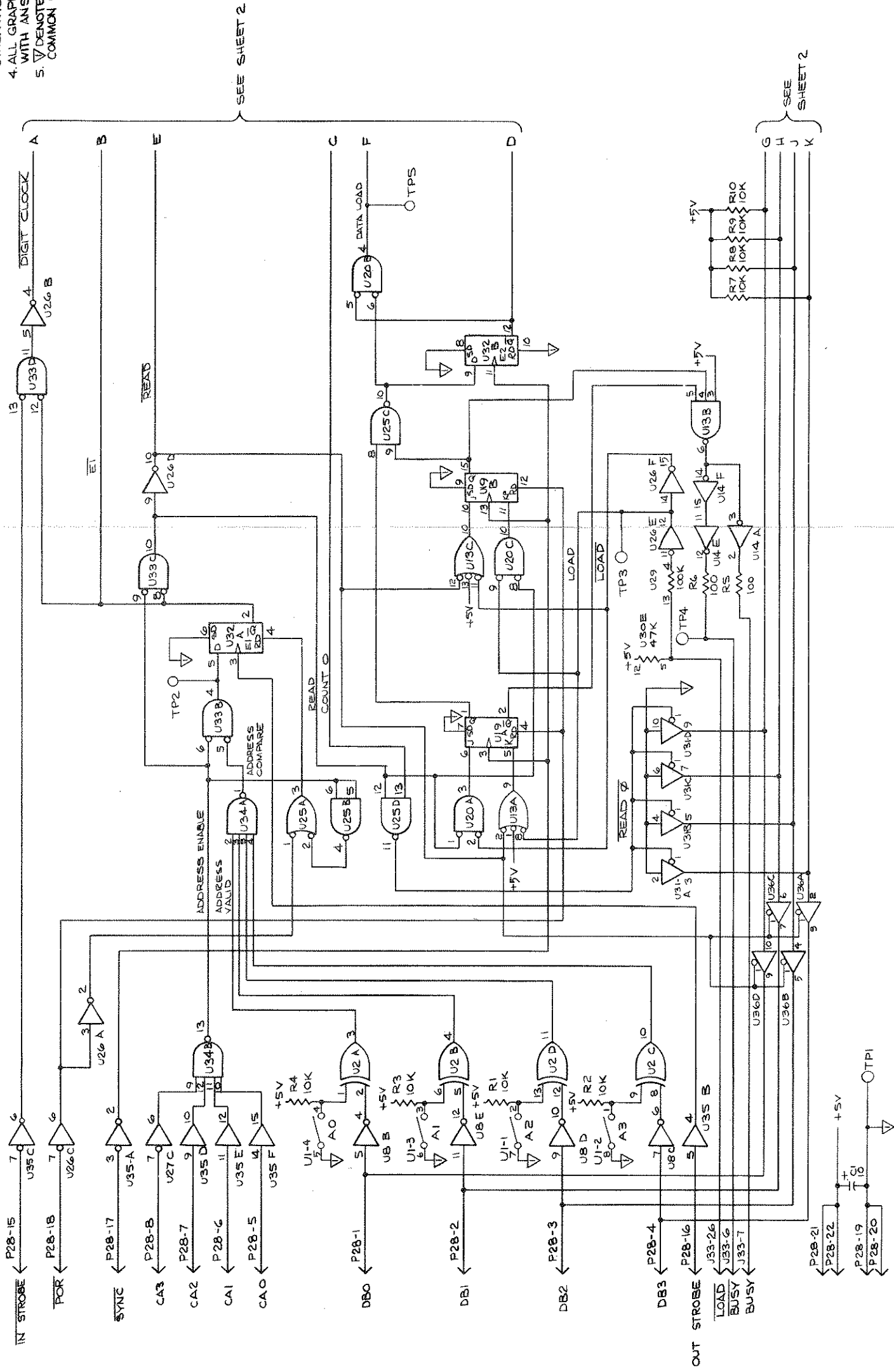

IC REF DES	PIN NO	IC REF DES	PIN NO
U1	5-8	U19	16
U2	7	U20	16
U3	14	U21	16
U4	16	U22	16
U5	9-16	U23	16
U6	16	U24	16
U7	16	U25	16
U8	16	U26	16
U9	16	U27	16
U10	16	U28	16
U11	16	U29	16
U12	16	U30	16
U13	16	U31	16
U14	16	U32	16
U15	16	U33	16
U16	16	U34	16
U17	16	U35	16
U18	16	U36	16

REFERENCE DESIGNATION	LAST USED	NOT USED
R10	F1	
C1		
U36		
TPS		

2200A-1017 (1 of 2)

Figure 8-19. Digital Input PCB Assembly, Option -16 (cont)

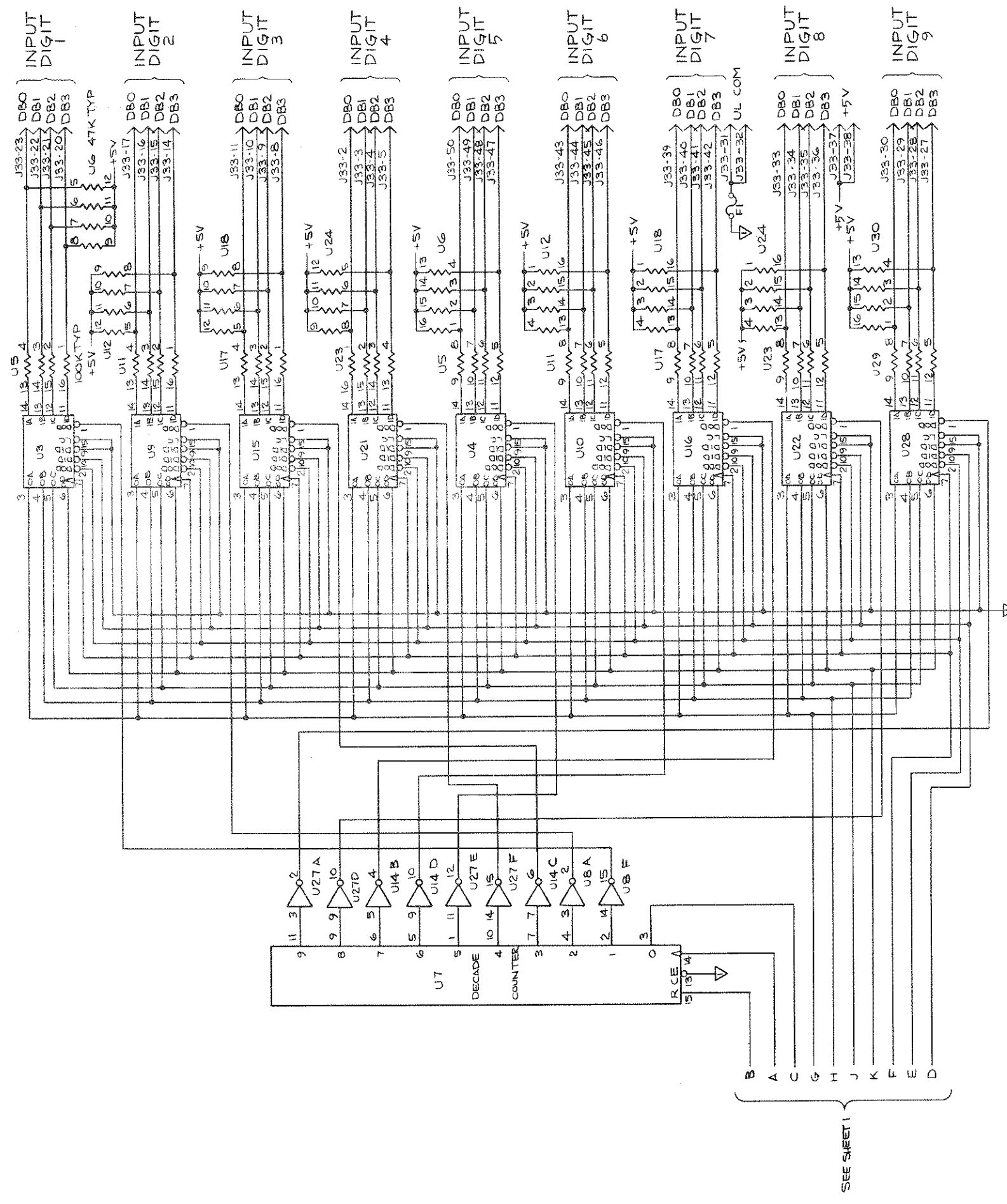

2200A-1017 (2 of 2)

Figure 8-19. Digital Input PCB Assembly, Option -16 (cont)



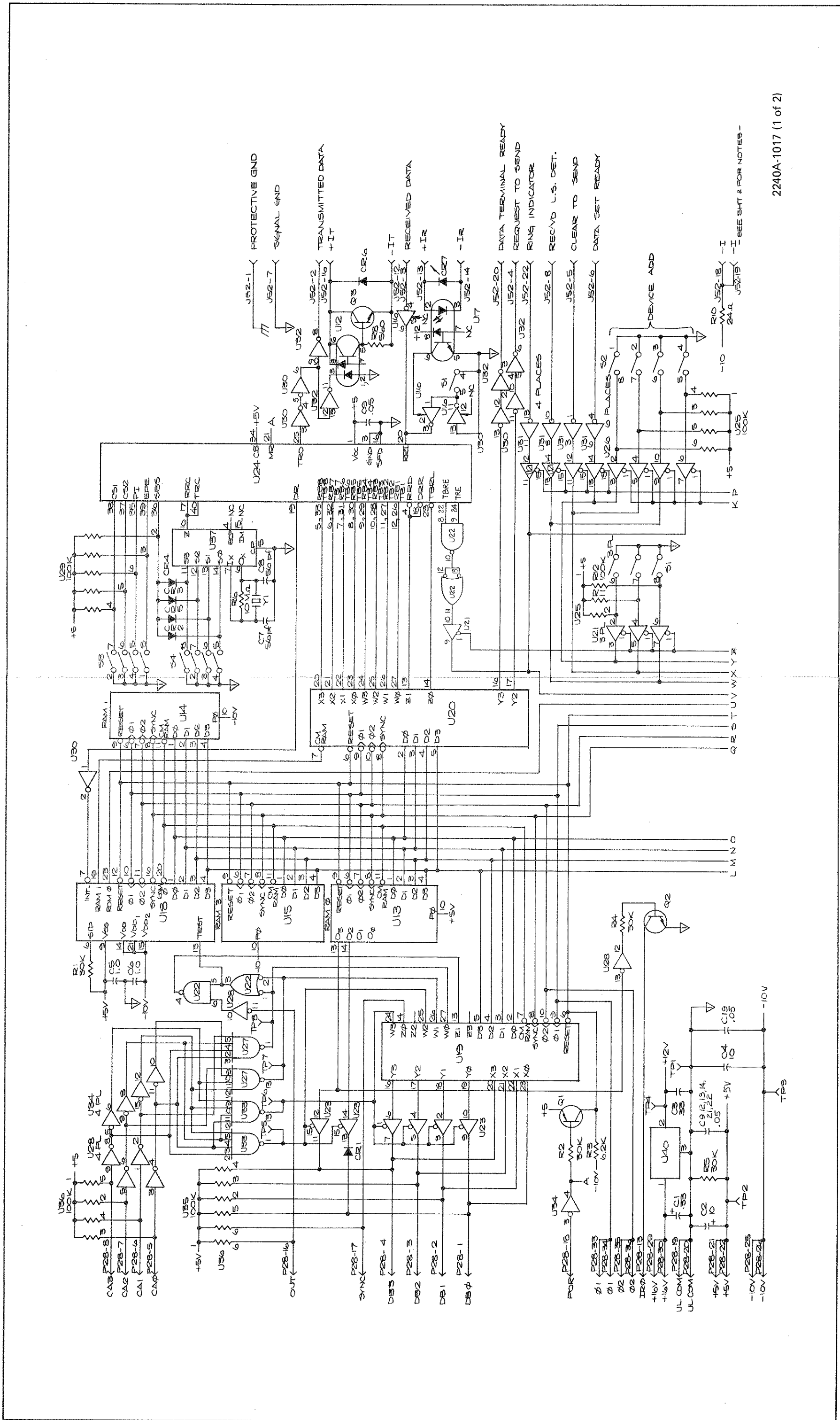
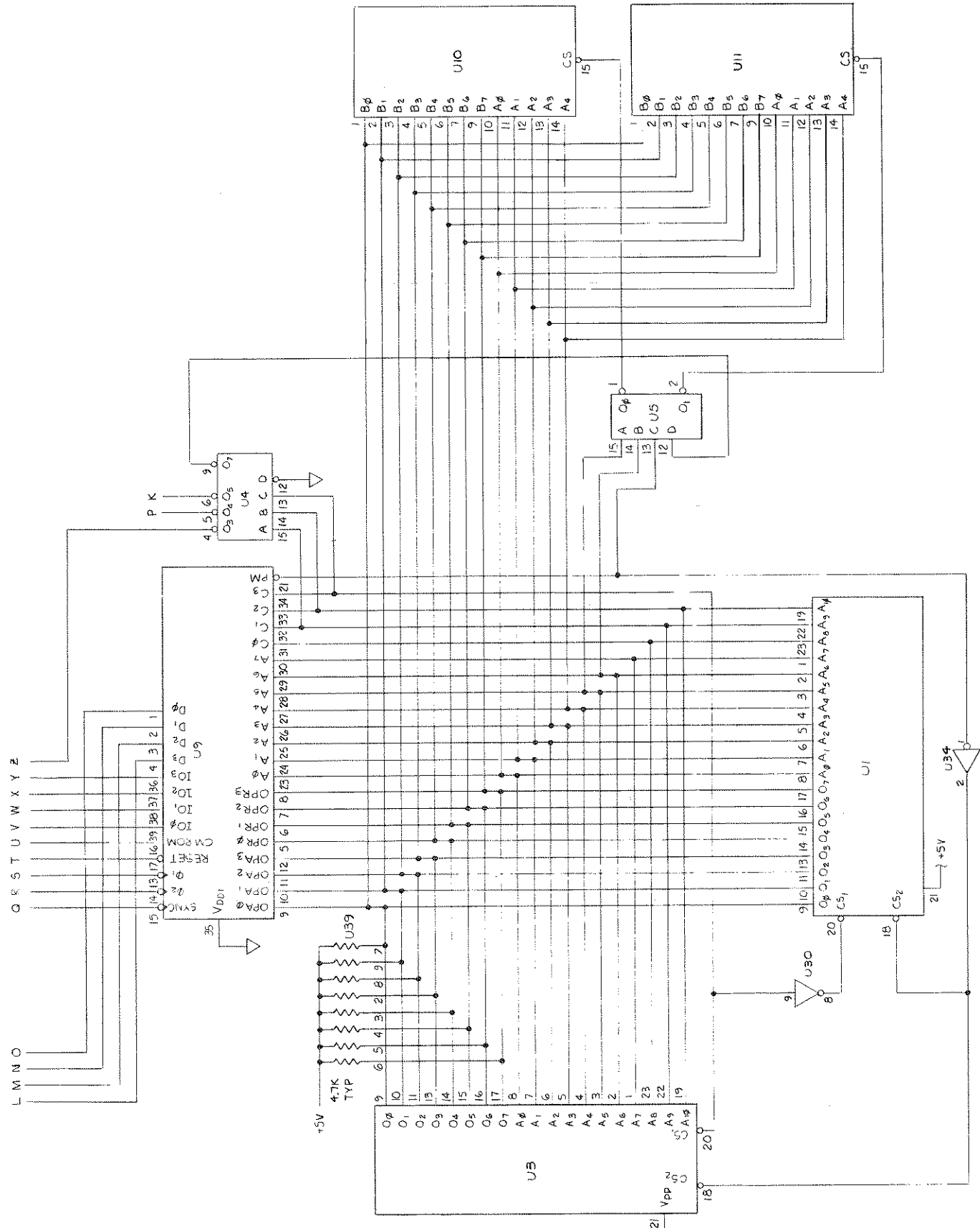

Figure 8-20. Remote Programming PCB Assembly, Option -17

2240A-1017 (1 of 2)



NOTES: UNLESS OTHERWISE SPECIFIED

1. ALL RESISTANCES ARE IN OHMS AND ALL CAPACITANCES ARE IN MICROFARADS.
2. ▽ DENOTES UNGUARDED LOGIC COMMON (UL COMMON).
3. ALL RESISTORS ARE 1/4W, 5% UNLESS OTHERWISE NOTED.
4. ALL GRAPHIC SYMBOLS ARE IN ACCORDANCE WITH ANSI Y32.2 AND Y32.14.
5. FOR ASSEMBLY DRAWING SEE 2240A-4017.
6. FOR REFERENCE DRAWING SEE 2240A-1617.
7. **WARNING:** ⊗ INDICATES USAGE OF MOS DEVICES WHICH MAY BE DAMAGED BY STATIC DISCHARGE. USE SPECIAL HANDLING PER SOP. 15.7.



**CAUTION**  
SUBJECT TO DAMAGE BY  
STATIC ELECTRICITY

IC	+5	UL	COM	-10	+12	+16
1	21,24	12				
3	16	8,12				
4	16	8	40			
5	20	8				
10	16	8				
12	16	1,2				
15	5,10		12			
14	5		10,12			
15	5		10,12			
16	14	7			8	
17	14	5				
18	9	15				
19	1	15				
20	16	8				
21	14	7				
22	14	7				
23	16	3				
24	1,2	3,16				
25	16	8				
26	16	7				
27	14	7				
28	14	7				
29	14	7				
30	14	7				
31	14	7				
32	14	7				
33	14	7				
34	14	7				
35	14	7				
36	14	7				
37	16	5,8				
39	1					
40		3				

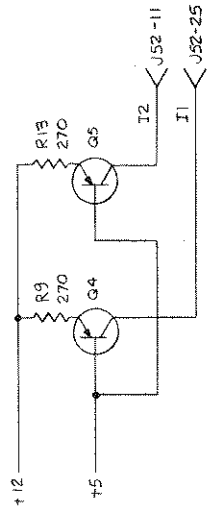

2240A-1017 (2 of 2)

Figure 8-20. Remote Programming PCB Assembly, Option -17 (cont)

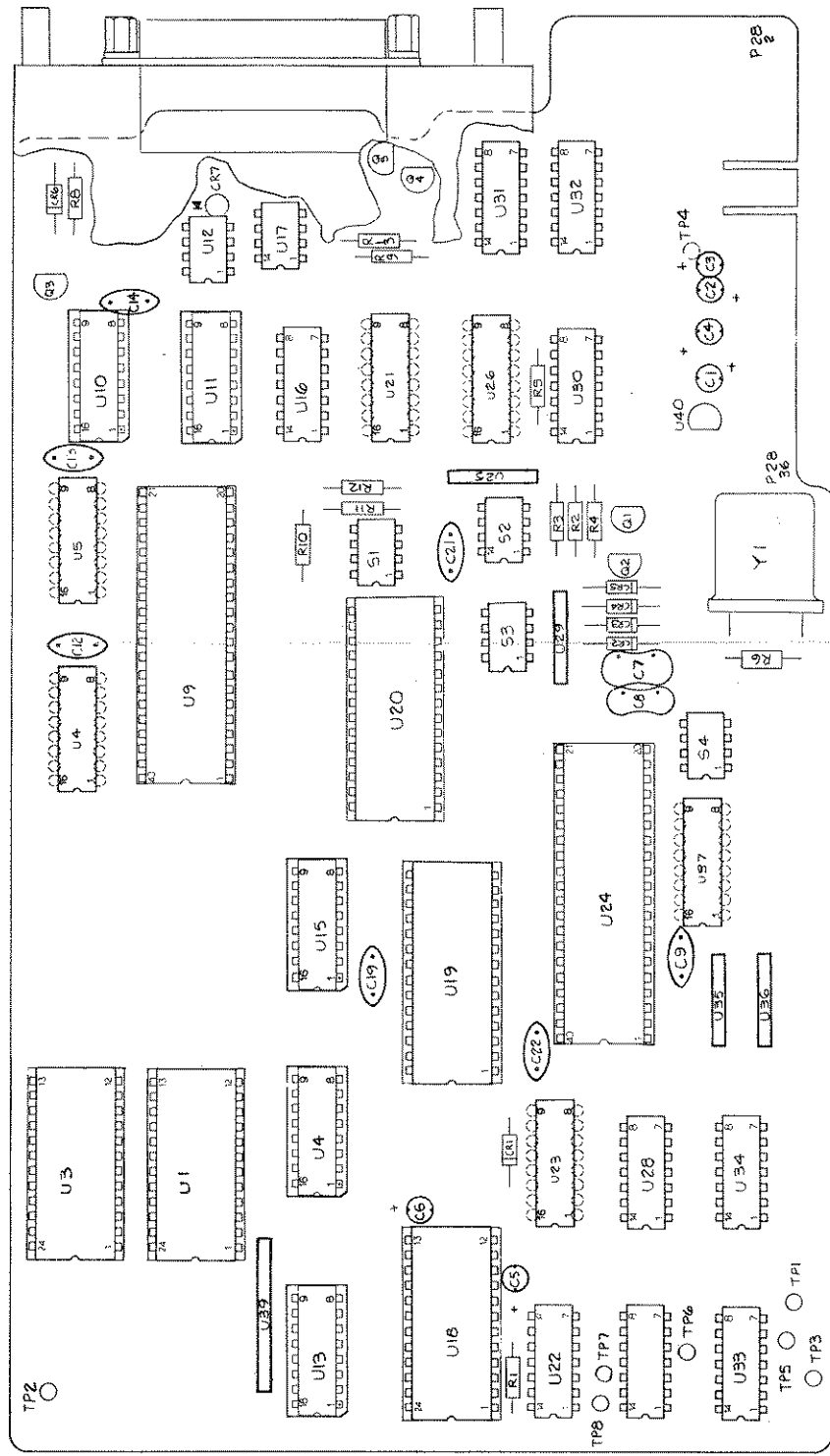

2240A-1617

Figure 8-20. Remote Programming PCB Assembly, Option -17 (cont)



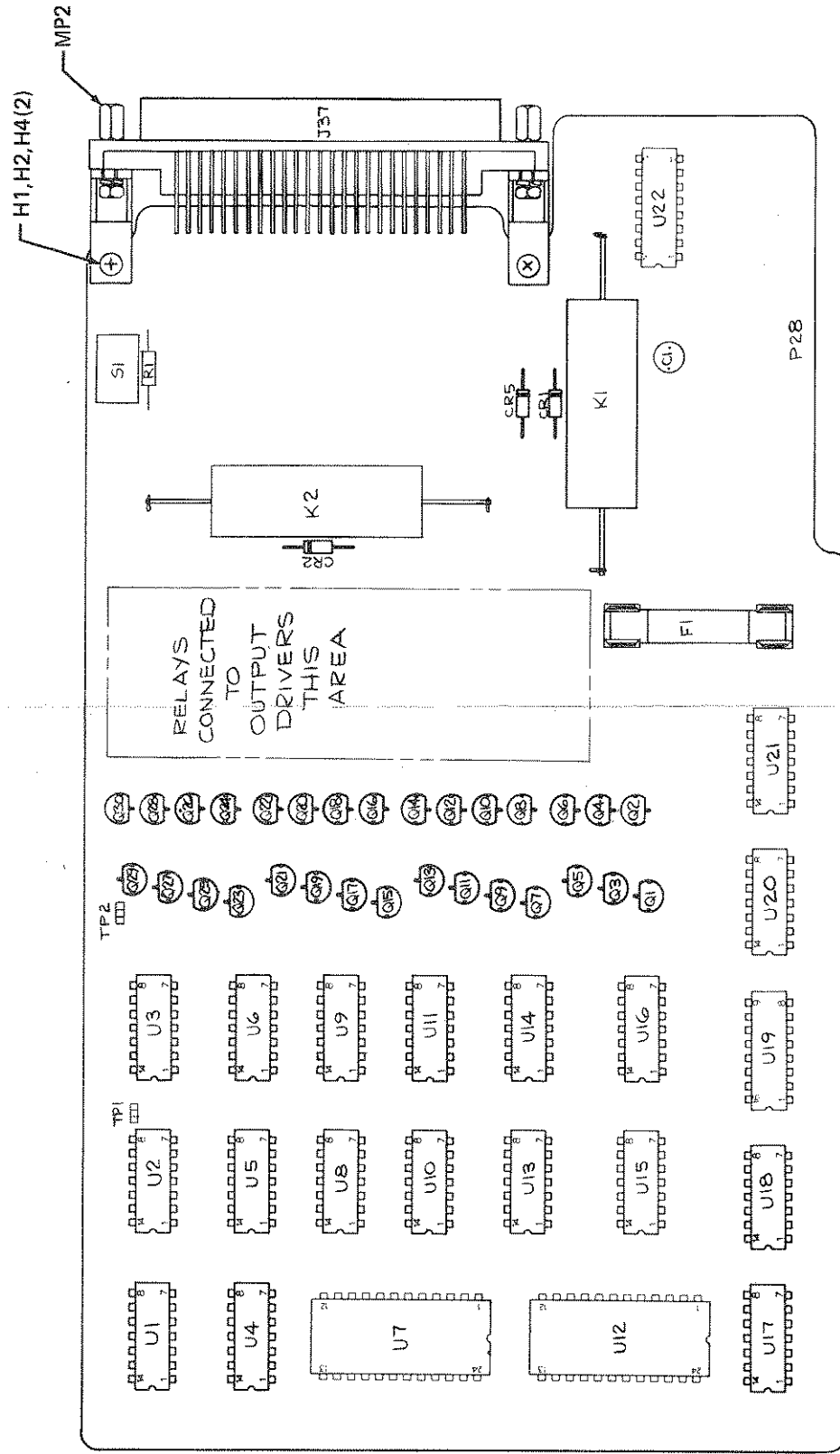
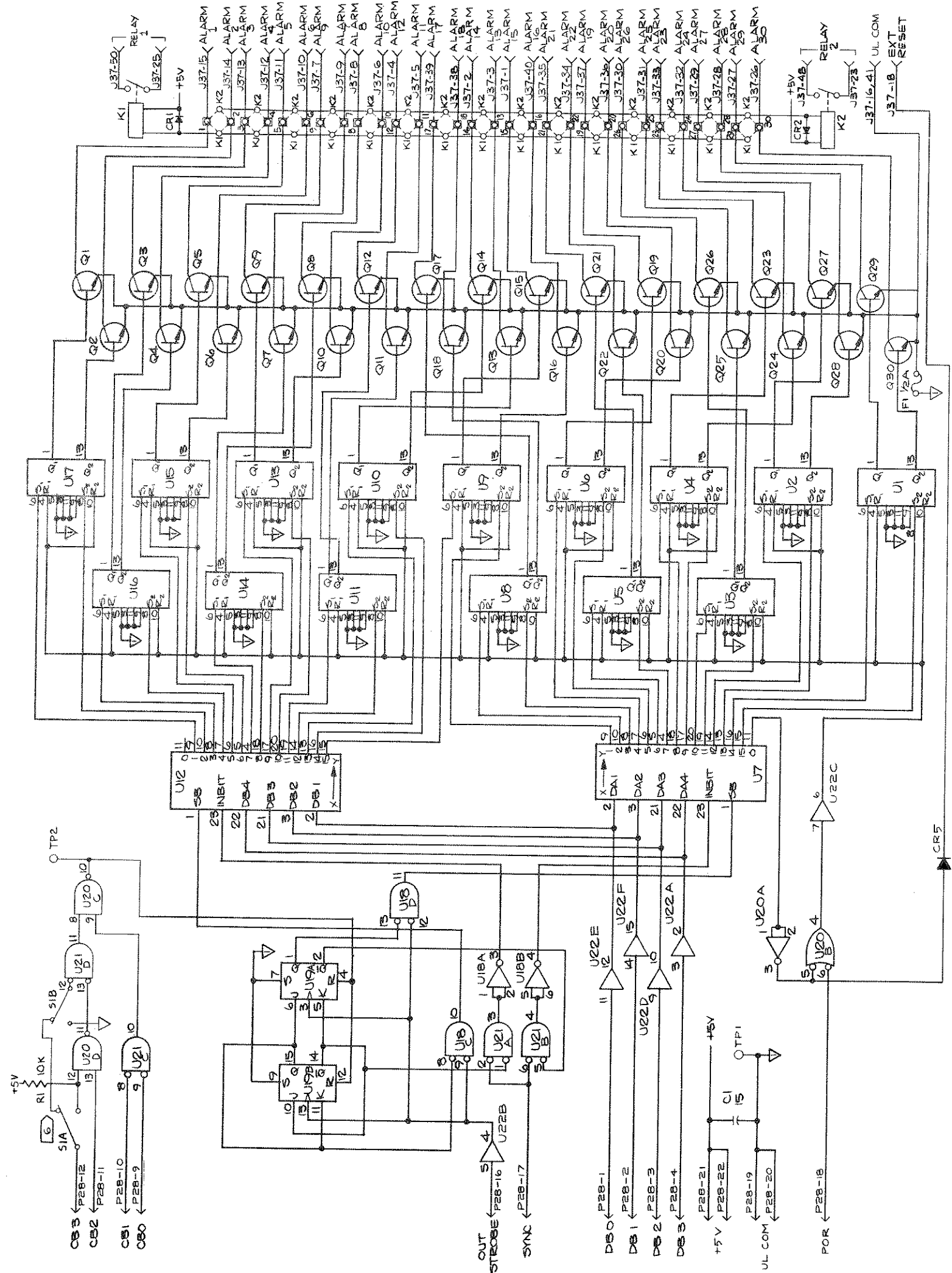

Figure 8-21. Alarm Set Point Output PCB Assembly, Option -23



- NOTES:
1. UNLESS OTHERWISE SPECIFIED ALL CAPACITANCES ARE IN MICROFARADS.
  2. ALL GRAPHIC SYMBOLS ARE IN ACCORDANCE WITH ANS Y32.2 & Y32.14.
  3. ▽ DENOTES UNGUARDED LOGIC COMMON (UL COM)
  4. FOR ASSY DWG SEE 2200A-4081
  5. FOR REF. DES. DWG SEE 2200A-1631.
  6. S1 SHOWN IN '31-60' POSITION.

REFERENCE DESIGNATIONS	
LAST USED	NOT USED
C1	S1
CR5	R1
K2	CR3,4
Q50	
U22	

IC. REF. DES.	PIN NO.	+5V	UL COM
U1	14		7
U2	14		7
U3	14		7
U4	14		7
U5	14		7
U6	14		7
U7	16		8
U8	14		7
U9	14		7
U10	14		7
U11	14		7
U12	16		8
U13	14		7
U14	14		7
U15	14		7
U16	14		7
U17	14		7
U18	14		7
U19	16		8
U20	14		7
U21	14		7
U22	16		8

2240A-1031

Figure 8-21. Alarm Set Point Output PCB Assembly, Option -23 (cont)

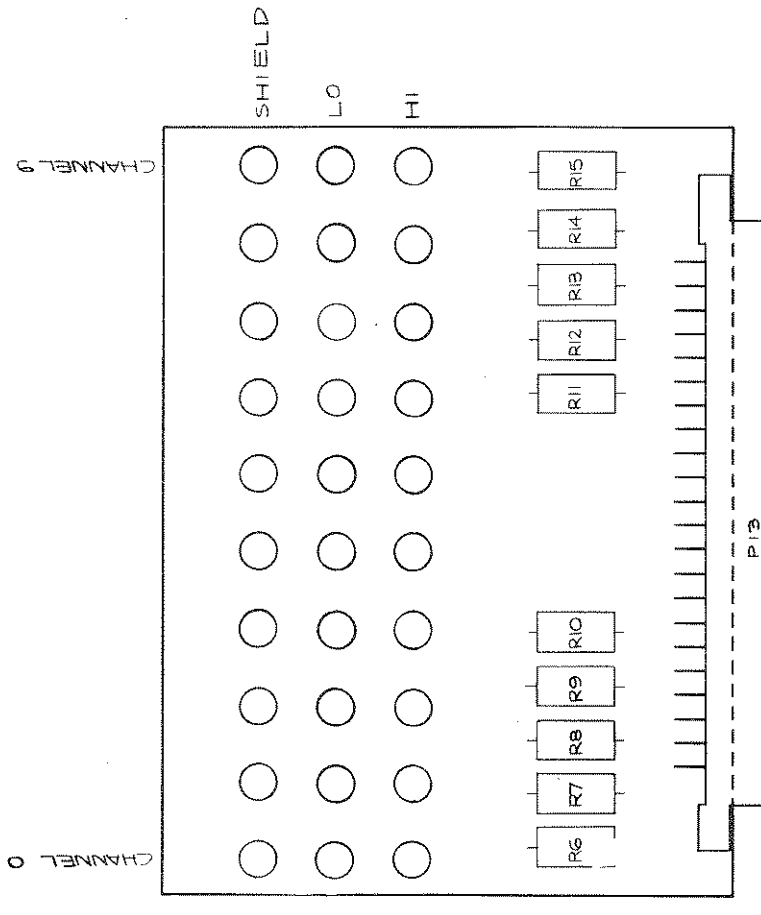

2200A-1633

Figure 8-22. 1.5 mA Transmitter Connector, Option -28

- NOTES:
1. UNLESS OTHERWISE SPECIFIED ALL RESISTANCES ARE IN OHMS AND ALL CAPACITANCES ARE IN MICROFARADS.
  2.  $\circ$  DENOTES CALIBRATION ADJ. POINTS. ALL POINTS ARE SCREWDRIVER ADJUST.
  3. ALL RESISTORS ARE 1/8w, .04% UNLESS OTHERWISE NOTED.
  4. ALL GRAPHIC SYMBOLS IN ACCORDANCE WITH ANSI Y32.2.
  5. FOR ASSY DWG. SEE 2200A-4033.

A	1
B	2
C	3
D	4
E	5
F	6
G	7
H	8
J	9
K	10
L	11
M	12
N	13
P	14
R	15
S	16
T	17
U	18
V	19
W	20
X	21
Y	22
Z	23

REAR VIEW OF P13

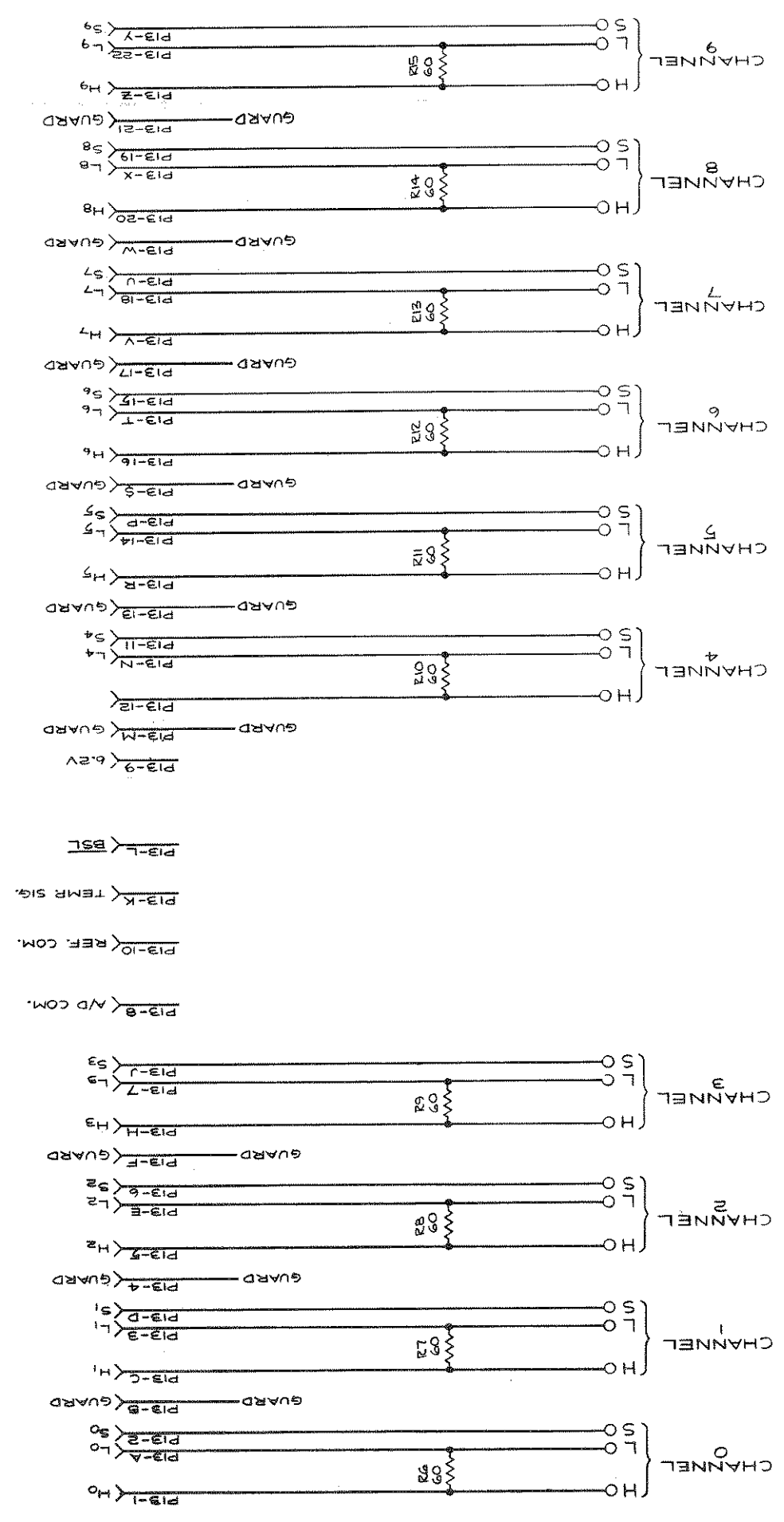

2200A-1033

Figure 8-22. 1-5 mA Transmitter Connector, Option -28 (cont)



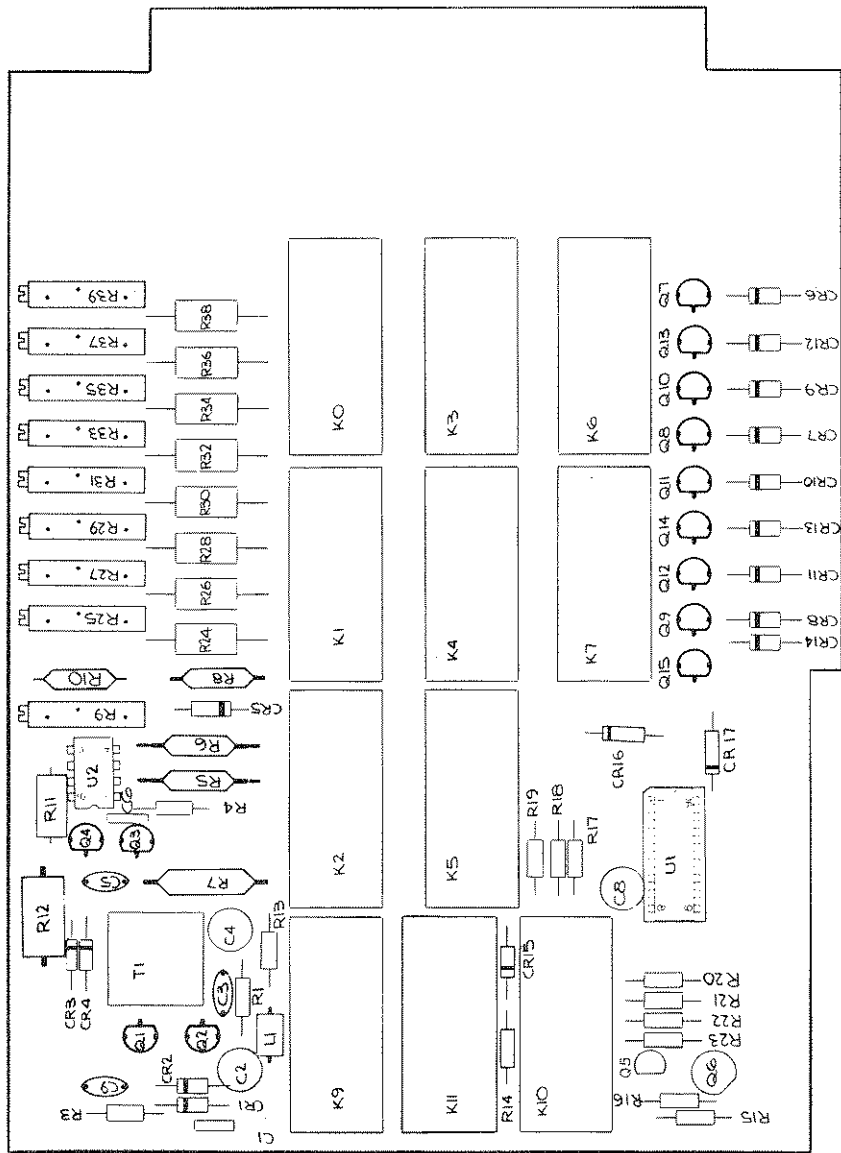

2240A-1638

Figure 8-25. Eight Channel RTD Scanner, Option -33

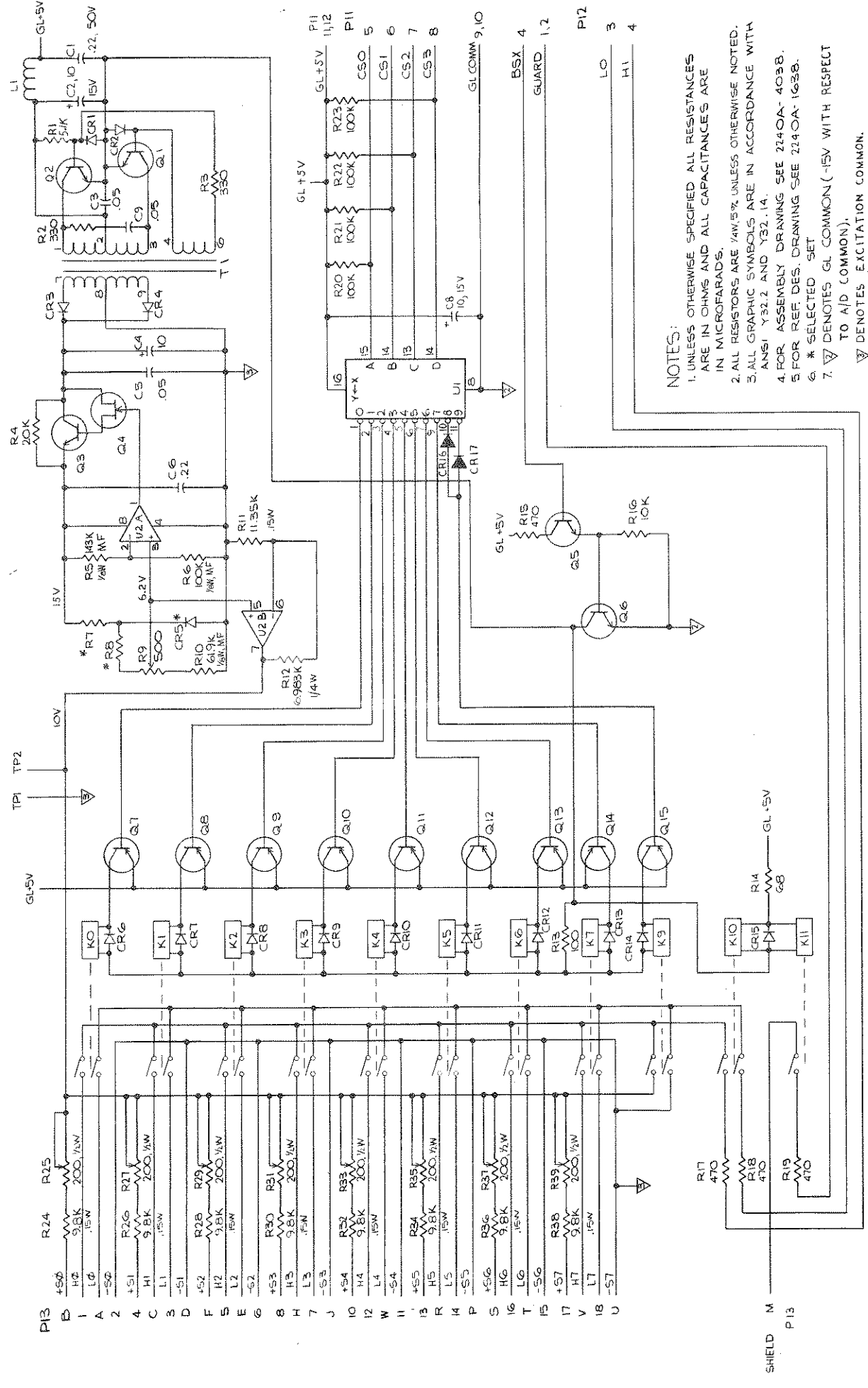

NOTES:

1. UNLESS OTHERWISE SPECIFIED ALL RESISTANCES ARE IN OHMS AND ALL CAPACITANCES ARE IN MICROFARADS.
2. ALL RESISTORS ARE 1/4W, 5% UNLESS OTHERWISE NOTED.
3. ALL GRAPHIC SYMBOLS ARE IN ACCORDANCE WITH ANSI Y32.2 AND Y32.14.
4. FOR ASSEMBLY DRAWING SEE 2240A-4038.
5. FOR REF DES. DRAWING SEE 2240A-1638.
6. \* SELECTED SET
7. ∇ DENOTES GL COMMON (-15V WITH RESPECT TO AID COMMON).

REFERENCE DESIGNATION	NOT USED
R39, C9, CR17	K8, C7
Q5, K11, U2	

2240A-1038

Figure 8-25. Eight Channel RTD Scanner, Option -33 (cont)

2200A-1621

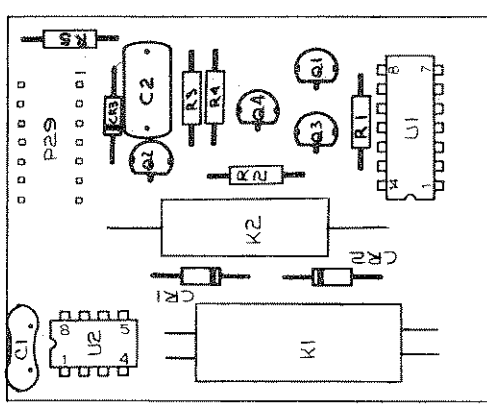
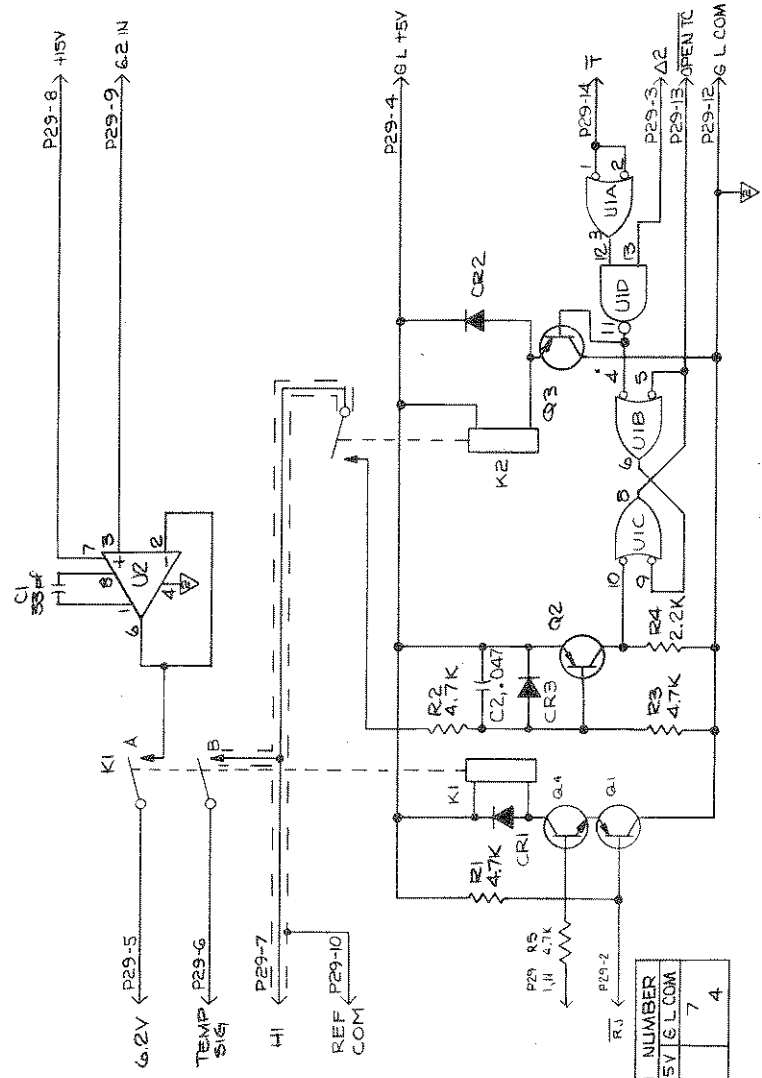

Figure 8-26. Temperature Option PCB Assembly, Options -43, -44 and -45

- NOTES:
1. UNLESS OTHERWISE SPECIFIED ALL RESISTANCES ARE IN OHMS AND ALL CAPACITANCES ARE IN MICROFARADS.
  2.  $\nabla$  DENOTES GUARDED LOGIC COMMON (GL COM)
  3. ALL RESISTORS ARE 1/4W, 5% UNLESS OTHERWISE NOTED.
  4. ALL GRAPHIC SYMBOLS IN ACCORDANCE WITH ANSI Y32.14 AND Y32.2.



IC	PIN NUMBER
REF DES	6 L+5V / 6 L COM
U1	14
U2	7
	4

REFERENCE DESIGNATIONS	
LAST USED	NOT USED
CR2	
CR3	
CR4	
CR5	
U2	

2200A 1021

Figure 8-26. Temperature Option PCB Assembly, Options -43, -44 and -45 (cont)

