

2280 SERIES

DATA LOGGER

System Guide

P/N 758292
February 1985

©1985, John Fluke Mfg. Inc., all rights reserved. Litho in U.S.A.



WARRANTY

John Fluke Mfg. Co., Inc. (Fluke) warrants this instrument to be free from defects in material and workmanship under normal use and service for a period of one (1) year from date of shipment. Software is warranted to operate in accordance with its programmed instructions on appropriate Fluke instruments. It is not warranted to be error free. This warranty extends only to the original purchaser and shall not apply to fuses, computer media, batteries or any instrument which, in Fluke's sole opinion, has been subject to misuse, alteration, abuse or abnormal conditions of operation or handling.

Fluke's obligation under this warranty is limited to repair or replacement of an instrument which is returned to an authorized service center within the warranty period and is determined, upon examination by Fluke, to be defective. If Fluke determines that the defect or malfunction has been caused by misuse, alteration, abuse, or abnormal conditions of operation or handling, Fluke will repair the instrument and bill purchaser for the reasonable cost of repair. If the instrument is not covered by this warranty, Fluke will, if requested by purchaser, submit an estimate of the repair costs before work is started.

To obtain repair service under this warranty purchaser must forward the instrument, (transportation prepaid) and a description of the malfunction to the nearest Fluke Service Center. The instrument shall be repaired at the Service Center or at the factory, at Fluke's option, and returned to purchaser, transportation prepaid. The instrument should be shipped in the original packing carton or a rigid container padded with at least four inches of shock absorbing material. **FLUKE ASSUMES NO RISK FOR IN-TRANSIT DAMAGE.**

THE FOREGOING WARRANTY IS PURCHASER'S SOLE AND EXCLUSIVE REMEDY AND IS IN LIEU OF ALL OTHER WARRANTIES, EXPRESS OR IMPLIED, INCLUDING BUT NOT LIMITED TO ANY IMPLIED WARRANTY OF MERCHANTABILITY, FITNESS FOR ANY PARTICULAR PURPOSE OR USE. FLUKE SHALL NOT BE LIABLE FOR ANY SPECIAL, INDIRECT, INCIDENTAL, OR CONSEQUENTIAL DAMAGES OR LOSS WHETHER IN CONTRACT, TORT, OR OTHERWISE.

CLAIMS

Immediately upon arrival, purchaser shall check the packing container against the enclosed packing list and shall, within thirty (30) days of arrival, give Fluke notice of shortages or any nonconformity with the terms of the order. If purchaser fails to give notice, the delivery shall be deemed to conform with the terms of the order.

The purchaser assumes all risk of loss or damage to instruments upon delivery by Fluke to the carrier. If an instrument is damaged in-transit, **PURCHASER MUST FILE ALL CLAIMS FOR DAMAGE WITH THE CARRIER** to obtain compensation. Upon request by purchaser, Fluke will submit an estimate of the cost to repair shipment damage.

Fluke will be happy to answer all questions to enhance the use of this instrument. Please address your requests or correspondence to: **JOHN FLUKE MFG. CO., INC., P.O. BOX C9090, EVERETT, WA 98206, ATTN: Sales Dept.** For European Customers: **Fluke (Holland) B.V., P.O. Box 5053, 5004 EB, Tilburg, The Netherlands.**

CONTENTS

Section 1 How to Use This Manual

Introduction	1-2
Organization	1-4
The 2280 Series Data Loggers	1-6
How to Use the Manual Set	1-6
User Guide	1-6
System Guide	1-6
Service Manual	1-7
Notation Conventions	1-7

Section 2 Data Logging Applications

Introduction	2-3
Data Logging Systems	2-3
The 2280 Series Data Logging System	2-6
General	2-6
Distributed System Design	2-6
Mainframe	2-8
Option Assemblies	2-8
Serial Link Option Assemblies	2-9
Connector Assemblies	2-12
Interface Option Assemblies	2-14
Other Option Assemblies	2-15
Extender Chassis	2-15
Accessories	2-17

Applications	2-18
Temperature Measurement Using	
Thermocouples	2-18
Temperature Measurement Using RTDs	2-19
Temperature Measurement Using	
Thermistors	2-20
AC Voltage Measurement	2-20
DC Voltage Measurement	2-20
Current Measurement	2-20
Resistance Measurement	2-21
Frequency Measurement	2-22
Totalizing Measurement	2-22
Strain Measurement	2-22
Digital and Status Inputs	2-22
Status Outputs	2-23
Analog Outputs	2-23
Using the 2280 Series Data Logger	2-23
Overview	2-23
The Programming Form	2-24
The Menu System	2-24
Moving Through the Menus	2-27
How the 2280 Series Data Loggers Differ	2-29
Features	2-29
Permissible Option Configurations	2-30
Summary	2-31

Section 3 Installation - Mainframe

Introduction	3-3
General Information	3-3
Shipping	3-3
Unpacking	3-4
Physical Layout	3-4
Physical Installation	3-7
Selecting a Location	3-7
Rack Mounting	3-8
Attaching the Front Panel Doors	3-11
Power Connections	3-11
Line Voltage	3-11
Battery Operation	3-13
Hardware Configuration	3-13
Extender Chassis (2281)	3-14
Option Assemblies	3-15
New Installation	3-15
Previously Installed	3-15
Addressing	3-15
A/D Converter	3-15
Digital I/O Assembly	3-16
Analog Output	3-18
Counter/Totalizer	3-18
IEEE-488 Interface	3-19
Other Switch Selections	3-19
Jumpers	3-19
External Connections	3-20
Master Alarm Output/Trigger Input	3-21
Programming	3-21
Operator Maintenance	3-22
Introduction	3-22
Fuse Replacement	3-22
General Cleaning	3-23
Paper Replacement	3-25
Service Information	3-27

Section 4 Installation - Options and Accessories

AC Voltage Input Connector (2280A-160)	160-1
High Performance A/D Converter (2280A-161) ..	161-1
Thermocouple/DC Volts Scanner (2280A-162) ...	162-1
RTD/Resistance Scanner (2280B-163)	163-1
Transducer Excitation (2280A-164)	164-1
Counter/Totalizer (2280B-167)	167-1
Digital I/O Assembly (2280A-168)	168-1
Status Output Connector (2280A-169)	169-1
Analog Output (2280B-170)	170-1
Current Input Connector (2280A-171)	171-1
Transducer Excitation Connector (2280A-174) .	174-1
Isothermal Input (2280A-175)	175-1
Voltage Input Connector (2280A-176)	176-1
RTD/Resistance Input Connector (2280B-177) ..	177-1
Digital/Status Input Connector (2280A-179) ..	179-1
Advanced Math Processor (2280A-211)	211-1
DC Cartridge Tape (2280A-214)	214-1
RS-232-C Interface (2280A-341)	341-1
IEEE-488 Interface (2280A-342)	342-1
2281A-402 Extender Chassis Cable	402-1
2281A-403 Connector Pair for -402 Cable	403-1
2281A-431 Extender Chassis Power Supply	431-1
Y2044 Rack Slide Kit	Y2044-1
Y2045 Rack Mount Kit	Y2045-1
Y2047 Serial Link Multiconnect	Y2047-1

Section 5 Using the 2280

Temperature Measurement	
Using Thermocouples	5a-1
Using RTDs	5a-13
Using Thermistors	5a-39
Voltage Measurement	
AC Voltage	5b-1
DC Voltage	5b-7
Current Measurement	5c-1
Resistance Measurement	5d-1
Frequency Measurement	5e-1
Totalizing Measurement	5f-1
Strain Measurement	5g-1
Digital Input	5h-1
Status Input	5h-9
Status Output	5i-1
Analog Output	5j-1
Writing Control Algorithms	5j-7

Section 6 Appendices

6a. Glossary	6a-1
6b. Sales and Service Centers	6b-1
6c. ASCII/IEEE-488	6c-1
6d. 2285B Documentation	6d-1
6e. 2280A Documentation	6e-1
6f. Connector Pinouts	6f-1
6g. System Specifications	6g-1
6h. Cartridge Tape Handling	6h-1
6i. Cartridge Tape Format	6i-1
6j. Memory Usage	6j-1

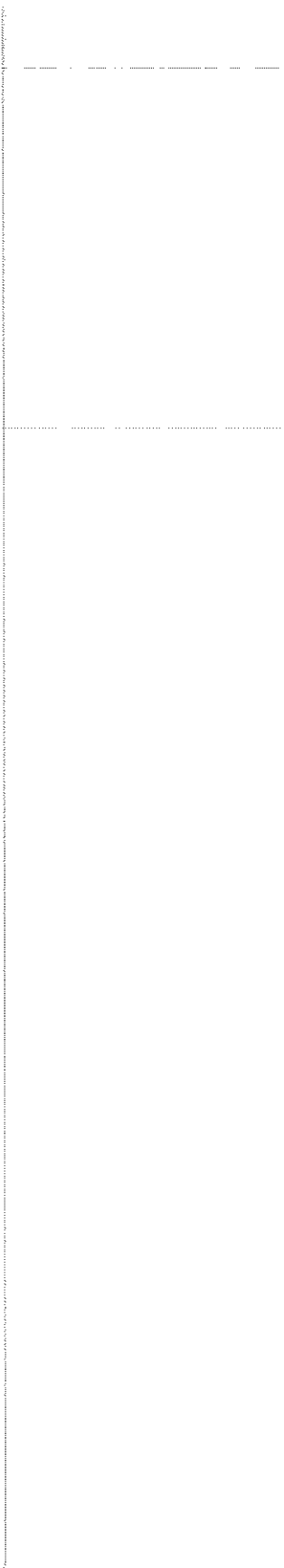

Section 1
How to Use This Manual

CONTENTS

Introduction	1-2
Organization	1-4
The 2280 Series Data Loggers	1-6
How to Use the Manual Set	1-6
User Guide	1-6
System Guide	1-6
Service Manual	1-7
Notation Conventions	1-7

1/Introduction

INTRODUCTION

The System Guide provides an overall reference for Data Logger installation and operation. It accomplishes this in two ways:

- o The System Guide is just that -- a guide to using the 2280 as a data logging system. The guide discusses what you can do, which option assemblies you need for each task, and how to go about accomplishing those tasks.

For example, temperature measurement with an RTD is a data measurement capability of the 2280. The System Guide identifies the various combinations of optional assemblies required to make RTD temperature measurements. The guide tells you how to install and test each assembly. Finally, the System Guide uses programming descriptions and application examples in demonstrating how to make RTD measurements. Each data logging measurement function is described in this comprehensive fashion.

- o The System Guide is also a reference manual. The installation process ranges from identifying the desired measurement or output function to seeing the results. And each step of this process is distinctly identified for ease of reference. General information can be found early on in the manual. Descriptive and installation information can be found for the 2280 mainframe and for each option assembly. And information on each data logging measurement or output function can be directly accessed. The System Guide allows you to conveniently look up only the information you need.

1/Introduction

The System Guide concentrates on hardware installation. It accomplishes this in three ways:

- o It identifies the data logging measurement or output function appropriate for a given problem.
- o It explains installation of the 2280 hardware required to solve the problem.
- o It provides a verification of correct installation.

Installation of the 2280 Series Data Logger is carried out on two levels. The first level involves the 2280 mainframe and is dealt with in a separate section. The second level of installation involves physical mounting and electrical connection of the optional assemblies. These options constitute circuit cards that, when inserted into the mainframe, become an integral part of the data logger. Each option (or combination of options) provides the hardware required for a specific data logging measurement or output function. The 2281A Extender Chassis permits the installation of additional option assemblies. Since these optional assemblies are more frequently configured than the mainframe, a separate section is devoted to their installation instructions. Each option assembly subsection is numerically indexed by option number.

The System Guide is not a complete "how to use it" manual. A wide range of data logging measurement and output techniques can be called upon for each hardware configuration. Documentation of so many possible programming and operating techniques requires a separate manual -- the User Guide.

The User Guide orchestrates any 2280 measurement or output function. It provides complete programming and operating information. It can be as much as a full tutorial or as little as a quick reference guide.

1/Organization

ORGANIZATION

Section 1 How to Use This Manual

Describes the System Guide contents and how to use them. Also discusses organization of the manual set and common notation found throughout.

Section 2 Data Logging Applications

This section acts as a road map to the rest of the System Guide. It provides an overview of 2280 capabilities. It identifies data logging measurement and output functions and their applicability in the data logging environment. Each function is covered separately later in the System Guide.

Section 3 Installation - The Mainframe

This section takes the user from unpacking through installation verification testing of the Data Logger mainframe. It includes descriptions of operator maintenance.

Section 4 Installation - Options and Accessories

This section includes complete information for installing and verifying operation of each optional assembly. Each option is treated as a discrete subsection, numerically indexed by option number. Often, multiple options are required for a single data logging measurement or output function. In such cases, this section serves to verify correct hardware installation only; the applicable data logging function description (later in the System Guide) provides a verification test for the complete installation. Specifications are provided in the Appendices.

1/Organization

Section 5 Applications

Each of the following subsections describes a type of data logging measurement or output function.

- 5a Temperature Measurement
- 5b Voltage Measurement
- 5c Current Measurement
- 5d Resistance Measurement
- 5e Frequency Measurement
- 5f Totalizing Measurement
- 5g Strain Measurement
- 5h Status/Data Inputs
- 5i Status Outputs
- 5j Analog Output

Section 6 Appendices

- o Glossary
- o Sales and Service Centers
- o ASCII/IEEE-488 Character Set
- o 2280B > 2285B Differences
- o 2280B > 2280A Differences
- o Connector Pinouts/Switch Settings
- o System Specifications
- o Cartridge Tape Handling
- o Cartridge Tape Format
- o Memory Usage

Index

1/The 2280 Series Data Loggers

THE 2280 SERIES DATA LOGGERS

The System Guide provides comprehensive documentation for all 2280 Series Data Loggers. The main body of this manual specifically documents the 2280B Data Logger. Most of this information also applies to the 2280A and 2285B Data Loggers. Differing descriptions are presented in the appendices:

- o 2285B Differences: Appendix 6d
- o 2280A Differences: Appendix 6e

HOW TO USE THE MANUAL SET

User Guide

This book describes the Data Logger from top to bottom. A beginner could use it as a complete course in programming the data logger in a data acquisition system, whereas a more experienced user would probably only need parts of it for orientation and quick reference. An untrained operator will find all of the basics here as well.

System Guide

This guide describes all aspects of 2280 installation in a data logging system. The guide serves as a complete course in defining the user's data logging measurement and output functions, identifying system requirements, making the necessary hardware connections, and verifying correct operation. An inexperienced user may need all of this information to get the Data Logger up and running. A user already familiar with data logging may only need incidental reference to this information. In either case, each element of the installation process is easily accessible and fully referenced.

1/Notation Conventions

Service Manual

The Service Manual is primarily a maintenance guide to the instrument. The manual covers theory of operation for mainframe and option assemblies, general maintenance and cleaning, performance testing, calibration, troubleshooting, and repair. Parts lists and schematic diagrams are also included.

NOTATION CONVENTIONS

Generally, the instrument is referred to as the 2280 Series Data Logger. The term 2280 is also frequently used for brevity. Either term is an all-encompassing reference to the 2280B, 2285B, and 2280A. Differences among these three models are defined in the Appendices to this manual.

The Data Logger uses literal notation for keyboard entries. Therefore, programming examples found in this manual are presented exactly as they should be entered from the keyboard.

Some notation conventions are used to identify and differentiate a keyboard entry. Parts of these conventions are not actually used in the keyboard entry.

- (xxx) Indicates a required input of your choice. For example, "NOT (operand)" specifies an inversion of the logical value of the operand in parentheses. Any operand can be specified.
- XXX Means to type the name of the input exactly as shown. For example, "TIME" requests the elapsed time since the start of scanning.
- <xxx> Refers to certain 2280 display or printer indications.



Section 2
Data Logging Applications

CONTENTS

Introduction	2-3
Data Logging Systems	2-3
The 2280 Series Data Logging System	2-6
General	2-6
Distributed System Design	2-6
Mainframe	2-8
Option Assemblies	2-8
Serial Link Option Assemblies	2-9
Connector Assemblies	2-12
Interface Option Assemblies	2-14
Other Option Assemblies	2-15
Extender Chassis	2-15
Accessories	2-17

2/Data Logging Applications

Applications	2-18
Temperature Measurement Using	
Thermocouples	2-18
Temperature Measurement Using RTDs	2-19
Temperature Measurement Using	
Thermistors	2-20
AC Voltage Measurement	2-20
DC Voltage Measurement	2-20
Current Measurement	2-20
Resistance Measurement	2-21
Frequency Measurement	2-22
Totalizing Measurement	2-22
Strain Measurement	2-22
Digital and Status Inputs	2-22
Status Outputs	2-23
Analog Outputs	2-23
Using the 2280 Series Data Logger	2-23
Overview	2-23
The Programming Form	2-24
The Menu System	2-24
Moving Through the Menus	2-27
How the 2280 Series Data Loggers Differ	2-29
Features	2-29
Permissible Option Configurations	2-30
Summary	2-31

2/Data Logging Applications

INTRODUCTION

This section acts as a road map, linking the concept of data logging with the set-up and operating information found elsewhere in this guide and in the User Guide. If you are already acquainted with the 2280 data logging system, this section may not produce any revelations. If you are new to the 2280, reading this section does provide a useful overview.

Data Logging Applications take you from the general to the specific. Why would you want to use a data logging system? What can a data logging system do? How does the 2280 do this? What kind of hardware is available and how do you configure it? And, most importantly, how do you get the 2280 to do something?

DATA LOGGING SYSTEMS

Precise measurement has become a cornerstone of modern technology. For example, the ability to measure and control ever finer machining tolerances allows us to create the optical devices necessary to produce smaller and smaller microcircuits. And precise temperature monitoring allows us to create incredibly tough alloys, exotic plastic compounds, and durable molded products.

Data loggers make these precise measurements. They can make a wide variety of precise measurements, virtually simultaneously. They can keep a very complete record of all these measurements. They can test at different intervals, at different places, for different reasons. They can make decisions about these tests and change some part of the data logging environment as a result.

2/Data Logging Applications

In the industrial process environment, it is essential to gather complex data from a variety of sources and interpret this data in a meaningful way. In the research laboratory, any experiment is meaningless unless the resulting data can be collected. We need tools to collect this information. Data collection tools can range from a strip of litmus paper, to a notebook, to a huge mainframe computer.

The Fluke 2280 Series of Data Loggers are the precision tools for the job. From simple data collection to fairly complex control functions, the 2280's provide the necessary precision for both industrial process monitoring and research tasks.

The data logger finds its best use simultaneously monitoring several channels of data and logging the returned values. Each channel is connected to some type of physical transducer such as a flowmeter, thermocouple, strain gauge, or RTD. The 2280 can perform scaling or data conversion functions on this raw data to render it more meaningful.

For example, many transducers output a voltage or resistance to indicate a physical value such as foot-pounds of force or cubic feet per minute. Collected information can later be analyzed to pinpoint failure causes, generate histograms or frequency distributions of various recurring phenomena, or to record the performance of individual specimens.

2/Data Logging Applications

Almost any manufacturing process, for example, can require some form of continuous quality monitoring. The 2280 has been used in a tremendous variety of environments, such as continuously monitoring autoclave temperature in sterilizing pharmaceutical products; comparing signal reproduction characteristics of digital audio disks against a reference standard; recording power supply performance under simulated forced-air cooling conditions; and recording the performance characteristics of helicopter-rotor air-speed sensors.

These types of environments have several features in common. They all require programming so that many channels of information are monitored, read frequently, and checked continually and simultaneously. The 2280 forms the heart of these various process-monitoring systems. In many instances the data logger is programmed to trigger alarm conditions that begin recording data performance only during out-of-range operating conditions.

Research applications, such as automobile performance tests, are also appropriate uses of a data logger. The 2280 is frequently used to monitor a variety of engine and chassis parameters under actual road conditions. Its portability (12V dc operation) allows it to be used in both unusual and demanding environments. In situations similar to automobile road tests, the 2280 can be used to collect real-time data under experimental conditions for later study and analysis with data processing equipment.

2/Data Logging Applications

THE 2280 SERIES DATA LOGGING SYSTEM

General

The 2280 Series Data Logging System consists of a hardware configuration controlled by a menu-driven programming and operating scheme. The hardware configuration includes a 2280 mainframe, and may, depending on the applications being supported, include any assortment of option assemblies. In addition, one or more 2281A Extender Chassis may be used for more remote connections to the data logging environment. The programming and operating scheme involves substantial pre-programmed capabilities, all accessed directly from either a front panel keyboard or a remote controller.

Distributed System Design

The 2280 Series Data Logger makes use of a distributed system design that allows great flexibility in hardware placement. Any of the serial link option assemblies (and respective connector assemblies) can be installed in a remote 2281A Extender Chassis. The 2281A can be installed up to 1 kilometer from the 2280. All measurements and conversions can be completed at the remote location, with serial data communications occurring over a single cable. This system is quite efficient: external measurement wiring is minimized and accurate communication in electrically noisy environments is assured.

Figure 2-1 illustrates the distributed system concept.

2/Data Logging Applications

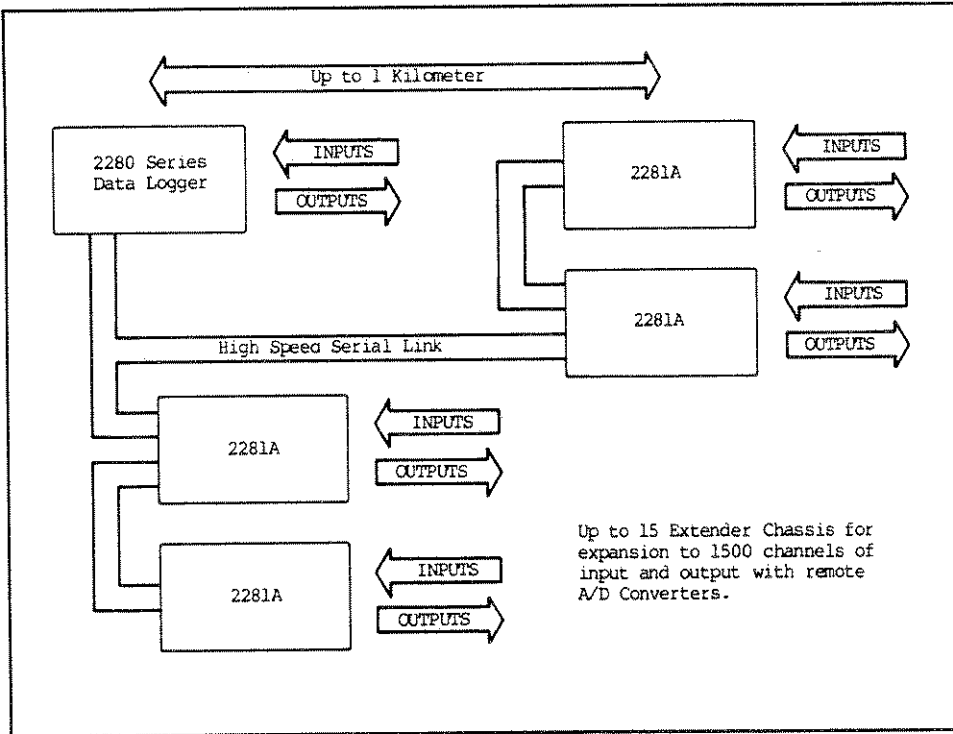

Figure 2-1. Distributed System Concept

2/Data Logging Applications

Mainframe

The 2280 mainframe houses the keyboard, printer, power supply, and memory for the data logger. The mainframe also provides space for the optional Cartridge Tape Drive and Advanced Math Option. Six horizontal slots are provided in the rear panel for any of the serial link option assemblies and their respective connectors. In addition, two rear panel slots are available for interface option assemblies. Section 3 of this guide deals with mainframe description and installation.

Option Assemblies

The use of option assemblies allows for a wide range of 2280 configurations. The option assemblies slip into position easily from the data logger's rear panel. Installation and use of each assembly is documented in Section 4 of this guide. The options can be categorized as follows:

- o Serial Link Options: circuit cards that can be installed in either the 2280 Series Data Logger or the 2281A Extender Chassis. These are the devices that link the data logging environment to the data logger.
- o Connector Options: modules that plug on to serial link options. They allow for wiring connections and routing to the data logging environment.
- o Interface Options: circuit cards (installed vertically from the 2280 Series rear panel) that tie the data logger to an external controller for remote operations.
- o Other Options: an Advanced Math Processor and a Cartridge Tape Drive are also available.

2/Data Logging Applications

SERIAL LINK OPTION ASSEMBLIES

- o High Performance A/D Converter (2280A-161)

The High Performance A/D Converter (2280A-161) provides high accuracy analog to digital conversion of scanner input voltages or resistances. At least one A/D Converter must be installed in the 2280 Series Data Logger to provide analog measurement capabilities.

NOTE

Scanners must be located immediately below the A/D Converter with which they are associated. A maximum of three A/D Converters is allowed in any one 2280 Series Data Logger or 2281A Extender Chassis.

- o Thermocouple/DC Volts Scanner (2280A-162)

The Thermocouple/DC Volts Scanner (Option -162) is a plug-in, one microvolt, 20-channel thermocouple and multi-voltage range relay scanner contained on a single pcb.

NOTE

A maximum of five Thermocouple/DC Volts Scanners is permitted in one 2280 Series Data Logger or 2281A Extender Chassis. This scanner accepts a variety of analog inputs, depending on the type of connector in use: AC Voltage Connector (160), Current Connector (171), Isothermal Connector (175), or Voltage Connector (176).

2/Data Logging Applications

- o RTD/Resistance Scanner (2280B-163)

The RTD/Resistance Scanner provides current excitation and resistance measurement for 20 channels. These assemblies are intended for applications involving RTD or resistance measurements.

NOTE

A maximum of five RTD/Resistance Scanners is permitted in one 2280 Series Data Logger or 2281A Extender Chassis.

- o Transducer Excitation Module (2280A-164)

The Transducer Excitation Module (2280A-164) is used to energize various resistive temperature transducers with an excitation current or voltage. It is used in conjunction with the Transducer Excitation Connector (2280A-174) and a Thermocouple/DC Volts Scanner (2280A-162) with connector. Together, each 164/174 set provides 20 channels of excitation. Each group of four channels can be configured for voltage or current output. Current output is used for most resistance and RTD measurements. Voltage output is used for strain gage measurements.

- o Counter/Totalizer (2280B-167)

The Counter/Totalizer (2280B-167) allows for event counting and frequency measurement on six channels.

NOTE

A maximum of six Counter/Totalizers is allowed in one 2280 Series Data Logger or 2281A Extender Chassis.

2/Data Logging Applications

- o Digital I/O Assembly (2280A-168)

The Digital Input/Output Assembly allows the 2280 Series Data Logger to exchange information with a digital peripheral device. Four types of data exchange are possible: Alarm or Status Output; Status Input; BCD Input; and Binary Input.

NOTE

A maximum of six Digital I/O Assemblies are allowed in either a 2280 Series Data Logger or a 2281A Extender Chassis. This option accommodates the Digital/Status Input Connector (2280A-179) or the Status Output Connector (2280A-169).

- o Analog Output (2280B-170)

Applications involving voltage or current outputs require the Analog Output (2280B-170) option assembly. This assembly can be installed in either the 2280 mainframe or the 2281A Extender Chassis. Each 170 assembly provides four independent output channels.

NOTE

A maximum of six Analog Output Options are allowed in one 2280 Series Data Logger or 2281A Extender Chassis.

2/Data Logging Applications

CONNECTOR ASSEMBLIES

Each connector assembly attaches to the rear of an appropriate serial link option assembly, allowing for external wiring connections and routing.

Connectors Used with the Thermocouple/DC Volts Scanner

Any of the following connector assemblies can be attached to the Thermocouple/DC Volts Scanner:

- o AC Voltage Input Connector (2280A-160)

The AC Voltage Input Connector provides terminal connections for 20 inputs. Of these 20 channels, ten are designated for ac voltage inputs. The remaining ten are designated for dc voltage inputs. The AC Voltage Input Connector attaches to the Thermocouple/DC Volts Scanner. The connector can be installed or removed without removing the scanner.

- o Current Input Connector (2280A-171)

The Current Input Connector provides terminal connections for 20 current input channels. The Current Input Connector attaches to the Thermocouple/DC Volts Scanner. The connector can be installed or removed without removing the scanner.

- o Isothermal Input Connector (2280A-175)

The Isothermal Input Connector contains the necessary hardware to ensure that the thermocouple connections are at the same temperature, and to measure the temperature of the thermocouple terminations. The Isothermal Input Connector attaches to the Thermocouple/DC Volts Scanner. The connector can be installed or removed without removing the scanner.

2/Data Logging Applications

- o Voltage Input Connector (2280A-176)

The Voltage Input Connector provides terminal connections for 20 dc voltage inputs. This assembly attaches to the Thermocouple/DC Volts Scanner; it can be installed or removed without removing the scanner.

RTD/Resistance Input Connector (2280B-177)

The RTD/Resistance Input Connector attaches to the rear of the RTD/Resistance Scanner. It provides wiring connections for 20 RTD or resistance measurements.

Transducer Excitation Connector (2280A-174)

The Transducer Excitation Connector (2280A-174) attaches to the rear of the Transducer Excitation Module and is used for wiring up to 20 channels of transducers with an excitation current or voltage.

Connectors Used with the Digital I/O Assembly

- o Status Output Connector (2280A-169)

The Status Output Connector can send 20 single-bit output signals from the Digital I/O board to external control points or terminals. Each output is individually selectable and can be used either to drive lamps and relays or change logic levels.

- o Digital/Status Input Connector

The Digital/Status Input Connector can be used for the mutually exclusive functions providing bcd digital input, binary digital input, or status input information to the 2280 Series Data Logger. This connector provides up to 20 input lines.

2/Data Logging Applications

INTERFACE OPTION ASSEMBLIES

Two interface option assemblies can be installed in vertical slots found on the 2280 rear panel. Any combination of RS-232-C and IEEE-488 interfaces can be installed at the same time.

- o RS-232-C Interface (2280A-341)

The RS-232-C Interface Board allows for an RS-232-C communications link with an external device. An RS-232-C Cable is enclosed. The board can be inserted at Port A or Port B. If installed at Port A, the RS-232-C Interface Board allows remote programming and operation of the 2280 Series Data Logger. Status and measurement information can also be made available to the outside world via this interface. If installed at Port B, the interface provides output capability only.

- o IEEE-488 Interface (2280A-342)

The IEEE-488 Interface allows an IEEE-488 communications link with external devices. A standard IEEE-488 connector provides the communications link at Port A or Port B on the 2280 rear panel. If installed at Port A, the IEEE-488 Interface Board allows remote programming and operation of the 2280 Series Data Logger. Status and measurement information can also be made available to the outside world via this interface. If installed at Port B, the interface provides output capability only.

2/Data Logging Applications

OTHER OPTION ASSEMBLIES

- o Advanced Math Processor (2280A-211)

The Advanced Math Processor (2280A-211) enhances both the calculation speed and the instructional repertoire of the 2280 Series Data Logger. Statistical calculations, Boolean operations, and user-entered interpolation tables are a few of the extended operations available.

- o DC-100 Cartridge Tape Drive (2280A-214)

The DC-100 Cartridge Tape Drive is a data storage system. It stores logged data in a format chosen by the user. It can also store an entire configuration program for later use. This capability allows for designing and storing special data logging configuration programs. Manual entry is only necessary when initially entering the program.

Extender Chassis

The 2281A Extender Chassis is a passive unit that acts as a serial link extension of the 2280. It may contain any of the serial link options that are available for the 2280 Series Data Logger. Installation and use procedures for 2281A serial link options are identical to those used for modules residing in the 2280 mainframe.

Installation for the 2281A is documented in Section 4 of this manual. The 2281A Instruction Manual provides a comprehensive description of the Extender Chassis and its uses.

2/Data Logging Applications

Several option assemblies apply specifically to use of the 2281A Extender Chassis with the 2280. Installation instructions for these options are provided in Section 4 of this guide. Complete documentation can be found in the 2281A Instruction Manual.

- o Option 2281A-402 Extender Cable

When used with the 2281A-403 cable connector, this assembly provides the serial link interface for transmitting and receiving data between the 2280A and 2281A. Power for the 2281A Extender Chassis is also provided over this cable from the 2280A or a 2281A-431.

- o Option 2281A-403 Extender Cable Connector

This is a set of male/female 15-pin, D-type connectors. A housing provides strain relief for cable connections and stand-off bolts for securing the cable connector to the mainframe connector.

- o Option 2281A-431 Power Supply

This assembly provides a regulated 20V dc source for serial link devices when the extender chassis placement (distance) and configuration (number of serial link devices) exceed the power capabilities of the 2280.

2/Data Logging Applications

Accessories

The following accessories are available to aid in installing the 2280 or the 2281A:

- o Y2044 Rack Slide Kit

This accessory facilitates servicing of the 2280 (or 2281A) while it is installed in a standard 19-inch electronic equipment rack. The unit is secured in the equipment rack, yet may be pulled out along the slide for servicing and reconfiguring of serial link devices.

- o Y2045 Rack Mount Kit

This kit facilitates the placement of a 2280 or 2281A into a standard 19-inch electronic equipment rack.

- o Y2047 Serial Link Multiconnect

This accessory is used in 2281A placements to support star configurations.

2/Data Logging Applications

APPLICATIONS

The 2280 can perform numerous data logging functions. Usually, these involve some sort of measurement input. Outputs are also available.

Using the 2280 to perform these functions is fully covered in the following sections:

- 5a Temperature Measurement
 - Using Thermocouples
 - Using RTDs
 - Using Thermistors
- 5b Voltage Measurement
 - AC
 - DC
- 5c Current Measurement
- 5d Resistance Measurement
- 5e Frequency Measurement
- 5f Totalizing Measurement
- 5g Strain Measurement
- 5h Data/Status Input
 - Digital Inputs
 - Status Inputs
- 5i Status Output
- 5j Analog Output

Temperature Measurement Using Thermocouples (Section 5a)

Thermocouple temperature measurement is frequently used. Thermocouples are relatively rugged and can measure a wide range of temperatures.

This application can use any of 11 standard thermocouple linearizations. Hardware required:

- High Performance A/D Converter (2280A-161)
- Thermocouple/DC Volts Scanner (2280A-162)
- Isothermal Input Connector (2280A-175)

2/Data Logging Applications

Temperature Measurement Using RTDs (Section 5a)

RTDs are commonly used in temperature measurement where a wide temperature range is encountered and good accuracy is required.

Linearizations are provided for 385 DIN, and 10 ohm Cu RTDs. Also, precise linearizations are provided for all calibrated Pt RTDs.

Two hardware configurations are possible. The first configuration is useful where exclusive RTD use is expected on a set of 2280 channels. This arrangement also provides more economical and accurate readings. Use the following hardware:

- High Performance A/D Converter (2280A-161)
- RTD/Resistance Scanner (2280B-163)
- RTD/Resistance Input Connector (2280B-177)

The second configuration proves useful where a blend of RTD temperature measurement and other measurements is desired. Use the following hardware:

- High Performance A/D Converter (2280A-161)
- Thermocouple/DC Volts Scanner (2280A-162)
- Voltage Input Connector (2280A-176)*
- Transducer Excitation Module (2280A-164)
- Transducer Excitation Connector (2280A-174)

* Any other input connector supporting dc voltage measurement can be used here. These include: AC Volts Input Connector and Isothermal Input Connector.

2/Data Logging Applications

Temperature Measurement Using Thermistors (Section 5a)

Thermistors can also be used for temperature measurements. They are useful over temperature ranges from -460°F to 600°F . They are also very sensitive to changes in temperature, sometimes producing a change in resistance of 100,000 ohms per degree F.

Thermistors require the following 2280 hardware:

- High Performance A/D Converter (2280A-161)
- RTD/Resistance Scanner (2280B-163)
- RTD/Resistance Input Connector (2280B-177)

AC Voltage Measurement (Section 5b)

Low frequency (45 to 450 Hz) sine wave signals can be measured using the following hardware:

- High Performance A/D Converter (2280A-161)
- Thermocouple/DC Volts Scanner (2280A-162)
- AC Volts Input Connector (2280A-160)

DC Voltage Measurement (Section 5b)

Sensors outputting a dc voltage are commonly encountered in the data logging environment. The following 2280 hardware is required:

- High Performance A/D Converter (2280A-161)
- Thermocouple/DC Volts Scanner (2280A-162)
- Voltage Input Connector (2280A-176)*

* Any other input connector supporting dc voltage measurement can be used here. These include: AC Volts Input Connector and Isothermal Input Connector.

2/Data Logging Applications

Current Measurement (Section 5c)

Current measurements over a range of 0 to 64 mA can be made with the following hardware:

- High Performance A/D Converter (2280A-161)
- Thermocouple/DC Volts Scanner (2280A-162)
- Current Input Connector (2280A-171)

Resistance Measurement (Section 5d)

Variable resistance outputs from the data logging environment can be measured with either of two hardware configurations. The first configuration provides economical and accurate RTD resistance measurements. It can also be used with other variable resistance transducers. Use the following hardware:

- High Performance A/D Converter (2280A-161)
- RTD/Resistance Scanner (2280B-163)
- RTD/Resistance Input Connector (2280B-177)

The second configuration is useful where a blend of resistance measurements and other measurements is desired. Use the following hardware:

- High Performance A/D Converter (2280A-161)
- Thermocouple/DC Volts Scanner (2280A-162)
- Voltage Input Connector (2280A-176)*
- Transducer Excitation Module (2280A-164)
- Transducer Excitation Connector (2280A-174)

* Any other input connector supporting dc voltage measurement can be used here. These include: AC Volts Input Connector and Isothermal Input Connector.

2/Data Logging Applications

Frequency Measurement (Section 5e)

Frequency (the number of events occurring in a given period of time) can be measured with the following hardware:

Counter/Totalizer (2280B-167)

Totalizing Measurement (Section 5f)

Event counting also requires the Counter/Totalizer (2280B-167).

Strain Measurement (Section 5g)

A variable resistance strain gage can measure the deformity of an object subjected to an external force. The following 2280 hardware is required to make such a measurement:

High Performance A/D Converter (2280A-161)

Thermocouple/DC Volts Scanner (2280A-162)

Input Connector (2280A-176) *

Excitation Module (2280A-164)

Excitation Connector (2280A-174)

* Any other input connector supporting dc voltage measurement can be used here. These include: AC Volts Input Connector and Isothermal Input Connector.

Digital and Status Inputs (Section 5h)

BCD and binary (or logic - on/off) outputs from the data logging environment can be read with the following hardware:

Digital I/O Assembly (2280A-168)

Digital/Status Input Connector (2280A-179)

2/Data Logging Applications

Status Outputs (Section 5i)

Status (on/off) outputs from the 2280 can be supplied with the following hardware:

Digital I/O Assembly (2280A-168)
Status Output Connector (2280A-169)

Analog Outputs (Section 5j)

Variable analog outputs (dc voltage or current) can be supplied by the 2280 when the following hardware is used:

Analog Output (2280B-170)

USING THE 2280 SERIES DATA LOGGER

Overview

Programming the 2280 involves little more than entering a series of simplified keystrokes from the front panel (or from a remote controller). Actually, a considerable part of what you do is pre-programmed. To this extent, programming involves linking parts of a stored program with a specific 2280 channel.

The display prompts you as you go with a series of menu choices; you respond by typing in the name or number of the feature you wish to select.

Operating the 2280 is even simpler. Four front panel keys (or their remote counterparts) do just about everything. These keys (SCAN, SINGLE SCAN, PLOT, MONITOR) allow you to examine channels you have previously programmed.

The 2280 Series User Guide provides comprehensive programming and operating information. The information presented here is solely an overview.

2/Data Logging Applications

The Programming Form

The Programming Form is an excellent place to start, or to refer back to, or to create a record of what you did. If something about the menu structure seems confusing, refer to the Programming Form; since it is worded in terms of the displayed prompts and menu printouts, it provides a convenient snapshot of the entire menu structure. See Figure 2-2.

Using the Programming Form aids in planning your entry before you commit it to the data logger's memory. And it's an easy matter to alter programs after they've been keyed in. In such cases, the record provided by the Programming Form tells you what not to do.

The Menu System

The 2280 series data loggers are menu-driven; all programming is done by making selections from menus. There are only a few user-defined entry fields. This kind of system takes most of the learning curve out of setting up process monitoring and makes programming and operating considerably easier for most users.

Programming is divided into six groups (referred to as modules), each of which contains sets, and then subsets of menus for programming the options present in that group. The desired option is selected by merely entering the indicated key. Each menu clearly spells out what is available, while simultaneously narrowing the entire field as you descend into the selected menu subset. You can access each programming module from the main menu, which you reach by using the keypad and following the display.

2/Data Logging Applications

Some menus are simple listings of programmable features available in a given section, and other menus actually allow you to set characteristics and limits, specify output devices, and the like. Along with the menu title, the display shows the previous program setting, if programmed, or the preset default selection.

Each of the modules is designed to handle a specific type of information; Channel Programming is for programming channels, Output Device Programming is for specifying output device characteristics and formats, and so on.

Moving Through the Menus

Following a few rules can make using the 2280 menu structure enjoyable:

- o Always start and finish at the Main Menu.

The Main Menu is the first menu displayed when power is applied. It appears as follows:

```
MAIN MENU CHOICE <M FOR MENU>?
```

- o There are two methods of observing your choices without changing anything:
 1. Use the up and down arrow keys (immediately left of the POWER switch) to sequentially display all choices within the existing menu level, or
 2. Use the M key to print all menu choices within the existing menu level.

<F> ALARM LIST PROGRAM

ALARM LIST MENU CHOICE <1.2>

ALM LIST #	P.C.D. OR L	LIMITS INFORMATION	LOGGING UNIT	LOGGING FORMAT	CHANNEL LABEL	LOGGING UNIT	LOGGING FORMAT	CHANNEL LABEL	LOGGING UNIT	LOGGING FORMAT	CHANNEL LABEL
1	0-100	ALARM MESSAGE EXAMPLE: EXHAUST TEMP OVER LIMIT	0-100	0-100	0-100	0-100	0-100	0-100	0-100	0-100	0-100
2											
3											
4											
5											
6											
7											
8											
9											
10											

<A> CHANNEL PROGRAM

CHANNEL MENU CHOICE <1.4>

CHANNEL FUNCTION #/BLOCK	P.C.D. OR L	CHANNEL UNITS	CHANNEL EXPRESSION or PROCEDURE	CHANNEL LABEL	LOGGING UNIT	LOGGING FORMAT	CHANNEL LABEL	LOGGING UNIT	LOGGING FORMAT	CHANNEL LABEL
1	0-100	0-100	EXAMPLE: EXHAUST TEMP OVER LIMIT	0-100	0-100	0-100	0-100	0-100	0-100	0-100
2										
3										
4										
5										
6										
7										
8										
9										
10										

<K> SCAN GROUP PROGRAM

SCAN GROUP MENU CHOICE <1.5>

GROUP #	P.C.D. or L	SCAN GROUP LABEL	SCAN GROUP CHANNEL LIST	SCAN TRIG MODE	DATA OUTPUT	OTHER SCAN GROUP TRIGGER
1	0-0	0-0	0-0	0-0	0-0	0-0
2						
3						
4						
5						
6						
7						
8						
9						
10						

Figure 2-2. The 2280 Programming Form (side 1)

2280 SERIES PROGRAMMING FORM

PLUKS

FORM 1044

< Z > SYSTEM PROGRAM

<p>< 1 > LINE FREQUENCY</p> <p>< 1 > 100 Hz</p> <p>< 2 > 200 Hz</p> <p>< 3 > 300 Hz</p>	<p>< 2 > CALENDAR DATE & TIME</p> <p>Mo Year: Day: Hr: Min: Sec: </p> <p>Mo: Day: Hr: Min: Sec: </p>	<p>< 3 > TEMPERATURE UNITS</p> <p>< 1 > Degrees C</p> <p>< 2 > Degrees F</p> <p>< 3 > Celsius</p>	<p>< 4 > ACCESS CODE</p> <p>0-9</p>	<p>< 5 > SCAN TRIGGER ENABLE TIMES</p> <p>Mo Year: Day: Hr: Min: Sec: </p> <p>Mo: Day: Hr: Min: Sec: </p>	<p>< 6 > INTERPOLATION TABLES</p> <p>Table # Enter: </p> <p>Mo Year: Day: Hr: Min: Sec: </p> <p>Mo: Day: Hr: Min: Sec: </p>	<p>< 7 > SELECT MENU OPTIONS</p> <p>Mo Year: Day: Hr: Min: Sec: </p> <p>Mo: Day: Hr: Min: Sec: </p>
---	--	---	---	---	---	---

< P > PLOT PROGRAM

<p>< 1 > PLOT R</p> <p>Mo Year: Day: Hr: Min: Sec: </p> <p>Mo: Day: Hr: Min: Sec: </p>	<p>< 2 > SYMBOL</p> <p>Mo Year: Day: Hr: Min: Sec: </p> <p>Mo: Day: Hr: Min: Sec: </p>	<p>< 3 > PLOT INTERVAL</p> <p>Mo Year: Day: Hr: Min: Sec: </p> <p>Mo: Day: Hr: Min: Sec: </p>	<p>< 4 > COMMON PLOT INTERVAL FOR ALL FOUR PLOTS</p> <p>Mo Year: Day: Hr: Min: Sec: </p> <p>Mo: Day: Hr: Min: Sec: </p>
--	--	---	---

< U > OUTPUT DEVICE PROGRAM

<p>< 1 > PRINTER FORMAT</p> <p>< 1 > ASCII</p> <p>< 2 > Binary</p> <p>< 3 > Character</p>	<p>< 2 > PORT A FORMAT</p> <p>< 1 > ASCII</p> <p>< 2 > Binary</p> <p>< 3 > Character</p>	<p>< 3 > PORT B FORMAT</p> <p>< 1 > ASCII</p> <p>< 2 > Binary</p> <p>< 3 > Character</p>	<p>< 4 > CARTRIDGE TAPE FORMAT</p> <p>< 1 > ASCII</p> <p>< 2 > Binary</p> <p>< 3 > Character</p>	<p>< 5 > DEVICE TYPE</p> <p>< 1 > 100 Hz</p> <p>< 2 > 200 Hz</p> <p>< 3 > 300 Hz</p> <p>< 4 > 400 Hz</p> <p>< 5 > 500 Hz</p> <p>< 6 > 600 Hz</p> <p>< 7 > 700 Hz</p> <p>< 8 > 800 Hz</p> <p>< 9 > 900 Hz</p> <p>< 0 > 1000 Hz</p>	<p>< 6 > PORT A CHARACTERISTICS</p> <p>< 1 > ASCII</p> <p>< 2 > Binary</p> <p>< 3 > Character</p>	<p>< 7 > PORT B CHARACTERISTICS</p> <p>< 1 > ASCII</p> <p>< 2 > Binary</p> <p>< 3 > Character</p>	<p>< 8 > ALARM ADVANCEMENT LOGGING DEVICE</p> <p>< 1 > ASCII</p> <p>< 2 > Binary</p> <p>< 3 > Character</p>	<p>< 9 > DATA TRANSFER FILTER</p> <p>< 1 > ASCII</p> <p>< 2 > Binary</p> <p>< 3 > Character</p>
---	--	--	--	---	---	---	---	---

Figure 2-2. The 2280 Programming Form (side 2)

2/Data Logging Applications

- o To go forward in the menu structure (from one menu level to the next), press ENTER. If no new value was selected, either the last selected value or the default value is used.
- o To go backward in the menu structure and not change any selection, press EXIT. Repeatedly pressing EXIT deposits you back at the Main Menu.
- o Use the alphanumeric keys for fields requiring user defined entries (i.e., scan group labels, alarm messages, etc.), and then press ENTER to store your entry.

2/Data Logging Applications

HOW THE 2280 SERIES DATA LOGGERS DIFFER

Features

- o 2280B

All features documented in this guide and the other 2280 Series manuals (User Guide and Service Manual) are available with the 2280B.

- o 2285B

The 2285B is an economical solution to a data logging system that does not require the expansion capabilities of the 2280B. Therefore:

- The channel total for the 2285B is limited to 100.
- One High Performance A/D Converter (Option 2280A-161) can be installed.

- o 2280A

Features of the 2280A differ from those of the 2280B in the following areas:

- Alarm Limits: alarm limits cannot be changed while scanning.
- Pseudo Channels: pseudo channels values cannot be changed while scanning.
- Scan Once Trigger Mode: not available on 2280A.
- Remotely Terminated Thermocouples: not supported by 2280A.
- Time of Day: not shown during scanning.
- Internal Tape Transfer Speed: increased speed not available with 2280A.

2/Data Logging Applications

Permissible Option Configurations

The permitted option configuration depends on the type of 2280 Series Data Logger in use.

- o 2280B

All options can be used with the 2280B.

- o 2285B

The following option assemblies cannot be used with the 2285B: Advanced Math Processor (2280A-211), DC Cartridge Tape (2280A-214), Counter/Totalizer (2280B-167), Analog Output (2280B-170).

- o 2280A

The following option assemblies cannot be used with the 2280A: RTD/Resistance Scanner and Connector (2280B-163/-177), Counter/Totalizer (2280B-167), Analog Output (2280B-170).

2/Data Logging Applications

SUMMARY

This section has covered a lot of ground. The general idea of a data logging system, the 2280 data logging hardware available, use of this hardware in various applications, and programming and operating the 2280 Series Data Logging System have all been dealt with to some extent.

At this point, if you need to understand how to program and operate the 2280, take a look at the User Guide. If you want to start using the data logger with minimal delay, the rest of this guide may have all the information you need. And you can always refer to the User Guide should programming or operating questions arise.



Section 3
Installation - Mainframe

CONTENTS

Introduction	3-3
General Information	3-3
Shipping	3-3
Unpacking	3-4
Physical Layout	3-4
Physical Installation	3-7
Selecting a Location	3-7
Rack Mounting	3-8
Attaching the Front Panel Doors	3-11
Power Connections	3-11
Line Voltage	3-11
Battery Operation	3-13
Hardware Configuration	3-13
Extender Chassis (2281)	3-14
Option Assemblies	3-15
New Installation	3-15
Previously Installed	3-15
Addressing	3-15
A/D Converter	3-15
Digital I/O Assembly	3-16
Analog Output	3-18
Counter/Totalizer	3-18
IEEE-488 Interface	3-19

3/Installation - Mainframe

Other Switch Selections	3-19
Jumpers	3-19
External Connections	3-20
Master Alarm Output/Trigger Input	3-21
Programming	3-21
Operator Maintenance	3-22
Introduction	3-22
Fuse Replacement	3-22
General Cleaning	3-23
Paper Replacement	3-25
Service Information	3-27

INTRODUCTION

This section of the manual contains unpacking, installation, and unit preparation information. It should be read and understood before any attempt is made to install or operate the 2280 Series Data Logger. If any difficulties arise during installation or operation, contact your nearest John Fluke Sales Representative.

GENERAL INFORMATION

Shipping

The 2280 is packaged and shipped in a foam-packed container. Upon receipt of the instrument, a thorough inspection should be made to reveal any possible shipping damage. Special instructions for inspection and claims are included on the shipping container.

If reshipment of the instrument is necessary, the original container should be used. If the original container is not available, a new one can be obtained from the John Fluke Mfg. Co., Inc. Please refer to the instrument model number when requesting a new shipping container.

3/Installation - Mainframe

Unpacking

To unpack the 2280 Series Data Logger, first examine the shipping container for any obvious damage. If no damage is apparent, open the container and remove enough packing material to expose the instrument and remove the 2280.

Verify that each pcb is firmly seated in the chassis. If shipping and handling have loosened any pcb, call your nearest Fluke representative. Also, refer to the appropriate option subsection of 2280 Series Service Manual.

Caution

Do not energize the 2280 until directed to do so later in this section. Any pcb loosened in shipment must be fully inserted at this time. If additional pcb's are to be installed, refer to the instructions presented in Section 4 of this manual.

Along with the data logger, the shipping container holds an accessory box. Check this box for the following items:

- o Manual Set (User Guide, System Guide, Service Manual)
- o Line Power Cord
- o Printer Dust Cover
- o Programmer Door
- o Alarm Output Hardware (Connector and Shell)
- o Getting Started Guide
- o Roll of Paper for Printer
- o Programming Form

Physical Layout

Features, controls, and connectors are identified in Figure 3-1 (front view) and Figure 3-2 (rear view).

3/Installation - Mainframe

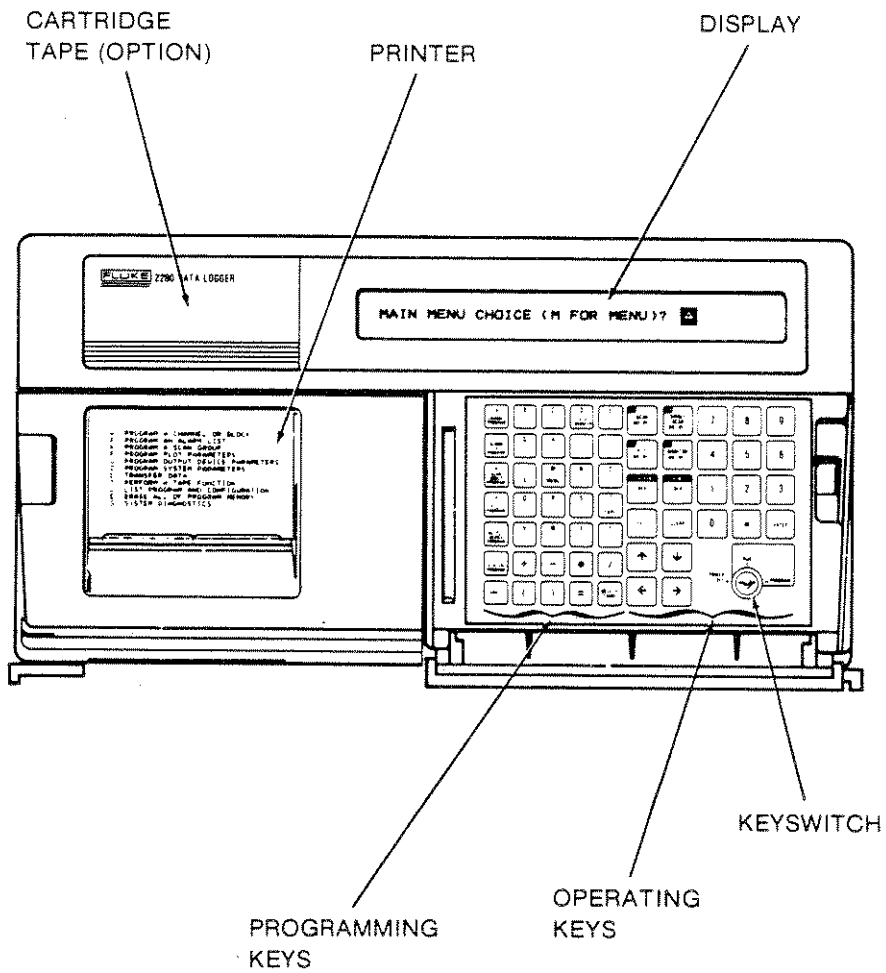

Figure 3-1. Front View

3/Installation - Mainframe

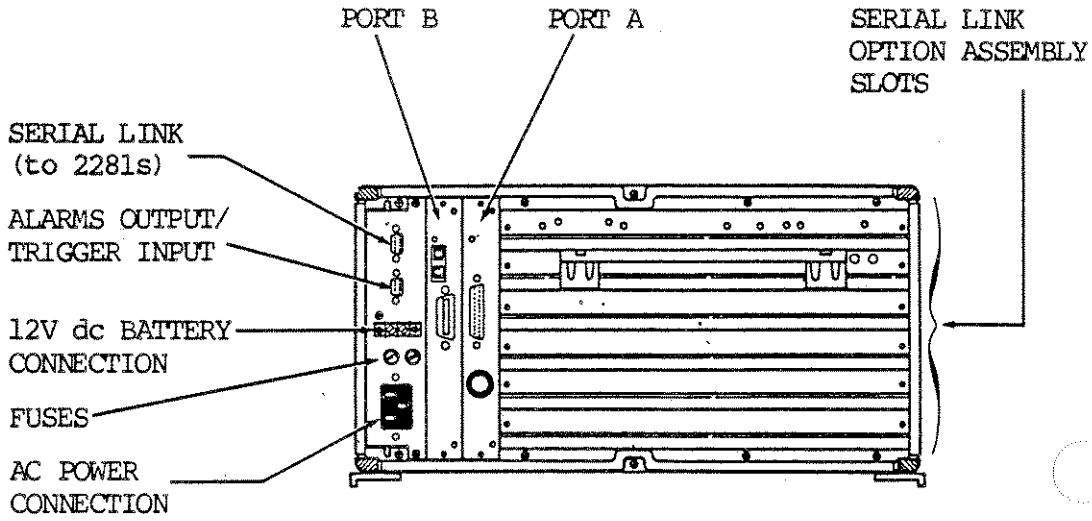

Figure 3-2. Rear View

PHYSICAL INSTALLATION

Selecting a Location

After unpacking and inspecting the 2280 Series Data Logger, select an appropriate location for installation. Case dimensions are shown in Figure 3-3. The self-contained case may be operated in any convenient location, but adequate clearance should be provided for rear-panel cabling.

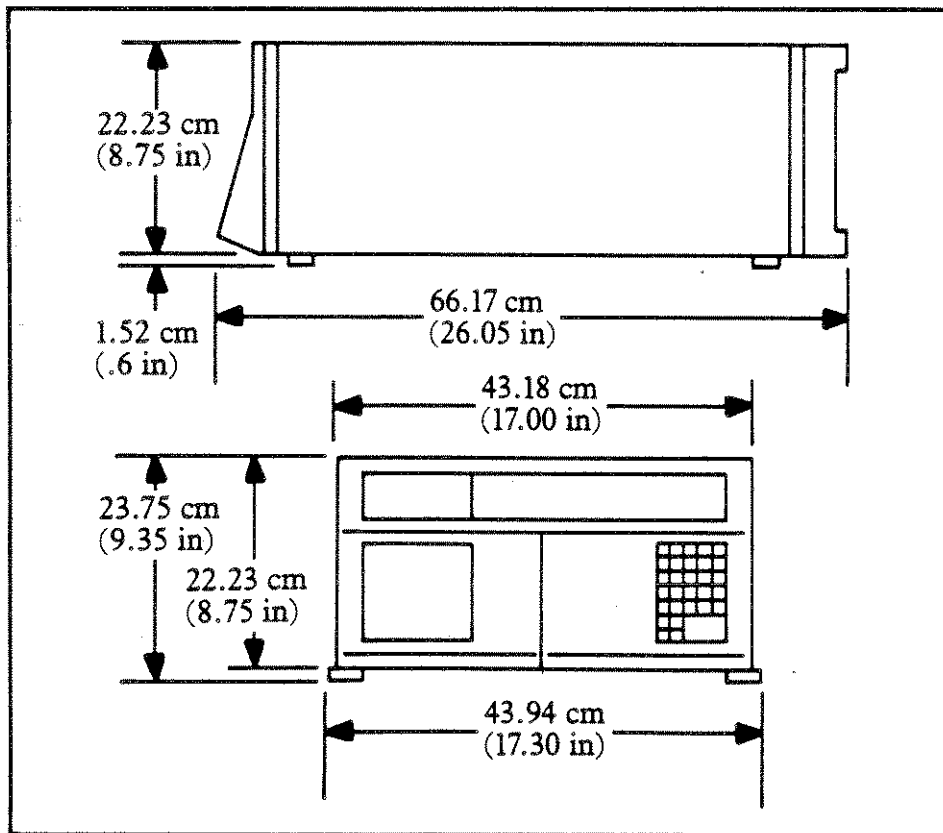

Figure 3-3. Case Dimensions

3/Installation - Mainframe

Rack Mounting

Two accessories are available to aid in mounting the 2280 Series Data Logger.

- o The Rack Mount Kit (Y2045)

The Y2045 Rack Mount Kit facilitates the placement of a 2280 into a standard 19-inch electronic equipment rack. The only tool required for installation is a medium-sized, Phillips screwdriver.

- o The Rack Slide Kit (Y2044)

The Y2044 Rack Slide Kit facilitates the servicing of the 2280 while it is installed in a standard 19-inch electronic equipment rack. The unit is secured in the equipment rack, yet may be pulled out along the slide for reconfiguring and servicing serial link devices. The only tools required for installation are medium-sized, Phillips and flat-head screwdrivers.

These accessories are shown in Figures 3-4 and 3-5, respectively. Full installation instructions are provided with each kit and in Section 4 of this manual.

3/Installation - Mainframe

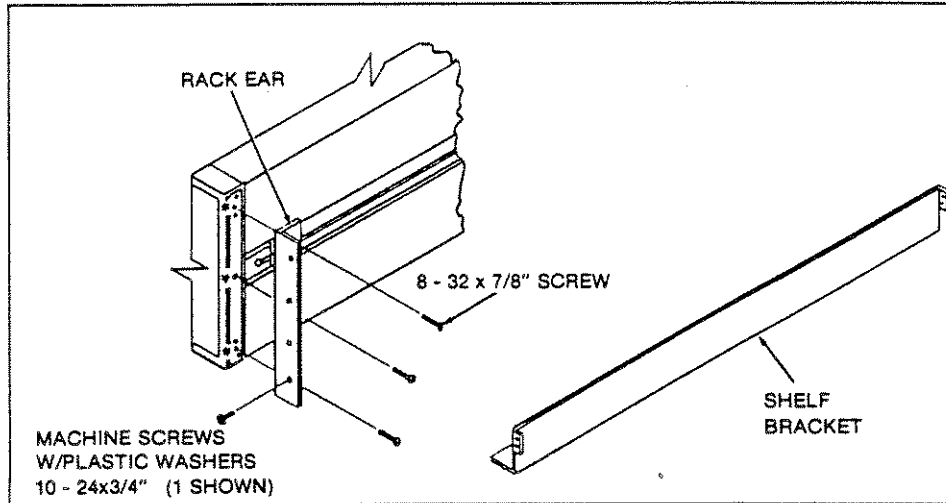

Figure 3-4. Rack Mount

3/Installation - Mainframe

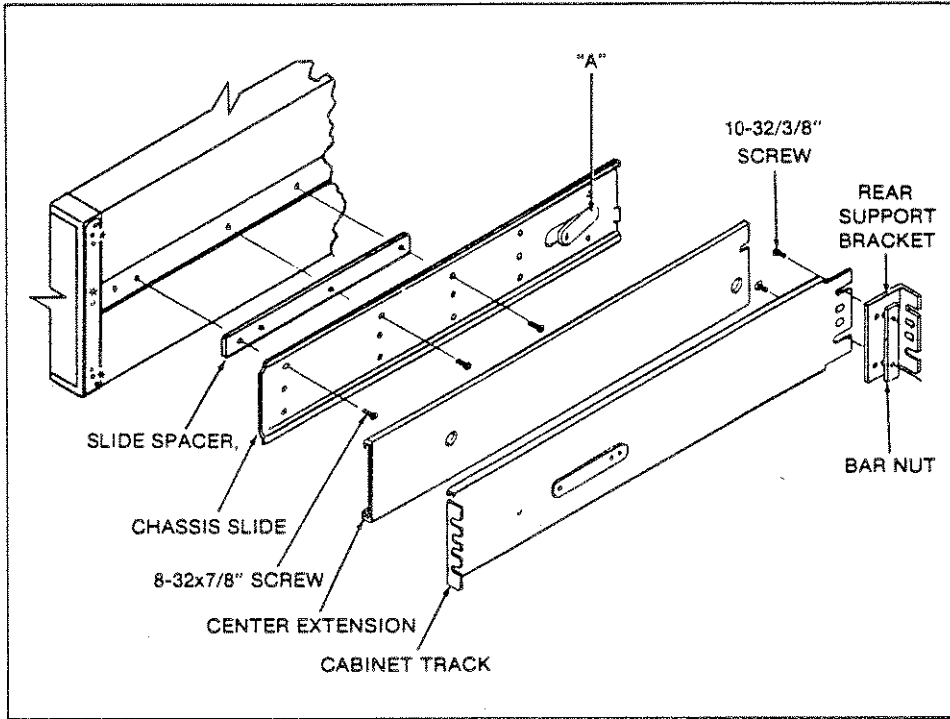

Figure 3-5. Rack Slide

ATTACHING THE FRONT PANEL DOORS

The two front panel doors are shipped separately and must be attached to the data logger. Identify these items as follows:

- o Printer Dust Cover: contains a single large window and fits on the lower left front of the data logger.
- o Programmer Door: contains multiple small windows (allowing access to Operator keys) and fits on the lower right front of the data logger.

Either door pivots on a set of two pins found at the bottom of the front panel. Each pin fits into a bracket on the inside bottom of the appropriate door.

Two steps are required to attach each door. First, fit a bracket (either side of the door) onto one of the pins. Then rotate the door into position so that the remaining bracket can be fitted to the remaining pin. Apply gentle pressure on this bracket to allow it to slip over the pin.

POWER CONNECTIONS

Line Voltage

The 2280 Series Data Logger is factory-set for a specific ac supply voltage. A decal on the instrument's rear panel identifies both the established setting and other available settings. Check this decal and verify that the instrument is set according to your needs.

Two switches located on the Transformer Assembly must be set for the desired ac line voltage. The rating for fuse F1 must be appropriate for the ac input voltage selected. Refer to Figure 3-6 when locating these switches. S1 is the upper of the two switches. Refer to the 2280 Series Service Manual for further line voltage setting information.

3/Installation - Mainframe

WARNING

LETHAL VOLTAGES MAY BE PRESENT WITHIN THE 2280 AND ON SOME OPTION ASSEMBLIES. INTERNAL ADJUSTMENTS AND OTHER SERVICING ON THE 2280 SERIES MUST BE DONE BY QUALIFIED PERSONNEL. DO NOT REMOVE ANY INSTRUMENT COVERS UNLESS YOU ARE QUALIFIED TO DO SO.

The required fuse value and switch positions for each voltage selection are shown below. Whenever the line voltage switches are checked or set, make sure that the fuse rating is the same as that shown.

AC INPUT	F1 VALUE (rear panel)	S1 POSITION (upper switch)	S2 POSITION (lower switch)
90-110V ac	1.5A SLO BLO	Red (up)	White (down)
108-132V ac	1.5A SLO BLO	Red (up)	Red (up)
198-242V ac	.75A SLO BLO	White (down)	White (down)
216-250V ac	.75A SLO BLO	White (down)	Red (up)

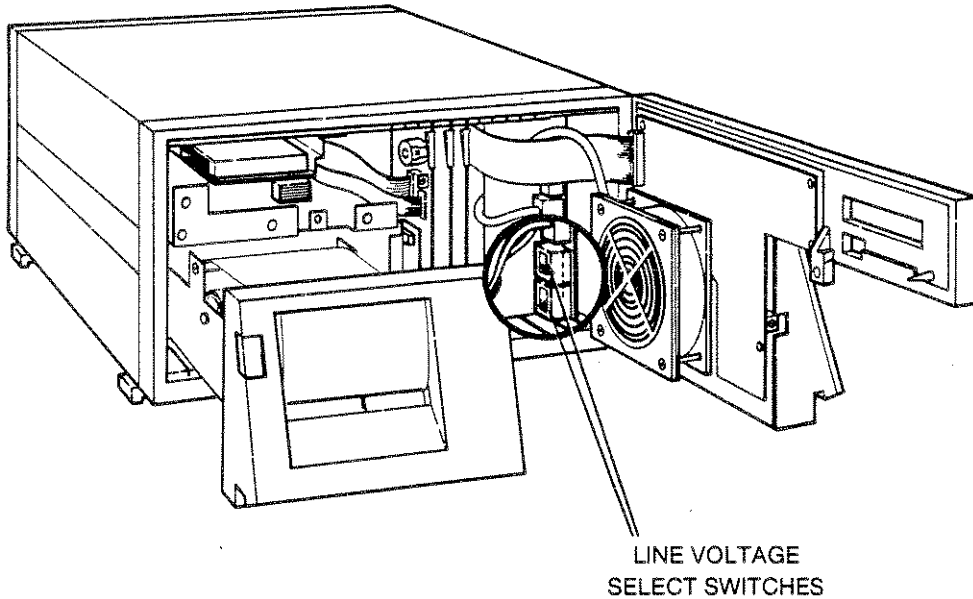

Figure 3-6. Line Voltage Selection

Battery Operation

WARNING

SAFETY AND EMI CONSIDERATIONS DICTATE THAT THE 2280 CHASSIS BE CONNECTED TO GROUND WHEN THE INSTRUMENT IS POWERED FROM A DC SOURCE. USE THE TERMINAL PROVIDED FOR THIS PURPOSE ON THE REAR PANEL.

Connections are provided on the rear panel for 12V dc operation. A trickle charge is provided to the dc supply whenever ac power is connected. If ac power is interrupted while a dc source is connected to the rear panel, the 2280 automatically switches to dc operation. Battery power can be used as either a primary or a backup supply. The battery input can range from 10.5 to 20V dc, but a minimum startup voltage of 11.2V dc is required.

HARDWARE CONFIGURATION

The 2280 Series Data Logger offers a substantial range of data logging configurations. Each configuration entails its own combination of optional assemblies, external connections, and system programming. This manual deals with this possibly bewildering array of configurations by approaching the task in two steps:

- o First, determine what your system configuration actually is.
- o Second, refer to sections of this manual that are appropriate to your configuration.

3/Installation - Mainframe

EXTENDER CHASSIS

The 2280B (or 2280A) Data Logger supports a system of up to 1500 channels. The 2285B supports a system maximum of 100 channels. Hardware for input and output channels can be installed in either the 2280 mainframe or the 2281A extender chassis. The 2281A can be located with considerable flexibility relative to the 2280.

- o Star configurations can be supported with the Y2047 multiconnect accessory.
- o Multi-drop configurations can be directly supported by the 2281A extender chassis.
- o For either configuration, the maximum allowable length of cable from the 2281A extender to the 2280 mainframe is one kilometer.

Using the 2281A extender in the 2280 Series Data Logger system can be advantageous. Cost effectiveness is realized when long runs of thermocouple wire are no longer necessary. For example, a maximum of 100 thermocouples can be connected to a 2281A extender, and each extender can be located up to 1 kilometer from the parent 2280. Data integrity at remote-sensing locations is also assured (up to 1 kilometer) by the use of digital communication between the 2281A and the 2280. Use of the 2281A broadens the operating temperature range of serial link options by removing those devices from more temperature-sensitive components residing within the 2280A.

Installation and use of the Extender Chassis are fully explained in the 2281A Instruction Manual.

OPTION ASSEMBLIES

New Installation

Most option assemblies can be installed directly from the rear panel. Full instructions are provided in Section 4 of this manual. Reference each option by its three-digit number (-161, -162, etc.)

Previously Installed

Installation of the 2280 mainframe may involve option assemblies that are already installed. For example, a new data logger is shipped with option assemblies installed. In such cases, it is important to verify that each option pcb is firmly seated in its position.

ADDRESSING

A/D Converter

A/D Converters are assigned channel numbers in blocks of 100. This is done by adjusting a single thumbwheel switch, which is located in the rear left corner of the board. It has settings 0-14, corresponding to starting channel numbers 000-1400 respectively. One A/D Converter cannot have more than 100 channels assigned to it. If the converter has fewer than 100 channels, they must occupy the lower channel numbers. The channel numbers above them are available for other I/O devices.

3/Installation - Mainframe

The switch can be read easily from the rear panel of the mainframe (or the extender chassis). The chosen addresses on the A/D Converter correspond to the range of channels being used, as follows:

ADDRESS	CHANNEL RANGE
0	000-099
1	100-199
2	200-299
3	300-399
4	400-499
5	500-599
6	600-699
7	700-799
8	800-899
9	900-999
10	1000-1099
11	1100-1199
12	1200-1299
13	1300-1399
14	1400-1499
15	Not Used

Refer to option 161 in Section 4 for more information.

Digital I/O Assembly

Digital I/O Assemblies are assigned channel numbers in blocks of 20. This is done with two thumbwheel switches, located in the rear left corner of the board. They are reached and set in the same way as the A/D switches were set (see above). The first switch has settings 0-14, and the second has settings 0-9. The switch settings correspond to channels numbered 000 to 1490, where the first switch sets the hundreds and the second switch sets the tens. So the number of the first channel on the Digital I/O board is set at a multiple of ten. For example, setting the switches at 9 and 4 means that the board's 20 channels are numbered 940 through 959.

3/Installation - Mainframe

NOTE

If a Digital I/O is configured as a BCD or binary word input, it uses only one channel (the lowest numbered one) within its block. The others are not available for use, except as pseudo channels. Thus, it is possible to set two Digital I/O boards at addresses 160 and 170, if the one at 160 is a BCD or binary word input.

To illustrate further, assume an A/D Converter is set at address 2, giving it an available channel range of 200-299. It has three associated scanners, each with 20 channels. Thus, it automatically occupies the space from 200 to 259. We could then have two Digital I/O cards, each with 20 channels, set at address 2,6 and 2,8 — giving these cards channel numbers 260 through 279 and 280 through 299 respectively. We could then have another A/D Converter set at address 3 (i.e. channels 300 to 399).

Suppose, however, we put those same two Digital I/O Assemblies at address 2,7 and 2,9. The Digital I/O Assembly at 2,9 will occupy channels 290 to 309, forcing us to set the other A/D Converter at address 4 (400-499), since 300 is occupied. The exception would be if the Digital I/O at 2,9 is used as a BCD/binary word input (which occupies only the channel numbered 290). In that case, channels starting at 300 are available.

Refer to option 168 in Section 4 for more information.

3/Installation - Mainframe

Analog Output

Address selection sets the channel numbers for each of the four output channels. These channel numbers are accessible through the rear panel of the Analog Option and can be set at any time.

The addressing procedure uses two settings (hundreds and tens) to select the first four numbers in any available block of ten channels. For example, if the block of ten channels from 120 through 129 is selected, channels 120, 121, 122, and 123 are actually set as analog output channels. The following chart further identifies this procedure:

SWITCH SELECTION		ANALOG OUTPUT CHANNEL			
100s	10s	0	1	2	3
0	0	0	1	2	3
0	1	10	11	12	13
0	2	20	21	22	23
.
9	9	990	991	992	993
.
14	9	1490	1491	1492	1493

Refer to option 170 in Section 4 for more information.

Counter/Totalizer

Two thumbwheel switches are accessible from the rear of the unit. The hundreds switch has a range of 0 to 15. Since the 2280 supports a maximum of 1499 channels, the last position of the hundreds switch (15) is not allowed. If the switch is set to this position, the Counter/Totalizer will not respond to any command. The tens switch has a range of 0 to 9. All settings of the tens switch are permissible.

IEEE-488 Interface

Two rotary decimal switches are mounted on the IEEE-488 Interface Board, accessible from the back of the instrument. The switches select the device address. The 2280 listen and talk addresses are identical are set with these address switches. The top digit represents the tens digit of the address, and the bottom digit represents the units digit. The address switches are read periodically by the IEEE-488 Interface and, if the switch value has been changed, the interface is reconfigured appropriately. The switches can be placed in positions 00 to 39. Refer to information on the 342 option in Section 4.

OTHER SWITCH SELECTIONS

Several option assemblies require special settings to specify the type of output or reading. These are fully described in the appropriate area (referenced by the three-digit option number) in Section 4.

JUMPERS

Some option assemblies require that a set of jumpers be installed for the application intended. Such procedures must be completed prior to installation of the option assembly. The procedures are fully described in the appropriate subsection of Section 4.

3/Installation - Mainframe

EXTERNAL CONNECTIONS

Generally, external wiring connections are made directly to the connector assemblies. Wiring schemes are explained in the appropriate optional assembly subsections later in this manual. These subsections are presented in numerical (three-digit) order. The following list serves as a guide:

Number	Option Assembly
162	Thermocouple/DC Volts Scanner
160	o AC Voltage Input Connector
171	o Current Input Connector
175	o Isothermal Input Connector
176	o Voltage Input Connector
163	RTD/Resistance Scanner
177	o RTD/Resistance Input Connector
164	Transducer Excitation Assembly
174	o Transducer Excitation Connector
168	Digital I/O Assembly
169	o Status Output Connector
179	o Digital/Status Input Connector

Other optional assemblies requiring external wiring include the Counter/Totalizer (167), the Analog Output (170), the RS-232-C Interface (341), and the IEEE-488 Interface (342).

3/Installation - Mainframe

MASTER ALARM OUTPUT/TRIGGER INPUT CONNECTOR

The rear panel Alarm Output/Trigger Input provides a master alarm relay output connection and a scan trigger input.

The master alarm relay is closed whenever there is an unacknowledged alarm in the alarm queue (front panel alarm LED on).

The pinout for this connector is as follows:

Pin:	Function:
1,3,5,6,7	Return connection for trigger input (connected to logic common)
2	Hardware trigger input (pulled up to +5V dc) Low-to-high transition causes scan trigger.
4,8	Master alarm output relay contacts (2.8 VA maximum)
9	Earth ground (shield)

PROGRAMMING

Programming for and operation of the 2280 Series Data Logger is fully explained in the User Guide. Also, each optional assembly subsection in this manual presents a sample program. Although primarily serving as installation test procedures, these programs can also be used as programming examples.

3/Installation - Mainframe

OPERATOR MAINTENANCE

Introduction

Operator maintenance includes those actions that do not require direct access to the interior of the Data Logger. For maintenance that does require access to the 2280 interior (such as line voltage settings), refer to the Service Manual.

Fuse Replacement

Two fuses are located just above the ac power input connector on the extreme lower left of the rear panel. Fuse F1 is the ac input fuse, and fuse F2 is the dc input fuse. Refer to the rear panel decal for correct fuse ratings for each voltage range. This information is as follows:

AC INPUT	F1 VALUE
90-110V ac	1.5A SLO BLO
108-132V ac	1.5A SLO BLO
198-242V ac	.75A SLO BLO
216-250V ac	.75A SLO BLO

To check or replace the fuses, unscrew the fuse covers with a slotted screwdriver or adjustment tool. After each fuse has been checked or replaced, reinstall the fuse covers.

General Cleaning

Before cleaning any part of the Data Logger, read the following words of caution:

Caution

Do not use aromatic hydrocarbons or chlorinated solvents for cleaning. They may damage plastic materials used in the instrument.

- o Do not handle the pcb's by the connector pins; handle them by the edges. Oil from the skin contaminates the pcb and degrades measurement accuracy.
- o Improper handling may also cause instantaneous or delayed electrostatic discharge damage. The yellow "Static Awareness" sheet inserted near the front of this manual explains some of the hazards of static electricity to sensitive components.
- o Do not use a static-inducing vacuum brush to clean pcb's. Possible electrostatic discharge can damage sensitive components.

Clean the Data Logger periodically to remove dust, grease, and other contamination. The Data Logger case may be cleaned using a soft cloth dampened with a mild solution of detergent and water. Dry the case after cleaning.

If visual inspection reveals significant contamination on printed circuit board surfaces, the pcb's may be cleaned using low pressure (<20 psi) air. If air is not available, clean the pcb's with commercial water-based cleaning equipment.

3/Installation - Mainframe

If commercial water-based cleaning equipment is not available, clean the pcb's by holding them under warm, running water. Observe the following precautions when using water-based cleaning equipment:

1. Read all precautions listed above under General Cleaning.
2. Remove all pcb shielding covers and separate any relay piggy-back assemblies.
3. In areas with exceptionally hard water, use either deionized or distilled water for a final wash to remove ions left by the hard water wash.
4. Dry all pcb's thoroughly. Use a low-temperature drying chamber or an infrared drying rack with a temperature range between 100 and 120 °F (38 to 46 °C) if available.
5. If a drying chamber or infrared drying rack is not available, air-dry the pcb's at room temperature for a minimum of 48 hours before reassembling.
6. Use a mixture of 70% isopropyl alcohol and 30% water and a lint-free cloth to clean edge-connector contacts. Never use an eraser to clean connector contacts; it might generate static or abrade the gold plating on the contacts.

Paper Replacement

When a new paper supply must be loaded the following steps should be taken. Also, refer to the detailed illustration inside the printer door.

Release the printer "drawer" by pressing the printer slidelatch located to the left of and behind the printer cover door latch. Pull the printer out as far as it will come.

Deactivate the printer by moving the main printer power switch to the OFF position. This switch is located in the right corner of the Printer Drive Interface board.

PAPER REMOVAL

If used paper must be removed, tear it off at the serrated edge where the paper re-enters the inside of the printer. Locate the spring plate that holds the take-up spindle in place and pull this spring plate out with one hand while lifting the take-up spindle (with the used paper) out of its position.

Pinch the split end of the spindle together. (The spindle is opposite the gear). Slide the used paper off the take-up spindle and reinsert the spindle the same way you took it out.

Push the spring-loaded printer door latch (on the left side of the printer window) to the right and fold down the printer cover door.

Release the print head by pushing down on the print head release lever, located in the lower left corner of the printer's panel area.

Remove the supply spindle by putting your thumb on the thumb rest while pushing up on the spindle with your forefinger. Dispose of the old paper reel and any remaining paper.

3/Installation - Mainframe

INSTALLING NEW PAPER

When you install the new roll of paper on the supply spindle make certain the loose end comes out from the bottom of the roll.

For best results, tear the loose end of the paper at a 45 degree angle, and insert it into the opening of the paper loading tray.

Use the slot in the tray to push the paper through the printer so the paper holds the switch arm down. Push the paper through until it slides past the print head and continues outside of the printer.

Once the paper is showing outside the printer, pull it out a few inches more. Run the paper through the return slot at the top of the printer, and pull it all the way back over the rear shaft.

Insert the paper through the slot in the take-up spindle. Secure it by turning the gear a few revolutions in a counterclockwise direction.

Secure the paper at the print head by pushing the print head release lever up into the operating position. Make sure the printer rocker switch is in the TAKE UP ON position.

Turn the main printer power switch to the ON position, close the printer cover door, and slide the printer back into the unit until it snaps into place.

Caution

We recommend that you use NCR T1302 or JUJO TP50KM-A paper in the 2280 printers. Both are available through John Fluke Mfg. Co., Inc. (Fluke Accessory Y2046). If any other type of paper is used, the printer warranty is voided.

3/Installation - Mainframe

SERVICE INFORMATION

The following additional information can be found in the 2280 Series Service Manual:

- o Theory of Operation
- o Calibration/Adjustment Procedures
- o Troubleshooting Procedures
- o Parts Lists
- o Schematic Diagram

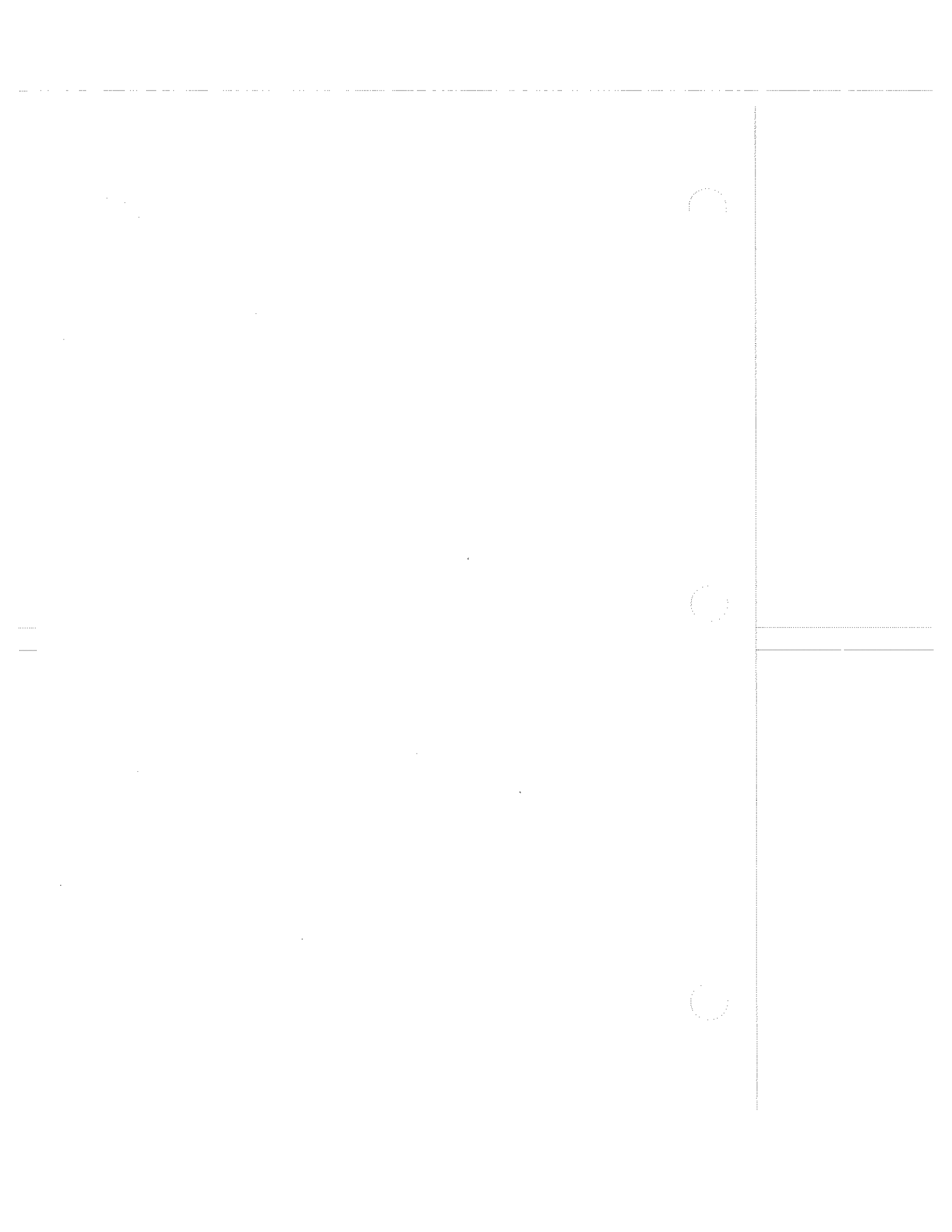

Section 4
Installation - Options and Accessories

CONTENTS

AC Voltage Input Connector (2280A-160)	160-1
High Performance A/D Converter (2280A-161) ..	161-1
Thermocouple/DC Volts Scanner (2280A-162) ...	162-1
RTD/Resistance Scanner (2280B-163)	163-1
Transducer Excitation (2280A-164)	164-1
Counter/Totalizer (2280B-167)	167-1
Digital I/O Assembly (2280A-168)	168-1
Status Output Connector (2280A-169)	169-1
Analog Output (2280B-170)	170-1
Current Input Connector (2280A-171)	171-1
Transducer Excitation Connector (2280A-174) .	174-1
Isothermal Input (2280A-175)	175-1
Voltage Input Connector (2280A-176)	176-1
RTD/Resistance Input Connector (2280B-177) ..	177-1
Digital/Status Input Connector (2280A-179) ..	179-1
Advanced Math Processor (2280A-211)	211-1
DC Cartridge Tape (2280A-214)	214-1
RS-232-C Interface (2280A-341)	341-1
IEEE-488 Interface (2280A-342)	342-1
2281A-402 Extender Chassis Cable	402-1
2281A-403 Connector Pair for -402 Cable	403-1
2281A-431 Extender Chassis Power Supply	431-1
Y2044 Rack Slide Kit	Y2044-1
Y2045 Rack Mount Kit	Y2045-1
Y2047 Serial Link Multiconnect	Y2047-1

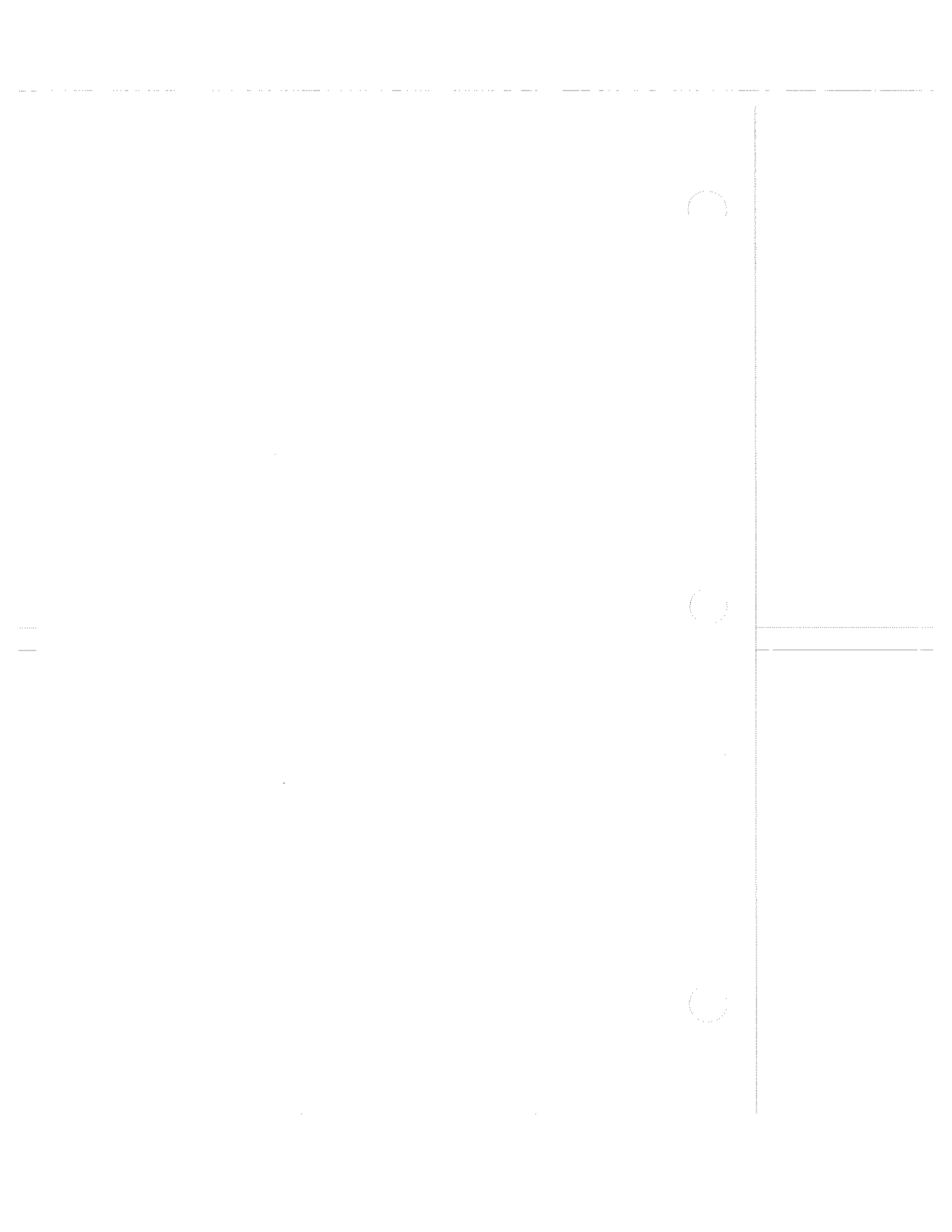

2280A-160
AC Voltage Input Connector

INTRODUCTION

The AC Voltage Input Connector is an assembly that attaches to the rear of the Thermocouple/DC Volts Scanner (option 162). This combination allows for voltage measurement on 20 channels (10 for ac volts, 10 for dc volts).

- o AC Volts: measurements ranging from 5V to 250V can be made on any of 10 ac channels. The voltage applied to any ac channel must not exceed 250V rms. The frequency range for ac measurements is 45 to 450 Hz. The AC Voltage Input Connector converts ac inputs to proportional dc voltages equal to the rms value of the input divided by 1000.
- o DC Volts: measurements up to 64V dc can be made on any of 10 dc channels.

The AC Voltage Input Connector is shown in Figure 160-1.

P/N 728147
February, 1985

160/AC Voltage Input Connector

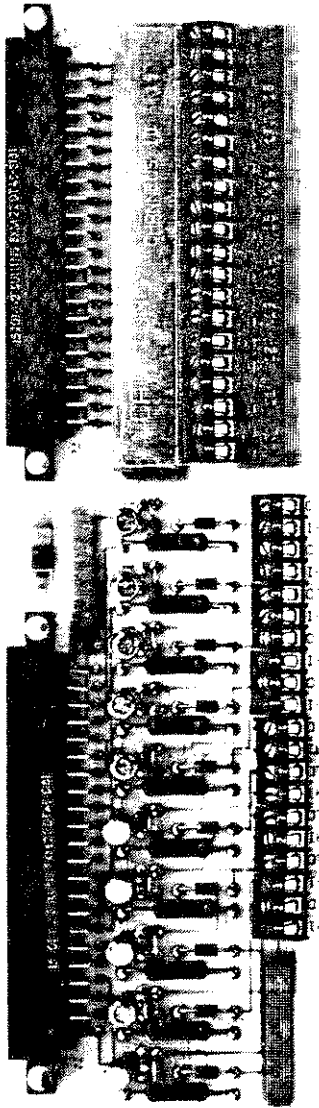

Figure 160-1. AC Voltage Input Connector

160/AC Voltage Input Connector

WHERE TO FIND MORE INFORMATION

This subsection presents information (description, specifications, installation) specifically related to the AC Voltage Input Connector. Since other system hardware is used in logging functions, system operating instructions are not repeated here.

Where the AC Voltage Input Connector is used in a specific data logging function, other sections provide more appropriate information. Examples include:

- o Section 5b. Voltage Measurement:
This section discusses use of the AC Voltage Input Connector and the Thermocouple/DC Volts Scanner in measuring ac (and dc) voltage.
- o Section 5a. Temperature Measurement
5d. Resistance Measurement
5g. Strain Measurement
These other data logging functions can also use the AC Voltage Input Connector. Any of these functions, when using the Transducer Excitation Module and Connector for stimulus, can use the dc voltage input capability of the AC Voltage Input Connector as the respective measurement input.

The User Guide presents overall operating instructions for the Data Logger. Information is presented in a general, and not option-specific, format. The User Guide treats operation with various levels of complexity, depending on user familiarity with the instrument. Some acquaintance with the User Guide is recommended. For any operation-related question, the User Guide is the ultimate authority.

SPECIFICATIONS

Table 160-1 presents specifications for the AC Voltage Input Connector.

160/AC Voltage Input Connector

Table 160-1. AC Voltage Input Connector Specifications

Channels	10V ac, 10V dc
Terminals	40 (2 per channel)
AC Voltage	
Range	5V to 250V rms
Resolution	0.1V ac
Maximum Input	250V rms between two terminals
Frequency Range	45 Hz to 450 Hz
Accuracy	See Section 6g.
Conversion Method	1/2 wave, average responding, calibrated to indicate the rms value of a sine wave.
DC Voltage	
Ranges and Accuracy	Determined by the Option 162. See Table 162-1.
Maximum Input	250V dc or ac rms between any two terminals
Maximum Common Mode Voltage	250V dc or ac rms between terminals or between a terminal and ground.
Compatibility	Attaches to the Thermocouple/DC Volts Scanner (option 162).
Temperature	
Operating	-20 to 70°C
Storage	-55 to 75°C
Relative Humidity (without condensation)	
Below 25°C	<= 95%
25 to 40°C	<= 75%
40 to 50°C	<= 45%
50 to 70°C	<= 40%
Altitude	
Non-Operating	40,000 feet
Operating	10,000 feet
Shock and Vibration	Meets MIL-T-28800C, Class 5 Standards

160/AC Voltage Input Connector

INSTALLATION

External measurement sources are connected to the 2280 Series Data Logger via wiring to the input connector block. Installation of the AC Voltage Input Connector involves assembling and connecting wiring to the terminals and attaching the connector to the appropriate scanner. The following steps detail this procedure:

1. With line power disconnected and the POWER switch set at OFF, locate the connector housing in the rear panel of the 2280.
2. Loosen the two retaining screws that hold the housing to the chassis.
3. Firmly grasp the housing at each end and pull until the enclosed connector block is disconnected from the scanner.
4. Open the housing by pressing each locking tab.

WARNING

BE SURE THAT THE WIRES BEING CONNECTED ARE NOT ENERGIZED. IF POSSIBLE, DISCONNECT THESE WIRES AT THE OTHER END. IN ANY EVENT, ENSURE THAT THE EXTERNAL CIRCUIT CONNECTED TO THESE WIRES IS NOT ENERGIZED. LETHAL VOLTAGE COULD OTHERWISE BE ENCOUNTERED.

5. The AC Voltage Input Connector is now ready to be wired to external measurement systems. For each connection, loosen the channel terminal screw, attach the external wire to the screw, then tighten the screw until the wire is firmly in place. Notice that the two terminals for each channel are marked HI and LO. Starting at Channel 0, attach the external wiring for the desired application.

160/AC Voltage Input Connector

NOTE

For proper reading polarity on the dc channels, ensure that the current flows into the HI terminal and out of the LO terminal.

6. Close the housing over the input connector, ensuring that the external wires exit the rear of the enclosure without being pinched.

WARNING

BEFORE INSTALLING THE WIRED INPUT CONNECTOR AT THE 2280 REAR PANEL, ENSURE THAT ALL LINE POWER TO THE MAINFRAME OR EXTENDER CHASSIS IS DISCONNECTED. LETHAL VOLTAGES MAY BE PRESENT WITHIN THE 2280 AND ON SOME OPTION CARDS. DO NOT REMOVE ANY INSTRUMENT COVERS UNLESS YOU ARE QUALIFIED TO DO SO.

7. Position the enclosed (and wired) input connector in the guides of the 2280 rear panel slot containing the appropriate scanner.
8. Push the connector onto the card edge connector at the rear of the scanner. Press the connector firmly into place.
9. Attach the connector housing to the chassis with the two retaining screws.

160/AC Voltage Input Connector

INSTALLATION TEST

AC Voltage Input Connector installation can be verified by successfully reading an ac voltage input channel. Be sure that system components other than the AC Voltage Input Connector are operational. The following equipment is required:

- o 2280 Series Data Logger
- o High Performance A/D Converter (option 161)
- o Thermocouple/DC Volts Scanner (option 162)
- o AC Voltage Input Connector (option 160)

NOTE

This test verifies basic operability. For accuracy tests, refer to the 2280 Series Service Manual subsection for this option assembly.

For example, the following steps would be used in completing the Channel Program for a block of ten ac voltage input channels.

Press:	Display:
A	MAIN MENU CHOICE <M FOR MENU>? A
ENTER	CHANNEL NUMBER (OR BLOCK) =
0..9	<P,C,D,L>? P
ENTER	A: CHANNEL FUNCTION <A-Z>?
D	A<D> VOLTS/CURRENT
ENTER	A<D> VOLTS/CURRENT RANGE <1-7>?
6	AD<6> 250.0 VAC
ENTER	AD: CHANNEL MENU CHOICE <1-5>?
EXIT ...	(return to MAIN MENU CHOICE)

160/AC Voltage Input Connector

MONITOR any of these channels (press MONITOR). A successful response verifies correct installation. If an ac voltage input is connected to the channel being monitored, verify that the displayed measurement is reasonable.

Press:	Display:
MONITOR	MAIN MENU CHOICE <M FOR MENU>? A
C0	MONITOR CHANNEL =
ENTER	MONITOR CHANNEL = C0
	C 0 (reading)

PROGRAMMING

Use of the AC Voltage Input Connector requires the following programming selections:

- o Channel Expression

When the AC Voltage Input Connector is used in a 2280A, the channel expression:

$$CX=CX+0.32$$

must be programmed for any ac voltage input channel to add in the diode voltage drop incurred in the ac-to-dc conversion. This expression is not required in 2280B or 2285B applications.

- o Logging Format

For 2280A applications only, logging format 6 must be selected for AC Voltage Input channels. This format is as follows:

nnnn.n

160/AC Voltage Input Connector

OPERATION

Once installed in the data logger, the AC Voltage Input Connector requires no further operator attention.

Use of the AC Voltage Input Connector (in conjunction with other option assemblies) is described under Voltage Measurement, Section 5b. Sections 5a, 5d, and 5g explain use of this connector's dc voltage input capabilities in temperature (RTD), resistance, and strain measurements, respectively. In addition, the data logger offers a wide range of programming and operating features that are fully documented in the User Guide.

SERVICE INFORMATION

The following additional information can be found in the 2280 Series Service Manual:

- o Theory of Operation
- o Parts List
- o Schematic Diagram

2280A-161
High Performance A/D Converter

INTRODUCTION

The High Performance A/D Converter (option -161) provides high accuracy analog to digital conversion of scanner input voltages. For analog measurements, at least one A/D Converter must be installed in either the 2280 Series Data Logger or the 2281A Extender Chassis. The voltage ranges and other parameters relative to the A/D Converter are programmable via the front panel. The configurations listed below are permissible:

- o A maximum of 15 High Performance A/D Converters can be supported by the 2280 System.
- o Each High Performance A/D Converter can support a maximum of five 20-channel Thermocouple/DC Volts Scanners (option 162) or 20-channel RTD/Resistance Scanners (option 163).
- o The normal capacity for the 2280 Series Mainframe is one A/D Converter and five Scanners (i.e., 100 channels). Alternately, up to three A/D Converters could be installed in the 2280 Series Mainframe if each is associated with only one scanner.
- o These same configurations are possible with the 2281A Extender Chassis.

P/N 647644, Rev 1
February, 1985

161/High Performance A/D Converter

The High Performance A/D Converter is illustrated in Figure 161-1.

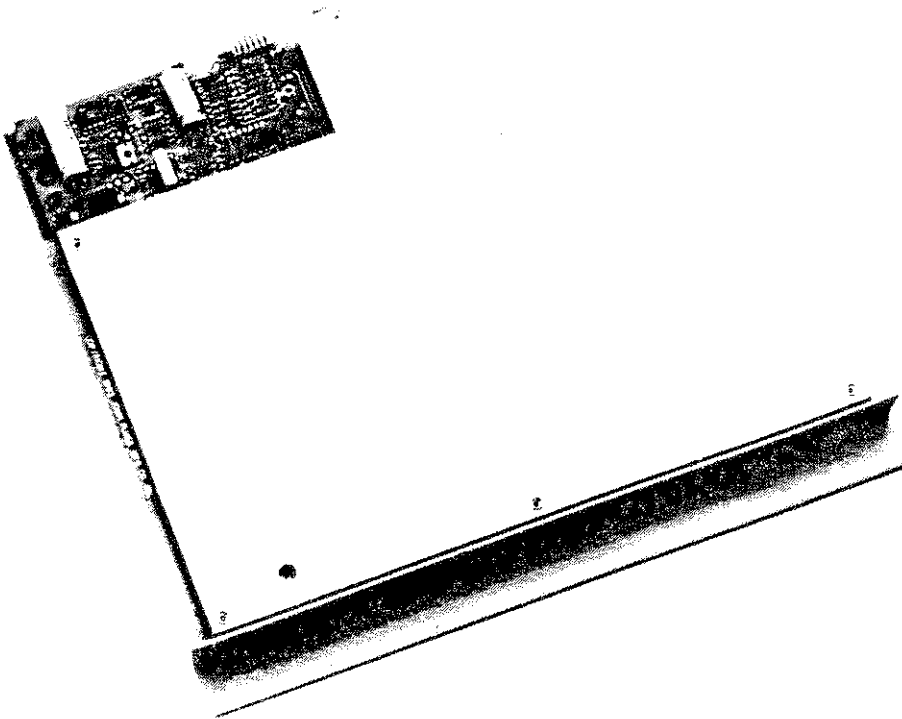

Figure 161-1. High Performance A/D Converter

161/High Performance A/D Converter

WHERE TO FIND MORE INFORMATION

This subsection of the System Guide presents information (description, specifications, installation) specifically related to the High Performance A/D Converter. Since other system hardware is used in logging functions, system operating instructions are not repeated here.

The High Performance A/D Converter is used wherever an analog measurement function is involved. Therefore, Sections 5a, 5b, 5c, and 5g describe functions using the A/D Converter.

The User Guide presents overall operating instructions for the Data Logger. Information is presented in a general, and not option-specific, format. The User Guide treats operation with various levels of complexity, depending on user familiarity with the instrument. Some acquaintance with the User Guide is recommended. For any operation-related question, the User Guide is the ultimate authority.

SPECIFICATIONS

Specifications for the High Performance A/D Converter are presented in Table 161-1.

161/High Performance A/D Converter

Table 161-1. High Performance A/D Converter Specifications

Dynamic Range (internal)	$\pm 131,071$ counts at 50 Hz $\pm 109,226$ counts at 60 Hz
Common Mode Rejection	170 dB at 50 Hz $\pm 0.1\%$ (with 100 ohm imbalance) 170 dB at 60 Hz $\pm 0.1\%$ 160 dB at dc
Normal Mode Rejection	60 dB at 50 Hz $\pm 0.1\%$ or 60 Hz $\pm 0.1\%$
Isolation	250V dc or ac rms between 2280A-161 and any other module.
Measurement Method	Dual slope, integrating over 1 line cycle
Zero Stability	Automatic zero
Ranges, Resolution, Accuracy ...	Determined by Scanner (see Tables 162-1 and 163-1) and application. See Accuracy sections: Temperature Measurement Using Thermocouples Temperature Measurement Using RTDs DC Voltage Measurement AC Voltage Measurement DC Current Measurement Resistance Measurement Strain Measurement
Temperature	
Operating	-20 to 70°C
Storage	-55 to 75°C
Relative Humidity (without condensation)	
Below 25°C	$\leq 95\%$
25 to 40°C	$\leq 75\%$
40 to 50°C	$\leq 45\%$
50 to 70°C	$\leq 40\%$
Altitude	
Non-Operating	40,000 feet
Operating	10,000 feet
Shock and Vibration	Meets MIL-T-28800C, Class 5 Standards

161/High Performance A/D Converter

INSTALLATION

Address Selection

An address must be established for each A/D Converter installed in the system. This address identifies the range of channel numbers associated with the A/D Converter. The A/D Converter address corresponds to the "hundreds" digit of the associated channel numbers. This correspondence is defined in Table 161-2. If an A/D Converter is associated with less than 100 channels, the lowest channel addresses available (within the respective block of 100) must be used. Higher, unused addresses are thereby made available for other serial link devices.

Table 161-2. A/D Address Switch Settings and Channel Ranges

ADDRESS SWITCH SETTING	CHANNEL RANGE
0	0-99
1	100-199
2	200-299
3	300-399
4	400-499
5	500-599
6	600-699
7	700-799
8	800-899
9	900-999
10	1000-1099
11	1100-1199
12	1200-1299
13	1300-1399
14	1400-1499
15	NOT USED

The address switch is located in the rear left corner of the board. The switch setting can be viewed through the window labeled ADDRESS.

161/High Performance A/D Converter

For each A/D Converter in your system, locate the A/D Converter address switch (left corner of the A/D Converter board). Using a screwdriver, move the switch to the desired address switch setting.

The High Performance A/D Converter requires no further operator adjustments.

Physical

The High Performance A/D Converter is installed in the slot directly above its associated scanner(s). Each High Performance A/D Converter should be installed as follows:

WARNING

ENSURE THAT ALL POWER TO THE MAINFRAME OR EXTENDER CHASSIS IS DISCONNECTED BEFORE STARTING THIS PROCEDURE. LETHAL VOLTAGES MAY BE PRESENT WITHIN THE 2280 SERIES DATA LOGGER AND ON SOME OPTION CARDS. DO NOT REMOVE ANY INSTRUMENT COVERS UNLESS YOU ARE QUALIFIED TO DO SO.

1. Turn the 2280 Series Data Logger Power Keyswitch to the POWER OFF position.
2. Locate the horizontal slot on the rear of the 2280 or 2281 where the A/D is to be installed. The A/D Converter should reside directly above its associated scanner(s).

CAUTION

Handle the board by its edges to avoid contamination with oil from the hands and to minimize the risk of damage by static discharge.

161/High Performance A/D Converter

3. Align the A/D Converter in the desired slot so that the board-edge connector, is toward the motherboard in the rear of the slot. Push the board straight in until it is mated with the motherboard connectors.
4. Secure the A/D to the chassis with the two retaining screws.

INSTALLATION TEST

Since measurement inputs are supplied to the A/D Converter through scanners and input connectors, at least one scanner and one input connector are required to form a minimal measurement system. The Installation Test can therefore be used to check the installation for any of the following option combinations:

- o Option 161, High Performance A/D Converter, and one of the following scanner-connector combinations:
- o Option 162, Thermocouple/DC Volts Scanner, and
 - Option 160, AC Voltage Input Connector, or
 - Option 171, Current Input Connector, or
 - Option 175, Isothermal Input Connector, or
 - Option 176, Voltage Input Connector.
- o Option 163, RTD/Resistance Scanner and
 - Option 177, RTD/Resistance Input Connector

WARNING

THE INSTALLATION VERIFICATION TEST IS FOR USE BY QUALIFIED SERVICE PERSONNEL ONLY. LETHAL VOLTAGES MAY BE PRESENT WITHIN THE 2280 SERIES DATA LOGGER AND ON SOME OPTION CARDS. DO NOT REMOVE ANY INSTRUMENT COVERS UNLESS YOU ARE QUALIFIED TO DO SO.

161/High Performance A/D Converter

Use the following procedure to test the installation of the High Performance A/D Converter:

1. Prepare the A/D Converter for installation by setting the A/D Converter address switch to 0.
2. Install the A/D Converter in the 2280.
3. Install either the Thermocouple/DC Volts Scanner (162) or the RTD/Resistance Scanner directly below the A/D Converter.
4. Apply power to the 2280.
5. Program the 2280 for a configuration list as follows:

Press:	Display:
	MAIN MENU CHOICE <M FOR MENU>? A
L	<L> LIST PROGRAM AND CONFIGURATION
ENTER	L: LIST MENU CHOICE <A-Z>? E
C	L<C> LIST HARDWARE CONFIGURATION
ENTER	LISTING <PRESS EXIT TO ABORT>
	(list is printed)
EXIT	MAIN MENU CHOICE <M FOR MENU>? A

6. Check the printed configuration list for correct hardware installation. In this case, a correct High Performance A/D Converter and Scanner installation yields a listing that identifies each associated channel block by beginning channel number and type. The following examples are possible:

161/High Performance A/D Converter

- o Example 1: A/D Converter and Thermocouple/DC Volts Scanner (no connector) installed. If a connector is not installed, the default type becomes VOLTS/CURRENT.

BEGINNING CHANNEL NUMBER = 0
TYPE = VOLTS/CURRENT
BEGINNING CHANNEL NUMBER = 10
TYPE = VOLTS/CURRENT

- o Example 2: A/D Converter and RTD/Resistance Scanner (no connector) installed.

BEGINNING CHANNEL NUMBER = 0
TYPE = RTD
BEGINNING CHANNEL NUMBER = 10
TYPE = RTD

- o Example 3: If the A/D Converter or the Scanner is not installed, no channel number and type listing appears.

OPERATION

Once installed in the data logger with the appropriate adjustments, the High Performance A/D Converter is ready for use. Complete the external wiring connections necessary to provide the A/D Converter with analog inputs. This is done using one or more of the scanners (Thermocouple/DC Volts; RTD/Resistance) equipped with a compatible input connector (Current, Isothermal, Voltage, AC Voltage; RTD/Resistance).

SERVICE INFORMATION

The following additional information can be found in the 2280 Series Service Manual:

- o Theory of Operation
- o Calibration/Adjustment Procedure
- o Parts List
- o Schematic Diagram

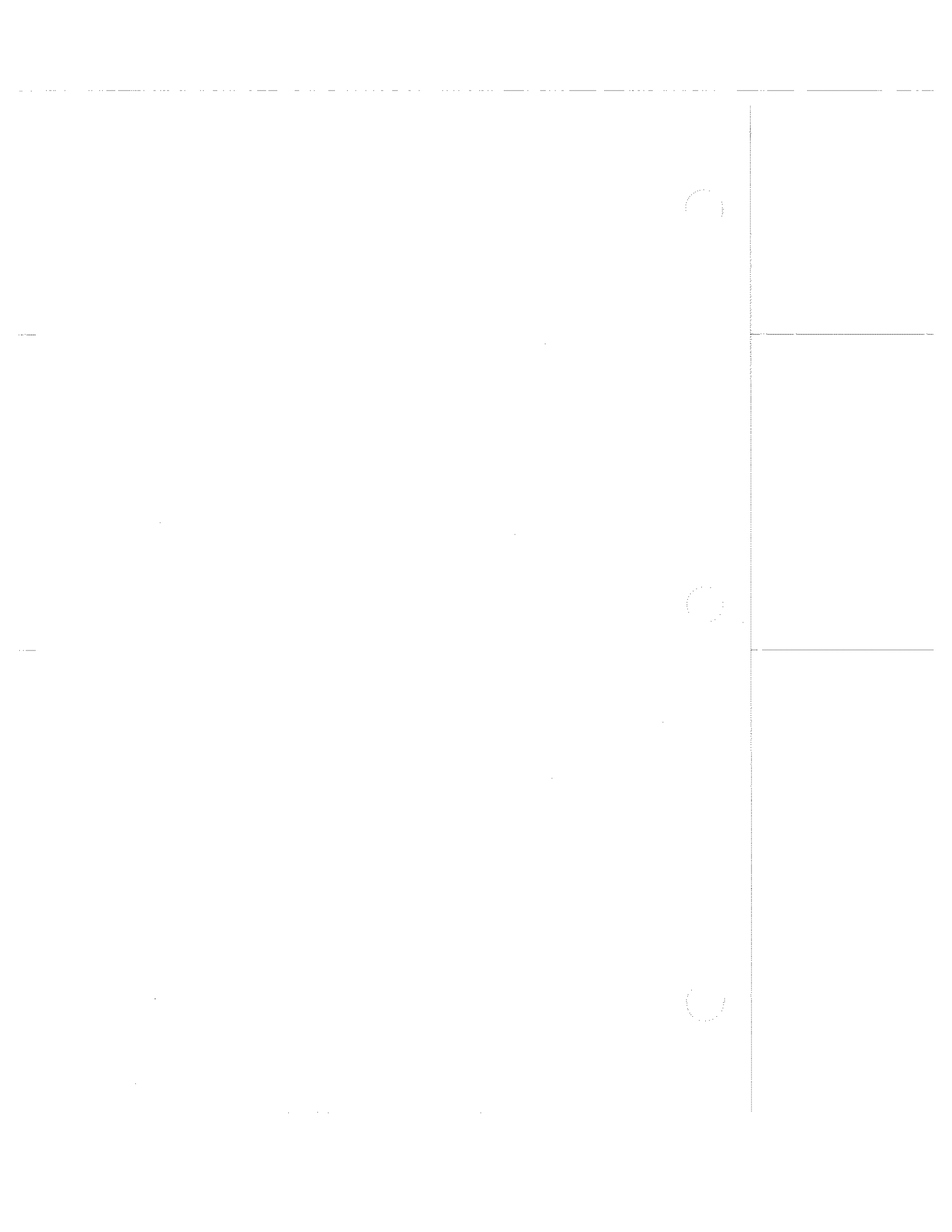

2280A-162
Thermocouple/DC Volts Scanner

INTRODUCTION

The Thermocouple/DC Volts Scanner (Option -162) is a plug-in, one microvolt, 20-channel thermocouple and multi-voltage range relay scanner contained on a single pcb. All channels are equipped with three poles, including a Shield input. The scanner operates as a self-calibrating analog data multiplexer, linking the A/D Converter to external measurement points. It accepts a variety of analog inputs, depending on the type of connector in use (Current Connector, Isothermal Connector, Voltage Connector, or AC Voltage).

The Thermocouple/DC Volts Scanner must be used with a High Performance A/D Converter. A maximum of five scanners can be used with a single A/D Converter. The Thermocouple/DC Volts Scanner is illustrated in Figure 162-1.

P/N 647651, Rev 1
February, 1985

162/Thermocouple/DC Volts Scanner

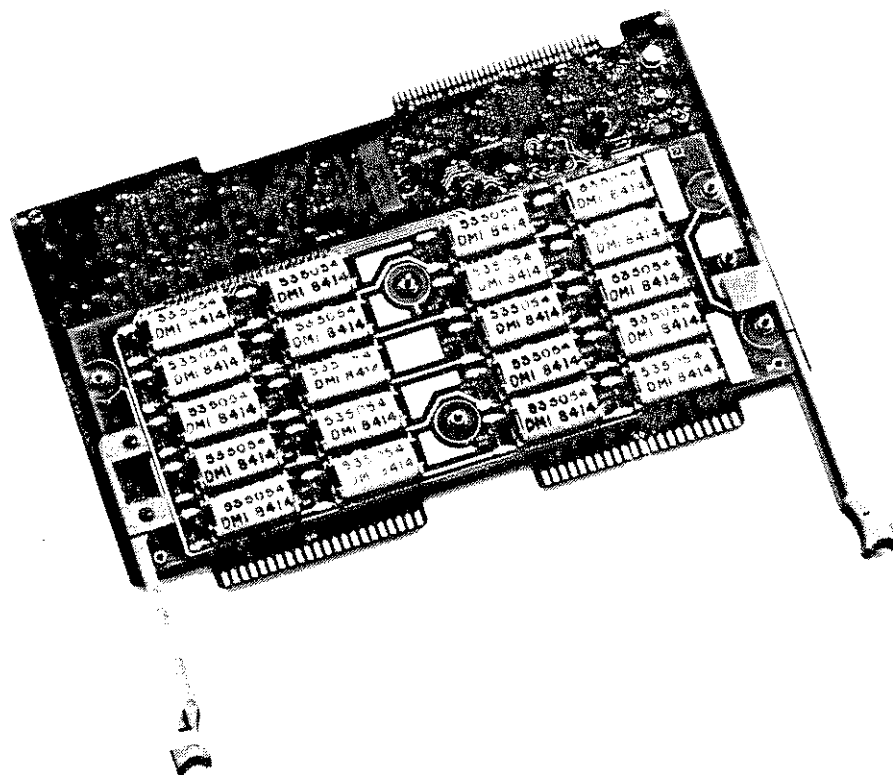

Figure 162-1. Thermocouple/DC Volts Scanner

162/Thermocouple/DC Volts Scanner

WHERE TO FIND MORE INFORMATION

This subsection of the System Guide presents information (description, specifications, installation) specifically related to the Thermocouple/DC Volts Scanner. Since other system hardware is used in most data logging functions, system operating instructions are not repeated here.

Where the Thermocouple/DC Volts Scanner is used in a specific data logging function, other sections of the System Guide provide more appropriate information. Examples include:

- o Section 5a: Temperature Measurement
This section discusses use of the Thermocouple/DC Volts Scanner (with Thermocouple Input Connector) in making thermocouple temperature measurements.
- o Section 5b: Voltage Measurement
Discusses measurements made with the Voltage Input Connector, AC Voltage Input Connector, or Thermocouple/DC Volts Input Connector attached to the Thermocouple/DC Volts Scanner.
- o Section 5c: Current Measurement
Use of the Current Input Connector with the scanner is discussed in this section.
- o Section 5d: Resistance Measurement
When the Transducer Excitation Module/Connector are used for stimulus of a resistance transducer, the Thermocouple/DC Volts Scanner is employed to measure the resulting dc voltage.
- o Section 5g: Strain Measurement
A strain gage constitutes a variable resistance transducer. With stimulus from the Transducer Excitation Module/Connector, resulting dc voltage measurement is accomplished with the Thermocouple/DC Volts scanner.

162/Thermocouple/DC Volts Scanner

The User Guide presents overall operating instructions for the Data Logger. Information is presented in a general, and not option-specific, format. The User Guide treats operation with various levels of complexity, depending on user familiarity with the instrument. Some acquaintance with the User Guide is recommended. For any operation-related question, the User Guide is the ultimate authority.

SPECIFICATIONS

Specifications for the Thermocouple/DC Volts Scanner are listed in Table 162-1.

Thermocouple accuracy specifications are detailed in the Appendices. These specifications apply when using the Thermocouple/DC Volts Scanner with the High Performance A/D Converter (Option 161) and the Isothermal Input Connector (Option 175).

Table 162-1. Thermocouple/DC Volts Scanner Specifications

Channels	20
Poles per Channel	3 (HI, LO, SHIELD)
Input Impedance	
64 mV and 512 mV Ranges	>200 megohm in parallel with 5600 pF
8V and 64V Ranges	10 megohm
Voltage Offset (max)	1 microvolt
Ranges and Displayed Resolution	
64 mV Range	1 uV
512 mV Range	10 uV
8V Range	100 uV
64V Range	1 mV

162/Thermocouple/DC Volts Scanner

Accuracy Determined by application.
See Accuracy sections:
 Temperature Measurement
 Using Thermocouples
 DC Voltage Measurement
 AC Voltage Measurement
 DC Current Measurement
 Strain Measurement

Zero Stability Automatic Zero

Input Isolation 250V dc or ac rms between
any two channels or any
channel and ground

Overload without Damage 250V dc or 250V ac rms

Common Mode Voltage (max) 250V dc or ac rms between
any 2 terminals or a
terminal and ground

Common Mode Rejection 170 dB at 50 Hz $\pm 0.1\%$
(with 100 ohm imbalance) 170 dB at 60 Hz $\pm 0.1\%$
160 dB at dc

Normal Mode Rejection 60 dB at 50 Hz $\pm 0.1\%$
or 60 Hz $\pm 0.1\%$

Temperature

 Operating -20 to 70°C

 Storage -55 to 75°C

Relative Humidity (without condensation)

 Below 25°C $\leq 95\%$

 25 to 40°C $\leq 75\%$

 40 to 50°C $\leq 45\%$

 50 to 70°C $\leq 40\%$

Altitude

 Non-Operating 40,000 feet

 Operating 10,000 feet

Shock and Vibration Meets MIL-T-28800C,
Class 5 Standards

162/Thermocouple/DC Volts Scanner

INSTALLATION

Physical

The Thermocouple/DC Volts Scanners (up to 5 per A/D Converter) are installed in the slot(s) directly below their associated A/D Converter. Install the Thermocouple/DC Volts Scanner using the following procedure:

WARNING

ENSURE THAT ALL LINE POWER TO THE MAINFRAME OR EXTENDER CHASSIS IS DISCONNECTED BEFORE STARTING THIS PROCEDURE. LETHAL VOLTAGES MAY BE PRESENT WITHIN THE 2280 SERIES DATA LOGGER AND ON SOME OPTION CARDS. DO NOT REMOVE ANY INSTRUMENT COVERS UNLESS YOU ARE QUALIFIED TO DO SO.

1. Turn the Power Keyswitch to the POWER OFF position.
2. From the rear of the Data Logger, identify the mounting slot(s) appropriate for the Thermocouple/DC Volts Scanner(s). A maximum of five scanners may be associated with one A/D Converter. All scanners must be positioned immediately below the associated A/D Converter. Any other serial link device (Counter/Totalizer, Digital I/O Assembly, Analog Output) must not interrupt this hierarchy.

CAUTION

For handling, use only the scanner board edges. Use of this technique avoids contamination with oil from the hands and minimizes the risk of damage by static discharge.

162/Thermocouple/DC Volts Scanner

3. Align the Thermocouple/DC Volts Scanner in the desired slot. The board-edge connector must face in (toward the motherboard).
4. Secure the scanner board in the slot. Push the board straight in until it makes contact with the motherboard connectors. Then continue pressing firmly until it is mated with these connectors. Ensure that the two plastic retainer clips (on either side of the board) snap into the slots on the chassis side wall.

NOTE

To extract the scanner board, first push the plastic retainer clips toward the center of the instrument. Then pull the assembly from the chassis.

Connections

Connections must be made between the Thermocouple/DC Volts Scanner and outside measurement points. These external connections are made through a connector card attached to the scanner card. Available connectors are:

- o Current Input Connector (option 171)
- o Isothermal Input Connector (option 175)
- o Voltage Input Connector (option 176)
- o AC Voltage Input Connector (option 160)

Refer to the appropriate option subsection for complete external connection instructions.

162/Thermocouple/DC Volts Scanner

INSTALLATION TEST

Use the following procedure to test the installation of the Thermocouple/DC Volts Scanner:

1. Prepare the A/D Converter for installation by setting the A/D Converter address switch to 0.
2. Install the A/D Converter in the 2280.
3. Install the Thermocouple/DC Volts Scanner (option 162) directly below the A/D Converter.
4. Apply power to the 2280.
5. Program the 2280 for a configuration list:

Press:	Display:
	MAIN MENU CHOICE <M FOR MENU>? A
L	<L> LIST PROGRAM AND CONFIGURATION
ENTER	L: LIST MENU CHOICE <A-Z>? E
C	L<C> LIST HARDWARE CONFIGURATION
ENTER	LISTING <PRESS EXIT TO ABORT>
	(list is printed)
EXIT	MAIN MENU CHOICE <M FOR MENU>? A

162/Thermocouple/DC Volts Scanner

6. Check the printed configuration list for correct hardware installation. Correct scanner installation yields a listing that identifies each associated channel block by beginning channel number and type. The following examples are possible:
 - o Example 1: Thermocouple/DC Volts Scanner installed with no connector. If a connector is not installed, the default type becomes VOLTS/CURRENT.

BEGINNING CHANNEL NUMBER = 0
TYPE = VOLTS/CURRENT
BEGINNING CHANNEL NUMBER = 10
TYPE = VOLTS/CURRENT
 - o Example 2: If the Scanner is not installed, no channel number and type listing appears.

PROGRAMMING

Programming for the Thermocouple/DC Volts Scanner involves procedures common to the 2280 Series Data Logger. The programming process is presented on the Programming Form and fully explained in the User Guide.

Instructions specific to the Thermocouple/DC Volts Scanner are found in the CHANNEL PROGRAM section of the Programming Form. Here, the voltage or current input range and the type of thermocouple can be selected.

SERVICE INFORMATION

Refer to the 2280 Series Service Manual for:

- o Theory of Operation
- o Performance Verification Procedure
- o Parts List
- o Schematic Diagram

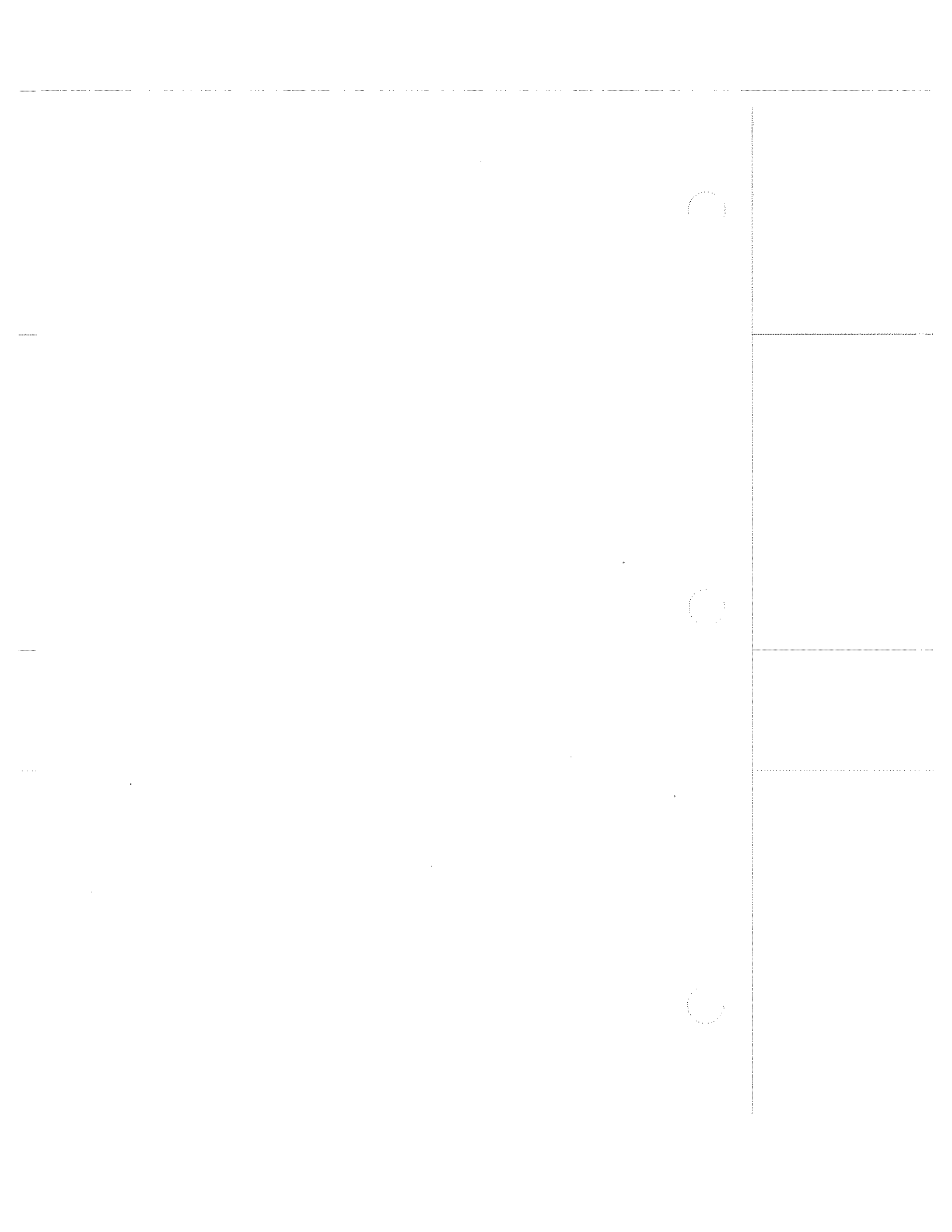

2280B-163
RTD/Resistance Scanner

INTRODUCTION

The RTD/Resistance Scanner is a 20-channel resistance measuring scanner. When used with the RTD/Resistance Connector (2280B-177), it can be used in the 2280 system to make measurements of resistances and variable resistance transducers. The RTD/Resistance Scanner is illustrated in Figure 163-1.

Resistance measurements are usually made to determine the value of some other parameter that they are directly related to, such as temperature. The 2280 software provides the ability to translate resistance measurements made on RTDs into appropriate temperature readings.

P/N 753046
February, 1985

163/RTD/Resistance Scanner

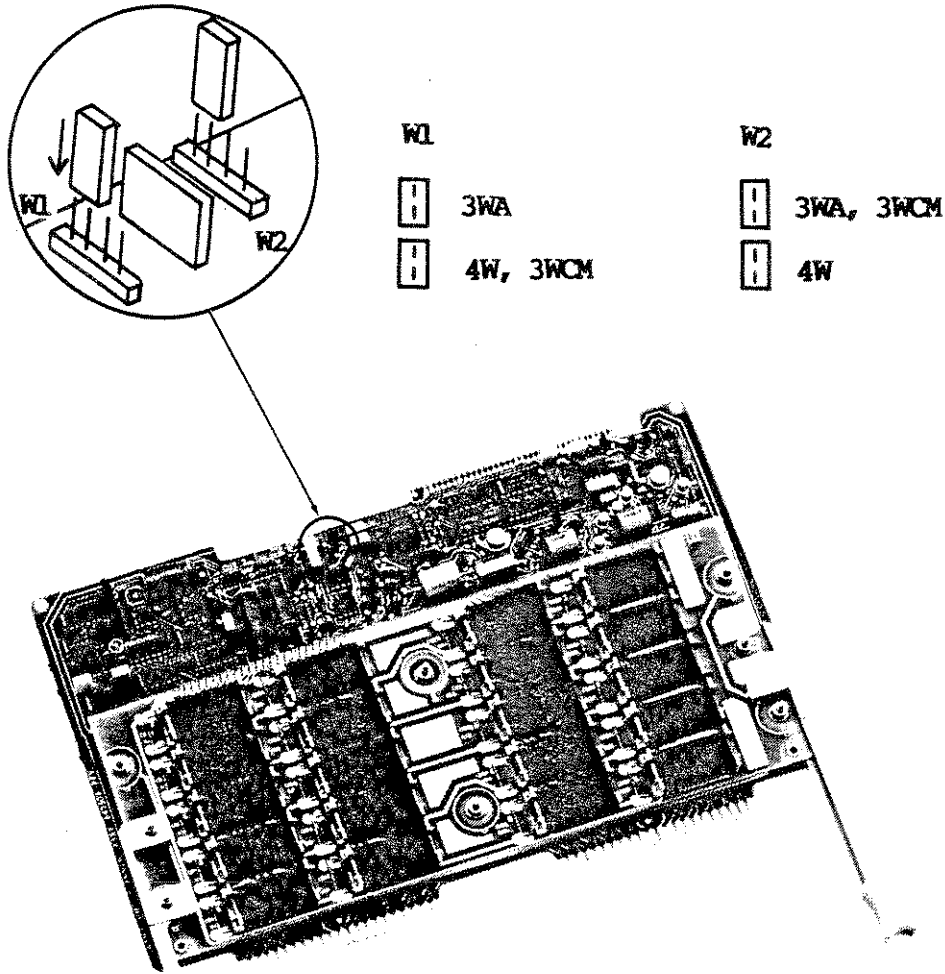

Figure 163-1. RTD/Resistance Scanner

163/RTD/Resistance Scanner

WHERE TO FIND MORE INFORMATION

This subsection of the System Guide presents description, installation, and specifications information specifically related to the RTD/Resistance Scanner.

Other sections in this manual provide more detailed information when the RTD/Resistance Scanner is to be used to implement a specific data logging function. Two sections are:

- o Section 5a: Temperature Measurement
This section discusses the use of the RTD/Resistance Scanner and Connector for measuring temperature with RTDs and thermistors.
- o Section 5d: Resistance Measurement
This section presents information helpful for making straight resistance measurements.

System operating instructions for the Data Logger are presented in the User Guide. The User Guide presents operation at various levels of complexity, to better match user familiarity with the instrument, and is the ultimate authority on operation-related questions.

SPECIFICATIONS

Specifications for the RTD/Resistance Scanner are presented in Table 163-1.

Specifications for the RTD/Resistance Input Connector can be found in the 177 option subsection (Section 4), while specifications that pertain to the use of both of these option assemblies together can be found in Appendix G of this manual.

163/RTD/Resistance Scanner

Table 163-1. Specifications

Channels	20
Poles per Channel	4 (HI EXCITATION, HI, LO, LO EXCITATION)
Common Return Poles	2 (LO COM for channels 0-9, LO COM for channels 10-19)
Measurement Modes (3)	4-Wire (4W) (no reed resistances in measurement path). 3-Wire Accurate (3WA) (no reed resistances in measurement path. Channels in a decade share a common return). 3-Wire Isolated (3WCM) (one reed resistance in measurement path).
Measurement Mode Selection	2 jumpers select scanner measurement mode
Current Sources	2 (1 mA, 32 uA)
Resistance Ranges, Resolution, and Excitation	
Range	256 ohm
Internal Resolution	2.4 megohm
Excitation	1 mA
Range	2048 ohm
Internal Resolution	19 megohm
Excitation	1 mA
Range	64 kilohm
Internal Resolution	0.6 ohm
Excitation	32 uA
Accuracy	Determined by application. See Accuracy sections: Temperature Measurement Using RTDs Resistance Measurement
Zero Stability	Automatic zero

163/RTD/Resistance Scanner

Input Channel Isolation

4-Wire (4W)	250V dc or ac rms between any two channels
3-Wire Accurate (3WA)	250V dc or ac rms between decades of channels
3-Wire Isolated (3WCM)	250V dc or ac rms between any two channels
Overload without Damage	30V dc or 24V ac rms between any two terminals of a channel
Common Mode Isolation	250V dc or ac rms between scanners, 250V dc or ac rms between decades of channels, 250V dc or ac rms between channels within a decade for 4-Wire (4W) and 3-Wire isolated (3WCM) measurement modes, 30V dc or 24V ac rms between any terminals in the same decade except between LO COM's for the 3-Wire Accurate (3WA) measurement mode

Temperature

Operating	-20 to 70°C
Storage	-55 to 75°C

Relative Humidity (without condensation)

Below 25°C	<= 95%
25 to 40°C	<= 75%
40 to 50°C	<= 45%
50 to 70°C	<= 40%

Altitude

Non-Operating	40,000 feet
Operating	10,000 feet
Shock and Vibration	Meets MIL-T-28800C, Class 5 Standards

163/RTD/Resistance Scanner

INSTALLATION

Mode Selection

One measurement mode, 4-Wire (4W), 3-Wire Accurate (3WA), or 3-Wire Isolated (3WCM), must be selected prior to physically installing the scanner. This choice is made through the two jumpers shown in Figure 163-1. The measurement modes are described in Sections 5a and 5d.

Physical

The RTD/Resistance Scanner(s), from one to five per A/D Converter, are installed in the slot(s) directly below the A/D Converter with which they are to work. This arrangement must be maintained in the 2280 mainframe and the 2281A Extender Chassis. Install each RTD/Resistance Scanner using the following procedure:

WARNING

ENSURE THAT ALL LINE POWER TO THE MAINFRAME OR EXTENDER CHASSIS IS DISCONNECTED BEFORE STARTING THIS PROCEDURE. LETHAL VOLTAGES MAY BE PRESENT WITHIN THE 2280 SERIES DATA LOGGER, THE 2281A EXTENDER CHASSIS, AND ON SOME OPTION CARDS. DO NOT REMOVE ANY INSTRUMENT COVERS UNLESS YOU ARE QUALIFIED TO DO SO.

1. Turn the Power Keyswitch to the POWER OFF position.

163/RTD/Resistance Scanner

2. From the rear of the Data Logger or Extender Chassis, identify the mounting slot(s) appropriate for the RTD/Resistance Scanner(s). A maximum of five RTD/Resistance or Thermocouple/DC Volts scanners in any combination may be associated with one A/D Converter. All scanners that are to work with an A/D Converter must be installed immediately below the A/D Converter. This order must not be interrupted by any other serial link device (such as the Counter/Totalizer, Digital I/O, or Analog Output.)

CAUTION

Only handle the scanner board by the edges, not including the gold fingers. This avoids contaminating the sensitive circuitry with oil from the hands while minimizing the risk of damage by static discharge.

3. Align the RTD/Resistance Scanner (component side up) in the desired slot, keeping the two plastic retainer handles located on both side edges pointed away from the motherboard.
4. Secure the scanner board in the slot, by pushing the board straight in until it makes contact with the motherboard connectors, and continuing to press firmly until the board mates fully with the connector. Ensure that the retainer handles snap into the slots on the chassis side wall.

NOTE

To extract the scanner board, first push or pull the plastic retainer handles away from the chassis sides.

163/RTD/Resistance Scanner

External Connections

Connections between the RTD/Resistance Scanner and outside measurement points are made through the RTD/Resistance Input Connector, which is attached to the rear of the scanner. Wiring from the external resistance to the connector terminals must be made while the connector is physically separated from the scanner. Refer to the RTD/Resistance Input Connector (option 177) subsection for complete external connection instructions.

INSTALLATION TEST

Use the following procedure to test for proper installation of the RTD/Resistance Scanner:

1. Ensure that power is not applied to the 2280.
2. Prepare the A/D Converter for installation by setting the A/D Converter address switch to 0.
3. Install the A/D Converter in the 2280.
4. Install the RTD/Resistance Scanner directly below the A/D Converter.
5. Install the RTD/Resistance Input Connector on the rear of the scanner.
6. Apply power to the 2280.

163/RTD/Resistance Scanner

7. Program the 2280 to list the hardware configuration as follows:

Press:	Display:
	MAIN MENU CHOICE <M FOR MENU>? A
L	<L> LIST PROGRAM AND CONFIGURATION
ENTER	L: LIST MENU CHOICE <A-Z>? E
C	L<C> LIST HARDWARE CONFIGURATION
ENTER	LISTING <PRESS EXIT TO ABORT> (list is printed)
EXIT	MAIN MENU CHOICE <M FOR MENU>? A

8. Check the printed configuration list for correct hardware installation. A RTD/Resistance Scanner installation should yield a listing that correctly identifies each decade of channels by beginning channel number and type. Look for the following:

```
BEGINNING CHANNEL NUMBER = 0  
TYPE = RTD  
BEGINNING CHANNEL NUMBER = 10  
TYPE = RTD
```

163/RTD/Resistance Scanner

PROGRAMMING

Programming the 2280 Series Data Logger to utilize the RTD/Resistance Scanner involves procedures common to other assemblies. This programming process fully explained in the User Guide, and is summarized on the Programming Form.

Instructions specific to the RTD/Resistance Scanner are listed in the CHANNEL PROGRAM section of the Programming Form. Several choices are available:

- o The RTD type associated with a channel can be programmed. If any of several common RTDs are selected, no further programming is necessary since the 2280 provides a stored set of applicable RTD constants.
- o If a user-defined RTD is associated with a given channel, unique R0, Alpha, Delta, and C4 RTD constants can be programmed.
- o Resistance measurement ranges can be selected. The following ranges are provided by the RTD/Resistance Scanner:

256.00 OHMS
2048.0 OHMS
64.000 KOHMS

OPERATION

Once installed in the data logger, the RTD/Resistance Scanner requires no further operator attention.

Use of the RTD/Resistance Scanner, in conjunction with the RTD/Resistance Input Connector, is described in more detail in sections 5a and 5d of this manual. Programming and operating capabilities that are fully documented in the User Guide.

163/RID/Resistance Scanner

SERVICE INFORMATION

The following additional information can be found in the 2280 Series Service Manual:

- o Theory of Operation
- o Performance Verification Procedure
- o Parts List
- o Schematic Diagram

2280A-164
Transducer Excitation Module

INTRODUCTION

The Transducer Excitation Module and the Transducer Excitation Connector (option 174) provide voltage or current excitation for variable resistance transducers. Multiple data logging functions (RTD temperature measurement, strain gage measurement, strain-based transducers measurement, and low resistance transducer measurement) can thereby be supported.

Measuring the voltage of the stimulated transducer is accomplished with other 2280 option assemblies. The Thermocouple/DC Volts Scanner (option 162) and either the Voltage Input Connector (option 176) or the Isothermal Input Connector (option 175) provide this measurement capability.

The Transducer Excitation Module is shown in Figure 164-1.

P/N 718510
February, 1985

164/Transducer Excitation Module

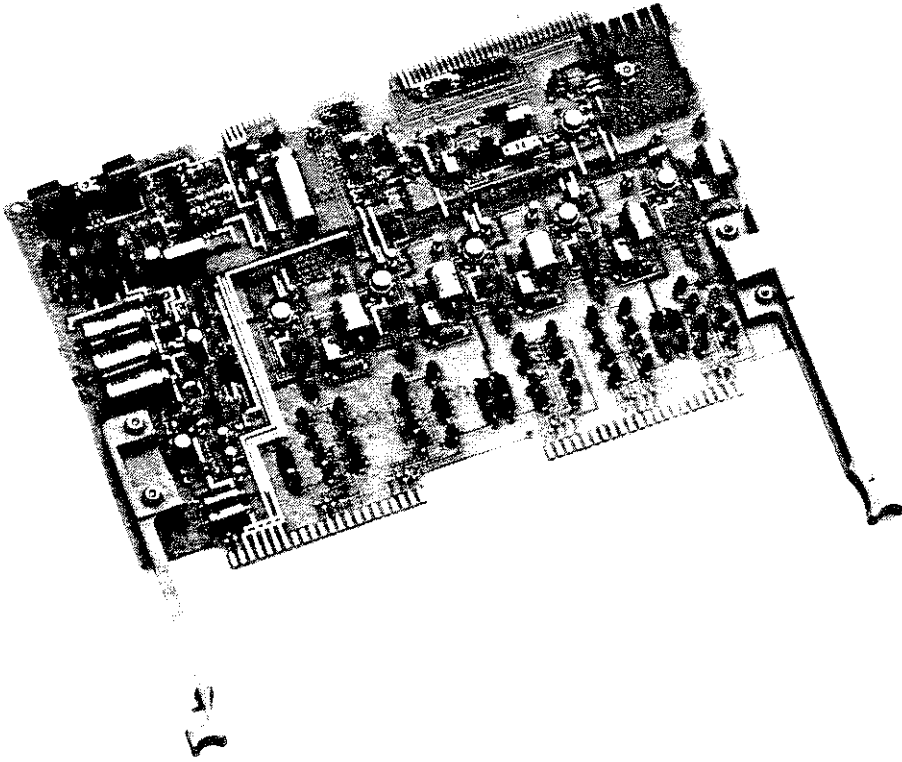

Figure 164-1. Transducer Excitation Module

164/Transducer Excitation Module

WHERE TO FIND MORE INFORMATION

This subsection of the System Guide presents information (description, specifications, installation) specifically related to the Transducer Excitation Module. Since other system hardware is used in most data logging functions, system operating instructions are not repeated here.

Where the Transducer Excitation Module is used in a specific data logging function, other sections of the System Guide provide more appropriate information. Examples include:

- o Section 5a: Temperature Measurement
This section discusses use of the Transducer Excitation Module and Connector in providing excitation for RTD temperature measurements.
- o Section 5d: Resistance Measurement
This section presents the overall view if a measurement expressed in ohms is desired.
- o Section 5g: Strain Measurement
This section discusses concepts and examples of strain measurement using the Transducer Excitation Module/Connector.

The User Guide presents overall operating instructions for the Data Logger. Information is presented in a general, and not option-specific, format. This volume treats operation with various levels of complexity, depending on user familiarity with the instrument. Some acquaintance with the User Guide is recommended. For any operation-related question, the User Guide is the ultimate authority.

164/Transducer Excitation Module

SPECIFICATIONS

Specifications for the Transducer Excitation Module are presented in Table 164-1.

Table 164-1. Transducer Excitation Module Specifications

Outputs	5 constant current sources 1 constant voltage source
Channels of Excitation	20, selectable in groups of 4 for either voltage or current outputs
Common Mode Voltage	No user-applied common mode voltage allowed. All sensors must be isolated.
4-Wire Resistance Measurements ..	5 constant current sources. Each source excites up to 4 transducers.
3-Wire Resistance and Strain Gage Measurements	Any combination of 1/4, 1/2, and/or Full Bridge strain gages or 3-wire RTDs with voltage excitation and user-supplied bridge completion resistors.
Current Excitation	
Excitation Current	1.0 mA
Accuracy	
Initial Setting	0.005%
Temperature 15 to 35°C	0.015%
Time since calibration ..	90 days
Temperature 15 to 35°C	0.030%
Time since calibration ..	1 year
Temperature -20 to 70°C ...	0.050%
Time since calibration ..	1 year
Temperature Coefficient (<15 or >35°C)	10 ppm per °C
Maximum Compliance Voltage ..	0.6V

164/Transducer Excitation Module

Voltage Excitation

Excitation Voltage switch selectable to 2.0V
dc or 4.0V dc

2 Volt Accuracy

Initial Setting 0.0025%

Temperature 15 to 35°C 0.03%

Time since calibration .. 90 days

Temperature 15 to 35°C 0.04%

Time since calibration .. 1 year

Temperature -20 to 70°C ... 0.05%

Time since calibration .. 1 year

4 Volt Accuracy

Initial Setting 0.0035%

Temperature 15 to 35°C 0.015%

Time since calibration .. 90 days

Temperature 15 to 35°C 0.030%

Time since calibration .. 1 year

Temperature -20 to 70°C ... 0.05%

Time since calibration .. 1 year

Temperature Coefficient

(<15 or >35°C) 7 ppm per °C

Maximum Current 250 mA

Accuracy Determined by application.
See the Accuracy
Specifications section.

Temperature

Operating -20 to 70°C

Storage -55 to 75°C

Relative Humidity (without condensation)

Below 25°C ≤ 95%

25 to 40°C ≤ 75%

40 to 50°C ≤ 45%

50 to 70°C ≤ 40%

Altitude

Non-Operating 40,000 feet

Operating 10,000 feet

Shock and Vibration Meets MIL-T-28800C,
Class 5 Standards

164/Transducer Excitation Module

Specifications for the Transducer Excitation Connector can be found in the related subsection (174). Other specifications pertain to use of the module and connector assemblies together. Such system-related specifications are presented in Appendix G of this manual.

INSTALLATION

Physical

The Transducer Excitation Module is installed directly below the associated Thermocouple/DC Volts Scanner in either the 2280 mainframe or the 2281A Extender Chassis. Use the following installation procedure:

WARNING

ENSURE THAT ALL LINE POWER TO THE MAINFRAME OR EXTENDER CHASSIS IS DISCONNECTED BEFORE STARTING THIS PROCEDURE. LETHAL VOLTAGES MAY BE PRESENT WITHIN THE 2280 SERIES DATA LOGGER, THE 2281A EXTENDER CHASSIS, AND ON SOME OPTION CARDS. DO NOT REMOVE ANY INSTRUMENT COVERS UNLESS YOU ARE QUALIFIED TO DO SO.

1. Turn the Power Keyswitch to the POWER OFF position.
2. From the rear of the Data Logger or Extender Chassis, identify the mounting slot(s) appropriate for the Transducer Excitation Module(s). Each module must occupy a slot immediately below the associated scanner. Any other serial link device (Counter/Totalizer, Digital I/O Assembly, Analog Output) must not interrupt this hierarchy.

164/Transducer Excitation Module

CAUTION

For handling, use only the board edges. Use of this technique avoids contamination with oil from the hands and minimizes the risk of damage by static discharge.

3. Align the Transducer Excitation Module in the desired slot. The board-edge connector must face in (toward the motherboard).
4. Secure the board in the slot. Push the board straight in until it makes contact with the motherboard connectors. Then continue pressing firmly until it is mated with these connectors. Ensure that the two plastic retainer clips (on either side of the board) snap into the slots on the chassis side wall.

NOTE

To extract the scanner board, first push the plastic retainer clips toward the center of the chassis.

External Connections

Connections must be made between the Transducer Excitation Module and the external resistance transducer. These external connections are made through the Transducer Excitation Connector, which is attached to the rear of the module. Wiring from the external resistance to the connector terminals must be made while the connector is physically separated from the scanner.

164/Transducer Excitation Module

The connector provides screw terminal connections for 20 channels. RTD channels each require four terminal connections. Strain gage channels require up to five terminals each.

Channels can be connected in blocks of four, allowing a mixture of RTD and strain gage connections to the same Transducer Excitation Connector.

Refer to the Transducer Excitation Connector option subsection (174) for complete external connection instructions.

INSTALLATION TEST

Use the following procedure to test for proper installation of the Transducer Excitation Module:

1. Ensure that power is not applied to the 2280.
2. Prepare the A/D Converter for installation by setting the A/D Converter address switch to 0.
3. Install the A/D Converter in the 2280.
4. Install a Thermocouple/DC Volts Scanner directly below the A/D Converter.
5. Install the Transducer Excitation Connector directly below the associated Thermocouple/DC Volts Scanner.
6. Install the Transducer Excitation Connector (option 174) on the rear of the module.
7. Apply power to the 2280.

164/Transducer Excitation Module

8. Program the 2280 to list the hardware configuration as follows:

Press:	Display:
	MAIN MENU CHOICE <M FOR MENU>? A
L	<L> LIST PROGRAM AND CONFIGURATION
ENTER	L: LIST MENU CHOICE <A-Z>? E
C	L<C> LIST HARDWARE CONFIGURATION
ENTER	LISTING <PRESS EXIT TO ABORT>
	(list is printed)
EXIT	MAIN MENU CHOICE <M FOR MENU>? A

9. Check the printed configuration list for correct hardware installation. A Transducer Excitation Module/Connector installation should yield a listing that correctly identifies each decade of channels by beginning channel number and type. Look for the following:

- o Example 1: Transducer Excitation Module installed.

```
BEGINNING CHANNEL NUMBER = 20
TYPE = TRANSDUCER EXCITATION
BEGINNING CHANNEL NUMBER = 30
TYPE = TRANSDUCER EXCITATION
```

- o Example 2: If the Transducer Excitation Module is not installed, no channel number and type listing appears.

164/Transducer Excitation Module

PROGRAMMING

Voltage or current excitation is manually selected through positioning of jumper assemblies on the Transducer Excitation Connector. This is not a programming function.

Measurement is a programming function and is accomplished by selecting an appropriate dc voltage range.

Programming with the Transducer Excitation module also depends on the type of measurement application. Programming instructions are presented in the appropriate area of Section 5. Briefly, these areas are:

- o Section 5a: Temperature Measurement
3-Wire and 4-Wire connections are supported for RTD or thermistor measurement.
- o Section 5d: Resistance Measurement
Although 3-wire or 4-wire connections for resistance measurement are the same as for RTD measurement, different programming entries are required.
- o Section 5g: Strain Measurement
This section covers the programming steps required for 1/4, 1/2, or full bridge configurations. A total of six configurations are possible.

Other programming for the Transducer Excitation Module involves procedures common to the 2280 Series Data Logger. The programming process is presented on the Programming Form and fully explained in the User Guide.

164/Transducer Excitation Module

OPERATION

Once installed in the data logger, the Transducer Excitation Module requires no further operator attention.

Use of the Transducer Excitation Module (in conjunction with the Transducer Excitation Module) is described in Section 5 of this manual (temperature, resistance, or strain measurement). In addition, the data logger offers a wide range of programming and operating features that are fully documented in the User Guide.

SERVICE INFORMATION

The following additional information can be found in the 2280 Series Service Manual:

- o Theory of Operation
- o Performance Verification Procedure
- o Calibration/Adjustment Procedure
- o Parts List
- o Schematic Diagram

2280B-167
Counter/Totalizer Assembly

INTRODUCTION

The Counter/Totalizer is a six-channel measurement option that supports two functions: event counting and frequency. The Counter/Totalizer can be installed in either the 2280B mainframe or the 2281A extender chassis. The assembly is shown in Figure 167-1.

WHERE TO FIND MORE INFORMATION

This subsection of the System Guide presents the description, specifications, and installation instructions for the Counter/Totalizer. Application instructions for the Counter/Totalizer are found in the following sections of the Guide:

- o Section 5e: Frequency Measurement
- o Section 5f: Totalizing Measurement

The User Guide presents complete operating instructions for the data logger. Information is presented in a general, not option-specific, format. Some acquaintance with the User Guide is recommended for understanding the information in this volume. For any operation-related question, the User Guide is the final authority.

P/N 753053
September, 1985

167/Counter/Totalizer Assembly

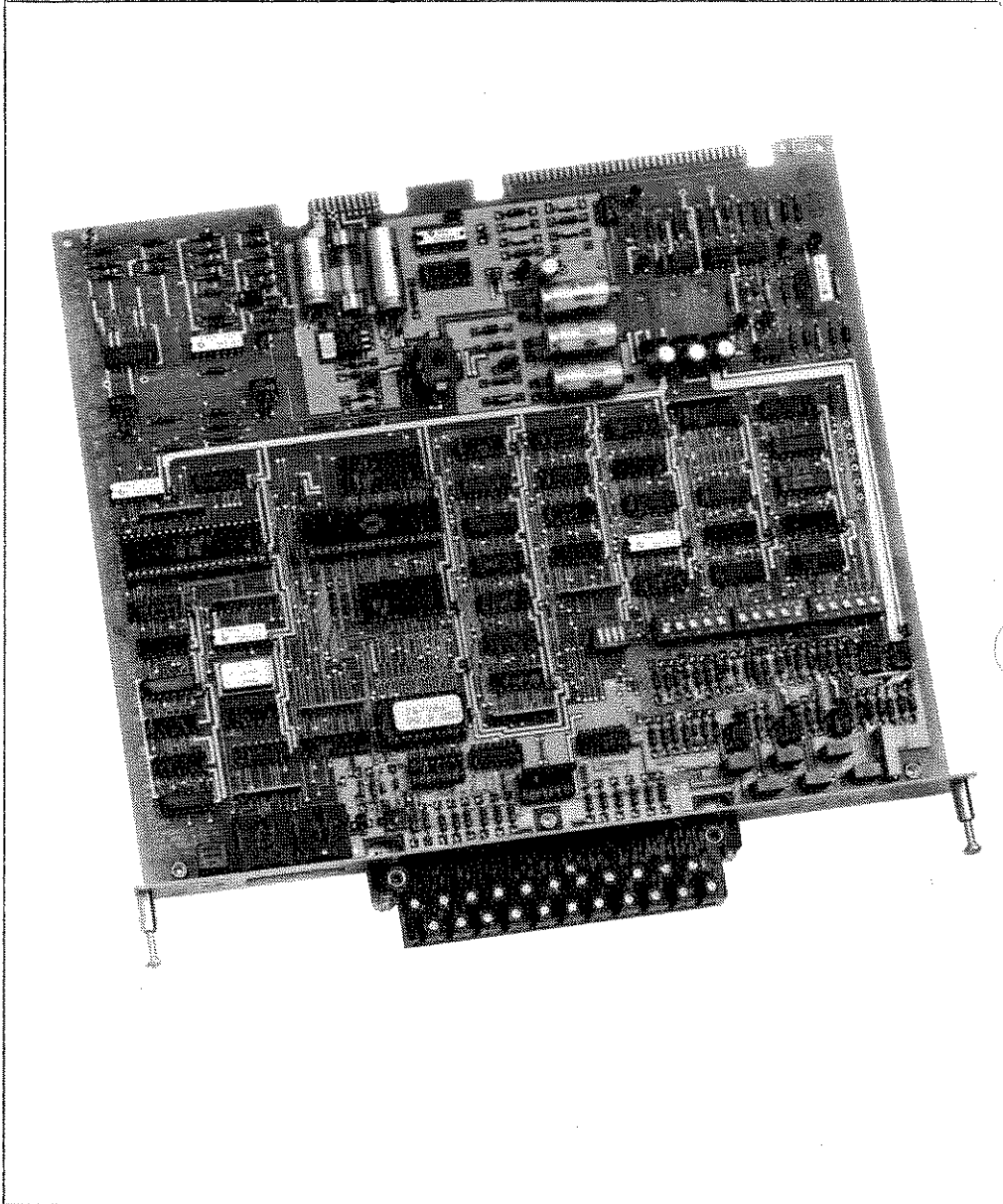

Figure 167-1. Counter/Totalizer Assembly

167/Counter/Totalizer Assembly

SPECIFICATIONS

Specifications for the Counter/Totalizer are presented in Table 167-1.

Table 167-1. Counter/Totalizer Specifications

Channels	6
Functions	Event counting and frequency measurement selectable by channel pairs
Timebase	
Frequency	10 MHz
Accuracy	$\pm 0.01\%$
Input Signals	
Types.....	TTL, CMOS, contacts, and analog waveforms
Minimum Pulse Width	1.25 microseconds
Minimum Signal Amplitude..	175 mV rms
Maximum Signal Amplitude..	0.5V p-p sine wave 0.35V p-p square wave
Adjustments	$\pm 15V$ dc or ac peak Signal threshold, deadband, and contact debounce
Frequency Measurement	
Minimum Frequency	2 Hz
Maximum Frequency	400 kHz
Accuracy	Timebase accuracy ± 1 display digit
Totalizing Measurement	
Maximum Counts	8,388,607
Counting Rate	dc to 400 kHz
Operation	Count is reset after each scan
Isolation	30V dc or ac rms between any terminal and ground. No isolation between channels.
Power Consumption	4.0 watts maximum

167/Counter/Totalizer Assembly

Temperature

Operating -20 to 70 degrees Celsius
Storage -55 to 75 degrees Celsius

Relative Humidity (without condensation)

Below 25 degrees Celsius $\leq 95\%$
25 to 40 degrees Celsius $\leq 75\%$
40 to 50 degrees Celsius $\leq 45\%$
50 to 70 degrees Celsius $\leq 40\%$

Altitude

Non-Operating 40,000 feet
Operating 10,000 feet

Shock and Vibration Meets MIL-T-28800C, Class 5
Standards

INSTALLATION

Adjustments

Switches on the Counter/Totalizer assembly select the function of each channel. The assembly also has adjustments that allow it to measure various signal types:

- o The reference voltage and input deadband are adjustable. These adjustments define the high and low voltage thresholds of the input.
- o Debouncers and input pull-ups allow the Counter/Totalizer to count contact closures.

The intended measurements, either frequency or totalizing, determine the adjustments needed on the Counter/Totalizer assembly. The setup instructions are found in Sections 5e and 5f of the System Guide. Refer to these sections to make the necessary adjustments during installation of the assembly.

167/Counter/Totalizer Assembly

Physical

The Counter/Totalizer can be installed in either the 2280B mainframe or the 2281A extender chassis.

WARNING

ENSURE THAT ALL LINE POWER TO THE MAINFRAME OR EXTENDER CHASSIS IS DISCONNECTED. LETHAL VOLTAGES MAY BE PRESENT WITHIN THE 2280 AND ON SOME OPTION CARDS. DO NOT REMOVE ANY INSTRUMENT COVERS UNLESS YOU ARE QUALIFIED TO DO SO.

1. Turn the Power Keyswitch to the POWER OFF position. If the Counter/Totalizer is being installed in a 2281A, verify that the POWER indicator is off.
2. Align the assembly with one of the slots in the back of the instrument. Orient the assembly with the component side up.
3. Slide the assembly into the chassis and press firmly until it is seated in the connectors. Secure the assembly in the chassis using the two rear panel retaining screws.

Channel Decade Selection

The channel decade switches on the Counter/Totalizer determine the channel numbers assigned to the assembly. The switches are accessible through the Counter/Totalizer rear panel. The channel decade switches select the channel numbers as shown in the following example:

167/Counter/Totalizer Assembly

SWITCH SETTING		CHANNELS ASSIGNED TO ASSEMBLY
HUNDREDS	TENS	
0	0	0 to 5
0	1	10 to 15
0	2	20 to 25
0	3	30 to 35
.	.	.
9	9	990 to 995
.	.	.
14	9	1490 to 1495

Note that position 15 of the hundreds switch is not allowed. If the hundreds switch is set to position 15, the assembly will not respond to any data logger commands.

Connections

The individual channels on the Counter/Totalizer assembly are not electrically isolated from each other. However, the entire card is isolated from chassis ground.

WARNING

ENSURE THAT ALL LINE POWER TO THE MAINFRAME OR EXTENDER CHASSIS IS DISCONNECTED. LETHAL VOLTAGES MAY BE PRESENT WITHIN THE 2280 AND ON SOME OPTION CARDS. DO NOT REMOVE ANY INSTRUMENT COVERS UNLESS YOU ARE QUALIFIED TO DO SO.

1. With line power disconnected and the POWER Keyswitch set to POWER OFF, locate the 22-pin screw terminal connector on the Counter/Totalizer at the rear panel of the instrument.

167/Counter/Totalizer Assembly

2. Remove the two retaining screws that hold the connector to the rear panel. Remove the connector from the Counter/Totalizer assembly.

WARNING

BE SURE THAT THE WIRES BEING CONNECTED ARE NOT ENERGIZED. IF POSSIBLE, DISCONNECT THESE WIRES AT THE OTHER END. IN ANY EVENT, ENSURE THAT THE EXTERNAL CIRCUIT CONNECTED TO THESE WIRES IS NOT ENERGIZED. LETHAL VOLTAGE COULD OTHERWISE BE ENCOUNTERED.

3. Each channel requires two connections, INPUT and RETURN. The terminal assignments for each channel are listed on the Counter/Totalizer rear panel. The THRESHOLD OUT and VAR REF VOLT OUT terminals are used to adjust the input threshold voltages. Refer to Sections 5e and 5f of the System Guide for instructions on setting the threshold levels for frequency and totalizing measurements.

CAUTION

Since individual channels are not isolated from each other, all RETURN terminals are connected together on the Counter/Totalizer assembly. All RETURN wires must be at the same voltage.

4. For each terminal, loosen the appropriate screw, insert the external wire into the connector, and tighten the screw until the wire is secured.
5. Install the wired connector on the Counter/Totalizer assembly, and secure the connector to the rear panel with the two retaining screws.

167/Counter/Totalizer Assembly

INSTALLATION TEST

To verify proper installation of the Counter/Totalizer, program the 2280 to list the hardware configuration as follows:

Press	Display
--	MAIN MENU CHOICE <M FOR MENU>? A
L	<L> LIST PROGRAM AND CONFIGURATION
ENTER	L: LIST MENU CHOICE <A-Z>? E
C	L<C> LIST HARDWARE CONFIGURATION
ENTER	LISTING <PRESS EXIT TO ABORT>
	(list is sent to printer)
EXIT	MAIN MENU CHOICE <M FOR MENU>? A

Check the printed configuration for the correct hardware installation. The channel type is determined by the function switch setting on the Counter/Totalizer. A typical listing is as follows:

```
BEGINNING CHANNEL NUMBER = 0
TYPE = FREQUENCY INPUT
BEGINNING CHANNEL NUMBER = 1
TYPE = FREQUENCY INPUT
BEGINNING CHANNEL NUMBER = 2
TYPE = COUNT INPUT
BEGINNING CHANNEL NUMBER = 3
TYPE = COUNT INPUT
BEGINNING CHANNEL NUMBER = 4
TYPE = FREQUENCY INPUT
BEGINNING CHANNEL NUMBER = 5
TYPE = FREQUENCY INPUT
```

167/Counter/Totalizer Assembly

PROGRAMMING

The only programming needed for each Counter/Totalizer channel is to select the function (counter/totalizer) and the function type (either counts or frequency) in the channel programming menu. Refer to the User Guide for a complete description of the data logger programming menus.

OPERATION

Sections 5e and 5f of the System Guide describe how to use the Counter/Totalizer for frequency and totalizing measurements. Once the assembly is installed in the data logger, it requires no further operator attention.

SERVICE INFORMATION

The following additional information can be found in the 2280 Series Service Manual:

- o Theory of Operation
- o Performance Test
- o Parts List
- o Schematic Diagram

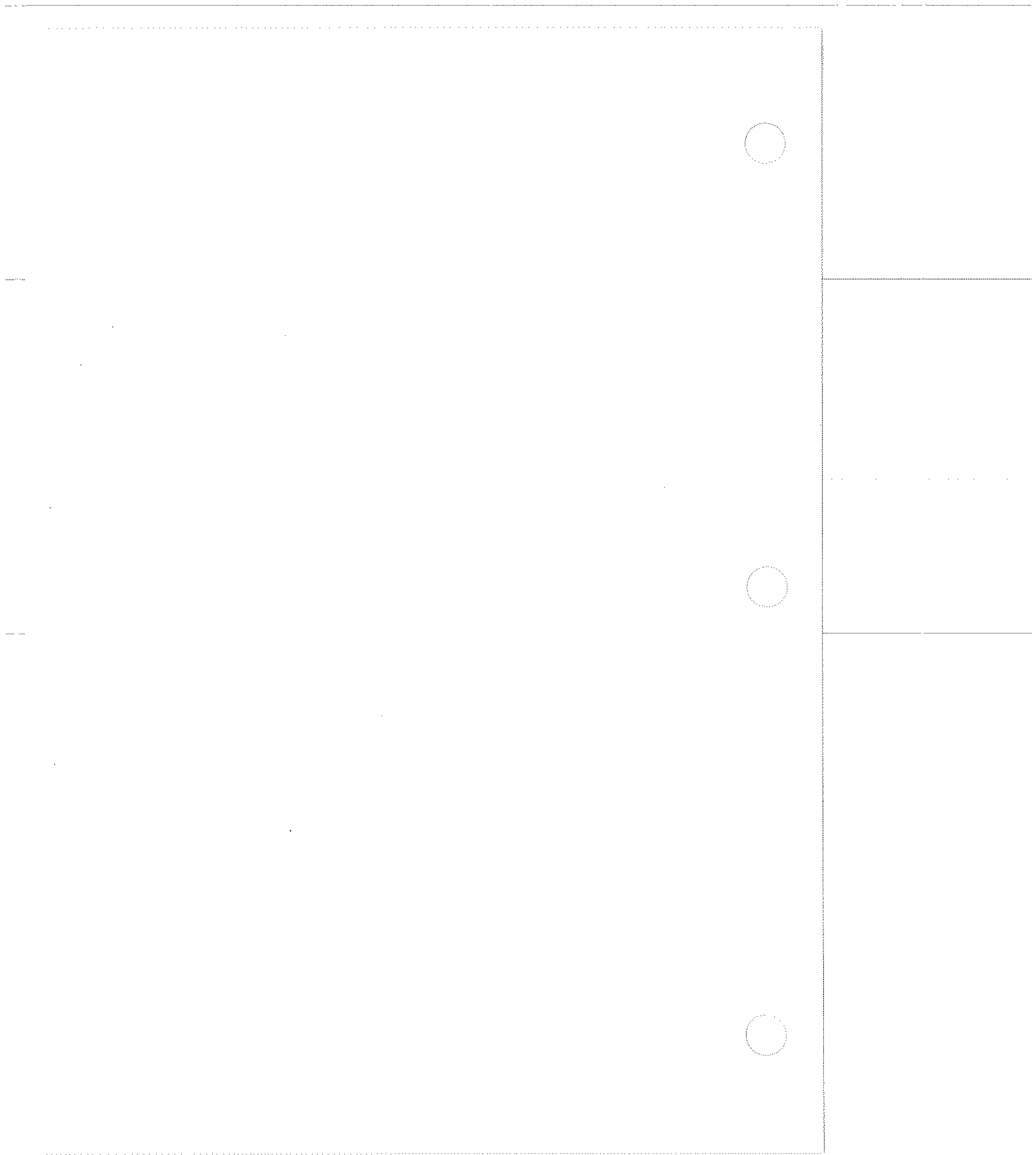

2280A-168
Digital I/O Assembly

INTRODUCTION

The Digital Input/Output Board allows the 2280 Series Data Logger to exchange information with a digital peripheral device. The type of exchange (input or output) allowed is determined by jumpers on the associated input or output connector. The four types of exchange are:

- o Alarm or Status Output
- o Status Input
- o BCD Input
- o Binary Input

The Digital I/O Assembly is illustrated in Figure 168-1.

The Digital I/O Assembly provides for information inputs or outputs. A separate connector must be installed for either type of information exchange.

- o For alarm or status outputs, the Digital I/O Board is used with a properly configured Status Output Connector. Refer to the option 169 subsection when configuring the Status Output Connector with the Digital I/O Board.

P/N 647677, Rev 1
February, 1985

168/Digital I/O Assembly

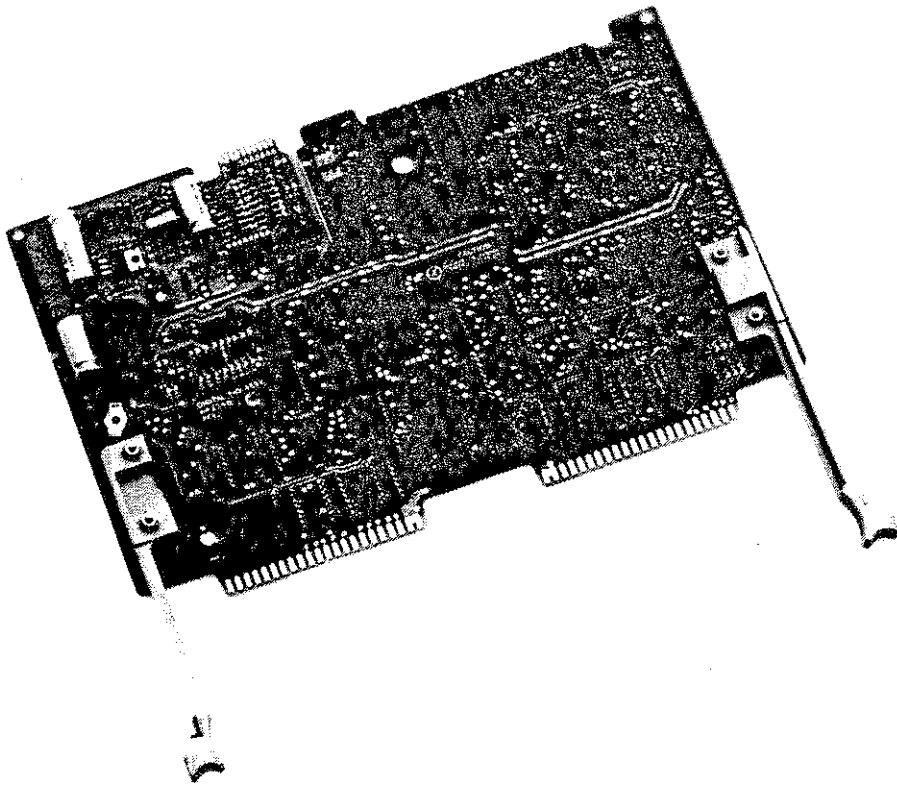

Figure 168-1. Digital I/O Assembly

168/Digital I/O Assembly

- o For status inputs, bcd inputs, or binary inputs, a Digital/Status Input Connector must be configured and used with the Digital I/O Board. Also, these digital input devices depend on a handshake procedure to accept data. Refer to the option 179 subsection when configuring the Digital/Status Input Connector with the Digital I/O Board.

WHERE TO FIND MORE INFORMATION

This subsection of the System Guide presents information (description, specifications, installation) specifically related to the Digital I/O Assembly. Since other system hardware is employed in most data logging functions, system operating instructions are not repeated here.

Additional information for related option assemblies (Status Output Connector and Digital/Status Input Connector) is presented elsewhere in this section. Related data logging functions are described in the following subsections:

- o Section 5h: Data/Status Input
- o Section 5i: Status Output

The User Guide presents complete operating instructions for the Data Logger. Information is presented in a general, and not option-specific, format. This volume treats operation with various levels of complexity, depending on user familiarity with the instrument. Some acquaintance with the User Guide is recommended. For any operation-related question, the User Guide is the ultimate authority.

168/Digital I/O Assembly

SPECIFICATIONS

Specifications for the Digital I/O Board are presented in Table 168-1.

Table 168-1. Digital I/O Specifications

Isolation	30V dc or ac rms between any terminal and ground.
Inputs	
Channels	20 single bit, or one 5 BCD digit word, or one 17-bit binary word
Type	Low Power Schottky TTL
Maximum Input Voltage	6V
Outputs	
Channels	20 single bit
Type	Open-collector, diode clamped, NPN transistors
Output Drive	100 mA with 1V drop
Maximum Voltage on Output ...	30V dc
Temperature	
Operating	-20 to 70°C
Storage	-55 to 75°C
Relative Humidity (without condensation)	
Below 25°C	<= 95%
25 to 40°C	<= 75%
40 to 50°C	<= 45%
50 to 70°C	<= 40%
Altitude	
Non-Operating	40,000 feet
Operating	10,000 feet
Shock and Vibration	Meets MIL-T-28800C, Class 5 Standards

INSTALLATION

WARNING

ENSURE THAT ALL LINE POWER TO THE 2280 SERIES MAINFRAME OR 2281A EXTENDER CHASSIS IS DISCONNECTED BEFORE STARTING THIS PROCEDURE. LETHAL VOLTAGES MAY BE PRESENT WITHIN EITHER UNIT AND ON SOME OPTION CARDS. DO NOT REMOVE ANY INSTRUMENT COVERS UNLESS YOU ARE QUALIFIED TO DO SO.

Addressing

Each Digital I/O Board must be assigned a unique numeric address. The numeric address is derived from the first channel number within the associated channel block. Dividing this channel number by 10 yields the numeric address. For example, for the channel block beginning with channel 200, the first channel (200) divided by 10 is 20 (the address).

Use the following procedure:

1. With line power disconnected, locate the address switches in the rear left corner of the Digital I/O Board.
2. Access the address switches by removing the Input (or Output) Connector from the Digital I/O Board.
3. Position the address switches to the desired numeric address setting. An appropriate setting corresponds to the block of channels being used.

Addressing depends somewhat on channel use for Status I/O or Digital Input. The following paragraphs define the differences.

168/Digital I/O Assembly

STATUS I/O

Status input/output addresses each specify a block of 20 channels. For maximum utilization of available channels, only even addresses should be used. Odd addresses, while possible, result in fewer available channels.

Channel Block: 0 - 19	Address Equals:	0 0
20 - 39		0 2
40 - 59		0 4
60 - 79		0 6
80 - 99		0 8
100 - 119		1 0
120 - 139		1 2
.		.
.		.
680 - 699		6 8
1000 - 1019		1 0 0
.		.
.		.
1400 - 1419		1 4 0
1480 - 1499		1 4 8

168/Digital I/O Assembly

DIGITAL INPUT

When used for BCD or binary word inputs, each address specifies a block of 10 channels. Therefore, odd or even addresses can be used without affecting channel utilization. But only the first (of the ten channels) is available for a digital input. The remaining nine are available for pseudo channels use only.

Channel Block: 0 - 9	Address Equals:	0 0
10 - 19		0 1
20 - 29		0 2
.		.
.		.
110 - 119		1 1
1030 - 1039		1 0 3
.		.
.		.
1400 - 1409		1 4 0
1490 - 1499		1 4 9

Communication Format

As shown above, each Digital I/O Board supports either 20 channels of status input/output or one channel of binary or BCD input.

If a Digital/Status Input Connector (option 179) is used with the Digital I/O Board, jumpers must be installed on the connector to configure the Digital I/O Board as desired. These instructions are presented in the option 179 subsection of this manual.

168/Digital I/O Assembly

Physical

The Digital Input/Output Board is installed in any one of the available option I/O slots in the 2280 Series Mainframe or 2281A Extender Chassis. Install the board as follows:

1. Verify that power is OFF.

CAUTION

Handle the board by its edges to minimize the risk of damage by static discharge.

2. From the rear of the instrument, align the Digital I/O board in the desired slot. The board-edge connector must be facing the motherboard.
3. Secure the board in position. Push the board straight in until it is mated with the motherboard connectors. Verify that the plastic retainers snap into place as the connector mates.

INSTALLATION TEST

Use the following procedure to test for proper installation of the Digital I/O Assembly:

1. Ensure that power is not applied to the 2280.
2. Set the Digital I/O Assembly address switch to 04.
3. Install the Digital I/O Assembly in the 2280.
4. Apply power to the 2280.

168/Digital I/O Assembly

5. Program the 2280 to list the hardware configuration as follows:

Press:	Display:
	MAIN MENU CHOICE <M FOR MENU>? A
L	<L> LIST PROGRAM AND CONFIGURATION
ENTER	L: LIST MENU CHOICE <A-Z>? E
C	L<C> LIST HARDWARE CONFIGURATION
ENTER	LISTING <PRESS EXIT TO ABORT> (list is printed)
EXIT	MAIN MENU CHOICE <M FOR MENU>? A

6. Check the printed configuration list for correct hardware installation. A Digital I/O Assembly installation should yield a listing that correctly identifies the channel block and type of I/O. Look for the following:

```
BEGINNING CHANNEL NUMBER = 40
TYPE = STATUS OUTPUT
BEGINNING CHANNEL NUMBER = 50
TYPE = STATUS OUTPUT
```

PROGRAMMING

Programming for the Digital I/O Assembly involves selection of the function (status input, status output, or digital input) through the Channel Program module (summarized on the Programming Form). For status inputs or outputs, special zero and non-zero designations can also be defined.

168/Digital I/O Assembly

OPERATION

Once installed in the data logger (or extender chassis) with the appropriate address setting, the Digital I/O board is ready for use. Complete the external wiring connections necessary to provide the Digital I/O Board with digital inputs. This is done using one of the connectors available for digital inputs: the Digital/Status Input Connector (Option - 179) or the Status Output Connector (Option -169).

SERVICE INFORMATION

The following additional information can be found in the 2280 Series Service Manual:

- o Theory of Operation
- o Performance Verification Procedure
- o Parts List
- o Schematic Diagram

2280A-169
Status Output Connector

INTRODUCTION

The Status Output Connector can send 20 single-bit output signals from the Digital I/O board to external control points or terminals. Each output is individually selectable and can be used either to drive lamps and relays or change logic levels.

The Status Output Connector is mounted to the 44-pin card-edge connector on the left, rear side of the Digital I/O Board. The connector assembly is enclosed in a plastic housing, allowing protection for the terminal connections and strain relief for the external wiring. The Status Output Connector is illustrated in Figure 169-1.

WHERE TO FIND MORE INFORMATION

This subsection of the System Guide presents information (description, specifications, installation) specifically related to the Status Output Connector. Since other system hardware is used in most data logging functions, system operating instructions are not repeated here. Status Output applications are discussed in Section 5i of this manual.

P/N 647685, Rev 1
February, 1985

169/Status Output Connector

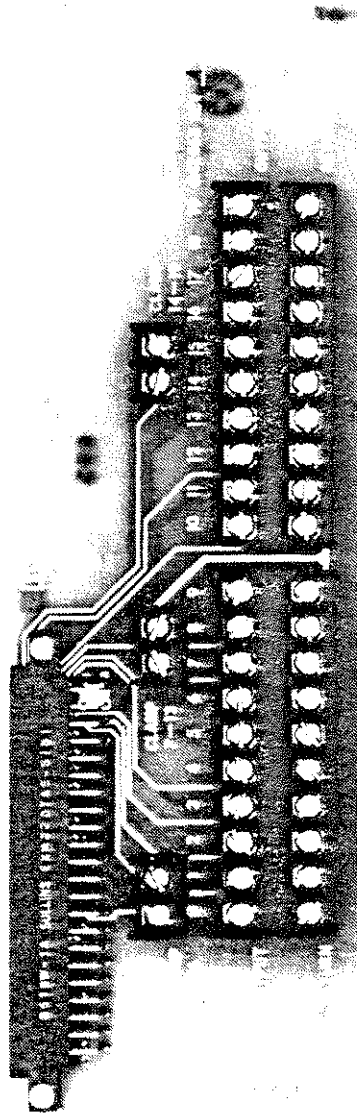

Figure 169-1. Status Output Connector

169/Status Output Connector

The User Guide presents complete operating instructions for the Data Logger. Information is presented in a general, and not option-specific, format. This volume treats operation with various levels of complexity, depending on user familiarity with the instrument. Some acquaintance with the User Guide is recommended. For any operation-related question, the User Guide is the ultimate authority.

SPECIFICATIONS

Specifications for the Status Output Connector are presented in Table 169-1.

Table 169-1. Status Output Connector Specifications

Outputs	20
Terminals	2 per channel
Compatibility	Connects to Digital I/O (option 168)
Temperature	
Operating	-20 to 70°C
Storage	-55 to 75°C
Relative Humidity (without condensation)	
Below 25°C	<= 95%
25 to 40°C	<= 75%
40 to 50°C	<= 45%
50 to 70°C	<= 40%
Altitude	
Non-Operating	40,000 feet
Operating	10,000 feet
Shock and Vibration	Meets MIL-T-28800C, Class 5 Standards

169/Status Output Connector

INSTALLATION

Connections from external control points or terminals to the 2280 Series Data Logger are made via external wiring to the Status Output Connector. Preparation of the Status Output Connector involves opening the connector housing, connecting the appropriate wiring on the terminals, closing the connector housing, and reconnecting it to the Digital I/O Board. The following steps detail this procedure:

WARNING

ENSURE THAT ALL LINE POWER TO THE MAINFRAME OR EXTENDER CHASSIS IS DISCONNECTED. LETHAL VOLTAGES MAY BE PRESENT WITHIN THE 2280 AND ON SOME OPTION CARDS. DO NOT REMOVE ANY INSTRUMENT COVERS UNLESS YOU ARE QUALIFIED TO DO SO.

1. With line power disconnected and the POWER switch set at OFF, locate the connector housing in the rear panel of the 2280.
2. Remove the two retaining screws that hold the housing assembly to the chassis.
3. Firmly grasp the housing at each end and pull until the enclosed connector block is disconnected from the Digital I/O Board.
4. Open the housing by gently pressing each locking tab.

169/Status Output Connector

WARNING

BE SURE THAT THE WIRES BEING CONNECTED ARE NOT ENERGIZED. IF POSSIBLE, DISCONNECT THESE WIRES AT THE OTHER END. IN ANY EVENT, ENSURE THAT THE EXTERNAL CIRCUIT CONNECTED TO THESE WIRES IS NOT ENERGIZED. LETHAL VOLTAGE COULD OTHERWISE BE ENCOUNTERED.

5. Starting at channel 0, attach the external wiring for the desired application. To make the attachments, loosen the channel terminal screws, attach the external wires to the screws, and tighten the screws until the wires are firmly in place. Notice that the two terminals for each channel are marked OUTPUT and RETURN.

NOTE

If the Digital I/O Board is also being used as a relay driver, the flyback diode terminals on the Status Output Connector must be used to suppress the voltage spike that is generated when the relay coil is shut off. The flyback diodes are connected to different channel blocks on the 20-channel Status Output Connector and are marked: CLAMP 0-6, CLAMP 7-13, and CLAMP 14-19. The 20 output channels may be protected by connecting the proper pin to the coil voltage of the relays being driven. See Figures 169-2 and 169-3. Users wishing to drive relays at varying coil voltages with a single group of channels should provide flyback protection using discrete components.

169/Status Output Connector

6. Close the connector housing, ensuring that external wires exit the rear unobstructed.

WARNING

BEFORE INSTALLING THE WIRED STATUS OUTPUT CONNECTOR AT THE 2280 REAR PANEL, ENSURE THAT ALL LINE POWER TO THE MAINFRAME OR EXTENDER CHASSIS IS DISCONNECTED. LETHAL VOLTAGES MAY BE PRESENT WITHIN THE 2280 AND ON SOME OPTION CARDS. DO NOT REMOVE ANY INSTRUMENT COVERS UNLESS YOU ARE QUALIFIED TO DO SO.

7. Position the assembled Status Output Connector in the guides of the 2280 rear panel slot containing the Digital I/O Board.
8. Push the Status Output Connector in firmly until it mates with the Digital I/O Board.
9. Attach the connector housing to the chassis with the two retaining screws.

169/Status Output Connector

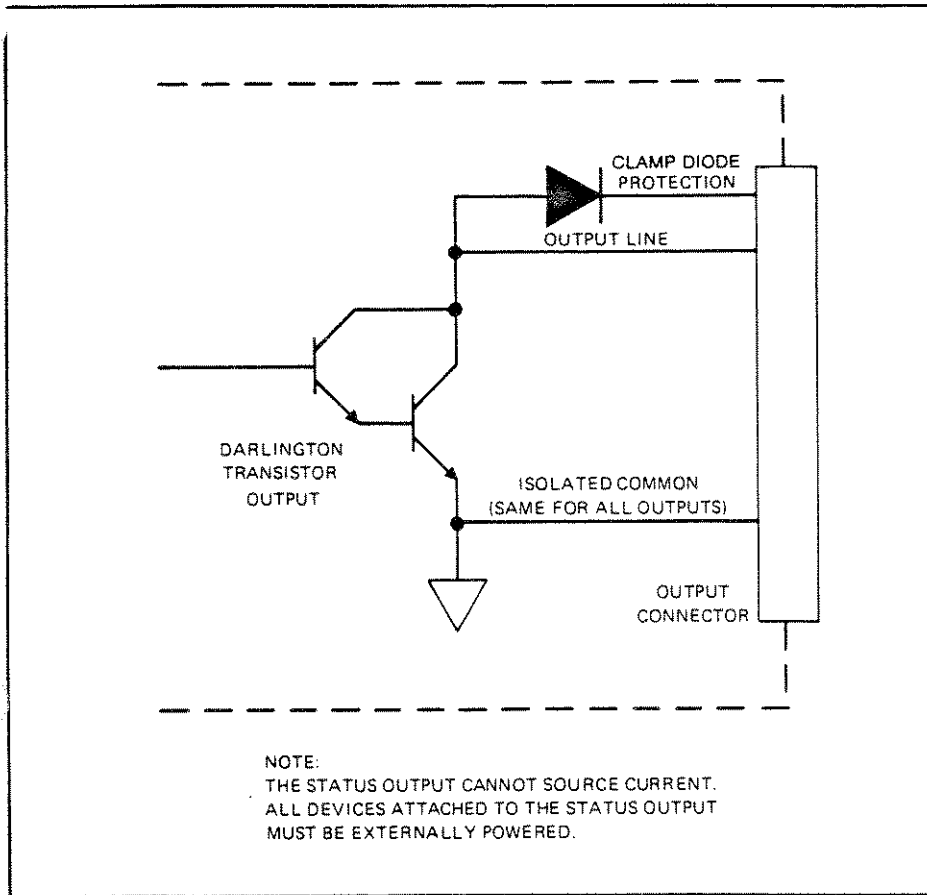

Figure 169-2. Equivalent Circuit for Each Status Output Signal

169/Status Output Connector

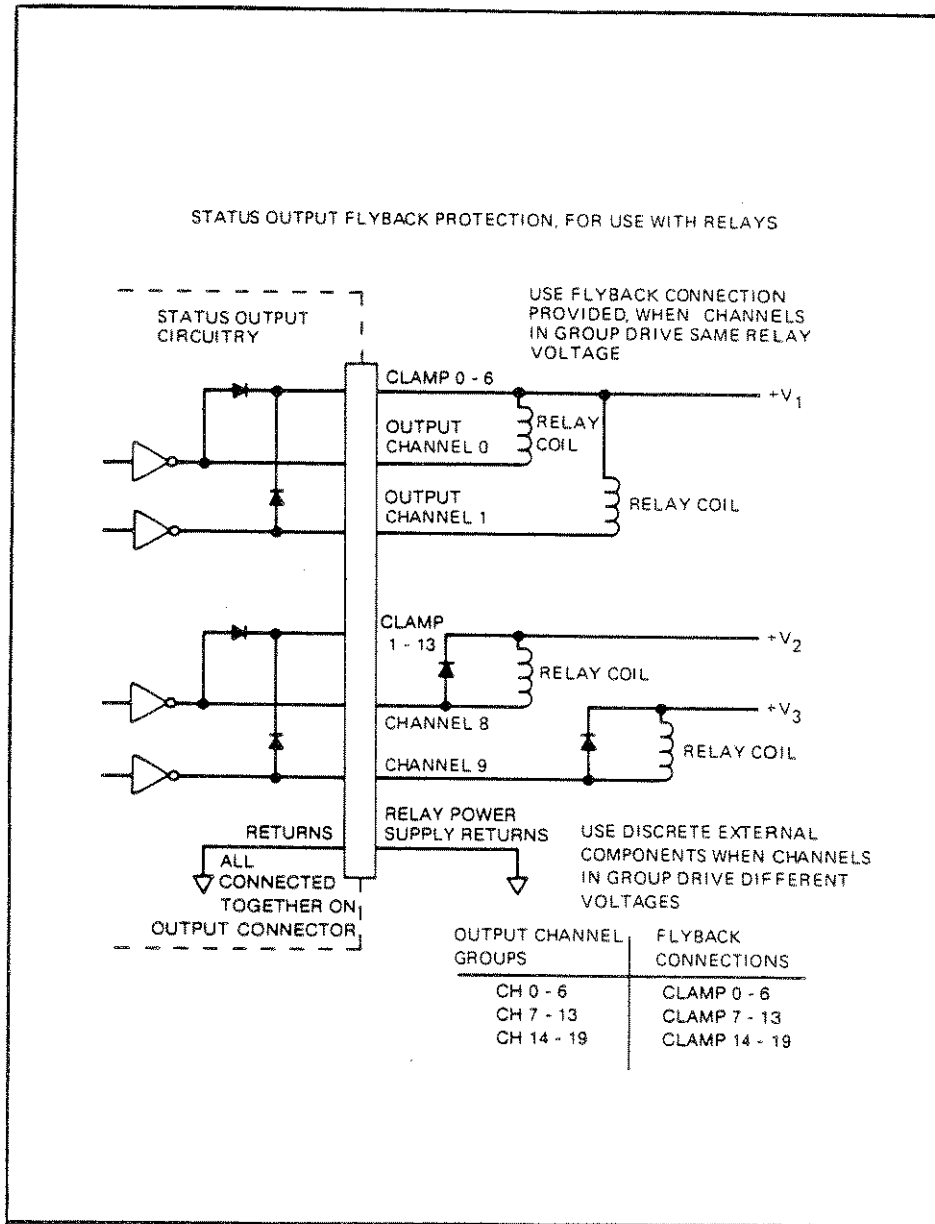

Figure 169-3. Status Output Flyback Protection

169/Status Output Connector

INSTALLATION TEST

Use the following procedure to test for proper installation of the Status Output Assembly:

1. Ensure that power is not applied to the 2280.
2. Set the Digital I/O Assembly address switch to 04.
3. Install the Digital I/O Assembly in the 2280.
4. Install the Status Output Assembly on the rear of the Digital I/O Assembly.
5. Apply power to the 2280.
6. Program the 2280 to list the hardware configuration as follows:

Press:	Display:
	MAIN MENU CHOICE <M FOR MENU>? A
L	<L> LIST PROGRAM AND CONFIGURATION
ENTER	L: LIST MENU CHOICE <A-Z>? E
C	L<C> LIST HARDWARE CONFIGURATION
ENTER	LISTING <PRESS EXIT TO ABORT>
	(list is printed)
EXIT	MAIN MENU CHOICE <M FOR MENU>? A

7. Check the printed configuration list for correct hardware installation. A Status Output Assembly installation should yield a listing that correctly identifies the channel block and type. Look for the following:

```
BEGINNING CHANNEL NUMBER = 40
TYPE = STATUS OUTPUT
BEGINNING CHANNEL NUMBER = 50
TYPE = STATUS OUTPUT
```

169/Status Output Connector

PROGRAMMING

Programming for the Status Output Assembly involves selection of the function for the appropriate channels. Special zero and non-zero designations can also be defined.

OPERATION

Once installed in the data logger (or extender chassis) with the appropriate connections, the Status Output Connector requires no further attention.

SERVICE INFORMATION

The following additional information can be found in the 2280 Series Service Manual:

- o Parts List
- o Schematic Diagram

2280B-170
Analog Output

INTRODUCTION

The Analog Output option provides four voltage or current output channels. The option interfaces with the 2280 Series system via the serial link and can be installed in the 2280 mainframe or the 2281A Extender Chassis. The Analog Option is shown in Figure 170-1.

WHERE TO FIND MORE INFORMATION

This subsection of the System Guide presents information (description, specifications, installation) related to the Analog Output. Since other system hardware is used in most data logging functions, operating instructions are not repeated here. Analog Output applications are discussed in Section 5j.

The User Guide presents overall operating instructions for the Data Logger. Information is presented in a general, and not option-specific, format. This volume treats operation with various levels of complexity, depending on user familiarity with the instrument. Some acquaintance with the User Guide is recommended. For any operation-related question, the User Guide is the ultimate authority.

P/N 753061
February, 1985

170/Analog Output

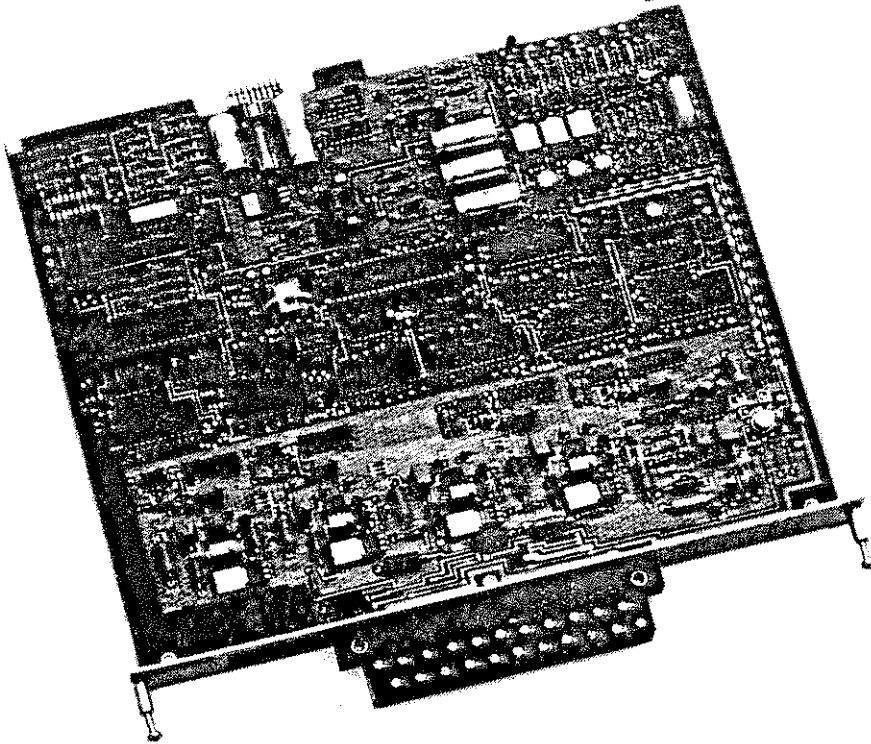

Figure 170-1. Analog Output

170/Analog Output

SPECIFICATIONS

Specifications for the Analog Output are presented in Table 170-1. System-related specifications are presented in Appendix G of this manual.

Table 170-1. Analog Output Specifications

Channels	4
Terminals	5 per channel
Accuracy	$\pm 0.1\%$ of range
Time since calibration	90 days
Operating Temperature	15 to 35 $^{\circ}$
Accuracy	$\pm 0.2\%$ of range
Time since calibration	1 year
Operating Temperature	15 to 35 $^{\circ}$ C
Accuracy	$\pm 0.4\%$ of range
Time since calibration	1 year
Operating Temperature	-20 to 70 $^{\circ}$ C
Noise	< 0.02% of range in a 10 kHz bandwidth
Voltage Outputs	
Ranges	-5 to +5V, 0 to +10V
Resolution	2.5 mV/count
Maximum Current	2 mA
Capacitive Load	10,000 pF maximum
Output Protection	short-circuit protected
Current Output	
Range	4 to 20 mA
Resolution	4 μ A
Maximum Compliance Voltage ..	10V
Maximum External Voltage	± 24 V
Isolation	30V dc or ac rms between any terminal and ground. No isolation between channels. Current outputs share a common return.
Power Consumption	4.1 watts maximum

170/Analog Output

Temperature

Operating -20 to 70^o
Storage -55 to 75^o

Relative Humidity (without condensation)

Below 25^o <= 95%
25 to 40^o <= 75%
40 to 50^o <= 45%
50 to 70^o <= 40%

Altitude

Non-Operating 40,000 feet
Operating 10,000 feet

Shock and Vibration Meets MIL-T-28800C,
Class 5 Standards

INSTALLATION

Connections

The individual channels on an Analog Output Option are not electrically isolated from each other. However, the entire card is isolated from chassis ground.

Each channel requires two terminal connections. But five screw terminal connections are provided on each of the four output channels. Connecting the correct two terminals on a given channel defines the type of output (current or voltage) for that channel. The three possibilities are:

- o Current: 4-20 mA "SOURCE" to "RETURN"
- o Unipolar Voltage: VOLTAGE "SOURCE" to "0 TO 10V RIN"
- o Bipolar Voltage: VOLTAGE "SOURCE" to "-5 TO +5 V RIN"

170/Analog Output

WARNING

BE SURE THAT THE WIRES BEING CONNECTED ARE NOT ENERGIZED. IF POSSIBLE, DISCONNECT THESE WIRES AT THE OTHER END. IN ANY EVENT, ENSURE THAT THE EXTERNAL CIRCUIT CONNECTED TO THESE WIRES IS NOT ENERGIZED. LETHAL VOLTAGE COULD OTHERWISE BE ENCOUNTERED.

For each terminal, loosen the appropriate screw, attach the external wire to the screw, then tighten the screw until the wire is firmly in place.

CHANNEL	SIGNAL NAME	TERMINAL NUMBER
0	VOLTAGE SOURCE	1
	0 TO 10V RIN	2
	-5 TO +5V RIN	3
	4-20 mA SOURCE	4
	RETURN	5
1	VOLTAGE SOURCE	6
	0 TO 10V RIN	7
	-5 TO +5V RIN	8
	4-20 mA SOURCE	9
	RETURN	10
2	VOLTAGE SOURCE	11
	0 TO 10V RIN	12
	-5 TO +5V RIN	13
	4-20 mA SOURCE	14
	RETURN	15
3	VOLTAGE SOURCE	16
	0 TO 10V RIN	17
	-5 TO +5V RIN	18
	4-20 mA SOURCE	19
	RETURN	20

170/Analog Output

Address Selection

Address selection sets the channel numbers for each of the four output channels. These switches are accessible through the rear panel of the Analog Option and can be set at any time.

The addressing procedure uses two switches to select the hundreds and tens address for the four channels on the assembly. The following chart further identifies the correspondence between the switch settings and the analog output channel numbers.

SWITCH SELECTION		ANALOG OUTPUT CHANNEL			
100s	10s	0	1	2	3
0	0	0	1	2	3
0	1	10	11	12	13
0	2	20	21	22	23
.
9	9	990	991	992	993
.
14	9	1490	1491	1492	1493

Physical

The Analog Output interfaces with the serial link and, therefore, can be installed in either the 2280 mainframe or the 2281A Extender Chassis.

Proceed as follows:

1. Turn the Power Keyswitch to the POWER OFF position. If an Analog Output is being installed in the 2281A, verify that the POWER indicator is off.
2. Set the Analog Output address switch to 05.
3. From the rear of the 2280 (or 2281A), identify the mounting slot appropriate for the Analog Output.
4. Align the Analog Output in the desired slot. The board-edge connector must face in (toward the motherboard).
5. Secure the Analog Output in the slot. Push the board straight in until it makes contact with the motherboard connectors. Then continue pressing firmly until it is mated with these connectors. Now secure the two retaining screws to the chassis.

170/Analog Output

INSTALLATION TEST

Proper installation can be checked by performing a hardware configuration list. Proceed as follows:

Press:	Display:
—	MAIN MENU CHOICE <M FOR MENU>? A
L	<L> LIST PROGRAM AND CONFIGURATION
ENTER	L: LIST MENU CHOICE <A-Z>? E
C	L<C> LIST HARDWARE CONFIGURATION
ENTER	LISTING <PRESS EXIT TO ABORT> (list is printed)
EXIT	MAIN MENU CHOICE <M FOR MENU>? A

Check the printed configuration list for correct hardware installation. For the Analog Output, the following sample printout is appropriate:

```
BEGINNING CHANNEL NUMBER = 50
TYPE = ANALOG OUTPUT
```

PROGRAMMING

An individual analog output channel is assigned an output value through a channel procedure evaluation. The assigned value can range from 0.0 through 1.0, signifying 0% to 100% of scale, respectively.

- o Any assigned value algebraically less than 0.0 (0%) causes 0% to be set.
- o Any assigned value greater than 1.0 (100%) causes 100% to be set.

170/Analog Output

The following chart presents some representative outputs for the three available pairs at output terminals.

ASSIGNED VALUE	4-20 mA	-5 to +5V	0 to +10V
0.0	4 mA	-4.9976V	0
0.5	12 mA	0	+5V
1.0	19.995 mA	+4.9976V	+9.9976V

OPERATION

Once installed in the data logger, the Analog Output requires no further operator attention.

All analog output channels are set to 0% when any one of the following operating conditions occurs:

- o Scanning (or single scan) is started
- o Plotting is started (if no scanning in progress)
- o Power up

Use of the Analog Output is described in section 5j this manual. In addition, the data logger offers a wide range of programming and operating features that are fully documented in the User Guide.

SERVICE INFORMATION

The following additional information can be found in the 2280 Series Service Manual:

- o Theory of Operation
- o Performance Verification Procedure
- o Calibration/Adjustment Procedure
- o Parts List
- o Schematic Diagram

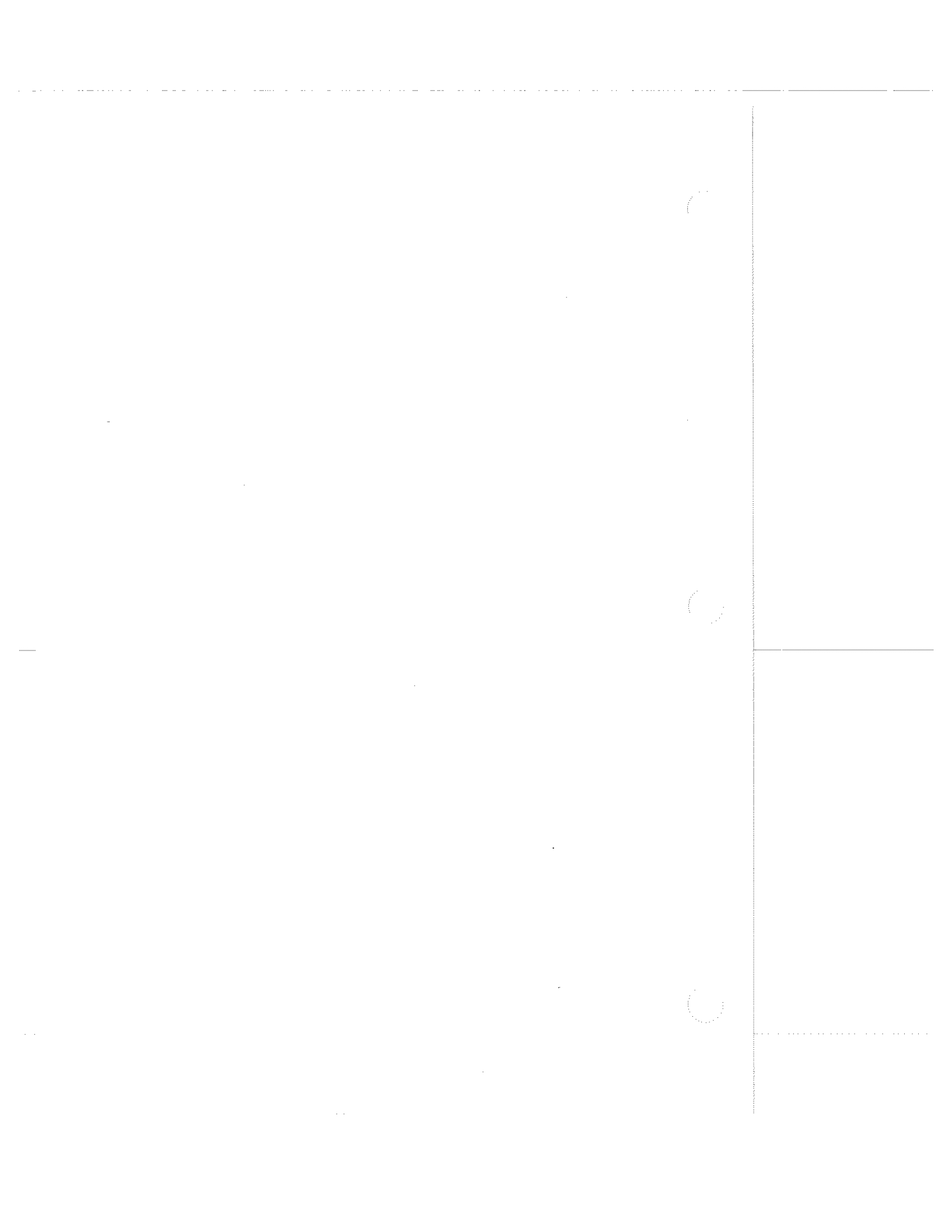

2280A-171
Current Input Connector

INTRODUCTION

The Current Input Connector routes a maximum of 20 current input channels to the scanner. The connector consists of an assembly that mounts to the rear 88-pin card edge connector on the scanner. The connector assembly is enclosed in a plastic housing to protect the terminal connections and provide strain relief for the external wiring. Two retaining screws attach this housing to the 2280 or 2281 chassis. The Current Input Connector is illustrated in Figure 171-1.

Each connector channel uses two screw terminals (HIGH and LOW), and one resistor. The shield is internally connected to LOW (no separate screw terminal is provided for the shield).

P/N 647693, Rev 1
February, 1985

171/Current Input Connector

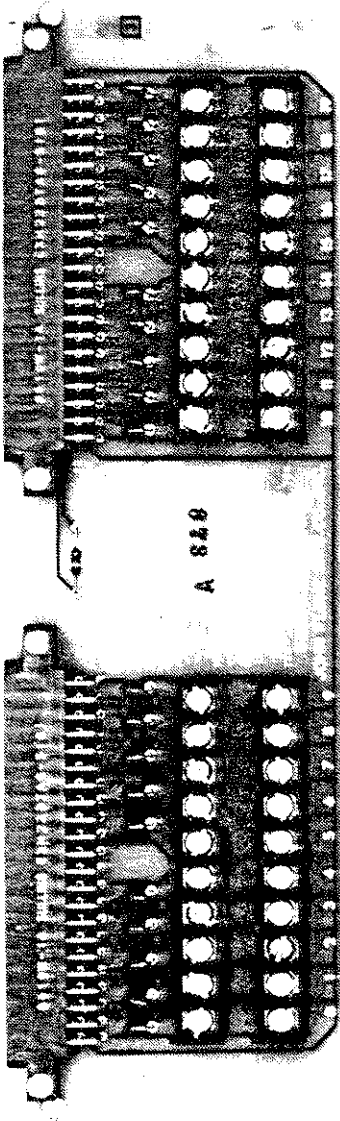

Figure 171-1. Current Input Connector

171/Current Input Connector

WHERE TO FIND MORE INFORMATION

This subsection of the System Guide presents information (description, specifications, installation) specifically related to the Current Input Connector. Since other system hardware is used in most data logging functions, system operating instructions are not repeated here. Applications using current measurements are discussed in Section 5c of this manual.

The User Guide presents overall operating instructions for the Data Logger. Information is presented in a general, and not option-specific, format. This volume treats operation with various levels of complexity, depending on user familiarity with the instrument. Some acquaintance with the User Guide is recommended. For any operation-related question, the User Guide is the ultimate authority.

SPECIFICATIONS

Specifications for the Current Input Connector are presented in Table 171-1.

171/Current Input Connector

Table 171-1. Current Input Connector Specifications

Channels	20
Terminals	2 per channel
Shunt Resistor	8 ohms ± 0.02 ohm
Measurement Range	64 mA
Overload without Damage	250 mA
Common Mode Voltage	250V dc or ac rms between any two channels or between a channel and ground.
Accuracy	0.25% Input ± 4 uA
Time since A/D calibration ..	90 days
Resolution	100 uA
Compatibility	Attaches to Thermocouple/DC Volts Scanner (option 162).
Temperature	
Operating	-20 to 70°C
Storage	-55 to 75°C
Relative Humidity (without condensation)	
Below 25°C	$\leq 95\%$
25 to 40°C	$\leq 75\%$
40 to 50°C	$\leq 45\%$
50 to 70°C	$\leq 40\%$
Altitude	
Non-Operating	40,000 feet
Operating	10,000 feet
Shock and Vibration	Meets MIL-T-28800C, Class 5 Standards

171/Current Input Connector

INSTALLATION

Connections from measurement sources to the 2280 Series Data Logger are made via external wiring to the input connector block. Installation of the Current Input Connector involves opening the housing, assembling and connecting the appropriate wiring to the terminals, closing the housing, and connecting it to the appropriate scanner. The following steps detail this procedure:

WARNING

ENSURE THAT ALL LINE POWER TO THE MAINFRAME OR EXTENDER CHASSIS IS DISCONNECTED. LETHAL VOLTAGES MAY BE PRESENT WITHIN THE 2280 AND ON SOME OPTION CARDS. DO NOT REMOVE ANY INSTRUMENT COVERS UNLESS YOU ARE QUALIFIED TO DO SO.

1. With line power disconnected and the POWER switch set at OFF, locate the connector housing in the rear panel of the 2280.
2. Loosen the two retaining screws that hold the housing assembly to the chassis.
3. Firmly grasping the housing at each end, pull the enclosed connector block until it is disconnected from the scanner.
4. Open the housing by pressing each locking tab.

WARNING

BE SURE THAT THE WIRES BEING CONNECTED ARE NOT ENERGIZED. IF POSSIBLE, DISCONNECT THESE WIRES AT THE OTHER END. IN ANY EVENT, ENSURE THAT THE EXTERNAL CIRCUIT CONNECTED TO THESE WIRES IS NOT ENERGIZED. LETHAL VOLTAGE COULD OTHERWISE BE ENCOUNTERED.

171/Current Input Connector

5. Connections can now be made to external wiring. For readings with the proper polarity, ensure that current flows into the HI terminal and out of the LOW terminal.
6. Attach the external wiring. For each channel (starting with channel 0), loosen the channel terminal screw, attach the external wire to the screw, then tighten the screw until the wire is firmly in place.
7. Ensuring that the external wires exit the rear of the enclosure without being pinched, close the input connector housing.

WARNING

BEFORE INSTALLING THE WIRED INPUT CONNECTOR AT THE 2280 REAR PANEL, ENSURE THAT ALL LINE POWER TO THE MAINFRAME OR EXTENDER CHASSIS IS DISCONNECTED. LETHAL VOLTAGES MAY BE PRESENT WITHIN THE 2280 AND ON SOME OPTION CARDS. DO NOT REMOVE ANY INSTRUMENT COVERS UNLESS YOU ARE QUALIFIED TO DO SO.

8. Position the assembled input connector in the guides of the 2280 rear panel slot containing the appropriate scanner.
9. Push the Current Input Connector in firmly until it mates with the Thermocouple/DC Volts Scanner.
10. Attach the connector housing to the chassis with the two retaining screws.

171/Current Input Connector

INSTALLATION TEST

Hardware Configuration

A quick method for verifying correct installation involves a hardware list. With a Current Input Connector and Thermocouple/DC Volts Scanner installed directly below the A/D Converter, enter the following keystrokes from the front panel:

Press:	Display:
	MAIN MENU CHOICE <M FOR MENU>? A
L	<L> LIST PROGRAM AND CONFIGURATION
ENTER	L: LIST MENU CHOICE <A-Z>? E
C	L<C> LIST HARDWARE CONFIGURATION
ENTER	LISTING <PRESS EXIT TO ABORT>
	(list is printed)
EXIT	MAIN MENU CHOICE <M FOR MENU>? A

Among other things, the resulting printed configuration list identifies each channel block by beginning channel number and type. The following printout example identifies channel blocks 00-09 and 10-19:

```
BEGINNING CHANNEL NUMBER = 0
TYPE = VOLTS/CURRENT
BEGINNING CHANNEL NUMBER = 10
TYPE = VOLTS/CURRENT
```

171/Current Input Connector

Monitoring the Channel

Current Input Connector installation can be verified by successfully reading an input channel. Be sure that system components other than the Current Input Connector are operational. Use the following equipment:

- o 2280 Series Data Logger
- o High Performance A/D Converter (option 161)
- o Thermocouple/DC Volts Scanner (option 162)
- o Current Input Connector (option 171)

NOTE

This test verifies basic operability. For accuracy tests, refer to the 2280 Series Service Manual subsection for this option assembly.

Complete the Channel Program for the first ten channels. A Programming Form example is shown below. The following steps are used in this example:

Press:	Display:
	MAIN MENU CHOICE <M FOR MENU>? A
ENTER	CHANNEL NUMBER OF (OR BLOCK) = C0
0..9 ENTER	PROGRAM COPY DELETE OR LIST <P,C,D,L>? P
ENTER	A: CHANNEL FUNCTION <A-Z>?
D	A<D> VOLTS/CURRENT
ENTER	AD: VOLTS/CURRENT RANGE <1-7>? 1
5	AD<5> 64.0 MA
ENTER	AD: CHANNEL MENU CHOICE <1-5>? 1
EXIT ...	(return to main menu)

171/Current Input Connector

PROGRAMMING

Current input programming is not complicated. One input range (64 mA) is available for current inputs. This range is specified for each current input channel as a CHANNEL PROGRAM input.

OPERATION

Once installed in the data logger with the appropriate connections, the Current Input Connector requires no further attention.

SERVICE INFORMATION

The following additional information can be found in the 2280 Series Service Manual:

- o Parts Lists
- o Schematic Diagram

2280A-174
Transducer Excitation Connector

INTRODUCTION

The Transducer Excitation Module and the Transducer Excitation Connector (option 174) provide voltage or current excitation for variable resistance transducers. Multiple data logging functions (RTD temperature measurement, strain gage measurement, strain-based transducers measurement, and low resistance transducer measurement) can thereby be supported.

Measuring the voltage of the stimulated transducer is accomplished with other 2280 option assemblies. The Thermocouple/DC Volts Scanner (option 162) and either the Voltage Input Connector (option 176) or the Isothermal Input Connector (option 175) provide this measurement capability.

The Transducer Excitation Connector is illustrated in Figure 174-1.

P/N 718528
February, 1985

174/Transducer Excitation Connector

WHERE TO FIND MORE INFORMATION

This subsection of the System Guide presents information (description, specifications, installation) specifically related to the Transducer Excitation Connector. Since other system hardware is used in most data logging functions, system operating instructions are not repeated here.

Where the Transducer Excitation Connector is used in a specific data logging function, other sections of the System Guide provide more appropriate information. Examples include:

- o Section 5a: Temperature Measurement
This section discusses use of the Transducer Excitation Module and Connector in providing excitation for RTD temperature measurements.
- o Section 5d: Resistance Measurement
This section presents the overall view if a measurement expressed in ohms is desired.
- o Section 5g: Strain Measurement
This section discusses concepts and examples of strain measurement using the Transducer Excitation Module/Connector.

The User Guide presents complete operating instructions for the Data Logger. Information is presented in a general, and not option-specific, format. This volume treats operation with various levels of complexity, depending on user familiarity with the instrument. Some acquaintance with the User Guide is recommended. For any operation-related question, the User Guide is the ultimate authority.

174/Transducer Excitation Connector

SPECIFICATIONS

Specifications for the Transducer Excitation Connector are presented in Table 174-1.

Specifications for the Transducer Excitation Module can be found in the related subsection (164). Other specifications pertain to use of the module and connector assemblies together. Such system-related specifications are presented in Appendix G of this manual.

Table 174-1. Transducer Excitation Connector Specifications

Channels	20
Terminals	5 per channel
Programming	5 jumpers select voltage or current excitation on 5 groups of 4 channels.
Compatibility	Attaches to Transducer Excitation Module (option 164)
Temperature	
Operating	-20 to 70°C
Storage	-55 to 75°C
Relative Humidity (without condensation)	
Below 25°C	<= 95%
25 to 40°C	<= 75%
40 to 50°C	<= 45%
50 to 70°C	<= 40%
Altitude	
Non-Operating	40,000 feet
Operating	10,000 feet
Shock and Vibration	Meets MIL-T-28800C, Class 5 Standards

174/Transducer Excitation Connector

INSTALLATION

Applications using the Transducer Excitation Module/Connector involve both excitation and measurement connections. Depending on the type of application, these connections vary somewhat.

Briefly, installation involves first making external connections to the Transducer Excitation Connector. Interconnections are then made between this connector (which performs the excitation function) and the connector performing the measurement function. Measurement is actually a dc voltage function and can be accomplished with any of the following three input connectors: Voltage Input Connector, Isothermal Input Connector, or AC Voltage Input Connector.

The connector (excitation or measurement) must then be attached to the appropriate option assembly already installed in the 2280. For the excitation function, this is the Transducer Excitation Module. The measurement function uses the Thermocouple/DC Volts Scanner.

Preliminary Steps

The following procedure describes Transducer Excitation Connector installation on two levels. First, wiring connections are explained. This procedure involves interconnections between the measurement connector (Voltage Input Connector, Isothermal Input Connector, or AC Voltage Input Connector) and the Transducer Excitation Connector. It also requires connections between the Transducer Excitation Connector and the external measurement source.

174/Transducer Excitation Connector

Once the Transducer Excitation Connector has been wired, it can be installed on the rear of the Transducer Excitation Module. Installation explanations for the measurement connector (Voltage Input Connector, Isothermal Input Connector, or AC Voltage Input Connector) are covered in the appropriate subsection (176, 175, or 160, respectively).

NOTE

Install the Transducer Excitation Module/Connector directly below the scanner/connector being used for the interconnections. This arrangement allows for maximum ease of installation.

1. Ensure that line power is disconnected and the POWER switch is set at OFF.
2. Open the Transducer Excitation Connector housing by gently pressing each locking tab.

WARNING

BE SURE THAT THE WIRES BEING CONNECTED ARE NOT ENERGIZED. IF POSSIBLE, DISCONNECT THESE WIRES AT THE OTHER END. IN ANY EVENT, ENSURE THAT THE EXTERNAL CIRCUIT CONNECTED TO THESE WIRES IS NOT ENERGIZED. LETHAL VOLTAGE COULD OTHERWISE BE ENCOUNTERED.

3. Familiarize yourself with the connecting terminal arrangement.
 - o Five connecting terminals are available for each channel.
 - o Twenty sets of terminals are provided on each input connector.

174/Transducer Excitation Connector

4. Wiring between the connectors and from the Transducer Excitation Connector to the external measurement source depends on the type of measurement being made. The figures mentioned below can be found at the end of this subsection.
 - o Strain measurements must be wired according to Figure 174-2, 174-3, or 174-4 for 1/4, 1/2, or full bridge configurations, respectively.
 - o RTD measurements using a 3-wire, constant voltage source must use the wiring shown in Figure 174-5.
 - o RTD measurements using a 3-wire, constant current source must use the wiring shown in Figure 174-6.
 - o RTD measurements using a 4-wire arrangement must use the wiring shown in Figure 174-7.
5. For each connection, loosen the channel terminal screw, attach the external wire (or jumper) to the screw, then tighten the screw until the wire is firmly in place.
6. For each connector, close the housing and ensure that the external wires exit the rear of the enclosure without being pinched.

174/Transducer Excitation Connector

Attaching the Connectors

WARNING

BEFORE INSTALLING THE WIRED INPUT CONNECTOR AT THE 2280 REAR PANEL, ENSURE THAT ALL LINE POWER TO THE MAINFRAME OR EXTENDER CHASSIS IS DISCONNECTED. LETHAL VOLTAGES MAY BE PRESENT WITHIN THE 2280 AND ON SOME OPTION CARDS. DO NOT REMOVE ANY INSTRUMENT COVERS UNLESS YOU ARE QUALIFIED TO DO SO.

Complete the installation by physically installing the connectors as follows:

1. Position the enclosed (and wired) connectors in the guides of the appropriate 2280 rear panel slots. Ideally, the Thermocouple/DC Volts Scanner will occupy the slot immediately above that of Transducer Excitation Module.
2. Push the connectors onto the card edge connectors. Continue pressing each connector until it is fully engaged.
3. Attach each connector housing to the chassis with the retaining screws.

174/Transducer Excitation Connector

INSTALLATION TEST

Use the following procedure to test for proper installation of the Transducer Excitation Connector:

1. Ensure that power is not applied to the 2280.
2. Prepare the A/D Converter for installation by setting the A/D Converter address switch to 0.
3. Install the A/D Converter in the 2280.
4. Install a Thermocouple/DC Volts Scanner directly below the A/D Converter.
5. Install the Transducer Excitation Connector directly below the associated Thermocouple/DC Volts Scanner.
6. Install the Transducer Excitation Connector (option 174) on the rear of the module.
7. Apply power to the 2280.
8. Program the 2280 to list the hardware configuration as follows:

Press:	Display:
	MAIN MENU CHOICE <M FOR MENU>? A
L	<L> LIST PROGRAM AND CONFIGURATION
ENTER	L: LIST MENU CHOICE <A-Z>? E
C	L<C> LIST HARDWARE CONFIGURATION
ENTER	LISTING <PRESS EXIT TO ABORT>
	(list is printed)
EXIT	MAIN MENU CHOICE <M FOR MENU>? A

174/Transducer Excitation Connector

9. Check the printed configuration list for correct hardware installation. A Transducer Excitation Module/Connector installation should yield a listing that correctly identifies each decade of channels by beginning channel number and type. Look for the following:

```
BEGINNING CHANNEL NUMBER = 20  
TYPE = TRANSDUCER EXCITATION  
BEGINNING CHANNEL NUMBER = 30  
TYPE = TRANSDUCER EXCITATION
```

PROGRAMMING

Programming with the Transducer Excitation Module/Connector depends on the type of measurement application. Programming instructions are presented in the appropriate area of Section 5. Briefly, these areas are:

- o Section 5a: Temperature Measurement

3-Wire and 4-Wire connections are supported for RTD or thermistor measurement.

- o Section 5d: Resistance Measurement

Although 3-wire or 4-wire connections for resistance measurement are the same as for RTD measurement, different programming entries are required.

- o Section 5g: Strain Measurement

This section covers the programming steps required for 1/4, 1/2, or full bridge configurations. A total of six configurations are possible.

174/Transducer Excitation Connector

OPERATION

Once installed in the data logger, the Transducer Excitation Input Connector requires no further operator attention.

Use of the Transducer Excitation Module (in conjunction with the Transducer Excitation Input Connector) is described in sections 5a and 5d of this manual. In addition, the data logger offers a wide range of programming and operating features that are fully documented in the User Guide.

SERVICE INFORMATION

The following additional information can be found in the 2280 Series Service Manual:

- o Parts List
- o Schematic Diagram

174/Transducer Excitation Connector

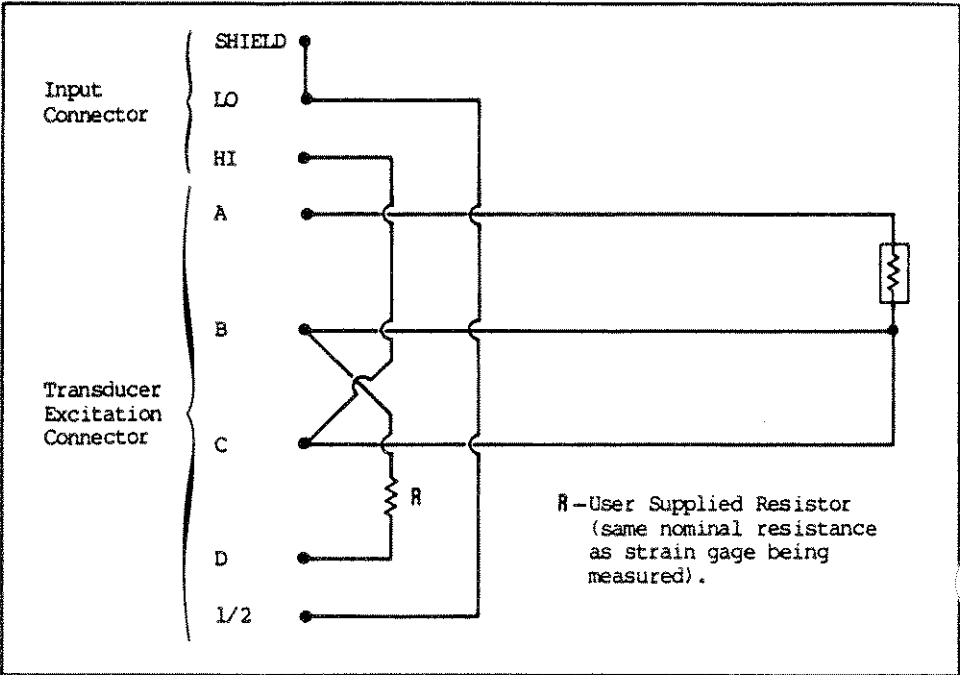

Figure 174-2. Wiring (1/4 Bridge Strain)

174/Transducer Excitation Connector

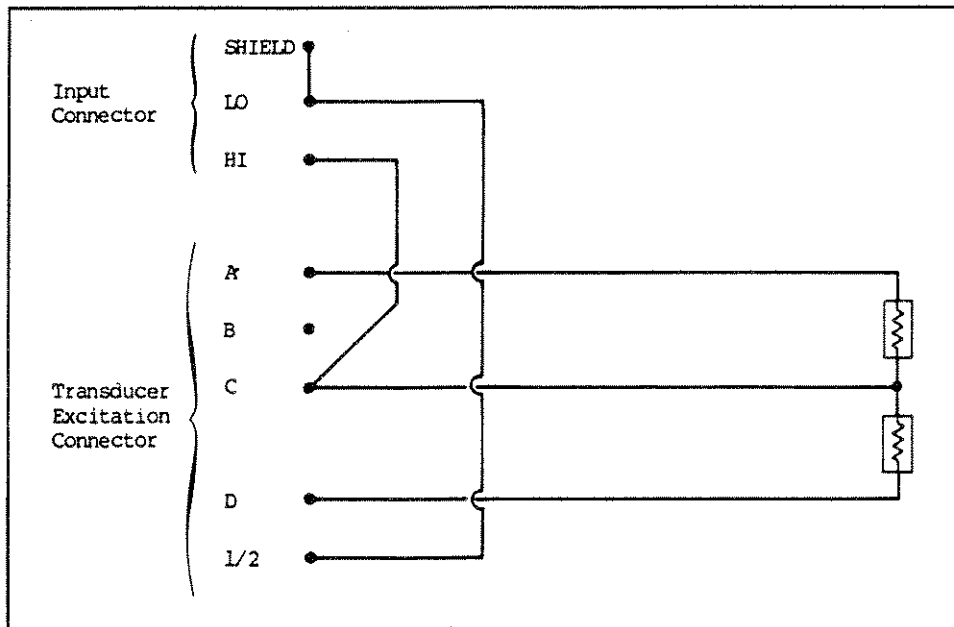

Figure 174-3. Wiring (1/2 Bridge Strain)

174/Transducer Excitation Connector

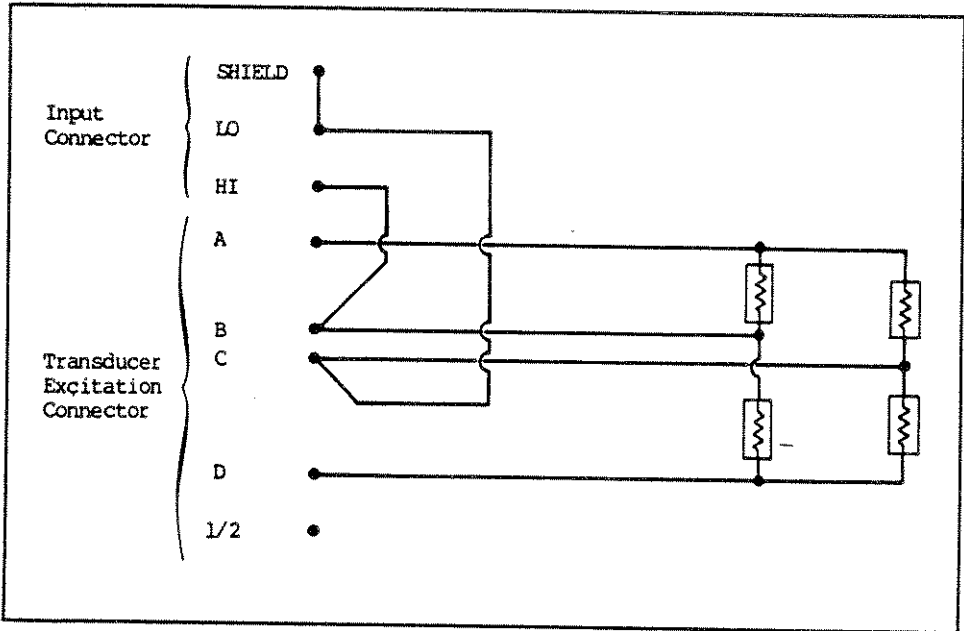
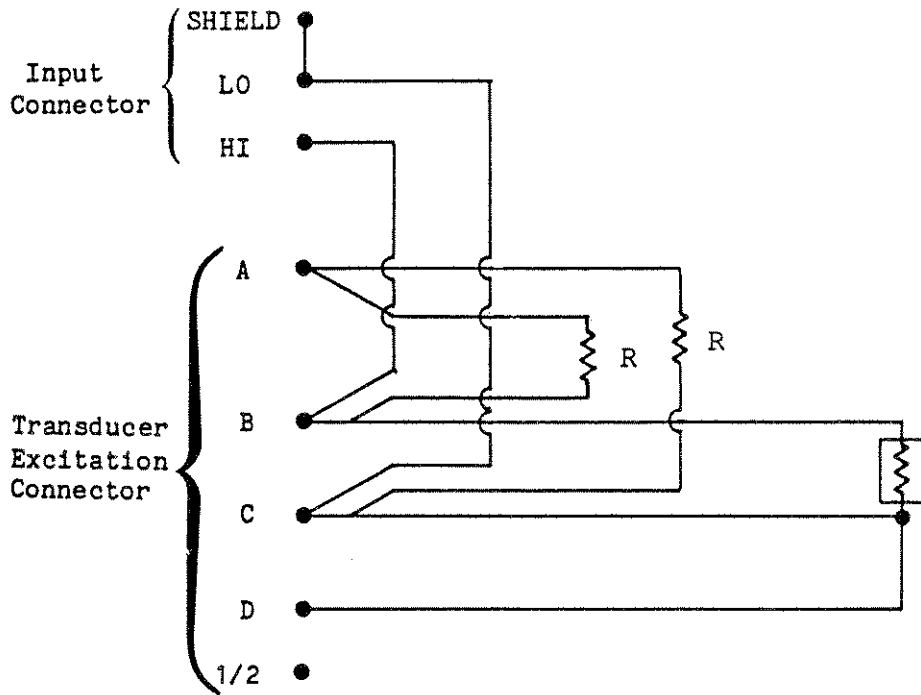

Figure 174-4. Wiring (Full Bridge Strain)

174/Transducer Excitation Connector



R, user supplied resistor

Figure 174-5. Wiring (3-Wire RTD, Constant Voltage)

174/Transducer Excitation Connector

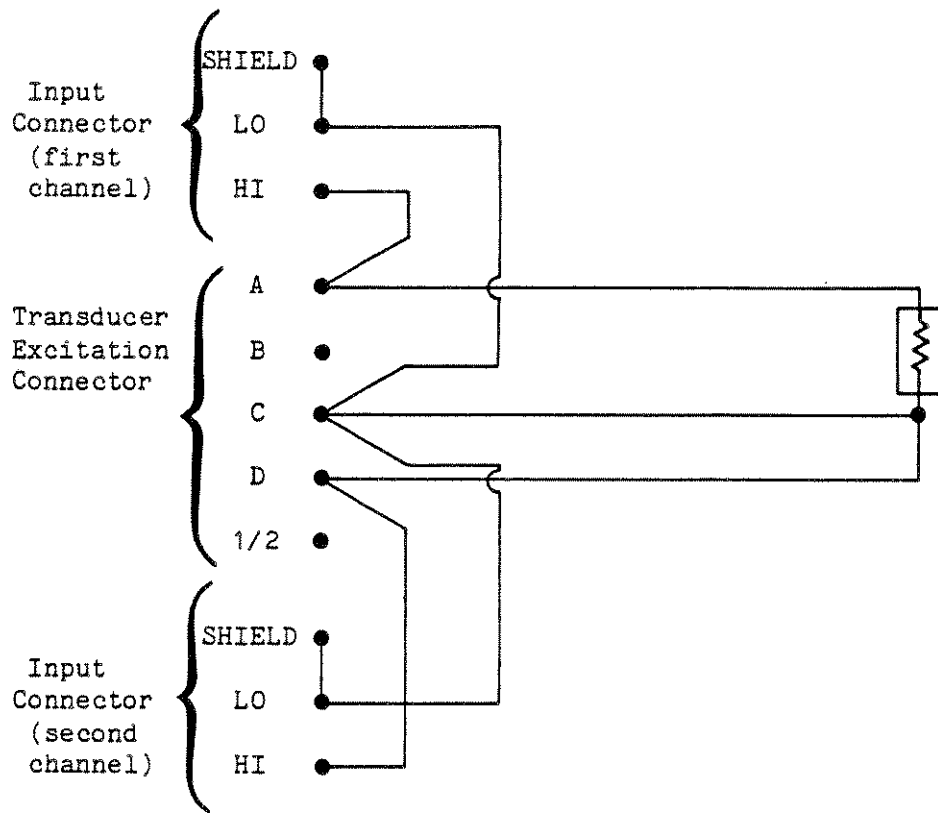

Figure 174-6. Wiring (3-Wire RTD, Constant Current)

174/Transducer Excitation Connector

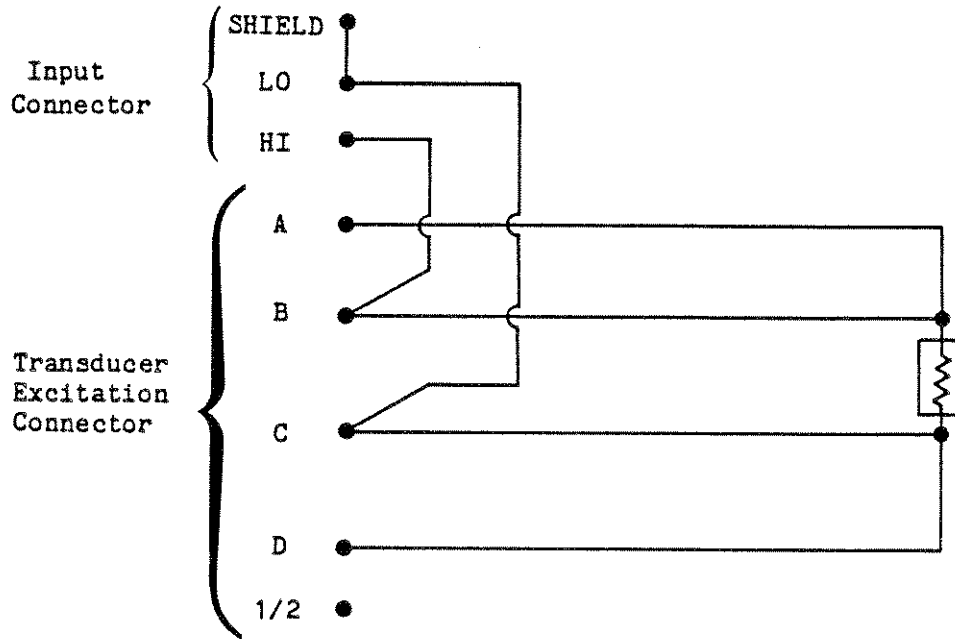

Figure 174-7. Wiring (4-Wire RTD, Constant Current)



2280A-175
Isothermal Input Connector

INTRODUCTION

The Isothermal Input Connector routes a maximum of 20 thermocouple or voltage input channels to the scanner. The connector attaches to the 88-pin edge connector at the rear of the scanner card. The Isothermal Input Connector is illustrated in Figure 175-1.

The connector assembly is enclosed in a plastic housing. This arrangement provides protection for the terminal connections and strain relief for the external wiring. Retaining screws secure the housing to the scanner chassis.

Each Input Connector channel uses three screw terminals (HIGH, LOW, and SHIELD). Each terminal can withstand a maximum of 250 volts rms. An isothermal block of aluminum surrounding the terminals helps to maintain a uniform temperature among all channel terminals.

P/N 647701, Rev 1
February, 1985

175/Isothermal Input Connector

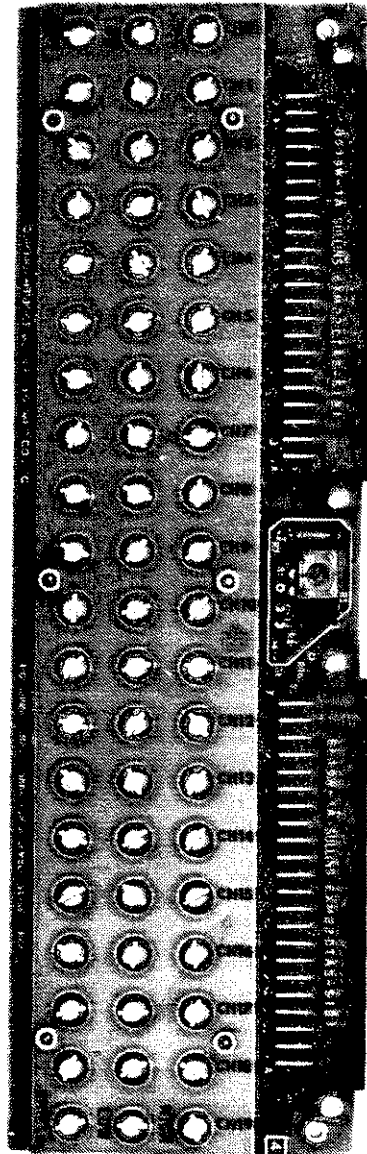

Figure 175-1. Isothermal Input Connector

175/Isothermal Input Connector

WHERE TO FIND MORE INFORMATION

This subsection of the System Guide presents operator-related information. A general description and list of specifications describe the option's capabilities. Installation instructions and installation test procedures then describe how to get the option up and running. Finally, operating instructions further define Data Logger use with this option. Since other system hardware is used in most applications, system operating instructions are not repeated here. Rather, references are made to application instructions elsewhere in the System Guide.

The User Guide presents complete operating instructions for the Data Logger. Information is presented in a general, and not option-specific, format. This volume treats operation with various levels of complexity, depending on user familiarity with the instrument. Some acquaintance with the User Guide is recommended. For any operation-related question, the User Guide is the ultimate authority.

SPECIFICATIONS

Table 175-1 lists the specifications for the Isothermal Input Connector.

175/Isothermal Input Connector

Table 175-1. Isothermal Input Connector Specifications

Channels	20
Terminals	60 (HI, LO, SHIELD per channel)
Maximum Voltage Rating	250V dc or ac rms from any terminal to any other terminal or ground.
Temperature	
Operating	-20 to 70°C
Storage	-55 to 75°C
Relative Humidity (without condensation)	
Below 25°C	<= 95%
25 to 40°C	<= 75%
40 to 50°C	<= 45%
50 to 70°C	<= 40%
Altitude	
Non-Operating	40,000 feet
Operating	10,000 feet
Shock and Vibration	Meets MIL-T-28800C, Class 5 Standards

175/Isothermal Input Connector

INSTALLATION

Connections from external measurement sources to the 2280 Series Data Logger are made via wiring to the input connector block. Installation of the Isothermal Connector involves assembling and connecting the wires to the terminals, and attaching the connector to the appropriate scanner.

Preliminary Steps

1. With line power disconnected and the POWER switch set at OFF, locate the connector housing in the rear panel of the 2280.
2. Remove the two retaining screws that hold the clamshell assembly to the chassis.
3. Firmly grasp the housing at each end and pull until the enclosed connector block is disconnected from the scanner.
4. Open the housing by gently pressing each locking tab.

Shield Considerations

Current resulting from a capacitive charge and discharge between the A/D Converter and the chassis can produce unstable readings. Therefore, a path for this current is utilized by connecting the SHIELD lead to the LOW lead at the measurement point. This arrangement improves common-mode noise rejection. It is shown in Figure 175-2. With the A/D Converter and the instrument shield tracking the same voltage, common-mode current in the HI and LOW leads is minimized. Note that HI, LOW and Shield are fully isolated and capable of being safely floated to 250 volts above ground.

175/Isothermal Input Connector

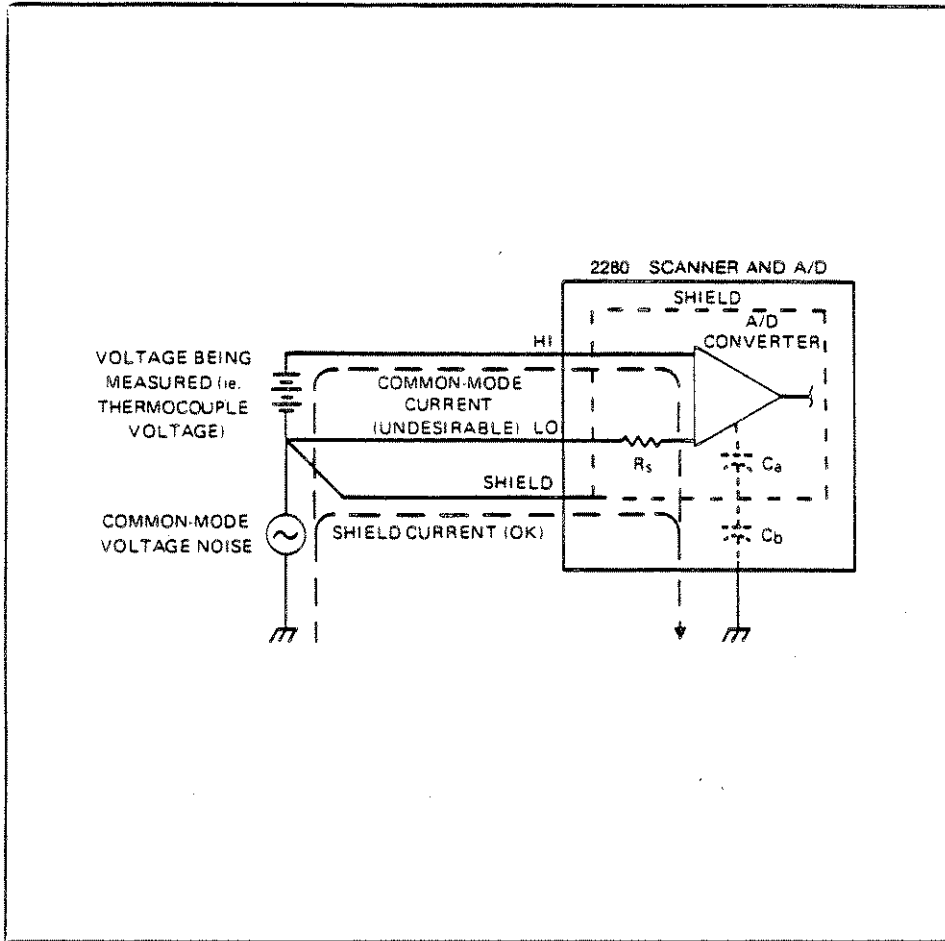

Figure 175-2. Shield Connection for Optimum Common Mode Rejection

175/Isothermal Input Connector

Use the following SHIELD guidelines when connecting the Isothermal Input Connector:

1. If significant RFI (Radio Frequency Interference) or EMI (Electro-Magnetic Interference) is present, the best measurement results are obtained by connecting SHIELD to LOW (on the input connector) with the shortest possible path.
2. If significant common mode voltage (greater than one volt) is present, connect SHIELD to LOW by means of a third wire at the measurement point. This arrangement is shown in Figure 175-2.
3. Never tie SHIELD to HI. This may actually amplify the effects of noise on the signal, causing a degradation in measurement performance.
4. Never leave SHIELD unconnected. Static charge buildup may cause the maximum SHIELD to LOW voltage to be exceeded, resulting in instrument damage.
5. Never connect SHIELD to earth ground unless the LOW terminal is also grounded. This results in greatly increased common mode currents due to the large value of capacitance between the Shield and the A/D Converter.

Connecting the Thermocouples

The Isothermal Input Connector is now ready to be wired to the external thermocouples. For each connection, loosen the channel terminal screw, attach the external wire to the screw, then tighten the screw until the wire is firmly in place. Notice that the three terminals for each channel are marked HIGH, LOW, and SHIELD. Starting at Channel 0, attach the external wiring for the desired application.

175/Isothermal Input Connector

WARNING

VERIFY THAT THERMOCOUPLES ONLY ARE BEING CONNECTED AS INPUTS TO THE ISOTHERMAL INPUT CONNECTOR. LETHAL VOLTAGE OR CURRENT COULD OTHERWISE BE PRESENT.

NOTE

For proper reading polarity, ensure that the red lead is always connected to LO and the remaining lead is always connected HIGH.

Close the housing over the input connector, ensuring that the external wires exit the rear of the enclosure without being pinched.

Attaching the Isothermal Input Connector

WARNING

BEFORE INSTALLING THE WIRED INPUT CONNECTOR AT THE 2280 REAR PANEL, ENSURE THAT ALL POWER TO THE MAINFRAME OR EXTENDER CHASSIS IS DISCONNECTED. LETHAL VOLTAGES MAY BE PRESENT WITHIN THE 2280 AND ON SOME OPTION CARDS. DO NOT REMOVE ANY INSTRUMENT COVERS UNLESS YOU ARE QUALIFIED TO DO SO.

Complete the Isothermal Input Connector installation as follows:

1. Position the assembled input connector in the guides of the 2280 rear panel slot containing the appropriate scanner.
2. Push the connector firmly into place on the card edge connector at the rear of the scanner.
3. Attach the connector housing to the chassis with the two retaining screws.

175/Isothermal Input Connector

INSTALLATION TEST

A quick method for verifying correct installation involves a hardware list. With an Isothermal Input Connector and Thermocouple/DC Volts Scanner installed directly below the A/D Converter, enter the following keystrokes from the front panel:

Press:	Display:
	MAIN MENU CHOICE <M FOR MENU>? A
L	<L> LIST PROGRAM AND CONFIGURATION
ENTER	L: LIST MENU CHOICE <A-Z>? E
C	L<C> LIST HARDWARE CONFIGURATION
ENTER	LISTING <PRESS EXIT TO ABORT>
	(list is printed)
EXIT	MAIN MENU CHOICE <M FOR MENU>? A

Among other things, the resulting printed configuration list identifies each channel block by beginning channel number and type. The following printout example identifies channel blocks 00-09 and 10-19:

```
BEGINNING CHANNEL NUMBER = 0
TYPE = THERMOCOUPLE
BEGINNING CHANNEL NUMBER = 10
TYPE = THERMOCOUPLE
```

PROGRAMMING

Isothermal Input Connector programming involves nothing more than specifying the function and type of thermocouple (or dc voltage range) for the desired channel. This procedure is summarized on the Programming Form. Full programming techniques are documented in the User Guide.

175/Isothermal Input Connector

OPERATION

Once installed in the Data Logger with the appropriate connections, the Isothermal Input Connector requires no further attention.

SERVICE INFORMATION

The following additional information can be found in the 2280 Series Service Manual:

- o Parts List
- o Schematic Diagram

2280A-176
Voltage Input Connector

INTRODUCTION

The Voltage Input Connector routes a maximum of 20 voltage input channels to the scanner. The connector assembly is enclosed in a plastic connector housing both for protection of the terminal connections and strain relief for the external wiring. This assembly is mounted to the 88-pin card-edge connector on the rear of the scanner. Retaining screws attach this housing to the chassis. The Voltage Input Connector is illustrated in Figure 176-1.

Each Input Connector channel uses three screw terminals (HIGH, LOW, and SHIELD). Each terminal can withstand a maximum of 250 volts rms.

P/N 647735, Rev 1
February, 1985

176/Voltage Input Connector

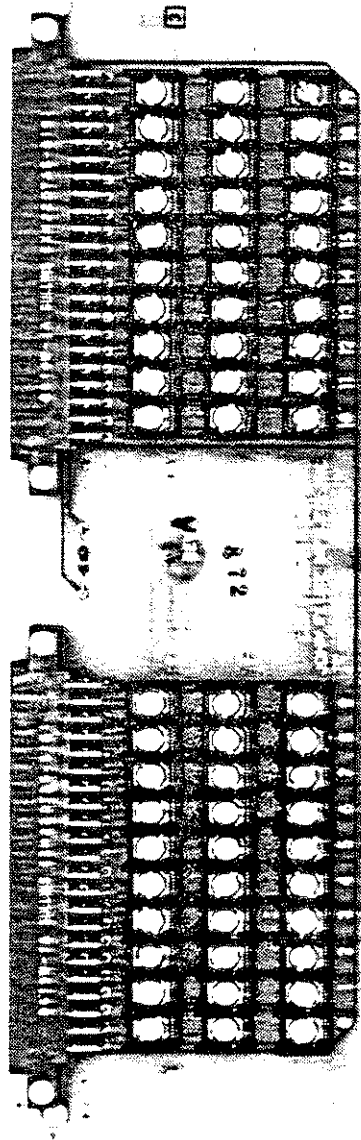

Figure 176-1. Voltage Input Connector

176/Voltage Input Connector

WHERE TO FIND MORE INFORMATION

This subsection of the System Guide presents operator-related information. A general description and list of specifications describe the option's capabilities. Installation instructions and installation test procedures then describe how to get the option up and running. Finally, operating instructions further define Data Logger use with this option. Since other system hardware is used in most applications, system operating instructions are not repeated here. Rather, references are made to application instructions elsewhere in the System Guide.

The User Guide presents complete operating instructions for the Data Logger. Information is presented in a general, and not option-specific, format. This volume treats operation with various levels of complexity, depending on user familiarity with the instrument. Some acquaintance with the User Guide is recommended. For any operation-related question, the User Guide is the ultimate authority.

SPECIFICATIONS

Specifications for the Voltage Input Connector are presented in Table 176-1.

176/Voltage Input Connector

Table 176-1. Voltage Input Connector Specifications

Channels	20
Terminals	60 (HI, LO, SHIELD per channel)
Maximum Voltage Rating	250V dc or ac rms from any terminal to any other terminal or ground.
Temperature	
Operating	-20 to 70°C
Storage	-55 to 75°C
Relative Humidity (without condensation)	
Below 25°C	<= 95%
25 to 40°C	<= 75%
40 to 50°C	<= 45%
50 to 70°C	<= 40%
Altitude	
Non-Operating	40,000 feet
Operating	10,000 feet
Shock and Vibration	Meets MIL-T-28800C, Class 5 Standards

176/Voltage Input Connector

INSTALLATION

External measurement sources are connected to the 2280 Series Data Logger via wiring to the input connector block. Installation of the Voltage Input Connector involves assembling and connecting wiring to the terminals and attaching the connector to the appropriate scanner.

Preliminary Steps

1. With line power disconnected and the POWER switch set at OFF, locate the connector housing in the rear panel of the 2280.
2. Loosen the two retaining screws that hold the housing to the chassis.
3. Firmly grasp the housing at each end and pull until the enclosed connector block is disconnected from the scanner.
4. Open the housing by gently pressing each locking tab.

Shield Considerations

Current resulting from a capacitive charge and discharge between the A/D Converter and the chassis can produce unstable readings. Therefore, a path for this current is utilized by connecting the SHIELD lead to the LOW lead at the measurement point. This arrangement improves common-mode noise rejection. It is shown in Figure 175-2. With the A/D Converter and the instrument shield tracking the same voltage, common-mode current in the HI and LOW leads is minimized. Note that HI, LOW and Shield are fully isolated and capable of being safely floated to 250 volts above ground.

176/Voltage Input Connector

Use the following guidelines when connecting the Voltage Input Connector:

1. If significant RFI (Radio Frequency Interference) or EMI (Electro-Magnetic Interference) is present, the best measurement results are obtained by connecting SHIELD to LOW (on the input connector) with the shortest possible path.
2. If significant common mode voltage (greater than one volt) is present, connect SHIELD to LOW by means of a third wire at the measurement point. This arrangement is shown in Figure 175-2.
3. Never tie SHIELD to HI. This may actually amplify the effects of noise on the signal, causing a degradation in measurement performance.
4. Never leave SHIELD unconnected. Static charge buildup may cause the maximum SHIELD to LOW voltage to be exceeded, resulting in instrument damage.
5. Never connect SHIELD to earth ground unless the LOW terminal is also grounded. This results in greatly increased common mode currents due to the large value of capacitance between the Shield and the A/D Converter.

Connecting the Voltage Input Wires

WARNING

BE SURE THAT THE WIRES BEING CONNECTED ARE NOT ENERGIZED. IF POSSIBLE, DISCONNECT THESE WIRES AT THE OTHER END. IN ANY EVENT, ENSURE THAT THE EXTERNAL CIRCUIT CONNECTED TO THESE WIRES IS NOT ENERGIZED. LETHAL VOLTAGE COULD OTHERWISE BE ENCOUNTERED.

176/Voltage Input Connector

The Voltage Input Connector is now ready to be wired to external measurement systems. Proceed as follows:

1. For each connection, loosen the channel terminal screw, attach the external wire to the screw, then tighten the screw until the wire is firmly in place.
2. Notice that the three terminals for each channel are marked HIGH, LOW, and SHIELD. Starting at Channel 0, attach the external wiring for the desired application. Observe proper polarity.
3. Close the housing over the input connector, ensuring that the external wires exit the rear of the enclosure without being pinched.

Attaching the Voltage Input Connector

WARNING

BEFORE INSTALLING THE WIRED INPUT CONNECTOR AT THE 2280 REAR PANEL, ENSURE THAT ALL LINE POWER TO THE MAINFRAME OR EXTENDER CHASSIS IS DISCONNECTED. LETHAL VOLTAGES MAY BE PRESENT WITHIN THE 2280 AND ON SOME OPTION CARDS. DO NOT REMOVE ANY INSTRUMENT COVERS UNLESS YOU ARE QUALIFIED TO DO SO.

Complete the Voltage Input Connector Installation as follows:

1. Position the enclosed (and wired) input connector in the guides of the 2280 rear panel slot containing the appropriate scanner.
2. Push the connector firmly into place on the card-edge connector at the rear of the scanner.
3. Attach the connector housing to the chassis with the two retaining screws.

176/Voltage Input Connector

INSTALLATION TEST

Correct installation is verified through the hardware listing function.

1. Ensure that the POWER switch is turned to OFF.
2. Check that the A/D Converter is installed in the 2280 (address switch set to 0).
3. Install the Thermocouple/DC Volts Scanner (162) directly below the A/D Converter.
4. Install the Voltage Input Connector on the scanner.
5. Apply power to the 2280.
6. Program the data logger for a hardware list as follows:

Press:	Display:
	MAIN MENU CHOICE <M FOR MENU>? A
L	<L> LIST PROGRAM AND CONFIGURATION
ENTER	L: LIST MENU CHOICE <A-Z>? E
C	L<C> LIST HARDWARE CONFIGURATION
ENTER	LISTING <PRESS EXIT TO ABORT>
	(list is printed)
EXIT	MAIN MENU CHOICE <M FOR MENU>? A

Among other things, the resulting printed configuration list identifies each channel block by beginning channel number and type. The following printout example identifies channel blocks 00-09 and 10-19:

```
BEGINNING CHANNEL NUMBER = 0
TYPE = VOLTS/CURRENT
BEGINNING CHANNEL NUMBER = 10
TYPE = VOLTS/CURRENT
```

176/Voltage Input Connector

PROGRAMMING

Voltage Input Connector programming involves nothing more than specifying the function and range for the desired channel. This procedure is summarized on the Programming Form. Full programming techniques are documented in the User Guide.

OPERATION

Once installed in the data logger with the appropriate wiring, the Voltage Input Connector requires no further attention.

SERVICE INFORMATION

The following additional information can be found in the 2280 Series Service Manual:

- o Parts List
- o Schematic Diagram

2280B-177
RTD/Resistance Input Connector

INTRODUCTION

The RTD/Resistance Input Connector provides 20 sets of connection points for wiring external resistance transducers to the RTD/Resistance Scanner. The RTD/Resistance Input Connector is illustrated in Figure 177-1.

Each of the 20 channels of terminals provides five termination points for accommodating 4-Wire, 3-Wire, and 2-Wire measurement configurations. The use of a 3mm (1/8 in) standard blade screwdriver is required for fastening the lead wires in the terminal blocks.

WHERE TO FIND MORE INFORMATION

This subsection of the System Guide presents description, specifications, and installation information directly related to the use of the RTD/Resistance Input Connector with the RTD/Resistance Scanner.

P/N 749648
February, 1985

177/RID/Resistance Input Connector

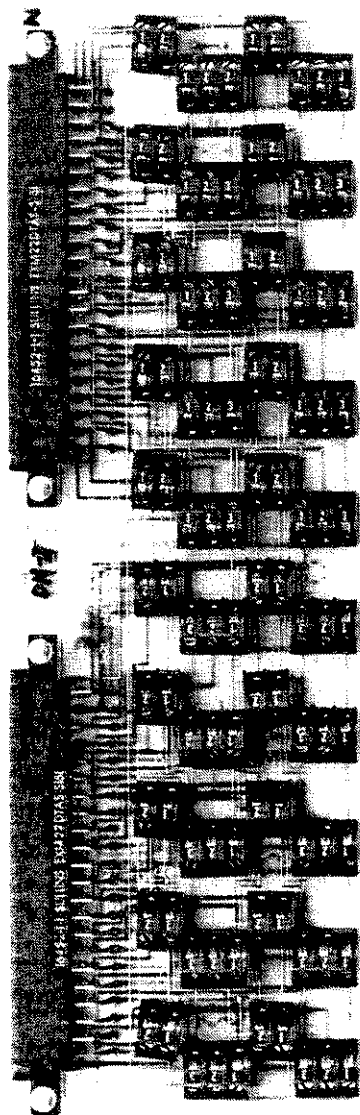

Figure 177-1. RID/Resistance Input Connector

177/RTD/Resistance Input Connector

When the RTD/Resistance Input Connector and Scanner are used to implement a specific data logging function, other sections of this System Guide provide more appropriate information. These sections include:

- o Section 5a: Temperature Measurement
This section discusses use of the RTD/Resistance Scanner (and Connector) in measuring temperature (RTDs or thermistors).
- o Section 5d: Resistance Measurements
This section discusses how to obtain a measurement expressed in ohms.

General Data Logger system operating instructions are not presented in this manual, but are given in the User Guide. The User Guide presents operation at various levels of complexity, to better match user familiarity with the instrument, and is the ultimate authority on operation-related questions.

SPECIFICATIONS

Specifications for the RTD/Resistance Input Connector are presented in Table 177-1.

Specifications for both the RTD/Resistance Scanner and Input Connector can be found in the 163 subsection. Other specifications which pertain to the use of these option assemblies in specific applications such as measuring RTDs are presented in Appendix G of this manual.

Table 177-1. RTD/Resistance Input Connector Specifications

Channels	20
Terminals	100 (HI EXC, HI, LO, LO EXC, and LO COM per channel)

177/RTD/Resistance Input Connector

Maximum Voltage Rating and mating RTD/Resistance Scanner Mode

163 Measurement Mode	4-Wire (4W)
Ratings	250V dc or ac rms between any two channels or any channel and ground, 30V dc or 24V ac rms between any terminals of a channel
163 Measurement Mode	3-Wire Accurate (3WA)
Ratings	250V dc or ac rms between channels in different decades or between channels in a decade and ground, 30V dc or 24V ac rms between any terminals within a decade except between LO COMs. (LO COMs of channels within a decade are connected together internally).
163 Measurement Mode	3-Wire Isolated (3WCM)
Ratings	same as for 4-Wire
Compatibility	Attaches to RTD/Resistance Scanner (option 163)
Temperature	
Operating	-20 to 70°C
Storage	-55 to 75°C
Relative Humidity (without condensation)	
Below 25°C	<= 95%
25 to 40°C	<= 75%
40 to 50°C	<= 45%
50 to 70°C	<= 40%
Altitude	
Non-Operating	40,000 feet
Operating	10,000 feet
Shock and Vibration	Meets MIL-T-28800C, Class 5 Standards

177/RID/Resistance Input Connector

INSTALLATION

External resistance sensors are connected to the 2280 Series Data Logger through the RID/Resistance Input Connector. Installation of this connector involves assembling and connecting the sensor lead wires to the connector terminals and attaching the connector to the RID/Resistance Scanner.

Preliminary Steps

1. With 2280 line power disconnected and the POWER switch set at OFF, locate the horizontal connector housing in the back.
2. Loosen the two retaining screws that hold the housing to the chassis.
3. Firmly grasp the housing at both ends and pull until the enclosed connector block is disconnected from the scanner.
4. Open the housing by gently pressing each locking tab.

Connecting the Resistance Sensor Input Wires

WARNING

BE SURE THAT THE WIRES BEING CONNECTED ARE NOT ENERGIZED. IF POSSIBLE, DISCONNECT THESE WIRES AT THE OTHER END. IN ANY EVENT, ENSURE THAT THE EXTERNAL CIRCUIT CONNECTED TO THESE WIRES IS NOT ENERGIZED. LETHAL VOLTAGE COULD OTHERWISE BE ENCOUNTERED.

177/RTD/Resistance Input Connector

The RTD/Resistance Input Connector can now be wired to external resistance sensors. Proceed as follows:

1. Familiarize yourself with the arrangement of the connecting terminals.
 - o Five connecting terminals are available for each channel.
 - o Twenty sets of terminals are provided on each input connector.
 - o Wiring for each set of terminals is defined by the 4-Wire (4W), 3-Wire Accurate (3WA), or 3-Wire Isolated (3WCM) measurement mode selected on the associated RTD/Resistance Scanner.
 - o Where lead wire resistance errors are negligible, 2-Wire connections can be used when the Scanner is set for 4-Wire operation.
 - o Refer to the following Figures 177-2 through 177-5. The connector housing decal is also a good reference source.
2. For each connection, loosen the terminal block screw with a 3mm standard blade screwdriver, place the stripped end of the external wire or jumper inside the terminal block opening, and tighten the screw until the wire is firmly clamped in place.

177/RTD/Resistance Input Connector

NOTE

To form jumpers with and connect all but the largest gauge lead wire, strip about 30mm (1.2in) of insulation from the end of the wire. Place the end in one of the two terminal block openings and clamp it in. Form a sharp "U" in the lead wire approximately 15mm (0.6in) from the terminal block. Stuff the bottom of the "U" in the second terminal block opening and clamp it in, thereby connecting the lead wire and forming a jumper at the same time.

3. Close the housing over the input connector, ensuring that the external wires exit the rear of the enclosure without being pinched.

Attaching the Input Connector

WARNING

BEFORE INSTALLING THE WIRED INPUT CONNECTOR AT THE 2280 REAR PANEL, ENSURE THAT ALL LINE POWER TO THE MAINFRAME OR EXTENDER CHASSIS IS DISCONNECTED. LETHAL VOLTAGES MAY BE PRESENT WITHIN THE 2280 AND ON SOME OPTION CARDS. DO NOT REMOVE ANY INSTRUMENT COVERS UNLESS YOU ARE QUALIFIED TO DO SO.

Complete the connector installation as follows:

1. Position the wired and enclosed input connector in the the 2280 rear panel slot containing the RTD/Resistance Scanner.
2. Push the input connector firmly into place on the scanner rear card-edge.
3. Attach the connector housing to the chassis with the two retaining screws.

177/RTD/Resistance Input Connector

INSTALLATION TEST

Proper RTD/Resistance Scanner installation can be checked by listing the hardware configuration. Proceed as follows:

Press:	Display:
	MAIN MENU CHOICE <M FOR MENU>? A
L	<L> LIST PROGRAM AND CONFIGURATION
ENTER	L: LIST MENU CHOICE <A-Z>? E
C	L<C> LIST HARDWARE CONFIGURATION
ENTER	(list is printed)
EXIT	MAIN MENU CHOICE <M FOR MENU>? A

Among other things, the resulting printed configuration list identifies each channel block by beginning channel number and type. The following printout example identifies two channel decades, 0-9 and 10-19:

```
BEGINNING CHANNEL NUMBER = 0
TYPE = RTD
BEGINNING CHANNEL NUMBER = 10
TYPE = RTD
```

To test for proper Input Connector installation, perform the appropriate installation test in the Temperature Measurements (RTD or Thermistor), and/or Resistance Measurements subsections of Section 5.

PROGRAMMING

Programming the 2280 Series Data Logger to utilize the RTD/Resistance Scanner/Connector involves procedures common to other assemblies. This programming process is summarized on the Programming Form and is fully explained in the User Guide.

177/RTD/Resistance Input Connector

Instructions specific to the RTD/Resistance Scanner/Connector are listed in the CHANNEL PROGRAM section of the Programming Form. Several choices are available:

- o The RTD type associated with a channel can be programmed. If any of several common RTDs is selected, no further programming is necessary: the 2280 provides a stored set of applicable RTD constants.
- o If a user-defined RTD is associated with a given channel, unique R0, Alpha, Delta, and C4 RTD constants can be programmed.
- o Resistance measurement ranges can be selected. The following ranges are provided by the RTD/Resistance Scanner/Connector:

256.00 OHMS
2048.0 OHMS
64.000 KOHMS

OPERATION

Once installed in the Data Logger, the RTD/Resistance Input Connector requires no further operator attention.

Use of the RTD/Resistance Scanner with the RTD/Resistance Input Connector is described in sections 5a and 5d of this manual. In addition, the User Guide documents the wide range of programming and operating features offered by the 2280 series.

SERVICE INFORMATION

The following additional information can be found in the 2280 Series Service Manual:

- o Parts List
- o Schematic Diagram

177/RTD/Resistance Input Connector

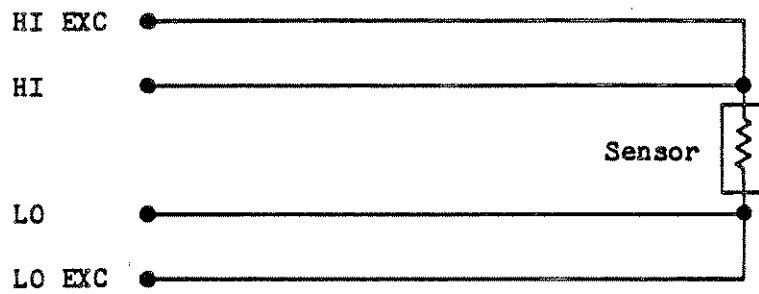

This is the most accurate measurement mode.

Figure 177-2. 4-Wire Connections

177/RTD/Resistance Input Connector

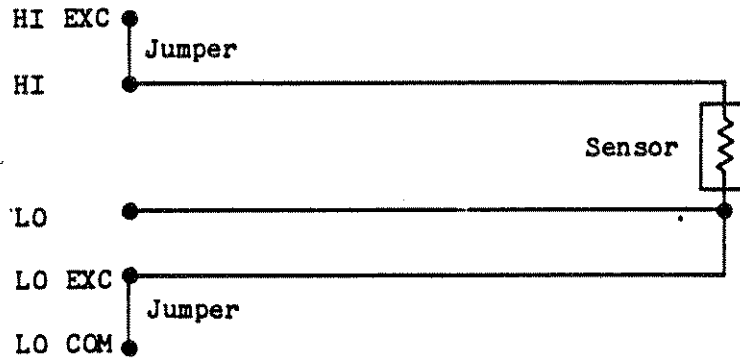

Ensure that the HI and LO EXC lead wires have the same length, composition, and resistance.

Use the 3-Wire configuration if possible. Remember that the LO COMs of ten channels (e.g. 0-9) are connected together inside the Connector PCB.

Figure 177-3. 3-Wire Accurate Connections

177/RID/Resistance Input Connector

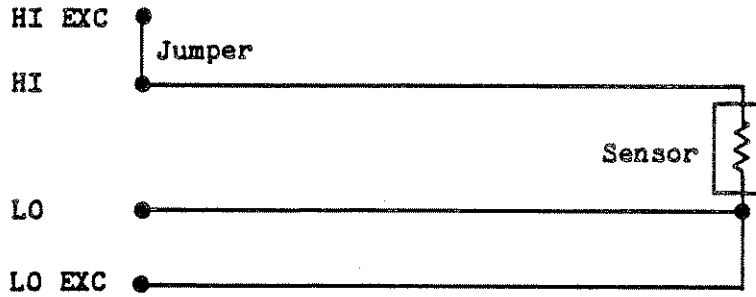

Ensure that the HI and LO EXC lead wires have the same length, composition, and resistance.

This is much less accurate than the 3WA mode for all but many-kilohm resistance measurements.

Figure 177-4. 3-Wire Isolated Connections

177/~~RTD~~/Resistance Input Connector

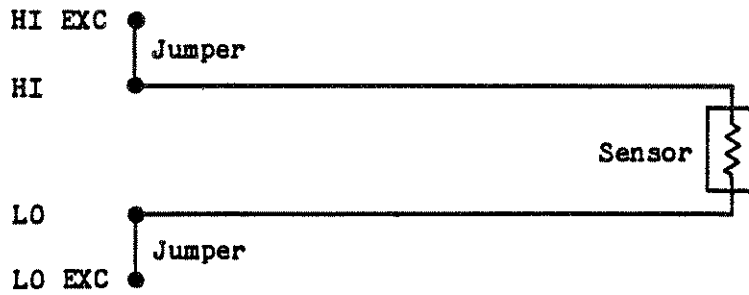

Lead wire resistances must be negligible when compared to the sensor resistance.

Figure 177-5. 2-Wire Connections



2280A-179
Status Input Connector

INTRODUCTION

The Digital/Status Input Connector can be used for the mutually exclusive functions of providing BCD digital input, binary digital input, or status input information to the 2280 Series Data Logger. This assembly connects to the Digital I/O Board (Option -168). It can be configured by the user.

The Digital/Status Input Connector is illustrated in Figure 179-1.

WHERE TO FIND MORE INFORMATION

This subsection of the System Guide presents operator-related information. A general description and list of specifications describe the option's capabilities. Installation instructions and installation test procedures then describe how to get the option up and running. Finally, operating instructions further define Data Logger use with this option. Since other system hardware is used in most applications, system operating instructions are not repeated here. Rather, references are made to application instructions elsewhere in the System Guide.

P/N 647669, Rev 1
February, 1985

179/Status Input Connector

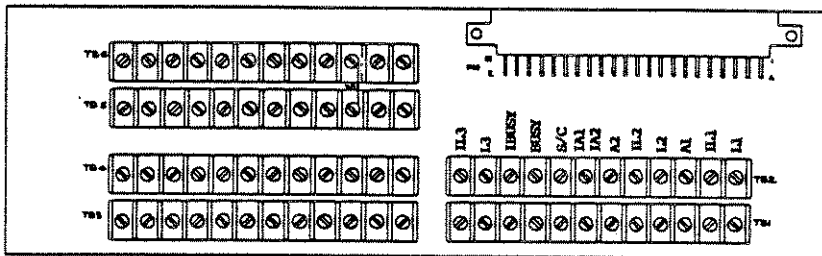

Handshake Terminal Abbreviations

Symbol	Name	Signal Direction
IL3	Invert LOAD3	Input
L3	LOAD3	Input
IBUSY	Invert BUSY	Output
BUSY	BUSY	Output
S/C	Single/Continuous Control	Input
IA1	Invert Acknowledge 1	Output
IA2	Invert Acknowledge 2	Output
A2	Acknowledge 2	Output
IL2	Invert LOAD2	Input
L2	LOAD2	Input
A1	Acknowledge 1	Output
IL1	Invert LOAD1	Input
L1	LOAD1	Input

Figure 179-1. Digital/Status Input Connector

179/Status Input Connector

The User Guide presents complete operating instructions for the Data Logger. Information is presented in a general, and not option-specific, format. This volume treats operation with various levels of complexity, depending on user familiarity with the instrument. Some acquaintance with the User Guide is recommended. For any operation-related question, the User Guide is the ultimate authority.

SPECIFICATIONS

Specifications for the Digital/Status Input Connector are presented in Table 179-1.

Table 179-1. Digital/Status Input Connector Specifications

Channels	20 single bit, or one 5 BCD digit word, or one 17-bit binary word
Terminals	72
Maximum Input Voltage	6V dc
Isolation	30V dc or ac rms between any terminal and ground.
Compatibility	Attaches to Digital I/O (option 168)
Temperature	
Operating	-20 to 70°C
Storage	-55 to 75°C
Relative Humidity (without condensation)	
Below 25°C	<= 95%
25 to 40°C	<= 75%
40 to 50°C	<= 45%
50 to 70°C	<= 40%
Altitude	
Non-Operating	40,000 feet
Operating	10,000 feet
Shock and Vibration	Meets MIL-T-28800C, Class 5 Standards

179/Status Input Connector

DIGITAL/STATUS INPUTS - GENERAL

Each Digital/Status Input Connector must be configured for use with the Digital I/O Board. Also, a handshake procedure must be specified to allow data exchange with external devices.

Input Data Format

Digital input data formats (BCD and Binary) are shown in Figure 179-2. One of the following two data formats can be specified by the user:

- o 5-digit BCD (Binary-Coded Decimal that ranges from +/- 79999), with polarity sign , or
- o 16-bit Binary Format with sign.

The desired format is chosen by configuring inputs 21 and 22 on the Digital/Status Input Connector as follows:

Binary:	Input 21 -- 0	BCD:	Input 21 -- 1
	Input 22 -- 0		Input 22 -- 0

Zero (0) indicates a jumper from the SIGNAL terminal to its RETURN. One (1) indicates no connection.

NOTE

Do not leave both inputs open. Digital I/O Board operation is undefined if the inputs are open.

179/Status Input Connector

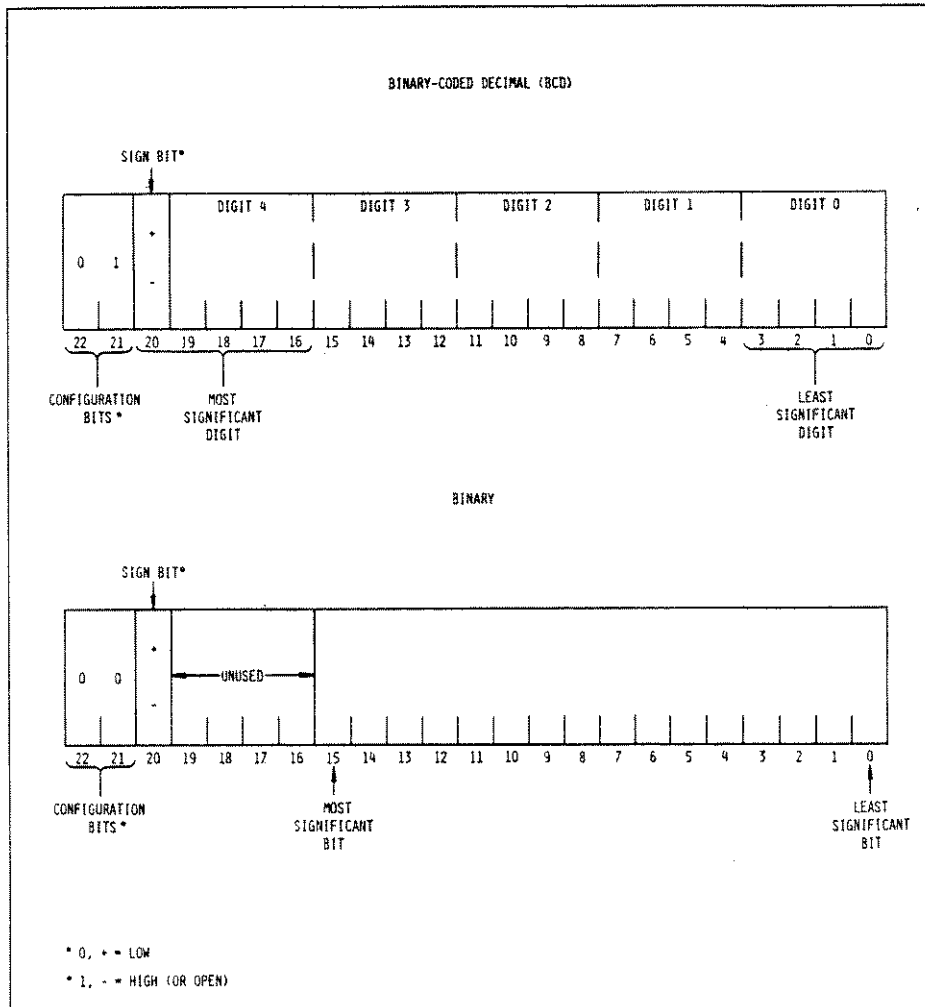

Figure 179-2. Digital Input Data Formats

179/Status Input Connector

Digital Input

When configured for digital input, the Digital/Status Input Connector allows the Digital I/O Board to accept parallel digital data from an external source. This data is received at the channel address set on the associated Digital I/O Board.

Digital Input Handshake Process

One of three data input handshake methods must be used to properly interface the connector with digital input data. The three methods are illustrated in Figure 179-3. Although any one handshake method acts independently of the other two, the functions performed by each are identical. Note that a data input handshake process is used for BCD or Binary input configurations only.

Select the desired method by connecting the external device to the proper handshake terminals on the Digital/Status Input Connector. These terminals are located on the right side of the assembly, directly below the connector pins. Refer to Figure 179-3 for the location of the proper handshake terminals. Also note the following:

- o Unless otherwise specified, all control signals are active (1) in HIGH logic state. Each signal may be set to zero by connecting it to its RETURN terminal or by driving it to a logic low level with respect to the RETURN.

179/Status Input Connector

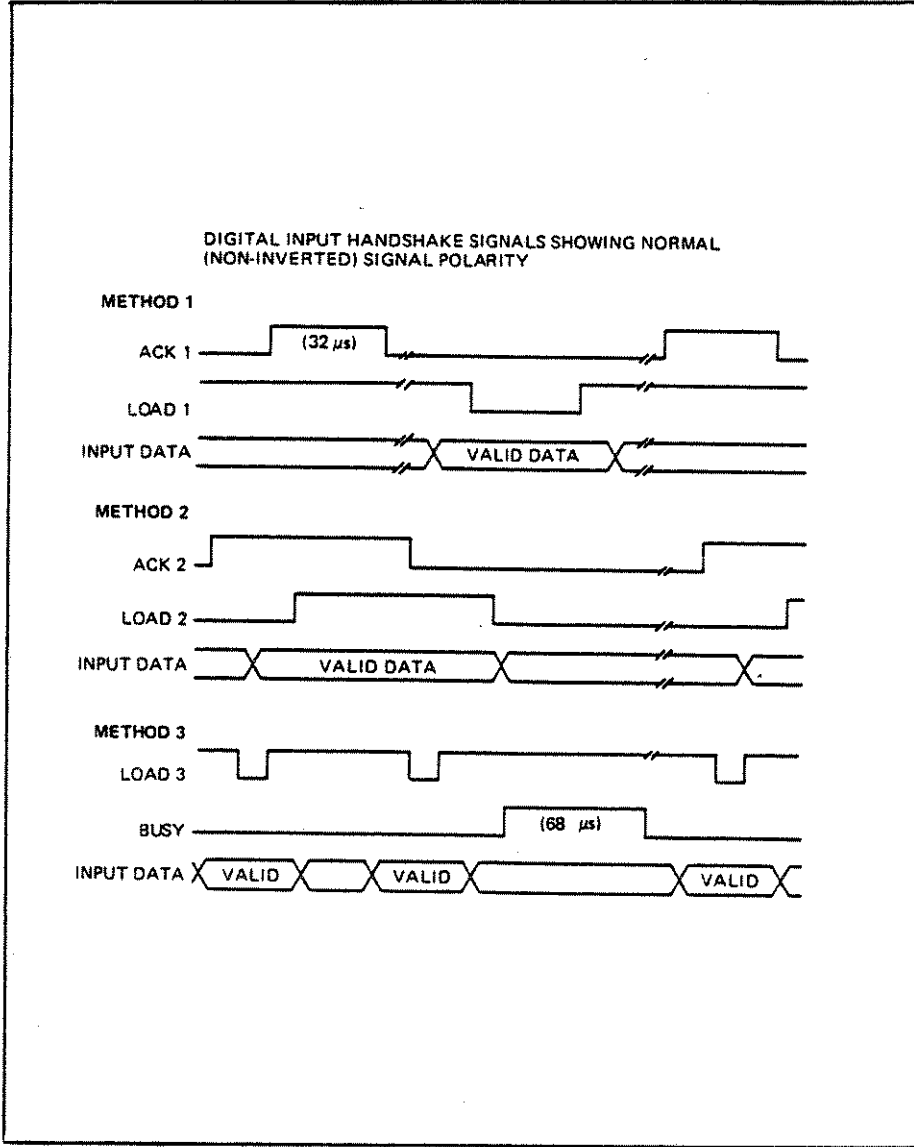

Figure 179-3. Digital Input Handshake Signals Showing Normal (Non-Inverted) Signal Polarity

179/Status Input Connector

- o The terminals marked S/C on the connector comprise the Single/Continuous control.
 - a. If left unconnected, this control line sets the Digital I/O Board in a continuous input mode. In this mode, the handshake and data loading process are performed repeatedly between input data sampling by the 2280. The 2280 reads only the latest data loaded.
 - b. If the S/C SIGNAL terminal is connected to RETURN, the Digital I/O board is placed in a single input mode. In this mode, data may be loaded only once between samplings by the 2280. Once a load has occurred, the handshake process is inhibited until the 2280 has retrieved the input data from the Digital I/O Board.

HANDSHAKE METHOD #1

Immediately following power-up, A1 (Acknowledge 1) is asserted (high). A1 is a 32-microsecond pulse generated by the Digital I/O board indicating that data may be loaded. Data is entered by the external device and latched with the L1 (LOAD1) control signal. In the continuous mode, A1 is again asserted after L1 is reset. In the single mode, A1 is inhibited until the input data is sampled by the 2280.

HANDSHAKE METHOD #2

Following power-up, A2 (Acknowledge 2) is asserted by the Digital I/O board. L2 (LOAD2) may then be asserted by the external device to load the data on the input lines. A2 is withdrawn once the data is received. L2 may then be withdrawn. In the continuous mode, A2 is again asserted after L2 becomes low. In the single mode, A2 remains inactive until the 2280 has sampled the data. In either case, L2 must be reset low before the cycle may be repeated.

179/Status Input Connector

HANDSHAKE METHOD #3

L3 (LOAD3) may be asserted by the external device at any time. In the continuous mode, each assertion of L3 causes the input data to be loaded. In the single mode, only the first L3 following power-up, or following a data sampling by the 2280E, is effective. The Digital I/O Board generates a BUSY signal during the time that the data is being sampled. L3 is not effective during this time. BUSY is asserted for a period of approximately 68 microseconds.

Status Input

When configured for status input, the Digital/Status Input Connector allows the Digital I/O Board to accept a maximum of 20 separate one-bit inputs from an external source for each Digital I/O Board installed in either the 2280 Mainframe or the 2281A Extender Chassis. Each bit is associated with a channel programmed as status input.

The Status Input configuration is achieved on the Digital/Status Input Connector by installing a jumper at input 21 and leaving input 22 open.

CAUTION

Do NOT leave both inputs 21 and 22 open.
This code makes the Digital I/O act as a
Status Output.

179/Status Input Connector

INSTALLATION

Connections from external control points or terminals to the 2280 Series Data Logger are made via external wiring to the Digital/Status Input Connector. Preparation of the Digital/Status Input Connector involves opening its connector housing, assembling and connecting the appropriate wiring on the terminals, closing the connector housing, and connecting it back to the Digital I/O board. The following steps detail this procedure:

WARNING

ENSURE THAT ALL LINE POWER TO THE MAINFRAME OR EXTENDER CHASSIS IS DISCONNECTED. LETHAL VOLTAGES MAY BE PRESENT WITHIN THE 2280 AND ON SOME OPTION CARDS. DO NOT REMOVE ANY INSTRUMENT COVERS UNLESS YOU ARE QUALIFIED TO DO SO.

Preliminary Steps

1. With line power disconnected and the POWER switch turned to OFF, locate the connector housing in the rear panel of the 2280.
2. Remove the two retaining screws that hold the housing assembly to the chassis.
3. Firmly grasp the connector housing at its midpoint and pull until the enclosed connector block is disconnected from the Digital I/O Board.
4. Open the housing by gently pressing each locking tab.
5. Configure the connector for either status input or digital input (BCD or Binary).

Connecting the Wires

WARNING

BE SURE THAT THE WIRES BEING CONNECTED TO THE DIGITAL/STATUS INPUT CONNECTOR ARE NOT ENERGIZED. IF POSSIBLE, DISCONNECT THESE WIRES AT THE OTHER END. IN ANY EVENT, ENSURE THAT THE ASSOCIATED EXTERNAL CIRCUIT IS DEENERGIZED. HAZARDOUS VOLTAGE COULD OTHERWISE BE ENCOUNTERED.

Use the following procedure when connecting wires from the external circuit. Notice that the two terminals for each channel are marked SIGNAL and RETURN. All returns are connected together on the card and are tied to logic common on the Digital I/O Board.

1. Starting at channel 0, attach the external wiring for the desired application. To make each attachment, do the following:
 - o Loosen the channel terminal screws.
 - o Attach the external wires to the screws.
 - o Tighten the screws until the wires are firmly in place.
2. Close the connector housing over the input connector, ensuring that the external wires exit the rear of the enclosure without being pinched.

179/Status Input Connector

Attaching the Digital/Status Input Connector

WARNING

BEFORE INSTALLING THE WIRED DIGITAL/STATUS INPUT CONNECTOR AT THE 2280 REAR PANEL, ENSURE THAT ALL LINE POWER TO THE MAINFRAME OR EXTENDER CHASSIS IS DISCONNECTED. LETHAL VOLTAGES MAY BE PRESENT WITHIN THE 2280 AND ON SOME OPTION CARDS. DO NOT REMOVE ANY INSTRUMENT COVERS UNLESS YOU ARE QUALIFIED TO DO SO.

With all external connections in place, attach the connector assembly as follows:

1. Position the enclosed (and wired) Digital/Status Input Connector at the guides of the 2280 rear panel slot containing the Digital I/O Assembly.
2. Then, grasping the Digital/Status Input Connector firmly, mate it with the Digital I/O Assembly until it is firmly in place.
3. Use the two retaining screws to secure the connector housing to the chassis.

INSTALLATION TEST

Use the following procedure to test for proper installation of the Digital/Status Input Assembly:

1. Ensure that power is not applied to the 2280.
2. Set the Digital I/O Assembly address switch to 04.
3. Install the Digital I/O Assembly in the 2280.
4. Install the Digital/Status Input Assembly on the rear of the Digital I/O Assembly.

179/Status Input Connector

5. Apply power to the 2280.
6. Program the 2280 to list the hardware configuration as follows:

Press:	Display:
	MAIN MENU CHOICE <M FOR MENU>? A
L	<L> LIST PROGRAM AND CONFIGURATION
ENTER	L: LIST MENU CHOICE <A-Z>? E
C	L<C> LIST HARDWARE CONFIGURATION
ENTER	LISTING <PRESS EXIT TO ABORT>
	(list is printed)
EXIT	MAIN MENU CHOICE <M FOR MENU>? A

7. Check the printed configuration list for correct hardware installation. A Digital/Status Input Assembly installation should yield a listing that correctly identifies the channel block and type. Look for the following:

```
BEGINNING CHANNEL NUMBER = 40
TYPE = STATUS INPUT
BEGINNING CHANNEL NUMBER = 50
TYPE = STATUS INPUT
```

PROGRAMMING

Programming for the Digital/Status Input Assembly involves selection of the function for the appropriate channels. Special zero and non-zero designations can also be defined.

SERVICE INFORMATION

The following additional information can be found in the 2280 Series Service Manual:

- o Parts List
- o Schematic Diagram



2280A-211
Advanced Math Processor

INTRODUCTION

The following information details the use of the 2280 Math Processor (option 211). This assembly allows for a considerable range of interchannel computations. Results are displayed as a channel reading.

The 2280 Series Data Logger handles computations on two levels.

- o Many simpler expressions (such as $mX+b$ scaling) can be programmed without installing an Advanced Math Processor. These expressions are described in the User Guide.

- o More complex expressions (such as interpolation tables) require use of the optional Advanced Math Processor. These expressions are described both in this section and in the User Guide.

Advanced Math entries are made during the Channel Program phase of data logging configuration. These entries use operands and operators to form math expressions and procedures.

P/N 647719, Rev 1
February, 1985

211/Advanced Math Processor

WHERE TO FIND MORE INFORMATION

This subsection of the System Guide presents operator-related information. A general description and list of specifications describe the option's capabilities. Installation instructions and installation test procedures then describe how to get the option up and running. Finally, operating instructions further define Data Logger use with this option. Since other system hardware is used in most applications, system operating instructions are not repeated here. Rather, references are made to application instructions elsewhere in the System Guide.

The User Guide presents complete operating instructions for the Data Logger. Information is presented in a general, and not option-specific, format. This volume treats operation with various levels of complexity, depending on user familiarity with the instrument. Some acquaintance with the User Guide is recommended. For any operation-related question, the User Guide is the ultimate authority.

SPECIFICATIONS

Specifications for the Advanced Math Processor are presented in Table 211-1.

211/Advanced Math Processor

Table 211-1. Advanced Math Processor Specifications

Functions	Absolute value, square root, exponential, sine, cosine, tangent, inverse sine, inverse cosine, inverse tangent, common logarithm, natural logarithm, table interpolation, integer part, maximum value, minimum value, standard deviation, group average, and elapsed time.
Logical Operators	AND, OR, NOT, EXCLUSIVE-OR
Relational Operators	<, <=, >, >=, =, /=
Interpolation Tables	Up to 10 user-defined.
Temperature	
Operating	0 to 50°C
Storage	-25 to 60°C
Humidity (without condensation)	
0 to 25°C	<95%
25 to 40°C	<75%
40 to 50°C	<45%
Altitude	
Non-Operating	40,000 feet
Operating	10,000 feet
Shock and Vibration	Meets MIL-T-28800C, Class 5 Standards

211/Advanced Math Processor

INSTALLATION

The Advanced Math Processor can only be installed at the factory or at an authorized service center.

INSTALLATION TEST

Proper installation can be checked by performing a hardware configuration list. Proceed as follows:

Press:	Display:
	MAIN MENU CHOICE <M FOR MENU>? A
L	<L> LIST PROGRAM AND CONFIGURATION
ENTER	L: LIST MENU CHOICE <A-Z>? E
C	L<C> LIST HARDWARE CONFIGURATION
ENTER	LISTING <PRESS EXIT TO ABORT>
	(list is printed)
EXIT	MAIN MENU CHOICE <M FOR MENU>? A

Check the printed configuration list for correct hardware installation. In this case, a correct Advanced Math Processor installation yields a listing with the following wording:

MATH BOARD INSTALLED

OPERATION

Once installed in the 2280 Series Data Logger, the Advanced Math Processor enables the user to program an extensive variety of interchannel math calculations.

Writing Mathematical Statements

Programming the channel expression or channel procedure allows the Data Logger to convert the results of a channel measurement from raw input to a relevant value. Refer to the 2280 Series User Guide for in-depth channel programming descriptions.

Definitions

Expressions

The term "expression" refers to the string of characters to the right of the assignment operator. An expression is used with measurement channel programming.

Procedure

A procedure is used with pseudo channel programming.

Assignment Operator

The "assignment operator" (=) separates the pseudo-channel, output channel, or measurement channel from the mathematical expression.

Operands

Operands are the components of a mathematical expression. Each, when evaluated, has an arithmetic value. Operands include:

Channel Numbers
Constants
Functions

Channel data used in a expression can be manipulated with a variety of special calculations (functions).

- o Alarm Status and Error Status can be used without the Math processor.
- o All other functions that necessitate the use of the Math Processor are documented here.

211/Advanced Math Processor

NOTE

In the functions listed below, the operand(s) indicated by (x) can be channel number(s), constant(s), function(s), expression(s) with operand(s) and operator(s), or combinations of these.

Operand	Meaning
ABS(x)	absolute value
SQR(x)	square root
EXP(x)	exponential
SIN(x)	sine
COS(x)	cosine
TAN(x)	tangent
ASIN(x)	inverse sine
ACOS(x)	inverse cosine
ATAN(x)	inverse tangent
LOG(x)	common logarithm
LN(x)	natural logarithm
TBLn(x)	table interpolation
INT(x)	integer part
MAX(1x//2x//3x//etc)	maximum value
MIN(1x//2x//3x//etc)	minimum value
SD(1x//2x//3x//etc)	standard deviation
GAV(x)	group average
TIME	elapsed time

Operators

Operators describe the mathematical activity that takes place between and among the components of the mathematical expression (the operands). Simple operators (such as addition, subtraction, multiplication, and division) are available in the Data Logger. More complex operators (such as exponentiation) are provided by the Advanced Math Processor (option 211). Operators include:

Logical Operators

The logical operators perform logical functions on adjacent operands. Non-zero operands are interpreted as logical "1", and zero valued operands interpreted as logical "0". These operators are useful when a status output channel is to be a function of status input, alarm status, or other status output channels.

Operator	Meaning
AND	logical and
OR	logical or
NOT	logical inverse
XOR	logical exclusive or

Relational Operators

These operators return a logical "1" if the relationship is true or a logical "0" in any other case.

Operator	Meaning
LT	less than
LE	less than or equal
GT	greater than
GE	greater than or equal
EQ	equal
NE	not equal

Exponentiation Operator

The exponentiation operator performs the function of raising an operand to the power of another operand. All of the operators are described in the following paragraphs.

****** exponentiation

211/Advanced Math Processor

Order of Operator Evaluation

The order in which operators are evaluated within an expression is as follows:

- o Parentheses
- o Unary + and -
- o Exponentiation
- o Multiplication & Division
- o Addition & Subtraction
- o Relational Operators (GT, GE, LT, LE, EQ, NE)
- o Logical Not (NOT)
- o Logical And (AND)
- o Logical Or and Logical Exclusive Or (OR, XOR)

Operators of the same precedence are evaluated left to right. The Unary - operator is used to change the sign of a number. The Unary + is included for completeness, but is almost never used.

SERVICE INFORMATION

The following additional information can be found in the 2280 Series Service Manual:

- o Theory of Operation
- o Parts List
- o Schematic Diagram

2280A-214
DC-100 Cartridge Tape Drive

INTRODUCTION

The DC-100 Cartridge Tape Drive is a data storage system. It stores logged data in a format chosen by the user. It can also store an entire configuration program for later use. This capability allows for designing and storing special data logging configuration programs. The Cartridge Tape Drive is located in the upper left corner of the Data Logger front panel.

The 2280 can be configured in software via the tape. Manual entry is only necessary when initially entering the program.

If ordered separately from the 2280, the DC-100 Cartridge Tape and Interface should be installed by a qualified Fluke Service Representative.

P/N 647727, Rev 1
February, 1985

214/DC-100 Cartridge Tape Drive

WHERE TO FIND MORE INFORMATION

This subsection of the System Guide presents operator-related information. A general description and list of specifications describe the option's capabilities. Installation instructions and installation test procedures then describe how to get the option up and running. Finally, operating instructions further define Data Logger use with this option. Since other system hardware is used in most applications, system operating instructions are not repeated here. Rather, references are made to application instructions elsewhere in the System Guide.

The User Guide presents complete operating instructions for the Data Logger. Information is presented in a general, and not option-specific, format. This volume treats operation with various levels of complexity, depending on user familiarity with the instrument. Some acquaintance with the User Guide is recommended. For any operation-related question, the User Guide is the ultimate authority.

Also refer to the Appendices in this manual. The following additional information is available there:

- o Appendix H: Cartridge Tape Handling
- o Appendix I: Cartridge Tape Format

SPECIFICATIONS

Specifications for the DC-100 Cartridge Tape and Interface are presented in Table 214-1.

214/DC-100 Cartridge Tape Drive

Table 214-1. Cartridge Tape Specifications

Drive	2 head, 2 track
Tape	DC100A cartridge
Tape Speeds	
Read and Write	30 inches/second
Search and Rewind	77 inches/second
Encoding Format	Manchester Phase Encoding
Capacity	500 Kbytes nominal
Record Size	1024 bytes
Density	200 bytes/inch (1600 bits/inch)
Compatibility	Readable using QANTEX model 1000 tape drive
Temperature	
Operating	0 to 40°C
Storage	-25 to 60°C
Humidity (without condensation)	
no tape installed	
0 to 25°C	<95%
25 to 40°C	<75%
tape installed	
0 to 40°C	20% to 80%
Altitude	
Non-Operating	40,000 feet
Operating	10,000 feet
Shock and Vibration	Meets MIL-T-28800C, Class 5 Standards

214/DC-100 Cartridge Tape Drive

CARTRIDGE TAPE LOADING AND REMOVAL

The following procedures must be followed if the tape cartridge is being used to store logged data or configure the system software:

1. Gain access to the Cartridge Tape slot in the front panel by opening the access door.
2. Eject the cartridge tape by pushing the button in the lower right corner of the Cartridge Tape front panel area. Then simply slide the cartridge out.
3. Insert the new Cartridge Tape (label up, open end toward instrument) into the slot until it clicks into place.
4. Push the Cartridge Tape door down.

214/DC-100 Cartridge Tape Drive

INSTALLATION - TEST

Use the following procedure to test for proper installation of the Cartridge Tape Option:

1. Apply power to the 2280.
2. Program the 2280 to list the hardware configuration as follows:

Press:	Display:
	MAIN MENU CHOICE <M FOR MENU>? A
L	<L> LIST PROGRAM AND CONFIGURATION
ENTER	L: LIST MENU CHOICE <A-Z>? E
C	L<C> LIST HARDWARE CONFIGURATION
ENTER	LISTING <PRESS EXIT TO ABORT>
	(list is printed)
EXIT	MAIN MENU CHOICE <M FOR MENU>? A

3. Check the printed configuration list for correct hardware installation. Look for the following:

TAPE DRIVE INSTALLED

PROGRAMMING AND OPERATION

The Cartridge Tape Drive is controlled by the following operator functions:

- o Request a directory of stored data.
- o Delete files on the tape.
- o Initialize the tape.
- o Write a configuration program on the tape.
- o Load a configuration program from the tape to the 2280 Series Data Logger.
- o Transfer a previously recorded data or program file to the printer, Port A, or Port B (RS-232 or IEEE-488 Interfaces).
- o Record Scan data onto cartridge tape.

214/DC-100 Cartridge Tape Drive

Detailed instructions for programming the Cartridge Tape data storage format in the user's desired configuration are detailed in Section 6 of the User's Guide.

SERVICE INFORMATION

The following additional information can be found in the 2280 Series Service Manual:

- o Theory of Operation
- o Calibration/Adjustment Procedure
- o Parts List
- o Schematic Diagram

2280A-341
RS-232-C Interface

INTRODUCTION

The RS-232-C Interface Board allows for an RS-232-C communications link with an appropriate external device. The board can be inserted at Port A or Port B. If installed at Port A, the RS-232-C Interface Board allows remote programming and operation of the 2280 Series Data Logger. Status and measurement information can also be made available to the outside world via this interface. If installed at Port B, the interface provides output capability only. The RS-232-C Interface Board is illustrated in Figure 341-1.

WHERE TO FIND MORE INFORMATION

This subsection of the System Guide presents operator-related information. A general description and list of specifications describe the option's capabilities. Installation instructions and installation test procedures then describe how to get the option up and running. Finally, operating instructions further define Data Logger use with this option. Since other system hardware is used in most applications, references are made to application instructions elsewhere in the System Guide.

P/N 647610
February, 1985

341/RS-232-C Interface

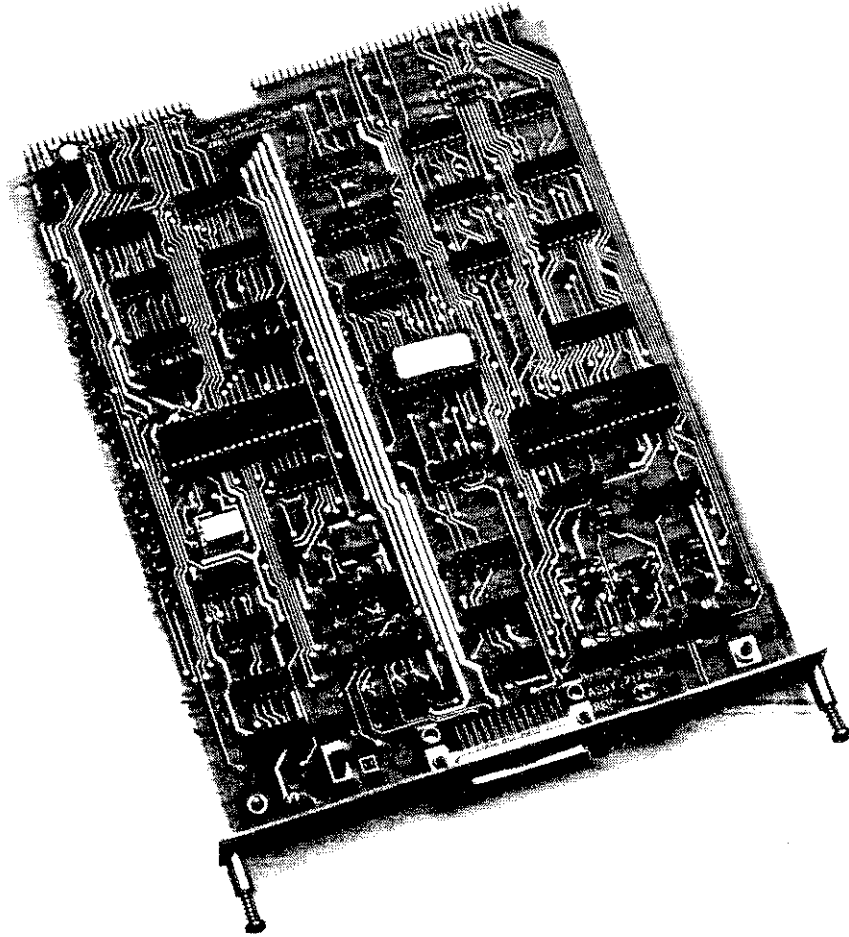

Figure 341-1. RS-232-C Interface

341/RS-232-C Interface

The User Guide presents overall operating instructions for the Data Logger. Information is presented in a general, and not option-specific, format. This volume treats operation with various levels of complexity, depending on user familiarity with the instrument. Some acquaintance with the User Guide is recommended. For any operation-related question, the User Guide is the ultimate authority.

SPECIFICATIONS

Specifications for the RS-232-C Interface are presented in Table 341-1.

Table 341-1. RS-232-C Interface Specifications

Interface Type	RS-232-C
Baud Rates	110, 300, 600, 1200, 4800, 9600
Character Format	7 bits plus one parity bit, one start bit, and one stop bit (except at 110 baud where there are 2 stop bits)
Parity	odd, even, or none
Output Signals	Request To Send Data Terminal Ready Transmit Data
Input Signals	Clear To Send Data Set Ready Received Line Signal Detect
Other Signals	Signal Ground Protective Ground

341/RS-232-C Interface

Transmission Flow Control Sending a control-S character to the interface halts the transmission (output) of data until a control-Q is sent to restart it.
De-asserting (setting false) a Clear To Send, Data Set Ready, or Received Line Signal Detect input signal halts the transmission (output) of data until the three signals are asserted (true).

Connector Pinout (J22)

Pin: Signal Direction:

1	Ground (shield)
2	Transmit Data (output)
3	Receive Data (input)
4	Request to Send (output)
5	Clear to Send (input)
6	Data Set Ready (input)
7	Signal Ground
8	Receive Line Signal Detect (input)
20	Data Terminal Ready (output)

341/RS-232-C Interface

INSTALLATION

The RS-232-C Interface Board can be installed in rear panel Port A or Port B. The installation instructions are as follows:

WARNING

ENSURE THAT ALL LINE POWER TO THE MAINFRAME OR EXTENDER CHASSIS IS DISCONNECTED BEFORE STARTING THIS PROCEDURE. LETHAL VOLTAGES MAY BE PRESENT WITHIN THE 2280 AND ON SOME OPTION CARDS. DO NOT REMOVE ANY INSTRUMENT COVERS UNLESS YOU ARE QUALIFIED TO DO SO.

1. Turn the 2280 POWER switch to OFF.
2. Remove the blank rear panel piece at Port A or Port B. If you are planning a remote control configuration, choose Port A. Port A is the position closest to the center of the instrument.

CAUTION

Handle the board by its edges to avoid damage by static discharge. Discharge yourself by touching the 2280 chassis, or by wearing a grounding strap while handling the board.

3. Align the RS-232-C Interface board in the desired slot (A or B) so that the board-edge connector is toward the motherboard in the rear of the slot. Push the board straight in until it is mated with the motherboard connectors.
4. Secure the RS-232-C I/O Interface board with the two holding screws.

341/RS-232-C Interface

INSTALLATION TEST

Proper installation can be checked by performing a hardware configuration list. Proceed as follows:

Press:	Display:
	MAIN MENU CHOICE <M FOR MENU>? A
L	<L> LIST PROGRAM AND CONFIGURATION
ENTER	L: LIST MENU CHOICE <A-Z>? E
C	L<C> LIST HARDWARE CONFIGURATION
ENTER	LISTING <PRESS EXIT TO ABORT> (list is printed)
EXIT	MAIN MENU CHOICE <M FOR MENU>? A

Check the printed configuration list for correct hardware installation. In this case, a correct RS-232-C Interface installation yields a listing with the following wording:

RS-232-C DEVICE INSTALLED IN PORT n

Port A or Port B define n.

Making 20 mA Current Loop Connections

The RS-232-C Interface is designed to transmit/receive data via either the standard connector (J22) or the 20 mA Current Loop. If the current loop interface is used, it is wired at the 10-pin connector labeled TB2, located near the board edge, just below the standard connector at J22. See Figure 341-2. The terminals are labeled 1 through 10. Table 341-5 identifies the use of each terminal.

341/RS-232-C Interface

PROGRAMMING

Programming the 2280 Series Data Logger for RS-232-C operation is best carried out using the Programming Form, aided with detailed instructions in the User Guide. Briefly, these instructions occur in two areas:

- o Output Device Programming

Used when programming RS-232 communications characteristics (i.e., Baud Rate, Parity, and number of fill characters).

Also used when programming the logging format for the RS-232-C port (A or B).

- o Scan Group Programming

Used to select the type of data to be sent through the RS-232-C Interface Board port. No data, all data, alarm data, or alarm transition data are possible.

341/RS-232-C Interface

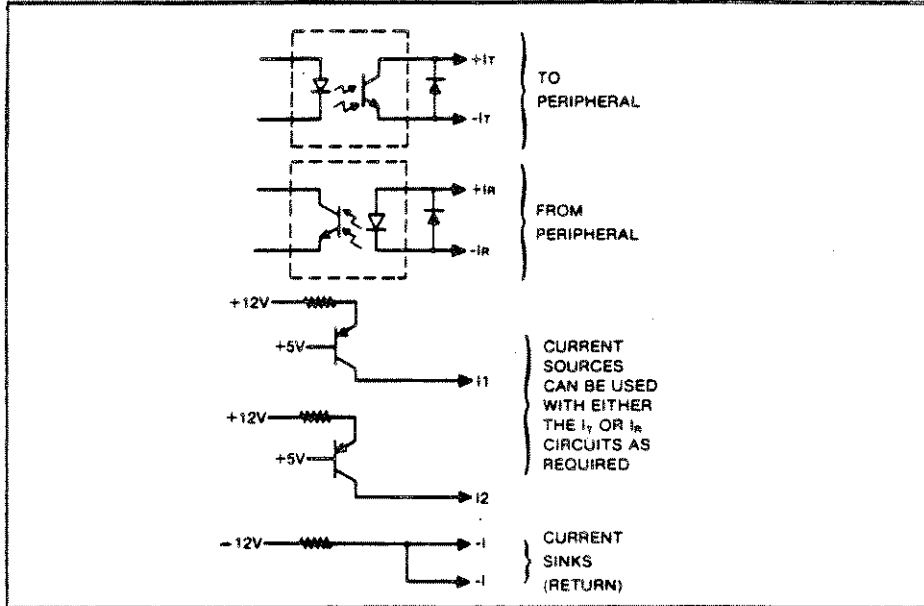

Figure 341-2. Current Loop Connections

341/RS-232-C Interface

Table 341-5. Current Loop Connection Wiring

TERM NO.	FUNCTION	CASE #1 USING 2280 CURRENT SOURCES 1 AND 2.	CASE #2 MODEM OR TERMINAL USING ITS OWN CURRENT SOURCES
1	-I _t Transmit	To one RECEIVE terminal of other device.	To one RECEIVE terminal of other device.
2	-I ₁ Current Sink 1	To second RECEIVE terminal of other device.	None
3	+I ₂ Current Source 2	To Pin 4	None
4	+I _r Receive	To Pin 3	To one TRANSMIT terminal of other device.
5	+I ₁ Current Source 1	To Pin 6	None
6	+I _t Transmit	To Pin 5	To second RECEIVE terminal of other device.
7	-I _r Receive	From one TRANSMIT terminal of the other device.	To second TRANSMIT terminal of the other device.
8	-I ₂ Current	From second TRANSMIT terminal of the other device.	None
9	CL1	To Pin 10	To Pin 10
10	CL2	To Pin 9	To Pin 9

NOTE

Terminals 9 and 10 must be configured as follows:

- o Open for RS-232-C operation
- o Shorted together for current loop operation.

341/RS-232-C Interface

OPERATION

Details on remote control operation are presented in the User Guide.

SERVICE INFORMATION

The following additional information can be found in the 2280 Series Service Manual:

- o Theory of Operation
- o Parts List
- o Schematic Diagram

2280A-342
IEEE-488 Interface

INTRODUCTION

The IEEE-488 Interface allows the 2280 to be used with computers having IEEE-488 interfaces. When the interface is installed in the Port A position (2280), the computer can remotely control (program and operate) the 2280. Installation in the Port B position allows output (talk) only operation.

For best results, a shielded IEEE-488 cable should be used. Fluke accessories Y8021 (one meter), Y8022 (two meter), and Y8023 (four meter) are available for this purpose.

The IEEE-488 Interface is illustrated in Figure 342-1.

P/N 647628, Rev 1
February, 1985

342/IEEE-488 Interface

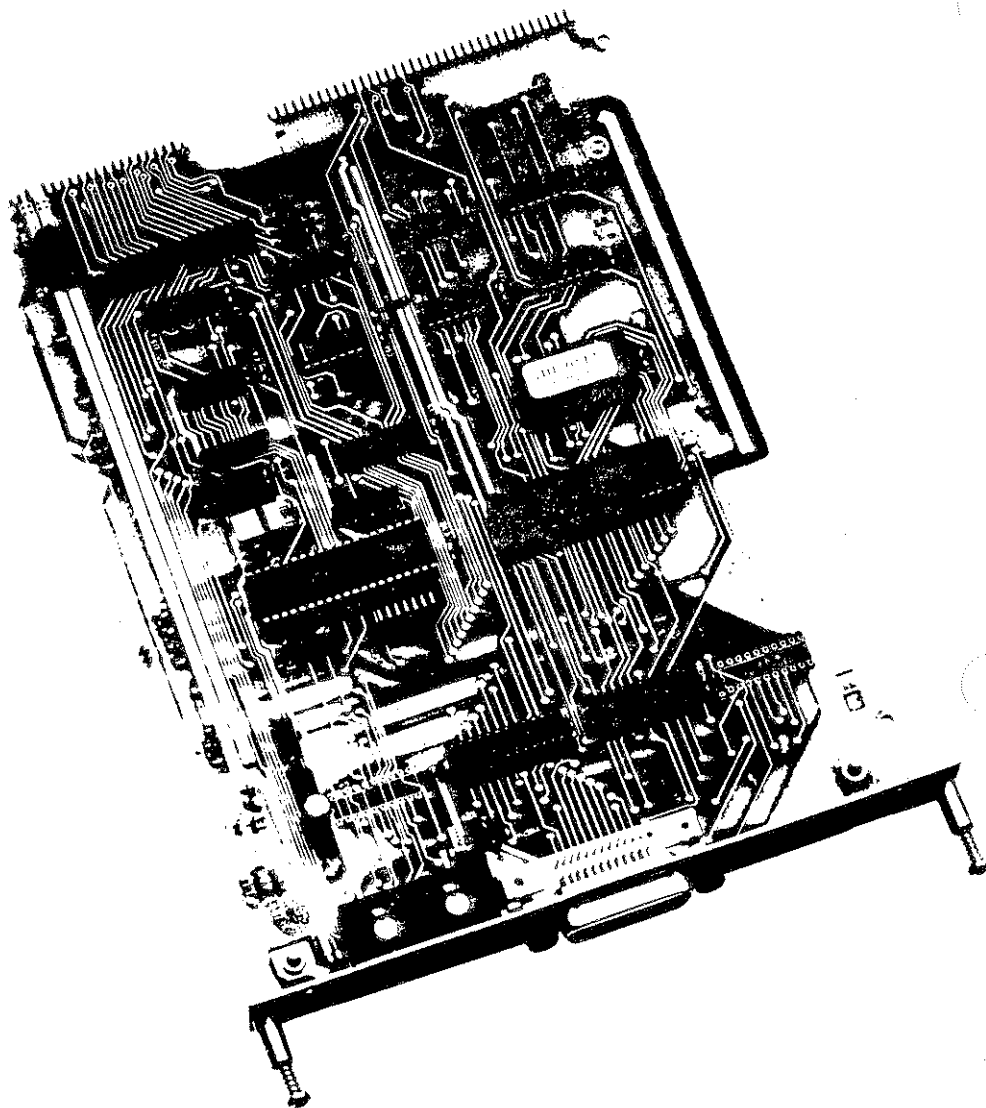

Figure 342-1. IEEE-488 Interface

WHERE TO FIND MORE INFORMATION

This subsection of the System Guide presents operator-related information. A general description and list of specifications describe the option's capabilities. Installation instructions and installation test procedures then describe how to get the option up and running. Finally, operating instructions further define Data Logger use with this option. Since other system hardware is used in most applications, system operating instructions are not repeated here. Rather, references are made to application instructions elsewhere in the System Guide.

The User Guide presents complete operating instructions for the Data Logger. Information is presented in a general, and not option-specific, format. This volume treats operation with various levels of complexity, depending on user familiarity with the instrument. Some acquaintance with the User Guide is recommended. For any operation-related question, the User Guide is the ultimate authority.

SPECIFICATIONS

Specifications for the IEEE-488 Interface are presented in Table 342-1.

342/IEEE-488 Interface

Table 342-1. IEEE-488 Interface Specifications

Operating Modes	Addressable talker/listener, or talker only (switch selectable). Responds to serial poll.
IEEE-488 Functional Subsets	SH1 Source Handshake (complete capability) AH1 Acceptor Handshake (complete capability) T5 Talker (talk only included) TE0 Talker Extended (single address only) L4 Listener (listen only excluded) LE0 Listener Extended (single address only) SR1 Serial Poll RL1 Remote Local (local lockout included) DC1 Device Clear (complete capability) E2 Electrical (tri-state drivers) PP0 Parallel Poll (no capability) DT0 Device Trigger (no capability) C0 Controller (no capability)

INSTALLATION

The IEEE-488 Interface can be installed in Port A or Port B in the 2280 rear panel. The installation instructions are as follows:

WARNING

ENSURE THAT ALL LINE POWER TO THE MAINFRAME OR EXTENDER CHASSIS IS DISCONNECTED BEFORE STARTING THIS PROCEDURE. LETHAL VOLTAGES MAY BE PRESENT WITHIN THE 2280 AND ON SOME OPTION CARDS. DO NOT REMOVE ANY INSTRUMENT COVERS UNLESS YOU ARE QUALIFIED TO DO SO.

1. Turn the 2280 POWER switch to OFF.
2. Remove the blank rear panel piece at Port A or Port B. If you are planning a remote control configuration, choose Port A. Port A is the position closest to the center of the instrument.

CAUTION

Handle the board by its edges to avoid damage by static discharge. Discharge yourself by touching the 2280 chassis or by wearing a grounding strap while handling the board.

3. Align the IEEE-488 Interface in the desired slot (A or B) so that the board-edge connector is toward the motherboard in the rear of the slot. Push the board straight in until it is mated with the motherboard connectors.
4. Secure the two holding screws at the edges of the IEEE-488 Interface rear panel.

342/IEEE-488 Interface

INSTALLATION TEST

Proper installation can be checked by performing a hardware configuration list. Proceed as follows:

Press:	Display:
	MAIN MENU CHOICE <M FOR MENU>? A
L	<L> LIST PROGRAM AND CONFIGURATION
ENTER	L: LIST MENU CHOICE <A-Z>? E
C	L<C> LIST HARDWARE CONFIGURATION
ENTER	LISTING <PRESS EXIT TO ABORT> (list is printed)
EXIT	MAIN MENU CHOICE <M FOR MENU>? A

Check the printed configuration list for correct hardware installation. In this case, a correct IEEE-488 Interface installation yields a listing with the following wording:

IEEE-488 DEVICE INSTALLED IN PORT n

Port A or Port B define n.

ADDRESS SWITCH SETTING

There are two rotary decimal switches mounted on the IEEE-488 Interface, accessible from the back of the instrument. They select the device address. The 2280 listen and talk addresses are the same, both being set by this address switch. The top digit represents the tens digit of the address, and the bottom digit represents the units digit. The address switches are read periodically by the IEEE-488 Interface and, if the switch value has been changed, the interface is reconfigured appropriately. The switches can be placed in positions 00 to 38. The meaning of each position is given in Table 342-2.

Table 342-2. Address Switch Positions And Functions

SWITCH POSITIONS	FUNCTION
00 thru 30	Addresses 0 thru 30
31 thru 38	Talker Only

PROGRAMMING

Programming the 2280 Series Data Logger for IEEE-488 operation is best carried out using the Programming Form, aided with detailed instructions in the User Guide. Briefly, these instructions occur in two areas:

- o Output Device Programming

Used when programming the format for the Port (A or B) housing the IEEE-488 Board.

- o Scan Group Programming

Used to select the type of data to be sent through the IEEE-488 Interface Board port. No data, all data, alarm data, or alarm change data are possible.

OPERATION

Remote operation is explained fully in the 2280 Series User Guide.

SERVICE INFORMATION

The following additional information can be found in the 2280 Series Service Manual:

- o Theory of Operation
- o Parts List
- o Schematic Diagram



Option 2281A-402
Extender Cable

DESCRIPTION

Option -402 Extender Cable with the -403 provides the serial link interface for transmitting and receiving data between the 2280 and 2281A. Power for the 2281A Extender Chassis is also provided over this cable from the 2280 or a 2281A-431. The extender cable consists of six shielded twisted pairs and is sold by the meter. The -403 connector option completes this assembly.

Three of the twisted pairs carry the +24V dc (and returns) from the 2280 to the 2281A. RS-442 data is transmitted over TX+ and TX- from the 2280 on one twisted pair while RX+ and RX-, the received data from the serial link devices within the 2281A, are carried over another pair of twisted wire. The last twisted pair connects the +5V dc return (+5RTN) from the 2280 for signal ground continuity with the 2281A.

Cable pin identification to the -403 connectors can be found in the section, Option 2281A-403. Also contained in that section is a diagram of the cable with the connectors installed.



Option 2281-403
Extender Cable Connectors

DESCRIPTION

Option 2281A-403 Extender Cable Connector is a set of male/female 15-pin, D-type connectors. A housing provides strain relief for cable connections and stand-off bolts for securing the cable connector to the mainframe connector. The cost includes factory installation onto the 2281A-402 Extender Cable and continuity testing before shipment.

Table 403-1 shows the pin identification of the two connectors. Figure 403-1 shows the -403 connectors assembled to the extender cable. Individual connector part numbers (for replacement only) are also listed in Figure 403-1.

403/Extender Cable Connectors

Table 403-1. Connector Pin Identification

SIGNAL MNEMONIC	P23 PIN NUMBER	P52 PIN NUMBER
+24 VDC	1	1
+24 VDC	2	2
+24 VDC	3	3
+5 RTN	5	5
+5 RTN	6	6
RX -	7	7
RX +	8	8
+24 RTN	9	9
+24 RTN	10	10
+24 RTN	11	11
TX -	13	13
TX +	14	14
SHIELD	15	15*

*For cables longer than 4 meters, no shield connection is made at P52.

403/Extender Cable Connectors

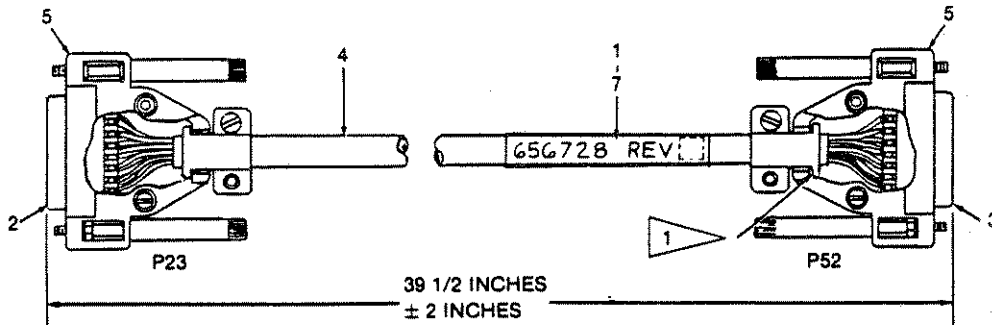

1 For cables longer than 4 meters, no shield connection is made at P52.

QTY	ITEM	PART NO.	DRAWING NO.	DESCRIPTION
1	1	610600	2281A-2010	LABEL
1	2	436881		CONN, 15 PIN
1	3	436899		CONN, 15 SOCKET
3.291ft	4	682773		CABLE
2	5	682765		CONNECTOR HOUSING
.55ft	6	113845		SLEEVING
.27ft	7	295782		THERMOFIT, CLEAR

Figure 403-1. Internal View

Option 2281-431
Power Supply

INTRODUCTION

This subsection presents descriptive and installation information for the 2281A-431 Power Supply.

The 2281A-431 is more fully described in the 2281A Instruction Manual. The following additional items can be found in this other manual: Specifications, Theory of Operation, Performance Test, Calibration Procedures, Parts List, and Schematic Diagram.

DESCRIPTION

Option -431 Power Supply is a rear panel-mounted dc power supply for the 2281A extender chassis. The power supply provides a regulated 20V dc source for the serial link devices when the extender chassis placement (distance) and configuration (number of serial link devices) exceeds the power capabilities of the 2280A. Information to determine whether the -431 is needed in a particular configuration can be found in Section 2 of this manual.

431/Power Supply

The -431 may accept input power sources of ac line voltages, +12V and +24V dc voltages. The power supply has an automatic crossover from ac line to 12V dc and 24V dc to the 12V dc input. In addition, while the -431 is operating from ac line or 24V dc, a trickle charge is provided to the 12V dc input for maintaining the charge of a backup battery.

The power supply pcb is installed in place of the extender interface card and the power supply rear panel assembly is installed in place of the extender interface rear panel. The power supply rear panel provides a serial link feed-through for interconnecting extender chassis. An illustration of the rear panel assembly is shown in Figure 431-1, and a detailed description is provided by Table 431-1.

431/Power Supply

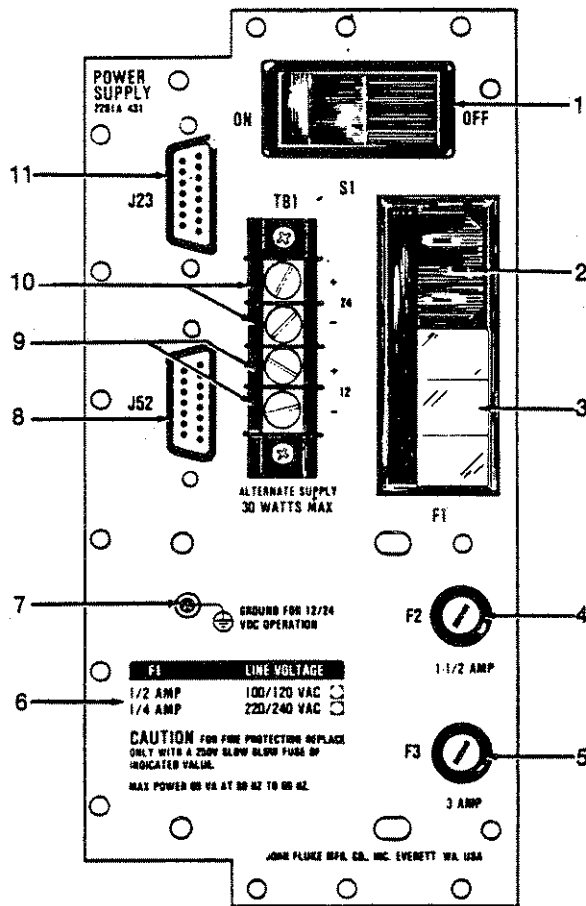

Figure 431-1

431/Power Supply

Table 431-1. Rear Panel Features

ITEM	FEATURE NAME	DESCRIPTION
1	S1	ON/OFF power switch, for ac line and dc voltages.
2	ac input	Standard male ac input socket.
3	F1	Fuse holder for ac line fuse. Sliding plastic door prevents access while ac line power is connected.
4	F2	Fuse holder for 24V dc input.
5	F3	Fuse holder for 12V dc input.
6	Fuse/Voltage	Silkscreened annotation of ac Fuse ratings and line voltage selection.
7	Ground Lug	Threaded ground lug termination for dc inputs.
8	J52	15 pin, male connector for serial link extender cable from the 2280A.
9	TB1 (12)	Terminal block connection points for the 12V dc input or backup battery.
10	TB1 (24)	Terminal block connection points for the 24V dc input.
11	J23	15 pin, female connector for serial link extender cable feedthrough to another 2281A.

INSTALLATION

Hardware Installation

Use the following procedure to install the Option -431 Power Supply into the extender chassis. After completing the hardware, electrical, and cabling installation sections, complete the initial verification procedure (given in the later part of this section).

431/Power Supply

1. Remove all the Phillips screws from the extender interface rear panel assembly.
2. Pull out the rear panel and pcb assembly (they should be affixed by the pcb connector cable retaining nuts).
3. Remove the connector cable retaining nuts from the power supply pcb.
4. Plug P54 (from power supply rear panel assembly) into J54 (on power supply pcb assembly).

NOTE

The connector is keyed; DO NOT FORCE. To release, squeeze the side tabs on the connector.

5. Slide the pcb into the left-most slot of the extender chassis until P12 is seated in the motherboard connector J12.
6. Secure the power supply rear panel assembly over the pcb using 12 Phillips screws.
7. Replace the cable retaining nuts of the power supply pcb connector.
8. Hardware installation is now complete.

Electrical Installation

The 2281A-431 is shipped with the proper operating voltage already selected as specified by the customer. The following paragraphs explain how to reconfigure the 2281A-431 for other voltage settings and how to connect the 2281A-431 to the system. After completing the hardware, electrical, and cable installation sections, complete the installation verification procedure (given later in this section).

431/Power Supply

Input Voltage Selection

To power the 2281A-431 with 24V or 12V dc, the appropriate supply is connected to a terminal block (TB1) on the power supply rear panel. It is recommended that power source cables be terminated with No. 6 spade lugs for safety and convenience. Table 431-2 lists the proper fuse ratings for all voltages. The following procedure and Figure 431-2 show how to reconfigure the 2281A-431 to a different ac line voltage.

1. Open the cover door on the ac input module (under S1) and rotate the "fuse-pull" lever to the left to remove the fuse.
2. Using a pair of pliers, grasp the small pcb, located underneath the fuse holders, between the metal tabs and remove.
3. Reinstall the pcb so that the required operating voltage is shown in the opening as in Figure 431-2A. Push the pcb in firmly.
4. Slide the fuse-pull lever to the right, and insert the proper fuse (F1) for the selected operating voltage. See Table 431-2 for fuse ratings.

Table 431-2. Fuse Ratings

REF DES	SUPPLY	RATING
F1	100/120V ac	1/2 A/250V Slow Blo
F1	220/240V ac	1/4 A/250V Slow Blo
F2	+24V dc	1.5 A/250V Fast Blo
F3	+12V dc	3.0 A/250V Fast Blo

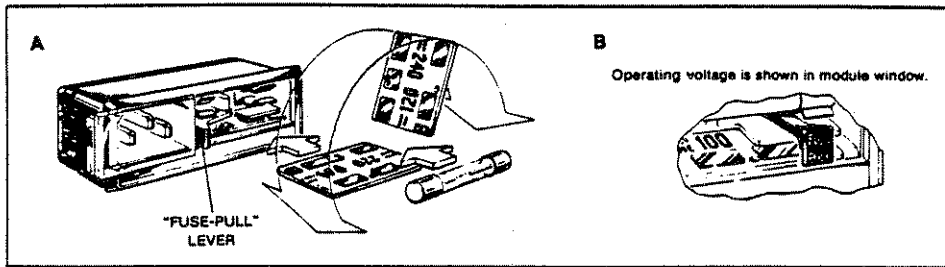

Figure 431-2. AC Voltage Selection

2281A-431 Cable Connections

Figure 431-3 illustrates the 2281A-431 cabling for ac and dc operation. After completing the hardware, electrical, and cable installation sections, complete the installation verification.

431/Power Supply

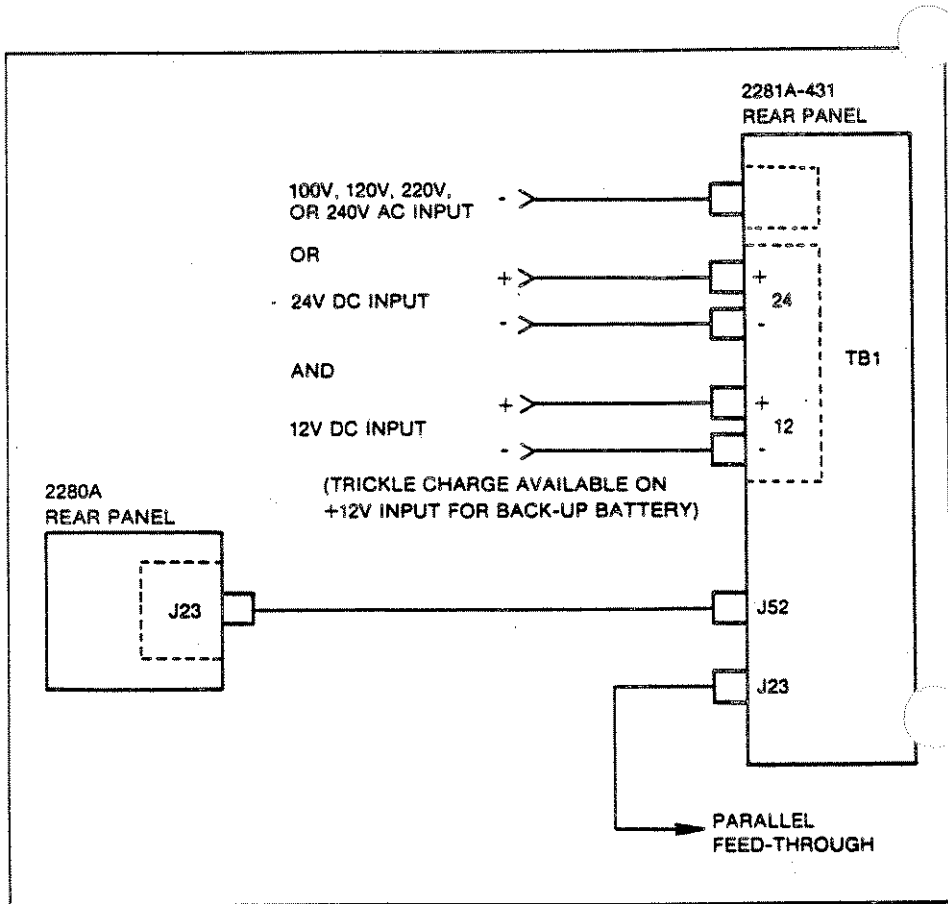

Figure 431-3. Cabling Diagram

INSTALLATION VERIFICATION

This procedure is used to verify the proper operation of the 2281A-431 after installation in the 2281A. No special tools or test equipment are required.

1. Connect ac or +24V dc power to the -431.
2. Set S1 on the 2281A-431 rear panel to ON.
3. Turn on power to the 2280A. Verify that the 2281A-431 front panel LED is illuminated.
4. Turn off power to the 2280A. Verify that the front panel LED extinguishes.
5. If a 12V back-up battery is connected to TB1, complete the following steps.
 - a. Set S1 to OFF.
 - b. Disconnect the ac line and/or +24V dc source.
 - c. Set S1 to ON.
 - d. Turn on power to the 2280A. Verify that the 2281A front panel LED is illuminated.
 - e. Turn off power to the 2280A. Verify that the 2281A front panel LED goes off.
6. This concludes the installation verification procedure for the 2281A-431. Turn off all power sources to the 2281A-431 before dismantling the test setup.



Y2044
Rack Slide Kit

DESCRIPTION

The Y2044 Rack Slide Kit facilitates the servicing of the 2280 (or 2281A) while it is installed in a standard 19-inch electronic equipment rack. The unit is secured in the equipment rack, yet may be pulled out along the slide for reconfiguring and servicing serial link devices. Parts and hardware for this kit are listed in Table 1. The only tools required for installation are medium-sized, Phillips and flat-head screwdrivers.

INSTALLATION

The rack slide kit is shipped in two separate containers. The hardware included in the long rectangular carton is not used and may be discarded. All necessary hardware for installing the kit is contained in the plastic-bubble wrapped package. All required parts and hardware for the rack slide kit are listed in Table 1. After verifying that all kit parts are present, proceed to the installation procedure.

Y2044

Table 1. Parts and Hardware

ITEM	NAME	DESCRIPTION
1	Chassis Track	Two gray metal slide tracks (packaged in a cardboard box).
2	Rear Support Bracket	Two machined metal angle brackets (packaged in a cardboard box).
3	Bar Nuts	Six metal strips with four threaded holes.
4	Rack Ears	Two white machined angle pieces.
5	Slide Spacer 8.4 inches	Two 8.4 inch pieces of metal bar stock with five punched holes.
6	Rack Ear Hardware	A small envelope containing eight machine screws with plastic washers, and clipnuts.
7	Miscellaneous Hardware	The following screws are used to install the Rack Slide Kit: twelve 8-32 x 7/8" Phillips twelve 10-32 x 3/8" pan-head Phillips

NOTE

Since this kit can be used with either the 2281A or the 2280, some parts will be left unused for one instrument or the other.

The installation procedure for the Y2044 is as follows.

1. Remove the four molded plastic feet from the bottom cover of the instrument.
2. On both front side corners of the instrument remove the decals bearing the Fluke name.

3. Refer to Figure 1 and complete these steps:
 - a. Remove the three screws (indicated by asterisks) from both sides of the instrument.
 - b. Placing the cutout side of the rack ears against the front corner of the instrument, align the recessed holes with the holes vacated in step a.
 - c. Secure the rack ears to the instrument using six of the 8-32 x 7/8 inch screws.
 - d. Remove the instrument side handles by unfastening the two Phillips screws.

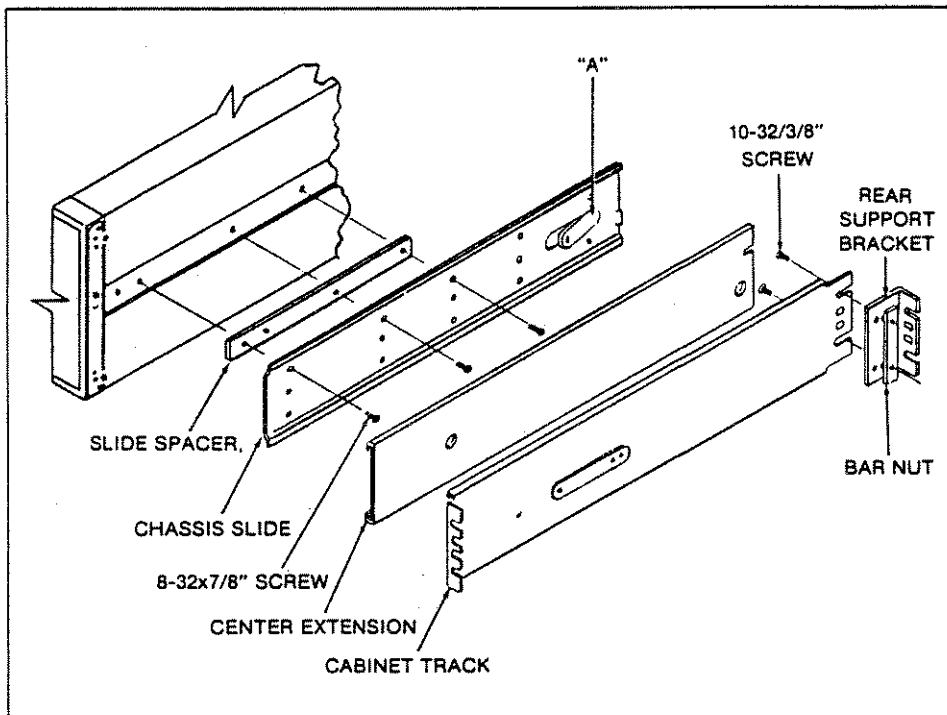

Y2044

- e. Disassemble the chassis slide of the chassis track by fully retracting the extensions and releasing the spring-loaded retaining button marked with an "A".
- f. With the slide spacer in place, secure the chassis slide to the instrument using three 8-32 x 7/8 inch screws (for both sides).

NOTE

Use the upper row of mounting holes on the chassis slide.

- g. Attach the rear support bracket flush with the end of the cabinet slide using a bar nut and two of the 10-32 x 3/8 inch screws (on each chassis track).
- h. Insert the center extension of the chassis track into the cabinet slide, aligning the retaining button with the center extension hole.
- i. Install the assembly from step (h) into the equipment rack using bar nuts and 10-32 x 3/8 inch screws in the top and bottom slots of the cabinet slide ends.
- j. Extend the center extension towards the front of the equipment rack until it locks.
- k. Insert the chassis slide into the center extension, depressing the retaining button as it slides in.

NOTE

At this point it may be necessary to readjust the chassis track to align the rack ear mounting holes with those of the equipment rack.

- l. Attach the clip nuts to the equipment rack, matching the hole pattern in the rack ears.
- m. Use the machine screws (with plastic washers) to secure the instrument and prevent it from sliding out.

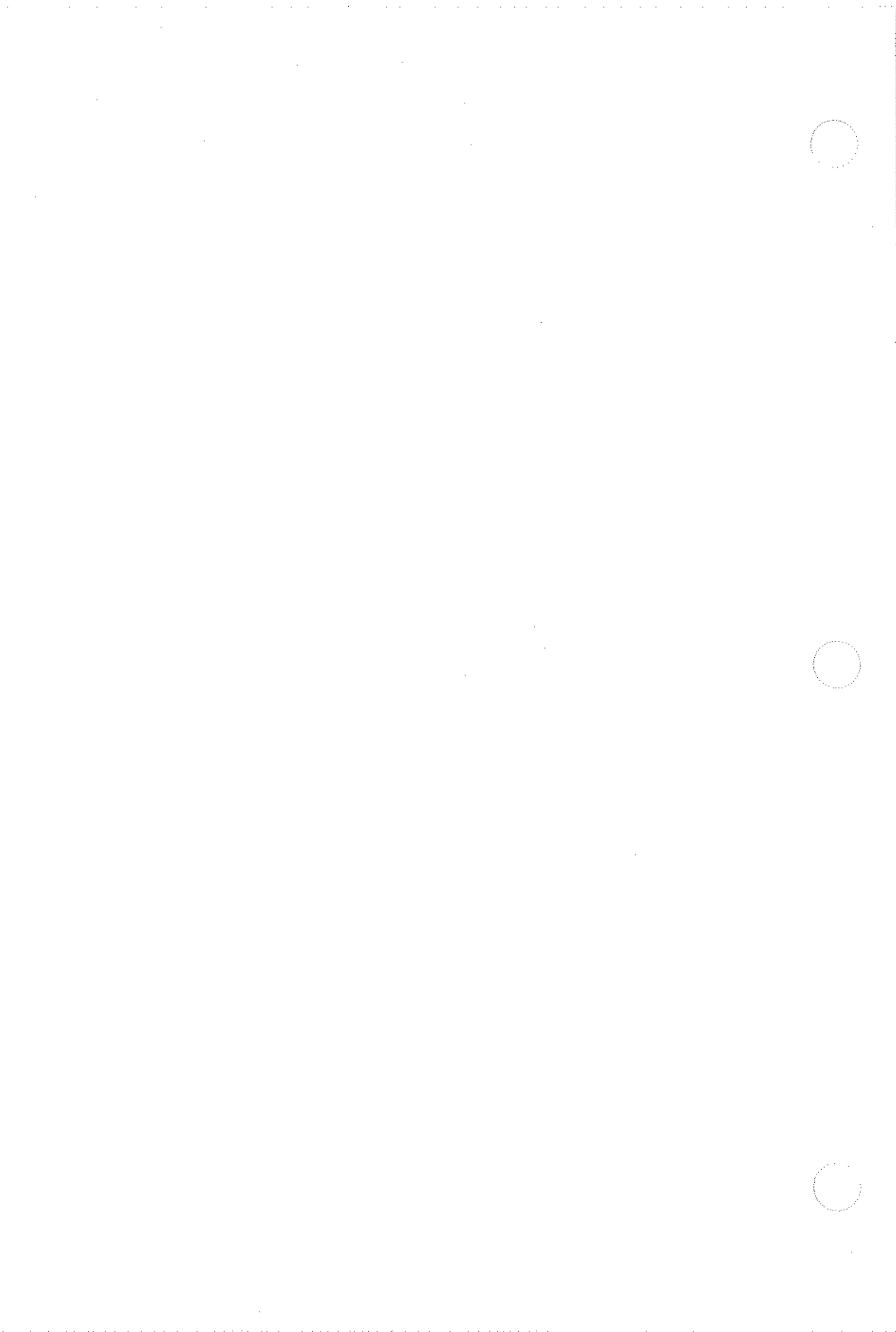

Y2045
Rack Mount Kit

DESCRIPTION

The Y2045 Rack Mount Kit facilitates the placement of a 2280 or 2281A into a standard 19-inch electronic equipment rack. Parts and hardware for this kit are listed in Table 1. The only tool required for installation is a medium-sized, Phillips screwdriver.

Table 1. Parts and Hardware

ITEM	NAME	DESCRIPTION
1	Shelf Bracket	Two large "L" shaped metal strips with press-fitted nuts.
2	Rack Ears	Two smaller "L" shaped metal strips with cutouts.
3	Hardware	One package of hardware containing: a. Six 8-32 x 7/8" Phillips screws. b. A small package of eight 10-32 x 3/8" Phillips screws. c. A small package of eight machine screws with plastic washers. d. A small package of 12 clip nuts.

Y2045

INSTALLATION

Remove the contents of the Y2045 from its shipping container and compare the contents to Table 1. After verifying that all kit parts are present, proceed with the installation procedure.

The installation procedure for the Y2045 is as follows.

1. Remove the four molded plastic feet from the bottom cover of the instrument.
2. On both front side corners of the instrument, remove the decals bearing the Fluke name.
3. Refer to Figure 1 while performing the following steps.
 - a. Remove the three screws indicated by the asterisk from both sides of the instrument and discard the screws.
 - b. Placing the cutout side of the rack ears against the front corner of the instrument, align the recessed holes with the holes vacated in step a.
 - c. Secure the rack ears to the instrument using the six 8-32 x 7/8 inch screws.
4. Note the orientation of the instrument's shelf bracket in Figure 1. Install the shelf bracket into the equipment cabinet using two 10-32 x 3/8 inch screws on each of the four tabs.
5. Insert the instrument three-fourths of the way into the equipment cabinet along the shelf bracket.

6. Attach the clip nuts to the front flange of the equipment cabinet aligning the clip nuts with the slotted holes of the rack ears.
7. Slide the instrument into the equipment cabinet and secure it using the machine screws.

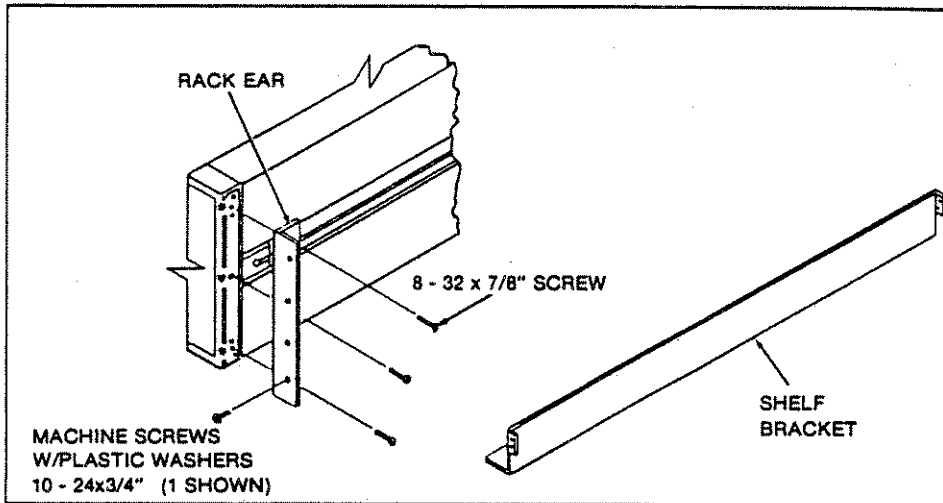
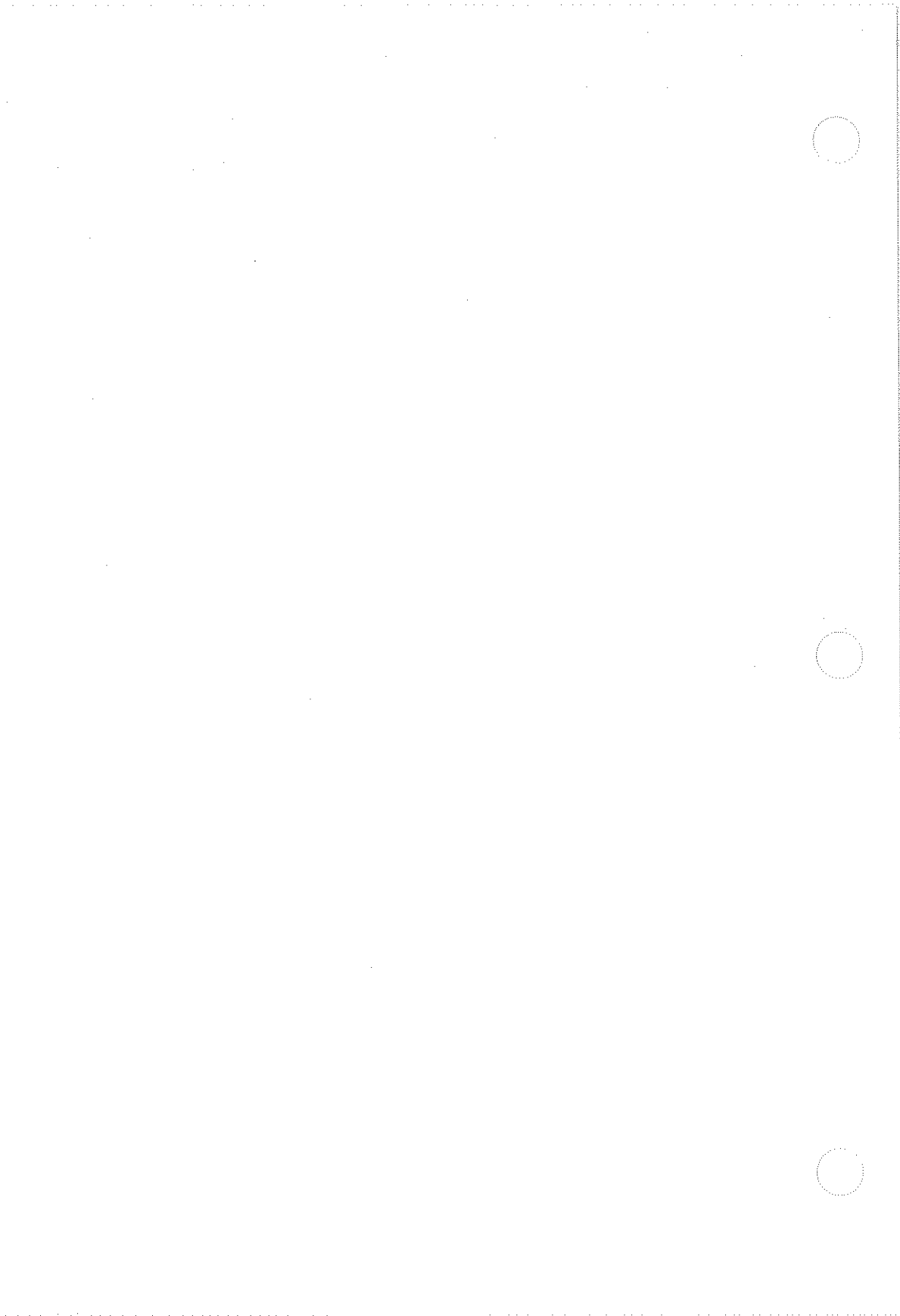

Figure 1. Installation Details



Y2047
Serial Link Multiconnect

The Y2047 Serial Link Multiconnect is used in 2281A placements to support star configurations. Examples of star configurations are shown in Section 2 of the 2281A Instruction Manual.

The Y2047 contains two D-type, 15-pin sockets on one face of its 1 3/4 inch x 1 inch x 1 3/4 inch metal housing and a single D-type, 15-pin plug on the opposite face.

The Y2047 male plug can be connected to J23 on the rear panel of the 2280A or the 2281A. If a star connection is desired from a 2281A with a -431 option installed, the Y2047 must be connected to J23 (2281A) using either a 2280A-402 Extender Cable (with 2280A-403 Extender Cable connectors) or the cable supplied with the 2281A. Use the two Phillips screws on the reverse side, between the two parallel sockets, to secure the Y2047 to the cable retaining nuts of J23.

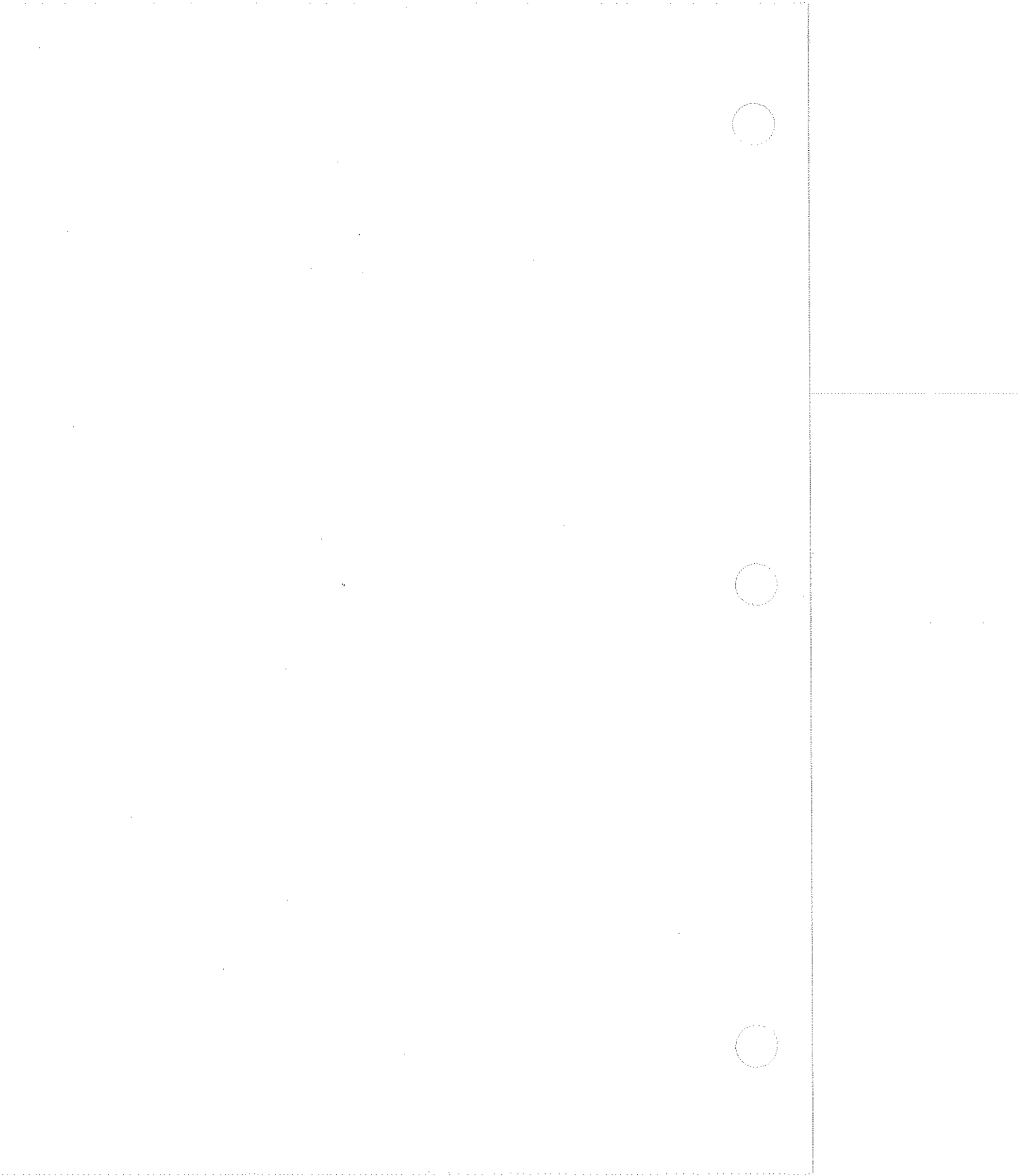

Section 5
Using the 2280

CONTENTS

Temperature Measurement	
Using Thermocouples	5a-1
Using RTDs	5a-13
Using Thermistors	5a-39
Voltage Measurement	
AC Voltage	5b-1
DC Voltage	5b-7
Current Measurement	5c-1
Resistance Measurement	5d-1
Frequency Measurement	5e-1
Totalizing Measurement	5f-1
Strain Measurement	5g-1
Digital Input	5h-1
Status Input	5h-9
Status Output	5i-1
Analog Output	5j-1
Writing Control Algorithms	5j-7

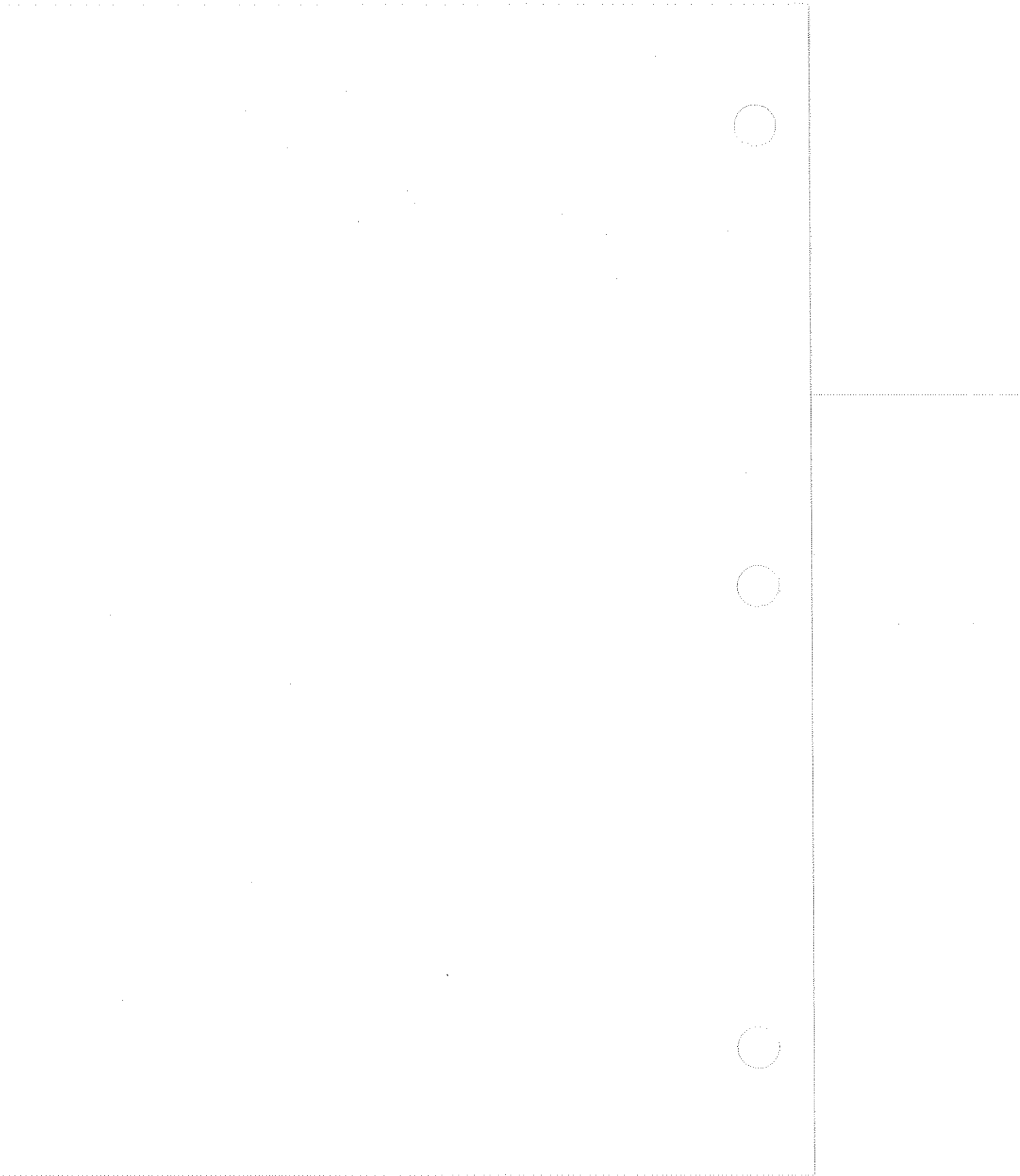

Section 5a
Temperature Measurement
Using Thermocouples

INTRODUCTION

Thermocouple measurements involve an input from a thermocouple-type temperature sensor. This input is converted to degrees Fahrenheit or Celsius.

This section explains use of the 2280 Series Data Logger and associated option assemblies for obtaining thermocouple temperature readings. The User Guide provides overall programming and operating instructions. Detailed information about the physical installation of the 2280 mainframe and related options is provided in the following sections of this manual:

- o Installation - Mainframe: Section 3
- o Installation - Option Assemblies: Section 4

THERMOCOUPLE TEMPERATURE MEASUREMENTS - GENERAL

Thermocouples are very useful temperature measurement sensors. Various types of thermocouples for different temperature ranges can be used. Cryogenic temperatures to temperatures above the melting point of steel can be measured.

5a/Using Thermocouples

A thermocouple is made of two dissimilar metal conductors. The thermocouple loops shown in Figure 5a-1 are each made up of two such conductors (A and B). Loop (a) shows a thermocouple loop in its simplest form. Conductors A and B are joined twice, creating two thermocouples. The current flow in this loop is related to the temperature difference between reference temperature T_R and measurement temperature T_M . Measuring this current presents a problem: any connection between a measurement circuit (usually made of copper) and the thermocouple loop would form additional thermocouples.

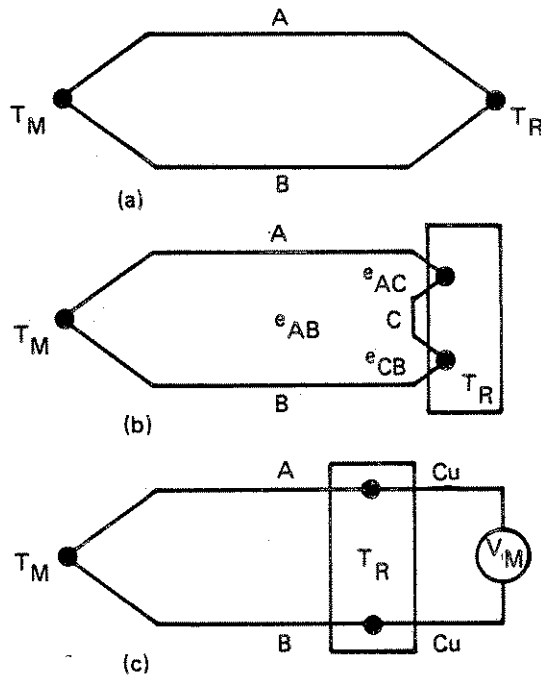

Figure 5a-1. Thermocouple

5a/Using Thermocouples

Loop (b) shows a circuit with connections to an additional material (C). As long as junctions C-A and C-B remain at the same temperature, no additional thermocouples are created. Electrical connections can thereby be made to measure the thermal emf. This is shown in loop (c). The 2280 reads a voltage (VM) related to the difference between T_M and T_R ; temperatures and gradients in the copper (C) have no effect. If T_R and the emf per degree are known, T_M can be determined. The measurement function is nonlinear and unique for each combination of metals used in thermocouple construction.

The 2280 automatically performs the somewhat involved thermocouple temperature measurement process. This process includes the following steps:

- o Two measurements (V_M and T_R) are taken.
- o Since the thermocouple is usually terminated at a temperature different from zero degrees C, the measured voltage (V_M) is compensated using the reference temperature (T_R) measurement.
- o This compensated voltage is converted to temperature using the voltage/temperature characteristics for the type of thermocouple.

The 2280 Series Data Logger satisfies these requirements in either of two ways. First, if the thermocouple is terminated at the Isothermal Input Connector (option 175), compensation and linearization are performed automatically. Second, if the thermocouple is externally terminated, compensation and linearization functions can be programmed to achieve the same result. These two methods are treated separately in the following descriptions.

5a/Using Thermocouples

REQUIRED HARDWARE

Applications involving thermocouple readings require the following option assemblies:

2280A-161	High Performance A/D Converter
2280A-162	Thermocouple/DC Volts Scanner
2280A-175	Isothermal Input Connector

The High Performance A/D Converter (2280A-161) provides high accuracy analog-to-digital conversion of scanner input voltages. At least one A/D Converter must be installed in the 2280 Series Data Logger or the 2281A Extender Chassis to provide thermocouple input capabilities.

The Isothermal Input Connector contains the necessary hardware to ensure that the thermocouple connections and reference temperature sensor are at the same temperature. The reference temperature sensor portion of the connector is used to measure the temperature of the thermocouple terminations.

The Thermocouple/DC Volts Scanner (option -162) is a plug-in, 20-channel thermocouple and multi-voltage range relay scanner. The scanner links the A/D Converter to external measurement points. It accepts a variety of analog inputs, depending on the type of connector in use (Current Connector, Isothermal Connector, Voltage Connector, or AC Voltage Input Connector).

INSTALLATION

Installation for any of the required option assemblies is detailed in Section 4 of this manual. Reference each option assembly by its option number (161, 162, or 175). These instructions can be consulted as required. The descriptions in this subsection assume that the require option assemblies have successfully completed an installation test.

5a/Using Thermocouples

The Isothermal Input Connector mates with the Thermocouple/DC Volts Scanner. This 20 channel, multi-range relay scanner selects the proper input channel for the High Performance A/D Converter.

At the Isothermal Input Connector, each input channel uses three lines (HIGH, LOW, SHIELD). The thermocouple is connected across the HIGH and LOW input lines as follows:

- o LOW: the RED wire on the thermocouple is the negative lead and must be attached to the LOW terminal.
- o HIGH: the wire color of the positive lead varies with the type of thermocouple. The color appropriate for a given thermocouple is defined in Table 5a-1.
- o SHIELD: If the thermocouple has a shield, it must be connected here. If the thermocouple has no shield (two wires only), a jumper must be connected between LOW and SHIELD.

The programming examples presented below (local termination or remote termination) can be used to verify correct installation. A reasonable response from the thermocouple channel constitutes a positive test result. Tests of temperature measurement accuracy are beyond the scope of an installation test; these are covered separately in the 2280 Series Service Manual.

5a/Using Thermocouples

This example designates channel 100 for automatic compensation and linearization of a "K" type thermocouple.

Monitor

Now, MONITOR the channel to verify correct operation.

Press:

Display:

MONITOR
C100
ENTER

MAIN MENU CHOICE <M FOR MENU>? A
MONITOR CHANNEL =
MONITOR CHANNEL = C100
C100 (reading)

MAKING THERMOCOUPLE MEASUREMENTS - EXTERNAL TERMINATION

Both temperature compensation and voltage/temperature linearization can be performed for a thermocouple terminated external to the Isothermal Input Connector.

Thermocouple Connections

Externally terminated thermocouple measurements required an additional channel for the reference junction temperature input.

Programming

A pseudo channel must be used to define the temperature compensation (REF) and temperature/voltage linearization (LIN). These two requirements are discussed below.

5a/Using Thermocouples

REFERENCE TEMPERATURE MEASUREMENT AND COMPENSATION

Use the function: REFx(TR)

x = the thermocouple type (J,K,T,R,S,E, etc)
TR = the temperature of the thermocouple
termination (in the temperature units
selected in System Programming).

- o TR could be a constant:

C100 = REFK (55)

Here, "TR" is specified as 55 degrees C for a K-type thermocouple on channel 100. This would be used when the external thermocouple termination is made in a constant temperature controlled oven.

- o A temperature channel could also be used to determine the thermocouple measurement termination reference temperature.

C100 = REFK (C15)

This example specifies "TR" as the temperature obtained by measuring channel 15.

VOLTAGE/TEMPERATURE LINEARIZATION

Use the function:

LINx(Cn)

x = the thermocouple type (J,K,T,R,S,E, etc)
Cn = the compensated channel to be linearized

Example

The following example (expressed in the appropriate module of the Programming Form) linearizes a K-type thermocouple reading (C5) with the reference junction temperature held constant at 55°C.

5a/Using Thermocouples

Table 5a-1. Thermocouple Lead Wire Color Code

ANSI Designation	Lead Material		Color of Positive Lead
	Positive (+)	Negative (-)	
J	Iron	Constantan	White
K	Chromel	Alumel	Yellow
T	Copper	Constantan	Blue
E	Chromel	Constantan	Purple
R	Platinum	Platinum (13% Rhodium)	Black
S	Platinum	Platinum (10% Rhodium)	Black
C (W5Re/ W26Re)	Tungsten (5% Rhenium)	Tungsten (26% Rhenium)	White

Table 5a-2. Thermocouple Temperature Ranges and Applications

Select	Type	Parameter	Usable Range (°C)
J	JNBS (Can be used in oxidizing, reducing, inert, or vacuum atmospheres.)	NBS J	-200 to 760
K	KNBS (Should not be used in reducing or sulphurous atmospheres. Can only be used in vacuum for short time until calibration shifts.)	NBS K	-225 to 1350
T	TNBS (Can be used in oxidizing, reducing, inert, or vacuum atmospheres.)	NBS T	-250 to 400
E	ENBS (Can be used in oxidizing or inert atmospheres. Should not be used in reducing or vacuum atmospheres.)	NBS E	-250 to 1000
R	RNBS	NBS R	0 to 1767
S	SNBS	NBS S	0 to 1767
B	BNBS	NBS B	200 to 1820
N	NNBS	NISIL-NICROSIL	-200 to 1300
C	CNBS	W5Re/W26Re	0 to 2315
V	TDIN	DIN T	-200 to 600
H	JDIN	DIN J	-200 to 900



Section 5a
Temperature Measurement
Using RTDs

INTRODUCTION

This type of temperature measurement employs a resistance-temperature detector (RTD). RTDs, which are usually larger and more expensive than thermocouples, are frequently used where accuracy and repeatability are important because they exhibit greater accuracy and stability. A comparison of thermocouple and RTD characteristics and uses is presented in Section 2 of this manual.

Thermistors, which can also be used to make temperature measurements, are covered elsewhere in Section 5a.

This section explains the use of the 2280 Series Data Logger and associated option assemblies for obtaining RTD temperature readings, while the User Guide provides overall programming and operating instructions. Detailed information regarding the physical installation of the 2280 mainframe and related options is provided in this manual in the following sections:

- o Installation - Mainframe: Section 3
- o Installation - Option Assemblies: Section 4

5a/Using RTDs

RTD TEMPERATURE MEASUREMENTS - GENERAL

The resistance of an RTD varies directly with the RTD sensor temperature. Passing a current through this resistance generates a proportional voltage that can be accurately translated into a temperature reading.

Most RTD types have temperature sensing elements that are made of platinum. Several other materials can be used in RTDs, but platinum remains the most popular and accurate type. Each type of RTD requires a unique algorithm for converting the measured resistance into temperature. This capability is provided by the 2280 operating software which contains conversion algorithms for platinum and copper RTDs. Conversion algorithms for other RTD types can be implemented using the 2280's user-defined RTD functions and other math computational capabilities.

REQUIRED HARDWARE

RTD temperature measurement applications require either of two option assembly configurations.

The High Performance A/D Converter, 2280A-161, must be used in both configurations to provide high accuracy analog to digital conversion of RTD, thermistor, or resistance measurements. This requires that at least one A/D Converter be installed in the 2280 Series Data Logger.

Configuration A

The first configuration employs the following two option assemblies:

2280B-163	RTD/Resistance Scanner
2280B-177	RTD/Resistance Input Connector

This configuration provides the most accurate and repeatable RTD readings with the fewest restrictions and lowest cost per channel. Each RTD/Resistance Scanner plus Connector provides current excitation and signal multiplexing for 20 RTD, thermistor, and/or resistance channels. These two assemblies are intended for use in applications more exclusively involving RTD, thermistor, and resistance measurements.

The RTD/Resistance Scanner configuration also provides lead-wire compensation for performing accurate 3-Wire resistance measurements. Two jumpers, W1 and W2, on the scanner along with proper input connector wiring allow a scanner and connector set to operate in one of three modes:

- o 4-Wire (4W) Measurement Mode
Two sense and two excitation wires must be connected to each channel. Lead-wire or reed switch resistances do not affect readings.
- o 3-Wire Accurate (3WA) Measurement Mode
One sense and two excitation wires must be connected to each channel. Equal lead-wire resistances are compensated for. Reed switch resistances do not affect readings. Ten channel returns are internally connected together; therefore, the RTDs must be electrically isolated.

5a/Using RTDs

- o 3-Wire Isolated (3WCI) Measurement Mode
One sense and two excitation wires must be connected to each channel. Equal lead-wire resistances are compensated for. One reed switch resistance error affects readings.

Where lead-wire errors are negligible, 2-Wire measurements can be made by setting the scanner to operate in 4-Wire mode, and wiring the 177 input connector properly.

Wiring diagrams are provided in this subsection.

Configuration B

The second configuration supports a wider mix of applications, providing both current and voltage excitation that will support the measurement of 4-Wire RTDs and transducers in bridge arrangements. For example, both strain gages and 4-Wire RTDs can be measured with the following set of option assemblies:

2280A-162	Thermocouple/DC Volts Scanner
2280A-176	Voltage Input Connector (or other)
2280A-164	Transducer Excitation Module
2280A-174	Transducer Excitation Connector

The 162 option Thermocouple/DC Volts Scanner is a 20 channel, thermocouple and voltage, signal multiplexing and conditioning, single-pcb scanner. This scanner allows the A/D Converter to make external dc voltage measurements on four ranges. Connections to external inputs are made through a Voltage Input, Isothermal Input, or AC Voltage Input (which also supports ten dc volt channels) Connector. The scanner and connector measure the voltages generated across the RTDs in this configuration.

The Transducer Excitation Module, 2280A-164, is used to energize the RTDs with an excitation current or the bridge configurations with a voltage. The 2280A-174 Transducer Excitation Connector provides connections for accessing the five current sources for exciting up to 4 channels per source, or the one voltage source, for exciting the resistances to be measured.

INSTALLATION

Installation of the required option assemblies is detailed in Section 4 of this manual, in the subsections under the option three-digit number. The descriptions in this measurement subsection assume that the required option assemblies have passed the installation tests also specified in Section 4. Installation tests normally require obtaining a hardware list that verifies that the option assembly has been correctly recognized by the 2280 mainframe.

NOTE

For accuracy tests, refer to the appropriate 2280 Series Service Manual.

After each option assembly has been installed as shown in Section 4, verify that all steps have been followed to properly configure the hardware. These include:

- o Configuration A (RTD Scanner and Connector)

Select the measurement mode. This is accomplished by setting the two jumpers on the RTD/Resistance Scanner pcb in the proper positions, and by wiring the RTD/Resistance Connector properly.

- o Configuration B (Transducer Excitation Module)

Correctly wire the Thermocouple/DC Volts Input Connector and the Transducer Excitation Connector for current excitation.

5a/Using RTDs

PROGRAMMING

General

RTD measurement programming depends on the hardware configuration and the type of RTD to be used, as indicated on the Programming Form. Using the Channel Program module, specify the channel number, function, and range as was done earlier in the Installation Test.

Both hardware configurations support the selection of both preset and user-defined RTD constants.

Preset RTD Constants

The preset RTD constants are:

- o Configuration A (RTD Scanner and Connector)
 - AR<4> 385 RTD SCANNER TEMP < 425.00 C
 - AR<5> 10 OHM CU RTD SCANNER
 - AR<7> 385 RTD SCANNER TEMP > 425.0 C

- o Configuration B (Transducer Excitation Module)
 - AR<1> 385 DC VOLTS SCANNER
 - AR<2> 10 OHM CU DC VOLTS SCANNER

User-Defined RTD Constants

User-defined RTD constants can also be specified for both configurations.

- o Configuration A (RTD Scanner and Connector)
 - AR<6> USER DEFINED RTD SCANNER LO RANGE
(maximum resistance 256 ohms)
 - AR<8> USER DEFINED RTD SCANNER HI RANGE
(maximum resistance 2048 ohms)
- o Configuration B (Transducer Excitation Module)
 - AR<3> USER DEFINED DC VOLTS SCANNER

Default constants are selected if no other user-defined RTD constants are programmed. The default constants are:

R0 VALUE = 100.00
ALPHA VALUE = 3.90E-3
DELTA VALUE = 1.494
C4 VALUE = -.20598E-11

When a user-defined menu choice, 6, 8, or 3, is selected, R0, ALPHA, DELTA, and C4 can be accessed by successively pressing the ENTER key. The default or more recently entered values are displayed as each constant is selected. These constant values can be changed by entering new numbers when each constant is accessed.

5a/Using RTDs

MONITORING

An RTD temperature measurement usually involves monitoring or scanning the programmed channel. The User Guide fully describes the various monitoring and scanning methods available for making measurements.

MONITOR any channel (0-9) programmed in this subsection's examples as follows:

Press:

Display:

MONITOR
C0
ENTER

MAIN MENU CHOICE <M FOR MENU>? A
MONITOR CHANNEL =
MONITOR CHANNEL = C0
C0 (reading)

EXAMPLES

The following pages contain wiring and programming examples for five types of RTD measurements. Briefly, these examples are:

Example:

Configuration A: (RTD Scanner and Connector)	1
Configuration B (Transducer Excitation Module)	
4-Wire, Constant Voltage	2
3-Wire, Constant Voltage, 385 DIN RTD	3
3-Wire, Constant Voltage, 10 Ohm CU RTD	4
3-Wire, Constant Current, 385 DIN RTD	5

5a/Using RTDs

Example 1: Configuration: A (RTD Scanner and Connector)
Type: 4-Wire, 3-Wire Accurate, 3-Wire Isolated

Figures 5a-2, 5a-3, and 5a-4 illustrate wiring for 4-Wire, 3-Wire Accurate, and 3-Wire Isolated modes, respectively.

The following steps can be used to program the 2280 for measuring ten RTD channels.

Press:	Display:
	MAIN MENU CHOICE <M FOR MENU>? A
A ENTER	CHANNEL NUMBER (OR BLOCK)
C0..9 ENTER	...<P,C,D,L>?
P ENTER	A: CHANNEL FUNCTION <A-Z>?
R	A<R> RTD
ENTER	AR: RTD TYPE <1-8>? (R = 4, 5, 6, 7, or 8)

NOTE

2280 RTD channel program menu choices are:

- AR<1> 385 DC VOLTS SCANNER
- AR<2> 10 OHM CU DC VOLTS SCANNER
- AR<3> USER DEFINED DC VOLTS SCANNER
- AR<4> 385 RTD SCANNER TEMP < 425.00 C
- AR<5> 10 OHM CU RTD SCANNER
- AR<6> USER DEFINED RTD SCANNER LO RANGE
- AR<7> 385 RTD SCANNER TEMP > 425.0 C
- AR<8> USER DEFINED RTD SCANNER HI RANGE

If type 6 or 8 is chosen, the 2280 sequences through four additional prompts; R0, ALPHA, DELTA, and C4. If no change is entered at the appropriate prompt, each of these constants is set to the displayed default or previously entered value.

ENTER	AR: CHANNEL MENU CHOICE <1-5>?
EXIT ...	(return to main menu)

5a/Using RTDs

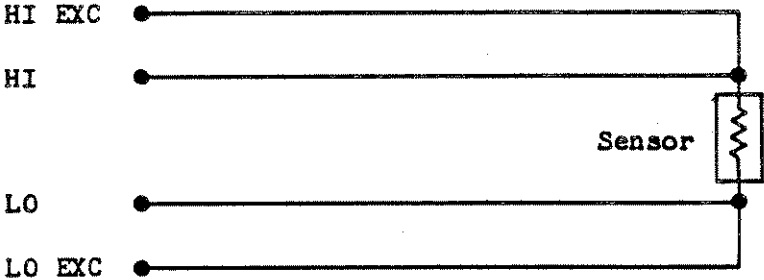

This is the most accurate measurement mode.

Figure 5a-2. Wiring: 4-Wire, Configuration A

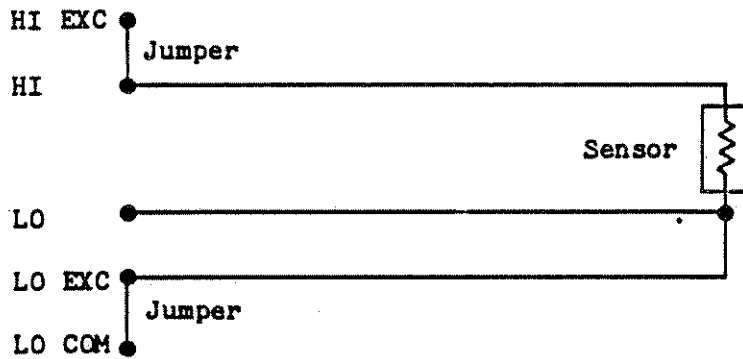

Ensure that the HI and LO EXC lead wires have the same length, composition, and resistance.

Use the 3-Wire configuration if possible. Remember that the LO COMs of ten channels (e.g. 0-9) are connected together inside the Connector PCB.

Figure 5a-3. Wiring: 3-Wire Accurate, Configuration A

5a/Using RTDs

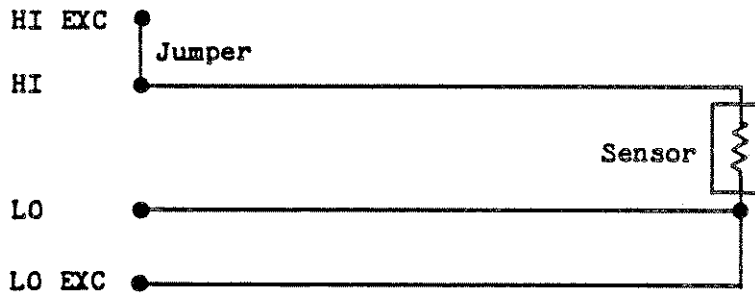

Ensure that the HI and LO EXC lead wires have the same length, composition, and resistance.

This is much less accurate than the 3WA mode for all but many-kilohm resistance measurements.

Figure 5a-4. Wiring: 3-Wire Isolated, Configuration A

**Example 2: Configuration: B (Transducer Excitation Module)
Type: 4-Wire**

Wiring for this type of RTD measurement is shown in Figure 5a-5.

The following steps can be used to program the 2280 for measuring ten RTD channels.

Press:	Display:
A ENTER	MAIN MENU CHOICE <M FOR MENU>? A
C0..9 ENTER	CHANNEL NUMBER (OR BLOCK) ...<P,C,D,L>?
P ENTER	A: CHANNEL FUNCTION <A-Z>?
R	A<R> RTD
ENTER	AR: RTD TYPE <1-8>? (R = 1 or 3)

NOTE

The 2280 RTD channel program menu choices are:

AR<1> 385 DC VOLTS SCANNER
 AR<2> 10 OHM CU DC VOLTS SCANNER
 AR<3> USER DEFINED DC VOLTS SCANNER
 AR<4> 385 RTD SCANNER TEMP < 425.00 C
 AR<5> 10 OHM CU RTD SCANNER
 AR<6> USER DEFINED RTD SCANNER LO RANGE
 AR<7> 385 RTD SCANNER TEMP > 425.0 C
 AR<8> USER DEFINED RTD SCANNER HI RANGE

If type 3 is chosen, the 2280 sequences through four additional prompts; R0, ALPHA, DELTA, and C4. If no change is entered at the appropriate prompt, each of these constants is set to the displayed default or previously entered value.

ENTER	AR: CHANNEL MENU CHOICE <1-5>?
EXIT ...	(return to main menu)

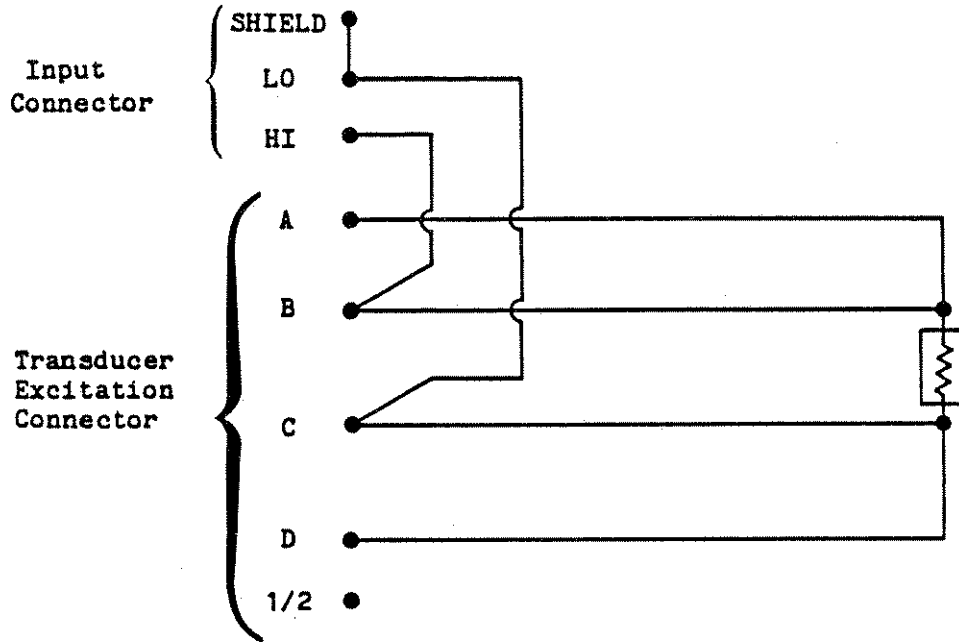

Figure 5a-5. Wiring: 4-Wire, Constant Current, Configuration B

5a/Using RTDs

**Example 3: Configuration: B (Transducer Excitation Module)
Method: 1 (Constant Voltage)
Type: 3-Wire, 385 DIN RTDs**

This method uses the +4V, constant voltage supply present on the Transducer Excitation Module. A bridge configuration, with the RTD as the unbalancing factor, is created. For 100 ohm Pt RTDs, suggested resistors would be 40 kilohms $\pm 0.1\%$ with 5ppm temperature coefficient wire-wound resistors. Although resistors with other values may be used, the following considerations should be noted:

- o The channel linearization expression must compensate for the actual current flowing through the RTD, and
- o The resistance value should be sufficiently high so that the initial unbalancing effect of the RTD in one of the legs is relatively small. For example, with 40 kilohm resistors, there is 1 part in 400 difference between the two legs.

Wiring for this type of RTD measurement is shown in Figure 5a-6.

The following example can be used to program the 2280 for measuring ten 3-wire, 385 DIN RTD channels when 40 kilohm resistors are used:

Press:	Display:
	MAIN MENU CHOICE <M FOR MENU>? A
A ENTER	CHANNEL NUMBER (OR BLOCK)
C0..9 ENTER	... <P,C,D,L>?
P ENTER	A: CHANNEL FUNCTION <A-Z>? A
D	A<D> VOLTS/CURRENT
ENTER	AR: VOLTS/CURRENT RANGE <1-7>?
4 ENTER	AD: CHANNEL MENU CHOICE <1-5>?
3	<3> CHANNEL EXPRESSION
ENTER	CX=
LINI (CX*10)	CX=LINI (CX*10)
ENTER	AD: CHANNEL MENU CHOICE
EXIT ...	(return to main menu)

NOTE

If other values of resistors are used, the expression must be adjusted. The linearization function expects the voltage measured to be generated from a 1 mA current source flowing through the RTD. In the example illustrated, only 0.1 mA is flowing (4 volts through 40 kilohms). Hence, 10*CX is used.

Example 4: Configuration: B (Transducer Excitation Module)
Method: 1 (Constant Voltage)
Type: 3-Wire, 10 Ohm Cu RTDs

For 10 ohm Cu RTDs, 4 kilohm resistors are used to establish the unbalanced bridge. Since 4 kilohm resistors maintain the desired 400 to 1 ratio and give 1 mA of excitation, no special linearization provisions are required.

Wiring for this type of RTD measurement is shown in Figure 5a-6.

The following steps can be used to program the 2280 for measuring ten 10 ohm Cu RTDs with the Transducer Excitation Module.

Press:	Display:
	MAIN MENU CHOICE <M FOR MENU>? A
A ENTER	CHANNEL NUMBER (OR BLOCK)
C0..9 ENTER	... <P,C,D,L>?
P ENTER	A: CHANNEL FUNCTION <A-Z>?
R	A<R> RTD
ENTER	AR: RTD TYPE <1-8>?
2	AR<2> 10 OHM CU DC VOLTS SCANNER
ENTER	AR: CHANNEL MENU CHOICE <1-5>?
EXIT ...	(return to main menu)

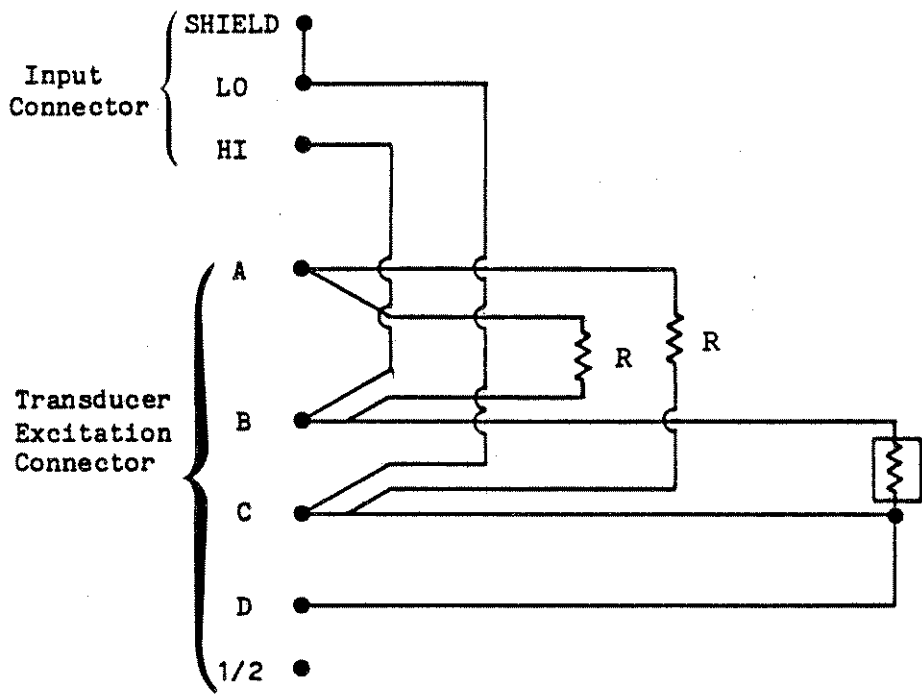

R = User-Supplied Resistor

Figure 5a-6. Wiring: 3-Wire, Constant Voltage, Configuration B

5a/Using RTDs

Example 5: Configuration: B (Transducer Excitation Module)
Method: 2 (Constant Current)
Type: 3-Wire, 385 DIN RTDs

This method uses the constant current supply in the Transducer Excitation Module. Two voltage measurement channels are employed to remove the effects of lead resistance. One channel measures both the lead resistance and the RTD, and another input channel is used to measure only the lead resistance. The difference between the two channels represents the resistance of the RTD. This difference is then linearized.

Wiring for this type of RTD measurement is illustrated in Figure 5a-7.

The following steps can be used to program the 2280 for measuring one 3-wire, 385 DIN RTD channel.

Press:	Display:
	MAIN MENU CHOICE <M FOR MENU>? A
A ENTER	CHANNEL NUMBER (OR BLOCK)
C0..1 ENTER	...<P,C,D,L>?
P ENTER	A: CHANNEL FUNCTION <A-Z>?
D	A<D> VOLTS/CURRENT
ENTER	AD: VOLTS/CURRENT RANGE <1-7>?
4	AD<4> 64.000 MVDC
ENTER	AD: CHANNEL MENU CHOICE <1-5>?
EXIT	A: CHANNEL FUNCTION <A-Z>?
EXIT	CHANNEL NUMBER (OR BLOCK)=
C10 ENTER	...<P,C,D,L>?
ENTER	A: CHANNEL FUNCTION <A-Z>?
ENTER	AP: CHANNEL MENU CHOICE <1-5>?
3	AP<3> CHANNEL PROCEDURE
ENTER	CP:
CX=LINI (C0-C1)	CP:CX=LINI (C0-C1)
ENTER	CP:
ENTER	AP: CHANNEL MENU CHOICE <1-5>?
EXIT ...	(return to main menu)

5a/Using RTDs

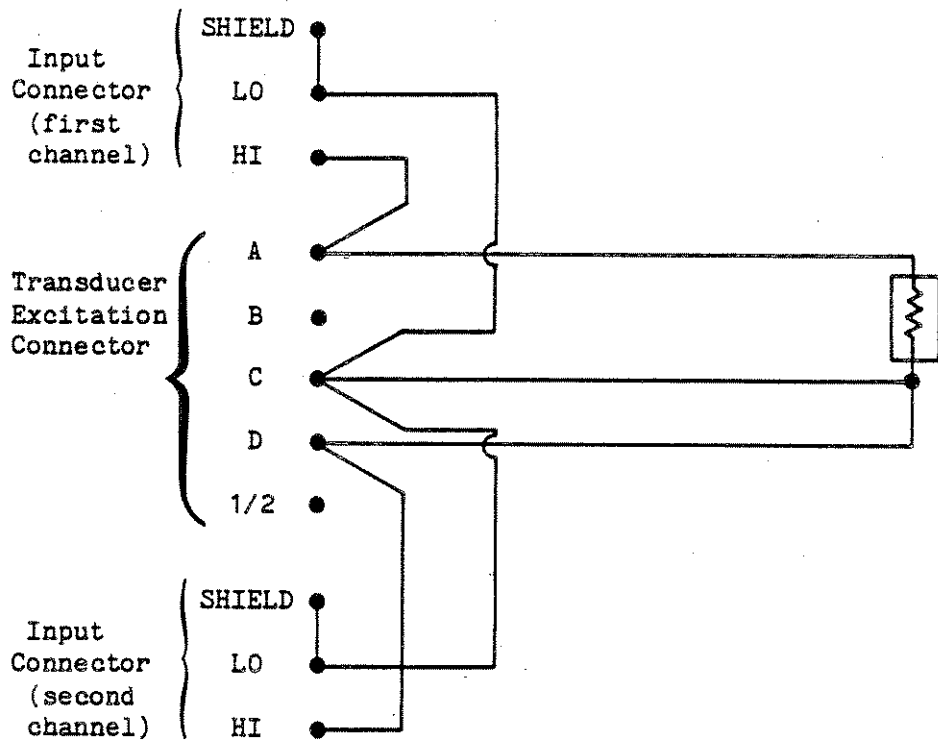

Figure 5a-7. Wiring: 3-Wire, Constant Current, Configuration B

Section 5a
Temperature Measurement
Using Thermistors

INTRODUCTION

Thermistors are another type of commonly-used variable resistance transducer. The resistance of thermistors varies greatly with temperature, thereby providing a means of making reliable temperature measurements over a range of -100 to +300°C.

RTDs, which can also be used to make temperature measurements, are covered elsewhere in this subsection.

Thermistors that are to be measured in bridge configurations, while not specifically covered in this subsection, can be implemented using techniques presented here and in the resistance measurements subsection.

This subsection explains the use of the 2280 Series Data Logger and associated option assemblies for obtaining thermistor temperature readings, while the User Guide provides overall programming and operating instructions. Detailed information regarding the physical installation of the 2280 mainframe and related options is provided in this manual in the following sections:

- o Installation - Mainframe: Section 3
- o Installation - Option Assemblies: Section 4

5a/Using Thermistors

GENERAL

Thermistors exhibit a large temperature coefficient of resistance when compared to other resistance temperature sensors. A large decrease in resistance usually results from a small increase in thermistor temperature, providing a measurement resolution not available with other temperature transducers.

A thermistor's resistance is often determined by passing a known current through it and measuring the resulting voltage drop, as is done by the 2280. Software programming converts this resistance measurement into a temperature reading.

REQUIRED HARDWARE

Thermistor temperature measurement applications require the following option assemblies, which provide the necessary selection, excitation, conditioning, measurement, and conversion functions.

2280A-161	High Performance A/D Converter
2280B-163	RTD/Resistance Scanner
2280B-177	RTD/Resistance Input Connector

NOTE

The 2280A-211 Advanced Math Processor is required when thermistor temperature versus resistance characteristics provided in tabular form must be implemented via an interpolation table.

Excitation And Measurement

The RTD/Resistance Scanner in conjunction with the RTD/Resistance Input Connector selects, excites, and conditions one of 20 channels. In addition to supporting 4-Wire measurements, this configuration provides lead-wire compensation for performing accurate 3-Wire resistance measurements. Two jumpers, W1 and W2, on the scanner along with proper input connector wiring allow a scanner and connector set to operate in one of three modes:

- o 4-Wire (4W) Measurement Mode
Two sense and two excitation wires must be connected to each channel. Lead-wire or reed switch resistances do not affect readings.
- o 3-Wire Accurate (3WA) Measurement Mode
One sense and two excitation wires must be connected to each channel. Equal lead-wire resistances are compensated for. Reed switch resistances do not affect readings. Ten channel returns are internally connected together; therefore, the thermistors must be electrically isolated.
- o 3-Wire Isolated (3WCM) Measurement Mode
One sense and two excitation wires must be connected to each channel. Equal lead-wire resistances are compensated for. One reed switch resistance error affects readings.

Where lead-wire resistances are very small in comparison with the resistance being measured, as may be true with high resistance thermistors, 2-Wire measurements can be made by setting the scanner to operate in 4-Wire mode, and wiring the 177 input connector properly.

Refer to the 177 option in Section 4 for input wiring diagrams and instructions.

5a/Using Thermistors

The resulting voltage sent to the 2280A-161 High Performance A/D Converter by the scanner is directly related to the resistance of the thermistor being measured. The A/D provides high accuracy analog to digital conversion of the thermistor, RTD, and/or resistance inputs. This requires that at least one A/D Converter be installed in the 2280 Series Data Logger.

INSTALLATION

Installation of the required option assemblies is detailed in Section 4 of this manual, where the options are referenced by their three-digit number; 161, 163, or 177. The descriptions in this thermistor subsection assume that the required option assemblies have been properly installed.

The RTD/Resistance Scanners, from one to five per A/D Converter, are installed in the slot(s) directly below the A/D Converter in either the 2280 mainframe of the 2281A Extender Chassis.

Installation testing involves a programmed hardware listing. This procedure is defined in Section 4 for each option assembly (referenced by option number).

NOTE

For accuracy tests, refer to the appropriate 2280 Series Service Manual subsection.

PROGRAMMING

General

Thermistor temperature is measured as a resistance that is then mathematically converted into a meaningful temperature measurement by the 2280. The proper RTD/Resistance Scanner measurement range must be chosen, and one of two programming methods must be employed to make this measurement and conversion. A mathematical equation can be entered when a conversion formula is provided by the thermistor manufacturer, or the 2280 interpolation table capabilities can be employed when a table of temperature versus resistance is available.

RTD/Resistance Scanner Range Programming

Since thermistors vary greatly in resistance, the Scanner ranges to be used must be chosen to match. Three ranges are provided:

256.00 OHMS
2048.0 OHMS
64.000 KOHMS

Refer to the temperature versus resistance table for the thermistor to be used, and examine the overall possible resistance range for that thermistor as well as the anticipated temperature range of the environment to be measured. Considering both of these variables, select the resistance measurement range most appropriate for the application.

Conversion Formula Programming

A conversion formula for the thermistor type, when it is known, can be entered as a channel expression. When a formula is not known, the following interpolation table approach must be used.

5a/Using Thermistors

Interpolation Table Programming

An interpolation table can be used to convert resistance measurements into temperature readings when the 2280A-211 Advanced Math Processor is installed. The table comprises a set of data points that describe the non-linear resistance versus temperature behavior of the thermistor being used.

Data points for an interpolation table should be entered in the Programming Form under the System Program module. Enter each data point in the form (Input)//(Output), where Input is defined as the resistance of the thermistor in resistance range units (eg. kilohms), and Output is the associated temperature. For example, a resistance to be measured on the 64 kilohm range of 10.25 kilohms that corresponds to a 25°C temperature requires that one table entry be 10.25//25.

The sample System Program module shown previously in Installation Test illustrates an application where a relatively tight temperature range of 100±5°C is being monitored. In most applications, a wider range of data points would be entered.

Example

Complete the Channel Program for the first ten channels using the following steps. This will match the Programming Form example that also follows.

Press: A ENTER C0..9 ENTER ENTER Z ENTER 3 ENTER 3 ENTER TBL1(CX) ENTER EXIT ...	Display: MAIN MENU CHOICE <M FOR MENU>? A CHANNEL NUMBER (OR BLOCK) ...<P,C,D,L>? A: CHANNEL FUNCTION <A-Z>? AZ: RESISTANCE RANGE <1-5>? AZ: CHANNEL MENU CHOICE <1-5>? AZ<3> CHANNEL EXPRESSION CX= AZ: CHANNEL MENU CHOICE <1-5>? (return to main menu)
---	---

Next, enter the thermistor's temperature versus resistance characteristics into a 2280 interpolation table.

Press: Z ENTER 6 ENTER 1 ENTER 177.16//95 ENTER 171.89//96 ENTER . . .	Display: MAIN MENU CHOICE <M FOR MENU>? A <Z> PROGRAM SYSTEM PARAMETERS Z: SYSTEM MENU CHOICE <1-7> Z<6> INTERPOLATION TABLES TABLE NUMBER = 0 IT: IT: IT:
---	--

(complete per the following System Program sample)

EXIT ...	(return to main menu)
----------	-----------------------

MONITORING

Thermistor temperature measurements usually involve monitoring or scanning the programmed channels. The User Guide fully describes the various monitoring and scanning methods available.

MONITOR any one of channels 0 through 9 with the following procedure:

Press:	Display:
MONITOR	MAIN MENU CHOICE <M FOR MENU>? A
9	MONITOR CHANNEL =
ENTER	MONITOR CHANNEL = C9
	C 9 (reading)

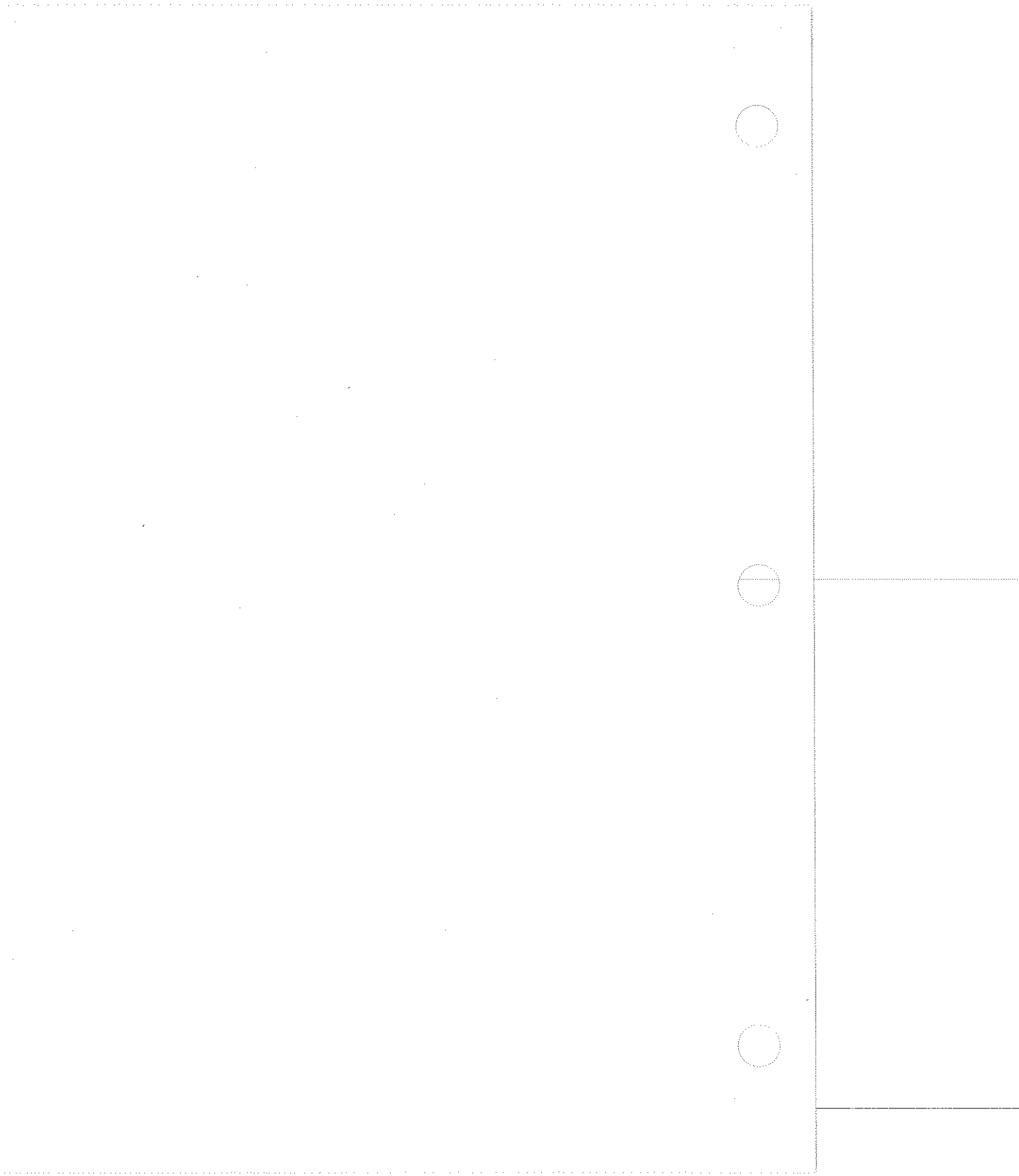

Section 5b
AC Voltage Measurement

INTRODUCTION

AC voltage measurements involve an analog input from the data logging environment.

This section explains use of the 2280 Series Data Logger and associated option assemblies for making ac voltage readings. The User Guide provides overall programming and operating instructions. Detailed information about the physical installation of the 2280 mainframe and related options is provided in the following sections of this manual:

- o Installation - Mainframe: Section 3
- o Installation - Option Assemblies: Section 4

AC VOLTAGE MEASUREMENT - GENERAL

The AC voltage capability of the 2280 is suitable for measuring low frequency (45 to 450 Hz) sine wave voltage signals. Power line monitoring is the most common use of the ac voltage measurement function.

5b/AC Voltage Measurement

REQUIRED HARDWARE

In addition to the standard 2280 mainframe, the following option assemblies are required for ac voltage measurements.

2280A-161	High Performance A/D Converter
2280A-162	Thermocouple/DC Volts Scanner
2280A-160	AC Voltage Input Connector

The High Performance A/D Converter (option -161) provides high accuracy analog-to-digital conversion of scanner input voltages. At least one A/D Converter must be installed in the 2280 Series Data Logger to provide full operating capabilities.

The Thermocouple/DC Volts Scanner (option -162) is a plug-in, 20-channel thermocouple and multi-voltage range relay scanner. The scanner links the A/D Converter to external measurement points.

The AC Voltage Input Connector provides terminal connections for routing 20 voltage input channels to the scanner. Of these 20 channels, ten are designated for ac voltage inputs. The remaining ten are designated for dc voltage inputs. The AC Voltage Input Connector attaches to the scanner; it can be installed or removed without removing the scanner.

5b/AC Voltage Measurement

INSTALLATION

Installation for any of the required option assemblies is detailed in Section 4 of this manual. Reference each option assembly by its option number (160, 161, or 162). These instructions can be consulted as required. The descriptions in this subsection assume that the required option assemblies have successfully completed an installation test.

The AC Voltage Input Connector mates with the Thermocouple/DC Volts Scanner. This 20 channel, multi-range relay scanner selects the proper input channel for the High Performance A/D Converter. Two connections (HI, LO) are made for each channel. Ten ac voltage and ten dc voltage channels are available.

Installation testing involves a programmed hardware listing. This procedure is defined in Section 4 for each option assembly (referenced by option number).

NOTE

For accuracy tests, refer to the appropriate 2280 Series Service Manual subsection.

PROGRAMMING

General

Programming unique to ac voltage inputs requires no more than assigning the appropriate function and range to the desired channels.

5b/AC Voltage Measurement

Example

For example, the following steps would be used in completing the Channel Program for a block of ten ac voltage input channels.

Press:	Display:
A	MAIN MENU CHOICE <M FOR MENU>? A
ENTER	CHANNEL NUMBER (OR BLOCK) =
0..9	<P,C,D,L>? P
ENTER	A: CHANNEL FUNCTION <A-Z>?
D	A<D> VOLTS/CURRENT
ENTER	A<D> VOLTS/CURRENT RANGE <1-7>?
6	AD<6> 250.0 VAC
ENTER	AD: CHANNEL MENU CHOICE <1-5>?
EXIT ...	(return to MAIN MENU CHOICE)

NOTE

If the 2280A is being used for ac voltage measurement, the following, slightly different key sequence is required:

```
A
ENTER
0..9
ENTER ENTER
D ENTER
3 ENTER
3 ENTER
CX+0.32 ENTER
EXIT ...
```

1

2

3

Vertical line of text, possibly a page number or header, running down the right side of the page.

Horizontal line of text, possibly a page number or header, running across the middle of the page.

Horizontal line of text, possibly a page number or header, running across the bottom of the page.

Section 5b
DC Voltage Measurement

INTRODUCTION

DC voltage measurements involve an analog input from the data logging environment.

This section explains use of the 2280 Series Data Logger and associated option assemblies for obtaining dc voltage readings. The User Guide provides overall programming and operating instructions. Detailed information about the physical installation of the 2280 mainframe and related options is provided in the following sections of this manual:

- o Installation - Mainframe: Section 3
- o Installation - Option Assemblies: Section 4

DC VOLTAGE MEASUREMENT - GENERAL

DC voltage measurement is a relatively simple use of the 2280 Series Data Logger. Numerous applications require dc voltage measurement. For example, many industrial sensors output 0 to 5 volts to indicate 0% to 100% of the measured parameter.

5b/DC Voltage Measurement

REQUIRED HARDWARE

In addition to the standard 2280 mainframe, the following option assemblies are required for dc voltage measurements.

2280A-161	High Performance A/D Converter
2280A-162	Thermocouple/DC Volts Scanner

One of the following connector assemblies is required:

2280A-160	AC Voltage Input Connector
2280A-175	Isothermal Input Connector
2280A-176	Voltage Input Connector

The High Performance A/D Converter (2280A-161) provides high accuracy analog-to-digital conversion of scanner input voltages. At least one A/D Converter must be installed in the 2280 Series Data Logger to provide full operating capabilities.

The Thermocouple/DC Volts Scanner (option -162) is a plug-in, 20-channel thermocouple and multi-voltage range relay scanner. The scanner links the A/D Converter to external measurement points. It accepts a variety of analog inputs, depending on the type of connector in use (Current Connector, Isothermal Connector, or Voltage Connector).

The Voltage Input Connector provides terminal connections for routing 20 dc voltage input channels to the scanner. This assembly attaches to the scanner: it can be installed or removed without removing the scanner. Connector assemblies can thereby be interchanged without affecting system operation.

Either the AC Voltage Input Connector (10 dc voltage channels) or the Thermocouple Input Connector (20 dc voltage channels) can be attached to the scanner in a similar fashion. These connectors fully support dc voltage measurements.

5b/DC Voltage Measurement

Use of 2281A Extender Chassis allows for a maximum of 15 A/D Converters in a 2280 system. Each A/D Converter assembly can operate with multiple Thermocouple/DC Volts Scanner assemblies (five maximum).

INSTALLATION

Installation for any of the required option assemblies is detailed in Section 4 of this manual. Reference each option assembly by its option number (161, 162, or 176/160/175). These instructions can be consulted as required. The descriptions in this subsection assume that the required option assemblies have successfully completed an installation test.

The input connector mates with the Thermocouple/DC Volts Scanner. This 20 channel, multi-range relay scanner selects the proper input channel for the High Performance A/D Converter.

For inputs to the Voltage Input Connector or the Thermocouple Input Connector, each input channel includes three lines (HIGH, LOW, SHIELD). The voltage is measured across HIGH and LOW. The following considerations apply to use of SHIELD:

- o To provide maximum protection from common-mode noise voltages, attach SHIELD to LOW at the point of measurement. Use a shield line from the 2280 connector to the measurement point.
- o To provide maximum rejection of radio frequency interference (RFI) or electro-magnetic interference (EMI), attach SHIELD to LOW at the connector with as short a wire as possible.
- o SHIELD must never be left disconnected or connected to HIGH or the chassis ground. For more information, see Fluke Application Bulletin AB-20 concerning guarded signal measurements.

5b/DC Voltage Measurement

Installation testing involves a programmed hardware listing. This procedure is defined in Section 4 for each option assembly (referenced by option number).

NOTE

For accuracy tests, refer to the appropriate 2280 Series Service Manual subsection.

PROGRAMMING

General

Programming the 2280 to make dc voltage inputs requires nothing more than specifying the channel number(s) and the range/function. These steps are found in the Channel Program module of the Programming Form.

Example

For example, the following steps would be used in completing the Channel Program for a block of ten dc voltage input channels using the 64V dc range.

Press:

A ENTER
C0..9 ENTER
P ENTER
D
ENTER
(1,2,3, or 4)

Display:

MAIN MENU CHOICE <M FOR MENU>? A
CHANNEL NUMBER (OR BLOCK)
...<P,C,D,L>?
A: CHANNEL FUNCTION <A-Z>?
A<D> VOLTS/CURRENT
AD: VOLTS/CURRENT RANGE <1-7>?

5b/DC Voltage Measurement

MONITORING

MONITOR any programmed channel in the following manner:

Press:

Display:

MONITOR
(channel number)
ENTER

MAIN MENU CHOICE <M FOR MENU>? A
MONITOR CHANNEL =
MONITOR CHANNEL = (channel number)
C xx (reading)

Section 5c Current Measurement

INTRODUCTION

The Current Input Connector accommodates inputs from 0 to 64 mA on a maximum of 20 channels. This range covers the useful range of standard current transmitters. Since this type of transmitter is often used to translate the output of another transducer (pressure, fluid flow, etc) to a current output, the current measurement function can serve a multitude of applications.

This section explains use of the 2280 Series Data Logger and associated option assemblies for obtaining current readings. The User Guide provides overall programming and operating instructions. Detailed information about the physical installation of the 2280 mainframe and related options is provided in the following sections of this manual:

- o Installation - Mainframe: Section 3
- o Installation: Option Assemblies: Section 4

5c/Current Measurement

CURRENT MEASUREMENT - GENERAL

Standard current transmitters output a current value proportional to the physical parameter being measured. This sensor type usually outputs a value of from 1 to 5 mA, 4 to 20 mA, or 10 to 50 mA across its measurement range. Scaling and conversion used by the 2280 are optimized to measure current values within these ranges.

REQUIRED HARDWARE

Applications involving current measurement require the following option assemblies:

2280A-161	High Performance A/D Converter
2280A-162	Thermocouple/DC Volts Scanner
2280A-171	Current Input Connector

The High Performance A/D Converter (option -161) provides high accuracy analog to digital conversion of scanner inputs. At least one A/D Converter must be installed in the 2280 Series Data Logger when analog measurements are being made.

The Thermocouple/DC Volts Scanner (option -162) is a plug-in, 20-channel thermocouple and multi-voltage range relay scanner. The scanner links the A/D Converter to external measurement points.

The Current Input Connector (option 171) routes a maximum of 20 current input channels to the Thermocouple/DC Volts Scanner.

INSTALLATION

Installation for any of the required option assemblies is detailed in Section 4 of this manual. Reference each option assembly by its option number (161, 162, or 171). These instructions can be consulted as required. The descriptions in this subsection assume that each option assembly has successfully completed the installation test specified in Section 4.

Installation testing involves a programmed hardware listing. This procedure is defined in Section 4 for each option assembly (referenced by option number).

NOTE

For accuracy tests, refer to the appropriate 2280 Series Service Manual subsection.

PROGRAMMING

One input range (64 mA) is available for current inputs. This range is specified for each current input channel as a CHANNEL PROGRAM input.

A channel expression may also be programmed to convert current measurement to engineering units.

First, compute the slope constant for the equation. The slope equals the difference between the desired engineering unit value corresponding to 20 mA and the engineering unit value at 4 mA, divided by 16. The offset constant is the difference between five times the engineering unit value at 4 mA and the engineering unit value at 20 mA, divided by 4.

5c/Current Measurement

For example, consider a pressure transmitter whose output is 4 mA with 0 psi and 20 mA with 500 psi.

- o Slope constant (m) = $(500-0)/16 = 31.25$
- o Offset constant (b) = $(5*0-500)/4 = -125$

The channel equation for this transmitter would be:

$$CX = 31.25 * CX - 125$$

The engineering units would be programmed to psi.

The following programming steps would be used for this example:

Press:	Display:
A ENTER	MAIN MENU CHOICE <M FOR MENU>? A
(Cxx.xx) ENTER	CHANNEL NUMBER (OR BLOCK)
P ENTER	...<P,C,D,L>?
D	A: CHANNEL FUNCTION <A-Z>?
ENTER	A<D> VOLTS/CURRENT
5	AD: VOLTS/CURRENT RANGE <1-7>?
ENTER	AD<5> 64.0 MA
3	AD: CHANNEL MENU CHOICE <1-5>?
ENTER	AD<3> CHANNEL EXPRESSION
31.25*CX-125	CX=
ENTER	CX= 31.25*CX-125
2	A<D> CHANNEL MENU CHOICE <1-5>?
ENTER	AD<2> CHANNEL UNITS
PSI	CHANNEL UNITS <6 CHRS MAX> =
ENTER	CHANNEL UNITS <6 CHRS MAX> = PSI
EXIT ...	AD: CHANNEL MENU CHOICE <1-5>?
	(return to main menu)



Section 5d
Resistance Measurement

INTRODUCTION

Resistance measurements involve an analog input from a resistive output sensor. This input is converted to representative units by the 2280.

This section explains use of the 2280 Series Data Logger and associated option assemblies for obtaining resistance readings. The User Guide provides overall programming and operating instructions. Detailed information about the physical installation of the 2280 mainframe and related options is provided in the following sections of this manual:

- o Mainframe installation - Section 3
- o Option assembly installation - Section 4

RESISTANCE MEASUREMENTS - GENERAL

Resistance measurements with the 2280 are usually made in order to measure something other than just resistance. Many sensors have variable resistance outputs to indicate some other parameter, such as measuring temperature with non-standard RTD's or sensing position with slide wire pots, and so on.

5d/Resistance Measurements

RESISTANCE MEASUREMENTS - GENERAL

Measurements can be made with the 2280 to determine resistance, or to determine the value of another directly related parameter. Many slide wire pots, non-standard RTDs, and other sensors with variable resistance outputs can be used to indicate temperature, position, and other physical parameters.

Several types of variable resistance transducers are discussed in greater detail in other subsections within this section. The related subsections are:

- o Section 5a: Using Thermistors
- o Section 5b: RTD Temperature Measurements
- o Section 5g: Strain Measurements

The 2280 measures resistance by passing a stable current through the resistor or sensor, and measuring the voltage that results. Appropriate conversions are then made to the sensed voltage and the output is displayed as a resistance reading.

REQUIRED HARDWARE

Resistance measurement applications require one of two option assembly configurations.

The 2280A-161 High Performance A/D Converter, which provides high accuracy analog to digital conversion of scanner inputs, must be used in both configurations. This requires that at least one A/D Converter be installed in the 2280 Series Data Logger.

5d/Resistance Measurements

Configuration A

The first configuration employs the following two option assemblies in addition to the A/D:

2280B-163	RTD/Resistance Scanner
2280B-177	RTD/Resistance Input Connector

This configuration provides the most accurate and repeatable resistance readings with the lowest cost per channel. Each RTD/Resistance Scanner and Connector set provides current excitation and measurement for 20 resistance channels and are intended for applications more exclusively involving resistance measurements.

The RTD/Resistance Scanner configuration also provides lead-wire compensation for performing accurate 3-Wire resistance measurements. Two jumpers, W1 and W2, on the scanner along with proper input connector wiring allow a scanner and connector set to operate in one of three modes:

- o 4-Wire (4W) Measurement Mode This mode offers the highest accuracy. Two sense and two excitation wires must be connected to each channel. Lead-wire or reed switch resistances do not affect readings.
- o 3-Wire Accurate (3WA) Measurement Mode This mode offers slightly reduced accuracy in comparison to the 4-Wire mode. One sense and two excitation wires must be connected to each channel. Equal lead-wire resistances are compensated for. Reed switch resistances do not affect readings. Ten channel returns are internally connected together; therefore, the resistors must be electrically isolated.

5d/Resistance Measurements

- o 3-Wire Isolated (3WCM) Measurement Mode This mode offers high channel-to-channel isolation at the expense of accuracy. One sense and two excitation wires must be connected to each channel. Equal lead-wire resistances are compensated for. One reed switch resistance error affects readings.

Where lead-wire resistances are very small in comparison with the resistance being measured, 2-Wire measurements can be made by setting the scanner to operate in 4-Wire mode, and wiring the 177 input connector properly.

Refer to the 177 option (Section 4) for input wiring diagrams and instructions.

Configuration B

The second configuration supports a wider mix of applications. Excitation and measurement can be provided for several types of 4-Wire resistance output sensors by the following assemblies:

2280A-162	Thermocouple/DC Volts Scanner
2280A-176	Voltage Input Connector (or other)
2280A-164	Transducer Excitation Module
2280A-174	Transducer Excitation Connector

The Thermocouple/DC Volts Scanner, 2280A-162, is a plug-in, 20 channel, thermocouple and dc voltage, reed relay scanner contained on a single pcb. This selects and conditions one channel at a time for conversion by the A/D Converter. Connections to the Scanner can be made through a Voltage Input, Isothermal Input, or AC Voltage Input Connector. The A/D, Scanner, and Connector measure the dc voltage generated across the resistance to be measured.

5d/Resistance Measurements

The 2280A-164 Transducer Excitation Module is used to energize the resistance sensors with an excitation current or the resistance bridge configurations with a voltage. Used in conjunction with the 2280A-174 Transducer Excitation Connector, each 164 option provides five current sources that can excite up to four channels per source, and one voltage source that can excite bridge configurations.

INSTALLATION

Installation of the required option assemblies is detailed in Section 4 of this manual, where the options can be referenced by their three-digit numbers. The descriptions in this resistance subsection assume that the required option assemblies have successfully passed their installation tests.

After each option assembly has been installed as shown in Section 4, verify that all hardware configuration steps have been followed. These steps include:

- o Configuration A (RTD/Resistance Scanner)

Select the measurement mode. Set the two jumpers on the RTD/Resistance Scanner PCB, in the desired positions, and wire the RTD/Resistance Connector properly.

- o Configuration B (Transducer Excitation Module)

Correctly wire the Thermocouple/DC Volts Input Connector and the Transducer Excitation Connector for current excitation.

5d/Resistance Measurements

Installation testing involves a programmed hardware listing. This procedure is defined in Section 4 for each option assembly (referenced by option number).

NOTE

For accuracy tests, refer to the appropriate 2280 Series Service Manual subsection.

PROGRAMMING

General

Resistance measurement programming depends on the hardware configuration and the measurement range, as shown on the Programming Form. Using the Channel Program module, specify the channel number(s), function, and range as was done in the Installation Test.

Example

Complete the Channel Program for the first ten channels, as illustrated in the sample Programming Form also presented.

Press:

A ENTER
C0..9 ENTER
P ENTER
Z
ENTER
x (see note)

Display:

MAIN MENU CHOICE <M FOR MENU>? A
CHANNEL NUMBER (OR BLOCK)
...<P,C,D,L>?
A: CHANNEL FUNCTION <A-Z>?
A<Z> RESISTANCE
AZ: RESISTANCE RANGE <1-5>?
AZ<x>

5d/Resistance Measurements

MONITORING

A resistance measurement usually involves monitoring or scanning the programmed channel. The User Guide fully describes the various monitoring and scanning methods available.

For example, MONITOR any one of channels 0 through 9 with the following procedure:

Press:	Displayed Response:
	MAIN MENU CHOICE <M FOR MENU>? A
MONITOR	MONITOR CHANNEL =
3	MONITOR CHANNEL = 3
ENTER	C 3 (reading)

Section 5e
Measuring Frequency

INTRODUCTION

Frequency is defined as the number of events that occur in a given time period. Frequency is expressed in hertz. Frequency measurements can be used to determine the linear or rotational speed of objects, the flow rate of fluids, and the oscillation rate of electrical signals.

This section explains the use of the 2280 Series Data Logger for measuring frequency. The User Guide provides general programming and operating instructions for the data logger. Detailed information on installing the 2280 and its options is found in the following sections of this manual:

- o Installation - Mainframe: Section 3
- o Installation - Option Assemblies: Section 4

5e/Frequency Measurements

FREQUENCY MEASUREMENTS - GENERAL

Frequency is measured by counting events for a known time period. The measurement represents the average frequency observed during the sampling time. In the 2280 Series Data Logger, the measurement time is about two-thirds of a second.

A transition between one voltage state and another constitutes an event. The boundary between a high and low voltage state may be different for different types of signals. The 2280 counts high-to-low transitions.

REQUIRED HARDWARE

To make frequency measurements, the following data logger option is needed:

2280B-167 Counter/Totalizer

Each Counter/Totalizer option supports six frequency measurement channels.

The Counter/Totalizer adjustments allow for measurement of a variety of signal types. The reference voltage and input deadband are adjustable. These adjustments define the high and low voltage thresholds of the input.

The Counter/Totalizer also supports an event counting (totalizing) function. Debouncers and input pull-up adjustments are provided for event counting measurements. These adjustments are normally not used when measuring frequency.

INSTALLATION GENERAL

The installation instructions for the Counter/Totalizer are found in Section 4 of this manual. Consult these instructions as necessary. To prepare a Counter/Totalizer channel for frequency measurement, perform the following steps. Refer to Figure 5e-1.

5e/Frequency Measurements

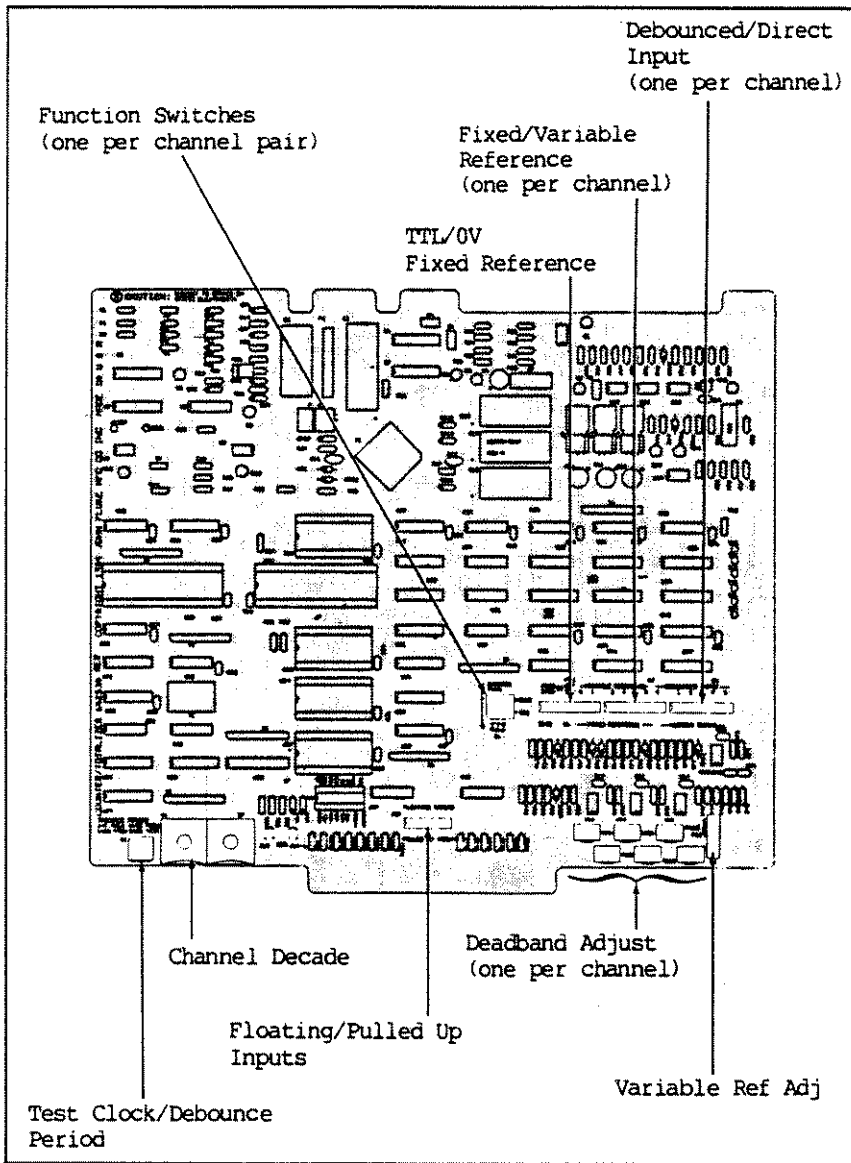

Figure 5e-1. Counter/Totalizer Adjustments

5e/Frequency Measurements

- o Move the channel function switch to the **FREQ** position. Notice that the channels are grouped in pairs. There are three pairs of channels: channels 0 and 1, channels 2 and 3, and channels 4 and 5. Both channels in a pair must have the same function.
- o Move the debounced/direct input switch to the **DIRECT INPUT** position. This turns off the debouncer. Since it alters the shape of the input signal, the debouncer can introduce errors during frequency measurements. Also, frequencies above 125 Hz cannot be measured with the debouncer on.
- o Move the floating/pulled-up resistor network to the **FLOATING** position. Pulled-up inputs are necessary when counting contact closures. They are usually not needed for frequency measurements.

INSTALLATION TEST

Repeat the following steps for each frequency channel.

Connections

Wire the test clock output on the Counter/Totalizer rear panel connector to the channel input terminal. The terminal assignments for the connector are listed on the rear panel. Since the test clock output and the channel inputs use the same ground, it is not necessary to wire a return line.

5e/Frequency Measurements

MAKING THE MEASUREMENT

To prepare the data logger to measure frequency, simply program the appropriate channels to the frequency function, and use the frequency channels in one or more scan groups as needed.

To ensure that the input signals are detected accurately, the Counter/ Totalizer input thresholds must be properly adjusted. The following paragraphs describe adjustment steps and measurement precautions.

Adjustments

Figure 5e-3 shows how input voltage levels are detected by the Counter/ Totalizer. The reference voltage defines the boundary between the high and low voltage states of the input signal. Deadband prevents input noise from being detected. As shown in the figure, the reference voltage and deadband define the high and low input voltage thresholds.

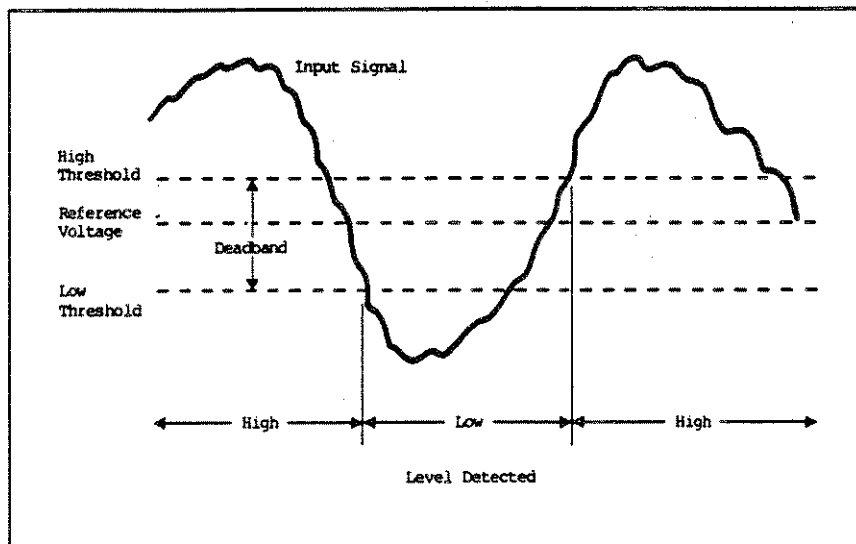

Figure 5e-3. Input Level Detection

5e/Frequency Measurements

On the Counter/Totalizer assembly, the reference voltage and deadband are adjustable. For each channel, a switch selects either a fixed or variable reference voltage. There is one variable reference on the assembly, adjustable from -10 to +10 volts. There is also one fixed reference, which is selectable for 0 volts or 1.4 volts (TTL level). The deadband is adjustable from 0 to 3 volts for each channel.

ADJUSTING REFERENCE VOLTAGE

To choose the proper reference voltage, follow these guidelines:

- o If the input signal is centered around 0 volts, select the 0 volt fixed reference.
- o If the input signal is TTL compatible, select the TTL fixed reference.
- o If the input signal is neither of the above, select the variable reference. To adjust the variable reference voltage, connect a voltmeter to the variable reference terminal and one of the return terminals on the rear panel connector. Using a small screwdriver, turn the variable reference adjustment screw until the desired voltage is displayed by the voltmeter.

ADJUSTING DEADBAND

To adjust the input deadband, there are several approaches. Use the method most suitable for your application.

- o Method 1. For TTL signals, turn the deadband adjustment screw counterclockwise until it stops. Then turn the screw clockwise to the position marked TTL on the rear panel.

5e/Frequency Measurements

- o Method 2. Connect the signal to be measured to one of the Counter/Totalizer input terminals, as for normal operation. Turn the appropriate deadband adjustment screw counterclockwise until it stops. Monitor the channel and turn the deadband screw clockwise until a stable reading is obtained.
- o Method 3. Temporarily select the 0 volt fixed reference for the channel in question. Remove any connections to the input terminal. Connect a voltmeter to one of the return terminals and to the threshold output terminal for this channel. Disregarding the polarity of the threshold voltage, turn the appropriate deadband adjustment screw until the threshold is one-half the desired deadband voltage. Restore the reference voltage to its original setting.

To ensure accurate measurements, adjust the deadband for each channel as high as possible.

CHECKING THRESHOLD VOLTAGES

The combination of reference voltage and deadband determines the high and low threshold voltages. To check the threshold levels, use the following procedure:

- o Connect a voltmeter to one of the return terminals and to the threshold output terminal for the channel in question. Connect the test clock output to the channel input terminal.
- o Turn the test clock switch to position 0 (+14 volt output) and read the low threshold on the voltmeter.
- o Turn the test clock switch to position 1 (-15 volt output) and read the high threshold on the voltmeter.

5e/Frequency Measurements

Connections

The terminal assignments for the Counter/Totalizer connector are listed on the rear panel. The maximum input voltage is $\pm 15\text{V}$ dc or ac peak.

The six channels on a Counter/Totalizer assembly are isolated from the data logger chassis and from ground but not from each other. The return lines on the input connector are common. All return lines must be connected to the same voltage.

Out-of-Range Conditions

The Counter/Totalizer is guaranteed to measure frequencies down to 2 hertz. Frequencies below 2 hertz may be declared out of range. An "OUT RANGE" reading indicates that the input frequency is too low to be measured.

The Counter/Totalizer is guaranteed to measure frequencies up to 400 kilohertz. Overrange conditions are not detected. When the input frequency exceeds 400 kilohertz, erroneous readings may be returned.



Vertical line of text or markings along the right edge of the page.

Section 5f
Totalizing Measurement

INTRODUCTION

Counting items, as in a production line, and monitoring the flow of gasses or liquids are common applications for event-counting measurements.

This section explains the use of the 2280 Series Data Logger for counting events. The User Guide provides general programming and operating instructions for the data logger. Detailed information on installing the 2280 and its options is found in the following sections of this manual:

- o Installation - Mainframe: Section 3
- o Installation - Option Assemblies: Section 4

EVENT COUNTING - GENERAL

To the electronic circuitry in the 2280 Series Data Logger, a transition between one voltage state and another constitutes an event. The 2280 counts high-to-low transitions. The boundary between a high and low voltage state may be different for different types of signals.

5f/Totalizing Measurement

On an event-counting channel, each reading indicates the number of events that have occurred since the channel was last scanned. The event counter is reset at the start of scanning. It is again reset after each scan reading. Monitoring an event channel does not reset the counter. This ensures that the monitoring and scanning operations do not interfere with each other. No counts are lost when an event counter is reset.

REQUIRED HARDWARE

To count events, the following data logger option is needed:

2280B-167 Counter/Totalizer

Each Counter/Totalizer option supports six event counting channels.

The Counter/Totalizer has adjustments that allow it to monitor a variety of signal types. The reference voltage and input deadband are adjustable. These adjustments define the high and low voltage thresholds of the input. Debouncers and input pull-ups allow accurate counting of contact closures.

INSTALLATION GENERAL

The installation instructions for the Counter/Totalizer are found in Section 4 of this manual. Consult these instructions as necessary. To prepare a Counter/Totalizer channel for event-counting, perform the following steps. Refer to Figure 5f-1.

- o Move the channel function switch to the COUNT position. Notice that the channels are grouped in pairs. There are three pairs of channels: channels 0 and 1, channels 2 and 3, and channels 4 and 5. Both channels in a pair must have the same function.

5f/Totalizing Measurement

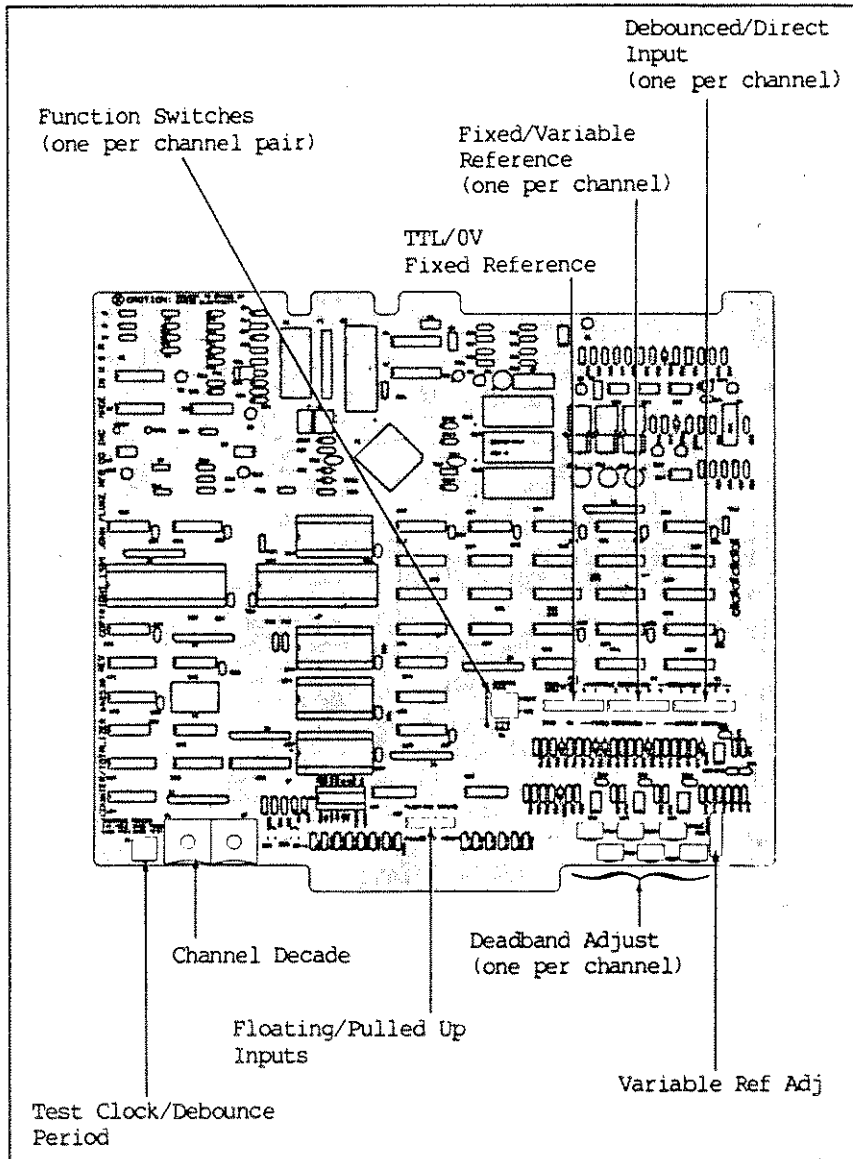

Figure 5f-1. Counter/Totalizer Adjustments

5f/Totalizing Measurement

- o Note the position of the debounced/direct input switch. For counting contact closures, move the switch to the DEBOUNCED INPUT position. This turns the debouncer on. If not counting contact closures, move the switch to the DIRECT INPUT position. This turns the debouncer off. In this configuration, the input signal is fed directly into the counter.
- o Note the position of the floating/pulled-up resistor network. For counting contact closures, move the resistor network to the PULLED UP position. In this configuration, each channel input is connected through a pull-up resistor to the positive power supply on the Counter/ Totalizer assembly. If not counting contact closures, move the resistor network to the FLOATING position. In this configuration, all inputs are floating.

INSTALLATION TEST

Repeat the these steps for each event-counting channel.

Connections

Wire the test clock output on the Counter/Totalizer rear panel connector to the channel input terminal. The terminal assignments for the connector are listed on the rear panel. Since the test clock output and the channel inputs use the same ground, it is not necessary to wire a return line.

Programming

Program the channel under test as shown in the programming form in Figure 5f-2. This example programs channel 100 to the event-counting function. The example also programs scan group 0 to scan channel 100 on a two-second interval. Make sure that the channel decade switches on the Counter/Totalizer are set properly. In this example, the decade switches should be set to 10.

5f/Totalizing Measurement

Operation

Using a small screwdriver, move the test clock switch to position 3 (50 Hz W/BOUNCE). With the switch in this position, the test clock simulates a 50-hertz square wave with switching bounce. Start scanning. If the channel under test has a debounced input, each scan reading should be 100 plus or minus 1 count. If the channel under test has a direct input, each scan reading should be 900 plus or minus 5 counts.

MAKING THE MEASUREMENT

There are many applications for event-counting measurements. Depending upon the signals to be monitored and the intended use of the measurements, the setup requirements may vary. The following paragraphs describe some common preparations and precautions.

Programming

The simplest event-counting measurement is obtained by programming a channel to the event-counting function and listing the channel in a scan group. Such a measurement was used in the installation test just described. In this kind of measurement, each reading indicates the number of events occurring between scans.

A more common measurement goal is to accumulate (or totalize) the number of events counted over a series of scans. To do this, use a pseudo channel as an accumulator. See the programming example in Figure 5f-3. In this example, C100 is an event-counting channel. Pseudo channel C110 keeps a running total of the events occurring on channel C100. At one minute intervals, scan group 0 logs both channels: the number of events occurring since the last scan and the number of events recorded since scanning began.

5f/Totalizing Measurement

Adjusting Input Thresholds

To ensure that the input signals are detected accurately, the Counter/ Totalizer input thresholds must be properly adjusted. Figure 5f-4 shows how input voltage levels are detected by the Counter/Totalizer. The reference voltage defines the boundary between the high and low voltage states of the input signal. Deadband prevents input noise from being counted as events. As shown in the figure, the reference voltage and deadband define the high and low input voltage thresholds.

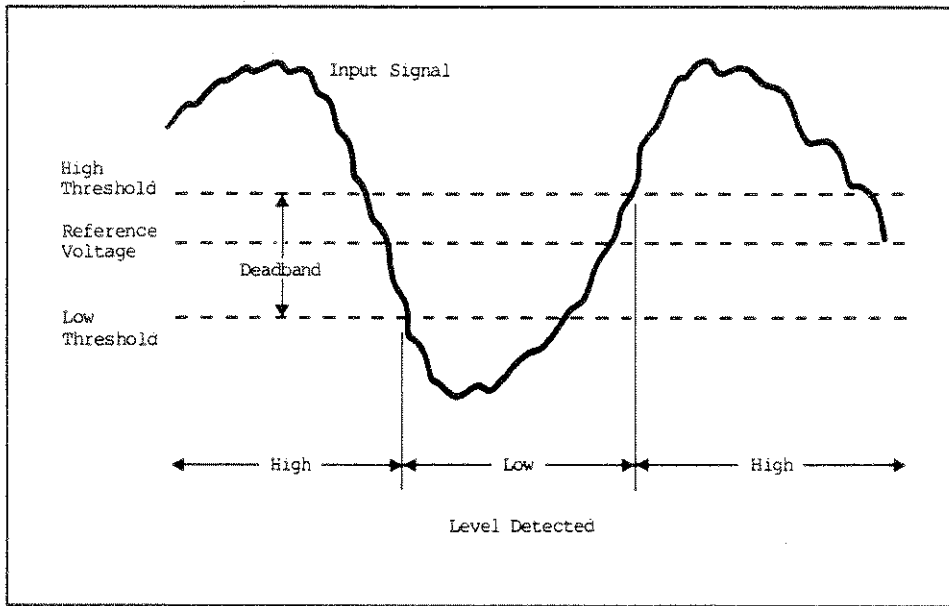

Figure 5f-4. Input Level Detection

5f/Totalizing Measurement

On the Counter/Totalizer assembly, the reference voltage and deadband are adjustable. For each channel, a switch selects either a fixed or variable reference voltage. There is one variable reference on the assembly, adjustable from -10 to +10 volts. There is also one fixed reference, which is selectable for either 0 volts or 1.4 volts (TTL level). The deadband is adjustable from 0 to 3 volts for each channel.

ADJUSTING REFERENCE VOLTAGE

To choose the proper reference voltage, follow these guidelines:

- o If the input signal is centered around 0 volts, select the 0 volt fixed reference.
- o If the input signal is TTL compatible, select the TTL fixed reference.
- o If the input signal is none of the above, select the variable reference. To adjust the variable reference voltage, connect a voltmeter to the variable reference terminal and one of the return terminals on the rear panel connector. Using a small screwdriver, turn the variable reference adjustment screw until the desired voltage is displayed by the voltmeter.
- o If the input is a contact closure, and the input pull-ups are being used to pull the input voltage to a high level, select the variable reference and adjust it to 7 volts. This level is half way between the high and low input voltages. (When the contacts are closed, the input is 0 volts. When the contacts are open, the input is pulled to +14 volts.)

5f/Totalizing Measurement

ADJUSTING DEADBAND

Use the input deadband adjustment method most suitable for your application.

- o Method 1. For TTL signals, turn the deadband adjustment screw counterclockwise until it stops. Then turn the screw clockwise to the position marked TTL on the rear panel.
- o Method 2. When counting contact closures, the deadband adjustment is not important. Instead, the debouncer must be used. See the paragraphs that follow on using the debouncer.
- o Method 3. Temporarily select the 0 volt fixed reference for the channel in question. Remove any connections to the input terminal. Connect a voltmeter to one of the return terminals and to the threshold output terminal for this channel. Disregarding the polarity of the threshold voltage, turn the appropriate deadband adjustment screw until the threshold is one-half the desired deadband voltage. Restore the reference voltage to its original setting.
- o Method 4. This method can be used when the input signal has a steady frequency. Set the function switch for the channel in question to FREQ. Program the channel to the frequency function. Connect the signal to the channel input terminals, as for normal operation. Turn the appropriate deadband adjustment screw counterclockwise until it stops. Monitor the channel and turn the deadband screw clockwise until a stable frequency reading is obtained. Return the channel to the COUNT function.

To ensure accurate measurements, adjust the deadband for each channel as high as possible.

5f/Totalizing Measurement

CHECKING THRESHOLD VOLTAGES

The combination of reference voltage and deadband determines the high and low threshold voltages. To check the threshold levels, use the following procedure:

- o Connect a voltmeter to one of the return terminals and to the threshold output terminal for the channel in question. Connect the test clock output to the channel input terminal.
- o Turn the test clock switch to position 0 (+14 volt output), and read the low threshold on the voltmeter.
- o Turn the test clock switch to position 1 (-15 volt output), and read the high threshold on the voltmeter.

Using the Debouncer

Relays, switches, and other mechanical devices frequently exhibit contact bounce when their contacts are opened or closed. In an event-counting application, contact bounce can cause extra, unwanted events to be counted. To prevent this, each Counter/Totalizer channel supports a debounce feature. The debouncer eliminates counting errors due to mechanical contact bounce.

Figure 5f-5 illustrates debouncer operation. When a debounced input is selected, the input signal must remain stable longer than the debounce period before a new input level will be recognized. There are three debounce periods available: 4 ms, 20 ms, and 80 ms. The debounce period is selected by turning a switch.

5f/Totalizing Measurement

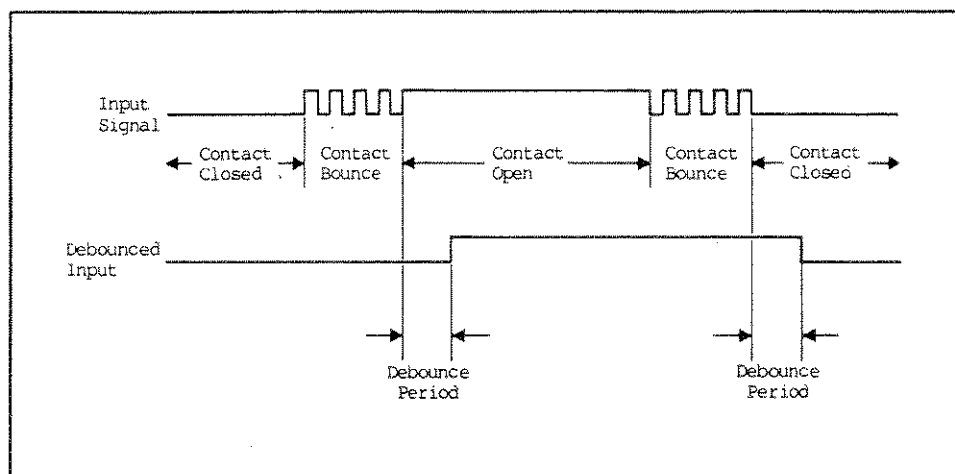

Figure 5f-5. Debouncer Operation

To set up the debouncer, use the following steps:

- o Verify that the Counter/Totalizer has been configured properly for counting contact closures. The debounced/direct input switch for the channel in question should be in the DEBOUNCED INPUT position. The floating/pulled-up resistor network should be in the PULLED UP position. The reference voltage switch for the channel should be set to VARIABLE REFERENCE, with the reference adjusted to 7 volts.
- o Using a small screwdriver, turn the debounce period switch to position 0 (4 MSEC).
- o Move the channel function switch to the COUNT position.
- o Connect the channel input terminal to one contact. Connect the return terminal to the other contact.

5f/Totalizing Measurement

- o Program the channel to the event-counting function and monitor the channel. Open and close the contact and notice the change in the monitored channel value. Increase the debounce period, if necessary, until each contact closure is counted only once.

Connections

The terminal assignments for the Counter/Totalizer connector are listed on the rear panel. The maximum input voltage is plus or minus 15 volts dc or ac peak.

The six channels on a Counter/Totalizer assembly are isolated from the data logger chassis and from ground but not from each other. The return lines on the input connector are common. All return lines must be connected to the same voltage.

Out-of-Range Conditions

The Counter/Totalizer can record 8,388,607 counts before going overrange. If more counts than this occur between scans, an "OUT RANGE" reading will be returned.

To prevent overrange readings, keep the scan interval time short. At its maximum counting rate of 400 kilohertz, a Counter/Totalizer channel must be scanned at least once every 20 seconds to ensure valid readings.

To accumulate larger count values, use a pseudo channel to totalize readings from a series of scans. This method is described in the Programming paragraph of this subsection. There is little risk of overflowing a pseudo channel. At 400 kilohertz, a pseudo channel will overflow after 700,000 years.

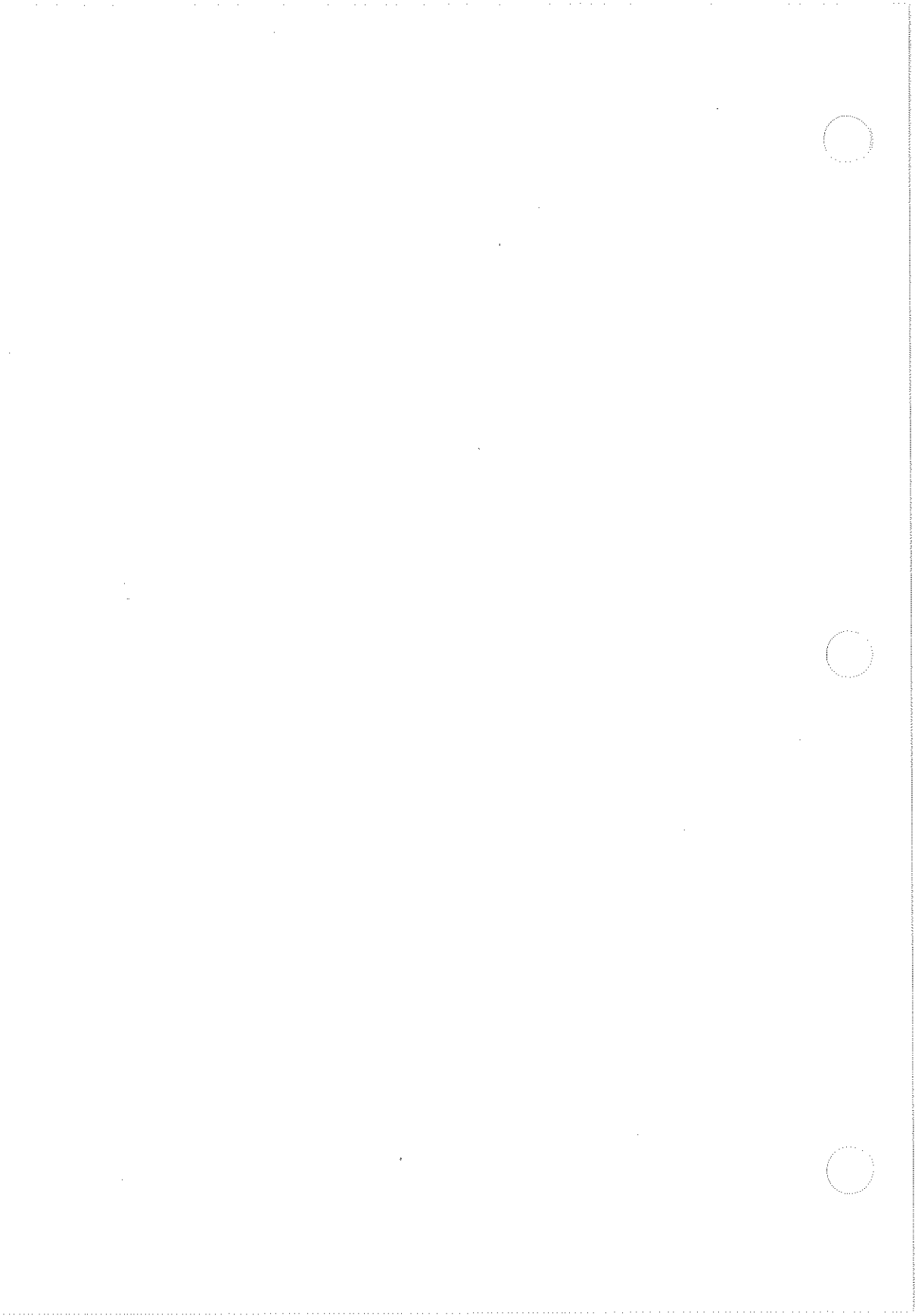

Section 5g
Strain Measurement

INTRODUCTION

Strain is the measurement of the deformity of an object subjected to an external force. This type of measurement is valid up to the elastic limit of the object being stressed. Strain gages are widely used in such measurements as:

- o Weight: load cells are commonly used to weigh heavy objects.
- o Pressure: pressure gages are actually strain gages mounted on a diaphragm that deforms in a predictable manner under pressure.
- o Fluid Level: the fluid level in a tank can be measured using a strain gage mounted on a support leg within the tank.

This subsection of the System Guide explains the concept of strain and its measurement by the 2280 Series Data Logger.

5g/Strain Measurement

STRAIN MEASUREMENT

General

The force deforming a body can cause an increase or a decrease in a dimension of that body. Any increase is considered positive and is termed tensile strain. A decrease is negative and is called compressive strain. Strain is normally expressed as the ratio of the change in dimension over the original dimension (the ratio itself is a dimensionless number.) See Figure 5g-1. Strain is defined by the following equation:

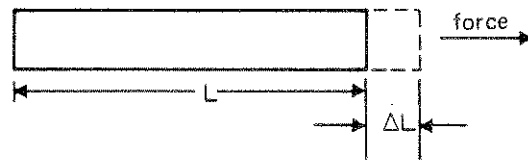

$$\epsilon = \Delta L / L$$

Figure 5g-1. Strain

Poisson's Ratio

When a material is stressed, it expands along the axis of the applied force and it contracts along an axis at a right angle to the applied force. The negative ratio of axial strain to perpendicular strain is called the Poisson ratio. The Poisson ratio is a constant that is a characteristic of the material. See Figure 5g-2.

5g/Strain Measurement

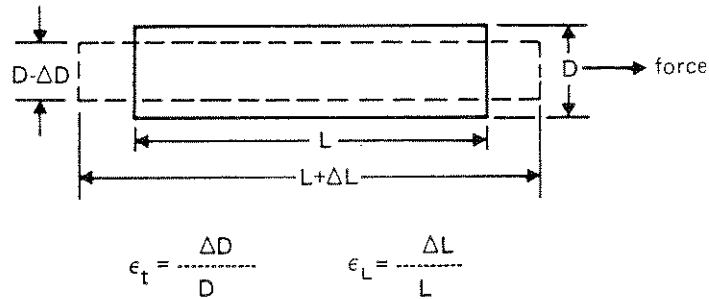

$$\nu = -\epsilon_t / \epsilon_L$$

Figure 5g-2. Poisson Ratio

Resistive Strain Gages

The resistive strain gage is the most common variety. It is composed of a serpentine of metal film on a thin piece of plastic. This arrangement is highly sensitive to strain in the longitudinal direction, but relatively insensitive to strain in the perpendicular direction. The resistive strain gage, when bonded to the material under test, changes resistance as the test material undergoes deformation.

5g/Strain Measurement

Gage Factor

The degree of change (resistance to strain) is expressed as the sensitivity of the gage (or "gage factor"). It is the calibration constant for the strain gage. The gage factor, K , varies with the material used in the gage, the temperature, and the stress. K is defined as:

$$K = (\Delta R/R) / (\Delta L/L)$$

Substituting ϵ for $\Delta L/L$, the general equation for a resistive strain gage becomes:

$$\epsilon = \Delta R/R * (1/K)$$

Typical gage factor values range from 2.0 to 4.0.

Micro Strain

Strain is typically measured with a resolution of $1.0E-6$ (one micro strain). Remember that strain is expressed as a ratio of the change in length divided by the original length. It is a dimensionless measurement.

If a strain gage has a resistance of 120 ohms and a gage factor of 2, one micro strain amounts to 0.2 milliohms change in resistance. Resolving 0.2 milliohms out of 120 ohms requires very precise instrumentation.

5g/Strain Measurement

Measurement Techniques

Special techniques are used to measure the incremental change in resistance caused by strain.

A Wheatstone bridge offers one method of measuring these small resistance changes. As strain occurs, V_{out} changes in proportion to the change in gage resistance. The relationship of this resistance change to V_{in} is non-linear. However, within the range of interest, a linear equation can very closely approximate accurate results.

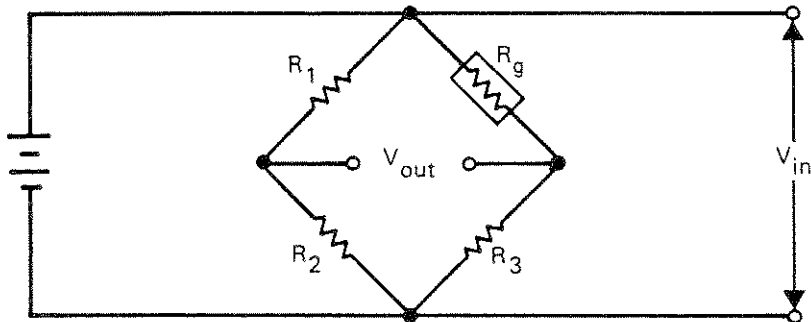

Where: V_{in} is the input voltage to the bridge
 R_g is the resistance of strain gage
 R_1, R_2, R_3 are bridge completion resistor
 V_{out} is the bridge output voltage

Figure 5g-3. Wheatstone Bridge

5g/Strain Measurement

A 1/4 bridge configuration exists when one arm of the bridge is active (R_g) and the other arms are either fixed value resistors or unstrained gages. V_{out} is a function of V_{in} , R_1 , R_2 , R_3 , and R_g as seen in the following equation:

$$V_{out} = V_{in} * (R_3 / (R_3 + R_g) - R_2 / (R_1 + R_2))$$

When $R_1/R_2 = R_g/R_3$, the bridge is balanced and V_{out} becomes zero. Referring back to the gage factor equation, it can be seen that the quantity to be measured is the fractional change in gage resistance from unstrained to strained).

In a manual strain measurement system, the bridge circuitry is usually modified by the addition of a balancing resistor. Stresses induced in the strain gage when it is bonded to the tested material are nulled (balanced) out by the balancing resistor when the gage is in its unstrained condition. While this method is often satisfactory for single-point measurements, the number of manual adjustments for balanced bridge methods becomes cumbersome in multichannel systems.

A two-measurement system solves the manual-adjustment problem. The first (initial) measurement is made after the strain gage has been mounted, but before it has been subjected to strain. Subsequent measurements are then subtracted from the initial measurement.

Anatomy of a Measurement

The equation for V_{out} can be rewritten as the ratio V_{out} to V_{in} :

$$V_{out}/V_{in} = (R_3 / (R_3 + R_g) - R_2 / (R_1 + R_2))$$

5g/Strain Measurement

This equation is relevant for both unstrained and strained gage conditions. With the unstrained value of gage resistance defined as R_g and the change due to strain defined as ΔR_g , the strained value of gage resistance is $R_g + \Delta R_g$. The effective value of resistance in each bridge arm is the sum of all resistances in that arm. Lead wires, printed circuit board traces, and interconnects may all contribute to this effective resistance. As long as these resistances remain constant between the strained and unstrained readings (and are relatively small compared to the gage resistance), the measurement is not affected. Later, we will introduce a term to compensate for these resistances.

The difference between the V_{out}/V_{in} ratio in the unstrained state and in the strained state requires a new term, V_r .

$$V_r = (V_{out}/V_{in})_{\text{strained}} - (V_{out}/V_{in})_{\text{unstrained}}$$

By substituting the resistor values that correspond to the two V_{out}/V_{in} terms into this equation, an equation for $\Delta R_g/R_g$ can be derived.

$$\Delta R_g/R_g = -4V_r/(1 + 2V_i)$$

When combined with the equation for gage factor (K), strain can be defined in terms of V_r and K . This equation describes the ideal behavior of a strain gage over a wide range of conditions:

$$\epsilon = -4V_r/K(1 + 2V_i)$$

5g/Strain Measurement

This equation can be modified as follows to compensate for conditions where there are significant lead wire and termination resistances.

$$\epsilon = -4V_r / K(1 + 2V_r) * (1 + R_L/R_g)$$

where: R_L = total of all lead resistances
 R_g = gage resistance

In practice, factors such as gage hysteresis and "creep" limit restrict the useful range of most resistive strain gages. In such cases, the V_r term in the denominator is very small and can be ignored. The 1/4 bridge equation can thereby be simplified to:

$$\epsilon = -4V_r / K * (1 + R_L/R_g)$$

REQUIRED HARDWARE

Applications involving strain measurement require the following option assemblies:

2280A-164	Transducer Excitation Module
2280A-174	Transducer Excitation Connector
2280A-161	High Performance A/D Converter
2280A-162	Thermocouple/DC Volts Scanner
2280A-176	Voltage Input Connector

These assemblies can be categorized within two logical functions: excitation and measurement.

5g/Strain Measurement

Excitation

The Transducer Excitation Module (2280A-164) is used to energize resistive strain gages with an excitation voltage. It is used in conjunction with the Transducer Excitation Connector (2280A-174). Together, each 164/174 set provides 20 channels of output. Each group of four channels must be configured for voltage output by correctly positioning the respective jumper on the Transducer Excitation Connector.

Measurement

The High Performance A/D Converter (2280A-161) provides high accuracy analog to digital conversion of scanner input voltages. At least one A/D Converter must be installed in the 2280 Series Data Logger.

The Thermocouple/DC Volts Scanner (Option -162) is a plug-in, 20-channel thermocouple and multi-voltage range relay scanner contained on a single pcb. The scanner operates as a self-calibrating analog data multiplexer, linking the A/D Converter to external measurement points. It accepts a variety of analog inputs, depending on the type of connector in use. For strain measurements, the Voltage Input Connector or Isothermal Input Connector is used.

The Voltage Input Connector (176) or Isothermal Input Connector (175) routes a maximum of 20 dc voltage input channels to the Thermocouple/DC Volts Scanner. This assembly is mounted to the 88-pin card-edge connector on the rear of the scanner.

5g/Strain Measurement

INSTALLATION

Strain measurements are performed with the system connections shown in the following wiring diagrams. A constant voltage power supply (the Transducer Excitation Module furnishes V_{in} . The Thermocouple/DC Volts Scanner is used to measure V_{out} . The voltage output of the unbalanced gage is measured before and after the strain is applied; the 2280 Series Data Logger performs the required calculations.

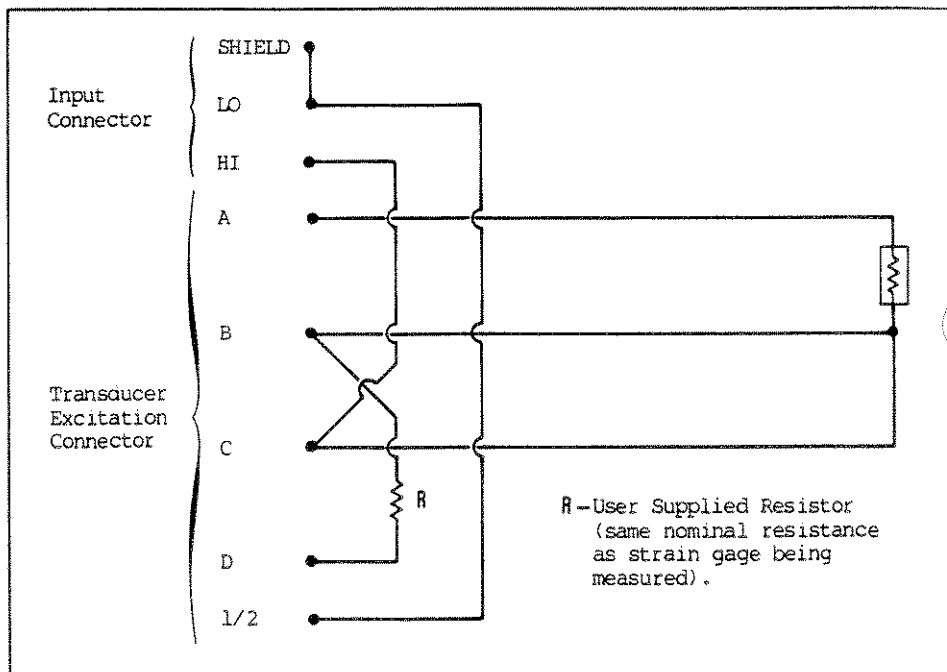

Figure 5g-4. Wiring: Quarter Bridge

5g/Strain Measurement

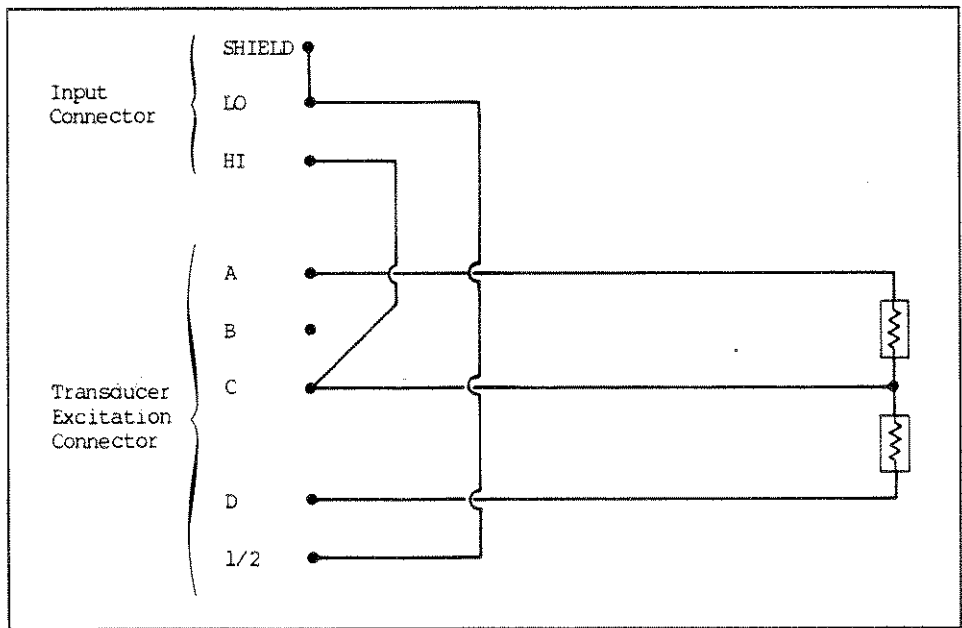

Figure 5g-5. Wiring: Half Bridge

5g/Strain Measurement

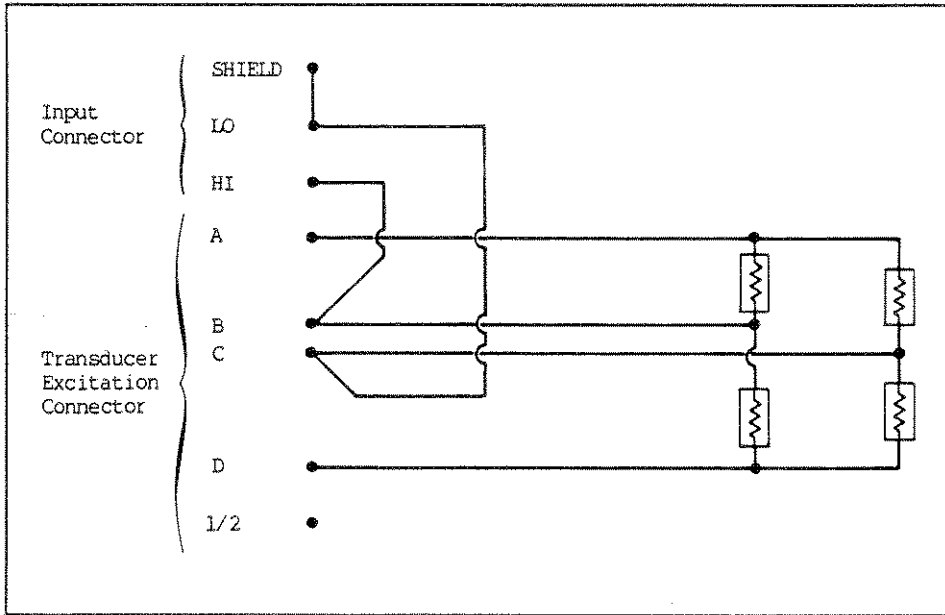

Figure 5g-6. Wiring: Full Bridge

5g/Strain Measurement

INSTALLATION TEST

Programming

GENERAL

Following are correction factors, resulting strain equations, and the required Programming Form entries for various bridge configurations. Each example is based on the following scan group programming:

<K> SCAN GROUP PROGRAM

GROUP #	SCAN GROUP MENU CHOICE < 1-5 >?							
	<1>	<2>	<3>	<4>			<5>	
	P.C.D. or L.	SCAN GROUP LABEL	SCAN GROUP CHANNEL LIST	SCAN TRIG MODE	DATA OUTPUT DEVICE CONTROL			OTHER SCAN GROUP TRIGGER
0-9	0-40 Alphanumeric characters EXAMPLE: ENGINE 2 TEST	<small>FORMAT: One channel only: C# Channel Block only: C# C# Channel and Blocks: C# C# C# C# C# C# C#</small>	<small>(pick only one see menu below)</small>	<small>PICK ONE FOR EACH DEVICE</small> <input type="checkbox"/> <small><1></small> <small>Quant</small> <input type="checkbox"/> <small><2></small> <small>Wave</small> <input type="checkbox"/> <small><3></small> <small>Trig</small> <input type="checkbox"/> <small><4></small> <small>Wave</small> <input type="checkbox"/> <small><5></small> <small>Wave</small>	<small>Scan Group to Trigger (1)</small>	<small>Trigger Condition (see menu below)</small>		
5	INITIALIZATION	C101	6					
4	DATA COLLECTION	C100	200:00:15	2				
<small><1> On Demand Only <2> Time Interval HH MM SS</small>		<small><3> Continuous <4> Decrease Time HH MM SS</small>		<small><5> Saturated Triggered <6> Scan Once</small>		<small><1> No Data <2> Alarm Data <3> All Data <4> Alarm Trans Data</small>		<small><1> Never <2> Any Alarm</small> <small><3> Any Alarm Transmittion <4> Always</small>

5g/Strain Measurement

In the 1/4, 1/2, and full bridge examples that follow, terminology is defined as:

$\mu\epsilon$	measured micro strain
V_{meas}	measured gage voltage (mV)
V_{init}	measured gage voltage in unstrained condition (mV)
ν	Poisson's ratio
V_{ex}	excitation voltage (defined as 4 in examples)
K	gage factor (defined as 2 in examples)

NOTE

The following channel programming examples load the unstrained reading (V_{init}) to a pseudo channel (C101), read the strained input on C10, and then perform the relevant strain equation on pseudo channel C100.

QUARTER BRIDGE

The quarter bridge configuration can be used where there is a single active strain gage.

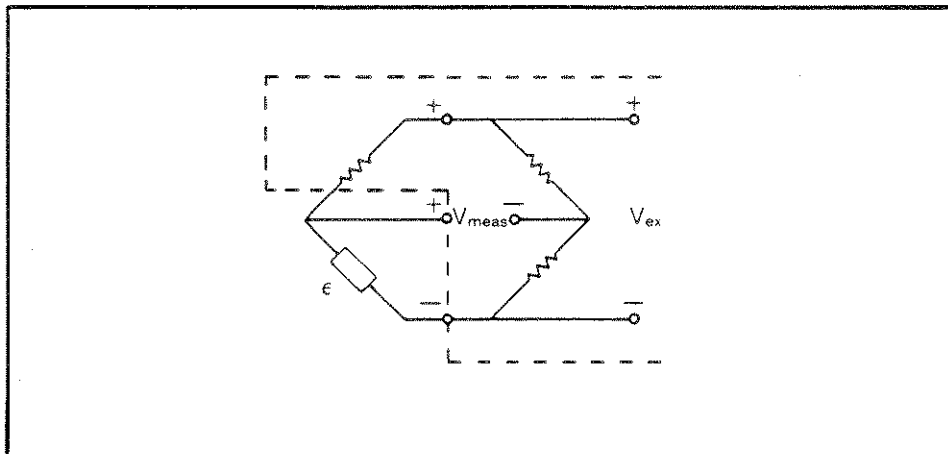

Figure 5g-7. Quarter Bridge Configuration

5g/Strain Measurement

Example 1: Two active strain gages, both with equal and opposite strains.

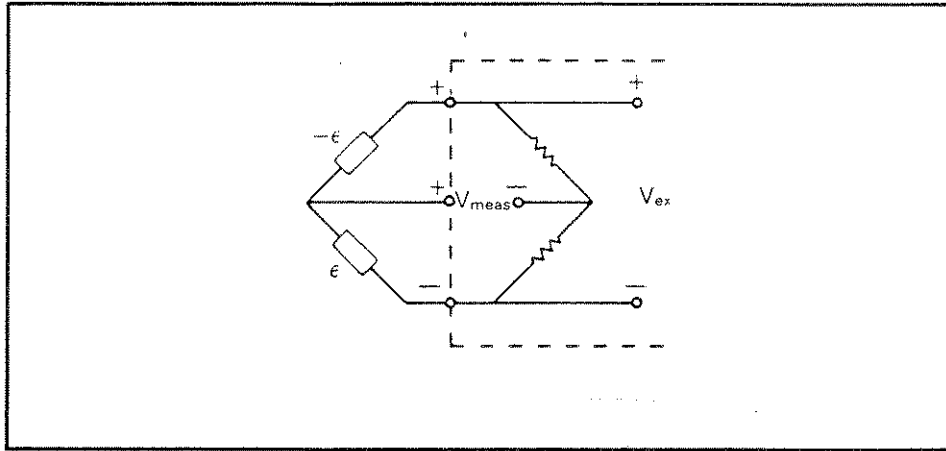

Figure 5g-8. Half Bridge Configuration: Example 1

With $\nu = 0$, the following half bridge strain equation can be used:

$$\mu\epsilon = -1E3 * 2 * (V_{meas} - V_{init}) / K * V_{ex}$$

5g/Strain Measurement

Example 2: Two active strain gages, one aligned with maximum principal strain, one aligned with Poisson strain.

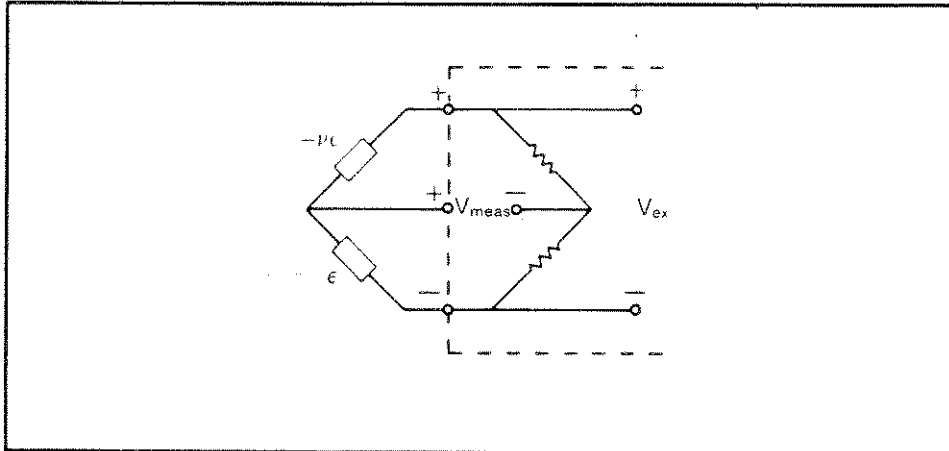

Figure 5g-9. Half Bridge Configuration: Example 2

With $\nu \neq 0$, the following half bridge strain equation can be used:

$$\mu\epsilon = -1E3 * 4 * (V_{meas} - V_{init}) / K * V_{ex} * (1 + \nu)$$

5g/Strain Measurement

FULL BRIDGE

The full bridge configuration allows for four active strain gages.

Example 1: Four active strain gages with pairs subjected to equal and opposite strains.

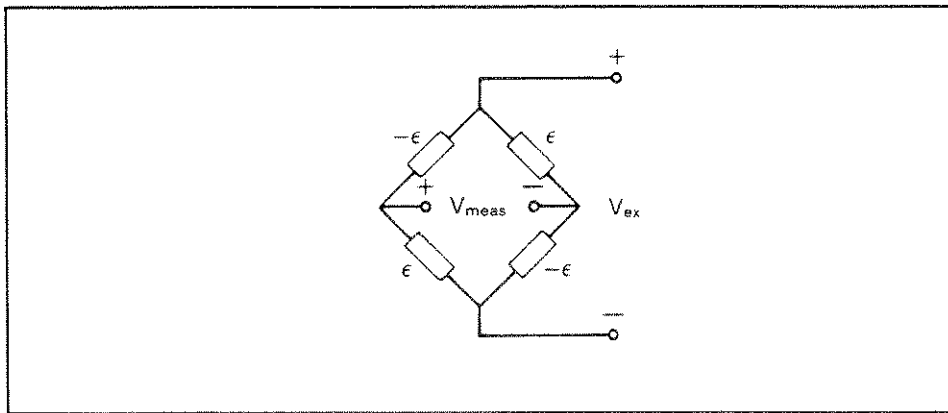

Figure 5g-10. Full Bridge Configuration: Example 1

With $\nu = 0$, the following full bridge strain equation can be used:

$$\mu\epsilon = -1E3 * (V_{meas} - V_{init}) / K * V_{ex}$$

5g/Strain Measurement

Example 2: Four active gages, two aligned with maximum principal strain, two aligned with Poisson strain.

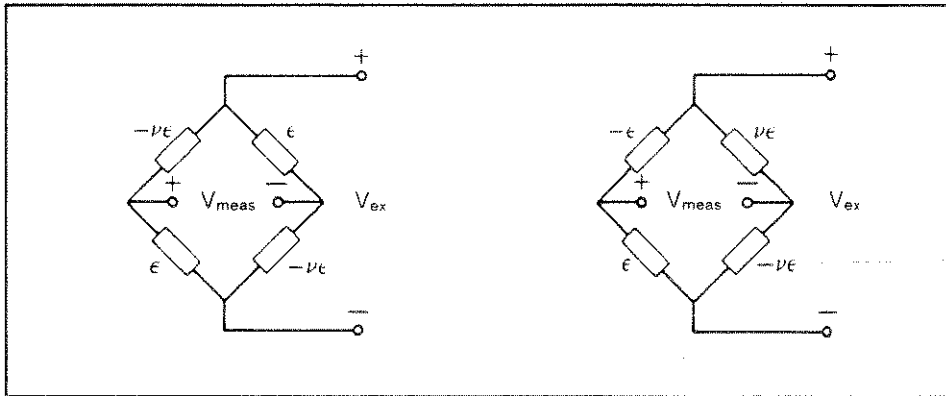

Figure 5g-11. Full Bridge Configuration: Example 2

With $\nu \neq 0$, the following full bridge strain equation can be used:

$$\mu\epsilon = -1E3 * 2 * (V_{meas} - V_{init}) / K * V_{ex} * (1 + \nu)$$

Section 5h
Digital Inputs

INTRODUCTION

The Digital Input function is a logic input for reading BCD (binary coded decimal) or straight binary output data from sensors and instruments.

This section explains use of the 2280 Series Data Logger and associated option assemblies in obtaining digital or status inputs. The User Guide provides overall programming and operating instructions. Detailed information about the physical installation of the 2280 mainframe and related options is provided in the following sections of this manual:

- o Installation - Mainframe: Section 3
- o Installation - Option Assemblies: Section 4

GENERAL

Digital inputs can be provided by simple system instruments and by such things as position sensors and event counters.

5h/Digital Inputs

REQUIRED HARDWARE

Applications involving digital or status inputs require the following option assemblies:

2280A-168	Digital I/O Assembly
2280A-179	Digital/Status Input Connector

The Digital I/O Assembly allows the 2280 Series Data Logger to exchange information with a digital peripheral device. Four types of data exchange are possible: Alarm or Status Output; Status Input; BCD Input; and Binary Input.

The Digital/Status Input Connector can be used for the mutually exclusive functions providing BCD digital input, binary digital input, or status input information to the 2280 Series Data Logger. This connector functions as a plug-in appendage to the Digital I/O Assembly, providing up to 20 input lines. It can be configured for one of three handshake methods.

INSTALLATION

Installation for any of the required option assemblies is detailed in Section 4 of this manual. Reference each option assembly by its option number (168 or 169). These instructions can be consulted as required.

Installation testing involves a programmed hardware listing. This procedure is defined in Section 4 for each option assembly (referenced by option number).

NOTE

For accuracy tests, refer to the appropriate 2280 Series Service Manual subsection.

5h/Digital Inputs

The Digital/Status Input Connector mates with the Digital I/O Assembly. Three different handshake sequences are available to ensure that the digital input is properly transferred from the sensor or instrument to the 2280. Note that a data input handshake process is used for BCD or BINARY input configurations only.

Selection of the proper handshake routine is explained in Section 4 of this manual (option 179).

Handshake information, along with Digital/Status Input Connector data **format** and signal flow information, are included at the end of this subsection.

PROGRAMMING

General

Programming for digital measurements involves specifying the channel and function and defining the zero and non-zero display indication.

Example

As an example, the following steps would be used in completing the Channel Program for ten digital input channels.

Press:	Display:
	MAIN MENU CHOICE <M FOR MENU>? A
A ENTER	CHANNEL NUMBER (OR BLOCK)
C40 ENTER	...<P,C,D,L>? P
ENTER	A: CHANNEL FUNCTION <A-Z>?
B	A BCD/BINARY INPUT
ENTER	AB: CHANNEL MENU CHOICE <1-5>?
EXIT ...	(return to main menu)

5h/Digital Inputs

MONITORING

Generally, making a digital input reading involves little more than monitoring the programmed channel. The User Guide fully describes the various monitoring methods available.

MONITOR any of these channels with the following procedure:

Press:	Display:
	MAIN MENU CHOICE <M FOR MENU>? A
MONITOR	MONITOR CHANNEL =
40	MONITOR CHANNEL =
ENTER	C40 (reading)

5h/Status Inputs

Symbol	Name	Signal Direction
IL3	Invert LOAD3	Input
L3	LOAD3	Input
IBUSY	Invert BUSY	Output
BUSY	BUSY	Output
S/C	Single/Continuous Control	Input
IA1	Invert Acknowledge 1	Output
IA2	Invert Acknowledge 2	Output
A2	Acknowledge 2	Output
IL2	Invert LOAD2	Input
L2	LOAD2	Input
A1	Acknowledge 1	Output
IL1	Invert LOAD1	Input
L1	LOAD1	Input

Handshake Terminal Abbreviations

5h/Status Inputs

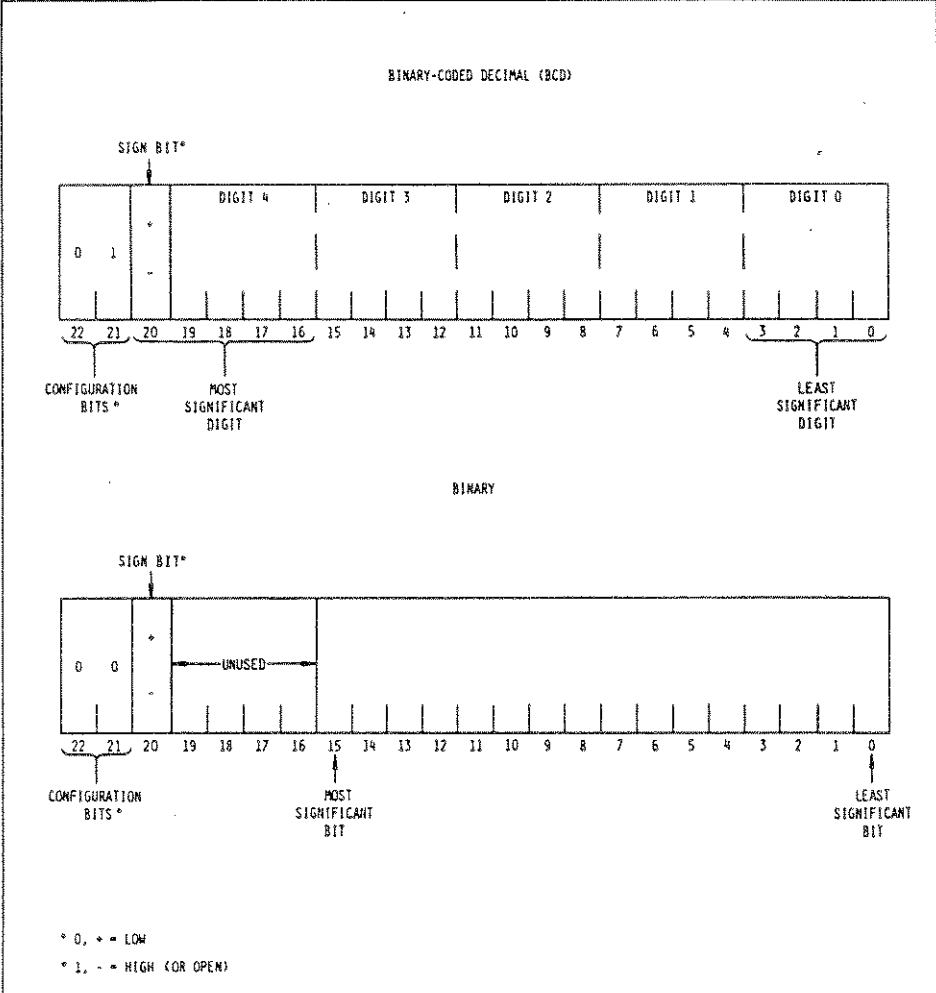

Digital Input Data Formats

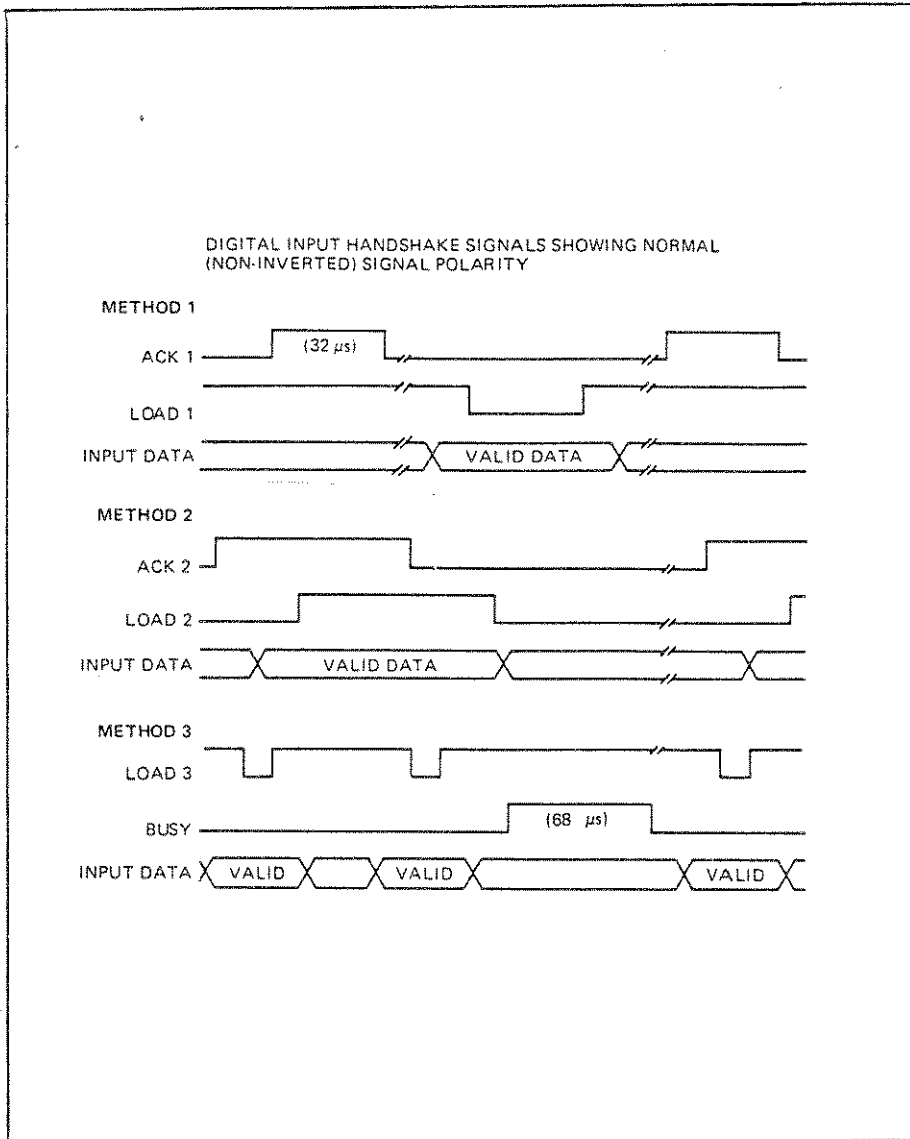

Digital Input Handshake Signals Showing Normal
(Non-Inverted) Signal Polarity



.....

Section 5h Status Inputs

INTRODUCTION

The Status Input function is a logic input for reading status (on/off) conditions from sensors, switches, and instruments.

This section explains use of the 2280 Series Data Logger and associated option assemblies in obtaining digital or status inputs. The User Guide provides overall programming and operating instructions. Detailed information about the physical installation of the 2280 mainframe and related options is provided in the following sections of this manual:

- o Installation - Mainframe: Section 3
- o Installation - Option Assemblies: Section 4

GENERAL

Status inputs are used to sample the state of one-bit inputs. They are used to determine if something is on or off, open or closed, enabled or disabled.

5h/Status Inputs

REQUIRED HARDWARE

Applications involving digital or status inputs require the following option assemblies:

2280A-168	Digital I/O Assembly
2280A-179	Digital/Status Input Connector

The Digital I/O Assembly allows the 2280 Series Data Logger to exchange information with a digital peripheral device. Four types of data exchange are possible: Alarm or Status Output, Status Input, BCD Input, and Binary Input.

The Digital/Status Input Connector can be used for the mutually exclusive functions providing bcd digital input, binary digital input, or status input information to the 2280 Series Data Logger. This connector functions as a plug-on appendage to the Digital I/O Assembly, providing up to 20 input channels. It can be configured for one of three handshake methods and for bcd or binary inputs.

INSTALLATION

Installation for any of the required option assemblies is detailed in Section 4 of this manual. Reference each option assembly by its three-digit option number. These instructions can be consulted as required. The descriptions in this subsection assume that the required option assemblies have successfully completed an installation test.

Handshake information, along with Digital/Status Input Connector data format and signal flow information, are included at the end of this subsection.

5h/Status Inputs

Installation testing involves a programmed hardware listing. This procedure is defined in Section 4 for each option assembly (referenced by option number).

NOTE

For accuracy tests, refer to the appropriate 2280 Series Service Manual subsection.

PROGRAMMING

General

Programming for status measurements involves specifying the channel and function and defining the zero and non-zero display indication.

Example

As an example, the following steps would be used in completing the Channel Program for ten status input channels.

Press:	Display:
	MAIN MENU CHOICE <M FOR MENU>? A
A ENTER	CHANNEL NUMBER (OR BLOCK)
C40..49 ENTER	...<P,C,D,L>? P
ENTER	
I	A<I> STATUS INPUT
ENTER	ZERO RESULT <14 CHRS MAX> = ZERO
ENTER	NON-ZERO RESULT <14 CHRS MAX> = ONE
ENTER	AI: CHANNEL MENU CHOICE <1-5>?
EXIT ...	(return to main menu)

Section 5i Status Outputs

INTRODUCTION

The Status Output control function is a single-bit logic state output.

This section explains use of the 2280 Series Data Logger and associated option assemblies for making status outputs. The User Guide provides overall programming and operating instructions. Detailed information about the physical installation of the 2280 mainframe and related options is provided in the following sections of this manual:

- o Installation - Mainframe: Section 3
- o Installation - Option Assemblies: Section 4

STATUS OUTPUT CONTROL - GENERAL

Status outputs are used for such activities as opening and closing relays, turning indicator lights on and off, or opening and closing valves. Status outputs can also be wired to provide logic inputs to other devices.

5i/Status Outputs

REQUIRED HARDWARE

Applications involving status outputs require the following option assemblies:

2280A-168	Digital I/O Assembly
2280A-169	Status Output Connector

The Digital Input/Output Assembly allows the 2280 Series Data Logger to exchange information with a digital peripheral device. Four types of data exchange are possible: Alarm or Status Output; Status Input; BCD Input; and Binary Input.

The Status Output Connector can send 20 single-bit output signals from the Digital I/O board to external control points or terminals. Each output is individually selectable and can be used either to drive lamps and relays or change logic levels. The Status Output Connector is used in conjunction with the Digital I/O Assembly (2280A-168).

INSTALLATION

Installation for any of the required option assemblies is detailed in Section 4 of this manual. Reference each option assembly by its option number (168 or 169). These instructions can be consulted as required. The descriptions in this subsection assume that the required option assemblies have successfully completed an installation test.

The Status Output Connector mates with the Digital I/O Assembly.

Installation testing involves a programmed hardware listing. This procedure is defined in Section 4 for each option assembly (referenced by option number).

NOTE

For accuracy tests, refer to the appropriate 2280 Series Service Manual subsection.

5i/Status Outputs

PROGRAMMING

General

Programming for status outputs involves specifying the channel, function, and output value. Any non-zero value is interpreted as "1".

Example

As an example, use the following steps to complete the Channel Program for ten status output channels.

Press:	Display:
	MAIN MENU CHOICE <M FOR MENU>? A
A ENTER	CHANNEL NUMBER (OR BLOCK)
C40..49 ENTER	...<P,C,D,L>? P
ENTER	A: CHANNEL FUNCTION <A-Z>?
S	A<S> STATUS OUTPUT
ENTER	ZERO RESULT <14 CHRS MAX> = ZERO
ENTER	NON-ZERO RESULT <14 CHRS MAX> = ONE
ENTER	AS: CHANNEL MENU CHOICE <1-5>?
3	AS<3> CHANNEL PROCEDURE
ENTER	CP:
CX=1 ENTER	CP:
ENTER	AS: CHANNEL MENU CHOICE <1-5>?
EXIT ...	(return to MAIN MENU CHOICE)
K	<K> PROGRAM A SCAN GROUP
ENTER	SCAN GROUP NUMBER = 0
ENTER	<P,C,D,L>? P
ENTER	K: SCAN GROUP MENU CHOICE <1-5>?
2	K<2> SCAN GROUP CHANNEL LIST
ENTER	CL:
C40..49	CL: C40..49
ENTER	CL:
ENTER	
EXIT ...	(return to Main Menu)

5i/Status Outputs

SCANNING

Use the following procedure to SCAN the output:

Press:

Display:

SINGLE SCAN
ENTER

MAIN MENU CHOICE <M FOR MENU>? A
SCAN GROUP NUMBER = 0
SELECT RUN MODE OPERATION <M FOR MENU>? A
(output for each channel in scan group is
printed)
MAIN MENU CHOICE <M FOR MENU>? A

INTRODUCTION

The 2280 Series Data Logger can produce two types of analog outputs: dc voltage or dc current. This section explains use of the 2280 mainframe and required option assemblies in generating these two outputs. Additional information can be found in Section 4 in the discussion of the Analog Output (option 170) assembly. Also, refer to the User Guide for programming and operating information.

DC Voltage Output

A dc voltage output is available to control devices requiring a continuously variable voltage. The 2280 Analog Output Option can supply 0V to 10V or -5V to 5V. Applications might include voltage controlled power supplies, process controllers, or 0 to 5 volt actuators.

Current Output

A current output allows for control of devices requiring a continuously variable current. Outputs from 4 mA to 20 mA are available. Applications could include current-controlled power supplies, process controllers, or 4 to 20 mA actuators.

5j/Analog Output

REQUIRED HARDWARE

Applications involving analog voltage or current outputs require the Analog Output (2280B-170) option assembly. This assembly can be installed in either the 2280 mainframe or the 2281A Extender Chassis. Each 170 assembly provides four independent output channels (0,1,2,3).

INSTALLATION

Installation for any of the required option assemblies is detailed in Section 4 of this manual. Reference this assembly by its option number (170). These instructions can be consulted as required. The descriptions in this subsection assume that the required option assemblies have successfully completed an installation test.

As an overview, installation requires the following actions:

- o Physical installation of the Analog Output option.
- o Address selection.
- o Wiring connections for each channel: the connections determine the type of output (current, bipolar voltage, or unipolar voltage).

Installation testing involves a programmed hardware listing. This procedure is defined in Section 4 for each option assembly (referenced by option number).

NOTE

For accuracy tests, refer to the appropriate 2280 Series Service Manual subsection.

PROGRAMMING

General

Programming entails definition of the channel, the function, and the output value. An overall example is presented under Installation Test above. The output value is assigned through a channel procedure evaluation.

The assigned value can range from 0.0 through 1.0, signifying 0% to 100% of scale, respectively.

- o Any assigned value algebraically less than 0.0 (0%) causes 0% to be set.
- o Any assigned value greater than 1.0 (100%) causes 100% to be set.

The scales involved depend on the output mode wired for a given channel. The following chart presents some representative outputs for the three available modes:

ASSIGNED VALUE	CURRENT	VOLTAGE	
		BIPOLAR	UNIPOLAR
0.0	4 mA	-4.9976V	0
0.5	10 mA	0	+5V
1.0	19.995 mA	+4.9976V	+9.9976V

Example

As an example, the following steps would be used in completing the Channel Program for four analog output channels. The channel(s) and function are first defined. The output level is then set: "CX=.5" specifies 50% of the output range. The actual output from the channel (10 mA, 0V, or +5V) depends on the wiring connections. Any of three output ranges are available.

5j/Analog Output

Press:	Display:
	MAIN MENU CHOICE <M FOR MENU>?
E	<E> ERASE ALL OF PROGRAM MEMORY
ENTER	REALLY ERASE ALL MEMORY <Y,N>?
A ENTER	CHANNEL NUMBER (OR BLOCK) =
C50..53 ENTER	<P,C,D,L>? P
ENTER	A: CHANNEL FUNCTION <A-Z>?
O	<O> ANALOG OUTPUT
ENTER	A0: CHANNEL MENU CHOICE <1-5>?
3	A0<3> CHANNEL PROCEDURE
ENTER	CP:
CX=.5	CP: CX=.5
ENTER	CP:
ENTER	A0: CHANNEL MENU CHOICE <1-5>?
EXIT ...	(return to MAIN MENU CHOICE)
K	<K> PROGRAM A SCAN GROUP
ENTER	SCAN GROUP NUMBER = 0
ENTER	<P,C,D,L>? P
ENTER	K: SCAN GROUP MENU CHOICE <1-5>? 1
2	K<2> SCAN GROUP CHANNEL LIST
ENTER	CL:
C50..53 ENTER ENTER	K: SCAN GROUP MENU CHOICE <1-5>? 3
EXIT ...	(return to MAIN MENU CHOICE)

5j/Analog Output

SCANNING

Use the following procedure to SCAN the output:

Press:	Display:
	MAIN MENU CHOICE <M FOR MENU>? A
SINGLE SCAN	SCAN GROUP NUMBER = 0
ENTER	SELECT RUN MODE OPERATION <M FOR MENU>? A (output for each channel in scan group is printed)
	MAIN MENU CHOICE <M FOR MENU>? A

The Analog Output channels are now set to their 50% levels. The voltage and current outputs of the option can be measured with a digital voltmeter to verify their correct operation.

All analog output channels are set to 0% when any one of the following operating conditions occurs:

- o Scanning (or single scan) is started
- o Plotting is started (if no scanning in progress)
- o Power up

5j/Analog Output

Normally, control calculations use error and output numbers expressed as a percentage of input span. In other words, the values are normalized. Normalizing the error term above gives us the new equation:

$$C50 = \text{SPAN} * (C10 - C100)$$

where SPAN is a constant. It is determined by the parameter being controlled. For example, suppose we are measuring and controlling a temperature. This temperature can vary between 100°C and 1000°C. So, to calculate the value for SPAN we would do the following:

$$\text{SPAN} = 100 / (1000 - 100) \quad \text{SPAN} = 0.1111$$

The basic Proportional control equation we can use is:

$$(\text{CONTROL OUTPUT}) = K_P * \text{ERROR}$$

5j/Analog Output

The higher the gain, the more the output changes for a given change in the error.

For all gain values greater than one, the control output of 0-100% occurs over an input span less than full range. For instance, a gain of 2 means that control occurs over 50% of the input span. This range over which control occurs is called the proportional band. It is expressed in percent of input span. As you can see, gain and proportional band are reciprocals of each other.

Adding Reset: The Integral Term (I)

Look at the equation for the proportional control loop above. When the error goes to zero, the output goes to zero. Usually, however, it is not possible to maintain the process at a setpoint with zero output. Therefore, we could add an offset or bias to the output. Bias might be done like this:

$$\text{OUTPUT} = K_P \cdot \text{ERROR} + \text{BIAS}$$

This offset, or bias, has been historically called manual reset. This name originated with analog controllers. They had both a setpoint pointer and a process pointer. When using only proportional control, the process and setpoint pointers won't point to the same place if the offset or bias adjustment is incorrect. The operator would twist a knob or screwdriver adjustment to "manually reset" the process variable pointer.

Bias is a constant. However, the best value for the bias may depend on the load. Processes which have many load upsets or setpoint changes require an operator to frequently reset the controller. This is generally not desirable. So, we need to add an "I" term to the PID equation.

In this example the output will equal $KP*ERROR$ plus the previous output. The new Integral term will automatically hold the process loop at the setpoint. This algorithm is good for applications where there is not a significant amount of transport delay. (Transport delay is the delay between the time when the output occurs and the time when you can measure the effect of the output.)

While the above algorithm is good for some processes, we need a more general algorithm. This algorithm would include a different automatic reset term (Integral term), expressed in repeats per minute. If the automatic reset action of the "I" term causes the output control signal to double in one minute, compared to the "P" term alone, then the automatic reset has one repeat per minute.

You can compute a more general Integral term using rectangular approximation. Simply multiply the time between readings (in minutes) by the error.

$$INTEGRAL=(PREVIOUS INTEGRAL VALUE)+(SCAN INTERVAL) *ERROR$$

If the process remains above or below setpoint, then the value of INTEGRAL will increase. The new control output equation is now:

$$(CONTROL OUTPUT)= KP* [ERROR + KI*INTEGRAL]$$

KI is the Integral gain or reset tuning constant and has the units of resets per minute. This Proportional and Integral control action is often used without a derivative (D) term, especially in fast processes.

Reset Wind-Up Inhibition

If a process takes a long time to warm up, or if the deviation existed for a long time, the integral term can grow to a large value. This is called reset windup. The term comes from the days of analog controllers where a capacitor would charge up (wind up) to the maximum power supply voltage

Once "wound up," the process will have to spend a long time above the setpoint before the integral term unwinds itself down. This causes the process variable to oscillate around the setpoint. Because of this, you will probably want to limit the size of the INTEGRAL term. With analog controllers, this was done by bypassing the integral circuit at a certain voltage limit.

5j/Analog Output

In the 2280B, you will do this using a software limit. You simply compare the value of the INTEGRAL term against a predetermined limit as shown:

<A> CHANNEL PROGRAM

CHANNEL #/BLOCK	CHANNEL FUNCTION & RANGE < A-Z >	CHANNEL MENU CHOICE < 1-5 >						
		<1> P.C.D. OR L. 0-1499 or C1-C5 EXAMPLE (17C) T	<2> ALARM LIST# 0-1499 EXAMPLE DEG F	<3> CHANNEL UNITS 0-6 chrs EXAMPLE DEG F	<4> CHANNEL EXPRESSION or PROCEDURE 0-75 characters Rule to programmed channel = C1 * EXAMPLE, C1 * C2 * (1.8 + 32.0)	<5> CHANNEL LABEL 0-15 characters EXAMPLE: EXHAUST TEMP	<6> LOGGING FORMAT 1000 menu below	
C10	T					MEASURED TEMP		
C146	P				$P146 = P146 + 0.02833 * (C10 - C100)$ $P146 = MIN (C146, P104)$ $P146 = MAX (C146, -P104)$	INTEGRAL TERM		
C150	0				$C50 = 0.1111 * (C101 + (1100 - C100) * (102 * P146))$	ANALOG OUTPUT		
C100	P				C100 = 500	SET POINT		
C101	P				C101 = 0.5	KP PROP GAIN		
C102	P				C102 = 3	KI INTEG GAIN		
C104	0				C104 = 5000	WINDUP INHIBIT		
CHANNEL FUNCTION MENU							USER DEFINED RTD CONSTANTS	LOGGING FORMAT MENU
<P> PSEUDO CHANNEL <D> VOLTS/CURRENT <1> 84 000 VDC <2> 8 0000 VDC <3> 512 00 MVDC <4> 84 000 MVDC <5> 84 0 MA <6> 250 0 VAC <7> 84 000 MV/OTO <8> 80 CALIBRATION <9> CALIBRATION <10> SPECIAL <11> THERMOCOUPLE <12> J (INBS) <13> R (INBS) <14> T (INBS) <15> E (INBS)		<A> R (INBS) S (INBS) <C> H (INBS) <D> W, SRE VS W-ZERE <E> J (OHMS) <F> T (OHMS) R = RTD <10> 84 DC VOLTS SCANNER <11> 10 OHM CU DC VOLTS SCANNER <12> USER DEFINED DC VOLTS SCANNER <13> 84 RTD SCANNER TEMP <14> 10 OHM CU RTD SCANNER LO RANGE		<E> USER DEFINED RTD SCANNER LO RANGE <F> 84 RTD SCANNER TEMP <G> 425 0 C <H> USER DEFINED RTD SCANNER HI RANGE User Defined RTD constants 1st PO (default = 100 Ohm) 2nd AL (default = 3 806-3) 3rd DELTA (default = 1 484) 4th C1 (default = 200MBE-11) <I> COUNTER TOTALIZER <J> COUNTERS <K> FREQUENCY <L> STATUS OUTPUT 1st Zero Result (1-14 chrs)		2nd Nonzero Result (1-14 chrs) <M> STATUS INPUT 1st Zero Result (1-14 chrs) 2nd Nonzero Result (1-14 chrs) <N> ANALOG OUTPUT <O> SECONDARY INPUT <P> RESISTANCE <1> 512 00 OHMS DC VOLTS SCANNER <2> 84 000 OHMS DC VOLTS SCANNER <3> 256 0 OHMS RTD SCANNER <4> 2048 0 OHMS RTD SCANNER <5> 84 000 OHMS RTD SCANNER		<10> Auto <11> J (INBS) <12> E (INBS) <13> R (INBS) <14> T (INBS) <15> E (INBS)

The Derivative Term (D)

This term in the PID equation is often added for processes with a slow time constant. The Derivative term senses the rate of change of the process variable. It then adds a correction in the opposite direction proportional to this rate. For this reason the Derivative term is also frequently called Rate.

If the process variable is approaching the setpoint, the Rate action opposes the Proportional action. This helps prevent overshoot. On the other hand, if the process variable is departing from the setpoint, then the Rate action slows it down. It thus helps to bring the process back to its desired level.

Rate is useful, for instance, if the door of an oven opens and the temperature drops rapidly. However, rate action is not normally used in fast or electrically noisy processes. It can cause instability when trying to correct for a frequently changing process variable. The Derivative term is found by computing the change in the process variable per unit of time as follows:

$$\text{DERIVATIVE} = \frac{\text{PRESENT_PROCESS_VAR} - \text{OLD_PROCESS_VAR}}{\text{DELTA_TIME} * \text{SPAN}}$$

5j/Analog Output

DERIVATIVE is the Derivative or rate term, and OLD PROCESS VAR is the previous value of the process variable. To compute this term using the 2280B you would do the following:

<A> CHANNEL PROGRAM

CHANNEL #/BLOCK	CHANNEL FUNCTION & RANGE <A-Z>	CHANNEL MENU CHOICE <1-5>?							
		P.C.D. OR L. 0-1499 of CX CX	<1> ALARM LIST# 0-1499 EXAMPLE: LT(C):1	<2> CHANNEL UNITS 0-6 UNITS EXAMPLE: DEG F	<3> CHANNEL EXPRESSION or PROCEDURE 0-75 characters Refer to programmed channel as CX. EXAMPLE: CX * CX * 1.8 + 32.0	<4> CHANNEL LABEL 0-15 characters EXAMPLE: EXHAUST TEMP	<5> LOGGING FORMAT (See menu below)		
110	TJ					Measured Temp			
149	P			149 = (110 - 244) / (0.0833 * 0.1111)		Derivative Term			
149	P			244 = C10		Old Proc Temp			
CHANNEL FUNCTION MENU							USER DEFINED RTD CONSTANTS		LOGGING FORMAT MENU
<P> PSEUDO CHANNEL <D> VOLTS/CURRENT <1> 84 000 VDC <2> 8 0000 VDC <3> 812 00 MVDC <4> 84 000 MVDC <5> 84 0 MA <6> 250.0 VAC <7> 84 000 MV/OTD <A> A/D CALIBRATION <1> CALIBRATION <2> SPECIAL <T> THERMOCOUPLE <1> J (INBS) <R> R (INBS) <T> T (INBS) <E> E (INBS)		<R> R (INBS) <S> S (INBS) <N> N (INBS) <W> W/SBE VS W-2ERE <I> I (OHM) <T> T (OHM) R -> RTD <1> 385 DC VOLTS SCANNER <2> 10 OHM CU DC VOLTS <3> CALIBRATION <4> USER DEFINED DC VOLTS <5> 385 RTD SCANNER TEMP <6> 10 OHM CU RTD SCANNER <7> 10 OHM CU RTD SCANNER <8> 10 OHM CU RTD SCANNER <9> 10 OHM CU RTD SCANNER <0> 10 OHM CU RTD SCANNER <1> 10 OHM CU RTD SCANNER <2> 10 OHM CU RTD SCANNER <3> 10 OHM CU RTD SCANNER <4> 10 OHM CU RTD SCANNER <5> 10 OHM CU RTD SCANNER <6> 10 OHM CU RTD SCANNER <7> 10 OHM CU RTD SCANNER <8> 10 OHM CU RTD SCANNER <9> 10 OHM CU RTD SCANNER <0> 10 OHM CU RTD SCANNER		<8> USER DEFINED RTD SCANNER LO RANGE <7> 385 RTD SCANNER TEMP GT 425 0 C <8> USER DEFINED RTD SCANNER HI RANGE User Defined RTD constants 1st R0 (default = 100.0) 2nd ALPRA (default = 3.80E-3) 3rd DELTA (default = 1.0E4) 4th C4 (default = 30000E-11) <6> COUNTER/TOTALIZER <1> COUNTS <2> FREQUENCY <3> STATUS OUTPUT 1st Zero Result (1-14 chars)		2nd Nonzero Result (1-14 chars) <12> STATUS INPUT 1st Zero Result (1-14 chars) 2nd Nonzero Result (1-14 chars) <0> ANALOG OUTPUT <8> SECONDARY INPUT <E> RESISTANCE <1> 512 00 OHMS DC VOLTS SCANNER <2> 84 000 OHMS DC VOLTS SCANNER <3> 104 00 OHMS RTD SCANNER <4> 104 0 OHMS RTD SCANNER <5> 84 000 OHMS RTD SCANNER		<1> Auto <2> Manual <3> Manual <4> Manual <5> Manual <6> Manual <7> Manual	

NOTE

You can also compute the rate term based on the rate of change of error, instead of the process variable. However, if you use the error, then changing the setpoint will cause a large change in the rate action, which you may not want.)

5j/Analog Output

The complete PID algorithm would also include a Derivative tuning constant, KD. It would look like:

$$(\text{CONTROL OUTPUT}) = \text{SPAN} * \text{KP} [(\text{ERROR}) + \text{KI} * \text{INTEGRAL} + \text{KD} * \text{DERIVATIVE}]$$

The 2280B program to implement this equation would be:

<A> CHANNEL PROGRAM

CHANNEL #/BLOCK	CHANNEL FUNCTION & RANGE < A-Z >	CHANNEL MENU CHOICE < 1-5 >?					
		< 1 > ALARM LIST# 0-1499 EXAMPLE: 1/7/1/1	< 2 > CHANNEL UNITS 0-4 CHRS EXAMPLE: DEG F	< 3 > CHANNEL EXPRESSION or PROCEDURE 0-75 characters Relat to programmed channel as CX. EXAMPLE: CX = CX * 1.8 + 32.0	< 4 > CHANNEL LABEL 0-15 characters EXAMPLE: EXHAUST TEMP	< 5 > LOGGING FORMAT (See Menu Below)	
P.C.D. OR L. 0-1499 C# C#							
C10	T J				MEASURED TEMP		
C46	P			$C46 = 1.46 * 0.083 * (C10 - 1100)$ $C46 = \text{MIN}(C46, 0.104)$ $C46 = \text{MAX}(C46, -0.104)$	INTEGRAL TERM		
C47	P			$C47 = (C10 - C46) / 0.00926$	DERIVATIVE TERM		
C49	P			$C49 = 110$	OLD MEAS TEMP		
C50	P			$C50 = 0.1111 * C101 * ((C10 - 1100) + 110.2 * C46 + C103 * C47)$	CONTROL OUTPUT		
C100	P			$C100 = 500$	SETPOINT		
C101	P			$C101 = 0.5$	KP PRP GAIN		
C102	P			$C102 = 3$	KI INTEG GAIN		
C103	P			$C103 = 2$	KD DERIV GAIN		
C104	P			$C104 = 5000$	WINDOW INHIBIT		
CHANNEL FUNCTION MENU						USER DEFINED RTD CONSTANTS	LOGGING FORMAT MENU
<P> PRELUD CHANNEL <D> VOLTS/CURRENT <1> 64 000 VDC <2> 4 000 VDC <3> 512 00 MVDC <4> 64 000 MYDC <5> 64 0 MA <6> 250 VAC <7> 64 000 MYOTD <A> AO CALIBRATION <1> CALIBRATION <2> SPECIAL <T> THERMOCOUPLE <J> J (INBS) <K> K (INBS) <I> I (INBS) <E> E (INBS)		<R> R (INBS) <S> S (INBS) B (INBS) <N> N (INBS) <W> W SRE VS W-28RE <J> J (OHM) <V> T (OHM) <A> RTD <1> 285 DC VOLTS SCANNER <2> 10 OHM CU DC VOLTS SCANNER <3> USER DEFINED DC VOLTS SCANNER <4> 285 RTD SCANNER TEMP LT 425 00 C <5> 10 OHM CU RTD SCANNER LO RANGE		<U> USER DEFINED RTD SCANNER LO RANGE <D> 285 RTD SCANNER TEMP ST 425 0 C <E> USER DEFINED RTD SCANNER HI RANGE User Defined RTD constants 1st RD (default = 100 0) 2nd ALPHA (default = 3.30E-3) 3rd DELTA (default = 1.89E-1) 4th C (default = .0086E-11) <C> COUNTER/TOTALIZER C1- COUNTS C2- FREQUENCY <S> STATUS OUTPUT 1st Zero Result (1-14 chrs) 2nd Nonzero Result (1-14 chrs) <1> STATUS INPUT 1st Zero Result (1-14 chrs) 2nd Nonzero Result (1-14 chrs) <O> ANALOG OUTPUT BCD/BINARY INPUT <R> RESISTANCE <1> 5-17 00 OHMS DC VOLTS SCANNER <2> 64 000 OHMS DC VOLTS SCANNER <3> 256 00 OHMS RTD SCANNER <4> 2048 0 OHMS RTD SCANNER <5> 64 000 OHMS RTD SCANNER		<1> AUTO <2> MANUAL <3> ALTERN <4> MANUAL <5> MANUAL <6> MANUAL <7> MANUAL	

5j/Analog Output

The Rate action anticipates future changes. For example, assume that the process variable is increasing towards the setpoint. It is doing so at a constant rate with only Proportional action. Since the error is decreasing, the control output will also be decreasing. In this case, adding Derivative action with $KD=1$ (minute) causes the control output to decrease. It will immediately decrease to a level which would have taken it another 1 minute to reach. A KD value of 2 reduces the output to a level previously 2 minutes away. In other words, this turns down the power and prevents the process from overshooting.

Tuning the PID Loop

The same control algorithms presented here can be used for many different processes. The user customizes the algorithms to the application by using different setpoints and constants. Properly setting these parameters is called tuning the loop. It is best performed by a person familiar with the process. Even so, it can take hours, or even days to do.

A common method for tuning loops is to increase the Proportional gain (KP) and change the setpoint until the process starts to act unstable. Then, decrease the gain slightly while continuing to make setpoint changes until stability returns. This procedure is then repeated for the Integral (KI) and Derivative (KD) constants.

5j/Analog Output

These control algorithms represent only the tip of the iceberg. Many others are possible depending on the needs of each process. For example, some processes are better controlled with a non-interactive Proportional gain. This means that a change in gain (KP) does not affect either the Integral or the Derivative action. Other possibilities include algorithms based on the error squared. This would increase the loop's response in fast processes. Another possibility would be to include a derivative smoothing term to prevent Rate-induced instabilities.

The mathematics may change, but the analysis and programming techniques described here should be very similar for almost all processes.



Section 6
Appendices

CONTENTS

6a. Glossary	6a-1
6b. Sales and Service Centers	6b-1
6c. ASCII/IEEE-488	6c-1
6d. 2285B Documentation	6d-1
6e. 2280A Documentation	6e-1
6f. Connector Pinouts	6f-1
6g. System Specifications	6g-1
6h. Cartridge Tape Handling	6h-1
6i. Cartridge Tape Format	6i-1
6j. Memory Usage	6j-1

Appendix 6a
Glossary

a/d converter

Analog-to-Digital Converter. A circuit used to convert information in analog form (such as voltage or current measurements) into digital form.

ADC

See a/d converter.

address

The channel number that represents an I/O channel.

6a/Glossary

alarm acknowledgement device

The device (printer, cartridge tape, port A, or port B) where alarm messages are acknowledged and the time of the alarm is recorded.

analog

The representation of numerical quantities that do not have discrete values but that are continuously variable. Electrical measurements are analog in nature until converted into digital signals by an a/d converter. See digital.

ANSI

American National Standards Institute; an industry supported U.S. organization that primarily serves to coordinate and publish technical standards requested by its members.

arithmetic expression

An equation with arithmetic operators producing a numerical result.

arithmetic operator

A process to be applied to numerical values in an equation (+, -, /, etc.).

array

A group of numbers sharing the same variable name, followed by a subscript.

ASCII

American Standard Code for Information Interchange; ASCII is a standardized code set of 128 characters, including upper and lower case alphabet, numerals, and a set of control characters (line feed, carriage return, etc.)

baud

Originally used to express the capabilities of a telegraph transmission facility in terms of "modulation rate per unit of time." For practical purposes, it is now used interchangeably with "bits per second" as a unit of measure for data flow.

BCD

Binary Coded Decimal; BCD is a digital data format in which each digit of a decimal (base 10) number is represented in order, by its binary equivalent. For example, the decimal number 597 is represented as (0101 1001 0111) in BCD. See binary.

binary

The base two number system; binary numbers are made up of ones and zeros. The least significant digit represents one, the next digit represents twos, the next digit represents fours, and so on with each digit of the binary number corresponding to the next higher exponent of two. See also BCD.

bit

The smallest element of a binary number; a bit (contraction of "binary digit") either represents a high or a low state (one or zero, also mark or space).

6a/Glossary

bridge

In a measuring system, an instrument in which part or all of its circuit measures one or more electrical quantities. In a 2280 Series system, quarter-, half-, and full-bridge strain gauges can be used. See microstrain, strain gauge.

CCITT

Comite Consultatif International Telegraphic et Telephonique; an international organization concerned with devising and proposing standards for international telecommunications.

CD

Carrier Detect; RS-232-C, line 8. This signal is sent by DCE to tell DTE that a suitable carrier is present at the DCE. See also DTE, DCE.

channel expression

A computation applied to the raw input of same (measurement) channel

channel procedure

A set of expressions involving more than one channel.

concise command string

A set of commands used when the 2280 is controlled remotely by a computer.

Counter/Totalizer

The 2280 Series option that measures frequency and totalizes event occurrences.

CTS

Clear to Send; RS-232-C line 5. Sent by DCE to DTE when it is ready to accept data. See also DCE, DTE.

current shunt

Traditionally, a precision, low-value resistor placed across an ammeter's terminals to increase its range. The 2280 uses a current shunt resistor in the input circuitry of each channel of the current input connector (Option 2400A-171). The shunt resistor allows the current input to develop a voltage which the 2280A-161 Analog to Digital Converter can measure.

DAV

Data Valid; an IEEE-488 bus handshake signal, bus line 6. Indicates the availability data byte. See also handshake, NDAC, NREFD.

DCE

Data Communication Equipment; the RS-232-C term for computer equipment that sends or receives data. Modems are examples of DCE. The other type of computer equipment specified by RS-232 is DTE, Data Terminal Equipment.

DCL

Device Clear, IEEE-488 Universal Command, ASCII code 20. This message, from the Controller, causes all instruments on the bus to reset the IEEE-488 interface of each instrument on the bus to a known state. The action taken by each instrument is unique for that instrument.

default

The value or state selected by system software (or firmware) when the user doesn't specify one.

6a/Glossary

delimiter

A character that sets the beginning and end of a string, and is not considered to be a part of the string. The two delimiters allowed by the 2280 Series are // (double slash) and : (colon).

digital

A circuit or device concerned only with high or low states (or pulses), generating a logical or numerical result. Digital computers, calculators, and digital watches use digital circuitry. See analog.

DSR

Data Set Ready; RS-232-C line 6. Indicator from DCE to DTE that a suitable line connection has been made, that all preliminary line protocol is complete, and that it is ready for data transfer. See also DCE, DTE.

DTE

Data Terminal Equipment; the RS-232-C Standard term for computer equipment where digital information originates or terminates. The 2280, terminals, and computers are examples of DTE. The other type of computer equipment specified by RS-232-C is DCE, Data Communication Equipment.

DTR

Data Terminal Ready; RS-232-C line 20. Sent by DTE to DCE when it is ready to transfer data.

EIA

Electronic Industries Association; the organization that devises electrical and data communication standards including RS-232-C and RS-422.

EOI

End Or Identify, IEEE-488 bus line 5. Often used by a Talker to designate the end of a data transfer sequence.

expression

A combination of variables, constants, numbers, or function references, separated by operators and parentheses in such a way that the whole can be reduced to a single result. See also arithmetic expression, logical expression, relational expression.

floating point

A numerical notation useful for computer calculations. In the 2280, the resolution of a floating point number is 7 digits, and its range is up to 38 places either side of the decimal. When the decimal point is out of range of the displayed digits, the number is displayed in exponential form (E+mn or E-mn, where mn represents the number of places the decimal point must be moved; + for right and - for left). See also floating point variable, integer variable.

frequency

The cycles-per-second (Hertz) of ac signal. Can be measured in a 2280 system using the Counter/Totalizer Option (2280B-167).

gauge factor

A strain gauge parameter, gauge factor specifies the characteristics of the strain gauge material being used.

GND

Ground; RS-232-C line 1. A chassis connection intended for the cable shield. Not to be used for signal reference.

6a/Glossary

GPIB

General Purpose Interface Bus. This is a commonly used name for the IEEE-488 instrument interconnection bus.

handshake

The three-wire hardware protocol used to exchange data on the IEEE-488 Bus. Three bus lines (DAV, NRFD, NDAC) coordinate sending and receiving of data.

IEEE

Institute of Electrical and Electronic Engineers, Inc., 345 East 47th Street, New York, NY 10017. The IEEE is the publisher of Standard IEEE-488-1978, for interconnection of electronic instruments.

IEEE-488 Bus

A parallel bus system agreed upon by participating instrument manufacturers for interconnecting instruments to form a system.

IFC

Interface Clear; IEEE-488 Bus line 9. Set high by the controller to reset the IEEE-488 interface of each instrument on the bus to a known state. The action taken by each instrument on the bus is unique for that instrument.

interface

A hardware and software connection of a device to a system. For example, either the Serial Interface or the IEEE-488 Interface must be used to connect a host computer to the 2280.

interference

The presence of undesirable energy in a circuit, caused by electrostatically or electromagnetically coupled external circuits.

I/O

Input/Output.

isothermal

Means an area of equal temperature. The 2280 Series Thermocouple Input Connector (Option 2280A-175) uses an alloy isothermal terminal block to stabilize and equalize input lead temperatures.

Limit Values

Reference points used in alarm list programming.

Listener

IEEE-488 bus device designated by a Controller to receive data or instructions from a designated Talker or controller. There can be more than one Listener on a bus at the same time.

logical expression

An expression that can contain variables, constants, and function references, and is separated by logical operators and parentheses, yielding a logical result (true or false).

logical operator

A function that compares, selects, or matches. In the 2280, the logical operators are AND, OR, and NOT. These are used for Boolean operation. See also Boolean Algebra.

6a/Glossary

microstrain

The unit of strain measured by a strain gauge in a 2280 system.

MLA

My Listen Address; IEEE-488 Bus Listen Address. ASCII codes 32 through 62 correspond to MLA 0 to MLA 30, respectively. Each instrument on the bus must have a unique Listen Address. See also MTA.

modem

A transmitter and receiver of digital data. One modem receives data from an attached computer terminal and sends the data on a modulated carrier signal to another modem. The other modem demodulates the received carrier and sends the recovered data to another computer terminal.

MTA

My Talk Address; IEEE-488 Talk Address. ASCII codes 64 through 94 correspond to MTA 0 to MTA 30, respectively. Each instrument on the bus must have a unique Talk Address. See also MLA.

NDAC

Not Data Accepted; IEEE-488 handshake signal, bus line 8. Held high by each Listener until the current data byte is accepted. Only when all Listeners on the bus have released NDAC will it go low. See also DAV, handshake, NRFD.

NRFD

Not Ready For Data; IEEE-488 handshake signal, bus line 7. Held high by each Listener until it is ready to receive a data byte. Only when all listeners on the bus have released NRFD will it go low. See also DAV, handshake, NDAC.

operand

The components of a mathematical expression. Each, when evaluated, has an arithmetic value.

operator

A term for symbols within an application program (such as + or <) that identify operations to be performed. Also see arithmetic operator, logical operator.

overrange

The state indicated by a measurement instrument when an input signal is greater (or lower) than the range that the instrument can measure.

parallel data

The system where each bit is sent on a separate line. The IEEE-488 Bus transfers parallel data. See also serial data.

parity

A method of error detection that uses one extra bit for each unit of information (such as a character). The parity bit is set to one or zero so that the total number of one-bits in the byte is even or odd, depending on the type of parity in use.

Poisson's ratio

A strain gauge parameter; the ratio of the lateral strain to the longitudinal strain in a specimen subjected to a longitudinal stress.

port

A connection point used for data transfer. See interface.

6a/Glossary

port A

The right-hand interface port on the 2280 rear panel. Used for remote control and measurement data acquisition.

port B

The left-hand interface port on the 2280 rear panel. Used for measurement data acquisition only.

protective ground

The common chassis ground that is connected to earth ground through the ground wire in the line power cord. See also signal ground.

pseudo channel

A channel dedicated to special tasks performed on measurement information supplied by other channels.

REC

Received Data, RS-232-C line 3. This line carries the stream of serial data from DCE to DTE. See also serial data, DCE, DTE.

relational expression

An expression containing variables, constants, numbers, and function references, separated by relational operators and parenthesis in such a way that the whole can be reduced to a single (true or false) result. See also relational operator.

relational operator

An operator that compares the relative value of one variable, constant, number, or expression with another variable, constant, number or expression. Examples of relational operators are "EQ", "GT", "LT", "GE", and "LE". See also operator, relational expression.

RET

Return; RS-232-C line 7. A signal return line that serves as a zero voltage reference point for all other signals.

RFI

Radio Frequency Interference; see interference.

RS-232-C

A digital communications standard agreed upon by participating manufacturers of data communication equipment for the transfer of serial digital data between data communication equipment (DCE) and data terminal equipment (DTE). The 2280 is a DTE device. The standard is published and maintained by the Electronic Industries Association, 2001 Eye Street, N.w., Washington, D.C. 20006. See also DCE, DTE, serial data.

RTD

Resistance Temperature Detector; a device with a resistance that varies predictably with changes in temperature. Made of various materials, with platinum the most popular and accurate.

RTS

Request To Send; RS-232-C line 4. The signal from DTE to DCE when it has data to transmit. See also DTE, DCE.

6a/Glossary

scanner

An option in the 2280 system that selects a desired analog input channel for measurement.

SDC

Selective Device Clear; IEEE-488 Addressed Command, ASCII code 4. From the controller, this command causes the addressed Talker or Listener to reset to some defined state. The action taken by the device is unique to that instrument.

serial data

Information transmitted one bit at a time over a single line at a predefined bit rate (baud). See also baud.

serial link address

Address for a serial link device. The address range is manually set on the A/D Converter, Analog Output, and Digital I/O Assemblies.

serial link device

A 2280 assembly performing an output or measurement input function. There are positions (horizontal slots) for six such devices in each 2280.

serial port

A connection point on a computer that is used to transfer information in a serial manner. Data transmission through a serial port in the 2280 is in the form of asynchronous ASCII codes.

shield input

The input lead on various 2280 options that can be grounded or connected to the low lead at a measurement point to reduce interference. The shield input is attached to the braided shield wire surrounding the conductor in the cable.

signal ground

A conductor establishing electrical ground reference potential for all transmitting circuits in a communications network.

SRQ

Service Request; IEEE-488 bus line 10. This line allows a Talker or Listener (such as the 2280) to interrupt the host computer when ever necessary.

strain gauge

A resistive transducer the electrical output of which is proportional to the amount it is deformed under stress or strain. Strain gauge circuits use fixed precision resistors and resistors bonded to a surface to be mechanically loaded, in quarter-, half-, or full-bridge configuration. See also bridge, gauge factor, microstrain.

Talker

An IEEE-488 connected instrument that has been designated by the Controller on the bus to send data to Listeners.

thermocouple

A pair of dissimilar conductors joined together, forming form a junction that generates a voltage when the opposite conductors are at different temperatures. The 2280 has provisions for 12 different types of thermocouples.

6a/Glossary

transducer

A device that converts energy from one form to another. An example of a transducer is a strain gauge.

XMT

Transmitted Data, RS-232-C line 2. The line that carries the stream of serial data from DTE to DCE. See also RS-232-C, serial data, DCE, DTE.

X-OFF

CTRL/S or DC3 ASCII code (decimal 19); sent by the receiving station to halt transmission from the sending station when information is coming too fast for the receiver to process. When able to receive more information, the receiving station sends X-ON to restart the transmitting station. See also X-ON.

X-ON

CTRL/Q or DC1 ASCII code (decimal 17); sent by the receiving station to cause the transmitting station to resume transmission of data after being halted by an X-OFF command. See also X-OFF.

Appendix 6b
Sales and Service Centers

U.S. SALES AREAS for all Fluke products

AK, Anchorage

Harry Lang & Associates
1371 Hillcrest Drive #303
Anchorage, AK 99503
(907) 279-5741

AL, Huntsville

John Fluke Mfg. Co., Inc.
3322 S. Memorial Parkway
Suite 96
Huntsville, AL 35801
(205) 881-8220

AZ, Tempe

John Fluke Mfg. Co., Inc.
2125 S. 48th Street
Suite 104
Tempe, AZ 85282
(602) 967-8724
Tucson
(602) 790-9881

CA, Los Angeles

John Fluke Mfg. Co., Inc.
20902 South Bonita St.
Carson, CA 90746
(213) 538-3900
or (714) 781-2449

San Diego

John Fluke Mfg. Co., Inc.
9801 Aero Dr., Suite 290
San Diego, CA 92123
(714) 226-1254

Santa Clara

John Fluke Mfg. Co., Inc.
2300 Wasan Ave., Bldg. K
Santa Clara, CA 95051
(408) 727-0513

Tustin

John Fluke Mfg. Co., Inc.
15445 Red Hill Ave., Suite F
Tustin, CA 92680
(714) 838-8863

CO, Denver

John Fluke Mfg. Co., Inc.
1980 South Quebec St. #4
Denver, CO 80231
(303) 750-1222

CT, Hartford

John Fluke Mfg. Co., Inc.
Glen Locken East
41-C New London Turnpike
Glastonbury, CT 06033
(203) 858-3541

FL, Orlando

John Fluke Mfg. Co., Inc.
940 N. Fern Creek Ave.
Orlando, FL 32803
(305) 896-4881

GA, Atlanta

John Fluke Mfg. Co., Inc.
2700 Deik Rd., Suite 250
Marietta, GA 30067
(404) 853-4747

HI, Honolulu

EMC Corporation
2979 Uaiena St.
Honolulu, HI 96819
(808) 836-1138

IA, Iowa City

(319) 354-2811

IL, Chicago

John Fluke Mfg. Co., Inc.
3740 Industrial Ave.
Rolling Meadows, IL 60008
(312) 398-0850

IN, Indianapolis

John Fluke Mfg. Co., Inc.
877 Purdue
Suite 101
Indianapolis, IN 46268
(317) 875-7870

KS, Kansas City

John Fluke Mfg. Co., Inc.
4550 W. 109th St., Suite 130
Shawnee Mission, KA 66211
(913) 381-9800

LA, New Orleans

(504) 455-0814

MA, Burlington

John Fluke Mfg. Co., Inc.
25 "B" Street
Burlington MA 01803
(617) 273-4674

MD, Baltimore

(301) 792-7060

Rockville

John Fluke Mfg. Co., Inc.
5840 Fishers Lane
Rockville, MD 20852
(301) 770-1570

MI, Detroit

John Fluke Mfg. Co., Inc.
13965 Farmington Rd.
Livonia, MI 48154
(313) 522-9140

MN, Bloomington

John Fluke Mfg. Co., Inc.
1801 E. 79th St., Suite 9
Bloomington, MN 55420
(612) 854-5528

MO, St. Louis

John Fluke Mfg. Co., Inc.
2029 Woodland Parkway
Suite 105
St. Louis, MO 63141
(314) 993-3805

NC, Greensboro

John Fluke Mfg. Co., Inc.
1310 Beaman Place
Greensboro, NC 27408
(919) 273-1918

NJ, Paramus

John Fluke Mfg. Co., Inc.
P.O. Box 930
West 75 Century Road
Paramus, NJ 07652
(201) 262-9550

NM, Albuquerque

John Fluke Mfg. Co., Inc.
1108 Alvarado Drive N.E.
Albuquerque, NM 87110
(505) 881-3550

NY, Rochester

John Fluke Mfg. Co., Inc.
4515 Culver Road
Rochester, NY 14622
(716) 323-1400

OH, Cleveland

John Fluke Mfg. Co., Inc.
7830 Freeway Circle
Middleburg Heights, OH 44130
(216) 234-4540

Columbus

(614) 889-5715

Dayton

John Fluke Mfg. Co., Inc.
4758 Fishburg Rd.
Dayton, OH 45424
(513) 233-2238

OR, Portland

John Fluke Mfg. Co., Inc.
18380 S.W. Springfield Lane
Alsea, OR 97007
(503) 642-1342

PA, Philadelphia

John Fluke Mfg. Co., Inc.
1010 West 8th Ave., Suite H
King of Prussia, PA 19406
(215) 265-4040

Pittsburgh

(412) 261-5171

TX, Austin

John Fluke Mfg. Co., Inc.
Creek Gardens, Suite 103
8705 Shoal Creek Blvd.
Austin, TX 78758
(512) 459-3344

Dallas

John Fluke Mfg. Co., Inc.
14400 Midway Road
Dallas, TX 75234
(214) 233-9990

Houston

John Fluke Mfg. Co., Inc.
4240 Blue Bonnet Dr.
Stafford, TX 77477
(713) 491-5995

San Antonio

John Fluke Mfg. Co., Inc.
10417 Gulfdale
San Antonio, TX 78218
(512) 340-2621

UT, Salt Lake City

John Fluke Mfg. Co., Inc.
5226 So. 300 West, Suite #2
Salt Lake City, UT 84107
(801) 268-9331

WA, Seattle

John Fluke Mfg. Co., Inc.
5020 148th Ave. N.E.
Suite #110
Redmond, WA 98052
(206) 881-6988

Service Center Areas

CA, Burbank (213) 849-4841
CA, Santa Clara (408) 727-8121
CO, Denver (303) 750-1228
FL, Orlando (305) 896-2298
IL, Chicago (312) 398-5800
MA, Burlington (617) 273-4878
MD, Rockville (301) 770-1578
NJ, Paramus (201) 262-9550
TX, Dallas (214) 233-9945
WA, Everett (206) 356-5560

INTERNATIONAL SALES OFFICES

- Argentina** •
Cosen, S.A.
Virrey del Pino 4071
Buenos Aires, Argentina
Tel: 552-5248, TLX: 22284
- Australia** •
Eimeasco Instruments Pty Ltd.
P.O. Box 30, Concord, N.S.W.
Australia 2137
Tel: (2) 736-2888, TLX: (790) 25687
Eimeasco Instruments Pty Ltd.
21-23 Anthony Drive
Mt. Waverley, VIC 3148
Australia
Tel: 233-4044, TLX: (790) 36206
Eimeasco Instruments Pty Ltd.
Professional Suites Bldg.
Q.P.O. Box 2390
Brisbane, 4001, Australia
Tel: (07) 229-3181
Eimeasco Instruments Pty Ltd.
G.P.O. Box 1240, Adelaide
South Australia 5001
Tel: (08) 271-1809
Eimeasco Instruments Pty Ltd.
P.O. Box 95, Geonessa
West Australia 6110
Tel: (08) 396-3362
- Austria** •
Walter Reiksch
Elektronische Geräte GmbH & Co.
Vertriebs KG
Obengasse 28
Vienna, Austria
Tel: (0222) 235555, TLX: 134759
- Bangladesh** •
Mosharraf Corporation
24 Hethkora Rd., Tikatuli
Dacca 3, Bangladesh
Tel: 257248 or 255776
- Belgium** •
Fluke (Belgium) S.A./N.V.
6, Rue de Genève
1140 Brussels, Belgium
Tel: (2) 2164090, TLX: 26312
- Bolivia** •
Cosen Bolivia S.R.L.
Casilla 7295, La Paz, Bolivia
Tel: 40982, TLX: 3233
- Brazil** •
Fluke Brasil-Industria E
Comercio LTDA
Al. Amazonas 422,
Aphrenie, Barueri,
CEP 06400 Sao Paulo, Brazil
Tel: (011) 421-5477, TLX: 01135589
Fluke Brasil-Industria E
Comercio LTDA
Av. Henrique Valadarez, 25/401
Rio de Janeiro, Brazil
Tel: 252-1297
- Brunei** •
Rink O'Connor's (PTE) Limited
No. 8, BK D
Surtin Shop House Complex
Mile 1, Jalan Tutong
Bandar Sen Begawan, Brunei
Tel: 29680
- Bulgaria** •
Armist Associates Ltd.
Clarence House, 31, Clarence St.
Staines, Middlesex TW18 4SY
United Kingdom
Tel: (784) 63555, TLX: 628655
- Canada** •
Alan Crawford Assoc., Ltd.
#14 1935 30th Ave. N.E.
Calgary, Alberta T2E 6Z3
Tel: (403) 230-1341, TLX: 03-821186
Alan Crawford Assoc., Ltd.
P.O. Bag 3967
Postal Station "D"
Edmonton, Alberta T5L 4K1
Tel: (403) 451-4893
Alan Crawford Assoc., Ltd.
3795 William Street
Burnaby, British Columbia V5C 3H3
Tel: (604) 294-1326, TLX: 04-54247
Alan Crawford Assoc., Ltd.
881 Lady Ellen Place
Ottawa, Ontario K1Z 5L3
Tel: (613) 722-7682, TLX: 05339600
Alan Crawford Assoc., Ltd.
6603 Northam Drive
Mississauga, Ontario L4V 1J2
Tel: (416) 678-1500, TLX: 08968789
Alan Crawford Assoc., Ltd.
7818 cote de Lesse
St. Laurent, Quebec H4T 1E7
Tel: (514) 731-8664, TLX: 05824844
- Chile** •
Fluke (Holland) B.V.
P.O. Box 5053, 5004 EB Tilburg
Zevenhewenweg 53, 5046 AN Tilburg
The Netherlands
Tel: (013) 673973, TLX: 52237
- China** •
Intronica Chile Ltda.
Manual Montt 024 - Of. D.
Casilla 16228, Santiago 9, Chile
Tel: 44940, TLX: 240301
Attn: Intronica Chile
China, People's Republic of •
Fluke International Corporation
P.O. Box C9090
Everett, WA 98206, U.S.A.
Tel: (206) 356-5611
TLX: 152662 JOHN FLUKE EVT
Colombia •
Sesemas E Instrumentacion, Ltda.
Carrera 13, No. 37-43, Of. 401
Ap. Aereo 29563
Bogota DE, Colombia SA
Tel: 232-45-32, TLX: 45787
- Cyprus** •
Chris Radiovision Ltd.
P.O. Box 1886, Nicosia, Cyprus
Tel: 69121, TLX: 6282386
- Czechoslovakia** •
Armist Associates Ltd.
Clarence House, 31, Clarence St.
Staines, Middlesex TW18 4SY
United Kingdom
Tel: (784) 63555, TLX: 628655
- Denmark** •
Tage Olsen A/S
Ballerup Byvej 222
DK - 2750 Ballerup, Denmark
Tel: (2) 968111, TLX: (865) 35283
- Ecuador** •
Proteco Cosen Cia., Ltda.
Edificio "Janco"
Ave. 12 de Octubre #2285 y
Ave. Orellana (Planta Baja)
Quito, Ecuador
Tel: 529464, TLX: (393) 2865
Proteco Cosen Cia., Ltda.
Caldaron 103 y Malecon
Cañita #9733
Guayaquil, Ecuador
Tel: 526083
- Egypt and Sudan** •
Electronic Engineering Liaison Office
P.O. Box 2861 Horreya
Heliopolis, Cairo, Egypt
Tel: 661588, TLX: (927) 92502
- England** •
Fluke (Great Britain) LTD.
Colonial Way
Watford, Herts, WD2 4TT
United Kingdom
Tel: (0923) 40611, TLX: (851) 834583
Rapifax: (0623) 25087
- Ethiopia** •
Fluke (Holland) B.V.
P.O. Box 5053, 5004 EB Tilburg
Zevenhewenweg 53, 5046 AN Tilburg
The Netherlands
Tel: (013) 673973, TLX: 52237
- Finland** •
Oy Findip AB, Teollisuute 7
02700 Kaunainen, Finland
Puh: (0) 5052255, TLX: (847) 123129
- France** •
M.B. Electronique S.A.
Rue Fourmy 808, ZI Centre
78530 BUC
S.P. No. 31
78530 BUC, France
Tel: (3) 9568131, TLX: (842) 696414
- German Democratic Republic** •
Armist Associates Ltd.
Clarence House, 31, Clarence St.
Staines, Middlesex TW18 4SY
United Kingdom
Tel: (784) 63555, TLX: 628655
- German Federal Republic** •
Fluke (Deutschland) GmbH
Max-Hueber-Strasse 4
8045 Ismaning, West Germany
Tel: (089) 96050, TLX: 522472
Rapifax: (089) 9605186
Fluke (Deutschland) GmbH
Meinckeistrasse 53
4000 Düsseldorf 30, West Germany
Tel: (0211) 450631, TLX: (841) 6585376
- Greece** •
Hellenic Scientific Representations Ltd.
11, Vrasside Street
Athens 812, Greece
Tel: (1) 711140, TLX: (863) 219330
- Hong Kong** •
Schmidt & Co. (H.K.) Ltd.
28th Fl. Wing on Centre
111 Connaught Road
Central Hong Kong
Tel: 5-555646
TLX: 74786
- Hungary** •
Armist Associates Ltd.
Clarence House, 31, Clarence St.
Staines, Middlesex TW18 4SY
United Kingdom
Tel: (784) 63555, TLX: 628655
- Iceland** •
Kristjan O. Skagfjord Ltd.
P.O. Box 906
Reykjavik, Iceland
Tel: 24126, TLX: 2153
- India** •
Hinditron Services Pvt. Ltd.
69/A.L. Jagmondas Marg
Bombay 400 006, India
Tel: 811318, TLX: 112328
Hinditron Services Pvt. Ltd.
8th Main Road
33/44-A Raj Mahal Vihar Extension
Bangalore 560 080, India
Tel: 33138, TLX: (853) 0645741
Hinditron Services Pvt. Ltd.
Shantivanetan, Office No. 8
6th Floor, 8 Camac Street
Calcutta 700 017, India
Tel: 434032, 447541
Hinditron Services Pvt. Ltd.
204-208 Henkunt Tower
98 Nehru Place
New Delhi, 110019, India
Tel: 640380, TLX: (96) 314880
Hinditron Services Pvt. Ltd.
Srinath Complex, 5th Floor
1-1-56/1 to 1-1-56/11
Sarjani Devi Road
Secunderabad 500 003, India
Tel: 821117, TLX: (963) 0155 375
- Indonesia** •
P.T. Dwi Tunggal Jaya Sakti
Kebayoran Baru
Jakarta Selatan, Indonesia
Tel: 716374, TLX: 45305
- Iran** •
Fluke (Holland) B.V.
P.O. Box 5053, 5004 EB Tilburg
Zevenhewenweg 53, 5046 AN
The Netherlands
Tel: (013) 673973, TLX: 52237
- Ireland** •
Euro Electronics
32 Brews Hill
Navan County Meath, Ireland
Tel: (46) 23577, TLX: (851) 3182
- Israel** •
R.D.T. Electronics Engineering Ltd.
P.O. Box 75
46, Sokolov Street
Ramat Hasharon 47235, Israel
Tel: (3) 483216, TLX: (922) 32143
- Italy** •
Sistrel S.p.A.
Via Pezzola de Volpedo 58
20082 Cinisello Balsamo
Milan, Italy
Tel: (2) 8181803, TLX: (843) 334643
Sistrel S.p.A.
Via Giuseppe Armetini No. 39
00143 Rome, Italy
Tel: (6) 5915551, TLX: (843) 66356
Sistrel S.p.A.
Via Cinto
Parco S. Paolo
80126 Naples, Italy
Tel: (81) 7679700
- Japan** •
John Fluke Mfg. Co., Inc.
Japan Branch
Sumitomo Higashi
Shinobani Bldg.
1-1-11 Mamanatsucho
Minato-ku, Tokyo, Japan
Tel: (03) 434-0181, TLX: 2424331

6b/Sales and Service Centers

Kenya •
ADCOM Ltd.
P.O. Box 30070
Nairobi, Kenya, East Africa
Tel: 331955, TLX: 22638

Korea •
Electro-Science Korea Co
C.P.O. Box 8444
Room 403, Boondo Bldg
56-12 Jangchung-Ka
Jung-Ku
Seoul, Korea
Tel: 281-7702, TLX: K25381

Kuwait •
Al-Bahar Int. Group
P.O. Box 26672 Safat
Kuwait, Arabian Gulf
Tel: 4501067, TLX: 44622

Lebanon and Jordan •
Mabek (Electronic Division)
P.O. Box 11-3823
Beirut, Lebanon
Tel: 812523, TLX: (823) 22886

Libya •
Fluke (Holland) B.V.
P.O. Box 5053, 5004 EB Tilburg
Zevenheuvelenweg 53, 5048 AN Tilburg
The Netherlands
Tel: (013) 673973, TLX: 52237

Malaysia •
Mecomo Melaka SDN BHD
Lot 2, Lorong 13/6A
Petaling Jaya, Malasia
Tel: 573455, TLX: MAJ37805

Mexico •
Electronica y Tecnologia
Avanzada S.A. de C.V.
Palmico Padilla 53
Circulo Comercial Satelite
Naucaclan Edo. De Mexico
Tel: 383 0602
TLX: (383) 017 2067

Nepal •
Associated Enterprises
GPO Box 790, Pysopal Tok
Kathmandu, Nepal
Tel: 13666

Netherlands •
Fluke (Nederland) B.V.
Geethuisweg 14
5041 DS Tilburg
The Netherlands

P.O. Box 115
5000 AC Tilburg
The Netherlands
Tel: (013) 352455, TLX: 52853

New Zealand •
McLaren Information Technology, Ltd.
P.O. Box 9484, Newmarket
Auckland 1, New Zealand
Tel: 501-801; TLX: (791) NZ 215 70
McLaren Information Technology, Ltd.
P.O. Box 486
Wellington, New Zealand
Tel: 851-450 or 844-424

Nigeria •
Motel Engineering Co., Ltd.
P.O. Box 8366
Lagos, Nigeria
Tel: 960744, TLX: 21353

Norway •
Morgenthorpe & Co A/S
Kongsholmen 3
P.O. Box 8686, Rosenkrantz
Oslo 5, Norway
Tel: (2) 356110, TLX: (856) 21718

Oman •
OHI Communications
P.O. Box 886
Muscat
Sultanate of Oman
Tel: 702956 or 703852
TLX: 3188

Pakistan •
Pak International Operations
505 Muhammadi House
11, Chundigar Road
P.O. Box 5323, Karachi, Pakistan
Tel: 221127, TLX: (952) 24494

PDR Yemen •
Fluke (Holland) B.V.
P.O. Box 5053, 5004 EB Tilburg
Zevenheuvelenweg 53, 5048 AN Tilburg
The Netherlands
Tel: (013) 673973, TLX: 52237

Peru •
Importaciones Y Representaciones
Electronicas S.A.
Avda. Franklin D. Roosevelt 105
Lima 1, Peru
Tel: 286650, TLX: (364) 25663

Philippines •
Spark Radio & Electronics, Corp.
1044 Ongpin St., Sta. Cruz
Manila, Philippines
Tel: 47-11-94, TLX: 27901
Spark Radio & Electronics Corp.
Greenhill P.O. Box 810
San Juan, Metro-Manila
Philippines Zip 3113
Tel: 77-51-92

Poland •
Amtest Associates Ltd.
Clarence House, 31, Clarence St.
Staines, Middlesex TW18 4SY
United Kingdom
Tel: (784) 63555, TLX: 928655

Portugal •
Decade-Equipamentos de
Electronica, Lda.
Rua Pedro Nunes, 47-C
1000 Lisboa, Portugal
P.O. Box 1128, 1000 Lisboa Codex
Tel: (19) 574964, TLX: (832) 18449

Qatar •
Technology Organisation
P.O. Box 5649, Doha, Qatar
Tel: 321431, TLX: (957) 4561

Romania •
Amtest Associates Ltd.
Clarence House, 31, Clarence St.
Staines, Middlesex TW18 4SY
United Kingdom
Tel: (784) 63555, TLX: 928655

Saudi Arabia •
Electronic Equipment Marketing Co.
P.O. Box 3750
Riyadh, Saudi Arabia
Tel: (1) 477-165001
TLX: (928) 201120

Singapore •
Rane O'Connor's (PTE) Limited
96 Pasir Panjang Road
Singapore 0511
Republic of Singapore
Tel: 637944
TLX: RS21023

Somalia •
Fluke (Holland) B.V.
P.O. Box 5053, 5004 EB Tilburg
Zevenheuvelenweg 53, 5048 AN Tilburg
The Netherlands
Tel: (013) 673973, TLX: 52237

South Africa •
Fluke S.A. (Pty) Ltd.
P.O. Box 39797, Bramley 2018
Republic of South Africa
Tel: (011) 780-3170, TLX: 424328

Spain •
Hispano Electronica S.A.
Poligono Industrial Urquina
Apartado de Correos 46
Alicorcon (Madrid), Spain
Tel: (1) 6194106
TLX: (831) 22404

Sri Lanka •
Jay-Ea Electronics
180 Poornavara Mawatha
Colombo 5, Sri Lanka
Tel: 073-2363

Sweden •
Telenstrument AB
P.O. Box 4490
162 04 Vallingby, Sweden
Tel: (8) 360370, TLX: (854) 15770

Switzerland •
Traco Electronic AG
Jentschstrasse 1
8002 Zurich, Switzerland
Tel: (1) 2010711, TLX: (845) 54318

Syria •
Mabek (Electronic Division)
P.O. Box 4234
Damasqus, Syria

Taiwan •
Schmidt Scientific Far East Ltd.
906, Chia Hsin Bldg.
96, Chung Shan N. Rd., Sec. 2
Taipei, Taiwan
Tel: 5414600, TLX: 11111

Thailand •
Measuratronix Ltd.
1869/10 Rama 9th Rd.
Huamark, Bangkok 24, Thailand
Tel: 3143369, TLX: 81143

Tunisia •
Sveco S.A.R.L.
6, Rue de Sparte
Tunis - 1000 RP, Tunisia
Tel: (1) 246093, TLX: (834) 13030

Turkey •
Ertan Elektronik Aletler
Ticaret Anonim Sirketi
Necatibey Cad 92/3
Karakoy, Istanbul, Turkey
Tel: 441548
TLX: (821) 23353

United Arab Emirates •
Al Sarani Trad. Est.
P.O. Box 7187
Abu-Dhabi, United Arab Emirates
Tel: 821370 or 821371
TLX: 23696

United Kingdom •
Fluke (Great Britain) Ltd.
Colonial Way
Watford, Herts, WD2 4TT
United Kingdom
Tel: (0823) 40511, TLX: 834583
Rapifax: (0823) 25067

Uruguay •
Coasen Uruguay S.A.
Casilla de Correos 1400
Libertad 2529
Montevideo, Uruguay
Tel: 78-90-18, TLX: UY9571

U.S.S.R. •
Amtest Associates Ltd.
Clarence House, 31, Clarence St.
Staines, Middlesex TW18 4SY
United Kingdom
Tel: (784) 63555, TLX: 928655

Venezuela •
Coasen, C.A.
Calle 9 Cor Calle 4, Edif. Edmundo
Apertado De Correos
NR-70, 136 Los Ruices
Caracas 1070A, Venezuela
Tel: 238-0867, TLX: (385) 21027

Yemen •
Fluke (Holland) B.V.
P.O. Box 5053, 5004 EB Tilburg
Zevenheuvelenweg 53, 5048 AN Tilburg
The Netherlands
Tel: (013) 673973, TLX: 52237

Yugoslavia •
Amtest Associates Ltd.
Clarence House, 31, Clarence St.
Staines, Middlesex TW18 4SY
United Kingdom
Tel: (784) 63555, TLX: 928655

■ Supplied and Supported by —

Fluke (Holland) B.V.
P.O. Box 5053, 5004 EB Tilburg
Zevenheuvelenweg 53, 5048 AN Tilburg
The Netherlands
Tel: (013) 673973, TLX: 52237

● Supplied and Supported by —

Fluke International Corporation
P.O. Box C3090
Everett, WA 98206 U.S.A.
Tel: (206) 356-5500
TLX: 152682 JOHN FLUKE EVT



TECHNICAL SERVICE CENTERS

U.S.A.

CA, Berkeley
John Fluke Mfg. Co., Inc.
(213) 849-4641

CA, Santa Clara
John Fluke Mfg. Co., Inc.
(408) 727-8121

CO, Denver
John Fluke Mfg. Co., Inc.
(303) 750-1228

FL, Orlando
John Fluke Mfg. Co., Inc.
(305) 894-2296

IL, Rolling Meadows
John Fluke Mfg. Co., Inc.
(312) 306-6800

MA, Burlington
John Fluke Mfg. Co., Inc.
(617) 273-4673

MD, Accotink
John Fluke Mfg. Co., Inc.
(301) 770-1578

MI, Farmington Hills
John Fluke Mfg. Co., Inc.
(201) 282-9550

TX, Dallas
John Fluke Mfg. Co., Inc.
(214) 233-4946

WA, Everett
John Fluke Mfg. Co., Inc.
(206) 356-5680

Other Countries

Argentina, Buenos Aires
Coasen S.A.
Tel: 562-6248/3486
TLX: 122284 COASAN AR

Australia, Concord
Eimeasco Instruments Pty Ltd.
Tel: (02) 736-2966
TLX: (780) 25867

Australia, Mount Waverley
Eimeasco Instruments Pty Ltd.
Tel: 03-233-4044
TLX: 36208

Australia, Brisbane
Eimeasco Instruments Pty Ltd.
Tel: (07) 229-3181

Austria, Vienna
Walter Reiskirch Electronische Geräte
GmbH & Co.
Tel: (0222) 235555
TLX: 134758

Belgium, Brussels
Fluke (Belgium) SA/NA
Tel: (02) 2164080
TLX: 28312

Brazil, São Paulo
Fluke Brasil-Industria E Comercio Ltda.
Tel: (011) 421-3803
TLX: 01136588 FLUXE BR

Canada, Calgary, AB
Allan Crawford Associates Ltd.
Tel: (403) 230-1341

Canada, Burnaby, BC
Allan Crawford Associates Ltd.
Tel: (604) 294-1328

Canada, Mississauga, ON
Allan Crawford Associates Ltd.
Tel: (416) 878-1800

Canada, St. Laurent, PQ
Allan Crawford Associates Ltd.
Tel: (514) 731-8554

Chile, Santiago
Intronica Chile Ltda.
Tel: 49840
TLX: 240301

China, Beijing
Beijing Radio Research Institute
Tel: 445812

Colombia, Bogotá
Sistemas E Instrumentación, Ltda.
Tel: 232-46-32
TLX: 48787 COASIN CO

Denmark, Sønderup
Tape Olsen A/S
Tel: (02) 858111
TLX: 35283 TOAS BK

Sweden, Gøttinge
Edificio "Jenico"
Tel: 529684, 528756
TLX: 2865 Proved Ed

Egypt, Cairo
Electronic Engineering Liaison Office
Tel: 681586
TLX: (827) 82502

England, Watford, Herts
Fluke (Great Britain) LTD
Tel: 44-825-40511
TLX: 834643

Finland, Kaunialampi
Oy Findo AB
Tel: (0) 5062256
TLX: 123129

France, BUC
M.B. Electronique S.A.
Tel: (01) 8568131
TLX: 895414

Germany, Athens
Hellenic Scientific Representations
Tel: (01) 711140
TLX: 219330

Hong Kong, Hong Kong
Schmidt & Co. (H.K.) Ltd.
Tel: 5-455644
TLX: 74788 SCHMAC HX

India, Bombay
Hindatron Services Pvt. Ltd.
Tel: 811316, 815344
TLX: 953-112228 HSPR IN

India, New Delhi
Hindatron Services Pvt. Ltd.
Tel: 619118
TLX: 031 4880 SARMP IN

Indonesia, Jakarta Selatan
P.T. Dwi Tunggal Jaya Sekti
Tel: 718374
TLX: 47308 DIJS IA

Israel, Ramat Hasharon
R.O.T. Electronics Engineering Ltd.
Tel: (03) 483216
TLX: 32143

Italy, Milan
Sietel S.p.A.
Tel: (02) 6181883
TLX: 354643

Japan, Tokyo
John Fluke Mfg. Co., Inc.
Japan Branch
Tel: (03) 434-0181
TLX: (781) 2424331 (FLUKJ/PJ)

Korea, Seoul
Electro-Science Korea Co.
Tel: 261-7702, 260-1908
TLX: K25361

Malaysia, Petaling Jaya
Measomb Malaysia SDN BHD
Tel: 573455
TLX: MA37605

Mexico, Mexico D.F.
Electronica y Tecnologia
Avanzada S.A. de C.V. (ETA)
Tel: 383 08 02 or 383 57 62
TLX: 0172697 BLOSME

Netherlands, Maastricht
Fluke (Nederland) B.V.
Tel: (030) 436514
TLX: 47128

Netherlands, Tilburg
Fluke (Holland) B.V.
Tel: (013) 873673
TLX: 52237

New Zealand, Auckland
McLean Information Technology, Ltd.
Tel: 501-801, 501-218, 567-037
TLX: N221870 THERMAL

Norway, Oslo
Morgenstjerne & Co A/S
Tel: (02) 358110
TLX: 71718

Pakistan, Karachi
Pak International Operations
Tel: 221127, 226052
TLX: 24494 PHO PK

Peru, Lima
Importaciones Y Representaciones
Electronicas S.A.
Tel: 288650
TLX: 37425883

Philippines, Metro Manila
Spartan Radio & Electronics Corp.
Tel: 78-78-18
TLX: 27801 RLA PH

Portugal, Lisboa
Decisio-Equipamentos de
Electronica, Lda.
Tel: (19) 574864
TLX: 18448

Republic of Singapore, Singapore
Rank O'Connor's (PTE) Limited
Tel: 637944, 239042
TLX: OCONRSIN RS21023

Republic of South Africa, Bramley
Fluke S.A. (Pty) Ltd.
Tel: (011) 786-3170
TLX: 494328

Spain, Alcorcón (Madrid)
Hispano Electronics S.A.
Tel: (01) 8184108
TLX: 22404/42854

Sweden, Vellingby
Tälsinstrument AB
Tel: (08) 380370
TLX: 15770

Switzerland, Zurich
Traco Electronic AG
Tel: (01) 2010711
TLX: 54318

Taiwan, Taipei
Schmidt Scientific Far East Ltd.
Tel: 5414600
TLX: 11111 Schmidt

Thailand, Bangkok
Measurtronix Ltd.
Tel: 2143388, 3143430
TLX: 81143 DEJOBKK TH

Turkey, Istanbul
Erturan Elektronik Alerder
Tel: (01) 5481
TLX: 23353

Uruguay, Montevideo
Coasen Uruguay S.R.L.
Tel: 26-31-952
TLX: UY 6671 OROCUER

Venezuela, Caracas
Coasen, C.A.
Tel: 38-78-42, 38-78-86
TLX: 21027 EMVEN VE

West Germany, Ismaning
Fluke (Deutschland) GmbH
Tel: (089) 96050
TLX: 0522472



Appendix 6c
ASCII/IEEE-488 Character Set

6c/Character Set

ASCII CHAR.	DECIMAL	OCTAL	HEX	BINARY		DEV. NO.	MESSAGE ATN=TRUE	
				7654	3210			
NUL	0	000	00	0000	0000			ADDRESSED COMMANDS
SQH	1	001	01	0000	0001		GTL	
STX	2	002	02	0000	0010			
ETX	3	003	03	0000	0011			
EOT	4	004	04	0000	0100		SDC	
ENQ	5	005	05	0000	0101		PPC	
ACK	6	006	06	0000	0110			
BELL	7	007	07	0000	0111			
BS	8	010	08	0000	1000		GET	
HT	9	011	09	0000	1001		TCT	
LF	10	012	0A	0000	1010			
VT	11	013	0B	0000	1011			
FF	12	014	0C	0000	1100			
CR	13	015	0D	0000	1101			
SO	14	016	0E	0000	1110			
SI	15	017	0F	0000	1111			
DLE	16	020	10	0001	0000			UNIVERSAL COMMANDS
DC1	17	021	11	0001	0001		LLO	
DC2	18	022	12	0001	0010			
DC3	19	023	13	0001	0011			
DC4	20	024	14	0001	0100		DCL	
NAK	21	025	15	0001	0101		PPU	
SYN	22	026	16	0001	0110			
ETB	23	027	17	0001	0111			
CAN	24	030	18	0001	1000		SPE	
EM	25	031	19	0001	1001		SPD	
SUB	26	032	1A	0001	1010			
ESC	27	033	1B	0001	1011			
FS	28	034	1C	0001	1100			
GS	29	035	1D	0001	1101			
RS	30	036	1E	0001	1110			
US	31	037	1F	0001	1111			

6c/Character Set

ASCII CHAR.	DECIMAL	OCTAL	HEX	BINARY 7654 3210	DEV. NO.	MESSAGE ATN=TRUE	LISTEN ADDRESSES
SPACE	32	040	20	0010 0000	0	MLA	
!	33	041	21	0010 0001	1	MLA	
"	34	042	22	0010 0010	2	MLA	
#	35	043	23	0010 0011	3	MLA	
\$	36	044	24	0010 0100	4	MLA	
%	37	045	25	0010 0101	5	MLA	
&	38	046	26	0010 0110	6	MLA	
'	39	047	27	0010 0111	7	MLA	
(40	050	28	0010 1000	8	MLA	
)	41	051	29	0010 1001	9	MLA	
*	42	052	2A	0010 1010	10	MLA	
+	43	053	2B	0010 1011	11	MLA	
,	44	054	2C	0010 1100	12	MLA	
-	45	055	2D	0010 1101	13	MLA	
.	46	056	2E	0010 1110	14	MLA	
/	47	057	2F	0010 1111	15	MLA	
0	48	060	30	0011 0000	16	MLA	
1	49	061	31	0011 0001	17	MLA	
2	50	062	32	0011 0010	18	MLA	
3	51	063	33	0011 0011	19	MLA	
4	52	064	34	0011 0100	20	MLA	
5	53	065	35	0011 0101	21	MLA	
6	54	066	36	0011 0110	22	MLA	
7	55	067	37	0011 0111	23	MLA	
8	56	070	38	0011 1000	24	MLA	
9	57	071	39	0011 1001	25	MLA	
:	58	072	3A	0011 1010	26	MLA	
;	59	073	3B	0011 1011	27	MLA	
<	60	074	3C	0011 1100	28	MLA	
=	61	075	3D	0011 1101	29	MLA	
>	62	076	3E	0011 1110	30	MLA	
?	63	077	3F	0011 1111		UNL	

6c/Character Set

ASCII CHAR.	DECIMAL	OCTAL	HEX	BINARY 7654 3210	DEV. NO.	MESSAGE ATN=TRUE	TALK ADDRESSES
@	64	100	40	0100 0000	0	MTA	
A	65	101	41	0100 0001	1	MTA	
B	66	102	42	0100 0010	2	MTA	
C	67	103	43	0100 0011	3	MTA	
D	68	104	44	0100 0100	4	MTA	
E	69	105	45	0100 0101	5	MTA	
F	70	106	46	0100 0110	6	MTA	
G	71	107	47	0100 0111	7	MTA	
H	72	110	48	0100 1000	8	MTA	
I	73	111	49	0100 1001	9	MTA	
J	74	112	4A	0100 1010	10	MTA	
K	75	113	4B	0100 1011	11	MTA	
L	76	114	4C	0100 1100	12	MTA	
M	77	115	4D	0100 1101	13	MTA	
N	78	116	4E	0100 1110	14	MTA	
O	79	117	4F	0100 1111	15	MTA	
P	80	120	50	0101 0000	16	MTA	
Q	81	121	51	0101 0001	17	MTA	
R	82	122	52	0101 0010	18	MTA	
S	83	123	53	0101 0011	19	MTA	
T	84	124	54	0101 0100	20	MTA	
U	85	125	55	0101 0101	21	MTA	
V	86	126	56	0101 0110	22	MTA	
W	87	127	57	0101 0111	23	MTA	
X	88	130	58	0101 1000	24	MTA	
Y	89	131	59	0101 1001	25	MTA	
Z	90	132	5A	0101 1010	26	MTA	
[91	133	5B	0101 1011	27	MTA	
\	92	134	5C	0101 1100	28	MTA	
]	93	135	5D	0101 1101	29	MTA	
^	94	136	5E	0101 1110	30	MTA	
_	95	137	5F	0101 1111		UNT	

6c/Character Set

ASCII CHAR.	DECIMAL	OCTAL	HEX	BINARY 7654 3210	DEV. NO.	MESSAGE ATN=TRUE	SECONDARY ADDRESSES
.	96	140	60	0110 0000	0	MSA	
a	97	141	61	0110 0001	1	MSA	
b	98	142	62	0110 0010	2	MSA	
c	99	143	63	0110 0011	3	MSA	
d	100	144	64	0110 0100	4	MSA	
e	101	145	65	0110 0101	5	MSA	
f	102	146	66	0110 0110	6	MSA	
g	103	147	67	0110 0111	7	MSA	
h	104	150	68	0110 1000	8	MSA	
i	105	151	69	0110 1001	9	MSA	
j	106	152	6A	0110 1010	10	MSA	
k	107	153	6B	0110 1011	11	MSA	
l	108	154	6C	0110 1100	12	MSA	
m	109	155	6D	0110 1101	13	MSA	
n	110	156	6E	0110 1110	14	MSA	
o	111	157	6F	0110 1111	15	MSA	
p	112	160	70	0111 0000	16	MSA	
q	113	161	71	0111 0001	17	MSA	
r	114	162	72	0111 0010	18	MSA	
s	115	163	73	0111 0011	19	MSA	
t	116	164	74	0111 0100	20	MSA	
u	117	165	75	0111 0101	21	MSA	
v	118	166	76	0111 0110	22	MSA	
w	119	167	77	0111 0111	23	MSA	
x	120	170	78	0111 1000	24	MSA	
y	121	171	79	0111 1001	25	MSA	
z	122	172	7A	0111 1010	26	MSA	
{	123	173	7B	0111 1011	27	MSA	
	124	174	7C	0111 1100	28	MSA	
}	125	175	7D	0111 1101	29	MSA	
~	126	176	7E	0111 1110	30	MSA	
	127	177	7F	0111 1111			



Appendix 6d
Documentation for 2285B

INTRODUCTION

The 2280 Series manual set (User Guide, System Guide, and Service Manual) documents the 2280B Data Logger. These manuals, although compatible with the 2285B Data Logger, do require some further explanation. Some features can be used with the 2280B, but not with the 2285B. Also, some option assemblies cannot be used with the 2285B. This Appendix describes these differences.

FEATURES

The 2285B is an economical solution to a data logging system not requiring the expansion capabilities of the 2280B. The following configuration is possible:

- o The channel total for the 2285B is limited to 100.
- o The number of alarm lists is limited to 100.
- o The TAPE and DATA TRANSFER front panel keys are not functional (the Cartridge Tape option is not available).

6d/2285B

OPTIONS

The following option assemblies cannot be used with the 2285B:

- o Advanced Math Processor (2280A-211)
- o DC Cartridge Tape (2280A-214)
- o Counter/Totalizer (2280B-167)
- o Analog Output (2280B-170)

Appendix 6e
Documentation for 2280A

INTRODUCTION

The 2280 Series manual set (User Guide, System Guide, and Service Manual) documents the 2280B Data Logger. These manuals, although compatible with the 2280A Data Logger, do require some further explanation. Some features can be used with the 2280B, but not on the 2280A. Several option assemblies can be used with the 2280B, but not with the 2280A. This Appendix describes these differences.

6e/2280A

FEATURES

Features of the 2280A differ from those of the 2280B in the following areas:

- o Alarm Limits: alarm limits cannot be changed while scanning.
- o Pseudo Channels: pseudo channels values cannot be changed while scanning.
- o Scan Once Trigger Mode: not available on 2280A.
- o Remotely Terminated Thermocouples: not supported by 2280A. (the 64.000 mV with open thermocouple detect measurement range is not available.)
- o Time of Day: not shown during scanning.
- o AC voltage measurement require a programmed math expression. This expression adds the diode voltage drop incurred in the ac-to-dc conversion.
- o The LIN1, LIN2, and RTD functions are not available.

OPTIONS

The following option assemblies cannot be used with the 2280A:

- o RTD/Resistance Scanner and Connector (2280B-163/-177)
- o Counter/Totalizer (2280B-167)
- o Analog Output (2280B-170)

Appendix 6f
Connector Pinouts

Alarms Connector (J25)	6f-2
Analog Output Connector	6f-3
Counter/Totalizer Connector	6f-4
Serial Link Connector (J23)	6f-5

6f/Pinouts

ALARM OUTPUT/TRIGGER INPUT Connector (J25, Rear Panel)

Pinouts for this rear panel connector are:

Pin:	Function:
1,3,5,6,7	Return connection for trigger input (connected to logic common)
2	Hardware trigger input (pulled up to +5V dc) Low-to-high transition causes scan trigger.
4,8	Master alarm output relay contacts (2.8 VA maximum)
9	Earth ground (shield)

6F/Pinouts

Analog Output (2280B-170)

Pinouts for the 22-pin screw terminal connector are:

Pin	Signal Name
1	Channel 0, Voltage Source
2	Channel 0, 0 to 10 Volt Return
3	Channel 0, -5 to 5 Volt Return
4	Channel 0, 4 to 20 Milliamp Source
5	Channel 0, 4 to 20 Milliamp Return
6	Channel 1, Voltage Source
7	Channel 1, 0 to 10 Volt Return
8	Channel 1, -5 to 5 Volt Return
9	Channel 1, 4 to 20 Milliamp Source
10	Channel 1, 4 to 20 Milliamp Return
11	Channel 2, Voltage Source
12	Channel 2, 0 to 10 Volt Return
13	Channel 2, -5 to 5 Volt Return
14	Channel 2, 4 to 20 Milliamp Source
15	Channel 2, 4 to 20 Milliamp Return
16	Channel 3, Voltage Source
17	Channel 3, 0 to 10 Volt Return
18	Channel 3, -5 to 5 Volt Return
19	Channel 3, 4 to 20 Milliamp Source
20	Channel 3, 4 to 20 Milliamp Return
21	-10 V Reference Voltage
22	14 V

6f/Pinouts

Counter/Totalizer (2280B-167)

Pinouts for the 22-pin screw terminal connector are:

Pin	Signal Name
1	Test Clock
2	Return
3	Return
4	Channel 0, Input
5	Channel 0, Threshold Test Point
6	Return
7	Channel 1, Input
8	Channel 1, Threshold Test Point
9	Return
10	Channel 2, Input
11	Channel 2, Threshold Test Point
12	Return
13	Channel 3, Input
14	Channel 3, Threshold Test Point
15	Return
16	Channel 4, Input
17	Channel 4, Threshold Test Point
18	Return
19	Channel 5, Input
20	Channel 5, Threshold Test Point
21	Return
22	Variable Reference Voltage Test Point

6f/Pinouts

Serial Link Connector (J23, Rear Panel)

Pinouts for the 25-pin connector (J22) are:

Pin:	Function:
4,5,6,12	Ground 1
14	TX+
13	TX-
8	RX+
7	RX-
1,2,3	+24V
9,10,11	-24V Return (Ground 3)
15	Earth Ground

Appendix 6g
System Specifications

General Specifications	6g-3
Accuracy Specifications	
Temperature Measurement	
Using Thermocouples	6g-7
Using RTDs	
With 163/177 Options	6g-7
With 164/174 Options	6g-17
DC Voltage Measurement	6g-18
AC Voltage Measurement	6g-19
DC Current Measurement	6g-20
Resistance Measurement	
With 163/177 Options	6g-21
With 164/174 Options	6g-25
Strain Measurement	6g-26

6g/General Specifications

6g/General Specifications

GENERAL SPECIFICATIONS

Channel Capacity

Mainframe 100 Analog or 120 Digital
2280B System 1500 maximum
2285B System 100 maximum

Program Memory Nonvolatile, with 90 day
typical, 30 day minimum
battery backup

Display 40 characters,
alphanumeric

Printer

Printing 40 characters/line, 5X7
dot matrix, 6.7 lines/inch
Plotting Up to 4 channels/line
Resolution 276 discrete points, 11.2
lines/inch
Paper Thermosensitive paper
roll, NCR T1302 or JUJO
50CM-A, 4000 lines/roll

6g/General Specifications

Master Alarm Relay Normally open, 2.8 VA max

Hardware Trigger Input Accepts an open-collector NPN transistor or contact closure input. Low to high transition triggers any scan group so programmed.

Scanning Speed

Dependent on system configuration and programming

Maximum System Scanning Speed in Channels per Second

A/D Converters in System	DC Voltage Readings	Thermocouple and RTD Readings
1	16	15
2	30	26
3	42	35
4	56	40
5	65	44

Power

AC 100, 120, 220, Vac $\pm 10\%$
240V ac +4%, -10%
50 or 60 Hz

DC 12V dc (10.5 to 20V dc)
Min. Startup Voltage ... 11.2V dc

Less than 120 Watts

Temperature

Operating 0 to 50°C
(without Cartridge Tape Option)

Operating 0 to 40°C
(with Cartridge Tape Option)

Storage -25 to 60°C

Humidity (non-condensing)

0 to 25°C <95%

25 to 40°C <75%

40 to 50°C <45%

6g/General Specifications

Weight 20 to 29 kg (45-66 lbs)
Depending on configuration

Dimensions 22.23 x 43.94 x 66.17 (cm)
 H W D
 9.35 x 17.30 x 26.05 (in)

Altitude
 Operating 3050M (10,000 feet)
 Non-operating 12,200M (40,000 feet)

Shock and Vibration Meets MIL-T-28800C Class 5

ACCURACY SPECIFICATIONS

Temperature Measurement Using Thermocouples

Hardware Used 2280A-161 High Performance A/D
 2280A-162 Thermocouple/DC Volts Scanner
 2280A-175 Isothermal Input Connector

Accuracy In $\pm^{\circ}\text{C}$

Thermocouple Type (Sensor Temperature Range)	Time Since A/D Calibration (Operating Temperature in $^{\circ}\text{C}$)			
	Sensor Temperature ($^{\circ}\text{C}$)	90 Days (15 to 35)	1 Year (15 to 35)	1 Year (-20 to +70)
J (-200 to 760 $^{\circ}\text{C}$)				
-100 to -25	0.45	0.5	0.8	
-25 to 760	0.35	0.4	0.7	
K (-275 to 1350 $^{\circ}\text{C}$)				
0 to 900	0.4	0.45	0.7	
900 to 1350	0.52	0.65	1.3	
T (-230 to 400 $^{\circ}\text{C}$)				
-100 to 75	0.58	0.65	1.1	
75 to 150	0.35	0.39	0.7	
150 to 400	0.3	0.34	0.6	
E (-250 to 900 $^{\circ}\text{C}$)				
-100 TO -25	0.47	0.54	0.9	
-25 TO 750	0.3	0.33	0.6	
750 TO 900	0.33	0.4	0.8	
R (0 to 1767 $^{\circ}\text{C}$)				
250 to 450	0.9	1.0	1.3	
450 to 1767	0.8	0.9	1.4	

6g/Thermocouple Accuracy

Accuracy In $\pm^{\circ}\text{C}$

Thermocouple Type (Sensor Temperature Range)	Time Since A/D Calibration (Operating Temperature in $^{\circ}\text{C}$)			
	Sensor Temperature ($^{\circ}\text{C}$)	90 Days (15 to 35)	1 Year (15 to 35)	1 Year (-20 to +70)
S (0 to 1767 $^{\circ}\text{C}$)				
200 to 1767	0.97	1.1	1.6	
B (200 to 1820 $^{\circ}\text{C}$)				
600 to 800	1.4	1.6	1.9	
800 to 1820	0.96	1.1	1.3	
N (-200 to 400 $^{\circ}\text{C}$) (For 28-gauge thermocouple wire)				
-100 to 150	0.6	0.7	1.1	
150 to 400	0.4	0.44	0.7	
C (0 to 2315 $^{\circ}\text{C}$)				
200 to 1000	0.57	0.66	0.94	
1000 to 2000	0.90	1.2	2.1	
2000 to 2315	1.3	1.7	2.9	
JDIN (-200 to 900 $^{\circ}\text{C}$)				
-100 to -25	0.5	0.56	0.9	
-25 to 900	0.4	0.45	0.7	
TDIN (-200 to 600 $^{\circ}\text{C}$)				
0 to 200	0.48	0.53	0.8	
200 to 600	0.37	0.41	0.7	

Temperature Measurement Using RTDs

Hardware Used 2280A-161 High Performance A/D
 2280B-163 RTD/Resistance Scanner
 2280B-177 RTD/Resistance Input Connector

Performance

RTD Type, Scanner Range, and Scanner Measurement Mode (sensor temperature range)		90 Days Since A/D Calibration		
		18 to 28°C Operating Temperature		
		Temperature Shift $dT/dt < 1^\circ\text{C} / 10\text{min}$		
Sensor Temperature (°C)		Accuracy	Resolution	Repeatability

Platinum 385 DIN, High Resolution, 4-Wire (4W), and
 Platinum 390, User-defined High Resolution, 4-Wire (4W)
 (-200 to 425°C)

-200 to 150	0.09°C*	0.006°C	0.03°C
150 to 425	0.13°C	0.006°C	0.04°C

Platinum 392, User-defined High Resolution, 4-Wire (4W)
 (-200 to 425°C)

-200 to 150	0.08°C*	0.006°C	0.03°C
150 to 425	0.12°C	0.006°C	0.04°C

Platinum 385 DIN, High Temperature, 4-Wire (4W), and
 Platinum 390, User-defined High Temperature, 4-Wire (4W)
 (-200°C to probe limit)

-200 to 600	0.25°C	0.05°C	0.14°C
-------------	--------	--------	--------

6g/RTD Accuracy

	Accuracy	Resolution	Repeatability
Platinum 392, User-defined High Temperature, 4-Wire (4W) (-200°C to probe limit)			
-200 to 600	0.24°C	0.05°C	0.14°C
10 Ohm Copper, 4-Wire (4W) (full range)	0.28°C	0.06°C	0.16°C
Platinum 385 DIN, 390, 392, 3-Wire Accurate (3WA) Full range: add °C per ohm lead resistance to 4W specs	+0.007°C	+0.001°C	
10 Ohm Copper, 3-Wire Accurate (3WA) Full range: add °C per ohm lead resistance to 4W specs	+0.065°C	+0.008°C	
Platinum 385 DIN, 390, 392, 3-Wire Isolated (3WCM) Full range: add °C to 3WA specs	+1.97°C	+1.97°C	
10 Ohm Copper, 3-Wire Isolated (3WCM) Full range: add °C to 3WA specs	+18.2°C	+18.2°C	

*NOTE: An ice-point initialization allows Platinum RTDs with user-defined linearization to have accuracies of 0.05°C (392Pt) and 0.06°C (390Pt), and 385 DIN RTDs to have an accuracy of 0.05°C + probe conformity.

6g/RTD Accuracy

Performance

RTD Type, Scanner Range, and Scanner Measurement Mode (sensor temperature range)	90 Days Since A/D Calibration 15 to 35°C Operating Temperature Temperature Shift $dT/dt < 1^{\circ}\text{C} / 10 \text{ min}$		
Sensor Temperature (°C)	Accuracy	Resolution	Repeatability

Platinum 385 DIN, High Resolution, 4-Wire (4W), and
Platinum 390, User-defined High Resolution, 4-Wire (4W)
(-200 to 425°C)

-200 to 150	0.10°C	0.006°C	0.04°C
150 to 425	0.15°C	0.006°C	0.04°C

Platinum 392, User-defined High Resolution, 4-Wire (4W)
(-200 to 425°C)

-200 to 150	0.09°C	0.006°C	0.04°C
150 to 425	0.14°C	0.006°C	0.04°C

Platinum 385 DIN, High Temperature, 4-Wire (4W), and
Platinum 390, User-defined High Temperature, 4-Wire (4W)
(-200°C to probe limit)

-200 to 600	0.27°C	0.05°C	0.16°C
-------------	--------	--------	--------

Platinum 392, User-defined High Temperature, 4-Wire (4W)
(-200°C to probe limit)

-200 to 600	0.26°C	0.05°C	0.16°C
-------------	--------	--------	--------

6g/RTD Accuracy

	Accuracy	Resolution	Repeatability
10 Ohm Copper, 4-Wire (4W) (full range)	0.3°C	0.06°C	0.16°C
Platinum 385 DIN, 390, 392, 3-Wire Accurate (3WA) Full range: add °C per ohm lead resistance to 4W specs	+0.007°C	+0.001°C	
10 Ohm Copper, 3-Wire Accurate (3WA) Full range: add °C per ohm lead resistance to 4W specs	+0.065°C	+0.008°C	
Platinum 385 DIN, 390, 392, 3-Wire Isolated (3WCM) Full range: add °C to 3WA specs	+1.97°C	+1.97°C	
10 Ohm Copper, 3-Wire Isolated (3WCM) Full range: add °C to 3WA specs	+18.2°C	+18.2°C	

6g/RTD Accuracy

Performance

RTD Type, Scanner Range, and Scanner Measurement Mode (sensor temperature range)	1 Year Since A/D Calibration 15 to 35°C Operating Temperature Temperature Shift $dT/dt < 1^{\circ}\text{C} / 10\text{min}$	
Sensor Temperature ($^{\circ}\text{C}$)	Accuracy	Resolution

Platinum 385 DIN, High Resolution, 4-Wire (4W), and
Platinum 390, User-defined High Resolution, 4-Wire (4W)
(-200 to 425°C)

-200 to 150	0.11°C	0.006°C
150 to 425	0.16°C	0.006°C

Platinum 392, User-defined High Resolution, 4-Wire (4W)
(-200 to 425°C)

-200 to 150	0.10°C	0.006°C
150 to 425	0.15°C	0.006°C

Platinum 385 DIN, High Temperature, 4-Wire (4W), and
Platinum 390, User-defined High Temperature, 4-Wire (4W)
(-200°C to probe limit)

-200 to 600	0.28°C	0.05°C
-------------	--------	--------

Platinum 392, User-defined High Temperature, 4-Wire (4W)
(-200°C to probe limit)

-200 to 600	0.27°C	0.05°C
-------------	--------	--------

10 Ohm Copper, 4-Wire (4W)
(full range)

	0.3°C	0.06°C
--	-------	--------

6g/RID Accuracy

Accuracy

Platinum 385 DIN, 390, 392, 3-Wire Accurate (3WA)
(full range) Add 0.008^oC
per ohm lead
resistance
to 4W specs

10 Ohm Copper, 3-Wire Accurate (3WA)
(full range) Add 0.073^oC
per ohm lead
resistance
to 4W specs

Platinum 385 DIN, 390, 392, 3-Wire Isolated (3WCM)
(full range) Add 2.53^oC
to 3WA specs

10 Ohm Copper, 3-Wire Isolated (3WCM)
(full range) Add 23.4^oC
to 3WA specs

6g/RTD Accuracy

Performance

RTD Type, Scanner Range, and Scanner Measurement Mode (sensor temperature range)	1 Year Since A/D Calibration -20 to 70°C Operating Temperature Temperature Shift $dT/dt < 1^{\circ}\text{C} / 10\text{min}$	
Sensor Temperature (°C)	Accuracy	Resolution

Platinum 385 DIN, High Resolution, 4-Wire (4W), and
Platinum 390, User-defined High Resolution, 4-Wire (4W)
(-200 to 425°C)

-200 to 150	0.19°C	0.006°C
150 to 425	0.29°C	0.006°C

Platinum 392, User-defined High Resolution, 4-Wire (4W)
(-200 to 425°C)

-200 to 150	0.18°C	0.006°C
150 to 425	0.28°C	0.006°C

Platinum 385 DIN, High Temperature, 4-Wire (4W), and
Platinum 390, User-defined High Temperature, 4-Wire (4W)
(-200°C to probe limit)

-200 to 600	0.44°C	0.05°C
-------------	--------	--------

Platinum 392, User-defined High Temperature, 4-Wire (4W)
(-200°C to probe limit)

-200 to 600	0.43°C	0.05°C
-------------	--------	--------

10 Ohm Copper, 4-Wire (4W)
(full range)

	0.4°C	0.06°C
--	-------	--------

6g/RTD Accuracy

Accuracy

Platinum 385 DIN, 390, 392, 3-Wire Accurate (3WA)
(full range) Add 0.010^oC
per ohm lead
resistance
to 4W specs

10 Ohm Copper, 3-Wire Accurate (3WA)
(full range) Add 0.096^oC
per ohm lead
resistance
to 4W specs

Platinum 385 DIN, 390, 392, 3-Wire Isolated (3WCM)
(full range) Add 2.53^oC
to 3WA specs

10 Ohm Copper, 3-Wire Isolated (3WCM)
(full range) Add 23.4^oC
to 3WA specs

Temperature Measurement Using RTDs

Hardware Used 2280A-161 High Performance A/D
 2280A-164 Transducer Excitation Module
 2280A-174 Transducer Excitation Connector
 (with current excitation selected)
 2280A-162 Thermocouple/DC Volts Scanner
 Choice of Connector:
 2280A-175 Isothermal Input
 2280A-176 Voltage Input
 2280A-160 AC Voltage Input

Performance

RTD Type and Scanner Range (sensor temperature range)	90 Days Since Calibration 15 to 35°C Operating Temperature		
Sensor Temperature (°C)	Accuracy	Resolution	Repeatability
Platinum 390 and 392, User-defined (-200°C to probe limit)			
-200 to 200	0.1°C	0.02°C	0.08°C
200 to 600	0.15°C	0.02°C	0.1°C
Platinum 385 DIN (-200°C to probe limit)			
-200 to 600	0.2°C	0.013°C	0.08°C
10 Ohm Copper (full range)			
	1.0°C	0.1°C	0.2°C

DC Voltage Measurement Accuracy

Hardware Used 2280A-161 High Performance A/D
 2280A-162 Thermocouple/DC Volts Scanner
 Choice of Connector:
 2280A-175 Isothermal Input
 2280A-176 Voltage Input
 2280A-160 AC Voltage Input

Accuracy

Range (Internal Resolution)	Time Since A/D Calibration (Operating Temperature in °C) (± % Input ± microvolts)		
	90 Days (15 to 35)	1 Year (15 to 35)	1 Year (-20 to +70)
±64 mV (0.6 μV)	0.005% + 7.0	0.01% + 8.0	0.03% + 9.0
±51.2 mV (5 μV)	0.005% + 30	0.01% + 40	0.03% + 50
±8V (73 μV)	0.005% + 700	0.01% + 800	0.03% + 900
±64V (0.6 mV)	0.009% + 3 mV	0.02% + 4 mV	0.05% + 5 mV

AC Voltage Measurement Accuracy

Hardware Used 2280A-161 High Performance A/D
2280A-162 Thermocouple/DC Volts Scanner
2280A-160 AC Voltage Input Connector

Performance

Range and Frequencies		90 Days Since A/D Calibration
		15 to 35°C Operating Temperature

		Resolution	Accuracy
--	--	------------	----------

5V to 250V ac rms, 45 Hz to 450 Hz
0.1V

±1% Input ±.1V

DC Current Measurement Accuracy

Hardware Used 2280A-161 High Performance A/D
2280A-162 Thermocouple/DC Volts Scanner
2280A-171 Current Input Connector

Performance

Range	90 Days Since A/D Calibration	
	15 to 35°C Operating Temperature	
	Resolution	Accuracy
±64 mA	0.6 uA	±.25% ±4 uA

Resistance Measurement Accuracy

Hardware Used 2280A-161 High Performance A/D
 2280B-163 RTD/Resistance Scanner
 2280B-177 RTD/Resistance Input Connector

Performance

Scanner Range and Measurement Mode	90 Days Since A/D Calibration 18 to 28°C Operating Temperature Temperature Shift dT/dt < 1°C / 10min		
	(mohm)	(±% Input ± mohm)	
	Resolution	Accuracy	Repeatability
256 ohm, 4-Wire (4W)	2.4	0.0142% + 5.7	0.0037% + 5.7
2048 ohm, 4-Wire (4W)	19	0.0137% + 38	0.0032% + 38
64 kilohm, 4-Wire (4W)	0.6 ohm	0.055% + 1.2 ohm	0.0040% + 1.2 ohm**
All, 3-Wire Accurate (3WA)	same as 4W	Add 2.4 mohm per ohm lead resistance to 4W specs	Add 0.2 mohm per ohm lead resistance to 4W specs
All, 3-Wire Isolated (3WCM)	same as 4W	Add 0.7 ohm per ohm lead resistance to 3WA specs	Add 0.7 ohm per ohm lead resistance to 3WA specs

**Humidity 15%RH less than listed for the 2280B-163 Scanner

6g/Resistance Accuracy

Performance

Scanner Range and Measurement Mode	90 Days Since A/D Calibration 15 to 35°C Operating Temperature Temperature Shift $dT/dt < 1^{\circ}C / 10 \text{ min}$		
	(mohm)	(% Input \pm mohm)	
	Resolution	Accuracy	Repeatability
256 ohm, 4-Wire (4W)	2.4	0.0170% + 5.7	0.0065% + 5.7
2048 ohm, 4-Wire (4W)	19	0.0165% + 38	0.0060% + 38
64 kilohm, 4-Wire (4W)	0.6 ohm	0.06% + 1.2 ohm	0.0075% + 1.2 ohm**
All, 3-Wire Accurate (3WA)	same as 4W	Add 2.5 mohm per ohm lead resistance to 4W specs	Add 0.3 mohm per ohm lead resistance to 4W specs
All, 3-Wire Isolated (3WCM)	same as 4W	Add 0.7 ohm per ohm lead resistance to 3WA specs	Add 0.7 ohm per ohm lead resistance to 3WA specs

**Humidity 15%RH less than listed for the 2280B-163 Scanner

6g/Resistance Accuracy

Performance

Scanner Range and Measurement Mode	1 Year Since A/D Calibration 15 to 35°C Operating Temperature Temperature Shift $dT/dt < 1^{\circ}C / 10 \text{ min}$	
	Resolution	Accuracy
256 ohm, 4-Wire (4W)	2.4 mohm	$\pm 0.0175\%$ Input $\pm 5.7 \text{ mohm}$
2048 ohm, 4-Wire (4W)	19 mohm	$\pm 0.0170\%$ Input $\pm 38 \text{ mohm}$
64 kilohm, 4-Wire (4W)	1.2 ohm	$\pm 0.06\%$ Input $\pm 1.2 \text{ ohm}$
All, 3-Wire Accurate (3WA)	same as 4W	Add 2.8 mohm per ohm lead resistance to the 4W specifications
All, 3-Wire Isolated (3WCM)	same as 4W	Add 0.9 ohm to the 3WA specifications

6g/Resistance Accuracy

Performance

Scanner Range and Measurement Mode	1 Year Since A/D Calibration	
	-20 to 70°C Operating Temperature Temperature Shift $dT/dt < 1^{\circ}\text{C} / 10 \text{ min}$	
	Resolution	Accuracy
256 ohm, 4-Wire (4W)	2.4 mohm	$\pm .0365\%$ Input ± 7 mohm
2048 ohm, 4-Wire (4W)	19 mohm	$\pm .0360\%$ Input ± 38 mohm
64 kilohm, 4-Wire (4W)	0.6 ohm	$\pm .23\%$ Input ± 1.2 ohm
All, 3-Wire Accurate (3WA)	same as 4W	Add 3.7 mohm per ohm lead resistance to the 4W specifications
All, 3-Wire Isolated (3WCM)	same as 4W	Add 0.9 ohm to the 3WA specifications

6g/Resistance Accuracy

Resistance Measurement Accuracy

Hardware Used 2280A-161 High Performance A/D
2280A-164 Transducer Excitation Module
2280A-174 Transducer Excitation Connector
(with current excitation selected)
2280A-162 Thermocouple/DC Volts Scanner
Choice of Connector:
2280A-175 Isothermal Input
2280A-176 Voltage Input
2280A-160 AC Voltage Input

Performance

Range	90 Days Since Calibration 15 to 35°C Operating Temperature	
	Resolution	Accuracy
64 ohm	1 mohm	±.02% Input ±7 mohm
512 ohm	10 mohm	±.02% Input ±30 mohm

Strain Measurement Accuracy

Hardware Used 2280A-161 High Performance A/D
 2280A-164 Transducer Excitation Module
 2280A-174 Transducer Excitation Connector
 (with voltage excitation selected)
 2280A-162 Thermocouple/DC Volts Scanner
 Choice of Connector:
 2280A-175 Isothermal Input
 2280A-176 Voltage Input
 2280A-160 AC Voltage Input

Performance

Gage Type	90 Days Since Calibration 20 to 30°C Operating Temperature	
	Resolution	Accuracy
Full Bridge	0.25 uE	±.05% Input ±2 uE
1/2 Bridge	0.5 uE	±.05% Input ±13 uE
1/4 Bridge	0.5 uE	±.05% Input ±25 uE

Appendix 6h
Cartridge Tape Handling

The DC100 Cartridge Tape Drive (option 2280A-214) requires some handling and usage precautions. These are:

- o Use the Correct Tape

Only Scotch brand DC100A certified tapes can be used in the DC100 Cartridge Tape Drive. DC100A certified tapes can be distinguished as having position indication holes that are at least 1/32 of an inch in diameter (approximately 1/4 the width of the tape). Some older tapes (no longer manufactured) have position indication holes that are approximately 1/64 of an inch in diameter. Do not use this older type of tape.

- o Allow for Tape Acclimation

Allow the tape to acclimate to the operating environment. Acclimation time can equal the amount of time the tape has been exposed to dissimilar conditions, or eight hours (whichever is less).

6h/Cartridge Tape Handling

The recommended operating environment for the cartridge is:

Temperature	5 to 45 °C
Relative Humidity	20% to 80% non-condensing
Wet Bulb Temperature (max)	26 °C

o Insert the Tape Correctly

Insert the tape by pushing firmly on the center of the cartridge. Verify that the tape seats firmly into place. The drive wheel of the cartridge tape must be in firm contact with the motorized drive wheel.

o Re-Tension the Tape

A conditioning pass (running the tape from end to end) may be necessary to re-tension the tape. Use this technique in any of the following situations:

1. The cartridge is loaded into a drive, or
2. The cartridge is exposed to temperature changes of 16.7 °C or more, or
3. One section of tape has been used excessively in a single operating period.

A cartridge tape can be re-tensioned using the Data Transfer operation. Transferring a dummy file (named TENSION123) causes the tape to wind forward (to the end of the tape) and then rewind. No data is actually transferred.

6h/Cartridge Tape Handling

- o Bulk Erase an Unknown Tape Before Use

If the previous usage of a cartridge tape is not known, do a bulk erase prior to further usage.

For best results, bulk erase the tape with a video tape eraser.

- o If a New Tape Is Being Used

Execute cartridge tape system test number 5 (read/write test) before recording data.

When using a new tape, the tape and drive compatibility should be verified by executing the cartridge read/write system test.

- o Avoid Writing a Tape on Different 2280s

Writing over tapes that have been previously recorded on a different 2280 may create a tape that is difficult to read. For best results, bulk erase the tape with a video tape eraser, then write exclusively with one 2280. Such tapes can be read by any 2280 or by Qantex 1000 units.

- o Cleaning

Periodically clean the tape drive head and capstan.

Contaminants build up on tape drive heads, impairing the ability of the tape to properly contact the heads. Loss of signal amplitude results. The head and capstan should be cleaned after eight hours of tape motion. Use a cotton swab moistened with isopropyl alcohol. Use extreme care when cleaning the head to prevent scratching or otherwise damaging the head surface. After cleaning, wipe the head with a clean cotton swab both to remove residue and to polish the head.

6h/Cartridge Tape Handling

Periodically clean the Tape Mark Sensor assembly.

Visual inspection of the emitter and sensor of the Tape Mark Sensor assembly should be performed monthly. Use a cotton swab to clean off any accumulated dust or dirt on the lenses of these devices.

Appendix 6i
Cartridge Tape Format

Introduction	6i-2
Track Format	6i-4
Character Set	6i-4
Directory Blocks	6i-5
Locating Previously Written Information	6i-6
Data Blocks	6i-8
File Types	6i-9
Recovering Blocks After a Power Failure	6i-11

6i/Cartridge Tape Format

INTRODUCTION

The DC100 Cartridge Tape Interface option (hereafter called the "Cartridge") is a two-track system, employing Manchester phase encoding at a density of 1600 bits per inch. Data is written to or read from the tape while it is traveling past the head at 30 inches per second. The data format closely follows the standard for DC300 tapes (ANSI X3.56-1977); however, at the time of this writing there is no explicit standard for DC100 tapes. Data is stored as magnetic flux transitions in block form (sections of data separated by erased sections called gaps.) A gap is characterized by the absence of flux transitions.

Manchester phase encoding is a "self-clocking" coding scheme. This means that both the data and the data rate information can be recovered from the read signal as it comes off the tape. Ideally, bit-to-bit spacing is constant with this method; however, in reality spacing between adjacent bits varies slowly from bit to bit and can vary widely (as motor speed changes) between different blocks or drive units. One bits are always recorded as positive transitions, while zero bits are always recorded as negative transitions. Since bit-to-bit spacing is constant, extra transitions have to be inserted between adjacent zero bits or adjacent one bits. Figure 6i-1 illustrates the encoded bit sequence 011001 using Manchester phase encoding.

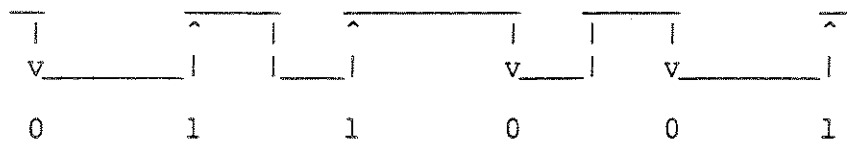

Figure 6i-1. Manchester Phase Encoding

6i/Cartridge Tape Format

The encoded format of a recorded block is illustrated in Figure 6i-2. The preamble (which always contains fifteen zero bits followed by a single one bit) immediately follows the gap. The preamble allows the hardware to sort out significant transitions by synchronizing the decoder hardware with the negative transitions: e.g., getting "on track" with the known fifteen zero bits.

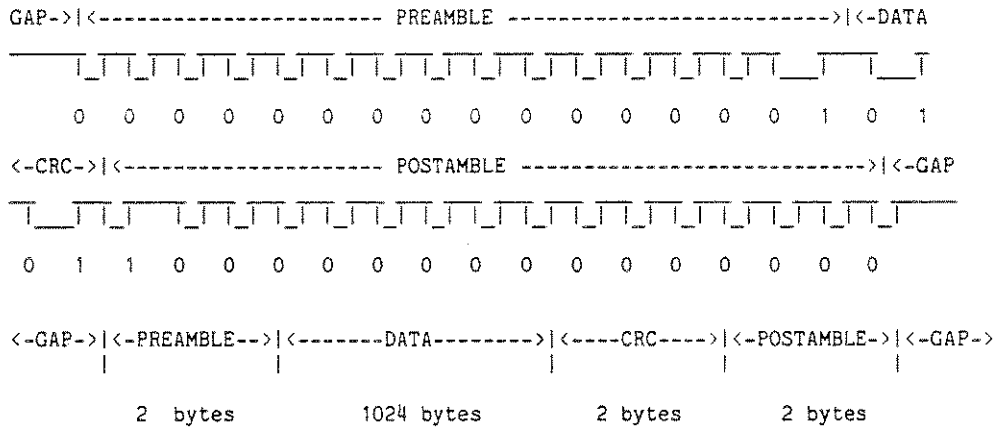

Figure 6i-2. Recorded Block Format

The data field of the block consists of a fixed number of bytes, followed by the two-byte crc (cyclic redundancy check). This code is used to check data integrity. The crc code is generated by the polynomial $x^{16} + x^{15} + x^2 + 1$.

6i/Cartridge Tape Format

TRACK FORMAT

The layout of blocks on the tape is the same for either track. The first block on the track starts approximately five inches after the Load Point hole. All gaps between blocks are approximately one inch long except for the gap between the second and third blocks on either track, which is about three inches long. Blocks are written only between the Load Point hole and the Early Warning hole.

CHARACTER SET

Characters recorded on the tape are restricted to the ASCII set; thus, the most significant bit of each byte in the data field of a block is cleared. In addition, characters from the range 60 to 7F (hexadecimal) are reserved for use as tokens (special symbols). The tokens currently used have the special meanings as described in Table 6i-1. Usage of these tokens is described later in the appropriate context.

Table 6i-1. Single Character Tokens

Token	Description
a	Encoded begin scan date marker
b	End-of-file marker
e	Equivalent to two space characters
f	Equivalent to four space characters
g	Equivalent to eight space characters
h	Equivalent to 16 space characters
i	Equivalent to 32 space characters
j	Begin forced line terminator
k	End forced line terminator
l	Data file type
m	Program file type

6i/Cartridge Tape Format

DIRECTORY BLOCKS

Information about all other blocks is contained in the two (redundant) "directory blocks" (the first two blocks on the first track.) All other valid blocks on tape (if any) are termed "data blocks".

The format of the directory blocks is given in Tables 6i-2 and 6i-3. All number fields are ASCII-encoded, right-justified decimal numbers. If the number is less than three digits long, it is padded with space characters on the left.

Table 6i-2. Directory Block Format

Byte Range	Description
0 - 2	Block number on this track (either 0 or 1)
3 - 5	Number of valid entries in the entry array
6 - 8	Next free block number
9 - 11	Number of blocks on track 1
12 - 14	Anti-aliasing number
15 - 29	Space padding
30 - 33	Programmed line terminator
34 - 1023	Entry array (55 entries using the format described in Table 6i-3. One entry is used for each file on the tape.

Table 6i-3. Directory Entry Format

Number of Bytes	Description
10	File name
1	File type token
3	File length, in blocks
4	Programmed line terminator

6i/Cartridge Tape Format

The information in the directory is used to locate any valid data block without ambiguity. But the recovery of data blocks after a power failure is an exception (covered later in this section).

Each track contains a variable number of data blocks, whose maximum is primarily related to tape speed. To accommodate this variation, the fourth field in the directory block contains the number of blocks on the first track (including directory blocks). If the first track is not full yet, this number is zero.

The third field in the directory contains the number of the next free block on the tape. If the tape is full, this number is set to zero. Data blocks are numbered consecutively, starting with the first block (block number 2) after the two directory blocks and ending with the last block on the second track.

LOCATING PREVIOUSLY WRITTEN INFORMATION

A previously recorded block is located by comparing its number to the directory field containing the number of blocks on track one. If this field is zero, all blocks are on track one and the block number is the distance from the load point. Otherwise, the block is on either track 1 (if its number is less than the number of blocks on track 1) or track 2 (if its number is greater than or equal to the number of blocks on track 1.)

If the block is on track 2, the location of the block is determined by subtracting the number of blocks on track 1 from the block's number, yielding the distance of the block from the load point. Note that blocks are numbered sequentially starting at zero (the two directory blocks are blocks 0 and 1), while block on track position numbers start at zero for each track.

Consider the following example. For a tape with three files and room left on track 2, a typical directory might look like Table 6i-4.

6i/Cartridge Tape Format

To locate the first block of PROGL, the length of the previous files is summed and added to the number of the first block after the directory blocks:

$$2 + 153 + 196 = 351$$

Next, block number 351 is compared to the number of blocks on track one:

$$351 \geq 261$$

implies that the block is on track 2, and has the block-on-track number $351 - 261 = 90$.

Locating the first block of SCAN1 is much easier. Since it is the first file on tape, it starts at block number two. Comparing this to the number of blocks on track one shows that its block-on-track number is also two.

DATA BLOCKS

The format of a data block differs from that for directory blocks. Table 6i-5 illustrates the format used for data blocks in both file types (data and program).

Table 6i-5. Data Block Format

Byte Range	Description
0 - 2	Block number on this track
3 - 12	File name
13 - 15	Anti-aliasing number
16 - 19	Programmed line terminator
20 - 1019	Data bytes
1020 - 1023	Programmed line terminator

6i/Cartridge Tape Format

When a data block is read, the block-on-track and file name fields are checked to verify that this is the desired block. When recovering blocks after a power failure, the anti-aliasing number is checked as well (see the section on recovering blocks). The block-on-track and anti-aliasing fields are decimal numbers, space-padded at the left if they are less than three digits long.

The data bytes field is surrounded by two four-character fields containing the programmed line termination sequence. If the sequence is less than four characters long, it is right-justified and padded with spaces at the left. These two line terminator fields guarantee that the data block header fields exist on a line of their own, easing the task of separating header information from data bytes.

FILE TYPES

Two file types are supported: data and program. The directory entry for a file contains a file type field which contains one of two tokens distinguishing the file type. Both file types use the same data block format (see Table 6i-5); the difference between them is in the contents of the data bytes field. Data files contain information logged from the 2280, while program files contain configuration and programming information.

In addition, if the data bytes field contains information obtained during a scan, the Cartridge prepends an encoded version of the date and time that the scan began. This is used by the Cartridge during a data transfer to filter out unwanted data. The encoded field contains 13 characters, the first of which is the token that marks the field (see Tables 6i-1 and 6i-6). The remaining twelve are digits representing the date and time. The data logged to the tape can be reformed by stripping every occurrence of the 'a' token and the twelve characters that follow.

6i/Cartridge Tape Format

Table 6i-6. Encoded Begin Scan Date Format

Byte Range	Description and Range of Values
0	'a' - Encoded begin scan date token
1 - 2	Year [00 , 01 , ... , 99]
3 - 4	Month [00 , 01 , ... , 11]
5 - 6	Day of Month [01 , 02 , ... , 31]
7 - 8	Hour [00 , 01 , ... , 23]
9 - 10	Minute [00 , 01 , ... , 59]
11 - 12	Second [00 , 01 , ... , 59]

Most files end with a partially full block. An end-of-file token is placed in the block immediately following the last valid character. The remainder of the data bytes field is padded with empty lines, using zero or more spaces per line combined with the programmed line terminator.

Data file information consists of a series of lines terminated with the programmed line terminator. The maximum line length is about 40 characters. Program file information (as received from the mainframe) has a much more mysterious structure, with no explicit line boundaries. (No attempt to describe the meaning of program file characters is made here.)

Consequently, a line terminator is forced onto the tape at periodic intervals by the Cartridge to turn program files into a series of lines. Each forced line terminator is prepended with a "begin line terminator" token and appended with an "end forced line terminator" token (see Table 6i-5). These tokens allow the Cartridge to strip these line terminators when loading programs into the 2280.

6i/Cartridge Tape Format

RECOVERING BLOCKS AFTER A POWER FAILURE

The 2280 possesses the ability to continue logging data to the same file on the tape after power has cycled. To do this, the Cartridge must be able to determine the number of blocks written successfully before power loss.

First, the directory is scanned to verify that the last directory entry was never closed - this is true if the entry's file length field is zero. Next, the potential blocks in the file are read until a read error occurs, the end of tape is encountered, or a block is read that does not belong to the file being recovered. To determine the latter, the filename and anti-aliasing fields of the block header are checked. The anti-aliasing field must match the anti-aliasing field in the directory header. When recovering blocks, examining the filename in the recovered block's header is not sufficient to make a reliable determination, since a file by the same name may have existed in the same place on tape before, and may be 'aliased' into reincarnation as blocks appended to the actual end of the file being recovered. This is not an altogether unlikely occurrence, since people tend to have pet names for files.

Anti-aliasing numbers were created to reduce the probability of aliasing to an acceptably low level. Every time the directory is rolled back (by initializing the tape or deleting files), a new random number (the anti-aliasing number) is placed in the directory header. A file being written also has the same number in every block header. Thus, an unclosed file has an anti-aliasing number in the header of every valid block that matches the anti-aliasing number in the directory. Aliasing candidates in the form of long-dead files are unlikely to have both the same filename and the same anti-aliasing number as the file currently being recovered.

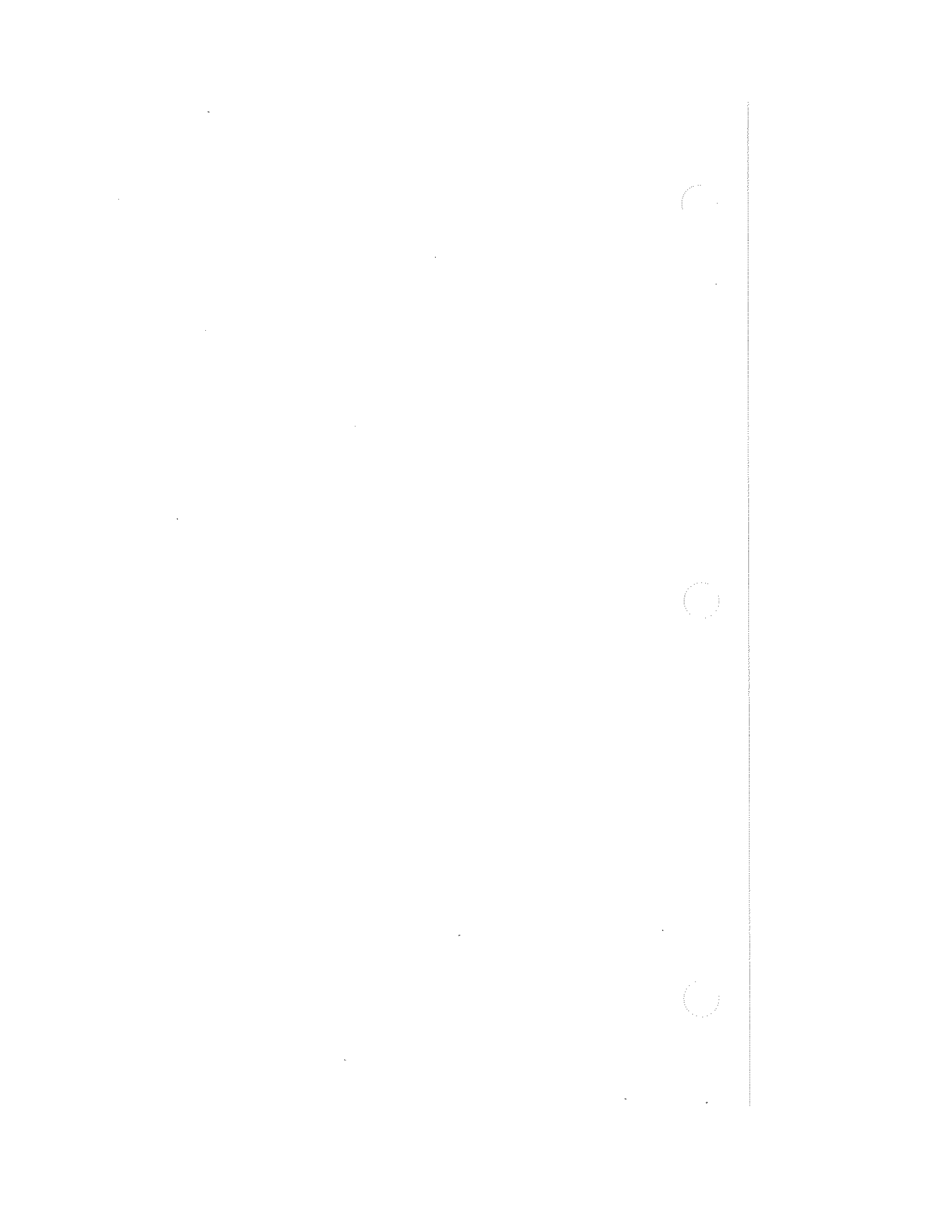

Appendix 6j
Memory Usage

OVERVIEW

This appendix provides a step-by-step method for determining total memory usage for 2280 user programs. This method can be used if there is any doubt about memory availability for a given program. The resulting byte total would then be useful in identifying areas in which to simplify the user program.

Starting with a completed Programming Form, memory usage for each module can be determined. Channel values and information storage and unacknowledged alarm message storage requirements can then be added. The resulting number of bytes is a reasonably accurate indication of memory usage requirements.

The following steps apply solely to items being programmed. For example, if the default channel units are satisfactory and are not being programmed separately, no additional memory usage is required.

6j/Memory Usage

A. CHANNEL PROGRAMMING REQUIREMENTS

Procedure

Calculate memory requirements for the channel programming module. The following calculation must be completed for each channel:

PROGRAMMING ITEM	REQUIRED BYTES
Standard	27
Channel Label (max length 15)	4 + length
CHANNEL Units (max length 6)	4 + length
Status Channel	33
User Defined RTD Channel	67

Channel expression, channel procedure rules:

Channel Expression (max length 75)	12 + length
Channel Procedure Line (max length 75)	8 + length

Plus, for each:

Single channel listed (C1234)	3
Channel block listed (C0..9)	5
Self channel reference listed (CX)	1
ALMn function listed	1
Constant listed (4, 5.5, 123.4E-9)	5
Operator or function listed (+, -, *, /, =, (,), TIME, GAV, ALMn, TBLn, etc)	1

Examples: Channel Expressions and Procedures

6j/Memory Usage

CHANNEL EXPRESSION

The following channel expression uses 81 bytes:

$$(1.2345E-12 * CX + 12.345E-11) * CX + 123.45E-10$$

This calculation is made as follows:

Standard expression	12
Expression length	49
Self channels referenced (CX)	2
Constants listed	12
Operators listed	6
(do not count sign of exponent)	
Total Bytes	<hr/> 81

CHANNEL PROCEDURES

$$CX=1.2345E-12 * CX + 12.345E-11$$

(uses 56 bytes)

$$CX=(C100+C101+C102+C103)/4$$

(uses 59 bytes)

$$C100=ALM2(C100)$$

(uses 31 bytes)

$$C100=ALM1(C100)+ALM2(C100)+ALM3(C100)+ALM4(C100)$$

(uses 79 bytes)

B. ALARM LIST PROGRAMMING REQUIREMENTS

Calculate memory requirements for the alarm list module. This procedure must be completed for each alarm list. Then add the number of bytes for all alarm list programming. Record this number in the Memory Usage Summary Table.

6j/Memory Usage

PROGRAMMING ITEM	REQUIRED BYTES
Standard	26
Each limit programmed (max 4)	24
Each alarm message (max length 40)	4 + length

C. SCAN GROUP PROGRAMMING REQUIREMENTS

Calculate memory required for scan group programming. This procedure must be completed for each scan group being programmed. Then add the number of bytes needed for all scan group programming. Record this number in the Memory Usage Summary Table.

PROGRAMMING ITEM	REQUIRED BYTES
Standard	24
Scan group label (max length 40)	4 + length
For each scan group channel list line (max length 75)	8 + length
For each scan group channel list line:	
Each single channel listed	3
Each channel block listed	5

D. PLOT PROGRAMMING REQUIREMENTS

Calculate memory required for plot programming by adding the number of bytes needed for a plot. Then add the number of bytes needed for all plot programming. Record this number in the Memory Usage Summary Table.

PROGRAMMING ITEM	REQUIRED BYTES
Standard	129
For each plot number programmed	105

E. OUTPUT DEVICE PROGRAMMING REQUIREMENTS

Calculate memory required by adding the number of bytes needed for a output device programming. Then add the number of bytes needed for all output device programming. Record this total in the Memory Usage Summary Table.

NOTE

If this module is never programmed or examined, no bytes are allocated. But, merely examining various output device programming areas does cause memory to be allocated.

PROGRAMMING ITEM	REQUIRED BYTES
Standard (includes normally optional programming)	30
Port A Logging Format	78
Port B Logging Format	78
Cartridge Tape Logging Format	78
Data Transfer Filter	51

F. INTERPOLATION TABLE PROGRAMMING REQUIREMENTS

Calculate bytes required for each interpolation table. Repeat this procedure for each interpolation table being programmed. Then add the number of bytes needed for all interpolation table programming. Record this figure in the Memory Usage Summary Table.

PROGRAMMING ITEM	REQUIRED BYTES
Standard	6
For each line in the interpolation table (max length 24)	16 + length

6j/Memory Usage

G. CHANNEL VALUES AND OTHER SCAN TIME INFORMATION

Calculate the amount of memory needed to store the channel values and other scan time information. Such storage is allocated on a channel decades basis. A channel decade is a block of 10 channels beginning with a channel number that is evenly divisible by 10 (C0..9, C10..19, C20..29). If any channel in a decade is used during the scanning process, an area is allocated for the storage of a channel decade associated with that channel.

For example, if C12 and C135 appear in a scan group channel list, channel decades C10..19 and C130..139 are allocated. Note that even though some channels in a decade are never used during the scanning process, storage is still allocated for them. For this reason it is recommended that channels be grouped together in blocks of channel decades and unused input/output channels be used as pseudo channels.

Use the following procedure to determine memory usage for this allocation.

1. Going through the scan group channel lists of all 10 scan groups, check off the channel decades that are associated with the channels in the scan group channel list. A check list of channel decades is provided below. For example, for a scan group channel list of C9 C12 C30..45 the channel decades C0..9, C10..12, C30..39, and C40..49 would be checked.

6j/Memory Usage

LIST OF CHANNEL DECADES

C00..09 _	C100..109 _	C200..209 _	C300..309 _
C10..19 _	C110..119 _	C210..219 _	C310..319 _
C20..29 _	C120..129 _	C220..229 _	C320..329 _
C30..39 _	C130..139 _	C230..239 _	C330..339 _
C40..49 _	C140..149 _	C240..249 _	C340..349 _
C50..59 _	C150..159 _	C250..259 _	C350..359 _
C60..69 _	C160..169 _	C260..269 _	C360..369 _
C70..79 _	C170..179 _	C270..279 _	C370..379 _
C80..89 _	C180..189 _	C280..289 _	C380..389 _
C90..99 _	C190..199 _	C290..299 _	C390..399 _
C400..409 _	C500..509 _	C600..609 _	C700..709 _
C410..419 _	C510..519 _	C610..619 _	C710..719 _
C420..429 _	C520..529 _	C620..629 _	C720..729 _
C430..439 _	C530..539 _	C630..639 _	C730..739 _
C440..449 _	C540..549 _	C640..649 _	C740..749 _
C450..459 _	C550..559 _	C650..659 _	C750..759 _
C460..469 _	C560..569 _	C660..669 _	C760..769 _
C470..479 _	C570..579 _	C670..679 _	C770..779 _
C480..489 _	C580..589 _	C680..689 _	C780..789 _
C490..499 _	C590..599 _	C690..699 _	C790..799 _
C800..809 _	C900..909 _	C1000..1009 _	C1100..1109 _
C810..819 _	C910..919 _	C1010..1019 _	C1110..1119 _
C820..829 _	C920..929 _	C1020..1029 _	C1120..1129 _
C830..839 _	C930..939 _	C1030..1039 _	C1130..1139 _
C840..849 _	C940..949 _	C1040..1049 _	C1140..1149 _
C850..859 _	C950..959 _	C1050..1059 _	C1150..1159 _
C860..869 _	C960..969 _	C1060..1069 _	C1160..1169 _
C870..879 _	C970..979 _	C1070..1079 _	C1170..1179 _
C880..889 _	C980..989 _	C1080..1089 _	C1180..1189 _
C890..899 _	C990..999 _	C1090..1099 _	C1190..1199 _

6j/Memory Usage

C1200..1209 _ C1300..1309 _ C1400..1409 _ C1500..1509 _
C1210..1219 _ C1310..1319 _ C1410..1419 _ C1510..1519 _
C1220..1229 _ C1320..1329 _ C1420..1429 _ C1520..1529 _
C1230..1239 _ C1330..1339 _ C1430..1439 _ C1530..1539 _
C1240..1249 _ C1340..1349 _ C1440..1449 _ C1540..1549 _
C1250..1259 _ C1350..1359 _ C1450..1459 _ C1550..1559 _
C1260..1269 _ C1360..1369 _ C1460..1469 _ C1560..1569 _
C1270..1279 _ C1370..1379 _ C1470..1479 _ C1570..1579 _
C1280..1289 _ C1380..1389 _ C1480..1489 _ C1580..1589 _
C1290..1299 _ C1390..1399 _ C1490..1499 _ C1590..1599 _

2. For each channel listed in the scan group channel lists of all 10 scan groups, do the following. If there is a channel procedure associated with that channel, then for each channel listed in the channel procedure, check off the respective channel decade.
3. Count up the number of checked off channel decades. The amount of memory required for the storage allocation of the channel decades is:

[Channel Decades X 10] bytes]

4. Record total number of bytes needed for channel value storage in the Memory Usage Summary Table.

H. UNACKNOWLEDGED ALARM MESSAGE REQUIREMENTS

Calculate memory required by adding the number of bytes needed for unacknowledged alarm messages. Then record the total number of bytes needed for unacknowledged alarm message in the Memory Usage Summary Table.

ITEM	REQUIRED BYTES
Each unacknowledged alarm message	23

MEMORY USAGE SUMMARY TABLE

Add memory usage for categories A-H.

USAGE AREA	REQUIRED BYTES
A. CHANNEL PROGRAMMING	_____
C. ALARM LIST PROGRAMMING	_____
B. SCAN GROUP PROGRAMMING	_____
D. PLOT PROGRAMMING	_____
E. OUTPUT DEVICE PROGRAMMING	_____
F. INTERPOLATION TABLE PROGRAMMING	_____
G. CHANNEL VALUE AND INFORMATION STORAGE	_____
H. UNACKNOWLEDGED ALARM MESSAGE STORAGE	_____
Total User Memory	_____
	=====

COMPARE MEMORY REQUIRED TO MEMORY AVAILABLE

Verify that the user program will fit within the 2280B or 2285B user program memory area. This is done by looking at the following table. If your total amount of user memory usage is over the maximum amount of user memory usage shown in the table, then you need to reduce your system needs.

6j/Memory Usage

MAXIMUM AMOUNT OF USER MEMORY USAGE

<u>2280 Series Data Logger</u>	<u>Maximum Amount of User Memory Usage</u>
2280B	25,890
2285B	14,025

REDUCING MEMORY USAGE

If the total amount of user memory usage exceeds the maximum allowed, refer to the steps listed below:

1. Remove any unused channel programs, scan groups, alarm lists, plot programming, or interpolation tables
2. Shorten or eliminate channel labels, scan group labels, or alarm messages
3. Don't program channel units; allowing the default units to be used
4. Remove spaced out of scan group channel lists, channel expressions, and channel procedures (spaces are not required)
5. Combine individually programmed channels into channel groups (this step can be your biggest saver of user program space)
6. Use an alarm list number for as many channels as possible instead of one alarm list number per channel.

INDEX

2280 Series Data Loggers 1-6
2280 Series Data Logging System 2-6
2280A Documentation 6e-1
2281A-402 Extender Chassis Cable 402-1
2281A-403 Connector Pair for -402 Cable 403-1
2281A-431 Extender Chassis Power Supply 431-1
2285B Documentation 6d-1

AC Voltage 5b-1
AC Voltage Input Connector (2280A-160) 160-1
AC Voltage Measurement 2-20
Accessories 2-17
A/D Converter 3-15
Addressing 3-15
Advanced Math Processor (2280A-211) 211-1
Analog Output 3-18, 5j-1, 170-1, 2-23
Applications 2-18
ASCII/IEEE-488 6c-1

Battery Operation 3-13

Cartridge Tape Format 6i-1
 Cartridge Tape Handling 6h-1
 Connector Assemblies 2-12
 Connector Pinouts 6f-1
 Control Algorithms 5j-7
 Counter/Totalizer 3-18, 167-1
 Current Input Connector (2280A-171) 171-1
 Current Measurement 2-20, 5c-1

 Data Logging Applications 2
 Data Logging Systems 2-3
 DC Cartridge Tape (2280A-214) 214-1
 DC Voltage 5b-7, 2-20
 Digital and Status Inputs 2-22
 Digital Input 5h-1
 Digital I/O Assembly 3-16, 168-1
 Digital/Status Input Connector (2280A-179) 179-1
 Distributed System Design 2-6

 Extender Chassis 2-15, 3-14
 External Connections 3-20

 Features 2-29
 Frequency Measurement 2-22, 5e-1
 Front Panel Doors 3-11
 Fuse Replacement 3-22

 General Cleaning 3-23
 General Information 3-3
 Glossary 6a-1

 Hardware Configuration 3-13
 High Performance A/D Converter (2280A-161) 161-1
 How the 2280 Series Data Loggers Differ 2-29
 How to Use the Manual Set 1-6

 IEEE-488 Interface 3-19, 342-1
 Installation - Options and Accessories
 Interface Option Assemblies 2-14
 Isothermal Input (2280A-175) 175-1

Jumpers 3-19

Line Voltage 3-11

Mainframe 2-8

Master Alarm Output/Trigger Input 3-21

Memory Usage 6j-1

Menu System 2-24

Menus 2-27

New Installation 3-15

Notation Conventions 1-7

Operator Maintenance 3-22

Option Assemblies 2-8, 3-15

Organization 1-4

Paper Replacement 3-25

Permissible Option Configurations 2-30

Physical Installation 3-7

Physical Layout 3-4

Power Connections 3-11

Programming 3-21

Programming Form 2-24

Rack Mounting 3-8

Resistance Measurement 2-21, 5d-1

RS-232-C Interface (2280A-341) 341-1

RTD/Resistance Input Connector (2280B-177) 177-1

RTD/Resistance Scanner (2280B-163) 163-1

RTDs 5a-13

Sales and Service Centers 6b-1
 Selecting a Location 3-7
 Serial Link Option Assemblies 2-9
 Service Information 3-27
 Service Manual 1-7
 Shipping 3-3
 Status Input 5h-9
 Status Output 5i-1, 2-23
 Status Output Connector (2280A-169) 169-1
 Strain Measurement 2-22, 5g-1
 Summary 2-31
 Switch Selections 3-19
 System Guide 1-6
 System Specifications 6g-1

 Temperature Measurement 5a
 Temperature Measurement Using RTDs 2-19
 Temperature Measurement Using Thermistors 2-20
 Temperature Measurement Using Thermocouples 2-18
 Thermistors 5a-39
 Thermocouple/DC Volts Scanner (2280A-162) 162-1
 Thermocouples 5a-1
 Totalizing Measurement 2-22, 5f-1
 Transducer Excitation (2280A-164) 164-1
 Transducer Excitation Connector (2280A-174) 174-1

 Unpacking 3-4
 User Guide 1-6
 Using the 2280
 Using the 2280 Series Data Logger 2-23

 Voltage Input Connector (2280A-176) 176-1
 Voltage Measurement 5b

 Y2044 Rack Slide Kit Y2044-1
 Y2045 Rack Mount Kit Y2045-1
 Y2047 Serial Link Multiconnect Y2047-1