

## A Wheatstone Bridge for the Computer Age

Les Huntley  
Metrology Manager  
John Fluke Mfg. Co., Inc.  
Everett, Washington 98206

### ABSTRACT

Guildline's 9975 Current Comparator Resistance Bridge [3, 4] provides excellent accuracy for values smaller than 10 kilohm, but is a manual instrument which requires a skilled operator. (Another system for making automated measurements of resistance in this range is presented at this conference [5].) Furthermore, while it excels in the measurement of low-valued resistors, its performance degrades rapidly at values above about 100 kilohm. Instruments for measuring high valued resistors automatically and with the desired accuracy were not available at the time this effort was undertaken. This paper describes a modification of the familiar Wheatstone bridge circuit which has the desired qualities.

### INTRODUCTION

Application of Process Metrology [1, 2] to the calibration control of the 5700A Multifunction Calibrator forced Fluke's Standards Laboratory to find means for rapidly and automatically verifying all ranges, levels and functions of the instrument. Since the calibrator contains internal resistance standards ranging in value from 1 ohm to 100 Megohm, and the internal metrology of the 5700A makes it possible to measure these resistors with very good accuracy, it was essential that the Standards Laboratory find means for making these same measurements with even greater accuracy.

The Wheatstone Bridge, the venerable workhorse of the resistance measuring laboratory, has seemed to be a candidate for inevitable replacement by modern, computer controlled measuring systems. A recent revision of the traditional circuit, in which two of the resistors are replaced by precision direct voltage calibrators, admirably adapts the Wheatstone bridge to the computer age. Addition of a bus-controlled switch for connecting standards and unknowns makes this a completely automated resistance measuring system, and provides means for comparing 4-terminal resistors. This paper describes the implementation in the Fluke Primary Standards Laboratory and presents results for measurement of resistors in the range 100 ohms to 290 Megohms.

### THEORY

The Wheatstone bridge circuit (Figure 1) has been widely used for many purposes. Its equations are simple:

$$i_1 = V / (R_1 + R_2)$$

$$i_2 = V / (R_3 + R_x)$$

At null,

$$i_1 R_2 = i_2 R_x$$

from which, substituting the currents,

$$R_x / R_2 = R_3 / R_1$$

In a common configuration,  $R_2$  is an adjustable resistor which is adjusted to produce a null reading at the detector. Often  $R_1$  and/or  $R_3$  can also be adjusted to vary the bridge ratio,  $R_3/R_1$ , and thus the range of resistance which can be measured with a given resistance range at  $R_2$ .

While this arrangement is well suited and much used for manual measurements of two-terminal resistors, it requires considerable modification (into a Kelvin bridge, for example) to be made compatible with four-terminal resistors. Equally serious in the present application is the fact that computer switchable, infinitely (or nearly so) adjustable resistance standards are not available. And, because of the inherent instability of resistors, if they were available, they would require frequent, highly accurate calibrations to maintain their accuracy.

In the process of looking at other nulling circuits, notably the twin-tee and transformer ratio arm bridges, it was realized that the Wheatstone circuit could operate very nicely with two resistors replaced by voltage sources. The basic idea is presented in Figure 2. At detector null, the equations are:

$$i = (V_1 + V_2) / (R_1 + R_2)$$

$$V_1 = iR_1 = (V_1 + V_2) R_1 / (R_1 + R_2)$$

$$V_2 = iR_2 = (V_1 + V_2) R_2 / (R_1 + R_2)$$

from which is obtained

$$V_1/V_2 = R_1/R_2$$

If one (or both) voltage source is sufficiently adjustable, the null condition can be obtained with arbitrary  $R_1$  and  $R_2$ . If it (or they) and the detector are computer controllable, the nulling process can be automated. If means can be found for automatically inserting standard and test resistors into the circuit for measurement, the whole measurement process can be completely automated.

A measurement is accomplished by connecting the standard as  $R_1$  then adjusting  $V_1$  for a null on the detector. This provides the first equation:

$$V_1/V_2 = R_S/R_2 \quad [1]$$

The test resistor is then substituted for the standard and  $V_1$  adjusted to restore null,

$$V_1'/V_2 = R_X/R_2 \quad [2]$$

Dividing [2] by [1]

$$V_1'/V_1 = R_X/R_S$$

and the value of the test resistor is obtained as a ratio of voltages times the value of the standard resistor. If  $V_1$  is provided by a highly linear variable voltage source, such as a modern calibrator utilizing a pulse-width-modulated DAC, the accuracy can be quite acceptably high.

Figure 3 shows that leakages to ground cannot affect the measurements. Resistance from the source end of  $R_1$  to ground shunts the source and has no effect other than increasing the current drawn from the source. Resistance from the detector end of  $R_1$  to ground shunts the detector, and may decrease sensitivity but cannot affect the null condition. From the symmetry of the circuit, it is apparent that the same conditions apply to  $R_2$ .

It should be kept in mind that this circuit provides a three-terminal measurement of resistance whether or not it is in fact a two-terminal or four-terminal device. This fact has implications for the measurement of high valued resistors for use in a two-terminal configuration.

As drawn, the circuits apply only to two-terminal resistors. Figure 4 shows the modifications needed to accommodate those with four-terminals. Also shown is the method for dealing with changes in connection resistance when resistors are substituted into the measuring circuit. The connection between the two resistors is made between the "current" or "source" terminals, and the voltage sources sense externally through leads attached to appropriate terminals on the resistors.

When the test resistor is substituted for the standard, there will be some change in connection resistance, as well as a change in the resistance between the "source" and "sense" terminals of the resistors. This small change in resistance can cause errors in measurement of resistors smaller than 10 to 100 kilohm, depending upon the accuracy desired and the magnitude of resistance change. These changes can be compensated for by making two null measurements for each resistor, one with the detector connected to point "a" and the other to point "b".

With the detector connected to point a,

$$V_a/V_2 = R_S / (R_2 + R_a) \quad [3]$$

where  $R_a$  is all the resistance between the sense-source connection points on the two resistors. With the detector connected to point b,

$$V_a'/V_2 = (R_S + R_a)/R_2 \quad [4]$$

Dividing equation [4] by [3],

$$V_a'/V_a = [(R_S + R_a)/R_2] [(R_2 + R_a)/R_S]$$

which can be reduced to

$$(V_a'/V_a - 1)R_2R_S = R_a(R_2 + R_S) + R_a^2$$

With  $R_2$  known to sufficient accuracy, this quadratic equation can be solved by the usual means

$$R_a = 0.5\{-(R_2 + R_S) + \text{Sqr}[(R_2 + R_S)^2 + 4R_2R_S(V_a'/V_a - 1)]\}$$

With the test resistor connected in place of the standard, and with  $R_b$  representing the connection resistance and  $V_b$  and  $V_b'$  the settings of  $V_1$ , a similar set of equations is obtained. Solving for  $R_b$ ,

$$R_b = 0.5\{-(R_2 + R_X) + \text{Sqr}[(R_2 + R_X)^2 + 4R_2R_X(V_b'/V_b - 1)]\}$$

We can solve for the value of the test resistance by observing that

$$V_b'/V_a' = (R_X + R_b) / (R_S + R_a)$$

from which is obtained

$$R_X = (V_b'/V_a') (R_S + R_a) - R_b$$

The value of  $R_2$  need be known only approximately when  $R_a$  and  $R_b$  are small compared to  $R_X$  and  $R_S$ . When they are not small, then  $R_2$  must be known with sufficient accuracy to make the error caused by differences in  $R_a$  and  $R_b$  insignificant. However, even when they are not small, the value of  $R_2$  need not be known with great accuracy when the test and standard resistors are nearly the same value and the connection resistances are nearly equal.

When the test and standard resistors are of approximately equal values, a measurement can be made quite simply by setting the two voltages equal, then adjusting one of the voltages to drive the detector to null. Measurements should be repeated with the voltages reversed and the results averaged to eliminate the effects of detector zero offset and thermal emfs in the circuit.

Starting with a known standard, e.g., an ESI SR-104 10 kilohm resistor, and stepping to higher values presents additional challenges. A typical calibration of this sort is encountered in calibrating the Fluke 5450A Resistance Calibrator and the internal resistors in the Fluke 5700A Multifunction Calibrator. Here we start with a known 10 kilohm standard and step up in 1, 1.9 sequence to 100 Megohm.  $R_2$  in this case is a Fluke 5450A Resistance calibrator which has all the resistance values needed for the measurements.

We start with the ESI SR-104 10 kilohm standard and set  $R_2$  to 19 kilohm. It is convenient to maintain  $V_2$  at 10 volts throughout the tests and vary  $V_1$  as required for null. Since the voltages will be in the same ratio as the resistances, approximately 5.263158 V is required for a null at the detector. Suppose the standard resistor is actually 10.1 kilohm and the tare resistor is exactly 19 kilohm. Neglecting the effect of the detector, which is assumed to have very large input resistance, the current flowing through the two resistors is simply

$$i = (V_1 + V_2)/(R_1 + R_2) = 0.524507 \text{ mA.}$$

The voltage across the 19 kilohm resistor is thus 9.965636 V, so the detector will read -0.034364 V. How should we adjust  $V_1$  to drive the detector to null? If  $R_2$  is known to be exactly 19 kilohm, we can compute the current needed for exactly 10 V drop across that resistor. It is 0.526316 ma. Dividing the **required** current by the **computed** current provides a correction factor to be applied to the total voltage, in this case, 1.003448. We calculate the required  $V_1$  from the total voltage times the correction factor

$$10 + V_1 = (15.263158) (1.003448)$$

from which is obtained  $V_1 = 5.315789$  V. Setting  $V_1$  to this value will drive the detector to null with the assumed values of voltage and resistance. When  $V_2$  and  $R_2$  are known only approximately, an exact null will not be obtained at the first try, and a new  $V_1$  should be computed and applied. The null will be obtained after only a few iterations.

To avoid needless repetition due to noise in the measurements, it is useful to bring the null to within some limiting value, e.g., 5 microvolts, then correct  $V_1$  by subtracting a fraction of the residual voltage. A convenient and approximately correct fraction for this purpose is given by the ratio of  $R_2$  to the total resistance,  $R_1 + R_2$ , in the example above, 0.655. If the residual is 5 microvolts, 3.28 microvolts will be subtracted from  $V_1$  to obtain a final value for use in calculations.

Continuing with the step-up from 10 kilohm, we have obtained values Of  $V_a$  and  $V_a'$  for the 19 kilohm tare and the 10 kilohm standard. We must at this point reverse the polarities of the voltages and repeat the measurements to eliminate the effects of thermal emfs and any offset in the detector zero. Final values to be used in calculations will be the average of the results with positive and negative voltages applied.

We now replace the standard resistor with the 19 kilohm resistor to be calibrated and obtain values for  $V_b$  and  $V_b'$ , then the value of the test resistor can be calculated from equation [5]. Stepping up to 100 kilohms from 19 kilohms is accomplished exactly as before, with the freshly calibrated 19 kilohm resistor serving as the standard. The accuracy of the calibrated values, referred to the standard value, is determined entirely by the accuracy of the voltage ratios obtained from the calibrator's DAC, except for noise and random effects in the measurements.

Experience has shown that values up 10 Megohm can be measured in this way, with quite good accuracy. Bias currents from the detector place a practical limit on the values of resistance which can be measured in this way, however. The detector input "sees" a resistance equal to the standard (or test) and tare resistors in parallel. When this value is too high, a significant voltage, which has the appearance of a zero offset, appears at the input to the detector. Because the currents are not particularly stable and time constants are long, it is very difficult to obtain sufficiently accurate readings. In such cases, it is best to maintain  $R_2$  at 1 or 10 Megohm, and  $V_2$  at 10 V, reduce  $V_1$  as required for null, and rely upon the ratio accuracy of the calibrator's DAC.

## IMPLEMENTATION

The block diagram of Figure 5 shows the configuration of the modified Wheatstone bridge as implemented for the calibration of 5450A Resistance Calibrators and resistance ranges of the 5700A Multifunction Calibrator. All the instruments and the reversing switch operate under control of the 1722A Instrument Controller. Data is stored on floppy disk for future processing and results are printed, as a data sheet, on the printer. The 8506A was chosen for the null detector simply because it was on hand and has the needed resolution -- 0.1 microvolt.

It has been found that the connections shown give the best results. The source resistance of the 732A and the 5440B on the 10 volt range is only a few milliohm, so both the 5450A and the test instrument operate with their "low" terminals at essentially ground potential. It is important to get the guarding right -- the arrangement shown has worked well for us.

The reversing switch, for reversing the polarity of the 732A, was constructed using low-thermal latching relays of the same kind as are used in the DataProof scanners. It is important that this switch have low, repeatable contact resistance and low thermal emfs, otherwise errors can be introduced into the measurements. An important assumption is that  $V_2$  and  $R_2'$  the 732A and 5450A, remain constant during a measurement.

Ground in the circuit is the ground connection on the 5440B. A fixture was made which plugs into the "Source" and "Sense" "Low" terminals, connecting them together. Using internal guard ties these to the "Guard" terminal, which is strapped to the "Ground" terminal. Two additional binding posts are provided on the fixture, to which the leads from the 732A and 8506A are attached.

The calibration begins with the ESI SR-104 connected in place of the 5700A and the 5450A set to 10 kilohm. Measurements ( $V_a$  and  $V_a'$ ) are made in this configuration, then the 5700A is connected as the test resistor and the measurements made to calibrate its 10 kilohm resistor. From then on, the measurements to 1 Megohm proceeds as discussed above.

Measurements above 1 Megohm are made with the 5450A set to 1 Megohm and the positions of the 5700A and 5450A reversed. (This is necessary because it is not possible to adjust the 732A output voltage, and voltages as small as 0.1 volts must be applied to the 1 Megohm resistor in order to null 100 Megohm with 10 volts applied.) With this arrangement of hardware, and with a reconfiguring of the circuit for measurements above 1 Megohm, it is easily possible to complete the calibration of the 5700A resistors at 10 kilohm and above in 30 minutes.

In some measurement situations, it is essential that  $V_2$  be adjusted to values smaller than 10 volts. In such cases, we have replaced the 732A and reversing switch with a second 5440 calibrator. (This calibrator will not work well with its High terminals tied to ground, so the Low terminals are grounded and negative voltages are output from the calibrator.) With this arrangement, external sense of the voltage applied to the 5450A is possible, eliminating any problems which might be caused by reversing-switch nonrepeatability. It should be noted that it is not strictly necessary that the positive and

negative voltages be identical for either calibrator. What is necessary is that these voltages repeat with adequate precision from one measurement to another.

One situation in which  $V_2$  must be smaller than 10 volts arises in the measurement of resistors smaller than 10 kilohm. In such situations accuracy degradation caused by power dissipation will limit the applied voltage. Resistors as small as 100 ohms can be measured with good accuracy using the 5440B at a setting of 1 volt on the 11 volt range.

One final configuration will be described. The block diagram of Figure 6 shows the arrangement for automated calibration of a number of resistors of nominally equal value. This situation arises when we participate in the NIST 10 kilohm RMAP, and in production testing of 742A resistors.

In this configuration, all test and standard resistor "Source High" terminals are tied together by a wiring harness, and then tied to the "Source High" terminal of the tare standard. The 5440B "Output" and "Sense" "High" terminals are connected to the Scanner "B Output" terminals, and a particular resistor to be measured is then connected through one of the Scanner channels. The A "Input High" terminal is connected to the Scanner "A Output High" terminal, and connection is made to the resistor "Sense High" terminal through another channel of the Scanner.

Channel 8 on the Scanner is connected to the tare standard "Sense High" terminal, and is used in evaluating  $R_a$  and  $R_b$  in the measurement Process. The Scanner is also used for this purpose in the other configurations, even though that was not discussed. The switch shown in Figures 2 - 4 is actually the DataProof Scanner.

## UNCERTAINTIES

As discussed in the Theory section above, this measuring circuit eliminates the major source of systematic error in high-valued resistor measurement, leakage resistance to ground or case. The most significant error contributor for low-valued resistor measurement, connection resistance, is measured and its effect eliminated from the result. Other contributors are controlled by proper attention to shielding, guarding and grounding. The remaining sources of error are DAC linearity error, the standard's calibration error and random noise in resistors, sources and detector.

One standard deviation of measurements made as part of the NIST RMAP is typically 0.043 ppm. Since each RMAP measurement is the average of five measurements, the standard deviation of a single measurement can be computed to be 0.097 ppm. In comparing nearly identical resistors in this way, measurements are unbiased, and DAC linearity error has no effect. Measurement uncertainty is thus determined almost entirely by measurement precision and the standard's uncertainty. Uncertainty assigned to the Fluke 10 kilohm resistance standard in the RMAP is typically just under 0.25 ppm.

In stepping up and down from a standard value, DAC linearity becomes an issue. Linearity spec for the 5440B for 0 to 11 volts on the 11 volt range is  $\pm (0.5 \text{ ppm} + 1.5 \mu\text{V})$ . In stepping from 10 kilohm to 19 kilohm, voltages used are 10 V and 5.26 V. Linearity uncertainty is  $\pm (0.5 + 0.28) \text{ ppm} = 0.78 \text{ ppm}$ . Total uncertainty for the 19 kilohm resistor is thus

$$U_t = \text{Sqr}(U_s^2 + U_1^2 + U_2^2 + U_L^2)$$

where

$$U_s = \text{standard uncertainty} = 0.5 \text{ ppm}$$

$$U_1 = \text{random uncertainty at 10 kilohm} = 0.4 \text{ ppm}$$

$$U_2 = \text{random uncertainty at 19 kilohm} = 0.3 \text{ ppm}$$

$$U_L = \text{linearity uncertainty} = 0.78 \text{ ppm}$$

$$U_t = 1.05 \text{ ppm}$$

using typical standard deviations, the uncertainty assigned to our standard 10 kilohm resistor, and the linearity spec of the 5440B. [It should be noted that statisticians do not approve of this method of combining uncertainties. But under the right conditions -- normal distributions, independent error sources and equal confidence levels -- this method will always overestimate uncertainty. It is in this sense, "conservative".]

In stepping to higher values, it would not be proper to simply r.s.s. the 19 kilohm uncertainty, for example, with the random and linearity uncertainties for the next step-up. That would not properly account for the linearity error, which will not be independent from step-up to step-up. We sum the linearity errors, then combine the result with the random errors by r.s.s. Table I shows typical uncertainties for the calibration of 5450A and 5700A resistors in the range 10 kilohm to 100 Megohm, and another instrument to 290 Megohm.

## SUMMARY

This paper has described a modification of the Wheatstone bridge circuit which makes it suitable for automatic highly accurate measurements of higher valued resistors. The system used by the Fluke Standards Laboratory for calibrating 5700A and 5450A resistors was described, as was an arrangement for measuring several resistors of the same value. An analysis of the uncertainties encountered in the use of the automated Wheatstone circuit indicates adequate accuracy to support calibrators which are now generally available.

## REFERENCES

1. Les Huntley, "Process Metrology and the Automated Factory," *presented at the 1986 Test and Measurement World Expo, April 1986.*
2. Les Huntley and Jill Ellen Murray, "An Application of Process Metrology to the Automatic Calibration of Instruments," *Proceedings of the Measurement Science Conference Symposium and Workshop, January 1987.*
3. M. P. McMartin and N. L. Kusters, "A Direct Current Comparator Ratio Bridge for Four Terminal Resistance Measurements," *IEEE Trans. I&M, Vol. IM-15, pp. 212-220, Dec. 1966.*
4. J. Sutcliffe, "A New D.C. Resistance Bridge and D.C. Potentiometer Based on the Kusters Current Comparator," *ISA Preprint No. M5-4-MESTIND-67, September 1967.*
5. Neil Faulkner, "An Automated System for the Comparison of Resistance Standards from 1 Ohm to Several Kilohms," *Proceedings of the Measurement Science Conference Symposium and Workshop, January 1992.*

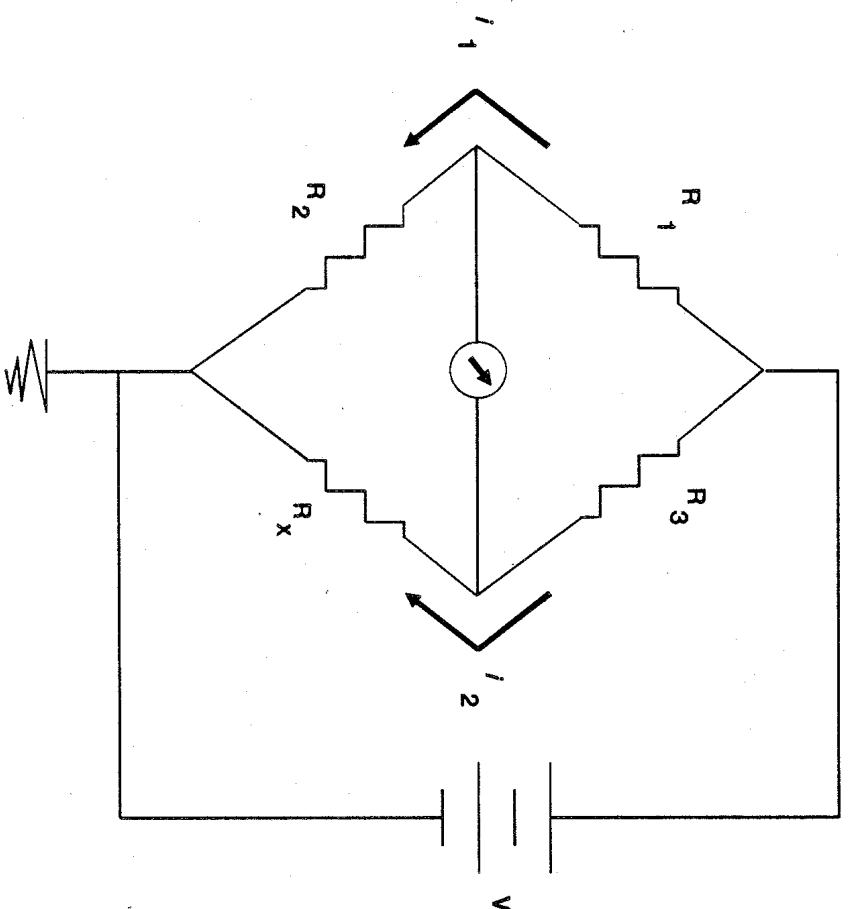

$$R_x/R_3 = R_2/R_1 \text{ At Null}$$

Figure 1. Basic Wheatstone Bridge Circuit

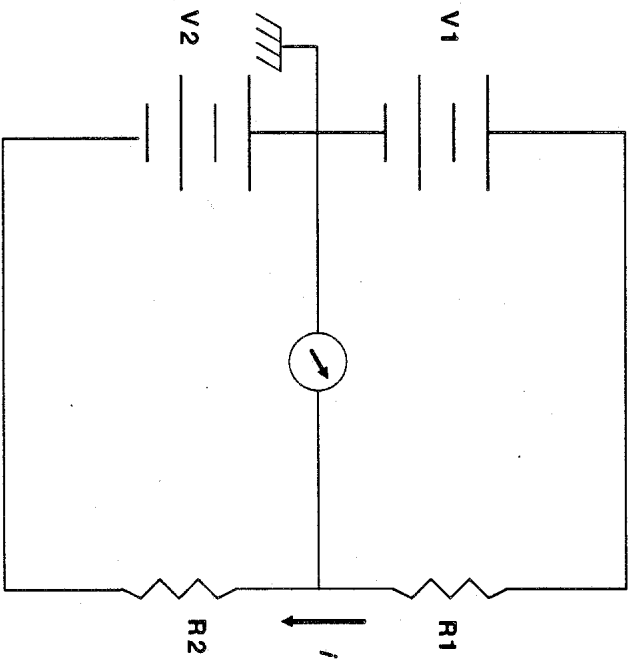

$$R1/R2 = V1/V2 \text{ At Null}$$

Figure 2. Modified Wheatstone Bridge Circuit



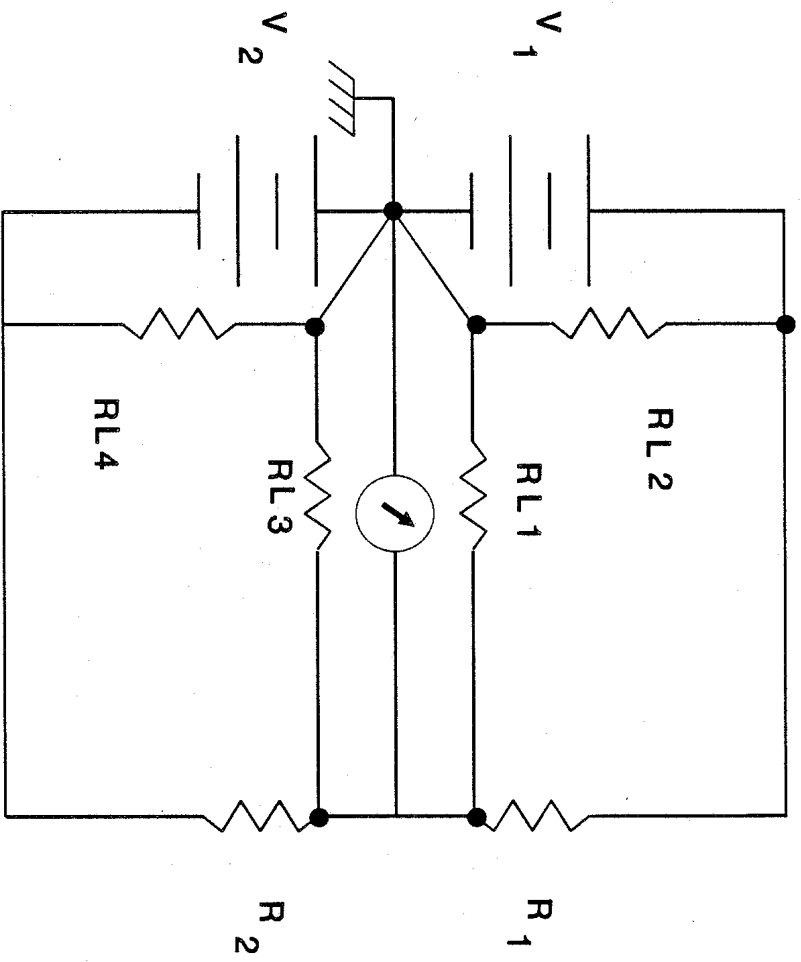

Figure 3. Modified Wheatstone Bridge With Leakage Resistance

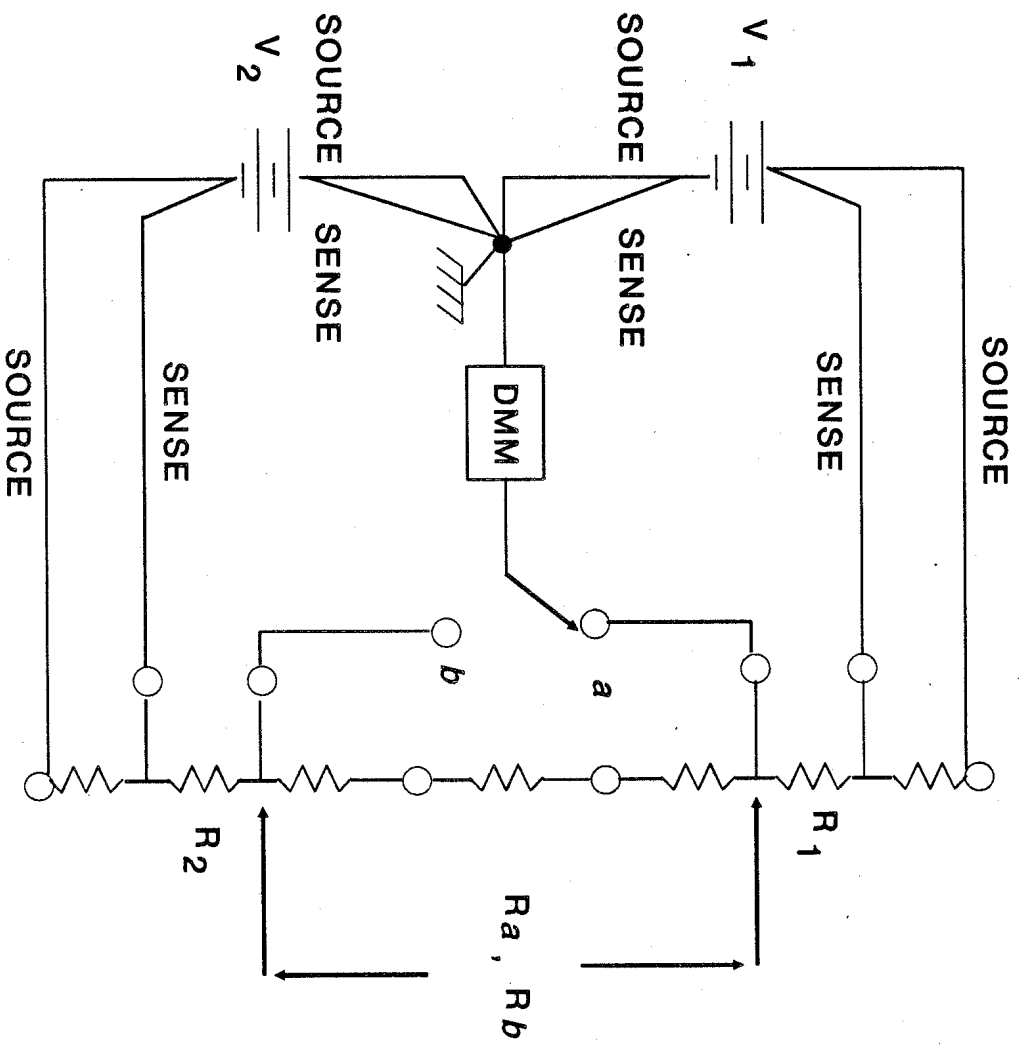

Figure 4. Modified Wheatstone Bridge Configured For 4-Terminal Measurements and Measurement of Connection Resistance

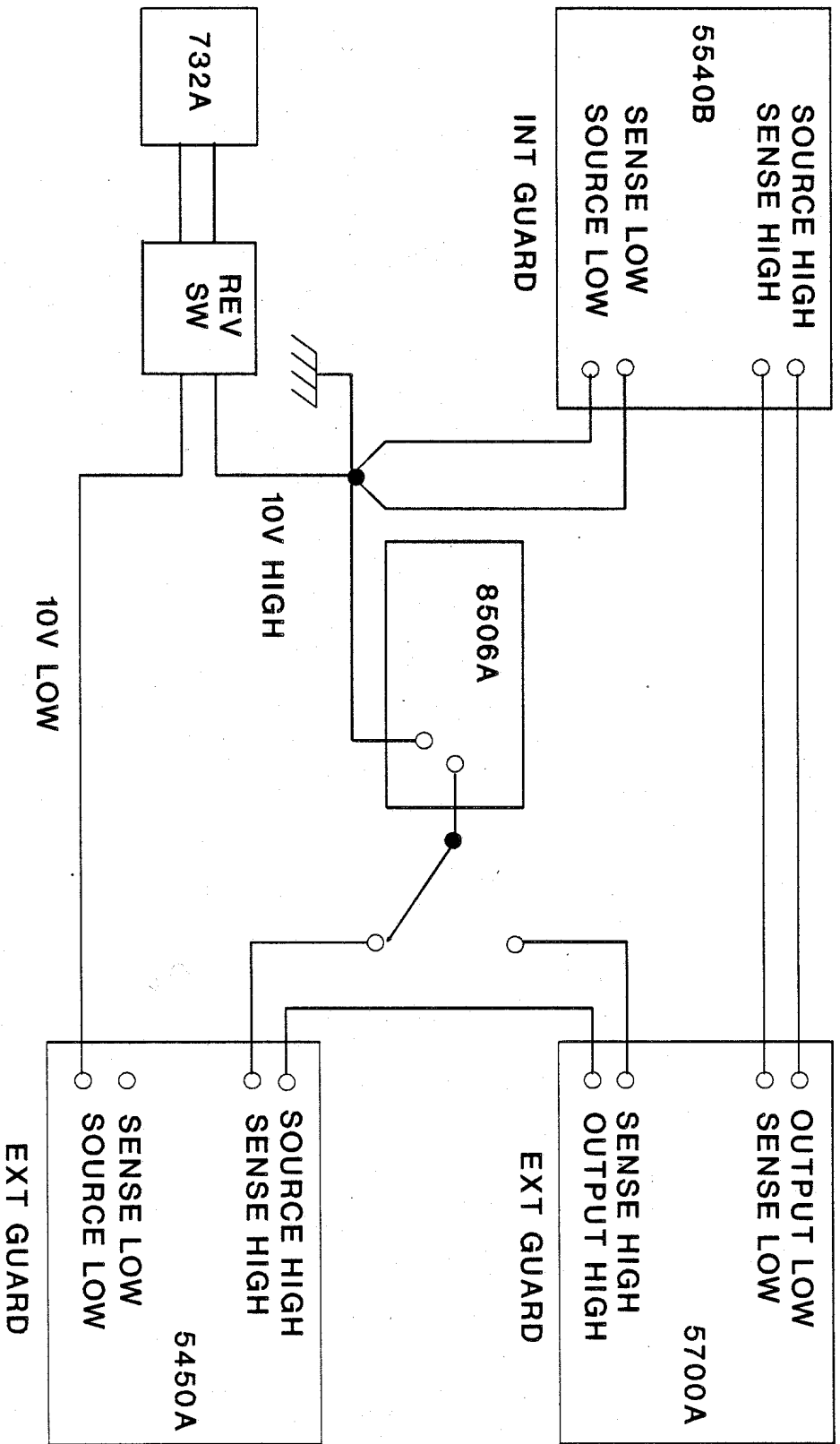

Figure 5. Block Diagram of Modified Wheatstone Bridge Implemented at Fluke

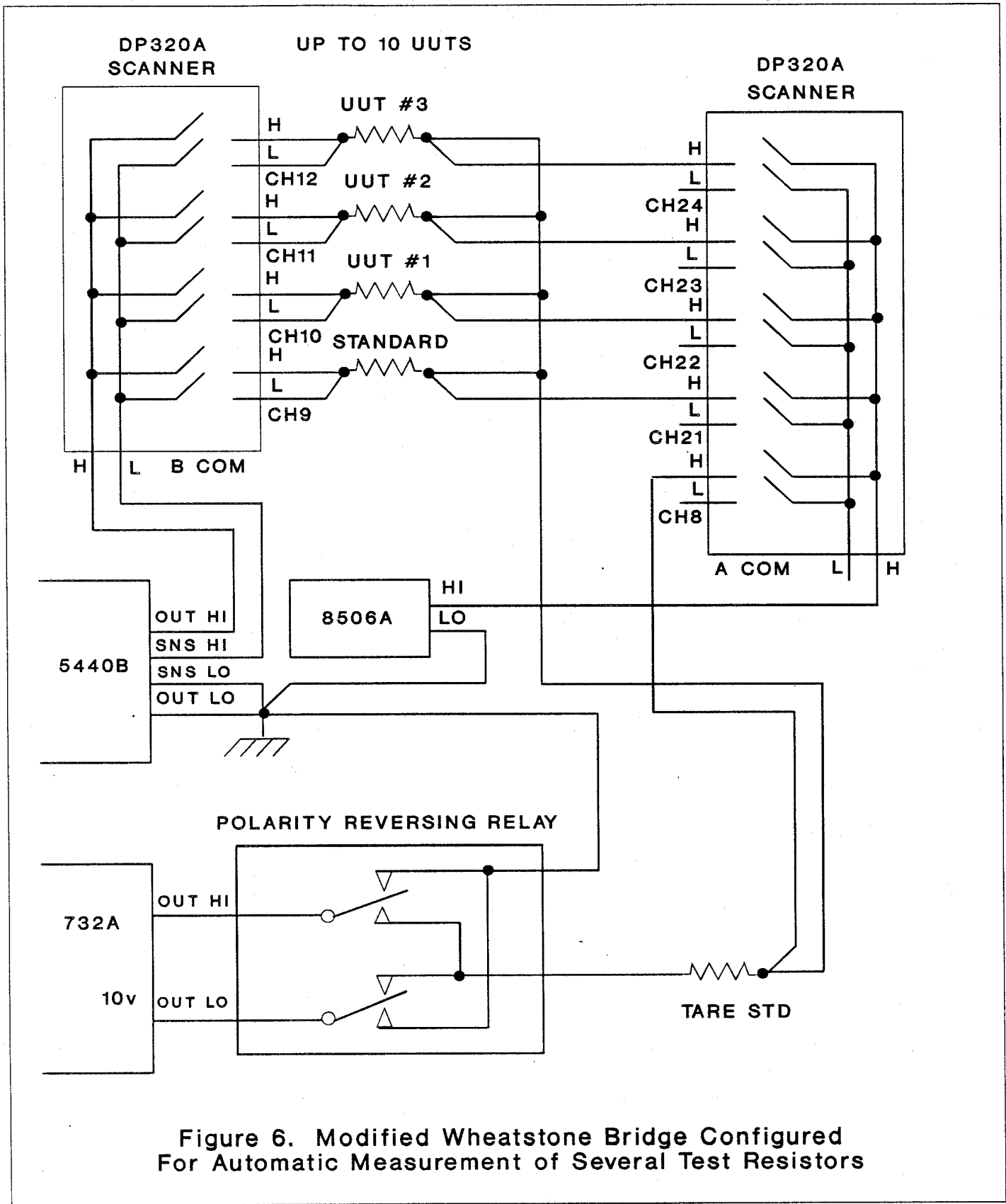

Figure 6. Modified Wheatstone Bridge Configured For Automatic Measurement of Several Test Resistors

<u>VALUE (OHM)</u>	<b>TOTAL UNCERT (ppm)</b>	<b>5700A <u>24 HR. SPEC</u></b>
10K	0.7	9
19K	2.2	9
100K	2.8	11
190K	2.9	11
1.0M	4.1	16
1.9M	5.7	17
10M	6.8	33
19M	8.2	43
100M	20.1	110
290M	27.3	NA

**Table 1. Typical Uncertainties for Measurement of High-Valued Resistors**