

**Type 1644
Megohm Bridge
User and Service Manual**

Copyright © 1988



IET LABS, INC.
formerly manufacturer by
GenRad

534 Main Street, Westbury, NY 11590 www.ietlabs.com
TEL: (516) 334-5959 • (800) 899-8438 • FAX: (516) 334-5988



IET LABS, INC.

534 Main Street, Westbury, NY 11590

Tel (516) 334-5959 (800) 899-8438 Fax (516) 334-5988 <http://www.ietlabs.com>

Manual & Programmable Standards, Substituters, & Test Instruments

- New Products
 - Find a Product
 - Technical Applications
 - Request a Quote
 - Price List
 - Place an Order
 - Request a Catalog
 - Contact Us
 - About IET
- If you need products or service by Genrad, esi, Biddle, or others.

STANDARDS, DECADES STROBES

Formerly Manufactured By:
QuadTech/GenRad(General Radio)

Now being manufactured, serviced, calibrated, and fully supported by IET LABS

COST-EFFECTIVE QUALITY STANDARD OR CUSTOM SOLUTION
R-L-C•RTD•VOLTAGE CURRENT•PROCESS CONTROL

Product Area of Interest



Widest Choice of Decades

IET is compliant with ISO 9001, ISO/IEC 17025, ANSI Z540-1-1994, and MIL-STD-45662A

Calibration Test Measurement Metrology

[Find a Products](#) | [Technical Applications](#) | [Request a Quote](#) | [Place an Order](#) | [Free Offer](#) | [Request a Catalog](#) | [Contact Us](#)

© Copyright 1999 - 2001 IET Labs, Inc. All rights reserved.
Problems or Comments? Contact webmaster@ietlabs.com

To navigate our easy to use website for quick access to specifications and prices:

1. Select **Find a Product** to go to a convenient scrolling thumbnail catalog and then to detailed data sheets as desired; or:
2. Select **STANDARDS DECADES STROBES** for products formerly manufactured by **GenRad (General Radio)** or **QuadTech**.

Since 1976, IET labs has had a long-standing commitment to **conform the instruments and standards we offer to the customer's needs** rather than to have the customer settle for what is available. We devote our customer service and applications entirely to the customer's satisfaction in the quality standards, test instruments and calibration service we provide.

- Combinations of functions, special ranges, ratings, or accuracies.
- Replacement for discontinued models from other manufacturers.
- Calibration and repair services - NIST traceable.
- Compliant with ISO 9001, ISO 17025, ANSI Z540-1-1994, and MIL-STD-45662A.

Capabilities

- R: 20 $\mu\Omega$ -1 T Ω
- C: <1 pF - 1 F
- L: 100 μ H-100 H
- Accuracy to 1 ppm
- Resolution to 0.1 ppm
- Voltage to 20 kV
- Power to over 1000 W
- Programmable IEEE-488 or BCD



The World Standard in Metrology
Since 1915
Now continuing the **GenRad** tradition

Featuring instruments formerly manufactured by **GenRad/General Radio/QuadTech**

WARRANTY

We warrant that this product is free from defects in material and workmanship and, when properly used, will perform in accordance with applicable IET specifications. If within one year after original shipment, it is found not to meet this standard, it will be repaired or, at the option of IET, replaced at no charge when returned to IET. Changes in this product not approved by IET or application of voltages or currents greater than those allowed by the specifications shall void this warranty. IET shall not be liable for any indirect, special, or consequential damages, even if notice has been given to the possibility of such damages.

THIS WARRANTY IS IN LIEU OF ALL OTHER WARRANTIES, EXPRESSED OR IMPLIED, INCLUDING BUT NOT LIMITED TO, ANY IMPLIED WARRANTY OF MERCHANTABILITY OR FITNESS FOR ANY PARTICULAR PURPOSE.



WARNING



OBSERVE ALL SAFETY RULES
WHEN WORKING WITH HIGH VOLTAGES OR LINE VOLTAGES.

**Dangerous voltages may be present inside this instrument. Do not open the case
Refer servicing to qualified personnel**

HIGH VOLTAGES MAY BE PRESENT AT THE TERMINALS OF THIS INSTRUMENT

WHENEVER HAZARDOUS VOLTAGES (> 45 V) ARE USED, TAKE ALL MEASURES TO
AVOID ACCIDENTAL CONTACT WITH ANY LIVE COMPONENTS.

USE MAXIMUM INSULATION AND MINIMIZE THE USE OF BARE
CONDUCTORS WHEN USING THIS INSTRUMENT.

Use extreme caution when working with bare conductors or bus bars.

WHEN WORKING WITH HIGH VOLTAGES, POST WARNING SIGNS AND
KEEP UNREQUIRED PERSONNEL SAFELY AWAY.



CAUTION



DO NOT APPLY ANY VOLTAGES OR CURRENTS TO THE TERMINALS OF THIS
INSTRUMENT IN EXCESS OF THE MAXIMUM LIMITS INDICATED ON
THE FRONT PANEL OR THE OPERATING GUIDE LABEL.

Specifications

Resistance Range: 1 k Ω to 1000 T Ω (10^3 to 10^{15} Ω) in ten ranges.
Accuracy: 10^3 Ω to 10^{10} Ω , $\pm 1\%$. After self-calibration: 10^{10} to 10^{12} Ω , $\pm 1\%$ *; 10^{13} Ω , $\pm 2\%$; 10^{14} Ω , $\pm 10\%$; 10^{15} Ω , \pm one scale division.
 $\Delta R\%$ Dial: $\pm 5\%$ range; accurate to $\pm 0.2\%$ or, for small changes, to $\pm 0.1\%$.
Test Voltage: Voltage accuracy is $\pm 3\% \pm 0.5$ V.

Fixed Voltages**	10	20	50	100	200	500	1000	V
Minimum Unknown R	1	3	7	20	50	150	500	k Ω
Minimum Test Voltage for 1% Resolution: for approx 1-mm meter deflection	Multiplier Setting		Max R.		Volts			
	100 G or less		10^{11}		10			
	100 G		10^{12}		100			
	1 T		10^{13}		200			

* At high voltages; 1% accuracy is obtainable at 10 V up to 10^{11} Ω ; see above.

** Any voltage between 10 and 1000 V may be obtained using an external resistor.

Short-Circuit Current: < 15 mA, 10-50 V; < 10 mA, 100-1000 V.

Power Required: 105 to 125 or 210 to 250 V, 50 to 400 Hz, 13 W.

Mounting: Flip-Tilt Case

Dimensions (width x height x depth): Portable model, $12\frac{3}{4}$ x $12\frac{1}{2}$ x $7\frac{3}{4}$ in. (325 x 320 x 200 mm); rack model, 19 x $12\frac{1}{4}$ x 5 in. (485 x 315 x 130 mm).

Weight: Net, 19 lb (9 kg); shipping, 31 lb (14.5 kg).

Catalog Number	Description
1644-9701	1644-A Megohm Bridge Portable Model

U.S. Patent Numbers D187,740 and 2,966,257.

SYMBOL INDICATES TERMINALS WHICH MAY HAVE A POTENTIAL OF 1000 VOLTS PRESENT.

SECTION 1

INTRODUCTION



WARNING

High voltage may be present at any of the red binding posts, depending on the switch settings. Lethal energy may be stored in a capacitance connected to the instrument. ALWAYS SET THE FUNCTION SWITCH TO DISCHARGE BEFORE CONNECTING OR DISCONNECTING THE UNKNOWN COMPONENTS.

1.1 PURPOSE.

The Type 1644-A Megohm Bridge (Figure 1-1) measures resistance from 10^3 to 10^{15} ohms. It is useful for measurements of resistors, of insulation resistance on components and machinery, for resistivity tests on samples of insulating material, and for leakage-resistance measurements on capacitors. The vernier ($\Delta R\%$) dial permits accurate measurements of voltage and temperature coefficient of resistance. The voltage applied to the unknown may be set from 10 volts to 1000 volts.

1.2 CONTROLS AND INDICATORS.

Table 1-1 (on page 2) lists the controls and connectors on the panel and sides of the Type 1644-A Megohm Bridge.

1.3 SYMBOLS.

The following abbreviations are on the RESISTANCE MULTIPLIER dial of the Type 1644-A Megohm Bridge:

$$1 \text{ k}\Omega = 10^3 \Omega$$

$$1 \text{ M}\Omega = 10^6 \Omega = 10^3 \text{ k}\Omega$$

$$1 \text{ G}\Omega = 10^9 \Omega = 10^6 \text{ k}\Omega = 10^3 \text{ M}\Omega$$

$$1 \text{ T}\Omega = 10^{12} \Omega = 10^9 \text{ k}\Omega = 10^6 \text{ M}\Omega = 10^3 \text{ G}\Omega$$

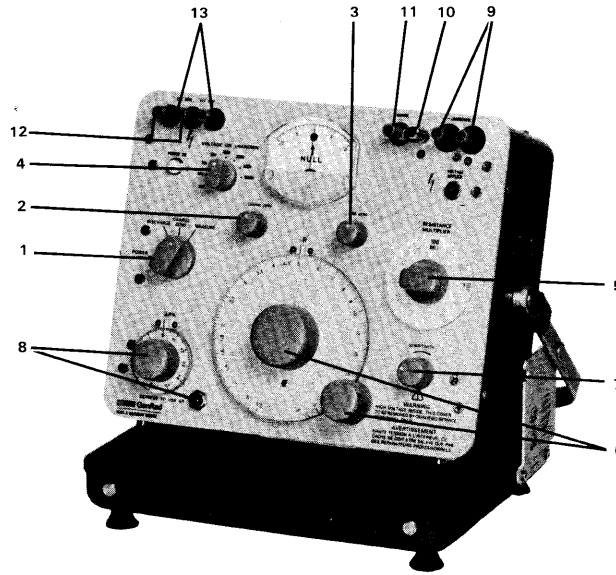

Figure 1. Type 1644 Megohm Bridge.

TABLE 1-1
CONTROLS AND CONNECTORS

Fig. Ref. No.	Name	Type	Function
1	Function	5-position rotary control	Turns instrument on, selects DISCHARGE, CHARGE-ZERO, or MEASURE function. (See paragraph 2.2.)
2	COARSE ZERO	Continuous rotary control	For coarse zero adjustment of detector.
3	FINE ZERO	Continuous rotary control	For sensitive zero adjustment of detector.
4	VOLTAGE ON UNKNOWN	8-position rotary control	Selects magnitude of internal voltage applied to the unknown or connects an external voltage source. (See paragraph 2.2.)
5	RESISTANCE MULTIPLIER	10-position rotary control	Selects the measurement range.
6	R	Continuous rotary control with dial	Balances bridge.
7	SENSITIVITY	Continuous rotary control	Adjusts the sensitivity of the detector circuit. (See paragraph 2.4.)
8	$\Delta R\%$	{ Pushbutton switch Continuous rotary control with dial	Inserts $\Delta R\%$ adjustment in the measurement circuit. (See paragraph 2.4.) Balances bridge over $\pm 5\%$ range. (See paragraphs 3.6, 3.7, and 3.8.)
9	- UNKNOWN +	Pair of insulated binding posts	For connection of component to be measured.
10	Ground	Uninsulated binding post	Ground connection to instrument chassis. (See paragraph 2.1.4.)
11	GUARD	Insulate 1 binding post	For connection to points to be guarded, such as shields of leads. (See paragraph 3.4.)
12	EXT GEN	Pair of insulated binding posts	For connection of an external voltage supply. (See paragraph 3.10.)
13	EXT ADJ	Pair of insulated binding posts	For connection of a resistor to adjust the voltage applied to the unknown to values between those supplied. (See paragraph 3.9.)

SECTION 2

OPERATING PROCEDURE

2.1 INSTALLATION.

2.1.1 OPENING AND TILTING THE CABINET.

The directions for opening the Type 1644-A are given on the handle support of the instrument. Once open, the instrument can be tilted to any convenient angle, as shown in Figure 1-1. The angle should be chosen to give the most comfortable access to the knobs and the best view of the meter and dials.

The instrument may be locked fully open by the same slide pins that are used to lock the instrument closed. Thus, the instrument can be carried in the open position with the cover firmly in place.

The cover forms a convenient storage place for the instruction manual and for any test data that should be kept with the instrument.

2.1.3 POWER CONNECTION. Any changes to line voltage configuration must be performed by qualified personnel.

The 1644 is normally supplied connected for 105- to 125-V, 50- to 400-Hz line voltage. The instrument is connected for 210- to 250-V, 50 to 400 Hz line voltage, if specified when ordered. Two fuses are supplied with the instrument; one, F501, is a spare, two 0.2-A Slo-Blo fuses, Bussman MDL 0.2 A or equivalent, are supplied for the 105-125-V connection. Two 0.1-A Slo-Blo fuses, Bussman MDL 0.1A or equivalent, are supplied when 210-250-V is specified.

To change line voltage, refer to the note in Figure 5-7. The power transformer can be reconnected for each line voltage. If the line voltage connection is changed, make sure the proper fuse is fitted in the F502 holder. Also, the voltage legend plate on the cabinet should be changed to ensure that the instrument is not inadvertently connected to the wrong line voltage. On instruments changed to 210-250 V, order a 210-250 V nameplate (P/N 5590-1665). For a change to 105-125 V, order nameplate P/N 5590-1660.

Check that the proper fuse is in holder F502 and connect the instrument, using the power cord provided.

2.1.4 GROUNDING THE INSTRUMENT.

To avoid electric shock the chassis must always be connected to ground. This is particularly important for very high resistance measurements where lack of a ground can cause difficulty. It is also advisable to ground the panels of nearby instruments to avoid electrostatic coupling to the detector.

2.1.5 CONNECTION OF GROUNDING LINK.

The grounding link, captive to the uninsulated (chassis) binding post, may be connected either to the GUARD terminal or to the - UNKNOWN terminal as shown in Figure 2-2. The ground-to-GUARD connection is preferable if the unknown is a small, separate component, or if it is mounted in an enclosure that should be guarded. (Refer to paragraph 3.4). However, if one terminal of the unknown must be grounded or is a large exposed surface, this terminal should be connected to the - UNKNOWN binding post and the grounding link connected between the - UNKNOWN post and the chassis ground post.

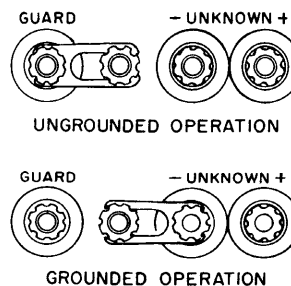

Figure 2-2. Grounding link connected to the GUARD terminal (top) and the - UNKNOWN terminal (bottom).

2.2 BASIC MEASUREMENT PROCEDURE.

Many types of measurements under various conditions can be made with this instrument. The following is the basic measurement procedure. References are given to paragraphs that discuss each step more fully or consider alternate procedures or special measurements.



WARNING

This instrument provides a high test voltage. Particular care should be used in the measurement of capacitor leakage, because LETHAL ENERGY may be stored in the unknown capacitor. DO NOT TOUCH THE CAPACITOR TERMINALS WHILE THE "VOLTAGE APPLIED" LIGHT IS ON. ALWAYS SET THE FUNCTION SWITCH TO DISCHARGE BEFORE CONNECTING OR DISCONNECTING THE UNKNOWN COMPONENT.

Proceed as follows:

- a. Turn the function switch from OFF to DISCHARGE. Allow a minute or two for warmup.
- b. Select the desired test voltage with the VOLTAGE ON UNKNOWN switch. (Refer to paragraph 3.9 for external adjustment of the voltage supply and to paragraph 3.10 for use of an external supply.) The minimum resistance that can be measured at each test voltage is given in Table 2-1. Avoid changing the test voltage when the function switch is in the MEASURE position as this will severely overload the detector amplifier which will then require several minutes to recover.
- c. Connect the component to the UNKNOWN terminals. Note polarity. (For grounding-link connection, refer to paragraph 2.1.5; for remote measurements, refer to paragraph 3.5.)
- d. Set the RESISTANCE MULTIPLIER switch to the desired range (if it is known).
- e. Set the SENSITIVITY control fully clockwise for measurements either on the highest ranges or at low voltages. Set it halfway (arrow up) for other measurements. (Refer to paragraph 2.4.)
- f. Set the function switch to CHARGE-ZERO and adjust the COARSE ZERO and then the FINE ZERO controls for a meter zero (null).
- g. Set the function switch to MEASURE and adjust the main R dial (and the RESISTANCE MULTIPLIER switch, if necessary) to give a null (meter zero). A deflection to the right indicates that the dial setting should be increased. For maximum accuracy on the highest ranges, rezero the meter (step f) when the RESISTANCE MULTIPLIER switch is reset.
- h. The value of the unknown resistance is the dial reading at null indication multiplied by the quantity indicated on the RESISTANCE MULTIPLIER dial. (For accuracy of measurement, refer to paragraph 2.3.)
- i. Return the function switch to DISCHARGE and then remove the component measured.

2.3 ACCURACY.

The bridge accuracy is $\pm 1\%$ between readings of 0.9 and 10 on the main R dial. Above a reading of 10, the accuracy tolerance increases proportionally so that it is $\pm 2\%$ at 20 and $\pm 10\%$ at 100. An indication of 1000 can be distinguished from 500 or ∞ . There are three exceptions to this:

- a. the three highest ranges will not necessarily be 1% accurate if they have not been recently calibrated or if the ambient temperature has changed appreciably (refer to paragraph 5.4.1);
- b. reduced sensitivity reduces the accuracy on the two highest ranges if less than 100 volts is applied to the unknown;
- c. on the 1-T Ω multiplier range, the accuracy is 2%.

For greatest accuracy, particularly at high resistance values, be sure that the component to be measured is not shunted by insulating materials with resistance low enough to introduce error. (See also paragraphs 3.11 and 3.12.)

2.4 SENSITIVITY.

The high sensitivity of the internal dc null detector (approximately 300 μ volts/division near zero) permits accurate measurements with low applied voltages, for measurement on the high ranges, and for measurements of small differences with the $\Delta R\%$ dial. For other measurements less sensitivity keeps the pointer on scale over a greater adjustment range and does not show the amplifier drift and the discontinuous meter jumps due to finite resolution of the main R dial. Balances to a precision well beyond the bridge accuracy offer no advantage, and take more time.

TABLE 2-1

MINIMUM MEASUREMENT RANGES	
<i>Test Voltage</i>	<i>Minimum R_x</i>
10 v	1 k Ω
20 v	3 k Ω
50 v	7 k Ω
100 v	20 k Ω
200 v	50 k Ω
500 v	150 k Ω
1000 v	500 k Ω

For maximum sensitivity, the measurement should be made on the highest range possible. The expression for the bridge output voltage is:

$$E_O = \frac{E_{IN} (\delta\%) M}{(\text{Dial Reading}) (10^4)}$$

where δ is the unbalance in percent

M is unity except on the 100-G Ω and 1-T Ω ranges where it is 0.1 and 0.05, respectively.

Thus, a low dial reading increases sensitivity. With careful zeroing, voltages as low as 50 μ volts can be detected. Therefore, with 10 volts applied and a dial indication of 1, resolution is 0.05% on all but the two highest ranges.

Note that the meter scale is nonlinear. This allows a wide dynamic range without adjustment of the SENSITIVITY control and still gives high sensitivity near null (zero). Full meter deflection is not possible when the SENSITIVITY control is fully counterclockwise. This low sensitivity is useful for limit measurements on the linear portion of the scale (refer to paragraph 3.13).

2.5 LINE-VOLTAGE REGULATION.

The accuracy of measurements accomplished with precision electronic test equipment operated from ac line sources can often be seriously degraded by fluctuations in primary input power. Line-voltage variations as much as $\pm 15\%$ are commonly encountered, even in laboratory environments. Although most modern electronic instruments incorporate some degree of regulation, possible power-source problems should be considered for every instrumentation set-up. The use of line-voltage regulators between power lines and the test equipment is recommended as the only sure way to rule out the effects on measurement data of low line voltage, transients, and other power phenomena.

SECTION 3

APPLICATIONS

3.1 RESISTOR MEASUREMENT.

The EIA standard test voltage for fixed composition resistors, film resistors, and wire-wound resistors is 100 volts for values above 100 k Ω , 10 volts between 1 k Ω and 9.9 k Ω , and 30 volts between 10 k Ω and 99 k Ω . (To obtain a 30-volt test voltage with the internal supply of the Type 1644-A, connect a 20-k Ω resistor between the EXTERNAL ADJ terminals and set the VOLTAGE ON UNKNOWN switch to 50, as described in paragraph 3.9.)

For many types of resistors, the value measured at some other voltage may be considerably different from that at the standard test voltage, due to a large voltage coefficient (refer to paragraph 3.7). In many cases, measurements at the voltage at which the resistor will be used are helpful.

Resistors as low as 1 k Ω may be measured easily to 1% on the Type 1644-A Megohm Bridge. More accurate substitution measurements are possible using the $\Delta R\%$ dial if an external standard is available (refer to paragraph 3.6).

If the resistors to be measured are small, separate units, they should be measured ungrounded with the grounding link connected between the GUARD and ground terminals. Resistors may be measured rapidly in a production-line setup using the procedure described in paragraph 3.13.

3.2 INSULATION TESTING.**3.2.1 COMPONENT, MACHINERY, AND SWITCH-GEAR INSULATION.**

Insulation testing on a wide variety of apparatus is possible with the Megohm Bridge, but different types of devices require different precautions. When one terminal is the case of the apparatus, or is a large, exposed surface, this terminal should be grounded, for both accuracy and safety, by connection to the - UNKNOWN terminal with the link connected between

this terminal and the chassis ground terminal (refer to paragraph 2.1.5). When the device to be measured includes polarized rectifiers or capacitors, the sign of the applied voltage must be correct. Note that the +UNKNOWN terminal may be grounded with an external lead if necessary (disconnect the link from both adjacent terminals), but errors may occur when this connection is used to measure resistances above approximately 100 M Ω .

The connection of leads to large equipment also requires some care, and the problems of a large capacitive time constant and dielectric absorption may also be present (refer to paragraphs 3.3.3 and 3.2.3, respectively).

3.2.2 TEST SAMPLES.

This bridge is well suited for resistance measurements on samples of insulating material as described by ASTM Standard D257. This standard describes in detail the techniques of both surface- and volume-resistivity measurements. Diagrams of several electrode configurations, applicable formulas, and suggested precautions are given.

The most commonly used electrode arrangement for solid materials is that shown in Figure 3-1. This configuration may be used for either surface- or volume-resistivity measurements, but for surface

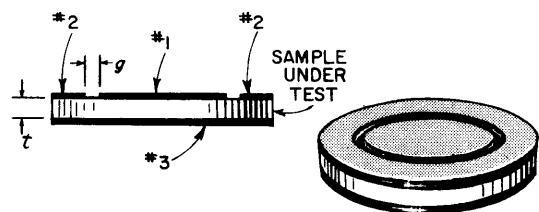

Figure 3-1. Electrode arrangement for insulation testing of solid materials.

measurements the gap, g, should be approximately twice the sample thickness, t. The connection of the electrodes to the bridge depend on the quantity to be measured as shown in Table 3-1. The ASTM Standard also describes other sample holders for both liquid and solid materials.

Standard voltages for this test are 100, 250, 500, 1000, 2500, 5000, 10,000, and 15,000 volts, of which the most common are 100 and 500 volts. The Type 1644-A Megohm Bridge will supply 100, 500, and 1000 volts directly, and 250 volts when an external resistor is used (235 kilohms when the VOLTAGE ON UNKNOWN switch set to 500; refer to paragraph 3.9).

3.2.3 DIELECTRIC ABSORPTION.

The apparent resistance of an insulator is the ratio of voltage applied to the current flowing through it. Unfortunately, the current is time-dependent and the true insulation resistance is the limiting, steady-state value.

The time-dependent currents are the simple charging current that depends on the capacitance of the sample and on the resistance of the voltage source, and the current due to dielectric absorption. The simple charging current is negligible after the function switch has been in the CHARGE-ZERO position for a very short time (except when large capacitors are tested; refer to paragraph 3.3.2). However, the absorption current may be appreciable for minutes, hours, or in rare cases, even days. This dielectric absorption is the result of dipole and interfacial polarization and ion mobility and is particularly large for laminated materials.

A measure of the dielectric absorption is the polarization index, which is defined as the ratio of the resistance measured after 10 minutes to that measured after one minute of electrification. Often, a single measurement after one minute is called the insulation resistance. Although this value may be far from the true resistance for some insulators, it is useful for comparison of measurements on materials with relatively low absorption.

3.2.4 MEASUREMENT PROCEDURE.

The procedure for measurement of insulation resistance is the same as the basic measurement procedure described in paragraph 2.2 except for charging and dielectric-absorption considerations.

The function switch should be left in the CHARGE position long enough to charge the sample. The time required for simple charging is usually well under one second except for capacitors or extremely large samples (refer to paragraph 3.3.2).

When dielectric absorption is present, the main R dial must be continually adjusted to maintain a balance. To measure resistance at any given moment, simply stop adjusting the dial at the desired time. Thus, it is not necessary to make a reading on a moving dial (see paragraph 3.3.4).

3.3 LEAKAGE RESISTANCE OF CAPACITORS.

3.3.1 GENERAL.



The energy stored in a capacitor may be LETHAL. The function switch should be set to discharge before you connect or disconnect the capacitor to be measured. DO NOT TOUCH THE CAPACITOR TERMINALS WHILE THE "VOLTAGE APPLIED" LIGHT IS ON.

The procedure for measurements of the leakage resistance on capacitors is basically the same as that for resistors except that the several effects described in the following paragraphs become more important as the capacitance and leakage resistance become greater.

3.3.2 CHARGING TIME.

The function switch should be left in the CHARGE position long enough to ensure that the capacitor is completely charged. If it is not fully charged, the charging current will reduce the measured value of leakage resistance, and the charging time constant in the MEASURE position can become quite large (refer to paragraph 3.3.3).

The charging time is limited mainly by the maximum current of about 8 ma that can be drawn from the power supply. Charging time is, therefore:

$$t = \frac{CV}{I} = \frac{CV}{8 \text{ ma}}$$

$$t = \frac{(C \text{ in } \mu\text{f})(V \text{ in volts})}{8} \times 10^{-3} \text{ sec}$$

This time is usually less than 1 second except for large electrolytic capacitance units. The current is somewhat greater than 8 ma at 50 volts or less.

TABLE 3-1

ELECTRODE CONNECTIONS FOR INSULATION TESTING				
For Volume Resistivity			For Surface Resistivity	
Electrode	Function	Connect to	Function	Connect to
#1	Guarded Electrode	+ UNKNOWN	Guarded Electrode	+ UNKNOWN
#2	Guard Electrode	GUARD	Unguarded Electrode	- UNKNOWN
#3	Unguarded Electrode	- UNKNOWN	Guard Electrode	GUARD

3.3.3 TIME-CONSTANT EFFECTS.

The time constant of the bridge-capacitor system for the MEASURE function is the product of the capacitance measured and the effective bridge output resistance, R_O , given in Table 3-2. If this product is greater than about 0.1 second, the bridge will appear to be sluggish and the user may adjust the bridge beyond balance before the null-detector deflection reverses sign. Adjustment will be easier, although the total balance time will not be less, if you wait for a period of several time constants between balances.

When the function switch is set to CHARGE, the capacitor being tested is charged to a voltage that is dependent upon the position of the R dial. This voltage may differ from the final capacitor voltage by as much as 1% of the applied voltage. The final charging or discharging must be done with the function switch set to MEASURE so the time required is independent of further adjustment of the R dial.

In extreme cases, this time constant may be so long that it is impractical to wait. An alternate procedure described below makes use of the fact that the bridge is initially at balance when the function switch is rotated from CHARGE-ZERO to MEASURE, and then drifts slowly off null. The direction of the null-detector drift indicates the direction that the main R dial should be rotated to obtain the final balance.

The alternate balance procedure for measurement of capacitors with long time constants is given below:

- a. Set the function switch to CHARGE and allow time for full charging (refer to paragraph 3.3.2).
- b. Rotate the function switch to MEASURE and note the direction of the drift from zero (discount the small, fast deflection caused switching phenomena).
- c. Make a large adjustment in the main R dial in the direction indicated by the null detector (i.e., a right-hand meter deflection indicates that the dial reading should be increased).
- d. Return the function switch to CHARGE and repeat the above steps until a balance is reached.

Note that the time constant is reduced if the measurement is made on a lower range (i.e. with a dial reading above 10) so that a lower-valued standard is used. This, of course, gives reduced accuracy, but high accuracy is rarely required for this type of measurement. Also, use reduced detector sensitivity, at least to get a rough balance.

3.3.4 DIELECTRIC ABSORPTION.

Dielectric absorption is present to some degree in all capacitors, but is particularly pronounced in some impregnated paper types and is lowest in unimpregnated polystyrene, polyethylene, and Teflon® units. The effect of dielectric absorption is discussed in paragraph 3.2.3. For measurements on most types of capacitors, electrification for two minutes is common practice.

TABLE 3-2
BRIDGE OUTPUT RESISTANCE

Range	R_S		R_O
	Value	Type	
1 k Ω	10 Ω	Wire-wound	5 k Ω †
10 k Ω	100 Ω	Wire-wound	5 k Ω †
100 k Ω	1 k Ω	Wire-wound	5 k Ω †
1 M Ω	10 k Ω	Wire-wound	15 k Ω †
10 M Ω	100 k Ω	Wire-wound	100 k Ω
100 M Ω	1 M Ω	Metal-film	1 M Ω
1 G Ω	10 M Ω	Metal-film	10 M Ω
10 G Ω	100 M Ω	Carbon-film**	100 M Ω
100 G Ω	1000 M Ω *	Carbon-film**	100 M Ω
1 T Ω	10,000 M Ω *	Carbon-film**	500 M Ω

* T network, effective value given, refer to paragraph 3.6.3.
 ** Adjustable, refer to paragraph 5.4.1.
 † Depends on setting of R dial.

When both appreciable dielectric absorption and a long time constant are present, measurements become quite difficult because it is hard to tell which effect causes the meter drift. In such cases, it is often useful to make limit measurements. Set the main R dial and the RESISTANCE MULTIPLIER switch to the acceptance limit and wait to see if the meter deflects to the left, which indicates that the resistance is below the limit. A time limit should be included in the specifications for such a limit measurement.

3.3.5 ERRATIC DEFLECTIONS CAUSED BY LINE TRANSIENTS.

When leakage resistance of capacitors is measured on the higher resistance ranges, the test-voltage supply must be extremely well regulated to avoid erratic meter deflections due to power-line transients. The capacitor being measured couples the high voltage supply to the detector so that rapid variations of less than 1 millivolt on the high voltage supply are easily seen. The regulation of the internal supply of the Type 1644-A is very good, but in extreme cases, when the power-line voltage is very noisy, an external battery should be used as the test-voltage supply (refer to paragraph 3.10).

3.3.6 SMALL VOLTAGE CHANGES DURING CAPACITANCE MEASUREMENTS.

In the measurement of high-capacitance, very-low-leakage capacitors (particularly polystyrene units), a small drift in the bridge voltage supply will cause an error in leakage measurements. This is particularly noticeable when the bridge indication is greater than infinity. This condition occurs when the voltage rate-of-change multiplied by the time constant ($C_{\text{unknown}} \times R_O$; see Table 3-2 for values of R_O) is in the order of a few millivolts. It is, therefore, most noticeable for measurements at high voltage and on the high RESISTANCE MULTIPLIER ranges.

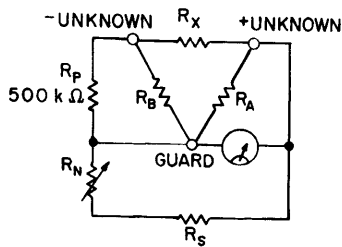

Figure 3-2. Three-terminal resistance measurement.

One source of this difficulty is the drift in the internal supply during warm-up. A warm-up period of one hour is recommended. In extreme cases, an external supply of high stability must be used (refer to paragraph 3.10). Another cause of this difficulty is ambient temperature change which changes both the internal supply voltage and the temperature of the capacitor being measured. If the capacitor has an appreciable temperature coefficient, a capacitor voltage change will result.

3.4 GUARDED (DIRECT) THREE-TERMINAL MEASUREMENTS.

In many cases it is necessary to measure the resistance between two points in the presence of resistance from one or both of these points to a third point (usually ground). This third point can often be guarded to avoid error due to shunting the unknown with the extraneous resistances.

This is shown diagrammatically as a three-terminal resistor in Figure 3-2. Here, R_X is the quantity to be measured (the direct resistance) despite the presence of R_A and R_B . If the junction of R_A and R_B is tied to guard, R_A is across the detector and causes no error, but reduces the sensitivity by the factor $\frac{R_A}{R_O + R_A}$ (see Table 3-2 for values of R_O).

The other extraneous resistance, R_B , is across the 500-kΩ resistor, R_P , where it causes an error of more than 1% if R_B is below 50 MΩ. The error due to R_B

is approximately $-\frac{R_P}{R_B} \times 100\%$.

The guard may be used whether the GUARD or the - UNKNOWN terminal is grounded. Note however, that if the - UNKNOWN terminal is grounded, the GUARD terminal will be at high potential. Often the terminal to be guarded is a large chassis or case and it is safer to ground the GUARD terminal.

3.5 REMOTE MEASUREMENTS.

Measurements can be made on components that are some distance from the instrument if care is used to prevent leakage between the connecting leads and to avoid shock. A convenient way to do this is to use a shielded cable as shown in Figure 3-3.

The +UNKNOWN terminal should be connected to the center conductor and the shield tied to the GUARD terminal. The lead to the - UNKNOWN terminal need not be shielded, but if it is, its shield should also be tied to GUARD.

The - UNKNOWN lead should be insulated unless this terminal is grounded. All shields tied to GUARD should be insulated if the GUARD terminal is not grounded.

3.6 SUBSTITUTION MEASUREMENTS.

3.6.1 GENERAL.

Substitution (or comparison) measurements can be made with accuracy up to 0.1% by means of the ΔR% dial. Substitution measurements require an external standard that is known to an accuracy substantially better than the desired measurement accuracy. Resistors of high accuracy are not available in the high megohm range but the three-terminal standard described below can be used. If only the differences between resistors are to be determined, and not absolute values, the value of the standard need not be accurately known.

3.6.2 PROCEDURE.

The procedure for a substitution measurement is simply to measure the unknown and then the standard and determine the difference between them. The value for R_X is then:

$$R_X = R_S + R_{xm} - R_{sm}$$

where R_X and R_S are the true values of the unknown and the standard

R_{xm} and R_{sm} are the measured values of the unknown and the standard.

The difference between R_{xm} and R_{sm} can be most accurately determined if this difference is small enough to be within the range of the ΔR% dial. The first balance should be made with the main R dial and then the ΔR% dial. The second balance should be made using only the ΔR% dial (leave the R dial as set). The value of the unknown is then:

$$R_X = R_S \left(1 + \frac{\Delta R\%}{100} \right)$$

Here, ΔR% is the ΔR% dial reading for the unknown minus that for the standard.

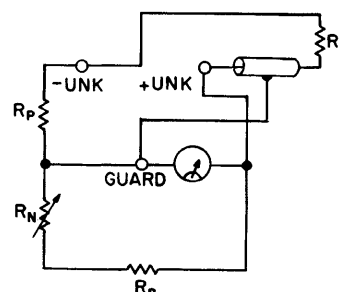

Figure 3-3. Connection for remote measurements.

An alternate scheme may be used if a T network with an adjustable resistor (refer to paragraph 3.6.3) is used as a standard. In this case, the T is used to make the second balance and is adjusted for a null without moving either dial of the bridge. The value of the unknown is calculated from:

$$R_x = R_1 + R_3 + \frac{(R_1)(R_3)}{R_2} + (0.5 \text{ M}\Omega) \frac{R_3}{R_2}$$

3.6.3 THREE-TERMINAL RESISTANCE STANDARDS.

The T or Y connection of resistors shown in Figure 3-4a is electrically identical to the Δ configuration of Figure 3-4b. This is the familiar Y- Δ transformation. If R2 is small and R1 and R3 are large, the resistance R_Y can be very large. R_Y can be used as a standard and will be very stable and accurate if wire-wound resistors are used for the resistors of the T.

Such a T network should be connected to the bridge as shown in Figure 3-2. Unfortunately, the resistances R_A and R_B shunt the bridge resistor R_P, which causes an error (refer to paragraph 3.4), and shunt the detector, which decreases sensitivity. The loss of sensitivity limits the attainable accuracy at low test voltages (refer to paragraph 3.6.4).

The error caused by the shunt on R_P can be compensated for in the calculation of the resistors of the T. For any desired value of R_Y, the value of R2 should be:

$$R_2 = \left(\frac{500 \text{ k}\Omega + R_1}{R_Y - R_1 - R_3} \right) R_3$$

The lowest value R_Y can have is R1 + R3.

For the most precise measurements, R1 and R3 should be the largest wire-wound units available, and R2 should be a multi-dial decade box. If R1 and R3 are 1-M Ω units, then the equation for R2 becomes:

$$R_2 = \frac{1.5}{R_Y - 2} \text{ M}\Omega$$

where R_Y is in megohms.

If R1 = R3 = 10 M Ω , then:

$$R_2 = \frac{105}{R_Y - 20} \text{ M}\Omega$$

Table 3-3 lists the values of R2 for decade values of R1 and R3 from 10 M Ω to 1 T Ω .

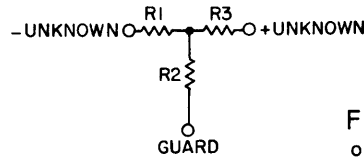

Figure 3-4a. Y configuration of a three-terminal standard.

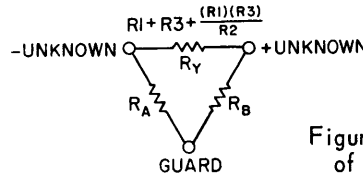

Figure 3-4b. Delta configuration of a three-terminal standard.

3.6.4 ACCURACY AND SENSITIVITY.

The bridge accuracy for substitution measurements using the $\Delta R\%$ dial is $\pm 0.1\%$ as long as the sensitivity is adequate (refer to paragraph 2.4). However, if the two balances are well within 1 percent of each other, the bridge accuracy can be as good as $\pm 0.02\%$. Measurements on the main R dial can be made to $\pm 1/4\%$ if the difference is small and the scale is carefully interpolated.

The accuracy of the standard must also be considered in the over-all accuracy determination. To determine the accuracy for the worst case, the tolerance of the standard must be added to the bridge tolerance. When a T network is used, the worst possible tolerance of the T is the sum of the tolerances of the separate resistors if

$$\frac{(R_1)(R_3)}{R_2} \gg R_1 + R_3$$

When a T standard is used to measure very high values, the sensitivity is generally the limiting factor. The approximate output voltage is:

$$E_O = \frac{(E_{IN})(\delta\%)(M)}{(\text{Dial Reading})(10^4)} \times \frac{R_1}{R_O + R_1}$$

where $\delta\%$ is the unbalance in percent

M is unity except on the 100-G Ω and 1-T Ω ranges where it is 0.1 and 0.05, respectively
R_O is given in Table 3-2.

Example:

A 10-G Ω component is measured on the 10-G Ω range.

A T network with 1-M Ω resistors is used.

E_{IN} = 1000 volts.

$\delta\%$ = 0.1%.

TABLE 3-3

RESISTANCE VALUES FOR T NETWORKS

R _Y , Equivalent Resistance	10 M Ω	100 M Ω	1 G Ω	10 G Ω	100 G Ω	1 T Ω
R ₂ , when R ₁ = R ₃ = 1 M Ω	187.5 k Ω	15.306 k Ω	1.5022 k Ω	150.02 Ω	15.000 Ω *	1.5000 Ω *
R ₂ , when R ₁ = R ₃ = 10 M Ω		1.3125 M Ω	107.14 k Ω	10.521 k Ω	1.0502 k Ω	105.0 Ω *

* Poor sensitivity

$R_O = 100 \text{ M}\Omega$ (see Table 3-2).

$$E_O = \frac{(1000)(0.1)}{(1)(10^4)} \times \frac{1 \text{ M}\Omega}{101 \text{ M}\Omega} = 100 \text{ }\mu\text{volts.}$$

This would give meter deflections of about 1 mm.

If the arms of the T network were increased to 10 M Ω , the sensitivity would be increased by a factor of 10.

3.7 MEASUREMENT OF VOLTAGE COEFFICIENT.

3.7.1 GENERAL.

The Type 1644-A Megohm Bridge is well suited for the measurement of voltage coefficient because of the high resolution of its $\Delta R\%$ dial and the wide range of applied voltage.

The voltage coefficient of a resistor is generally defined as:

$$VC = \frac{R_1 - R_2}{R_2 (V_1 - V_2)} \times 100\%$$

where $V_1 > V_2$

R_1 is the resistance at V_1

R_2 is the resistance at V_2

VC is in % per volt.

Any two voltages may be used, but, because the voltage coefficient is not necessarily a constant (i.e., the resistance is not always a linear function of voltage), the voltages used should be specified.

A common practice is to use two voltages differing by a factor of ten to one, in which case the formula reduces to:

$$VC = \frac{\Delta R}{R} \times \frac{1}{0.9 V} \times 100\%$$

where ΔR is the resistance difference

R is the resistance at the lower voltage

V is the higher voltage.

The EIA Standard RS172 (Fixed Composition Resistors) specifies the use of the rated voltage for V in the above formula.

If the applied voltage is high enough to cause appreciable power dissipation, the measurement should be made quickly to determine the true voltage coefficient and to avoid temperature effects. The EIA specification suggests that the time for measurement (at the higher voltage) be less than 5 seconds.

Most resistors have a negative voltage coefficient (a lower resistance value at higher voltage), except for semiconductor back resistance which has a positive voltage coefficient as long as the voltage is well below the break-down value.

3.7.2 PROCEDURE.

The procedure for voltage-coefficient measurement is as follows:

- a. Measure the resistance of the unknown at the lower voltage. For best accuracy use the $\Delta R\%$ dial as the final balance adjustment, and note the $\Delta R\%$ dial indication.

- b. Change the position of the VOLTAGE ON UNKNOWN switch to the higher voltage and re-zero the bridge with the function switch set to CHARGE-ZERO, if necessary.
- c. Balance the bridge with the $\Delta R\%$ dial only (do not change the setting of the main R dial).
- d. The voltage coefficient is:

- 1) Initial balance made only with R dial:

$$VC = \frac{\Delta R\% \text{ Dial Reading}}{\text{Voltage Change}}$$

- 2) Initial balance made using $\Delta R\%$ dial:

$$VC = \frac{\text{Change in } \Delta R\% \text{ Dial Reading}}{\text{Voltage Change}}$$

3.8 MEASUREMENT OF TEMPERATURE COEFFICIENT.

3.8.1 GENERAL.

The $\Delta R\%$ dial allows the precise measurement of temperature coefficient, which is defined as:

$$TC\% / ^\circ\text{C} = \frac{\Delta R}{R} \times \frac{100\%}{\Delta t}$$

where ΔR is the resistance change between the test temperature and the reference temperature

R is the resistance at the reference temperature

Δt is the temperature change in $^\circ\text{C}$ from the reference temperature.

The EIA Standards RS196 (Fixed Film Resistors) and RS172 (Fixed Compensation Resistors) specify that measurements be made at -15°C . The EIA Standard RS229 (Wire-Wound Resistors) specifies measurements at -55°C , $+105^\circ\text{C}$, and $+145^\circ\text{C}$, and a reference temperature of $+25^\circ\text{C}$.

Shielded leads should be used to connect the sample in the temperature chamber to the bridge to avoid pickup and leakage (refer to paragraph 3.5).

3.8.2 PROCEDURE.

The procedure for the measurement of temperature coefficient is as follows:

- a. With the resistor in an environment held at 25°C , measure the resistance. For best accuracy use the $\Delta R\%$ dial as a final balance adjustment. (Standard voltages should be used, refer to paragraph 3.1.) Note the $\Delta R\%$ dial reading.
- b. Change the temperature of the resistor environment to the test temperature and, after stabilization, measure the resistance again, using only the $\Delta R\%$ dial. (Leave the main R dial set as is.)
- c. The temperature coefficient is:

$$TC = \frac{\text{Change in } \Delta R\% \text{ Dial Reading}}{\text{Temperature Difference in } ^\circ\text{C}}$$

3.9 EXTERNAL ADJUSTMENT OF THE INTERNAL TEST VOLTAGE.

Any test voltage between 10 volts and 1000 volts may be obtained by connection of the proper resistor between the EXTERNAL ADJ terminals.



Voltage is present on the EXTERNAL ADJ terminals unless the VOLTAGE ON UNKNOWN switch is set to EXT or the instrument is turned off.

To adjust the internal test voltage proceed as follows:

- a. Set the VOLTAGE ON UNKNOWN switch to EXT and connect a resistor of value R between the EXTERNAL ADJ terminals:

$$R = \frac{500 (V_S - 10) (V_D - 10)}{V_S - V_D} \text{ ohms}$$

where V_S is the VOLTAGE ON UNKNOWN switch setting
 V_D is the desired voltage.

It is generally preferable to set V_S to the closest value above the desired voltage, V_D . Table 3-4 gives the values of resistance to obtain many common voltages. The external resistor should be rated for $(V_D - 10)$ volts.

- b. Set the VOLTAGE ON UNKNOWN switch to V_S and proceed with the measurement.

If a resistor of the required value is not available, a rheostat larger than this value may be used. With the VOLTAGE ON UNKNOWN switch set to EXT, attach the rheostat between the EXTERNAL ADJ terminals, then set the VOLTAGE ON UNKNOWN switch to V_S . Set the function switch to CHARGE-ZERO and adjust to the desired voltage using a voltmeter connected between the UNKNOWN terminals. Note that the - UNKNOWN terminal will be negative by an amount equal to V_D if the GUARD terminal is grounded, or the + UNKNOWN terminal will be positive by an amount equal to V_D if the - UNKNOWN terminal is grounded.

3.10 EXTERNAL TEST-VOLTAGE SUPPLY.

An external supply for the test voltage is useful for voltages below 10 volts, for continuous voltage adjustment, or for extreme stability for measurements on capacitors (refer to paragraph 3.3.5). For best stability, a battery is recommended. The maximum voltage that may be applied to the bridge is 1000 volts.

TABLE 3-4
RESISTANCE VALUES FOR EXTERNAL VOLTAGE ADJUSTMENT

V_D	V_S	R
12 v	20 v	1.25 kΩ
15 v	20 v	5 kΩ
25 v	50 v	12 kΩ
30 v	50 v	20 kΩ
40 v	50 v	60 kΩ
60 v	100 v	56.25 kΩ
70 v	100 v	90 kΩ
80 v	100 v	157.5 kΩ
90 v	100 v	360 kΩ
125 v	200 v	145.7 kΩ
150 v	200 v	266 kΩ
175 v	200 v	627 kΩ
250 v	500 v	235.2 kΩ
300 v	500 v	355.3 kΩ
350 v	500 v	555.3 kΩ
400 v	500 v	955.5 kΩ
475 v	500 v	4.557 MΩ
600 v	1000 v	730.1 kΩ
700 v	1000 v	1.139 MΩ
750 v	1000 v	1.465 MΩ
800 v	1000 v	1.955 MΩ
900 v	1000 v	4.406 MΩ

Set the VOLTAGE ON UNKNOWN switch to EXT, and connect the external supply to the EXTERNAL GEN terminals. To keep the same polarity as the internal supply, the negative terminal should be connected to the right-hand GEN terminal (that is, the middle of the three EXTERNAL terminals). The external supply should be current-limited to protect it from short circuits. It is also advisable to limit the current to a safe value to avoid shock.



With the external supply connected as described above and the GUARD terminal of the bridge grounded, the negative side of this supply is at a negative potential when the function switch is set to CHARGE-ZERO or MEASURE, and the positive terminal is at high potential when the function switch is set to discharge. With the - UNKNOWN terminal grounded, the negative supply of the external supply is also grounded, and the positive side will be at a positive voltage for all positions of the function switch.

With the external generator connected as described above, the function switch will perform its operations. Note that the external supply is disconnected but not shorted in the DISCHARGE position. The circuit diagram for each position of the function switch is shown in Figure 3-5.

3.11 MEASUREMENTS ON VERY HIGH-VALUED RESISTORS.

3.11.1 GENERAL.

Extra precautions and careful technique are required for precise measurements on very high-valued resistors for several reasons.

The ratio-arm resistors used for the three highest ranges are carbon-film types and are not as stable as those used on the lower ranges. For accurate measurements on the highest ranges, the ratio arms may be adjusted by the procedure given in paragraph 5.4.1.

On the two highest ranges the sensitivity is reduced by a factor of 1/10 and 1/20, respectively, because T networks are used as standards (refer to paragraph 4.1). Measurements made at test voltages below 100 volts are difficult.

Other difficulties in measuring high valued resistors are discussed in the following paragraphs.

3.11.2 ELECTROSTATIC COUPLING.

On the three highest ranges the + UNKNOWN terminal is at a very high impedance and, as a result, a very small capacitive coupling to this terminal can cause a large voltage on the detector input. Two separate phenomena are present:

- Variable capacitance to a point at a fixed voltage will induce a transient voltage on the detector. To observe this, set the main R dial to ∞ , the function switch to MEASURE, and move your hands above the +UNKNOWN terminal.
- Fixed capacitance to a variable voltage will also induce a voltage on the + UNKNOWN terminal, but it should have no dc component and will not cause a detector deflection unless it overdrives the detector, or is low enough in frequency (refer to paragraph 3.12.4).

3.11.3 SWITCH TRANSIENTS.

The movement of the function switch and the RESISTANCE MULTIPLIER switch will also cause transient detector voltages because of the changing capacitance of these switches (refer to paragraph 3.11.2) and more subtle contact phenomena. These fluctuations should be ignored.

3.11.4 SHUNT LEAKAGE BETWEEN LEADS.

At high resistance levels one must be sure that the component being measured forms the only path between the + UNKNOWN and - UNKNOWN terminals. Leads should not touch each other, even if they are insulated with high-quality material. Shielding is the best way to avoid leakage between leads (refer to paragraph 3.5). If the - UNKNOWN terminal is grounded, leakage between the +UNKNOWN terminal and ground shunts the unknown. Therefore, ungrounded measurements should be used wherever possible.

3.11.5 MOISTURE ON THE UNKNOWN.

The device measured should be clean and dry. High-valued resistors should be handled only by their leads to avoid surface dirt. Surface moisture will reduce the resistance value considerably. For example, breathing on a glass-enclosed resistor of only 1 G Ω will cause a momentary change of several percent.

3.12 MEASUREMENTS UNDER ADVERSE CONDITIONS.

3.12.1 HIGH HUMIDITY.

The Type 1644 - A Megohm Bridge has been designed to operate under conditions of rather high humidity but, nevertheless, errors will occur on the highest ranges when the relative humidity is over approximately 90%. However, the most serious errors generally result from the effects of humidity in the external unknown connections. A few simple precautions should be taken:

- Clean the binding posts with a dry, clean cloth. Make sure that there is no dust or moisture between the UNKNOWN binding posts or between them and the panel.
- Use ungrounded measurements if possible. That is, connect the GUARD terminal to the adjacent chassis ground terminal with the connecting link.
- Be particularly careful to keep the leads that connect the bridge to the unknown separate from each other.

To determine possible errors due to humidity, balance the bridge with no connections to the UNKNOWN terminals; it should balance at ∞ .

The most important precaution necessary under humid conditions is to avoid leakage on the surface of

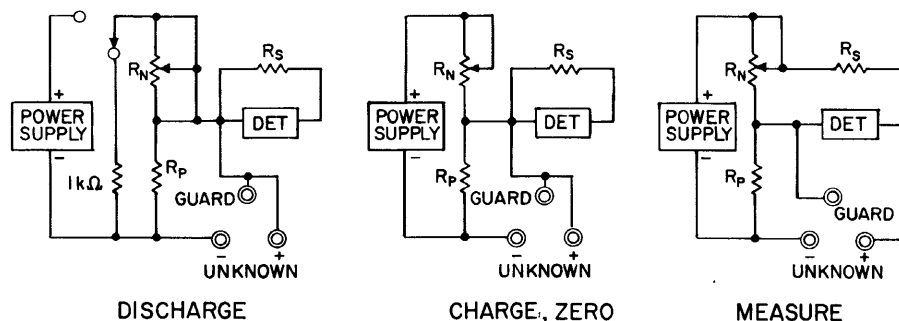

Figure 3-5. Circuit diagrams for the Type 1644-A Megohm Bridge for each position of function switch.

the component being measured. In almost all cases, the error due to this leakage will be many times larger than errors due to improper operation of the bridge itself. Many high resistances simply cannot be measured in a humid environment. Often, a simple solution is to place the component in a box with a light bulb or other source of heat. Shielded leads should be used to connect to the bridge (refer to paragraph 3.5).

3.12.2 TEMPERATURE EXTREMES.

The Type 1644-A Megohm Bridge should operate satisfactorily over a range from -30 to +50°C. The instrument may be exposed to temperatures from -40 to +85°C without damage.

For accurate measurements on the three highest resistance ranges, the ratio arms used should be adjusted at the temperature of use to take into account their temperature coefficients (refer to paragraph 5.4.1).

The temperature coefficient of the component being measured is often high enough so that it cannot be neglected and the bridge should not be expected to give the room-temperature value of the unknown when the component is not at room temperature.

3.12.3 VIBRATION AND SHOCK.

The vacuum-tube electrometer used in the detector is somewhat subject to mechanical shock and will give a transient deflection under these conditions. The detector mounting reduces this effect. However, if the bridge is set on a vibrating platform it should be mechanically isolated from the platform by a thick layer of some spongy material, such as foam rubber.

Vibration or other movement of the leads connecting the unknown can also cause transient detector deflection (refer to paragraph 3.11.2).

3.12.4 HIGH AC FIELDS.

Unshielded components and any unshielded leads that connect the component to the + UNKNOWN terminal may have a voltage induced on them because of capacitance coupling to objects which carry an ac voltage. The bridge is more sensitive to this capacitance pickup on the higher resistance ranges. The detector input circuit contains a low-pass filter that gives 50-db rejection at 60 cps, but large pickup can cause enough signal to overdrive the amplifier, shift its effective dc voltage, and yield an erroneous indication.

Such pickup can be easily detected by a change in meter deflection when the function switch is rotated counterclockwise from DISCHARGE to the adjacent, detented, unlabeled position. In this switch position, the bridge is connected just as in the MEASURE position except that the test voltage is not applied. (When the switch is in the DISCHARGE and CHARGE-ZERO positions, the + UNKNOWN terminal is not connected to the detector, see Figure 3-5.)

If ac pickup is a problem, the best solution is to shield the + UNKNOWN connecting lead and corresponding terminal of the unknown component, to ground the bridge and all nearby equipment, and to keep power cables as far from the bridge, the component measured, and the leads, as possible. If the effect of pickup cannot be completely removed, improved accuracy will result if this unlabeled switch position is used when the meter is zeroed.

3.12.5 SAMPLES WITH SOURCES OF EMF.

Some samples may contain either known or unsuspected sources of voltage due to chemical action, thermal emf, contact potential, or the presence of electrets. If such voltages are additive to the applied voltage, they will cause a bridge error.

If these voltages appear between the + UNKNOWN terminal and the GUARD terminal in a guarded system, they are particularly troublesome because they are applied directly across the detector. If the polarity is the same, this may result in a balance beyond ∞. Such a difficulty is apt to occur during guarded measurements on heterogeneous mechanical assemblies under high humidity.

3.13 PRODUCTION LIMIT TESTING.

Resistors, or the leakage resistance of all types of components, can be rapidly checked without repeated adjustment of the main R dial by using the meter as a limit indicator. Two types of operation are possible:

- a. Simple, single-limit testing. To check rapidly that components are above or below some resistance level, set the RESISTANCE MULTIPLIER switch and the main R dial to the limit value, and connect the components to be measured, one at a time, to the UNKNOWN terminals. A deflection to the right indicates the resistance is higher than the limit and a deflection to the left indicates that it is lower. The function switch should be set to DISCHARGE between measurements to avoid shock, to avoid repeated meter banging, to check the zero between measurements, and to start each measurement at zero.
- b. Lo-go-hi measurements. The meter deflection may be used to separate the components tested into three groups: those below the tolerance range, those in the tolerance range, and those above the tolerance range. The main R dial and the SENSITIVITY control (or VOLTAGE ON UNKNOWN switch) can be adjusted so that a meter deflection to the left of a certain value represents the lower limit, and a meter deflection to the right of a certain value represents the upper limit. A deflection of 5 divisions is recommended, since beyond that the meter is quite nonlinear. Once the controls are set, the components may be tested without adjustment of the dials. It is, however, preferable to zero the bridge between measurements.

3.15 BATTERY OPERATION.

The bridge may be battery-operated if a power line is not available. Two batteries are required: one battery to supply the test voltage should be connected to the EXTERNAL GEN terminals and may supply any voltage up to 1000 volts (refer to paragraph 3.10). The second battery to power the detector should supply 45 volts at about 20 ma. It should be connected with its positive terminal to AT13 and its negative terminal to AT12 on the detector board (see Figure 5-3). The cable connections to these terminals should be removed.

NOTE

Connections made internally for battery operation should be performed by qualified personnel.

SECTION 4

THEORY OF OPERATION

4.1 BRIDGE.

The bridge circuit in the Type 1644-A Megohm Bridge is a conventional Wheatstone bridge (see Figure 4-1). The equation of balance for this bridge is:

$$R_X = \frac{R_P R_S}{R_N}$$

When the balance condition is met, there will be no voltage across the detector.

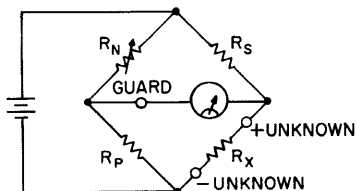

Figure 4-1. Elementary schematic diagram of the bridge circuit.

In the Type 1644-A Megohm Bridge, the resistor R_N is the main R adjustment which is a precision wire-wound rheostat of 5.5 k Ω . The value of R_N is inversely proportional to R_X , so that, when R_N is set to zero, the corresponding dial reading is infinity. The winding mandrel of this rheostat is exponentially shaped in the region between dial readings of 0.9 and 10 so that the scale in this region is logarithmic. This results in a constant angular displacement for a given percent unbalance. From 10 to ∞ , the rheostat is lin-

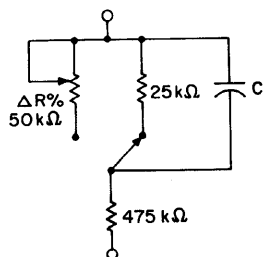

Figure 4-2. Bridge circuit with $\Delta R\%$ control added.

ear which yields a simple inverse scale. The rheostat has a mechanical compensating mechanism which can be set to give a tracking accuracy far better than 1%.

The resistor R_P represents a fixed 500-k Ω resistor unless the $\Delta R\%$ switch is depressed to put the $\Delta R\%$ adjustment in the circuit (see Figure 4-2). When R_2 is in the circuit, R_P may be adjusted $\pm 5\%$ which gives a $\pm 5\%$ change in the balance adjustment. This small adjustment is used for precise substitution measurements of small changes of resistance. The $\Delta R\%$ switch, S104, has a spring return so that this adjustment will not be left in the circuit accidentally and thereby cause an error in the main R dial indication. The capacitor C is added to avoid a switching transient when R_2 is added to, or removed from, the circuit.

The ratio-arm resistors, R_S , are selected by the RESISTANCE MULTIPLIER switch. The lowest range uses a wire-wound ratio-arm resistor, the next six ranges use metal film-type resistors, and the three highest ranges use high-valued carbon-film types. Because the carbon-film resistors are less stable, the three highest ranges are adjustable and may be set precisely using the calibration procedure described in paragraph 5.4.1.

Both ends of the ratio-arm resistors are switched and the unused resistors are guarded to avoid leakage resistance between terminals of switch wafers (see Figure 5-7). The two highest ratio-arm resistors actually consist of two T networks, as shown in Figure 4-3. This is done so that more stable, lower-valued resistors may be used, trimming adjustments can be made with rheostats of reasonable values, and the bridge output impedance is small enough to minimize time-constant problems (refer to paragraph 3.3.3). These T networks are equivalent to Δ networks as explained in paragraph 3.6.3. The loading on the adjustment R_N is always greater than 10 M Ω , which causes negligible error. The use of the T's does reduce the bridge sensitivity, however. The ratio between

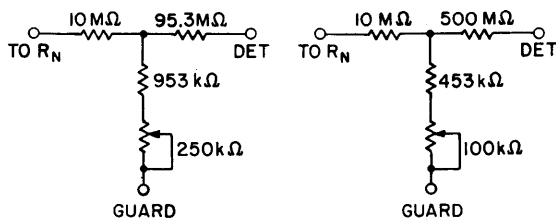

Figure 4-3. The ratio-arm T networks for the two highest ranges.

the voltage on R_N and R_S is always 1/100th or less of the voltage on R_P and R_X . This large "bridge ratio" results in less sensitivity than would be available if it were smaller, but has the following advantages:

- The standard is 1/100th or less of the unknown resistor and, therefore, on many ranges it is a much more stable resistor than any unknown resistor would be. For example, resistors up to 100 M Ω are measured using wire-wound standards, and resistors to 10 G Ω are measured using 1/4% metal-film types.
- The voltage applied to the unknown varies by only 1% over the entire range of R_N . (This would be 10% on a bridge with a 10-to-1 ratio.)
- Because R_S is smaller, several effects resulting from high bridge output impedance, such as time-constant problems in capacitance measurement, and capacitance pickup and zero shift resulting from grid current on the highest ranges, are reduced.
- Because a much lower voltage is applied to R_S than to R_X , changes in R_S due to its voltage coefficient are negligible. This is particularly important when voltage coefficients are measured with the $\Delta R\%$ dial.

The use of the T networks on the highest ranges can be considered as a further increase of this bridge ratio.

The bridge is mounted on a subpanel which is tied to the GUARD point which is the low side of the detector. Both UNKNOWN terminals are mounted on a plate connected to this GUARD point to avoid any leakage resistance across the UNKNOWN terminals. Leakage resistance from any point on the bridge to GUARD causes negligible effect if it is over 200 M Ω or so. This value is easily obtained with good insulating materials.

In use, either the GUARD point or the - UNKNOWN terminal can be tied to the panel ground. In the latter case, there may be a high voltage between the subpanel and the outside panel.

When the switch on the side of the instrument is set in the CAL position, the ratio-arm resistor normally used for the range selected is connected instead across the UNKNOWN terminals, and the ratio-arm resistor normally used two ranges lower is used as

the standard. Thus, each resistor is checked against one that is 1/100th of its value. (Refer to paragraph 5.4.1.)

4.2 DETECTOR.

The detector circuit consists of a multistage, dc-feedback amplifier, with an electrometer-tube input stage, that drives the panel meter. The over-all sensitivity of the circuit is about 100 $\mu\text{V}/\text{mm}$.

The electrometer tube provides the high input resistance necessary to prevent loading the bridge and, thus, decreasing sensitivity. It also has a very low grid current to avoid appreciable zero shifts when the bridge output resistance is changed as the range is changed. Preceding the input tube is a two-stage RC filter to reduce the effects of pickup. This grid circuit also includes a neon tube, which, with a series resistor, limits the grid current drawn to less than 1 microampere, whatever voltage is applied.

The second stage in the amplifier is also a vacuum tube because of the high plate resistance of the first stage. Following the second stage are a common-collector and then a common-emitter transistor stage. The output voltage is fed back through a divider to the second grid of the input stage. This grid is also used for the ZERO adjustments.

The amplifier output drives the zero-center panel meter. This meter has shaped pole pieces to give high sensitivity near a bridge null and decreased sensitivity up scale. This nonlinearity facilitates balance by eliminating the need for readjustment of the SENSITIVITY control during balance.

The supply voltage for this detector is very well regulated. The heater current in the vacuum tubes is taken from the plate supply and is, thus, also well regulated. The critical voltages on the first stage are further regulated by a low-temperature-coefficient Zener diode.

4.3 TEST-VOLTAGE SUPPLY.

The internal test voltage is regulated by a series regulator using a 2 mosfet transistors as the series element. The reference for this regulator is a Zener diode and the amplifier consists of cascaded transistor stages. The control circuit is connected to the output and has a maximum of only 10 volts across it while the remaining output voltage is dropped across a resistor.

The current through this dropping resistor is adjusted to be precisely 2 ma by the internal ADJ 100 V adjustment and the voltage across the amplifier is adjusted to 10 volts with the ADJ 10 V adjustment. The output voltage is the sum of 10 volts plus 2 ma times the dropping resistor. This resistor is used to change the test voltage. The EXTERNAL ADJ terminals shunt this resistor so that its value may be modified to get intermediate values (refer to paragraph 3.9).

This supply is current-limited to about 6 ma for ranges over 50 volts and to about 14 ma at 50 volts and lower. Shorting the supply will not damage it.

SECTION 5

SERVICE AND MAINTENANCE

**WARNING**

These servicing instructions are for use by qualified personnel only. To avoid electric shock, do not perform any servicing other than that contained in the operating instructions unless you are qualified to do so. Dangerous voltages are present inside this case. When troubleshooting, a ground strap should be connected between GUARD and GROUND on panel to keep subpanel (Guard) at ground potential. Refer all servicing to qualified service personnel.

5.1 WARRANTY.

The warranty attests the quality of materials and workmanship in our products. When difficulties do occur, our service engineers will assist in any way possible. If the difficulty cannot be eliminated by use of the following service instructions, please write or telephone our Service Department at GenRad, 300 Baker Ave, Concord, MA 01742 giving full information of the trouble and of steps taken to remedy it. Be sure to mention the serial and type numbers of the instrument.

5.2 SERVICE.

Before returning an instrument to GenRad for service, please write to our Service Department, 300 Baker Ave, Concord, MA 01742, requesting a Returned Material Tag. Use of this tag will ensure proper handling and identification. For instruments not covered by the warranty, a purchase order should be forwarded to avoid unnecessary delay.

5.3 REMOVAL FROM CABINET.

To remove the instrument from the cabinet, remove the four screws near the panel on the sides of the instrument and pull the instrument up out of the cabinet.

5.4 BRIDGE CALIBRATION.**5.4.1 RATION ARMS.**

The ratio arms (and the R_p -arm resistor) may be checked easily without external standards or test equipment. Resistance between the UNKNOWN terminals will not interfere with the calibration, but impedance between the - UNKNOWN and GUARD terminals will cause calibration error. The eight lower-valued arms should maintain their values accurately for many years, but the three highest-valued units are less stable. They can be adjusted to value as follows:

- a. Set the function switch to DISCHARGE. Adjust the sensitivity control.
- b. Set the VOLTAGE ON UNKNOWN switch to 10 v.
- c. Connect the captive link between the GUARD terminal and the panel ground terminal.
- d. Rotate the measure-calibrate screw-driver control on the right-hand side of the instrument (see Figure 5-1) fully clockwise.
- e. Set the RESISTANCE MULTIPLIER switch to 100 k Ω .
- f. Set the function switch to CHARGE-ZERO and zero the bridge with the COARSE ZERO and FINE ZERO controls.

TABLE 5-1 - RATIO-ARM RESISTORS

RESISTANCE MULTIPLIER Setting	100 k Ω	1 M Ω	10 M Ω	100 M Ω	1 G Ω
Resistor Used as Standard	R105 (10 Ω)	R106 (100 Ω)	R107 (1 K Ω)	R108 (10 k Ω)	R109 (100 k Ω)
Resistor Used as Unknown	R107 (1 k Ω)	R108 (10 k Ω)	R109 (100 k Ω)	R110 (1 M Ω)	R111 (10 M Ω)

- g. Set the function switch to MEASURE and balance the bridge. It should balance near a reading of 1. Make note if the balance point differs from 1 by more than 1/2% (1/4 dial division).
- h. Set the RESISTANCE MULTIPLIER switch to each range up to 1 G Ω , in turn. For each range, rezero the meter and then balance the bridge. Note any ranges that do not balance within 1/2%.
- i. If any measurements are off, the resistor in error can be identified by the chart of Table 5-1. Note that the 10- Ω , 100- Ω , 1-M Ω , and 10-M Ω resistors appear only once in this table. An error in any one of these would cause only one inaccurate balance. Values in between would cause two inaccurate balances that would be off in opposite directions. If all the values are off in the same direction, R_p is in error.
- j. Set the RESISTANCE MULTIPLIER switch to 10 G Ω and set the main R dial to 1. Balance the bridge by means of the adjustment on the side of the instrument in the left-hand hole (see Figure 5-1).
- k. Repeat step i. for the 100-G Ω and 1-T Ω ranges, making the balance with the middle and right-hand adjustments, respectively (see Figure 5-1).

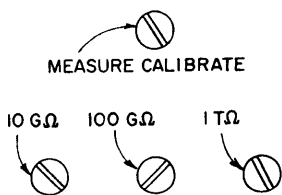

Figure 5-1. Calibration controls for the three highest ratio arms. The measure-calibrate switch is shown in the measure position. Rotate the switch clockwise to calibrate.

5.4.2 MAIN DIAL.

To check the accuracy of the main dial, set the MEASURE-CALIBRATE switch to measure, connect a decade resistance box to the UNKNOWN terminals and measure at various points over the dial range. A Type GenRad 1433-Q Decade Resistor (1 M Ω in 100- Ω steps) that permits readings up to 1000 (1 k) on the 1-k Ω range is recommended.

The main dial should give readings to approximately 1/2% over the range from 0.9 to 10 and to an equivalent scale distance (approximately 1/2 mm) over the rest of the range. If the readings differ by substantially more than this, the main rheostat should be readjusted.

To readjust the main rheostat, use a dc bridge with an accuracy of $\pm 0.1\%$. Remove the Type 1644-A from its cabinet and swing the detector board out on its cable. (Unsolder leads to terminals 1 and 2 on the board and remove the screws at the corners of the board.) Disconnect one of the internal leads that is connected to the rheostat and connect the dc bridge across the rheostat.

The main rheostat has a mechanism that permits accurate adjustment at eight points with adjustment screws. Table 5-2 lists the dial readings and resistance values for these eight points and for intermediate points that should also be within $\pm 1/2\%$ or 2-1/2 ohms, whichever is larger. These adjustments are numbered clockwise starting at the slot in the cam plate. After any adjustments are made, rotate the dial over its entire range and recheck all points.

TABLE 5-2
MAIN DIAL CALIBRATION

Dial Reading	Resistance	Screw Adjustment
0.9	5556 Ω	-
1.0	5000 Ω	1
1.3	3846 Ω	-
1.5	3333 Ω	2
1.9	2632 Ω	-
2.5	2000 Ω	3
3.2	1563 Ω	-
4.0	1250 Ω	4
5.0	1000 Ω	-
6.3	793.7 Ω	5
8.0	625.0 Ω	-
10.0	500.0 Ω	6
13.0	384.6 Ω	-
20.0	250.0 Ω	7
32.0	156.3 Ω	-
100.0	50.0 Ω	8
200.0	25.0 Ω	-
∞	0.0 Ω	-

5.5 TEST-VOLTAGE ADJUSTMENTS.

To check the test voltages connect an accurate, high-impedance voltmeter between the UNKNOWN terminals and set the function switch to CHARGE-ZERO. Connect the link between the GUARD terminal and the chassis ground terminal to keep the negative terminal of the voltmeter near ground potential. The test voltages should be within $\pm 3\%$. They will vary 1% over the range of the R dial so that, if they are readjusted, the R dial should be set to 2 to obtain center values.

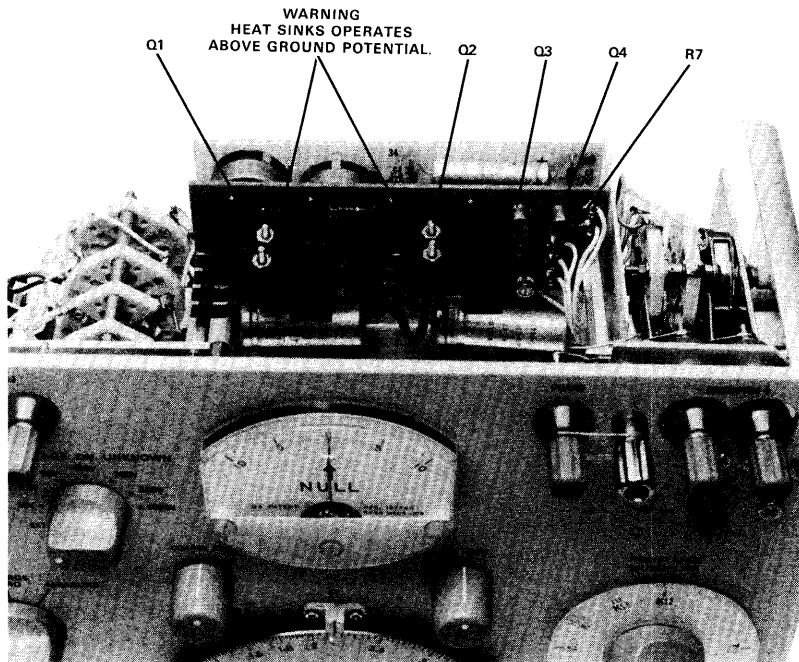

5-1A Top View.

The test voltages may be readjusted by means of the internal adjustments R509 and R513 (located on the 1644-2712 board) (see Figure 5-2). R509 should be set to give 10 volts and R513 to give 100 volts (with the corresponding settings of the VOLTAGE ON UNKNOWN switch). If these voltages are correct, but others are in error, the fault is with one of the dropping resistors, R517 through R527. If the voltages are way off, check the circuit voltages against those of Tables 5-3 and 5-4 to help determine the faulty component.

The voltages in Tables 5-3 and 5-4 are measured under the following conditions:

- Function switch set to CHARGE-ZERO
- RESISTANCE MULTIPLIER switch set to 1 k
- Measure-calibrate switch set to measure
- VOLTAGE ON UNKNOWN switch set to 10 v
- Power-line voltage of 115 volts.

5.5.1 CURRENT LIMIT ADJUSTMENTS

WARNING

The heat sinks on the 1644-4730 board operates above ground potential. Use an insulated tool if adjustment of R7 is required.

Set the function switch to discharge. Connect a milliammeter between the unknown terminals.

Set the initial conditions:

- Voltage on unknown switch set to 10V
- Resistance multiplier switch to 1 K
- R dial fully ccw ∞
- function switch set to charge-zero

Measure current according to Table 5-4.

**TABLE 5-3
DETECTOR VOLTAGES**

Connect the captive link between the ground and GUARD terminals. Adjust R231 for 35.0 volts dc between TP1 and ground.

Tube or Transistor (Type)	Pin	DC Volts to Ground	Tube or Transistor (Type)	Pin	DC Volts to Ground
V201 (CK5886)	1	10.8	Q202 (2N910)	C	32.5
	2	6.65		B	26.0
	3	3.20		E	25.5
	4	2.0	Q203 (2N910)	C	27.5
	7	0.0		B	18.0
		E		17.5	
V202 (CK6418)	1	26.0	Q204 (2N1304)	C	45.7
	2	25.7		B	27.5
	3	13.1		E	27.4
	4	10.8	Q205 (2N1131)	C	35.0
	5	11.8		B	45.7
		E		46.5	

TABLE 5-4

Test Voltage	Current
10.V	14.0 MA (Adjust R7 if necessary)
20.V	14.0 ± .5 MA
50.V	14.0 ± .5 MA
100.V	6.0 ± .5 MA
200.V	6.0 ± .5 MA
500.V	6.0 ± .5 MA
1000.V	6.0 ± .5 MA

5.6.2 DETECTOR SUPPLY VOLTAGE.

The detector supply voltage from TP1 to AT12 should be 35 volts. This is set using R231 (see Figure 5-2).

**TABLE 5-5
POWER SUPPLY VOLTAGES**

Connect the captive link between the ground and - UNKNOWN terminals. Adjust R509 for 10.0 volts dc across the UNKNOWN terminals.

(Board 1644-4730)

Transistor (Type)	DC Volts to Ground	
Q ₁ (MTPIN100)	G	89.0
	D	185.0
	S	90.0
Q ₂ (MTPIN100)	G	2.9
	D	90.0
	S	0
Q ₃ (2N3440)	C	2.9
	B	0
	E	-1.6
Q ₄ (SN3440)	C	46.0
	B	.4
	E	-1.6
Q501 (2N910)	C	6.6
	B	2.7
	E	2.1
Q502 (2N1131)	C	2.7
	B	4.7
	E	5.5

6.7 TROUBLE SHOOTING.

5.7.1 NOISY OR ERRATIC BALANCE.

If the bridge has not been used in some time, surface contamination in the wire-wound R or ΔR% adjustment may cause erratic behavior of the null indicator. To remedy this situation, rotate these controls over their ranges several times.

5.7.2 LOW BRIDGE SENSITIVITY.

To check the bridge sensitivity proceed as follows:

- a. Set the VOLTAGE ON UNKNOWN switch to 10 v, the measure-calibrate switch (on the side panel) to calibrate (fully clockwise), the SENSITIVITY control fully clockwise, and the RESISTANCE MULTIPLIER to 100 kΩ.
- b. Balance the bridge. It should balance near 1.

A 1% change in the ΔR% dial is 1 millivolt and should give a 2-1/2-division deflection. If the gain is insufficient, check the voltage in the detector board and compare them with those of Table 5-3. This should help locate a faulty component.

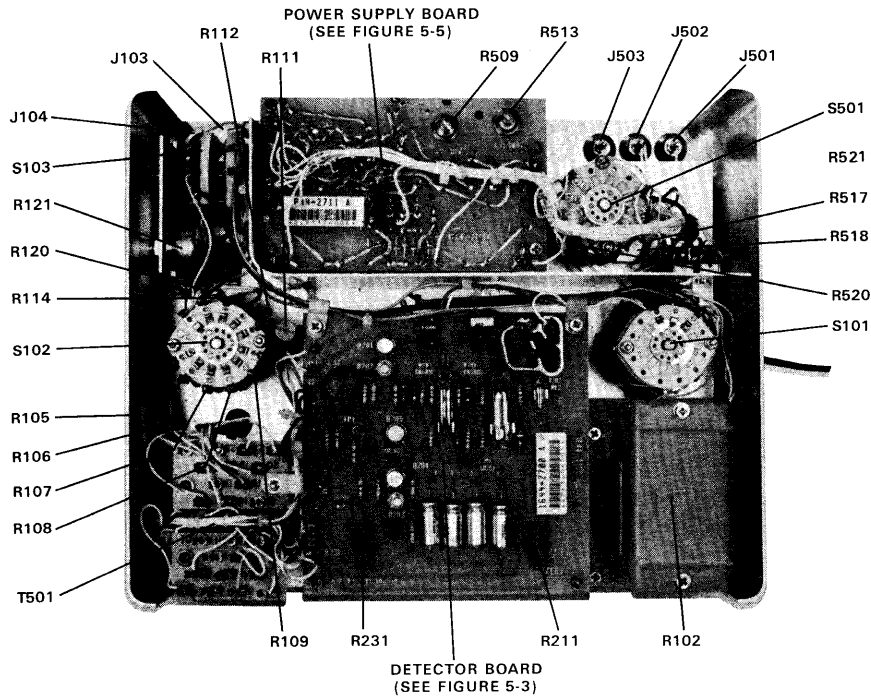

Figure 5-2. Interior view of the Type 1644-A.

5.7.3 INABILITY TO BALANCE OR LARGE ERROR.

If the bridge does not balance, several things should be considered before the bridge is returned for service:

- a. Make sure that the measure-calibrate switch (side panel) is in the measure position (counterclockwise), see Figure 5-1. The bridge will always balance near 1 when this switch is in the calibrate position.
- b. Make sure that the component is correctly connected.
- c. Check all panel switch settings.
- d. Try measuring a known resistor.
- e. Refer to paragraph 3.11 for measurement of high-valued resistors and to paragraph 3.12 for measurements under adverse conditions.

5.8 SWITCH REMOVAL-REPLACEMENT.

5.8.1 REMOVAL.

To remove the knobs:

- a. Set the controls full ccw (any position for R knob).
- b. Hold the instrument securely and pull the knob off with the fingers.

CAUTION

Do not use a screwdriver or other instrument to pry off the knob if it is tight, since this might mar or crack the dial. Do not lose the retention spring in the knob when the knob is removed. Do not attempt to further remove any part of the large R control, since this control must be calibrated at a GR service center when the control is reinstalled.

- c. Remove the setscrew from the bushing; use a hex-socket key wrench.
- d. Remove the bushing.

NOTE

If the knob and bushing are combined when the knob is removed, turn a machine tap a turn or two into the bushing on the dial for sufficient grip for easy separation of the knob.

- e. If the switch is to be removed, remove the dress nut exposed after step d.

5.8.2 REPLACEMENT.

Install the switches by reversing the removal procedure and performing the following steps:

- a. Make sure the control shafts are turned full ccw.
- b. Install the dress nut, if applicable.
- c. Install the bushing on the shaft; tighten the setscrew.

NOTE

Make sure that the end of the shaft does not protrude through the bushing, or the knob won't seat properly.

- d. Install the knob on the bushing, making sure the retention spring is opposite the setscrew.

NOTE

If the retention spring in the knob comes loose, reinstall it in the interior notch with the thin flange set into the small slit in the wall of the knob

5.9 ELAPSED-TIME INDICATOR.

An elapsed-time indicator is furnished to show the actual total elapsed hours that the instrument has been operated. It is mounted inside the case adjacent to S103, the MEASURE CALIBRATE Switch (Figure 5-2) and indicates up to 5000 hours elapsed time. It is a glass capillary tube marked with 10 graduations that read 0 through 5000. Elapsed time is indicated by the height of an electrolytic column in the tube.

The indicator is non-reversible and should be replaced when it gets to full scale reading. It is mounted in a polarized fuse clip for easy replacement. Polarity is indicated by the size of the electrode at each end.

WARNING

The elapsed time indicator contains a corrosive liquid. When replacing the indicator element use caution and proper tools. Do not use a screwdriver to pry off the indicator. The glass tube may fracture causing contamination of the instrument or minor injury. A cartridge fuse-puller is a suitable tool for extraction of the element.

MECHANICAL PARTS LIST

Qty.	Figure Ref. No.	Name	Description	GR Part No.	FMC	Mfg. Part No.	Federal Stock No.
6	1	Insulator	Insulator	0938-7120	24655	0938-7120	
4	2	Binding post	Binding post, J501, EXTERNAL; J502, EXTERNAL; J503, EXTERNAL; J101, GUARD	0938-3003	24655	0938-3003	
1	3	Knob	Knob, VOLTAGE ON UNKNOWN, including retainer 5220-5402	5500-5321	24655	5500-5321	
1	4	Meter cover	Meter cover	5720-3713	24655	5720-3713	
1	5	Shorting link	Shorting link	5080-4800	24655	5080-4800	5940-927-7452
1	6	Binding post	Binding post, J102, Ground	0938-3022	24655	0938-3022	5940-130-8081
2	7	Binding post	Binding post, J103, -UNKNOWN; J104, +UNKNOWN	0938-4258	24655	0938-4258	
2	8	Knob	Knob, FINE ZERO; COARSE ZERO, including retainer 5220-5402	5520-5221	24655	5520-5221	
1	9	Dial asm.	Dial asm.	1644-1040	24655	1644-1040	
1	10	Knob	Knob, RESISTANCE MULTIPLIER, including retainer, 5220-5401	5500-5420	24655	5500-5420	
1	11	Stop	Stop, rubber bumper to stop instrument rotation	5260-0700	24655	5260-0700	5340-738-6329
2	12	Indicator	Indicator, R; $\Delta R\%$	5460-1303	24655	5460-1303	
1	13	Knob	Knob, SENSITIVITY, including retainer 5220-5402	5520-5321	24655	5520-5321	
2	14	Knob	Knob, verrier for R Dial; $\Delta R\%$, including retainer 5220-5401	5520-5420	24655	5520-5420	
1	15	Dial asm.	Dial asm., R	1644-1510	24655	1644-1510	
1	16	Knob	Knob for R dial, including retainer 5220-5401	5520-5520	24655	5520-5520	
1	17	Switch	Switch, pushbutton, DEPRESS TO USE ΔR , S104	7870-1514	81073	7-26 (gray)	
1	18	Dress nut	Dress nut, 15/32-32, 7/16	5800-0800			
1	19	Dial asm.	Dial asm., $\Delta R\%$	1644-1500			
1	20	Knob	Knob, CHARGE, including retainer 5220-5401	5500-5421			
1		Power cord	Power cord, PL501	4200-1903			

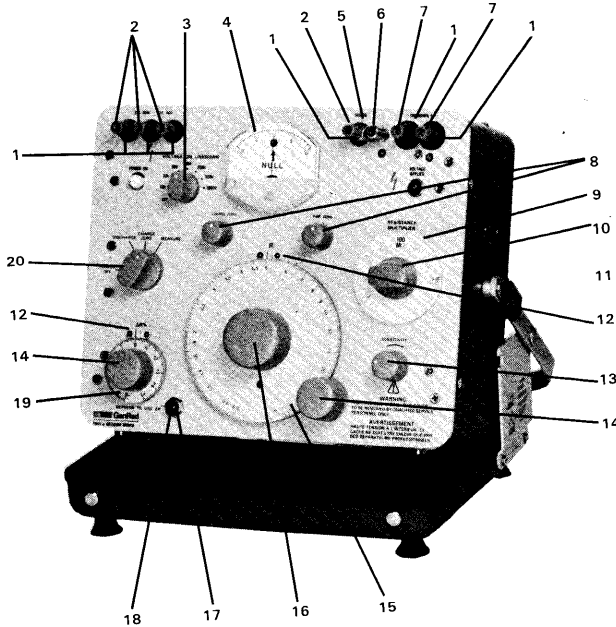

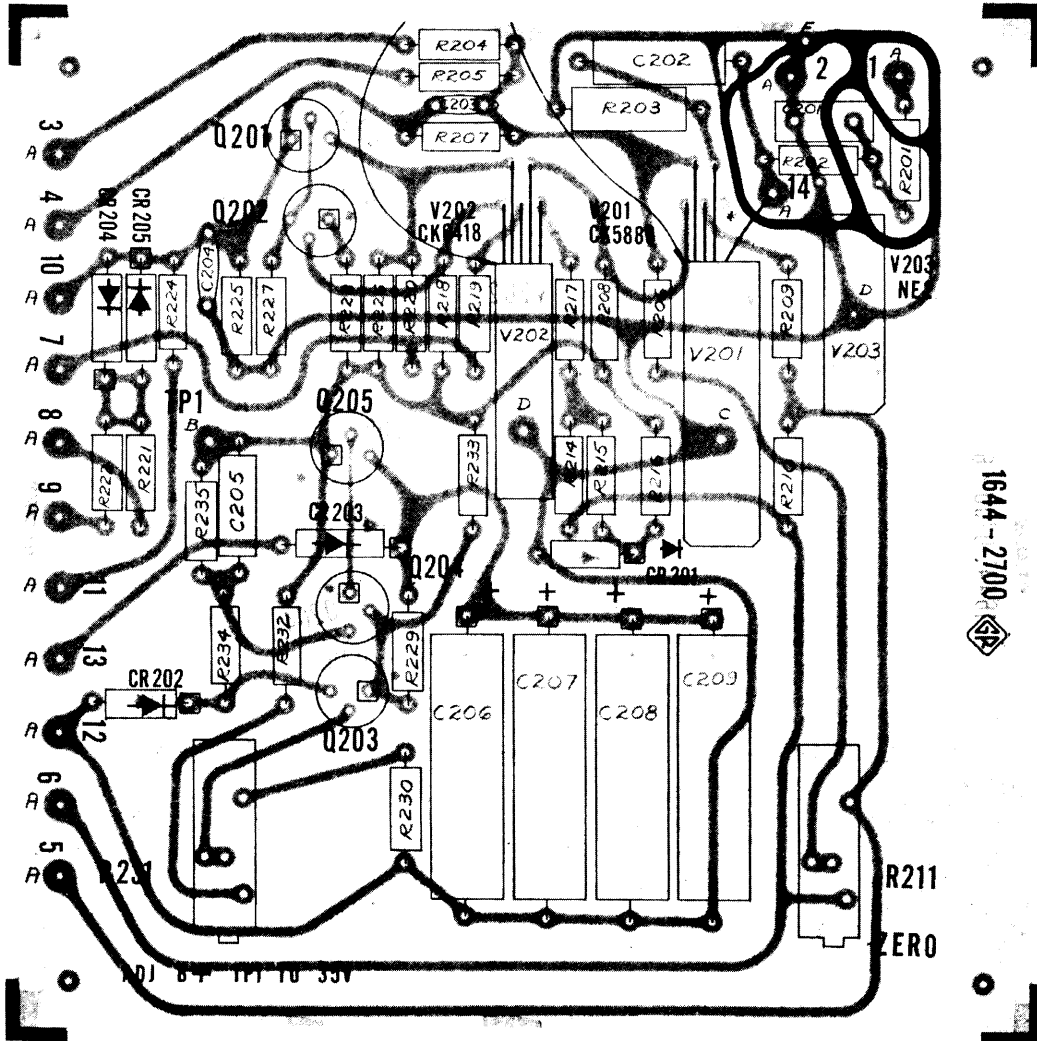

Figure 5-3. Etched-board layout for detector circuit

ELECTRICAL PARTS LIST

DETECTOR CIRCUIT PC BOARD P/N 1644-2700

REFDES	DESCRIPTION	PART NO.	FMC	MFGK	PART NUMBER
C 201	CAP MICA 470PF 10PCT 500V	4700-0600	81349	CM05FD471KN	
C 202	CAP MYLAR .001UF 10 PCT 200V	4860-7309	56289	410P .001 UF 10PCT	
C 203	CAP CER DISC 100PF 80/20PCT 500V	4404-1109	72982	0831082Z5U00101Z	
C 204	CAP CER DISC .047/.05UF80/20 100V	4403-3500	56289	0845024Z5U05032	
C 205	CAP CER TUB 100PF 10PCT 500V NM	4400-4600	72982	0315 000 R3A0 101 K	
C 206	CAP ALUM 30 UF 75V	4450-6173	56289	43D300G075	
C 207	CAP ALUM 30 UF 75V	4450-6173	56289	43D300G075	
C 208	CAP ALUM 30 UF 75V	4450-6173	56289	43D300G075	
C 209	CAP ALUM 30 UF 75V	4450-6173	56289	43D300G075	
CR 201	ZENER 1N935 9V .5PCT .35W	6083-1026	03877	1N935	
CR 202	ZENER 1N967B 18V 5PCT .4W	6083-1016	14433	1N967B	
CR 203	DIODE RECTIFIER 1N4003	6081-1001	14433	1N4003	
CR 204	DIODE 1N191 90PIV IR 125UA GE	6082-1008	14433	1N191	
CR 205	DIODE 1N191 90PIV IR 125UA GE	6082-1008	14433	1N191	
Q 201	TRANSISTOR 2N1377	8210-1377	01295	2N1377	
Q 202	TRANSISTOR 2N910	8210-1037	04713	2N910	
Q 203	TRANSISTOR 2N910	8210-1037	04713	2N910	
Q 204	TRANSISTOR 2N1304	8210-1304	01295	2N1304	
Q 205	TRANSISTOR 2N1131	8210-1025	04713	2N1131	
R 201	RESISTOR	1644-0420	24655	1644-0420	
R 202	RESISTOR	1644-0420	24655	1644-0420	
R 203	RES WW MOLDED 200 OHM 5 PCT 2W	6760-1205	75042	BWH 200 OHM 5PCT	
R 204	RES COMP 10 M 5PCT 1/2W	6100-6105	81349	RCR20G106J	
R 205	RES COMP 150 K 5PCT 1/2W	6100-4155	81349	RCR20G154J	
R 206	RES COMP 22 K 5PCT 1/2W	6100-3225	81349	RCR20G223J	
R 207	RES COMP 2.2 M 5PCT 1/2W	6100-5225	81349	RCR20G225J	
R 208	RES COMP 4.7 M 5PCT 1/2W	6100-5475	81349	RCR20G475J	
R 209	RES COMP 150 OHM 5PCT 1/2W	6100-1155	81349	RCR20G151J	
R 210	RES COMP 390 OHM 5PCT 1/2W	6100-1395	81349	RCR20G391J	
R 211	POT WW TRM 5K OHM 10 PCT 20T	6051-2509	80294	3005P-1-502	
R 214	RES COMP 120 OHM 5PCT 1/2W	6100-1125	81349	RCR20G121J	
R 215	RES COMP 110 OHM 5PCT 1/2W	6100-1115	81349	RCR20G111J	
R 216	RES COMP 6.2 K OHM 5PCT 1/2W	6100-2625	81349	RCR20G622J	
R 217	RES COMP 270 OHM 5PCT 1/2W	6100-1275	81349	RCR20G271J	
R 218	RES COMP 100 K 5PCT 1/2W	6100-4105	81349	RCR20G104J	
R 219	RES COMP 470 OHM 5PCT 1/2W	6100-1475	81349	RCR20G471J	
R 220	RES COMP 750 OHM 5PCT 1/2W	6100-1755	81349	RCR20G751J	
R 221	RES COMP 10 K 5PCT 1/2W	6100-3105	81349	RCR20G103J	
R 222	RES COMP 1.0 K 5PCT 1/2W	6100-2105	81349	RCR20G102J	
R 224	RES COMP 300 OHM 5PCT 1/2W	6100-1305	81349	RCR20G301J	
R 225	RES COMP 20 K OHM 5PCT 1/2W	6100-3205	81349	RCR20G203J	
R 226	RES COMP 820 OHM 5PCT 1/2W	6100-1825	81349	RCR20G821J	
R 227	RES COMP 47 K 5PCT 1/2W	6100-3475	81349	RCR20G473J	
R 228	RES COMP 4.7 K 5PCT 1/2W	6100-2475	81349	RCR20G472J	
R 229	RES COMP 470 K 5PCT 1/2W	6100-4475	81349	RCR20G474J	
R 230	RES COMP 20 K OHM 5PCT 1/2W	6100-3205	81349	RCR20G203J	
R 231	POT WW TRM 5K OHM 10 PCT 20T	6051-2509	80294	3005P-1-502	
R 232	RES COMP 20 K OHM 5PCT 1/2W	6100-3205	81349	RCR20G203J	
R 233	RES COMP 22 K 5PCT 1/2W	6100-3225	81349	RCR20G223J	
R 234	RES COMP 4.7 K 5PCT 1/2W	6100-2475	81349	RCR20G472J	
R 235	RES COMP 4.7 K 5PCT 1/2W	6100-2475	81349	RCR20G472J	
V 201	TUBE VACUUM	8380-5887	24655	8380-5887	
V 202	TUBE VACUUM CK6418	8380-6418	49956	CK6418	
V 203	GE NEON LAMP NE 2	8390-0200	24455	NE-2 (A1A)	

ELECTRICAL PARTS LIST

CHASSIS MOUNTED PARTS

REFDES	DESCRIPTION	PART NO.	FMC	MFR	PART NUMBER
F 501	FUSE SLO-BLOW 2/10A 250V	5330-0600	75915	313	.200
F 502	FUSE SLO-BLOW 2/10A 250V	5330-0600	75915	313	.200
J 101	BINDING POST ASM	0938-3003	24655	0938-3003	
J 102	BINDING POST ASM	0938-3022	24655	0938-3022	
J 103	BINDING POST	0938-4258	24655	0938-4258	
J 104	BINDING POST	0938-4258	24655	0938-4258	
J 501	BINDING POST ASM	0938-3003	24655	0938-3003	
J 502	BINDING POST ASM	0938-3003	24655	0938-3003	
J 503	BINDING POST ASM	0938-3003	24655	0938-3003	
M 201	METER	5730-1090	24655	5730-1090	
P 501	SOCKET AND LAMP ASM	7510-1360	24655	7510-1360	
P 502	SOCKET AND LAMP ASM	7510-1380	24655	7510-1380	
PL 501	CORD 3WR 10A 120V US 5.5FTHAMMER	4200-1903	24655	4200-1903	
R 101	POTENTIOMETER	0433-4120	24655	0433-4120	
R 103	POTENTIOMETER	0975-4060	24655	0975-4060	
R 105	RES GR 9.92 OHM .25 PCT 1W	6983-1000	24655	6983-1000	
R 106	RES FLM 100OHM 1/10PCT 50PPM1/2W	6188-0100	81349	RN70C1000B	
R 107	RES FLM 1 K 1/10PCT 50PPM1/2W	6188-1100	81349	RN70C1001B	
R 108	RES FLM 10 K 1/10PCT 50PPM1/2W	6188-2100	81349	RN70C1002B	
R 109	RES FLM 100 K 1/10PCT 50PPM1/2W	6188-3100	81349	RN70C1003B	
R 110	RES FLM 1M 1/4 PCT 50PPM 1/2W	6193-4100	81349	RN70C1004C	
R 111	RES FLM 10M 1/4PCT 50PPM 2W	6195-5100	81349	RN80C1005C	
R 112	RES FLM 95.3M 2 PCT 1/2W	6619-3408	24655	6619-3408	
R 113	POT COMP SCDR 10M OHM 20PCT LIN	6010-2800	01121	JA1G0325106MZ	
R 114	RES FLM 95.3M 2 PCT 1/2W	6619-3408	24655	6619-3408	
R 115	RES FLM 10 M 1PCT 100PPM 1/4W	6188-5100	24655	6188-5100	
R 116	RES FLM 953K 1 PCT 1/8W	6250-3953	81349	RN5509533F	
R 117	POT COMP SCDR 250KOHM 10PCT LIN	6010-2000	01121	JA1G0325254UZ	
R 118	RES FILM CARBON 500M OHM 2 PCT	6740-1500	63060	RX-1	
R 119	RES FLM 10 M 1PCT 100PPM 1/4W	6188-5100	24655	6188-5100	
R 120	RES FLM 475K 1 PCT 1/8W	6250-3475	81349	RN5504753F	
R 121	POT COMP SCDR 100KOHM 10PCT LIN	6010-1700	01121	JA1G0325104UZ	
R 122	RES FLM 110K 1 PCT 1/2W	6450-3110	81349	RN6501103F	
R 212	POTENTIOMETER	0971-3913	24655	0971-3913	
R 213	POTENTIOMETER	0971-3913	24655	0971-3913	
R 223	POT COMP KNOB 10K OHM 10PCT LOG	6020-0400	01121	JA1N0565103AZ	
R 517	RES FLM 249K 1 PCT 2W	6590-3249	81349	RN8002493F	
R 518	RES FLM 150K 1 PCT 1W	6550-3150	81349	RN7501503F	
R 519	RES FLM 49.9K 1 PCT 1/2W	6450-2499	81349	RN6504992F	
R 520	RES FLM 24.9K 1 PCT 1/4W	6350-2249	81349	RN6002492F	
R 521	RES FLM 15K 1 PCT 1/8W	6250-2150	81349	RN5501502F	
R 522	RES FLM 4.99K 1 PCT 1/8W	6250-1499	81349	RN5504991F	
R 523	RES WW MOLDED 6.8 OHM 5 PCT 2W	6760-9685	75042	BWH 6.8 OHM 5PCT	
R 524	RES WW MOLDED 6.8 OHM 5 PCT 2W	6760-9685	75042	BWH 6.8 OHM 5PCT	
R 525	RES WW AX LEAD 10K OHM 5 PCT 5W	6660-3105	75042	AS-5 10K 5PCT	
S 101	SWITCH ROTARY ASM	7890-3270	24655	7890-3270	
S 102	SWITCH ROTARY ASM	7890-3280	24655	7890-3280	
S 103	SWITCH ROTARY ASM	7890-3290	24655	7890-3290	
S 104	SWITCH PUSHBUTTON SPDT	7870-1514	81073	7-26B	
S 501	SWITCH ROTARY ASM	7890-3300	24655	7890-3300	
T 501	TRANSFORMER POWER	0345-4004	24655	0345-4004	
	ELAPSED TIME INDICATOR	1644-0440		T-0004	
	ELAPSED TIME INDICATOR HCLDER	1644-0441		T-103	
R 537	RES FILM 1 M OHM ± 1%	6250-4100			
R 538	REL FILM 1.5 M OHM ± 1%	6250-4150			

DN

NOTE UNLESS SPECIFIED

- 1 POSITION OF ROTARY SWITCHES
- 2 CONTACT NUMBERING OF SWITCHES
- 3 REFER TO SERVICE NOTES IN INSTRUCTION BOOK FOR VOLTAGE TEST POINTS
- 4 RESISTORS 1/2 WATT
- 5 RESISTANCE IN OHMS
- 6 CAPACITANCE IN MICROFARADS
- 7 KNOB CONTROL
- 8 SCREWDRIVER CONTROL
- 9 AT ANCHOR TERMINAL
- 10 TP TEST POINT

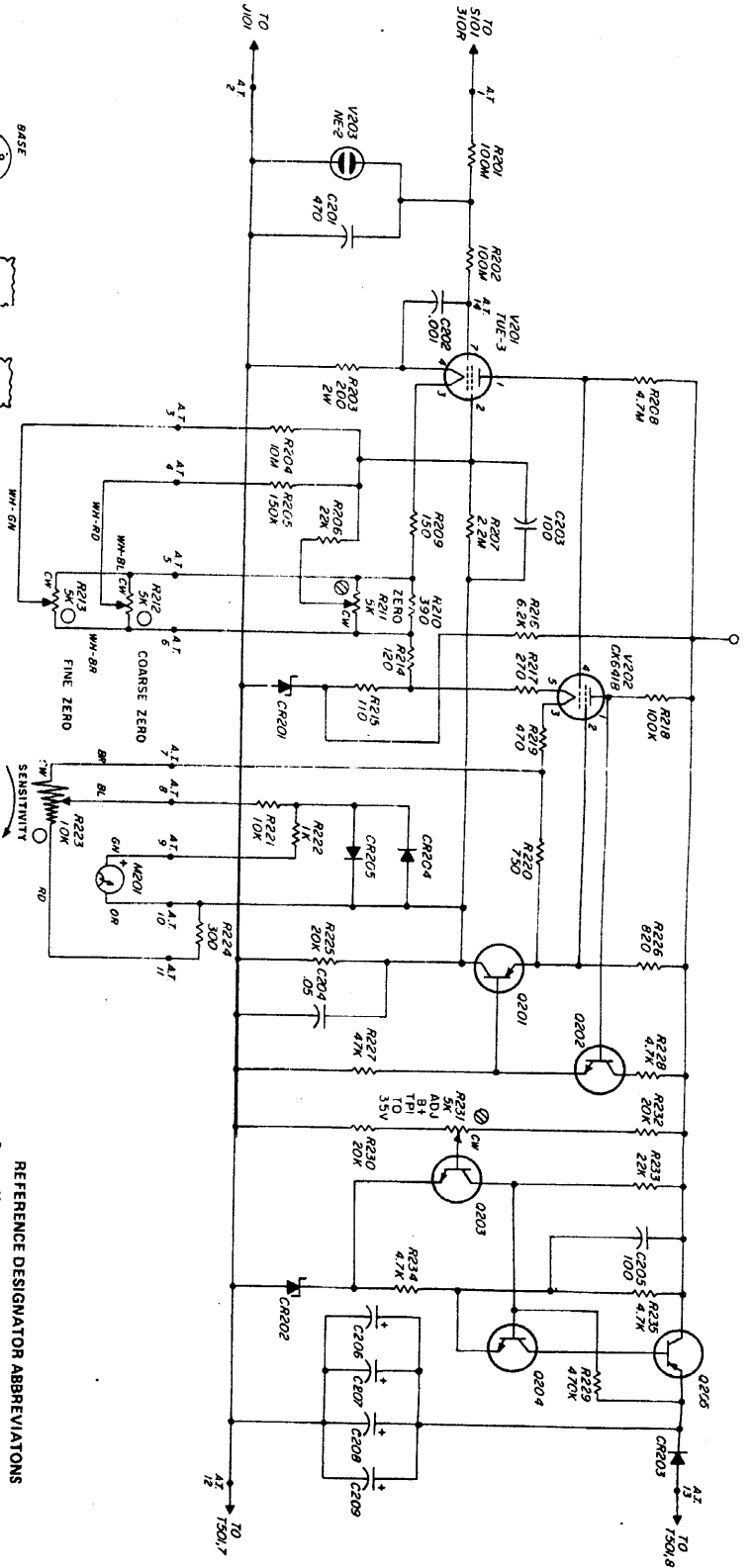
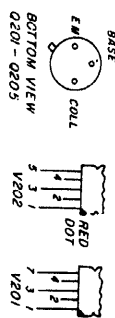

- REFERENCE DESIGNATOR ABBREVIATIONS
- B = Motor
 - BT = Battery
 - C = Capacitor
 - CR = Diode
 - DS = Lamp
 - F = Fuse
 - J = Jack
 - K = Relay Coil
 - KL = Socket for Plug-in
 - KS = Relay Switch
 - L = Inductor
 - M = Meter
 - NK = Microphone
 - P = Plug
 - O = Transistor
 - R = Resistor
 - S = Switch
 - T = Transformer
 - U = Integrated Circuit
 - VR = Diode, Varier
 - X = Socket for Plug-in
 - Y = Crystal
 - Z = Network
- References
ASA Y32-18 and MIL-STD-10C

Figure 5-4. Schematic diagram of detector circuit.

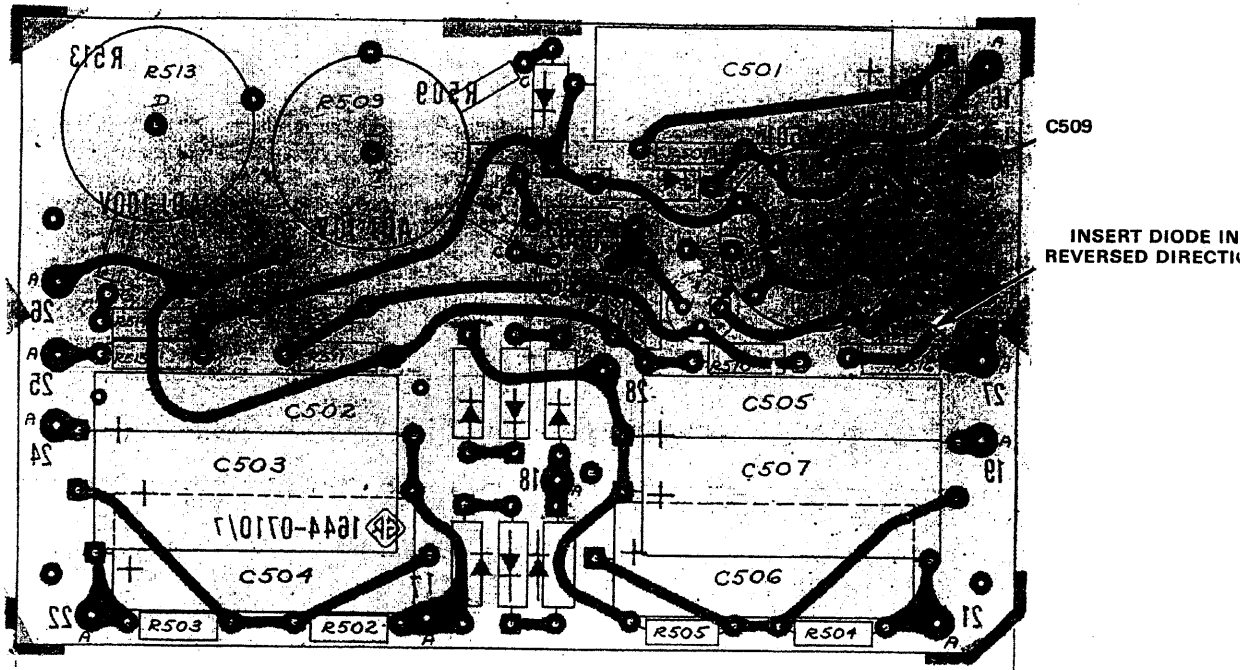
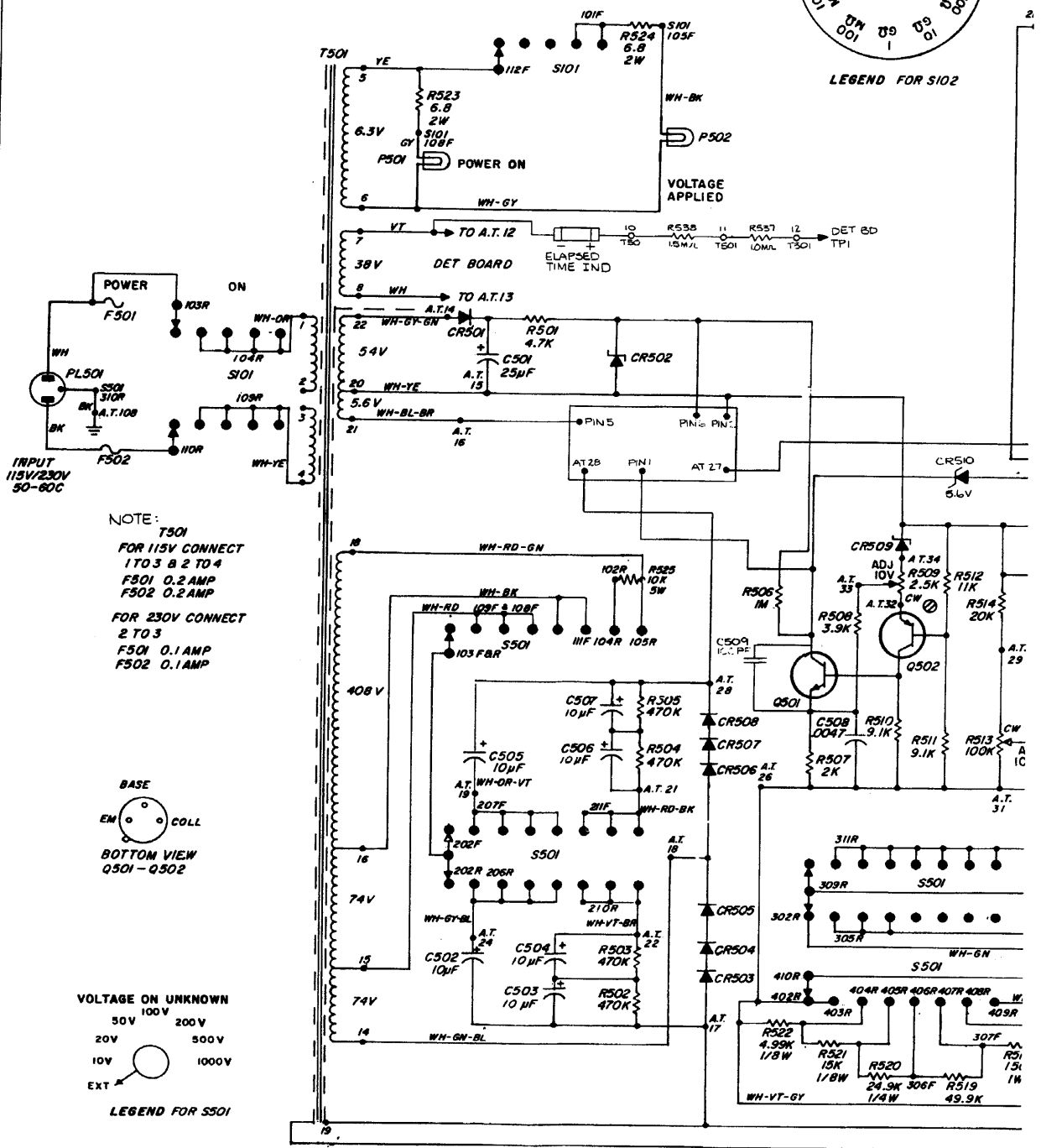
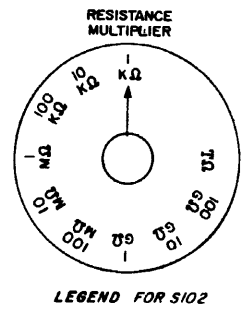
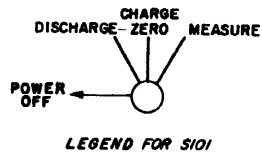

Figure 5-5. Etched-board layout for power supply

ELECTRICAL PARTS LIST

POWER SUPPLY CIRCUIT PC BOARD P/N 1644-2712

REFDES	DESCRIPTION	PART NO.	FMC	MFGR	PART NUMBER
C 501	CAP ALUM 25 UF 100V	4450-5596	56289	30D256G100	
C 502	CAP ALUM 10 UF 250V	4450-2100	90201	TCW 10UF 250V	
C 503	CAP ALUM 10UF 475V	4450-6175	90201	TCG 10UF 475V	
C 504	CAP ALUM 10UF 475V	4450-6175	90201	TCG 10UF 475V	
C 505	CAP ALUM 10 UF 250V	4450-2100	90201	TCW 10UF 250V	
C 506	CAP ALUM 10UF 475V	4450-6175	90201	TCG 10UF 475V	
C 507	CAP ALUM 10UF 475V	4450-6175	90201	TCG 10UF 475V	
C 508	CAP CER DISC 4700PF 10PCT 500V	4407-2478	72982	0811087Z5F00472K	
C 509	CAP CER DISC 100FF 400V	4404-1105			
CR 501	DIODE RECTIFIER 1N4003	6081-1001	14433	1N4003	
CR 502	ZENER LMZ-47A 47V 5PCT 1.5W	6083-1025	24444	LMZ-47.0A 1.5R47B	
CR 503	RECT 1N4005 600PIV .75A SI A50A	6081-1003	14433	1N4005	
CR 504	RECT 1N4005 600PIV .75A SI A50A	6081-1003	14433	1N4005	
CR 505	RECT 1N4005 600PIV .75A SI A50A	6081-1003	14433	1N4005	
CR 506	RECT 1N4005 600PIV .75A SI A50A	6081-1003	14433	1N4005	
CR 507	RECT 1N4005 600PIV .75A SI A50A	6081-1003	14433	1N4005	
CR 508	RECT 1N4005 600PIV .75A SI A50A	6081-1003	14433	1N4005	
CR 509	ZENER 1N748A 3.9V 5PCT .4W	6083-1002	14433	1N748A	
CR 510	ZENER 1N752 3.9V	6083-1004	14433	1N752	
Q 501	TRANSISTOR 2N910	8210-1037	04713	2N910	
Q 502	TRANSISTOR 2N1131	8210-1025	04713	2N1131	
R 501	RES COMP 4.7 K 5PCT 1/2W	6100-2475	81349	RCR20G472J	
R 502	RES COMP 470 K 5PCT 1/2W	6100-4475	81349	RCR20G474J	
R 503	RES COMP 470 K 5PCT 1/2W	6100-4475	81349	RCR20G474J	
R 504	RES COMP 470 K 5PCT 1/2W	6100-4475	81349	RCR20G474J	
R 505	RES COMP 470 K 5PCT 1/2W	6100-4475	81349	RCR20G474J	
R 506	RES COMP 1.0 M 5PCT 1/2W	6100-5105	81349	RCR20G474J	
R 507	RES COMP 2.0 K OHM 5PCT 1/2W	6100-2205	81349	RCR20G202J	
R 508	RES COMP 3.9 K 5PCT 1/2W	6100-2395	81349	RCR20G392J	
R 509	POT COMP SCDR 2.5KOHM 10PCT LIN	6010-0700	01121	JA1G032S252UZ	
R 510	RES COMP 10 K 5PCT 1/2W	6100-3105	81349	RCR20G103J	
R 511	RES COMP 9.1 K OHM 5PCT 1/2W	6100-2915	81349	RCR20G912J	
R 512	RES COMP 11 K OHM 5PCT 1/2W	6100-3115	81349	RCR20G113J	
R 513	POT COMP SCDR 100KOHM 10PCT LIN	6010-1700	01121	JA1G032S104UZ	
R 514	RES COMP 20 K OHM 5PCT 1/2W	6100-3205	81349	RCR20G203J	
R 515	RES COMP 47 OHM 5PCT 1/2W	6100-0475	81349	RCR20G470J	
R 516	RES COMP 62 OHM 5PCT 1/2W	6100-0265	81349	RCR20G301J	
V 501	TUBE VACUUM 7239	8380-7239	02639	7239	



NOTE:
T501
FOR 115V CONNECT
1 TO 3 & 2 TO 4
F501 0.2 AMP
F502 0.2 AMP
FOR 230V CONNECT
2 TO 3
F501 0.1 AMP
F502 0.1 AMP

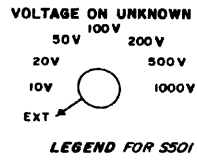
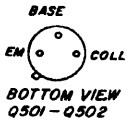

SCHMATIC DIAGRAM
FOR
1644-A MEGOHM BRIDGE

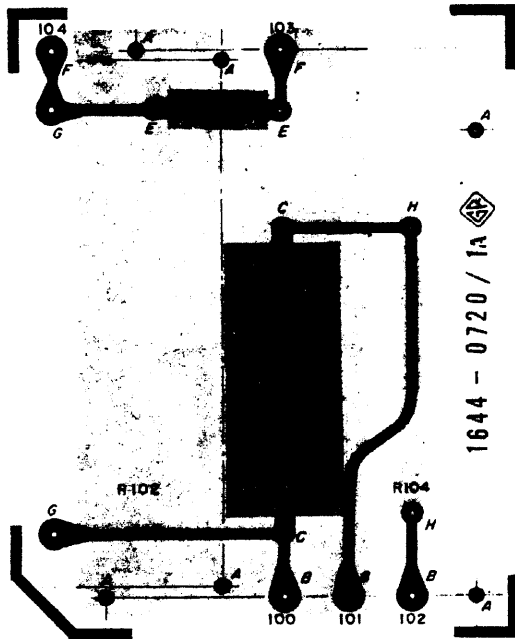

NOTE: The number appearing on the foil side is not the part number.
The dot on the foil at the transistor socket indicates the collector lead.

Figure 5-6. Etched-board layout for bridge circuit (P/N 1644-2721).

ELECTRICAL PARTS LIST

PC BOARD ASM P/N 1644-2721

REFDES	DESCRIPTION	PART NO.	FMC	MFR	PART NUMBER
C 101	CAP MYLAR 1UF 10 PCT 100V	4860-8274	56289	410P	1 UF 10PCT
R 102	RESISTANCE UNIT	0510-2301	24655	0510-	2001
R 104	RES GR 25K OHM .2 PCT 1W	6983-5024	24655	6983-	5024
R 123	RES WM MCLDED 1K OHM 10 PCT 2W	6760-2109	75042	BWH	1 K 10PCT

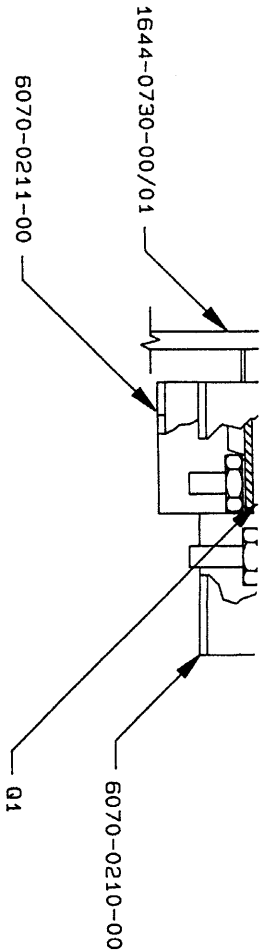

VIEW A-A (TYPICAL)

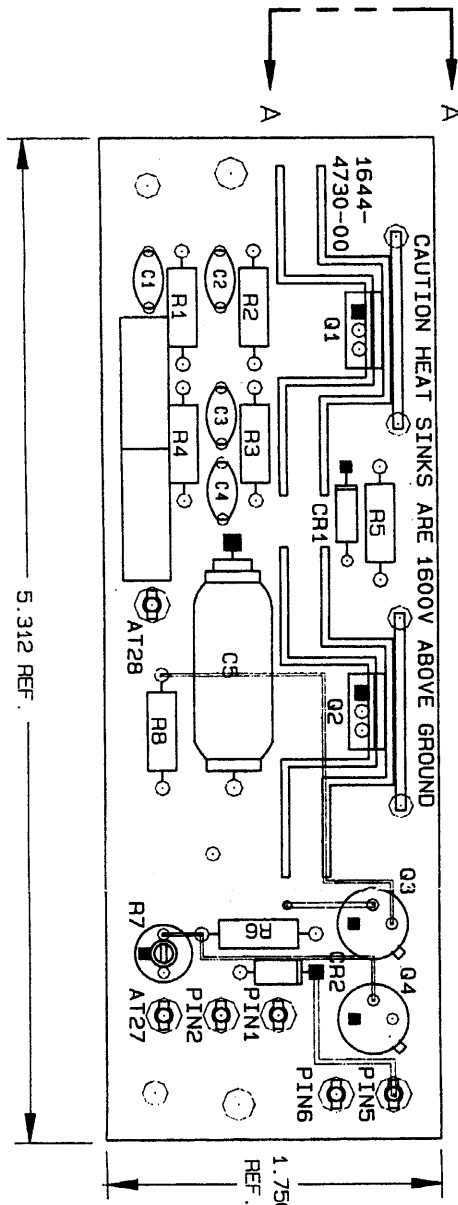

NOTES :

1. BARE BOARD NO. 1644-0730-00 REV. 02
2. BOARD VIEWED FROM COMPONENT SIDE.
3. CIRCUITRY SHOWN, REPRESENTS COMPONENT SIDE.
4. CONTACT FINGERS, IF APPLICABLE, ARE TO BE FREE OF SOLDER AND ADHESIVE .
5. SQUARE PAD ■ DENOTES THE FOLLOWING :
 POSITIVE + END OF CAPACITORS
 ROTOR OF TRIMMER CAPACITORS
 ARM OF POTENTIOMETERS
 COLLECTOR OF TRANSISTORS
 CATHODE END OF DIODES
 PIN # 1 OF IC S, RELAYS, AND CONNECTORS.

TOLERANCES	
UNLESS SPECIFIED ARE	
GIVE TO HOLE ± .015	
NON-DIM.	
HOLE TO HOLE ± .005	
NON-DIM.	
HOLE TO HOLE ± .010	
NON-DIM.	
HOLE TO HOLE ± .015	
NON-DIM.	

PRINT DISTRIBUTION	
1	CP

REGULATOR BOARD COMPLETE									
SHEET 1 OF 1									

PARTS LIST

Item Number: 1644-4730
 Description: REGULATOR BOARD

Comp. Desig.	Item Description	Item No.	Qty
Supports	RADIATOR	10220	2
	HEAT SINK	10220	2
	RADIATOR	112-40	2
	SCREEN PAN	EXT 100TH	2
	MUT. SER LK	EXT 0.250 HEX	4
	MUT. SER LK	EXT 0.250 HEX	4
	CAP ALUM	100 UF 25 V	4
	CAP ALUM	100 UF 25 V	4
	RECT COMP	120 CHM 5% 1/2W	1
	RECT COMP	120 CHM 5% 1/2W	1
	TRANS	2N3440 NS	1
	TRANS	2N3440 NS	1
	REGULATOR	C.089 C X 0.281 BK	1

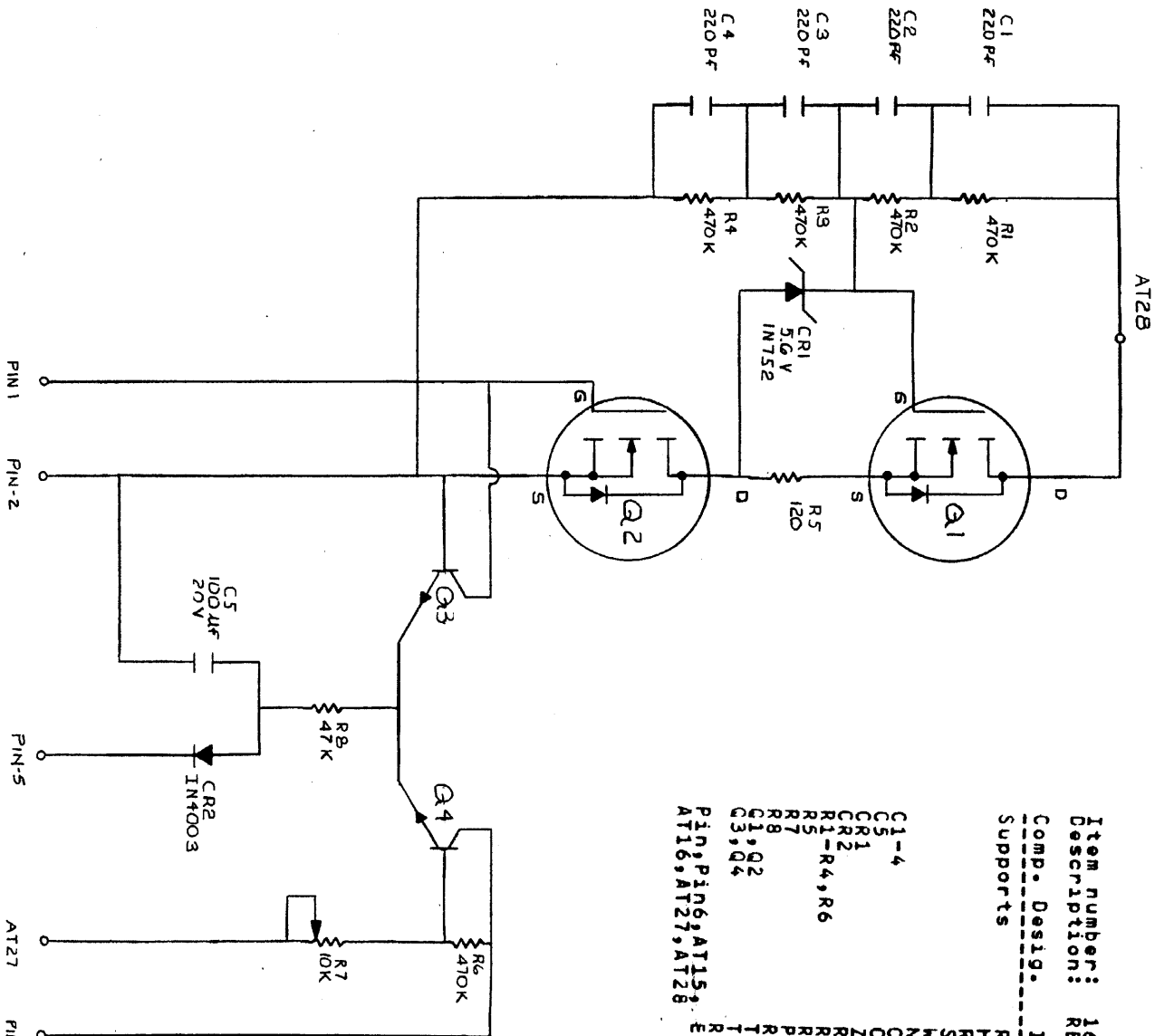

Pin 1, Pin 6, AT15, AT16, AT17, AT27, AT28

Supports

TOLERANCES
 UNLESS SPECIFIED ARE
 ANGLES ±
 DECIMALS ±

REGULATOR BOARD
 SHEET 1 OF 1

PRINT DISTRIBUTION

SCALE	FILED AT	CHEK'D	APPROV'D
1/4"	C	MEF	1/7/67
SIZE	DWG NO.	DATE	REV.
C	1644-4730-00-5D		1

Complete cabinet assembly (P/N 1559-2001).

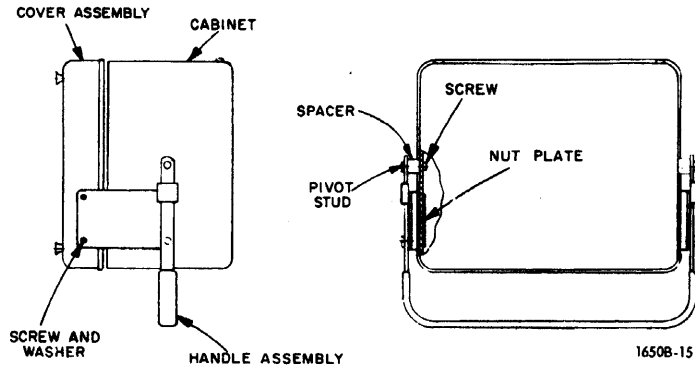

Name	GR Part No.	Fed		Fed Stock No.
		Mfg Code	Mfg Part No.	
Cabinet	1644-1001	24655	1644-1001	
Spacer	4170-0700	24655	4170-0700	
Pivot Stud	4170-1000	24655	4170-1000	
Screw*	7098-0160	24655	7090-0160	
Handle Assembly	5360-1013	24655	5360-1013	
Cover Assembly	4170-0402	24655	4170-0402	
Nut Plate	4170-1350	24655	4170-1350	
Screw	7080-1000	24655	7080-1000	5305-974-0373
Washer	8040-2400	96906	MS35337-81	5310-058-2951
(4) Feet	5250-1902	24655	5250-1902	
(1) Foot, stop	5260-0700	24655	5260-0700	

Complete handle and mounting plate assembly (P/N 1559-2010)

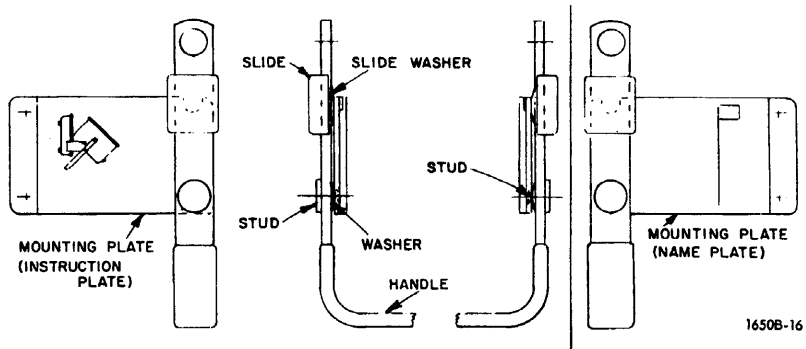

Name	GR Part No.	Fed		Fed Stock No.
		Mfg Code	Mfg Part No.	
Mouting Plate** (Instruction Plate)	7860-5800	24655	7860-5800	
Stud	4170-1100	24655	4170-1100	
Slide	4170-1270	24655	4170-1270	
Handle	5360-1013	24655	5360-1013	
Mounting Plate (Name Plate)	7864-8220	24655	7864-8220	
Washer	8140-0105	24655	8140-0105	
Slide Washer	4170-7030	24655	4170-7030	

*Tighten 1/4-28 screws to 45-55 in. lbs torque.

**Bend mounting plate to give 1/32 to 1/16 spacing, both sides.



IET LABS, INC.

Standards • Decades • Strobes • Sound Level Meters • Bridges

Formerly manufactured by

GenRad

534 Main Street, Westbury, NY 11590

TEL: (516) 334-5959 • (800) 899-8438 • FAX: (516) 334-5988

www.ietlabs.com



IET LABS, INC.

Standards • Decades • Strobes • Sound Level Meters • Bridges

Formerly manufactured by

GenRad

534 Main Street, Westbury, NY 11590

TEL: (516) 334-5959 • (800) 899-8438 • FAX: (516) 334-5988

www.ietlabs.com