

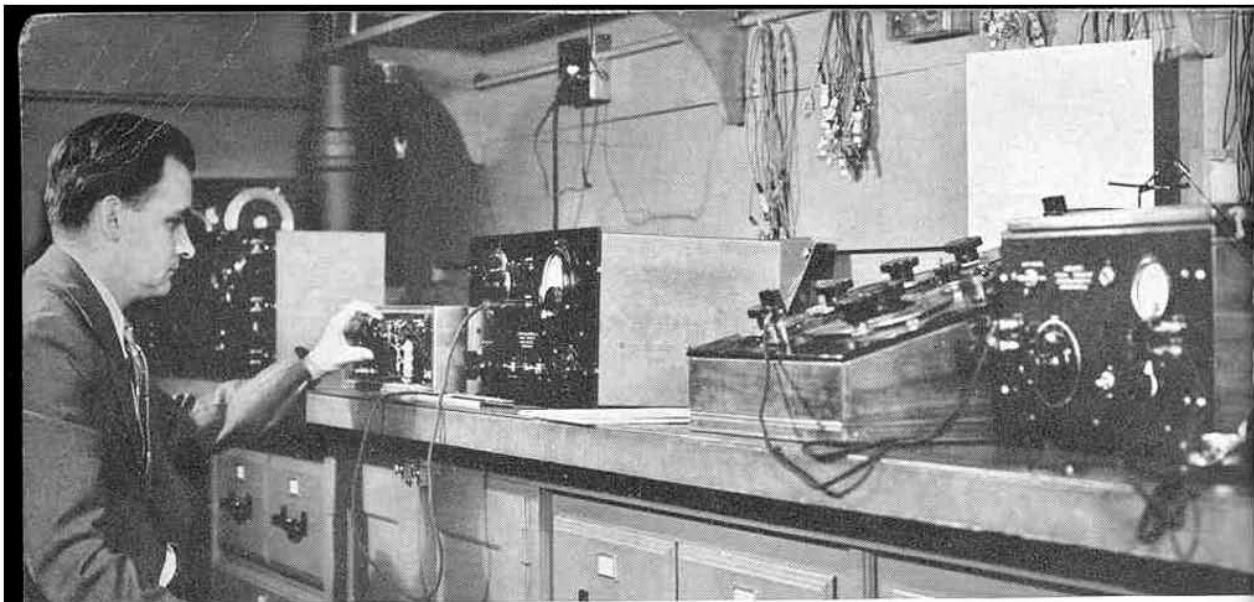

CATALOG K



GENERAL RADIO COMPANY · CAMBRIDGE, MASS., U.S.A.



Above—Tests on an experimental model of Type 732-B Distortion and Noise Meter.

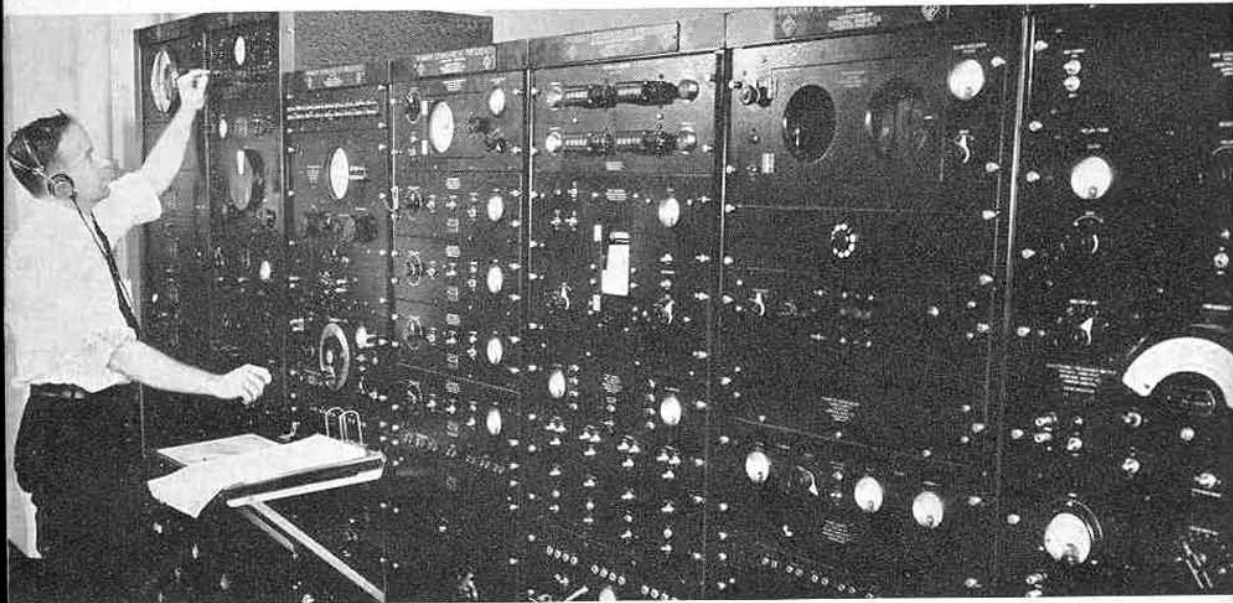

Above—Measuring frequencies with the General Radio Primary Standard of Frequency.
Below—Engineering tests on a high-voltage, 60-cycle Schering Bridge.

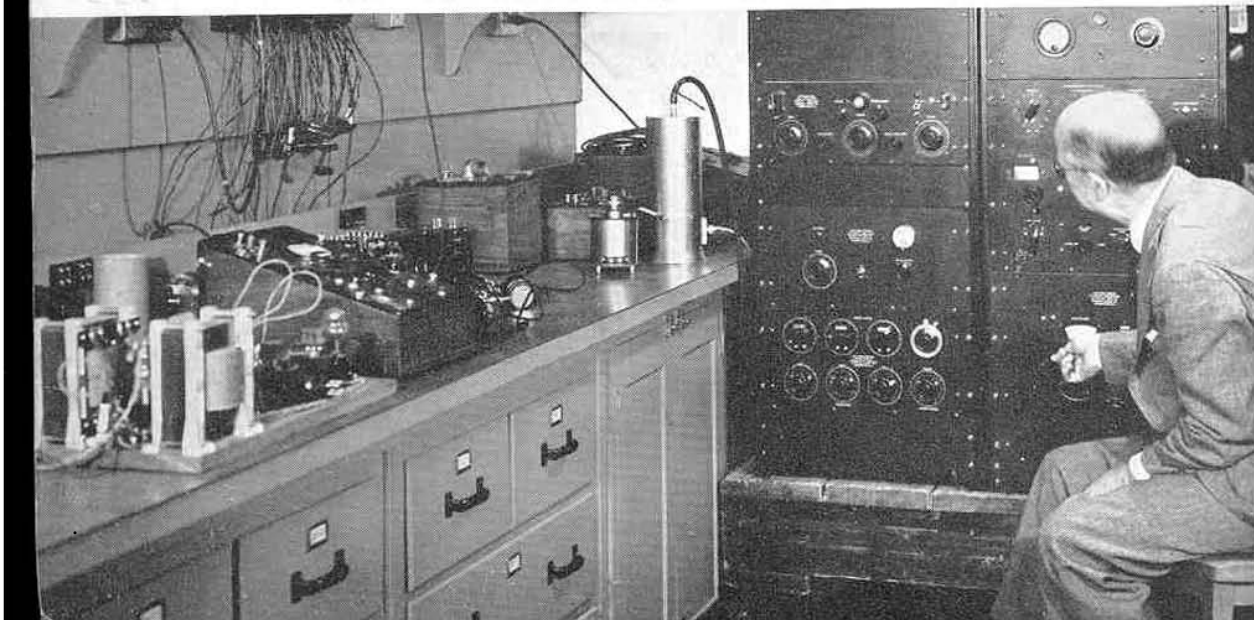

QUICK INDEX

HOW TO ORDER	v
INDUSTRIAL DEVICES	3
RESISTORS	19
CAPACITORS	45
INDUCTORS	63
BRIDGES AND ACCESSORIES	67
OSCILLATORS	99
AMPLIFIERS	111
METERS	117
FREQUENCY-MEASURING INSTRUMENTS	131
WAVEFORM-MEASURING INSTRUMENTS	167
STANDARD-SIGNAL GENERATORS	181
POWER SUPPLIES	183
AUDIO-FREQUENCY TRANSFORMERS	187
PARTS AND ACCESSORIES	193
REACTANCE CHARTS	205
DECIBEL TABLES	207
INDEX BY TYPE NUMBER	213
INDEX BY TITLE	215

WE SELL DIRECT . . .

To develop the type of product manufactured by the General Radio Company requires a large staff of engineers, each a specialist in one or more phases of the work involved. One of the functions of this staff is to assist the customer in the selection of instruments in order that the correct equipment may be purchased with a minimum expenditure.

There has always been an intimate contact between our engineers and customers. The technical nature and the manifold uses of our product make the maintenance of this contact essential. For this reason, the General Radio Company maintains no sales agencies in the United States, but distributes its products directly to the consumer on a net, no discount, basis.

In order that customers outside the United States may receive equivalent technical service, exclusive agencies have been appointed in many foreign countries, each capable of giving technical information regarding General Radio products. In all matters regarding General Radio apparatus the customer should communicate with the agent from whom this catalog was received. Prices listed in the catalog are for domestic use only. Costs in foreign countries, where import duty and freight must be added, can be obtained from the agents in those countries.

GENERAL RADIO COMPANY

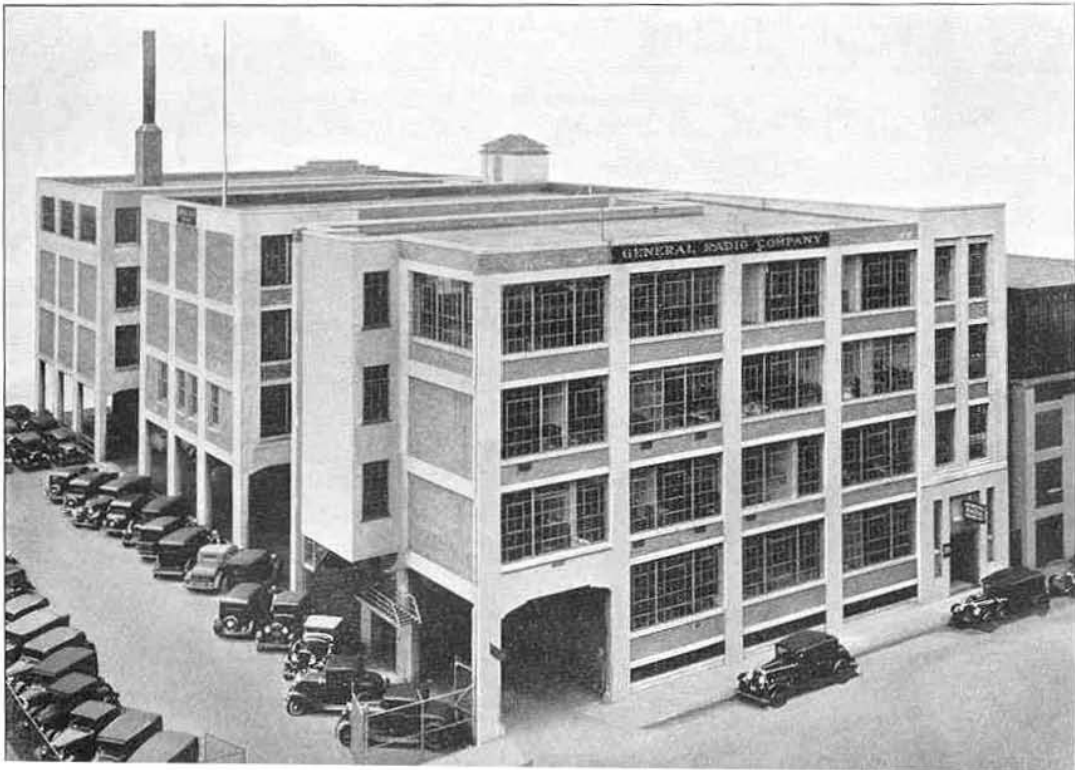

CATALOG K

1 9 3 9



GENERAL RADIO COMPANY
CAMBRIDGE, MASS., U.S.A.

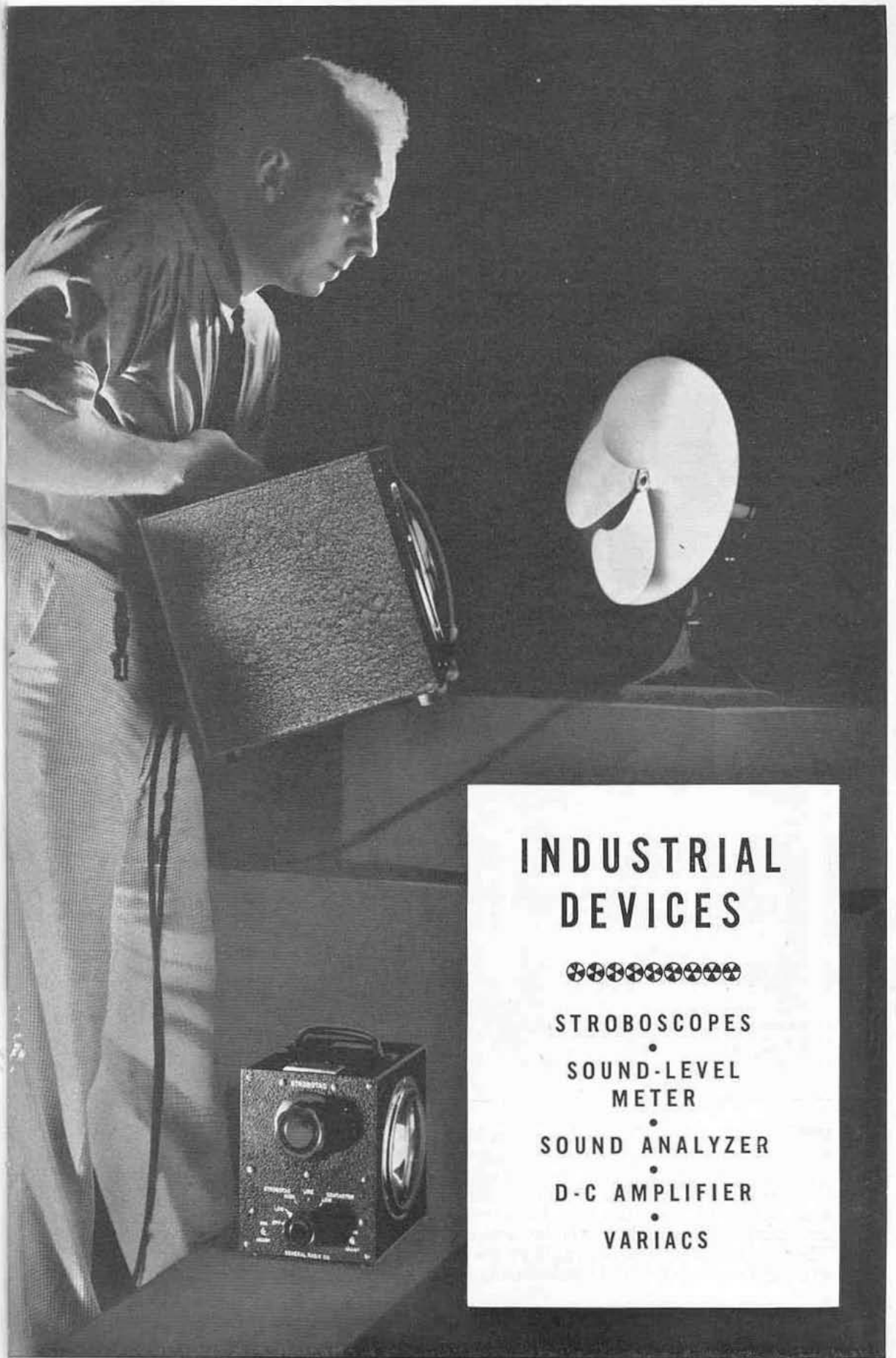

INDUSTRIAL DEVICES



STROBOSCOPES

•
SOUND-LEVEL
METER

•
SOUND ANALYZER

•
D-C AMPLIFIER

•
VARIACS

THE STROBOSCOPE is a device which permits a moving object to be viewed intermittently and thus produces the optical effect of slowing down or stopping motion. If, for example, an electric fan revolving at 1200 rpm is viewed under a light which flashes 1200 times per minute, the fan will apparently be standing still. A slight decrease in the flashing rate will make the fan appear to revolve slowly in the direction of its actual rotation, and an increase will produce a similar motion in the reverse direction.

Stroboscopes with mechanically operated shutters for interrupting vision have been in use for many years but are subject to the limitations of slow speed and insufficient illumination. General Radio Stroboscopes use the flashing lamp principle as developed by Professor Harold E. Edgerton and Mr. Kenneth Germeshausen of the Massachusetts Institute of Technology. Brilliant light flashes are produced by a lamp filled with rare gases, and the speed of the flash is controlled by an oscillator or a motor-driven contactor. Flashing speeds up to 14,000 per minute, for visual investigation, can be obtained by this method and up to 120,000 per minute for high-speed photography.

When mechanisms operating at high speeds are viewed by stroboscopic light, in slow motion, all irregularities of the motion present in the original motion are made visible, thus making it possible to observe high-speed mechanisms under actual operating conditions.

When the speed of flash coincides with the speed of rotation, and motion is apparently stopped, the stroboscope becomes an excellent means of measuring speed, and for this purpose the dial which controls the flashing rate can be calibrated directly in rpm. Speed measurement by the stroboscopic method absorbs no power from the mechanism under measurement.

TYPE 631-B STROBOTAC*



USES: The Strobotac is used for measuring the speed of rotating, reciprocating, or vibrating mechanisms, and for observing their operation in slow motion. In the design and testing of machines and high-speed mechanisms, the Strobotac is invaluable. The operation of motors, fans, pulleys, gears and cams can be examined in slow motion.

Speed measurements for overload and underload tests can be made. It is ideally suited for rapidly adjusting the speeds of a number of machines intended to operate at the same speed, as, for instance, textile spindles. In production testing, it provides a means of rapidly aligning mechanisms which operate under close tolerances. It is approved for use in checking the calibration of aircraft tachometers.

DESCRIPTION: The Strobotac is a small, portable stroboscope calibrated to read speed directly in revolutions per minute. The light source is a Strobotron neon lamp mounted in a parabolic reflector. The frequency of a vacuum-tube relaxation oscillator determines the flashing speed, which can be adjusted, by means of a direct-reading dial, to any value between 600 rpm and 14,400 rpm. If desired, the flashing speed can be controlled by an external contactor or by the a-c line frequency.

The accuracy of the scale is one per cent when standardized in terms of a frequency-controlled a-c power line.

The Strobotron is designed to give an extremely short flash (between 5 and 10 microseconds), and hence sharp images are obtained even at speeds up to several times the scale values.

Speeds outside the scale range of the instrument can be measured by using multiples of the flashing speed. The upper limit is not

sharply defined, but, in general, speeds up to about 100,000 rpm can be measured. Speeds below 600 rpm can also be measured, but the use of the Strobotac for this range is not recommended, because of difficulties caused by the lack of persistence of vision.

FEATURES: For speed measurement, the Strobotac has one outstanding advantage over other types of tachometers: no contact with the mechanism under measurement is required, and hence no power is absorbed.

The Strobotac is portable, compact, and

light in weight. Because of this, it can be used in places inaccessible to larger instruments. The speed scale is on a drum-type dial, easily read when the instrument is held in the position of normal use. High accuracy and a wide speed range are further advantages for general speed measurement.

When a larger area is to be illuminated, or sufficient light for photography is required, the Strobotac can be used to control the flashing speed of the TYPE 648-A Strobulox described on page 4.

*Reg. U. S. Pat. Office.

SPECIFICATIONS

Range: The fundamental range of flashing speed is from 600 to 14,400 per minute. The speed is read directly from a dial calibrated in rpm. By using multiples of the flashing speed, the range of measurement can be extended up to about 100,000 rpm and, by multiple images, speeds somewhat below 600 rpm can be measured.

Accuracy: ±1% of the dial reading above 900 rpm when the Strobotac is standardized in terms of a frequency-controlled power line. Controls for this standardization adjustment are provided.

Power Supply: 115 volts, 60 cycles. Prices for operation

from lines of other voltages and frequencies will be quoted on request.

Power Input: 25 watts.

Vacuum Tubes: One TYPE 631-P1 Strobotron, one 6X5-type and one 6N7-type are required. A complete set of tubes is furnished with the instrument.

Mounting: Aluminum case with carrying handle. Cord and plug for connection to the power line are included.

Dimensions: 7½ x 8¾ x 9¾ inches, over-all.

Net Weight: 10 pounds.

Type	Code Word	Price
631-B	BRAVO	\$95.00
631-P1	SENA	5.00
Replacement Strobotron		

PATENT NOTICE. See Note 15, page v.

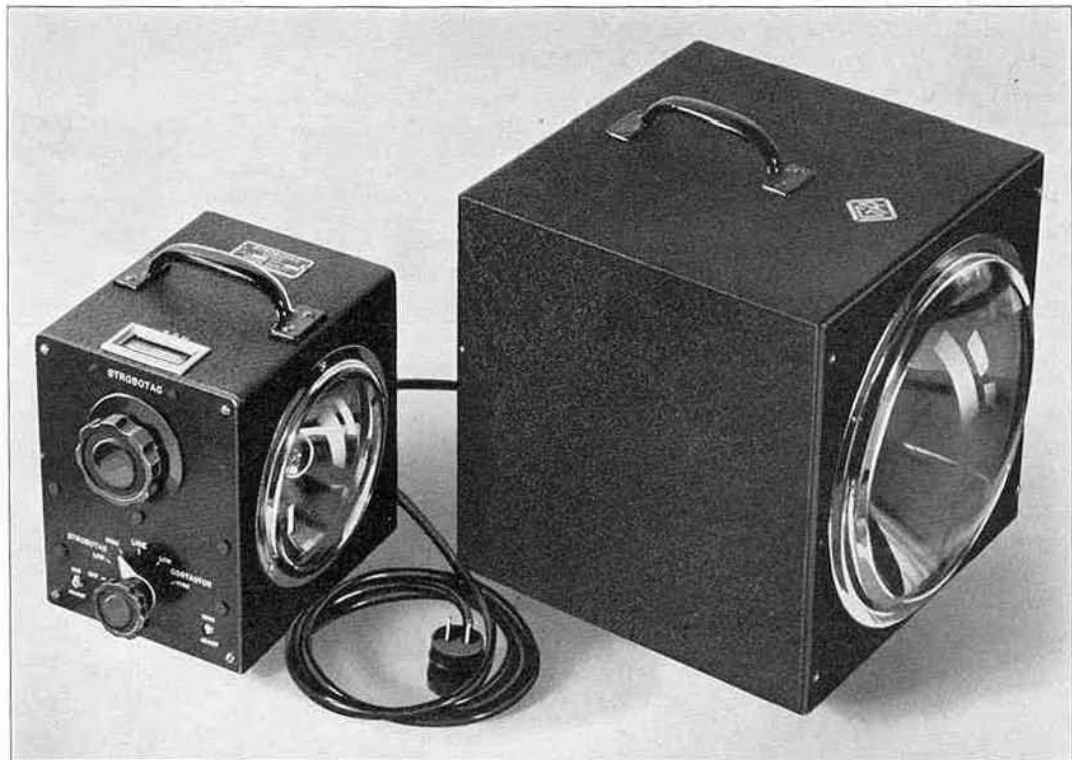

TYPE 631-B Strobotac and TYPE 648-A Strobulox with connecting cables.

• STROBOSCOPES

GENERAL RADIO CO.

TYPE 648-A STROBOLUX



phenomena up to 100 frames per second; single flash photographs of limited areas are possible, as are multiple images on a single film.

DESCRIPTION: TYPE 648-A Strobolux consists of a power supply and lamp, capable of producing brilliant light flashes at speeds up to 6000 per minute. The flashing source is a TYPE 631-B Strobotac and consequently can be controlled by (1) the self-contained oscillator in the Strobotac, (2) the a-c line, (3) an external contactor (TYPE 549-C), or (4) an external oscillator such as TYPE 713-B.

The lamp, filled with a rare gas, furnishes about one hundred times as much light as that of the Strobotac.

The entire assembly is housed in a metal cabinet with the lamp and its 9-inch reflector on one side. The lamp is removable and is furnished with a 10-foot extension cable.

USES: The TYPE 648-A Strobolux extends the usefulness of the Strobotac to applications requiring considerably more light than the Strobotron lamp is capable of supplying. Specifically, it should be used where larger areas are to be illuminated or where photography is required.

In photography, it can be used with a continuous-film camera (TYPE 651-AE) to provide a slow-motion record of high-speed

FEATURES: The combination of the TYPE 631-B Strobotac and TYPE 648-A Strobolux has all the advantages of the Strobotac itself plus the feature of high illumination, sufficient for photographic use. No appreciable duplication of facilities is involved, so that the purchase of the TYPE 648-A Strobolux is an economical solution to problems requiring greater illumination than is provided by the Strobotac.

SPECIFICATIONS

Range: Up to 100 flashes per second (6000 per minute). Single flashes for photography can also be obtained.

Accuracy: The accuracy is that of the source controlling the flashing speed. See specifications for TYPE 631-B Strobotac, page 2.

Power Supply: 115 volts, 60 cycles.

Power Input: 250 watts, maximum.

Vacuum Tube: One 5Z3, supplied.

Mounting: The complete assembly is housed in a sheet metal case. The lamp and its 9-inch reflector are mounted on one side, the power supply on the other. Cables for connection to the power line and to the Strobotac are supplied.

Dimensions: 13 x 11 $\frac{1}{8}$ x 13 $\frac{1}{8}$ inches, over-all.

Net Weight: 25 pounds.

Type	Code Word	Price
648-A	SCALY	\$175.00

PATENT NOTICE. See Note 15, page v.

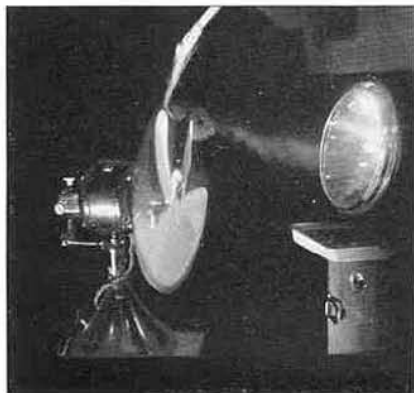

THE STROBOSCOPE STOPS MOTION

These two pictures were taken with a TYPE 648-A Strobolux. Both are single flash pictures of the smoke patterns used to study air currents. The picture at the left shows a fan blade, that at the right an organ pipe. Neither of these photographs has been retouched.

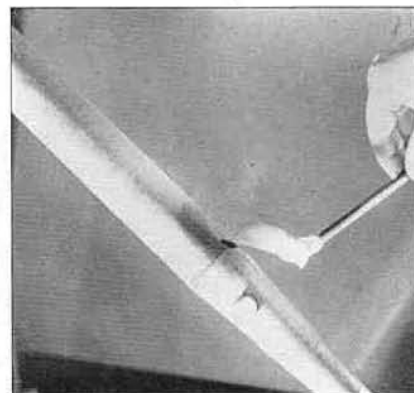

• STROBOSCOPES

GENERAL RADIO CO.

TYPE 621 POWER STROBOSCOPE

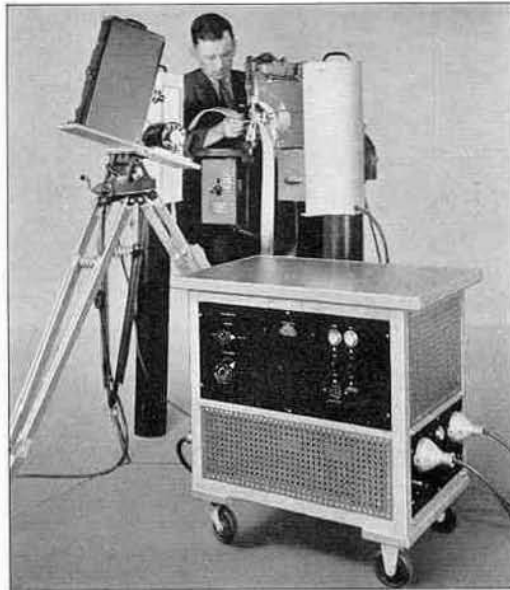

The power stroboscope supplies the same light intensity per flash as does TYPE 648-A Strobolux, but is capable of operating at much higher flashing speeds. The power supply requirements are correspondingly greater. It is used where very high flashing speeds are required, whether for visual work, or for taking high-speed motion pictures.

In conjunction with the CLASS 651-A-M Camera Assembly, motion pictures can be taken at a maximum speed of 2000 per second, permitting the examination of the motion of mechanical systems not previously observable by any method. Specifications and prices will gladly be sent on request.

The photograph at the left shows a TYPE 621-H Power Stroboscope and a CLASS 651-A-M Camera Assembly, set up for taking high-speed motion pictures of a stitching machine.

TYPE 715-A DIRECT-CURRENT AMPLIFIER

USES: The TYPE 715-A Direct-Current Amplifier is designed primarily for use with the Esterline-Angus 5-milliamperere recorder. This combination of amplifier and recorder is capable of accurately recording small d-c voltages and currents. In addition to its obvious use as a recording d-c milliammeter or millivoltmeter, it has a number of applications in process control and laboratory measurements. It can be arranged to operate from photo-electric and photronic cells, frequency meters, oxide rectifiers, resistance thermometers, sound-level meters, and other instruments which respond to physical stimuli.

DESCRIPTION: The amplifier is an a-c operated instrument, highly stable, and operating over a wide range of input voltages from 0.1 volt to 1.0 volt. Means are provided for selecting input resistances between 100 ohms and 10 megohms.

The circuit employs one type 6F6-G and two type 6J7-G tubes for the amplifiers in a degenerative circuit arrangement giving high stability of calibration. A bridge-type balancing network using a voltage regulator tube provides for balancing out the steady plate current in the meter, so that the meter indicates current change. Both fine and

coarse zero adjustments are provided for setting the meter for normal zero. A special circuit arrangement is used to obtain freedom from changes in a-c supply voltage, resulting in changes in plate voltage.

In the design of a direct-current amplifier the most critical point is the temperature of the cathode of the first amplifier. Very effective means have been provided for overcoming any variations in temperature of this cathode. A regulating transformer and a filament ballast lamp are employed. This system maintains the heater voltage constant for line voltage changes from 100 to 130 volts.

FEATURES: Particular care has been taken in the design and construction of this new instrument to combine, with high gain and simplicity of operation, stability of calibration with freedom from effects of ambient temperature and line voltage variations—features which for so long prevented the development of the d-c amplifier as a commercial instrument.

Operation from the a-c power line, convenient size, and mounting, together with a wide range of input voltage and resistance combinations, make this amplifier a convenient, as well as reliable, adjunct to the graphic recorder.

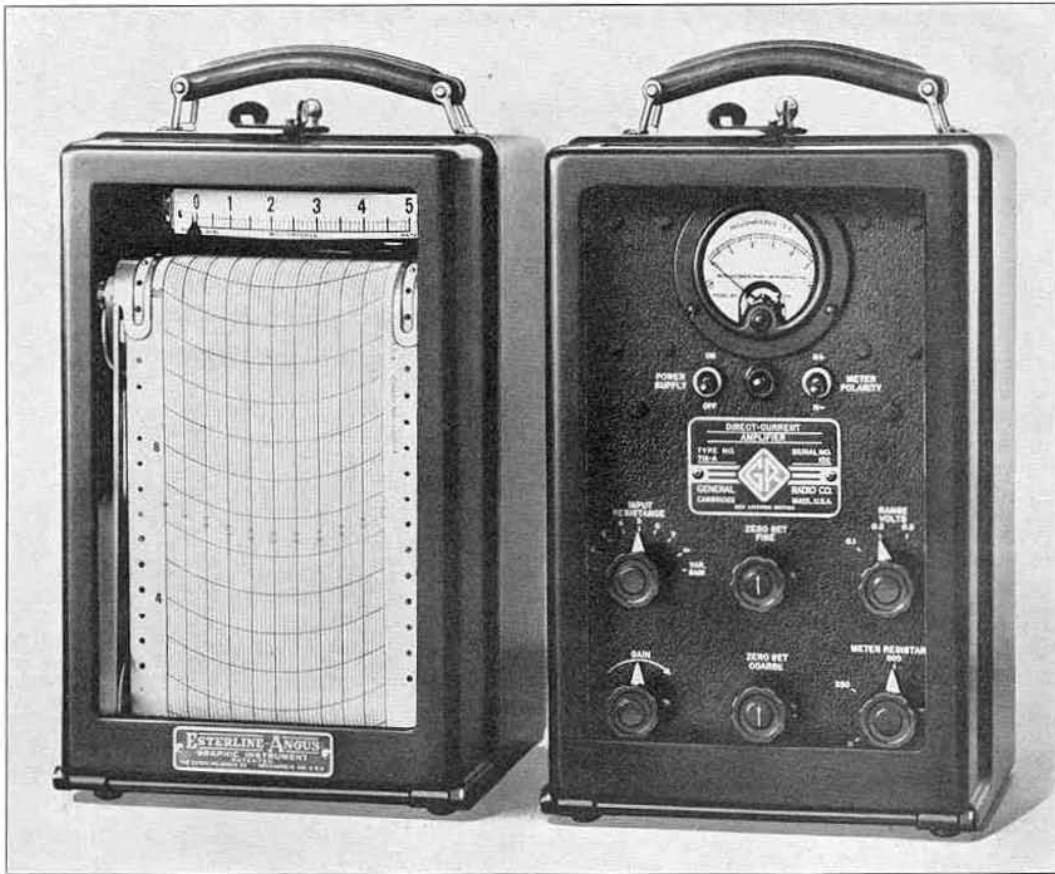

Esterline-Angus Recorder.

TYPE 715-AE Direct-Current Amplifier.

SPECIFICATIONS

Range: The instrument is provided with four calibrated ranges, selected by means of a switch, giving 5 milliamperes linear output in the recorder circuit of 1000 ohms, for input voltages of 0.1, 0.2, 0.5, and 1.0 volt applied at the input terminals with either polarity. The gain is best expressed as a transconductance; the maximum value is 50,000 micromhos.

Accuracy: As a calibrated voltmeter, the accuracy of calibration is approximately 1%, this accuracy being maintained over considerable periods of time.

Input Circuit: Means are provided for selecting any one of a number of input resistances, so that the instrument not only has an adjustable input resistance, but can serve as a calibrated millivoltmeter or microammeter. The input resistances range in powers of 10 from 100 ohms to 10 megohms. Short-circuit and open-circuit positions are also supplied on the selector switch.

For those applications where relative values only are of interest and where the voltage available exceeds 1 volt, one of the switch positions connects the input to a variable gain control, so that the voltage applied to the first grid can be adjusted to any desired value. The input resistance for this position is 150,000 ohms approximately.

Output: The output circuit is designed to operate a 5-milliamperere meter mounted on the panel and an external meter or device such as the Esterline-Angus 5-milliamperere recorder, and is provided with a manually

adjusted compensating resistance. The compensating resistance is adjusted to allow for the resistance of the external device, so that the instrument always works into a normal resistance of 1000 ohms. Although the instrument functions perfectly when operating into resistances from 0 to 2000 ohms, its calibration is affected slightly if the total impedance deviates materially from the 1000-ohm value.

Power Supply: The instrument is intended for operation directly from 105-125 or 210-250 volts, 60-cycle mains. Other voltages or other frequencies can be supplied on special order only.

Power Input: The power drawn from the 60-cycle mains is approximately 35 watts. No batteries of any kind are employed.

Vacuum Tubes: The tubes furnished with the instrument are: two type 6J7-G, one 6F6-G, one 6X5-G, one VR90, one 4A1.

Mounting: The amplifier is mounted in a cast metal case identical with that used on the Esterline-Angus recorder, or in walnut cabinet, as desired.

Dimensions: TYPE 715-AM, (height) 15 1/4 x (width) 9 x (length) 8 1/2 inches, over-all; TYPE 715-AE, (height) 15 x (width) 8 1/4 x (length) 8 3/4 inches, over-all.

Net Weight: With Esterline-Angus case, 26 1/4 pounds; with walnut cabinet, 23 pounds.

Type	Code Word	Price
715-AE	ASIDE	\$250.00
715-AM	ALOFT	225.00

PATENT NOTICE. See Note 1, page v.

• SOUND-LEVEL METER

GENERAL RADIO CO.



TYPE 759-A SOUND-LEVEL METER

USES: The TYPE 759-A Sound-Level Meter is suitable for all types of commercial and industrial noise measurement. Manufacturers of machinery and appliances use it for measuring product noise both in the research laboratory and in production. Sound transmission and absorption and the acoustical properties of materials can also be measured with it. It meets equally well the requirements for noise measurement in surveys of the psychological and physiological effects of noise.

For the industrial plant, it provides a means of measuring product noise, setting up noise standards, accepting or rejecting products on the basis of noise tests, and, finally, analyzing and correcting trouble in the rejected units.

In this last use, as in many others, a frequency analysis of the noise is usually valuable. For this purpose, the TYPE 760-A Sound Analyzer (see page 10) has been designed.

In conjunction with a vibration pickup, the sound-level meter can be used to study vibration in machines and structures. Loca-

tion, magnitude, and nature of the vibration can be determined as a first step toward its reduction or elimination.

DESCRIPTION: TYPE 759-A Sound-Level Meter is an accurate, portable, low priced meter for reading, in terms of a standard reference level, the sound level at its microphone.

The sound-level meter consists of a non-directional microphone, an amplifier, a calibrated attenuator, and an indicating meter. It is battery-operated and completely self-contained.

This sound-level meter complies with all the tentative standards for sound-level meters specified by the American Standards Association, the American Institute of Electrical Engineers, and the Acoustical Society of America.

FEATURES: Ease of operation was a primary consideration in the design of this meter. Of equal importance were small size and light weight, so that the meter is easily portable. Other features are:

1. A non-directional crystal microphone which responds satisfactorily over a wide range of frequencies, including the high frequencies which make up "hissing" sounds.
2. Unusual sensitivity extending to 24 decibels above a zero reference level of 10^{-16} watts per square centimeter.
3. Three separate weighting networks for adjusting the frequency response characteristics, consisting of a low level network, a high level network, and a network giving a substantially flat over-all response.
4. No rheostats or other battery adjustments.
5. Special tube suspension, providing a freedom from microphonic noises.
6. No inductance coils or transformers whatsoever are used in the instrument, thus eliminating error due to magnetic pickup.
7. Linear decibel scale.

SPECIFICATIONS

Sound-Level Range: Calibrated in decibels from +24 db to +130 db above a reference level of 10^{-16} watts per square centimeter.

Frequency Characteristics: The frequency characteristic of the sound-level meter is adjustable to follow three different curves. The first and second of these are, respectively, the 40 and 70 db equal-loudness contours in accordance with the tentative standard proposed by the American Standards Association. The third frequency response characteristic gives a substantially equal response to all frequencies within the range of the instrument. This characteristic is used when measuring extremely high sound levels or when using the instrument with TYPE 760-A Sound Analyzer.

Microphone: The non-directional piezo-electric microphone mounts directly on a folding bracket on the top of the instrument and folds down out of the way when not in use. It may also be removed from the bracket and used on an extension cord. The microphone is of the sound cell type.

Attenuators: A 10-db-per-step attenuator precedes the third stage of amplification and provides control of the instrument up to 90 db by means of a single knob. For measurements of higher sound levels an additional 40-db attenuator is provided. This attenuator is directly on the input of the amplifier. Since the attenuators are at low levels the possibility of errors due to amplifier non-linearity is eliminated.

Circuit: The amplifier consists of four stages of resistance-capacitance-coupled amplification followed by an output stage arranged to match the especially-designed rectifier-type meter. This combination provides a high degree of stability and minimizes change in sensitivity resulting from variations in battery voltage. A ballast tube is provided for maintaining constant filament current.

Meter: The indicating meter has a scale which is approximately linear in decibels and which covers a range

of 16 db, thus providing satisfactory and accurate interpolation between the steps of the attenuator. The ballistic characteristics of the meter match closely those of the human ear and agree with the tentative standards specified by the American Standards Association.

Telephones: A jack is provided on the panel for plugging in a pair of head telephones in order to listen to the sounds being measured, or for connecting the TYPE 760-A Sound Analyzer.

Vibration Pickup: If desired, a piezo-electric vibration pickup may be used in place of the microphone.

Tubes: Five 1A4-type tubes and one 1D1-type tube are required. A complete set of tubes is supplied.

Tripod: A tripod and extension cable can be supplied for using the microphone at a distance from the sound-level meter. See price list below.

Batteries: The batteries required are two Burgess No. 4FA (little 6's), or equivalent, two Burgess No. Z30N 45-volt B batteries, or equivalent, and one Burgess No. F2BP 3-volt battery, or equivalent. A compartment is provided in the case of the sound-level meter for holding all batteries, and connections are automatically made to the batteries when the cover of this compartment is closed. A set of batteries is supplied with the instrument.

Case: The meter is built into a shielded carrying case of airplane-luggage construction, covered with a durable black waterproof material and equipped with chromium-plated corners, clasps, etc. When operating the sound-level meter, the cover is ordinarily removed. An additional handle is provided on the panel of the instrument for convenience in moving it about while it is in operation.

Dimensions: The over-all dimensions are approximately (height) $11\frac{1}{2}$ x (length) $13\frac{1}{2}$ x (width) $9\frac{1}{2}$ inches.

Net Weight: $23\frac{1}{2}$ pounds, with batteries; $17\frac{1}{2}$ pounds, without batteries.

Type	Code Word	Price
759-A	NOMAD	\$195.00*
Set of replacement batteries for above	NOMADADHAT	5.40
759-P1 Tripod and Extension Cable (25-foot)	NOVEL	9.50

*Price includes both tubes and batteries.

PATENT NOTICE. See Notes 1, 2, page v.

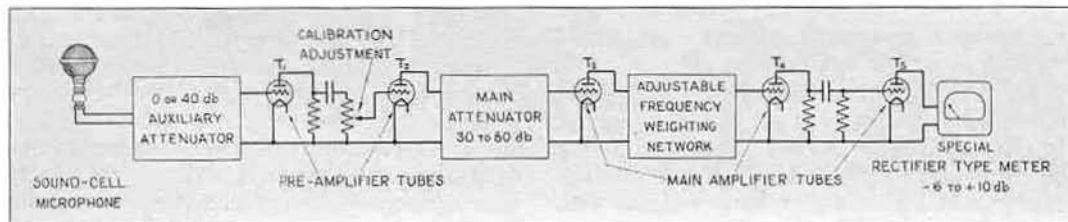

Functional schematic diagram of TYPE 759-A Sound-Level Meter.

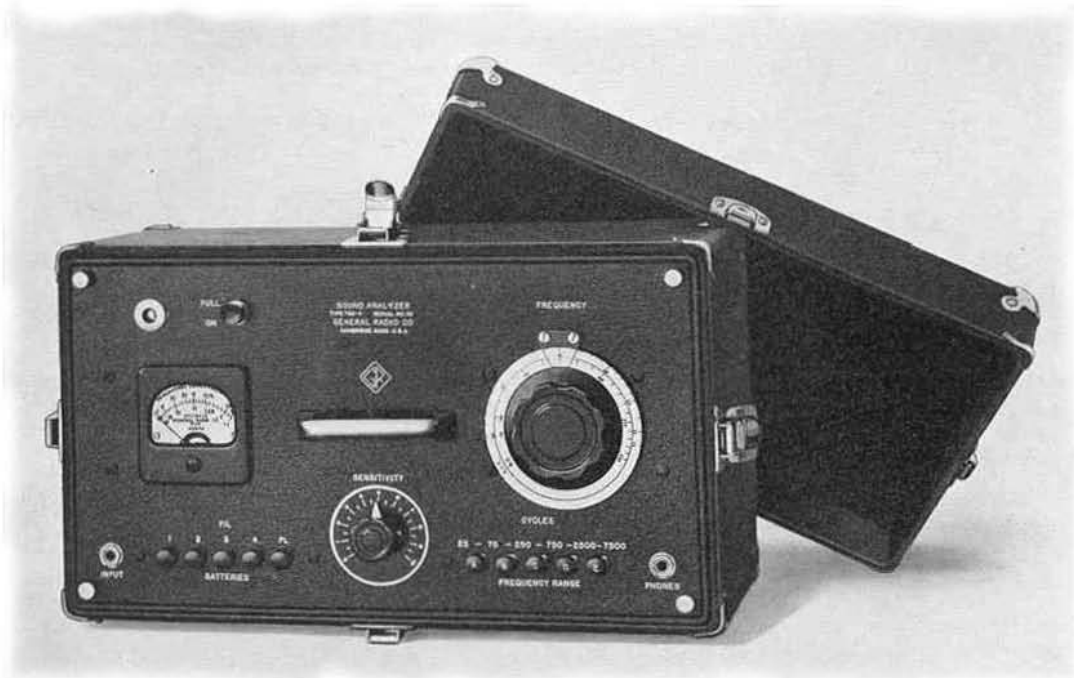

TYPE 760-A SOUND ANALYZER

USES: The TYPE 760-A Sound Analyzer was designed particularly for analyzing machinery noises or noise levels caused mainly by electrical or mechanical equipment. The fact that the selectivity curve widens proportionally as the frequency is increased makes it suitable for measuring noises caused by machines which do not run at absolutely constant speed. The instrument is particularly well adapted for analyzing the sound made by automobile and airplane motors and industrial or household equipment.

Although intended for use with the sound-level meter, the analyzer is not necessarily restricted to this application. It may be used in conjunction with any microphone and amplifier combination which provides sufficient output voltage. It is also useful as a bridge-balancing indicator, since it may be tuned to the bridge frequency, thus eliminating errors caused by harmonics. The logarithmic indicating meter is of great advantage in this application also.

Another important use is the analysis of vibrations by means of a vibration pickup. In this application the vibration pickup may be coupled to the sound-level meter in the conventional manner, or may be used with any suitable amplifier to provide the necessary input voltage for the analyzer.

DESCRIPTION: The TYPE 760-A Sound Analyzer is an accurate, portable, low-priced analyzer for measuring the relative amplitudes of the component frequencies in a sound wave.

It consists of a selective amplifier, operating on the degeneration principle and having a constant percentage band width, combined with a vacuum-tube voltmeter having approximately logarithmic characteristics over a wide range. The instrument was designed particularly for use with the TYPE 759-A Sound-Level Meter, and this combination provides an accurate and convenient means for measuring not only the actual level of sound, but also the relative amplitudes of the component frequencies.

FEATURES: In the development of this analyzer, simplicity and convenience of operation were considered of primary importance. The frequency calibration is read directly on a large dial, which may be rotated continuously to cover the entire frequency range of the instrument with a minimum of effort. A push-button switch operates the multipliers, so that it is a simple matter to scan quickly the entire frequency range of the analyzer or to change the tuning between two remote points in the range. A stabilized

circuit eliminates the need of any battery adjustments, and a neon ballast lamp provides satisfactory accuracy of the logarithmic voltmeter circuit, regardless of the condition of the batteries.

A volume control is included to adjust the instrument for use at various input levels, but, when analyzing a sound, no meter multipliers or volume controls are used since the complete range may be read on the single logarithmic meter scale.

Since the instrument was designed as a companion to the TYPE 759-A Sound-Level Meter, small size and low weight were considered extremely important, and the instrument is smaller and lighter than most of the analyzers which have been used for noise work in the past. The complete instrument is mounted in an airplane-luggage type of case matching that of the sound-level meter in appearance.



This photograph shows the TYPE 759-A Sound-Level Meter used to measure automobile noise.

SPECIFICATIONS

Frequency Range: Calibrated directly in cycles from 25 to 7500. This total range is covered in five complete turns of the tuning knob, the ranges on the various dial rotations being 25 to 75, 75 to 250, 250 to 750, 750 to 2500, and 2500 to 7500 cycles. A push-button switch allows immediate change of the main control to any of these ranges.

Voltage Range: The analyzer will give usable indications on input voltages ranging from 1 millivolt to 10 volts. The meter scale is calibrated for reading directly component tones down to 1% of the sound pressure (or voltage) of the fundamental or loudest component. Accordingly, to make full use of this feature, the input voltage at the loudest component or fundamental should be 0.1 volt or higher.

Band Width: The average selectivity is such that the relative attenuation is 3 db at 1% off the peak to which the analyzer is tuned.

Circuit: The circuit consists of a three-stage amplifier made selective by the use of degeneration, and an approximately logarithmic vacuum-tube voltmeter circuit, which allows a range slightly in excess of 40 decibels, or 100 to 1, to be read on the meter scale.

Meter: The indicating meter is calibrated down to 1% of the fundamental or loudest component of the sound. A decibel scale is also included, extending to 40 decibels below the fundamental or loudest component.

Telephones: A jack is provided on the panel for plugging in a pair of head telephones, in order to listen to the actual component of the sound to which the instrument is tuned. This is also useful when using the analyzer as a bridge-balance indicator.

Tubes: Three 1H4G and one 1F7GV tubes are required. A neon regulator tube is also used. A complete set of tubes is supplied with the instrument.

Batteries: The batteries required are four Burgess No. F2BP 3-volt batteries, or the equivalent, and three Burgess No. Z30N 45-volt batteries, or the equivalent. A compartment is provided in the case of the analyzer for holding all batteries, and connections are auto-

matically made to the batteries when the cover of this compartment is closed. A set of batteries is included in the price of the instrument.

Case: The analyzer is built into a shielded carrying case of airplane-luggage construction, covered with a durable black waterproof material and equipped with chromium-plated corners, clasps, etc. This case has been designed to combine durability with light weight and good appearance. When operating the analyzer, the cover is ordinarily removed. An additional handle is provided on the panel of the instrument for convenience in moving it about while it is in operation.

Dimensions: (Length) 15 x (width) 10 x (height) 11½ inches, over-all.

Net Weight: 37 pounds, with batteries; 30 pounds, without batteries.

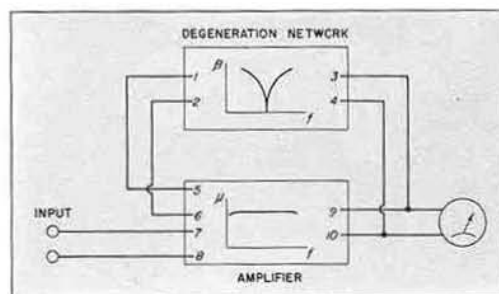

A functional diagram of the general type of circuit used in TYPE 760-A Sound Analyzer. The system consists of an amplifier with a propagation constant μ and a feedback network with a propagation constant β having the frequency characteristics shown above. The degeneration network is highly selective, and at its null point the normal gain of the amplifier is obtained. At lower and higher frequencies, degeneration occurs, and the gain of the amplifier is greatly reduced.

Type	Code Word	Price
760-A	ATTAR	\$260.00
Set of replacement batteries for above	ATTARADBAT	8.00

PATENT NOTICE. See Note 1, page v.

VARIAC*

USES: The VARIAC is a new type of a-c voltage control. Its applications to industrial control and to experimental problems in the laboratory are literally numberless. Wherever a-c voltage must be adjusted, and, by means of voltage, other quantities such as speed, heat, light, etc., there is a use for the VARIAC. Typical applications are motor speed control, heat control on electric furnaces and laboratory heaters, illumination control in small theaters, photographic studios, and darkrooms, output voltage control on transformer-rectifier systems, and voltage control for electrical testing, calibration, and measurement.

DESCRIPTION: The VARIAC is an auto-transformer supplying an output voltage continuously adjustable between zero and full line voltage or above.

It consists of a single layer of copper wire wound on a toroidally-shaped iron core. Rotation of a dial causes the winding to be

traversed by a moving contact, which "taps off" any desired portion of the total voltage across the winding. Since at least one turn of the winding is covered by the contact at all times, a continuous adjustment of voltage is obtained. The voltage between turns is between 0.2 and 0.9 volts. The contact is a carbon brush designed to limit the current in the short-circuited turn so that no undue heating results.

FEATURES: The advantages of the VARIAC over rheostats and other types of voltage control devices are high efficiency, smooth control, and good voltage regulation. Because the output voltage is essentially independent of load, a linear variation of voltage is obtained. Most models furnish output voltages above line voltage, making it possible to compensate for under-voltage lines.

Another important feature is small size. VARIACS are smaller than any other voltage control of equivalent power rating.

GENERAL SPECIFICATIONS

Models ranging from 170 watts to 2 kilowatts are listed on the following pages. Specifications, unless otherwise stated, are for 50-to-60 cycle service.

RATED CURRENT can be drawn from the VARIAC at any dial position. It is limited by heat loss in the winding.

MAXIMUM CURRENT can be drawn at low volt-

ages or at voltages near the input voltage. It is limited by losses in the carbon brush.

LOAD RATING is maximum output current multiplied by input voltage. A VARIAC can handle, at any lower setting, a load which draws at input voltage a current no greater than the "maximum current."

NO-LOAD LOSS is measured at 60 cycles.

PATENT NOTICE. See Note 11, page v.
*Reg. U. S. Pat. Off.

TYPE 200-B VARIAC



SPECIFICATIONS

Load Rating: 170 va.

Rated Current: 1 a.

Maximum Current: 1.5 a.

Input Voltage: 115 v.

Output Voltage: 0-115 v or 0-135 v.

No-Load Loss: 3 watts.

Dial: The dial reads directly in output voltage with an accuracy of 2% when the input voltage has its rated value.

Terminals: Threaded terminal studs with nuts and soldering lugs are provided.

Mounting: Either table mounting or back-of-panel mounting can be used.

Dimensions: For base and mounting dimensions, see sketch on page 15. Over-all height is 4 inches for table mounting. When panel mounting is used, the depth behind panel is 2¹⁵/₁₆ inches.

Net Weight: 3³/₄ pounds.

Type	Code Word	Price
200-B	BALSA	\$10.00

TYPE 90-B VARIAC

TYPE 90-B Variac provides several output voltages. It consists of a TYPE 200-B Variac controlling the input to a step-down transformer.

SPECIFICATIONS

Load Rating: 170 va, total. **Input Voltage:** 115 volts.

Output Voltage and Current:

Output Voltage	Rated Current	Maximum
0-135 v	1 a	1.5 a
0-7.4 v	4 a	4 a
0-2.9 v	4 a	4 a

Two 7.4-volt windings and two 2.9-volt windings are provided.

No-Load Loss: 8 watts.

Dial: The dial is that of TYPE 200-B Variac and reads directly the output voltage at the 0-135 volt terminals.

Terminals: Four sets of low-voltage terminals are provided. The 0- to 135-volt output is available at a standard plug receptacle. A 6-foot line cord and plug are supplied.

Mounting: Sheet metal case.

Dimensions: 7 $\frac{1}{4}$ x 5 x 5 $\frac{5}{16}$ inches.

Net Weight: 8 $\frac{3}{4}$ pounds.

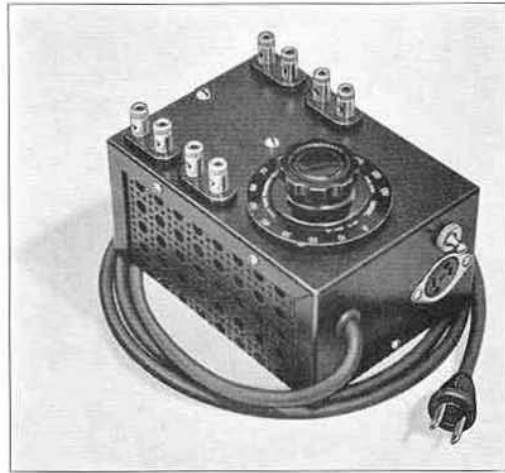

Type	Code Word	Price
90-B	PIVOT	\$19.00

TYPE 200-C and TYPE 200-CH VARIACS

SPECIFICATIONS

Type	Load Rating	Input Voltage	Current		Output Voltage	No-Load Loss
			Rated	Maximum		
200-CM	860 va	115 v	5 a	7.5 a	0-135 v	10 watts
200-CU						
200-CMH	580 va	230 v	2 a	2.5 a	0-270 v	10 watts
200-CUH						

Dial: The dial reads directly in output voltage with an accuracy of 2% when the input voltage has its rated value.

Terminals: TYPE 200-CM and TYPE 200-CMH are furnished complete with attachment cord and plug for connection to the line, an ON-OFF switch, and a standard plug receptacle for the output circuit. TYPE 200-CU and TYPE 200-CUH have threaded terminal studs with nuts and soldering lugs.

Mounting: TYPE 200-CM and TYPE 200-CMH are mounted in cases as shown in the photograph. TYPE 200-CU and TYPE 200-CUH are supplied without case and can be used for either table or back-of-panel mounting.

Dimensions: For base and mounting dimensions, see sketch on page 15. Over-all height, 5 $\frac{1}{2}$ inches; depth behind panel, 4 $\frac{1}{8}$ inches.

Net Weight: TYPE 200-CM and TYPE 200-CMH, 10 pounds; TYPE 200-CU and TYPE 200-CUH, 9 pounds.



Type	Code Word	Price
200-CM	BALMY	\$17.50
200-CU	BAKER	14.50
200-CMH	BAIRN	21.50
200-CUH	BAGUE	18.50

• VARIAC S

GENERAL RADIO CO.

TYPE 100 VARIAC



SPECIFICATIONS

Type	100-K	100-L
Load Rating	2 kva	2 kva
Primary Voltage	115 v	230 v, 115 v
Rated Current	15 a	8 a, 4 a
Maximum Current	17.5 a	9 a, 9 a
Output Voltage	0-115 v	0-230 v
No-Load Loss	20 watts	25 watts

Dial: A fixed dial plate bearing 100 divisions is provided, indicating per cent of maximum output voltage.

Terminals: Threaded terminal studs with nuts and soldering lugs.

Mounting: Table or back-of-panel mounting.

Dimensions: See sketch on page 15 for base and mounting dimensions. Over-all height for table mounting, 7 $\frac{3}{8}$ inches; depth behind panel, 5 $\frac{3}{8}$ inches.

Net Weight: TYPE 100-K, 20 $\frac{3}{4}$ pounds; TYPE 100-L, 23 $\frac{3}{4}$ pounds.

Type	Code Word	Price
100-K	BEAMY	\$40.00
100-L	BEARD	40.00

TYPE 70 AND TYPE 80 VARIAC TRANSFORMERS

USES: Variac Transformers are intended for use where only small voltage variations are desired. One important use for the -B and -C models is voltage correction on under-voltage or over-voltage lines. For this purpose, they can be built into low-power apparatus, particularly transformer-rectifier systems such as are used on radio transmitters.

Special units for many other applications can be built to order.

DESCRIPTION: Variac Transformers are built on rectangular cores with windings in several layers on the two legs of the core. The top layers of wire are exposed to two sliding carbon contacts. These contacts are directly connected, eliminating flexible leads. By means of a steel tape, a 320° rotation of

the control knob drives the contacts along the entire length of the windings.

The windings beneath the top layer of each coil are conventional transformer coils and can be used for a number of special purposes.

Five stock models are available and can be supplied either mounted or unmounted. Mounted units are those with the letter M in the type number.

FEATURES: Very precise adjustments of voltage are possible with the Variac Transformer because a small range of voltage is spread over a 320° rotation of the dial. The availability of special models makes possible individual designs for specific purposes.

SPECIFICATIONS

Type	Line Volts	Output Volts	No-Load Loss	Maximum Current
70-A	115	0-10	5 w	6 a
70-B	100-125	115	5 w	2 a
	115	100-125		2 a
80-A	115	0-10	10 w	20 a
80-B	90-130	115	10 w	7.5 a
	115	90-130		7.5 a
80-C	200-240	220	10 w	7.5 a
	220	200-240		7.5 a

Load Rating: The rating of Variac Transformers is expressed differently from the rating of Variacs and other transformers. A conventional transformer is rated by the output power available. A Variac Transformer is rated by the variation in output power which can be obtained by turning the control knob. This variable power is 50 watts for the TYPE 70 core and 250 watts for the TYPE 80 core.

Mounting: Both mounted and unmounted models are available. Mounted models are enclosed in drawn steel

cases and are equipped with ON-OFF switch, 6-foot line cord and plug, and plug receptacle for the output circuit.

Terminals: Threaded terminal studs with soldering lugs.

Dimensions: TYPE 70, (length) 4 $\frac{3}{4}$ x (width) 3 $\frac{3}{8}$ x (height) 4 inches; TYPE 80, (length) 8 $\frac{1}{2}$ x (width) 4 $\frac{1}{4}$ x (height) 5 $\frac{1}{2}$ inches, over-all.

Net Weight: TYPE 70, 4 $\frac{1}{4}$ pounds; TYPE 80, 13 $\frac{1}{4}$ pounds.

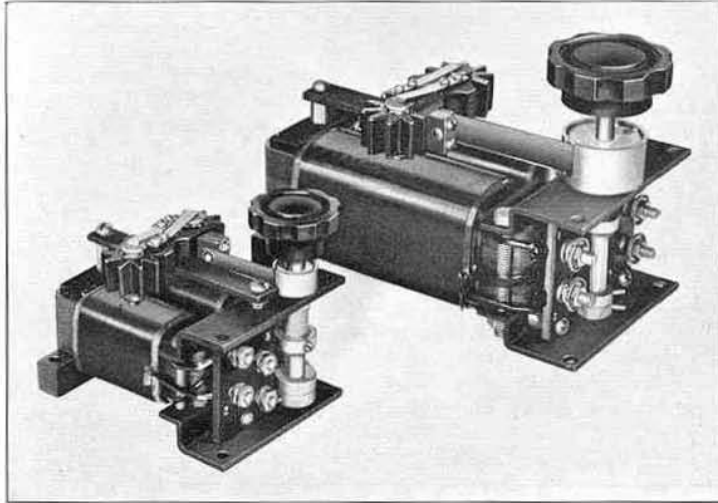

Type		Code Word	Price
70-A	Unmounted.....	BASIN	\$10.00
70-AM	Mounted.....	PLAZA	14.50
70-B	Unmounted.....	BASSO	10.00
70-BM	Mounted.....	POKER	14.50
80-A	Unmounted.....	BATON	15.00
80-AM	Mounted.....	TABBY	20.50
80-B	Unmounted.....	BATY	15.00
80-BM	Mounted.....	TESTY	20.50
80-C	Unmounted.....	BARON	15.00
80-CM	Mounted.....	TIGER	20.50

SPECIAL VARIAC TRANSFORMERS

Only ten models of Variac Transformers are carried in stock. Other models are built to individual customer's specifications.

For good efficiency the design limitations on the special transformers are 10 amperes and a maximum voltage variation of 30 volts for the TYPE 70 Core and 20 amperes and 60 volts variation for the TYPE 80 Core, provided the product of voltage variation and current does not exceed the variable power

rating for the core. (See preceding page.) Within these limits special transformers can be supplied promptly and economically.

Prices for special designs are as follows:

Quantity	Type 70	Type 80
1	\$37.00	\$44.50
5	17.00	24.50
10	14.50	20.00
20	13.25	18.25
25	12.75	17.75
50	11.00	16.00
100	10.00	15.00

Mounting dimensions for TYPES 100, 200-C, and 200-B Variacs.

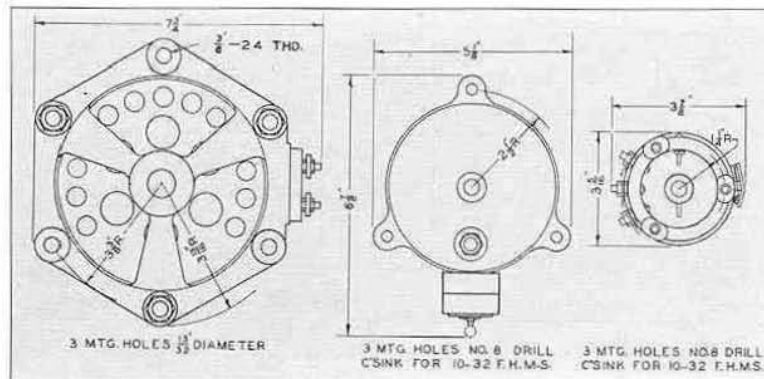

MULTIPLE OPERATION OF VARIACS

Variacs can be ganged for operation of several units from a single shaft. With these multiple assemblies, several circuits can be controlled by one dial and the effective load rating is correspondingly increased. To avoid circulating currents, however, Variac windings should *not* be connected in parallel.

In three-phase circuits, two- and three-gang Variac assemblies can be used in exactly the same manner that single Variacs are used in single-phase circuits. The most common methods of connection are the wye and open-delta. A closed-delta connection may be useful for certain types of work. Characteristics of wye and open-delta assemblies of Variacs are given in the table below. Prices are as follows:

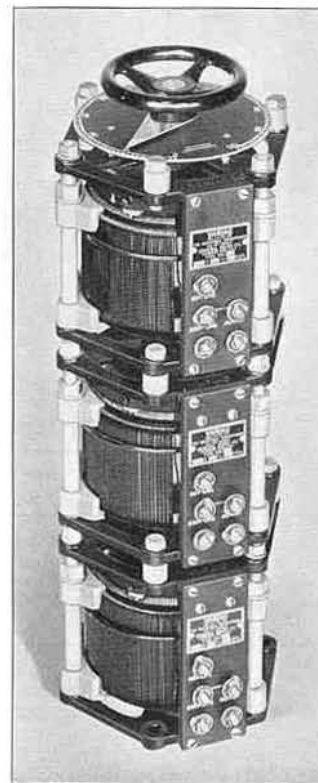

Type	Description	Code Word	Price
100-KG2	2-gang 100-K	BEAMYGANDU	\$85.00
100-KG3	3-gang 100-K	BEAMYGANTY	130.00
100-LG2	2-gang 100-L	BEARDGANDU	85.00
100-LG3	3-gang 100-L	BEARDGANTY	130.00
200-CUG2	2-gang 200-CU	BAKERGANDU	36.50
200-CUG3	3-gang 200-CU	BAKERGANTY	56.00
200-CUHG2	2-gang 200-CUH	BAGUEGANDU	44.50
200-CUHG3	3-gang 200-CUH	BAGUEGANTY	68.00

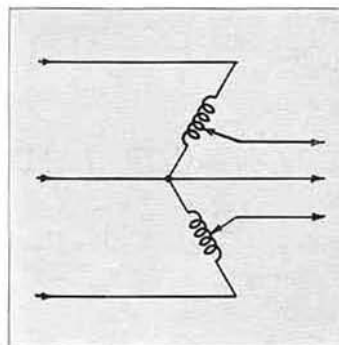
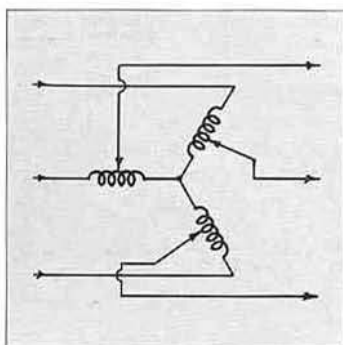

At the left are shown wye and open-delta connections for ganged Variacs. The diagram shows the Variac connected across the full phase or line voltage. By connecting a tapped portion of the winding to the line or a phase, obviously output voltages greater than input voltage can be obtained.

Volt-Amperes		Line Current		Line Voltage	Input 3-Phase Line Voltage	Type of Variac Assembly	Circuit
At Maximum Voltage	At Input Voltage	Rated	Maximum				
115-VOLT CIRCUITS							
235	500	0.5	2.5	0-270	115	200-CUHG2	Open-delta
1170	1500	5	7.5	0-135	115	200-CUG2	Open-delta
1600	1800	4	9	0-230	115	100-LG2	Open-delta
3500	3500	15	17.5	0-115	115	100-KG2	Open-delta
230-VOLT CIRCUITS							
430	1000	0.5	2.5	0-500	230	200-CUHG3	Wye
700	1000	1.5	2.5	0-270	230	200-CUHG2	Open-delta
3000	3000	5	7.5	0-230	230	200-CUG3	Wye
3000	3600	4	9	0-440	230	100-LG3	Wye
3600	3600	8	9	0-230	230	100-LG2	Open-delta
6000	6000	13	15	0-230	230	100-KG3	Wye
440-VOLT CIRCUITS							
1900	1900	1.5	2.5	0-440	440	200-CUHG3	Wye
6000	6000	7	8	0-440	440	100-LG3	Wye

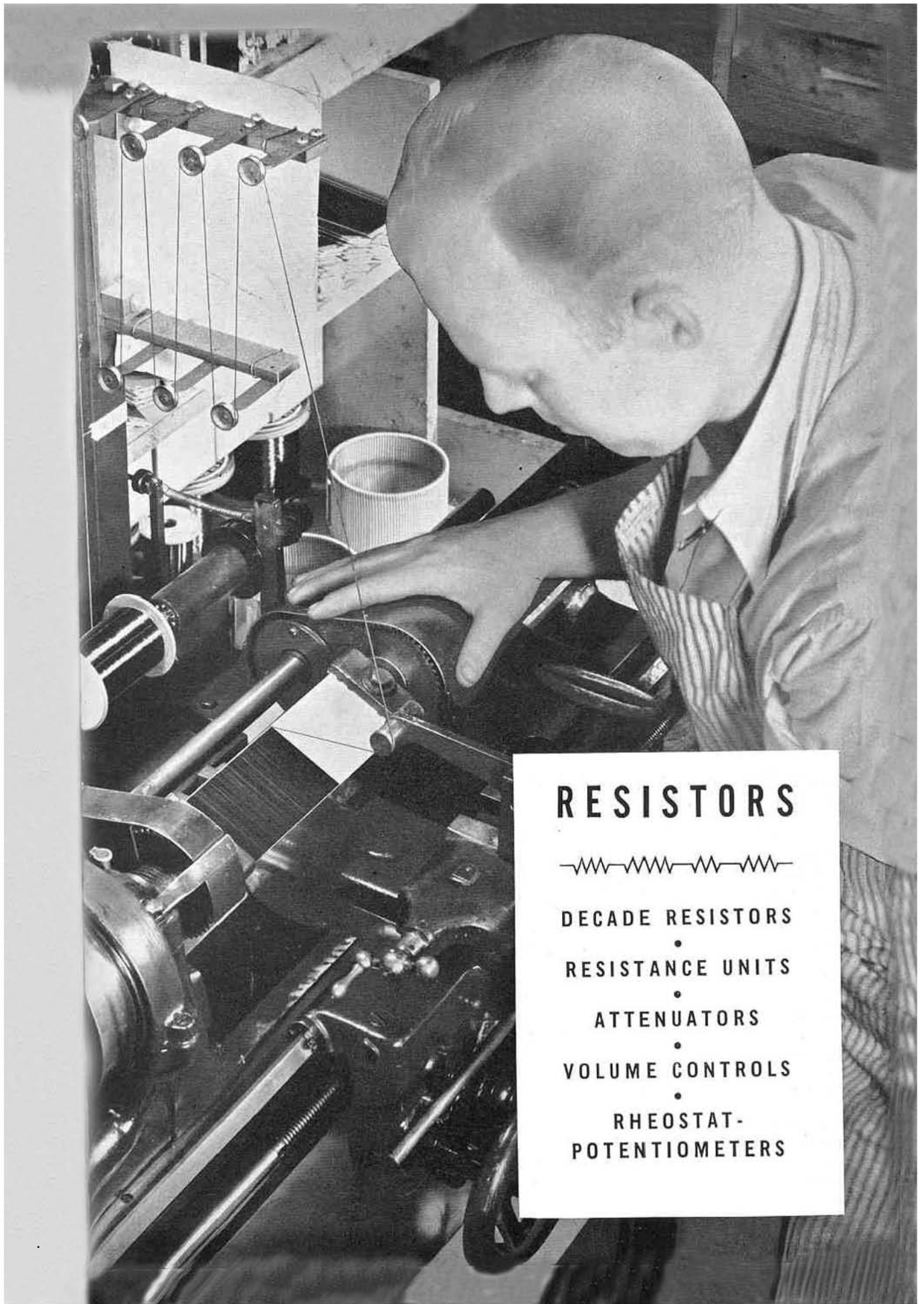

RESISTORS

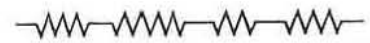

DECADE RESISTORS

•
RESISTANCE UNITS

•
ATTENUATORS

•
VOLUME CONTROLS

•
RHEOSTAT-
POTENTIOMETERS

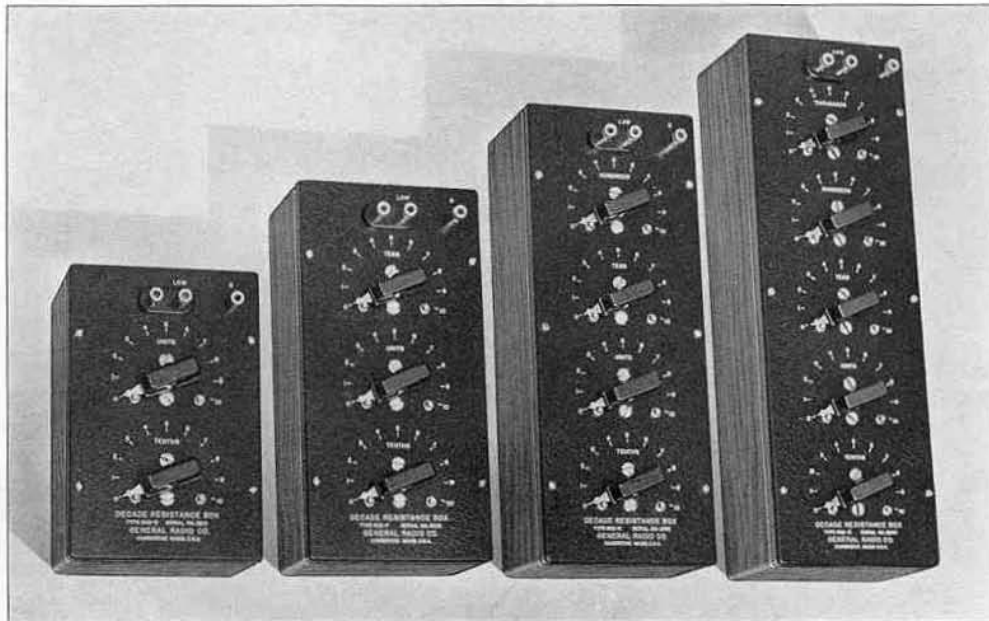

TYPE 602 DECADE-RESISTANCE BOX

USES: Accurate resistance boxes are extremely valuable wherever electrical measurements are made. Such boxes are constantly used in circuits where a wide range of resistance values is required or where variable dummy generator and load resistances are needed. The accuracy of TYPE 602 Decade-Resistance Boxes also permits them to be used as laboratory standards and as ratio arms for direct- and alternating-current bridges.

DESCRIPTION: The TYPE 602 Decade-Resistance Box is an assembly of two or more TYPE 510 Decade-Resistance Units in a single cabinet. Mechanical and electrical protection of the units is provided by the shielded walnut cabinet and aluminum panel, which completely enclose both the resistance units and switch contacts. The resistance elements have no electrical connection to the shield, which is brought out to a separate terminal connected to the panel.

Two-, three-, four-, and five-dial decade assemblies are available. Each decade has eleven contact studs and ten resistance units, so that the dials overlap. A positive detent mechanism assists in setting squarely on the contacts and so permits adjustments to be made without looking at the dials.

FEATURES: The switch resistance of all the TYPE 602 Decade-Resistance Boxes has been kept at about 0.002 ohm per decade by careful mechanical design. This fact is very

important in applications where it is desired to keep the zero resistance of a box as low as possible.

The individual resistors in the TYPE 602 Decade-Resistance Boxes are adjusted to have their specified values at their own terminals and not at the terminals of the box. This method of adjustment has been adopted primarily because no method in which the switch resistance is absorbed in some one unit of a decade can give the correct value of the total resistance for all settings of the various decades.

There are also many types of measurement, such as voltage-divider and substitution measurements, in which the difference between two settings of a resistance box is the important value. This difference is given correctly only when the individual resistors have been adjusted independently of switch resistance.

All General Radio resistance boxes are designed for both direct- and alternating-current applications and their usefulness for many applications extends well into the radio-frequency range. Inasmuch as manganese wire is used in all boxes except in the highest decades of the TYPES 602-M and 602-L, no difficulty is encountered in direct-current measurements because of thermal emf's (see discussion under TYPE 510 Decade-Resistance Units). The lower decades are the most satisfactory at high frequencies, but there is no serious frequency error in any of

the units below 50 kilocycles. Frequency characteristics for the individual decades are given under the TYPE 510 Decade-Resistance Units on page 21. When several decades are assembled in a single box, the box wiring and capacitance to shield of the individual decades will, of course, affect the frequency characteristic, especially at the higher frequencies.

The maximum allowable current for each

decade, based on a 40° Centigrade temperature rise, is engraved just above each decade switch knob. This information is therefore always before the student or laboratory worker and so eliminates guesses as to how much current can be carried by a given decade.

The temperature coefficient of resistance for all the boxes is less than ± 0.002 per cent per degree Centigrade at room temperatures.

SPECIFICATIONS

Type of Winding: See specifications for TYPE 510 Decade-Resistance Units, page 20.

Accuracy of Adjustment: All cards are adjusted within 0.1% of the stated value between card terminals, except the 1-ohm cards which are adjusted within 0.25% and the 0.1-ohm cards which are adjusted within 1%.

Zero Resistance: The zero resistance of the various boxes varies with the number of dials as follows:

No. of Dials	Zero Resistance
2	0.004-0.006 ohm
3	0.006-0.009 ohm
4	0.008-0.012 ohm
5	0.010-0.015 ohm

Temperature Coefficient: Less than $\pm 0.002\%$ per degree Centigrade at room temperatures.

Frequency Characteristics: There is no serious frequency error below 50 kc. At higher frequencies the error results from skin effect and the effect of the reactance in the cards, and from the inductance of the box wiring which is about 0.1 microhenry per dial.

For characteristics of the individual decades, see tabulations for TYPE 510 Decade-Resistance Units, page 21.

Maximum Current: See specifications for TYPE 510 Decade-Resistance Units, page 21. Values for 40° Centigrade rise are engraved on panels directly above switch knobs.

Switches: Quadruple-leaf, phosphor-bronze switches bear on contact studs $\frac{3}{8}$ inch in diameter. Switch brushes are bent so as not to be tangent to the arc of travel, thus avoiding cutting. A cam-type detent is provided. There are eleven contact points (0 to 10 inclusive).

Terminals: Jack-top binding posts set on General Radio standard $\frac{3}{4}$ -inch spacing for resistance connections. There is an extra post at the corner of the panel for connections to the shield.

Mounting: A copper-lined walnut cabinet, with aluminum panel, completely encloses switches and resistance units. The panel finish is black crackle lacquer.

Dimensions: Panel length depends on the number of dials (see price list), being $7\frac{3}{4}$ for 2-dial, $10\frac{3}{8}$ for 3-dial, 13 for 4-dial, and $15\frac{5}{8}$ inches for 5-dial boxes. Panel width, 5 inches. Over-all height, 5 inches.

Net Weight: $3\frac{1}{4}$ for 2-dial, $4\frac{1}{4}$ for 3-dial, 5 for 4-dial, and $6\frac{1}{4}$ pounds for 5-dial boxes.

This shows the interior construction of a TYPE 602-J Decade-Resistance Box.

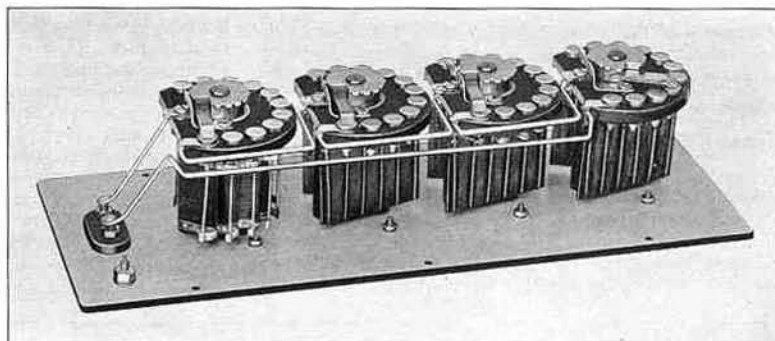

Type	Resistance	No. of Dials	Type 510 Decades Used	Code Word	Price
602-D	11 ohms, total, in steps of 0.1 ohm	2	A, B	DECOY	\$25.00
602-E	110 ohms, total, in steps of 1 ohm	2	B, C	DECRY	25.00
602-F	111 ohms, total, in steps of 0.1 ohm	3	A, B, C	DELTA	35.00
602-G	1110 ohms, total, in steps of 1 ohm	3	B, C, D	DIGIT	35.00
602-K	1111 ohms, total, in steps of 0.1 ohm	4	A, B, C, D	DEFER	45.00
602-J	11,110 ohms, total, in steps of 1 ohm	4	B, C, D, E	DEBIT	50.00
602-N	11,111 ohms, total, in steps of 0.1 ohm	5	A, B, C, D, E	DEMON	62.00
602-M	111,110 ohms, total, in steps of 1 ohm	5	B, C, D, E, F	DEMIT	70.00
602-L	111,100 ohms, total, in steps of 10 ohms	4	C, D, E, F	DECAY	58.00

TYPE 510 DECADE-RESISTANCE UNIT

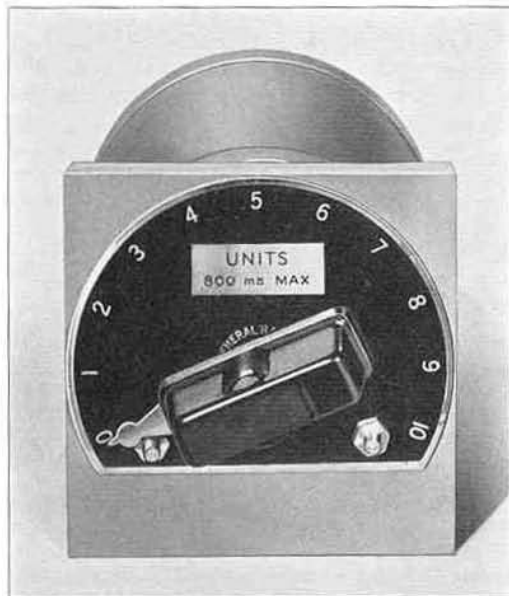

USES: The TYPE 510 Decade-Resistance Units are precision resistors admirably suited for assembly into either experimental or permanent equipment where only a single decade is desired or where a TYPE 602 Decade-Resistance Box cannot be mounted conveniently.

DESCRIPTION: Each decade is enclosed in an aluminum shield, and a knob and etched-

metal dial plate are supplied. The unit is also available complete with shield, blank dial plate, switch stops, and knob, but without resistors, as the TYPE 510-P3 Switch.

FEATURES: Each resistor is carefully adjusted and aged before being assembled into the units. The construction is such that frequency errors are negligible below 50 kilocycles. Complete information is given in the specifications under "Frequency Characteristics."

All resistors have a temperature coefficient of resistance of less than ± 0.002 per cent per degree Centigrade at room temperatures. Manganin wire is used in all decades except the TYPES 510-F and 510-G. Since the thermal emf's generated at a manganin-copper junction are very small, no difficulties arise in low-voltage direct-current measurements when these boxes are used. Since the 10,000-ohm and 100,000-ohm cards are not wound with manganin, care should be taken in low-voltage direct-current work to see that temperature differences are kept at a minimum.

Each resistor, with the exception of the 0.1-ohm steps, will dissipate approximately one-half watt of power with a temperature rise of 40° Centigrade. The allowable current for this temperature rise is engraved on the dial plate.

SPECIFICATIONS

Accuracy of Adjustment: Resistors are adjusted to be accurate at card terminals within the tolerances given in Table I on next page.

Maximum Current: See Table I on next page.

Type of Winding: See Table I on next page.

Frequency Characteristics: Tables II and III list, respectively, the percentage change in resistance and impedance for each decade, at maximum setting, as a function of frequency. These values indicate the error occurring when the decade is used as a series circuit element or as a voltage divider, respectively. For the

low-resistance decades the errors are almost entirely due to skin effect, while in the high-resistance decades the shunt capacitance causes most of the error. When these decades are shunted across a tuned circuit where the reactance is tuned out, the remaining error is only that owing to skin effect. That is, the parallel resistance of the higher-resistance decades changes by only a fraction of the amount that is indicated in the tables as the series resistance error. This fact is particularly important with reference to the TYPE 510-G which has 100,000-ohm steps. At maximum setting this unit has a -1% change in series resistance at 1 kilocycle, but its parallel resistance is changed by only -1% at 10 kilocycles.

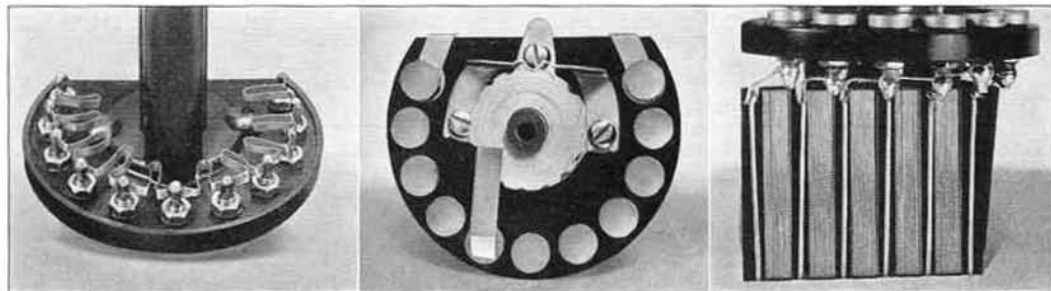

These pictures show some of the constructional details of TYPE 510 Decade-Resistance Units. (Left) The resistance elements of the TYPE 510-A; (center) Details of contact and switch mechanisms; (right) The resistance elements for TYPE 510-C.

TABLE I

Type	Resistance per Step	Accuracy	Type of Winding	Maximum Current		Maximum Power per Resistor
				20° C. Rise	40° C. Rise	40° C. Rise
510-A	0.1 Ω	±1.0%	Bifilar	1 a	1.6 a	0.25 watt
510-B	1 Ω	±0.25%	Ayrton-Perry	550 ma	800 ma	0.6 watt
510-C	10 Ω	±0.1%	Ayrton-Perry	170 ma	250 ma	0.6 watt
510-D	100 Ω	±0.1%	Ayrton-Perry	55 ma	80 ma	0.6 watt
510-E	1000 Ω	±0.1%	Unifilar on Mica	16 ma	23 ma	0.5 watt
510-F	10,000 Ω	±0.1%	Unifilar on Mica	5 ma	7 ma	0.5 watt
510-G	100,000 Ω	±0.1%	Spool	1.5 ma	2.5 ma	0.6 watt

TABLE II

Percentage Change in Resistance for Maximum Setting of Each Decade as a Function of Frequency

Decade	Frequency in kc						
	50	100	200	500	1000	2000	5000
0.1-ohm steps	0	0.1%	0.2%	1.5%	5%	—	—
1-ohm steps	0	0	0.1%	0.3%	1%	4%	—
10-ohm steps	0	0	0	0.1%	0.5%	2%	11%
100-ohm steps	0	0	0	0.1%	0.3%	0.8%	4%
1000-ohm steps	0	-0.1%	-0.5%	-3%	-11%	—	—
10,000-ohm steps	-2.5%	-12%	—	—	—	—	—

TABLE III

Change in Impedance (as a percentage of nominal resistance) for Maximum Setting of Each Decade as a Function of Frequency

Decade	Frequency in kc						
	50	100	200	500	1000	2000	5000
0.1-ohm steps	0.2%	0.7%	2%	—	—	—	—
1-ohm steps	0.1%	0.2%	1%	5%	—	—	—
10-ohm steps	0	0	0.1%	0.2%	2%	—	—
100-ohm steps	0	0	0	0.1%	0.3%	1%	5%
1000-ohm steps	0	-0.1%	-0.5%	-2%	-6%	—	—
10,000-ohm steps	-2%	-10%	—	—	—	—	—

Switches: Quadruple-leaf, phosphor-bronze switches bear on contact studs $\frac{3}{8}$ inch in diameter. Switch brushes are bent so as not to be tangent to the arc of travel, thus avoiding cutting. A cam-type detent is provided. There are eleven contact points (0 to 10 inclusive). The switch resistance is between 0.002 and 0.003 ohm.

Temperature Coefficient: The temperature coefficient of resistance is less than $\pm 0.002\%$ per degree Centigrade at room temperatures.

Resistance Wire: Manganin is used on all the smaller decades. The 10,000-ohm cards are wound with a combination of Nichrome and Ohmax, which gives a nearly zero temperature coefficient. Advance wire is used on the 100,000-ohm units.

Terminals: Soldering lugs are provided.

Mounting: Each decade is complete with dial plate and knob and can be mounted on any panel between $\frac{1}{4}$ inch and $\frac{3}{8}$ inch in thickness.

Dimensions: See sketch; shaft diameter is $\frac{3}{8}$ inch.

Net Weight: TYPE 510 Units, 11 ounces; TYPE 510-P3, $9\frac{1}{2}$ ounces.

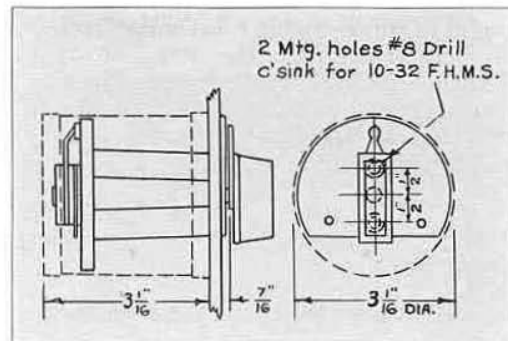

Type	Resistance		Code Word	Price
	Total	Per Step		
510-A	1 Ω	0.1 Ω	ELATE	\$8.50
510-B	10 Ω	1 Ω	ELDER	8.50
510-C	100 Ω	10 Ω	ELEGY	8.50
510-D	1000 Ω	100 Ω	ELBOW	8.50
510-E	10,000 Ω	1000 Ω	ELECT	12.00
510-F	100,000 Ω	10,000 Ω	ELVAN	14.00
510-G	1,000,000 Ω	100,000 Ω	ENTER	30.00
510-P3 Switch		ENVOY	5.00

TYPE 670 COMPENSATED DECADE RESISTOR

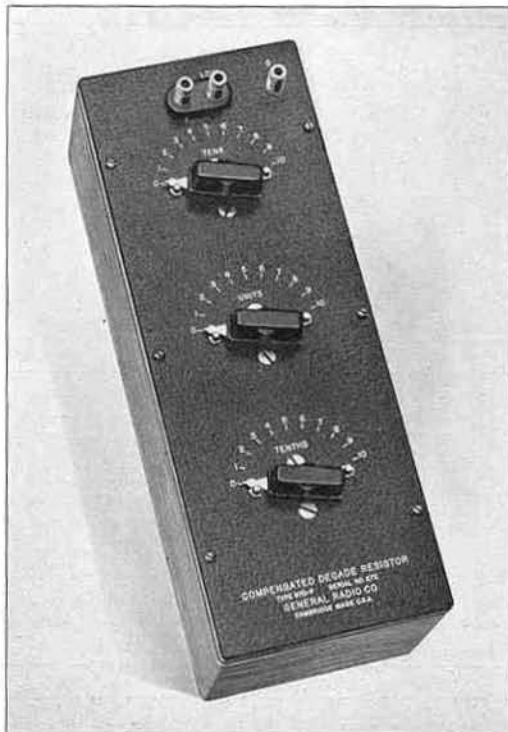

USES: The TYPE 670 Compensated Decade Resistors are intended for use in a-c impedance measurements, where non-reactive increments of resistance are desired. This type of decade is practically an essential for radio-frequency bridge measurements, and has made possible the development of TYPE 516-C Radio-Frequency Bridge. It is equally useful in tuned-circuit substitution methods of measurement. In the TYPE 667-A Inductance Bridge, for the precise measurement of inductance at audio frequencies, this decade resistor is also necessary.

DESCRIPTION: The TYPE 670 Boxes are assemblies of TYPE 668 Compensated Decade-Resistance Units and TYPE 669 Compensated Slide-Wire Resistors.

The decade-resistance units use a double card system, as shown on next page, and the switch is so arranged that a copper coil is substituted when a resistance coil is switched out of circuit. The inductance of the copper coil is equal to the inductance of the resistance coil but its resistance is very small. Consequently, as the position of the switch is changed, the inductance of the decade is kept constant and only the resistance is varied.

A completely shielded cabinet is provided with the shield brought to a separate terminal for independent connection.

FEATURES: The greatest advantage of the TYPE 670 Compensated Decade Resistor is that its inductance is constant within 0.05 microhenry regardless of the resistance setting of the box. Furthermore, the total inductance of the box is but one microhenry and so little difficulty is encountered in balancing out this amount in preliminary adjustments.

Two of the boxes have continuously-adjustable compensated slide wires thus allowing extra fine adjustment of resistance, a feature especially useful in bridges where accurate balance is desired.

High accuracy and low temperature coefficient of resistance are maintained in the TYPE 670 Boxes. The current ratings for all decades, based on a 40° Centigrade temperature rise, are engraved on the panel.

SPECIFICATIONS

Type of Winding: The 10-ohm and 1-ohm steps are Ayrton-Perry resistance cards, while the 0.1-ohm steps are bifilar ribbon units. The construction of the slide wires is shown on the next page.

All decades are compensated by copper coils as shown in the diagram on the next page.

Accuracy of Adjustment: Resistance increments are correct within 0.1% for the 10-ohm steps, 0.25% for the 1-ohm steps, and 1% for the 0.1-ohm steps. The 1-ohm and 0.1-ohm slide wires are correct within 1% and 5% of full-scale value, respectively.

Zero Resistance: The zero resistance of the different boxes is given below.

Type	Zero Resistance	Zero Inductance
670-BW	0.035-0.055 ohm	0.70 microhenry
670-F	0.030-0.050 ohm	1.05 microhenry
670-FW	0.070-0.090 ohm	1.05 microhenry

Inductance: The zero inductance of the boxes is given in the table above. This value remains constant regardless of resistance setting within 0.05 microhenry.

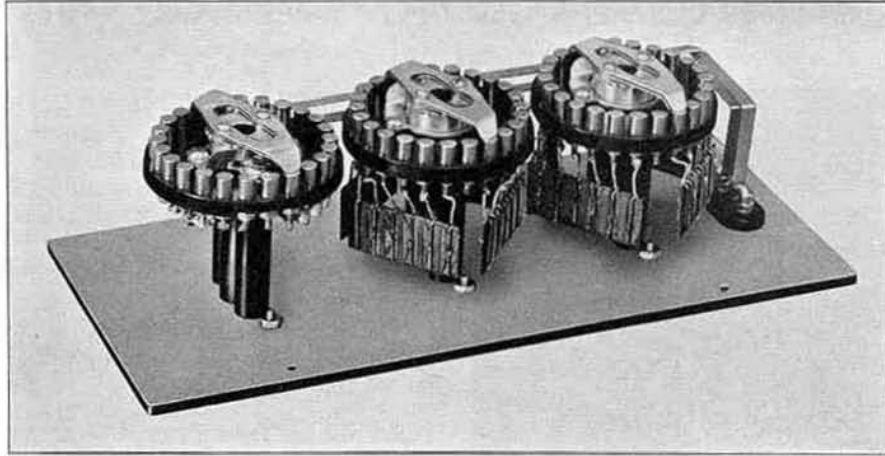

Interior of TYPE 670-F Compensated Decade Resistor.

Maximum Current: See specifications for TYPE 668 Compensated Decade-Resistance Unit and TYPE 669 Compensated Slide-Wire Resistor on pages 24 and 25. Values for 40° Centigrade rise are engraved on the panels directly above the switch knob.

Frequency Characteristics: The frequency characteristics of the TYPE 670 Compensated Decade Resistor are similar to those of the TYPE 668 and TYPE 669 Units which are used in the boxes. However, the box wiring and cabinet shield affect these characteristics somewhat.

Temperature Coefficient: Less than $\pm 0.002\%$ per degree Centigrade at room temperatures.

Switches: Double-leaf, phosphor-bronze switches bear

on contact studs $\frac{1}{4}$ inch in diameter. Switch brushes are bent so as not to be tangent to the arc of travel, thus avoiding cutting. A cam-type detent is provided. There are eleven contact points (0 to 10 inclusive).

Terminals: Standard $\frac{3}{4}$ -inch spacing is used on the terminals. A ground post connected to shield and panel is also provided.

Mounting: The dials are mounted on aluminum panels in copper-lined walnut cabinets.

Dimensions: Panel, (length) 13 x (width) 5 inches. Cabinet, (height) 5 inches, over-all.

Net Weight: 5 pounds (all types).

Type	Resistance	Type Units Used	Code Word	Price
*670-BW	0 to 11.1 ohms, total, with slide wire	668-A, -B; 669-R	ABRID	\$60.00
670-F	0 to 111 ohms, total, in steps of 0.1 ohm	668-A, -B, -C	ABYSS	45.00
*670-FW	0 to 111 ohms, total, with slide wire	668-B, -C; 669-A	ADOWN	55.00

*PATENT NOTICE. See Note 17, page v.

These two diagrams show the construction of TYPE 668 Compensated Decade-Resistance Units and TYPE 669 Compensated Slide-Wire Resistor.

The compensated decade resistance is shown at the right. Opposite ends of the switch blade make contact with resistance or inductance windings, respectively. As a resistance step is added to the circuit, a compensating inductance step is removed and vice versa. The construction of the compensated slide wire is shown below. As the slider is moved along, a length of copper wire is substituted for an equivalent length of manganin wire and vice versa.

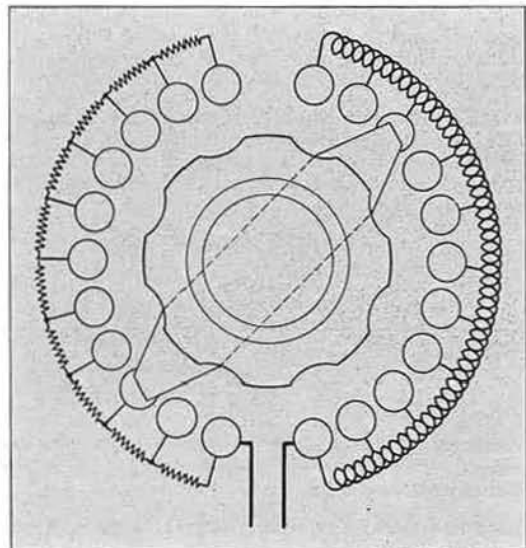
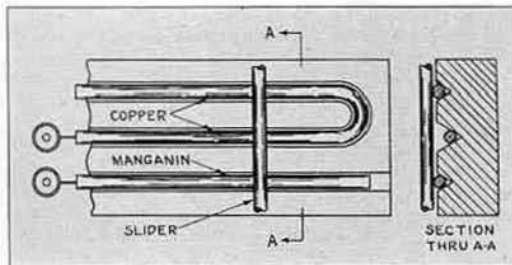

TYPE 668 COMPENSATED DECADE-RESISTANCE UNIT

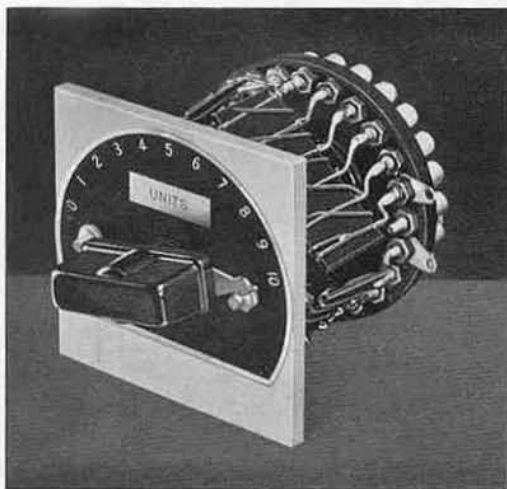

USES: The TYPE 668 Compensated Decade-Resistance Unit is the basic unit for the TYPE 670 Boxes and can be built into experimental or permanent equipment. For precise impedance measurements at radio frequencies and many measurements at audio frequencies the TYPE 668 Units are indispensable as bridge elements.

DESCRIPTION: The TYPE 668 Compensated Decade-Resistance Unit is equipped with a double set of switch contacts, by means of which a copper winding is exchanged, step by step, for the resistance cards, thus keeping the total inductance constant regardless of resistance setting. (See diagram under TYPE 670 on page 23.)

The units are mounted with an etched-metal dial plate, knob, and stops, but with no shield.

FEATURES: The TYPE 668 Compensated Decade-Resistance Units are accurately adjusted resistances with a low temperature coefficient of resistance.

Since it is impossible to build a resistance with no inductance, the next best condition is a unit with a low but constant inductance. Accordingly, the TYPE 668 Units have been built to have but a few tenths of a microhenry inductance and this value remains constant to within 0.05 microhenry regardless of resistance setting.

Careful construction has made it possible to keep the frequency errors small and so all units are useful up to several megacycles.

SPECIFICATIONS

Type of Winding: The 10-ohm and 1-ohm cards are Ayrton-Perry wound, while the 0.1-ohm steps are bifilar ribbon. Compensated windings are used on all decades to maintain constant inductance. (See diagram on page 23.)

Switch: A double-leaf, phosphor-bronze switch bears on contact studs $\frac{1}{4}$ inch in diameter. Switch brushes are bent so as not to be tangent to the arc of travel, thus avoiding cutting. A cam-type detent is provided and there are eleven contact points (0 to 10 inclusive).

Maximum Current: The following table gives the allowable current for the different units. The values of current for a 40° Centigrade temperature rise, based on one-quarter watt dissipation per resistor are engraved on the dial plate.

Type	Current for 20° C. Rise	Current for 40° C. Rise
668-A	1.0 a	1.6 a
668-B	300 ma	500 ma
668-C	100 ma	160 ma

Accuracy of Adjustment: Resistance increments are correct within 1% for the 0.1-ohm steps, 0.25% for the 1-ohm steps, and 0.1% for the 10-ohm steps.

Zero Resistance: The zero resistance of the different units is given in Table II.

TABLE II

Type	Zero Resistance	Inductance
668-A	0.001-0.010 ohm	0.15 microhenry
668-B	0.015-0.025 ohm	0.30 microhenry
668-C	0.010-0.020 ohm	0.50 microhenry

Inductance: The inductance of the different units is given in the table above. The inductance remains constant regardless of resistance setting within 0.05 microhenry.

Temperature Coefficient: The temperature coefficient of resistance is less than $\pm 0.002\%$ per degree Centigrade at room temperatures.

Frequency Characteristics: The frequency characteristics of TYPE 668 Compensated Decade-Resistance Units are similar to those of TYPE 510 Decade-Resistance Units, page 20. Because 10-ohm cards are the largest used, the effects of shunt capacitance are entirely negligible, and the change in resistance with frequency results almost entirely from skin effect.

Although skin effect produces a positive effect on the total resistance, the skin effect in the compensating winding is greater than that in the resistance cards. Accordingly there is a net negative change in resistance increments. That is, the increment in resistance between one switch point and the next higher one will be less at high frequencies than at low. This "negative skin effect," at one megacycle, is about -0.8% for the units decade and about -0.6% for the tens decade.

Terminals: Soldering lugs are provided.

Mounting: Interchangeable (except for switch stops) with TYPE 510 (see page 21.) A combination dial plate and drilling template is furnished.

Dimensions: Diameter, $3\frac{1}{8}$ inches; depth behind panel, 3 inches, over-all; shaft diameter, $\frac{3}{8}$ inch.

Net Weight: 10 ounces.

Type	Resistance		Code Word	Price
	Total	Per Step		
668-A	1 Ω	0.1 Ω	GABLE	\$10.00
668-B	10 Ω	1.0 Ω	GAILY	12.50
668-C	100 Ω	10.0 Ω	GALOP	12.50

TYPE 669 COMPENSATED SLIDE-WIRE RESISTOR

USES: The TYPE 669 Compensated Slide-Wire Resistor is designed for use in bridge and other circuits, requiring constant-inductance resistors, where it is desired to secure a closer adjustment of resistance than is possible with a TYPE 668 Compensated Decade-Resistance Unit. It is also used in TYPE 670-BW and TYPE 670-FW Compensated-Decade Resistors.

DESCRIPTION: Three parallel wires, two of copper and one of manganin, are mounted on the circumference of a bakelite disc. The two copper wires are connected at one end and a short-circuiting arm connects one copper wire and the manganin wire, as shown in the diagram on page 23. As the arm rotates, the resistance is changed but the inductance of the unit is unchanged.

FEATURES: The TYPE 669 Compensated Slide-Wire Resistor is a continuously adjustable resistor and is very useful in obtaining a precise balance in bridge circuits. Its



inductance is low and remains constant within 0.005 microhenry, regardless of setting.

SPECIFICATIONS

Type of Winding: See diagram on page 23.

Accuracy of Calibration: Each unit is fitted with a dial individually engraved at 24 points giving the incremental slide-wire resistance within 1% of full-scale value for the 1-ohm units and 5% of full-scale value for the 0.1-ohm units.

Zero Resistance: The zero resistance of the TYPE 669-A is 0.04 to 0.06 ohm while that of the TYPE 669-R is 0.015 to 0.020 ohm.

Maximum Current and Power: The following table gives the values of allowable current for the two units:

Type	Maximum Current	
	for 20° C. Rise	for 40° C. Rise
669-A	1.0 a	1.6 a
669-R	3.0 a	5.0 a

For a 40° Centigrade rise a maximum of 2.5 watts

Type	Incremental Resistance	Code Word	Price
669-A	1.15 ohms	GAMIN	\$17.50
669-R	0.115 ohm	GAZEL	22.50

will be dissipated by each unit. The value of current for this rise is engraved on the dial.

Inductance: The inductance of both slide wires is 0.15 microhenry. This value remains constant within 0.005 microhenry regardless of the setting.

Temperature Coefficient: Less than $\pm 0.002\%$ per degree Centigrade at room temperatures.

Frequency Characteristics: Shunt capacitance effects are negligible, and the largest errors are due to skin effect, which produces an error on the incremental resistance of -2% at 550 kilocycles and -4% at 1 megacycle.

Terminals: Soldering lugs are provided.

Mounting: Interchangeable with TYPE 668, except for the use of dial and slow-motion drive. A dial indicator is supplied.

Dimensions: Diameter, $3\frac{1}{8}$ inches; depth behind panel, 3 inches, over-all.

Net Weight: 8 ounces.

PATENT NOTICE. See Note 17, page v.

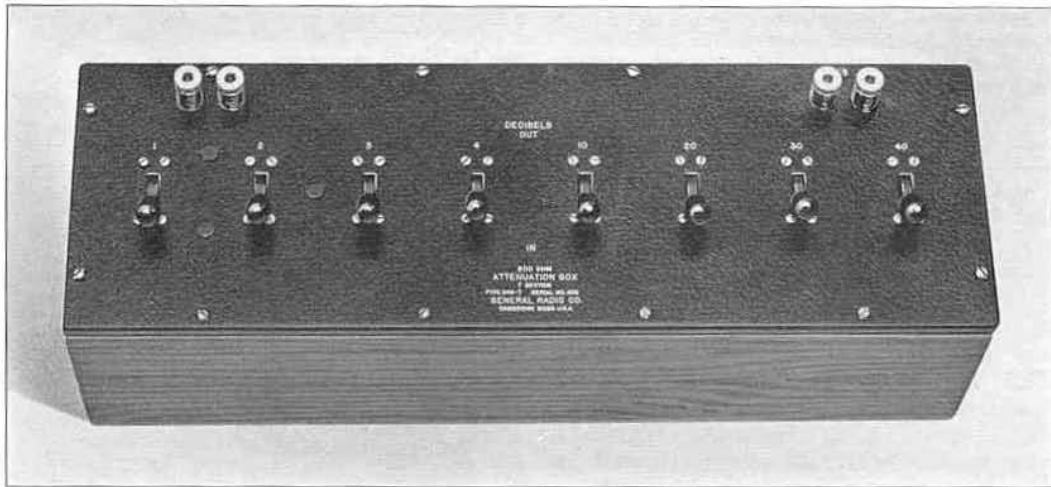

TYPE 249 ATTENUATION BOX

USES: The TYPE 249 Attenuation Box is useful in power-level measurements, transmission-efficiency tests, and in gain or loss measurements on transformers, filters, amplifiers, and similar equipment. It is also used as a power-level control in circuits not equipped with other volume controls.

DESCRIPTION: The TYPE 249 Attenuation Box is a constant impedance attenuator which contains a group of resistance elements so arranged that definite and known amounts of power loss can be introduced by operating

the key switches, when the box is used between specified values of input and output impedances. The total attenuation is given by adding the decibel values engraved by each of the keys.

FEATURES: The outstanding features of this box are its wide range and high accuracy. It can be used on frequencies as high as fifty kilocycles without introducing any appreciable error. Both the T-type section and the balanced-H section are available.

SPECIFICATIONS

Attenuation Range: 110 decibels in steps of 1.0 decibel. Boxes with other attenuation ranges can be made on special order.

Terminal Impedance: 500 ohms. Boxes for other impedances can be made on special order.

Accuracy: Each individual resistor is adjusted within 0.5% of its correct value. At frequencies below 50 kc the maximum error in attenuation is 0.2 db.

Type of Section: Both the T-section and balanced-H-section models are available. Both types present a constant impedance in both directions, but the balanced-H should be used where both sides of the circuit must be balanced to ground.

Type of Winding: Ayrton-Perry windings are used for the low-resistance elements, while unifilar windings on thin mica cards are used for the high-resistance units.

Maximum Voltage: The maximum permissible voltage varies somewhat with the attenuation, but the power-handling capacity of the boxes will not be exceeded, for any setting, if the voltage applied to the input of the TYPE 249-T is kept below 25 volts and that applied to the TYPE 249-H below 35 volts.

Switches: Eight low-capacity key switches control the eight attenuation sections.

Mounting: The units are mounted in shielded walnut cabinets with aluminum panels. The panel and shield are connected to the terminal marked G.

Terminals: Jack-top binding posts with 3/4-inch spacing.

Dimensions: Panel, (length) 10 x (width) 5 1/4 inches. Cabinet, (depth) 5 1/4 inches, over-all.

Net Weight: 7 3/8 pounds.

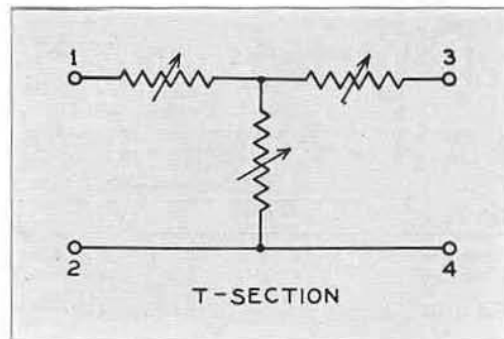

Type	Range	Impedance	Type of Section	Code Word	Price
249-H	110 db in steps of 1.0 db	500 ohms	Balanced-H	NETWORKROD	\$120.00
249-T	110 db in steps of 1.0 db	500 ohms	T	NETWORKTOP	100.00

TYPE 329-J ATTENUATION BOX

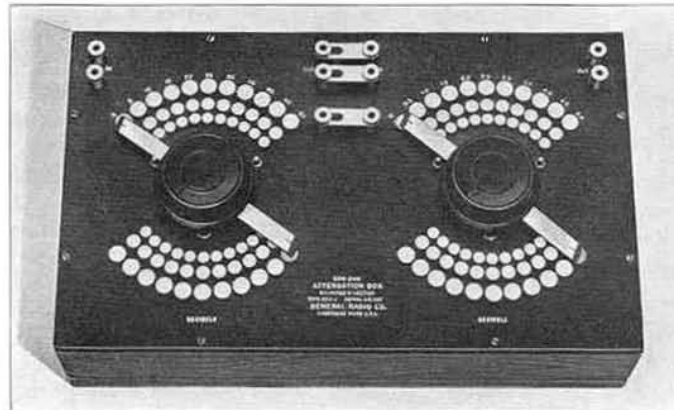

USES: The TYPE 329-J Attenuation Box is used where small steps in attenuation are desired.

DESCRIPTION: This attenuation box is made in two sections which can be used separately or in tandem. Each section is arranged so that the attenuation is increased from zero by turning a large knob. A positive detent mechanism is used which centers the multiple-blade switch at each step. When the two sections are used in tandem, the total atten-

uation is given by the sum of the readings of the individual sections.

FEATURES: The TYPE 329-J Attenuation Box is made of balanced-H sections and has separate ground terminals on the panel. The two attenuation sections may be used either separately or together, since separate terminals are provided. Good accuracy and frequency characteristics, together with the convenience of having small steps of attenuation, make this box a useful adjunct to every communications laboratory.

SPECIFICATIONS

Attenuation Range: Two sections are used, one having a range of 5 decibels in steps of 0.5 decibel and the other having a range of 50 decibels in steps of 5 decibels. By means of removable links either section is made separately available.

Terminal Impedance: 500 ohms. Boxes for other impedances can be made on special order.

Accuracy: Each individual resistor is adjusted within 0.5% of its correct value. At frequencies below 50 kilocycles the maximum error is 0.2 decibel.

Type of Section: The TYPE 329-J uses balanced-H sections which present a constant impedance in both directions. Both sides of the circuit must be balanced to ground when this type box is used. T-section boxes can be supplied on special order.

Type of Winding: Ayrton-Perry windings on bakelite cards are used for the low-resistance elements, while unifilar windings on thin mica cards are used for the high-resistance units.

Maximum Voltage: The maximum allowable voltage varies slightly with the attenuation, but the power-handling capacity of the sections will not be exceeded for any setting, if no more than 45 volts are applied to the input of either section.

Switches: Multiple-blade switches are used with a

positive detent which centers the blade at each step.

Mounting: A walnut cabinet is used with an engraved bakelite panel.

Terminals: Jack-top binding posts with $\frac{3}{4}$ -inch spacing. Separate terminals for each section and their grounds are provided.

Dimensions: Panel, (length) $16\frac{7}{8}$ x (width) $10\frac{3}{4}$ inches.

Cabinet, (depth) 6 inches, over-all.

Net Weight: 12 pounds.

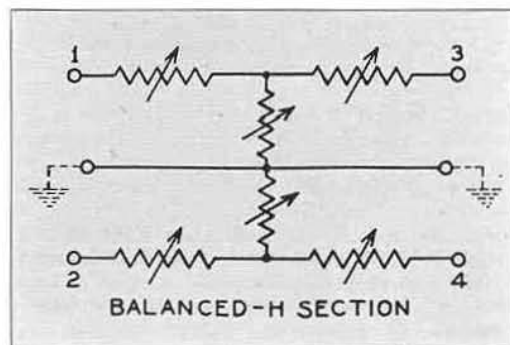

Type	Range	Impedance	Type of Section	Code Word	Price
329-J	55 db in steps of 0.5 db	500 ohms	Balanced-H	TENUTORPIG	\$155.00

• RESISTORS

GENERAL RADIO CO.

TYPE 449-A ADJUSTABLE ATTENUATOR



USES: The TYPE 449-A Adjustable Attenuator has been designed as a convenient and compact unit to be used in broadcast speech circuits, motion-picture recording channels, or any other audio-frequency circuit where definitely known amounts of attenuation are to be easily inserted and removed. It also is useful as an isolation network or a taper pad for changing impedance levels either up or down.

DESCRIPTION: Three lever-key switches control six separate balanced-H networks. The action of the first two keys inserts from

0 to 60 decibels attenuation in 10-decibel steps. The third key operates an impedance-tapering network, which tapers the impedance from 500 to 250 ohms and inserts 10 decibels attenuation, in one position, and tapers from 500 to 50 ohms and inserts 20 decibels attenuation in another position. The middle position of this key inserts no attenuation and allows the box to work from and into 500 ohms.

The keys and pads are housed in a small cast aluminum case together with standard input and output jacks. Mounting holes are provided on the base for use where the attenuator is to be permanently attached to other equipment.

FEATURES: The salient features of the TYPE 449-A Adjustable Attenuator are convenience, compactness, and accuracy. Furthermore, this unit can be used as a taper pad where changes in impedance levels are desired. Two pairs of jacks are provided on both input and output so that parallel connections can be easily made. Either end of the attenuator can be used as the input. Complete shielding is afforded by a cast-aluminum case. The unit will dissipate up to 1.5 watts at the nominal input impedance and can be used without error on frequencies up to 20,000 cycles.

SPECIFICATIONS

Attenuation Range: When operating between 500-ohm impedances, the range is 0 to 60 decibels in 10-decibel steps. When operating between 250- and 500-ohm impedances, the range is 10 to 70 decibels, while between 50 and 500 ohms it is 20 to 80 decibels, also in 10-decibel steps.

Terminal Impedance: The impedance is 500 ohms in one direction, and either 50, 250, or 500 ohms in the other direction. Either end may be used as the input.

Accuracy: Each individual resistor is adjusted within 1% of its correct value. For frequencies below 20 kilocycles, the greatest possible error in attenuation is 0.2 decibel.

Type of Section: A balanced-H section is used. The center connection is not grounded, but provision is made for grounding it to the case if the user so desires.

Type of Winding: All cards are unifilar wound on bakelite.

Maximum Power: The unit will safely dissipate a maximum of 1.5 watts at the nominal input impedance.

Switches: Three Western Electric lever-key switches are used to control the separate attenuating networks.

Terminals: Two pairs of jacks, parallel connected and designed to take the standard Western Electric TYPE 241-A Plugs, are provided at both input and output.

Mounting: The unit is mounted in a cast-aluminum case. An aluminum panel is used.

Dimensions: Panel, (length) $7\frac{1}{4}$ x (width) $3\frac{3}{8}$ inches. Case, (depth) $5\frac{1}{2}$ inches, over-all.

Net Weight: $4\frac{1}{4}$ pounds.

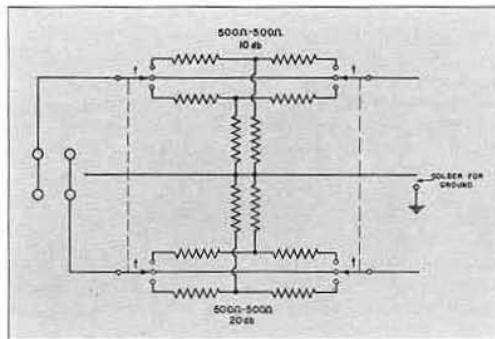

Wiring diagram of the first switch of TYPE 449-A Adjustable Attenuator. Connections for the other switches are identical.

Type	Code Word	Price
449-A	AMISS	\$70.00

TYPE 646-A LOGARITHMIC RESISTOR

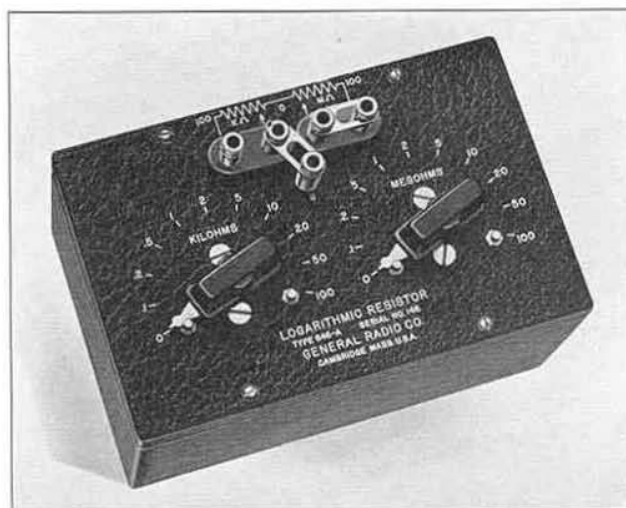

USES: The TYPE 646-A Logarithmic Resistor is used in measuring circuits where a wide range of resistance values must be covered and where, though each value used must be accurately known, using, for example, 5000 ohms instead of 6000 ohms would cause no trouble. It can be used as a test load in transformer or amplifier measurements where the logarithmic arrangement of the resistance values makes it quite easy to cover quickly a wide range of impedances. Because of the convenient terminal arrangement it is also

possible to use this box as a logarithmic voltage divider.

DESCRIPTION: Two decade switches are used, the one with resistance values from 0.1 to 100 kilohms and the other with values from 0.1 to 100 megohms. Both switches are brought out to panel terminals.

FEATURES: The main features of this unit are its wide range in approximately logarithmic steps, its compactness, and accuracy. The box is completely shielded, and a separate terminal is provided for ground.

SPECIFICATIONS

Range: 0 to 100.1 megohms in approximately logarithmic steps.

Accuracy of Adjustment: Individual resistors are adjusted as follows:

Between 0.1 k Ω and 2 k Ω , 0.1%; between 5 k Ω and 1.0 M Ω , 0.25%; 2 M Ω to 20 M Ω , 5%; 50 M Ω and 100 M Ω , 10%.

Type of Winding: The construction of the units below

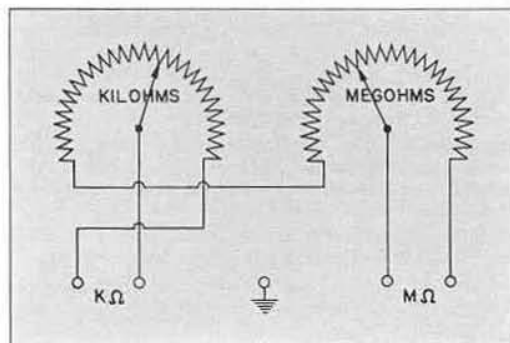

the 20,000- Ω point is similar to General Radio standard resistance-card construction. Between the 20,000- Ω and the 1-M Ω steps, wire-wound units are used; above 1 M Ω , the units are of the metallized type.

Frequency Characteristics: The impedance for alternating currents of any frequency is given approximately by considering a capacitance of 20 μf with a power factor of 0.05 to be in parallel with the used portion of the "megohms" dial. Second order corrections may be made for a 2 μf capacitance between the high-resistance terminal of the "megohms" dial and ground. For resistance uses the unused portion of the "megohms" dial should be short-circuited.

Maximum Current: Individual resistors between 0.1 k Ω and 0.5 k Ω will safely carry 70 ma. Between 1 k Ω and 1 M Ω each resistor will dissipate 1 watt. Resistors greater than 1 M Ω will dissipate 2 watts.

Maximum Voltage: 500 volts.

Terminals: Jack-top binding posts with $\frac{3}{4}$ -inch spacing.

Mounting: A copper-lined cabinet with an aluminum panel completely encloses both switches and resistors. The panel finish is black crackle lacquer.

Dimensions: (Length) $7\frac{3}{4}$ x (depth) 5 x (height) 5 inches.

Net Weight: $3\frac{3}{4}$ pounds.

Type	Resistance	Code Word	Price
646-A	100.1 megohms, total	AWAKE	\$50.00

TYPE 654-A DECADE VOLTAGE DIVIDER

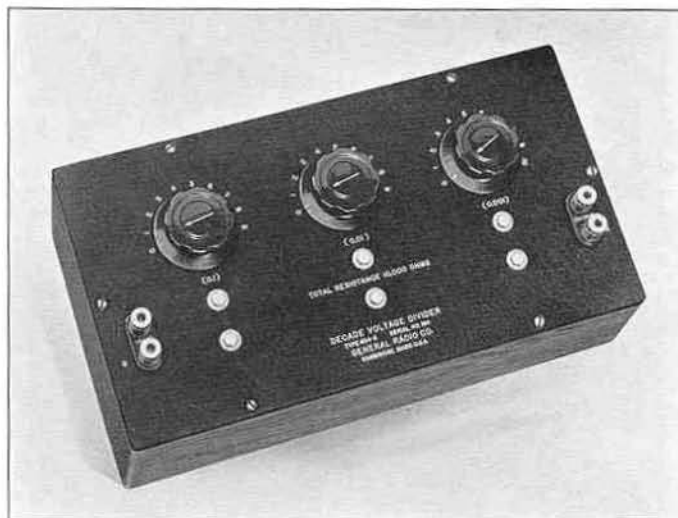

USES: The TYPE 654-A Decade Voltage Divider will supply exact voltage ratios between 0.001 and 1.000 in steps of 0.001, and so is useful on the input of amplifiers and similar high-impedance circuits for reducing the input voltage by a definitely known ratio which can be varied in very small steps.

DESCRIPTION: This instrument is equivalent to a pair of TYPE 602 Decade-Resistance Boxes connected in series and so manipulated that as resistance is taken out of one box it is added to the other to maintain the total

resistance constant at 10,000 ohms. This action is accomplished through the use of two TYPE 510 Decade-Resistance Units operated from each control knob by means of a chain drive.

FEATURES: The TYPE 654-A Decade Voltage Divider covers a very wide range of voltage ratios. It is possible to obtain 1000 different ratios from 0.001 to 1.000, and each one is known with excellent accuracy. The input resistance remains constant regardless of dial settings, and so reaction on the input voltage is eliminated.

SPECIFICATIONS

Range: Voltage ratios from 0.001 to 1.000 in steps of 0.001 can be obtained by setting up the desired value on the three switches.

Accuracy: Each individual resistor is adjusted within 0.1%, so the error in voltage ratio is never greater than 0.2%.

Frequency Characteristics: If the external capacitance

which is placed across the output terminals is less than 20 μmf , the frequency error is less than 0.1% for all frequencies below 10,000 cycles.

Input Impedance: The input impedance is a constant resistance of 10,000 ohms regardless of the ratio setting. This value is engraved on the panel.

Output Impedance: The voltage divider is accurate only when the output impedance is essentially infinite.

Maximum Voltage: The maximum allowable input voltage for a 40° Centigrade temperature rise is 230 volts. This value is engraved on the panel.

Temperature Coefficient: The temperature coefficient of the resistors is less than $\pm 0.002\%$ per degree Centigrade at normal room temperatures.

Terminals: Jack-top binding posts are provided and standard $\frac{3}{4}$ -inch spacing is used. The shield is connected to one terminal of both input and output which is marked G.

Mounting: The decades are mounted on an aluminum panel which is enclosed in a shielded walnut cabinet.

Dimensions: Panel, (length) 13 x (width) 7 inches. Cabinet, (depth) $5\frac{1}{4}$ inches, over-all.

Net Weight: $8\frac{1}{4}$ pounds.

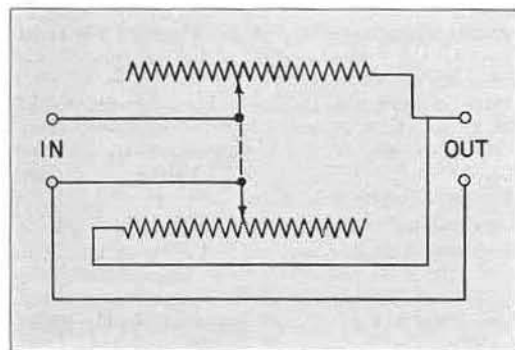

Type	Voltage Ratio	Code Word	Price
654-A	0.001 to 1.000 in steps of 0.001.....	ABACK	\$85.00

TYPE 526 MOUNTED RHEOSTAT-POTENTIOMETER

USES: A calibrated slide-wire resistor is an extremely useful laboratory accessory. TYPE 526 Mounted Rheostat-Potentiometer is sufficiently accurate for use in many bridge measurements and is recommended for use as the power-factor control in TYPE 625-A Bridge.

It is a convenient resistor to use in determining resistance values in experimental circuits.

DESCRIPTION: A standard TYPE 471 Rheostat-Potentiometer is mounted in a steel case and furnished with a calibrated dial plate and standard terminals. The resistance unit uses a four-finger contact arm which gives smooth and accurate variation of resistance.

FEATURES: This rheostat is calibrated directly in resistance with an accuracy of 5 per cent. It is much smaller in size than a decade resistance box of equal resistance. Consequently, where accuracy permits, it is much more convenient to use.

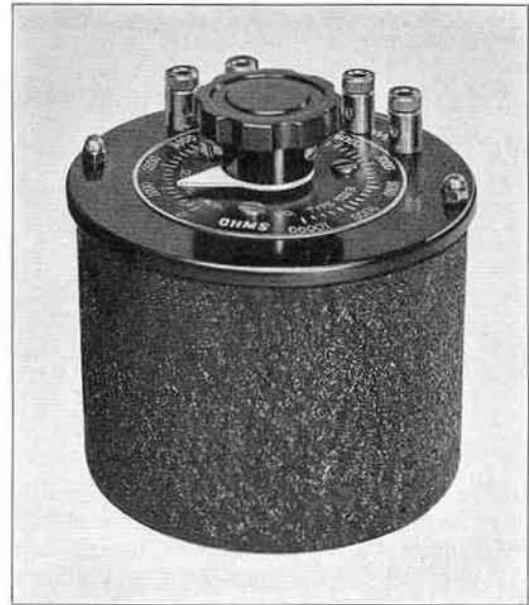

TYPE 526-B Mounted Rheostat-Potentiometer.

SPECIFICATIONS

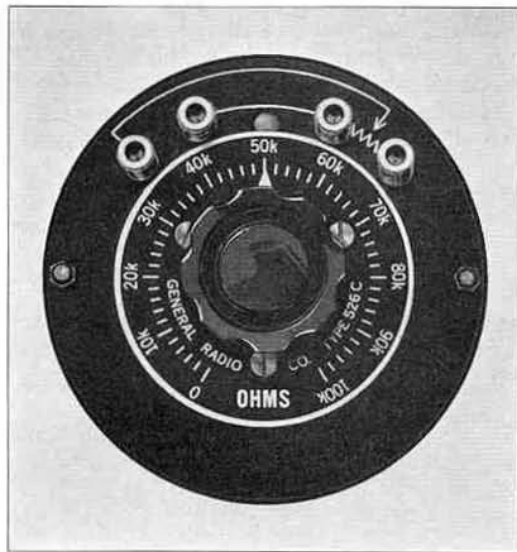

Panel view of TYPE 526-C, showing dial and connections.

Range: The ranges listed in the table below are stocked. Other ranges can be made to special order.

Winding: The winding is a carefully adjusted TYPE 471-A Rheostat-Potentiometer.

Accuracy: The total resistance has been adjusted within $\pm 2.5\%$ of the rated value. The calibration is accurate within $\pm 5\%$ of full scale.

Maximum Current: The maximum allowable current for the different units is tabulated below. This value is also engraved on the dial plate.

Mounting: Drawn-steel cases with hard-rubber panel for protection of unit and for convenience in wiring into experimental circuits. The case may be used as an electrostatic shield.

Terminals: Two pairs of jack-top binding posts, one for input and one for output, on standard $\frac{3}{4}$ -inch spacing, are provided.

Dial Plate: Each unit has a 3-inch photo-engraved dial plate with 50 divisions and is calibrated directly in ohms.

Finish: Black crystalline lacquer.

Dimensions: (Diameter) $4\frac{1}{2}$ x (height) $4\frac{3}{8}$ inches, overall.

Net Weight: $1\frac{1}{2}$ pounds.

Type	Resistance	Max. Current	Code Word	Price
526-D	0- 100 ohms	330 ma	ETHER	\$8.50
526-A	0- 1000 ohms	110 ma	EVADÉ	8.50
526-B	0- 10,000 ohms	33 ma	EVENT	8.50
526-C	0-100,000 ohms	11 ma	EVOKE	8.50

TYPE 663 RESISTOR

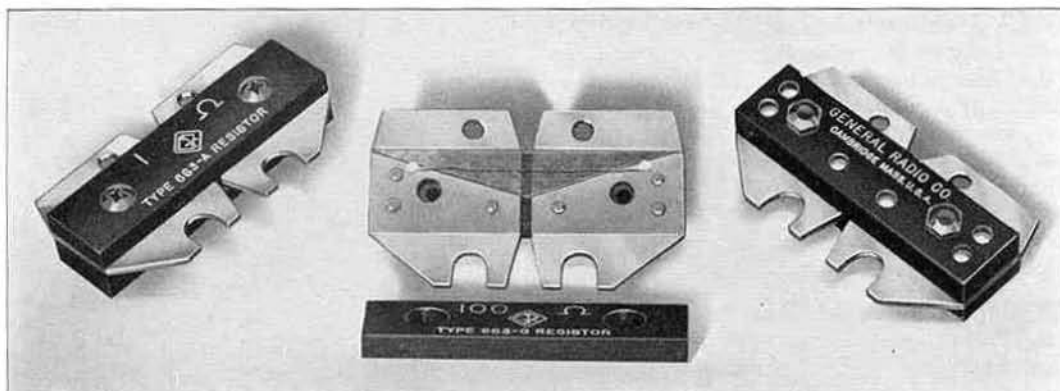

Photograph of TYPE 663 Resistors. The disassembled units show the method of construction.

USES: The TYPE 663 Resistor is designed to have an accurately known impedance at high frequencies. It is particularly useful as a standard resistor for the resistance-variation method of impedance measurement at radio frequencies and as a circuit element in bridges and similar equipment. It is also useful as a terminating resistor for matching radio-frequency transmission lines and, generally, as a low-resistance standard in high-frequency applications where small residual reactance, accurately known resistance, and moderate power-handling capacity are required.

DESCRIPTION: A straight piece of resistance wire is soldered to two flat metal plates which are mounted close together on a strip of insulating material. A thin piece of mica insulates the wire from the plates, except at the soldered ends. This assembly is rigidly clamped together with a top piece of insulating material. The flat metal plates extend on either side to form slotted terminals.

FEATURES: A resistor for high-frequency use should have an impedance which varies as little as possible with frequency and which is as nearly resistive in nature as possible. These requirements demand that skin effect be kept at a minimum and that residual inductance and capacitance be made very small.

The straight-wire resistor approaches this ideal more closely than any other type through the use of short pieces of fine wire. In the conventional form, however, two disadvantages occur. First, the fine wire has relatively high series inductance compared to its shunt capacitance, and low-resistance units consequently tend to have relatively high inductive reactances. Second, the fine wire cannot dissipate any appreciable power without overheating.

The design of the TYPE 663 Resistor overcomes these disadvantages. The straight wire is clamped down upon the flat metal fins and, as a result, the inductance is decreased over the free space value by virtue of the shielding effect of the current flow in the plates. By this same construction the power dissipation is greatly increased because the heat is carried away from the wire by the terminal fins.

The equivalent circuit for the TYPE 663 Resistor, when mounted approximately one inch above a metal panel, is given on page 33. Values of the residual inductance, L , for the different units are tabulated in the specifications.

Residual inductance and capacitance cause two effects. First, they cause the resistance component to vary with frequency and, second, they create a residual reactive component. If the resistance, R , is large compared to $\sqrt{\frac{L}{C}}$, where L is the effective series resistance and C the effective shunt capacitance, the resistive component decreases

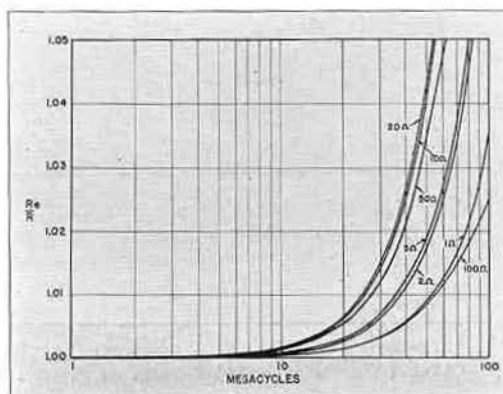

Ratio of effective resistance to d-c resistance as a function of frequency.

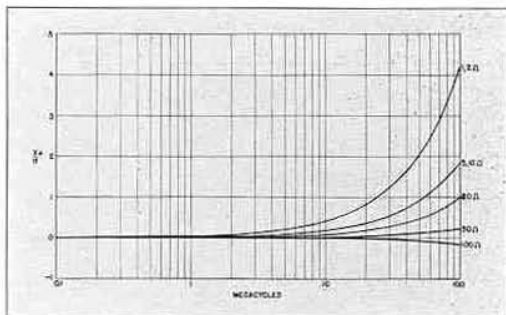

Ratio of equivalent series reactance to d-c resistance as a function of frequency.

with frequency; if the resistance is small compared to $\sqrt{\frac{L}{C}}$ the resistance increases with frequency up to a peak beyond which it decreases. For values of R large compared with $\sqrt{\frac{L}{C}}$, the reactance is capacitive; for values of R less than $\sqrt{\frac{L}{C}}$, the reactance is inductive up to the resistance peak. It is desirable to maintain $\sqrt{\frac{L}{C}}$ of the same order of magnitude as the resistance in order to

minimize both resistance change and reactive component. The construction of the TYPE 663 Resistor, which gives low inductance at the expense of increased capacitance, fulfills this condition.

The accompanying curves illustrate the behavior of TYPE 663 Resistors as a function of frequency when mounted on a pair of TYPE 138-VD Binding Posts with one end grounded to a $\frac{1}{4}$ -inch metal panel upon which the binding posts are assembled with TYPE 274-Y Mounting Plates. With this setup, the effective shunt capacitance consists of the sum of (1) the direct capacitance of the resistor, (2) the capacitance to ground of one mounting lug, (3) the direct capacitance between binding posts, and (4) the capacitance of one binding post to ground.* The total capacitance in this case is approximately $6.5 \mu\text{mf}$ and the conditions are therefore more severe than would exist if a low-capacitance mounting were used.

It will be seen that the reactance is large compared to the resistance for low values of resistance and high frequencies. In most applications, this is not important because the reactance can be tuned out.

*See R. F. Field, "Direct Capacitance and Its Measurement," *General Radio Experimenter*, Vol. VIII, No. 6, page 5; Nov. 1933.

SPECIFICATIONS

Resistance Values: Standard units are available in the following resistances: 1, 2, 5, 10, 20, 50, and 100 ohms.

Accuracy: All units are adjusted within 1%.

Residual Parameters: The following table gives approximate values for L for the different units:

Resistance	L	Current for 40° C. Rise
1 ohm	0.0065 μh	1.4 a
2 ohms	0.013 μh	1.0 a
5 ohms	0.015 μh	0.5 a
10 ohms	0.029 μh	0.35 a
20 ohms	0.032 μh	0.2 a
50 ohms	0.034 μh	0.1 a
100 ohms	0.039 μh	0.06 a

Skin Effect: For all units the skin effect is less than 1% for frequencies below 50 megacycles.

Temperature Coefficient: At normal room temperature the temperature coefficient is less than $\pm 0.002\%$ per degree Centigrade.

Maximum Power and Current: The allowable power dissipation for a 40° Centigrade temperature rise varies slightly with resistance, being 2 watts for the 1-ohm unit and 0.4 watt for the 100-ohm unit. The rated

current for this temperature rise for the different units is given in the table.

Terminals: The flat metal plates to which the resistance wire is attached are used as terminals, and are both slotted and drilled for convenience in mounting.

Dimensions: (Length) $2\frac{1}{4}$ x (width) $1\frac{1}{4}$ inches. Over-all height, $\frac{5}{8}$ inch.

Net Weight: 2 ounces.

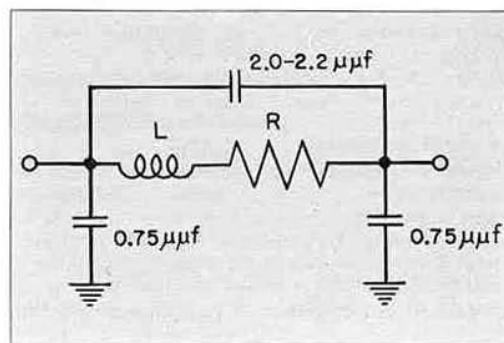

Equivalent circuit of TYPE 663 Resistor.

Type	Resistance	Code Word	Price
663-A	1 ohm	PANIC	\$5.00
663-B	2 ohms	PARTY	5.00
663-C	5 ohms	PATTY	5.00
663-D	10 ohms	PEDAL	5.00
663-E	20 ohms	PENAL	5.00
663-F	50 ohms	PENNY	5.00
663-G	100 ohms	PETTY	5.00

TYPE 500 RESISTOR

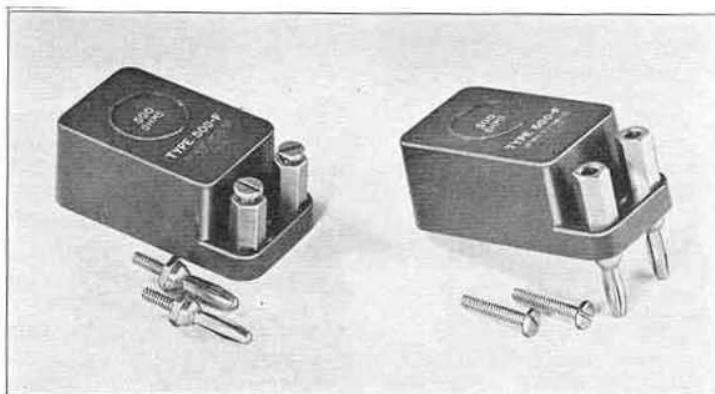

USES: The TYPE 500 Resistors are particularly recommended as resistance standards for use in impedance bridges. They are also valuable as secondary standards for laboratory use. The plug-type terminals make them convenient for terminating impedances for attenuation boxes, lines, and similar circuits and as circuit elements in either experimental or permanent equipment.

DESCRIPTION: This resistor is an accurately-adjusted resistance card, sealed in a bakelite

case. Both screw-type and plug-type terminals are provided.

FEATURES: In the TYPE 500 Resistors both convenience and accuracy are combined. The terminal arrangement allows either permanent or temporary connections to be made in the simplest possible manner. Low temperature coefficient and excellent high-frequency characteristics make these resistors suitable for a wide variety of applications.

SPECIFICATIONS

Resistance: Nine standard values, as tabulated below, are stocked. Other values can be built to special order.

Accuracy of Adjustment: Each resistor is adjusted within 0.1% of its stated value at the terminals of the unit, except the 1-ohm unit which is adjusted within 0.25%.

Frequency Characteristics: The error is less than 0.1% below 50 kc. At higher frequencies errors result from skin effect and the effect of reactance in the resistor. The tables on page 21 represent accurately the performance of the 1-ohm through 600-ohm values. For the higher values, the errors are much less than those tabulated, because of the relatively negligible shunt capacitance of an isolated resistor.

Maximum Power and Current: All units will dissipate one watt for a temperature rise of 40° Centigrade. The value of current for this rise is given in the table below and is engraved on each unit.

Temperature Coefficient: At normal room temperature, the temperature coefficient is less than $\pm 0.002\%$ per degree Centigrade.

Type of Winding: For resistances of less than 200 ohms Ayrton-Perry windings are used; for higher values of resistance the winding is unifilar on mica cards.

Terminals: Both terminal screws and plugs are supplied,

and both can be used. Each terminal stud is recessed as a jack to accommodate a plug. Standard $\frac{3}{4}$ -inch spacing is used.

Mounting: Each resistor is sealed in a case of black moulded bakelite with an impregnating wax. Two mounting holes are provided.

Dimensions: (Length) $2\frac{3}{4}$ x (width) $1\frac{1}{16}$ inches. Over-all height, exclusive of plugs, 1 inch.

Net Weight: 2 ounces.

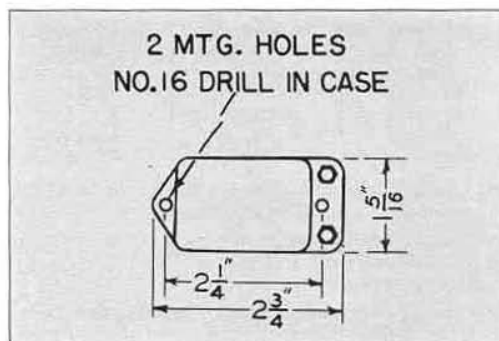

Type	Resistance	Maximum Current	Code Word	Price
500-A	1 Ω	1.0 a	RESISTBIRD	\$2.00
500-B	10 Ω	310 ma	RESISTDESK	2.00
500-C	50 Ω	140 ma	RESISTFORD	2.00
500-D	100 Ω	100 ma	RESISTFROG	2.00
500-E	200 Ω	70 ma	RESISTGIRL	2.00
500-F	500 Ω	45 ma	RESISTGOAT	2.00
500-G	600 Ω	40 ma	RESISTGOOD	2.00
500-H	1000 Ω	30 ma	RESISTHYMN	2.00
500-J	10,000 Ω	10 ma	RESISTMILK	2.00

TYPE 525 RESISTOR

USES: This precision-type resistor is intended as a dummy-antenna in measuring the output power of radio transmitters, and for use in general laboratory work requiring a resistor of both high precision and high power-handling capacity.

DESCRIPTION: The TYPE 525 Resistor consists of a mica card wound with resistance wire, which is clamped between two aluminum castings and insulated from them by two thin mica sheets. The aluminum castings are heavily ribbed to give a large radiating surface, and the whole unit is supported on heavy porcelain insulators.

FEATURES: The outstanding features of these units are their high power rating and accurate calibration.

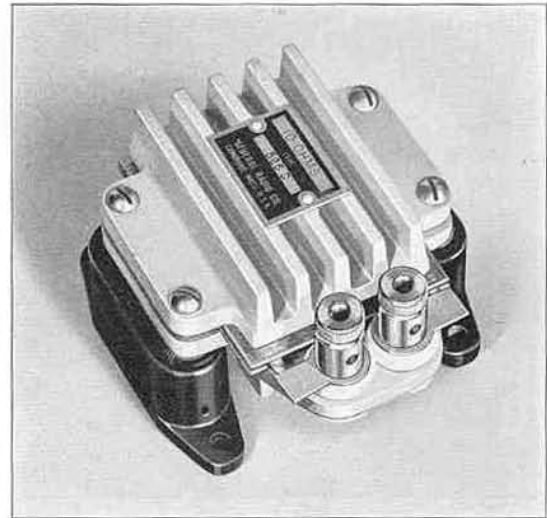

SPECIFICATIONS

Resistance: Standard stock models are available with the resistance values tabulated below. Other values may be had on special order.

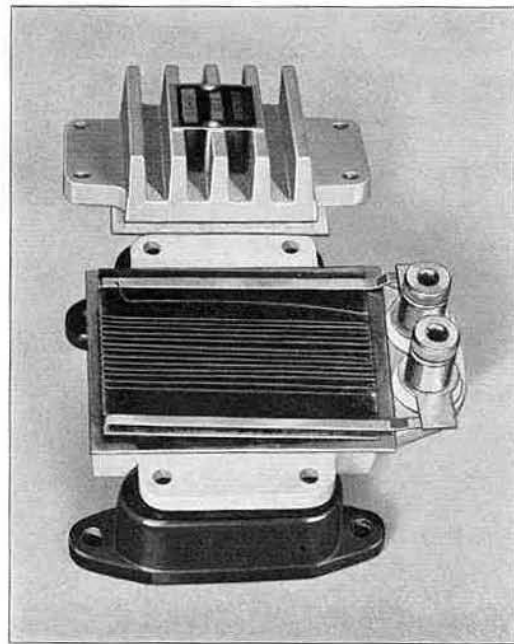

Photograph of TYPE 525-D Resistor with upper casting removed, showing construction of the resistance card.

Accuracy of Adjustment: All resistors, except the 4-ohm unit, are adjusted within 0.1% of the rated value at the terminals of the unit. The 4-ohm resistor is adjusted within 0.25%.

Frequency Characteristics: The frequency characteristics of these resistors are in general similar to those of TYPE 510 Decade-Resistance Units. Resistors of 100 ohms and below will increase in resistance with frequency and the increase is greater when the shield is connected to one side of the resistor than when it is floating. The 600-ohm unit shows an increase in resistance at frequencies up to several megacycles when the shield is floating, but with the shield grounded to one side of the winding, the resistance decreases with frequency and never rises above its nominal value.

Power and Current Rating: All sizes will dissipate 50 watts for a temperature rise of 100° Centigrade. For a temperature rise of 150° Centigrade, a maximum of 100 watts can be dissipated.

Values of current for the 100° Centigrade rise in temperature are given in the table below.

Temperature Coefficient: For temperatures below 100° Centigrade the temperature coefficient is less than $\pm 0.002\%$ per degree Centigrade.

Terminals: Jack-top binding posts mounted on isolantite washers are provided. Standard $\frac{3}{4}$ -inch spacing is used.

Shielding: The aluminum castings can be used as an electrostatic shield, both resistor terminals being insulated from them.

Mounting: Resistors are wound unifilarly on mica and clamped between two pieces of mica and two heavily ribbed aluminum castings, the whole unit being supported on porcelain insulators.

Dimensions: (Length) 4 x (width) 4 x (height) $2\frac{1}{2}$ inches.

Net Weight: $1\frac{1}{4}$ pounds.

Type	Resistance	Current, 100° C. Rise	Code Word	Price
525-C	4 ohms	3.5 a	CABAL	\$8.00
525-D	10 ohms	2.2 a	CABIN	8.00
525-F	40 ohms	1.1 a	CABOB	8.00
525-H	100 ohms	0.7 a	CADDY	8.00
525-L	600 ohms	0.09 a	CADET	8.00

TYPE 642-D VOLUME CONTROL

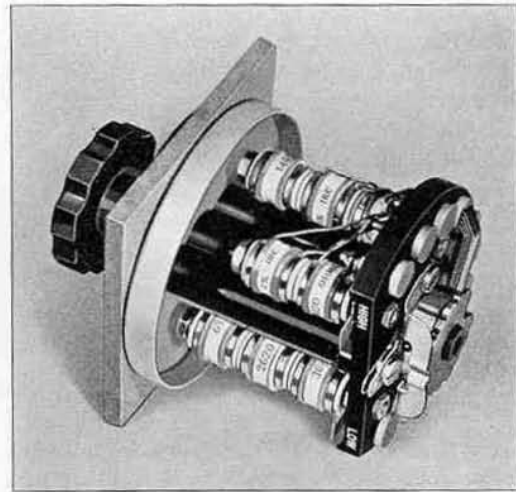
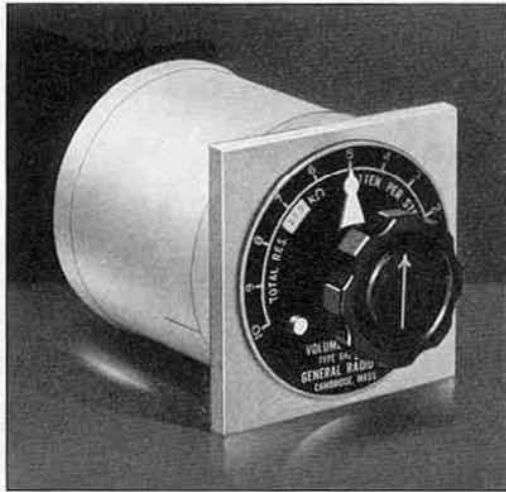

USES: This high-impedance volume control is intended for use as a gain control in the grid circuit of a vacuum tube. It can also be used as a multiplier for a vacuum-tube voltmeter.

DESCRIPTION: The TYPE 642-D Volume Control is a potentiometer-type voltage divider made up of wire-wound resistance units. A four-leaf phosphor bronze switch

is used to reduce wear and noise. A positive detent is normally provided but this may be easily removed.

FEATURES: The high impedance of this control allows it to be used in vacuum tube circuits where low-impedance controls would be impractical. Its noiseless control, covering a wide range of attenuation, allows it to be used in even very low-level circuits.

SPECIFICATIONS

Range: The standard unit has a range of attenuation from 0 to 30 decibels in 3-decibel steps. Other ranges can be made to special order.

Accuracy: All resistors are adjusted within $\pm 1\%$ of their correct value. Accordingly, the attenuation is accurate within ± 0.2 decibel.

Frequency Characteristic: If the external capacitance of tube and wiring which is placed across the output is less than $20 \mu\mu\text{f}$, as it usually is, the frequency error will be less than 0.1 decibel at all frequencies below 10,000 cycles.

Input Impedance: The input impedance is 200,000 ohms, resistive.

Output Impedance: The unit is intended to work into an essentially infinite impedance, such as the grid of a vacuum tube.

Type of Winding: Wire-wound resistors are used.

Maximum Current: Although normally used in circuits drawing no current, a current of 4 ma will not cause a temperature rise sufficient to affect the rated accuracy.

Switch: The switch arm is constructed of four-leaf phosphor bronze, which provides for long wear and exceptionally low contact noise. The cam-type detent can be easily removed if smooth switch action is required.

Mounting: This unit is similar in construction to the TYPE 510 Decade-Resistance Units.

Terminals: Three soldering lugs are placed at the end of the unit for making connections, and the shield has a small opening for connecting wires.

Dimensions: Shield diameter, $3\frac{1}{16}$ inches; depth behind panel, $3\frac{1}{16}$ inches.

Net Weight: 16 ounces.

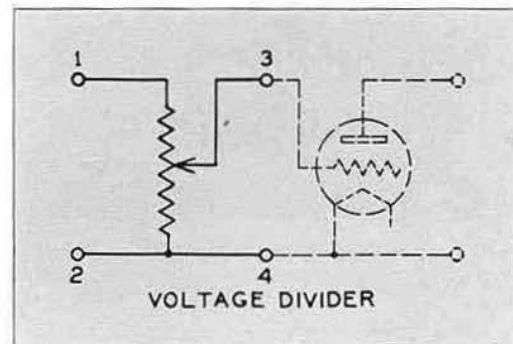

Type	Attenuation		Impedance	Code Word	Price
	Total	Per Step			
642-D	30 db	3 db	200,000 Ω	EXALT	\$25.00

TYPE 653 VOLUME CONTROL

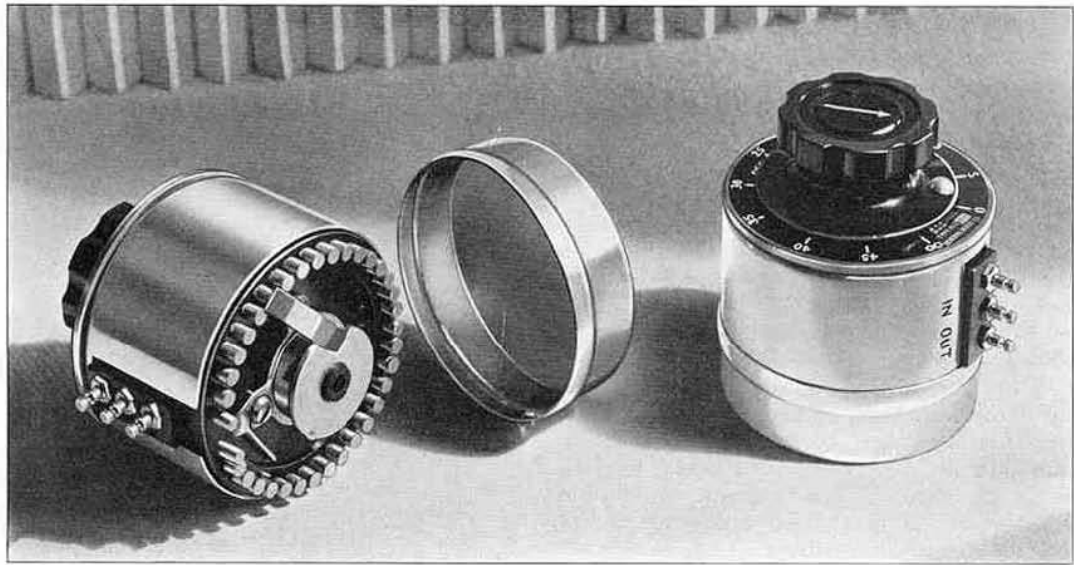

USES: The TYPE 653 Volume Controls are intended for use as microphone mixers and master gain controls in broadcasting and recording studios.

DESCRIPTION: The individual resistors are wound on cylindrical spools which are part of the bakelite moulding which holds the beryllium-copper switch contacts. A three-bladed beryllium-copper contact arm wipes these contacts at an angle, thus helping to eliminate wear and noise. One section of the

aluminum shield is used to cover the winding. The other section covers the contacts and is easily removed for cleaning and lubrication of the contacts.

FEATURES: The TYPE 653 Volume Control is a small, compact, and convenient unit that gives smooth and noiseless control even when used in very low-level circuits. The attenuation is linear with dial setting, and the impedance remains practically constant in both directions throughout the attenuation range.

SPECIFICATIONS

Attenuation Range: The attenuation between contacts is 1.5 decibels, but, since the switch arm bridges two contacts in passing from one to another, the attenuation actually changes in fractional decibel steps from 0 to 45 decibels. There is an initial insertion loss of 6 decibels. Above 45 decibels the attenuation increases rapidly to "infinity" (about 120 decibels with the usual type of mixer wiring).

Terminal Impedance: 50-, 200-, 250-, and 500-ohm units are stocked but others can be built to special order. The impedance is practically constant in both directions.

Type of Section: A ladder-type network is employed.

Frequency Characteristics: Variations in attenuation with frequency are less than 1 decibel up to 20,000 cycles.

Maximum Power: All units will dissipate a maximum of 1.5 watts at the nominal terminal impedance.

Shielding: A two-section aluminum cover is provided. One section is removable and gives access to the con-

tacts for cleaning; the other acts as a dust cover and shield for the windings.

Switch: A 3-bladed beryllium-copper switch makes firm contact with beryllium-copper contact points.

Dial Plate: A dial plate calibrated directly in decibels also serves as a drilling template.

Knob: TYPE 637-K, with engraved white arrow. A button is provided on the skirt of the knob for convenience when the control is used in dimly-lighted monitoring booths.

Terminals: Pins for making soldered connections are provided.

Mounting: The unit is arranged for panel mounting by means of two screws which are supplied. It may be mounted on panels up to $\frac{3}{8}$ inch in thickness. Holes are spaced $1\frac{1}{2}$ inches apart.

Dimensions: Maximum over-all radius, $1\frac{3}{4}$ inches. Maximum depth behind panel, $2\frac{5}{8}$ inches. Shield diameter, $2\frac{3}{4}$ inches.

Net Weight: 13 ounces.

Type	Impedance	Code Word	Price
653-MA	50 Ω	CLUMP	\$12.50
653-MB	200 Ω	COACH	12.50
653-MD	250 Ω	CARAT	12.50
653-MC	500 Ω	COAST	12.50

• RESISTORS

GENERAL RADIO CO.

RHEOSTAT-POTENTIOMETERS

(Voltage Dividers)

USES: Variable resistors and potentiometers are useful in assembling experimental equipment where tube voltages and circuit elements are to be varied until the final design is obtained. In standard equipment such as oscillators, bridges, test equipment, and industrial instruments, many manufacturers find General Radio rheostats extremely useful as filament- and plate-supply controls, output potentiometers, bridge arms, and as parts of almost any instrument where variable resistances are needed. Ganged units can be used where simultaneous control is desired. Units with special resistance values or tolerances can be made to order. In addition to the ordinary linear models, tapered units of both the straight and logarithmic type can be made to satisfy particular requirements.

GENERAL DESCRIPTION: The resistance wire is wound on a strip of insulating material

such as bakelite, which is then bent around and fastened to the moulded bakelite supporting form. All units are so constructed that the shaft may extend through either or both ends of the rheostat. Terminals and mounting holes are provided on all models.

FEATURES: A large variety of models is available with power ratings from 3 to 250 watts and maximum-resistance ranges from 0.75 ohm to 200,000 ohms. Three terminals are provided, so that all models can be used either as rheostats or as potentiometers.

All but the largest and smallest models are interchangeable on the standard three-hole mounting, and every type except one, the TYPE 410, can be converted for top-of-table mounting. The units are normally furnished ready for panel mounting and the conversion is accomplished by only a few moments' work with a screw driver.

TYPE 533

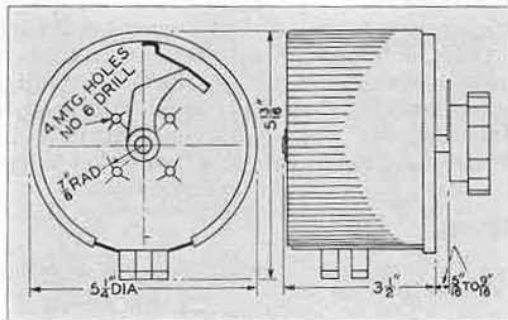

TYPE 301

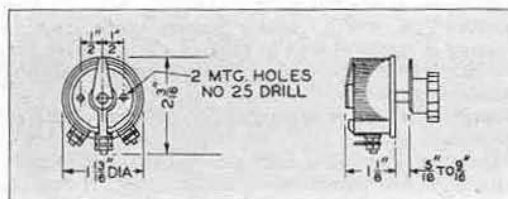

TYPE 410

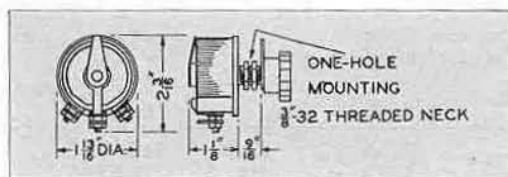

SPECIFICATIONS

Accuracy: All types are wound to an accuracy of $\pm 10\%$.

Terminals: Screw terminals with soldering lugs are provided on all models except TYPE 533 and TYPE 333, which are furnished with jack-top binding posts.

Dimensions: Over-all size and mounting dimensions are shown on the accompanying sketches.

TYPES 214, 314, 371, 471, 333, 154

Type	A(Inches)	B(Inches)
214-A	3 1/4	1 1/4
314-A	3 1/4	1 3/8
371-A	3 1/8	2 1/2
471-A	3 1/8	2 5/8
333-A	4	2 5/8
154-A	3 1/4	1 1/4
154-B	3 1/4	2 1/2

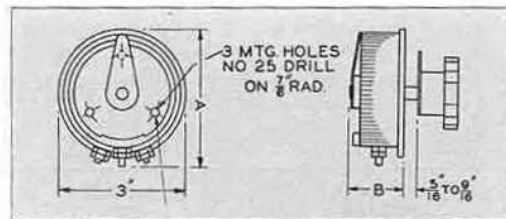

TYPE 371 RHEOSTAT-POTENTIOMETER

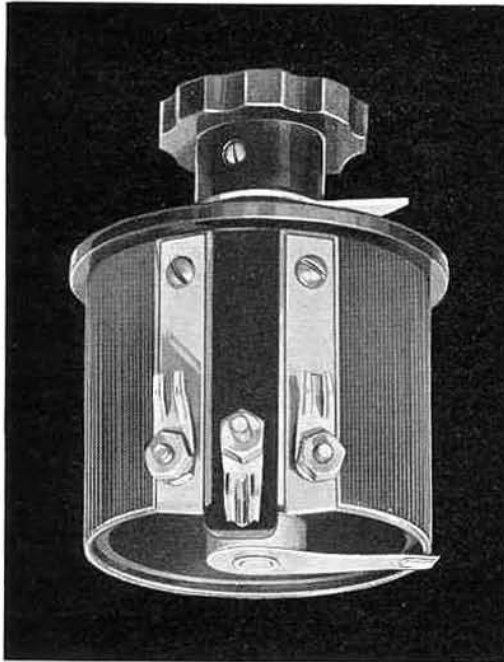

All of the TYPE 371 Rheostat-Potentiometers have a single-blade contact arm which wipes the edge of the winding.

In TYPE 371-T the resistance is approximately proportional to the square of the

angle, increasing with clockwise rotation of the knob in a panel-mounted unit. It is also possible to obtain other tapers, such as logarithmic, and other values of total resistance on special order.

SPECIFICATIONS

Maximum Resistance: Nine stock models are listed in the table below. Units with total resistances from 1 ohm to 100,000 ohms can be wound to special order.

Power Rating: 20 watts except for the TYPE 371-T which is 8 watts.

Rotation Angle: 303° (approx.). No OFF position.

Shaft: Steel, 1/4-inch diameter. **Knob:** TYPE 637-G.

Mounting: Standard 3-hole; machine screws, nuts, and template furnished. (See page 38.)

Net Weight: 6 ounces.

Type	Maximum Resistance	Maximum Current	Code Word	Price
371-A	1 Ω	4.5 a	RALLY	\$4.00
371-A	5 Ω	2.0 a	RELAY	4.00
371-A	1000 Ω	140 ma	REDAN	4.00
371-A	2500 Ω	90 ma	REFIT	4.00
371-A	5000 Ω	60 ma	ROTOR	4.00
371-A	10,000 Ω	45 ma	ROWDY	4.00
371-A	18,000 Ω	33 ma	RULER	4.00
371-A	50,000 Ω	20 ma	SATYR	4.00
*371-T	10,000 Ω	28 ma	SULLY	4.00

*Tapered model.

TYPE 214-A RHEOSTAT-POTENTIOMETER

SPECIFICATIONS

Maximum Resistance: Ten stock models are listed in the table below. Units with total resistances from 0.4 ohm to 70,000 ohms can be wound to special order.

Power Rating: 9 watts.

Rotation Angle: 315° (approx.). No OFF position.

Shaft: Steel, 1/4-inch diameter. **Knob:** TYPE 637-G.

Mounting: Standard 3-hole; machine screws, nuts, and template furnished. (See page 38.)

Net Weight: 5 ounces.

Type	Maximum Resistance	Maximum Current	Code Word	Price
214-A	0.75 Ω	3.5 a	SHINY	\$1.50
214-A	2 Ω	2.1 a	RUDDY	1.50
214-A	7 Ω	1.1 a	RURAL	1.50
214-A	20 Ω	0.67 a	RAZOR	1.50
214-A	50 Ω	425 ma	RAPID	1.50
214-A	100 Ω	300 ma	RIVET	1.50
214-A	200 Ω	210 ma	EMPTY	1.50
214-A	400 Ω	150 ma	ROBIN	1.50
214-A	1000 Ω	95 ma	ENACT	1.50
214-A	2500 Ω	60 ma	SYRUP	1.50

The construction of this unit is similar to that of the TYPE 371. Owing to its smaller size, the power rating of this type is somewhat less than that of the TYPE 371.

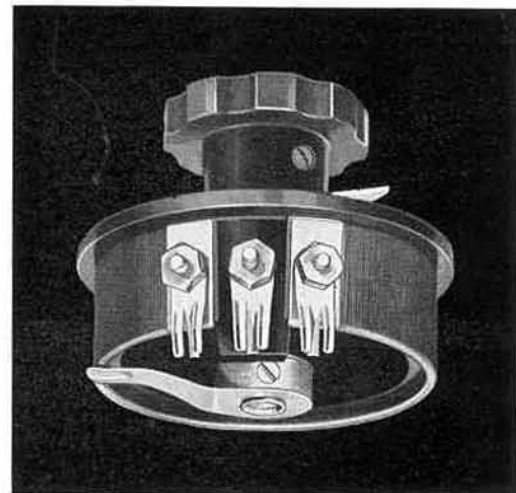

• RESISTORS

GENERAL RADIO CO.

TYPE 471-A RHEOSTAT-POTENTIOMETER

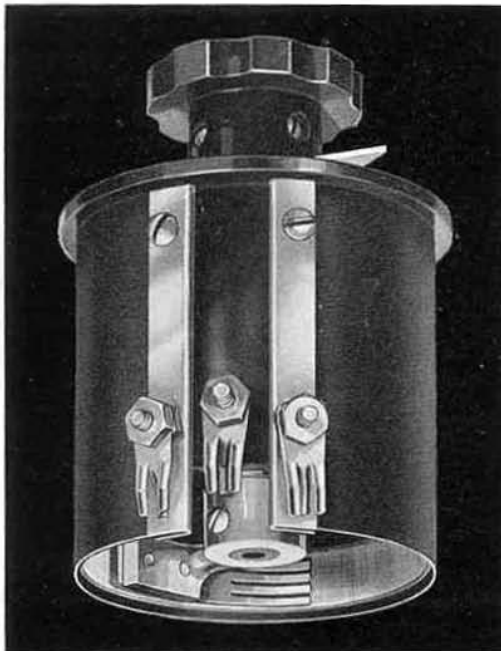

This rheostat-potentiometer is suitable for use in high-impedance vacuum-tube circuits where high values of resistance and low noise level are required.

The high resistance is obtained by winding the card with fine wire and then protecting

it externally from mechanical damage or derangement of the turns by means of a securely anchored band of linen bakelite.

Low noise levels are assured through the use of a contact arm bearing four separate wiping fingers whose average contact resistance is essentially constant for any position of the knob. The unit may be mounted directly on a metal panel without the necessity of insulating bushings, for the bakelite shaft removes all possibilities of short circuits.

SPECIFICATIONS

Maximum Resistance: Six stock models are available as listed below. Units with total resistance from 50 ohms to 200,000 ohms can be made on special order.

Power Rating: 11 watts.

Rotation Angle: 294° (approx.). No OFF position.

Shaft: Bakelite, 3/8-inch diameter. **Knob:** TYPE 637-H.

Mounting: Standard 3-hole; machine screws, nuts, and template furnished. (See page 38.)

Net Weight: 9 ounces.

Type	Maximum Resistance	Maximum Current	Code Word	Price
*471-A	100 Ω	330 ma	EQUIP	\$6.00
471-A	1000 Ω	104 ma	ERASE	6.00
471-A	10,000 Ω	33 ma	ERECT	6.00
471-A	50,000 Ω	15 ma	ERODE	6.00
471-A	100,000 Ω	10 ma	ERUPT	6.00
471-A	200,000 Ω	7 ma	ESKER	6.00

*Does not have linen-bakelite protecting strip.

TYPE 314-A RHEOSTAT-POTENTIOMETER

This type is of the same mechanical and electrical construction as the TYPE 471-A

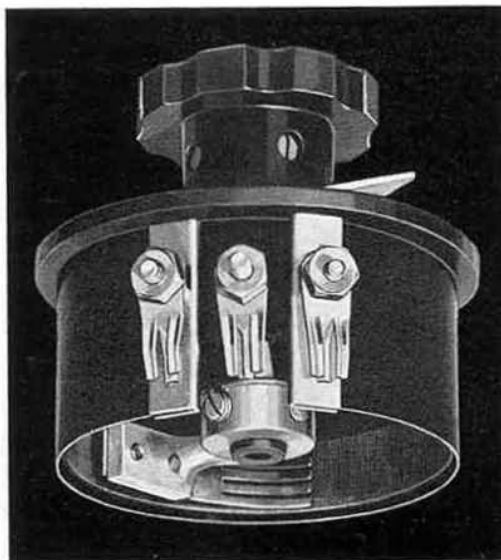

but differs from it in that a shorter winding form is used.

The physical dimensions of this unit are the same as those of the TYPE 214-A but because of the protecting strip the TYPE 314-A has a reduced power rating.

SPECIFICATIONS

Maximum Resistance: Five stock models are listed below. Units having total resistance between 2 ohms and 100,000 ohms can be made on special order.

Power Rating: 6 watts.

Rotation Angle: 294° (approx.). No OFF position.

Shaft: Bakelite, 3/8-inch diameter. **Knob:** TYPE 637-H.

Mounting: Standard 3-hole; machine screws, nuts, and template furnished. (See page 38.)

Net Weight: 6 ounces.

Type	Maximum Resistance	Maximum Current	Code Word	Price
314-A	200 Ω	170 ma	ENATE	\$4.00
314-A	600 Ω	100 ma	ENDOW	4.00
314-A	2000 Ω	55 ma	ENEMY	4.00
314-A	6000 Ω	32 ma	ENJOY	4.00
314-A	20,000 Ω	17 ma	ENROL	4.00

TYPE 301-A RHEOSTAT-POTENTIOMETER

This type is the smallest size rheostat manufactured by General Radio and is very useful for many applications because of its compactness. It will dissipate 6 watts maximum except on the 10,000-ohm and 20,000-ohm models which, because of the small wire size used, have a linen-bakelite protecting strip around the outside of the winding, with a consequent reduction in heat-radiating capacity.

SPECIFICATIONS

Maximum Resistance: Six stock models are available as listed here. Units with total resistance from 0.25 ohm to 50,000 ohms can be wound on special order.

Power Rating: 6 watts except for 10,000-ohm and 20,000-ohm models which will dissipate 3 watts.

Rotation Angle: 254° (approx.). No OFF position.

Shaft: Steel, 1/4-inch diameter. **Knob:** TYPE 637-A.

Mounting: Two-hole mounting is used; machine screws, nuts, and template are furnished. (See page 38.)

Net Weight: 3 ounces.

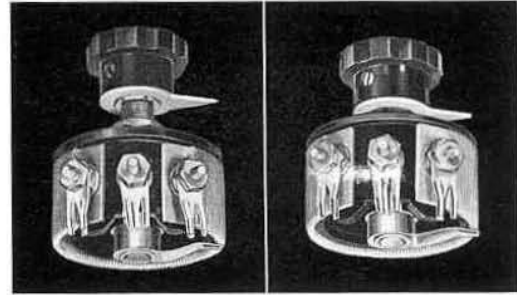

Type 410-A.

Type 301-A.

Type	Maximum Resistance	Maximum Current	Code Word	Price
301-A	6 Ω	1 a	PALSY	\$1.00
301-A	12 Ω	0.7 a	REMIT	1.00
301-A	25 Ω	0.5 a	RENEW	1.00
301-A	200 Ω	175 ma	REBUS	1.00
*301-A	10,000 Ω	17 ma	CURRY	1.50
*301-A	20,000 Ω	12 ma	CRUMB	1.50

*Supplied with linen-bakelite protecting strip.

TYPE 410-A RHEOSTAT-POTENTIOMETER

This type is identical with the TYPE 301-A Rheostat-Potentiometer except that it is made for single-hole panel mounting only.

Although this feature does not ordinarily allow the unit to be used on metal panels, it is very convenient for many applications.

SPECIFICATIONS

Maximum Resistance: Four stock models are available as listed here. Units with total resistance from 0.25 ohm to 50,000 ohms can be made on special order.

Power Rating: 6 watts.

Rotation Angle: 250° (approx.). No OFF position.

Shaft: Steel, 1/4-inch diameter. **Knob:** TYPE 637-A.

Mounting: Single-hole panel type only. (See page 38.)

Net Weight: 3 ounces.

Type	Maximum Resistance	Maximum Current	Code Word	Price
410-A	6 Ω	1 a	SABOT	\$1.00
410-A	12 Ω	0.7 a	SALON	1.00
410-A	25 Ω	0.5 a	SALTY	1.00
410-A	200 Ω	175 ma	SATIN	1.00

TYPE 154 VOLTAGE DIVIDER

These adjustable voltage dividers have three rotary taps instead of the usual sliders. The winding of the TYPE 154-A is similar in construction to the TYPE 314-A Rheostat-Potentiometer, and the TYPE 154-B is similar to the TYPE 471-A.

Power Rating: TYPE 154-A, 6 watts; TYPE 154-B, 11 watts.

Mounting: Standard 3-hole. Supplied as table mounting.

Net Weight: TYPE 154-A, 6 oz.; TYPE 154-B, 9 oz.

Type	Total Resistance	Maximum Current	Code Word	Price
154-A	5000 Ω	35 ma	DIVIDARMY	\$6.50
154-A	10,000 Ω	24 ma	DIVIDBOAT	6.50
154-A	20,000 Ω	17 ma	DIVIDCAPE	6.50
154-B	50,000 Ω	15 ma	DIVIDEYRE	8.50
154-B	100,000 Ω	10 ma	DIVIDFACT	8.50
154-B	200,000 Ω	7 ma	DIVIDGIRL	8.50

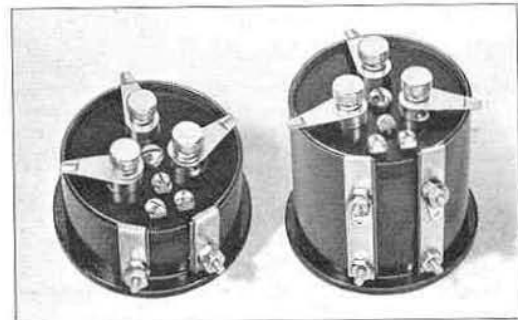

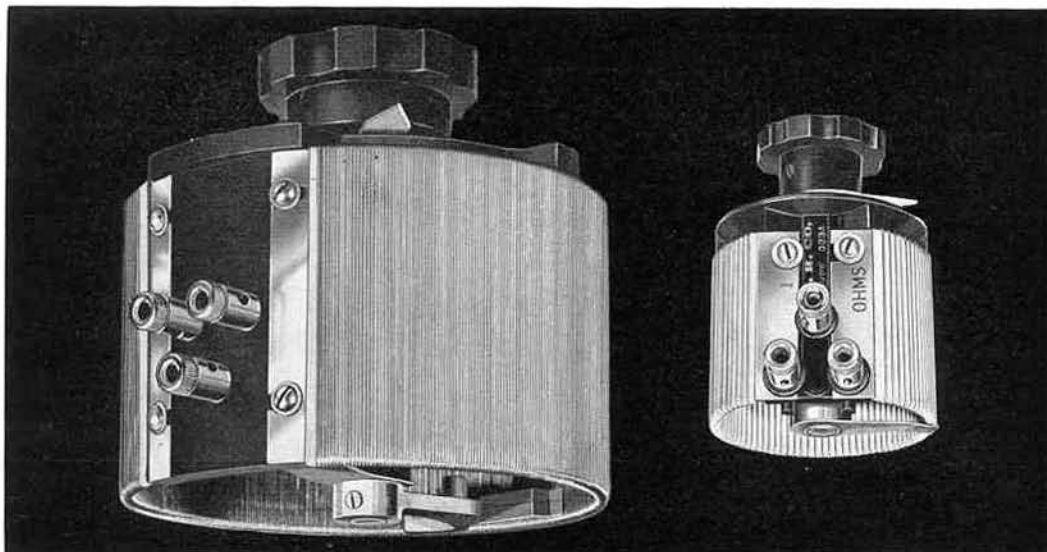

TYPE 533-A

TYPE 333-A

TYPE 533-A RHEOSTAT-POTENTIOMETER

This is a heavy-duty unit which can dissipate 250 watts under continuous load. The frame is of moulded bakelite, and the resistance element is wound on an asbestos-covered aluminum strip that serves to distribute the heat to be dissipated to all portions of the element for better radiation.

This unit should not be used in closed compartments or where a means of ventilation has not been provided to keep the temperature of associated apparatus at a reasonable value.

The standard jack-top binding posts used on this type facilitate the rapid making of connections with TYPE 274 Plugs.

SPECIFICATIONS

Maximum Resistance: Seven stock models are listed here. Units with other values of total resistance from 1 ohm to 3500 ohms can be made on special order.

Power Rating: 250 watts.

Rotation Angle: 305° (approx.). No OFF position.

Shaft: Steel, 3/8-inch diameter. **Knob:** TYPE 637-Q.

Terminals: Jack-top binding posts are provided. Standard 3/4-inch spacing is used.

Mounting: Four-hole mounting is used. Machine screws, nuts, and template are furnished. (See page 38.)

Net Weight: 1 1/8 pounds.

Type	Maximum Resistance	Maximum Current	Code Word	Price
533-A	1 Ω	15.8 a	MOLAR	\$6.00
533-A	3 Ω	9.1 a	MONAD	6.00
533-A	10 Ω	5.0 a	MORAL	6.00
533-A	30 Ω	2.9 a	MOTTO	6.00
533-A	100 Ω	1.6 a	MUGGY	6.00
533-A	300 Ω	0.9 a	MUMMY	6.00
533-A	600 Ω	0.6 a	MUSTY	6.00

TYPE 333-A RHEOSTAT-POTENTIOMETER

This type, although smaller, has, in general, the same constructional features as the TYPE 533-A. The asbestos-covered

aluminum strip is used, and jack-top binding posts are used for the terminals. A single-blade contact arm is used.

SPECIFICATIONS

Maximum Resistance: Seven stock models are listed here. Units having other values of total resistance from 1 ohm to 1200 ohms can be made on special order.

Power Rating: 100 watts.

Rotation Angle: 289° (approx.). No OFF position.

Shaft: Steel, 3/8-inch diameter. **Knob:** TYPE 637-II.

Terminals: Jack-top binding posts are provided. Standard 3/4-inch spacing is used.

Mounting: Standard 3-hole; machine screws, nuts, and template furnished. (See page 38.)

Net Weight: 11 ounces.

Type	Maximum Resistance	Maximum Current	Code Word	Price
333-A	1 Ω	10.0 a	VALOR	\$4.00
333-A	3 Ω	5.8 a	VAPID	4.00
333-A	10 Ω	3.2 a	VENUS	4.00
333-A	30 Ω	1.8 a	VIGIL	4.00
333-A	100 Ω	1.0 a	VIGOR	4.00
333-A	300 Ω	0.6 a	VILLA	4.00
333-A	600 Ω	0.4 a	VIPER	4.00



CAPACITORS

|||||

AIR AND MICA
CAPACITANCE
STANDARDS

•

GENERAL-PURPOSE
CONDENSERS WITH
AIR, MICA, AND
PAPER DIELECTRIC

• CAPACITORS

LOSSES IN AIR CONDENSERS

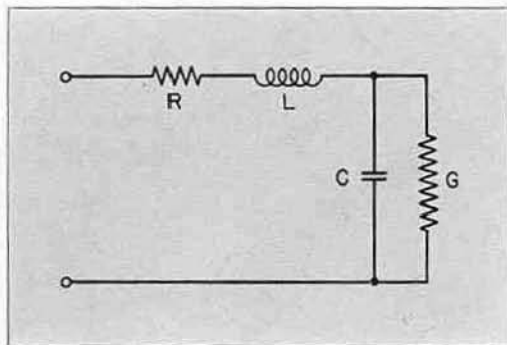

Equivalent circuit of a variable air condenser, showing residual impedances.

As a continuously adjustable standard of impedance the variable air condenser approaches very closely the ideal circuit element. For many uses at audio and low radio frequencies the residual components are negligible and it is permissible to consider the condenser as having a pure, constant capacitance. However, for use in precise measurements of impedance, especially at high radio frequencies, it is necessary to take account of the small residual parameters.

In a variable air condenser these residual impedances are caused by: (1) losses in the solid dielectric material, (2) losses in the metallic structure, and (3) inductance in the leads and stack supports. An equivalent circuit representing a variable air condenser including these residual parameters is shown above.

In the diagram the conductance, G , corresponds to losses in the solid dielectric parts of the condenser; the resistance, R , corresponds to losses in the metal parts of the condenser; and the inductance, L , corresponds to the magnetic flux set up by conduction currents in the condenser. The capacitance, C , is the static capacitance of the condenser.

The parameters, R , L , and G , are all essentially constant as a function of dial setting for TYPE 722 Precision Condensers. The dielectric conductance, G , may be considered as the sum of two components, one the d-c leakage conductance of the dielectric supports and the other a conductance corresponding to polarization losses in the supports. The first of these is constant as a function of frequency; the second increases approximately as the first power of the frequency. Except at very low frequencies (order of 5 cycles or less), the leakage conductance is negligible.

The metallic resistance, R , is essentially constant as a function of frequency for low

frequencies and increases approximately as the square root of the frequency at frequencies sufficiently high so that skin effect is essentially complete (order of 1 Mc).

The inductance, L , remains very closely constant as a function of frequency.

The metallic resistance, R , and the dielectric conductance, G , combine to cause a dissipative component approximately equivalent to a resistance

$$R_e = R + \frac{G}{(\omega C)^2}$$

in series with a perfect capacitance, or to a conductance

$$G_e = G + R(\omega C)^2$$

in parallel with a perfect capacitance.

The residual inductance, L , causes the effective terminal capacitance, C_e , to depart from the static capacitance, C , according to the law

$$C_e = \frac{C}{1 - \omega^2 LC}$$

At low frequencies the effect of the residual parameters, R and L , is negligible, and the condenser acts like a pure capacitance, C , in parallel with a conductance

$$G_e = G$$

or in series with a resistance

$$R_e = \frac{G}{(\omega C)^2}$$

Under this condition

$$\frac{G}{\omega} = R_e \omega C^2 = DC = \text{constant}$$

where D is the dissipation factor of the condenser. The numerical value of this constant is a convenient figure of merit to define the magnitude of the losses.

At high frequencies the other residual parameters become important. The losses in the metal parts of the condenser increase with frequency until they are first comparable to and finally in excess of the losses in the dielectric parts. At high frequencies it is, therefore, necessary to consider both components of loss.*

*R. F. Field and D. B. Sinclair, "A Method for Determining the Residual Inductance and Resistance of a Variable Air Condenser at Radio Frequencies," *Proc. I.R.E.*, 24, 2, February, 1936.

TYPE 722 PRECISION CONDENSER



USES: The TYPE 722 Precision Condenser is a variable air condenser intended for use as a standard of capacitance.

It is widely used in a-c bridges both as a built-in standard and as an external standard for substitution measurements. It is also used as a tuning condenser in oscillators, frequency meters, and other instruments where accuracy and stability are important.

DESCRIPTION: The whole condenser assembly is mounted in a cast frame, which is used to give the unit rigidity. This frame, the stator rods and spacers, and the rotor shaft are made of an alloy of aluminum and copper which combines the mechanical strength of brass with the weight and temperature coefficient of aluminum. The condenser plates are of aluminum, so that all parts have the same temperature coefficient of linear expansion. In models where space permits, increased stability is obtained by the use of $\frac{1}{16}$ -inch plates.

A worm drive is used in this condenser to obtain the desired precision of setting. In order to avoid the slight eccentricity which is almost inevitable when a worm gear is mounted on a shaft, the worm in the TYPE 722 Precision Condenser is cut directly on the shaft. The dial end of this worm shaft runs in ball bearings, while the other end is supported by an adjustable spring mounting. Ball bearings are used at both ends of the rotor shaft. Electrical connection to the rotor is made, not through the bearing, but by means of a phosphor-bronze brush run-

ning on a brass drum. This method assures a positive electrical contact.

FEATURES: Both the materials and the mechanical arrangement used in the TYPE 722 Precision Condenser have been carefully selected to give the instrument a high degree of stability under constant laboratory use. The entire mounting is extremely rigid, and the bearings and drive mechanism have been arranged so as to reduce the backlash to less than one-half a worm division, and to give an extremely small worm correction.

The temperature coefficient of capacitance has been kept low by using parts which all have the same coefficient of expansion. In order to keep the dielectric losses low, only a small amount of dielectric is used, and this is placed in a weak electric field. When it is desired to reduce the dielectric losses still further, quartz insulation may be used instead of the standard isolantite.

All models can be set to one part in 25,000 of full scale, a precision of setting which is more than adequate for most measurement uses. Standard calibrations are accurate to $1.0 \mu\mu\text{f}$ and give an internal consistency of calibration good to 0.1 per cent of full scale. A more precise calibration with a worm correction can be supplied, giving corrections which permit an internal consistency of $0.1 \mu\mu\text{f}$. The accuracy at the terminals, however, may still be limited to approximately $1 \mu\mu\text{f}$ by the lack of a standard technique for connecting the condenser into a measuring circuit. (See *General Radio Experimenter*, Vol. XII, No. 8, January, 1938, for a complete discussion of connection errors.)

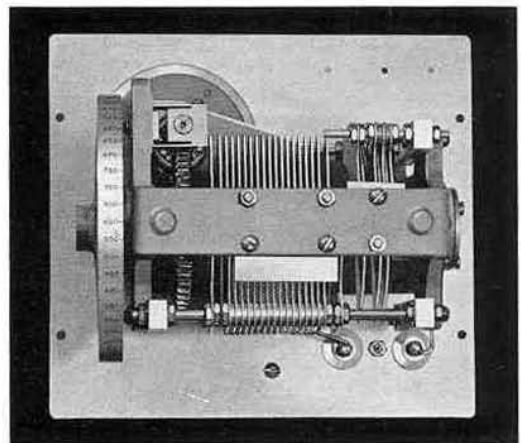

Interior view of a TYPE 722-D Precision Condenser.

CAPACITORS

SPECIFICATIONS

Capacitance Range: Three stock models are available: TYPE 722-D, direct reading in capacitance over two ranges, 25 to 110 $\mu\mu\text{f}$, and 100 to 1100 $\mu\mu\text{f}$; TYPE 722-F, calibrated every half-worm turn, 500 $\mu\mu\text{f}$ maximum; TYPE 722-M, intended for bridge-substitution measurements and direct reading in capacitance removed from the condenser over a range of 1000 $\mu\mu\text{f}$.

Rotor Plate Shape: Semicircular for all models, to give a linear capacitance characteristic.

Standard-Calibration Accuracy: TYPE 722-D: The capacitance of the HIGH section, 100 to 1100 $\mu\mu\text{f}$, is indicated directly in micromicrofarads by the dial and drum readings within $\pm 1 \mu\mu\text{f}$. The capacitance of the LOW section, 25 to 110 $\mu\mu\text{f}$, is indicated directly in micromicrofarads by one-tenth of the dial and drum readings within $\pm 0.2 \mu\mu\text{f}$.

TYPE 722-F: The capacitance at every half-worm turn is given in a mounted chart to 0.1 $\mu\mu\text{f}$, accurate within $\pm 0.5 \mu\mu\text{f}$. The capacitance differences between succeeding half-worm turns is also given to 0.1 $\mu\mu\text{f}$, and is accurate to $\pm 1 \mu\mu\text{f}$.

TYPE 722-M: The capacitance at a reading of zero for the dial and drum is indicated on a small card mounted on the panel. This capacitance, about 1150 $\mu\mu\text{f}$ in magnitude, is given to 0.1 $\mu\mu\text{f}$, and is accurate within $\pm 1 \mu\mu\text{f}$. The condenser is adjusted to indicate directly in micromicrofarads the capacitance removed from the circuit to an accuracy of $\pm 1 \mu\mu\text{f}$.

These accuracies are indicated on the certificate or chart which accompanies each mounted condenser. No calibration is furnished with unmounted models.

Worm-Correction Calibration: Worm corrections can be supplied for all three models according to the price list. Mounted charts are supplied which give the corrections to at least one more figure than the guaranteed accuracies, which are stated below.

TYPE 722-D: When this correction is used, the capacitance of both sections can be determined within $\pm 0.1 \mu\mu\text{f}$ or $\pm 0.1\%$, whichever is the greater, and capacitance differences can be measured to an accuracy of $\pm 0.2 \mu\mu\text{f}$ or $\pm 0.1\%$, whichever is the greater, with the HIGH section; and $\pm 0.04 \mu\mu\text{f}$ or $\pm 0.1\%$, whichever is the greater, with the LOW section.

TYPE 722-F: The capacitance can be determined within $\pm 0.1 \mu\mu\text{f}$ or $\pm 0.1\%$, whichever is the greater. Capacitance differences can be measured within $\pm 0.1 \mu\mu\text{f}$ or $\pm 0.1\%$, whichever is the greater.

TYPE 722-M: Capacitance differences, in capacitance removed, can be measured within $\pm 0.2 \mu\mu\text{f}$ or $\pm 0.1\%$, whichever is the greater.

Maximum Voltage: All models, 1000 volts, peak.

Dielectric Supports: Two bars of isolantite support the stator assembly, and conical bushings insulate the terminals from the panel. Quartz insulation can be supplied on special order. (See price list.)

Dielectric Losses: The figure of merit, $R\omega C^2$, when measured at 1000 cycles is approximately 0.04×10^{-12} for isolantite insulation and 0.003×10^{-12} for quartz.

Residual Parameters: The series metallic resistance is about 0.02 ohm at 1 megacycle and increases directly as the square root of the frequency.

The series inductance is approximately 0.065 μh .

Temperature Coefficient: The temperature coefficient of capacitance is approximately $+0.002\%$ per degree Centigrade.

Drive: A worm and gear drive is used. To reduce irregularities and backlash the worm is cut integral with the shaft. The backlash is less than one-half worm division (there are 250 divisions per worm turn for the TYPE 722-D and the TYPE 722-M; 200 divisions for the TYPE 722-F). If the desired setting is always approached in the direction of increasing scale reading, no calibration error from this cause will result.

Terminals: Jack-top binding posts are provided. Standard $\frac{3}{4}$ -inch spacing is used. The rotor terminal is connected to the panel and shield.

Mounting: Mounted models are attached to an aluminum panel finished in black crackle lacquer and enclosed in a shielded walnut cabinet. A wooden storage case with lock and carrying handle is included.

Dimensions: (Mounted models) Panel, 8 x $9\frac{1}{8}$ inches; depth, $8\frac{1}{8}$ inches. (Unmounted models) $7\frac{3}{4}$ (length) x $6\frac{3}{8}$ (width) x 7 (depth) inches.

Weight: $11\frac{1}{8}$ pounds; $20\frac{1}{4}$ pounds with carrying case.

MOUNTED MODELS

Type	Capacitance Range	Code Word	Price
722-F	45 to 500 $\mu\mu\text{f}$	CUBIT	\$85.00
722-D	25 to 110 $\mu\mu\text{f}$ and 100 to 1100 $\mu\mu\text{f}$, direct reading	CRUEL	110.00
722-M	0 to 1000 $\mu\mu\text{f}$, direct reading in capacitance removed from circuit	COMIC	100.00
Worm-Correction Calibration for Types 722-F and 722-M		WORMY	35.00
Worm-Correction Calibration for Type 722-D		WORMY	50.00

When ordering, use compound code word, CUBITWORMY, etc.

UNMOUNTED MODEL

Type	Maximum Capacitance	Code Word	Price
722-FU	500 $\mu\mu\text{f}$	CUBITPANEL	\$65.00

QUARTZ INSULATION

Any TYPE 722 Precision Condenser can be obtained with quartz insulation.

	Code Word	Additional Price
Quartz Insulators	QUATZ	\$55.00

When ordering, use compound code word, CUBITQUATZ, etc.

TYPE 722-N PRECISION CONDENSER

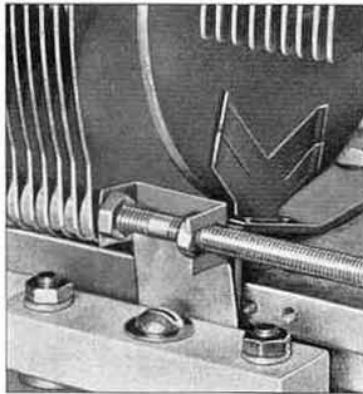

Details of Brushes and Disc.

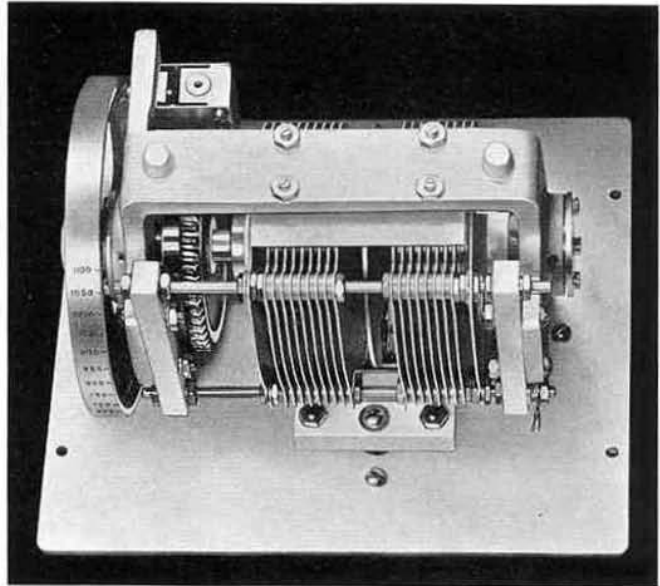

Right: Interior photograph of a TYPE 722-N Precision Condenser, showing the leads and the method of connection to the rotor.

USES: This condenser is a capacitance standard which has been designed particularly for use at radio frequencies in series- or parallel-resonance methods of impedance measurement. It is also useful as a variable capacitor in radio-frequency bridges.

DESCRIPTION: The frame, bearing, and drive mechanism of this condenser are identical with those used on the other TYPE 722 Precision Condensers. The rotor and stator leads, however, are not brought out in the conventional manner. In the TYPE

722-N Precision Condenser connection is made at the center of both plate stacks, phosphor-bronze brushes bearing on a brass disc being used for the rotor connection.

FEATURES: The important features of this condenser are its low metallic resistance and low inductance. Both of these quantities are about one-third the magnitude of those in the TYPE 722-D Precision Condenser. The accuracy of calibration is as excellent and the dielectric losses as low as in the other TYPE 722 Condensers.

SPECIFICATIONS

Capacitance Range: 100 to 1100 μf , direct reading.

Rotor Plate Shape: Semicircular to give a linear capacitance characteristic.

Standard-Calibration Accuracy: The capacitance, measured at 1000 cycles, is indicated directly in microfarads by the dial and drum readings to $\pm 1 \mu\text{f}$.

Worm-Correction Calibration: A worm correction can be supplied on special order. (See price list.) A mounted chart is supplied giving the corrections to at least one more figure than the guaranteed accuracy stated below.

When this correction is used, the capacitance can be determined within $\pm 0.1 \mu\text{f}$ or $\pm 0.1\%$, whichever is the greater, and capacitance differences can be measured to an accuracy of $\pm 0.2 \mu\text{f}$ or $\pm 0.1\%$, whichever is the greater.

Dielectric Supports: Two bars of isolantite support the stator assembly, and a third insulates the high terminal from the panel.

Dielectric Losses: The figure of merit, $R\omega C^2$, when measured at 1000 cycles, is approximately 0.05×10^{-12} . (See discussion on "Condenser Losses" on page 44.)

Other Residual Parameters: The series metallic resist-

ance is about 0.008 ohm at 1 megacycle and increases directly as the square root of the frequency. The dielectric and metallic losses are approximately equal at a setting of 1000 μf and a frequency of 1 Mc.

The series inductance is approximately 0.024 μh . The increase in capacitance caused by this inductance reaches 10% at a setting of 1000 μf and a frequency of 10 Mc.

At smaller capacitance settings the effects of residual parameters are less. The equal division of losses occurs at 20 Mc for a setting of 100 μf and the 10% capacitance rise occurs at 30 Mc for the same setting.

Maximum Voltage: 1000 volts, peak.

Temperature Coefficient: Approximately $+0.002\%$ per degree Centigrade.

Mounting: The condenser is mounted on an aluminum panel finished in black crackle lacquer and enclosed in a shielded walnut cabinet. A wooden storage case with lock and carrying handle is included.

Dimensions: Panel, 8 x 9 $\frac{1}{8}$ inches; depth, 8 $\frac{1}{8}$ inches.

Net Weight: 11 $\frac{1}{8}$ pounds; 20 $\frac{1}{4}$ pounds with carrying case.

Type	Description	Code Word	Price
722-N	100 to 1100 μf , direct reading.	BOXER	\$150.00
Worm-Correction Calibration		WORMY	35.00

When ordering use compound code word, BOXERWORMY.

TYPE 539 VARIABLE AIR CONDENSER



TYPE 539-K Condenser.

USES: The TYPE 539 Variable Air Condenser is a general-purpose unit which can be used in experimental circuits or built into standard instruments. Many manufacturers, including the General Radio Company, have used these condensers as the variable capacitance in bridges, beat-frequency oscillators, standard-signal generators, and other measuring equipment. Different plate shapes are available for different applications, and one model is available with an insulated rotor so that both rotor and stator may be above ground potential.

DESCRIPTION: Three brass rods, extensions of which serve as mounting pillars, rigidly support the two end plates. On each end plate is mounted a block of isolantite which carries the two rods to which the stator is attached. This method of mounting insures low losses and facilitates the use of special plate shapes.

In the mounted models, which are supplied only with semicircular plates, a 100-division dial, using a friction-drive vernier, is provided. Capacitance calibrations can be furnished to order on these units.

FEATURES: This condenser is a rugged and stable unit which is also low in price. The mechanical design is such that it may very easily be built into other instruments, and the fact that special plate shapes are available makes it very adaptable for use in oscillators, signal generators, and similar apparatus.

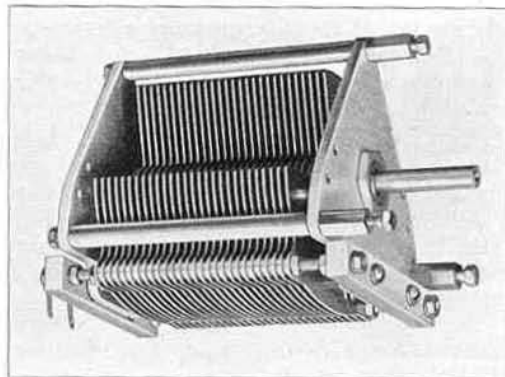

SPECIFICATIONS

Capacitance Range: Six unmounted and three mounted models having the nominal capacitances listed on the next page are stocked.

Calibration: No calibration is normally supplied with any of the units, but the mounted models carry an engraved nameplate which gives the actual maximum and minimum capacitance, accurate within 0.5% of full scale.

On special order a mounted calibration curve, accurate within 0.5% of full scale, or a mounted calibration table for 11 points, accurate within 0.5% of full scale, can be supplied for the mounted models. See the price list on the next page.

Dielectric Losses: The figure of merit, $R\omega C^2$, is approximately 0.04×10^{-12} .

Insulated Rotor Model (Type 539-TA): Direct capacitance between rotor and stator is given in the price list. The power factor of this capacitance is less than 0.00002. The capacitance between rotor and frame is 24 μf ; that between stator and frame is 12 μf .

Plate Shape: Semicircular rotor plates giving linear capacitance variation with setting are used on TYPES 539-J, 539-K, and 539-L and on all mounted models.

Rotor plates for TYPES 539-T and 539-TA are cut to give a linear frequency variation with setting over 250° of a possible 270° angle of rotation when a capacitance of 25 μf is connected in parallel with the condenser.

TYPE 539-X has a spread-out scale for use on a beat-frequency oscillator. A counterclockwise rotation from the minimum capacitance position of 40°, 90°, 230°, and 255° increases the capacitance by 0.4%, 5%, 82%, and 100%, respectively, of the total increment.

Maximum Voltage: TYPE 539-J is rated at 1100 volts peak; TYPE 539-K at 800 volts, peak; and TYPES 539-L, 539-T, 539-TA, and 539-X at 550 volts, peak.

Knobs and Dials: Mounted models are furnished with 180-division dials and a friction-drive vernier, but none are supplied with the unmounted models. Note that all models have $\frac{3}{8}$ -inch shafts and that TYPES 539-T,

539-TA, and 539-X require a scale spread over 270°, instead of the 180° required by the other types.

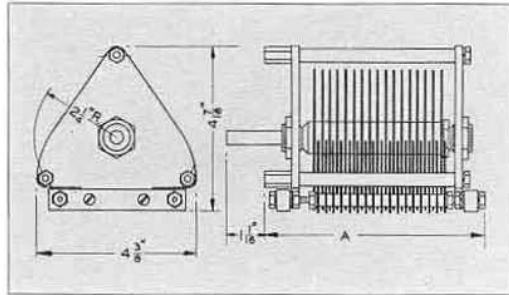

Terminals: On unmounted models, soldering lugs are mounted on the lower isolantite support of all except TYPE 539-TA. The rotor connection for this condenser is brought out through an isolantite bushing in the rear end plate. Mounted models have jack-top binding posts mounted on the panel.

Mounting: TYPES 539-A, 539-B, and 539-C are mounted on an aluminum panel and enclosed in a shielded walnut cabinet. All other models are unmounted.

Dimensions: Unmounted models, see accompanying outline drawing; depth behind panel (A) 6 inches, over-all. Mounted models, panel, 6 1/2 x 6 1/2 inches; height, 8 3/4 inches, over-all.

Net Weight: Approximately 2 3/4 pounds for unmounted models; 6 3/4 pounds for mounted models.

UNMOUNTED MODELS

Type	Nominal Capacitance		Description	Code Word	Price
	Maximum	Minimum			
539-J	500 μmf	40 μmf	Straight-line capacitance	ATLAS	\$10.00
539-K	1000 μmf	40 μmf	Straight-line capacitance	ATONE	11.00
539-L	2000 μmf	40 μmf	Straight-line capacitance	ATTIC	12.00
539-T	500 μmf	30 μmf	Straight-line frequency	CLOSE	12.00
539-TA	500 μmf	18 μmf	Straight-line frequency, insulated rotor	CLOTH	15.00
539-X	900 μmf	40 μmf	Special spread-out scale	AUGER	12.00

MOUNTED MODELS

Type	Nominal Capacitance		Code Word	Price
	Maximum	Minimum		
*539-A	500 μmf	50 μmf	ASSAY	\$22.00
*539-B	1000 μmf	55 μmf	ASSET	23.00
*539-C	2000 μmf	60 μmf	ASTER	24.00
Mounted Calibration Curve			CURVE	4.00
11-point Calibration Table			CHART	3.50

*Calibrations supplied only when ordered. Use compound code words, ASSAYCHART, ASSETCHART, or ASTERCHART. PATENT NOTICE. See Note 17, page v.

An antenna measuring set using TYPE 539 Condensers for tuning elements. Note also the TYPE 358 Condensers and TYPE 510 Decade-Resistance Units.

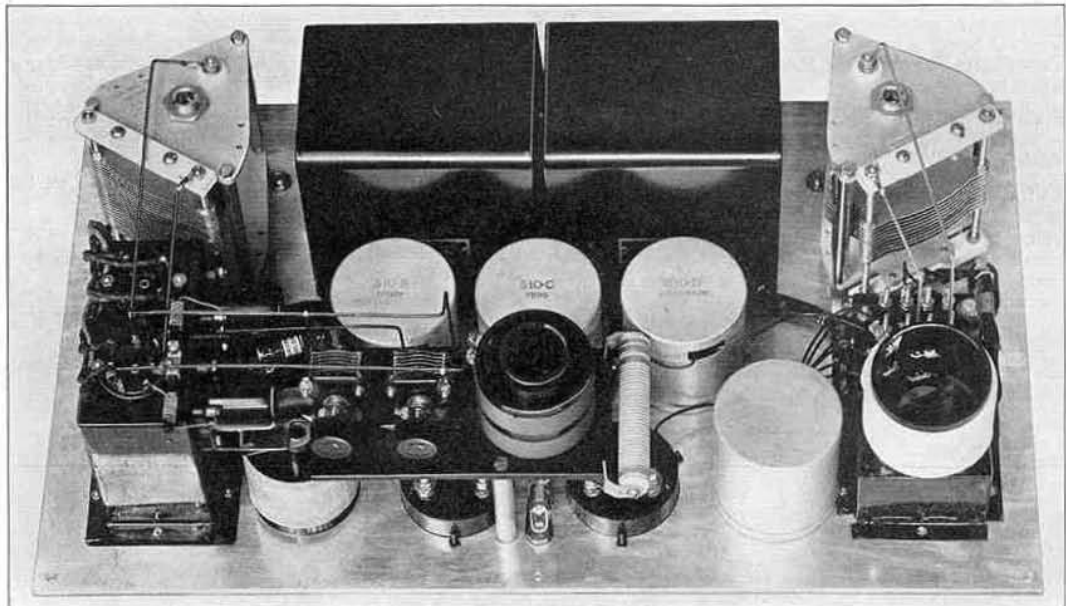

• CAPACITORS

TYPE 246 VARIABLE AIR CONDENSER

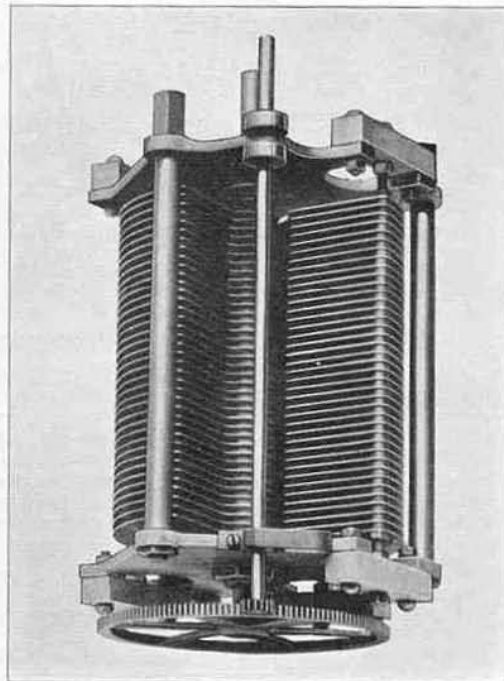
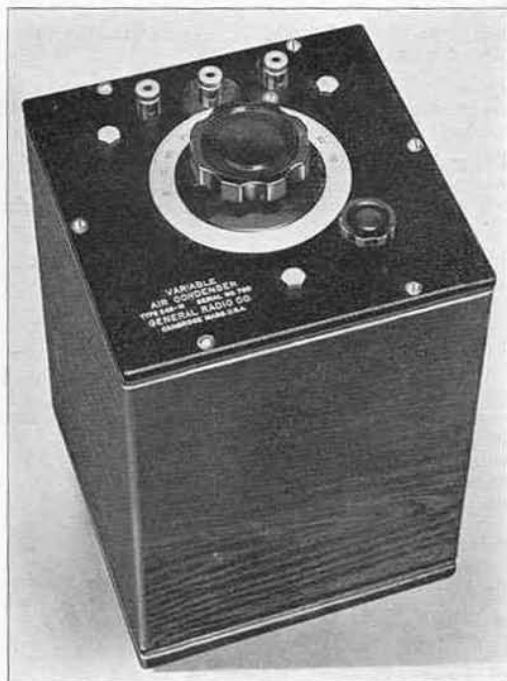

USES: This condenser is for use in measuring and experimental circuits which require a high-grade capacitor but where extreme precision of setting and accuracy of calibration are not needed. It is ideal as the "balancing condenser" in the substitution method of capacitance measurement.

DESCRIPTION: The TYPE 246 Variable Air Condenser is rigidly constructed, using cast-

aluminum end plates, heavy supporting pillars and isolantite insulation. The plates are of aluminum, separated by accurately turned spacers. A geared slow-motion drive giving a reduction of 10:1 is provided in addition to direct drive by the main dial.

FEATURES: This condenser is a rigidly constructed, stable, and inexpensive variable air condenser with high values of capacitance.

SPECIFICATIONS

Capacitance Range: Three stock models are available as listed below.

Plate Shape: Semicircular rotor plates giving linear capacitance variation with setting are used on all models.

Calibration: No calibration is supplied with this condenser, but the actual values of maximum and minimum values of capacitance, accurate within 0.5% of full scale, are engraved on the nameplate. A mounted calibration curve, accurate within 0.5% of full scale, or a mounted calibration table for 11 points, accurate within 0.5% of full scale, can be prepared to order. (See the price list below.)

Losses: The figure of merit, $R\omega C^2$, is approximately 0.06×10^{-12} .

Maximum Voltage: TYPE 246-L and TYPE 246-M are rated at 800 volts, peak; TYPE 246-P, 500 volts, peak.

Drive: A spur-gear slow-motion drive having a ratio of 10:1 is an auxiliary control for the large knob and dial mounted on the rotor shaft.

Terminals: Jack-top binding posts are mounted on the panel.

Mounting: The condenser is mounted on an aluminum panel, finished in black crackle lacquer and enclosed in a shielded walnut cabinet.

Dimensions: Panel, $7\frac{1}{2} \times 7\frac{1}{2}$ inches. Cabinet, (height) for TYPE 246-L, $8\frac{3}{8}$ inches; for TYPES 246-M and 246-P, $11\frac{3}{8}$ inches, over-all.

Net Weight: TYPE 246-L, $11\frac{1}{4}$ pounds; TYPES 246-M and 246-P, 15 pounds.

Type	Nominal Capacitance		Code Word	Price
	Maximum	Minimum		
*246-L	1500 $\mu\mu\text{f}$	55 $\mu\mu\text{f}$	CEDAR	\$38.00
*246-M	3000 $\mu\mu\text{f}$	70 $\mu\mu\text{f}$	CHAOS	45.00
*246-P	5000 $\mu\mu\text{f}$	72 $\mu\mu\text{f}$	CHARY	54.00
Mounted Calibration Curve			CURVE	4.00
Mounted 11-point Calibration Table			CHART	3.50

*Calibrations supplied only when ordered. Use compound code words, e.g., CEDARCHART, CHAOSCHART, etc

TYPE 739 LOGARITHMIC AIR CONDENSER

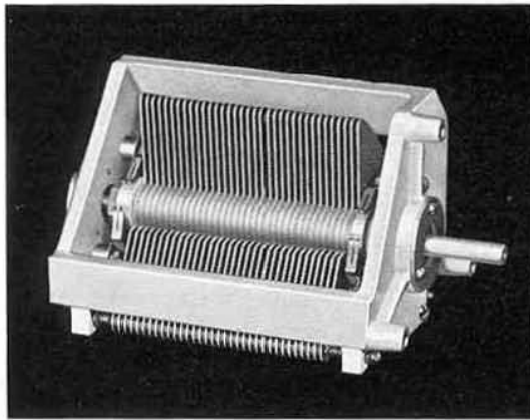

TYPE 739-B Condenser.

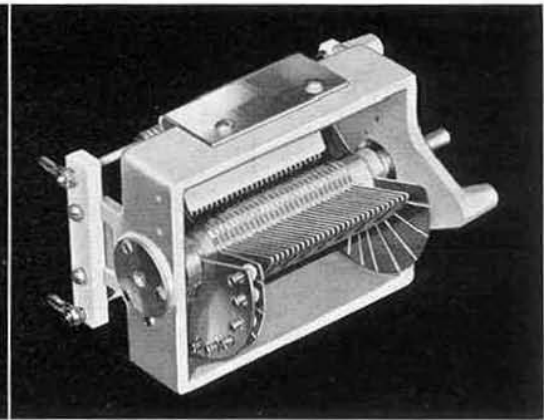

TYPE 739-A Condenser.

USES: In vacuum-tube oscillators which cover a wide range of frequency, a logarithmic variation in frequency with dial rotation is usually desirable. TYPE 739 Logarithmic Air Condensers are designed to give this frequency variation in tuned-circuit oscillators and beat-frequency oscillators. One model, TYPE 739-A, intended for use with beat-frequency oscillators, is used in TYPE 713-B and TYPE 700-A Beat-Frequency Oscillators; the other, TYPE 739-B, is used in TYPE 605-B Standard-Signal Generator and TYPE 684-A Modulated Oscillator.

DESCRIPTION: Two isolantite sections support the stator from the cast aluminum

frame. Both plates and supporting rods are also of aluminum. The rotor, which has specially-shaped plates, is mounted in ball bearings and grounded to the frame; in addition, brass collars with phosphor-bronze contact springs are used to connect the rotor to the frame.

FEATURES: The outstanding feature of these condensers is the plate shape, which gives an accurately logarithmic variation in frequency. The cast frame and rugged construction, low and constant contact resistance, and low temperature coefficient insure stable electrical characteristics and dependable operation.

SPECIFICATIONS

Capacitance Range: The nominal capacitance ranges are given in the price list.

Plate Shape and Frequency Characteristics: The rotor plates are so shaped as to give an approximately logarithmic frequency variation when the condensers are used as follows:

The TYPE 739-A is to be used as the tuning condenser of the variable oscillator of a beat-frequency oscillator. With the condenser set at minimum capacitance, sufficient capacitance should be placed in parallel with the unit to make the effective zero capacitance (of condenser, tube, and associated circuit) 1720 $\mu\mu\text{f}$. When this is done and the frequencies of the fixed and variable oscillators

are made the same with the TYPE 739-A set at its minimum capacitance, the beat frequency will vary approximately logarithmically with dial setting over three decades, about 250°. The actual range of the audio frequency output will depend on the frequency of the fixed oscillator.

The TYPE 739-B is for use in a tuned-circuit radio-frequency oscillator. With the effective zero capacitance exactly one-tenth the maximum capacitance, the effective frequency range is $\sqrt{10}$, covered by a dial rotation of 165°. The variation of frequency with dial setting is approximately logarithmic.

Adjustment: Slotted plates are provided on the TYPE

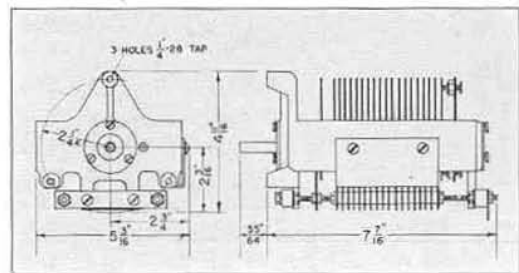
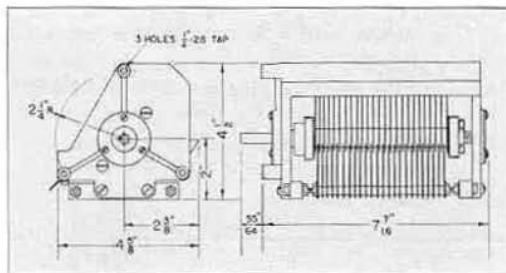

Mounting dimensions of TYPE 739 Condensers: Left, TYPE 739-B; right, TYPE 739-A.

• CAPACITORS

739-A with adjusting screws. When these plates and the effective zero capacitance are correctly adjusted, the variation of frequency with dial setting will be logarithmic within 2%.

The TYPE 739-B has no adjustable plates, but, by proper adjustment of the padding condenser and circuit inductance, the variation in frequency with dial setting, over 150°, can be made logarithmic within 1%.

Maximum Voltage: 500 volts, peak.

Losses: The figure of merit, $R\omega C^2$, is approximately 0.04×10^{-12} .

Knobs and Dials: None are supplied; TYPE 704 or TYPE 706 Precision Dials are recommended. The TYPE 739-A has 270° rotation while the TYPE 739-B has 180°.

Terminals: Soldering lugs are provided.

Mounting: See sketch on preceding page.

Dimensions: See sketch on preceding page.

Net Weight: 3½ pounds.

Type	Nominal Capacitance		Code Word	Price
	Maximum	Minimum		
739-A	468 μf	28 μf	COUPE	\$28.00
739-B	1460 μf	35 μf	COILY	28.00

TYPE 368 VARIABLE AIR CONDENSER

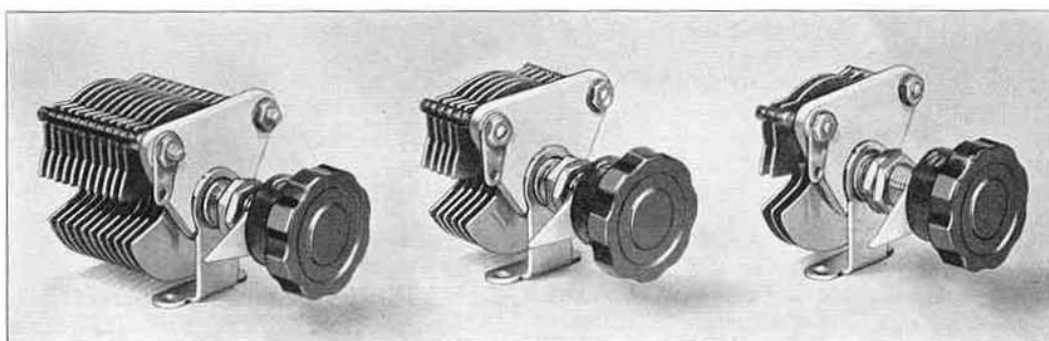

USES: The TYPE 368 Variable Air Condenser is useful as an auxiliary balancing or trimmer condenser in bridges, oscillators, and similar equipment. It is also used as a tuning or trimmer condenser in high-frequency receivers.

DESCRIPTION: Soldered brass plates are used in this condenser. The stator is mounted on

a single isolantite end plate. An angle bracket is provided so that the condenser can be mounted either on a baseboard or on a panel.

FEATURES: The TYPE 368 Variable Air Condenser is compact and easy to mount. It has extremely low losses and low minimum capacitance.

SPECIFICATIONS

Capacitance Range: Three stock models are available as listed below.

Plate Shape: All models have straight-line-capacitance plates.

Dielectric Losses: The figure of merit, $R\omega C^2$, is approximately 0.004×10^{-12} .

Support: A single, isolantite end plate supports the entire assembly.

Maximum Voltage: 500 volts, peak.

Knob: TYPE 637-A Knob is supplied with all units.

Terminals: A soldering lug is provided as a stator terminal. Contact to the rotor is made through the angle bracket or shaft bushing.

Mounting: A bushing is provided for single-hole panel mounting, and a bracket is provided for baseboard mounting. See accompanying sketch.

Dimensions: See accompanying sketch. Depth (dimension X) is given in the table below.

Net Weight: Approximately 3 ounces, all sizes.

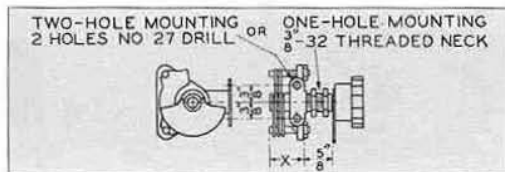

Type	Capacitance		Depth (X)	Code Word	Price
	Maximum	Minimum			
368-A	15 μf	2 μf	1 1/16 in.	BULLY	\$0.90
368-B	50 μf	3 μf	1 3/16 in.	BURIN	1.00
368-C	100 μf	4 μf	1 1/2 in.	AZURE	1.50

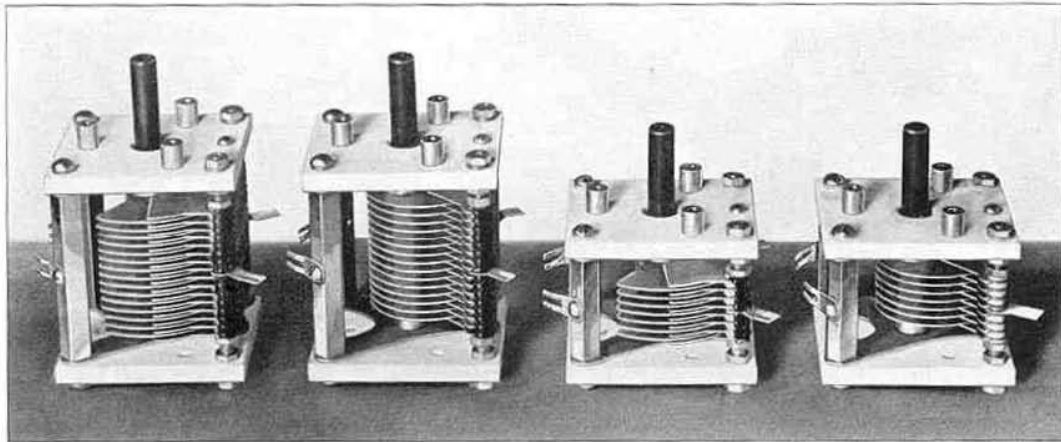

TYPE 568 VARIABLE AIR CONDENSER

USES: The TYPE 568 Variable Air Condenser has been designed for use as a tuning element in high-frequency receivers, transmitters, wavemeters, and experimental circuits.

DESCRIPTION: The rotor and stator stacks are made up of several brass plates securely soldered into an integral piece. The terminals are brought out at the center of the stacks to reduce resistance and improve the

high-frequency characteristics. Contact to the rotor is made through an eight-fingered conical bearing kept under heavy spring pressure.

FEATURES: This condenser is specifically designed for high-frequency work. The losses are low and the terminal arrangement is convenient where short leads are necessary. The shaft arrangement allows several units to be ganged for tandem operation.

SPECIFICATIONS

Capacitance Range: Four stock models are available as listed below.

Dielectric Losses: The figure of merit, $R\omega C^2$, is approximately 0.03×10^{-12} .

Plate Shape: Straight-line capacitance for TYPES 568-D and 568-E; approximately straight-line frequency for TYPES 568-K and 568-L.

Supports: End plates are of isolantite treated to prevent moisture absorption.

Maximum Voltage: 500 volts, peak.

Knobs: None supplied. Shaft diameter, $\frac{3}{8}$ inch; rotation angle, 180° for TYPES 568-D and 568-E, 270° for TYPES 568-K and 568-L.

Mounting: See accompanying sketch. Drilling template and 3 flat-head screws are furnished.

Terminals: Soldering lugs are provided. These are brought out from the centers of the plate stacks.

Dimensions: See accompanying sketch. Depth (dimension A) is $2\frac{1}{16}$ inches for TYPES 568-D and 568-K, and $3\frac{1}{16}$ inches for TYPES 568-E and 568-L.

Net Weight: $\frac{3}{4}$ pound for TYPES 568-D and 568-K; 1 pound for TYPES 568-E and 568-L.

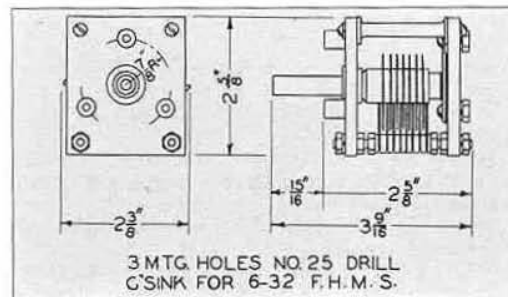

Type	Nominal Capacitance		Code Word	Price
	Maximum	Minimum		
568-D	175 μf	13 μf	CLOVE	\$4.50
568-E	360 μf	18 μf	CLOWN	7.00
568-K	50 μf	11 μf	CLOUD	4.50
568-L	100 μf	14 μf	CAGED	7.00

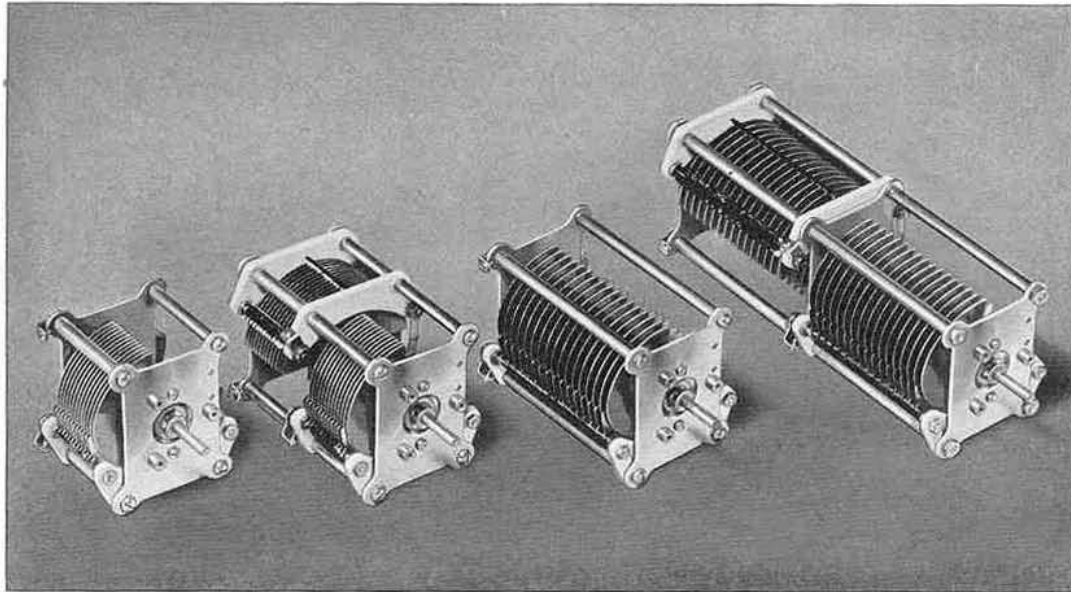

TYPES 334 and 335 VARIABLE AIR CONDENSERS

USES: This group of condensers is available in a variety of sizes for general experimental use and as components of power oscillators, transmitters, and receivers.

DESCRIPTION: Brass plates are used and in each stack all plates are soldered together. Metal end plates are grounded to the rotor

stacks and to the shaft. The stator stacks are supported by isolantite insulators.

FEATURES: A wide range of maximum capacitances are available in both high- and low-voltage models. Isolantite insulation keeps the losses at a minimum.

SPECIFICATIONS

Capacitance Range: Six stock models are available as listed below.

Plate Shape: Approximately straight-line wavelength, decreasing wavelength for clockwise rotation, for all except the TYPE 335-Z which has straight-line-capacitance plates.

Dielectric Losses: $R\omega C^2$ is approximately 0.01×10^{-12} for all units except TYPES 334-Z and 335-Z which have a figure of merit of approximately 0.02×10^{-12} .

Supports: Small sections of isolantite support the stator. **Maximum Voltage:** Peak values are given in table below.

Knobs and Dials: None are supplied. Shaft diameter, $\frac{1}{4}$ inch; rotation angle, 180° for all sizes.

TYPES 334-Z and 335-Z have balanced rotors; all others, a counterweight.

Mounting: Standard General Radio 3-hole mounting. See accompanying sketch. Drilling template and 3 flat-head screws are furnished.

Four removable feet are furnished with each of the high-voltage models.

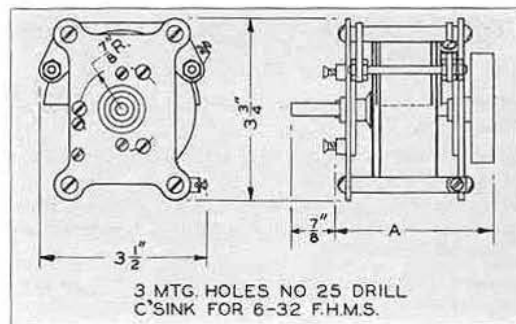

Terminals: Screw terminals are provided; see accompanying sketch.

Dimensions: See accompanying sketch. Depth (dimension A) is given in the table below.

Net Weight: See table below.

Type	Nominal Capacitance		Maximum Peak Voltage	Depth (A)	Net Weight	Code Word	Price
	Maximum	Minimum					
335-Z	1150 μmf	50 μmf	500 v	$5\frac{1}{4}$ in.	$2\frac{1}{8}$ lb.	BOGUS	\$7.50
334-F	500 μmf	20 μmf	500 v	$3\frac{5}{16}$ in.	$1\frac{1}{2}$ lb.	BEGIN	4.25
334-K	250 μmf	15 μmf	500 v	$2\frac{5}{8}$ in.	1 lb.	BELOW	2.75
334-Z	500 μmf	35 μmf	1500 v	$10\frac{1}{8}$ in.	$3\frac{3}{8}$ lb.	BOGEX	10.00
334-R	250 μmf	30 μmf	1500 v	$6\frac{1}{2}$ in.	2 lb.	BISON	5.50
334-T	100 μmf	15 μmf	1500 v	$3\frac{1}{4}$ in.	$1\frac{1}{8}$ lb.	BILLY	3.00

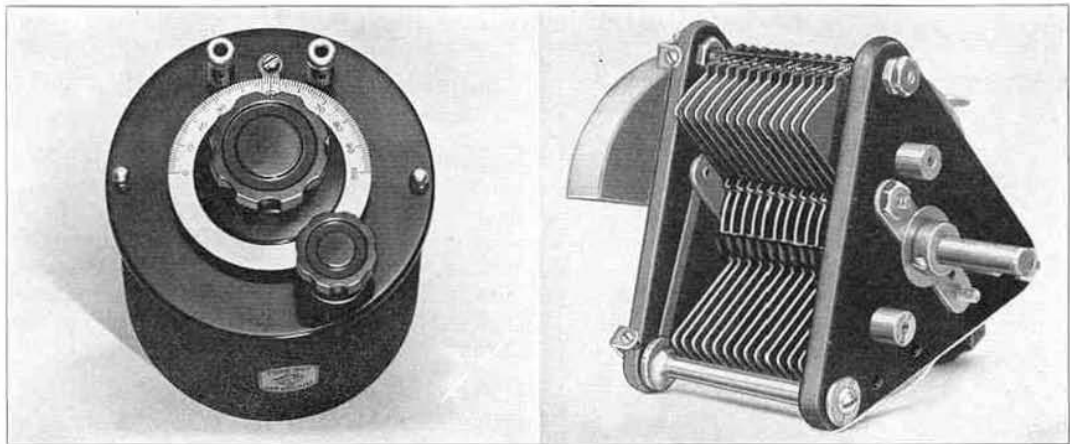

TYPE 247 VARIABLE AIR CONDENSER

USES: This condenser is useful as a laboratory accessory in the development of apparatus, and as a component of experimental and permanent equipment.

The TYPE 247-G can be used as the tuning condenser in an absorption type wavemeter. The coils can be mounted directly by means of the binding posts, as is done in the TYPE 358 Wavemeter which uses a modified TYPE 247 Condenser.

DESCRIPTION: Brass plates are used and are

carefully soldered in each stack to form a rugged assembly. The end plates are of hard rubber. The TYPE 247-G is mounted on a hard rubber panel in a steel case, and furnished with a dial and vernier drive.

FEATURES: The TYPE 247 Variable Air Condenser is a compact and low-priced unit which, because of its rugged construction, can be given hard usage in the laboratory without impairing its stability.

SPECIFICATIONS

Capacitance Range: Two stock models are available as listed below.

Dielectric Losses: The figure of merit, $R\omega C^2$, is approximately 0.08×10^{-12} .

Plate Shape: TYPE 247-G, straight-line capacitance; TYPE 247-F, straight-line wavelength, decreasing for clockwise rotation.

Maximum Voltage: 500 volts, peak.

Drive: TYPE 247-G is supplied with a gear drive having a 6:1 reduction ratio. TYPE 247-F is supplied without knob. The shaft diameter is $\frac{3}{4}$ inch.

Mounting: TYPE 247-G is mounted in a drawn-steel case with hard rubber panel. A drilling template and three flat-head screws are supplied with TYPE 247-F, which is furnished unmounted.

Terminals: Jack-top binding posts on TYPE 247-G and screw terminals on TYPE 247-F.

Dimensions: TYPE 247-G, (diameter) $4\frac{1}{2}$ x (height) $4\frac{1}{4}$ inches. TYPE 247-F, panel space, $3\frac{7}{8}$ x $3\frac{7}{8}$ inches; depth behind panel, $3\frac{3}{8}$ inches.

Net Weight: TYPE 247-G, $2\frac{1}{2}$ pounds; TYPE 247-F, $1\frac{3}{8}$ pounds.

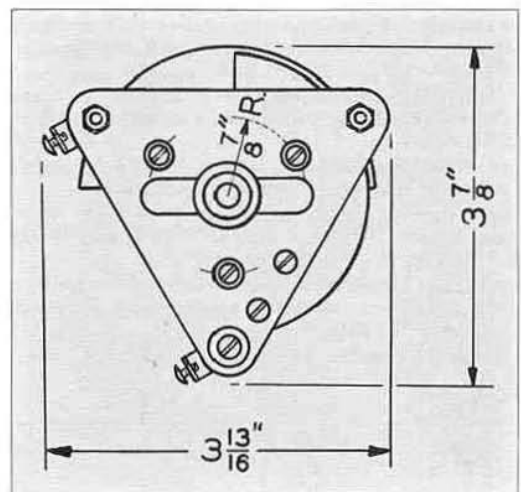

Type	Nominal Capacitance		Code Word	Price
	Maximum	Minimum		
247-G	500 μf	30 μf	COLIC	\$5.75
247-F	500 μf	20 μf	COCOA	3.00

TYPE 509 STANDARD CONDENSER

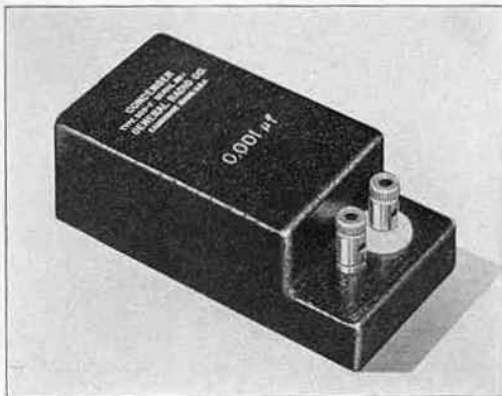

USES: These condensers are fixed standards of capacitance for laboratory use. When they are used in conjunction with a TYPE 722-D or a TYPE 722-M Precision Condenser in a parallel substitution method of measurement, precise measurements of capacitance up to several microfarads can be made. For condenser manufacturers who maintain a capacitance standardization laboratory, a set of

TYPE 509 Condensers, used with a TYPE 716-A Capacitance Bridge, is recommended.

DESCRIPTION: Each TYPE 509 Standard Condenser consists of two TYPE 505 Condenser units which have been put through an additional aging process. The final accuracy and stability are thus increased markedly. The units are mounted in cast aluminum cases and are furnished with jack-top binding posts.

FEATURES: In addition to being very accurately adjusted and stable, the TYPE 509 Standard Condenser is a compact plug-in unit which can be used with extreme convenience. The terminals are so arranged that several units may be stacked one upon the other without using leads. There is no cumulative connection error* when the condensers are so stacked, so that these units can be used in parallel in much the same way that precision gauges are added in mechanical measurements.

*See R. F. Field, "Connection Errors in Capacitance Measurement," General Radio *Experimenter*, January, 1938.

SPECIFICATIONS

Capacitance: Ten stock units are available as listed below.

Accuracy of Adjustment: Each condenser is carefully adjusted within 0.25% of the nominal capacitance value engraved on the case.

Accuracy of Calibration: After each condenser has been aged, adjusted, and mounted, its capacitance is measured as carefully as possible, and the value of capacitance, accurate within 0.1%, is entered on a certificate of calibration which is packed with each unit.

Stability: Over reasonable periods of time (e.g., one year) each condenser will maintain its calibrated value within 0.1%.

Temperature Coefficient: Less than +0.01% per degree Centigrade between 10° and 50° Centigrade.

Power Factor: The power factor of all units, when measured at 1000 cycles and 25° Centigrade, is less than 0.05%.

Frequency Characteristics: The frequency characteristics of these units are similar to those of the TYPE 505 Condenser. (See page 57.)

Leakage Resistance: The leakage resistance, when

measured at 500 volts, is greater than 100,000 megohms except for the TYPES 509-U, 509-X, and 509-Y. In these units the product of capacitance and leakage resistance will always be greater than 10 ohm-farads.

Maximum Voltage and Frequency: The maximum peak voltage is 500 volts, at frequencies below the limiting frequencies tabulated below. At higher frequencies the allowable voltage decreases and is inversely proportional to the square root of the frequency. These limits correspond to a temperature rise of 40° C.

Mounting: Cast aluminum cases are used.

Terminals: Two jack-top binding posts spaced 3/4 of an inch apart are mounted on the case. One terminal is grounded, and the other one is insulated by means of an isolantite bushing.

Dimensions: Small case, (length) 4 7/8 inches x (width) 2 1/2 inches x (height) 1 7/8 inches, over-all. Large case, (length) 6 inches x (width) 3 3/8 inches x (height) 2 3/8 inches, over-all.

Net Weight: 1 1/2 pounds for all condensers mounted in small cases; 2 1/2 pounds to 3 1/2 pounds for all condensers mounted in large cases.

Type	Capacitance	Peak Volts	Frequency	Case	Code Word	Price
509-F	0.001 μf	500	2500 kc	Small	GOODCONBOY	\$12.50
509-G	0.002 μf	500	1250 kc	Small	GOODCONBUG	12.50
509-K	0.005 μf	500	500 kc	Small	GOODCONCAT	12.50
509-L	0.01 μf	500	250 kc	Small	GOODCONDOG	12.50
509-M	0.02 μf	500	125 kc	Small	GOODCONEYE	15.00
509-R	0.05 μf	500	80 kc	Large	GOODCONPIG	18.00
509-T	0.1 μf	500	40 kc	Large	GOODCONRDD	22.00
509-U	0.2 μf	500	20 kc	Large	GOODCONSIN	25.00
509-X	0.5 μf	500	8 kc	Large	GOODCONSUM	32.00
509-Y	1.0 μf	500	4 kc	Large	GOODCONTOP	48.00

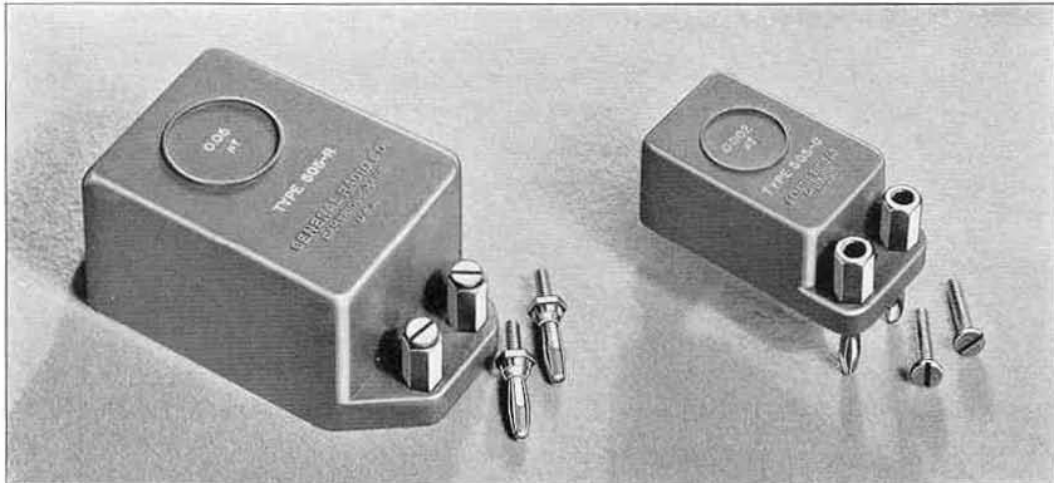

TYPE 505 CONDENSER

USES: The TYPE 505 Condensers are convenient and accurate plug-in units which can be used as secondary laboratory standards and circuit elements in all types of equipment. An assortment of various sizes is indispensable to any communications laboratory.

DESCRIPTION: The condenser unit, consisting of a mica and foil pile, is held by a heavy metal clamp. This unit is placed in the low-loss bakelite case and surrounded by silica gel and ground cork. The clamp is not connected to either condenser terminal but is left floating. The whole unit is covered with paper and sealed with wax.

FEATURES: In addition to being a small, convenient and accurate condenser the TYPE 505 has excellent stability and very low

losses. India mica has been chosen because of its electrical characteristics, and the mounting method used makes the capacitance practically independent of temperature, and the power factor independent of humidity. Every piece of mica is inspected for mechanical defects and other imperfections which might cause large dielectric losses.

Each unit is carefully aged to increase stability and is heated to eliminate moisture before sealing. Silica gel in the case absorbs any moisture which may collect on the condenser after it is in use for some time.

Low-loss (yellow) bakelite cases are used to insure better power factor and other characteristics. The plug-type terminals permit the condensers to be stacked in parallel and so build up to any required value of capacitance.

SPECIFICATIONS

Capacitance: The sizes listed in the price list are available from stock. Other sizes can be built to order; prices furnished on request.

Accuracy of Adjustment: All units are adjusted within 1% or 10 micromicrofarads, whichever is the larger.

Temperature Coefficient: The temperature coefficient of capacitance is less than +0.01% per degree Centigrade between 10° and 50° Centigrade.

Frequency Characteristics: The effective terminal capacitance is essentially constant over a wide frequency range. At very low frequencies a very slight rise in capacitance occurs because of dielectric absorption. At high frequencies a rise is caused by a constant residual inductance which is effectively in series with the condenser. For the units in the small cases this inductance is about .055 microhenry, while for the units in the large cases it is about 0.085 microhenry. The effect of this inductance on the capacitance of several TYPE 505 Condensers is shown in the accompanying plot.

Power Factor: The power factor of all units, except the three smallest sizes, measured at 1000 cycles and at 25° Centigrade, is less than 0.05%. Because of the increasing effect of the losses in the bakelite case on the power

This shows the increase in capacitance at high frequencies which is caused by the series inductance of the condenser terminals and leads.

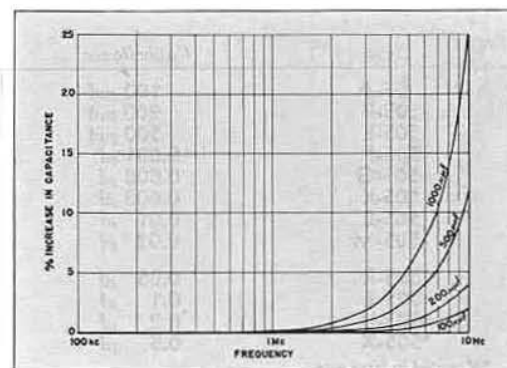

• CAPACITORS

GENERAL RADIO CO.

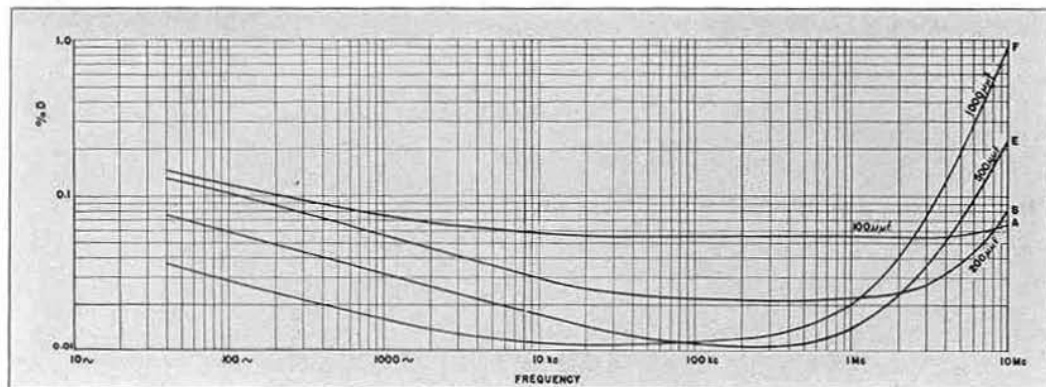

factor as the capacitance decreases, the power factor, at 1000 cycles and 25° Centigrade, of the TYPES 505-A, 505-B, and 505-E is less than 0.1%, 0.08%, and 0.06%, respectively. A change of about +5% of its value occurs in the power factor for a temperature rise of 1° Centigrade.

The changes in power factor with frequency are shown, for some sample condensers, in the accompanying plot. At very low frequencies, the rise in power factor is caused by losses due to absorption currents. At the high frequencies the rise is caused by the effect of the series resistance in the metal parts of the condensers. This resistance, practically independent of capacitance, varies with frequency because of skin effect and is about 0.03 ohm at 1 megacycle and about 0.1 ohm at 10 megacycles. The effect of this resistance on the power factor is increased as the capacitance increases.

Leakage Resistance: The leakage resistance, when measured at 500 volts, is greater than 100,000 megohms except for the TYPES 505-U and 505-X. In these units the resistance is greater than 50,000 and 20,000 megohms respectively.

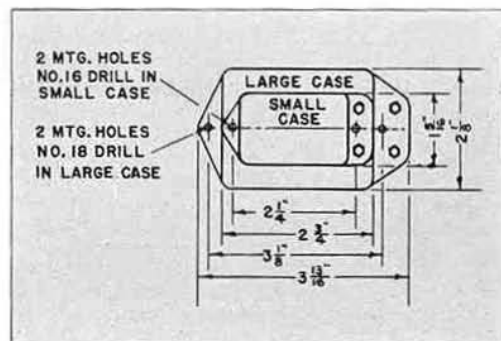

Maximum Voltage and Frequency: The maximum peak voltage which the condensers will safely withstand is 500 volts for all but the two smallest units which will withstand 700 volts peak. As the frequency of a constant applied voltage increases, the power dissipated in the unit also increases. If an a-c voltage, whose maximum value equals the allowable peak voltage previously specified, is applied to the condensers, the following table shows the maximum allowable frequency. This table is based on the ability of the units in the small cases to dissipate 1 watt and those in the large cases to dissipate 2.5 watts. For higher frequencies the allowable voltage decreases and is inversely proportional to the square root of the frequency.

Type	Frequency
505-A	2000 kc
505-B	1000 kc
505-E	980 kc
505-F	800 kc
505-G	400 kc
505-K	160 kc
505-L	80 kc
505-M	40 kc
505-R	40 kc
505-T	20 kc
505-U	10 kc
505-X	4 kc

Terminals: Screw terminals spaced 3/4 inch apart. Two TYPE 274-P Plugs are supplied with each condenser so that it may be converted to plug-terminal model.

Mounting: Low-loss (yellow) bakelite cases in two sizes as shown in the sketch. TYPES 505-R, 505-T, 505-U, and 505-X take the large case.

Dimensions: See sketch.

Net Weight: 4 ounces for small, 12 ounces for large size.

Type	Capacitance	Code Word	Price
505-A	100 µf	CONDENALLY	\$3.50
505-B	200 µf	CONDENBELL	3.50
505-E	500 µf	CONDENCOAT	3.50
505-F	0.001 µf	CONDENDRAM	3.50
505-G	0.002 µf	CONDENEYRE	3.50
505-K	0.005 µf	CONDENFACT	4.00
505-L	0.01 µf	CONDENGIRL	4.50
505-M	0.02 µf	CONDENHEAD	5.50
*505-R	0.05 µf	CONDENCALM	6.50
*505-T	0.1 µf	CONDENCROW	7.50
*505-U	0.2 µf	CONDENWIPE	12.00
*505-X	0.5 µf	CONDENWILT	20.00

*Mounted in large case.

TYPE 219 DECADE CONDENSER

USES: The TYPE 219 Decade Condensers find uses in every laboratory as tuned circuit elements, bridge impedances, filter elements, or as components of any circuit where a wide-range variable condenser is necessary.

DESCRIPTION: The TYPE 219 Decade Condensers are assemblies of two or three TYPE 380 Decade-Condenser Units mounted in a shielded cabinet. Each decade has eleven positions, 0 to 10 inclusive, so that the dials overlap. A positive detent mechanism allows the switch to be set accurately.

FEATURES: The TYPE 219 Decade Condensers are direct-reading units covering a wide range of capacitance values. Although not designed as standards, their accuracy is good and sufficient for most laboratory work. The zero capacitance has been kept at a minimum and its value is marked on each box for ready reference. By employing mica condensers on all decades except the 0.1-microfarad decade of the TYPE 219-L and TYPE 219-M, the power factor has also been held low.

TYPE 219-K uses mica dielectric throughout and has many uses where the comparatively higher losses of paper condensers cannot be tolerated. For applications where still lower losses are desired, boxes using TYPE 505 Condensers throughout can be built to order.

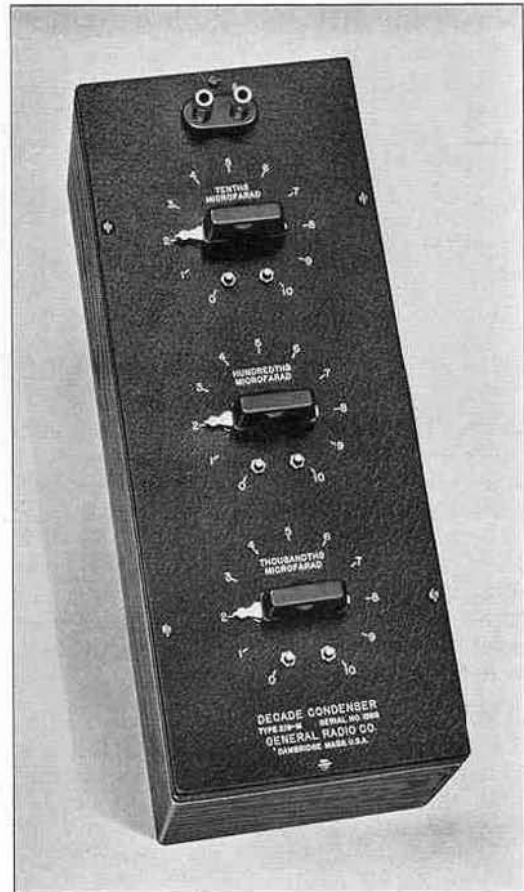

SPECIFICATIONS

Accuracy: All units are accurate at the decade terminals within 1%, except the 0.1-microfarad decades of the TYPE 219-L and TYPE 219-M which are within 2%. To obtain these accuracies at the box terminals, account must be taken of the effective zero capacitance of the box, which is made up of the true zero capacitance and the mutual capacitance between units. The values for the different boxes follow:

Type	Effective Zero Capacitance
219-K	35 μf
219-L	20 μf
219-M	30 μf
219-N	20 μf

These values are engraved on the Instruction Plate on every box.

Power Factor: The power factor for the individual decades is given in the specifications for the TYPE 380 Decade-Condenser Units. For the very lowest decades the power factor may be increased slightly because of the losses in the switches and mounting.

Maximum Voltage and Frequency: These values for the different decades are given in the specifications for the TYPE 380 Decade-Condenser Units. The limiting values for the different TYPE 219 Decade Condensers are engraved on the Instruction Plate for each box.

Terminals: Standard jack-top binding posts with a $\frac{3}{4}$ -

Inside view of TYPE 219-M Decade Condenser.

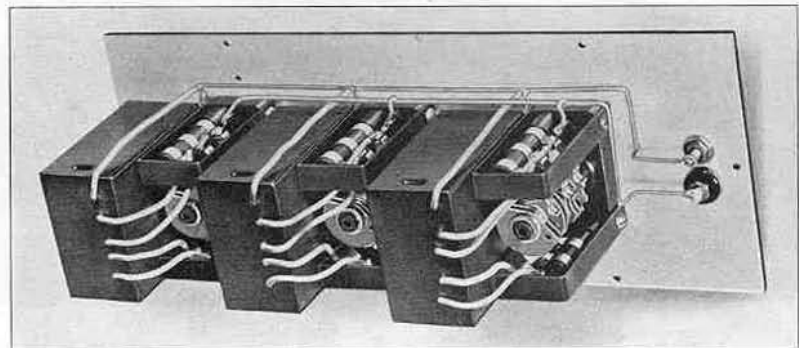

• CAPACITORS

inch spacing are used. The shield is connected to the "G" terminal.

Mounting: The decades are assembled on an aluminum panel and mounted in a shielded walnut cabinet.

Dimensions: TYPES 219-K and 219-M, (length) $13\frac{3}{4}$ x

(width) $5\frac{1}{2}$ x (height) $5\frac{3}{4}$ inches. TYPES 219-L and 219-N, (length) $10\frac{5}{8}$ x (width) $5\frac{1}{2}$ x (height) $5\frac{3}{4}$ inches.

Net Weight: TYPE 219-K, $10\frac{3}{4}$ pounds; TYPE 219-L, $6\frac{1}{2}$ pounds; TYPE 219-M, $8\frac{3}{8}$ pounds; TYPE 219-N, $6\frac{3}{8}$ pounds.

Type	Capacitance	No. of Dials	Type 380 Decades Used	Code Word	Price
219-K	1.110 μ f in 0.001 μ f steps	3	F, M, N	CROSS	\$90.00
219-L	1.10 μ f in 0.01 μ f steps	2	L, M	COVER	35.00
219-M	1.110 μ f in 0.001 μ f steps	3	L, M, N	BRIER	45.00
219-N	0.110 μ f in 0.001 μ f steps	2	M, N	CRONY	35.00

TYPE 380 DECADE-CONDENSER UNIT

USES: The TYPE 380 Decade-Condenser Units are extremely useful as elements in tuned circuits, wave filters, and other experimental or permanent equipment where a rather large variable capacitance is desired. They are also useful in oscillators, analyzers, amplifiers, and similar apparatus, especially during the preliminary design period when exact values for different capacitances are to be determined by experiment.

DESCRIPTION: Each decade is an assembly of four individual mica or paper condensers. A selector switch is arranged to make parallel combinations of the units so that any one of ten values may be obtained.

The switch is of rigid construction and carries a detent mechanism for positive loca-

tion of the switch positions. A bakelite shaft is used and contact is made by means of cams bearing on phosphor-bronze springs. This switch together with dial plate and knob is available separately as the TYPE 380-P3. (See price list.)

All standard units are furnished complete with knob, photo-etched dial plate, and stops.

FEATURES: The TYPE 380 Decade-Condenser Units are carefully aged and assembled so as to be stable and rugged. The smaller decades consist of moulded mica condensers while the mica 0.1-microfarad decade employs TYPE 505 Condensers. The paper condensers which are used are thoroughly impregnated with molten paraffin during winding. Suc-

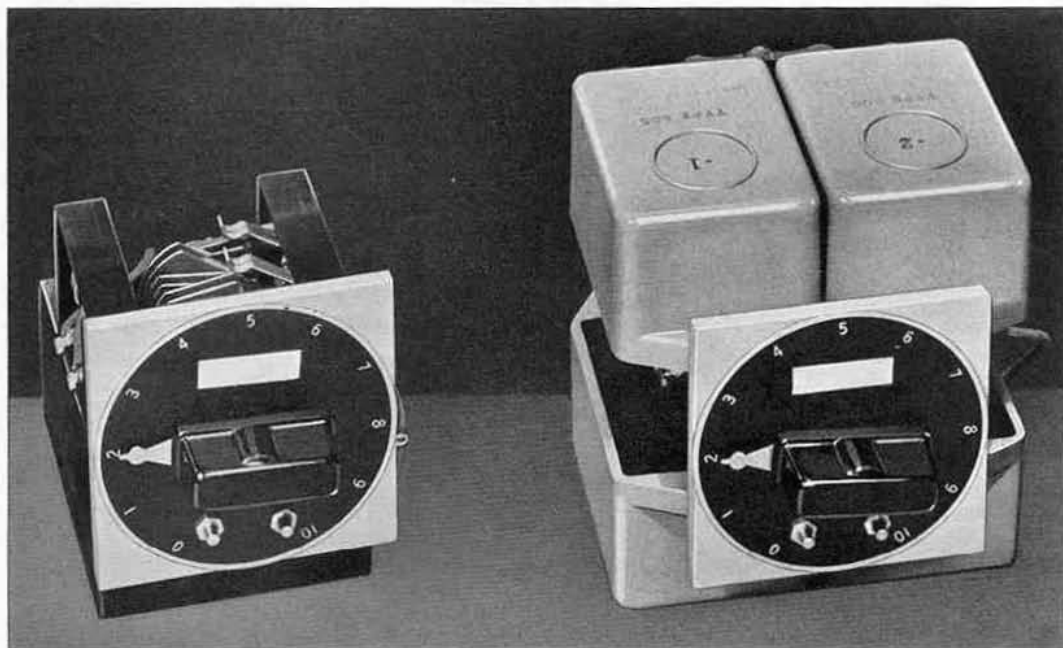

TYPE 380-M.

TYPE 380-F.

ceeding layers of the conducting foil are connected thus avoiding the large increases in power factor and effective capacitance which occurs at high frequencies when only the ends are connected.

For applications where losses must be extremely low, special 0.001 μf and 0.01 μf decades using TYPE 505 Condensers can be built to order.

SPECIFICATIONS

Accuracy: All units are within 1% when measured at 1000 cycles except the TYPE 380-L which is accurate within 2%. The units are checked with the switch mechanism high, electrically, and the common lead and case grounded.

Dielectric: The TYPE 380-F is made up of TYPE 505 Condensers which have mica as the dielectric. The TYPE 380-L uses paraffin-impregnated paper condenser units while the TYPE 380-M and TYPE 380-N use mica condensers which are moulded in bakelite cases.

Power Factor: The power factor of the different units, when measured at 1000 cycles and 25° Centigrade, will be less than the values in the following table, with the exception of the lowest settings on the smallest decades. Here, because of the losses in the switch and mounting, the tabulated power factor may be exceeded by a slight amount.

Type	Power Factor
380-F	0.05%
380-L	1.0 %
380-M	0.1 %
380-N	0.25%

Maximum Voltage and Frequency: The maximum peak voltage which the units will safely withstand is 300 volts with the exception of the TYPE 380-F which will withstand 500 volts. As the frequency of the applied voltage increases, the current increases and more power must be dissipated by the unit. In order that this power does not become excessive, the frequencies listed here must not be exceeded when peak voltages equal to the maxima just specified are applied. For higher frequencies

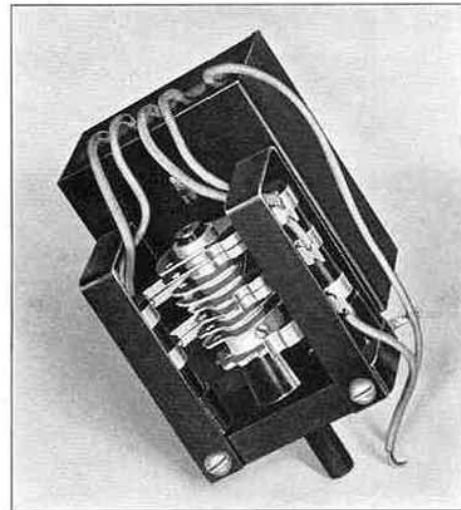

Rear View of TYPE 380-M.

the maximum safe voltage decreases and is inversely proportional to the square root of the frequency.

Type	Frequency
380-F	5 kc
380-L	1 kc
380-M	100 kc
380-N	1000 kc

Terminals: Flexible, rubber-insulated leads are provided.

Mounting: Machine screws for attaching the decade to a panel are supplied.

Dimensions: TYPE 380-F, panel space, 4 3/4 x 4 1/4 inches; behind panel, 4 inches. TYPES 380-L, 380-M, and 380-N, see accompanying sketch.

Net Weight: TYPE 380-F, 3 pounds, 10 ounces; TYPES 380-L and 380-M, 1 1/2 pounds; TYPE 380-N, 1 pound, 6 ounces.

Over-all dimensions of TYPE 380-L, -M, and -N Decade-Condenser Units; dimension A is 3 5/16 inches. While TYPE 380-F uses the same switch mechanism, condensers are mounted on both sides of the switch and the panel space required is 4 3/4 x 4 1/4 inches.

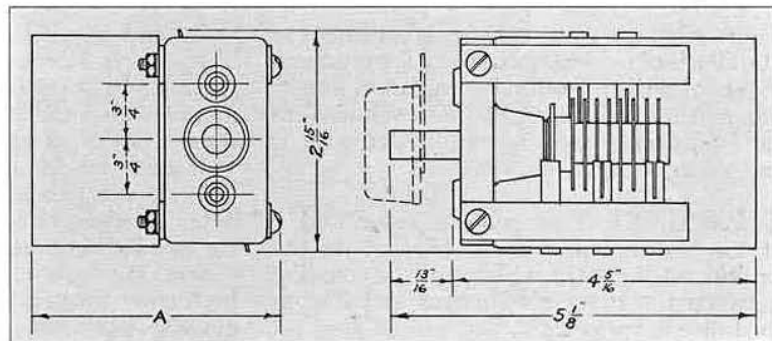

Type	Capacitance	Code Word	Price
380-F	1.0 μf in 0.1 μf steps	ACUTE	\$58.00
380-L	1.0 μf in 0.1 μf steps	ADAGE	10.00
380-M	0.1 μf in 0.01 μf steps	ADDER	12.00
380-N	0.01 μf in 0.001 μf steps	ADDLE	10.00
380-P3	Switch only.....	SWITCHFORD	5.00



TYPE 107 VARIABLE INDUCTOR

USES: The TYPE 107 Variable Inductors find their greatest uses in the laboratory as standards of moderate accuracy for measurements of self- and mutual inductance, and as components of bridges, oscillators, and similar equipment where a variable inductor is needed as a circuit element.

DESCRIPTION: Two coils, a rotor and a stator, are mounted concentrically. As the position of the rotor is changed the coupling between the two coils changes and the inductance is varied.

The coils are wound with stranded wire in which the separate strands are insulated from each other. The coils are impregnated and baked in a high-melting-point material before being securely mounted to the bakelite panel.

FEATURES: The TYPE 107 Variable Inductor

is direct reading in inductance for both series and parallel connections of the coils. The inductances of the rotor and stator have been carefully equalized, and the coils are so mounted that the inductance for the parallel connection is exactly one-fourth the value shown by the dial for the series connection. This equalization of the two coils also eliminates losses from circulating currents when the parallel connection is used.

Separate terminals are brought out for both rotor and stator so that they may be quickly connected in either series or parallel as a self-inductor, or used separately as a mutual inductor. The formula for the mutual inductance is given on the nameplate together with the value of d-c resistance and maximum current.

Other features of these inductors are their permanence of construction, low losses, and high current-carrying capacity.

SPECIFICATIONS

Self-Inductance Range: Five sizes are available in stock covering a total range of approximately 1.7 microhenrys to 500 millihenrys by the use of both the series and parallel connections. Maximum and minimum values for both connections are shown in the price list.

Mutual Inductance: Either positive or negative values of mutual inductance can be obtained. The exact formula for the mutual inductance is engraved on each individual instrument. The approximate ranges are given in Table I.

Calibration: The inductance for the series connection, measured at 1000 cycles and accurate within 1% of full-scale reading, is engraved on the dial. The inductance for the parallel connection is within 0.1% of one-fourth of the series inductance.

Frequency Error: Disregarding errors due to skin effect, the fractional change in inductance with frequency will be f^2/f_0^2 where f is the operating frequency and f_0 the natural frequency. Accordingly, at one-tenth the natural frequency, the frequency error is but 1%. At higher frequencies skin effect errors, which are different for the different units, may become appreciable. Table I gives the natural frequencies for the different standard units, for full setting with series connection.

Losses: The maximum value of the storage factor $Q = \frac{X}{R}$ for full-scale setting with the series connection is given in Table I for each inductor together with the frequency at which this value of Q is obtained.

Maximum Power and Current: The total amount of power which each inductor is capable of dissipating is 15 watts. This amount causes a temperature rise of 40° Centigrade.

The maximum allowable current, for the series connection, is given below in Table I and is engraved on each nameplate.

Direct-Current Resistance: The approximate values of

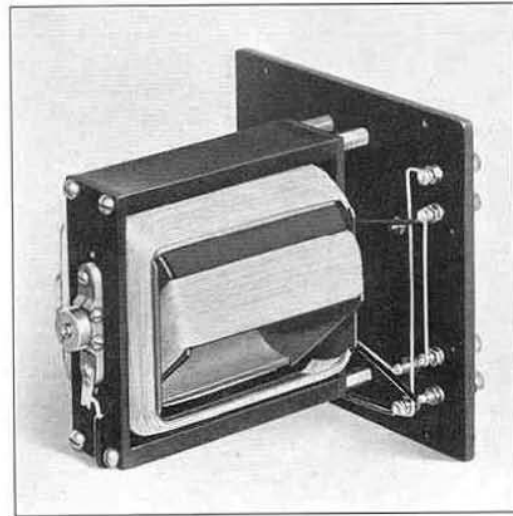

d-c resistance for the different units are given in Table I. Each nameplate is also engraved with the same value.

Terminals: Standard 3/4-inch spacing, jack-top binding posts are provided which allow separate connections to rotor and stator. Connecting links are supplied so that either a series or parallel connection of the rotor and stator can be made available at a third pair of binding posts.

Mounting: All units are mounted on bakelite panels and enclosed in walnut cabinets.

Dimensions: 6 1/2 x 6 1/2 x 8 3/4 inches, over-all.

Net Weight: 5 pounds, all ranges.

TABLE I

Type	Mutual Inductance	D-C Resistance	Maximum Current	Maximum Q*	Frequency for Maximum Q*	Natural Frequency*
107-J	0-10.8 μh	0.17 Ω	8.5 a	110	400 kc	5000 kc
107-K	0-110 μh	0.7 Ω	4.0 a	140	200 kc	1500 kc
107-L	0-1.1 mh	4.8 Ω	1.7 a	125	60 kc	500 kc
107-M	0-11 mh	40 Ω	0.60 a	65	20 kc	150 kc
107-N	0-110 mh	660 Ω	0.14 a	20	7 kc	30 kc

*For full-scale setting, series connection.

Self-Inductance

Type	Series	Parallel	Code Word	Price
107-J	7- 50 μh	1.7-12.5 μh	HAREM	\$35.00
107-K	60-500 μh	15-125 μh	HARPY	35.00
107-L	0.6- 5 mh	0.15-1.25 mh	HARRY	35.00
107-M	6- 50 mh	1.5-12.5 mh	HOTEL	40.00
107-N	60-500 mh	15-125 mh	HOVER	40.00

PATENT NOTICE. See Note 17, page v.



OTHER INDUCTORS

TYPE 119 R-F Chokes are described on page 201. Because of their low capacitances, high inductance, and high Q, these chokes are useful as inductance elements in filters and tuned circuits.

TYPE 106 STANDARD INDUCTANCE



USES: The TYPE 106 Standard Inductance is an accurate standard of self-inductance for

use in bridge and other measurements at audio frequencies.

DESCRIPTION: An astatic form of mounting is used wherein two D-shaped coils are mounted parallel to each other. The coils are form wound, bound with tape, and impregnated with wax before being mounted. No metal is used in the construction.

FEATURES: Low and nearly constant resistance at audio frequencies is insured by the use of stranded wire in which the separate strands are insulated from each other.

The inductance has been made independent of surroundings by using an astatic form of mounting in which the fields of the two coil sections neutralize each other in regions external to the case. Thus, interaction between external fields and the field of the inductor is reduced to a minimum.

SPECIFICATIONS

Type	Nominal D-C Resistance	Maximum Current	Maximum Q	Frequency for Maximum Q	Natural Frequency
106-L	0.18 Ω	3.5 a	210	300 kc	6000 kc
106-G	1.80 Ω	1.0 a	190	150 kc	2000 kc
106-J	12.2 Ω	0.5 a	170	60 kc	500 kc
106-K	85.3 Ω	250 ma	80	20 kc	150 kc
106-M	545 Ω	150 ma	40	7 kc	35 kc

Accuracy: The 0.1 millihenry unit is adjusted at 1000 cycles within 0.2% of its labeled value. All the other units are adjusted within 0.1% at 1000 cycles.

Resistance: The resistance at 1000 cycles is the same as the d-c resistance. This resistance, together with the temperature, is entered on a certificate mounted on the bottom of the cabinet when the inductor is measured in the Standardizing Laboratory. The nominal values are given in the table above.

Temperature Coefficient: The temperature coefficient is less than ±0.004% per degree Centigrade.

Maximum Current: See table.

Losses: The maximum value of the storage factor $Q = \frac{X}{R}$, and the frequency for which it occurs for each size are given in the table.

Frequency Error: Disregarding skin effect the fractional change in inductance with frequency is f^2/f_0^2 where f is operating frequency and f_0 the natural frequency. At one-tenth the natural frequency, therefore, the error is 1%.

Terminals: Binding posts are provided.

Mounting: All units are assembled in walnut cabinets with bakelite panels.

Dimensions: Panel, 5 $\frac{7}{8}$ x 5 $\frac{1}{8}$ inches. Cabinet, (height) 3 $\frac{1}{2}$ inches, over-all, except TYPE 106-M which is 5 $\frac{5}{8}$ inches, over-all.

Net Weight: Approximately 2 $\frac{5}{8}$ pounds, except TYPE 106-M which is 5 pounds.

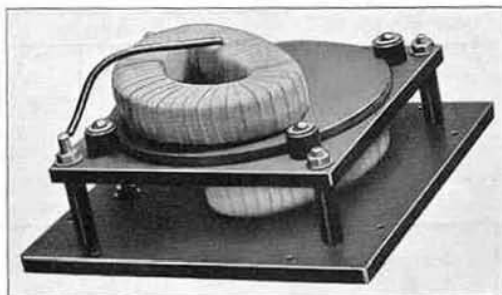

Type	Inductance	Code Word	Price
106-L	0.1 mh	INNER	\$25.00
106-G	1 mh	INERT	25.00
106-J	10 mh	IRATE	25.00
106-K	100 mh	ISLET	25.00
106-M	1 henry	ISSUE	30.00



BRIDGES



for measuring
CAPACITANCE
•
POWER FACTOR
•
INDUCTANCE
•
RESISTANCE
•
VACUUM-TUBE
CHARACTERISTICS

IMPEDANCE BRIDGES

For the measurement of all types of impedances, resistive or reactive, inductive or capacitive, the Wheatstone bridge circuit in its many modifications has proved best fitted on grounds of both accuracy and convenience.

The balance of the bridge is attained by a null method, that is, by reducing to zero the voltage between two opposite corners of the bridge. The precision of balance is not limited by the scale length of a deflecting instrument, but only by the voltage which can be applied to the bridge and by the sensitivity of the null detector. It is, therefore, possible to utilize completely the accuracy of the standards.

Because of the variety of possible bridge circuits, a bridge can usually be devised, the controls of which can be made direct reading in any particular impedance or circuit characteristic. The direct-reading feature adds greatly to convenience in measurement, since it obviates laborious calculations which are always a bar to rapid work.

The fundamental bridge network is shown in Figure 1. The condition of balance is that the voltage across the detector is zero. This will occur when

$$\frac{A}{B} = \frac{N}{P} \text{ or } AP = BN \quad (1)$$

The four arms of the bridge are not necessarily simple impedances, but are frequently series and parallel combinations of resistance, inductance, and capacitance. Hence the bridge arms represented by the symbols used

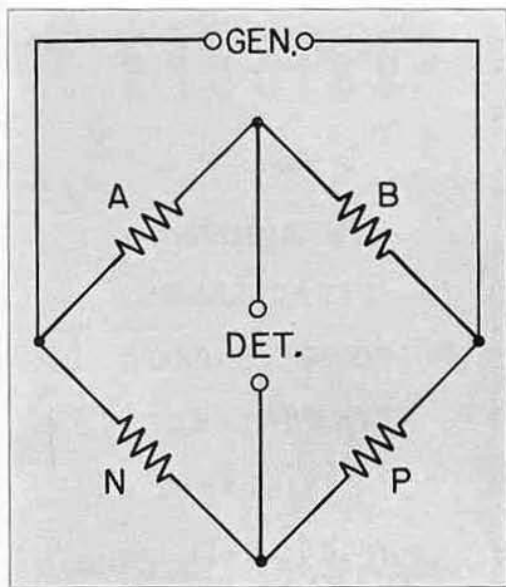

FIGURE 1. General Wheatstone Bridge Circuit.

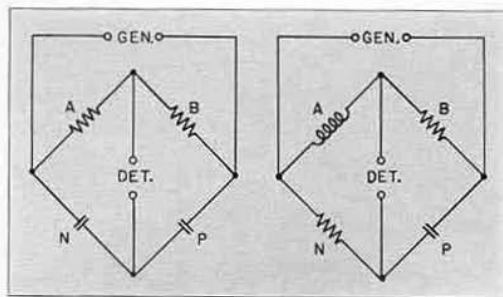

FIGURE 2. (Left) A bridge in which two like reactance arms, *N* and *P*, are compared. (Right) A bridge in which unlike reactance arms, *A* and *P*, are compared.

in Equations (1) are, in general, complex impedances, and there are two balance conditions, one for the resistive component and the other for the reactive component. The principal balance component of bridges designed specifically to measure inductance or capacitance should preferably be independent of frequency.

Usually, at least one of these balance conditions varies with frequency, but no frequency limitation on the use of the bridge is inherent in the variation. Alternating current bridges can be used at frequencies extending to several million cycles. The upper frequency limit for any particular design is set by the increasing effect of residual impedances in the various impedance standards and in the wiring.

BRIDGE CIRCUITS: Impedance bridges can be divided into two classes, the one in which like reactances are compared, and the other in which unlike reactances are compared. Both classes are illustrated in Figure 2. In bridges of the first class, referred to as inductance or capacitance bridges, arms *A* and *B* are resistance arms, while arms *N* and *P* are either both inductive or both capacitive, one arm containing the known standard the other the unknown reactance. Of the bridges described in this section, TYPES 740, 716, 671, 516, 667 are of this kind, the first four being capacitance bridges and the last an inductance bridge. TYPE 650 also falls in this class for the measurement of capacitance.

Bridges in the second class carry the names of their discoverers, Maxwell, Hay, Owen, and others. The inductance and capacitance arms are opposite one another. For bridges of this class the main component of balance is independent of frequency. These circuits derive their greatest importance from the fact that they use capacitance standards.

As impedance standards, condensers are usually much better than inductors. The TYPE 650-A Impedance Bridge makes use of the Maxwell and Hay circuits for the measurement of inductance.

Of the other bridges listed in this section, TYPES 293 and 625 are skeleton bridge circuits which may be utilized for any bridge network. TYPE 721 Coil Comparator makes use of a bridged-T network, the most important characteristic of which is a common terminal, usually grounded, between generator and detector. This circuit obviates the need of a shielded transformer and simplifies direct impedance measurements.

The TYPE 544-B Megohm Bridge is a d-c Wheatstone bridge for high resistance measurements in which the detector is a vacuum tube voltmeter, which has an input resistance comparable to the unknown resistance.

RESISTIVE BALANCE: All impedances have resistive components and the bridges used for impedance measurement must be capable of measuring this resistance in some manner. Three methods are in general use: (1) series resistance, in which the balancing resistor is placed in series with the standard reactance; (2) parallel resistance, in which the balancing resistor is placed in parallel with the standard reactance; and (3) the Schering bridge method used for capacitance measurement, and in which a balancing condenser is placed in parallel with the ratio arm opposite the unknown condenser. TYPES 650, 740, 516, 667 use series resistance, and TYPES 716, 671, 516 the Schering circuit. The parallel resistance method can be used with TYPES 516, 716, 650.

Two important characteristics of condensers and inductors are the ratios, dissipation factor $D = \frac{R}{X}$ and storage factor $Q = \frac{X}{R}$,

where R and X refer to the equivalent series circuit representation of the impedance. For small numerical values, the power factor, $\frac{R}{Z}$, is very nearly equal to the dissipation factor, $\frac{R}{X}$.

Certain bridges which use the series resistance or Schering method of resistive balance can have this resistive control calibrated in terms of dissipation factor or storage factor. TYPES 740, 716, 516 have dials calibrated in dissipation factor; TYPE 650 reads both dissipation factor for condensers and storage factor for inductors.

ERRORS: A bridge circuit provides a means of comparing two impedances, an unknown and a standard. It does not provide an absolute measurement. The possible error in the measurement is always greater than the error in the standard itself by the errors in the other bridge arms entering into the comparison. If, for instance, the error in the standard and in each of the two ratio arms is ± 0.1 per cent, there can then occur in the most unfavorable case an error of ± 0.3 per cent in the measurement. This accuracy limitation is common to all direct-reading bridges in which a result is obtained from a single balance of the bridge. The errors in three of the bridge arms can be eliminated from the measurement through the use of a substitution method in which the unknown impedance is connected in the standard arm. Two readings of the standard are required, one with the unknown disconnected and one with it connected. With an error in the standard of ± 0.1 per cent, the maximum error of measurement is ± 0.2 per cent. If auxiliary balances are provided so that the standard can always be set initially at the same point, the error can be reduced. This auxiliary

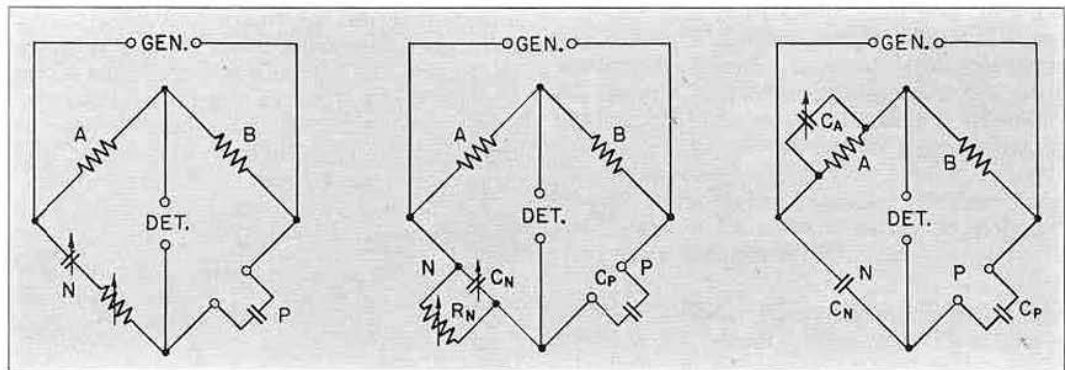

FIGURE 3. Circuits illustrating the three methods of obtaining a resistive balance: (Left) series resistance, (center) parallel resistance, and (right) Schering method.

balance is provided in the TYPE 671-A Schering Bridge.

RESIDUAL IMPEDANCES: The bridge equations derived from Equation (1) presuppose an accurate knowledge of the behavior of the impedances in each bridge arm. No impedance, however carefully constructed, is free from residual impedances. Resistors have series inductance and shunt capacitance. Inductors have relatively large series resistance and shunt capacitance. Even air condensers, while more nearly perfect than other impedance standards, have resistive and inductive residual impedances. All of these extra impedances must be included in the values used for calculation in order to avoid error. The over-all residuals are greatly increased by the various connections forming the bridge circuit.

Shunt capacitance across the various arms is an important source of error even at audio frequencies. When occurring across a resistive arm its effect on the resistive component of balance varies directly as the magnitude of the capacitance and directly as the operating frequency. Errors arising from this source account for the large differences between the listed errors in dissipation factor given for TYPE 650 and TYPE 740 Bridges. TYPE 650 not only operates at a higher frequency but has unavoidably large switching capacitances.

Shunt capacitance across a reactive arm is also serious. In the TYPE 667-A Inductance Bridge it increases the inductance error from ± 0.2 per cent to ± 0.4 per cent on the highest multiplier. In the TYPE 516-C Radio Frequency Bridge it is balanced out by a compensating condenser. In the TYPE 716-A Capacitance Bridge complete shielding of the ratio arms reduces it to less than $1 \mu\mu\text{f}$.

Residual series inductance in bridge arms is ordinarily negligible at audio frequencies, except in measurements of very small inductors. The TYPE 667-A Inductance Bridge uses TYPE 668 Compensated Decade Resistors in order to avoid change in residual inductance as the resistance is varied. At radio frequencies the effect of inductance is much more serious. In the TYPE 516-C Radio-Frequency Bridge, which also uses compensated resistors, it is necessary to balance out the resultant constant inductance by means of a compensating coil.

SHIELDING AND GROUNDING: The readings of any bridge should be sensibly independent of its surroundings and the position of the operator. To satisfy these conditions, bridges are completely sur-

rounded by a grounded shield and care is taken to use either grounded or insulated shafts on all controls. It is also common practice to ground the junction of the unknown and standard arms to this shield. Residual capacitances of the bridge arms to the shield are placed across the two arms thus grounded. Although a relatively large error is introduced by these capacitances, it can be largely corrected by an initial zero reading. If, on the other hand, neither of the unknown terminals is grounded, the bridge will measure the direct impedance across these terminals, not the total impedance which includes the terminal impedances to ground. TYPES 650 and 740 have neither unknown terminals grounded and hence measure direct impedance. They cannot be used to measure a grounded impedance. TYPES 716, 671, 516, 617 have one unknown terminal grounded and measure total impedance. The TYPE 544-B Megohm Bridge can be connected either way and can, therefore, measure either total or direct resistance.

SHIELDED TRANSFORMER: The bridge balance should be independent of the type of generator and detector used. This condition is met by the use of a TYPE 578 Shielded Transformer. The transformer secondary is connected between two opposite corners of the bridge neither of which is grounded. It is immaterial whether the primary is connected to generator or detector, except as the sensitivity of the bridge is affected. For bridge balances, the small, constant, and known terminal capacitances of the transformer are then substituted for the large, variable, and unknown capacitances of the generator or detector.

SENSITIVITY: The precision to which a bridge can be balanced depends primarily upon the voltage applied to the bridge and the sensitivity of the detector. It also depends upon the ratio of impedances of the two arms across which the generator is placed and the ratio of the impedance of the detector to the bridge impedance. For a d-c bridge, in which the detector resistance is high compared to that of the bridge, the ratio of output to input voltage is

$$\frac{E_o}{E_i} = \frac{\frac{A}{B}}{\left(1 + \frac{A}{B}\right)^2} d \quad (2)$$

where A and B are the arms across which the generator is connected, and d is the fractional accuracy desired in balancing the bridge. For a-c bridges, when A and B are

resistive* arms, the same equation holds for the reactive component of balance if the resistance component is small. It also holds for the resistive component where d is the minimum value of dissipation factor to be detected. From Equation (2) and the known input voltage, the output voltage corresponding to the desired accuracy can be determined. The ratio of this voltage to the minimum voltage which will actuate the detector is the amplification required. As an example, consider the TYPE 716-A Capacitance Bridge. For equal ratio arms 100 volts can be applied to the bridge from a 0.5 watt generator. To make a capacitance balance to ± 0.1 per cent demands the detection of 25 mv. To make a dissipation factor balance to ± 0.00001 requires a sensitivity of 250 μ v. The first voltage is easily within the range of head telephones without an amplifier, while the second is not. The TYPE 814-A Amplifier has a gain of 77 db or 7000 when working with head telephones or a rectifier voltmeter such as the TYPE 483-F Output Meter. With the telephones the gain is more than sufficient. With the rectifier meter (minimum deflection = 0.2 volt), the gain is also sufficient, since even for the dissipation factor balance a gain of only 800 is needed. Now suppose these same measurements to be made on a 1 μ f condenser for which the ratio arms must be 1000 to 1. Using the full gain of the amplifier, the rectifier meter can only balance for dissipation factor to ± 0.0003 , so that telephones must be used to obtain the required sensitivity.

WAVEFORM: It is always desirable in balancing a bridge to be able to obtain a complete null balance. Only by so doing can the maximum precision of balance be realized. Because the balance depends to a greater or less extent upon frequency, the presence of harmonics in the input to the bridge or their production in the bridge by a non-linear impedance will prevent a complete null balance, unless the detector is highly selective. Selective networks, such as the TYPE 814-P Tuned Circuits or the TYPE 830 Wave Filters, should be added to the detector circuit. The radio receiver recommended with the TYPE 516-C Radio-Frequency Bridge is inherently selective. The TYPE 707-A Cathode-Ray Null Detector has a gain of 80 db and a discrimination of

*If the two bridge arms across which the generator is connected are not alike, but one is resistive and one reactive, Equation (2) becomes

$$\frac{E_o}{E_i} = \frac{\frac{A}{B}}{1 + \left(\frac{A}{B}\right)^2} d$$

40 db against the second harmonic. The important feature of this instrument is its ability to indicate separately the resistive and reactive balances. The TYPE 760-A Noise Analyzer and the TYPE 736-A Wave Analyzer are also very satisfactory selective bridge detectors. The TYPE 736-A Wave Analyzer is particularly useful when extreme selectivity at the higher audio frequencies is necessary.

POWER SOURCES: The main factors to be considered in selecting a power source for a-c bridge measurements are frequency, power output, and harmonic content.

Of the a-c bridges described in this section, two, TYPE 740 and TYPE 671 are designed for 60-cycle measurements and operate directly from the power line. TYPE 650 and TYPE 625 have self-contained microphone hummers and require no external generator, unless measurements are to be made at frequencies other than 1000 cycles. For all other types an oscillator is necessary. Where the power required is low, TYPE 813 Oscillator and TYPE 572 Microphone Hummer are satisfactory for single-frequency measurements at 1000 cycles. For measurements over a wide range of audio frequencies, TYPE 613 Beat-Frequency Oscillator can be used. All these operate from batteries.

When a highly precise balance is necessary, considerably more power is required than can be furnished by battery-operated oscillators. For measurement at 1000 cycles, or at a number of fixed audio frequencies, TYPE 608-A Oscillator is recommended. If a continuously variable frequency is needed, TYPE 713 Beat-Frequency Oscillator should be used. Both are a-c operated and deliver at least $\frac{1}{2}$ watt.

Measurements at radio frequencies with the TYPE 516-C Radio-Frequency Bridge require a radio-frequency oscillator, preferably modulated. TYPE 684-A Modulated Oscillator is suitable.

CLASSIFICATION: The bridges listed in this section fall into natural groups according to their accuracy, frequency range, and kind of impedance measured. The following table separates them by type number in this manner:

	Accuracy		Frequency
	Unknown		
Capacitance.....	671	740	60 c
	716	650	1 kc
Inductance.....	...	516	1 Mc
	667	650	1 kc
Resistance.....	...	721	1 Mc
	...	544	dc
General.....	...	650	dc and 1 kc
	293	625	1 kc



TYPE 650-A IMPEDANCE BRIDGE

USES: Whether in the laboratory or on the test bench, the uses of the TYPE 650-A Impedance Bridge are literally numberless. Rapid measurements of resistance, capacitance, and inductance are constantly required in any electrical laboratory. With the TYPE 650 these measurements can be made conveniently and with sufficient accuracy for all but precise work.

This bridge is designed to measure the inductance and Q of coils, the capacitance and power factor of condensers, the d-c resistance of all types of resistors. In the laboratory it is extremely useful for measuring the circuit constants in experimental equipment, testing preliminary samples, and identifying unlabeled parts. In the shop and on the test bench, it has many applications in routine testing and fault location. Hundreds of these bridges are in use all over the world, in government and industrial laboratories, educational institutions, electric generating stations, and radio broadcasting stations.

DESCRIPTION: TYPE 650-A Impedance Bridge is a conventional 4-arm impedance bridge. It is entirely self-contained, including standards, batteries, and tone source, and is direct reading over wide ranges of d-c resistance, a-c resistance at 1000 cycles, capacitance and dissipation factor $D = \frac{R}{X}$ at 1000 cycles, and inductance and storage factor $Q = \frac{X}{R}$ at 1000 cycles.

Results are read directly from dials having approximately logarithmic scales. The position of the decimal point and the electrical unit in terms of which the measurement is made are indicated by the positions of two selector switches.

Resistance is measured in terms of a standard resistance arm; inductance and capacitance are measured in terms of mica condenser standards, similar in construction to the TYPE 505 Condensers. Power is supplied from dry cells, which operate a 1000-cycle

hummer for a-c measurements. The bridge may also be used with an external generator of any audio frequency.

The detector for d-c measurements is a built-in galvanometer. For 1000-cycle measurements, head telephones are used.

FEATURES: The particular value of this bridge lies in its complete availability and the speed with which the results can be obtained. Self-contained, including standards and power source, it is always set up ready for use. The only accessory needed is a pair of head telephones. Direct-reading dials make its operation simple and rapid. The photograph shows the simplicity of the controls.

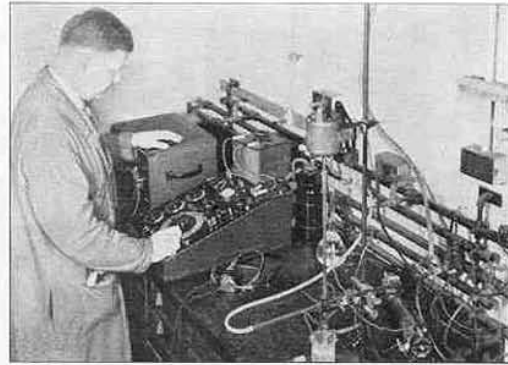

The TYPE 650-A Impedance Bridge has a wide variety of uses. The photograph above shows it in use in a chemical laboratory.

SPECIFICATIONS

Range: The ranges of the instrument are given in the following table. The numerical values are the readings of the calibrated dials multiplied by the settings of the decade selector switches.

	Minimum	Maximum
Resistance	1 milliohm	1 megohm
Capacitance	1 micromicrofarad	100 microfarads
Inductance	1 microhenry	100 henrys
Dissipation Factor $\left(\frac{R}{X}\right)$.002	1
Storage Factor $\left(\frac{X}{R} \text{ or } Q\right)$.02	1000

Accuracy: The large direct-reading dial covers two decades, the main decade being spread out over 12 inches (three-quarters of the dial). It may be set to 0.2%.

Accuracy of readings for capacitance and d-c resistance is 1% for the intermediate multiplier decades; for inductance, 2%. The accuracy falls off in the lower ranges because of the extremely small values to be measured. The error increases to 5% for very large values of capacitance and d-c resistance, and to 10% for large values of inductance.

Accuracy of reading for dissipation factor or for storage factor in terms of its reciprocal is either 20% or 0.005, whichever is the larger.

The frequency of the microphone hummer is 1000 cycles within $\pm 5\%$.

External Generator: Provision has been made for using an external generator, although its capacitance to ground may introduce some error. Subject to this limitation, the frequency may be varied over a wide range from a few cycles to 10 kc. The reading of the main dial is independent of frequency, while the readings of the storage and dissipation factor dials must be multiplied by or divided by the generator frequency in kilocycles to give the correct values. Provision is made for adding external resistance if it is necessary to increase the ranges of these dials.

Power Supply: Four No. 6 dry cells for the d-c measurements and for driving the microphone hummer are required, and space for them is provided in the cabinet. Batteries are not supplied with the instrument. A higher d-c voltage may be connected to the bridge for high-resistance measurements.

Other Accessories Required: Head telephones; Western Electric No. 1002-C are recommended. To increase the sensitivity, a TYPE 814-A Amplifier can be used.

Mounting: Black crackle-finish aluminum panel mounted in a shielded walnut cabinet.

Dimensions: (Width) 12 x (depth) 20 x (height) 8½ inches, over-all.

Net Weight: 22 pounds without batteries; 30½ pounds with batteries.

Type	Code Word	Price
650-A	BEAST	\$175.00*

*Without batteries or telephones.
PATENT NOTICE. See Note 17, page v.

Schematic diagrams of the circuits used in TYPE 650-A Impedance Bridge.

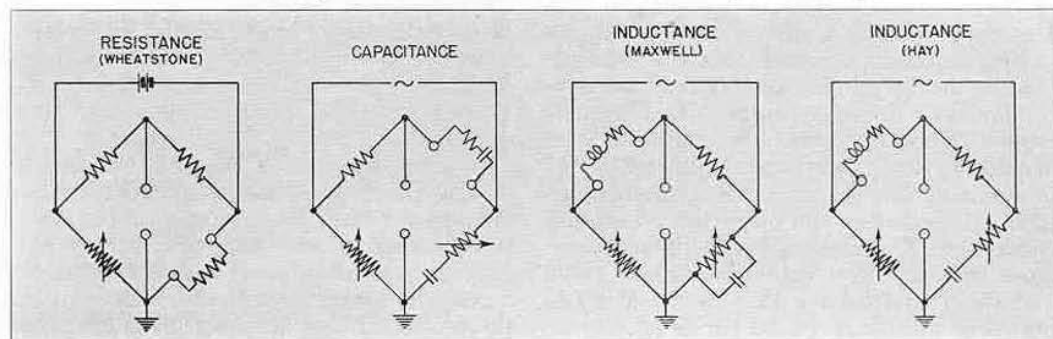



TYPE 716-A CAPACITANCE BRIDGE

USES: This direct-reading capacitance bridge can be used for a wide variety of capacitance and power-factor measurements. Within its scope are the determination of power factor, dielectric constant, dielectric loss factor, phase angle, and other dielectric properties of insulating materials, as well as their change with such factors as temperature and humidity.

It has been used for measuring the power factor of insulated switch and transformer bushings in power systems. In the General Radio laboratories the TYPE 716-A Capacitance Bridge is used for all capacitance standardization measurements. In production, it is used for the testing and adjustment of TYPE 505 Condensers and TYPE 380 Decade-Condenser Units.

By adding an external decade resistance box, the bridge can be converted to a series- or parallel-resistance bridge. The latter is especially useful in measuring the resistance of electrolytes. A guard circuit (TYPE 716-P2) is available for use in the measurement of guarded specimens and other three-terminal condensers. This makes possible the measurement of the power factor of insulating oils and other materials with power factors as low as 20 millionths (0.002 per cent).

DESCRIPTION: The TYPE 716-A Capacitance Bridge is a modified Schering bridge, direct reading in capacitance and in power factor at 1000 cycles.

A wide capacitance range is obtained by providing four sets of ratio arms giving multiplying factors from 1 to 1000 in decade steps. The standard condenser is a TYPE 722 Precision Condenser calibrated to read directly in total capacitance. The capacitance across the unknown terminals is not greater than $1 \mu\text{f}$. All capacitances to ground of the input transformer and ratio arms are removed from the capacitance arms by placing them in a shielded compartment insulated from the grounded panel and connected to the junction of the ratio arms.

Power factor is read directly in per cent from the setting of a TYPE 539 Condenser connected across the fixed ratio arm. Its 12-inch scale is approximately logarithmic, so that, while having a maximum reading of 6 per cent, its smallest division near zero is 0.01 per cent, thus allowing the estimation of 0.001 per cent. The accuracy of the power factor reading over the wide capacitance range is made possible by adding capacitance across the lower-valued ratio arms, so that the product RC of all the arms is the same.

The bridge is furnished for mounting with its panel vertical on a standard relay rack, upon which may also be mounted the oscillator and amplifier. With no change in shielding, it is also furnished mounted in a walnut cabinet.

FEATURES: Three highly desirable properties are combined in this bridge: wide range, high accuracy, and direct-reading dials. Operation is simple, and both terminals and controls are arranged for convenience and flexibility of operation. Because of these features, it can be used for practically any type of capacitance measurement.

(Right) A schematic circuit diagram of the TYPE 716-A Capacitance Bridge.

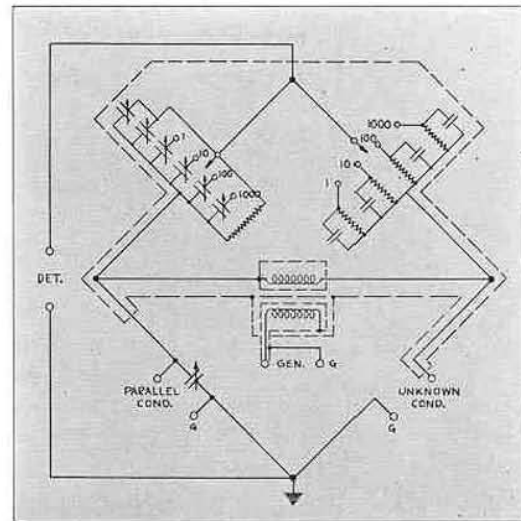

SPECIFICATIONS

Ranges: Direct Reading—capacitance, 100 μf to 1 μf ; power factor, 0.002% to 6% (0.00002 to 0.06 expressed as a ratio).

Substitution Method—capacitance, 0.1 μf to 1000 μf with internal standard; to 1 μf with external standards; power factor, $6\% \times \frac{C'}{C_x}$ where C' is the capacitance of the standard condenser and C_x that of the unknown.

Accuracy: Direct Reading—capacitance, $\pm 0.2\%$ or $\pm 2 \mu\text{f}$ x multiplier reading (0.2% of full scale for each range); power factor ± 0.0005 or $\pm 2\%$ of dial reading.

Substitution Method—capacitance $\pm 0.2\%$ or $\pm 2 \mu\text{f}$; power factor, ± 0.00005 or $\pm 2\%$ for change in power factor observed.

Ratio Arms: The arm across which the power factor condenser is connected has a resistance of 20,000 ohms. The other arm has four values, 20,000 ohms, 2000 ohms, 200 ohms, 20 ohms, providing the four multiplying factors 1, 10, 100, 1000. Suitable condensers are placed across these arms, so that the product RC is constant.

Standards: Capacitance, TYPE 722 Precision Condenser direct reading from 100 μf to 1100 μf ; power factor, TYPE 539-T Condenser calibrated directly in power factor at 1 kc with semilogarithmic scale.

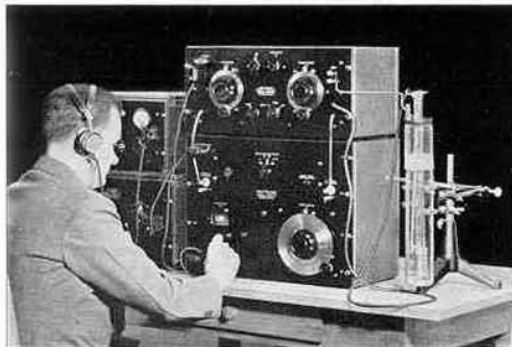

Shielding: Ratio arms, power-factor condenser, and shielded transformer are enclosed in an insulated shield. The unknown terminals are shielded so that the capacitance across them is not greater than 1 μf . A metal dust cover and the aluminum panel form a complete external shield.

Frequency Range: All calibration adjustments are made at 1 kc and the accuracy statements above hold for an operating frequency of 1 kc. The bridge can be used, however, at any frequency between 60 cycles and 10 kc. Power-factor readings must be corrected by multiplying the dial reading by the frequency in kilocycles.

Voltage: Voltage applied at the GENERATOR terminals is stepped up by a 1-to-4 ratio shielded transformer. A maximum of 50 volts can be applied to the transformer. If desired, power can be applied to the bridge between the junctions of the pairs of resistance and capacitance arms. With equal ratio arms, a maximum of 700 volts can be applied.

Mounting: The bridge is supplied for mounting on a 19-inch relay rack or for cabinet mounting.

Accessories Required: Oscillator, amplifier, and telephones or rectifier meter, TYPE 608-A Oscillator (see page 102), TYPE 814-A Amplifier (see page 110) and Western Electric TYPE 1002-C Telephones are recommended. If a visual detector is required, TYPE 483-F Output Meter (see page 118) or TYPE 707-A Cathode-Ray Null Detector is recommended.

For substitution measurements, a balancing condenser is needed. This may be either an air-dielectric model, such as TYPE 246-L and TYPE 539-C, or a fixed mica condenser of the TYPE 505 series.

Dimensions: (Length) 19 x (height) 14 x (depth) 9 inches, over-all.

Net Weight: 41 pounds, relay-rack model; 52 pounds, cabinet model.

(Left) This photograph shows the TYPE 716-A Capacitance Bridge set up to measure the power factor of insulating oil. When measuring low-power-factor oils, the guard circuit shown above the bridge is needed.

Type	Description	Code Word	Price
716-AR	For Relay-Rack Mounting	BONUS	\$335.00
716-AM	Cabinet Mounted	BOSOM	360.00

PATENT NOTICE. See Note 17, page v.

TYPE 716-P2 GUARD CIRCUIT



USES: This guard circuit is designed for use with the TYPE 716-A Capacitance Bridge so that measurements can be made with that bridge on three-terminal condensers and cells having guard electrodes.

DESCRIPTION: The TYPE 716-P2 Guard Circuit consists of a capacitance arm and a resistance arm having the same impedance values as the standard capacitance arm and fixed ratio arm of the TYPE 716-A Capacitance Bridge. It provides a junction point to which the guard electrode or third terminal of any three-terminal condenser may be connected. Suitable switches are provided for connecting and disconnecting the three-terminal condenser and for placing it in either arm of the bridge so that direct-reading or substitution measurements can be made.

FEATURES: This guard circuit can be used with any TYPE 716-A Capacitance Bridge without altering the bridge in any way. All switching of circuits and measuring cell occurs in the guard circuit. Both guard circuit and coupling circuit are balanced by connecting them in parallel with the proper bridge arms. In this way the bridge detector does not need to be transferred from bridge to guard. Generator and detector may also be transposed with no effect on the ease of guard balance.

Ability to balance the guard circuit when the terminal capacitance of the measuring cell has large power factors is made possible by placing an inductance, controlled by a shunt resistance, in series with the resistance arm of the guard circuit. This in effect introduces a negative power factor into this arm.

SPECIFICATIONS

Ranges: The ranges of the TYPE 716-A Capacitance Bridge are not altered by the use of the guard circuit.

Accuracy: The accuracy of reading of the bridge is also unaltered if certain small corrections are made.

Resistance Arm: 0 to 20 kΩ in series with 0 to 1 h and in parallel with 20 to 5000 μμf.

Capacitance Arm: 40 to 1150 μμf with a fine adjustment.

Coupling Circuit: 180 to 525 μμf.

Shielding: The three transfer and disconnecting switches are mounted in an insulated shield kept at guard potential. A metal dust cover and the aluminum panel form a complete grounded shield.

Frequency Range: The guard circuit is intended to be used at a frequency of 1 kc. It can be used however over the same range as the TYPE 716-A Capacitance Bridge, provided the power factors of the terminal capacitances are not excessive at the lower frequencies.

Mounting: Relay rack or cabinet mounting.

Dimensions: Panel, 19 x 7½ inches; depth behind panel, 9 inches.

Net Weight: 30 pounds.

Type	Description	Code Word	Price
716-P2M	Cabinet	BOSOMGUARD	\$190.00
716-P2R	Relay Rack	BONUSGUARD	170.00

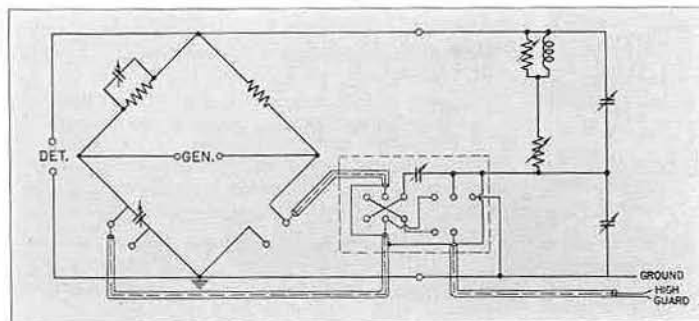

Schematic diagram showing TYPE 716-P2 Guard Circuit connected to TYPE 716-A Capacitance Bridge.

TYPE 625-A BRIDGE

USES: When used with the proper standards, this skeleton-type bridge substantially duplicates in performance the TYPE 650-A Impedance Bridge. Consequently, it can be used for many of the same types of resistance, capacitance, and inductance measurements. It is particularly well suited for student instruction and demonstration purposes, for all types of a-c bridge circuits can be assembled using the TYPE 625-A Bridge as a basis.

DESCRIPTION: TYPE 625-A Bridge is a bridge in skeleton form. It contains the basic elements of TYPE 650-A Impedance Bridge. One arm contains a 10,000-ohm, direct-reading, logarithmic rheostat, and the other three arms are brought out to pairs of terminals on the panel, making provision for plugging in standard and unknown units to obtain a variety of circuits. A 1000-cycle microphone hummer is included.

FEATURES: Where only one quantity is to be measured at a time, the TYPE 625-A Bridge is a simpler and more economical instrument than the TYPE 650-A.



SPECIFICATIONS

Range: With the recommended accessories the ranges are: for resistance, 1 milliohm to 1 megohm; for capacitance, 1 micromicrofarad to 100 microfarads; for inductance, 1 microhenry to 100 henrys.

Accuracy: The accuracy of results depends upon the type of standards used. With the accessories recommended, an accuracy of 2% for measurements of inductance, capacitance, and d-c resistance can be obtained. The accuracy of the component parts of the bridge itself is 1%. The frequency of the microphone hummer is 1000 cycles to within $\pm 5\%$.

Power Supply: Two $4\frac{1}{2}$ -volt batteries (Burgess No. 2370, Eveready No. 711, or equivalent) for the d-c

measurements, and for driving the microphone hummer, are required, and space for them is provided in the cabinet. Batteries are not supplied with the instrument. An external a-c voltage source having any frequency up to 5000 cycles may be used.

Accessories Recommended: In addition to head telephones for a-c measurements and a zero-center, 200- μ a, full-scale galvanometer for d-c measurements, purchase of the following units is recommended if the full range is to be covered. Omission of some items is possible if narrower ranges are satisfactory.

Resistors

- 1—TYPE 500-A 1 Ω
- 1—TYPE 500-B 10 Ω
- 1—TYPE 500-D 100 Ω
- 1—TYPE 500-H 1000 Ω
- 2—TYPE 500-J 10,000 Ω

Condensers

- 1—TYPE 505-F 0.001 μ f
- 1—TYPE 505-L 0.01 μ f
- 1—TYPE 625-P1 1- μ f
Condenser
(Adjusted to within $\pm 2\%$.
Dimensions: $2\frac{1}{4}$ x 1 x
 $3\frac{1}{4}$ inches, over-all. Net
Weight: 4 ounces.)

- 1—TYPE 526-B Mounted Rheostat and Potentiometer required for dissipation and storage factor measurements.

Mounting: This instrument is assembled on a black crackle-finish aluminum panel and mounted in a shielded walnut cabinet. A drawer in the lower part of the cabinet provides space for storing the standards suggested.

Dimensions: (Width) 9 x (depth) 13 x (height) 7 inches, over-all.

Net Weight: 9 pounds without batteries; 11 pounds with batteries.

Schematic diagram of the TYPE 625-A Bridge. The generator and switches are not shown.

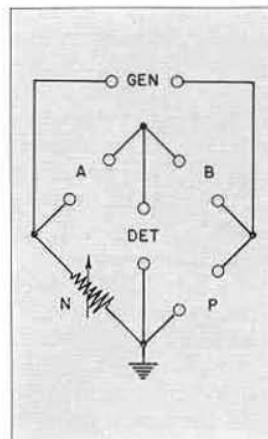

Type	Description	Code Word	Price
625-A	Bridge	BEACH	\$65.00
625-P1	1- μ f Condenser	BAIZE	2.00

PATENT NOTICE. See Note 17, page v.

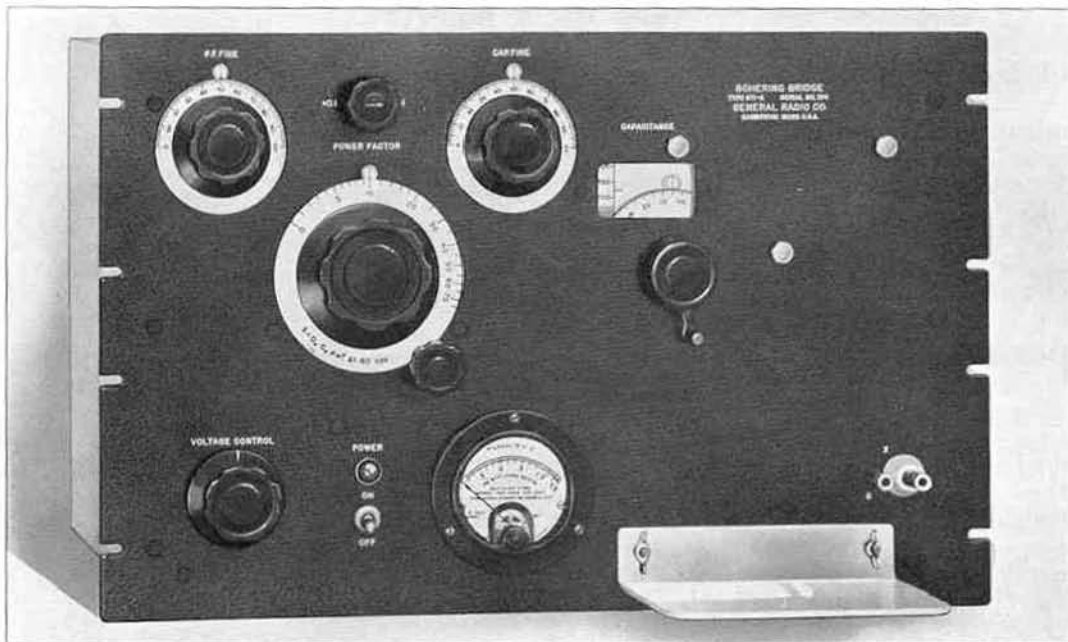

TYPE 671-A SCHERING BRIDGE

USES: The TYPE 671-A Schering Bridge is designed to measure the dielectric properties of insulating materials at power-line frequencies. Among its applications are the testing of materials used as dielectrics in capacitors and as insulation in transformers, cables, and electrical machinery. In general industry it can be used for a multitude of tests on ceramic, fabric, paper, and plastic products to determine such properties as composition and moisture content, as well as the change in these characteristics with temperature, humidity, and voltage gradient.

DESCRIPTION: Measurements are made by the substitution method. Capacitance is read directly from a TYPE 722 Precision Condenser; power factor is calculated from the capacitance of the specimen and the reading of the power-factor dial.

The inverted Schering bridge circuit is used, as shown in the schematic diagram on page 77. Compensating condensers are provided so that both the capacitance and power-factor dials can be set to zero in the initial balance of the bridge before the unknown is connected. The capacitance range is from zero to 1030 $\mu\mu\text{f}$. The product of dissipation factor and capacitance of the unknown can have a maximum value of 80, where the capacitance is expressed in microfarads.

A voltage control is provided, by means of which the voltage applied to the bridge (and, in effect, to the unknown) can be varied between zero and 10 times line voltage. A panel meter reads the r-m-s value of this voltage.

The entire assembly is mounted on a relay-rack panel and a dust-cover shield is provided.

FEATURES: This bridge is simple to operate and gives accurate results. Operation at power-line frequency eliminates the necessity of a separate oscillator, and, for tests on most insulating materials, has the advantage of making the measurements at the frequency at which the materials will be used.

Both input and output transformers are astatically wound, and the bridge is electrostatically shielded, so that external fields do not affect the enclosed bridge circuits. Moderate external fields impinging upon the unknown capacitor are of no consequence providing that they do not vary during the period of measurement. The use of a substitution method of measurement avoids a number of errors which are difficult to eliminate in direct-reading bridges. In the contemplated uses of this bridge no guard circuits are required, so the bridge measures two terminal capacitors only.

The ability to vary the voltage applied to the sample under measurement is also a considerable advantage.

A doubly-shielded output transformer

permits one terminal of the unknown capacitor, one terminal of the detector, and one side of the power line to be grounded directly during measurements.

SPECIFICATIONS

Capacitance Range: 0 to 1030 μmf direct reading; larger values can be measured by using a series substitution method.

Accuracy of Capacitance Measurements: The scale is calibrated in steps of 0.2 μmf . The absolute accuracy of capacitance measurement is $\pm 0.1\%$ of full scale or $\pm 1.0 \mu\text{mf}$. Small differences between two capacitors, or small changes in a given capacitor with time, temperature, humidity, voltage gradient, etc., may be determined with an accuracy of from $\pm 0.1 \mu\text{mf}$ to $\pm 0.3 \mu\text{mf}$.

Power-Factor Range: Readings of the power-factor dial are in terms of the product $D_x C_x$ where D_x is the dissipation factor of the unknown and C_x is the unknown capacitance expressed in μmf . The maximum scale value of this product is 80 on the x1 multiplier setting and 8 on the x.1 setting. Larger values of $D_x C_x$ may be measured by a series substitution method. The smallest scale division is unity on the x1 position and 0.1 on the x.1 position. Hence, for a 100 μmf capacitor under measurement, the maximum measurable dissipation factor is 0.8 or 80%, and the minimum is 1/5 the smallest division, 0.0002 or 0.02%. Both of these limits vary inversely as the capacitance of the sample.

Accuracy of Power-Factor Measurements: The accuracy of dissipation factor readings is also expressed in terms of the $D_x C_x$ product. The maximum error in the determination of this product is, for the x1 multiplier, ± 0.2 or $\pm 2\%$ of the dial reading, whichever is larger. For the x.1 multiplier, the error is ± 0.05 or $\pm 2\%$, whichever is larger.

Power Supply: 0-130 volts, 40-60 cycles. The power input is approximately 30 watts. A constant correction factor must be applied to the power-factor dial reading for any line frequency other than 60 cycles.

Applied Voltage: A transformer and potentiometer apply from zero up to 10 times line voltage to the bridge, and, in effect, to the unknown capacitor.

Controls: Main capacitance dial, capacitance zero adjustment, power-factor dial, power-factor zero adjustment, power-factor multiplier switch, voltage control, power ON-OFF switch.

Meters: A panel voltmeter indicates the voltage applied to the bridge.

Null Detector: Some form of balance detector, or null indicator, is required. This is not included in the bridge. Headphones cannot be used, owing to the low supply frequency. The TYPE 707-A Cathode-Ray Null Detector (see page 92) is strongly recommended. An alternative detector for 60-cycle use consists of TYPE 814-A Amplifier (page 110), TYPE 814-P3 Tuned Circuit (page 112), and TYPE 483-F Output Meter (page 118).

Accessories: Supplied with the bridge are a shelf for holding specimens under measurement, a cord and plug assembly for power connection, and a shielded cord for joining the bridge to the external detector unit.

Mounting: 19-inch relay-rack panel.

Dimensions: Panel, 19 x 12 $\frac{1}{4}$ inches; depth behind panel, 9 $\frac{3}{4}$ inches.

Net Weight: 36 $\frac{1}{2}$ pounds.

Type	Code Word	Price
671-A	BEGET	\$325.00

PATENT NOTICE. See Note 17, page v.

Schematic circuit diagram of TYPE 671-A Schering Bridge.

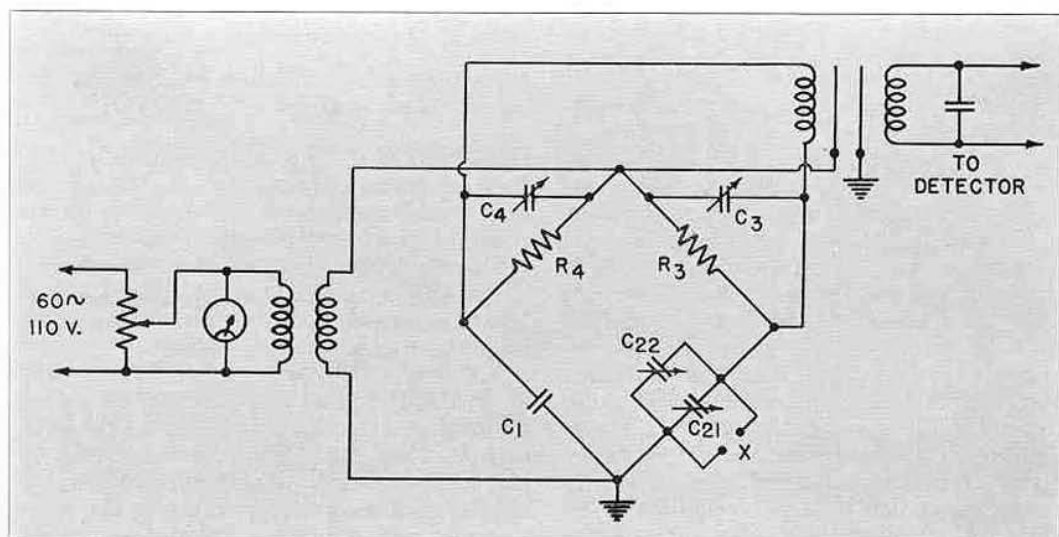

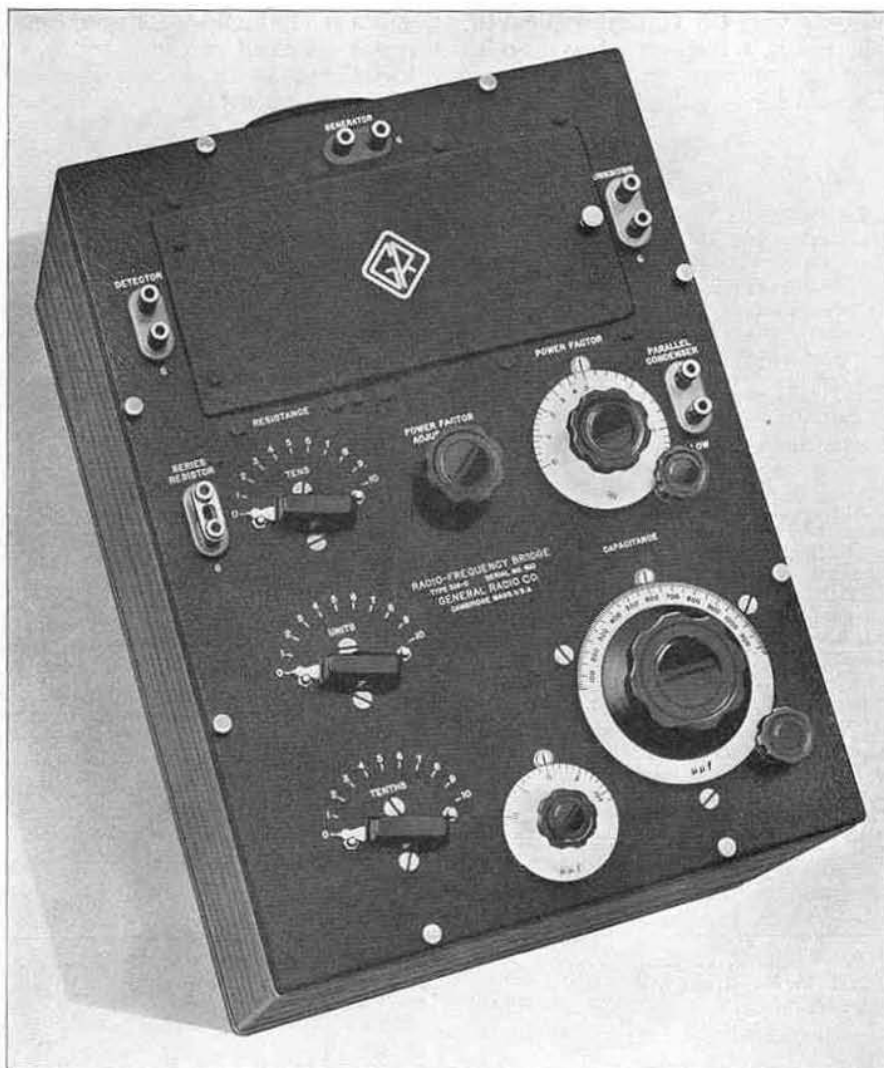

TYPE 516-C RADIO-FREQUENCY BRIDGE

USES: The radio-frequency bridge extends to radio frequencies bridge methods of impedance measurement which formerly were useful only at low frequencies. This bridge has been widely used for measuring the impedance of radiators, r-f transmission lines, coupling units, and other elements of radio antenna systems. Other applications include measurements of the inductance and storage factor, Q , of coils, the capacitance and power factor of condensers, the resistance and reactance of resistors, and the frequency characteristics of the circuit elements at radio frequencies up to about 4 megacycles.

Although this bridge is designed primarily for use at radio frequencies, the useful frequency range can be extended down to 60 cycles by changing the ratio arms and the

output transformer. Both ratio arms and transformers are listed on page 93.

DESCRIPTION: The TYPE 516-C Radio-Frequency Bridge is a capacitance bridge and can be used as a Schering bridge with direct-reading power-factor dial, or as a series-resistance bridge. The resistance decade is a TYPE 670 Compensated Decade Resistor (see page 22) which has a constant low value inductance regardless of setting.

The TYPE 516-C Bridge is direct reading up to 110 ohms and 1150 $\mu\mu\text{f}$. For the measurement of inductance or of higher values of capacitance, a small fixed condenser may be placed in series with the unknown. When the resistance of the unknown is above 111 ohms a parallel condenser or a combination of series

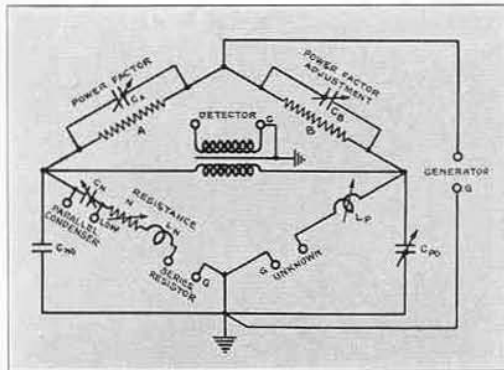

Schematic circuit diagram of the TYPE 516-C Radio-Frequency Bridge. By using the capacitance C_{PO} to balance the stray capacitance C_{NO} , and the inductance L_N of the standard resistor, the bridge is made direct reading in both capacitance and resistance.

or parallel units can be selected to produce a balance. While in neither of these cases is the bridge direct reading, the necessary calculations are not difficult. The substitution method for capacitance and resistance meas-

urements is recommended where precise results are desired. When the bridge is used as a direct-reading instrument, some accuracy is sacrificed. The over-all accuracy obtainable is, however, extremely good in the range where the bridge is direct reading. Even at frequencies in the vicinity of 5 Mc, the direct-reading accuracy is about 5 per cent. At broadcast frequencies it is about 1 per cent.

FEATURES: The accuracy, wide range, and ease of operation of the TYPE 516-C Radio-Frequency Bridge make it the most satisfactory device available for radio-frequency impedance measurement. It should be emphasized, however, that the bridge requires on the part of the user an appreciation of the fundamental problems involved in high-frequency measurement if erroneous results are not to be obtained. Stray capacitance and the reactance of leads, factors which are negligible at lower frequencies, are often an appreciable part of the impedance measured at radio frequencies. A recognition of the importance of these factors is necessary to a correct interpretation of the results.

SPECIFICATIONS

Capacitance Range: Main dial, 40 μmf to 1150 μmf ; vernier dial, $\pm 0.1 \mu\text{mf}$ to 10 μmf . The range can be extended to 10 μf by using a series condenser.

Resistance Range: 0.1 ohm to 111 ohms. The range can be extended to 11 k Ω by using a known condenser in parallel with the unknown.

Power-Factor Range: 0.005% to 3% at 1 Mc. The range can be extended to 30%, by using a known condenser in parallel with the unknown.

Frequency Range: 500 kc to 4000 kc with output transformer furnished. With suitable output transformers and ratio arms (see below), range can be extended down to include audio frequencies.

Accuracy: As a direct-reading bridge, $\pm 5 \mu\text{mf}$ or $\pm 1\%$ at 1 Mc for measurements of capacitance, $\pm 0.2 \Omega$ or $\pm 2\%$ for resistance, and ± 0.001 or $\pm 5\%$ for power factor. With substitution methods, greater accuracy can be obtained.

Controls: Large and small capacitance dials, three decade resistance switches, power-factor dial, power-factor zero adjustment dial.

Accessories Recommended: The bridge is supplied with 100-ohm ratio arms and a TYPE 516-P10 Output Transformer for the 500-kc to 4000-kc band. A suitable radio-frequency generator and detector are required.

The TYPE 684-A Modulated Oscillator (see page 104) is suggested. As a detector, a radio receiver covering the desired range is recommended. Two shielded conductors are needed for generator and detector connections. Two TYPE 274-NE Shielded Plugs are furnished. (See also "Condensers" below.)

Condensers: If measurements outside the direct-reading range of the bridge are to be made, plug-in fixed condensers are required. TYPE 505 Condensers are recommended. A set of four of these with capacitances of

100 μmf , 200 μmf , 500 μmf , and 1000 μmf , respectively, is adequate for most purposes. (See page 57.)

Dimensions: (Length) 18 x (width) 12 x (height) 8 inches, over-all.

Net Weight: 21 $\frac{3}{4}$ pounds.



The photograph above shows the bridge with TYPE 684-A Modulated Oscillator set up for measuring antenna characteristics in a radio broadcasting station.

Type	Code Word	Price
516-C	BATCH	\$225.00

PATENT NOTICE. See Notes 3, 10, 17, page v.



TYPE 740-B CAPACITANCE TEST BRIDGE

USES: The TYPE 740-B Capacitance Test Bridge is a 60-cycle capacitance and power-factor bridge for use in both laboratory and production testing. Condenser manufacturers can use it for checking the capacitance and power factor of paper, electrolytic and mica condensers; cable and wire manufacturers for measuring dielectric constant, interconductor and conductor-to-shield capacitance; transformer manufacturers for measuring interwinding and winding-to-shield capacitance; spark-plug manufacturers for testing spark-plug capacitance on the production line; and power companies for measuring the power factor of insulators.

DESCRIPTION: The circuit used in this instrument is that of a series-resistance capacitance bridge. It is the capacitance portion of the TYPE 650-A Impedance Bridge adapted for 60 cycles. One ratio arm is variable in decade steps, and the other is continuously variable and calibrated directly in capacitance.

By means of this combination, capacitances between 5 micromicrofarads and 1100 microfarads can be measured. Power factor is measured by means of a dual-range variable

resistor in series with the standard condenser. The dial is direct reading in dissipation factor ($R\omega C$) and, in conjunction with a multiplier switch, has a total range of 0 to 50 per cent.

Operating instructions are conveniently mounted in the cover of the instrument, and a complete circuit diagram is attached to the base of the cabinet.

Power is obtained from the 60-cycle line through a shielded isolating transformer.

A visual null indicator is used, consisting of tuned amplifier and an electron-ray tube (the so-called magic eye). A sensitivity control is provided. With this type of null indicator, it is possible to use the bridge as a limit bridge in production testing.

The complete bridge assembly is mounted in an airplane-luggage type of carrying case.

FEATURES: For production testing, this bridge has many advantages. Power-line operation and the visual indicator make it completely self-contained. It can be used in noisy locations where headphones would be useless. Its small size and light weight are important features, since it can be moved easily and set up wherever necessary.

The range of measurement is wide, the

operation is simple, and the construction is rugged and practically foolproof.

Care was taken in the design and construction of the power transformer to insure a minimum of capacitance between generator terminals and ground. As a result of this and other design features, an accuracy of 1 per cent for capacitance, and 1.5 per cent of full scale for power factor, has been obtained over most of the range.

In testing electrolytic condensers, a polarizing voltage is frequently needed. Although no provision for this is made in the standard bridge, terminals for introducing such a voltage can be added at a slight extra charge.



Testing condensers with the TYPE 740-B Capacitance Test Bridge.

SPECIFICATIONS

Capacitance Range: 5 micromicrofarads to 1100 microfarads in six ranges. Capacitance values are read directly from a logarithmic dial and multiplier switch.

Capacitance Accuracy: Within $\pm 1\%$ over the main decade (1 to 11) of the CAPACITANCE dial for all multiplier settings except .0001. Within $\pm 1.5\%$ or ± 3 micromicrofarads, whichever is the larger, on the .0001 multiplier on the main decade of the CAPACITANCE dial. Below 100 micromicrofarads the error gradually increases to ± 5 micromicrofarads as zero is approached.

Dissipation Factor Range: 0 to 50% in two ranges. Dissipation factor values are read directly from an engraved scale and multiplier switch.

Dissipation Factor Accuracy: Within 1.5% of full-scale reading for all capacitance multipliers except .0001.

On the .0001 capacitance multiplier a correction of 0.3% should be subtracted from the dial reading. When this correction is made the calibration is within ± 2 divisions on the $\times 1$ multiplier and within ± 1 division on the $\times 10$ multiplier.

Voltage Applied to Unknown: The voltage impressed across the unknown terminals varies continuously with

the bridge setting. For very small capacitances in the lowest range, this voltage is approximately 35 volts, and it decreases with increasing capacitance, so that at $100 \mu\text{f}$, it is approximately one volt.

Polarizing Voltage: No provision is made for connecting a polarizing voltage, but terminals for this purpose can be added. (See price list below.)

Power Supply: 115 volts, 60 cycles. The power input is 15 watts.

Controls: Capacitance dial and multiplier, dissipation factor control and multiplier, sensitivity control.

Accessories: Attachment cord and plug for power connection are supplied.

Vacuum Tubes: One each of types 6X5, 6J7, 6E5; all are supplied with the bridge.

Mounting: Portable carrying case, of airplane-luggage construction.

Net Weight: 19 pounds.

Dimensions: (Length) $14\frac{1}{2}$ x (width) 15 x (height) $9\frac{1}{4}$ inches, over-all, including cover and handles.

Type	Code Word	Price
740-B	BABEL	\$140.00
Extra terminals installed for polarizing voltage	POLAR	10.00

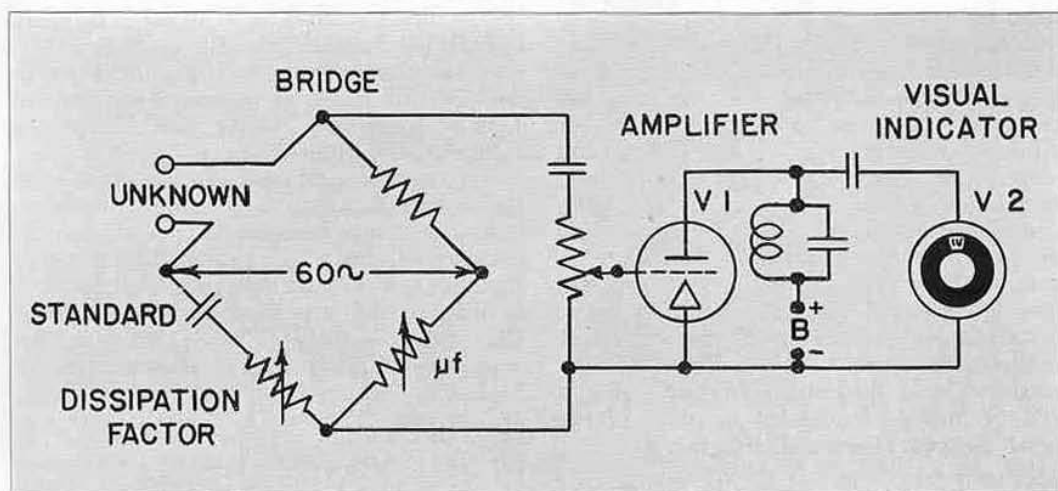

Schematic circuit diagram of the TYPE 740-B Capacitance Test Bridge.

TYPE 667-A INDUCTANCE BRIDGE



USES: This bridge is designed for accurately measuring the inductance of small coils having a low value of storage factor, Q , at audio frequencies, such as are used in radio receivers. It is used by many coil and receiver manufacturers for all audio-frequency measurements on the tuning coils for radio receivers. It is capable of measuring higher values of inductance (up to 1 henry) and hence can be used as a general-purpose inductance bridge. When connected as a Campbell mutual inductance bridge, it can be used to measure mutual inductance in terms of the internal standard. Terminals are provided so that the bridge can be connected as a resonance bridge for such measurements as the ratio of a-c to d-c resistance. The d-c resistance can be determined by using a battery and galvanometer in place of the usual a-c generator and detector.

DESCRIPTION: The schematic diagram of TYPE 667-A Inductance Bridge is shown on page 83. It differs little from that of the usual

inductance bridge. Certain design features, however, have been introduced to eliminate residual sources of error and to make the bridge direct reading. The variable resistors in both the standard and the unknown arms are inductance compensated, identical in construction with TYPE 668 Compensated Decade-Resistance Units and TYPE 669 Compensated Slide Wire.

The variable inductor, L_p , in series with the unknown makes it possible to obtain a final inductance balance independent of the resistive balance of the bridge. The standard inductor is wound on a ceramic toroidal form in order to minimize magnetic coupling with the variable inductor. The switch, K , is used when the bridge is connected as a resonance bridge.

FEATURES: High accuracy (within $0.1 \mu\text{h}$) for the measurement of small inductances is one of the outstanding features of this bridge. Coils of a few microhenrys inductance cannot be measured accurately on the ordi-

nary bridge, owing to the errors introduced by the (1) sliding-zero balance (reactive and resistive balances not independent), (2) variation of inductance with setting of any decade resistors used in the bridge, and (3) capacitance across the resistive component of any of the arms. These are eliminated in the TYPE 667-A Inductance Bridge. The small variable inductor in series with the unknown eliminates the sliding-zero balance. An inductance-compensated resistor (similar to TYPE 670 Compensated Decade Resistor) is used to eliminate the effect of reactance changes when obtaining the resistive balance. The constant residual inductance of the resistance decades is compensated for by a small change in the standard inductor. The effect of shunt capacitance is minimized by keeping the resistive components of the various arms at a low value. The result is a bridge that has independent balances for resistance and inductance, is capable of measuring inductance with an accuracy of 0.1 microhenry, and which is direct reading.

SPECIFICATIONS

Range: Inductance, 0.1 microhenry to 1 henry. The range can be extended to 1000 henrys by using TYPE 106 Standard Inductors or external standards. The bridge will balance for storage factors between 0.06 and infinity at 1 kc.

Accuracy: Inductance, $\pm 0.2\%$ or $\pm 0.1 \mu\text{h}$, whichever is the greater, for three smaller multiplier settings and at 1 kc; $\pm 0.4\%$ for the largest multiplier at 1 kc. The larger error is caused by the capacitance across the unknown terminals and is reduced at lower frequencies.

Frequency Range: All calibration adjustments are made at a frequency of 1 kc. The bridge can be used at any frequency between 60 cycles and 10 kilocycles.

Ratio Arms: The ratio arm controlled by the multiplier switch has four values, 1, 10, 100, 1000 ohms. The other ratio arm which is calibrated to be direct reading in inductance, is identical with a four-dial TYPE 602-K Decade-Resistance Box.

Standards: The standard inductor is a 1 millihenry toroid wound on a ceramic form. Resistance balance of the bridge is made by means of a three-dial inductance-compensated resistor, identical with the TYPE 670-FW Compensated Decade Resistor, placed in series with the standard inductor. Two switches, having logarithmically spaced resistors ranging from 1 to 10,000 ohms, are connected in series with the unknown inductor.

Shielding: The bridge arms are shielded from one another by grounded shields connected to the panel and copper lining of the cabinet.

Mounting: The bridge is supplied for cabinet mounting only.

Accessories Required: Oscillator, amplifier, and head telephones. TYPE 608-A Oscillator (see page 102), TYPE 814-A Amplifier (see page 110), TYPE 814-P Tuned Circuits (see page 112) are recommended.

Dimensions: (Length) $17\frac{1}{2}$ x (width) 16 x (height) $9\frac{1}{2}$ inches, over-all.

Net Weight: $30\frac{3}{8}$ pounds.

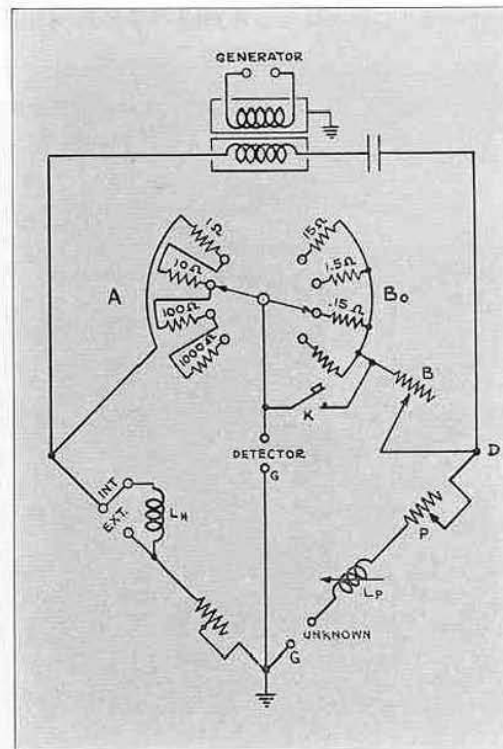

Schematic circuit diagram of the TYPE 667-A Inductance Bridge.

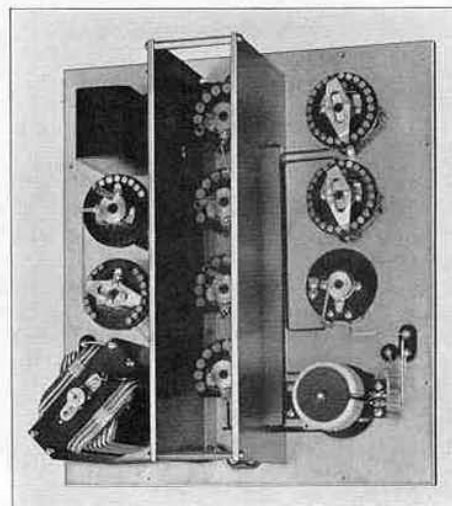

Interior view of the bridge, showing details of construction.

Type	Code Word	Price
667-A	AEIRE	\$325.00

TYPE 293-A UNIVERSAL BRIDGE

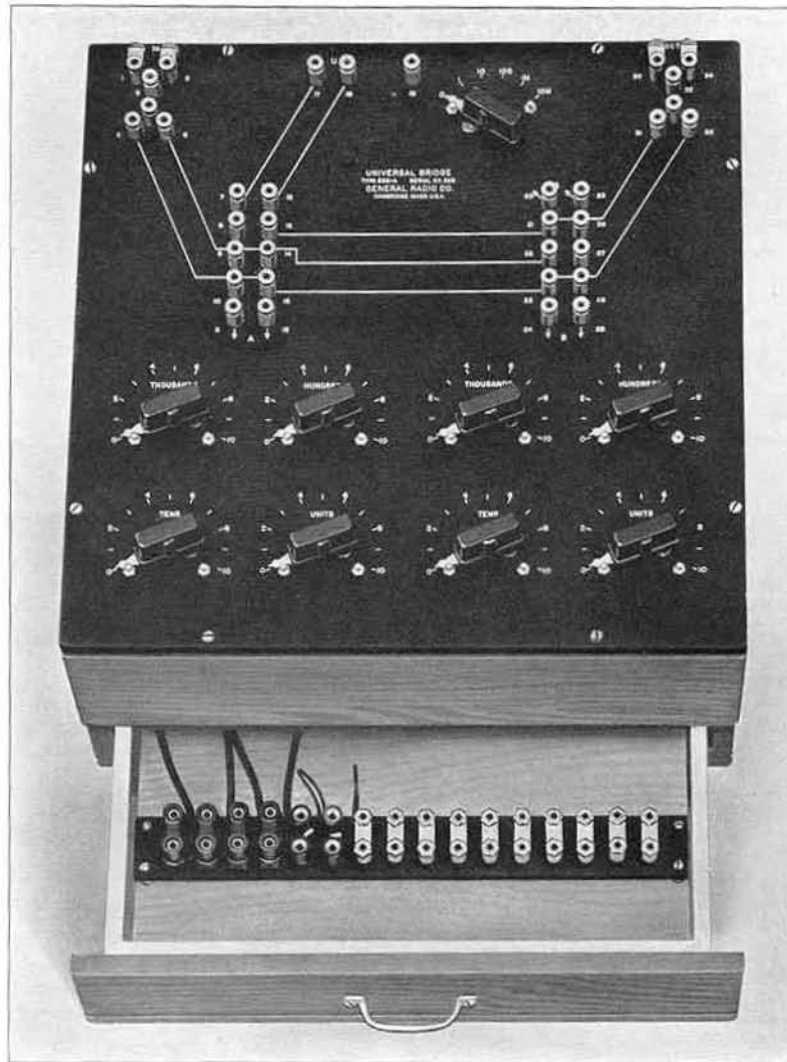

USES: The TYPE 293-A Universal Bridge is a fundamental bridge circuit which can be connected to produce a wide variety of direct- and alternating-current bridges. Among these are bridges for the measurement of inductance, capacitance, and resistance over a wide frequency range (0-50,000 cycles). It can also be set up as a frequency meter. The instrument has, therefore, a much wider general usefulness in a college or measurement laboratory than the usual form of permanently connected bridge circuit.

DESCRIPTION: The bridge consists of three resistance arms and a terminal board by means of which the various circuits can be set up with plugs and jacks.

The resistance arms of the bridge consist of two similar arms, each having a total

resistance of 11,110 ohms in four decade dials (1, 10, 100, and 1000 ohms), and a third arm having resistances of 1, 10, 100, 1000, and 10,000 ohms.

The bridge elements are shown diagrammatically in the accompanying drawing, which illustrates the points in the circuits where terminals are located. The bridge circuit is shown connected for the standard Wheatstone bridge. The dotted lines are connections made by means of the plug connectors on the terminal board. The plugs are arranged in two groups, each group terminating the elements of one side of the bridge. The plug arrangement permits the connection of additional elements in series with any of the bridge arms. The input and output (power and null detector) circuits can

be brought out directly or through transformers for which plug-in jacks are provided.

When used for resistance measurements no additional standard is required, the *S* arm of the bridge being used as a standard. For inductance and capacitance measurements, an external standard is required. The bridge

does not include a null detector or power supply.

FEATURES: The advantage of this bridge lies in its extreme flexibility, which makes possible a variety of measurements with a minimum of equipment.

SPECIFICATIONS

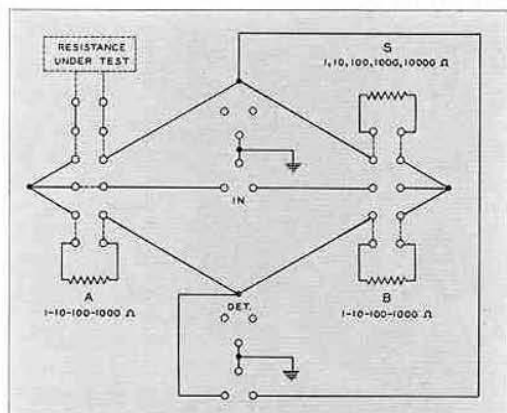

Schematic diagram of a TYPE 293-A Universal Bridge set up for measuring resistance.

Bridge Arms: The *A* and *B* arms each consist of four decade resistors covering a range of 1 ohm to 11,110 ohms in 1-ohm steps. The *S* arm is a resistor with 1-, 10-, 100-, 1000-, and 10,000-ohm sections. The characteristics are similar to those of the TYPE 602 Decade-Resistance Box.

Accuracy: All resistors are adjusted to within 0.1% of the specified value except the 1-ohm units which are adjusted to within 0.25%.

Type	Code Word	Price
293-A	BACON	\$140.00

TYPE 293-P ACCESSORIES

In using the TYPE 293-A Bridge for alternating-current measurements, shielded input and output transformers are desirable. The following transformers are available and are satisfactory for measurements in the audio-frequency range. Both transformers can be used with either coil as input or output.

When the impedance under measurement is low, it is desirable to extend the range of the bridge arms downward. This may be done by the use of one or two TYPE 293-P3 Slide-Wire Resistors, a shielded resistor calibrated directly and having a range of 0-1.3 ohm. The slide-wire calibration is accurate to 0.02 ohm at any setting. The unit is arranged for plug mounting on the bridge terminal board.

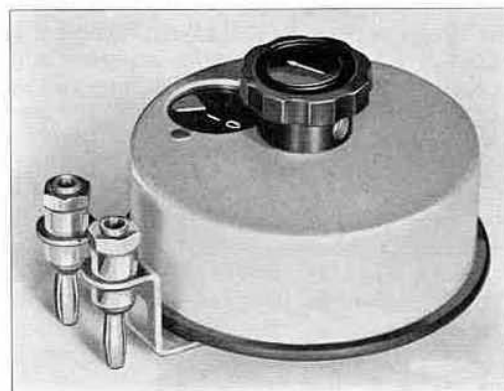

TYPE 293-P3 Slide Wire.

Type	Turns Ratio	Inductance High Side	Frequency Range	Circuit Impedance		Net Weight	Code Word	Price
				High Side	Low Side			
293-P1	3:1	2.5 h	50-5000 cycles	2700 Ω	300 Ω	2 lb.	BADGE	\$12.00
293-P2	2.55:1	25 h	50-5000 cycles	25,000 Ω	4000 Ω	2 lb.	BAFFY	12.00
293-P3	Slide-Wire Resistor, 0-1.3 Ω					8 oz.	BAGGY	20.00

TYPE 721-A COIL COMPARATOR

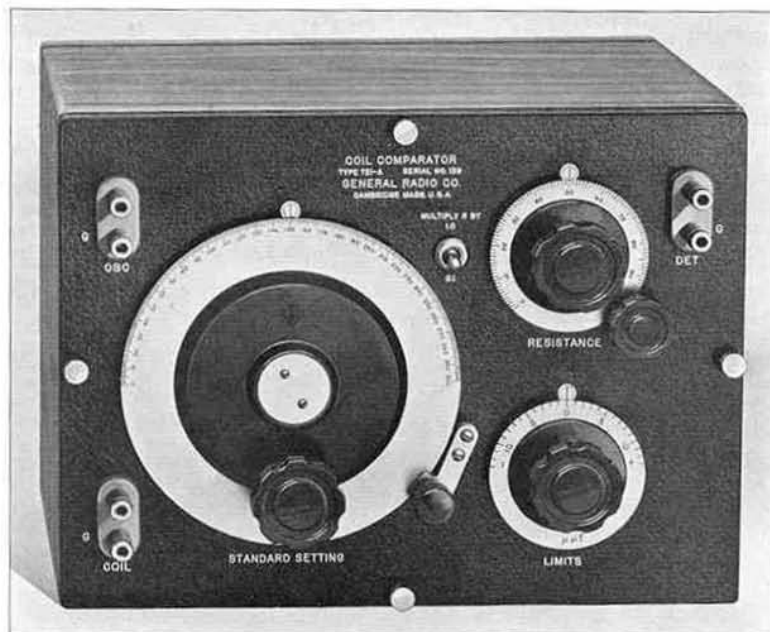

USES: The coil comparator is used for production measurements of the reactance and resistance of r-f coils and condensers. It is intended to be used solely as a comparator, i.e., the coil under test is compared with a standard sample and the difference noted. Although the comparator is also capable of making direct measurements, it is not recommended for this purpose.

DESCRIPTION: The TYPE 721-A Coil Comparator uses a bridged-T circuit as shown in the diagram on page 87. Like a bridge, it is capable of being balanced for a perfect null indication, but, unlike a bridge, one side of the generator, the detector, and the coil under test are connected to a common grounded point.

The elements of the comparator are the two-gang condenser, C_1C_2 , and the variable resistor, R_s . The coil under test is indicated by the inductance, L , and the resistance, R . The conditions for balance, if the two condenser sections are approximately equal and if the coil has a reasonably high Q , are as follows:

$$L\omega = \frac{1}{(C_1 + C_2)\omega} \quad (1)$$

$$R = \frac{R_s}{4} \quad (2)$$

In other words, the sum of the capacitance of the two sections of the tuning condenser must be sufficient to tune the coil to reso-

nance, and the bridging resistance must be equal to four times the coil resistance.

The two condensers, C_1 and C_2 , are equal and are operated by a single control which determines the reactance setting. A small condenser, also in two sections, is in parallel with the main condenser and is used to show small differences in reactance in comparison measurements. The resistor, R_s , is non-reactively wound and reads directly in coil resistance.

The procedure for checking coils with this instrument is extremely simple and straightforward.

The small condenser, marked **LIMITS**, is set at the center-scale zero, and balance obtained for the standard coil by varying the resistance control and the control of the main condenser, marked **STANDARD SETTING**. The reactance setting is locked by a clamp provided, the standard coil is replaced by the production coil, and balance restored by varying the auxiliary **LIMITS** condenser and the resistance control. If the production coil is similar in construction to the standard, the test can almost invariably be made with sufficient precision by adjusting only the **LIMITS** condenser, leaving the resistance setting unaltered.

Condensers can be checked as readily as coils, but it is necessary to use an external coil to obtain balance.

Production coils can also be checked for resistance or for Q in comparison with a

standard coil. Although a correction factor for the effects of stray capacitance must be applied when making absolute measurements of R or Q , it need not be considered for comparisons with a standard coil. For coils of the same reactance the setting of the resistance control is always directly proportional to the coil resistance. The percentage deviation in R or Q is equal in magnitude to the percentage deviation of the resistance control setting.

FEATURES: The circuit used in the TYPE 721-A Coil Comparator combines the simplicity of a resonant method with the precision of a null method. Readings are completely independent of both generator and detector impedances. The effective low impedance of the circuit, moreover, makes other effects, such as capacitance between input and output and capacitance to the operator's body, almost unnoticeable.

The new circuit makes it possible to provide an almost ideal arrangement: a single control, with an incremental adjustment, for reactance, and an independent control for resistance.

Although a single frequency test is generally adequate for production checking, the circuit of the comparator lends itself particularly well to more detailed tests. For example a convenient arrangement for checking coils at two frequencies to obtain a measure of the



Measuring radio-receiver coils with the TYPE 721-A Coil Comparator.

distributed capacitance can be made by employing two TYPE 721-A Coil Comparators side by side, each with its separately-tuned detector. If the oscillator fundamental and second harmonic are used for the test frequencies, the two inputs can be connected together. It is then only necessary to shift the high-potential coil lead to test at the two frequencies and to insure that the reactance value in each case falls within the specified limits.

SPECIFICATIONS

Tuning Capacitance: The effective tuning capacitance is adjustable between 75 μf and 1200 μf when the auxiliary condenser is set at zero (mid-scale). This includes a stray capacitance of 25 to 32 μf , depending on the setting of the main condenser.

Resistance: The resistance control reads directly within 5% the "nominal" coil resistance from 0.5 Ω to 95 Ω , in two ranges. The correction for stray capacitance, however, lowers the maximum measurable coil resistance to 46 Ω when the tuning capacitance is 100 μf , and to 85 Ω at 1000 μf .

Inductance Range: Any coil can be tested which can be tuned to resonance at the test frequency by a capacitance between the limits given above, and which has a series resistance lying within the range specified above.

Calibration: An approximate capacitance calibration is supplied for the main dial; this is actually the average of a number of instruments and is within $\pm 5\%$. The auxiliary condensers dial is direct reading in micromicrofarads and the resistance dial in ohms. A correction curve for the effects of stray capacitance is supplied.

Mounting: The instrument can be supplied in a walnut cabinet for table use, or with a metal dust cover for building into test equipment.

Terminals: Panel terminals are provided for connecting generator detector and coil under test.

Controls: Main tuning condenser, with dial lock, resistance dial with 10:1 multiplier, and capacitance LIMITS dial.

Accessories Required: TYPE 684-A Modulated Oscillator is recommended as a power source. A sensitive radio receiver is a satisfactory detector. Shielded cables such as TYPE 274-NC or TYPE 274-NE should be used for connections to the generator and detector.

Dimensions: Panel, 12 x 9 inches; depth behind panel, TYPE 721-AM, 9 $\frac{1}{8}$ inches; TYPE 721-AR, 8 $\frac{3}{4}$ inches.

Net Weight: TYPE 721-AM, 12 $\frac{7}{8}$ pounds; TYPE 721-AR, 8 $\frac{3}{4}$ pounds.

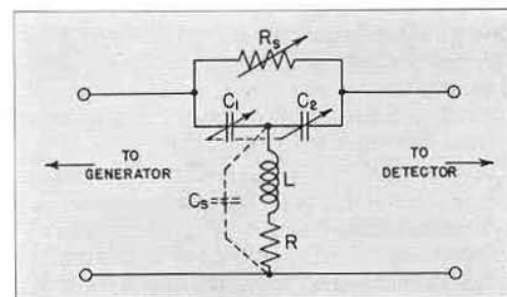

Schematic circuit diagram of the TYPE 721-A Coil Comparator with coil under test connected. The test coil is designated by the inductance L and resistance R . C_s is the stray capacitance of the comparator itself.

Type	Description	Code Word	Price
721-AM	With Cabinet	BIBLE	\$85.00
721-AR	With Metal Dust Cover	BIGOT	80.00

TYPE 561-C VACUUM-TUBE BRIDGE



USES: This instrument makes possible accurate measurements of the three fundamental vacuum-tube parameters; amplification factor, mutual conductance or transconductance, and plate resistance; over wide ranges of values. The accuracy is sufficient so that the bridge has found acceptance among tube manufacturers as a standard of reference for tube measurements, particularly where extreme values of the parameters are encountered and where ordinary measuring circuits become untrustworthy.

In the field of development and research the instrument, in addition to providing accurate measurements of the usual tube parameters, affords a means of studying the behavior of tubes used in unconventional and special circuits, when any one of the electrodes may be used as the operating electrode and where negative values of the parameters may be encountered.

The tube circuits have large enough current-carrying capacity and sufficient insulation so that low-power transmitting tubes may be tested in addition to receiving tubes.

DESCRIPTION: The bridge makes use of improved alternating-current null methods of measurement, in which phase shift and capacitance errors have been given special consideration in order that the operating range of the bridge may be as wide as possible. Each of the three coefficients is obtained in terms of the ratio of two alternating test voltages. A third voltage is employed in the capacitance balancing circuit, but its value does not enter into the results. A complete analysis of the bridge circuits will be found in the paper "Dynamic Measurement of Electron-Tube Coefficients" by W. N. Tuttle, *Proc. I.R.E.*, June, 1933.

FEATURES: The procedure in making measurements is simple and straightforward, and is exactly the same for the three coefficients: amplification factor, plate resistance, and transconductance. A three-position switch is turned to whichever quantity is desired, multiplier switches are set at the appropriate value for the tube being tested, and balance is obtained by adjusting a three-decade attenuator and a variable condenser. At balance

the decades read directly, to three significant figures, the quantity being measured.

The three main tube parameters are measured independently, i.e., none of the balances depends in any way on any other so that independent cross checks can be obtained from the known relationship among the three coefficients. Negative values of the tube coefficients may be measured as readily as positive values.

The method of balancing out the effects of the tube inter-electrode capacitances is a more satisfactory one than has heretofore been available. Not only is the accuracy of the measurement thereby considerably improved, but all three of the usual parameters may be measured independently over a much wider range. For instance, the mutual conductance of a tube having a high value of grid to plate capacitance can be measured without any error from this capacitance.

The measuring circuits and the tube-control circuits may be separated by opening link connectors on the top of the panel. This not only facilitates the testing of tubes associated with other control apparatus,

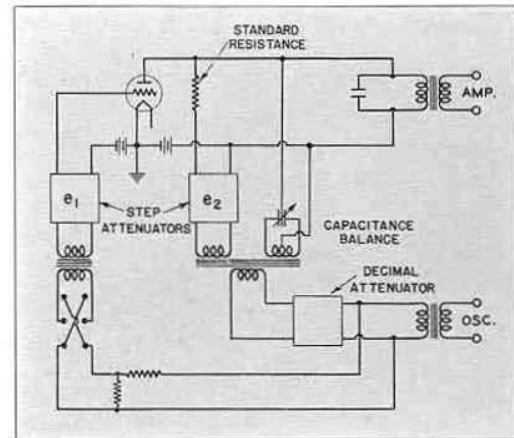

Simplified diagram of circuit employed for measurement of transconductance. The points of introduction of the test voltages e_1 and e_2 are changed by a switch when the other constants are measured.

but also makes it possible by changing the cross connections in a very simple manner to measure grid-circuit parameters, or parameters referred to any pair of electrodes.

SPECIFICATIONS

Range: Amplification factor (μ): 0.001 to 10,000.

Dynamic internal plate resistance (r_p): 50 ohms to 20 megohms.

Mutual conductance (g_m): 0.02 to 20,000 micromhos. Under proper conditions, the above ranges can be exceeded. The various parameters can also be measured with respect to various elements, such as screen grids, etc. Negative, as well as positive, values can be measured.

Range of Tubes Covered: All standard four-, five-, six-, and seven-prong receiving tubes can be measured on this instrument without the use of adapters, except that five-, six-, or seven-prong tubes not having separate heaters require the use of a single TYPE 561-P2 Universal Adapter furnished with the bridge. A switch is provided for switching the control-grid connection from the base to the cap.

An octal adapter is also supplied, by means of which all octal-base tubes, either glass or metal, can be tested with any desired connections to the electrodes.

The Universal Adapter supplied permits the testing of tubes with non-standard base connections. Un-mounted tubes are connected directly to the panel binding posts for test measurements.

A special shield terminal is provided so that long leads to an external socket can be effectively shielded and will not impair the accuracy of measurement.

The tube circuits have large enough current-carrying capacity and sufficient insulation so that low-power transmitting tubes may be tested in addition to receiving tubes. Maximum allowable plate current is 150 milliamperes and maximum plate voltage is 1500 volts.

Filament Supply Circuits: A double-range rectifier-type alternating-current and direct-current filament voltmeter and a source of alternating-current heater power

are contained in the instrument. No external filament connections need be made for alternating-current tubes, unless voltage greater than 8 volts or current greater than 3.5 amperes is required. The filament rheostat for direct-current filament supply has a capacity of 750 milliamperes.

When measuring alternating-current heated tubes, the bridge requires connection to a source of 115-volt, 60-cycle alternating current.

Electrode Voltage Supply: Batteries or suitable power supplies are necessary for providing the various voltages required by the tube under test.

Bridge Source: A source of 1000 cycles is required. The TYPE 608-A Oscillator is suitable for this purpose.

Null Indicator: A suitable null indicator is required. The TYPE 814-A Amplifier used in conjunction with a sensitive pair of telephones is recommended for this purpose.

Constructional Features: The lower half of the front panel of the instrument contains the special bridge circuit used in measuring the coefficients. The upper half of the panel contains tube sockets, alternating-current filament supply, filament voltmeter, rheostats, terminals for various voltages, and terminals for direct connection of an external tube to the bridge circuit. This arrangement provides the greatest flexibility for general use.

Mounting: The instrument is mounted on a black crackle lacquered aluminum panel and is furnished in a polished walnut cabinet. A leatherette cover is supplied to protect the instrument from dust when not in use.

Dimensions: (Length) $18\frac{3}{8}$ x (width) $15\frac{3}{4}$ x (height) 11 inches.

Net Weight: 45 pounds.

Type	Code Word	Price
561-C	BEIGE	\$375.00

PATENT NOTICE. See Note 17, page v.

TYPE 544-B MEGOHM BRIDGE



DESCRIPTION: The TYPE 544-B Megohm Bridge is a combination of Wheatstone bridge and vacuum-tube voltmeter.

The bridge is composed of the four arms, *A, B, N, P*, as shown for the OPERATE position in the diagram at the top of the next page, with the power applied across the arms, *A* and *B*, and the vacuum-tube voltmeter connected across the conjugate pairs, *A-N* and *B-P*. For checking the galvanometer zero, the tube is isolated from the bridge voltage as shown in the CHECK position, with the high resistors, *N* and *P*, connected to the grid exactly as in the OPERATE position. The effects of any voltages, alternating or direct, in the unknown resistor, *P*, and of any grid current of the tube will not appear in the bridge balance because they are balanced out in the zero adjustment. There is also a CHARGE position, in which the unknown resistor, *P*, is placed across the arm, *B*. This is valuable in measuring the resistance of large condensers because full voltage is applied directly to the condenser which can then charge at a maximum rate. The zero of the galvanometer can also be checked at any time without being affected by the residual charge in the condenser.

FEATURES: The use of a vacuum tube detector, which absorbs a negligible amount of power, makes possible the direct measurement of resistances up to 1,000,000 megohms. The resistance scale is approximately logarithmic over one decade, which gives a constant fractional accuracy, regardless of

USES: The megohm bridge is very useful for measuring cartridge-type resistors in the megohm ranges, such as those used as grid leaks and coupling resistors in vacuum-tube circuits. It is also capable of measuring the insulation resistance of electrical machinery such as generators, motors, and transformers, of electrical equipment such as rheostats and household appliances, of single conductors, cables, and condensers; of sufficiently long sections of high-voltage cables; of paper condensers; and of slabs of insulating materials. Volume resistivity can be determined and its change with temperature and humidity. Guard connections are provided for the measurement of three-terminal resistors such as multi-wire cables, three-terminal condensers, networks, and guarded specimens of insulating materials.

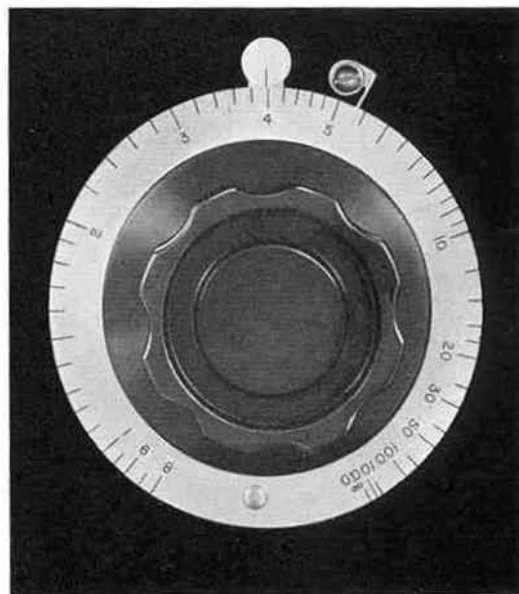

(Right) The MEGOHMS dial of TYPE 544-B Megohm Bridge. The scale is logarithmic over the main decade from 1 to 10.

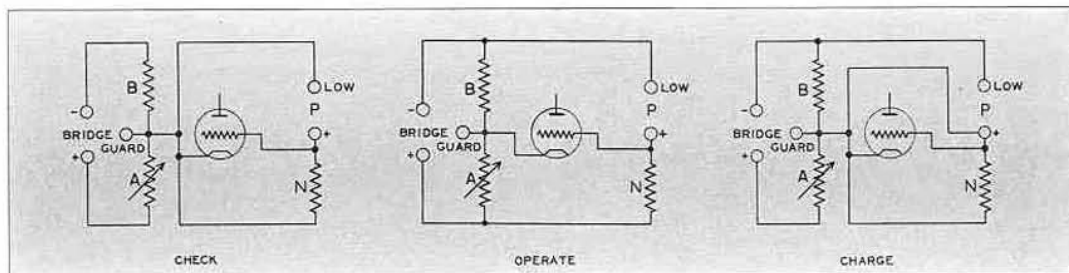

These diagrams show the bridge connections for the three positions of the CHECK-OPERATE-CHARGE switch.

setting. The effective scale length for the range of 100,000 ohms to 10,000 megohms is 35 inches.

Approximately constant voltage is applied

to the unknown resistor. Both a-c power supplies are voltage stabilized. This eliminates surges in charging current when measuring the leakage resistance of condensers.

SPECIFICATIONS

Range: 0.1 megohm to 10,000 megohms, covered by a dial and a 5-position multiplier switch. A resistance of 1,000,000 megohms can be detected.

Accuracy:

Resistance	Error
.1 MΩ - 100 MΩ	± 3%
100 MΩ - 1000 MΩ	± 6%
1000 MΩ - 10,000 MΩ	± 10%

Above 10,000 megohms, the error is essentially that with which the scale on the MEGOHMS dial can be read.

Terminals: The terminals for connecting the unknown resistor include connections for guard electrodes so that either two- or three-terminal resistors can be measured.

Controls: Megohms dial, with multiplier; zero adjustment; CHECK-OPERATE-CHARGE switch; power ON-OFF switch.

Power Supply: Three types of power supply are available: (1) an a-c unit delivering 90 volts to the bridge, (2) an a-c unit delivering 500 volts and 100 volts, and (3) a battery power supply of 90 volts. Both a-c units operate upon a 115-volt, 60-cycle line.

Operating Voltage: Terminals are provided so that the bridge voltage can be obtained from an external source if desired. Up to 500 volts can be applied.

Vacuum Tubes: With battery power supply, a 1D5G detector tube is used; the 90-volt a-c power supply uses a 6K7G detector, two 6X5G rectifiers, and two 874 ballast tubes; the 500-volt power supply uses a 6K7G detector, a 6X5G rectifier, a 5U4G rectifier, and, in the

voltage regulators, a 6J5G, a 6K6G, and two CD-2005 neon lamps. All tubes are supplied.

Mounting: Shielded oak cabinet.

Dimensions: Cabinet with cover closed, (width) 8½ x (length) 22½ x (height) 8 inches, over-all.

Net Weight: With battery power supply, 30¼ pounds; with a-c power supply, 25¼ pounds.

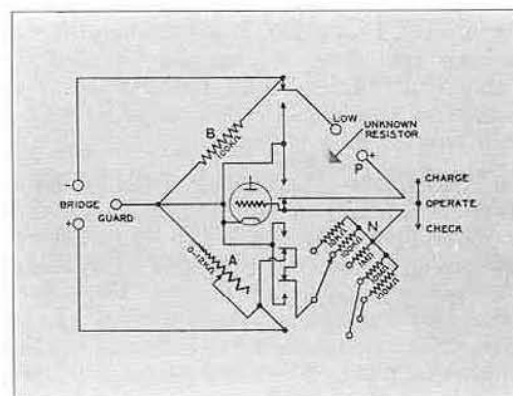

Schematic circuit diagram of the Megohm Bridge.

Type	Description	Code Word	Price
544-B	Battery Operated	AL00F	\$175.00
544-B	A-C Operated (90 volts)	ANNOY	225.00
544-B	A-C Operated (500 volts)	AGREE	235.00
544-P2	90-volt a-c Power Supply Only	ANNOYAPACK	65.00
544-P3	500-volt Power Supply Only	AGREEAPACK	75.00
544-P10	Battery Power Supply Only	AL00FAPACK	15.00



TYPE 487-A Megohmmeter, a direct-reading instrument operating on the ohmmeter principle, is described on page 123.

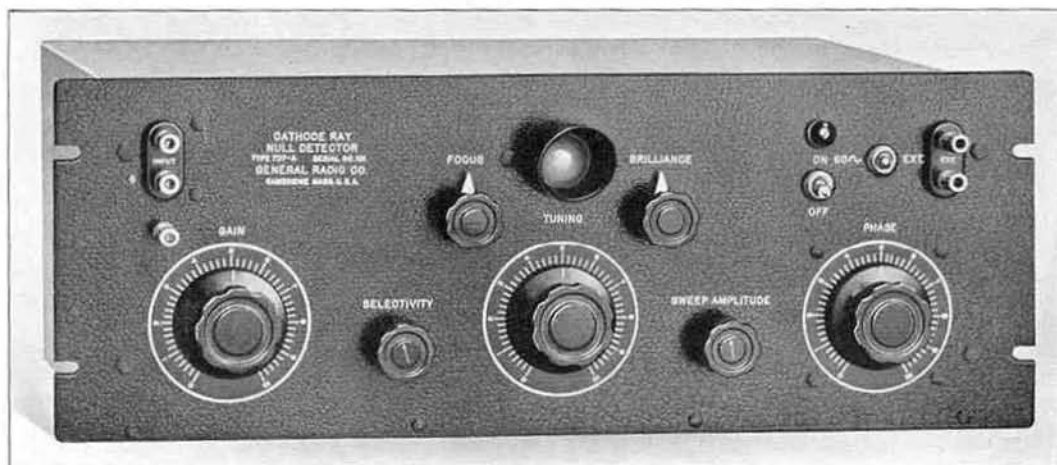

TYPE 707-A CATHODE-RAY NULL DETECTOR

USES: This visual null indicator is intended for use as a balance detector in bridge and other null-method measurements at power-line and audio frequencies. When calibrated for a given frequency, it can be operated as a limit indicator. It can also be used for comparing frequencies by means of Lissajous figures or, when calibrated, used as an a-c millivoltmeter.

DESCRIPTION: The output of the bridge is applied through an 80-db highly selective amplifier, operating on the degenerative principle, to the vertical deflecting plates of a one-inch cathode-ray tube. The bridge generator voltage is applied through an adjustable phase-shifting network to the horizontal plates. The tilted ellipse so formed is reduced to a horizontal straight line at balance.

FEATURES: Independent indications are given of the effect of balancing either the reactive or the resistive bridge control separately. This adds considerably to the speed and convenience of routine bridge measurements, and permits either bridge control to be balanced accurately without necessitating an accurate balance of the other. Indication is also given of the direction of balance of either one of the bridge controls, chosen at will.

This null indicator cannot be injured by overloading and is instantaneous in response and recovery. External fields do not affect its operation, and it radiates no appreciable field.

For bridge balancing, it is less fatiguing than headphones and can be used in noisy locations.

SPECIFICATIONS

Input Impedance: One megohm.

Sensitivity: 100 μv at 60 cycles; 200 to 300 μv at 1000 cycles.

Selectivity: 40 decibels against second harmonic.

Frequency Range: Plug-in units tune the amplifier for any desired operating frequency between 20 and 2000 cycles. Continuous tuning range $\pm 5\%$ for each unit.

Controls: Panel controls are provided for adjusting the focus and brilliance of the cathode-ray pattern, the phase and amplitude of the horizontal sweeping voltage, and the gain, selectivity, and tuning of the amplifier.

Accessories Supplied: One power cord and one shielded input cord.

Accessories Required: One plug-in phasing circuit is used at any frequency below 400 cycles; one plug-in tuning unit. These are not included in the price of the instrument. (See price list on page 93.)

Power Supply: 115 volts, 40 to 60 cycles.

Power Input: 20 watts at 60 cycles.

Vacuum Tubes: One 6K7G pentode, one 6F8G twin triode, one 6J5G triode, one 913 cathode-ray tube, and one 6X5 rectifier; all are supplied with the instrument.

Mounting: Standard 19-inch relay-rack panel.

Dimensions: Panel, 19 x 7 inches; depth behind panel, 9 inches.

Net Weight: 30 $\frac{1}{2}$ pounds.

Type	Code Word	Price
707-A	NULTY	\$195.00

PATENT NOTICE. See Notes 1, 9, page v.

PLUG-IN UNITS FOR TYPE 707-A CATHODE-RAY NULL DETECTOR

These units are required for use with TYPE 707-A Cathode-Ray Null Detector and are not included in the price of that instrument.

A phasing unit is necessary for operation at any frequency *below* 400 cycles. At 400

cycles and above, none is required. A tuning unit is required for each operating frequency. The tuning range is ± 5 per cent.

All units plug into mounting jacks provided inside the null detector.

PHASING UNITS

<i>Type</i>	<i>Description</i>	<i>Code Word</i>	<i>Price</i>
707-P1	For Frequencies below 100 Cycles	NULLTECANT	\$7.00
707-P2	For Frequencies between 100 and 400 Cycles	NULLTECBOY	7.00

AMPLIFIER TUNING UNITS

<i>Type</i>	<i>Frequency</i>	<i>Code Word</i>	<i>Price</i>
707-P42	42 cycles	NULLTECCAT	\$25.00
707-P50	50 cycles	NULLTECDOG	25.00
707-P60	60 cycles	NULLTECEYE	25.00
707-P400	400 cycles	NULLTECFIG	25.00
707-P1000	1000 cycles	NULLTECGUM	25.00
707-P2000	2000 cycles	NULLTECHIM	25.00

Units designed for use at any other frequency may be supplied on order.

ACCESSORIES FOR TYPE 516-C RADIO-FREQUENCY BRIDGE

By changing the ratio arms and shielded transformer, the frequency range of the TYPE 516-C Radio-Frequency Bridge can be extended downward to frequencies as low as 60 cycles.

Ratio arms for frequencies other than 1 Mc are listed below. The resistance of the ratio arms is chosen to make the power factor dial read correctly at the frequency specified.

Transformers for other frequencies are

listed under TYPE 578 Transformer, page 95. These are fitted with plug bases to fit the jack plate in the bridge.

For frequencies below 150 kc, the TYPE 814-A Amplifier (page 110), used with a tuned circuit, and the TYPE 726-A Vacuum-Tube Voltmeter (page 116) are recommended for use as the bridge detector. At audio frequencies, headphones can be used.

RATIO ARMS FOR TYPE 516-C RADIO-FREQUENCY BRIDGE

<i>Type</i>	<i>Resistance</i>	<i>Frequency</i>	<i>Code Word</i>	<i>Price</i>
516-P2	10 Ω	10 Mc	ADAPTORANT	\$6.00
*516-P3	100 Ω	1 Mc	ADAPTORBUG	6.00
516-P4	1 k Ω	100 kc	ADAPTORPIG	6.00
516-P5	10 k Ω	10 kc	ADAPTORTOE	6.00
516-P6	100 k Ω	1 kc	ADAPTORTOP	8.00
516-P7	1667 k Ω	60 c	ADAPTORVIZ	15.00

SHIELDED TRANSFORMERS

<i>Type</i>	<i>Frequency Range</i>	<i>Code Word</i>	<i>Price</i>
*516-P10	500 kc - 10 Mc	ADAPTORWAY	\$8.00
578-AR	50 c - 10 kc	TABLEMOUNT	20.00
578-BR	20 c - 5 kc	TENORMOUNT	20.00
578-CR	2 kc - 500 kc	TEPIDMOUNT	20.00

*Furnished with the bridge.



TYPE 578 SHIELDED TRANSFORMER

USES: A shielded transformer is necessary in a direct-reading a-c bridge to isolate the bridge from changes of electrostatic potential in the external circuit and to reduce the effect of the capacitance of this external circuit to ground. Obviously, the transformer can be used to isolate the bridge from either generator or detector.

TYPE 578 Transformer has been designed for this application. It is also useful in other types of circuits to isolate measuring circuits from the generator and to produce a balanced output from a grounded generator.

DESCRIPTION: This transformer is provided with two shields, one around each winding. A third shield effectively grounds the core laminations. The accompanying diagram shows the arrangement of shields and the capacitances between elements.

FEATURES: The direct capacitance between windings is less than $0.3 \mu\mu\text{f}$. The capacitance placed across the bridge arms by the inter-shield capacitance is only $30 \mu\mu\text{f}$ in place of the large generator-to-ground capacitance which exists when no transformer is used. This small value of capacitance is obtained by maintaining an air space between primary and secondary shields, using eight hard rubber spacers 0.1-inch thick.

This shows the winding used in TYPE 578 Shielded Transformer. The capacitance between shields is kept at a low value by spacing the windings as shown.

Each transformer covers a wide range of frequency and load impedance, and can be used in either direction, i.e., can be used to step up or step down from generator to bridge. Used thus, the frequency range is 200 to 1 and the impedance range 100 to 1.

Transformers for intermediate frequency and impedance ranges can be supplied on special order.* A transformer similar to that used in the TYPE 716-A Capacitance Bridge can also be built to order.* (See page 72.) In this unit a fourth shield is placed between the two winding shields. With this shield, the case, and the core connected to the junction of the ratio arms, no extra capacitances are placed across the bridge arms whose junction is grounded.

*Prices on request.

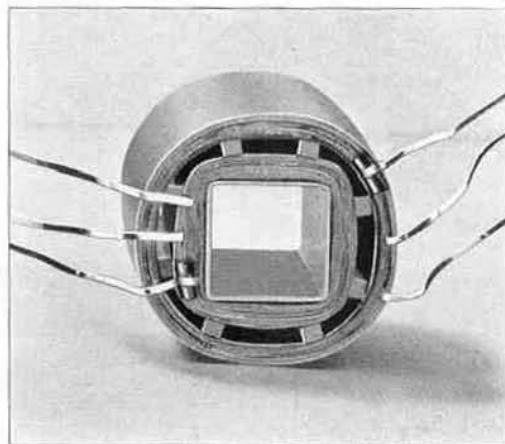

This diagram shows a grounded bridge supplied through a doubly-shielded transformer. When the case is grounded, the capacitance placed across each capacitance arm is $40 \mu\text{f}$. This value is known and is considerably smaller than the unknown generator-to-ground capacitance which usually exists when a transformer is not used.

SPECIFICATIONS

Ratio: The transformer has a turns ratio of 4:1. It may be used in either direction.

Frequency and Impedance Range: See table.

Capacitance: The direct capacitance between primary and secondary windings is less than $0.3 \mu\text{f}$; that between the primary and secondary shields is less than $90 \mu\text{f}$. Average values for the capacitances in the diagram at the right are:

C_1, C_2, C_5, C_6	each $200 \mu\text{f}$
C_3	$0.3 \mu\text{f}$
C_7, C_8	each $70 \mu\text{f}$
C_4	$30 \mu\text{f}$

Shielding: Each winding is separately shielded, and a third shield effectively grounds the core laminations.

Mounting: Three types of mounting are available: (1) mounted in a Model B case (see page 188) with windings and both shields brought out to soldering lugs; (2) same as (1) with a plug base for use in TYPE 516-C Radio-Frequency Bridge; (3) mounted in clamps with no external shield, leads terminated on soldering lugs. This model is for use where external shielding is provided by the user. All three types are illustrated on page 94.

Dimensions: Dimensions for Model B case are given on page 188. The over-all height of -R models is $5\frac{3}{8}$ inches, including plugs. Dimensions for -T models are $2\frac{3}{4} \times 2\frac{3}{4}$ x (height) $3\frac{7}{8}$ inches, over-all.

Net Weight: -R models, $2\frac{3}{4}$ pounds; all others, $2\frac{1}{2}$ pounds.

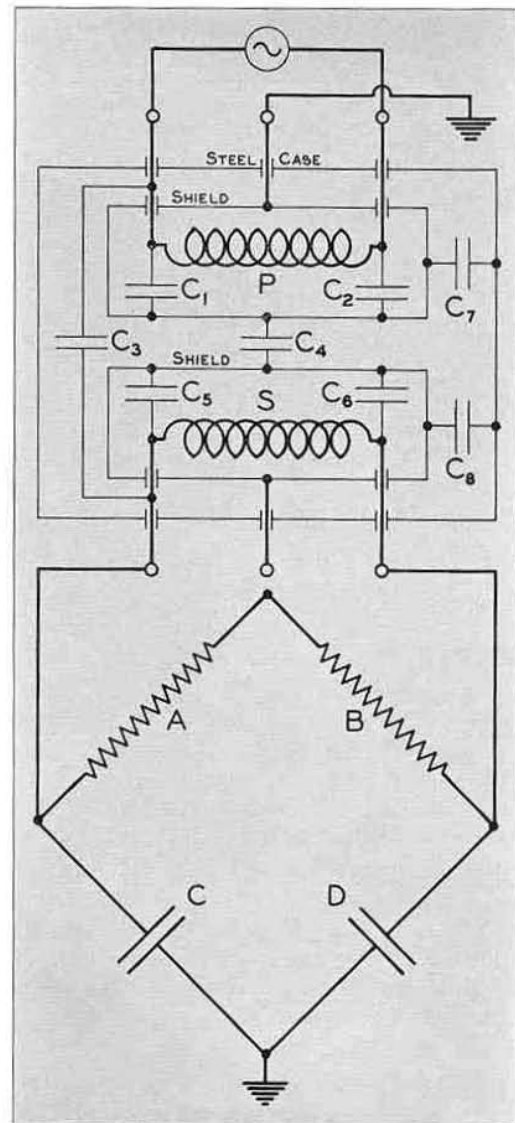

Type	Frequency Range*	Impedance Range*	
		Primary	Secondary
578-A, -AR, -AT	50 cycles to 10 kc	50 Ω to 5 k Ω	1 k Ω to 100 k Ω
578-B, -BR, -BT	20 cycles to 5 kc	60 Ω to 6 k Ω	1.2 k Ω to 120 k Ω
578-C, -CR, -CT	2 kc to 500 kc	20 Ω to 2 k Ω	0.4 k Ω to 40 k Ω

*These ranges are for transmission within 6 db. At extremes of both impedance and frequency ranges, the transmission may be down by 12 db.

Type	Mounting	Code Word	Price
578-A	Model B Case.....	TABLE	\$15.00
578-B	Model B Case.....	TENOR	15.00
578-C	Model B Case.....	TEPID	15.00
578-AR	Plug-in for TYPE 516-C Radio-Frequency Bridge.....	TABLEMOUNT	20.00
578-BR	Plug-in for TYPE 516-C Radio-Frequency Bridge.....	TENORMOUNT	20.00
578-CR	Plug-in for TYPE 516-C Radio-Frequency Bridge.....	TEPIDMOUNT	20.00
578-AT	Without case, in clamps.....	TABLEPLACE	12.50
578-BT	Without case, in clamps.....	TENORPLACE	12.50
578-CT	Without case, in clamps.....	TEPIDPLACE	12.50

TYPE 610-A RATIO-ARM BOX



USES: A ratio-arm box is a suitable nucleus around which to assemble any bridge circuit. When combined with suitable capacitance and inductance standards, any of the conventional bridge circuits can be set up.

DESCRIPTION: This box contains a pair of ratio arms giving ratios from 0.001 to 1000 in twelve steps, ranging in value from 1 to 1000 ohms. The switches, as well as the individual resistance cards used in the ratio-arm box, are similar to those employed in

TYPE 510 Decade-Resistance Units. (See description on pages 20 and 21.)

FEATURES: The individual ratio arms are brought out to separate pairs of terminals so that, if desired, they need not be adjacent arms in the bridge. The ground shield is extended between the ratio arms to eliminate capacitance between them. Links are provided for connection between the arms and to the shield.

SPECIFICATIONS

Resistances: Each arm, 1, 3, 10, 30, 100, 300, 1000 ohms.

Type of Winding: Ayrton-Perry, manganin wire.

Accuracy: Correct at box terminals to within 0.25% for 1-ohm, 0.15% for 3-ohm, and 0.1% for other units.

Switches: TYPE 510-P1, 7-point. Enclosed contacts.

Mounting: Switches and terminals mounted on black crackle-finish aluminum panel and enclosed in a shielded walnut cabinet.

Terminals: Jack-top binding posts with separate ground terminal.

Dimensions: (Length) $7\frac{3}{4}$ x (width) 5 x (height) $5\frac{1}{4}$ inches, over-all.

Net Weight: $3\frac{5}{8}$ pounds.

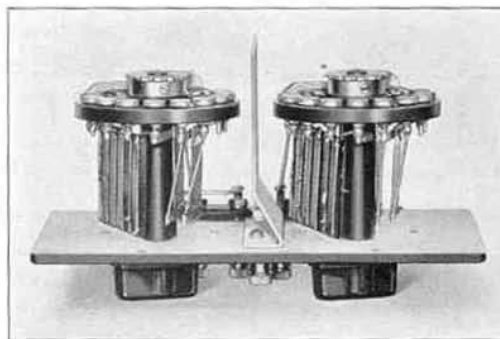

Interior view of the TYPE 610-A Ratio-Arm Box, showing the grounded shield.

Type	Code Word	Price
610-A	RABID	\$32.00

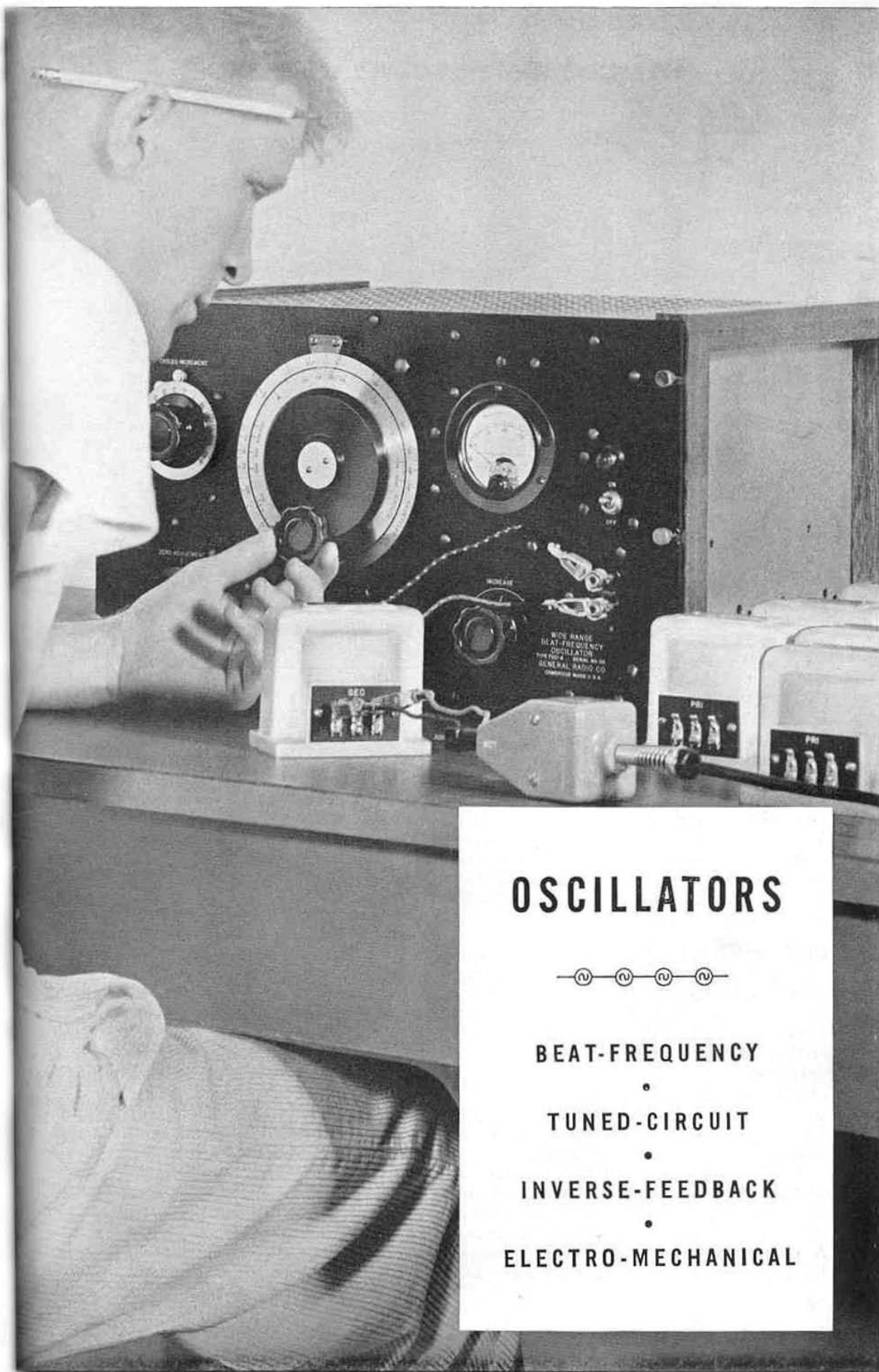

OSCILLATORS



BEAT-FREQUENCY

•

TUNED-CIRCUIT

•

INVERSE-FEEDBACK

•

ELECTRO-MECHANICAL

TYPE 713-B BEAT-FREQUENCY OSCILLATOR

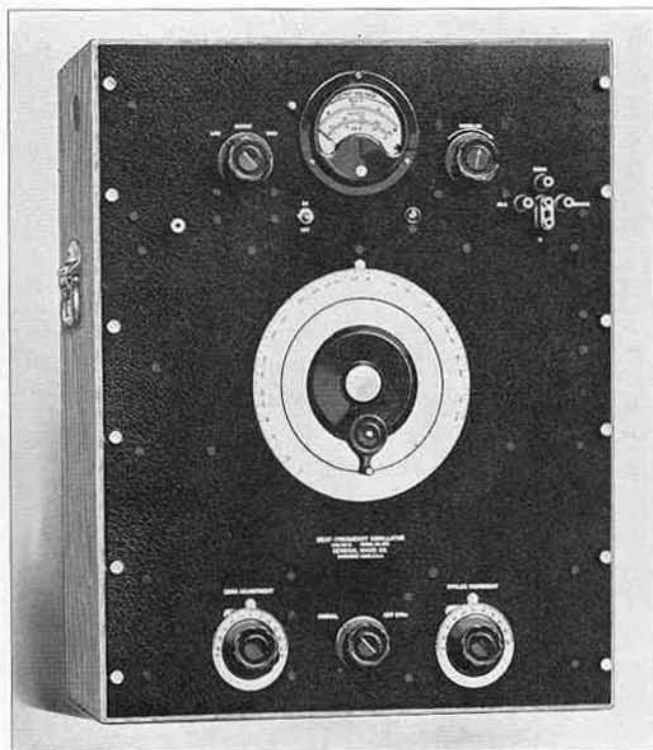

USES: The TYPE 713-B Beat-Frequency Oscillator is a convenient power source at audio and supersonic frequencies for studying the frequency characteristics of transformers, transmission lines, amplifiers, broadcast transmitters, and similar equipment. It is also an excellent generator for bridge measurements and general testing. Its power output is sufficient for use as a modulating source for signal generators where over-all fidelity tests are being made.

DESCRIPTION: In this instrument the outputs of two high-frequency oscillators are fed through a buffer amplifier into a balanced detector from which the difference or beat-frequency is obtained. This beat frequency is then amplified and is the low-frequency output of the system. The frequency of one of the oscillators is varied by means of a specially designed condenser, the plates of which are shaped to give a logarithmic variation of frequency with dial rotation.

A frequency range switch is provided so that the frequency of the fixed oscillator may be changed by 20 kilocycles to give an output frequency range from 20 to 40 kilocycles. A CYCLES INCREMENT dial also varies the fixed frequency over a narrow range. This

control allows small changes in frequency to be made easily at any frequency.

A degenerative audio amplifier is used, with the output tubes coupled through a doubly shielded transformer to a constant-impedance attenuator and a tapped autotransformer. The autotransformer provides three different output impedances and is enclosed in a shield to prevent hum pickup.

FEATURES: Among the more important features of this oscillator are its wide frequency range, 0 to 40,000 cycles, excellent waveform, and very low hum level. An improved output circuit with three impedances, which remain practically constant regardless of setting of the volume control, is also an outstanding feature. Furthermore, the output circuit may be operated either grounded or ungrounded.

Slightly over one watt of power may be obtained into a matched load, and the output voltage remains constant over a wide range of frequencies. A vacuum-tube voltmeter is provided for measuring the output voltage.

The large logarithmic dial facilitates the taking of frequency response data. The dial may be geared directly to a recorder using logarithmic or semi-logarithmic paper.

SPECIFICATIONS

Frequency Range: 0 to 40,000 cycles.

Frequency Control: The main control is engraved with a logarithmic frequency scale extending from 20 cycles to 20 kilocycles, the total scale length being approximately 17 inches. The frequency range switch extends the range to 40 kilocycles. There is also an incremental frequency control.

Frequency Calibration: The calibration may be standardized within 1 cycle at any time by setting the instrument to zero beat. The calibration of the frequency-control dial can be relied upon within $\pm 2\%$ ± 1 cycle after the oscillator has been correctly set to zero beat. The incremental frequency dial is marked with one division for every 1-cycle interval over a range of -50 to +50 cycles. Its calibration is correct to ± 2 cycles or better.

Frequency Stability: Adequate thermal insulation and ventilation are provided to minimize frequency drifts due to temperature changes. The oscillator may be accurately reset to zero beat at any time, eliminating errors caused by any small remaining frequency drifting.

Output Impedance: The output circuit is sufficiently well balanced for operating into the average audio-frequency transmission lines throughout the entire frequency range of the oscillator when using the 50-ohm output terminals. When using the 500-ohm output terminals, the balance is satisfactory up to 15 kilocycles. When using the 5000-ohm output terminals, the balance is satisfactory up to 3 kilocycles. Obviously, the output circuit may be operated ungrounded at higher frequencies than those specified, provided a close balance to ground is not necessary.

Output Power: One watt maximum when the output control is in the HIGH position; in the LOW position, approximately 0.02 watt maximum.

Output Voltage: Approximately 150 volts, open circuit. For a matched resistive load the output voltage varies by less than ± 0.5 db between 30 and 12,000 cycles, and by less than ± 1 db between 15 and 16,000 cycles.

Waveform: When the OUTPUT switch is on the LOW

position, the total harmonic content is less than 0.2% between 250 and 2000 cycles and less than 1% between 70 and 10,000 cycles. At 20 cycles the harmonic content is approximately 3%. When operating on the LOW output position, the harmonic content is practically unaffected by any load impedance between one-half of the rated value and an open circuit.

With the output switch on the HIGH position and with a matched load, the total distortion is less than 2% of the output voltage in the audio-frequency range above 70 cycles, regardless of the setting of the volume control. The harmonics increase to about 8% at 20 cycles.

A-C Hum: When the oscillator is operated from a 60-cycle line, the power-supply ripple is less than 0.1% of the output voltage for either position of the OUTPUT switch and for any value of output voltage which can be read on the panel voltmeter.

Voltmeter: A balanced vacuum-tube voltmeter is provided on the panel for indicating the output voltage of the oscillator.

Terminals: Jack-top binding posts with standard 3/4-inch spacing are provided for the output connections.

Mounting: This instrument is available in either an oak cabinet, with carrying handles, or a metal dust cover and shield for relay-rack mounting.

Power Supply: 105 to 125 volts, 40 to 60 cycles, ac. A simple change in the connections to the power transformer allows the instrument to be used on 210 to 250 volts. The total consumption is about 115 watts.

Tubes: The following tubes are supplied:

- 2 — Type 41
- 1 — Type 6D6
- 2 — Type 6C6
- 2 — Type 6L6
- 2 — Type 6H6
- 1 — Type 5T4

Accessories: A 7-foot connecting cord and spare fuses are supplied.

Dimensions: Panel, (width) 19 x (height) 24 1/4 inches, over-all. Cabinet size, including handles, (width) 20 1/2 x (height) 25 x (depth) 11 inches.

Net Weight: 93 pounds.

Type	Description	Code Word	Price
713-BM	Cabinet Model	DEBAR	\$485.00
713-BR	Relay-Rack Model	DETER	510.00

PATENT NOTICE. See Notes 1, 3, 10, page v.

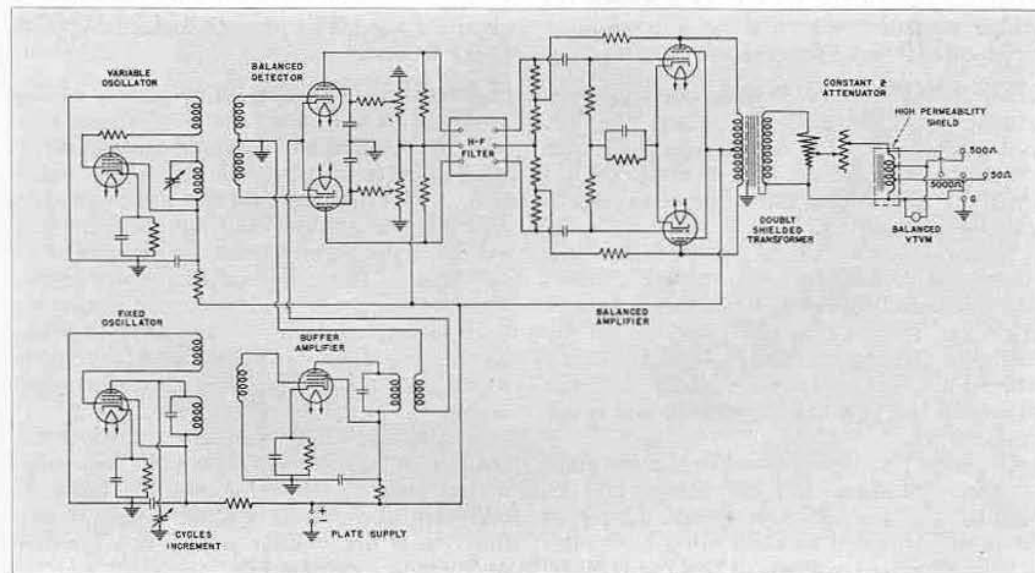

• OSCILLATORS

GENERAL RADIO CO.



TYPE 700-A WIDE-RANGE BEAT-FREQUENCY OSCILLATOR

USES: This oscillator is useful for taking selectivity curves on tuned circuits over a wide range of frequencies, for measuring the transmission characteristics of filters, and for testing wide-band systems such as television amplifiers and coaxial cables. The instrument is also an excellent general laboratory oscillator for use as a source for bridge measurements and as a modulator for standard-signal generators.

DESCRIPTION: Two high-frequency oscillators, one fixed and the other variable, feed a detector from which the difference frequency is obtained. The detector is followed by a low-pass filter and a two-stage wide-band amplifier.

Both oscillator circuits are mounted in a heavy cast-aluminum box to assure uniform heat distribution and practically perfect shielding. Two ranges are provided for by changing the frequencies of both the oscillators by a factor of one hundred. A single switch on the panel changes from one range to the other.

Degeneration is employed in the amplifier to minimize hum and distortion, and to equalize the frequency response. Low-pass filters are provided to maintain a high ratio of desired output voltage to beating voltage.

A pentagrid mixer tube and a buffer amplifier are used to isolate the two oscillators electrically.

An automatic volume control circuit is included for maintaining the output voltage constant with frequency, and a vacuum-tube voltmeter is used to measure the output voltage. A grounded potentiometer output circuit is used. The potentiometer is Ayrton-Perry wound.

FEATURES: The outstanding feature of this oscillator is the wide range of frequencies which is covered with a single control, direct reading in frequency. The frequency variation with dial setting is approximately logarithmic. Small variations in frequency can be made at any point by the use of an incremental frequency control which is also direct reading. A low-frequency range has been incorporated in the TYPE 700-A Wide-Range Beat-Frequency Oscillator for convenience in working in the audio-frequency range.

A constant delay voltage is used in the automatic volume control circuit. The automatic volume control therefore tends to maintain the output voltage constant as a function of line voltage as well as a function of frequency and load.

SPECIFICATIONS

Frequency Range: Two ranges are provided: 50 cycles to 40 kilocycles, and 10 kilocycles to 5 megacycles.

Frequency Control: The main dial is direct reading in frequency and carries two approximately logarithmic frequency scales covering the ranges specified above. A frequency range switch is provided for rapidly changing from one range to the other. There is also an incremental frequency control which is calibrated between -100 and +100 cycles on the low range and -10 and +10 kilocycles on the high range. Any frequency change made with this control adds algebraically to the frequency of the main control.

Frequency Calibration: The calibration may be standardized at any time by setting the instrument to zero beat with the zero adjustment control. This adjustment can be made within 5 cycles on the low range or 500 cycles on the high range.

After the oscillator has been correctly set to zero beat, the calibration of the main frequency-control dial can be relied upon within $\pm 2\% \pm 5$ cycles on the low range and $\pm 2\% \pm 500$ cycles on the high range. The calibration of the incremental frequency dial is within ± 5 cycles or ± 500 cycles on the low and high ranges, respectively.

Frequency Stability: Through careful design adequate thermal distribution and ventilation are provided for minimizing frequency drifts. The oscillator can be accurately reset to zero beat at any time, thereby eliminating errors caused by any small remaining frequency drifting.

Output Impedance: The output is taken from a 1500-ohm Ayrton-Perry-wound potentiometer. One output terminal is grounded.

Output Voltage: The maximum open-circuit output voltage of the oscillator is between 10 and 15 volts. Because of the automatic volume control circuit, this voltage remains constant within ± 1.5 decibels over each entire frequency range.

Waveform: The total harmonic content of the open-circuit voltage is less than 3% for frequencies above 200 cycles on the low range and above 20 kilocycles on the high range.

A-C Hum: When the oscillator is operated from a 60-cycle line the power-supply ripple is less than 2% of the output voltage on either range.

Voltmeter: A vacuum-tube voltmeter circuit is used in the oscillator for measuring the output voltage. The indicating meter on the panel is calibrated directly in volts at the output terminals.

Controls: In addition to the main frequency-control dial and the incremental frequency dial, there is a frequency range switch, and a zero beat adjustment. The output voltage is varied by a potentiometer control provided near the output terminals.

Terminals: The output terminals are jack-top binding posts with standard $\frac{3}{4}$ -inch spacing. The lower terminal is grounded to the panel and shields.

Mounting: The instrument is normally supplied for table mounting, but can be easily adapted for relay-rack mounting by removing two walnut brackets at the ends of the panel.

Power Supply: A-C power supply, 110 to 120 volts, 40 to 60 cycles, is used. A simple change in the connections to the power transformer allows the instrument to be used on 220 to 240 volts.

The total power consumption is approximately 85 watts.

Tubes: The following tubes are used:

- 2 — Type 6C5
- 1 — Type 6J7
- 1 — Type 6L7
- 2 — Type 25L6
- 1 — Type 6H6
- 1 — Type 5T4

All tubes are supplied.

Accessories: A 7-foot power cord, spare fuses, and a TYPE 274-ND Plug are supplied.

Dimensions: Panel, (width) 19 x (height) 10½ inches, over-all; depth behind panel, 11 inches.

Screw holes in the panel are the standard spacing for mounting the instrument in a standard 19-inch relay rack.

Net Weight: 55 pounds.

Type	Code Word	Price
700-A	ORGAN	\$555.00

PATENT NOTICE. See Notes 1, 10, page v.

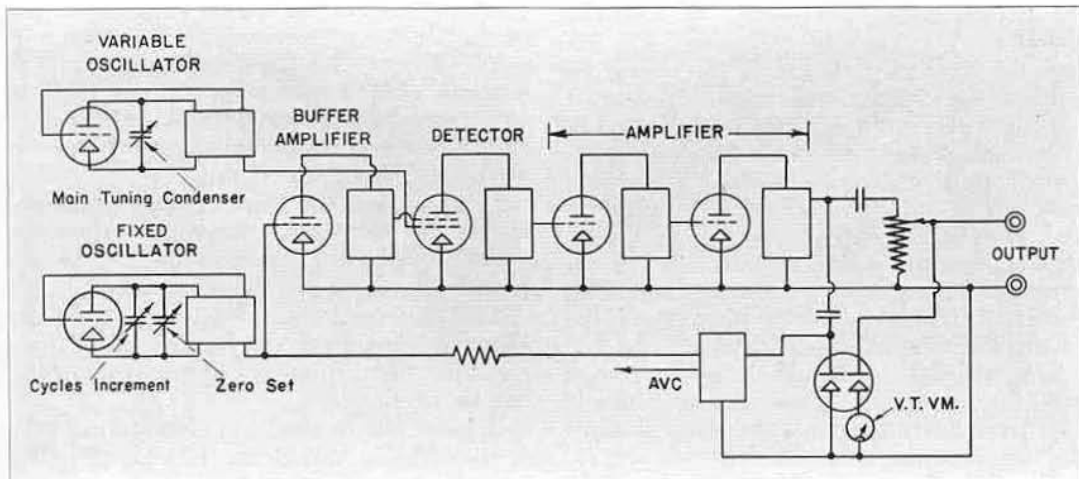

Functional schematic diagram of the TYPE 700-A Wide-Range Beat-Frequency Oscillator.

• OSCILLATORS

GENERAL RADIO CO.

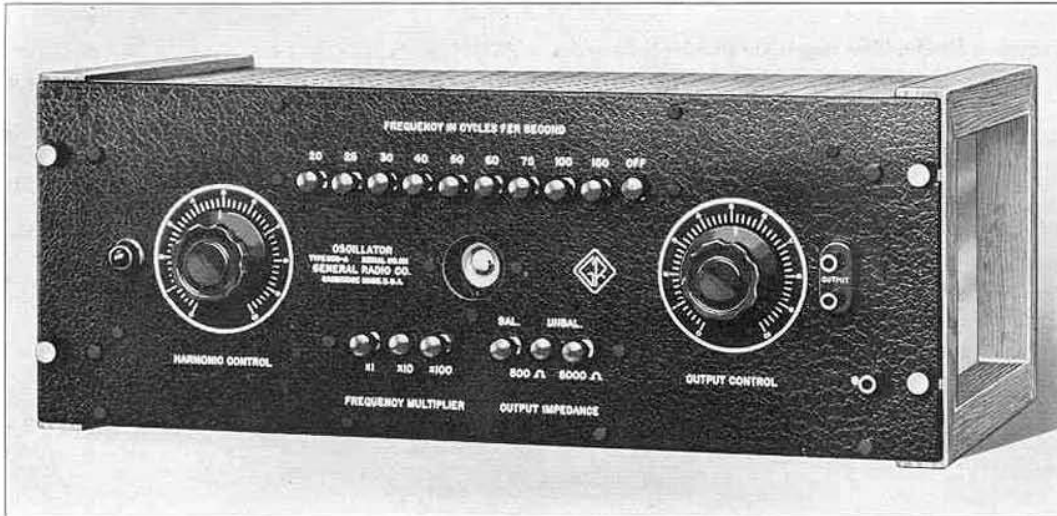

TYPE 608-A OSCILLATOR

USES: The TYPE 608-A Oscillator was designed particularly for use as a tone source for distortion measurements and a power source for bridge measurements at audio frequencies. Because of the large number of frequencies at which this oscillator will operate, it is also satisfactory for measuring frequency characteristics and for use as a general laboratory oscillator.

The output frequencies obtainable include those generally used in distortion measurements on broadcast transmitters.

The unusually pure waveform delivered by this oscillator at low frequencies makes distortion measurements possible at considerably lower frequencies than have hitherto been practicable.

DESCRIPTION: This oscillator operates on the inverse feedback principle. By means of a resistance capacitance network all frequencies except the oscillation frequency are fed from the output of an amplifying circuit back into the input in such a manner as to cancel the gain at all but the oscillation frequency. Sufficient regeneration is introduced into the circuit to produce self-oscillation and, since this is controlled by the resistance-capacitance network, no inductances or transformers are required in the oscillating circuit. A functional block diagram of the circuit is shown on the next page.

The amount of feedback is controlled from the panel, and an electron-ray tube is used to indicate the strength of oscillations and the harmonic content.

The desired frequency is selected by push-button switches. Another push-button switch

determines the output impedance. An output control is provided for regulating the output voltage.

FEATURES: Both electrically and mechanically the design of this oscillator is new and represents a considerable advance over previous practice.

In the electrical circuit, the principle of inverse feedback is applied to the production of electrical oscillation with the result that a high power output is obtained with low distortion. Since the feedback circuit is highly selective, the frequency of the oscillator is unusually stable. The absence of iron-core inductances minimizes the amount of power-supply hum picked up by the circuit elements.

An outstanding mechanical feature is the push-button system for selecting the frequency.

The TYPE 608-A Oscillator will operate at any one of 27 frequencies, ranging from 20 to 15,000 cycles per second, and the frequency can be changed rapidly and simply by means of the push-button switches.

Provision is made for obtaining frequencies within the range, but other than those for which push-buttons are provided, by merely plugging in three external resistances.

For any additional frequency three resistors are required, and for any set of three resistors, three frequencies, in decade steps, can be obtained.

A harmonic control and electron-ray tube are provided so that the unit can be adjusted for minimum distortion under all conditions of operation.

SPECIFICATIONS

Frequency Range: 20 to 15,000 cycles.

Frequency Control: The frequency is controlled by two push-button switches. The first provides frequencies of 20, 25, 30, 40, 50, 60, 75, 100, and 150 cycles, while the second multiplies these frequencies by 1, 10, and 100. The frequencies included cover practically the entire audible range in increments small enough so that oscillator may be used for measuring frequency characteristics. Furthermore, these frequencies include all important standard bridge and broadcast test frequencies.

Other frequencies within the operating range of the instrument may be obtained by plugging in external resistances.

Frequency Calibration: Each instrument is adjusted within $\pm 2\%$ or 1 cycle, whichever is the greater, of the frequency engraved on the panel. The best accuracy is secured when the harmonic control is adjusted for low distortion.

Frequency Stability: When this oscillator is operated at normal room temperatures, the frequency will not drift by more than 1% over a period of several hours. The harmonic control provides a means whereby the operating conditions of the oscillator may be brought back to the correct values regardless of ordinary changes in load or line voltage.

Output Impedance: Three output circuits are provided. Selection among them is obtained by means of a push-button switch on the panel. The output impedances are as follows:

1. 500-ohm balanced to ground.
2. 500-ohm unbalanced.
3. 5000-ohm unbalanced.

The volume control is a potentiometer in the 5000-ohm circuit. The actual output impedance of the 5000-ohm output circuit will vary between 1000 and 8500 ohms, depending upon the setting of the volume control. Suitable resistance pads keep the impedance of the 500-ohm output circuit between 400 and 600 ohms regardless of the volume control setting.

Output Power: The 5000-ohm output circuit provides an output power of approximately 0.5 into a matched load watt when the instrument is operated on a 115-volt line. The maximum power obtainable from the 500-ohm output circuit is approximately 80 milliwatts.

Waveform: With the harmonic control turned full on, and the oscillator delivering its maximum power output, the harmonics will be approximately 5% of the output voltage.

The harmonic control provides a means of obtaining unusually pure waveform at some sacrifice in output voltage. When this control is adjusted to reduce the output voltage by approximately 10%, the total harmonic content will be reduced to approximately 0.2% of the fundamental voltage. A further reduction in the output voltage reduces the total harmonic content to less than 0.1% for all output frequencies on the 5000-ohm output circuit. Because of the impedance-matching transformer, the harmonic distortion on the 500-ohm output terminals is slightly greater at frequencies below 50 cycles.

Hum Level: When the oscillator is properly grounded

and operated from a 60-cycle line, the hum level is less than 0.05% or 0.1 millivolt, whichever is the greater.

Controls: In addition to the push-button switches for adjusting the frequency and the output impedance, harmonic output controls are provided on the panel. An electron-ray tube provides a means for adjusting the harmonic control correctly under all conditions of operation. Except where minimum harmonic distortion is an absolute necessity, the harmonic control need not be readjusted.

Terminals: Jack-top binding posts with standard $\frac{3}{4}$ -inch spacing are provided for the output connection. A ground terminal is also provided.

Mounting: The instrument is designed for either table or relay-rack mounting. The wooden ends supplied with the oscillator are removed when it is used on a relay rack. A perforated metal shield is provided.

Power Supply: 110 to 120 volts, 25 to 60 cycles, ac. A simple change in the connections to the power transformer allows the instrument to be used on 220 to 240 volts. The total power consumption is approximately 60 watts.

Tubes: The following tubes are used: 1 6F5G, 1 6Y6G, 1 6X5G, 1 6E5. A complete set of tubes is supplied with each instrument.

Accessories: A 7-foot connecting cord and spare fuses and pilot bulb are supplied.

Dimensions: (Length) $19\frac{1}{2}$ x (depth) $11\frac{1}{2}$ x (height) $7\frac{3}{8}$ inches, over-all. Panel, 19 x 7 inches.

Net Weight: 35 pounds.

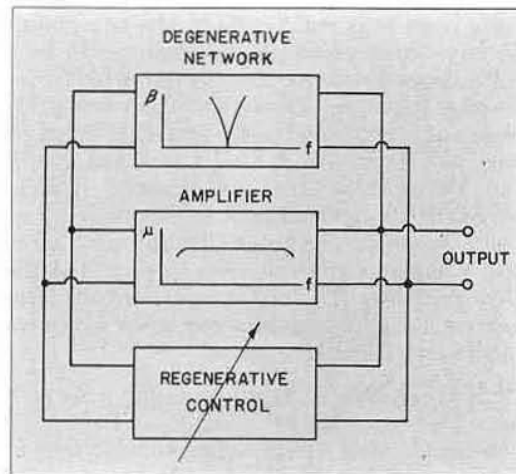

Functional schematic diagram of TYPE 608-A Oscillator. The amplifier, which has a propagation constant μ , is made degenerative, except at the frequency of oscillation, by means of the network with propagation constant β , thus providing a sharply selective circuit. Sufficient regeneration is provided to cause self-oscillation.

Type	Code Word	Price
608-A	ORBIT	\$260.00

PATENT NOTICE. See Notes 1, 9, page v.

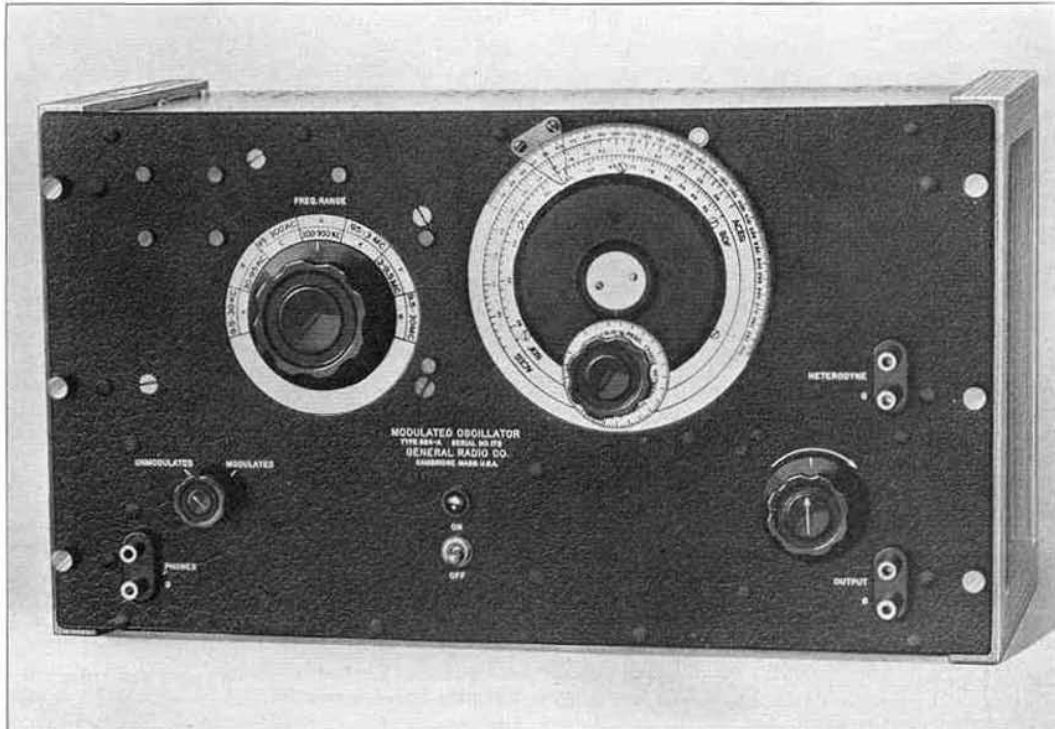

TYPE 684-A MODULATED OSCILLATOR

USES: This wide range radio-frequency oscillator is an important item in the equipment of any communication laboratory. It is a suitable power source for impedance measurement at high frequencies by either bridge or resonant-circuit methods, and can be used with the TYPE 721-A Coil Comparator and the TYPE 516-C Radio-Frequency Bridge. Frequency measurements to an accuracy of one per cent can be made with this oscillator, and a heterodyne detector is provided for this purpose. The 1000-cycle output frequency is useful in audio-frequency measurements and testing.

DESCRIPTION: A master oscillator, which uses the same tuned circuit as the TYPE 605-B Standard Signal Generator, is followed by an amplifier which also acts as a buffer to isolate the output circuit from the oscillator. A 1000-cycle modulating oscillator is provided, and a 1000-cycle voltage is available at terminals on the panel.

The main frequency control is a TYPE 739-B Condenser which gives a logarithmic variation in frequency with angular rotation of the dial. The frequency ratio for each range is equal to $\sqrt{10}$, and seven bands are used to cover the frequency range of 9.5 kc to 30 Mc. The condenser dial reads directly in frequency.

A heterodyne detector is built into the instrument, and terminals are provided for introducing unknown frequencies which can then be measured by the heterodyne method.

A removable power supply is used in order that the instrument may be easily converted from a-c to battery operation and vice versa.

FEATURES: The TYPE 684-A Modulated Oscillator furnishes a wide range of frequencies without the bother of plug-in coils. The ability to change the frequency rapidly and the direct-reading frequency dial save a considerable amount of time in measurements.

The main tuning dial is driven by a slow-motion vernier which is calibrated in percentage frequency change. This control is very useful in obtaining small known changes in frequency.

The output of the oscillator is ample for measurement purposes. The oscillator circuit has been designed for frequency stability and a voltage-regulated power supply minimizes frequency and output changes caused by line voltage fluctuations.

The general usefulness of the oscillator is greatly increased by the inclusion of a heterodyne detector and a 1000-cycle generator.

SPECIFICATIONS

Carrier Frequency Range: 9.5 kilocycles to 30 megacycles, direct reading; 30 to 50 megacycles, not direct reading.

Frequency Calibration: Direct-reading dial accurate to $\pm 1\%$ up to 10 Mc and accurate to $\pm 2\%$ up to 30 Mc. A correction curve is supplied for the 10- to 30-Mc range, yielding an accuracy of calibration of $\pm 1\%$. A frequency calibration curve is supplied for the 30- to 50-Mc range.

Open Circuit Output Voltage: 15 to 25 volts up to 2 Mc, decreasing with frequency to 1.0 volt at 30 Mc, when using the a-c supply or 225-volt battery plate supply. This output is approximately halved when using a 135-volt battery plate supply.

Output Impedance: Essentially 1800 Ω shunted by 35 μf .

Modulation: Internal modulation of about 35% at 1000 cycles ($\pm 5\%$) controlled by switch.

1000-Cycle Tone: A 1000-cycle ($\pm 5\%$) voltage of 10 or 20 volts (depending on power supply) is available at the PHONE terminals. The output impedance for this frequency is 20 k Ω .

Heterodyne: A heterodyne detector for checking frequencies is built into the instrument.

Controls: A frequency-range switch and the main tuning dial determine the output frequency. A slow-motion drive, which carries a dial calibrated in divisions representing a change of 0.1% in the frequency, is used on this frequency-control dial. A modulation control turns the modulation on or off, and an output control regulates the output voltage.

Power Supply: Either a-c operation or battery operation is possible. The a-c power supply operates from 40- to 60-cycle lines of 110 to 120 volts, but connections on the transformer can be easily changed for use on 220 to 240 volts. The power supply includes a voltage regulator to compensate for ordinary line voltage fluctuations.

With the battery model, a battery control panel is supplied which provides filters and connections for an external 6-volt battery and for an external 225-volt

"B" battery. If desired, three 45-volt "B" batteries can be installed inside the instrument.

Power Consumption:

A-C Operation: 60 watts.
 Battery Operation: 6 volts, 1.2 amperes; 135 volts, 20 ma or 225 volts, 40 ma.

Shielding: Sufficient shielding has been provided to permit the use of the instrument for bridge measurements.

Mounting: The instrument is supplied for table mounting, but can be easily adapted for relay-rack mounting by removing two brackets at the ends of the panel.

Either power supply is mounted directly in the instrument.

Terminals: Jack-top binding posts with standard $\frac{3}{4}$ -inch spacing are provided for the output and for listening for heterodyne beats. The lower terminals are grounded to the panel and shield.

Tubes:

- With battery supply:
 - One 89-type
 - Two 76-type
- With a-c supply:
 - One 5Z4-type
 - One 6F6-type
 - One 6F5-type
 - Four type T-4 $\frac{1}{2}$ neon lamps
 - One 89-type
 - Two 76-type

All necessary tubes are furnished.

Accessories Supplied: One each of TYPE 274-M, 274-ND, and 274-NE.

One 7-foot cable for line connection, with TYPE 684-P1 Power Supply.

One 10-foot shielded cable for battery connection, with TYPE 684-P10 Battery Supply Panel.

Weight:

- With a-c power supply: 47 pounds.
- With battery supply panel: 38 pounds.

Dimensions: 19 $\frac{1}{2}$ inches wide, 10 $\frac{1}{2}$ inches high, 11 inches deep, over-all. Panel, 19 x 10 $\frac{1}{2}$ inches.

Type	Description	Code Word	Price
684-A	Oscillator with a-c Power Supply, 115 or 230 Volts, 40 to 60 Cycles.....	BANJO	\$340.00
684-A	Oscillator with Battery Supply Panel.....	BANDY	320.00

PATENT NOTICE. See Notes 1, 10, page v.

Schematic wiring diagram of TYPE 684-A Modulated Oscillator. The power supply is omitted for purposes of simplicity, as is the switching system for using the modulator tube as a detector.

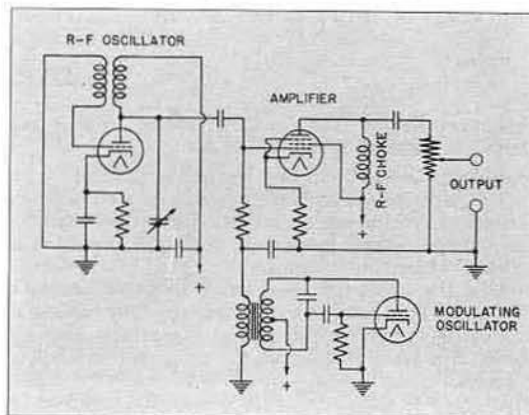

TYPE 613-B BEAT-FREQUENCY OSCILLATOR

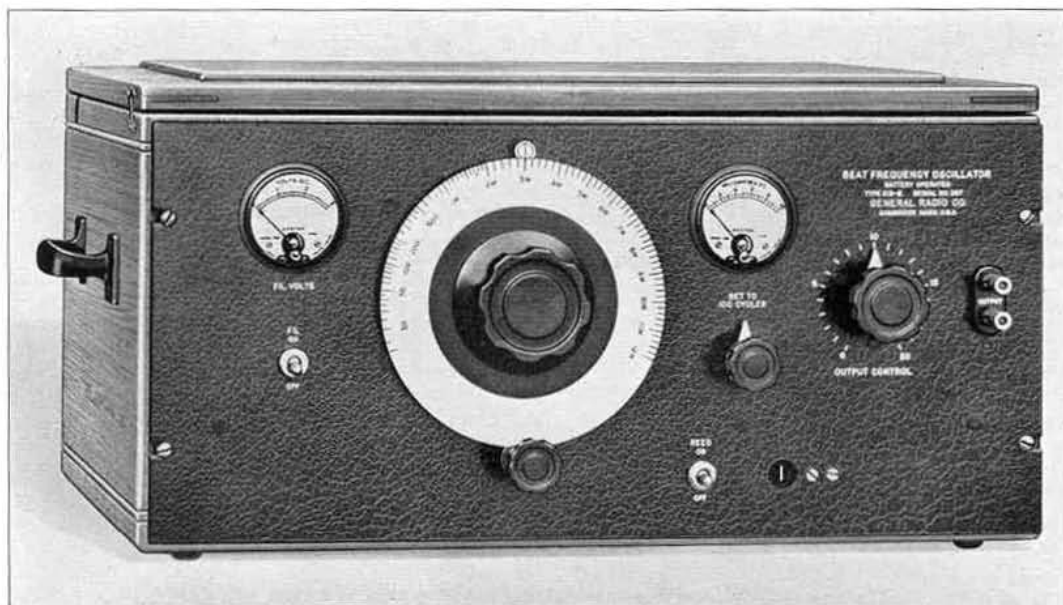

USES: For applications where portability is a major consideration and where a convenient, low-power audio oscillator is desired, the TYPE 613-B Beat-Frequency is very useful. Thus, it is valuable in physiological and psychological research at audio frequencies, especially when used with the TYPE 539-P Incremental Pitch Condenser. (See page 108.) Being battery operated, the oscillator has a low capacitance to ground, and hence can be used as a power source for ungrounded bridges, such as the TYPE 650-A Impedance Bridge.

DESCRIPTION: As can be seen from the schematic diagram, this oscillator is similar in principle of operation to the larger TYPE 713-B Oscillator in that the output of two high frequency oscillators is fed into a detector which is followed by a low-pass filter. One stage of audio amplification is then used,

following the detector, to provide the necessary power output.

The output frequency is read directly from a large dial which has been pre-engraved with the frequency calibration. The scale is spread out to facilitate the setting and reading of the scale markings. The calibration can be standardized at any time by means of a one-hundred-cycle tuned reed which is placed behind a hole in the panel.

Space has been provided in the cabinet for the necessary batteries or for the TYPE 613-P1 Power Supply which converts the oscillator for a-c operation.

FEATURES: Low harmonic content and good frequency stability are among the features of this compact and portable oscillator. The instrument also has a convenient open scale which is spread out over nearly 14 inches.

SPECIFICATIONS

Frequency Range: The frequency-control dial is calibrated between 10 cycles and 12,000 cycles.

Frequency Calibration: The frequency calibration can be standardized at any time by setting the main tuning control to the 100-cycle graduation and then adjusting the compensating condenser until the tuned reed vibrates at maximum amplitude.

After the oscillator has been correctly adjusted at 100 cycles by means of the tuned reed, the calibration can be relied upon within 2% at frequencies above 80 cycles. For lower frequencies the error will be less than 3 cycles.

Frequency Stability: The high-frequency oscillators are stable, and under uniform temperature conditions the

beat frequency will stay within a few cycles over a period of several hours. Changes in ambient temperature will cause slight changes in frequency because of the temperature coefficient of the tuned circuits. When a drift in frequency is observed, it can be corrected by readjusting for maximum amplitude of the tuned reed.

Output Impedance: The output impedance is 5000 ohms. One terminal of the output is grounded.

Output Voltage and Power: The maximum open-circuit output voltage is approximately 16 volts. This voltage remains constant within ± 1.5 decibels over the entire frequency range.

The maximum power output varies slightly with different instruments but is approximately 15 milliwatts.

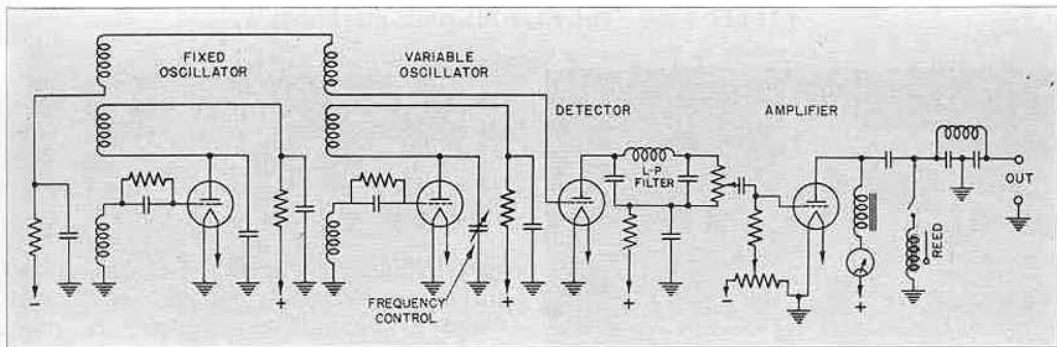

Waveform: On open circuit the total harmonic content is less than 2% of the fundamental above 100 cycles. With a 5000-ohm load it is less than 5% above 100 cycles; below 100 cycles it increases rapidly as the frequency is reduced.

Controls: In addition to the main tuning control and the auxiliary control for adjusting to the 100-cycle reference frequency, there are the output voltage divider and the filament and tuned-reed ON-OFF switches.

Meters: A filament voltmeter and a detector plate-current meter are mounted on the panel.

Tubes: Three 30-type and one 31-type tubes are used and are supplied as initial equipment.

Terminals: Two binding posts on the panel are provided for making connections to the oscillator.

Power Supply: Space for mounting three 45-volt plate batteries and two No. 6 dry cells for filament supply is provided inside the cabinet. No batteries are supplied.

The TYPE 613-P1 Power Supply (see below), for a-c operation, will also fit into this compartment.

Mounting: The instrument is mounted on an aluminum panel finished in black crackle lacquer and contained in a polished walnut cabinet with carrying handles.

Dimensions: Panel, (width) 19 x (height) 8³/₄ inches. Cabinet, (width) 22 x (height) 12¹/₄ x (depth) 9 inches, over-all.

Net Weight: 33¹/₄ pounds without batteries.

Type	Code Word	Price
613-B	NAVAL	\$210.00

PATENT NOTICE. See Notes 1, 3, 10, 17, page v.

TYPE 613-P1 POWER SUPPLY

USES: When the TYPE 613-B Beat-Frequency Oscillator is operated in a laboratory where alternating current is available, the TYPE 613-P1 Power Supply is a very convenient battery eliminator for use with the instrument.

DESCRIPTION: The filament supply is obtained from an oxide rectifier whose output is completely filtered to eliminate hum. The high-voltage supply is voltage regulated by means of a vacuum-tube circuit which follows the conventional rectifier and filter.

The entire unit is so built that it fits into the battery compartment of the TYPE 613-B Beat-Frequency Oscillator. Binding posts are

provided for convenience in making the necessary connections.

FEATURES: The elimination of frequent battery replacements when the oscillator is being used constantly in a laboratory is the great advantage obtained when this power supply is used. And since the power supply can be slipped into the battery compartment without being permanently installed, the shift from a-c to battery operation and vice versa can be made in a few moments. The performance of the oscillator is in no way lowered since the power supply has a voltage regulator circuit, and the hum voltage in the output is very low at all times.

SPECIFICATIONS

Output: 2 volts at 0.3 ampere, and 135 volts at 8.5 milliamperes.

Regulation: The high voltage varies between 134 and 137 volts as the line voltage is varied from 100 to 130 volts.

A-C Hum: The hum voltage in the oscillator output is less than 5 millivolts when the line frequency is 50 to 60 cycles. The hum voltage rises slightly for lower line frequencies.

Input: The power supply will operate on 100- to 130-volt supplies of from 25 to 60 cycles. The input power is approximately 15 watts.

Control: An ON-OFF switch is provided.

Tubes: One 6X5, one 6C5, and one T-4¹/₂ neon lamp are used. All tubes are supplied.

Terminals: Binding posts are provided.

Mounting: Sheet aluminum frame and base to fit battery compartment of TYPE 613-B Beat-Frequency Oscillator.

Accessories: Line cord, spare fuses, and a spare neon lamp are furnished.

Dimensions: 13¹/₂ x 8³/₈ x 2⁵/₈ inches, over-all.

Net Weight: 12¹/₂ pounds.

Type	Description	Code Word	Price
613-P1	A-C Power Supply	POWPACKANT	\$70.00

• OSCILLATORS

TYPE 572-B MICROPHONE HUMMER

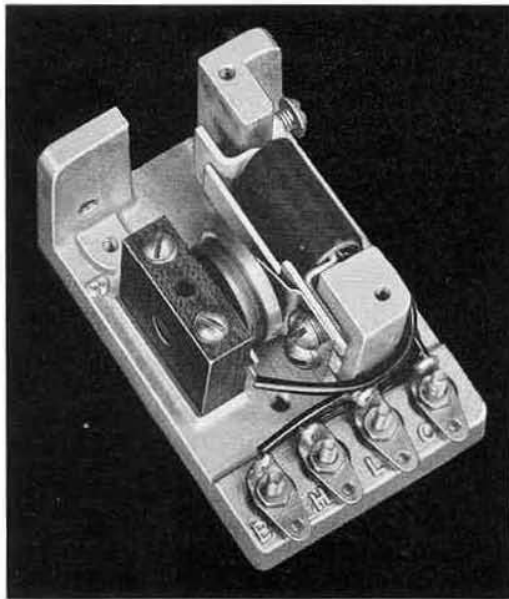

oscillator. A microphone button is mounted near the reed to pick up energy for continuing the oscillations. Mounting holes are provided on the cast aluminum mounting base for a 0.5 μ f condenser which can be added for improving the waveform of the output.

FEATURES: The TYPE 572-B Microphone Hummer is extremely compact, convenient, simple to use, and inexpensive.

SPECIFICATIONS

Frequency: 1000 cycles \pm 10%.

Output Power: Approximately 15 milliwatts with 4½-volt drive.

Internal Output Impedance: Two impedances are available, 10 or 300 ohms.

Power Supply: The hummer is designed to operate from a 4½-volt battery. A 6-volt drive may be used if more power is desired.

Terminals: Soldering lugs are provided.

Mounting: A cast-aluminum mounting base is used. (See sketch).

Dimensions: (Length) 3¼ x (width) 2⅛ x (height) 1⅝ inches, over-all.

Net Weight: 9 ounces.

USES: The hummer is intended for use as a low-power a-c source for bridge and other measurements where extreme purity of waveform and frequency stability are not essential. It is used in the TYPE 650-A Impedance Bridge as the 1000-cycle internal generator.

DESCRIPTION: A tuned reed determines the frequency of this electro-mechanical

Type	Code Word	Price
572-B	APHIS	\$10.00

TYPE 539-P INCREMENTAL-PITCH CONDENSER

USES: In many psychological tests it is often desirable to change the frequency by small known amounts at any point in the audio range. The TYPE 539-P Incremental-Pitch Condenser when connected to the TYPE 613-B Oscillator is used for producing such changes.

DESCRIPTION: This condenser is identical in construction with the mounted TYPE 539 Condensers described on page 48.

FEATURES: The TYPE 539-P Condenser is a convenient attachment for obtaining small frequency increments from the TYPE 613-B Beat-Frequency Oscillator.

SPECIFICATIONS

Calibration: 0 to 100 cycles, frequency increase, in steps of one cycle.

Dimensions: Panel, 6½ x 6½ inches; height, 8¾ inches, over-all.

Construction: Identical with the mounted TYPE 539 Condensers. (See page 48.) Continuous rotation is possible and the unit may be driven by a motor for producing "warble" tones.

Net Weight: 6¼ pounds.

Type	Description	Code Word	Price
539-P	Incremental-Pitch Condenser	AUDIT	\$50.00*

*Price includes necessary modifications to TYPE 613-B Beat-Frequency Oscillator, calibration, and also a shielded connecting cable.

TYPE 813 AUDIO OSCILLATOR

USES: A compact, fixed-frequency, and stable oscillator, such as the TYPE 813, is useful as a power source for alternating current bridges, as a modulating source for signal generators, radio beacons, and similar equipment, and as a source for transmission measurements on lines and cables.

DESCRIPTION: This instrument is a battery-operated electro-mechanical oscillator in which the frequency is determined by a tuning fork. Two microphone buttons, one for the driving circuit and one for the output circuit, are mounted at the side of the fork in such a manner as to load the tines equally and to affect only slightly the free vibration of the fork.

The fork itself is mounted rigidly at the heel beneath a metal base panel which carries the driving electromagnet. This base panel is suspended from the bakelite panel with four resilient mountings.

A filter and output transformer are placed inside the cabinet underneath the fork. A battery compartment is also provided al-

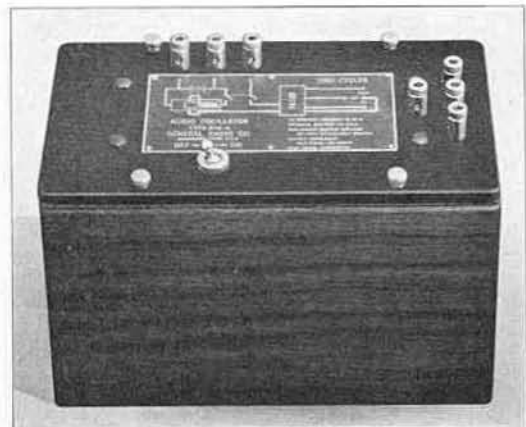

though external batteries may be used, if desired.

FEATURES: Excellent waveform and frequency stability are among the features of this convenient tuning-fork oscillator. The mechanical construction is rugged and the fork is protected from dirt and external injury.

SPECIFICATIONS



View of the interior of TYPE 813-A Audio Oscillator showing the tuning fork and its mounting. Inside the cabinet are a filter and an output transformer.

Frequency: Two models are available, one operating at 1000 cycles and one at 400 cycles, but special instruments can be constructed for any frequency between

300 cycles and 1000 cycles. Designs for multiples of 100 cycles are on file; prices on request.

Frequency Stability: The temperature coefficient of frequency is -0.007% per degree F. The voltage coefficient is less than 0.01% per volt. The frequency is entirely independent of load impedance.

Accuracy: The frequency is adjusted within 0.5% of its specified value. The actual frequency is measured and recorded on the base of the cabinet to an accuracy of 0.1% .

Output: The output to a matched load impedance is 20 to 30 milliwatts with 6-volt drive and 10 to 15 milliwatts with $4\frac{1}{2}$ -volt drive. The output is somewhat less on special forks having frequencies greater than 1000 cycles.

Internal Output Impedance: Output impedances of 50, 500, and 5000 ohms are provided.

Waveform: The total harmonic content is approximately 1% with $4\frac{1}{2}$ -volt drive and approximately 1.5% with 6-volt drive.

Power Supply: For intermittent operation with a moderate power output, an internal $4\frac{1}{2}$ -volt battery can be used. For greater output or continuous operation, an external battery of $4\frac{1}{2}$ to 6 volts should be used.

Terminals: Binding posts for the power supply and for the output circuit are provided on the panel.

Mounting: The fork is suspended from a metal plate on a bakelite panel and is enclosed in a walnut cabinet.

Dimensions: Both models, (length) 9 x (width) 5 x (height) 6 inches, over-all.

Net Weight: $8\frac{1}{4}$ pounds.

Type	Frequency	Code Word	Price
813-A	1000 cycles	ANGEL	\$34.00
813-B	400 cycles	AMUSE	36.00



TYPE 814-A AMPLIFIER

USES: A high-gain portable amplifier is extremely useful in any laboratory in connection with bridge measurements and oscillographic work. It is also convenient as a pre-amplifier with crystal microphones and vibration pickups.

DESCRIPTION: The TYPE 814-A Amplifier is a three-stage screen-grid amplifier which operates from batteries which are contained in the cabinet. A switch is provided for attenuating the input by about 20 decibels when the input voltage is high. Blocking condensers are used in both the input and output circuits for preventing the flow of direct current.

FEATURES: High gain, extreme portability, a logarithmic gain control, and good frequency response are the important characteristics which make the TYPE 814-A Amplifier outstanding. The high gain is sufficient to increase the sensitivity of ordinary headphones by 80 decibels at 1000 cycles. Furthermore, a simple and effective means has been provided for restricting the amplifier response to a narrow range of frequencies, thus eliminating harmonics and noise when balancing a bridge. A jack on the panel is connected to the grid circuit of the last stage, and it is only necessary to plug in anti-resonant filters such as the TYPE 814-P (see page 112) to make the amplifier selective.

SPECIFICATIONS

Amplification: The gain of the amplifier throughout the greater portion of the audio-frequency range is approximately 90 db when operating into a high impedance (1 megohm or more) such as a vacuum-tube voltmeter or a cathode-ray oscillograph. When operating into a 20,000-ohm load such as, for instance, a TYPE 483-F Output Meter, the gain is approximately 77 db. About this same amount of gain is secured at 1000 cycles when operating into an average pair of telephones.

The above figures for gain in the amplifier represent merely voltage ratios and do not take into account the fact that the input impedance of the amplifier is generally considerably higher than the impedance to which it is connected. Naturally, an input transformer greatly increases the sensitivity in cases where the amplifier is

operating from a low impedance. Care must be taken, however, to see that the transformer does not introduce undesirable hum pickup.

It is also possible to increase the sensitivity in many cases by using an output transformer for matching the output circuit to the load.

Frequency Range: From 20 cycles up, the gain of the amplifier is practically constant throughout the audio-frequency range, dropping approximately 4 db at 10,000 cycles. The amplifier has sufficient gain at higher frequencies to be useful for many purposes. For instance, when operating into 1 megohm the maximum gain at 20 kc is slightly over 80 db, and at 50 kc, it is about 65 db.

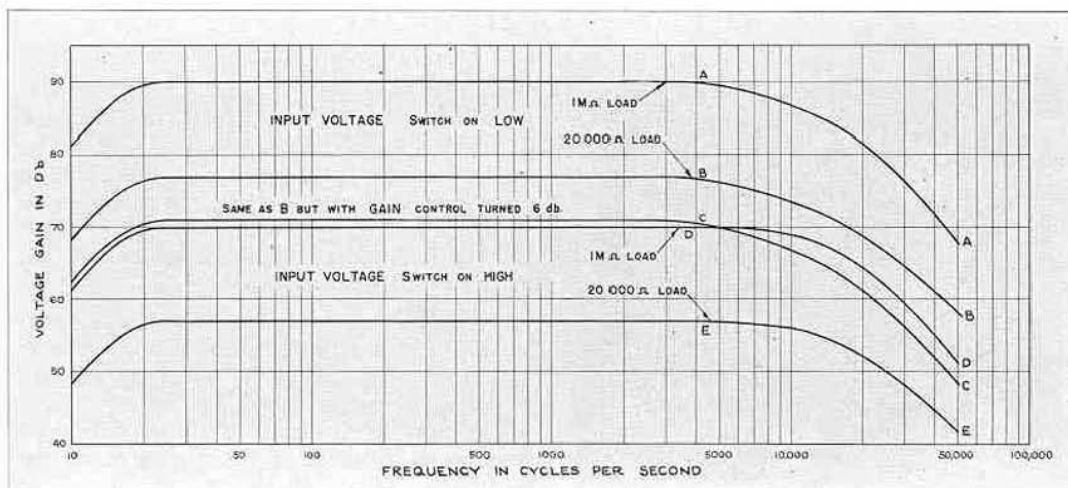

Over-all amplification characteristics of TYPE 814-A Amplifier.

Gain Control: The gain varies by approximately 10 decibels for each large division on the dial.

Input Voltage: The LOW position of the INPUT VOLTAGE switch should be used for input voltage up to 0.5 volt and the HIGH position for voltages up to 5 volts. Higher input voltages will result in distortion in the output.

Input Impedance: In order that the amplifier may be used directly from conventional types of piezo-electric microphones or vibration pickups, the resistance leak in the input circuit has been made 5 megohms. The actual input impedance, accordingly, consists of this leak in parallel with a shunting capacitance. This capacitance amounts to approximately 35 μf when the INPUT VOLTAGE is on the LOW position. When this switch is set on the HIGH position, the effective shunting capacitance is reduced to approximately 22 μf . A series capacitance of 0.02 μf is provided in the input circuit so that the application of a direct voltage to the input terminals will not affect the operation of the amplifier.

Output Impedance: The output impedance of the amplifier is approximately 70,000 ohms. A blocking condenser of 1 μf is included in series with the output terminals.

Tuning: A parallel resonant circuit can be plugged into a jack on the panel to modify the frequency characteristic of the amplifier. The TYPE 814-P3 (60 cycles) and TYPE 814-P2 (400 and 1000 cycles) Tuned Circuits (see page 112) are designed for this purpose.

Tubes: The amplifier requires three 34-type tubes, which are included in the price of the instrument.

Power Supply: Batteries are supplied. The following batteries are furnished for the TYPE 814-AM Amplifier: two 1.5-volt No. 6 dry cells, three 45-volt batteries, Burgess No. 5308, and one Eveready type 950 1.5-volt battery.

For use with the relay-rack mounted TYPE 814-AR the following batteries are used: two Burgess No. 4FA (Little 6's), three Burgess No. Z30N 45-volt batteries and one Burgess No. 2370 1.5-volt battery.

Accessories: One TYPE 274-ND Plug and one TYPE 274-M plug are furnished.

Mounting: The amplifier is supplied in two types of mounting. The TYPE 814-AM Amplifier is mounted in a walnut cabinet having space for batteries. The TYPE 814-AR Amplifier is provided with a panel extension for relay-rack mounting. This panel extension includes battery space and provision is made for mounting a rectifier-type meter.

Dimensions: Panel size, (width) 12 x (height) 7 inches. Cabinet size for TYPE 814-AM, (width) 15 x (height) 8 1/4 x (depth) 12 1/4 inches, over-all. Size for TYPE 814-AR, (width) 19 x (height) 7 x (depth) 10 inches, over-all.

Net Weight: TYPE 814-AM, 17 3/4 pounds; necessary batteries, approximately 14 pounds. TYPE 814-AR, 13 pounds; necessary batteries, approximately 7 1/2 pounds.

Type	Description	Code Word	Price
814-AM	Cabinet Mounting	APPLE	\$97.50*
814-AR	For Relay-Rack Mounting	ALONE	97.50*

*Price includes both tubes and batteries. PATENT NOTICE. See Note 1, page v.

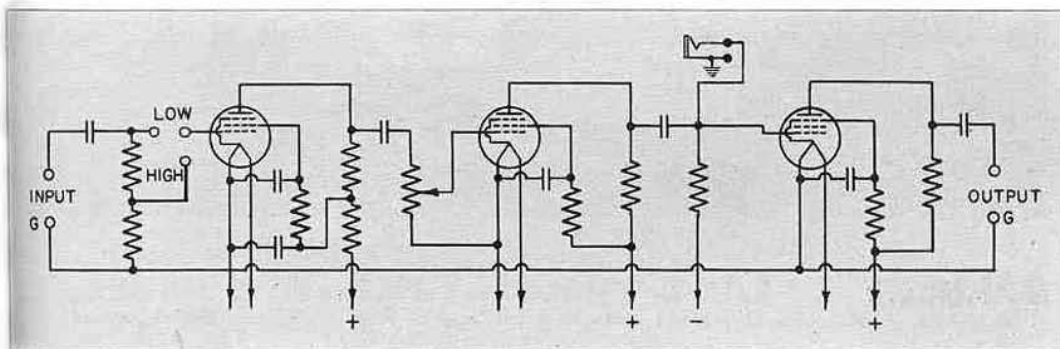

TYPE 814-P TUNED CIRCUIT

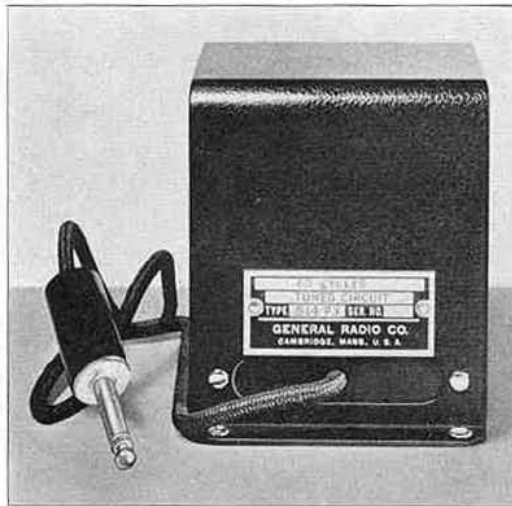

Attenuation characteristics of TYPE 814-P Tuned Circuits.

and hum in single-frequency measurements, such as the balancing of a bridge.

DESCRIPTION: The TYPE 814-P Tuned Circuits are parallel resonant circuits. The 400- and 1000-cycle circuits are mounted in the same case, and a toggle switch is installed for selecting the desired frequency. A plug and a length of shielded cable are furnished with all units.

FEATURES: A convenient means of eliminating harmonics as well as hum and noise from the detector circuit of a bridge is provided without sacrificing gain. The insertion loss of the filter is small and quite negligible for most cases because of the high gain of the amplifier. Furthermore, when the TYPE 814-P Tuned Circuit is used with the TYPE 814-A Amplifier the frequency characteristic obtained is independent of the terminating impedances.

USES: These tuned-circuit filters are primarily designed for use with the TYPE 814-A Amplifier for suppressing harmonics, noise,

SPECIFICATIONS

Frequency: Two units are stocked, one for 60 cycles and the other for both 400 and 1000 cycles. Units for other frequencies can be made on special order.

Attenuation: (See accompanying curves.) Note that the TYPE 814-P2 is effective in removing 60-cycle hum as well as harmonics of the resonant frequency.

Mounting: Standard drawn-steel case.

Dimensions: Base, 3 $\frac{5}{8}$ x 4 inches; height, 4 $\frac{1}{8}$ inches.

Net Weight: 4 pounds.

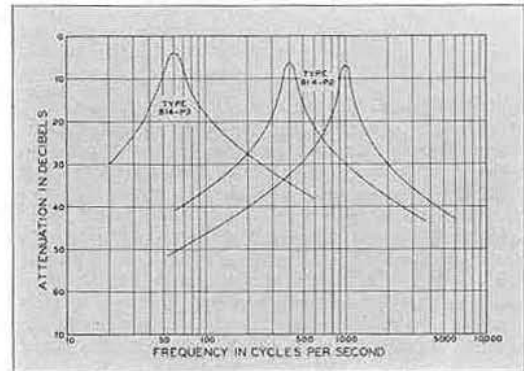

Type	Frequency	Code Word	Price
814-P2	400 and 1000 cycles	AMBLE	\$17.50
814-P3	60 cycles	AMPLE	12.00

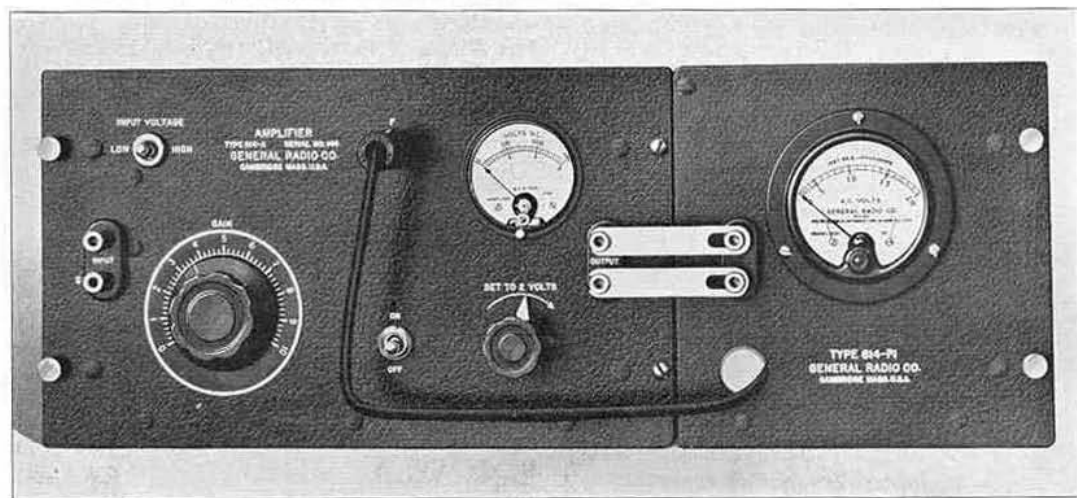

Panel view of TYPE 814-AR Amplifier with a TYPE 814-P Tuned Circuit installed. The relay-rack amplifier (TYPE 814-AR) consists of a TYPE 814-A Unit and a TYPE 814-P1 Panel Extension. Space is provided for mounting an output meter as shown.

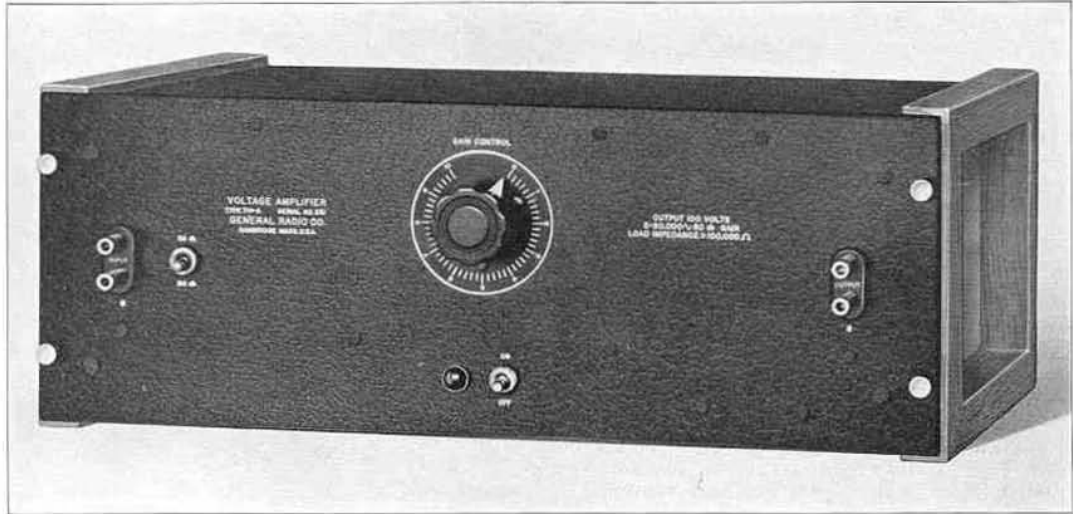

TYPE 714-A AMPLIFIER

USES: The TYPE 714-A Amplifier is a high-gain and wide-range instrument which has been designed mainly for use with cathode-ray oscillographs. It is also useful as a bridge amplifier and for general purpose work.

Its excellent performance characteristics make it suitable for nearly any laboratory application.

Because its low-frequency response extends to 5 cycles, this amplifier has a number of applications where ordinary amplifiers are not suitable, as, for instance, in amplifying the voltages encountered in the study of vibrations in machinery and other mechanical systems.

DESCRIPTION: A three-stage resistance-capacitance-coupled amplifier circuit, employing pentode tubes, is used. An inter-

stage potentiometer and an input attenuator pad control the gain. The instrument operates directly from the a-c supply mains.

FEATURES: A-C operation, high gain, and a wide frequency range are several points of superiority in the TYPE 714-A Amplifier. The power supply filter has been carefully designed to prevent low-frequency "motor-boating" as well as to keep the hum level very low. The hum is equivalent to 10 microvolts on the grid of the first tube. All stages are completely shielded, and microphonic effects have been minimized by the use of tubes with indirectly-heated cathodes.

For a given output, the amplifier can work over a range of 60 db in input levels, or, for an output variation of 10:1, the input range is 80 db.

SPECIFICATIONS

Gain: The gain is continuously adjustable between 20 db and 80 db, by means of a gain control and a switch. With the switch set at 50 db, the range of the gain control is from 20 to 50 db; with the switch on 80, the range is from 50 to 80 db.

Frequency Characteristics: The gain at 5 cycles and at 50 ke is down 3 db from the flat portion of the characteristic.

Maximum Input Voltage: 14 volts, maximum peak; 10 volts r-m-s on a sinusoidal wave.

Maximum Output Voltage: 140 volts, maximum peak; 100 volts r-m-s on a sinusoidal wave.

Load Impedance: Although the internal output impedance is about 20,000 ohms, the load resistance should not be less than 100,000 ohms for an undistorted output

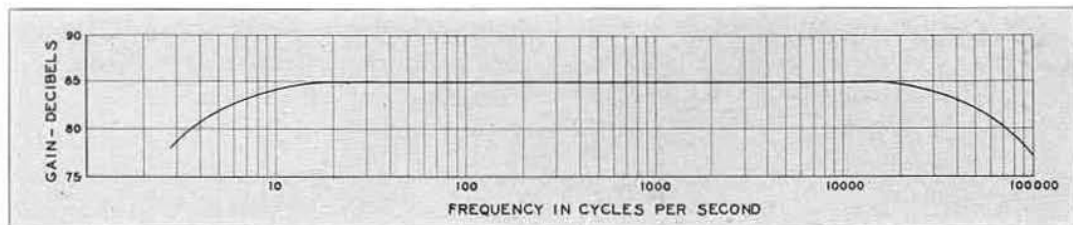

Amplification characteristic of TYPE 714-A Amplifier.

• AMPLIFIERS

GENERAL RADIO CO.

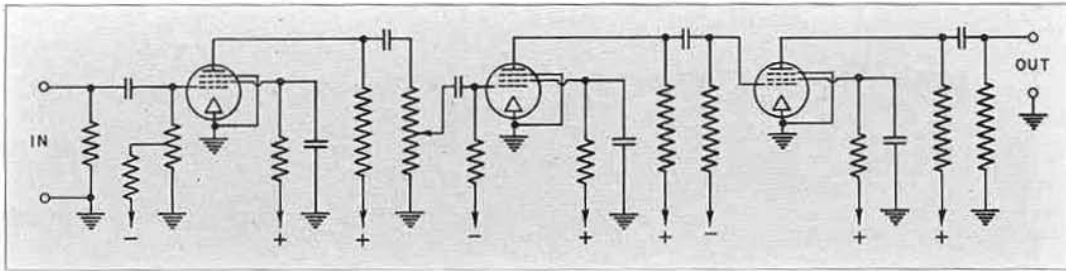

Schematic wiring diagram of TYPE 714-A Amplifier. Power supply and its filters are not shown.

of 100 volts. As a bridge null detector this is not important, and maximum power gain will be obtained into a load of about 20,000 ohms. One output terminal is grounded.

Input Impedance: The input resistance is over one megohm. The shunt capacitance is about $15 \mu\text{f}$ with the gain switch on 50 and about $40 \mu\text{f}$ with the switch set at 80.

Power Supply: 110 to 120 volts, 40 to 60 cycles, a-c mains.

Power Consumption: 25 watts.

A-C Hum Level: Equivalent to approximately 10 microvolts on the grid of the first tube.

Vacuum Tubes: Two 6C6, one 89 and one 80, all of which are supplied with the instrument.

Mounting: Wooden ends are used for table mounting and are removable if the amplifier is to be used on a relay rack.

Accessories Supplied: Spare fuses, 7-foot power cord, spare pilot light, TYPE 274-ND Plug, and TYPE 274-M Plug.

Dimensions: (Length) 19 x (depth) $10\frac{1}{2}$ x (height) 7 inches, over-all.

Net Weight: 40 pounds.

Type	Code Word	Price
714-A	AURAL	\$190.00

PATENT NOTICE. See Note 1, page v.

TYPE 715-A DIRECT-CURRENT AMPLIFIER



TYPE 715-A Direct-Current Amplifier is described on pages 6 and 7 in the section on Industrial Devices. Designed mainly for use with graphic recorders in industrial applications, this amplifier has many uses in the laboratory. It is particularly useful in amplifying to usable levels the small d-c voltages obtained from photo-electric cells, resistance thermometers, sound-level meters, and similar instruments. In conjunction with the graphic recorder it can be used as a recording d-c milliammeter or millivoltmeter.

Some of the features of this amplifier are high gain, simplicity of operation, and stability of calibration. It is essentially unaffected by variations in line voltage and changes in ambient temperature.

The amplifier is available in either the walnut cabinet shown in the photograph, or in a case to match the Esterline-Angus 5-milliampererecorder, as shown on page 7.

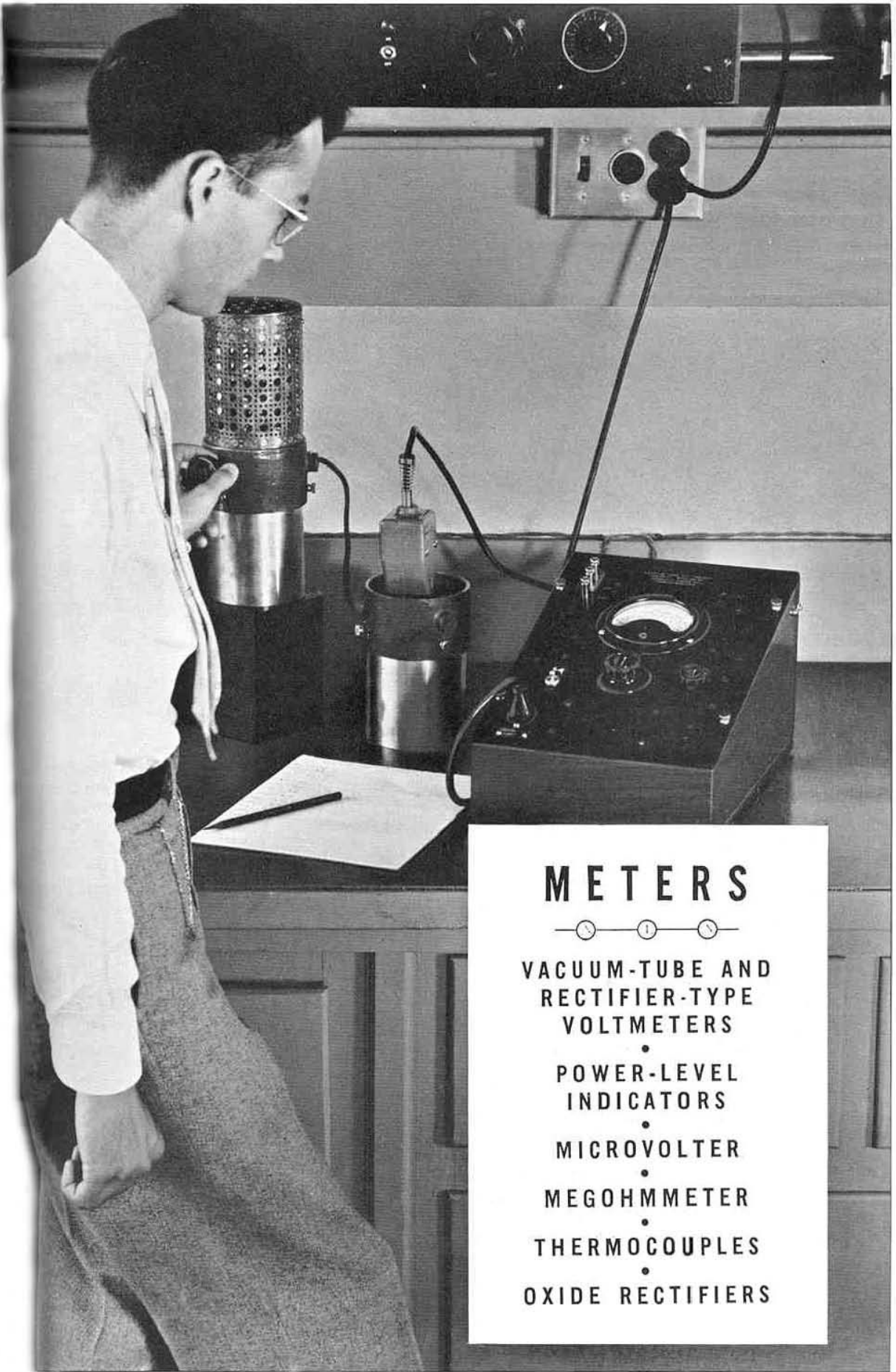

METERS



- VACUUM-TUBE AND
RECTIFIER-TYPE
VOLTMETERS
-
- POWER-LEVEL
INDICATORS
-
- MICROVOLTER
-
- MEGOHMMETER
-
- THERMOCOUPLES
-
- OXIDE RECTIFIERS



TYPE 726-A VACUUM-TUBE VOLTMETER

USES: A high-impedance wide-range voltmeter, such as the TYPE 726-A Vacuum-Tube Voltmeter, which can be used at both audio and radio frequencies, is an extremely valuable instrument to the communications engineer. In the TYPE 726-A Vacuum-Tube Voltmeter the frequency range, by special design, has been extended to correspond to that of a high-frequency thermocouple. In addition to its use as a voltmeter, it is an excellent ammeter at radio frequencies when used with capacitive shunts.

Although calibrated to give readings of the r-m-s values of approximately sinusoidal voltages the voltmeter may be used, except on the lowest voltage ranges, to determine the peak value of complex voltage waves.

DESCRIPTION: An improved type of diode-condenser rectifier circuit, using an acorn tube, is built into a small probe which is made of low-loss bakelite. A cable, which also supplies heater voltage to the tube in the probe, carries the rectified voltage to a d-c amplifier and indicating meter in the cabinet of the instrument.

The d-c amplifier is of the degenerative

type using but one tube. The rectified voltage is applied directly to the amplifier control grid, rather than through a voltage-dividing network, and the change from one

Meter scales of TYPE 726-A Vacuum-Tube Voltmeter.

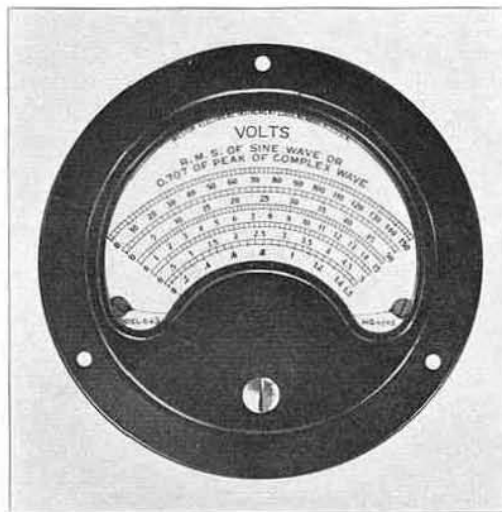

voltage range to another is accomplished by varying the degeneration factor.

FEATURES: The arrangement described above makes it possible to use constants in the diode circuit which will maintain high input impedance over all the ranges of the instrument. Thus, very little power is taken from the source under measurement.

The degeneration in the d-c amplifier stabilizes the gain and results in the calibration being permanent and substantially independent of tube characteristics. Except on the lowest range, the calibration is substantially linear. There is sufficient overlapping of the various ranges, in consequence, so that all readings may be made well up on the scale.

A regulated power supply is employed, so that line variations do not result either in fluctuating readings or zero shifts. One zero adjustment serves for all ranges. There is a slight initial zero drift when the instrument is first turned on, but this becomes negligible after a brief warming-up period. Severe overloads will not damage the instrument, so that in making measurements it is merely necessary to connect the unknown

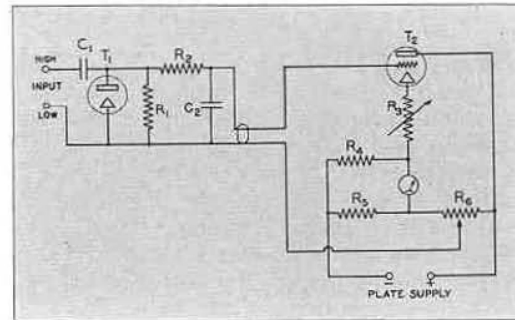

Schematic circuit diagram of TYPE 726-A Vacuum-Tube Voltmeter.

voltage to the terminals and vary the range switch until the reading obtained is on scale.

Since the entire a-c measuring circuit is mounted in the small probe, the leads to the source of voltage can be kept short, and good accuracy is obtained even at high radio frequencies. The plug terminals of the probe can be removed when necessary to shorten the leads still more. For measurements at low frequencies, where the effect of the leads is not important, the probe and cable can be placed inside the instrument and connections made to terminals on the panel.

SPECIFICATIONS

Range: 0.1 to 150 volts in five ranges (1.5 - 5 - 15 - 50 - 150 volts, full scale).

Accuracy: ±2% of full scale on all five ranges, on sinusoidal voltages.

Waveform Error: The instrument is essentially a peak voltmeter calibrated to read r-m-s values of a sine wave, or 0.707 of the peak value of a complex wave. On distorted waveforms the percentage deviation of the

reading from the r-m-s value may be as large as the percentage of harmonics present.

Frequency Error: Less than 1% between 20 cycles and 50 megacycles. At 100 megacycles, with the probe tips removed, the voltage indicated is about 3% larger than the voltage across the probe terminals.

Input Impedance: Plots of parallel reactance and resistance are given on this page. The reactance component is caused by a capacitance of 6 μmf between the input terminals. The parallel resistance is about 5 megohms at low frequencies but is reduced at higher frequencies by the effect of the power factor of the shunt capacitance. This power factor is about 2.5%.

The resonant frequency of the input circuit is about 380 megacycles with the probe tips in place and about 500 megacycles with them removed.

Power Supply: 100 to 130 volts, ac, 60, 50, or 42 cycles and 200 to 260 volts, 50 cycles. (See price list.) The instrument incorporates a voltage regulator to compensate for supply variations over this voltage range. The power input is less than 30 watts.

Tubes: One type 955, one type 6Q7-G, and one type 1-V are used; all are supplied.

Mounting: Black crackle-finish aluminum panel mounted in a shielded walnut cabinet.

Dimensions: (Width) 9½ x (depth) 14 x (height) 8½ inches, over-all.

Net Weight: 17½ pounds.

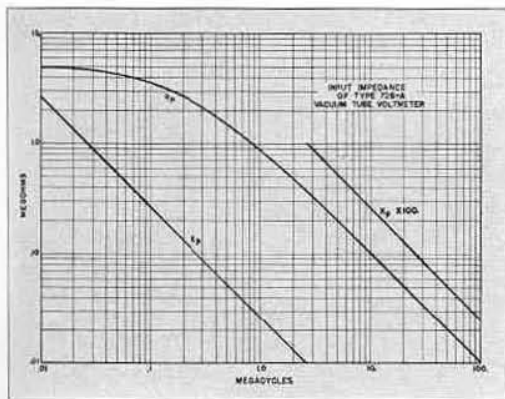

Equivalent parallel reactance and resistance of the input circuit as a function of frequency.

Type	Power Supply		Code Word	Price
	Frequency	Voltage		
726-A	60 cycles	100 to 130 v	ALLOT	\$165.00
726-A	50 cycles	100 to 130 v	ABAFT	165.00
726-A	50 cycles	200 to 260 v	ALTER	165.00
726-A	42 cycles	100 to 130 v	AMASS	165.00

TYPE 483-F OUTPUT METER

USES: The TYPE 483-F Output Meter finds its greatest uses in the routine laboratory measurements of voltages at audio frequencies and for comparison measurements of various types, where the meter is used to match two voltages.

When used in conjunction with a TYPE 814-A Amplifier, this meter is an excellent bridge null detector for commercial and audio frequencies.

DESCRIPTION: A copper-oxide-rectifier voltmeter is used as the indicating meter. An L-type multiplying network is used to extend the range and to furnish a constant input impedance.

FEATURES: Ruggedness and convenience are the great advantages which the TYPE 483-F Output Meter offers for audio-frequency voltage measurements. Its wide range and its high and essentially constant input impedance are also features which make it an essential laboratory instrument.

SPECIFICATIONS

Voltage Range: Below 0.5 volt to 200 volts in seven ranges (2-4-10-20-40-100-200 volts, full scale).

Accuracy: The fundamental accuracy is $\pm 5\%$ of full scale, which is equivalent to 0.1 volt multiplied by the multiplier setting. This accuracy applies only when the instrument is operated on sinusoidal voltages and on the flat portions of the characteristic curves shown below.

Input Impedance: The impedance on the 100 multiplier is 20,000 ohms $\pm 2\%$. For lower multiplier settings, however, the impedance varies slightly with voltage. The greatest change in impedance occurs on the 1 multiplier where the impedance increases by approximately 15% as the voltage is dropped from full scale, 2 volts, to quarter scale, 0.5 volt.

Scale Length: $2\frac{1}{2}$ inches.

Terminals: Jack-top binding posts are provided. Standard $\frac{3}{4}$ -inch spacing is used.



Mounting: The copper-oxide-rectifier voltmeter and the multiplier switch are mounted on an aluminum panel which is mounted in a walnut cabinet.

Dimensions: (Length) $9\frac{3}{8}$ x (width) $4\frac{1}{4}$ x (height) $5\frac{1}{4}$ inches, over-all.

Net Weight: $3\frac{1}{2}$ pounds.

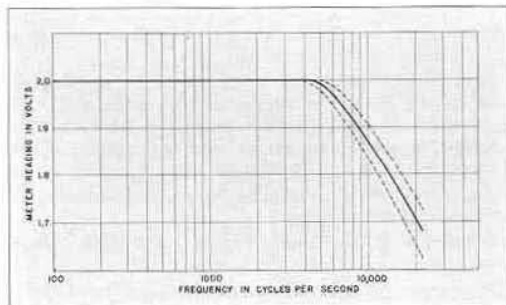

Average frequency characteristic of the meter. The dotted lines show the maximum deviation from average found in a group of instruments tested.

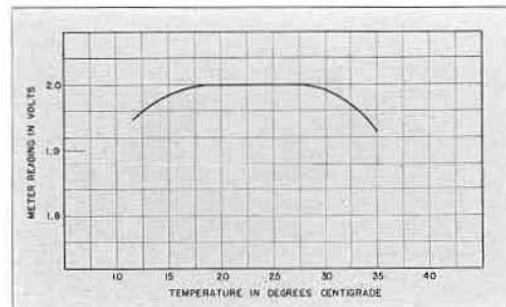

Plot showing the effect of temperature on the meter indication. Note that in the normal room temperature range the temperature coefficient is practically zero. Data plotted here are the average from a number of instruments.

Type	Range	Code Word	Price
483-F	0-200 volts	AVOID	\$54.00

PATENT NOTICE. See Note 5, page v.

TYPE 583-A OUTPUT POWER METER

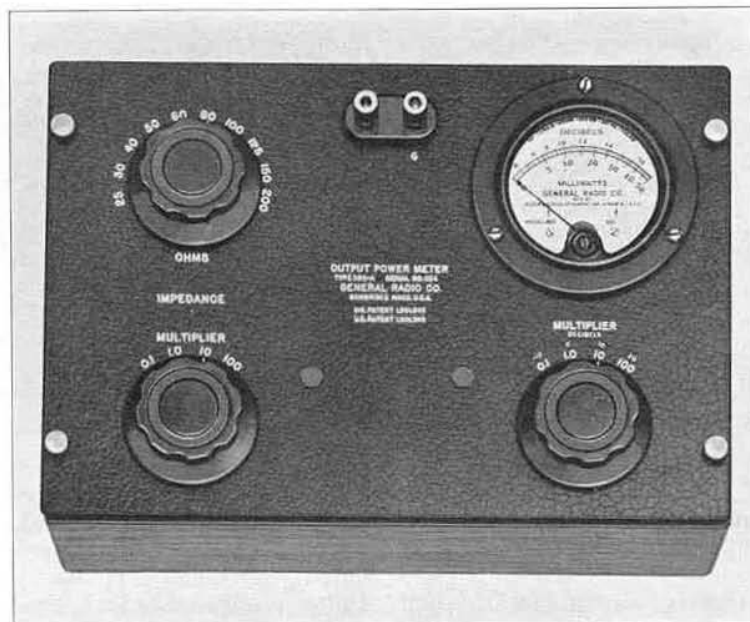

USES: This unusual instrument reads directly the amount of audio-frequency power that a source is capable of delivering into any desired load. Thus, the effect of load impedance on power delivered can be easily measured, and the characteristic impedance of telephone lines, phonograph pickups, oscillators, and similar equipment can be found by observing the impedance which gives the maximum reading on the instrument.

In testing radio receivers the TYPE 583-A Output Power Meter is very useful as an output indicator for standard selectivity, sensitivity, band-width, and fidelity tests, and an auxiliary decibel scale is furnished on the meter for this purpose.

DESCRIPTION: This instrument may be considered to be an adjustable load impedance across which is connected a voltmeter that is calibrated directly in watts lost in the load. Actually the input is connected through a multi-tap transformer and a resistance network to an output meter.

FEATURES: The TYPE 583-A Output Power Meter covers a wide range of both power and impedance values. The power range is 50,000:1, and the impedance range is 8000:1. All readings can be made directly and quickly. The indicating element is a rectifier-type voltmeter and will stand considerable overload for short periods.

SPECIFICATIONS

Power Range: 0.1 to 5000 milliwatts in four ranges (5-50-500-5000 milliwatts full scale). The copper-oxide meter is calibrated from 1 to 50 milliwatts with an auxiliary scale reading from 0 to 17 decibels above a reference level of 1 milliwatt.

Impedance Range: 2.5 to 20,000 ohms. Forty discrete impedances, distributed approximately logarithmically, are obtained by means of a ten-step OHMS dial and a four-step MULTIPLIER.

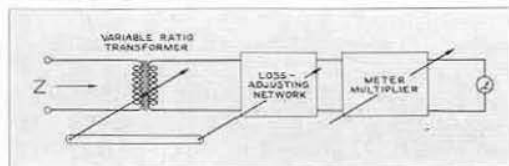

Accuracy: The accuracy of both power and impedance measurements varies with frequency. The maximum error in full-scale power reading does not exceed 0.5 decibel between 150 and 2500 cycles, nor does it exceed 1.5 decibels at 20 and 10,000 cycles. The average error is 0.3 decibel at 30 and 5000 cycles, and 0.6 decibel at 20 and 10,000 cycles.

The maximum error in impedance does not exceed 7% between 150 and 3000 cycles, nor does it exceed 50% at 20 and 10,000 cycles. The average error is 8% at 30 and 5000 cycles and 20% at 20 and 10,000 cycles.

Mounting: The instrument is mounted on an aluminum panel in a shielded walnut cabinet.

Dimensions: (Length) 10 x (width) 7 x (height) 6 inches, over-all.

Net Weight: 8¼ pounds.

Type	Power Range	Code Word	Price
583-A	0-5000 milliwatts	ABUSE	\$95.00

PATENT NOTICE. See Notes 5, 6, page v.

TYPE 586 POWER-LEVEL INDICATOR

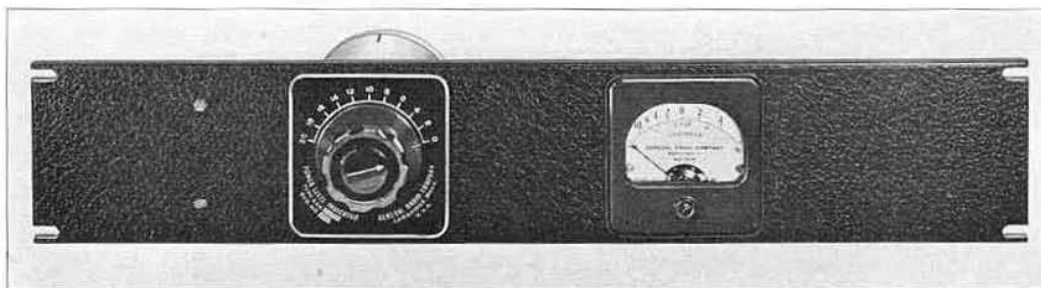

USES: For monitoring and measuring signal levels in telephone lines, broadcasting and sound-recording systems, and amplifiers, a power-level indicator is necessary.

DESCRIPTION: The Type 586-A Power-Level Indicator utilizes the copper-oxide-rectifier type of indicating meter. The moving element of the meter is of the high-speed type for the models, TYPES 586-DM and -DR, and is normal speed for the more sensitive models, TYPES 586-EM and -ER. Because of the design limitations imposed by meter dynamics a high-speed movement cannot be achieved in the high-impedance ultra-sensitive meters.

An adjustable L-type attenuator is inserted between the line and the meter. This

pad acts as a multiplier to increase the measuring range of the instrument while maintaining constant the input resistance of the power-level indicator.

FEATURES: This assembly is compact, rugged, and accurate, and, because no batteries or other power supply is needed, is entirely portable. The indicator is sensitive to low levels and has a range of 36 decibels.

The standard panel finish is black crackle lacquer, but in order to match the finish of other studio or transmitter equipment, panels for the rack-mounting models are also available, to order and at a small additional price, finished in either Western Electric or RCA gray, or RCA flat black.

SPECIFICATIONS

Power-Level Range: (See price list.) All ratings are for a zero level of 6 milliwatts in a 500-ohm line. A chart is supplied showing the correction to be applied when the meter is used across impedances other than 500 ohms.

Accuracy: The average error is from 0.5 decibel to 0.7 decibel. Near the lowest reading of the meter the error may be as much as 1.0 decibel.

Internal Input Impedance: 5000 ohms resistive. There is, therefore, an insertion loss of 0.8 decibel. Essentially, no distortion is introduced into the line.

Frequency Characteristics: There is no appreciable error for frequencies up to 10,000 cycles.

Scale Reading: For TYPE 586-DM and TYPE 586-DR zero level is at midscale. The meter is graduated in 2-decibel steps between -10 and +6 decibels.

For TYPE 586-EM and TYPE 586-ER -10 decibel level occurs at midscale. Midscale is, however, marked zero. When both multiplier switch and meter are at zero, the level is -10 decibels.

The multiplier attenuator of all models is adjustable in 2-decibel steps over a total range of 20 decibels.

Indicating Element: A copper-oxide-rectifier voltmeter calibrated to read power level in decibels. High-speed movement for models -DM and -DR; normal speed for models -EM and -ER.

Terminals: Jack-top binding posts are provided on all models. Binding posts are located behind the panel on relay-rack models. Standard 3/4-inch spacing is used.

Mounting: The TYPE 586-DM and TYPE 586-EM are mounted on an aluminum panel in a polished walnut cabinet. TYPE 586-DR and TYPE 586-ER are designed for mounting on a standard 19-inch relay rack. All switches are back-of-panel mounted.

Dimensions: For the cabinet models, (length) 9 3/8 x (width) 4 1/4 x (depth) 4 1/4 inches, over-all. For the relay-rack models, (length) 19 x (width) 3 1/2 x (depth) 3 1/4 inches, over-all.

Net Weight: 3 3/8 pounds for cabinet models, 3 1/4 pounds for relay-rack models.

Type	Power-Level Range	Mounting	Code Word	Price
586-DM	-10 to +26 decibels	Cabinet Model	HABIT	\$55.00
586-DR	-10 to +26 decibels	Relay-Rack Model	HANDY	55.00*
586-EM	-20 to +16 decibels	Cabinet Model	HONEY	60.00
586-ER	-20 to +16 decibels	Relay-Rack Model	HONOR	60.00*
586-P6	High-speed meter for Type 586-DM or -DR		OURMETBELL	25.00
586-P5	Normal-speed meter for Type 586-DM or -DR		OURMETFOOT	20.00
586-Q1	Normal-speed meter for Type 586-EM or -ER		OURMETPIPE	30.00

*Panel finish to match Western Electric or RCA gray, or RCA flat black, \$7.50 additional.
PATENT NOTICE. See Note 6, page v.

TYPE 686-A POWER-LEVEL INDICATOR

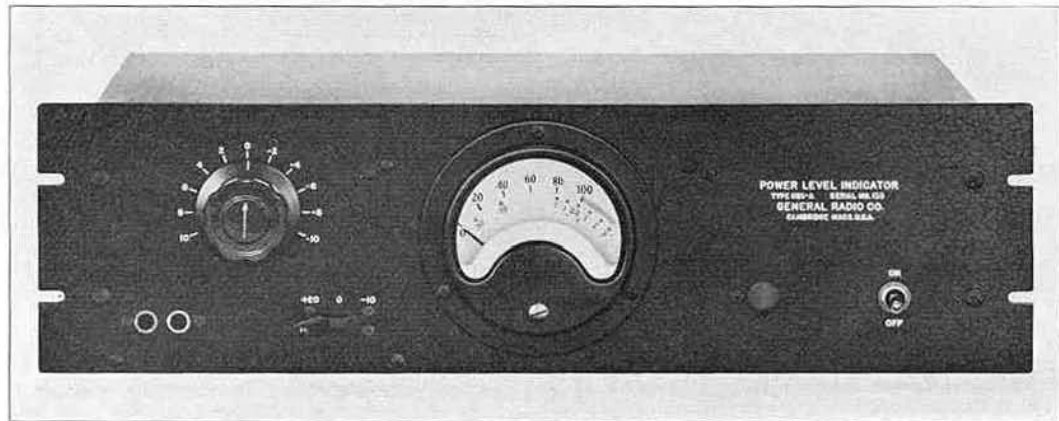

USES: The TYPE 686-A Power-Level Indicator has been designed in collaboration with broadcast engineers to eliminate the difficulties and shortcomings of previous types of power-level indicators which have been used to monitor program level in the studio, control-room, and transmitter. In addition to its application in the broadcasting field, the TYPE 686-A Power-Level Indicator is useful for monitoring sound recording and other audio channels.

DESCRIPTION: The input circuit consists of a doubly-shielded transformer and an attenuator which controls the voltage applied to the grid of the first tube, a linear degenerative amplifier. The second stage acts both as an amplifier and a phase divider for feeding the full wave rectifier. The output of this rectifier is fed through a delay discharge circuit to the vacuum-tube voltmeter which has in its plate circuit the large indicating microammeter.

FEATURES: From the standpoint of the station operator and engineer, the outstanding feature of the TYPE 686-A Power-Level Indicator is the indicating meter and its action. The scale is large and the calibration points are clearly marked. Both a decibel and a percentage scale are printed on a soft yellow background, and the entire meter is so illuminated from above that readings are easily made from positions several feet away even in dimly-lighted monitoring booths. Eyestrain, even in close quarters, is eliminated.

A high-speed movement is used in the meter itself, so that a maximum deflection is reached in approximately 0.15 second. This

fact means that it will respond to the shortest pulses occurring in most speech and music circuits. The mechanical damping stops the swing at maximum amplitude with no appreciable overshoot, and an electrical delay circuit then allows the needle to slowly return to zero. Therefore, the meter registers accurately each peak, but appears to "float" on the peaks without any erratic jumping movement. Accordingly, the psychological effect is excellent and the meter seems to show the audio wave as it sounds to the ear from a monitoring speaker.

Provision has been made on the terminal strip in the rear of the instrument for connecting an external extension meter which can be used for remote monitoring.

A balanced input circuit is used, and the impedance is made high and resistive, so that only a very low bridging loss occurs, and no distortion is introduced into the line. The input can be connected in the rear of the instrument as well as plugged in at the panel.

Besides having a good frequency characteristic, the instrument covers the extremely wide operating range of 73 decibels. It can, therefore, be used on both low- and high-level lines with the same satisfactory results.

A self-contained a-c power supply is used and is so designed that no transformers or other inductors are necessary. Consequently, no hum can be induced from surrounding equipment which may be operating at a high level.

All vacuum tubes, as well as the terminals, are available from the rear, and so the instrument does need to be removed from the relay rack for changes in tubes and connections. The a-c line is brought in at the side through a standard connector for supply conduit.

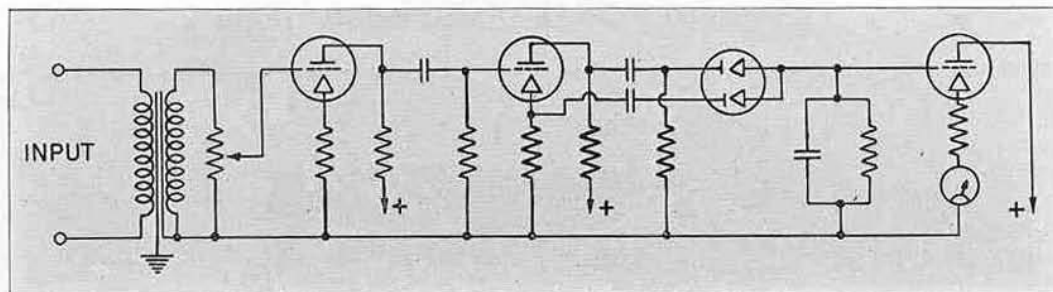

Schematic circuit diagram of the TYPE 686-A Power-Level Indicator.

SPECIFICATIONS

Power-Level Range: Zero decibels on the meter scale (100 on the black scale) will represent from -20 to +30 decibels depending on the attenuator setting. The total over-all calibrated range is -40 to +33 decibels. All ratings are for a zero level of 6 milliwatts in a 500-ohm line. Calibrations at other reference levels or for other line impedances can be supplied on special order.

Meter and Scale: A large high-speed meter with a 3¼-inch scale is used. Connections are provided for an external meter.

The scale has two sets of figures, the principal one reading from 0 to 100 in black figures. With the peak operating point set at 100, indicating 100% modulation, the other black figures indicate percentage utilization of the channel. The auxiliary scale is printed in red and gives the power level in decibels. The scale above the 100 mark is also red to warn against over-modulation.

Two lamps are set above the meter so as to illuminate the scale completely for use in dark locations.

Calibration: The instrument is precalibrated at the factory, but any change because of tube replacements can be easily corrected.

Frequency Characteristics: The frequency response is flat within ± 1 decibel from 60 to 10,000 cycles and within ±2 decibels from 40 to 12,000 cycles.

Internal Input Impedance: The input impedance is greater than 15,000 ohms. There is an insertion loss of 0.15 decibel, but no distortion is introduced because the impedance is resistive and linear. The input transformer is balanced to ground and doubly shielded.

Power Supply: 110 to 120 volts, 50 to 60 cycles, ac. Approximately 50 watts are taken from the line.

Vacuum Tubes: The following tubes are used: 3 type 6P5, 1 type 6H6, and 1 type 25Z6. All are supplied.

Terminals: Screw terminals are provided at the rear for the a-c power, the input, and an external meter. A set of double patch-cord jacks is also provided on the panel for the input.

Mounting: Standard 19-inch relay-rack mounting.

Dimensions: Panel, 19 x 5¼ inches; depth behind panel, 8½ inches.

Net Weight: 23½ pounds.

Type	Description	Code Word	Price
*686-A	Power-Level Indicator.....	ANGER	\$195.00
686-P1	Extension Meter.....	45.00

Panel can be furnished in Western Electric and RCA gray or RCA flat black on special order at a slight additional cost.
*PATENT NOTICE. See Note 1, page v.

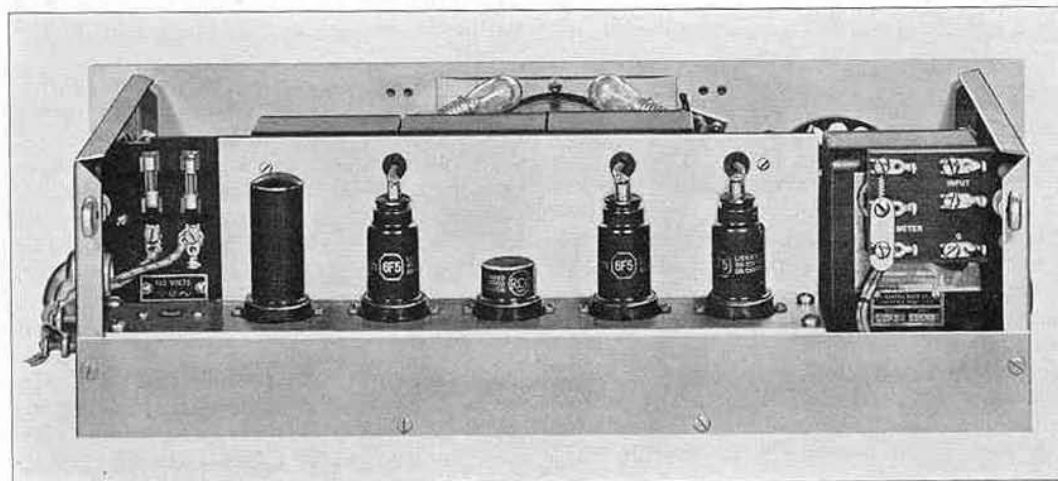

Rear view of the TYPE 686-A Power-Level Indicator. Note the easily accessible tubes and terminals.

TYPE 487-A MEGOHMMETER



USES: The TYPE 487-A Megohmmeter is a direct-reading ohmmeter for measuring relatively high resistances, such as carbon resistors, and the leakage resistance of cables and samples of insulating material. It can also be used to locate defective insulation in electrical equipment.

The leakage resistance of condensers can also be measured, but in measuring large condensers with low leakage, the time constant results in equilibrium being reached slowly. For example, a condenser of 1 μf capacitance, having a leakage resistance of 1000 megohms, could be shown in a few seconds to have a resistance greater than 500 megohms, but perhaps a minute would be required to obtain the resistance within 10 per cent. If a higher test voltage or a

lower time constant is required, the TYPE 544-B Megohm Bridge is recommended. (See page 90.)

DESCRIPTION: This instrument is very similar to the ordinary ohmmeter, except that, in order to obtain high ranges, a vacuum-tube voltmeter is used instead of the conventional indicator. A zero adjustment is provided for rapidly checking any of the four ranges.

FEATURES: The TYPE 487-A Megohmmeter indicates resistance directly on the large meter scale. Its operation is just as simple as that of an ordinary ohmmeter, and a wide range of resistances can be measured on the four overlapping ranges. The instrument is completely a-c operated and takes only ten watts of power.

SPECIFICATIONS

Range: 20,000 ohms to 50,000 megohms in four overlapping ranges.

Scale: The standard direct-reading ohmmeter calibration is used; center scale values are 1, 10, 100, and 1000 megohms. Length of scale, $3\frac{1}{2}$ inches; center decade, $1\frac{3}{4}$ inches.

Accuracy: Within 5% on the 1, 10, and 100 multipliers; within 8% on the 1000 multiplier.

Voltage on Sample: The applied voltage on the unknown varies with indication and is between 50 and 100 volts over the greater portion of the scale.

Tubes: The necessary tubes, one type 1-V, and one type 85, are supplied.

Power Supply: 110 to 120 volts, 42 to 60 cycles, ac. The power required is 10 watts.

Accessories: A 7-foot connecting cord and spare fuses are supplied.

Mounting: The instrument is supplied in a walnut case and is mounted on an engraved black crackle-finish aluminum panel.

Dimensions: (Width) 10 x (height) 8 x (depth) $5\frac{1}{2}$ inches.

Net Weight: $9\frac{1}{4}$ pounds.

Type	Code Word	Price
487-A	ONION	\$95.00

• METERS

GENERAL RADIO CO.

TYPE 546-A MICROVOLTER*



USES: This audio-frequency microvolter furnishes small, known, a-c voltages. It can be used to measure other small voltages by substitution methods. It provides an excellent means for measuring the input voltage in gain tests on amplifiers, transformers, and similar equipment.

DESCRIPTION: The TYPE 546-A Microvolter consists, essentially, of a constant-impedance attenuator and a voltmeter by means of which the input to the attenuator is standardized. The output is varied by means of

switches, for the large steps, and a continuously adjustable dial for small steps.

An input transformer is used to transfer the low impedance of the attenuator to a higher level, but since it precedes the voltmeter, it does not enter into the measurements in any way.

FEATURES: An extremely wide range of low audio-frequency voltages is made available by using this instrument which is compact and simple, and requires only a small amount of power from the driving source.

SPECIFICATIONS

Output Voltage Range: From 1 microvolt to 1 volt for a reference voltage of 2 volts. The use of other reference voltages produces proportional changes in the output voltage.

Accuracy: For output voltage ratios the error is less than 2% above 100-microvolt settings. The error is somewhat greater for smaller output voltages. In absolute measurements the characteristics of the copper-oxide voltmeter must be considered. For output voltages greater than 100 microvolts the error is less than 10%, 12.5%, or 17% at 1000, 5000, or 10,000 cycles, respectively.

Power Source: To obtain the standard 2-volt reference voltage it is necessary to have an audio-frequency source capable of maintaining approximately 9 volts across 7000 ohms. It is, of course, necessary to have a voltage

control on the source in order to set the reference voltage accurately.

Output Impedance: The internal output impedance is 200 ohms. This fact must be taken into account when the instrument works into low-impedance loads.

Input Impedance: Approximately 7000 ohms. The frequency-characteristic is reasonably flat but in any case it does not affect measurements since the voltmeter is on the secondary side of the input transformer.

Terminals: Jack-top binding posts with standard 3/4-inch spacing are used.

Mounting: The instrument is mounted on an aluminum panel in a shielded walnut cabinet.

Dimensions: (Length) 10 x (width) 7 1/4 x (height) 6 1/8 inches, over-all.

Net Weight: 8 3/8 pounds.

Type	Code Word	Price
546-A	CROWN	\$80.00

*Reg. U. S. Pat. Off.

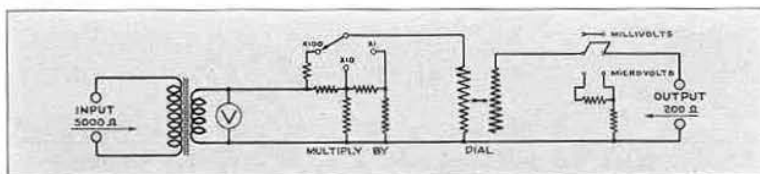

Functional schematic diagram of the microvolter.

TYPE 492-A OXIDE RECTIFIER

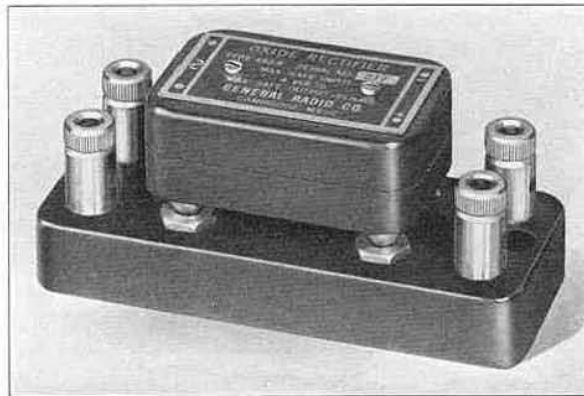

USES: When only direct-current instruments are available, and it is desired to measure alternating current and voltage, the TYPE 492-A Oxide Rectifier can be used, in conjunction with suitable shunts or multipliers.

This unit can also be used where it is necessary to rectify alternating voltages to operate relays, recorders, or similar equipment.

DESCRIPTION: The TYPE 492-A Oxide Rectifier consists of four copper-oxide rectifier units arranged in the form of a bridge, as shown in the accompanying diagram. Each of these units consists of the type of copper oxide junction which has the property of unilateral conduction. Accordingly, the bridge is so arranged that two of the junc-

tions pass current on one-half of the cycle and the other two pass current, in the same direction, during the other half of the cycle. In this manner full-wave rectification is obtained.

The oxide units are mounted in a bakelite protecting case which is furnished with plugs and a nameplate.

FEATURES: Although extremely good accuracy cannot be obtained when copper-oxide units are used, and their characteristics do change with load and temperature, the TYPE 492-A Oxide Rectifier is offered as a compact, simple, and convenient unit which is very useful for experimental work.

SPECIFICATIONS

Input Voltage: This rectifier may be used safely with a-c input voltages up to 4 volts, rms. This value is engraved on the nameplate.

Load Impedance: Maximum power is transferred to the load, for a given input voltage, when its resistance is between 500 and 1000 ohms. Short circuit will not injure the rectifier.

Meter: If a 1-milliamper meter, of about 500 ohms resistance, is used, full-scale deflection will be obtained with about 2 volts, rms, across the input of the rectifier. If the TYPE 588-AM Direct-Current Meter is used, about 1 volt on the rectifier input will be sufficient to produce full-scale deflection.

Input Impedance: The a-c input impedance varies with the d-c load impedance. It also varies somewhat with the input voltage, but by the proper use of shunt and series resistances on the input, it is possible to greatly reduce this apparent change with voltage.

Frequency Characteristics: For frequencies below 5000 cycles the frequency error is negligible. For higher frequencies the sensitivity of the unit decreases slightly.

Temperature Characteristics: Over the normal range of room temperatures the sensitivity of the rectifier unit may change by as much as 5% because of temperature effects.

Mounting: The rectifier units are mounted in small bakelite cases which are provided with a nameplate and TYPE 274 Plugs using the standard spacing which fits

the TYPE 274-RJ Mounting Base. The base is not supplied. (See page 199.)

Dimensions: (Length) $2\frac{1}{8}$ x (breadth) $1\frac{3}{8}$ x (depth) $\frac{3}{4}$ inches, exclusive of plugs.

Net Weight: 2 ounces.

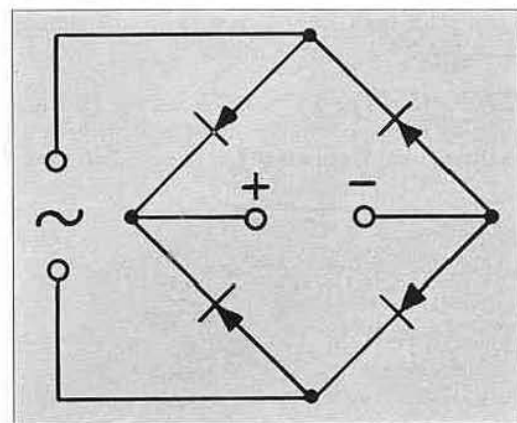

TYPE 492-A Oxide Rectifier is made up of four individual rectifiers connected in a bridge circuit as shown here.

Type	Description	Code Word	Price
492-A	Oxide Rectifier.....	FLORA	\$7.00

TYPE 493 VACUUM THERMOCOUPLE

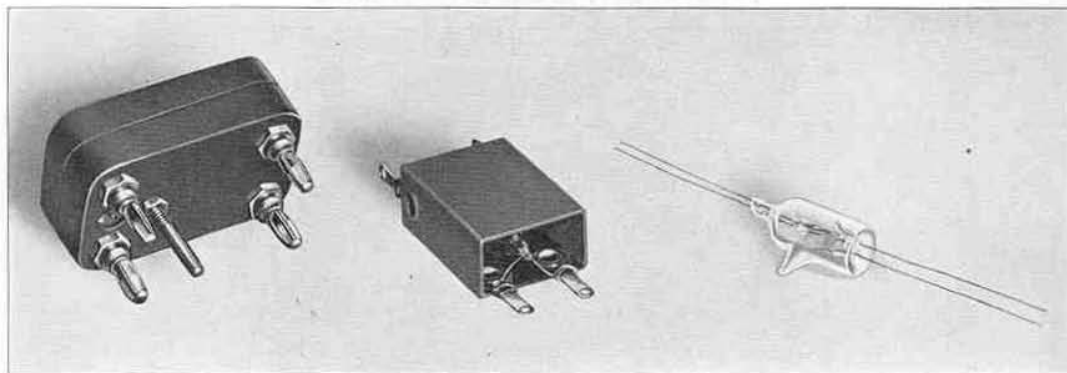

(Left) Mounted TYPE 493 Thermocouple; (center) Unmounted model in shipping case; (right) Unmounted model.

USES: TYPE 493 Vacuum Thermocouples are designed for use in measuring accurately voltage and current at frequencies extending into the ultra-high radio spectrum.

DESCRIPTION: The thermocouple consists of two elements mounted in vacuum in a small glass bulb. These elements are: (1) the heater, which is a short, straight piece of resistance wire through which the current to be measured passes and, (2) the couple which consists of a thermo-junction attached to the center of the heater. The current to be measured raises the temperature of the heater wire and the thermo-junction generates a d-c voltage which is proportional to the temperature rise. The output voltage, as measured on a d-c meter, varies approximately as the square of the heater current.

Both mounted and unmounted models of TYPE 493 Vacuum Thermocouples are available. For work at high radio frequencies the unmounted thermocouples are preferable because the lead inductance is much smaller than for the mounted units.

FEATURES: The TYPE 493 Vacuum Thermocouples are specifically designed for use up to ultra-high frequencies. The constructional

features particularly chosen for this service are as follows:

1. The heater and couple leads are brought out at opposite ends of the glass bulb. In addition, the presses are so oriented that the planes in which the leads lie are normal to each other. This method of construction decreases to a minimum both capacitive and mutual inductive coupling between the heater and thermo-junction circuits.

2. The thermo-junction is separated from the heater wire by a small insulating bead. This separate heater type of construction has been improved so that the sensitivity is practically the same as that obtained with the conventional contact type of construction. The advantage gained is that the heater and thermo-junction are electrically isolated except for a minute capacitance through the bead.

3. The leads to the heater wire are made as short as possible and are led through only one glass press. The residual inductance and capacitance of the heater leads are thereby minimized. The spacing of the wires is chosen to effect a compromise between inductance and capacitance. The lead wires may be considered as a transmission line of approximately 280Ω characteristic impedance.

4. The heater wires are all made of non-magnetic materials—platinum, platinum-silver, and carbon. They therefore have minimum inductance and skin-effect.

From a general standpoint, the thermocouple is an excellent device for measuring current and voltage at any frequency, when a loss of 6 to 20 milliwatts can be tolerated. Since the reading depends upon heating, it indicates r-m-s values of current or voltage truly, irrespective of waveform. The high vacuum type of mounting results in maximum sensitivity, since thermal losses from the heater are minimized. The separate-

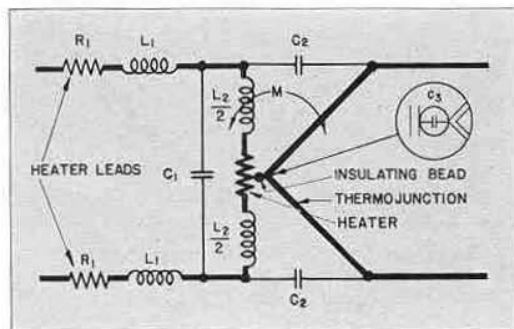

Equivalent circuit of the TYPE 493 Thermocouple.

heater construction prevents current flowing in the heater circuit from straying into the couple circuit. The thermocouple is therefore independent of polarity on dc and may be calibrated on either ac or dc interchangeably.

To a first approximation, the thermocouple can be represented by the equivalent circuit shown on page 126.

In this circuit R_1 and L_1 are the resistance and inductance of the heater leads; C_1 is the capacitance between the heater leads, mostly concentrated in the glass press; R_2 and L_2 are the resistance and inductance of the heater wire; C_2 is the capacitance between heater and thermo-junction; M is the mutual

inductance between heater and thermo-junction circuits; C_3 is the capacitance through the insulating bead. Typical values for these quantities, with 2 cm leads to the heater wire, are:

$$R_1 = 0.05 \Omega \text{ (at 300 Mc)}$$

$$L_1 = 0.01 \mu\text{h} \quad M < 0.0003 \mu\text{h}$$

$$C_1 = 0.7 \mu\mu\text{f}$$

$$L_2 = 0.007 \mu\text{h} \quad C_3 < 0.05 \mu\mu\text{f}$$

$$C_2 = 0.3 \mu\mu\text{f}$$

The curves below illustrate the effect of these residual parameters on the performance of the thermocouples at high frequencies.

SPECIFICATIONS

Heater Resistance: Heater resistances, at rated current, are adjusted approximately to the nominal values given in the table. The actual value, at rated heater current, is given within 1% for each thermocouple.

Temperature Coefficient: The temperature coefficient of resistance for the heaters is -0.0005 per degree Centigrade for TYPE 493-L, and $+0.004$ per degree Centigrade for TYPES 493-P, -Q, and -R.

Frequency Characteristics: See discussion above regarding residual parameters. The curves below show the frequency characteristics when the thermocouples are used to measure either current or voltage.

Overload Characteristics: All heaters will withstand a continuous overload of 50% of rated heater current, given in table below.

Thermo-junction Resistance: The resistance is adjusted between 10 and 12 ohms for all couples. The actual value, accurate to 0.1 ohm, is given for each thermocouple.

Output Voltage: With rated heater current the open-circuit output voltage is 10 millivolts $\pm 10\%$.

Thermal Sensitivity: 47 microvolts per degree Centigrade.

Meter: The TYPE 588-AM Direct-Current Meter, de-

scribed on page 128 is specifically recommended for use with the TYPE 493 Thermocouples.

The couple may be considered as a generator of internal impedance 10 to 12 ohms, and an open-circuit voltage of 10 millivolts, at rated heater current. Maximum power is transferred to the meter when it also has a resistance of about 10 ohms.

Mounting: The thermocouples are supplied either mounted or unmounted. (See price list.) The letter "M" distinguishes the mounted from the unmounted models. That is, TYPE 493-L is unmounted, and TYPE 493-ML is mounted.

The unmounted units are shipped in small rectangular tubes as shown in the photograph. Lugs are provided so that the tube may be used as a protective mounting.

The mounted models are supplied in yellow bakelite cases with TYPE 274 Plugs. The TYPE 274-RJ Mounting Base is recommended for use with the mounted units.

Dimensions: Mounted models, (length) $2\frac{1}{8}$ x (breadth) $1\frac{3}{8}$ x (depth) $\frac{3}{4}$ inches, exclusive of plugs.

Unmounted models: Dimensions of thermocouple, length $1\frac{1}{8}$ inches; diameter $\frac{1}{2}$ inch. Over-all dimensions of packing tube, (length) $2\frac{1}{2}$ x (breadth) 1 x (depth) $\frac{3}{16}$ inches.

Net Weight: 2 ounces, all models.

Type	Rated Current	Heater Resistance at Rated Current	Cole Word	Price
493-L	3 ma	600 Ω	ESTOP	\$10.00
493-P	10 ma	60 Ω	EXCEL	10.00
493-Q	30 ma	8 Ω	EXERT	10.00
493-R	100 ma	2 Ω	EXULT	10.00
493-ML	3 ma	600 Ω	FABLE	12.50
493-MP	10 ma	60 Ω	FACET	12.50
493-MQ	30 ma	8 Ω	FAIRY	12.50
493-MR	100 ma	2 Ω	FATTY	12.50

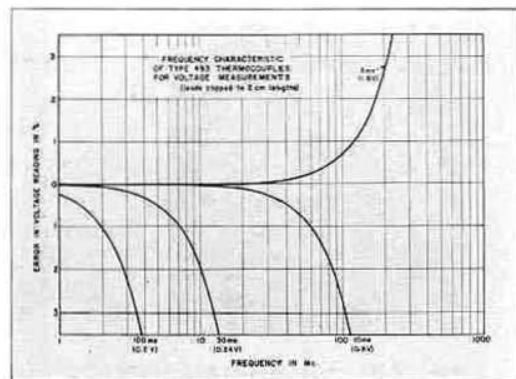
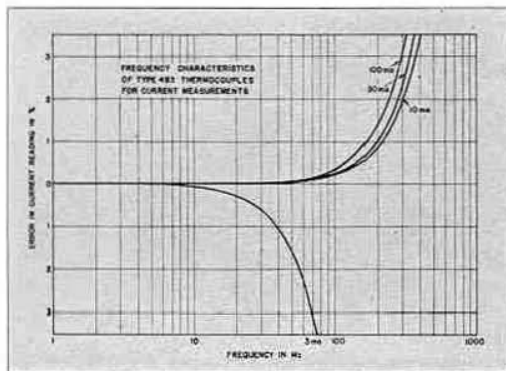

TYPE 588-AM DIRECT-CURRENT METER

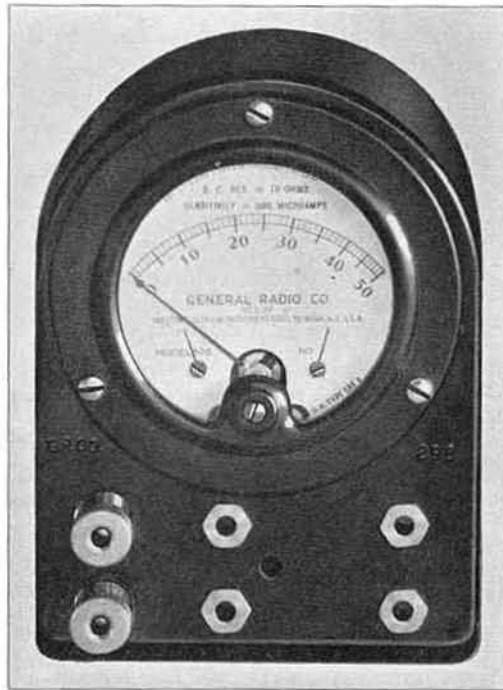

USES: This meter and mounting have been designed for use with the TYPE 493 Vacuum

Thermocouples and the TYPE 492-A Oxide Rectifier.

The TYPE 588-AM Direct-Current Meter is also suited as a galvanometer or microammeter for use in balancing direct-current bridges.

DESCRIPTION: The meter is a low-resistance galvanometer, having a full-scale sensitivity of 500 microamperes or 5 millivolts. The scale is laid out with fifty equal divisions marked from 0 to 50.

The meter mounting is a moulded bakelite case which supports the instrument at an angle of about 30° from the horizontal. Jacks are provided for plugging in the thermocouples and oxide rectifiers and separate binding posts are furnished as the input terminals.

FEATURES: The TYPE 588-AM Direct-Current Meter is a sensitive instrument requiring but 2.5 microwatts of power for full-scale deflection. Its mounting is complete with jacks for both the TYPE 492-A Oxide Rectifier and TYPE 493 Vacuum Thermocouples. The meter is held at an angle, thus making it easier to read, and the linear scale makes easy the preparation and reading of calibration curves.

SPECIFICATIONS

Range: 0 to 500 microamperes, or 0 to 5 millivolts.
Calibration: Full-scale sensitivity is adjusted within 2% of the rated value of 500 microamperes. The scale is 2 1/8 inches in length and is divided into 50 equal divisions marked 0 to 50. Points other than full scale are not calibrated, but deflection is closely proportional to current over the entire scale.
Resistance: The resistance of the meter is adjusted within 2% of the rated value of 10 ohms.

Zero Adjustment: An adjusting screw is provided in the glass face.
Terminals: Jack-top binding posts and plug terminals, all with standard 3/4-inch spacing, are provided.
Mounting: The bakelite case with terminals is provided.
Dimensions: (Length) 5 7/8 x (width) 3 13/16 x (height) 2 7/8 inches, over-all.
Net Weight: 1 1/8 pounds.

Type	Range	Code Word	Price
588-AM	0-500 microamperes, 0-5 millivolts	OURMETMUSH	\$26.00



TYPE 664-A THERMOCOUPLE

An accurate voltage standard for use at ultra-high frequencies. Complete with plate for mounting in the shield or panel of an r-f generator. (See description on page 182.)

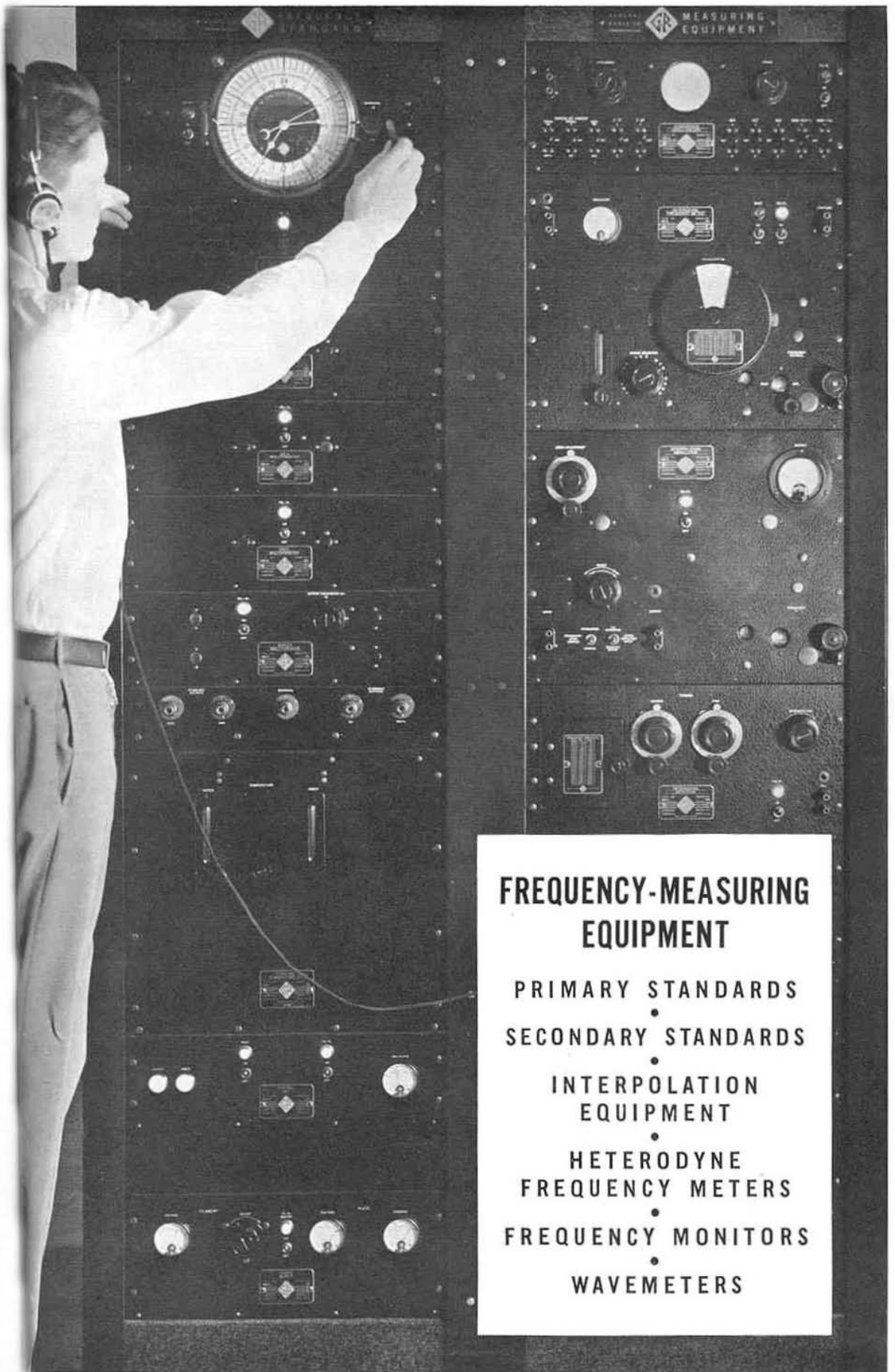

FREQUENCY-MEASURING EQUIPMENT

PRIMARY STANDARDS

•
SECONDARY STANDARDS

•
INTERPOLATION
EQUIPMENT

•
HETERODYNE
FREQUENCY METERS

•
FREQUENCY MONITORS

•
WAVEMETERS

FREQUENCY AND TIME

THE PRIMARY STANDARD

The determination of frequency directly in terms of time is a fundamental measurement, since frequency is the *time* rate of recurrence of a cyclical phenomenon. A primary standard of frequency is, therefore, defined as one whose frequency may be determined directly in terms of time. A secondary standard of frequency is one whose frequency is determined by comparison with a primary standard or by comparison with other secondary standards some one of which originally was compared with a primary standard.

In order to establish a primary standard of frequency, it is first necessary to establish a reliable standard of time. A cyclical system, having a substantially constant rate, then becomes a primary frequency standard when referred to the time standard.

In practice, the responsibility of establishing and maintaining accurate time determinations by astronomical observations is not assumed by the individuals desiring a primary standard of frequency. The time determinations are carried out by observatories especially equipped for the purpose, and the results are made available to a large number of users by standard time transmissions by radio and wire. In the United States, the U. S. Naval Observatory transmits high-precision time signals by radio through the facilities of the U. S. Naval Radio Service. The Arlington transmission on 113 kc is now available 21 of the 24 hours of the day and can be received over a large part of the continental United States. Less frequent transmissions on high frequencies can be received nearly all over the world.

The user of a primary frequency standard can then conveniently determine the frequency of the standard in terms of the standard time interval sent to him by radio. In the General Radio equipment means are provided for quickly and conveniently making this comparison.

In principle, the constant-frequency oscillator, checked in terms of time, is a primary frequency standard, but is a single-frequency device. For convenience in use, it is desirable to have means of obtaining from such a source many other frequencies above and below the oscillator frequency.

FREQUENCY MULTIPLICATION AND DIVISION

For practical reasons it is desirable to divide a standard frequency, if this frequency be a low radio frequency, to obtain an output frequency such that an easily constructed synchronous motor can be operated for the purpose of counting the number of cycles executed by the standard oscillator in a standard time interval. In measurements of frequencies and particularly of high radio frequencies, it is desirable to multiply the standard frequency by some factor to obtain an output frequency near the frequency being measured. Both of these objectives are obtained by using a relaxation oscillator called a multivibrator.

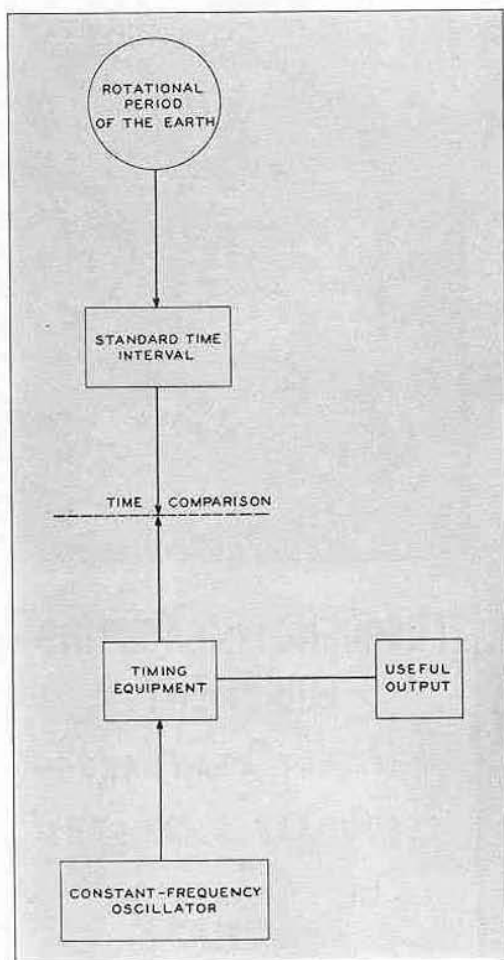

FIGURE 1. Functional diagram of a primary standard of frequency. The frequency of a primary standard is measured by direct comparison with the rotational period of the earth. Hence any primary standard will consist of a constant-frequency oscillator (such as a pendulum, or a piezoelectric crystal) and some means for counting the number of its oscillations in a given standard time interval.

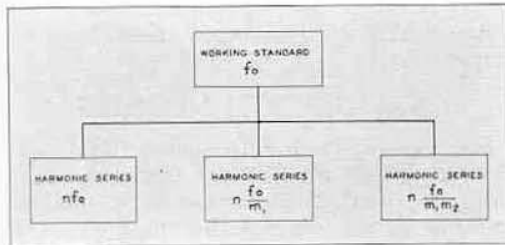

FIGURE 2. Showing functionally the operation of a frequency division system.

An oscillator of this type is characterized by its susceptibility to control by an introduced voltage whose frequency lies near its fundamental or a low-order harmonic frequency. In this condition of control, the relaxation oscillator locks into step with the control voltage, and the frequency bears an integral relationship to the frequency of the controlling voltage.

If the frequency of the standard oscillator is f , a multivibrator, controlled by it and acting as a frequency divider, would have a fundamental frequency of f/m_1 , where m_1 is a whole number (generally less than 10). This frequency divider can, in turn, control a second divider operating at a frequency $1/m_2$ below its fundamental frequency. The two dividers then give a division of $1/m_1 m_2$ for the standard oscillator.

From each of the three fundamental frequencies f , f/m_1 , and $f/m_1 m_2$ a series of multiple frequencies can be derived by the generation of harmonics. The multivibrators have extremely distorted waveforms, and their outputs contain hundreds of harmonics useful for measurement purposes.

By these two processes, a great number of standard frequencies, each of which is known with the same accuracy as the frequency of the standard oscillator, can be produced from a single-frequency source. By suitable choice of the factors by which the standard frequency is divided, the derived frequencies may be made to cover a large part of the communication-frequency spectrum, from low audio frequencies to high- and even ultra-high radio frequencies. The range of output frequencies obtainable from the General Radio Primary Frequency Standard is shown in Figure 3. Complete specifications for this standard are given on page 134.

FIGURE 3. Functional diagram of CLASS C-21-HLD Primary Standard of Frequency. The output frequencies are shown in the spectra at the right of the diagram.

THE SECONDARY STANDARD

In many cases an elaborate and costly primary frequency standard may not be justified for the work at hand. Satisfactory secondary standards can be assembled to meet the particular requirements of measurements at some loss in accuracy, but at a considerable saving in cost. Since accurate standard frequencies are now available by radio, it is possible to check the standard frequently, and, if necessary, readjust the frequency into agreement with standard-frequency radio transmissions. A secondary standard of moderately good performance will maintain its frequency sufficiently well over the periods between standard-frequency transmissions so that entirely satisfactory average accuracy may be maintained.

In general, a secondary frequency standard consists of a standard-frequency oscillator and one or more multivibrators, depending upon the output harmonic frequencies desired and the purposes for which they are required. A generally useful combination is shown functionally in Figure 4 and is described under the CLASS C-10-H Secondary Standard, page 138.

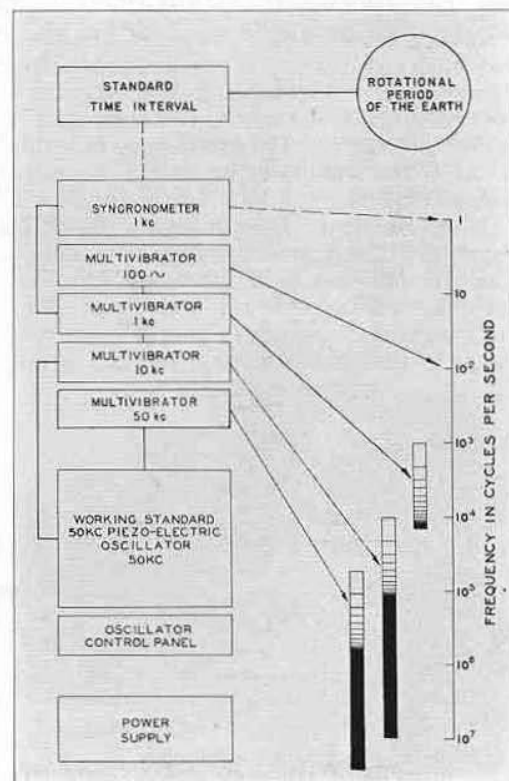

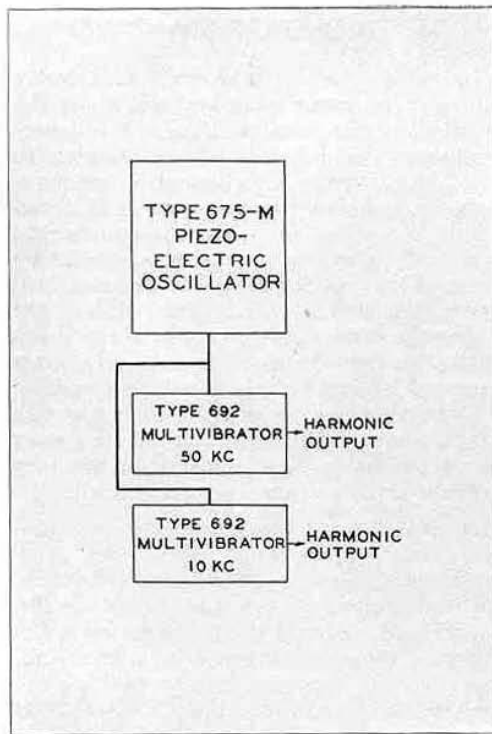

FIGURE 4. Functional diagram of CLASS C-10-H Secondary Frequency Standard.

FREQUENCY MEASUREMENT

Having established a series of standard frequencies embracing a portion of the frequency spectrum in which measurements of frequency are to be made, the next step is to evaluate any unknown frequency in terms of one of the standard frequencies. Any unknown frequency will lie between two of the standard-frequency harmonics, as shown in Figure 5. The simplest process is to determine the difference in frequency between the unknown frequency and the nearest of the standard frequencies. This difference is added to the standard frequency if the un-

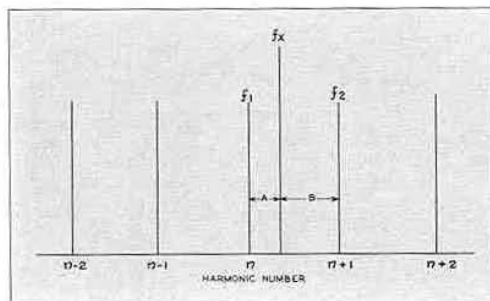

FIGURE 5. This diagram shows the relation between an unknown frequency and a standard harmonic series.

known lies above the standard, or subtracted if the unknown lies below the standard frequency.

INTERPOLATION METHODS

For evaluating the frequency difference (A or B, Figure 5), either of two methods is ordinarily used, the direct-beating method and the linear interpolation method. The direct-beating method, outlined in Figure 6, consists of beating the standard and unknown frequencies in a detector, and measuring the beat frequency by comparison with a calibrated audio oscillator.

The linear-interpolation method uses a radio-frequency oscillator whose output frequency varies linearly with scale setting. This linear scale is used to interpolate directly between the two standard frequencies to locate the unknown. Figure 7 shows how this is accomplished.

When the oscillator is successively adjusted to zero beat with the unknown frequency f_x and with each of the standard frequencies f_1 and f_2 , between which f_x lies, three dial settings S_x , S_1 , and S_2 are obtained. Since the frequency intervals are proportional to corresponding scale intervals,

$$\frac{f_x - f_1}{f_2 - f_1} = \frac{S_x - S_1}{S_2 - S_1}$$

and

$$f_x = f_1 + \frac{S_x - S_1}{S_2 - S_1} (f_2 - f_1)$$

or

$$f_x = f_2 - \frac{S_2 - S_x}{S_2 - S_1} (f_2 - f_1).$$

Assemblies of frequency-measuring equipment for measuring unknown frequencies in terms of standard-frequency harmonics are described on pages 136 and 138.

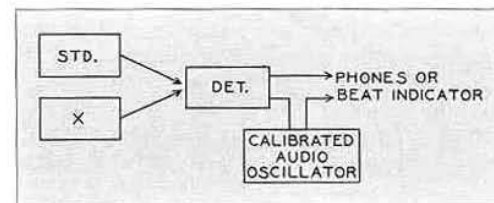

FIGURE 6. Functional diagram showing the operation of the direct-beating method of frequency measurement.

When portability and simplicity are important requirements for a frequency measuring system, the secondary standard and interpolation device can be combined in a single cabinet. The heterodyne frequency meter, with built-in crystal calibrator, described on page 150, is an example of this type of instrument. For rapid operation and

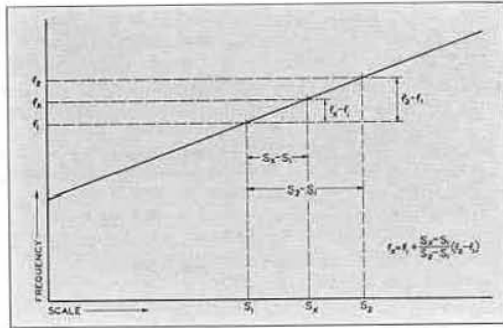

FIGURE 7. Plot of frequency vs. scale setting for a linear-scale oscillator.

freedom from ambiguity in the identification of harmonics, a direct-reading dial is provided. Numerous checking points are obtained on each range of the heterodyne frequency meter so that any drift caused by aging or by temperature is easily corrected for. Interpolation between known checking points is accomplished by use of the main dial.

FREQUENCY MONITORING

As contrasted with the problem of frequency measurements over wide ranges of frequencies, certain operating requirements demand the continuous measurement of a single, or a very few, frequencies. The continuous monitoring of the frequency of a radio transmitter is one instance. Frequency monitors are now required by law for many classes of service in the United States and foreign countries.

For continuous monitoring, the process of measurement must be reduced either to automatic or very simple operation. In the monitoring of a broadcast transmitter frequency, the carrier frequency is compared with that of a piezo-electric oscillator which is generally offset from the assigned carrier frequency by a definite amount, such as 1000 cycles. The carrier and secondary-standard frequencies are fed to a detector, where the beat-frequency difference is obtained and is then amplified. The amplified output is then passed to a frequency-indicating device, usually referred to as a frequency-deviation meter. If the transmitter frequency varies with reference to the frequency of the secondary standard, the beat-frequency also varies, and the departure from the normal value is a measure of the carrier-frequency deviation in both magnitude and sign. The carrier-frequency deviation may thus be continuously indicated on a meter; the operating personnel can easily check the frequency at any time and make any necessary adjustments to correct any deviations which occur. If desired, such deviations may

be recorded, so that a permanent record of the station performance is obtained.

In some cases, a simpler type of monitor is more desirable, for example, one in which the station deviation is indicated only if it exceeds a prescribed limit. One such type is described on page 154, where the operating range of the monitor may be adjusted to meet the requirements imposed on the particular channel to which a station may be assigned. Once adjusted, the monitor operates either of two signal lights, one for positive and one for negative deviations, but only if the carrier frequency deviation exceeds the limit for which the monitor has been set. Since the sign of the deviation is indicated, the operating personnel may at once make the proper readjustment of the transmitter to bring it within the tolerance permitted.

WAVEMETERS

For making preliminary adjustments on transmitters, and for general experimental work, the simple resonant-circuit wavemeter is still a valuable tool. Sufficient accuracy is possible so that preliminary adjustments may be made closely enough to be representative of final conditions. Several models of wavemeters are described on pages 161 to 164, covering different frequency ranges, with various accuracies and with different types of resonance indicators adapted to the type of service for which the instruments are intended.

In the following pages assemblies of standard frequency and frequency-measuring equipment, which have been found to meet conveniently most general requirements, are described. Modifications in choice and grouping of units are possible to meet efficiently many and varied special requirements. Suggestions on equipment will gladly be made by our Engineering Department.

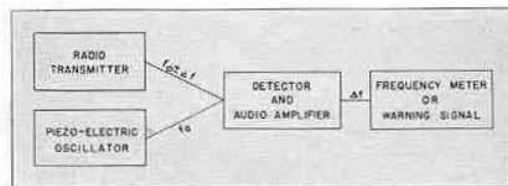

FIGURE 8. General functional diagram of a frequency monitoring system. The difference in frequency Δf between transmitter and piezo-electric oscillator is obtained in the detector, is amplified, and operates the frequency meter. To overcome ambiguity as to the sense of the deviation, Δf is made to have a definite value, say 1000 cycles, when the transmitter is at correct frequency, by adjusting the piezo-electric oscillator for a frequency 1000 cycles above or below the assigned transmitter frequency.

• FREQUENCY

GENERAL RADIO CO.

PRIMARY FREQUENCY STANDARD
Class C-21-HLD

The CLASS C-21-HLD Standard-Frequency Assembly is a complete and highly precise primary standard of frequency. Units have been installed and are now operating in all parts of the world in industrial organizations, research laboratories, observatories, and frequency monitoring stations. Many of them are used as national standards of frequency by communications administrations in American, European, and Asiatic countries.

The assembly is provided with a means of measuring

its output frequencies in terms of standard time without reference to any other standard of frequency. Harmonic series based on fundamentals of 0.1, 1, 10, and 50 kilocycles are available at its output terminals to furnish standard frequencies over the entire communication-frequency spectrum. From it can also be obtained one-second pulses. The accuracy of all output frequencies is better than ± 5 parts in 10 million over periods of several months. Each of the output frequencies is known with the same accuracy.

SPECIFICATIONS

Frequency Range: Standard frequencies ranging from one pulse per second to frequencies of several megacycles can be obtained from this equipment.

The output frequencies are as follows. The upper frequency limit depends upon the method used to detect and utilize the harmonics. The values here quoted are easily reached when using the TYPE 619-E Heterodyne Detector.

From 50-ke Multivibrator, 50 kc and its harmonics up to 25 megacycles (limit of 619-E).

From 10-ke Multivibrator, 10 kc and its harmonics up to 10 megacycles.

From 1-ke Multivibrator, 1 kc and its harmonics in the audio-frequency range.

From 100-cycle Multivibrator, 100 cycles and its harmonics in the lower audio range.

From the Synchronometer unit, one-second contactor. The time of occurrence of the contact may be phased to occur at any instant over a range of one second.

Output Voltage: The harmonic outputs of the 50 and 10 kc are at low impedance (65 ohms). The r-m-s voltages, measured at the terminal strip of the frequency standard, across a 65-ohm load are: at 50 kc, 0.3 volt, and 10 kc, 0.3 volt. The audio-frequency outputs are at high-impedance (10,000 to 20,000 ohms). The r-m-s voltages measured at the terminal strip of the standard, across a 10,000-ohm load, are: 1 kc, 25 volts; 100 cycles, 15 volts. These voltages are representative only; they are not guaranteed values.

Frequency Adjustment: The frequency of the quartz bar in its oscillator circuit is adjusted to within 1 part in ten million of its specified frequency in terms of standard time. Slight changes in frequency may occur during shipment. A control is provided for adjusting the frequency over a range of approximately plus or minus 5 parts in ten million. Complete instructions for making adjustments over a wider range are given.

Frequency Stability: When the assembly is operated in accordance with instructions, the frequency will remain within 5 parts in ten million over long periods of time. Since time comparisons can be made several times daily, the frequency is known with a high degree of precision at all times.

The temperature coefficient of frequency of the quartz bar is of the order of 2 parts per million per degree C. The temperature regulation is within 0.01° C. so that the effect of ambient temperature fluctuations should not cause any change in frequency greater than 0.2 part in ten million. The voltage coefficient of frequency of the oscillator is approximately 5 parts per ten million for line voltage changes of 10%. The average frequency variation from this cause will be substantially less.

Output Terminals: The various output frequencies are made available at shielded plug connections on a terminal panel at the front of the rack. This panel is permanently wired into the cable assembly. Since all necessary wiring, for all interconnections between units of the assembly, is provided in the form of cables, no connections need be made by the user other than power-supply connections, and a connection to the point where the standard frequencies are to be used.

Vacuum Tubes: The following tubes are supplied with the assembly:

- 26—Type 6J5-G
- 1—Type 6J7-G
- 1—Type 6K6-G
- 1—Type VR-90
- 1—Type 83

Power Supply: 115 or 230 volts, 50 to 60 cycles. Provision is made to change from 115-volt to 230-volt supply by change of transformer primary connections.

When the TYPE 696-B Power Supply is used, no batteries of any kind are required.

When the TYPE 695-B Charging Equipment is used, the following lead-type storage batteries are required:

- Two 6-volt, 150 ampere hour
- Four 48-volt, 6 ampere hour

In addition, a reserve power supply for the heaters is recommended. This should be capable of supplying 100 watts at 115 volts. Batteries must be purchased separately. None are supplied.

Power Input: The power demand from the supply line is approximately 210 watts; with heaters off, the power required is approximately 128 watts. The average heating power at normal room temperatures is approximately 80 watts.

Accessories Supplied: Complete set of tubes, spare sets of fuses, fusible links, pilot lights. All connecting cables, including power-supply leads, and complete operating instructions.

Mounting: All units are mounted on standard 19-inch relay-rack panels. A cabinet rack, black wrinkle finish, is supplied for mounting the units of the assembly.

Dimensions: The over-all dimensions of the assembly in cabinet rack are: (height) $76\frac{1}{8}$ x (width) 22 x (depth) $24\frac{1}{4}$ inches.

Net Weight: 530 pounds for floating-battery assembly (TYPE 695-B Charging Equipment); 500 pounds for a-c operation (TYPE 696-B Power Supply). Cabinet rack is included in both cases.

Class	Description	Code Word	Price
C-21-HLD	For Complete a-c Operation	LAYER	\$2595.00
C-21-HLD	For Floating-Battery Operation	LYRIC	2720.00

PATENT NOTICE. See Notes 1, 3, 8, 11, 12, 19, 20, page v.

TYPE 693-B SYNCHRONOMETER

This panel includes a 1000-cycle synchronous motor for effectively counting the number of cycles executed by the standard piezo-electric oscillator in a standard time interval. A large, illuminated, 24-hour dial with a long sweep hand makes for easy visibility. A microdial contactor, operating once each 50,000 cycles of the standard oscillator, is provided for comparison with time signals. The microdial mechanism may be phased by means of a panel control. Comparison of the Synchronometer reading with standard time may be made on the microdial scale to one part in ten million over a 24-hour interval. The 1000-cycle synchronous motor is started by a 60-cycle motor controlled by a push-button on the panel.

TYPE 692-B MULTIVIBRATOR

The 10-ke and 1-ke multivibrators act as frequency dividers to divide the standard frequency of 50 ke down to 1 ke for operation of the Synchronometer. The 50-ke and 100-cycle multivibrators provide additional output frequencies for use in measurements of high radio frequencies and audio frequencies, respectively. (See also page 140.)

TYPE 698-A DUPLEX MULTIVIBRATOR

The TYPE 698-A Duplex Multivibrator supplies frequencies of 9 and 11 ke and is for the purpose of avoiding measurements near zero beat, particularly on channels whose frequencies lie at multiples of 10 ke.

TERMINAL BOARD

Shielded low-impedance cable is used for all radio-frequency circuits. On the connecting panel, shielded output plugs are provided for outputs at 50, 10, and 1 ke, 100 cycles, and for the microdial.

TYPE 690-C PIEZO-ELECTRIC OSCILLATOR

**TYPE 691-C TEMPERATURE CONTROL
TYPE 676-A QUARTZ BAR**

This group constitutes the standard-frequency oscillator of the system. Double temperature control of the quartz bar holds the temperature to better than 0.01° C. over a range in ambient temperature from -6° to +50° C. A dial at the rear permits adjustment of the oscillator over a range of plus or minus 0.75 part per million, approximately.

TYPE 694-C CONTROL PANEL

This unit contains the necessary meters, relays, controls, and signal lights for operation of both the piezo-electric oscillator and the temperature control system.

TYPE 696-B POWER SUPPLY

For complete alternating current operation, the TYPE 696-B Power Supply is used. In this case no batteries of any kind are required. If floating-battery operation is desired, to avoid interruptions due to supply line failures, replace this unit by the TYPE 695-B Charging Equipment.

TYPE 480-P RELAY RACK

A cabinet rack is furnished to house all the equipment of the Standard-Frequency Assembly. Openings, with removable finished covers, are provided in the sides for cabling between the frequency standard and measuring equipment. (See page 136.)

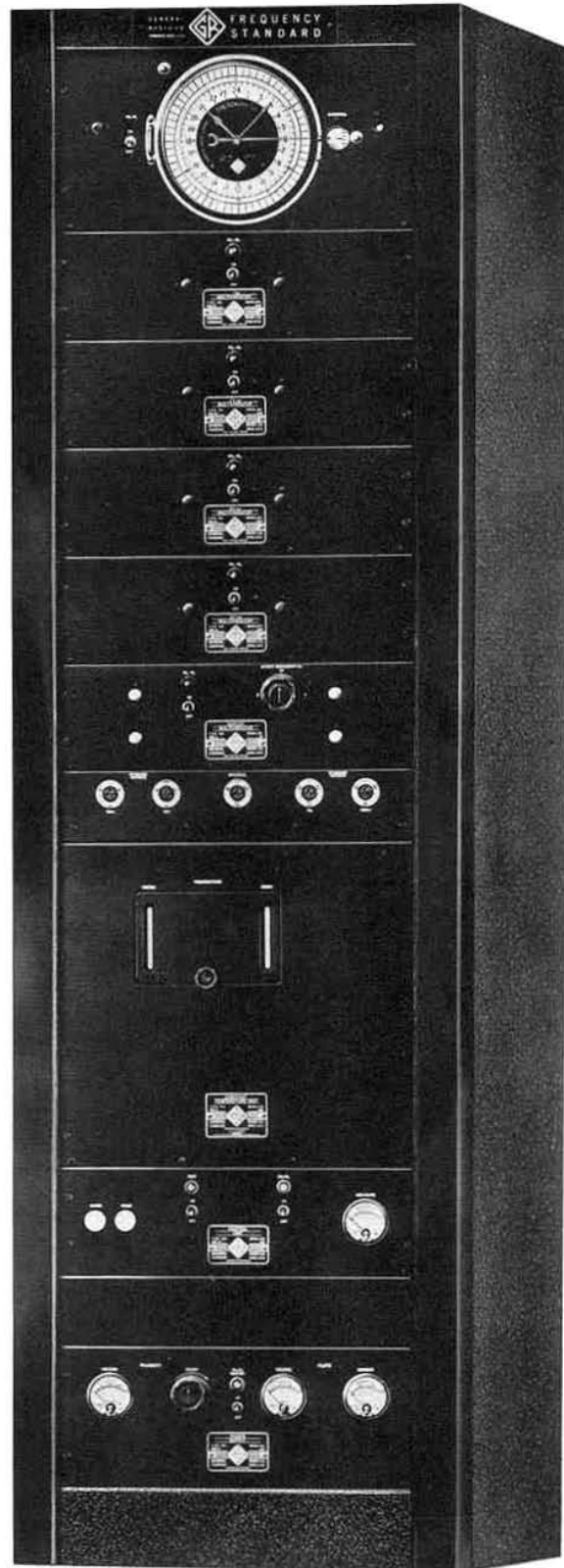

FREQUENCY-MEASURING EQUIPMENT

FOR USE WITH CLASS C-21-HLD PRIMARY FREQUENCY STANDARD

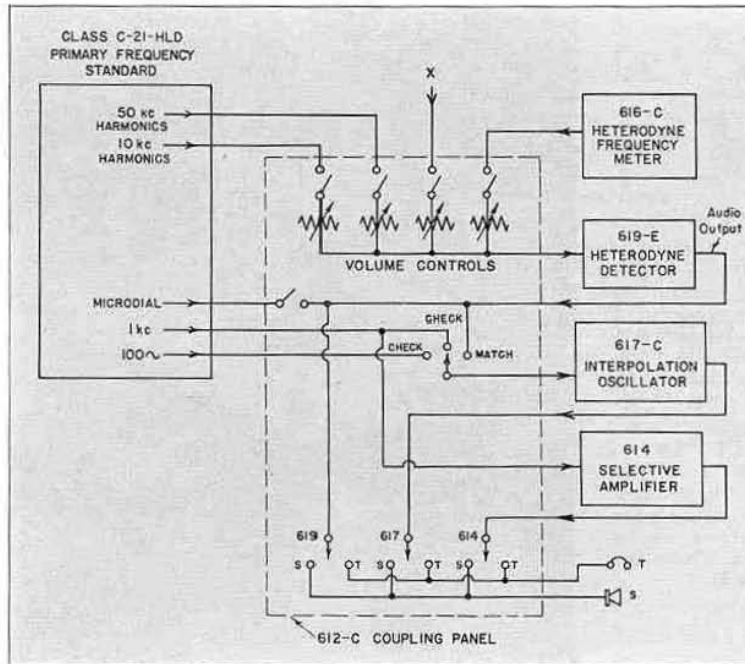

This diagram shows in functional form the operation of the frequency-measuring assembly. The TYPE 612-C Coupling Panel is the central unit from which all operations are controlled.

Both the unknown frequency, X, and a series of standard-frequency harmonics are applied through radio-frequency attenuators to the heterodyne detector. The unknown can then be measured by the direct-beating method, using the interpolation oscillator, or by the linear-interpolation method, using the heterodyne frequency meter.

Switching is provided for the standard and unknown radio-frequency circuits; for connecting the output of the detector to the interpolation oscillator and to headphones or loudspeaker; for standardizing the interpolation oscillator in terms of 1000-cycle and 100-cycle har-

monics; and for controlling the operation of the selective amplifier and comparison oscilloscope. In order to keep the diagram as simple as possible, connections to the oscilloscope are not shown.

This assembly of frequency-measuring equipment, in conjunction with the primary frequency standard, makes possible the direct precision measurement of any frequency up to 25 megacycles. At frequencies above 25 megacycles, measurements can be made with almost equal ease by making use of heterodyne methods. Other uses include

the calibration of audio- and radio-frequency equipment in terms of the primary standard.

The assembly is illustrated on the opposite page. Brief descriptions of the units are given, and each instrument is more completely described on another page. Each instrument can be purchased separately, if desired.

SPECIFICATIONS

Terminals and Connections: All instruments are equipped with multi-point protected plug connectors on the rear of each unit. A complete interconnecting cable, using low-impedance shielded cable for all radio-frequency circuits, and shielded cable for all audio-frequency circuits, is furnished with the CLASS C-21-HLD Standard Frequency Assembly.

Power Supply: 105 to 125 volts, 50 to 60 cycles. Other voltages or other frequencies on special order only.

Power Input: 100 watts with heaters of TYPE 616-C Heterodyne Frequency Meter off. Heater demand is

182 watts; average heater power is 60 watts, approximately. Average power input is 160 watts.

Mounting: The complete assembly mounts in a standard 19-inch TYPE 480-M Cabinet Rack. The TYPE 480-M Rack includes power service outlets for each instrument.

Dimensions: (Height) 76 $\frac{1}{8}$ x (width) 22 x (depth) 24 $\frac{1}{2}$ inches, over-all. The total rack space is 40 rack units, or 70 inches.

Net Weight: 530 pounds, including cabinet rack.

Description	Code Word	Price
Frequency-Measuring Equipment	BASIC	\$2325.00

PATENT NOTICE. See Notes 1, 3, 14, 17, 19, page v.

**TYPE 699-A COMPARISON
OSCILLOSCOPE**

This unit contains a cathode-ray oscilloscope, with its power supply, 100-cycle and 1-kilocycle smoothing filters, networks for obtaining circular sweeps at these frequencies, and switching for the interconnection of units of the frequency standard and measuring equipment to the oscilloscope. Over twenty different operations in comparing the frequency of one source with that of another may be quickly carried out, without the use of any temporary connections. (See also page 141.)

**TYPE 616-C HETERODYNE FREQUENCY
METER**

This frequency meter covers a fundamental frequency range of 100 to 5000 kc. Harmonic frequencies, or the fundamental frequency, may be utilized in measurements, through a low impedance output circuit. For quick measurements, the interpolation dial, used in conjunction with the direct-reading finder dial, will give results with sufficient accuracy for many purposes. For more accurate measurements, use is made of the Interpolation Oscillator. (See also page 142.)

**TYPE 617-C INTERPOLATION
OSCILLATOR**

A direct-reading linear-scale audio-frequency oscillator covering frequencies between 0 and 5000 cycles. It is used to measure the audio-frequency difference between the unknown frequency and a standard 10-kilocycle harmonic. A mixer circuit is included to obtain maximum beat amplitude between the oscillator frequency and the frequency under measurement. (See also page 144.)

TYPE 619-E HETERODYNE DETECTOR

The heterodyne detector is used to obtain beats between standard and unknown radio frequencies. The instrument includes a tuned, regenerative detector and an audio-frequency amplifier. Low-impedance radio-frequency input circuits are provided. The detector is more sensitive and more stable than in previous models. Plug-in coils for a range of 25 kc to 25 Mc are furnished. (See also page 148.)

TYPE 612-C COUPLING PANEL

This unit is the centralized control point at which all switching and level control, necessary for using the various combinations of the measuring equipment, may be easily and quickly carried out. (See also page 146.)

TYPE 619-P1 COIL DRAWER

Space for all coils normally supplied with the Type 619 Heterodyne Detector is provided.

TYPE 614-B SELECTIVE AMPLIFIER

A regenerative selective amplifier which is employed to select any multiple of 1 kc between 1 and 10. These selected output frequencies are very useful in cases where a frequency is to be adjusted to a multiple of 1 kc, or when the Cathode-Ray Oscilloscope is to be used in calibrating oscillators in the upper audio-frequency and low-frequency ranges. (See also page 149.)

LOUDSPEAKER

The permanent magnet speaker and its baffle are permanently mounted in the relay rack. A grilled opening is provided in the panel.

TYPE 480-M CABINET RACK

Power outlets are provided for all instruments in the rack.

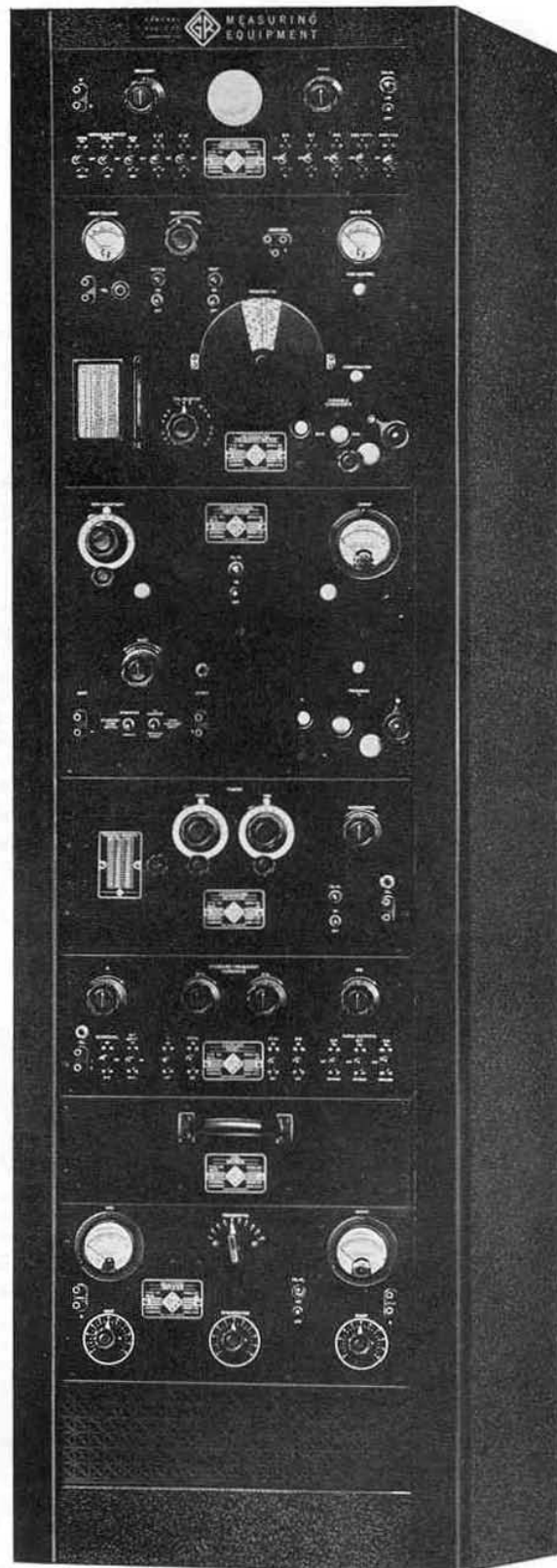

• FREQUENCY

CLASS C-10-H SECONDARY FREQUENCY STANDARD AND FREQUENCY-MEASURING EQUIPMENT

Where the extreme precision of the primary standard is not required, the less expensive secondary standard is usually quite satisfactory. It can be used as a source of standard frequencies for the laboratory or as the basic unit of a frequency-measuring assembly as shown on the next page.

The CLASS C-10-H Secondary Frequency Standard consists of the following instruments:

- TYPE 675-M Piezo-Electric Oscillator
- TYPE 676-A Quartz Bar (50 kc)
- TYPE 692-B Multivibrator (50 kc)

- TYPE 602-B Multivibrator (10 kc)
- TYPE 480-B Relay Rack
- Terminal strip and connecting cables

The frequency-measuring equipment consists of:

- TYPE 616-C Heterodyne Frequency Meter
- TYPE 619-E Heterodyne Detector
- TYPE 612-K Coupling Panel

When the measuring equipment is supplied, TYPE 480-A Relay Rack replaces TYPE 480-B. Blank panels to fill the rack are provided with each assembly.

SPECIFICATIONS

CLASS C-10-H SECONDARY FREQUENCY STANDARD

Output Frequency Range: When the TYPE 619-E Heterodyne Detector is used for detecting and utilizing the standard-frequency harmonics, the output frequency ranges of the multivibrator are:

- 10 kc and its harmonics up to 10 Mc
- 50 kc and its harmonics up to 25 Mc

Output Amplitude: 0.3 volt, rms, across a 65-Ω load.

Accuracy: Before shipment, the frequency of the piezo-electric oscillator is adjusted within ± 1 part in 1,000,000 of its specified frequency. Slight changes in frequency may occur during shipment. The frequency is, therefore, guaranteed to ± 20 parts per million. Means for adjusting the frequency are provided, and the frequency can be brought into agreement with standard-frequency transmissions such as those of the U. S. Bureau of Standards. Periodic checks against these transmissions make it possible to maintain the frequency to an accuracy of 1 part in 1,000,000 over long periods of time.

Quartz Bar: A 50-kc quartz bar (TYPE 676-A) is supplied. On special order, TYPE 476-A Quartz Bar can be furnished. The 50-kc bar is recommended because of its better frequency stability.

Temperature Control: A single-stage temperature-control unit is provided, at 60° Centigrade. Control of the

temperature of the inner space is maintained within 0.1° Centigrade for ambient temperature changes of ± 20° Centigrade from a normal of 25° Centigrade. The frequency changes by 0.2 part per million for a change of 0.1° Centigrade.

Terminals and Connections: All interconnecting cables are supplied, and the output is available at shielded plug connections on the terminal panel.

Vacuum Tubes: The following tubes are required and are furnished:

- 1—Type 77
- 2—Type 76
- 1—Type 83
- 10—Type 6J5G

Power Supply: 105 to 125 volts, 50 to 60 cycles. Other voltages or other frequencies on special order only. The power supply of the TYPE 675-M Piezo-Electric Oscillator will furnish power to a maximum of three TYPE 692-B Multivibrators.

Power Input: Maximum, 175 watts; average, 115 watts.

Mounting: TYPE 480-B Relay Rack.

Dimensions: (Height) 44 x (width) 20 x (depth) 15 inches, over-all.

Net Weight: 125 pounds.

Class	Description	Code Word	Price
C-10-H	Secondary Frequency Standard	EPOCH	\$805.00

PATENT NOTICE. See Notes 1, 3, 8, 11, 12, 19, 20, page v.

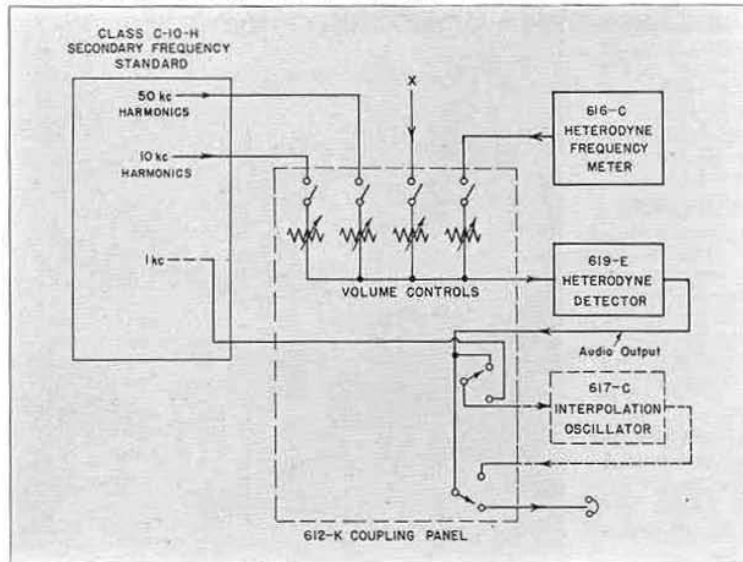

Functional diagram of the frequency-measuring assembly. All switching and amplitude adjustment is accomplished by means of the TYPE 612-K Coupling Panel.

The unknown and standard frequencies are applied through attenuators to the heterodyne detector. The unknown is then measured by linear interpolation, using the heterodyne frequency meter.

The interpolation oscillator (shown by broken lines) is not included with this assembly. It can be ordered separately or added later, if desired. Provision for using it is made in the TYPE 612-K Coupling Panel as shown.

TYPE 616-C HETERODYNE FREQUENCY METER

The heterodyne frequency meter is used to measure unknown frequencies in terms of standard-frequency harmonics by the linear-interpolation method. (See page 132.) This instrument is completely described on page 142.

TYPE 619-E HETERODYNE DETECTOR

Beats and zero-beat settings between the heterodyne frequency meter and a standard or unknown frequency are obtained in the heterodyne detector. (See page 148 for a complete description.)

TYPE 612-K COUPLING PANEL

This is a simplified form of the TYPE 612-C Coupling Panel used with the assembly described on page 137. All amplitude control and switching necessary in making frequency measurements are accomplished here. (See page 147 for description.)

TYPE 619-P1 COIL DRAWER

This drawer for storing the heterodyne detector coils is supplied as an accessory with the heterodyne detector.

TYPE 692-B MULTIVIBRATORS

Two multivibrators are supplied with the secondary frequency standard, one operating at 10 kc, the other at 50 kc. (See also page 140.)

TERMINAL STRIP AND CABLE

Complete shielded interconnecting cables are supplied and the multivibrator outputs are brought out to shielded plugs on the terminal strip.

**TYPE 675-M PIEZO-ELECTRIC OSCILLATOR
TYPE 676-A QUARTZ BAR**

This piezo-electric oscillator, like the TYPES 690 and 691 units used in the primary standard, is especially designed for use as a low-frequency standard. The TYPE 676-A Quartz Bar is identical with that used in the primary standard. Since the accuracy requirements for the secondary standard are less severe, only one stage of temperature control is provided. The power supply furnishes power for operating the multivibrators and is capable of supplying a maximum of three such units.

**TYPE 480-A RELAY RACK AND
BLANK PANELS**

Blank panels to fill the rack are supplied. The CLASS C-10-H Secondary Frequency Standard, when sold as a single unit, is mounted on a TYPE 480-B Relay Rack. The secondary standard and measuring equipment shown here uses a TYPE 480-A Relay Rack. (See page 203.)

SPECIFICATIONS

SECONDARY STANDARD AND MEASURING EQUIPMENT

Frequency Range: Frequencies up to 25 megacycles can be measured directly by the linear interpolation method. Through the use of heterodyne methods, higher frequencies are easily measured.

Connections: All connecting cables are supplied.

Mounting: TYPE 480-A Relay Rack.

Power Supply: 105 to 115 volts, 50 to 60 cycles, ac. Other voltages and frequencies on special order only.

Power Input: Maximum demand, 375 watts; average, 200 watts.

Dimensions: (Height) 69 1/8 x (width) 20 x (depth) 18 inches, over-all.

Net Weight: 340 pounds.

Description	Code Word	Price
Class C-10-H Secondary Frequency Standard with Frequency-Measuring Equipment	BAYAN	\$1920.00

PATENT NOTICE. See Notes 1, 3, 8, 12, 14, 17, 19, 20, page v.

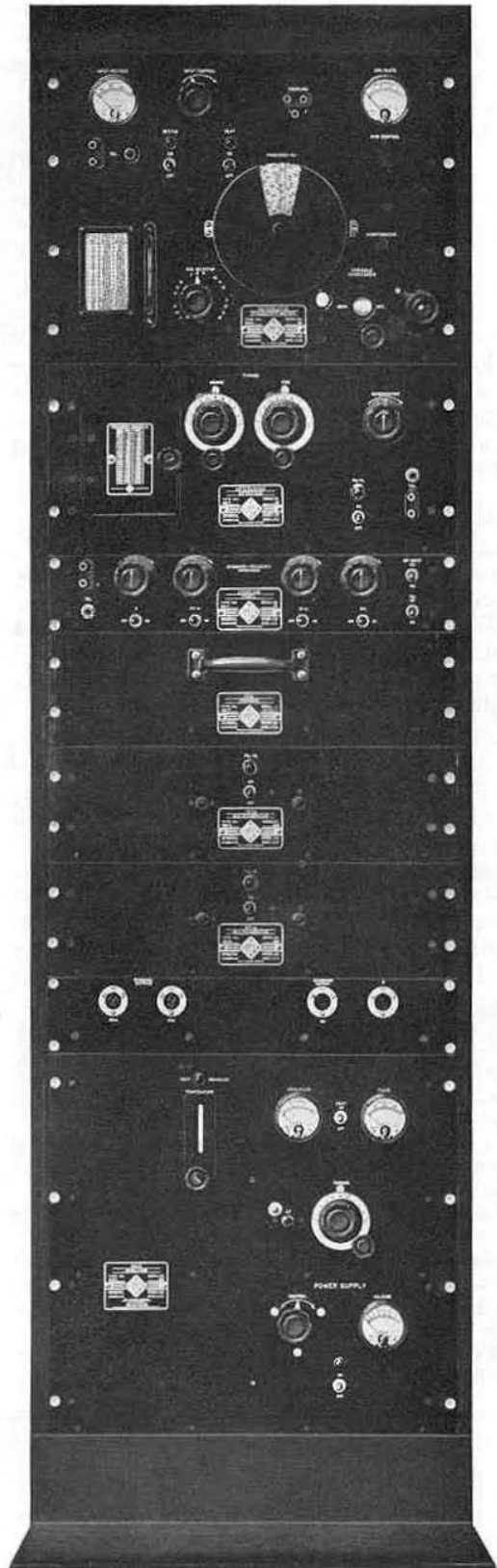

• FREQUENCY

GENERAL RADIO CO.

TYPE 692-B MULTIVIBRATOR

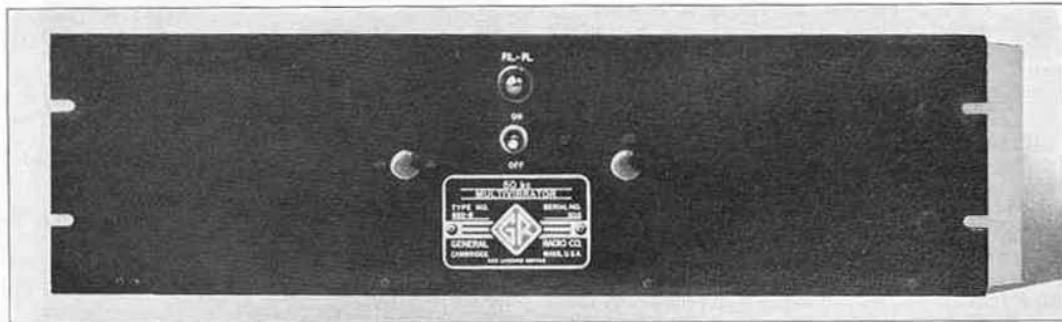

USES: These multivibrators are designed for use as frequency dividers and multipliers in General Radio standard-frequency assemblies. They are also available for general laboratory or experimental use.

DESCRIPTION: Each multivibrator includes an input amplifier, a two-tube multivibrator, and two output amplifiers. Protected screw-driver adjustments provide for regulation of the control voltage input and for adjustment of the fundamental frequency over a limited range; protected controls are used to avoid unauthorized tampering.

FEATURES: The frequency adjustment permits the uncontrolled frequency to be set exactly to the desired controlled value, leading to greatest reliability of control over long periods of time.

One output amplifier is provided for the control of succeeding multivibrators, where a number of stages of frequency division are desired. The other output amplifier is designed for use with low-impedance circuits (65 ohms, approximately) and is intended for use on the harmonic frequencies of the multivibrator. Either or both amplifiers may be used as desired.

TYPE 698-A DUPLEX MULTIVIBRATOR

The TYPE 698-A Duplex Multivibrator is a special-purpose unit intended for use in standard-frequency assemblies to avoid measurements very near zero beat on multiples of 10 kc (as in the broadcast band). The multivibrator operates at either 9 or 11 kc controlled by selected harmonics of the 10 kc

standard output, either frequency being selected by a switch. If a frequency lies very close to a multiple of 10 kc, giving a very low-beat frequency, it will give a beat which is very close to 1 kc, or to a multiple of 1 kc, when referred to a harmonic from the 9 or 11 kc multivibrator.

SPECIFICATIONS

Frequency: Standard models are available for operation at the frequencies listed below. Multivibrators for operation at other frequencies can be supplied on special order.

Vacuum Tubes: Five type 6J5-G tubes are supplied with TYPE 692-B; four 6J5-G tubes with TYPE 698-A.

Power Supply: 6 volts, ac or dc, for cathode heaters; 180 volts for plates. Power supply is not incorporated in instruments.

Terminals: All external connections are made through multipoint enclosed connectors.

Mounting: Standard 19-inch relay rack.

Dimensions: Panel, (length) 19 x (height) 5 1/4 inches; behind panel, (length) 17 3/8 x (height) 5 x (depth) 10 3/4 inches.

Weight: TYPE 692-B Multivibrators, 16 pounds; TYPE 698-A Duplex Multivibrator, 18 pounds.

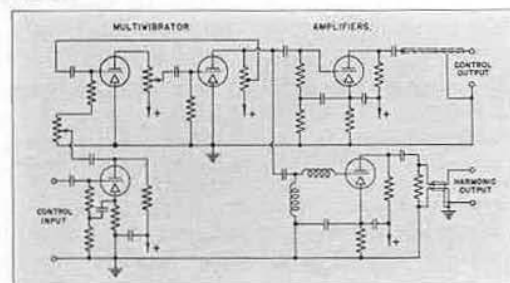

Schematic circuit diagram of a TYPE 692-B Multivibrator. The circuit of TYPE 698-A Duplex Multivibrator is the same in principle, but switching is provided for operating on either of two frequencies.

Type	Frequency	Code Word	Price
692-B	100 cycles	STANFREAPE	\$140.00
692-B	1 kc	STANFREANT	140.00
692-B	10 kc	STANFREBOY	140.00
692-B	50 kc	STANFRECAT	140.00
698-A	9 or 11 kc	STANFREFIB	220.00

PATENT NOTICE. See Note 1, page v.

TYPE 699-A COMPARISON OSCILLOSCOPE

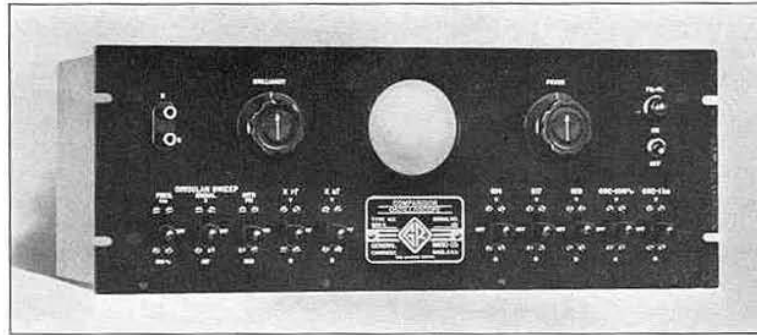

USES: This instrument is intended for use with a CLASS C-21-HLD Primary Frequency Standard and interpolation equipment as a useful aid in making interpolations with high accuracy, in calibrating the interpolation equipment in terms of the standard, and in calibrating or measuring the frequencies of audio-frequency or low radio-frequency oscillators external to the frequency measuring assembly.

DESCRIPTION: The TYPE 699-A Comparison Oscilloscope contains a 3-inch cathode-ray tube, with its power supply. Filters are supplied for smoothing the 100-cycle and 1-kilocycle outputs of the CLASS C-21-H Primary Frequency Standard, so that sharply defined patterns may be obtained. Circular sweep circuits are provided for both 100- and 1000-cycle operation.

Ten key-type switches are provided for selection of the type of pattern to be observed and the sources whose frequencies are to be compared. Over twenty different comparisons are easily and quickly carried out by simple settings of these switches. While a full list of

all the possible operations cannot be given here, it may be said that comparisons for calibration or measurements may be made between any pair of the following sources: external source, selective amplifier, interpolation oscillator, heterodyne detector, 100-cycle standard frequency, and 1000-cycle standard frequency.

FEATURES: Shielded cabling; all connections to the various sources are made through shielded cable, supplied as part of the frequency-measuring equipment, page 136.

Built-in power supply; brilliancy and focusing adjustments for cathode-ray tube.

Key-type switches for setting up all required circuit arrangements. No temporary connections are needed except those to an external source for measurement.

The circular sweep circuits for standard frequencies of 100 and 1000 cycles result in very simple and easily interpreted patterns, particularly when the frequency being measured or checked is a rather high multiple of the standard frequency. The usual Lissajous figures may also be obtained.

SPECIFICATIONS

Frequency Range: Useful patterns may be obtained over the range from very low audio frequencies to radio frequencies of the order of 50 kc, or more, dependent upon the voltage available from the source being calibrated or measured.

Controls: ON-OFF switch; BRILLIANCY and FOCUS adjustments for cathode-ray tube; ten key-type circuit selecting switches.

Terminals: All interconnections to other units of the frequency standard and measuring equipment are made through protected multipoint connectors at rear of instrument. Connections to an external source are made through panel terminals on the front of the instrument.

Mounting: Standard 19-inch relay rack.

Dimensions: Panel, (length) 19 x (height) 7 inches; behind panel, (depth) 15 $\frac{3}{4}$ inches.

Power Supply: 105 to 125 or 210 to 250 volts, 50 to 60 cycles. Other voltages or other frequencies on special order only.

Power Input: 13 watts, approximately.

Tubes Supplied:
 1—Type 906 three-inch Cathode-Ray Tube
 1—Type 879 Rectifier

Net Weight: 41 pounds.

Type	Code Word	Price
699-A	ODIUM	\$215.00

• FREQUENCY

TYPE 616-C HETERODYNE FREQUENCY METER

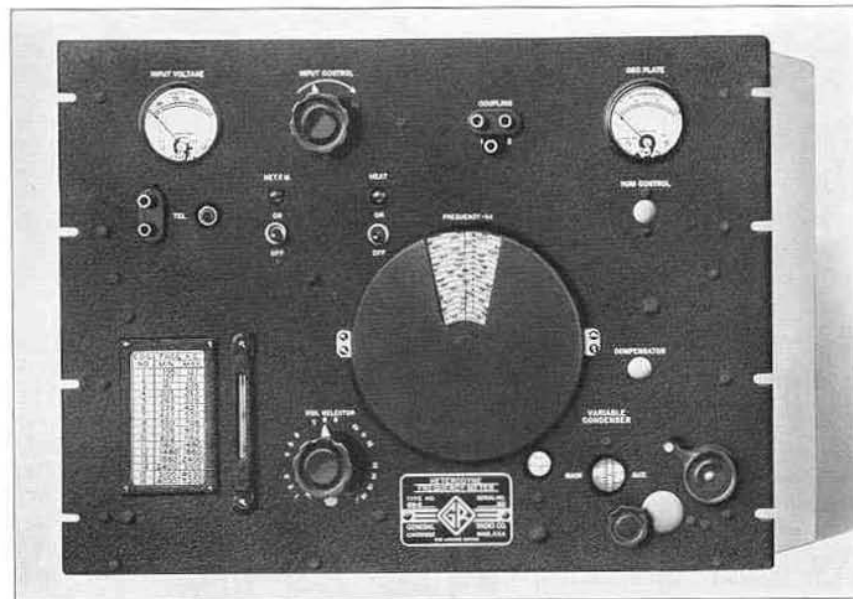

USES: The TYPE 616-C Heterodyne Frequency Meter may be used either as a calibrated frequency meter or as an important element in an interpolation assembly for use with a frequency standard.

A detector and audio-frequency amplifier are included, so that when the instrument is used as a calibrated frequency meter, beats can be obtained between the heterodyne frequency and the frequency under measurement. Frequencies both below and above the fundamental frequency range of 100 to 5000 kc may be measured by harmonic methods, provided only that a reasonable signal voltage is available.

When used in conjunction with a frequency standard, the heterodyne frequency meter provides a means of rapid identification of standard frequency harmonics and harmonics of the frequency meter itself which may be used in the measurement of an unknown frequency. The instrument also is used in the measurement of high frequencies, as a "stepping stone," to pass from the frequency range where direct beating of the unknown against the frequency standard may be accomplished into the higher frequency ranges where such direct beating is not feasible.

In either the fundamental or harmonic ranges, the heterodyne frequency meter provides a means of linear interpolation between standard frequencies for the measurement of an unknown frequency.

DESCRIPTION: The instrument contains a very stable temperature-controlled radio-

frequency oscillator with tube-controlled plate voltage supply. A detector and audio-frequency amplifier are provided for listening for heterodyne beats between the frequency being measured and that of the oscillator.

The oscillator tuned circuit includes a heavy cast-frame, straight-line-frequency variable condenser with precision worm drive. Spring-pressed ball bearings are used, which maintain the condenser adjustment, with practically no backlash, over long periods of time. Phosphor-bronze contactor springs make contact between the frame and brass contactor cups mounted on the condenser shaft. Twenty-five turns of the control knob are required to traverse the condenser scale.

The oscillator inductances are wound on isolantite forms, the windings being impregnated with low-loss wax for moisture-proofing. Each coil is individually shielded.

The direct-reading finder dial is nearly 6 inches in diameter and carries a separate scale for each of the sixteen ranges of the instrument. The dial is driven through spring pressed gearing directly from the main condenser shaft. Nearly 360-degree rotation of the dial is utilized. Since the variation in frequency is very closely linear with dial rotation, each scale is essentially uniformly divided and can be easily read.

FEATURES: Temperature control, a ruggedly constructed precision condenser, low-loss inductances, and stabilized plate voltage make this instrument an accurate and stable frequency meter.

The direct-reading finder dial is very useful

for obtaining a quick approximation to the frequency measured, for presetting the instrument to a desired frequency, or for identifying harmonics of the heterodyne frequency meter which may be used in making the measurement.

When the heterodyne frequency meter is used with a harmonic frequency standard, the finder dial makes possible the rapid identification of standard-frequency harmonics without reference to calibration charts. Direct interpolation (see page 132) is, of course, always possible using the readings of the main scale. As a convenience, an auxiliary dial is provided which makes pos-

sible interpolation without the need of taking differences of dial readings, as must be done when the main scale is used. By means of a panel control the auxiliary dial may be set to zero at a known standard frequency; when the heterodyne frequency meter is set to the unknown frequency one reading is obtained; when set to the next higher standard frequency a second reading is obtained. The ratio of these two readings gives the fractional part of the standard-frequency interval that the unknown frequency is above the lower standard frequency. This fractional part is readily determined from a simple chart constructed from standard cross-section paper.

SPECIFICATIONS

Frequency Range: The fundamental frequency range is from 100 to 5000 kc, covered in 16 bands. The harmonic output may be utilized in suitable receivers up to 30 megacycles or more.

Calibration: The direct-reading finder dial provides a calibration at approximately 700 points throughout the range, at frequency intervals varying from 1 kc at the low frequencies to 10 kc at the high frequencies. Adjustment is provided to correct the principal part of any error resulting from long-time drift of the calibration.

Calibration Chart: A list of settings of the *main condenser scale* for 10 or more frequencies in each range will be supplied if desired. This list is supplied *on order only* and a charge for it is made. (See price list.)

Accuracy: When used with a frequency standard accuracy sufficient for positive identification of standard-frequency harmonics is all that is required. This is provided by the direct-reading finder dial. When used as a calibrated instrument, the calibration chart data can be relied upon to 0.1%.

Output: Two coupling systems are provided. One, high-impedance capacity coupling to the detector for listening for beats in the heterodyne frequency meter itself, is provided with terminals on the front panel. The second is a low-impedance shielded output, 65 ohms approximately, connected to terminals at the rear for permanent cable connection in frequency-measuring assemblies. Harmonics of the oscillator frequency may easily be used up to 30 megacycles or more.

Power Supply: 115 volts at 50 to 60 cycles. Other voltages and frequencies on special order only.

Power Input: Approximately 20 watts, heaters off; 202 watts, heaters on. Heaters operate approximately 20% of the time at normal room temperatures. Total average power input 80 watts.

Frequency Stability: Tube stabilization of plate voltage to the oscillator tube prevents frequency changes due to supply voltage changes from exceeding 0.5 part per million for plus or minus 10% change in supply line voltage.

Meters: Oscillator plate current (line voltmeter).

- Tubes:** Supplied with instrument:
- 1—Type 57 Oscillator
 - 2—Type 56 Detector; Amplifier
 - 1—Type 82 Rectifier
 - 1—Type VR-90 Plate Regulator

Controls: Tube supply ON-OFF switch; heater supply ON-OFF switch; range selector; frequency control; input supply voltage control.

Mounting: Standard 19-inch relay-rack mounting. Can be supplied in walnut cabinet on special order.

Dimensions: Panel, (length) 19 x (height) 14 inches; behind panel, (length) 17 $\frac{1}{4}$ x (height) 15 $\frac{5}{8}$ x (depth) 11 $\frac{3}{4}$ inches.

Net Weight: 68 pounds.

Type	Code Word	Price
616-C	MANOR	\$575.00
Calibration Chart	CHART	20.00

*Calibrations supplied only when ordered. Use compound code word, MANORCHART.

PATENT NOTICE. See Notes 1, 3, 14, page v.

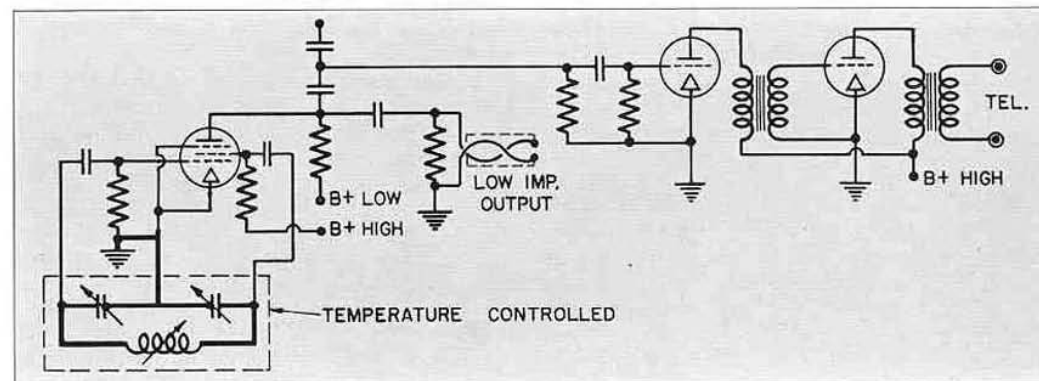

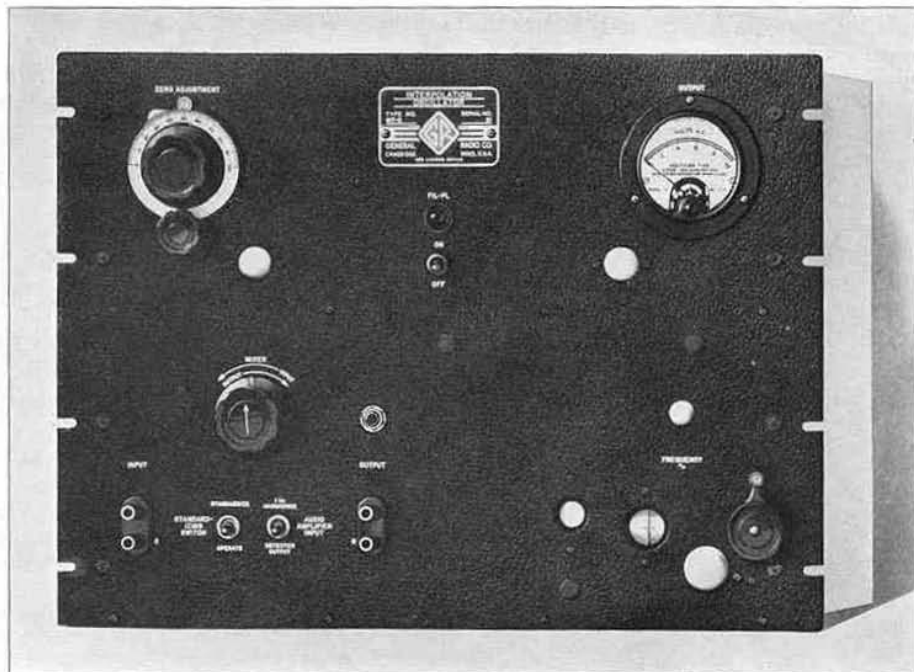

TYPE 617-C INTERPOLATION OSCILLATOR

USES: The principal use of the TYPE 617-C Interpolation Oscillator is, in connection with a frequency standard, to measure the difference between the unknown and standard frequencies. The direct-reading linear scale of 5000 divisions for 5000 cycles makes possible the rapid evaluation of this difference with an accuracy sufficient for many requirements. For certain other purposes, in audio-frequency testing, a linear frequency scale is desirable, and, in such instances, this oscillator is very useful.

When used in connection with the TYPE 698-A Duplex Multivibrator of a Primary Frequency Standard, the direct-reading, small, incremental dial of the TYPE 617-C Interpolation Oscillator may be used to evaluate very small frequency differences, of a fraction of a cycle to a few cycles, in those cases where an unknown frequency lies very close to a multiple of 10 kc. This situation occurs, for example, throughout the broadcast band, where stations are rarely off frequency by more than a very few cycles.

DESCRIPTION: The oscillator is of the beat-frequency type, with the radio-frequency oscillators operating in the region of 43 to 48 kc. A vacuum-tube regulator is employed in the plate supply of the oscillators and detector, by means of which changes in output frequency and amplitude due to changes in supply line voltage are made negligibly small.

The variable-frequency oscillator is controlled by a cast-frame, ball-bearing variable condenser, having a precision worm drive. The inductors are wound on ceramic forms which have low losses and a low-temperature coefficient of inductance. Each inductor is enclosed in a balsa-wood box which reduces the effect of changes in ambient temperature.

The instrument contains an output meter on which the beats between an unknown and the oscillator frequency may be observed. Telephone connections are also provided, so that the beat may be observed visually, or aurally, or both. When adjusting the oscillator quickly, to obtain an approximate match between the oscillator and the unknown, the aural method is easier. When setting the oscillator to obtain as close a match as possible, the visual method is preferable.

Means are also provided so that the output meter may be used as a beat meter in matching a given audio frequency to multiples of 1 kc (obtained from a frequency standard). For example, in adjusting piezo-electric crystals to integral multiples of 1 kc, the beat meter indicates the frequency difference between the crystal oscillator being adjusted and the frequency standard.

FEATURES: Stability of the output frequency was one of the design requirements of this oscillator. The use of low-temperature-

coefficient materials in the tuned circuits, heat insulation to reduce differential temperature effects, a cast-frame variable air condenser, and a voltage-stabilized power supply have made possible a high degree of stability.

The condenser is provided with a precision worm drive so that very precise frequency settings can be made. While the direct-reading calibration is adjusted to within ± 2 cycles, the small residual errors are easily and quickly removed in the region of any frequency in the range by fine adjustment of the zero by reference to a frequency standard having a 1-ke or 100-cycle multivibrator, or both. For evaluating very small frequency differences, a direct-reading frequency-increment dial is provided.

In obtaining the maximum beat amplitude between the interpolation oscillator and the frequency being matched, it is essential that the amplitude of the two signals be adjusted to be very nearly alike when applied to the mixer tube. In many cases one of the signals, the beat-frequency output of the heterodyne detector, for example, may be very weak as compared with the voltage available from the interpolation oscillator. In such a case, using two volume controls, one must be advanced while the other is set near zero. In this instrument these two volume controls are placed on a single shaft, but operate in opposite senses. Thus, the stronger signal is reduced while the weaker is increased, until the maximum beat is obtained; the optimum position is quickly and easily found.

SPECIFICATIONS

Frequency Range: 0 to 5000 cycles per second.

Accuracy: The instrument is aligned to agree with the linear direct-reading scale within ± 2 cycles. A correction chart is furnished giving the deviations at 100-cycle intervals throughout the range.

Output: The output voltage is approximately 7 volts across a 20,000-ohm load.

Power Supply: 105 to 125 or 210 to 250 volts, 50 to 60 cycles. A change of transformer connections provides for using 115- or 230-volt service. Other voltages or frequencies on special order only.

Power Input: 20 watts, approximately.

Controls: ON-OFF switch; STANDARDIZE-RUN switch; AMPLIFIER-INPUT switch; MIXER control, which operates also as oscillator output control; incremental frequency control and zero set; oscillator frequency control.

Meters: Output voltmeter; used also as a beat-indicator meter.

Terminals: Terminals, both on panel and at rear, are provided for both mixer input and oscillator output. Rear terminals are provided for introducing 1-ke stand-

ard frequency and its harmonics when the beat-indicator is to be used for adjusting a frequency to exact multiples of 1 ke.

Tubes: Furnished with instrument:

- 2—Type 6J7-G R. F. Oscillators
- 2—Type 6J5-G Detector; Amplifier
- 1—Type 6X5-G Rectifier
- 1—Type VR-90 Voltage Regulator

Accessories: Supplied with instrument:

- 2—TYPE 274-M Plugs
- Pilot Light
- Dual Light } with spares
- Fuses
- Attachment Cord
- 1—Multipoint Connector

Mounting: Standard 19-inch relay-rack mounting. Can be supplied in walnut cabinet on special order.

Dimensions: Panel, (length) 19 x (height) 14 inches; behind panel, (length) $17\frac{1}{4}$ x (height) $13\frac{5}{8}$ x (depth) $11\frac{3}{4}$ inches.

Net Weight: 57 pounds.

Type	Code Word	Price
617-C	MAPLE	\$500.00

PATENT NOTICE. See Notes 1, 3, 17, page v.

Schematic circuit diagram of TYPE 617-B Interpolation Oscillator.

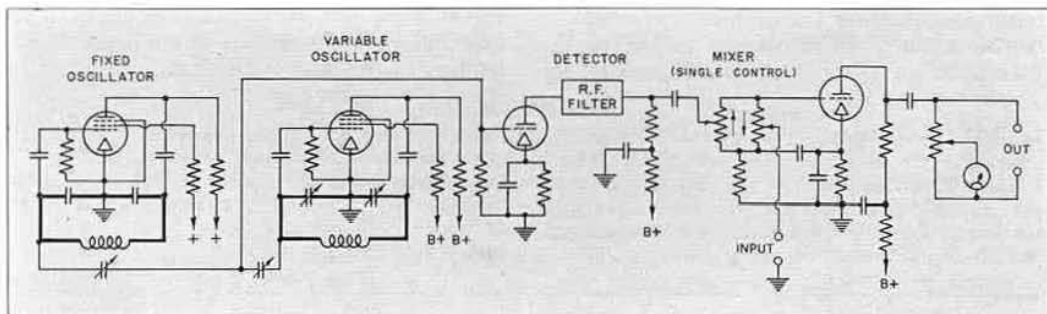

TYPE 612-C COUPLING PANEL



USES: This coupling panel is designed specifically for use as a centralized control panel in a frequency-measuring equipment employing a Primary Frequency Standard, as described on pages 134 and 135. The panel carries the necessary switches and volume controls for transferring frequencies from one unit to another in the assembly, and for mixing frequencies to obtain the beat-frequency difference in the output of the heterodyne detector.

DESCRIPTION: The instrument includes four low-impedance shielded L-type attenuators, or volume controls, for the four radio-frequency circuits involved in measuring frequencies: (1) the unknown, or "X", frequency; (2) 50-kc harmonics from the frequency standard; (3) 10-kc harmonics from the frequency standard, and (4) the output of the heterodyne frequency meter. These controls, in general, are operated to regulate the amplitudes of the voltages, from two of the above sources, fed to the heterodyne detector.

Switching is provided for a number of audio-frequency operations, including: (1) checking the frequency of the Primary Standard against time signals, using the microdial; (2) checking the calibration of the Interpolation Oscillator against the standard, either on a 1-kc or a 100-cycle basis; (3) matching the frequency of an audio beat-frequency difference by means of the Interpolation Oscillator; (4) adjusting the

frequency under measurement to a specified value by means of the Interpolation Oscillator; (5) adjusting the frequency under measurement to an integral number of kilocycles directly against the frequency standard employing the Selective Amplifier.

FEATURES: The radio-frequency volume controls are designed for use with low-impedance (65-ohm) circuits. They are of the constant-impedance L-type, in cast aluminum housings. The windings are Ayrton-Perry. Every effort has been made to obtain a satisfactory control, with minimum noise, small reaction on the tuning of the heterodyne detector, and with low minimum signal and cross-talk. When used with the shielded interconnecting cables designed for the measuring equipment, very satisfactory freedom from cross-talk is obtained.

Anti-capacity key-type ON-OFF switches are provided with each volume control, so that the corresponding signals may be removed from the detector without the necessity of turning the volume control back to zero. The same type of switch is also used for all audio-frequency circuits, where, although the frequencies are lower, the voltages may be much greater than in the radio-frequency circuits, necessitating care to prevent cross-talk.

All wiring is done with two-conductor shielded cable. Connections are made to the external cable by means of multipoint connectors at the rear of the instrument.

SPECIFICATIONS

Terminals: All connections to the various instruments comprising the Measuring Equipment used with a Primary Frequency Standard (see page 136) are made through multi-point protected connectors mounted at the rear of the instrument. Telephone terminals and jack are brought out on the panel.

Mounting: Standard 19-inch relay-rack mounting. The instrument is fitted with dust cover.

Dimensions: Panel, (length) 19 x (height) 7 inches; behind panel, (length) 17 $\frac{3}{4}$ x (height) 6 $\frac{3}{4}$ x (depth) 11 inches.

Net Weight: 24 $\frac{1}{2}$ pounds.

Type	Code Word	Price
612-C	OCUR	\$190.00

TYPE 612-K COUPLING PANEL

USES: This coupling panel is a smaller and somewhat simplified unit to serve the same purpose as the more elaborate TYPE 612-C instrument when used with a Secondary Frequency Standard. All necessary switches and volume controls for complete and flexible operation of the units of the assembly are provided.

DESCRIPTION: The instrument includes four low-impedance, shielded attenuators, or volume controls, for the four radio-frequency

circuits: (1) the unknown, or "X," frequency; (2) 50-kc harmonic series from the Secondary Standard; (3) 10-kc harmonic series from the standard, and (4) the output of the heterodyne frequency meter. Provision is made on the coupling panel for the addition of a TYPE 617-C Interpolation Oscillator, with switching provided both for checking of the oscillator against a standard 1-kc source and for matching the beat-frequency difference appearing in the detector output.

SPECIFICATIONS

Terminals: All connections to the various instruments comprising the Secondary Standard and Measuring Equipment (see page 139) are made through multipoint protected connectors mounted at the rear of the instrument. Telephone terminals and jack are provided on the panel.

Mounting: Standard 19-inch relay-rack mounting. The instrument is supplied with a dust cover.

Dimensions: Panel, (length) 19 x (height) 3½ inches; behind panel, (length) 17¼ x (height) 3¼ x (depth) 8 inches.

Net Weight: 9 pounds.

Type	Code Word	Price
612-K	OFFER	\$125.00

REPLACEMENT THERMOSTATS AND THERMOMETERS

Replacement thermostats and thermometers can be supplied for all temperature-controlled instruments listed in this catalog. Part numbers and prices for these are given below.

Instrument Type No.	Type No.	Thermometer Temp. Range	Price
475-B	139-509	57°-63° C.	\$4.00
675-M	139-509	57°-63° C.	4.00
691-C (Inner)	139-489	56°-64° C.	4.00
691-C (Outer)	139-481	40°-60° C.	4.00
616-C	139-181	40°-60° C.	4.00

Instrument Type No.	Type No.	Thermostat Operating Temp.	Price
475-B	139-503 (Specify operating temperature)	60° C.	\$22.00
675-M	139-503 (Specify operating temperature)	60° C.	22.00
691-C (Inner)	139-503 (Specify operating temperature)	60° C.	22.00
691-C (Outer)	139-503 (Specify operating temperature)	55° C.	22.00
616-C	139-503 (Specify operating temperature)	50° C.	22.00

When ordering replacement thermometers for obsolete instruments, specify type number and serial number of instrument, temperature range of thermometer, and the fraction

of a degree which each scale division covers.

When ordering thermostats, state operating temperature, and type number and serial number of instrument.

TYPE 619 HETERODYNE DETECTOR

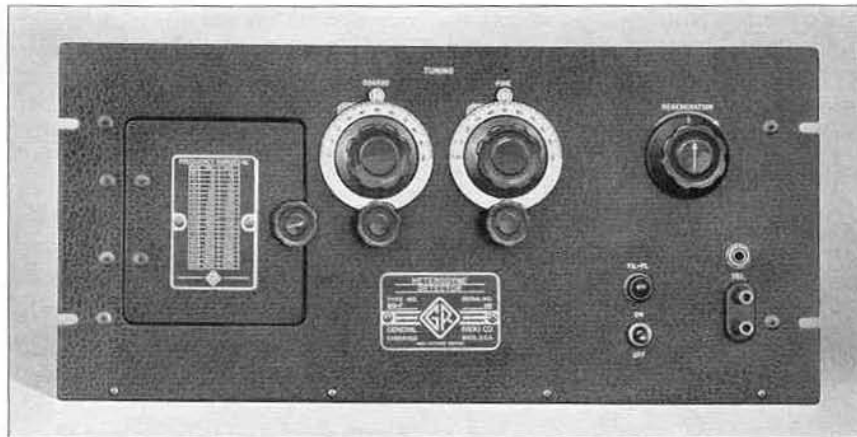

USES: This heterodyne detector is designed primarily for use with a frequency standard and frequency-measuring equipment for obtaining the beat-frequency difference between standard and unknown frequencies. It can also be used as a detector in conjunction with a radio-frequency bridge.

DESCRIPTION: The instrument contains a regenerative detector and two stages of audio-frequency amplification. A regeneration control is provided so that the detector may be operated either oscillating or non-oscillating, as the conditions of use require.

Plug-in coils are used, and a complete set

is supplied with the instrument. A relay-rack-size drawer for holding the coils is supplied.

FEATURES: Some of the features of this instrument are high sensitivity, wide frequency range, and low-impedance radio-frequency input.

The tuned circuit for the regenerative detector is provided with an auxiliary fine-tuning condenser. The detector plate voltage is stabilized, which contributes to the frequency stability. Regeneration is controlled by adjusting the screen voltage, a noise filter giving smooth and quiet control.

SPECIFICATIONS

Frequency Range: A frequency range of 25 kc to 25 Mc is covered by the 21 coils supplied with the instrument. Two tuning condensers, on the same shaft, are used. The condenser in use is automatically selected by the coil plugged in the circuit, for the low- and high-frequency ranges.

R-F Input Impedance: 65 ohms, approximately.

Calibration: A calibration is supplied. While this calibration is accurately determined, it is not guaranteed, as the instrument is not intended for use as a calibrated-frequency measuring device. The calibration is useful in making approximate settings, identifying standard-frequency harmonics, etc.

Controls: ON-OFF switch; coarse and fine tuning; regeneration.

Terminals: Shielded, low-impedance radio-frequency input connections are provided in rear. Telephone connections are provided at rear and on panel.

Mounting: Standard 19-inch relay rack. Can be supplied in walnut cabinet on special order.

Dimensions: Panel, (length) 19 x (height) 8 $\frac{3}{4}$ inches; behind panel, (length) 17 $\frac{1}{4}$ x (height) 8 $\frac{1}{2}$ x (depth) 10 $\frac{3}{4}$ inches. TYPE 619-P1, panel, (length) 19 x (height) 5 $\frac{1}{4}$ inches; behind panel, (length) 17 $\frac{1}{4}$ x (height) 5 x (depth) 13 $\frac{1}{2}$ inches.

Net Weight: TYPES 619-E and 619-P1, 61 pounds.

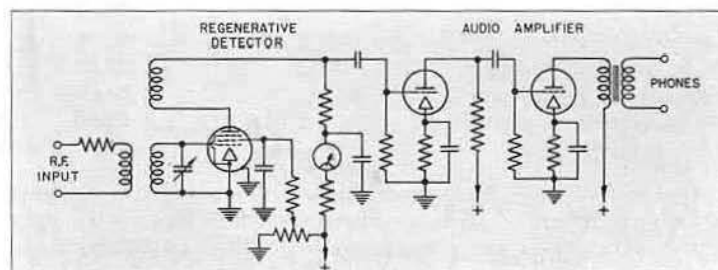

Schematic circuit diagram of the TYPE 619-E Heterodyne Detector. Power supply is not shown. The radio-frequency input is connected by low-impedance cable to the terminals at the left. The tuning condenser is in two sections—one being used for low frequencies and the other for high. The correct condenser is automatically selected when the coil is plugged in.

Tubes: Supplied with instrument:

- 1—Type 6J7-G Detector
- 2—Type 6J5-G Amplifiers
- 1—Type 6X5-G Rectifier
- 1—Type VR-90 Voltage Regulator

Power Supply: 105 to 125 or 210 to 250 volts, 50 to 60 cycles. Transformer connections changed for 115- or 230-volt supply. Other frequencies or voltages on special order only.

Power Input: 20 watts, approximately.

Accessories Supplied:

- 1—TYPE 274-M Plug
- Pilot Light } with spares
- Fuses }
- 1—Attachment Cord
- 1—Multipoint Connector
- 21—Plug-in Coils
- 1—TYPE 619-P1 Coil Drawer

Type	Description	Code Word	Price
619-E	A-C Operated, Rack Mounted	MATIN	\$360.00

PATENT NOTICE. See Notes 1, 17, page v.

TYPE 614-B SELECTIVE AMPLIFIER

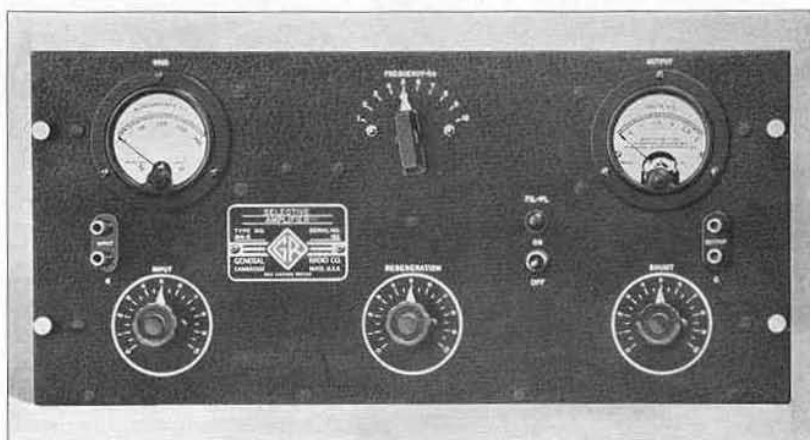

USES: This amplifier is used for selecting individual harmonics from the 1 kc output of a frequency standard. Multiples of 1 kc between 1 and 10 may be chosen, with good suppression of the fundamental and adjacent harmonics. The selected output frequency is useful for many audio-frequency measurements, particularly in making frequency

comparisons by means of a cathode-ray tube.

DESCRIPTION: The instrument contains a harmonic-generating amplifier stage, a regenerative selective stage, and an output stage. The selective stage may be tuned to any one of the first 10 multiples of 1 kc by means of a single switch.

SPECIFICATIONS

- Frequency Range:** 1 to 10 kc in steps of 1 kc.
- Calibration:** Amplifier is adjusted for maximum response at each of the 10 frequencies at the factory. Trimming adjustments are provided, which may be used in realigning the tuned circuits, if necessary.
- Tubes:** Supplied with instrument:
 - 3—Type 56 Amplifiers
 - 1—Type 82 Rectifier

- Power Supply:** 105 to 125 volts, 50 to 60 cycles.
- Power Input:** 25 watts, approximately.
- Mounting:** Standard 19-inch relay rack.
- Dimensions:** Panel, (length) 19 x (height) 8¾ inches; behind panel, (length) 17¼ x (height) 8½ x (depth) 8¾ inches.
- Net Weight:** 38 pounds.

Type	Code Word	Price
614-B	DICKY	\$275.00

PATENT NOTICE. See Note 1, page v.

Schematic circuit diagram of the TYPE 614-B Selective Amplifier. Power supply is not shown. A voltage from a 1-kc source is applied to the terminals at the left. Harmonics are generated in the first amplifier, selected in the second, regenerative, amplifier, and the selected harmonic is amplified by the output amplifier.

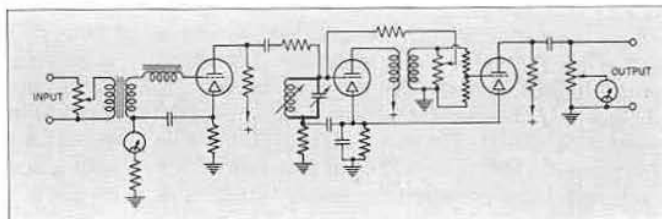

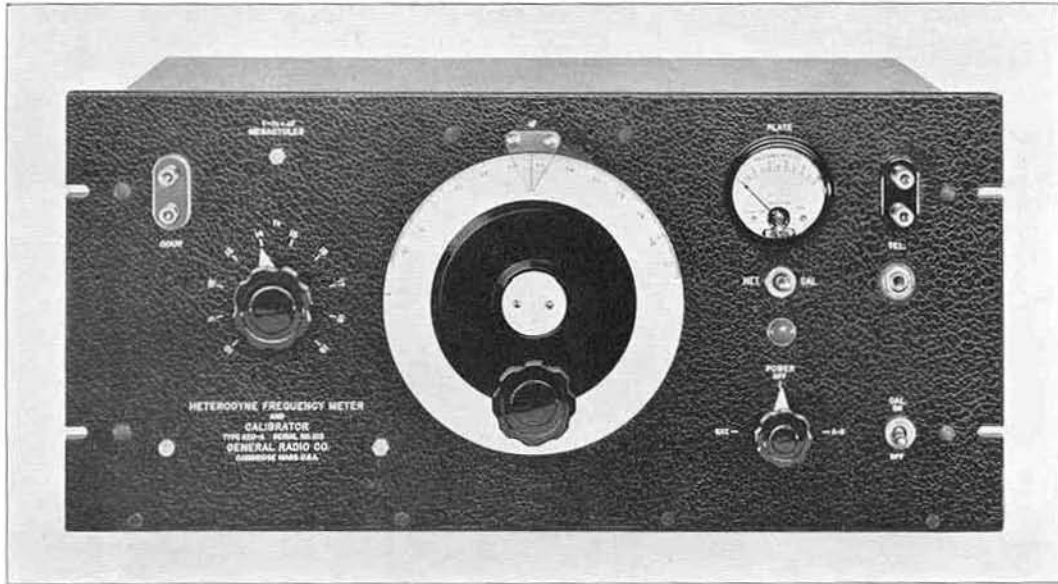

TYPE 620-A HETERODYNE FREQUENCY METER AND CALIBRATOR

USES: Although designed primarily for measuring frequencies above 10 megacycles, this instrument can be used to measure frequencies as low as 300 kilocycles, through the use of harmonic methods. As a general-purpose instrument in the communication laboratory, it is invaluable. For communication companies it provides an excellent means of rapidly measuring the frequencies of a large number of transmitters (either local or remote) in addition to its use in calibrating and servicing receiving equipment. Receiver manufacturers will find it useful in checking the ranges of receivers and oscillators. It is suitable for monitoring the frequencies of radio transmitters where the allowable frequency tolerance is 0.02 per cent or greater.

DESCRIPTION: The schematic diagram shows the essential elements of the instrument: (1) a heterodyne frequency meter, (2) a crystal calibrator, and (3) a detector and audio amplifier.

The heterodyne frequency meter is direct reading, which is an important operating convenience particularly when using harmonics. The fundamental frequency range is 10 to 20 Mc, divided into 10 steps of 1 Mc each. The main tuning condenser covers a range of 1 Mc for each coil, the dial being engraved to read fractions of a megacycle directly. The smallest divisions on the dial represent 0.005 Mc (or 5000 cycles). The frequency reading is given by the sum of the coil switch and condenser dial readings. For example, with the coil switch at 14 and the

condenser dial at 0.35 the frequency is 14.35 Mc. Fifths of divisions may be estimated corresponding to 0.001 Mc (1000 cycles).

For checking the heterodyne frequency meter the piezo-electric calibrator, employing a one-megacycle low-temperature-coefficient quartz plate, is provided. Several points on each coil range of the heterodyne frequency meter may be checked. Harmonics of 1 Mc fall at the upper and lower limits of the dial, giving a bracketing check on each coil range of the heterodyne frequency meter. Harmonics of the heterodyne also produce beats with harmonics of the calibrator, giving checking points at multiples of $\frac{1}{2}$, $\frac{1}{3}$, $\frac{1}{4}$, and $\frac{1}{5}$ Mc, etc., over the dial range. Since these points occur at the same dial readings for each range, checking is made very simple and convenient.

The procedure in making measurements is simple. When the unknown frequency is within the fundamental range of the heterodyne, the heterodyne frequency is set to zero beat with the unknown, and the frequency is read directly from the dial. When the unknown is above or below the heterodyne fundamental range, the dial reading must be multiplied or divided by the harmonic number.

The fundamental frequency range being 10 to 20 Mc, measurements of high and ultra-high frequencies are easily made. Because of the direct-reading feature and the widespread frequency scale, no confusion as to harmonics is encountered in measuring ultra-high frequencies.

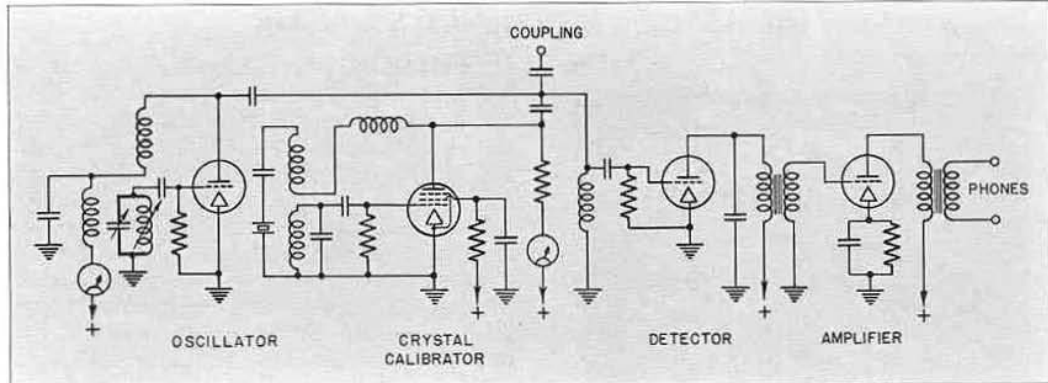

Schematic circuit diagram of TYPE 620-A Heterodyne Frequency Meter and Calibrator. To simplify the diagram, power supply is not shown.

When measuring frequencies below the fundamental of the heterodyne, harmonics of adequate strength for measurement can be generated in the detector tube provided a sufficiently strong signal is applied to the instrument. For weak signals, a local harmonic-generating means is necessary.

FEATURES: The TYPE 620-A Heterodyne Frequency Meter and Calibrator is designed for the greatest flexibility and for simplicity of operation. It covers a wide range of frequencies and is capable of a high accuracy of measurement.

The direct-reading frequency scale makes rapid measurements possible. The oscillator has been designed and constructed to give a high degree of frequency stability. The variable air condenser has ball bearings to insure smooth operation without backlash. The inductors are wound on isolantite forms to keep the losses and the temperature coefficient of inductance as low as possible.

The same model can be used on either battery or a-c power supply; this is a considerable convenience when the same instrument is to be used both in the laboratory and in the field.

SPECIFICATIONS

Frequency Range: The fundamental frequency range is from 10 to 20 megacycles, in 10 ranges of 1 megacycle each. By harmonic methods frequencies between 300 kc and 300 Mc are easily measured.

Calibration: The condenser dial is graduated to read fractions of megacycles directly, the smallest division corresponding to 0.005 Mc (5000 cycles). Fifths of divisions are readily estimated, corresponding to 0.001 Mc (1000 cycles).

Calibrator: A 1-Mc piezo-electric oscillator, employing a low-temperature coefficient quartz plate, is provided for checking the calibration of the frequency meter.

Accuracy: The over-all accuracy of measurement is 0.01% or better.

Vacuum Tubes: The following tubes are used and are supplied with the instrument:

- 1—954-type
- 3—955-type
- 1—84-type

Power Supply: Either 105 to 125 volts, 50 to 60 cycles, or 6 and 180 volts, dc.

Power Input: 15 watts; from 115-volt, 60-cycle supply.

Mounting: The instrument is supplied either for relay-rack mounting (TYPE 620-AR) or in a portable aluminum cabinet (TYPE 620-AM).

Accessories: A battery plug is supplied with the relay-rack model, a plug and cable with the cabinet model.

No other accessories except a pair of head telephones are necessary to operate the instrument.

Dimensions: TYPE 620-AR, panel, (length) 19 x (height)

8 $\frac{3}{4}$ inches; behind panel, (length) 17 $\frac{1}{4}$ x (height) 8 $\frac{3}{8}$ x (depth) 10 $\frac{3}{4}$ inches; TYPE 620-AM, 20 $\frac{1}{2}$ x 14 $\frac{1}{2}$ x 10 inches, over-all.

Net Weight: TYPE 620-AR, 32 $\frac{1}{2}$ pounds; TYPE 620-AM, 45 $\frac{1}{2}$ pounds.

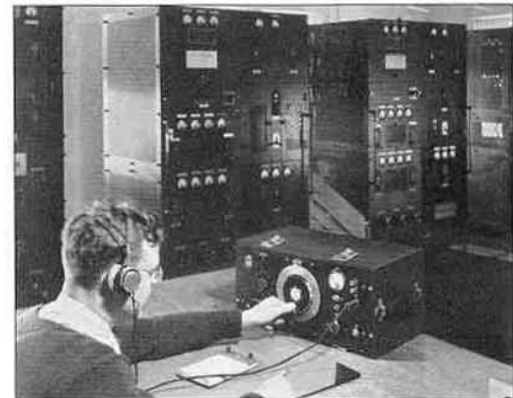

This view shows the TYPE 620-A Heterodyne Frequency Meter and Calibrator in use in a radio-telegraph station. The cabinet model shown is particularly useful for marine work since it can be used both in shore stations and on shipboard and with either a-c supply or batteries.

Type	Description	Code Word	Price
620-AR	Relay-Rack Model	DAISY	\$490.00
620-AM	Portable Model	DALLY	555.00

PATENT NOTICE. See Notes 1, 3, 12, 20, page v.

BROADCAST FREQUENCY MONITOR

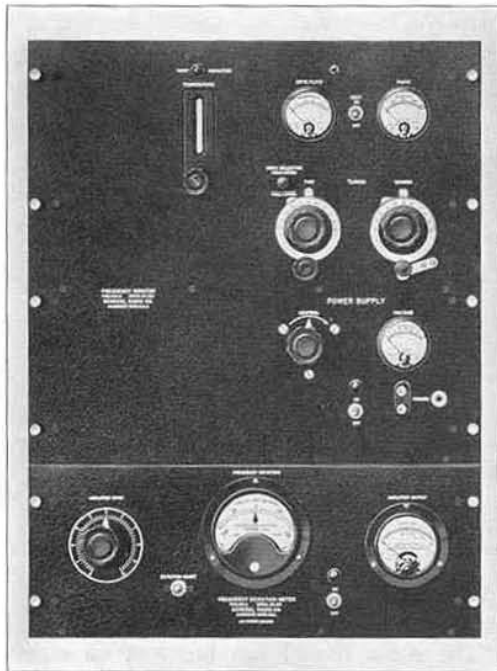

USES: This visual-type frequency monitor indicates directly the deviations of radio broadcasting transmitters from their assigned frequencies. The monitoring oscillator (TYPE 475-B Frequency Monitor) can also be used with headphones or loudspeaker for audible monitoring.

DESCRIPTION: This monitor consists of TYPE 475-B Frequency Monitor, TYPE 681-A (or TYPE 682-B) Frequency-Deviation Meter, and TYPE 376-L Quartz Plate. Both monitor and deviation meter are mounted on relay-rack panels. Complete specifications for the individual instruments are given on the next page; those for the quartz plate will be found on page 159. When the complete monitor is ordered, all necessary interconnecting cables are furnished. For use at frequencies above the standard broadcast band, TYPE 682-B Frequency-Deviation Meter (see page 157) can be substituted for TYPE 681-A at a corresponding increase in price.

For use with the TYPE 681-A Frequency-Deviation Meter, the frequency of the crystal oscillator is offset from that of the transmitter by 1000 cycles, as shown in the accompanying diagram. When TYPE 682-B Frequency-Deviation Meter is used, the crystal is ground to zero beat.

FEATURES: The outstanding feature of the visual-type frequency monitor is its accurate and direct indication of frequency deviations. The General Radio monitor is a highly stable and reliable instrument, easily installed and operated. It is approved by the Federal Communications Commission for broadcast use (Approval No. 1452).

SPECIFICATIONS

Frequency Range: ± 100 cycles.

Accuracy: When received, ± 25 parts in one million; an adjustment is provided to bring the reading into agreement with monitoring station measurements.

Vacuum Tubes: The following tubes are required and are supplied with the instrument:

- | | |
|-----------|-----------|
| 1—77-type | 3—76-type |
| 1—75-type | 1—41-type |
| | 1—83-type |

Stability: ± 5 parts in one million.

Coupling to Transmitter: The monitor must be coupled to the transmitter at a point where the carrier is un-

modulated. Only a small degree of capacitive coupling is required. A coupling wire is provided in the connecting cable supplied with the monitor.

Other Accessories Supplied: Connecting cables, pilot lights, and fuses (with spares).

Power Supply: 110- to 115-volt, 50- to 60-cycle, a-c line.

Power Input: 155 watts with heat on.

Mounting: Standard 19-inch relay-rack panels.

Dimensions: Panel, (length) 19 x (height) $22\frac{3}{4}$ inches; behind panel, (length) $17\frac{1}{4}$ x (height) $22\frac{1}{2}$ x (depth) $11\frac{3}{4}$ inches.

Net Weight: 95 pounds.

Description	Code Word	Price
Visual-type Frequency Monitor.....	DEVOR	\$560.00

PATENT NOTICE. See Notes 1, 3, 7, 11, 12, 17, 19, 20, page v.

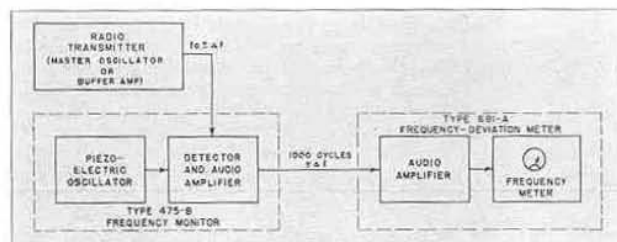

Block diagram of the broadcast frequency monitor. The beat between transmitter and monitoring oscillator is normally 1000 cycles. Variations in this beat frequency are indicated directly in cycles on the frequency-deviation meter.

TYPE 475-B FREQUENCY MONITOR

SPECIFICATIONS

Frequency Range: 100 kc to 4000 kc (fundamental frequency), using TYPE 376-L Quartz Plates. Frequencies up to 60 Mc can be monitored against harmonics of the crystal oscillator, if the audible-beat method of monitoring is used. Deviation meters can be operated at carrier frequencies up to 45 megacycles.

Accuracy: ± 20 parts per million (0.002%) when using TYPE 376-L Quartz Plate. The frequency stability is ± 5 parts per million (0.0005%) over long periods of time.

Circuit: As shown in the accompanying diagram, the monitor consists of a piezo-electric oscillator, a detector, and an audio amplifier.

The detector and amplifier are resistance coupled to give satisfactory performance at low-beat frequencies. The output transformer may be used to operate telephone receivers or, by interchanging the windings, to operate a 4000-ohm loudspeaker.

Temperature Control: The temperature control is capable of maintaining the temperature of the quartz plate within $\pm 0.1^\circ$ C. over changes in room temperature of $\pm 16^\circ$ C. (29° F.). The normal operating temperature is 60° C.

Output: The audio-frequency output depends upon the beat frequency and upon the coupling employed between the monitor and the transmitter. With very moderate coupling an output of 40 volts at 500 cycles

may be obtained across 20,000 ohms (telephones), beating at crystal fundamental frequency.

Power Supply: 105 to 125 volts, 50 to 60 cycles. Other voltages or other frequencies on special order only. Provision is made through a multipoint, protected, plug-type connector for obtaining power supply (3 filament circuits at 6 volts and plate supply at 180 volts) for external devices such as amplifiers or deviation indicators.

Power Input: 45 watts with heat off; 125 watts with heat on.

Tubes: Furnished with the instrument:
 1—75-type 1—5Z3-type
 1—77-type 1—6-type

Mounting: Standard 19-inch relay-rack mounting.

Accessories Supplied with Instrument: Vacuum tubes, thermostat, and thermometer; pilot light, fuses, and fusible link, with spares; 110-volt attachment cord, 1 TYPE 575-EP Inductor, and 2 multipoint connectors.

Additional Accessories Required:
 TYPE 376-L Quartz Plate

Dimensions: Panel, (length) 19 x (height) $17\frac{1}{2}$ inches; behind panel, (length) $17\frac{1}{4}$ x (height) $17\frac{1}{4}$ x (depth) $10\frac{3}{4}$ inches.

Net Weight: 68 pounds.

Type	Code Word	Price
475-B	MOGUL	\$330.00

PATENT NOTICE. See Notes 1, 3, 11, 12, 17, 19, 20, page v.

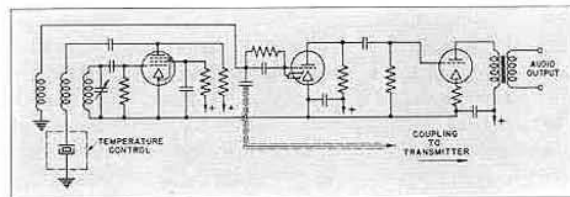

Schematic circuit diagram of TYPE 475-B Frequency Monitor.

The oscillator circuit is designed to operate the quartz plate nearer to its fundamental frequency than is possible in most other types of circuits. A distinct advantage from the standpoint of operation lies in the method of tuning. The proper operating point is indicated by a minimum in the oscillator plate current.

TYPE 681-A FREQUENCY-DEVIATION METER

SPECIFICATIONS

Frequency Range: -100 cycles to +100 cycles (transmitter frequency deviation).

Accuracy: ± 5 cycles for frequency deviations below 50 cycles.

Circuit: See accompanying diagram.

Power Supply: Derived from TYPE 475-B Frequency Monitor.

Controls: Input level control; scale correction adjustment; ON-OFF switch.

Meters: Frequency-deviation indicator; amplifier output voltage.

Tubes: Furnished with the instrument:
 2—76-type 1—41-type

Mounting: 19-inch relay-rack panel.

Dimensions: Panel, (length) 19 x (height) 7 inches; behind panel, (length) $17\frac{1}{4}$ x (height) $6\frac{3}{4}$ x (depth) $11\frac{3}{4}$ inches.

Net Weight: 26 pounds.

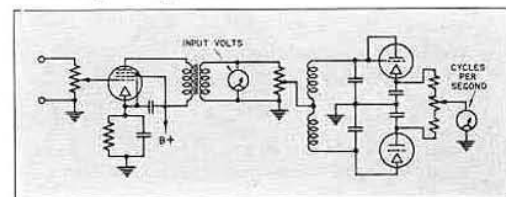

Circuit diagram of TYPE 681-A Frequency-Deviation Meter.

Type	Code Word	Price
681-A	MASON	\$145.00

PATENT NOTICE. See Notes 1, 7, page v.

TYPE 775-A FREQUENCY-LIMIT MONITOR



USES: The frequency-limit monitor is suitable for monitoring any radio-telephone transmitter between 1600 kc and 45 Mc. Included in this range are high-frequency broadcast, international broadcast, police, and aviation services. It satisfies the requirements of the Federal Communications Commission for broadcast stations above 1500 kc (Rule 981) and for police transmitters (Rule 206).

In addition to the station frequency, the frequencies of police mobile and portable broadcast transmitters can be checked or monitored with this instrument.

DESCRIPTION: This monitor provides a visual warning signal which operates whenever the frequency deviation of the transmitter exceeds a definite tolerance limit which has been set on a dial. Two warning lamps are used, one lighting when the frequency is high, the other when it is low.

This monitor operates on the beat frequency between the transmitter and a local crystal oscillator. The block diagram shows

the essential elements of the system. The frequency of the crystal is normally offset from the assigned transmitter frequency by 6.5 kc. The audio-frequency beat ($6.5 \text{ kc} \pm \Delta f$) is applied to a frequency-discriminating circuit, which, in turn, operates the lamps.

The frequency tolerance at which the lamps light is adjustable by means of a dial on the panel. This dial is calibrated in cycles per second frequency deviation. The standard calibration is from 500 to 3000 cycles per second. An alternate calibration is available covering frequency deviations between 100 and 1000 cycles. For this range the crystal is offset by 2.3 kc.

Four crystals can be mounted in the temperature-controlled chamber. They can be used for multi-channel monitoring by the limit method or by the audible-beat method outlined in the accompanying diagram.

The monitor is a-c operated and mounted on a relay-rack panel. All tubes and terminals are easily accessible from the rear.

FEATURES: The limit method of monitoring,

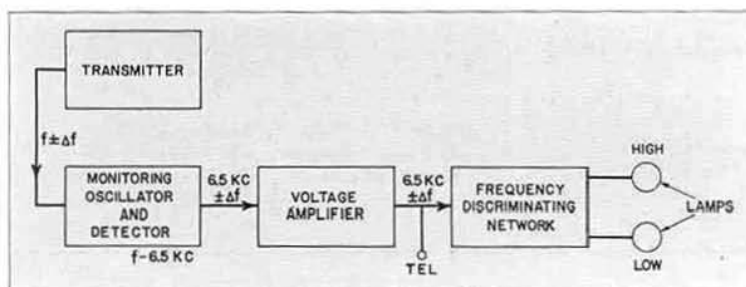

Functional block diagram showing the operation of the frequency-limit monitor. For the limit-dial calibration of 500 to 3000 cycles, the frequency of the monitoring oscillator differs from that of the transmitter by 6.5 kc as shown. For the 100- to 1000-cycle limit range, this frequency difference is made 2.3 kc.

using warning lamps, is particularly convenient when operating personnel must be kept at a minimum and spare time is at a premium. A glance at the panel, even from a distance, tells whether or not the transmitter frequency is within the desired tolerance. The price of the limit monitor is considerably lower than that of older types, placing it within the reach of stations operating in a limited class of service, where the total investment in plant cannot justify the purchase of more expensive types of monitors.

The four crystal positions make it possible to monitor four different frequencies. For instance, a local transmitter can be monitored by the limit method with one crystal, and distant or mobile transmitters by the audible-beat method with one or more of the remaining crystals.

Since both warning lamps are extinguished when the transmitter is within its frequency tolerance, some test for correct operation is desirable. This is provided in the form of a push-button which lights both lamps when all circuits are in proper operating condition.

SPECIFICATIONS

Frequency Range: 1600 kc to 45 Mc.

Accuracy of Monitoring Frequency: The absolute accuracy is 0.003% when using TYPE 376-M Quartz Plate.

Stability of Monitoring Frequency: The frequency stability is 0.001% over long periods of time.

Quartz Plate: TYPE 376-M Quartz Plates are to be used with this instrument and must be ordered separately.

Accuracy of Frequency Discriminating Network: When operated at proper input voltage, the warning lamps will light at frequencies which are within ± 200 cycles $\pm 10\%$ of the LIMIT dial reading.

Coupling to Transmitter: The frequency-limit monitor must be coupled to the transmitter at a point where the carrier is unmodulated in order to avoid false flashing of the warning lamps on modulation peaks. When continuous monitoring is not necessary, satisfactory results can be obtained by coupling the monitor directly to the transmitter output and using the monitor only under stand-by conditions.

A one- or two-turn coil, coupled loosely to one of the transmitter tuned circuits, will ordinarily provide

sufficient voltage to operate the monitor. Fifteen feet of shielded cable are supplied with the instrument to connect this low-impedance magnetic pickup to the monitor.

Tubes: Supplied with instrument:

- 1—Type 6A8 Pentagrid Converter
- 1—Type 6J7 Pentode
- 1—Type 6R7 Duplex-Diode Triode
- 1—Type 6N7 Dual Triode
- 2—Type 885 Gas Triodes
- 1—Type 6X5 Rectifier

Mounting: Standard 19-inch relay-rack mounting or table mounting.

Accessories Required: TYPE 376-M Quartz Plate.

Power Supply: 110 to 120 volts, 40 to 60 cycles.

Power Input: Approximately 72 watts with heater ON and approximately 45 watts with heater OFF, with 115-volt line.

Dimensions: Panel, (width) 19 inches x (height) 7 inches x (depth) $10\frac{3}{8}$ inches, over-all.

Net Weight: $29\frac{3}{8}$ pounds.

Type	Description	Code Word	Price
775-A	(Including Tubes, But Less Quartz Plate) . . .	DOUGH	\$240.00
376-M			

PATENT NOTICE. See Notes 1, 12, 20, page v.

Block diagram showing how the monitor can be used to check the frequencies of distant or mobile stations by the zero-beat method. For this method of monitoring, the frequency of the monitoring crystal is the same as that of the transmitter. The limit indicators are not used and the transmitter is adjusted to zero beat with the monitoring oscillator.

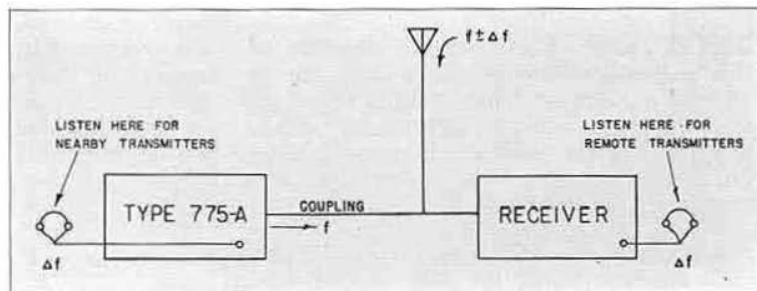

HOW TO ORDER

Order one crystal (quartz plate) for each channel to be monitored. For each crystal, specify channel frequency, station frequency tolerance, class of service, and whether crystal is to be used for monitoring by the warning lamp method or the zero-beat method.

We will supply the LIMIT dial calibration best suited to the specified class of service.



TYPE 834-A ELECTRONIC FREQUENCY METER

USES: The TYPE 834-A Electronic Frequency Meter fills the need for a general-purpose audio-frequency meter with a pointer-type, direct-reading indication. It is extremely useful in a frequency-measuring system for rapidly determining beat frequencies. In the educational field it can be used in classroom demonstrations of audio-frequency phenomena. Its industrial applications are numerous, among them the tuning of automobile horns. A simplified model, TYPE 682-A Frequency-Deviation Meter, is available for use in frequency monitoring.

DESCRIPTION: The essential elements of this instrument are an electronic counter and a d-c indicator. The circuit is shown on the next page. When an alternating voltage is applied to the grids of the gas-discharge

tubes, each tube becomes alternately conducting and non-conducting. At each transition of the current from one tube to the other, a current pulse is sent through the indicator circuit. The meter reading depends upon the number of such pulses per second, i.e., upon the frequency.

FEATURES: The immediate, direct-reading indication which the electronic frequency meter provides is a considerable advantage in audio-frequency measurements. The full accuracy of the indicator (2 per cent of full scale) is utilized, and stability of calibration is assured by a voltage-regulated plate supply and scale-correction adjustments for each range. A sufficient number of full-scale values is provided to give adequate precision at any point in the 5000-cycle range.

SPECIFICATIONS

Frequency Range: 0 to 5000 cycles in five ranges. Full-scale values are 200, 500, 1000, 2000, and 5000 cycles.

Accuracy: 2% of full-scale reading or better.

Stability: With the exception of a drift of about 1% of full-scale reading in the first few minutes after starting, there is no material change in indication with time.

Input Impedance: 1 megohm, approximately.

Input Voltage: 2 volts, minimum; the input voltage may be increased to 200 volts with no change in the frequency indication.

Scale Adjustment: Independent adjustment is provided on each range. This adjustment is made at the factory, but may be changed if correction is required in the field.

Tubes: Supplied with instrument:

- 1—76 amplifier
- 2—885 gas-discharge tubes
- 1—874 regulator
- 1—82 rectifier
- 1—84 diode switching

Power Supply: 115 volts, 50 to 60 cycles.

Power Input: 45 watts.

Controls: Power supply ON-OFF switch; plate voltage adjustment; deionization switch; multiplier (range selector) switch.

Meters: Plate voltage; frequency.

Accessories Supplied with Instrument: Vacuum tubes, fuses, and pilot lamps (with spares), 115-volt cord-and-plug assembly, multipoint connector.

Mounting: Standard 19-inch relay-rack mounting. Unit fitted with dust cover.
Additional Accessories Required: None.

Dimensions: Panel, (width) 19 x (height) 8 $\frac{3}{4}$ x (depth) 12 inches.
Net Weight: 37 pounds.

Type	Code Word	Price
834-A	MUCUS	\$250.00

PATENT NOTICE. See Notes 1, 24, page v.

TYPE 682-B FREQUENCY-DEVIATION METER



USES: This instrument is intended for use with TYPE 475-B Frequency Monitor to indicate frequency deviations of radio transmitters operating at frequencies above the standard broadcast band.

DESCRIPTION: The circuit of TYPE 682-B Frequency-Deviation Meter is identical with that of TYPE 834-A Electronic Frequency Meter. No power supply is included, and but two frequency scales are provided.

SPECIFICATIONS

Frequency Range: 0 to 5000 cycles in two ranges. Full-scale values are 1000 and 5000 cycles.

Accuracy: $\pm 2\%$ of full-scale reading or better.

Input Impedance: Approximately 1 megohm.

Input Voltage: 2 volts, minimum; the input voltage may be increased to 200 volts with no change in the frequency indication.

Scale Adjustment: Independent adjustment is provided on each range. This adjustment is made at the factory, but may be changed if correction is required in the field.

Power Supply: Usually obtained from TYPE 475-B Fre-

quency Monitor. The plate supply is 180 volts, dc; filaments, 6 volts, ac.

Stability: With the exception of a drift of about 1% of full-scale reading in the first few minutes after starting, there is no material change in indication with time.

Tubes: Supplied with instrument:
 2—885 1—874 1—84

Mounting: Standard 19-inch relay-rack panel, with dust cover.

Dimensions: Panel, (width) 19 x (height) 8 $\frac{3}{4}$ x (depth) 12 inches.

Net Weight: 24 pounds.

Type	Code Word	Price
682-B	MISTY	\$160.00

PATENT NOTICE. See Notes 1, 24, page v.

Schematic circuit diagram of TYPE 834-A Electronic Frequency Meter and TYPE 682-B Frequency-Deviation Meter. An a-c power supply is included in the electronic frequency meter, but is not shown in the diagram.

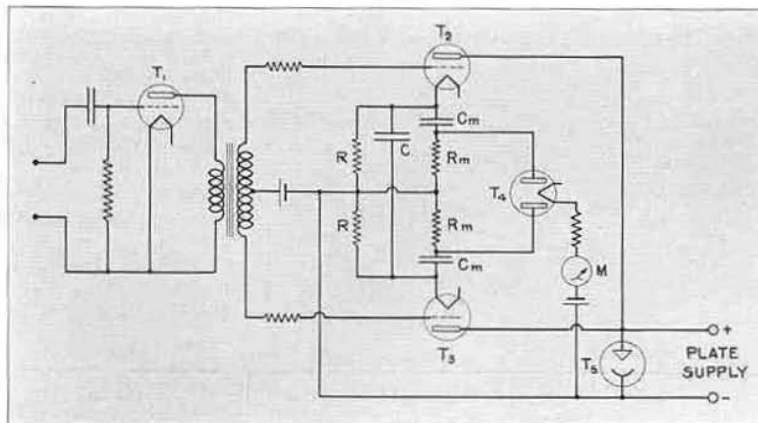

• FREQUENCY

TYPE 434-B AUDIO-FREQUENCY METER



USES: This bridge-type frequency meter is a general-purpose laboratory instrument. It is useful in measuring the frequency of oscillators used as power sources for audio-frequency measurements. In the measurement of radio frequencies, it can be used to measure the audio-beat frequency between an unknown frequency and a standard-frequency harmonic of 10 kc.

DESCRIPTION: The TYPE 434-B Audio-Frequency Meter uses a bridge circuit and

a null method of indication. The circuit is that of the Wien bridge, containing only resistances and capacitances. Three ranges are provided, each covering one decade, so that the total range is 1000:1.

FEATURES: The use of the Wien bridge circuit has two definite advantages: (1) no magnetic pickup is possible, and (2) the scale can be made logarithmic by tapering the resistance elements.

SPECIFICATIONS

Frequency Range: 20 to 20,000 cycles in three ranges by means of a selector switch, 20 to 200 cycles, 200 to 2000 cycles, 2000 to 20,000 cycles.

Calibration: Each instrument is individually calibrated in terms of a primary standard of frequency.

Accuracy: The null point is narrow enough so that, with sufficient supply voltage or sufficient amplification on the null detector and with a fairly pure waveform, the dial may be set to 0.1%. The calibration on the dial may be relied upon to within 0.5% at all positions.

Drive: The 6-inch dial turns through an angle of 320°

which gives a scale length of about 17 inches for each 10 to 1 frequency range. The whole scale length is over 4 feet. The dial has a slow-motion drive.

Impedances: Input, 3 to 10 kilohms; output, 1 to 4 kilohms, the smaller values corresponding to the higher frequencies.

Input Voltage: 110 volts, maximum.

Accessories: A null detector will be required to operate the instrument. This may be head telephones such as the Western Electric TYPE 1002-C or an amplifier-meter combination such as a TYPE 814-A Amplifier and a TYPE 483-F Output Meter or a TYPE 726-A Vacuum-Tube Voltmeter, used in conjunction with TYPE 830 Filter Sections. Even with head telephones an amplifier and filter sections may prove useful.

Controls: Frequency dial, range selector switch, resistance balance knob.

Mounting: Aluminum panel, ¼ inch thick, finished in black crackle lacquer, mounted in copper-lined walnut cabinet.

Dimensions: (Length) 12 x (width) 8¾ x (height) 8¼ inches, over-all.

Net Weight: 15¼ pounds.

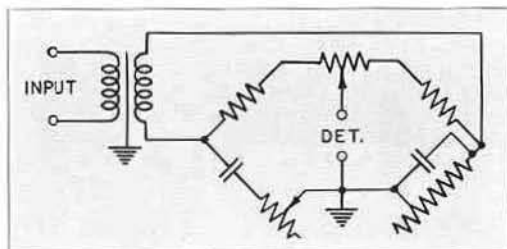

Type	Frequency Range	Code Word	Price
434-B	20 to 20,000 cycles	COLOR	\$140.00

PATENT NOTICE. See Notes 17, 18, page v.

TYPE 376 QUARTZ PLATES

These are low-temperature coefficient quartz plates intended solely for use in General Radio frequency monitors (TYPE 475-B and TYPE 775-A). These plates are not sold for the direct frequency control of radio transmitters.

All plates are manufactured from high grade piezo-electric quartz, free from twinning. The plates are accurately cut by modern optical manufacturing methods.

The holder is designed to maintain the greatest stability of the oscillator frequency. This holder is of the air-gap type, with a sealed electrode-spacing adjustment and an isolantite base. The quartz plate is held securely so that changes in orientation or mechanical jars will not shift the frequency. The method of mounting allows the plate to vibrate freely but restricts random motion or appreciable changes in position. The holder is intended for use with the base in a horizontal position.



SPECIFICATIONS

Frequency Range: Plates can be made for any frequency in the range between 450 kc and 4000 kc.

Accuracy of Adjustment: The frequency of the plate is adjusted until it differs from the ordered frequency by less than one cycle per second or 0.0001%, whichever is smaller.

Accuracy of Calibration: After the frequency of the plate has been adjusted, as described in the preceding paragraph, the frequency is accurately measured and the result entered in the calibration certificate.

Certified Accuracy: When operated in General Radio frequency monitors, under conditions specified in the calibration certificate, the accuracy of TYPE 376-L Quartz Plate is guaranteed to be within 0.002% (20 parts per million) of the frequency ordered for a period

of one year, and the frequency of TYPE 376-M is guaranteed to 0.003% for a similar period.

Temperature Coefficient: The temperature coefficient of frequency is less than 3 parts per million per degree Centigrade between 20° and 70° Centigrade (68° and 158° F.).

Mounting: The crystal holder consists of an isolantite base carrying an aluminum cap with a means for adjusting, locking, and sealing the air gap. It is practically dust proof and is fitted with plugs for use in General Radio piezo-electric oscillators.

Dimensions: Base, (length) 2 3/4 x (width) 2 x (height) 1 1/2 inches, over-all.

Net Weight: 10 ounces.

Type	Description	Code Word	Price
376-L	For Use with Type 475-B	NEVER	\$85.00
376-M	For Use with Type 775-A	LABOR	50.00

PATENT NOTICE. See Note 19, page v.

TYPE 676-A AND TYPE 476-A QUARTZ BARS

TYPE 676-A Quartz Bar is intended for use in CLASS C-21-HLD Primary Frequency Standard and CLASS C-10-H Secondary Frequency Standard. It will operate at correct frequency only in TYPE 690-C and TYPE 675-M Piezo-Electric Oscillator.

TYPE 476-A Quartz Bar with TYPE 476-P1 Adapter is intended for use with the secondary standard only.

The mounting has been designed to have a minimum of effect on the frequency of the bar. Electrodes are deposited directly on the quartz, thus eliminating the effect of air gaps. Baffles are provided to eliminate the effects of high-frequency sound energy radiated from the ends of the bar. The bar is zero-angle cut. The temperature coefficient is less than 2 parts per million per degree Centigrade.

Type	Frequency	Code Word	Price
676-A	50 kc	PIEZOMUSHY	\$145.00
476-A	100 kc	MOCHA	95.00
476-P1	Adapter	ADAPTORCOP	20.00

PATENT NOTICE. See Notes 8, 12, page v.

• FREQUENCY

TYPE 815-A PRECISION FORK

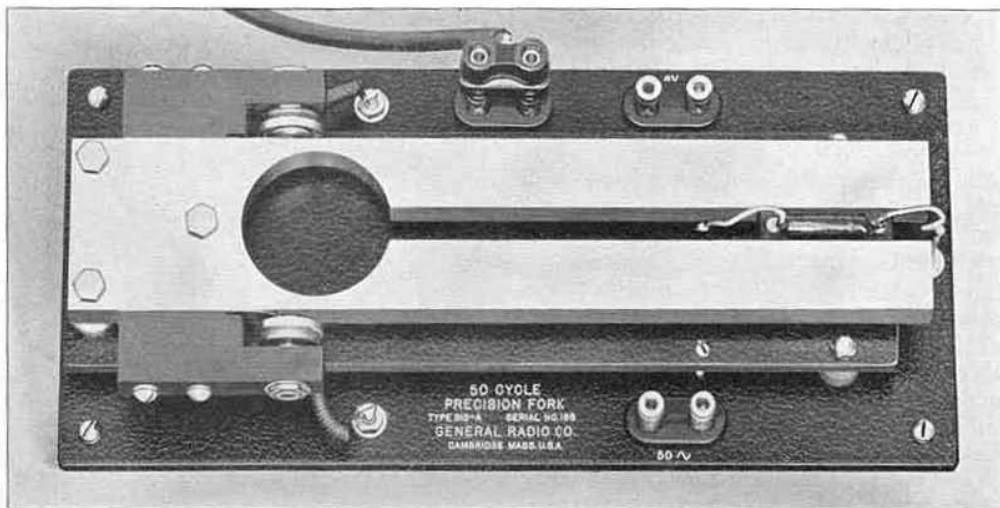

USES: TYPE 815-A Precision Fork is designed for such uses as timing in geophysical exploration, rating clocks and watches, synchronizing facsimile transmission, and low-frequency standardization.

DESCRIPTION: The fork is made of low-temperature-coefficient stainless steel. It is mounted at the heel on a metal panel which is attached to the main base by means of rubber shock absorbers to reduce energy dissipation through the mounting.

One microphone button is mounted on each tine near the heel of the fork, where the amplitude of vibration is low. This minimizes the damping action which the presence of the microphones exerts on the fork. At the end of each tine, adjusting screws are

provided. By means of these, the loading on the tines is equalized. This factor, too, is important in reducing the decrement.

Separate microphone buttons are used for the driving and output circuits. No output filter or transformer is included, since different uses may require different circuit arrangements.

The frequency stability is considerably improved by the use of the condenser, *C*, shown in the diagram below. This condenser is supplied with the fork.

FEATURES: TYPE 815-A Precision Fork combines high accuracy and stability with simplicity of construction and operation. Because of its small size and low power requirements the fork is easily portable.

SPECIFICATIONS

Frequency: 50 cycles per second. Forks can, however, be supplied at any frequency between 40 and 200 cycles. (Prices on request.)

Calibration: The frequency is adjusted within 0.005% of rated value and measured to 0.001%. The calibration temperature is supplied.

Frequency Stability: The over-all stability is better than 0.01% under normal room-temperature conditions.

Temperature Coefficient: The temperature coefficient of frequency is negative and less than 10 parts per million (0.001%) per degree F.

Voltage Coefficient: The voltage coefficient of frequency is less than 50 parts per million per volt (0.005%).

Power Supply: A 4-volt battery is used as the driving source. Driving current is less than 50 milliamperes.

Output: The fork is usually operated into a step-up transformer and an amplifier. A TYPE 585-M Transformer (price \$6.00) is recommended as a coupling de-

vice. With a 6-volt output battery this combination will furnish about 50 volts open circuit.

Mounting: The fork assembly is mounted on a metal base for table or bench use.

Dimensions: 13 x 6 x 3 inches, over-all.

Weight: 8 pounds.

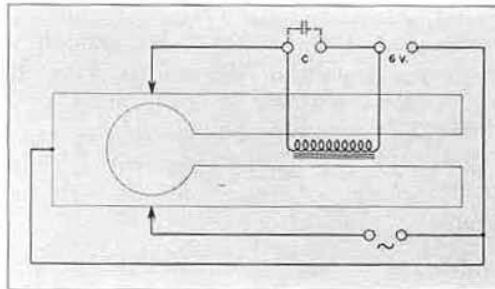

Type	Frequency	Code Word	Price
815-A	50 cycles	FAUNA	\$165.00

TYPE 611 SYNCRO-CLOCK

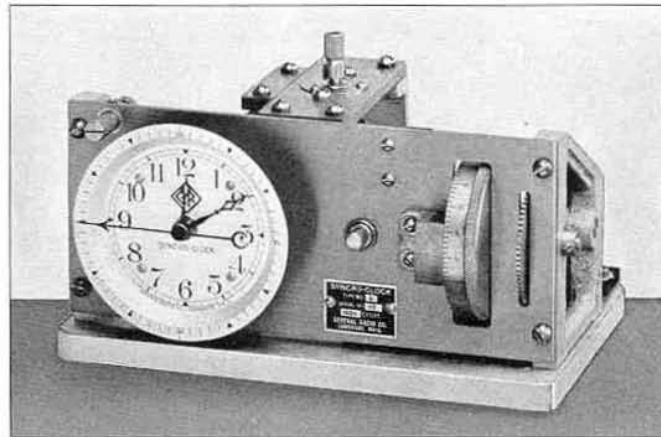

USES: The syncro-clock is used to relate a standard-frequency source to a standard time interval. When driven by a stable oscillator, this device may be used as a source of precisely determined time intervals and, conversely, when its indication is compared with standard time, a measure of the driving frequency is obtained. This type of syncro-clock is used in the TYPE 693-B Syncronometer.

DESCRIPTION: The TYPE 611 Syncro-Clock is designed to operate from the output circuit of a low-power vacuum tube. The motor is of the impulse type and is brought up to synchronous speed by means of a 60-cycle,

115-volt motor. Clocks are normally supplied to keep true time on an exactly 1000-cycle source. The microdial attachment consists of a rotary contact closing once a second, the instant of contact (or phase) being adjustable over a range of one second.

FEATURES: For use in standard-frequency systems, TYPE 611 Syncro-Clock has a number of advantages. It is rugged in construction and reliable in operation. The 60-cycle starting motor is a considerable convenience. The microdial makes possible time comparisons with a precision of one one-hundredth of a second.

SPECIFICATIONS

Frequency: Clocks are normally supplied to keep true time when the frequency is exactly 1000 cycles.

Power Input: One 41-type or 45-type tube supplies sufficient power.

Mounting: Cabinet-mounted models (for use on the

laboratory bench) and panel-mounting models are available, but only the panel-mounting type with a microdial is regularly carried in stock.

Dimensions: (Width) 9 3/8 x (depth) 6 x (height) 6 inches.

Net Weight: 14 pounds.

Type	Description	Code Word	Price
611-C	Panel Mounting with Microdial	SYNCRGOOD	\$220.00

TYPE 724-A PRECISION WAVEMETER

USES: The precision wavemeter fills a definite need in the field of frequency measurement. Its accuracy is sufficient for many measurements which require a fairly close knowledge of the frequency but where more precise heterodyne methods are neither necessary nor convenient. Among these applications is the preliminary lining up of radio transmitters and checking the frequency span of oscillators.

DESCRIPTION: The TYPE 724-A Precision Wavemeter is a tuned-circuit instrument, consisting of a condenser, a resonance indicator, and a set of inductors.

The condenser is similar in constructional details to TYPE 722. (See page 45.) The condenser setting is indicated on the dial and drum and is controlled from the front of the panel. There are 7500 divisions for the entire 270-degree angular rotation of the condenser rotor. The precision of setting is better than one part in 25,000. The plates are shaped to give an approximately linear variation in frequency with scale setting.

Seven coils are used to cover a frequency range between 16 kilocycles and 50 megacycles. The coils are enclosed in moulded bakelite cases and are wound on isolantite

• FREQUENCY



forms to give low losses and a high degree of stability.

FEATURES: The straight-line-frequency condenser obviates the use of cumbersome calibration curves. The calibration data are in tabular form, and specific frequencies are found by interpolating between the points in the table. The plug-in coil mounting allows the coil to be rotated to obtain differ-

ent degrees of coupling. This is a considerable aid to convenience in operation, making it unnecessary to hold the wavemeter in awkward positions to couple it to oscillator tuned circuits.

The resonance indicator is a rectifier-type vacuum-tube voltmeter, a distinct advantage over the thermocouple formerly used, since the danger of overloads burning out the indicator is eliminated.

SPECIFICATIONS

Frequency Range: 16 kilocycles to 50 megacycles.

Accuracy: $\pm 0.25\%$ between 50 kc and 50 Mc; $\pm 1.0\%$ between 16 kc and 50 kc.

Calibration: The calibration is supplied in the form of a table of calibrated points. Linear interpolation between these points is used to obtain settings for other frequencies.

Condensers: Precision worm-drive type similar to TYPE 722. Plates are shaped to give a straight-line-frequency characteristic. The effective angle of rotation is approximately 270° .

Inductors: Coils are wound on isolantite forms and enclosed in moulded bakelite cases.

Resonance Indicator: A vacuum-tube voltmeter is used to indicate resonance. This is coupled to the tuned circuit through a capacitive voltage divider.

Vacuum Tube: One 30-type tube is required and is furnished with the instrument.

Mounting: A wooden storage case, fitted with lock and carrying handle, is furnished. This has compartments for holding the condenser, inductors, and calibration charts.

Dimensions: Carrying case, $17\frac{7}{8} \times 13 \times 12\frac{1}{2}$ inches, over-all.

Net Weight: With carrying case, $35\frac{1}{4}$ pounds; without carrying case, $18\frac{3}{4}$ pounds.

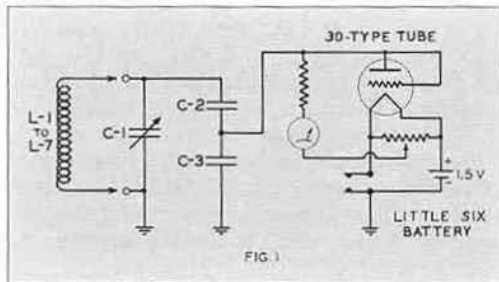

Type	Frequency Range	Code Word	Price
724-A	16 kc to 50 Mc	WOMAN	\$190.00

TYPE 419-A RECTIFIER-TYPE WAVEMETER

USES: The TYPE 419-A Rectifier-Type Wavemeter is intended for general use in experimental work in the short-wave band between 1 and 15 meters.

DESCRIPTION: This wavemeter is a tuned-circuit instrument, using plug-in coils. The resonance indicator is a thermionic rectifier which can be used in conjunction with either its microammeter or a pair of telephone receivers. Reaction methods can, of course, be used as well.

FEATURES: Accuracy and sensitivity are the features of this instrument.

SPECIFICATIONS

Frequency Range: 300 Mc to 20 Mc, or 1 meter to 15 meters, by using the four plug-in inductors supplied with the instrument.

Calibration: Each inductor is individually calibrated with the greatest possible accuracy at several points in terms of the General Radio Company's primary standard of frequency. Each one is supplied with an individually mounted calibration curve.

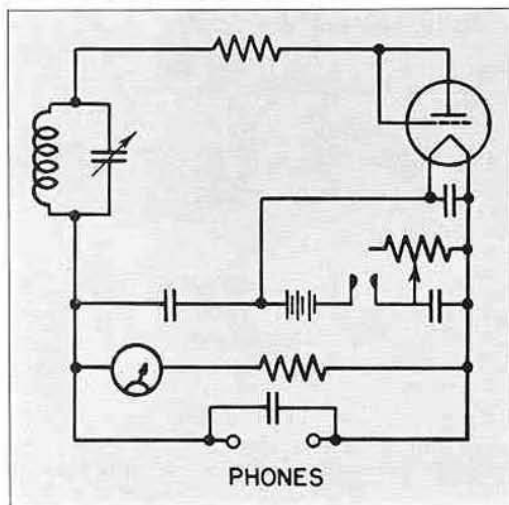

Wiring diagram of TYPE 419-A Rectifier-Type Wavemeter.

Accuracy: $\pm 1\%$ of the indicated frequency.

Tube: The necessary 30-type tube is supplied.

Power Supply: Filament current for the tube is taken from a 1.5-volt, No. 6 dry cell, mounting space for which is contained in the bottom of the cabinet. It is not supplied with the instrument.

Mounting: Aluminum panel finished in black crackle lacquer, mounted on a polished walnut cabinet. The bottom holds the four inductors and their charts.

Dimensions: Panel, (height) $10\frac{1}{4}$ x (width) $7\frac{5}{16}$ inches. Case, (height) $7\frac{1}{4}$ inches, over-all.

Net Weight: $7\frac{3}{4}$ pounds with tube but without battery.

Type	Frequency Range	Equivalent Wavelength Range	Code Word	Price
419-A	300 Mc to 20 Mc	1 to 15 meters	CATER	\$100.00

TYPE 574 WAVEMETER

USES: This direct-reading, tuned-circuit wavemeter is well adapted for general purpose work in commercial, experimental, and educational laboratories. It is unusually compact, and its wide frequency range and direct-reading scale make it useful for determining quickly the frequencies of transmitters, receivers, and oscillators.

Its precision is adequate for most routine frequency measurements. Even in high-precision work the time-wasting and bothersome process of locating an unknown frequency on a precision wavemeter can often be simplified by first determining the approximate frequency with the TYPE 574 Wavemeter.

• FREQUENCY

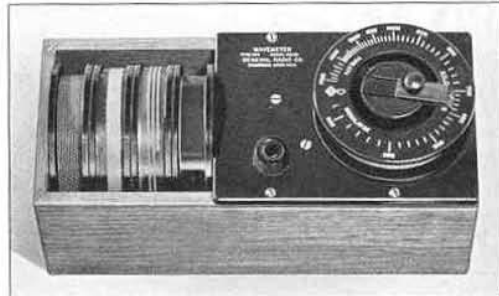

DESCRIPTION: The TYPE 574 Wavemeter consists of a variable air condenser and five plug-in inductors. No resonance indicator is provided, and the reaction method of indication is used. The calibration is engraved directly on each coil form which, when plugged in, becomes the wavemeter dial.

FEATURES: The features of this instrument are compactness, rugged construction, and a direct-reading dial.

SPECIFICATIONS

Frequency Range: 166 kc to 70,000 kc (1800 meters to 4.3 meters), by using the five plug-in inductors supplied with the instrument.

Accuracy: The construction and calibration of this wavemeter are such that, if carefully made, measurements can be relied upon within $\pm 3\%$ of the indicated frequency.

Condenser: A special TYPE 334 Variable Air Condenser modified by a reduction gear is used to spread the calibration scale over approximately 345° . This facilitates precise settings. The condenser is driven by a slow-motion knob geared to the condenser shaft.

Calibration: Each inductor is individually calibrated at five points in terms of the General Radio Company's

primary standard of frequency, and intermediate points are secured by interpolation. The scales themselves are engraved on the inductors, thus making the instrument direct reading. Coil A and Coil B are engraved in units of megacycles, others in kilocycles.

Mounting: The condenser is mounted on a bakelite panel attached to the polished walnut case, at one end of which is the storage compartment for spare inductors which are held in place by a spring clamp.

Dimensions: (Length) 11 x (width) 5 x (height) $5\frac{1}{2}$ inches, over-all.

Net Weight: $4\frac{5}{8}$ pounds.

Type	Frequency Range	Equivalent Wavelength Range	Code Word	Price
574	166 kc to 70,000 kc	1800 to 4.3 meters	CARRY	\$50.00

TYPE 358 WAVEMETER

TYPE 358 Wavemeter is a compact, low-priced instrument of moderate accuracy. It covers a wide frequency range, and it is particularly well adapted to general purpose frequency checking in the laboratory.

The normal frequency range of 1350 kc to 20,000 kc (220 to 15 meters) can be extended to 315 kc (950 meters) by ordering the two additional coils mentioned in price list.

SPECIFICATIONS

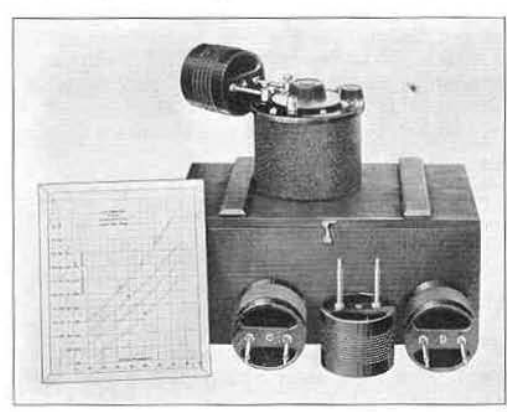

Range: 1350 kc to 20,000 kc (220 to 15 meters). By ordering the two extra inductors* mentioned in the price list, the range can be extended to 315 kc (950 meters).

Accuracy of Calibration: 1%. Calibrated in frequency.

Condenser: TYPE 247 Condenser with slow-motion pinion-gear drive in drawn-steel case.

Inductors: Four, on bakelite forms, fitted with pins to fit condenser terminals.

Resonance Indicator: Small flashlight bulb in special socket which closes circuit on removal of bulb.

Carrying Case: Space provided in wooden case for four inductors, condenser, and calibration chart.

Dimensions: Carrying case, (length) $11\frac{3}{4}$ x (width) 7 x (height) $5\frac{3}{4}$ inches, over-all.

Net Weight: $4\frac{1}{2}$ pounds.

Type	Frequency Range	Code Word	Price
358	1350 kc to 20,000 kc	UPPER	\$17.50
	Additional inductors for extending range to 315 kc	*COILY	12.00

*Use compound code word UPPERCOILY when wavemeter with extra inductors is wanted.

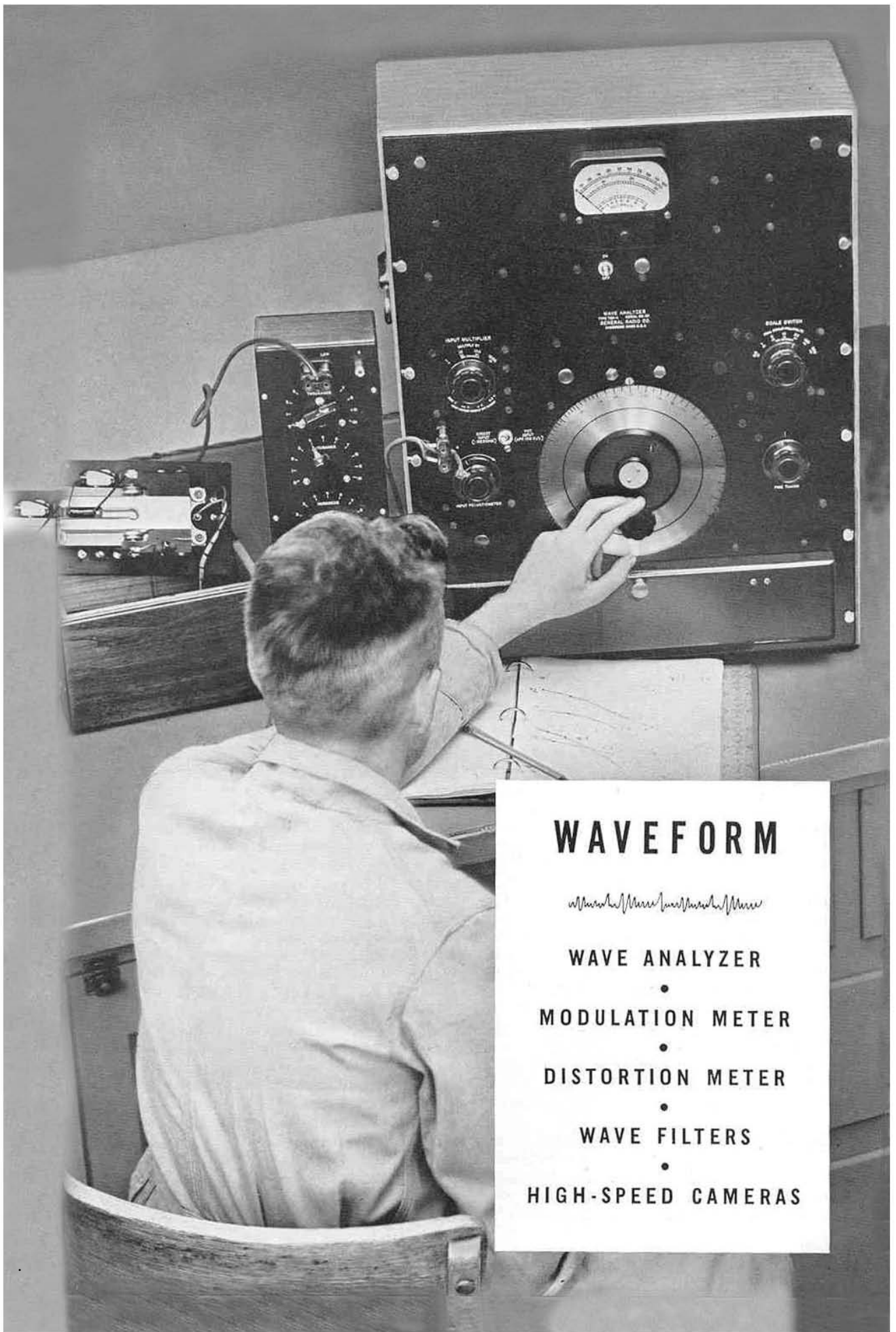

WAVEFORM

~~~~~

WAVE ANALYZER

•
MODULATION METER

•
DISTORTION METER

•
WAVE FILTERS

•
HIGH-SPEED CAMERAS

TYPE 736-A WAVE ANALYZER

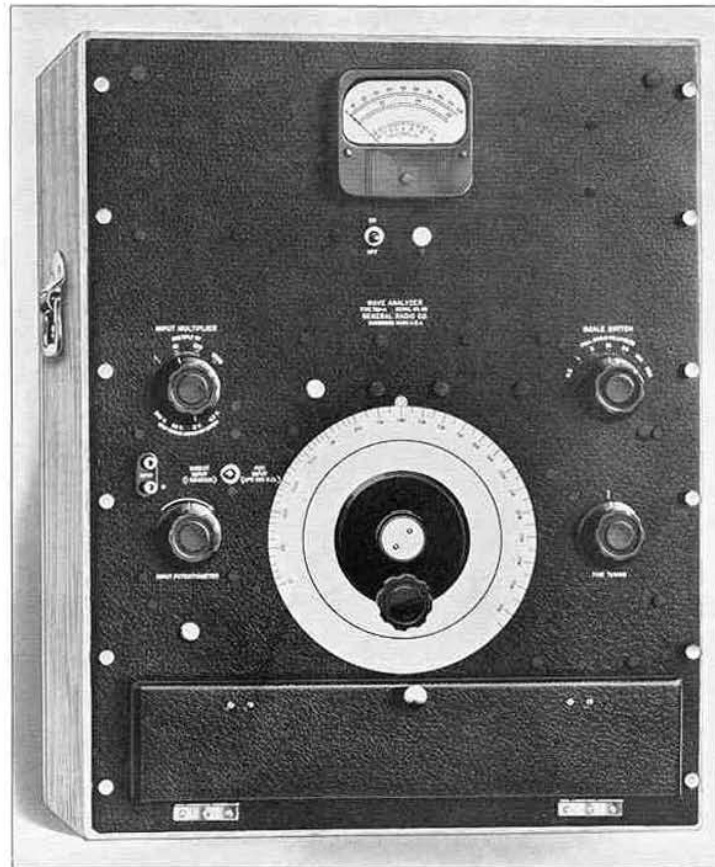

USES: The wave analyzer is used to measure the amplitude and frequency of the components of a complex electrical waveform. These include not only the components of harmonic distortion, but also non-multiple voltages such as noise and hum.

Specific uses of the TYPE 736-A Wave Analyzer include the measurement of harmonic distortion in audio-frequency equipment, broadcast receivers and transmitters, telephone systems, public address equipment, oscillators, amplifiers, and vacuum-tube circuits in general; harmonic studies on electric power systems and electrical machinery; hum measurement in a-c operated communication equipment; noise analysis; and induction studies on telephone lines. As a sharply-tuned voltmeter, it is invaluable in the measurement of the transmission characteristics of electric wave filters.

DESCRIPTION: The TYPE 736-A Wave Analyzer is a heterodyne type of vacuum-tube voltmeter. The intermediate-frequency amplifier includes a highly selective filter using three quartz crystals. The use of a

heterodyne method makes it possible to vary the response frequency of the analyzer while using a fixed-frequency filter.

The output of the local oscillator and the whole of the complex waveform to be examined are fed to a balanced modulator where their combination produces both the sum and difference frequencies, or side bands, in the output. The original of the complex waveform is not passed by the modulator intermediate-frequency output transformer, and the local oscillator carrier frequency is suppressed in the output because of the two-tube balanced modulator employed.

The 50-kilocycle component of the upper side band, proportional to the voltage of that frequency present in the original wave to which the main dial is set, is selected and amplified by the intermediate stages. The adjustable gain control of the amplifier gives the many values listed below for full-scale deflections of the output meter. The standards for the voltage and frequency calibrations are self-contained within the instrument.

The entire assembly is a-c operated from a 115- or 230-volt, 40- to 60-cycle line.

FEATURES: The advantages of the heterodyne type of analyzer are well known, and the older TYPE 636-A Wave Analyzer was a very satisfactory instrument based on the heterodyne principle. The new TYPE 736-A Wave Analyzer has a number of advantages over its predecessor. Among these are:

- (1) A-C operation.
- (2) The crystal filter is designed to give a flat top characteristic.
- (3) The analyzer has greater sensitivity, greater voltage range, and greater flexibility.
- (4) The input impedance is constant at 1 megohm, but a built-in 100,000-ohm potentiometer is provided as an alternate input system.
- (5) The meter scale is linear. This, together with the broader band, flat top, crystal filters, makes tuning much easier and the apparent stability of tuning adjustment much better.
- (6) The calibration is obtained from an a-c source and is much less critical than the d-c calibration which was used on the TYPE 636-A Wave Analyzer.
- (7) There is no pickup from external magnetic fields since the balanced modulator is fed by a phase inverter tube instead of by a transformer.
- (8) All critical parts are sealed to minimize the effects of humidity.



Testing the experimental model of TYPE 736-A Wave Analyzer under unusually severe operating conditions. This photograph was taken during an airplane flight to determine the frequency spectrum of airplane noise.

SPECIFICATIONS

Frequency Range: 20 to 16,000 cycles.

Selectivity: Approximately 4 cycles "flat top" band width. The response is down 15 db at 5 cycles, 30 db at 10 cycles, 60 db at 30 cycles from the peak. The selectivity is constant over the frequency range.

Voltage Range: 300 microvolts to 300 volts full scale. The lowest division on the meter corresponds to 10 μ v. The over-all range is divided into four major ranges: 300 μ v-300 mv, 3 mv-3 v, 30 mv-30 v, .3 v-300 v. Each of these ranges is divided into seven scale ranges; for example, the .3 v-300 v range has the following full-scale ranges: 0.3 v, 1 v, 3 v, 10 v, 30 v, 100 v, 300 v.

In addition to the voltage scales, direct-reading decibel scales are provided.

Voltage Accuracy: Within $\pm 5\%$ on all ranges. Spurious voltages from higher order modulation products introduced by the detector are suppressed by at least 70 db. Hum is suppressed by at least 75 db.

Input Impedance: One megohm when used for direct

voltage measurements. When used with the input potentiometer it is approximately 100,000 ohms.

Accuracy of Frequency Calibration: $\pm 2\%$.

Vacuum Tubes Required:

- 3—Type 6C6
- 2—Type 6K6G
- 3—Type 6J7
- 1—Type 6B8
- 1—Type 6C5
- 1—Type 6X5G
- 1—Type 6E5G
- 3—Type T-41½ neon lamps

These are supplied with the instrument.

Power Supply: 115-volt, 40- to 60-cycle, vacuum-tube voltage regulator included. A change in the power transformer connection permits the use of 230 volts, 40- to 60-cycles.

Accessories Supplied: Vacuum tubes, spare fuses, spare pilot light, spare neon lamp, one TYPE 274-ND Shielded Plug Assembly.

Mounting: Shielded oak cabinet.

Dimensions: (Width) 19½ x (height) 25½ x (depth) 10⅞ inches, over-all. **Net Weight:** 85 pounds.

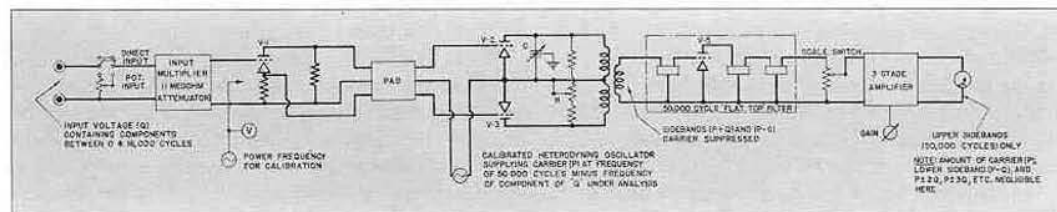

Type	Code Word	Price
736-A	ASKEW	\$640.00

PATENT NOTICE. See Notes 1, 3, 8, page v.

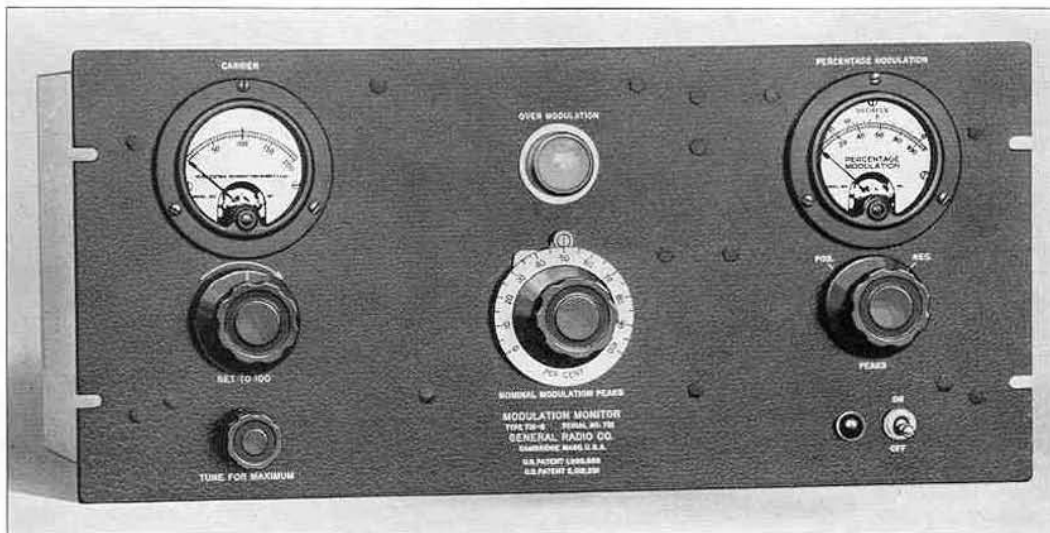

TYPE 731-B MODULATION MONITOR

USES: The modulation monitor is used to measure and to indicate continuously the percentage modulation of broadcast and other radio-telephone transmitters. It meets the requirements for modulation monitors specified in Rule 139, amended, of the Federal Communications Commission. It has been approved by the Commission and assigned Approval No. 1551.

The following specific measurements can be made with the TYPE 731-B Modulation Monitor:

1. Measurement of percentage modulation on either positive or negative peaks.
2. Program level monitoring.
3. Measurement of carrier shift when modulation is applied.
4. Indication of modulation peaks exceeding a predetermined degree of modulation (i.e., over-modulation indicator).
5. Transmitter audio-frequency response.

DESCRIPTION: TYPE 731-B Modulation Monitor consists of three essential elements: (1) a linear diode rectifier which gives an instantaneous output voltage proportional to the carrier envelope, (2) a peak voltmeter which gives a continuous indication of the peak modulation, and (3) a trigger circuit which flashes a light whenever the modulation momentarily exceeds any value which has been previously set by the operator.

In the output of the linear rectifier is a d-c meter which indicates the carrier level at which the instrument is operating and also shows any carrier shift during modulation.

The meter which reads modulation percentage has a high-speed movement. It is used in conjunction with electrical delay circuits to give a rapid upswing and a slower return.

The flashing lamp is extremely useful as a monitoring device. It is set to flash with moderate frequency when the transmitter is operating normally. If the flashing rate changes markedly, the operator is made aware that something is wrong.

FEATURES: Speed and simplicity of operation, essential for monitoring instruments, are available in this instrument. It operates over a wide carrier-frequency range, and a tuned input circuit is provided to facilitate coupling to the transmitter.

The biasing circuit which controls the operation of the over-modulation indicator is so designed that the accuracy of the lamp is entirely independent of shifts in carrier amplitude.

The type of movement used in the direct-reading meter is extremely easy to follow with the eye and is the most satisfactory thus far devised.

Terminals are provided so that remote percentage modulation indicators or over-modulation indicator lamps can be connected to the instrument externally. Provision is also made for connecting a peak counter or a recorder. The modulation monitor will operate at frequencies between 0.5 Mc and 60 Mc. Two sets of plug-in coils are used to cover the complete range. One set is supplied with the instrument.

SPECIFICATIONS

Range: Modulation percentage, 0 to 110% indicated by meter on positive peaks, 0 to 100% on negative peaks; flashing incandescent lamp adjustment, 0 to 100% on negative peaks.

Carrier Frequency Range: The monitor is designed to operate at any carrier frequency between 0.5 and 60 Mc. This range is covered by two sets of coils. A single set of coils (either for the 0.5- to 8-Mc or 3- to 60-Mc range) is supplied with the instrument unless both sets are specifically ordered. The sets are readily interchangeable. (See price list.)

Accuracy: The over-all accuracy of measurement at 400 cycles is $\pm 2\%$ of full scale at 0% and 100% and $\pm 4\%$ of full scale at any other modulation percentage.

Audio-Frequency Response: The frequency response of the meter indication is constant within 0.5 db between 40 and 15,000 cycles.

Power Supply: 115 volts, 40 to 60 cycles.

Meters: Rectified-carrier meter and high-speed per cent modulation meter are provided. The latter has a decibel scale as well, which is useful when adjusting transmitter input. It can also be used for taking over-all fidelity characteristics.

Controls: Controls are included for tuning the MONITOR input circuit to resonance with the carrier and for adjusting the carrier amplitude. A switch is provided for measuring the positive or the negative peaks, as desired. A NOMINAL MODULATION PEAKS dial, calibrated, and continuously variable from 0 to 100%, is provided.

An ON-OFF switch with pilot lamp controls the power input.

Vacuum Tubes: The following tubes are used: two 1-V, one 6C6, one 75, one 885, and one 84. All are supplied with the instrument.

Lamp: The OVER-MODULATION lamp will flash at the instant when the modulation exceeds the value to which the NOMINAL MODULATION PEAKS dial is set, and will remain lighted so long as this condition persists. An incandescent lamp is used, giving a brilliant light.

Shielding: The modulation monitor is well shielded so that it may be operated in radio-frequency fields encountered in the operating room.

Terminals: A pair of binding posts at the rear is provided for the radio-frequency input. Terminals are provided on the multipoint connector at the rear for connecting an additional remote "over-modulation" indicator lamp, or a remote high-speed modulation meter. Provision is also made for connecting a peak counter or recorder.

Other Accessories Supplied: Spare pilot lamps and fuses, multipoint connector, and cord-and-plug assembly for the a-c line connection.

Mounting: The instrument is relay-rack mounted. The panel is aluminum with the standard General Radio black-crackle lacquer finish.

Dimensions: Panel, (length) 19 x (height) 8 $\frac{3}{4}$ inches; depth behind panel, 12 inches.

Net Weight: 30 pounds.

Type	Description	Code Word	Price
731-B	Equipped for 0.5- to 8-Mc Carrier Range	EXIST	\$195.00
731-B	Equipped for 3- to 60-Mc Carrier Range	ENTRY	195.00
731-P5-1 } 731-P5-2 }	Set of Coils for 0.5- to 8-Mc Carrier Range	CAROM	10.00
731-P6-1 } 731-P6-2 }	Set of Coils for 3- to 60-Mc Carrier Range	CALYX	10.00

PATENT NOTICE. See Notes 13, 21, 22, page v

Functional schematic diagram of TYPE 731-B Modulation Monitor.

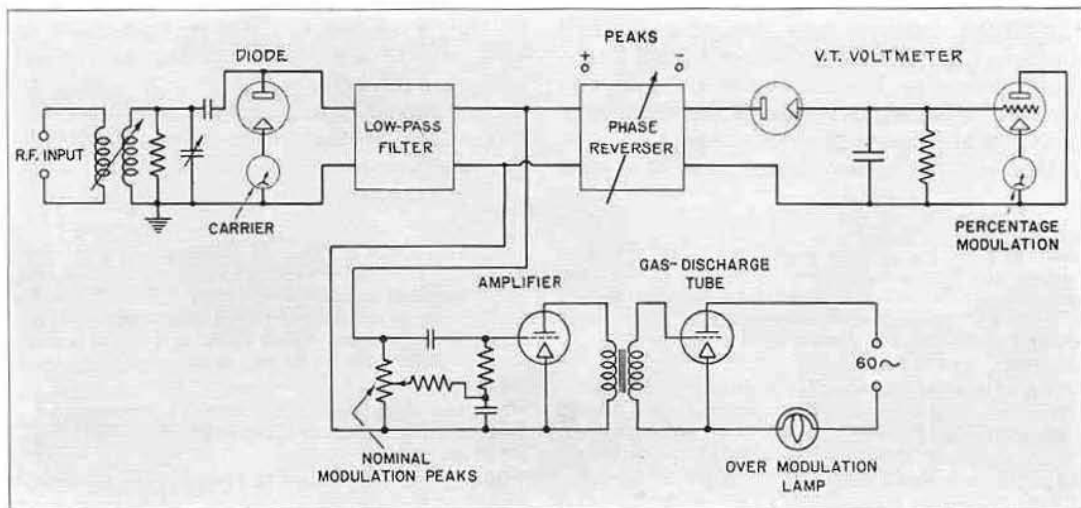

• WAVEFORM

GENERAL RADIO CO.

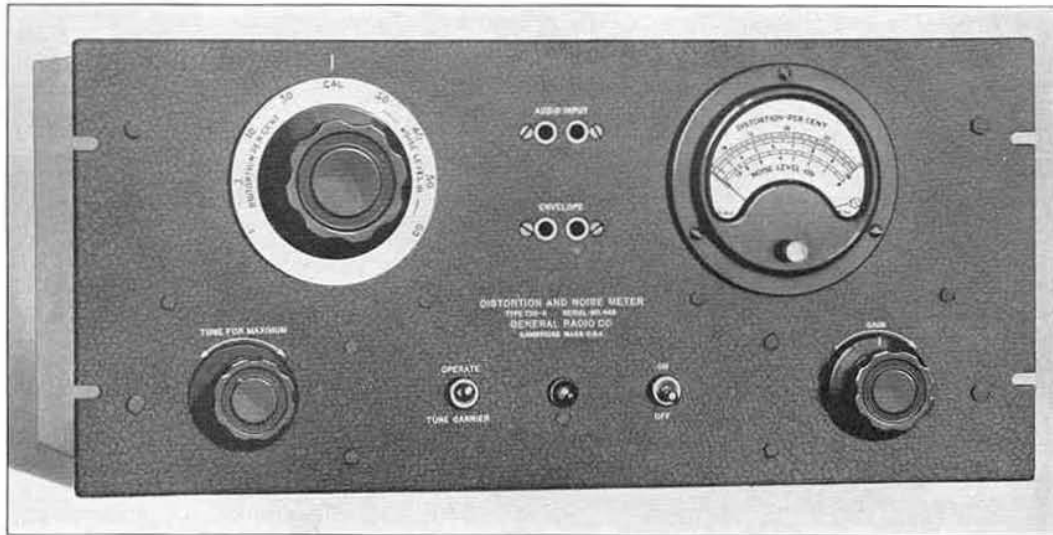

TYPE 732-B DISTORTION AND NOISE METER

USES: The TYPE 732-B Distortion and Noise Meter is intended for use in radio broadcasting stations to measure audio-frequency distortion, noise, and hum level in the transmitter output as well as in the audio-frequency portion of the transmitting equipment. It can be used for similar measurements on other types of audio-frequency equipment, such as lines, amplifiers, etc. It finds many uses in the laboratory and production testing of radio receivers where, as a wide-range, highly sensitive voltmeter, it is invaluable for such tests as signal-to-noise ratio, AVC characteristic, and hum level.

DESCRIPTION: This instrument consists of a linear rectifier, a filter, an amplifier, and a vacuum-tube voltmeter. The meter reads distortion directly in per cent of fundamental voltage and reads carrier noise or hum level directly in decibels with respect to normal modulating input to the transmitter.

Provision has been made, by the inclusion of front-panel jacks, for using the equipment with audio-frequency inputs.

The output of the linear rectifier is also

available from panel jacks so that a wave analyzer may be used to analyze the waveforms of the carrier envelope over the complete audio-frequency range. A TYPE 736-A Wave Analyzer is recommended for this purpose.

The test is made at a single frequency, 400 cycles. Where tests at other frequencies are desired, the TYPE 732-P1 Range-Extension Filter can be used. For a single-frequency test, TYPE 733-A Oscillator is recommended as a source of test voltage. When TYPE 732-P1 Range-Extension Filters are used, TYPE 608-A Oscillator is recommended.

ADVANTAGES: Speed and convenience of operation have been emphasized in the design of this instrument. Only a few seconds are required for a single measurement. The range of distortion which can be measured is wide, from below 1 per cent up to 30 per cent. While a single-frequency test yields adequate information for most purposes, the TYPE 732-P1 Range-Extension Filter provides a convenient means of making multi-frequency tests.

SPECIFICATIONS

Distortion Range: Distortion is read directly from a large meter. Full-scale values of 30%, 10%, 3%, and 1% are provided, and are selected by a multiplier switch. The range for carrier-noise measurement is from 30 to 70 db below 100% modulation or 65 db below an audio-frequency signal of zero level.

Audio-Frequency Range: 380 to 420 cycles for distortion measurements; 30 to 24,000 cycles for noise or hum measurements. For extending the distortion measurements range, see TYPE 732-P1 Range-Extension Filters, page 171.

Carrier Frequency Range: The TYPE 732-B Distortion

and Noise Meter is designed to operate at any carrier frequency between 0.5 and 60 megacycles. This range is covered by two coils. A single coil (either for the 0.5- to 8-Mc range or for the 3- to 60-Mc range) is supplied with the instrument unless both coils are specifically ordered. The coils are readily interchanged. (See price list.)

Accuracy: The over-all accuracy of measurement of each distortion range is better than $\pm 5\%$ of full scale $\pm 0.1\%$ distortion.

Meter: A Weston Model 643 Meter, calibrated directly in per cent distortion and decibels noise level, is pro-

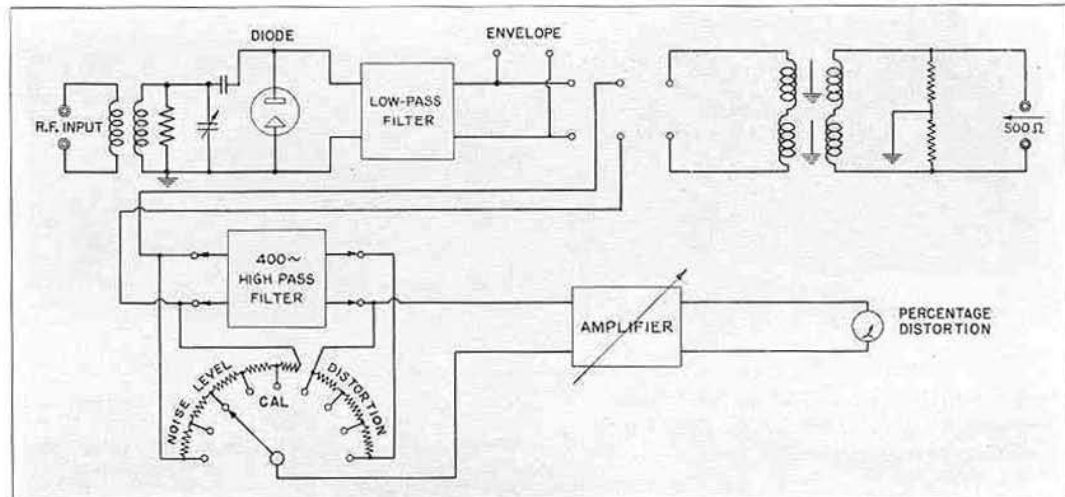

Functional schematic diagram of TYPE 732-B Distortion and Noise Meter

vided. Zero adjustment of the meter is made by a knob projecting from the meter face.

Controls: A carrier control is provided for tuning the input circuit of the instrument to resonance with the carrier. A switch is provided for selecting the proper distortion or noise range. An amplifier gain control and an on-off switch with pilot lamp are also provided.

Vacuum Tubes: One 37, two 6C6, one 1-V, and one 84 are supplied.

Other Accessories Supplied: Spare fuses and pilot lamps. Two dummy plugs to be used if the TYPE 732-P1 Range-Extension Filters are not connected. One carrier input coil.

Terminals: In addition to the radio-frequency input binding posts at the rear, two normal-through Western Electric output double jacks are provided on the panel, one at high impedance for the modulated envelope from the rectifier, and one at 500 ohms for use in audio-frequency testing.

Power Supply: 115 or 230 volts, 40 to 60 cycles.

Mounting: The instrument is relay-rack mounted. The panel is aluminum with the standard General Radio black-crackle lacquer finish.

Dimensions: Panel, 19 x 8 $\frac{3}{4}$ inches; depth behind panel, 12 inches.

Net Weight: 40 pounds.

Type	Description	Code Word	Price
732-B	Equipped for 0.5- to 8-Mc Carrier Range	EXPEL	\$245.00
732-B	Equipped for 3- to 60-Mc Carrier Range	EQUAL	245.00
732-P5	Coils for 0.5- to 8-Mc Carrier Range	CULER	10.00
732-P6	Coils for 3- to 60-Mc Carrier Range	CYNIC	10.00

PATENT NOTICE. See Note 1, page v.

TYPE 732-P1 RANGE-EXTENSION FILTERS

USES: This assembly of filters is designed specifically for use with TYPE 732-B Distortion and Noise Meter to extend the frequency range for distortion measurements.

DESCRIPTION: The instrument consists of five high-pass filters to pass harmonics of 50, 100, 1000, 5000, and 7500 cycles, respectively. These filters are mounted behind a relay-rack

panel. Selection is controlled by a panel switch. Cables for connecting to the TYPE 732-B Distortion and Noise Meter are provided.

ADVANTAGES: This panel provides an extremely simple and economical method of extending the range of the TYPE 732-B. No critical adjustments are necessary.

SPECIFICATIONS

Audio-Frequency Range: 50, 100, 1000, 5000, and 7500 cycles $\pm 5\%$.

Accuracy: At distortions greater than 0.5%, the error is less than 10% of the true value $\pm 0.15\%$ distortion.

Test Voltage: TYPE 608-A Oscillator is recommended as a source of test voltage.

Controls: A single control is provided for selecting the proper filter.



Accessories: Two shielded cables are supplied for connecting the TYPE 732-P1 Range-Extension Filters to a TYPE 732-B Distortion and Noise Meter.

panel is aluminum with the standard General Radio black-crackle lacquer finish.

Dimensions: Panel, 19 x 5 1/4 inches; depth behind panel, 1 1/2 inches.

Mounting: The instrument is relay-rack mounted. The

Net Weight: 25 pounds.

Type	Description	Code Word	Price
732-P1	Range-Extension Filters	ESSAY	\$150.00

PATENT NOTICE. See Note 1, page v.

TYPE 733-A OSCILLATOR



USES: The function of this oscillator is to provide a 400-cycle test voltage for distortion measurements with the TYPE 732-B Distortion and Noise Meter.

and is designed for relay-rack mounting. A filter to eliminate harmonics is provided.

DESCRIPTION: The oscillator is a-c operated

FEATURES: The important feature of this oscillator is the excellent waveform of the output voltage.

SPECIFICATIONS

Frequency: 400 cycles $\pm 2\%$. The frequency of the oscillator does not change by more than 1% because of heat dissipation in the unit or changes in ambient temperature. The design of the filter of the TYPE 732-B Distortion and Noise Meter with which this oscillator is used is such that much wider changes than this would have entirely negligible effect.

load. The distortion is less than 0.1% when the load is 5 milliwatts and is 0.05% at no load.

Output Power: 30 milliwatts.

Controls: There is an output volume control and an ON-OFF switch.

Internal Output Impedance: 50, 500, or 5000 ohms. This is obtained by changing a connection between the output terminals and the filter. These values of output impedance enable a wide range of impedances to be connected to the oscillator without large mismatch loss.

Tubes: One 76 and one 25Z5 are supplied.

Terminals: A Western Electric output double jack is provided on the panel and binding posts at the rear.

Waveform: 0.1% to 0.2% distortion, depending upon

Power Supply: 115 volts, 40 to 60 cycles, ac.

Mounting: The instrument is relay-rack mounted. The panel is aluminum with the standard General Radio black-crackle lacquer finish.

Dimensions: 19 x 5 1/4 x 8 inches deep.

Net Weight: 18 pounds.

Type	Description	Code Word	Price
733-A	Oscillator	EXTOL	\$62.00

PATENT NOTICE. See Note 1, page v.

TYPE 530 BAND-PASS FILTER



USES: Distortion measurements require a test voltage with a negligibly small harmonic content. TYPE 530 Band-Pass Filter is intended for use with 400-cycle oscillators to supply this voltage.

DESCRIPTION: This filter is available in two models, differing only in terminal impedance.

Inasmuch as the type of filter section employed is unbalanced to ground, this band-pass filter may not be used in balanced-circuit inputs to the apparatus under test. For balanced-line inputs the use of a TYPE

641-A Transformer, described on page 186, between the filter section and the apparatus input is recommended. This transformer is designed for the interconnection of balanced and unbalanced lines and will not introduce harmonics into the 400-cycle test signal.

FEATURES: The use of one of these filters reduces the harmonic content by at least 50 decibels. They may be used with a fundamental frequency of from 375 to 425 cycles. Sufficient attenuation is provided at the low-frequency end to remove any power-supply hum voltage which may be present.

SPECIFICATIONS

Attenuation Characteristic: (See accompanying curve.) A peak of maximum attenuation is set for rejection of the 800-cycle second harmonic.

Voltage Limit: Input voltages up to 5 volts can be applied.

Impedance: Designs are on file for a filter of 600-ohm characteristic impedance for line use and for a 6000-ohm filter for use, with a blocking condenser, directly on the output of an oscillator or an amplifier stage. Filters ordered for other impedances are obtainable at a slight increase in cost.

Mounting: Filters are mounted in standard drawn steel, wax-filled Model D cases.

Dimensions: Case, (width) $5\frac{3}{4}$ x (height) $5\frac{1}{2}$ x (depth) $5\frac{1}{2}$ inches, over-all. See also dimensioned drawing, page 175.

Net Weight: 8 pounds.

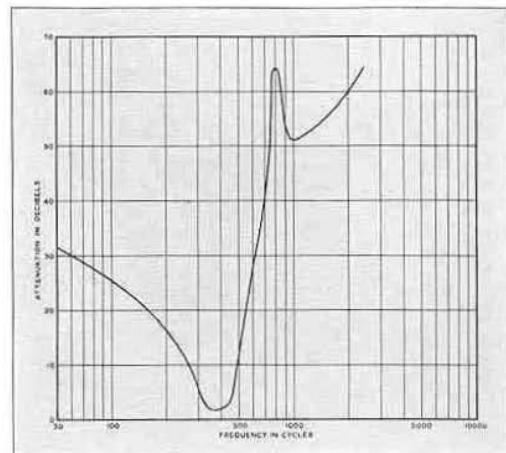

(Right) Transmission characteristic of TYPE 530 Band-Pass Filter.

Type	Impedance	Pass Band	Code Word	Price
530-A	600 ohms	375 to 425 cycles	FOCAL	\$30.00
530-C	6000 ohms	375 to 425 cycles	FURRY	30.00

PATENT NOTICE. See Note 1, page v.

TYPE 830 WAVE FILTERS



USES: Electric wave filters are used to eliminate harmonics from distorted waveform, to isolate specific components of complex waveforms for measurement, to equalize the transmission frequency characteristics of communication systems, and, in general, to remove voltages of undesired frequencies from measuring and communication circuits.

DESCRIPTION: TYPE 830 Wave Filters are compact, two-section filters having excep-

tionally good characteristics. They are available in low-pass, high-pass, and band-pass models. The sections co-operate to give both a sharp cut-off and high discrimination against frequencies outside the pass band.

The band-pass model, TYPE 830-R, is sharply tuned to pass 1000 cycles and discriminate against other frequencies, the design being such that a maximum of attenuation is provided for the second harmonic at 2000 cycles. The input and output coils of this unit are tapped so that the filter can be used with high or low terminating impedances, or to replace the combination of a filter and transformer to work between different impedances.

FEATURES: It will be seen that the insertion loss at the cut-off frequency is less than 3 decibels and that a discrimination of at least 40 decibels is maintained for all frequencies greater than 1.5 times the cut-off frequency for the low-pass types or less than two-thirds of the cut-off frequency for the high-pass types.

The 500-cycle high-pass and 1000-cycle low-pass types can be used in tandem to provide a band-pass filter covering one octave. The attenuation curve of this combination is also shown.

TYPE 830-R makes it possible to work from either a 500-ohm line or a vacuum tube into a circuit of almost any impedance with very little impedance mismatch.

The attenuation characteristics are the same for either connection on the two-

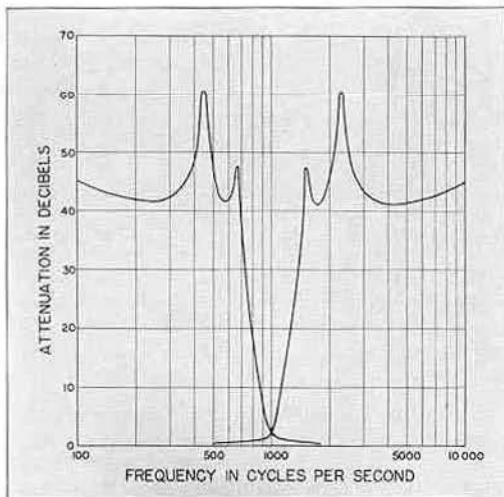

Characteristics of 1000-cycle low-pass and 1000-cycle high-pass filters.

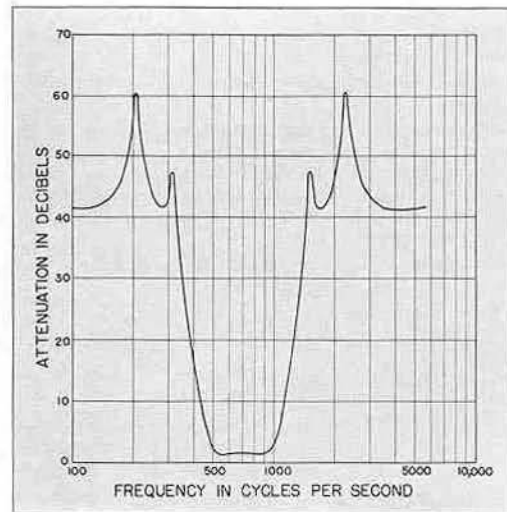

The 500-cycle high-pass and 1000-cycle low-pass models can be used in tandem to give a one-octave band-pass characteristic.

impedance side, but differ somewhat for different connections on the four-impedance side. From the plot at the right, it will be seen that greatest attenuation to harmonics is obtained on the 5000-ohm output tap. An attenuation peak at the second harmonic occurs when the 500- and 5000-ohm taps on the four-impedance side are used. This peak is not present with the other two taps.

Since either side may be used as input or output, two different connections are possible when working between 500 and 5000 ohms. From the curves shown, it is evident that somewhat better characteristics will be obtained if the 500-ohm connection is made at the two-impedance side.

The attenuation for the desired frequency is about 5 decibels, so the discrimination against harmonics is 5 db less than the actual height of the curves.

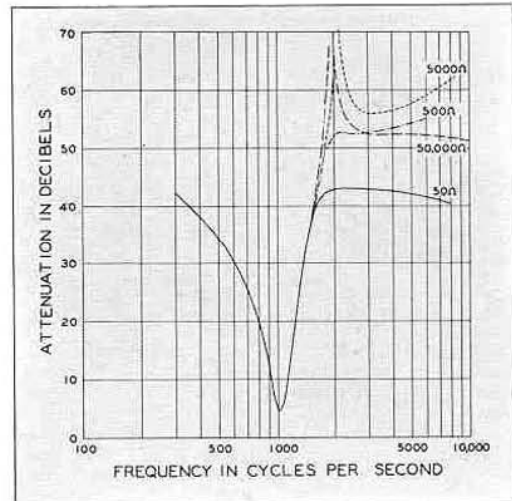

Characteristics of TYPE 830-R Band-Pass Filter.

SPECIFICATIONS

Attenuation Characteristic: (See accompanying curves.)

Voltage Limit: Input voltages up to 5 volts can be applied.

Mounting: All models except TYPE 830-B are mounted in Model C cases, dimensions for which are given below. TYPE 830-B is mounted in a Model D case.

Terminals: TYPES 830-A to 830-H inclusive are pro-

vided with both soldering lugs and jack-top binding posts. TYPE 830-R has soldering lugs only.

Dimensions: See dimensions for Model C and Model D cases below.

Net Weight: TYPE 830-B, 7½ pounds; all others, 3½ pounds.

Type	Cut-Off Frequency	Impedance		Code Word	Price
*830-A	500 cycles	500 Ω	Low-Pass	FILTERGOAT	\$18.50
*830-B	500 cycles	500 Ω	High-Pass	FILTERGIRL	21.50
*830-C	500 cycles	5000 Ω	Low-Pass	FILTERSHOE	18.50
*830-D	500 cycles	5000 Ω	High-Pass	FILTERSEAT	18.50
*830-E	1000 cycles	500 Ω	Low-Pass	FILTERTOAD	18.50
*830-F	1000 cycles	500 Ω	High-Pass	FILTERMUSH	18.50
*830-G	1000 cycles	5000 Ω	Low-Pass	FILTERSIGN	18.50
*830-H	1000 cycles	5000 Ω	High-Pass	FILTERPIPE	18.50
830-R	1000 cycles	5000, 500 Ω 50,000, 5000, 500, 50 Ω	Band-Pass	FILTERROTE	19.50

*PATENT NOTICE. See Note 1, page v.

SPECIAL FILTERS

Electric wave filters having other values of characteristic impedance and cut-off frequency can be built to order. Other types

of filters with characteristics to meet the customer's requirements can also be supplied. Prices will be quoted on request.

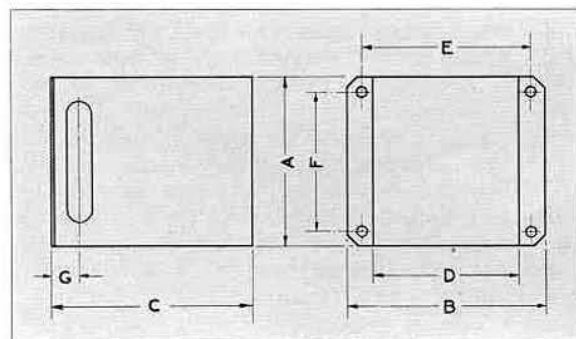

DIMENSIONS OF FILTER CASES

	MODEL C	MODEL D
A	3¾ inches	5¾ inches
B	4 inches	5¼ inches
C	4⅛ inches	5⅝ inches
D	3¼ inches	4¼ inches
E	3½ inches	4¾ inches
F	2⅞ inches	4½ inches
G	⅝ inch	⅝ inch

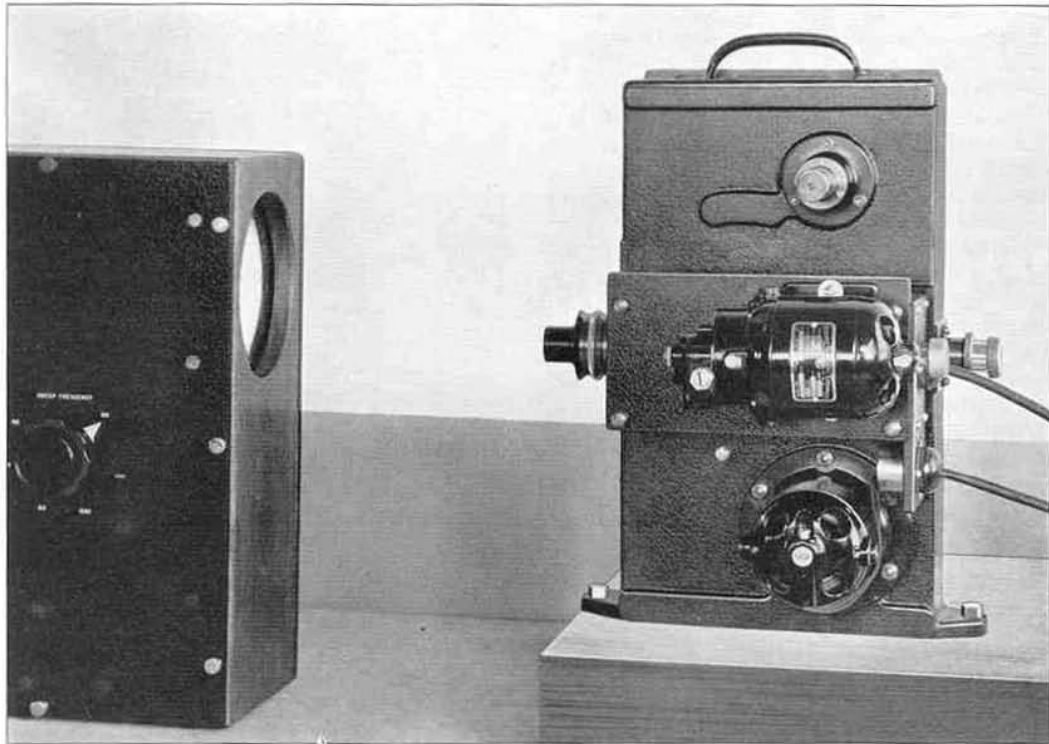

CLASS 651-A-E Camera Assembly set-up for taking cathode-ray oscillograms of high-frequency transients.

CLASS 651 CAMERA ASSEMBLIES

USES: The many applications of high-speed photography to industrial research have prompted the manufacture of a new continuous-film camera based on the designs of Professor Harold E. Edgerton of the Massachusetts Institute of Technology. Originally designed to photograph rapid mechanical actions by the light from an Edgerton Stroboscope for subsequent projection at normal speed to give the effect of slow motion, the camera is also ideal for recording high-speed transients with a cathode-ray oscillograph.

In the few years that these cameras have been commercially available they have been applied to a variety of uses in scientific and industrial research. The flight and impact of bullets, the operation of high-speed automatic machinery, the action of high-speed meter movements, and sound and vibration phenomena are a few of the subjects which have been studied.

DESCRIPTION: The General Radio camera differs from conventional motion-picture cameras in its continuous film feed, its lack of a shutter, and its ability to drive at speeds as high as 85 miles per hour (2000 frames per second) without damage to the film. Careful

attention to the dynamical design of all moving parts has made this possible. Separate motors are used to drive the film and the take-up reel on which the exposed film is wound. Provision has been made for operation at different film speeds over a wide range so that the new camera can be made to fill almost every research need for a continuous film camera.

For oscillographic studies, no shutter action is needed, and the trace of the cathode-ray spot is recorded as a continuous line on the film. In stroboscopic photography, a light flash from the stroboscope determines the length of exposure for each frame. The pictures can be framed for projection by tripping the stroboscope from a commutator mounted on the camera sprocket shaft.

The two types of assembly listed will meet most of the usual applications. The A-E group is designed for medium speeds, while the A-M assembly offers a camera suitable for extremely high-film speeds. Interchangeable motors provide wide speed ranges, and a number of commercial lenses may be fitted to meet inflexible conditions without departing from the standard camera design.

Special assemblies to meet particular requirements can be built to order.

CLASS 651-A-E CAMERA ASSEMBLY

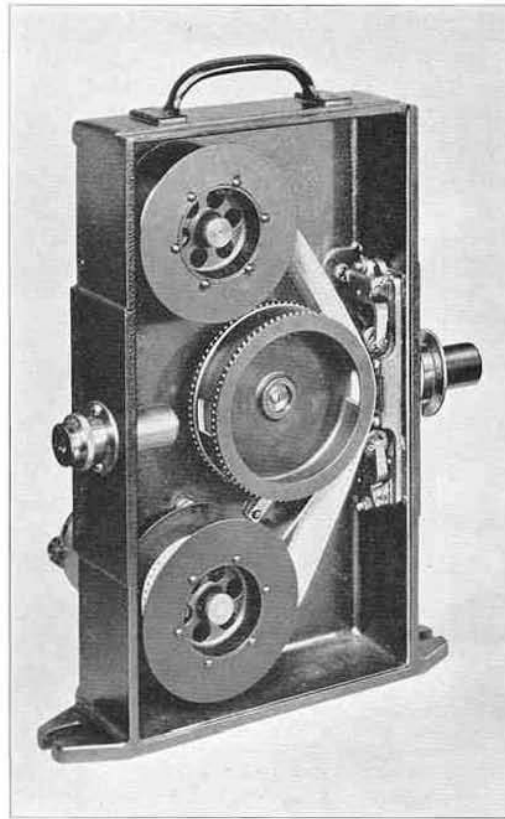

Interior view of the high-speed camera.

SPECIFICATIONS

Film: Any 35-mm film or paper with standard perforations can be run. Daylight loading and unloading with negligible waste. Capacity of reels, 100 feet.

Film-Speed Range: When the motors are operated at the voltages mentioned in "Power Supply" below, film speeds between 3 and 35 feet per second are obtainable.

Lens System: Lens must be purchased separately. An *f*/2.5 lens is available in an adjustable mounting that permits focusing for distances between 8 and 20 inches. The image for focusing is observed directly on the equivalent of a ground glass in the plane of the film.

The lens is sufficiently "fast" to permit the recording of traces from a cathode-ray oscillograph on super-sensitive panchromatic film at a speed of 35 feet per second, when the ratio of total length along the trace to length of film is less than 5 to 1.

Drive System: Both the film-drive sprocket and the take-up reel are driven by universal (a-c or d-c) motors.

Power Supply: The wide range of film speeds is obtained by applying voltages between 50 volts and 230 volts to both the driving and take-up motors. When 115-volt or 230-volt 50- to 60-cycle service is available, voltage control over the entire range can be obtained by using a Variac. For d-c service, a rheostat must be used.

USES: This assembly is recommended for low- and medium-speed work (film speeds below 35 feet per second). Its main use is in conjunction with a cathode-ray oscillograph to record transient phenomena, but it can also be used for relatively slow-speed stroboscopic photography. In the standard model, no commutator is provided for governing the speed of the stroboscopic flash, but if framing for projection is desired, the commutator can be installed on special order.

DESCRIPTION: The illustration on this page shows the TYPE 651-A High-Speed Camera of the CLASS 651-A-E Camera Assembly, illustrated on the opposite page, with its slide removed to show the internal design. The manner in which the camera is focused and in which the film is threaded is shown by the illustration. The large central driving sprocket and the bottom take-up reel are each driven by separate motors. The type of main-sprocket drive determines the assembly class letter to which the camera belongs. The camera is focused by viewing the image through the focusing eyepiece when the two apertures in the driving sprocket are aligned as shown. The image forms on a small piece of translucent film inserted in the gate.

The two frames of film shown here illustrate an interesting use of the high-speed camera. In the design of the TYPE 731-B Modulation Monitor, it was necessary to make accurate measurements of the meter deflection characteristic when a short pulse was applied. By means of the high-speed camera and stroboscope, the meter and the cathode-ray trace of the pulse were photographed simultaneously.

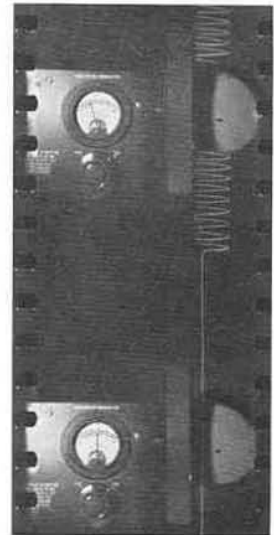

Dimensions: (Length) 11 $\frac{7}{8}$ x (width) 6 $\frac{1}{2}$ x (height) 16 $\frac{1}{2}$ inches, over-all.

Net Weight: 32 pounds.

Class	Description	Code Word	Price
*651-A-E	Camera Assembly	DINER	\$410.00
651-P1	Lens		†

*Consists of camera (including take-up motor) and driving motor, as described, but without lens.
 †Price on request. PATENT NOTICE. See Note 15, page v.

CLASS 651-A-M CAMERA ASSEMBLY

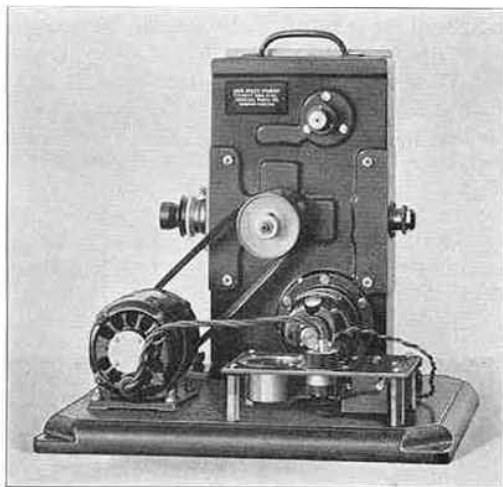

Photograph of CLASS 651-A-M Camera Assembly showing the commutator, and drive and pick-up motors.

USES: The Class 651-A-M Camera Assembly is designed particularly for ultra-high-speed stroboscopic photography where the film is

later to be printed and projected for study or demonstration purposes. At maximum film speed this equipment gives "slow-motion" results in the ratio of about 120 to 1 when compared with the original action.

DESCRIPTION: Inasmuch as the camera is of the shutterless continuous-film type, an intermittent flashing light source is required to produce the individual exposures. Because of the speeds involved, a TYPE 621 Edgerton Power Stroboscope, illustrated on page 6, is recommended for the source of illumination.

Where high-speed films are to be projected to give slow-motion action, provision for accurately framing the separate exposures is required. A commutator is provided for this purpose. Mounted on the shaft of the main film-drive sprocket, it is connected to the stroboscope circuit and provides the impulse which sets off the flash for each exposure. The exposures are thus accurately spaced on the film, and the film may be projected, without jumping of the image, using standard projection equipment.

SPECIFICATIONS

Film: Any 35-mm perforated film or paper can be run. Capacity of reels, 100 feet.

Film Speed: Using the $\frac{3}{4}$ -inch masking gate and the drive supplied with the assembly, 1200 standard-size frames per second are exposed with a motor speed of 3600 rpm giving a linear speed for the film of about 75 feet per second.

Lens System: Lens must be purchased separately. An $f/1.5$ lens is available in an adjustable mounting that permits focusing for distances between 8 and 20 inches.

Drive System: The drive motor is a 115-volt, 3600 r-p-m, 60-cycle, 3-phase, induction motor that drives the sprocket through a 1-to-1 belt drive. The take-up motor is a 115-volt universal motor.

If the film is to be projected, a commutator is required. The commutator supplied is for full-size, $\frac{3}{4}$ -inch frames.

Dimensions: Camera, (length) $11\frac{7}{8}$ x (width) $6\frac{1}{2}$ x (height) $16\frac{1}{2}$ inches, over-all; base, (length) 18 x (width) 15 x (height) $1\frac{1}{2}$ inches, over-all.

Net Weight: 60 pounds.

Class	Description	Code Word	Price
*651-A-M	Camera Assembly	DIRGE	\$490.00
651-P2	Lens	†

*Consists of camera (including take-up motor), driving motor, base, commutator, as described, but without lens.

†Price on request.

PATENT NOTICE. See Note 15, page v.

A high-speed motion-picture record of the operation of a sewing machine shuttle. The motion of the thread can be clearly seen. These photographs were taken at a speed of approximately 1200 frames per second.

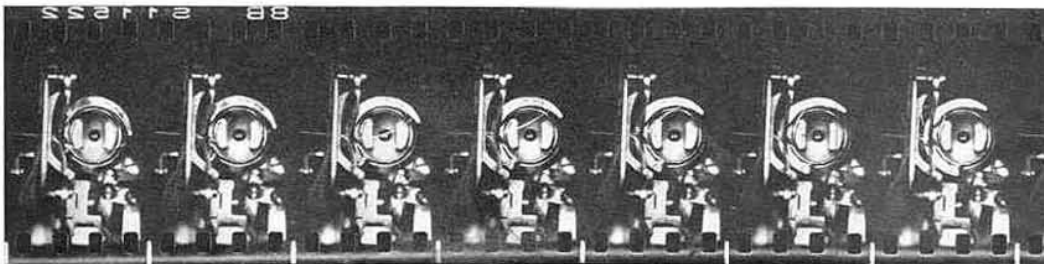

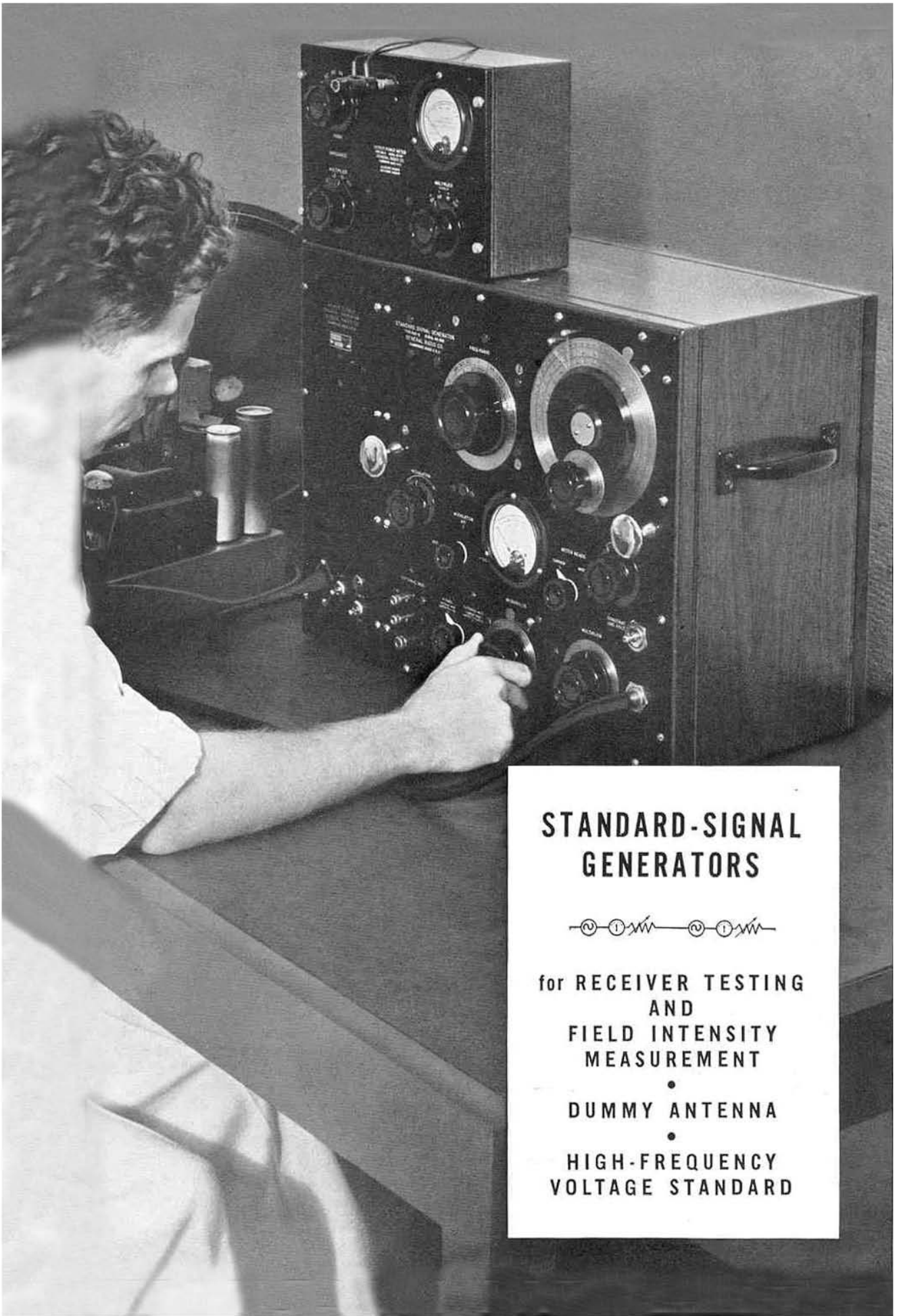

STANDARD-SIGNAL GENERATORS



for RECEIVER TESTING
AND
FIELD INTENSITY
MEASUREMENT

•
DUMMY ANTENNA

•
HIGH-FREQUENCY
VOLTAGE STANDARD

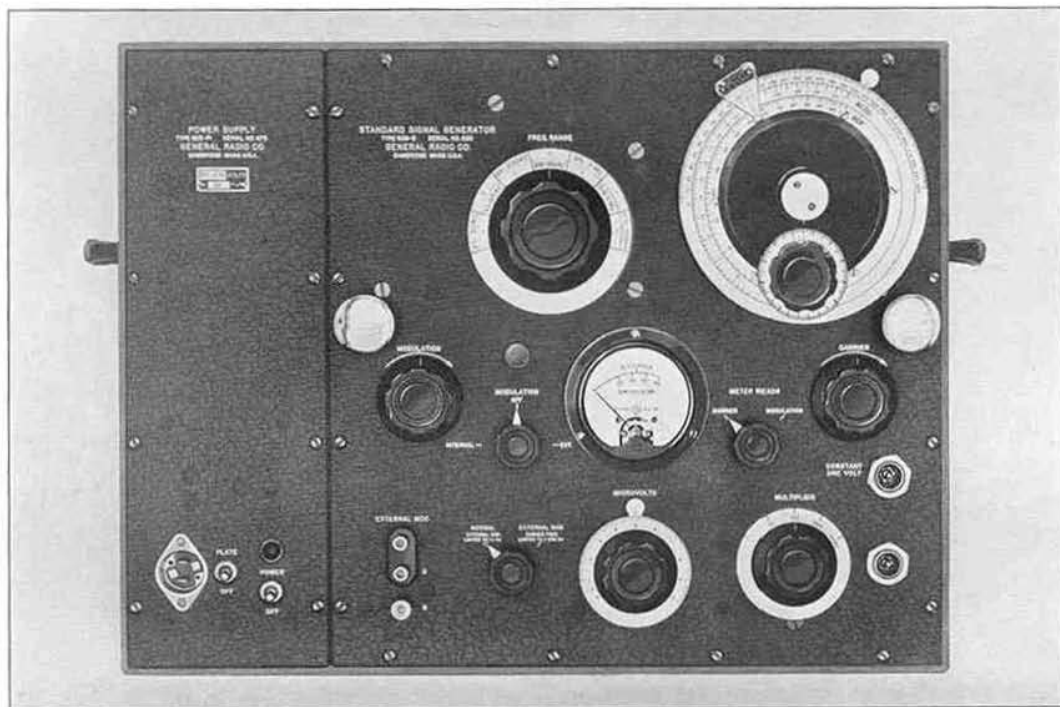

TYPE 605-B STANDARD-SIGNAL GENERATOR

USES: The standard-signal generator supplies a continuously adjustable and accurately known radio-frequency voltage for making performance tests on radio receivers. Other uses include the measurement of field intensity and general laboratory measurements.

DESCRIPTION: The TYPE 605-B Standard-Signal Generator combines excellent electrical characteristics with a number of operating conveniences. The schematic wiring diagram below shows the essentials of the electrical circuit. The elements of the generator are (1) a carrier-frequency oscillator, (2) an output amplifier, (3) an attenuator, (4) an audio-frequency oscillator for internal, 400-cycle modulation, and (5) vacuum-tube voltmeters for measuring output voltage and percentage modulation.

The direct-reading carrier frequency range of 9.5 kilocycles to 30 megacycles is covered in seven bands, selected by means of a switch. An additional range, not direct reading, extends from 30 Mc to 50 Mc, for which neither frequency nor output is guaranteed, although a frequency calibration is supplied.

Modulation, which takes place in the amplifier tube, is adjustable up to a maximum of 80 per cent. An internal 400-cycle oscillator is provided. For other frequencies an external source can be used.

The output level is controlled by a resistive network consisting of a constant-impedance Ayrton-Perry-wound slide-wire and a ladder-type attenuator.

An internal power supply with automatic voltage regulator provides for operation from the a-c power line. Since a given design of the voltage regulating transformer is suitable for operation only from one supply frequency, separate models are available for use on 60-, 50-, or 42-cycle supply.

If desired, battery power supply can be used. For this service, a control panel carrying the necessary meters, rheostats, and switches is supplied in place of the a-c power unit.

Excellent over-all shielding is provided and all power leads are adequately filtered to prevent radio-frequency leakage.

FEATURES: To facilitate selectivity measurements, the direct-reading logarithmic frequency dial is supplemented by a geared slow-motion dial with which frequency increments as small as 0.05 per cent can be obtained.

Both the inductors and the condensers in the tuned circuit of the carrier oscillator are provided with trimming adjustments, making it possible to compensate for long-period drifts in the calibration, if necessary. The band-change switch is provided with a

positive detent mechanism. Silver contacts are used to assure low and permanent contact resistance.

Frequency modulation, side-band cutting, and reaction of attenuator setting on carrier frequency have been practically eliminated

through the use of an aperiodic amplifier as a buffer and modulator.

Both carrier level and modulation percentage are measured with a vacuum-tube voltmeter—a distinct improvement over the fragile thermocouples frequently used.

SPECIFICATIONS

Carrier Frequency Range: 9.5 kilocycles to 30 megacycles, direct reading; an additional range, not direct reading, extends to 50 megacycles.

Frequency Calibration: The direct-reading dial is logarithmic in frequency and accurate to $\pm 1\%$ up to 10 Mc, and to $\pm 1.5\%$ between 10 and 30 Mc. A correction to 1% is supplied for the latter range. An individual calibration for the 30 to 50 Mc range is provided in the instruction book.

Output Voltage Range: Continuously adjustable from 0.5 microvolt to 0.1 volt. At another panel jack an output constant at 1 volt is provided. Above 5 megacycles, this voltage falls off and is about 0.5 volt at 30 Mc.

Output System: 10-ohm constant resistive output from 0 to 0.01 volt and constant 50 ohms from 0.01 to 0.1 volt. The internal output impedance at the 1-volt jack is 500 ohms.

Accuracy of Attenuator Output:

- Below 3 Mc: $\pm 3\%$ ± 0.1 microvolt
- 3 to 10 Mc: $\pm 5\%$ ± 0.2 microvolt
- 10 to 30 Mc: $\pm 10\%$ ± 0.4 microvolt

Modulation: Continuously variable up to 80%. Setting accuracy: $\pm 10\%$ of the indicated modulation percentage.

Internal modulation—400 cycles accurate within $\pm 5\%$.

External modulation—modulation characteristic constant within 1 decibel from 30 to 15,000 cycles. Internal input impedance approximately 4000 ohms. Five-volt external modulation voltage needed for 30% modulation (6 milliwatts).

Frequency Modulation: Frequency modulation and side-band cutting are negligible.

Stray Fields: Electrostatic and magnetic stray fields are negligible within the output voltage range at more than five inches distant from the instrument.

Power Supply: Four a-c operated models are available. See price list below. A built-in voltage regulator compensates for line voltage fluctuations between 100 and 130 or 200 and 260 volts. Power consumption is about 40 watts.

Battery Operation: The a-c power supply panel can be replaced by a control panel with plate and filament meters and controls for battery operation.

Battery Power Required: Filament supply 6 volts, 1.7 amperes. Plate supply 200 volts, 40 milliamperes.

Tubes: The following tubes are required and furnished with the instrument:

- 2 76-type
- 1 89-type
- 1 955-type
- 2 84-type

Tubes for the battery model are the same except that only one 84-type tube is used.

Accessories: Three-foot shielded cable and two-foot open lead connector for output connection.

One spare 955-type tube for vacuum-tube voltmeter.

One 6-foot cable for line connection of a-c operated models or one 10-foot shielded cable for battery connection on d-c operated models.

Mounting: Panels are of aluminum finished in black crackle lacquer. The instrument and power supply are enclosed in a shielded two-section walnut cabinet.

Dimensions: 23 inches wide, 15 $\frac{3}{4}$ inches high, 10 $\frac{3}{4}$ inches deep, over-all.

Net Weight: 67 pounds for a-c operated models; 63 pounds for battery model.

Type	Power Supply		Code Word	Price
	Voltage	Frequency		
605-B	100 to 130	60 cycles	ANNUL	\$415.00
605-B	100 to 130*	50 cycles	ABBOT	415.00
605-B	200 to 260*	50 cycles	ANODE	415.00
605-B	100 to 130	42 cycles	ANVIL	415.00
605-B		Battery	APART	415.00

*Either 50-cycle model can be converted to the other by changing connections on the power transformer.
 PATENT NOTICE. See Note 1, page v.

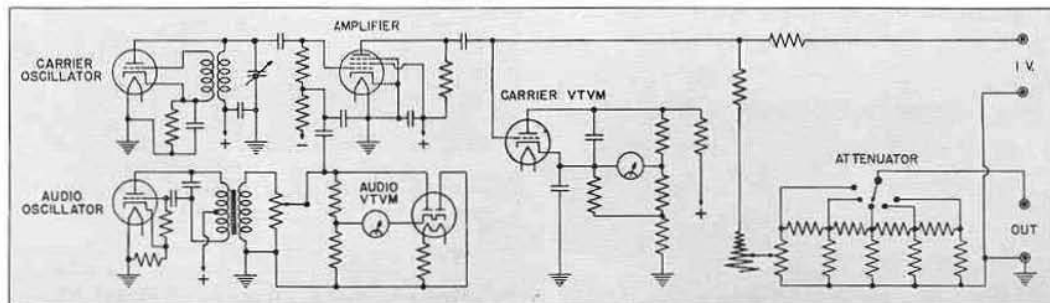

• SIGNAL GENERATORS

TYPE 664-A THERMOCOUPLE

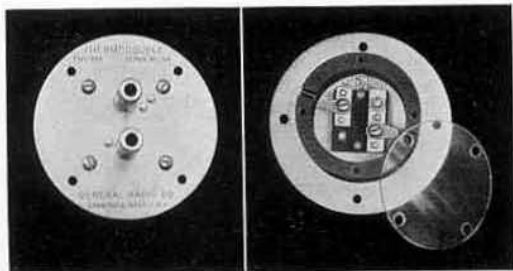

USES: TYPE 664-A Thermocouple is a standard of voltage for use at high frequencies. Such a standard is extremely useful in the design, testing, and maintenance of high-frequency instruments which have a voltage calibration, such as vacuum-tube voltmeters and the standard-signal generators.

The standard can be calibrated on direct current by reference to a standard cell.

DESCRIPTION: This voltage standard is a thermocouple in which the heater serves also as the standard resistor across which the standard voltage appears. The heater is a fine carbon wire, 0.003 inch in diameter and 0.25 inch in length.

The general construction is shown in the accompanying photograph and sketch.

FEATURES: Owing to its small diameter, the heater has an extremely low ratio of inductance to resistance. For this reason, the temperature of the heater is a good measure of the heater voltage, even at very high fre-

quencies. Since this standard is the best which we have found, no independent check on its accuracy is available. The computed error resulting from inductance is one per cent at 700 Mc and two per cent at 1000 Mc. Estimated bead capacitance gives an error of one per cent at 10,000 Mc, and skin effect is one per cent at 16,000 Mc.

SPECIFICATIONS

Rating: The safe limit of output voltage is about 7 volts.

Sensitivity: At 7 volts across the heater the couple output is approximately 8 millivolts.

Heater Resistance: 200 ohms, with 7 volts applied.

Couple Resistance: 10 ohms.

Dimensions: Diameter of shield panel, 3 inches; diameter of case, 2 inches; depth behind panel, 3/4 inch.

Net Weight: 7 ounces.

Type	Code Word	Price
664-A	FANCY	\$25.00

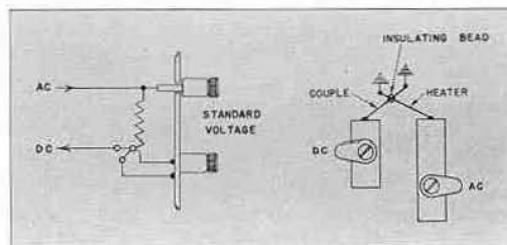

(Left) Wiring diagram of the voltage standard showing the arrangement of output terminals. (Right) Sketch of the interior, showing the heater and couple terminals.

TYPE 418-G DUMMY ANTENNA

USES: In measuring the sensitivity of radio receivers, the calibrated test voltage from the standard-signal generator is applied to the receiver through a dummy antenna, which simulates the characteristics of a receiving antenna.

DESCRIPTION: The TYPE 418-G Dummy Antenna meets the specifications recently adopted by the I. R. E. Standards Committee on Radio Receivers.

The dummy antenna is mounted in a cylindrical metal case, with plug and jack terminals to fit the TYPE 605-B Standard-Signal Generator and its output cable.

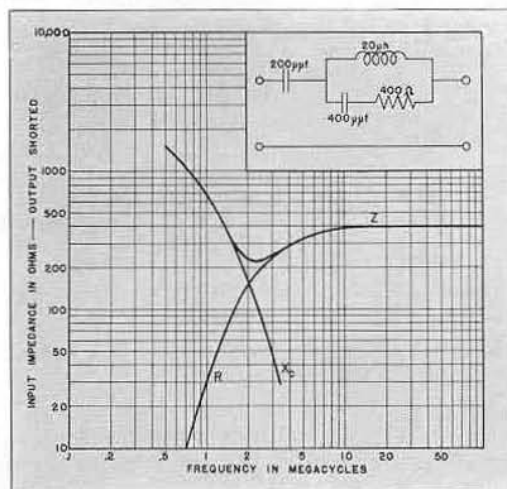

Dimensions: (Length) 4 1/8 x (diameter) 1 3/8 inches.

Net Weight: 6 ounces.

Type	Code Word	Price
418-G	DITCH	\$10.00

TYPE 672-A POWER SUPPLY

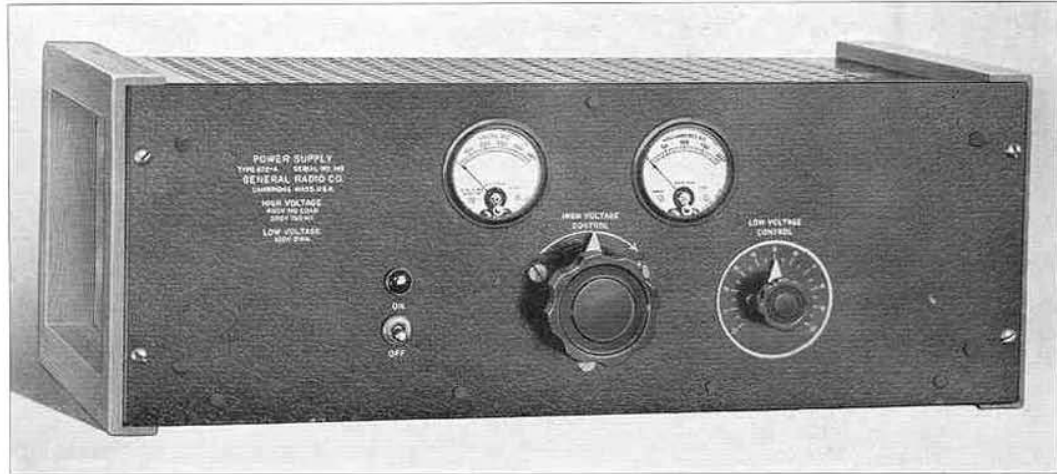

USES: The TYPE 672-A Power Supply is designed for general laboratory use, particularly for supplying power to vacuum-tube circuits.

DESCRIPTION: This power supply delivers d-c power up to 45 watts at 150 ma and 300 volts, with a no-load voltage of over 400 volts. An additional rectifier circuit supplies 2 ma dc at 100 volts. Two separate a-c supplies are also provided at 6.3 and 2.5 volts, from which a total of 45 watts may be taken.

The high-voltage input is controlled by a Variac (adjustable autotransformer) with a control on the panel so that continuous variation of the d-c output voltage (0 to over 400

volts) is possible. Meters on the panel indicate the output voltage and current. The low-voltage dc is convenient as a grid supply, and a ground connection can be used on any of the d-c supply terminals. A calibrated potentiometer mounted on the panel controls the low-voltage supply.

FEATURES: A convenient source of plate grid and filament power for vacuum tubes, this power supply has excellent regulation at any output setting owing to the use of a Variac voltage control. A carefully designed filter insures a very low residual hum level in the high-voltage circuits.

SPECIFICATIONS

Output Range:

High Voltage: 150 ma at 300 volts, dc. No-load voltage, over 400 volts, dc.

Low Voltage: 2 ma at 100 volts, dc.

A-C Voltage: 2.5 and 6.3 volts, giving a total of 45 watts.

Meters: The high-voltage supply output is indicated by an ammeter and a voltmeter mounted on the panel.

Regulation: The regulation of the high-voltage supply corresponds to an internal output resistance of 700 ohms for direct current. The 1000-cycle internal output impedance of the high-voltage supply is equivalent to 3.9 μ f in series with 1.13 ohms. That of the low-voltage supply is equivalent to 2.12 μ f in series with 0.82 ohm.

Power Supply: The power-supply unit will operate from a 105- to 120-volt, 50- to 60-cycle, a-c line.

Power Consumption: With the a-c and d-c supplies

operating at full load, the power consumption from the mains is about 175 watts. Under these conditions the loss in the power-supply unit is about 85 watts, including rectifier cathode power.

Hum Voltage: At full-load current the hum voltage of the high-voltage supply is less than 0.1% for all voltages above 150 volts. For lower voltages the per cent is slightly higher.

At full-load current the hum voltage of the low-voltage supply is less than 0.1% for all voltages. For a load current of 1 ma, the hum decreases to 0.03%.

Tubes: One 5Z3-type and one 80-type are supplied.

Mounting: The instrument is suitable for either table or relay-rack mounting.

Dimensions: (Length) 19 $\frac{1}{2}$ x (depth) 11 $\frac{1}{2}$ x (height) 7 $\frac{3}{8}$ inches, over-all. Panel 19 x 7 inches.

Net Weight: 41 pounds.

Type	Code Word	Price
672-A	AFOOT	\$130.00

PATENT NOTICE. See Note 11, page v.

TYPE 673-A POWER SUPPLY

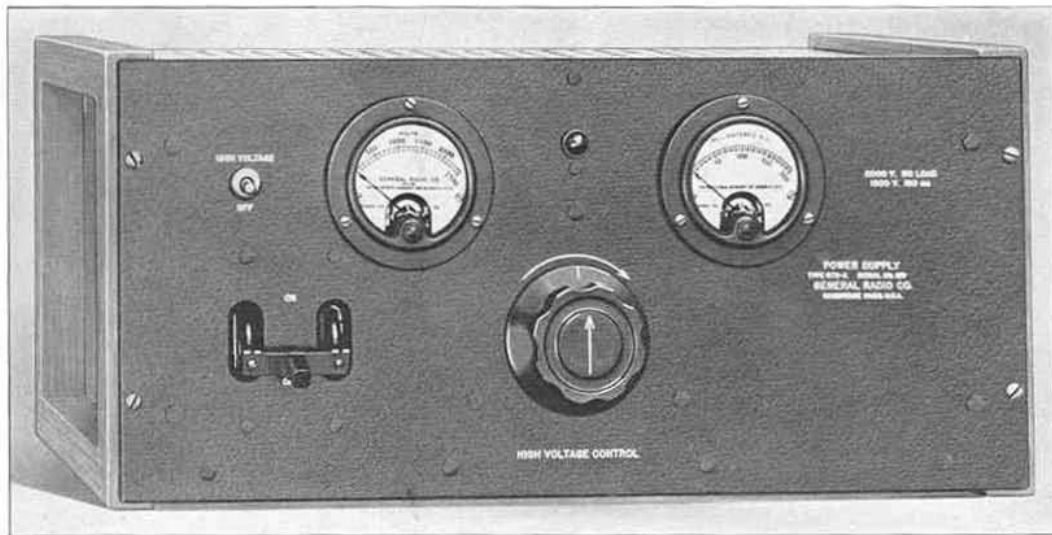

USES: This laboratory power supply is useful in many applications where higher output voltage is required than is supplied by the TYPE 672-A unit.

DESCRIPTION: The high-voltage output is supplied by a transformer-rectifier system and delivers 150 ma at 1500 volts. A 10-volt filament circuit is also provided. The high-voltage output is controlled by a Variac.

FEATURES: Several distinguishing features make the TYPE 673-A Power Supply unit a very handy piece of apparatus about the laboratory. A knob on the panel gives a continuous control of the high voltage, which

is indicated by a meter on the panel. The output current is also indicated by a panel meter. Consequently, besides using the unit as a supply for, say, two 852-type tubes, it can be operated as a continuously-variable-voltage d-c supply (from below 50 to over 2000 volts). Transformer control in the high-voltage input and careful design of the filter have produced good regulation and low-hum voltage. The power-supply unit is equipped with a time switch so that the a-c supply is on about 30 seconds before the d-c supply begins to operate. An auxiliary switch, for the sake of convenience and safety, is supplied to control the high voltage separately.

SPECIFICATIONS

High Voltage: 150 ma at 1500 volts, open-circuit voltage, 2000 volts.

Low Voltage: 6.5 a at 10 volts, center tapped.

Output Range: The power supply will deliver direct current up to 150 ma at 1500 volts. The open-circuit voltage is over 2000 volts.

The power supply also gives 6.5 amperes at 10 volts ac. The 10-volt supply is center-tapped at 5 volts.

Meters: The d-c voltage and the load current are indicated by meters mounted on the panel. A panel knob controls the input to the rectifiers.

Regulation: The internal output resistance of the power-supply unit corresponds to about 1100 ohms for load currents of 50 to 150 ma. For lower load currents the internal output resistance increases to about 20,000 ohms at no load. The 1000-cycle internal output impedance is equivalent to 1.1 μ f.

Power Supply: The power-supply unit will operate from a 105- to 120-volt, 50- to 60-cycle line. A suitable power cord is supplied with the instrument.

Power Consumption: With the a-c and d-c supplies operating at full load, the power consumption from the mains is about 380 watts. Under these conditions the loss in the power-supply unit is about 90 watts including rectifier cathode power.

Hum Voltage: At full-load current the hum voltage is less than 3 volts or 0.2% of full-load voltage. For lower load currents, the hum decreases.

Tubes: Two 866-A-type rectifiers are supplied.

Mounting: The instrument is suitable for table or relay-rack mounting.

Dimensions: (Length) 19 $\frac{1}{2}$ x (depth) 11 $\frac{1}{2}$ x (height) 9 inches, over-all. Panel, 19 x 8 $\frac{3}{4}$ inches.

Net Weight: 73 pounds.

Type	Code Word	Price
673-A	AGONY	\$180.00

PATENT NOTICE. See Note 11, page v.

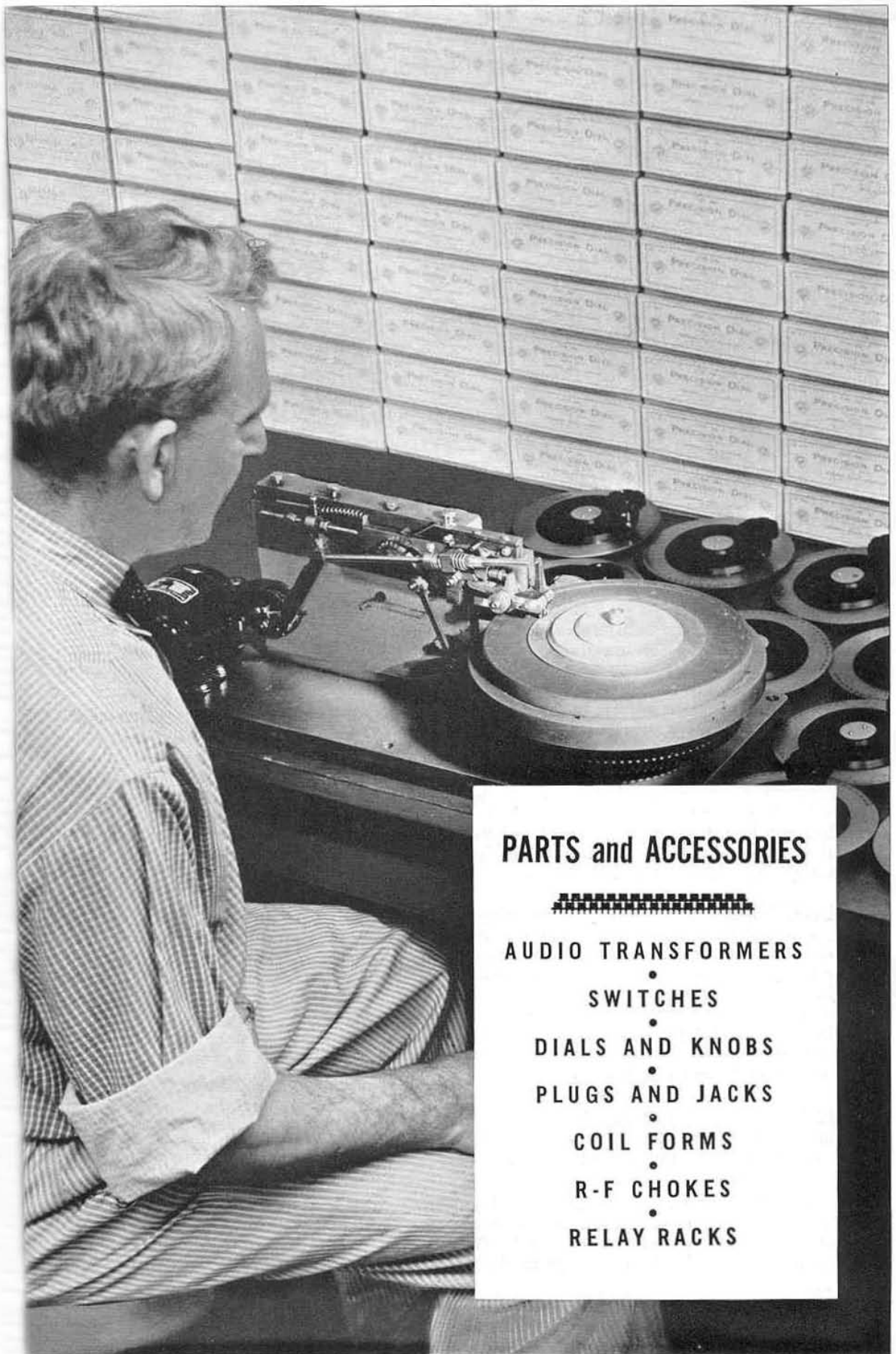

PARTS and ACCESSORIES



AUDIO TRANSFORMERS

•
SWITCHES

•
DIALS AND KNOBS

•
PLUGS AND JACKS

•
COIL FORMS

•
R-F CHOKES

•
RELAY RACKS

• TRANSFORMERS

TYPE 641 TRANSFORMER

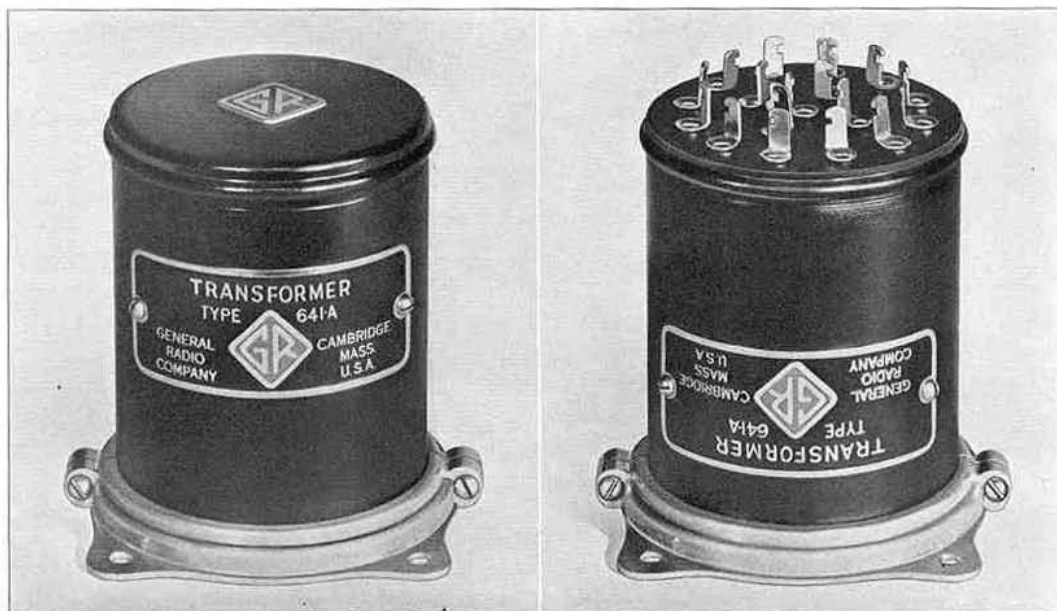

USES: High-quality transformers are necessary for matching the impedance of transmission networks, for coupling components of speech amplifiers and pickup circuits used in broadcasting, recording, and public address work, and for isolating circuits.

The frequency response characteristic of the TYPE 641 Transformers is so flat that several can be cascaded in the same circuit, without causing enough insertion loss at low and high frequencies to affect seriously the transmission characteristics of the highest quality audio systems.

DESCRIPTION: The TYPE 641 Transformers are wound with alternate primary and secondary layers, which are insulated from each other with low-loss paper dielectric. In many instances a sectionalized winding, consisting of two pies, is used to maintain electrical balance. Electrostatic shields are also used in several models, such as the bridging and input transformers, for this same purpose.

The cores are made of thinly laminated, high-permeability material. They are insulated from the windings with a low-loss dielectric, and all units must withstand a 1000-volt insulation test.

The cylindrical cases are made of aluminum. In some models, such as the input and interstage units, which operate frequently at low levels, a high-permeability

magnetic shield (Mu-metal) is placed between the transformer itself and the aluminum case to provide effective elimination of hum pickup.

All terminals are brought out at one end of the cylindrical case. An adjustable mounting base is provided so the unit can be mounted either above or below the mounting shelf, with the terminals projecting in either direction. (See the illustrations.) This base also allows the transformer to be rotated without changing the mounting holes.

FEATURES: The outstanding features of the TYPE 641 Transformers are their excellent frequency characteristics and the high degree of electrical balance which has been obtained by careful design. Efficient electrostatic shields between windings and magnetic shielding around the complete unit have been provided whenever it is at all necessary.

The new type of mounting used on these units is outstanding mechanically. The mounting base is rugged and strong, and holds the case firmly, an important feature for portable installations. However, by loosening one clamping screw, the unit can be rotated in its mounting without disturbing the base itself, or it can be completely turned over with the terminals projecting in the other direction.

SPECIFICATIONS

Uses: See tables. Numbers refer to the more common types of tubes with which the model can be used.

Frequency Range: The tables give the frequency range over which the voltage ratio is less than 1 decibel below its value on the flat portion of the characteristic, and the operating conditions for this performance. Sample frequency curves are given on the following pages.

The frequency range naturally holds only when the primary source has an internal impedance equal to that specified under "Out of (ohms)," and the load is as specified under "Into (ohms)." In several of the output transformers the source impedance from which they are to work is different from the impedance which should be reflected back to the tube by the transformer. The table gives the proper source impedance (the plate resistance of the tubes), while the footnotes give the load impedance as seen by the tube.

The column headed "Pri. DC" gives the maximum direct current which can be handled by each section of the primary winding under balanced conditions, while the "Unbalance DC" column gives the maximum allowable current unbalance for the stated frequency range, and the allowable direct current when the unit is operated single-ended.

Maximum Level: Under the column "Max. Level" is

given the audio power or primary voltage which each transformer will handle with negligible distortion. At higher values some low frequency distortion occurs.

Turns Ratio: The ratio of turns of the whole primary winding to the whole secondary winding is given in the "Turns Ratio" column.

Electrostatic Shielding: The line-to-line, bridging, input, and low-impedance matching transformers, TYPES 641-A, -B, -C, and -D, respectively, all have an electrostatic shield to assure isolation between the primary and secondary windings.

Magnetic Shielding: The line-to-line, bridging, input, low-impedance matching, and interstage transformers, TYPES 641-A, -B, -C, -D, -E, and -F, respectively, all have a high permeability magnetic shield which introduces about 50 decibels of attenuation to hum pickup.

Terminals: Soldering lugs are provided.

Mounting: Each transformer is mounted in a cylindrical aluminum case. The base clamps on and is arranged so that the unit can be mounted above or below the mounting shelf with the terminals either up or down.

Dimensions: See sketch on page 188.

Net Weight: 3 pounds, all types.

Type	Uses	Out of ¹ (ohms)	Into ¹ (ohms)	Pri. DC (bal) (ma)	Un- balance DC (ma)	Freq. Range Down 1 db		Max. Level	Turns Ratio	Code Word	Price
						From (cycles)	To (cycles)				
641-A	Line, Mixer to Line, Mixer ⁵	50 to 60 125 to 150 200 to 240 500 to 600	50 to 60 125 to 150 200 to 240 500 to 600	—	—	20	20,000	6 watts	1 to 1	UDDER	\$17.50*
641-B	Bridging 500 to 600Ω Lines ⁵	10 to 1000 ²	50 to 60 125 to 150 200 to 240 500 to 600	—	—	20	20,000	20 watts in line	4.1 to 1	ULCER	17.50*
641-C	Line, Mixer ⁵ to P-P or Single Grids	50 to 60 125 to 150 200 to 240 500 to 600	P-P Grids or Single Grid (Class A)	—	—	20	20,000 ³	30 volts across total primary	1 to 8.9	UMBER	17.50 ⁴
641-D	Low- Impedance Matching ⁵	1.2, 2.5, 5, 7.5, 10, 15, 20, 30	50 to 60 125 to 150 200 to 240 500 to 600	—	—	20	20,000 ¹	6 watts	1 to 4.5	UNDER	17.50*
641-E	P-P Plates (6C5, 6J5, 6L5-G, etc.) to P-P Grids Single Plate (6C5, etc.) to Single or P-P Grids	16,000 to 24,000 plate-to- plate 4000 to 6000	P-P Grids or Single Grid (Class A)	40	—	20	20,000	120 volts, plate-to- plate 60 volts, single plate	1 to 2.1	UNION	17.50*
641-F	Single Plate (6C5, etc.) to Single Grid	9000 to 13,000	Single Grid (Class A)	—	10	30	14,000	70 volts across primary	1 to 3	UNITY	17.50*

¹ These limits may be changed by as much as 10% without causing appreciable changes in the transformer characteristics.

² This transformer places a load of 5000 or 20,000 ohms across the line, depending on which tap is used. To do this and still match output impedances, series resistors are built into the unit.

³ On the 240Ω tap the response is down 1 db at 17,000.

⁴ On the 2.5Ω tap the response is down 1 db at 17,000.

⁵ 240Ω and 600Ω taps can be used either balanced or single-ended; these transformers have electrostatic shielding between windings.

* These transformers can be furnished without Mu-metal shield at a price of \$15.00.

GENERAL RADIO CO. • TRANSFORMERS

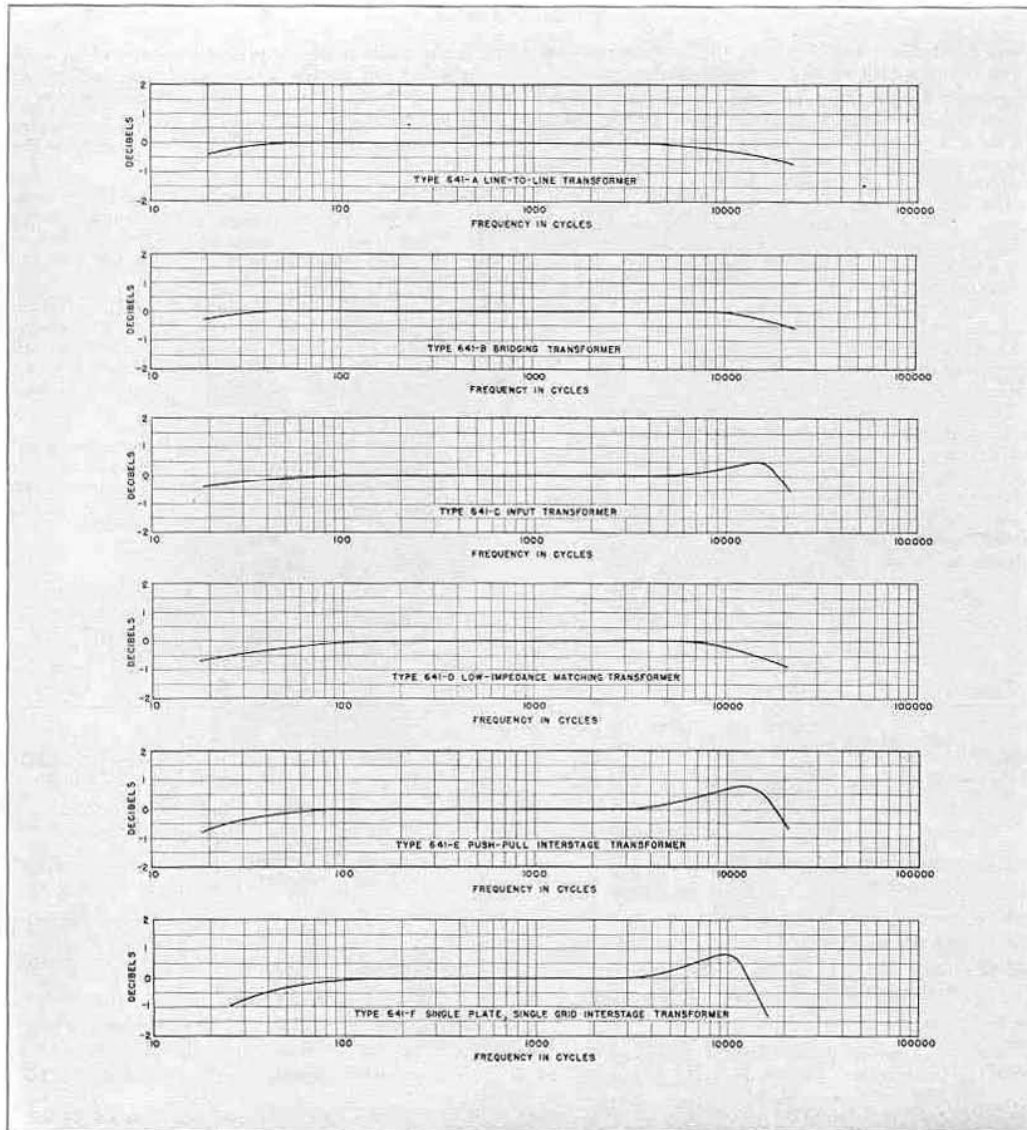

Frequency characteristics of input and interstage models.

Dimensions of case for TYPE 641 Transformer.

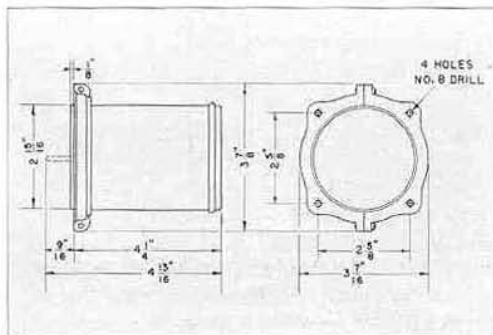

Dimensions of Model B case, in which other transformers, such as TYPE 578, are mounted.

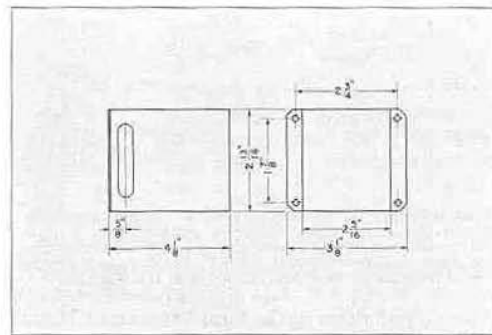

Type	Uses	Out of ¹ (ohms) (plate-to-plate)	Into ¹ (ohms)	Pri. DC balance (bal) (ma)	Un- DC (ma)	Freq. Range Down 1 db		Max. Level	Turns Ratio	Code Word	Price
						From (cycles)	To (cycles)				
641-G	P-P Plates (6C5, 6J5, etc.) to Line ⁵	10,000 to 40,000	50 to 60 125 to 150 200 to 240 500 to 600	40	—	20	20,000	6 watts	6.3 to 1	UNCLE	\$14.00
641-H	P-P or Single Plates (2A3, 6A3, 45, etc.) to Speaker	800 to 2200 ²	2.5, 5, 7.5, 10, 15, 20, 30	95	60	30 ³	20,000 ³	20 watts	12.9 to 1	VIZOR	14.00
641-J	P-P or Single Plates (2A3, 6A3, etc.) to Line	800 to 2200 ²	50 to 60 125 to 150 200 to 240 500 to 600	95	60	30 ³	20,000 ³	20 watts	3.2 to 1	VOCAL	14.00
641-K	P-P Plates (6L6, etc.) to Speaker	20,000 to 40,000 ⁴	2.5, 5, 7.5, 10, 15, 20, 30	90	5	20	20,000	20 watts	14.3 to 1	WEARY	14.00
641-L	P-P Plates (6L6, etc.) to Line ⁵	20,000 to 40,000 ⁴	50 to 60 125 to 150 200 to 240 500 to 600	90	5	20	20,000	20 watts	3.5 to 1	WINDY	14.00

¹ These limits may be changed as much as 10% without appreciably changing the transformer characteristics.
² This transformer places a load of either 3000 or 6000 ohms across the tubes. These are the proper loads for 2A3's operating with fixed or self-bias respectively.

³ Response is down 2 db at these frequencies except on 2.5Ω and 10Ω taps of TYPE 641-H where response is down 2 db at 15,000.
⁴ This transformer places a load of 6000 ohms across the tubes. This is the proper load for 6L6's operating CLASS A or AB. 240Ω and 600Ω taps can be used either balanced or single-ended.

Frequency characteristics of output models.

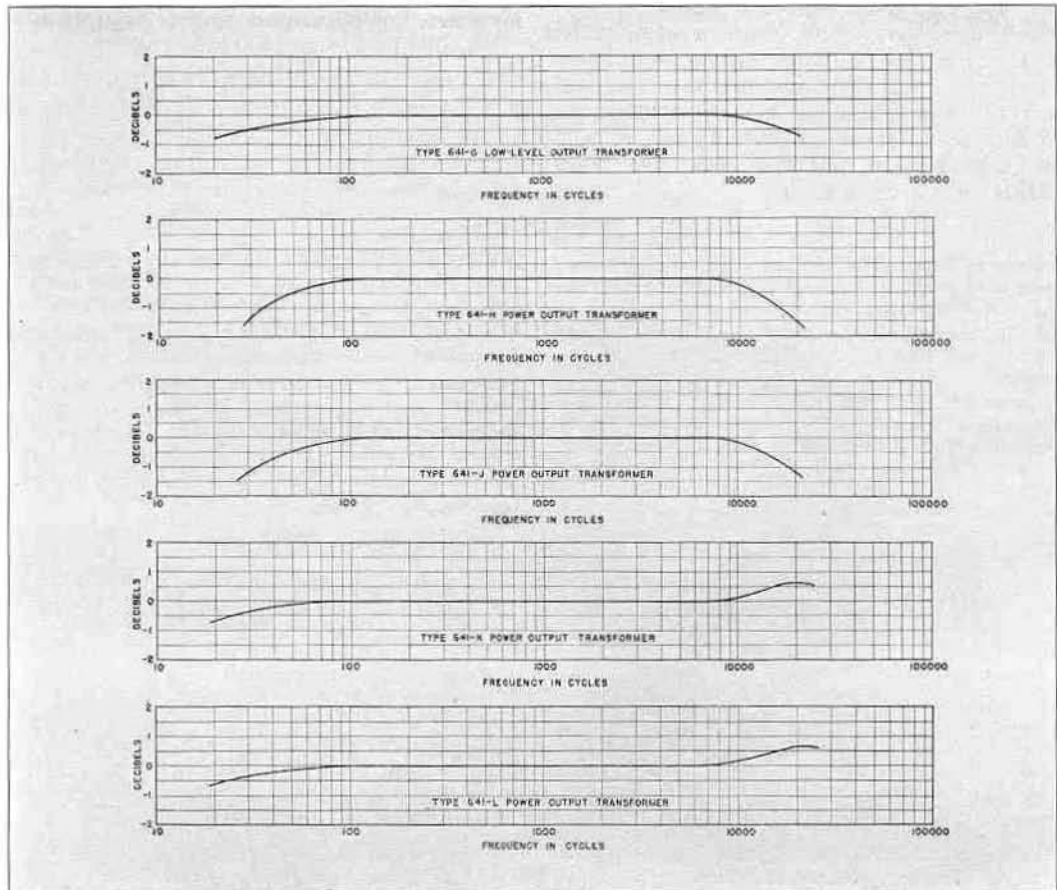

TYPE 741 TRANSFORMER

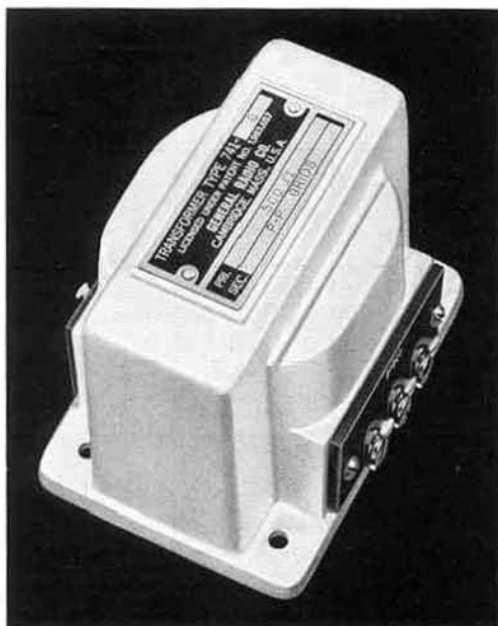

USES: TYPE 741 Transformers are intended for use in vacuum-tube amplifier circuits where a wide range of frequencies must be transmitted. They are useful in many phases of experimental investigation at carrier and low radio frequencies, such as wide-range audio circuits, facsimile transmission, experimental television, and amplifiers for use with cathode-ray oscillographs.

DESCRIPTION: The coils for these transformers are made of several pies, each of which is wound with alternate layers of sections of primary and secondary windings. The structure is such as to reduce the leakage reactance and distributed capacity to very low values. A high-permeability nickel-iron alloy is used for the core material.

All models are contained in cast-aluminum cases. Cast iron is a somewhat more effective shield at power frequencies than is aluminum, and such cases can be supplied on special order. Generally it has been found, however, that power-line hum interference is less serious than that produced by high-frequency sources, against which the aluminum is an excellent shield.

FEATURES: The extremely wide frequency range of the TYPE 741 Transformers is their main feature. The cast-aluminum housings provide good shielding at audio frequencies and are particularly useful in reducing inductive feedback which may cause "singing." The cases also shield against high-frequency disturbances, such as those caused by circuit breakers, switches, and similar equipment.

Excellent electrical balance is maintained over entire band of transmitted frequencies.

The output transformer will safely carry 5 watts. The input and interstage transformers will handle any range of voltages ordinarily used in low-power vacuum-tube work.

SPECIFICATIONS

Frequency Range: The response is within ± 2 decibels from 50 to 200,000 cycles. The accompanying diagrams show representative curves.

Circuit: All models are for use only in balanced circuits. Line-to-grid, interstage, and plate-to-line models are available.

Impedance: The interstage and plate-to-line models are designed to work from tubes having a plate-to-plate resistance of about 18,000 ohms. The plate-to-line transformer is designed to work into lines with impedances from 500 to 600 ohms. The line-to-grid model will also work out of impedances in this range.

D-C Current: The primary windings of all models will safely carry 15 milliamperes, but there must not be more than 2 milliamperes current unbalance between the two halves of the winding.

Turns Ratio: (See table below.)

Terminals: Screw terminals with soldering lugs are provided.

Mounting: Cast-aluminum case with four mounting holes in the base.

Dimensions: $3\frac{3}{8} \times 3\frac{7}{8} \times$ (height) $3\frac{7}{16}$ inches, over-all.
Net Weight: 3 pounds.

Type	Use	Turns Ratio	Code Word	Price
741-G	500-ohm line to p-p grids.....	1 to 6.4	WIDTRANANT	\$22.50
741-J	Push-pull interstage.....	1 to 1	WIDTRANBOY	22.50
741-P	P-p plates to 500-ohm line.....	6.4 to 1	WIDTRANCAT	22.50

PATENT NOTICE. See Note 25, page v.

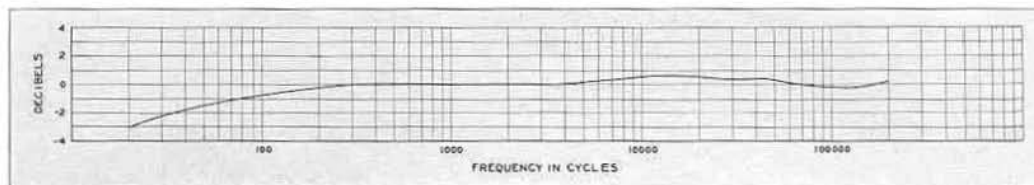

Frequency characteristic TYPE 741-G Line-to-Grid Transformer. Voltage step-up ratio 1:6.4.

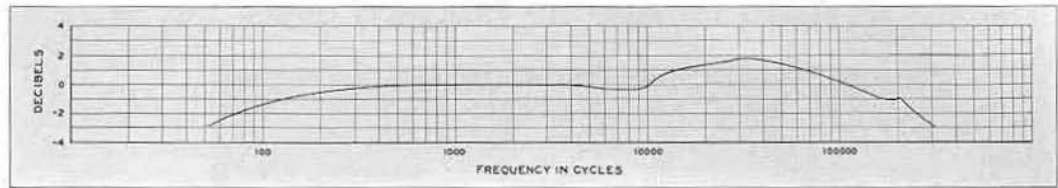

Frequency characteristic TYPE 741-J Interstage Transformer. Voltage ratio 1:1.

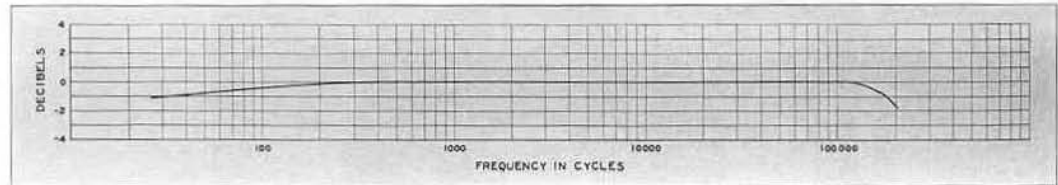

Frequency characteristic TYPE 741-P Plate-to-Line Transformer. Voltage step-down ratio 6.35:1.

TYPE 666-A VARIABLE TRANSFORMER

USES: The TYPE 666-A Variable Transformer is an impedance-matching model which is recommended where it is desired to have the impedance easily adjustable, but where flat frequency response is not needed.

DESCRIPTION: The transformer windings are tapped at several points and then brought out to jacks on the panel. The binding posts are jack-topped and are connected to plugs by means of flexible leads. In this manner the various combinations of turns are ob-

tained by plugging into the different jacks. (See photograph below.)

FEATURES: This transformer is primarily a laboratory instrument for obtaining many impedance combinations. By means of the plug arrangement ten different combinations of turns are easily obtainable on both primary and secondary. The number of turns, from one end, are clearly marked on the panel at each jack so no guesswork is involved in setting up proper turns ratios.

SPECIFICATIONS

Impedance Range: By using the taps provided, it is possible to work out of 100 to 8000 ohms and into 1 to 800 ohms and vice versa.

Turns Ratio: The turns ratio of the whole primary to the whole secondary winding is 10 to 1. Turns are engraved on the panel.

Maximum Current: The maximum allowable direct current is 60 milliamperes for the primary and 150 milliamperes for the secondary.

Mounting: A walnut case with a bakelite panel.

Dimensions: 3½ x 4½ x 5 inches.

Net Weight: 3½ pounds.

Type	Code Word	Price
666-A	ABOON	\$12.50

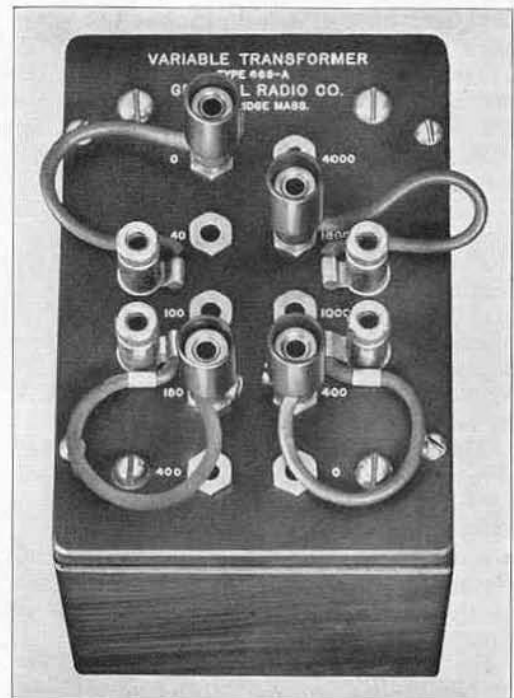
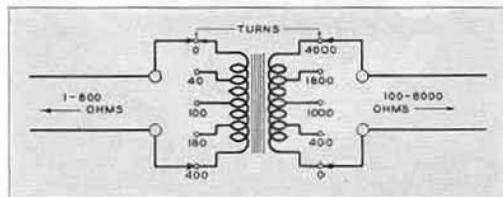

• PARTS AND ACCESSORIES

GENERAL RADIO CO.

TYPES 704 AND 706 PRECISION DIALS

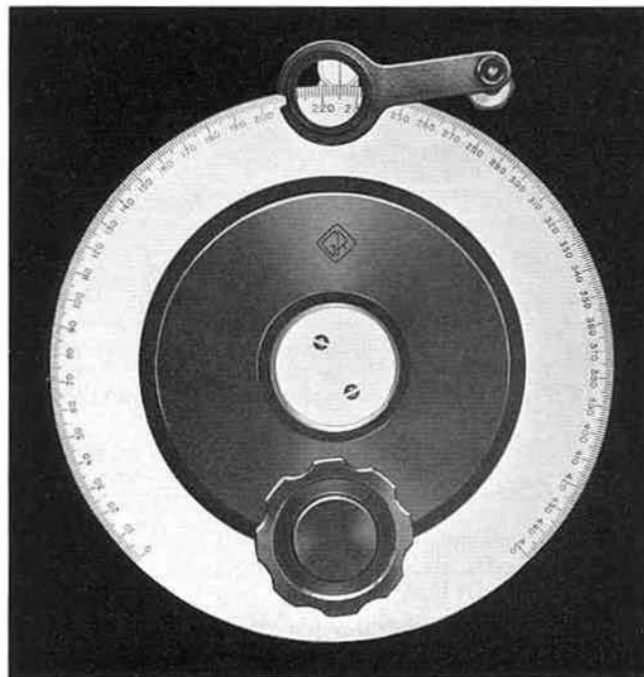

TYPE 706-D Precision Dial with TYPE 519-A Dial Lens. The photograph is approximately one-half actual size.

These are high-grade precision dials, with scales individually engraved on an automatic self-indexing engraving machine in fine, radial, and accurately located lines. The dial scale and the slow-motion knob rotate in the same direction.

The accuracy of the engraving and the precision of setting obtainable justify the use of a TYPE 519-A Dial Lens.

Backlash has been eliminated in the construction of these long-scale dials by setting the scale permanently and securely on the main shaft which thus has its angular position accurately indicated. The tension of the friction drive is adjustable to suit the load and the preference of the operator, and the position of the friction drive shaft may be adjusted to compensate for errors in the centering of the main shaft in the center hole by means of an eccentric bushing.

These dials are secured to their shafts through the use of two setscrews separated by 120° and are supplied bored to receive a 3/8-inch shaft. For use with a 1/4-inch shaft, a split collar bushing is provided which securely grips the shaft throughout one inch of its length, averting all possibility of slipping.

Settings of these dials can consistently be duplicated to one-fifth of a division,

allowing an accuracy of resetting, for the TYPE 706-D, of better than 0.05 per cent. Parallax is eliminated through the use of an indicator which always remains flush with the surface of the dial, and at the same time absorbs the slight eccentricities of the main shaft through the flexibility of its mounting arm.

TYPE 704-D Precision Dial showing the indicator. The photograph is approximately one-half actual size.

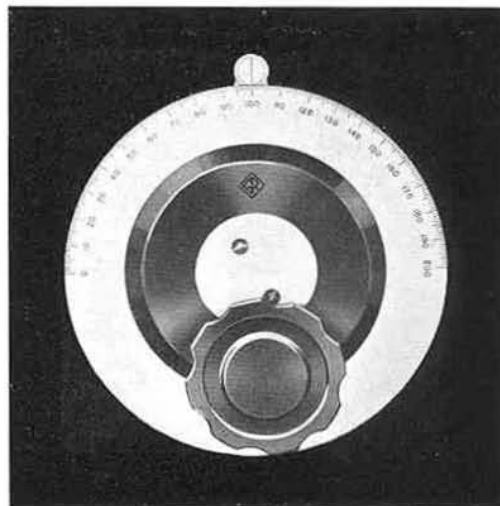

The dial indicator is supplied, as are complete instructions for mounting. Only one additional hole in the panel is required for mounting; the drilling template furnished enables it to be accurately located.

This type of dial is used as the main frequency control on General Radio beat-frequency oscillators and wave analyzers.

At the right is a sectional view of a TYPE 706 Precision Dial showing the parts in detail. The drive shaft extends through a curved slot in the dial. The dial is driven by friction between the dial and collars (4) and (5).

(Below) TYPE 706-D Precision Dial with TYPE 519-A Dial Lens. Approximately one-half actual size.

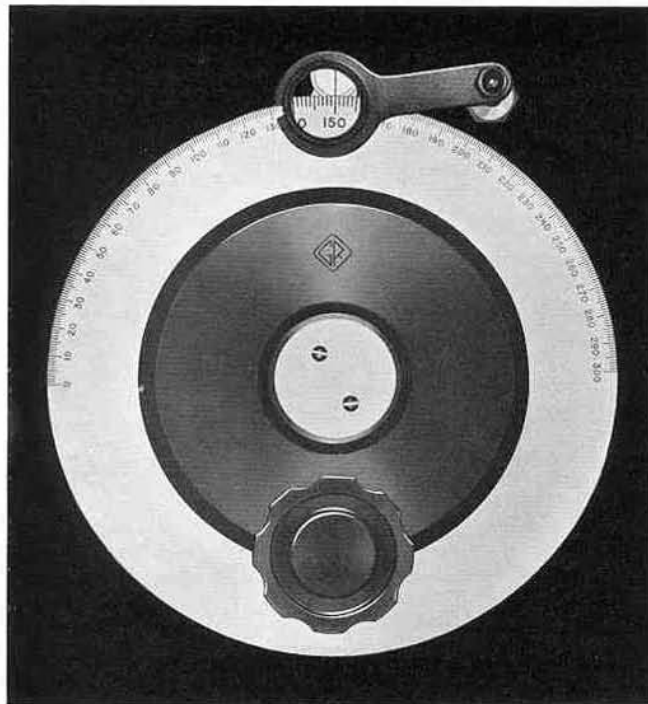
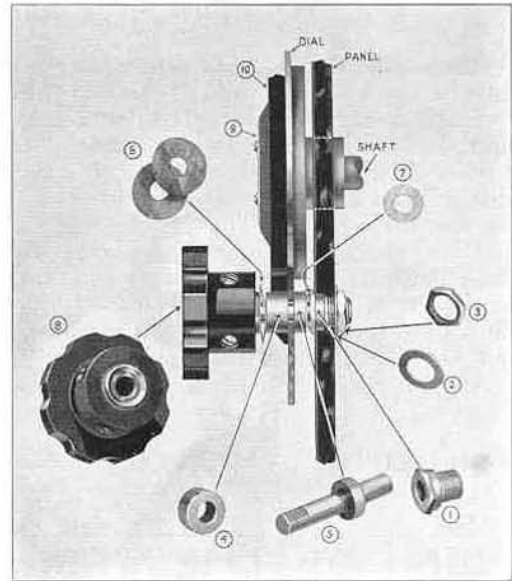

TYPE 519-A DIAL LENS

(See Illustration at Left)

This consists of a small lens with an adjustable holder to mount on a panel over the dial indicator, and makes possible the reading of a dial (especially those shown on these pages) to a high degree of precision. When not in use the arm can be swung out of the way and the lens pushed against the panel to minimize space requirements. When in use the lens is held in proper position by a detent device.

SPECIFICATIONS

Dimensions: (Height above panel) 2 x (width) $1\frac{1}{8}$ x (length or radius) $2\frac{3}{8}$ inches.

Focal length, $1\frac{1}{4}$ inches.

Mounting: One $\frac{3}{8}$ -inch hole required for mounting.

Net Weight: 2 ounces.

Type	Code Word	Price
519-A	ABASH	\$1.75

• 4-INCH DIAMETER PRECISION DIALS

Type	Dial		Friction-Drive Ratio	Net Weight	Code Word	Price
	Arc	Divisions				
704-C	180°	200	1:6	9 oz.	DABBY	\$6.00
704-D	270°	300	1:6	9 oz.	DATRY	6.00

• 6-INCH DIAMETER PRECISION DIALS

Type	Dial		Friction-Drive Ratio	Net Weight	Code Word	Price
	Arc	Divisions				
706-C	180°	300	1:8	15 oz.	DASHY	\$6.50
706-D	270°	450	1:8	15 oz.	DATUM	6.50

• PARTS AND ACCESSORIES

FRICION-DRIVE AND DIRECT-DRIVE DIALS

These dials have photo-etched nickel-silver scales and TYPE 637 Knobs. They are available in three diameters, two shaft sizes, and with or without friction drive. The friction-drive mechanism consists of a thin disc gripped and driven by two other discs on the driving shaft. This is shown in the sectional views of each size. The direct-drive dials TYPES 710, 712, and 717 are the same as the TYPES 702, 705, and 703, respectively, illustrated on pages 194 and 195, but do not have the friction-drive mechanism.

indicator shown in the photographs is supplied, as is a template, for mounting.

The photographs shown here are one-half actual size. The cut-away views are photographs and are correct in all details and relative dimensions.

Although the scale divisions are not as accurately determined as those of the TYPE 704 and TYPE 706 Precision Dials, they are, nevertheless, completely satisfactory for most uses, particularly where a smooth-acting and attractive dial is needed. They are used on many General Radio instruments.

All dials are insulated from the shaft. The

● 4-INCH DIAMETER — TYPE 703 FRICTION-DRIVE DIALS*

Type	Shaft Diameter	Dial		Friction-Drive Ratio	Net Weight	Code Word	Price
		Arc	Divisions				
703-A	1/4 in.	180°	100	1:5	8 oz.	DIANT	\$2.00
703-B	1/4 in.	270°	200	1:5	8 oz.	DIBUT	2.00
703-F	3/8 in.	180°	100	1:5	8 oz.	DIFUN	2.00
703-G	3/8 in.	270°	200	1:5	8 oz.	DIGUM	2.00

● 4-INCH DIAMETER — TYPE 717 DIRECT-DRIVE DIALS

717-A	1/4 in.	180°	100	5 oz.	DIARM	\$1.50
717-B	1/4 in.	270°	200	5 oz.	DIBAR	1.50
717-F	3/8 in.	180°	100	5 oz.	DIFIT	1.50
717-G	3/8 in.	270°	200	5 oz.	DIGAR	1.50

*PATENT NOTICE. See Note 17, page v.

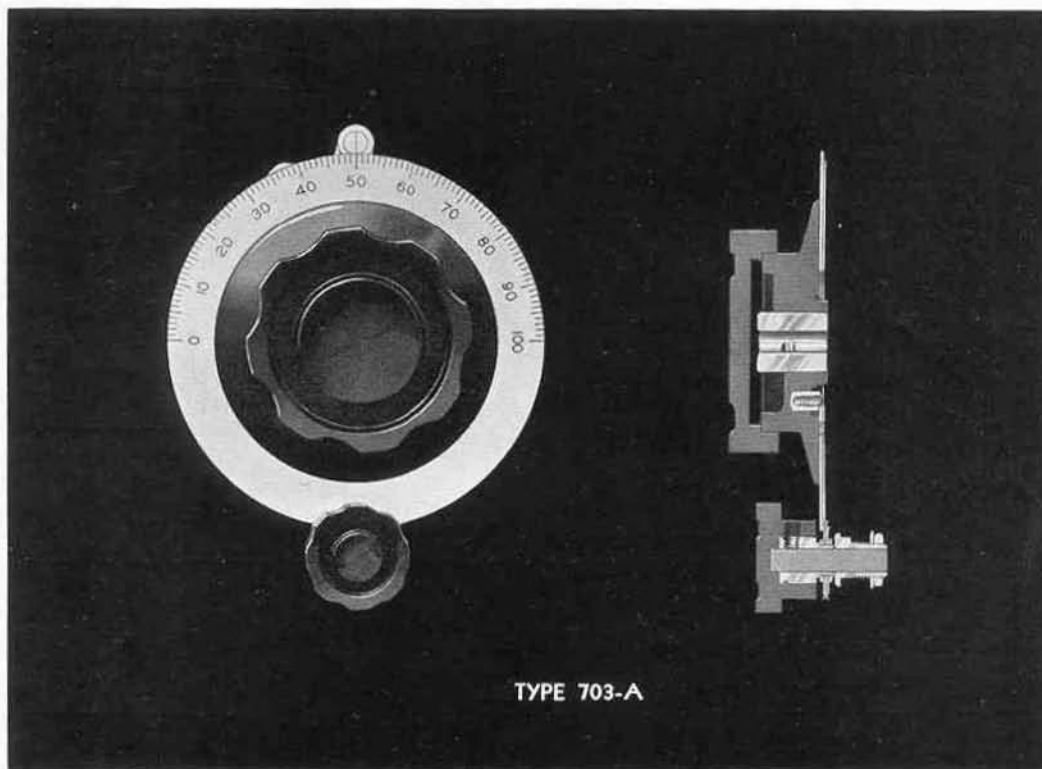

TYPE 703-A

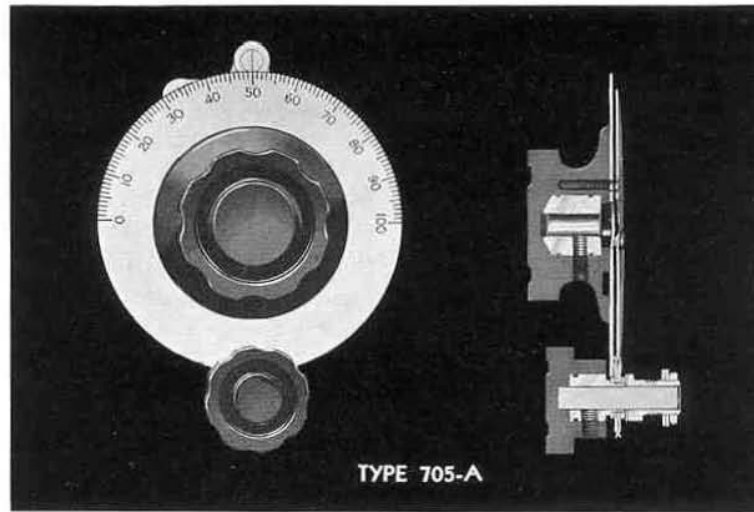

TYPE 705-A

● 3/4-INCH DIAMETER — TYPE 705 FRICTION-DRIVE DIALS*

Type	Shaft	Dial		Friction-Drive	Net Weight	Code Word	Price
	Diameter	Arc	Divisions	Ratio			
705-A	1/4 in.	180°	100	1:4	5 oz.	DIARK	\$1.75
705-F	3/8 in.	180°	100	1:4	5 oz.	DIFAL	1.75

● 3/4-INCH DIAMETER — TYPE 712 DIRECT-DRIVE DIALS

712-A	1/4 in.	180°	100	3 oz.	DIAPE	\$1.25
712-F	3/8 in.	180°	100	3 oz.	DIFAR	1.25

● 2 3/4-INCH DIAMETER — TYPE 702 FRICTION-DRIVE DIALS*

702-A	1/4 in.	180°	100	1:3.3	4 oz.	DIACK	\$1.75
702-B	1/4 in.	270°	100	1:3.3	4 oz.	DIBOG	1.75
702-F	3/8 in.	180°	100	1:3.3	4 oz.	DIFAG	1.75
702-G	3/8 in.	270°	100	1:3.3	4 oz.	DIGOD	1.75

● 2 3/4-INCH DIAMETER — TYPE 710 DIRECT-DRIVE DIALS

710-A	1/4 in.	180°	100	2 1/2 oz.	DIALY	\$1.25
710-B	1/4 in.	270°	100	2 1/2 oz.	DIBIN	1.25
710-F	3/8 in.	180°	100	2 1/2 oz.	BEFIT	1.25
710-G	3/8 in.	270°	100	2 1/2 oz.	DIGUT	1.25

*PATENT NOTICE. See Note 17, page v.

These dials are ordinarily mounted with the slow-motion drive located 45 degrees to the right of the position shown in these photographs. The drive is located here directly below the main shaft in order to show all details in the sectional views. All photographs are approximately one-half actual size. The direct-drive dials do not have the vernier drive but are otherwise the same.

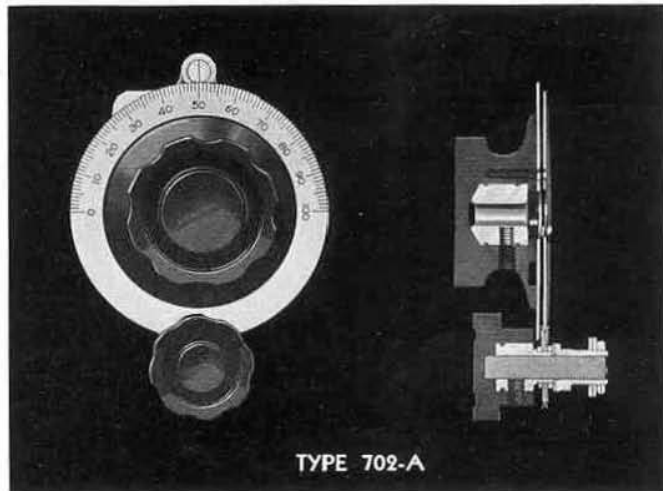

TYPE 702-A

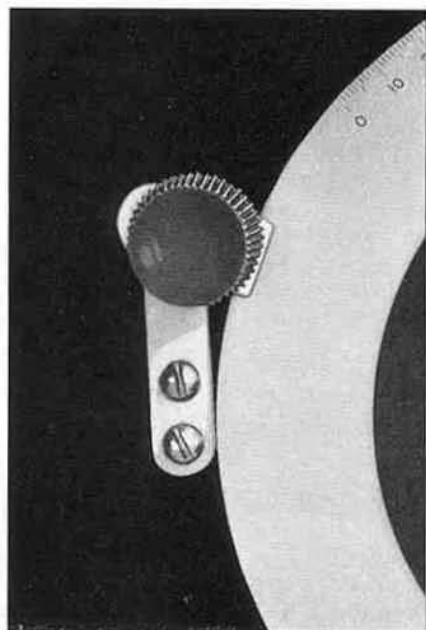

TYPE 520-A DIAL LOCK

Any General Radio dial may be firmly clamped in any position by means of the TYPE 520-A Dial Lock which holds the edge of the dial in a vise-like grip, without exerting appreciable force on the shaft on which the dial is mounted. The lock does not alter the dial setting and may be unclamped by loosening the knurled knob when it is desired to change dial to a new setting.

SPECIFICATIONS

Dimensions: (Length) 2 x (width) 1 x (height) 1½ inches, over-all. Height above panel, 1 inch.

Mounting: Two No. 28 holes, 3/8 inch apart, are required for mounting.

Net Weight: 1½ ounces.

Type	Code Word	Price
520-A	ABATE	\$0.75

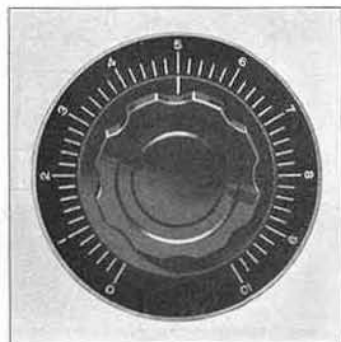

DIAL PLATES

These two dial plates have photo-etched scales with raised nickel-silver graduations on a flat black background. Each can be attached to the panel with the same screws which hold the rheostat - potentiometer with which the dial plate is used.

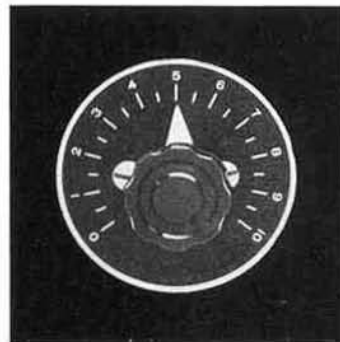

TYPE 318-B

A 3-inch diameter plate for use with a 15/8-inch knob, either pointer or skirt, and with any rheostat-potentiometer having standard 3-hole mounting. Marked with 50 divisions around 298°.

Type	Net Weight	Code Word	Price
318-B	½ oz.	DEVIL	\$0.35

TYPE 522-A

A 2½-inch diameter plate for use with a TYPE 637-A Knob and a TYPE 301-A or 410-A Rheostat-Potentiometer. Marked with 20 divisions around 254°.

Type	Net Weight	Code Word	Price
522-A	½ oz.	DOGMA	\$0.35

TYPE 202 SWITCH KNOB

This is the bakelite knob that is used on our resistance boxes and decade condensers because it enables the operator to estimate the value of a setting by his sense of touch. The pointer is of nickel-plated brass. It is not insulated from the shaft.

Type	Shaft Diameter	Net Weight	Code Word	Unit Price	Package of 10
202-Y	3/8 in.	3/4 oz.	SWITCHARMY	\$0.45	\$3.00
202-Z	1/4 in.	3/4 oz.	SWITCHBURG	.45	3.00

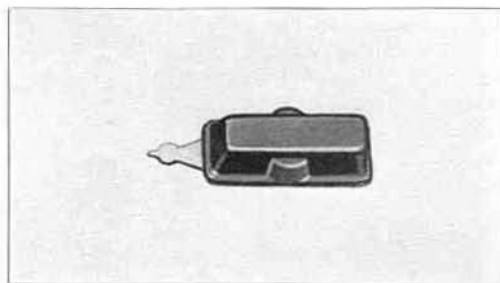

TYPE 637 FLUTED KNOBS

These moulded bakelite knobs are used on nearly all General Radio apparatus. They were chosen from among dozens of preliminary designs as the ones best suited to the requirements of measuring instruments. The smoothed fluted knurling affords a positive, cramp-free grip for the most delicate adjustments.

The white pointers are made of non-conducting material, and they can be easily pried off when knobs alone are required. Each knob is provided with two setscrews to insure permanence of setting.

1 1/8-INCH DIAMETER — WITH POINTER

Type	Shaft Diameter	Code Word	Unit Price	Package of 10
637-A	1/4 in.	NURLNOBANT	\$0.30	\$2.10
637-B	3/8 in.	NURLNOBBOY	.35	2.35

Net Weight: 3/4 ounce

1 5/8-INCH DIAMETER — WITH POINTER

Type	Shaft Diameter	Code Word	Unit Price	Package of 10
637-G	1/4 in.	NURLNOBGUN	\$0.35	\$2.35
637-H	3/8 in.	NURLNOBHAT	.35	2.35

Net Weight: 1 1/4 ounces

1 5/8-INCH DIAMETER — WITH SKIRT

Type	Shaft Diameter	Code Word	Unit Price	Package of 10
637-J	1/4 in.	NURLNOBJIM	\$0.40	\$2.75
637-K	3/8 in.	NURLNOBKOP	.45	3.25

(Diameter of skirt, 2 1/16 inches)
Net Weight: 1 1/2 ounces

2 3/8-INCH DIAMETER — WITH POINTER

Type	Shaft Diameter	Code Word	Unit Price	Package of 10
637-P	1/4 in.	NURLNOBPIG	\$0.50	\$3.75
637-Q	3/8 in.	NURLNOBQUO	.50	3.75

Net Weight: 3 ounces

2 3/8-INCH DIAMETER — WITH SKIRT

Type	Shaft Diameter	Code Word	Unit Price	Package of 10
637-R	1/4 in.	NURLNOBRAM	\$0.50	\$3.75
637-S	3/8 in.	NURLNOBSUM	.50	3.75

(Diameter of skirt, 3 inches)
Net Weight: 3 1/2 ounces

TYPE 637 Knobs are shown approximately one-half actual size in the photographs at the right.

THE QUANTITY DISCOUNTS MENTIONED ON PAGE IV ALSO APPLY TO QUANTITIES OF PACKAGES.

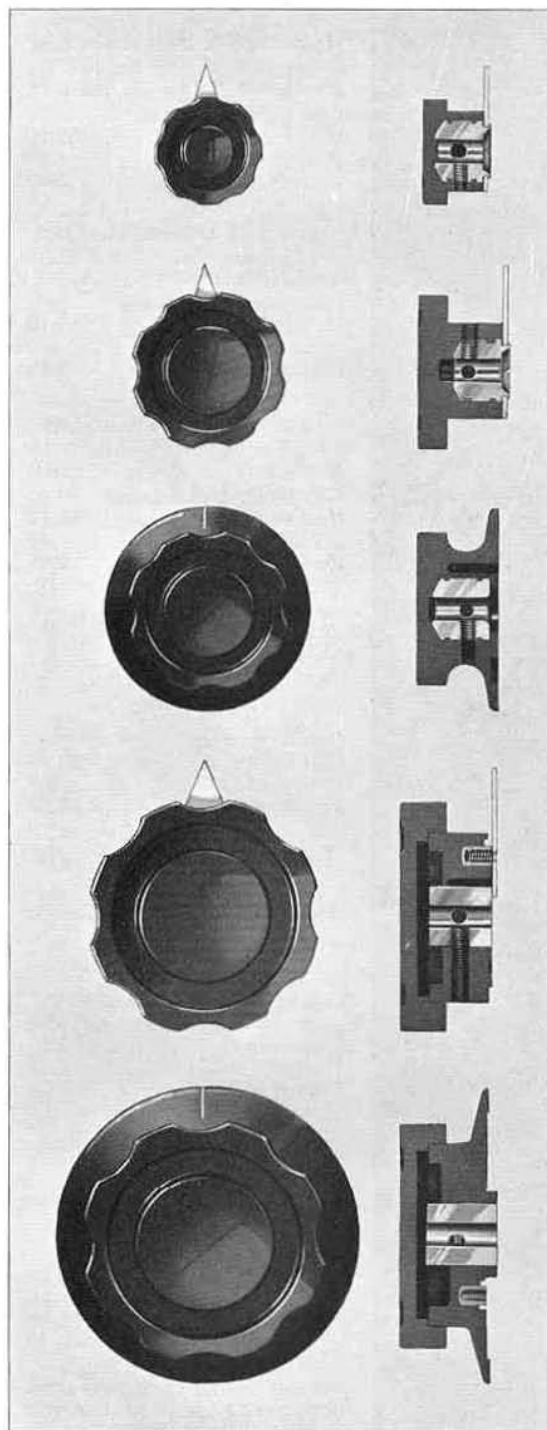

TYPE 138 STANDARD PARTS



Type 138-B Switch Contact

A = 1/4 inch C = No. 10 drill
 B = 3/16 inch D = 3/8 inch max
 Code Word: CONTACTANT
 Unit Price \$0.10
 Package of 1040
 Package of 100 2.25

Type 138-C Switch Contact

A = 5/16 inch C = No. 10 drill
 B = 3/16 inch D = 1/2 inch max.
 Code Word: CONTACTBUG
 Unit Price \$0.10
 Package of 1050
 Package of 100 3.20

Type 138-D Switch Contact

A = 3/16 inch C = No. 28 drill
 B = 3/16 inch D = 1/2 inch
 Code Word: CONTACTCAT
 Unit Price \$0.10
 Package of 1040
 Package of 100 2.25

Type 138-Q Switch Stop

A = 3/16 inch C = 6 - 32
 B = 3/16 inch D = 3/8 inch max.
 Code Word: STANPARBUL
 Unit Price \$0.10
 Package of 1040
 Package of 100 2.25

Type 138-A Binding Post

A = 3/4 inch
 B = 3/4 inch min.
 C = 10 - 32
 D = 3/8 inch max.
 Code Word: STANPARCUP
 Unit Price \$0.25
 Package of 10 1.50
 Package of 100 13.50

Types 138-V and 138-VD Binding Posts

A = 3/8 inch B = 1/16 inch min.
 C = 10 - 32
 D = 1/2 inch max. for -V
 3/8 inch max. for -VD
 Code Words: STANPARANT (for -V)
 STANPARFUN (for -VD)
 Unit Price \$0.25
 Package of 10 1.35
 Package of 100 12.00

Type 138-X Binding Post

A = 1/2 inch
 B = 1/16 inch min.
 C = 10 - 32
 D = 1/2 inch max.
 Code Word: STANPARBOY
 Unit Price \$0.25
 Package of 10 1.35
 Package of 100 12.00

THE QUANTITY DISCOUNTS MENTIONED ON PAGE IV ALSO APPLY TO QUANTITIES OF PACKAGES.

USES: The TYPE 138 parts have been designed for use in the assembly of high-quality laboratory and experimental equipment. These parts have been used for many years in General Radio instruments, as well as in those of other manufacturers.

DESCRIPTION: Switch Contacts: The three styles of TYPE 138 Switch Contacts are made of cadmium-plated bronze. The faces of all the contacts are plane. TYPES 138-B and 138-C have knurled shoulders which, when drawn into the panel by tightening the nut, prevent rotation of the contact heads. TYPE 138-D is not threaded but has a knurled stud which gives a driving fit.

Switch Stop: The TYPE 138-Q Switch Stop is made of nickel-plated brass. This stop does not have a knurled shoulder.

Binding Posts: Four different styles of binding posts are available. The TYPE 138-A has a bakelite top which screws down onto a metal collar. The TYPES 138-V and 138-VD are small nickel-plated brass binding posts which also have a jack top for receiving plugs of the TYPE 274 series. The TYPE 138-V Binding Post is illustrated; the TYPE 138-VD is identical except for a longer stud. The TYPE 138-X is a larger binding post which also has the jack top. All binding posts are complete with tinned terminals and nuts.

Binding Post Assemblies: When it is necessary to mount binding posts on metal panels some assembly such as the TYPES 274-K or 274-L is desirable. These assemblies consist of a bakelite strip, which has two tapped inserts for mounting purposes, with two binding posts mounted 3/4 of an inch on centers. Double plugs, such as the TYPE 274-M, can be used with either assembly, since the only difference is in the outer diameter of the binding posts, TYPE 138-V posts being used on the TYPE 274-K and TYPE 138-X posts on the TYPE 274-L.

Types 274-K and 274-L Binding Post Assemblies

A = 2 3/16 inches C = 6 - 32
 B = 1 inch D = 1/4 inch
 Code Words: STANPARBAG (for 274-K)
 STANPARTAG (for 274-L) Price: \$0.65

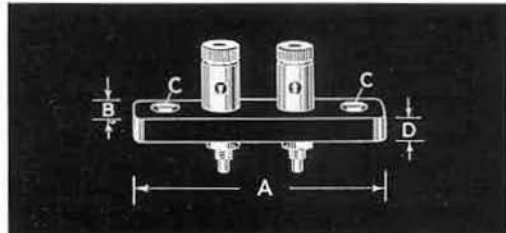

TYPE 274 PLUGS AND JACKS

USES: The TYPE 274 parts are made available for the laboratory worker, manufacturer, or amateur who wishes to use rugged, well-constructed parts. They are used on all General Radio instruments, as well as on those of other manufacturers. School and industrial laboratories also have found them very useful as connectors on leads.

DESCRIPTION: Single Plugs: The TYPE 274-P, the basic unit, consists of a threaded nickel-plated brass stud which is fitted with a beryllium copper spring. A nut and terminal are furnished. TYPE 274-X is similar to TYPE 274-P, except the stud is not threaded but has a tubular rivet top. TYPE 274-U has a larger threaded stud which is recessed to take a TYPE 274 Plug. TYPE 274-D is similar to TYPE 274-U but has an insulating bakelite sleeve and a thumbscrew.

All plugs will carry a maximum current of 15 amperes on a resistive load.

Jacks: The basic jack unit is the TYPE 274-J which is made of nickel-plated brass. All TYPE 274-J Jacks are furnished with tinned terminals and nuts. TYPES 274-U and 274-D Plugs and all double plugs are recessed in the top, thus making jacks for other plugs.

Double Plugs: The TYPE 274-M Double Plug uses black bakelite which is moulded around two plugs set $\frac{3}{4}$ inch on centers. The top is recessed, forming a double jack. Small setscrews are used for holding cord tips and wire leads. The TYPE 274-ML is identical with the TYPE 274-M, except that low-loss yellow bakelite is used. This material has a much higher leakage resistance and lower power factor than the black bakelite.

Short-Circuit Plug: The TYPE 274-SB Short-Circuit Plug consists of two TYPE 274-U Plugs and a nickel-plated brass bar.

Jack Base: The TYPE 274-RJ is a bakelite base with two pairs of binding posts connected to two pairs of jacks. Each pair is $\frac{3}{4}$ inch on centers and the jacks are spaced to take the TYPE 493 Thermocouples and TYPE 492 Oxide Rectifier.

Type 274-RJ Four-Gang Jack Base

A = $3\frac{3}{4}$ inches B = $1\frac{1}{2}$ inches C = $\frac{5}{16}$ inch

Code Word: STANPARPUP Price: \$1.00

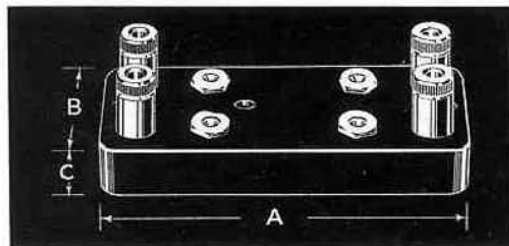

Type 274-P Plug

A = $\frac{5}{16}$ inch max.
B = $\frac{1}{8}$ inch max.
C = 6-32
D = $\frac{5}{8}$ inch

Code Word: STANPARCAT
Unit Price \$0.12
Package of 1070
Package of 100 5.25



Type 274-J Jack

A = $\frac{7}{16}$ inch B = $\frac{3}{8}$ inch max.
C = $\frac{1}{4}$ -28

Code Word: STANPARTOP
Unit Price \$0.10
Package of 1045
Package of 100 2.25



Type 274-X Plug

A = 0.135 inch diam. C = $\frac{1}{8}$ inch
B = $\frac{3}{16}$ inch D = $\frac{1}{2}$ inch

Code Word: STANPARTIN
Unit Price \$0.10
Package of 1060
Package of 100 4.25



Type 274-U Plug

A = $\frac{7}{16}$ inch
B = $\frac{3}{8}$ inch max.
C = $\frac{1}{4}$ -28
D = $\frac{1}{4}$ inch

Code Word: STANPARGOT
Unit Price \$0.15
Package of 10 1.00
Package of 100 8.00



Type 274-D Insulated Plug

A = $\frac{1}{2}$ inch B = $1\frac{1}{16}$ inch

Code Word: STANPAREYE
Unit Price \$0.25
Package of 10 2.25

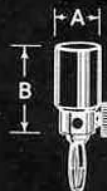

Types 274-M and -ML Double Plugs

A = $1\frac{1}{4}$ inches B = $1\frac{3}{4}$ inches

Code Word: STANPARBUG
Unit Price \$0.40
Package of 10 2.60

Code Word: STANPARBUY
Unit Price \$0.45
Package of 10 3.00

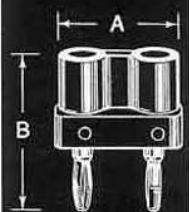

Type 274-SB Short-Circuit Plug

A = $1\frac{1}{8}$ inches B = $1\frac{1}{16}$ inches

Code Word: STANPARZIP
Unit Price \$0.65

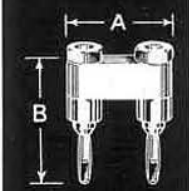

THE QUANTITY DISCOUNTS MENTIONED ON PAGE IV ALSO APPLY TO QUANTITIES OF PACKAGES.

• PARTS AND ACCESSORIES

TYPE 274 PANEL TERMINAL INSULATOR ASSEMBLY

This assembly, to be used with TYPE 138-VD Binding Posts for mounting on a metal panel, consists of two black or low-loss yellow bakelite insulators.

A = 1½ inches C = ⅜ inch diam.
B = ¾ inch D = ⅛ inch to ⅜ inch

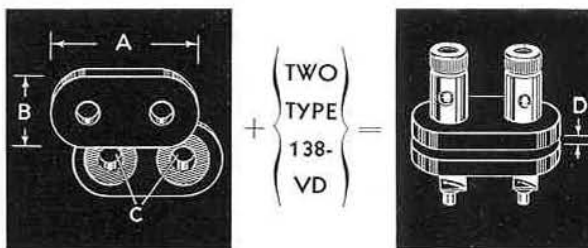

Type	Bakelite Material	Code Word	Price	
			Pair	Package of 10 Pairs
274-Y	Black	STANPARBEL	\$0.20	\$1.35
274-Z	Yellow	STANPARHOD	.30	2.10

TYPE 274-NC SHIELDED CONDUCTOR

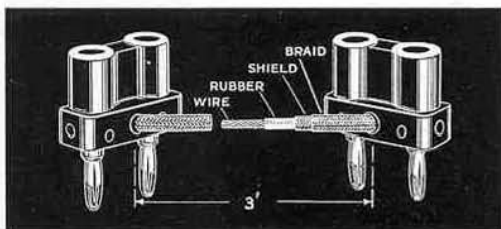

The TYPE 274-NC is useful for connections between bridges, oscillators, and similar equipment at audio and radio frequencies. It is a concentric-shielded cable with one TYPE 274-M Plug connected to each end.

Capacitance: 140 μf (at 1 megacycle).
Impedance: Approximately 40 ohms (at 1 megacycle).
274-NC: Code Word: STANPARZOO Price: \$1.50

**TYPE 274-ND SHIELDED PLUG
TYPE 274-NE SHIELDED PLUG and CABLE**

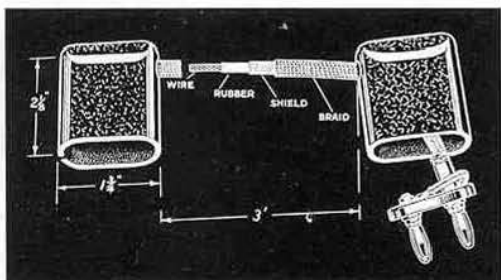

These connectors are useful in high-frequency work and in measurements where extreme shielding precautions must be used.

The shielded plugs have a cast-aluminum cap which fits over the plugs and is connected to the ground terminal. The plugs are mounted on low-loss yellow bakelite.

TYPE 274-NE (illustrated above) consists of a concentric cable with two TYPE 274-ND Shielded Plugs.

Capacitance: 160 μf (for TYPE 274-NE at 1 megacycle).
Impedance: Approximately 40 ohms (at 1 megacycle).
274-ND: Code Word: STAPLUGDOG Price: \$1.50
274-NE: Code Word: STAPLUGEYE Price: 4.00

TYPE 674 JUMBO PLUGS AND JACKS

USES: These parts are convenient connectors for circuits carrying large currents.

DESCRIPTION: The TYPE 674-P has a threaded shank, while the TYPE 674-C has a soldered-filled shank for sweating in ¼-inch tubing. The TYPE 674-D has an insulated shank with a jack top and a soldering lug. Nickel-plated brass is used except for the plug springs which are a special phosphor bronze. The maximum current is 35 amperes. The TYPES 674-J and 674-P are supplied with nuts and terminals.

Type 674-P Jumbo Plug

A = ¾ inch C = ⅜ - 32
B = ⅜ inch D = 1 1/16 inches

Code Word: STANPARAPE
Unit Price \$0.30
Package of 10 1.75

Type 674-J Jumbo Jack

A = ¾ inch B = ⅜ inch max.
C = ½ - 20

Code Word: STANPARAYE
Unit Price \$0.30
Package of 10 1.65

Type 674-C Jumbo Plug

A = ½ inch B = ¾ inch

Code Word: STANPARCOX
Unit Price \$0.25
Package of 10 1.50

Type 674-D Insulated Jumbo Plug

A = ¾ inch B = 1 1/16 inches

Code Word: STANPARARK
Unit Price \$0.50
Package of 10 4.00

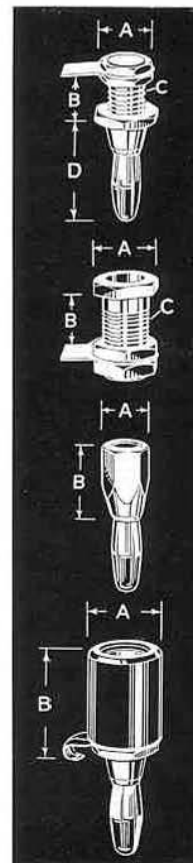

THE QUANTITY DISCOUNTS MENTIONED ON PAGE IV ALSO APPLY TO QUANTITIES OF PACKAGES.

TYPE 677 INDUCTOR FORM

USES: These coil forms are suitable for use in low-power oscillators and amateur transmitters.

DESCRIPTION: The forms are made of moulded porcelain in two convenient sizes. The eight notched ribs provide permanent winding spacing while the series of small holes gives adequate anchorage. Taps and separate windings up to a total of seven terminals are accommodated by a matched plug-in base and jack, separately available.

For complete assembly two TYPE 677-P1 Coil Form Spacers, with which are included the necessary machine screws, nuts, and lead washers, are required. These spacers may also be used to support the jack plate.

The V-cut threads permit use of wire size up to No. 10 B. & S., and extend over three inches.

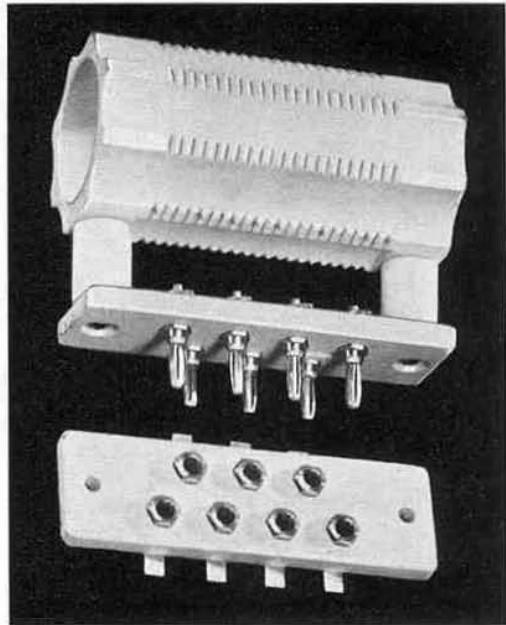

SPECIFICATIONS

Dimensions: Length, all units, $4\frac{5}{8}$ inches. Diameter, TYPE 677-U, $2\frac{1}{2}$ inches; TYPE 677-Y, $3\frac{1}{4}$ inches. Width, TYPES 678-P, 678-J, $1\frac{1}{2}$ inches. Height, TYPE 677-P1, 1 inch.

Net Weight: TYPE 677-U, 10 ounces. TYPE 677-P1 (per pair), 2 ounces. TYPE 678-P, 4 ounces. TYPE 678-J, 4 ounces. TYPE 677-Y, $1\frac{5}{8}$ pounds.

Type	Description	Code Word	Price
677-U	Coil Form	MIMIC	\$0.50
677-Y	Coil Form	MISER	.75
677-P1	Spacer (2 req'd)	MINIM	.30 (pair)
678-P	Base with 7 Plugs	MINOR	.70
678-J	Base with 7 Jacks	MINNY	.65

TYPE 119 RADIO-FREQUENCY CHOKE

USES: TYPE 119 Choke is useful not only as a radio-frequency choke in vacuum-tube circuits, but also as an inductance element in filters and tuned circuits.

DESCRIPTION: The winding is the so-called helical type, composed of a large number of thin, spiral-wound pies. TYPE 119-B uses a dust-type core.

FEATURES: The method of winding produces only one resonant point; minor resonances are practically eliminated. The shunt capacitance is low, so that the choke can be used at frequencies as high as 40 megacycles. The use of an iron-dust core in TYPE 119-B makes possible a high-inductance unit with very little increase in capacitance and resistance.

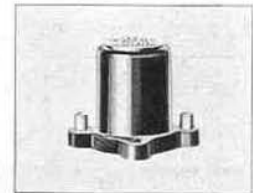
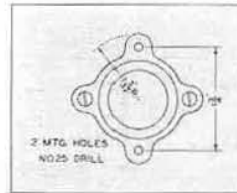

SPECIFICATIONS

Accuracy of Inductance: $\pm 20\%$.

Dimensions: (Height) 2 inches; for base dimensions, see sketch.

Net Weight: TYPE 119-A, $2\frac{1}{2}$ oz.; TYPE 119-B, 3 oz.

Type	Inductance	Capacitance	D-C Resistance
119-A	0.25 h	4 μmf	450 Ω
119-B	0.5 h	5 μmf	450 Ω

Type	Code Word	Price
119-A	IMAGE	\$1.50
119-B	IMBED	2.00

TYPE 339 SWITCH

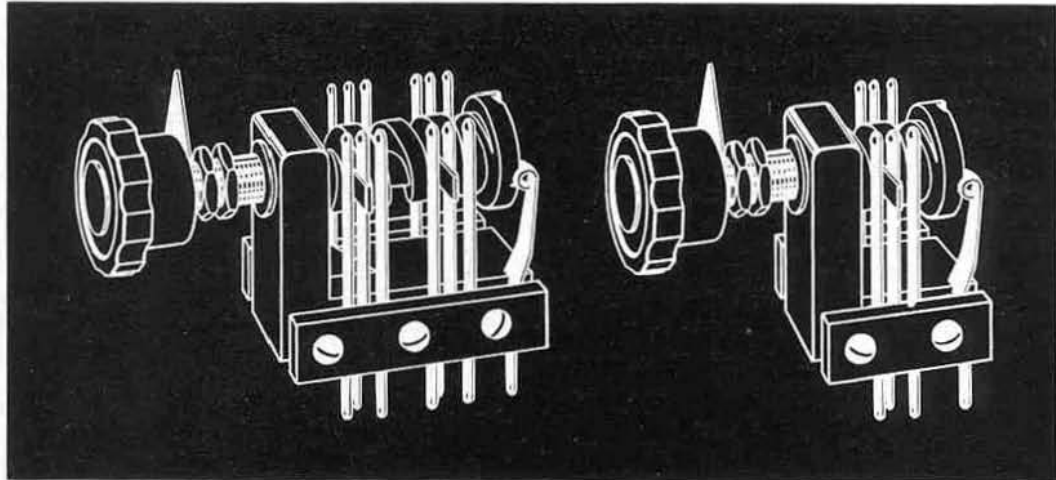

USES: The TYPE 339 Switch is designed for low-power service as, for instance, in vacuum-tube circuits, where a low capacitance, high-quality switch is needed. It can be used to replace the older type of "anti-capacity" toggle switch.

DESCRIPTION: A rotary control is used, actuating the blades by means of a moulded bakelite worm. The mounting is a single-hole type and will fit panels up to $\frac{3}{8}$ -inch in

thickness. The total throw is 180° from one position to the other. Both ON positions as well as the intermediate OFF position are marked by a positive detent device.

FEATURES: Among the features of this switch are rotary action and low capacitance. The single-hole mounting is a convenience, and the blades can be bent for switching in unusual circuits.

SPECIFICATIONS

Insulation: Moulded bakelite.

Voltage and Current Rating: The insulation will withstand 250 volts. The maximum current is 2 amperes in a non-inductive circuit. The switch is designed for use in low-power, vacuum-tube circuits.

Dimensions: Panel space required, $1\frac{5}{8} \times 2\frac{3}{8}$ inches;

depth behind panel, TYPE 339-A, $2\frac{1}{2}$ inches; TYPE 339-B, $1\frac{7}{8}$ inches.

Mounting: Single-hole type, $\frac{3}{8}$ -inch diameter. Will fit panels up to $\frac{3}{8}$ inch thick.

Net Weight: TYPE 339-A, $4\frac{1}{4}$ ounces. TYPE 339-B, $3\frac{1}{4}$ ounces.

Type	Description	Code Word	Price
339-A	4-Pole, Double Throw	PUPPY	\$2.50
339-B	2-Pole, Double Throw	PUPPY	2.00

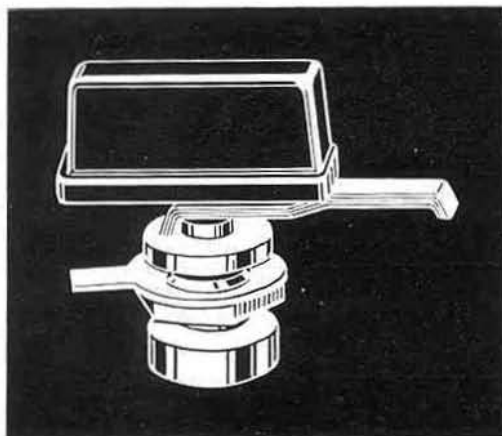

TYPE 202 SWITCH

This is a quadruple-leaf phosphor-bronze switch which makes wiping contact on both the switch points and the fixed bushing. It is intended for use with TYPE 138-B or TYPE 138-C Switch Contacts mounted on a $1\frac{3}{8}$ -inch radius.

SPECIFICATIONS

Net Weight: TYPE 202-A, 2 ounces. TYPE 202-B, $2\frac{1}{4}$ ounces.

Type	Panel Thickness	Code Word	Price
202-A	$\frac{1}{8}$ to $\frac{1}{4}$ in.	SWITCHTOAD	\$0.75
202-B	$\frac{1}{4}$ to $\frac{3}{8}$ in.	SWITCHGOOD	.75

TYPE 480 RELAY RACK

This rack is intended for mounting standard 19-inch panels whose heights are integral multiples of $1\frac{3}{4}$ inches. Racks of this type have been in use in telephone plants for many years, and they are fast becoming standard in laboratories for mounting apparatus. Two sizes are available.

SPECIFICATIONS

Construction: Steel frame with welded joints. Both models have provision for bolting them to the floor or table, but they are stable enough to stand without fastening for all ordinary service.

Drilling: Standard drilling for 19-inch relay-rack panels is employed. Holes are tapped and cleaned for a 10-32 panel-mounting screw.

Accessories: Panel-mounting screws, panel-protecting washers, and bridle rings for cabled wiring are supplied.

Dimensions: TYPE 480-A: Frame, (height) $69\frac{1}{8}$ x (width) 20 x (depth) 3 inches, over-all. Base, (width) 20 x (depth) 15 inches. Panel-mounting space, 63 inches or 36 "rack units."

TYPE 480-B: Frame, (height) 44 x (width) 20 x (depth) $1\frac{1}{2}$ inches, over-all. Base, (width) 20 x (depth) 15 inches. Panel-mounting space, $43\frac{3}{4}$ inches or 25 "rack units."

Net Weight: TYPE 480-A, 81 pounds. TYPE 480-B, 20 pounds.

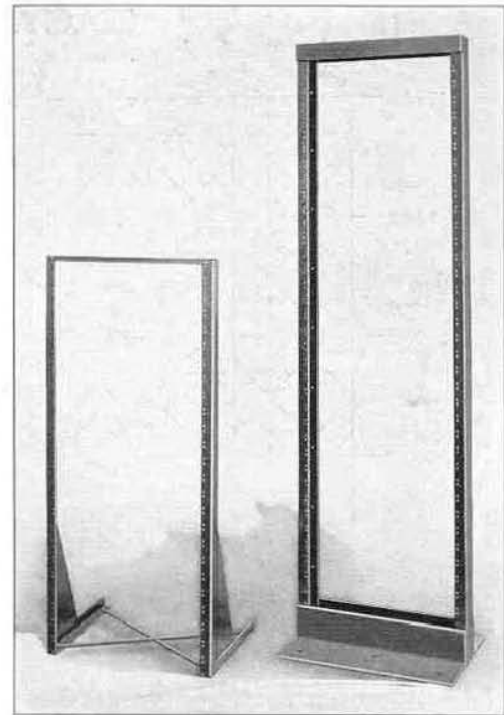

(Left) TYPE 480-B; (right) TYPE 480-A

Type	Panel Space		Code Word	Price
	Inches	Rack Units		
480-A	63	36	NEEDY	\$40.00
480-B	$43\frac{3}{4}$	25	NEGRO	15.00

NOTES ON LAYING OUT RELAY-RACK PANELS

1. Make panel height a multiple of $1\frac{3}{4}$ inches less $\frac{1}{32}$ inch for clearances.
2. Both top and bottom edges of a properly mounted panel will, neglecting clearances, always fall half way between a pair of holes spaced $\frac{1}{2}$ inch apart on the rack.
3. It is seldom necessary to cut all the possible mounting-screw slots in a panel, but it can be done if desired.
4. Any panel laid out to fit the rack will also fit if the panel is turned end-for-end or back-for-front.

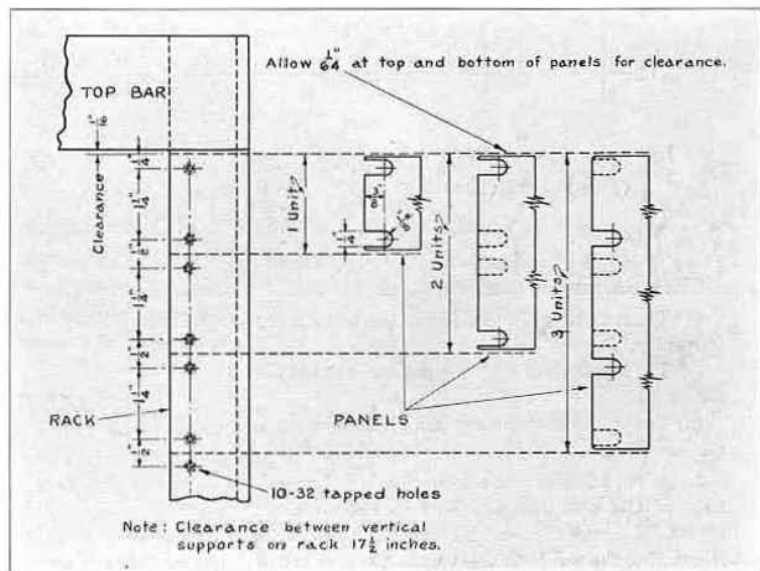

REACTANCE CHART

Always use corresponding scales

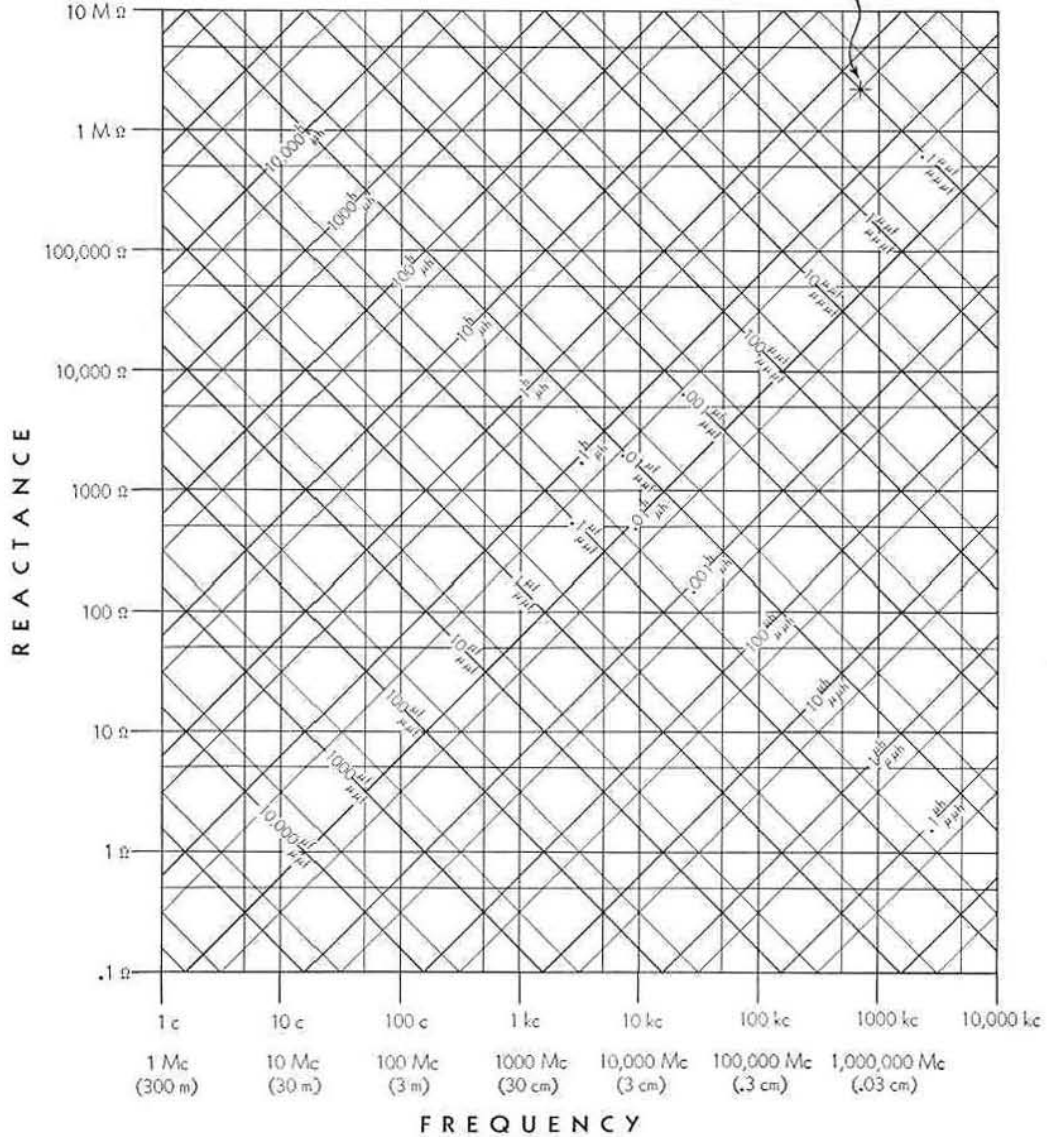

FIG. 1

- The accompanying chart may be used to find:
- (1) The reactance of a given inductance at a given frequency.
 - (2) The reactance of a given capacitance at a given frequency.
 - (3) The resonant frequency of a given inductance and capacitance.

In order to facilitate the determination of magnitude of the quantities involved to two or three significant figures the chart is divided into two parts. Figure 1 is the complete chart to be used for rough

calculations. Figure 2, which is a single decade of Figure 1 enlarged approximately 7 times, is to be used where the significant two or three figures are to be determined.

TO FIND REACTANCE

Enter the charts vertically from the bottom (frequency) and along the lines slanting upward to the left (inductance) or to the right (capacitance). Corresponding scales (upper or lower) must be used throughout. Project horizontally to the left from the intersection and read reactance.

Always obtain approximate value from Figure 1 before using Figure 2

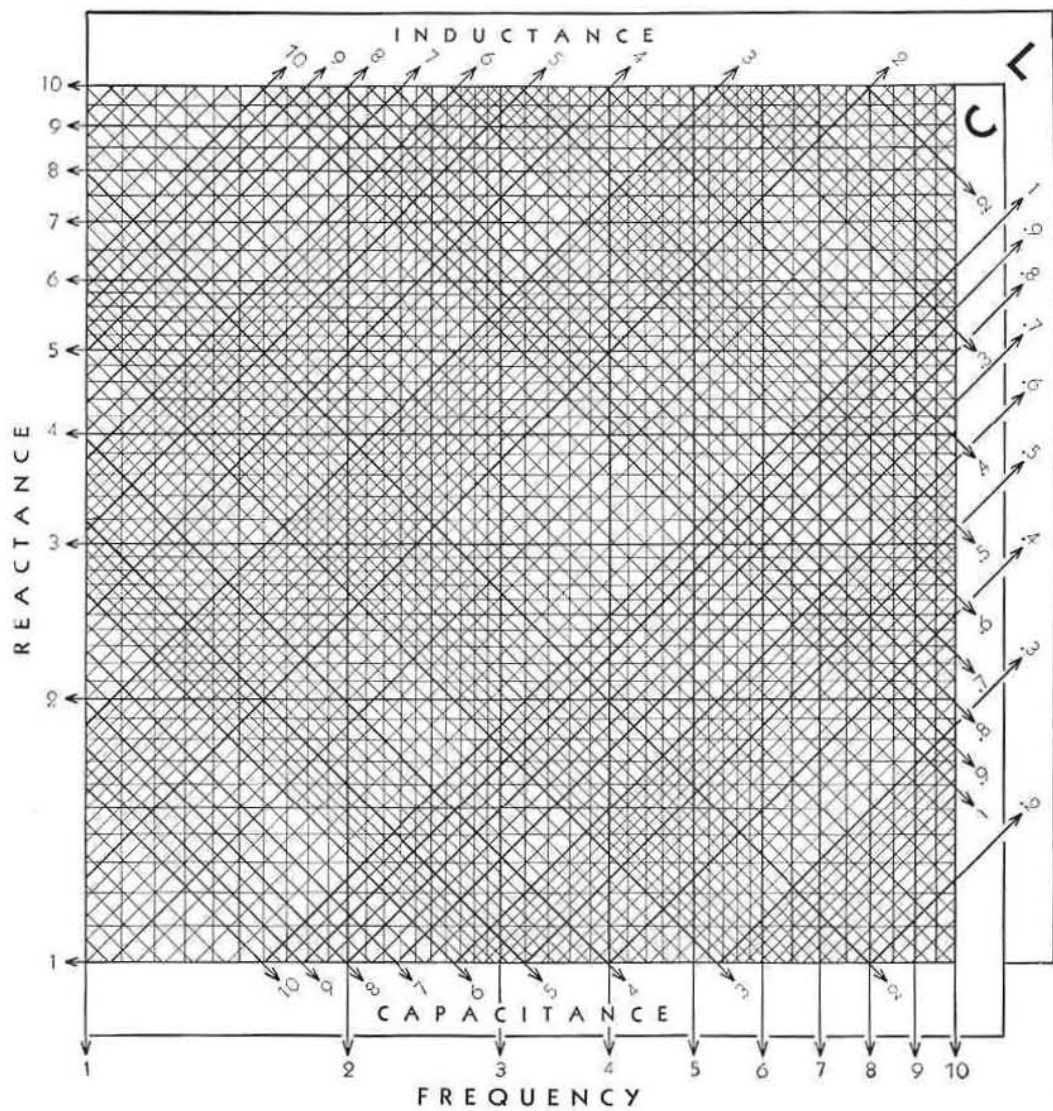

FIG. 2

TO FIND RESONANT FREQUENCY

Enter the slanting lines for the given inductance and capacitance. Project downward from their intersection and read resonant frequency from the bottom scale. Corresponding scales (upper or lower) must be used throughout.

Example: The sample point indicated (Figure 1) corresponds to a frequency of about 700 kc and an inductance of 0.5 henry, or a capacitance of 0.1 $\mu\mu\text{f}$, giving in either case a reactance of about 2,000,000 ohms. The resonant frequency of a circuit containing these values of inductance and capacitance is, of course, 700 kc, approximately.

USE OF FIGURE 2

Figure 2 is used to obtain additional precision of reading but does not place the decimal point which must be located from a preliminary entry on Figure 1. Since the chart necessarily requires two logarithmic decades for inductance and capacitance for every single decade of frequency and reactance, unless the correct decade for L and C is chosen, the calculated values of reactance and frequency will be in error by a factor of 3.16.

Example: (Continued.) The reactance corresponding to 0.5 henry or 0.1 $\mu\mu\text{f}$ is 2,230,000 ohms at 712 kc, their resonant frequency.

DECIBEL CONVERSION TABLES

It is convenient in measurements and calculations on communications systems to express the ratio between any two amounts of electric or acoustic power in units on a logarithmic scale. The *decibel* (1/10th of the *bel*) on the briggsian or base-10 scale and the *neper* on the napierian or base-*e* scale are in almost universal use for this purpose.

Since voltage and current are related to power by impedance, both the *decibel* and the *neper* can be used to express voltage and current ratios, if care is taken

to account for the impedances associated with them. In a similar manner the corresponding acoustical quantities can be compared.

Table I and Table II on the following pages have been prepared to facilitate making conversions in either direction between the number of *decibels* and the corresponding power, voltage, and current ratios. Both tables can also be used for *nepers* and the *mile of standard cable* by applying the conversion factors from the table on the opposite page.

Decibel—The number of decibels N_{db} corresponding to the ratio between two amounts of power P_1 and P_2 is

$$N_{db} = 10 \log_{10} \frac{P_1}{P_2} \quad (1)$$

When two voltages E_1 and E_2 or two currents I_1 and I_2 operate in the same or equal impedances,

$$N_{db} = 20 \log_{10} \frac{E_1}{E_2} \quad (2)$$

and
$$N_{db} = 20 \log_{10} \frac{I_1}{I_2} \quad (3)$$

If E_1 and E_2 or I_1 and I_2 operate in unequal impedances,

$$N_{db} = 20 \log_{10} \frac{E_1}{E_2} + 10 \log_{10} \frac{Z_2}{Z_1} + 10 \log_{10} \frac{k_1}{k_2} \quad (4)$$

and
$$N_{db} = 20 \log_{10} \frac{I_1}{I_2} + 10 \log_{10} \frac{Z_1}{Z_2} + 10 \log_{10} \frac{k_1}{k_2} \quad (5)$$

where Z_1 and Z_2 are the absolute magnitudes of the corresponding impedances and k_1 and k_2 are the values of power factor for the impedances. Note that Table I and Table II can be used to evaluate the impedance and power factor terms, since both are similar to the expression for power ratio, equation (1).

Neper—The number of nepers N_{nep} corresponding to a power ratio $\frac{P_1}{P_2}$ is

$$N_{nep} = \frac{1}{2} \log_e \frac{P_1}{P_2} \quad (6)$$

For voltage ratios $\frac{E_1}{E_2}$ or current ratios $\frac{I_1}{I_2}$ working in the same or equal impedances,

$$N_{nep} = \log_e \frac{E_1}{E_2} \quad (7)$$

and
$$N_{nep} = \log_e \frac{I_1}{I_2}$$

When E_1 and E_2 or I_1 and I_2 operate in unequal impedances,

$$N_{nep} = \log_e \frac{E_1}{E_2} + \frac{1}{2} \log_e \frac{Z_2}{Z_1} + \frac{1}{2} \log_e \frac{k_1}{k_2} \quad (8)$$

and
$$N_{nep} = \log_e \frac{I_1}{I_2} + \frac{1}{2} \log_e \frac{Z_1}{Z_2} + \frac{1}{2} \log_e \frac{k_1}{k_2} \quad (9)$$

where Z_1 and Z_2 and k_1 and k_2 are as in equations (4) and (5).

RELATIONS BETWEEN DECIBELS, NEPERS, AND MILES OF STANDARD CABLE

<i>Multiply</i>	<i>By</i>	<i>To Find</i>
decibels.....	.1151	nepers
decibels.....	1.056	miles of standard cable
miles of standard cable	.947	decibels
miles of standard cable	.109	nepers
nepers.....	8.686	decibels
nepers.....	9.175	miles of standard cable

TO FIND VALUES OUTSIDE THE RANGE OF CONVERSION TABLES

Values outside the range of either Table I or Table II on the following pages can be readily found with the help of the following simple rules:

TABLE I: DECIBELS TO VOLTAGE AND POWER RATIOS

Number of decibels positive (+):
 Subtract +20 decibels successively from the given number of decibels until the remainder falls within range of Table I. *To find the voltage ratio*, multiply the corresponding value from the right-hand voltage-ratio column by 10 for each time you subtracted 20 db. *To find the power ratio*, multiply the corresponding value from the right-hand power-ratio column by 100 for each time you subtracted 20 db.

Example—Given: 49.2 db
 $49.2 \text{ db} - 20 \text{ db} - 20 \text{ db} = 9.2 \text{ db}$
Voltage ratio: 9.2 db →
 $2.884 \times 10 \times 10 = 288.4$
Power ratio: 9.2 db →
 $8.318 \times 100 \times 100 = 83180$

Number of decibels negative (—):
 Add +20 decibels successively to the given number of decibels until the sum falls within the range of Table I. *For the voltage ratio*, divide the value from the left-hand voltage-ratio column by 10 for each time you added 20 db. *For the power ratio*, divide the value from the left-hand power-ratio column by 100 for each time you added 20 db.

Example—Given: -49.2 db
 $-49.2 \text{ db} + 20 \text{ db} + 20 \text{ db} = -9.2 \text{ db}$
Voltage ratio: -9.2 db →
 $.3467 \times 1/10 \times 1/10 = .003467$
Power ratio: -9.2 db →
 $.1202 \times 1/100 \times 1/100 = .00001202$

TABLE II: VOLTAGE RATIOS TO DECIBELS

For ratios smaller than those in table—Multiply the given ratio by 10 successively until the product can be found in the table. From the number of decibels thus found, subtract +20 decibels for each time you multiplied by 10.

Example—Given: Voltage ratio = .0131
 $.0131 \times 10 = .131 \times 10 = 1.31$
 From Table II, 1.31 →
 $2.345 \text{ db} - 20 \text{ db} - 20 \text{ db} = -37.655 \text{ db}$

For ratios greater than those in table—Divide the given ratio by 10 successively until the remainder can be found in the table. To the number of decibels thus found, add +20 db for each time you divided by 10.

Example—Given: Voltage ratio = 712
 $712 \times 1/10 = 71.2 \times 1/10 = 7.12$
 From Table II, 7.12 →
 $17.050 \text{ db} + 20 \text{ db} + 20 \text{ db} = 57.050 \text{ db}$

TABLE I

GIVEN: Decibels

TO FIND: Power and $\left\{ \begin{matrix} \text{Voltage} \\ \text{Current} \end{matrix} \right\}$ Ratios

TO ACCOUNT FOR THE SIGN OF THE DECIBEL

For positive (+) values of the decibel— Both voltage and power ratios are greater than unity. Use the two right-hand columns.

For negative (−) values of the decibel— Both voltage and power ratios are less than unity. Use the two left-hand columns.

Example—Given: ±9.1 db. Find:

	Power Ratio	Voltage Ratio
+9.1 db	8.128	2.851
−9.1 db	0.1230	0.3508

← -db+ →					← -db+ →				
Voltage Ratio	Power Ratio	db	Voltage Ratio	Power Ratio	Voltage Ratio	Power Ratio	db	Voltage Ratio	Power Ratio
1.0000	1.0000	0	1.0000	1.0000	.5623	.3162	5.0	1.778	3.162
.9886	.9772	.1	1.012	1.023	.5559	.3090	5.1	1.799	3.236
.9772	.9550	.2	1.023	1.047	.5495	.3020	5.2	1.820	3.311
.9661	.9333	.3	1.035	1.072	.5433	.2951	5.3	1.841	3.388
.9550	.9120	.4	1.047	1.096	.5370	.2884	5.4	1.862	3.467
.9441	.8913	.5	1.059	1.122	.5309	.2818	5.5	1.884	3.548
.9333	.8710	.6	1.072	1.148	.5248	.2754	5.6	1.905	3.631
.9226	.8511	.7	1.084	1.175	.5188	.2692	5.7	1.928	3.715
.9120	.8318	.8	1.096	1.202	.5129	.2630	5.8	1.950	3.802
.9016	.8128	.9	1.109	1.230	.5070	.2570	5.9	1.972	3.890
.8913	.7943	1.0	1.122	1.259	.5012	.2512	6.0	1.995	3.981
.8810	.7762	1.1	1.135	1.288	.4955	.2455	6.1	2.018	4.074
.8710	.7586	1.2	1.148	1.318	.4898	.2399	6.2	2.042	4.169
.8610	.7413	1.3	1.161	1.349	.4842	.2344	6.3	2.065	4.266
.8511	.7244	1.4	1.175	1.380	.4786	.2291	6.4	2.089	4.365
.8414	.7079	1.5	1.189	1.413	.4732	.2239	6.5	2.113	4.467
.8318	.6918	1.6	1.202	1.445	.4677	.2188	6.6	2.138	4.571
.8222	.6761	1.7	1.216	1.479	.4624	.2138	6.7	2.163	4.677
.8128	.6607	1.8	1.230	1.514	.4571	.2089	6.8	2.188	4.786
.8035	.6457	1.9	1.245	1.549	.4519	.2042	6.9	2.213	4.898
.7943	.6310	2.0	1.259	1.585	.4467	.1995	7.0	2.239	5.012
.7852	.6166	2.1	1.274	1.622	.4416	.1950	7.1	2.265	5.129
.7762	.6026	2.2	1.288	1.660	.4365	.1905	7.2	2.291	5.248
.7674	.5888	2.3	1.303	1.698	.4315	.1862	7.3	2.317	5.370
.7586	.5754	2.4	1.318	1.738	.4266	.1820	7.4	2.344	5.495
.7499	.5623	2.5	1.334	1.778	.4217	.1778	7.5	2.371	5.623
.7413	.5495	2.6	1.349	1.820	.4169	.1738	7.6	2.399	5.754
.7328	.5370	2.7	1.365	1.862	.4121	.1698	7.7	2.427	5.888
.7244	.5248	2.8	1.380	1.905	.4074	.1660	7.8	2.455	6.026
.7161	.5129	2.9	1.396	1.950	.4027	.1622	7.9	2.483	6.166
.7079	.5012	3.0	1.413	1.995	.3981	.1585	8.0	2.512	6.310
.6998	.4898	3.1	1.429	2.042	.3936	.1549	8.1	2.541	6.457
.6918	.4786	3.2	1.445	2.089	.3890	.1514	8.2	2.570	6.607
.6839	.4677	3.3	1.462	2.138	.3846	.1479	8.3	2.600	6.761
.6761	.4571	3.4	1.479	2.188	.3802	.1445	8.4	2.630	6.918
.6683	.4467	3.5	1.496	2.239	.3758	.1413	8.5	2.661	7.079
.6607	.4365	3.6	1.514	2.291	.3715	.1380	8.6	2.692	7.244
.6531	.4266	3.7	1.531	2.344	.3673	.1349	8.7	2.723	7.413
.6457	.4169	3.8	1.549	2.399	.3631	.1318	8.8	2.754	7.586
.6383	.4074	3.9	1.567	2.455	.3589	.1288	8.9	2.786	7.762
.6310	.3981	4.0	1.585	2.512	.3548	.1259	9.0	2.818	7.943
.6237	.3890	4.1	1.603	2.570	.3508	.1230	9.1	2.851	8.128
.6166	.3802	4.2	1.622	2.630	.3467	.1202	9.2	2.884	8.318
.6095	.3715	4.3	1.641	2.692	.3428	.1175	9.3	2.917	8.511
.6026	.3631	4.4	1.660	2.754	.3388	.1148	9.4	2.951	8.710
.5957	.3548	4.5	1.679	2.818	.3350	.1122	9.5	2.985	8.913
.5888	.3467	4.6	1.698	2.884	.3311	.1096	9.6	3.020	9.120
.5821	.3388	4.7	1.718	2.951	.3273	.1072	9.7	3.055	9.333
.5754	.3311	4.8	1.738	3.020	.3236	.1047	9.8	3.090	9.550
.5689	.3236	4.9	1.758	3.090	.3199	.1023	9.9	3.126	9.772

DB TO POWER AND VOLTAGE RATIOS •

GENERAL RADIO CO

TABLE I (continued)

← -db+ →					← -db+ →				
Voltage Ratio	Power Ratio	db	Voltage Ratio	Power Ratio	Voltage Ratio	Power Ratio	db	Voltage Ratio	Power Ratio
.3162	.1000	10.0	3.162	10.000	.1585	.02512	16.0	6.310	39.81
.3126	.09772	10.1	3.199	10.23	.1567	.02455	16.1	6.388	40.74
.3090	.09550	10.2	3.236	10.47	.1549	.02399	16.2	6.457	41.69
.3055	.09333	10.3	3.273	10.72	.1531	.02344	16.3	6.531	42.66
.3020	.09120	10.4	3.311	10.96	.1514	.02291	16.4	6.607	43.65
.2985	.08913	10.5	3.350	11.22	.1496	.02239	16.5	6.683	44.67
.2951	.08710	10.6	3.388	11.48	.1479	.02188	16.6	6.761	45.71
.2917	.08511	10.7	3.428	11.75	.1462	.02138	16.7	6.839	46.77
.2884	.08318	10.8	3.467	12.02	.1445	.02089	16.8	6.918	47.86
.2851	.08128	10.9	3.508	12.30	.1429	.02042	16.9	6.998	48.98
.2818	.07943	11.0	3.548	12.59	.1413	.01995	17.0	7.079	50.12
.2786	.07762	11.1	3.589	12.88	.1396	.01950	17.1	7.161	51.29
.2754	.07586	11.2	3.631	13.18	.1380	.01905	17.2	7.244	52.48
.2723	.07413	11.3	3.673	13.49	.1365	.01862	17.3	7.328	53.70
.2692	.07244	11.4	3.715	13.80	.1349	.01820	17.4	7.413	54.95
.2661	.07079	11.5	3.758	14.13	.1334	.01778	17.5	7.499	56.23
.2630	.06918	11.6	3.802	14.45	.1318	.01738	17.6	7.586	57.54
.2600	.06761	11.7	3.846	14.79	.1303	.01698	17.7	7.674	58.88
.2570	.06607	11.8	3.890	15.14	.1288	.01660	17.8	7.762	60.26
.2541	.06457	11.9	3.936	15.49	.1274	.01622	17.9	7.852	61.66
.2512	.06310	12.0	3.981	15.85	.1259	.01585	18.0	7.943	63.10
.2483	.06166	12.1	4.027	16.22	.1245	.01549	18.1	8.035	64.57
.2455	.06026	12.2	4.074	16.60	.1230	.01514	18.2	8.128	66.07
.2427	.05888	12.3	4.121	16.98	.1216	.01479	18.3	8.222	67.61
.2399	.05754	12.4	4.169	17.38	.1202	.01445	18.4	8.318	69.18
.2371	.05623	12.5	4.217	17.78	.1189	.01413	18.5	8.414	70.79
.2344	.05495	12.6	4.266	18.20	.1175	.01380	18.6	8.511	72.44
.2317	.05370	12.7	4.315	18.62	.1161	.01349	18.7	8.610	74.13
.2291	.05248	12.8	4.365	19.05	.1148	.01318	18.8	8.710	75.86
.2265	.05129	12.9	4.416	19.50	.1135	.01288	18.9	8.811	77.62
.2239	.05012	13.0	4.467	19.95	.1122	.01259	19.0	8.913	79.43
.2213	.04898	13.1	4.519	20.42	.1109	.01230	19.1	9.016	81.28
.2188	.04786	13.2	4.571	20.89	.1096	.01202	19.2	9.120	83.18
.2163	.04677	13.3	4.624	21.38	.1084	.01175	19.3	9.226	85.11
.2138	.04571	13.4	4.677	21.88	.1072	.01148	19.4	9.333	87.10
.2113	.04467	13.5	4.732	22.39	.1059	.01122	19.5	9.441	89.13
.2089	.04365	13.6	4.786	22.91	.1047	.01096	19.6	9.550	91.20
.2065	.04266	13.7	4.842	23.44	.1035	.01072	19.7	9.661	93.33
.2042	.04169	13.8	4.898	23.99	.1023	.01047	19.8	9.772	95.50
.2018	.04074	13.9	4.955	24.55	.1012	.01023	19.9	9.886	97.72
.1995	.03981	14.0	5.012	25.12	.1000	.01000	20.0	10.000	100.00
.1972	.03890	14.1	5.070	25.70					
.1950	.03802	14.2	5.129	26.30					
.1928	.03715	14.3	5.188	26.92					
.1905	.03631	14.4	5.248	27.54					
.1884	.03548	14.5	5.309	28.18					
.1862	.03467	14.6	5.370	28.84					
.1841	.03388	14.7	5.433	29.51					
.1820	.03311	14.8	5.495	30.20					
.1799	.03236	14.9	5.559	30.90					
.1778	.03162	15.0	5.623	31.62					
.1758	.03090	15.1	5.689	32.36					
.1738	.03020	15.2	5.754	33.11					
.1718	.02951	15.3	5.821	33.88					
.1698	.02884	15.4	5.888	34.67					
.1679	.02818	15.5	5.957	35.48					
.1660	.02754	15.6	6.026	36.31					
.1641	.02692	15.7	6.095	37.15					
.1622	.02630	15.8	6.166	38.02					
.1603	.02570	15.9	6.237	38.90					

← -db+ →				
Voltage Ratio	Power Ratio	db	Voltage Ratio	Power Ratio
3.162×10^{-1}	10^{-1}	10	3.162	10
10^{-1}	10^{-2}	20	10^{-1}	10^2
3.162×10^{-2}	10^{-3}	30	3.162×10^{-1}	10^3
10^{-2}	10^{-4}	40	10^{-1}	10^4
3.162×10^{-3}	10^{-5}	50	3.162×10^2	10^5
10^{-3}	10^{-6}	60	10^3	10^6
3.162×10^{-4}	10^{-7}	70	3.162×10^3	10^7
10^{-4}	10^{-8}	80	10^4	10^8
3.162×10^{-5}	10^{-9}	90	3.162×10^4	10^9
10^{-5}	10^{-10}	100	10^5	10^{10}

To find decibel values outside the range of this table, see page 207

TABLE II

GIVEN: $\left\{ \begin{matrix} \text{Voltage} \\ \text{Current} \end{matrix} \right\}$ Ratio TO FIND: Decibels

POWER RATIOS

To find the number of decibels corresponding to a given power ratio—Assume the given power ratio to be a voltage ratio and find the corresponding number of decibels from the table. The desired result is exactly

one-half of the number of decibels thus found.

Example—Given: a power ratio of 3.41.
Find: 3.41 in the table:

$$3.41 \rightarrow 10.655 \text{ db} \times \frac{1}{2} = 5.328 \text{ db}$$

Voltage Ratio	.00	.01	.02	.03	.04	.05	.06	.07	.08	.09
1.0	.000	.086	.172	.257	.341	.424	.506	.588	.668	.749
1.1	.828	.906	.984	1.062	1.138	1.214	1.289	1.364	1.438	1.511
1.2	1.584	1.656	1.727	1.798	1.868	1.938	2.007	2.076	2.144	2.212
1.3	2.279	2.345	2.411	2.477	2.542	2.607	2.671	2.734	2.798	2.860
1.4	2.923	2.984	3.046	3.107	3.167	3.227	3.287	3.346	3.405	3.464
1.5	3.522	3.580	3.637	3.694	3.750	3.807	3.862	3.918	3.973	4.028
1.6	4.082	4.137	4.190	4.244	4.297	4.350	4.402	4.454	4.506	4.558
1.7	4.609	4.660	4.711	4.761	4.811	4.861	4.910	4.959	5.008	5.057
1.8	5.105	5.154	5.201	5.249	5.296	5.343	5.390	5.437	5.483	5.529
1.9	5.575	5.621	5.666	5.711	5.756	5.801	5.845	5.889	5.933	5.977
2.0	6.021	6.064	6.107	6.150	6.193	6.235	6.277	6.319	6.361	6.403
2.1	6.444	6.486	6.527	6.568	6.608	6.649	6.689	6.729	6.769	6.809
2.2	6.848	6.888	6.927	6.966	7.008	7.044	7.082	7.121	7.159	7.197
2.3	7.235	7.272	7.310	7.347	7.384	7.421	7.458	7.495	7.532	7.568
2.4	7.604	7.640	7.676	7.712	7.748	7.783	7.819	7.854	7.889	7.924
2.5	7.959	7.993	8.028	8.062	8.097	8.131	8.165	8.199	8.232	8.266
2.6	8.299	8.333	8.366	8.399	8.432	8.465	8.498	8.530	8.563	8.595
2.7	8.627	8.659	8.691	8.723	8.755	8.787	8.818	8.850	8.881	8.912
2.8	8.943	8.974	9.005	9.036	9.066	9.097	9.127	9.158	9.188	9.218
2.9	9.248	9.278	9.308	9.337	9.367	9.396	9.426	9.455	9.484	9.513
3.0	9.542	9.571	9.600	9.629	9.657	9.686	9.714	9.743	9.771	9.799
3.1	9.827	9.855	9.883	9.911	9.939	9.966	9.994	10.021	10.049	10.076
3.2	10.103	10.130	10.157	10.184	10.211	10.238	10.264	10.291	10.317	10.344
3.3	10.370	10.397	10.423	10.449	10.475	10.501	10.527	10.553	10.578	10.604
3.4	10.630	10.655	10.681	10.706	10.731	10.756	10.782	10.807	10.832	10.857
3.5	10.881	10.906	10.931	10.955	10.980	11.005	11.029	11.053	11.078	11.102
3.6	11.126	11.150	11.174	11.198	11.222	11.246	11.270	11.293	11.317	11.341
3.7	11.364	11.387	11.411	11.434	11.457	11.481	11.504	11.527	11.550	11.573
3.8	11.596	11.618	11.641	11.664	11.687	11.709	11.732	11.754	11.777	11.799
3.9	11.821	11.844	11.866	11.888	11.910	11.932	11.954	11.976	11.998	12.019
4.0	12.041	12.063	12.085	12.106	12.128	12.149	12.171	12.192	12.213	12.234
4.1	12.256	12.277	12.298	12.319	12.340	12.361	12.382	12.403	12.424	12.444
4.2	12.465	12.486	12.506	12.527	12.547	12.568	12.588	12.609	12.629	12.649
4.3	12.669	12.690	12.710	12.730	12.750	12.770	12.790	12.810	12.829	12.849
4.4	12.869	12.889	12.908	12.928	12.948	12.967	12.987	13.006	13.026	13.045
4.5	13.064	13.084	13.103	13.122	13.141	13.160	13.179	13.198	13.217	13.236
4.6	13.255	13.274	13.293	13.312	13.330	13.349	13.368	13.386	13.405	13.423
4.7	13.442	13.460	13.479	13.497	13.516	13.534	13.552	13.570	13.589	13.607
4.8	13.625	13.643	13.661	13.679	13.697	13.715	13.733	13.751	13.768	13.786
4.9	13.804	13.822	13.839	13.857	13.875	13.892	13.910	13.927	13.945	13.962
5.0	13.979	13.997	14.014	14.031	14.049	14.066	14.083	14.100	14.117	14.134
5.1	14.151	14.168	14.185	14.202	14.219	14.236	14.253	14.270	14.287	14.303
5.2	14.320	14.337	14.353	14.370	14.387	14.403	14.420	14.436	14.453	14.469
5.3	14.486	14.502	14.518	14.535	14.551	14.567	14.583	14.599	14.616	14.632
5.4	14.648	14.664	14.680	14.696	14.712	14.728	14.744	14.760	14.776	14.791
5.5	14.807	14.823	14.839	14.855	14.870	14.886	14.902	14.917	14.933	14.948
5.6	14.964	14.979	14.995	15.010	15.026	15.041	15.056	15.072	15.087	15.102
5.7	15.117	15.133	15.148	15.163	15.178	15.193	15.208	15.224	15.239	15.254
5.8	15.269	15.284	15.298	15.313	15.328	15.343	15.358	15.373	15.388	15.402
5.9	15.417	15.432	15.446	15.461	15.476	15.490	15.505	15.519	15.534	15.549

TABLE II (continued)

Voltage Ratio	.00	.01	.02	.03	.04	.05	.06	.07	.08	.09
6.0	15.563	15.577	15.592	15.606	15.621	15.635	15.649	15.664	15.678	15.692
6.1	15.707	15.721	15.735	15.749	15.763	15.778	15.792	15.806	15.820	15.834
6.2	15.848	15.862	15.876	15.890	15.904	15.918	15.931	15.945	15.959	15.973
6.3	15.987	16.001	16.014	16.028	16.042	16.055	16.069	16.083	16.096	16.110
6.4	16.124	16.137	16.151	16.164	16.178	16.191	16.205	16.218	16.232	16.245
6.5	16.258	16.272	16.285	16.298	16.312	16.325	16.338	16.351	16.365	16.378
6.6	16.391	16.404	16.417	16.430	16.443	16.456	16.469	16.483	16.496	16.509
6.7	16.521	16.534	16.547	16.560	16.573	16.586	16.599	16.612	16.625	16.637
6.8	16.650	16.663	16.676	16.688	16.701	16.714	16.726	16.739	16.752	16.764
6.9	16.777	16.790	16.802	16.815	16.827	16.840	16.852	16.865	16.877	16.890
7.0	16.902	16.914	16.927	16.939	16.951	16.964	16.976	16.988	17.001	17.013
7.1	17.025	17.037	17.050	17.062	17.074	17.086	17.098	17.110	17.122	17.135
7.2	17.147	17.159	17.171	17.183	17.195	17.207	17.219	17.231	17.243	17.255
7.3	17.266	17.278	17.290	17.302	17.314	17.326	17.338	17.349	17.361	17.373
7.4	17.385	17.396	17.408	17.420	17.431	17.443	17.455	17.466	17.478	17.490
7.5	17.501	17.513	17.524	17.536	17.547	17.559	17.570	17.582	17.593	17.605
7.6	17.616	17.628	17.639	17.650	17.662	17.673	17.685	17.696	17.707	17.719
7.7	17.730	17.741	17.752	17.764	17.775	17.786	17.797	17.808	17.820	17.831
7.8	17.842	17.853	17.864	17.875	17.886	17.897	17.908	17.919	17.931	17.942
7.9	17.953	17.964	17.975	17.985	17.996	18.007	18.018	18.029	18.040	18.051
8.0	18.062	18.073	18.083	18.094	18.105	18.116	18.127	18.137	18.148	18.159
8.1	18.170	18.180	18.191	18.202	18.212	18.223	18.234	18.244	18.255	18.266
8.2	18.276	18.287	18.297	18.308	18.319	18.329	18.340	18.350	18.361	18.371
8.3	18.382	18.392	18.402	18.413	18.423	18.434	18.444	18.455	18.465	18.475
8.4	18.486	18.496	18.506	18.517	18.527	18.537	18.547	18.558	18.568	18.578
8.5	18.588	18.599	18.609	18.619	18.629	18.639	18.649	18.660	18.670	18.680
8.6	18.690	18.700	18.710	18.720	18.730	18.740	18.750	18.760	18.770	18.780
8.7	18.790	18.800	18.810	18.820	18.830	18.840	18.850	18.860	18.870	18.880
8.8	18.890	18.900	18.909	18.919	18.929	18.939	18.949	18.958	18.968	18.978
8.9	18.988	18.998	19.007	19.017	19.027	19.036	19.046	19.056	19.066	19.075
9.0	19.085	19.094	19.104	19.114	19.123	19.133	19.143	19.152	19.162	19.171
9.1	19.181	19.190	19.200	19.209	19.219	19.228	19.238	19.247	19.257	19.266
9.2	19.276	19.285	19.295	19.304	19.313	19.323	19.332	19.342	19.351	19.360
9.3	19.370	19.379	19.388	19.398	19.407	19.416	19.426	19.435	19.444	19.453
9.4	19.463	19.472	19.481	19.490	19.499	19.509	19.518	19.527	19.536	19.545
9.5	19.554	19.564	19.573	19.582	19.591	19.600	19.609	19.618	19.627	19.636
9.6	19.645	19.654	19.664	19.673	19.682	19.691	19.700	19.709	19.718	19.726
9.7	19.735	19.744	19.753	19.762	19.771	19.780	19.789	19.798	19.807	19.816
9.8	19.825	19.833	19.842	19.851	19.860	19.869	19.878	19.886	19.895	19.904
9.9	19.913	19.921	19.930	19.939	19.948	19.956	19.965	19.974	19.983	19.991

Voltage Ratio	0	1	2	3	4	5	6	7	8	9
10	20.000	20.828	21.584	22.279	22.923	23.522	24.082	24.609	25.105	25.575
20	26.021	26.444	26.848	27.235	27.604	27.959	28.299	28.627	28.943	29.248
30	29.542	29.827	30.103	30.370	30.630	30.881	31.126	31.364	31.596	31.821
40	32.041	32.256	32.465	32.669	32.869	33.064	33.255	33.442	33.625	33.804
50	33.979	34.151	34.320	34.486	34.648	34.807	34.964	35.117	35.269	35.417
60	35.563	35.707	35.848	35.987	36.124	36.258	36.391	36.521	36.650	36.777
70	36.902	37.025	37.147	37.266	37.385	37.501	37.616	37.730	37.842	37.953
80	38.062	38.170	38.276	38.382	38.486	38.588	38.690	38.790	38.890	38.988
90	39.085	39.181	39.276	39.370	39.463	39.554	39.645	39.735	39.825	39.913
100	40.000	—	—	—	—	—	—	—	—	—

To find ratios outside the range of this table, see page 207

INDEX BY TYPE NUMBER

<i>Type</i>	<i>Item</i>	<i>Page</i>	<i>Type</i>	<i>Item</i>	<i>Page</i>
70	Variac Transformer	14	476-A	Quartz Bar	159
80	Variac Transformer	14	480	Relay Rack	203
90-B	Variac	13	483-F	Output Meter	118
100	Variac	14	487-A	Megohmmeter	123
106	Standard Inductance	64	492-A	Oxide Rectifier	125
107	Variable Inductor	62	493	Vacuum Thermocouple	126
119	Radio-Frequency Choke	201	500	Resistor	34
138	Binding Posts	198	505	Condenser	57
138	Switch Contacts and Stops	198	509	Standard Condenser	56
154	Voltage Divider	41	510	Decade-Resistance Unit	20
200	Variac	12, 13	516-C	Radio-Frequency Bridge	78
202	Switch	202	516-P	Accessories	93
202	Switch Knob	196	519-A	Dial Lens	193
214-A	Rheostat-Potentiometer	39	520-A	Dial Lock	196
219	Decade Condenser	59	522-A	Dial Plate	196
246	Variable Air Condenser	50	525	Resistor	35
247	Variable Air Condenser	55	526	Mounted Rheostat-Potentiometer	31
249	Attenuation Box	26	530	Band-Pass Filter	173
274	Plugs and Jacks	199	533-A	Rheostat-Potentiometer	42
274-RJ	Mounting Base	199	539	Variable Air Condenser	48
274	Panel Terminal Insulators	200	539-P	Incremental-Pitch Condenser	108
274	Shielded Plugs and Cables	200	544-B	Megohm Bridge	90
293-A	Universal Bridge	84	544-P	Power Supplies	91
293-P	Accessories	85	546-A	Microvolter	124
301-A	Rheostat-Potentiometer	41	549-C	Synchronous-Motor Contactor	5
314-A	Rheostat-Potentiometer	40	549-P2	Hand Contactor	5
318-B	Dial Plate	196	561-C	Vacuum-Tube Bridge	88
329-J	Attenuation Box	27	568	Variable Air Condenser	53
333-A	Rheostat-Potentiometer	42	572-B	Microphone Hummer	108
334	Variable Air Condenser	54	574	Wavemeter	163
335-Z	Variable Air Condenser	54	578	Shielded Transformer	94
339	Switch	202	583-A	Output Power Meter	119
358	Wavemeter	164	586	Power-Level Indicator	120
368	Variable Air Condenser	52	588-AM	Direct-Current Meter	128
371	Rheostat-Potentiometer	39	602	Decade-Resistance Box	18
376	Quartz Plate	159	605-B	Standard-Signal Generator	180
380	Decade-Condenser Unit	60	608-A	Oscillator	102
410-A	Rheostat-Potentiometer	41	610-A	Ratio-Arm Box	96
418-G	Dummy Antenna	182	611-C	Syncro-Clock	161
419-A	Rectifier-Type Wavemeter	163	612	Coupling Panel	137, 139, 146, 147
434-B	Audio-Frequency Meter	158	613-B	Beat-Frequency Oscillator	106
449-A	Adjustable Attenuator	28	613-P1	Power Supply	107
471-A	Rheostat-Potentiometer	40	614-B	Selective Amplifier	137, 149
475-B	Frequency Monitor	153	616-C	Heterodyne Frequency Meter	137, 139, 142

INDEX BY TYPE NUMBER (continued)

<i>Type</i>	<i>Item</i>	<i>Page</i>	<i>Type</i>	<i>Item</i>	<i>Page</i>
617-C	Interpolation Oscillator	137, 144	696-B	A-C Power Supply	135
619-E	Heterodyne Detector	137, 139, 148	698-A	Duplex Multivibrator	135, 140
620-A	Heterodyne Frequency Meter and Calibrator	150	699-A	Comparison Oscilloscope	137, 141
621	Power Stroboscope	6	700-A	Wide-Range Beat-Frequency Os- cillator	100
625-A	Bridge	75	702	Friction-Drive Dial	194
631-B	Strobotac	2	703	Friction-Drive Dial	194
637	Fluted Knobs	197	704	Precision Dial	192
641	Transformer	186	705	Friction-Drive Dial	194
642-D	Volume Control	36	706	Precision Dial	192
646-A	Logarithmic Resistor	29	707-A	Cathode-Ray Null Detector	92
648-A	Strobolux	4	707-P	Plug-In Units	93
650-A	Impedance Bridge	70	710	Direct-Drive Dial	194
651-A-E	Camera Assembly	177	712	Direct-Drive Dial	194
651-A-M	Camera Assembly	178	713-B	Beat-Frequency Oscillator	98
653	Volume Control	37	714-A	Amplifier	113
654-A	Decade Voltage Divider	30	715-A	Direct-Current Amplifier	6, 114
663	Resistor	32	716-A	Capacitance Bridge	72
664-A	Thermocouple	182	716-P2	Guard Circuit	74
666-A	Variable Transformer	191	717	Direct-Drive Dial	194
667-A	Inductance Bridge	82	721-A	Coil Comparator	86
668	Compensated Decade-Resistance Unit	24	722	Precision Condenser	45, 47
669	Compensated Slide-Wire Resistor	25	724-A	Precision Wavemeter	161
670	Compensated Decade Resistor	22	726-A	Vacuum-Tube Voltmeter	116
671-A	Schering Bridge	76	731-B	Modulation Monitor	168
672-A	Power Supply	183	732-B	Distortion and Noise Meter	170
673-A	Power Supply	184	732-P1	Range-Extension Filters	171
674	Plugs and Jacks	200	733-A	Oscillator	172
675-M	Piezo-Electric Oscillator	138, 139	736-A	Wave Analyzer	166
676-A	Quartz Bar and Mounting	135, 139, 159	739	Logarithmic Air Condenser	51
677	Inductor Form	201	740-B	Capacitance Test Bridge	80
678	Plug and Jack Base	201	741	Transformer	190
681-A	Frequency-Deviation Meter	153	759-A	Sound-Level Meter	8
682-B	Frequency-Deviation Meter	157	760-A	Sound Analyzer	10
684-A	Modulated Oscillator	104	775-A	Frequency-Limit Monitor	154
686-A	Power-Level Indicator	121	813	Audio Oscillator	109
690-C	Piezo-Electric Oscillator	135	814-A	Amplifier	110
691-C	Temperature-Control Unit	135	814-P	Tuned Circuit	112
692-B	Multivibrator	135, 139, 140	815-A	Precision Fork	160
693-B	Synchrometer	135	830	Wave Filter	174
694-C	Control Panel	135	834-A	Electronic Frequency Meter	156
695-B	Charging Panel	135	C-21-HLD	Primary Frequency Standard	134
			C-10-H	Secondary Frequency Standard	138

INDEX BY TITLE

	<i>Page</i>
Adjustable attenuator	28
Adjustable transformer (Variac)	12-16
Alternating-current meter	116, 118
Amplifier	110-114
direct-current	6
oscillograph	113
selective	149
Analyzer, sound	10
wave	166
Antenna, dummy	182
Attenuation box	26-28
Attenuator, adjustable	28
Audio-frequency meter	156, 158
oscillator	98, 102, 106-109
transformer	186
Band-pass filter	173, 174
Bars, quartz	159
Base, jack	199
Beat-frequency oscillators	98, 100, 106
wide range	100
Binding posts and assemblies	198
Bridges	65-96
Bridge accessories	93-96
Bridge, capacitance	72, 76, 78
capacitance test	80
decade	84
frequency	158
high-resistance	90
impedance	70
inductance	82
megohm	90
power-factor	72, 76
radio-frequency	78
resistance	70, 90
Schering	72, 76
skeleton-type	75
transformer	94
universal	84
vacuum-tube	88
Cable, shielded	200
Camera, high-speed	176, 178
Capacitance bridge	72, 76, 78, 80
Capacitance test bridge	80
Capacitors	43-61
Choke, radio-frequency	201
Clock, synero-	161
Comparator, coil	86
Comparison oscilloscope	137, 141
Compensated decade-resistance unit	24
decade resistor	22
slide-wire resistor	25
Condenser, air dielectric	44-55
decade	59-61
fixed	56-58
incremental-pitch	108
logarithmic	51
precision	45-47
standard	45-47, 56
straight-line-frequency	48, 53
Contact, stroboscope	5
Contacts, switch	198
Copper-oxide rectifier	125
voltmeter	118
Coupling panel	135, 137, 139, 146, 147

	<i>Page</i>
Decade bridge	84
condenser	59
-condenser unit	60
-resistance box	18, 22
-resistance unit	20, 24
voltage divider	30
Detector, heterodyne	148
Dial, direct-drive	194, 195
friction-drive	192-195
lens	193
lock	196
plates	196
precision	192, 193
Direct-current meter	128
Distortion and noise meter	170
Dummy antenna	182
Duplex multivibrator	135, 140
Electronic frequency meter	156
Filter, band-pass	173, 174
high-pass	174
low-pass	174
range extension	171
wave	173-175
Fork, precision	160
Frequency-deviation meter	153, 157
Frequency-measuring equipment	129-164
Frequency meter, audio-	156, 158
meter, electronic	156
meter, heterodyne	142, 150
monitor	152, 154
standard	134, 138
Friction-drive dial	192-195
Galvanometer, direct-current	128
Generator, standard-signal	180
Harmonic analyzer	166
Heterodyne detector	148
frequency meter	142, 150
Hummer, microphone	108
Impedance bridge	70
Incremental-pitch condenser	108
Indicator, power-level	120-122
Inductance bridge	82
standard	64
Inductors	62-64
Inductor form	201
variable	62
Industrial devices	1-16
Interpolation equipment	136
oscillator	144
Inverse feedback oscillator	102
Jack base	199
Jacks	199, 200
Knob, fluted	197
Lens, dial	192
Lock, dial	196
Logarithmic condenser	51
resistor	29
Losses in air condensers	44
Megohm bridge	90
meter	123
Meters	115-128

INDEX BY TITLE (continued)

	<i>Page</i>		<i>Page</i>
Meter, alternating-current	116, 118	Rectifier, oxide	125
audio-frequency	156, 158	laboratory	183, 184
direct-current	128	Rectifier-type wavemeter	163
distortion and noise	170	Relay rack	203
electronic frequency	156	Resistance box, decade	18, 22
frequency-deviation	153, 157	bridge	90
heterodyne frequency	142, 150	unit, compensated decade	24
megohm	123	unit, decade	20, 24
modulation	168	compensated decade	22
noise	8, 170	compensated slide-wire	25
output	118, 119	fixed	32-35
output power	119	heavy-duty	35
oxide-rectifier	118, 119, 120	high frequency	32
sound-level	8	logarithmic	29
thermocouple	128	standard	34
Microphone hummer	108	Resistors	17-42
mixing control	37	Rheostat-potentiometer	31, 38-42
transformer	186	Schering bridge	72, 76
Microvolter	124	Secondary frequency standard	138
Modulated oscillator	104	Selective amplifier	149
Modulation meter	168	Shielded conductors	200
Monitor, frequency	152, 154	transformer	94, 186
modulation	168	Signal generator	180
Mounted rheostat-potentiometer	31	Slide-wire resistor	25, 85
Mounting base	199	compensated	25
Multivibrator	135, 139, 140	Sound analyzer	10
Multivibrator, duplex	135, 140	Sound-level meter	8
Mutual inductance standard	62	Standard condenser	45-47, 56
Network, attenuation	26-28	inductance	64
Noise meter	8, 170	mutual inductance	62
Oscillators	97-109	resistor	34
Oscillator, audio	98, 102, 106-109	-signal generators	179-182
beat-frequency	98, 100, 106	Strobolux	4
interpolation	144	Stroboscope	2-6
inverse feedback	102	Strobotac	2
modulated	104	Switch contacts and stops	198
piezo-electric	135, 139	Switch knob	196
radio-frequency	100, 104	Switches	202
tuning-fork	109	Synchronous-motor contactor	5
Oscillograph amplifier	113	Synco-clock	161
camera	177	Synchrometer	135
Output meter	118	Thermocouple, vacuum	126
power meter	119	Thermometers	147
Oxide rectifier	125	Thermostats	147
Panel terminal insulator	200	Transformer, adjustable (Variac)	12-16
Parts and accessories	185-203	audio-frequency	186
Piezo-electric oscillator	135, 139	bridge	94
Plate, quartz	159	shielded	94, 186
Plugs and jacks	199, 200	wide range	190
Potentiometers, mounted	31	Transmitting inductor form	201
unmounted	38-42	Universal bridge	84
Power-level indicator	120-122	Vacuum-tube bridge	88
meter, output	119	voltmeter	116
supply	107, 183, 184	Variable air condenser	44-55
Precision condenser	45-47	inductor	62
dial	192	Variac	12-16
fork	160	Variometer	62
wavemeter	161	Voltage divider	30, 41
Primary frequency standard	134	Voltmeter, oxide-rectifier	118
Quartz bars	159	vacuum-tube	116
plate	159	Volume control	37
Rack, relay	203	indicator	120-122
Radio-frequency bridge	78	Waveform-measuring instruments	165-178
choke	201	Wave analyzer	166
oscillator	100, 104	filter	173-175
Range-extension filters	171	Wavemeters	161-164
Ratio-arm box	96	heterodyne	142, 150
		precision	161
		rectifier-type	163

QUICK INDEX

iv	HOW TO ORDER
2	INDUSTRIAL DEVICES
18	RESISTORS
44	CAPACITORS
62	INDUCTORS
66	BRIDGES AND ACCESSORIES
98	OSCILLATORS
110	AMPLIFIERS
116	METERS
130	FREQUENCY-MEASURING INSTRUMENTS
166	WAVEFORM-MEASURING INSTRUMENTS
180	STANDARD-SIGNAL GENERATORS
184	POWER SUPPLIES
186	AUDIO-FREQUENCY TRANSFORMERS
192	PARTS AND ACCESSORIES
204	REACTANCE CHARTS
206	DECIBEL TABLES
212	INDEX BY TYPE NUMBER
214	INDEX BY TITLE



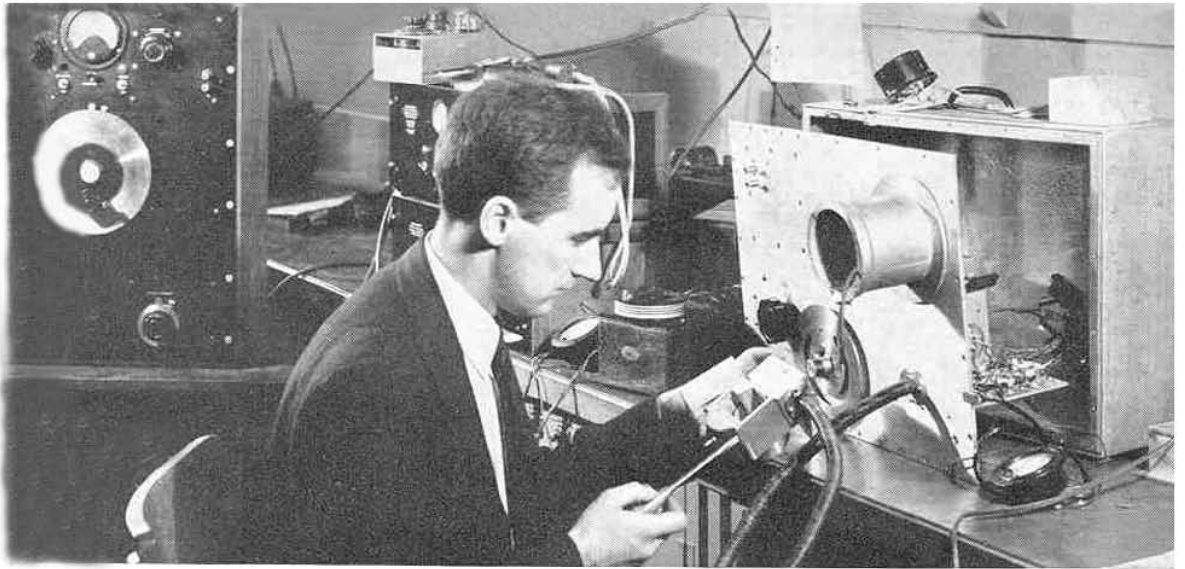

Above—Development work on an experimental standard-signal generator.



Above—Calibrating Type 724-A Precision Wavemeters in the standardization laboratory.
Below—Analyzing fan noise with the Type 760-A Sound Analyzer.

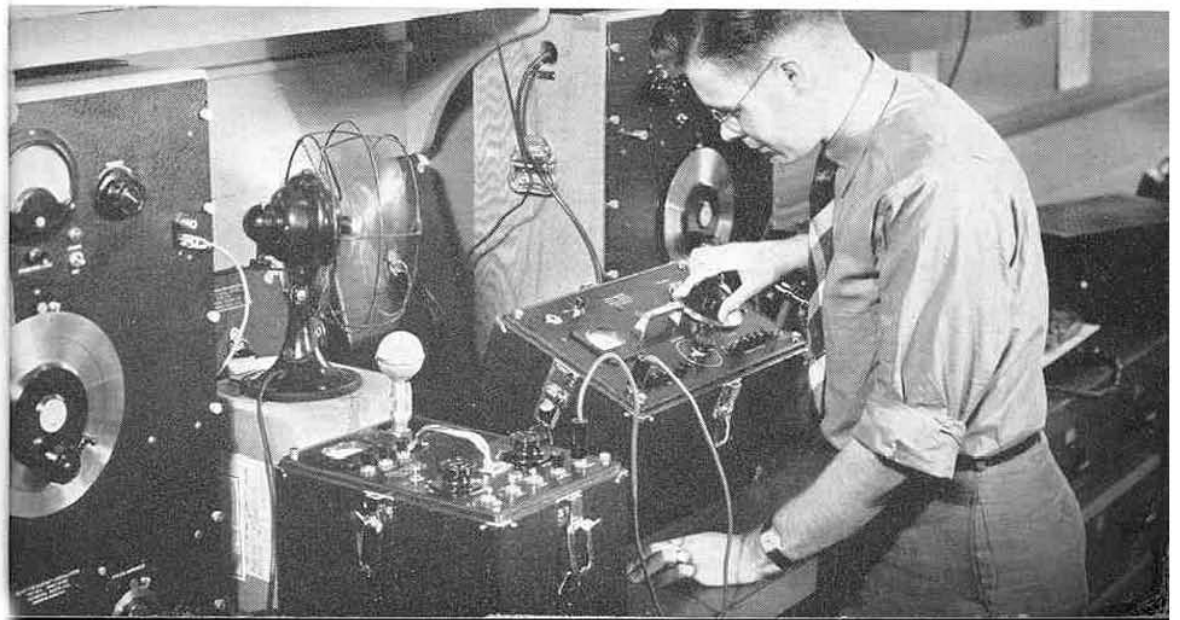

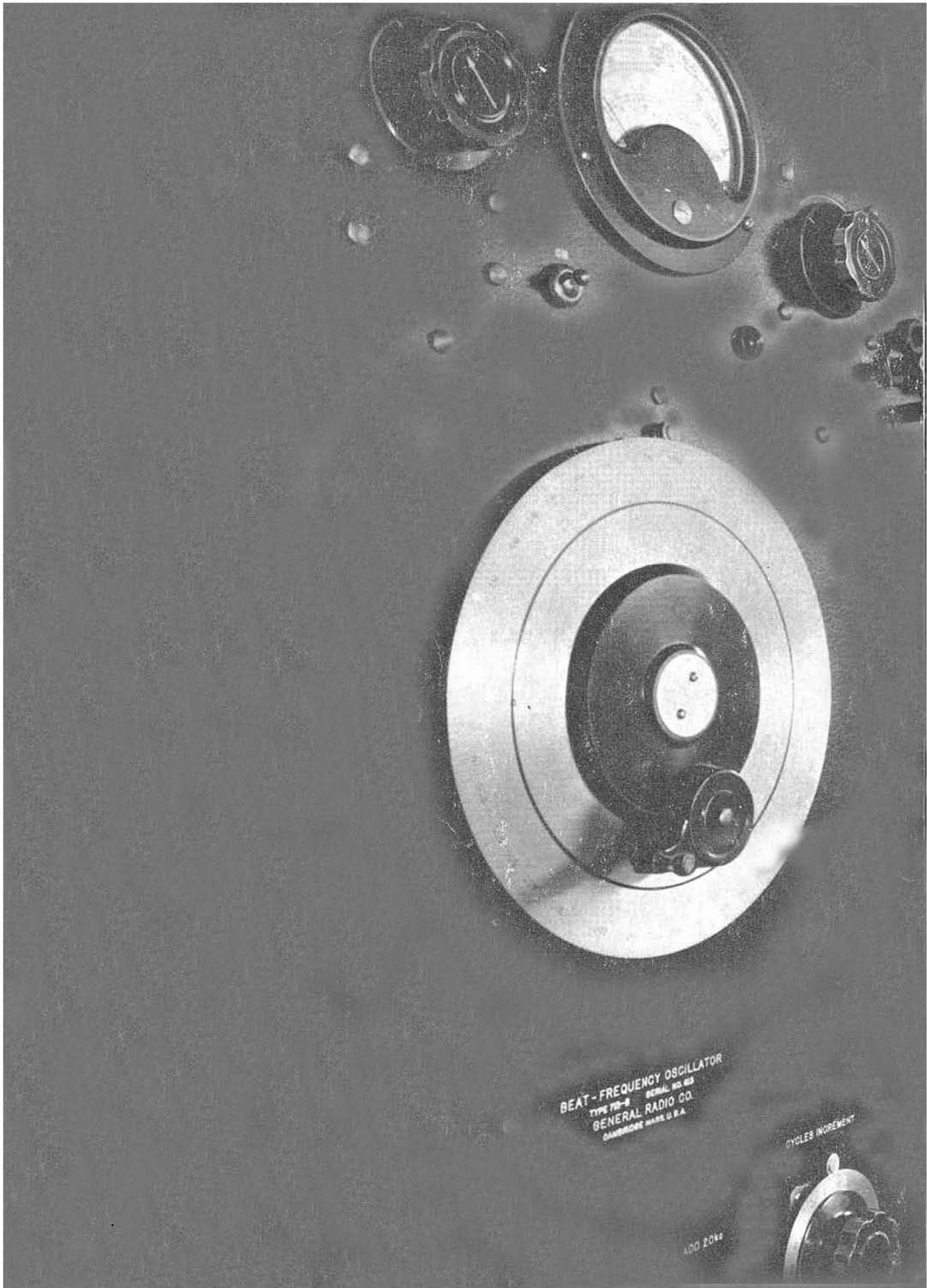

BEAT-FREQUENCY OSCILLATOR
SERIAL NO. 413
TYPE PB-8
GENERAL RADIO CO.
CAMBRIDGE MASS. U.S.A.

CYCLES INCREMENT

100 20K