

INSTRUCTION MANUAL



Type **AUTOMATIC**  
1680-A **CAPACITANCE BRIDGE**  
**ASSEMBLY**

**GENERAL RADIO COMPANY**

WEST CONCORD, MASSACHUSETTS 01781

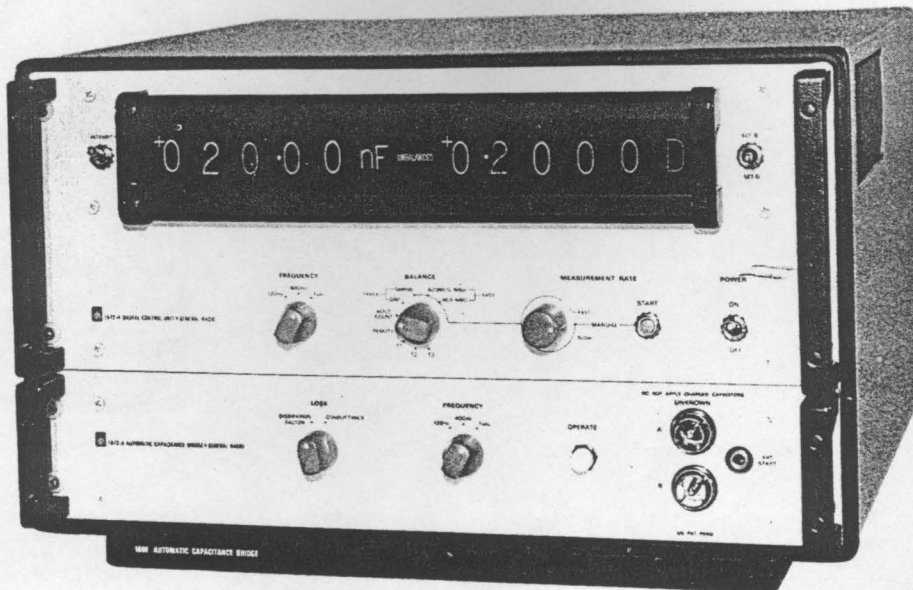

## SPECIFICATIONS

		At 120 Hz	At 400 Hz	At 1000 Hz
<b>RANGES</b>	<b>Capacitance (parallel)*:</b> <b>Conductance (parallel):</b> <b>Dissipation Factor (direct reading)</b> (Measured as conductance):	0.0001 $\mu$ F-1000 $\mu$ F 0.1 $\mu$ mho-1.0 mho 0.0001-1.00 (100%)  0 to $\infty$	0.01 pF-100 $\mu$ F 0.0001 $\mu$ mho-1.0 mho 0.0001-1.00 (100%)  0 to $\infty$	0.01 pF-100 $\mu$ F 0.0001 $\mu$ mho-1.0 mho 0.0001-1.00 (100%)  0 to $\infty$
<b>BASIC ACCURACY (see curves)</b>	<b>Capacitance:</b> <b>Conductance:</b> <b>Dissipation Factor:</b>	0.1% of reading 0.1% of reading 1% of reading $\pm 0.001$	0.1% of reading 0.1% of reading 1% of reading $\pm 0.001$	0.1% of reading 0.1% of reading 1% of reading $\pm 0.001$
<b>SPEED OF BALANCE (approx)</b> (Speed may be somewhat lower than that listed when dissipation factor is measured near the low end of each range.)	<b>Fast Modes:</b> No range changes With range changes	2.5 seconds 5.0 seconds	0.35 second 0.6 second	0.25 second 0.5 second
	<b>Tracking Modes:</b> 10-count change 100-count change 1000-count change	1.0 second 2.0 seconds 11.0 seconds	0.1 second 0.35 seconds 2.6 seconds	0.1 second 0.2 second 1.1 seconds

\*For series capacitance measurements the correction chart (on page 3-19) can be used:

If  $D_x = 0.1$  (10%), correction = 1%.  
 If  $D_x = 0.03$  (3%), correction = 0.1%.

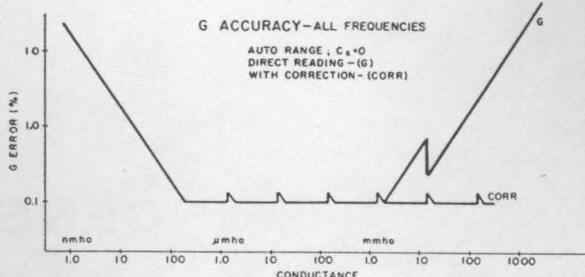
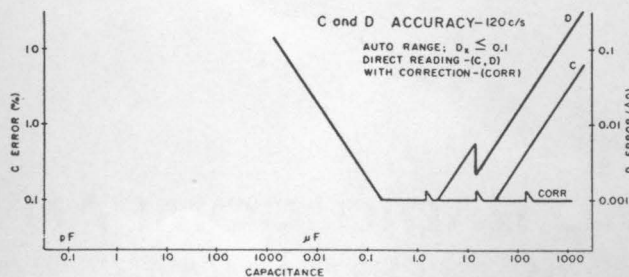
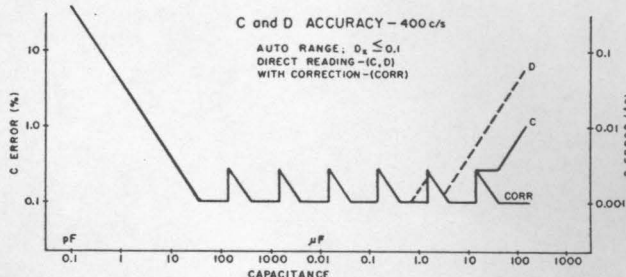
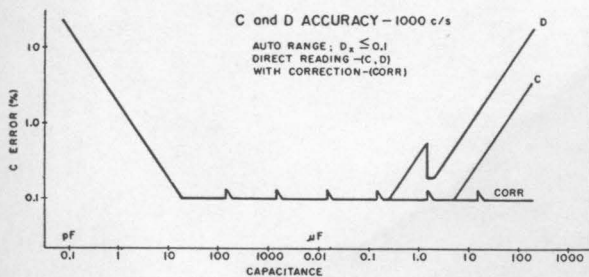

## Specifications (cont)

**EFFECTS OF LEADS:** There is no error introduced by stray capacitance if shielded cables are used. Series resistance of leads can cause errors on the highest range. Accuracy curves include the effects of up to 50 mΩ of external cable.

**Voltage Across Unknown:** At 120 Hz, 1 V to 1.5 μF, 100 mV to 15 μF, 10 mV to 150 μF, 1 mV to 1000 μF; at 400 and 1000 Hz, 1 V to 150 nF, 100 mV to 1.5 μF, 10 mV to 15 μF, 1 mV to 100 μF. Voltage can be set internally to as little as 1/10 these values with proportionate loss in resolution.

**DISPLAY:** Two 5-digit banks of bright-light, numerical indicators, with decimal points and units of measurement. Lamp burnout does not affect instrument operation or coded output. Lamps can be replaced from front panel.

**DC BIAS:** Can be introduced from external source.

**REMOTE CONTROL:** Start and balance controls can be activated remotely by contact closures.

### OUTPUT SIGNALS

**Numerical Data:** 10 digits BCD 1-2-4-2 code (1-2-4-8 available).

**Range Code (1 to 7):** 1 digit BCD 1-2-4-2 code (1-2-4-8 available).

**Print Command at Completion of Balance:** Change from "1" level to "0" level — returns to "1" level at end of display interval.

**Signal Levels:** "1" level, 0 V; "0" level, -12 V; both with respect to reference line, which is at +6 V above chassis ground. Impedance of lines = 12 kΩ.

**MEASUREMENT RATE:** Panel control allows adjustment of measurement rate so that display time between measurements is between approx 0.1 and 5 s. The rate can be set manually (or remotely) at any rate compatible with balance time.

**OPERATION AT OTHER MEASUREMENT FREQUENCIES:** With internal modification, the measurement frequencies can be changed to any frequency between 100 Hz and 2 kHz.

**DIFFERENCE MEASUREMENTS:** By the addition of a suitable standard to terminals provided, the bridge can be made to indicate the deviation, either positive or negative, from a nominal value.

### GENERAL

**Power Required:** 105 to 125 V, 195 to 235, or 210 to 250 V, 50 to 60 Hz, 100 W. Internal 120-Hz oscillator is locked to power line for 60-Hz operation.

**Auxiliary Controls:** A rear-panel sensitivity control can be used to minimize balance time by a decrease in resolution.

**Dimensions (width x height x depth):** 19½ x 12 x 19 in. (495 x 305 x 485 mm).

**Weight:** Net, 77 lb (35 kg); shipping, 150 lb (70 kg).

Catalog Number	Description
	<b>1680-A Automatic Capacitance Bridge Assembly</b>
1680-9702	115 V, 60 Hz, Bench
1680-9703	115 V, 60 Hz, Rack
1680-9704	115 V, 50 Hz, Bench
1680-9705	115 V, 50 Hz, Rack
1680-9706	220 V, 50 Hz, Bench
1680-9707	220 V, 50 Hz, Rack
1680-9708	230 V, 50 Hz, Bench
1680-9709	230 V, 50 Hz, Rack
1680-9601	<b>1680-P1 Test Fixture</b>

## ● CONTENTS

Section 1	INTRODUCTION - . . . . .	1-1
Section 2	INSTALLATION - . . . . .	2-1
Section 3	OPERATING PROCEDURE - . . . . .	3-1
Section 4	PRINCIPLES OF OPERATION - . . . . .	4-1
Section 5	SERVICE AND MAINTENANCE - . . . . .	5-1
Section 6	PARTS AND SCHEMATICS - . . . . .	6-1

## CONDENSED OPERATING INSTRUCTIONS

Referenced paragraphs contain unabridged information.

### CAUTION

**DO NOT ATTACH CHARGED CAPACITORS.**  
Charged capacitors can damage the bridge.

### RANDOM-VALUE MEASUREMENTS (paragraph 3.3)

**AUTOMATIC RANGE.** This is the fastest mode for general measurements, especially if the measurement values differ by more than 100 counts.

100 counts =

1 pF on range 1 range does not exist at 120 c/s  
 10 pF on range 2 range does not exist at 120 c/s  
 0.1 nF on range 3 range does not exist at 120 c/s  
 1 nF on range 4 at 400 c/s and 1 kc/s; 10 nF at 120 c/s  
 10 nF on range 5 at 400 c/s and 1 kc/s; 0.1  $\mu$ F at 120 c/s  
 0.1  $\mu$ F on range 6 at 400 c/s and 1 kc/s; 1  $\mu$ F at 120 c/s  
 1  $\mu$ F on range 7 at 400 c/s and 1 kc/s; 10  $\mu$ F at 120 c/s

- a. Set BALANCE control to AUTOMATIC RANGE.
- b. Connect unknown and start balance operation.

### SIMILAR-VALUE MEASUREMENTS (paragraph 3.4)

**TRACK SAMPLED.** This is the fastest mode for measurement of unknowns which differ by 100 counts or less.

- a. Select range (AUTOMATIC RANGE BALANCE).
- b. Set BALANCE control to TRACK SAMPLED and start balance operation.

### CONTINUOUS TRACKING (paragraph 3.5)

**TRACK CONT.** This mode is used when a continuous record of the changes in the value of the unknown is desired.

- a. Select range (AUTOMATIC RANGE BALANCE).
- b. Set BALANCE control to TRACK CONT. Balance operation starts automatically whenever unbalance exceeds one count.

### COMPARISON MEASUREMENTS (paragraph 3.6)

**HOLD RANGE.** This mode is used for the comparison of a series of values which fall within the same range on the bridge.

- a. Select range (AUTOMATIC RANGE BALANCE).
- b. Set BALANCE control to HOLD RANGE.
- c. Connect new unknown and start balance operation.

### STOP BALANCE (paragraph 3.7)

**HOLD COUNT.** This mode is used to hold a measurement value or to stop a system.

- a. After measurement has been made, set BALANCE control to HOLD COUNT.

### SENSITIVITY ADJUSTMENT (paragraph 3.8)

Occasionally, the bridge will not balance because the error signal cannot be completely nulled. This may occur when:

1. The unknown lies at the lower extreme of the bridge range. This is particularly true of unknowns of less than 50 pF, measured in the TRACK CONT mode.
2. The connections to the unknown are not shielded. The affects are most noticeable at 120 c/s.
3. The unknown is nonlinear. Nonlinear unknowns include many semiconductors, and some ceramic capacitors and electrolytic capacitors.
4. The unknown is heat sensitive or photo sensitive.

In most cases, the trouble can be overcome by re-adjustment of the SENSITIVITY control on the rear of the measurement unit. To readjust, turn it counterclockwise until the bridge balances. This decreases the resolution below the specified 0.01% but such resolution is usually not meaningful for nonlinear or environment-sensitive components.

To reset the SENSITIVITY control to its original position, turn it clockwise until the bridge fails to stop when a 0.1- $\mu$ F capacitor is measured at 1 kc/s in the TRACK CONT program; then turn it slightly counterclockwise (if the bridge does not hunt; i.e., it reaches a balance even with the SENSITIVITY control fully clockwise, simply leave it fully clockwise).

### RANGE INFORMATION (paragraph 3.9)

RANGE	VOLTAGE rms, across UNKNOWN	CAPACITANCE				LOSS			
		120 c/s		400 c/s, 1 kc/s		CONDUCTANCE		DISSIPATION	
		MIN	MAX	MIN	MAX	MIN	MAX	MIN	MAX
1	1 V			000.01 pF	150.00 pF	0000.1 n $\cup$	1500.0 n $\cup$	0.0000 D	1.5000 D
2	1 V			0150.0 pF	1500.0 pF	01.500 $\mu$ $\cup$	15.000 $\mu$ $\cup$	0.0000 D	1.5000 D
3	1 V			01.500 nF	15.000 nF	015.00 $\mu$ $\cup$	150.00 $\mu$ $\cup$	0.0000 D	1.5000 D
4	1 V	0000.1 nF	1500.0 nF	015.00 nF	150.00 nF	0150.0 $\mu$ $\cup$	1500.0 $\mu$ $\cup$	0.0000 D	1.5000 D
5	100 mV	01.500 $\mu$ F	15.000 $\mu$ F	0150.0 nF	1500.0 nF	01.500 m $\cup$	15.000 m $\cup$	0.0000 D	1.5000 D
6	10 mV	015.00 $\mu$ F	150.00 $\mu$ F	01.500 $\mu$ F	15.000 $\mu$ F	015.00 m $\cup$	150.00 m $\cup$	0.0000 D	1.5000 D
7	1 mV	0150.0 $\mu$ F	1500.0 $\mu$ F	015.00 $\mu$ F	150.00 $\mu$ F	0150.0 m $\cup$	1500.0 m $\cup$	0.0000 D	1.5000 D

# INSTRUCTION MANUAL

## Introduction

section 1

### Type 1680-A | **AUTOMATIC CAPACITANCE BRIDGE ASSEMBLY**

#### contents

1.1 PURPOSE .....	1-2
1.2 DESCRIPTION .....	1-3
1.3 ACCESSORIES SUPPLIED .....	1-3
1.4 FRONT-PANEL INDICATORS, CONTROLS, AND CONNECTORS .....	1-4
1.5 REAR-PANEL CONTROLS AND CONNECTORS .....	1-6
1.6 ACCESSORIES AND SUPPLEMENTARY EQUIPMENT AVAILABLE .....	1-7

BOSTON • PHILADELPHIA • CHICAGO • ORLANDO • DALLAS  
NEW YORK • SYRACUSE • LOS ANGELES • SAN FRANCISCO  
WASHINGTON, D.C. • CLEVELAND • TORONTO • MONTREAL

**GENERAL RADIO COMPANY**  
WEST CONCORD, MASSACHUSETTS 01781

## ● 1.1 PURPOSE

The Type 1680-A Automatic Capacitance Bridge Assembly is an accurate, fast, and economical test device for production and laboratory applications where a great many capacitance measurements are needed. Its range and accuracy cover most capacitor-measurement requirements.

In component-inspection applications, measurement rate is up to ten times faster than is possible with manually balanced bridges. A simple test fixture, the Type 1680-P1, is available for rapid manual connection of capacitors. With a suitable-limit comparator, automatic testing and sorting are possible.

In capacitor production applications, the bridge can be used as an integral part of automatic manufacturing processes to monitor production automatically.

In qualification testing, quality control, and reliability studies, freedom from stray-capacitance effects permits accurate measurements at the end of long cables such as those necessary to connect to capacitors in environmental chambers. Lead resistance is negligible in the measurement of all but very large capacitors. Control and output signals are provided for use in data-acquisition systems that include scanners and automatic data-logging equipment such as card punches, tape punches, and electric typewriters.

There are four operating modes, selected by a front-panel switch:

**AUTOMATIC RANGE** - Provides fully automatic range switching as well as automatic balancing. For fastest measurements of capacitors that differ widely in value from unit to unit.

**HOLD RANGE** - Prevents bridge from dropping to lower ranges. Retains a common decimal-point location for ease in comparison of a series of recorded values.

**TRACK CONTINUOUS** - Tracks changing capacitance and loss, supplying a continuous indication of the values of the unknown -- useful for temperature-coefficient determination and similar measurements.

**TRACK SAMPLED** - Like the TRACKING-CONTINUOUS mode, tracks changing C and D but balances and supplies indication only on command, as set either by a front-panel control or remotely. For fastest measurement of components near a fixed value, as in sorting.

Additional switch positions (T1, T2, and T3) are provided for use in checking internal operations.

Output and control signals are provided for use with data-logging systems. For digital recording a data printer is available and for analog plotting, a digital-to-analog converter and a graphic level recorder are available. Systems for limit comparison, punched cards, and punched-tape output are also available. Inquiries are invited for systems incorporating such auxiliary devices.

## ● 1.2 DESCRIPTION

The Automatic Capacitance Bridge Assembly is a fully automatic, all-solid-state, three-terminal, capacitance bridge. It is a true bridge, relying on stable, passive standards for its accuracy. The bridge not only provides four different operating modes to fit a variety of measurement requirements but also includes built-in test programs for rapid, convenient checkout of all internal circuit modules.

The circuit is a transformer-ratio-arm bridge. It is in balance when the currents through the standard capacitor and the unknown capacitor are equal so that the current in the phase detector is zero. The range is chosen automatically by dry-reed and mercury-wetted relays, which select decade taps on a ratio transformer. The phase detector determines whether the current passing through the unknown arm of the bridge is higher or lower than that through the standard arm and produces an error signal, which indicates whether more or less voltage is required on the standard capacitor to reach a balance. This information is used by a counter decade which controls, through electronic switching circuits, the voltage on the standard capacitor. The counter counts in a direction to minimize the error signal until balance is reached. At balance, the value of the unknown is displayed on an in-line digital readout, which indicates capacitance, dissipation factor or conductance, decimal points, and units. This information is also presented in binary-coded-decimal form for use with printers and other data-handling equipment.

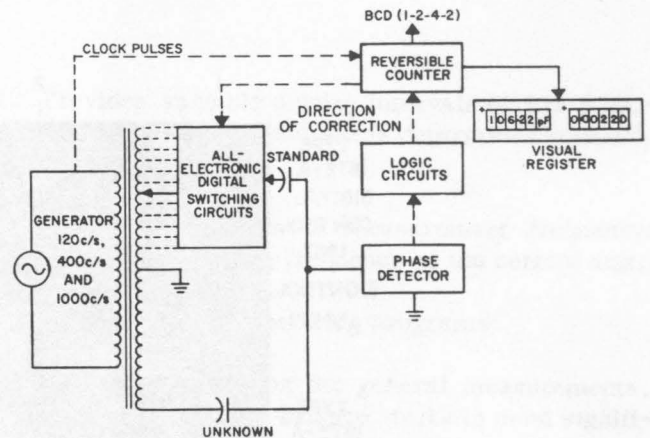

Components in the automatic capacitance bridge are arranged in modules consisting of plug-in, fiber-glass-epoxy, etched-circuit boards. A malfunction can be readily traced to an individual module by means of the internal test programs. The defective module can then be removed and serviced, or replaced, with minimum down time.

The Type 1680-A Automatic Capacitance Bridge Assembly is constructed in two parts, the Type 1672-A Digital Control Unit, which has most of the logic and digital circuitry, and the Type 1673-A Automatic Capacitance Bridge, which contains the bridge circuits. This system permits other bridges to be added to or substituted for the capacitance bridge as they become available. Thus, the utility of the Digital Control Unit can be extended to cover a wide range of measurement applications.

## ● 1.3 ACCESSORIES SUPPLIED

1	Instruction Manual	1680-0100
1	Power cord, 3-wire, Type CAP-22	4200-9622
2	Coaxial locking connectors Type 874-CL58A	0874-9415
2	Fuses, 1.25 ampere for 115-volt operation or 0.6 ampere for 230-volt operation	5330-1600 5330-1100
2	15-pin board extenders	4215-2015
2	24-pin board extenders	4215-2024
	The board extenders are stored inside the control unit. They are used for trouble-shooting and calibration and allow an etched board to be extended above the others for access to components and test points.	
1	End-frame set for control unit	5310-9646
1	End-frame set for measurement unit	5310-9626
	The bridge is normally shipped with the end frames attached and with the units bolted together to form a single assembly.	
1	Rack-support set for control unit	7863-9646
1	End-frame set for measurement unit	7863-9624
	When the end frames are removed, the rack-support sets can be used to rack-mount the units.	

● 1.4 FRONT-PANEL INDICATORS, CONTROLS, AND CONNECTORS

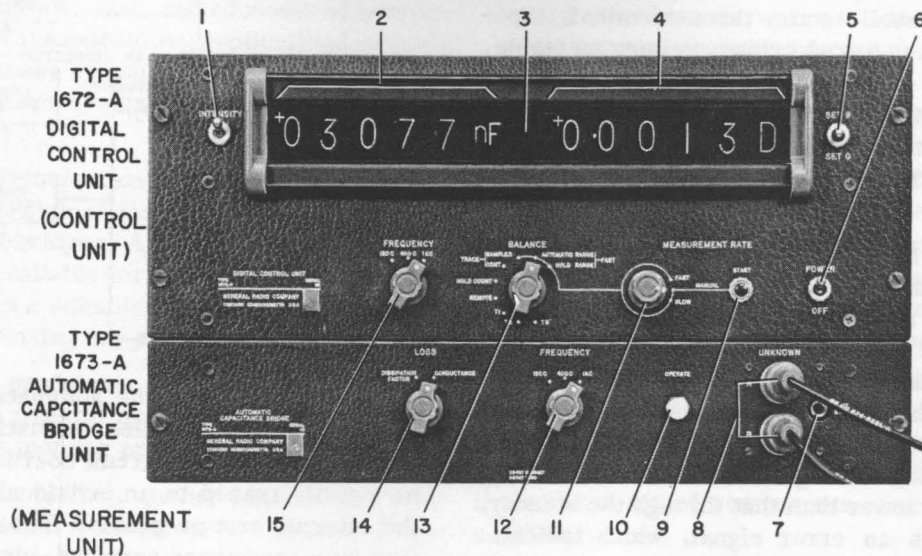

- |    |                            |  |
|----|----------------------------|--|
| 1  | INTENSITY                  | Three-position toggle switch. Provides a choice of display brightness. Lowest intensity position (down) gives longest lamp life.   |
| 2  | A DISPLAY<br>(capacitance) | Six incandescent-lamp-operated indicators. Provides visual indication of capacitance measurement to five places. Includes sign (negative sign indicates the unknown is an inductor), decimal point, and symbol (pF, nF, $\mu$ F).  |
| 3  | UNBALANCED                 | Incandescent-lamp-operated indicator. Lights when bridge is unbalanced by over 10 counts.  |
| 4  | B DISPLAY<br>(loss)        | Six incandescent-lamp-operated indicators. Provides visual indication of loss measurement to five places. Includes sign (negative sign indicates loss of unknown is less than loss of internal standard), decimal point, and symbol (D, n $\Omega$ , $\mu\Omega$ , m $\Omega$ ). |
| 5  | SET                        | Three-position toggle switch. Sets registers to zero or nine (full scale) for recorder or converter calibration.   |
| 6  | POWER                      | Two-position toggle switch. Applies or interrupts the line voltage supplied to the instrument.   |
| 7  | EXT START                  | Two terminal telephone jack. Momentary short between terminals performs same function as START button (starts balance operation). For connection to remote start button such as to the Type 1680-P1 Test Fixture.  |
| 8  | UNKNOWN terminals          | Two GR874 Locking Connectors. For connection to unknown.   |
| 9  | START                      | Momentary push-button switch. Initiates the balance operation.   |
| 10 | OPERATE                    | Incandescent lamp. Lights when logic interconnecting cable is in place and when both units are set to the same frequency.  |



- 11 MEASUREMENT RATE Switch-potentiometer control. Provides variable display intervals (0.1 to 5 seconds) and a MANUAL position in which the display interval is determined manually by the START button.
- 12 FREQUENCY Four-position rotary switch. Provides selection of measurement frequency; 120 c/s, 400 c/s, or 1 kc/s). Must be set to same frequency as the control unit.
- 13 BALANCE Nine-position rotary switch. Provides choice of operating programs:
- AUTOMATIC RANGE. Fastest mode of operation for general measurements. Automatically selects proper range and balances. Balance starts in most significant figure and a print command is issued when balance is complete.
- HOLD RANGE. For comparison of a series of values. Automatically balances but will only change to higher ranges, not to lower ranges. Balance starts in most significant figure and a print command is issued when balance is complete.
- TRACK CONT. For continuous tracking of the value of the unknown. Automatically balances but will only change to higher ranges, not to lower ranges. Balance proceeds from previous value and starts in least significant figure. A print command is issued when balance is complete.
- TRACK SAMPLED. For measurement of many capacitors that differ only slightly in value. Same as TRACK CONT. except balance is held until start button is pushed.
- HOLD COUNT. Holds count and prevents further balances even if START button is pushed; releases count when SET switch is set to 0 or 9. Useful to stop a system.
- REMOTE. Disconnects front-panel BALANCE control so that operating programs can be externally selected.
- T1. Test mode for trouble-shooting. Presets registers to 02000 when START button is pushed.
- T2. Test mode for trouble shooting. Steps through balance program, one digit each time the START button is pushed.
- T3. Test mode for trouble-shooting. Steps through all counts in each decade at the normal balance rate.
- 14 LOSS Two-position rotary switch. Provides choice of loss measurement; conductance or dissipation factor.
- 15 FREQUENCY Four-position rotary switch. Provides selection of measurement frequency; 120 c/s, 400 c/s, 1 kc/s, or, with internal modification, any other frequency from 100 c/s to 2 kc/s. Must be set to same frequency as the Type 1673-A.

### ● 1.5 REAR-PANEL CONTROLS AND CONNECTORS

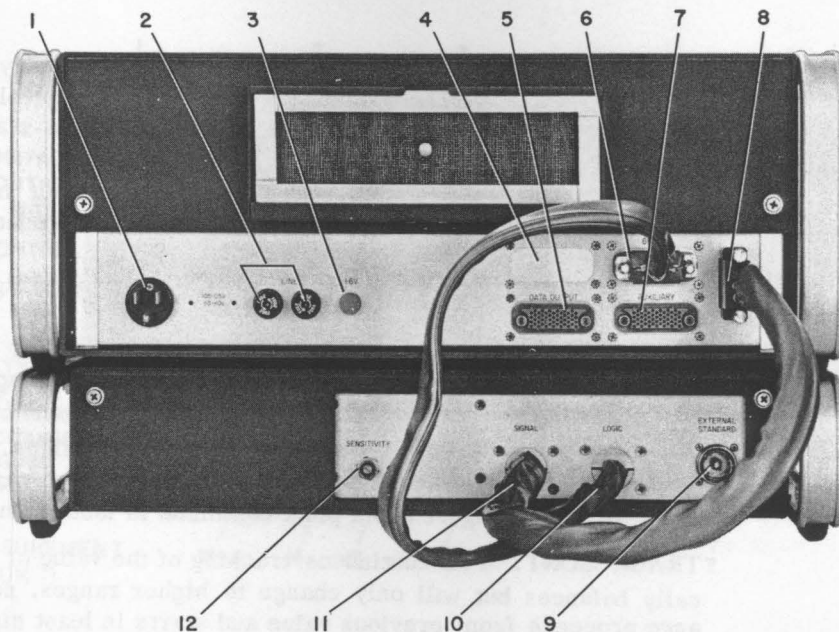

- |    |                                   |  |
|----|-----------------------------------|--|
| 1  | POWER                             | Three-pin connector. Accepts Type CAP-22 Power Cord supplied. For connection to power line.                |
| 2  | LINE fuses                        | Two 1.25-A fuses for 115-V operation or two 0.6-A fuses for 215-V or 230-V operation.                      |
| 3  | +6V fuse                          | One 4-A fuse for +6-V supply. Fuses both the <u>internal and external</u> +6-V busses.                     |
| 4  | Connector provision               | Mounting plate (5660-1590) for installation of an additional 52-pin connector.                             |
| 5  | DATA OUTPUT<br>(formerly PRINTER) | 52-pin socket. For connection to printer, digital-to-analog converter, or other data processing equipment. |
| 6  | BRIDGE                            | 52-pin socket. For connection of LOGIC cable from Type 1673-A.   |
| 7  | AUXILIARY                         | 52-pin socket. For connection to remote-programming equipment.   |
| 8  | Socket                            | 7-pin socket. For connection of SIGNAL cable from Type 1673-A.   |
| 9  | EXTERNAL<br>STANDARD              | GR874 Locking Connector. For connection to an external standard.   |
| 10 | LOGIC cable                       | Cable and 52-pin plug. Connects to BRIDGE socket on Type 1672-A.   |
| 11 | SIGNAL cable                      | Cable and 7-pin plug. Connects to 7-pin socket on Type 1672-A.   |
| 12 | SENSITIVITY                       | Potentiometer adjustment. Sets sensitivity of bridge.  |

## ● 1.6 ACCESSORIES AND SUPPLEMENTARY EQUIPMENT AVAILABLE

### 1.6.1 COMPONENT TEST FIXTURE

The only accessory required by the bridge assembly is some means to connect the unknown to the assembly terminals. One of the simplest methods is manually, by means of a test jig such as the Type 1680-P1 Component Test Fixture.

The Type 1680-P1 includes adjustable, insulated, fast-action spring dips to receive the component leads and a built-in switch to start the balance operation. Its top plate can be removed to adapt it to special contact arrangements. Use of the fixture does not derate the accuracy specifications because shielded cables are used to connect it to the bridge.

The fixture is designed primarily for axial-lead components. However, it can be easily adapted to accept parallel lead components or transistors by means of a Transistor Jig manufactured by Daymarc Corp., 191 High Street, Waltham, Mass. 02154.



### 1.6.2 DIGITAL RECORDING

The bridge assembly can be used with the Type 1137 Data Printer to record data permanently in digital form.

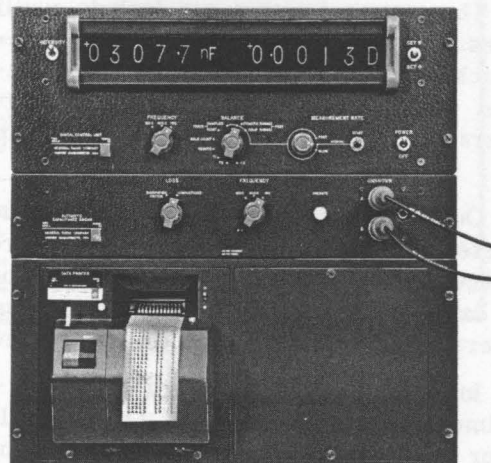

### 1.6.3 ANALOG RECORDING

The bridge assembly can be used with the Type 1510 Digital-to-Graphic Recording Assembly to record data permanently in analog form. The Type 1510 consists of a Type 1136 Digital-To-Analog Converter and a Type 1521 Graphic Level Recorder.

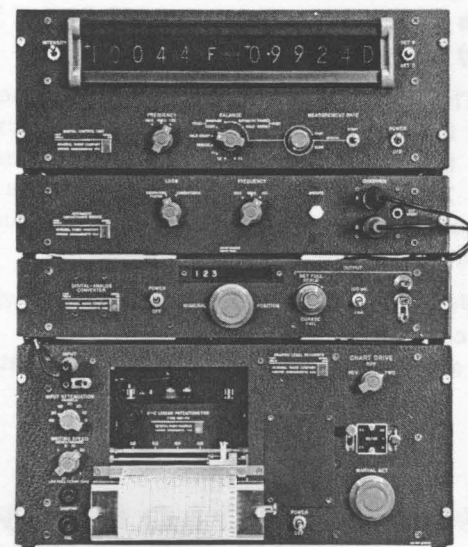

#### 1.6.4 ANALOG OUTPUT

The bridge assembly can be used with the Type 1136 Digital-To-Analog Converter to convert digital data to voltage or current for analog use.

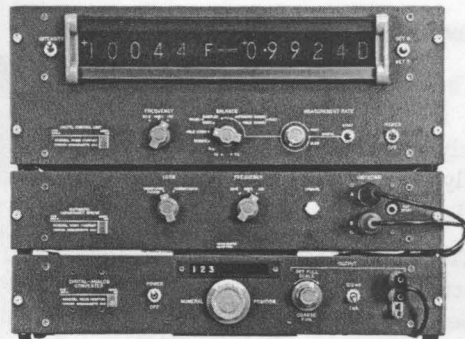

#### 1.6.5 SYSTEMS

Since the bridge assembly will often be the nucleus of a larger measurement system, General Radio has arranged to supply complete systems which incorporate a large variety of auxiliary instrumentation. Inquiries are invited.

The instrumentation can include auxiliary input devices such as conveyor-sorting, reel-type-handling, or stick-and-indexer equipment, scanners, environmental test chambers, and transducers to convert temperature to voltage, displacement to capacitance, etc.

Output devices can also be supplied, such as data printers, digital-to-analog converters, dc recorders, x-y recorders, limit comparators for component sorting, card or tape punches with the necessary intercouplers, magnetic tape recorders, and typewriters.

In addition, such ancillary equipment as clocks for time-of-day records (Type 1123 Digital Synchronometer with Type 1115-B Standard-Frequency Oscillator) and electronic counters for serial number records (Types 1150, 1151, or 1153 Digital Frequency Meters) is available.

The bridge assembly can also be specially arranged for difference measurements to increase resolution, for special measurement frequencies from 100 c/s to 2 kc/s, for lower or higher voltages across the unknown (remotely selectable if desired) and for dc-bias voltages to the unknown.

Future measurement units, which will use the same control unit, include an automatic inductance bridge and an automatic impedance comparator.



INSTRUCTION MANUAL  
**Installation**  
section 2

**Type 1680-A** | **AUTOMATIC  
CAPACITANCE BRIDGE  
ASSEMBLY**

**contents**

2.1	DIMENSIONS -----	2-3
2.2	ENVIRONMENTAL -----	2-3
2.3	MOUNTING -----	2-4
2.4	POWER CONNECTION -----	2-6
2.5	UNKNOWN CONNECTION -----	2-7
2.6	AUXILIARY SOCKET, SO2 -----	2-8
2.7	DATA OUTPUT SOCKET, SO3 (formerly PRINTER) -----	2-10
2.8	CABLE ASSEMBLIES -----	2-12
2.9	ANALOG OUTPUT -----	2-13
2.10	DIGITAL RECORDING -----	2-14
2.11	DC RECORDING -----	2-16
2.12	X-Y RECORDING -----	2-16
2.13	PERIPHERAL EQUIPMENT -----	2-17

BOSTON • PHILADELPHIA • CHICAGO • ORLANDO • DALLAS  
NEW YORK • SYRACUSE • LOS ANGELES • SAN FRANCISCO  
WASHINGTON, D.C. • CLEVELAND • TORONTO • MONTREAL

**GENERAL RADIO COMPANY**  
WEST CONCORD, MASSACHUSETTS 01781

## 2.1 DIMENSIONS

DIMENSIONS IN INCHES

### 2.1.1 TYPE 1680 AUTOMATIC CAPACITANCE BRIDGE ASSEMBLY

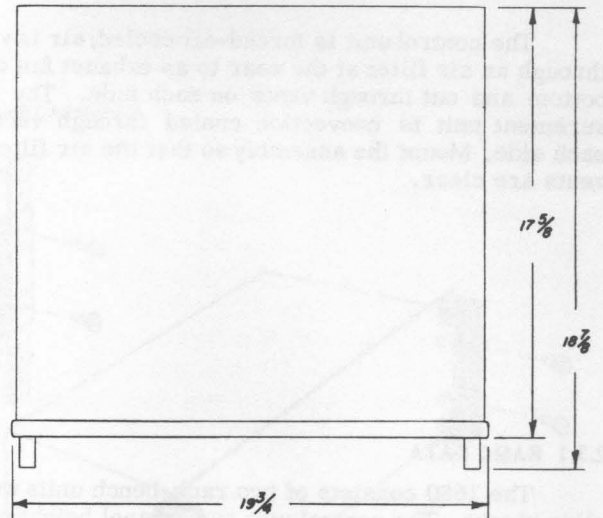
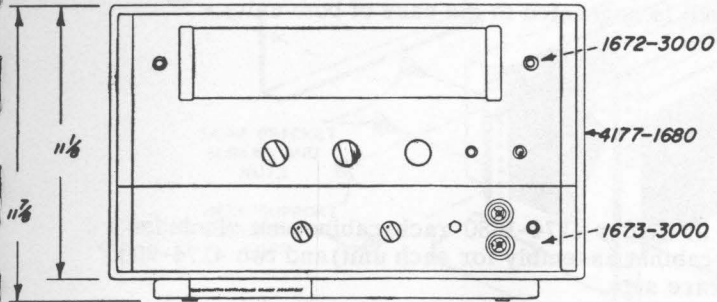

### 2.1.2 TYPE 1672-A DIGITAL CONTROL UNIT

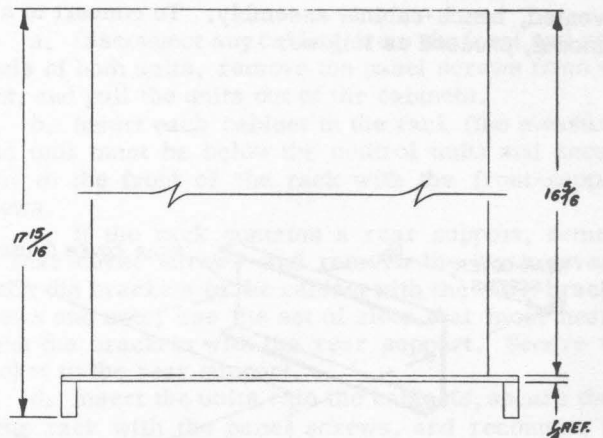
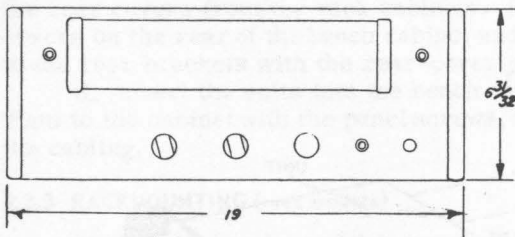

### 2.1.3 TYPE 1673-A AUTOMATIC CAPACITANCE BRIDGE

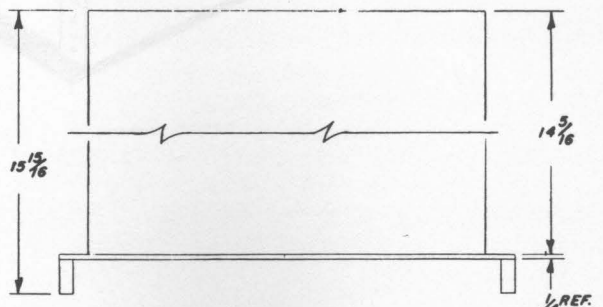
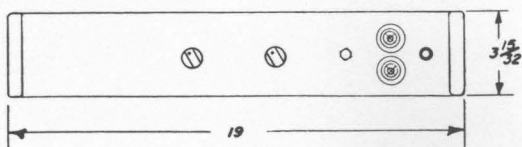

## 2.2 ENVIRONMENTAL

The control unit is forced-air cooled; air is vented through an air filter at the rear to an exhaust fan on the bottom and out through vents on each side. The measurement unit is convection cooled through vents on each side. Mount the assembly so that the air filter and vents are clear.

The bridge assembly is designed to operate within a wide range of temperatures normally encountered in the laboratory and is designed to be stored with ambient temperatures of from  $-40^{\circ}$  to  $70^{\circ}\text{C}$ .

The instrument is not appreciably affected by conditions of high humidity.

A three-wire power cord is used; the third wire (ground) is connected to the case of both units.

## 2.3 MOUNTING

### 2.3.1 BASIC DATA

The 1680 consists of two rack-bench units without slide blocks. The control unit has a panel height of 7 in (4 units) and a depth of 16 in. The measurement unit has a panel height of  $3\frac{1}{2}$  in (2 units) and a depth of 14 in. The assembly dissipates 100 W.

### 2.3.2 CABINET OPTIONS

**Bench model.** For bench use. Includes a tilt-base, vented, bench-cabinet assembly. To convert to a rack model, proceed as follows:

a. Order 4174-1680 rack-cabinet set (includes a rack-cabinet assembly for each unit) and two 4174-2000 hardware sets.

b. Disconnect any cabling from the front and rear panels of both units, remove the panel screws from the front, and pull the units out of the bench cabinet.

c. Remove the rear-cover screws and remove the rear covers from the bench cabinet. Place the rear covers on the rear of the rack cabinets and secure them to the rack cabinet with the rear-cover screws.

d. Install the rack cabinets in the rack and insert the units into them (see paragraph 2.3.3).

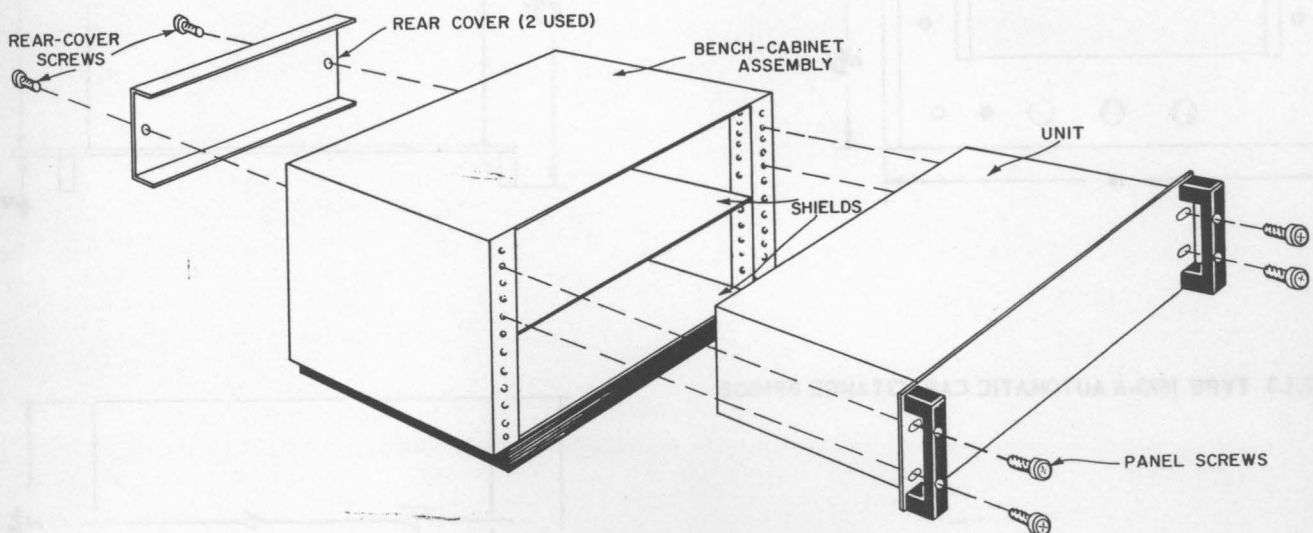

**Rack model.** For installation in a standard 19-inch relay rack. Includes a rack-cabinet set. To convert to a bench model proceed as follows:

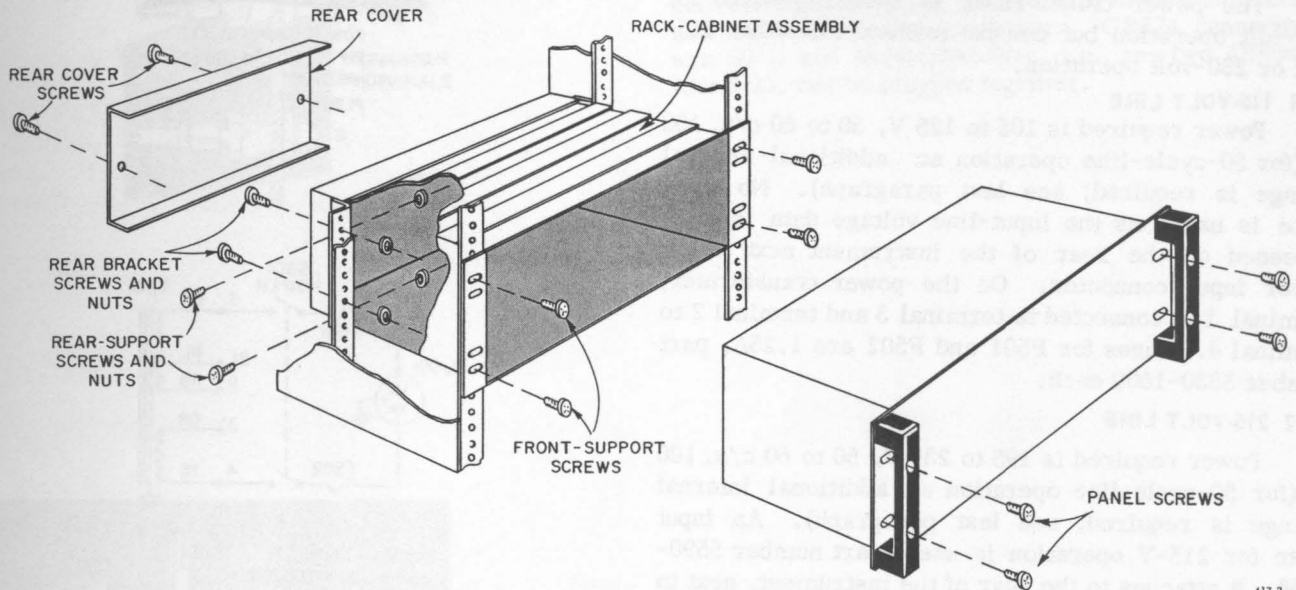

417-3

- a. Order a 4177-1680 bench-cabinet assembly.
- b. Disconnect any cabling from the front and rear panels of both units, remove the panel screws from the front, and pull the units out of the bench cabinet.
- c. Remove the rear-cover screws and remove the rear covers from the rack cabinets. Place the rear covers on the rear of the bench cabinet and secure them to the rear brackets with the rear-cover screws.
- d. Insert the units into the bench cabinet, secure them to the cabinet with the panel screws, and reconnect the cabling.

### 2.3.3 RACKMOUNTING (rack models)

To install a rack-model instrument in a standard 19-inch relay rack, proceed as follows:

- a. Disconnect any cabling from the front and rear panels of both units, remove the panel screws from the front, and pull the units out of the cabinets.
- b. Insert each cabinet in the rack (the measurement unit must be below the control unit) and secure them to the front of the rack with the front-support screws.
- c. If the rack contains a rear support, remove the rear-cover screws and remove the rear covers. Attach the brackets to the cabinet with the rear-bracket screws and nuts; use the set of slots that most nearly aligns the brackets with the rear support. Secure the bracket to the rear support.
- d. Insert the units onto the cabinets, secure them to the rack with the panel screws, and reconnect the cabling.



## • 2.4 POWER CONNECTION

Use the Type CAP-22 Three-Wire Power Cord, provided, to connect the frequency meter to a source of power as indicated on the chassis next to the power input connector. The long cylindrical pin (ground) is connected directly to the metal case of the instrument.

The power transformer is normally wired for 115-volt operation but can be rewired for either 215-volt or 230-volt operation.

### 2.4.1 115-VOLT LINE

Power required is 105 to 125 V, 50 to 60 c/s, 100 W (for 50-cycle-line operation an additional internal change is required; see last paragraph). No input plate is used, as the input-line voltage data is silk-screened on the rear of the instrument next to the power input connector. On the power transformer, terminal 1 is connected to terminal 3 and terminal 2 to terminal 4. Fuses for F501 and F502 are 1.25A, part number 5330-1600 each.

### 2.4.2 215-VOLT LINE

Power required is 195 to 235 V, 50 to 60 c/s, 100 W (for 50-cycle-line operation an additional internal change is required; see last paragraph). An input plate for 215-V operation is used, part number 5590-1668. It attaches to the rear of the instrument, next to the power input connector, by means of two 4-40 x 3/16" screws with attached lockwashers, part number 7090-4030, each. On the power transformer, terminal 2L is connected to terminal 3. Fuses for F501 and F502 are 0.6A, part number 5330-1100 each.

### 2.4.3 230-VOLT LINE

Power required is 210 to 250 V, 50 to 60 c/s, 100 W (for 50-cycle-line operation an additional internal change is required; see last paragraph). An input plate for 230-V operation is used, part number 5590-1664. It attaches to the rear of the instrument, next to the power input connector, by means of two 4-40 x 3/16" screws with attached lockwashers, part number 7090-4030 each. On the power transformer, connect terminal 1 to terminal 2. Fuses for F501 and F502 are 0.6A, part number 5330-1100 each.

### 2.4.4 50-CYCLE LINE

When the assembly is supplied for 60-cycle-line operation, the oscillator is synchronized to 120-cycle ripple from the power supply to prevent beats between the line frequency and the 120-cycle measurement frequency. For 50-cycle-line operation this synchronization is not necessary and must be removed.

To remove the synchronization signal, unsolder and tape the white-orange-red-brown lead from terminal 505 of the power transformer on the bottom of the control unit. There is no degradation of oscillator accuracy or bridge performance with the synchronization signal removed.

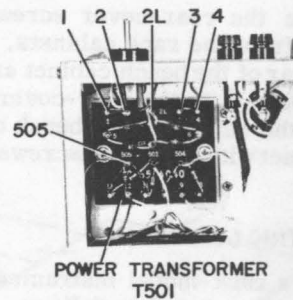
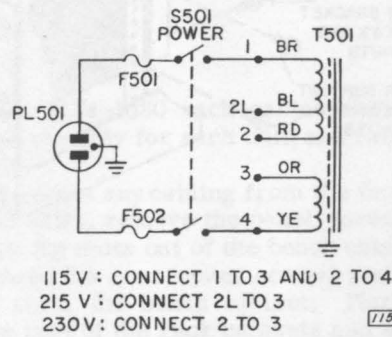
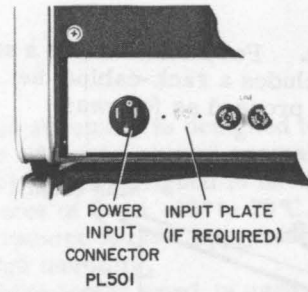

## • 2.5 UNKNOWN CONNECTION

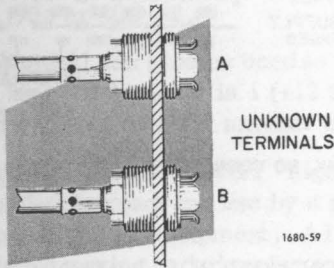

The UNKNOWN terminals accept a wide variety of GR patch cords, as well as broad line of adaptors to convert the terminals for use with most commercial and military coaxial connectors. GR874 connectors are 50  $\Omega$  and hermaphroditic, i.e., any two although identical, can be plugged together.

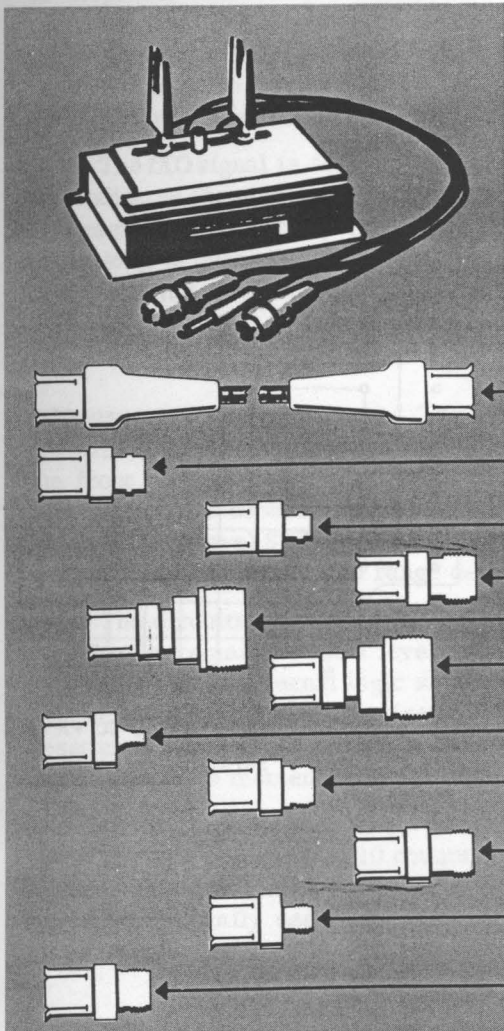

1680-P1	Component Test Fixture	1680-9601
874-R20A	Coaxial patch cord, low-loss	0874-9680
874-R20LA	Coaxial patch cord, low-loss cable, locking connectors	0874-9681
874-R22A	Coaxial patch cord, general-purpose cable	0874-9682
874-R22LA	Coaxial patch cord, general-purpose cable, locking connectors	0874-9683
874-QBJA	Adaptor, GR874 to Type BNC	0874-9700
874-QBJL	Locking adaptor, GR874 to Type BNC	0874-9701
874-QCJA	Adaptor, GR874 to Type C	0874-9702
874-QCJL	Locking adaptor, GR874 to Type C	0874-9703
874-QHJA	Adaptor, GR874 to Type HN	0874-9704
874-QLJA	Adaptor, GR874 to Type LC	0874-9706
874-QLTJ	Adaptor, GR874 to Type LT	0874-9708
874-QMDJ	Adaptor, GR874 to Type Microdot	0874-9720
874-QMDJL	Locking adaptor, GR874 to Type Microdot	0874-9721
874-QNJA	Adaptor, GR874 to Type N	0874-9710
874-QNJL	Locking adaptor, GR874 to Type N	0874-9711
874-QSCJ	Adaptor, GR874 to Type SC	0874-9712
874-QSCJL	Locking adaptor, GR874 to Type SC	0874-9713
874-QTNJ	Adaptor, GR874 to Type TNC	0874-9716
874-QTNJL	Locking adaptor, GR874 to Type TNC	0874-9717
874-QUJ	Adaptor, GR874 to Type UHF	0874-9718
874-QUJL	Locking adaptor, GR874 to Type UHF	0874-9719

1680-88

## • 2.6 AUXILIARY SOCKET, SO2

The AUXILIARY socket, SO2, on the rear of the control unit, provides connections for remote control of the assembly by the user and for checks on the bridge by the factory. This socket, as well as the DATA OUTPUT socket (SO3) and the BRIDGE socket (SO1) requires special tools for assembly or disassembly (see Section 6, Type 1672-A socket listing).

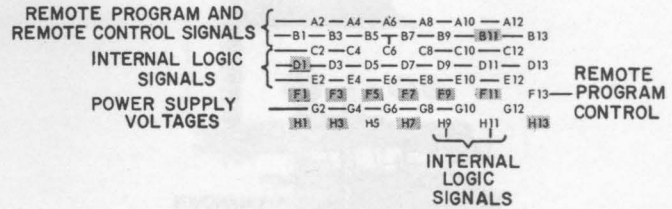

### 2.6.1 INTERNAL LOGIC SIGNALS

Internal-logic signals are for factory checks and are normally not otherwise used.

CIRCUIT	DECADE INPUTS								SIGN INPUTS		DIRECTION-CONTROL INPUTS				MAIN-GATE SIGNALS			
SIGNAL	D0	D1	D2	D3	D4	FA	FB	FO	VA	VB	HSA	HSB	REA'	REB'	GX	MGF	XR1	XR4
SO2 PIN	E2	D13	D11	D3	D7	E4	C10	C12	E8	D9	D5	C8	E10	E6	C4	C2	H9	H11

### 2.6.2 POWER SUPPLY VOLTAGES

CIRCUIT	POWER SUPPLY				
SIGNAL	-15V	-9V	GND	+6V	+12V
SO2 PIN	G10	G8	G2	G6	G4

### 2.6.3 REMOTE PROGRAM SIGNALS

CIRCUIT	INPUT AND SET CONTROL								
SIGNAL	REM	T3	T2	HO	CO	GC	FR	FH	
SO2 PIN	B13	A10	A12	B1	A6	A4	B3	B5	

Programming (selecting the type of balance operation desired) is accomplished by enabling various gates in the control unit and disabling others. Although the BALANCE control ordinarily performs this function, it also has a REMOTE position which allows the gates to be remotely controlled. The gates are enabled when +6 volts is applied and disabled when it is removed.

To program the assembly remotely, set the BALANCE control to REMOTE. This removes +6 volts from all program gates and applies it, instead, to pin B13 of SO2 (REM). The assembly can then be programmed by connecting B13 to one of the program connections as shown. For example, for AUTOMATIC RANGE, connect B13 to B3.

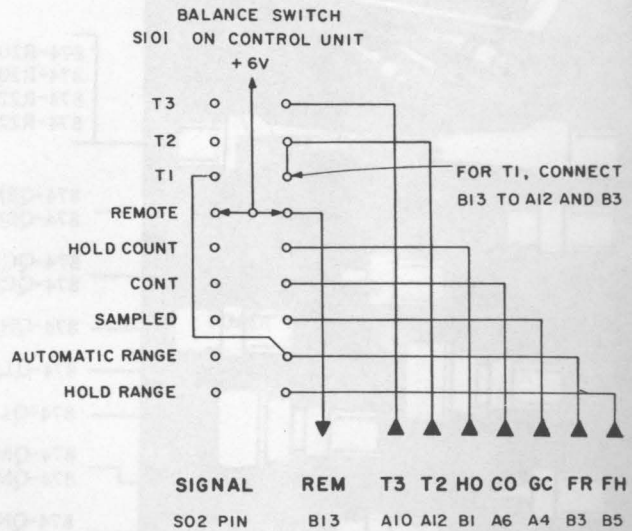

### 2.6.4 REMOTE CONTROL SIGNALS

CIRCUIT	INPUT AND SET CONTROL			PROGRAM		COMPAR-ATOR
SIGNAL	STW	PRT'	IX0	SNS	SZS	MT
SO2 PIN	A2	F13	A8	B7	B9	C6

STW, remote start. To start the balance operation remotely, apply +12 to +25 volts to J904 on the front of the measurement unit or S02-A2 on the rear of the control unit, or apply a positive pulse (+12 to +25 volts, risetime  $< 1 \mu\text{s}$ , duration  $> 5\text{ms}$ ) through a  $0.001\text{-}\mu\text{F}$  capacitor to J904 or S02-A2.

An STW signal can also be used as a bridge inhibit signal. As long as the level is 1 (+12 to +25 volts) the bridge will not preset or start another balance.

PRT', data ready. A 0-level PRT' signal indicates the measurement data is ready for use by a printer or other piece of supplementary equipment. A 1-level indicates the bridge is presetting or balancing and the measurement data is changing and should not be used. The 1-to-0 transition is ordinarily used to trigger a printer or digital-to-analog converter, etc.

The PRT' signal is also available on pins A12 and B13 of the DATA OUTPUT socket, S03.

IXO, balance inhibit. A 1-level IXO input to S02-A8 prevents the bridge from starting a balance operation or stops the balance operation if it is already in progress. It does not prevent or stop presetting (setting the registers to 02000 before the start of a balance) but it can be used to delay the start of the actual balance operation until the external circuit is ready.

The IXO signal is derived from an external source and indicates the source is busy; e.g., if the source is a printer it indicates the printer is setting up for a print operation, printing, or recovering from a print operation and is not ready to receive new data.

The IXO input is identical to the IXP input (S03-G12).

SNS, set nine; SZS, set zero. The SNS and SZS inputs perform the same function as the SET switch, S201 on the front panel of the control unit. A 1-level SNS input sets the counter decades, spill circuit, and indicators to 09999. A 1-level SZS input sets the counter decades, spill circuit, indicators and range decade to 00000.

The circuits remain 9-set or 0-set for as long as the signals remain at the 1 level, regardless of the state of the other internal logic signals. When the signals return to the 0 level the circuits remain 9-set or 0-set until a balance operation starts. An SNS or SZS signal should be momentary only.

MT, slowed measurement. A 1-level MT signal indicates the bridge is within 10 counts of balance and has slowed the count rate to prevent overshoot. The MT signal is generally used only for checks on the bridge by the factory.

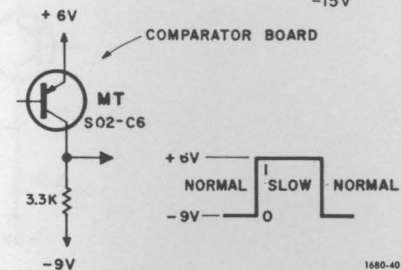
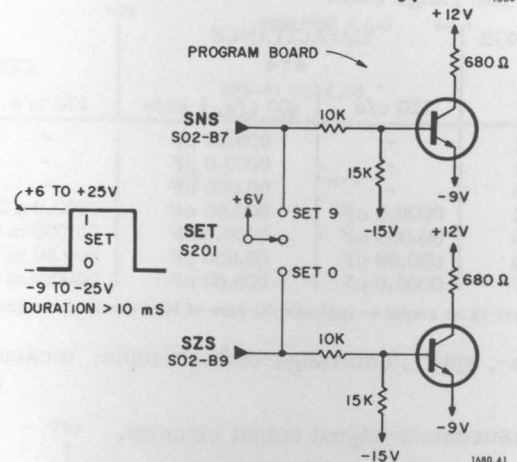
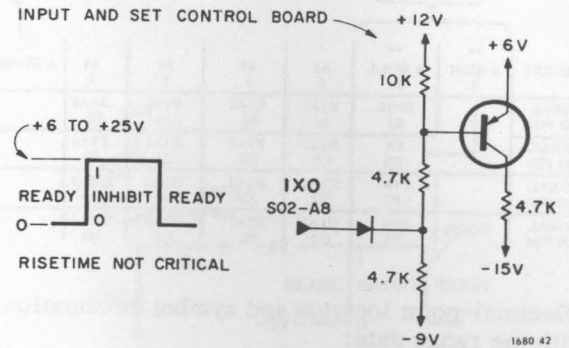
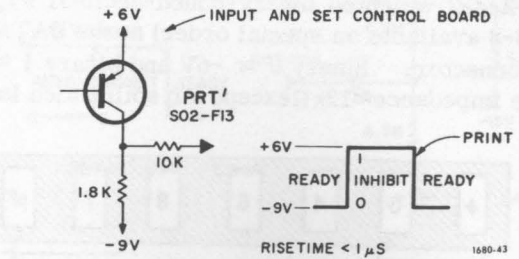
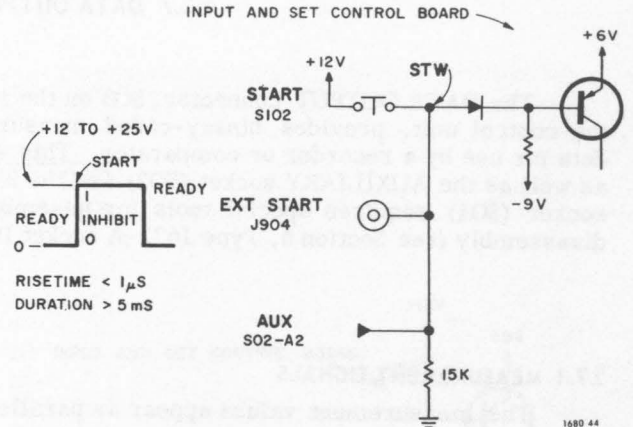

## • 2.7 DATA OUTPUT SOCKET, SO3 (formerly PRINTER)

The DATA OUTPUT connector, SO3 on the rear of the control unit, provides binary-coded measurement data for use by a recorder or comparator. This socket, as well as the AUXILIARY socket (SO2) and the BRIDGE socket (SO1) requires special tools for assembly and disassembly (see Section 6, Type 1672-A socket listing).

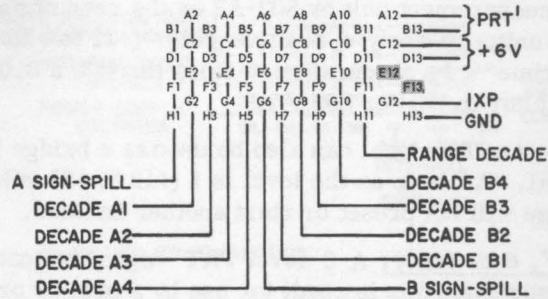

### 2.7.1 MEASUREMENT SIGNALS

The measurement values appear as parallel output 1-2-4-2 weighted binary-coded-decimal signals (1-2-4-8 available on special order) at the DATA OUTPUT connector. Binary 0  $\approx$  -6V and binary 1  $\approx$  +6V. Source impedance  $\approx$  12k $\Omega$  except for spill which is  $\approx$  1k $\Omega$ .

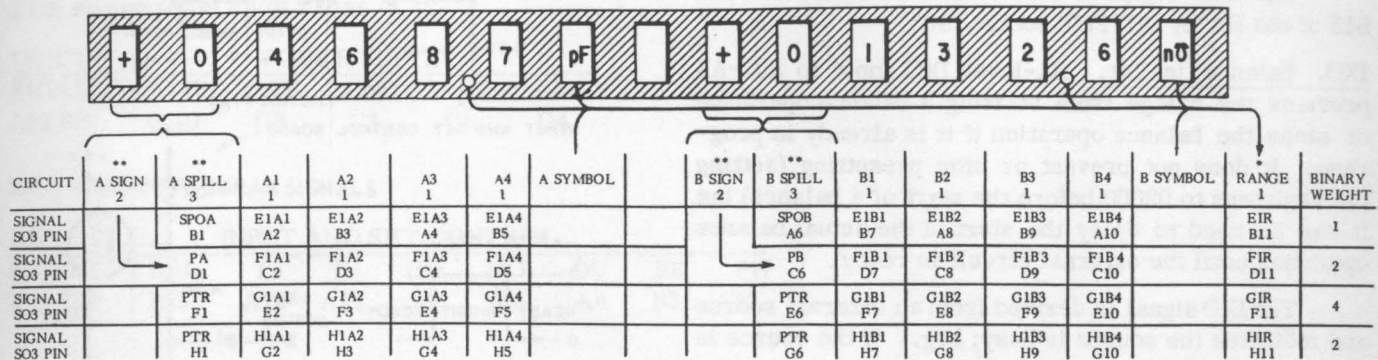

\*Decimal-point location and symbol information is combined with the range data:

RANGE	CAPACITANCE		LOSS			SIGN	SPILL	BCD	DECIMAL
	120 c/s	400 c/s, 1 kc/s	CONDUCTANCE		DISSIPATION				
			120 c/s	400 c/s, 1 kc/s	FACTOR				
1	-	000.00 pF	-	0000.0 n $\Omega$	0.0000 D	+	0	0000	0
2	-	0000.0 pF	-	00.000 $\mu\Omega$	0.0000 D	+	1	1000	1
3	-	00.000 nF	-	000.00 $\mu\Omega$	0.0000 D	-	0	0100	2
4	0000.0 nF	000.00 nF	0000.0 $\mu\Omega$	0000.0 $\mu\Omega$	0.0000 D	-	1	1100	3
5	00.000 $\mu$ F	0000.0 nF	00.000 m $\Omega$	00.000 m $\Omega$	0.0000 D				
6	000.00 $\mu$ F	00.000 $\mu$ F	000.00 m $\Omega$	000.00 m $\Omega$	0.0000 D				
7	0000.0 $\mu$ F	000.00 $\mu$ F	0000.0 m $\Omega$	0000.0 m $\Omega$	0.0000 D				

\*\*Sign and spill information is combined in a single output:

There is no output to indicate the type of loss measurement (conductance or dissipation factor) or measurement frequency (120 c/s, 400 c/s, or 1 kc/s).

Sign-, spill-, and range-code example: measurement values + 1 0 2.0 1 nF - 0 0 0 1.2  $\mu\Omega$   
 printed record 1 0 2 0 1 2 0 0 1 2 4

Measurement-signal output circuits.

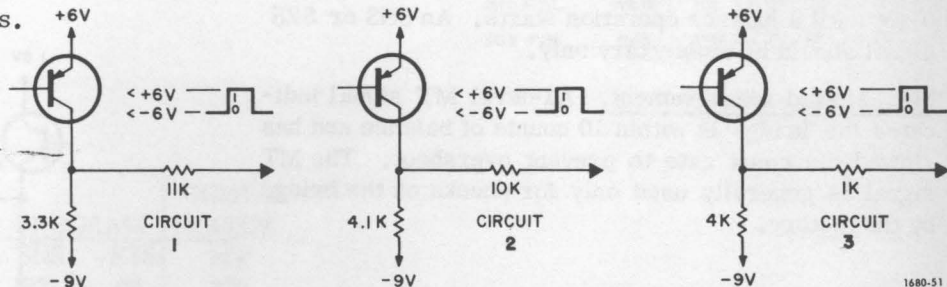

1680-51

## 2.7.2 CONTROL SIGNALS

CIRCUIT SIGNAL S03 PIN	INPUT AND SET CONTROL		POWER SUPPLY		
	IXP	PRT'	PTR	+6V	GND
	G12	A12, B13	F1, H1, E6, G6	C12, D13	H13

**IXP, balance inhibit.** A1-level IXP input to S03-G12 prevents the bridge from starting a balance operation or stops the balance operation if it is already in progress. It does not, prevent or stop presetting (setting the registers to 02000 before the start of a balance) but it can be used to delay the start of the actual balance operation until the external circuit is ready.

The IXP signal is derived from an external source and indicates the source is busy; e.g., if the source is a printer it indicates the printer is setting up for a print operation, printing, or recovering from a print operation and is not ready to receive new data.

The IXP input is identical to the IXO input (S02-A8).

**PRT', data ready.** A0-level PRT' signal indicates the measurement data is ready for use by a printer or other piece of supplementary equipment. A1-level indicates the bridge is presetting or balancing and the measurement data is changing and should not be used. The 1-to-0 transition is ordinarily used to trigger a printer or digital-to-analog converter, etc.

The PRT' signal is also available on pin F13 of the AUX socket, S02.

**PTR, 0 level.** The PTR signal is a 0-level (-9-V) signal whose only function is to complete the sign-spill binary code (measurement signals, opposite page).

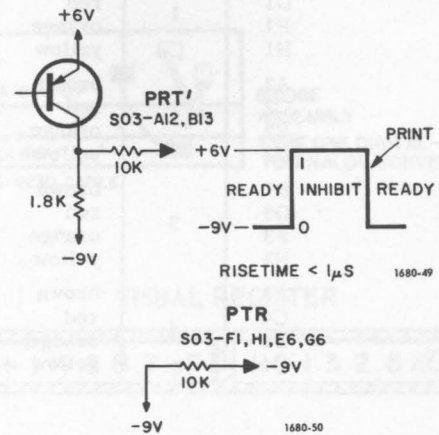
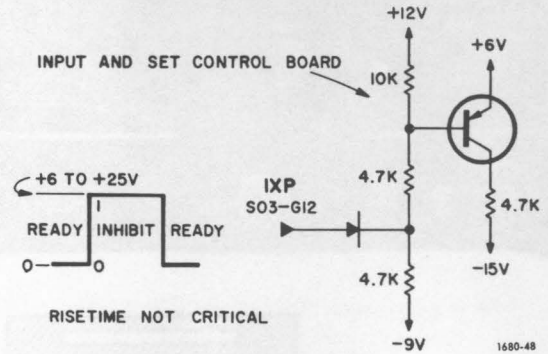

## • 2.8 CABLE ASSEMBLIES

### 2.8.1 4205-1010 UNIVERSAL CABLE, ONE CONNECTOR

The 4205-1010 universal-cable assembly is primarily intended to connect non-GR instruments to the DATA OUTPUT socket, SO3, or the AUXILIARY socket socket, SO2, of the control unit.

PLUG, 52-PIN PLUG,  
CONNECTS TO DATA OUTPUT SOCKET SO3 OR  
AUXILIARY SOCKET SO2 OF CONTROL UNIT



LEADS, THIRTEEN 4-WIRE  
GROUPS, CONNECTS TO  
SUPPLEMENTARY EQUIPMENT

Connections:

PLUG PIN	LEAD		PLUG PIN	LEAD		PLUG PIN	LEAD	
	GROUP	COLOR		GROUP	COLOR		GROUP	COLOR
B1	1	brown	B5	5	brown	B9	9	brown
D1		red	D5		red	D9		red
F1		orange	F5		orange	F9		orange
H1		yellow	H5		yellow	H9		yellow
A2	2	brown	A6	6	brown	A10	10	brown
C2		red	C6		red	C10		red
E2		orange	E6		orange	E10		orange
G2		yellow	G6		yellow	G10		yellow
B3	3	brown	B7	7	brown	B11	11	brown
D3		red	D7		red	D11		red
F3		orange	F7		orange	F11		orange
H3		yellow	H7		yellow	H11		yellow
A4	4	brown	A8	8	brown	A12	12	brown
C4		red	C8		red	C12		red
E4		orange	E8		orange	E12		orange
G4		yellow	G8		yellow	G12		yellow
						H13	C	black
						B13		green
						D13		blue
						F13		white

### 2.8.2 4205-1000 UNIVERSAL CABLE, TWO CONNECTORS

The 4205-1000 universal cable assembly is identical to the 4205-1010 cable assembly, above, except both ends are terminated in 52-pin plugs.

PLUG, 52-PIN-  
CONNECTS TO DATA OUTPUT SOCKET SO3  
OR AUXILIARY SOCKET SO2 ON CONTROL UNIT

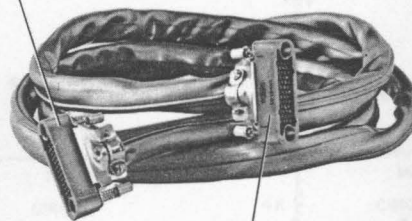

PLUG, 52-PIN PLUG,  
CONNECTS TO SUPPLEMENTARY  
EQUIPMENT

## • 2.9 ANALOG OUTPUT

A digital-to-analog converter can be used to convert the digital information from the bridge to analog information. An analog output is useful to plot capacitance vs temperature, capacitance vs bias voltage, or dissipation factor vs temperature, etc. The Type 1136 Digital-to-Analog Converter will select any three consecutive columns, or the last two columns, from the bridge and convert them to a voltage or a current.

### 2.9.1 EQUIPMENT

- 1136-9402 Bench model Type 1136 Digital-to-Analog Converter for use with the bridge assembly. Includes 1136-0230 cable.
- 1136-9502 Rack model Type 1136 Digital-to-Analog Converter for use with the bridge assembly. Includes 1136-0230 cable.
- 1136-0230 Single converter cable; supplied with 1136-9402 and 1136-9502 converters.
- 1136-0270 Double converter cable; available to connect two converters to bridge assembly.

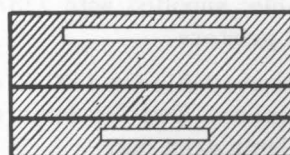
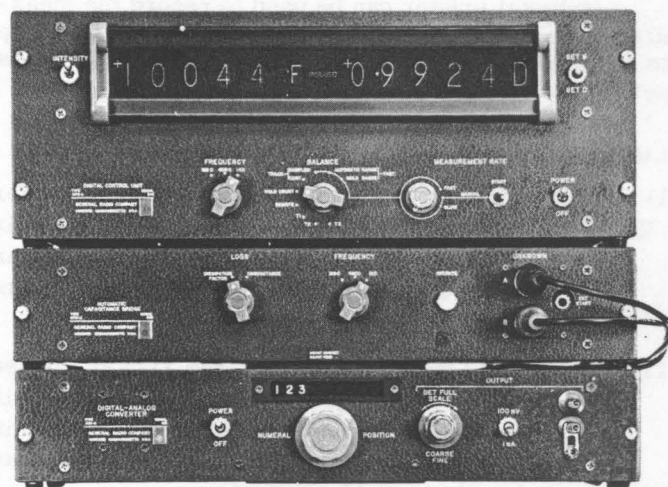

BRIDGE ASSEMBLY  
TYPE 1136 DIGITAL-TO-ANALOG CONVERTER

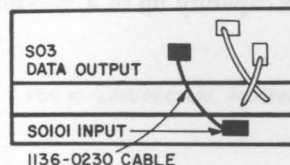

BRIDGE ASSEMBLY  
TYPE 1136 DIGITAL-TO-ANALOG CONVERTER  
1136-0230 CABLE

### 2.9.2 OUTPUT

The 1136-0230 cable is wired so that capacitance data from the bridge is connected to digits 1 through 5 in the converter, nothing is connected to digit 6, and the last three loss figures are connected to digits 7 through 9. Other formats are possible with changes in the cable wiring.

Simultaneous analog outputs of both capacitance and loss requires two converters and an 1136-0270 double converter cable.

The full scale output (999 level) is adjustable by means of two front-panel controls.

CONVERTER SOURCE IMPEDANCE	BINARY INPUT	CONVERTER VOLTAGE	OUTPUT CURRENT
15 kΩ	000	0	0
	999	15 V	1 mA
100 Ω	000	0	0
	999	100 mV	1 mA

### VISUAL REGISTER



### OUTPUT CONVERTER DIGITS

1 2 3 4 5 6 7 8 9

1 4 6

or

4 6 8

or

6 8 7

or

8 7

or

3 2 6

or

2 6 0



## • 2.10 DIGITAL RECORDING

A digital printer can be used to record the measurements. The Type 1137 Data Printer can record up to 12 columns at a maximum print rate of three lines per second.

### 2.10.1 EQUIPMENT

- 1137-9743 Portable model Type 1137 Data Printer for use with the bridge assembly. Includes six BCD Plug-In Code Modules for 6-column print out and an 1137-0220 cable which can handle up to 11 columns.
- 1137-9744 Rack model Type 1137 Data Printer for use with the bridge assembly. Includes six BCD Plug-In Code Modules for 6-column print out and an 1137-0220 cable which can handle up to 11 columns.
- 1137-0220 11-column cable; supplied with 1137-9743 and 1137-9744 printers.
- 1137-9607 7-column cable; available for 1137-9743 and 1137-9744 printers. Two 7-column cables provide 12-column print out.
- 1137-9604 BCD Plug-In Code Modules; available to increase printer capacity up to a maximum of 12 columns.

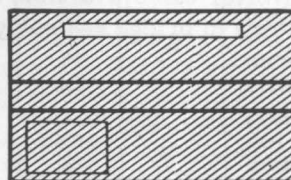
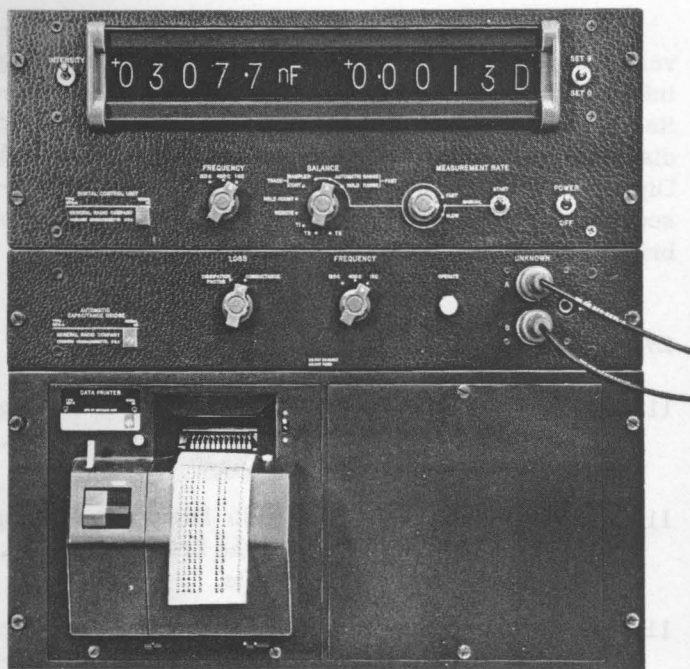

BRIDGE ASSEMBLY  
TYPE 1137 DATA PRINTER

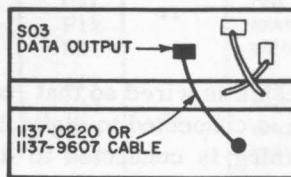

BRIDGE ASSEMBLY  
TYPE 1137 DATA PRINTER  
1680-35

### 2.10.2 RECORD

6 column. Standard 1137-9743 or 1137-9744 printer. Columns 1 through 5 indicate capacitance and column 12 indicates range!

11 column. 1137-9747 or 1137-9744 with 5 additional 1137-9604 modules. Columns 1 through 5 indicate capacitance, columns 7 through 11 indicate loss, and column 12 indicates range.

11 column. Same as above except first digit of loss was dropped (it is usually zero when capacitors are measured) to provide a space between loss and range.

Digits can be arranged in any order by interchanging the socket for each digit. This is done inside the printer where the modules plug into the cable connectors. A table on the rear of the printer shows which socket is associated with each column of the printer.

### VISUAL REGISTER



### PRINT OUT PRINTER COLUMNS

	1	2	3	4	5	6	7	8	9	10	11	12
6 column	1	4	6	8	7							2
11 column	1	4	6	8	7	0	1	3	2	6		2
11 column	1	4	6	8	7	1	3	2	6			2

### 2.10.3 DATA READY AND BALANCE

In addition to the measurement BCD signals, a signal is required to tell the printer when to print. For the Type 1137 Data Printer, this signal must be a 1-to-0 transition, must remain 0 for at least 100 ms to allow the printer to recover.

Also, in order not to record false data, the print command must be given when the bridge is ready; i.e., not presetting or balancing.

**PRT'.** The 1-to-0 transition of the PRT' signal from the bridge is the print command signal to the printer. The 0 level of the PRT' signal indicates the bridge has completed a balance and the measurement data is ready to be used.

**IXP.** The IXP input to the bridge from the printer prevents the bridge from starting a balance operation while the printer is setting up for a printing operation, printing, or recovering from a printing operation.

An IXP signal does not prevent the bridge from presetting and therefore is not normally used. Instead, the MEASUREMENT RATE control on the control unit of the bridge assembly is set so the maximum print rate of the printer is not exceeded. This ensures the print command is issued at a time when both the printer and bridge are ready.

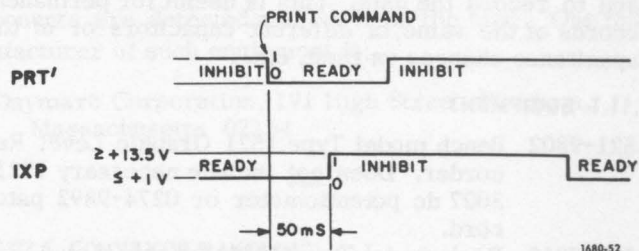

1680-52

### 2.10.4 MANUAL PRINT

FOR 4-LINE-BCD PRINTER MODULES

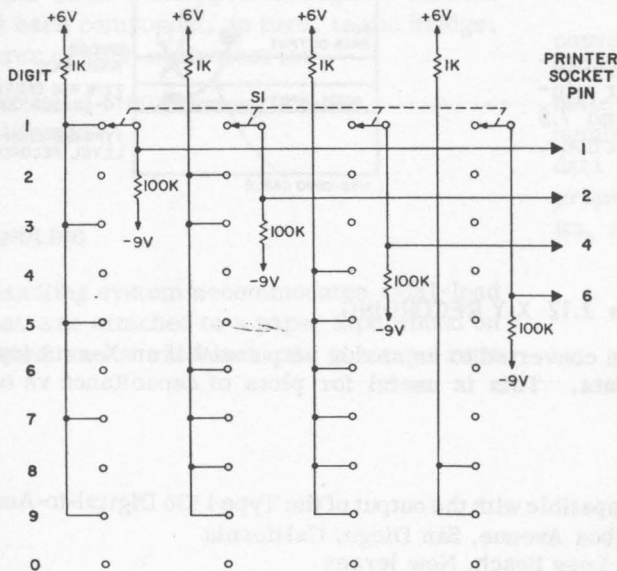

FOR 10-LINE-DECIMAL PRINTER MODULES

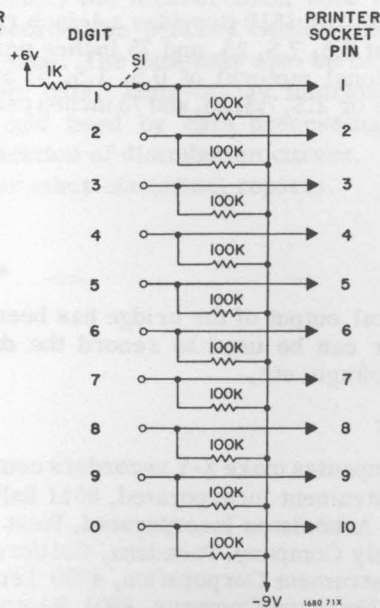

Serial number information can be manually inserted in the printer by means of an external switch box. The circuit configuration of the box depends on the type of code modules used in the printer (1137-9604 4-line or 1137-9605 10-line). One switch for each digit

is necessary; i.e., if the highest serial number is 999, three switches are required.

In addition to the wiring shown, a PRT' signal (available from the bridge) is required to initiate the print operation.

## ● 2.11 DC RECORDING

If the digital output of the bridge has been converted to an analog output, a dc level recorder can be used to record the data. This is useful for permanent records of the value of different capacitors or of the capacitance changes vs time, etc.

### 2.11.1 EQUIPMENT

- 1521-9802 Bench model Type 1521 Graphic Level Recorder. Does not include necessary 1521-3007 dc potentiometer or 0274-9892 patch cord.
- 1521-9812 Rack model Type 1521 Graphic Level Recorder. Does not include necessary 1521-3007 dc potentiometer or 0274-9892 patch cord.
- 1510-9402 Type 1510 Digital-to-Graphic Recording Assembly for either bench or rack mount. Includes Type 1136 Digital-to-Analog Converter, Type 1521 Graphic Level Recorder, 1521-3007 dc potentiometer, 0274-9892 patch cord, and 1136-0230 single converter cable.
- 1521-3007 Dc potentiometer. Necessary to adapt Type 1521 for use with Type 1136. Supplied with 1510-9402 recording assembly.
- 0274-9892 Type 274-NPM Double-Plug Patch Cord; double 3/4-inch-spaced banana plugs on each end. For connection from converter to recorder. Supplied with 1510-9402 recording assembly.
- 1521-3007 Dc potentiometer. Necessary to adapt Type 1521 for use with Type 1136. Supplied with 1510-9402 recording assembly.

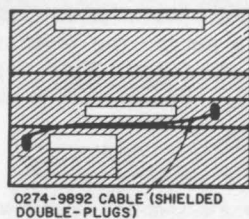
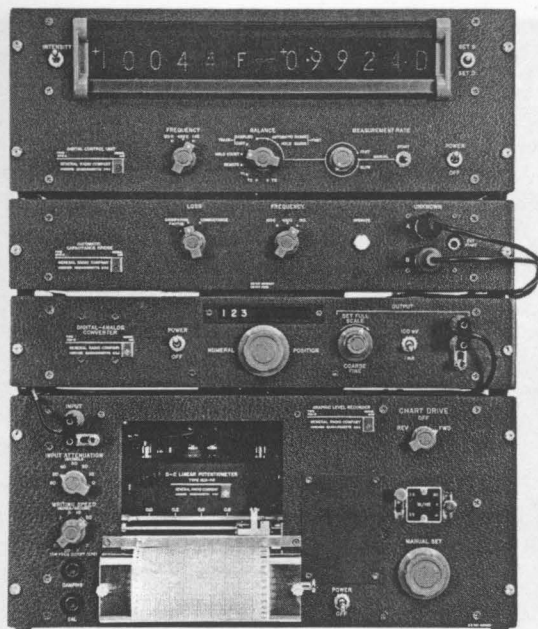

BRIDGE ASSEMBLY  
TYPE 1136 DIGITAL-TO-ANALOG CONVERTER  
TYPE 1521 GRAPHIC LEVEL RECORDER

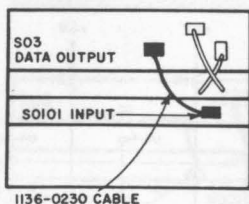

BRIDGE ASSEMBLY  
TYPE 1136 DIGITAL-TO-ANALOG CONVERTER  
TYPE 1521 GRAPHIC LEVEL RECORDER

1680-83

### 2.11.2 RECORD

The Type 1521 or 1510 provides a 4-inch recording with a speed of 2.5, 7.5, 25, and 75 inches per minute or (with optional motors) of 0.5, 1.5, 5, and 7.5 inches per minute or 2.5, 7.5, 25, and 75 inches per hour.

## ● 2.12 X-Y RECORDING

If the digital output of the bridge has been converted to an analog output and if an X-axis input is provided, an X-Y recorder can be used to record the data. This is useful for plots of capacitance vs temperature, or capacitance vs voltage, etc.

### 2.12.1 EQUIPMENT

The following companies make X-Y recorders compatible with the output of the Type 1136 Digital-to-Analog Converter:

- Electro Instrument Incorporated, 8611 Balboa Avenue, San Diego, California
- Electronic Associates Incorporated, West Long Beach, New Jersey
- F. L. Mosely Company, Pasadena, California
- Houston Instrument Corporation, 4950 Terminal Avenue, Bellaire, Texas
- Leads and Northrup Company, 4901 Stanton Avenue, Philadelphia, Pennsylvania
- Sanborn Company, 175 Wyman Street, Waltham, Massachusetts
- Varian Associates, 611 Hansen Way, Palo Alto, California.

The following companies make transducers to convert temperature to voltage (for the X-axis input):

- Lion Research Corporation, 32 Potter Street, Cambridge, Massachusetts 02142
- Disa Elektronik A/S, Herley, Denmark.

## ● 2.13 PERIPHERAL EQUIPMENT

For further details on this equipment or its incorporation into a system, contact your nearest General Radio Sales Engineering Office (listed on the rear of the book).

### 2.13.1 LIMIT COMPARISON

A limit comparator is a digital calculator with upper and lower limits to which the measurement values from the bridge are compared. It is used to sort or classify components and often provides an output for automatic sorting equipment.

### 2.13.2 SCANNING

A scanner is a switching device that automatically selects, in sequence, each unit from a group of components (1 to 100) for measurement by the bridge.

### 2.13.3 STICK HANDLING

A stick-and-indexer handling system accommodates 10 to 100 components which are loaded into a magazine (stick). The stick can be placed in a test chamber (high temperature, high humidity, or other desired test conditions such as provisions for energizing, life testing, or aging the components). When measurements are desired, the stick is stepped through an indexer which connects each component, in turn, to the bridge. One manufacturer of such equipment is:

Atescar of California, 11008 Downey Avenue,  
Downey, California.

### 2.13.4 REEL HANDLING

A reel-handling system accommodates axial-lead components that are attached to a paper tape wound on a reel and loaded into a machine. As the tape runs

through the machine, the component is measured and, if a limit comparator is used, out-of-tolerance components are detected and cut from the tape. One manufacturer of such equipment is:

Daymarc Corporation, 191 High Street, Waltham,  
Massachusetts 02154

### 2.13.5 CONVEYOR HANDLING

A conveyor handling system accommodates axial-lead components which are placed in a drum or vibratory-bowl feed system. The components pass through lead-straightening devices to a conveyor line where each component is connected to the bridge, measured, and, if a limit-comparator and sorting device is used, sorted into the proper bin. Two manufacturers of such equipment are:

Daymarc Corporation, 191 High Street, Waltham,  
Massachusetts 02154  
Universal Instruments Corporation, 137 East Frederick  
Street, Binhamton, New York.

### 2.13.6 DATA PROCESSING

With the proper intercoupler (parallel-to-serial converter) the measurement data from the bridge can be recorded on punched cards, punched tape, or magnetic tape. The data may also be combined with serial-number data, time-of-day information, or other test data and used by data processing equipment for the preparation of distribution curves, environmental limits, or other statistical reports.

...the ... of ...

...the ... of ...

...the ... of ...

...the ... of ...

...the ... of ...

...the ... of ...

...the ... of ...

...the ... of ...

...the ... of ...

...the ... of ...

...the ... of ...

...the ... of ...

...the ... of ...

...the ... of ...

...the ... of ...

...the ... of ...

...the ... of ...

...the ... of ...

...the ... of ...

...the ... of ...

...the ... of ...

...the ... of ...

...the ... of ...

...the ... of ...

...the ... of ...

...the ... of ...

...the ... of ...

...the ... of ...

...the ... of ...

...the ... of ...

...the ... of ...

...the ... of ...

...the ... of ...

...the ... of ...

...the ... of ...

...the ... of ...

...the ... of ...

...the ... of ...

...the ... of ...

...the ... of ...

...the ... of ...

...the ... of ...

...the ... of ...

2.1.2 STICK HANDLING

A stick-and-bridge assembly is used to handle a stick...

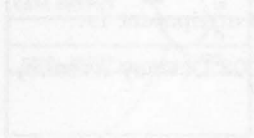

2.1.3 REEL HANDLING

A reel-handling system is used to handle a reel...

REFERENCES

- 1. ...
- 2. ...
- 3. ...
- 4. ...
- 5. ...
- 6. ...
- 7. ...
- 8. ...
- 9. ...
- 10. ...