

**OPERATING AND MAINTENANCE  
INSTRUCTIONS**

for

**TYPE 1110-A  
INTERPOLATING  
FREQUENCY STANDARD**

ASCO LABORATORY CORPORATION  
1976 S. RICHLEY STREET  
SANTA ANA, CALIFORNIA



**GENERAL RADIO COMPANY**

**CAMBRIDGE 39**

**MASSACHUSETTS**

**NEW YORK**

**CHICAGO**

**LOS ANGELES**

**U. S. A.**

**OPERATING AND MAINTENANCE  
INSTRUCTIONS**

for

**TYPE 1110-A  
INTERPOLATING  
FREQUENCY STANDARD**

Form 678-C  
July, 1953



**GENERAL RADIO COMPANY**

**CAMBRIDGE 39**

**MASSACHUSETTS**

**NEW YORK**

**CHICAGO**

**LOS ANGELES**

**U. S. A.**

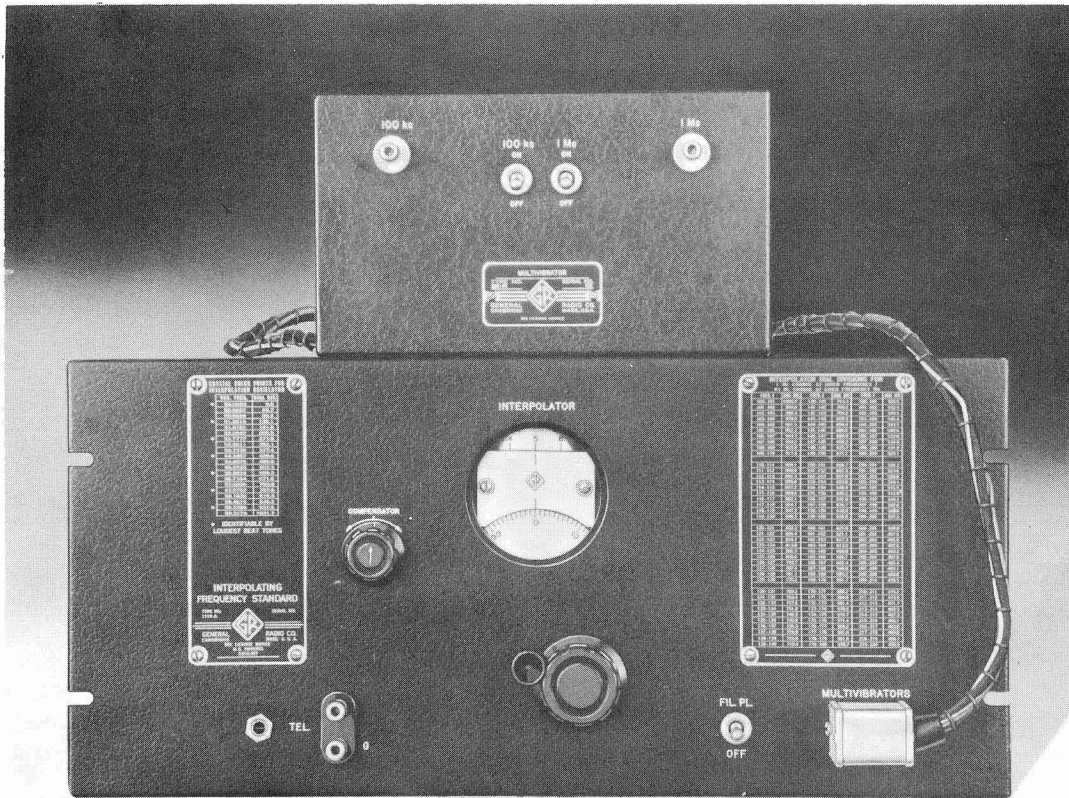

Panel View of the Type 1110-A Interpolating Frequency Standard and the Type 1110-P1 Multivibrator

### SPECIFICATIONS

**Frequency Range:** The output frequency range of the 1110-A Interpolating Frequency Standard is from 1000 to 1010 kc. The output frequencies of the 1110-P1 Multivibrator Unit are 1.0- and 0.1-Mc fundamentals with harmonics up to 200 or more.

**Calibration:** The variable frequency oscillator dial has 1000 divisions corresponding to 0.001 per cent or 10 parts per million per division.

A list of check settings is provided on the panel. This check can be made at any time by simply plugging a set of headphones into the jack or binding posts provided on the panel. A trimmer control on the panel provides for adjusting the oscillator to agreement with the crystal.

To facilitate conversion of the dial readings from their basic percentage or parts per million values of frequency increment to fractions of a megacycle or of 0.1 Mc (100 kc), a table listing the number of dial divisions for frequency increments of 1.0 Mc and 0.1 Mc at each harmonic from 100 to 220 is given on the panel. A simple slide-rule ratio then gives the desired frequency increment.

**Crystal Oscillator:** The crystal oscillator is adjusted to within 1 part in a million of correct frequency at room temperature. It should be reliable to within  $\pm 10$  parts per million at ordinary room temperatures. The crystal frequency can be checked and adjusted in terms of standard frequency transmissions from WWV using an

external receiver, maintaining the variable oscillator at exactly 50 kc in terms of the crystal.

**Accuracy of Measurement:** The over-all accuracy of measurement is  $\pm 25$  parts per million using the oscillator dial directly. If the oscillator is carefully trimmed in terms of the crystal, the over-all accuracy is limited principally by the error of the crystal.

**Vacuum Tubes:** The following tubes are supplied:

2 — 6AC7	3 — 6J5GT/G
4 — 6SN7-GT	1 — 5R4GY
1 — 6SJ7	1 — 9001
1 — 6SA7	1 — 2LAP-430 (Bridge Circuit Lamp)

**Power Supply:** Either 105-125 or 210-250 volts, 50-60 cycles.

**Power Input:** 85 watts from 115-volt, 60-cycle line.

**Mounting:** TYPE 1110-A Relay Rack; TYPE 1110-P1 (attached to 1110-A by cable) small metal cabinet.

**Accessories Supplied:** Line connector cord, and TYPE 1110-P1 Multivibrator Unit with connecting cable.

**Accessories Required:** Head telephones.

**Dimensions:** 1110-A Panel (length) 19 x (height)  $8\frac{3}{4}$ ; behind panel, (length)  $17\frac{1}{4}$  x (height)  $8\frac{3}{8}$  x (depth) 14 inches. 1110-P1 (length)  $9\frac{1}{4}$  x (height)  $5\frac{1}{4}$  x (depth)  $5\frac{1}{4}$  inches.

**Net Weights:** Type 1110-A assembly, 40 pounds; TYPE 1110-P1 Multivibrator Unit,  $7\frac{1}{2}$  pounds.

Manufactured and sold under United States Letters Patent:

2,012,497

United States Letters Patent owned or controlled by American Telephone and Telegraph Company, and under all patents and patent applications of Dr. G. W. Pierce pertaining to piezo-electric crystals and their associated circuits.

# OPERATING INSTRUCTIONS

for

## Type 1110-A Interpolating Frequency Standard

### SECTION 1.0 INTRODUCTION

The Type 1110-A Interpolating Frequency Standard is designed as a means to improve greatly the accuracy of frequency measurements made with the heterodyne-frequency meters, such as the Types 720-A and 620-A.

The Type 1110-A Interpolating Frequency Standard comprises a standard frequency source having a range of 1 per cent, from 1000 to 1010 kc, and is used with the Type 1110-P1, a harmonic generator of the multivibrator type which generates multiples of 1 Mc and 100 kc. By adjustment of the frequency of the standard, complete coverage is obtained at frequencies above 100 Mc, using 1 Mc harmonics and above 10 Mc, using 100 kc harmonics.

Thus integral standard frequencies can be generated for calibration purposes, or an accurately known frequency can be generated to match any desired frequency.

With the Type 620-A Heterodyne Frequency Meter, the approximate range of measurement is from 10 Mc to 200 Mc. With the Type 720-A Heterodyne Frequency Meter, the range is from 100 Mc to 2000 Mc. The dial setting for zero beat with the unknown signal, either fundamental or harmonic, is obtained in the usual manner on the heterodyne frequency meter. The Type 1110-A Interpolating Frequency Standard provides a means of evaluating more precisely the frequency to which the dial is set.

### SECTION 2.0 PRINCIPLES OF OPERATION

The output of the Type 1110-A Interpolating Standard is a single frequency, lying between 1000 and 1010 kc, and is the sum of a crystal oscillator frequency of 950 kc and of a bridge-type tuned-circuit oscillator of 50 to 60 kc. The oscillator is controlled by a dial having 1000 divisions.

The output frequency of the standard is used to control the multivibrators of the Type 1110-P1 Multivibrator Unit. The multivibrator fundamental frequencies are 1.0 Mc and 100 kc. A large number of harmonics are available but in particular the range from the 100th to 200th is utilized with the Types 720-A and 620-A Heterodyne Frequency Meters.

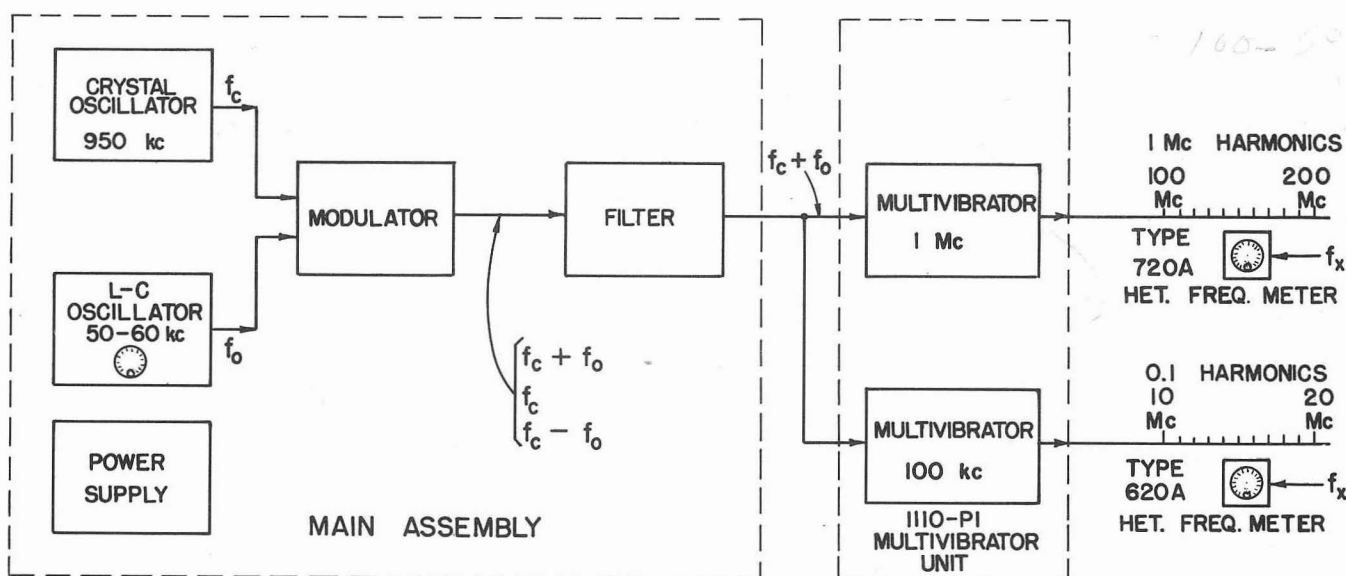

Figure 1. Block Diagram for Type 1110-A and Type 1110-P1

## GENERAL RADIO COMPANY

Figure 1 is a block diagram of the system.

Interpolation is accomplished by the method of "sliding harmonics." This process is illustrated in Figure 2. When the dial of the interpolating frequency standard is set at zero, harmonics of the output frequency,  $f_s$ , are spaced at frequency intervals  $f_s$  in the spectrum. When  $n$  is 100, the available 1% range of variation of  $f_s$  is just sufficient to cover the range from  $nf_s$  to  $(n+1)f_s$ , that is,  $\Delta f$  is equal to  $f_s$ . At the 200th harmonic ( $n=200$ ), the range is therefore  $2f_s$ . To measure a frequency, the dial is advanced to move  $nf_s$  to  $nf'_s$ , giving a scale difference,  $\Delta$ , from which  $\Delta f$  can be calculated.

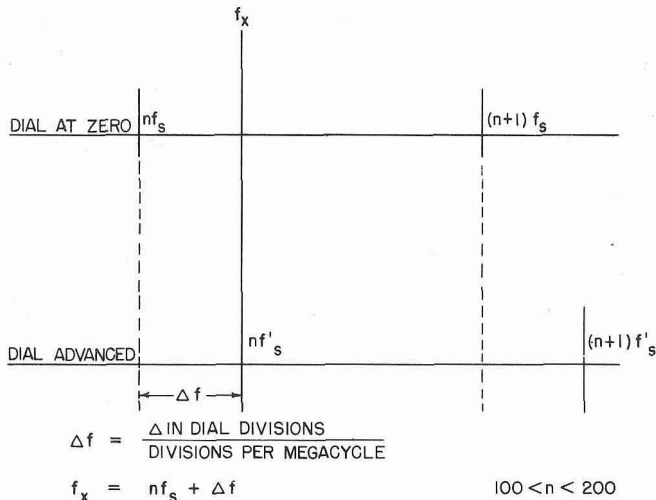

Figure 2.

As the oscillator control is moved from zero to full scale, the output frequency of the standard is varied from 1000 to 1010 kc, a range of 1%. The frequencies of the harmonics of the multivibrators controlled by these output frequencies are similarly changed by 1%. At the 100th harmonic, the increase of 1% gives a frequency 101 times the original fundamental, that is, the 100th harmonic is moved through the range from 100 to 101 Mc for the 1 Mc multivibrator, or from 10.0 to 10.1 Mc for the 100

kc multivibrator. For all higher harmonics the range of variation is greater than the fundamental frequency so that complete coverage is obtained at all frequencies above that of the 100th harmonic.

While complete coverage is not obtained at frequencies below that of the 100th harmonic, the substantial coverage is often very useful. The range covered at each harmonic is 1%, so that the extent of the available coverage is readily estimated. For example, at 95 Mc the coverage is 0.95 Mc, that is, from 95.00 Mc to 95.95 Mc. And again, at 67 Mc the coverage is 0.67 Mc, that is, from 67.00 Mc to 67.67 Mc.

When the oscillator control of the Type 1110-A Interpolating Frequency Standard is set at zero, or more precisely, when the oscillator is set at 50 kc, (which can be checked in terms of the internal crystal frequency) the output frequency is just 1000 kc, and all multivibrator harmonics are then integral standard frequencies which can be conveniently used in calibrating, or in checking the calibration of, the heterodyne frequency meters. Such calibrations are needed to identify the multivibrator harmonic used in a measurement. The accuracy of the frequency meter calibration does not otherwise enter into the final result.

The basic method of measurement is then as follows:

1. Set the heterodyne frequency meter to zero beat with the frequency being measured. An approximate result is then given by the dial reading of the heterodyne frequency meter.
2. Couple the output of the multivibrator to the frequency meter. Advance the control of the interpolating standard from zero until the first strong beat between a multivibrator harmonic and the frequency meter is obtained. Set to zero beat.
3. The frequency being measured is then given by the frequency of the multivibrator harmonic being used (identified automatically by the frequency meter reading), plus an increment in frequency (determined from the dial of the interpolating frequency standard).

Detailed examples are given under Operation, Section 4.

### SECTION 3.0 INSTALLATION

1. Plug the power cord into the instrument (rear) and connect to power line of voltage and frequency as marked on nameplate beside the socket.

2. Plug the cable of the Type 1110-P1 Multivibrator Unit into the multipoint socket on the panel of the Type 1110-A Interpolating Frequency Standard.

3. Provide a short coupling wire from the desired output terminal of the multivibrator unit to the frequency meter.

4. A pair of telephone receivers, which can be plugged into the heterodyne frequency meter, or the jack on the panel of the interpolating frequency standard, should be provided.

# TYPE 1110-A INTERPOLATING FREQUENCY STANDARD

## SECTION 4.0 OPERATION

### 4.1 Use of Instrument

4.11 Throw on power switch of the interpolating frequency standard. Throw on one of the power switches of the multivibrator unit, according to whether a 1 Mc or 0.1 Mc harmonics output is desired. It is not recommended that both multivibrators be used continuously.

4.12 Set dial of interpolating frequency standard to zero. Adjust compensator control for zero beat with phones plugged into jack on interpolating frequency standard.

4.13 Plug telephones into heterodyne frequency meter output. Turn on heterodyne frequency meter and vary its frequency. Zero beat points should be obtained at every 1 Mc in the range 100 to 200 Mc or at every 0.1 Mc in the range 10 to 20 Mc.

4.14 In making measurements, set the fundamental (or known harmonic) frequency of the heterodyne frequency meter to zero beat with the frequency to be measured. Note reading of frequency meter. Couple the output of the multivibrator unit to the frequency meter and listen in telephones plugged into the heterodyne frequency meter output. Advance the dial of the interpolating frequency standard from zero until the first strong beat is obtained within the dial range corresponding to the harmonic used (see 4.16). In this example, the first strong beat in the interval from zero to 617.3 divisions is used.

4.15 Carefully set the interpolating frequency standard dial for zero beat. Note the final dial reading. (For example, 199.8 divisions). For the most precise results, the oscillator calibration should be checked before the final dial reading is taken. See Section 4.2 following.

4.16 From the reading of the heterodyne frequency meter determine which multivibrator harmonic was used. (Example: Reading is 162.3 Mc. The harmonic used is 162. Enter the table on the panel at 162-163 Mc and find the number of divisions required to cover 1 Mc between 162 and 163 Mc.) The final dial reading of the interpolating frequency standard divided by the number of divisions from the table gives the fraction of a megacycle (or 0.1 Mc) which must be added to the frequency of the used harmonic to obtain the final result. Example: Table value at 162-163 Mc is 617.3 divisions. Final dial reading was 199.8 divisions. The final result is

$$f_x = 162 + \frac{199.8}{617.3} \times 1 \text{ Mc}$$

$$f_x = 162.324 \text{ Mc}$$

In other words, the frequency of the 162nd harmonic was increased 0.324 Mc in going from 162 Mc to  $f_x$ .

4.17 Many times it is desired to measure changes in frequency of an oscillator resulting from arbitrary changes in the conditions of operation. In this case, the

initial frequency is measured as previously described. The changes in frequency can then be read as the changes in dial reading from the reading for the initial condition. Since each division very closely represents a change of 10 parts per million (see Section 4.18), the changes in dial reading are easily converted to frequency changes in parts per million. Also, since each dial division represents a change in the control frequency of 10 cycles, the changes in dial reading are convertible into cycles change at the test oscillator frequency by multiplying by 10 and by the number of the harmonic used in the measurement of the initial frequency.

4.18 When observing changes in frequency of an oscillator whose frequency is only slightly higher than a multiple of 1 Mc, the parts per million change by dial readings corresponds almost exactly with the parts per million change in the oscillator frequency. However, if the oscillator frequency lies just below the next higher multiple of 1 Mc for example 162.98 Mc, it is evident that 1 part per million is 162.98 cycles. This frequency would be measured by raising the 162 harmonic from 162 Mc to 162.98 Mc. On the dial, each division then corresponds to 10 parts per million of 162 Mc or 1620.0 cycles. One part per million would be 162.00 cycles, instead of 162.98 cycles, which error is negligible for many purposes.

### 4.2 Checking the Interpolation Oscillator

4.21 By plugging the telephones into the jack on the panel of the Type 1110-A Interpolating Frequency Standard, the calibration of the 50-60 kc oscillator can be checked in terms of the crystal oscillator. A number of check points, over the entire range of the oscillator dial, are listed in the table on the panel.

4.22 Assuming the oscillator alignment is normal, any small errors in calibration can be made zero at any of the check settings by use of the compensator control. To do this, set the dial to the number of divisions given in the table and adjust the compensator knob to get zero beat.

4.23 When the best possible accuracy of measurement is desired, the oscillator should be checked, and corrected, if necessary, immediately after the beat is obtained between the standard and the frequency meter, Paragraph 4.14 above. The final reading is then taken.

### 4.3 Checking the Crystal Oscillator

4.31 Since the multivibrator unit provides output frequencies at all of the frequencies used for the Bureau of Standards' Standard Frequency Transmissions, it is possible to check the crystal oscillator by obtaining a beat between the standard frequency and multivibrator harmonic in a short-wave receiver. If the receiver can be made to oscillate or if it includes a heterodyning oscillator, the check can be made very precisely.

## GENERAL RADIO COMPANY

4.32 After picking up the standard frequency transmission, couple the appropriate multivibrator output into the receiver. The dial of the interpolating frequency standard may be advanced slightly from zero so as to produce an audible beat in the receiver. This will facilitate making the coupling adjustments.

4.33 Plug the telephones into the panel jack on the interpolating frequency standard and carefully set the oscillator to obtain zero beat at the check point "O" on the dial. It does not matter if the dial reading is not exactly zero as long as the zero beat is maintained. Check in the short wave receiver to determine the difference in frequency between the standard frequency and the output of the interpolating frequency standard. This difference should be only a few parts in a million.

4.34 To correct the crystal frequency, remove the snap cover in the lower left of the interpolating frequency standard panel and use a screw driver to adjust C-17. NOTE: At each adjustment of C-17, carefully reset the oscillator dial to zero beat against the crystal at the "O" reference point. Then check the output frequency of the standard against the standard frequency transmission. The normal crystal frequency is 950 kc. When the oscillator is set to zero beat against the crystal at the "O" reference point, its frequency is close to 50 kc and is actually 1/19th of the crystal frequency. The control frequency for the multivibrator unit is the sum of these, and is close to 1000 kc. The output frequency matched against the standard frequency transmission is this frequency multiplied by the number of the harmonic used. (For example, if the 5 Mc standard frequency transmission is used, the output frequency must be five times the control frequency.)

### 4.4 Checking the Oscillator Alignment

4.41 To obtain a direct-reading linear calibration of the oscillator several conditions must be met simultaneously. First, the plate shape of the condenser must be correct. Second, the initial circuit capacitance must have the correct value, appropriate to the change in capacitance produced by the shaped rotor plates. When these conditions are met, the calibration will be linear and the correct frequency ratio (maximum frequency divided by minimum frequency) will be obtained. In this case, the correct ratio is  $60/50 = 1.20$ , since it is desired to have the oscillator cover the range from 50 to 60 kc, between the zero and 1000 division points on the dial. In order to have the oscillator cover exactly the specified range it is then necessary to adjust the circuit inductance so that the initial frequency is exactly 50 kc. Manufacturing tolerances impose a limit on just how closely this ideal can be approached. In this instrument, alignment to within  $\pm$  two divisions is considered satisfactory.

4.42 Small corrections can be made by means of the compensator condenser (part of C-7) panel control. For small corrections, the primary effect of changing the initial capacitance is to move the calibration curve bodily up or down, and the secondary effect is to change the shape of the calibration curve. Over small portions of the

curve, the change in shape is negligible. The dial reading can thus be made to fit the ideal curve at any point where a means for comparison is available. In this instrument the crystal oscillator furnishes this means at a sufficiently large number of points covering the entire range of the oscillator.

4.43 The list of oscillator check points on the panel plate includes the principal points. Many other points can be found and these can be identified and used to advantage in many instances. The oscillator frequency at any zero beat point is given by  $f_o = \frac{m}{n} 950$  kc, where m and n are integers. The principal points are given when m = 1 and n has such value as to give  $f_o$  values lying between 50 and 60 kc. In this case, the 16th to 19th harmonic of the oscillator beats with the fundamental frequency of the crystal. The dial reading of the ideal oscillator is given by subtracting 50 kc from  $f_o$  and multiplying the remainder (in kc) by 100. For example, a check point is found at 52.055 kc, (where n = 73, m = 4). Subtracting 50 kc, 2.055 kc gives a dial reading of 205.5 divisions (as listed in the table).

4.44 If the oscillator requires realignment, it is evident from the foregoing that the misalignment might be due to a change of capacitance, or of inductance or a combination of both. The first test, then, should be to check the capacitance. This is done by measuring the oscillator frequency at equal steps in dial reading, or observing dial readings for equal steps in frequency. The latter is generally more convenient where a frequency standard is available. The oscillator is checked at every 1 kc (or 500 cycles) from 50 to 60 kc and dial readings noted. If the differences of successive dial readings are constant, the capacitance adjustment is correct. If these differences are not constant readjustment of the initial capacitance must be made. If the differences increase toward the high frequency end of the dial, the curve slopes "uphill" and an increase of initial capacitance is required to correct it. (Part of C-7, accessible through the openings of the top dial.)

4.45 When the capacitance has been checked, the next step is to adjust the inductance. This is done by removing the shield can from L-2 (to right of C-7 condenser assembly) and loosening the set screw holding the upper coil just sufficiently to permit the coil to be moved. Replace the shield can. Set the condenser dial at zero and check the oscillator frequency against a frequency standard. Adjust L-2 by carefully moving the the upper coil (upward to raise the frequency). When the frequency is exactly 50 kc, lock the upper coil in position.

4.46 If the calibration of the oscillator is not badly in error, the frequency can be checked against the internal crystal, but there is danger of setting to the wrong frequency if the error is appreciable. However, if, after setting to the 50 kc point, zero on the dial, a quick check of the principal check points at 277.8, 588.3 and 937.5 divisions is made, any error will immediately be disclosed because these additional points will not then agree at all settings listed in the table.

## TYPE 1110-A INTERPOLATING FREQUENCY STANDARD

### 4.5 Checking Control of Multivibrators

4.51 For checking the 1 Mc Multivibrator, use an oscillating receiver set to obtain a beat against a low harmonic of the multivibrator, at 2, 3, 4, or 5 Mc. Because of the direct signal from the control oscillator, it is not recommended that a setting of 1 Mc be used. No attempt to adjust multivibrators should be made until they have been in operation at least 15 minutes.

4.52 If the multivibrator is not in control, the frequency of the harmonic will vary erratically and the beat tone heard in the receiver will be very unsteady. The multivibrator adjustments are accessible from the top of the Type 1110-P1 Unit, on removing the dust cover. Check that R-108, in the Type 1110-P1 Multivibrator, is in the full clockwise position. Then adjust C-108 (using an insulated screw driver or alignment tool) to either side of its previous setting, checking with the receiver to obtain a clear and steady beat tone. When such a point has been obtained, leaving the receiver adjusted, note the range over which C-108 can be turned while obtaining a steady beat tone in the receiver. Make the final setting of C-108 at the center of this range.

4.53 For checking the 100 kc Multivibrator, use an oscillating receiver set to obtain a beat against a low harmonic of the multivibrator, at 200 to 900 kc. Because of the direct signal from the control oscillator, it is not recommended that a setting of 1 Mc be used. No attempt to adjust multivibrators should be made until they have been in operation at least 15 minutes.

4.54 If the multivibrator is not in control, the frequency of the harmonic will vary erratically and the beat tone heard in the receiver will be very unsteady. The multivibrator adjustments are accessible from the top of the Type 1110-P1 Unit, on removing the dust cover. Check that R-101, in the Type 1110-P1 Multivibrator is in full clockwise position. Then adjust C-101 (using an insulated screwdriver or alignment tool) to either side of its previous setting, checking with the receiver to obtain a clear and steady beat tone. When such a point has been obtained, leaving the receiver adjusted, note the range over which C-101 can be turned while obtaining a steady beat tone in the receiver. Make the final setting of C-101 at the center of this range.

4.55 Unless the screwdriver has only a very small metal tip, the capacity added when the screwdriver is in

the slot of the condenser will shift the multivibrator frequency slightly. The range of adjustment of the condenser must then be determined by lifting the screwdriver out of the slot after each adjustment.

### 4.6 Checking Calibration of Frequency Meter

4.61 As described, the use of the interpolating frequency standard depends on the calibration of the frequency meter for the identification of the harmonic used. If the calibration were in error, the final result would be in error in that an incorrect harmonic number would be used.

4.62 The calibration is readily checked, or a frequency meter may be calibrated, as follows: Set the dial of the interpolating frequency standard at zero. Set the frequency meter at the reading believed to be 101 Mc, and carefully adjust to zero beat. Leaving the frequency meter alone, move the dial of the interpolating frequency standard to 1000 divisions. Zero beat should again be obtained. If it is, the frequency meter has been set to 101 Mc, and from this key the other calibration points are identified. If zero beat is reached at 990 or 1010 divisions, then the frequency was set at 102 or 100 Mc respectively.

4.63 If the frequency meter covers 10 to 20 Mc, the process is the same as before, using the 0.1 Mc output of the interpolating frequency standard. Set the dial of the interpolating frequency standard to zero. Set the frequency meter to the reading believed to be 10.1 Mc and carefully adjust to zero beat. Leaving the frequency meter alone, move the dial of the interpolating frequency standard to 1000 divisions. Zero beat should again be obtained. If it is, the frequency meter has been set to 10.1 Mc, and from this key the other calibration points are identified. If zero beat is reached at 990 or 1010 divisions, then the frequency meter was set at 10.2 or 10.0 Mc respectively.

4.64 In either case, a calibration can be made after identifying the key point by setting the dial of the interpolating frequency standard for zero beat at the "O" crystal check point. The output frequencies are then accurately 1.0 or 0.1 Mc. By tuning the frequency meter over its range and marking each point, a complete calibration can be made.



## Type 1110-A

# Service and Maintenance Instructions

### 1.0 FOREWORD

1.1 This Service Information together with the information given in the Operating Instructions should enable the user to locate and correct ordinary difficulties resulting from normal usage.

1.2 Most of the components mentioned in these instructions can be located by referring to the photographs.

1.3 Major service problems should be referred to the Service Department which will cooperate as far as possible by furnishing information and instructions, as well as by shipping any replacements parts which may be required. If the instrument is more than one year old, a reasonable charge may be expected for replacement parts or for complete reconditioning if the standard is returned.

1.4 Detailed facts giving type and serial numbers of the instrument and parts, as well as operating conditions, should always be included in your report to the Service Department.

### 2.0 GENERAL

If the standard becomes inoperative, a few simple checks should be made before any circuit checks are made.

2.1 Make certain the voltage and frequency of the power line source are correct.

2.2 Test the power supply cord for open circuits or for poor contacts in the power outlets.

2.3 Check fuses F-1 and F-2, mounted at the rear of the instrument, for open circuits and be sure they are tight in their holders.

2.4 Be sure that all tubes are completely seated in their sockets.

### 3.0 INSTRUMENT INOPERATIVE

3.1 NO OUTPUT SIGNAL AT THE 1 MC OUTPUT JACK; refer to Section 4.0.

3.2 NO OUTPUT SIGNAL AT THE 100 KC OUTPUT JACK; refer to Section 5.0.

3.3 NO OUTPUT SIGNAL AT SOCKET SO-1; refer to Section 6.0.

3.4 NO OUTPUT SIGNAL AT TEL JACK, J-1; refer to Section 7.0.

3.5 NO OUTPUT FROM THE CRYSTAL OSCILLATOR; refer to Section 8.0.

3.6 NO OUTPUT FROM THE VARIABLE OSCILLATOR; refer to Section 9.0.

3.7 OUTPUT SIGNAL IS ROUGH OR UNSTEADY; refer to Section 10.0.

3.8 OUTPUT BEATS INDISTINGUISHABLE FROM THOSE PLUS OR MINUS 50 KC AWAY; refer to Section 11.0.

3.9 MAIN DIAL IS OFF CALIBRATION; refer to Section 12.0.

3.10 POWER SUPPLY INOPERATIVE; refer to Section 13.0.

3.11 VACUUM-TUBE DATA; refer to Section 14.0.

### 4.0 NO OUTPUT SIGNAL AT THE 1 MC OUTPUT JACK

This condition can be readily detected by a lack of beat notes in the heterodyne-frequency meter when attempting to identify an unknown frequency.

4.1 Check switch S-102 for proper operation.

4.2 Make sure that rheostat R-108 is at its maximum clockwise position.

4.3 Check tube V-103 and operating voltages; refer to Section 14.0.

4.4 Check resistors R-108 through R-112 for open and short circuits and proper values.

4.5 Check capacitors C-108 through C-112 for open and short circuits. Capacitors C-108 and C-110 should have any accumulated dust blown out of their plates.

4.6 Check inductor L-101 for an open or a short circuit.

## TYPE 1110-A INTERPOLATING FREQUENCY STANDARD

4.7 Check tube V-104 and operating voltages; refer to Section 14.0.

4.8 Check resistors R-113, R-114 and R-115 for open and short circuits and proper values.

4.9 Check capacitors C-113, C-114 and C-115 for open and short circuits.

4.10 Check L-102 for an open or a short circuit.

### 5.0 NO OUTPUT SIGNAL AT THE 100 KC OUTPUT JACK

5.1 Check switch S-101 for proper operation.

5.2 Make sure that rheostat R-101 is set to its maximum clockwise position.

5.3 Check tube V-101 and operating voltages; refer to Section 14.0.

5.4 Check resistors R-101 through R-105 for open and short circuits and proper values.

5.5 Check capacitors C-101 through C-105 for open and short circuits. Capacitors C-101 and C-103 should have any accumulated dust blown out of their plates.

5.6 Check tube V-102 and operating voltages; refer to Section 14.0.

5.7 Check resistors R-106 and R-107 for open and short circuits.

5.8 Check capacitor C-106 for an open circuit.

### 6.0 NO OUTPUT SIGNAL AT SOCKET SO-1

This condition can be detected by the following procedure. Disconnect the Type 1110-P1 Multivibrator from the Type 1110-A Standard by pulling out plug PL-101. Connect a 1000-ohm resistor between terminals #7 or #8 and #12 of socket SO-1. Measure the voltage across this resistor using a vacuum-tube voltmeter. This should be 6 - 11 volts a.c. A low voltage or no voltage will cause the multivibrators to fall out of control.

6.1 Check tubes V-6, V-7 and V-8 and operating voltages; refer to Section 14.0.

6.2 Check resistors R-24 and R-30 for open and short circuits and proper values.

6.3 Check capacitors C-37 through C-44 for open and short circuits and leakage. Capacitors C-40 and C-42 should have any accumulated dust blown out of their plates.

6.4 Check tube V-5 and operating voltages; refer to Section 14.0.

6.5 Check resistors R-14A, R-20 through R-23 for open and short circuits and proper values.

6.6 Check capacitors C-25 through C-29 for open and short circuits.

6.7 Check inductor L-6 for an open or a short circuit.

6.8 Check the elements of the filter sections LC-1, LC-2, LC-3 and LC-4 for open and short circuits.

### 7.0 NO OUTPUT SIGNAL AT TEL JACK, J-1

This condition can be detected by plugging a pair of headphones into the TEL jack and listening for the beats listed on the left hand plate on the panel.

The voltage from the high potential terminal of TEL jack, J-1, to ground should be about 5.0 volts  $\pm 20\%$  with the main dial set to 0. (Tone will be heard for all positions of the COMPENSATOR control.)

7.1 Check that jack J-1 is making proper contacts.

7.2 Check tube V-3 and operating voltages; refer to Section 14.0.

7.3 Check resistors R-15, R-16 and R-17 for open and short circuits and proper values.

7.4 Check capacitors C-12 through C-16 for open and short circuits. Turn the main dial to settings both above and below 10 divisions which is necessary in the event that the variable oscillator has gotten out of alignment.

7.5 Check inductor L-4 for an open or a short circuit.

7.6 Refer to Sections 8.0 and 9.0.

### 8.0 NO OUTPUT FROM THE CRYSTAL OSCILLATOR

The output measured from the arm of rheostat R-14A to ground should be 0.9 - 1.5 volts a.c. as measured with a vacuum-tube voltmeter.

8.1 Check tube V-4 and operating voltages; refer to Section 14.0.

8.2 Check resistors R-13, R-18 and R-19 for open and short circuits and proper values.

8.3 Check capacitors C-17 through C-24 for open and short circuits.

8.4 Check inductor L-5 for an open or a short circuit.

8.5 The Quartz Plate, Type 376-L, may have stopped oscillating. If so a very light tap on its case should start it again.

8.6 In case this crystal is defective it should be reported to the Service Department immediately. Under no circumstances should the holder be opened or the seals broken by the user unless authorized by the Service Department as this procedure will void the guarantee.

## GENERAL RADIO COMPANY

The General Radio Company will not be responsible for the proper operation of the standard if the crystal seals have been broken.

### 9.0 NO OUTPUT FROM THE VARIABLE OSCILLATOR

The output of this oscillator, measured from pin #8 of tube V-5 to ground, should be approximately 1.4 volts a.c. measured with a vacuum-tube voltmeter. (The main dial should be set at 500 divisions.)

9.1 Check tubes V-1, V-2 and V-10 and operating voltages; refer to Section 14.0.

9.2 Check resistors R-1 through R-12 and R-14 for open and short circuits and proper values.

9.3 Check capacitors C-1 through C-5 and C-7 through C12 for open and short circuits.

9.4 Check inductors L-1, L-2 and L-3 for open and short circuits.

9.5 Set dial at 500, adjust rheostat R-7A so that the voltage measured across R-10 (or pin #4, V-2 to ground) is 3.0 volts.

### 10.0 OUTPUT SIGNAL IS ROUGH OR UNSTEADY

The multivibrators in the Type 1110-P1 are probably out of control. Check that a control voltage for the multivibrators is available by following the procedure of Section 6.0. The multivibrators can be checked and set by following the procedure of Paragraph 4.5 of the Operating Instructions.

10.1 Refer to Sections 4.0 and 5.0.

### 11.0 OUTPUT BEATS INDISTINGUISHABLE FROM THOSE PLUS OR MINUS 50 KC AWAY

This is an abnormal situation but little can be done to correct it. Normally if such spurious beat notes are present, they are the result of a modulation of the multivibrator control voltage. The multivibrator harmonics are modulated and each appears as a carrier frequency with upper and lower side bands, where the desired harmonic frequency is the carrier. If each beat has the same amplitude or intensity the correct one can always be identified as the center beat note. In a normal instrument the middle beat is always the stronger.

### 12.0 MAIN DIAL IS OFF CALIBRATION

The dial readings should be within +2 divisions of the settings shown on the panel when the variable oscillator is checked in terms of the crystal oscillator frequency. The COMPENSATOR control should be set for zero beat with the main dial set to 0.

12.1 The frequency of the crystal oscillator should be checked against a frequency standard or by the method outlined in Paragraph 4.3 of the Operating Instructions by comparing it with the standard frequency transmissions of the National Bureau of Standards, radio station WWV. The crystal oscillator frequency is 950 kilocycles. The crystal frequency can be adjusted by resetting capacitor C-17, available from the front panel.

12.2 Check the frequency alignment of the variable oscillator as outlined in Paragraphs 4.42 and 4.43 of the Operating Instructions. If realignment is necessary, follow the procedure of Paragraphs 4.44, 4.45, 4.46 of the Operating Instructions.

12.3 If the above procedure does not serve to adjust the frequency and span of the variable oscillator correctly, then the main capacitor is probably at fault. If this is the case, it will be necessary to return the complete instrument to the factory for repair.

### 13.0 POWER SUPPLY INOPERATIVE

13.1 Check tube V-9 and operating voltages; refer to Section 14.0.

13.2 Check condition of fuses F-1 and F-2.

13.3 Check capacitors C-45 and C-46 for short circuits.

13.4 Check operation of switch S-1.

13.5 Check that transformer T-1 has continuity of windings.

13.6 Check resistors R-26 through R-29 for open and short circuits and proper values.

13.7 Check capacitors C-47 through C-50 for open and short circuits.

TYPE 1110-A INTERPOLATING FREQUENCY STANDARD

14.0 VACUUM TUBE DATA

Table of tube socket voltages measured from socket pin to ground, unless otherwise indicated, using a 20,000 ohms-per-volt voltmeter (Weston 772 Analyzer). D-C voltages may vary  $\pm 20\%$ .

TYPE 1110-A

SYMBOL	TYPE	SOCKET PIN NUMBER								FUNCTION
		1	2	3	4	5	6	7	8	
V-1	6AC7		2 and 7 6.3 v. a.c.		0	2.2	130	---	125	Amplifier
V-2 <sup>a</sup> <sub>b</sub>	6SN7-GT	15	200	28	0	170	5.7	7 and 8 6.3 v. a.c.	---	Coupling Coupling
V-3 <sup>a</sup> <sub>b</sub>	6SN7-GT	-4.1	155		-23	-23	0	7 and 8 6.3 v. a.c.	---	Detector Audio Amplifier
V-4	6SJ7		2 and 7 6.3 v. a.c.			0.25	60	---	230	Crystal Oscillator
V-5	6SA7		2 and 7 6.3 v. a.c.	235	90	0.9 - 1.5 v. a.c.	5.4	---	5.7	Mixer
V-6	6AC7		2 and 7 6.3 v. a.c.		0	2.9	185	---	235	Band Pass Amplifier
V-7	6J5GT/G		2 and 7 6.3 v. a.c.	230	---	0	---	---	12.0	Amplifier
V-8	6J5GT/G		2 and 7 6.3 v. a.c.	230	---	0	---	---	9.0	Amplifier
V-9	5R4GY	---	2 and 8 5.0 v. a.c.	---	270 v. a.c.	---	270 v. a.c.	---	270	Rectifier
V-10	2LAP-430									Amplitude Control

TYPE 1110-P1

SYMBOL	TYPE	SOCKET PIN NUMBER								FUNCTION
		1	2	3	4	5	6	7	8	
V-101 <sup>a</sup> <sub>b</sub>	6SN7-GT	-24	100	0	-25	95	0	7 and 8 6.3 v. a.c.	---	Multivibrator
V-102	6J5GT/G	0	2 and 7 6.3 v. a.c.	240	---	0	---	---	25	Amplifier
V-103 <sup>a</sup> <sub>b</sub>	6SN7-GT	0	130	0	-6.4	140	0	7 and 8 6.3 v. a.c.	---	Multivibrator
V-104	9001	-1.3	3.9	3 and 4 6.3 v. a.c.	---	230	125	3.9	---	Amplifier

CONDITIONS:

Type 1110-P1 connected to Type 1110-A.  
 Input: 115 v. a.c., 60 cycles, power ON.  
 1 Mc multivibrator turned ON.  
 Main dial set to 0.

PARTS LIST

RESISTORS

R-1	= 220 or 200	$\Omega$ $\pm 10\%$	IRC	BW-1/2
R-2	= 47	$K\Omega$ $\pm 10\%$	IRC	BT-1
R-3	= 15	$K\Omega$ $\pm 10\%$	IRC	BT-1
R-4	= 1	$M\Omega$ $\pm 10\%$	IRC	BT-1/2
R-5	= 470	$\Omega$ $\pm 10\%$	IRC	BT-1/2
R-6	= 2200	$\Omega$ $\pm 10\%$	IRC	BT-1
R-7	= 120	$\Omega$ $\pm 2\%$	(C.C.Co.)	X-1/2
R-7A	= 1	$K\Omega$ $\pm 10\%$	IRC	W
R-8	= 300	$\Omega$ $\pm 2\%$	(C.C.Co.)	X-1/2
R-9	= 2700	$\Omega$ $\pm 10\%$	IRC	BT-1
R-10	= 1	$M\Omega$ $\pm 10\%$	IRC	BT-1/2
R-11	= 1	$K\Omega$ $\pm 10\%$	IRC	BT-1
R-12	= 10	$K\Omega$ $\pm 10\%$	IRC	BT-1
R-13	= 100	$K\Omega$ $\pm 10\%$	IRC	BT-1
R-14	= 15	$K\Omega$ $\pm 10\%$	IRC	BT-1
R-14A	= 2	$K\Omega$ $\pm 10\%$	IRC	W
R-15	= 100	$K\Omega$ $\pm 10\%$	IRC	BT-1
R-16	= 3.3	$M\Omega$ $\pm 10\%$	IRC	BT-1
R-17	= 22	$K\Omega$ $\pm 10\%$	IRC	BT-1
R-18	= 3.3	$M\Omega$ $\pm 10\%$	IRC	BT-1
R-19	= 220	$K\Omega$ $\pm 10\%$	IRC	BT-1
R-20	= 18	$K\Omega$ $\pm 10\%$	IRC	BT-1
R-21	= 1	$K\Omega$ $\pm 10\%$	IRC	BT-1
R-22	= 2700	$\Omega$ $\pm 10\%$	IRC	BT-1
R-23	= 100	$K\Omega$ $\pm 10\%$	IRC	BT-1
R-24	= 220 or 200	$\Omega$ $\pm 10\%$	IRC	BW-1/2
R-25	= 15	$K\Omega$ $\pm 10\%$	IRC	BT-1
R-26	= 100	$\Omega$ $\pm 10\%$	IRC	BW-2
R-27	= 100	$\Omega$ $\pm 10\%$	IRC	BW-2
R-28	= 100	$\Omega$ $\pm 10\%$	IRC	BW-2
R-29	= 100	$K\Omega$ $\pm 10\%$	IRC	BT-2
R-30	= 47	$K\Omega$ $\pm 10\%$	REC-21BF*	
R-31	= 68	$\Omega$ $\pm 10\%$	REC-20BF	
R-32	= 68	$\Omega$ $\pm 10\%$	REC-20BF	
R-101	= 1	$K\Omega$ $\pm 10\%$	GR	301-465
R-102	= 10	$K\Omega$ $\pm 10\%$	IRC	BT-1/2
R-103	= 10	$K\Omega$ $\pm 10\%$	IRC	BT-2
R-104	= 10	$K\Omega$ $\pm 10\%$	IRC	BT-1/2
R-105	= 10	$K\Omega$ $\pm 10\%$	IRC	BT-2
R-106	= 1	$M\Omega$ $\pm 10\%$	IRC	BT-1/2
R-107	= 3300	$\Omega$ $\pm 10\%$	IRC	BT-1/2
R-108	= 1	$K\Omega$ $\pm 10\%$	GR	301-465
R-109	= 3300	$\Omega$ $\pm 10\%$	IRC	BT-1/2
R-110	= 4100	$\Omega$ $\pm 10\%$		+++
R-111	= 3900	$\Omega$ $\pm 10\%$	IRC	BT-1/2
R-112	= 4100	$\Omega$ $\pm 10\%$		+++
R-113	= 100	$K\Omega$ $\pm 10\%$	IRC	BT-1/2
R-114	= 1	$K\Omega$ $\pm 10\%$	IRC	BT-1/2
R-115	= 100	$K\Omega$ $\pm 10\%$	IRC	BT-1/2

MISCELLANEOUS

S-1	= Switch	DPST	A.H. and H.	81024BM
S-101	= Switch	DPST	A.H. and H.	81024BM
S-102	= Switch	DPST	A.H. and H.	81024BM
Q-1	= Quartz	950 kc	GR	376-L
T-1	= Transformer		GR	365-439
SO-1	= Socket		H. B. Jones	S-406-AB
PL-1	= Plug		GE	39X370
PL-101	= Plug		H. B. Jones	P-406-RSE
J-1	= Jack		Prec. Parts	#1 Imp Jack

CAPACITORS

C-1	= 0.25	$\mu f$ $\pm 10\%$	Ind. Cond.	8289BAB
C-2	= 1.0	$\mu f$ $\pm 10\%$	Ind. Cond.	8232BAB
C-3	= 0.02	$\mu f$ $\pm 10\%$	CD	Type 4
C-4	= 0.8	$\mu f$ $\pm 10\%$	Aerovox	#355
C-5	= 0.8	$\mu f$ $\pm 10\%$	Aerovox	#355
C-6	=			
C-7	= 175	$\mu\mu f$	GR	779-400
C-8	= 0.01	$\mu f$ $\pm 10\%$	CD	Type 4
C-9	= 1.0	$\mu f$ $\pm 10\%$	Ind. Cond.	8232BAB
C-10	= 0.005	$\mu f$ $\pm 10\%$	CD	Type 4
C-11	= 0.005	$\mu f$ $\pm 10\%$	CD	Type 4
C-12	= 0.01	$\mu f$ $\pm 10\%$	CD	Type 4
C-13	= 0.00005	$\mu f$ $\pm 10\%$	CD	Type 5W
C-14	= 0.00025	$\mu f$ $\pm 10\%$	CD	Type 4
C-15	= 0.01	$\mu f$ $\pm 10\%$	CD	Type 4
C-16	= 1.0	$\mu f$ $\pm 10\%$	Ind. Cond.	8232BAB
C-17	= 13 - 320	$\mu\mu f$	Hammarlund	MC-325S, locking
C-18	= 0.0003	$\mu f$ $\pm 10\%$	CD	Type 4
C-19	= 0.00001	$\mu f$ $\pm 10\%$	CD	Type 4
C-20	= 0.00025	$\mu f$ $\pm 10\%$	CD	Type 4
C-21	= 0.02	$\mu f$ $\pm 10\%$	CD	Type 4
C-22	= 0.25	$\mu f$ $\pm 10\%$	Ind. Cond.	8289BAB
C-23	= 0.02	$\mu f$ $\pm 10\%$	CD	Type 4
C-24	= 0.00001	$\mu f$ $\pm 10\%$	CD	Type 5W
C-25	= 0.25	$\mu f$ $\pm 10\%$	Ind. Cond.	8289BAB
C-26	= 0.25	$\mu f$ $\pm 10\%$	Ind. Cond.	8289BAB
C-27	= 6 - 100	$\mu\mu f$	Hammarlund	APC Type C
C-28	= 0.0005	$\mu f$ $\pm 10\%$	CD	Type 4
C-29	= 1.0	$\mu f$ $\pm 10\%$	Ind. Cond.	8232BAB
C-30	= 0.000470	$\mu f$ $\pm 1\%$	Sickles	ESC Silvercap**
C-31	= 4 - 50	$\mu\mu f$	Hammarlund	APC Type C**
C-32	= 0.000470	$\mu f$ $\pm 1\%$	Sickles	ESC Silvercap***
C-33	= 4 - 50	$\mu\mu f$	Hammarlund	APC Type C***
C-34	= 0.000470	$\mu f$ $\pm 1\%$	Sickles	ESC Silvercap+
C-35	= 4 - 50	$\mu\mu f$	Hammarlund	APC Type C+
C-36	= 4 - 50	$\mu\mu f$	Hammarlund	APC Type C++
C-36A	= 20	$\mu\mu f$ $\pm 5\%$	COM-20E	(Part of LC-4)
C-37	= 0.25	$\mu f$ $\pm 10\%$	Ind. Cond.	8289BAB
C-38	= 0.25	$\mu f$ $\pm 10\%$	Ind. Cond.	8289BAB
C-39	= 0.000100	$\mu f$ $\pm 5\%$	Sickles	ESC Silvercap
C-40	= 6 - 100	$\mu\mu f$	Hammarlund	APC Type C
C-41	= 0.03	$\mu f$ $\pm 10\%$	CD	Type 4
C-42	= 5 - 100	$\mu\mu f$	Hammarlund	APC Type C
C-43	= 0.000100	$\mu f$ $\pm 5\%$	Sickles	ESC Silvercap
C-44	= 2.0	$\mu f$ $\pm 10\%$	Ind. Cond.	9235SARU
C-45	= 0.01	$\mu f$ $\pm 10\%$	CD	Type 3L
C-46	= 0.01	$\mu f$ $\pm 10\%$	CD	Type 3L'
C-47	= 100	$\mu f$ $\pm 50\%$ , $-10\%$	Sprague	DFP
C-48	= 100	$\mu f$ $\pm 50\%$ , $-10\%$	Sprague	DFP
C-49	= 100	$\mu f$ $\pm 50\%$ , $-10\%$	Sprague	DFP
C-50	= 100	$\mu f$ $\pm 50\%$ , $-10\%$	Sprague	DFP
C-51	= 200	$\mu\mu f$ $\pm 10\%$	COM-20B	
C-101	= 6 - 100	$\mu\mu f$	Hammarlund	APC Type C
C-102	= 0.000200	$\mu f$ $\pm 10\%$	CD	Type 5W
C-103	= 6 - 100	$\mu\mu f$	Hammarlund	APC Type C
C-104	= 0.000200	$\mu f$ $\pm 10\%$	CD	Type 5W
C-105	= 0.0001	$\mu f$ $\pm 10\%$	CD	Type 5W
C-106	= 0.00005	$\mu f$ $\pm 10\%$	CD	Type 5W
C-107	= 1.0	$\mu f$ $\pm 10\%$	Ind. Cond.	8341BAT
C-108	= 4 - 50	$\mu\mu f$	Hammarlund	APC Type C
C-109	= 0.000025	$\mu f$ $\pm 10\%$	CD	Type 5W
C-110	= 4 - 50	$\mu\mu f$	Hammarlund	APC Type C
C-111	= 0.000025	$\mu f$ $\pm 10\%$	CD	Type 5W
C-112	= 0.0001	$\mu f$ $\pm 10\%$	CD	Type 5W
C-113	= 0.0005	$\mu f$ $\pm 10\%$	CD	Type 5W
C-114	= 0.0005	$\mu f$ $\pm 10\%$	CD	Type 5W
C-115	= 0.00002	$\mu f$ $\pm 10\%$	CD	Type 5W

\*REC- = JAN RC-

\*\*Part of LC-1

\*\*\*Part of LC-2

+Part of LC-3

++Part of LC-4

+++Two 8200  $\Omega$   $\pm 10\%$  REC-41BF in parallel

**INDUCTORS**

L-1	=	8 mh	GR	379-T	
L-2	=	23.0 mh	GR	1110-25	
L-3	=	2.5 mh	National	Type R-100	
L-4	=		GR	CHA-3	
L-5	=	2.5 mh	National	Type R-100	
L-6	=	500 μh	GR	ZCHA-28	} Part of LC-1
L-7	=	57.3 μh	GR	ZCHA-20	
L-8	=	131.5 μh	GR	ZCHA-21	} Part of LC-2
L-9	=	57.3 μh	GR	ZCHA-20	
L-10	=	131.5 μh	GR	ZCHA-21	} Part of LC-3
L-11	=	57.3 μh	GR	ZCHA-20	
L-12	=	57.3 μh	GR	ZCHA-20	} Part of LC-4
L-13	=	500 μh	GR	ZCHA-28	
L-14	=	150 μh	GR	Part of	} ZCHA-24
L-15	=	150 μh	GR	Part of	

L-101	=	17.8 μh	GR	ZCHA-26
L-102	=	2.5 μh	GR	ZCHA-25

**FUSES**

For 115 volt input

F-1	=	1.25 amp. Slow Blow 3AG	GR	FUF-1
F-2	=	1.25 amp. Slow Blow 3AG	GR	FUF-1

For 230 volt input

F-1	=	0.6 amp. Slow Blow 3AG	GR	FUF-1
F-2	=	0.6 amp. Slow Blow 3AG	GR	FUF-1

**TUBES**

V-1	=	6AC7
V-2	=	6SN7-GT
V-3	=	6SN7-GT
V-4	=	6SJ7
V-5	=	6SA7
V-6	=	6AC7
V-7	=	6J5-GT
V-8	=	6J5-GT
V-9	=	5R4GY
V-10	=	GR 2LAP-430 Mazda S6

**FILTERS**

LC-1	=	GR 1110-28-1
LC-2	=	GR 1110-28-2
LC-3	=	GR 1110-28-3
LC-4	=	GR 1110-28-4

V-101	=	RCA 6SN7-GT
V-102	=	RCA 6J5-GT
V-103	=	RCA 6SN7-GT
V-104	=	RCA 9001

Wiring Diagram for Type 1110-A Interpolating Frequency Standard and Type 1110-P1 Multivibrator

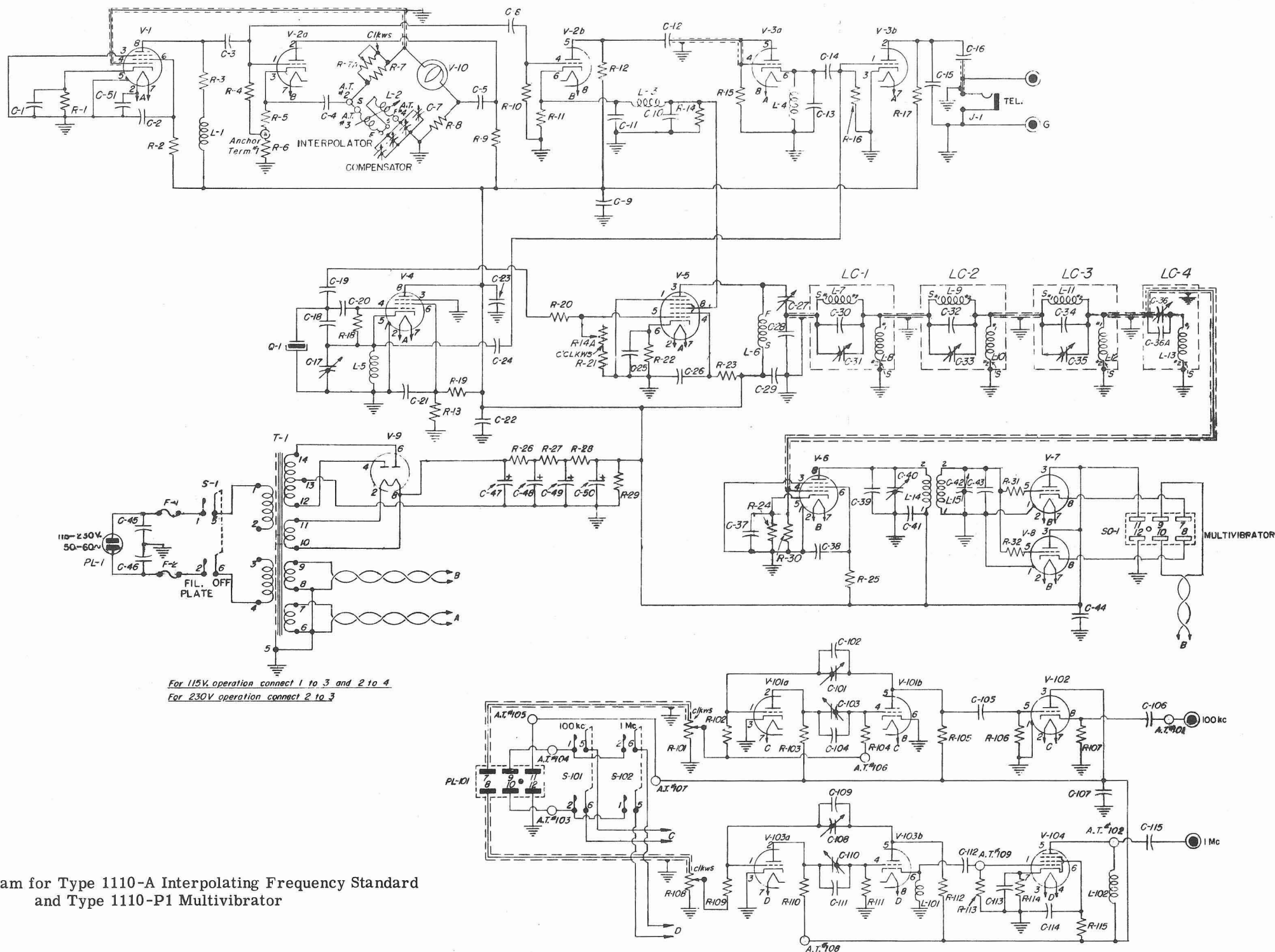

For 115V. operation connect 1 to 3 and 2 to 4  
For 230V operation connect 2 to 3

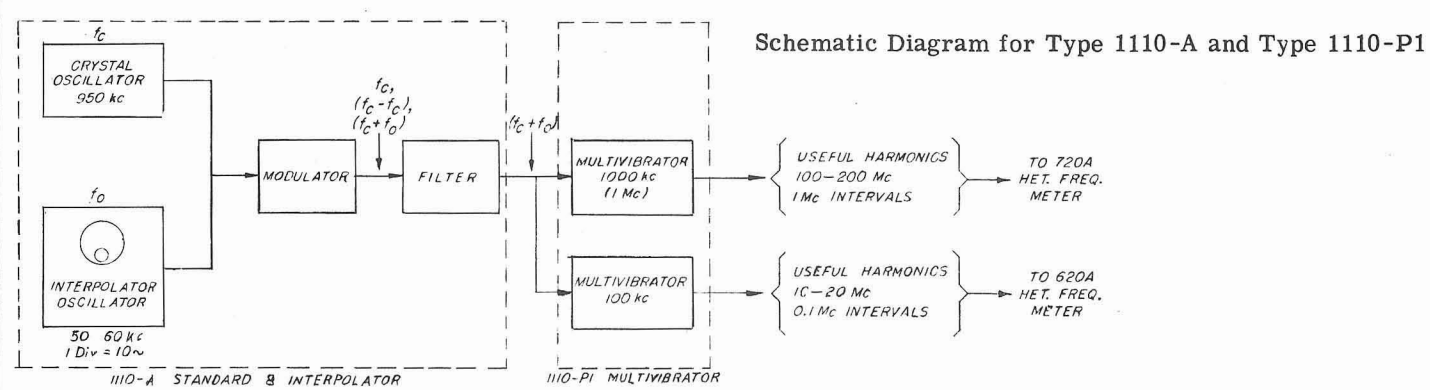
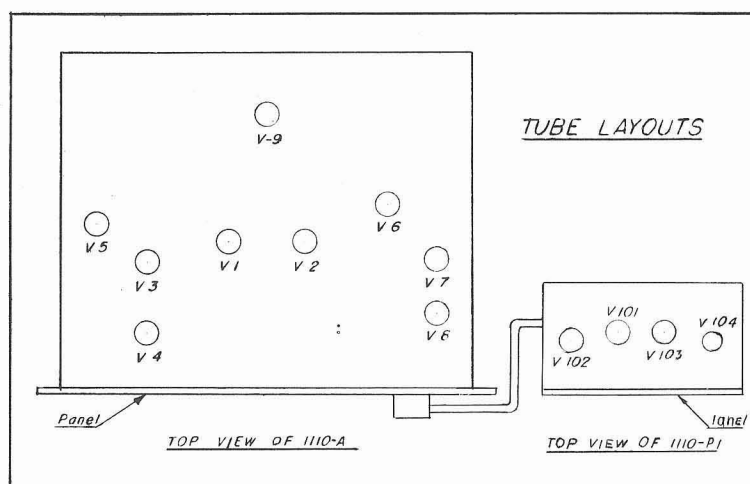

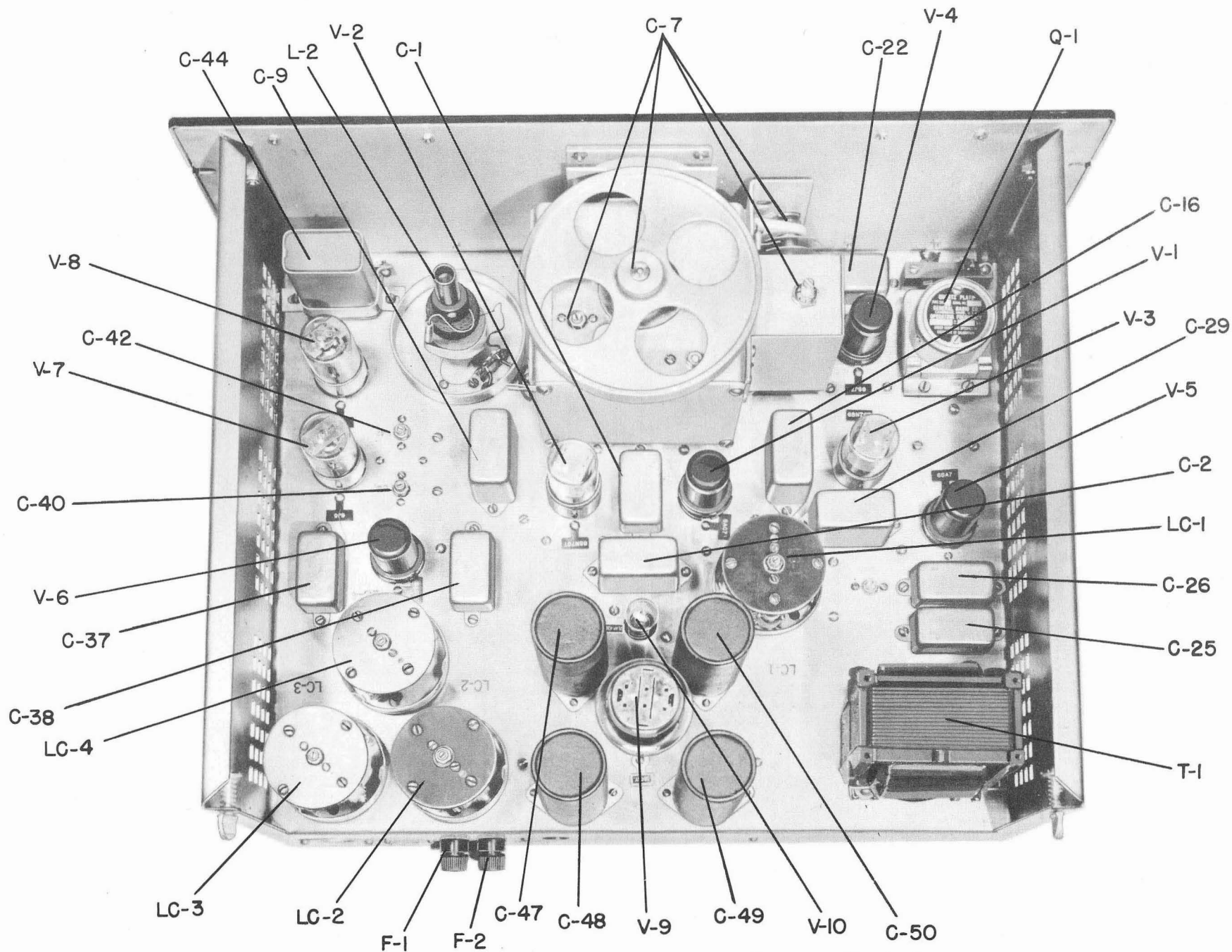

Interior Top View of Type 1110-A Interpolating Frequency Standard

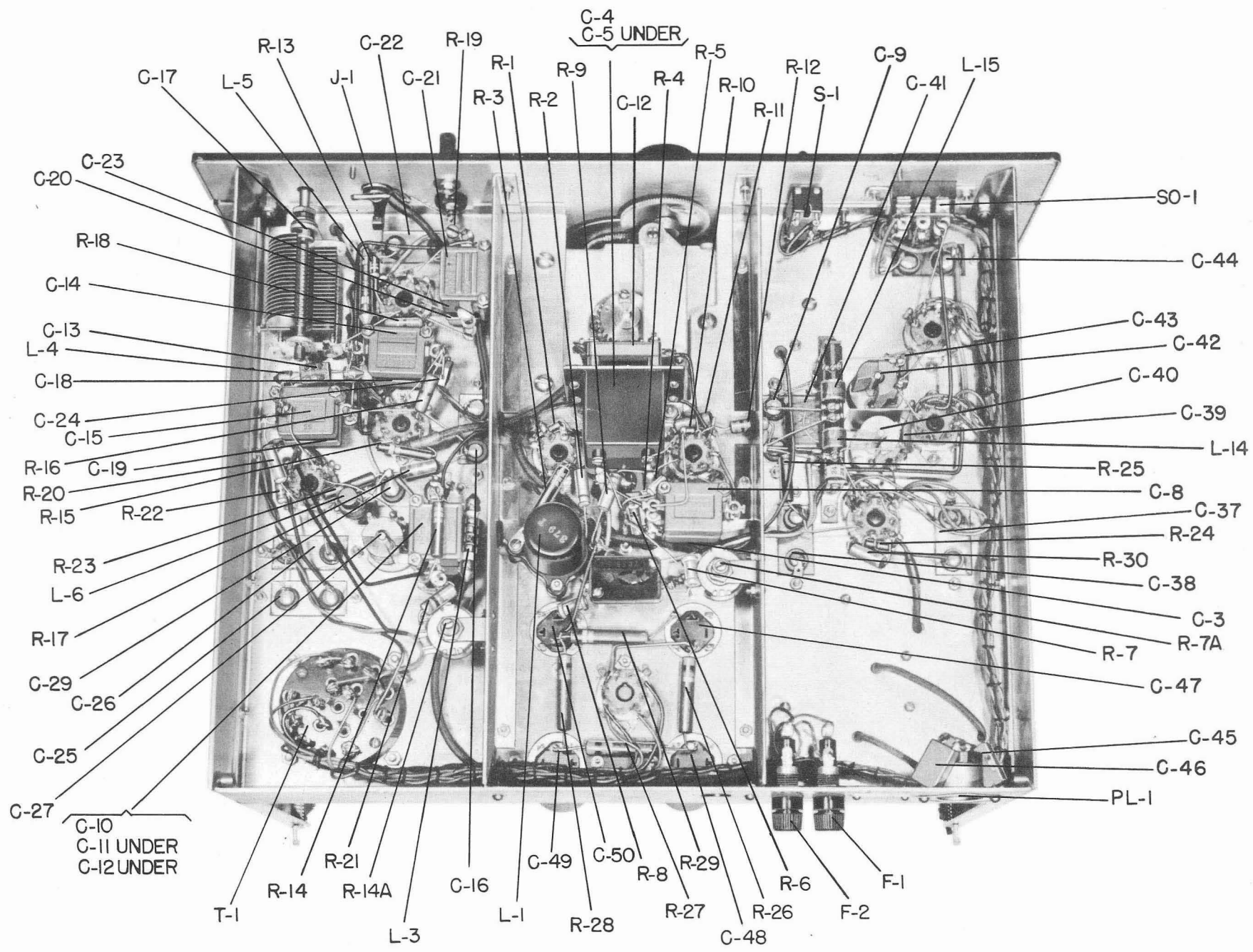

Interior Bottom View of Type 1110-A Interpolating Frequency Standard



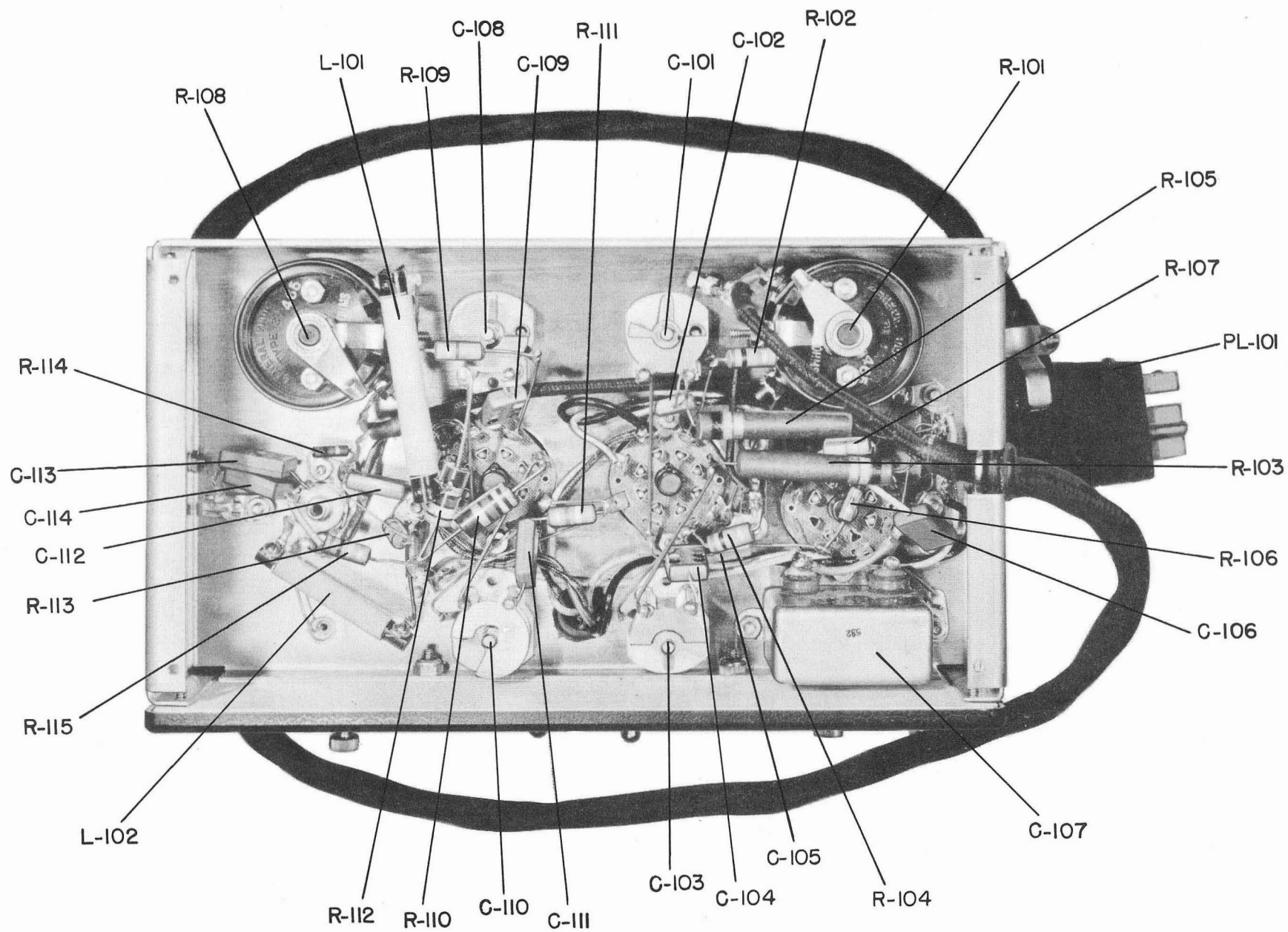

Interior Bottom View of Type 1110-P1 Multivibrator

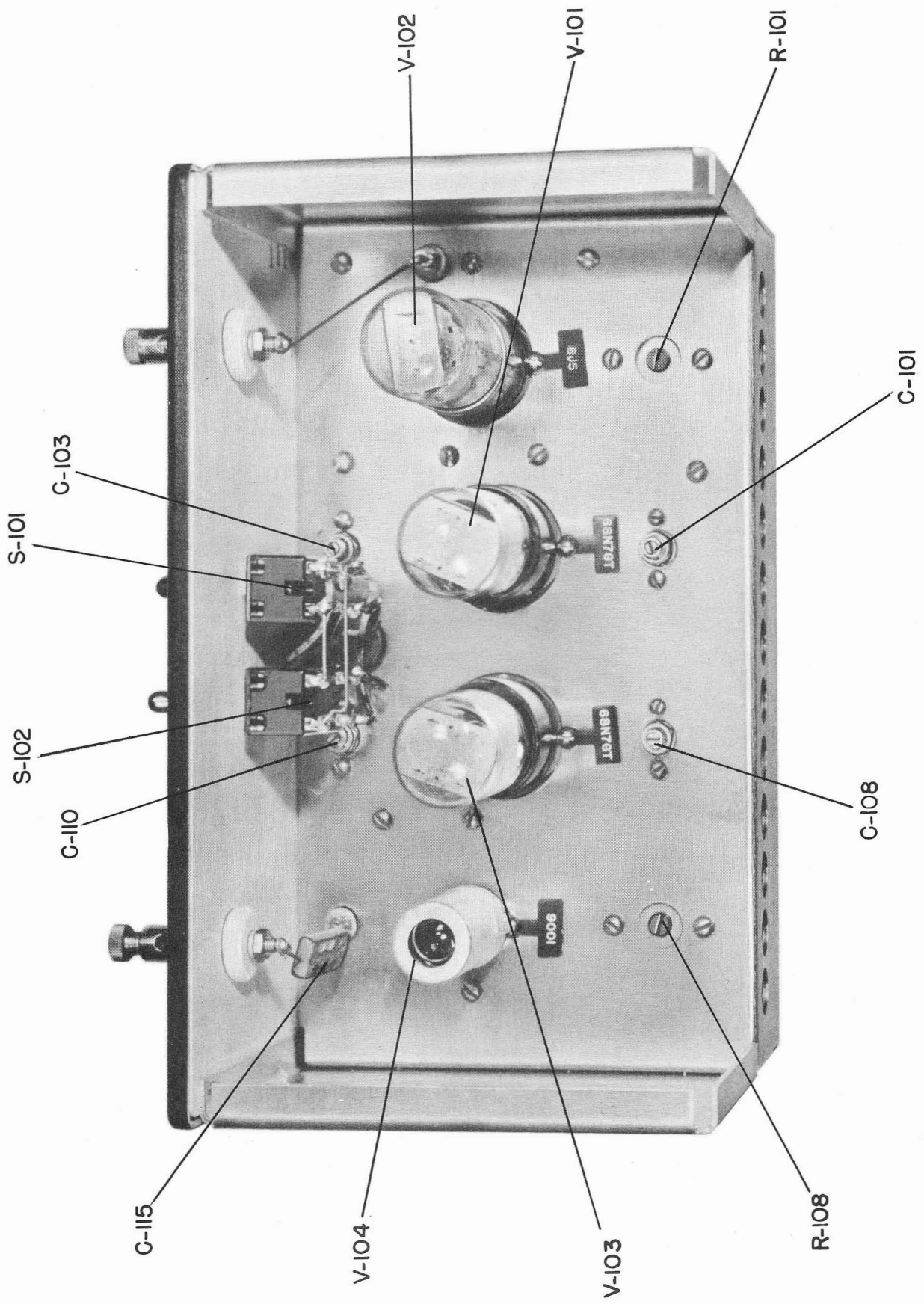

Interior Top View of Type 1110-P1 Multivibrator

