



INSTRUCTION MANUAL

Type 1362 UHF Oscillator
(220-920 Megahertz)

B

GENERAL RADIO

Contents

SPECIFICATIONS
TABLE OF CONTENTS
INTRODUCTION – SECTION 1
INSTALLATION – SECTION 2
OPERATING PROCEDURE – SECTION 3
APPLICATIONS – SECTION 4
PRINCIPLES OF OPERATION – SECTION 5
SERVICE AND MAINTENANCE – SECTION 6

WARRANTY

We warrant that each new instrument manufactured and sold by us is free from defects in material and workmanship and that, properly used, it will perform in full accordance with applicable specifications for a period of two years after original shipment. Any instrument or component that is found within the two-year period not to meet these standards after examination by our factory, District Office, or authorized repair agency personnel will be repaired or, at our option, replaced without charge, except for tubes or batteries that have given normal service.



Type 1362 UHF Oscillator (220-920 Megahertz)

B

©GENERAL RADIO COMPANY 1967

Concord, Massachusetts, U.S.A. 01742
Form 1362-0100-B
January, 1971
1D-B552

SPECIFICATIONS

Frequency Range: 220 to 920 MHz.

Tuned Circuit: Butterfly, with no sliding contacts.

Frequency Accuracy: $\pm 1\%$.

Warmup Frequency Drift: 0.2% typical total.

Frequency Control: A four-inch dial with calibration over 300° , with a slow-motion drive of about 9 turns.

Output Power (into 50 ohms): At least 160 mW with Type 1267 or 1264 Power Supply, 200 mW with Type 1269 Power Supply.

Output System: A coupling loop feeds a waveguide-below-cut-off attenuator calibrated over an 80-dB range with 5-dB scale divisions, relative attenuation. Additional uncalibrated range is provided. Output adjustment and locking GR 874 output connector are at the front of the instrument.

Modulation: An external audio-frequency plate modulator may be connected to the front panel MOD jack. The modulation impedance is approximately 3 k Ω .

A sinewave of 20 V rms, amplitude will produce approximately 30% amplitude modulation. For 400 Hz, 1000 Hz and other audio frequency modulation the Type 1311 Audio Oscillator is recommended. The Type 1263 Amplitude-Regulating Power Supply can be used for 1-kHz square-wave modulation, the Type 1264 Modulating Power Supply for square-wave or pulse modulation.

Power Supply: Four types of power supplies are recommended; the choice depends on the intended application. Refer to Table of Accessories, paragraph 1.5.

Tube: One Y-1266.

Mounting: Rack-bench cabinet.

Accessories Available: Refer to paragraph 1.5.

Dimensions: Width 8, height 7-5/8, depth 9 1/2 inches (205 by 195 by 240 mm). See outline below.

Net Weight: 8 pounds (3.6 kg).

GR 874 Patent No. 2,548,457.

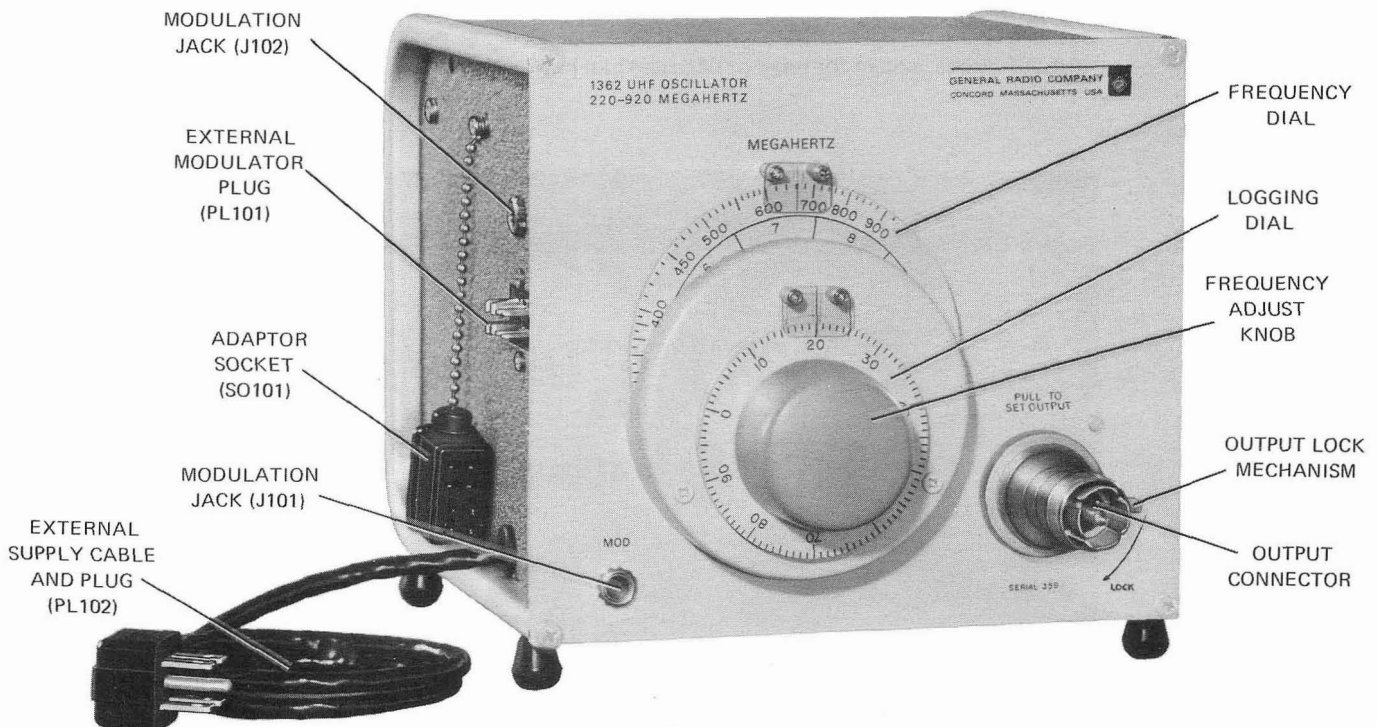

Figure 1-1. Panel view of Type 1362 UHF Oscillator with accessories .

TABLE OF CONTENTS

Section 1 INTRODUCTION		
1.1 Purpose	1	
1.2 Description	1	
1.3 Amplitude Modulation	3	
1.4 Sweep Operation	3	
1.5 Auxiliary Equipment	3	
Section 2 INSTALLATION		
2.1 Connection to Power Supply	5	
2.2 Bench Mounting	5	
2.3 Rack Mounting	7	
2.4 Modulator Connection	8	
2.5 RF Output Connections	8	
Section 3 OPERATING PROCEDURE		
3.1 Equipment Turn-On	9	
3.2 Frequency Adjustment	9	
3.3 Output Adjustment	9	
Section 4 APPLICATIONS		
4.1 General	10	
4.2 Signal Generator for Receiver Testing	10	
4.3 Local Oscillator in a Frequency Converter	10	
4.4 Transfer Oscillator	11	
4.5 Swept Oscillator	11	
4.6 Observation of Modulation	11	
Section 5 PRINCIPLES OF OPERATION		
5.1 General	12	
5.2 Circuitry	12	
Section 6 SERVICE AND MAINTENANCE		
6.1 Warranty	13	
6.2 Service	13	
6.3 Minimum Performance Standards	13	
6.4 Trouble Analysis	15	
6.5 Removal of Covers	16	
6.6 Installation of Oscillator Tube	18	
6.7 Frequency Calibration	19	
6.8 Lubrication	19	
6.9 Adjustment for Maximum Tube Life	19	

SECTION 1

INTRODUCTION

1.1 PURPOSE.

The 1362 UHF Oscillator (Figure 1-1) is a general-purpose oscillator for the radio-frequency laboratory. Covering the calibrated range from 220 to 920 MHz, this oscillator provides adequate power to drive bridges, slotted lines, impedance comparators, and other measuring equipment. The output is brought through an attenuator, calibrated in relative power levels, making the oscillator suitable for the testing of receivers. Direct sine-wave, square-wave, or pulse amplitude modulation is possible. Amplitude modulation free from incidental fm can be obtained with an external diode modulator. Connected to a mixer, the oscillator can be used as the local oscillator in a heterodyne receiver to convert the GR 1236 I-F Amplifier, or a low-frequency communications receiver, into a detector for uhf signals. Square-wave and pulse amplitude modulation can be obtained with the GR Type 1264 Modulating Power Supply (Figure 1-2), or leveled

output can be obtained with the GR Type 1263 Amplitude-Regulating Power Supply.

1.2 DESCRIPTION.

1.2.1 GENERAL.

The 1362 Oscillator uses a planar triode and is tuned by a butterfly resonator, to provide wide tuning range without switching or sliding contacts. For details refer to paragraph 5.2.

The butterfly rotor is driven 85° through anti-backlash gears by the main dial, turning 330°, and the vernier drive, whose 9 turns are each resolved into 100 arbitrary (logging) divisions. Frequency calibration is accurate to ±1%. Resolution of 0.1% or better with the logging scale is described in paragraph 3.2.

Jacks are provided for modulation, connection of special-purpose power supplies, and the measurement of plate current.

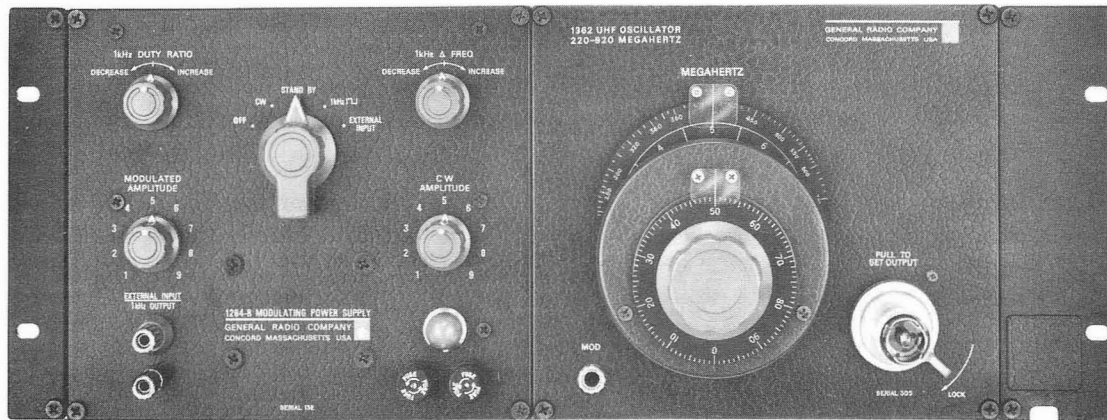

Figure 1-2. The Type 1362 UHF Oscillator and the Type 1264 Modulating Power Supply assembled with the Type 0481-P416 Adaptor Plate Set for rack mounting.

1.2.2 OUTPUT SYSTEM.

The output system is an adjustable coaxial line with a coupling loop on one end and a locking GR874 coaxial connector on the other. Coupling between the loop and the oscillator can be adjusted over a wide, continuous range, and the loop can be clamped in the desired position. With close coupling, maximum power can be delivered to load impedances normally encountered in coaxial systems. Power available into a 50-ohm load is plotted against frequency in Figure 1-3 for a typical 1362 Oscillator. With loose coupling, the movable line becomes a piston attenuator, calibrated over a range of 80 dB (refer to paragraph 3.3).

1.2.3 FREQUENCY STABILITY.

For most applications a well-regulated and filtered power supply should be used to avoid amplitude and frequency variations caused by line-voltage fluctuation and to produce a clear audible tone when the output beats with a stable reference. With an *unregulated* power supply, a line-voltage variation of 10 percent causes an immediate (1 second) frequency change of about 0.002 percent at frequencies up to 500 MHz, and a change of about 0.02 percent at 900 MHz.

If the line voltage is held steady for 5 minutes after the shift of 10 percent, the frequency change is about 0.02% up to 500 MHz and 0.04% at 900 MHz. Of the power supplies listed in paragraph 1.5, only the Type 1269 is unregulated. The Type 1267, for example, reduces the effect of line-voltage change by a factor of 100 or more.

When the oscillator is turned on for use, a warmup frequency drift (0.2% typical total) will occur until the circuit stabilizes at the set frequency. Figure 1-4 shows typical warmup frequency drift curves.

Individual instruments may drift considerably more or less, or even in the opposite sense from the typical.

1.2.4 POWER REQUIREMENTS.

The 1362 UHF Oscillator requires an external power supply. The choice among the four General Radio power supplies recommended in paragraph 1.5 should be based on the intended application of the oscillator. If a power supply other than one of those recommended is used, it should be capable of delivering 300 to 330 volts, dc, at 35 mA for the plate, and 6.3 volts at 0.24 ampere for the heater. The negative side of the power supply must be floating, since the positive side is grounded inside the oscillator.

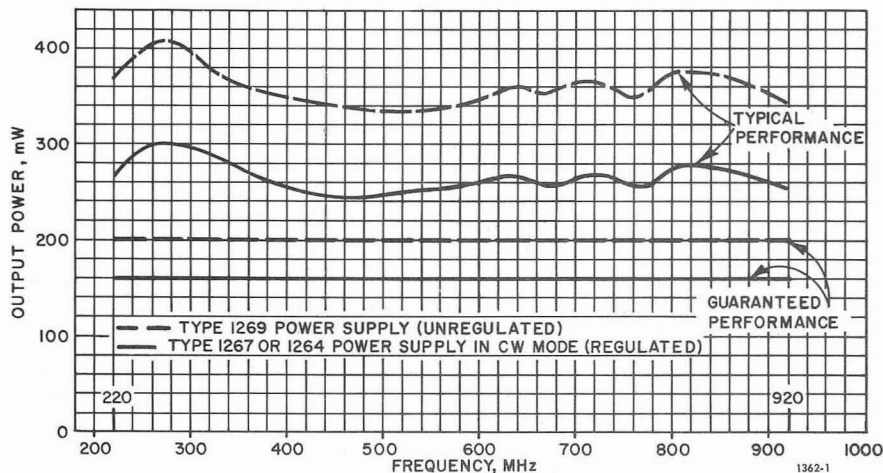

Figure 1-3. Output power into a 50-ohm load for a typical Type 1362 oscillator.

1.2.5 ACCESSORIES SUPPLIED.

Supplied with the oscillator are a three-foot coaxial double-shielded Type 874-R22LA Patch Cord, and a phone plug (P/N 4220-2000, Figure 1-1).

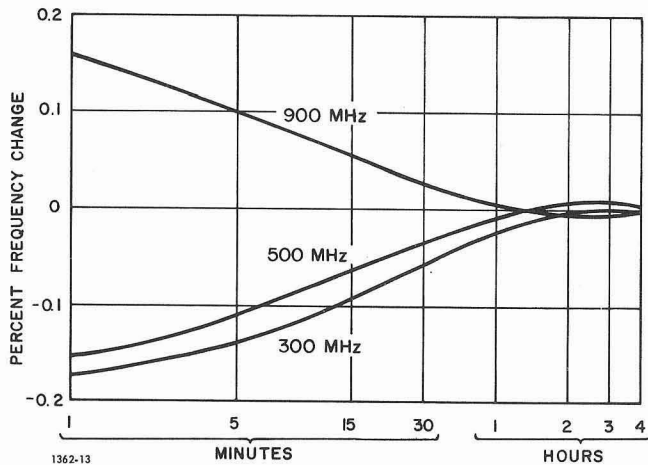

Figure 1-4. Typical warmup frequency-drift characteristics for the Type 1362 UHF Oscillator with a Type 1267-A Regulated Power Supply.

1.3 AMPLITUDE MODULATION.

1.3.1 GENERAL

Amplitude modulation of the signal source (in a test setup having a demodulator followed by a tuned amplifier) permits increased sensitivity of measurement compared to cw operation. Recommended auxiliary equipment is described in paragraph 1.5.

1.3.2 SINUSOIDAL AMPLITUDE MODULATION.

A jack on the front panel of the oscillator permits plate modulation by connection of an audio oscillator, such as the Type 1311. This function is also supplied at another jack on the left-hand side plate. The modulator must supply a dc path and must be able to carry 30 milliamperes dc. A sine wave of 20-volts, rms, amplitude, will produce approximately 30% amplitude modulation.

Incidental frequency modulation is about 60 kHz (peak deviation) with 25% a-m at a carrier frequency of 500 MHz, and increases with frequency.

1.3.3 SQUARE-WAVE AMPLITUDE MODULATION.

Modulation at full-rated output power is obtained with the Type 1264 Modulating Power Supply. When operated with a Type 1263 Amplitude-Regulating Power Supply, the oscillator provides a levelled rf output of 20 milliwatts, peak, into a 50 ohm load, with 1-kHz square-wave modulation (or cw).

1.3.4 PULSE AMPLITUDE MODULATION.

The rise time, starting delay, and jitter of the 1362 Oscillator depend on the frequency and load conditions. Typical values obtained with a Type 1217 Unit Pulse Generator used to drive the Type 1264 Modulating Power Supply are shown in Figure 1-5.

1.4 SWEEP OPERATION.

The 1362 Oscillator is well suited for swept operation due to the use of ball bearings in the tuning drive mechanism and to the absence of sliding contacts in the rf circuit.

A sweep drive can be coupled either to the slow-motion dial or to the main frequency dial of the oscillator. When the main frequency dial is driven directly, the sweep rate should be restricted to one excursion per second or less. The slow-motion dial can be driven at rates up to 5 cycles per second. The Type 1263 Amplitude-Regulating Power Supply will maintain a constant rf output amplitude as the oscillator is swept.

When the oscillator is driven by a sweep or dial drive, all moving parts in the oscillator must be lubricated in accordance with paragraph 6.8. For recommended dial drives, refer to paragraph 1.5.

1.5 AUXILIARY EQUIPMENT.

The 1362 Oscillator can be used in conjunction with a variety of auxiliary General Radio equipment

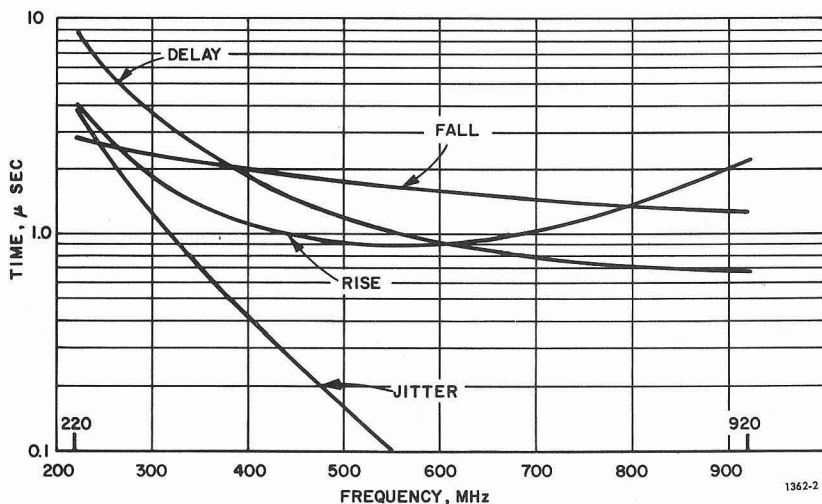

Figure 1-5. Typical rise time, starting delay, and jitter when the oscillator is pulsed by the Type 1264 Modulating Power Supply, driven by the Type 1217 Unit Pulse Generator.

to build a signal-source system that is suited to specific requirements. Typical systems are shown in Figure 1-6.

Table 1-1 lists the accessories recommended for use with the 1362 Oscillator. The choice of a recommended power supply, modulator, or sweep drive

should be based on the intended application of the oscillator.

The Type 1263, 1264, 1267 and 1269 power supplies can be readily attached to the oscillator to form a single unit for bench use or for relay-rack mounting with the listed adaptor plates.

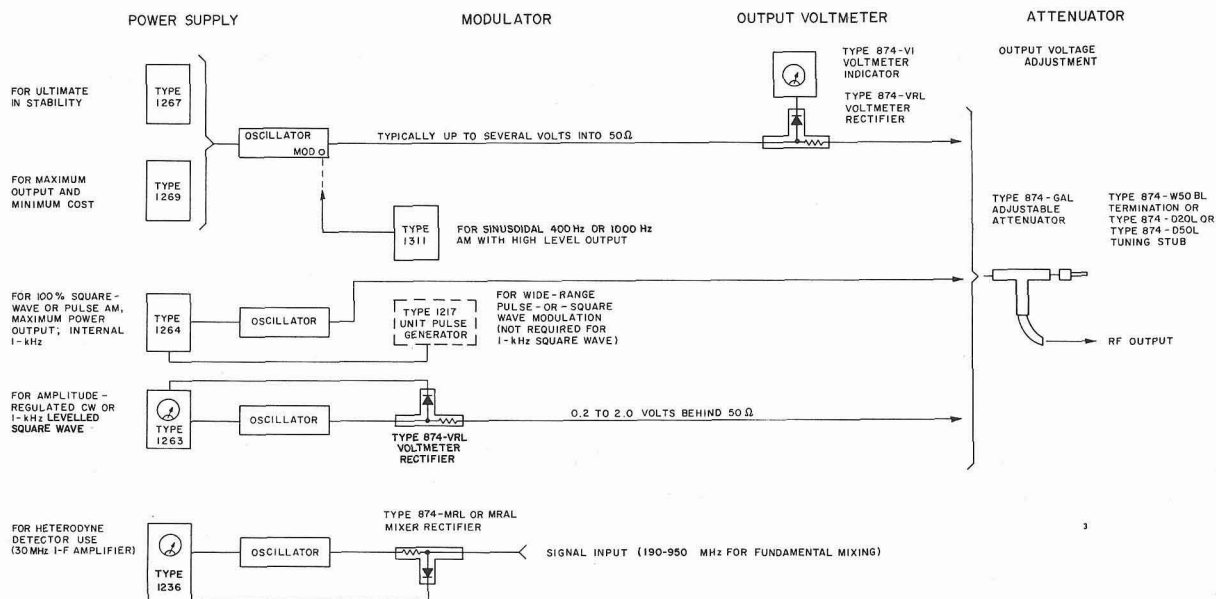
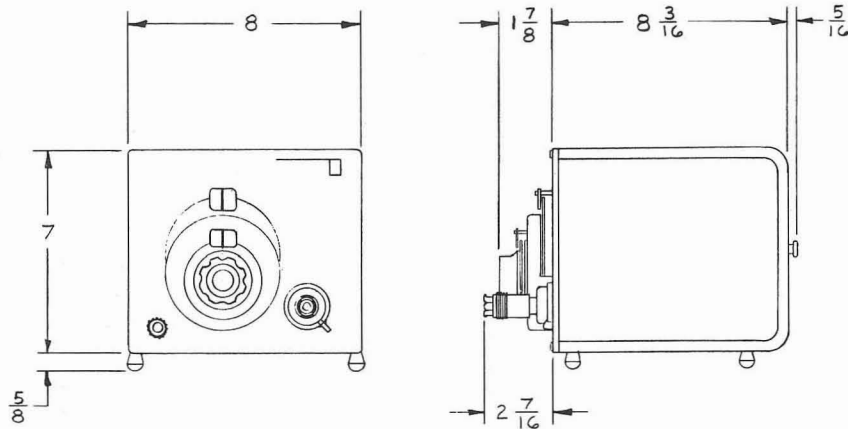

Figure 1-6. Typical signal-source systems built with a Type 1362 UHF Oscillator and associated equipment.

Table 1-1
ACCESSORIES

Function	GR Instrument*	Remarks
POWER SUPPLIES		
For best stability, freedom from line-voltage variations, and minimum residual fm.	Type 1267 Power Supply	Regulated dc plate and heater supplies.
For full-power square-wave, pulsed a-m, or cw operation.	Type 1264 Modulating Power Supply	Internal 1-kHz square-wave generator or external pulser (20 Hz to 50 kHz).
For amplitude-regulated cw or 1-kHz square-wave modulated output.	Type 1263 Amplitude-Regulating Power Supply	Leveled output of 20 mW into 50 ohms. Requires Type 874-VRL Voltmeter Rectifier.
ADAPTOR PLATE SETS		
To rack-mount the oscillator alone.	Type 480-P408 Adaptor Plate Set	
To rack-mount the oscillator with a Type 1267 or 1269 Power Supply.	Type 481-P412 Adaptor Plate Set	
To rack-mount the oscillator with a Type 1263 or 1264 Power Supply.	Type 481-P416 Adaptor Plate Set	



1362 UHF Oscillator dimensions (inches).

SECTION 2

INSTALLATION

2.1 CONNECTION TO POWER SUPPLY.

The 1362 Oscillator is shipped complete with tube installed and is ready for use when connected to a suitable power supply. A cord and connector are supplied with the instrument for direct connection to a General Radio power supply. Refer to paragraph 1.5 for recommendations.

To connect the oscillator to the power supply, plug the oscillator power cable into the receptacle on the side of the power supply. The dummy socket chained to the left-hand side of the cabinet must be connected to the associated plug, except for use with the Type 1264 Modulating Power Supply, when the socket on the power-supply cable replaces the dummy. When the Type 1263 Amplitude-Regulating Power Supply is used, the small cable supplied with it should be plugged into the telephone jack on the left-hand side of the oscillator and into the power supply (refer to the power-supply instruction book).

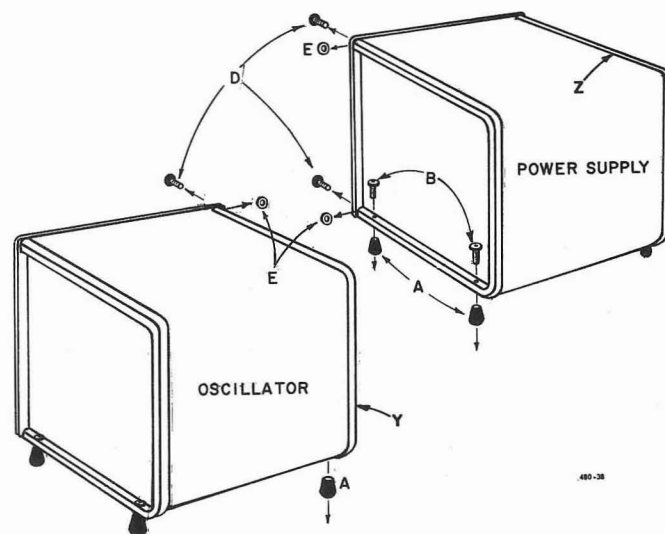

Figure 2-1. Preparation for bench mounting hardware.

2.2 BENCH MOUNTING.

To bench mount the 1362 Oscillator with a Type 1264, 1267, or 1269 Power Supply, proceed with step a; however, if the Type 1263 Power Supply is used, proceed with step j. The procedure is as follows:

a. Remove the exterior cover from both the oscillator and power supply by turning the captive thumbscrews at the rear counterclockwise and sliding the cover toward the rear.

b. Release the two end-frame attaching screws (D) at the left-hand edge (as seen from the front) of the oscillator and the power supply (Figure 2-1).

c. Withdraw the screws and remove the spacers (E) between the panels and the end frames.

- d. Slide end frame Y toward the rear and off the oscillator.
- e. Slide end frame Z toward the rear and off the power supply.
- f. Slide end frame Y into place where end frame Z was removed.
- g. Slide end frame Z into place where end frame Y was removed.
- h. Replace and tighten screws D and spacers E at the left-hand edge of the power supply.

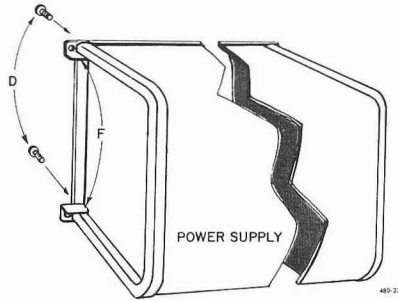

Figure 2-2. Installation of clip in place of washers.

- i. Replace the exterior oscillator and power supply covers.
- j. Remove both rubber feet (A) at the right-hand side of the power supply and the left-hand side of the oscillator so that the feet won't interfere with one another (see Figure 2-1). Retain screws (B).

NOTE

The legs on the front feet of the Type 1263 Power Supply and the oscillator thread into the feet.

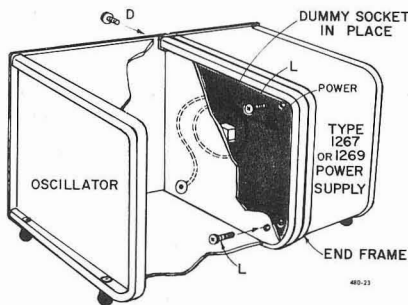

Figure 2-3. Installation of oscillator with Type 1267 or 1269 Power Supply.

- k. Release the two end-frame attaching screws (D) at the right-hand edge of the power supply. (For Type 1263 installation, apply this step to the left-hand edge of the oscillator.)

- l. Withdraw the screws and remove the spacers (E) between the panel and the end frame.

- m. Install one clip (F) in place of each spacer on the power supply, with the plain surface of the clip against the inner surface of the end frame. Align one hole in each clip with the appropriate panel hole (Figure 2-2).

- n. Reinstall the panel screws (D) through the clips, into the end frames.
- o. Place the power supply on its left-hand side close to the oscillator.
- p. Attach the 5-pin plug from the oscillator to the POWER jack on the supply. Figures 2-3 to 2-5 show the oscillator/power supply combination as finally assembled.

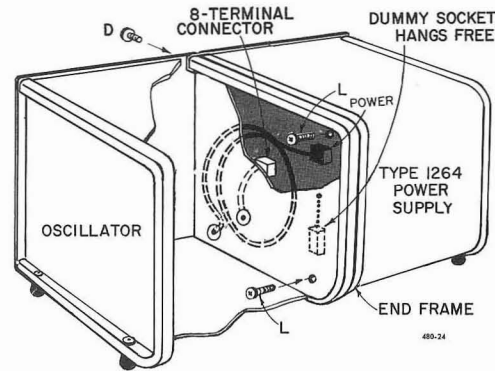

Figure 2-4. Installation of oscillator with Type 1264 Power Supply.

With the Type 1264 Power Supply, remove the dummy socket from the plug on the left-hand side of the oscillator. Plug the eight-terminal connector of the attached modulation patch cord on the power supply to the connector on the oscillator (Figure 2-4).

With the Type 1263 Power Supply, connect the 2-pin plug of the Type 1263-B-40 Patch Cord (supplied) to the MODULATION plug on the right-hand side panel of the power supply (Figure 2-5). Connect the other end of this cable to the MOD jack on the left-hand side panel of the oscillator, as shown. Plug the shorter side of the straight-through section of the Type 874-VRL Voltmeter Rectifier into the rf output of the oscillator (Figure 2-6). The longer side of the straight-through section (marked "R") connects to the load. Install the Type 874-ELL directly at the OUTPUT RECTIFIER (GR874) connector of the power supply, with the free end facing to the rear. Connect the dc output (center arm) of the Type 874-VRL Voltmeter Rectifier to the ell, using the Type 874-R22LA Patch Cord. (The Types 874-VRL, -R22LA, and -ELL are furnished with the power supply.)

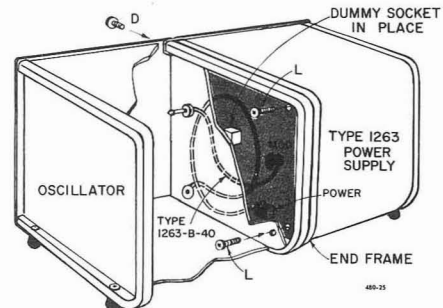

Figure 2-5. Installation of oscillator with Type 1263 Power Supply.

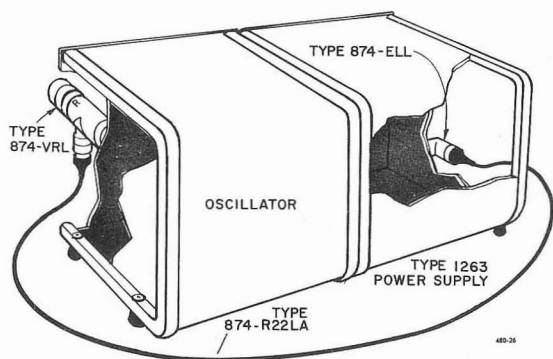

Figure 2-6. Completion of the control loop with Type 1263 Power Supply.

q. Hold the oscillator immediately above the supply, oriented as it will be in final assembly. Form the patch cords into flat coils between the side walls of the instruments.

r. Lower the oscillator, so that the instruments slide together, with the exposed ends of the clips (F) in the supply entering the spacer slots behind the oscillator front panel.

s. Reinstall the front-panel screws (D) in the oscillator, through the clips, into the end frames.

t. Remove the cover of the oscillator from the rear and pass the 10-32 screws (L) (supplied) through the rear clearance holes (top and bottom) on the oscillator left-side panel (Figures 2-3 through 2-5).

u. Thread the screws into the matching tapped holes in the joining wall of the supply.

NOTE

If the power supply in the combination doesn't have tapped holes in the joining wall, a No. 10-32 nut and lockwasher will be necessary for each screw.

v. Tighten all six screws and remount the oscillator cover. Retain the surplus rubber feet and attaching hardware, in case it may be desired to restore the instruments to their original form in the future.

2.3 RACK MOUNTING.

To mount the assembly in a standard 19-inch relay rack, attach the rack-adaptor set as follows:

NOTE

The coaxial patch cord assembly supplied can be mounted on the appropriate adaptor plate to bring the rf output from the front of the oscillator to the back of the panel, if desired.

a. Release the two end-frame attaching screws (D) at the left-hand edge of the oscillator.

b. Attach oscillator to power supply as described in paragraph 2.2 starting at step j.

c. Remove the remaining rubber feet from both instruments.

d. Install clips (F) on panels (U) and (V), using screws (G), lockwashers (H), and nuts (I) supplied (Figure 2-7).

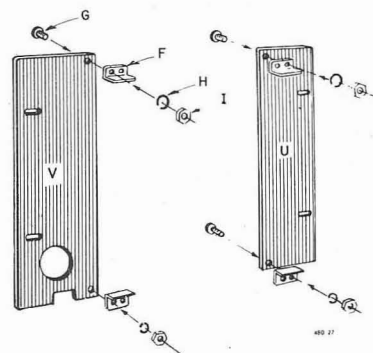

Figure 2-7. Subassembly of rack adaptor plates.

e. If the coaxial patch cord is used to bring the output of the 1362 Oscillator from the front of the panel to the back, the mounting cup, locked to the connector with a large hex nut, should be reversed to obtain a neater assembly. The sequence of parts for this method of assembly is shown in Figure 2-8.

f. Install the four 4-40 screws (P) with lockwashers (Q) from the front of panel (V) and thread them into the mounting cup of the patch-cord assembly (O).

g. If the patch cord assembly is not to be used, assemble the cover plate (R) and mount it over the hole (insert, Figure 2-8). To do this, push the spring into the mounting hole from the front.

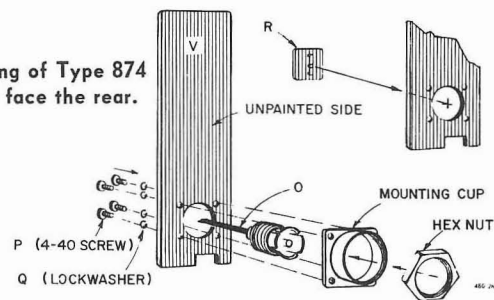

Figure 2-8. Mounting of Type 874 panel connector to face the rear.

h. Remove the outside pairs of front-panel screws (D) and spacers (E) from both instruments.

i. Attach panels (U) and (V) as shown in Figure 2-9. Install the clips in place of the spacers (E) and fasten them with the screws (D).

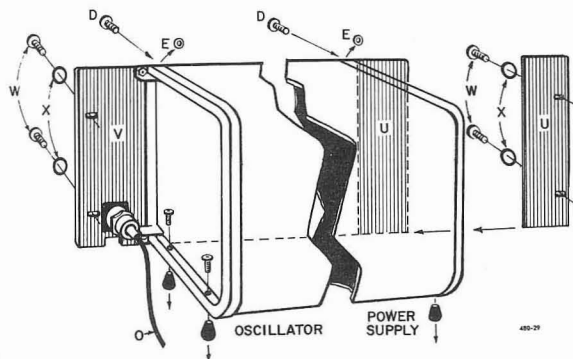

Figure 2-9. Rack installation of oscillator with power supply.

j. Use the 5/8-inch, No. 10-32 screws (W) and nylon washers (X) (supplied) to attach the assembly to the relay rack. Patch cords connecting front and rear points (if any) can pass easily through the small notch at the bottom of panel (V).

2.4 MODULATOR CONNECTION.

WARNING

An open circuited plug in either of the phone jacks will stop the oscillator and cause full power-supply voltage to appear at the terminals.

For sinusoidal amplitude modulation the audio modulation voltage should be inserted at the MOD jack on the front panel or at the phone jack on the left side. Full plate current (about 30 mA) must flow through the modulating source. A modulation voltage of about 20 volts is required for 30-percent modulation. The input impedance is about 3000 ohms. The Type 1311 Audio Oscillator is an economic audio frequency modulator for the uhf oscillator.

2.5 RF OUTPUT CONNECTIONS.

With the Type 1264, 1267, or 1269 Power Supply, the oscillator rf output may be connected directly to the equipment under test by means of the three-foot coaxial cable supplied.

Attenuator pads may help to reduce standing waves on the cable where the equipment under test

does not provide a good termination. Without padding, cable resonance effects may be quite pronounced since the output coupling loop of the oscillator is not a matched source. A low-pass filter may be beneficial in cases where oscillator harmonics must be kept to very low values.

When the Type 1263 Amplitude-Regulating Power Supply is used, care must be taken to avoid damaging the diode in the voltmeter rectifier.

CAUTION

The following connections *must* be made with the power OFF. Before the power is applied, refer to the Type 1263 Instruction Manual for proper operating procedure.

The oscillator rf output should be connected directly to the short end of the Type 874-VRL Voltmeter Rectifier. The attenuator should be pushed in and locked; it is not used to control output level in this system. The longer end of the rectifier (labelled "R") contains a 50-ohm series resistor, which is the effective generator source impedance. The levelled rf output available at the corresponding connector may now be connected to the equipment under test.

If cables equipped with other connectors are to be used, a suitable adaptor may be semipermanently attached to the locking GR874 output receptacle of the oscillator. See the table at the rear of this book for a listing of available adaptors.

SECTION 3

OPERATING PROCEDURE

3.1 EQUIPMENT TURN-ON.

The power switch on any of the recommended power supplies controls the application of heater power to the oscillator. On all supplies except the Type 1269 Power Supply, plate voltage is applied by appropriate setting of a standby or function switch. Rf output is obtainable from the oscillator about 30 seconds after power is turned on, an interval required for the heater to come up to temperature.

NOTE

Do not attempt to operate the oscillator with the 8-pin plug on the left-side panel disconnected. For good oscillator frequency stability, allow a one-half-hour warmup period. Refer to paragraph 1.2.3.

3.2 FREQUENCY ADJUSTMENT.

The calibration accuracy of the frequency dial is $\pm 1\%$, but the frequency can be reset by use of the logging scales to a precision of 1.3 MHz at midscale. This precision increases to 0.2 MHz at the low end and falls off to 2.5 MHz at the high end. By interpolation within the 1/8-inch interval between the vernier-scale marks, the precision of the setting can be increased by a factor of at least two, to $\pm 0.1\%$ at midscale.

The inner scale on the main frequency-control dial serves as the first digit in a three-digit logging

scale, the last two digits being indicated by the vernier dial. The 0 mark on the vernier corresponds to any one of the lines separating the nine numbered segments, 0 through 8. Combined, the dials furnish 900 dial settings throughout the range of the oscillator, to permit rapid and precisely repeatable frequency settings.

The mesh of the main- and vernier-dial drive gears is maintained by a spring return, which automatically disengages the drive if the vernier knob is lifted. To restore proper mesh, rotate the main dial to an intersegment mark, lift up gently on the knob, and reset the vernier 0 mark.

3.3 OUTPUT ADJUSTMENT.

Maximum output is obtained with the attenuator barrel pushed all the way in. To reduce output, pull the attenuator out. The output lock is activated by clockwise rotation. The output attenuator is calibrated at 5-dB intervals over an 80-dB range, and has an additional uncalibrated region near maximum output. The output power or voltage level at any setting of the attenuator is known if it is measured at one setting, such as "zero", provided that frequency and load impedance are not changed.

Load reaction on the oscillator frequency will be negligible for adjustments of load or attenuator in the calibrated region of the attenuator, but padding (refer to paragraph 2.5) may still be desirable to reduce standing waves in the rf output cable.

SECTION 4

APPLICATIONS

4.1 GENERAL.

The versatility of the 1362 UHF Oscillator is greatly increased by the large selection of Type 874 coaxial elements available from General Radio Company. These elements are part of a broad, integrated line of equipment for measurements of voltage, power, and standing-wave ratio at very-high and ultra-high frequencies. Use of the coaxial elements can adapt the oscillator to various applications in the radio-frequency laboratory in place of more expensive equipment that is not always available.

Five applications are described in detail in the following paragraphs. Others will be suggested by a study of the complete list of GR874 coaxial elements included in the General Radio catalog. Coaxial elements with locking connectors are preferred over non-locking ones because of better impedance matching, shielding, mechanical stability, and repeatability. A condensed list of GR874 elements appears in the rear of this manual.

4.2 SIGNAL GENERATOR FOR RECEIVER TESTING.

The 1362 UHF Oscillator, being a well shielded power source, can be used as a signal generator to test receivers if means are available to measure the output. The Type 874-VRL Voltmeter Rectifier and the Type 874-VI Voltmeter Indicator are suitable for this purpose, and should be connected to the oscillator as shown in Figure 4-1.

The signal level is established at a convenient setting of the attenuator, such as -10 dB, and the output is measured by a crystal diode in the voltmeter rectifier and indicated on the meter of the voltmeter indicator. (Means are provided to standardize the meter indication.) A 50-ohm resistor after the diode determines the output impedance.

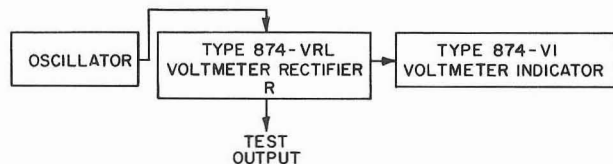

Figure 4-1. Setup of a voltmeter indicator and rectifier with the 1362 Oscillator for use as a standard-signal generator.

CAUTION

Do not apply full output to the rectifier or it may be damaged.

With the above-described arrangement, the maximum available output is several tenths of a volt. The attenuator calibration covers 80 dB. Shielding of the oscillator and of other components is adequate for accurate measurements over this range.

4.3 LOCAL OSCILLATOR IN A FREQUENCY CONVERTER.

Connected to a Type 874-MRAL Mixer Rectifier, the oscillator can provide the local signal in a heterodyne converter to adapt the 1236 I-F Amplifier for use as a sensitive detector for uhf signals (see Figure 4-2). Without additional tuning, the conversion loss is about 6 dB at an intermediate frequency of 30

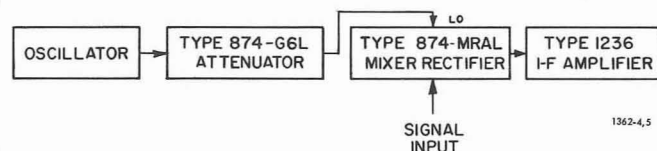

Figure 4-2. Setup of a superheterodyne receiver using the 1362 Oscillator as the local oscillator.

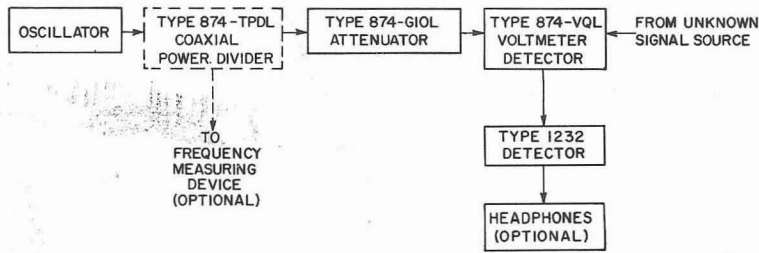

Figure 4-3. Setup for frequency measurement, using the 1362 Oscillator as a transfer oscillator or heterodyne frequency meter.

MHz. The Type 1236 I-F Amplifier has a built-in precision attenuator, a panel meter, which normally indicates signal level, and a separate built-in power supply for operating the oscillator. The panel meter, besides indicating signal level, can also be used to measure the mixer current (and hence local-oscillator level).

4.4 TRANSFER OSCILLATOR.

The 1362 Oscillator can be used as a transfer oscillator to measure the frequency of a microwave source, or as a heterodyne frequency meter of $\pm 1\%$ accuracy.

Auxiliary equipment required, in addition to a power supply, includes a Type 1232 Tuned Amplifier and Null Detector, a Type 874-VQL Voltmeter Detector, a Type 874-G10L Attenuator, a Type 874-R22LA Patch Cord, and two patch cords such as Type 874-R22LA for connection to the signal and, if greater accuracy is desired, to frequency-measuring equipment. The necessary connections are shown in Figure 4-3.

The oscillator should be tuned to zero beat with the source at two or more points on the dial, noting the frequencies of a pair of successive, strong beats. The harmonic order (H) can then be determined as follows:

Let: f_s = the source frequency
 f_h = the higher frequency of two successive, strong beats
 f_l = the lower frequency to two successive, strong beats

$$f_d = f_h - f_l = \text{the difference}$$

$$H = f_h / f_d \text{ (always an integer)}$$

and the signal frequency, f_s , is:

$$f_s = Hf_l = (H-1)f_h$$

4.5 SWEPT OSCILLATOR.

The 1362 Oscillator, employed in the equipment setup shown in Figure 4-4, can be used for rapid insertion-loss measurements on uhf devices. This is indicative of a number of applications in which the oscillator can be operated in a swept-frequency mode. Long life is assured by the design (ball bearings in the tuning mechanism) and proper lubrication (refer to paragraph 1.4 and 1.5).

Use of the Type 1263 Power Supply (which includes the Type 874-VRL Voltmeter Rectifier) ensures a leveled output from the oscillator throughout the sweep range. The internal 1-kHz square-wave modulator of the power supply permits use of the extremely sensitive Type 1232 Tuned Amplifier and Null Detector as the indicator, with an auxiliary output that can drive an X-Y recorder, if desired.

4.6 OBSERVATION OF MODULATION.

The envelope of the amplitude-modulated rf signal can be displayed on an oscilloscope with the setup shown in Figure 4-5. Since the detector provides a negative signal, the use of a scope with polarity inversion is recommended, so that the display will show increasing voltage upward.

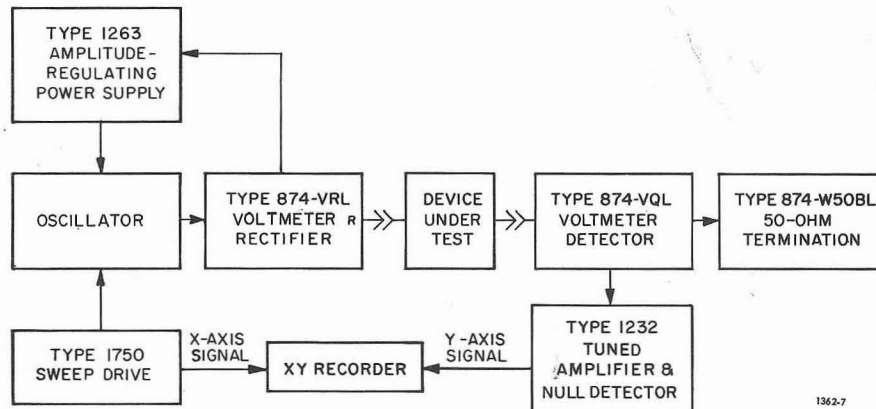

Figure 4-4. Setup for measurement of insertion loss or gain vs frequency using the 1362 Oscillator as a swept and leveled source.

1362-7

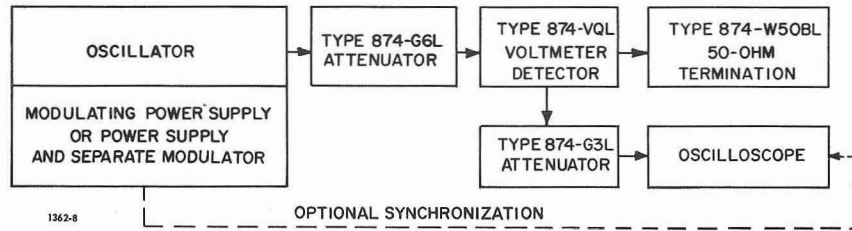

Figure 4-5. Setup for observation of modulation envelope.

SECTION 5

PRINCIPLES OF OPERATION

5.1 GENERAL.

The Type 1362 UHF Oscillator is a vacuum-tube oscillator intended for use as a general-purpose laboratory rf source. Its frequency range, which extends from 220 to 920 MHz, is tuned with a single control, without band switching. Frequency setting is indicated on a large, easy-to-read, engraved dial, individually calibrated to give $\pm 1\%$ accuracy.

The oscillator is capable of delivering rf power in excess of 160 milliwatts into 50 ohms over its frequency range. Power-supply, modulation, and output-calibration circuitry have been omitted from the instrument, in order to leave the user the greatest possible latitude of choice to arrange the oscillator in a system that meets his particular needs.

5.2 CIRCUITRY.

5.2.1 TUBE CIRCUIT.

The oscillator uses the General Electric type Y-1266 metal-and-ceramic, planar, triode tube (Figure 5-1). The tube is designed to operate with 6.3 volts and 0.24 amperes on the heater and a maximum plate voltage of 350 volts.

The tube is used in a Colpitts circuit (Figure 5-2) with the plate and grid connected to the tuned circuit LC101. The feedback is determined by the inter-electrode capacitances of the tube, with addi-

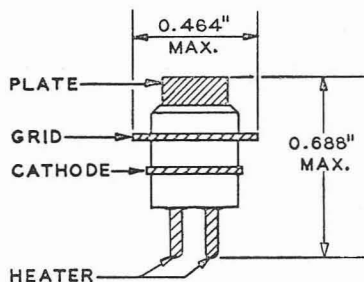

Figure 5-1. Type Y-1266 oscillator tube, outline drawing.

tional cathode-to-plate capacitance, C105, built into its mount.

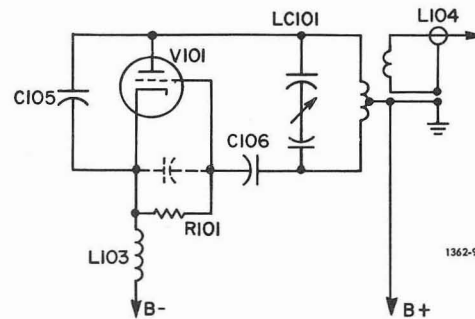

Figure 5-2. Elementary schematic diagram of the 1362 UHF Oscillator.

5.2.2 TUNING.

The 1362 Oscillator uses a butterfly tuning circuit, which combines a variable air capacitor and a variable inductor in a single unit with no sliding contacts. Inductance varies from 10 nH at the low-frequency end of the tuning range to 4 nH at the high-frequency end, and capacitance varies from 50 pF to 7 pF.

5.2.3 OUTPUT COUPLING.

Radio-frequency power is coupled from one of the inductive parts of the butterfly to a loop at one end of a short air line having the output connector at the other end. A waveguide-below-cutoff (piston) attenuator is provided by permitting the air line to slide axially in a suitable tube.

Maximum output is obtained with the loop in close to the butterfly, reduced output with the loop retracted. Reasonably linear and frequency-insensitive attenuator calibration is possible only while the loop is withdrawn beyond the zero-dB mark. Calibration extends over a range of 80 dB from that point.

SECTION 6

SERVICE AND MAINTENANCE

6.1 WARRANTY.

We warrant that each new instrument manufactured and sold by us is free from defects in material and workmanship, and that, properly used, it will perform in full accordance with applicable specifications for a period of two years after original shipment. Any instrument or component that is found within the two-year period not to meet these standards after examination by our factory, District Office, or authorized repair agency personnel will be repaired or, at our option, replaced without charge, except for tubes or batteries that have given normal service.

Typical life of the Type Y-1266 tube is 2000 hours. Tubes are guaranteed for 1000 hours or 12 months; replacement for defective tubes will be made on a prorated basis within this period.

6.2 SERVICE.

The two-year warranty stated above attests the quality of materials and workmanship in our products. When difficulties do occur, our service engineers will assist in any way possible. If the difficulty cannot be eliminated by use of the following service instructions, please write or phone our Service Department (see rear cover), giving full information of the trouble and of steps taken to remedy it. Be sure to mention the type and serial numbers of the instrument.

Before returning an instrument to General Radio for service, please write to our Service Department or nearest District Office, requesting a Returned Material Tag. Use of this tag will ensure proper handling and identification. For instruments not covered by the warranty, a purchase order should be forwarded to avoid unnecessary delay.

6.3 MINIMUM PERFORMANCE STANDARDS.

6.3.1 GENERAL.

The following paragraphs contain necessary information on means to determine rapidly that the oscillator is performing within specifications. The procedures given will be useful to instrument-standards laboratories and equivalently equipped service facilities, to perform routine calibration checks on properly functioning instruments and to determine that a repaired instrument has been restored to proper operation. The procedures that follow immediately apply to bench checks that use only front-panel controls and externally available test points (i.e., instrument disassembly is neither required nor recommended).

A list of recommended test equipment appears in Table 6-1.

6.3.2 OPERATING CHECK.

To check the dc operating conditions, plug a dc milliammeter into either MOD jack (J101 or J102) and measure the plate current of V101. Oscillation is indicated by a gradual variation of the plate current as the oscillator is tuned over its frequency range. Maximum plate current normally occurs near the high end of the tuning range and should be 25 to 35 mA for CW operation with a 300-volt power supply.

6.3.3 FREQUENCY CHECK.

One method of determining that the calibration of the main tuning dial is within the specified $\pm 1\%$ accuracy is to compare the oscillator rf output with the harmonically related output of another signal source. The signals are combined in a broadband

Table 6-1

RECOMMENDED TEST EQUIPMENT

<i>GR Type (or equivalent)</i>	<i>Name</i>	<i>Function</i>
1264	Modulating Power Supply	Power and modulate oscillator for frequency, output, and modulation measurements.
1215	Oscillator, 50 to 250 MHz	Furnish strong reference signal to measure oscillator frequency.
1267	Power Supply (Regulated)	For 1215 Oscillator.
1191-Z	Frequency Measuring Assembly, dc to 500 MHz	Furnish digital indication of signal-source output frequency.
1232	Null Detector, tunable to 1-kHz, 1 μ V sensitivity	Null indicator for frequency measurements.
1862	Megohmmeter	Measure butterfly rotor isolation with high potential.
—	Voltohmmeter, 20 k Ω /V, minimum	Measure voltage and resistance values.
—	Microwave power meter, $\pm 3\%$ accuracy	Measure rf power output of oscillator.
874-R22LA	Patch Cord	To interconnect system components.
874-R34	Patch Cord	To connect GR 874-VI into a system.
874-W50BL	Termination, 50-ohm	Terminate rf system for noise and modulated-output measurements.
874-TPDL	Power Divider	Means of balanced coaxial interconnection.
874-VI	Voltmeter Indicator	Measures output voltage of oscillator.
874-VQL	Coaxial Crystal Detector	Used to generate harmonics of reference signal and mix these with oscillator output. Also used to detect the rf envelope in modulation.
874-G101 or -G20L	Coaxial Attenuator Pads, 10 dB and 20 dB	Reduce oscillator output to protect sensitive measuring instruments.

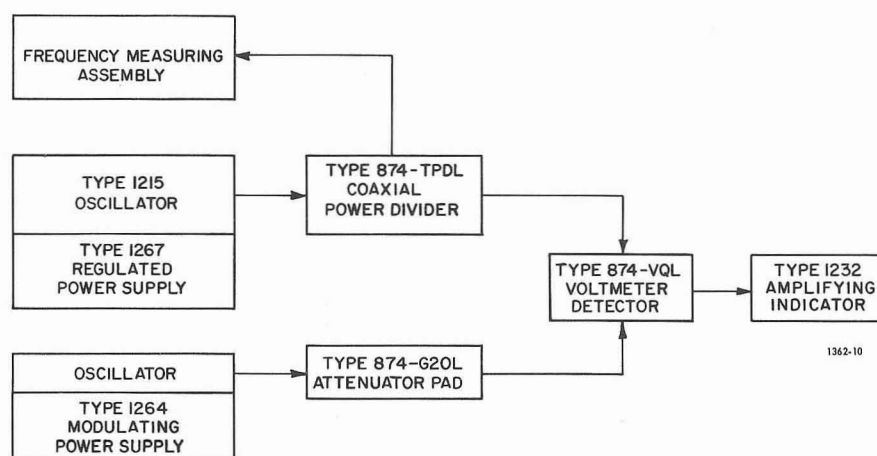

Figure 6-1. Setup to check frequency calibration of the Type 1362 Oscillator.

crystal detector and the resultant output is observed on a sensitive null detector serving as a beat indicator. Refer to Figure 6-1 for the test set-up and proceed as follows:

a. Connect the 1362 Oscillator to the power supply, apply power, and allow for a one-half hour warmup in the STANDBY mode.

b. Apply power to the signal source (Type 1215 Unit Oscillator) and allow for at least one-half hour warmup. (This should be unmodulated.)

c. Apply power to the Type 1143 Frequency Measuring Assembly and allow for a one-half hour warmup.

d. Set the output loop of the 1215 Oscillator about one-half inch from maximum coupling and tune carefully to 150 MHz. Observe the frequency indication on the Counter assembly and adjust the oscillator, as necessary, for at least one significant figure after the decimal point, i.e., 150.0 \pm 0.1 MHz.

e. Turn on the 1232 Detector, set its amplifier in the FLAT (broadband) mode, its meter for LOG indication, and its GAIN control for negligible response (1 division on the meter).

f. Turn the mode switch on the 1264 Power Supply to CW.

g. Adjust the main tuning dial slowly around 300 MHz, and look for a beat indication (peak response) on the 1232 Detector. The beat should occur well within \pm 1%.

h. Repeat the procedure of step g at 600 MHz and at 900 MHz. If the 1362 Oscillator dial is correct at these frequencies, it is quite reasonable to assume that the other engraved lines are accurate to the specified \pm 1%.

If the oscillator frequency calibration is outside specification, refer to paragraph 6.7 for corrective action.

6.3.4 POWER OUTPUT CHECK.

To check the available rf power output from the oscillator, use any suitable rf power meter. Alternatively, a GR Type 874-VI Voltmeter Indicator may be used with a GR Type 874-VQL Voltmeter Detector. The detector will produce a dc current to drive the indicator, which can be calibrated in volts. The 874-VQL Detector introduces no appreciable discontinuity when inserted in a 50-ohm coaxial line and should be terminated with a 50-ohm load, such as the Type 874-W50BL 50-ohm Termination.

To make a measurement, set up the equipment as in Figure 6-2. The use of a GR Type 874-G10L Attenuator limits the power level to prevent damage

to the diode in the detector. The oscillator output voltage is measured by suitable adjustments of sensitivity and calibration controls on the voltmeter indicator. That value in volts must be squared, multiplied by ten for each 10 dB attenuator pad inserted in the system, and divided by the termination resistance in ohms, to obtain the output power in watts. (Example: Given a measurement of 1.0 volt, a 10 dB pad in the system, and a 50-ohm load. Solution: $1.0^2 \times 10/50 = 0.2$ watts = 200 milliwatts.) Refer to Figure 1-3 for guaranteed and typical performance with various General Radio power supplies.

If the output power is very low, refer to the trouble analysis section 6.4. On the other hand, if the output power is slightly below specification, it may be corrected by adjustment of R107. Refer to paragraph 6.6, g.

6.4 TROUBLE ANALYSIS.

6.4.1 GENERAL.

If the 1362 Oscillator performs outside of specification, as determined by use of paragraph 6.3, the procedures below can be used to isolate the trouble to a defective assembly or part. Suggestions for trouble analysis are given in Tables 6-2 and 6-3. The former is based on operating parameters, the latter on cold resistances. (Refer to Figures 6-3 and 6-4 and to the schematic diagram, Figure 6-8, at the end of the book.) Instructions for adjustment and repair are given in subsequent paragraphs of Section 6.

6.4.2 DETAILS OF TROUBLE ANALYSIS.

If the oscillator is weak, and the analysis suggested in Tables 6-2 and 6-3 show no defects except low plate current and high cathode voltage, the tube has a defective (worn-out) cathode. Proceed to paragraph 6.6.

If oscillation ceases and restarts very abruptly as the tuning dial is rotated, recheck Table 6-3, step k several times. The Type 1862 Megohmmeter may be used, applying 500 volts to the test. If there is a short-circuit caused by a loose piece of material between rotor and stator, its behavior may be erratic and difficult to analyze. If a short-circuit is the result of bent plates, the malfunction will be repeatable and the instrument should be serviced as described in paragraph 6.2.

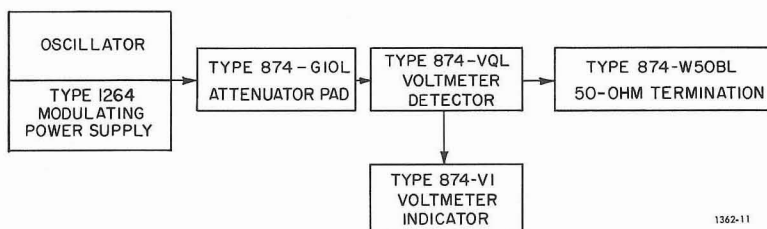

Figure 6-2. Setup to check output level of the Type 1362 oscillator.

Table 6-2
CURRENT AND VOLTAGE ANALYSIS*

Step	Measurement (by use of)	Test Points	Indication	Comments
a	Plate current (50-mA dc meter and phone plug)	MODulation jack on panel (J101, Figure 6-4)	0 mA	Check power supply and connections. Check voltages.
			18 to 35 mA, varies with tuning	Normal
			18 mA steady	Open grid
			22 mA fixed when tuning dial is rotated	No oscillation. (Suspect LC101 shorted or short circuit from grid to cathode.)
			42 mA	Short circuit from plate to cathode. (Check resistances)
b	Cathode voltage (300-Vdc meter)	"Ground" or sub-panel (+); orange wire at C107 or R105 (-) (Figure 6-4)	0 V	Lack of voltage from power supply or grounded cathode circuit.
			Less than 75 V	Suspect C107 (Set up both steps a and b, disconnect PL101)
			75 to 160 V, varies with tuning	Normal
			300 V	Open circuit to cathode or "dead" tube (check heater)
c	Heater voltage (10-V dc or ac meter depending on power supply)	FL101 to FL102 (Figure 6-5)	0 V	Lack of voltage from power supply (check connections, resistances)
			6.5 V	Normal (If 300 V in step b go to Table 6-3, step a)

*Power supply: Type 1267, or 1264 set to cw with amplitude control clockwise. RF shield cover in place.

NOTE

If measurements are attempted on this oscillator with power on and the rf shield cover removed, one may expect the instrument in good repair to oscillate over most of its tuning range but to deviate appreciably from specified frequency calibration and output power level.

When the oscillator is being serviced and repaired, a visual inspection is appropriate. All soldered joints should be secure, mechanical fasteners tight, dial-drive mechanism operating smoothly without backlash, and the tiny damping resistors on the rotor secure and unbroken. For lubrication, refer to paragraph 6.8.

6.5 REMOVAL OF COVERS.

6.5.1 GENERAL.

When it becomes necessary to carry the trouble analysis beyond step "a" in either Table 6-2 or 6-3, the exterior cover will have to be removed. Steps "b and c" in Table 6-2 must be made with the rf shield cover in place; however, the rf shield cover will have to be removed to perform steps "b through l" in Table 6-3 and to replace the oscillator tube (V101).

6.5.2 REMOVAL OF EXTERIOR COVER.

To remove the exterior cover, loosen the captive thumb screws that hold the exterior cover on by ro-

tating them counter-clockwise (as seen from the rear). Slide the cover off the rear of the instrument.

6.5.3 REMOVAL OF RF SHIELD COVER.

To remove the rf shield cover proceed as follows:

a. Remove the snap button from the right side of the instrument (Figure 6-5). This is done by pushing out the button from the inside with a blunt tool, such as the end of a small screwdriver handle.

b. Insert a Phillips-head screwdriver through the hole left by the snap button and remove the No. 6-32, 1/4-inch screw in the rf shield cover.

c. Unscrew the two captive No. 10-32 Phillips-head screws on opposite sides of the shield cover. Unscrew several turns at a time, alternating between screws.

d. Slide the rf shield cover off. Figure 6-4 identifies the major interior components.

CAUTION

The positions of parts in the rf section are critical. Do not move any part unless it is defective. When a part must be replaced, install the new one in the same position and orientation, with the same lengths of leads and lead dress.

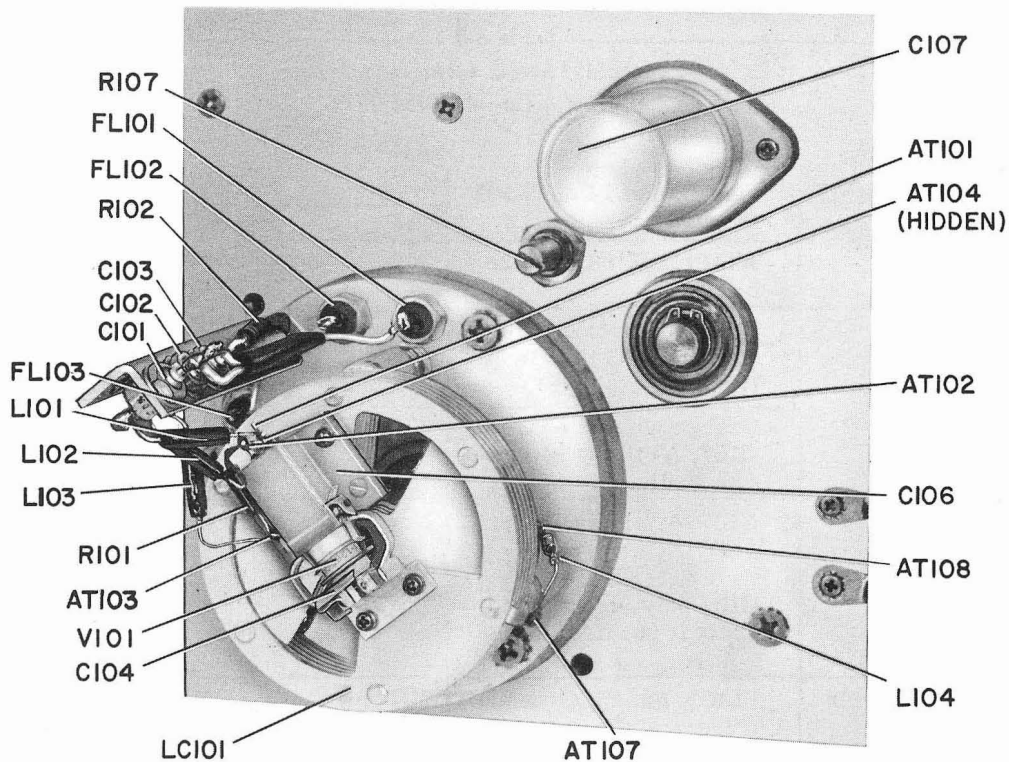

Figure 6-3. Interior rear view of Type 1362 Oscillator with shield cover removed.

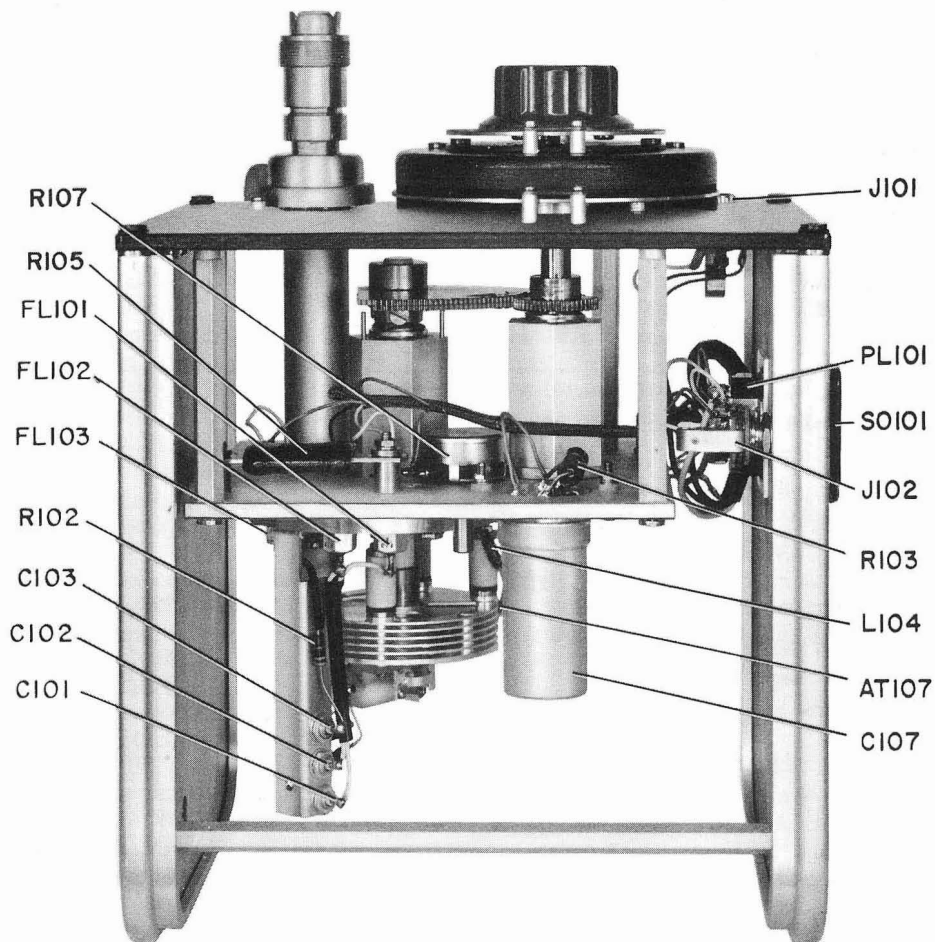

Figure 6-4. Interior top view of Type 1362 Oscillator with shield cover removed.

Table 6-3

RESISTANCE ANALYSIS				
CAUTION – Turn all power OFF.				
Step	Measurement (by use of)	Test Points	Indication	Comments
a	Heater (ohmmeter)	Pins 13 and 14 of PL102 (Figure 6-8)	10 Ω	Normal
			$\infty \Omega$	Open circuit (Go to step b)
b		AT101; AT102 (Figure 6-3)	$\infty \Omega$	Open heater in tube (See paragraph 6.6)
c	Cathode string (ohmmeter)	PL102, pin 16; orange wire at R105 or C107 (Figures 6-4, 6-8)	5.5 to 8.2 k Ω	Normal
d		Orange wire at R105 or C107; AT103 (Figures 6-3, 6-4)	33 Ω	Normal
e	C107 (ohmmeter)	C107 terminals (Figure 6-4) WARNING C107 may be charged; short it out first.	Low Ω	Leaky or shorted
			100 k Ω	Normal
f	Modulation circuit (ohmmeter)	PL102, pin 15; Ground (Figure 6-8)	0 Ω	Normal
			$\infty \Omega$	Fault in J101, J102, or SO101
g	Cathode to grid (ohmmeter)	AT103; AT104 (Figure 6-3)	0 Ω	Suspect tube (V101)
			1 k Ω	Normal
h	Grid to plate (ohmmeter)	AT104; AT107 (Figures 6-3, 6-4)	0 Ω	C106 or C104 shorted
			$\infty \Omega$	Normal
i	Cathode to plate (ohmmeter)	AT103; AT107 (Figures 6-3, 6-4)	0 Ω	Short in V101 or C105
			$\infty \Omega$	Normal
j	L104 (ohmmeter)	AT107; AT108 (Figures 6-3, 6-4)	0 Ω	Normal
k	Butterfly rotor (megohmmeter)	AT107; LC101 rotor (Figures 6-3, 6-4)	∞ (over whole tuning range)	Normal
l	Heater to cathode (ohmmeter)	FL101; FL103 (Figure 6-3, 6-4, 6-5)	1 m Ω	Normal
			$\infty \Omega$	Check SO101

Conditions: PL102 (5-pin plug) floating, SO101-PL101 (8-pin plug and socket) connected, no phone plugs.

6.6 INSTALLATION OF OSCILLATOR TUBE.

When it is necessary to replace the Type Y-1266 tube, proceed as follows (Figure 6-6):

CAUTION
Turn all power OFF.

- a. Remove the covers as described in paragraph 6.5.
- b. Remove the two plate-clamp-mounting screws, and withdraw the tube from the heater socket.
- c. Loosen the plate-clamp screw and withdraw the tube from the plate clamp.
- d. Plug replacement tube into heater socket, using care not to snag the grid fingers on the smaller (cathode) flange of the tube. Be sure that the tube is fully seated, and that the two grid fingers are making contact.

e. Slip the plate clamp over the plate terminal and secure the assembly to the butterfly capacitor by means of original hardware.

f. Tighten the plate-clamp screw, making sure that tube is still fully seated in heater socket. Replace the rf shield cover and tighten its 3 screws.

g. Connect a 0-50 milliammeter at the MOD jack; apply power using a 1267 Power Supply; set the dial to 920 MHz; connect a 50-ohm load to the output connector; push the attenuator in; allow 5 minutes for warm-up. Adjust R107 with a screwdriver (refer to Figure 6-3) for 30 mA \pm 3 mA plate current. (The current may be set higher to provide more rf power output at the expense of reduced tube life; conversely, for economy, refer to paragraph 6.9.)

h. Restore frequency calibration if necessary, in accordance with paragraph 6.7.

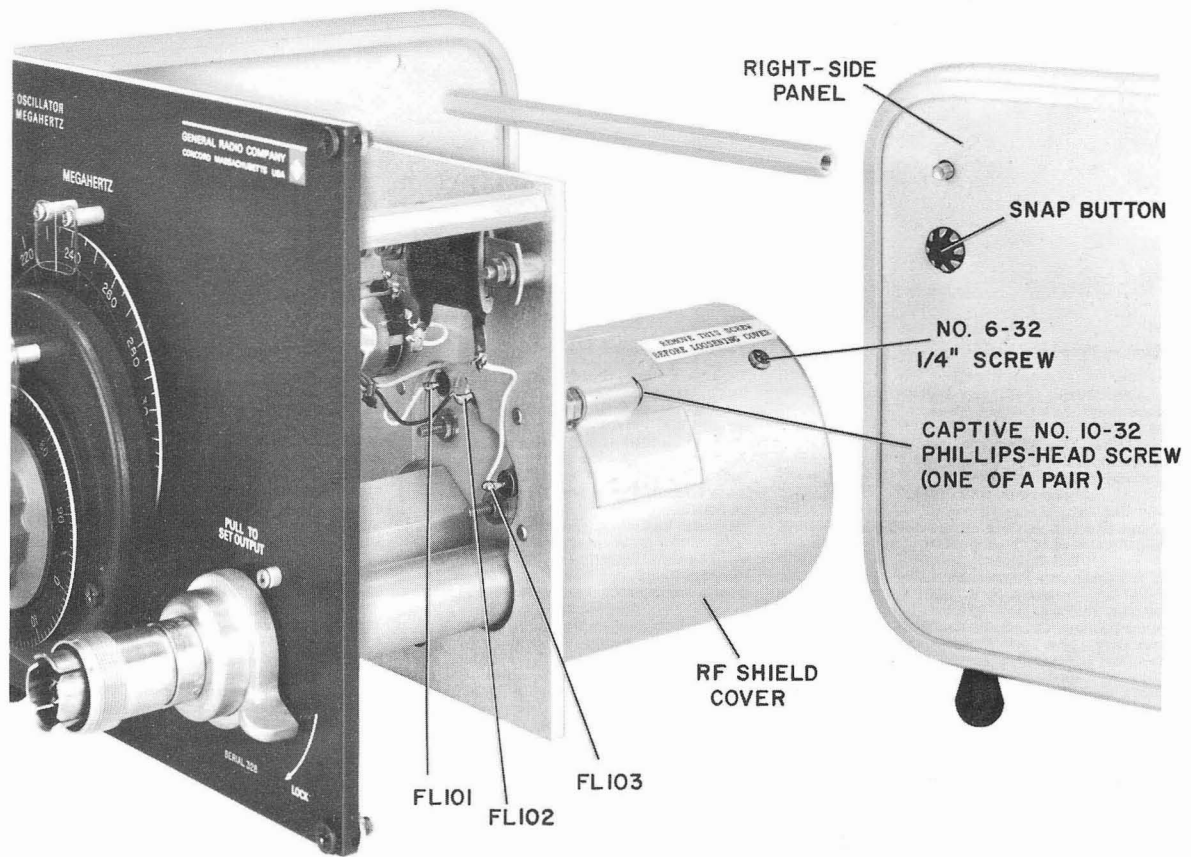

Figure 6-5. Interior right-side view with shield cover in place (right side of cabinet removed).

6.7 FREQUENCY CALIBRATION.

Replacement of the oscillator tube may affect frequency calibration. This can be checked by the method described in paragraph 6.3.3, during which process the shield cover must be in place with all three screws tight, and the output loop withdrawn at least to the zero-dB mark. If necessary, remove the shield cover and set the trimmer capacitor C104 by rotation (not bending) to make the output signal frequency agree with the dial calibration at any convenient frequency above 800 MHz. To free C104, temporarily loosen the plate clamp screw slightly.

If there is inadequate range to reach 920 MHz by rotating C104, it may be necessary to bend the feedback tabs (C105 A, B) as well. Moving each tab away from the tube raises the top frequency of the oscillator, but the feedback tabs, unlike C104, also affect the power output at the low-frequency end of the tuning range.

6.8 LUBRICATION.

Proper lubrication consists of occasional light grease on the gears behind the panel and the dial assembly. (Remove only the dust cover and the two screws near the vernier knob.) Lubrication is particularly important when the oscillator is driven by a sweep or dial drive.

6.9 ADJUSTMENT FOR MAXIMUM TUBE LIFE.

Longest tube life will be obtained by the use of regulated plate and heater voltages as supplied by the 1263, 1264, or 1267 power supplies. When the 1269 (unregulated) power supply is used, tube life can be prolonged at the expense of maximum power output by readjusting R107 to reduce plate current as far as possible, normally to 31 or 32 mA. (Refer to paragraph 6.6, step g.)

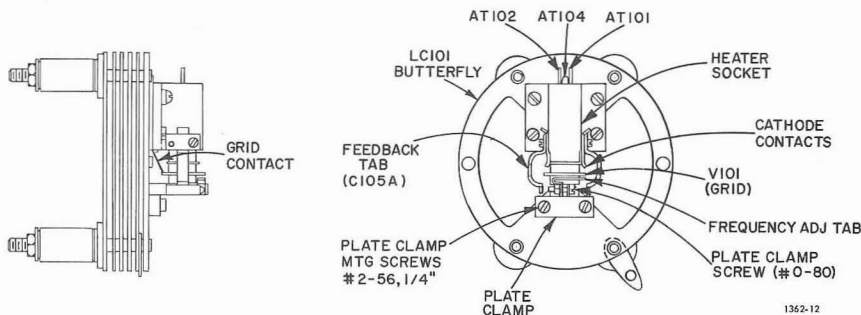

Figure 6-6. Details of oscillator-tube mounting.

FEDERAL MANUFACTURERS CODE

From Federal Supply Code for Manufacturers Cataloging Handbooks H4-1 (Name to Code) and H4-2 (Code to Name) as supplemented through June, 1967.

Code	Manufacturers Name and Address	Code	Manufacturers Name and Address	Code	Manufacturers Name and Address
00192	Jones Mfg. Co., Chicago, Illinois	53021	Sangamo Electric Co., Springfield, Ill. 62705	80583	Hammarlund Co. Inc., New York, N. Y.
00194	Walsco Electronics Corp., Los Angeles, Calif.	54294	Shallcross Mfg. Co., Selma, N. C.	80740	Beckman Instruments, Inc., Fullerton, Calif.
00656	Aerovox Corp., New Bedford, Mass.	54715	Shure Brothers, Inc., Evanston, Ill.	81073	Grayhill Inc., LaGrange, Ill. 60525
01009	Alden Products Co., Brockton, Mass.	56289	Sprague Electric Co., N. Adams, Mass.	81143	Isolantite Mfg. Corp., Stirling, N. J. 07980
01121	Allen-Bradley, Co., Milwaukee, Wisc.	59730	Thomas and Betts Co., Elizabeth, N. J. 07207	81349	Military Specifications
01295	Texas Instruments, Inc., Dallas, Texas	59875	TRW Inc. (Accessories Div), Cleveland, Ohio	81350	Joint Army-Navy Specifications
02114	Ferroxcube Corp. of America, Saugerties, N. Y. 12477	60399	Torrington Mfg. Co., Torrington, Conn.	81751	Columbus Electronics Corp., Yonkers, N. Y.
02606	Fenwal Lab. Inc., Morton Grove, Ill.	61637	Union Carbide Corp., New York, N. Y. 10017	81831	Filton Co., Flushing, L. I., N. Y.
02660	Amphenol Electronics Corp., Broadview, Ill.	61864	United-Carr Fastener Corp., Boston, Mass.	81860	Barry Controls Div. of Barry Wright Corp., Watertown, Mass.
02768	Fastex Division of Ill. Tool Works, Des Plaines, Ill. 60016	63743	Ward Leonard Electric Co., Mt. Vernon, N. Y.	82219	Sylvania Electric Products, Inc., (Electronic Tube Div.), Emporium, Penn.
03508	G. E. Semiconductor Products Dept., Syracuse, N. Y. 13201	65083	Westinghouse (Lamp Div), Bloomfield, N. J.	82273	Indiana Pattern and Model Works, LaPort, Ind.
03636	Grayburne, Yonkers, N. Y. 10701	65092	Weston Instruments, Weston-Newark, Newark, N. J.	82389	Switchcraft Inc., Chicago, Ill. 60630
03888	Pyrofilm Resistor Co., Cedar Knolls, N. J.	70485	Atlantic-India Rubber Works, Inc., Chicago, Ill. 60607	82647	Metals and Controls Inc., Attleboro, Mass.
03911	Clairex Corp., New York, N. Y. 10001	70563	Amperite Co., Union City, N. J. 07087	82807	Milwaukee Resistor Co., Milwaukee, Wisc.
04009	Arrow, Hart and Hegeman Electric Co., Hartford, Conn. 06106	70903	Belden Mfg. Co., Chicago, Ill. 60644	83058	Carr Fastener Co., Cambridge, Mass.
04713	Motorola Semi-Conduct Product, Phoenix, Ariz. 85008	71126	Bronson, Homer D., Co., Beacon Falls, Conn.	83186	Victory Engineering Corp (IVECO), Springfield, N. J. 07081
05170	Engineered Electronics Co., Inc., Santa Ana, Calif. 92702	71294	Canfield, H. O. Co., Clifton Forge, Va. 24422	83361	Bearing Specialty Co., San Francisco, Calif.
05624	Barber-Colman Co., Rockford, Ill. 61101	71400	Bussman Mfg. Div. of McGraw Edison Co., St. Louis, Mo.	83587	Solar Electric Corp., Warren, Penn.
05820	Wakefield Eng., Inc., Wakefield, Mass. 01880	71590	Centralab, Inc., Milwaukee, Wisc. 53212	83740	Union Carbide Corp., New York, N. Y. 10017
07127	Eagle Signal Div. of E. W. Bliss Co., Baraboo, Wisc.	71666	Continental Carbon Co., Inc., New York, N. Y.	84411	TRW Capacitor Div., Ogallala, Nebr.
07261	Avnet Corp., Culver City, Calif. 90230	71707	Coto Coil Co. Inc., Providence, R. I.	84835	Lehigh Metal Products Corp., Cambridge, Mass. 02140
07263	Fairchild Camera and Instrument Corp., Mountain View, Calif.	71744	Chicago Miniature Lamp Works, Chicago, Ill.	84971	TA Mfg. Corp., Los Angeles, Calif.
07387	Birtcher Corp., No. Los Angeles, Calif.	71785	Cinch Mfg. Co. and Howard B. Jones Div., Chicago, Ill. 60624	86577	Precision Metal Products of Malden Inc., Stoneham, Mass. 02180
07595	American Semiconductor Corp., Arlington Heights, Ill. 60004	71823	Darnell Corp., Ltd., Downey, Calif. 90241	86684	RCA (Electrical Component and Devices) Harrison, N. J.
07828	Bodine Corp., Bridgeport, Conn. 06605	72136	Electro Motive Mfg. Co., Willmington, Conn.	88140	Cutler-Hammer Inc., Lincoln, Ill.
07829	Bodine Electric Co., Chicago, Ill. 60618	72259	Nytronics Inc., Berkeley Heights, N. J. 07922	88219	Gould Nat. Batteries Inc., Trenton, N. J.
07910	Continental Device Corp., Hawthorne, Calif.	72619	Dialight Co., Brooklyn, N. Y. 11237	88419	Cornell Dubilier Electric Corp., Fuquay-Varina, N. C.
07983	State Labs Inc., N. Y., N. Y. 10003	72699	General Instrument Corp., Capacitor Div., Newark, N. J. 07104	88627	K and G Mfg. Co., New York, N. Y.
07999	Amphenol Corp., Borg Inst. Div., Delavan, Wisc. 53115	72765	Drake Mfg. Co., Chicago, Ill. 60656	89482	Holtzer Cabot Corp., Boston, Mass.
08730	Vemaline Prod. Co., Franklin Lakes, N. J.	72825	Hugh H. Eby, Inc., Philadelphia, Penn. 19144	89665	United Transformer Co., Chicago, Ill.
09213	General Electric Semiconductor, Buffalo, N. Y.	72962	Elastic Stop Nut Corp., Union, N. J. 07083	90201	Mallory Capacitor Co., Indianapolis, Ind.
09823	Burgess Battery Co., Freeport, Ill.	72982	Erie Technological Products Inc., Erie, Penn.	90750	Westinghouse Electric Corp., Boston, Mass.
09922	Burndy Corp., Norwalk, Conn. 06852	73445	Amperex Electronics Co., Hicksville, N. Y.	90952	Hardware Products Co., Reading, Penn. 19602
11599	Chandler Evans Corp., W. Hartford, Conn.	73559	Carling Electric Co., W. Hartford, Conn.	91032	Continental Wire Corp., York, Penn. 17405
12498	Teledyn Inc., Crystallines Div., Cambridge, Mass. 02140	73690	Elco Resistor Co., New York, N. Y.	91146	ITT Cannon Electric Inc., Salem, Mass.
12672	RCA Commercial Receiving Tube and Semi- conductor Div., Woodridge, N.J.	73899	J. F. D. Electronics Corp., Brooklyn, N. Y.	91293	Johanson Mfg. Co., Boonton, N. J. 07005
12697	Clarostat Mfg. Co. Inc., Dover, N. H. 03820	74193	Heinemann Electric Co., Trenton, N. J.	91598	Chandler Co., Wethersfield, Conn. 06109
12954	Dickson Electronics Corp., Scottsdale, Ariz.	74861	Industrial Condenser Corp., Chicago, Ill.	91637	Dale Electronics Inc., Columbus, Nebr.
13327	Solitron Devices, Tappan, N. Y. 10983	74970	E. F. Johnson Co., Waseca, Minn. 56093	91662	Elco Corp., Willow Grove, Penn.
14433	ITT Semiconductors, W. Palm Beach, Florida	75042	IRC Inc., Philadelphia, Penn. 19108	91719	General Instruments, Inc., Dallas, Texas
14655	Cornell Dubilier Electric Co., Newark N. J.	75382	Kulka Electric Corp., Mt. Vernon, N. Y.	91929	Honeywell Inc., Freeport, Ill.
14674	Corning Glass Works, Corning, N. Y.	75608	Linden and Co., Providence, R. I.	92519	Electra Insulation Corp., Woodside, Long Island, N. Y.
14936	General Instrument Corp., Hicksville, N. Y.	75915	Littelfuse, Inc., Des Plaines, Ill. 60016	92678	Edgerton, Germeshausen and Grier, Boston, Mass.
15238	ITT, Semiconductor Div. of Int. T. and T., Lawrence, Mass.	76005	Lord Mfg. Co., Erie, Penn. 16512	93332	Sylvania Electric Products, Inc., Woburn, Mass.
15605	Cutler-Hammer Inc., Milwaukee, Wisc. 53233	76487	James Millen Mfg. Co., Malden, Mass. 02148	93916	Cramer Products Co., New York, N. Y. 10013
16037	Spruce Pine Mica Co., Spruce Pine, N. C.	76545	Mueller Electric Co., Cleveland, Ohio 44114	94144	Raytheon Co. Components Div., Quincy, Mass.
19701	Electra Mfg. Co., Independence, Kansas 67301	76684	National Tube Co., Pittsburg, Penn.	94154	Tung Sol Electric Inc., Newark, N. J.
21335	Fafnir Bearing Co., New Briton, Conn.	77147	Oak Mfg. Co., Crystal Lake, Ill.	95076	Garde Mfg. Co., Cumberland, R. I.
24446	G. E. Schenectady, N. Y. 12305	77166	Patton MacGuay Co., Providence, R. I.	95146	Alco Electronics Mfg. Co., Lawrence, Mass.
24454	G. E., Electronic Comp., Syracuse, N. Y.	77263	Pierce Roberts Rubber Co., Trenton, N. J.	95238	Continental Connector Corp., Woodside, N. Y.
24455	G. E. (Lamp Div), Nela Park, Cleveland, Ohio	77339	Positive Lockwasher Co., Newark, N. J.	95275	Vitramon, Inc., Bridgeport, Conn.
24655	General Radio Co., W. Concord, Mass 01781	77542	Ray-O-Vac Co., Madison, Wisc.	95354	Methode Mfg. Co., Chicago, Ill.
26806	American Zettler Inc., Costa Mesa, Calif.	77630	TRW, Electronic Component Div., Camden, N. J. 08103	95412	General Electric Co., Schenectady, N. Y.
28520	Hayman Mfg. Co., Kenilworth, N. J.	77638	General Instruments Corp., Brooklyn, N. Y.	95794	Ansonda American Brass Co., Torrington, Conn.
28959	Hofman Electronics Corp., El Monte, Calif.	78189	Shakeproof Div. of Ill. Tool Works, Elgin, Ill. 60120	96095	Hi-Q Div. of Aerovox Corp., Orlean, N. Y.
30874	International Business Machines, Armonk, N.Y.	78277	Sigma Instruments Inc., S. Braintree, Mass.	96214	Texas Instruments Inc., Dallas, Texas 75209
32001	Jensen Mfg. Co., Chicago, Ill. 60638	78488	Stackpole Carbon Co., St. Marys, Penn.	96256	Thordarson-Meissner Div. of McGuire, Mt. Carmel, Ill.
35929	Constanta Co. of Canada Limited, Montreal 19, Quebec	78553	Timmerman Products, Inc., Cleveland, Ohio	96341	Microwave Associates Inc., Burlington, Mass.
37942	P. R. Mallory and Co. Inc., Indianapolis, Ind.	79089	RCA, Commercial Receiving Tube and Semi- conductor Div., Harrison, N. J.	96906	Military Standards
38443	Marlin-Rockwell Corp., Jamestown, N. Y.	79725	Wiremold Co., Hartford, Conn. 06110	97966	CBS Electronics Div. of Columbia Broadcast- ing Systems, Danvers, Mass.
40931	Honeywell Inc., Minneapolis, Minn. 55408	79963	Zierick Mfg. Co., New Rochelle, N. Y.	98291	Sealctro Corp., Mamaroneck, N. Y. 10544
42190	Muter Co., Chicago, Ill. 60638	80030	Prestole Fastener Div. Bishop and Babcock Corp., Toledo, Ohio	98821	North Hills Electronics Inc., Glen Cove, N. Y.
42498	National Co. Inc., Melrose, Mass. 02176	80048	Vickers Inc. Electric Prod. Div., St. Louis, Mo.	99180	Transitron Electronics Corp., Melrose, Mass.
43991	Norma-Hoffman Bearings Corp., Stanford, Conn. 06904	80131	Electronic Industries Assoc., Washington, D.C.	99378	Atlee Corp., Winchester, Mass. 01890
49671	RCA, New York, N. Y.	80211	Motorola Inc., Franklin Park, Ill. 60131	99800	Delevan Electronics Corp., E. Aurora, N. Y.
49956	Raytheon Mfg. Co., Waltham, Mass. 02154	80258	Standard Oil Co., Lafayette, Ind.		
		80294	Bourns Inc., Riverside, Calif. 92506		
		80431	Air Filter Corp., Milwaukee, Wisc. 53218		

PARTS LIST - MECHANICAL

Ref. Des. Figure 6-7	Description	Part Number	Fed. Mfg. Code	Mfg. Part No.	Fed. Stock No.
1	Slider to raise front of instrument	5250-1800	24655	5250-1800	
2	Rubber feet	5260-0700	24655	5260-0700	5340-738-6329
3	Screw, binder head, 10-32, 3/8 in.	7080-1000	24655	7080-1000	
4,5	Screw, binder head, 6-32, 3/8 in.	7070-1700	24655	7070-1700	
	Split lock washer, number 6	8040-1800	96906	MS35338-79	5310-011-1041
	Hex nut, number 6-32	5810-2400	24655	5810-2400	5310-964-5861
6	Dress nut	5800-0805	24655	5800-0805	
	Tooth lock washer, 3/8 in.	8050-0400	78189	1920-02	5310-209-3989
	Metal flat washer	8100-1104	24655	8100-1104	
7	Screw, binder head, 6-32, 1/4 in.	7070-0600	24655	7070-0600	5305-929-9387
	Split lock washer, number 6	8040-1800	96906	MS35338-79	5310-011-1041
	Metal flat washer	8100-0200	24655	8100-0200	
8	Screw, binder head with lock washer, 10-32, 3/8 in.	7090-0700	24655	7090-0700	
9	Left end frame	5310-4087	24655	5310-4087	
10	Metal flat washer	8100-1517	24655	8100-1517	5310-849-7166
11	Screw, binder head with washer, 10-32, 1/2 in.	7098-0161	24655	7098-0161	
12	Cover	4429-0600	24655	4429-0600	
13	Right end frame	5310-4086	24655	5310-4086	
14	Screw, binder head, 4-40, 5/8 in. (2 required)	7060-2200	24655	7060-2200	5305-997-3054
	Spacer, metal, number 4, 11/32 in. (2 required)	7640-0900	24655	7640-0900	
	Plastic indicator	5470-0651	24655	5470-0651	
15	Frequency dial (blank)	1362-2050	24655	1362-2050	
16	Screw, binder head, 4-40, 7/16 in. (2 required)	7060-1700	24655	7060-1700	5305-995-6716
	Spacer, metal, number 4, 9/32 in. (2 required)	7640-0750	24655	7640-0750	
	Plastic indicator	5470-0650	24655	5470-0650	6625-738-6353
17	Logging dial	5120-2336	24655	5120-2336	
	Screw, binder head, 6-32, 1/2 in.	7070-2400	86113	BH 6-32 1/2 (NP)	
	Foot, nylon	5250-1913	24655	5250-1913	
	Split lock washer, number 6	8040-1800	96906	MS35338-79	5310-011-1041
	Hex nut, 6-32	5810-2400	24655	5810-2400	5310-964-5861
19	Output Coupling Assembly	1362-2030	24655	1362-2030	
20	Screw, binder head, 6-32, 1 in.	7070-4100	24655	7070-4100	
21	Frequency control knob	5520-2500	24655	5520-2500	
22	Frequency dial housing	0907-1062	24655	0907-1062	
23	Screw, binder head, 6-32, 1 in.	7070-4100	24655	7070-4100	
24	Dress nut	5800-0805	24655	5800-0805	
	Tooth lock washer, 3/8 in.	8050-0400	78189	1920-02	5310-209-3989

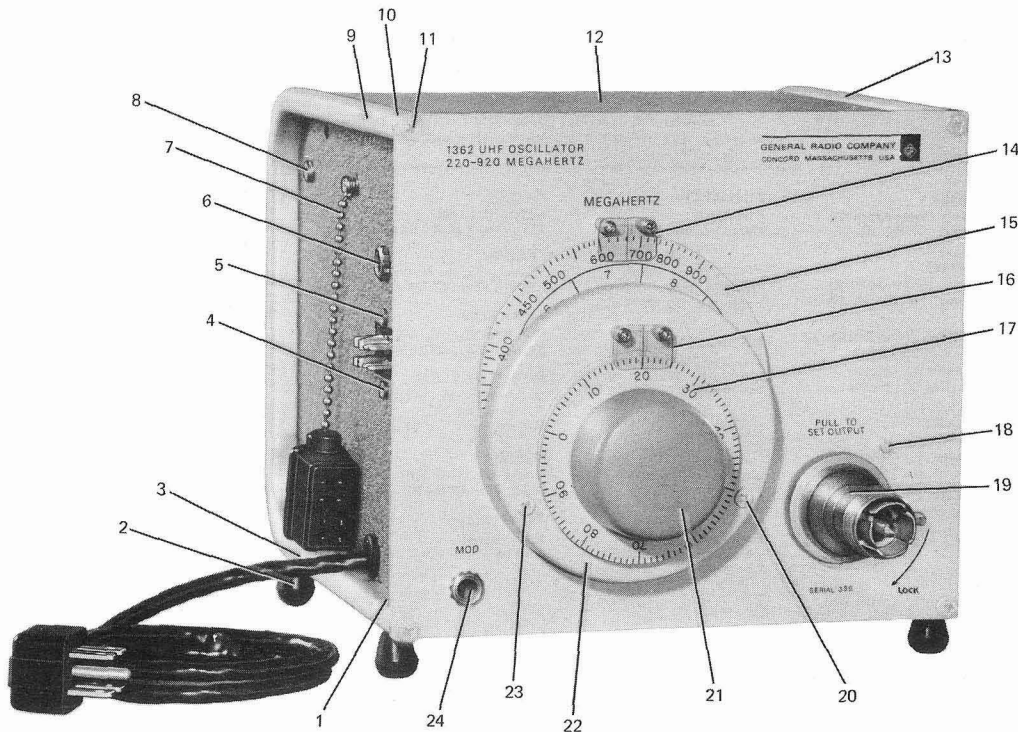

Figure 6-7. Exterior replaceable parts identification.

PARTS LIST— ELECTRICAL

<i>Ref. No.</i>	<i>Description</i>	<i>Part Number</i>	<i>Fed. Mfg. Code</i>	<i>Mfg. Part No.</i>	<i>Fed. Stock No.</i>
CAPACITORS					
C101 thru C103 C104 C107A C107B **C106	Ceramic, 100 pF ±20% 500 V Electrolytic, 10 µF 450 V	4400-1700 1362-8120 4450-0300 1362-7010	01121 24655 37942 24655	FB2B, 100 pF ±20% 1362-8120 20-10945 1362-7010	 5910-918-4073
RESISTORS					
R101 R102 R103 R105 *R106 R107	Composition, 1 kΩ ±5% 1/2 W Composition, 33 Ω ±5% 1/2 W Composition, 100 kΩ ±10% 2 W Power, 5.6 kΩ ±10% 10 W Composition, 1 MΩ ±5% 1/2 W Potentiometer, 2.5 kΩ ±10%	6100-2105 6100-0335 6120-4109 6630-2569 6100-5105 6000-0400	01121 01121 01121 82087 01121 12697	RC20GF102J RC20GF330J HB, 100 kΩ ±10% RW20, 5.6 k ±10% RC20GF105J 53MS, 2.5 kΩ ±10%	5905-195-6806 5905-192-4490 5905-254-7101 5905-192-0390 5905-034-5378
TUBE					
V101		8320-1266	24446	GE-Y1266	
INDUCTORS					
L101 thru L103 L104	4.3 µH ±10% 0.16 µH Approx.	4290-4550 4290-3800	24655 24655	4290-4550 4290-3800	
FILTERS					
FL101 FL102 FL103	2500 pF 2500 pF 200 pF ±20%	5280-0100 5280-0100 5280-0400	01121 01121 24655	FIB, 2500 pF FIB, 2500 pF 5280-0400	5915-908-1892 5915-908-1892 5915-908-1891
PLUGS					
PL101 PL102		4220-4600 1362-2070	75173 24655	P308-AB 1362-2070	5935-351-3739
SOCKET					
SO101		1361-0410	24655	1361-0410	
JACKS					
J101 J102		4260-1042 4260-1040	93916 82389	L112A 112A	

*Part of 1361-41
**Part of 1362-2090

- NOTE UNLESS SPECIFIED**
1. POSITION OF ROTARY SWITCHES SHOWN COUNTERCLOCKWISE.
 2. CONTACT NUMBERING OF SWITCHES EXPLAINED ON SEPARATE SHEET SUPPLIED IN INSTRUCTION BOOK.
 3. REFER TO SERVICE NOTES IN INSTRUCTION BOOK FOR VOLTAGES APPEARING ON DIAGRAM.
 4. RESISTORS 1/8 WATT.
 5. RESISTANCE IN OHMS K - 1000 OHMS M - 1 MEGOHM
 6. CAPACITANCE VALUES ONE AND OVER IN PICOFARADS. LESS THAN ONE IN MICROFARADS.
 7. ○ KNOB CONTROL
 8. ⊕ SCREWDRIVER CONTROL
 9. AT - ANCHOR TERMINAL
 10. TP - TEST POINT

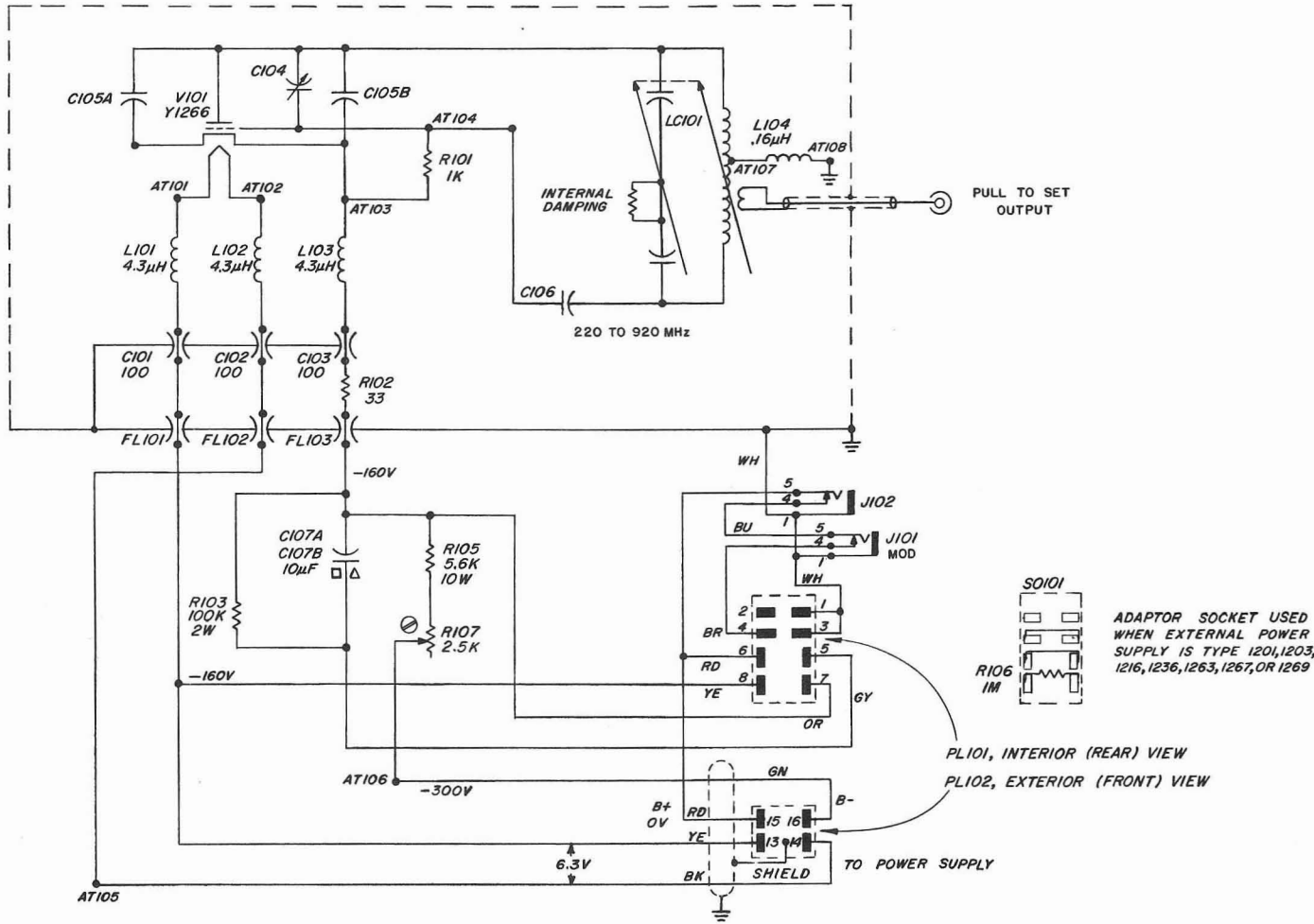

Figure 6-8. Schematic diagram of the Type 1362 UHF Oscillator.



General Radio

*Concord, Massachusetts 01742
617 369-4400

SALES AND SERVICE

ALBUQUERQUE	505 265-1097	DETROIT	800 621-8105	*NEW YORK (NY)	212 964-2722
ANCHORAGE	907 279-5741	ERIE	412 327-7200	(NJ)	201 943-3140
ATLANTA	800 638-0833	GREENSBORO	800 638-0833	PHILADELPHIA	215 646-8030
BOLTON	617 779-5562	GROTON	203 445-8445	PITTSBURGH	412 327-7200
BOSTON	617 646-0550	HARTFORD	203 658-2496	ROCHESTER	315 454-9323
BURBANK	714 540-9830	HOUSTON	713 464-5112	SAN DIEGO	714 540-9830
*CHICAGO	312 992-0800	HUNTSVILLE	800 638-0833	*SAN FRANCISCO	415 948-8233
CLEVELAND	800 621-8105	INDIANAPOLIS	800 621-8105	SEATTLE	206 747-9190
COCOA BEACH	800 638-0833	LONG ISLAND	212 964-2722	SYRACUSE	315 454-9323
*DALLAS	214 637-2240	*LOS ANGELES	714 540-9830	*WASHINGTON,	
DAYTON	800 621-8105			BALTIMORE	301 881-5333

INTERNATIONAL DIVISION CONCORD, MASSACHUSETTS 01742, USA

*ARGENTINE and PARAGUAY Coasin S.A. Buenos Aires, Tel. 52-3185	ECUADOR Suministros Tecnicos Ltda. Guayaquil, Tel. 512-419	PAKISTAN Pak Land Corporation Karachi, Tel. 472315
*AUSTRALIA Warburton Franki Industries Pty. Ltd. Sydney, Tel. 29.1111 Melbourne, Tel. 69.0151 Brisbane, Tel. 51.5121 Adelaide, Tel. 56.7333	HONG KONG and MACAU Gilman & Co. Ltd. Hong Kong, B.C.C., Tel. 227011	PERU Importaciones y Representaciones Electronicas S. A. Lima, Tel. 272076
*BRAZIL Ambriex S.A. Rio de Janeiro, Tel. 242-7990 São Paulo, Tel. 52-7806	INDIA Motwane Private Limited Bombay, Tel. 252337, Calcutta, Lucknow, Kanpur, New Delhi, Bangalore, Madras	PHILIPPINES T. J. Wolff & Company Makati, Rizal, Tel. 89-34-86
*CANADA General Radio Canada Limited Toronto, Tel. (416) 252-3395 Montreal, Ottawa	*JAPAN Midoriya Electric Co., Ltd. Tokyo, Tel. 561-8851	SINGAPORE Vanguard Company Singapore, Tel. 94695
CHILE Coasin Chile Ltda. Santiago, Tel. 39-6713	KOREA M-C International San Francisco, Tel. (415) 397-1455 Seoul, Tel. 22-6891	TAIWAN Heighten Trading Co., Ltd. Taipei, Tel. 518324
COLOMBIA Manuel Trujillo Venegas e Hijo, Ltda. Bogota 2, D. E., Tel. 320679	MALAYSIA Vanguard Company Kuala Lumpur, Tel. 88213	THAILAND G. Simon Radio Co., Ltd. Bangkok, Tel. 30991-3
	*MEXICO Electronica Fredin, S. A. Mexico, 10 D. F., Tel. 20-89-48	URUGUAY Coasin Uruguay S. A. Montevideo, Tel. 9 79 78
	NEW ZEALAND W & K. McLean Limited Auckland, Tel. 587-039 Wellington, Tel. 555-869	VENEZUELA Coasin C. A. Caracas, Tel. 72 96 37

***GENERAL RADIO COMPANY (OVERSEAS)**
P.O. Box 124, CH-8034, Zürich, Switzerland, Tel. 47 70 20

AUSTRIA Dipl. Ing. Peter Marchetti Wien, Tel. 57 82 30	FINLAND Into O/Y Helsinki, Tel. 11 123	ISRAEL Eastronics Ltd. Tel Aviv, Tel. 44 04 66	REPUBLIC OF SOUTH AFRICA Associated Electronics (Pty.) Ltd. Johannesburg, Tel. 724-5396
BELGIUM Groenpol-Belgique S. A. Bruxelles, Tel. 02/25 16 36	*FRANCE General Radio France Paris, Tel. 023 5774, Lyon	*ITALY General Radio Italia S.p.A. Milano, Tel. 29 31 29	SPAIN Hispano Electronica S. A. Madrid, Tel. 233.16.01
DEMOCRATIC REPUBLIC OF THE CONGO Desco de Schulthess Zürich, Tel. 25 44 50	*GERMANY General Radio GmbH München, Tel. 40 18 17 Hamburg, Tel. 45 06 56	LEBANON Projects Beirut, Tel. 241200	SWEDEN Firma Johan Lagercrantz KB Solna, Tel. 08/83 07 90
DENMARK SEMCO A/S Glostrup, Tel. 45 21 22	GREECE Marios Dalleggio Representations Athens, Tel. 710 669	NETHERLANDS Groenpol Industriele Verkoop N. V. Amsterdam, Tel. 020/64/474	SWITZERLAND Seyffer & Co. A. G. Zürich, Tel. 25 54 11
EASTERN EUROPE General Radio Company (Overseas) Tel. 47 70 20	IRAN Berkeh Co. Ltd. Tehran, Tel. 62 82 94	NORWAY Gustav A. Ring A/S Oslo, Tel. 46 68 90	*UNITED KINGDOM General Radio Company (U.K.) Limited Bourne End, Buckinghamshire Tel. 22 567
EIRE General Radio Company (Overseas), Tel. 47 70 20 General Radio Company (U.K.) Limited, Tel. 22567		PORTUGAL Casa Serras Lisboa	YUGOSLAVIA General Radio Company (Overseas) Tel. 47 70 20

*Repair services are available at these offices.

PRINTED IN USA

GENERAL RADIO
WEST CONCORD, MASSACHUSETTS 01781