

**OPERATING INSTRUCTIONS**

for

**TYPE 1862-A**

**MEGOHMMETER**



**GENERAL RADIO COMPANY**

**CAMBRIDGE 39**

**MASSACHUSETTS**

**NEW YORK**

**CHICAGO**

**LOS ANGELES**

**U. S. A.**

# OPERATING INSTRUCTIONS

for

## TYPE 1862-A MEGOHMMETER

Form 755-B  
April, 1953



**GENERAL RADIO COMPANY**

**CAMBRIDGE 39**

**MASSACHUSETTS**

**NEW YORK**

**CHICAGO**

**LOS ANGELES**

**U. S. A.**

Printed in U.S.A.



Panel View of the Type 1862-A Megohmmeter

## Specifications

**Range:** 0.5 megohm to 2,000,000 megohms. There are six decade steps as selected by a multiplier switch.

**Scale:** Each resistance decade up to 500,000 megohms utilizes 90% of the meter scale. Center-scale values are 1, 10, 100, 1000, 10,000 and 100,000 megohms.

**Accuracy:** The accuracy in percent of indicated value up to 50,000 megohms is  $\pm 3\%$  at the low-resistance end of each decade,  $\pm 8\%$  at mid-scale and  $\pm 12\%$  at the high-resistance end. There can be an additional  $\pm 2\%$  error over the top decade (50,000 to 500,000 megohms).

**Voltage on Unknown:** The voltage applied to the unknown resistor is 500 volts. Over a 105-125-volt range in line voltage and over the resistance range of the instrument, the variation in voltage across the unknown resistor will be less than  $\pm 2\%$ . At resistance values below 0.5 megohms, the applied voltage drops to limit the current to safe values.

**Terminals:** In addition to terminals for connecting the unknown, ground and guard terminals are provided. At two positions of the panel switch, all voltage is removed from all terminals to permit connection of the unknown in safety. In one of the positions, the UNKNOWN terminals are shunted to discharge the capacitive component of the unknown. All but the ground terminal are insulated.

**Check:** A switch position is provided for standardizing the calibration.

**Design:** Since field applications are more severe than laboratory use, the instrument, including its panel meter, was designed to be unusually rugged. The carrying case can be completely closed; accessory power cable and test leads are carried in the case. Controls are simplified for use by untrained personnel.

**Tubes:** Supplied with the instrument: one 12AU7, one ~~6B2~~<sup>0A-2</sup>, one 6X4, one 2X2-A, one 6C4, one 6AU6 and one 5651.

**Controls:** A switch for selecting the multiplying factor, a control for standardizing the calibration, a control for setting the meter to the infinity reading and a power switch.

**Mounting:** The instrument is assembled on an aluminum panel finished in black crackle lacquer and is mounted in an aluminum cabinet with black-wrinkle finish and with black-phenolic protective sides. The aluminum-cover finish is black wrinkle. The case is provided with a carrying handle.

**Power Supply:** 115 (or 230) volts at 40 to 60 cycles. The power input is about 25 watts.

**Accessories Supplied:** Two 3-foot color-coded test leads with phone tips, two insulated probes, two alligator clips and a 274-M-type plug.

**Dimensions:** (Height) 10-1/8 inches x (width) 9-1/8 inches x (depth) 11-3/4 inches overall.

**Weight:** 15-1/4 pounds.

# OPERATING INSTRUCTIONS

for

## TYPE 1862-A MEGOHMMETER

The Type 1862-A Megohmmeter is designed to indicate directly on the panel meter the resistance value of any resistor within the range of 0.5 to 2,000,000 megohms. The voltage applied to the unknown resistance is 500 volts, within two percent.

### SECTION 1.0 OPERATING CONTROLS AND PROCEDURE

#### 1.1 CAUTION-DANGER

When the instrument is on, there is a potential of 500 volts at the terminals except when the **MULTIPLIER** switch is set to **CHECK** or **DISCHARGE**.

#### 1.2 POWER SUPPLY

The instrument is supplied complete, with tubes installed, and is ready for operation.

The power-line voltage and frequency are indicated on the panel label near the power input cable. The voltage is either 115 volts or 230 volts. To change from one input voltage to the other, see Paragraph 2.1 below.

#### 1.3 CONNECTION OF UNKNOWN

Strap the ground terminal to the **GUARD** terminal or to the adjacent **UNKNOWN** terminal.

With the **MULTIPLIER** switch at **DISCHARGE**, connect the unknown resistance to the **UNKNOWN** terminals. The meter should read  $\infty$  (full counter-clockwise position of meter pointer). If it does not, adjust the **SET  $\infty$**  control to obtain an  $\infty$  reading of the meter.

GENERAL RADIO COMPANY

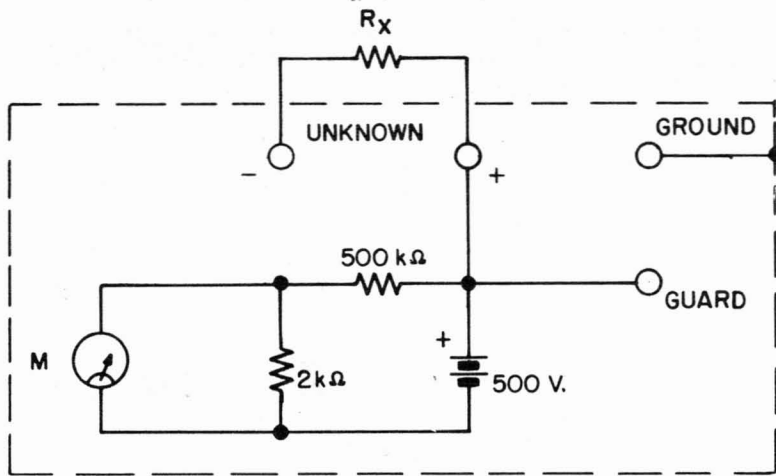

Figure 1. Check position of multiplier.

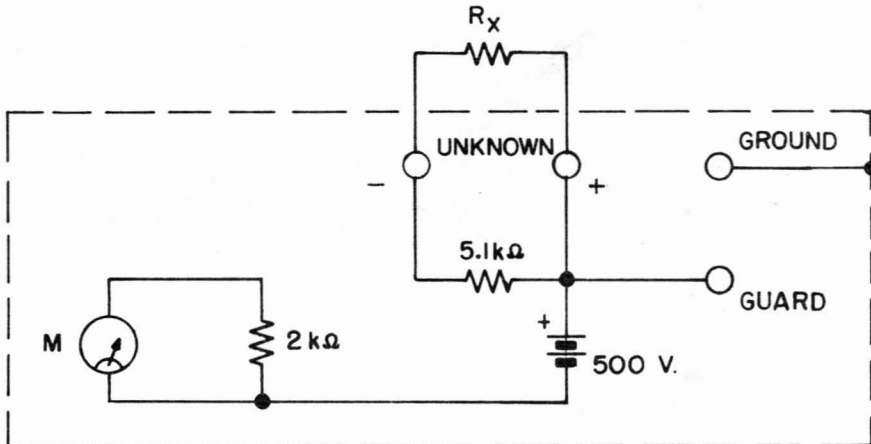

Figure 2. Discharge position of multiplier.

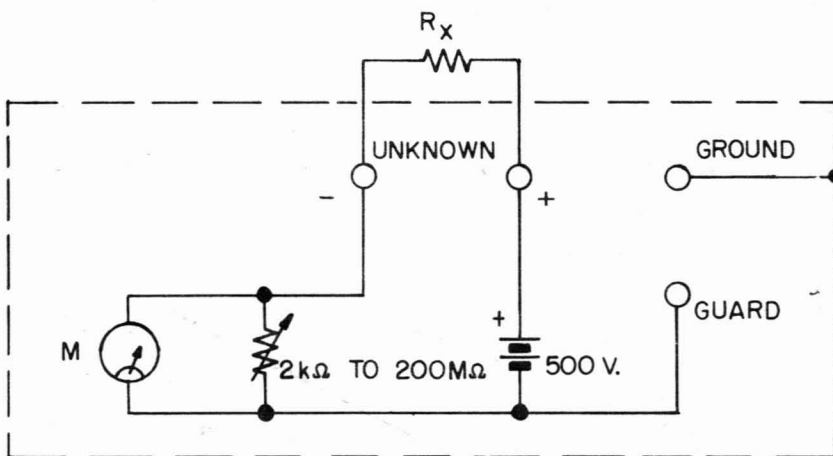

Figure 3. Operating position of multiplier.

## TYPE 1862-A MEGOHMMETER

For a discussion of the CHECK position and of the GUARD and ground terminals, see Section 2.0 below.

The instrument is designed for operation with the panel in a horizontal position.

### 1.4 RESISTANCE INDICATION

With the unknown resistance connected to the UNKNOWN terminals, move the MULTIPLIER switch to the "1" position.

If the meter indicates beyond full scale (0.5), the resistance is less than 0.5 megohm and cannot be measured with this instrument. Return the MULTIPLIER to DISCHARGE immediately.

If the meter indicates on scale, select the MULTIPLIER position that yields a meter reading between 0.5 and 5. The resistance value is the product of the meter reading and of the MULTIPLIER setting.

For resistances exceeding 500,000 megohms, the meter reading will be between 5 and  $\infty$  and the MULTIPLIER setting will be at 100,000.

**CAUTION:** Return MULTIPLIER to the DISCHARGE position before attempting to disconnect the resistor from the UNKNOWN terminals.

## SECTION 2.0 SECONDARY CONTROLS AND PROCEDURE

### 2.1 POWER SUPPLY

The power-line frequency range is 40 to 60 cycles. The voltage is either 115 volts or 230 volts. If it is desired to change from one input voltage to another, change the power transformer connections as shown on the wiring diagram, reverse the power-line label (near the power input cable) to indicate the proper line voltage and change the fuses (on the panel) to the proper rating (0.4 ampere Slo-Blo 3AG fuses for 115-volt operation and 0.2 ampere Slo-Blo 3AG fuses for 230-volt operation). For access to the power transformer connections, remove the instrument from its cabinet.

### 2.2 TERMINALS

In addition to the insulated terminals to which the UNKNOWN resistance is connected, there is an insulated terminal labelled GUARD and an uninsulated ground terminal which is connected to the panel and which includes a strap for grounding either the GUARD terminal or the adjacent (positive) UNKNOWN terminal. In the operating positions of the MULTIPLIER switch, there is a poten-

## GENERAL RADIO COMPANY

tial of 500 volts between the GUARD terminal and the positive UNKNOWN terminal. Therefore, do not ever connect these two terminals together.

For most applications, strap the ground terminal to the adjacent UNKNOWN terminal. The polarity at this terminal is positive and is so indicated.

If the unknown resistor is a three-terminal type, it can be measured by connecting the third terminal to GUARD and by grounding the GUARD terminal of the positive UNKNOWN terminal, as shown in Figure 4 and Figure 5, provided that the resistances of the second and third resistors in the network are sufficiently large.  $R_B$  is connected directly across the internal standard,  $R_S$ , and must be at least one hundred times as large as  $R_S$  ( $R_S$  equals  $2k\Omega$  times the multiplying factor of the MULTIPLIER switch).  $R_C$  is connected directly across the 500-volt supply and must not be so small as to lower the voltage of this supply. At the "10" or higher positions of the MULTIPLIER,  $R_C$  can be as small as  $300 k\Omega$ . At the 1 MULTIPLIER position, it must not be less than  $500 k\Omega$ .

**CAUTION:** Do not short-circuit the UNKNOWN terminals. A short-circuit can draw excessive current from the high-voltage power supply and will shorten the life of the rectifier and regulator tubes (V-4 and V-5).

### 2.3 CHECK AND DISCHARGE POSITIONS

With the MULTIPLIER switch in either of these positions, there is no voltage at any of the terminals; in the DISCHARGE position, the UNKNOWN terminals are shunted with a 2-watt,  $5.1 k\Omega$  resistor (R-2).

With the switch at DISCHARGE, the meter should indicate  $\infty$ . If it does not, adjust the SET  $\infty$  control.

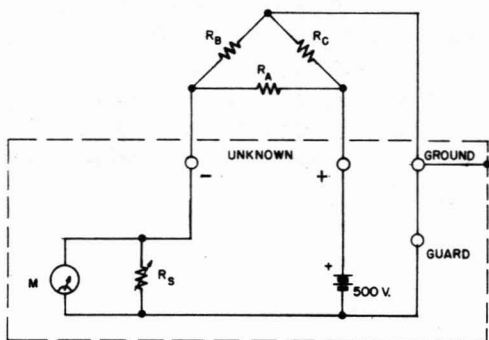

Figure 4. Connections for measuring ungrounded three-terminal resistor.

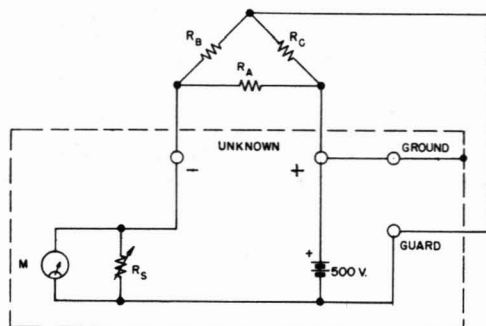

Figure 5. Connections for measuring grounded three-terminal resistor.

## TYPE 1862-A MEGOHMMETER

As the **MULTIPLIER** switch is rotated through the operating positions (1 through 100,000), the meter will continue to indicate  $\infty$  if nothing is connected to the **UNKNOWN** terminals. If there is a meter indication at the 10,000 setting, this can be caused by leakage or by grid current in the voltmeter tube (V-1). Leakage due to moisture or dirt can be eliminated by wiping the **UNKNOWN** terminals with a clean dry cloth. Grid-current effects can occur when V-1 has been replaced with a new tube or when the instrument has not been used for some time. The grid-current effect will be eliminated or reduced to a negligible value (a meter reading that is less than halfway between  $\infty$  and 20 is considered negligible) by leaving the instrument on for a short while. (See 3.0 under Service and Maintenance Notes.) If there is no meter indication at the lower multiplier settings, but an indication appears at the 100,000 setting, reset to  $\infty$  by adjusting the screw-driver control accessible through a small panel hole just above the **SET  $\infty$**  knob.

When the **MULTIPLIER** is set to the **CHECK** position, an internal resistance standard is connected in circuit. The meter should read 0.5. If it does not, readjust the **CHECK** control knob.

### 2.4 FIVE-HUNDRED-VOLT SUPPLY

In the operating position, there is a potential of 500 volts between the positive **UNKNOWN** terminal and the **GUARD** terminal. If, because of tube changes or any other reason, this voltage, as measured by a voltmeter of at least 500 k $\Omega$  resistance, is found to be incorrect, it can be adjusted by setting the screw-driver control accessible through a small panel hole just above the **CHECK** control knob. If this screw-driver control is reset, the megohmmeter calibration must be standardized by again setting the **MULTIPLIER** to **CHECK** and obtaining a 0.5 (or **CHK**) reading on the meter, readjusting the **CHECK** control knob if need be.

### 2.5 RESISTANCE OF CAPACITORS

The leakage resistance of capacitors is measured in exactly the same manner as the resistance of resistors except that the charge- and discharge-currents involved require some precaution.

2.51 Always short-circuit the capacitor for several seconds before connecting to the megohmmeter, to assure that it has no dangerous residual charge.

2.52 Always start the **MULTIPLIER** at the **DISCHARGE** position.

2.53 Always set the **MULTIPLIER** at the "1" position for a few seconds to assure rapid charge of the capacitor. To prevent damage to the meter, do not set the **MULTIPLIER** to higher values until the capacitor is well charged.

2.54 As the **MULTIPLIER** is set to higher settings, an appreciable drift in the reading indicates that the capacitor is not fully charged. Time will be saved by returning to the "1" position of the **MULTIPLIER** until the capacitor is fully charged.



## GENERAL RADIO COMPANY

2.55 When the measurement has been completed, discharge the capacitor by setting the **MULTIPLIER** to **DISCHARGE** for several seconds before disconnecting the capacitor. In the **DISCHARGE** position, the capacitor is discharged by the 5.1-k $\Omega$ , 2-watt resistor (R-2) which appears in shunt at the **UNKNOWN** terminals.

### 2.6 CHARGING TIME

Since the panel meter reading of the megohmmeter depends on the current through the unknown resistor, the leakage resistance of a capacitor or of an insulator cannot be correctly indicated until the charging current due to the capacitive component is negligible.

When the capacitor has very little dielectric absorption, the charging current is limited mainly by the resistance standard in the megohmmeter. In the lowest multiplier position, this resistance is 2000 ohms and for even large capacitance values the charging time is relatively small, being of the order of one second per hundred microfarads.

### 2.7 INSULATION TESTING

Some capacitors and most insulators (especially those of laminated structure) exhibit appreciable dielectric absorption (dipole and interfacial polarization). When a voltage is applied, the charge slowly diffuses throughout the volume and it may require minutes or hours (even days in some special cases) before equilibrium is established and the charging current is small compared to the true leakage current.

Fortunately, in testing the insulation of electrical machinery, transformers, etc., while the leakage resistance is important, it is only one of several parameters that have a bearing on the condition of the insulation. Routine measurements of capacitance and dissipation factor as well as leakage resistance provide useful data in monitoring the condition of the insulator and in guarding against incipient breakdown.

A routine test that has been fairly widely adopted in the insulation-testing field consists of measuring the apparent leakage resistance after a testing voltage of 500 volts has been applied for one minute and again for ten minutes. The ratio of the indicated resistances, sometimes referred to as the polarization index, can have some relation to the condition of the insulator. The results of course are really a measure of the charging current at the two time intervals and can be much more dependent on the dielectric absorption of the insulator than on its true leakage resistance. To extend the usefulness of such information, complete charge-current vs. time data should be obtained.<sup>1</sup>

---

<sup>1</sup>"The Basis for the Nondestructive Testing of Insulation", R.F. Field, AIEE Transactions, September, 1941. "Interpretation of Current-Time Curves as Applied to Insulation Testing", R.F. Field, Boston District Meeting AIEE, April 19-20, 1944.

## TYPE 1862-A MEGOHMMETER

The Type 1862-A Megohmmeter is useful in measuring the true leakage resistance by the method outlined in Paragraph 2.5 above and in measuring the apparent leakage at the end of one minute and ten-minute intervals.

The resistance in series with the insulator during the charging period is determined by the setting of the MULTIPLIER control; it is the product of the MULTIPLIER reading and 2000 ohms.

The charge current is easily measured when the meter is on scale; the charge current is 500 volts divided by the apparent resistance at any moment; the meter will be off scale at the start of the charge-current vs. time characteristic.

### 2.8 TEST LEADS AND ACCESSORIES

A red and a black rubber-covered test lead are supplied. Each is 30 inches long and has a pin terminal at each end. Also supplied are a red and a black test probe with pin terminals, two alligator clips and a Type 274-MB Double Plug.

Pin terminals on test leads and on probes can fit into probes, into alligator clips, into the double plugs and into the panel binding posts. In a typical arrangement the double plug is connected to one end of the test leads and is plugged into the UNKNOWN terminals of the instrument; the test probes are connected to the other end.

**CAUTION:** In using the test leads, remember that there are 500 volts between them except when the instrument switch is at CHECK or DISCHARGE.

### 2.9 SHOCK HAZARD

Every precaution has been taken in the design of the Type 1862-A Megohmmeter to reduce the possibility of shock. However, the operator should be aware of the dangers<sup>2</sup> involved because of the high voltages present.

If electricity is passed from one hand through the body to the other hand, the value of "let-go" current is given in Table I.

Table I. "LET-GO" CURRENTS.<sup>2</sup>

	<u>MEN</u>	<u>WOMEN</u>
60 CYCLES	9 ma	6 ma
DIRECT CURRENT	62 ma	41 ma

<sup>2</sup>See articles in August, 1946 and August, 1947 issues of *Electrical Engineering* by C.F. Dalziel; see also "Life Insurance in the Shack" by G.J. Nichols, M.D. in *CQ* for November, 1947.

## GENERAL RADIO COMPANY

As the electric current is increased, a value is reached where the test patient cannot release the electrodes. This is just above the "let-go" value. Prolonged exposure to the "let-go" current or shorter exposure to currents not too much greater than the tabulated currents can be fatal.

Resistance to current depends, of course, on humidity conditions. From arm to arm, leg to arm, leg to leg, it can be as low as 300 ohms but under some circumstances it can be as high as one megohm. At low voltages, the skin offers a fair protection but at higher voltages, the skin is burned, its resistance is lowered and the low internal body resistance is controlling.

When the MULTIPLIER switch of the Type 1862-A Megohmmeter is in an operating position, touching the two UNKNOWN terminals with one finger is painful and can cause a slight burn. The amount of direct current that will flow for various values of "body" resistance connected from the GUARD terminal to the positive UNKNOWN terminal is shown plotted in Figure 6. Currents due to connection to the UNKNOWN terminals will always be less; the value depends on the setting of the MULTIPLIER switch. In any case, direct current "let-go" values are never exceeded.

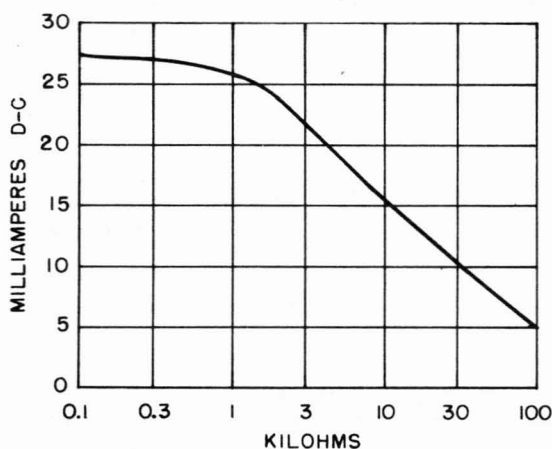

Figure 6. Current due to a load from GUARD to positive UNKNOWN terminals.

However, when a large capacitor is connected to the UNKNOWN terminals, it should be treated with great caution because there are 500 volts at its terminals and it may have no appreciable inherent current-limiting series resistance. The current that will flow through the body upon connecting the "body resistance" to its terminals will at first be very great and the speed with which the current is damped depends on the capacitance as well as the resistance. A current-limiting resistor of at least 20 k $\Omega$  should be connected as near to the capacitor as possible. Current decay curves for various values of capacitance and of "body resistance" are shown in Figure 7.

### 3.0 VOLTAGE COEFFICIENT OF RESISTORS

The resistance of some small resistors and of many insulators is affected by the voltage applied. A voltage coefficient of -0.05 percent per volt is not un-

## TYPE 1862-A MEGOHMMETER

usual. At 500 volts, if the coefficient is -.05 percent, the resistance will be lower than its "zero volts" value by 25 percent.

The Type 1862-A Megohmmeter is essentially a fixed 500-volt supply, a high input-resistance vacuum-tube voltmeter and a selection of accurate high-resistance standards.

If an adjustable power supply (such as the General Radio Type 1204-B Unit Variable Power Supply) and an accurate d-c voltmeter are available, they can be used with the Type 1862-A to measure resistance with less than 500 volts applied to the unknown. From these data the voltage coefficient of resistance can be calculated.

The procedure is as follows: Remove V-4 and V-5 (2X2-A and 6C4) to disconnect the internal 500-volt supply. Connect the external supply and the external voltmeter to the GUARD and to the positive UNKNOWN terminals.

**CAUTION:** Do not set to CHECK or DISCHARGE since the power supply will be shorted under these conditions.

The resistance of the UNKNOWN is then measured in the normal manner. The resistance of the unknown is

$$R_X = \frac{E}{500} M$$

where E is the voltage due to the external supply and M is the resistance indi-

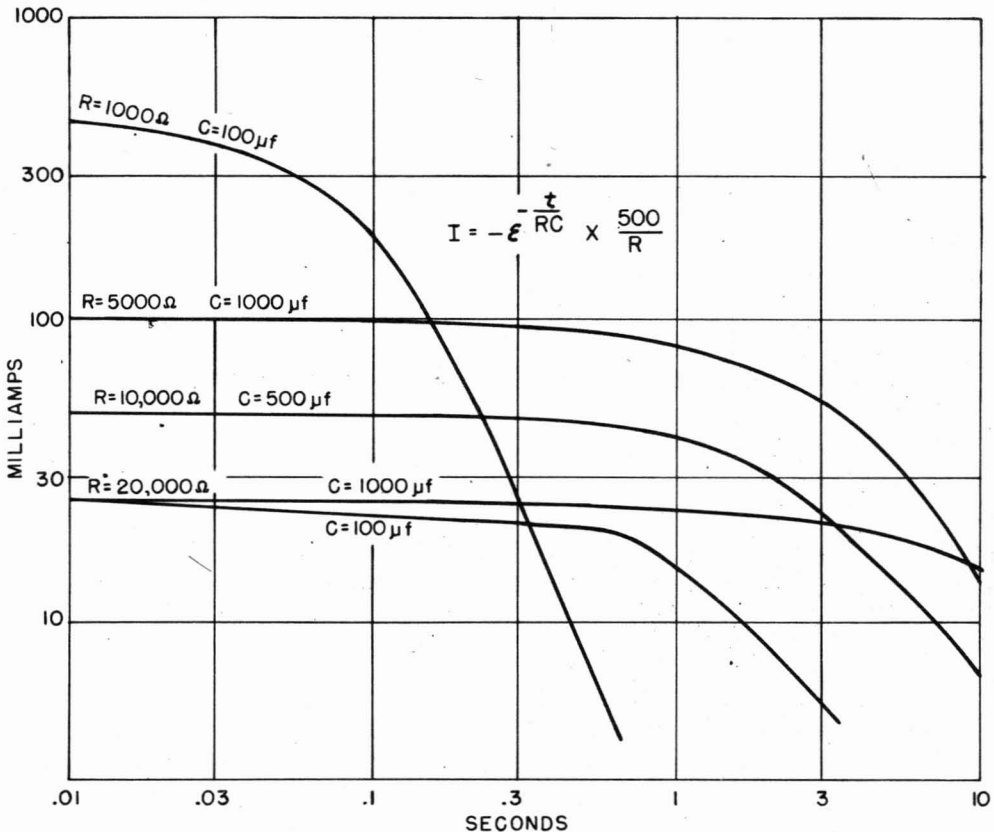

Figure 7. Discharge currents for 500 volts at charge.

## GENERAL RADIO COMPANY

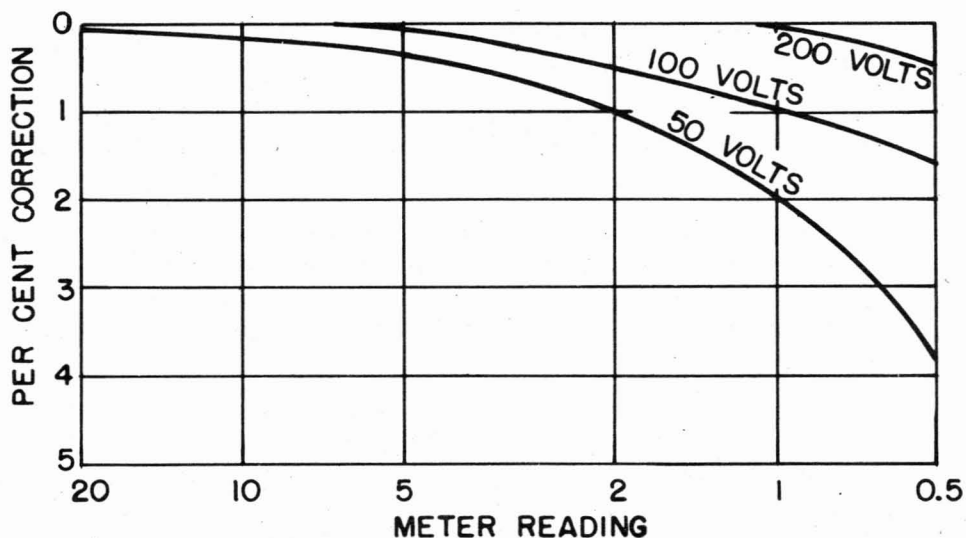

Figure 8. Correction when using external supply. See text.

cated by the Megohmmeter (meter reading multiplied by **MULTIPLIER** setting). If the external voltage is under 100 volts, the calculated resistance must be reduced by the amount indicated in Figure 8.

### SERVICE AND MAINTENANCE NOTES

#### 1.0 INSTRUMENT IN CABINET

- 1.1 At 115-volt (or 230-volt) line, the power input is about 25 watts.
- 1.2 Fuses and pilot light are accessible from the panel.

#### 2.0 INSTRUMENT OUT OF CABINET

- 2.1 All tubes and components are accessible.
- 2.2 Note that the shaft of the selector switch (S-1) and the switch-mounting screws can be 500 volts above ground. The switch is mounted on a black phenolic plate and the control-knob (**MULTIPLIER**) set-screw holes are plugged with wax.

#### 3.0 GRID CURRENT

To test for grid current (see 2.3 of Operating Instructions), set to the "1" multiplier and obtain an " $\infty$ " meter reading, then set to the "10,000" multiplier and obtain a meter reading that is less than halfway between  $\infty$  and 20. A meter reading greater than this indicates excessive grid current or leakage.

## TYPE 1862-A MEGOHMMETER

Leakage is eliminated by cleaning the terminals. Grid current may be excessive if the instrument has not been used for some time; normal operation for ten minutes will reduce the grid current satisfactorily. Grid current may also be excessive if the tube (V-1) has been replaced.

If the tube has been replaced and grid current is excessive even after several minutes of operation, age the tube by leaving the power on for several hours (at least eight). If indicated grid current is still excessive, obtain a new operating condition on the tube characteristic by resetting R-34, which is mounted on the shelf under the meter. When the indicated grid current is satisfactorily low for the 10,000 multiplier, set to the 100,000 multiplier and obtain an  $\infty$  meter reading by adjusting the screw-driver control accessible through a small panel hole just above the set  $\infty$  knob.

### 4.0 METER FLUCTUATIONS

If the line voltage is erratic or fluctuates seriously, the meter reading will also fluctuate when measuring the leakage of capacitors unless the 500-volt supply is very well stabilized. The potentiometer, R-33, has been set for almost perfect stabilization. If, however, V-6 or V-7 or particularly V-4 have been replaced, it may be necessary to readjust R-33. This is important only for capacitance leakage measurements. The procedure is simple. A Variac<sup>®</sup> or other means is used to vary the line voltage and R-33 (mounted on the shelf, under the meter) is adjusted for negligible meter variation when the UNKNOWN is a capacitor, (e.g., a mica 10,000  $\mu\mu\text{f}$  with resistance indication on the 100,000 multiplier range).

### 5.0 VACUUM-TUBE DATA

The following table gives tube-socket voltages measured from socket pin to ground. The data were obtained with the instrument operating under the following conditions: 115-volts, 60-cycle line, ground terminal strapped to GUARD terminal, MULTIPLIER switch at "1", CHECK control full counter-clockwise, SET  $\infty$  control at about the middle of its range.

The d-c voltages were measured with a 20,000-ohm-per-volt instrument whose full-scale ranges were 10 volts, 50 volts, 250 volts, and 1000 volts. D-C voltages can be expected to vary  $\pm 20\%$ . Tabulated voltages are d.c.

Symbol	Type	Socket Pin Number										Function
		1	2	3	4	5	6	7	8	9	Cap	
V-1	12AU7	+36	0	+1.8	---	---	+36	0	+1.8	---	---	V-T Voltmeter
V-2	<del>6BE6</del> 86-2	+36	-70	---	-70	+36	---	-70	---	---	---	B Supply Regulator
V-3	6X4	---	0	---	---	0	---	+476	---	---	---	B Supply Rectifier
V-4	2X2-A	+900	+500	---	+900	---	---	---	---	---	+820	500-v Supply Rectifier
V-5	6C4	+900	+85	---	---	+900	+470	+500	---	---	---	Series Regulator
V-6	6AU6	+85	+88	---	---	+470	+220	+88	---	---	---	Regulator Amplifier
V-7	5651	+88	0	---	0	+88	---	0	---	---	---	Reference Voltage

## RESISTORS

R-1	=	10 Megohms	±10%
R-2	=	5.1 k Ohms	± 5%
R-3	=	4.3 k Ohms	± 5%
R-4	=	3.3 k Ohms	±10%
R-5	=	100 k Ohms	± 5%
R-6	=	100 k Ohms	± 5%
R-7	=	140 k Ohms	±10%
R-8	=	495 k Ohms	±1/2%
R-9	=	2 k Ohms	±1/2%
R-10	=	20 k Ohms	± 1%
R-11	=	200 k Ohms	± 1%
R-12	=	2 Megohms	± 1%
R-13	=	20 Megohms	± 1%
R-14	=	100 Megohms	± 1%
R-15	=	100 Megohms	± 1%
R-16	=	1 Megohm	±10%
R-17	=	15 k Ohms	± 5%
R-18	=	62 k Ohms	± 5%
R-19	=	22 k Ohms	±10%
R-20	=	22 k Ohms	±10%
R-21	=	500 Ohms	±10%
R-22	=	330 Ohms	±10%
R-23	=	<del>7.2</del> k Ohms	± 5%
R-24	=	560 k Ohms	± 5%
R-25	=	20 k Ohms	±10%
R-26	=	100 k Ohms	± 5%
R-27	=	1 Megohm	±10%
R-28	=	270 k Ohms	± 5%
R-29	=	62 k Ohms	± 5%
R-30	=	100 k Ohms	±10%
R-31	=	100 k Ohms	±10%
R-32	=	15 Ohms	±10%
R-33	=	50 k Ohms	±10%
R-34	=	20 k Ohms	±10%

## TYPE

REC-30BF
REW-6C
REW-4C
POSW-3
REC-20BF
REC-20BF
POSC-11
WW4
WW4
X-1
X-1
X-1/2
CPI
CP2
CP2
REC-20BF
REC-20BF
REC-20BF
REC-20BF
REC-20BF
POSW-3
REC-20BF
REW-6C
REC-30BF
POSC-11
REC-30BF
REC-20BF
REC-41BF
REC-30BF
REC-20BF
REC-20BF
REW-3C *
POSC-11
POSC-11

IRC  
IRC  
CCCo  
CCCo  
CCCo  
Wilker  
Wilker  
Wilker

## \*Part of P-1 Socket

## CONDENSERS

C-1	=	.005 $\mu$ f	±10%	COM-35B
C-2				
C-3				
C-4				
C-5	=	20 $\mu$ f	450WV	} COEB-24
C-6	=	20 $\mu$ f	450WV	
C-7				
C-8				
C-9	=	.15 $\mu$ f	±10%	COL-57
C-10				
C-11	=	.25 $\mu$ f	±10%	COL-26

## MISCELLANEOUS

S-1	=	Switch	4P8T	SWRW-63
S-2	=	Switch	DPST	SWT-333
M-1	=	Meter	200 $\mu$ a	MEDS-50
F-1, F-2	=	0.4 amp for 115V Slo-Blo 3AG	GR	FUF-1
F-1, F-2	=	0.2 amp for 230V Slo-Blo 3AG	GR	FUF-1
P-1	=	Pilot Light		2LAP-939
PL-1	=	Plug	Part of	CAP-1-2
T-1	=	Transformer		485-468

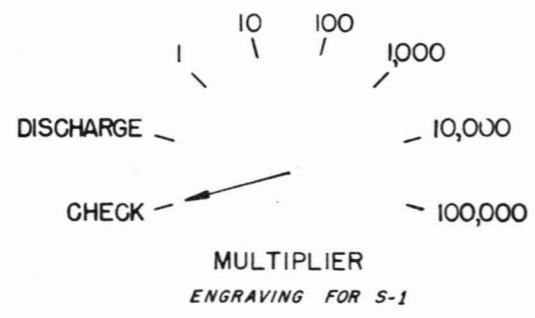
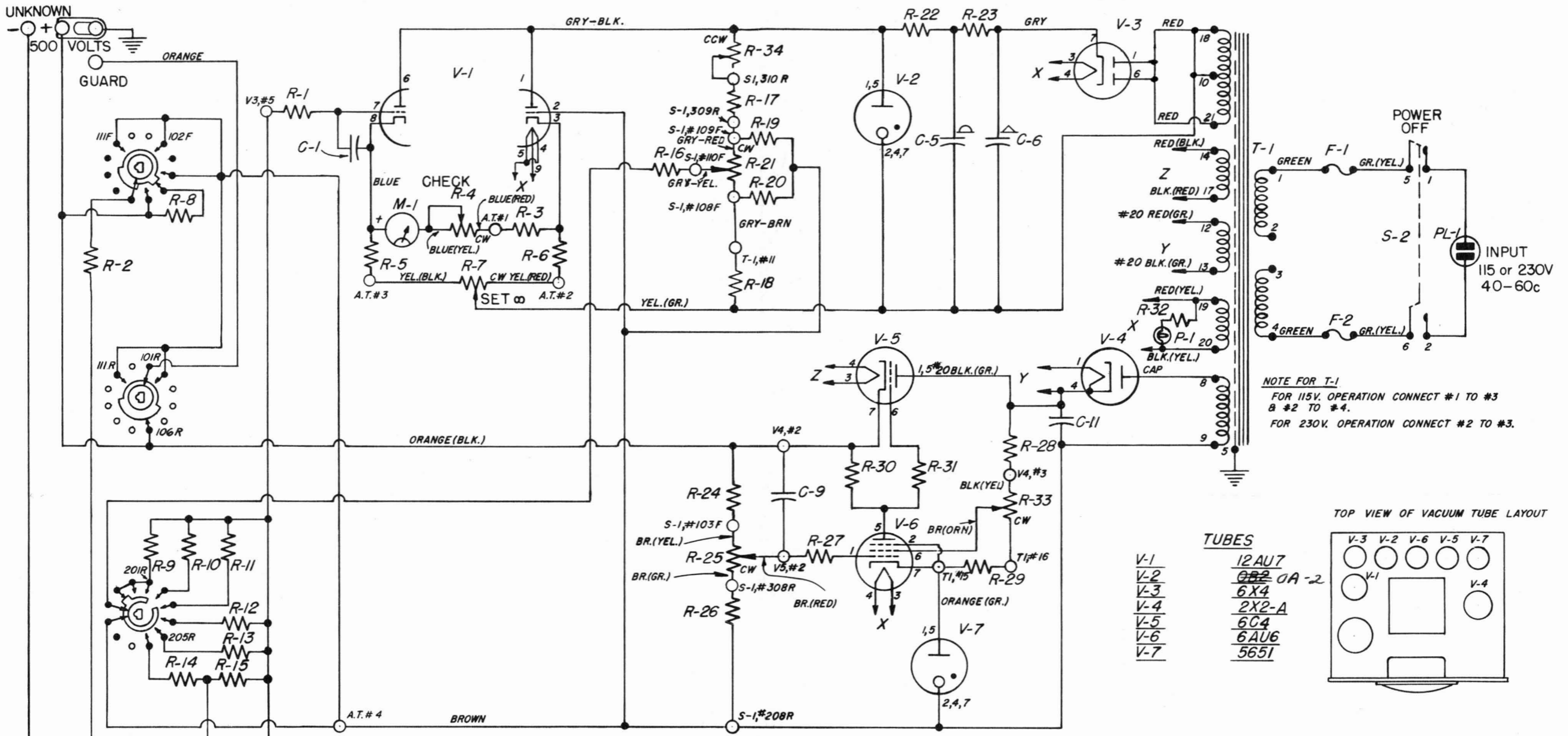

WIRING DIAGRAM FOR THE TYPE 1862-A MEGOHMMETER.

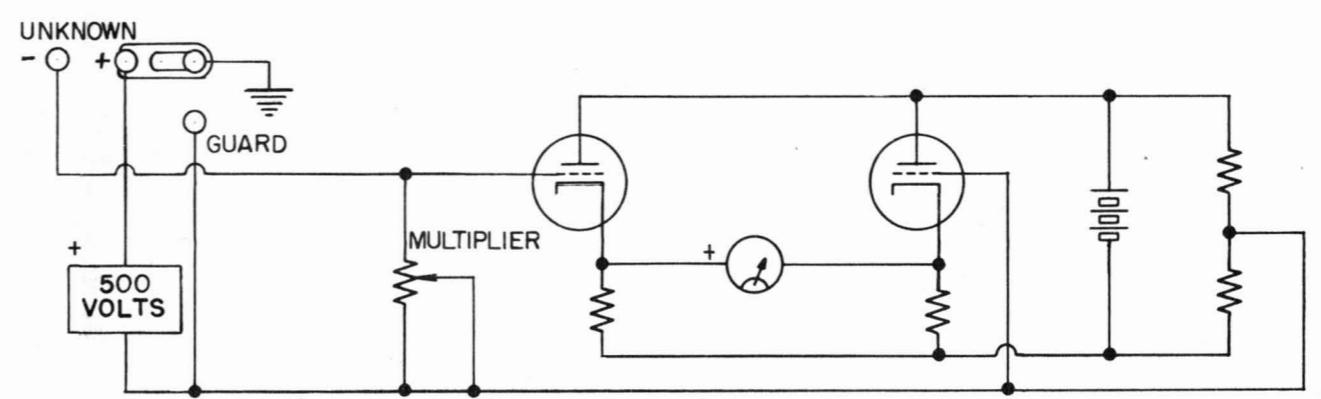

ELEMENTARY SCHEMATIC WIRING DIAGRAM



