



VARIAC[®]

CONTINUOUSLY ADJUSTABLE
AUTOTRANSFORMERS



FOR CONTROL OF

- VOLTAGE
- LIGHT
- HEAT
- SPEED

GENERAL RADIO COMPANY _____

_____ WEST CONCORD, MASSACHUSETTS, USA

Index

Commonly Used Single Units and Ganged Assemblies 50-60 Cycle Models—Uncased

← SINGLE PHASE →

120-VOLT INPUT			240-VOLT INPUT		
<i>KVA</i>	<i>Type</i>	<i>Page</i>	<i>KVA</i>	<i>Type</i>	<i>Page</i>
0.37	W2	4	0.62	W5H	5
0.94	W5	4	0.74	W2G2	8
1.32	W5L*	4	1.25	W10H	5
1.56	W10	4	1.87	W5G2	8
3.12	W20	4	2.50	W20H	5
4.32	W30	4	3.12	W10G2	8
6.0	W50	4	3.74	W30H	5
6.2	W20G2	8	4.99	W20HG2	8
8.6	W30GE	8	6.24	W20G2	8
9.4	W20G3	8	7.50	W30HG2	8
12.0	W50G2	8	7.80	W50H	5
13.0	W30G3	8	8.60	W30G2	8
18.0	W50G3	8	15.6	W50HG2	8
24.0	W50G4BB	8	23.4	W50HG3	8
36.0	W50G6BB	8	31.2	W50HG4BB	8
			46.8	W50HG6BB	8

← THREE PHASE →

208-VOLT INPUT			240-VOLT INPUT		
<i>KVA</i>	<i>Type</i>	<i>Page</i>	<i>KVA</i>	<i>Type</i>	<i>Page</i>
3.96	W5LG3*	9	13.50	W50HG2	9
			15.0	W30G3	9
			20.8	W50G3	9
			27.0	W50HG4BB	9
			41.6	W50G6BB	9
460-VOLT INPUT					
1.08	W5HG2	9	2.16	W5HG3	9
1.29	W2G3	9	4.32	W10HG3	9
2.16	W10HG2	9	8.65	W20HG3	9
3.24	W5G3	9	13.0	W30HG3	9
4.32	W20HG2	9	27.0	W50HG3	9
5.40	W10G3	9	54.0	W50HG6BB	9
6.48	W30HG2	9			
10.80	W20G3	9			

*60-CYCLE INPUT ONLY

**See Inside Back Cover
for Ordering Information**

VARIAC® AUTOTRANSFORMERS



General Radio's Variac®* autotransformers give smooth, continuous, manual control of ac voltage from zero to 17% above the input line voltage. They are available in single units and in combinations, with ratings from 300 va to 54 kva. Variac autotransformers are designed for maximum efficiency, continuous service, and long life with minimum maintenance.

USES: A few of the applications of the Variac autotransformer in the shop and in the laboratory are:

- Control of ac voltage in testing and development work.
- Overvoltage and undervoltage tests.
- Voltage control of aging racks for lamps, vacuum tubes, dry-disk rectifiers, etc.
- Voltage control in power supplies.
- Voltage control for meter calibration.
- Phase-angle control in the calibration of wattmeters and power-factor meters.
- Motor speed control.
- Control of electric heaters and ovens in laboratory, pilot plant, and production line.
- Lighting control in theaters, auditoriums, photographic studios, and darkrooms.

Although built for 120- or 240-volt circuits, Variac autotransformers can be used on circuits of higher or lower voltage in conjunction with fixed-ratio auxiliary transformers. Ganged units are available for parallel, series, and polyphase connections (page 7).

DESCRIPTION: The Variac autotransformer consists of a single-layer winding on a toroidal silicon-steel core. As the control knob is rotated, a carbon brush traverses the winding, tapping off a portion of the total voltage across

* VARIAC is the registered trade name of the General Radio brand of adjustable autotransformers and associated control equipment in which these adjustable autotransformers are used.

† Developed in the General Radio Laboratories.
U S Patent 2,949,592.

the winding. The brush is in continuous contact with the winding, and the voltage between turns is always less than 1 volt, even in the largest model; in the smallest model it is only about 0.3 volt.

The discrete voltage increments obtained as the knob is rotated are always less than the voltage between turns. Since the brush spans more than one turn, the change in voltage is practically continuous. The brush is so designed that excessive heating cannot occur in the turns that it spans.

DURATRAK†: All Variac autotransformers have *Duratrak* coating process. The brush-track surface is coated with a uniform silver alloy to prevent injurious high-temperature oxidation and resultant brush-track deterioration. The track shows no significant wear after one million cycles of brush operation (zero to maximum, and return). The *Duratrak* process makes the Variac autotransformer as durable as a fixed-ratio autotransformer. *Duratrak* means long life, high overload capacity, and minimum maintenance. With this treatment the Variac autotransformer can withstand a momentary overload of 1000 percent without damage.

FEATURES:

- High efficiency.
- Smooth control.
- Good voltage regulation.
- Output voltage may be greater than line voltage.
- Negligible waveform distortion.
- Linear voltage variation with dial rotation.
- Adaptability to motor drive.

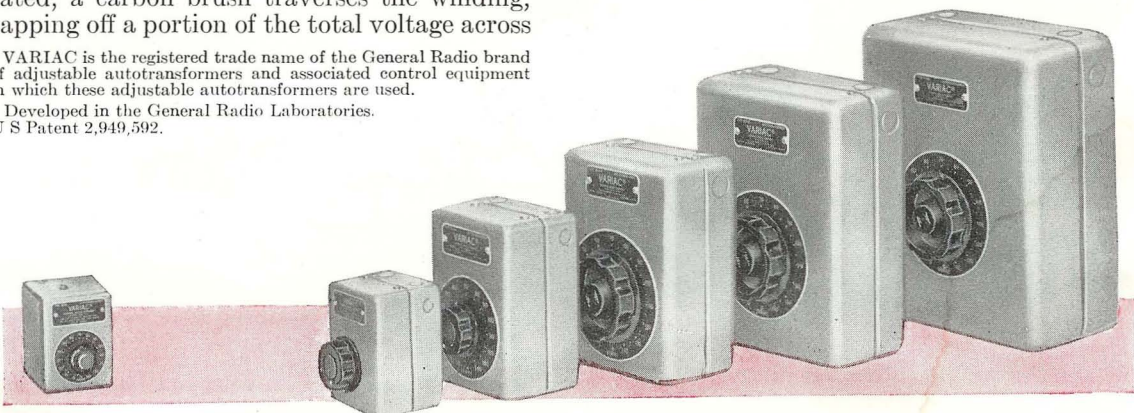



VARIAC® AUTOTRANSFORMER TYPE-NUMBER TERMINOLOGY

Type numbers for Variac® autotransformers, in their various combinations, consist of letters and numerals that indicate exactly what elements are included in each assembly. The following examples will serve to illustrate the system:

TYPE W10MT3 indicates a 120-volt, single-unit, portable, TYPE W10 Variac autotrans-

former with a three-wire line cord.

TYPE W50G6BBM indicates a six-gang, TYPE W50 model, with ball bearings and case.

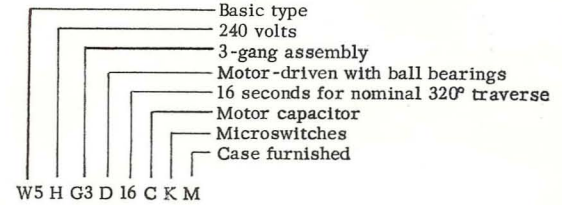

GENERAL SPECIFICATIONS

Dial: Dial plates are reversible — 0 to 120 volts on one side, 0 to 140 on the other. H types have similar scales — 0 to 240 and 0 to 280. Dials for ganged assemblies are marked 0 to 10.

Frequency: W models are designed for 50- to 60-cycle service, M models for 350- to 1200-cycle service. Most W models, however, can be operated at rated current and voltage at line frequencies of 50 to 400 cps. Models designed for 240-volt, 50- to 60-cycle service can be used on a 25-cycle supply at full current rating, but one-half their voltage and kva ratings.

Protective Devices: TYPES MT and MT3 have built-in circuit breakers with manual resets. TYPES W5L, W20H, W30, W30H, W50, and W50H have built-in fuse-type protectors (Figure 1). However, these are not a substitute for standard fusing practices.

Overload Ratings: Rated current may be safely exceeded with short-time overloads, as indicated by the curves below. The shaded area (Figure 1) shows the limits for the models with built-in, fuse-type protectors.

Temperature Rise: Ratings are based on a temperature rise of not more than 50 C above room temperature. When the ambient temperature exceeds 50 C, the kva ratings must be decreased as shown by the chart below (Figure 2).

Rated Current is that current which may be drawn at any dial position.

Maximum Current is that current which may be drawn at maximum output voltage when the line-voltage connection (see below) is used.

Figure 1. For use when high initial surge current may be expected (motor starting, incandescent lamp load, etc.) and for short-time overloads, the rated current may be exceeded on a time-current basis when line-voltage connection is used, as shown in this figure.

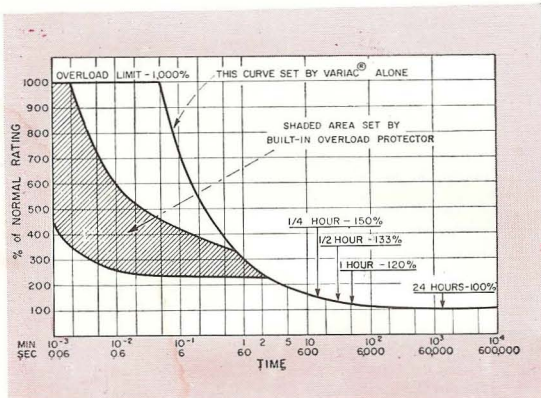

Output Voltage is the range of voltage available at the output terminals with rated voltage applied to the input terminals.

Line-Voltage Connection refers to that connection which gives an output voltage range of zero to line voltage.

Overvoltage Connection refers to that connection which gives an output voltage range of zero to 17% above line voltage.

Kva Rating is the maximum current multiplied by the normal input line voltage. At any lower setting, a Variac autotransformer can handle a constant-impedance load that draws a current no greater than the maximum current with rated input voltage.

No-Load Loss is measured in watts at 60 cps with rated input voltage. Losses are guaranteed not to exceed the values given in the tables of ratings on the following pages.

Driving Torque is the torque required to turn the shaft.

Terminals: The following types have combination soldering- and screw-type terminals: W2, W5, W5L, W5H, W10, W10H, W20, W20H, W30H, and W50H. The TYPES W30 and W50 models have clamp-type terminals to accommodate the higher available current.

Dimensions: Essential dimensions are given in the diagrams for each type of Variac autotransformer. Detailed dimension drawings and drilling templates will be furnished on request.

Weight: See tables of ratings on the following pages.

Panel Thickness is the maximum thickness of the panel on which the unit can be mounted, using the length of shaft that is normally supplied.

Figure 2. For ambient temperatures above 50 C, the unit should be derated according to this curve.

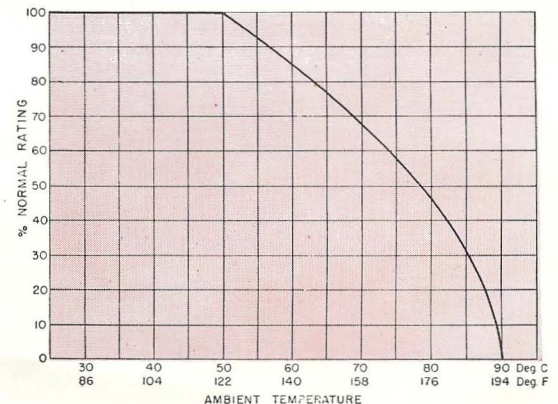



Portable models with convenient handles have overload protector and are available with 2- or 3-wire cords.

Cased models for wall mounting have conduit knock-outs.

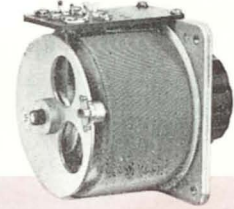

Uncased models for panel mounting.

THE W SERIES VARIAC® AUTOTRANSFORMER

The present W series, with *Duratrak*, is the result of a continuous development program that started more than 25 years ago, when General Radio introduced the first commercial variable autotransformer. The introduction of the W series was a major step forward in this program. Most W models are listed under the Re-examination Service of the Underwriters' Laboratory and have the approval of the Canadian Standards Association.

All W series Variac autotransformers are *Duratrak* treated. Other special features include counterbalanced rotating parts, a wiring diagram on the terminal board, and military ruggedization. The basic open units have square mounting bases for convenient installation. Cased models are totally enclosed for protection from dust, but covers are easily removed for access to the interior. Cased models for wall mounting contain conduit

knockouts for both individual units and ganged assemblies. A portable model, with a built-in circuit breaker and carrying handle, may be used in either a horizontal or a vertical position. This model is available with either the new standardized, three-wire, grounding cord set or with the more usual two-wire arrangement.

The flexibility of the W series models permits the manufacture of units incorporating many special modifications, such as the addition of ball bearings, motor drive, continuous 360-degree rotation, or two separate brush tracks.

Series W models are interchangeable with the comparable-size, older, series V models; corresponding mounting holes are provided.

Series M models, (page 12) for 350- to 1200-cycle service, are similar in design to series W models.

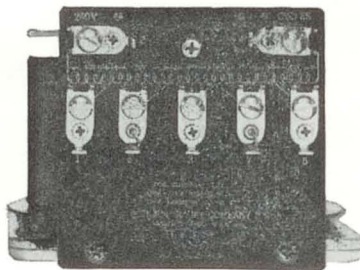
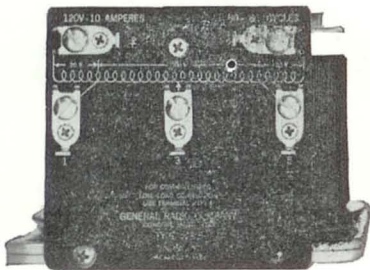

Terminal plates on both 120- and 240-volt models are stamped with wiring diagram and ratings.

Overload protector, an important feature on portable models, is quickly reset from front panel.



Shaft can be easily adjusted or replaced without disturbing other parts of the assembly.

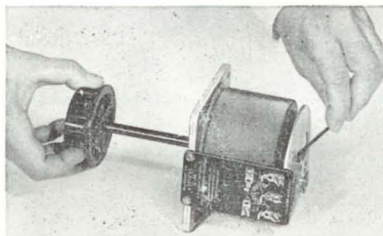

Cover of cased model is easily removable for access to terminals, mounting holes, and brush.

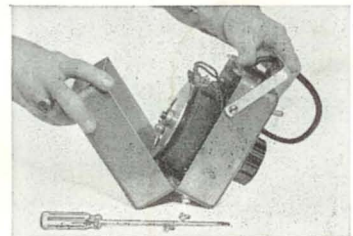



RATINGS for SINGLE-UNIT W-SERIES VARIAC® AUTOTRANSFORMERS with DURATRAK COATING PROCESS

This table lists commonly used single units and does not include all possible applications.

INPUT VOLTAGE	OUTPUT						TYPE	60-CYCLE NO-LOAD LOSS WATTS	DRIVING TORQUE OUNCE—INCHES	NET WEIGHT POUNDS	APPROXIMATE SHIPPING WEIGHT—POUNDS	CODE WORD	PRICE	REPLACEMENT BRUSH	ADD. FOR BALL BEARINGS (NOTE E)
	Line-Voltage Connection				Overvoltage Connection										
	KVA LOAD RATING (SEE NOTE A)	VOLTAGE RANGE	RATED CURRENT AMPERES	MAXIMUM CURRENT AMPERES (SEE NOTE A)	VOLTAGE RANGE	RATED CURRENT AMPERES (SEE NOTE B)									
120		See Note C			0-140	2.0	W2MT† (Portable 2-wire)	3.5	5-10	4¾	10	BAGIC	\$26.00	Type VB-1 75¢	\$5.00
120		See Note C			0-140	2.0	W2MT3† (Portable 3-wire)	3.5	5-10	4¾	10	BAGOM	28.00		
120	0.31	0-120	2.0	2.6	0-140	2.0	W2M† (With case)	3.5	5-10	4¼	9	BAGER	21.00		
120	0.37	0-120	2.4	3.1	0-140	2.4	W2† (Uncased)	3.5	5-10	3½	6	BAGAL	15.00		
120		See Note C			0-140	5	W3MT*† (Portable 2-wire)	9	10-20	8¼	15	COTIC	30.00	Type VB-2 75¢	\$6.00
120		See Note C			0-140	5	W5MT3*† (Portable 3-wire)	9	10-20	8¼	15	COTOM	32.50		
120	0.78	0-120	5.0	6.5	0-140	5	W5M*† (With case)	9	10-20	7¼	13	COTER	24.00		
120	0.94	0-120	6.0	7.8	0-140	6	W5*† (Uncased)	9	10-20	6½	12	COTAL	18.00		
120	1.1	0-120	7.1	9.2	See Note D		W5LM (With case)	12	10-20	7¼	13	COTAT	23.50		
120	1.1	0-120	7.1	9.2	See Note D		W5LMT3 (Portable 3-wire)	12	10-20	8½	15	COTOS	34.50		
120	1.32	0-120	8.5	11	See Note D		W5L*† (Uncased)	12	10-20	6¾	12	COTUG	17.50		
120	1.56	0-120	10	13	0-140	10	W10*† (Uncased)	17	15-30	12½	18	DOGAL	31.00	Type VBT-10 \$1.25	\$7.00
120	1.56	0-120	10	13	0-140	10	W10M† (With case)	17	15-30	15½	21	DOGER	44.00		
120		See Note C			0-140	10	W10MT† (Portable 2-wire)	17	15-30	16	24	DOGIC	51.00		
120		See Note C			0-140	10	W10MT3† (Portable 3-wire)	17	15-30	16	24	DOGOM	53.50		
120	3.12	0-120	20	26	0-140	20	W20*† (Uncased)	27	45-90	21½	27	FEDAL	48.00	Type VBT-8 \$2.50	\$8.00
120	3.12	0-120	20	26	0-140	20	W20M† (With case)	27	45-90	24½	27	FEDER	61.00		
120		See Note C			0-140	20	W20MT3† (Portable 3-wire)	27	45-90	28	38	FEDOM	90.00		
120	3.84	0-120	28	32	0-140	28	W30M (With case)	35	50-100	37	46	KALER	97.00	Type VBT-13 \$4.00	\$11.00
120	4.32	0-120	30	36	0-140	30	W30 (Uncased)	35	50-100	30	36	KALAL	75.00		
120	5.40	0-120	40	45	0-140	40	W50M*† (With case)	50	150-300	57	74	GATER	145.00	Type VBT-6 \$5.50	\$15.00
120	6.00	0-120	50	50	0-140	50	W50*† (Uncased)	50	150-300	50	65	GATAL	120.00		

See footnotes on following page.



RATINGS

for

SINGLE-UNIT W-SERIES VARIAC® AUTOTRANSFORMERS

with DURATRAK COATING PROCESS

This table lists commonly used single units and does not include all possible applications.

INPUT VOLTAGE	OUTPUT					TYPE	60-CYCLE NO-LOAD LOSS WATTS	DRIVING TORQUE OUNCE—INCHES	NET WEIGHT POUNDS	APPROXIMATE SHIPPING WEIGHT—POUNDS	CODE WORD	PRICE	REPLACEMENT BRUSH	ADD FOR BALL BEARINGS (NOTE E)	
	Line-Voltage Connection				Overvoltage Connection										
	KVA LOAD RATING (SEE NOTE A)	VOLTAGE RANGE	RATED CURRENT AMPERES	MAXIMUM CURRENT AMPERES (SEE NOTE A)	VOLTAGE RANGE										RATED CURRENT AMPERES (SEE NOTE B)
240		See Note C			0-280	2	W5HMT (Portable 2-wire)	9	10-20	8¼	15	JOBIC	\$33.50		
240 120	0.62 —	0-240 —	2.0 —	2.6 —	0-280 0-280	2 1	W5H† (Uncased)	9	10-20	6½	10	JOBAL	21.50	Type VB-1 75c \$6.00	
240 120	0.62 —	0-240 —	2.0 —	2.6 —	0-280 0-280	2 1	W5HM† (Cased)	9	10-20	7¼	13	JOBER	27.50		
240 120	1.25 —	0-240 —	4 —	5.2 —	0-280 0-280	4 2	W10H† (Uncased)	17	15-30	12	18	LUTAL	33.00		
240 120	1.25 —	0-240 —	4 —	5.2 —	0-280 0-280	4 2	W10HM† (With Case)	17	15-30	14½	21	LUTER	46.00	Type VBT-11 \$1.25 \$7.00	
240		See Note C			0-280	4	W10HMT (Portable 2-wire)	17	15-30	15½	24	LUTIC	53.00		
240		See Note C			0-280	4	W10HMT3† (Portable 3-wire)	17	15-30	15½	24	LUTOM	55.50		
240 120	2.50 —	0-240 —	8 —	10.4 —	0-280 0-280	8 4	W20H*† (Uncased)	27	45-90	20½	27	MEPAL	50.00	Type VBT-12 \$2.50 \$8.00	
240 120	2.50 —	0-240 —	8 —	10.4 —	0-280 0-280	8 4	W20HM† (With case)	27	45-90	23½	31	MEPER	63.00		
240		See Note C			0-280	8	W20HMT3† (Portable 3-wire)	27	45-90	27	35	MEPOM	92.00		
240 120	3.74 —	0-240 —	12 —	15.6 —	0-280 0-280	12 6	W30H (Uncased)	35	50-100	29	36	ZABAL	75.00	Type VBT-14 \$4.00 \$11.00	
240 120	3.74 —	0-240 —	12 —	15.6 —	0-280 0-280	12 6	W30HM (With case)	35	50-100	36	46	ZABER	97.00		
240 120	7.45 —	0-240 —	20 —	31 —	0-280 0-280	20 10	W50HM*† (With case)	50	150-300	60	76	NITER	145.00	Type VBT-7 \$5.50 \$15.00	
240 120	7.80 —	0-240 —	25 —	32.5 —	0-280 0-280	25 12.5	W50H*† (Uncased)	50	150-300	53	67	NITAL	120.00		

NOTES

- A. Maximum current can be drawn at maximum voltage for the line-voltage connection only. Kva as listed = normal input line voltage times maximum current.
- B. Rated current should not be exceeded for the overvoltage connection. Output kva for overvoltage connection = output voltage times rated current.
- C. Type MT and MT3 models have overvoltage connection and corresponding dial scales but can be supplied on special order with line-voltage connections and dial scales.
- D. For 60-cycle use only; no overvoltage connection provided.
- E. When ordering a unit with ball bearings, add the suffix '-BB' to the type number and the suffix BALLY to the code word.

*Listed under the Re-examination Service of the Underwriters' Laboratories.

†Approved by the Canadian Standards Association.



SINGLE UNIT W-SERIES

VARIAC® AUTOTRANSFORMER DIMENSIONS †

Type W5MT, Portable Model with 2-wire Cord.

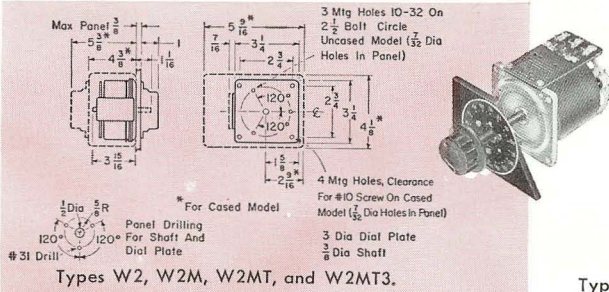

Types W2, W2M, W2MT, and W2MT3.

Type W2, Uncased Basic Model.

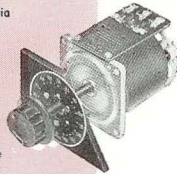

Type W10M, Cased Model.

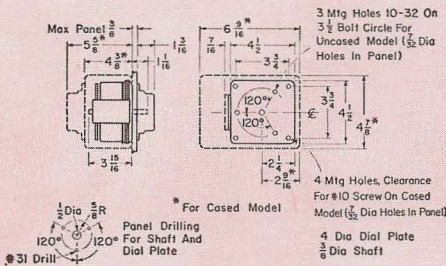

Types W5, W5L, W5M, W5LM, W5MT, W5LMT, W5LMT3, W5H, W5HM, and W5HMT.

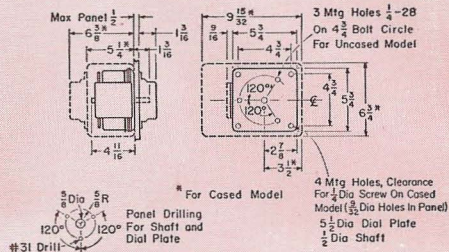

Types W10, W10M, W10MT, W10H, W10HM, W10HMT, and W10HMT3.

Type W50M, Cased Model



Type W30, Uncased Basic Model.

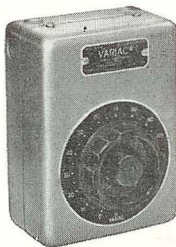
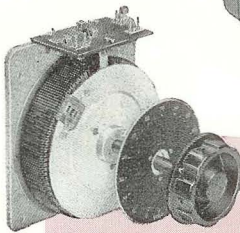

Type W20M, Cased Model.

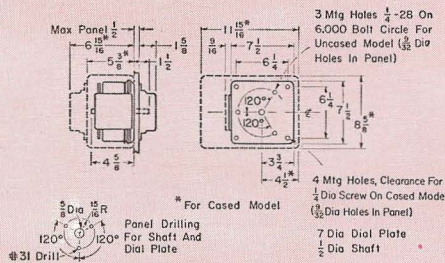

Types W20, W20M, W20MT, W20H, W20HM, and W20HMT3.

Types W30, W30M, W30H, and W30HM.

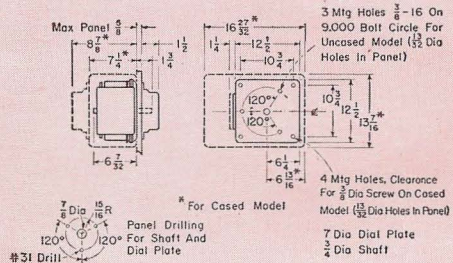
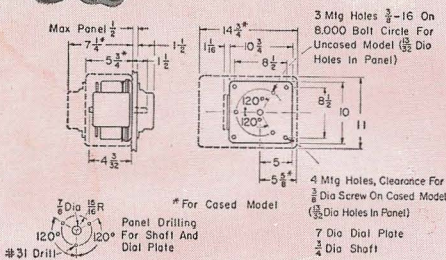

Types W50, W50M, W50H, and W50HM.

† Given in inches; to convert to mm, multiply by 25.4.



GANGED VARIAC® AUTOTRANSFORMER ASSEMBLIES

for parallel, series, and three-phase operation

The usefulness of the Variac autotransformer is greatly extended by means of multigang assemblies (two, three, four or six). They can be used to control

several circuits from a single knob and to control three-phase circuits, either wye- or delta-connected.

PARALLEL COMBINATIONS

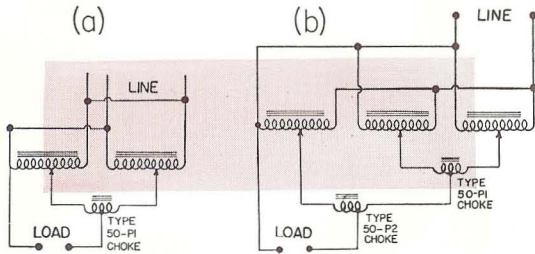

The larger models (TYPES W20, W30, and W50) can be operated in parallel if a TYPE 50-P1 Choke is used to limit circulating current, as shown in circuit (a) at the left. Load rating of two identical units in parallel is twice that of a single unit. Parallel operation is not usually recommended for smaller models, since the use of the next larger size is more economical. Where a load rating in excess of two TYPE W50 units is needed, a third unit can be added by use of a TYPE 50-P2 Choke, as shown in circuit (b). Four-gang and six-gang units can also be paralleled. See page 8 for prices of chokes, and number required.

THREE-PHASE COMBINATIONS

Open-Delta Connection: With this connection, two Variac autotransformers will control a three-phase load from a three-phase source. Maximum output voltage can be either line voltage or 17 percent above line voltage. The load rating of a two-gang, open-delta circuit is 1.732 times that of a single unit. With 240-volt models, output voltages of more than double the supply voltage can be obtained, although current and power ratings are halved. **Wye Connection:** Wye-connected models can be operated from three-phase lines of twice the voltage rating. This is because the voltage across each leg of a wye-connected assembly equals line volts divided by $\sqrt{3}$, and because 120-volt models are wound for a maximum of 140 volts and 240-volt models are wound for a maximum of 280 volts. With a wye connection, the voltage across a unit on a 480-volt line is 277 volts, and on a 240-volt line it is 138 volts. Although the overvoltage

feature is sacrificed in this circuit, the kva rating is increased by the ratio 138:120. The load rating of a wye-connected assembly is 3.47 times that of a single unit.

As with single-phase assemblies, Variac autotransformers can also be paralleled on three-phase circuits. A 4-gang delta connection requires two TYPE 50-P1 Chokes and a 6-gang delta connection requires two TYPE 50-P1 and two TYPE 50-P2 Chokes. A 6-gang wye requires three TYPE 50-P1 Chokes.

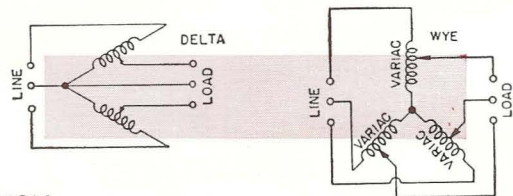

SERIES OPERATION

The series connection is useful in the operation of 120-volt units from 240-volt lines and 240-volt units from 480-volt lines. This circuit cannot be used, however, when a common connection between line and load is required, as, for instance, when the load is grounded.

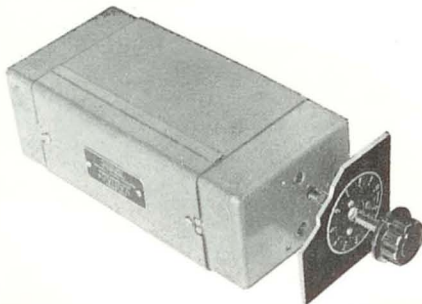
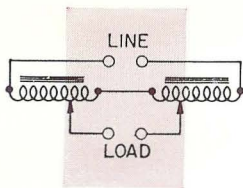

Type W2G3M, a three-gang, cased Variac autotransformer.

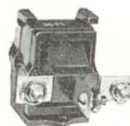

Type 50-P1 Choke for limiting circulating current in parallel combinations.

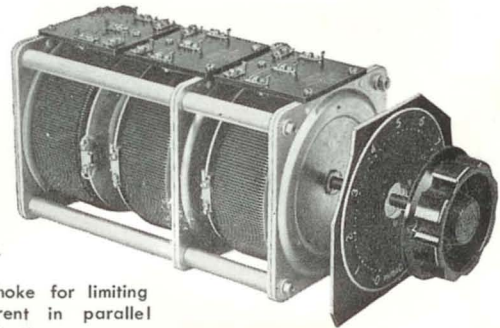

A three-gang uncased model, Type W20G3.



RATINGS

for

SINGLE-PHASE W-SERIES GANGED VARIAC® ASSEMBLIES

This table lists commonly used ganged assemblies and does not include all possible applications.

INPUT VOLTAGE	OUTPUT				TYPE	DESCRIPTION (SEE NOTE B)	NUMBER OF CHOICES REQUIRED		NET WEIGHT POUNDS	APPROXIMATE SHIPPING WEIGHT—POUNDS	CODE WORD	PRICE	ADD. FOR BALL BEARINGS (NOTE C)
	KVA LOAD RATING (SEE NOTE A)	VOLTAGE RANGE	RATED CURRENT AMPERES	MAXIMUM CURRENT AMPERES (SEE NOTE A)			TYPE 50-P1 \$16.00	TYPE 50-P2 \$16.00					
120	2.2	0-120	14.2	18.4	W5LG2M*	2-Gang, cased (P)	1		15¼	23	COTUGBONDU	\$53.00	\$8.00
120	2.6	0-120	17.0	22.0	W5LG2*	2-Gang, uncased (P)	1		13¾	21	COTUGGANDU	41.00	8.00
120	3.3	0-120	21.3	27.6	W5LG3M*	3-Gang, cased (P)	1	1	22½	32	COTUGBONTY	71.50	10.00
120	4.0	0-120	25.5	33.0	W5LG3*	3-Gang, uncased (P)	1	1	20½	30	COTUGGANTY	59.50	10.00
120	6.2	0-140	40.0	52.0	W20G2M	2-Gang, cased (P)	1		48	63	FEDALBONDU	131.00	10.00
120	6.2	0-140	40.0	52.0	W20G2	2-Gang, uncased (P)	1		43½	57	FEDALGANDU	106.00	10.00
120	7.7	0-140	56.0	64.0	W30G2M	2-Gang, cased (P)	1		67	83	KALALBONDU	190.00	14.00
120	8.6	0-140	60.0	72.0	W30G2	2-Gang, uncased (P)	1		61½	77	KALALGANDU	160.00	14.00
120	9.4	0-140	60.0	78.0	W20G3M	3-Gang, cased (P)	1	1	71	84	FEDALBONTY	182.00	12.00
120	9.4	0-140	60.0	78.0	W20G3	3-Gang, uncased (P)	1	1	65	78	FEDALGANTY	156.00	12.00
120	10.8	0-140	80.0	90.0	W50G2M	2-Gang, cased (P)	1		123	160	GATALBONDU	310.00	20.00
120	11.5	0-140	84.0	96.0	W30G3M	3-Gang, cased (P)	1	1	99	115	KALALBONTY	275.00	17.50
120	12.0	0-140	100.0	100.0	W50G2	2-Gang, uncased (P)	1		112	147	GATALGANDU	260.00	20.00
120	13.0	0-140	90.0	108.0	W30G3	3-Gang, uncased (P)	1	1	93	108	KALALGANTY	240.00	17.50
120	16.2	0-140	120.0	135.0	W50G3M	3-Gang, cased (P)	1	1	179	221	GATALBONTY	440.00	25.00
120	18.0	0-140	150.0	150.0	W50G3	3-Gang, uncased (P)	1	1	163	206	GATALGANTY	385.00	25.00
120	21.6	0-140	160.0	180.0	W50G4BBM	4-Gang, Ball Bearings, cased (P)	4		240	313	GATALBONKA	600.00	—
120	24.0	0-140	200.0	200.0	W50G4BB	4-Gang, Ball Bearings, uncased (P)	4		215	288	GATALGANKA	540.00	—
120	32.4	0-140	240.0	270.0	W50G6BBM	6-Gang, Ball Bearings, cased (P)	5	2	355	430	GATALBONSA	870.00	—
120	36.0	0-140	300.0	300.0	W50G6BB	6-Gang, Ball Bearings, uncased (P)	5	2	325	400	GATALGANSA	800.00	—
240	0.62	0-560	1.0	1.3	W5HG2	2-Gang, uncased (S) †			13¼	21	JOBALGANDU	49.00	8.00
240	0.62	0-560	1.0	1.3	W5HG2M	2-Gang, cased (S) †			15	23	JOBALBONDU	61.00	8.00
240	0.62	0-280	2.0	2.6	W2G2M	2-Gang, cased (S) †			8½	15	BAGALBONDU	48.00	7.00
240	0.74	0-280	2.4	3.1	W2G2	2-Gang, uncased (S) †			7¼	14	BAGALGANDU	36.00	7.00
240	1.56	0-280	5.0	6.5	W5G2M	2-Gang, cased (S) †			15	23	COTALBONDU	54.00	8.00
240	1.87	0-280	6.0	7.8	W5G2	2-Gang, uncased (S) †			13¾	21	COTALGANDU	42.00	8.00
240	3.12	0-280	10.0	13.0	W10G2	2-Gang, uncased (S) †			25½	34	DOGALGANDU	72.00	9.00
240	3.12	0-280	10.0	13.0	W10G2M	2-Gang, cased (S) †			29½	38	DOGALBONDU	93.00	9.00
240	4.99	0-280	16.0	20.8	W20HG2	2-Gang, uncased (P)	1		41	55	MEPALGANDU	110.00	10.00
240	4.99	0-280	16.0	20.8	W20HG2M	2-Gang, cased (P)	1		45	59	MEPALBONDU	135.00	10.00
240	6.24	0-280	20.0	26.0	W20G2	2-Gang, uncased (S) †			44	57	FEDALGANDU	106.00	10.00
240	6.24	0-280	20.0	26.0	W20G2M	2-Gang, cased (S) †			48	63	FEDALBONDU	131.00	10.00
240	7.5	0-280	24.0	31.2	W30HG2	2-Gang, uncased (P)	1		59	75	ZABALGANDU	160.00	14.00
240	7.5	0-280	24.0	31.2	W30HG2M	2-Gang, cased (P)	1		64½	81	ZABALBONDU	190.00	14.00
240	7.7	0-280	28.0	32.0	W30G2M	2-Gang, cased (S) †			67	83	KALALBONDU	190.00	14.00
240	8.6	0-280	30.0	36.0	W30G2	2-Gang, uncased (S) †			61½	77	KALALGANDU	160.00	14.00
240	14.9	0-280	40.0	62.0	W50HG2M	2-Gang, cased (P)	1		126	165	NITALBONDU	310.00	20.00
240	15.6	0-280	50.0	65.0	W50HG2	2-Gang, uncased (P)	1		116	153	NITALGANDU	260.00	20.00
240	22.3	0-280	60.0	93.0	W50HG3M	3-Gang, cased (P)	1	1	183	230	NITALBONTY	440.00	25.00
240	23.4	0-280	75.0	97.5	W50HG3	3-Gang, uncased (P)	1	1	167	214	NITALGANTY	385.00	25.00
240	29.8	0-280	80.0	124.0	W50HG4BBM	4-Gang, Ball Bearings, cased (P)	3		255	328	NITALBONKA	600.00	—
240	31.2	0-280	100.0	130.0	W50HG4BB	4-Gang, Ball Bearings, uncased (P)	3		230	300	NITALGANKA	540.00	—
240	44.6	0-280	120.0	186.0	W50HG6BBM	6-Gang, Ball Bearings, cased (P)	4	1	385	458	NITALBONSA	870.00	—
240	46.8	0-280	150.0	195.0	W50HG6BB	6-Gang, Ball Bearings, uncased (P)	4	1	355	428	NITALGANSA	800.00	—

See footnotes on following page.



RATINGS

for

THREE-PHASE W-SERIES GANGED VARIAC® ASSEMBLIES

This table lists commonly used ganged assemblies and does not include all possible applications.

INPUT VOLTAGE	OUTPUT				TYPE	DESCRIPTION	NUMBER OF CHOKES REQUIRED	NET WEIGHT POUNDS	APPROXIMATE SHIPPING WEIGHT — POUNDS	CODE WORD	PRICE	ADD. FOR BALL BEARINGS (NOTE C)
	KVA LOAD RATING (SEE NOTE A)	VOLTAGE RANGE	RATED CURRENT AMPERES	MAXIMUM CURRENT AMPERES (SEE NOTE A)								
208	3.31	0-208	7.1	9.2	W5LG3M*§	3-Gang, cased, Wye circuit		22½	32	COTUGBONTY	\$71.50	\$10.00
208	3.96	0-208	8.5	11.0	W5LG3*§	3-Gang, uncased, Wye circuit		20½	30	COTUGGANTY	59.50	10.00
240	1.08	0-280	2.0	2.6	W5HG2	2-Gang, uncased, Open Delta		13½	21	JOBALGANDU	49.00	8.00
240	1.08	0-280	2.0	2.6	W5HG2M	2-Gang, cased, Open Delta		14	23	JOBALBONDU	61.00	8.00
240	1.08	0-240	2.0	2.6	W2G3M‡	3-Gang, cased, Wye circuit		12½	21	BAGALBONTY	64.00	9.00
240	1.29	0-240	2.4	3.1	W2G3‡	3-Gang, uncased, Wye circuit		10¾	19	BAGALGANTY	52.00	9.00
240	2.16	0-280	4.0	5.2	W10HG2	2-Gang, uncased, Open Delta		24½	33	LUTALGANDU	76.00	9.00
240	2.16	0-280	4.0	5.2	W10HG2M	2-Gang, cased, Open Delta		29	37	LUTALBONDU	97.00	9.00
240	2.71	0-240	5.0	6.5	W5G3M‡	3-Gang, cased, Wye circuit		22½	32	COTALBONTY	73.00	10.00
240	3.24	0-240	6.0	7.8	W5G3‡	3-Gang, uncased, Wye circuit		21	30	COTALGANTY	61.00	10.00
240	4.32	0-280	8.0	10.4	W20HG2	2-Gang, uncased, Open Delta		41	55	MEPALGANDU	110.00	10.00
240	4.32	0-280	8.0	10.4	W20HG2M	2-Gang, cased, Open Delta		45	59	MEPALBONDU	135.00	10.00
240	5.40	0-240	10.0	13.0	W10G3‡	3-Gang, uncased, Wye circuit		39	48	DOGALGANTY	105.00	11.00
240	5.40	0-240	10.0	13.0	W10G3M‡	3-Gang, cased, Wye circuit		43	54	DOGALBONTY	128.00	11.00
240	6.48	0-280	12.0	15.6	W30HG2	2-Gang, uncased, Open Delta		59	75	ZABALGANDU	160.00	14.00
240	6.48	0-280	12.0	15.6	W30HG2M	2-Gang, cased, Open Delta		64½	81	ZABALBONDU	190.00	14.00
240	10.8	0-240	20.0	26.0	W20G3‡	3-Gang, uncased, Wye circuit		65	78	FEDALGANTY	156.00	12.00
240	10.8	0-240	20.0	26.0	W20G3M‡	3-Gang, cased, Wye circuit		71	84	FEDALBONTY	182.00	12.00
240	12.9	0-280	20.0	31.0	W50HG2M	2-Gang, cased, Open Delta		126	165	NITALBONDU	310.00	20.00
240	13.3	0-240	28.0	32.0	W30G3M‡	3-Gang, cased, Wye circuit		99	115	KALALBONTY	275.00	17.50
240	13.5	0-280	25.0	32.5	W50HG2	2-Gang, uncased, Open Delta		116	153	NITALGANDU	260.00	20.00
240	15.0	0-240	30.0	36.0	W30G3	3-Gang, uncased, Wye circuit		93	108	KALALGANTY	240.00	17.50
240	18.7	0-240	40.0	45.0	W50G3M‡	3-Gang, cased, Wye circuit		179	221	GATALBONTY	440.00	25.00
240	20.8	0-240	50.0	50.0	W50G3‡	3-Gang, uncased, Wye circuit		163	206	GATALGANTY	385.00	25.00
240	25.8	0-280	40.0	62.0	W50HG4BBM	4-Gang, cased, Open Delta	2	255	328	NITALBONKA	600.00	—
240	27.0	0-280	50.0	65.0	W50HG4BB	4-Gang, uncased, Open Delta	2	230	300	NITALGANKA	540.00	—
240	37.4	0-240	80.0	90.0	W50G6BBM‡	6-Gang, cased, Wye circuit	3	355	430	GATALBONSA	870.00	—
240	41.6	0-240	100.0	100.0	W50G6BB‡	6-Gang, uncased, Wye circuit	3	325	400	GATALGANSA	800.00	—
480	2.16	0-480	2.0	2.6	W5HG3‡	3-Gang, uncased, Wye circuit		20½	29	JOBALGANTY	71.50	10.00
480	2.16	0-480	2.0	2.6	W5HG3M‡	3-Gang, cased, Wye circuit		22	31	JOBALBONTY	83.50	10.00
480	4.32	0-480	4.0	5.2	W10HG3‡	3-Gang, uncased, Wye circuit		36	46	LUTALGANTY	111.00	11.00
480	4.32	0-480	4.0	5.2	W10HG3M‡	3-Gang, cased, Wye circuit		42	52	LUTALBONTY	134.00	11.00
480	8.65	0-480	8.0	10.4	W20HG3‡	3-Gang, uncased, Wye circuit		61	73	MEPALGANTY	162.00	12.00
480	8.65	0-480	8.0	10.4	W20HG3M‡	3-Gang, cased, Wye circuit		67	81	MEPALBONTY	188.00	12.00
480	13.0	0-480	12.0	15.6	W30HG3‡	3-Gang, uncased, Wye circuit		90½	107	ZABALGANTY	240.00	17.50
480	13.0	0-480	12.0	15.6	W30HG3M‡	3-Gang, cased, Wye circuit		97	113	ZABALBONTY	275.00	17.50
480	25.8	0-480	20.0	31.0	W50HG3M‡	3-Gang, cased, Wye circuit		183	230	NITALBONTY	440.00	25.00
480	27.0	0-480	25.0	32.5	W50HG3‡	3-Gang, uncased, Wye circuit		167	214	NITALGANTY	385.00	25.00
480	51.5	0-480	40.0	62.0	W50HG6BBM‡	6-Gang, cased, Wye circuit	3	385	458	NITALBONSA	870.00	—
480	54.0	0-480	50.0	65.0	W50HG6BB‡	6-Gang, uncased, Wye circuit	3	355	428	NITALGANSA	800.00	—

NOTES

A. Maximum current can be drawn at maximum voltage for the line-voltage connection only. Kva, as listed, = normal input line voltage times maximum current.
 B. P = parallel windings; S = series windings.
 C. When ordering a unit with ball bearings, add the suffix "—BB" to the

type number and the suffix BALLY to the code word.
 * For 60-cycle use only; no overvoltage connection provided.
 ‡ Do not use with grounded load.
 †† Overvoltage connection not recommended.
 § Can be used in Wye connection on 208-volt, 60-cycle, 3-phase line

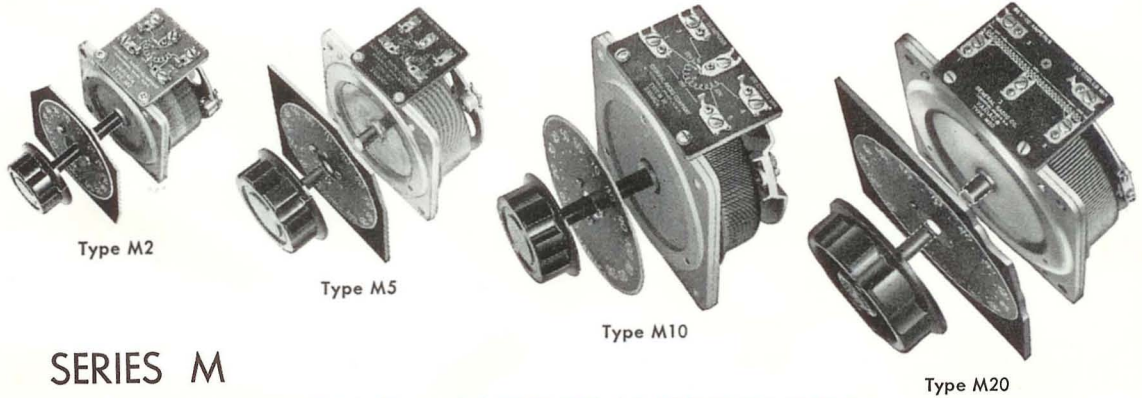

SERIES M

VARIAC® AUTOTRANSFORMERS

for 350- to 1200-Cycle Service

Series M Variac autotransformers are the high-frequency equivalents of the TYPES W2, W5, W10, and W20; they are designed for frequencies from 350 to 1200 cps. Mechanically similar to the 60-cycle Series W models, they are much smaller and lighter. Series M models are especially useful with the 400-cycle power supplies used in air-borne and marine equipment. The regulation obtained with the TYPE M units at 400 cps is considerably better than that of the 60-cycle models. Available in 2-, 5-, 10-, and 20-ampere single units, or in gangs, Series M units can be supplied with ball bearings and 60-cycle motor drives (pages 14 and 17).

FEATURES:

- Usable from 350 to 1200 cycles per second.
- DURATRAK coating process provides an extra factor of reliability under overloads.

Instantaneous peaks of ten times rated current can be tolerated.

- Brush track shows no significant wear after one million cycles of brush operation (zero to maximum and return).
- Manufactured to conform with military specifications for shock, vibration, salt-spray and tropicalization.
- Designed to provide excellent thermal conductivity between coil and base and between base and panel.
- Four corner mounting holes are provided for ganging and mounting, in addition to the three standard mounting holes (on radius).
- Contain wide-temperature-range lubrication which meets most military specifications.
- Two-ampere models (TYPE M2) have 400 turns, giving adequate resolution for many computing and control operations.
- Wiring diagram stamped on terminal board.

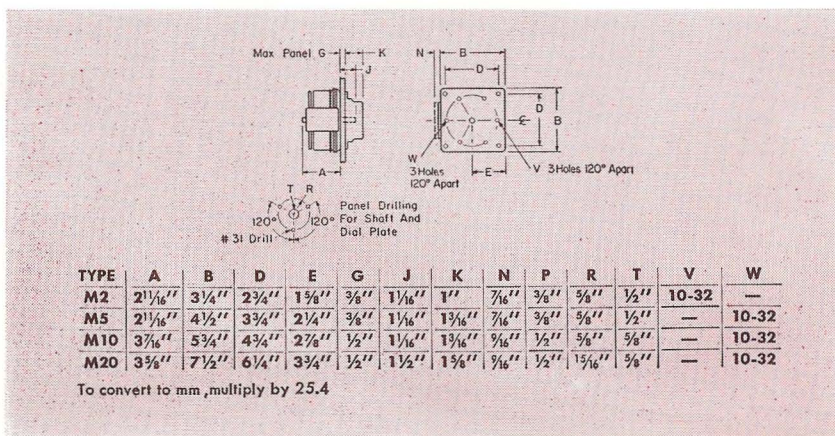



SERIES M SINGLE UNIT RATINGS AND PRICE LIST (UNCASED)

TYPE	RATED INPUT VOLTAGE	OUTPUT					400-CYCLE NO-LOAD LOSS WATTS	DRIVING TORQUE OUNCE-INCHES	NET WEIGHT POUNDS	SHIPPING WEIGHT POUNDS (APPROX.)	CODE WORD	PRICE	ADD FOR REPLACEMENT BRUSH VB-1: 75¢ VB-2: 75¢ VB-10: \$1.25 VB-8: \$2.50	ADD FOR BALL BEARINGS* \$5.00 \$6.00 \$7.00 \$8.00
		LINE-VOLTAGE CONNECTION			OVERVOLTAGE CONNECTION									
		OUTPUT KVA AT MAXIMUM OUTPUT VOLTAGE (NOTE A)	RATED OUTPUT CURRENT AMPERES	OUTPUT VOLTAGE RANGE	MAXIMUM OUTPUT CURRENT AMPERES (NOTE A)	OUTPUT VOLTAGE RANGE								
M2†	120	0.37	2.4	0-120	3.1	0-140	2.4	3.5	5-10	2	4	BAGGY	\$14.50	
M5†	120	0.94	6	0-120	7.8	0-140	6	9	10-20	3½	6	CANNY	18.50	
M10†	120	1.56	10	0-120	13	0-140	10	17	15-30	6½	11	CABIN	30.00	
M20†	120	3.12	20	0-120	26	0-140	20	27	45-90	13	18	CAVIL	48.00	

A. Maximum current can be drawn at maximum voltage for the line-voltage connection only. Maximum output voltage = line input voltage. Kva as listed = normal input line voltage × maximum current.
 B. Rated current should not be exceeded for the overvoltage connection. Output kva for overvoltage connection = output voltage × rated current.
 *When ordering a unit with ball bearings, add the suffix "-BB" to the type number and the suffix "bally" to the code word.
 †Approved by Canadian Standards Association.

SERIES M GANGED VARIAC® AUTOTRANSFORMER ASSEMBLIES

Series M models are available as two-gang assemblies for 120-volt, three-phase, open-delta connection (or for controlling two circuits from a single shaft) and as three-gang assemblies for 208- or 240-volt, three-phase, wye connection (or for controlling three circuits from a single shaft). Ganged assemblies

are designed to occupy minimum volume.

A TYPE 50-P1 Choke is required when a two-gang unit is to be operated in parallel; for three-gang combinations, a TYPE 50-P2 Choke is required in addition to the TYPE 50-P1.

Dials for ganged models are marked 0-10.

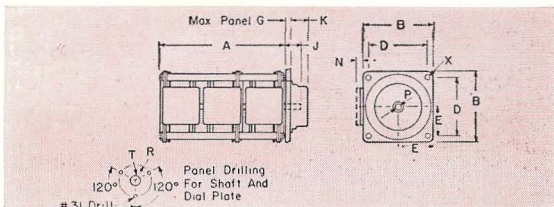

TYPE	A	B	D	E	G	J	K	N	P	R	T	X
M2G2	5 13/32"	3 1/4"	2 3/4"	1 5/8"	3/8"	1 1/16"	1"	7/16"	3/8"	5/8"	1/2"	10-32
M2G3	8 7/32"	3 1/4"	2 3/4"	1 5/8"	3/8"	1 1/16"	1"	7/16"	3/8"	5/8"	1/2"	10-32
M5G2	5 15/32"	4 1/2"	3 3/4"	2 1/4"	3/8"	1 1/16"	1 3/16"	7/16"	3/8"	5/8"	1/2"	10-32
M5G3	8 11/32"	4 1/2"	3 3/4"	2 1/4"	3/8"	1 1/16"	1 3/16"	7/16"	3/8"	5/8"	1/2"	10-32
M10G2	6 1 3/16"	5 3/4"	4 3/4"	2 7/8"	1/2"	1 3/16"	1 3/16"	7/16"	1/2"	3/8"	5/8"	1/4-28
M10G3	10 1/4"	5 3/4"	4 3/4"	2 7/8"	1/2"	1 3/16"	1 3/16"	7/16"	1/2"	3/8"	5/8"	1/4-28
M20G2	7 3/16"	7 1/2"	6 1/4"	3 3/4"	1/2"	1 1/2"	1 1/8"	7/16"	1/2"	1 3/16"	5/8"	1/4-28
M20G3	10 3/4"	7 1/2"	6 1/4"	3 3/4"	1/2"	1 1/2"	1 1/8"	7/16"	1/2"	1 3/16"	5/8"	1/4-28

SERIES M GANGED ASSEMBLY PRICE LIST (UNCASED)

TYPE	DESCRIPTION	DRIVING TORQUE (OZ.-IN.)	NET WEIGHT (LB.)	SHIPPING WEIGHT POUNDS	CODE WORD	PRICE	ADD FOR BALL BEARINGS*
M2G2	2-Gang M2	10-20	3 3/4	6	BAGGYGANDU	\$33.00	\$7.00
M2G3	3-Gang M2	15-30	5 1/2	9	BAGGYGANTY	49.50	9.00
M5G2	2-Gang M5	20-40	6 3/4	12	CANNYGANDU	41.00	8.00
M5G3	3-Gang M5	30-60	10 1/4	14	CANNYGANTY	61.50	10.00
M10G2	2-Gang M10	30-60	12 1/4	18	CABINGANDU	65.00	9.00
M10G3	3-Gang M10	45-90	19	27	CABINGANTY	97.00	11.00
M20G2	2-Gang M20	90-180	26 1/2	34	CAVILGANDU	107.00	10.00
M20G3	3-Gang M20	135-270	38	48	CAVILGANTY	155.00	12.00
Type 50-P1	Choke	—	1 1/4	1 3/4	PARALLCHOK	16.00	—
Type 50-P2	Choke	—	1 1/4	1 3/4	TRIPLECHOK	16.00	—

*When ordering a unit with ball bearings, add the suffix "-BB" to the type number and the suffix "bally" to the code word.



MOTOR-DRIVEN VARIAC® AUTOTRANSFORMERS

All Variac® autotransformers, both single units and gangs, can be furnished with motor drive. The motor mounting plate is attached to the base by four posts, and the motor is geared to the shaft. *All motor-driven models are equipped with ball bearings.*

Fully enclosed, two-phase, gear-reduction motors of the servo type, having very low moments of inertia, are used. Three basic speeds are available, which, together with a selection of stocked standard coupling gears, make possible the assembly of units having nominal full-traverse rates of 2, 4, 8, 16, 32, 64, or 128 seconds at 60 cps (approximately 20% slower at 50 cps). The 2- and 4-second models are intended for high-speed servo applications. Those with slower traverse speeds are primarily for remote positioning requirements, although they are often used

for slower-speed servo work. Motors are 115-volt, 50/60-cycle units.

The two-phase motor supply may be derived from either (1) a servo amplifier or (2) the 115-volt line, with a capacitor (supplied) to produce the necessary phase shift.

Electrical limit switches are listed on all models to limit traverse to approximately 320°. However, they are not required on models with speeds of 2, 4, 8, or 16 seconds and they may be so ordered.*

Cased, motor-driven models are available in either single units or gangs, and are similar to those used with Series W gangs.

In the tables on pages 16 and 17, available combinations are listed for each size. When less than 5 units are ordered, the setup charge must be included.

* If microswitches are not desired, omit "K" from type number and subtract \$7.00 from listed price.

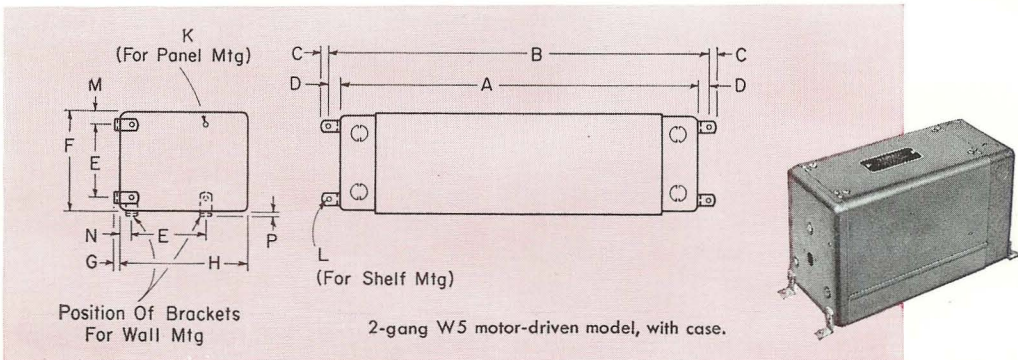

DIMENSIONS† OF MOTOR-DRIVEN CASED MODELS

	A	B	C	D	E	F	G	H	K	L	M	N	P
W2 Single	10 ¹ / ₃₂	11 ² / ₃₂	3/16	1 ⁷ / ₃₂	2 ³ / ₄	4 ³ / ₈	1/8	5 ³ / ₄	10-32	7/32 Drill	1 ³ / ₁₆	3/4	1/16
W2 2-Gang	13 ²³ / ₃₂	14 ²⁵ / ₃₂	3/16	1 ⁷ / ₃₂	2 ³ / ₄	4 ³ / ₈	1/8	5 ³ / ₄	10-32	7/32 Drill	1 ³ / ₁₆	3/4	1/16
W2 3-Gang	17 ²⁵ / ₃₂	18 ²⁷ / ₃₂	3/16	1 ⁷ / ₃₂	2 ³ / ₄	4 ³ / ₈	1/8	5 ³ / ₄	10-32	7/32 Drill	1 ³ / ₁₆	3/4	1/16
W5 Single	10 ²³ / ₃₂	11 ²⁵ / ₃₂	5/16	1 ⁷ / ₃₂	3 ³ / ₄	5 ¹ / ₈	1/8	6 ³ / ₄	10-32	7/32 Drill	1 ¹ / ₁₆	3/4	3/16
W5 2-Gang	13 ²⁷ / ₃₂	14 ²⁹ / ₃₂	5/16	1 ⁷ / ₃₂	3 ³ / ₄	5 ¹ / ₈	1/8	6 ³ / ₄	10-32	7/32 Drill	1 ¹ / ₁₆	3/4	3/16
W5 3-Gang	17 ¹ / ₃₂	19 ¹ / ₃₂	5/16	1 ⁷ / ₃₂	3 ³ / ₄	5 ¹ / ₈	1/8	6 ³ / ₄	10-32	7/32 Drill	1 ¹ / ₁₆	3/4	3/16
W10 Single	12 ⁵ / ₁₆	13 ¹ / ₁₆	7/16	1 ¹ / ₁₆	4 ³ / ₄	7 ¹ / ₈	5/16	9 ¹ / ₁₆	1/4-28	9/32 Drill	1 ³ / ₁₆	1 ¹ / ₄	5/16
W10 2-Gang	15 ⁷ / ₈	17 ¹ / ₄	7/16	1 ¹ / ₁₆	4 ³ / ₄	7 ¹ / ₈	5/16	9 ¹ / ₁₆	1/4-28	9/32 Drill	1 ³ / ₁₆	1 ¹ / ₄	5/16
W10 3-Gang	20 ⁹ / ₁₆	21 ¹³ / ₁₆	7/16	1 ¹ / ₁₆	4 ³ / ₄	7 ¹ / ₈	5/16	9 ¹ / ₁₆	1/4-28	9/32 Drill	1 ³ / ₁₆	1 ¹ / ₄	5/16
W20 Single	12 ¹ / ₁₆	13 ⁷ / ₁₆	7/16	1 ¹ / ₁₆	6 ¹ / ₄	9	1/16	12 ¹ / ₁₆	1/4-28	9/32 Drill	1 ³ / ₈	1 ³ / ₈	1/8
W20 2-Gang	15 ³ / ₈	17	7/16	1 ¹ / ₁₆	6 ¹ / ₄	9	1/16	12 ¹ / ₁₆	1/4-28	9/32 Drill	1 ³ / ₈	1 ³ / ₈	1/8
W20 3-Gang	20 ³ / ₁₆	21 ¹ / ₁₆	7/16	1 ¹ / ₁₆	6 ¹ / ₄	9	1/16	12 ¹ / ₁₆	1/4-28	9/32 Drill	1 ³ / ₈	1 ³ / ₈	1/8
W30 Single	12 ⁵ / ₁₆	14 ³ / ₁₆	7/16	1	8 ¹ / ₂	11 ³ / ₈	3/16	14 ¹ / ₁₆	3/8-16	1 ³ / ₃₂ Drill	1 ⁷ / ₁₆	1 ¹ / ₂	1/4
W30 2-Gang	15 ¹ / ₁₆	17 ¹ / ₁₆	7/16	1	8 ¹ / ₂	11 ³ / ₈	3/16	14 ¹ / ₁₆	3/8-16	1 ³ / ₃₂ Drill	1 ⁷ / ₁₆	1 ¹ / ₂	1/4
W30 3-Gang	20 ⁹ / ₁₆	22 ⁹ / ₁₆	7/16	1	8 ¹ / ₂	11 ³ / ₈	3/16	14 ¹ / ₁₆	3/8-16	1 ³ / ₃₂ Drill	1 ⁷ / ₁₆	1 ¹ / ₂	1/4
W50 Single	14 ¹ / ₁₆	16 ¹ / ₁₆	7/16	1	10 ³ / ₄	13 ¹³ / ₁₆	1/4	17 ¹ / ₁₆	3/8-16	1 ³ / ₃₂ Drill	1 ¹ / ₂	1 ⁵ / ₈	5/16
W50 2-Gang	21 ¹ / ₁₆	23 ¹ / ₁₆	7/16	1	10 ³ / ₄	13 ¹³ / ₁₆	1/4	17 ¹ / ₁₆	3/8-16	1 ³ / ₃₂ Drill	1 ¹ / ₂	1 ⁵ / ₈	5/16
W50 3-Gang	27 ¹ / ₁₆	29 ¹ / ₁₆	7/16	1	10 ³ / ₄	13 ¹³ / ₁₆	1/4	17 ¹ / ₁₆	3/8-16	1 ³ / ₃₂ Drill	1 ¹ / ₂	1 ⁵ / ₈	5/16

† Given in inches; to convert to mm, multiply by 25.4.

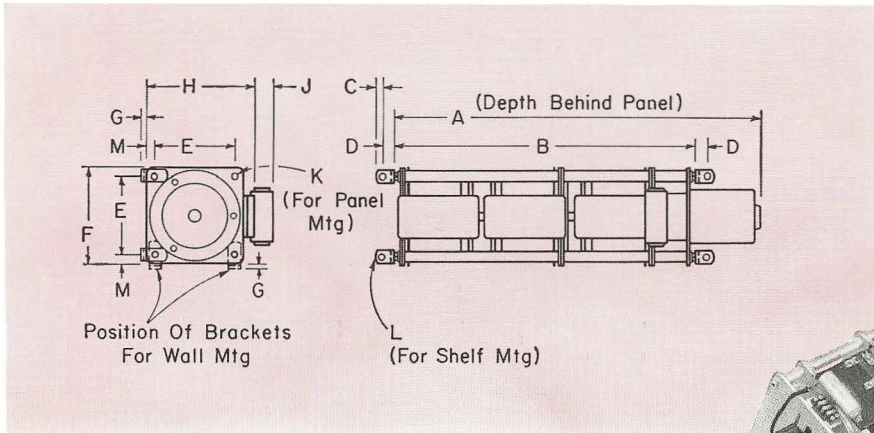

3-gang W20 motor-driven model.

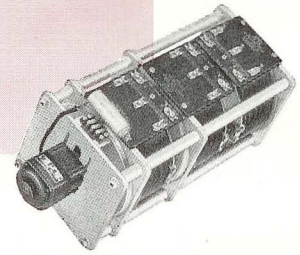

DIMENSIONS† OF MOTOR-DRIVEN UNCASSED MODELS

W-SERIES MODELS

	A	B	C	D	E	F	G	H	J	K	L	M
W2 Single	9 3/8	6 13/16	5/16	1 7/32	2 3/4	3 1/4	5/32	3 11/16	7/8	10-32	7/32 Drill	1/4
W2 2-Gang	12 1/2	9 17/32	5/16	1 7/32	2 3/4	3 1/4	5/32	3 11/16	7/8	10-32	7/32 Drill	1/4
W2 3-Gang	16 9/16	13 13/32	5/16	1 7/32	2 3/4	3 1/4	5/32	3 11/16	7/8	10-32	7/32 Drill	1/4
W5 Single	9 7/16	6 13/32	5/16	1 7/32	3 3/4	4 1/2	5/32	4 19/16	—	10-32	7/32 Drill	3/8
W5 2-Gang	12 1/16	9 19/32	5/16	1 7/32	3 3/4	4 1/2	5/32	4 19/16	—	10-32	7/32 Drill	3/8
W5 3-Gang	16 11/16	13 23/32	5/16	1 7/32	3 3/4	4 1/2	5/32	4 19/16	—	10-32	7/32 Drill	3/8
W10 Single	10 9/32	7 7/16	7/16	1 1/16	4 3/4	5 3/4	3/16	6 5/16	—	1/4-28	5/32 Drill	1/2
W10 2-Gang	13 27/32	11	7/16	1 1/16	4 3/4	5 3/4	3/16	6 5/16	—	1/4-28	5/32 Drill	1/2
W10 3-Gang	18 17/32	15 11/16	7/16	1 1/16	4 3/4	5 3/4	3/16	6 5/16	—	1/4-28	5/32 Drill	1/2
W20 Single	10 5/32	7 3/16	7/16	1 1/16	6 1/4	7 1/2	1/16	8 1/16	—	1/4-28	5/32 Drill	1/2
W20 2-Gang	13 23/32	10 7/8	7/16	1 1/16	6 1/4	7 1/2	1/16	8 1/16	—	1/4-28	5/32 Drill	1/2
W20 3-Gang	18 9/32	15 5/16	7/16	1 1/16	6 1/4	7 1/2	1/16	8 1/16	—	1/4-28	5/32 Drill	1/2
W30 Single	10 3/4	6 1/4	7/16	1	8 1/2	10	1/8	11 13/16	—	3/8-16	1 3/32 Drill	3/4
W30 2-Gang	14 3/8	9 7/8	7/16	1	8 1/2	10	1/8	11 13/16	—	3/8-16	1 3/32 Drill	3/4
W30 3-Gang	19	14 1/2	7/16	1	8 1/2	10	1/8	11 13/16	—	3/8-16	1 3/32 Drill	3/4
W50 Single	12 5/8	8 1/16	7/16	1	10 3/4	12 1/2	1/8	13 3/4	—	3/8-16	1 3/32 Drill	7/8
W50 2-Gang	19 1/16	14 1/2	7/16	1	10 3/4	12 1/2	1/8	13 3/4	—	3/8-16	1 3/32 Drill	7/8
W50 3-Gang	25 3/16	20 7/8	7/16	1	10 3/4	12 1/2	1/8	13 3/4	—	3/8-16	1 3/32 Drill	7/8

M-SERIES MODELS

M2 Single	8 1/8	5 5/32	5/16	1 7/32	2 3/4	3 1/4	5/32	3 11/16	7/8	10-32	7/32 Drill	1/4
M2 2-Gang	10	7 1/32	5/16	1 7/32	2 3/4	3 1/4	5/32	3 11/16	7/8	10-32	7/32 Drill	1/4
M2 3-Gang	12 13/16	9 27/32	5/16	1 7/32	2 3/4	3 1/4	5/32	3 11/16	7/8	10-32	7/32 Drill	1/4
M5 Single	8 3/16	5 7/32	5/16	1 7/32	3 3/4	4 1/2	5/32	4 19/16	—	10-32	7/32 Drill	3/8
M5 2-Gang	10 1/16	7 3/32	5/16	1 7/32	3 3/4	4 1/2	5/32	4 19/16	—	10-32	7/32 Drill	3/8
M5 3-Gang	12 15/16	9 31/32	5/16	1 7/32	3 3/4	4 1/2	5/32	4 19/16	—	10-32	7/32 Drill	3/8
M10 Single	9 1/32	6 3/16	7/16	1 1/16	4 3/4	5 3/4	3/16	6 5/16	—	1/4-28	5/32 Drill	1/2
M10 2-Gang	11 11/32	8 1/2	7/16	1 1/16	4 3/4	5 3/4	3/16	6 5/16	—	1/4-28	5/32 Drill	1/2
M10 3-Gang	14 25/32	11 15/16	7/16	1 1/16	4 3/4	5 3/4	3/16	6 5/16	—	1/4-28	5/32 Drill	1/2
M20 Single	9 5/32	6 3/16	7/16	1 1/16	6 1/4	7 1/2	1/16	8 1/16	—	1/4-28	5/32 Drill	5/8
M20 2-Gang	11 23/32	8 3/8	7/16	1 1/16	6 1/4	7 1/2	1/16	8 1/16	—	1/4-28	5/32 Drill	5/8
M20 3-Gang	15 5/32	12 7/16	7/16	1 1/16	6 1/4	7 1/2	1/16	8 1/16	—	1/4-28	5/32 Drill	5/8

See following pages for Price List of motor-driven models.

† Given in inches; to convert to mm multiply by 25.4.



PRICE LIST¹ FOR MOTOR-DRIVEN VARIAC® AUTOTRANSFORMERS

MOTOR	STANDARD EXTERNAL GEAR RATIOS								ADD TO TYPE NUMBER ³			SET-UP CHARGE PRORATED 1-4 UNITS	ADD FOR CASE	
	ALL MOTORS SHOWN ARE 60-CYCLE	2:1	4:1	8:1	16:1	32:1	64:1	128:1	CAPACITOR	MICROSWITCH	CASED MODEL			
		A B C												
SECONDS FOR 320° TRAVERSE ²	2	4	8	16	32	32	64	128						
TYPE ³														
M2	\$101.50	\$101.50	\$101.50	\$101.50	NA	\$101.50	\$101.50	SO	C	K		\$6.00	NA	
M2G2	122.00	122.00	122.00	122.00	NA	122.00	122.00	SO	C	K		6.00	NA	
M2G3	NA	140.50	140.50	140.50	NA	140.50	140.50	SO	C	K		6.00	NA	
M5	106.50	106.50	106.50	106.50	NA	106.50	106.50	SO	C	K		6.00	NA	
M5G2	131.00	131.00	131.00	131.00	NA	131.00	131.00	SO	C	K		6.00	NA	
M5G3	NA	153.50	153.50	153.50	NA	153.50	153.50	SO	C	K		6.00	NA	
M10	142.00	142.00	142.00	142.00	\$142.00	NA	142.00	\$142.00	C	K		12.00	NA	
M10G2	NA	179.00	179.00	179.00	179.00	NA	179.00	179.00	C	K		12.00	NA	
M10G3	NA	NA	213.00	213.00	213.00	NA	213.00	213.00	C	K		12.00	NA	
M20	NA	166.00	166.00	166.00	166.00	NA	166.00	166.00	C	K		12.00	NA	
M20G2	NA	NA	227.00	227.00	227.00	NA	227.00	227.00	C	K		12.00	NA	
M20G3	NA	NA	277.00	277.00	277.00	NA	277.00	277.00	C	K		12.00	NA	
W2	102.00	102.00	102.00	102.00	NA	102.00	102.00	NA	C	K	M	6.00	\$12.00	
W2G2	125.00	125.00	125.00	125.00	NA	125.00	125.00	NA	C	K	M	6.00	12.00	
W2G3	NA	143.00	143.00	143.00	NA	143.00	143.00	NA	C	K	M	6.00	12.00	
W5	106.00	106.00	106.00	106.00	NA	106.00	106.00	NA	C	K	M	6.00	16.00	
W5G2	132.00	132.00	132.00	132.00	NA	132.00	132.00	NA	C	K	M	6.00	16.00	
W5G3	NA	153.00	153.00	153.00	NA	153.00	153.00	NA	C	K	M	6.00	16.00	
W5L	105.50	105.50	105.50	105.50	NA	105.50	105.50	NA	C	K	M	6.00	16.00	
W5LG2	NA	131.00	131.00	131.00	NA	131.00	131.00	NA	C	K	M	6.00	16.00	
W5LG3	NA	151.50	151.50	151.50	NA	151.50	151.50	NA	C	K	M	6.00	16.00	
W5H	109.50	109.50	109.50	109.50	NA	109.50	109.50	NA	C	K	M	6.00	16.00	
W5HG2	139.00	139.00	139.00	139.00	NA	139.00	139.00	NA	C	K	M	6.00	16.00	
W5HG3	NA	163.50	163.50	163.50	NA	163.50	163.50	NA	C	K	M	6.00	16.00	
W10	135.00	135.00	135.00	135.00	135.00	NA	135.00	135.00	C	K	M	12.00	32.00	
W10G2	NA	178.00	178.00	178.00	178.00	NA	178.00	178.00	C	K	M	12.00	34.00	
W10G3	NA	NA	213.00	213.00	213.00	NA	213.00	213.00	C	K	M	12.00	36.00	
W10H	137.00	137.00	137.00	137.00	137.00	NA	137.00	137.00	C	K	M	12.00	32.00	
W10HG2	NA	182.00	182.00	182.00	182.00	NA	182.00	182.00	C	K	M	12.00	34.00	
W10HG3	NA	NA	219.00	219.00	219.00	NA	219.00	219.00	C	K	M	12.00	36.00	
TORQUE—OUNCE-INCHES	30	60	120	240	480	240	480	960						

NOTES

NA = not available. SO = available on special order only; prices on request.
 Note: Microswitches, capacitors, and ball bearings are included in the above prices. If microswitches are not desired, omit "K" from type number and subtract \$7.00 from listed price.

¹ Prices in table are for quantities of 5 or more. Add appropriate set-up charge for quantities of 1 to 4.
² Traverse speeds are nominal for 60-cycle supply. Actual speeds may vary ±15% from these values. Specify speed on order (e.g. D4, D32, etc.)
³ See page 2 for example of type numbers.



PRICE LIST¹ FOR MOTOR-DRIVEN MODELS (cont.)

MOTOR ALL MOTORS SHOWN ARE 60-CYCLE	STANDARD EXTERNAL GEAR RATIOS								ADD TO TYPE NUMBER ³			SET-UP CHARGE PRORATED 1-4 UNITS	ADD FOR CASE	
	A	2:1	4:1						CAPACITOR	MICROSWITCH	CASED MODEL			
	B			2:1	4:1	8:1								
SECONDS FOR 320° TRAVERSE ²	C	2	4	8	16	32	32	64	128					
TYPE ³														
W20	SO	\$158.00	\$158.00	\$158.00	\$158.00	NA	\$158.00	\$158.00		C	K	M	\$12.00	\$35.00
W20G2	SO	SO	218.00	218.00	218.00	NA	218.00	218.00		C	K	M	12.00	38.00
W20G3	NA	SO	270.00	270.00	270.00	NA	270.00	270.00		C	K	M	12.00	41.00
W20H	SO	160.00	160.00	160.00	160.00	NA	160.00	160.00		C	K	M	12.00	35.00
W20HG2	SO	SO	222.00	222.00	222.00	NA	222.00	222.00		C	K	M	12.00	38.00
W20HG3	NA	SO	276.00	276.00	276.00	NA	276.00	276.00		C	K	M	12.00	41.00
W30	SO	207.00	207.00	207.00	207.00	NA	207.00	207.00		C	K	M	12.00	49.00
W30G2	NA	SO	SO	287.00	287.00	NA	287.00	287.00		C	K	M	12.00	53.00
W30G3	NA	NA	SO	SO	367.00	NA	367.00	367.00		C	K	M	12.00	57.00
W30H	SO	207.00	207.00	207.00	207.00	NA	207.00	207.00		C	K	M	12.00	49.00
W30HG2	NA	SO	SO	287.00	287.00	NA	287.00	287.00		C	K	M	12.00	53.00
W30HG3	NA	NA	SO	SO	367.00	NA	367.00	367.00		C	K	M	12.00	57.00
W50	NA	SO	SO	260.00	260.00	NA	260.00	260.00		C	K	M	12.00	55.00
W50G2	NA	NA	SO	SO	390.00	NA	390.00	390.00		C	K	M	12.00	60.00
W50G3	NA	NA	SO	SO	520.00	NA	520.00	520.00		C	K	M	12.00	65.00
W50G4	NA	NA	NA	SO	SO	NA	SO	650.00		C	K	M	—	70.00
W50G6	NA	NA	NA	NA	SO	NA	SO	910.00		C	K	M	—	80.00
W50H	NA	SO	SO	260.00	260.00	NA	260.00	260.00		C	K	M	12.00	55.00
W50HG2	NA	NA	SO	SO	390.00	NA	390.00	390.00		C	K	M	12.00	60.00
W50HG3	NA	NA	SO	SO	520.00	NA	520.00	520.00		C	K	M	12.00	65.00
W50HG4	NA	NA	NA	SO	SO	NA	SO	650.00		C	K	M	—	70.00
W50HG6	NA	NA	NA	NA	SO	NA	SO	910.00		C	K	M	—	80.00
TORQUE—OUNCE-INCHES		30	60	120	240	480	240	480	960					

NOTES

NA = not available. SO = available on special order only; prices on request.
Note: Microswitches, capacitor, and ball bearings are included in the above prices. If microswitches are not desired, omit "K" from type number and subtract \$7.00 from listed price.

¹ Prices in table are for quantities of 5 or more. Add appropriate set-up charge for quantities of 1 to 4.
² Traverse speeds are nominal for 60-cycle supply. Actual speeds may vary ±15% from these values.
³ See page 2 for example of type numbers.



TYPE 1590-A REMOTE CONTROL

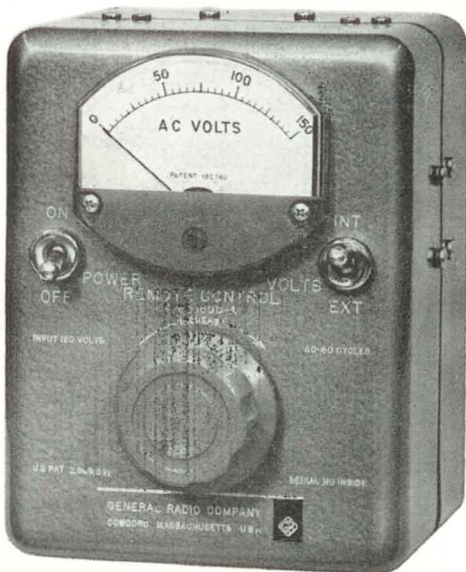

The TYPE 1590-A Remote Control is a simple, accurate, servo control for the remote positioning of a motor-driven Variac® autotransformer. This control can be set for any desired voltage from zero to 140 volts. The remote, motor-driven autotransformer will automatically position itself for the same voltage. This voltage is indicated on an accurate quasi-rms panel meter.

Since this control is a servomechanism, any change in output voltage due to Variac regulation is automatically corrected. The correction rate depends on the size of the Variac autotransformer and can be as high as 60 volts per second for small units.

If a regulated line is available to supply a small amount of power to operate the Remote Control, corrections can also be automatically obtained for fluctuations in line voltage at the remote autotransformer. This regulated line must have low impedance at 60 cps and must have the same phase angle as the unregulated

line to the remote unit. This combination can provide large amounts of power at a regulated voltage which is adjustable from zero to 140 volts. The addition of a buck-boost transformer, to limit the correction range to $\pm 10\%$ about the normal line voltage, will result in an increase of five times in the power rating.

Knockouts and a terminal strip are provided in the case for the four leads necessary to connect the Control Unit to the remote Variac autotransformer.

If continuous control is not required, one TYPE 1590-A can be switched to control any number of remote units, one at a time.

TRAVERSE TIME AND CORRECTION RATE FOR 2% POSITIONING ERROR

DRIVEN VARIAC AUTO-TRANSFORMER MODEL	SINGLE UNIT		TWO-GANG (G2)		THREE-GANG (G3)	
	Traverse Time* (Sec-onds)	Approximate Correction Rate (Volts/sec)	Traverse Time* (Sec-onds)	Approximate Correction Rate (Volts/sec)	Traverse Time* (Sec-onds)	Approximate Correction Rate (Volts/sec)
W2	2	60	2	60	4	30
W5	2	60	4	30	8	15
W10	4	30	8	15	16	8
W20	8	15	16	8	32	4
W30	16	8	32	4	32†	4
W50	32	4	64‡	2	64‡†	2

* If half the positioning error is desired, the traverse time can be doubled, giving half the correction rate. Traverse time greater than 64 seconds should not be used.
 † 3% positioning error.

To order the proper motor-driven Variac autotransformer, use the same type-numbering system as for our standard motor-driven units (page 2). The motor capacitor and microswitches, specified by C and K in the type numbers for standard units, are not used with the TYPE 1590-A.‡ These letters should be omitted from the type numbers. Thus, for 2% positioning accuracy with a TYPE W10G2 Variac autotransformer, order TYPE W10G2D8.

‡ Exception: microswitches necessary on 64-second models.

SPECIFICATIONS

Tracking Accuracy: $\pm 2\%$ of input line voltage, when used with motor speeds listed in the table. (Halving the speed increases the accuracy to $\pm 1\%$).

Correction Rate: See table.

Power: 105 to 125 volts, 50 to 60 cps.

Accessories Required: Standard motor-driven Variac autotransformer less capacitor and microswitches.

Dimensions: Width $4\frac{1}{8}$, height $6\frac{5}{8}$, depth $5\frac{7}{8}$ inches (124 by 169 by 149 mm) over-all.

Net Weight: $6\frac{1}{2}$ pounds (3 kg).

TYPE	CODE WORD	PRICE
1590-A Remote Control.....	REMCO	\$95.00



BALL BEARINGS

Series W and Series M models can be supplied with ball bearings, which provide more precise alignment, with slightly lower and more nearly constant torque.

When ordering a single unit or gang equipped with ball bearings, add the suffix "-BB" to the type number, the suffix **BALLY**

to the code word, and add the price shown in the tables.

Ball bearings are standard equipment on all motor-driven units and on all 4- and 6-gang W50 and W50H models, and are included in the price.

SPECIAL VARIAC AUTOTRANSFORMERS

Special models can be supplied to meet specific requirements, such as with additional winding taps, fungicide treatment, special shaft lengths, or with voltage outputs or ranges differing from those of standard models. They can also be supplied on special order

less knob, dial, etc., at lower net prices and with slightly extended delivery time.

The General Radio Company welcomes inquiries on special models, and is glad to furnish them when the quantities involved are sufficient to make production economically practicable.



Type W5MT3A

METERED VARIAC® AUTOTRANSFORMERS

Type W5MT3AW



Metered Variac autotransformer assemblies are portable testing devices, each consisting of a Variac autotransformer, a voltmeter, and an ammeter or wattmeter or both. Switching, fuses, and power cord are also provided. These handy, compact assemblies have many uses both in the laboratory and on the test bench, among them overvoltage and undervoltage tests, measurements of voltage, current, and power, and trouble shooting. The meter shielding reduces stray fields sufficiently to permit an over-all accuracy of 3% (full scale) with 2% meters. Connections are made through a three-wire cord (line) and a three-wire outlet (load). The output (load) circuit, containing the meters, is fused. A double-pole on-off switch disconnects both sides of the line. Make-

before-break range switches permit the dual-range meters to be switched under load. All meters have expanded scales for easier reading.

Two models include a voltmeter and ammeter: **TYPE W5MT3A** (0-5 amperes) and **TYPE W10MT3A** (0-10 amperes); two models include a voltmeter and wattmeter: **TYPE W5MT3W** (0-750 watts) and **TYPE W10MT3W** (0-1500 watts); one model includes a voltmeter, ammeter, and wattmeter: **TYPE W5MT3AW** (0-5 amperes and 0-750 watts).

The metal case enclosing the metered units is finished to match the case used with the standard Series W Variac autotransformers. A convenient carrying handle assures ready portability.

METERED VARIAC AUTOTRANSFORMER RATINGS AND PRICES

TYPE	METERS INCLUDED	INPUT VOLTS*	OUTPUT VOLTAGE RANGE	VOLT METER RANGE	AMMETER RANGES	WATT METER RANGES	60-CYCLE NO-LOAD LOSS-WATTS	FUSING AMPERES		WEIGHT POUNDS		DIMENSIONS INCHES			CODE WORD	PRICE
								LOW RANGE	HIGH RANGE	NET	SHIPPING	WIDTH	HEIGHT	DEPTH		
W5MT3A	V, A	120	0-140	0-150	0-1, 0-5	—	9	1	5	11½	19	6¾	10	6½	CABAL	\$85.00
W5MT3W	V, W	120	0-140	0-150	—	0-150, 0-750	9	2	5	11¾	19	6¾	10	6½	CABOB	110.00
W5MT3AW	V, A, W	120	0-140	0-150	0-1, 0-5, 0-2, 0-10	0-150, 0-750	9	A=1 W=2	5	12½	20	12¾	9	6½	CABEX	150.00
W10MT3A	V, A	120	0-140	0-150	0-2, 0-10	—	17	2	10	18¾	24	9¼	12	6½	DOGEN	110.00
W10MT3W	V, W	120	0-140	0-150	—	0-300, 0-1500	17	4	10	18¾	24	9¼	12	6½	DOGID	138.00

V = Voltmeter

A = Ammeter

W = Wattmeter

* 50 to 60 cps for all models.

Ordering Information

Order direct from nearest distributor listed on back cover. If none is in your area, orders may be directed to the factory or to a General Radio District Office.

Prices are net, f.o.b. West Concord. Quantity discounts apply to identical units purchased at the same time for shipment to a single destination. They apply only for sales within the Continental United States (except the Canal Zone) and Canada.

QUANTITY DISCOUNTS

<i>Quantity</i>	<i>Discount</i>	<i>Quantity</i>	<i>Discount</i>
1 to 9	Net	20 to 99	10%
10 to 19	5%	100 and over	15%

DISTRIBUTORS

For the convenience of its customers, General Radio Company has appointed several distributors for Variac® Autotransformers throughout the United States.

The address of the distributor nearest you is shown on the back cover. He stocks a supply of most of the standard Variac® Autotransformers and is prepared to give you efficient and prompt service.

DISTRICT OFFICES

Technical assistance is available from any of the District Offices listed on the back cover. Stocks are maintained at Chicago and Los Angeles.

Distributors for VARIAC® Autotransformers

LAFAYETTE RADIO ELECTRONICS CORPORATION

BOSTON:

110 Federal St.
Boston 10, Mass.
617 HUBbard 2-0311

JAMAICA:

165-08 Liberty Ave.
Jamaica 33, N. Y.
212 OLYmpia 8-5050

NEWARK:

24 Central Ave.
Newark 2, N. J.
201 MItchell 3-6868

ELECTRONIC WHOLESALERS, INC.

WASHINGTON:

2345 Sherman Ave., N.W.
Washington, D. C.
HUdson 3-5200

BALTIMORE:

3004 Wilkens Ave.
Baltimore, Md.
WIlkens 5-3400

WINSTON-SALEM:

Dalton Hege, Inc..
Subsidiary
938 Burke St.
Winston-Salem, N. C.
PArk 5-8711

MELBOURNE:

1301 Hibiscus Blvd.
Melbourne, Fla.
PArkway 3-1441

MIAMI:

9390 NW 27th Ave.
Miami, Fla.
OXford 6-1620

ELECTRICAL SPECIALTIES CO.

DAYTON: 3130 Valleywood Dr., Dayton 29, Ohio

AXminster 8-7461

DENVER ELECTRONIC SUPPLY CO.

DENVER: 2170 So. Grape St., Denver 22, Colo.

SKyline 7-3351. TWX: DN 941

GENERAL RADIO COMPANY

MAIN OFFICE AND FACTORY: WEST CONCORD, MASSACHUSETTS, USA
Telephones: (Concord) EMerson 9-4400; (Boston) MIssion 6-7400
Cable Address: GENRADCO, CONCORD; TWX: CONC MASS 972

DISTRICT OFFICES

NEW YORK

Broad Avenue at Linden, Ridgefield, New Jersey (N. Y.) WOrth 4-2722. (N. J.) WHitney 3-3140

SYRACUSE

Pickard Building, East Molloy Road, Syracuse 11, New York GLenview 4-9323

PHILADELPHIA

1150 York Road, Abington, Pennsylvania (Phila.) HAncock 4-7419. (Abington) TUrner 7-8486

WASHINGTON AND BALTIMORE

8055 13th Street, Silver Spring, Maryland JUniper 5-1088

FLORIDA

113 East Colonial Drive, Orlando, Florida GArden 5-4671

CHICAGO

6605 West North Avenue, Oak Park, Illinois VillAge 8-9400

SAN FRANCISCO

1186 Los Altos Avenue, Los Altos, California WHitecliff 8-8233

LOS ANGELES

1000 North Seward Street, Los Angeles, California HOLlywood 9-6201

CANADA

99 Floral Parkway, Toronto, Ontario CHerry 6-2171