

6675A AUTOMATIC DCC RESISTANCE/TEMPERATURE BRIDGE

COMPLETE WITH ResCal™ - THE BEST JUST GOT BETTER!



6675A FEATURES

- > Fully Programmable IEEE-488.2 or RS232C
- > Range 1mΩ to 1GΩ and 1μΩ to GΩ with Extender
- > Accuracy: ±0.1 ppm of Reading
- > Linearity: ±0.01 ppm of f.s.
- > Resolution: ±0.001 ppm of f.s.
- > Ratio: 0 to 13.4
 - > Suitable for Quantum Hall Measurements
- > Auto Balancing
- > Normal Ohms Mode:
 - > Automatic Current Reversal
 - > Internal Currents 3μA – 150 mA
- > High Ohms Mode:
 - > Automatic Voltage Reversal
 - > Internal Voltage 16 V to 990 V
- > Sofcal™ On Board Diagnostic Software
- > ResCal™ Data Acquisition Software
- > Temperature Measurement
 - Resolution: ±0.0001°C
 - Accuracy: ±0.00005°C

The Guildline 6675A is an Automatic Direct Current Comparator (DCC) Resistance and Temperature Bridge, complete with ResCal™ Data Acquisition Software. The automatic bridge has a front panel keypad and a built-in menu driven display. It is micro-processor based and enables the ratio measurement of two resistances, or PRT's, to an accuracy of better than 0.1 ppm. The linearity of the bridge is better than 0.01 ppm of full scale and the resolution is one part in 10⁹. It has a measurement range of 1mΩ to 1GΩ, or with the use of the 6623 range extender, 1μΩ to 1GΩ. Direct reading in ohms or degrees Celsius can be selected on the front panel display or through ResCal™ Software. These impressive specifications make the 6675A state-of-the-art and provide the best performance available in a wide range commercial instrument of this type.

The bridge is designed for flexibility and ease of use and is based on the world renowned 9975 DCC Resistance/Temperature Bridge manufactured by Guildline for over 25 years.

The 9975 is in use in many Standards Laboratories around the world and, in many countries, is used to maintain the national value of the ohm. The new 6675A carries on the tradition and with its improved performance is suitable for Quantum Hall measurements for the determination of the ohm. This impressive instrument is the culmination of years of work by Guildline and is based on the original research by the National Research Council of Canada (NRCC).

All of the familiar features of Guildline resistance bridges are built in as standard, as well as some new features consistent with a fully automatic instrument. Many of these features have been improved and expanded in range. Guildline's own on-board, diagnostic firmware, Sofcal™, enables the 6675A to be maintained at peak performance.

The bridge can be used in Normal or High Ohms while maintaining automatic ampere turn balancing. Automatic current reversal is selectable from 4 seconds to greater than 5 minutes. The built in extremely stable current supply permits selection of output currents between 3μA and 150 mA. Standard on the 6675A is a built in voltage source enabling selection from 16 volts to 990 volts with automatic voltage reversal for measurements above 10kΩ

6675A RESISTANCE/TEMPERATURE BRIDGE

The 6675A is truly a versatile instrument. There are a variety of different configurations to choose from to suit many different requirements. With the addition of the 6623 range extender, very low value measurements can be made down to $1\mu\Omega$. The 6623 current range extender has a reversal switch already built in, with a current capability of up to 100A.

Lead set options allow for quick system setups with a minimum of delay for determination and preparation of interconnections. The 6675A is designed to work with a wide variety of programmable and manual scanners. The Guildline 6664A Low Thermal Scanner is recommended for use with the 6675A. Full control and measurement configuration is available through ResCal™ Software.

The 6675A can be configured to measure temperature directly in Kelvin, Centigrade or Fahrenheit degrees. Depending on the probe selected, temperature measurement range is -260°C to 990°C .

Calibration coefficients for the full ITS 90 and IPTS 68 temperature range can be stored in non-volatile memory of the 6675A or specified in ResCal probe setup files. Probe files are password protected in the 6675A to prevent inadvertent modification.



The 6675A can generally be used with Standard Platinum Resistance Thermometer (SPRT) probes in the nominal range of 0.25 ohms to 100 ohms.

Resolution is 0.0001°C and measurement uncertainties are better than $\pm 0.00005^{\circ}\text{C}$ depending on the quality of the probe used and the accuracy of calibration.

6675A SYSTEM

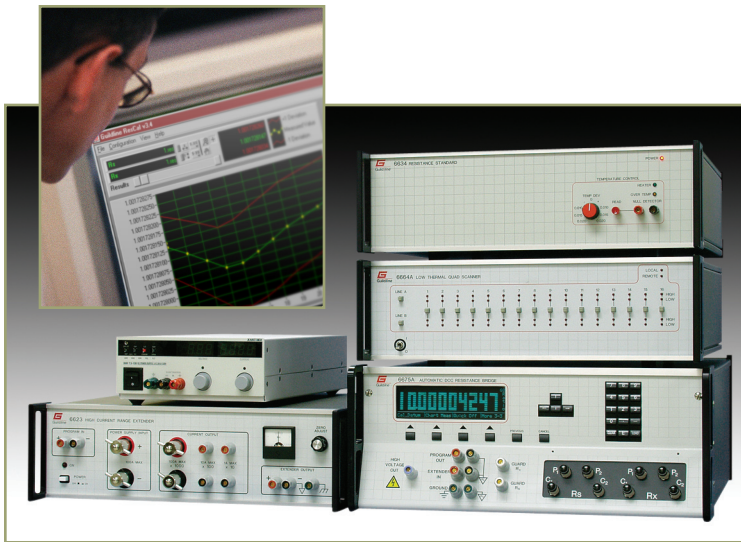

THE 6675A SYSTEM

The 6675A with 6623 Range Extender, 6664A Low Thermal Scanner, 6634 Resistance Standard and 100A Power Supply Integrated as a complete Resistance Measurement System, when connected to a computer system with Guildline Data Acquisition Software will provide automated resistance measurement capability from 1 micro ohm to 100 meg. ohm.

6675A ORDERING INFORMATION

6675A Automatic DCC Resistance Bridge

OPTIONS:

- 6675A-01A** National Instruments IEEE-488.2 Interface for a PCI slot
- 6675A-01B** National Instruments IEEE-488.2 Interface for an ISA slot
- 6675A-02A** National Instruments IEEE-488.2 Interface cable, 2m double shielded
- 6675A-02B** National Instruments IEEE-488.2 Interface cable, 1 m double shielded
- 6675A-09** Rack Mount Kit for 6675A
- 6675A-11** 2 metres double shielded RS232 interface cable
- 6675A-12** Lead set for 6675A
- 66001** Lead compensator for 6675A

- 6623** Range Extender for 6675A Resistance Bridge
- 66231** Adaptor for 9975
- 66232** Extender lead set for 6623
- 66233** 100A Power Supply

- 6664A** Low Thermal Quad Scanner with Terminal Inputs
- 6664A-10** SCW Lead set, low thermal
- 6664A-11** SCW Lead pair with gold plated banana plug, 1 m in length
- 6664A-12** SCW Lead pair with gold plated banana plugs 2 m in length
- 6664A-13** SCW Lead pair with gold plated banana plugs X m in length

Temperature Probes Available on Request

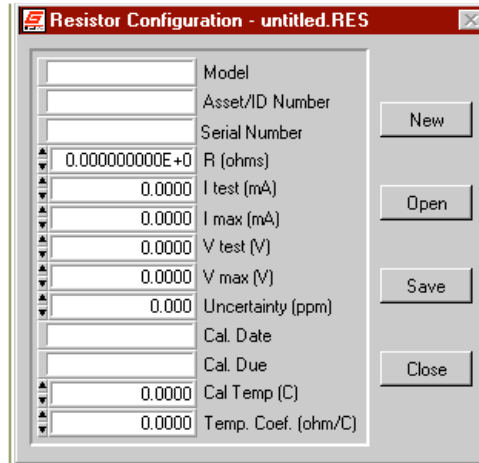
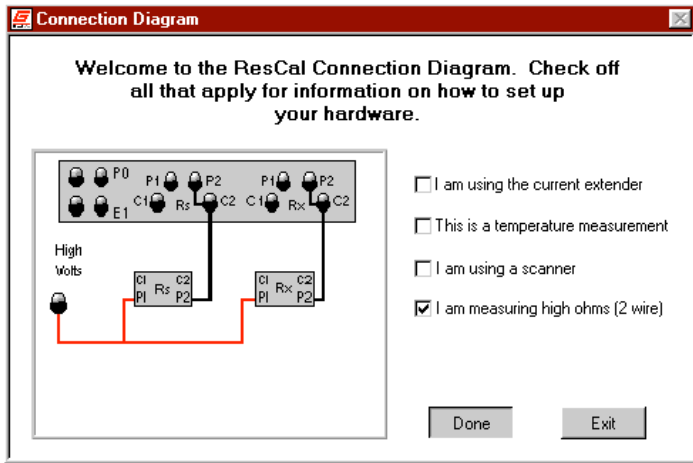

BUILT IN SIMPLICITY

The resistor set up window automatically suggests proper excitation and maximum excitation values for the device. This saves setup time and helps prevent unintended resistor stress.

RESCAL™

COMPREHENSIVE RESISTANCE/TEMPERATURE SURVEILLANCE SOFTWARE

ResCal™ contains a comprehensive mathematics package. This provides the ability to review previous measurement data, calculate new measurement uncertainties, and provide trends analysis of resistors and PRTs.

ResCal™, the convenient Windows-based software program, developed on a National Instruments Labview™ platform is written for metrologists. It incorporates the features metrologists need to improve the efficiency of resistance measurements. A series of configuration files are established for each resistor standard and test to be used and measured by the system. Each resistor entered will have a separate file. These files will contain the following information:

- > Model Number
- > Resistance Value
- > Serial Number: 14 alpha numeric characters
- > Control/Asset/ID Numbers up to 14 digits alpha numeric characters
- > Last Cal Date: as above
- > Test current for normal ohms measurements
- > Maximum Current: maximum applicable current level
- > Test Voltage: for high ohms measurements
- > Maximum Voltage: maximum applicable voltage level
- > Temperature calculations are done automatically after ITS-90 or IPTS-68 coefficients are entered into a probe definition file.
- > Auto reversal rate can be used to "track" a dynamic temperature reading or to "stabilize" a static resistance reading.
- > Real time functions that can double the excitation for self heating calculation as well as data file transfer to Excel are important features in ResCal

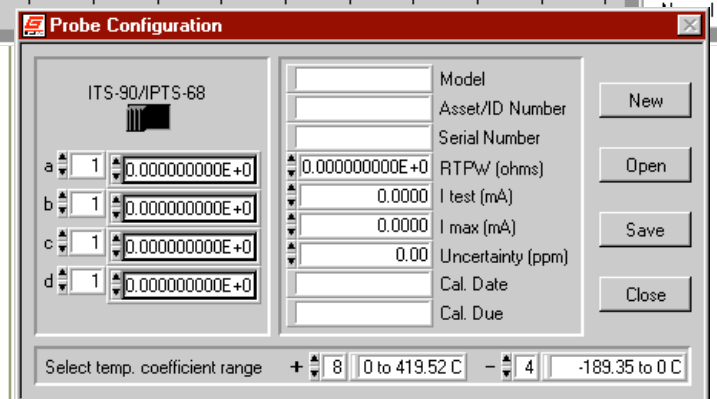
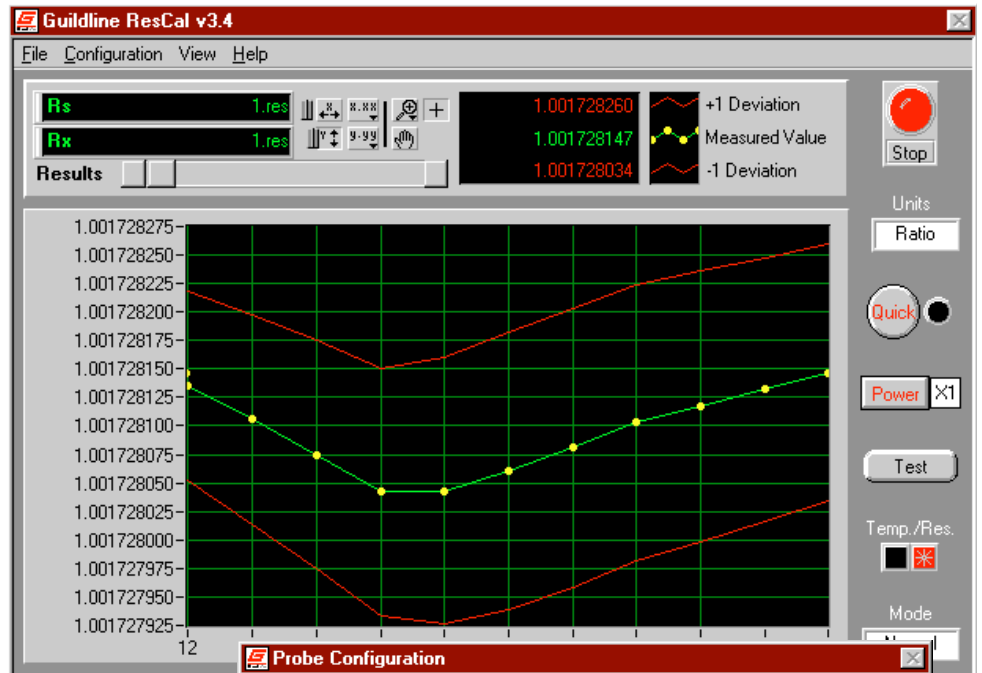

SPECIFICATIONS, RESISTANCE MEASUREMENT

Range	Resolution ±ppm f.s.	Stability 24 hours ± ppm		Uncertainty @ 23°C ± 3°C 1 Year ± ppm	
		6675A only	w. range extender	6675A only	w. range extender
1µΩ - 10µΩ	0.01	-	<8	-	<20
10µΩ - 100µΩ	0.001	-	<4	-	<10
100µΩ - 1mΩ	0.001	-	<0.4	-	<1.0
1mΩ - 10mΩ	0.001	<10	<0.3	<50	<0.8
10mΩ - 100mΩ	0.001	<0.5	<0.2	<5	<0.6
0.1Ω - 1Ω	0.001	<0.2	<0.2	<0.5	<0.6
1Ω - 10Ω	0.001	<0.03		<0.1	
10Ω - 100Ω	0.001	<0.03		<0.1	
100Ω - 1KΩ	0.001	<0.03		<0.1	
1KΩ - 10KΩ	0.001	<0.04		<0.15	
10KΩ - 100KΩ	0.001	<0.05		<0.35	
100KΩ - 1MΩ	0.001	<0.2		<0.5	
1MΩ - 10MΩ	0.001	<0.3		<0.75	
10MΩ - 100MΩ	0.001	<1.5		<2.5	
100MΩ - 1GΩ	0.001	<3		<8.0	

SPECIFICATIONS, TEMPERATURE MEASUREMENT

The uncertainty of temperature measurement is primarily determined by the uncertainty of the temperature probe. The 6675A's contributions to resolution and uncertainty are listed below.

Nominal PRT Resistance (Ω)	Recommended Excitation (mA)	Resolution (°C)	Uncertainty (equivalent °C)
0.25	10	0.0001	<0.0002
2.5	3	0.0001	<0.00005
25.5	1	0.0001	<0.00005
100	0.5	0.0001	<0.0001

GUILDLINE IS DISTRIBUTED BY:



SPECIFICATIONS, GENERAL

Linearity	±0.01 ppm of full scale
Temperature Coefficient	±0.01 ppm/°C
Warm-up time to full rated accuracy	1 hour
Test Currents	From internal current source, 3µA to 150mA in 2.8µA steps with 30 V compliance
Test Current Accuracy	±100ppm ±10µA
Test Current Stability	±1ppm of f.s./10 minutes
Extender Output Terminals	Are provided with compliance to 30V for programming a current range extender
Automatic Current Reversal	Settable from 4 seconds to 1 hour in 2 second steps
Recorder Output	±5 Vdc 1 mA max., 12 bit resolution
Dimensions	Height 206 mm (8.1 in) Width 470 mm (18.5 in) Depth 584 mm (23.2 in)
Weight	27.3 kg (60 lb)
Power Supply	100V, 120V, 220V, 240V ± 10%, 50Hz±5%, 60Hz±5%, 200VA
Environment	Operating 18°C to +28°C, <15-70% RH Storage -20°C to +60°C, 15 to 80% RH

GUILDLINE INSTRUMENTS LIMITED

Guildline Instruments Limited
P.O. Box 99, 21 Gilroy Street
Smiths Falls, Ontario, Canada
K7A 4S9
(613) 283-3000
Fax: (613) 283-6082
info@guildline.ca
www.guildline.ca

6675AV1.0 Copyright ©2002.06.03, Guildline Instruments Limited
All rights reserved. Subject to change without notice.