

## Errata

**Title & Document Type:** 4275A Multi-Frequency LCR Meter Service Manual

**Manual Part Number:** 04275-90012

**Revision Date:** March 1990

---

### HP References in this Manual

This manual may contain references to HP or Hewlett-Packard. Please note that Hewlett-Packard's former test and measurement, semiconductor products and chemical analysis businesses are now part of Agilent Technologies. We have made no changes to this manual copy. The HP XXXX referred to in this document is now the Agilent XXXX. For example, model number HP8648A is now model number Agilent 8648A.

### About this Manual

We've added this manual to the Agilent website in an effort to help you support your product. This manual provides the best information we could find. It may be incomplete or contain dated information, and the scan quality may not be ideal. If we find a better copy in the future, we will add it to the Agilent website.

### Support for Your Product

Agilent no longer sells or supports this product. You will find any other available product information on the Agilent Test & Measurement website:

[www.tm.agilent.com](http://www.tm.agilent.com)

Search for the model number of this product, and the resulting product page will guide you to any available information. Our service centers may be able to perform calibration if no repair parts are needed, but no other support from Agilent is available.

# 4275A MULTI-FREQUENCY LCR METER

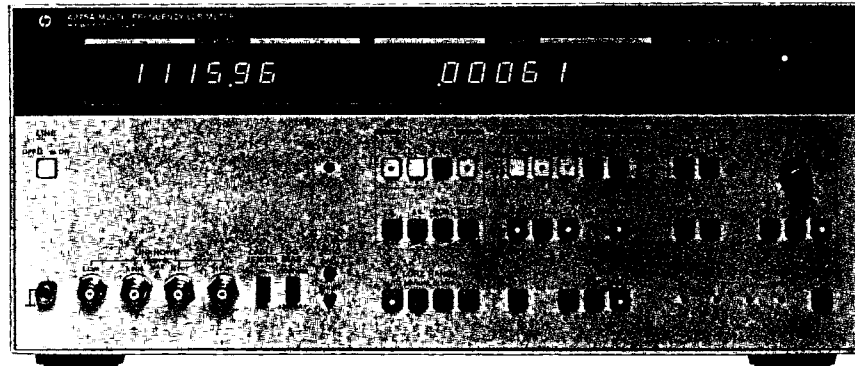

**HEWLETT  
PACKARD**

## **SAFETY SUMMARY**

The following general safety precautions must be observed during all phases of operation, service, and repair of this instrument. Failure to comply with these precautions or with specific warnings given elsewhere in this manual violates safety standards of design, manufacture, and intended use of the instrument. Hewlett-Packard Company assumes no liability for the customer's failure to comply with these requirements.

### **GROUND THE INSTRUMENT**

To minimize shock hazard, the instrument chassis and cabinet must be connected to an electrical ground. The instrument is equipped with a three-conductor ac power cable. The power cable must either be plugged into an approved three-contact electrical outlet or used with a three-contact to two-contact adapter with the grounding wire (green) firmly connected to an electrical ground (safety ground) at the power outlet. The power jack and the mating plug of the power cable meet International Electrotechnical Commission (IEC) safety standards.

### **DO NOT OPERATE IN AN EXPLOSIVE ATMOSPHERE**

Do not operate the instrument in the presence of flammable gases or fumes. Operation of any electrical instrument in such an environment constitutes a definite safety hazard.

### **KEEP AWAY FROM LIVE CIRCUITS**

Operating personnel must not remove instrument covers. Component replacement and internal adjustments must be made by qualified maintenance personnel. Do not replace components with power cable connected. Under certain conditions, dangerous voltages may exist even with the power cable removed. To avoid injuries, always disconnect power and discharge circuits before touching them.

### **DO NOT SERVICE OR ADJUST ALONE**

Do not attempt internal service or adjustment unless another person, capable of rendering first aid and resuscitation, is present.

### **DO NOT SUBSTITUTE PARTS OR MODIFY INSTRUMENT**

Because of the danger of introducing additional hazards, do not install substitute parts or perform any unauthorized modification to the instrument. Return the instrument to a Hewlett-Packard Sales and Service Office for service and repair to ensure that safety features are maintained.

### **DANGEROUS PROCEDURE WARNINGS**

Warnings, such as the example below, precede potentially dangerous procedures throughout this manual. Instructions contained in the warnings must be followed.

#### **WARNING**

Dangerous voltages, capable of causing death, are present in this instrument. Use extreme caution when handling, testing, and adjusting.

## SAFETY SYMBOLS

### General Definitions of Safety Symbols Used On Equipment or In Manuals:



**Instruction manual symbol:** the product will be marked with this symbol when it is necessary for the user to refer to the instruction manual in order to protect against damage to the instrument.



Indicates dangerous voltage (terminals fed from the interior by voltage exceeding 1000 volts must be so marked).

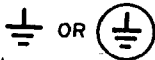

**Protective conductor terminal.** For protection against electrical shock in case of a fault. Used with field wiring terminals to indicate the terminal which must be connected to ground before operating equipment.



**Low-noise or noiseless, clean ground (earth) terminal.** Used for a signal common, as well as providing protection against electrical shock in case of fault. A terminal marked with this symbol must be connected to ground in the manner described in the installation (operating) manual, and before operating the equipment.

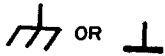

**Frame or chassis terminal.** A connection to the frame (chassis) of the equipment which normally includes all exposed metal structures.



Alternating current (power line).



Direct current (power line).



Alternating or direct current (power line).

### WARNING

A **WARNING** denotes a hazard. It calls attention to a procedure, practice, condition or the like, which, if not correctly performed or adhered to, could result in injury or death to personnel.

### CAUTION

The **CAUTION** sign denotes a hazard. It calls attention to an operating procedure, practice, condition or the like, which, if not correctly performed or adhered to, could result in damage to or destruction of part or all of the product.

### Note

A **Note** denotes important information. It calls attention to a procedure, practice, condition or the like, which is essential to highlight.

# MANUAL CHANGES

## HP 4275A

### Multi Frequency LCR Meter

#### MANUAL IDENTIFICATION

Model Number: HP 4275A  
Date Printed: Not Specified  
Part Number: 04275-90012

This supplement contains information for correcting manual errors and for adapting the manual to newer instruments that contain improvements or modifications not documented in the existing manual.

To use this supplement

1. Make all ERRATA corrections
2. Make all appropriate serial-number-related changes listed below

SERIAL PREFIX OR NUMBER	MAKE MANUAL CHANGES
All	1

SERIAL PREFIX OR NUMBER	MAKE MANUAL CHANGES

► New Item

- Some LCR components used in the HP 4275A have been standardized to decrease the number of similar components. For example, if a unit uses both 6.8k $\Omega$  5% and 6.81k $\Omega$  1% resistors, the standard resistor will be 6.81k $\Omega$  1%.

Change the part numbers in the Replaceable Parts List of Section 6 as given in the table on the next page.

#### NOTE

Manual change supplements are revised as often as necessary to keep manuals as current and accurate as possible. Hewlett-Packard recommends that you periodically request the latest edition of this supplement. Free copies are available from all HP offices. When requesting copies, quote the manual identification information from your supplement, or the model number and print date from the title page of the manual.

Table 1. Parts Standardization Change

Old Part		New Part	
Part Number	Description	Part Number	Description
0683-1005	Resistor 10Ω 5%	0757-0346	Resistor 10Ω 1%
0683-1015	Resistor 100Ω 5%	0757-0401	Resistor 100Ω 1%
0683-1025	Resistor 1kΩ 5%	0757-0280	Resistor 1kΩ 1%
0683-1035	Resistor 10kΩ 5%	0757-0442	Resistor 10kΩ 1%
0683-1045	Resistor 100kΩ 5%	0757-0465	Resistor 100kΩ 1%
0683-1055	Resistor 1MΩ 5%	0698-8827	Resistor 1MΩ 1%
0683-1205	Resistor 12Ω 5%	0757-0379	Resistor 12.1Ω 1%
0683-1215	Resistor 120Ω 5%	0757-0403	Resistor 121Ω 1%
0683-1225	Resistor 1.2kΩ 5%	0757-0274	Resistor 1.21kΩ 1%
0683-1235	Resistor 12kΩ 5%	0757-0444	Resistor 12.1kΩ 1%
0683-1515	Resistor 150Ω 5%	0698-3438	Resistor 147Ω 1%
0683-1525	Resistor 1.5kΩ 5%	0757-1094	Resistor 1.47kΩ 1%
0683-1535	Resistor 15kΩ 5%	0698-3156	Resistor 14.7kΩ 1%
0683-1545	Resistor 150kΩ 5%	0698-3452	Resistor 147kΩ 1%
0683-1825	Resistor 1.8kΩ 5%	0757-0278	Resistor 1.78kΩ 1%
0683-1835	Resistor 18kΩ 5%	0698-3136	Resistor 17.8kΩ 1%
0683-2205	Resistor 22Ω 5%	0698-3430	Resistor 21.5Ω 1%
0683-2215	Resistor 220Ω 5%	0698-3441	Resistor 215Ω 1%
0683-2225	Resistor 2.2kΩ 5%	0698-0084	Resistor 2.15kΩ 1%
0683-2235	Resistor 22kΩ 5%	0757-0199	Resistor 21.5kΩ 1%
0683-2245	Resistor 220kΩ 5%	0698-3454	Resistor 215kΩ 1%
0683-2715	Resistor 270Ω 5%	0698-3132	Resistor 261Ω 1%
0683-2725	Resistor 2.7kΩ 5%	0698-0085	Resistor 2.61kΩ 1%
0683-2745	Resistor 270kΩ 5%	0698-3455	Resistor 261kΩ 1%
0683-3305	Resistor 33Ω 5%	0757-0180	Resistor 31.6Ω 1%
0683-3315	Resistor 330Ω 5%	0698-3444	Resistor 316Ω 1%
0683-3325	Resistor 3.3kΩ 5%	0757-0279	Resistor 3.16kΩ 1%
0683-3335	Resistor 33k 5%	0698-3160	Resistor 31.6kΩ 1%
0683-4705	Resistor 47Ω 5%	0698-4037	Resistor 46.4Ω 1%
0683-4715	Resistor 470Ω 5%	0698-0082	Resistor 464Ω 1%
0683-4725	Resistor 4.7kΩ 5%	0698-3155	Resistor 4.64kΩ 1%
0683-4735	Resistor 47kΩ 5%	0698-3162	Resistor 46.4kΩ 1%
0683-4745	Resistor 470k 5%	0698-3260	Resistor 464kΩ 1%
0683-5605	Resistor 56Ω 5%	0757-0395	Resistor 56.2Ω 1%
0683-5615	Resistor 560Ω 5%	0757-0417	Resistor 562Ω 1%
0683-6805	Resistor 68Ω 5%	0757-0397	Resistor 68.1Ω 1%
0683-6815	Resistor 680Ω 5%	0757-0419	Resistor 681Ω 1%
0683-6825	Resistor 6.8kΩ 5%	0757-0439	Resistor 68.1kΩ 1%
0683-8205	Resistor 82Ω 5%	0757-0399	Resistor 82.5Ω 1%
0683-8215	Resistor 820Ω 5%	0757-0421	Resistor 825Ω 1%
9140-0114	Inductor 10uH 10%	9100-0539	Inductor 10uH 5%
9140-0179	Inductor 22uH 10%	9100-3313	Inductor 22uH 5%

# MANUAL CHANGES

## HP 4275A

### Multi Frequency LCR Meter

#### MANUAL IDENTIFICATION

Model Number: HP 4275A  
 Date Printed: March 1990  
 Part Number: 04275-90012

This supplement contains information for correcting manual errors and for adapting the manual to newer instruments that contain improvements or modifications not documented in the existing manual

To use this supplement

1. Make all ERRATA corrections
2. Make all appropriate serial-number-related changes listed below

SERIAL PREFIX OR NUMBER	MAKE MANUAL CHANGES	SERIAL PREFIX OR NUMBER	MAKE MANUAL CHANGES
ALL	1		
2517J03535 and above	2		
2517J03612 and above	3		

► New Item

CHANGE	PAGE	Note	Reference Designator	HP Part Number	Description
1	6-46	►D	34	04275-00201 7120-0478	FRONT PANEL (YHP) TRADE MARK (YHP)
	6-46	►D	36		
2	6-39	►C	A11W3	1251-3276	CONN-POST TYPE. 156-PIN-SPCG 6-CONT x 2ea.
3	6-7	►C	A1U1	1826-1465 1826-1465	OP-AMP LT1056CH OP-AMP LT1056CH
	6-26	►C	A5U18		

►: New Item      C: Change      D: Delete      A: Add

#### NOTE

Manual change supplements are revised as often as necessary to keep manuals as current and accurate as possible. Hewlett-Packard recommends that you periodically request the latest edition of this supplement. Free copies are available from all HP offices. When requesting copies, quote the manual identification information from your supplement, or the model number and print date from the title page of the manual.



SERVICE MANUAL

**MODEL 4275A**

**MULTI-FREQUENCY LCR METER**

(Including Options 001, 002, and 004)

SERIAL NUMBERS

This manual applies directly to instruments  
with serial numbers prefixed 2429J.

© COPYRIGHT YOKOGAWA-HEWLETT-PACKARD, LTD., 1979  
9-1, TAKAKURA-CHO, HACHIOJI-SHI, TOKYO, JAPAN

MANUAL PART NO. 04275-90012  
Microfiche Part No. 04275-90062

Printed: MAR. 1990



## TABLE OF CONTENTS

Section	Title	Page	Section	Title	Page
IV	PERFORMANCE TESTS .....	4-1	VI	REPLACEABLE PARTS .....	6-1
	4-1. Introduction .....	4-1		6-1. Introduction .....	6-1
	4-3. Equipment Required .....	4-1		6-3. Abbreviations .....	6-1
	4-5. Test Record .....	4-1		6-5. Replaceable Parts List .....	6-1
	4-7. Calibration Cycle .....	4-1		6-7. Operating Information .....	6-2
	Accuracy Test Considerations	4-2		6-10. Spare Parts Kit .....	6-2
	Accuracy Test Standards .....	4-4		6-12. Direct Mail Order System .....	6-2
	4-9. Test Frequency Accuracy Test	4-6			
	4-11. Test Signal Level		VII	MANUAL CHANGES .....	7-1
	(Variable Range Test) ...	4-7		7-1. Introduction .....	7-1
	4-13. Self-Operating Test .....	4-8		7-3. Manual Changes .....	7-1
	4-15. Capacitance Accuracy Test ..	4-11			
	4-17. Resistance Accuracy Test ...	4-14	VIII	SERVICE .....	8-1
	4-19. Inductance Accuracy Test			8-1. Introduction .....	8-1
	(Confirmation Test) .....	4-16		8-3. Theory of Operation .....	8-1
	4-21. Frequency-phase			8-5. Troubleshooting .....	8-1
	Accuracy Test .....	4-18		8-7. Recommended Test Equipment ..	8-1
	4-23. Int DC Bias			8-9. Repair .....	8-1
	Supply Test (Option 001) .	4-20		8-11. Basic Theory .....	8-2
	4-25. Int DC Bias			8-22. Block Diagram Discussion ....	8-8
	Supply Test (Option 002) .	4-21		8-23.    A6 Oscillator .....	8-8
	4-27. HP-IB Interface Test			8-29.    A3 Power Amplifier .....	8-9
	(Option 101) .....	4-23		8-31.    A1 Range Resistor/ Null Detector .....	8-9
V	ADJUSTMENT .....	5-1		8-33.    A2 Modulator .....	8-11
	5-1. Introduction .....	5-1		8-38.    A4 Process Amplifier ....	8-12
	5-3. Safety Requirements .....	5-1		8-41.    A5 A-D Converter .....	8-13
	5-7. Equipment Required .....	5-1		8-46. Digital Control Section ....	8-20
	5-9. Factory Selected Components	5-1		8-48.    A9 Microprocessor Unit ..	8-20
	5-11. Adjustment Relationships ...	5-1		8-56.    A7 Peripheral Control ...	8-22
	5-13. Adjustment Locations .....	5-1		8-60.    A8 Display Control .....	8-23
	5-15. DC Power Supply Voltage			8-65. Options .....	8-25
	Adjustment .....	5-6		8-66.    Option 001:	
	5-19. Process Amplifier DC offset			±35V DC Bias Supply .....	8-25
	Adjustment .....	5-7		8-69.    Option 002:	
	5-21. Test Signal Level Adjustment	5-9		±100V DC Bias Supply ....	8-26
	5-23. Test Signal Level Flatness			8-72.    Option 101:	
	Adjustment .....	5-11		HP-IB Interface .....	8-26
	5-25. Bridge Balance Adjustment .	5-12		8-74. Troubleshooting .....	8-29
	5-27. Process Amplifier Gain			8-79. Initial Memory Test .....	8-30
	Adjustment .....	5-16		8-82. Self Test Instructions .....	8-31
	5-29. Attenuator Adjustment .....	5-18		8-84.    Automatic Self	
	5-31. Test Signal Level Check			Diagnostic Test .....	8-31
	Accuracy Adjustment .....	5-22		8-86.    Manual Step Selection of	
	5-33. CMR Amplifier Gain			Self Diagnostic Test ....	8-31
	Adjustment .....	5-25		8-89. Disassembly of A10 Board ...	8-40
	5-35. Range Resistor Adjustment .	5-26		8-90. Product Safety Checks .....	8-41
	5-37. CMR Amplifier 2MHz Gain				
	Adjustment .....	5-29			
	5-39. 4MHz/10MHz CMR Amplifier and				
	Range Resistor Phase				
	Adjustment .....	5-30			
	5-41. ±35V Internal DC Bias Supply				
	Adjustment (Opt. 001) ...	5-33			
	5-42. ±100V Internal DC Bias				
	Supply Adjustment				
	(Opt. 002) .....	5-34			

**LIST OF TABLES**

Number	Title	Page	Number	Title	Page
4-1.	Recommended Performance Test Equipment .....	4-0	5-3.	Adjustment Requirements ....	5-5
4-2.	Test Frequency Accuracy Test	4-6	5-4.	DC Power Supply Voltage Test Limits .....	5-6
4-3.	Test Signal Level Variable Range Test .....	4-7	6-1.	List of Reference Designators and Abbreviations .....	6-1
4-4.	Self Operating Test Summary	4-10	6-2.	Manufacturers Code List ....	6-2
4-5.	Capacitance Accuracy Tests	4-13	6-3.	Replaceable Parts .....	6-3
4-6.	Resistance Accuracy Tests ..	4-15	7-1.	Manual Changes by Serial Number .....	7-1
4-7.	Frequency-Phase Accuracy Tests .....	4-19	7-2.	Summary of Changes by Assembly .....	7-2
4-8.	DC Bias Voltage Test Limits	4-21	8-1.	Test Frequency Selection (Standard) .....	8-10
4-9.	DC Bias Voltage Test Limits	4-22	8-2.	Test Frequency Selection (Option 004) .....	8-10
4-10.	Controller Instructions and Operator Responses for Test Program 1 .....	4-25	8-3.	Range Resistor and AM Attenuator Control Matrix	8-13
4-11.	Controller Instructions and Operator Responses for Test Program 2 .....	4-26	8-4.	Self Test Program Organization .....	8-32
4-12.	Controller Instructions and Operator Responses for Test Program 3 .....	4-28	8-5.	Automatic Self Test Setups	8-33
4-13.	Controller Instructions and Operator Responses for Test Program 4 .....	4-31	8-6.	Self Test Step Selection ..	8-31
5-1.	Adjustable Components .....	5-2	8-7.	Self Diagnostic Test Instructions .....	8-33
5-2.	Factory Selected Components	5-4	8-8.	Front Panel Troubleshooting Guide .....	8-44

**LIST OF ILLUSTRATIONS**

Number	Title	Page	Number	Title	Page
4-1.	Test Frequency Accuracy Test Setup .....	4-6	5-4.	Test Signal Flatness Adjustment Setup .....	5-11
4-2.	Test Signal Level Variable Range Test Setup ..	4-7	5-5.	Bridge Zero Offset Adjustment Setup .....	5-12
4-3.	Self Operating Test Setup ...	4-8	5-6.	Balance Control Phase Tracking Adjustment Setup	5-13
4-4.	Capacitance Accuracy Test Setups .....	4-11	5-7.	Process Amplifier Gain Adjustment Setup .....	5-16
4-5.	Resistance Accuracy Test Setup .....	4-14	5-8.	Attenuator Adjustment Setup	5-18
4-6.	HP 16047A Quasi-Inductor ...	4-16	5-9.	Test Signal Level Check Accuracy Adjustment Setup	5-22
4-7.	Option 001 Int DC Bias Supply Test Setup .....	4-20	5-10.	CMR Amplifier 2MHz Gain Adjustment Setup .....	5-29
4-8.	Option 002 Int DC Bias Supply Test Setup .....	4-21	5-11.	10MHz CMR Amplifier and Range Resistor Phase Adjustment Setup .....	5-30
4-9.	HP-IB Interface Test Setup .	4-23	5-12.	Internal DC Bias Supply Adjustment Setup .....	5-33
5-1.	Process Amplifier DC Offset Adjustment Setup .....	5-7	6-1.	Major Mechanical Parts - Exploded View .....	6-47
5-2.	Waveform at TPI .....	5-8			
5-3.	Test Signal Level Adjustment Setup .....	5-9			

Number	Title	Page	Number	Title	Page
8-1.	4275A Block Diagram .....	8-2	8-32.	Digital Section	
8-2.	4275A Vector Voltage-current Method .....	8-4		Troubleshooting	
8-3.	Usual Vector Voltage Ratio Measurement .....	8-3		Flow Diagram AL .....	8-50
8-4.	4275A Relative Vector Detection .....	8-5	8-33.	Flow Diagram BL .....	8-51
8-5.	Integrator Vector Voltage Ratio Detection Timing ...	8-6	8-34.	Flow Diagram CL .....	8-52
8-6.	Test Signal Voltage and Current Relationship to Sample Impedance .....	8-7	8-35.	Flow Diagram DL .....	8-53
8-7.	A6 Oscillator Block Diagram	8-8	8-36.	Flow Diagram EL .....	8-54
8-8.	Sinusoidal Synthesizer Waveforms .....	8-9	8-37.	Flow Diagram FL .....	8-55
8-9.	Frequency Follow-up Filter Operating Theory .....	8-9	8-38.	Flow Diagram GL .....	8-56
8-10.	A2 Modulator Block Diagram	8-11	8-39.	Assembly Locations .....	8-57
8-11.	A4 Process Amplifier Block Diagram .....	8-12	8-40.	Schematic Diagram Notes ...	8-58
8-12.	AM Amplifier Gain Control	8-12	8-41.	A1 Range Resistor and Null Detector Board	
8-13.	A5 A-D Converter Block Diagram .....	8-14		Troubleshooting Tree ....	8-60
8-14.	4275A Phase Detector Operating Principle .....	8-15	8-42.	A1 Range Resistor and Null Detector Board Assembly	
8-15.	Detection Phase Shifter Operating Principle .....	8-15		Component Locations .....	8-61
8-16.	Analog Measurement Section Schematic Block Diagram .	8-17	8-43.	A1 Range Resistor and Null Detector Board Assembly	
8-17.	Timing Diagram .....	8-19		Schematic Diagram .....	8-61
8-18.	Address Timing Control ....	8-21	8-44.	A2 Modulator Board	
8-19.	PIA Internal Circuit Configuration .....	8-22		Troubleshooting Tree ....	8-62
8-20.	Display Data RAM Read/Write Operating Sequence .....	8-24	8-45.	A2 Modulator Board Assembly Component Locations .....	8-63
8-21.	Bias Output Amplifier Gain Control .....	8-25	8-46.	A2 Modulator Board Assembly Schematic Diagram .....	8-63
8-22.	Equivalent DC Bias Circuit	8-25	8-47.	A3 Power Amplifier Board Troubleshooting Tree ....	8-64
8-23.	Microport Internal Register Configuration .....	8-26	8-48.	A3 Power Amplifier Board Assembly Component	
8-24.	Digital Control Section Block Diagram .....	8-27		Locations .....	8-65
8-25.	How to Use Troubleshooting Guides .....	8-29	8-49.	A3 Power Amplifier Board Assembly Schematic	
8-26.	A10 Display and Keyboard Disassembly .....	8-40		Diagram .....	8-65
8-27.	Signature Analysis Guide ..	8-42	8-50.	A4 Process Amplifier Board Troubleshooting Tree ....	8-66
8-28.			8-51.	A4 Process Amplifier Board Assembly Component	
8-29.	Analog and Digital Section Isolation Procedure .....	8-45		Locations .....	8-67
8-30.	Analog Section Troubleshooting to Assembly Level .....	8-47	8-52.	A4 Process Amplifier Board Assembly Schematic	
8-31.	Digital Section Troubleshooting to Assembly Level .....	8-49		Diagram .....	8-67
			8-53.	A5 A-D Converter Board Troubleshooting Tree ....	8-68
			8-54.	A5 A-D Converter Board Assembly Component	
				Locations .....	8-69
			8-55.	A5 A-D Converter Board Assembly Schematic	
				Diagram .....	8-69
			8-56.	A6 Oscillator Board Troubleshooting Tree ....	8-70
			8-57.	A6 Oscillator Board Assembly Component	
				Locations .....	8-71

Number	Title	Page	Section	Title	Page
8-58.	A6 Oscillator Board Assembly Schematic Diagram (A) ... Schematic Diagram (B) ...	8-71 8-72	8-67.	A11 Power Supply Board Assembly Component Locations.....	8-81
8-59.	A7 Peripheral Control Board Assembly Component Locations .....	8-73	8-68.	A11 Power Supply Board Assembly Schematic Diagram .....	8-81
8-60.	A7 Peripheral Control Board Assembly Schematic Diagram .....	8-73	8-69.	A21 DC Bias Supply Board Assembly Component Locations .....	8-83
8-61.	A8 Display Control Board Assembly Component Locations .....	8-75	8-70.	A21 DC Bias Supply Board Assembly Schematic Diagram .....	8-83
8-62.	A8 Display Control Board Assembly Schematic Diagram .....	8-75	8-71.	A22 HP-IB Interface Board Assembly Component Locations .....	8-85
8-63.	A9 Microprocessor Unit Board Assembly Component Locations .....	8-77	8-72.	A22 HP-IB Interface Board Schematic Diagram .....	8-85
8-64.	A9 Microprocessor Unit Board Assembly Schematic Diagram .....	8-77	8-73.	A23 DC Bias Supply Board Assembly Component Locations .....	8-87
8-65.	A10 Display and Keyboard Assembly Component Locations .....	8-79	8-74.	A23 DC Bias Supply Board Assembly Schematic Diagram .....	8-87
8-66.	A10 Display and Keyboard Assembly Schematic Diagram .....	8-79			

**PERFORMANCE TESTS**

Table 4-1. Recommended Performance Test Equipment.

Equipment	Critical Specifications	Recommended Model/Note
Capacitance Standards	1pF $\pm 0.03\%$ 10pF $\pm 0.03\%$ 100pF $\pm 0.03\%$ 1000pF $\pm 0.03\%$ Useable frequencies: up to 100K	HP 16381A HP 16382A HP 16383A HP 16384A
Resistance Standards	0.1 $\Omega$ $\pm 10\%$ 1 $\Omega$ $\pm 10\%$ 10 $\Omega$ $\pm 10\%$ 100 $\Omega$ $\pm 0.03\%$ 1000 $\Omega$ $\pm 0.03\%$ 10k $\Omega$ $\pm 0.03\%$ 100k $\Omega$ $\pm 0.03\%$ Useable frequencies: up to 10MHz	HP 16074A Standard Resistor Set
Frequency Counter	Maximum frequency: >10MHz Accuracy: 0.001% ( $1 \times 10^{-5}$ )	HP 5314A
RF Voltmeter	Voltage range: 1mV to 3V rms f.s. Bandwidth: 10kHz to 10MHz Accuracy: 1%	HP 3400A
DC Voltmeter	Voltage range: 10mV to 100V f.s. Sensitivity: 0.1mV min. Accuracy: 0.05% Input impedance: >10M $\Omega$	HP 3465A/B
Test Cable	BNC to BNC cable	1 ea.
Test Cable	BNC to BNC cable ( $\leq 10$ cm) (Replaceable by Open Termination included in HP 16074A).	2 ea.
Bias Controller	(Needed for Option 001 or 002 Internal DC Bias Supply Test).	HP 16023B
Test Fixture	(Needed for Option 001 Internal DC Bias Supply Test).	HP 16047A
Test Leads	(Needed for Option 002 Internal DC Bias Supply Test).	HP 16048A
HP-IB Controller	(Needed for Option 101 HP-IB Interface Test).	HP85/ w 82936A/ w 82937A/ w 00085-15003
Signature Analyzer		HP 5004A *

## SECTION IV PERFORMANCE TESTS

### 4-1. INTRODUCTION.

4-2. This section provides the check procedures to verify the 4275A specifications listed in Table 1-1. All tests can be performed without access to the interior of the instrument. A simpler operational test is presented in Section III under Self Test (paragraph 3-5). The performance test procedures in this section can also be used to do an incoming inspection of the instrument and to verify whether the instrument meets its specified performance after troubleshooting or making adjustments. If specifications are found to be out of limits, check that controls are properly set, and then proceed to adjustments or troubleshooting.

**Note**

Allow a 30-minute warm-up and stabilization period before conducting any performance test.

### 4-3. EQUIPMENT REQUIRED.

4-4. Equipment required for the performance tests is listed in Table 4-1 Recommended Performance Test Equipment. Any equipment whose characteristics equal the critical specifications given in the table may be substituted for the recommended model(s).

Accuracy checks in this section use 16380 series standard capacitors (16381A, 16382A, 16383A and 16384A) and the 16074A Standard Resistor Set. These accessory standards have the specifications which satisfy the performance requirements for the accuracy checks and are especially fit for use as 4275A accuracy test standards.

**Note**

All components used as standards should be calibrated by an instrument whose specifications are traceable to NBS, PTB, LNE, NRC, JEMIC, or equivalent standards group; or all components should be calibrated directly by an authorized calibration organization such as NBS. The calibration cycle should be determined by the stability specification for each component.

### 4-5. TEST RECORD.

4-6. Results of the performance tests may be tabulated on the Test Record at the end of these procedures. The Test Record lists all the tested specifications and their acceptable limits. Test results recorded at incoming inspection can be used for comparison in periodic maintenance and troubleshooting and after repairs or adjustments.

### 4-7. CALIBRATION CYCLE.

4-8. This instrument requires periodic verification of performance. Depending on the use and environmental conditions, the instrument should be checked with the following performance tests at least once every year. To maximize instrument "up time", the recommended preventive maintenance frequency for the 4275A is twice a year.

Performance Test Table

Accuracy Test Considerations ..... 4-2	Inductance Accuracy Test ..... 4-16
Accuracy Test Standards ..... 4-4	Frequency-Phase Accuracy Test .... 4-18
Test Frequency Accuracy Test ..... 4-6	Opt. 001 Int. DC Bias Test ..... 4-20
Test Signal Level Test ..... 4-7	Opt. 002 Int. DC Bias Test ..... 4-21
Self Operating Test ..... 4-8	
Capacitance Accuracy Test ..... 4-11	Opt. 101 HP-IB Interface Test ... 4-23
Resistance Accuracy Test ..... 4-14	

## ACCURACY TEST CONSIDERATIONS

This paragraph discusses how the 4275A accuracy is tested and verified. As the 4275A has (because of its wider measurement capabilities), to a great extent, expanded the selectable measurement parameters, frequency and range along with high accuracy (as its features), the accuracy check ranges that need to be verified include some critical measuring regions where accuracies are difficult to be directly compared to the specifications by using standards.

Measurement accuracies are tested by reading the displays when measuring standard capacitors, inductors, resistors and other devices as references whose values are calibrated and certified by transfer of values from national standards. Certain 4275A measurement range capabilities are out of the applicable ranges of the practical standards; so such standards, to satisfy the requirements for checking on all the 4275A ranges, will be unavailable. The method then, is to check accuracies on the specific ranges at which the standards are applicable. Further corroboration for the entire range (to the instrument performance limits), is done by particular tests for evaluating full range accuracy.

## Theoretical Background of Accuracy Checks.

The 4275A, in accord with its measurement principles, detects the vector impedance (or its reciprocal value: admittance) of the unknown sample to be tested. The various measurement data provided, with respect to the 13 possible measurement parameters (L, C, R, D, etc.), are arithmetically derived from measured values of the right-angle vector components (resistance and reactance). For example, the capacitance value of a sample is calculated by the following equation relative to the capacitance-to-reactance values:

$$C_x = \frac{1}{2\pi f X_m}$$

Where,  $C_x$  is capacitance value of sample,  
 $f$  is measurement frequency,  
 $X_m$  is measured reactance value of sample.

As discussed above, each measurement parameter is interrelated with the impedance (or admittance) value so the accuracies on all ranges can be verified if the instrument satisfies specified accuracies for each one of its resistive and reactive measurement parameters, e.g. resistance and capacitance from the lowest through the highest test frequencies.

It is important to note that the accuracy is based on arithmetic relationships as are the parameter relationships. This theoretical background is pertinent to the corroboration of the accuracy evaluations which are done by simplified test procedures instead of time-consuming-tests on the 600 (approximately) possible combinations of the fundamental test parameters (measurement parameter, frequency, range, etc.).

## ACCURACY TEST CONSIDERATIONS

## Corroboration Check Considerations

The test for measurement accuracy with respect to the vector impedance is made on specific ranges using standards, and on the other ranges by using alternate methods which are (theoretically and experimentally) proven to be practicable for verification of the ranges which otherwise would be uncertifiable because of the limitations of the standards. If the end results of these checks meet all the individual test limits, the instrument should satisfy its specified accuracies across its entire range. Then, how can these methods be explained? Let's look at the performance test articles.

Accuracy test procedures include checks for the following circuit sections:

- 1) Bridge Circuit Range Resistors.
- 2) Range Multiplier.
- 3) Bridge Balance Control.
- 4) Phase Detector.
- 5) A-D (Analog to Digital) Converter.

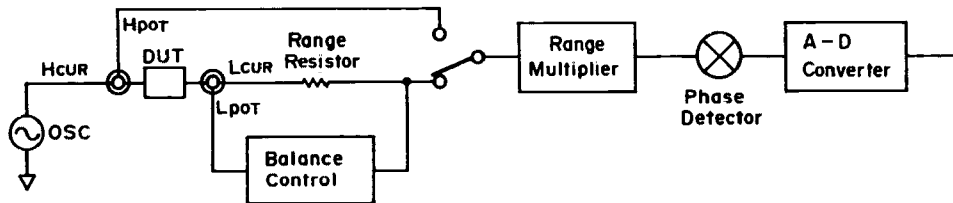

4275A Measurement Section

**CAPACITANCE ACCURACY TEST** verifies Range Resistor accuracy for the reactive impedance measurement from the lowest through the highest test frequencies. (Balance Control linearity and normal operations of the Phase Detector and A-D Converter are also verified).

**RESISTANCE ACCURACY TEST** does its verification in a manner similar to that for the Capacitance Accuracy Test, but for resistive impedance measurements. Thus, accuracies for both reactive and resistive components of the vector impedance are verified.

**SELF OPERATING TEST** verifies the multiples of the Range Multiplier which extends the measurement ranges. The A-D Converter accuracy is also checked by this combined self-test function which enables automatic check of each one of these circuits.

**FREQUENCY-PHASE ACCURACY TEST** verifies phase-flatness characteristics (minimum phase shift) of the overall measurement section and Phase Detector phase accuracy from the lowest through the highest test frequencies.

## Note

A set of detection phases, each different by 90 degrees, is used in the Phase Detector. If their relative phase angles are exactly 90 degrees, the phase relationships of the detection phases on the vector DUT voltage (or current) detected have no influence on the resultant accuracy. The accuracy of the right-angle detection phases is verified by both this test and dissipation factor checks associated with the capacitance Accuracy Test.



## ACCURACY TEST STANDARDS

## 1) Standard Capacitors.

The HP 16380 Series Standard Capacitors, featuring the four terminal pair configuration, are recommended for use as performance test standards. The four standard capacitors 16381A (1pF), 16382A (10pF), 16383A (100pF) and 16384A (1000pF) are calibrated at 0.01% accuracy (within 0.1% of their nominal capacitance values) at 1kHz. For values at frequencies to 10MHz, an extrapolation of the calibrated values at 1kHz is used (this is based on the careful consideration of their inherent residual parameter values and on the actual test measurement to verify the frequency dependency of the values). Capacitance values at frequencies up to 10MHz are read from the graph given on the data sheet of each standard.

## Note

A high capacitance standard, useable in the high frequency region, is unavailable. Here's why:

A 10 $\mu$ F capacitor, for example, has an impedance value of 0.16 $\Omega$  at 100kHz. A capacitance standard would have, in addition, residual impedances which could not be neglected when compared to the pure impedance of 0.16 $\Omega$ . Thus, an attempt at tests which would use the standard capacitor at the higher operating frequency ranges is not practicable.

## 2) Standard Resistors.

The standard resistors used for accuracy checks should be practically pure resistances and should maintain an extremely low order of residual reactance at frequencies to 10MHz. The HP 16074A Standard Resistor Set, especially designed as standards useable over a broad frequency region, with four terminal pair configurations, is suitable for the accuracy checks. These thin film resistors, which ensure negligible low stray capacitance and less skin effect, provide the standard resistance values of 0.1 $\Omega$ , 1 $\Omega$  and 10 $\Omega$  at  $\pm 10\%$  and 100 $\Omega$ , 1000 $\Omega$ , 10k $\Omega$  and 100k $\Omega$  at  $\pm 0.01\%$  calibration accuracies to 10MHz (1MHz at 100k $\Omega$ ). Open (0S) and short (0 $\Omega$ ) terminations which facilitate optimum zero offset adjustment as well as two quasi-inductors for inductance accuracy checks are included in the 16074A.

## Note

The 0.1 $\Omega$ , 1 $\Omega$  and 10 $\Omega$  resistors are used as the (pure resistance) reference samples in the Frequency-Phase Accuracy Test.

## 3) Standard Inductors.

The 4275A inductance accuracy is theoretically certified if the capacitance accuracy meets the specifications. Generally, inductors have unwanted parasitic impedances to some extent (that is, coil resistance and distributed capacitance). As these residuals significantly dominate the inductance values at high frequencies, inductance standards useable in RF region (higher than about 100kHz) are substantially unavailable. Inductors with higher inductance values have lower frequency limits.

ACCURACY TEST STANDARDS

If it is desired to check inductance measurement accuracy on least at one range, a quasi-inductor may be useful as a substitution test sample. The quasi-inductor offers an equivalent inductance (when connected to the 4275A) by a simple network circuit consisting of a capacitor and resistors. A quasi-inductor circuit is shown in the figure below:

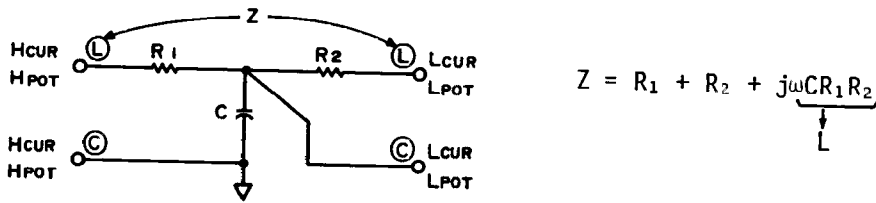

The equivalent inductance value is given by the equation:

$$L = C \cdot R_1 \cdot R_2$$

The values of R and C are respectively measured to calculate the equivalent inductance value (prior to the inductance accuracy check). The HP 16074A Quasi-inductors offer the composite inductance values of 100μH and 100mH. Useable frequency ranges for these inductors are given in the table below:

Sample	Useable frequency range	Recommended test frequency
100μH	100kHz to 10MHz	1MHz
100mH	10kHz to 1MHz	100kHz

Note

Component resistors R<sub>1</sub> and R<sub>2</sub> in the quasi circuit may be measured at dc with a high accuracy DMM. These high stability resistors need only be re-calibrated at the recommended calibration period of 6 months. The capacitors should be checked before each test.

GENERAL

The standards should be of the four terminal pair configuration design to provide compatibility with the instrument. This minimizes reduction in reliability of the values due to the effects of the residuals associated with cabling and connections.

Note

Skin effect should be considered as it affects the value of the standards in the high frequency region. The contribution of skin effect to the resistive factor of the sample increases in proportion to the square root of the frequency and is dominant at high frequencies (generally, in the megahertz region).

**PERFORMANCE TESTS**

4-9. TEST FREQUENCY ACCURACY TEST

4-10. This test verifies that test signal frequencies for 4275A meet the specified frequency accuracy of 0.01%.

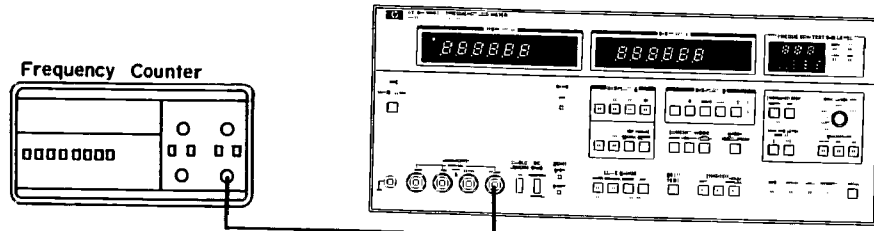

Figure 4-1. Test Frequency Accuracy Test Setup.

**EQUIPMENT:**

- Frequency Counter ..... HP 5314A.
- Test cable ..... BNC to BNC cable.

**PROCEDURE:**

1. Connect BNC to BNC cable to 4275A UNKNOWN H<sub>CUR</sub> terminal and to frequency counter input as shown in Figure 4-1.
2. Set 4275A controls as follows:
  - MULTIPLIER ..... x1
  - OSC LEVEL ..... fully cw
  - Test frequency ..... 1.00MHz
  - DC BIAS switch (rear panel) ..... OFF
  - Other controls ..... any setting
3. Read display output of frequency counter. Frequency readouts must be within 999.9kHz and 1000.1kHz.
4. Change test frequency setting and read frequency counter display output at each of the 10 spot test frequencies (and any optional frequency). Frequency readouts must be within the test limits given in Table 4-2.

Table 4-2. Test Frequency Accuracy Test.

Frequency setting	Test limits
10.0kHz	9.999 - 10.001kHz
20.0kHz	19.998 - 20.002kHz
40.0kHz	39.996 - 40.004kHz
100kHz	99.99 - 100.01kHz
200kHz	199.98 - 200.02kHz
400kHz	399.96 - 400.04kHz
1.00MHz	0.9999 - 1.0001MHz
2.00MHz	1.9998 - 2.0002MHz
4.00MHz	3.9996 - 4.0004MHz
10.0MHz	9.999 - 10.001MHz
Opt. Freq.	±0.01%

**Note**

- 1) Test limits in above table do not account for reading error contributed by measurement errors in the test equipment.
- 2) If this test fails, the instrument requires troubleshooting.

**PERFORMANCE TESTS**

4-11. TEST SIGNAL LEVEL (VARIABLE RANGE TEST).

4-12. This test verifies that the variable range of the test signal level for the 4275A meets the specified range span of 1mV and 1V rms at 10kHz.

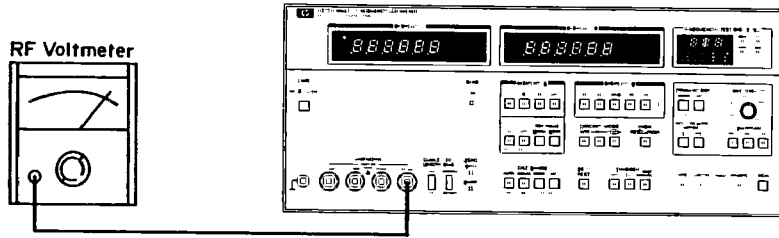

Figure 4-2. Test Signal Level Variable Range Test Setup.

**EQUIPMENT:**

- RF Voltmeter ..... HP 3400A and HP 3465A/B
- Test cable ..... BNC to BNC cable 20cm or less/BNC to dual banana cable

**Note**

Use RF Voltmeter calibrated for frequency response of 10kHz.

**PROCEDURE:**

1. Connect BNC to BNC cable to 4275A UNKNOWN H<sub>CUR</sub> terminal and to RF voltmeter input as shown in Figure 4-2.
2. Set RF voltmeter range as appropriate to measure voltage of 1V rms.
3. Set 4275A controls as follows:
  - MULTIPLIER ..... x1
  - OSC LEVEL ..... fully cw
  - Test frequency ..... 10kHz
  - DC BIAS switch (rear panel) ..... OFF
  - Other controls ..... Any setting
4. RF voltmeter readout should be 1.00V rms or more (when the value is corrected for the voltmeter frequency response).
5. Set 4275A controls in accord with table 4-3 and verify that all the test limits given in the table are satisfied.

Table 4-3. Test Signal Level Variable Range Test.

Control setting		Test Limits
OSC LEVEL	MULTIPLIER	
fully cw	x1	greater than 1.00V rms
fully ccw	x1	less than 100mV rms
fully cw	x0.1	greater than 100mV rms
fully cw	x0.01	greater than 10mV rms

**PERFORMANCE TESTS**

4-13. SELF-OPERATING TEST

4-14. The Self-operating test checks operating conditions of the circuits (Range Multiplier for extending measurement capability to higher and lower ranges; Null Detector for bringing bridge into optimum balance; Buffer Amplifiers for accurately detecting potentials across DUT and range resistor; and Integrator for converting analog measurement quantities into digital) which are especially significant for sustaining the specified accuracies. All the tests on these individual circuits can be accomplished easily and simply with the SELF TEST function. To ascertain that these circuits satisfy the performance requirements for ensuring the specified accuracies, display readouts are compared with severe test limits. Because basic circuit operating conditions related to the accuracy are verified in this test, the instrument should be initially checked with this test for acceptability.

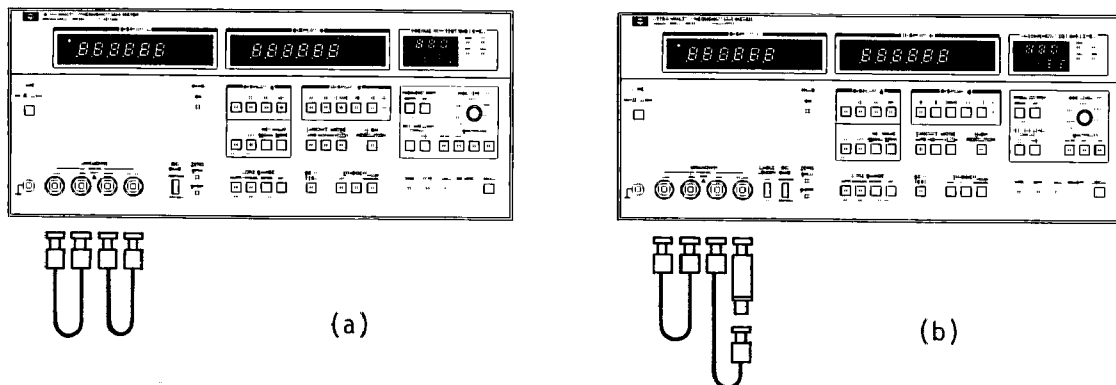

Figure 4-3. Self Operating Test Setup.

**EQUIPMENT:**

- BNC to BNC cable ..... 10cm long, 2 required.
- 50Ω feed-through termination ..... -hp- 11048C

**PROCEDURE:**

1. Set CABLE LENGTH switch to "0" position.
2. Connect L<sub>CUR</sub> and L<sub>POT</sub> terminals with a BNC to BNC cable as shown in Figure 4-3 (a). Similarly Connect H<sub>CUR</sub> and H<sub>POT</sub> terminals.

**CAUTION**

VERIFY THAT DC BIAS INDICATOR LAMP DOES NOT LIGHT. IF ILLUMINATED, SET REAR PANEL DC BIAS SWITCH TO OFF.

3. Set test signal frequency to 100kHz.
4. Press SELF TEST button and then DISPLAY B function D button.

**Note**

Self test item number (in this case "1" which means the first step) is displayed in DISPLAY A unit indicator as shown below:



**PERFORMANCE TESTS**

5. DISPLAY A and DISPLAY B readouts should be within the following test limits:
 

DISPLAY A .....	.00±100 counts
DISPLAY B .....	.00±100 counts
6. Remove the BNC cable from the H<sub>CUR</sub> terminal and connect a 50Ω feed-through termination between the H<sub>CUR</sub> terminal and the BNC cable. See Figure 4-3(b).
7. Press DISPLAY B function Q button. Self test item number "2" is displayed.
8. Set test signal level and frequency as follows:
 

MULTIPLIER .....	x1
OSC LEVEL .....	fully cw
Test frequency .....	100kHz
9. DISPLAY A readout should be within the following test limit:
 

DISPLAY A .....	-1000.00±100 counts.
-----------------	----------------------
10. Change test frequency to 1.00MHz.
11. DISPLAY B readout should be within the following test limit:
 

DISPLAY B .....	.00±1000 counts.
-----------------	------------------
12. Remove the 50Ω feed-through termination and connect the BNC cable between the H<sub>CUR</sub> and H<sub>POT</sub> terminals, as shown in Figure 4-3(a).
13. Press DISPLAY B function ESR/G button. Self test item number "3" is displayed.
14. Set test signal in accord with step 8 and repeat test steps 9, 10 and 11 above with respect to the third self-test step.
15. Press DISPLAY B function X/B button. Self test item number "4" is displayed.
16. Set test signal in accord with step 8 other than setting MULTIPLIER to x 0.1. Repeat test steps 9, 10 and 11 above with respect to the fourth self-test step.
17. Press DISPLAY B function L/C button. Self test item number "5" is displayed.
18. Set test signal in accord with step 8 other than setting MULTIPLIER to x 0.01. Repeat test steps 9, 10 and 11 with respect to the fifth self test step.
19. Press DISPLAY A Δ% button. Self test item number "7" is displayed and MULTIPLIER is automatically set to x 0.1.
20. Set test frequency to 100kHz.
21. Display readouts should be within the following test limits:
 

DISPLAY A .....	.00±1000 counts
DISPLAY B .....	.00±1000 counts

Note Self test item 6 does not exist.

PERFORMANCE TESTS

Table 4-4. Self Operating Test Summary.

Test item	Press button	Control settings			Test Limits	
		MULTIPLIER	OSC LEVEL	Frequency	DISPLAY A	DISPLAY B
1	D	—	—	100kHz	.00±100 counts	.00±100 counts
2	Q	x1	fully cw	100kHz	-1000.00 ±100 counts	—
		x1	fully cw	1.00MHz	—	.00±1000 counts
3	ESR/G	x1	fully cw	100kHz	-1000.00 ±100 counts	—
		x1	fully cw	1.00MHz	—	.00±1000 counts
4	X/B	x0.1	fully cw	100kHz	-1000.00 ±100 counts	—
		x0.1	fully cw	1.00MHz	—	.00±1000 counts
5	L/C	x0.01	fully cw	100kHz	-1000.00 ±100 counts	—
		x0.01	fully cw	1.00MHz	—	.00±1000 counts
7	Δ%	x0.1	fully cw	100kHz	.00±1000 counts	.00±1000 counts

1.414

7.14の Adj に 5.2  
100 count を 超えることある  
が 問題ない





**PERFORMANCE TESTS**

Note

- 1) If short ( $0\Omega$ ) and open ( $0S$ ) terminations of the HP 16074A Standard Resistor Set are available, use them for zero offset adjustment instead of BNC to BNC cables and BNC Tee adapters.
- 2) Use BNC to BNC cables of 10cm long or less. Using a longer cable may affect test results.

PROCEDURE:

1. Set CABLE LENGTH switch to "0" position.
2. Connect  $L_{CUR}$  and  $L_{POT}$  terminals with a BNC to BNC cable as shown in Figure 4-4 (a). Similarly connect  $H_{CUR}$  and  $H_{POT}$  terminals.
3. Set 4275A controls as follows:

DISPLAY A function .....	C
Deviation measurement function .....	off
LCRZ RANGE .....	AUTO
DISPLAY B function .....	D
CIRCUIT MODE .....	AUTO (  )
<del>HIGH RESOLUTION</del> .....	<del>on</del>
SELF TEST .....	off
TRIGGER .....	INT
OSC LEVEL .....	fully cw
MULTIPLIER .....	x1

CAUTION

VERIFY THAT DC BIAS INDICATOR LAMP DOES NOT LIGHT. IF ILLUMINATED, SET REAR PANEL DC BIAS SWITCH TO OFF.

4. Press ZERO OPEN button and wait approximately 15 seconds until "open" offset adjustment is completed ("CAL" letters in DISPLAY A disappear).
5. Connect cables and terminal adapters as shown in Figure 4-4 (b). Connect BNC tee adapters to each other.
6. Press ZERO SHORT button and wait approximately 15 seconds until "short" offset adjustment is completed.
7. Disconnect cables and connect 1pF Standard Capacitor direct to UNKNOWN terminals as shown in Figure 4-4 (c).
8. Set test frequency and test signal level MULTIPLIER in accord with Table 4-5. Capacitance and dissipation factor readouts should be within tolerances given in the table.
9. Change standard capacitor successively to 10pF, 100pF and 1000pF and verify that the instrument satisfies Table 4-5.

Note

1. Table 4-5 applies to the tests at both MULTIPLIER x1 and x 0.1 settings.
2. When 1000pF standard capacitor is measured at 4MHz or 10MHz test frequency, CIRCUIT MODE is automatically set to  mode.

## PERFORMANCE TESTS

Table 4-5. Capacitance Accuracy Tests.

Test frequency	Standard capacitance			
	1pF		10pF	
	C test limits	D test limits	C test limits	D test limits
10.0kHz	—	—	C.V. $\pm 0.0130\text{pF}$ ( $\pm 0.040\text{pF}$ )	$0 \pm 0.00090$ ( $0 \pm 0.0018$ )
20.0kHz	—	—	C.V. $\pm 0.0120\text{pF}$ ( $\pm 0.030\text{pF}$ )	$0 \pm 0.00075$ ( $0 \pm 0.0017$ )
40.0kHz	C.V. $\pm 5.10\text{fF}$ ( $\pm 15.0\text{fF}$ )	$0 \pm 0.00360$ ( $0 \pm 0.0045$ )	C.V. $\pm 0.0420\text{pF}$	$0 \pm 0.00360$
100kHz	C.V. $\pm 4.50\text{fF}$ ( $\pm 9.0\text{fF}$ )	$0 \pm 0.00210$ ( $0 \pm 0.0030$ )	C.V. $\pm 0.0360\text{pF}$	$0 \pm 0.00210$
200kHz	—	—	C.V. $\pm 0.0120\text{pF}$ ( $\pm 0.030\text{pF}$ )	$0 \pm 0.00075$ ( $0 \pm 0.0017$ )
400kHz	C.V. $\pm 4.60\text{fF}$ ( $\pm 10.0\text{fF}$ )	$0 \pm 0.00260$ ( $0 \pm 0.012$ )	C.V. $\pm 0.0160\text{pF}$	$0 \pm 0.00135$
1.00MHz	C.V. $\pm 4.30\text{fF}$ ( $\pm 7.0\text{fF}$ )	$0 \pm 0.00170$ ( $0 \pm 0.011$ )	C.V. $\pm 0.0130\text{pF}$	$0 \pm 0.00090$
2.00MHz	—	—	C.V. $\pm 0.0330\text{pF}$ ( $\pm 0.060\text{pF}$ )	$0 \pm 0.00260$ ( $0 \pm 0.0035$ )
4.00MHz	C.V. $\pm 14.00\text{fF}$ ( $\pm 32.0\text{fF}$ )	$0 \pm 0.00710$ ( $0 \pm 0.017$ )	C.V. $\pm 0.1220\text{pF}$	$0 \pm 0.00710$
10.0MHz	C.V. $\pm 24.00\text{fF}$ ( $\pm 42.0\text{fF}$ )	$0 \pm 0.01110$ ( $0 \pm 0.021$ )	C.V. $\pm 0.2220\text{pF}$	$0 \pm 0.01110$

C.V. = Calibrated value of standard capacitor.

C and D test limit values in parenthesis apply to MULTIPLIER X0.1 setting.

Table 4-5. Capacitance Accuracy Tests (continued).

Test frequency	Standard capacitance			
	100pF		1000pF	
	C test limits	D test limits	C test limits	D test limits
10.0kHz	C.V. $\pm 0.130\text{pF}$	$0 \pm 0.00090$	C.V. $\pm 1.30\text{pF}$	$0 \pm 0.00090$
20.0kHz	C.V. $\pm 0.120\text{pF}$	$0 \pm 0.00075$	C.V. $\pm 1.20\text{pF}$	$0 \pm 0.00075$
40.0kHz	C.V. $\pm 0.160\text{pF}$	$0 \pm 0.00135$	C.V. $\pm 1.60\text{pF}$	$0 \pm 0.00135$
100kHz	C.V. $\pm 0.130\text{pF}$	$0 \pm 0.00090$	C.V. $\pm 1.30\text{pF}$	$0 \pm 0.00090$
200kHz	C.V. $\pm 0.120\text{pF}$	$0 \pm 0.00075$	C.V. $\pm 1.20\text{pF}$	$0 \pm 0.00075$
400kHz	C.V. $\pm 0.160\text{pF}$	$0 \pm 0.00135$	C.V. $\pm 1.60\text{pF}$	$0 \pm 0.00135$
1.00MHz	C.V. $\pm 0.130\text{pF}$	$0 \pm 0.00090$	C.V. $\pm 1.30\text{pF}$	$0 \pm 0.00090$
2.00MHz	C.V. $\pm 0.330\text{pF}$	$0 \pm 0.00260$	C.V. $\pm 3.30\text{pF}$	$0 \pm 0.00260$ $-0.00230$
4.00MHz	C.V. $\pm 1.202\text{pF}$	$0 \pm 0.00710$	C.V. $\pm 32.0\text{pF}$	$0 \pm 0.01210$ $-0.01130$
10.0MHz	C.V. $\pm 2.200\text{pF}$	$0 \pm 0.01110$	—	—

C.V. = Calibrated value of standard capacitor.



**PERFORMANCE TESTS**

HIGH RESOLUTION ..... on  
 SELF TEST ..... off  
 TRIGGER ..... INT  
 OSC LEVEL ..... fully cw  
 MULTIPLIER ..... x1

**CAUTION**

VERIFY THAT DC BIAS INDICATOR LAMP DOES NOT LIGHT. IF ILLUMINATED, SET REAR PANEL DC BIAS SWITCH TO OFF.

**Note**

If Capacitance Accuracy Test (paragraph 4-15) has not been performed before doing this test, perform zero offset adjustment in accord with Capacitance Accuracy Test steps 2, 4, 5 and 6.

3. Connect 100Ω standard resistor direct to UNKNOWN terminals as shown in Figure 4-5.
4. Set test frequency and test signal level MULTIPLIER in accord with Table 4-6. Resistance readouts should be within tolerances given in the table.
5. Change standard resistor successively to 1000Ω, 10kΩ and 100kΩ and verify that the instrument satisfies Table 4-6.

**Note**



1. Table 4-6 applies to tests at both MULTIPLIER x1 and X0.1 settings.
2. Measurement CIRCUIT MODE is automatically set to  mode on 100Ω range and to  mode on other ranges.

Table 4-6. Resistance Accuracy Test.

Test Frequency	Test Limits			
	100Ω	1000Ω	10kΩ	100kΩ
10.0kHz	C.V. ±0.130Ω	C.V. ±4.0Ω	C.V. ±0.040kΩ	C.V. ±0.40kΩ
20.0kHz				
40.0kHz				
100kHz				
200kHz	C.V. ±0.230Ω	C.V. ±5.0Ω	C.V. ±0.050kΩ	—
400kHz				
1.00MHz				
2.00MHz	C.V. ±0.550Ω	C.V. ±12.0Ω	—	—
4.00MHz				
10.0MHz				

C.V. = Calibrated value of standard resistor

**PERFORMANCE TESTS**

4-19. INDUCTANCE ACCURACY TEST (Confirmation Test).

4-20. Inductance accuracy is verified if the instrument meets both capacitance and resistance accuracy test limits. If it is desired to confirm the inductance accuracy on at least at one range, perform the following test:

Note

This confirmation test does not necessarily have to be done.

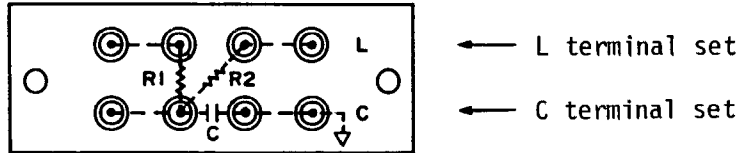

Figure 4-6. HP 16074A Quasi-inductor.

{ Internal Connection Configuration }  
 is shown in the figure.

EQUIPMENT:

Quasi-inductor ..... from HP 16074A Standard Resistor Set.

PROCEDURE:

1. Set CABLE LENGTH switch to "0" position.
2. Set 4275A controls as follows:

DISPLAY A function .....	L
Deviation measurement function .....	off
LCRZ RANGE .....	AUTO
CIRCUIT MODE .....	<input checked="" type="checkbox"/>
HIGH RESOLUTION .....	on
SELF TEST .....	off
TRIGGER .....	INT
OSC LEVEL .....	fully cw
MULTIPLIER .....	x1

CAUTION

VERIFY THAT DC BIAS INDICATOR LAMP DOES NOT LIGHT. IF ILLUMINATED, SET REAR PANEL DC BIAS SWITCH TO OFF.

Note

If Capacitance Accuracy Test (paragraph 4-15) has not been performed before doing this test, perform a zero offset adjustment in accord with Capacitance Accuracy Test steps 2, 4, 5 and 6.

**PERFORMANCE TESTS**100 $\mu$ H range check

3. Connect 100 $\mu$ H quasi-inductor "L" terminals direct to 4275A UNKNOWN terminals. See Figure 4-6.
4. Set test signal frequency to 1.00MHz.
5. Inductance display readout should be within  $\pm 0.50\mu$ H of the calibrated inductance value.
6. Disconnect quasi-inductor sample.

100mH range check

7. Connect the 100mH quasi-inductor "L" terminals directly to the 4275A's UNKNOWN terminals. See Figure 4-6.
8. Set the test signal frequency to 100kHz.
9. Inductance display readout should be within  $\pm 0.30$ mH of the calibrated inductance value.

**PERFORMANCE TESTS**

4-23. INT DC BIAS SUPPLY TEST (OPTION 001)

4-24. This test verifies that the Option 001 Internal DC BIAS Supply applies the specified bias voltages to the device under test.

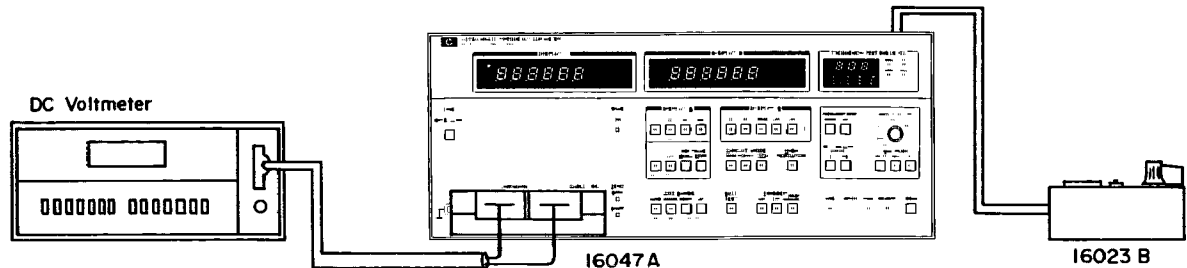

Figure 4-7. Option 001 Int DC Bias Supply Test Setup.

**EQUIPMENT:**

DC Voltmeter .....	HP 3465A/B
Test Fixture .....	HP 16047A
Bias Controller .....	HP 16023B

**PROCEDURE:**

1. Set 4275A front panel DC BIAS switch to  $\pm 35V$  MAX and CABLE LENGTH switch to "0" position. Attach 16047A Test Fixture to UNKNOWN terminals.
2. Connect 16023B DC Bias Controller to rear panel INT DC BIAS CONTROL connector.

**CAUTION**

BEFORE OPERATING DC BIAS SWITCH, VERIFY THAT DC BIAS VOLTAGE HAS BEEN SET TO ZERO VOLTS.

3. Set rear panel DC BIAS switch to INT  $\pm 35V/100V$  ( $\leq 1\mu F$ ) position.
4. Connect an appropriate pair of wire leads between dc voltmeter input and 16047A Test Fixture (see Figure 4-7).
5. Set dc bias voltage into 16023B DC Bias Controller in accord with Table 4-8. DC voltmeter readouts should be identical with the bias setting voltages within tolerances given in the table.

**Note**

To change bias voltage:

1. Set a new bias voltage value into the three digit thumbwheel switch of the 16023B.
2. Press 16023B ENTER button (this actuates the 4275A to read the new value).

**PERFORMANCE TESTS**

Table 4-8. DC Bias Voltage Test Limits.

DC Bias Setting	Tolerance	DC Bias Setting	Tolerance
.000V	-.0020 - .0020V	.100V	.0975 - .1025V
.001	-.0010 - .0030	.200	.1970 - .2030
.002	.0000 - .0040	.300	.2965 - .2035
.003	.0010 - .0050	.400	.3960 - .4040
.004	.0020 - .0060	.500	.4955 - .5045
.005	.0030 - .0070	.600	.5950 - .6050
.006	.0040 - .0080	.700	.6945 - .7055
.007	.0050 - .0090	.800	.7940 - .8060
.008	.0060 - .0100	.900	.8935 - .9065
.009	.0070 - .0110	1.00	.9910 - 1.009
.010	.0080 - .0120	2.00	1.986 - 2.014
.020	.0179 - .0221	3.00	2.982 - 3.018
.030	.0279 - .0321	4.00	3.977 - 4.023
.040	.0378 - .0422	5.00	4.972 - 5.028
.050	.0478 - .0522	6.00	5.967 - 6.033
.060	.0577 - .0623	7.00	6.962 - 7.038
.070	.0677 - .0723	8.00	7.958 - 8.042
.080	.0776 - .0824	9.00	8.953 - 9.047
.090	.0876 - .0924	10.0	9.930 - 10.07
		20.0	19.88 - 20.12
		30.0	29.82 - 30.16

**Note**

When dc bias voltage is measured at rear panel INT DC BIAS MONITOR connector, voltmeter readout will be somewhat lower than the actual (applied) voltage because of monitor output impedance (30kΩ).  
Measured voltage value Em is:

$$E_m = E_{\text{bias}} \times \frac{Z_i}{30 + Z_i} \text{ (V)}$$

Where, Zi is voltmeter input impedance (in kΩ).

**4-25. INT DC BIAS SUPPLY TEST (OPTION 002)**

4-26. This test verifies that the Option 002 Internal DC Bias Supply applies the specified bias voltages to the device under test.

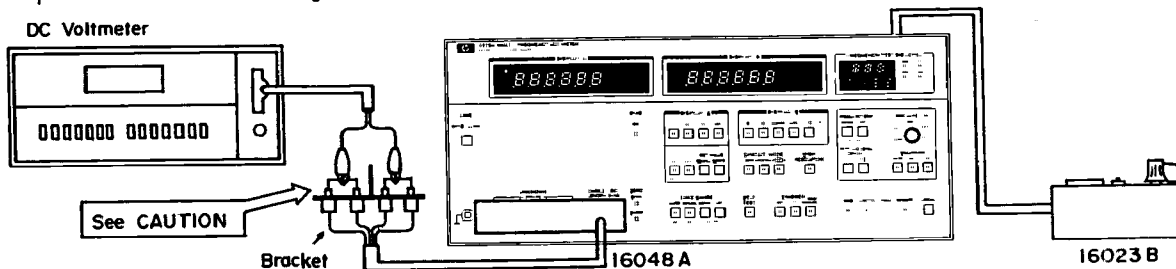

Figure 4-8. Option 002 Int DC Bias Supply Test Setup.

**EQUIPMENT:**

- DC Voltmeter ..... HP 3465A/B
- Test Leads ..... HP 16048A
- Bias Controller ..... HP 16023B



**PERFORMANCE TESTS**

PROCEDURE:

1. Set 4275A front panel DC BIAS switch to  $\pm 200V$  MAX and CABLE LENGTH switch to "1m" position. Connect 16048A Test Leads to UNKNOWN terminals.
2. Connect 16023B DC BIAS Controller to rear panel INT DC BIAS CONTROL connector.

CAUTION

BEFORE OPERATING DC BIAS SWITCH, VERIFY THAT DC BIAS VOLTAGE HAS BEEN SET TO ZERO VOLTS.

3. Set rear panel DC BIAS switch to INT  $\pm 35V/100V$  ( $\leq .1\mu F$ ) position.
4. Connect 16048A Test Leads to dc voltmeter input (see Figure 4-8).

**CAUTION**

DO NOT TOUCH BNC CONNECTOR CENTER PIN WHERE A LIVE VOLTAGE MAY EXIST.

5. Set dc bias voltage into 16023B DC Bias Controller switch in accord with Table 4-9. DC Voltmeter readouts should be identical with the bias setting voltages within tolerances given in the table.

Note

To change bias voltage:

1. Set a new bias voltage value into the three digit thumbwheel switch of the 16023B.
2. Press 16023B ENTER button (this actuates the 4275A to read the new value).

TABLE 4-9. DC Bias Voltage Test Limits.

DC Bias Setting	Tolerance	DC Bias Setting	Tolerance
00.0V	-0.040 - 0.040V	05.0V	4.86 - 5.14V
00.1	0.058 - 0.142	06.0	5.84 - 6.16
00.2	0.156 - 0.244	07.0	6.82 - 7.18
00.3	0.254 - 0.346	08.0	7.80 - 8.20
00.4	0.352 - 0.448	09.0	8.78 - 9.22
00.5	0.450 - 0.550	10.0	9.76 - 10.24
00.6	0.548 - 0.652	20.0	19.56 - 20.44
00.7	0.646 - 0.754	30.0	29.37 - 30.63
00.8	0.744 - 0.856	40.0	39.17 - 40.83
00.9	0.842 - 0.958	50.0	48.97 - 51.03
01.0	0.940 - 1.060	60.0	58.77 - 61.23
02.0	1.920 - 2.08	70.0	68.58 - 71.42
03.0	2.90 - 3.10	80.0	78.38 - 81.62
04.0	3.88 - 4.12	90.0	88.18 - 91.82

Note

When dc bias voltage is measured at rear panel INT DC BIAS MONITOR connector, voltmeter readout will be somewhat lower than the actual bias voltage. Refer to note in Paragraph 4-24.

**PERFORMANCE TESTS**

4-27. HP-IB INTERFACE TEST (OPTION 101 ONLY).

4-28. This test verifies that the HP-IB circuitry has the capabilities (listed in Table 3-10) to correctly communicate between external HP-IB devices and the 4275A through the interface bus cable.

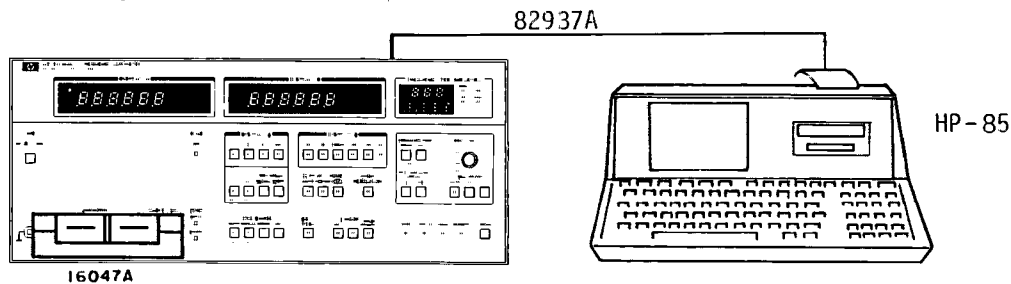

Figure 4-9. HP-IB Interface Test Setup.

**EQUIPMENT:**

Personal Computer .....	HP85
I/O ROM .....	HP00085-15003
ROM DRAWER .....	HP82936A
HP-IB Interface Module .....	HP82937A
Sample Capacitor .....	1000pF--100nF
Test Fixture .....	HP16047A

**PROCEDURE:**

1. Turn power switches of both the 4275A and HP-85 to OFF.
2. Connect 82937A Interface Module with cable between HP85 I/O slot and 4275A rear panel HP-IB connector as shown in Figure 4-9.
3. Remove 4275A top cover.
4. Set 4275A A22S1 HP-IB Control Switch to following settings:
  - bit 1~5 : 10001 (17 in binary code)
  - bit 6 : 0
  - bit 7 : 0
5. Replace top cover.
6. Connect 16047A Test Fixture to 4275A UNKNOWN terminals.
7. Turn 4275A and HP85 ON.
8. Set 4275A controls as follows:
  - OSC LEVEL ..... 1
  - 16047A Test Fixture ..... Open
  - Other Controls ..... Initial control settings.
9. Load test program as shown on Pages 4-24 through 4-27 in computer.
10. Execute the program.
11. Check that 4275A display, 9825A display, and printed data are in accord with Controller Instructions and Operator Responses for each test program.
12. Perform steps 10 thru 13 with respect to individual test programs and verify that 4275A and HP85 correctly communicates through the HP-IB interface.

## PERFORMANCE TESTS

## TEST PROGRAM 1

## [PURPOSE]

This test verifies that 4275A Opt. 101 has the following capabilities:

- (1) Remote/Local Capability.
- (2) Local Lockout.
- (3) Talk Address Disabled by Listen Address.
- (4) Listen Address Disabled by Talk Address.

## [PROGRAM LISTING]

```

10 ! REMOTE/LOCAL TEST
20 OPTION BASE 1
30 DIM B$(20),C$(25)
40 A1=717 @ A=7
50 B$="REMOTE/LOCAL TEST "
60 C$="LISTEN= TALK= REMOTE= "
70 N=0
80 S=SPOLL(A1)
90 PRINT B$
100 REMOTE A
110 OUTPUT A1 ;"T1"
120 C1$="1" @ C2$="0" @ C3$="1"
130 GOSUB 460
140 ABORTIO A
150 C1$="0" @ C2$="0" @ C3$="1"
160 GOSUB 460
170 LOCAL A
180 C1$="0" @ C2$="0" @ C3$="0"
190 GOSUB 460
200 REMOTE A1
210 C1$="1" @ C2$="0" @ C3$="1"
220 GOSUB 460
230 LOCAL LOCKOUT A
240 LOCAL A1
250 C1$="1" @ C2$="0" @ C3$="0"
260 GOSUB 460
270 REMOTE A
280 OUTPUT A1 ;"T1"
290 C1$="1" @ C2$="0" @ C3$="1"
300 GOSUB 460
310 GOSUB 530
320 N=0
330 B$="LISTEN:TALK TEST "
340 PRINT B$
350 ENTER A1 ; X,Y
360 C1$="0" @ C2$="1" @ C3$="1"
370 GOSUB 460
380 OUTPUT A1 ;"T1"
390 C1$="1" @ C2$="0" @ C3$="1"
400 GOSUB 460
410 GOSUB 530
420 ABORTIO A
430 LOCAL A
440 PRINT "END"
450 END
460 ! ***** SUB A$ *****
470 C$(8,8)=C1$ @ C$(15,15)=C2$
480 C$(24,24)=C3$
490 DISP C$
500 INPUT A$
510 IF A$="N" THEN N=1
520 RETURN
530 ! ***** SUB PRT *****
540 PRINT B$;
550 IF N=1 THEN PRINT "FAIL" ELSE PRINT "PASS"
560 RETURN

```

- (80) Clears 4275A SRQ Status Byte.
- (100) Sets REN (Remote Enable) line of the bus line to "1". Switches selected devices (Interface Select Code 7) to remote operation allowing parameters and device characteristics to be controlled by data message.
- (110) Addresses HP85 to talk and 4275A to listen.
- (140) Sets IFC (Interface Clear) line of the bus line to "1". Unconditionally causes control to pass back to 9825A (independent of the device currently in control) and stops all communication.
- (170) Sets REN to "0". Removes all devices (Interface Select Code 7) from local lockout mode and causes all devices to revert to local.
- (200) Sets REN to "1". Switches 4275A to remote operation.
- (230) Prevents the device operator from switching the unit to manual control.
- (240) Causes 4275A to revert to manual control for future parameter modifications (REN remains at "1").
- (280) Returns to the status of line 230.
- (350) Disables listen address by talk address.
- (380) Disables talk address by listen address.

## PERFORMANCE TESTS

Table 4-10. Controller Instructions and Operator Responses for Test Program 1.

Controller Instructions		Operator Response
Displays	Printout	
	REMOTE/LOCAL TEST	
LISTEN=1 TALK=0 REMOTE=1 ? LISTEN=0 TALK=0 REMOTE=1 ? LISTEN=0 TALK=0 REMOTE=0 ? LISTEN=1 TALK=0 REMOTE=1 ? LISTEN=1 TALK=0 REMOTE=0 ? LISTEN=1 TALK=0 REMOTE=1 ?		If the 4275A HP-IB Status Indicators and Controller Display are the same, press <b>Y</b> , and <b>END LINE</b> . If not, press <b>N</b> , and <b>END LINE</b> .
	REMOTE/LOCAL TEST PASS	If all steps are correct, this message is output.
	REMOTE/LOCAL TEST FAIL	If any step fails, this message is output.
	LISTEN/TALK TEST	
LISTEN=0 TALK=1 REMOTE=1 ? LISTEN=1 TALK=0 REMOTE=1 ?		If the 4275A HP-IB Status Indicators and Controller Display are the same, press <b>Y</b> , and <b>END LINE</b> . If not, press <b>N</b> , and <b>END LINE</b> .
	LISTEN/TALK TEST PASS	If both steps are correct, this message is output.
	LISTEN/TALK TEST FAIL	If any step fails, this message is output.
	END	

## PERFORMANCE TESTS

## TEST PROGRAM 3

## [PURPOSE]

This test verifies that 4275A Opt. 101 has following capabilities:

- (1) Talker.
- (2) Device Trigger.

## [PROGRAM LISTING]

```

10 | TALKER TEST
20 DIM A$(50),C$(30)
30 A1=717 @ A2=7
40 C$="DATA OUTPUT TEST "
50 PRINT "TALKER TEST"
60 DISP "CONNECT A CAPACITOR TO 16047A"
70 DISP TAB(15);"PRESS [CONT] KEY"
80 PAUSE
90 PRINT C$
100 C=SPOLL(A1)
110 REMOTE A2
120 ABORTIO A2
130 CLEAR A1
140 OUTPUT A1 ;"T3E"
150 ENTER A1 ; A,B
160 IMAGE D.5DE,5%,.5D
170 PRINT USING 160 ; A,B
180 DISP "IS OUTPUT DATA TRUE(Y or N)";
190 INPUT F$
200 PRINT C$;
210 IF F$="N" THEN PRINT "FAIL" ELSE PRINT "PASS"
220 C$="COMPLETE "&C$
230 PRINT C$
240 OUTPUT A1 ;"E"
250 GOSUB 430
260 C$="DEVICE TRIGGER TEST "
270 PRINT C$
280 TRIGGER A1
290 GOSUB 430
300 C$="REFERENCE VALUE TEST "
310 PRINT C$
320 OUTPUT A1 ;"STRE"
330 GOSUB 430
340 C$="TEST SIG. LEVEL CHECK TEST "
350 PRINT C$
360 OUTPUT A1 ;"LV"
370 ENTER A1 ; A$
380 PRINT A$
390 OUTPUT A1 ;"LA"
400 GOSUB 430
410 PRINT "TEST END"
420 END
430 ! ***** SUB *****
440 ENTER A1 ; A$
450 PRINT A$
460 DISP "IS OUTPUT DATA TRUE(Y or N)";
470 INPUT F$
480 PRINT C$;
490 IF F$="N" THEN PRINT "FAIL" ELSE PRINT "PASS"
500 RETURN

```

(280) Causes 4275A to simultaneously initiate a device-dependent action.

**PERFORMANCE TESTS**

Table 4-12. Controller Instructions and Operator Responses for Test Program 3

Controller Instructions		Operator Response
Displays	Printout	
	TALKER TEST	
CONNECT A CAPACITOR TO 16047A PRESS [CONT] KEY		Connect a capacitor (1000pF -- 100nF) to 16047A Test Fixture. Press <b>[CONT]</b> .
	DATA OUTPUT TEST	
IS OUTPUT DATA TRUE (Y or N) ?	DATA OUTPUT TEST PASS	If outputted data and values of DISPLAYs A and B are same, press <b>[Y]</b> and <b>[END LINE]</b> . If not, press <b>[N]</b> and <b>[END LINE]</b> .
	DATA OUTPUT TEST FAIL	
	COMPLETE DATA OUTPUT TEST	
IS OUTPUT DATA TRUE (Y or N) ?	COMPLETE DATA OUTPUT TEST PASS	If outputted data is true, press <b>[Y]</b> and <b>[END LINE]</b> . If not, press <b>[N]</b> and <b>[END LINE]</b> .
	COMPLETE DATA OUTPUT TEST FAIL	
	DEVICE TRIGGER TEST	
IS OUTPUT DATA TRUE (Y or N) ?	DEVICE TRIGGER TEST PASS	If outputted data is true, press <b>[Y]</b> and <b>[END LINE]</b> . If not, press <b>[N]</b> and <b>[END LINE]</b> .
	DEVICE TRIGGER TEST FAIL	
	REFERENCE VALUE TEST	Press Recall key on 4275A front panel and read stored reference value.

**PERFORMANCE TESTS**

Table 4-12. Controller Instructions and Operator Responses for Test Program 3 (Cont'd)

Controller Instructions		Operator Response
Displays	Printout	
IS OUTPUT DATA TRUE (Y or N) ?	REFERENCE VALUE TEST PASS	If outputted data is true, press <input type="checkbox"/> Y and <input type="checkbox"/> END LINE. If not, press <input type="checkbox"/> N and <input type="checkbox"/> END LINE.
	REFERENCE VALUE TEST FAIL	
	TEST SIG LEVEL CHECK TEST	Press TEST SIG LEVEL CHECK keys on 4275A front panel and read test signal level.
IS OUTPUT DATA TRUE (Y or N) ?	TEST SIG LEVEL CHECK TEST PASS	If outputted data is true, press <input type="checkbox"/> Y and <input type="checkbox"/> END LINE. If not, press <input type="checkbox"/> N and <input type="checkbox"/> END LINE.
	TEST SIG LEVEL CHECK TEST FAIL	
	TEST END	

## PERFORMANCE TESTS

## TEST PROGRAM 4

## [PURPOSE]

This test program verifies that 4275A Opt. 101 has following capabilities:

- (1) Service Request.
- (2) Serial Poll.

## [PROGRAM LISTING]

```

10 1 SRQ TEST
20 PRINT "SRQ TEST "
30 A1=717 @ A2=7
40 ON INTR ? GOSUB 470
50 REMOTE A2
60 ABORTIO A2
70 CLEAR A1
80 A=SPOLL(A1)
90 A=0
100 PRINT "DATA READY"
110 OUTPUT A1 ;"I1T3E"
120 GOSUB 410
130 A=0
140 PRINT "SELF TEST -PASS"
150 OUTPUT A1 ;"I0S1"
160 GOSUB 410
170 A=0
180 PRINT "SELF TEST -FAIL"
190 OUTPUT A1 ;"A1"
200 GOSUB 410
210 A=0
220 PRINT "ZERO OFFSET -PASS"
230 OUTPUT A1 ;"S0Z0"
240 GOSUB 410
250 A=0
260 PRINT "ZERO OFFSET -FAIL(Err1)"
270 OUTPUT A1 ;"ZS"
280 GOSUB 410
290 A=0
300 PRINT "Err5"
310 OUTPUT A1 ;"D1"
320 WAIT 9000
330 OUTPUT A1 ;"ST"
340 GOSUB 410
350 A=0
360 PRINT "SINTAX ERROR"
370 OUTPUT A1 ;"A5"
380 GOSUB 410
390 PRINT "TEST END"
400 END
410 1 ***** SUB LOOP *****
420 ENABLE INTR ?;8
430 B=0
440 B=BIT(A,0) OR BIT(A,1) OR BIT(A,2) OR BIT(A,3)
450 IF B=1 THEN PRINT A @ RETURN
460 GOTO 410
470 1 ***** SUB SRQ *****
480 A=SPOLL(A1)
490 STATUS ?;1 ; S1
500 IF BIT(A,6)=0 THEN DISP "OTHER DEVICE SRQ"
510 ENABLE INTR ?;8
520 RETURN

```

- (40) Designates label (SRQ) for service routing to be performed when an interrupt is set by a device on select code 7 bus line.
- (420) Labels Loop. Enables Service Request to be sent from device on select code 7 Bus Line. Checks status of SRQ line on the bus line.
- (510) Again enables acceptance of SRQ from device because SRQ is disabled when Status Byte signal transfer is completed.
- (520) After service subroutine is completed, return to the step that follows step 130, 170 or 210 (as appropriate) to main programming sequence.



**PERFORMANCE TESTS**

Table 4-13. Controller Instructions and Operator Responses for Test Program 4.

Controller Instructions (Printout)	Operator Response
SRQ TEST	
DATA READY	Outputted SRQ Status Byte data should be 65 (= 01000001).
65	
SELF TEST -PASS	Outputted SRQ Status Byte data should be 68 (= 01000100).
68	
SELF TEST -FAIL	Outputted SRQ Status Byte data should be 76 (= 01001100).
76	
ZERO OFFSET -PAS S	Outputted SRQ Status Byte data should be 68 (= 01000100).
68	
ZERO OFFSET -FAI L(Err1)	Outputted SRQ Status Byte data should be 76 (= 01001100).
76	
Err5	Outputted SRQ Status Byte data should be 72 (= 01001000).
72	
SYNTAX ERROR	Outputted SRQ Status Byte data should be 66 (= 01000010).
66	
TEST END	

PERFORMANCE TEST RECORD

Hewlett-Packard  
 Model 4275A  
 Multi Frequency LCR Meter  
 Serial No. \_\_\_\_\_

Tested by \_\_\_\_\_  
 Date \_\_\_\_\_

Paragraph Number	TEST	Results		
		Minimum	Actual	Maximum
4-9	TEST FREQUENCY ACCURACY TEST  Frequency setting  10.0kHz 20.0kHz 40.0kHz 100kHz 200kHz 400kHz 1.00MHz 2.00MHz 4.00MHz 10.0MHz  Opt. freq. ( Hz) ( Hz)	9.999kHz 19.998kHz 39.996kHz 99.99kHz 199.98kHz 399.96kHz 0.9999MHz 1.9998MHz 3.9996MHz 9.999MHz  _____ _____	_____ _____ _____ _____ _____ _____ _____ _____ _____ _____  _____ _____	10.001kHz 20.002kHz 40.004kHz 100.01kHz 200.02kHz 400.04kHz 1.0001MHz 2.0002MHz 4.0004MHz 10.001MHz  _____ _____
4-11	TEST SIGNAL LEVEL VARIABLE RANGE TEST  MULTIPLIER: x1 OSC LEVEL: fully cw  MULTIPLIER: x1 OSC LEVEL: fully ccw  MULTIPLIER: x0.1 OSC LEVEL: fully cw  MULTIPLIER: x0.01 OSC LEVEL: fully cw	1.00V rms   100mV rms  10mV rms	_____   _____  _____	_____   100mV rms  _____
4-13	SELF OPERATING TEST  Test item  1 ..... DISPLAY A ..... DISPLAY B  2 ..... DISPLAY A ..... DISPLAY B  3 ..... DISPLAY A ..... DISPLAY B  4 ..... DISPLAY A ..... DISPLAY B  5 ..... DISPLAY A ..... DISPLAY B  7 ..... DISPLAY A ..... DISPLAY B	-1.00 -1.00  -999.00 -10.00  -999.00 -10.00  -999.00 -10.00  -999.00 -10.00  -10.00 -10.00	_____ _____  _____ _____  _____ _____  _____ _____  _____ _____  _____ _____	1.00 1.00  -1001.00 10.00  -1001.00 10.00  -1001.00 10.00  -1001.00 10.00  10.00 10.00

Paragraph Number	TEST	Results			
		Minimum	Actual	Maximum	
4-15	CAPACITANCE ACCURACY TEST				
	1pF	MULTIPLIER x1			
	40.0kHz (D)	C.V. -5.10fF -0.00360	_____	C.V. +5.10fF 0.00360	
	100kHz (D)	C.V. -4.50fF -0.00210	_____	C.V. +4.50fF 0.00210	
	400kHz (D)	C.V. -4.60fF -0.00260	_____	C.V. +4.60fF 0.00260	
	1.00MHz (D)	C.V. -4.30fF -0.00170	_____	C.V. +4.30fF 0.00170	
	4.00MHz (D)	C.V. -14.00fF -0.00710	_____	C.V. +14.00fF 0.00710	
	10.0MHz (D)	C.V. -24.00fF -0.01110	_____	C.V. +24.00fF 0.01110	
	1pF	MULTIPLIER x0.1			
	40.0kHz (D)	C.V. -15.0fF -0.0045	_____	C.V. +15.0fF 0.0045	
	100kHz (D)	C.V. -9.0fF -0.0030	_____	C.V. +9.0fF 0.0030	
	400kHz (D)	C.V. -10.0fF -0.012	_____	C.V. +10.0fF 0.012	
	1.00MHz (D)	C.V. -7.0fF -0.011	_____	C.V. +7.0fF 0.011	
	4.00MHz (D)	C.V. -32.0fF -0.017	_____	C.V. +32.0fF 0.017	
	10.0MHz (D)	C.V. -42.0fF -0.021	_____	C.V. +42.0fF 0.021	
	10pF	MULTIPLIER x1			
	10.0kHz (D)	C.V. -0.0130pF -0.00090	_____	C.V. +0.0130pF 0.00090	
	20.0kHz (D)	C.V. -0.0120pF -0.00075	_____	C.V. +0.0120pF 0.00075	
	40.0kHz (D)	C.V. -0.0420pF -0.00360	_____	C.V. +0.0420pF 0.00360	
	100kHz (D)	C.V. -0.0360pF -0.00210	_____	C.V. +0.0360pF 0.00210	
	200kHz (D)	C.V. -0.0120pF -0.00075	_____	C.V. +0.0120pF 0.00075	
	400kHz (D)	C.V. -0.0160pF -0.00135	_____	C.V. +0.0160pF 0.00135	
	1.00MHz (D)	C.V. -0.0130pF -0.00090	_____	C.V. +0.0130pF 0.00090	
	2.00MHz (D)	C.V. -0.0330pF -0.00260	_____	C.V. +0.0330pF 0.00260	
	4.00MHz (D)	C.V. -0.1220pF -0.00710	_____	C.V. +0.1220pF 0.00710	
	10.0MHz (D)	C.V. -0.2220pF -0.01110	_____	C.V. +0.2220pF 0.01110	
		Opt. freq. ( Hz)	_____	_____	
		Opt. freq. ( Hz)	_____	_____	
		Opt. freq. ( Hz)	_____	_____	
		 1.00MHz (D)	C.V. -0.0130pF -0.00090	_____	C.V. +0.0130pF 0.00090

C.V. = Calibrated Value

Paragraph Number	TEST	Results		
		Minimum	Actual	Maximum
4-15	10pF MULTIPLIER x0.1			
	10.0kHz (D)	C.V. -0.040pF -0.0018	_____	C.V +0.040pF 0.0018
	20.0kHz (D)	C.V. -0.030pF -0.0017	_____	C.V +0.030pF 0.0017
	40.0kHz (D)	C.V. -0.0420pF -0.00360	_____	C.V +0.0420pF 0.00360
	100kHz (D)	C.V. -0.0360pF -0.00210	_____	C.V +0.0360pF 0.00210
	200kHz (D)	C.V. -0.030pF -0.0017	_____	C.V +0.030pF 0.0017
	400kHz (D)	C.V. -0.0160pF -0.00135	_____	C.V +0.0160pF 0.00135
	1.00MHz (D)	C.V. -0.0130pF -0.00090	_____	C.V +0.0130pF 0.00090
	2.00MHz (D)	C.V. -0.060pF -0.0035	_____	C.V +0.060pF 0.0035
	4.00MHz (D)	C.V. -0.1220pF -0.00710	_____	C.V +0.1220pF 0.00710
	10.0MHz (D)	C.V. -0.2220pF -0.01110	_____	C.V +0.2220pF 0.01110
	Opt. freq. ( Hz) (D)	_____	_____	_____
	Opt. freq. ( Hz) (D)	_____	_____	_____
	Opt. freq. ( Hz) (D)	_____	_____	_____
	100pF MULTIPLIER x1			
	10.0kHz (D)	C.V. -0.130pF -0.00090	_____	C.V +0.130pF 0.00090
	20.0kHz (D)	C.V. -0.120pF -0.00075	_____	C.V +0.120pF 0.00075
	40.0kHz (D)	C.V. -0.160pF -0.00135	_____	C.V +0.160pF 0.00135
	100kHz (D)	C.V. -0.130pF -0.00090	_____	C.V +0.130pF 0.00090
	200kHz (D)	C.V. -0.120pF -0.00075	_____	C.V +0.120pF 0.00075
	400kHz (D)	C.V. -0.160pF -0.00135	_____	C.V +0.160pF 0.00135
	1.00MHz (D)	C.V. -0.130pF -0.00090	_____	C.V +0.130pF 0.00090
	2.00MHz (D)	C.V. -0.330pF -0.00260	_____	C.V +0.330pF 0.00260
	4.00MHz (D)	C.V. -1.202pF -0.00710	_____	C.V +1.202pF 0.00710
	10.0MHz (D)	C.V. -2.200pF -0.01110	_____	C.V +2.200pF 0.01110
	Opt. freq. ( Hz) (D)	_____	_____	_____
	Opt. freq. ( Hz) (D)	_____	_____	_____
Opt. freq. ( Hz) (D)	_____	_____	_____	

C.V. = Calibrated Value



Paragraph Number	TEST	Results			
		Minimum	Actual	Maximum	
4-15	1000pF MULTIPLIER x0.1				
	10.0kHz (D)	C.V. -1.30pF -0.00090	_____	C.V. +1.30pF 0.00090	
	20.0kHz (D)	C.V. -1.20pF -0.00075	_____	C.V. +1.20pF 0.00075	
	40.0kHz (D)	C.V. -1.60pF -0.00135	_____	C.V. +1.60pF 0.00135	
	100kHz (D)	C.V. -1.30pF -0.00090	_____	C.V. +1.30pF 0.00090	
	200kHz (D)	C.V. -1.20pF -0.00075	_____	C.V. +1.20pF 0.00075	
	400kHz (D)	C.V. -1.60pF -0.00135	_____	C.V. +1.60pF 0.00135	
	1.00MHz (D)	C.V. -1.30pF -0.00090	_____	C.V. +1.30pF 0.00090	
	2.00MHz (D)	C.V. -3.30pF -0.00230	_____	C.V. +3.30pF 0.00260	
	4.00MHz (D)	C.V. -32.0pF -0.01130	_____	C.V. +32.0pF 0.01210	
	Opt. freq. ( Hz)	_____	_____	_____	
	Opt. freq. ( Hz)	_____	_____	_____	
	4-17	RESISTANCE ACCURACY TEST			
		100Ω MULTIPLIER x1			
		10.0kHz	C.V. -0.130Ω	_____	C.V. +0.130Ω
20.0kHz		C.V. -0.130Ω	_____	C.V. +0.130Ω	
40.0kHz		C.V. -0.130Ω	_____	C.V. +0.130Ω	
100kHz		C.V. -0.130Ω	_____	C.V. +0.130Ω	
200kHz		C.V. -0.230Ω	_____	C.V. +0.230Ω	
400kHz		C.V. -0.230Ω	_____	C.V. +0.230Ω	
1.00MHz		C.V. -0.230Ω	_____	C.V. +0.230Ω	
2.00MHz		C.V. -0.550Ω	_____	C.V. +0.550Ω	
4.00MHz		C.V. -2.070Ω	_____	C.V. +2.070Ω	
10.0MHz		C.V. -2.070Ω	_____	C.V. +2.070Ω	
Opt. freq. ( Hz)		_____	_____	_____	
Opt. freq. ( Hz)		_____	_____	_____	
100Ω MULTIPLIER x0.1					
10.0kHz	C.V. -0.130Ω	_____	C.V. +0.130Ω		
20.0kHz	C.V. -0.130Ω	_____	C.V. +0.130Ω		
40.0kHz	C.V. -0.130Ω	_____	C.V. +0.130Ω		
100kHz	C.V. -0.130Ω	_____	C.V. +0.130Ω		
200kHz	C.V. -0.230Ω	_____	C.V. +0.230Ω		
400kHz	C.V. -0.230Ω	_____	C.V. +0.230Ω		
1.00MHz	C.V. -0.230Ω	_____	C.V. +0.230Ω		
2.00MHz	C.V. -0.550Ω	_____	C.V. +0.550Ω		
4.00MHz	C.V. -2.070Ω	_____	C.V. +2.070Ω		
10.0MHz	C.V. -2.070Ω	_____	C.V. +2.070Ω		

C.V. = Calibrated Value

Paragraph Number	TEST	Results		
		Minimum	Actual	Maximum
4-17	1000 $\Omega$ MULTIPLIER x1			
	10.0kHz	C.V. -4.0 $\Omega$	_____	C.V. +4.0 $\Omega$
	20.0kHz	C.V. -4.0 $\Omega$	_____	C.V. +4.0 $\Omega$
	40.0kHz	C.V. -4.0 $\Omega$	_____	C.V. +4.0 $\Omega$
	100kHz	C.V. -4.0 $\Omega$	_____	C.V. +4.0 $\Omega$
	200kHz	C.V. -5.0 $\Omega$	_____	C.V. +5.0 $\Omega$
	400kHz	C.V. -5.0 $\Omega$	_____	C.V. +5.0 $\Omega$
	1.00MHz	C.V. -5.0 $\Omega$	_____	C.V. +5.0 $\Omega$
	2.00MHz	C.V. -12.0 $\Omega$	_____	C.V. +12.0 $\Omega$
	4.00MHz	C.V. -33.0 $\Omega$	_____	C.V. +33.0 $\Omega$
	10.0MHz	C.V. -33.0 $\Omega$	_____	C.V. +33.0 $\Omega$
	Opt. freq. ( Hz)	_____	_____	_____
	Opt. freq. ( Hz)	_____	_____	_____
	1000 $\Omega$ MULTIPLIER x0.1			
	10.0kHz	C.V. -4.0 $\Omega$	_____	C.V. +4.0 $\Omega$
	20.0kHz	C.V. -4.0 $\Omega$	_____	C.V. +4.0 $\Omega$
	40.0kHz	C.V. -4.0 $\Omega$	_____	C.V. +4.0 $\Omega$
	100kHz	C.V. -4.0 $\Omega$	_____	C.V. +4.0 $\Omega$
	200kHz	C.V. -5.0 $\Omega$	_____	C.V. +5.0 $\Omega$
	400kHz	C.V. -5.0 $\Omega$	_____	C.V. +5.0 $\Omega$
	1.00MHz	C.V. -5.0 $\Omega$	_____	C.V. +5.0 $\Omega$
	2.00MHz	C.V. -12.0 $\Omega$	_____	C.V. +12.0 $\Omega$
	4.00MHz	C.V. -33.0 $\Omega$	_____	C.V. +33.0 $\Omega$
	10.0MHz	C.V. -33.0 $\Omega$	_____	C.V. +33.0 $\Omega$
	Opt. freq. ( Hz)	_____	_____	_____
	Opt. freq. ( Hz)	_____	_____	_____
	10k $\Omega$ MULTIPLIER x1			
	10.0kHz	C.V. -0.040k $\Omega$	_____	C.V. +0.040k $\Omega$
	20.0kHz	C.V. -0.040k $\Omega$	_____	C.V. +0.040k $\Omega$
	40.0kHz	C.V. -0.040k $\Omega$	_____	C.V. +0.040k $\Omega$
	100kHz	C.V. -0.040k $\Omega$	_____	C.V. +0.040k $\Omega$
	200kHz	C.V. -0.050k $\Omega$	_____	C.V. +0.050k $\Omega$
	400kHz	C.V. -0.050k $\Omega$	_____	C.V. +0.050k $\Omega$
	1.00MHz	C.V. -0.050k $\Omega$	_____	C.V. +0.050k $\Omega$
	Opt. freq. ( Hz)	_____	_____	_____
	Opt. freq. ( Hz)	_____	_____	_____
	10k $\Omega$ MULTIPLIER x0.1			
	10.0kHz	C.V. -0.040k $\Omega$	_____	C.V. +0.040k $\Omega$
	20.0kHz	C.V. -0.040k $\Omega$	_____	C.V. +0.040k $\Omega$
	40.0kHz	C.V. -0.040k $\Omega$	_____	C.V. +0.040k $\Omega$
	100kHz	C.V. -0.040k $\Omega$	_____	C.V. +0.040k $\Omega$
	200kHz	C.V. -0.050k $\Omega$	_____	C.V. +0.050k $\Omega$
400kHz	C.V. -0.050k $\Omega$	_____	C.V. +0.050k $\Omega$	
1.00MHz	C.V. -0.050k $\Omega$	_____	C.V. +0.050k $\Omega$	
Opt. freq. ( Hz)	_____	_____	_____	
Opt. freq. ( Hz)	_____	_____	_____	

Paragraph Number	TEST	Results						
		Minimum	Actual	Maximum				
4-17	100kΩ MULTIPLIER x1	10.0kHz	C.V. -0.40kΩ	_____	C.V. +0.40kΩ			
		20.0kHz	C.V. -0.40kΩ	_____	C.V. +0.40kΩ			
	40.0kHz	C.V. -0.40kΩ	_____	C.V. +0.40kΩ				
	100kHz	C.V. -0.40kΩ	_____	C.V. +0.40kΩ				
	Opt. freq. ( Hz)	_____	_____	_____				
	Opt. freq. ( Hz)	_____	_____	_____				
	100kΩ MULTIPLIER x0.1	10.0kHz	C.V. -0.40kΩ	_____	C.V. +0.40kΩ			
		20.0kHz	C.V. -0.40kΩ	_____	C.V. +0.40kΩ			
		40.0kHz	C.V. -0.40kΩ	_____	C.V. +0.40kΩ			
		100kHz	C.V. -0.40kΩ	_____	C.V. +0.40kΩ			
		Opt. freq. ( Hz)	_____	_____	_____			
		Opt. freq. ( Hz)	_____	_____	_____			
		4-21	FREQUENCY-PHASE ACCURACY TEST	1000mΩ	10.0kHz	-1.50mΩ	_____	1.50mΩ
					20.0kHz	-1.50mΩ	_____	1.50mΩ
40.0kHz	-1.50mΩ				_____	1.50mΩ		
100kHz	-1.69mΩ				_____	1.69mΩ		
200kHz	-1.87mΩ				_____	1.87mΩ		
400kHz	-2.25mΩ				_____	2.25mΩ		
1.00MHz	-3.38mΩ				_____	3.38mΩ		
10Ω	10.0kHz		-0.0130Ω	_____	0.0130Ω			
	20.0kHz		-0.0130Ω	_____	0.0130Ω			
	40.0kHz		-0.0130Ω	_____	0.0130Ω			
	100kHz		-0.0136Ω	_____	0.0136Ω			
	200kHz		-0.0142Ω	_____	0.0142Ω			
	400kHz		-0.0155Ω	_____	0.0155Ω			
	1.00MHz		-0.0193Ω	_____	0.0193Ω			
2.00MHz	-0.0275Ω	_____	0.0275Ω					
4.00MHz	-0.1400Ω	_____	0.1400Ω					
10.0MHz	-0.1780Ω	_____	0.1780Ω					

C.V. = Calibrated Value



Paragraph Number	TEST	Results		
		Minimum	Actual	Maximum
4-23	INT DC BIAS SUPPLY TEST (OPTION 001 ONLY)			
	.000V	-.0020V	_____	.0020V
	.002V	.0000V	_____	.0040V
	.005V	.0030V	_____	.0070V
	.010V	.0080V	_____	.0120V
	.020V	.0179V	_____	.0221V
	.050V	.0478V	_____	.0522V
	.100V	.0975V	_____	.1025V
	.200V	.1970V	_____	.2030V
	.500V	.4955V	_____	.5045V
	1.00V	.9910V	_____	1.009V
	2.00V	1.986V	_____	2.014V
	5.00V	4.972V	_____	5.028V
	10.0V	9.930V	_____	10.07V
20.0V	19.88V	_____	20.12V	
30.0V	29.82V	_____	30.16V	
4-25	INT DC BIAS SUPPLY TEST (OPTION 002 ONLY)			
	00.0V	-0.040V	_____	0.040V
	00.2V	0.156V	_____	0.244V
	00.5V	0.450V	_____	0.550V
	01.0V	0.940V	_____	1.060V
	02.0V	1.920V	_____	2.08V
	05.0V	4.86V	_____	5.14V
	10.0V	9.76V	_____	10.24V
	20.0V	19.56V	_____	20.44V
	50.0V	48.97V	_____	51.03V
	90.0V	88.18V	_____	91.82V

Table 5-0. Recommended Test Equipment.

Equipment	Critical Specifications	Recommended Model/Note	Use
Digital Voltmeter	Voltage range: 10mV to 100V f.s. Accuracy: 0.05% Input impedance: >10M $\Omega$	HP 3465A/B	A T
Oscilloscope	Bandwidth: 100MHz Sensitivity: 5mV/div Dual channel input.	HP 1740A	A T
RF Voltmeter	Voltage range: 1mV to 3Vrms f.s. Bandwidth: 10KHz to 10MHz Accuracy	HP 3403C	A
Pulse Generator	Output: 5V p-p to 50 $\Omega$ load. Pulsewidth: 100mS Duty: 50%	HP 8011A	A
Signature Analyzer		HP 5004A	T
Capacitance Standards	1pF $\pm$ 0.03% 10pF $\pm$ 0.03% 100pF $\pm$ 0.03% 1000pF $\pm$ 0.03%	HP 16381A HP 16382A HP 16383A HP 16384A	A
Resistance Standards	100 $\Omega$ $\pm$ 0.03% 1K $\Omega$ $\pm$ 0.03% 10K $\Omega$ $\pm$ 0.03% 100K $\Omega$ $\pm$ 0.03% Open termination Short termination	HP 16074A Standard Resistor Set	A T
Bias Controller	(Option 001 or 002 only)	HP 16023B	A
Test Leads	Accessory test leads, 1m	HP 16048A	A
Bracket	(Accessory for HP 16048A)	1 ea.	A
DVM input cable	Dual banana-to-alligator clip cable	1 ea.	AT
Oscilloscope probe	10M $\Omega$ , 10:1	HP 10004D	AT
BNC cable	20cm or less	1 ea.	A
	10cm	4 ea.	A
50 $\Omega$ Feed-through Termination		-hp- 11048C	A
BNC Tee Adapter	Female-to-female-to-male	-hp- 1250-0781	A
Reed relay	Drive voltage: 5V	-hp- 0490-0916	A
Resistor	500 $\Omega$ 10% 5K $\Omega$ 10%	-hp- 0757-0416 -hp- 0757-0438	A
Extender board	-	-hp- 5060-4025	AT

## SECTION V ADJUSTMENT

### 5-1. INTRODUCTION.

5-2. This section provides the information needed to adjust the 4275A to its specifications (listed in Table 1-1). The prime purpose of adjustment is to return the instrument to its peak operating capabilities after repairs have been made. Adjustment procedures can also be periodically performed to maintain top notch performance. Recommended adjustment cycle for the 4275A is once every six months. All adjustable components referred to in individual adjustments are summarized in Table 5-1. If proper performance cannot be achieved after adjustment procedure has been performed, refer to Section VIII Troubleshooting Procedures.

#### Note

Before proceeding to any adjustment, allow a warm up time of more than 30 minutes to stabilize operating conditions.

### 5-3. SAFETY REQUIREMENTS.

5-4. Although the instrument has been designed in accordance with international safety standards, this manual contains information, cautions and warnings which must be followed to ensure safe operation and to keep the instrument in safe condition. Adjustments described in this section should be performed only by qualified service personnel.

#### WARNING

ANY INTERRUPTION OF THE PROTECTIVE (GROUNDED) CONDUCTOR (INSIDE OR OUTSIDE OF THE INSTRUMENT) OR DISCONNECTION OF THE PROTECTIVE EARTH TERMINAL IS LIKELY TO MAKE THE INSTRUMENT DANGEROUS. INTENTIONAL INTERRUPTION IS PROHIBITED.

5-5. The opening of covers for removal of parts, except those to which access can be gained by hand, is likely to expose live parts.

5-6. Capacitors inside instrument may still be charged even if instrument has been disconnected from its source of supply.

#### WARNING

ADJUSTMENTS DESCRIBED HEREIN ARE PERFORMED WITH POWER SUPPLIED TO THE INSTRUMENT AFTER PROTECTIVE COVERS HAVE BEEN REMOVED. ENERGY EXISTING AT MANY POINTS MAY, IF CONTACTED, RESULT IN PERSONAL INJURY.

### 5-7. EQUIPMENT REQUIRED.

5-8. The equipment needed to adjust the Model 4275A is listed in Table 5-0 (page 5-0). This equipment should always be calibrated to satisfy its own specifications and those of the required characteristics. If the recommended model is not available, any instrument that has specifications equal to or better than required specifications may be substituted.

### 5-9. FACTORY SELECTED COMPONENTS.

5-10. Factory selected components can be recognized by an asterisk adjacent to the reference designator on the schematic diagrams in Section VIII (nominal value is shown). Table 5-2 lists all factory selected components with their nominal value ranges and their influence on instrument performance.

Adjustable components, with reference designators are listed in Table 5-1. The table gives the name of the control to be adjusted and the purpose of its adjustment.

### 5-11. ADJUSTMENT RELATIONSHIPS.

5-12. The adjustment procedures, beginning with paragraph 5-18, should be performed in step sequence as they are interactive. Neglecting or changing procedures may make it impossible to obtain best 4275A performance. Table 5-3 shows necessary adjustment procedures to be used after repair to the instrument.

### 5-13. ADJUSTMENT LOCATIONS.

5-14. To help you to identify the appropriate adjustment points, the locations of the components to be adjusted are illustrated throughout the adjustment procedures. The locations of the factory selected components, connectors and other components related to the adjustments are shown in the individual board assembly component illustrations (fold-out service sheet).

Table 5-1. Adjustable Components.

Reference Designator	Name of Control	Purpose
A1C5 C19  (Para 5-40)		To properly compensate for range resistor signal phase shift due to residual reactive factors in the range resistor input/output circuits (at 4MHz and 10MHz test frequencies).
A1C20 C21 C22 C23  (Para 5-36)		To compensate for stray capacitances in the range resistor circuit and to eliminate measurement errors due to range resistor current phase shift.
A1R1 R2  (Para 5-40)		To properly compensate for range resistor signal amplitude error due to residual resistive factors in the range resistor input/output circuits (at 4MHz and 10MHz test frequencies).
A1R3  (Para 5-34) (Para 5-38)		To properly compensate for residual impedances in range resistor input/output circuits.
A1R28 R29 R30 R31  (Para 5-36)		To set range resistor values for maximizing measurement accuracy on each measurement range.
A2C8 C9 C13 C14  (Para 5-26)	Q1 ADJ Q2 ADJ Q3 ADJ Q4 ADJ	To optimize bridge balance settling time.
A2R13 R14  (Para 5-26)	OS1 ADJ OS2 ADJ	To eliminate phase errors from modulator circuit and to optimize bridge circuit balance condition.
A2R92  (Para 5-32)	LEVEL ADJ	To set sensitivity of test signal level monitor circuitry and to maximize monitor display accuracy.
A3C13  (Para 5-24)		To equalize test signal level for all test signal frequencies.
A3R1  (Para 5-22) (Para 5-32)		To set maximum test signal level (1V) applicable to samples.

Table 5-1. Adjustable Components (Cont'd).

Reference Designator	Name of Control	Purpose
A3R9 (Para 5-22)		To set test signal level variable range as well as to calibrate level control dial.
A4A1C3 (Para 5-28)	PHASE	To equalize phase characteristics for the two channel amplifiers in process amplifier input stages and to maximize accuracy at higher test frequencies.
A4A1R1 (Para 5-20)	TRACKING	To eliminate a dc offset voltage from process amplifier.
A4A1R8 (Para 5-28)	AMP	To set process amplifier gain for maximizing measurement accuracy.
A4A2R1 (Para 5-20)	TRACKING	To eliminate dc offset voltage from process amplifier.
A4A3C3 R10 (Para 5-30)	PHASE AMP	To eliminate both attenuation errors and phase shift from process amplifier gain attenuator circuits and to maximize accuracy of measurement for each test signal level MULTIPLIER setting (x1, x0.1 and x0.01).
A4A4C3 R2 (Para 5-30)	PHASE AMP	
A5C15 (Para 5-30)	1/4 $\phi$ ADJ	To eliminate both attenuation errors and phase shift from A-D converter input attenuator circuits and to maximize measurement accuracy for each test signal level MULTIPLIER setting (x1, x0.1 and x0.01).
A5R4 R11 (Para 5-30)	1/2 $\phi$ ADJ 1/2 AMP ADJ	
A5R16 (Para 5-30)	1/4 AMP ADJ	
A5R120 (Para 5-18)	REF ADJ	To maximize conversion accuracy of A-D converter circuit.
A11R3 (Para 5-16)	STD ADJ	To set dc power supply output voltages.

Table 5-2. Factory Selected Components.

Component	Nominal Value Range	Effect on Performance
A1C24 C25	HP P/N 0160-2236 C:FXD 1.0pF HP P/N 0160-2241 C:FXD 2.2pF HP P/N 0150-0059 C:FXD 3.3pF * HP/P/N 0160-2248 C:FXD 4.3pF HP P/N 0160-2251 C:FXD 5.6pF HP P/N 0160-2253 C:FXD 6.8pF HP P/N 0160-2255 C:FXD 8.2pF HP P/N 0160-2257 C:FXD 10.0pF	Changes phase compensation adjustment range for 100Ω range resistor.
A1C26	HP P/N 0160-2239 C:FXD 1.8pF HP P/N 0160-2243 C:FXD 2.7pF HP P/N 0160-2247 C:FXD 3.9pF * HP P/N 0160-2250 C:FXD 5.1pF HP P/N 0160-2252 C:FXD 6.2pF HP P/N 0160-2254 C:FXD 7.5pF HP P/N 0160-2255 C:FXD 8.2pF HP P/N 0160-2257 C:FXD 10.0pF	Changes phase compensation adjustment range for 1000Ω range resistor.
A1C27	HP P/N 0160-2239 C:FXD 1.8pF HP P/N 0160-2243 C:FXD 2.7pF HP P/N 0160-2247 C:FXD 3.9pF HP P/N 0160-2250 C:FXD 5.1pF HP P/N 0160-2252 C:FXD 6.2pF * HP P/N 0160-2254 C:FXD 7.5pF HP P/N 0160-2255 C:FXD 8.2pF HP P/N 0160-2256 C:FXD 9.1pF HP P/N 0160-2257 C:FXD 10.0pF	Changes phase compensation adjustment range for 10kΩ range resistor.
A1C28	HP P/N 0140-0190 C:FXD 39.0pF HP P/N 0160-2200 C:FXD 43.0pF HP P/N 0160-2201 C:FXD 51.0pF * HP P/N 0140-0205 C:FXD 62.0pF HP P/N 0160-2202 C:FXD 75.0pF HP P/N 0140-0193 C:FXD 82.0pF	Changes range resistor phase compensation adjustment range for 10MHz test signal frequency.
A1R4	HP P/N 0698-3132 R:FXD 261.0Ω HP P/N 0698-3443 R:FXD 287.0Ω * HP P/N 0698-3444 R:FXD 316.0Ω	Changes compensation adjustment range for display offset error count due to residual impedances in range resistor signal circuit.
A3C6 C21	HP P/N 0160-2256 C:FXD 9.1pF HP P/N 0160-2257 C:FXD 10.0pF * HP P/N 0160-2258 C:FXD 11.0pF HP P/N 0160-2259 C:FXD 12.0pF HP P/N 0160-2260 C:FXD 13.0pF	Changes magnitude of frequency compensation value in test signal level attenuation circuitry (which responds to MULTIPLIER function setting).
A3C20 C22	HP P/N 0160-2206 C:FXD 160.0pF HP P/N 0140-0197 C:FXD 180.0pF HP P/N 0140-0198 C:FXD 200.0pF * HP P/N 0160-0134 C:FXD 220.0pF HP P/N 0140-0199 C:FXD 240.0pF HP P/N 0140-0210 C:FXD 270.0pF HP P/N 0160-2207 C:FXD 300.0pF	
A3C76	* None HP P/N 0160-2197 C:FXD 10.0pF HP P/N 0160-2198 C:FXD 20.0pF HP P/N 0140-0179 C:FXD 33.0pF HP P/N 0140-0182 C:FXD 47.0pF HP P/N 0140-0191 C:FXD 56.0pF HP P/N 0140-0192 C:FXD 68.0pF HP P/N 0140-0193 C:FXD 82.0pF HP P/N 0160-2204 C:FXD 100.0pF HP P/N 0160-2205 C:FXD 120.0pF HP P/N 0160-2206 C:FXD 160.0pF	Changes sensitivity of test signal level monitor display at high frequencies.

Table 5-2. Factory Selected Components (Cont'd).

Component	Nominal Value Range	Effect on Performance
A4A2C3	HP P/N 0160-2236 C:FxD 1.0pF HP P/N 0160-2239 C:FxD 1.8pF HP P/N 0160-2243 C:FxD 2.7pF * HP P/N 0160-2246 C:FxD 3.6pF HP P/N 0160-2248 C:FxD 4.3pF HP P/N 0160-2249 C:FxD 4.7pF	Changes process amplifier frequency response adjustment range.
A4A3R16 R30 A4A4R12	* HP P/N 0757-0180 R:FxD 31.6Ω HP P/N 0757-0403 R:FxD 121.0Ω HP P/N 0757-0405 R:FxD 162.0Ω	Changes offset adjustment for AM Amplifier.
A5C7	HP P/N 0160-2239 C:FxD 1.8pF HP P/N 0160-2241 C:FxD 2.2pF	Changes 1/2 attenuator phase compensation adjustment range
A5C70	None HP P/N 0160-2201 C:FxD 51.0pF HP P/N 0160-2204 C:FxD 100.0pF HP P/N 0140-0196 C:FxD 150.0pF HP P/N 0140-0198 C:FxD 200.0pF HP P/N 0140-0199 C:FxD 240.0pF HP P/N 0160-2207 C:FxD 300.0pF HP P/N 0160-2209 C:FxD 360.0pF HP P/N 0160-0939 C:FxD 430.0pF HP P/N 0160-2210 C:FxD 470.0pF	Eliminates display count errors due to A-D converter output zero offset.
A6C67	HP P/N 0160-2204 C:FxD 100pF * HP P/N 0140-0195 C:FxD 130pF HP P/N 0140-0196 C:FxD 150pF	Compensates input capacitance of U18
A6C67 (OPT 004)	HP P/N 0140-0196 C:FxD 150pF HP P/N 0160-2206 C:FxD 160pF * HP P/N 0140-0197 C:FxD 180pF HP P/N 0140-0198 C:FxD 200pF	

Note: Component marked (\*) in table is usually used.

## INITIAL OPERATING PROCEDURE.

Preparatory to adjusting the 4275A, do the following to locate and to gain access to the adjustment controls (this procedure facilitates a thoroughgoing adjustment):

## [FUNDAMENTAL OPERATING CHECKS]

Confirm that instrument power line selector switches are set for local power line voltage. Program Memory Test described on page 3-1 and the SELF TEST procedure in Figure 3-0 on page 3-0 should be completely performed and successfully passed before progressing to adjustment procedure.

## [TOP COVER REMOVAL]

Remove top cover as follows:

- Loosen the retaining screw at rear of top cover.
- Pull top cover towards the rear and lift off.

## WARNING

TO INSURE PERSONAL SAFETY FROM POSSIBLE ELECTRICAL SHOCK HAZARDS AND RESULTANT INJURY, USE INSULATED ADJUSTMENT TOOL.

Table 5-3. Adjustment Requirements.

Assembly repaired or replaced	Required adjustment(s)
A1 04275-66501 (Range Resistor & Null Detector)	Para. 5-33, 5-35, 5-37, 5-39.
A2 04275-66502 (Modulator)	Para. 5-25, 5-31.
A3 04275-66503 (Power Amplifier)	Para. 5-21, 5-23, 5-31.
A4 04275-66504 (Process Amplifier)	Para. 5-19, 5-27, 5-29.
A5 04275-66505 (A-D Converter)	Para. 5-17, 5-29.
A6 04275-66506 (Oscillator)	None.
A7 04275-66507 A8 04274-66508 A9 04275-66529 A10 04275-66520	None.
A11 04274-66551 (Power Supply)	Para. 5-15.
A21 04274-66521 (Opt. 001 DC Bias)	Para. 5-41.
A22 04274-66522	None.
A23 04274-66523 (Opt. 002 DC Bias)	Para. 5-42.

**ADJUSTMENTS**

5-15. DC POWER SUPPLY VOLTAGE ADJUSTMENT (A11).

5-16. This adjustment sets internal dc power supply output voltages to their nominal values to ensure that the instrument functions under proper operating voltages.

EQUIPMENT:

Digital Voltmeter ..... HP 3465 A/B  
Voltmeter input cable ..... Dual banana to  
dual alligator clip cable

PROCEDURE:

1. Connect Digital Voltmeter input to TP1 (+12V) on 4275A A11 Power Supply board.
2. Set DVM range as appropriate to measure 12V and read the display output.
3. Adjust potentiometer A11R3 (STD ADJ) so that the display readout is within 11.76V to 12.12V.
4. Check voltages at A11TP5, TP10 and TP17. DVM display readouts should satisfy the test limits given in Table 5-4. If any check fails, re-adjust A11R3.

Table 5-4. DC Power Supply Voltage Test Limits.

Test Point	Test limits
TP 1	11.76 to 12.12V
TP 5	-11.79 to -12.15V
TP10	- 4.89 to - 5.04V
TP17	4.81 to 4.96V

5-17. A-D CONVERTER ACCURACY ADJUSTMENT (A5).

5-18. This adjustment equalizes the (absolute) values of both positive and negative reference voltages used in the A-D converter and optimizes A-D conversion accuracy.

EQUIPMENT:

No test equipment is required for this adjustment.

PROCEDURE:

1. Press SELF TEST key. Verify that the key indicator lamp lights. Next, press DISPLAY B "D" function key. Test step item number "1" is displayed in DISPLAY A unit indicator as shown below.

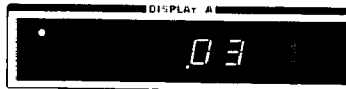

2. Set test frequency to 100kHz by pressing FREQUENCY STEP DOWN or UP key.



## ADJUSTMENTS

3. Check that DISPLAY A readout is .00 within  $\pm 3$  counts.

## Note

If the display readout exceeds the above test limits, change capacitance value of A5\*C70. Increasing the capacitance value by 30pF decreases the display by 1 count. Selectable capacitance value range is 500pF maximum.

4. Adjust potentiometer A5R120 (DC ref ADJ) so that DISPLAY B display output is .00 within  $\pm 10$  counts. See page 5-19 for the location of R120.

## -----Troubleshooting hints-----

If the A5R120 adjustment can not be achieved, an excessive dc offset voltage of A5U16 or a failure in A5U11 circuitry is a probable cause of the trouble. Relative difference in resistance values of A5R116 and R117 is also one of the possibilities.

- 5-19. PROCESS AMPLIFIER DC OFFSET ADJUSTMENT (A4).

- 5-20. This adjustment eliminates any residual dc offset voltage from A4 Process Amplifier and maximizes accuracy of measurement.

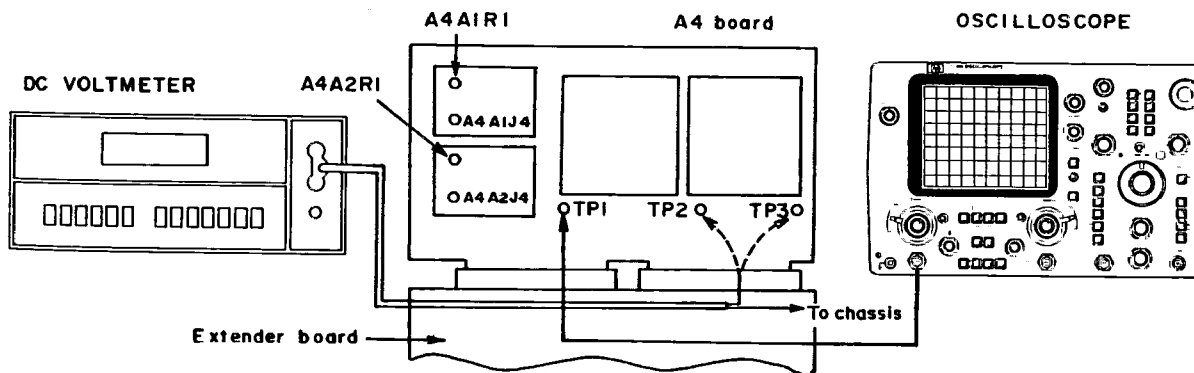

Figure 5-1. Process Amplifier DC Offset Adjustment Setup.

## EQUIPMENT:

Digital Voltmeter .....	HP 3465 A/B
Voltmeter input cable .....	Dual banana to dual alligator clip cable
Oscilloscope .....	HP 1740A
Probe (10M $\Omega$ , 10:1) .....	HP 10004D

## Note

Use extender board (HP Part No: 5060-4025) to gain access to test points and adjustment components on A4 board.

**ADJUSTMENTS**

PROCEDURE:

1. Disconnect the two coaxial cable SMB connectors from A4A1J4 (ERR BLK) and A4A2J4 (EDUT WHT).
2. Connect Digital Voltmeter input to 4275A A4 Process Amplifier board TP2 (-10). Voltmeter display readout should be -10.3V dc within  $\pm 0.5V$ .
3. Connect voltmeter input to A4TP3 (+10). Verify that voltmeter readout is 10.3V within  $\pm 0.5V$ .
4. Remove voltmeter input cable.
5. Set oscilloscope controls as follows:

Vertical sensitivity ..... 5mV/div  
Sweep time ..... 10ms/div

Center baseline with vertical position adjustment control. Externally trigger the oscilloscope from A5TP2.

6. Set 4275A controls as follows:

SELF TEST ..... on  
MULTIPLIER ..... X1  
OSC LEVEL ..... fully cw  
Test signal frequency ..... 100kHz

\* Press REF VALUE STORE key (to select self test step 20, 21, 22, 31, 41 or 51). Now select test step 31 by repeatedly pressing LCRZ RANGE DOWN or UP key (as necessary). The selected test step number is displayed in DISPLAY B unit indicator as shown below:



7. Connect oscilloscope input probe (10:1) to A4TP1. The waveform observed on the oscilloscope will probably be quite similar to that shown in Figure 5-2 below.

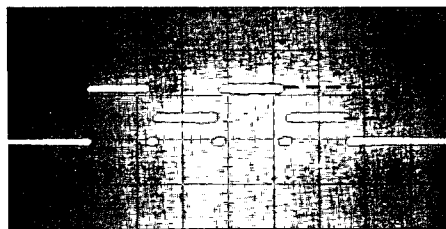

The waveform varies depending on amount of the adjustment error and type of misadjustment.

Figure 5-2. Waveform at A4TP1.

**ADJUSTMENTS**

8. Individually adjust potentiometers \*A4A1R1 and \*A4A2R1 so that peak voltages of both V1 and V2 are 0V within  $\pm 20\text{mV}$  peak (2 minor scale divisions).

**\*Note**

These potentiometers are accessible through an adjustment hole in the shield cover of each sub-board.

---Troubleshooting hints---

If either A4A1R1 or A4A2R1 adjustment can not be achieved, excessive pinch-off current in A4A1Q1 or A4A2Q1 is a probable cause of the trouble. These transistors should be selected in terms of their current characteristics.

9. Reconnect coaxial cable SMB connectors to A4A1J4 and A4A2J4.

5-21. TEST SIGNAL LEVEL ADJUSTMENT (A3).

5-22. This adjustment properly sets test signal level variable range and calibrates front panel level control dial (dial accuracy is unspecified).

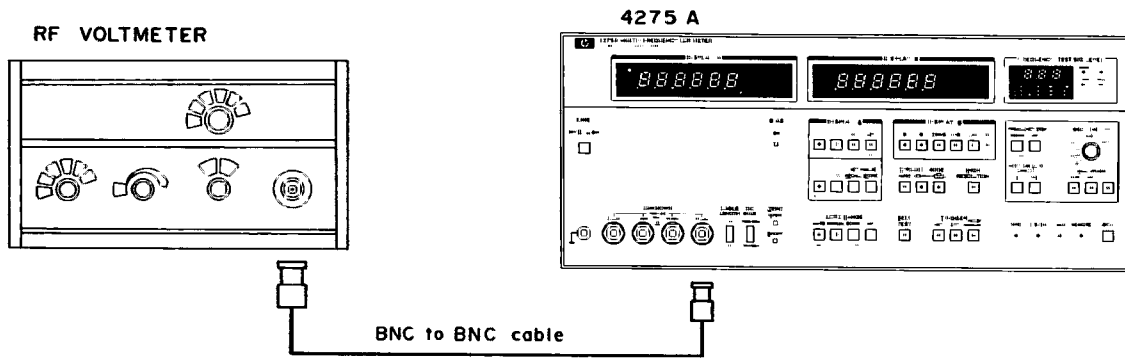

Figure 5-3. Test Signal Level Adjustment Setup.

**EQUIPMENT:**

- RF Voltmeter ..... HP 3403C  
or HP 400E
- Voltmeter input cable ..... BNC to BNC cable

**PROCEDURE:**

1. Connect a BNC to BNC cable between RF voltmeter input and 4275A UNKNOWN  $H_{CUR}$  terminal.
2. Set RF voltmeter range to 1V f.s.

**ADJUSTMENTS**

3. Set 4275A test signal as follows:

Test signal frequency ..... 100kHz  
MULTIPLIER ..... X1  
OSC LEVEL ..... fully cw

4. Read voltmeter indication and note its value.

Voltmeter reading \_\_\_\_\_ mV rms

5. Set 4275A MULTIPLIER to x0.1 and RF voltmeter range to 0.1V f.s.  
6. Adjust potentiometer A3R9 so that voltmeter readout is 1/10 of the voltage value noted in step 4 (within  $\pm 1$ mV rms).  
7. Set 4275A MULTIPLIER to x1 and RF voltmeter range to 1V f.s.  
8. Set 4275A OSC LEVEL control knob to its 1V dial scale point on the front panel.  
9. Adjust A2R92 so that voltmeter readout is 1.02V rms  $\pm 0.01$ V. (refer to A2 Board Adjustment Location page 5-23.)

**Note**

If OSC LEVEL control knob has been mechanically shifted from its normal position, restore as follows:

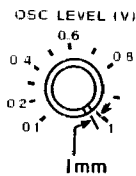

1. Rotate the knob fully cw.
2. Loosen knob retaining screws (two) and set the knob as illustrated at left.
3. Fasten the knob at this position.

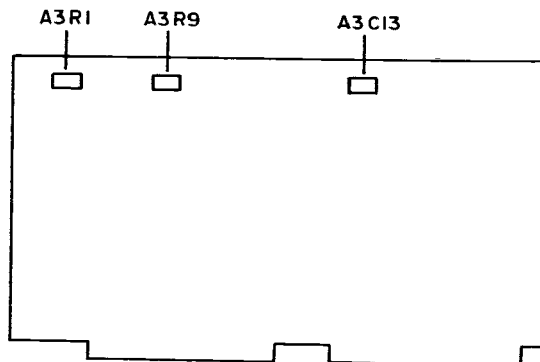

A3 Board Adjustment Locations.

**ADJUSTMENTS**

5-23. TEST SIGNAL LEVEL FLATNESS ADJUSTMENT (A3).

5-24. This adjustment equalizes test signal level for all selectable test frequency points.

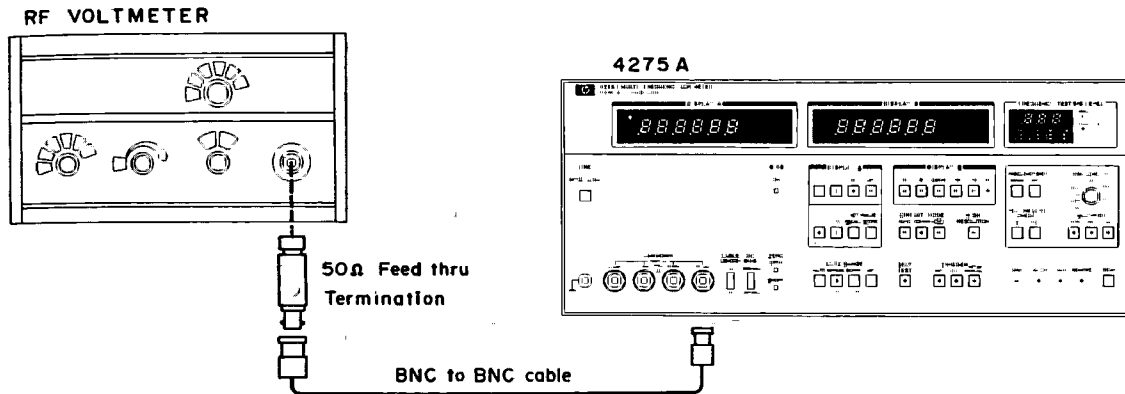

Figure 5-4. Test Signal Level Flatness Adjustment Setup.

**EQUIPMENT:**

- RF Voltmeter ..... HP 3403C  
or HP 400E
- 50Ω feed-through termination ..... -hp- 11048C
- Voltmeter input cable ..... BNC to BNC cable  
(20cm or less)

**PROCEDURE:**

1. Connect a 50Ω feed through termination between 4275A UNKNOWN H CUP terminal and RF voltmeter input using a BNC to BNC cable. See Figure 5-4.
2. Set 4275A controls as follows:
  - Test frequency ..... 100kHz
  - MULTIPLIER ..... x1
  - OSC LEVEL ..... fully cw
3. Set RF voltmeter range to 1V f.s.
4. Read the voltmeter and calculate the formula.
 
$$\text{Voltmeter reading (mVrms)} - 10\text{mV} = \text{___mv}$$
5. Set 4275A test signal frequency to 10MHz.
6. Adjust trimmer capacitor A3C13 so that voltmeter readout is identical to the value calculated in step 4 (within ±5mV).

### ADJUSTMENTS

#### 5-25. BRIDGE BALANCE ADJUSTMENT (A2).

5-26. The bridge balance adjustment is comprised of two independent adjustments for bringing measurement bridge circuit into the optimum balance condition and for maximizing accuracy of measurement. The adjustments included are:

- 1) Bridge zero offset adjustment.
- 2) Balance control phase tracking adjustment.

#### 1. Bridge zero offset adjustment (preliminary).

This adjustment is a preliminary operation to facilitate optimizing the bridge zero offset adjustment. By appropriately performing the zero offset adjustment, any balance control phase error which could cause a slight bridge unbalance with a resultant offset phase count error in the measurement display output to occur is minimized. Final adjustment should be done after the phase tracking adjustment is completed.

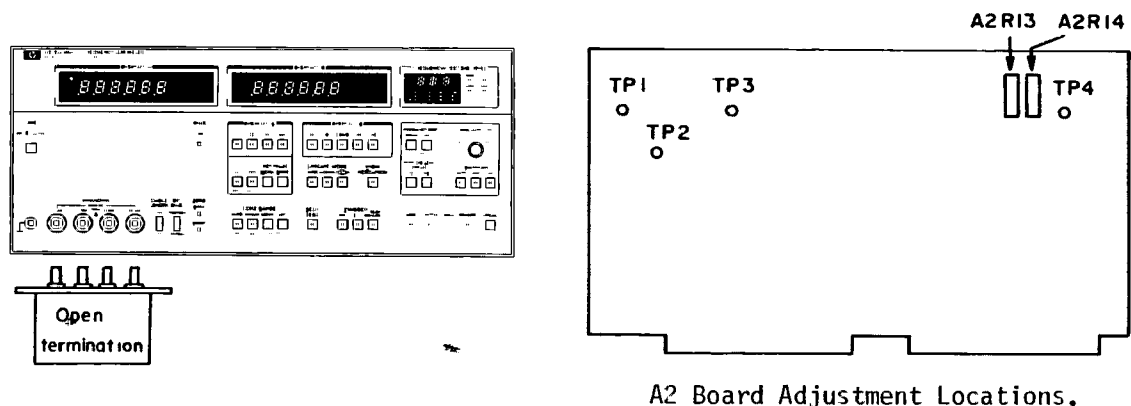

Figure 5-5. Bridge Zero Offset Adjustment Setup.

#### EQUIPMENT:

Open termination ..... HP 16074A Standard Resistor Set

#### Note

If the 16074A Standard Resistor Set is unavailable, use two BNC cables (10cm long).

#### PROCEDURE:

1. Set 4275A CABLE LENGTH switch to "0" position.
- 2. Connect "Open" termination (of the HP 16074A Standard Resistor Set) direct to 4275A UNKNOWN terminals.

#### Note

Otherwise, connect H<sub>CUR</sub> and H<sub>POT</sub> terminals together with a short BNC cable. Similarly connect L<sub>CUR</sub> and L<sub>POT</sub> terminals together.

**ADJUSTMENTS**

3. Set 4275A controls as follows:

DISPLAY A function ..... R  
 Test signal frequency ..... 100kHz  
 MULTIPLIER ..... x1  
 OSC LEVEL ..... fully cw  
 SELF TEST ..... on

4. Press  $\Delta\%$  key to select self test step "7". Test step number "7" is displayed in DISPLAY A unit indicator as illustrated below:



5. Adjust A2R13 (OS1 ADJ) so that DISPLAY A readout is  $.00 \pm 30$  counts.

6. Adjust A2R14 for (OS2 ADJ) for  $.00 \pm 30$  counts on DISPLAY B.

7. Since the A2R13 and R14 adjustments interact, alternately perform steps 5 and 6 until both DISPLAY A and DISPLAY B readouts meet the allowable range limits.

8. Set test signal frequency to 4MHz and verify that both DISPLAY A and DISPLAY B display outputs are  $.00$  within  $\pm 30$  counts. If either of the display outputs exceeds the test limits, repeat steps 5 and 6.

--- Troubleshooting hints ---

If either A2R13 or A2R14 adjustment can not be achieved, an excessive output offset voltage in A2U3 or A2U4 is a probable cause of the trouble.

2. Balance control phase tracking adjustment.

This adjustment optimizes the bridge circuit balance settling time (when a sample device is connected to the UNKNOWN terminals).

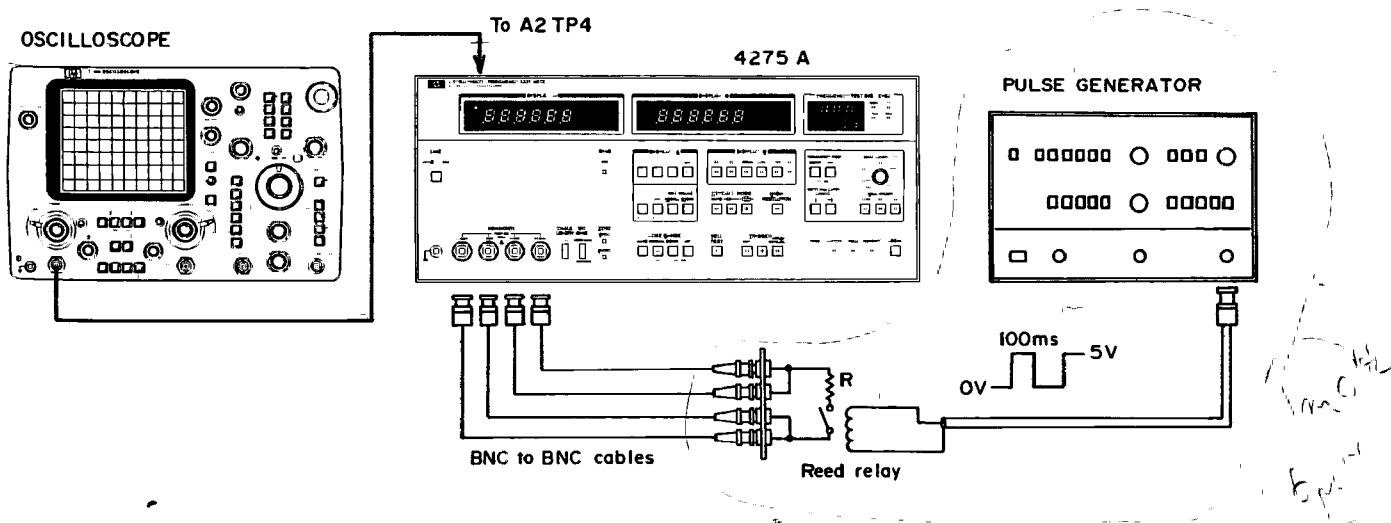

Figure 5-6. Balance Control Phase Tracking Adjustment Setup.

**ADJUSTMENTS**

**EQUIPMENT:**

OSCILLOSCOPE .....	HP 1740A
Probe (10M $\Omega$ , 10:1) .....	HP 10004D
Pulse Generator .....	HP 8011A
Cable .....	BNC to BNC Cable (10cm long, 4ea. required)
.....	BNC cable
Reed relay (5V) .....	-hp- 0490-0916 or equivalent
Resistor: 500 $\Omega$ .....	-hp- 0757-0416 (511 $\Omega$ )
5k $\Omega$ .....	-hp- 0757-0438 (5.11k $\Omega$ )
Bracket .....	HP 16048A accessory

**PROCEDURE:**

1. Connect test equipment as illustrated in Figure 5-6.

Note

Connect a short lead (0 $\Omega$ ) instead of resistor R shown in the figure.

2. Set 4275A controls as follows:

DISPLAY A function ..... R  
 Test frequency ..... 10MHz  
 MULTIPLIER ..... x1  
 OSC LEVEL ..... fully cw  
 SELF TEST ..... on  
 CABLE LENGTH ..... 0

3. Press REF VALUE STORE key.
4. Press 4275A LCRZ RANGE UP and DOWN key until self test step "21" is selected. The selected test step number is displayed in DISPLAY B unit indicator as shown below:



( $\Omega$  unit is displayed)  
 in DISPLAY A.)

5. Set pulse generator output for a 5V peak (0V  5V) squarewave with a periodic rate of 200ms.
6. Set oscilloscope controls as follows:

Vertical sensitivity ..... 0.2V/div  
 Sweep time ..... 10ms/div or longer

Trigger the oscilloscope externally from pulse generator.

7. Connect oscilloscope to A2TP4 to observe waveform.
8. Adjust trimmer capacitors A2C8 and C13 so that damped vibration waveform at A2TP4 decays in the shortest time (see illustration below).

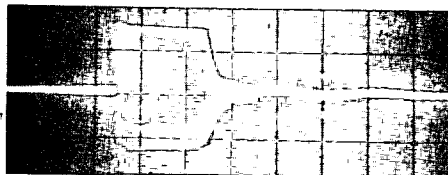



**ADJUSTMENTS**

Since the A2C8 and C13 adjustments interact, alternately repeat the adjustments several times.

9. Change 4275A test signal frequency, in turn, to 4MHz, 2MHz and to 1MHz. Verify that transient time T of the damped vibration waveform at each test frequency is shorter than 20msec.
  10. Connect a 500 $\Omega$  resistor in series with the reed relay contacts (see Figure 5-5).
  11. Press 4275A LCRZ RANGE UP and DOWN key until self test step "20" is selected.
  12. Check that the transient time T of the waveform at A2TP4 is within 20ms at 10MHz, 4MHz, 2MHz and 1MHz test frequencies.
  13. Connect a 5k $\Omega$  resistor in place of the 500 $\Omega$  resistor.
  14. Press 4275A LCRZ RANGE UP and DOWN key until self test step "31" is selected. Set test signal frequency to 10MHz.
  15. Adjust trimmer capacitors A2C9 and C14 so that the transient time T of the waveform at A2TP4 is as short as possible.
  16. Check that the transient time T is within 20ms at 4MHz, 2MHz and 1MHz test frequencies.
3. Bridge zero offset adjustment (final adjustment).
    1. Perform preliminary adjustment procedure steps 1, 2 and 3.
    2. Alternately adjust A2R13 and R14 so that both DISPLAY A and DISPLAY B readouts are .00 within  $\pm 30$  counts.

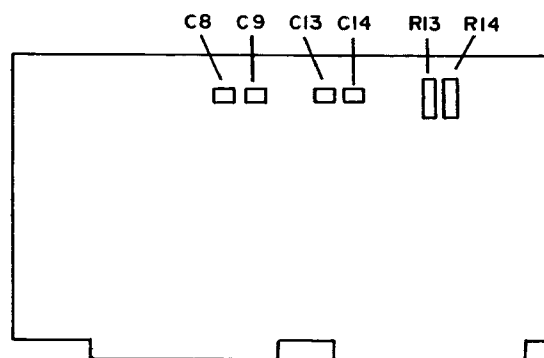

A2 Board Adjustment Locations.

**ADJUSTMENTS**

5-27. PROCESS AMPLIFIER GAIN ADJUSTMENT (A4).

5-28. This adjustment eliminates any amplification factor errors from A4 Process Amplifier so that bridge circuit vector signal voltages are exactly detected thus maximizing accuracy of measurement.

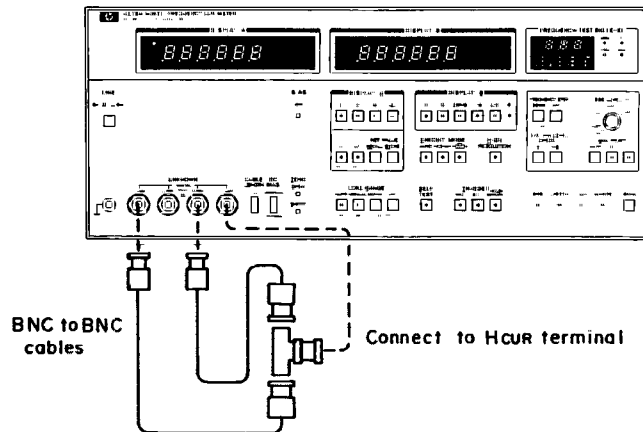

Figure 5-7. Process Amplifier Gain Adjustment Setup.

**EQUIPMENT:**

- Connection cable (10cm long) ..... BNC to BNC cable  
 2ea. required
- BNC Tee adapter ..... -hp- 1250-0781

**Note**

The relative difference in cable length of the two BNC cables used must be within  $\pm 0.3\text{cm}$ .

**PROCEDURE:**

1. Connect BNC cables and a BNC Tee adapter as illustrated in Figure 5-7.
2. Disconnect coaxial cable connector from A1J2 (Lc) and connect it to A4A1J4 in place of the normal cable connector.
3. Set 4275A controls as follows:
  - DISPLAY A function ..... R
  - Test signal frequency..... 100kHz
  - MULTIPLIER ..... x1
  - OSC LEVEL ..... fully cw
  - SELF TEST ..... on
4. Press REF VALUE STORE key.
5. Press LCRZ RANGE UP and DOWN key until self test step "20" is selected and is displayed in DISPLAY B unit indicator as shown below:

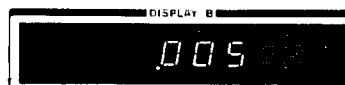

**ADJUSTMENTS**

6. Adjust potentiometer A4A1R8 so that DISPLAY A display output is -100000 within  $\pm 20$  counts.
7. Set test signal frequency to 10MHz.
8. Adjust trimmer capacitor A4A1C3 so that DISPLAY B display output is .000 within  $\pm 20$  counts.

**Note**

Check that DISPLAY A readout is within  $100000 \pm 300$  counts (after doing the A4A1C3 adjustment).

9. Reconnect the cables shifted in step 2 to their normal connection points.

**Troubleshooting hints**

If the A4A1C3 adjustment can not be achieved, change value of A4A2C3 (normally 3.6pF) to a value calculated from the DISPLAY B offset count by using the equation below:

A4A1C3 is in its fully ccw position --

$$\text{Value of A4A2C3} = \left( 5.6 + \frac{\text{Offset count}}{135} \right) \text{ pF}$$

A4A1C3 is in its fully cw position --

$$\text{Value of A4A2C3} = \left( 1.6 - \frac{\text{Offset count}}{135} \right) \text{ pF}$$

C3 selectable value range is 0pF to 8pF.

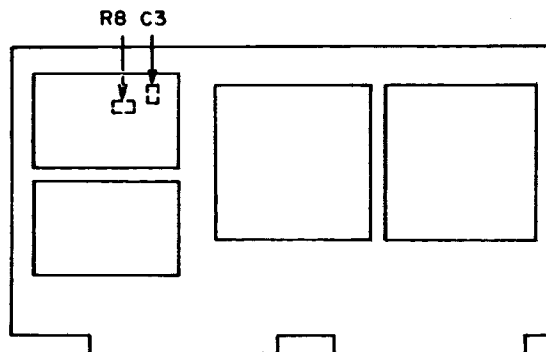

A4 Board Adjustment Locations.

**ADJUSTMENTS**

5-29. ATTENUATOR ADJUSTMENT (A5, A4).

5-30. This adjustment eliminates errors in the attenuation circuit attenuation ratios from A5 A-D Converter input circuit for maximizing accuracy of measurement for each test signal level setting. This adjustment consists of four adjustment steps, which are:

- 1) 1/2 attenuator adjustment (A5)
- 2) 1/4 attenuator adjustment (A5)
- 3) 1/10 attenuator adjustment (A4)
- 4) 1/100 attenuator adjustment (A4)

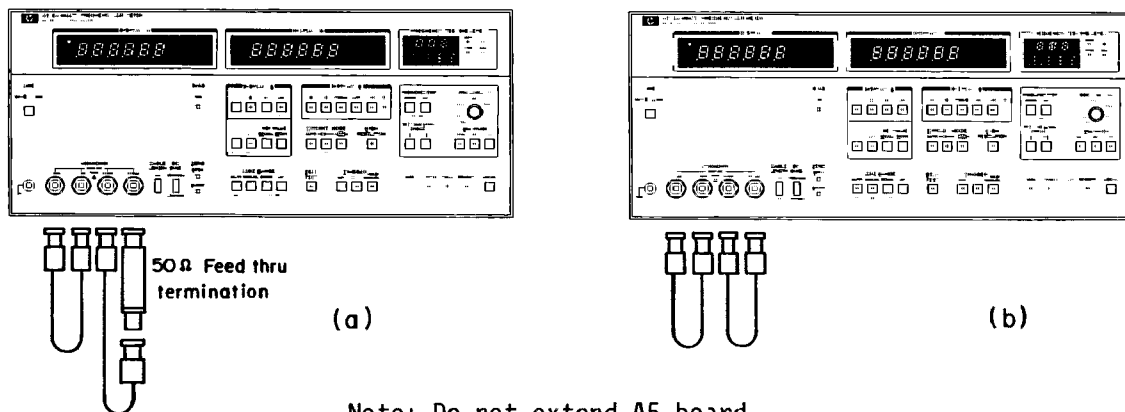

Note: Do not extend A5 board.

Figure 5-8. Attenuator Adjustment Setup.

**EQUIPMENT:**

- 50Ω feed-through termination ..... -hp- 11048C
- Connection cable (10cm long) ..... BNC to BNC cables  
 2ea. required

**PROCEDURE:**

1) 1/2 attenuator adjustment.

1. Connect a 50Ω feed-through termination and two BNC cables to 4275A UNKNOWN terminals as shown in Figure 5-8 (a).
2. Set 4275A controls as follows:

Test signal frequency ..... 100kHz  
 MULTIPLIER ..... x1  
 OSC LEVEL ..... fully cw  
 CABLE LENGTH ..... 0  
 SELF TEST ..... on

3. Press DISPLAY B function Q button to select self test step "2". The test step number "2" is displayed in DISPLAY A unit indicator as shown below:



**ADJUSTMENTS**

4. Adjust potentiometer A5R11 so that DISPLAY A display output is -100000 within  $\pm 10$  counts.
5. Set test signal frequency to 10MHz.
6. Adjust potentiometer A5R4 (1/2 $\phi$  ADJ) so that DISPLAY B display output is .00 within  $\pm 20$  counts.

Note

Check that DISPLAY A display output is -100000 within  $\pm 600$  counts after doing the A5R4 adjustment.

2) 1/4 attenuator adjustment.

1. Remove 50 $\Omega$  feed-through termination and connect BNC cable between UNKNOWN H CUR and H POT terminals. See Figure 5-8 (b).
2. Set 4275A controls as follows:

Test signal frequency ..... 100kHz  
 MULTIPLIER ..... x1  
 OSC LEVEL ..... fully cw  
 SELF TEST ..... on

3. Press DISPLAY B function ESR/G key to select self test step "3". DISPLAY A unit indicator displays the number "3" as shown below.



4. Adjust potentiometer A5R16 so that DISPLAY A display readout is -100000 within  $\pm 10$  counts.
5. Set test signal frequency to 10MHz.
6. Adjust trimmer capacitor A5C15 (1/4  $\phi$  ADJ) so that DISPLAY B display output is .00 within  $\pm 20$  counts.

Note

Check that DISPLAY A display output is -100000 within  $\pm 600$  counts (after doing the A5C15 adjustment).

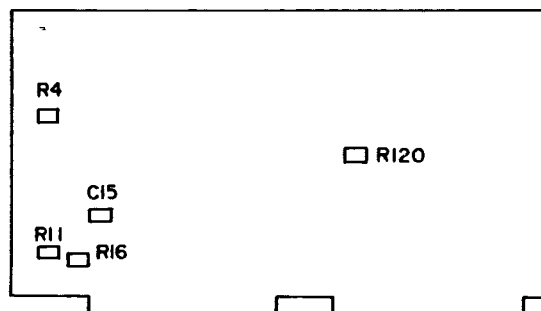

A5 Board Adjustment Locations.

**ADJUSTMENTS**

- 3) 1/10 attenuator adjustment.
  1. Connect BNC cables to UNFOWN terminals as shown in Figure 5-8 (b).
  2. Set 4275A controls as follows:

Test signal frequency ..... 100kHz  
MULTIPLIER ..... x0.1  
OSC LEVEL ..... fully cw  
SELF TEST ..... on

3. Press DISPLAY B function X/B key to select self test step "4".  
DISPLAY A unit indicator displays the number "4" as shown below.



4. Adjust potentiometer A4A3R10 so that DISPLAY A display output is -100000 within  $\pm 10$  counts.
5. Set test signal frequency to 10MHz.
6. Adjust trimmer capacitor A4A3C3 so that DISPLAY B display output is .00 within  $\pm 40$  counts.

Note

Check that DISPLAY A display output is -100000 within  $\pm 800$  counts (after doing the A4A3C3 adjustment).

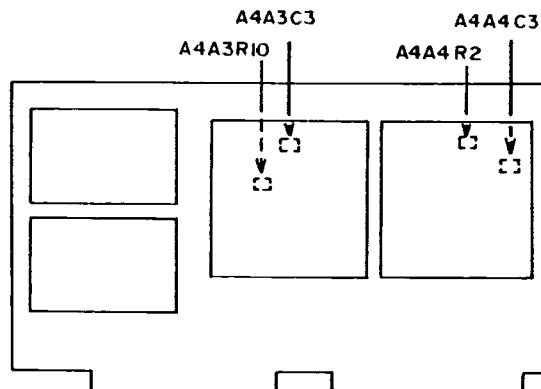

A4 Board Adjustment Locations.

**ADJUSTMENTS**

## 4) 1/100 attenuator adjustment.

1. Connect BNC cables to UNKNOWN terminals as shown in Figure 5-8 (b).
2. Set 4275A controls as follows:

Test signal frequency ..... 100kHz  
 MULTIPLIER ..... x0.01  
 OSC LEVEL ..... fully cw  
 SELF TEST ..... on

3. Press DISPLAY B function L/C key to select self test step "5".  
 DISPLAY A unit indicator displays the number "5" as shown below:



4. Adjust potentiometer A4A4R2 so that DISPLAY A display output is -100000 within  $\pm 10$  counts.
5. Set test signal frequency to 10MHz.
6. Adjust trimmer capacitor A4A4C3 so that DISPLAY B display output is .00 within  $\pm 40$  counts.

**Note**

Check that DISPLAY A display output is -100000 within  $\pm 800$  counts (after doing the A4A4C3 adjustment).

**ADJUSTMENTS**

5-31. TEST SIG LEVEL CHECK ACCURACY ADJUSTMENT (A3, A2).

5-32. This adjustment appropriately adjusts the test signal level monitor circuit for appropriate sensitivity and frequency flatness to maximize the accuracy of test signal level display (FREQUENCY/TEST SIG LEVEL display) for all test signal level and frequency settings.

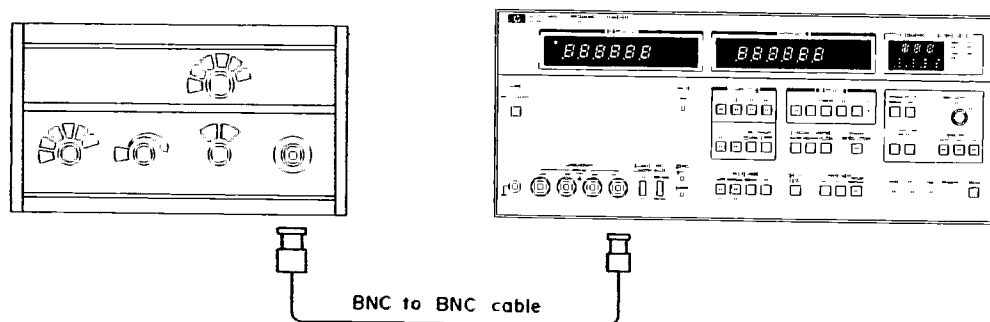

Figure 5-9. Test Signal Level Check Accuracy Adjustment Setup.

**EQUIPMENT:**

- RF Voltmeter ..... HP 3403C  
 or HP 400E
- Voltmeter input cable ..... BNC to BNC cable
- Open termination ..... HP 16074 Standard  
 Resistor Set

**Note**

If the 16074A Standard Resistor Set is unavailable, use two BNC cables (10cm long).

**PROCEDURE:**

1. Connect "Open" termination (of the HP 16074A Standard Resistor Set) to 4275A UNKNOWN terminals.

**Note**

Otherwise, connect H<sub>CUP</sub> and H<sub>POT</sub> terminals together with a short BNC cable. Similarly connect L<sub>CUP</sub> and L<sub>POT</sub> terminals.

2. Set 4275A controls as follows:

- DISPLAY A function ..... C
- DISPLAY B function ..... ESR/G
- Test signal frequency ..... 100kHz
- MULTIPLIER ..... x1
- OSC LEVEL ..... 1
- LCRZ RANGE ..... AUTO



**ADJUSTMENTS**

## Note

Set OSC LEVEL control knob to its "1" dial position (not to its full cw position).

## Note

Check that both DISPLAY A and DISPLAY B display outputs are  $.0 \pm 20$  counts.

3. Press and hold TEST SIG LEVEL CHECK V key.
4. Adjust potentiometer A3R1 so that FREQUENCY/TEST SIG LEVEL display output is 1.01 (V) within  $\pm 1$  count.
5. Connect RF voltmeter input to 4275A UNKNOWN H COUP terminal with a BNC to BNC connector as shown in Figure 5-9.
6. Adjust potentiometer A2R92 for  $1.02V \pm 0.01V$  rms on the RF voltmeter indication.
7. Set test signal frequency to 10MHz. Connect "Open" termination to 4275A UNKNOWN terminals.
8. Check that FREQUENCY/TEST SIG LEVEL display output is  $0.90V \pm 0.05V$ .

## Note

Do not use an extender board with A3 board for this check.

## Note

Test signal level actually falls to about  $0.95V_{rms}$  at 10MHz because of residual capacitance between inner conductor and outer shield of the OPEN termination.

9. If the display value is incorrect, change the value of A3C76. Increasing the capacitance increases the displayed voltage value.

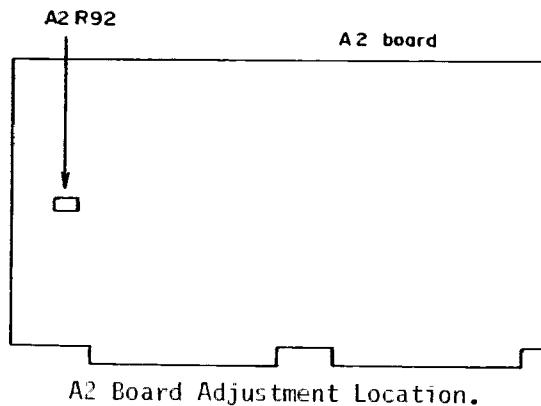

**ADJUSTMENTS**

Confirmation check 1

Set MULTIPLIER to x0.1 and to x0.01. Check that the test limits given in the table below are satisfied (at 10MHz).

MULTIPLIER Setting	TEST SIG LEVEL display
x0.1	.088 to .112
x0.01	.007 to .013

Confirmation check 2

- a. Connect "Short" termination (of the HP 16074A Standard Resistor Set) to 4275A UNKNOWN terminals.

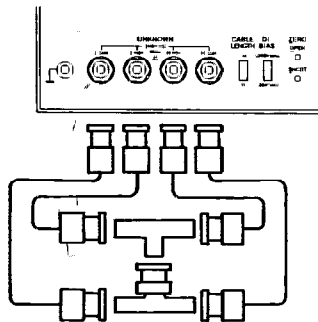

Note

Otherwise, connect short BNC cables and BNC Tee adapters as illustrated at left.

- b. Set 4275A controls as follows:

DISPLAY A function ..... R  
 DISPLAY B function ..... X/B  
 Test signal frequency ..... 100kHz  
 MULTIPLIER ..... x1  
 OSC LEVEL ..... 1  
 LCRZ RANGE ..... AUTO

- c. Press and hold TEST SIG LEVEL CHECK mA key.  
 d. Check that FREQUENCY/TEST SIG LEVEL display output is 10.0mA within  $\pm 0.5$ mA.

**ADJUSTMENTS**

5-33. CMR AMPLIFIER GAIN ADJUSTMENT (A1).

5-34. This adjustment properly sets the amplification factor of A1 CMR amplifier which compensates for test signal propagation losses in the range resistor circuit (internal wiring losses) to maximize accuracy of measurement.

EQUIPMENT:

Cable (10cm long) ..... BNC to BNC cable

PROCEDURE:

1. Connect 4275A UNKNOWN H<sub>CUP</sub> and H<sub>POT</sub> terminals together with a short BNC cable.
2. Set 4275A controls as follows:

Test signal frequency ..... 100kHz  
 OSC LEVEL ..... fully cw  
 SELF TEST ..... on

3. Press REF VALUE RECALL key to select self test step "8". DISPLAY A unit indicator displays the number "8" as shown below.

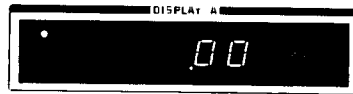

4. Adjust potentiometer A1R3 for minimum display readout (less than 10000 counts) on DISPLAY A.

Note

If the A1R3 adjustment can not be achieved, change value of A1R4 (normally 316Ω). Adjustable range is 256Ω to 316Ω.

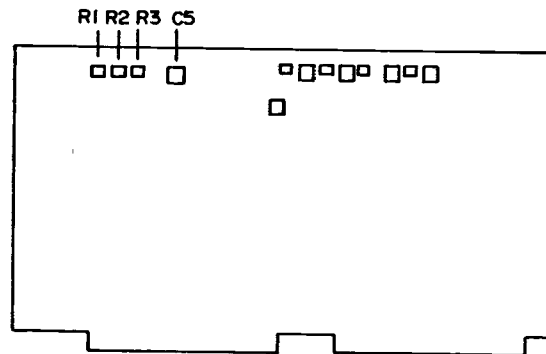

A1 Board Adjustment Locations.

### ADJUSTMENTS

#### 5-35. RANGE RESISTOR ADJUSTMENTS (A1).

5-36. The range resistor adjustments fix the values of the bridge circuit reference resistor elements (range resistors) to maximize accuracy on each measurement range. The adjustments are made by connecting a standard resistor or a standard capacitor as a DUT, and by setting the range resistor adjustment potentiometers and phase compensators for the calibrated values of the standard on measurement display outputs.

#### EQUIPMENT:

Standard resistors ..... HP 16074A Standard  
(100 $\Omega$ , 1k $\Omega$ , 10k $\Omega$ , 100k $\Omega$  $\pm$ 0.03%) Resistor Set

10pF Standard capacitor ( $\pm$ 0.03%) ..... HP 16382A

#### Note

The HP 16382A is a component of  
the HP 16380A Standard Capacitor Set.

#### PROCEDURE:

##### 1) Range resistor adjustments.

1. Set 4275A controls as follows:

DISPLAY A function ..... R  
DISPLAY B function ..... X  
Test signal frequency ..... 100kHz  
MULTIPLIER ..... x0.1  
OSC LEVEL ..... fully cw  
SELF TEST ..... on  
CABLE LENGTH switch ..... 0

2. Press REF VALUE STORE key. Self test step number "21" is displayed in DISPLAY B unit indicator as shown below:

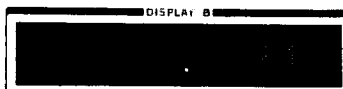

3. Press LCRZ RANGE UP or DOWN key to select self test step "50" (monitor DISPLAY B unit indicator display).
4. Connect a 100k $\Omega$  standard resistor (direct) to 4275A UNKNOWN terminals.
5. Adjust potentiometer A1R31 so that DISPLAY A display output is the calibrated value of the standard resistor within  $\pm$ 20 counts.

#### Note

Unit indicator displays " $\mu$ S" instead of k $\Omega$ .

6. Press LCRZ RANGE DOWN key once to select self test step "40".
7. Connect a 10k $\Omega$  standard resistor in place of the 100k $\Omega$  resistor.
8. Adjust potentiometer A1R30 so that DISPLAY A display output is the calibrated value of the standard resistor within  $\pm$ 20 counts.

**ADJUSTMENTS**

9. Press LCRZ RANGE DOWN key once to select self test step "30".
10. Connect a 1kΩ standard resistor in place of the 10kΩ resistor.
11. Adjust potentiometer AIR29 so that DISPLAY A display output is the calibrated value of the standard resistor within ±20 counts.
12. Press LCRZ RANGE DOWN key once to select self test step "20".

Note

DISPLAY A unit indicator displays "mS".

13. Connect a 100Ω standard resistor in place of the 1kΩ resistor.
14. Adjust potentiometer AIR28 so that DISPLAY A display output is the calibrated value of the standard resistor within ±20 counts.

15 - 22 >

2) Range resistor phase adjustments.

1. Set 4275A controls as follows:

DISPLAY A function ..... C  
 DISPLAY B function ..... D  
 Test signal frequency ..... 100kHz  
 MULTIPLIER ..... X0.1  
 OSC LEVEL ..... fully cw  
 SELF TEST ..... off  
 HIGH RESOLUTION ..... off  
 CABLE LENGTH switch ..... 0  
 LCRZ RANGE ..... AUTO

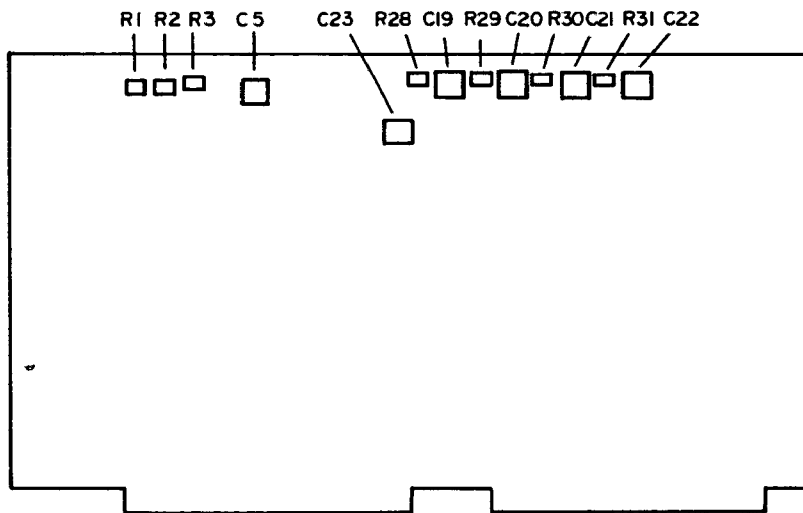

A1 Board Adjustment Locations.

### ADJUSTMENTS

2. Connect a 10pF standard capacitor direct to 4275A UNKNOWN terminals.

Note

Test leads should not be used for any phase adjustment.

3. Adjust trimmer capacitor A1C22 so that dissipation factor readout on DISPLAY B is within the range of .0000 and .0004.
4. Set test signal frequency to 1MHz.
5. Adjust trimmer capacitor A1C21 so that dissipation factor readout is within the range of -.0001 and .0003.
6. Set test signal frequency to 10MHz.
7. Adjust trimmer capacitor A1C23 so that capacitance readout on DISPLAY A is the calibrated value of the standard capacitor within  $\pm 20$  counts ( $\pm 0.02\text{pF}$ ).
8. Adjust trimmer capacitor A1C20 so that dissipation factor readout on DISPLAY B is .0010 within  $\pm 20$  counts.

----- Troubleshooting hints -----

- 1) If correct results cannot be obtained in adjustments 3, 5, 7, or 8, try raising the related range resistor away from the printed circuits. This will reduce the stray capacitance.
- 2) If A1C21 adjustment can not be achieved, change value of capacitor A1C27 (normally 7.5pF). Increasing the capacitance of C27 decreases DISPLAY B display counts. Adjustable value range is 0 to 10pF.
- 3) If A1C23 adjustment can not be achieved, change value of capacitor A1C28 (normally 62pF). Increasing the capacitance of C28 decreases DISPLAY A display counts. Adjustable value range is 37 to 87pF.
- 4) If A1C20 adjustment can not be achieved, change value of capacitor A1C26 (normally 5.1pF). Increasing the capacitance of C26 decreases DISPLAY B display counts. Adjustable value range is 0 to 10pF.

**ADJUSTMENTS**

5-37. CMR AMPLIFIER 2MHz GAIN ADJUSTMENT (A1).

5-38. This adjustment optimizes CMR amplifier gain (preliminarily adjusted in paragraph 5-34) to maximize accuracy of measurement at 2MHz test signal frequency.

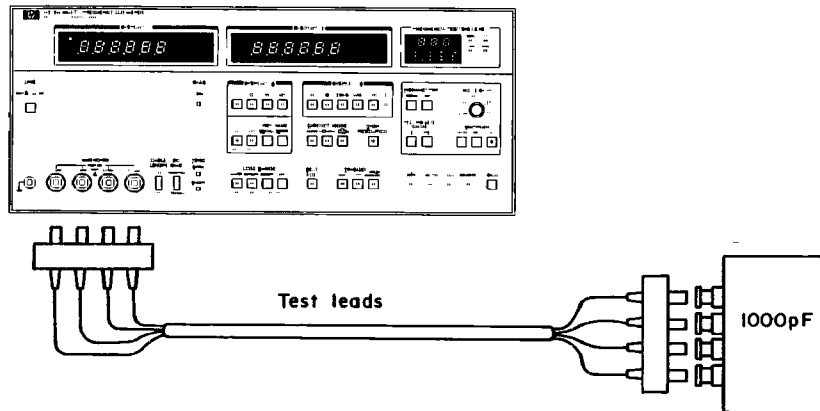

Figure 5-10. CMR Amplifier 2MHz Gain Adjustment Setup.

**EQUIPMENT:**

- 1000pF standard capacitor ..... HP 16384A
- Test leads (1m long) ..... HP 16048A

**Note**

The HP 16384A is a component of the Hp 16380A Standard Capacitor Set.

**PROCEDURE:**

1. Set 4275A controls as follows:

- DISPLAY A function ..... C
- DISPLAY B function ..... D
- CIRCUIT MODE ..... AUTO
- Test signal frequency ..... 2MHz
- MULTIPLIER ..... x0.1
- OSC LEVEL ..... fully cw
- CABLE LENGTH ..... 0

2. Connect a 1000pF standard capacitor direct to 4275A UNKNOWN terminals.
3. Read dissipation factor display output on DISPLAY B and note its value as "X".
4. Set 4275A CABLE LENGTH switch to "1m" position.
5. Connect the 1000pF standard capacitor using 1m test leads as shown in Figure 5-10.

**ADJUSTMENTS**

6. Read dissipation factor display output (as "Y" value).

0.016

7. Calculate the value given by the following equation:

$$X_{adj} = \frac{X+Y}{2}$$

$$\frac{0.002 + 0.016}{2} = 0.009$$

8. Adjust potentiometer A1R3 so that the dissipation factor readout (on DISPLAY B) is identical to the calculated Xadj value.

9. Repeat steps 1 through 8 until the following condition is satisfied.

$$X_{adj} = \frac{X+Y}{2} \pm 5 \text{ counts}$$

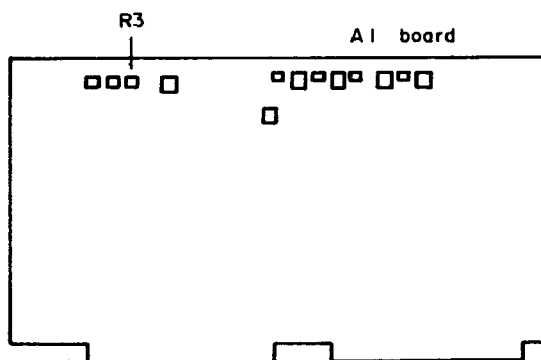

A1 Board Adjustment Locations.

5-39. 4MHz/10MHz CMR AMPLIFIER AND RANGE RESISTOR PHASE ADJUSTMENTS (A1).

5-40. This adjustment optimizes CMR amplifier gain and properly sets range resistor signal phase compensator to maximize accuracy of measurement at 4MHz and 10MHz test signal frequencies.

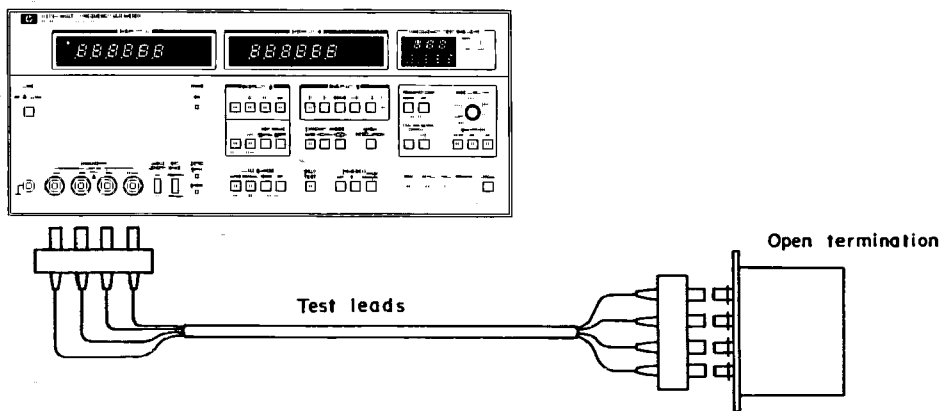

Figure 5-11. 10MHz CMR Amplifier and Range Resistor phase Adjustment Setup.



**ADJUSTMENTS****EQUIPMENT:**

Standard capacitor 10pF .....	HP 16382A
100pF .....	HP 16383A
Test leads (1m long) .....	HP 16048A
Open termination .....	HP 16074A
Short termination .....	Standard Resistor Set

**Note**

The 16074A accessory test leads can be used as 1m test leads (instead of HP 16048A).

**PROCEDURE:**

1. Set 4275A controls as follows:

DISPLAY A function .....	C
DISPLAY B function .....	D
Test signal frequency .....	10MHz
MULTIPLIER .....	x0.1
OSC LEVEL .....	fully cw
CABLE LENGTH .....	1m

2. Connect 1m test leads to 4275A UNKNOWN terminals and to "Open" termination (of the 16074A Standard Resistor Set) as illustrated in Figure 5-11.
3. Press 4275A ZERO OPEN button to perform (open) zero offset adjustment.
4. Connect "Short" termination (of the 16074A Standard Resistor Set) in place of the "Open" termination.
5. Press ZERO SHORT button to perform (short) zero offset adjustment.
6. Connect a 10pF standard capacitor at end of test leads in place of the "Short" termination.
7. Read capacitance and dissipation factor display outputs (in DISPLAY A and DISPLAY B). Note the readouts in counts as follows:
 

Capacitance value .....	X counts	9.55 PF
Dissipation factor value .....	Y counts	0.078
8. Connect a 100pF standard capacitor in place of the 10pF capacitor.
9. Adjust trimmer capacitor A1C5 so that capacitance display output in DISPLAY A is X counts within  $\pm 50$  counts.
10. Adjust potentiometer A1R2 so that dissipation factor display output in DISPLAY B is Y counts within  $\pm 50$  counts.
11. Since A1C5 and A1R2 adjustments interact, repeat steps 7 and 10 several times.

**ADJUSTMENTS**

12. Set test signal frequency to 4MHz.
13. Adjust potentiometer A1R1 so that dissipation factor display output in DISPLAY B is 00 counts within  $\pm 20$  counts.
14. Disconnect test leads. Set 4275A CABLE LENGTH switch to "0" position.
15. Connect "Open" termination direct to 4275A UNKNOWN terminals.
16. Press ZERO OPEN button to perform (open) zero offset adjustment.
17. Connect "Short" termination direct to 4275A UNKNOWN terminals in place of the "Open" termination.
18. Press ZERO SHORT button to perform (short) zero offset adjustment.
19. Connect a 100pF standard capacitor direct to 4275A UNKNOWN terminals in place of the "Short" termination.
20. Adjust trimmer capacitor A1C19 so that dissipation factor display output in DISPLAY B is .0010 within  $\pm 20$  counts.
21. Since A1C5, A1R2, A1R1 and A1C19 adjustments interact, again perform steps 1 through 20 (to improve adjustment accuracy).

----- Troubleshooting hints -----

If A1C19 adjustment can not be achieved, change values of both A1C24 and C25 (normally 4.3pF). Increasing the value increases display counts. Adjustable value range is 0pF to 10pF.



A1 Board Adjustment Locations.

**ADJUSTMENTS**

5-41.  $\pm 35V$  INTERNAL DC BIAS SUPPLY ADJUSTMENT (A21) (Opt. 001 only).

PURPOSE:

To set internal dc voltage and the gain of DAC and Amplifier so that accurate dc bias voltages can be applied to the sample in response to bias control input.

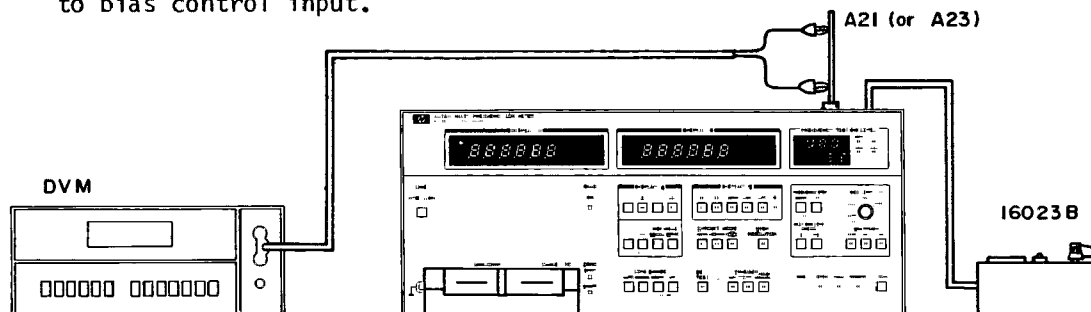

Figure 5-12. Internal DC Bias Supply Adjustment Setup.

EQUIPMENT:

- Bias Controller ..... HP 16023B
- Digital Voltmeter ..... HP 3465B

PROCEDURE:

1. Set 4275A controls as follows:

- DC BIAS Switch.....  $\pm 35v$  MAX
- DISPLAY A function ..... C
- TRIGGER ..... MANUAL
- MULTIPLIER ..... X .01
- OSC LEVEL ..... Fully CCW
- Other Controls ..... Any Settings
- DC BIAS Selector SW ..... INT 35V/100V ( $C \leq .1\mu F$ )  
(rear panel)

2. Set 16023B DC Bias Controller thumbwheel switch to 0.00 and connect its 24 pin male connector to INT DC BIAS CONTROL Connector on the 4275A rear panel. See Figure 5-12.
3. Take out A21 board. Install extender board in A21 slot and install A21 board in extender.

CAUTION:

Before taking A21 board out, DC Bias connector board must be pulled out toward the rear panel by loosening its two screws.

4. Set DVM controls as follows:

- FUNCTION ..... V
- RANGE ..... 200V

5. Connect DVM plus input to the negative lead of A21C19 ( $-42V$ ) and minus input to the positive lead of A21C19 ( $GND \nabla$ ) with dual banana to alligator clip cable.

**ADJUSTMENTS**

6. Adjust A21R83 so the DVM reads  $-42V \pm 0.1V$  and check that the voltage across A21C18 is within  $+42.0V \pm 1.0V$ .

Note

Change DVM range control to the appropriate setting for the adjustments that follow.

7. Change 16023B thumbwheel switch setting to  $-.00V \times 1$ . Press ENTER button.
8. Connect DVM plus input to A21TP3 and minus input to XA21 16R connector pin (GND  $\nabla$ ).
9. Adjust A21R12 until the DVM reads  $0V \pm 0.1mV$ .
10. Change 16023B thumbwheel switch setting to  $+.00V \times 1$ . Press ENTER button.
11. Adjust A21R11 until the DVM reads  $0V \pm 0.1mV$ .
12. Remove DVM plus input from A21TP3 and connect it to TP2.
13. Adjust A21R8 until the DVM reads  $0V \pm 0.1mV$ .
14. Change 16023B thumbwheel switch setting to  $-9.00V \times 1$ . Press ENTER button.
15. Adjust A21R13 until the DVM reads  $-9V \pm .002V$ .
16. Remove DVM input cable and 16023B from 4275A.

Note

Although the variable resistor A21R48 is mounted on the A21 board, it is a "factory only" adjustable component and is not field adjustable.

5-42.  $\pm 100V$  INTERNAL DC BIAS SUPPLY ADJUSTMENT (A23) (Opt. 002 only).

PURPOSE and EQUIPMENT:

Same as in Para. 5-41.

PROCEDURE:

1. Set 4275A controls as follows:

DC BIAS Switch .....  $\pm 200V$  MAX  
TRIGGER ..... MANUAL  
DISPLAY A function ..... C  
OSC LEVEL ..... Fully CCW  
Other Controls ..... Any settings  
DC BIAS Selector SW ..... INT 35V/100V ( $C \leq .1\mu F$ )  
(rear panel)

2. Set 16023B DC Bias Controller thumbwheel switch to .000 and connect its 24 pin male connector to INT DC BIAS CONTROLLER connector on the 4275A rear panel. Refer to Figure 5-12 except for the difference in test pins and board number.

**ADJUSTMENTS**

3. Take out A23 board. Install extender board in A23 slot and install A23 board in extender.

Note

Before taking A23 board out, DC Bias connector board must be pulled out toward rear panel by loosening its two screws.

4. Set DVM controls as follows:

FUNCTION ..... V  
RANGE ..... 200V

5. Connect DVM plus input to the negative lead of A23C26 and minus input to the positive lead of A23C26 with dual banana to alligator clip cable.
6. Adjust A23R55 until the DVM reads  $-42.0V \pm 0.1V$ .

Note

Change DVM range control to the appropriate setting for the adjustments that follow:

7. Connect DVM plus input to the A23TP2 and minus input to the XA23 16R connector pin (GND  $\nabla$ ).
8. Set 16023B thumbwheel switch control to  $-.00V \times 1$ . Press ENTER button.
9. Adjust A23R11 until the DVM reads  $0V \pm 0.1mV$ .
10. Change 16023B thumbwheel switch setting to  $+0.00 \times 1$ . Press ENTER button.
11. Adjust A23R10 until the DVM reads  $0V \pm 0.1mV$ .
12. Disconnect DVM plus input from A23TP2 and connect it to TP1.
13. Change 16023B thumbwheel switch setting to  $-0.00V \times 1$ . Press ENTER button.
14. Adjust A23R8 until the DVM reads  $0V \pm 2mV$ .
15. Change 16023B thumbwheel switch setting to  $-9.00V \times 10$ . Press ENTER button.
16. Adjust A23R9 until the DVM reads  $-90V \pm 40mV$ .
17. Remove DVM input cable and 16023B from 4275A.

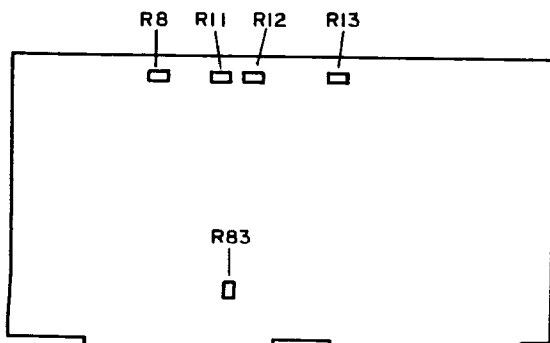

A21 Board Adjustment Locations.

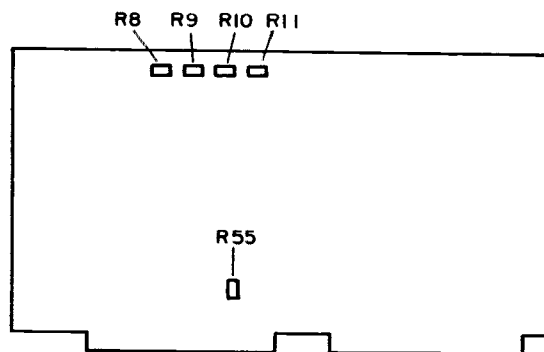

A23 Board Adjustment Locations.

## SECTION VI REPLACEABLE PARTS

### 6-1. INTRODUCTION.

6-2. This section contains information for ordering parts. Table 6-1 lists abbreviations used in the parts list and throughout the manual. Table 6-3 lists all replaceable parts in reference designator order. Table 6-2 contains the names and addresses that correspond to the manufacturer's code numbers.

### 6-3. ABBREVIATIONS.

6-4. Table 6-1 lists abbreviations used in parts list, schematics and throughout the manual. In some cases, two forms of abbreviations are used, one in all capital letters, and one in partial capitals or no capitals. This occurs because the abbreviations in parts list are always all capitals. However, in the schematics and in other parts of the manual, other abbreviation forms with both lower case and upper case letters are used.

### 6-5. REPLACEABLE PARTS LIST.

6-6. Table 6-3 is a list of replaceable parts and is organized as follows:

- a. Electrical assemblies and their components in alphanumerical order by reference designation.
- b. Chassis-mounted parts in alphanumerical order by reference designation.
- c. Miscellaneous parts.
- d. Illustrated parts breakdowns, if appropriate.

The information for each part includes:

- a. The Hewlett-Packard part number.
- b. The total quantity (Qty) in the instrument.

Table 6-1. List of Reference Designators and Abbreviations

REFERENCE DESIGNATORS			
A = assembly B = motor BT = battery C = capacitor CP = coupler CR = diode DL = delay line DS = device signaling (lamp)	E = misc electronic part F = fuse FL = filter J = jack K = relay L = inductor M = meter MP = mechanical part	P = plug Q = transistor R = resistor RT = thermistor S = switch T = transformer TB = terminal board TP = test point	U = integrated circuit V = vacuum, tube, neon bulb, photocell, etc VR = voltage regulator W = cable X = socket Y = crystal
ABBREVIATIONS			
A = amperes A F C = automatic frequency control AMPL = amplifier B F O = beat frequency oscillator BE CU = beryllium copper BH = binder head BP = bandpass BRS = brass BWO = backward wave oscillator CCW = counter-clockwise CER = ceramic CMO = cabinet mount only COEF = coefficient COM = common COMP = composition COMPL = complete CONN = connector CP = cadmium plate CRT = cathode-ray tube CW = clockwise DEPC = deposited carbon DR = drive ELECT = electrolytic ENCAP = encapsulated EXT = external F = farads f = femto = 10 <sup>-15</sup> FH = flat head FIL H = fillister head FXD = fixed G = giga = 10 <sup>9</sup> GE = germanium GL = glass GRD = ground(ed)	H = henries HEX = hexagonal HG = mercury HR = hour(s) Hz = hertz IF = intermediate freq. IMPG = impregnated INCD = incandescent INCL = include(s) INS = insulation(ed) INT = internal k = kilo = 1000 LH = left hand LIN = linear taper LK WASH = lock washer LOG = logarithmic taper LPF = low pass filter m = milli = 10 <sup>-3</sup> M = meg = 10 <sup>6</sup> MET FLM = metal film MET OX = metallic oxide MFR = manufacturer MINAT = miniature MOM = momentary MTG = mounting MY = 'mylar' n = nano = 10 <sup>-9</sup> N C = normally closed NE = neon NI PL = nickel plate N O = normally open NPO = negative positive zero (zero temperature coefficient)	NPN = negative-positive-negative NRFR = not recommended for field replacement NSR = not separately replaceable OBD = order by description OH = oval head OX = oxide P = peak PC = printed circuit p = pico = 10 <sup>-12</sup> PH BRZ = phosphor bronze PHL = Phillips PIV = peak inverse voltage PNP = positive-negative-positive P O = part of POLY = polystyrene PORC = porcelain POS = position(s) POT = potentiometer PP = peak-to-peak PT = point PWV = peak working voltage RECT = rectifier RF = radio frequency RH = round head or right hand RMO = rack mount only RMS = root-mean square	RWV = reverse working voltage S-B = slow-blow SCR = screw SE = selenium SECT = section(s) SEMICON = semiconductor SI = silicon SIL = silver SL = slide SPG = spring SPL = special SST = stainless steel SR = split ring STL = steel TA = tantalum TD = time delay TGL = toggle THD = thread TI = titanium TOL = tolerance TRIM = trimmer TWT = traveling wave tube μ = micro = 10 <sup>-6</sup> VAR = variable VDCW = dc working volts W = with W = watts WIV = working inverse voltage WW = wirewound W O = without 0001-9700

Section VI  
Paragraphs 6-7 to 6-14

Model 4275A

- c. A description of the part.
- d. A typical manufacturer of the part in a five-digit code.
- e. The manufacturer's number for the part.

The total quantity for each part is given only once at the first appearance of the part number in the list.

6-7. ORDERING INFORMATION.

6-8. To order a part listed in the replaceable parts table, give the Hewlett-Packard part number, indicate the quantity required, and address the order to the nearest Hewlett-Packard office.

6-9. To order a part that is not listed in the replaceable parts table, state the full instrument model and serial number, the description and function of the part, and the number of parts required. Address your order to the nearest Hewlett-Packard office.

6-10. DIRECT MAIL ORDER SYSTEM.

6-11. Within the USA, Hewlett-Packard can supply parts through a direct mail order system. Advantages of using the system are:

- a. Direct ordering and shipment from the HP Parts Center in Mountain View, California.
- b. No maximum or minimum on any mail order (there is a minimum order amount for parts ordered through a local HP Office when the orders require billing and invoicing).
- c. Prepaid transportation (there is a small handling charge for each order).
- d. No invoices --- to provide these advantages, a check or money order must accompany each order.

6-12. Mail order forms and specific ordering information is available through your local HP Office. Addresses and phone numbers are located at the back of this manual.

Table 6-2. Manufacturers Code Lists.

MFR NO.	MANUFACTURER NAME	ADDRESS	ZIP CODE
▲ 00633	AKTIEBOLAGET RIFA	BROMMA SE	
00000	ANY SATISFACTORY SUPPLIER		
01121	ALLEN-BRADLEY CO	MILWAUKEE WI	53204
01295	TEXAS INSTR INC SEMICOND CMPNT DIV	DALLAS TX	75222
01928	RCA CORP SOLID STATE DIV	SOMERVILLE NJ	08876
02111	SPECTROL ELECTRONICS CORP	CITY OF IND CA	91745
02114	FERROXCUBE CORP	SAUGERTIES NY	12477
03888	FDI PYROFILM CORP	WHIPPANY NJ	07981
04713	MOTOPOLA SEMICONDUCTOR PRODUCTS	PHOENIX AZ	85062
07263	FAIRCHILD SEMICONDUCTOR DIV	MOUNTAIN VIEW CA	94042
12954	SIEMENS CORP COMPONENTS GROUP	SCOTTSDALE AZ	85252
18324	SIGNETICS CORP	SUNNYVALE CA	94086
19701	NEPCO/ELECTRA CORP	MINERAL WELLS TX	76067
24046	TRANSITRON ELECTRONIC CORP	WAKEFIELD MA	01880
24355	ANALOG DEVICES INC	NORWOOD MA	02062
24546	CORNING GLASS WORKS (BRADFORD)	BRADFORD PA	16701
27014	NATIONAL SEMICONDUCTOR CORP	SANTA CLARA CA	95051
27167	CORNING GLASS WORKS (WILMINGTON)	WILMINGTON NC	28401
28480	HEWLETT-PACKARD CO CORPORATE HQ	PALO ALTO CA	94304
30983	NEPCO/ELECTPA CORP	SAN DIEGO CA	92121
32293	INTERSIL INC	CUPERTINO CA	95014
32997	BOUPNS INC TRIMPOT PPOD DIV	RIVERSIDE CA	92507
34649	INTEL CORP	MOUNTAIN VIEW CA	95051
52763	STETTNER-TRUSH INC	CAZENOVIA NY	13035
56289	SPRAGUE ELECTRIC CO	NORTH ADAMS MA	01247
72136	ELECTRO MOTIVE CORP SUB IEC	WILLIMANTIC CT	06226
73138	BECHMAN INSTRUMENTS INC HELIPOT DIV	FULLERTON CA	92634
75915	LITTELFUSE INC	DES PLAINES IL	60016

Table 6-3. Replaceable Parts

Reference Designation	HP Part Number	C D	Qty	Description	Mfr Code	Mfr Part Number
A1	04275-66501 05275-26501	9 7	1	RANGE RESISTOR & NULL DETECTOR BD. ASSY PC BOARD, BLANK	28480 28480	04275-66501 05275-26501
A1C1	0160-2055	9	120	CAPACITOR-FXD .01UF +80-20% 100VDC CER	28480	0160-2055
A1C2	0180-1083	3	51	CAPACITOR-FXD 33uF +75-10% 25VDC	28480	0180-1083
A1C3	0180-1083	3		CAPACITOR-FXD 33uF +75-10% 25VDC	28480	0180-1083
A1C4	0160-4790	8	1	CAPACITOR-FXD 12PF +-5% 100VDC CER	28480	0160-4790
A1C5	0121-0105	4	4	CAPACITOR-V TRMR-CER 9-35PF 200V PC-MTG	52763	304324 9/35PF N650
A1C6	0160-2055	9		CAPACITOR-FXD .01UF +80-20% 100VDC CER	28480	0160-2055
A1C7	0180-1077	5	12	CAPACITOR-FXD 220uF +50-10% 16VDC	28480	0180-1077
A1C8	0180-1085	5	46	CAPACITOR-FXD 4.7uF 20% 16VDC	28480	0180-1085
A1C9	0160-3443	1	33	CAPACITOR-FXD .1UF +80-20% 50VDC CER	28480	0160-3443
A1C10	0160-2055	9		CAPACITOR-FXD .01UF +80-20% 100VDC CER	28480	0160-2055
A1C11	0180-1083	3		CAPACITOR-FXD 33uF +75-10% 25VDC	28480	0180-1083
A1C12	0160-2055	9		CAPACITOR-FXD .01UF +80-20% 100VDC CER	28480	0160-2055
A1C13	0160-2055	9		CAPACITOR-FXD .01UF +80-20% 100VDC CER	28480	0160-2055
A1C14	0160-3443	1		CAPACITOR-FXD .1UF +80-20% 50VDC CER	28480	0160-3443
A1C15	0160-2307	4	6	CAPACITOR-FXD 47PF +-5% 300VDC MICA	28480	0160-2307
A1C16	0160-2055	9		CAPACITOR-FXD .01UF +80-20% 100VDC CER	28480	0160-2055
A1C17	0160-3443	1		CAPACITOR-FXD .1UF +80-20% 50VDC CER	28480	0160-3443
A1C18	0160-3443	1		CAPACITOR-FXD .1UF +80-20% 50VDC CER	28480	0160-3443
A1C19	0121-0036	0	2	CAPACITOR-V TRMR-CER 5.5-16PF 350V	52763	304324 5.5/16PF NPD
A1C20	0121-0453	5	3	CAPACITOR-V TRMR-AIR 1.3-5.4PF 250V	74970	187-0303-105
A1C21	0121-0453	5		CAPACITOR-V TRMR-AIR 1.3-5.4PF 250V	74970	187-0303-105
A1C22	0121-0453	5		CAPACITOR-V TRMR-AIR 1.3-5.4PF 250V	74970	187-0303-105
A1C23	0121-0105	4		CAPACITOR-V TRMR-CER 9-35PF 200V PC-MTG	52763	304324 9/35PF N650
A1C24	0160-2248	2	2	CAPACITOR-FXD 4.3PF +-25PF 500VDC CER	28480	0160-2248
A1C25	0160-2248	2		CAPACITOR-FXD 4.3PF +-25PF 500VDC CER	28480	0160-2248
A1C26	0160-2250	6	2	CAPACITOR-FXD 5.1PF +-25PF 500VDC CER	28480	0160-2250
A1C27	0160-2161	0	1	CAPACITOR-FXD 15PF +-25PF 500VDC CER	28480	
A1C28	0140-0205	5	1	CAPACITOR-FXD 62PF +-5% 300VDC MICA	72136	DM15E620J0300HV1CR
A1C29	0180-1077	5		CAPACITOR-FXD 220uF +50-10% 16VDC	28480	0180-1077
A1C30	0180-1077	5		CAPACITOR-FXD 220uF +50-10% 16VDC	28480	0180-1077
A1C31	0160-2055	9		CAPACITOR-FXD .01UF +80-20% 100VDC CER	28480	0160-2055
A1C32	0160-2055	9		CAPACITOR-FXD .01UF +80-20% 100VDC CER	28480	0160-2055
A1C33	0160-2055	9		CAPACITOR-FXD .01UF +80-20% 100VDC CER	28480	0160-2055
A1C34	0160-2055	9		CAPACITOR-FXD .01UF +80-20% 100VDC CER	28480	0160-2055
A1C35	0160-2055	9		CAPACITOR-FXD .01UF +80-20% 100VDC CER	28480	0160-2055
A1C36	0160-2055	9		CAPACITOR-FXD .01UF +80-20% 100VDC CER	28480	0160-2055
A1C37	0160-2055	9		CAPACITOR-FXD .01UF +80-20% 100VDC CER	28480	0160-2055
A1C38	0180-1085	5		CAPACITOR-FXD 4.7uF 20% 16VDC	28480	0180-1085
A1C39	0180-1083	3		CAPACITOR-FXD 33uF +75-10% 25VDC	28480	0180-1083
A1C40	0180-1083	3		CAPACITOR-FXD 33uF +75-10% 25VDC	28480	0180-1083
A1C41	0160-3443	1		CAPACITOR-FXD .1UF +80-20% 50VDC CER	28480	0160-3443
A1C42	0160-3443	1		CAPACITOR-FXD .1UF +80-20% 50VDC CER	28480	0160-3443
A1C43	0160-3443	1		CAPACITOR-FXD .1UF +80-20% 50VDC CER	28480	0160-3443
A1C44	0160-2208	4	2	CAPACITOR-FXD 330PF +-5% 300VDC MICA	28480	0160-2208
A1C45	0160-2307	4		CAPACITOR-FXD 47PF +-5% 300VDC MICA	28480	0160-2307
A1C46	0160-3443	1		CAPACITOR-FXD .1UF +80-20% 50VDC CER	28480	0160-3443
A1C47	0180-1083	3		CAPACITOR-FXD 33uF +75-10% 25VDC	28480	0180-1083
A1C48	0180-1083	3		CAPACITOR-FXD 33uF +75-10% 25VDC	28480	0180-1083
A1C49	0160-3443	1		CAPACITOR-FXD .1UF +80-20% 50VDC CER	28480	0160-3443
A1C50	0160-2055	9		CAPACITOR-FXD .01UF +80-20% 100VDC CER	28480	0160-2055
A1C51	0160-3443	1		CAPACITOR-FXD .1UF +80-20% 50VDC CER	28480	0160-3443
A1C52	0180-1085	5		CAPACITOR-FXD 4.7uF 20% 16VDC	28480	0180-1085
A1C53	0160-3443	1		CAPACITOR-FXD .1UF +80-20% 50VDC CER	28480	0160-3443
A1C54	0180-1085	5		CAPACITOR-FXD 4.7uF 20% 16VDC	28480	0180-1085
A1C55	0160-2264	2	1	CAPACITOR-FXD 20PF +-5% 500VDC CER 0+-30	28480	0160-2264
A1C56	0160-2204	0	5	CAPACITOR-FXD 100PF +-5% 300VDC MICA	28480	0160-2204
A1C57	0160-2055	9		CAPACITOR-FXD .01UF +80-20% 100VDC CER	28480	0160-2055
A1C58	0160-3443	1		CAPACITOR-FXD .1UF +80-20% 50VDC CER	28480	0160-3443
A1C59	0160-3443	1		CAPACITOR-FXD .1UF +80-20% 50VDC CER	28480	0160-3443
A1C60	0160-2055	9		CAPACITOR-FXD .01UF +80-20% 100VDC CER	28480	0160-2055
A1C61	0160-3443	1		CAPACITOR-FXD .1UF +80-20% 50VDC CER	28480	0160-3443
A1C62	0160-2249	3	7	CAPACITOR-FXD 4.7PF +-25PF 500VDC CER	28480	0160-2249
A1C63	0180-1083	3		CAPACITOR-FXD 33uF +75-10% 25VDC	28480	0180-1083
A1C64	0180-1051	5	2	CAPACITOR, FXD 100 UF 16V M	28480	0180-1051
A1C65	0180-1051	5		CAPACITOR, FXD 100 UF 16V M	28480	0180-1051
A1C66	0160-2249	3		CAPACITOR-FXD 4.7PF +-25PF 500VDC CER	28480	0160-2249
A1C67	0160-2204	0		CAPACITOR-FXD 100PF +-5% 300VDC MICA	28480	0160-2204
A1C68	0160-2208	4		CAPACITOR-FXD 330PF +-5% 300VDC MICA	28480	0160-2208
A1C69	0160-2150	5	2	CAPACITOR-FXD 33PF +-5% 300VDC MICA	28480	0160-2150
A1C70	0160-2055	9		CAPACITOR-FXD .01UF +80-20% 100VDC CER	28480	0160-2055

See introduction to this section for ordering information  
\*Indicates factory selected value



Table 6-3. Replaceable Parts (Cont'd).

Reference Designation	HP Part Number	C D	Qty	Description	Mfr Code	Mfr Part Number
A1C71	0160-2055	9	1	CAPACITOR-FXD .01UF +80-20% 100VDC CER	28480	0160-2055
A1C72	0160-2055	9		CAPACITOR-FXD .01UF +80-20% 100VDC CER	28480	0160-2055
A1C73	0180-1085	5		CAPACITOR-FXD 4.7UF 20% 16VDC	28480	0180-1085
A1C74	0150-0059	8		CAPACITOR-FXD 3.3PF +- .25PF 500VDC CER	28480	0150-0059
A1C75	0160-3443	1		CAPACITOR-FXD .1UF +80-20% 50VDC CER	28480	0160-3443
A1C76	0180-1085	5	1	CAPACITOR-FXD 4.7UF 20% 16VDC	28480	0180-1085
A1C77	0180-1085	5		CAPACITOR-FXD 4.7UF 20% 16VDC	28480	0180-1085
A1C78	0160-3443	1		CAPACITOR-FXD .1UF +80-20% 50VDC CER	28480	0160-3443
A1C79	0180-1085	5		CAPACITOR-FXD 4.7UF 20% 16VDC	28480	0180-1085
A1C80	0160-2260	8		CAPACITOR-FXD 13PF +-5% 500VDC CER 0+-30	28480	0160-2260
A1C81	0160-3443	1	3	CAPACITOR-FXD .1UF +80-20% 50VDC CER	28480	0160-3443
A1C82	0160-2249	3		CAPACITOR-FXD 4.7PF +- .25PF 500VDC CER	28480	0160-2249
A1C83	0160-3443	1		CAPACITOR-FXD .1UF +80-20% 50VDC CER	28480	0160-3443
A1C84	0160-2249	3		CAPACITOR-FXD 4.7PF +- .25PF 500VDC CER	28480	0160-2249
A1C85	0160-2055	9		CAPACITOR-FXD .01UF +80-20% 100VDC CER	28480	0160-2055
A1C86	0160-2055	9	9	CAPACITOR-FXD .01UF +80-20% 100VDC CER	28480	0160-2055
A1C87	0160-2055	9		CAPACITOR-FXD .01UF +80-20% 100VDC CER	28480	0160-2055
A1C88	0160-2055	9		CAPACITOR-FXD .01UF +80-20% 100VDC CER	28480	0160-2055
A1C89	0160-2055	9		CAPACITOR-FXD .01UF +80-20% 100VDC CER	28480	0160-2055
A1C90	0160-2055	9		CAPACITOR-FXD .01UF +80-20% 100VDC CER	28480	0160-2055
A1C91	0160-2055	9	9	CAPACITOR-FXD .01UF +80-20% 100VDC CER	28480	0160-2055
A1C92	0160-2055	9		CAPACITOR-FXD .01UF +80-20% 100VDC CER	28480	0160-2055
A1C93	0160-2055	9		CAPACITOR-FXD .01UF +80-20% 100VDC CER	28480	0160-2055
A1C94	0160-2055	9		CAPACITOR-FXD .01UF +80-20% 100VDC CER	28480	0160-2055
A1C95	0160-2055	9		CAPACITOR-FXD .01UF +80-20% 100VDC CER	28480	0160-2055
A1C96	0160-2055	9	9	CAPACITOR-FXD .01UF +80-20% 100VDC CER	28480	0160-2055
A1C97	0160-2055	9		CAPACITOR-FXD .01UF +80-20% 100VDC CER	28480	0160-2055
A1C98	0160-2055	9		CAPACITOR-FXD .01UF +80-20% 100VDC CER	28480	0160-2055
A1C99	0160-2055	9		CAPACITOR-FXD .01UF +80-20% 100VDC CER	28480	0160-2055
A1C100	0160-2055	9		CAPACITOR-FXD .01UF +80-20% 100VDC CER	28480	0160-2055
A1C101	0160-2055	9	5	CAPACITOR-FXD .01UF +80-20% 100VDC CER	28480	0160-2055
A1C102	0180-1085	5		CAPACITOR-FXD 4.7UF 20% 16VDC	28480	0180-1085
A1C103	0180-1077	5		CAPACITOR-FXD .22UF +50-10% 16VDC	28480	0180-1077
A1C104	0180-1077	5		CAPACITOR-FXD .22UF +50-10% 16VDC	28480	0180-1077
A1C105	0180-1085	5		CAPACITOR-FXD 4.7UF 20% 16VDC	28480	0180-1085
A1C106	0180-1085	5	5	CAPACITOR-FXD 4.7UF 20% 16VDC	28480	0180-1085
A1C107	0180-1085	5		CAPACITOR-FXD 4.7UF 20% 16VDC	28480	0180-1085
A1C108	0180-1085	5		CAPACITOR-FXD 4.7UF 20% 16VDC	28480	0180-1085
A1C109	0180-1085	5		CAPACITOR-FXD 4.7UF 20% 16VDC	28480	0180-1085
A1C110	0160-2255	1		CAPACITOR-FXD 8.2PF +- .25PF 500VDC CER	28480	0160-2255
A1C111	0160-3443	1	3	CAPACITOR-FXD .1UF +80-20% 50VDC CER	28480	0160-3443
A1C112	0180-1086	6		CAPACITOR-FXD 33UF +50-30% 16VDC	28480	0180-1086
A1C130	0160-2203	2		CAPACITOR-FXD 91PF +-5% 300VDC MICA 0+70	28480	0160-2203
A1CR1	1901-0040	1	76	DIODE-SWITCHING 30V 50MA 2N8 DO-35	28480	1901-0040
A1CR2	1901-0040	1		DIODE-SWITCHING 30V 50MA 2N8 DO-35	28480	1901-0040
A1CR3	1902-3149	9		DIODE-ZNR 9.09V 5% DO-7 PD=.4W TC=+.057X	28480	1902-3149
A1CR4	1902-3149	9		DIODE-ZNR 9.09V 5% DO-7 PD=.4W TC=+.057X	28480	1902-3149
A1CR5	1901-0033	2		DIODE-GEN PRP 180V 200MA DO-7	28480	1901-0033
A1CR6	1901-0033	2	2	DIODE-GEN PRP 180V 200MA DO-7	28480	1901-0033
A1CR7	1901-0033	2		DIODE-GEN PRP 180V 200MA DO-7	28480	1901-0033
A1CR8	1901-0033	2		DIODE-GEN PRP 180V 200MA DO-7	28480	1901-0033
A1CR9	1901-0033	2		DIODE-GEN PRP 180V 200MA DO-7	28480	1901-0033
A1CR10	1901-0033	2		DIODE-GEN PRP 180V 200MA DO-7	28480	1901-0033
A1CR11	1901-0025	2	8	DIODE-GEN PRP 100V 200MA DO-7	28480	1901-0025
A1CR12	1901-0025	2		DIODE-GEN PRP 100V 200MA DO-7	28480	1901-0025
A1CR13	1901-0025	2		DIODE-GEN PRP 100V 200MA DO-7	28480	1901-0025
A1CR14	1901-0025	2		DIODE-GEN PRP 100V 200MA DO-7	28480	1901-0025
A1CR15	1901-0025	2		DIODE-GEN PRP 100V 200MA DO-7	28480	1901-0025
A1CR16	1901-0029	6	4	DIODE-PWR RECT 600V 750MA DO-29	28480	1901-0029
A1CR17	1901-0029	6		DIODE-PWR RECT 600V 750MA DO-29	28480	1901-0029
A1CR18	1901-0029	6		DIODE-PWR RECT 600V 750MA DO-29	28480	1901-0029
A1CR19	1901-0029	6		DIODE-PWR RECT 600V 750MA DO-29	28480	1901-0029
A1CR20	1901-0033	2		DIODE-GEN PRP 180V 200MA DO-7	28480	1901-0033
A1CR21	1901-0033	2	7	DIODE-GEN PRP 180V 200MA DO-7	28480	1901-0033
A1CR22	1901-0040	1		DIODE-SWITCHING 30V 50MA 2N8 DO-35	28480	1901-0040
A1CR23	1902-0049	2		DIODE-ZNR 6.19V 5% DO-7 PD=.4W TC=+.022X	28480	1902-0049
A1CR24	1901-0040	1		DIODE-SWITCHING 30V 50MA 2N8 DO-35	28480	1901-0040
A1CR25	1902-0049	2		DIODE-ZNR 6.19V 5% DO-7 PD=.4W TC=+.022X	28480	1902-0049
A1CR26	1902-0049	2	9	DIODE-ZNR 6.19V 5% DO-7 PD=.4W TC=+.022X	28480	1902-0049
A1CR27	1902-3149	9		DIODE-ZNR 9.09V 5% DO-7 PD=.4W TC=+.057X	28480	1902-3149
A1CR28	1901-0025	2		DIODE-GEN PRP 100V 200MA DO-7	28480	1901-0025
A1CR29	1902-3082	2		DIODE-ZNR 4.64V 5% DO-7 PD=.4W TC=+.023X	28480	1902-3082
A1CR30	1902-0049	2		DIODE-ZNR 6.19V 5% DO-7 PD=.4W TC=+.022X	28480	1902-0049
A1CR31	1901-0040	1	DIODE-SWITCHING 30V 50MA 2N8 DO-35	28480	1901-0040	

Table 6-3. Replaceable Parts (Cont'd).

Reference Designation	HP Part Number	C D	Qty	Description	Mfr Code	Mfr Part Number
A1K1	0490-0234	9	7	RELAY-REED	28480	
A1K2	0490-0234	9		RELAY-REED	28480	
A1K3	0490-0240	1	11	RELAY, REED	28480	
A1K4	0490-0240	1		RELAY, REED	28480	
A1K5	0490-0234	1		RELAY, REED	28480	0490-0234
A1K6	0490-0234	1		RELAY, REED	28480	0490-0234
A1K7	0490-0234	1		RELAY, REED	28480	0490-0234
A1K8	0490-0234	1		RELAY, REED	28480	0490-0234
A1K9	0490-0234	1		RELAY, REED	28480	0490-0234
A1K10	0490-0234	1		RELAY, REED	28480	0490-0234
A1K11	0490-0234	1		RELAY, REED	28480	0490-0234
A1K12	0490-0240	9		RELAY-REED	28480	0490-0240
A1K13	0490-0240	9		RELAY-REED	28480	0490-0240
A1K14	0490-0240	9		RELAY-REED	28480	0490-0240
A1L1	9170-0029	3	36	CORE-SHIELDING BEAD	28480	9170-0029
A1L2	9170-0029	3		CORE-SHIELDING BEAD	28480	9170-0029
A1L3	9140-0210	1	4	COIL-MLD 100UM 5% Q=50 .155DX,375LG-NOM	28480	9140-0210
A1L4	9140-0210	1		COIL-MLD 100UM 5% Q=50 .155DX,375LG-NOM	28480	9140-0210
A1L5	9140-0210	1		COIL-MLD 100UM 5% Q=50 .155DX,375LG-NOM	28480	9140-0210
A1L6	9140-0137	1	1	COIL-MLD 1MM 5% Q=60 .19DX,44LG-NOM	28480	9140-0137
A1L7	9140-0179	1	5	COIL-MLD 22UM 10% Q=75 .155DX,375LG-NOM	28480	9140-0179
A1L8	9140-0179	1		COIL-MLD 22UM 10% Q=75 .155DX,375LG-NOM	28480	9140-0179
A1Q1	1853-0018	0	1	TRANSISTOR PNP 8I TO-72 PD=200MW FT=16HZ	28480	1853-0018
A1Q2	1854-0130	9	1	TRANSISTOR NPN 5I PD=350mW FT=4.56HZ	28480	1854-0130
A1Q3	1854-0092	2	31	TRANSISTOR NPN 8I PD=200MW FT=600MHZ	28480	1854-0092
A1Q4	1855-0081	1	13	TRANSISTOR J-FET N-CHAN D-MODE 8I	01295	2N5245
A1Q5	1853-0020	4	13	TRANSISTOR PNP 8I PD=300MW FT=150MHZ	28480	1853-0020
A1Q6	1854-0345	6	10	TRANSISTOR NPN 2N5179 8I TO-72 PD=200MW	04713	2N5179
A1Q7	1854-0345	6		TRANSISTOR NPN 2N5179 8I TO-72 PD=200MW	04713	2N5179
A1Q8	1854-0071	7	26	TRANSISTOR NPN 8I PD=300MW FT=200MHZ	28480	1854-0071
A1Q9	1854-0071	7		TRANSISTOR NPN 8I PD=300MW FT=200MHZ	28480	1854-0071
A1Q10	1854-0071	7		TRANSISTOR NPN 8I PD=300MW FT=200MHZ	28480	1854-0071
A1Q11	1854-0071	7		TRANSISTOR NPN 8I PD=300MW FT=200MHZ	28480	1854-0071
A1Q12	1854-0071	7		TRANSISTOR NPN 8I PD=300MW FT=200MHZ	28480	1854-0071
A1Q13	1854-0071	7		TRANSISTOR NPN 8I PD=300MW FT=200MHZ	28480	1854-0071
A1Q14	1854-0071	7		TRANSISTOR NPN 8I PD=300MW FT=200MHZ	28480	1854-0071
A1Q15	1854-0071	7		TRANSISTOR NPN 8I PD=300MW FT=200MHZ	28480	1854-0071
A1Q16	1854-0345	6		TRANSISTOR NPN 2N5179 8I TO-72 PD=200MW	04713	2N5179
A1Q17	1855-0125	2	1	TRANSISTOR DUAL-FET N-CHANNEL V <sub>DMAX</sub> =30V	28480	
A1Q18	1853-0020	4		TRANSISTOR PNP 8I PD=300MW FT=150MHZ	28480	1853-0020
A1Q19	1854-0019	3	5	TRANSISTOR NPN 8I TO-18 PD=360MW	28480	1854-0019
A1Q20	1854-0345	6		TRANSISTOR NPN 2N5179 8I TO-72 PD=200MW	04713	2N5179
A1Q21	1854-0477	7	3	TRANSISTOR NPN 2N2222A 8I TO-18 PD=500MW	04713	2N2222A
A1Q22	1853-0007	7	1	TRANSISTOR PNP 2N3251 8I TO-18 PD=360MW	04713	2N3251
A1Q23	1854-0092	2		TRANSISTOR NPN 8I PD=200MW FT=600MHZ	28480	1854-0092
A1Q24	1854-0092	2		TRANSISTOR NPN 8I PD=200MW FT=600MHZ	28480	1854-0092
A1Q25	1854-0092	2		TRANSISTOR NPN 8I PD=200MW FT=600MHZ	28480	1854-0092
A1Q26	1854-0071	7		TRANSISTOR NPN 8I PD=300MW FT=200MHZ	28480	1854-0071
A1Q27	1854-0071	7		TRANSISTOR NPN 8I PD=300MW FT=200MHZ	28480	1854-0071
A1Q28	1854-0071	7		TRANSISTOR NPN 8I PD=300MW FT=200MHZ	28480	1854-0071
A1Q29	1854-0092	2		TRANSISTOR NPN 8I PD=200MW FT=600MHZ	28480	1854-0092
A1Q30	1854-0092	2		TRANSISTOR NPN 8I PD=200MW FT=600MHZ	28480	1854-0092
A1Q31	1854-0092	2		TRANSISTOR NPN 8I PD=200MW FT=600MHZ	28480	1854-0092
A1Q32	1854-0092	2		TRANSISTOR NPN 8I PD=200MW FT=600MHZ	28480	1854-0092
A1Q33	1854-0092	2		TRANSISTOR NPN 8I PD=200MW FT=600MHZ	28480	1854-0092
A1Q34	1854-0092	2		TRANSISTOR NPN 8I PD=200MW FT=600MHZ	28480	1854-0092
A1Q35	1855-0261	9	4	TRANSISTOR MOS-FET PD=100mW ID=15mA	28480	1855-0261
A1Q36	1854-0071	7		TRANSISTOR NPN 8I PD=300MW FT=200MHZ	28480	1854-0071
A1Q37	1853-0020	4		TRANSISTOR PNP 8I PD=300MW FT=150MHZ	28480	1853-0020
A1Q38	1853-0020	4		TRANSISTOR PNP 8I PD=300MW FT=150MHZ	28480	1853-0020
A1Q39	1854-0071	7		TRANSISTOR NPN 8I PD=300MW FT=200MHZ	28480	1854-0071
A1Q40	1854-0071	7		TRANSISTOR NPN 8I PD=300MW FT=200MHZ	28480	1854-0071
A1Q41	1854-0071	7		TRANSISTOR NPN 8I PD=300MW FT=200MHZ	28480	1854-0071
A1Q42	1854-0092	2		TRANSISTOR NPN 8I PD=200MW FT=600MHZ	28480	1854-0092
A1Q43	1854-0092	2		TRANSISTOR NPN 8I PD=200MW FT=600MHZ	28480	1854-0092
A1Q44	1854-0092	2		TRANSISTOR NPN 8I PD=200MW FT=600MHZ	28480	1854-0092
A1R1	2100-2489	9	1	RESISTOR-TMR 5K 10% C SIDE-ADJ 1-TRN	30983	ET50X502
A1R2	2100-2521	0	2	RESISTOR-TMR 2K 10% C SIDE-ADJ 1-TRN	30983	ET50X202
A1R3	2100-2432	4	1	RESISTOR-TMR 100 10% C SIDE-ADJ 1-TRN	30983	ET50X101
A1R4	0698-3444	1	26	RESISTOR 316 1% .125W F TC=0+-100	24546	C4-1/8-T0-316R-F
A1R5	0698-0082	7	8	RESISTOR 464 1% .125W F TC=0+-100	24546	C4-1/8-T0-4640-F
A1R6	0757-0416	7	10	RESISTOR 51 1% .125W F TC=0+-100	24546	C4-1/8-T0-511R-F
A1R7	0757-0438	3	5	RESISTOR 5.1K 1% .125W F TC=0+-100	24546	C4-1/8-T0-5111-F
A1R8	0757-0280	3	40	RESISTOR 1K 1% .125W F TC=0+-100	24546	C4-1/8-T0-1001-F
A1R9	0698-3430	5	1	RESISTOR 21.5 1% .125W F TC=0+-100	03688	PME35-1/8-T0-21R5-F
A1R10	0757-0410	1	4	RESISTOR 301 1% .125W F TC=0+-100	24546	C4-1/8-T0-301R-F

See introduction to this section for ordering information  
\*Indicates factory selected value

Table 6-3. Replaceable Parts (Cont'd).

Reference Designation	HP Part Number	C D	Qty	Description	Mfr Code	Mfr Part Number
A1R11	0683-1035	1	17	RESISTOR 10K 5% .25W FC TC=400/+700	01121	CB1035
A1R11	0757-0416	7		RESISTOR 511 1% .125W F TC=0+100	24546	C4-1/8-T0-511R-F
A1R12	0683-1028	9	30	RESISTOR 1K 5% .25W FC TC=400/+500	01121	CB1028
A1R13	0683-2225	3	34	RESISTOR 2.2K 5% .25W FC TC=400/+700	01121	CB2225
A1R14	0683-4705	8	43	RESISTOR 47 5% .25W FC TC=400/+500	01121	CB4705
A1R17	0757-1094	9	3	RESISTOR 1.47K 1% .125W F TC=0+100	24546	C4-1/8-T0-1471-F
A1R18	0698-3242	1	1	RESISTOR 40.2 1% .125W F TC=0+100	24546	C4-1/8-T0-4022-F
A1R19	0683-1015	7	12	RESISTOR 100 5% .25W FC TC=400/+500	01121	CB1015
A1R20	0683-1005	5	14	RESISTOR 10 5% .25W FC TC=400/+500	01121	CB1005
A1R21	0757-0401	0	12	RESISTOR 100 1% .125W F TC=0+100	24546	C4-1/8-T0-101-F
A1R22	0683-4705	8		RESISTOR 47 5% .25W FC TC=400/+500	01121	CB4705
A1R23	0683-4705	8		RESISTOR 47 5% .25W FC TC=400/+500	01121	CB4705
A1R24	0757-0417	8	3	RESISTOR 562 1% .125W F TC=0+100	24546	C4-1/8-T0-562R-F
A1R25	0757-0401	0	7	RESISTOR 100 1% .125W F TC=0+100	24546	C4-1/8-T0-101-F
A1R26	0683-1015	7		RESISTOR 100 5% .25W FC TC=400/+500	01121	CB1015
A1R27	0683-1005	5		RESISTOR 10 5% .25W FC TC=400/+500	01121	CB1005
A1R28	2100-2522	1	1	RESISTOR-TRMR 10K 10% C 8IDE-ADJ 1-TRN	30983	ETS0K103
A1R29	2100-3199	0	2	RESISTOR-TRMR 20 20% C 8IDE-ADJ 1-TRN	30983	ETS0K200
A1R30	2100-2413	0	1	RESISTOR-TRMR 200 10% C 8IDE-ADJ 1-TRN	30983	ETS0K201
A1R31	2100-2521	9	9	RESISTOR-TRMR 2K 10% C 8IDE-ADJ 1-TRN	30983	ETS0K202
A1R32	0757-0438	3		RESISTOR 5.1K 1% .125W F TC=0+100	24546	C4-1/8-T0-5111-F
A1R33	0698-2316	4	2	RESISTOR, FXD MET FLM 101.3 OHM 0.1% 1/8	24546	C4-1/8-T0-51R1-F
A1R34	0757-0394	0	1	RESISTOR 51.1 1% .125W F TC=0+100	24546	0698-2338
A1R35	0698-2330	0	1	RESISTOR 950 .1% .125W	24546	C4-1/8-T0-215R-F
A1R36	0698-3441	8	3	RESISTOR 215 1% .125W F TC=0+100	24546	C4-1/8-T0-215R-F
A1R37	0698-2339	1	1	RESISTOR 10.5K .1% .125W	24546	0698-2339
A1R38	0757-0280	3		RESISTOR 1K 1% .125W F TC=0+100	24546	C4-1/8-T0-1001-F
A1R39	0698-2340	4	1	RESISTOR 95K .1% .125W	24546	0698-2340
A1R40	0683-5605	9	1	RESISTOR 56 5% .25W FC TC=400/+500	01121	CB5605
A1R41	0683-1035	1		RESISTOR 10K 5% .25W FC TC=400/+700	01121	CB1035
A1R42	0683-4725	2	35	RESISTOR 4.7K 5% .25W FC TC=400/+700	01121	CB4725
A1R43	0683-4725	2		RESISTOR 4.7K 5% .25W FC TC=400/+700	01121	CB4725
A1R44	0683-4725	2		RESISTOR 4.7K 5% .25W FC TC=400/+700	01121	CB4725
A1R45	0683-1035	1		RESISTOR 10K 5% .25W FC TC=400/+700	01121	CB1035
A1R46	0683-1035	1		RESISTOR 10K 5% .25W FC TC=400/+700	01121	CB1035
A1R47	0683-4725	2		RESISTOR 4.7K 5% .25W FC TC=400/+700	01121	CB4725
A1R48	0757-0442	9	10	RESISTOR 10K 1% .125W F TC=0+100	24546	C4-1/8-T0-1002-F
A1R49	0757-0280	3		RESISTOR 1K 1% .125W F TC=0+100	24546	C4-1/8-T0-1001-F
A1R50	0757-0401	0		RESISTOR 100 1% .125W F TC=0+100	24546	C4-1/8-T0-101-F
A1R51	0757-0465	6	11	RESISTOR 100K 1% .125W F TC=0+100	24546	C4-1/8-T0-1003-F
A1R52	0757-0442	9		RESISTOR 10K 1% .125W F TC=0+100	24546	C4-1/8-T0-1002-F
A1R53	0683-3325	6	10	RESISTOR 3.3K 5% .25W FC TC=400/+700	01121	CB3325
A1R54	0698-3155	1	15	RESISTOR 4.64K 1% .125W F TC=0+100	24546	C4-1/8-T0-4641-F
A1R55	0698-0084	9	18	RESISTOR 2.15K 1% .125W F TC=0+100	24546	C4-1/8-T0-2151-F
A1R56	0757-0428	1	3	RESISTOR 1.62K 1% .125W F TC=0+100	24546	C4-1/8-T0-1621-F
A1R57	0698-0083	8	4	RESISTOR 1.96K 1% .125W F TC=0+100	24546	C4-1/8-T0-1961-F
A1R58	0698-0083	8		RESISTOR 1.96K 1% .125W F TC=0+100	24546	C4-1/8-T0-1961-F
A1R59	0757-0458	7	1	RESISTOR 51.1K 1% .125W F TC=0+100	24546	C4-1/8-T0-5112-F
A1R60	2100-1788	9	2	RESISTOR-TRMR 500 10% C TOP-ADJ 1-TRN	73138	82PR500
A1R61	0683-1035	1		RESISTOR 10K 5% .25W FC TC=400/+700	01121	CB1035
A1R62	0683-4705	8		RESISTOR 47 5% .25W FC TC=400/+500	01121	CB4705
A1R63	0757-0416	9	3	RESISTOR 619 1% .125W F TC=0+100	24546	C4-1/8-T0-619R-F
A1R64	0683-4725	2		RESISTOR 4.7K 5% .25W FC TC=400/+700	01121	CB4725
A1R65	0757-0346	2	7	RESISTOR 10 1% .125W F TC=0+100	24546	C4-1/8-T0-10R0-F
A1R66	0757-0346	2		RESISTOR 10 1% .125W F TC=0+100	24546	C4-1/8-T0-10R0-F
A1R67	0683-2205	9	22	RESISTOR 22 5% .25W FC TC=400/+500	01121	CB2205
A1R68	0757-0280	3		RESISTOR 1K 1% .125W F TC=0+100	24546	C4-1/8-T0-1001-F
A1R69	0757-0279	0	10	RESISTOR 3.16K 1% .125W F TC=0+100	24546	C4-1/8-T0-3161-F
A1R70	0683-2225	3		RESISTOR 2.2K 5% .25W FC TC=400/+700	01121	CB2225
A1R71	0757-0346	2		RESISTOR 10 1% .125W F TC=0+100	24546	C4-1/8-T0-10R0-F
A1R72	0683-4705	8		RESISTOR 47 5% .25W FC TC=400/+500	01121	CB4705
A1R73	0757-0416	7		RESISTOR 511 1% .125W F TC=0+100	24546	C4-1/8-T0-511R-F
A1R74	0757-0280	3		RESISTOR 1K 1% .125W F TC=0+100	24546	C4-1/8-T0-1001-F
A1R75	0757-0346	2		RESISTOR 10 1% .125W F TC=0+100	24546	C4-1/8-T0-10R0-F
A1R76	0757-0416	7		RESISTOR 511 1% .125W F TC=0+100	24546	C4-1/8-T0-511R-F
A1R77	0757-0280	3		RESISTOR 1K 1% .125W F TC=0+100	24546	C4-1/8-T0-1001-F
A1R78	0698-3444	1		RESISTOR 316 1% .125W F TC=0+100	24546	C4-1/8-T0-316R-F
A1R79	0683-4725	2		RESISTOR 4.7K 5% .25W FC TC=400/+700	01121	CB4725
A1R80	0683-2205	9		RESISTOR 22 5% .25W FC TC=400/+500	01121	CB2205
A1R81	0698-3444	1		RESISTOR 316 1% .125W F TC=0+100	24546	C4-1/8-T0-316R-F
A1R82	0757-0280	3		RESISTOR 1K 1% .125W F TC=0+100	24546	C4-1/8-T0-1001-F
A1R83	0683-4705	8		RESISTOR 47 5% .25W FC TC=400/+500	01121	CB4705
A1R84	0757-0401	2	4	RESISTOR 121 1% .125W F TC=0+100	24546	C4-1/8-T0-121R-F
A1R85	0698-0084	9		RESISTOR 2.15K 1% .125W F TC=0+100	24546	C4-1/8-T0-2151-F
A1R86	0683-1035	1		RESISTOR 10K 5% .25W FC TC=400/+700	01121	CB1035

See introduction to this section for ordering information  
\*Indicates factory selected value

Table 6-3. Replaceable Parts (Cont'd).

Reference Designation	HP Part Number	C D	Qty	Description	Mfr Code	Mfr Part Number
A1R87	0683-1035	1		RESISTOR 10K 5% .25W FC TC=400/+700	01121	CB1035
A1R88	0683-2205	9		RESISTOR 22 5% .25W FC TC=400/+500	01121	CB2205
A1R89	0683-2205	9		RESISTOR 22 5% .25W FC TC=400/+500	01121	CB2205
A1R90	0683-1035	1		RESISTOR 10K 5% .25W FC TC=400/+700	01121	CB1035
A1R91	0683-2205	9		RESISTOR 22 5% .25W FC TC=400/+500	01121	CB2205
A1R92	0757-0280	3		RESISTOR 1K 1% .125W F TC=0/+100	24546	C4-1/8-T0-1001-F
A1R93	0757-0279	0		RESISTOR 3.16K 1% .125W F TC=0/+100	24546	C4-1/8-T0-3161-F
A1R94	0683-2225	3		RESISTOR 2.2K 5% .25W FC TC=400/+700	01121	CB2225
A1R95	0683-2205	9		RESISTOR 22 5% .25W FC TC=400/+500	01121	CB2205
A1R96	0757-0280	3		RESISTOR 1K 1% .125W F TC=0/+100	24546	C4-1/8-T0-1001-F
A1R97	0757-0279	0		RESISTOR 3.16K 1% .125W F TC=0/+100	24546	C4-1/8-T0-3161-F
A1R98	0683-2225	3		RESISTOR 2.2K 5% .25W FC TC=400/+700	01121	CB2225
A1R99	0698-3444	9		RESISTOR 2.15K 1% .125W F TC=0/+100	24546	C4-1/8-T0-2151-F
A1R100	0683-2205	9		RESISTOR 22 5% .25W FC TC=400/+500	01121	CB2205
A1R101	0757-0418	5	5	RESISTOR 619 1% .125W F TC=0/+100	24546	C4-1/8-T0-1471-F
A1R102	0757-1094	9		RESISTOR 1.47K 1% .125W F TC=0/+100	24546	C4-1/8-T0-1471-F
A1R103	0757-0279	0		RESISTOR 3.16K 1% .125W F TC=0/+100	24546	C4-1/8-T0-3161-F
A1R104	0683-2205	9		RESISTOR 22 5% .25W FC TC=400/+500	01121	CB2205
A1R105	0698-3444	1		RESISTOR 316 1% .125W F TC=0/+100	24546	C4-1/8-T0-316R-F
A1R106	0757-0280	3		RESISTOR 1K 1% .125W F TC=0/+100	24546	C4-1/8-T0-1001-F
A1R107	0683-4705	8		RESISTOR 47 5% .25W FC TC=400/+500	01121	CB4705
A1R108	0698-3444	1		RESISTOR 316 1% .125W F TC=0/+100	24546	C4-1/8-T0-316R-F
A1R109	0757-0280	3		RESISTOR 1K 1% .125W F TC=0/+100	24546	C4-1/8-T0-1001-F
A1R110	0683-4705	8		RESISTOR 47 5% .25W FC TC=400/+500	01121	CB4705
A1R111	0683-1035	1		RESISTOR 10K 5% .25W FC TC=400/+700	01121	CB1035
A1R112	0683-4725	2		RESISTOR 4.7K 5% .25W FC TC=400/+700	01121	CB4725
A1R113	0683-4725	2		RESISTOR 4.7K 5% .25W FC TC=400/+700	01121	CB4725
A1R114	0683-3335	8	6	RESISTOR 33K 5% .25W FC TC=400/+800	01121	CB3335
A1R115	0683-2225	3		RESISTOR 2.2K 5% .25W FC TC=400/+700	01121	CB2225
A1R116	0683-2225	3		RESISTOR 2.2K 5% .25W FC TC=400/+700	01121	CB2225
A1R117	0683-2205	9		RESISTOR 22 5% .25W FC TC=400/+500	01121	CB2205
A1R118	0683-1035	1		RESISTOR 10K 5% .25W FC TC=400/+700	01121	CB1035
A1R119	0683-1035	1		RESISTOR 10K 5% .25W FC TC=400/+700	01121	CB1035
A1R120	0683-1035	1		RESISTOR 10K 5% .25W FC TC=400/+700	01121	CB1035
A1R121	0683-1025	9		RESISTOR 1K 5% .25W FC TC=400/+600	01121	CB1025
A1R122	0683-1025	9		RESISTOR 1K 5% .25W FC TC=400/+600	01121	CB1025
A1R123	0683-1025	9	2	RESISTOR 1K 5% .25W FC TC=400/+600	01121	CB1025
A1R124	0683-0475	1		RESISTOR 4.7 5% .25W FC TC=400/+700	01121	CB4725
A1R125	0683-4725	2		RESISTOR 4.7K 5% .25W FC TC=400/+700	01121	CB4725
A1R126	0683-1025	9		RESISTOR 1K 5% .25W FC TC=400/+600	01121	CB1025
A1R127	0683-1025	9		RESISTOR 1K 5% .25W FC TC=400/+600	01121	CB1025
A1R128	0683-1025	9		RESISTOR 1K 5% .25W FC TC=400/+600	01121	CB1025
A1R129	0683-1025	9		RESISTOR 1K 5% .25W FC TC=400/+600	01121	CB1025
A1R130	0683-1025	9		RESISTOR 1K 5% .25W FC TC=400/+600	01121	CB1025
A1R131	0683-0475	1		RESISTOR 4.7 5% .25W FC TC=400/+700	01121	CB4725
A1R131	0683-4725	2		RESISTOR 4.7K 5% .25W FC TC=400/+700	01121	CB4725
A1R132	0683-1035	1		RESISTOR 10K 5% .25W FC TC=400/+700	01121	CB1035
A1R133	0683-2225	3		RESISTOR 2.2K 5% .25W FC TC=400/+700	01121	CB2225
A1R134	0683-3325	6		RESISTOR 3.3K 5% .25W FC TC=400/+700	01121	CB3325
A1R135	0683-2225	3		RESISTOR 2.2K 5% .25W FC TC=400/+700	01121	CB2225
A1R136	0683-2205	9		RESISTOR 22 5% .25W FC TC=400/+500	01121	CB2205
A1R137	0683-2205	9		RESISTOR 22 5% .25W FC TC=400/+500	01121	CB2205
A1R138	0757-0416	7		RESISTOR 511 1% .125W F TC=0/+100	24546	C4-1/8-T0-511R-F
A1R139	0757-0280	3		RESISTOR 1K 1% .125W F TC=0/+100	24546	C4-1/8-T0-1001-F
A1R140	0757-0279	0		RESISTOR 3.16K 1% .125W F TC=0/+100	24546	C4-1/8-T0-3161-F
A1R141	0757-0280	3		RESISTOR 1K 1% .125W F TC=0/+100	24546	C4-1/8-T0-1001-F
A1R142	0683-2205	9		RESISTOR 22 5% .25W FC TC=400/+500	01121	CB2205
A1R143	0698-3444	1		RESISTOR 316 1% .125W F TC=0/+100	24546	C4-1/8-T0-316R-F
A1R144	0757-0280	3		RESISTOR 1K 1% .125W F TC=0/+100	24546	C4-1/8-T0-1001-F
A1R145	0683-4705	8		RESISTOR 47 5% .25W FC TC=400/+500	01121	CB4705
A1R146	0698-3268	7	1	RESISTOR 11.5K 1% .125W F TC=0/+100	24546	C4-1/8-T0-1152-F
A1R147	0757-0416	7		RESISTOR 511 1% .125W F TC=0/+100	24546	C4-1/8-T0-511R-F
A1R148	0757-0280	3		RESISTOR 1K 1% .125W F TC=0/+100	24546	C4-1/8-T0-1001-F
A1R149	0757-0280	3		RESISTOR 1K 1% .125W F TC=0/+100	24546	C4-1/8-T0-1001-F
A1R150	0757-0279	0		RESISTOR 3.16K 1% .125W F TC=0/+100	24546	C4-1/8-T0-3161-F
A1R151	0698-3444	1		RESISTOR 316 1% .125W F TC=0/+100	24546	C4-1/8-T0-316R-F
A1R150	0698-3153	9	4	RESISTOR 3.83K 1% .125W F TC=0/+100	24546	C4-1/8-T0-3831-F
A1T1	9100-0877	2	1	TRANSFORMER-SIGNAL 300uH 1:1:1	28480	9100-0877
A1T2	9100-0879	4	3	TRANSFORMER-SIGNAL 10mH 20%	28480	9100-0879
A1T3	9100-0879	4	3	TRANSFORMER-SIGNAL 10mH 20%	28480	9100-0879
A1T4	9100-0823	8	5	TRANSFORMER(TDK113B1) 1:1:1	28480	9100-0823
A1U1	5080-3069	7	2	IC LF356H SEL	27014	LF356H
A1U2	1820-0203	6	1	IC OP AMP GP T0-99	01928	CA741C1
A1W2	04275-61610		1	CABLE ASSY AI MISCELLANEOUS PARTS		

See introduction to this section for ordering information  
\*Indicates factory selected value

Table 6-3. Replaceable Parts (Cont'd).

Reference Designation	HP Part Number	C D	Qty	Description	Mfr Code	Mfr Part Number
A2	1250-0257	1	12	CONNECTOR-RF 8MB M PC 50-OHM	28480	1250-0257
	04275-00602	3	1	PLATE SHIELD, A1	28480	04275-00602
	04275-00621	6	1	PLATE, SHIELD	28480	04275-00621
A2C1	04275-66502	0	1	MODULATOR BOARD ASSEMBLY	28480	04275-66502
	04275-26502	6	1	PC BOARD, BLANK	28480	04275-26502
A2C1*	0150-0121	5	27	CAPACITOR-FXD .1UF +80-20% 50VDC CER	28480	0150-0121
A2C2*	0160-2940	1		CAPACITOR-FXD 470PF +-5% 300VDC MICA	28480	0160-2940
A2C3*	0160-2940	1		CAPACITOR-FXD 470PF +-5% 300VDC MICA	28480	0160-2940
A2C4	0150-0121	5		CAPACITOR-FXD .1UF +80-20% 50VDC CER	28480	0150-0121
A2C5*	0160-2255	1		CAPACITOR-FXD 8.2PF +-25PF 500VDC CER	28480	0160-2255
A2C6	0150-1063	3		5	CAPACITOR-FXD 33UF +75-10% 25VDC	28480
A2C7	0150-0121	5	CAPACITOR-FXD .1UF +80-20% 50VDC CER		28480	0150-0121
A2C8	0121-0105	4	CAPACITOR-V TRMR-CER 9-35PF 200V PC-MTG		52763	0121-0105
A2C9	0121-0105	4	CAPACITOR-V TRMR-CER 9-35PF 350V PC-MTG		52763	304324 9/35PF N650
A2C10	0160-2055	7	CAPACITOR-FXD .01UF +80-20% 100VDC CER		28480	0160-2055
A2C11	0160-2055	9	5	CAPACITOR-FXD .01UF +80-20% 100VDC CER	28480	0160-2055
A2C12	0150-0121	5		CAPACITOR-FXD .1UF +80-20% 50VDC CER	28480	0150-0121
A2C13	0121-0105	4		CAPACITOR-V TRMR-CER 9-35PF 200V PC-MTG	52763	0121-0105
A2C14	0121-0105	7		CAPACITOR-V TRMR-CER 9-35PF 350V PC-MTG	52763	304324 9/35PF N650
A2C15	0160-2055	9		CAPACITOR-FXD .01UF +80-20% 100VDC CER	28480	0160-2055
A2C16	0160-2055	9	1	CAPACITOR-FXD .01UF +80-20% 100VDC CER	28480	0160-2055
A2C17	0150-0121	5		CAPACITOR-FXD .1UF +80-20% 50VDC CER	28480	0150-0121
A2C18	0160-0174	9		CAPACITOR-FXD .47UF +80-20% 25VDC CER	28480	0160-0174
A2C19	0150-0121	5		CAPACITOR-FXD .1UF +80-20% 50VDC CER	28480	0150-0121
A2C20	0150-0121	5		CAPACITOR-FXD .1UF +80-20% 50VDC CER	28480	0150-0121
A2C21	0150-0121	5	10	CAPACITOR-FXD .1UF +80-20% 50VDC CER	28480	0150-0121
A2C22	0160-2265	3		CAPACITOR-FXD 2.2UF +-10% 20VDC TA	56289	0160-2265
A2C23	0160-2265	3		CAPACITOR-FXD 22PF +-5% 500VDC CER 0+-30	28480	150D225X9020A2
A2C24	0160-2265	3		CAPACITOR-FXD 22PF +-5% 500VDC CER 0+-30	28480	0160-2265
A2C25	0160-2265	3		CAPACITOR-FXD 22PF +-5% 500VDC CER 0+-30	28480	0160-2265
A2C26	0160-2265	3	26	CAPACITOR-FXD 22PF +-5% 500VDC CER 0+-30	28480	0160-2265
A2C27	0160-0127	2		CAPACITOR-FXD 1UF +-20% 25VDC CER	28480	0160-0127
A2C28	0160-0197	8		CAPACITOR-FXD 2.2UF+-10% 20VDC TA	56289	0160-0127
A2C29	0160-2265	3		CAPACITOR-FXD 22PF +-5% 500VDC CER 0+-30	28480	150D225X9020A2
A2C30	0160-2265	3		CAPACITOR-FXD 22PF +-5% 500VDC CER 0+-30	28480	0160-2265
A2C31	0160-2265	3	1	CAPACITOR-FXD 22PF +-5% 500VDC CER 0+-30	28480	0160-2265
A2C32	0160-2265	3		CAPACITOR-FXD 22PF +-5% 500VDC CER 0+-30	28480	0160-2265
A2C33	0160-0127	2		CAPACITOR-FXD 1UF +-20% 25VDC CER	28480	0160-0127
A2C34	0160-2255	1		CAPACITOR-FXD 8.2PF +-25PF 500VDC CER	28480	0160-2255
A2C35	0160-2255	1		CAPACITOR-FXD 8.2PF +-25PF 500VDC CER	28480	0160-2255
A2C36	0150-0121	5	5	CAPACITOR-FXD .1UF +80-20% 50VDC CER	28480	0150-0121
A2C37	0150-0121	5		CAPACITOR-FXD .1UF +80-20% 50VDC CER	28480	0150-0121
A2C38	0150-0121	5		CAPACITOR-FXD .1UF +80-20% 50VDC CER	28480	0150-0121
A2C39	0150-0197	8		CAPACITOR-FXD 2.2UF+-10% 20VDC TA	56289	0150-0121
A2C40	0150-0197	8		CAPACITOR-FXD 2.2UF+-10% 20VDC TA	56289	150D225X9020A2
A2C41	0150-0121	5	1	CAPACITOR-FXD .1UF +80-20% 50VDC CER	28480	0150-0121
A2C42	0160-2055	9		CAPACITOR-FXD .01UF +80-20% 100VDC CER	28480	0160-2055
A2C43	0140-0190	7		CAPACITOR-FXD 39PF +-5% 300VDC MICA	72136	DM15E390J0300WV1CR
A2C44	0160-0156	9		CAPACITOR-FXD 5600PF +-10% 20VDC POLYE	28480	0160-0156
A2C45	0160-2055	9		CAPACITOR-FXD .01UF +80-20% 100VDC CER	28480	0160-2055
A2C46	0150-0121	5	1	CAPACITOR-FXD .1UF +80-20% 50VDC CER	28480	0150-0121
A2C47	0140-0176	1		CAPACITOR-FXD 560PF +-2% 300VDC MICA	72136	DM15F56180300WV1CR
A2C48	0160-0197	8		CAPACITOR-FXD 2.2UF+-10% 20VDC TA	56289	0160-0197
A2C49	0160-0197	8		CAPACITOR-FXD 2.2UF+-10% 20VDC TA	56289	150D225X9020A2
A2C50	0150-0121	5		CAPACITOR-FXD .1UF +80-20% 50VDC CER	28480	0150-0121
A2C51	0150-0121	5	6	CAPACITOR-FXD 2.2UF+-10% 20VDC TA	56289	0150-0121
A2C52	0160-2206	0		CAPACITOR-FXD 12PF +-5% 500VDC CER 0+-30	28480	150D225X9020A2
A2C53	0150-0121	5		CAPACITOR-FXD 160PF +-5% 300VDC MICA	72136	0160-2259
A2C54	0150-0121	5		CAPACITOR-FXD .1UF +80-20% 50VDC CER	28480	0150-0121
A2C55	0150-0121	5		CAPACITOR-FXD .1UF +80-20% 50VDC CER	28480	0150-0121
A2C56	0160-0197	8	0	CAPACITOR-FXD 2.2UF+-10% 20VDC TA	56289	0160-0197
A2C57	0160-2259	5		CAPACITOR-FXD 12PF +-5% 500VDC CER 0+-30	28480	150D225X9020A2
A2C58	0160-2206	0		CAPACITOR-FXD 160PF +-5% 300VDC MICA	72136	0160-2259
A2C59	0159-0121	5		CAPACITOR-FXD .1UF +80-20% 50VDC CER	28480	0150-0121
A2C60	0160-2940	1		CAPACITOR-FXD 470PF +-5% 300VDC MICA	28480	0160-2940
A2C61	0160-2940	1	1	CAPACITOR-FXD 33UF +75-10% 25VDC	28480	0160-1063
A2C62	0160-1063	3		CAPACITOR-FXD 33UF +75-10% 25VDC	28480	0160-1063
A2C63	0160-2940	1		CAPACITOR-FXD 470PF +-5% 300VDC MICA	28480	0160-2940
A2C64	0160-2940	1		CAPACITOR-FXD 470PF +-5% 300VDC MICA	28480	0160-2940
A2C65	0160-2150	5		CAPACITOR-FXD 33PF +-5% 300VDC MICA	28480	0160-2150
A2C66	0160-2055	9	9	CAPACITOR-FXD .01UF +80-20% 100VDC CER	28480	0160-2055
A2C67	0160-2055	9		CAPACITOR-FXD .01UF +80-20% 100VDC CER	28480	0160-2055
A2C68	0160-0127	2		CAPACITOR-FXD 1UF +-20% 25VDC CER	28480	0160-0127
A2C69	0150-0121	5		CAPACITOR-FXD .1UF +80-20% 50VDC CER	28480	0150-0121
A2C70	0160-2055	9		CAPACITOR-FXD .01UF +80-20% 100VDC CER	28480	0160-2055

See introduction to this section for ordering information  
\*Indicates factory selected value

Table 6-3. Replaceable Parts (Cont'd).

Reference Designation	HP Part Number	C D	Qty	Description	Mfr Code	Mfr Part Number
APC72	0160-2055	9		CAPACITOR-FXD .01UF +80-20% 100VDC CER	28480	0160-2055
APC73	0160-0127	2		CAPACITOR-FXD 1UF +-20% 25VDC CER	28480	0160-0127
APC74	0160-2055	9		CAPACITOR-FXD .01UF +80-20% 100VDC CER	28480	0160-2055
APC75	0160-2255	1		CAPACITOR-FXD 8.2PF +-25PF 500VDC CER	28480	0160-2255
APC76	0160-0127	2		CAPACITOR-FXD 1UF +-20% 25VDC CER	28480	0160-0127
APC77	0160-0197	8		CAPACITOR-FXD 2.2UF +-10% 20VDC TA	56289	1500225X9020A2
APC78	0160-0127	2		CAPACITOR-FXD 1UF +-20% 25VDC CER	28480	0160-0127
APC79	0160-2255	1		CAPACITOR-FXD 8.2PF +-25PF 500VDC CER	28480	0160-2255
APC80	0160-0127	2		CAPACITOR-FXD 1UF +-20% 25VDC CER	28480	0160-0127
APC81	0160-0127	2		CAPACITOR-FXD 1UF +-20% 25VDC CER	28480	0160-0127
APC82	0160-0127	2		CAPACITOR-FXD 1UF +-20% 25VDC CER	28480	0160-0127
APC83	0160-1603	1	2	CsFXD MY 1 UF 10X 100VDCM	28480	0160-1603
APC84	0160-0121	5		CAPACITOR-FXD .1UF +80-20% 50VDC CER	28480	0160-0121
APC85	0160-2940	1		CAPACITOR-FXD 470PF +-5% 300VDC MICA	28480	0160-2940
APC86	0160-1603	1		CsFXD MY 1 UF 10X 100VDCM	28480	0160-1603
APC87	0150-0121	5		CAPACITOR-FXD .1UF +80-20% 50VDC CER	28480	0150-0121
APC88	0160-2055	9		CAPACITOR-FXD .01UF +80-20% 100VDC CER	28480	0160-2055
APC89	0160-1083	3		CAPACITOR-FXD 1UF +-20% 25VDC CER	28480	0160-1083
APC90	0160-0127	2		CAPACITOR-FXD .01UF +80-20% 100VDC CER	28480	0160-0127
APC91	0160-2055	9		CAPACITOR-FXD .01UF +80-20% 100VDC CER	28480	0160-2055
APC92	0160-1083	3		CAPACITOR-FXD 33uF +75-10% 25VDC	28480	0160-1083
APC93	0160-2259	5		CAPACITOR-FXD 12PF +-5% 500VDC CER 0+-30	28480	0160-2259
APC94	0160-2259	5	2	CAPACITOR-FXD 2.2PF +-25PF 500VDC CER	28480	0160-2259
APC95	0160-2055	9		CAPACITOR-FXD .01UF +80-20% 100VDC CER	28480	0160-2055
APC96	0150-0121	5		CAPACITOR-FXD .1UF +80-20% 50VDC CER	28480	0150-0121
APC97	0160-2055	9		CAPACITOR-FXD .01UF +80-20% 100VDC CER	28480	0160-2055
APC98	0160-2203	4	6	CAPACITOR-FXD 91PF +-5% 300VDC MICA	72136	
APC99	0160-2217	4	5	CAPACITOR-FXD 910PF +-5% 300VDC MICA	28480	
APC100	0160-2055	9		CAPACITOR-FXD .01UF +80-20% 100VDC CER	28480	0160-2055
APC101	0160-2055	9		CAPACITOR-FXD .01UF +80-20% 100VDC CER	28480	0160-2055
APC102	0160-2055	9		CAPACITOR-FXD .01UF +80-20% 100VDC CER	28480	0160-2055
APC103	0160-1083	3		CAPACITOR-FXD 33uF +75-10% 25VDC	28480	0160-1083
APC104	0160-1083	3		CAPACITOR-FXD 33uF +75-10% 25VDC	28480	0160-1083
APC105	0160-0127	2		CAPACITOR-FXD 1UF +-20% 25VDC CER	28480	0160-0127
APC106	0160-2259	5		CAPACITOR-FXD 12PF +-5% 500VDC CER 0+-30	28480	0160-2259
APC107	0160-0127	2		CAPACITOR-FXD 1UF +-20% 25VDC CER	28480	0160-0127
APC108	0160-2241	5		CAPACITOR-FXD 2.2PF +-25PF 500VDC CER	28480	0160-2241
APC109	0160-1083	3		CAPACITOR-FXD 33uF +75-10% 25VDC	28480	0160-1083
APC110	0160-1083	3		CAPACITOR-FXD 33uF +75-10% 25VDC	28480	0160-1083
APC111	0160-2055	9		CAPACITOR-FXD .01UF +80-20% 100VDC CER	28480	0160-2055
APC112	0160-2055	9		CAPACITOR-FXD .01UF +80-20% 100VDC CER	28480	0160-2055
APC113	0160-1083	3		CAPACITOR-FXD 33uF +75-10% 25VDC	28480	0160-1083
APC114	0160-1083	3		CAPACITOR-FXD 33uF +75-10% 25VDC	28480	0160-1083
APCP1	1990-0104	5	2	PHOTOCELL LAMP	28480	1990-0104
APCR1	1901-0040	1		DIODE-SWITCHING 30V 50MA 2N8 DO-35	28480	1901-0040
APCR2	1901-0518	8	10	DIODE-SCHOTTKY	28480	1901-0518
APCR3	1901-0518	6		DIODE-SCHOTTKY	28480	1901-0518
APCR4	1901-0518	8		DIODE-SCHOTTKY	28480	1901-0518
APCR5	1902-0041	4	2	DIODE-ZNR 5.11V 5% DO-7 PDM,4W TCR=-.004X	28480	1902-0041
APCR6	1901-0040	1		DIODE-SWITCHING 30V 50MA 2N8 DO-35	28480	1901-0040
APCR7	1901-0040	1		DIODE-SWITCHING 30V 50MA 2N8 DO-35	28480	1901-0040
APCR8	1901-0040	1		DIODE-SWITCHING 30V 50MA 2N8 DO-35	28480	1901-0040
APCR9	1901-0040	1		DIODE-SWITCHING 30V 50MA 2N8 DO-35	28480	1901-0040
APCR10	1901-0040	1		DIODE-SWITCHING 30V 50MA 2N8 DO-35	28480	1901-0040
APCR11	1901-0040	1		DIODE-SWITCHING 30V 50MA 2N8 DO-35	28480	1901-0040
APCR12	1901-0040	1		DIODE-SWITCHING 30V 50MA 2N8 DO-35	28480	1901-0040
APCR13	1901-0040	1		DIODE-SWITCHING 30V 50MA 2N8 DO-35	28480	1901-0040
APCR14	1901-0040	1		DIODE-SWITCHING 30V 50MA 2N8 DO-35	28480	1901-0040
APCR15	1902-3036	3	4	DIODE-ZNR 3.16V 5% DO-7 PDM,4W TCR=-.004X	28480	1902-3036
APCR16	1901-0040	1		DIODE-SWITCHING 30V 50MA 2N8 DO-35	28480	1901-0040
APCR17	1902-3036	3		DIODE-ZNR 3.16V 5% DO-7 PDM,4W TCR=-.004X	28480	1902-3036
APCR18	1902-3036	3		DIODE-ZNR 3.16V 5% DO-7 PDM,4W TCR=-.004X	28480	1902-3036
APCR19	1902-3036	3		DIODE-ZNR 3.16V 5% DO-7 PDM,4W TCR=-.004X	28480	1902-3036
APCR20	1902-3036	3		DIODE-ZNR 3.16V 5% DO-7 PDM,4W TCR=-.004X	28480	1902-3036
APCR25A-ZB	1901-0040			DIODE-SWITCHING		
ASR1	0490-0240	9		RELAY-REED	28480	0490-0240
ASR2	0490-0240	9		RELAY-REED	28480	0490-0240
ASL1	9100-0880	7	4	COIL-FXD 22uH 5%	28480	9100-0880
ASL2	9100-0880	7		COIL-FXD 22uH 5%	28480	9100-0880
ASL3	9100-0880	7		COIL-FXD 22uH 5%	28480	9100-0880
ASL4	9100-0880	7		COIL-FXD 22uH 5%	28480	9100-0880
ASL5	9100-0881	6	4	COIL-FXD 5.6uH 5%	28480	9100-0881
ASL6	9100-0881	8		COIL-FXD 5.6uH 5%	28480	9100-0881
ASL7	9100-0881	8		COIL-FXD 5.6uH 5%	28480	9100-0881
ASL8	9100-0881	8		COIL-FXD 5.6uH 5%	28480	9100-0881
ASL9	9140-0114	6	6	COIL-MLD 10UH 10% Q855 .155DX,175LG-NOM	28480	9140-0114
ASL10	9140-0114	4		COIL-MLD 10UH 10% Q855 .155DX,175LG-NOM	28480	9140-0114

See introduction to this section for ordering information  
\*Indicates factory selected value

Table 6-3. Replaceable Parts (Cont'd).

Reference Designation	HP Part Number	C D	Qty	Description	Mfr Code	Mfr Part Number
A2L11- A2L20	9170-0029	3		CORE-SHIELDING BEAD	26460	0170-0029
A2Q1	1654-0215	1	28	TRANSISTOR NPN SI PD=350MH FT=300MHZ	04713	2N3904
A2Q2	1654-0215	1		TRANSISTOR NPN SI PD=350MH FT=300MHZ	04713	2N3904
A2Q3	1654-0071	7		TRANSISTOR NPN SI PD=300MH FT=200MHZ	26480	1654-0071
A2Q4	1654-0215	1		TRANSISTOR NPN SI PD=350MH FT=300MHZ	04713	2N3904
A2Q5	1653-0089	5	6	TRANSISTOR PNP 2N4917 SI PD=200MH	07263	2N4917
A2Q6	1653-0089	5		TRANSISTOR PNP 2N4917 SI PD=200MH	07263	2N4917
A2Q7	1653-0089	5		TRANSISTOR PNP 2N4917 SI PD=200MH	07263	2N4917
A2Q8	1654-0215	1		TRANSISTOR NPN SI PD=350MH FT=300MHZ	04713	2N3904
A2Q9	1653-0089	5		TRANSISTOR PNP 2N4917 SI PD=200MH	07263	2N4917
A2Q10	1655-0261	9		TRANSISTOR MOS-FET PD=100mW ID=15mA	26480	1655-0261
A2Q11	1653-0091	3	21	TRANSISTOR J-FET N-CHAN D-MODE SI	26480	1653-0091
A2Q12	1653-0091	3		TRANSISTOR J-FET N-CHAN D-MODE SI	26480	1653-0091
A2Q13	1654-0215	1		TRANSISTOR NPN SI PD=350MH FT=300MHZ	04713	2N3904
A2Q14	1653-0091	3		TRANSISTOR J-FET N-CHAN D-MODE SI	26480	1653-0091
A2Q15	1654-0215	1		TRANSISTOR NPN SI PD=350MH FT=300MHZ	04713	2N3904
A2Q16	1654-0215	1		TRANSISTOR NPN SI PD=350MH FT=300MHZ	04713	2N3904
A2Q17	1653-0091	3		TRANSISTOR J-FET N-CHAN D-MODE SI	26480	1653-0091
A2Q18	1654-0215	1		TRANSISTOR NPN SI PD=350MH FT=300MHZ	04713	2N3904
A2Q19	1654-0071	7		TRANSISTOR NPN SI PD=300MH FT=200MHZ	26480	1654-0071
A2Q20	1654-0215	1		TRANSISTOR NPN SI PD=350MH FT=300MHZ	04713	2N3904
A2Q21	1654-0477	7		TRANSISTOR NPN 2N2222A SI TO-18 PD=500MH	04713	2N2222A
A2Q22	1653-0281	9	2	TRANSISTOR PNP 2N2907A SI TO-18 PD=400MH	04713	2N2907A
A2Q23	1653-0089	5		TRANSISTOR PNP 2N4917 SI PD=200MH	07263	2N4917
A2Q24	1654-0215	1		TRANSISTOR NPN SI PD=350MH FT=300MHZ	04713	2N3904
A2Q25	1654-0215	1		TRANSISTOR NPN SI PD=350MH FT=300MHZ	04713	2N3904
A2Q26	1654-0071	7		TRANSISTOR NPN SI PD=300MH FT=200MHZ	26480	1654-0071
A2Q27	1654-0071	7		TRANSISTOR NPN SI PD=300MH FT=200MHZ	26480	1654-0071
A2Q28	1654-0477	7		TRANSISTOR NPN 2N2222A SI TO-18 PD=500MH	04713	2N2222A
A2Q29	1653-0281	9		TRANSISTOR PNP 2N2907A SI TO-18 PD=400MH	04713	2N2907A
A2Q30	1653-0089	5		TRANSISTOR PNP 2N4917 SI PD=200MH	07263	2N4917
A2Q31	1654-0215	1		TRANSISTOR NPN SI PD=350MH FT=300MHZ	04713	2N3904
A2Q32	1654-0215	1		TRANSISTOR NPN SI PD=350MH FT=300MHZ	04713	2N3904
A2Q33	1654-0215	1		TRANSISTOR NPN SI PD=350MH FT=300MHZ	04713	2N3904
A2R1	0698-3160	8	4	RESISTOR 31.6K 1% .125W F TC=0+-100	24546	C4-1/8-T0-3162-F
A2R2	0797-0199	3	4	RESISTOR 21.5K 1% .125W F TC=0+-100	24546	C4-1/8-T0-2152-F
A2R3	0797-0199	3		RESISTOR 21.5K 1% .125W F TC=0+-100	24546	C4-1/8-T0-2152-F
A2R4	0698-3160	8		RESISTOR 31.6K 1% .125W F TC=0+-100	24546	C4-1/8-T0-3162-F
A2R5	0797-0278	9	10	RESISTOR 1.78K 1% .125W F TC=0+-100	24546	C4-1/8-T0-1781-F
A2R6	0683-4725	2		RESISTOR 4.7K 5% .25W FC TC=400/+700	01121	C84725
A2R7	0797-0278	3		RESISTOR 1.78K 1% .125W F TC=0+-100	24546	C4-1/8-T0-1781-F
A2R8	0683-2225	9		RESISTOR 2.2K 5% .25W FC TC=400/+700	01121	C82225
A2R9	0683-3325	6		RESISTOR 3.3K 5% .25W FC TC=400/+700	01121	C83325
A2R10	0683-4725	2		RESISTOR 4.7K 5% .25W FC TC=400/+700	01121	C84725
A2R11	0698-3447	3		RESISTOR 422 1% .125W F TC=0+-100	24546	
A2R12	0698-3447	3		RESISTOR 422 1% .125W F TC=0+-100	24546	
A2R13	2100-3161	8	2	RESISTOR-TRMR 20K 10% C BIDE-ADJ 17-TRN	02111	43P203
A2R14	2100-3161	8		RESISTOR-TRMR 20K 10% C BIDE-ADJ 17-TRN	02111	43P203
A2R15	0683-4725	2		RESISTOR 4.7K 5% .25W FC TC=400/+700	01121	C84725
A2R16	0683-4725	2		RESISTOR 4.7K 5% .25W FC TC=400/+700	01121	C84725
A2R17	0683-3325	6		RESISTOR 3.3K 5% .25W FC TC=400/+700	01121	C83325
A2R18	0683-1025	9		RESISTOR 1K 5% .25W FC TC=400/+600	01121	C81025
A2R19	0683-3325	6		RESISTOR 3.3K 5% .25W FC TC=400/+700	01121	C83325
A2R20	0797-0442	9		RESISTOR 10K 1% .125W F TC=0+-100	24546	C4-1/8-T0-1002-F
A2R21	0683-1045	3	13	RESISTOR 100K 5% .25W FC TC=400/+800	01121	C81045
A2R22	0683-2245	7		RESISTOR 220K 5% .25W FC TC=400/+900	01121	C82245
A2R23	0683-1045	3	1	RESISTOR 100K 5% .25W FC TC=400/+800	01121	C81045
A2R24	0683-4735	4	9	RESISTOR 47K 5% .25W FC TC=400/+800	01121	C84735
A2R25	0683-1825	7	7	RESISTOR 1.8K 5% .25W FC TC=400/+700	01121	C81825
A2R26	0683-2725	8	6	RESISTOR 2.7K 5% .25W FC TC=400/+700	01121	C82725
A2R27	0683-2725	8		RESISTOR 2.7K 5% .25W FC TC=400/+700	01121	C82725
A2R28	0797-0442	9		RESISTOR 10K 1% .125W F TC=0+-100	24546	C4-1/8-T0-1002-F
A2R29	0683-4705	8		RESISTOR 47 5% .25W FC TC=400/+500	01121	C84705
A2R30	0683-1525	4	2	RESISTOR 1.5K 5% .25W FC TC=400/+700	01121	C81525
A2R31	0683-4705	8		RESISTOR 47 5% .25W FC TC=400/+500	01121	C84705
A2R32	0683-1025	9		RESISTOR 1K 5% .25W FC TC=400/+600	01121	C81025
A2R33	0797-0442	9		RESISTOR 10K 1% .125W F TC=0+-100	24546	C4-1/8-T0-1002-F
A2R34	0683-4705	8		RESISTOR 47 5% .25W FC TC=400/+500	01121	C84705
A2R35	0683-1525	4		RESISTOR 1.5K 5% .25W FC TC=400/+700	01121	C81525
A2R36	0683-4705	8		RESISTOR 47 5% .25W FC TC=400/+500	01121	C84705
A2R37	0683-4735	4		RESISTOR 47K 5% .25W FC TC=400/+800	01121	C84735
A2R38	0683-1025	9		RESISTOR 1K 5% .25W FC TC=400/+600	01121	C81025
A2R39	0683-2235	5	17	RESISTOR 22K 5% .25W FC TC=400/+800	01121	C82235
A2R40	0683-2235	5		RESISTOR 22K 5% .25W FC TC=400/+800	01121	C82235

See introduction to this section for ordering information  
\*Indicates factory selected value

Table 6-3. Replaceable Parts (Cont'd).

Reference Designation	HP Part Number	C D	Qty	Description	Mfr Code	Mfr Part Number
APR41	0683-4735	4	4	RESISTOR 47K 5% .25W FC TC=400/+800	01121	CB4735
APR42	0683-1825	7		RESISTOR 1.8K 5% .25W FC TC=400/+700	01121	CB1825
APR43	0683-2725	8		RESISTOR 2.7K 5% .25W FC TC=400/+700	01121	CB2725
APR44	0698-3700	2		RESISTOR 715 1% .125W F TC=0+100	24546	C4-1/8-T0-715R-F
APR45	0698-3700	2		RESISTOR 715 1% .125W F TC=0+100	24546	C4-1/8-T0-715R-F
APR46	0683-2725	8	2	RESISTOR 2.7K 5% .25W FC TC=400/+700	01121	CB2725
APR47	0698-3700	2		RESISTOR 715 1% .125W F TC=0+100	24546	C4-1/8-T0-715R-F
APR48	0698-3700	2		RESISTOR 715 1% .125W F TC=0+100	24546	C4-1/8-T0-715R-F
APR49	0683-4735	4		RESISTOR 47K 5% .25W FC TC=400/+800	01121	CB4735
APR50	0683-1825	9		RESISTOR 1K 5% .25W FC TC=400/+600	01121	CB1825
APR51	0683-1055	5	6	RESISTOR 1M 5% .25W FC TC=800/+900	01121	CB1055
APR52	0683-1055	5		RESISTOR 1M 5% .25W FC TC=800/+900	01121	CB1055
APR53	0683-1035	1		RESISTOR 10K 5% .25W FC TC=400/+700	01121	CB1035
APR54	0683-2725	8		RESISTOR 2.7K 5% .25W FC TC=400/+700	01121	CB2725
APR55	0698-3447	3		RESISTOR 422 1% .125W F TC=0+100	24546	
APR56	0683-1055	5	6	RESISTOR 1M 5% .25W FC TC=800/+900	01121	CB1055
APR57	0683-2725	8		RESISTOR 2.7K 5% .25W FC TC=400/+700	01121	CB2725
APR58	0683-1035	1		RESISTOR 10K 5% .25W FC TC=400/+700	01121	CB1035
APR59	0683-2725	8		RESISTOR 2.7K 5% .25W FC TC=400/+700	01121	CB2725
APR60	0698-3447	3		RESISTOR 422 1% .125W F TC=0+100	24546	
APR61	0683-1055	5	6	RESISTOR 1M 5% .25W FC TC=800/+900	01121	CB1055
APR62	0683-2725	8		RESISTOR 2.7K 5% .25W FC TC=400/+700	01121	CB2725
APR63	0683-8215	3		RESISTOR 820 5% .25W FC TC=400/+600	01121	CB8215
APR64	0698-6624	5		RESISTOR 2K .1% .125W F TC=0+25	28480	0698-6624
APR65	0683-4715	0		RESISTOR 470 5% .25W FC TC=400/+600	01121	CB4715
APR66	0698-6624	5	6	RESISTOR 2K .1% .125W F TC=0+25	28480	0698-6624
APR67	0683-4725	2		RESISTOR 4.7K 5% .25W FC TC=400/+700	01121	CB4725
APR68	0683-3325	6		RESISTOR 3.3K 5% .25W FC TC=400/+700	01121	CB3325
APR69	0683-3325	6		RESISTOR 3.3K 5% .25W FC TC=400/+700	01121	CB3325
APR70	0683-4725	2		RESISTOR 4.7K 5% .25W FC TC=400/+700	01121	CB4725
APR71	0698-6624	5	6	RESISTOR 2K .1% .125W F TC=0+25	28480	0698-6624
APR72	0683-4715	0		RESISTOR 470 5% .25W FC TC=400/+600	01121	CB4715
APR73	0698-6624	5		RESISTOR 2K .1% .125W F TC=0+25	28480	0698-6624
APR74	0683-1025	9		RESISTOR 1K 5% .25W FC TC=400/+600	01121	CB1025
APR75	0683-1825	7		RESISTOR 1.8K 5% .25W FC TC=400/+700	01121	CB1825
APR76	0698-3457	6	3	RESISTOR 316K 1% .125W F TC=0+100	28480	0698-3457
APR77	0757-0200	3		RESISTOR 1K 1% .125W F TC=0+100	24546	C4-1/8-T0-1001-F
APR78	0757-0288	1		RESISTOR 9.09K 1% .125W F TC=0+100	19701	MF4C1/8-T0-9091-F
APR79	0698-3260	9		RESISTOR 464K 1% .125W F TC=0+100	28480	0698-3260
APR80	0757-0465	6		RESISTOR 100K 1% .125W F TC=0+100	24546	C4-1/8-T0-1003-F
APR81	0757-0465	6	4	RESISTOR 100K 1% .125W F TC=0+100	24546	C4-1/8-T0-1003-F
APR82	0683-1025	9		RESISTOR 1K 5% .25W FC TC=400/+600	01121	CB1025
APR83	0683-1035	1		RESISTOR 10K 5% .25W FC TC=400/+700	01121	CB1035
APR84	0698-7842	1		RESISTOR 26.1K .1% .125W F TC=0+25	19701	MF4C1/8-T9-2612-B
APR85	0698-6943	1		RESISTOR 20K .1% .125W F TC=0+50	28480	0698-6943
APR86	0698-6943	1	4	RESISTOR 20K .1% .125W F TC=0+50	28480	0698-6943
APR87	0698-7842	1		RESISTOR 26.1K .1% .125W F TC=0+25	19701	MF4C1/8-T9-2612-B
APR88	0698-7842	1		RESISTOR 26.1K .1% .125W F TC=0+25	19701	MF4C1/8-T9-2612-B
APR89	0698-6943	1		RESISTOR 20K .1% .125W F TC=0+50	28480	0698-6943
APR90	0698-6943	1		RESISTOR 20K .1% .125W F TC=0+50	28480	0698-6943
APR91	0698-7842	1	9	RESISTOR 26.1K .1% .125W F TC=0+25	19701	MF4C1/8-T9-2612-B
APR92	2100-2574	9		RESISTOR-TURN 500 10% C TOP-ADJ 1-TRN	73136	
APR93	0683-2235	5		RESISTOR 22K 5% .25W FC TC=400/+800	01121	CB2235
APR94	0683-1015	7		RESISTOR 100 5% .25W FC TC=400/+500	01121	CB1015
APR95	0698-3260	9		RESISTOR 464K 1% .125W F TC=0+100	28480	0698-3260
APR97	0683-3315	4	1	RESISTOR 330 5% .25W FC TC=400/+600	01121	CB3315
APR98	0683-4725	2		RESISTOR 4.7K 5% .25W FC TC=400/+700	01121	CB4725
APR100	0683-1225	1		RESISTOR 1.2K 5% .25W FC TC=400/+700	01121	CB1225
APR101	0683-4725	2		RESISTOR 4.7K 5% .25W FC TC=400/+700	01121	CB4725
APR102	0683-4725	2		RESISTOR 4.7K 5% .25W FC TC=400/+700	01121	CB4725
APR103	0757-0442	9	2	RESISTOR 10K 1% .125W F TC=0+100	24546	C4-1/8-T0-1002-F
APR104	0683-4725	2		RESISTOR 4.7K 5% .25W FC TC=400/+700	01121	CB4725
APR105	0683-2225	3		RESISTOR 2.2K 5% .25W FC TC=400/+700	01121	CB2225
APR106	0683-4705	8		RESISTOR 47 5% .25W FC TC=400/+500	01121	CB4705
APR107	0683-2225	3		RESISTOR 2.2K 5% .25W FC TC=400/+700	01121	CB2225
APR108	0683-4705	8	3	RESISTOR 47 5% .25W FC TC=400/+500	01121	CB4705
APR109	0683-2225	3		RESISTOR 2.2K 5% .25W FC TC=400/+700	01121	CB2225
APR110	0683-1825	7		RESISTOR 1.8K 5% .25W FC TC=400/+700	01121	CB1825
APR111	0683-4725	2		RESISTOR 4.7K 5% .25W FC TC=400/+700	01121	CB4725
APR112	0683-1825	1		RESISTOR 1.8K 5% .25W FC TC=400/+700	01121	CB1825
APR113	0683-4725	2	3	RESISTOR 4.7K 5% .25W FC TC=400/+700	01121	CB4725
APR114	0683-4725	2		RESISTOR 4.7K 5% .25W FC TC=400/+700	01121	CB4725
APR115	0757-0442	9		RESISTOR 10K 1% .125W F TC=0+100	24546	C4-1/8-T0-1002-F
APR116	0683-4725	2		RESISTOR 4.7K 5% .25W FC TC=400/+700	01121	CB4725
APR117	0683-2225	3		RESISTOR 2.2K 5% .25W FC TC=400/+700	01121	CB2225

See introduction to this section for ordering information  
\*Indicates factory selected value



Table 6-3. Replaceable Parts (Cont'd).

Reference Designation	HP Part Number	C D	Qty	Description	Mfr Code	Mfr Part Number
AR118	0683-4705	8		RESISTOR 47 5% .25W FC TC=400/+500	01121	CB4705
AR119	0683-2225	3		RESISTOR 2.2K 5% .25W FC TC=400/+700	01121	CB2225
AR120	0683-4705	8		RESISTOR 47 5% .25W FC TC=400/+500	01121	CB4705
AR121	0683-2225	3		RESISTOR 2.2K 5% .25W FC TC=400/+700	01121	CB2225
AR122	0683-1825	7		RESISTOR 1.8K 5% .25W FC TC=400/+700	01121	CB1825
AR123	0698-3453	2	2	RESISTOR 196K 1% .125W F TC=0/+100	24546	C4-1/8-T0-1963-F
AR124	0757-0280	3		RESISTOR 1K 1% .125W F TC=0/+100	24546	C4-1/8-T0-1001-F
AR125	0683-2225	3		RESISTOR 2.2K 5% .25W FC TC=400/+700	01121	CB2225
AR126	0698-3453	2		RESISTOR 196K 1% .125W F TC=0/+100	24546	C4-1/8-T0-1963-F
AR127	0757-0280	3		RESISTOR 1K 1% .125W F TC=0/+100	24546	C4-1/8-T0-1001-F
AR128	0683-2225	3		RESISTOR 2.2K 5% .25W FC TC=400/+700	01121	CB2225
AR129	0683-2205	9		RESISTOR 22 5% .25W FC TC=400/+500	01121	CB2205
AR130	0683-2205	9		RESISTOR 22 5% .25W FC TC=400/+500	01121	CB2205
AR131	0683-2225	3		RESISTOR 2.2K 5% .25W FC TC=400/+700	01121	CB2225
AR132	0683-6805	3	2	RESISTOR 68 5% .25W FC TC=400/+500	01121	CB6805
AR133	0683-1015	7		RESISTOR 100 5% .25W FC TC=400/+500	01121	CB1015
AR134	0698-3444	1		RESISTOR 316 1% .125W F TC=0/+100	24546	C4-1/8-T0-316R-F
AR135	0757-0280	3		RESISTOR 1K 1% .125W F TC=0/+100	24546	C4-1/8-T0-1001-F
AR136	0698-3160	8		RESISTOR 31.6K 1% .125W F TC=0/+100	24546	C4-1/8-T0-316R-F
AR137	0683-3325	6		RESISTOR 3.3K 5% .25W FC TC=400/+700	01121	CB3325
AR138	0683-1025	9		RESISTOR 1K 5% .25W FC TC=400/+600	01121	CB1025
AR139	0757-0277	8	5	RESISTOR 49.9 1% .125W F TC=0/+100	24546	C4-1/8-T0-4992-F
AR140	0683-1825	7		RESISTOR 1.8K 5% .25W FC TC=400/+700	01121	CB1825
AR141	0757-0277	8		RESISTOR 49.9 1% .125W F TC=0/+100	24546	C4-1/8-T0-4992-F
AR142	0757-0123	3	1	RESISTOR 34.8K 1% .125W F TC=0/+100	26480	0757-0123
AR143	0683-1035	1		RESISTOR 10K 5% .25W FC TC=400/+700	01121	CB1035
AR144	0683-1055	5		RESISTOR 1M 5% .25W FC TC=800/+900	01121	CB1055
AR145	0683-1055	5		RESISTOR 1M 5% .25W FC TC=800/+900	01121	CB1055
AR146	0683-4705	8		RESISTOR 47 5% .25W FC TC=400/+500	01121	CB4705
AR147	0683-2205	9		RESISTOR 22 5% .25W FC TC=400/+500	01121	CB2205
AR148	0683-2205	9		RESISTOR 22 5% .25W FC TC=400/+500	01121	CB2205
AR149	0683-6805	3		RESISTOR 68 5% .25W FC TC=400/+500	01121	CB6805
AR150	0683-2225	3		RESISTOR 2.2K 5% .25W FC TC=400/+700	01121	CB2225
AR151	0683-1015	7		RESISTOR 100 5% .25W FC TC=400/+500	01121	CB1015
AR152	0683-2225	3		RESISTOR 2.2K 5% .25W FC TC=400/+700	01121	CB2225
AR153	0757-0277	8		RESISTOR 49.9 1% .125W F TC=0/+100	24546	C4-1/8-T0-4992-F
AR154	0683-1825	7		RESISTOR 1.8K 5% .25W FC TC=400/+700	01121	CB1825
AR155	0757-0277	8		RESISTOR 49.9 1% .125W F TC=0/+100	24546	C4-1/8-T0-4992-F
AR156	0683-2225	3		RESISTOR 2.2K 5% .25W FC TC=400/+700	01121	CB2225
AR156	0698-3444	1		RESISTOR 316 1% .125W F TC=0/+100	24546	C4-1/8-T0-316R-F
AR157	0757-0280	3		RESISTOR 1K 1% .125W F TC=0/+100	24546	C4-1/8-T0-1001-F
AR158	0683-1025	9		RESISTOR 1K 5% .25W FC TC=400/+600	01121	CB1025
AR160	0683-1025	9		RESISTOR 1K 5% .25W FC TC=400/+600	01121	CB1025
AR161	0683-3335	8		RESISTOR 33K 5% .25W FC TC=400/+800	01121	CB3335
AR162	0683-4725	2		RESISTOR 4.7K 5% .25W FC TC=400/+700	01121	CB4725
AR163	0683-2235	5		RESISTOR 22K 5% .25W FC TC=400/+800	01121	CB2235
AR164	0683-2235	5		RESISTOR 22K 5% .25W FC TC=400/+800	01121	CB2235
AR165	0683-1835	9	3	RESISTOR 18K 5% .25W FC TC=400/+800	01121	CB1835
AR166	0683-1835	9		RESISTOR 18K 5% .25W FC TC=400/+800	01121	CB1835
AR167	0683-1025	9		RESISTOR 1K 5% .25W FC TC=400/+600	01121	CB1025
AR168	0683-1025	9		RESISTOR 1K 5% .25W FC TC=400/+600	01121	CB1025
AR169	0683-1025	9		RESISTOR 1K 5% .25W FC TC=400/+600	01121	CB1025
AR170	0683-1025	9		RESISTOR 1K 5% .25W FC TC=400/+600	01121	CB1025
AR171	0683-2235	5		RESISTOR 22K 5% .25W FC TC=400/+800	01121	CB2235
AR172	0683-2235	5		RESISTOR 22K 5% .25W FC TC=400/+800	01121	CB2235
AR173	0683-1835	9		RESISTOR 18K 5% .25W FC TC=400/+800	01121	CB1835
AR174	0683-1015	7		RESISTOR 100 5% .25W 250WVDC	01121	CB1015
AR175	9100-0855	6	5	TRANSFORMER-PULSE 1:1:1	26480	9100-0855
AR176	9100-0855	6		TRANSFORMER-PULSE 1:1:1	26480	9100-0855
AR177	9100-0855	6		TRANSFORMER-PULSE 1:1:1	26480	9100-0855
AR178	9100-0855	6		TRANSFORMER-PULSE 1:1:1	26480	9100-0855
AR179	9100-0855	6		TRANSFORMER-PULSE 1:1:1	26480	9100-0855
AR180	9100-0879	4		TRANSFORMER-SIGNAL 10mH 20%	26480	9100-0879
AR181	9100-0823	8		TRANSFORMER(TDK113B1) 1:1:1:1	26480	9100-0823
AR182	1826-0139	9		IC OP AMP GP DUAL 8-DIP-P	01928	CA14586
AR183	1820-0427	6	5	IC MODULATOR TO-100	04713	MC14966
AR184	5080-3056	6		IC MODULATOR TO-100	04713	04713
AR185	5080-3056	6		IC MODULATOR TO-100	04713	04713
AR186	1826-0139	9		IC OP AMP GP DUAL 8-DIP-P	01928	CA14586
AR187	1820-0427	6		IC MODULATOR TO-100	04713	MC14966
AR188	1820-0427	6		IC MODULATOR TO-100	04713	MC14966
AR189	1826-0139	6	2	IC OP AMP LOW-BIAS-H-IMPD TO-99	27014	27014
AR190	1826-0139	6		IC OP AMP LOW-BIAS-H-IMPD TO-99	27014	27014
AR191	1826-0138	8	9	IC COMPARTOR GP QUAD 14-DIP-P	04713	MLM339P

Table 6-3. Replaceable Parts (Cont'd).

Reference Designation	HP Part Number	C D	Qty	Description	Mfr Code	Mfr Part Number
<b>A2 MISCELLANEOUS PARTS</b>						
	04275-00606	7	1	PLATE SHIELD, A2	28480	04275-00606
	04275-00607	6	1	PLATE SHIELD, A2	28480	04275-00607
	04275-00622	7	2	PLATE SHIELD	28480	04275-00622
	04275-00623	6	1	PLATE SHIELD	28480	04275-00623
<b>A3</b>	04275-66503	1	1	POWER AMPLIFIER BOARD ASSEMBLY	28480	04275-66503
	04275-26503	7		PC BOARD, BLANK	28480	04275-26503
<b>ASC1</b>	0180-1085	5		CAPACITOR-FXD 4.7uF 20% 16VDC	28480	0180-1085
<b>ASC2</b>	0180-3443	1		CAPACITOR-FXD .1UF +80-20% 50VDC CER	28480	0180-3443
<b>ASC3</b>	0180-2055	9		CAPACITOR-FXD .01UF +80-20% 100VDC CER	28480	0180-2055
<b>ASC4</b>	0180-2055	9		CAPACITOR-FXD .01UF +80-20% 100VDC CER	28480	0180-2055
<b>ASC5</b>	0180-1085	5		CAPACITOR-FXD 4.7uF 20% 16VDC	28480	0180-1085
<b>ASC6</b>	0180-2256	4	4	CAPACITOR-FXD 11PF +-5% 500VDC CER 0+-30	28480	0180-2256
<b>ASC7</b>	0180-1085	5		CAPACITOR-FXD 4.7uF 20% 16VDC	28480	0180-1085
<b>ASC8</b>	0180-2249	3		CAPACITOR-FXD 4.7PF +-25PF 500VDC CER	28480	0180-2249
<b>ASC9</b>	0180-1085	5		CAPACITOR-FXD 4.7uF 20% 16VDC	28480	0180-1085
<b>ASC10</b>	0180-1085	5		CAPACITOR-FXD 4.7uF 20% 16VDC	28480	0180-1085
<b>ASC11</b>	0180-2055	9		CAPACITOR-FXD .01UF +80-20% 100VDC CER	28480	0180-2055
<b>ASC12</b>	0180-2207	3	1	CAPACITOR-FXD 300PF +-5% 300VDC MICA	28480	0180-2207
<b>ASC13</b>	0121-0059	7		CAPACITOR-V YMR-CER 2-8PF 350V PC-MTG	52763	304324 2.8PF NPO
<b>ASC14</b>	0180-1085	5		CAPACITOR-FXD 4.7uF 20% 16VDC	28480	0180-1085
<b>ASC15</b>	0180-1083	3		CAPACITOR-FXD 33uF +75-10% 25VDC	28480	0180-1083
<b>ASC16</b>	0180-3443	1		CAPACITOR-FXD .1UF +80-20% 50VDC CER	28480	0180-3443
<b>ASC17</b>	0180-3443	1		CAPACITOR-FXD .1UF +80-20% 50VDC CER	28480	0180-3443
<b>ASC18</b>	0180-1085	5		CAPACITOR-FXD 4.7uF 20% 16VDC	28480	0180-1085
<b>ASC19</b>	0180-1085	5		CAPACITOR-FXD 4.7uF 20% 16VDC	28480	0180-1085
<b>ASC20</b>	0180-0134	1	3	CAPACITOR-FXD 220PF +-5% 300VDC MICA	28480	0180-0134
<b>ASC21</b>	0180-2256	4		CAPACITOR-FXD 11PF +-5% 500VDC CER 0+-30	28480	0180-2256
<b>ASC22</b>	0180-0134	1		CAPACITOR-FXD 220PF +-5% 300VDC MICA	28480	0180-0134
<b>ASC23</b>	0180-1083	3		CAPACITOR-FXD 33uF +75-10% 25VDC	28480	0180-1083
<b>ASC24</b>	0180-1083	3		CAPACITOR-FXD 33uF +75-10% 25VDC	28480	0180-1083
<b>ASC25</b>	0180-1086	6		CAPACITOR-FXD 33uF +50-30% 16VDC	28480	0180-1086
<b>ASC26</b>	0150-0052	1	4	CAPACITOR-FXD .05UF +-20% 400VDC CER	28480	0150-0052
<b>ASC27</b>	0180-1085	5		CAPACITOR-FXD 4.7uF 20% 16VDC	28480	0180-1085
<b>ASC28</b>	0180-1077	5		CAPACITOR-FXD 220uF +50-10% 16VDC	28480	0180-1077
<b>ASC29</b>	0180-1085	5		CAPACITOR-FXD 4.7uF 20% 16VDC	28480	0180-1085
<b>ASC30</b>	0180-1077	5		CAPACITOR-FXD 220uF +50-10% 16VDC	28480	0180-1077
<b>ASC31</b>	0180-2055	9		CAPACITOR-FXD .01UF +80-20% 100VDC CER	28480	0180-2055
<b>ASC32</b>	0180-2055	9		CAPACITOR-FXD .01UF +80-20% 100VDC CER	28480	0180-2055
<b>ASC33</b>	0180-1085	5		CAPACITOR-FXD 4.7uF 20% 16VDC	28480	0180-1085
<b>ASC34</b>	0180-3443	1		CAPACITOR-FXD .1UF +80-20% 50VDC CER	28480	0180-3443
<b>ASC35</b>	0180-2055	9		CAPACITOR-FXD .01UF +80-20% 100VDC CER	28480	0180-2055
<b>ASC36</b>	0180-1085	5		CAPACITOR-FXD 4.7uF 20% 16VDC	28480	0180-1085
<b>ASC37</b>	0180-1083	3		CAPACITOR-FXD 33uF +75-10% 25VDC	28480	0180-1083
<b>ASC38</b>	0180-0197	4		CAPACITOR-FXD 180PF +-5% 300VDC MICA	72136	DM15F181J0300HV1CR
<b>ASC39</b>	0180-1085	5		CAPACITOR-FXD 4.7uF 20% 16VDC	28480	0180-1085
<b>ASC41</b>	0180-3443	1		CAPACITOR-FXD .1UF +80-20% 50VDC CER	28480	0180-3443
<b>ASC42</b>	0180-2055	9		CAPACITOR-FXD .01UF +80-20% 100VDC CER	28480	0180-2055
<b>ASC43</b>	0180-2055	9		CAPACITOR-FXD .01UF +80-20% 100VDC CER	28480	0180-2055
<b>ASC44</b>	0180-1085	5		CAPACITOR-FXD 4.7uF 20% 16VDC	28480	0180-1085
<b>ASC45</b>	0180-2256	4		CAPACITOR-FXD 11PF +-5% 500VDC CER 0+-30	28480	0180-2256
<b>ASC46</b>	0180-1085	5		CAPACITOR-FXD 4.7uF 20% 16VDC	28480	0180-1085
<b>ASC47</b>	0180-2249	3		CAPACITOR-FXD 4.7PF +-25PF 500VDC CER	28480	0180-2249
<b>ASC48</b>	0180-1085	5		CAPACITOR-FXD 4.7uF 20% 16VDC	28480	0180-1085
<b>ASC49</b>	0180-1085	5		CAPACITOR-FXD 4.7uF 20% 16VDC	28480	0180-1085
<b>ASC50</b>	0180-2055	9		CAPACITOR-FXD .01UF +80-20% 100VDC CER	28480	0180-2055
<b>ASC51</b>	0180-0199	6	1	CAPACITOR-FXD 240PF +-5% 300VDC MICA	72136	DM15F241J0300HV1CR
<b>ASC52</b>	0180-4794	6		CAPACITOR-FXD 5.6PF +-5 PF 100 VDC CER	28480	0180-4794
<b>ASC53</b>	0180-1085	5		CAPACITOR-FXD 4.7uF 20% 16VDC	28480	0180-1085
<b>ASC54</b>	0180-1083	3		CAPACITOR-FXD 33uF +75-10% 25VDC	28480	0180-1083
<b>ASC55</b>	0180-1085	5		CAPACITOR-FXD 4.7uF 20% 16VDC	28480	0180-1085
<b>ASC56</b>	0180-3443	1		CAPACITOR-FXD .1UF +80-20% 50VDC CER	28480	0180-3443
<b>ASC57</b>	0180-3443	1		CAPACITOR-FXD .1UF +80-20% 50VDC CER	28480	0180-3443
<b>ASC58</b>	0180-1085	5		CAPACITOR-FXD 4.7uF 20% 16VDC	28480	0180-1085
<b>ASC59</b>	0180-0195	9		CAPACITOR-FXD 130PF +-5% 300VDC MICA 0+70	28480	
<b>ASC60</b>	0180-2256	4		CAPACITOR-FXD 11PF +-5% 500VDC CER 0+-30	28480	0180-2256
<b>ASC61</b>	0180-0199	1		CAPACITOR-FXD 240PF +-5% 300VDC MICA	28480	
<b>ASC62</b>	0180-1083	3		CAPACITOR-FXD 33uF +75-10% 25VDC	28480	0180-1083
<b>ASC63</b>	0180-1083	3		CAPACITOR-FXD 33uF +75-10% 25VDC	28480	0180-1083
<b>ASC64</b>	0180-1086	6		CAPACITOR-FXD 33uF +50-30% 16VDC	28480	0180-1086
<b>ASC65</b>	0180-1083	3		CAPACITOR-FXD 33uF +75-10% 25VDC	28480	0180-1083

See introduction to this section for ordering information  
\*Indicates factory selected value

Table 6-3. Replaceable Parts (Cont'd).

Reference Designation	HP Part Number	C D	Qty	Description	Mfr Code	Mfr Part Number
A3C66	0160-0197	4		CAPACITOR-FXD 180PF +5% 300VDC MICA	72136	DM15F181J0300MV1CR
A3C67	0180-1077	5		CAPACITOR-FXD 220uF +50-10% 16VDC	28480	0180-1077
A3C68	0180-1085	5		CAPACITOR-FXD 4.7uF 20% 16VDC	28480	0180-1085
A3C69	0180-1077	5		CAPACITOR-FXD 220uF +50-10% 16VDC	28480	0180-1077
A3C70	0160-3443	1		CAPACITOR-FXD .1UF +80-20% 50VDC CER	28480	0160-3443
A3C71	0160-2055	9		CAPACITOR-FXD .01UF +80-20% 100VDC CER	28480	0160-2055
A3C72	0180-1085	5		CAPACITOR-FXD 4.7uF 20% 16VDC	28480	0180-1085
A3C73	0160-3443	1		CAPACITOR-FXD .1UF +80-20% 50VDC CER	28480	0160-3443
A3C74	0160-2055	9		CAPACITOR-FXD .01UF +80-20% 100VDC CER	28480	0160-2055
A3C75	0180-1085	5		CAPACITOR-FXD 4.7uF 20% 16VDC	28480	0180-1085
A3C76*						
A3C77	0160-3443	1		CAPACITOR-FXD .1UF +80-20% 50VDC CER	28480	0160-3443
A3C78	0180-1077	5		CAPACITOR-FXD 220uF +50-10% 16VDC	28480	0180-1077
A3C79	0160-3443	1		CAPACITOR-FXD .1UF +80-20% 50VDC CER	28480	0160-3443
A3C80	0160-3443	1		CAPACITOR-FXD .1UF +80-20% 50VDC CER	28480	0160-3443
A3C81	0180-1085	5		CAPACITOR-FXD 4.7uF 20% 16VDC	28480	0180-1085
A3C82	0180-1085	5		CAPACITOR-FXD 4.7uF 20% 16VDC	28480	0180-1085
A3C83	0180-1085	5		CAPACITOR-FXD 4.7uF 20% 16VDC	28480	0180-1085
A3C84	0180-1077	5		CAPACITOR-FXD 220uF +50-10% 16VDC	28480	0180-1077
A3C85	0180-1077	5		CAPACITOR-FXD 220uF +50-10% 16VDC	28480	0180-1077
A3C86	0180-1078	6	1	CAPACITOR-FXD 330uF +50-10% 6.3VDC	28480	0180-1078
A3C87	0160-3443	1		CAPACITOR-FXD .1UF +80-20% 50VDC CER	28480	0160-3443
A3C88	0160-3443	1		CAPACITOR-FXD .1UF +80-20% 50VDC CER	28480	0160-3443
A3CR1	1902-3160	4	4	DIODE-ZNR 10V 2% DO-7 PDS.4W TC=+.06%	28480	1902-3160
A3CR2	1902-0049	2		DIODE-ZNR 6.19V 5% DO-7 PDS.4W TC=+.022%	28480	1902-0049
A3CR3	1901-0040	1		DIODE-SWITCHING 30V 50MA 2NS DO-35	28480	1901-0040
A3CR4	1901-0040	1		DIODE-SWITCHING 30V 50MA 2NS DO-35	28480	1901-0040
A3CR5	1901-0033	2		DIODE-GEN PRP 180V 200MA DO-7	28480	1901-0033
A3CR6	1901-0033	2		DIODE-GEN PRP 180V 200MA DO-7	28480	1901-0033
A3CR7	1901-0040	1		DIODE-SWITCHING 30V 50MA 2NS DO-35	28480	1901-0040
A3CR8	1901-0040	1		DIODE-SWITCHING 30V 50MA 2NS DO-35	28480	1901-0040
A3CR9	1901-0040	1		DIODE-SWITCHING 30V 50MA 2NS DO-35	28480	1901-0040
A3CR10	1901-0040	1		DIODE-SWITCHING 30V 50MA 2NS DO-35	28480	1901-0040
A3CR11	1902-0049	2		DIODE-ZNR 6.19V 5% DO-7 PDS.4W TC=+.022%	28480	1902-0049
A3CR12	1901-0040	1		DIODE-SWITCHING 30V 50MA 2NS DO-35	28480	1901-0040
A3CR13	1901-0040	1		DIODE-SWITCHING 30V 50MA 2NS DO-35	28480	1901-0040
A3CR14	1901-0040	1		DIODE-SWITCHING 30V 50MA 2NS DO-35	28480	1901-0040
A3CR15	1901-0040	1		DIODE-SWITCHING 30V 50MA 2NS DO-35	28480	1901-0040
A3CR16	1901-0040	1		DIODE-SWITCHING 30V 50MA 2NS DO-35	28480	1901-0040
A3CR17	1901-0040	1		DIODE-SWITCHING 30V 50MA 2NS DO-35	28480	1901-0040
A3CR18	1902-3160	4		DIODE-ZNR 10V 2% DO-7 PDS.4W TC=+.06%	28480	1902-3160
A3CR19	1902-3160	4		DIODE-ZNR 10V 2% DO-7 PDS.4W TC=+.06%	28480	1902-3160
A3CR20	1902-3160	4		DIODE-ZNR 10V 2% DO-7 PDS.4W TC=+.06%	28480	1902-3160
A3CR21	1902-3160	4		DIODE-ZNR 10V 2% DO-7 PDS.4W TC=+.06%	28480	1902-3160
A3CR22	1901-0025	2		DIODE-GEN PRP 100V 200MA DO-7	28480	1901-0025
A3CR23	1901-0025	2		DIODE-GEN PRP 100V 200MA DO-7	28480	1901-0025
A3CR24	1902-0064	1	1	DIODE-ZNR 7.5V 5% DO-7 PDS.4W TC=+.05%	28480	1902-0064
A3J1	1250-0257	1		CONNECTOR-RF 8MB M PC 50-OHM	28480	1250-0257
A3J2	1250-0257	1		CONNECTOR-RF 8MB M PC 50-OHM	28480	1250-0257
A3J3	1250-0257	1		CONNECTOR-RF 8MB M PC 50-OHM	28480	1250-0257
A3J4	1250-0257	1		CONNECTOR-RF 8MB M PC 50-OHM	28480	1250-0257
A3K1	0490-0234	1		RELAY, REED	28480	0490-0234
A3K2	0490-0234	1		RELAY, REED	28480	0490-0234
A3L1	9140-0179	1		COIL-MLD 22UM 10% 8=75 .155DX.375LG-NOM	28480	9140-0179
A3L2	9140-0179	1		COIL-MLD 22UM 10% 8=75 .155DX.375LG-NOM	28480	9140-0179
A3L3	9140-0210	1		COIL-MLD 100UM 5% 8=50 .155DX.375LG-NOM	28480	9140-0210
A3M1	1854-0345	8		TRANSISTOR NPN 2N5179 SI TO-72 PD=200MW	04713	2N5179
A3M2	1853-0203	5		TRANSISTOR MOS-FET PD=100mW ID=15mA	28480	1853-0203
A3M3	1854-0019	3		TRANSISTOR NPN 8I TO-18 PD=360MW	28480	1854-0019
A3M4	1854-0092	2		TRANSISTOR NPN 8I PD=200MW FT=600MHZ	28480	1854-0092
A3M5	1854-0071	7		TRANSISTOR NPN 8I PD=300MW FT=200MHZ	28480	1854-0071
A3M6	1854-0092	2		TRANSISTOR NPN 8I PD=200MW FT=600MHZ	28480	1854-0092
A3M7	1854-0092	2		TRANSISTOR NPN 8I PD=200MW FT=600MHZ	28480	1854-0092
A3M8	1854-0092	2		TRANSISTOR NPN 8I PD=200MW FT=600MHZ	28480	1854-0092
A3M9	1854-0071	7		TRANSISTOR NPN 8I PD=300MW FT=200MHZ	28480	1854-0071
A3M10	1854-0345	8		TRANSISTOR NPN 2N5179 SI TO-72 PD=200MW	04713	2N5179
A3M11	1854-0345	8		TRANSISTOR NPN 2N5179 SI TO-72 PD=200MW	04713	2N5179
A3M12	1853-0203	5	4	TRANSISTOR PNP 8I PD=360MW FT=700MHZ	28480	1853-0203
A3M13	1854-0019	3		TRANSISTOR NPN 8I TO-18 PD=360MW	28480	1854-0019
A3M14	1854-0247	9	2	TRANSISTOR NPN 8I TO-39 PDS.1W FT=800MHZ	28480	1854-0247
A3M15	1853-0203	5		TRANSISTOR PNP 8I PD=360MW FT=700MHZ	28480	1853-0203
A3M16	1853-0012	4	5	TRANSISTOR PNP 2N2904A SI TO-39 PD=600MW	01295	2N2904A
A3M17	1854-0345	8		TRANSISTOR NPN 2N5179 SI TO-72 PD=200MW	04713	2N5179
A3M18	1853-0261	9		TRANSISTOR NPN 8I PD=200MW FT=600MHZ	28480	1853-0261
A3M19	1854-0019	3		TRANSISTOR NPN 8I TO-18 PD=360MW	28480	1854-0019
A3M20	1854-0092	2		TRANSISTOR NPN 8I PD=200MW FT=600MHZ	28480	1854-0092
				TRANSISTOR MOS-FET PD=100mW ID=15mA		

See introduction to this section for ordering information  
\*Indicates factory selected value

Table 6-3. Replaceable Parts (Cont'd).

Reference Designation	HP Part Number	C D	Qty	Description	Mfr Code	Mfr Part Number
AS001	1854-0071	7		TRANSISTOR NPN SI PD=300MW FT=200MHZ	28480	1854-0071
AS002	1854-0092	2		TRANSISTOR NPN SI PD=200MW FT=600MHZ	28480	1854-0092
AS003	1854-0092	2		TRANSISTOR NPN SI PD=200MW FT=600MHZ	28480	1854-0092
AS004	1854-0092	2		TRANSISTOR NPN SI PD=200MW FT=600MHZ	28480	1854-0092
AS005	1854-0071	7		TRANSISTOR NPN SI PD=300MW FT=200MHZ	28480	1854-0071
AS006	1854-0345	8		TRANSISTOR NPN 2N5179 SI TO-72 PD=200MW	04713	2N5179
AS007	1854-0345	8		TRANSISTOR NPN 2N5179 SI TO-72 PD=200MW	04713	2N5179
AS008	1853-0203	5		TRANSISTOR PNP SI PD=360MW FT=700MHZ	28480	1853-0203
AS009	1854-0019	3		TRANSISTOR NPN SI TO-18 PD=360MW	28480	1854-0019
AS010	1854-0247	9		TRANSISTOR NPN SI TO-39 PD=1W FT=800MHZ	28480	1854-0247
AS031	1853-0203	5		TRANSISTOR PNP SI PD=360MW FT=700MHZ	28480	1853-0203
AS032	1853-0012	4		TRANSISTOR PNP 2N2904A SI TO-39 PD=600MW	01295	2N2904A
AS033	1853-0084	0	2	TRANSISTOR PNP 2N4918 SI PD=30W FT=3MHZ	04713	2N4918
AS034	1854-0389	0	2	TRANSISTOR NPN 2N4922 BI PD=30W FT=3MHZ	04713	2N4922 → 1854-0197 1:変更
AS035	1854-0071	7		TRANSISTOR NPN SI PD=300MW FT=200MHZ	28480	1854-0071 (Fc 0 389=6)
ASR1	2100-0552	3	1	RESISTOR-TRMR 50 10% C SIDE-ADJ 1-TRN	28480	2100-0552
ASR2	0683-2225	3		RESISTOR 2.2K 5% .25W FC TC=400/+700	01121	C82225
ASR3	0757-0279	0		RESISTOR 3.16K 1% .125W F TC=0+-100	24546	C4-1/8-T0-3161-F
ASR4	0683-1045	3		RESISTOR 100K 5% .25W FC TC=400/+800	01121	CB1045
ASR5	0683-1045	3		RESISTOR 100K 5% .25W FC TC=400/+800	01121	CB1045
ASR6	0698-2234	5	1	RESISTOR 330 5% .125W	28480	0698-2234
ASR7	0683-4705	8		RESISTOR 47 5% .25W FC TC=400/+500	01121	CB4705
ASR8	0683-2225	3		RESISTOR 2.2K 5% .25W FC TC=400/+700	01121	C82225
ASR9	2100-3207	1	1	RESISTOR-TRMR 5K 10% C SIDE-ADJ 1-TRN	28480	2100-3207
ASR10	0698-0084	9		RESISTOR 2.15K 1% .125W F TC=0+-100	24546	C4-1/8-T0-2151-F
ASR11	0757-0280	3		RESISTOR 1K 1% .125W F TC=0+-100	24546	C4-1/8-T0-1001-F
ASR12	0757-0416	7		RESISTOR 511 1% .125W F TC=0+-100	24546	C4-1/8-T0-511R-F
ASR13	0698-4433	0	2	RESISTOR 2.26K 1% .125W F TC=0+-100	24546	C4-1/8-T0-2261-F
ASR14	0698-0084	9		RESISTOR 2.15K 1% .125W F TC=0+-100	24546	C4-1/8-T0-2151-F
ASR15	0698-0084	9		RESISTOR 2.15K 1% .125W F TC=0+-100	24546	C4-1/8-T0-2151-F
ASR16	0757-0401	0		RESISTOR 100 1% .125W F TC=0+-100	24546	C4-1/8-T0-101-F
ASR17	0757-0416	7		RESISTOR 511 1% .125W F TC=0+-100	24546	C4-1/8-T0-511R-F
ASR18	0757-0416	7		RESISTOR 511 1% .125W F TC=0+-100	24546	C4-1/8-T0-511R-F
ASR19	0757-0420	3	10	RESISTOR 750 1% .125W F TC=0+-100	24546	C4-1/8-T0-751-F
ASR20	0757-0420	3		RESISTOR 750 1% .125W F TC=0+-100	24546	C4-1/8-T0-751-F
ASR21	0757-0402	1	5	RESISTOR 110 1% .125W F TC=0+-100	24546	C4-1/8-T0-111-F
ASR22	0757-0410	1		RESISTOR 301 1% .125W F TC=0+-100	24546	C4-1/8-T0-301R-F
ASR23	0683-4705	8		RESISTOR 47 5% .25W FC TC=400/+500	01121	CB4705
ASR24	0698-3444	1		RESISTOR 316 1% .125W F TC=0+-100	24546	C4-1/8-T0-316R-F
ASR25	0683-4705	8		RESISTOR 47 5% .25W FC TC=400/+500	01121	CB4705
ASR26	0683-4705	8		RESISTOR 47 5% .25W FC TC=400/+500	01121	CB4705
ASR27	0698-0082	7		RESISTOR 464 1% .125W F TC=0+-100	24546	C4-1/8-T0-4640-F
ASR28	0757-0405	4	3	RESISTOR 162 1% .125W F TC=0+-100	24546	C4-1/8-T0-162R-F
ASR29	0757-0402	1		RESISTOR 110 1% .125W F TC=0+-100	24546	C4-1/8-T0-111-F
ASR30	0698-0084	9		RESISTOR 2.15K 1% .125W F TC=0+-100	24546	C4-1/8-T0-2151-F
ASR31	0698-4406	1		RESISTOR 115 1% .125W F TC=0+-100	24546	C4-1/8-T0-2151-F
ASR32	0698-0084	9		RESISTOR 2.15K 1% .125W F TC=0+-100	24546	C4-1/8-T0-2151-F
ASR33	0683-4705	8		RESISTOR 47 5% .25W FC TC=400/+500	01121	CB4705
ASR34	0683-4705	8		RESISTOR 47 5% .25W FC TC=400/+500	01121	CB4705
ASR35	0683-1005	5		RESISTOR 10 5% .25W FC TC=400/+500	01121	CB1005
ASR36	0683-1005	5		RESISTOR 10 5% .25W FC TC=400/+500	01121	CB1005
ASR37	0698-3404	3	4	RESISTOR 383 1% .5W F TC=0+-100	28480	0698-3404
ASR38	0698-3404	3		RESISTOR 383 1% .5W F TC=0+-100	28480	0698-3404
ASR39	0698-3404	3		RESISTOR 383 1% .5W F TC=0+-100	28480	0698-3404
ASR40	0698-3404	3		RESISTOR 383 1% .5W F TC=0+-100	28480	0698-3404
ASR41	0683-3325	6		RESISTOR 3.3K 5% .25W FC TC=400/+700	01121	CB3325
ASR42	0683-3335	8		RESISTOR 33K 5% .25W FC TC=400/+800	01121	CB3335
ASR43	0683-2205	8		RESISTOR 22 5% .25W FC TC=400/+500	01121	CB2205
ASR44	0683-3335	8		RESISTOR 33K 5% .25W FC TC=400/+800	01121	CB3335
ASR45	0683-2225	3		RESISTOR 2.2K 5% .25W FC TC=400/+700	01121	CB2225
ASR46	0683-1025	9		RESISTOR 1K 5% .25W FC TC=400/+600	01121	CB1025
ASR47	0683-2205	9		RESISTOR 22 5% .25W FC TC=400/+500	01121	CB2205
ASR48	0698-3450	9		RESISTOR 42.2K 1% .125W F TC=0+-100	24546	C4-1/8-T0-4222-F
ASR49	0683-1515	2	5	RESISTOR 150 5% .25W FC TC=400/+600	01121	CB1515
ASR50	0683-4725	2		RESISTOR 4.7K 5% .25W FC TC=400/+700	01121	CB4725
ASR51	0683-1005	5		RESISTOR 10 5% .25W FC TC=400/+500	01121	CB1005
ASR52	0683-1005	5		RESISTOR 10 5% .25W FC TC=400/+500	01121	CB1005
ASR53	0757-0280	3		RESISTOR 1K 1% .125W F TC=0+-100	24546	C4-1/8-T0-1001-F
ASR54	0683-4705	8		RESISTOR 47 5% .25W FC TC=400/+500	01121	CB4705
ASR55	0683-4725	2		RESISTOR 4.7K 5% .25W FC TC=400/+700	01121	CB4725
ASR56	0683-3305	2	4	RESISTOR 33 5% .25W FC TC=400/+500	01121	CB3305
ASR57	0698-4458	9	2	RESISTOR 590 1% .125W F TC=0+-100	24546	C4-1/8-T0-590R-F
ASR58	0683-3305	2		RESISTOR 33 5% .25W FC TC=400/+500	01121	CB3305
ASR59	0683-4705	8		RESISTOR 47 5% .25W FC TC=400/+500	01121	CB4705
ASR60	0683-4705	8		RESISTOR 47 5% .25W FC TC=400/+500	01121	CB4705

See introduction to this section for ordering information  
\*Indicates factory selected value

Table 6-3. Replaceable Parts (Cont'd)

Reference Designation	HP Part Number	C D	Qty	Description	Mfr Code	Mfr Part Number
ASR61	0757-0274	5		RESISTOR 1.21K 1% .125W F TC=0+/-100	24546	C4-1/8-T0-1213-F
ASR62	0683-4705	8		RESISTOR 47 5% .25W FC TC=400/+500	01121	CB4705
ASR63	0698-3444	1		RESISTOR 316 1% .125W F TC=0+/-100	24546	C4-1/8-T0-316R-F
ASR64	0683-4705	8		RESISTOR 47 5% .25W FC TC=400/+500	01121	CB4705
ASR66	0683-1535	6	2	RESISTOR 15K 5% .25W FC TC=400/+800	01121	CB1535
ASR67	0683-1535	6		RESISTOR 15K 5% .25W FC TC=400/+800	01121	CB1535
ASR67	0683-4705	8		RESISTOR 47 5% .25W FC TC=400/+500	01121	CB4705
ASR68	0757-0277	8		RESISTOR 49.9 1% .125W F TC=0+/-100	24546	C4-1/8-T0-4992-F
ASR69	0683-2225	3		RESISTOR 2.2K 5% .25W FC TC=400/+700	01121	CB2225
ASR70	0757-0279	0		RESISTOR 3.16K 1% .125W F TC=0+/-100	24546	C4-1/8-T0-3161-F
ASR71	0683-1045	3		RESISTOR 100K 5% .25W FC TC=400/+800	01121	CB1045
ASR72	0683-1045	3		RESISTOR 100K 5% .25W FC TC=400/+800	01121	CB1045
ASR73	0757-0411	2	1	RESISTOR 332 1% .125W F TC=0+/-100	24546	C4-1/8-T0-332R-F
ASR74	0683-4705	8		RESISTOR 47 5% .25W FC TC=400/+500	01121	CB4705
ASR75	0683-2225	3		RESISTOR 2.2K 5% .25W FC TC=400/+700	01121	CB2225
ASR76	0698-0084	9		RESISTOR 2.15K 1% .125W F TC=0+/-100	24546	C4-1/8-T0-2151-F
ASR77	0757-0280	3		RESISTOR 1K 1% .125W F TC=0+/-100	24546	C4-1/8-T0-1001-F
ASR78	0698-3447	4	1	RESISTOR 422 1% .125W F TC=0+/-100	24546	C4-1/8-T0-422R-F
ASR79	0683-4705	8		RESISTOR 47 5% .25W FC TC=400/+500	01121	CB4705
ASR79	0698-4433	0		RESISTOR 2.26K 1% .125W F TC=0+/-100	24546	C4-1/8-T0-2261-F
ASR80	0698-0084	9		RESISTOR 2.15K 1% .125W F TC=0+/-100	24546	C4-1/8-T0-2151-F
ASR81	0698-0084	9		RESISTOR 2.15K 1% .125W F TC=0+/-100	24546	C4-1/8-T0-2151-F
ASR82	0757-0401	0		RESISTOR 100 1% .125W F TC=0+/-100	24546	C4-1/8-T0-101-F
ASR83	0757-0416	7		RESISTOR 511 1% .125W F TC=0+/-100	24546	C4-1/8-T0-511R-F
ASR84	0698-4460	3	1	RESISTOR 649 1% .125W F TC=0+/-100	24546	C4-1/8-T0-649R-F
ASR85	0757-0433	2	1	RESISTOR 3.32K 1% .125W F TC=0+/-100	24546	C4-1/8-T0-111-F
ASR86	0757-0402	1		RESISTOR 110 1% .125W F TC=0+/-100	24546	C4-1/8-T0-111-F
ASR87	0757-0410	1		RESISTOR 301 1% .125W F TC=0+/-100	24546	C4-1/8-T0-301R-F
ASR88	0683-4705	8		RESISTOR 47 5% .25W FC TC=400/+500	01121	CB4705
ASR88	0698-3444	1		RESISTOR 316 1% .125W F TC=0+/-100	24546	C4-1/8-T0-316R-F
ASR90	0683-4705	8		RESISTOR 47 5% .25W FC TC=400/+500	01121	CB4705
ASR91	0683-4705	8		RESISTOR 47 5% .25W FC TC=400/+500	01121	CB4705
ASR92	0698-3442	9	1	RESISTOR 237 1% .125W F TC=0+/-100	24546	C4-1/8-T0-237R-F
ASR93	0757-0280	9		RESISTOR 1K 1% .125W F TC=0+/-100	24546	C4-1/8-T0-111-F
ASR94	0757-0402	1		RESISTOR 110 1% .125W F TC=0+/-100	24546	C4-1/8-T0-111-F
ASR95	0698-0084	9		RESISTOR 2.15K 1% .125W F TC=0+/-100	24546	C4-1/8-T0-2151-F
ASR96	0683-4705	8		RESISTOR 47 5% .25W FC TC=400/+500	01121	CB4705
ASR98	0683-1005	5		RESISTOR 10 5% .25W FC TC=400/+500	01121	CB1005
ASR99	0683-1005	5		RESISTOR 10 5% .25W FC TC=400/+500	01121	CB1005
ASR100	0683-3325	6		RESISTOR 3.3K 5% .25W FC TC=400/+700	01121	CB3325
ASR101	0683-3335	8		RESISTOR 33K 5% .25W FC TC=400/+800	01121	CB3335
ASR102	0683-2205	9		RESISTOR 22 5% .25W FC TC=400/+500	01121	CB2205
ASR103	0683-3335	8		RESISTOR 33K 5% .25W FC TC=400/+800	01121	CB3335
ASR104	0683-2225	3		RESISTOR 2.2K 5% .25W FC TC=400/+700	01121	CB2225
ASR105	0683-1025	9		RESISTOR 1K 5% .25W FC TC=400/+600	01121	CB1025
ASR106	0683-2205	9		RESISTOR 22 5% .25W FC TC=400/+500	01121	CB2205
ASR107	0683-4725	2		RESISTOR 4.7K 5% .25W FC TC=400/+700	01121	CB4725
ASR108	0683-1005	5		RESISTOR 10 5% .25W FC TC=400/+500	01121	CB1005
ASR109	0683-1005	5		RESISTOR 10 5% .25W FC TC=400/+500	01121	CB1005
ASR110	0757-0280	1		RESISTOR 1K 1% .125W F TC=0+/-100	24546	C4-1/8-T0-1001-F
ASR111	0683-4705	8		RESISTOR 47 5% .25W FC TC=400/+500	01121	CB4705
ASR112	0683-4725	2		RESISTOR 4.7K 5% .25W FC TC=400/+700	01121	CB4725
ASR113	0683-3305	2		RESISTOR 33 5% .25W FC TC=400/+500	01121	CB3305
ASR114	0698-4458	9		RESISTOR 590 1% .125W F TC=0+/-100	24546	C4-1/8-T0-590R-F
ASR115	0683-3305	2		RESISTOR 33 5% .25W FC TC=400/+500	01121	CB3305
ASR116	0683-4705	8		RESISTOR 47 5% .25W FC TC=400/+500	01121	CB4705
ASR117	0683-4705	8		RESISTOR 47 5% .25W FC TC=400/+500	01121	CB4705
ASR118	0757-0274	5		RESISTOR 1.21K 1% .125W F TC=0+/-100	24546	C4-1/8-T0-1213-F
ASR119	0683-4705	8		RESISTOR 47 5% .25W FC TC=400/+500	01121	CB4705
ASR120	0698-3444	1		RESISTOR 316 1% .125W F TC=0+/-100	24546	C4-1/8-T0-316R-F
ASR121	0683-4705	8		RESISTOR 47 5% .25W FC TC=400/+500	01121	CB4705
ASR122	0683-4705	8		RESISTOR 47 5% .25W FC TC=400/+500	01121	CB4705
ASR123	0698-2344	2	1	RESISTOR 2.45K .25W .125W	28480	0698-2344
ASR124	0683-1205	8		RESISTOR 150 5% .25W FC TC=400/+600	01121	CB1515
ASR125	0683-1205	7	8	RESISTOR 12 5% .25W FC TC=400/+500	01121	CB1205
ASR126	0683-1205	7		RESISTOR 12 5% .25W FC TC=400/+500	01121	CB1205
ASR127	0683-1515	2		RESISTOR 150 5% .25W FC TC=400/+600	01121	CB1515
ASR128	0683-1515	2		RESISTOR 150 5% .25W FC TC=400/+600	01121	CB1515
ASR129	0683-1205	7		RESISTOR 12 5% .25W FC TC=400/+500	01121	CB1205
ASR130	0683-1205	7		RESISTOR 12 5% .25W FC TC=400/+500	01121	CB1205
ASR131	0757-0442	9		RESISTOR 10K 1% .125W F TC=0+/-100	24546	C4-1/8-T0-1002-F
ASR132	0757-0401	0		RESISTOR 100 1% .125W F TC=0+/-100	24546	C4-1/8-T0-101-F
ASR133	1810-0205	7	2	NETWORK-RES 8-81P4.7K OHM X 7	01121	208A472
ASR134	1810-0205	7		NETWORK-RES 8-81P4.7K OHM X 7	01121	208A472
ASR135	1810-0212	6	1	NETWORK-RES 16-81P22.0K OHM X 8	01121	3168223

See introduction to this section for ordering information  
\*Indicates factory selected value

Table 6-3. Replaceable Parts (Cont'd).

Reference Designation	HP Part Number	C D	Qty	Description	Mfr Code	Mfr Part Number	
A3R136	0683-4725	2	5	RESISTOR 4.7K 5% .25W FC TC=400/+700	01121	C84725	
A3R137	0683-2235	5		RESISTOR 22K 5% .25W FC TC=400/+800	01121	C82235	
A3R138	0696-2343	7		RESISTOR 50 1% .125W	28480	0696-2343	
A3R139	0683-4725	2		RESISTOR 4.7K 5% .25W FC TC=400/+700	01121	C84725	
A3R140	0683-4715	0		RESISTOR 470 5% .25W FC TC=400/+600	01121	C84715	
A3R141	0683-2235	5	5	RESISTOR 22K 5% .25W FC TC=400/+800	01121	C82235	
A3R142	0683-2235	5		RESISTOR 22K 5% .25W FC TC=400/+800	01121	C82235	
A3T1	9100-0823	0	2	TRANSFORMER(TDK11301) 11111	28480	9100-0823	
A3T2	9100-0876	1		TRANSFORMER-SIGNAL 2mH 30% 1:1	28480	9100-0876	
A3T3	9100-0823	0		TRANSFORMER(TDK11301) 11111	28480	9100-0823	
A3T4	9100-0822	7		TRANSFORMER(PULSE(11307)	28480	9100-0822	
A3T5	9100-0823	0		TRANSFORMER(TDK11301) 11111	28480	9100-0823	
A3T6	9100-0876	1	7	TRANSFORMER-SIGNAL 2mH 30% 1:1	28480	9100-0876	
A3T7	9100-0822	7		TRANSFORMER(PULSE(11307)	28480	9100-0822	
A3U1	1826-0138	0	6	IC COMPARATOR GP QUAD 14-DIP-P	04713	MLM339P	
A3U2	1826-0138	0		IC COMPARATOR GP QUAD 14-DIP-P	04713	MLM339P	
A3U3	1826-0138	0		IC COMPARATOR GP QUAD 14-DIP-P	04713	MLM339P	
A3U4	1820-1730	6		IC FF TTL LS D-TYPE POS-EDGE-TRIG COM	01295	8N74L0273N	
A3U5	1820-1730	6		IC FF TTL LS D-TYPE POS-EDGE-TRIG COM	01295	8N74L0273N	
				A3 MISCELLANEOUS PARTS			
	1205-0050	7	4	HEAT SINK TO-5/TO-39-C8	28480	1205-0050	
	04274-00612	4		SHIELD PLATE A3	28480	04274-00612	
	04275-00608	9		SHIELD PLATE A3	28480	04275-00608	
	04275-00609	0		SHIELD PLATE A3	28480	04275-00609	
	04275-00610	3		SHIELD PLATE A3	28480	04275-00610	
A4	04275-06504	2	1	PROCESS AMPLIFIER BOARD ASSEMBLY	28480	04275-06504	
	04275-26504	0		PC BOARD, BLANK	28480	04275-26504	
A4C1	0180-1083	3	6	CAPACITOR-FXD 33uF +75-10% 25VDC	28480	0180-1083	
A4C2	0180-1083	3		CAPACITOR-FXD 33uF +75-10% 25VDC	28480	0180-1083	
A4C3	0180-1083	3		CAPACITOR-FXD 33uF +75-10% 25VDC	28480	0180-1083	
A4C4	0180-1083	3		CAPACITOR-FXD 33uF +75-10% 25VDC	28480	0180-1083	
A4C5	0180-1083	3		CAPACITOR-FXD 33uF +75-10% 25VDC	28480	0180-1083	
A4C6	0180-1083	3		CAPACITOR-FXD 33uF +75-10% 25VDC	28480	0180-1083	
A4C7	0160-3456	6		CAPACITOR-FXD 1000PF +-10% 1KVDC CER	28480	0160-3456	
A4C8	0160-3456	6		CAPACITOR-FXD 1000PF +-10% 1KVDC CER	28480	0160-3456	
A4C9	0180-1083	3		CAPACITOR-FXD 33uF +75-10% 25VDC	28480	0180-1083	
A4C10	0180-1083	3		CAPACITOR-FXD 33uF +75-10% 25VDC	28480	0180-1083	
A4C11	0180-1083	3	3	CAPACITOR-FXD 33uF +75-10% 25VDC	28480	0180-1083	
A4C12	0180-1083	3		CAPACITOR-FXD 33uF +75-10% 25VDC	28480	0180-1083	
A4C13	0160-3456	6		CAPACITOR-FXD 1000PF +-10% 1KVDC CER	28480	0160-3456	
A4C14	0180-1083	3		CAPACITOR-FXD 33uF +75-10% 25VDC	28480	0180-1083	
A4C15	0160-2055	9		CAPACITOR-FXD .01UF +80-20% 100VDC CER	28480	0160-2055	
A4C16	0160-2055	9		CAPACITOR-FXD .01UF +80-20% 100VDC CER	28480	0160-2055	
A4C17	0180-1083	3		CAPACITOR-FXD 33uF +75-10% 25VDC	28480	0180-1083	
A4CR1	1901-0376	6		25	DIODE-GEN PRP 35V 50MA DO-35	28480	1901-0376
A4CR2	1901-0376	6			DIODE-GEN PRP 35V 50MA DO-35	28480	1901-0376
A4CR3	1901-0376	6			DIODE-GEN PRP 35V 50MA DO-35	28480	1901-0376
A4CR4	1901-0376	6	DIODE-GEN PRP 35V 50MA DO-35		28480	1901-0376	
A4CR5	1901-0376	6	DIODE-GEN PRP 35V 50MA DO-35		28480	1901-0376	
A4L1	9140-0129	1	12	COIL-MLD 220UH 5% Q=65 .155DX,375LG-NOM	28480	9140-0129	
A4L2	9140-0129	1		COIL-MLD 220UH 5% Q=65 .155DX,375LG-NOM	28480	9140-0129	
A4L3	9140-0129	1		COIL-MLD 220UH 5% Q=65 .155DX,375LG-NOM	28480	9140-0129	
A4L4	9140-0129	1		COIL-MLD 220UH 5% Q=65 .155DX,375LG-NOM	28480	9140-0129	
A4L5	9140-0129	1		COIL-MLD 220UH 5% Q=65 .155DX,375LG-NOM	28480	9140-0129	
A4L6	9140-0129	1		COIL-MLD 220UH 5% Q=65 .155DX,375LG-NOM	28480	9140-0129	
A4L7	9100-1788	6	7	CHOKE-WIDE BAND ZMAX=680 OHMS 180 MHZ	02114	VK200 20/40	
A4L8	9100-1788	6		CHOKE-WIDE BAND ZMAX=680 OHMS 180 MHZ	02114	VK200 20/40	
A4Q1	1853-0091	3	4	TRANSISTOR J-FET N-CHAN D-MODE SI	28480	1853-0091	
A4Q2	1853-0091	3		TRANSISTOR J-FET N-CHAN D-MODE SI	28480	1853-0091	
A4Q3	1853-0300	3		TRANSISTOR PNP SI TO-18 PD=300MW	28480	1853-0300	
A4Q4	1853-0012	4		TRANSISTOR PNP 2N2904A SI TO-39 PD=600MW	01295	2N2904A	
A4Q5	1853-0300	3		TRANSISTOR PNP SI TO-18 PD=300MW	28480	1853-0300	
A4Q6	1854-0071	7	3	TRANSISTOR NPN SI PD=300MW FT=200MHZ	28480	1854-0071	
A4Q7	1854-0039	7		TRANSISTOR NPN 2N3053B SI TO-39 PD=1W	01928	2N3053B	
A4Q8	1854-0071	7		TRANSISTOR NPN SI PD=300MW FT=200MHZ	28480	1854-0071	
A4Q9	1853-0091	3		TRANSISTOR J-FET N-CHAN D-MODE SI	28480	1853-0091	
A4Q10	1853-0020	4		TRANSISTOR PNP SI PD=300MW FT=150MHZ	28480	1853-0020	
A4Q11	1853-0091	3	TRANSISTOR J-FET N-CHAN D-MODE SI	28480	1853-0091		
A4R1	0757-0487	2	25	RESISTOR 825K 1% .125W F TC=0+-100	28480	0757-0487	
A4R2	0757-0487	2		RESISTOR 825K 1% .125W F TC=0+-100	28480	0757-0487	
A4R3	0757-0487	2		RESISTOR 825K 1% .125W F TC=0+-100	28480	0757-0487	
A4R4	0757-0487	2		RESISTOR 825K 1% .125W F TC=0+-100	28480	0757-0487	
A4R5	1810-0207	9		NETWORK-RES 8-SIP22.0K OHM X 7	01121	208A223	

See introduction to this section for ordering information  
\*Indicates factory selected value

Table 6-3. Replaceable Parts (Cont'd).

Reference Designation	HP Part Number	C D	Qty	Description	Mfr Code	Mfr Part Number
AQR6	1010-0207	9		NETWORK-RES 8-81P22.0K OHM X 7		
AQR7	0757-0442	9		RESISTOR 10K 1% .125W F TC0+/-100	01121	208A223
AQR8	0757-0209	2	1	RESISTOR 13.3K 1% .125W F TC0+/-100	24546	C4-1/8-T0-1002-F
AQR9	0698-3155	1		RESISTOR 4.64K 1% .125W F TC0+/-100	19701	MP4C1/8-T0-1332-F
AQR10	0683-2745	2	2	RESISTOR 270K 5% .25W FC TC0-800/+900	24546	C4-1/8-T0-4641-F
AQR11	0683-2745	2			01121	C82745
AQR12	0683-1505	0		RESISTOR 270K 5% .25W FC TC0-800/+900	01121	C82745
AQR13	0683-1505	0	2	RESISTOR 150K 5% .25W FC TC0-800/+900	01121	C81345
AQR14	0683-0275	9		RESISTOR 150K 5% .25W FC TC0-800/+900	01121	C81345
AQR15	0757-0278	9	4	RESISTOR 2.7 5% .25W FC TC0-400/+500	01121	C82755
AQR16	0757-0278	9		RESISTOR 1.78K 1% .125W F TC0+/-100	24546	C4-1/8-T0-1781-F
AQR17	0683-0275	9		RESISTOR 1.78K 1% .125W F TC0+/-100		
AQR18	0757-0442	9		RESISTOR 2.7 5% .125W F TC0+/-100	24546	C4-1/8-T0-1781-F
AQR19	0757-0442	9		RESISTOR 10K 1% .125W F TC0+/-100	01121	C82755
AQR20	0757-0278	9		RESISTOR 1.78K 1% .125W F TC0+/-100	24546	C4-1/8-T0-1781-F
AQR21	0757-0442	9		RESISTOR 1.78K 1% .125W F TC0+/-100	24546	C4-1/8-T0-1781-F
AQR22	0698-3150	6		RESISTOR 10K 1% .125W F TC0+/-100		
AQR23	0757-1094	9	3	RESISTOR 2.37K 1% .125W F TC0+/-100	24546	C4-1/8-T0-1002-F
AQR24	0757-0278	9		RESISTOR 1.47K 1% .125W F TC0+/-100	24546	C4-1/8-T0-2371-F
AQR25	0757-0487	2		RESISTOR 1.78K 1% .125W F TC0+/-100	24546	C4-1/8-T0-1781-F
AQR26	0757-0487	2		RESISTOR 1.78K 1% .125W F TC0+/-100	24546	C4-1/8-T0-1781-F
AQR27	0698-3155	1		RESISTOR 825K 1% .125W F TC0+/-100	28480	0757-0487
AQR28	0757-0487	2		RESISTOR 4.64K 1% .125W F TC0+/-100	24546	C4-1/8-T0-4641-F
AQR29	0757-0487	2		RESISTOR 825K 1% .125W F TC0+/-100	28480	0757-0487
AQR30	0757-0278	9		RESISTOR 825K 1% .125W F TC0+/-100	28480	0757-0487
AAT1	9100-0871	6	3	TRANSFORMER-SIGNAL 500uH 20% 1:1:1	28480	C4-1/8-T0-1781-F
AQU1	1026-0138	8		IC COMPARATOR GP QUAD 14-DIP-P		9100-0871
AQU2	1026-0138	8		IC COMPARATOR GP QUAD 14-DIP-P	04713	MLM339P
AQU3	1026-0138	8		IC COMPARATOR GP QUAD 14-DIP-P	04713	MLM339P
				A4 MISCELLANEOUS PARTS		
	04275-00612	5	2	SHIELD COVER A4	28480	04275-00612
	04275-00613	6	2	SHIELD COVER A4	28480	04275-00613
AAA1	04275-66541	7	1	ERR BUFFER AMPLIFIER BOARD ASSEMBLY	28480	04275-66541
	04275-26541	3		PC BOARD, BLANK	28480	04275-26541
AAA1C1	0160-3060	8	36	CAPACITOR-FXD .1UF +/-20% 25VDC CER	28480	0160-3060
AAA1C2	0160-3060	8		CAPACITOR-FXD .1UF +/-20% 25VDC CER	28480	0160-3060
AAA1C3	0121-0517	8	1	CAPACITOR-V TRMR-P8TN .8-4.5PF 750V	18736	
AAA1C4	0160-3060	8		CAPACITOR-FXD .1UF +/-20% 25VDC CER	28480	0160-3060
AAA1C5	0150-0052	1		CAPACITOR-FXD .05UF +/-20% 400VDC CER	28480	0150-0052
AAA1C6	0160-3060	8		CAPACITOR-FXD .1UF +/-20% 25VDC CER	28480	0160-3060
AAA1C7	0160-3060	8		CAPACITOR-FXD .1UF +/-20% 25VDC CER	28480	0160-3060
AAA1C8	0160-3456	6		CAPACITOR-FXD 1000PF +/-10% 1KVDC CER	28480	0160-3456
AAA1CR1	1901-0050	3	4	DIODE-SWITCHING 60V 200MA 2NS DO-35	28480	1901-0050
AAA1CR2	1901-0040	1		DIODE-SWITCHING 30V 50MA 2NS DO-35	28480	1901-0040
AAA1CR3	1901-0040	1		DIODE-SWITCHING 30V 50MA 2NS DO-35	28480	1901-0040
AAA1CR4	1901-0050	3		DIODE-SWITCHING 60V 200MA 2NS DO-35	28480	1901-0050
AAA1CR5	1901-0376	6		DIODE-GEN PRP 35V 50MA DO-35	28480	1901-0376
AAA1CR6	1901-0376	6		DIODE-GEN PRP 35V 50MA DO-35	28480	1901-0376
AAA1CR7	1901-0040	1		DIODE-SWITCHING 30V 50MA 2NS DO-35	28480	1901-0040
AAA1J4	1250-0257	1		CONNECTOR-RF 8MB M PC 50-OHM	28480	1250-0257
AAA1L1	9170-0029	3		CORE-SHIELDING BEAD	28480	9170-0029
AAA1L2	9170-0029	3		CORE-SHIELDING BEAD	28480	9170-0029
AAA1L3	9170-0029	3		CORE-SHIELDING BEAD	28480	9170-0029
AAA1L4	9170-0029	3		CORE-SHIELDING BEAD	28480	9170-0029
AAA1L5	9170-0029	3		CORE-SHIELDING BEAD	28480	9170-0029
AAA1L6	9170-0029	3		CORE-SHIELDING BEAD	28480	9170-0029
AAA1D1	1855-0268	6	2	TRANSISTOR J-FET N-CHAN D-MODE T0-92 8I	17856	J309
AAA1D2	1854-0620	0	9	TRANSISTOR NPN 8I T0-92 PD=625MW	04713	MP8-M17
AAA1D3	1855-0091	3		TRANSISTOR J-FET N-CHAN D-MODE 8I	28480	1855-0091
AAA1D4	1853-0020	4		TRANSISTOR PNP 8I PD=300MW FT=150MHZ	28480	1853-0020
AAA1D5	1854-0620	0		TRANSISTOR NPN 8I T0-92 PD=625MW	04713	MP8-M17
AAA1D6	1853-0354	7	12	TRANSISTOR PNP 8I T0-92 PD=150MW	28480	1853-0354
AAA1R1	2100-3252	6	2	RESISTOR-TRMR 5K 10% C TOP-ADJ 1-TRN	28480	2100-3252
AAA1R2	0698-3136	8	5	RESISTOR 17.8K 1% .125W F TC0+/-100	24546	C4-1/8-T0-1782-F
AAA1R3	0698-3429	2	8	RESISTOR 19.6 1% .125W F TC0+/-100	03888	PM55-1/8-T0-19R6-F
AAA1R4	0698-3457	8		RESISTOR 316K 1% .125W F TC0+/-100	28480	0698-3457
AAA1R5	0698-3136	8		RESISTOR 17.8K 1% .125W F TC0+/-100	24546	C4-1/8-T0-1782-F
AAA1R6	0698-3439	4	2	RESISTOR 178 1% .125W F TC0+/-100	24546	C4-1/8-T0-178R-F
AAA1R7	0698-4037	0	4	RESISTOR 46.4 1% .125W F TC0+/-100	24546	C4-1/8-T0-46R4-F
AAA1R8	2100-3199	0		RESISTOR-TRMR 20 20% C SIDE-ADJ 1-TRN	30983	ET50X200
AAA1R9	0757-0439	4		RESISTOR 6.81K 1% .125W F TC0+/-100	24546	C4-1/8-T0-6811-F
AAA1R10	0698-3429	2	3	RESISTOR 19.6 1% .125W F TC0+/-100	03888	PM55-1/8-T0-19R6-F

Table 6-3. Replaceable Parts (Cont'd).

Reference Designation	HP Part Number	C D	Qty	Description	Mfr Code	Mfr Part Number
AA41R11	0757-0420	3		RESISTOR 750 1% .125W F TC0+100	24546	C4-1/8-T0-751-F
AA41R12	0757-0420	3		RESISTOR 750 1% .125W F TC0+100	24546	C4-1/8-T0-751-F
AA41R13	0757-0487	2		RESISTOR 825K 1% .125W F TC0+100	28480	0757-0487
AA41R14	0757-0487	2		RESISTOR 825K 1% .125W F TC0+100	28480	0757-0487
AA41R15	0757-0438	3		RESISTOR 5.11K 1% .125W F TC0+100	24546	C4-1/8-T0-5111-F
AA41R16	0698-0084	9		RESISTOR 2.15K 1% .125W F TC0+100	24546	C4-1/8-T0-2151-F
AA41R17	0698-3444	1		RESISTOR 316 1% .125W F TC0+100	24546	C4-1/8-T0-316R-F
AA41T1	9100-0871	6		TRANSFORMER-SIGNAL 500uH 20:1 1:1	28480	9100-0871
				<b>AA41 MISCELLANEOUS PARTS</b>		
	1251-0600	0	5	CONNECTOR-SGL CONT PIN 1,14-MM-88C-8Z 80	28480	1251-0600
AA42	04275-66542	8	1	EDUT BUFFER AMPLIFIER BOARD ASSEMBLY	28480	04275-66542
	04275-26542	4		PC BOARD, BLANK	28480	04275-26542
AA42C1	0160-3060	8		CAPACITOR-FXD .1UF +-20% 25VDC CER	28480	0160-3060
AA42C2	0160-3060	8		CAPACITOR-FXD .1UF +-20% 25VDC CER	28480	0160-3060
AA42C3	0160-2246	0	1	CAPACITOR-FXD 3.6PF +-25PF 500VDC CER	28480	0160-2246
AA42C4	0160-3060	8		CAPACITOR-FXD .1UF +-20% 25VDC CER	28480	0160-3060
AA42C5	0150-0052	1		CAPACITOR-FXD .05UF +-20% 400VDC CER	28480	0150-0052
AA42C6	0160-3060	8		CAPACITOR-FXD .1UF +-20% 25VDC CER	28480	0160-3060
AA42C7	0160-3060	8		CAPACITOR-FXD .1UF +-20% 25VDC CER	28480	0160-3060
AA42C8	0160-3456	6		CAPACITOR-FXD 1000PF +-10% 1KVDC CER	28480	0160-3456
AA42CR1	1901-0050	3		DIODE-SWITCHING 80V 200MA 2N8 DO-35	28480	1901-0050
AA42CR2	1901-0040	1		DIODE-SWITCHING 30V 50MA 2N8 DO-35	28480	1901-0040
AA42CR3	1901-0040	1		DIODE-SWITCHING 30V 50MA 2N8 DO-35	28480	1901-0040
AA42CR4	1901-0050	6		DIODE-SWITCHING 80V 200MA 2N5 DO-35	28480	1901-0050
AA42CR5	1901-0376	3		DIODE-GEN PRP 35V 50MA DO-35	28480	1901-0376
AA42CR6	1901-0376	6		DIODE-GEN PRP 35V 50MA DO-35	28480	1901-0376
AA42CR7	1901-0040	1		DIODE-SWITCHING 30V 50MA 2N8 DO-35	28480	1901-0040
AA42J4	1250-0257	1		CONNECTOR-RF 8MB M PC 50-OHM	28480	1250-0257
AA42L1	9170-0029	3		CORE-SHIELDING BEAD	28480	9170-0029
AA42L2	9170-0029	3		CORE-SHIELDING BEAD	28480	9170-0029
AA42L3	9170-0029	3		CORE-SHIELDING BEAD	28480	9170-0029
AA42L4	9170-0029	3		CORE-SHIELDING BEAD	28480	9170-0029
AA42L5	9170-0029	3		CORE-SHIELDING BEAD	28480	9170-0029
AA42L6	9170-0029	3		CORE-SHIELDING BEAD	28480	9170-0029
AA42Q1	1855-0268	6		TRANSISTOR J-PET N-CHAN D-MODE T0-92 8I	17856	J309
AA42Q2	1855-0628	0		TRANSISTOR NPN 8I T0-92 PD=625MW	04713	MP8-M17
AA42Q3	1855-0091	3		TRANSISTOR J-PET N-CHAN D-MODE 8I	28480	1855-0091
AA42Q4	1855-0020	4		TRANSISTOR PNP 8I PD=300MW FT=150MHZ	28480	1855-0020
AA42Q5	1855-0628	0		TRANSISTOR NPN 8I T0-92 PD=625MW	04713	MP8-M17
AA42Q6	1855-0354	7		TRANSISTOR PNP 8I T0-92 PD=350MW	28480	1855-0354
AA42R1	2100-3252	6		RESISTOR-TRMR 5K 10% C TOP-ADJ 1-TRN	28480	2100-3252
AA42R2	0698-3136	8		RESISTOR 17.8K 1% .125W F TC0+100	24546	C4-1/8-T0-1782-F
AA42R3	0698-3429	2		RESISTOR 19.6 1% .125W F TC0+100	03888	PME55-1/8-T0-19R6-F
AA42R4	0698-3457	6		RESISTOR 316 1% .125W F TC0+100	28480	0698-3457
AA42R5	0698-3136	8		RESISTOR 17.8K 1% .125W F TC0+100	24546	C4-1/8-T0-1782-F
AA42R6	0698-3439	4		RESISTOR 178 1% .125W F TC0+100	24546	C4-1/8-T0-178R-F
AA42R7	0698-4037	0		RESISTOR 46.4 1% .125W F TC0+100	24546	C4-1/8-T0-46R4-F
AA42R8	0757-0146	2		RESISTOR 10 1% .125W F TC0+100	24546	C4-1/8-T0-10R0-F
AA42R9	0757-0439	4		RESISTOR 4.81K 1% .125W F TC0+100	24546	C4-1/8-T0-6811-F
AA42R10	0698-3429	2		RESISTOR 19.6 1% .125W F TC0+100	03888	PME55-1/8-T0-19R6-F
AA42R11	0757-0420	3		RESISTOR 750 1% .125W F TC0+100	24546	C4-1/8-T0-751-F
AA42R12	0757-0420	3		RESISTOR 750 1% .125W F TC0+100	24546	C4-1/8-T0-751-F
AA42R13	0757-0487	2		RESISTOR 825K 1% .125W F TC0+100	28480	0757-0487
AA42R14	0757-0487	2		RESISTOR 825K 1% .125W F TC0+100	28480	0757-0487
AA42R15	0757-0438	3		RESISTOR 5.11K 1% .125W F TC0+100	24546	C4-1/8-T0-5111-F
AA42R16	0698-0084	9		RESISTOR 2.15K 1% .125W F TC0+100	24546	C4-1/8-T0-2151-F
AA42R17	0698-3444	1		RESISTOR 316 1% .125W F TC0+100	24546	C4-1/8-T0-316R-F
AA42T1	9100-0871	6		TRANSFORMER-SIGNAL 500uH 20:1 1:1	28480	9100-0871
				<b>AA42 MISCELLANEOUS PARTS</b>		
	1251-4683	7	23	CONNECTOR-SGL CONT 8KT .04-IN-88C-8Z RND	28480	1251-4683
AA43	04275-66543	9	1	AM AMPLIFIER BOARD ASSEMBLY	28480	04275-66543
	04275-26543	5		PC BOARD, BLANK	28480	04275-26543
AA43C1	0160-1083	3		CAPACITOR-FXD 3uF +75-10% 25VDC	28480	0160-1083
AA43C2	0160-3060	8		CAPACITOR-FXD .1UF +-20% 25VDC CER	28480	0160-3060
AA43C3	0121-0099	7		CAPACITOR-V TRMR-CER 2-8PF 350V PC-MTG	52763	304324 2/8PF NPO
AA43C4	0160-3060	8		CAPACITOR-FXD .1UF +-20% 25VDC CER	28480	0160-3060
AA43C5	0160-2307	4		CAPACITOR-FXD 47PF +-5% 300VDC MICA	28480	0160-2307

See introduction to this section for ordering information  
\*Indicates factory selected value



Table 6-3. Replaceable Parts (Cont'd).

Reference Designation	HP Part Number	C D	Qty	Description	Mfr Code	Mfr Part Number
AQ43C6	0160-3060	8		CAPACITOR-FXD .1UF +-20% 25VDC CER	28480	0160-3060
AQ43C7	0160-2266	3		CAPACITOR-FXD 24PF +-5% 500VDC CER 0+-30	28480	0160-2266
AQ43C8	0160-3060	8		CAPACITOR-FXD .1UF +-20% 25VDC CER	28480	0160-3060
AQ43C9	0160-3060	8		CAPACITOR-FXD .1UF +-20% 25VDC CER	28480	0160-3060
AQ43C10	0160-0127	2		CAPACITOR-FXD 1UF +-20% 25VDC CER	28480	0160-0127
AQ43C11	0160-0127	2		CAPACITOR-FXD 1UF +-20% 25VDC CER	28480	0160-0127
AQ43C12	0160-0127	2		CAPACITOR-FXD 1UF +-20% 25VDC CER	28480	0160-0127
AQ43C13	0160-3060	8		CAPACITOR-FXD .1UF +-20% 25VDC CER	28480	0160-3060
AQ43C14	0160-3060	8		CAPACITOR-FXD .1UF +-20% 25VDC CER	28480	0160-3060
AQ43C15	0160-2055	9		CAPACITOR-FXD .01UF +80-20% 100VDC CER	28480	0160-2055
AQ43C16	0160-3060	8		CAPACITOR-FXD .1UF +-20% 25VDC CER	28480	0160-3060
AQ43C17	0160-1083	3		CAPACITOR-FXD 33UF +75-10% 25VDC	28480	0160-1083
AQ43C18	0160-2055	9		CAPACITOR-FXD .01UF +80-20% 100VDC CER	28480	0160-2055
AQ43CR1	1901-0040	1		DIODE-SWITCHING 30V 50MA 2N8 DO-35	28480	1901-0040
AQ43CR2	1901-0040	1		DIODE-SWITCHING 30V 50MA 2N8 DO-35	28480	1901-0040
AQ43CR3	1901-0376	6		DIODE-GEN PRP 35V 50MA DO-35	28480	1901-0376
AQ43CR4	1901-0376	6		DIODE-GEN PRP 35V 50MA DO-35	28480	1901-0376
AQ43CR5	1901-0376	6		DIODE-GEN PRP 35V 50MA DO-35	28480	1901-0376
AQ43CR6	1901-0376	6		DIODE-GEN PRP 35V 50MA DO-35	28480	1901-0376
AQ43CR7	1901-0376	6		DIODE-GEN PRP 35V 50MA DO-35	28480	1901-0376
AQ43L1	9100-1629	4	5	COIL-MLD 47UH 5% Q55 .155DX.375LG-NOM	28480	9100-1629
AQ43L2	9170-0029	3		CORE-SMELTING BEAD	28480	9170-0029
AQ43L3	9100-1629	4		COIL-MLD 47UH 5% Q55 .155DX.375LG-NOM	28480	9100-1629
AQ43Q1	1854-0215	1		TRANSISTOR NPN 81 PD=350MHZ FT=300MHZ	04713	2N3904
AQ43Q2	1853-0061	1		TRANSISTOR J-FET N-CHAN D-MODE 81	01295	2N5245
AQ43Q3	1854-0215	1		TRANSISTOR NPN 81 PD=350MHZ FT=300MHZ	04713	2N3904
AQ43Q4	1853-0061	1		TRANSISTOR J-FET N-CHAN D-MODE 81	01295	2N5245
AQ43Q5	1853-0354	7		TRANSISTOR PNP 81 TO-92 PD=350MH	28480	1853-0354
AQ43Q6	1854-0215	1		TRANSISTOR NPN 81 PD=350MHZ FT=300MHZ	04713	2N3904
AQ43Q7	1853-0354	7		TRANSISTOR PNP 81 TO-92 PD=350MH	28480	1853-0354
AQ43Q8	1853-0091	3		TRANSISTOR J-FET N-CHAN D-MODE 81	28480	1853-0091
AQ43Q9	1853-0020	4		TRANSISTOR PNP 81 PD=300MHZ FT=150MHZ	28480	1853-0020
AQ43Q10	1854-0628	0		TRANSISTOR NPN 81 TO-92 PD=625MH	04713	MP8-H17
AQ43Q11	1853-0061	1		TRANSISTOR J-FET N-CHAN D-MODE 81	01295	2N5245
AQ43Q12	1853-0091	3		TRANSISTOR J-FET N-CHAN D-MODE 81	28480	1853-0091
AQ43Q14	1853-0061	1		TRANSISTOR J-FET N-CHAN D-MODE 81	01295	2N5245
AQ43Q15	1853-0020	4		TRANSISTOR PNP 81 PD=300MHZ FT=150MHZ	28480	1853-0020
AQ43Q16	1853-0020	4		TRANSISTOR PNP 81 PD=300MHZ FT=150MHZ	28480	1853-0020
AQ43Q17	1853-0354	7		TRANSISTOR PNP 81 TO-92 PD=350MH	28480	1853-0354
AQ43Q18	1853-0354	7		TRANSISTOR PNP 81 TO-92 PD=350MH	28480	1853-0354
AQ43R1	0698-3153	9		RESISTOR 3.83K 1% .125W F TC=0+-100	24546	C4-1/8-T0-3631-F
AQ43R2	0683-2205	9		RESISTOR 22 5% .25W FC TC=400/+500	01121	C82205
AQ43R3	0698-3160	8		RESISTOR 31.6K 1% .125W F TC=0+-100	24546	C4-1/8-T0-3162-F
AQ43R4	0757-0180	2	11	RESISTOR 31.6 1% .125W F TC=0+-100	28480	0757-0180
AQ43R5	0683-1005	5		RESISTOR 10 5% .25W FC TC=400/+500	01121	C81005
AQ43R6	0757-0399	5	1	RESISTOR 82.5 1% .125W F TC=0+-100	24546	C4-1/8-T0-8298-F
AQ43R7	0757-0420	3		RESISTOR 750 1% .125W F TC=0+-100	24546	C4-1/8-T0-751-F
AQ43R8	0698-3441	8		RESISTOR 215 1% .125W F TC=0+-100	24546	C4-1/8-T0-215R-F
AQ43R9	0757-0405	4		RESISTOR 162 1% .125W F TC=0+-100	24546	C4-1/8-T0-162R-F
AQ43R10	2100-0589	6	4	RESISTOR-TYMR 10 10% C 810E-ADJ 1-TRN	28480	2100-0589
AQ43R11	0757-0487	2		RESISTOR 825K 1% .125W F TC=0+-100	28480	0757-0487
AQ43R12	0757-0487	2		RESISTOR 825K 1% .125W F TC=0+-100	28480	0757-0487
AQ43R13	0698-3260	9		RESISTOR 464K 1% .125W F TC=0+-100	28480	0698-3260
AQ43R14	0757-0180	2		RESISTOR 31.6 1% .125W F TC=0+-100	28480	0757-0180
AQ43R15	0683-1005	5		RESISTOR 10 5% .25W FC TC=400/+500	01121	C81005
AQ43R16	0757-0180	2		RESISTOR 31.6 1% .125W F TC=0+-100	28480	0757-0180
AQ43R17	0698-3153	9		RESISTOR 3.63K 1% .125W F TC=0+-100	24546	C4-1/8-T0-3631-F
AQ43R18	0683-1025	9		RESISTOR 1K 5% .25W FC TC=400/+600	01121	C81025
AQ43R19	0698-2239	0	4	RESISTOR 1.5	28480	0698-2239
AQ43R20	0698-2343	7		RESISTOR 50 .1% .125W	28480	0698-2343
AQ43R21	0698-3153	1		RESISTOR 4.64K 1% .125W F TC=0+-100	24546	C4-1/8-T0-4641-F
AQ43R22	0757-0294	9	5	RESISTOR 17.8 1% .125W F TC=0+-100	19701	MF4C1/8-T0-178-F
AQ43R23	0757-0294	9		RESISTOR 17.8 1% .125W F TC=0+-100	19701	MF4C1/8-T0-178-F
AQ43R24	0698-3151	7	2	RESISTOR 3.87K 1% .125W F TC=0+-100	24546	C4-1/8-T0-2871-F
AQ43R25	0757-0401	0		RESISTOR 100 1% .125W F TC=0+-100	24546	C4-1/8-T0-101-F
AQ43R26	0683-2205	9		RESISTOR 22 5% .25W FC TC=400/+500	01121	C82205
AQ43R27	0698-2342	6	2	RESISTOR 450 .1% .125W	28480	0698-2342
AQ43R28	0757-0487	2		RESISTOR 825K 1% .125W F TC=0+-100	28480	0757-0487
AQ43R29	0757-0180	2		RESISTOR 31.6 1% .125W F TC=0+-100	28480	0757-0180
AQ43R31	0757-0274	2		RESISTOR 1.21K 1% .125W F TC=0+-100	24546	C4-1/8-T0-1213-F
AQ43R32	0757-0420	3		RESISTOR 750 1% .125W F TC=0+-100	24546	C4-1/8-T0-751-F
AQ43R33	0698-0082	7		RESISTOR 464 1% .125W F TC=0+-100	24546	C4-1/8-T0-4640-F
AQ43R34	0757-0417	8		RESISTOR 562 1% .125W F TC=0+-100	24546	C4-1/8-T0-562R-F
AQ43R35	0698-0083	8		RESISTOR 1.96K 1% .125W F TC=0+-100	24546	C4-1/8-T0-1961-F
AQ43R36	0683-1025	9		RESISTOR 1K 5% .25W FC TC=400/+600	01121	C81025

See introduction to this section for ordering information  
\*Indicates factory selected value

Table 6-3. Replaceable Parts (Cont'd).

Reference Designation	HP Part Number	C D	Qty	Description	Mfr Code	Mfr Part Number
AQ4R37	0698-3155	1		RESISTOR 4.64K 1% .125W F TC0+-100	24546	C4-1/8-T0-4641-F
	1251-4683	7		AQ43 MISCELLANEOUS PARTS		
	1251-4683	7		CONNECTOR-BGL CONT SKT .04-IN-88C-8Z RND	28480	1251-4683
AQ44	04275-66544	0	1	AM AMPLIFIER BOARD ASSEMBLY	28480	04275-66544
	04275-26544	6		PC BOARD, BLANK	28480	04275-26544
AQ4C1	0160-2055	9		CAPACITOR-FXD .01UF +-80-20% 100VDC CER	28480	0160-2055
AQ4C2	0160-2055	9		CAPACITOR-FXD .01UF +-80-20% 100VDC CER	28480	0160-2055
AQ4C3	0121-0059	7		CAPACITOR-V TRMR CER 2-8PF 350V DC-MTC	52763	304324 2/8PF NPO
AQ4C4	0160-2259	5		CAPACITOR-FXD 12PF +-5% 500VDC CER 0+-30	28480	0160-2259
AQ4C5	0160-3060	8		CAPACITOR-FXD .1UF +-20% 25VDC CER	28480	0160-3060
AQ4C6	0160-3060	8		CAPACITOR-FXD .1UF +-20% 25VDC CER	28480	0160-3060
AQ4C7	0160-2307	4		CAPACITOR-FXD 47PF +-5% 300VDC MICA	28480	0160-2307
AQ4C8	0160-0127	2		CAPACITOR-FXD 1UF +-20% 25VDC CER	28480	0160-0127
AQ4C9	0160-3060	8		CAPACITOR-FXD .1UF +-20% 25VDC CER	28480	0160-3060
AQ4C10	0160-3060	8		CAPACITOR-FXD .1UF +-20% 25VDC CER	28480	0160-3060
AQ4C11	0160-3060	8		CAPACITOR-FXD .1UF +-20% 25VDC CER	28480	0160-3060
AQ4C12	0160-3060	8		CAPACITOR-FXD .1UF +-20% 25VDC CER	28480	0160-3060
AQ4C13	0160-3060	8		CAPACITOR-FXD .1UF +-20% 25VDC CER	28480	0160-3060
AQ4C14	0160-0127	2		CAPACITOR-FXD 1UF +-20% 25VDC CER	28480	0160-0127
AQ4C15	0160-3060	8		CAPACITOR-FXD .1UF +-20% 25VDC CER	28480	0160-3060
AQ4C16	0160-3060	8		CAPACITOR-FXD .1UF +-20% 25VDC CER	28480	0160-3060
AQ4CR1	1901-0376	4		DIODE-GEN PRP 35V 50MA DO-35	28480	1901-0376
AQ4CR2	1901-0376	6		DIODE-GEN PRP 35V 50MA DO-35	28480	1901-0376
AQ4CR3	1901-0376	6		DIODE-GEN PRP 35V 50MA DO-35	28480	1901-0376
AQ4CR4	1901-0376	6		DIODE-GEN PRP 35V 50MA DO-35	28480	1901-0376
AQ4CR5	1901-0376	6		DIODE-GEN PRP 35V 50MA DO-35	28480	1901-0376
AQ4CR6	1901-0040	1		DIODE-SWITCHING 30V 50MA 2NS DO-35	28480	1901-0040
AQ4CR7	1901-0040	1		DIODE-SWITCHING 30V 50MA 2NS DO-35	28480	1901-0040
AQ4CR8	1901-0040	1		DIODE-SWITCHING 30V 50MA 2NS DO-35	28480	1901-0040
AQ4CR9	1901-0040	1		DIODE-SWITCHING 30V 50MA 2NS DO-35	28480	1901-0040
AQ4CR10	1901-0040	1		DIODE-SWITCHING 30V 50MA 2NS DO-35	28480	1901-0040
AQ4CR11	1901-0040	1		DIODE-SWITCHING 30V 50MA 2NS DO-35	28480	1901-0040
AQ4L1	9170-0029	3		CORE-SHIELDING BEAD	28480	9170-0029
AQ4Q1	1853-0354	7		TRANSISTOR PNP SI TO-92 PD=350MW	28480	1853-0354
AQ4Q2	1853-0091	3		TRANSISTOR J-FET N-CHAN D-MODE SI	28480	1853-0091
AQ4Q3	1853-0091	3		TRANSISTOR J-FET N-CHAN D-MODE SI	28480	1853-0091
AQ4Q4	1853-0091	1		TRANSISTOR J-FET N-CHAN D-MODE SI	01295	2N5245
AQ4Q5	1853-0091	1		TRANSISTOR J-FET N-CHAN D-MODE SI	01295	2N5245
AQ4Q6	1854-0628	0		TRANSISTOR NPN SI TO-92 PD=625MW	04713	MP8-M17
AQ4Q7	1853-0354	7		TRANSISTOR PNP SI TO-92 PD=350MW	28480	1853-0354
AQ4Q8	1854-0628	0		TRANSISTOR NPN SI TO-92 PD=625MW	04713	MP8-M17
AQ4Q9	1853-0354	7		TRANSISTOR PNP SI TO-92 PD=350MW	28480	1853-0354
AQ4Q10	1853-0354	7		TRANSISTOR PNP SI TO-92 PD=350MW	28480	1853-0354
AQ4Q11	1854-0628	0		TRANSISTOR NPN SI TO-92 PD=625MW	04713	MP8-M17
AQ4Q12	1853-0354	7		TRANSISTOR PNP SI TO-92 PD=350MW	28480	1853-0354
AQ4Q13	1854-0039	7		TRANSISTOR NPN 2N3053B SI TO-18 PD=1W	01928	2N3053B
AQ4Q14	1853-0012	4		TRANSISTOR PNP 2N2904A SI TO-18 PD=600MW	01295	2N2904A
AQ4R1	0698-2342	6		RESISTOR 450 .1% .125W	28480	0698-2342
AQ4R2	2100-0589	6		RESISTOR-TNMR 10 10% C SIDE-ADJ 1-TRN	28480	2100-0589
AQ4R3	0698-2343	7		RESISTOR 50 1% .125W	28480	0698-2343
AQ4R4	0698-2239	0		RESISTOR 1.5	28480	0698-2239
AQ4R5	0698-3155	1		RESISTOR 4.64K 1% .125W F TC0+-100	24546	C4-1/8-T0-4641-F
AQ4R6	0757-0487	2		RESISTOR 825K 1% .125W F TC0+-100	28480	0757-0487
AQ4R7	0757-0487	2		RESISTOR 825K 1% .125W F TC0+-100	28480	0757-0487
AQ4R8	0757-0487	2		RESISTOR 825K 1% .125W F TC0+-100	28480	0757-0487
AQ4R9	0757-0487	2		RESISTOR 825K 1% .125W F TC0+-100	28480	0757-0487
AQ4R10	0698-3260	9		RESISTOR 444K 1% .125W F TC0+-100	28480	0698-3260
AQ4R11	0698-3155	1		RESISTOR 4.64K 1% .125W F TC0+-100	24546	C4-1/8-T0-4641-F
AQ4R12	0757-0180	2		RESISTOR 31.6 1% .125W F TC0+-100	28480	0757-0180
AQ4R13	0757-0180	2		RESISTOR 31.6 1% .125W F TC0+-100	28480	0757-0180
AQ4R14	0757-0294	9		RESISTOR 17.8 1% .125W F TC0+-100	19701	MF4C1/8-T0-1780-F
AQ4R15	0698-3434	9	1	RESISTOR 34.8 1% .125W F TC0+-100	24546	C4-1/8-T0-3480-F
AQ4R16	0757-0420	3		RESISTOR 750 1% .125W F TC0+-100	24546	C4-1/8-T0-751-F
AQ4R17	0757-0294	9		RESISTOR 17.8 1% .125W F TC0+-100	19701	MF4C1/8-T0-1780-F
AQ4R18	0757-0274	5		RESISTOR 1.21K 1% .125W F TC0+-100	24546	C4-1/8-T0-1211-F
AQ4R19	0698-3441	8		RESISTOR 215 1% .125W F TC0+-100	24546	C4-1/8-T0-2150-F
AQ4R20	0698-3155	1		RESISTOR 4.64K 1% .125W F TC0+-100	24546	C4-1/8-T0-4641-F
AQ4R21	0757-0420	3		RESISTOR 750 1% .125W F TC0+-100	24546	C4-1/8-T0-751-F
AQ4R22	0698-3151	7		RESISTOR 2.87K 1% .125W F TC0+-100	24546	C4-1/8-T0-2871-F
AQ4R23	0757-0405	4		RESISTOR 162 1% .125W F TC0+-100	24546	C4-1/8-T0-1620-F
AQ4R24	0698-0082	7		RESISTOR 464 1% .125W F TC0+-100	24546	C4-1/8-T0-4640-F
AQ4R25	0757-0417	8		RESISTOR 562 1% .125W F TC0+-100	24546	C4-1/8-T0-5620-F

See introduction to this section for ordering information  
\*Indicates factory selected value

Table 6-3. Replaceable Parts (Cont'd).

Reference Designation	HP Part Number	C D	Qty	Description	Mfr Code	Mfr Part Number
A4A4R26	0757-0403	2		RESISTOR 121 1% .125W F TC=0/+100	24546	C4-1/8-T0-121R-F
A4A4R27	0698-0083	6		RESISTOR 1.94K 1% .125W F TC=0/+100	24546	C4-1/8-T0-1961R-F
A4A4R28	0698-3444	1		RESISTOR 316 1% .125W F TC=0/+100	24546	C4-1/8-T0-316R-F
A4A4R29	0683-2205	4		RESISTOR 22 5% .25W FC TC=400/+300	01121	CB2205
A4A4R30	0683-2205	9		RESISTOR 22 5% .25W FC TC=400/+300	01121	CB2205
A4A4R31	0683-1025	9		RESISTOR 1K 5% .25W FC TC=400/+600	01121	CB1025
				A4A4 MISCELLANEOUS PARTS		
	1251-4683	7		CONNECTOR-SGL CONT 8KY .04-IN-88C-82 RND	28480	1251-4683
AS	04275-66505	3	1	A-D CONVERTER BOARD ASSEMBLY	28480	04275-66505
	04275-26505	9		PC BOARD, BLANK	28480	04275-26505
ASC1	0180-1083	3		CAPACITOR-FXD 33uF +75-10% 25VDC	28480	0180-1083
ASC2	0160-2261	9		CAPACITOR-FXD 15PF +-5% 500VDC CER 0+-30	28480	0160-2261
ASC3	0160-3060	8		CAPACITOR-FXD .1UF +-20% 25VDC CER	28480	0160-3060
ASC4	0160-0127	2		CAPACITOR-FXD .1UF +-20% 25VDC CER	28480	0160-0127
ASC5	0160-3060	8		CAPACITOR-FXD .1UF +-20% 25VDC CER	28480	0160-3060
ASC6	0160-2261	9		CAPACITOR-FXD 15PF +-5% 500VDC CER 0+-30	28480	0160-2261
ASC7	0160-2239	1	2	CAPACITOR-FXD 1.8PF +-23PF 500VDC CER	28480	0160-2239
ASC8	0160-2239	1		CAPACITOR-FXD 1.8PF +-23PF 500VDC CER	28480	0160-2239
ASC9	0160-3060	8		CAPACITOR-FXD .1UF +-20% 25VDC CER	28480	0160-3060
ASC10	0160-3060	8		CAPACITOR-FXD .1UF +-20% 25VDC CER	28480	0160-3060
ASC11	0160-3060	8		CAPACITOR-FXD .1UF +-20% 25VDC CER	28480	0160-3060
ASC12	0160-2200	6	1	CAPACITOR-FXD 43PF +-5% 300VDC MICA	28480	0160-2200
ASC13	0160-3060	8		CAPACITOR-FXD .1UF +-20% 25VDC CER	28480	0160-3060
ASC14	0160-0127	2		CAPACITOR-FXD .1UF +-20% 25VDC CER	28480	0160-0127
ASC15	0121-0036	0		CAPACITOR-V TRMR-CER 5.5-18PF 350V	52763	304324 5.5/18PF NPO
ASC16	0160-0127	2		CAPACITOR-FXD .1UF +-20% 25VDC CER	28480	0160-0127
ASC17	0160-3060	8		CAPACITOR-FXD .1UF +-20% 25VDC CER	28480	0160-3060
ASC18	0160-0127	2		CAPACITOR-FXD .1UF +-20% 25VDC CER	28480	0160-0127
ASC19	0160-3060	8		CAPACITOR-FXD .1UF +-20% 25VDC CER	28480	0160-3060
ASC20	0180-1083	3		CAPACITOR-FXD 33uF +75-10% 25VDC	28480	0180-1083
ASC21	0160-2257	3	1	CAPACITOR-FXD 10PF +-5% 500VDC CER 0+-60	28480	0160-2257
ASC22	0160-3060	8		CAPACITOR-FXD .1UF +-20% 25VDC CER	28480	0160-3060
ASC23	0160-2055	9		CAPACITOR-FXD .01UF +-80-20% 100VDC CER	28480	0160-2055
ASC24	0160-2055	9		CAPACITOR-FXD .01UF +-80-20% 100VDC CER	28480	0160-2055
ASC25	0160-2055	9		CAPACITOR-FXD .01UF +-80-20% 100VDC CER	28480	0160-2055
ASC26	0160-2055	9		CAPACITOR-FXD .01UF +-80-20% 100VDC CER	28480	0160-2055
ASC27	0160-2055	9		CAPACITOR-FXD .01UF +-80-20% 100VDC CER	28480	0160-2055
ASC28	0160-2055	9		CAPACITOR-FXD .01UF +-80-20% 100VDC CER	28480	0160-2055
ASC29	0160-3456	6		CAPACITOR-FXD 1000PF +-10% 1KVDC CER	28480	0160-3456
ASC30	0160-2055	9		CAPACITOR-FXD .01UF +-80-20% 100VDC CER	28480	0160-2055
ASC31	0160-2055	9		CAPACITOR-FXD .01UF +-80-20% 100VDC CER	28480	0160-2055
ASC32	0160-2055	9		CAPACITOR-FXD .01UF +-80-20% 100VDC CER	28480	0160-2055
ASC33	0160-2055	9		CAPACITOR-FXD .01UF +-80-20% 100VDC CER	28480	0160-2055
ASC34	0160-2055	9		CAPACITOR-FXD .01UF +-80-20% 100VDC CER	28480	0160-2055
ASC35	0160-2055	9		CAPACITOR-FXD .01UF +-80-20% 100VDC CER	28480	0160-2055
ASC36	0160-0939	4	1	CAPACITOR-FXD 430PF +-5% 300VDC MICA	28480	0160-0939
ASC37	0160-2055	9		CAPACITOR-FXD .01UF +-80-20% 100VDC CER	28480	0160-2055
ASC38	0160-2055	9		CAPACITOR-FXD .01UF +-80-20% 100VDC CER	28480	0160-2055
ASC39	0160-1674	6	1	CAPACITOR-FXD .33uF 5% 200VDC	28480	0160-1674
ASC40	0180-0197	8		CAPACITOR-FXD 2.2UF+-10% 20VDC TA	56289	1500225X9020A2
ASC41	0160-2204	0		CAPACITOR-FXD 100PF +-5% 300VDC MICA	28480	0160-2204
ASC42	0160-2055	9		CAPACITOR-FXD .01UF +-80-20% 100VDC CER	28480	0160-2055
ASC43	0160-2055	9		CAPACITOR-FXD .01UF +-80-20% 100VDC CER	28480	0160-2055
ASC44	0180-1083	3		CAPACITOR-FXD 33uF +75-10% 25VDC	28480	0180-1083
ASC45	0180-1083	3		CAPACITOR-FXD 33uF +75-10% 25VDC	28480	0180-1083
ASC46	0180-1083	3		CAPACITOR-FXD 33uF +75-10% 25VDC	28480	0180-1083
ASC47	0180-1083	3		CAPACITOR-FXD 33uF +75-10% 25VDC	28480	0180-1083
ASC48	0180-1083	3		CAPACITOR-FXD 33uF +75-10% 25VDC	28480	0180-1083
ASC49	0180-1083	3		CAPACITOR-FXD 33uF +75-10% 25VDC	28480	0180-1083
ASC50	0180-1083	3		CAPACITOR-FXD 33uF +75-10% 25VDC	28480	0180-1083
ASC51	0180-1083	3		CAPACITOR-FXD 33uF +75-10% 25VDC	28480	0180-1083
ASC52	0160-2055	9		CAPACITOR-FXD .01UF +-80-20% 100VDC CER	28480	0160-2055
ASC53	0160-2055	9		CAPACITOR-FXD .01UF +-80-20% 100VDC CER	28480	0160-2055
ASC54	0160-2055	9		CAPACITOR-FXD .01UF +-80-20% 100VDC CER	28480	0160-2055
ASC55	0160-2055	9		CAPACITOR-FXD .01UF +-80-20% 100VDC CER	28480	0160-2055
ASC56	1901-0040	1		DIODE-SWITCHING 30V 50MA 2N8 DO-35	28480	1901-0040
ASC57	1901-0040	1		DIODE-SWITCHING 30V 50MA 2N8 DO-35	28480	1901-0040
ASC58	1901-0040	1		DIODE-SWITCHING 30V 50MA 2N8 DO-35	28480	1901-0040
ASC59	1901-0040	1		DIODE-SWITCHING 30V 50MA 2N8 DO-35	28480	1901-0040
ASC60	1901-0040	1		DIODE-SWITCHING 30V 50MA 2N8 DO-35	28480	1901-0040
ASC61	1901-0040	1		DIODE-SWITCHING 30V 50MA 2N8 DO-35	28480	1901-0040
ASC62	1901-0040	1		DIODE-SWITCHING 30V 50MA 2N8 DO-35	28480	1901-0040
ASC63	1901-0376	6		DIODE-GEN PRP 35V 50MA DO-35	28480	1901-0376
ASC64	1901-0376	6		DIODE-GEN PRP 35V 50MA DO-35	28480	1901-0376
ASC65	1901-0376	6		DIODE-GEN PRP 35V 50MA DO-35	28480	1901-0376

See introduction to this section for ordering information  
\*Indicates factory selected value

Table 6-3. Replaceable Parts (Cont'd).

Reference Designation	HP Part Number	C D	Qty	Description	Mfr Code	Mfr Part Number
ASCR11	1901-0376	6		DIODE-GEN PRP 35V 50MA DO-35	28480	1901-0376
ASCR12	1901-0040	1		DIODE-SWITCHING 30V 50MA 2N8 DO-35	28480	1901-0040
ASCR13	1901-0040	1		DIODE-SWITCHING 30V 50MA 2N8 DO-35	28480	1901-0040
ASCR14	1901-0040	1		DIODE-SWITCHING 30V 50MA 2N8 DO-35	28480	1901-0040
ASCR15	1901-0040	1		DIODE-SWITCHING 30V 50MA 2N8 DO-35	28480	1901-0040
ASCR16	1901-0040	1		DIODE-SWITCHING 30V 50MA 2N8 DO-35	28480	1901-0040
ASCR17	1901-0040	1		DIODE-SWITCHING 30V 50MA 2N8 DO-35	28480	1901-0040
ASCR18	1901-0040	1		DIODE-SWITCHING 30V 50MA 2N8 DO-35	28480	1901-0040
ASCR19	1901-0040	1		DIODE-SWITCHING 30V 50MA 2N8 DO-35	28480	1901-0040
ASCR20	1901-0040	1		DIODE-SWITCHING 30V 50MA 2N8 DO-35	28480	1901-0040
ASCR21	1901-0040	1		DIODE-SWITCHING 30V 50MA 2N8 DO-35	28480	1901-0040
ASCR22	1901-0040	1		DIODE-SWITCHING 30V 50MA 2N8 DO-35	28480	1901-0040
ASCR23	1901-0040	1		DIODE-SWITCHING 30V 50MA 2N8 DO-35	28480	1901-0040
ASCR24	1901-0376	6		DIODE-GEN PRP 35V 50MA DO-35	28480	1901-0376
ASCR25	1901-0376	6		DIODE-GEN PRP 35V 50MA DO-35	28480	1901-0376
ASCR26	1901-0040	1		DIODE-SWITCHING 30V 50MA 2N8 DO-35	28480	1901-0040
ASCR27	1901-0040	1		DIODE-SWITCHING 30V 50MA 2N8 DO-35	28480	1901-0040
ASCR28	1901-1011	6	1	DIODE-ARRAY VF DIFF=5MV	28480	1901-1011
ASCR29	1902-0049	2		DIODE-ZNR 6.19V 5x DO-7 PD=4W TC=+.022X	28480	1902-0049
ASCR30	1901-0040	1		DIODE-SWITCHING 30V 50MA 2N8 DO-35	28480	1901-0040
ASCR31	1901-0040	1		DIODE-SWITCHING 30V 50MA 2N8 DO-35	28480	1901-0040
ASCR32	1901-0518	8		DIODE-8CHOTKY	28480	1901-0518
ASCR33	1901-0518	8		DIODE-8CHOTKY	28480	1901-0518
ASL1	9170-0029	3		CORE-SHIELDING BEAD	28480	9170-0029
ASL2	9170-0029	3		CORE-SHIELDING BEAD	28480	9170-0029
ASL3	9140-0114	4		COIL-MLD 10UH 10% Q=55 .155DX.375LG-NOM	28480	9140-0114
ASL4	9140-0114	4		COIL-MLD 10UH 10% Q=55 .155DX.375LG-NOM	28480	9140-0114
ASL5	9170-0029	3		CORE-SHIELDING BEAD	28480	9170-0029
ASL6	9100-1788	6		CHOKE-WIDE BAND ZMAX=680 OHMS 180 MHZ	02114	VK200 20/48
ASL7	9100-1788	6		CHOKE-WIDE BAND ZMAX=680 OHMS 180 MHZ	02114	VK200 20/48
ASL8	9100-1788	6		CHOKE-WIDE BAND ZMAX=680 OHMS 180 MHZ	02114	VK200 20/48
ASL9	9100-1788	6		CHOKE-WIDE BAND ZMAX=680 OHMS 180 MHZ	02114	VK200 20/48
ASQ1	1854-0215	1		TRANSISTOR NPN 8I PD=350MW FT=300MHZ	04713	2N3904
ASQ2	1854-0215	1		TRANSISTOR NPN 8I PD=350MW FT=300MHZ	04713	2N3904
ASQ3	1855-0081	1		TRANSISTOR J-FET N-CHAN D=MODE 8I	01295	2N5245
ASQ4	1855-0127	9	1	TRANSISTOR FET N-CHANNEL 5I	28480	
ASQ5	1854-0215	1		TRANSISTOR NPN 8I PD=350MW FT=300MHZ	04713	2N3904
ASQ6	1855-0081	1		TRANSISTOR J-FET N-CHAN D=MODE 8I	01295	2N5245
ASQ7	1853-0015	7	2	TRANSISTOR PNP 8I PD=200MW FT=500MHZ	28480	1853-0015
ASQ8	1854-0092	2		TRANSISTOR NPN 8I PD=200MW FT=600MHZ	28480	1854-0092
ASQ9	1854-0092	2		TRANSISTOR NPN 8I PD=200MW FT=600MHZ	28480	1854-0092
ASQ10	1853-0015	7		TRANSISTOR PNP 8I PD=200MW FT=500MHZ	28480	1853-0015
ASQ11	1854-0092	2		TRANSISTOR NPN 8I PD=200MW FT=600MHZ	28480	1854-0092
ASQ12	1854-0092	2		TRANSISTOR NPN 8I PD=200MW FT=600MHZ	28480	1854-0092
ASQ13	1855-0091	3		TRANSISTOR J-FET N-CHAN D=MODE 8I	28480	1855-0091
ASQ14	1855-0091	3		TRANSISTOR J-FET N-CHAN D=MODE 8I	28480	1855-0091
ASQ15	1853-0020	4		TRANSISTOR PNP 8I PD=300MW FT=150MHZ	28480	1853-0020
ASQ16	1855-0081	1		TRANSISTOR J-FET N-CHAN D=MODE 8I	01295	2N5245
ASQ17	1853-0020	4		TRANSISTOR PNP 8I PD=300MW FT=150MHZ	28480	1853-0020
ASQ18	1853-0020	4		TRANSISTOR PNP 8I PD=300MW FT=150MHZ	28480	1853-0020
ASQ19	1855-0081	1		TRANSISTOR J-FET N-CHAN D=MODE 8I	01295	2N5245
ASQ20	1853-0354	7		TRANSISTOR PNP 8I TO-92 PD=350MW	28480	1853-0354
ASQ21	1855-0571	8	8	TRANSISTOR FET N-CHANNEL	28480	1855-0571
ASQ22	1855-0571	8		TRANSISTOR FET N-CHANNEL	28480	1855-0571
ASQ23	1855-0571	8		TRANSISTOR FET N-CHANNEL	28480	1855-0571
ASQ24	1855-0571	8		TRANSISTOR FET N-CHANNEL	28480	1855-0571
ASQ25	1855-0571	8		TRANSISTOR FET N-CHANNEL	28480	1855-0571
ASQ26	1855-0571	8		TRANSISTOR FET N-CHANNEL	28480	1855-0571
ASQ27	1855-0571	8		TRANSISTOR FET N-CHANNEL	28480	1855-0571
ASQ28	1855-0571	8		TRANSISTOR FET N-CHANNEL	28480	1855-0571
ASQ29	1854-0092	2		TRANSISTOR NPN 8I PD=200MW FT=600MHZ	28480	1854-0092
ASQ30	1854-0092	2		TRANSISTOR NPN 8I PD=200MW FT=600MHZ	28480	1854-0092
ASQ31	1854-0092	2		TRANSISTOR NPN 8I PD=200MW FT=600MHZ	28480	1854-0092
ASQ32	1854-0092	2		TRANSISTOR NPN 8I PD=200MW FT=600MHZ	28480	1854-0092
ASQ33	1854-0092	2		TRANSISTOR NPN 8I PD=200MW FT=600MHZ	28480	1854-0092
ASQ34	1854-0092	2		TRANSISTOR NPN 8I PD=200MW FT=600MHZ	28480	1854-0092
ASQ35	1855-0091	3		TRANSISTOR J-FET N-CHAN D=MODE 8I	28480	1855-0091
ASQ36	1855-0091	3		TRANSISTOR J-FET N-CHAN D=MODE 8I	28480	1855-0091
ASQ37	1854-0071	7		TRANSISTOR NPN 8I PD=300MW FT=200MHZ	28480	1854-0071
ASQ38	1853-0300	3		TRANSISTOR PNP 8I TO-18 PD=300MW	28480	1853-0300
ASQ39	1853-0012	4		TRANSISTOR PNP 2N2904A 8I TO-39 PD=600MW	01295	2N2904A
ASQ40	1853-0300	3		TRANSISTOR PNP 8I TO-18 PD=300MW	28480	1853-0300
ASQ41	1854-0039	7		TRANSISTOR NPN 2N3053B 8I TO-39 PD=1W	01928	2N3053B
ASQ42	1854-0071	7		TRANSISTOR NPN 8I PD=300MW FT=200MHZ	28480	1854-0071

See introduction to this section for ordering information  
\*Indicates factory selected value

Table 6-3. Replaceable Parts (Cont'd).

Reference Designation	HP Part Number	C D	Qty	Description	Mfr Code	Mfr Part Number
A4A3C6	0160-3060	8		CAPACITOR-FXD .1UF +-20% 25VDC CER	28480	0160-3060
A4A3C7	0160-2266	3		CAPACITOR-FXD 24PF +-5% 500VDC CER 0+-30	28480	0160-2266
A4A3C8	0160-3060	6		CAPACITOR-FXD .1UF +-20% 25VDC CER	28480	0160-3060
A4A3C9	0160-3060	6		CAPACITOR-FXD .1UF +-20% 25VDC CER	28480	0160-3060
A4A3C10	0160-0127	2		CAPACITOR-FXD .1UF +-20% 25VDC CER	28480	0160-0127
A4A3C11	0160-0127	2		CAPACITOR-FXD .1UF +-20% 25VDC CER	28480	0160-0127
A4A3C12	0160-0127	2		CAPACITOR-FXD .1UF +-20% 25VDC CER	28480	0160-0127
A4A3C13	0160-3060	8		CAPACITOR-FXD .1UF +-20% 25VDC CER	28480	0160-3060
A4A3C14	0160-3060	8		CAPACITOR-FXD .1UF +-20% 25VDC CER	28480	0160-3060
A4A3C15	0160-2055	9		CAPACITOR-FXD .01UF +80-20% 100VDC CER	28480	0160-2055
A4A3C16	0160-3060	8		CAPACITOR-FXD .1UF +-20% 25VDC CER	28480	0160-3060
A4A3C17	0180-1083	3		CAPACITOR-FXD 33UF +75-10% 25VDC	28480	0180-1083
A4A3C18	0160-2055	9		CAPACITOR-FXD .01UF +80-20% 100VDC CER	28480	0160-2055
A4A3CR1	1901-0040	1		DIODE-SWITCHING 30V 50MA 2N8 DO-35	28480	1901-0040
A4A3CR2	1901-0040	1		DIODE-SWITCHING 30V 50MA 2N8 DO-35	28480	1901-0040
A4A3CR3	1901-0376	6		DIODE-GEN PRP 35V 50MA DO-35	28480	1901-0376
A4A3CR4	1901-0376	6		DIODE-GEN PRP 35V 50MA DO-35	28480	1901-0376
A4A3CR5	1901-0376	6		DIODE-GEN PRP 35V 50MA DO-35	28480	1901-0376
A4A3CR6	1901-0376	6		DIODE-GEN PRP 35V 50MA DO-35	28480	1901-0376
A4A3CR7	1901-0376	6		DIODE-GEN PRP 35V 50MA DO-35	28480	1901-0376
A4A3L1	9100-1629	4	5	COIL-MLD 47UH 5% Q=55 .155DX.375LG-NOM	28480	9100-1629
A4A3L2	9170-0029	3		CORE-SHIELDING BEAD	28480	9170-0029
A4A3L3	9100-1629	4		COIL-MLD 47UH 5% Q=55 .155DX.375LG-NOM	28480	9100-1629
A4A3Q1	1854-0215	1		TRANSISTOR NPN SI PD=350MH FT=300MHZ	04713	2N3904
A4A3Q2	1855-0081	1		TRANSISTOR J-FET N-CHAN D-MODE SI	01295	2N5245
A4A3Q3	1854-0215	1		TRANSISTOR NPN SI PD=350MH FT=300MHZ	04713	2N3904
A4A3Q4	1855-0081	1		TRANSISTOR J-FET N-CHAN D-MODE SI	01295	2N5245
A4A3Q5	1853-0354	7		TRANSISTOR PNP SI TO-92 PD=350MH	28480	1853-0354
A4A3Q6	1854-0215	1		TRANSISTOR NPN SI PD=350MH FT=300MHZ	04713	2N3904
A4A3Q7	1853-0354	7		TRANSISTOR PNP SI TO-92 PD=350MH	28480	1853-0354
A4A3Q8	1855-0091	3		TRANSISTOR J-FET N-CHAN D-MODE SI	28480	1855-0091
A4A3Q9	1853-0020	4		TRANSISTOR PNP SI PD=300MH FT=150MHZ	28480	1853-0020
A4A3Q10	1854-0628	0		TRANSISTOR NPN SI TO-92 PD=625MH	04713	MP8-H17
A4A3Q11	1854-0628	0		TRANSISTOR NPN SI TO-92 PD=625MH	04713	MP8-H17
A4A3Q12	1855-0081	1		TRANSISTOR J-FET N-CHAN D-MODE SI	01295	2N5245
A4A3Q13	1855-0091	3		TRANSISTOR J-FET N-CHAN D-MODE SI	28480	1855-0091
A4A3Q14	1855-0081	1		TRANSISTOR J-FET N-CHAN D-MODE SI	01295	2N5245
A4A3Q15	1853-0020	4		TRANSISTOR PNP SI PD=300MH FT=150MHZ	28480	1853-0020
A4A3Q16	1853-0020	4		TRANSISTOR PNP SI PD=300MH FT=150MHZ	28480	1853-0020
A4A3Q17	1853-0354	7		TRANSISTOR PNP SI TO-92 PD=350MH	28480	1853-0354
A4A3Q18	1853-0354	7		TRANSISTOR PNP SI TO-92 PD=350MH	28480	1853-0354
A4A3R1	0698-3153	9		RESISTOR 3.63K 1% .125W F TC=0+-100	24546	C4-1/8-T0-3831-F
A4A3R2	0683-2205	9		RESISTOR 22 5% .25W FC TC=400/+500	01121	CB2205
A4A3R3	0698-3160	8		RESISTOR 31.6K 1% .125W F TC=0+-100	24546	C4-1/8-T0-3162-F
A4A3R4	0757-0180	2	11	RESISTOR 31.6 1% .125W F TC=0+-100	28480	0757-0180
A4A3R5	0683-1005	5		RESISTOR 10 5% .25W FC TC=400/+500	01121	CB1005
A4A3R6	0757-0399	3	1	RESISTOR 82.5 1% .125W F TC=0+-100	24546	C4-1/8-T0-82R5-F
A4A3R7	0757-0420	5		RESISTOR 750 1% .125W F TC=0+-100	24546	C4-1/8-T0-751-F
A4A3R8	0698-3441	8		RESISTOR 215 1% .125W F TC=0+-100	24546	C4-1/8-T0-215R-F
A4A3R9	0757-0405	4		RESISTOR 162 1% .125W F TC=0+-100	24546	C4-1/8-T0-162R-F
A4A3R10	2100-0589	6	4	RESISTOR-TYRNR 10 10% C 8IDE-ADJ 1-TRN	28480	2100-0589
A4A3R11	0757-0487	2		RESISTOR 825K 1% .125W F TC=0+-100	28480	0757-0487
A4A3R12	0757-0487	2		RESISTOR 825K 1% .125W F TC=0+-100	28480	0757-0487
A4A3R13	0698-3260	9		RESISTOR 464K 1% .125W F TC=0+-100	28480	0698-3260
A4A3R14	0757-0180	2		RESISTOR 31.6 1% .125W F TC=0+-100	28480	0757-0180
A4A3R15	0683-1005	5		RESISTOR 10 5% .25W FC TC=400/+500	01121	CB1005
A4A3R16	0757-0180	2		RESISTOR 31.6 1% .125W F TC=0+-100	28480	0757-0180
A4A3R17	0698-3153	9		RESISTOR 3.63K 1% .125W F TC=0+-100	24546	C4-1/8-T0-3831-F
A4A3R18	0683-1025	9		RESISTOR 1K 5% .25W FC TC=400/+600	01121	CB1025
A4A3R19	0698-2239	0	4	RESISTOR 1.5	28480	0698-2239
A4A3R20	0698-2343	7		RESISTOR 50 1% .125W	28480	0698-2343
A4A3R21	0698-3155	1		RESISTOR 4.64K 1% .125W F TC=0+-100	24546	C4-1/8-T0-4641-F
A4A3R22	0757-0294	9	5	RESISTOR 17.8 1% .125W F TC=0+-100	19701	MF4C1/8-T0-17R8-F
A4A3R23	0757-0294	9		RESISTOR 17.8 1% .125W F TC=0+-100	19701	MF4C1/8-T0-17R8-F
A4A3R24	0698-3151	7	2	RESISTOR 2.87K 1% .125W F TC=0+-100	24546	C4-1/8-T0-2871-F
A4A3R25	0757-0401	0		RESISTOR 100 1% .125W F TC=0+-100	24546	C4-1/8-T0-101-F
A4A3R26	0683-2205	9		RESISTOR 22 5% .25W FC TC=400/+500	01121	CB2205
A4A3R27	0698-2342	6	2	RESISTOR 450 1% .125W	28480	0698-2342
A4A3R28	0757-0487	2		RESISTOR 825K 1% .125W F TC=0+-100	28480	0757-0487
A4A3R29	0757-0180	2		RESISTOR 31.6 1% .125W F TC=0+-100	28480	0757-0180
A4A3R30	0757-0274	5		RESISTOR 1.21K 1% .125W F TC=0+-100	24546	C4-1/8-T0-1213-F
A4A3R31	0757-0274	5		RESISTOR 1.21K 1% .125W F TC=0+-100	24546	C4-1/8-T0-1213-F
A4A3R32	0757-0420	3		RESISTOR 750 1% .125W F TC=0+-100	24546	C4-1/8-T0-751-F
A4A3R33	0698-0082	7		RESISTOR 464 1% .125W F TC=0+-100	24546	C4-1/8-T0-4640-F
A4A3R34	0757-0417	8		RESISTOR 562 1% .125W F TC=0+-100	24546	C4-1/8-T0-562R-F
A4A3R35	0698-0083	8		RESISTOR 1.96K 1% .125W F TC=0+-100	24546	C4-1/8-T0-1961-F
A4A3R36	0683-1028	9		RESISTOR 1K 5% .25W FC TC=400/+600	01121	CB1025

See introduction to this section for ordering information  
\*Indicates factory selected value

Table 6-3 Replaceable Parts (Cont'd).

Reference Designation	HP Part Number	C D	Qty	Description	Mfr Code	Mfr Part Number
AQ43R37	0698-3155	1		RESISTOR 4.64K 1% .125W F TC0+/-100	24546	C4-1/8-T0-4641-F
	1251-4683	7		AQ43 MISCELLANEOUS PARTS		
AQ44	04275-66544	0	1	CONNECTOR-8GL CONT SKT .04-IN-88C-8Z RND	28480	1251-4683
	04275-26544	6		AN AMPLIFIER BOARD ASSEMBLY PC BOARD, BLANK	28480 28480	04275-66544 04275-26544
AQ44C1	0160-2055	9		CAPACITOR-FXD .01UF +80-20% 100VDC CER	28480	0160-2055
AQ44C2	0160-2055	9		CAPACITOR-FXD .01UF +80-20% 100VDC CER	28480	0160-2055
AQ44C3	0121-0059	7		CAPACITOR-V TRMR-CER 2-8PF 350V PC-MTG	52763	304324 2/8PF NPO
AQ44C4	0160-2259	5		CAPACITOR-FXD 12PF +/-5% 500VDC CER 0+-30	28480	0160-2259
AQ44C5	0160-3060	8		CAPACITOR-FXD .1UF +/-20% 25VDC CER	28480	0160-3060
AQ44C6	0160-3060	8		CAPACITOR-FXD .1UF +/-20% 25VDC CER	28480	0160-3060
AQ44C7	0160-2307	4		CAPACITOR-FXD 47PF +/-5% 300VDC MICA	28480	0160-2307
AQ44C8	0160-0127	2		CAPACITOR-FXD 1UF +/-20% 25VDC CER	28480	0160-0127
AQ44C9	0160-3060	8		CAPACITOR-FXD .1UF +/-20% 25VDC CER	28480	0160-3060
AQ44C10	0160-3060	8		CAPACITOR-FXD .1UF +/-20% 25VDC CER	28480	0160-3060
AQ44C11	0160-3060	8		CAPACITOR-FXD .1UF +/-20% 25VDC CER	28480	0160-3060
AQ44C12	0160-3060	8		CAPACITOR-FXD .1UF +/-20% 25VDC CER	28480	0160-3060
AQ44C13	0160-3060	8		CAPACITOR-FXD .1UF +/-20% 25VDC CER	28480	0160-3060
AQ44C14	0160-0127	2		CAPACITOR-FXD 1UF +/-20% 25VDC CER	28480	0160-0127
AQ44C15	0160-3060	8		CAPACITOR-FXD .1UF +/-20% 25VDC CER	28480	0160-3060
AQ44C16	0160-3060	8		CAPACITOR-FXD .1UF +/-20% 25VDC CER	28480	0160-3060
AQ44CR1	1901-0376	6		DIODE-GEN PRP 35V 50MA DO-35	28480	1901-0376
AQ44CR2	1901-0376	6		DIODE-GEN PRP 35V 50MA DO-35	28480	1901-0376
AQ44CR3	1901-0376	6		DIODE-GEN PRP 35V 50MA DO-35	28480	1901-0376
AQ44CR4	1901-0376	6		DIODE-GEN PRP 35V 50MA DO-35	28480	1901-0376
AQ44CR5	1901-0376	6		DIODE-GEN PRP 35V 50MA DO-35	28480	1901-0376
AQ44CR6	1901-0040	1		DIODE-SWITCHING 30V 50MA 2N8 DO-35	28480	1901-0040
AQ44CR7	1901-0040	1		DIODE-SWITCHING 30V 50MA 2N8 DO-35	28480	1901-0040
AQ44CR8	1901-0040	1		DIODE-SWITCHING 30V 50MA 2N8 DO-35	28480	1901-0040
AQ44CR9	1901-0040	1		DIODE-SWITCHING 30V 50MA 2N8 DO-35	28480	1901-0040
AQ44CR10	1901-0040	1		DIODE-SWITCHING 30V 50MA 2N8 DO-35	28480	1901-0040
AQ44CR11	1901-0040	1		DIODE-SWITCHING 30V 50MA 2N8 DO-35	28480	1901-0040
AQ44L1	9170-0029	3		CORE-SHIELDING BEAD	28480	9170-0029
AQ44Q1	1853-0354	7		TRANSISTOR PNP SI TO-92 PD=350MH	28480	1853-0354
AQ44Q2	1853-0091	3		TRANSISTOR J-FET N-CHAN D-MODE SI	28480	1853-0091
AQ44Q3	1853-0091	3		TRANSISTOR J-FET N-CHAN D-MODE SI	28480	1853-0091
AQ44Q4	1853-0081	1		TRANSISTOR J-FET N-CHAN D-MODE SI	01295	2N5245
AQ44Q5	1853-0081	1		TRANSISTOR J-FET N-CHAN D-MODE SI	01295	2N5245
AQ44Q6	1854-0628	0		TRANSISTOR NPN SI TO-92 PD=625MH	04713	MP8-H17
AQ44Q7	1853-0354	7		TRANSISTOR PNP SI TO-92 PD=350MH	28480	1853-0354
AQ44Q8	1854-0628	0		TRANSISTOR NPN SI TO-92 PD=625MH	04713	MP8-H17
AQ44Q9	1853-0354	7		TRANSISTOR PNP SI TO-92 PD=350MH	28480	1853-0354
AQ44Q10	1853-0354	7		TRANSISTOR PNP SI TO-92 PD=350MH	28480	1853-0354
AQ44Q11	1854-0628	0		TRANSISTOR NPN SI TO-92 PD=625MH	04713	MP8-H17
AQ44Q12	1853-0354	7		TRANSISTOR PNP SI TO-92 PD=350MH	28480	1853-0354
AQ44Q13	1854-0039	7		TRANSISTOR NPN 2N3053B SI TO-18 PD=1W	01928	2N3053B
AQ44Q14	1853-0012	4		TRANSISTOR PNP 2N2904A SI TO-18 PD=600MH	01295	2N2904A
AQ44R1	0698-2342	6		RESISTOR 450 .1% .125W	28480	0698-2342
AQ44R2	2100-0589	6		RESISTOR-TRMR 10 10% C SIDE-ADJ 1-TRN	28480	2100-0589
AQ44R3	0698-2343	7		RESISTOR 50 .1% .125W	28480	0698-2343
AQ44R4	0698-2239	0		RESISTOR 1.5	28480	0698-2239
AQ44R5	0698-3155	1		RESISTOR 4.64K 1% .125W F TC0+/-100	24546	C4-1/8-T0-4641-F
AQ44R6	0757-0487	2		RESISTOR 825K 1% .125W F TC0+/-100	28480	0757-0487
AQ44R7	0757-0487	2		RESISTOR 825K 1% .125W F TC0+/-100	28480	0757-0487
AQ44R8	0757-0487	2		RESISTOR 825K 1% .125W F TC0+/-100	28480	0757-0487
AQ44R9	0757-0487	2		RESISTOR 825K 1% .125W F TC0+/-100	28480	0757-0487
AQ44R10	0698-3260	9		RESISTOR 464K 1% .125W F TC0+/-100	28480	0698-3260
AQ44R11	0698-3155	1		RESISTOR 4.64K 1% .125W F TC0+/-100	24546	C4-1/8-T0-4641-F
AQ44R12	0757-0180	2		RESISTOR 31.6 1% .125W F TC0+/-100	28480	0757-0180
AQ44R13	0757-0180	2		RESISTOR 31.6 1% .125W F TC0+/-100	28480	0757-0180
AQ44R14	0757-0294	9		RESISTOR 17.8 1% .125W F TC0+/-100	19701	MF4C1/8-T0-178-F
AQ44R15	0698-3434	9	1	RESISTOR 34.8 1% .125W F TC0+/-100	24546	C4-1/8-T0-348-F
AQ44R16	0757-0420	3		RESISTOR 750 1% .125W F TC0+/-100	24546	C4-1/8-T0-751-F
AQ44R17	0757-0294	9		RESISTOR 17.8 1% .125W F TC0+/-100	19701	MF4C1/8-T0-178-F
AQ44R18	0757-0274	5		RESISTOR 1.21K 1% .125W F TC0+/-100	24546	C4-1/8-T0-1213-F
AQ44R19	0698-3441	8		RESISTOR 215 1% .125W F TC0+/-100	24546	C4-1/8-T0-215R-F
AQ44R20	0698-3155	1		RESISTOR 4.64K 1% .125W F TC0+/-100	24546	C4-1/8-T0-4641-F
AQ44R21	0757-0420	3		RESISTOR 750 1% .125W F TC0+/-100	24546	C4-1/8-T0-751-F
AQ44R22	0698-3155	7		RESISTOR 2.87K 1% .125W F TC0+/-100	24546	C4-1/8-T0-2871-F
AQ44R23	0757-0405	4		RESISTOR 162 1% .125W F TC0+/-100	24546	C4-1/8-T0-162R-F
AQ44R24	0698-0082	7		RESISTOR 464 1% .125W F TC0+/-100	24546	C4-1/8-T0-4640-F
AQ44R25	0757-0417	8		RESISTOR 562 1% .125W F TC0+/-100	24546	C4-1/8-T0-562R-F

See introduction to this section for ordering information  
\*Indicates factory selected value

Table 6-3. Replaceable Parts (Cont'd).

Reference Designation	HP Part Number	C D	Qty	Description	Mfr Code	Mfr Part Number
A4A4R26	0757-0403	2		RESISTOR 121 1X .125W F TC=0+-100	24546	C4-1/8-T0-121R-F
A4A4R27	0698-0063	8		RESISTOR 1.96K 12 .125W F TC=0+-100	24546	C4-1/8-T0-1961-F
A4A4R28	0698-3444	1		RESISTOR 316 1X .125W F TC=0+-100	24546	C4-1/8-T0-316R-F
A4A4R29	0683-2205	9		RESISTOR 22 5X .25W FC TC=-400/+500	01121	CB2205
A4A4R30	0683-2205	9		RESISTOR 22 5X .25W FC TC=-400/+500	01121	CB2205
A4A4R31	0683-1025	9		RESISTOR 1K 5X .25W FC TC=-400/+600	01121	CB1025
				A4A4 MISCELLANEOUS PARTS		
	1251-4683	7		CONNECTOR-8GL CONT 8KT .04-IN-88C-82 RND	28480	1251-4683
AS	04275-66505	3	1	A-D CONVERTER BOARD ASSEMBLY	28480	04275-66505
	04275-26505	9		PC BOARD, BLANK	28480	04275-26505
ASC1	0180-1083	3		CAPACITOR-FXD 33uF +75-10% 25VDC	28480	0180-1083
ASC2	0160-2261	1		CAPACITOR-FXD 15PF +-5% 500VDC CER 0+-30	28480	0160-2261
ASC3	0160-3060	8		CAPACITOR-FXD .1UF +-20% 25VDC CER	28480	0160-3060
ASC4	0160-0127	2		CAPACITOR-FXD .1UF +-20% 25VDC CER	28480	0160-0127
ASC5	0160-3060	8		CAPACITOR-FXD .1UF +-20% 25VDC CER	28480	0160-3060
ASC6	0160-2261	9		CAPACITOR-FXD 15PF +-5% 500VDC CER 0+-30	28480	0160-2261
ASC7	0160-2239	1	2	CAPACITOR-FXD 1.8PF +--.25PF 500VDC CER	28480	0160-2239
ASC8	0160-2239	1		CAPACITOR-FXD 1.8PF +--.25PF 500VDC CER	28480	0160-2239
ASC9	0160-3060	8		CAPACITOR-FXD .1UF +-20% 25VDC CER	28480	0160-3060
ASC10	0160-3060	8		CAPACITOR-FXD .1UF +-20% 25VDC CER	28480	0160-3060
ASC11	0160-3060	8		CAPACITOR-FXD .1UF +-20% 25VDC CER	28480	0160-3060
ASC12	0160-2200	6	1	CAPACITOR-FXD 43PF +-5% 300VDC MICA	28480	0160-2200
ASC13	0160-3060	8		CAPACITOR-FXD .1UF +-20% 25VDC CER	28480	0160-3060
ASC14	0160-0127	2		CAPACITOR-FXD .1UF +-20% 25VDC CER	28480	0160-0127
ASC15	0121-0036	0		CAPACITOR-V TRMR-CER 5.5-18PF 350V	52763	304324 5.5/18PF NPO
ASC16	0160-0127	2		CAPACITOR-FXD .1UF +-20% 25VDC CER	28480	0160-0127
ASC17	0160-3060	8		CAPACITOR-FXD .1UF +-20% 25VDC CER	28480	0160-3060
ASC18	0160-0127	2		CAPACITOR-FXD .1UF +-20% 25VDC CER	28480	0160-0127
ASC19	0160-3060	8		CAPACITOR-FXD .1UF +-20% 25VDC CER	28480	0160-3060
ASC20	0180-1083	3		CAPACITOR-FXD 33uF +75-10% 25VDC	28480	0180-1083
ASC21	0160-2257	3	1	CAPACITOR-FXD 10PF +-5% 500VDC CER 0+-60	28480	0160-2257
ASC22	0160-3060	8		CAPACITOR-FXD .1UF +-20% 25VDC CER	28480	0160-3060
ASC23	0160-2055	9		CAPACITOR-FXD .01UF +80-20% 100VDC CER	28480	0160-2055
ASC24	0160-2055	9		CAPACITOR-FXD .01UF +80-20% 100VDC CER	28480	0160-2055
ASC25	0160-2055	9		CAPACITOR-FXD .01UF +80-20% 100VDC CER	28480	0160-2055
ASC26	0160-2055	9		CAPACITOR-FXD .01UF +80-20% 100VDC CER	28480	0160-2055
ASC27	0160-2055	9		CAPACITOR-FXD .01UF +80-20% 100VDC CER	28480	0160-2055
ASC28	0160-2055	9		CAPACITOR-FXD .01UF +80-20% 100VDC CER	28480	0160-2055
ASC29	0160-3456	6		CAPACITOR-FXD 1000PF +-10% 1KVDC CER	28480	0160-3456
ASC30	0160-2055	9		CAPACITOR-FXD .01UF +80-20% 100VDC CER	28480	0160-2055
ASC31	0160-2055	9		CAPACITOR-FXD .01UF +80-20% 100VDC CER	28480	0160-2055
ASC32	0160-2055	9		CAPACITOR-FXD .01UF +80-20% 100VDC CER	28480	0160-2055
ASC33	0160-2055	9		CAPACITOR-FXD .01UF +80-20% 100VDC CER	28480	0160-2055
ASC34	0160-2055	9		CAPACITOR-FXD .01UF +80-20% 100VDC CER	28480	0160-2055
ASC35	0160-2055	9		CAPACITOR-FXD .01UF +80-20% 100VDC CER	28480	0160-2055
ASC36	0160-0939	4	1	CAPACITOR-FXD 430PF +-5% 300VDC MICA	28480	0160-0939
ASC37	0160-2055	9		CAPACITOR-FXD .01UF +80-20% 100VDC CER	28480	0160-2055
ASC38	0160-2055	9		CAPACITOR-FXD .01UF +80-20% 100VDC CER	28480	0160-2055
ASC39	0160-1674	6	1	CAPACITOR-FXD .33uF 5% 200VDC	28480	0160-1674
ASC40	0180-0197	8		CAPACITOR-FXD 2.2UF+-10% 20VDC TA	56289	150D225X9020A2
ASC41	0160-2204	0		CAPACITOR-FXD 100PF +-5% 300VDC MICA	28480	0160-2204
ASC42	0160-2055	9		CAPACITOR-FXD .01UF +80-20% 100VDC CER	28480	0160-2055
ASC43	0160-2055	9		CAPACITOR-FXD .01UF +80-20% 100VDC CER	28480	0160-2055
ASC44	0180-1083	3		CAPACITOR-FXD 33uF +75-10% 25VDC	28480	0180-1083
ASC45	0180-1083	3		CAPACITOR-FXD 33uF +75-10% 25VDC	28480	0180-1083
ASC46	0180-1083	3		CAPACITOR-FXD 33uF +75-10% 25VDC	28480	0180-1083
ASC47	0180-1083	3		CAPACITOR-FXD 33uF +75-10% 25VDC	28480	0180-1083
ASC48	0180-1083	3		CAPACITOR-FXD 33uF +75-10% 25VDC	28480	0180-1083
ASC49	0180-1083	3		CAPACITOR-FXD 33uF +75-10% 25VDC	28480	0180-1083
ASC50	0180-1083	3		CAPACITOR-FXD 33uF +75-10% 25VDC	28480	0180-1083
ASC51	0180-1083	3		CAPACITOR-FXD 33uF +75-10% 25VDC	28480	0180-1083
ASC52	0160-2055	9		CAPACITOR-FXD .01UF +80-20% 100VDC CER	28480	0160-2055
ASC53	0160-2055	9		CAPACITOR-FXD .01UF +80-20% 100VDC CER	28480	0160-2055
ASC54	0160-2055	9		CAPACITOR-FXD .01UF +80-20% 100VDC CER	28480	0160-2055
ASC55	0160-2055	9		CAPACITOR-FXD .01UF +80-20% 100VDC CER	28480	0160-2055
ASC56	1901-0040	1		DIODE-SWITCHING 30V 50MA 2N8 DO-35	28480	1901-0040
ASC57	1901-0040	1		DIODE-SWITCHING 30V 50MA 2N8 DO-35	28480	1901-0040
ASC58	1901-0040	1		DIODE-SWITCHING 30V 50MA 2N8 DO-35	28480	1901-0040
ASC59	1901-0040	1		DIODE-SWITCHING 30V 50MA 2N8 DO-35	28480	1901-0040
ASC60	1901-0040	1		DIODE-SWITCHING 30V 50MA 2N8 DO-35	28480	1901-0040
ASC61	1901-0040	1		DIODE-SWITCHING 30V 50MA 2N8 DO-35	28480	1901-0040
ASC62	1901-0040	1		DIODE-SWITCHING 30V 50MA 2N8 DO-35	28480	1901-0040
ASC63	1901-0376	6		DIODE-GEN PRP 35V 50MA DO-35	28480	1901-0376
ASC64	1901-0376	6		DIODE-GEN PRP 35V 50MA DO-35	28480	1901-0376
ASC65	1901-0376	6		DIODE-GEN PRP 35V 50MA DO-35	28480	1901-0376

See introduction to this section for ordering information  
\*Indicates factory selected value

Table 6-3. Replaceable Parts (Cont'd).

Reference Designation	HP Part Number	C D	Qty	Description	Mfr Code	Mfr Part Number
ASCR11	1901-0376	6		DIODE-GEN PRP 35V 50MA DO-35	28480	1901-0376
ASCR12	1901-0040	1		DIODE-SWITCHING 30V 50MA 2N8 DO-35	28480	1901-0040
ASCR13	1901-0040	1		DIODE-SWITCHING 30V 50MA 2N8 DO-35	28480	1901-0040
ASCR14	1901-0040	1		DIODE-SWITCHING 30V 50MA 2N8 DO-35	28480	1901-0040
ASCR15	1901-0040	1		DIODE-SWITCHING 30V 50MA 2N8 DO-35	28480	1901-0040
ASCR16	1901-0040	1		DIODE-SWITCHING 30V 50MA 2N8 DO-35	28480	1901-0040
ASCR17	1901-0040	1		DIODE-SWITCHING 30V 50MA 2N8 DO-35	28480	1901-0040
ASCR18	1901-0040	1		DIODE-SWITCHING 30V 50MA 2N8 DO-35	28480	1901-0040
ASCR19	1901-0040	1		DIODE-SWITCHING 30V 50MA 2N8 DO-35	28480	1901-0040
ASCR20	1901-0040	1		DIODE-SWITCHING 30V 50MA 2N8 DO-35	28480	1901-0040
ASCR21	1901-0040	1		DIODE-SWITCHING 30V 50MA 2N8 DO-35	28480	1901-0040
ASCR22	1901-0040	1		DIODE-SWITCHING 30V 50MA 2N8 DO-35	28480	1901-0040
ASCR23	1901-0040	1		DIODE-SWITCHING 30V 50MA 2N8 DO-35	28480	1901-0040
ASCR24	1901-0376	6		DIODE-GEN PRP 35V 50MA DO-35	28480	1901-0376
ASCR25	1901-0376	6		DIODE-GEN PRP 35V 50MA DO-35	28480	1901-0376
ASCR26	1901-0040	1		DIODE-SWITCHING 30V 50MA 2N8 DO-35	28480	1901-0040
ASCR27	1901-0040	1		DIODE-SWITCHING 30V 50MA 2N8 DO-35	28480	1901-0040
ASCR28	1901-1011	8	1	DIODE-ARRAY VP DIFF=5MV	28480	1901-1011
ASCR29	1902-0049	2		DIODE-ZNR 6.19V 5% DO-7 PD=4W TC=+.022X	28480	1902-0049
ASCR30	1901-0040	1		DIODE-SWITCHING 30V 50MA 2N8 DO-35	28480	1901-0040
ASCR31	1901-0040	1		DIODE-SWITCHING 30V 50MA 2N8 DO-35	28480	1901-0040
ASCR32	1901-0518	8		DIODE-8CNOTTKY	28480	1901-0518
ASCR33	1901-0518	8		DIODE-8CNOTTKY	28480	1901-0518
ASL1	9170-0029	3		CORE-SHIELDING BEAD	28480	9170-0029
ASL2	9170-0029	3		CORE-SHIELDING BEAD	28480	9170-0029
ASL3	9140-0114	4		COIL-MLD 10UH 10% Q=55 .155DX.375LG-NOM	28480	9140-0114
ASL4	9140-0114	4		COIL-MLD 10UH 10% Q=55 .155DX.375LG-NOM	28480	9140-0114
ASL5	9170-0029	3		CORE-SHIELDING BEAD	28480	9170-0029
ASL6	9100-1788	6		CHOKE-WIDE BAND ZMAX=680 OHMS 180 MHZ	02114	VK200 20/48
ASL7	9100-1788	6		CHOKE-WIDE BAND ZMAX=680 OHMS 180 MHZ	02114	VK200 20/48
ASL8	9100-1788	6		CHOKE-WIDE BAND ZMAX=680 OHMS 180 MHZ	02114	VK200 20/48
ASL9	9100-1788	6		CHOKE-WIDE BAND ZMAX=680 OHMS 180 MHZ	02114	VK200 20/48
ASQ1	1854-0215	1		TRANSISTOR NPN SI PD=350MH FT=300MHZ	04713	2N3904
ASQ2	1854-0215	1		TRANSISTOR NPN SI PD=350MH FT=300MHZ	04713	2N3904
ASQ3	1855-0081	1		TRANSISTOR J-FET N-CHAN D-MODE SI	01295	2N5245
ASQ4	1855-0127	9	1	TRANSISTOR FET N-CHANNEL SI	28480	
ASQ5	1854-0215	1		TRANSISTOR NPN SI PD=350MH FT=300MHZ	04713	2N3904
ASQ6	1855-0081	1		TRANSISTOR J-FET N-CHAN D-MODE SI	01295	2N5245
ASQ7	1853-0015	7	2	TRANSISTOR PNP SI PD=200MH FT=500MHZ	28480	1853-0015
ASQ8	1854-0092	2		TRANSISTOR NPN SI PD=200MH FT=600MHZ	28480	1854-0092
ASQ9	1854-0092	2		TRANSISTOR NPN SI PD=200MH FT=600MHZ	28480	1854-0092
ASQ10	1853-0015	7		TRANSISTOR PNP SI PD=200MH FT=500MHZ	28480	1853-0015
ASQ11	1854-0092	2		TRANSISTOR NPN SI PD=200MH FT=600MHZ	28480	1854-0092
ASQ12	1854-0092	2		TRANSISTOR NPN SI PD=200MH FT=600MHZ	28480	1854-0092
ASQ13	1855-0091	3		TRANSISTOR J-FET N-CHAN D-MODE SI	28480	1855-0091
ASQ14	1855-0091	3		TRANSISTOR J-FET N-CHAN D-MODE SI	28480	1855-0091
ASQ15	1853-0020	4		TRANSISTOR PNP SI PD=300MH FT=150MHZ	28480	1853-0020
ASQ16	1855-0081	1		TRANSISTOR J-FET N-CHAN D-MODE SI	01295	2N5245
ASQ17	1853-0020	4		TRANSISTOR PNP SI PD=300MH FT=150MHZ	28480	1853-0020
ASQ18	1853-0020	4		TRANSISTOR PNP SI PD=300MH FT=150MHZ	28480	1853-0020
ASQ19	1855-0081	1		TRANSISTOR J-FET N-CHAN D-MODE SI	01295	2N5245
ASQ20	1853-0354	7		TRANSISTOR PNP SI TO-92 PD=350MH	28480	1853-0354
ASQ21	1855-0571	8	8	TRANSISTOR FET N-CHANNEL	28480	1855-0571
ASQ22	1855-0571	8		TRANSISTOR FET N-CHANNEL	28480	1855-0571
ASQ23	1855-0571	8		TRANSISTOR FET N-CHANNEL	28480	1855-0571
ASQ24	1855-0571	8		TRANSISTOR FET N-CHANNEL	28480	1855-0571
ASQ25	1855-0571	8		TRANSISTOR FET N-CHANNEL	28480	1855-0571
ASQ26	1855-0571	8		TRANSISTOR FET N-CHANNEL	28480	1855-0571
ASQ27	1855-0571	8		TRANSISTOR FET N-CHANNEL	28480	1855-0571
ASQ28	1855-0571	8		TRANSISTOR FET N-CHANNEL	28480	1855-0571
ASQ29	1854-0092	2		TRANSISTOR NPN SI PD=200MH FT=600MHZ	28480	1854-0092
ASQ30	1854-0092	2		TRANSISTOR NPN SI PD=200MH FT=600MHZ	28480	1854-0092
ASQ31	1854-0092	2		TRANSISTOR NPN SI PD=200MH FT=600MHZ	28480	1854-0092
ASQ32	1854-0092	2		TRANSISTOR NPN SI PD=200MH FT=600MHZ	28480	1854-0092
ASQ33	1854-0092	2		TRANSISTOR NPN SI PD=200MH FT=600MHZ	28480	1854-0092
ASQ34	1854-0092	2		TRANSISTOR NPN SI PD=200MH FT=600MHZ	28480	1854-0092
ASQ35	1855-0091	3		TRANSISTOR J-FET N-CHAN D-MODE SI	28480	1855-0091
ASQ36	1855-0091	3		TRANSISTOR J-FET N-CHAN D-MODE SI	28480	1855-0091
ASQ37	1854-0071	7		TRANSISTOR NPN SI PD=300MH FT=200MHZ	28480	1854-0071
ASQ38	1853-0300	3		TRANSISTOR PNP SI TO-18 PD=300MH	28480	1853-0300
ASQ39	1853-0012	4		TRANSISTOR PNP 2N2904A SI TO-18 PD=600MH	01295	2N2904A
ASQ40	1853-0300	3		TRANSISTOR PNP SI TO-18 PD=300MH	28480	1853-0300
ASQ41	1854-0639	7		TRANSISTOR NPN 2N3053B SI TO-18 PD=1W	01928	2N3053B
ASQ42	1854-0071	7		TRANSISTOR NPN SI PD=300MH FT=200MHZ	28480	1854-0071

See introduction to this section for ordering information  
\*Indicates factory selected value



Table 6-3. Replaceable Parts (Cont'd).

Reference Designation	HP Part Number	C D	Qty	Description	Mfr Code	Mfr Part Number
ASR4	0698-4037	0		RESISTOR 46.4 1X .125W F TC=0+-100	24546	C4-1/8-T0-46R4-F
ASR2	0757-0280	3		RESISTOR 1K 1X .125W F TC=0+-100	24546	C4-1/8-T0-1001-F
ASR3	0698-3444	1		RESISTOR 316 1X .125W F TC=0+-100	24546	C4-1/8-T0-316R-F
ASR4	2100-3273	1	1	RESISTOR-TRMR 2K 10% C SIDE-ADJ 1-TRN	26480	2100-3273
ASR5	0698-3429	2		RESISTOR 19.6 1X .125W F TC=0+-100	03888	PME55-1/8-T0-19R6-F
ASR6	0698-3444	1		RESISTOR 316 1X .125W F TC=0+-100	24546	C4-1/8-T0-316R-F
ASR7	0757-0280	3		RESISTOR 1K 1X .125W F TC=0+-100	24546	C4-1/8-T0-1001-F
ASR8	0698-4037	0		RESISTOR 46.4 1X .125W F TC=0+-100	24546	C4-1/8-T0-46R4-F
ASR9	0757-0487	2		RESISTOR 825K 1X .125W F TC=0+-100	26480	0757-0487
ASR10	0757-0487	2		RESISTOR 825K 1X .125W F TC=0+-100	26480	0757-0487
ASR11	2100-0589	6		RESISTOR-TRMR 10 10% C SIDE-ADJ 1-TRN	26480	2100-0589
ASR12	0698-2316	4		RESISTOR, FXD MET FLM 101.3 OHM 0.1% 1/8	26480	
ASR13	0698-3429	2		RESISTOR 19.6 1X .125W F TC=0+-100	03888	PME55-1/8-T0-19R6-F
ASR14	0757-0180	2		RESISTOR 31.6 1X .125W F TC=0+-100	26480	0757-0180
ASR15	0698-3260	9		RESISTOR 464K 1X .125W F TC=0+-100	26480	0698-3260
ASR16	2100-0589	6		RESISTOR-TRMR 10 10% C SIDE-ADJ 1-TRN	26480	2100-0589
ASR17	0698-2343	7		RESISTOR 50 1X .125W	26480	0698-2343
ASR18	0698-2239	0		RESISTOR 1.5	26480	0698-2239
ASR19	0757-0346	2		RESISTOR 10 1X .125W F TC=0+-100	24546	C4-1/8-T0-10R0-F
ASR20	0757-0346	2		RESISTOR 10 1X .125W F TC=0+-100	24546	C4-1/8-T0-10R0-F
ASR21	0757-0180	2		RESISTOR 31.6 1X .125W F TC=0+-100	26480	0757-0180
ASR22	0757-0401	0		RESISTOR 100 1X .125W F TC=0+-100	24546	C4-1/8-T0-101-F
ASR23	0757-0401	0		RESISTOR 100 1X .125W F TC=0+-100	24546	C4-1/8-T0-101-F
ASR24	0757-0401	0		RESISTOR 100 1X .125W F TC=0+-100	24546	C4-1/8-T0-101-F
ASR25	0757-0418	9		RESISTOR 619 1X .125W F TC=0+-100	24546	C4-1/8-T0-619R-F
ASR26	0698-3153	9		RESISTOR 3.03K 1X .125W F TC=0+-100	24546	C4-1/8-T0-3031-F
ASR27	0757-0401	0		RESISTOR 100 1X .125W F TC=0+-100	24546	C4-1/8-T0-101-F
ASR28	0757-0180	2		RESISTOR 31.6 1X .125W F TC=0+-100	26480	0757-0180
ASR29	0757-0180	2		RESISTOR 31.6 1X .125W F TC=0+-100	26480	0757-0180
ASR30	0757-0487	2		RESISTOR 825K 1X .125W F TC=0+-100	26480	0757-0487
ASR31	0757-0487	2		RESISTOR 825K 1X .125W F TC=0+-100	26480	0757-0487
ASR32	0757-0487	2		RESISTOR 825K 1X .125W F TC=0+-100	26480	0757-0487
ASR33	0757-0487	2		RESISTOR 825K 1X .125W F TC=0+-100	26480	0757-0487
ASR34	0698-2239	0		RESISTOR 1.5	26480	0698-2239
ASR35	0757-0294	9		RESISTOR 17.8 1X .125W F TC=0+-100	19701	MF4C1/8-T0-17R8-F
ASR36	0698-3429	2		RESISTOR 19.6 1X .125W F TC=0+-100	03888	PME55-1/8-T0-19R6-F
ASR37	0698-3150	6		RESISTOR 2.37K 1X .125W F TC=0+-100	24546	C4-1/8-T0-2371-F
ASR38	0757-0418	9		RESISTOR 619 1X .125W F TC=0+-100	24546	C4-1/8-T0-619R-F
ASR39	0757-0428	1		RESISTOR 1.62K 1X .125W F TC=0+-100	24546	C4-1/8-T0-1621-F
ASR40	0698-3429	2		RESISTOR 19.6 1X .125W F TC=0+-100	03888	PME55-1/8-T0-19R6-F
ASR41	0698-3150	6		RESISTOR 2.37K 1X .125W F TC=0+-100	24546	C4-1/8-T0-2371-F
ASR42	0698-0084	9		RESISTOR 2.15K 1X .125W F TC=0+-100	24546	C4-1/8-T0-2151-F
ASR43	0757-0418	0	3	RESISTOR 681 1X .125W F TC=0+-100	24546	C4-1/8-T0-681R-F
ASR44	0757-0428	1		RESISTOR 1.62K 1X .125W F TC=0+-100	24546	C4-1/8-T0-1621-F
ASR45	0757-0180	2		RESISTOR 31.6 1X .125W F TC=0+-100	26480	0757-0180
ASR46	0757-0438	3		RESISTOR 5.11K 1X .125W F TC=0+-100	24546	C4-1/8-T0-5111-F
ASR47	0698-2343	7		RESISTOR 50 1X .125W	26480	0698-2343
ASR48	0757-0280	3		RESISTOR 1K 1X .125W F TC=0+-100	24546	C4-1/8-T0-1001-F
ASR49	0698-4479	4	2	RESISTOR 14K 1X .125W F TC=0+-100	24546	C4-1/8-T0-1402-F
ASR50	0698-3157	3	2	RESISTOR 19.6K 1X .125W F TC=0+-100	24546	C4-1/8-T0-1962-F
ASR51	0698-3438	3	9	RESISTOR 147 1X .125W F TC=0+-100	24546	C4-1/8-T0-147R-F
ASR52	0698-3438	3		RESISTOR 147 1X .125W F TC=0+-100	24546	C4-1/8-T0-147R-F
ASR53	0698-3438	3		RESISTOR 147 1X .125W F TC=0+-100	24546	C4-1/8-T0-147R-F
ASR54	0698-3154	0	1	RESISTOR 4.22K 1X .125W F TC=0+-100	24546	C4-1/8-T0-4221-F
ASR55	0757-0280	3		RESISTOR 1K 1X .125W F TC=0+-100	24546	C4-1/8-T0-1001-F
ASR56	0698-4479	4		RESISTOR 14K 1X .125W F TC=0+-100	24546	C4-1/8-T0-1402-F
ASR57	0698-3157	3		RESISTOR 19.6K 1X .125W F TC=0+-100	24546	C4-1/8-T0-1962-F
ASR58	0698-3438	3		RESISTOR 147 1X .125W F TC=0+-100	24546	C4-1/8-T0-147R-F
ASR59	0698-3438	3		RESISTOR 147 1X .125W F TC=0+-100	24546	C4-1/8-T0-147R-F
ASR60	0698-3438	3		RESISTOR 147 1X .125W F TC=0+-100	24546	C4-1/8-T0-147R-F
ASR61	0757-0442	9		RESISTOR 10K 1X .125W F TC=0+-100	24546	C4-1/8-T0-1002-F
ASR62	1810-0207	9		NETWORK-RES 8-81P22.0K OHM X 7	01121	20BA223
ASR63	0698-3444	1		RESISTOR 316 1X .125W F TC=0+-100	24546	C4-1/8-T0-316R-F
ASR64	0698-3438	3		RESISTOR 147 1X .125W F TC=0+-100	24546	C4-1/8-T0-147R-F
ASR65	0698-3444	1		RESISTOR 316 1X .125W F TC=0+-100	24546	C4-1/8-T0-316R-F
ASR66	0698-3444	1		RESISTOR 316 1X .125W F TC=0+-100	24546	C4-1/8-T0-316R-F
ASR67	0698-3438	3		RESISTOR 147 1X .125W F TC=0+-100	24546	C4-1/8-T0-147R-F
ASR68	0698-3444	1		RESISTOR 316 1X .125W F TC=0+-100	24546	C4-1/8-T0-316R-F
ASR69	0698-3444	1		RESISTOR 316 1X .125W F TC=0+-100	24546	C4-1/8-T0-316R-F
ASR70	0698-3438	3		RESISTOR 147 1X .125W F TC=0+-100	24546	C4-1/8-T0-147R-F
ASR71	0698-3444	1		RESISTOR 316 1X .125W F TC=0+-100	24546	C4-1/8-T0-316R-F
ASR72	0757-0401	0		RESISTOR 100 1X .125W F TC=0+-100	24546	C4-1/8-T0-101-F
ASR73	0757-0280	3		RESISTOR 1K 1X .125W F TC=0+-100	24546	C4-1/8-T0-1001-F
ASR74	0683-5615	1	15	RESISTOR 560 5% .25W FC TC=-400/+600	01121	CB5615
ASR75	0683-5615	1		RESISTOR 560 5% .25W FC TC=-400/+600	01121	CB5615

See introduction to this section for ordering information  
\*Indicates factory selected value

Table 6-3. Replaceable Parts (Cont'd).

Reference Designation	HP Part Number	C D	Qty	Description	Mfr Code	Mfr Part Number
	0683-5615	1		RESISTOR 560 5% .25W FC TC=400/+600	01121	C85615
	0683-5615	1		RESISTOR 560 5% .25W FC TC=400/+600	01121	C85615
	0683-5615	1		RESISTOR 560 5% .25W FC TC=400/+600	01121	C85615
	0683-5615	1		RESISTOR 560 5% .25W FC TC=400/+600	01121	C85615
	0683-5615	1		RESISTOR 560 5% .25W FC TC=400/+600	01121	C85615
	0683-3315	6	4	RESISTOR 330 5% .25W FC TC=400/+600	01121	C85615
	0683-5615	1		RESISTOR 560 5% .25W FC TC=400/+600	01121	C85615
	0683-5615	1		RESISTOR 560 5% .25W FC TC=400/+600	01121	C85615
	0683-5615	1		RESISTOR 560 5% .25W FC TC=400/+600	01121	C85615
	0683-5615	1		RESISTOR 560 5% .25W FC TC=400/+600	01121	C85615
	0683-5615	1		RESISTOR 560 5% .25W FC TC=400/+600	01121	C85615
	0683-5615	1		RESISTOR 560 5% .25W FC TC=400/+600	01121	C85615
	0683-5615	1		RESISTOR 560 5% .25W FC TC=400/+600	01121	C85615
	0683-3315	6		RESISTOR 330 5% .25W FC TC=400/+600	01121	C85615
	0698-0082	7		RESISTOR 464 1% .125W F TC=0/+100	24546	C4-1/8-T0-4640-F
	0757-0403	2		RESISTOR 121 1% .125W F TC=0/+100	24546	C4-1/8-T0-121R-F
	0757-0442	9		RESISTOR 10K 1% .125W F TC=0/+100	24546	C4-1/8-T0-100R-F
	0757-0444	4		RESISTOR 12.1K 1% .125W F TC=0/+100	24546	C4-1/8-T0-121R-F
	0698-3155	1		RESISTOR 4.64K 1% .125W F TC=0/+100	24546	C4-1/8-T0-4641-F
	0683-5615	1		RESISTOR 560 5% .25W FC TC=400/+600	01121	C85615
	0698-0082	6	2	RESISTOR 42.2 1% .125W F TC=0/+100	24546	C4-1/8-T0-42R2-F
	0698-0082	7		RESISTOR 464 1% .125W F TC=0/+100	24546	C4-1/8-T0-4640-F
	0757-0403	2		RESISTOR 121 1% .125W F TC=0/+100	24546	C4-1/8-T0-121R-F
	0757-0442	9		RESISTOR 10K 1% .125W F TC=0/+100	24546	C4-1/8-T0-100R-F
	0757-0444	4		RESISTOR 12.1K 1% .125W F TC=0/+100	24546	C4-1/8-T0-121R-F
	0698-3155	1		RESISTOR 4.64K 1% .125W F TC=0/+100	24546	C4-1/8-T0-4641-F
	0757-0439	4	3	RESISTOR 6.81K 1% .125W F TC=0/+100	24546	C4-1/8-T0-6811-F
	0757-0440	7		RESISTOR 7.5K 1% .125W F TC=0/+100	24546	C4-1/8-T0-7501-F
	0698-0084	9		RESISTOR 2.1K 1% .125W F TC=0/+100	24546	C4-1/8-T0-2151-F
	0757-0444	1		RESISTOR 12.1K 1% .125W F TC=0/+100	24546	C4-1/8-T0-121R-F
	0757-0444	1		RESISTOR 12.1K 1% .125W F TC=0/+100	24546	C4-1/8-T0-121R-F
	0698-0084	9		RESISTOR 2.1K 1% .125W F TC=0/+100	24546	C4-1/8-T0-2151-F
	0757-0440	7		RESISTOR 7.5K 1% .125W F TC=0/+100	24546	C4-1/8-T0-7501-F
	0757-0440	7		RESISTOR 7.5K 1% .125W F TC=0/+100	24546	C4-1/8-T0-7501-F
	0757-0442	9		RESISTOR 10K 1% .125W F TC=0/+100	24546	C4-1/8-T0-100R-F
	0757-0442	9		RESISTOR 10K 1% .125W F TC=0/+100	24546	C4-1/8-T0-100R-F
	0757-0279	0		RESISTOR 3.16K 1% .125W F TC=0/+100	24546	C4-1/8-T0-3161-F
	0757-0279	4	1	RESISTOR 16.2K 1% .125W F TC=0/+100	24546	C4-1/8-T0-162R-F
	0698-3156	4	2	RESISTOR 23.7K 1% .125W F TC=0/+100	24546	C4-1/8-T0-237R-F
	0698-3156	4		RESISTOR 23.7K 1% .125W F TC=0/+100	24546	C4-1/8-T0-237R-F
	0698-4158	1	2	RESISTOR 100K -1% .125W F TC=0/+25	28480	
	0698-4158	1		RESISTOR 100K -1% .125W F TC=0/+25	28480	
	0757-0279	0		RESISTOR 3.16K 1% .125W F TC=0/+100	24546	C4-1/8-T0-3161-F
	0757-0280	3		RESISTOR 1K 1% .125W F TC=0/+100	24546	C4-1/8-T0-1001-F
	2100-3350	5	1	RESISTOR-TMR 200 10% C SIDE-ADJ 1-TRN	28480	2100-3350
	0698-3155	1		RESISTOR 4.64K 1% .125W F TC=0/+100	24546	C4-1/8-T0-4641-F
	0698-3155	1		RESISTOR 4.64K 1% .125W F TC=0/+100	24546	C4-1/8-T0-4641-F
	0698-3155	1		RESISTOR 4.64K 1% .125W F TC=0/+100	24546	C4-1/8-T0-4641-F
	0698-6943	3		RESISTOR 20K 1% .125W F TC=0/+100	24546	C4-1/8-T0-2001-F
	0698-6943	3		RESISTOR 20K 1% .125W F TC=0/+100	24546	C4-1/8-T0-2001-F
	0757-0443	0	1	RESISTOR 11K 1% .125W F TC=0/+100	24546	C4-1/8-T0-110R-F
	0757-0280	3		RESISTOR 1K 1% .125W F TC=0/+100	24546	C4-1/8-T0-1001-F
	0698-3460	7	1	RESISTOR 422K 1% .125W F TC=0/+100	28480	0757-0482
	0698-3136	6		RESISTOR 17.8K 1% .125W F TC=0/+100	24546	C4-1/8-T0-178R-F
	0698-3155	1		RESISTOR 4.64K 1% .125W F TC=0/+100	24546	C4-1/8-T0-4641-F
	0698-3155	1		RESISTOR 4.64K 1% .125W F TC=0/+100	24546	C4-1/8-T0-4641-F
	0683-0275	9		RESISTOR 2.7 5% .25W FC TC=400/+500	01121	C82705
	0683-0275	9		RESISTOR 2.7 5% .25W FC TC=400/+500	01121	C82705
	0757-0280	3		RESISTOR 1K 1% .125W F TC=0/+100	24546	C4-1/8-T0-1001-F
	0757-0280	3		RESISTOR 1K 1% .125W F TC=0/+100	24546	C4-1/8-T0-1001-F
	0757-0442	9		RESISTOR 10K 1% .125W F TC=0/+100	24546	C4-1/8-T0-100R-F
	0757-0280	3		RESISTOR 1K 1% .125W F TC=0/+100	24546	C4-1/8-T0-1001-F
	0757-0280	3		RESISTOR 1K 1% .125W F TC=0/+100	24546	C4-1/8-T0-1001-F
	0757-0442	9		RESISTOR 10K 1% .125W F TC=0/+100	24546	C4-1/8-T0-100R-F
	9100-0822	7		TRANSFORMER;PULSE(11307)	28480	9100-0822
	9100-0822	7		TRANSFORMER;PULSE(11307)	28480	9100-0822
	1820-0817	8	6	IC FF ECL D-M/S DUAL	04713	MC10131P
	1820-0808	7	4	IC GATE ECL NOR DUAL 3-INP	04713	MC10111P
	1820-0808	7		IC GATE ECL NOR DUAL 3-INP	04713	MC10111P
	1820-0817	8		IC FF ECL D-M/S DUAL	04713	MC10131P
	1820-0809	8	1	IC RCVR ECL LINE RCVR QUAD 2-INP	04713	MC10159P
	1820-0817	8		IC FF ECL D-M/S DUAL	04713	MC10131P
	1820-0808	7		IC GATE ECL NOR DUAL 3-INP	04713	MC10111P
	1820-0808	7		IC GATE ECL NOR DUAL 3-INP	04713	MC10111P
	1820-0817	8		IC FF ECL D-M/S DUAL	04713	MC10131P
	1820-0806	5	1	IC GATE ECL OR-NOR DUAL 4-3-INP	04713	MC10109P

See introduction to this section for ordering information  
\*Indicates factory selected value

Table 6-3. Replaceable Parts (Cont'd).

Reference Designation	HP Part Number	C D	Qty	Description	Mfr Code	Mfr Part Number
ASU11	1826-0013	8	2	IC OP AMP LOW-NOISE TO-99	06665	388741CJ
ASU12	1826-0013	8		IC OP AMP LOW-NOISE TO-99	06665	388741CJ
ASU13	1826-0138	8		IC COMPARTOR GP QUAD 14-DIP-P	04713	MLM339P
ASU14	1826-1195	7		IC FF TTL LS D-TYPE POS-EDGE-TRIG COM	01295	8N74LS273N
ASU15	1826-0138	8		IC COMPARTOR GP QUAD 14-DIP-P	04713	MLM339P
ASU16	5080-3833	4	1	IC OP AMP LOW-DRIFT TO-99	27014	LM308AH
ASU17	1826-0081	0		IC OP AMP HS TO-99	27014	LM318H
ASU18	5080-3069	7		IC LF356H SEL	27014	LF356H
ASU19	1820-1730	6		IC FF TTL LS D-TYPE POS-EDGE-TRIG COM	01295	8N74LS273N
ASU20	1820-1730	6		IC FF TTL LS D-TYPE POS-EDGE-TRIG COM	01295	8N74LS273N
ASU21	1820-1730	6	1	IC FF TTL LS D-TYPE POS-EDGE-TRIG COM	01295	8N74LS273N
ASU22	1826-0210	7		IC COMPARTOR HS 14-DIP-P	27014	LM361N
				AS MISCELLANEOUS PARTS		
	04275-00614	7	1	PLATE-SHIELD	28480	04275-00614
A6	04275-66506	4	1	OSCILLATOR BOARD ASSEMBLY	28480	04275-66506
	04275-26506	0		PC BOARD, BLANK	28480	04275-26506
A6C1	0160-2055	9		CAPACITOR-FXD .01UF +80-20% 100VDC CER	28480	0160-2055
A6C2	0150-0121	5		CAPACITOR-FXD .1UF +80-20% 50VDC CER	28480	0150-0121
A6C3	0160-2055	9		CAPACITOR-FXD .01UF +80-20% 100VDC CER	28480	0160-2055
A6C4	0160-0127	2		CAPACITOR-FXD 1UF +-20% 25VDC CER	28480	0160-0127
A6C5	0160-2055	9		CAPACITOR-FXD .01UF +80-20% 100VDC CER	28480	0160-2055
A6C6	0160-2217	4		CAPACITOR-FXD 910PF +-5% 300VDC MICA	28480	0160-2055
A6C7	0160-2055	9		CAPACITOR-FXD .01UF +80-20% 100VDC CER	28480	
A6C8	0160-2203	4		CAPACITOR-FXD 93PF +-5% 300VDC MICA	72136	
A6C9	0160-2055	9		CAPACITOR-FXD .01UF +80-20% 100VDC CER	28480	
A6C11	0150-0121	5	7	CAPACITOR-FXD .1UF +80-20% 50VDC CER	28480	0150-0121
A6C12	0180-0374	3		CAPACITOR-FXD 10UF+-10% 20VDC TA	56289	150D106X9020B2
A6C13	0180-1085	5		CAPACITOR-FXD 4.7UF 20% 16VDC	28480	0180-1085
A6C14	0160-2055	9		CAPACITOR-FXD .01UF +80-20% 100VDC CER	28480	0160-2055
A6C15	0160-2055	9		CAPACITOR-FXD .01UF +80-20% 100VDC CER	28480	0160-2055
A6C16	0160-2055	9	4	CAPACITOR-FXD .01UF +80-20% 100VDC CER	28480	0160-2055
A6C17	0160-2055	9		CAPACITOR-FXD .01UF +80-20% 100VDC CER	28480	0160-2055
A6C18	0180-0376	5		CAPACITOR-FXD .47UF+-10% 35VDC TA	56289	150D474X9035A2
A6C19	0180-0376	5		CAPACITOR-FXD .47UF+-10% 35VDC TA	56289	150D474X9035A2
A6C20	0180-1085	5		CAPACITOR-FXD 4.7UF 20% 16VDC	28480	0180-1085
A6C21	0180-1050	4	3	CAPACITOR-FXD 470UF +50-10% 16VDC	28480	0180-1050
A6C22	0180-1085	5		CAPACITOR-FXD 4.7UF 20% 16VDC	28480	0180-1085
A6C23	0160-2055	9		CAPACITOR-FXD .01UF +80-20% 100VDC CER	28480	0160-2055
A6C24	0180-0127	2		CAPACITOR-FXD 1UF +-20% 25VDC CER	28480	0180-0127
A6C25	0160-2055	9		CAPACITOR-FXD .01UF +80-20% 100VDC CER	28480	0160-2055
A6C26	0160-2217	4		CAPACITOR-FXD 910PF +-5% 300VDC MICA	28480	0160-2055
A6C27	0160-2055	9		CAPACITOR-FXD .01UF +80-20% 100VDC CER	28480	
A6C28	0160-2203	4		CAPACITOR-FXD 91PF +-5% 300VDC MICA	72136	
A6C29	0160-2055	9		CAPACITOR-FXD .01UF +80-20% 100VDC CER	28480	
A6C31	0180-0374	3	4	CAPACITOR-FXD 10UF+-10% 20VDC TA	56289	150D106X9020B2
A6C32	0180-1050	4		CAPACITOR-FXD 470UF +50-10% 16VDC	28480	0180-1050
A6C33	0160-0127	2		CAPACITOR-FXD 1UF +-20% 25VDC CER	28480	0160-0127
A6C34	0180-1085	5		CAPACITOR-FXD 4.7UF 20% 16VDC	28480	0180-1085
A6C35	0160-2055	9		CAPACITOR-FXD .01UF +80-20% 100VDC CER	28480	0160-2055
A6C36	0160-2055	9	2	CAPACITOR-FXD .01UF +80-20% 100VDC CER	28480	0160-2055
A6C37	0160-0127	2		CAPACITOR-FXD 1UF +-20% 25VDC CER	28480	0160-0127
A6C38	0160-0127	2		CAPACITOR-FXD 1UF +-20% 25VDC CER	28480	0160-0127
A6C39	0180-0376	5		CAPACITOR-FXD .47UF+-10% 35VDC TA	56289	150D474X9035A2
A6C40	0180-0376	5		CAPACITOR-FXD .47UF+-10% 35VDC TA	56289	150D474X9035A2
A6C41	0180-0374	3	3	CAPACITOR-FXD 10UF+-10% 20VDC TA	56289	150D106X9020B2
A6C42	0160-2055	9		CAPACITOR-FXD .01UF +80-20% 100VDC CER	28480	0160-2055
A6C43	0180-1085	5		CAPACITOR-FXD 4.7UF 20% 16VDC	28480	0180-1085
A6C44	0150-0121	5		CAPACITOR-FXD .1UF +80-20% 50VDC CER	28480	0150-0121
A6C45	0180-1050	4		CAPACITOR-FXD 470UF +50-10% 16VDC	28480	0180-1050
A6C46	0140-0208	8	2	CAPACITOR-FXD 680PF +-5% 300VDC MICA	72136	DM15F681J0300WV1CR
A6C47	0140-0197	4		CAPACITOR-FXD 180PF +-5% 300VDC MICA	72136	DM15F181J0300WV1CR
A6C48	0140-0208	8		CAPACITOR-FXD 680PF +-5% 300VDC MICA	72136	DM15F681J0300WV1CR
A6C49	0160-2206	0		CAPACITOR-FXD 160PF +-5% 300VDC MICA	28480	0160-2206
A6C50	0140-0200	2		CAPACITOR-FXD 390PF +-5% 300VDC MICA	72136	DM15F391J0300WV1CR
A6C51	0160-2055	9		CAPACITOR-FXD .01UF +80-20% 100VDC CER	28480	0160-2055
A6C52	0180-1085	5		CAPACITOR-FXD 4.7UF 20% 16VDC	28480	0180-1085
A6C53	0160-2307	4		CAPACITOR-FXD 47PF +-5% 300VDC MICA	28480	0160-2307
A6C54	0150-0121	5		CAPACITOR-FXD .1UF +80-20% 50VDC CER	28480	0150-0121
A6C55	0150-0121	5		CAPACITOR-FXD .1UF +80-20% 50VDC CER	28480	0150-0121

Table 6-3. Replaceable Parts (Cont'd).

Reference Designation	HP Part Number	C D	Qty	Description	Mfr Code	Mfr Part Number
A6C56	0160-2055	9		CAPACITOR-FXD .01UF +80-20% 100VDC CER	28480	0160-2055
A6C57	0160-2055	9		CAPACITOR-FXD .01UF +80-20% 100VDC CER	28480	0160-2055
A6C58	0160-2055	9		CAPACITOR-FXD .01UF +80-20% 100VDC CER	28480	0160-2055
A6C59	0160-2055	9		CAPACITOR-FXD .01UF +80-20% 100VDC CER	28480	0160-2055
A6C60	0160-2055	9		CAPACITOR-FXD .01UF +80-20% 100VDC CER	28480	0160-2055
A6C61	0160-2055	9		CAPACITOR-FXD .01UF +80-20% 100VDC CER	28480	0160-2055
A6C62	0150-0121	5		CAPACITOR-FXD .1UF +80-20% 50VDC CER	28480	0150-0121
A6C63	0160-2055	9		CAPACITOR-FXD .01UF +80-20% 100VDC CER	28480	0160-2055
A6C64	0160-2307	4		CAPACITOR-FXD 47PF +-5% 300VDC MICA	28480	0160-2307
A6C65	0160-2259	5		CAPACITOR-FXD 12PF +-5% 500VDC CER 0+-30	28480	0160-2259
A6C66	0160-2249	3		CAPACITOR-FXD 4.7PF +-25PF 500VDC CER	28480	0160-2249
A6C67	0140-0195	0		CAPACITOR-FXD 130PF +-5% 300VDC MICA	28480	0160-2204
A6C68	0160-2055	9		CAPACITOR-FXD .01UF +80-20% 100VDC CER	28480	0160-2055
A6C69	0160-2204	0		CAPACITOR-FXD 100PF +-5% 300VDC MICA	28480	0160-2204
A6C70	0160-2055	9		CAPACITOR-FXD .01UF +80-20% 100VDC CER	28480	0160-2055
A6C71	0160-2055	9		CAPACITOR-FXD .01UF +80-20% 100VDC CER	28480	0160-2055
A6C72	0160-2055	9		CAPACITOR-FXD .01UF +80-20% 100VDC CER	28480	0160-2055
A6C73	0180-0374	3		CAPACITOR-FXD 10UF+-10% 20VDC TA	56289	150D106X902082
A6C74	0180-0374	3		CAPACITOR-FXD 10UF+-10% 20VDC TA	56289	150D106X902082
A6C75	0180-0374	3		CAPACITOR-FXD 10UF+-10% 20VDC TA	56289	150D106X902082
A6C76	0180-0374	3		CAPACITOR-FXD 10UF+-10% 20VDC TA	56289	150D106X902082
A6CP1	1990-0104	5		PHOTOCELL LAMP	28480	1990-0104
A6CR1	1901-0518	8		DIODE-8SCHOTTKY	28480	1901-0518
A6CR2	1901-0518	8		DIODE-8SCHOTTKY	28480	1901-0518
A6CR3	1901-0040	1		DIODE-SWITCHING 30V 50MA 2N8 DO-35	28480	1901-0040
A6CR4	1901-0040	1		DIODE-SWITCHING 30V 50MA 2N8 DO-35	28480	1901-0040
A6CR5	1901-0040	1		DIODE-SWITCHING 30V 50MA 2N8 DO-35	28480	1901-0040
A6CR6	1902-0041	4		DIODE-ZNR 5.11V 5% DO-7 PDM,4W TC=-.009%	28480	1902-0041
A6CR7	1901-0518	8		DIODE-8SCHOTTKY	28480	1901-0518
A6CR8	1901-0518	8		DIODE-8SCHOTTKY	28480	1901-0518
A6CR9	1901-0518	8		DIODE-8SCHOTTKY	28480	1901-0518
A6CR10	1901-0040	1		DIODE-SWITCHING 30V 50MA 2N8 DO-35	28480	1901-0040
A6CR11	1901-0040	1		DIODE-SWITCHING 30V 50MA 2N8 DO-35	28480	1901-0040
A6CR12	1901-0040	1		DIODE-SWITCHING 30V 50MA 2N8 DO-35	28480	1901-0040
A6CR13	1901-0040	1		DIODE-SWITCHING 30V 50MA 2N8 DO-35	28480	1901-0040
A6CR14	1901-0040	1		DIODE-SWITCHING 30V 50MA 2N8 DO-35	28480	1901-0040
A6CR15	1901-0040	1		DIODE-SWITCHING 30V 50MA 2N8 DO-35	28480	1901-0040
A6CR16	1901-0040	1		DIODE-SWITCHING 30V 50MA 2N8 DO-35	28480	1901-0040
A6CR17	1901-0040	1		DIODE-SWITCHING 30V 50MA 2N8 DO-35	28480	1901-0040
A6CR18	1902-3082	9		DIODE-ZNR 4.64V 5% DO-7 PDM,4W TC=-.023%	28480	1902-3082
A6CR19	1902-3082	9		DIODE-ZNR 4.64V 5% DO-7 PDM,4W TC=-.023%	28480	1902-3082
A6CR20	1902-3082	9		DIODE-ZNR 4.64V 5% DO-7 PDM,4W TC=-.023%	28480	1902-3082
A6CR21	1902-3082	9		DIODE-ZNR 4.64V 5% DO-7 PDM,4W TC=-.023%	28480	1902-3082
A6CR22	1902-3082	9		DIODE-ZNR 4.64V 5% DO-7 PDM,4W TC=-.023%	28480	1902-3082
A6CR23	1902-3082	9		DIODE-ZNR 4.64V 5% DO-7 PDM,4W TC=-.023%	28480	1902-3082
A6CR24	1902-3082	9		DIODE-ZNR 4.64V 5% DO-7 PDM,4W TC=-.023%	28480	1902-3082
A6CR25	1902-3082	9		DIODE-ZNR 4.64V 5% DO-7 PDM,4W TC=-.023%	28480	1902-3082
A6J1	1250-0257	1		CONNECTOR-RF 8MB M PC 50-OHM	28480	1250-0257
A6J2	1250-0257	1		CONNECTOR-RF 8MB M PC 50-OHM	28480	1250-0257
A6L1	9140-0129	1		COIL-MLD 220UH 5% Q=65 .155DX,375LG-NOM	28480	9140-0129
A6L2	9140-0129	1		COIL-MLD 220UH 5% Q=65 .155DX,375LG-NOM	28480	9140-0129
A6L3	9140-0129	1		COIL-MLD 220UH 5% Q=65 .155DX,375LG-NOM	28480	9140-0129
A6L4	9100-1629	4		COIL-MLD 47UH 5% Q=55 .155DX,375LG-NOM	28480	9100-1629
A6L5	9140-0114	4		COIL-MLD 10UH 10% Q=55 .155DX,375LG-NOM	28480	9140-0114
A6L6	9100-1629	4		COIL-MLD 47UH 5% Q=55 .155DX,375LG-NOM	28480	9100-1629
A6L7	9140-0179	1		COIL-MLD 22UH 10% Q=75 .155DX,375LG-NOM	28480	9140-0179
A6L8	9100-1629	4		COIL-MLD 47UH 5% Q=55 .155DX,375LG-NOM	28480	9100-1629
A6L9	9140-0114	4		COIL-MLD 10UH 10% Q=55 .155DX,375LG-NOM	28480	9140-0114
A6L10	9100-2254	3	2	COIL-MLD 390NH 10% Q=35 .095DX,25LG-NOM	28480	9100-2254
A6L11	9100-2254	3		COIL-MLD 390NH 10% Q=35 .095DX,25LG-NOM	28480	9100-2254
A6L12	9100-1788	6		CHOKE-WIDE BAND ZMAX=680 OHMS 180 MHZ	02114	VK200 20/48
A6L13	9140-0129	1		COIL-MLD 220UH 5% Q=65 .155DX,375LG-NOM	28480	9140-0129
A6L14	9140-0129	1		COIL-MLD 220UH 5% Q=65 .155DX,375LG-NOM	28480	9140-0129
A6L15	9100-3139	5	1	COIL 75UH 1% .5DX,875LG-NOM	28480	9100-3139
A6L16	9140-0129	1		COIL-MLD 220UH 5% Q=65 .155DX,375LG-NOM	28480	9140-0129
A6L17	9170-0029	3		CORE-SHIELDING BEAD	28480	9170-0029
A6L18	9170-0029	3		CORE-SHIELDING BEAD	28480	9170-0029
A6L19	9170-0029	3		CORE-SHIELDING BEAD	28480	9170-0029
A6L20	9170-0029	3		CORE-SHIELDING BEAD	28480	9170-0029
A6L21	9170-0029	3		CORE-SHIELDING BEAD	28480	9170-0029
A6L22	9170-0029	3		CORE-SHIELDING BEAD	28480	9170-0029
A6L23	9170-0029	3		CORE-SHIELDING BEAD	28480	9170-0029

See introduction to this section for ordering information  
\*Indicates factory selected value

Table 6-3. Replaceable Parts (Cont'd)

Reference Designation	HP Part Number	C D	Qty	Description	Mfr Code	Mfr Part Number
A601	1854-0215	1	4	TRANSISTOR NPN 81 PD=350mW FT=300MHZ	04713	2N3904
A602	1854-0215	1		TRANSISTOR NPN 81 PD=350mW FT=300MHZ	04713	2N3904
A603	1855-0081	1		TRANSISTOR J-FET N-CHAN D-MODE 81	01295	2N5245
A604	1854-1041	6		TRANSISTOR NPN 51 PD=300mW FT=30MHZ	28480	1854-1041
A605	1854-1041	6		TRANSISTOR NPN 51 PD=300mW FT=30MHZ	28480	1854-1041
A606	1854-0215	1	4	TRANSISTOR NPN 81 PD=350mW FT=300MHZ	04713	2N3904
A607	1854-0215	1		TRANSISTOR NPN 81 PD=350mW FT=300MHZ	04713	2N3904
A608	1854-0215	1		TRANSISTOR NPN 81 PD=350mW FT=300MHZ	04713	2N3904
A609	1855-0081	1		TRANSISTOR J-FET N-CHAN D-MODE 81	01295	2N5245
A6010	1854-1041	6		TRANSISTOR NPN 51 PD=300mW FT=30MHZ	28480	1854-1041
A6011	1854-1041	6	2	TRANSISTOR NPN 51 PD=300mW FT=30MHZ	28480	1854-1041
A6012	1854-0215	1		TRANSISTOR NPN 81 PD=350mW FT=300MHZ	04713	2N3904
A6013	1854-0215	1		TRANSISTOR NPN 81 PD=350mW FT=300MHZ	04713	2N3904
A6014	1853-0036	2		TRANSISTOR PNP 81 PD=310mW FT=250MHZ	28480	1853-0036
A6015	1855-0091	3		TRANSISTOR J-FET N-CHAN D-MODE 81	28480	1855-0091
A6016	1853-0036	2	3	TRANSISTOR PNP 81 PD=310mW FT=250MHZ	28480	1853-0036
A6017	1855-0091	3		TRANSISTOR J-FET N-CHAN D-MODE 81	28480	1855-0091
A6018	1855-0091	3		TRANSISTOR J-FET N-CHAN D-MODE 81	28480	1855-0091
A6019	1854-0215	1		TRANSISTOR NPN 81 PD=350mW FT=300MHZ	04713	2N3904
A6020	1854-0348	0		TRANSISTOR NPN 2N4922 81 PD=30mW FT=3MHZ	04713	2N4922 → 1854-0347E 変更 (Pc 0 38906) opt of 10012E
A6021	1853-0084	0	TRANSISTOR PNP 2N4918 81 PD=30mW FT=3MHZ	04713	2N4918	
A6R1	0683-4715	0	2	RESISTOR 470 5% .25W FC TC=400/+600	01121	C84715
A6R2	0757-0419	0		RESISTOR 681 1% .125W F TC=0/+100	24546	C4-1/8-T0-681R-F
A6R3	0698-3440	7		RESISTOR 196 1% .125W F TC=0/+100	24546	C4-1/8-T0-196R-F
A6R4	0683-2225	3		RESISTOR 2.2K 5% .25W FC TC=400/+700	01121	C82225
A6R5	0683-2235	3		RESISTOR 2.2K 5% .25W FC TC=400/+800	01121	C82235
A6R6	0683-6815	5	4	RESISTOR 680 5% .25W FC TC=400/+600	01121	C86815
A6R7	0683-6815	5		RESISTOR 680 5% .25W FC TC=400/+600	01121	C86815
A6R8	0683-4725	2		RESISTOR 4.7K 5% .25W FC TC=400/+700	01121	C84725
A6R9	0757-0278	9		RESISTOR 1.78K 1% .125W F TC=0/+100	24546	C4-1/8-T0-1781-F
A6R10	0683-1015	7		RESISTOR 100 5% .25W FC TC=400/+500	01121	C81015
A6R11	0683-2235	5	3	RESISTOR 22K 5% .25W FC TC=400/+800	01121	C82235
A6R12	0683-4745	6		RESISTOR 470K 5% .25W FC TC=800/+900	01121	C84745
A6R13	0683-1015	7		RESISTOR 100 5% .25W FC TC=400/+500	01121	C81015
A6R14	0683-4745	6		RESISTOR 470K 5% .25W FC TC=800/+900	01121	C84745
A6R15	0683-1015	7		RESISTOR 100 5% .25W FC TC=400/+500	01121	C81015
A6R16	0757-0465	6	4	RESISTOR 100K 1% .125W F TC=0/+100	24546	C4-1/8-T0-1003-F
A6R17	0757-0465	6		RESISTOR 100K 1% .125W F TC=0/+100	24546	C4-1/8-T0-1003-F
A6R18	0683-4735	4		RESISTOR 47K 5% .25W FC TC=400/+800	01121	C84735
A6R19	0683-4735	4		RESISTOR 47K 5% .25W FC TC=400/+800	01121	C84735
A6R20	0757-0465	6		RESISTOR 100K 1% .125W F TC=0/+100	24546	C4-1/8-T0-1003-F
A6R21	0757-0465	6	1	RESISTOR 100K 1% .125W F TC=0/+100	24546	C4-1/8-T0-1003-F
A6R22	0683-2235	5		RESISTOR 22K 5% .25W FC TC=400/+800	01121	C82235
A6R23	0698-3132	4		RESISTOR 261 1% .125W F TC=0/+100	24546	C4-1/8-T0-2610-F
A6R24	0698-3433	8		RESISTOR 28.7 1% .125W F TC=0/+100	03888	PHE55-1/8-T0-28R7-F
A6R25	0757-0419	0		RESISTOR 681 1% .125W F TC=0/+100	24546	C4-1/8-T0-681R-F
A6R26	0698-3440	7	3	RESISTOR 196 1% .125W F TC=0/+100	24546	C4-1/8-T0-196R-F
A6R27	0683-2225	3		RESISTOR 2.2K 5% .25W FC TC=400/+700	01121	C82225
A6R28	0683-2235	5		RESISTOR 2.2K 5% .25W FC TC=400/+800	01121	C82235
A6R29	0683-6815	5		RESISTOR 680 5% .25W FC TC=400/+600	01121	C86815
A6R30	0683-6815	5		RESISTOR 680 5% .25W FC TC=400/+600	01121	C86815
A6R31	0683-2235	5	5	RESISTOR 22K 5% .25W FC TC=400/+800	01121	C82235
A6R32	0683-4725	2		RESISTOR 4.7K 5% .25W FC TC=400/+700	01121	C84725
A6R33	0698-3444	1		RESISTOR 316 1% .125W F TC=0/+100	24546	C4-1/8-T0-316R-F
A6R35	0683-1015	7		RESISTOR 100 5% .25W FC TC=400/+500	01121	C81015
A6R36	0683-2235	5		RESISTOR 22K 5% .25W FC TC=400/+800	01121	C82235
A6R37	0683-4745	6	7	RESISTOR 470K 5% .25W FC TC=800/+900	01121	C84745
A6R38	0683-1015	7		RESISTOR 100 5% .25W FC TC=400/+500	01121	C81015
A6R39	0757-0278	9		RESISTOR 1.78K 1% .125W F TC=0/+100	24546	C4-1/8-T0-1781-F
A6R40	0683-1015	7		RESISTOR 100 5% .25W FC TC=400/+500	01121	C81015
A6R41	0757-0465	6		RESISTOR 100K 1% .125W F TC=0/+100	24546	C4-1/8-T0-1003-F
A6R42	0757-0465	6	4	RESISTOR 100K 1% .125W F TC=0/+100	24546	C4-1/8-T0-1003-F
A6R43	0683-4735	4		RESISTOR 47K 5% .25W FC TC=400/+800	01121	C84735
A6R44	0683-4735	4		RESISTOR 47K 5% .25W FC TC=400/+800	01121	C84735
A6R45	0757-0465	6		RESISTOR 100K 1% .125W F TC=0/+100	24546	C4-1/8-T0-1003-F
A6R46	0757-0465	6		RESISTOR 100K 1% .125W F TC=0/+100	24546	C4-1/8-T0-1003-F
A6R47	0683-1005	5	9	RESISTOR 10 5% .25W FC TC=400/+500	01121	C81005
A6R48	0683-1005	5		RESISTOR 10 5% .25W FC TC=400/+500	01121	C81005
A6R49	0683-2225	3		RESISTOR 2.2K 5% .25W FC TC=400/+700	01121	C82225
A6R50	0757-0442	7		RESISTOR 10K 1% .125W F TC=0/+100	24546	C4-1/8-T0-1002-F
A6R51	0683-1205	9		RESISTOR 12 5% .25W FC TC=400/+500	01121	C81205
A6R52	0683-1205	7	7	RESISTOR 12 5% .25W FC TC=400/+500	01121	C81205
A6R53	0683-2715	6		RESISTOR 270 5% .25W FC TC=400/+600	01121	C82715
A6R54	0683-1025	9		RESISTOR 1K 5% .25W FC TC=400/+600	01121	C81025
A6R55	0683-1205	7		RESISTOR 12 5% .25W FC TC=400/+500	01121	C81205
A6R56	0683-1205	7		RESISTOR 12 5% .25W FC TC=400/+500	01121	C81205

See introduction to this section for ordering information  
\*Indicates factory selected value

Table 6-3. Replaceable Parts (Cont'd).

Reference Designation	HP Part Number	C D	Qty	Description	Mfr Code	Mfr Part Number
A6R57	0683-2715	6		RESISTOR 270 5% .25W FC TC=400/+600	01121	CB2715
A6R58	0683-1025	9		RESISTOR 1K 5% .25W FC TC=400/+600	01121	CB1025
A6R59	0683-1015	7		RESISTOR 100 5% .25W FC TC=400/+500	01121	CB1015
A6R60	0683-4725	2		RESISTOR 4.7K 5% .25W FC TC=400/+700	01121	CB4725
A6R61	0683-2225	3		RESISTOR 2.2K 5% .25W FC TC=400/+700	01121	CB2225
A6R62	0683-2225	3		RESISTOR 2.2K 5% .25W FC TC=400/+700	01121	CB2225
A6R63	0683-2225	3		RESISTOR 2.2K 5% .25W FC TC=400/+700	01121	CB2225
A6R64	0683-2225	3		RESISTOR 2.2K 5% .25W FC TC=400/+700	01121	CB2225
A6R65	0683-1045	3		RESISTOR 100K 5% .25W FC TC=400/+800	01121	CB1045
A6R66	0683-1045	3		RESISTOR 100K 5% .25W FC TC=400/+800	01121	CB1045
A6R67	0683-1045	3		RESISTOR 100K 5% .25W FC TC=400/+800	01121	CB1045
A6R68	0683-2235	5		RESISTOR 22K 5% .25W FC TC=400/+800	01121	CB2235
A6R69	0683-1045	3		RESISTOR 100K 5% .25W FC TC=400/+800	01121	CB1045
A6R70	0683-1045	3		RESISTOR 100K 5% .25W FC TC=400/+800	01121	CB1045
A6R71	0757-0410	1		RESISTOR 301 1% .125W F TC=0/+100	24546	C4-1/8-T0-301R-F
A6R72	0683-1045	3		RESISTOR 100K 5% .25W FC TC=400/+800	01121	CB1045
A6R73	0683-1045	3		RESISTOR 100K 5% .25W FC TC=400/+800	01121	CB1045
A6R74	0683-1045	3		RESISTOR 100K 5% .25W FC TC=400/+800	01121	CB1045
A6R75	0683-4735	4		RESISTOR 47K 5% .25W FC TC=400/+800	01121	CB4735
A6R76	0683-4715	0		RESISTOR 470 5% .25W FC TC=400/+600	01121	CB4715
A6R77	0683-4705	8		RESISTOR 47 5% .25W FC TC=400/+500	01121	CB4705
A6R78	0757-0379	1	1	RESISTOR 12.1 1% .125W F TC=0/+100	19701	MF4C1/8-T0-12R1-F
A6R79	0698-3444	1		RESISTOR 314 1% .125W F TC=0/+100	24546	C4-1/8-T0-314R-F
A6R80	0698-0082	7		RESISTOR 464 1% .125W F TC=0/+100	24546	C4-1/8-T0-464R-F
A6R81	0698-0082	7		RESISTOR 464 1% .125W F TC=0/+100	24546	C4-1/8-T0-464R-F
A6R82	0683-4715	0		RESISTOR 470 5% .25W FC TC=400/+600	01121	CB4715
A6R83	0683-4715	0		RESISTOR 470 5% .25W FC TC=400/+600	01121	CB4715
A6R84	0683-4715	0		RESISTOR 470 5% .25W FC TC=400/+600	01121	CB4715
A6R85	1810-0203	3	5	NETWORK-RES 8-81P470,0 OHM X 7	01121	208A471
A6R86	1810-0203	3		NETWORK-RES 8-81P470,0 OHM X 7	01121	208A471
A6R87	1810-0203	3		NETWORK-RES 8-81P470,0 OHM X 7	01121	208A471
A6R88	1810-0305	8	1	NETWORK-RES 9-81P4.7K OHM X 8	28480	1810-0305
A6R89	1810-0269	3	1	NETWORK-RES 9-81P10.0K OHM X 8	28480	1810-0269
A6R90	1810-0203	5		NETWORK-RES 8-81P470,0 OHM X 7	01121	208A471
A6R91	1810-0207	9		NETWORK-RES 8-81P22.0K OHM X 7	01121	208A223
A6R92	0683-4725	2		RESISTOR 4.7K 5% .25W FC TC=400/+700	01121	CB4725
A6R93	1810-0203	5		NETWORK-RES 8-81P470,0 OHM X 7	01121	208A471
A6R94	0683-1515	2		RESISTOR 150 5% .25W FC TC=400/+600	01121	CB1515
A6R95	0757-0316	6		RESISTOR 42.2 1% .125W F TC=0/+100	24546	C4-1/8-T0-42R2-F
A6R96	0683-8205	1	1	RESISTOR 82 5% .25W FC TC=400/+500	01121	CB8205
A6U1	1820-0139	9		IC OP AMP OP DUAL 8-DIP-P	01928	CA1458G
A6U2	1820-0139	9		IC OP AMP OP DUAL 8-DIP-P	01928	CA1458G
A6U3	1820-0215	2	1	IC V RGLTR T0-220	04713	MC7905.2CT
A6U4	1820-0174	2	1	IC COMPARATOR OP QUAD 14-DIP-P	28480	1820-0174
A6U5	1820-1730	6		IC FF TTL LS D-TYPE POS-EDGE-TRIG COM	01295	8N74L0273N
A6U6	1820-0802	1	5	IC GATE ECL NOR QUAD 2-INP	04713	MC10102P
A6U7	1820-0802	1		IC GATE ECL NOR QUAD 2-INP	04713	MC10102P
A6U8	1820-0802	1		IC GATE ECL NOR QUAD 2-INP	04713	MC10102P
A6U9	1820-0817	8		IC FF ECL D-M/S DUAL	04713	MC10131P
A6U10	1820-0817	8		IC FF ECL D-M/S DUAL	04713	MC10131P
A6U11	1820-1383	5	4	IC CNTR ECL BCD POS-EDGE-TRIG	04713	MC10138L
A6U12	1820-1383	5		IC CNTR ECL BCD POS-EDGE-TRIG	04713	MC10138L
A6U13	1820-1383	5		IC CNTR ECL BCD POS-EDGE-TRIG	04713	MC10138L
A6U14	1820-0802	1		IC GATE ECL NOR QUAD 2-INP	04713	MC10102P
A6U15	1820-1383	5		IC CNTR ECL BCD POS-EDGE-TRIG	04713	MC10138L
A6U16	1820-1359	5	1	IC MUXR/DATA-SEL ECL 4-T0-1-LINE DUAL	04713	MC10174P
A6U17	1820-0802	1		IC GATE ECL NOR QUAD 2-INP	04713	MC10102P
A6U18	1820-1950	2	1	IC GATE ECL OR-NOR 3-INP	04713	MC10212P
A6Y1	0410-0213	8	1	CRYSTAL-QUARTZ 80,000MHz +/-20ppm	28480	0410-0213
A6Y2	0410-0214	9	1	CRYSTAL-QUARTZ 32,000MHz +/-20ppm	28480	0410-0214
				A6 MISCELLANEOUS PARTS		
	04275-00615	8	1	PLATE-SHIELD	28480	04275-00615
	04275-00616	9	2	PLATE-SHIELD A5	28480	04275-00616
	04275-00617	0	3	PLATE-SHIELD	28480	04275-00617
				OPTION 004		
A6Y2	0140-0215		1	CRYSTAL-QUARTZ 24,000 MHz		
A6C67*	0140-0197		2	CAPACITOR-FXD 180pF 5%		
A6C69	0140-0197		2	CAPACITOR-FXD 180pF 5%		

See introduction to this section for ordering information  
\*Indicates factory selected value

Table 6-3. Replaceable Parts (Cont'd)

Reference Designation	HP Part Number	C D	Qty	Description	Mfr Code	Mfr Part Number
A7	04275-66507	4	1	PERIPHERAL CONTROL BOARD ASSEMBLY	28480	04275-66507
A7	04275-66537	0	1	PERIPHERAL CONTROL BOARD ASSEMBLY (FOR OPTION 004 ONLY)	28480	04275-66537
A7C1	0160-4832	9		CAPACITOR-FXD .01UF +-10% 100VDC CER	28480	0160-4832
A7C2	0160-4835	5		CAPACITOR-FXD .1UF +-10% 50VDC CER	28480	0160-4835
A7C3	0160-4832	9		CAPACITOR-FXD .01UF +-10% 100VDC CER	28480	0160-4832
A7C4	0160-4832	9		CAPACITOR-FXD .01UF +-10% 100VDC CER	28480	0160-4832
A7C5	0160-4832	9		CAPACITOR-FXD .01UF +-10% 100VDC CER	28480	0160-4832
A7C6	0160-4832	9		CAPACITOR-FXD .01UF +-10% 100VDC CER	28480	0160-4832
A7C7	0160-4832	9		CAPACITOR-FXD .01UF +-10% 100VDC CER	28480	0160-4832
A7C8	0160-4832	9		CAPACITOR-FXD .01UF +-10% 100VDC CER	28480	0160-4832
A7C9	0160-2055	9		CAPACITOR-FXD .01UF +80-20% 100VDC CER	28480	0160-2055
A7C10	0160-4832	9		CAPACITOR-FXD .01UF +-10% 100VDC CER	28480	0160-4832
A7C11	0160-4832	9		CAPACITOR-FXD .01UF +-10% 100VDC CER	28480	0160-4832
A7C12	0160-4835	5		CAPACITOR-FXD .1UF +-10% 50VDC CER	28480	0160-4835
A7C13	0160-4832	9		CAPACITOR-FXD .01UF +-10% 100VDC CER	28480	0160-4832
A7C14	0180-0197	8		CAPACITOR-FXD 2.2UF+-10% 26VDC TA	56289	150D225#9020A2
A7C15	0180-0197	8		CAPACITOR-FXD 2.2UF+-10% 26VDC TA	56289	150D225#9020A2

See introduction to this section for ordering information  
\*Indicates factory selected value

Table 6-3. Replaceable Parts (Cont'd).

Reference Designation	HP Part Number	C D	Qty	Description	Mfr Code	Mfr Part Number
A7C16	0160-4832	9		CAPACITOR-FXD .01UF +-10% 100VDC CER	28480	0160-4832
A7C17	0180-0197	8		CAPACITOR-FXD 2.2UF+-10% 20VDC 1A	56289	1500225X9020A2
A7C18	0180-0228	6		CAPACITOR-FXD 22UF+-10% 15VDC 1A	56289	1500226X901582
A7C19	0160-4835	5		CAPACITOR-FXD .1UF +-10% 50VDC CER	28480	0160-4835
A7C20	0160-2247					
A7CR1	1902-0041	4		DIODE-ZNR 5.11V 5% DO-7 PDS=.4W TC=-.009%	28480	1902-0041
A7J2	1200-0654	1	5	SOCKET-IC 40-CONT	28480	
A7J3	1200-0567	8	1	SOCKET-IC 28-CONT DIP DIP-SLDR	28480	
A7L1	9100-1788	6	6	CHOKE-WIDE BAND ZMAX=680 OHMS 180 MHZ	02114	VK200 20/48
A7L2	9100-1788	6		CHOKE-WIDE BAND ZMAX=680 OHMS 180 MHZ	02114	VK200 20/48
A7L3	9100-1788	6		CHOKE-WIDE BAND ZMAX=680 OHMS 180 MHZ	02114	VK200 20/48
A7L4	9100-3139	5		COIL 75UH 15% .5DX,875LG-NUM	28480	9100-3139
A7R1	1810-0269	3	15	NETWORK-RES 9-PIN-SIP .1-PIN-SPCG	28480	1810-0269
A7R2	0683-1235	3	13	RESISTOR 12K 5% .25W FC TC=-400/+800	01121	C81235
A7R3	0683-6825	7	1	RESISTOR 6.8K 5% .25W FC TC=-400/+700	01121	C86825
A7R4	1810-0269	3		NETWORK-RES 9-PIN-SIP .1-PIN-SPCG	28480	1810-0269
A7R5	1810-0269	3		NETWORK-RES 9-PIN-SIP .1-PIN-SPCG	28480	1810-0269
A7R6	1810-0269	3		NETWORK-RES 9-PIN-SIP .1-PIN-SPCG	28480	1810-0269
A7R7	1810-0269	3		NETWORK-RES 9-PIN-SIP .1-PIN-SPCG	28480	1810-0269
A7R8	1810-0269	3		NETWORK-RES 9-PIN-SIP .1-PIN-SPCG	28480	1810-0269
A7R9	0683-5615	1	6	RESISTOR 560 5% .25W FC TC=-400/+600	01121	C85615
A7R10	0683-2215	1	2	RESISTOR 220 5% .25W FC TC=-400/+600	01121	C82215
A7R11	0683-1825	7		RESISTOR 1.8K 5% .25W FC TC=-400/+700	01121	C81825
A7R12	0683-2215	1		RESISTOR 220 5% .25W FC TC=-400/+600	01121	C82215
A7T1	9100-0822	7	2	TRANSFORMER, PULSE	28480	9100-0822
A7T2	9100-0822	7		TRANSFORMER, PULSE	28480	9100-0822
A7U1	1820-0909	9	1	IC MULTY TTL	01295	8N74187N
A7U2	1820-1112	8		IC FF TTL LS D-TYPE POS-EDGE-TRIG	01295	8N74LS74N
A7U3	1820-1199	1		IC INV TTL LS HEX 1-INP	01295	8N74LS04N
A7U4	1820-1112	8		IC FF TTL LS D-TYPE POS-EDGE-TRIG	01295	8N74LS74N
A7U5	1820-1197	9		IC GATE TTL LS NAND QUAD 2-INP	01295	8N74LS00N
A7U6	1820-1112	8		IC FF TTL LS D-TYPE POS-EDGE-TRIG	01295	8N74LS74N
A7U7	1820-1201	6	1	IC GATE TTL LS AND QUAD 2-INP	01295	8N74LS08N
A7U8	1820-1112	8		IC FF TTL LS D-TYPE POS-EDGE-TRIG	01295	8N74LS74N
A7U9	1820-1211	8	1	IC GATE TTL LS EXCL-OR QUAD 2-INP	01295	8N74LS86N
A7U10	1820-1199	1		IC INV TTL LS HEX 1-INP	01295	8N74LS04N
A7U11	1820-1730	6		IC FF TTL LS D-TYPE POS-EDGE-TRIG COM	01295	8N74LS273N
A7U12	1820-1430	3		IC CNTR TTL LS BIN SYNCHRO POS-EDGE-TRIG	01295	8N74LS161AN
A7U13	1820-1197	9		IC GATE TTL LS NAND QUAD 2-INP	01295	8N74LS00N
A7U14	1820-1054			IC TRANSLATOR ECL QUAD ECL-TO-TTL		MC10125L
A7U15	1820-0054	9		IC-DIGITAL TTL QUAD 2-INP NAND GATE	01295	
A7U16	1820-1828	3	4	IC DRVR TTL BUS DRVR QUAD	18324	N8T28N
A7U17	1820-1481	4	3	IC PIA NMOS	04713	MC6821L
A7U18	1820-1828	3		IC DRVR TTL BUS DRVR QUAD	18324	N8T28N
A7U19	1820-1470	1	2	IC MUXR/DATA-SEL TTL LS 2-TO-1-LINE QUAD	01295	8N74LS157N
A7U20	1820-1112	8		IC FF TTL LS D-TYPE POS-EDGE-TRIG	01295	8N74LS74N
A7U21	1820-1206	1	1	IC GATE TTL LS NOR TPL 3-INP	01295	8N74LS27N
A7U22	1820-1430	3		IC CNTR TTL LS BIN SYNCHRO POS-EDGE-TRIG	01295	8N74LS161AN
A7U23	1820-1430	3		IC CNTR TTL LS BIN SYNCHRO POS-EDGE-TRIG	01295	8N74LS161AN
A7U24	1820-1144	6		IC GATE TTL LS NOR QUAD 2-INP	01295	8N74LS02N
A7U25	1820-2255	6	1	IC CNTR C-MOS	28480	U20-181
A7U26	1820-1210	7		IC GATE TTL LS AND-OR-INV DUAL 2-INP	01295	8N74LS51N
A7U27	1820-1828	3		IC DRVR TTL BUS DRVR QUAD	18324	N8T28N
A7U28	1820-1828	3		IC DRVR TTL BUS DRVR QUAD	18324	N8T28N
A7U29	1820-1470	1		IC MUXR/DATA-SEL TTL LS 2-TO-1-LINE QUAD	01295	8N74LS157N
A7U30	1820-1216	3	4	IC ODDR TTL LS 3-TO-8-LINE 3-INP	01295	8N74LS138N
A7U31	1820-0495	8	3	IC ODDR TTL 4-TO-16-LINE 4-INP	01295	8N74LS48N
A7U32	1820-1430	3		IC CNTR TTL LS BIN SYNCHRO POS-EDGE-TRIG	01295	8N74LS161AN
A7U33	1820-1430	3		IC CNTR TTL LS BIN SYNCHRO POS-EDGE-TRIG	01295	8N74LS161AN
A7W4	8159-0005	0		WIRE 22AWG W PVC 1X22 80C	28480	8159-0005
A7W5	8159-0005	0		WIRE 22AWG W PVC 1X22 80C	28480	8159-0005
A7W6	8159-0005	0		WIRE 22AWG W PVC 1X22 80C	28480	8159-0005
A7W7	8159-0005	0		WIRE 22AWG W PVC 1X22 80C	28480	8159-0005
A7W9	8159-0005	0		WIRE 22AWG W PVC 1X22 80C	28480	8159-0005
A7Y1	0410-0211	6	1	CRYSTAL, QUARTZ 9.95 MHZ	28480	0410-0211
				A7 MISCELLANEOUS PARTS		
	04274-26507	0		PC BOARD, BLANK	28480	04274-26507
A8	04274-66508	5	1	DISPLAY AND KEY CONTROL BOARD ASSEMBLY	28480	04274-66508
A8C1	0160-4832	9		CAPACITOR-FXD .01UF +-10% 100VDC CER	28480	0160-4832
A8C2	0160-4832	9		CAPACITOR-FXD .01UF +-10% 100VDC CER	28480	0160-4832
A8C3	0160-4832	9		CAPACITOR-FXD .01UF +-10% 100VDC CER	28480	0160-4832
A8C4	0160-4832	9		CAPACITOR-FXD .01UF +-10% 100VDC CER	28480	0160-4832
A8C5	0160-4832	9		CAPACITOR-FXD .01UF +-10% 100VDC CER	28480	0160-4832

1820  
-1052



Table 6-3. Replaceable Parts (Cont'd)

Reference Designation	HP Part Number	C D	Qty	Description	Mfr Code	Mfr Part Number
ABC6	0160-4832	9		CAPACITOR-FXD .01UF +-10% 100VDC CER	28480	0160-4832
ABC7	0160-4832	9		CAPACITOR-FXD .01UF +-10% 100VDC CER	28480	0160-4832
ABC8	0160-4832	9		CAPACITOR-FXD .01UF +-10% 100VDC CER	28480	0160-4832
ABC9	0160-4832	9		CAPACITOR-FXD .01UF +-10% 100VDC CER	28480	0160-4832
ABC10	0160-0155	8		CAPACITOR-FXD 3.3NF +-10% 200VDC POLYE	56289	
ABC11	0160-0155	8		CAPACITOR-FXD 3.3NF +-10% 200VDC POLYE	56289	
ABC12	0160-0155	8		CAPACITOR-FXD 3.3NF +-10% 200VDC POLYE	56289	
ABC13	0180-1050	4		CAPACITOR, FXD 100 UF 25VDCM	28480	0180-1050
ABC14	0180-0228	6		CAPACITOR-FXD 22UF+-10% 15VDC TA	56289	1500226X901582
ABC15	0160-4832	9		CAPACITOR-FXD .01UF +-10% 100VDC CER	28480	0160-4832
ABC16	0160-4832	9		CAPACITOR-FXD .01UF +-10% 100VDC CER	28480	0160-4832
ABC17	0160-4832	9		CAPACITOR-FXD .01UF +-10% 100VDC CER	28480	0160-4832
ABC18	0160-4832	9		CAPACITOR-FXD .01UF +-10% 100VDC CER	28480	0160-4832
ABC19	0160-4832	9		CAPACITOR-FXD .01UF +-10% 100VDC CER	28480	0160-4832
ABC20	0160-4832	9		CAPACITOR-FXD .01UF +-10% 100VDC CER	28480	0160-4832
ABC21	0160-4832	9		CAPACITOR-FXD .01UF +-10% 100VDC CER	28480	0160-4832
ABC22	0160-4832	9		CAPACITOR-FXD .01UF +-10% 100VDC CER	28480	0160-4832
ABC23	0160-4835	5		CAPACITOR-FXD 1UF +-10% 50VDC CER	28480	0160-4835
ABC24	0180-0228	6		CAPACITOR-FXD 22UF+-10% 15VDC TA	56289	1500226X901582
ABL1	9100-3139	5		COIL 75UH 15% .50X.875LG-NOM	28480	9100-3139
ABL2	9100-3139	5		COIL 75UH 15% .50X.875LG-NOM	28480	9100-3139
ABL3	9100-1788	6		CHOKER WIDE BAND ZMAX=680 OHMS 180 MHZ	02114	VK200 20/48
ABQ1	1854-0019	3	1	TRANSISTOR NPN SI TO-18 PD=360MH	28480	1854-0019
ABR1	1810-0205	7		NETWORK-RES 8-PIN-SIP .1-PIN-SPCG	01121	208A472
ABR2	1810-0205	7		NETWORK-RES 8-PIN-SIP .1-PIN-SPCG	01121	208A472
ABR3	1810-0205	7		NETWORK-RES 8-PIN-SIP .1-PIN-SPCG	01121	208A472
ABR6	1810-0301	4	3	NETWORK-RES 16-PIN-DIP .1-PIN-SPCG	01121	316B510
ABR7	1810-0301	4		NETWORK-RES 16-PIN-DIP .1-PIN-SPCG	01121	316B510
ABR8	1810-0301	4		NETWORK-RES 16-PIN-DIP .1-PIN-SPCG	01121	316B510
ABR9	1810-0205	7		NETWORK-RES 8-PIN-SIP .1-PIN-SPCG	01121	208A472
ABR10	0683-1205	2		RESISTOR 12 5% .25W FC TC=400/+600	01121	
ABR11	0683-1205	2		RESISTOR 12 5% .25W FC TC=400/+600	01121	
ABR12	0683-1205	2		RESISTOR 12 5% .25W FC TC=400/+600	01121	
ABR1	3101-2061	6	1	SWITCH, TOGGLE DIP-ROCKER	28480	3101-2061
ABU1	1858-0023	7	3	TRANSISTOR ARRAY	0192B	CA3081E
ABU2	1858-0023	7		TRANSISTOR ARRAY	0192B	CA3081E
ABU3	1858-0023	7		TRANSISTOR ARRAY	0192B	CA3081E
ABU4	1820-0628	9	6	IC TTL 64-BIT RAM 60-NS 0-C	01295	8N7489N
ABU5	1820-0628	9		IC TTL 64-BIT RAM 60-NS 0-C	01295	8N7489N
ABU6	1820-0628	9		IC TTL 64-BIT RAM 60-NS 0-C	01295	8N7489N
ABU7	1820-1194	6	1	IC CNTR TTL LS 8 BIN UP/DOWN SYNCHRO	01295	8N74LS193N
ABU8	1820-1278	7	2	IC CNTR TTL LS 8 BIN UP/DOWN SYNCHRO	01295	8N74LS191N
ABU9	1820-1112	8		IC FF TTL LS 0-TYPE POS-EDGE-TRIG	01295	8N74LS74N
ABU10	1820-0628	9		IC TTL 64-BIT RAM 60-NS 0-C	01295	8N7489N
ABU11	1820-0628	9		IC TTL 64-BIT RAM 60-NS 0-C	01295	8N7489N
ABU12	1820-0628	9		IC TTL 64-BIT RAM 60-NS 0-C	01295	8N7489N
ABU13	1820-1199	1		IC INV TTL LS HEX 1-INP	01295	8N74LS04N
ABU14	1820-1415	4	1	IC SCHMITT-TRIG TTL LS NAND OUAL 4-INP	01295	8N74LS13N
ABU15	1820-1278	7		IC CNTR TTL LS 8 BIN UP/DOWN SYNCHRO	01295	8N74LS191N
ABU16	1820-1202	7	1	IC GATE TTL LS NAND TPL 3-INP	01295	8N74LS10N
				AB MISCELLANEOUS PARTS		
ABZ1	04274-26508	1		PC BOARD, BLANK	28480	04274-26508
AP	04275-66549	1		MPU BOARD ASSEMBLY	28480	
APC1	0160-4832	9		CAPACITOR-FXD .01UF +-10% 100VDC CER	28480	0160-4832
APC2	0160-4832	9		CAPACITOR-FXD .01UF +-10% 100VDC CER	28480	0160-4832
APC3	0160-4832	9		CAPACITOR-FXD .01UF +-10% 100VDC CER	28480	0160-4832
APC4	0160-4832	9		CAPACITOR-FXD .01UF +-10% 100VDC CER	28480	0160-4832
APC5	0160-4832	9		CAPACITOR-FXD .01UF +-10% 100VDC CER	28480	0160-4832
APC6	0160-4832	9		CAPACITOR-FXD .01UF +-10% 100VDC CER	28480	0160-4832
APC7	0140-0191	1		CAPACITOR-FXD .56PF +-5% 300VDC MICA	28480	
APC8	0160-4832	9		CAPACITOR-FXD .01UF +-10% 100VDC CER	28480	0160-4832
APC9	0160-4835	5		CAPACITOR-FXD 1UF +-10% 50VDC CER	28480	0160-4835
APC10	0160-2307	4	2	CAPACITOR-FXD 47PF +-5% 300VDC MICA	28480	0160-2307

See introduction to this section for ordering information  
\*Indicates factory selected value

Table 6-3. Replaceable Parts (Cont'd).

Reference Designation	HP Part Number	C D	Qty	Description	Mfr Code	Mfr Part Number
A9C11	0160-2307	4	1	CAPACITOR-FXD 47PF +-5% 30VDC MICA	28480	0160-2307
A9C12	0180-2205	7		CAPACITOR-FXD 33UF+-10% 15VDC	56289	
A9C13	0180-0291	3		CAPACITOR-FXD 1UF+-10% 35VDC TA	28480	150D105X9035A2
A9C14	0160-4832	9		CAPACITOR-FXD .01UF +-10% 100VDC CER	28480	0160-4832
A9C15	0160-4832	9		CAPACITOR-FXD .01UF +-10% 100VDC CER	28480	0160-4832
A9C16	0160-4832	9	CAPACITOR-FXD .01UF +-10% 100VDC CER	28480	0160-4832	
A9C17	0160-4832	9	CAPACITOR-FXD .01UF +-10% 100VDC CER	28480	0160-4832	
A9C18	0160-4832	9	CAPACITOR-FXD .01UF +-10% 100VDC CER	28480	0160-4832	
A9C19	0160-4832	9	CAPACITOR-FXD .01UF +-10% 100VDC CER	28480	0160-4832	
A9C20	0160-4832	9	CAPACITOR-FXD .01UF +-10% 100VDC CER	28480	0160-4832	
A9C21	0160-4835	5	1	CAPACITOR-FXD 1UF +-10% 50VDC CER	28480	0160-4835
A9C22	0180-0197	8		CAPACITOR-FXD 2.2UF+-10% 20VDC TA	56289	150D225X9020A2
A9C23	0180-0228	6		CAPACITOR-FXD 22UF+-10% 15VDC TA	56289	150D226X9015B2
A9C24	0160-4832	9		CAPACITOR-FXD .01UF +-10% 100VDC CER	28480	0160-4832
A9C25	0180-0197	8		CAPACITOR-FXD 2.2UF+-10% 20VDC TA	56289	150D225X9020A2
A9C26	0160-4835	5	1	CAPACITOR-FXD 1UF +-10% 50VDC CER	28480	0160-4835
A9C27	0160-4835	5		CAPACITOR-FXD 1UF +-10% 50VDC CER	28480	0160-4835
A9C28	0160-2208	4		CAPACITOR-FXD 330PF +-5% 30VDC MICA	28480	0160-2208
A9C31	1901-0518	8	1	DIODE-SCHOTTKY	28480	1901-0518
A9C32	1901-0518	8		DIODE-SCHOTTKY	28480	1901-0518
A9C33	1901-0518	2		DIODE-SCHOTTKY	28480	
A9C34	1901-0025	2		DIODE-GEN PRP 100V 200MA DO-7	28480	1901-0025
A9C35	1901-0040	1		DIODE-SWITCHING 30V 50MA 2MS DO-35	28480	1901-0040
A9J12	1200-0654	1	1	SOCKET-IC 40-COINT	28480	
A9L1	9100-178A	6	1	CHOKE-WIDE BAND ZMAX=680 OHMS 18c MHZ	02114	VK200 20/48
A9L2	9100-3139	5		COIL 75UH 15% .50X.875LG-NDM	28480	9100-3139
A9Q1	1853-0015	7	2	TRANSISTOR PNP SI PD=200MW FT=500MHZ	28480	1853-0015
A9Q2	1853-0015	7		TRANSISTOR PNP SI PD=200MW FT=500MHZ	28480	1853-0015
A9Q3	1853-0405	8	3	TRANSISTOR PNP PD=700MW FT=850MHZ	28480	
A9R1	1810-0305	8		NETWORK-RES 9-PIN-SIP .1-PIN-SPCG	28480	1810-0305
A9R2	1810-0305	8		NETWORK-RES 9-PIN-SIP .1-PIN-SPCG	28480	1810-0305
A9R3	1810-0305	8		NETWORK-RES 9-PIN-SIP .1-PIN-SPCG	28480	1810-0305
A9R4	0683-1035	1		RESISTOR 10K 5% .25W FC TC=400/+700	01121	C81035
A9R5	0683-2205	9	RESISTOR 22 5% .25W FC TC=400/+500	01121	C82205	
A9R6	0683-1205	7	1	RESISTOR 12 5% .25W FC TC=400/+500	01121	C81205
A9R7	0683-2205	9		RESISTOR 22 5% .25W FC TC=400/+500	01121	C82205
A9R8	0683-1205	7		RESISTOR 12 5% .25W FC TC=400/+500	01121	C81205
A9R9	0683-1515	2		RESISTOR 150 5% .25W FC TC=400/+600	01121	C81515
A9R10	0683-1515	2		RESISTOR 150 5% .25W FC TC=400/+600	01121	C81515
A9R11	1810-0269	3	1	NETWORK-RES 9-PIN-SIP .1-PIN-SPCG	28480	1810-0269
A9R12	0683-2715	6		RESISTOR 270 5% .25W FC TC=400/+600	01121	C82715
A9R13	0683-2715	6		RESISTOR 270 5% .25W FC TC=400/+600	01121	C82715
A9R14	0683-4715	0		RESISTOR 470 5% .25W FC TC=400/+600	01121	C84715
A9R15	0698-3515	3		RESISTOR 5 9% 1% .125W F TC=0+-100	24546	
A9R16	0698-0084	1		RESISTOR 2.15K 1% .125W F TC=0+-100		
A9R17	0683-1035	1		RESISTOR 10K 5% .25W FC TC=400/+700	01121	C81035
A9R18	0683-1035	1		RESISTOR 10K 5% .25W FC TC=400/+700	01121	C81035
A9R19	0683-4745	6		RESISTOR 470K 5% .25W FC TC=800/+900	01121	C84745
A9R20	0683-1025	9		RESISTOR 1K 5% .25W FC TC=400/+600	01121	C81025
A9R21	1810-0269	3		NETWORK-RES 9-PIN-SIP .1-PIN-SPCG	28480	1810-0269
A9R22	0683-4745	6		RESISTOR 470K 5% .25W FC TC=800/+900	01121	C84745
A9R23	0683-1015	7		RESISTOR 100 5% .25W FC TC=400/+500	01121	C81015
A9R24	0683-1035	1		RESISTOR 10K 5% .25W FC TC=400/+700	01121	C81035
A9R25		1		NOT ASSIGNED		
A9R26	1810-0269	3	NETWORK-RES 9-PIN-SIP .1-PIN-SPCG			
A9R27	1810-0269	3	NETWORK-RES 9-PIN-SIP .1-PIN-SPCG			
A9R28		1	NOT ASSIGNED			
A9R29	0757-0442	1	RESISTOR 10K 1% .125W F TC=0+-100			
A9R30	0698-3158	1	RESISTOR 23 7% 1% .125W F TC=0+-100			
A9R31	0683-4725	1	RESISTOR 4.7K 5% .25W FC TC=400/+700			
A9S1	3101-1973	7	2	SWITCH, BLUE 7-1A-NS	28480	3101-1973
A9U1	04274-85041	7		IC, PROM PROGRAMMED	28480	
A9U3	04274-85042	7		IC, PROM PROGRAMMED	28480	
A9U5	04274-85043	9		IC, PROM PROGRAMMED	28480	
A9U7	04274-85047	1		IC, PROM PROGRAMMED	28480	
A9U9	04274-85045	1		IC, PROM PROGRAMMED	28480	
A9U10	04274-85046	3		IC, PROM PROGRAMMED	28480	
A9U12	1818-0438	4		IC NMOS 4K RAM 8TAT 450-NS 3-S	34649	P2114
A9U13	1818-0438	4		IC NMOS 4K RAM 8TAT 450-NS 3-S	34649	P2114
A9U14	1818-1750	7		IC CMOS 1K RAM 8TAT 350-NS 3-S	28480	
A9U15	1818-1750	7	IC CMOS 1K RAM 8TAT 350-NS 3-S	28480		
A9U16	1824-1216	3	IC DCDR TTL L8 3-TO-8-LINE 3-INP	01295	SN74LS138N	
A9U17	1824-2024	3	IC DCDR TTL LS LINE ORVR OCTL	01295	SN74LS244N	
A9U18	1820-1480	3	1	IC MICPROC NMOS 8-BIT	04713	MC6800L
A9U19	1820-1144	6		IC GATE TTL LS NOR QUAD 2-INP	01295	SN74LS02N
A9U20	1820-0683	6		IC INV TTL S HEX 1-INP	01295	SN74S04N
A9U21	1820-1197	9		IC GATE TTL LS NAND QUAD 2-INP	01295	SN74LS00N
A9U22	1824-1216	3		IC DCDR TTL LS 3-TO-8-LINE 3-INP	01295	SN74LS138N

See introduction to this section for ordering information  
\*Indicates factory selected value

Table 6-3. Replaceable Parts (Cont'd).

Reference Designation	HP Part Number	C	D	Qty	Description	Mfr Code	Mfr Part Number
A9U21	1820-1491	6		2	IC BFR TTL LS NON-INV HEX 1-INP	01295	8N74L8367AN
A9U25	1826-0408	5		1	8-DIP-P	32293	1CL8212CPA
A9U26	1820-0661	0		1	IC GATE TTL OR QUAD 2-INP	01295	8N7432N
A9U27	1820-1197	9			IC GATE TTL LS NAND QUAD 2-INP	01295	8N74L800N
A9U28	1820-1216	3			IC OADR TTL LS 3-TO-8-LINE 3-INP	01295	8N74L8150N
A9U29	1820-2024	3			IC DRVR TTL LS LINE DRVR OCTL	01295	8N74L8244N
A9U30	1906-0075	2		1	DIODE-ARRAY 40V 400MA	28480	1906-0075
A9U31	1820-1994	4		2	IC DRVM TTL LS LINE DRVR OCTL	01295	8N74L8243N
A9U32	1820-1994	4			IC DRVR TTL LS LINE DRVR OCTL	01295	8N74L8243N
A9U33	1820-1491	6			IC BFR TTL LS NON-INV HEX 1-INP	01295	8N74L8367AN
A9U34	1820-1199	1			IC INV TTL LS HEX 1-INP	01295	8N74L804N
A9U35	1826-0180	0		1	IC TIMER TTL MONO/ASTBL	04713	MC1455P1
A9 MISCELLANEOUS PARTS							
	04274-26529	2			PC BOARD, BLANK	28480	04274-26509
A10	04275-66520	9		1	DISPLAY AND KEYBOARD ASSEMBLY	28480	04275-66520
A10C1	0160-0228	6			CAPACITOR-FXD 22UF±10% 15VDC TA	56289	1500226X901582
A10C2	0160-4832	9			CAPACITOR-FXD .01UF ±10% 100VDC CEP	28480	0160-4832
A10C3	0160-4832	9			CAPACITOR-FXD .01UF ±10% 100VDC CEP	28480	0160-4832
A10C4	0160-4832	9			CAPACITOR-FXD .01UF ±10% 100VDC CER	28480	0160-4832
A10C5	0160-4832	9			CAPACITOR-FXD .01UF ±10% 100VDC CEP	28480	0160-4832
A10C6	0160-4832	9			CAPACITOR-FXD .01UF ±10% 100VDC CER	28480	0160-4832
A10C7	0160-4832	9			CAPACITOR-FXD .01UF ±10% 100VDC CEP	28480	0160-4832
A10C8	0160-4832	9			CAPACITOR-FXD .01UF ±10% 100VDC CEP	28480	0160-4832
A10C9	0160-4832	9			CAPACITOR-FXD .01UF ±10% 100VDC CER	28480	0160-4832
A10C10	0160-4832	9			CAPACITOR-FXD .01UF ±10% 100VDC CER	28480	0160-4832
A10C11	0160-4832	9			CAPACITOR-FXD .01UF ±10% 100VDC CER	28480	0160-4832
A10C12	0160-4832	9			CAPACITOR-FXD .01UF ±10% 100VDC CEP	28480	0160-4832
A10C13	0160-4832	9			CAPACITOR-FXD .01UF ±10% 100VDC CER	28480	0160-4832
A10D81	1990-0486	6		35	LED-VISIBLE LUM-INT#1MCD IF#20MA-MAX	28480	5082-4684
A10D82	1990-0540	3		12	DISPLAY-NUM-SEG 1-CHAR .43-H	28480	5082-7650
A10D83	1990-0540	3			DISPLAY-NUM-SEG 1-CHAR .43-H	28480	5082-7650
A10D84	1990-0540	3			DISPLAY-NUM-SEG 1-CHAR .43-H	28480	5082-7650
A10D85	1990-0540	3			DISPLAY-NUM-SEG 1-CHAR .43-H	28480	5082-7650
A10D86	1990-0540	3			DISPLAY-NUM-SEG 1-CHAR .43-H	28480	5082-7650
A10D87	1990-0540	3			DISPLAY-NUM-SEG 1-CHAR .43-H	28480	5082-7650
A10D88	1990-0617	5		4	DISPLAY-AN-DOT MAT 1-CHAR .3-H	28480	1990-0617
A10D89	1990-0617	5			DISPLAY-AN-DOT MAT 1-CHAR .3-H	28480	1990-0617
A10D810	1990-0540	3			DISPLAY-NUM-SEG 1-CHAR .43-H	28480	5082-7650
A10D811	1990-0540	3			DISPLAY-NUM-SEG 1-CHAR .43-H	28480	5082-7650
A10D812	1990-0540	3			DISPLAY-NUM-SEG 1-CHAR .43-H	28480	5082-7650
A10D813	1990-0540	3			DISPLAY-NUM-SEG 1-CHAR .43-H	28480	5082-7650
A10D814	1990-0540	3			DISPLAY-NUM-SEG 1-CHAR .43-H	28480	5082-7650
A10D815	1990-0540	3			DISPLAY-NUM-SEG 1-CHAR .43-H	28480	5082-7650
A10D816	1990-0617	5			DISPLAY-AN-DOT MAT 1-CHAR .3-H	28480	1990-0617
A10D817	1990-0617	5			DISPLAY-AN-DOT MAT 1-CHAR .3-H	28480	1990-0617
A10D818	1990-0434	4		3	DISPLAY-NUM-SEG 1-CHAR .3-H	28480	5082-7730, CAT 8-E
A10D819	1990-0434	4			DISPLAY-NUM-SEG 1-CHAR .3-H	28480	5082-7730, CAT 8-E
A10D820	1990-0434	4			DISPLAY-NUM-SEG 1-CHAR .3-H	28480	5082-7730, CAT 8-E
A10D821	1990-0486	6			LED-VISIBLE LUM-INT#1MCD IF#20MA-MAX	28480	5082-4684
A10D822	1990-0486	6			LED-VISIBLE LUM-INT#1MCD IF#20MA-MAX	28480	5082-4684
A10D823	1990-0486	6			LED-VISIBLE LUM-INT#1MCD IF#20MA-MAX	28480	5082-4684
A10D824	1990-0486	6			LED-VISIBLE LUM-INT#1MCD IF#20MA-MAX	28480	5082-4684
A10D825	1990-0517	4		1	LED-VISIBLE LUM-INT#3MCD IF#20MA-MAX	28480	5082-4655
A10D826	1990-0665	6			LED-VISIBLE LUM-INT#1MCD IF#20MA-MAX	28480	
A10D827	1990-0665	6			LED-VISIBLE LUM-INT#1MCD IF#20MA-MAX	28480	
A10D828	1990-0665	6			LED-VISIBLE LUM-INT#1MCD IF#20MA-MAX	28480	
A10D829	1990-0665	6			LED-VISIBLE LUM-INT#1MCD IF#20MA-MAX	28480	
A10D830	1990-0665	6			LED-VISIBLE LUM-INT#1MCD IF#20MA-MAX	28480	
A10D831	1990-0665	6			LED-VISIBLE LUM-INT#1MCD IF#20MA-MAX	28480	
A10D832	1990-0665	6			LED-VISIBLE LUM-INT#1MCD IF#20MA-MAX	28480	
A10D833	1990-0665	6			LED-VISIBLE LUM-INT#1MCD IF#20MA-MAX	28480	
A10D834	1990-0665	6			LED-VISIBLE LUM-INT#1MCD IF#20MA-MAX	28480	
A10D835	1990-0486	6			LED-VISIBLE LUM-INT#1MCD IF#20MA-MAX	28480	5082-4684

See introduction to this section for ordering information  
\*Indicates factory selected value

Table 6-3. Replaceable Parts (Cont'd)

Reference Designation	HP Part Number	C D	Qty	Description	Mfr Code	Mfr Part Number
A10D836	1990-0665	6		LED-VISIBLE LUM-INT=1MCD IF=20MA-MAX	28480	
A10D837	1990-0665	6		LED-VISIBLE LUM-INT=1MCD IF=20MA-MAX	28480	
A10D838	1990-0665	6		LED-VISIBLE LUM-INT=1MCD IF=20MA-MAX	28480	
A10D839	1990-0665	6		LED-VISIBLE LUM-INT=1MCD IF=20MA-MAX	28480	
A10D840	1990-0665	6		LED-VISIBLE LUM-INT=1MCD IF=20MA-MAX	28480	
A10D841	1990-0665	6		LED-VISIBLE LUM-INT=1MCD IF=20MA-MAX	28480	
A10D842	1990-0486	6		LED-VISIBLE LUM-INT=1MCD IF=20MA-MAX	28480	5082-4684
A10D843	1990-0665	6		LED-VISIBLE LUM-INT=1MCD IF=20MA-MAX	28480	
A10D844	1990-0665	6		LED-VISIBLE LUM-INT=1MCD IF=20MA-MAX	28480	
A10D845	1990-0665	6		LED-VISIBLE LUM-INT=1MCD IF=20MA-MAX	28480	
A10D846	1990-0665	6		LED-VISIBLE LUM-INT=1MCD IF=20MA-MAX	28480	
A10D847	1990-0665	6		LED-VISIBLE LUM-INT=1MCD IF=20MA-MAX	28480	
A10D848	1990-0665	6		LED-VISIBLE LUM-INT=1MCD IF=20MA-MAX	28480	
A10D849	1990-0665	6		LED-VISIBLE LUM-INT=1MCD IF=20MA-MAX	28480	
A10D850	1990-0665	6		LED-VISIBLE LUM-INT=1MCD IF=20MA-MAX	28480	
A10D851	1990-0665	6		LED-VISIBLE LUM-INT=1MCD IF=20MA-MAX	28480	
A10D852	1990-0486	6		LED-VISIBLE LUM-INT=1MCD IF=20MA-MAX	28480	5082-4684
A10D853	1990-0486	6		LED-VISIBLE LUM-INT=1MCD IF=20MA-MAX	28480	5082-4684
A10D854	1990-0486	6		LED-VISIBLE LUM-INT=1MCD IF=20MA-MAX	28480	5082-4684
A10D855	1990-0486	6		LED-VISIBLE LUM-INT=1MCD IF=20MA-MAX	28480	5082-4684
A10J2	1200-0638	9	12	SOCKET-IC 14-CONT DIP-SLDR SOCKET FOR DS2 THROUGH DS7	28480	
A10J3	1200-0638	9		SOCKET-IC 14-CONT DIP-SLDR	28480	
A10J4	1200-0638	9		SOCKET-IC 14-CONT DIP-SLDR	28480	
A10J5	1200-0638	9		SOCKET-IC 14-CONT DIP-SLDR	28480	
A10J6	1200-0638	9		SOCKET-IC 14-CONT DIP-SLDR	28480	
A10J7	1200-0638	9		SOCKET-IC 14-CONT DIP-SLDR	28480	
A10J8	1200-0424	9	4	SOCKET-ELEC (MISC ITEM) 14-PIN SOCKET FOR DS8, 9, 16, AND 17	28480	1200-0424
A10J9	1200-0424	9		SOCKET-ELEC (MISC ITEM)	28480	1200-0424
A10J10	1200-0638	9		SOCKET-IC 14-CONT DIP-SLDR	28480	
A10J11	1200-0638	9		SOCKET-IC 14-CONT DIP-SLDR	28480	
A10J12	1200-0638	9		SOCKET-IC 14-CONT DIP-SLDR	28480	
A10J13	1200-0638	9		SOCKET-IC 14-CONT DIP-SLDR	28480	
A10J14	1200-0638	9		SOCKET-IC 14-CONT DIP-SLDR	28480	
A10J15	1200-0638	9		SOCKET-IC 14-CONT DIP-SLDR	28480	
A10J16	1200-0424	9		SOCKET-ELEC (MISC ITEM)	28480	1200-0424
A10J17	1200-0424	9		SOCKET-ELEC (MISC ITEM)	28480	1200-0424
A10J18	1200-0508	0	3	SOCKET-IC 14-CONT DIP-SLDR SOCKET FOR DS18 THROUGH DS20	28480	1200-0508
A10J19	1200-0508	0		SOCKET-IC 14-CONT DIP-SLDR	28480	1200-0508
A10J20	1200-0508	0		SOCKET-IC 14-CONT DIP-SLDR	28480	1200-0508
A10KC1	5041-0252	7	6	KEY CAP	28480	5041-0252
A10KC2	5041-0252	7		KEY CAP	28480	5041-0252
A10KC3	5041-0351	7	3	KEY CAP	28480	5041-0351
A10KC4	5041-0252	7		KEY CAP	28480	5041-0252
A10KC5	5041-0252	7		KEY CAP	28480	5041-0252
A10KC6	5041-0252	7		KEY CAP	28480	5041-0252
A10KC7	5041-0252	7		KEY CAP	28480	5041-0252
A10KC8	5041-0351	7		KEY CAP	28480	5041-0351
A10KC9	5041-0351	7		KEY CAP	28480	5041-0351
A10KC10	5041-0309	5	8	KEY CAP	28480	5041-0309
A10KC11	5041-0309	5		KEY CAP	28480	5041-0309
A10KC12	5041-0318	6	15	*LK CAP- PTY GRAY	28480	5041-0318
A10KC13	5041-0318	6		*LK CAP- PTY GRAY	28480	5041-0318
A10KC14	5041-0309	5		KEY CAP	28480	5041-0309
A10KC15	5041-0309	5		KEY CAP	28480	5041-0309
A10KC16	5041-0318	6		*LK CAP- PTY GRAY	28480	5041-0318
A10KC17	5041-0318	6		*LK CAP- PTY GRAY	28480	5041-0318
A10KC18	5041-0318	6		*LK CAP- PTY GRAY	28480	5041-0318
A10KC19	5041-0318	6		*LK CAP- PTY GRAY	28480	5041-0318
A10KC20	5041-0309	5		KEY CAP	28480	5041-0309
A10KC21	5041-0309	5		KEY CAP	28480	5041-0309
A10KC22	5041-0318	6		*LK CAP- PTY GRAY	28480	5041-0318
A10KC23	5041-0318	6		*LK CAP- PTY GRAY	28480	5041-0318
A10KC24	5041-0318	6		*LK CAP- PTY GRAY	28480	5041-0318
A10KC25	5041-0318	6		*LK CAP- PTY GRAY	28480	5041-0318
A10KC30	5041-0318	6		*LK CAP- PTY GRAY	28480	5041-0318
A10KC31	5041-0318	6		*LK CAP- PTY GRAY	28480	5041-0318
A10KC32	5041-0309	5		KEY CAP	28480	5041-0309
A10KC33	5041-0309	5		KEY CAP	28480	5041-0309
A10KC34	5041-0375	5	1	KEY-Q-SMOKE GRAY	28480	5041-0375
A10KC35	5041-0318	6		*LK CAP- PTY GRAY	28480	5041-0318
A10KC36	5041-0318	6		*LK CAP- PTY GRAY	28480	5041-0318
A10KC37	5041-0318	6		*LK CAP- PTY GRAY	28480	5041-0318
A10KC38	5041-0384	6	1	KEY-Q-SMOKE GRAY	28480	5041-0384

See introduction to this section for ordering information  
\*Indicates factory selected value

Table 6-3. Replaceable Parts (Cont'd).

Reference Designation	HP Part Number	C D	Qty	Description	Mfr Code	Mfr Part Number
A10R1	0757-0400	9	14	RESISTOR 90.9 1% .125W F TC=0+-100	24546	C4-1/8-T0-90R9-F
A10R2	0757-0400	9		RESISTOR 90.9 1% .125W F TC=0+-100	24546	C4-1/8-T0-90R9-F
A10R3	0757-0400	9		RESISTOR 90.9 1% .125W F TC=0+-100	24546	C4-1/8-T0-90R9-F
A10R4	0757-0400	9		RESISTOR 90.9 1% .125W F TC=0+-100	24546	C4-1/8-T0-90R9-F
A10R5	1810-0203	7		NETWORK-RES 8-PIN-SIP .1-PIN-SPCG	01121	C4-1/8-T0-90R9-F
A10R6	1810-0203	7	NETWORK-RES 8-PIN-SIP .1-PIN-SPCG	01121		
A10R7	1810-0203	7	NETWORK-RES 8-PIN-SIP .1-PIN-SPCG	01121		
A10R8	0698-3447	4	RESISTOR 422 1% .125W F TC=0+-100	24546	C4-1/8-T0-422R-F	
A10R9	0757-0400	9	RESISTOR 90.9 1% .125W F TC=0+-100	24546	C4-1/8-T0-90R9-F	
A10R10	0757-0400	9	RESISTOR 90.9 1% .125W F TC=0+-100	24546	C4-1/8-T0-90R9-F	
A10R11	0757-0400	9	16	RESISTOR 90.9 1% .125W F TC=0+-100	24546	C4-1/8-T0-90R9-F
A10R12	0683-1215	9		RESISTOR 120 5% .25W FC TC=-400/+600	01121	CB1215
A10R13	0683-1215	9		RESISTOR 120 5% .25W FC TC=-400/+600	01121	CB1215
A10R14	0683-1215	9		RESISTOR 120 5% .25W FC TC=-400/+600	01121	CB1215
A10R15	0683-1215	9		RESISTOR 120 5% .25W FC TC=-400/+600	01121	CB1215
A10R16	0683-1215	9	RESISTOR 120 5% .25W FC TC=-400/+600	01121	CB1215	
A10R17	0683-1215	9	RESISTOR 120 5% .25W FC TC=-400/+600	01121	CB1215	
A10R18	0683-1215	9	RESISTOR 120 5% .25W FC TC=-400/+600	01121	CB1215	
A10R19	0683-1215	9	RESISTOR 120 5% .25W FC TC=-400/+600	01121	CB1215	
A10R20	0683-1215	9	RESISTOR 120 5% .25W FC TC=-400/+600	01121	CB1215	
A10R21	0683-1215	9	RESISTOR 120 5% .25W FC TC=-400/+600	01121	CB1215	
A10R22	0683-1215	9	RESISTOR 120 5% .25W FC TC=-400/+600	01121	CB1215	
A10R23	0683-1215	9	RESISTOR 120 5% .25W FC TC=-400/+600	01121	CB1215	
A10R24	0683-1215	9	RESISTOR 120 5% .25W FC TC=-400/+600	01121	CB1215	
A10R25	0683-1215	9	RESISTOR 120 5% .25W FC TC=-400/+600	01121	CB1215	
A10R26	0683-1215	9	1	RESISTOR 120 5% .25W FC TC=-400/+600	01121	CB1215
A10R27	0683-1215	9		RESISTOR 120 5% .25W FC TC=-400/+600	01121	CB1215
A10R28	2100-1174	7		RESISTOR, VAR 2K 10%	28480	2100-1174
A10R29	0757-0400	9		RESISTOR 90.9 1% .125W F TC=0+-100	24546	C4-1/8-T0-90R9-F
A10R30	0757-0400	9		RESISTOR 90.9 1% .125W F TC=0+-100	24546	C4-1/8-T0-90R9-F
A10R31	0757-0400	9	RESISTOR 90.9 1% .125W F TC=0+-100	24546	C4-1/8-T0-90R9-F	
A10R32	0757-0400	9	RESISTOR 90.9 1% .125W F TC=0+-100	24546	C4-1/8-T0-90R9-F	
A10R33	0757-0400	9	RESISTOR 90.9 1% .125W F TC=0+-100	24546	C4-1/8-T0-90R9-F	
A10R34	0757-0400	9	RESISTOR 90.9 1% .125W F TC=0+-100	24546	C4-1/8-T0-90R9-F	
A10R35	0757-0400	9	RESISTOR 90.9 1% .125W F TC=0+-100	24546	C4-1/8-T0-90R9-F	
A10S1			33	PUSHBUTTON SWITCH P.C. MOUNT	28480	5060-9436
A10S25	5060-9436	7		SWITCH, SLIDE DPDT-NS	28480	3101-2046
A10S27	3101-2046	7		SWITCH, PUSHBUTTON SPST NO	28480	3101-1074
A10S28	3101-1074	9		SWITCH, PUSHBUTTON SPST NO	28480	3101-1074
A10S29	3101-1074	9		SWITCH, SLIDE DPDT-NS	28480	3101-1074
A10S26	3101-2046	7	PUSHBUTTON SWITCH P.C. MOUNT	28480	5060-9436	
A10S30						
A10S38	5060-9436	7				
A10U1	1858-0038	4	4	TRANSISTOR ARRAY	28480	1858-0038
A10U2	1858-0038	4		TRANSISTOR ARRAY	28480	1858-0038
A10U3	1858-0038	4		TRANSISTOR ARRAY	28480	1858-0038
A10U4	1858-0038	4		TRANSISTOR ARRAY	28480	1858-0038
A10U5	1820-0668	7		IC BFR TTL NON-INV HEX 1-INP	01295	8N7407N
A10U6	1820-0668	7	IC BFR TTL NON-INV HEX 1-INP	01295	8N7407N	
A10U7	1820-0668	7	IC BFR TTL NON-INV HEX 1-INP	01295	8N7407N	
A10U8	1820-0495	8	IC DCDR TTL 4-T0-16-LINE 4-INP	01295	8N74154N	
A10U9	1820-0495	8	IC DCDR TTL 4-T0-16-LINE 4-INP	01295	8N74154N	
A10W1	04274-61621	3	1	WIRING ASSEMBLY	28480	04274-61621
	0360-1706	9		CABLE TRANSITION	28480	0360-1706
				A10 MISCELLANEOUS PARTS		
	04274-26510	5	1	PC BOARD, BLANK	28480	04274-26510
A11	04274-66551	0	1	POWER SUPPLY BOARD ASSEMBLY	28480	
A11C1	0180-1073	1	1	CAPACITOR-FXD 22000uF +30-10% 16VDC	28480	0180-1073
A11C2	0180-1071	9		CAPACITOR-FXD 15000uF +30-10% 16VDC	28480	0180-1071
A11C3	0180-1072	0		CAPACITOR-FXD 10000uF +30-10% 25VDC	28480	0180-1072
A11C4	0180-1072	0		CAPACITOR-FXD 10000uF +30-10% 25VDC	28480	0180-1072
A11C5	0180-1074	2		CAPACITOR-FXD 470uF +50 -10% 100VDC	28480	0180-1074
A11C6	0180-1074	2	6	CAPACITOR-FXD 470uF +50-10% 100VDC	28480	0180-1074
A11C7	0180-1076	4		CAPACITOR-FXD 470uF +50-10% 35VDC	28480	0180-1076
A11C8	0180-1076	4		CAPACITOR-FXD 470uF +50-10% 35VDC	28480	0180-1076
A11C9	0180-1076	4		CAPACITOR-FXD 470uF +50-10% 35VDC	28480	0180-1076
A11C10	0180-1076	4		CAPACITOR-FXD 470uF +50-10% 35VDC	28480	0180-1076
A11C11	0180-1076	4		CAPACITOR-FXD 470uF +50-10% 35VDC	28480	0180-1076
A11C12	0180-1051	5	1	CAPACITOR, FXD 100 UF 16V M	28480	0180-1051 → 0180-1297
A11C13	0180-1076	4		CAPACITOR-FXD 470uF +50-10% 35VDC	28480	0180-1076
A11C14	0180-1075	3		CAPACITOR-FXD 2200uF +30-10% 16VDC	28480	0180-1075
A11C15	0180-1075	3		CAPACITOR-FXD 2200uF +30-10% 16VDC	28480	0180-1075

See introduction to this section for ordering information  
\*Indicates factory selected value

Table 6-3. Replaceable Parts (Cont'd).

Reference Designation	HP Part Number	C D	Qty	Description	Mfr Code	Mfr Part Number
A11C16	0180-1075	3		CAPACITOR-FID 2200uF +30-10% 16VDC	28480	0180-1075
A11C17	0180-1075	3		CAPACITOR-FID 2200uF +30-10% 16VDC	28480	0180-1075
A11C18	0160-2150			CAPACITOR-FAD 33PF +-5% 300VDC MICA	28480	0160-2150
A11CR1	1901-0416	5	10	DIODE-PWR RECT 200V 1.5A	28480	1901-0416
A11CR2	1901-0416	5		DIODE-PWR RECT 200V 1.5A	28480	1901-0416
A11CR3	1901-0416	5		DIODE-PWR RECT 200V 1.5A	28480	1901-0416
A11CR4	1901-0416	5		DIODE-PWR RECT 200V 1.5A	28480	1901-0416
A11CR5	1901-0416	5		DIODE-PWR RECT 200V 1.5A	28480	1901-0416
A11CR6	1901-0416	5		DIODE-PWR RECT 200V 1.5A	28480	1901-0416
A11CR7	1901-0416	5		DIODE-PWR RECT 200V 1.5A	28480	1901-0416
A11CR8	1901-0416	5		DIODE-PWR RECT 200V 1.5A	28480	1901-0416
A11CR9	1901-0416	5		DIODE-PWR RECT 200V 1.5A	28480	1901-0416
A11CR10	1901-0416	5		DIODE-PWR RECT 200V 1.5A	28480	1901-0416
A11CR11	1902-0021	0	2	DIODE-ZNR 1N2992RB 39V 5% DO-4 PD=10W	04713	1N2992RB
A11CR12	1902-0021	0		DIODE-ZNR 1N2992RB 39V 5% DO-4 PD=10W	04713	1N2992RB
A11CR13	1901-0364	2	2	DIODE-FW BRDG 200V 1A	28480	1901-0364
A11CR14	1901-0364	2		DIODE-FW BRDG 200V 1A	28480	1901-0364
A11CR15	1901-0025	2		DIODE-GEN PRP 100V 200MA DO-7	28480	1901-0025
A11CR16	1901-0025	2		DIODE-GEN PRP 100V 200MA DO-7	28480	1901-0025
A11CR17	1901-0025	2		DIODE-GEN PRP 100V 200MA DO-7	28480	1901-0025
A11CR18	1901-0025	2		DIODE-GEN PRP 100V 200MA DO-7	28480	1901-0025
A11CR19	1901-0025	2		DIODE-GEN PRP 100V 200MA DO-7	28480	1901-0025
A11CR20	1902-3094	3	1	DIODE-ZNR 5.11V 2% DO-7 PD=.4W TC=-.009%	28480	1902-3094
A11CR21	1902-0033	4	1	DIODE-ZNR 1N823 6.2V 5% DO-7 PD=.4W	24046	1N823
A11CR22	1901-0025	2		DIODE-GEN PRP 100V 200MA DO-7	28480	1901-0025
A11CR23	1901-0025	2		DIODE-GEN PRP 100V 200MA DO-7	28480	1901-0025
A11CR24	1901-0025	2		DIODE-GEN PRP 100V 200MA DO-7	28480	1901-0025
A11CR25	1901-0028	5	2	DIODE-PWR RECT 400V 750MA DO-29	28480	1901-0028
A11CR26	1901-0028	5		DIODE-PWR RECT 400V 750MA DO-29	28480	1901-0028
A11CR27	1901-0025	2		DIODE-GEN PRP 100V 200MA DO-7	28480	1901-0025
A11CR28	1901-0025	2		DIODE-GEN PRP 100V 200MA DO-7	28480	1901-0025
A11CR29	1901-0025	2		DIODE-GEN PRP 100V 200MA DO-7	28480	1901-0025
A11CR30	1902-1200	9	2	DIODE-ZNR 1N2980B 16V 5% DO-4 PD=10W	12954	1N2980B
A11CR31	1902-1200	9		DIODE-ZNR 1N2980B 16V 5% DO-4 PD=10W	12954	1N2980B
A11CR32	1902-1232	7	2	DIODE-ZNR 1N3997AR 5.6V 5% DO-4 PD=10W	04713	1N3997AR
A11CR33	1902-1232	7		DIODE-ZNR 1N3997AR 5.6V 5% DO-4 PD=10W	04713	1N3997AR
A11DP1	1976-0076	8	1	TURE-ELECTRON SURGE V PTCR	28480	1976-0076
A11F1	2110-0007	4	3	FUSE 1A 250V SLO-BLO 1.25x.25 UL	75915	313001
A11F2	2110-0007	4		FUSE 1A 250V SLO-BLO 1.25x.25 UL	75915	313001
A11F3	2110-0303	3	1	FUSE 2A 250V SLO-BLO 1.25x.25 UL	28480	2110-0303
A11F4	2110-0014	3	1	FUSE 4A 250V SLO-BLO 1.25x.25 UL	75915	313004
A11F5	2110-0201	0	1	FUSE .25A 250V SLO-BLO 1.25x.25 UL	75915	313.250
A11F6	2110-0012	1	1	FUSE .5A 250V FAST-BLO 1.25x.25 UL	28480	2110-0012
A11F7	2110-0007	4		FUSE 1A 250V SLO-BLO 1.25x.25 UL	75915	313001
A11F8	2110-0659			FUSE 1A 250V TIME-DELAY		
A11F9	2110-0659			FUSE 1A 250V TIME-DELAY		
A11K1	0490-0238	5	7	RELAY-REED	28480	0490-0238
A11Q1	1853-0027	1		TRANSISTOR PNP 8I TO-39 PD=1W FT=100MHZ	28480	1853-0027
A11Q2	1853-0027	1		TRANSISTOR PNP 8I TO-39 PD=1W FT=100MHZ	28480	1853-0027
A11Q3	1854-0023	7	1	TRANSISTOR NPN 5I TO-18 PD=360MW	04713	
A11Q4	1854-0448	2		TRANSISTOR NPN 8I TO-39 PD=1W FT=100MHZ	28480	1854-0448
A11Q5	1854-0448	2		TRANSISTOR NPN 8I TO-39 PD=1W FT=100MHZ	28480	1854-0448
A11Q6	1953-0281	9	4	TRANSISTOR PNP 2N2907A 8I TO-18 PD=400MW	04713	2N2907A
A11Q7	1953-0281	9		TRANSISTOR PNP 2N2907A 8I TO-18 PD=400MW	04713	2N2907A
A11Q8	1953-0281	9		TRANSISTOR PNP 2N2907A 8I TO-18 PD=400MW	04713	2N2907A
A11Q9	1953-0281	9		TRANSISTOR PNP 2N2907A 8I TO-18 PD=400MW	04713	2N2907A
A11R1	0690-1541	9	1	RESISTOR 150K 10% 1W CC TC=0+882	01121	081941
A11R2	0708-0001	9	1	RESISTOR 1K 10% 3W MO TC=0+250	27167	FP3-3-250-1001-K
A11R3	2100-3212	8	1	RESISTOR-TRM 200 10% C TOP-ADJ 1-TRN	28480	2100-3212
A11R4	0812-0072	9	2	RESISTOR .23 5% 3W PW TC=0+90	28480	0812-0072
A11R5	0683-3325	6		RESISTOR 3.3K 5% .25W FC TC=-400/+700	01121	C83325
A11R6	0812-0072	9		RESISTOR .23 5% 3W PW TC=0+90	28480	0812-0072
A11R7	0683-1015	7		RESISTOR 100 5% .25W FC TC=-400/+500	01121	C81015
A11R8	0683-1525	4	3	RESISTOR 1.5K 5% .25W FC TC=-400/+700	01121	C81525
A11R9	0683-1015	7		RESISTOR 100 5% .25W FC TC=-400/+500	01121	C81015
A11R10	0683-1035	1		RESISTOR 10K 5% .25W FC TC=-400/+700	01121	C81035
A11R11	0698-3445	2		RESISTOR 348 1% .125W F TC=0+100	24546	C4-1/8-TO-348R-F
A11R12	0698-3438	3	1	RESISTOR 147 1% .125W F TC=0+100	24546	C4-1/8-TO-147R-F
A11R13	0811-2771	7	1	RESISTOR .18 3% 3W PW TC=0+90	28480	0811-2771
A11R14	0683-3325	6		RESISTOR 3.3K 5% .25W FC TC=-400/+700	01121	C83325
A11R15	0811-3290	7	2	RESISTOR .1 5% 2W PW TC=0+800	28480	0811-3290
A11R16	0811-3290	7		RESISTOR .1 5% 2W PW TC=0+800	28480	0811-3290
A11R17	0683-6215	3	3	RESISTOR 820 5% .25W FC TC=-400/+600	01121	C86215
A11R18	0683-1025	3	9	RESISTOR 1K 5% .25W FC TC=-400/+600	01121	C81025
A11R19	0683-2235	5		RESISTOR 22K 5% .25W FC TC=-400/+800	01121	C82235
A11R20	0686-1235	9	1	RESISTOR 12K 5% .5W CC TC=0+765	01121	E81235

Table 6-3. Replaceable Parts (Cont'd).

Reference Designation	HP Part Number	C D	Qty	Description	Mfr Code	Mfr Part Number
A11R21	06M3-2235	5		RESISTOR 22K 5% .25W FC TC=400/+800	01121	C82235
A11R22	06M3-4725	2		RESISTOR 4.7K 5% .25W FC TC=400/+700	01121	C84725
A11P25	06M3-3325	6		RESISTOR 3.3K 5% .25W FC TC=400/+700	01121	C83325
A11P26	06M3-1015	7		RESISTOR 100 5% .25W FC TC=400/+500	01121	C81015
A11P27	0757-0442	9		RESISTOR 10K 1% .125W F TC=0/+100	24546	C4=1/8-T0=1002-F
A11P28	0757-0442	9		RESISTOR 10K 1% .125W F TC=0/+100	24546	C4=1/8-T0=1002-F
A11P29	06M3-1015	7		RESISTOR 100 5% .25W FC TC=400/+500	01121	C81015
A11R30	0757-0438	3	1	RESISTOR 5.1K 1% .125W F TC=0/+100	24546	C4=1/8-T0=5111-F
A11F31	069B-4471	6	1	RESISTOR 7.15K 1% .125W F TC=0/+100	24546	C4=1/8-T0=7151-F
A11R32	06M3-2225	3		RESISTOR 2.2K 5% .25W FC TC=400/+700	01121	C82225
A11R33	0757-0280	3		RESISTOR 1K 1% .125W F TC=0/+100	24546	C4=1/8-T0=1001-F
A11P34	06M3-1015	7		RESISTOR 100 5% .25W FC TC=400/+500	01121	C81015
A11R35	06M3-4725	2		RESISTOR 4.7K 5% .25W FC TC=400/+700	01121	C84725
A11R36	06M3-1045	3		RESISTOR 100K 5% .25W FC TC=400/+800	01121	C81045
A11R37	06M3-2225	3		RESISTOR 2.2K 5% .25W FC TC=400/+700	01121	C82225
A11R38	06M3-2225	3		RESISTOR 2.2K 5% .25W FC TC=400/+700	01121	C82225
A11R39	06M3-1045	3		RESISTOR 100K 5% .25W FC TC=400/+800	01121	C81045
A11P40	0757-0442	9		RESISTOR 10K 1% .125W F TC=0/+100	24546	C4=1/8-T0=1002-F
A11R41	0757-0442	9		RESISTOR 10K 1% .125W F TC=0/+100	24546	C4=1/8-T0=1002-F
A11U1	1A20-0493	6	5	OP AMP GP 8-DIP-P	27014	LM307N
A11U2	1A20-0493	6		OP AMP GP 8-DIP-P	27014	LM307N
A11U3	1A20-0493	6		OP AMP GP 8-DIP-P	27014	LM307N
A11U4	1A20-0493	6		OP AMP GP 8-DIP-P	27014	LM307N
A11U5	1A20-0493	6		OP AMP GP 8-DIP-P	27014	LM307N
A11W1	1251-3198	7	2	CONNECTOR 15-PIN M POST TYPE	28480	1251-3198
A11W2	1251-3198	7		CONNECTOR 15-PIN M POST TYPE	28480	1251-3198
A11W3	1251-3197	6	1	CONNECTOR 12-PIN M POST TYPE	28480	1251-3197
				All MISCELLANEOUS PARTS		
	04274-26551	6		PC BOARD, BLANK	28480	04274-26511
A12	04274-66552	1	1	MOTHER BOARD ASSEMBLY	28480	
A12J1	1251-3141	0	1	CONNECTOR 50-PIN M RECTANGULAR	28480	1251-3141
A12W1	04274-61608			CABLE ASSY M-BD INT		
A12W2	04274-61609			CABLE ASSY M-BD MON		
A12W3	04274-61610			CABLE ASSY M-BD BIAS		
A12XA1L	1251-5564	7	22	CONNECTOR-PC EDGE 22-CUNT/ROW 2-ROWS	28480	7 1251-1365 1-变更 (Pc033-3148)
A12XA1R	1251-5564	7		CONNECTOR-PC EDGE 22-CUNT/ROW 2-ROWS	28480	
A12XA2L	1251-5564	7		CONNECTOR-PC EDGE 22-CUNT/ROW 2-ROWS	28480	
A12XA2R	1251-5564	7		CONNECTOR-PC EDGE 22-CUNT/ROW 2-ROWS	28480	
A12XA3L	1251-5564	7		CONNECTOR-PC EDGE 22-CUNT/ROW 2-ROWS	28480	
A12XA3R	1251-5564	7		CONNECTOR-PC EDGE 22-CUNT/ROW 2-ROWS	28480	
A12XA4L	1251-5564	7		CONNECTOR-PC EDGE 22-CUNT/ROW 2-ROWS	28480	
A12XA4R	1251-5564	7		CONNECTOR-PC EDGE 22-CUNT/ROW 2-ROWS	28480	
A12XA5L	1251-5564	7		CONNECTOR-PC EDGE 22-CUNT/ROW 2-ROWS	28480	
A12XA5R	1251-5564	7		CONNECTOR-PC EDGE 22-CUNT/ROW 2-ROWS	28480	
A12XA6L	1251-5564	7		CONNECTOR-PC EDGE 22-CUNT/ROW 2-ROWS	28480	
A12XA6R	1251-5564	7		CONNECTOR-PC EDGE 22-CUNT/ROW 2-ROWS	28480	
A12XA7L	1251-5564	7		CONNECTOR-PC EDGE 22-CUNT/ROW 2-ROWS	28480	
A12XA7R	1251-5564	7		CONNECTOR-PC EDGE 22-CUNT/ROW 2-ROWS	28480	
A12XA8L	1251-5564	7		CONNECTOR-PC EDGE 22-CUNT/ROW 2-ROWS	28480	
A12XA8R	1251-5564	7		CONNECTOR-PC EDGE 22-CUNT/ROW 2-ROWS	28480	
A12XA9L	1251-5564	7		CONNECTOR-PC EDGE 22-CUNT/ROW 2-ROWS	28480	
A12XA9R	1251-5564	7		CONNECTOR-PC EDGE 22-CUNT/ROW 2-ROWS	28480	
A12XA11L	1251-4978	8	2	CONNECTOR-PC EDGE 15-CUNT/ROW 2-ROWS	28480	
A12XA11R	1251-4978	8		CONNECTOR-PC EDGE 15-CUNT/ROW 2-ROWS	28480	
A12XA21L	1251-5564	7		CONNECTOR-PC EDGE 22-CUNT/ROW 2-ROWS	28480	
A12XA21R	1251-5564	7		CONNECTOR-PC EDGE 22-CUNT/ROW 2-ROWS	28480	
A12XA22L	1251-5564	7		CONNECTOR-PC EDGE 22-CUNT/ROW 2-ROWS	28480	
A12XA22R	1251-5564	7		CONNECTOR-PC EDGE 22-CUNT/ROW 2-ROWS	28480	
				A12 MISCELLANEOUS PARTS		
	04274-26552	7		PC BOARD, BLANK	28480	
A13				NOT ASSIGNED		
A14				NOT ASSIGNED		
A15	04274-66515	4	1	HP-IB CONNECTOR BOARD ASSEMBLY	28480	04274-66515
A15J1	1251-3283	1	1	CONNECTOR 24-PIN F MICRORIBBON	28480	1251-3283
A15J2	1251-2159	8	2	CONNECTOR-PC EDGE 12-CUNT/ROW 2-ROWS	28480	1251-2159

See introduction to this section for ordering information  
\*Indicates factory selected value

Table 6-3. Replaceable Parts (Cont'd).

Reference Designation	HP Part Number	C D	Qty	Description	Mfr Code	Mfr Part Number
	04274-26515	0		PC BOARD, BLANK	28480	04274-26515
A16	04274-66516	5	1	DC BIAS CONNECTOR BOARD ASSEMBLY	28480	04274-66516
A16J1	1251-0292	6	1	CONNECTOR 24-PIN F MICRO RIBBON	28480	1251-0292
A16J2	1251-2159	8		CONNECTOR-PC EDGE 12-CONT/ROW 2-ROWS	28480	1251-2159
	04274-26515	0		PC BOARD, BLANK	28480	04274-26515
A17				NOT ASSIGNED		
A18				NOT ASSIGNED		
A19				NOT ASSIGNED		
A20				NOT ASSIGNED		
A21	04274-66521	2	1	DC BIAS(+/-35V) BOARD ASSEMBLY (OPTION 001 ONLY)	28480	04274-66521
A21C1	0160-2204	0		CAPACITOR-FXD 100PF +-5% 30VDC MICA	28480	0160-2204
A21C2	0160-2242	6	1	CAPACITOR-FXD 2.4PF +-0.25PF 500VDC CER	28480	0160-2242
A21C3	0160-2257	3		CAPACITOR-FXD 10PF +-5% 500VDC CER 0+-60	28480	0160-2257
A21C4	0160-4832	9	1	CAPACITOR-FXD .01UF +-10% 100VDC CER	28480	0160-4832
A21C5	0160-2261	8	1	CAPACITOR-FXD 15PF +-5% 500VDC CER 0+-30	28480	0160-2261
A21C9	0160-0191	9		CAPACITOR-FXD 56PF +-5% 300VDC MICA	72136	DM15E560J0300MV1CR
A21C10	0160-4832	4		CAPACITOR-FXD .01UF +-10% 100VDC CER	28480	0160-4832
A21C11	0180-1050	4		CAPACITOR, FXD 100 UF 25VDCW	28480	0180-1050
A21C12	0180-1050	9		CAPACITOR, FXD 100 UF 25VDCW	28480	0180-1050
A21C13	0160-4832	7	1	CAPACITOR-FXD .01UF +-10% 100VDC CER	28480	0160-4832
A21C14	0160-0859	9		CAPACITOR-FXD 1UF +-10% 50VDC POLYE	28480	0160-0859
A21C15	0180-1084	4	1	CAPACITOR, FXD 100 UF 50VDCW BI	28480	0180-1084
A21C16	0180-1081	1	9	CAPACITOR, FXD 47 UF 50 VDCW AL	28480	0180-1081
A21C17	0180-1081	1		CAPACITOR-FXD 47 UF 50 VDCW AL	28480	0180-1081
A21C18	0180-1081	1		CAPACITOR, FXD 47 UF 50 VDCW AL	28480	0180-1081
A21C19	0180-1081	1		CAPACITOR, FXD 47 UF 50 VDCW AL	28480	0180-1081
A21C20	0180-1082	2	6	CAPACITOR, FXD 10 UF 100VDCW AL	28480	0180-1082
A21C21	0160-4832	9		CAPACITOR-FXD .01UF +-10% 100VDC CER	28480	0160-4832
A21C22	0180-1050	4		CAPACITOR, FXD 100 UF 25VDCW	28480	0180-1050
A21C23	0180-1081	1		CAPACITOR, FXD 47 UF 50 VDCW AL	28480	0180-1081
A21C24	0180-1050	4		CAPACITOR, FXD 100 UF 25VDCW	28480	0180-1050
A21C25	0180-1050	4		CAPACITOR, FXD 100 UF 25VDCW	28480	0180-1050
A21C26	0160-4832	9		CAPACITOR-FXD .01UF +-10% 100VDC CER	28480	0160-4832
A21C27	0180-2951	6	6	CAPACITOR-FXD 33UF+-20% 16VDC AL	28480	0180-2951
A21C28	0180-2951	6		CAPACITOR-FXD 33UF+-20% 16VDC AL	28480	0180-2951
A21C29	0180-2951	6		CAPACITOR-FXD 33UF+-20% 16VDC AL	28480	0180-2951
A21C30	0180-1082	2		CAPACITOR, FXD 10 UF 100VDCW AL	28480	0180-1082
A21CR1	1902-3234	3	4	DIODE-ZNR 19.6V 5% DO-7 PDS.4W TC=+.073%	28480	1902-3234
A21CR2	1902-3234	3		DIODE-ZNR 19.6V 5% DO-7 PDS.4W TC=+.073%	28480	1902-3234
A21CR3	1902-3234	3		DIODE-ZNR 19.6V 5% DO-7 PDS.4W TC=+.073%	28480	1902-3234
A21CR4	1902-3234	3		DIODE-ZNR 19.6V 5% DO-7 PDS.4W TC=+.073%	28480	1902-3234
A21CR5	1901-0033	2		DIODE-GEN PRP 180V 200MA DO-7	28480	1901-0033
A21CR6	1901-0033	2		DIODE-GEN PRP 180V 200MA DO-7	28480	1901-0033
A21CR7	1901-0025	2		DIODE-GEN PRP 100V 200MA DO-7	28480	1901-0025
A21CR8	1901-0025	2		DIODE-GEN PRP 100V 200MA DO-7	28480	1901-0025
A21CR9	1901-0025	2		DIODE-GEN PRP 100V 200MA DO-7	28480	1901-0025
A21CR10	1901-0025	2		DIODE-GEN PRP 100V 200MA DO-7	28480	1901-0025
A21CR11	1901-0025	2		DIODE-GEN PRP 100V 200MA DO-7	28480	1901-0025
A21CR12	1902-1259	8	4	DIODE-ZNR 1N5357B 20V 5% PDS.5W IR=500NA	04713	1N5357B
A21CR13	1902-1259	8		DIODE-ZNR 1N5357B 20V 5% PDS.5W IR=500NA	04713	1N5357B
A21CR14	1902-1259	8		DIODE-ZNR 1N5357B 20V 5% PDS.5W IR=500NA	04713	1N5357B
A21CR15	1902-1259	8		DIODE-ZNR 1N5357B 20V 5% PDS.5W IR=500NA	04713	1N5357B
A21CR16	1901-0033	2		DIODE-GEN PRP 180V 200MA DO-7	28480	1901-0033
A21CR17	1901-0033	2		DIODE-GEN PRP 180V 200MA DO-7	28480	1901-0033
A21CR18	1901-0025	2		DIODE-GEN PRP 100V 200MA DO-7	28480	1901-0025
A21CR19	1901-0033	2		DIODE-GEN PRP 180V 200MA DO-7	28480	1901-0033
A21CR20	1901-0033	2		DIODE-GEN PRP 180V 200MA DO-7	28480	1901-0033
A21CR21	1901-0025	2		DIODE-GEN PRP 100V 200MA DO-7	28480	1901-0025
A21CR22	1901-0025	2		DIODE-GEN PRP 100V 200MA DO-7	28480	1901-0025
A21CR23	1901-0460	9	2	DIODE-STABISTOR 30V 150MA DO-7	28480	1901-0460
A21CR24	1901-0460	9		DIODE-STABISTOR 30V 150MA DO-7	28480	1901-0460
A21CR25	1901-0025	2		DIODE-GEN PRP 100V 200MA DO-7	28480	1901-0025
A21CR26	1901-0025	2		DIODE-GEN PRP 100V 200MA DO-7	28480	1901-0025
A21CR27	1902-3122	8	2	DIODE-ZNR 6.65V 2% DO-7 PDS.4W TC=+.038%	28480	1902-3122
A21CR28	1901-0025	2		DIODE-GEN PRP 100V 200MA DO-7	28480	1901-0025
A21CR29	1901-0025	2		DIODE-GEN PRP 100V 200MA DO-7	28480	1901-0025



Table 6-3. Replaceable Parts (Cont'd).

Reference Designation	HP Part Number	C D	Qty	Description	Mfr Code	Mfr Part Number
	1200-0607	8	4	SOCKET-IC 16-CONT DIP-SLDR	28480	1200-0607
	1200-0607	8		SOCKET-IC 16-CONT DIP-SLDR	28480	1200-0607
	1200-0654	1		SOCKET-IC 40-CONT	28480	1200-0654
	1200-0541	1	2	SOCKET-IC 24-CONT DIP DIP-SLDR	28480	1200-0541
	0490-0240	9		RELAY-REED 1A	28480	0490-0240
	0490-0242	1	1	RELAY-REED	28480	0490-0242
	9100-1618	1	4	COIL-MLD 5.6UH 10% Q=45 .155DX,375LG-NOM	28480	9100-1618
	9100-1618	1		COIL-MLD 5.6UH 10% Q=45 .155DX,375LG-NOM	28480	9100-1618
	9100-3139	5		COIL 75UH 15% .5DX,875LG-NOM	28480	9100-3139
	1853-0204	6	7	TRANSISTOR PNP 2N4920 SI PD=30W FT=3MHZ	04713	2N4920
	1854-0271	9	2	TRANSISTOR NPN SI TO-39 PD=1W FT=150MHZ	28480	1854-0271
	1853-0232	0	1	TRANSISTOR PNP SI TO-39 PD=1W FT=200MHZ	28480	1853-0232
	1853-0080	6	12	TRANSISTOR PNP SI PD=300MW FT=30MHZ	28480	1853-0080
	1854-0474	4	12	TRANSISTOR NPN SI PD=310MW FT=100MHZ	04713	2N5551
	1854-0474	4		TRANSISTOR NPN SI PD=310MW FT=100MHZ	04713	2N5551
	1853-0080	6		TRANSISTOR PNP SI PD=300MW FT=30MHZ	28480	1853-0080
	1855-0571	8		TRANSISTOR J-FET N-CHAN 51	28480	1855-0571
	1855-0571	8		TRANSISTOR J-FET N-CHAN 51	28480	1855-0571
	1855-0571	8		TRANSISTOR J-FET N-CHAN 51	28480	1855-0571
	1855-0571	8		TRANSISTOR J-FET N-CHAN 51	28480	1855-0571
	1855-0571	8		TRANSISTOR J-FET N-CHAN 51	28480	1855-0571
	1855-0571	8		TRANSISTOR J-FET N-CHAN 51	28480	1855-0571
	1853-0204	6		TRANSISTOR PNP 2N4920 SI PD=30W FT=3MHZ	04713	2N4920
	1853-0080	6		TRANSISTOR PNP SI PD=300MW FT=30MHZ	28480	1853-0080
	1854-0474	4		TRANSISTOR NPN SI PD=310MW FT=100MHZ	04713	2N5551
	1853-0080	6		TRANSISTOR PNP SI PD=300MW FT=30MHZ	28480	1853-0080
	1853-0204	6		TRANSISTOR PNP 2N4920 SI PD=30W FT=3MHZ	04713	2N4920
	1853-0080	6		TRANSISTOR PNP SI PD=300MW FT=30MHZ	28480	1853-0080
	1853-0204	6		TRANSISTOR PNP 2N4920 SI PD=30W FT=3MHZ	04713	2N4920
	1854-0347	0	4	TRANSISTOR NPN 2N4923 SI PD=30W FT=3MHZ	04713	2N4923
	1854-0474	4		TRANSISTOR NPN SI PD=310MW FT=100MHZ	04713	2N5551
	1853-0080	6		TRANSISTOR PNP SI PD=300MW FT=30MHZ	28480	1853-0080
	1854-0474	4		TRANSISTOR NPN SI PD=310MW FT=100MHZ	04713	2N5551
	1854-0347	0		TRANSISTOR NPN 2N4923 SI PD=30W FT=3MHZ	04713	2N4923
	1854-0474	4		TRANSISTOR NPN SI PD=310MW FT=100MHZ	04713	2N5551
	1854-0347	0		TRANSISTOR NPN 2N4923 SI PD=30W FT=3MHZ	04713	2N4923
	1853-0080	6		TRANSISTOR PNP SI PD=300MW FT=30MHZ	28480	1853-0080
	1854-0474	4		TRANSISTOR NPN SI PD=310MW FT=100MHZ	04713	2N5551
	1853-0204	6		TRANSISTOR PNP 2N4920 SI PD=30W FT=3MHZ	04713	2N4920
	0683-1835	9		RESISTOR 18K 5% .25W FC TC=400/+800	01121	C81835
	0683-8215	3		RESISTOR 820 5% .25W FC TC=400/+600	01121	C88215
	0683-2225	3		RESISTOR 2.2K 5% .25W FC TC=400/+700	01121	C82225
	0683-1225	1	11	RESISTOR 1.2K 5% .25W FC TC=400/+700	01121	C81225
	0683-1235	3		RESISTOR 12K 5% .25W FC TC=400/+800	01121	C81235
	0683-5615	1		RESISTOR 560 5% .25W FC TC=400/+600	01121	C85615
	2100-3274	2		RESISTOR-TRMR 10K 10% C SIDE=ADJ 1-TRN	28480	2100-3274
	0683-1835	9		RESISTOR 18K 5% .25W FC TC=400/+800	01121	C81835
	0683-1835	9		RESISTOR 18K 5% .25W FC TC=400/+800	01121	C81835
	2100-3274	2		RESISTOR-TRMR 10K 10% C SIDE=ADJ 1-TRN	28480	2100-3274
	2100-3274	2		RESISTOR-TRMR 10K 10% C SIDE=ADJ 1-TRN	28480	2100-3274
	2100-3426	6		RESISTOR-TRMR 20 10% C SIDE=ADJ 1-TRN	28480	2100-3426
	0683-1515	2		RESISTOR 150 5% .25W FC TC=400/+600	01121	C81515
	0683-8215	3		RESISTOR 820 5% .25W FC TC=400/+600	01121	C88215
	0683-2225	3		RESISTOR 2.2K 5% .25W FC TC=400/+700	01121	C82225
	0683-1225	1		RESISTOR 1.2K 5% .25W FC TC=400/+700	01121	C81225
	0683-1235	3		RESISTOR 12K 5% .25W FC TC=400/+800	01121	C81235
	0683-5615	1		RESISTOR 560 5% .25W FC TC=400/+600	01121	C85615
	0698-3260	9	2	RESISTOR 464K 1% .125W F TC=0+-100	28480	0698-3260
	0757-0458	7		RESISTOR 51.1K 1% .125W F TC=0+-100	24546	C4=1/8-T0=5112-F
	0698-3260	9		RESISTOR 464K 1% .125W F TC=0+-100	28480	0698-3260
	0683-4725	2		RESISTOR 4.7K 5% .25W FC TC=400/+700	01121	C84725
	0699-0391	3	4	RESISTOR 25K .1% .125W F TC=0+-25	28480	0699-0391
	0699-0391	3		RESISTOR 25K .1% .125W F TC=0+-25	28480	0699-0391
	0683-4725	2		RESISTOR 4.7K 5% .25W FC TC=400/+700	01121	C84725
	0698-3442	9	4	RESISTOR 237 1% .125W F TC=0+-100	24546	C4=1/8-T0=237R-F
	0757-0403	2		RESISTOR 121 1% .125W F TC=0+-100	24546	C4=1/8-T0=121R-F
	0699-0390	2	2	RESISTOR 450K .1% .125W F TC=0+-25	28480	0699-0390
	0698-2198	0	2	RIFXD MET FLM 50K OHM 0.1% 1/8W	28480	0698-2198
	0683-8205	1	1	RESISTOR 82 5% .25W FC TC=400/+500	01121	C88205
	0683-1225	1		RESISTOR 1.2K 5% .25W FC TC=400/+700	01121	C81225
	0683-5615	1		RESISTOR 560 5% .25W FC TC=400/+600	01121	C85615
	0698-2198	0		RIFXD MET FLM 50K OHM 0.1% 1/8W	28480	0698-2198
	0699-0390	2		RESISTOR 450K .1% .125W F TC=0+-25	28480	0699-0390

See introduction to this section for ordering information  
\*Indicates factory selected value

Table 6-3. Replaceable Parts (Cont'd)

Reference Designation	HP Part Number	C D	Qty	Description	Mfr Code	Mfr Part Number
A21R40	0683-5625	3		RESISTOR 5.6K 5% .25W FC TC=400/+700	01121	C85625
A21R41	0683-5625	3		RESISTOR 5.6K 5% .25W FC TC=400/+700	01121	C85625
A21R42	0683-5625	3		RESISTOR 5.6K 5% .25W FC TC=400/+700	01121	C85625
A21R43	0683-5625	3		RESISTOR 5.6K 5% .25W FC TC=400/+700	01121	C85625
A21R44	0683-1235	3		RESISTOR 12K 5% .25W FC TC=400/+800	01121	C81235
A21R45	0683-1235	3		RESISTOR 12K 5% .25W FC TC=400/+800	01121	C81235
A21R46	0683-3335	8		RESISTOR 33K 5% .25W FC TC=400/+800	01121	C83335
A21R47	0683-1835	9		RESISTOR 18K 5% .25W FC TC=400/+800	01121	C81835
A21R48	2100-3354	8		RESISTOR-TRMP 50K 10% C SIDE-ADJ 1-TRN	32997	
A21R49	0683-5625	3		RESISTOR 5.6K 5% .25W FC TC=400/+700	01121	C85625
A21R50	0698-3442	9		RESISTOR 237 1% .125W F TC=0+/-100	24546	C4-1/8-T0-237R-F
A21R51	0698-3442	9		RESISTOR 237 1% .125W F TC=0+/-100	24546	C4-1/8-T0-237R-F
A21R52	0698-3442	9		RESISTOR 237 1% .125W F TC=0+/-100	24546	C4-1/8-T0-237R-F
A21R53	0683-1835	9		RESISTOR 18K 5% .25W FC TC=400/+800	01121	C81835
A21R54	0683-1505	0	2	RESISTOR 15 5% .25W FC TC=400/+500	01121	C81505
A21R55	0683-3335	8		RESISTOR 33K 5% .25W FC TC=400/+800	01121	C83335
A21R56	0683-5605	9	3	RESISTOR 56 5% .25W FC TC=400/+500	01121	C85605
A21R57	0698-3450	9		RESISTOR 42.2K 1% .125W F TC=0+/-100	24546	C4-1/8-T0-4222-F
A21R58	0698-3450	9		RESISTOR 42.2K 1% .125W F TC=0+/-100	24546	C4-1/8-T0-4222-F
A21R59	0683-4735	4		RESISTOR 47K 5% .25W FC TC=400/+800	01121	C84735
A21R60	0683-1225	1		RESISTOR 1.2K 5% .25W FC TC=400/+700	01121	C81225
A21R61	0683-1235	3		RESISTOR 12K 5% .25W FC TC=400/+800	01121	C81235
A21R62	0683-1235	3		RESISTOR 12K 5% .25W FC TC=400/+800	01121	C81235
A21R63	0683-1225	1		RESISTOR 1.2K 5% .25W FC TC=400/+700	01121	C81225
A21R64	0683-3335	8		RESISTOR 33K 5% .25W FC TC=400/+800	01121	C83335
A21R65	0683-5615	1		RESISTOR 560 5% .25W FC TC=400/+600	01121	C85615
A21R66	0757-0439	4		RESISTOR 6.81K 1% .125W F TC=0+/-100	24546	C4-1/8-T0-6811-F
A21R67	0757-0439	4		RESISTOR 6.81K 1% .125W F TC=0+/-100	24546	C4-1/8-T0-6811-F
A21R68	1810-0269	3		NETWORK-RES 9-PIN-BIP .1-PIN-SPCG	28480	1810-0269
A21R69	0683-1055	5		NETWORK 1M 5% .25W FC TC=800/+900	01121	C81055
A21R70	0683-1835	9		RESISTOR 18K 5% .25W FC TC=400/+800	01121	C81835
A21R71	0683-1505	0		RESISTOR 15 5% .25W FC TC=400/+500	01121	C81505
A21R72	0683-3335	8		RESISTOR 33K 5% .25W FC TC=400/+800	01121	C83335
A21R73	0683-5605	9		RESISTOR 56 5% .25W FC TC=400/+500	01121	C85605
A21R74	0683-4725	2		RESISTOR 4.7K 5% .25W FC TC=400/+700	01121	C84725
A21R75	0683-3335	8		RESISTOR 33K 5% .25W FC TC=400/+800	01121	C83335
A21R76	0683-4735	4		RESISTOR 47K 5% .25W FC TC=400/+800	01121	C84735
A21R77	0683-1225	1		RESISTOR 1.2K 5% .25W FC TC=400/+700	01121	C81225
A21R78	0683-1235	3		RESISTOR 12K 5% .25W FC TC=400/+800	01121	C81235
A21R79	0683-1835	9		RESISTOR 18K 5% .25W FC TC=400/+800	01121	C81835
A21R80	0683-1225	1		RESISTOR 1.2K 5% .25W FC TC=400/+700	01121	C81225
A21R81	0683-5605	9		RESISTOR 56 5% .25W FC TC=400/+500	01121	C85605
A21R82	1810-0269	3		NETWORK-RES 9-PIN-BIP .1-PIN-SPCG	28480	1810-0269
A21R83	2100-3252	6	2	RESISTOR-TRMR 5K 10% C TOP-ADJ 1-TRN	28480	2100-3252
A21R84	1810-0269	3		NETWORK-RES 9-PIN-BIP .1-PIN-SPCG	28480	1810-0269
A21R85	0683-1235	3		RESISTOR 12K 5% .25W FC TC=400/+800	01121	C81235
A21R86	0683-5625	3		RESISTOR 5.6K 5% .25W FC TC=400/+700	01121	C85625
A21U1	1826-0319	7		OP AMP BIFET TO-99	27014	LF356H
A21U2	1826-0357	7		OP AMP NB TO-99	27014	LF357H
A21U3	1826-0319	7		OP AMP BIFET TO-99	27014	LF356H
A21U4	1820-1856	7	2	CONV 12-B/D/A 24-DIP-C	24355	AD563KD/8CD
A21U5	1820-1730	6		IC FF TTL LS D-TYPE POS-EDGE-TRIG COM	01295	8N74LS273N
A21U6	1826-0122	0		IC 7805 V RGLTR TO-220	07263	7805UC
A21U7	1826-0174	2		COMPARATOR GP QUAD 14-DIP-P	28480	1826-0174
A21U8	1820-1730	6		IC FF TTL LS D-TYPE POS-EDGE-TRIG COM	01295	8N74LS273N
A21U9	1826-0222	1		OP AMP GP QUAD 14-DIP-P	07263	UA4136PC
A21U10	1820-1197	9		IC GATE TTL LS NAND QUAD 2-INP	01295	8N74LS00N
A21U11	1820-1481	4		IC PIA NMOS	04713	MC6821L
A21U12	1820-2024	3		IC DRVR TTL LS LINE DRVR OCTL	01295	8N74LS244N
A21U13	1820-2024	3		IC DRVR TTL LS LINE DRVR OCTL	01295	8N74LS244N
				A21 MISCELLANEOUS PARTS		
	04274-26521	8		PC BOARD, BLANK	28480	04274-26521
A22	04274-66522	3	1	HP-IB INTERFACE BOARD ASSEMBLY (OPTION 101 ONLY)	28480	04274-66522
A22C1	0160-4832	9		CAPACITOR-FXD 01UF +-10% 100VDC CEP	28480	0160-4832
A22C2	0160-4832	9		CAPACITOR-FXD 01UF +-10% 100VDC CEP	28480	0160-4832
A22C3	0160-4832	9		CAPACITOR-FXD 01UF +-10% 100VDC CEP	28480	0160-4832
A22C4	0160-4832	9		CAPACITOR-FXD 01UF +-10% 100VDC CEP	28480	0160-4832
A22C5	0160-0228	6		CAPACITOR-FXD 22UF+-10% 15VDC TA	56289	1500228X901582
A22J1	1200-0654	1		SOCKET-IC 40-CONT	28480	1200-0608

Table 6-3. Replaceable Parts (Cont'd).

Reference Designation	HP Part Number	C D	Qty	Description	Mfr Code	Mfr Part Number
2L1	9100-3139	5		COIL 75UH 15% .90x.875LG=NDM	28480	9100-3139
2L2	9100-1788	6		CHOKE-WIDE BAND 2MAX=680 OHM@ 180 MHZ	02114	VK200 20/48
2R1	1810-0269	3		NETWORK-RES 9-PIN-SIP .1-PIN-SPCG	28480	1810-0269
2R2	0683-1835	9		RESISTOR 18K 5% .25W FC TC=400/+800	01121	C81835
2R3	0683-4725	2		RESISTOR 4.7K 5% .25W FC TC=400/+700	01121	C84725
2R4	0683-4725	2		RESISTOR 4.7K 5% .25W FC TC=400/+700	01121	C84725
2R5	0683-4725	2		RESISTOR 4.7K 5% .25W FC TC=400/+700	01121	C84725
2R6	0683-4725	2		RESISTOR 4.7K 5% .25W FC TC=400/+700	01121	C84725
2R7	0683-4725	2		RESISTOR 4.7K 5% .25W FC TC=400/+700	01121	C84725
2S1	3101-1973	7		SWITCH-8L 7-1A DIP-8SLIDE-A899 .1A 50VDC	28480	3101-1973
2U1	1820-1873	8	1	IC BFR TTL LS INV OCTL 2-INP	27014	DM81L988N
2U2	1820-1204	1	1	IC GATE TTL LS NAND DUAL 4-INP	01295	8N74LS20N
2U3	1820-2113	1	1	IC MICPROC-ACCESS NMOS	04713	MC68488L
2U4	1820-1199	1	1	IC INV TTL LS HEX 1-INP	01295	8N74LS04N
2U5	1820-2058	3	4	IC MISC TTL S QUAD	28480	1820-2058
2U6	1820-2058	3		IC MISC TTL S QUAD	28480	1820-2058
2U8	1820-1144	6		IC GATE TTL LS NOR QUAD 2-INP	01295	8N74LS02N
2U9	1820-2058	3		IC MISC TTL S QUAD	28480	1820-2058
2U10	1820-2058	3		IC MISC TTL S QUAD	28480	1820-2058
2W1	8159-0005	0		WIRE 22AWG W PVC 1X22 80C	28480	8159-0005
2W2	8159-0005	0		WIRE 22AWG W PVC 1X22 80C	28480	8159-0005
				A22 MISCELLANEOUS PARTS		
	04274-26522	9		PC BOARD, BLANK	28480	04274-26522
	04274-66523	4	1	DC BIAS (+/-100V) BOARD ASSEMBLY (OPTION 002 ONLY)	28480	04274-66523
3C1	0140-0210	2	1	CAPACITOR-FXD 270PF +/-5% 300VDC MICA	72136	DM15F271J0300MV1CR
3C3	0160-4832	9		CAPACITOR-FXD .01UF +/-10% 100VDC CER	28480	0160-4832
3C4	0160-4832	9		CAPACITOR-FXD .01UF +/-10% 100VDC CER	28480	0160-4832
3C5	0180-1050	4		CAPACITOR-FXD 100uF +50-10% 25VDC	28480	0180-1050
3C6	0160-4832	9		CAPACITOR-FXD .01UF +/-10% 100VDC CER	28480	0160-4832
3C7	0160-0127	2		CAPACITOR-FXD 1UF +/-20% 25VDC CER	28480	0160-0127
3C8	0160-4832	9		CAPACITOR-FXD .01UF +/-10% 100VDC CER	28480	0160-4832
3C9	0160-4832	9		CAPACITOR-FXD .01UF +/-10% 100VDC CER	28480	0160-4832
3C10	0180-1080	0	2	CAPACITOR-FXD 4.7uF +100-10% 160VDC	28480	0180-1080
3C11	0180-1080	0	2	CAPACITOR-FXD 4.7uF +100-10% 160VDC	28480	0180-1080
3C12	0180-1082	2		CAPACITOR-FXD 10uF +50-10% 100VDC	28480	0180-1082
3C13	0180-1082	2		CAPACITOR-FXD 10uF +50-10% 100VDC	28480	0180-1082
3C14	0160-4832	9		CAPACITOR-FXD .01UF +/-10% 100VDC CER	28480	0160-4832
3C15	0180-1050	4		CAPACITOR-FXD 100uF +50-10% 25VDC	28480	0180-1050
3C16	0170-0066	9	2	CAPACITOR-FXD .027UF +/-10% 200VDC POLYE	28480	0170-0066
3C17	0170-0066	9		CAPACITOR-FXD .027UF +/-10% 200VDC POLYE	28480	0170-0066
3C18	0160-3456	6		CAPACITOR-FXD 1000PF +/-10% 1KVDC CER	28480	0160-3456
3C19	0160-3456	6		CAPACITOR-FXD 1000PF +/-10% 1KVDC CER	28480	0160-3456
3C20	0160-3456	6		CAPACITOR-FXD 1000PF +/-10% 1KVDC CER	28480	0160-3456
3C21	0180-1050	4		CAPACITOR-FXD 100uF +50-10% 25VDC	28480	0180-1050
3C22	0180-1050	4		CAPACITOR-FXD 100uF +50-10% 25VDC	28480	0180-1050
3C23	0180-1081	1		CAPACITOR-FXD 47uF +50-10% 50VDC	28480	0180-1081
3C24	0180-1081	1		CAPACITOR-FXD 47uF +50-10% 50VDC	28480	0180-1081
3C25	0180-1081	1		CAPACITOR-FXD 47uF +50-10% 50VDC	28480	0180-1081
3C26	0180-1081	1		CAPACITOR-FXD 47uF +50-10% 50VDC	28480	0180-1081
3C27	0180-1082	2		CAPACITOR-FXD 10uF +50-10% 100VDC	28480	0180-1082
3C28	0180-1082	2		CAPACITOR-FXD 10uF +50-10% 100VDC	28480	0180-1082
3C29	0180-1050	4		CAPACITOR-FXD 100uF +50-10% 25VDC	28480	0180-1050
3C30	0160-4832	9		CAPACITOR-FXD .01UF +/-10% 100VDC CER	28480	0160-4832
3C31	0180-1081	1		CAPACITOR-FXD 47uF +50-10% 50VDC	28480	0180-1081
3C32	0180-1050	4		CAPACITOR-FXD 100uF +50-10% 25DC	28480	0180-1050
3C33	0180-1050	4		CAPACITOR-FXD 100uF +50-10% 25DC	28480	0180-1050
3C34	0160-4832	9		CAPACITOR-FXD .01UF +/-10% 100VDC CER	28480	0160-4832
3C35	0180-2951	6		CAPACITOR-FXD 33UF +/-20% 16VDC AL	28480	0180-2951
3C36	0180-2951	6		CAPACITOR-FXD 33UF +/-20% 16VDC AL	28480	0180-2951
3C37	0180-2951	6		CAPACITOR-FXD 33UF +/-20% 16VDC AL	28480	0180-2951
3CR1	1902-3385	5	4	DIODE-ZNR 69.8V 2% DO-7 PDS.4W TC=+.079%	28480	1902-3385
3CR2	1902-3385	5		DIODE-ZNR 69.8V 2% DO-7 PDS.4W TC=+.079%	28480	1902-3385
3CR3	1902-3385	5		DIODE-ZNR 69.8V 2% DO-7 PDS.4W TC=+.079%	28480	1902-3385
3CR4	1902-3385	5		DIODE-ZNR 69.8V 2% DO-7 PDS.4W TC=+.079%	28480	1902-3385
3CR5	1901-0025	2		DIODE-GEN PRP 100V 200MA DO-7	28480	1901-0025
3CR6	1901-0025	2		DIODE-GEN PRP 100V 200MA DO-7	28480	1901-0025
3CR7	1901-0025	2		DIODE-GEN PRP 100V 200MA DO-7	28480	1901-0025
3CR8	1901-0033	2		DIODE-GEN PRP 180V 200MA DO-7	28480	1901-0033
3CR9	1901-0033	2		DIODE-GEN PRP 180V 200MA DO-7	28480	1901-0033
3CR10	1901-0033	2		DIODE-GEN PRP 180V 200MA DO-7	28480	1901-0033

See introduction to this section for ordering information  
\*Indicates factory selected value

Table 6-3. Replaceable Parts (Cont'd)

Reference Designation	HP Part Number	C D	Qty	Description	Mfr Code	Mfr Part Number
A23CR11	1901-0033	2		DIODE-GEN PHP 180V 200MA 00-7	28480	1901-0033
A23CR12	1901-0025	2		DIODE-GEN PRP 100V 200MA 00-7	28480	1901-0025
A23CR13	1901-0025	2		DIODE-GEN PRP 100V 200MA 00-7	28480	1901-0025
A23CR14	1901-0025	2		DIODE-GEN PRP 100V 200MA 00-7	28480	1901-0025
A23CR15	1902-3122	8		DIODE-ZNR 6.65V 2x 00-7 PD=.4W TC=+.038x	28480	1902-3122
A23J1	1200-0607	8		SOCKET-IC 16-CONT DIP DIP-SLDR	28480	1200-0607
A23J2	1200-0607	8		SOCKET-IC 16-CONT DIP DIP-SLDR	28480	1200-0607
A23J3	1200-0654	1		SOCKET-IC 40-CONT	28480	1200-0654
A23J4	1200-0541	1		SOCKET-IC 24-CONT DIP DIP-SLDR	28480	1200-0541
A23L1	9140-0137	1	6	COIL-MLD 1MH 5x Q860 .190x.44LG-NOM	28480	9140-0137
A23L2	9140-0137	1		COIL-MLD 1MH 5x Q860 .190x.44LG-NOM	28480	9140-0137
A23L3	9140-0137	1		COIL-MLD 1MH 5x Q860 .190x.44LG-NOM	28480	9140-0137
A23L4	9140-0137	1		COIL-MLD 1MH 5x Q860 .190x.44LG-NOM	28480	9140-0137
A23L5	9140-0137	1		COIL-MLD 1MH 5x Q860 .190x.44LG-NOM	28480	9140-0137
A23L6	9140-0137	1		COIL-MLD 1MH 5x Q860 .190x.44LG-NOM	28480	9140-0137
A23L7	9100-1618	1		COIL-MLD 5.6UH 10x Q845 .155DX.375LG-NOM	28480	9100-1618
A23L8	9100-1618	1		COIL-MLD 5.6UH 10x Q845 .155DX.375LG-NOM	28480	9100-1618
A23L9	9100-3139	5		COIL 75UH 15x .5DX.875LG-NOM	28480	9100-3139
A2301	1853-0414	0	1	TRANSISTOR PNP 2N6423 SI TO-66 PD=15W	04713	2N6423
A2302	1854-0324	3	1	TRANSISTOR NPN 2N3739 SI TO-66 PD=20W	04713	2N3739
A2303	1854-0474	4		TRANSISTOR NPN SI PD=310MW FT=100MHZ	04713	2N5551
A2304	1853-0080	6		TRANSISTOR PNP SI PD=300MW FT=30MHZ	28480	1853-0080
A2305	1855-0571	8		TRANSISTOR J-FET N-CHAN 51	28480	1855-0571
A2306	1855-0571	6		TRANSISTOR J-FET N-CHAN 51	28480	1855-0571
A2307	1853-0204	6		TRANSISTOR PNP 2N4920 SI PD=30W FT=3MHZ	04713	2N4920
A2308	1853-0037	3	1	TRANSISTOR PNP SI TO-39 PD=1W FT=100MHZ	28480	1853-0037
A2309	1854-0271	9		TRANSISTOR NPN SI TO-39 PD=1W FT=150MHZ	28480	1854-0271
A23010	1854-0474	4		TRANSISTOR NPN SI PD=310MW FT=100MHZ	04713	2N5551
A23011	1853-0080	6		TRANSISTOR PNP SI PD=300MW FT=30MHZ	28480	1853-0080
A23012	1854-0347	0		TRANSISTOR NPN 2N4923 SI PD=30W FT=3MHZ	04713	2N4923
A23013	1854-0474	4		TRANSISTOR NPN SI PD=310MW FT=100MHZ	04713	2N5551
A23014	1853-0080	6		TRANSISTOR PNP SI PD=300MW FT=30MHZ	28480	1853-0080
A23015	1853-0204	6		TRANSISTOR PNP 2N4920 SI PD=30W FT=3MHZ	04713	2N4920
A23016	1853-0080	6		TRANSISTOR PNP SI PD=300MW FT=30MHZ	28480	1853-0080
A23017	1854-0474	4		TRANSISTOR NPN SI PD=310MW FT=100MHZ	04713	2N5551
A23018	1853-0080	6		TRANSISTOR PNP SI PD=300MW FT=30MHZ	28480	1853-0080
A23019	1854-0474	4		TRANSISTOR NPN SI PD=310MW FT=100MHZ	04713	2N5551
A23R1	0683-2725	8	2	RESISTOR 2.7K 5x .25W FC TC=400/+700	01121	C82725
A23R2	0683-5625	3		RESISTOR 5.6K 5x .25W FC TC=400/+800	01121	C85625
A23R3	0683-3335	6		RESISTOR 33K 5x .25W FC TC=400/+800	01121	C83335
A23R4	0683-3325	6		RESISTOR 3.3K 5x .25W FC TC=400/+700	01121	C83325
A23R5	0683-1535	6		RESISTOR 15K 5x .25W FC TC=400/+800	01121	C81535
A23R6	0683-1535	6		RESISTOR 15K 5x .25W FC TC=400/+800	01121	C81535
A23R7	0683-2225	3		RESISTOR 2.2K 5x .25W FC TC=400/+700	01121	C82225
A23R8	2100-3274	2		RESISTOR-TRMR 10K 10x C SIDE-ADJ 1-TRN	28480	2100-3274
A23R9	2100-3207	1		RESISTOR-TRMR 5K 10x C SIDE-ADJ 1-TRN	28480	2100-3207
A23R10	0683-4755	8	2	RESISTOR 4.7M 5x .25W FC TC=900/+1100	01121	C84755
A23R11	2100-3274	2		RESISTOR-TRMR 10K 10x C SIDE-ADJ 1-TRN	28480	2100-3274
A23R12	0683-4755	8		RESISTOR 4.7M 5x .25W FC TC=900/+1100	01121	C84755
A23R13	2100-3274	2		RESISTOR-TRMR 10K 10x C SIDE-ADJ 1-TRN	28480	2100-3274
A23R14	0683-1835	9		RESISTOR 18K 5x .25W FC TC=400/+800	01121	C81835
A23R15	0683-1835	9		RESISTOR 18K 5x .25W FC TC=400/+800	01121	C81835
A23R16	0683-3335	6		RESISTOR 33K 5x .25W FC TC=400/+800	01121	C83335
A23R17	0683-3325	6		RESISTOR 3.3K 5x .25W FC TC=400/+700	01121	C83325
A23R18	0683-1535	6		RESISTOR 15K 5x .25W FC TC=400/+800	01121	C81535
A23R19	0683-2225	3		RESISTOR 2.2K 5x .25W FC TC=400/+700	01121	C82225
A23R20	0683-2225	3		RESISTOR 2.2K 5x .25W FC TC=400/+700	01121	C82225
A23R21	0757-0464	5	2	RESISTOR 90.9K 1x .125W F TC=0/+100	24546	C4-1/8-T0-9092-F
A23R22	0699-0391	3		RESISTOR 25K .1x .125W F TC=0/+25	28480	0699-0391
A23R23	0699-0391	3		RESISTOR 25K .1x .125W F TC=0/+25	28480	0699-0391
A23R24	0683-4725	2		RESISTOR 4.7K 5x .25W FC TC=400/+700	01121	C84725
A23R25	0698-4486	3	2	RESISTOR 24.9K 1x .125W F TC=0/+100	24546	C4-1/8-T0-2492-F
A23R26	0698-4486	3		RESISTOR 24.9K 1x .125W F TC=0/+100	24546	C4-1/8-T0-2492-F
A23R27	0683-2235	3		RESISTOR 22K 5x .25W FC TC=400/+800	01121	C82235
A23R28	0757-0468	5		RESISTOR 90.9K 1x .125W F TC=0/+100	28480	0757-0468
A23R29	0757-0464	5		RESISTOR 90.9K 1x .125W F TC=0/+100	24546	C4-1/8-T0-9092-F
A23R30	0683-4725	2		RESISTOR 4.7K 5x .25W FC TC=400/+700	01121	C84725
A23R31	0683-1835	9		RESISTOR 18K 5x .25W FC TC=400/+800	01121	C81835
A23R32	0683-1835	9		RESISTOR 18K 5x .25W FC TC=400/+800	01121	C81835
A23R33	0683-3335	6		RESISTOR 33K 5x .25W FC TC=400/+800	01121	C83335
A23R34	0683-3335	6		RESISTOR 33K 5x .25W FC TC=400/+800	01121	C83335
A23R35	0698-3450	9		RESISTOR 42.2K 1x .125W F TC=0/+100	24546	C4-1/8-T0-4222-F
A23R36	0698-3450	9		RESISTOR 42.2K 1x .125W F TC=0/+100	24546	C4-1/8-T0-4222-F
A23R37	0683-4735	4		RESISTOR 47K 5x .25W FC TC=400/+800	01121	C84735
A23R38	0683-1225	1		RESISTOR 1.2K 5x .25W FC TC=400/+700	01121	C81225
A23R39	0683-1235	3		RESISTOR 12K 5x .25W FC TC=400/+800	01121	C81235
A23R40	0683-1525	4		RESISTOR 1.5K 5x .25W FC TC=400/+700	01121	C81525
A23R41	0683-1005	5		RESISTOR 10 5x .25W FC TC=400/+500	01121	C81005
A23R42	0683-1005	5		RESISTOR 10 5x .25W FC TC=400/+500	01121	C81005

See introduction to this section for ordering information  
\*Indicates factory selected value

Table 6-3. Replaceable Parts (Cont'd)

Reference Designation	HP Part Number	C D	Qty	Description	Mfr Code	Mfr Part Number
3R43	0683-1405	5		RESISTOR 10 5% .25W FC TC=400/+500	01121	CB1005
3R44	0683-1525	4		RESISTOR 1.5K 5% .25W FC TC=400/+700	01121	CB1525
3R45	0683-2235	5		RESISTOR 22K 5% .25W FC TC=400/+800	01121	CB2235
3R46	0683-2235	5		RESISTOR 22K 5% .25W FC TC=400/+800	01121	CB2235
3R47	0683-4735	4		RESISTOR 47K 5% .25W FC TC=400/+800	01121	CB4735
3R48	0683-1535	6		RESISTOR 15K 5% .25W FC TC=400/+800	01121	CB1535
3R49	0683-1535	6		RESISTOR 15K 5% .25W FC TC=400/+800	01121	CB1535
3R50	0683-3335	8		RESISTOR 33K 5% .25W FC TC=400/+800	01121	CB3335
3R51	0683-4725	2		RESISTOR 4.7K 5% .25W FC TC=400/+700	01121	CB4725
3R52	0683-4735	4		RESISTOR 47K 5% .25W FC TC=400/+800	01121	CB4735
3R53	0683-1225	1		RESISTOR 1.2K 5% .25W FC TC=400/+700	01121	CB1225
3R54	0683-1235	3		RESISTOR 12K 5% .25W FC TC=400/+800	01121	CB1235
3R55	2100-3252	6		RESISTOR-TMPR 5K 10% C TOP-ADJ 1-TRN	28480	2100-3252
3R56	0683-1225	1		RESISTOR 1.2K 5% .25W FC TC=400/+700	01121	CB1225
3R57	0683-3335	8		RESISTOR 33K 5% .25W FC TC=400/+800	01121	CB3335
3R58	0683-5615	1		RESISTOR 560 5% .25W FC TC=400/+600	01121	CB5615
3R59	0757-0439	4		RESISTOR 6.81K 1% .125W F TC=+100	24546	C4=1/8-T0=6811=F
3R60	0757-0439	4		RESISTOR 6.81K 1% .125W F TC=+100	24546	C4=1/8-T0=6811=F
3R61	0683-1835	9		RESISTOR 18K 5% .25W FC TC=400/+800	01121	CB1835
3R62	0683-1225	1		RESISTOR 1.2K 5% .25W FC TC=400/+700	01121	CB1225
3R63	0683-1015	7		RESISTOR 100 5% .25W FC TC=400/+500	01121	CB1015
3R64	0683-1015	7		RESISTOR 100 5% .25W FC TC=400/+500	01121	CB1015
3R65	1810-0269	3		NETWORK-RES 9-PIN-8IP .1-PIN-8PCG	28480	1810-0269
3R66	1810-0269	3		NETWORK-RES 9-PIN-8IP .1-PIN-8PCG	28480	1810-0269
3R67	1810-0269	3		NETWORK-RES 9-PIN-8IP .1-PIN-8PCG	28480	1810-0269
3R68	0683-1235	3		RESISTOR 12K 5% .25W FC TC=400/+800	01121	CB1235
3R69	0683-5625	3		RESISTOR 5.6K 5% .25W FC TC=400/+700	01121	CB5625
3R70	0683-1235	3		RESISTOR 12K 5% .25W FC TC=400/+800	01121	CB1235
3R71	0683-1005	5		RESISTOR 10 5% .25W FC TC=400/+500	01121	CB1005
3U1	1826-0319	7		OP AMP BIFET TO-99	27014	LF356H
3U2	1826-0319	7		OP AMP BIFET TO-99	27014	LF356H
3U3	1826-0319	7		OP AMP BIFET TO-99	27014	LF356H
3U4	1820-1856	7		CONV 12-B/D/A 24-DIP-C	24355	ADS63KD/BCD
3U5	1826-0122	0		IC 7805 V RGLTR TO-220	07263	7805UC
3U6	1826-0161	7	3	OP AMP GP QUAD 14-DIP-P	04713	MLM324P
3U7	1826-0161	7		OP AMP GP QUAD 14-DIP-P	04713	MLM324P
3U8	1826-0161	7		OP AMP GP QUAD 14-DIP-P	04713	MLM324P
3U9	1826-0174	2		COMPARATOR GP QUAD 14-DIP-P	28480	1826-0174
3U10	1820-1730	6		IC FF TTL LS D-TYPE POS-EDGE-TRIG COM	01295	8N74L8273N
3U11	1820-1730	6		IC FF TTL LS D-TYPE POS-EDGE-TRIG COM	01295	8N74L8273N
3U12	1826-0319	7		OP AMP BIFET TO-99	27014	LF356H
3U13	1826-0222	1		OP AMP GP QUAD 14-DIP-P	07263	UA4136PC
3U14	1820-1197	9		IC GATE TTL LS NAND QUAD 2-INP	01295	8N74LS00N
3U15	1820-1481	4		IC PIA NMOS	04713	MC6821L
3U16	1820-2024	3		IC DRVR TTL LS LINE DRVR OCTL	01295	8N74LS244N
3U17	1820-2024	3		IC DRVR TTL LS LINE DRVR OCTL	01295	8N74LS244N
				A23 MISCELLANEOUS PARTS		
	04274-26523	0		PC BOARD, BLANK	28480	04274-26523
				CHASSIS MOUNTED COMPONENTS		
	0160-4259	9	1	CAPACITOR, FXD .22UF +/-10% 250VDCW	C0633	PME271M622
	0140-0200	0	4	CAPACITOR-FXD 390PF +/-5% 300VDC MICA	72136	DM15F391J0300MV1CR
	0160-2227	0		CAPACITOR-FXD 2400PF +/-5% 300VDC MICA	72136	
	0160-2227	0		CAPACITOR-FXD 2400PF +/-5% 300VDC MICA	72136	
	0160-2227	0		CAPACITOR-FXD 2400PF +/-5% 300VDC MICA	72136	
	0150-0070	3	3	CAPACITOR-FXD .02UF +/-20% 500VDC CER	28480	0150-0070
	0150-0070	3		CAPACITOR-FXD .02UF +/-20% 500VDC CER	28480	0150-0070
	0150-0070	3		CAPACITOR-FXD .02UF +/-20% 500VDC CER	28480	0150-0070
11	1901-0496	1		DIODE-PWR RECT 100V 12A DO-4	04713	MR1121
12	1901-0496	1		DIODE-PWR RECT 100V 12A DO-4	04713	MR1121
	2110-0059	5	1	FUSE 1.5A 250V SLO-BLO 1.25X.25 UL	75915	
	2110-0360	5	1	FUSE 0.75A 250V SLO-BLO 1.25X.25 UL	75915	
1	9135-0035	7	1	FILTER-LINE WIRES-TERMS	28480	9135-0035
	04274-85008	0	1	COIL ASSEMBLY	28480	04274-85008
	1854-0313	0	1	TRANSISTOR NPN 2N3771 SI TO-3 PD=150W	01928	2N3771
	1854-0063	7	1	TRANSISTOR NPN 2N3055 SI TO-3 PD=115W	28480	1854-0063
	1853-0252	4	2	TRANSISTOR PNP SI TO-3 PD=150W FT=4MHZ	28480	1853-0252
	1853-0252	4	4	TRANSISTOR PNP SI TO-3 PD=150W FT=4MHZ	28480	1853-0252
2	3101-2298	1	2	SWITCH, SLIDE DPDT-NS	28480	3101-2298
3	3101-2298	1		SWITCH, SLIDE DPDT-NS	28480	3101-2298
1	3160-0311			BLOWER		

See introduction to this section for ordering information  
\*Indicates factory selected value

Table 6-3. Replaceable Parts (Cont'd).

Reference Designation	HP Part Number	C D	Qty	Description	Mfr Code	Mfr Part Number
W1	04275-61601	9	1	CABLE ASSEMBLY, INPUT(LC) (40 CM)	28480	04275-61601
W2	04275-61602	U	1	CABLE ASSEMBLY, INPUT(LP) (32 CM)	28480	04275-61602
W3	04275-61603	1	1	CABLE ASSEMBLY, INPUT(MC) (50 CM)	28480	04275-61603
W4	04275-61604	2	1	CABLE ASSEMBLY, INPUT(MP) (40 CM)	28480	04275-61604
W5	04275-61605	3	1	CABLE ASSEMBLY, INPUT(A1 THRU A3) (40 CM)	28480	04275-61605
W6	04275-61606	4	1	CABLE ASSEMBLY, INPUT(A1 THRU A4) (48 CM)	28480	04275-61606
W7	04275-61607	4	1	CABLE ASSEMBLY, INPUT(A5 THRU A6) (36 CM)	28480	04275-61607
W8	04275-61608	5	1	CABLE ASSEMBLY, INPUT(A5 THRU A6) (31 CM)	28480	04275-61608
W9	04275-61609	9	2	CABLE ASSEMBLY, DELAY LENE (300CM)	28480	04275-61609
XF1	2110-0565	9	2	FUSEHOLDER CAP 12A MAX FOR UL	28480	2110-0565
XF1	2110-0565	9	2	FUSEHOLDER CAP 12A MAX FOR UL	28480	2110-0565
MISCELLANEOUS PARTS						
1	5040-7219	A	2	FRONT CAP	28480	5040-7219
2	5060-9805	4	2	HANDLE	28480	5060-9805
3	5060-9943	1	2	SIDE COVER	28480	5060-9943
4	5040-7220	1	2	REAR CAP	28480	5040-7220
5	2680-0172	1	2	SCREW-MACH 10-32 .375-IN-LG 100 DEG	28480	2680-0172
6	3101-2216	3	1	SWITCH-PB DPDT ALTNG 4A 250VAC	28480	3101-2216
7	0570-0368	2	2	SCREW	28480	0570-0368
8	2190-0225	6	2	WASHER	28480	2190-0225
9	1200-0080	3	4	INSULATOR-DIO ALUMINUM HD-ANDZ	28480	1200-0080
10	3050-0226	2	4	WASHER-FL MTLG NO. 10 .203-IN-ID	28480	3050-0226
11	2740-0003	5	2	NUT-HEX-W/LKWR 10-32-THD .125-IN-THK	00000	ORDER BY DESCRIPTION
12	1901-0496	1	4	DIODE-PWR RECT 100V 12A DO-4	04713	MR1121
13	9100-0870	5	1	TRANSFORMER	28480	9100-0870
14	1250-0118	2	4	CONNECTOR RF BNC	28480	1250-0118
15	5040-0345	7	6	INSULATOR;CONNECTOR	28480	5040-0345
16	0624-0260	8	8	SCREW-TPG 6-20 .5-IN-LG PAN-HD-PHL STL	00000	ORDER BY DESCRIPTION
17	2190-0020	9	8	WASHER-LK HLCL NO. 5 .128-IN-ID	28480	2190-0020
18	0340-0833	9	4	INSULATOR-XSTR NYLON BLACK	28480	0340-0833
19	0624-0248	2	4	SCREW-TPG 8-32 .75-IN-LG HEX WSHR-HD STL	28480	0624-0248
20	0370-2994	U	1	KNDR	28480	0370-2994
21	2510-0045	8	4	SCREW-MACH 8-32 .375-IN-LG PAN-HD-POZI	00000	ORDER BY DESCRIPTION
22	0360-0270	U	1	TERMINAL-SLDR LUG LK-MTG FOR-#10-8CR	28480	0360-0270
23	3100-1205	6	1	SWITCH-POTARY	28480	3100-1205
24	0360-1190	5	4	TERMINAL-SLDR LUG PL-MTG FUN-#3/8-8CR	28480	0360-1190
25	2950-0001	8	4	NUT-HEX-DBL-CHAM 3/8-32-THD .094-IN-THK	00000	ORDER BY DESCRIPTION
26	5020-8806	9	1	REAR FRAME	28480	5020-8806
27	5060-9836	1	1	TOP COVER	28480	5060-9836
28	04274-00617	9	1	PLATE	28480	04274-00617
29	04274-00602	2	2	PLATE SHIELD	28480	04274-00602
30	5040-7202	9	1	TRIM, TOP	28480	5040-7202
31	5020-8805	8	1	FRONT FRAME	28480	5020-8805
32	04274-25002	8	1	WINDOW (FREQ)	28480	04274-25002
33	0370-1097	2	1	KNOB	28480	0370-1097
34	04275-00201	9	1	FRONT PANEL (YMP)	28480	04275-00201
35	04275-00211	0	1	FRONT PANEL (MP)	28480	04275-00211
36	04274-25001	7	2	WINDOW DISP. A,B)	28480	04274-25001
37	7120-1254	1	1	NAMEPLATE .312-IN-WD .54-IN-LG AL	28480	7120-1254
38	7120-0478	9	1	TRADE MARK (YMP)	28480	7120-0478
39	04271-50024	4	4	INSULATOR	28480	04271-50024
40	2950-0035	8	4	NUT-HEX-DBL-CHAM 15/32-32-THD	00000	ORDER BY DESCRIPTION
41	1510-0038	8	1	BINDING POST ASSY SGL THD=8TUD	28480	1510-0038
42	1250-0252	6	4	CONNECTOR-RF BNC FEM SGL-HOLE-RR 50-OHM	28480	1250-0252
43	04271-50025	5	4	INSULATOR	28480	04271-50025
44	5041-0564	4	1	KEY CAP	28480	5041-0564
45	0370-0451	U	2	BEZEL	28480	0370-0451
46	1460-1345	5	2	TILT STAND SST	28480	1460-1345
47	5040-7201	6	4	FOOT(STANDARD)	28480	5040-7201
48	5020-8838	7	4	STRUT	28480	5020-8838
49	04274-40001	9	1	ROD (POWER SWITCH)	28480	04274-40001
50	04274-01202	0	1	ANGLE (POWER SWITCH)	28480	04274-01202
51	04274-40002	0	3	GUIDE (ANGLE)	28480	04274-40002
52	04274-00618	0	3	PLATE, SHIELD	28480	04274-00618
53	04274-00601	1	5	PLATE, SHIELD	28480	04274-00601
54	5060-9848	1	5	BOTTOM COVER	28480	5060-9848
55	04274-00205	1	1	SUB PANEL	28480	04274-00205
56	04274-60203	1	1	REAR PANEL		
57	3160-0311	1	1	FAN		

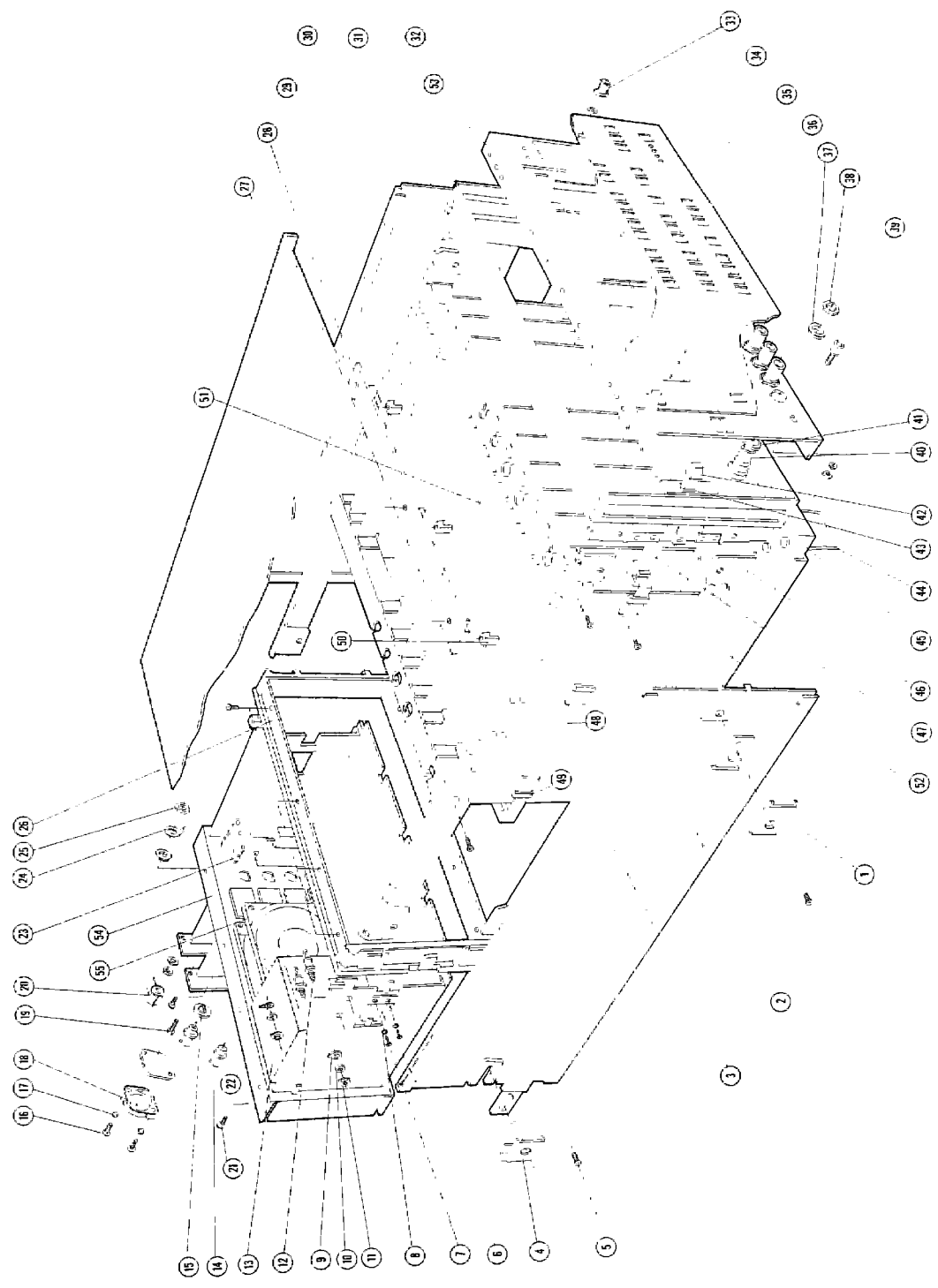

Figure 6-1. Major Mechanical Parts - Exploded View.  
6-47

**SECTION VII  
MANUAL CHANGES**

Table 7-1. Manual Changes by Serial Number.

7-1. INTRODUCTION.

7-2. This section contains information for adapting this manual to instruments to which the contents do not directly apply. The following paragraphs explain how to adapt this manual to apply to other instruments with lower serial prefixes.

7-3. MANUAL CHANGES.

7-4. To adapt this manual to your particular instrument, refer to Table 7-1 and make all of the manual changes listed opposite your instrument serial number. Perform these changes in the summary by assembly.

7-5. If your instrument serial number is not listed on the title page of this manual or in Table 7-1 to the right, it may be documented in a yellow MANUAL CHANGES supplement. For additional information about serial number coverage, refer to INSTRUMENT COVERED BY MANUAL in Section I.

Serial Prefix or Number	Make Manual Changes
1851J00232 and below	A, B, C, D, E, F, G H, K, J, K, L, M, O P, Q, S
1851J00262 and below	B, C, D, E, F, G, H I, J, K, L, M, O, P Q, S
1851J00299 and below	C, D, E, F, G, H, I J, K, L, M, O, P, Q S
1851J00392 and below	D, E, F, G, H, I, J K, L, M, O, P, Q, S
1851J00527 and below	E, F, G, H, I, J, K L, M, O, P, Q, S
1851J00577 and below	F, G, H, I, J, K, L M, C, P, Q, S
1851J00742 and below	G, H, I, J, K, L, M O, P, Q, S
2016J00802 and below	H, I, J, K, L, M, O P, Q, S
2016J00862 and below	I, J, K, L, M, O, P Q, S
2045J00922 and below	J, K, L, M, O, P, Q R, S
2045J01042 and below	K, L, M, N, O, P, Q R, S
2045J01132 and below	L, M, N, O, P, Q, R S
2045J01222 and below	M, N, O, P, Q, R, S
2045J01251 and below to 2045JU0923	N, O, P, Q, R, S
2045J01284 and below	O, P, Q, R, S
2045J01306 and below	P, Q, R, S
2045J01342 and below	Q, R, S
2045J01432 and below to 2045J00863	R, S
2045J01462 and below to 2045J00863	S
2148J01732 and below	T
2148J02782 and below	U



Table 7-2. Summary of Changes by Assembly (Sheet 1 of 2).

CHANGE	Assembly									
	A1	A2	A3	A4	A5	A6	A7	A8	A9	A10
A									U1, U5 C70*	
B		C25~28								
C		C9, C14 R11, R12 R55, R60	C59, C61 R93							
D		C98, C99 C100				C10, C30 C6, C26				
E					S1					
F		R174								
H										
I									U1~U10 W7	
J									CR3, Q3 R31, U14 U15	
K									U10	
L			C76							
M			C52							
N									CR3	
O									C12	
P									C7	
Q										
R									R15, P16 R26, P27 R28, P29 R30	
S									W1~W5, W8	
T										
U									CR3, R25 R28, U1 U3, U5 U7, U9 U10, U14 U15	

Table 7-2. Summary of Changes by Assembly (Sheet 2 of 2).

CHANGE	Assembly							
	A11	A12	A15	A16	A21	A22	A23	No Prefix
A								
B								
C								
D								
E								
F								
H	C18							
I								
J								
K								
L								
M								
N								
O								
P								
Q								
R								
S								
T	F8, F9 R23, R24							

## CHANGE A

Page 6-34, Table 6-3. Replaceable Parts, A9U1 and U5:  
Change the part number for A9U1 and U5 to read:

A9U1; 04274-85021 (PROM)  
A9U5; 04274-85015 (PROM)

## Note

04274-85031 (new U1) cannot be used with 04274-85015 (old U5).  
Also, 04274-85025 (new U5) cannot be utilized with 04274-85021 (old U1).

Page 6-22, Table 6-3. Replaceable Part:  
Delete the following part:

A5C70\*; 0140-0197 CAPACITOR-FXD 180PF +-5% 300WVDC MICA

## CHANGE B

Page 6-9, Table 6-3. Replaceable Parts:  
Delete the following parts:

A2CR25 to CR28 1901-0040 DIODE-SWITCHING

Page 8-63, Figure 8-45. A2 Component Locations:  
Partially change the diagram as follows:

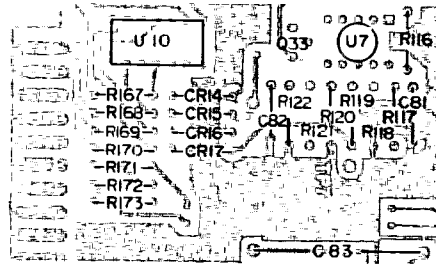

Figure 8-45. A2 Component Locations.

## CHANGE C

Page 6-8, Table 6-3. Replaceable Parts, A2C9 and C14:

Change the part numbers and descriptions for A2C9 and C14 to read:

0121-0059 CAPACITOR-V TRMR-CER 2 8PF

Page 6-10, Table 6-3. Replaceable Parts, A2R11 and R12:

Change the part numbers and descriptions for A2R11 and R12 to read:

0757-0280 RESISTOR 1K 1%

Page 6-11, Table 6-3. Replaceable Parts, A2R55 and R60:

Change the part numbers and descriptions for A2R55 and R60 to read:

0757-0280 RESISTOR 1K 1%

Page 6-13, Table 6-3. Replaceable Parts, A3C59 and C61:

Change the part numbers and descriptions for A3C59 and C61 to read:

A3C59; 0160-2203 CAPACITOR-FXD 91PF  
A3C61; 0160-0134 CAPACITOR-FXD 220PF

Page 6-16, Table 6-3. Replaceable Parts, A3R93:

Change the part number and description for A3R93 to read:

0698-0084 RESISTOR 2.15K 1%

## CHANGE D

Page 6-9, Table 6-3. Replaceable Parts:

Add the following part:

A2C98; 0160-2261 CAPACITOR-FXD 15PF +-5%

Change the part numbers and descriptions for A2C99 and C100 to read:

A2C99; 0140-0197 CAPACITOR-FXD 180PF +-5%  
A2C100; 0160-2224 CAPACITOR-FXD 1800PF +-5%

Page 6-26, Table 6-3. Replaceable Parts:

Add the following parts:

A6C10; 0160-2262 CAPACITOR-FXD 16PF +-5%  
A6C30; 0160-2262 CAPACITOR-FXD 16PF +-5%

Change the part numbers and descriptions for A6C6 and C26 to read:

0160-2224 CAPACITOR-FXD 1800PF +-5%

Change the part numbers and descriptions for A6C8 and C28 to read:

0140-0197 CAPACITOR-FXD 180PF +-5%

Section VII

Page 8-63, Figure 8-45. As Component Locations:  
Partially change the diagram as follows:

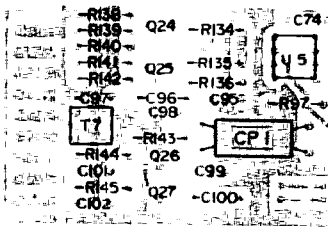

Figure 8-45. As Component Locations:

Page 8-63, Figure 8-46. As Schematic Diagram:  
Partially change the diagram as follows:

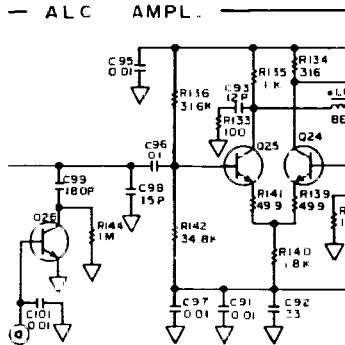

Figure 8-46. A2 Schematic Diagram.

Page 8-71, Figure 8-57. A6 Component Locations:  
Partially change the diagram as follows:

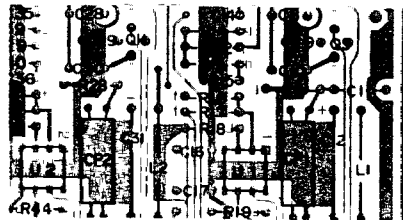

Figure 8-57. A6 Component Locations.

Page 8-72, Figure 8-58 (B). A6 Schematic Diagram (Sheet 2 of 2):  
Partially change the diagram as follows:

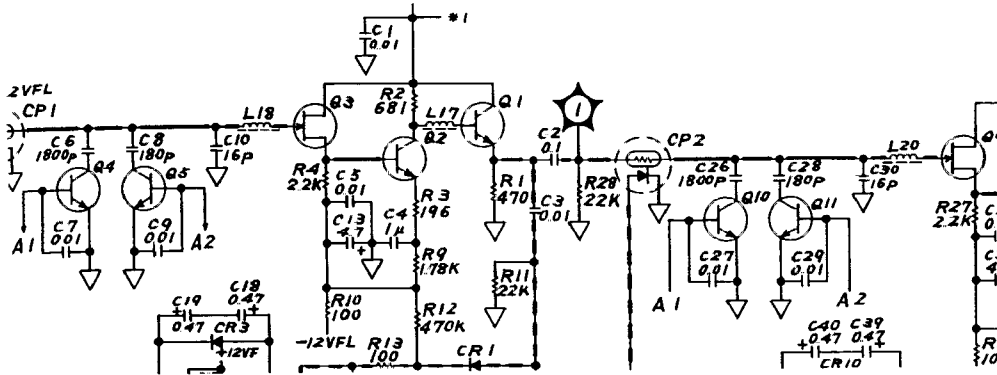

Figure 8-58 (B). A6 Schematic Diagram.

CHANGE E

Page 6-25, Table 6-3. Replaceable Parts, A5S1:  
Add the following part:

A5S1; 3101-1274 SWITCH-SL SPOT

Page 8-69, Figure 8-54. A5 Component Locations:  
Partially change the diagram as follows:

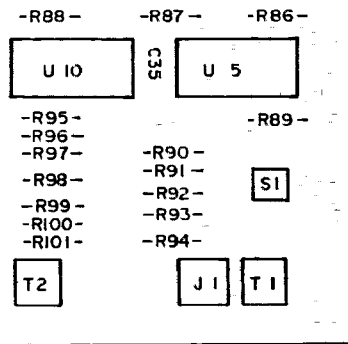

Figure 8-54. A5 Component Locations.

## Section VII

Page 8-69, Figure 8-55. A5 Schematic Diagram:  
Partially change the diagram as follows:

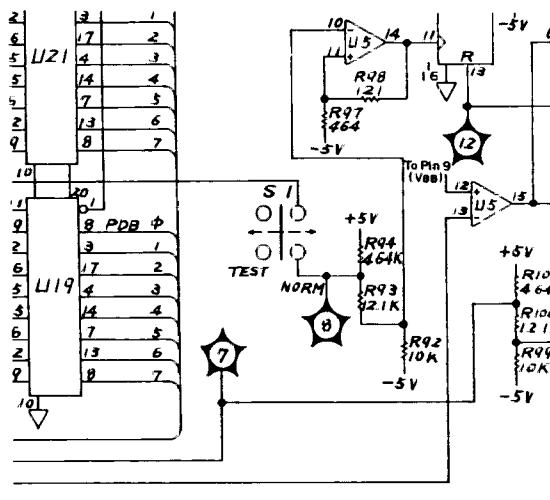

Figure 8-55. A5 Schematic Diagram:

## CHANGE F

Page 6-12, Table 6-3. Replaceable Parts, A2R174:  
Delete the following part:

A2R174; 0683-1015 RESISTOR 100+-5%

## CHANGE G

Page 5-5, Table 5-3. Adjustment Requirements;  
Page 6-37, Table 6-3. Replaceable Parts; and  
Page 8-81, Figure 8-68. All Schematic Diagram:  
Change the part number of the A11 board assembly to 04274-66511.

Note: The old 04274-66511 and the new 04274-66551  
are not interchangeable.

Page 6-39, Table 6-3. Replaceable Parts:  
Change the part number for the blank PC board of the A11 board  
assembly to 04274-26511.

Change the part number of the A12 board assembly to 04274-66512.

Note: The old 04274-66512 and the new 04274-66552  
are not interchangeable.

Change the part numbers of A12XA11L and A12XA11R to 1251-4189.

CHANGE H

Page 6-38, Table 6-3. Replaceable Parts:  
Delete the following part:

A11C18 0160-2150 CAPACITOR-FXD 33PF  $\pm 5\%$  300VDC MICA

CHANGE I

Page 6-33, Table 6-3. Replaceable Parts:  
Change the part number for A9MPU BOARD ASSEMBLY (STANDARD) to read:

04275-66513

Page 6-34, Table 6-3. Replaceable Parts:  
Add the following parts:

A9U2; 04274-85022 IC, PROM, PROGRAMMED  
A9U4; 04274-85014 IC, PROM, PROGRAMMED  
A9U6; 04274-85016 IC, PROM, PROGRAMMED  
A9U8; 04275-85058 IC, PROM, PROGRAMMED

Change the part numbers and descriptions for A9U1/U3/U5/U7/U10 to read:

A9U1; 04274-85031 IC, PROM, PROGRAMMED  
A9U3; 04274-85013 IC, PROM, PROGRAMMED  
A9U5; 04274-85025 IC, PROM, PROGRAMMED  
A9U7; 04275-85057 IC, PROM, PROGRAMMED  
A9U10; 04274-85019 IC, PROM, PROGRAMMED

Page 6-35, Table 6-3. Replaceable Parts:  
Add the following parts:

A9W7 to W10 8159-0005 WIRE 22AWG W PVC 1 x 22 80C

Page 8-49, Figure 8-31. Digital Section Troubleshooting to Assembly Level"  
Partially change the flow diagram as follows:

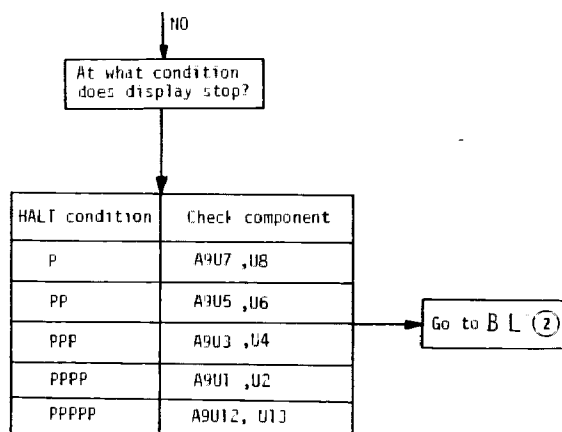

Page 8-50 and 8-76, signatures table:  
Change the table as follows:



This table can be used to check signatures at A9U1 thru A9U10 ROM's. Signature test point is established at input of Data Buffer (pins 8 thru 6 of A9U31 and A9U32) instead of the respective ROM outputs (A9U1 thru A9U10). This signature list can be used for units with its serial number suffixes of -00266 and above

For other instruments whose serial number suffixes are earlier than 00266, check that unstable signature display appears or that output states of these ROM's pull up and pull down. If you find above states active in earlier instruments, the program contents in these ROM may be alive.

DSA NAME		DSA-12	DSA-14	DSA-15	DSA-16	DSA-17	DSA-18	DSA-19	DSA-20	DSA-21	DSA-13
TEST PIN NO											
SIGNAL NAME	ROM NO. TEST POINT	A9U1	A9U1 A9U2	A9U3 A9U4	A9U5 A9U6	A9U7 A9U8	A9U1	A9U3	A9U5	A9U7	A9U10
WINDOW(+5V)	U1 pin-24	755U	P254	P254	P254	P254	826P	826P	826P	826P	826P
DB0	U31 pin-3	475P	853H	7994	264C	0H5H	H084	1FFU	4840	00AC	UUPA
DB1	pin-4	594H	A0AH	307F	08CA	U02C	UUOF	H20P	63UF	69F4	HAUH
DB2	pin-5	F997	57U9	HPF4	9FBF	8102	A41A	7303	CP67	FA15	A63F
DB3	pin-6	H561	H926	379A	CP1U	741F	6927	23FF	9587	2110	3094
DB4	U32 pin-3	897F	C6U0	2U43	5H23	A2H2	A0FP	3987	F598	4HCH	565C
DB5	pin-4	8F6H	2562	5410	U899	2UHU	6824	HF08	UF80	F389	501H
DB6	pin-5	2116	AF61	69HH	89PP	3265	FF7P	U888	521H	A092	39A1
DB7	pin-6	UFF8	56PC	0P76	FP5F	52AC	UA7H	A33H	5H5C	AU4F	F454

Page 8-51, Signature Connections tables:

Add the tables for DSA-18, DSA-19, DSA-20 and DSA-21 as follows.

Change the table for DSA-12, DSA-14, DSA-15, DSA-16 and DSA-17 as follows:

Signature Connections for DSA-1 and DSA-12 thru DSA-21.

Signature Connections Window (+5V) : APC4

DSA NO	START	STOP	CLOCK	A9 DSA-SW
DSA-1 RAM DATA BUS	A9Tp-13 	A9Tp-13 	A9Tp-7 	OFF  ON

Signature Connections Window (+5V) : P254

DSA NO	START	STOP	CLOCK	A9 DSA-SW
DSA-17 NOP (U7,8)	A9U16-15 	A9U16-14 	A9Tp-6 	OFF  ON

Signature Connections Window (+5V) : 755U

DSA NO	START	STOP	CLOCK	A9 DSA-SW
DSA-12 NOP (U1-U8)	A9U27-11 	A9U16-5 	A9Tp-6 	OFF  ON

Signature Connections Window (+5V) : 826P

DSA NO	START	STOP	CLOCK	A9 DSA-SW
DSA-18 NOP (U1)	A9U16-9 	A9U16-7 	A9Tp-6 	OFF  ON

Signature Connections Window (+5V) : 826P

DSA NO	START	STOP	CLOCK	A9 DSA-SW
DSA-13 NOP (U10)	A9U22-9 	A9U10-20 	A9Tp-6 	OFF  ON

Signature Connections Window (+5V) : 826P

DSA NO	START	STOP	CLOCK	A9 DSA-SW
DSA-19 NOP (U3)	A9U16-11 	A9U16-10 	A9Tp-6 	OFF  ON

Signature Connections Window (+5V) : P254

DSA NO	START	STOP	CLOCK	A9 DSA-SW
DSA-14 NOP (U1,2)	A9U16-9 	A9U16-7 	A9Tp-6 	OFF  ON

Signature Connections Window (+5V) : 826P

DSA NO	START	STOP	CLOCK	A9 DSA-SW
DSA-20 NOP (U5)	A9U16-13 	A9U16-12 	A9Tp-6 	OFF  ON

Signature Connections Window (+5V) : P254

DSA NO	START	STOP	CLOCK	A9 DSA-SW
DSA-15 NOP (U3,4)	A9U16-11 	A9U16-10 	A9Tp-6 	OFF  ON

Signature Connections Window (+5V) : 826P

DSA NO	START	STOP	CLOCK	A9 DSA-SW
DSA-21 NOP (U7)	A9U16-15 	A9U16-14 	A9Tp-6 	OFF  ON

Signature Connections Window (+5V) : P254

DSA NO	START	STOP	CLOCK	A9 DSA-SW
DSA-16 NOP (U5,6)	A9U16-13 	A9U16-12 	A9Tp-6 	OFF  ON

Section VII

Page 8-51, Figure 8-33. Digital Section Troubleshooting Flow Diagram BL:  
Partially change the flow diagram as follows:

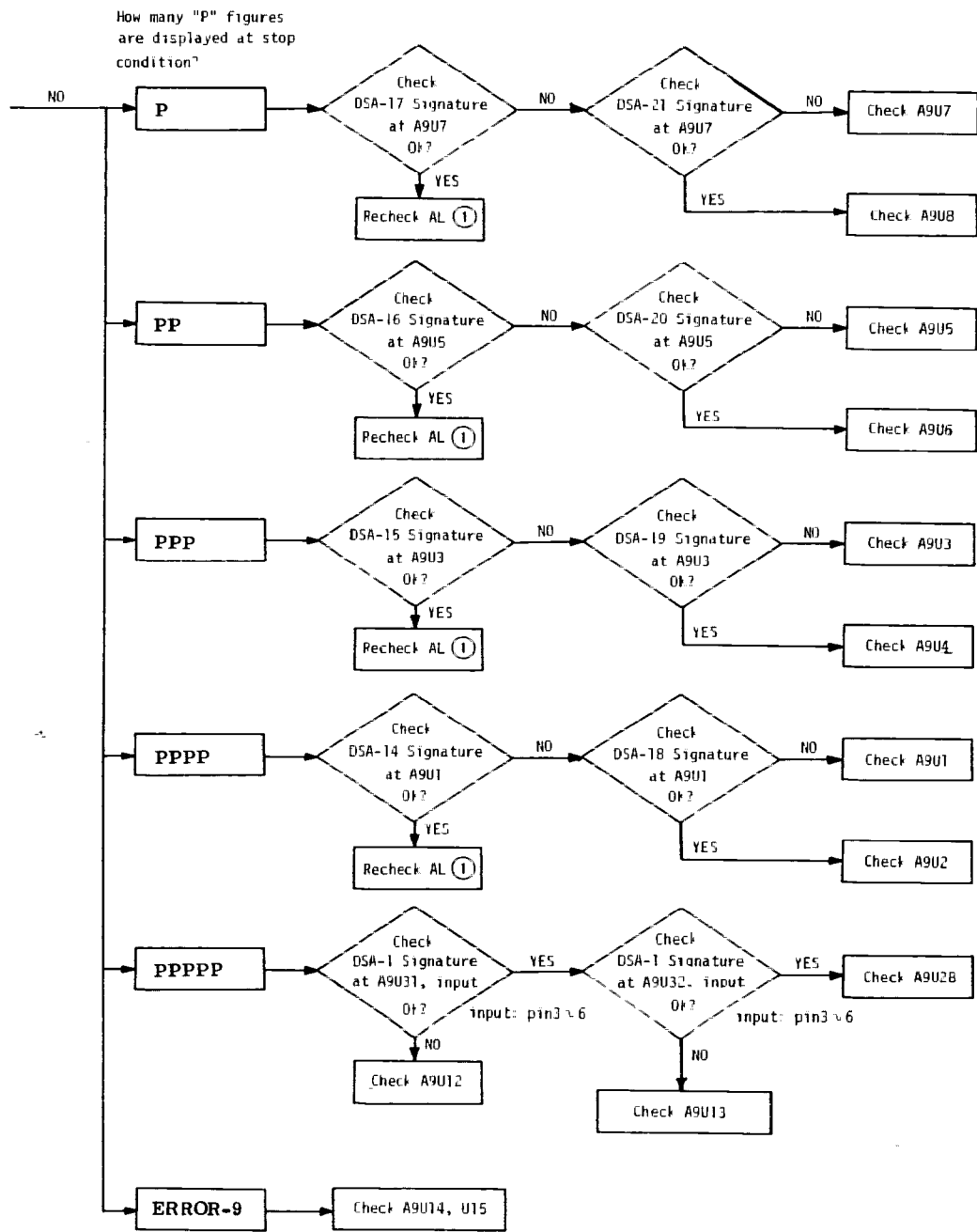





Figure 8-33. Digital Section Troubleshooting Flow Diagram BL.

Page 8-76, Signature Connections tables:





Add the tables for DSA-18, DSA-19, DSA-20 and DSA-21 as follows:

Change the table for DSA-12, DSA-14, DSA-15, DSA-16 and DSA-17 as follows:





Signature Connections Window (+5V): CCC3

DSA NO	START	STOP	CLOCK	A9 DSA-SW
DSA-10	A9Tp-13	A9Tp-13	A9Tp-7	OFF  ON
IRQ				





Signature Connections Window (+5V) : P254

DSA NO	START	STOP	CLOCK	A9 DSA-SW
DSA-16	A9U16-13	A9U16-12	A9Tp-6	OFF  ON
NOP (U5,6)				





Signature Connections Window (+5V) : 0003

DSA NO	START	STOP	CLOCK	A9 DSA-SW
DSA-11	A9Tp-3	A9Tp-3	A9Tp-6	OFF  ON
NOP ADDRESS				





Signature Connections Window (+5V) : P254

DSA NO	START	STOP	CLOCK	A9 DSA-SW
DSA-17	A9U16-15	A9U16-14	A9Tp-6	OFF  ON
NOP (U7,8)				





Signature Connections Window (+5V) : 755U

DSA NO	START	STOP	CLOCK	A9 DSA-SW
DSA-12	A9U27-11	A9U16-5	A9Tp-6	OFF  ON
NOP (U1-U8)				





Signature Connections Window (+5V) : 826P

DSA NO	START	STOP	CLOCK	A9 DSA-SW
DSA-18	A9U16-9	A9U16-7	A9Tp-6	OFF  ON
NOP (U1)				





Signature Connections Window (+5V) : 826P

DSA NO	START	STOP	CLOCK	A9 DSA-SW
DSA-13	A9U22-9	A9U10-20	A9Tp-6	OFF  ON
NOP (U10)				





Signature Connections Window (+5V) : 826P

DSA NO	START	STOP	CLOCK	A9 DSA-SW
DSA-19	A9U16-11	A9U16-10	A9Tp-6	OFF  ON
NOP (U3)				





Signature Connections Window (+5V) : P254

DSA NO	START	STOP	CLOCK	A9 DSA-SW
DSA-14	A9U16-9	A9U16-7	A9Tp-6	OFF  ON
NOP (U1,2)				





Signature Connections Window (+5V) : 826P

DSA NO	START	STOP	CLOCK	A9 DSA-SW
DSA-20	A9U16-13	A9U16-12	A9Tp-6	OFF  ON
NOP (U5)				

Signature Connections Window (+5V) : P254

DSA NO	START	STOP	CLOCK	A9 DSA-SW
DSA-15	A9U16-11	A9U16-10	A9Tp-6	OFF  ON
NOP (U3,4)				

Signature Connections Window (+5V) : 826P

DSA NO	START	STOP	CLOCK	A9 DSA-SW
DSA-21	A9U16-15	A9U16-14	A9Tp-6	OFF  ON
NOP (U7)				

Page 8-77, Figure 8-63. A9 Component Locations:  
Partially change the diagram as follows:

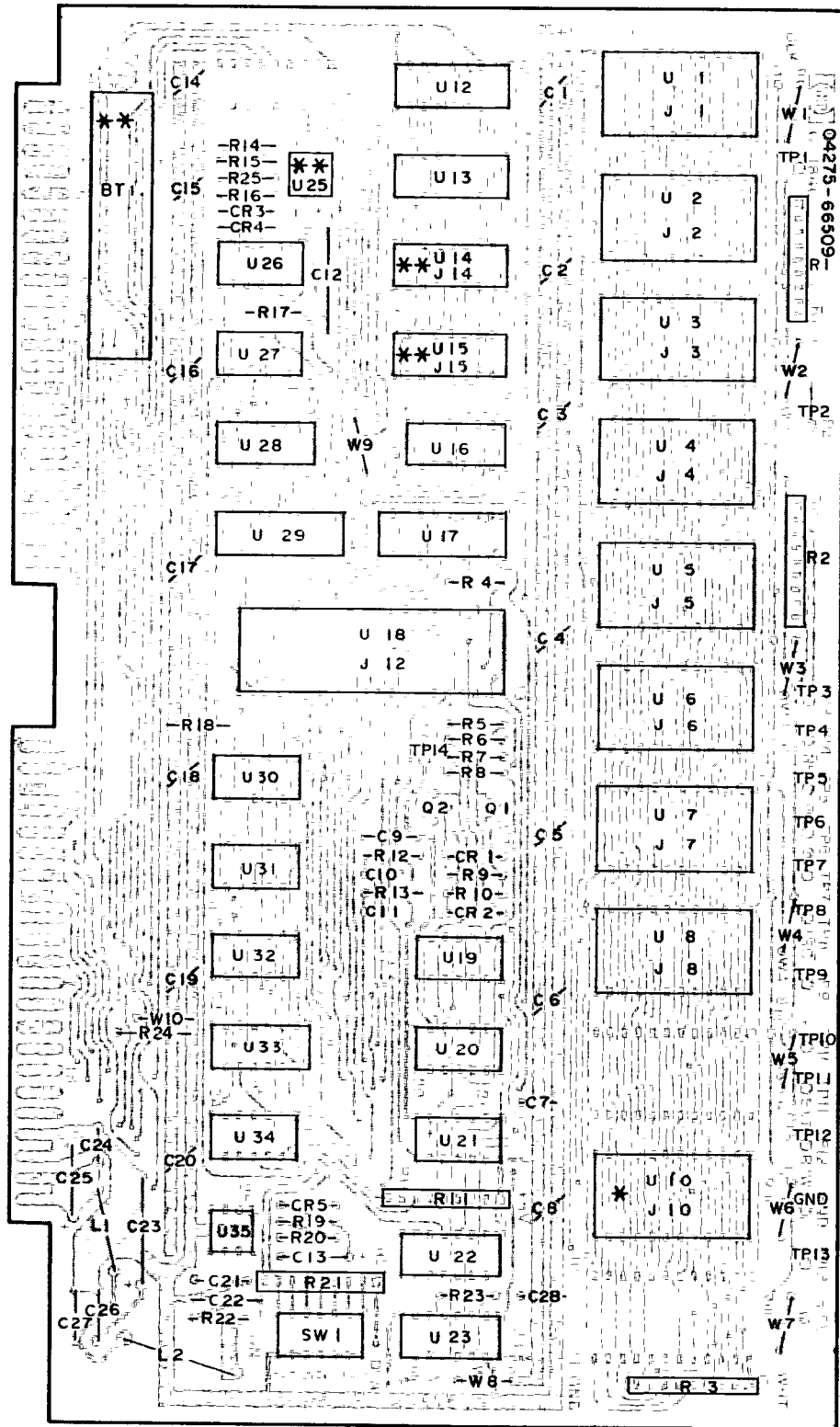

Figure 8-63. A9 Component Locations.

Page 8-77, Figure 8-64. A9 MPU Assembly Schematic Diagram:  
Change the diagram as follows:

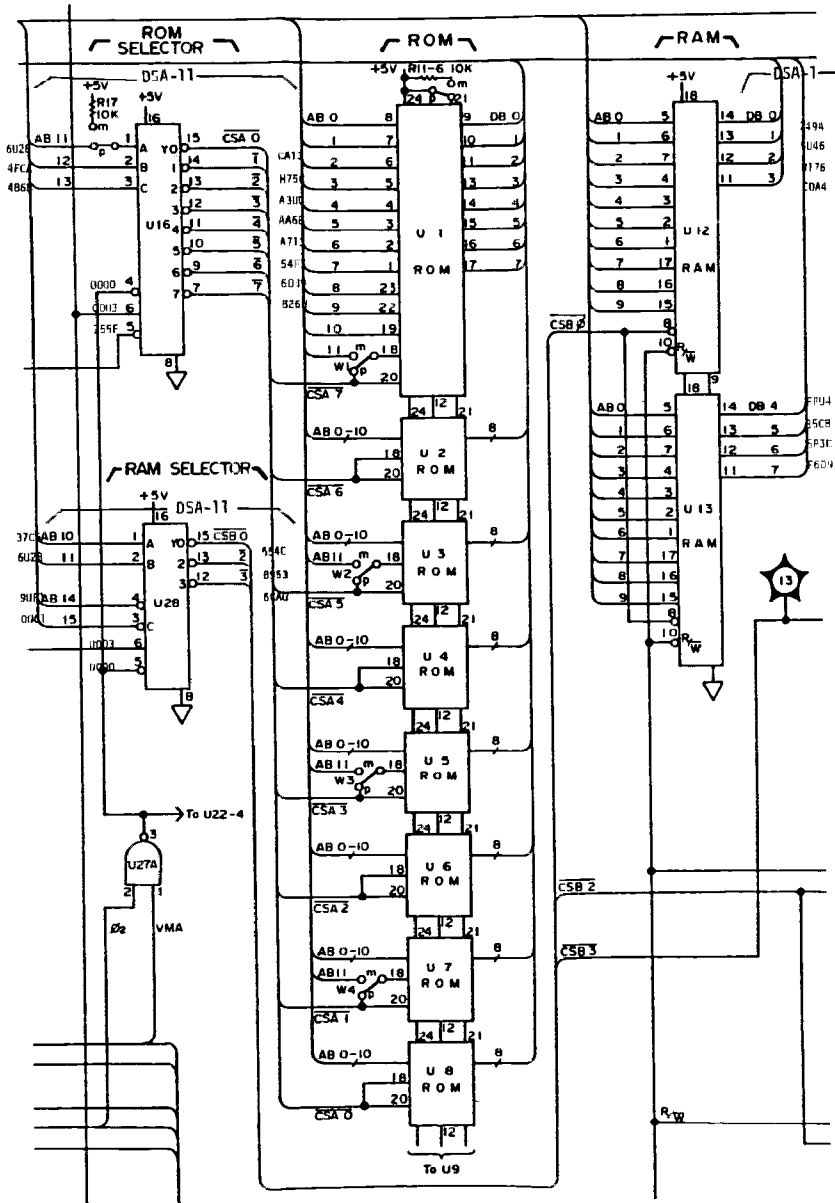

Figure 8-64. A9 MPU Assembly Schematic Diagram.

CHANGE J

Page 6-34, Table 6-3. Replaceable Parts:  
Change the part number and description for A9CR3 to read:

A9CR3 1901-0025 DIODE-GEN PRP 100V 200MA DO-7

Delete the following parts:

A9Q3: P/N 1853-0405; TRANSISTOR PNP SI PD=700mW  
A9R31: P/N 0683-4275; RESISTOR 4.7K 5% 0.25W TC=-400/+700

Change the part number for A9U14 and U15 to read:

1818-0796

Page 8-77, Figure 8-63. A9 Component Locations:  
Change the diagram as follows:

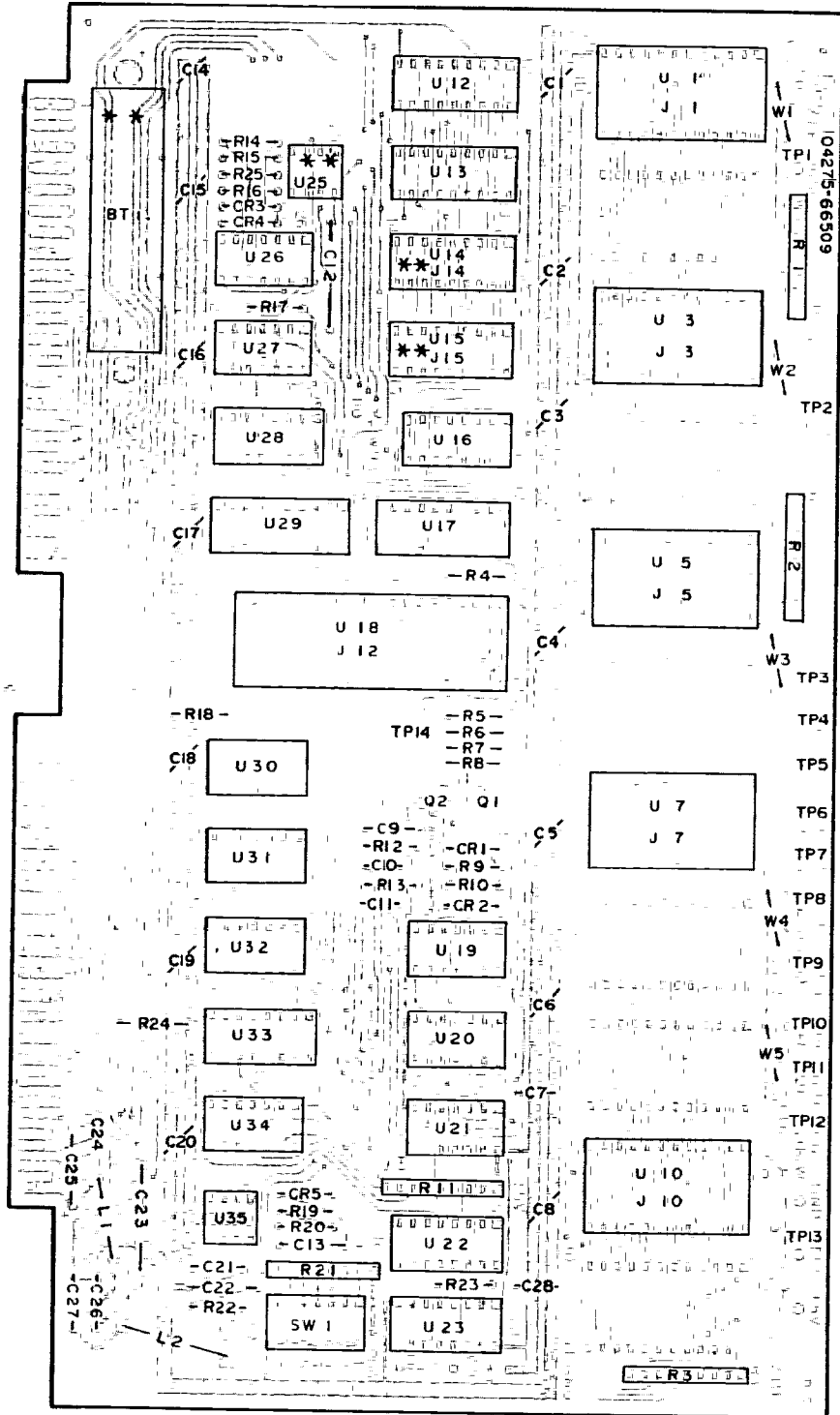

Figure 8-63. A9 MPU Component Locations.

Page 8-77, Figure 8-64. A9 MPU Assembly Schematic Diagram:  
Partially change the diagram as follows:

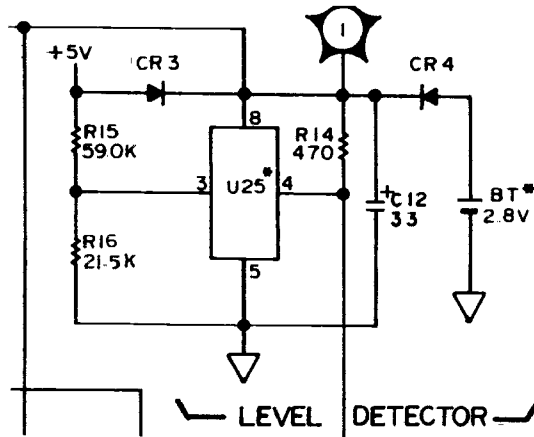

Figure 8-64. A9 MPU Assembly Schematic Diagram.

CHANGE K.

Page 6-34, Table 6-3. Replaceable Parts:  
Change the part number for A9U10 to read:

1818-1139

Page 8-50 and 8-76. Signature table:  
Change the DSA-13 to read:

DSA-13
A9U10
826P
UUPA
HAUH
A63F
3094
565C
501H
39A1
F454



Page 8-77, Figure 8-63. A9 Component Locations:  
Partially change the diagram as follows:

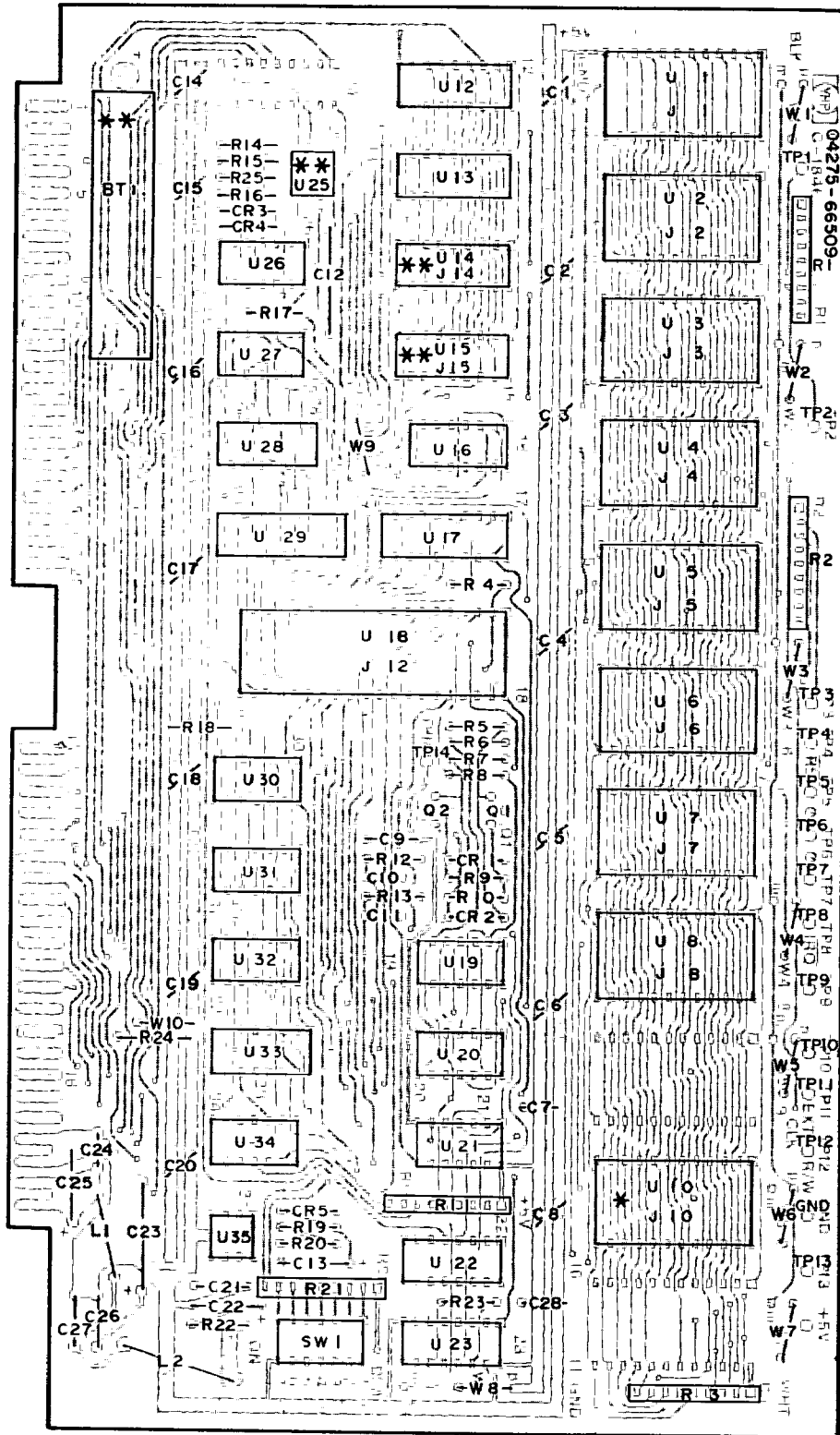

Figure 8-63. A9 Component Locations.

Page 8-77, Figure 8-64. A9 MPU Assembly Schematic Diagram:  
Change the diagram as follows:

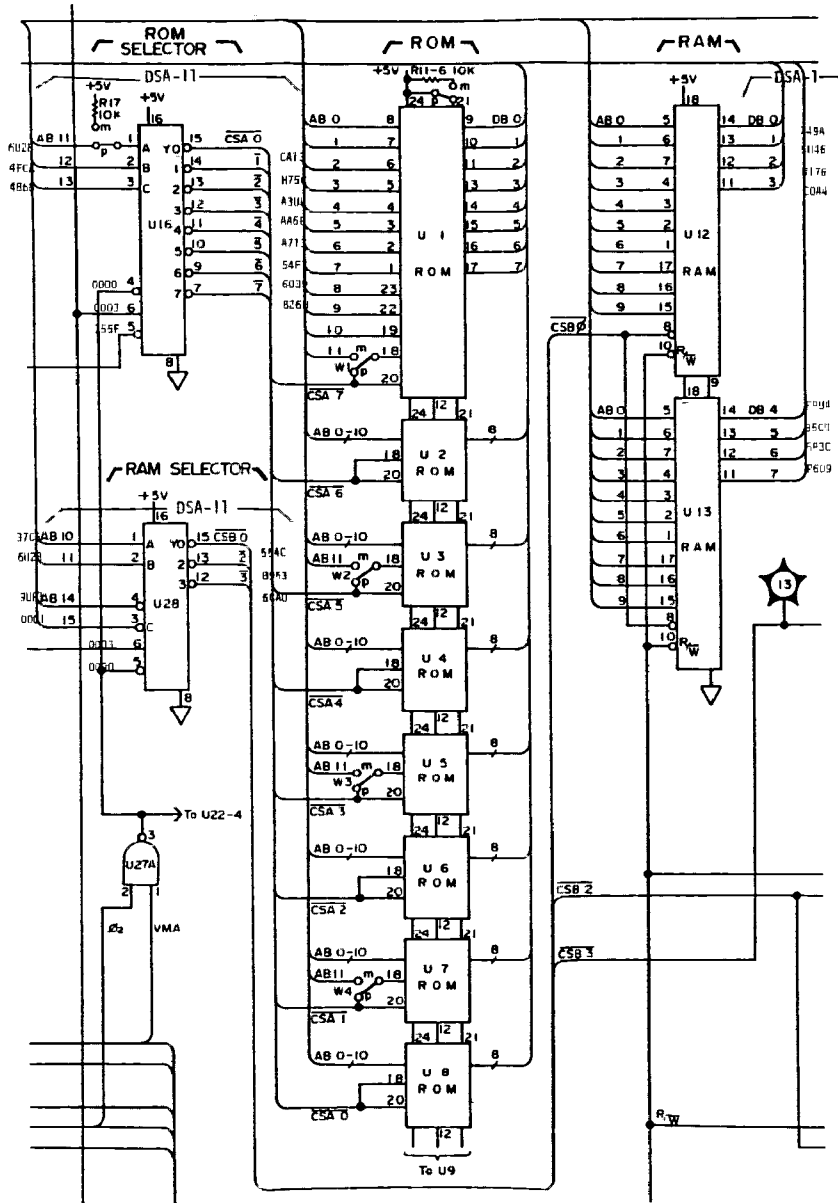

Figure 8-64. A9 MPU Assembly Schematic Diagram.

CHANGE J

Page 6-34, Table 6-3. Replaceable Parts:  
Change the part number and description for A9CR3 to read:

A9CR3 1901-0025 DIODE-GEN PRP 100V 200MA DO-7

Delete the following parts:

A9Q3: P/N 1853-0405; TRANSISTOR PNP SI PD=700mW  
A9R31: P/N 0683-4275; RESISTOR 4.7K 5% 0.25W TC=-400/+700

Page 8-51, Figure 8-33. Digital Section Troubleshooting Flow Diagram BL:  
Partially change the flow diagram as follows:

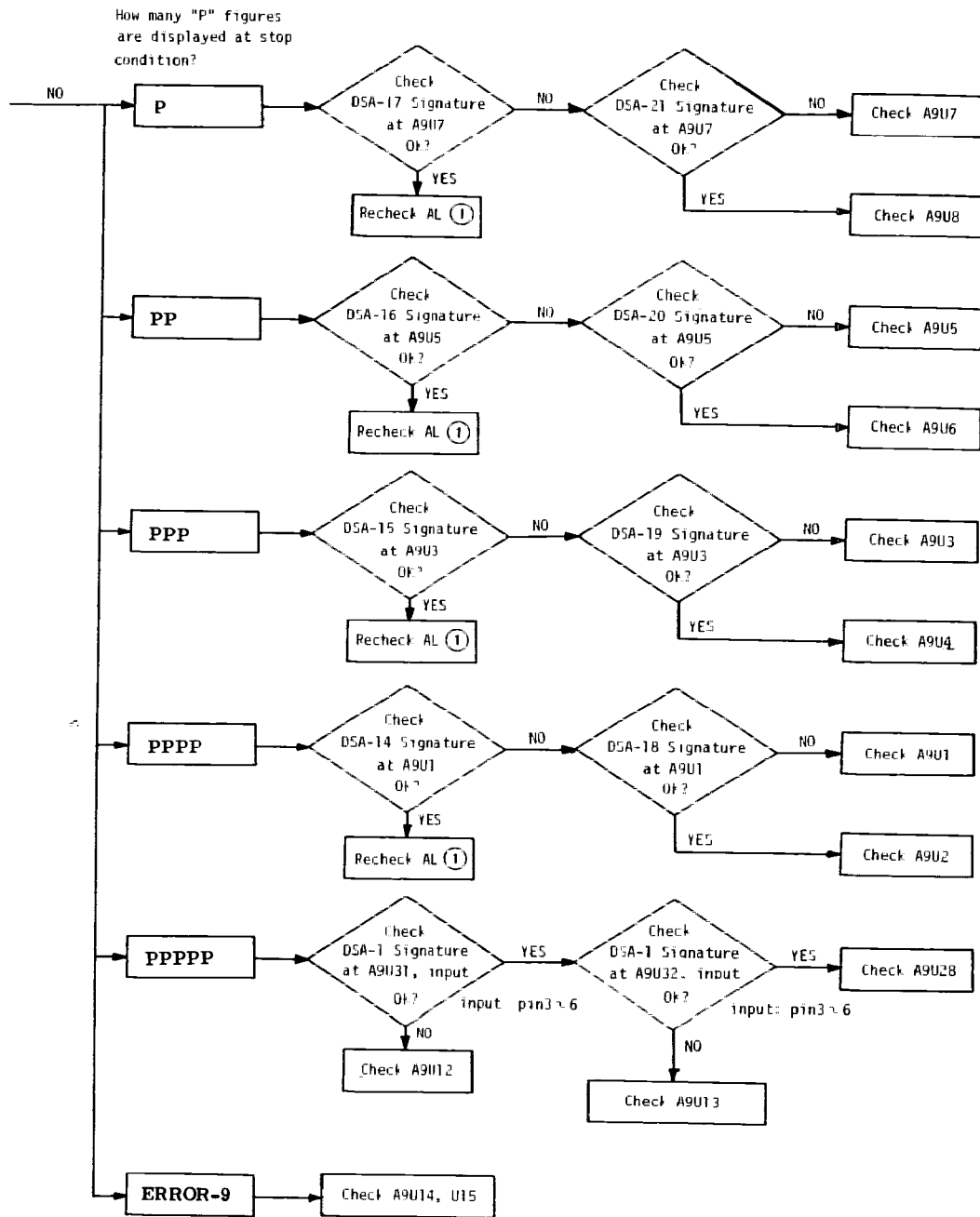





Figure 8-33. Digital Section Signature Troubleshooting Flow Diagram BL.

Page 8-76, Signature Connections tables:





Add the tables for DSA-18, DSA-19, DSA-20 and DSA-21 as follows:

Change the table for DSA-12, DSA-14, DSA-15, DSA-16 and DSA-17 as follows:





Signature Connections Window (+5V): CCC3

DSA NO	START	STOP	CLOCK	A9 DSA-SW
DSA-10	A9Tp-13	A9Tp-13	A9Tp-7	OFF  ON
IRQ				





Signature Connections Window (+5V) P254

DSA NO	START	STOP	CLOCK	A9 DSA-SW
DSA-16	A9U16-13	A9U16-12	A9Tp-6	OFF  ON
NOP (U5,6)				





Signature Connections Window (+5V) : 0003

DSA NO	START	STOP	CLOCK	A9 DSA-SW
DSA-11	A9Tp-3	A9Tp-3	A9Tp-6	OFF  ON
NOP ADDRESS				





Signature Connections Window (+5V) : P254

DSA NO	START	STOP	CLOCK	A9 DSA-SW
DSA-17	A9U16-15	A9U16-14	A9Tp-6	OFF  ON
NOP (U7,8)				





Signature Connections Window (+5V) : 755U

DSA NO	START	STOP	CLOCK	A9 DSA-SW
DSA-12	A9U27-11	A9U16-5	A9Tp-6	OFF  ON
NOP (U1-U8)				





Signature Connections Window (+5V) : 826P

DSA NO	START	STOP	CLOCK	A9 DSA-SW
DSA-18	A9U16-9	A9U16-7	A9Tp-6	OFF  ON
NOP (U1)				





Signature Connections Window (+5V) : 826P

DSA NO	START	STOP	CLOCK	A9 DSA-SW
DSA-13	A9U22-9	A9U10-20	A9Tp-6	OFF  ON
NOP (U10)				





Signature Connections Window (+5V) : 826P

DSA NO	START	STOP	CLOCK	A9 DSA-SW
DSA-19	A9U16-11	A9U16-10	A9Tp-6	OFF  ON
NOP (U3)				





Signature Connections Window (+5V) : P254

DSA NO	START	STOP	CLOCK	A9 DSA-SW
DSA-14	A9U16-9	A9U16-7	A9Tp-6	OFF  ON
NOP (U1,2)				





Signature Connections Window (+5V) : 826P

DSA NO	START	STOP	CLOCK	A9 DSA-SW
DSA-20	A9U16-13	A9U16-12	A9Tp-6	OFF  ON
NOP (U5)				

Signature Connections Window (+5V) : P254

DSA NO	START	STOP	CLOCK	A9 DSA-SW
DSA-15	A9U16-11	A9U16-10	A9Tp-6	OFF  ON
NOP (U3,4)				

Signature Connections Window (+5V) : 826P

DSA NO	START	STOP	CLOCK	A9 DSA-SW
DSA-21	A9U16-15	A9U16-14	A9Tp-6	OFF  ON
NOP (U7)				

## CHANGE L

Page 5-5, Table 5-2. Factory Selected Components:  
Change Nominal Value Range for A3C76 as shown below.

Component	Nominal Value Range
A3C76	HP P/N 0160-0179 C:FXD 33.0pF
	HP P/N 0160-0182 C:FXD 47.0pF
	*HP P/N 0140-0191 C:FXD 56.0pF
	HP P/N 0140-0192 C:FXD 68.0pF
	HP P/N 0140-0193 C:FXD 82.0pF
	HP P/N 0160-2204 C:FXD 100.0pF
	HP P/N 0160-2205 C:FXD 120.0pF
	HP P/N 0160-2206 C:FXD 160.0pF
	HP P/N 0140-0197 C:FXD 180.0pF
	HP P/N 0140-0198 C:FXD 200.0pF

Page 6-14, Table 6-3. Replaceable Parts:  
Add the following parts:

A3C76 0140-0191 CAPACITOR FXD 56PF±5% 300VDC MICA

## CHANGE M

Page 6-13, Table 6-3. Replaceable Parts:  
Change the part number and description for A3C52 to read:

A3C52 0160-2250 CAPACITOR-FXD 5.6pF±.25pF500VDC CER

Page 8-65, Figure 8-48. A3 Component Locations:  
Partially change the diagram as follows:

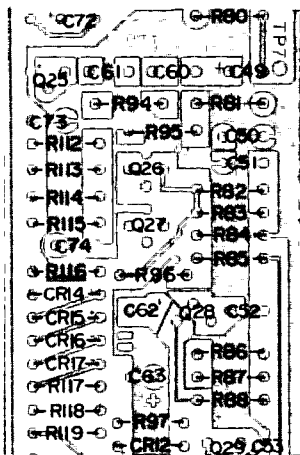

Figure 8-48. A3 Component Locations.

CHANGE N

Page 6-34, Table 6-3. Replaceable Parts:  
Delete the following part:

A9CR3 1910-0016 DIODE-GERMANIUM 60V 60MA DO-7

Page 8-77, Figure 8-63. A9 Component Locations:  
Partially change the diagram as follows:

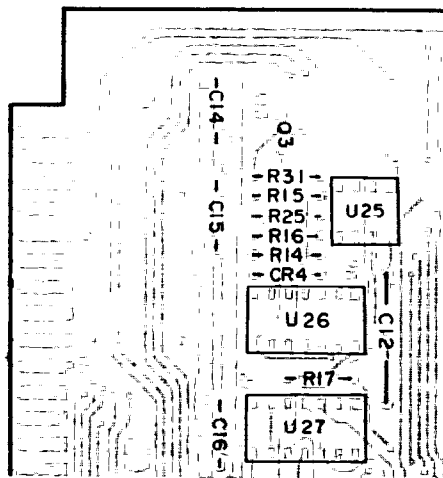

Figure 8-63. A9 Component Locations.

Page 8-77, Figure 8-64. A9 MPU Assembly Schematic Diagram.  
Partially change the diagram as follows:

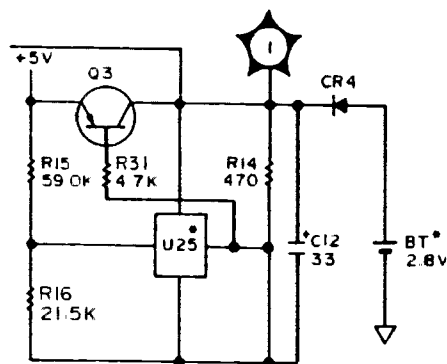

Figure 8-64. A9 MPU Assembly Schematic Diagram.

CHANGE O

Page 6-34, Table 6-3. Replaceable Parts:

Change the part number and description for A9C12 to read:

A9C12 0180-0229 CAPACITOR-FXD 33 $\mu$ F $\pm$ 10% 10VDC TA

CHANGE P

Page 6-33, Table 6-3. Replaceable Parts:

Change the part number and description for A9C7 to read:

A9C7 0160-0134 CAPACITOR-FXD 220PF $\pm$ 5% 300VDC MICA

CHANGE Q

Page 8-65, Figure 8-48. A3 Component Locations:

Partially change the diagram as follows:

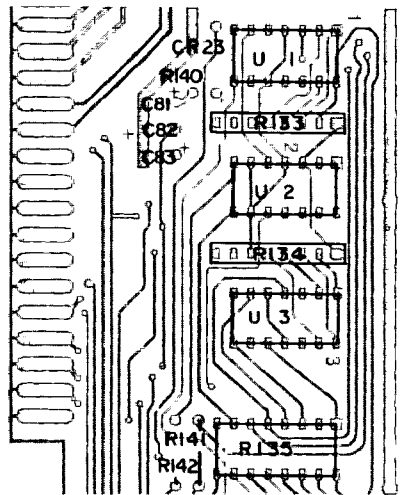

Figure 8-48. A3 Component Locations.

## CHANGE R

Page 6-33, Table 6-3. Replaceable Parts:

Change the part number and description for A9 MPU BOARD ASSEMBLY to read:

A9 04275-66509 MPU BOARD ASSEMBLY (STANDARD)  
A9 04275-66519 MPU BOARD ASSEMBLY (FOR OPT. 003)

Page 6-34, Table 6-3. Replaceable Parts.

Change the part number and description for A9R15 and R16 to read:

A9R15 0698-4501 RESISTOR 59K $\Omega$  1% .125W F TC=0 $\pm$ 100  
A9R16 0757-0199 RESISTOR 21.5K $\Omega$  1% .125W F TC=0 $\pm$ 100

Delete the following parts:

A9R26 1810-0269 NETWORK-RES 9-PIN-SIP .1-PIN-SPCG  
A9R27 1810-0269 NETWORK-RES 9-PIN-SIP .1-PIN-SPCG  
A9R28 0698-3158 RESISTOR 23.7K 1% .125W F TC=0 $\pm$ 100  
A9R29 0757-0442 RESISTOR 10K 1% .125W F TC=0 $\pm$ 100  
A9R30 0698-3158 RESISTOR 23.7k 1% .125W F TC=0 $\pm$ 100



CHANGE S

Page 8-77, Figure 8-63. A9 Microprocessor Unit Board Assembly Component Locations:  
 Change the diagram as follows:

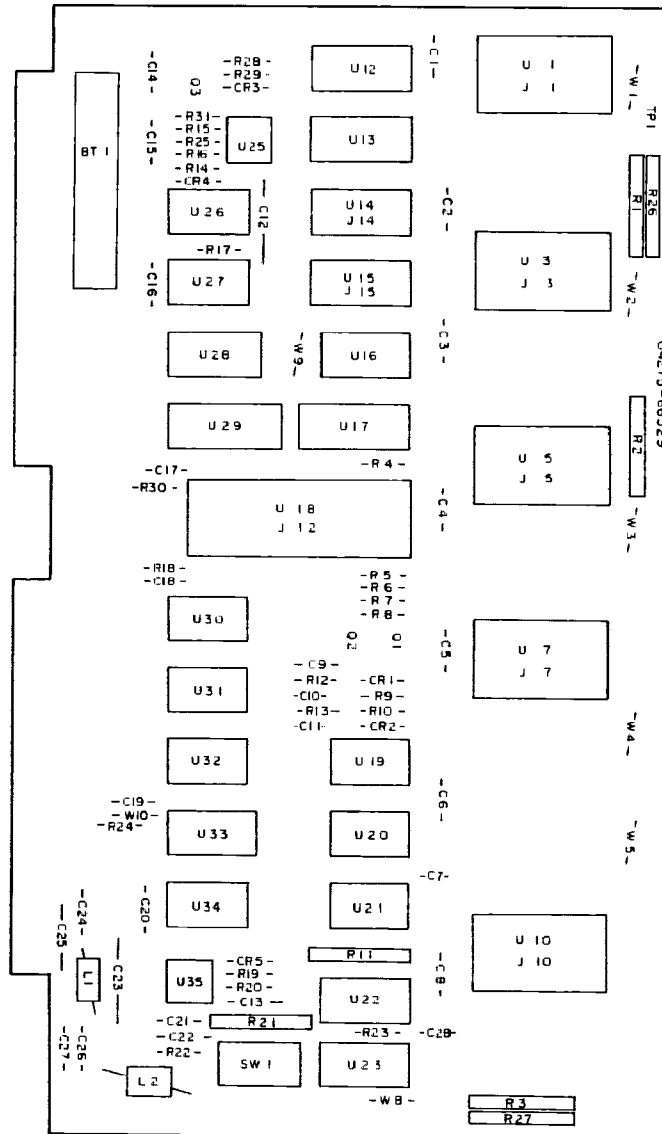

CHANGE T

Page 6-38, Table 6-3. Replaceable Parts:

Delete the following parts:

A11F8 2110-0659 FUSE .1A 250V TIME-DELAY

A11F9 2110-0659 FUSE .1A 250V TIME-DELAY

Page 6-39, Table 6-3. Replaceable Parts:

Add the following parts:

A11R23 0683-0475 RESISTOR 4.7 5% .25W FC TC=-400/+500

A11R24 0683-0475 RESISTOR 4.7 5% .25W FC TC=-400/+500

Page 8-81, Figure 8-67. All Component Locations:

Partially change the diagram as follows:

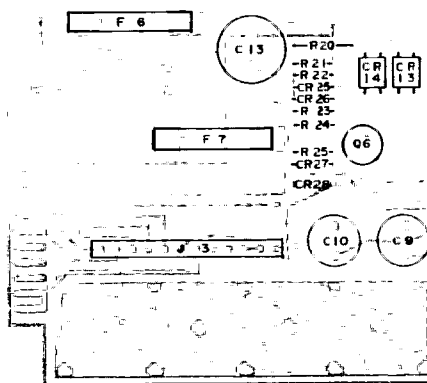

Figure 8-67. All Component Locations.

Page 8-81, Figure 8-68. All Schematic Diagram:  
Partially change the diagram as follows:

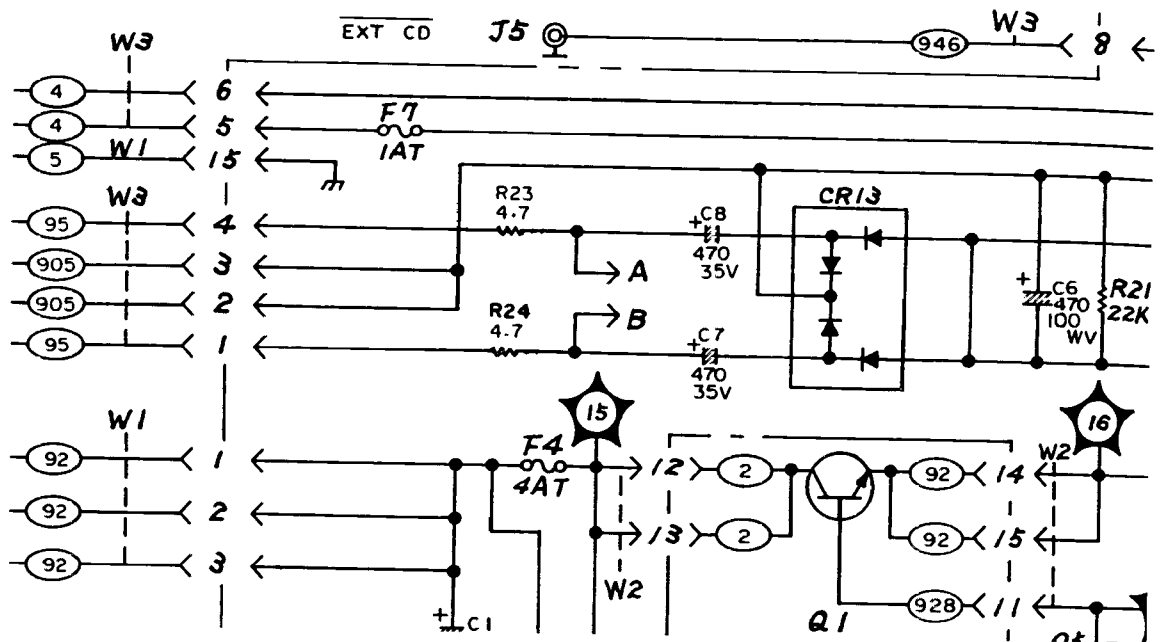

Figure 8-68. All Schematic Diagram.

CHANGE U

Page 6-33, Table 6-2. Replaceable Parts:  
Change the part number for A9 MPU BOARD ASSEMBLY to read:

04275-66529

Page 6-34, Table 6-2. Replaceable Parts:  
Change the part numbers and descriptions for A9CR3, A9U1, A9U3, A9U5, A9U7, A9U10, A9U14 and A9U15 to read:

A9CR3	1910-0016	DIODE-GERMANIUM 60MA DO-7
A9U1	1818-1134	IC, MASK ROM
A9U3	1818-1135	IC, MASK ROM
A9U5	1818-1136	IC, MASK ROM
A9U7	1818-1138	IC, MASK ROM
A9U10	1818-1548	IC, MASK ROM
A9U14	1818-1750	IC CMOS 4K RAM STAT 350-NS 3-S
A9U15	1818-1750	IC CMOS 4K RAM STAT 350-NS 3-S

Delete the following part:

A9U9 04274-85045 IC, PROM PROGRAMMED

Add the following parts:

A9R25 0683-1035 RESISTOR 10K 5% .25W  
A9R28 0698-3158 RESISTOR 23.7K 1% .125W

Page 8-50, Figure 8-32. Digital Section Troubleshooting Flow Diagram AL:  
Delete DSA-18 from the DSA table:

Change DSA-13 to read:

DSA-13
A9U10
826P
1H62
F0AP
46A9
2UFA
54F9
F63A
9208
F15P

Page 8-51, Figure 8-33. Digital Section Troubleshooting Flow Diagram BL  
Delete the Signature Connections for DSA-18:

Partially change the flow diagram as shown below:

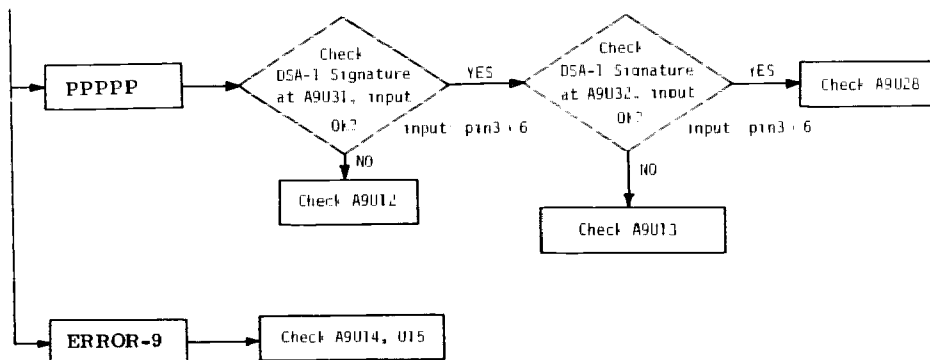

Page 8-76

Delete DSA-18 and the Signature Connections for DSA-18:

Change DSA-13 to read:

DSA-13
A9U10
826P
1H62
F0AP
46A9
2UFA
54F9
F63A
9208
F15P

Page 8-77, Figure 8-63. A9 Microprocessor Unit Board Assembly Component Locations:

Change the figure as shown on the next page:

Page 8-77, Figure 8-64. A9 Microprocessor Unit Board Assembly Schematic Diagram:

Change the figure as shown on the next page:

85 MPU ASSY 04275 - 55353

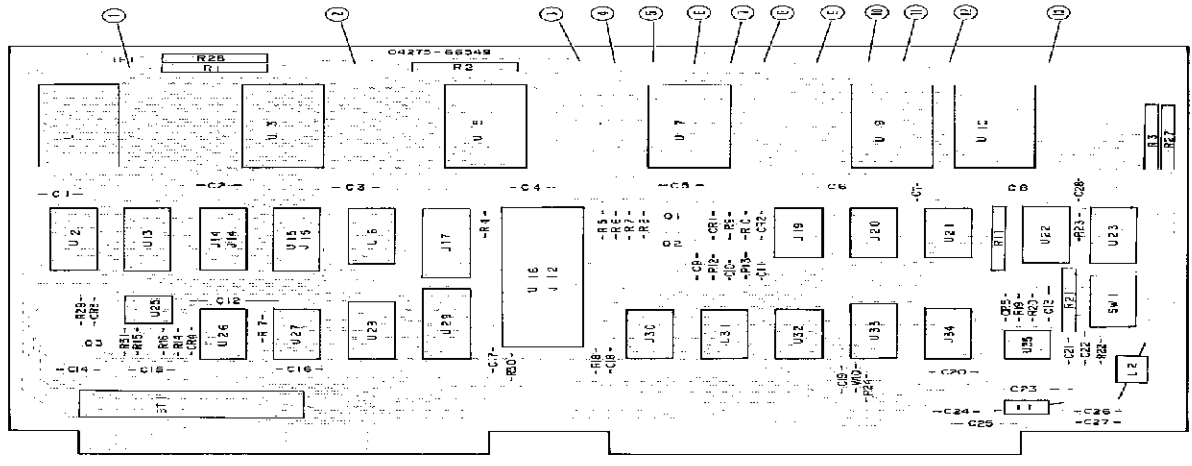
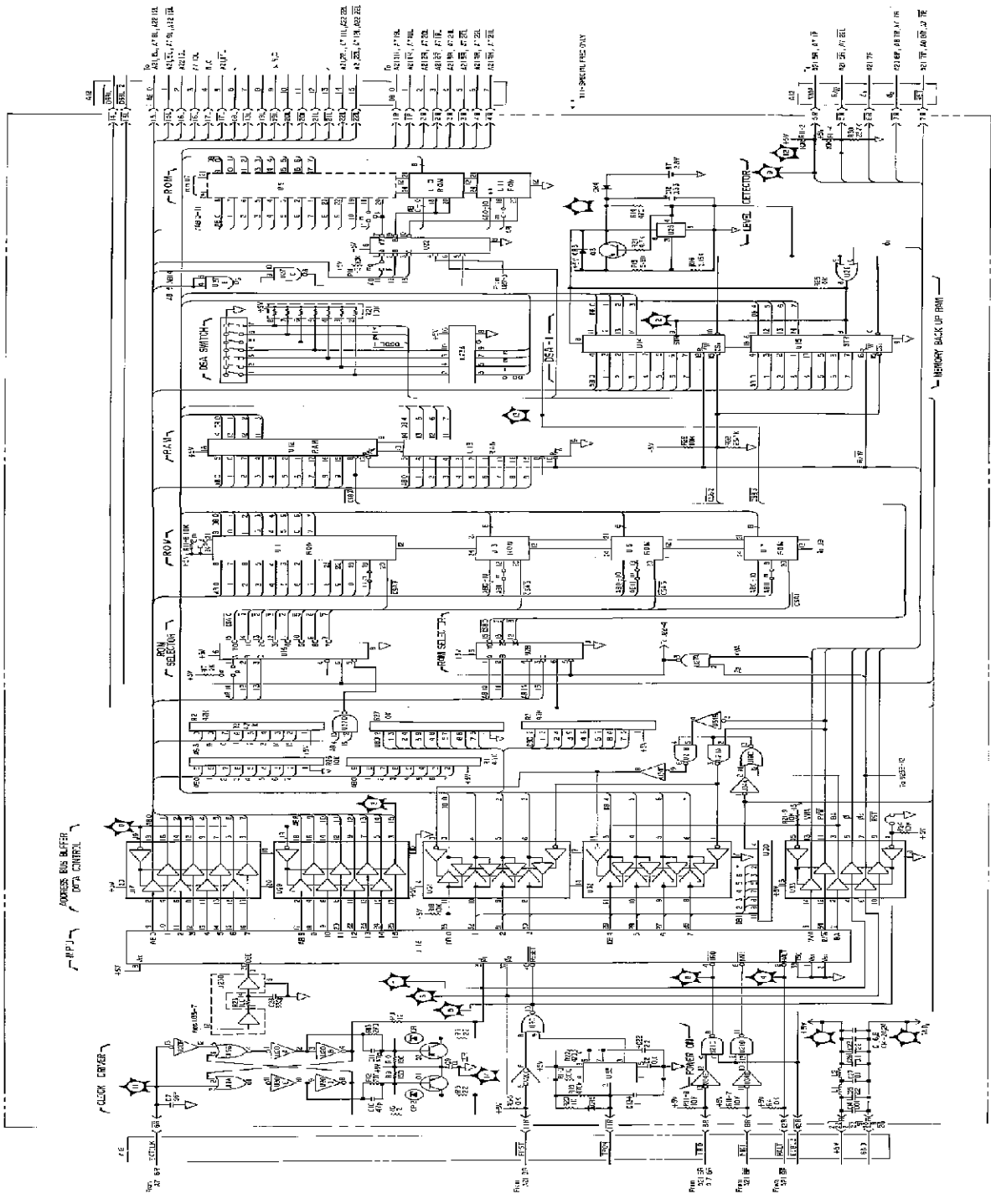

Figure 8-51. 85 Microprocessor Unit Board Assembly Schematic Diagram.

Figure 8-53. 85 Microprocessor Unit Board Assembly Component Locations.



## SECTION VIII

### SERVICE

#### 8-1. INTRODUCTION

8-2. This manual section provides the information and instructions required for servicing the HP Model 4275A MULTI-FREQUENCY LCR Meter. Included are Theory of Operation and Troubleshooting Guide with Circuit Schematics. The Theory of Operation describes fundamental principles and circuit operating theory of the 4275A with block diagrams. Circuit schematics, locator illustrations, troubleshooting guide, and other technical data necessary for repairs are integrated into the service sheet foldouts. An illustration of the instrument interior is shown in Figure 8-49.

#### Note

When the instrument circuitry includes expanded capabilities provided by optional equipment, refer to paragraphs entitled OPTIONS for specific option service information.

#### WARNING

TROUBLESHOOTING AND REPAIR ARE ALLOWED FOR QUALIFIED TECHNICAL PERSONNEL ONLY. IF YOUR INSTRUMENT FAILS, REFER INSTRUMENT TO SERVICE PERSONNEL. H-P SERVICE OFFICES OFFER YOU THE BEST ANSWER TO YOUR PROBLEM. A GUIDE TO YOUR LOCAL H-P SERVICE OFFICES MAY BE FOUND ON THE BACK COVER OF THIS MANUAL.

#### 8-3. THEORY OF OPERATION.

8-4. This theory of operation has been organized into three sections: basic theory, a block diagram discussion, and circuit analysis. The basic theory, beginning with paragraph 8-11, explains the concepts and fundamental theory of the 4275A instrument technique adapted for accurately measuring the DUT and for fully achieving automated measurement performance. The block diagram discussion describes the overall circuit operating theory of the 4275A with block-to-block signal flow. Included are block and timing diagrams. The circuit analysis provides a detailed description of how the circuit on

each board functions. For reference convenience, when servicing the instrument, a circuit description is included in the service sheets.

#### 8-5. TROUBLESHOOTING.

8-6. This troubleshooting guide provides instructions and information for locating a faulty circuit instrument component that requires service. All instructions consider the safety of service personnel who will perform the procedures. These diagnostic guides are in the form of step-by-step procedures with flow diagrams. The board level troubleshooting diagrams are the procedures for isolating the problem to an individual malfunctioning circuit board assembly. The guides for locating a defective component are given on the individual board service sheets and integrate service support data -- test point locations, waveform illustrations, voltage data, timing diagrams, and other technical information in addition to providing schematic diagrams for each board.

#### 8-7. RECOMMENDED TEST EQUIPMENT.

8-8. The test equipment required to perform operations outlined in this section is listed in Table 5-0. The table includes: type of instrument required, critical specifications, use, and recommended model. If the recommended model is not available, equipment which meets or exceeds critical specifications listed may be substituted.

#### 8-9. REPAIR.

8-10. Repair explanations tell how to replace defective circuit components. The recommended replacement procedures for components and parts which require special repair, replacement tools, or test equipment should be observed. Correct disassembly and the exchange procedures for such special parts are outlined in Paragraphs 8-89. To prevent damage from improper repair procedure, refer to the appropriate manual section before proceeding with repair.



8-11. BASIC THEORY

8-12. To ascertain unknown ac impedance values, most modern instruments use a bridge circuit or the vector voltage-current measurement method. The vector voltage-current method applies a test frequency signal to the sample to be measured and calculates the unknown impedance as the ratio of the test signal voltage to the sample current detected. As this method permits a multi-terminal measurement circuit configuration (three terminal, kelvin connection, or four terminal pair) which can eliminate the effects of residual impedances in the measuring circuit and, in addition, because the measurement circuit is relatively simple, wide range capabilities can be featured. Furthermore, the balance control that is typically used in a bridge circuit is not required. This hardware advantage facilitates high speed measurement and ease of operation. The 4275A employs vector voltage current measurement architecture in its measuring circuit.

8-13. Figure 8-1 is the block diagram of the 4275A. In the figure, the measuring circuit is denoted as a bridge circuit consisting of the unknown sample, a Range Resistor, Null Detector and Modulator. Actually, the 4275A incorporates the advantages of an auto-balance (controlled) bridge to extend the measurement capability of the vector voltage-current measurement method at high frequencies. The principle of the 4275A vector measurement method is outlined in Figure 8-2 comparing it to an ordinary vector voltage-current measurement method.

8-14. If the range resistor value is appropriately set, the "bridge" circuit is automatically balanced for the DUT impedance under control of the Null Detector and Modulator. When the bridge is balanced, the potential at Lpot (Lcur) terminal is zero volts. The current flowing through the DUT is then equal to that flowing through the range resistor. The DUT current is related to the voltage across the range resistor by the following equation:

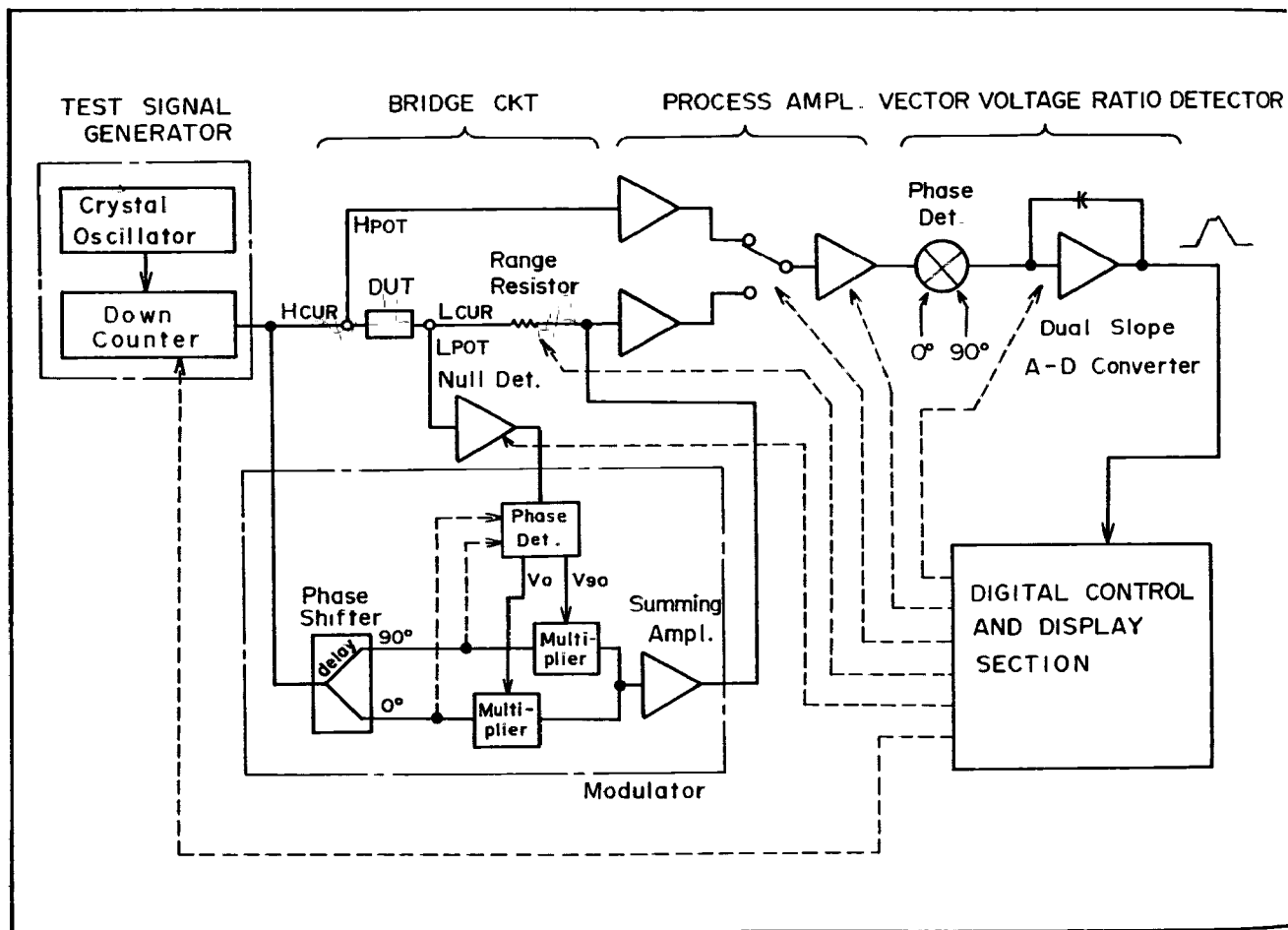

Figure 8-1. 4275A block Diagram.

$$i_x = \frac{E_{dut}}{Z_x} = \frac{Err}{R_r} \text{ ----- (8-1)}$$

Where  $E_{dut}$  is the voltage applied to the DUT (that is, the test signal voltage).  
 $Z_x$  is DUT impedance value.  
 $Err$  is voltage across range resistor.  
 $R_r$  is range resistor value.

The unknown impedance  $Z_x$  (or admittance  $Y_x$ ) can be calculated from the measured  $E_{dut}$  and  $Err$  signals as:

$$Z_x = -R_r \frac{E_{dut}}{Err} \text{ ----- (8-2)}$$

or 
$$Y_x = \frac{1}{R_r} \frac{Err}{E_{dut}} \text{ ----- (8-3)}$$

The Process Amplifier selectively and serially feeds the  $E_{dut}$  or  $Err$  signal in sequence to the Vector Voltage Ratio Detector section. Selection rules and timing for this operation are described in paragraph 8-16.

As the charge time  $T_1$  is fixed, the  $E_a/E_{dut}$  value (conductance value) can be derived by counting time  $T_2$ . The ratio for the  $E_b$  and  $E_{dut}$  signals are also derived in the same manner. Thus, basically, two integrator operating cycles are performed in one measurement.

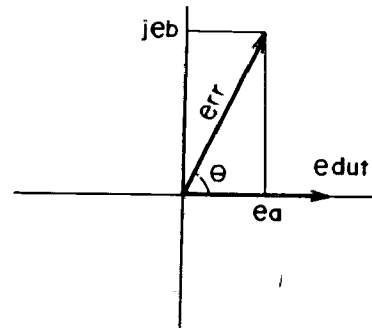

Basic Vector Detection

$-R_r \frac{E_{dut}}{Err}$   
-724

8-15. In general, the vector voltage ratio  $Err/E_{dut}$  (or  $E_{dut}/Err$ ) is measured in the following manner:

Figure 8-3 is a graphic representation of the  $E_{dut}$  and  $Err$  signal vectors ( $E_{dut}$  signal is taken as the reference for the phase angle of the  $Err$  signal). The  $Err$  signal vector can be divided into its real and imaginary components:

$$Err = E_a + jE_b \text{ ----- (8-4)}$$

The vector ratios  $E_a/E_{dut}$  and  $E_b/E_{dut}$  represent the real and imaginary components of the unknown admittance, that is, the conductance and susceptance value of the sample, respectively. The vector voltage components  $E_a$  and  $E_b$  are obtained by phase detecting the  $Err$  signal using detection phase signals which have  $0^\circ$  and  $90^\circ$  phase angles referenced to the  $E_{dut}$  signal. A dual slope integration technique is used for measuring the ratio of the  $E_a$  (or  $E_b$ ) and  $E_{dut}$  signals. In a typical voltage ratio measurement, an integrator charges and discharges in proportion to the  $E_a$  and  $E_{dut}$  signals, respectively, as illustrated below:

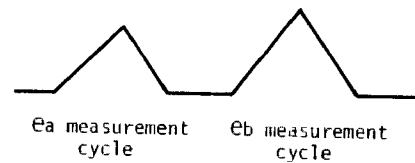
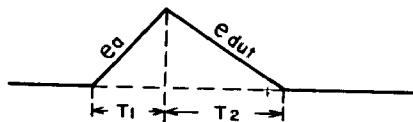

Figure 8-3. Usual Vector Voltage Ratio Measurement.



$T_1$ : Charge period by  $E_a$  signal  
 $T_2$ : Discharge period by  $E_{dut}$  signal

The charge and discharge relationship is represented by the following equations:

$$k_1 \cdot E_a \cdot T_1 + k_2 \cdot E_{dut} \cdot T_2 = 0$$

$$k \frac{E_a}{E_{dut}} = \frac{T_2}{T_1} \quad (k = \text{constant})$$

8-16. The 4275A employs a relative phase detection method to enhance its measurement accuracy over a broad measurement frequency region. The basic vector ratio measurement method, outlined in the above paragraph, requires that the detection phase signals must be exactly in phase or at right angles with respect to the  $E_{dut}$  (or  $Err$ ) signal. However, in actuality, it is difficult to produce detection phases with high accuracy at the multiple test frequencies ranging from 10kHz to 10MHz at which the instrument operates. This is because of the phase shifts in the detection phases that are incident to the amplifiers, lines and other circuits. Furthermore, the S/N ratio of the  $E_{dut}$  signal is apt to be degraded because measuring circuit is exposed to external fields. The relative phase detection method improves vector component detection accuracy by eliminating performance limitations attributable to these effects.

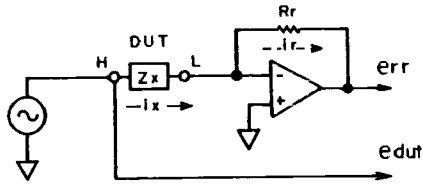

Figure A Low Frequency Vector Voltage-Current Method with Feedback Amplifier.

In the low frequency vector voltage-current method, a high gain amplifier which has a feedback resistor (range resistor)  $R_r$  operates as current-to-voltage (I-V) converter. The feedback amplifier causes a range resistor current  $I_r$  equal to DUT current  $I_x$  to flow (irrespective of the range resistor value). Amplifier output voltage  $E_{err}$  is equal to the product of  $R_r$  and  $I_r$  values. Thus, the  $E_{err}$  voltage is proportional to DUT current  $I_x$ . The  $I_x$  value is calculated as follows:

$$I_x = \frac{E_{dut}}{Z_x} = \frac{E_{err}}{R_r}$$

Accordingly, the DUT impedance value  $Z_x$  can be derived by measuring the  $E_{dut}$  and  $E_{err}$  voltages:

$$Z_x = R_r \frac{E_{dut}}{E_{err}}$$

As is explained in the feedback theory, the voltage at the "L" terminal is approximately zero volts (virtual ground). Thus, the range resistor value has no effect on DUT current  $I_x$  (the  $I_x$  value is determined only by the test signal voltage and DUT value). Though this method features simple circuit configuration and a relatively high accuracy, it is difficult to design a range resistor amplifier which can cause the range resistor feedback current to be in exact proportion to the DUT current (with negligibly low phase shift) at high frequencies.

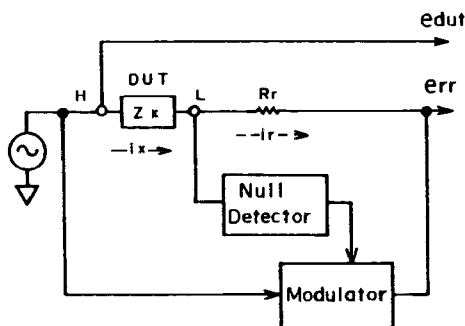

An auto-balance bridge employed in the 4275A operates to establish accurate DUT current-range resistor current relationships such as outlined above. To cause an accurate range resistor current to flow (at high frequencies), the amplitude and phase of the  $E_{err}$  signal is appropriately controlled by the Modulator. See Figure 8-2B. When the bridge circuit is unbalanced, the Null Detector picks up the unbalance current through the UNKNOWN "L" terminal. The null detector output vector indicates how the bridge is unbalanced for the real and imaginary vector components of the  $E_{err}$  signal. The Multipliers develop products of the null detector output vector components and the orthogonal vector signals which are produced from test frequency input signal. As a result of this multiplication, the real and imaginary vector component magnitudes of the null detector output signal are transferred to the orthogonal vectors of the test frequency input signal. The summing amplifier compounds the multiplier output signal vectors to establish the  $E_{err}$  signal. The  $E_{err}$  signal is, consequently, a reverse directional vector for the null detector input, that is an unbalance current (the summing amplifier performs an inverting amplification). The  $E_{err}$  signal responds to the unbalance current so as to suppress an increase in the unbalance current. The  $E_{err}$  signal vector is controlled with respect to the individual magnitude of the real and imaginary components of the unbalance current. Thus, the unbalance current approaches exact zero (for both vector components). This balance control loop operates quickly and continuously.

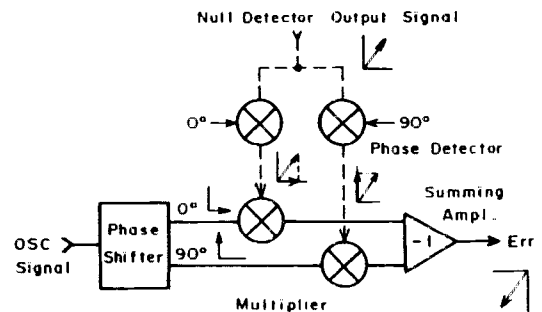

4275A Modulator Operating Principle.

Figure B. 4275A Vector Voltage-Current Method with Auto-balance Bridge.

Figure 8-2. 4275A Vector Voltage-current Method.

This method uses a set of detection phase signals each different by exactly 90 degrees in phase from the other. Neither of the detection phase signals need be in phase with the Edut (or Err) signal. With these detection phase signals, both Err and Edut signals are respectively divided into orthogonal phase components. See Figure 8-4. Impedance or admittance values of the DUT are calculated from the four phase components Ea, Eb, Ec and Ed in accord with the following equations:

$$Z_x = R_r \frac{E_{dut}}{E_{rr}} = R_r \frac{E_c + jE_d}{E_a + jE_b}$$

$$= R_r \frac{E_a E_c + E_b E_d + j(E_a E_d - E_b E_c)}{E_a^2 + E_b^2} \quad (8-6)$$

$$Y_x = \frac{1}{R_r} \frac{E_{rr}}{E_{dut}} = \frac{1}{R_r} \frac{E_a + jE_b}{E_c + jE_d}$$

$$= \frac{1}{R_r} \frac{E_a E_c + E_b E_d + j(E_b E_c - E_a E_d)}{E_c^2 + E_d^2} \quad (8-7)$$

The calculated Zx and Yx values are constant for the rotation of the coordinate axes around the origin. Therefore, the phase relationships of the detection phase signals and measurement signals (Err and Edut) have no effect on the calculation results if the relative phase angle of the detection phase signals is exactly 90 degrees. Since any possible phase shift in the circuits rotates both the 0° and 90° detection phases by the same angle, an exact orthogonal phase relationship is maintained. Consequently, accurate detection of the vector components over the entire test frequency range is enabled.

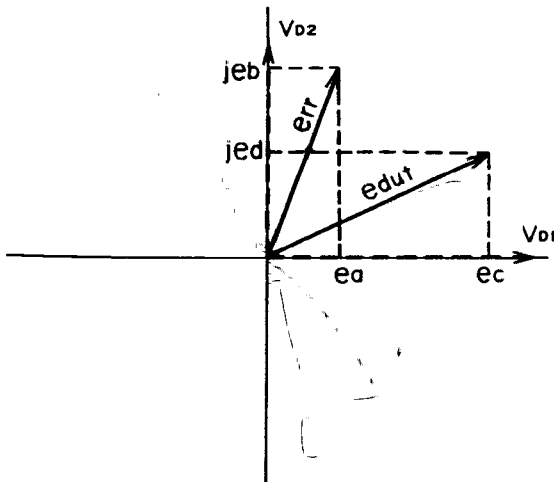

V<sub>D1</sub>, V<sub>D2</sub>: Orthogonal phase detection signals

Figure 8-4. 4275A Relative Vector Detection.

Resistance and reactance (conductance and susceptance) values of the sample are calculated as follows:

$$R_x = Z_x | \text{real} = R_r \frac{E_a E_c + E_b E_d}{E_a^2 + E_b^2} \quad (8-8)$$

$$X_x = Z_x | \text{imaginary} = R_r \frac{E_a E_d - E_b E_c}{E_a^2 + E_b^2} \quad (8-9)$$

$$G_x = Y_x | \text{real} = \frac{1}{R_r} \frac{E_a E_c + E_b E_d}{E_c^2 + E_d^2} \quad (8-10)$$

$$B_x = Y_x | \text{imaginary} = \frac{1}{R_r} \frac{E_b E_c - E_a E_d}{E_c^2 + E_d^2} \quad (8-11)$$

To measure the magnitude of each vector component (Ea, Eb, Ec and Ed), the phase detected vector voltages are sequentially converted to time periods. In the first integration cycle, for example, the Ec voltage charges the integrator for a constant time T1. The decay slope in the integrator discharge period is developed by using a dc reference voltage (Es or -Es) as in the popular dual slope DVM method. Relationship of the integrator input voltages and time periods are:

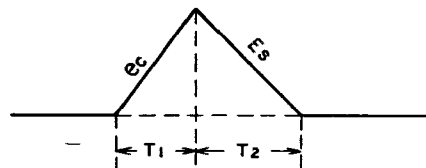

$$k_1 E_c T_1 = k_2 E_s T_2$$

$$E_c = k \cdot E_s \frac{T_2}{T_1} \quad E_c \propto T_2 \quad (8-12)$$

Where, constant k is the product of: (process amplifier gain) x (phase detector efficiency) x (integrator time constant).

Note

The integrator charge time constant (T1) is set to a multiple of the selected test frequency cycle period and is approximately 10ms. This suppresses the effects of any phase detector output ripple voltage which can not be fully filtered out because a small filtering time constant is used for shortening transient response time. The result of charge time (T1) control is stable measurement display outputs with low fluctuation.

The dual slope integration operation is done in four cycles to measure times T2 for Ea, Eb, Ec and Ed vector components (Ta, Tb, Tc and Td) in one measurement. The timing of the vector voltage ratio detector input/output signal is illustrated in Figure 8-5.

8-17. Equations 8-8 through 8-11 can be represented in terms of the counted time periods Ta, Tb, Tc and Td as follows:

$$R_x = \frac{T_a T_c + T_b T_d}{T_a^2 + T_b^2} \text{ ----- (8-13)}$$

$$X_x = \frac{T_a T_d - T_b T_c}{T_a^2 + T_b^2} \text{ ----- (8-14)}$$

$$G_x = \frac{T_a T_c + T_b T_d}{T_c^2 + T_d^2} \text{ ----- (8-15)}$$

$$B_x = \frac{T_b T_c - T_a T_d}{T_c^2 + T_d^2} \text{ ----- (8-16)}$$

When the sample impedance value is measured on a range below 100Ω, the 4275A calculates the vector impedance component values Rx and Xx. For samples which have higher impedance values, the 4275A calculates the vector admittance component values Gx and Bx. Other measurement parameter values are subsequently calculated from the measured Rx and Xx (Gx and Bx) values using memorized parameter conversion formulas.

8-18. When a high impedance sample is measured, a constant test signal voltage is applied to the sample irrespective of the sample value. Therefore, the Eref voltage is constant and the voltage across range resistor (Err) changes in proportion to the sample value. On the other hand, when a low impedance sample is measured, a 100Ω source resistor (test signal generator output resistor) causes a constant test signal cur-

rent to flow through the sample. In this case, the range resistor voltage Err is constant and, the voltage across the sample (Edut) is proportional to the sample value. The relationship of the test signal voltage and current to the sample impedance value is given in Figure 8-6.

8-19. The dual slope A-D conversion sequence adds two auto offset cycles to eliminate the effects of residual dc offset voltages in the Vector Voltage Ratio Detector. One offset cycle precedes the four vector measurement cycles each time a measurement is taken. When (and only when) the test frequency is set at 2MHz or a higher frequency, another offset cycle follows after completion of the vector measurement cycles. During the offset measurement periods, the process amplifier (Edut and Err) selector switches are opened to accept no input. The integrator develops a low level dual slope waveform and time T0 (T5) is proportional to the comprehensive residual offset voltage at the integrator output. At high frequencies, the offset measurement is performed for each of the 0° and 90° detection phase operations because the residual dc offset voltage differs for the respective detection phases. Times T0 and T5 are arithmetically subtracted from the counted vector measurement time values as:

$$\begin{aligned} T_a' &= T_a - T_0 \\ T_b' &= T_b - T_0 \\ T_c' &= T_c - T_5 \\ T_d' &= T_d - T_5 \end{aligned}$$

where the prime mark (') indicates compensated time values. When an offset measurement cycle (T5) is not implemented, time value T0 is used for (instead of) T5.

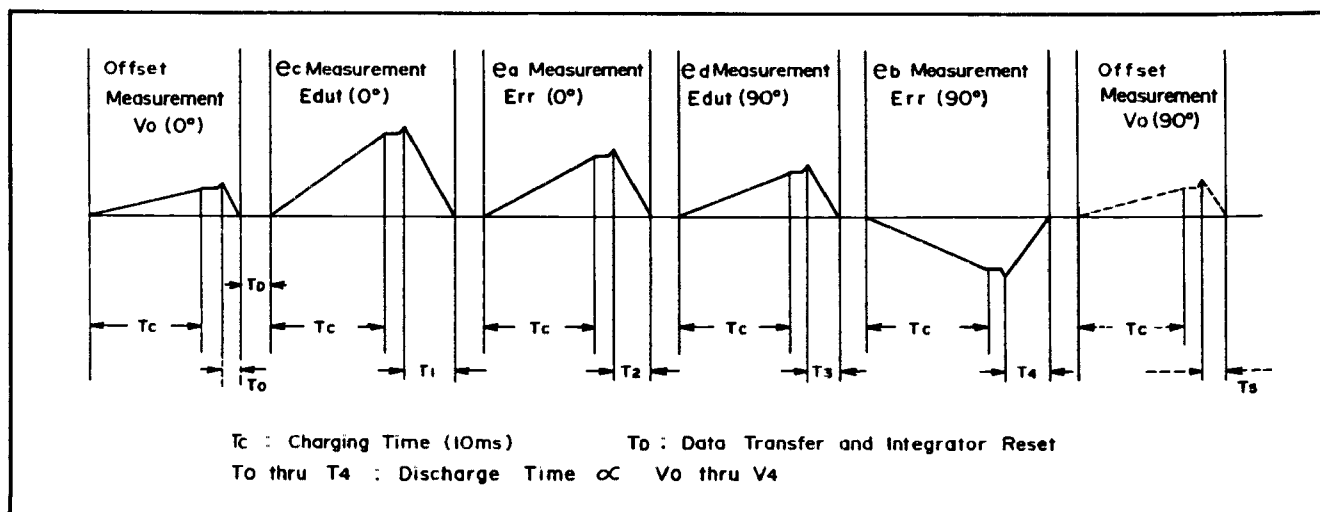

Figure 8-5. Integrator Vector Voltage Ratio Detection Timing.

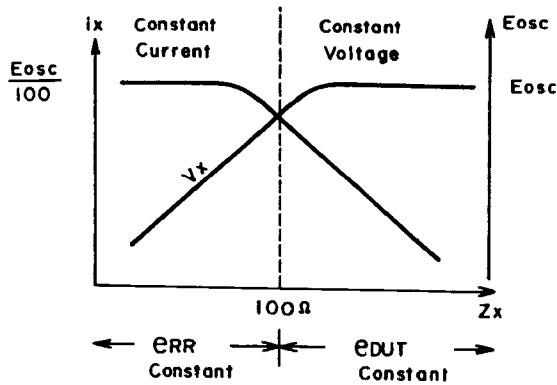

Figure 8-6. Test Signal Voltage and Current Relationship to Sample Impedance.

Where, Zc: Corrected impedance value  
 Yc: Corrected admittance value  
 Zo: Residual impedance value  
 Yo: Residual admittance value  
 Zm: Measured DUT impedance value  
 Ym: Measured DUT admittance value

8-20. Range resistor value is selected as either 100Ω, 1kΩ, 10kΩ and 100kΩ depending on the DUT value. To magnify measurement range capabilities, the process amplifier gain can be attenuated by 1/10 or 1/100. This permits developing vector voltage ratios equivalent to that obtained when lower or higher range resistor values are used. For example, when the process amplifier gain is decreased by 1/10 during integrator charge or discharge periods, the calculated Rx and Xx values are 10 times that measured without the attenuation process.

Note

When Ea and Eb signals are attenuated by 1/10 in Process Amplifier, calculated resistance value Rx is magnified and is given by the equation below:

$$R_x' = R_r \frac{0.1 E_a E_c + 0.1 E_b E_d}{(0.1 E_a)^2 + (0.1 E_b)^2}$$

$$= 10 R_r \frac{E_a E_c + E_b E_d}{E_a^2 + E_b^2} = 10 R_x$$

8-21. Zero Offset Adjustment (Open and Short) function measures residual impedance of the test fixture under short-circuit conditions and residual admittance under open-circuited conditions. Correction calculations in the subsequent DUT measurements are made using the following equations:

$$Z_c = \frac{Z_m - Z_o}{1 - Y_o Z_m} \text{ -----(8-17)}$$

$$Y_c = \frac{Y_m - Y_o}{1 - Z_o Y_m} \text{ -----(8-18)}$$

8-22. BLOCK DIAGRAM DISCUSSION

8-23. A6 OSCILLATOR

8-24. Demands for accurate and high resolution measurements necessitate a stable test frequency signal of high accuracy with low distortion (including minimum harmonics and noise). To generate 10 standard spot test frequencies, the 80MHz and 32MHz crystal oscillator frequencies are first counted down to  $8f$  (8 times the selected frequency) signal. The 80MHz oscillator provides the source frequency for the 10kHz, 20kHz, 100kHz, 200kHz, 1MHz, 2MHz and 10MHz test frequencies. For 20kHz, 200kHz and 2MHz frequencies, a 16MHz source frequency divided down (by 5) from 80MHz oscillator frequency is used. On the other hand, a 32MHz oscillator provides the source frequency for the 40kHz, 400kHz and 4MHz test frequencies. The source frequency signals are gated for selecting the decade down-counter input frequency signal (to be divided into lower test frequency signals). Source frequency selection and frequency count-down rules are summarized in Table 8-1.

8-25. The sinusoidal waveform synthesizer generates a periodic staircase waveform whose envelope is similar to a sinusoidal waveform. The staircase waveform has appropriate step voltages developed by level synthesis circuitry in synchronism with the "8f" pulse signal. See Figure 8-8. A Harmonic Suppressor Adjustment control permits adjusting the step voltage levels so that the periodic staircase signal, whose cyclic period is that of the selected test frequency, includes only lower order magnitudes of the third and the fifth harmonics (theoretically, even degree harmonics are not included in the signal).

8-26. The three LPF (Low Pass Filter) stages pass the fundamental of the sinusoidal waveform synthesizer output signal and eliminate the harmonics to a level of -50dB or more from the fundamental. The filter roll-off frequency automatically follows the input fundamental frequency so that the filtered output (sinusoidal waveform) is maintained at a constant level. Operating theory for the frequency follow-up filter circuit is illustrated in Figure 8-9. The roll-off frequency control range is varied to cover all test frequencies in three decade ranges as follows:

- Range 1: 10kHz to 100kHz
- Range 2: 100kHz to 1MHz (excludes 100kHz)
- Range 3: 1MHz to 10MHz (excludes 1MHz)

Because the test frequency always comes at a particular point on the characteristic slope of the filter, the filtering effect (harmonic rejection) is constant for all test frequencies.

8-27. 1-3-5 step test frequency (Opt. 004). Option 004 unit employs 24MHz instead of the standard 32MHz crystal oscillator frequency and 40MHz divided down from 80MHz (by 2) instead of the 16MHz source frequency. Frequency selection method for option 004 test frequencies is summarized in Table 8-2.

8-28. Installation of a special test frequency option adds a crystal resonator to the oscillator circuit which has a resonant frequency which is appropriate for use at the optional frequency. Additionally, appropriate inductor and capacitor values are used as blank circuitry to complete the optional oscillator circuit.

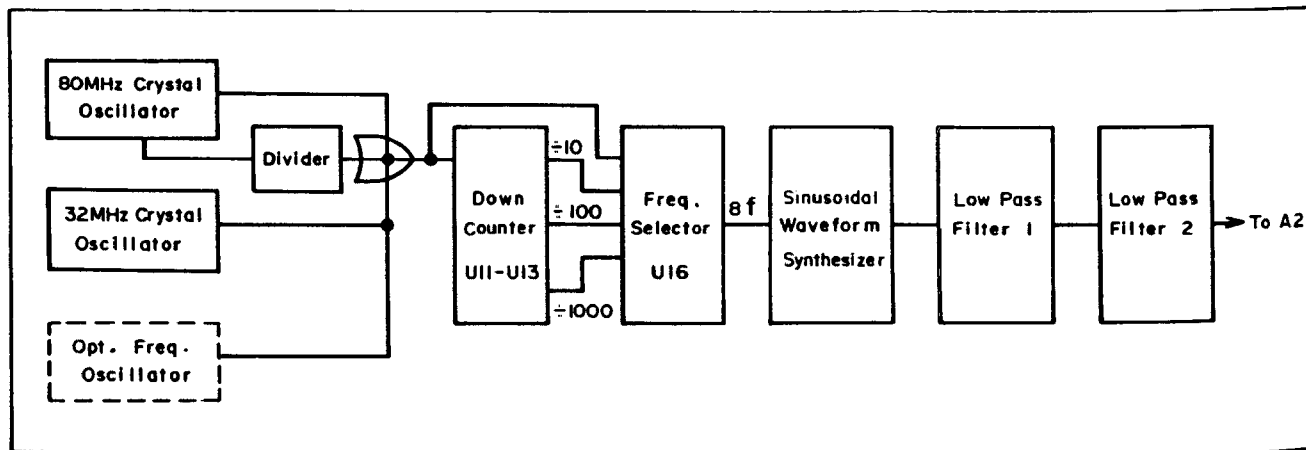

Figure 8-7. A6 Oscillator Block Diagram.

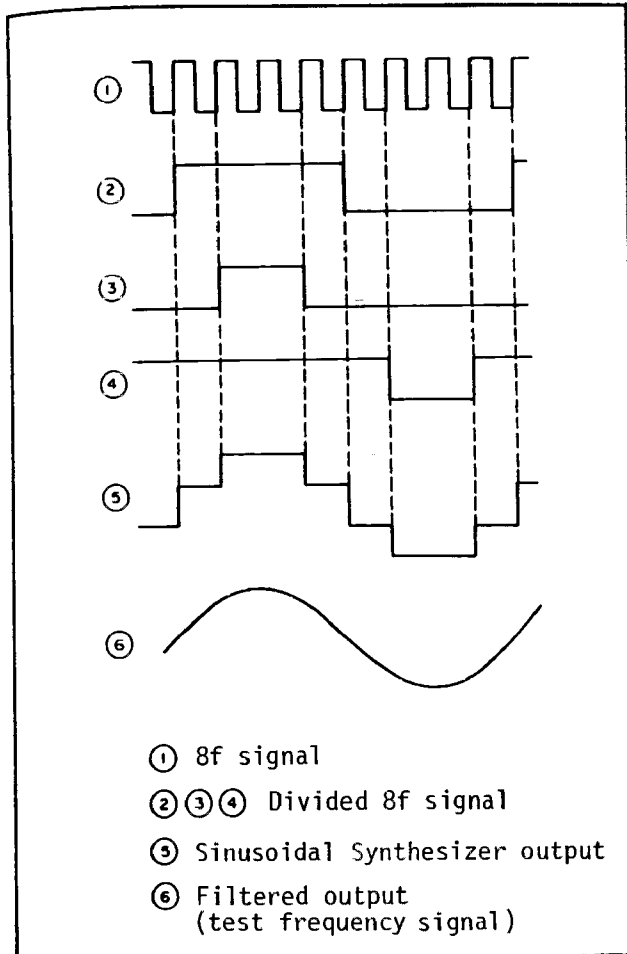

Figure 8-8. Sinusoidal Synthesizer Waveforms.

8-29. A3 POWER AMPLIFIER

8-30. The sinusoidal test frequency signal of 500mVrms is processed in the Power Amplifier section to allow control of test signal amplitude and the application of any desired dc bias. Additionally, the modulator output signal (Err) flows in the other amplifier channel which has almost the same circuit configuration as that for the test signal channel. The modulator output signal amplitude is also controlled in proportion to the test signal amplitude to maintain the bridge balance condition constant. The 1/10 and 1/100 attenuators in the middle stage amplifiers provide attenuation linked to the test signal level MULTIPLIER control. Front panel OSC LEVEL control changes feedback amplification gain of the preamplifier stages. The power amplifier circuit feeds the test frequency signal to the DUT and the modulator signal to the range resistor circuit with low amplifier output impedance.

8-31. A1 RANGE RESISTOR/NUL DETECTOR

8-32. The A1 board assembly combines two circuit sections: the Range Resistor circuit (on the upper part) and the Null Detector (on the lower part of the circuit board).

1) Range Resistor circuit.

To ensure accurate range resistor value and minimum residual reactance (mainly stray capacitance) effects, an adjustment potentiometer and a phase compensation trimmer capacitor are provided in association with in-

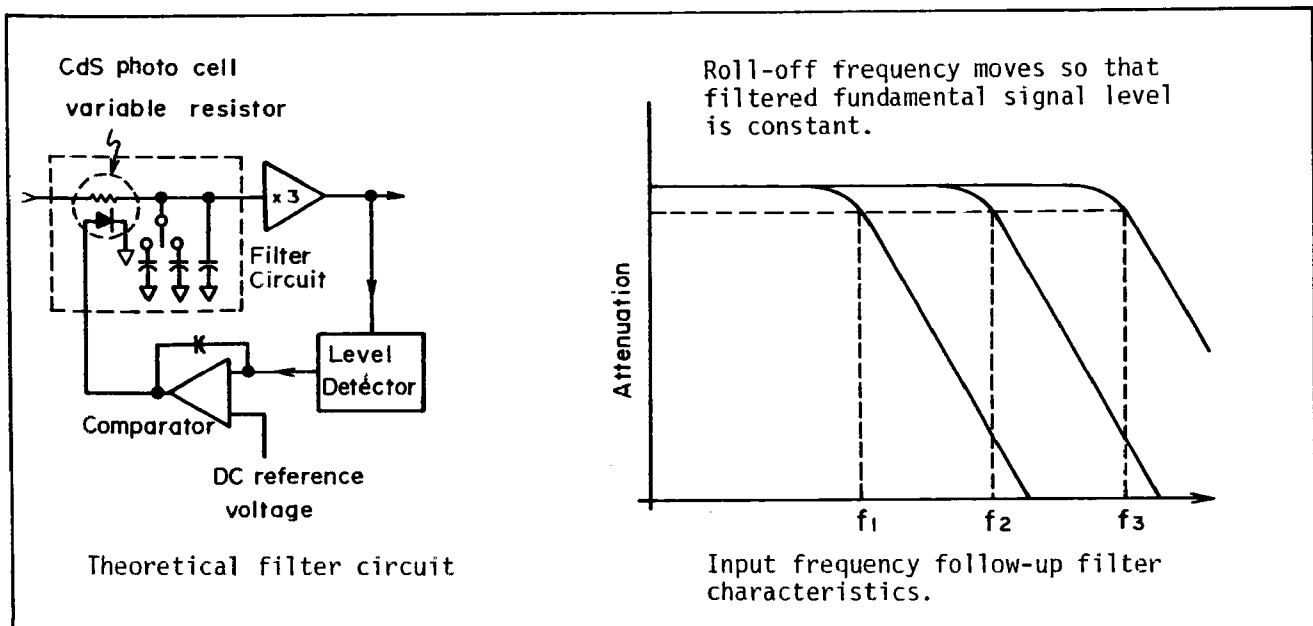

Figure 8-9. Frequency Follow-up Filter Operating Theory.



dividual range resistors. The CMR (Common Mode Rejection) amplifier properly compensates for any voltage drop in the range resistor signal which is caused by impedance inherent in the internal cabling. The Cable Length Compensator delays the range resistor signal to offset the effect of long test cables (when 1m test cables are used).

2) Null Detector

Bridge unbalance vector current is converted into a vector voltage at the I-V converter output. To improve amplifier gain at high frequencies, the I-V converter employs a staggered amplifier circuit configuration.

Because I-V converter feedback magnitude varies depending on the DUT impedance, the feedback circuit element value is changed in response to selection of measurement range. The Level Normalizer Amplifier amplifies the unbalance signal vector voltage maintaining the output signal level constant (irrespective of the OSC LEVEL control setting). These gain controls (in the I-V Converter and the Level Normalizer Amplifier) suppress variations in the bridge balance control loop gain. Consequently, bridge balance settling time (transient response time when bringing the bridge into balance) is almost equal for various measurement conditions.

Table 8-1. Test Frequency Selection (Standard).

Test Signal frequency	Oscillator source frequency	Division fraction			Total division fraction	8f frequency
		1st	2nd	3rd		
10kHz	80MHz	1/10	1/10	1/10	1/1000	80kHz
20kHz	16MHz	1/10	1/10	—	1/100	160kHz
40kHz	32MHz	1/10	1/10	—	1/100	320kHz
100kHz	80MHz	1/10	1/10	—	1/100	800kHz
200kHz	16MHz	1/10	—	—	1/10	1.6MHz
400kHz	32MHz	1/10	—	—	1/10	3.2MHz
1MHz	80MHz	1/10	—	—	1/10	8MHz
2MHz	16MHz	—	—	—	—	16MHz
4MHz	32MHz	—	—	—	—	32MHz
10MHz	80MHz	—	—	—	—	80MHz

Table 8-2. Test Frequency Selection (Opt. 004).

Test signal frequency	Oscillator source frequency	Division fraction			Total division fraction	8f frequency
		1st	2nd	3rd		
10kHz	80MHz	1/10	1/10	1/10	1/1000	80kHz
30kHz	24MHz	1/10	1/10	—	1/100	240kHz
50kHz	40MHz	1/10	1/10	—	1/100	400kHz
100kHz	80MHz	1/10	1/10	—	1/100	800kHz
300kHz	24MHz	1/10	—	—	1/10	2.4MHz
500kHz	40MHz	1/10	—	—	1/10	4MHz
1MHz	80MHz	1/10	—	—	1/10	8MHz
3MHz	24MHz	—	—	—	—	24MHz
5MHz	40MHz	—	—	—	—	40MHz
10MHz	80MHz	—	—	—	—	80MHz

8-33. A2 MODULATOR

8-34. Simplified block diagram of the A2 Modulator is shown in Figure 8-10. The test frequency input signal, which is transformed into a range resistor signal (Err) for counter-balancing the bridge circuit, splits into 0° and 90° phase signals at the Phase Shifter output. The auto-phase adjustment circuit adopted in the phase shifter continuously operates to bring the relative difference in phase of the phase shifter output signals to an accurate 90 degrees. Discrimination of the phase difference is performed by phase detecting the 90° phase signal using the 0° phase signal as the detection signal. When an accurate 90° phase difference occurs, the detector signal level is zero. The phase detector output voltage controls the 90° phase shifter so that the phase error is minimum.

8-35. Null detector output signal is phase detected to extract the vector components of the unbalance current. DC levels at the integrator outputs are proportional to magnitudes of the null detector signal vector components. These dc voltages, proportional to the 0° and 90° phase components of the unbalance current, are the control signals for transforming the test frequency signal (divided into 0° and 90° phase signals) into the required Err signal. The Phase Tracking Amplifiers compensate for any phase shift in detection phase signals to ensure accurate phase detector outputs over the entire test frequency range.

8-36. The Multipliers are the key circuits for controlling the Err signal vector voltage. The multipliers provide individual outputs proportional to the product of their input signals. Thus, the two multipliers produce outputs which can be represented by the following equations:

$$1) V_s(0) \times V_c(0) = V_{m1}$$

$$2) V_s(90) \times V_c(90) = V_{m2}$$

Where,  $V_s(0)$ : 0° phase test frequency signal  
 $V_s(90)$ : 90° phase test frequency signal  
 $V_c(0)$ : Null detector output 0° phase component (dc)  
 $V_c(90)$ : Null detector output 90° phase component (dc)  
 $V_{m1}, V_{m2}$ : Multiplier output signals

The Summing Amplifier sums the  $V_{m1}$  and  $V_{m2}$  signals which are the products of the null detector output (unbalance current). The blended signal comprises the Err signal and may be represented as:

$$Err = -(V_{m1} + V_{m2})$$

8-37. If the imaginary component of the unbalance current increases, it causes the  $V_c(90)$  signal level to simultaneously increase. Thereupon, the Err signal changes to a new vector voltage which is composed of a greater  $-V_{m2}$  vector component magnitude. Note that the Err signal is the reverse vector of the composite vector  $V_{m1}$  plus  $V_{m2}$ . See illustration below:

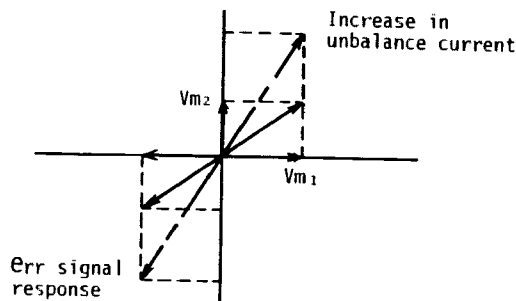

The response of the Err signal increases the reverse vector of the unbalance current and, thus, the unbalance current is reduced (approaches zero).

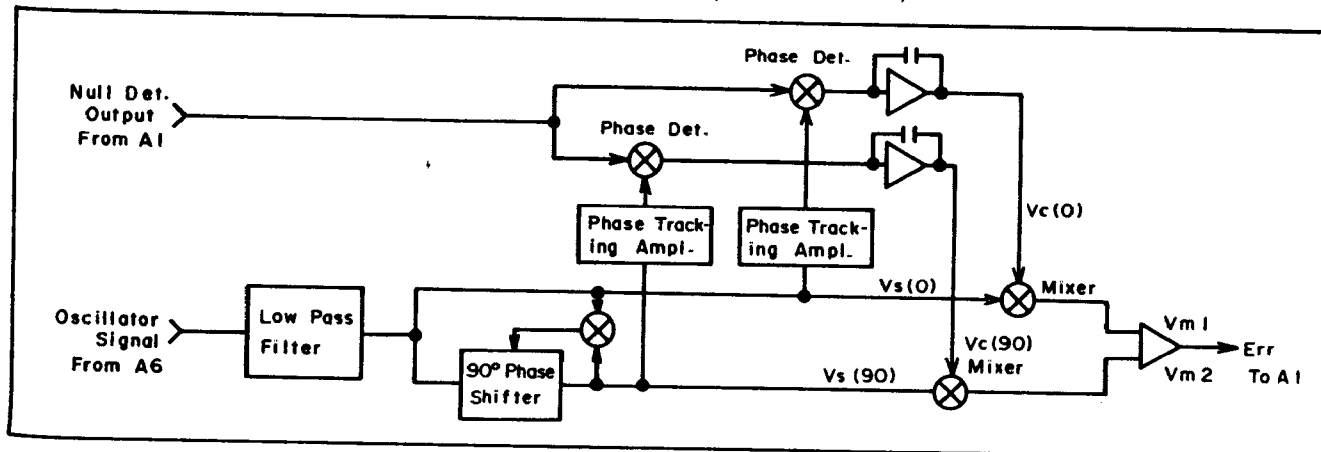

Figure 8-10. A2 Modulator Block Diagram.

8-38. A4 PROCESS AMPLIFIER

8-39. The Err and Edut Buffer Amplifier (A4A1 and A4A2) detect the bridge circuit measurement signals (Err and Edut) with a minimum phase error (to 10MHz). The signal selector switches at the output stage of the Buffer Amplifiers turn on and off according to the measurement sequence and allow transmission of either the Err or Edut signal to the later amplifier stages. For switch control timing, refer to Figure 8-17 Timing Diagram.

The signal selector switches channel the test frequency input signal which is fed at 10mVrms from the A6 Oscillator when TEST SIGNAL LEVEL CHECK function is activated. Test signal voltage or current is calculated from the detected Edut, Err and the 10mV reference test signal level (by the micro-processor). These selector switches do not connect with any input channel during the A-D converter offset control period.

8-40. The AM Amplifier (A4A3 and A4A4) expand measurement range capabilities and compress variations of the Err and Edut signals in relation to the test frequency signal level. The two 1/10 attenuators located between the series amplifier stages are used for the following purposes:

- 1) They change the attenuation factors in conjunction with the test signal level MULTIPLIER settings as follows:

MULTIPLIER setting	Attenuation factor
x 1	1/100 (1/10 x 1/10)
x 0.1	1/10 (1/10 x 1)
x 0.01	1 (1 x 1)

- 2) Their attenuation only applies to the Err or Edut signal depending on the selected range. This selective attenuation magnifies the ratio of the Err and Edut signal levels to 10 or 100 times the normal ratio. Thereby, the measurement range can be multiplied by the same factors.

The Level Comparator monitors the OSC LEVEL control setting to compare the control signal level with the four step voltage ranges. When the OSC LEVEL control is rotated from its minimum to maximum position, the Level Comparator changes its output logic at the "A" to "D" outputs from low to high level (in D to A order). The comparator outputs an amplification gain change to the individual x10 amplifiers (x10, x4 or x2). The relationship of the OSC LEVEL control setting and the amplification gain is illustrated in Figure 8-12.

As the result of the attenuation (amplification) control for a desired change of test signal level, the amplitude of the AM amplifier output is corrected at an approximately constant level. This maintains the A-D converter input signal level constant and improves vector ratio detection accuracy for low level test signal measurements. Note that the ratio of the Err and Edut signal levels are preserved throughout these processes.

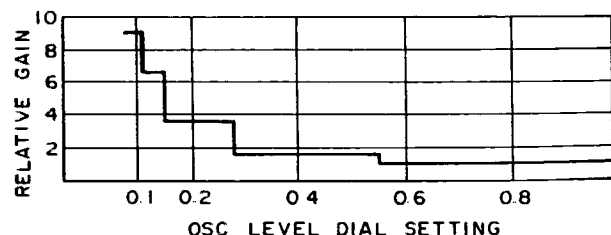

Figure 8-12. AM Amplifier Gain Control.

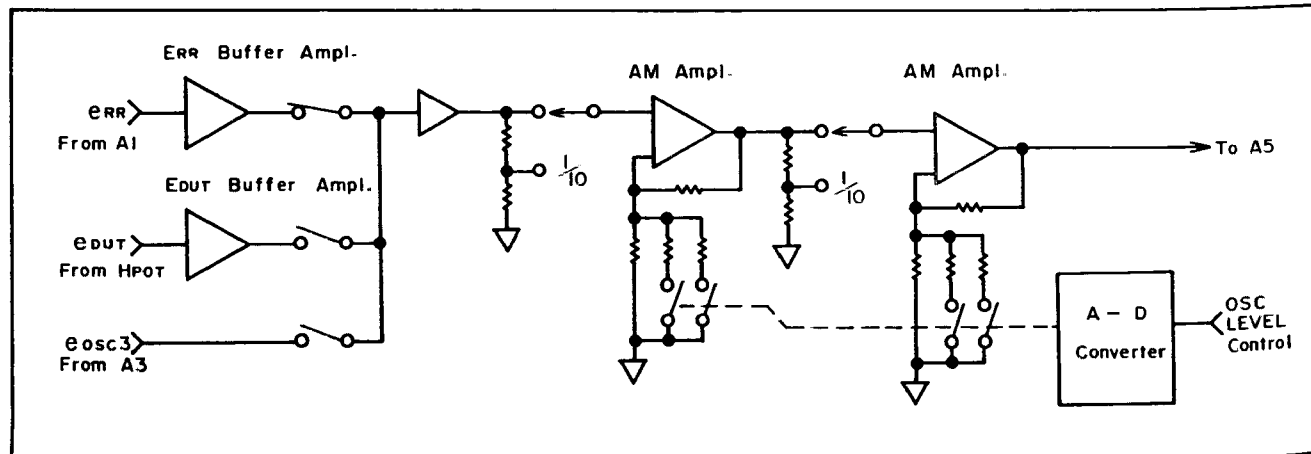
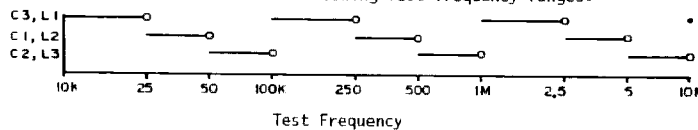

Figure 8-11. A4 Process Amplifier Block Diagram.

Table 8-3. Range Resistor and AM Attenuator Control Matrix.

Function	Test Frequency	L, C, R,  Z  Range								
		Z-1	Z-2	Z-3	Y-5	Y-4	Y-3	Y-2	Y-1	
C Capacitance	10kHz~24.9kHz	100uF	10uF	1000nF	100mF	10nF	1000pF	100pF	10pF	
	25kHz~249kHz	10uF	1000nF	100nF	10nF	1000pF	100pF	10pF	1000fF	
	250kHz~2.49MHz	1000nF	100nF	10nF	1000pF	100pF	10pF	1000fF	—	
	2.5MHz~10MHz	—	10nF	1000pF	100pF	10pF	1000fF	—	—	
L Inductance	10kHz~99.9kHz	10uH	100uH	1000uH	10mH	100mH	1000mH	—	—	
	100kHz~999kHz	1000nH	10uH	100uH	1000uH	10mH	100mH	—	—	
	1MHz~9.99MHz	100nH	1000nH	10uH	100uH	1000uH	10mH	—	—	
	10MHz	—	100nH	1000nH	10uH	100uH	—	—	—	
P,  Z  Resistance Impedance	10kHz~10MHz	1000mΩ	10Ω	100Ω	1000Ω	10kΩ	100kΩ	1MΩ	10MΩ	
Range resistor used		100Ω	100Ω	100Ω	100Ω	100Ω	1kΩ	10kΩ	100kΩ	
Combination of AM and AF attenuator control	C1	AM	x10	x1	x1	x1	x10	x10	x10	x10
		AF	2	2	1	4	4	4	4	4
	C2	AM	x10	x1	x1	x1	x10	x10	x10	x10
		AF	4	4	1	2	2	2	2	2
	C3	AM	x100	x10	x1	x1	x10	x10	x10	x10
		AF	1	1	1	1	1	1	1	1
	L1	AM	x100	x10	x1	x1	x10	x10	x10	x10
		AF	1	1	1	1	1	1	1	1
	L2	AM	x10	x1	x1	x1	x10	x10	x10	x10
		AF	4	4	1	2	2	2	2	2
	L3	AM	x10	x1	x1	x1	x10	x10	x10	x10
		AF	2	2	1	4	4	4	4	4
	P,  Z	AM	x100	x10	x1	x1	x10	x10	x10	x10
		AF	1	1	1	1	1	1	1	1

Note: C1, C2, C3, L1, L2 and L3 indicates capacitance and inductance measurements in the following test frequency ranges:



This table applies only when MULTIPLIER is set to X1.

8-41. A5 A-D CONVERTER

8-42. For both capacitance and inductance measurements, the attenuator at the input stage of the A-D Converter equalizes the input signal (Edut and Err) level for any test frequency. The Edut or Err signal level detected for the same sample value (capacitance or inductance) changes in proportion to (or in inverse proportion to) the test signal frequency. The attenuation factor is set to 1/2 or 1/4 so that the Edut and Err input signal levels are, respectively, almost equal in one decade frequency range (for example, at 100kHz, 200kHz and 400kHz). In the same manner, the input signal levels are also equalized for other decade frequency ranges in combination with different range resistor values or process amplifier attenuation factors.

8-43. The Phase Detector extracts 0° phase and 90° phase vector components independent-

ly with appropriate timing from the Edut and Err input signals. The phase detector employs an unique circuit configuration for decreasing odd order harmonic component signals which may occur in the output signal. When a square waveform detection signal is used (as is popular), the phase detector output signal also includes low amplitude harmonics corresponding to their vector products [harmonics (distortion) of the input signal multiplied by harmonic components of the square waveform detection signal (in the same frequency vector)]. These harmonic signals, mainly consisting of odd order components, cause a measurement error to occur. Use of a sinusoidal waveform detection signal ensures less harmonics but offers more difficulty in achieving detection phase accuracy in comparison to the square waveform operation.

The phase detector employed in the vector ratio detector uses a periodic staircase waveform detection signal synthesized into a sinusoidal waveform. See Figure 8-14. The quasi-sinusoidal waveform detection signal generates lower order third and fifth degree harmonics. This new phase detector circuit configuration is a parallel connection of two ordinary phase detectors. To accomplish phase detection on the basis of this concept, four switching signals operate in synchronization for each detection phase ( $0^\circ$  and  $90^\circ$ ). The combined circuit operation of these switching signals is in consonance with theoretical phase detection. The phase detector output current waveform is the sum of the input signal segments detected for the individual switching time periods (as shown in Figure 8-14).

8-44. The Detection Phase Generator develops the synchronized switching signals by counting down the frequency of the 8f pulse signal (fed from A6 Oscillator). The switching pulses generate one cycle for each 8 cycle period of the 8f signal. Thus, the  $0^\circ$  and  $90^\circ$  detection phase signals are exactly synchronized with the test frequency signal. Selection of the detection phase is performed by shifting the timing of the down counter by 2 cycle periods of the 8f signal.

8-45. A dual slope A-D converter charges on the phase detector output signal (a vector component of the Edut or Err signal) during

the time the input switch is closed for a constant period (approximately 10ms). The charge time interval is set to an exact multiple of the test signal cycle period. See Figure 8-17 Timing Diagram. A short hold time is provided before beginning charge and before beginning with the discharge period. During the hold time, the integrator input switch is opened to intercept any transient response signals incident to switching of measurement vector signal. A small triangular precharge waveform done before going into the discharge period improves measurement accuracy when input signal is of extremely low level. The integrator discharges at a constant decay rate until the output voltage reaches zero volts. The reference voltage supply circuit feeds a positive or negative dc voltage to discharge the integrator depending on the polarity of the charge input. The positive and negative reference voltages do not effect measurement results if their absolute values are equal. The Zero Detector reverses its output logic the moment the integrator output crosses the zero level. This signals completion of the discharge to the digital section. The amplifier combined with the integrator magnifies the integrator output waveform to facilitate detection of crossing the zero level point with minimum time error. The feedback loop switch (A5Q36) closes to keep the integrator discharged except when a dual slope integration operation is being performed.

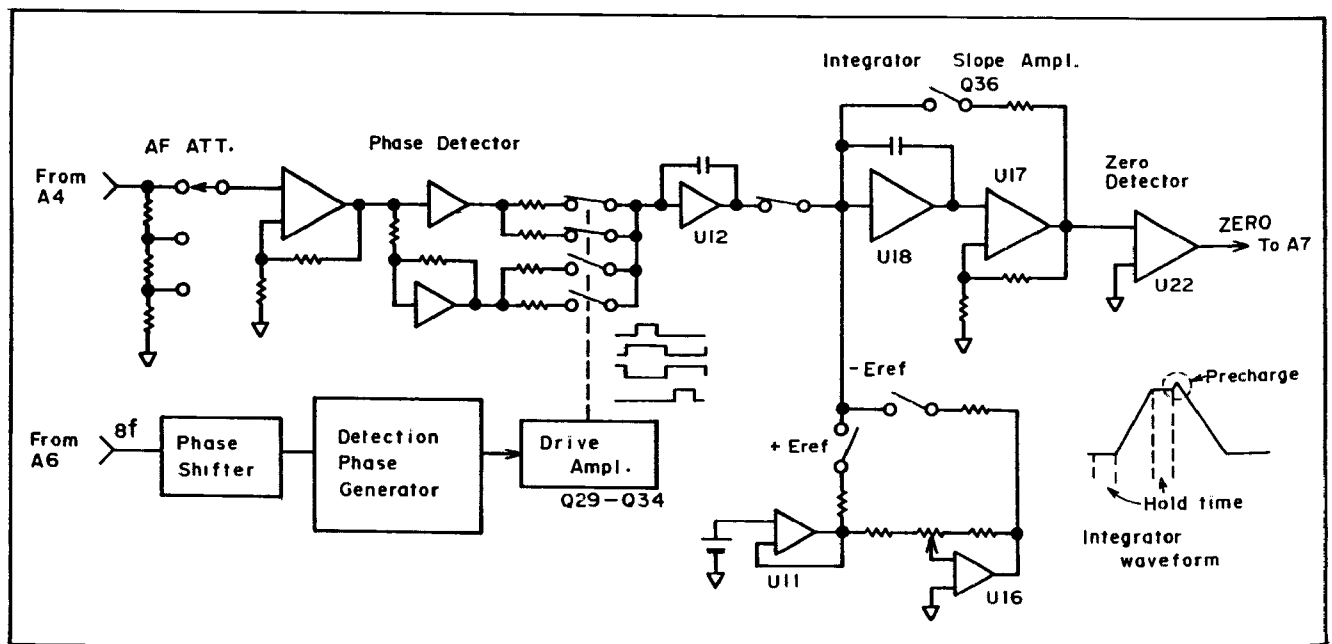

Figure 8-13. A5 A-D Converter Block Diagram.

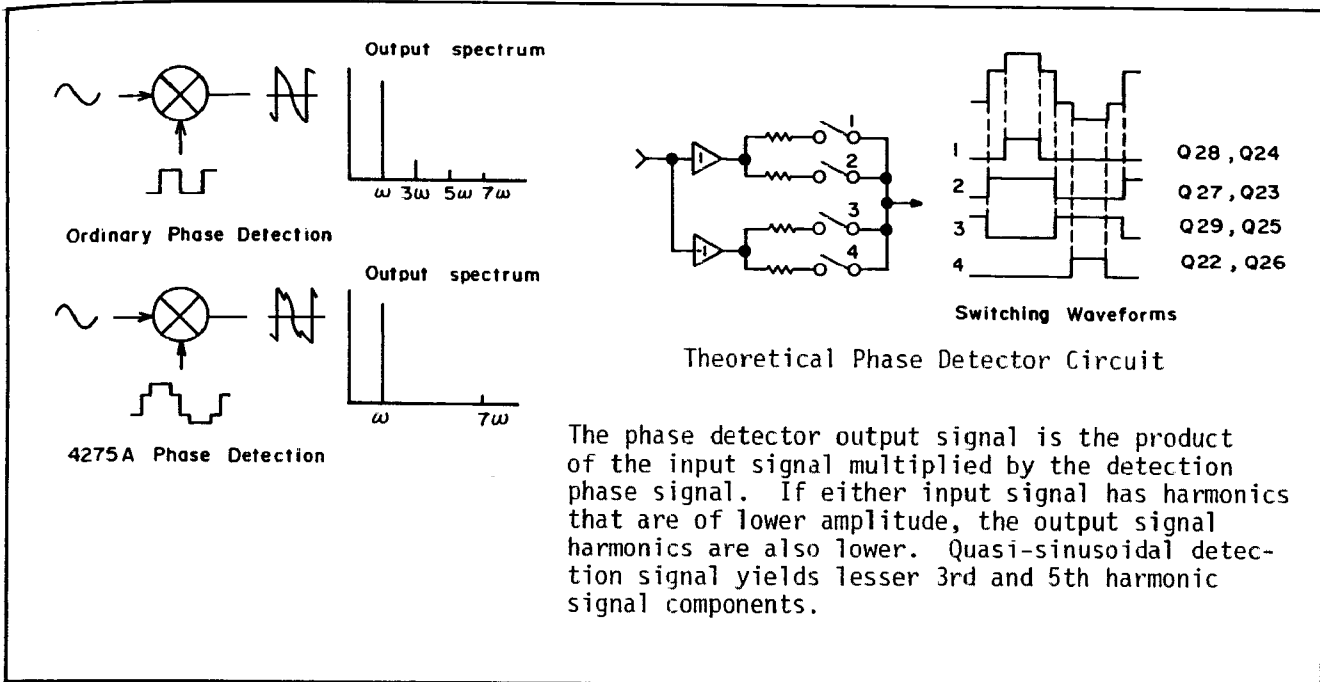

Figure 8-14. 4275A Phase Detector Operating Principle.

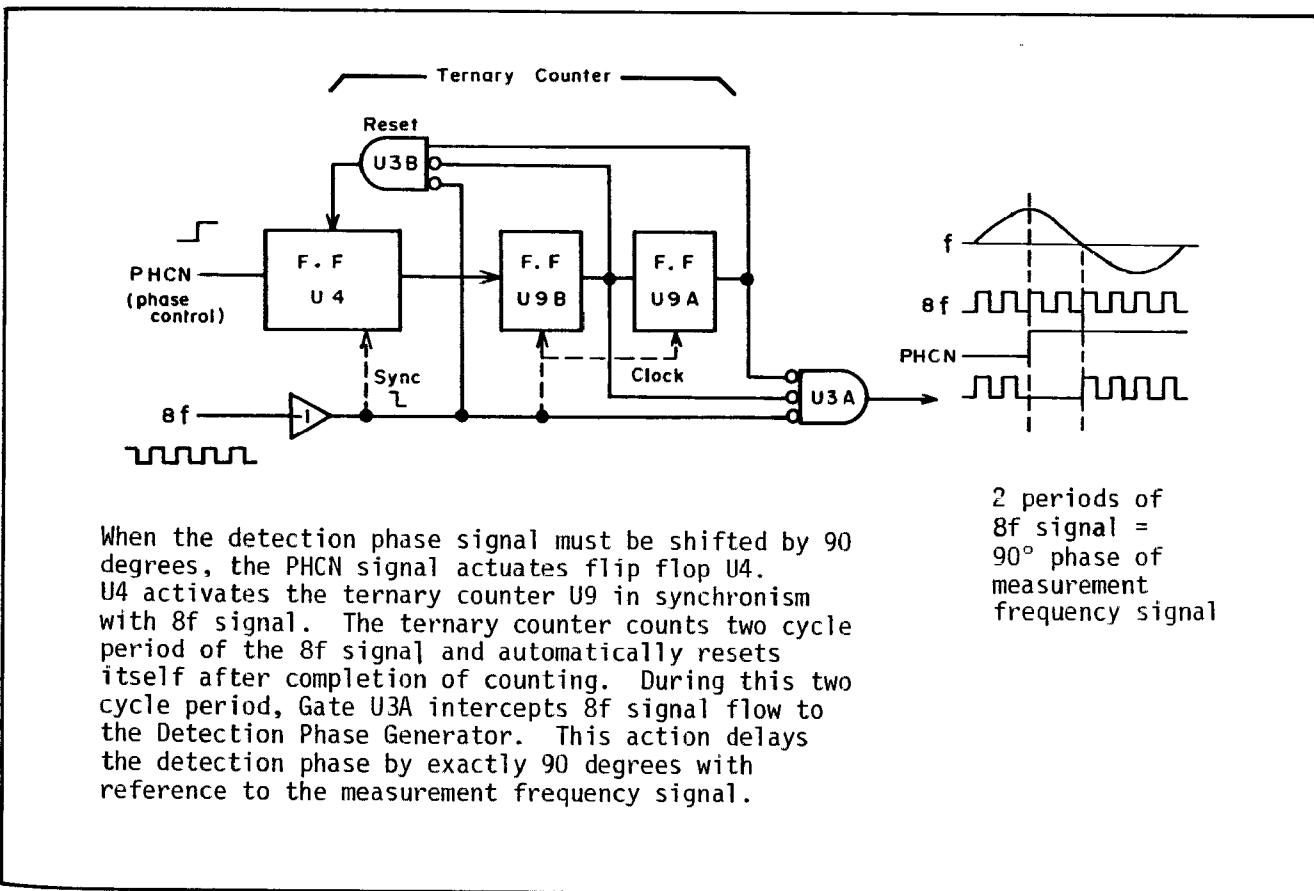

Figure 8-15. Detection Phase Shifter Operating Principle.



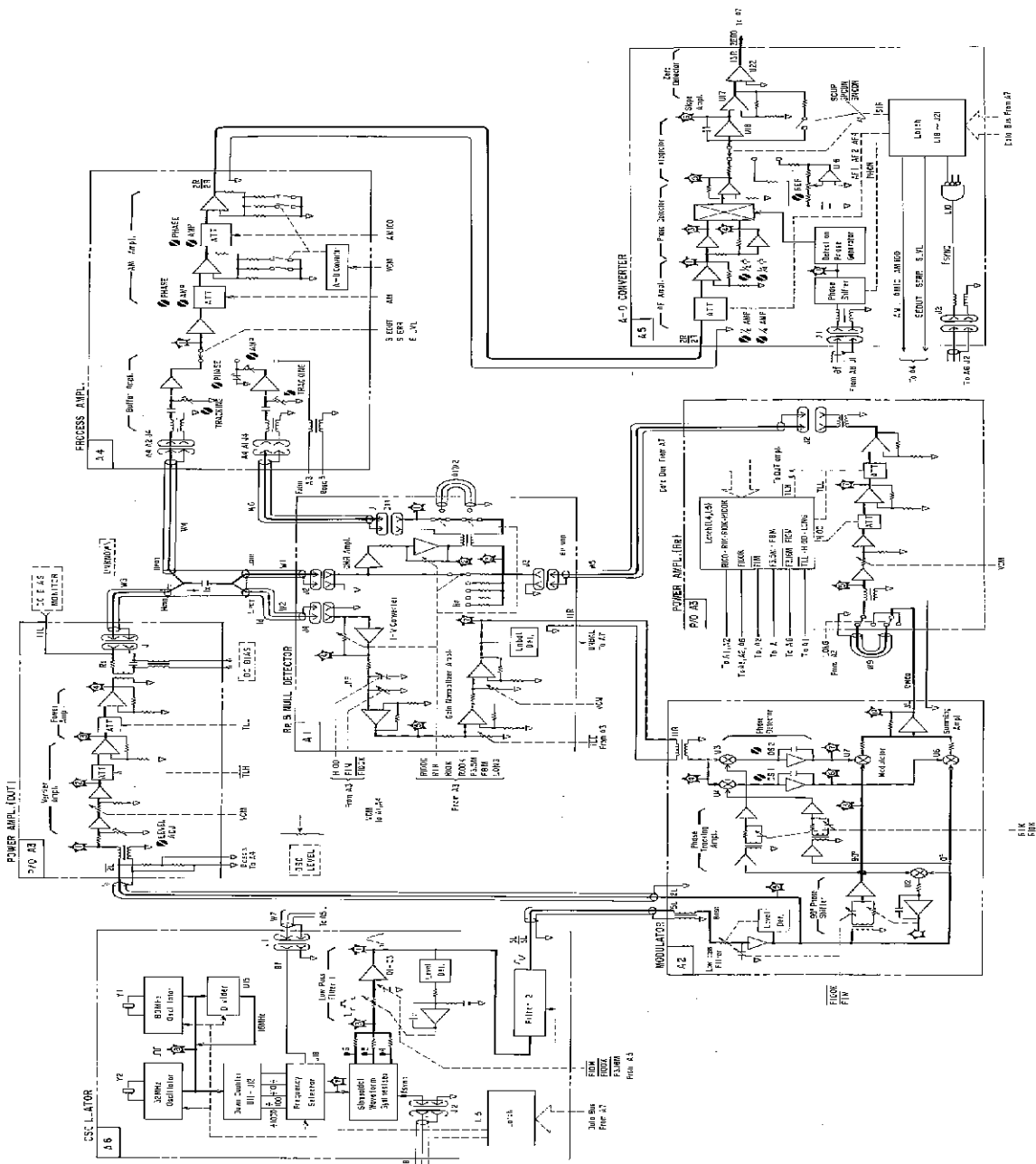

Figure 6-16. Analog Measurement Section Schematic Block Diagram.





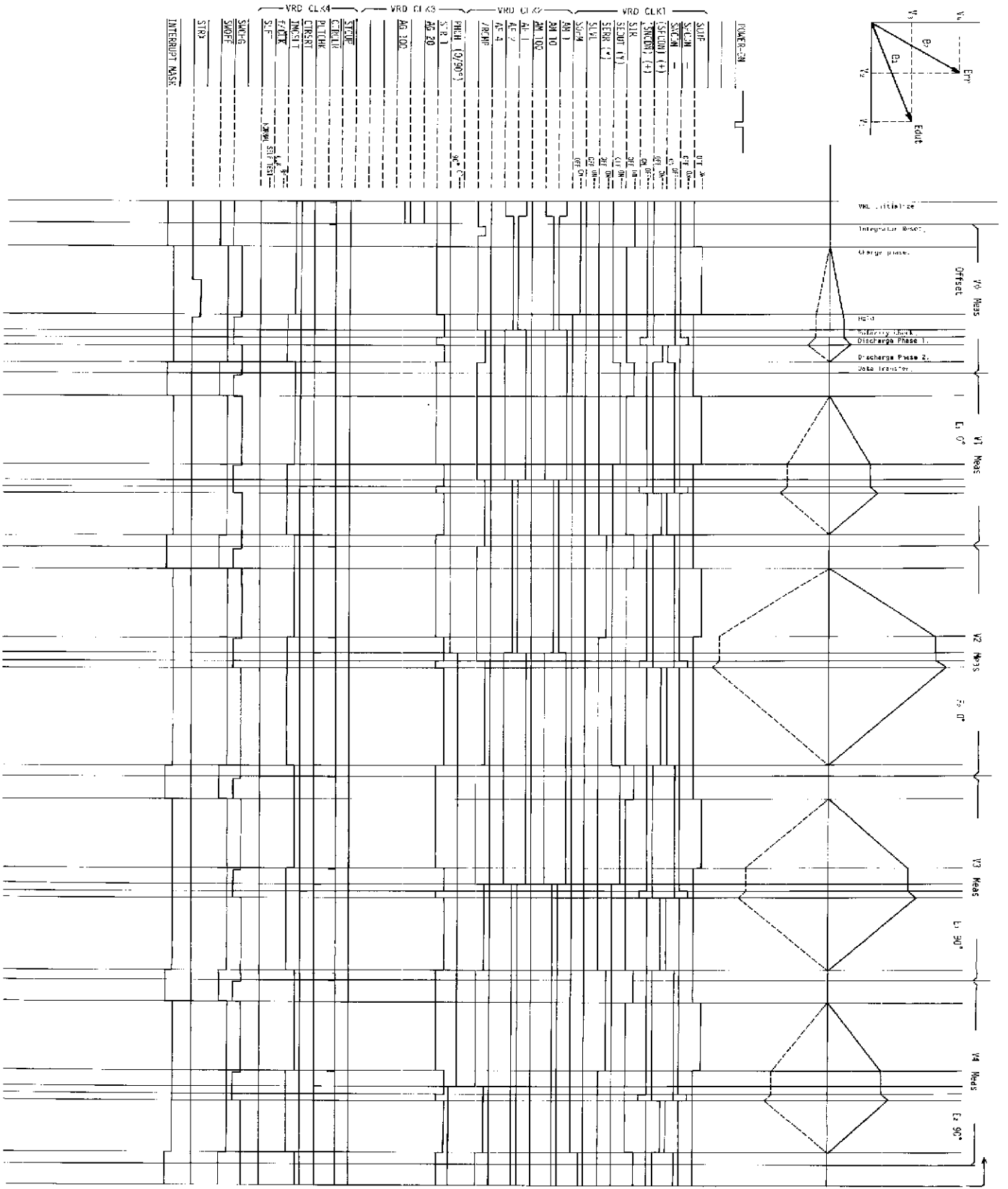

Figure 8-17. Timing Diagram.

8-46. DIGITAL CONTROL SECTION.

8-47. Figure 8-24 is the block diagram of the 4275A digital control section. The basic instrument includes three logic circuit boards and an operational keyboard combined with displays. These are integrated as necessary to handle their various functions and comprise the following assembly units:

- A7 Peripheral Control Board Assembly.
- A8 Microprocessor Unit Board Assembly.
- A9 Display and Keyboard Control Board Assembly.
- A11 Display and Keyboard Assembly.

The instruments allow the installation of one or two additional board assemblies for adding optional capabilities. These boards provide the circuits necessary for equipping the instrument with the following options:

- A21 DC Bias Supply Board Assembly (Option 001)
- A22 HP-1B Board Assembly (Option 101)
- A23 DC Bias Supply Board Assembly (Option 002)

Optional boards can not offer their utility without the installation of an additional ROM on the microprocessor board for memorizing optional control programs. Installation of an optional board without the requisite program ROM disables normal operation of the instrument.

8-48. A9 MICROPROCESSOR UNIT.

8-49. The microprocessor interfaces with other devices through the three data bus lines and governs all digital data processing as well as providing analog measurement circuit timing control. These bus lines are allotted for the following purposes:

Data Bus Line (8 bit): Bidirectional bus line for transfer of program and measurement data from/to the microprocessor.

Address Bus Line (16 bit): Unidirectional bus line from microprocessor for addressing program ROM and data RAM. Additionally, sets PIA (Peripheral Interface Adapter) or Microport to enable data transfer to/from microprocessor.

Control Bus Line (VMA, R/W,  $\phi$ 1,  $\phi$ 2, RST): Unidirectional bus line for transfer of digital section control signals. VMA line controls synchronous access timing of RAM, PIA and Microport in con-

junction with clock signal. R/W control line sets RAM, PIA or Microport to "read" or "write" operating mode to control data transfer direction (in time sharing) on the Data Bus Line from to the microprocessor (definition for the R/W control logic is described in paragraph 8-53).  $\phi$ 1 and  $\phi$ 2 signal lines offer a set of clock pulse trains for mutual timing synchronization in the digital control circuits. RST line resets PIA's and Microport devices to their initial "clear" states after power-on and each time before the measurement is taken.

8-50. Program Control ROM has an 18 kilobyte total memory capacity and has already memorized the analog section control programs along with digital data processing routines (counting, calculation, transfer and storage of data). To accept the measurement control instructions from the Program ROM, the microprocessor sequentially addresses the ROM through the address bus line. The measurement control instructions, timely outputted from the ROM, are stored in the latches in the analog section via A7 Peripheral Control. The microprocessor also addresses the Data RAM and bus line control devices (PIA's and Microport) to sequentially execute microprocessor program steps in accord with the program given by the ROM.

A 16 bit address code comprises an unique 4 digit number (from 0000 to FFFF). Each digit number of the address is represented by a 4 bit code set (from 0 to F). The two more significant bits of the most significant digit address number assign a particular memory group or bus control devices as shown below:

Designation	Address code	MSD bit status ABCD
ROM	FFFF C000	11xx
PIA or Microport	↑ 8000	10xx
ROM (for option)	↑ 4000	01xx
RAM	↑ 0000	00xx

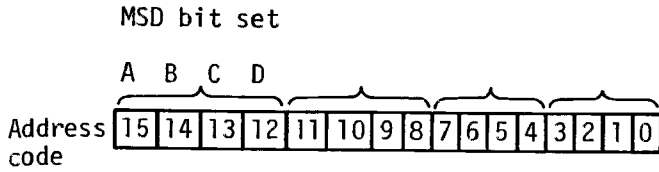

A program ROM is accessible while the status for AB of the MSD (most significant digit) bit set, ABCD, is 11 (or 01). The two lesser significant bits of the set (C D) of the MSD assign each individual ROM device. When both 15th and 14th bit states are 1 (AB = 11) Gate A9U27D turns its output logic to low level. This activates ROM Selector U16. The ROM selector decodes 13th, 12th and 11th bit address signals to 8 bit CSA (Chip Select A) signals which cause the appropriate ROM device to become valid (low level sets the RAM). When both the 15th and 14th bit states are 0 (AB = 00), the RAM Selector U28 is activated. The RAM selector decodes 11th and 10th bit address signals to 3 bit CSB (Chip Select B) signals. The CSB signals enable RAM devices or a data register in the following manner:

Designation	CSB control
DSA switch data register	CSB 3
Memory backup RAM (for option 003)	CSB 2
Data RAM	CSB 0

VMA (Valid Memory Address) and  $\phi 2$  clock signals cooperate for securely addressing correct devices. A9U27A gates the VMA and  $\phi 2$  clock signals to pull down its output to a low level only when both input signals are at high level. During this period, address bus data can be recognized by the addressed device. See Figure 8-18.

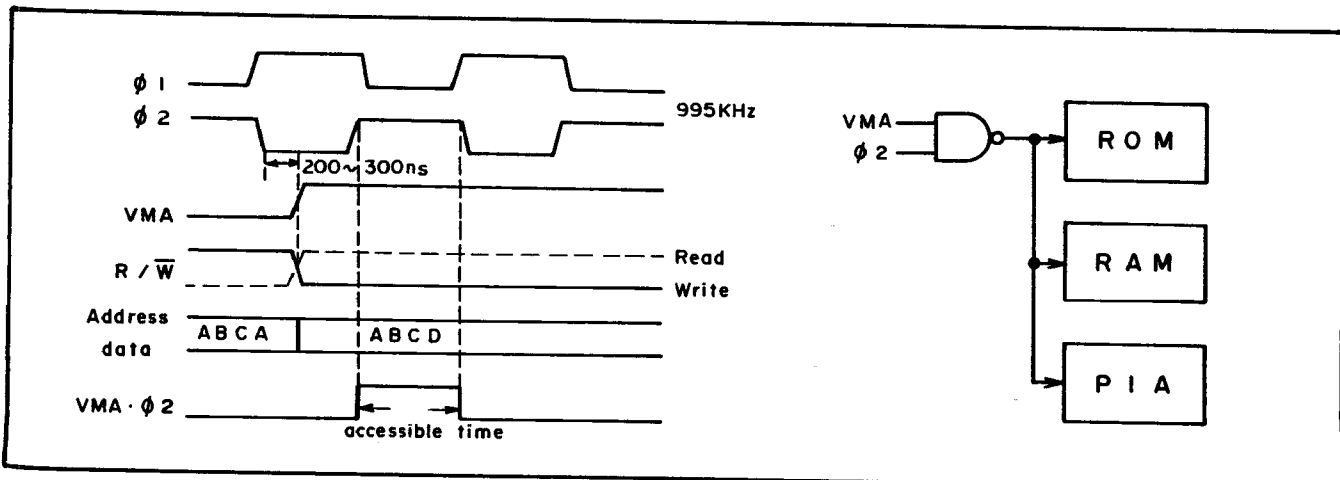

Figure 8-18. Address Timing Control.

8-51. The Turn-on reset circuit (A9U35) always sets the microprocessor to its definite initial states after a 1 second delay when the instrument is turned on. The microprocessor initially accesses ROM address FFFF to read the memory data. The microprocessor program sequential steps progress in synchronism with a pair of 995 kHz complementary clock signals ( $\phi 1$  and  $\phi 2$  fed from A7 board). High level intervals of the clock signal must extend over the low level intervals of the other clock (as shown in Figure 8-18).

8-52. IRQ (Interrupt Request) control line transmits the response demand to the function control input from keyboard or from the HP-IB control line. When a 4275A function is selected or changed, the IRQ line goes to low level. The regular measurement sequence control of the microprocessor immediately pauses to determine the nature of the control input except during integrator operating periods (dual slope A-D conversion operation). Program address jumps to IRQ service program routine to manage the function control prior to program processes. The IRQ control line is always active so as to allow for servicing of interrupt requests.

8-53. A Read/Write (R/W) timing control signal manipulates memory devices, registers, PIA's and microport in the following manner:

**Read:** Causes Register or Memory to output data or sets PIA or Microport to driver mode. Microprocessor accesses (reads) the data sent from the addressed device.

**Write:** Enables Register or RAM to store data or set PIA or Microport to receiver mode. Microprocessor sends (writes out) data to the device.

The read/write control is performed in conjunction with address signals to qualify the valid device for the data transfer.

8-54. Optional Circuits.

8-55. The ROM selector A9U22 decodes its address bus inputs (11th, 12th and 13th bit set) to select optional program ROM (U9, U10 or U11) when 15th and 14th address bit states are 01. The Memory Backup RAM (U14 and U15) stores 8 bit data (4 bits for each RAM device) which are continuously protected by a lithium battery. When instrument operating power is lost, the battery feeds minimum power sufficient for preservation of the stored memory in the RAM. Simultaneously the Level Detector (U25) disables writing to the RAM to avoid memorizing random data at the moment the power line voltage drops.

8-56. A7 PERIPHERAL CONTROL.

8-57. The key function of the A7 Peripheral Control is to manage the analog section control signals and to count the measurement quantities transferred in the form of time intervals. The PIA (Peripheral Interface Adapter) directs the incoming or outgoing data stream to/from the A7 board. Internal

circuit configuration of the PIA is illustrated in Figure 8-19. When the 15th, 14th and third bit states of the address signal are set to (1, 0, 1), the PIA has access to the microprocessor. Address bus ABO and AB1 bit set selects internal control register and data output register in the PIA which momentarily stores the input data. When R/W control line is pulled down to low level, the PIA allows transfer of data from the microprocessor to Bus Buffer/Data Control (U16, U18, U27 and U28) in channels A or B. PA7 and CA2 (PIA control output) signals control the direction of the input/output data which can flow through the Bus Buffer/Data control. Measurement control signals are transferred through the 8 bit PDB bus line and are registered in the latches (of A3, A5 and A6 boards). These control signals designate the states of the analog switches to be set for the temporary measurement phase. For accurate measurement timing control, the Strobe Clock Decoder (U31) transfers properly timed measurement clock signals to the latches. The measurement clock signals cause specific latch(es) to store the data and to output the control signals to individual analog switches. Additionally, the Strobe Clock Decoder also acts to enable the display data RAM of A8 Display Control to store measurement display data which are transferred from the microprocessor.

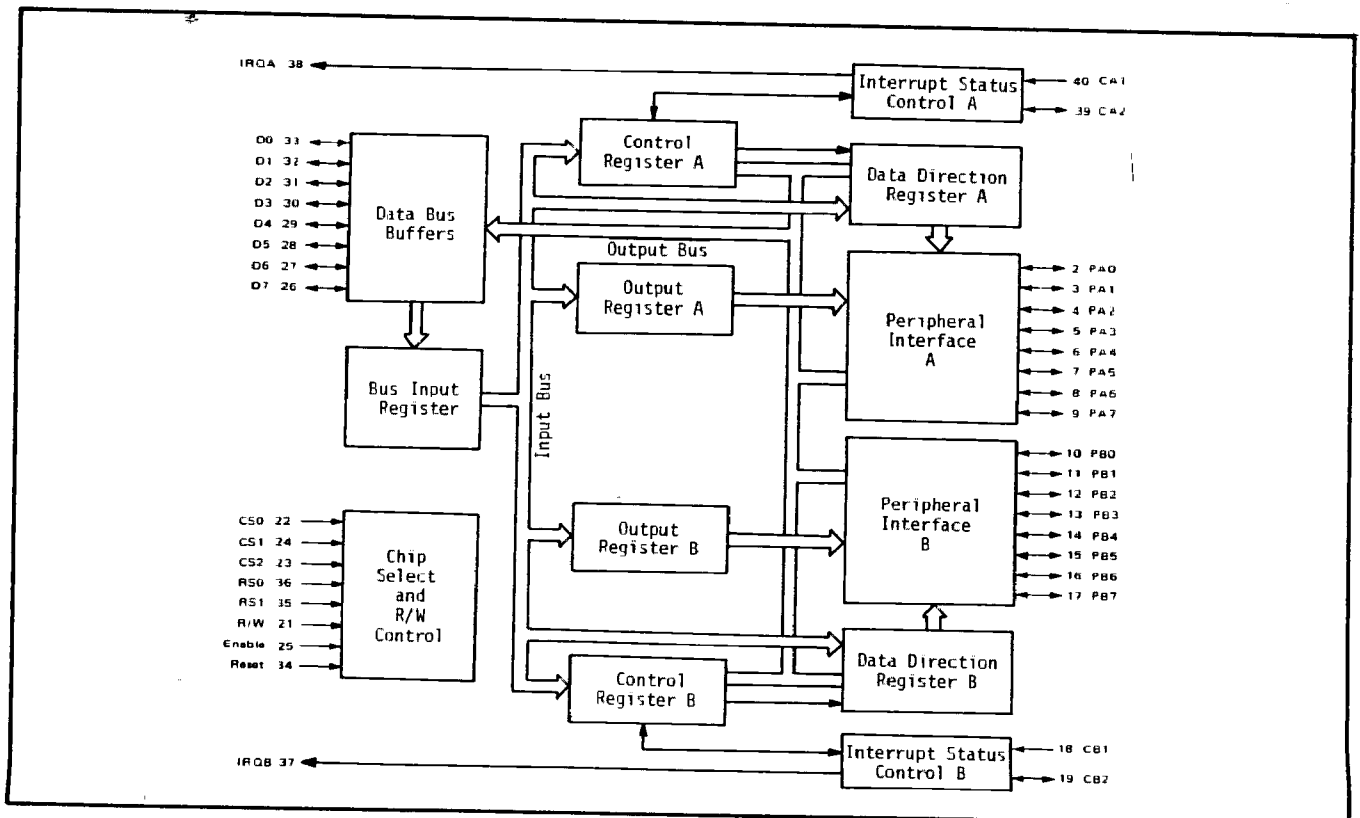

Figure 8-19. PIA Internal Circuit Configuration.

8-58. The Timer Counter (U22, U32, U23 and U33) generates an integrator charge time (approximately 10ms) by counting a \*1MHz clock signal. This programmable counter begins counting the clock from the preset number toward the maximum counts. The program number is first set to U22 and U32 in 8 bit data format and, successively, to U23 and U33 (thus, two LOAD control signals are used). When the Timer Counter overflows, TMEND output signal (at TP24) causes the Timing End Decoder (U6, U7A and U7B) to develop integrator switch control signals (SWOFF and SWCHG).

## \*Note

When test frequency is 10kHz, the Timer Counter counts 8f signal (fed from A6 Oscillator) instead of the 1MHz clock.

The Clock Synchronizer gate circuit (U26) selects the timer counter clock signal from either the 8f signal or 1MHz clock generator signal. The 1MHz (actually 995kHz) clock signal is counted down from the 9.95MHz crystal oscillator (U15 A/D) signal. When the integrator charge period ends, the Data Counter (U25) begins counting the integrator discharge time interval using the 1MHz clock signal in response to a CTRSRT Signal (sent from U11). The Data Counter stops counting when a ZERO signal is transferred from the A5 board to signal that the integrator output has crossed the zero level. Successively, the Data Counter outputs the data towards the 4 bit bus line in series data transfer fashion in LSD to MSD order. If the counted number exceeds 199999 counts, flip flop U12 generates an OVFW (overflow) signal. To accommodate the measurement data, R/W signal sets the PIA to driver mode. The microprocessor accesses the data counter output through the PIA.

8-59. The Polarity Detector (U8) monitors the ZERO signal level to discriminate between positive and negative going integrator ramps in the integrator charge period. During the charge period, the microprocessor accesses the polarity data and determines the polarity of the reference voltage used for discharging the integrator. When the bridge circuit is unbalanced, an UNBAL input signal turns output logic of Flip-flop U20. The UNBAL signal is detected at the charge period of the first integrator operating cycle. When a keyboard function control button is pushed, KYIPT line (TP7) goes to low level. The PIA pulls down the IRQ line (TP8) to low level to annunciate the interrupt request to the microprocessor.

## 8-60. A8 DISPLAY CONTROL.

8-61. The Display Control section consists of three major circuits: Display Decoder RAMs, Display Drivers and Key Scan Counter. The Display Decoder RAM (U4, U5, U6, U10, U11 and U12) does conversion and storage of measured data to be displayed on the seven segment numeric (and dot matrix alphanumeric) displays. Before beginning transfer of the measurement display data to the RAM, the RAM address for initially storing the data is sent to the RAM Address/Anode Counter U7. Successively, the display data is transferred to the RAM as the Address/Anode Counter simultaneously advances the address (4 bit) from the preceding address for each incoming display data fraction (serially transferred from the microprocessor through A7 board). The 7 bit display data fractions are previously coded by the microprocessor as appropriate for driving the seven segment (or dot matrix) displays when the data is, in turn, written out from the RAM. Three pairs of 4 bit RAMs do the storage of the 7 bit display data in the following manner:

U4 and U10: Stores 7 segment numeric display data for DISPLAY A, DISPLAY B and FREQUENCY/TEST SIG LEVEL displays (including unit lamp indicator).

U5 and U11: Stores dot matrix display data for DISPLAY A unit indicator and part of pushbutton lamp annunciator data.

U6 and U11: Stores dot matrix display data for DISPLAY B unit indicator and part of pushbutton lamp annunciator data.

Write Enable (WE1, WE2 and WE3) signals cause the appropriate pair of RAMs to become valid for the data store period. Since the RAM Address/Anode Counter can start counting from the desired address number, it is possible to change a part of the memory in the RAM to new display data.

8-62. Each Display Decoder RAM memorizes 16 sets of 7 bit display data fractions. When Write Enable signals are at high level, the Display Decoder RAM writes out the data as periodically addressed by the RAM Address/Anode Counter. The address number advances in the reverse direction of the memory store mode. The RAM outputs the display segment signals which alternately illuminate the numeric figure of each measured count digit of the displays. The RAM address signals are simultaneously decoded by the Anode Scan Decoder (A10U8) to periodic anode scan signals which activate, in sequence, the display for each digit (and for each dot matrix row segment). Synchronous operation of the display data RAM and the Anode Scan Decoder accomplishes matrix drive of the display.

8-63. The Clock Generator (U8 and U9) drives the RAM Address/Anode Counter with a 100kHz clock frequency counted down from the  $\phi 2$  clock signal. Additionally, down counter U8 feeds a 1/32MHz clock pulse signal to drive the Key Scan Counter (U15). When the display data RAM is set to "write" mode, STPSCN signal stops the clock signal flow to reverse count input of the RAM Address/Anode Counter and blanks the display. After the instrument is turned on, RST signal actuates to blank display (so as to prevent a meaningless display from occurring) until all circuits are settled in their normal conditions.

8-64. The Key Scan Counter U15 outputs periodic KY signals (KY0 to KY3) to A10 board. These 4 bit output signals are decoded by the Multiplexer (A10U9) to keyboard scan signals which, in turn, cause individual keys of three particular key groups to become valid. Each control key in the key group is enabled in sequence, to perform its function. When keyboard pushbutton (for example, "Z" key) is pressed, one of the keyboard output lines KY4, KY5 or KY6 goes to low level at the moment the pushbutton switch input is pulled down to low level by keyboard scan signal (in this example, KY4 line goes to low level when the Multiplexer turns its K4 control output line to low level). The output logic of the Key Decoder U14A goes to low level and subsequently the Key Scan Counter stops. The contents of the Key Scan Counter and the keyboard output states given by KY4, KY5 and KY6 signals are coordinated with the address of the key depressed. Simultaneously, gate U13C outputs KYIPT signal causing the IRQ line to go to low level (interrupt request is set). The microprocessor reads the scan counter and keyboard output data to identify the pushbutton function actuated.

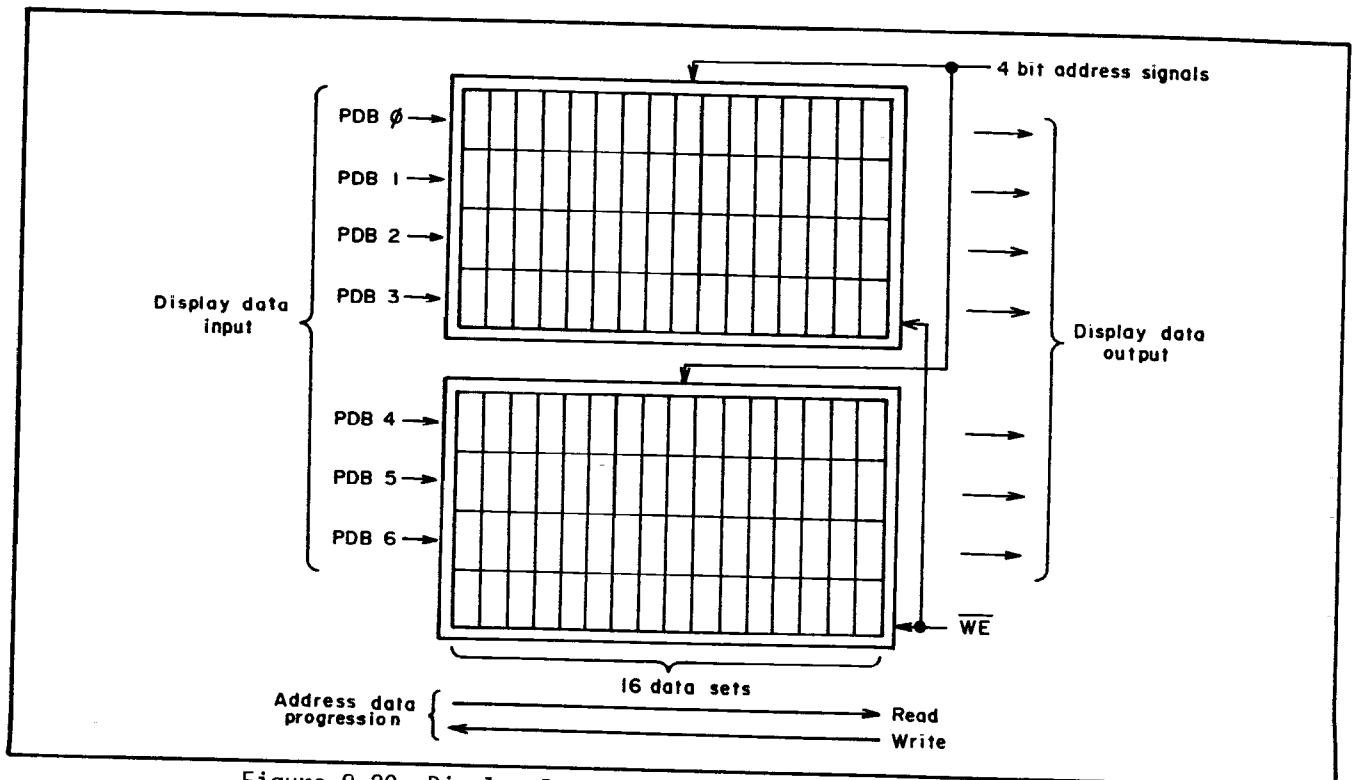

Figure 8-20. Display Data RAM Read/Write Operating Sequence.

8-65. OPTIONS.

8-66. OPTION 001:  $\pm 35V$  DC BIAS SUPPLY (A21).

8-67. The A21 DC Bias Supply is linked to the microprocessor control bus lines via PIA (U11) which manages bias control data input/output timing. External bias controller setting data is sent to Latches U12 and U13 through the rear panel INT DC BIAS CONTROL connector. When the bias controller ENTER button is depressed, LOAD line goes to low level causing the PIA to output IRQ signal. An R/W control signal sets the PIA to driver mode and the Latches hold the bias control input data. Subsequently, the microprocessor accesses the bias control input data to translate it to data appropriate for setting 12 bit DAC (Digital to Analog Converter) and voltage range/polarity selector of the DC Bias Supply. The bias supply control data, transferred from the microprocessor, is stored in Latches U5 and U8 (PIA is set to receiver mode).

8-68. The DAC (U4) outputs an accurate dc voltage in the range of 0 volts and 10 volts in accord with the voltage data assigned by 12 bit binary input code. The Polarity Selector switches (Q7 and Q8) permit selecting either positive or negative dc bias in response to bias controller polarity setting. The Output Amplifier is capable of changing its amplification factor to  $\times 1/10$ ,  $\times 1$  or  $\times 10$  to magnify the bias output variable range depending on the bias controller MULTIPLIER setting. The simplified schematic for the output amplifier gain control circuit is shown in Figure 8-21. The filter circuit at the output stage of the amplifier eliminates pulse noises from the dc bias output. The filter capacitor is essentially located in series with the measurement circuit as illustrated in Figure 8-22. Note that the A21 board is of a floating bias supply design.

Because this filter capacitor decreases the actual test signal level applied to the sample, the filter capacitor value must be selected (from  $1\mu F$  and  $100\mu F$ ) so that capacitor impedance value is less than  $1/10$  times the sum of the sample impedance and source resistor impedance. Filter selection relays K1 and K2 are energized when rear panel DC BIAS Selector switch is set to its INT 35V/100V ( $\leq 1\mu F$ ) position. Sockets SC1 and SC2 configure a signature test circuit loop consisting of PIA and latches when a jumper element or a low value ladder resistor device (below  $100\Omega$ ) is installed in each socket.

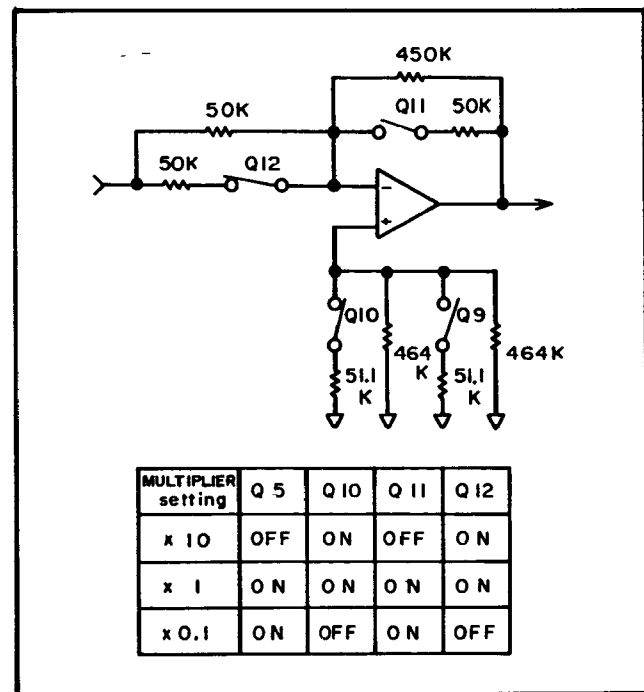

Figure 8-21. Bias Output Amplifier Gain Control.

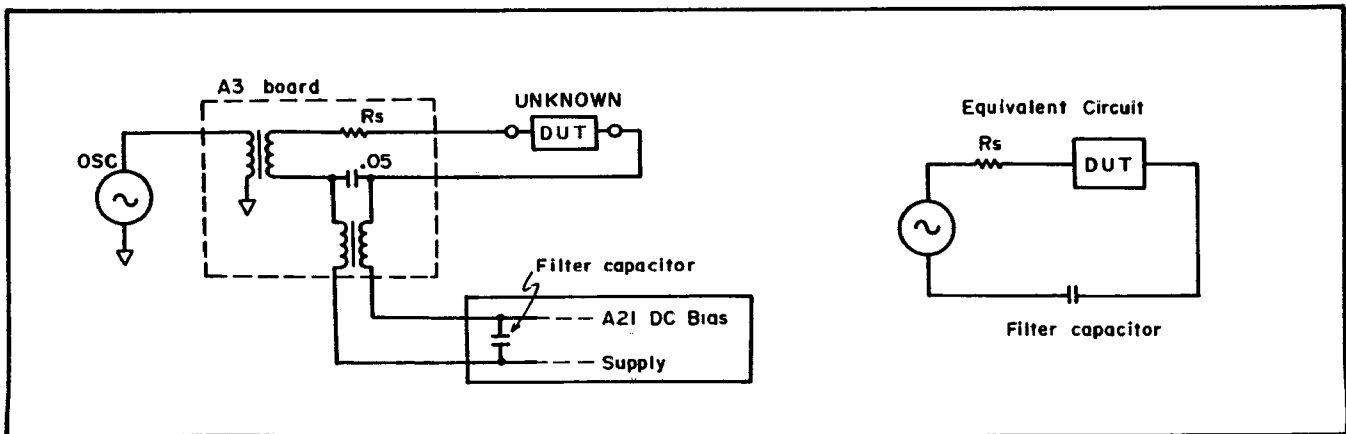

Figure 8-22. Equivalent DC Bias Circuit.



8-69. OPTION 002:  $\pm 100V$  DC BIAS SUPPLY (A23)

8-70. Option 002 DC BIAS Supply has a circuit configuration similar to the A21 circuit board (Option 001). This paragraph and that following describe only the circuit unique to Option 002. Therefore, it is suggested that you read paragraphs 8-66 and 8-67 to become acquainted with circuit operating theory common to both Option 001 and 002 before proceeding to the following paragraph.

8-71. Gate U14D resets latches U10 and U11 to their "clear" states when front panel DC BIAS switch is set to  $\pm 35V$  MAX position. Thereby, the DAC (U4) output voltage falls to zero volts in response to zero input. This inhibits a bias voltage from being fed to an inappropriate test fixture of 35V dc bias design. Comparators U6, U7 and U8 provide stable control input data to DAC and prevent digital pulse noises from appearing on DAC output voltage. The Output Amplifier multiplies the DAC output voltage by 10 to step up the bias voltage control range.

8-72. OPTION 101: HP-IB INTERFACE (A22).

8-73. All the HP-IB interface functions are accomplished by the integrated Microport device which mediate the "handshake" of the microprocessor and external HP-IB equipment on an HP-IB program basis. The microport circuit architecture is illustrated in Figure 8-23. The stack of 8 register pairs of the Microport connects the data transferred to/from external equipment as directed by asynchronous operation of the control bus signals. Each register pair stores the data fraction which flows through one of the 8 bit data bus lines. When the instrument is turned on, the Microport pulls down its  $\overline{ASE}$  control line to low level. The microprocessor accesses the HP-IB address data in register U1 to display the instrument address number on the front panel display.

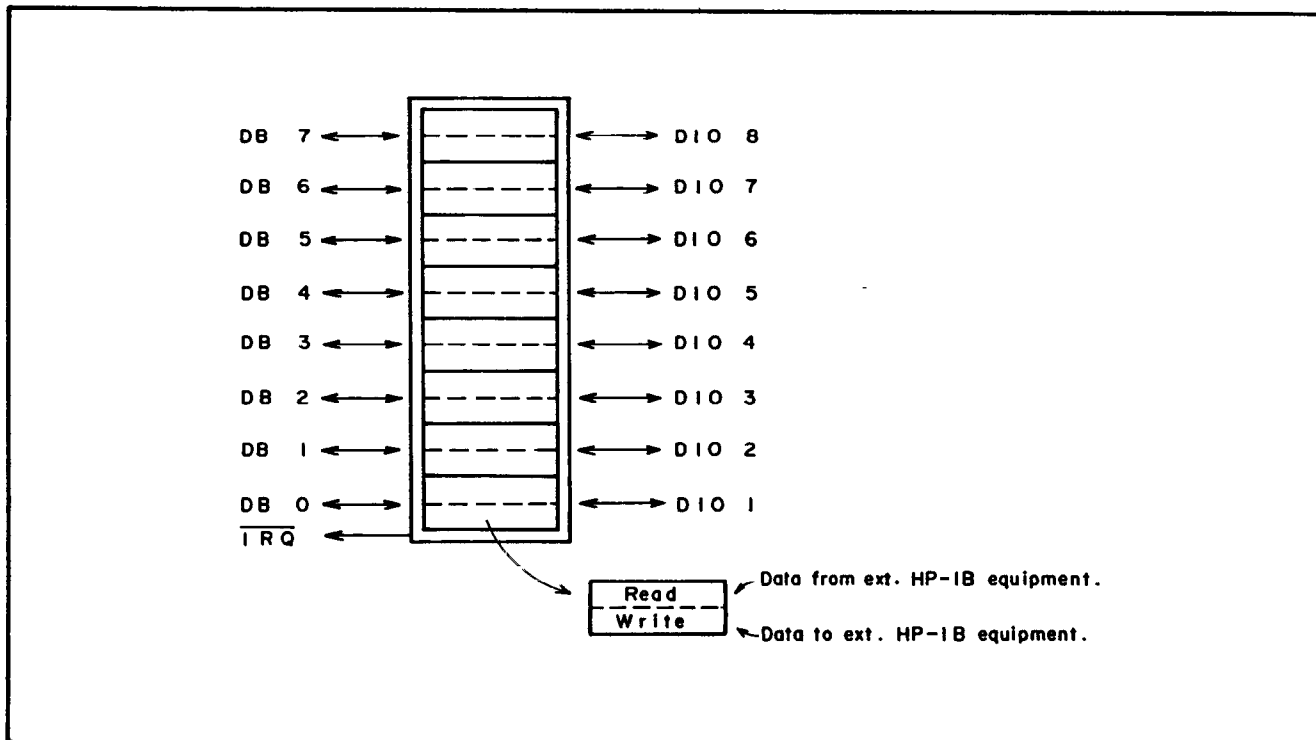

Figure 8-23. Microport Internal Register Configuration.

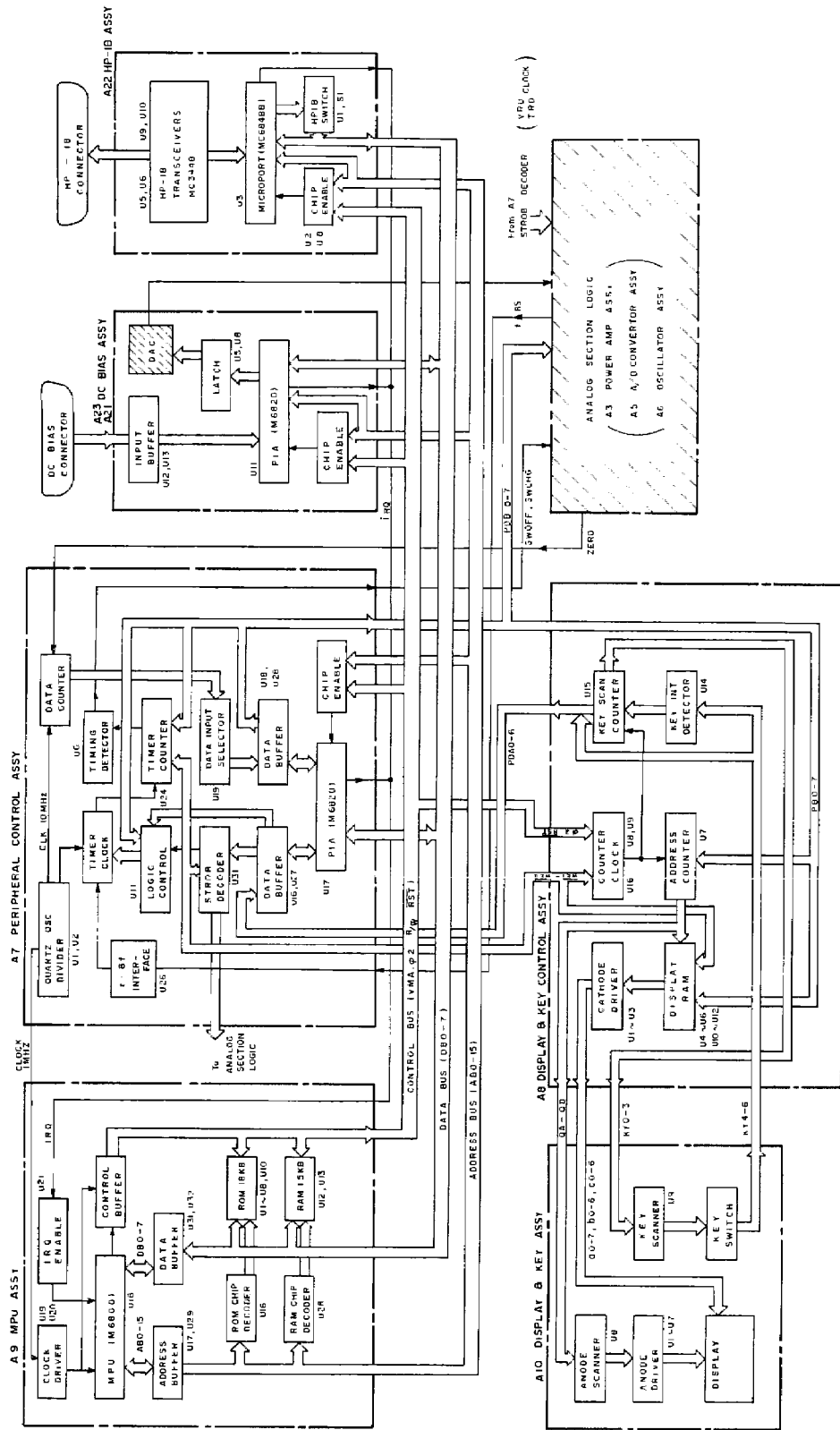

Figure 8-24. Digital Control Section Block Diagram.



8-74. TROUBLESHOOTING.

CAUTION

THE OPENING OF COVERS OR REMOVAL OF PARTS, EXCEPT THOSE TO WHICH ACCESS CAN BE GAINED BY HAND, IS LIKELY TO EXPOSE LIVE PARTS; IN ADDITION, ACCESSIBLE TERMINALS MAY ALSO BE LIVE.

THE APPARATUS SHALL BE DISCONNECTED FROM ALL VOLTAGE SOURCES BEFORE ANY ADJUSTMENT, PARTS REPLACEMENT OR MAINTENANCE AND REPAIR ARE PERFORMED FOR WHICH THE APPARATUS MUST BE OPENED.

IF, AFTERWARDS, ANY ADJUSTMENT, MAINTENANCE OR REPAIR OF THE OPENED APPARATUS UNDER VOLTAGE IS REQUIRED, IT SHALL BE CARRIED OUT ONLY BY A SKILLED PERSON WHO IS AWARE OF THE HAZARD INVOLVED.

8-75. Figure 8-25 "How to Use Troubleshooting Guides" is helpful when starting to troubleshoot the 4275A. As the analog boards include the latches which are controlled through bus lines by the MPU, the signature analysis technique is useful for analog board troubleshooting. The sequence of the digital section troubleshooting depends upon the program routine and it is difficult to provide individual flow diagrams. AL thru GL all contain digital section troubleshooting aids.

8-76. Follow the troubleshooting procedure in Figure 8-29 which provides specific instructions for isolating the Analog and Digital section from each other.

WARNING

WHENEVER IT IS LIKELY THAT THE PROTECTION PROVIDED BY THE FUSES HAS BEEN IMPAIRED, THE INSTRUMENT MUST BE MADE IN OPERATING AND MUST BE SECURED AGAINST ANY UNINTENDED OPERATION.

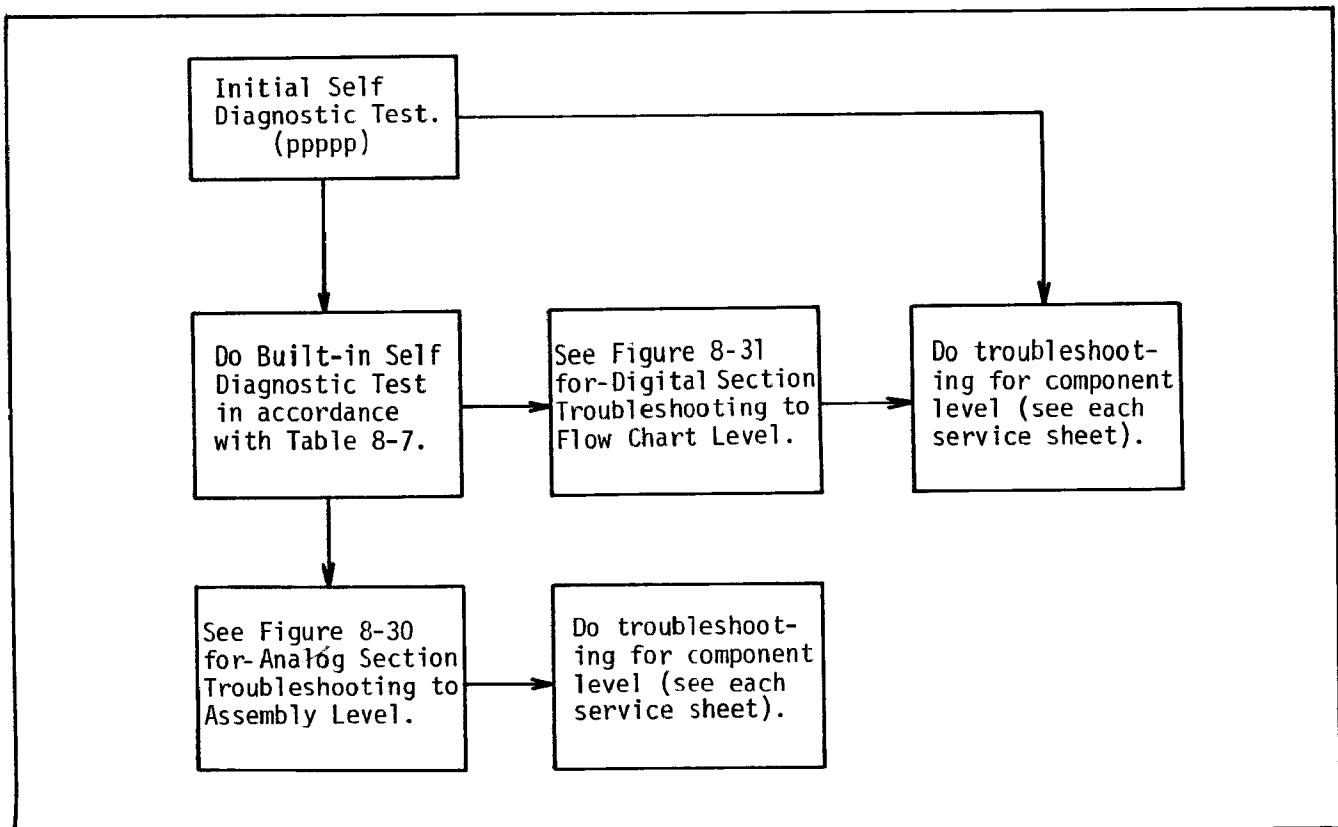

Figure 8-25. How to Use Troubleshooting guides.

CAUTION

CAPACITORS INSIDE THE INSTRUMENT MAY STILL BE CHARGED EVEN IF THE INSTRUMENT HAS BEEN DISCONNECTED FROM ALL VOLTAGE SOURCES.

BE SURE THAT ONLY FUSES OF THE REQUIRED RATED CURRENT AND OF THE SPECIFIED TYPE ARE USED FOR REPLACEMENT. THE USE OF MENDED FUSES AND THE SHORT-CIRCUITING OF FUSE HOLDERS MUST BE AVOIDED.

8-77. Troubleshooting Analog Section to Assembly Level. Follow the troubleshooting procedure in Figure 8-30 Analog Section Troubleshooting Guide to isolate an analog fault to a board assembly. Troubleshooting to component level is covered in the service sheet for each assembly.

8-78. Digital Section Troubleshooting Figure 8-31 is helpful in speeding the troubleshooting. The signals circulate through the bus line and the flow diagrams are given in accordance with the main instructions of the 4275A for efficient problem isolation. The signature analysis technique is a most helpful method for following the component isolation flows AL thru GL (A Logic flow thru G Logic flow). Except for the HP 5004A Signature Analyzer, no additional boards or equipment are necessary.

8-79. INITIAL MEMORY TEST.

8-80. The initial operating program of the 4275A is a brief memory test routine begun immediately after the instrument power is turned on. This memory test confirms integral memory of the measurement control programs stored in the program ROM and the normal read/write operating capability of the data RAM. The program memory test is accomplished in a short time (about 1 second) by using the popular "check sum" method.

Before proceeding with the initial measurement function control, the microprocessor calculates the sum of the binary numbers of the program codes for all memory addresses and checks this result with the correct number.

The check sum procedure proves the memory of each individual ROM to be faultless. As the last of the memory test, test data is memorized in the RAM and is written out to verify its complete data registration capability.

8-81. The instrument indicates the normal test result by the display of five P figures when a perfect test result is identified. The P figures appear in DISPLAY A and progress in a left to right direction. If not all the tests are passed with normal results, the process test stops halfway and the instrument can not go through the subsequent automatic control settings. In such case, the number of P figures displayed indicates the ROM or RAM in which an abnormality is detected as follows:

*No display .....	A9U10
P .....	A9U7 or U8
PP .....	A9U5 or U6
PPP .....	A9U3 or U4
PPPP .....	A9U1 or U2
PPPPP .....	A9U12 or U13

\*Note

No P figure also appears in the following cases:

- 1) Microprocessor malfunctions.
- 2) A faulty component obstructs normal addressing of the ROM (RAM) or a function of the data bus line.
- 3) Self test program ROM (A9U3) is defective. There is also the rare possibility of a defective A9U1

8-82. SELF TEST INSTRUCTIONS.

8-83. The built-in self diagnostic test function which is operated from front panel keys provides various display outputs helpful in maintenance of the 4275A. This automatic diagnostic test capability, featured in the 4275A decreases the loading of users and service personnel who are concerned with performance testing, adjustment, calibration and repair.

The self diagnostic test function is designed to perform functional testing of the major circuit sections of the sophisticated 4275A measurement circuit in accord with programmed procedures and to display the diagnostic test results for each test.

The test program is organized in a total of 19 test routines (sequentially executed) for the automatic test. Nine independent tests can be done selectively from these automatic tests or exclusively by manual operation. The self test program organization is given in Table 8-4.

8-84. Automatic Self Diagnostic Test.

8-85. The automatic self diagnostic test function sequentially performs all test steps and displays the decision results of go/no-go comparisons with the memorized test limits. The test items are divided into two sequential routines which require different UNKNOWN terminal connection configurations (Open or Short tests). These tests are accomplished by pressing the front panel SELF TEST button using the test setup given in Table 8-5. Normal diagnostic results are indicated by a display of OP for open test or of SH for the short test on DISPLAY A. If an abnormal result occurs during an open or short test, the number of the abnormal test step is displayed in DISPLAY A as OP3 or SH24. For detailed instructions of the automatic self test procedure, refer to 4275A Operating Manual Page 3-0.

8-86. Manual Step Selection of Self Diagnostic Tests.

8-87. The circuit test operating modes which can be independently set by front panel push-button operation are used for supplemental accuracy checks of performance testing as well as for facilitating adjustment procedures. Furthermore, display outputs of the

test results offer considerable clues and hints useful in troubleshooting. If the analog measurement section malfunctions, the abnormal measurement outputs which arise from the faulty circuit sometimes obstructs the process of the normal measurement control sequence and, therefore, measurement triggering stops. In such cases, uncontrolled circuits cause some difficulty in attempts at trouble isolation. The self test function relieves service personnel from this kind of blind alley troubleshooting. During the circuit test mode of operation, periodic triggering never stops because of any trouble in the analog measurement section and thus the analog circuits are operated under the regular control signals of test program. This allows checking circuits by means of signal flow tracing using defined control rules. For setting individual test function modes, press SELF TEST button beforehand (to activate SELF TEST function) then press a pushbutton selected from Table 8-6.

Table 8-6. Self Test Step Selection.

Test step	1	2	3	4	5	6	7	8	9
Selection button	D	Q	ESR/G	x/B	L/C	A	Δ%	RECALL	STORE
	<input checked="" type="radio"/>	<input checked="" type="radio"/>	<input checked="" type="radio"/>	<input checked="" type="radio"/>	<input checked="" type="radio"/>	<input checked="" type="radio"/>	<input checked="" type="radio"/>	<input type="checkbox"/>	<input type="checkbox"/>

Note: The number of the selected test step, except for step 9, is displayed in DISPLAY A unit indicator.

8-88. Display outputs for manually selected test steps are the numbers of the measurement results obtained by the test condition. The circuit tested, test circuit operation, meanings of the display outputs for each individual test steps are outlined in the tabulation below.

Note

Test limit values in the table are comparison reference values used in automatic diagnosis. In the automatic test, test step numbers for the abnormal test steps are displayed in DISPLAY A (instead of measurement data).

Note

OSC LEVEL control should be set to its fully cw position for all self test steps.

Table 8-4. Self Test Program Organization.

Test step		Item	Test step		Item
Auto test	Manual test		Auto test	Manual test	
OP 1 ( $\leq 100\text{kHz}$ )	1	A-D converter test (A4 and A5)	OP14	Auto test only	Bridge balance test on $100\mu\text{S}$ Y range MULTIPLIER x1 setting (A1)
OP 2	2	AF4 attenuator test (A5)	OP15	Auto test only	Bridge balance test on $1000\mu\text{S}$ Y range at MULTIPLIER x1 setting (A1)
OP 3	3	AF2 attenuator test (A5)			
OP 4	4	AM10 attenuator test (A4)			
OP 5	5	AM100 attenuator test (A4)			
Test step 6 is non-existent					
OP 7 ( $\leq 1\text{MHz}$ )	7	Modulator phase offset test (A2)	OP17 ( $\leq 1\text{MHz}$ )	Auto test only	Bridge balance test on $10\text{mS}$ Y range at MULTIPLIER x0.01 setting (A1)
Manual test only	8	CMR amplifier test (A1)	SH21	Auto test only	Bridge balance test on $100\Omega$ Z range at MULTIPLIER x0.1 setting (A1)
Manual test only	9	Range control and Z or Y measurement test (all analog boards)			
OP10 ( $\leq 1\text{MHz}$ )	Auto test only	1V test signal level test (A3 and A6)			
OP11 ( $\leq 1\text{MHz}$ )	Auto test only	0.1V test signal level test (A3)	SH22 ( $\leq 100\text{kHz}$ )	Auto test only	Bridge balance test on $100\Omega$ Z range at MULTIPLIER x0.01 setting (A1)
OP12 ( $\leq 1\text{MHz}$ )	Auto test only	0.01V test signal level test (A3)	SH23	Auto test only	Bridge balance test on $100\Omega$ Z range at MULTIPLIER x1 setting (A1)
OP13 ( $\leq 1\text{MHz}$ )	Auto test only	Bridge balance test on $10\mu\text{S}$ Y range at MULTIPLIER x1 setting (A1)	SH24 ( $\leq 1\text{MHz}$ )	Auto test only	Test signal current test (A4)
			SH25 ( $\leq 1\text{MHz}$ )	Auto test only	$100\Omega$ , $1\text{k}\Omega$ and $10\text{k}\Omega$ range resistor check (A1)

Note: When the test frequency setting is higher than the limit frequency given for the specific test steps, such test steps are omitted from automatic diagnostic test sequence.

Table 8-5. Automatic Self Test Setups.

Test step	UNKNOWN terminals	DISPLAY A function	OSC LEVEL control
Open test (steps 1 to 17)	Open Connect 16047A Test Fixture with nothing as DUT.	C	fully cw
Short test (steps 21 to 25)	Short Connect 16047A Test Fixture with a shorting strap.	L or R	fully cw

Table 8-7. Self Diagnostic Test Instructions.

Test step 1	A-D Converter test (A4, A5)	
<p>Test condition: Integrator develops small precharge waveforms for two integrator operating cycles under a no input signal condition (A4 AM Amplifier input is grounded). For the other two integrator operating cycles, a dc -Eref voltage charges the integrator and the +Eref voltage causes it to discharge (integrator input switch A5Q35 is open). Test signal frequency should be below 100kHz to obtain correct DISPLAY A display output.</p> <p>Note: The integrator section (Integrator, Slope Amplifier, Zero Detector, DC Reference Voltage Supply and associated control switches) is operated independent of prior circuit stages (Phase Detector etc.) with respect to DISPLAY B display output. Thus this test positively isolates possible integrator trouble from any other sections.</p>		
Display section	Display meanings	Test limits
DISPLAY A	Total operating delay time of the integrator slope amplifier and zero detector.	.00±160 counts
DISPLAY B	Difference in absolute values between dc -Eref and +Eref voltages.	.00±160 counts
<p>ADJUSTMENT: A5R120 and *A5C70.</p> <p>TROUBLESHOOTING HINTS:</p> <p>If DISPLAY B output is abnormal, check A5 Integrator, Zero Detector, DC Reference Voltage Supply and Decoder/Latch. If only DISPLAY A output is abnormal, check dc offset error of AM Amplifier (A4) and AF Amplifier (A5).</p>		



Test step 2.	AF 4 Attenuator test (A5)	
Test step 3.	AF 2 Attenuator test (A5)	
<p>Test condition: UNKNOWN H<sub>CUR</sub> and H<sub>POT</sub> terminals must be connected to each other. MULTIPLIER should be set to x1. Edut signal is timely attenuated by AF2 attenuator (or alternately with AF4 attenuator for step 2) and is phase detected to compare the vector voltage ratio of the attenuated signal to the original (non-attenuated) signal by the integrator. A 50Ω feed-through termination is necessary for performing test step2.</p>		
Display section	Display meanings	Test limits
DISPLAY A	Attenuation accuracy of in-phase signal component.	-100000 ±*160 counts
DISPLAY B	Attenuation phase error represented by magnitude of 90 degree out-of-phase signal component.	.00±*160 counts
<p>Note: *1280 counts for test frequencies above 1MHz.</p> <p>ADJUSTMENT: A5R11, A5R16, A5R4 and A5C15.</p> <p>TROUBLESHOOTING HINTS:</p> <p>If a failure is located in the A6, A3, A4 or A5 circuit boards ahead of the integrator, an abnormal test result may first occur in step 2 and for all subsequent test steps. If step 3 is normal, A5 AF4 attenuator is faulty.</p>		

Test step 4	AM10 Attenuator test (A4).	
Test step 5	AM100 Attenuator test (A4).	
<p>Test condition: UNKNOWN H<sub>CUR</sub> and H<sub>POT</sub> terminals must be connected to each other. MULTIPLIER should be set to x0.1 for step 4 and to x0.01 for step 5. Edut signal is timely attenuated by A4A3 AM attenuator (or alternately with A4A4 AM attenuator for step 5) and is phase detected to compare the vector voltage ratio of the attenuated signal with the original (non-attenuated) signal by the integrator.</p>		
Display section	Display meanings	Test limits
DISPLAY A	Attenuation accuracy of in-phase signal component.	-100000 ±*160 counts
DISPLAY B	Attenuation phase error represented by magnitude of 90 degree out-of-phase signal component.	.00±*160 counts
<p>Note: *1280 counts for test frequencies above 1MHz.</p> <p>ADJUSTMENT: A4A3R10 and A4A4R2.</p> <p>TROUBLESHOOTING HINTS:</p> <p>The attenuation and phase errors indicated on displays are cumulative values which represent both AM and AF attenuators.</p>		

Test step 7 Modulator phase offset test (A2)

Test condition: UNKNOWN terminals must be so connected as to constitute an open measurement condition (attach 16047A test fixture with nothing connected as DUT). Test frequency should be below 1MHz.

Measurement is taken to detect the bridge balance error which arises from phase detector residual offset voltage in the Modulator. To maximize the offset voltage effects on the displays (to facilitate detection), null detector amplification gain is set to minimum. Range resistor value is automatically set to 100Ω

Display section	Display meanings	Test limits
DISPLAY A	Bridge balance error for in-phase (real) vector signal component.	.00±1280 counts
DISPLAY B	Bridge balance error for 90 degree out-of-phase (imaginary) vector signal component.	.00±1280 counts

ADJUSTMENT: A2R13 and R14.

TROUBLESHOOTING HINTS.

If display outputs are quite different from normal values, bridge circuit is not being balanced. A1, A2 or A3 board is faulty.

Test step 8 CMR Amplifier test (A1)

Test condition: UNKNOWN H<sub>CUR</sub> and H<sub>POT</sub> terminals are connected to each other (no connection to L<sub>CUR</sub> and L<sub>POT</sub> terminals). Test frequency should be 100kHz. Err signal is fed to CMR Amplifier input through 100Ω range resistor from A2 Modulator. Because DUT current is zero, the Err signal detected by A4 Process Amplifier must also be zero. If CMR amplifier gain is appropriate, the amplifier output transformer current completely offsets the Err signal current to zero. This test measures the Err voltage detected by the Process Amplifier to determine CMR amplifier gain error.

Display section	Display meanings	Test limits
DISPLAY A	Err signal offset error which arises from CMR amplifier gain misadjustment.	(.00+10000counts at well adjusted condition)

ADJUSTMENT: A1R3

TROUBLESHOOTING HINTS:

If test step 7 is passed with a normal result, A1 CMR Amplifier is faulty.

Test step 9 Range control and Z or Y measurement test.

This self test mode enables selecting the desired range resistor value and AM attenuator setting by pressing LCRZ RANGE UP and DOWN keys. DISPLAY B unit indicator provides a display of 2 digit numeric codes which indicate the selected range resistor and AM attenuator settings as shown below:



code	Range Resistor Value
2	100Ω
3	1kΩ
4	10kΩ
5	100kΩ

code	AM attenuator setting	
	A4A3 board	A4A4 board
0	x1/10	x1/10
1	x1/10	x1
2	x1	x1

When 100Ω range resistor value is selected, DISPLAY A and B provide display outputs for resistance and reactance values, respectively, of the measurement result taken under the test condition. When a 1kΩ (or greater) range resistor value is selected, conductance and susceptance measurement values are displayed. This test helps troubleshoot the bridge circuit and process amplifier sections.

Test step 10 1V test signal level test (A3 and A6)

Test step 11 0.1V test signal level test (A3)

Test step 12 0.01V test signal level test (A3)

Test condition: UNKNOWN terminals must be so connected as to constitute an open measurement condition (attach 16047A test fixture with nothing connected as DUT). Test frequency should be below 1MHz. Test signal voltage is measured for each MULTIPLIER setting (x1, x0.1 and x0.01).

Display section	Display meanings	Test limits
DISPLAY B	OP10, OP11 or OP12 figure appears when the test signal level is too high or too low.	1V (0.1V or 0.01V) ±20%

ADJUSTMENT: A3R1 and A3R9

TROUBLESHOOTING HINTS:

A3, A4 or A6 board is faulty. If abnormal test results occur only on test steps 10, 11, 12 and 24 (all), EN5C3 input channel of A4 board is faulty.

Test step 13	10 $\mu$ S bridge balance test (MULTIPLIER: x1)
Test step 14	100 $\mu$ S bridge balance test (MULTIPLIER: x1)
Test step 15	1000 $\mu$ S bridge balance test (MULTIPLIER: x1)
Test step 16	1000 $\mu$ S bridge balance test (MULTIPLIER: x0.1)
Test step 17	10mS bridge balance test (MULTIPLIER: x0.01)

Test condition: UNKNOWN terminals must be so connected as to constitute an open measurement condition (attach 16047A test fixture with nothing connected as DUT) Test steps 13 and 17 should be done at a test frequency below 1MHz. Admittance measurements (G-B) are taken for ascertaining bridge balance condition at a given range and MULTIPLIER control setting.

Display section	Display meanings	Step	Test limits
DISPLAY B	One or more of OP13 through OP17 annunciators appear when an abnormal bridge balance error is detected.	13	$.00 \pm (160 + 200\pi f)^* \text{ counts}$
		14	$.00 \pm (160 + 20\pi f)^* \text{ counts}$
		15	$.00 \pm (160 + 2\pi f)^* \text{ counts}$
		16	$.00 \pm (160 + 2\pi f)^* \text{ counts}$
		17	$.00 \pm 1280 \text{ counts}$

\*f: Test frequency in kHz.

**TROUBLESHOOTING HINTS:**

If abnormal test result occurs at a specific test step in steps 13 through 17, a range resistor is open (OS) or shorted (0 $\Omega$ ). Otherwise, a range resistor selection relay is not properly operating. The range resistors associated with the individual test steps are listed below:

Test step	Range resistor	MULTIPLIER setting
13	100k $\Omega$	x1
14	100k $\Omega$	x1
15	10k $\Omega$	x1
16	10k $\Omega$	x0.1
17	1k $\Omega$	x0.01

If abnormality occurs only on step 16 and/or 17, a defective MULTIPLIER function control (TLL or TLH) switch in the A1 or A3 board is the probable cause of trouble.

Test step 21	100Ω bridge balance test (MULTIPLIER: x0.1)
Test step 22	100Ω bridge balance test (MULTIPLIER: x0.01)
Test step 23	100Ω bridge balance test (MULTIPLIER: x1)

Test condition: UNKNOWN terminals must be so connected as to constitute a short circuit condition (attach 16047A test fixture with a shorting strap). Test step 22 should be done at a test frequency below 100kHz. Impedance measurements (R-X) are taken for ascertaining bridge balance condition at a given range and MULTIPLIER control setting.

Display section	Display meanings	Step	Test limits
DISPLAY B	SH21, SH22 or SH23 figure appears when an abnormal bridge balance error is detected.	21	.00±(160+20πf)* counts
		22	.00±1280 counts
		23	.00±(160+20πf)* counts

\*f: test frequency in kHz.

**TROUBLESHOOTING HINTS:**

If abnormal test result occurs on all of these test steps, the 100Ω range resistor is open (OS) or shorted (0Ω). Otherwise, the associated range resistor selection relay is not properly operating. If the abnormality occurs on specific test step(s), a defective MULTIPLIER function control (TLL or TLH) switch in the A1 or A3 board is the probable cause of trouble.

Test step 24	Test signal current test (A3, A4)
--------------	-----------------------------------

Test condition: UNKNOWN terminals must be so connected as to constitute a short circuit condition (attach 16047A test fixture with a shorting strap). Test frequency should be below 1MHz. Test signal current across the short circuited UNKNOWN terminals for MULTIPLIER setting of x1 is measured.

Display section	Display meanings	Test limits
DISPLAY B	SH24 figure appears when test signal current detected is abnormally low or high.	10±2mA

**TROUBLESHOOTING HINTS:**

If abnormal test result only occurs on this test step, source resistor on A3 board is defective.

Test step 25

100Ω, 1kΩ and 10kΩ range resistor test

Test condition: UNKNOWN terminals must be so connected as to constitute a short circuit condition (attach 16047A test fixture with a shorting strap). Test frequency should be below 1MHz.

This test compares the Err signal voltages detected for a range resistance of 100Ω and for the parallel synthetic resistance of 100Ω, 1kΩ and 10kΩ range resistors.  
This comparison test helps check range resistor selection relay operations and to find a range resistor which may be open.

Display section	Display meanings	Test limits
DISPLAY B	SH25 figure appears when the parallel synthetic resistance is too high in comparison with the 100Ω range resistor.	Parallel synthetic resistance value must be less than 90.75% of 100Ω range resistor.

**TROUBLESHOOTING HINTS:**

The 100Ω, 1kΩ and 10kΩ range resistors should be checked for change from their nominal values.

8-89. Disassembly of A10 (Display and key) Board.

To replace the parts mounted on A10 board assembly, the front panel has to be removed from the front frame of the 4275A. The procedure is as follows:

1. Carefully remove trim strip from top of front frame (without bending trim strip).
2. Remove the three screws from top of front frame.
3. Remove the two foot assemblies and three screws from bottom of front frame.
4. Press front panel assembly forward (from inside) without adding strong stress to the cable assemblies which are connected between front panel and main body.
5. Remove the nine (9) screws from A10 board assembly and the now accessible associated parts around the front panel and the A10 board assembly.

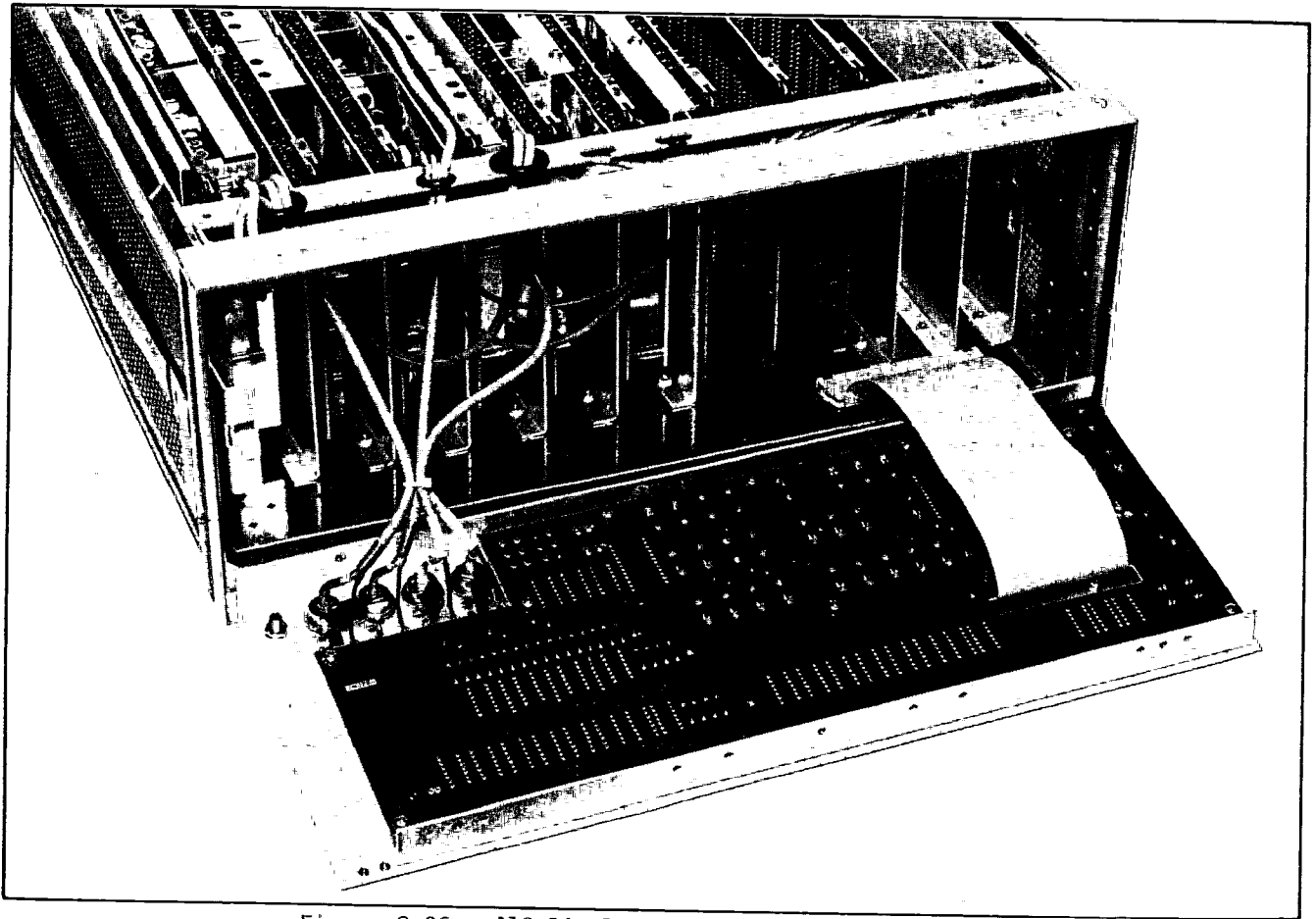

Figure 8-26. A10 Display and Key Board Disassembly.

8-90. PRODUCT SAFETY CHECKS.

WARNING

WHENEVER IT APPEARS LIKELY THAT SAFETY PROTECTIVE PROVISIONS HAVE BEEN IMPAIRED, THE APPARATUS SHALL BE MADE INOPERATIVE AND BE SECURED AGAINST ANY UNINTENDED OPERATION. THE PROTECTION IS LIKELY TO BE COMPROMISED IF, FOR EXAMPLE:

- THE APPARATUS SHOWS VISIBLE DAMAGE.
- THE INSTRUMENT FAILS TO PERFORM THE INTENDED MEASUREMENT.
- THE UNIT HAS UNDERGONE PROLONGED STORAGE UNDER UNFAVORABLE CONDITIONS.
- THE INSTRUMENT HAS SUFFERED SEVERE TRANSPORT STRESS.

8-91. The following five checks are recommended to verify the product safety of the 4275A LCR Meter (these checks may also be done to check for product safety after troubleshooting and repair). When such checks are needed, perform the following:

1. Visually inspect interior of instrument for any signs of abnormal internally generated heat such as discolored printed circuit boards or components, damaged insulation, or evidence of arcing. Determine and remedy cause of any such condition.
2. Using a suitable ohmmeter, check resistance from instrument enclosure to ground pin on power cord plug. The reading must be less than 0.5 ohm. Flex the power cord while making this measurement to determine whether intermittent discontinuities exist.
3. Check GUARD terminal on front panel using procedure (2).

4. Disconnect instrument from power source. Turn power switch to on. Check resistance from instrument enclosure to line and neutral (tied together). The minimum acceptable resistance is two megohms. Replace any component which fails or causes a failure.
5. Check line fuse to verify that a correctly rated fuse is installed.



### Digital Section Troubleshooting Using Signature Analyzer.

The advantage of troubleshooting based on "Signature Analysis" is accuracy and ease in finding failures. It is generally difficult to search for an error by means of observing waveforms on an oscilloscope for the reason that bit trains in a digital circuit seem to be much the same whichever is observed. Specifically, to find the errors in a stream of large bit size (or word length) data takes much time and requires the use of an instrument such as a logic state analyzer. Hewlett-Packard has proposed a method called "Signature Analysis" which recognizes the bit pattern measured in a 4 digit hexa-decimal code (signature) for running an easy diagnostic test program. With the Signature Analyzer (HP 5004A), the signatures are displayed in a readable 4 digit-figure set of alphanumeric figures (0 1 2 3 4 5 6 7 8 9 A C F H P U). The signature analysis is based the usual signal tracing method followed in troubleshooting an analog circuit. According to signature analysis, devices in a digital circuit are checked with the signal analyzer by comparing signal input and output signatures to and from each device for the "correct" signature denoted in the service manual signature map. If a signature is not identical, the troubleshooter need only trace the bit train in opposite direction to the signal flow and, when a device is noted which generates an erratic signature despite a correct input, the component may be regarded as faulty.

#### Signature Analysis for the 4275A.

For doing signature analysis, a DSA (Data Stream Analysis) switch is provided on the A9 (MPU) board of the 4275A. No additional test board is required. There are twenty-one (21) kinds of DSA for performing signature troubleshootings and they are identified by the abbreviated names of DSA-1 thru DSA-21. These names are denoted around the signature pattern in the respective schematic and troubleshooting trees for setting the signature analyzer and the 4275A for appropriate control settings, window setting, DSA switch position of A9 board and other necessary conditions of the 4275A.

#### SIGNATURE ANALYZER TECHNIQUE.

An active digital hand-held logic tracer coupled with an active pod (with four miniature clip connection leads) is sufficient for detecting the test signal and for development of the signature on the Signature Analyzer display. The active probe has access to the desired node in the circuit being tested and transfers this input data to the analyzer. The four input leads of the test cable active pod connect the gate signals --- START, STOP and CLOCK --- from the instrument being tested to the analyzer. The remaining lead is connected to instrument GND. The START signal is an open "window" (measurement gate) signal which causes the signature analyzer to prepare for receiving data via the active probe. The STOP signal causes the window to close. The CLOCK is taken from the time base of the instrument and permits receiving input data and gate signals in synchronization. Polarity of the gate signal active (enable) edges (positive or negative) can be selected by the front panel controls of the signature analyzer. Probing points and connection locations of START, STOP and CLOCK leads are designated on the troubleshooting flow diagrams.

Figure 8-27. Signature Analysis Guide (Sheet 1 of 2).

Signature Analysis Diagnostic Flow Diagram Notes.

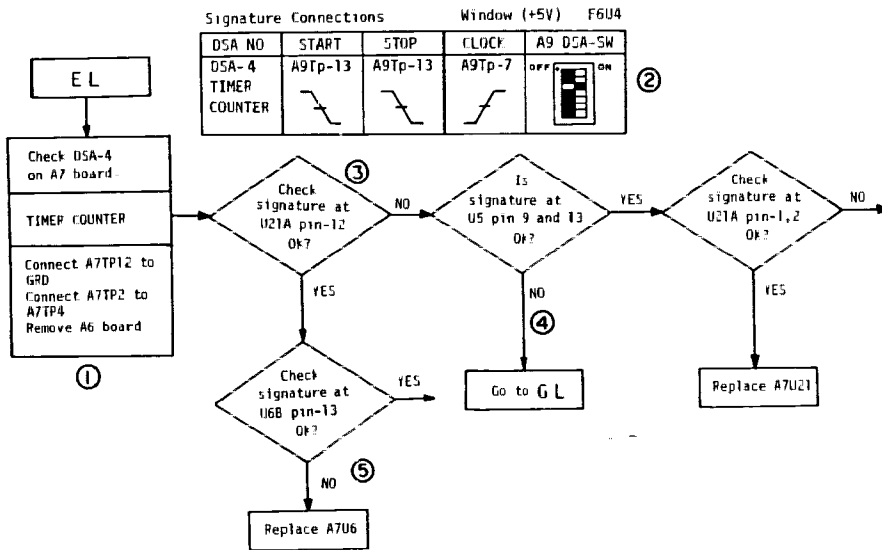

Figure A.

1. For doing Signature Analysis in an EL flow chart, arrange the settings as given in bottom box.
2. Set DSA switch of A9 MPU board as shown in right box. Both START and STOP signals are taken from A9TP13. CLOCK signal is taken from A9TP7. Front panel control settings for Signature Analyzer are:

START button: depressed (■)  
 STOP button: depressed (■)  
 CLOCK button: released (■)

Check that signature of +5V supply is F6U4 (this step is omitted from step by step flow chart).

3. Compare actual signatures with signatures of DSA-4 signature map (see Figure-B). If not identical, go to step 4.
4. In like manner, compare actual signature and if not identical, go to GL flow chart.
5. In like manner, compare actual signature and if not identical, replace A7U6.

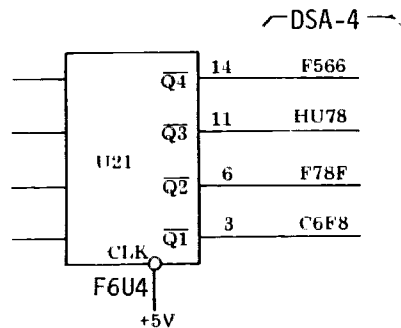

Figure B.

Figure 8-27. Signature Analysis Guide (Sheet 2 of 2).

Table 8-8. Front Panel Troubleshooting Guide.

Symptom	Probable faulty board
Measured value is incorrect at a particular range setting.	A1, A4
Measurement is not made correctly at particular MULTIPLIER setting(s).	A2, A3
Measurement is not made correctly at particular test frequency setting(s).	A6
Measurement is not made correctly only at 10kHz test frequency.	A1, A7
Measured value is 1/100, 1/10, 10, or 100 times the normal value.	A4
OF annunciation display occurs on all ranges.	A1, A2, A3
Trigger lamp does not light or stays lit but begins flashing when SELF TEST function is set.	A5, A6
Figure(s) in numeric (or alphanumeric) display is (are) defective.	A8, A9
An indicator lamp does not light or stays lit.	A8, A10
SELF TEST function can not be activated (triggering stops).	A7, A9
Pushbutton controls do not work (always invalid).	A8, A7
All numeric displays or all except one digit are blank.	A9, A10
Autorange control malfunctions.	A7

**Table A. Signature Test Codes.**

Signature Connectors		Links (49) 1836	
Pin No.	Signature	Code	Pin No.
1	1836	1836	1836
2	1837	1837	1837
3	1838	1838	1838
4	1839	1839	1839
5	1840	1840	1840
6	1841	1841	1841
7	1842	1842	1842
8	1843	1843	1843
9	1844	1844	1844
10	1845	1845	1845
11	1846	1846	1846
12	1847	1847	1847
13	1848	1848	1848
14	1849	1849	1849
15	1850	1850	1850
16	1851	1851	1851
17	1852	1852	1852
18	1853	1853	1853
19	1854	1854	1854
20	1855	1855	1855
21	1856	1856	1856
22	1857	1857	1857
23	1858	1858	1858
24	1859	1859	1859
25	1860	1860	1860
26	1861	1861	1861
27	1862	1862	1862
28	1863	1863	1863
29	1864	1864	1864
30	1865	1865	1865
31	1866	1866	1866
32	1867	1867	1867
33	1868	1868	1868
34	1869	1869	1869
35	1870	1870	1870
36	1871	1871	1871
37	1872	1872	1872
38	1873	1873	1873
39	1874	1874	1874
40	1875	1875	1875
41	1876	1876	1876
42	1877	1877	1877
43	1878	1878	1878
44	1879	1879	1879
45	1880	1880	1880
46	1881	1881	1881
47	1882	1882	1882
48	1883	1883	1883
49	1884	1884	1884
50	1885	1885	1885
51	1886	1886	1886
52	1887	1887	1887
53	1888	1888	1888
54	1889	1889	1889
55	1890	1890	1890
56	1891	1891	1891
57	1892	1892	1892
58	1893	1893	1893
59	1894	1894	1894
60	1895	1895	1895
61	1896	1896	1896
62	1897	1897	1897
63	1898	1898	1898
64	1899	1899	1899
65	1900	1900	1900
66	1901	1901	1901
67	1902	1902	1902
68	1903	1903	1903
69	1904	1904	1904
70	1905	1905	1905
71	1906	1906	1906
72	1907	1907	1907
73	1908	1908	1908
74	1909	1909	1909
75	1910	1910	1910
76	1911	1911	1911
77	1912	1912	1912
78	1913	1913	1913
79	1914	1914	1914
80	1915	1915	1915
81	1916	1916	1916
82	1917	1917	1917
83	1918	1918	1918
84	1919	1919	1919
85	1920	1920	1920
86	1921	1921	1921
87	1922	1922	1922
88	1923	1923	1923
89	1924	1924	1924
90	1925	1925	1925
91	1926	1926	1926
92	1927	1927	1927
93	1928	1928	1928
94	1929	1929	1929
95	1930	1930	1930
96	1931	1931	1931
97	1932	1932	1932
98	1933	1933	1933
99	1934	1934	1934
100	1935	1935	1935

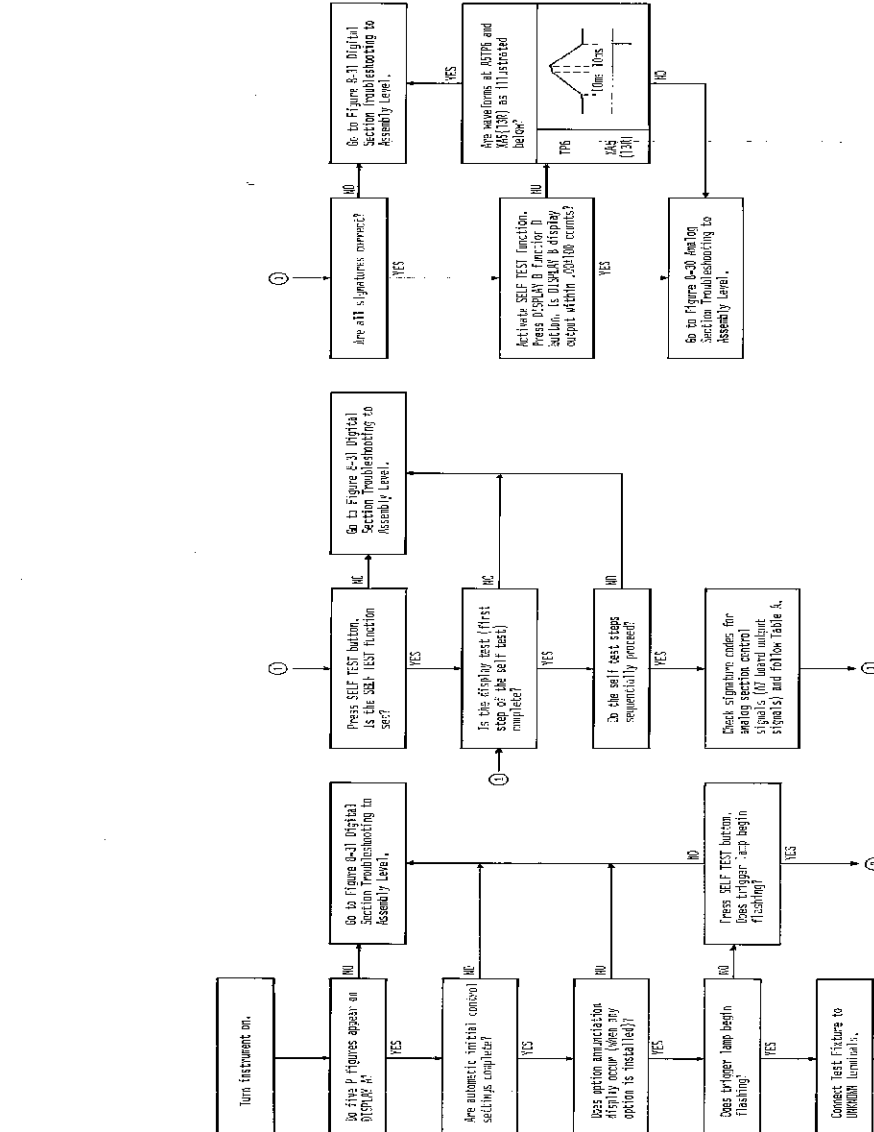

Figure 8-29. Analog and Digital Section Isolation Procedure.

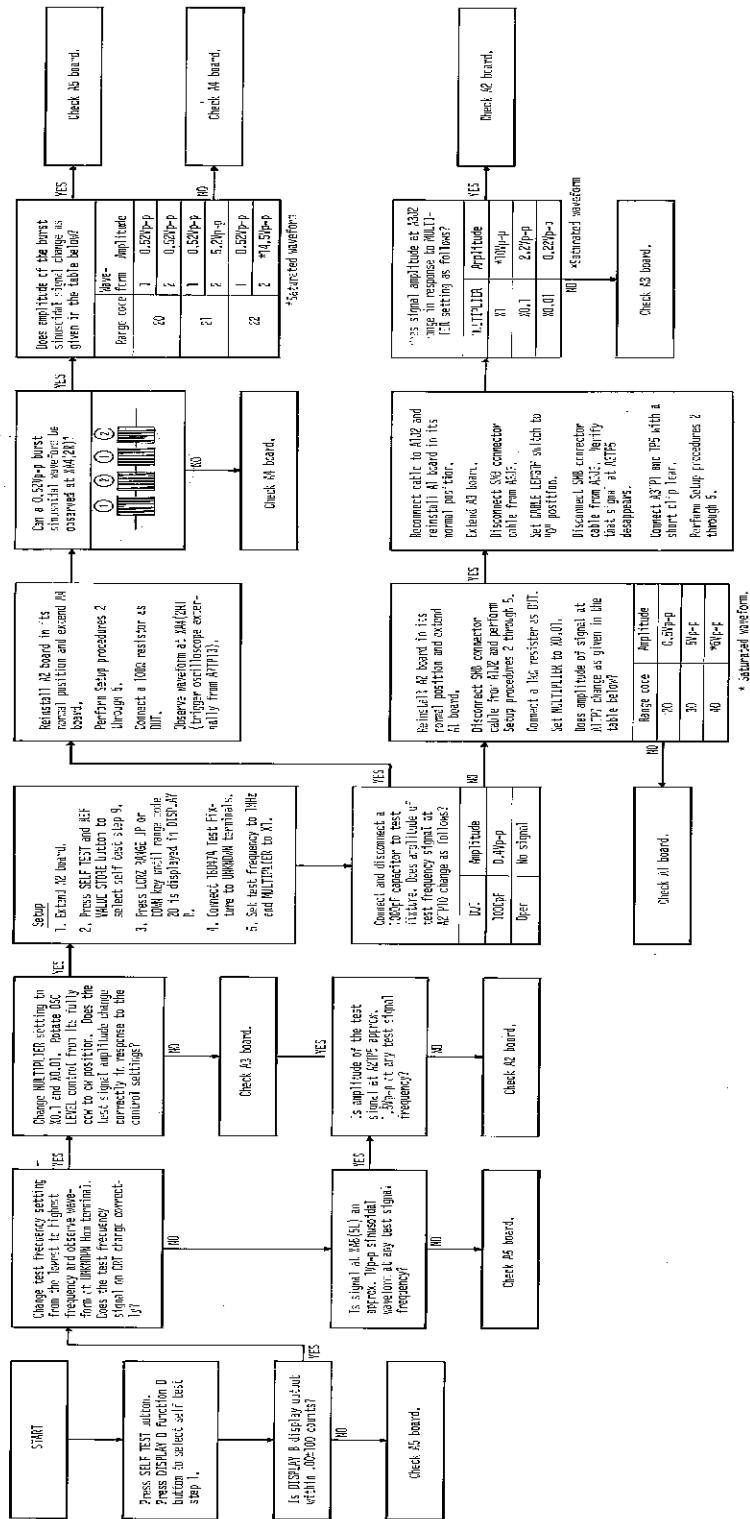

Figure 8-30. Analog Section Troubleshooting to Assembly Level.



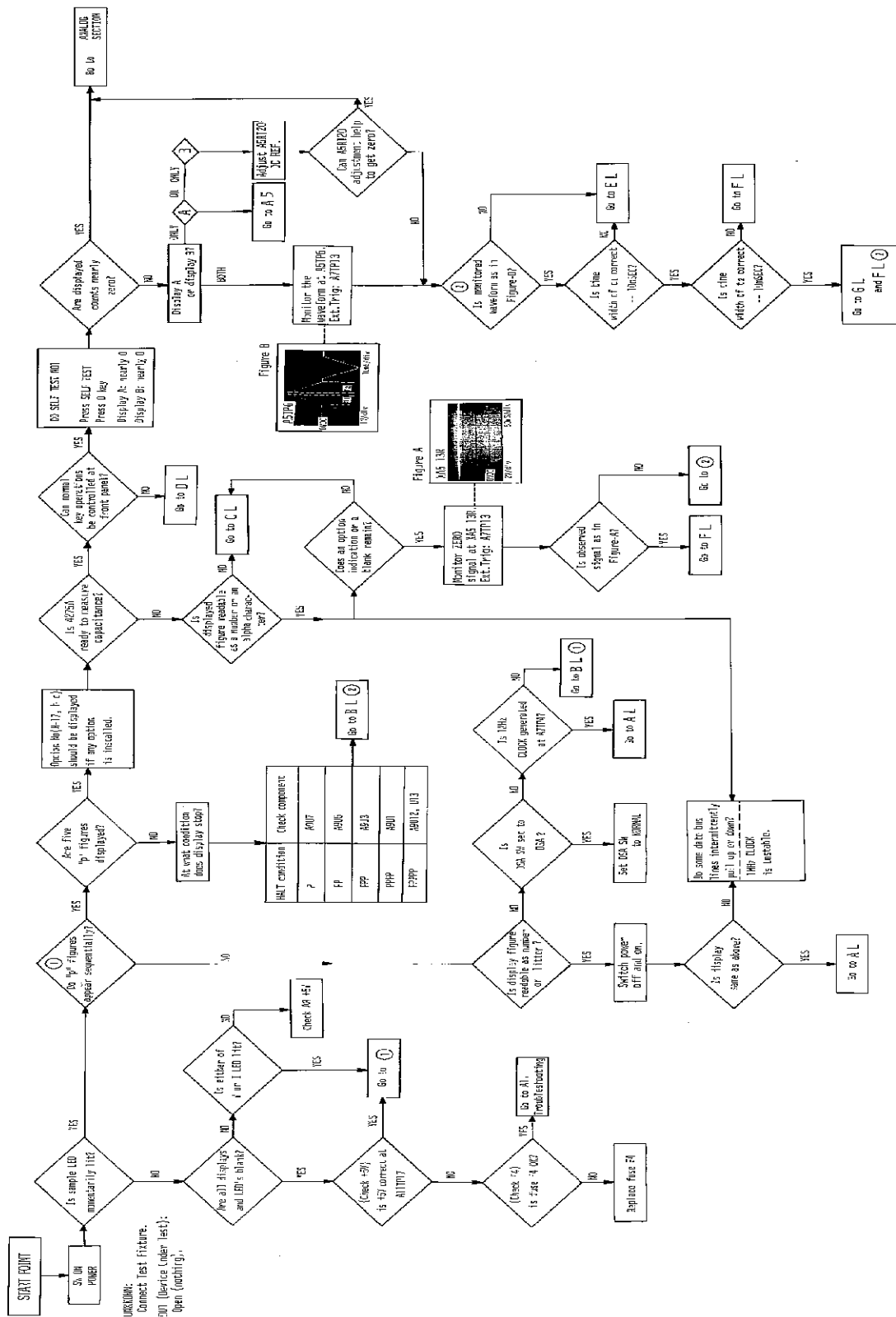

Figure 6-31. Digital Section Troubleshooting to Assembly Level.

Note: Set DSA-TEST-SW to Normal Position after replacing defective components on each flow.

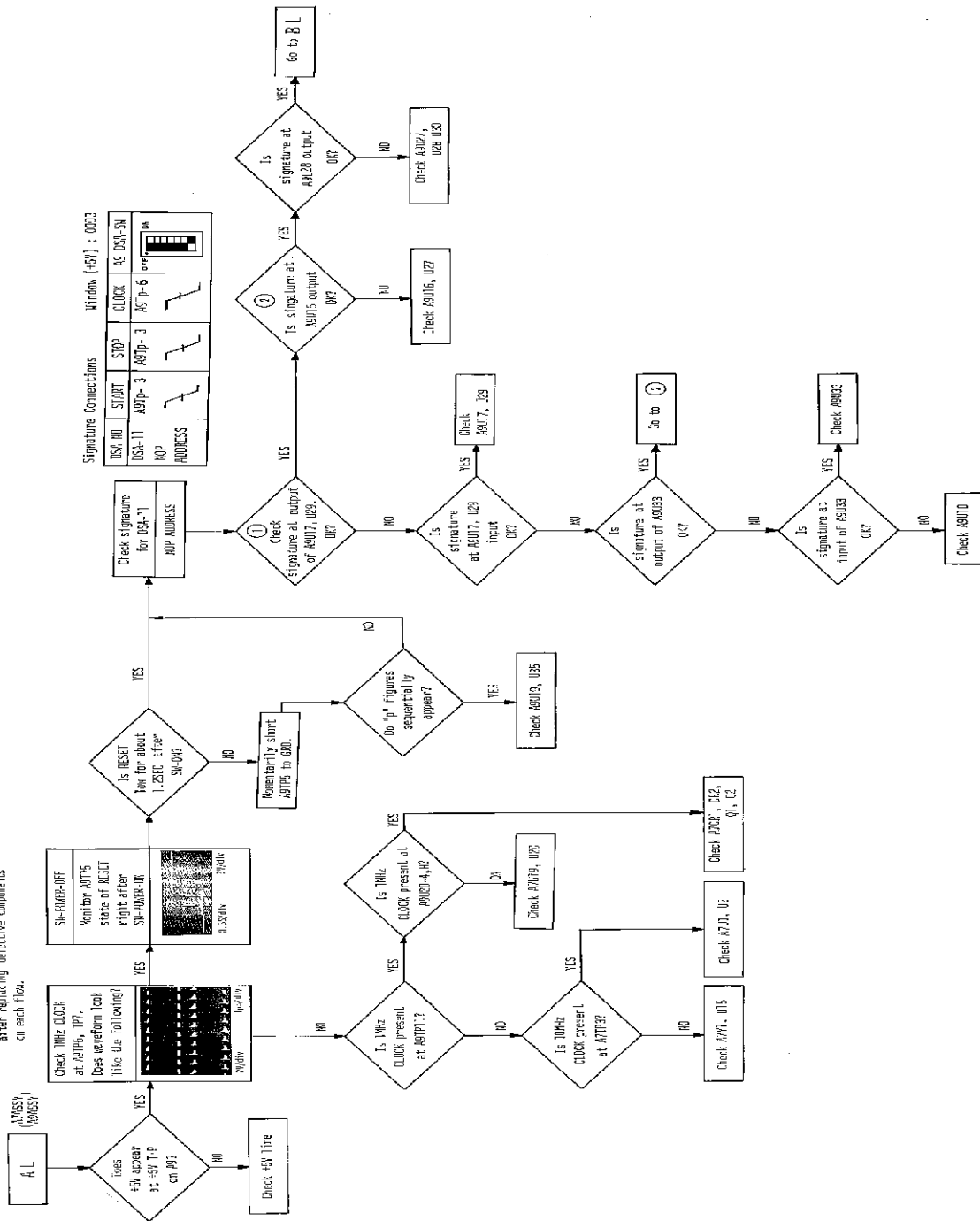
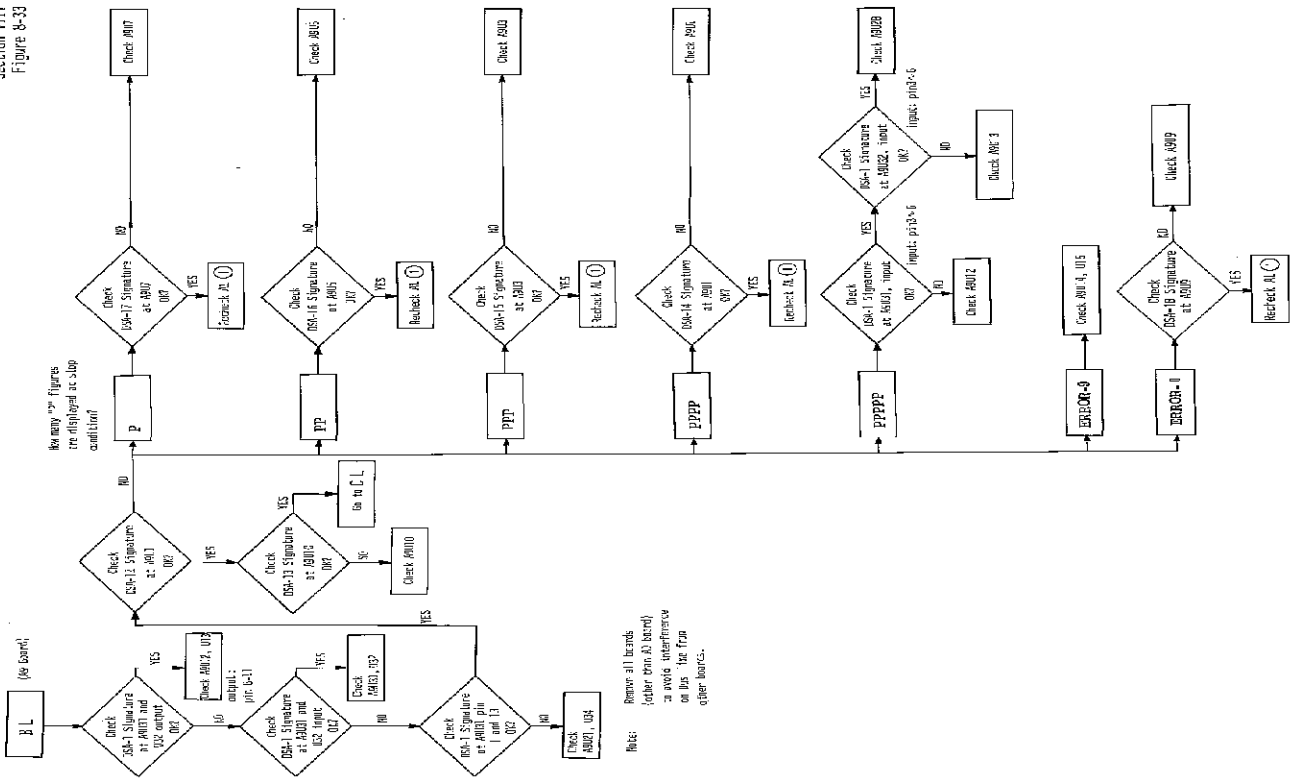

Figure 8-32. Digital Section Troubleshooting Flow Diagram A...

This table can be used to check signatures at A01 thru A010 ROM's. Signature test point is established at Input of Data Buffer (pins 3 thru 6 of A013 and A012). Instead of the respective ROM outputs (A01 thru A010). This signature list can be used for units with its serial number suffixes of -0063 and above.

TEST P/N (R)	DSA NAME	DSA-12	DSA-14	DSA-15	DSA-16	DSA-17	DSA-13	DSA-18
SIGNAL NAME	ROM TEST NO. POINT	A01 A017	A01 A017	A03 A013	A05 A015	A07 A017	A09 A019	A09 A019
A100(A45)	U1 pin-24	7550	7254	7254	7254	7254	8269	8269
A01	U1 pin-3	8031	8292	7994	244C	016F	2045	8103
A02	pin-4	6049	9949	307F	08CA	02CC	539F	497C
A03	pin-5	1105	808E	8FF4	9F0F	3102	8705	590C
A04	pin-5	751P	7909	3794	C71U	747F	1A7A	6966
A05	U32 pin-3	6375	8E09	2443	5423	4242	C047	A17E
A06	pin-5	615C	F954	5410	0899	244C	H60E	0C77
A07	pin-5	7200	0FF8	681H	899F	30CE	5535	1643
A08	pin-5	A03H	052D	0E76	F75F	324C	094E	F194





Remarks: Figures are displayed at >top condition!

(No board)

Signature Connectors for DS4-1 and DS4-12 thru DS4-16

Signature Connections Window (+S) : P254

DS4-10	START	STOP	CLOCK	STOP	CLOCK	STOP	CLOCK	STOP	CLOCK
DS4-17	START	STOP	CLOCK	STOP	CLOCK	STOP	CLOCK	STOP	CLOCK
DS4-18	START	STOP	CLOCK	STOP	CLOCK	STOP	CLOCK	STOP	CLOCK

Signature Connections Window (+S) : P267

DS4-10	START	STOP	CLOCK	STOP	CLOCK	STOP	CLOCK	STOP	CLOCK
DS4-12	START	STOP	CLOCK	STOP	CLOCK	STOP	CLOCK	STOP	CLOCK
DS4-13	START	STOP	CLOCK	STOP	CLOCK	STOP	CLOCK	STOP	CLOCK

Signature Connections Window (+S) : P272

DS4-10	START	STOP	CLOCK	STOP	CLOCK	STOP	CLOCK	STOP	CLOCK
DS4-13	START	STOP	CLOCK	STOP	CLOCK	STOP	CLOCK	STOP	CLOCK
DS4-14	START	STOP	CLOCK	STOP	CLOCK	STOP	CLOCK	STOP	CLOCK

Signature Connections Window (+S) : P283

DS4-10	START	STOP	CLOCK	STOP	CLOCK	STOP	CLOCK	STOP	CLOCK
DS4-14	START	STOP	CLOCK	STOP	CLOCK	STOP	CLOCK	STOP	CLOCK
DS4-15	START	STOP	CLOCK	STOP	CLOCK	STOP	CLOCK	STOP	CLOCK

Signature Connections Window (+S) : P284

DS4-10	START	STOP	CLOCK	STOP	CLOCK	STOP	CLOCK	STOP	CLOCK
DS4-12	START	STOP	CLOCK	STOP	CLOCK	STOP	CLOCK	STOP	CLOCK
DS4-16	START	STOP	CLOCK	STOP	CLOCK	STOP	CLOCK	STOP	CLOCK

Signature Connections Window (+S) : P284

DS4-10	START	STOP	CLOCK	STOP	CLOCK	STOP	CLOCK	STOP	CLOCK
DS4-12	START	STOP	CLOCK	STOP	CLOCK	STOP	CLOCK	STOP	CLOCK
DS4-15	START	STOP	CLOCK	STOP	CLOCK	STOP	CLOCK	STOP	CLOCK

Figure 8-33. Digital Section Troubleshooting Flow Diagram BL



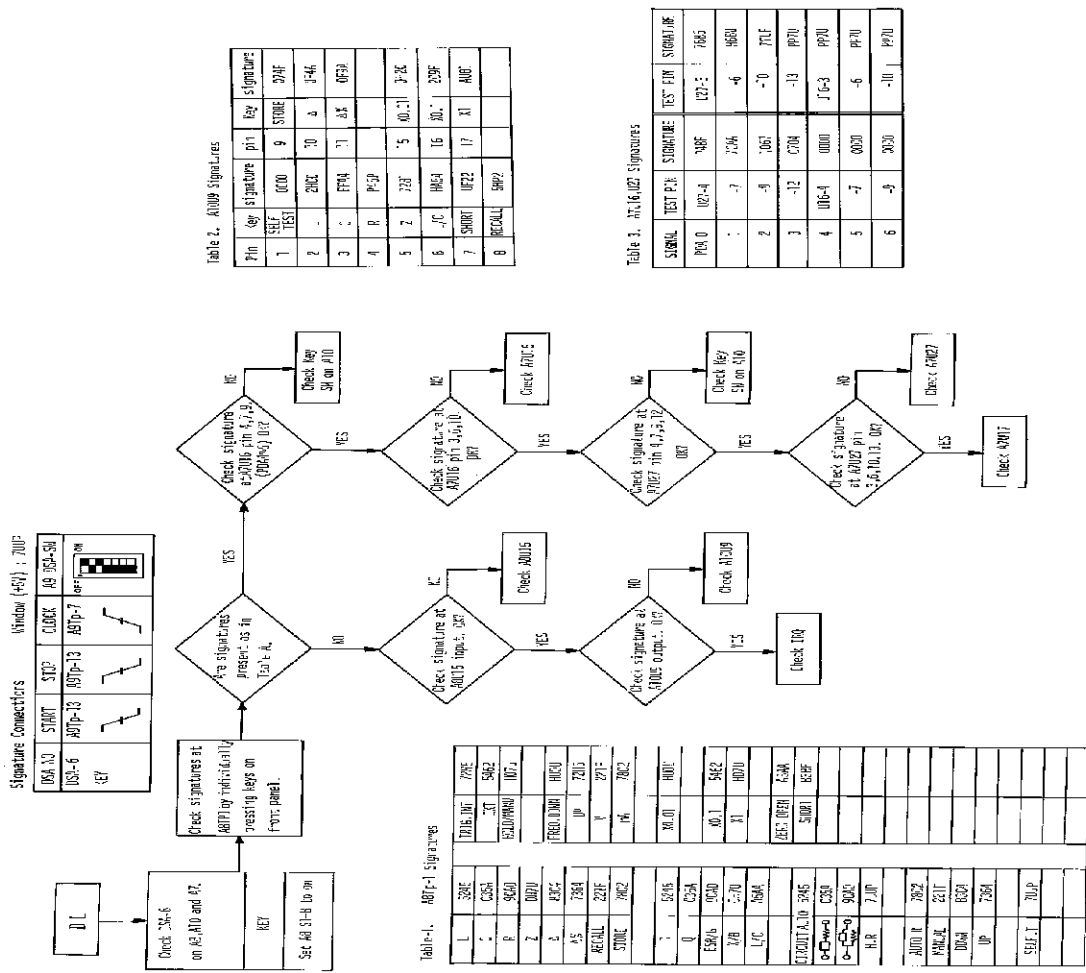

Table 2. A015 Signatures

Pin	Key signature	Pin	Key signature
1	TEST	9	STOR
2	CHK	10	546
3	PRM	11	0F3
4	R	12	PS
5	2	13	5
6	LC	14	16
7	SHORT	17	31
8	RECALL	18	0F2

Table 3. A015 027 Signatures

SIGNAL	TEST P.K.	STORAGE	TEST KEY	SIGNAL
PA0	102-4	NRF	122-5	785
	3	776	4	980
2	8	105	20	71F
3	12	210	13	0F0
4	106-4	000	16-3	0F0
5	7	000	6	0F0
6	8	000	11	0F0

Table 4. A015 Signatures

1	38E	706	70E
	CSA	ST	582
2	840	B310	0F7
	0F2	0F0	0F0
3	384	IP	705
RECALL	22E	R	271
STOR	0E2	16	702
	545	34.0	002
0	024	40.1	542
2/8	5.0	31	000
LC	784	253	0E0
0-0-0-0	0-0-0-0	000	0E0
H.R	71P		
A015	202		
PARAL	211		
004	0E0		
UP	784		
STRT	70P		





Section VIII  
Figure R-38

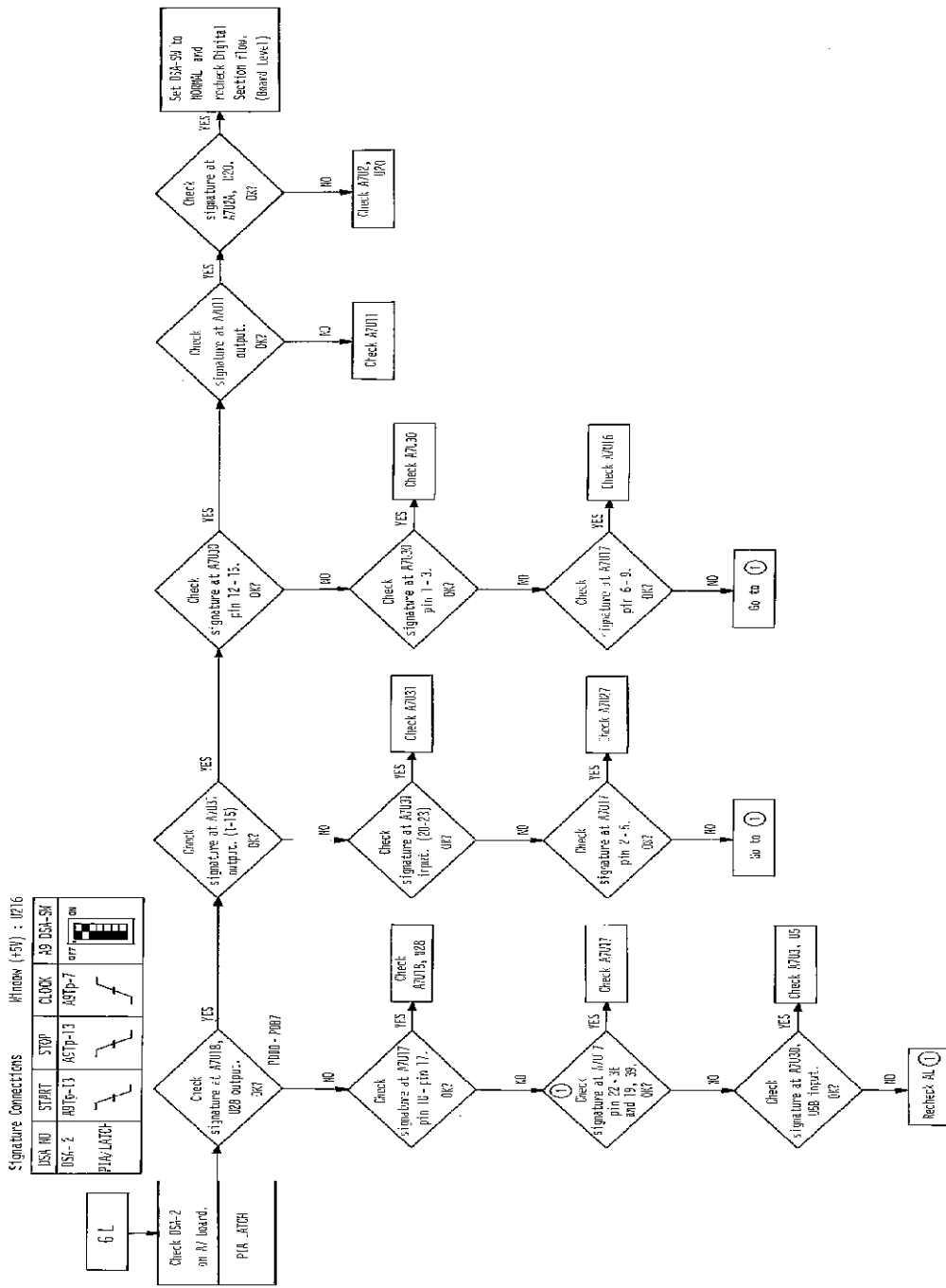

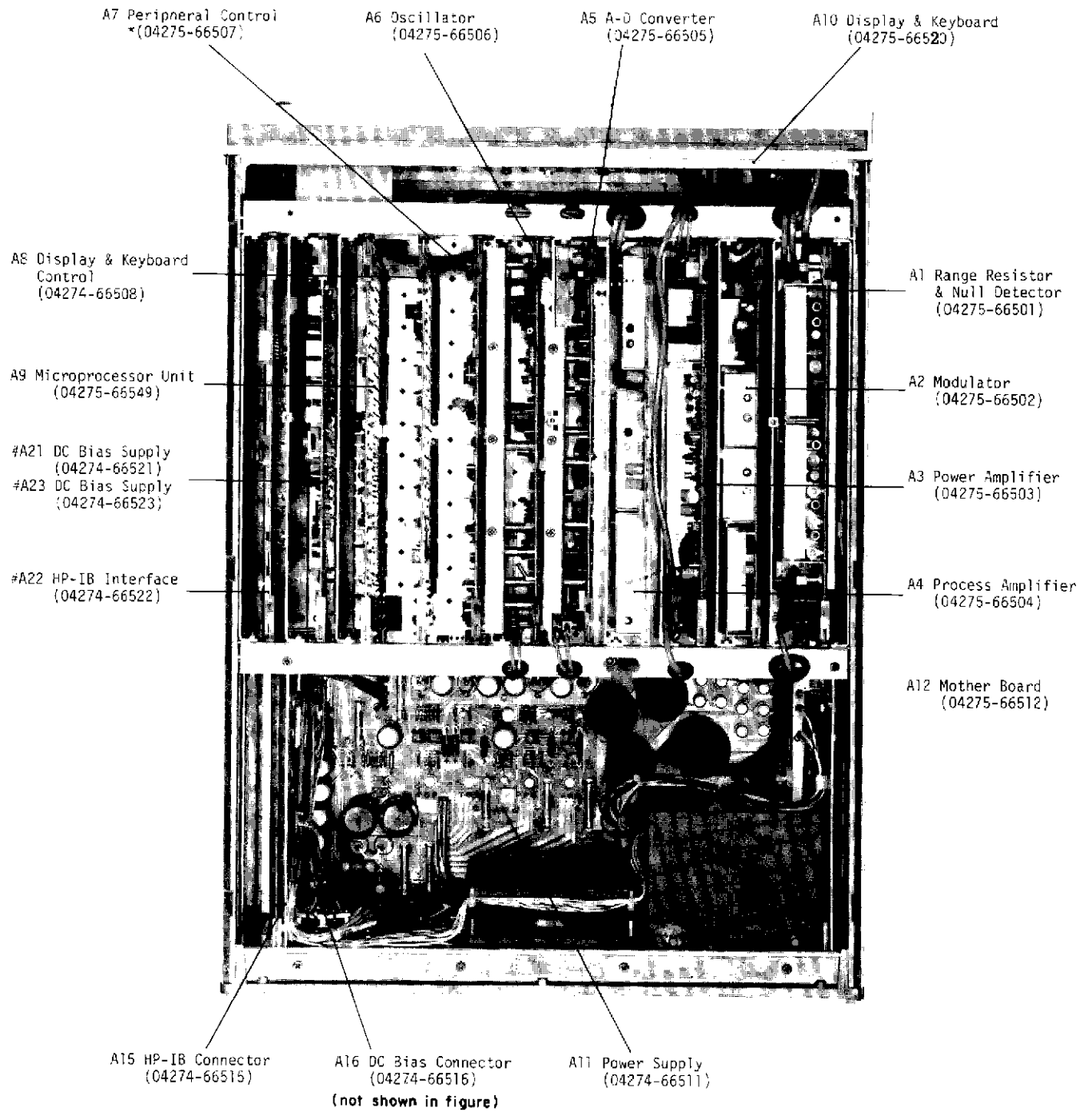

#A21: Option 001 only.  
 #A22: Option 101 only.  
 #A23: Option 002 only.

\*P/N 04275-66537 for Option 004

Figure 8-39. Assembly Locations.

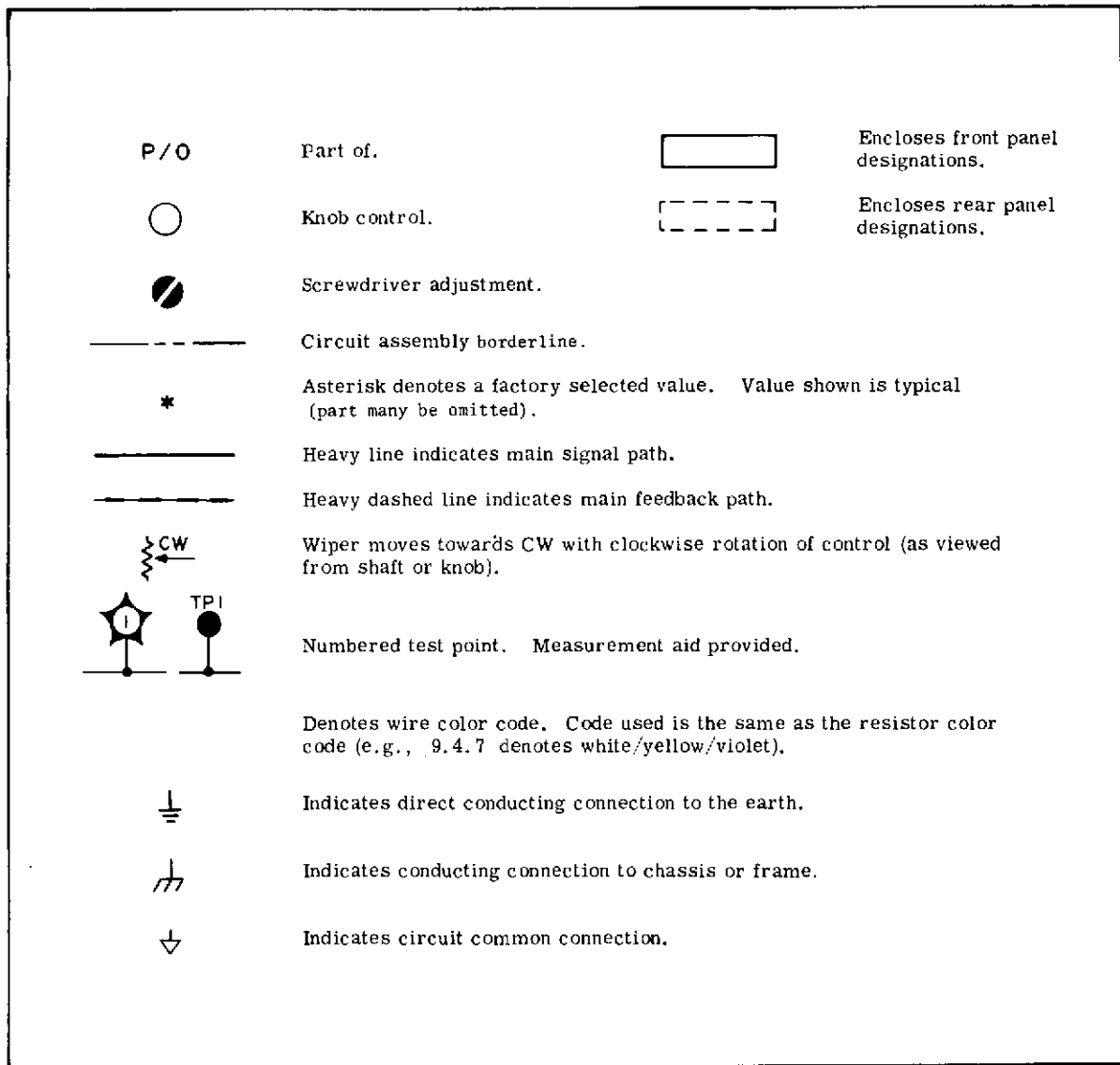

Figure 8-40. Schematic Diagram Notes.





81 Band Translating Flow Diagram Notes

1. If the instrument has bandwidths for measurement error across the cable, ENOVI, within setting of either 40 or 60 degrees, select Q1 or cable width, K1 and K2.

CABLE ENOVI setting	Q1 cable width	K1	K2
0	17V	OFF	OFF
1 n	19V	ON	ON

1. Turn on top 4 external clock delay: A15, or V2

2. If measurement error across a specified frequency range, select the following error signals

Clock points	Red frequency window			
	10MHz	1MHz	100kHz	10kHz
Q1: collector	+2V	-12V	11V	2V
Q1: emitter	+17V	11V	0V	+12V
Q2: collector	-2V	+1V	-12V	-4V
Q2: emitter	-2V	-3V	-12V	-4V

If these values do not correct, check the following component associated with these output signals

K3	2.0V or 1.4MHz
K4	2.0V or 1.0MHz
Q2	Time in 1.0Hz, 1.1Hz, 4.0Hz, and 10.0Hz
Q3	Time in 1.0MHz, 40.0Hz and 1.0Hz

3. Check the signal across the Q1 and Q2 and the red and blue display when the speed is in either 40 or 60.

4. If measurement error across the frequency range (only a measure of the bandwidth range), check Q1A Amplifier output (Q1 through Q3)

5. Check the error output signals as summarized in the table below

Error	Red signal (input channels)					
	Q1A	Q1B	Q1C	Q1D	Q1E	Q1F
Q1A	ON	OFF	OFF	OFF	OFF	ON
Q1B	OFF	ON	OFF	OFF	OFF	ON
Q1C	OFF	OFF	ON	OFF	OFF	ON
Q1D	OFF	OFF	OFF	ON	OFF	ON

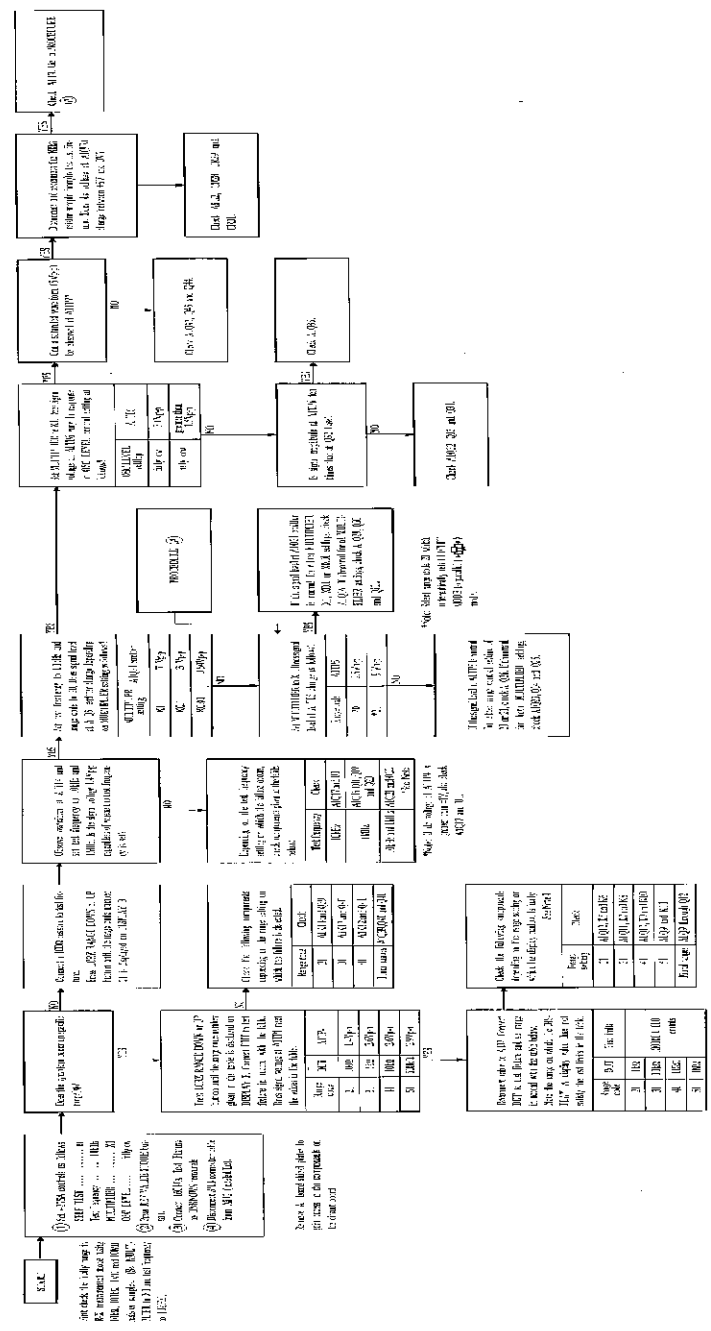

Figure 8-41. Error Test 1 and 2. Error Test 1 and 2. Error Test 1 and 2.

**A1 Board Troubleshooting Flow Diagram Notes.**

1. If the instrument malfunctions or measurement error increases under CABLE LENGTH switch settings of either "0" or "1 m" positions, check Q15 collector voltage, K1 and K2.

CABLE LENGTH setting	Q15 collector	K1	K2
0	12V	OFF	OFF
1 m	0V	ON	ON

If normal voltage is observed, check relays A1K1 and K2.

2. If measurement error increases at specific test frequency setting(s), check the following control signals:

Check points	Test frequency setting				* 5 MHz for option 004
	100 kHz	1 MHz	*4 MHz	10 MHz	
Q13 collector	+12V	+12V	+12V	0V	
Q14 collector	+12V	+12V	0V	+12V	
Q37 collector	- 3V	+ 2V	-4.3V	-4.3V	
Q38 collector	+ 2V	- 3V	-4.3V	-4.3V	

If these voltages are normal, check the following components associated with these control signals:

K3	Turns on at 4 MHz
K4	Turns on at 10 MHz
Q27	Turns on at 10 kHz, 20 kHz 40 kHz and 100 kHz
Q28	Turns on at 200 kHz, 400 kHz and 1 MHz

Check that signal waveforms at Q27 and Q28 collector leads individually disappear when the respective transistors are on.

3. If measurement error increases on low impedance measurement ranges (high capacitance and low inductance ranges), check CMR Amplifier circuit (A1Q1 through Q8).
4. States of the range resistor relays are summarized in the tabulation below:  
Condition – Function: R-X, Test frequency: 10 kHz

Range	Relay states (drive transistors)						
	K5, K6 (Q12)	K7, K8 (Q11)	K9, K10 (Q10)	K11 (Q9)	K12 (Q41)	K13 (Q40)	K14 (Q39)
10 k $\Omega$	ON	OFF	OFF	OFF	OFF	OFF	ON
100 k $\Omega$	OFF	ON	OFF	OFF	OFF	ON	OFF
1 M $\Omega$	OFF	OFF	ON	OFF	ON	OFF	OFF
10 M $\Omega$	OFF	OFF	OFF	ON	OFF	OFF	OFF

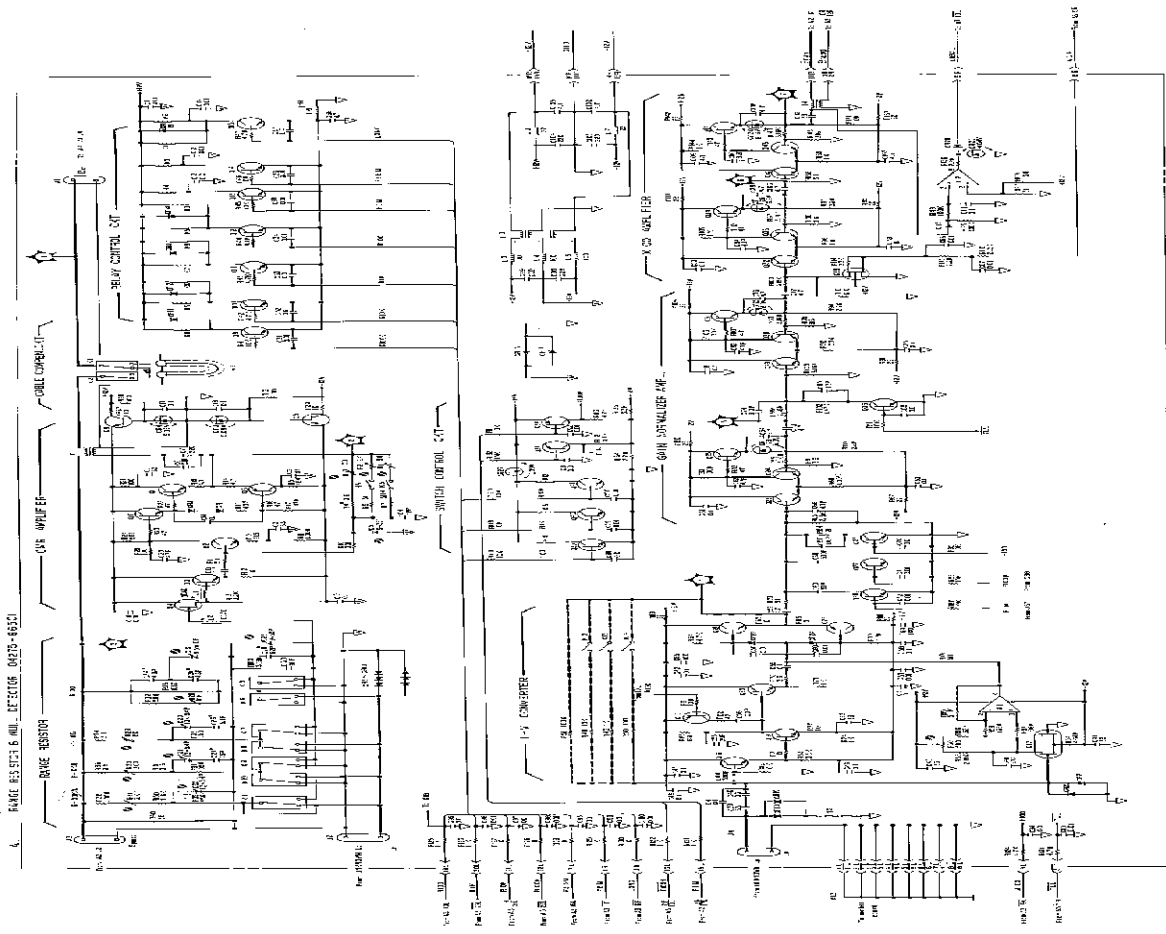

Figure 2-41. All Range Reactor and All Reactor Board Assembly Schematic Diagram. 8-1

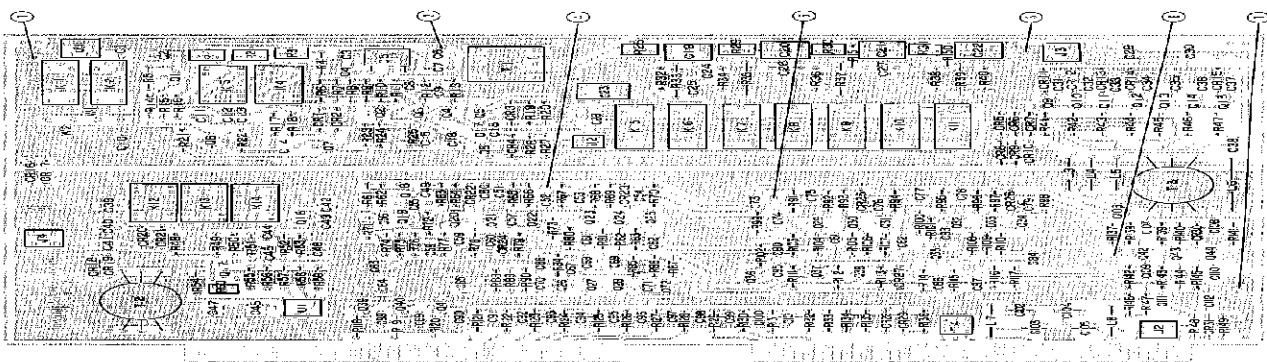

Figure 2-42. All Range Reactor and All Reactor Board Assembly Component Locations.

A2 Bead Troubleshooting Flow Diagram Notes

1. If the instrument malfunctions or assessment error increases at specific test frequencies, or on specific range settings, first check A201 using the table below.

	Control output signals					
	a	b	c	d	e	f
Frequency Setting	100 kHz	-11V	+0.7V	-11V	0V	-
Range Setting	1 MHz	+0.7V	-11V	0V	-11V	-
	100.00	-	-	-	-11V	+0.7V
	1000.00	-	-	-	-	-11V

2. The ALC Amplifier performs loading of the test frequency input signal using an automatic level control operation as the frequency follows the circuit. For the frequency follow-up after operating delay, see Figure 8-3.

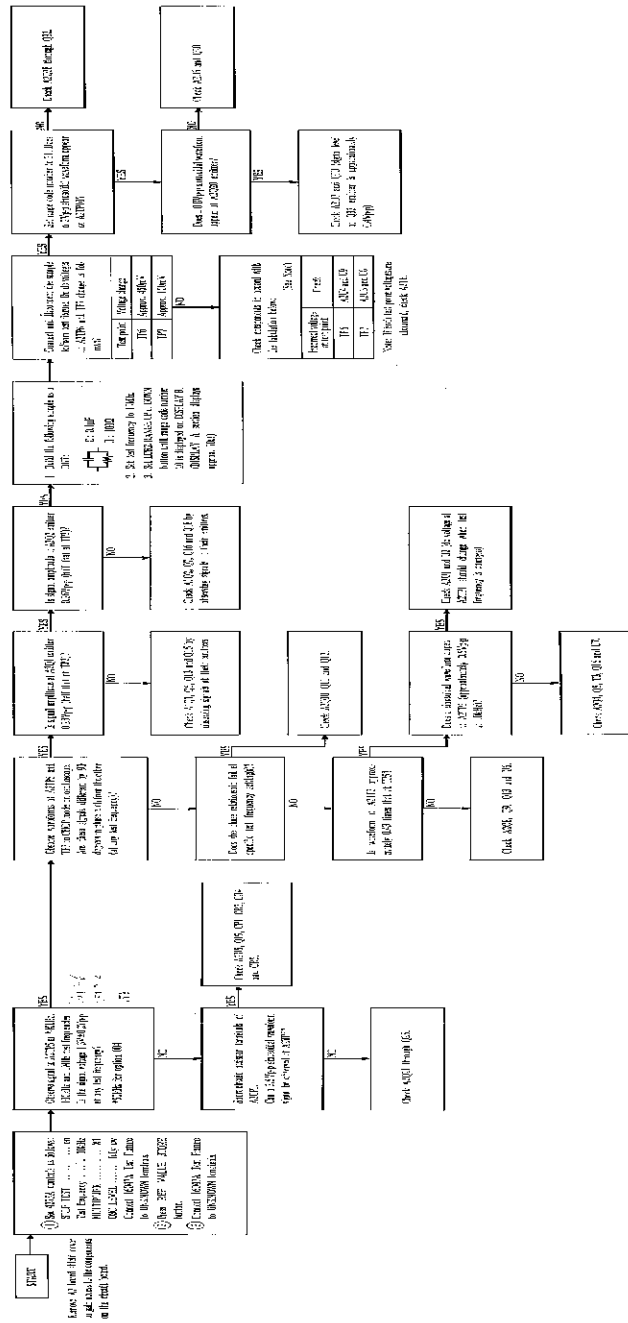

Figure 8-44. A2 Bead Troubleshooting Tree.



A3 Board Troubleshooting Flow Diagram (cont.)

1. If measurement error increases under CASBLE LENGTH switch settings of either the "0" or "1" in positions C and D, check these delay times to accord with the table below.

CASBLE LENGTH setting	Q55 collector	X1	X2
0	12V	OFF	OFF
1 in	0V	ON	ON

2. If no dc bias can be applied to sample, check A3T3 for open-circuit.

3. To check level shifters and their capacity (A3T1 through A3T5), set DSA switch on A3 board (A3S1) as follows:



Set second bit switch to ON and the others to OFF.

4. TEST 1, 11 and 11X control signal logic is given in the table below.

MULTIPLIER setting	TEST		11		MULTIPLIER
	00 pin 2	A3S2 Q55	00 pin 1	A3S2 Q55	
01	OFF	OFF	OFF	OFF	40
02	ON	OFF	OFF	OFF	46.2V
03	ON	ON	ON	ON	46.2V

\*Active SELF TEST function: Press REF-VALUE STORE button. Press LEVEL RANGE UP or DOWN button until scope mode number 20 is displayed on DISPLAY B.

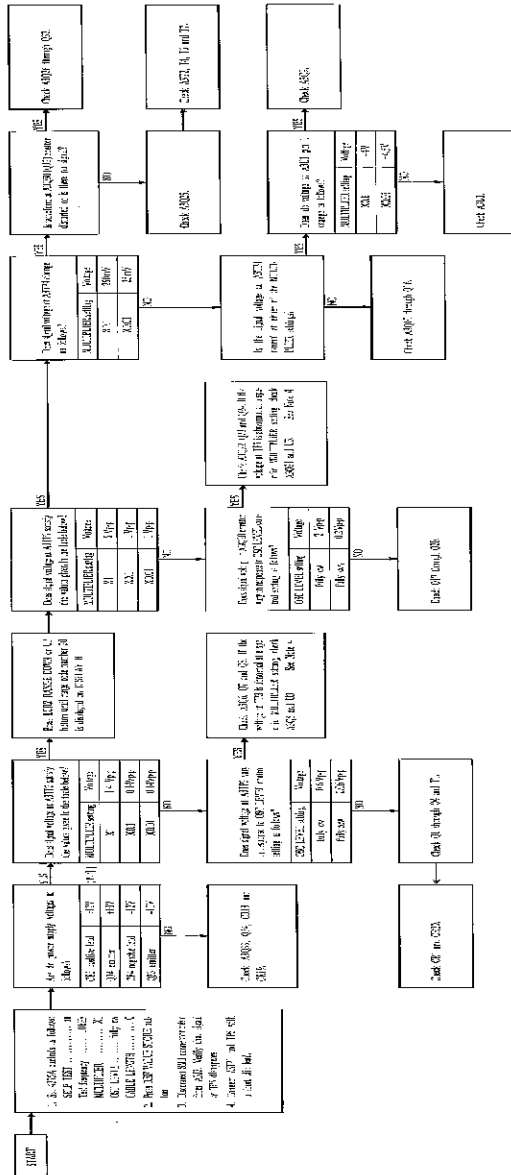

Figure 2-41. 45 Power Amplifier Board Test/Selection Test.

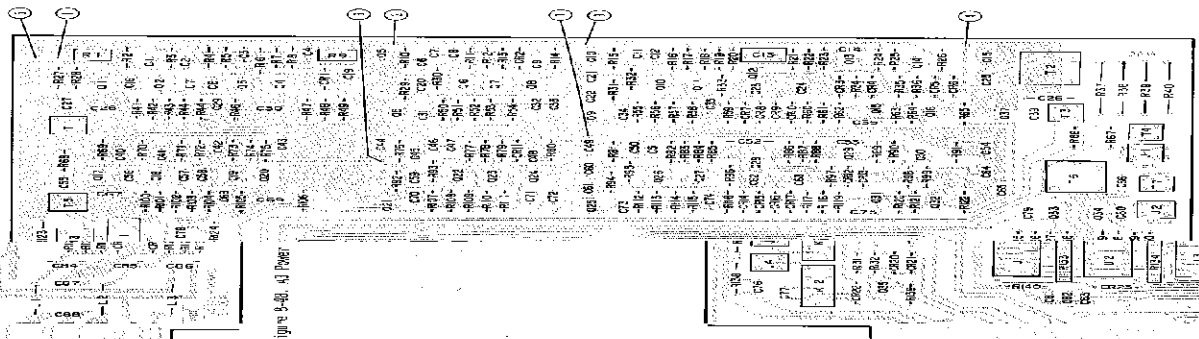
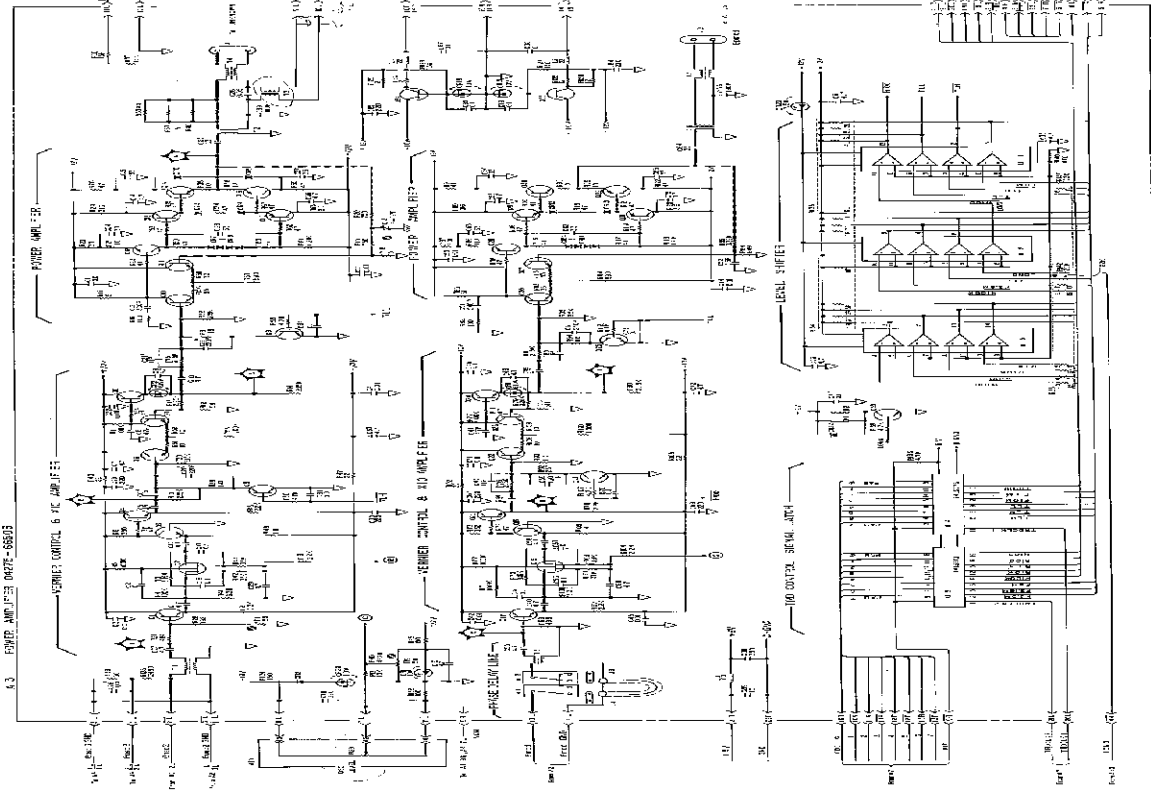

Figure 4-28. 41 Power

Amplifier Board Assembly Component Locations.



M4 Board Troubleshooting Flow Diagram Notes

1. If measurement functions are normal but TEST SIG LEVEL CHECK function is faulty, first check that the dc voltage of A411 pin 2 ranges from +13V to +24V when TEST SIG LEVEL "ON" or "OFF" function is pushed. If normal, check A413 Q10 and Q11.

2. If the waveform at A417P1 shows a 30 MHz sinusoidal signal as opposed to the normal signal, check A410 (pin 3 should normally be at -13V).

3. Signal waveforms at A413, Q10, Q11 and Q18 indicate a problem with the respective transistors.

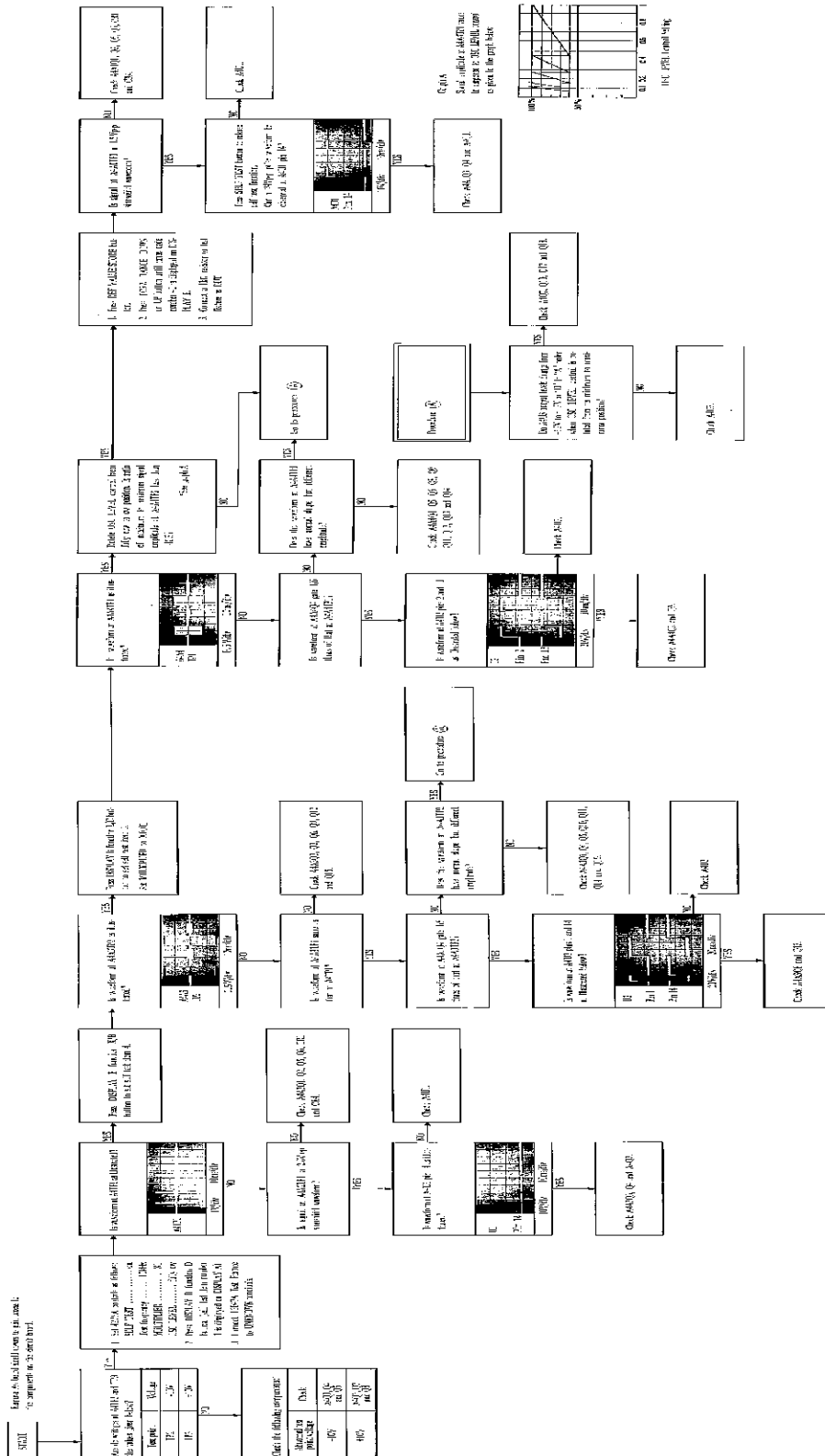

Figure 6-53. M4 Process Amplifier Board Test and Troubleshooting Tree.

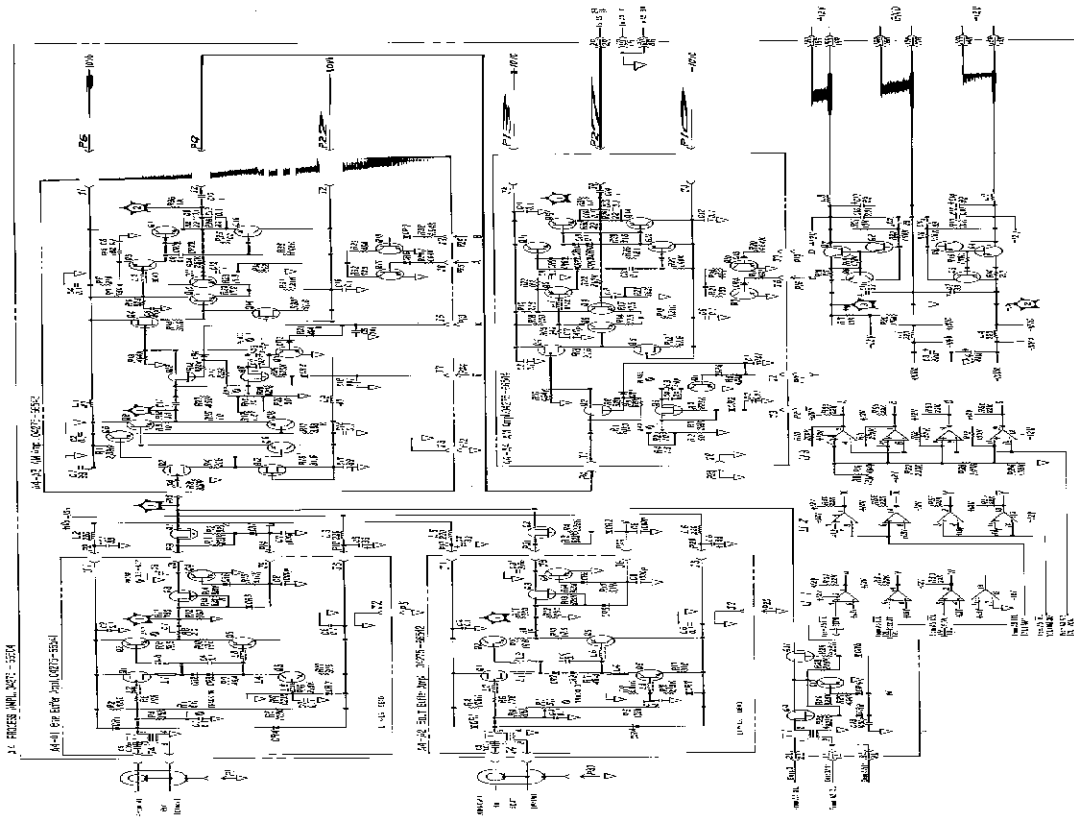

Figure 8-22. A Process Amplifier Board Assembly

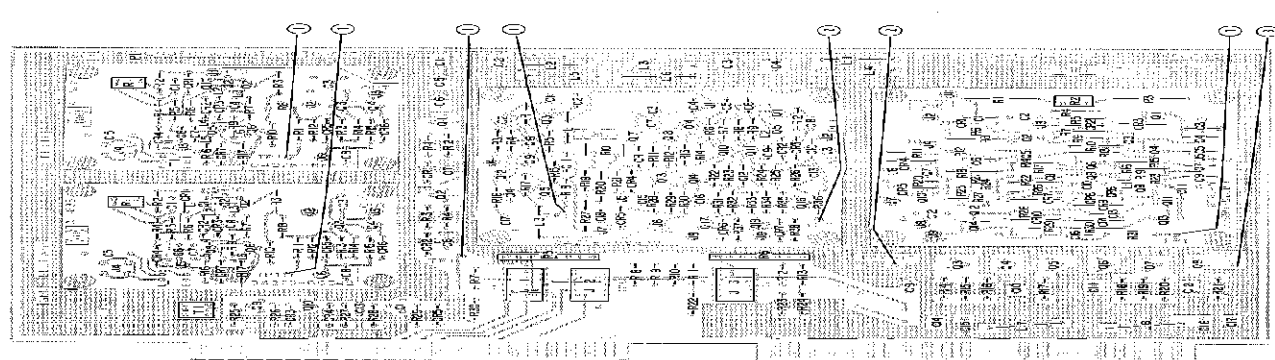

Figure 8-23. A Process Amp (Pre Board Ass'y) Component Locations

A5 Bead Troubleshooting Flow Diagram Notes

1. Connect A5777 to circuit connector. Check that all "Y" outputs of Flip Logic U1 and U2 are at high level. These flip-flops output "Y" as high level ("Y" as low level). This check allows locating the defective flip-flop component with a 25% probability.
2. Connect A5777 to circuit connector. Check that all "Y" outputs of Flip Logic U1 and U2 are at high level. These flip-flops output "Y" as high level ("Y" as low level). This check allows locating the defective flip-flop with a 50% probability.
3. A5110 outputs a single pulse when the instrument is normal in a test frequency setting is changed. The pulse width is equal to that of 80 input signal (i.e. A511). This signal increases the photo detector calibration signals with the excitation signal (i.e. A5) through to increase stability of the measurement results at high frequency. If the signal is not present, the measurement signal output will generate errors approximately 0.5% at 100MHz when the test frequency is changed and is equal to the preceding frequency.

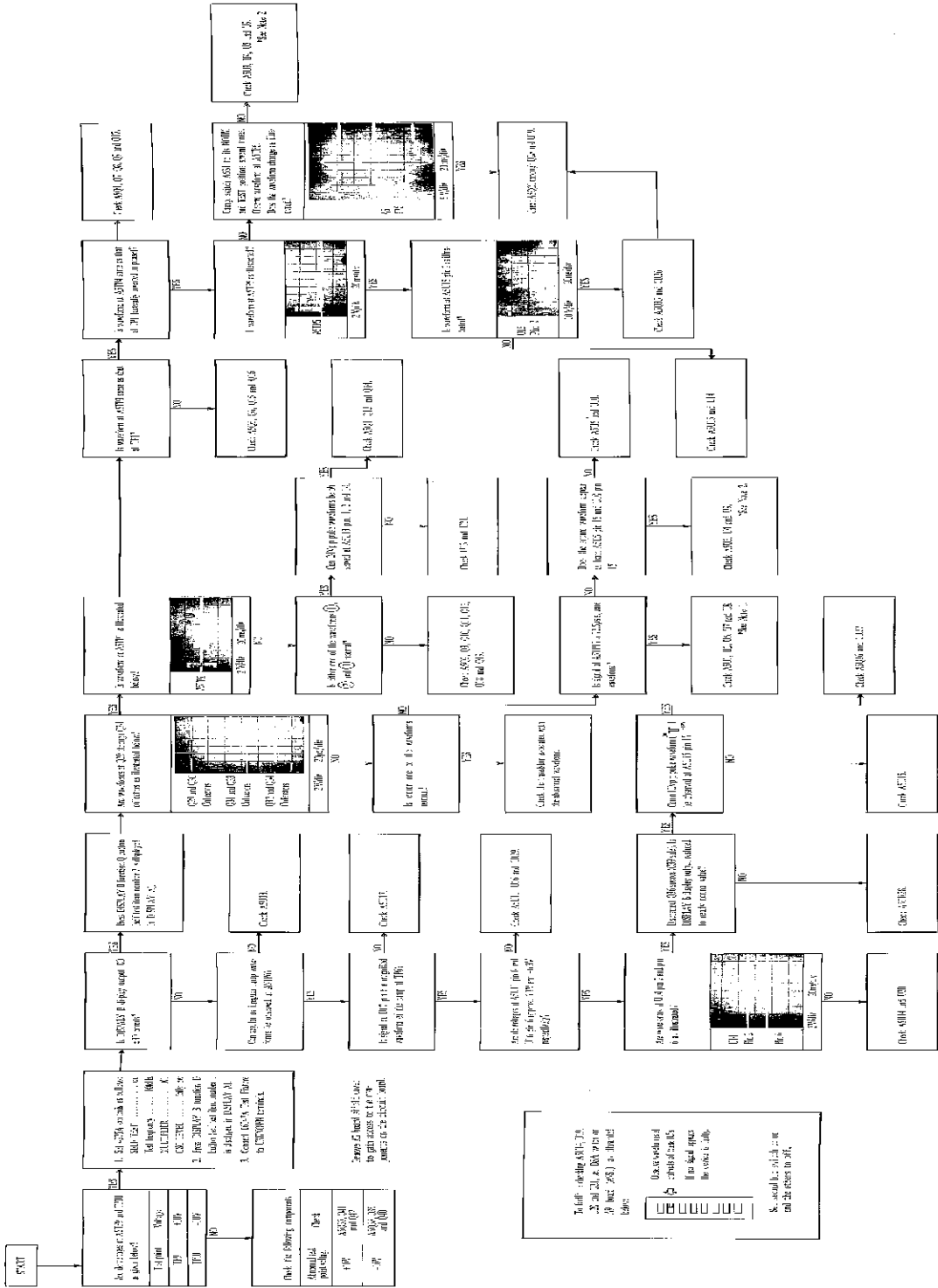

Figure 5-31. A5 A4 Converter Bead Troubleshooting Tree.







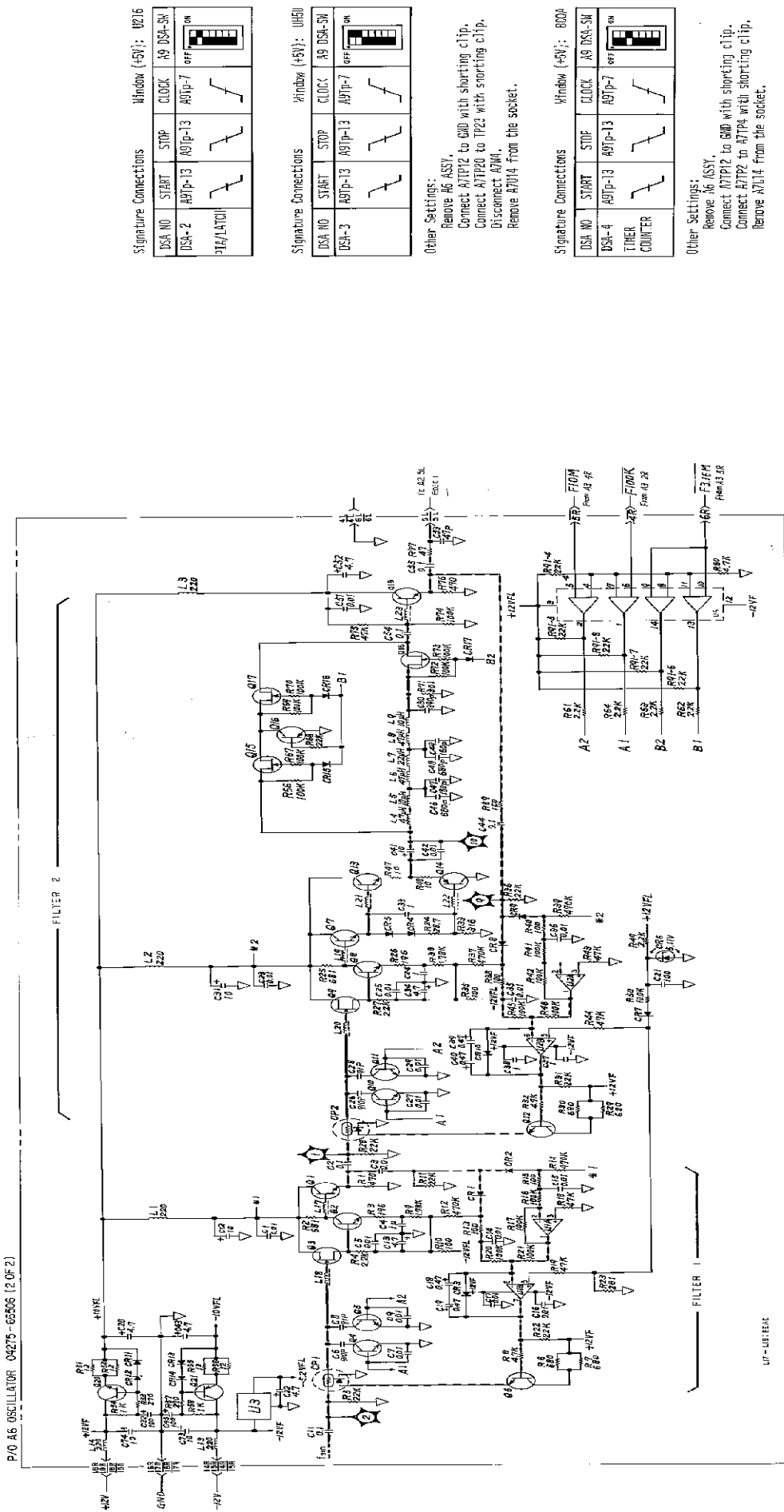

Figure 8-38(B). A6 Oscillator Board Assembly Schematic Diagram (Sheet 2 of 2).

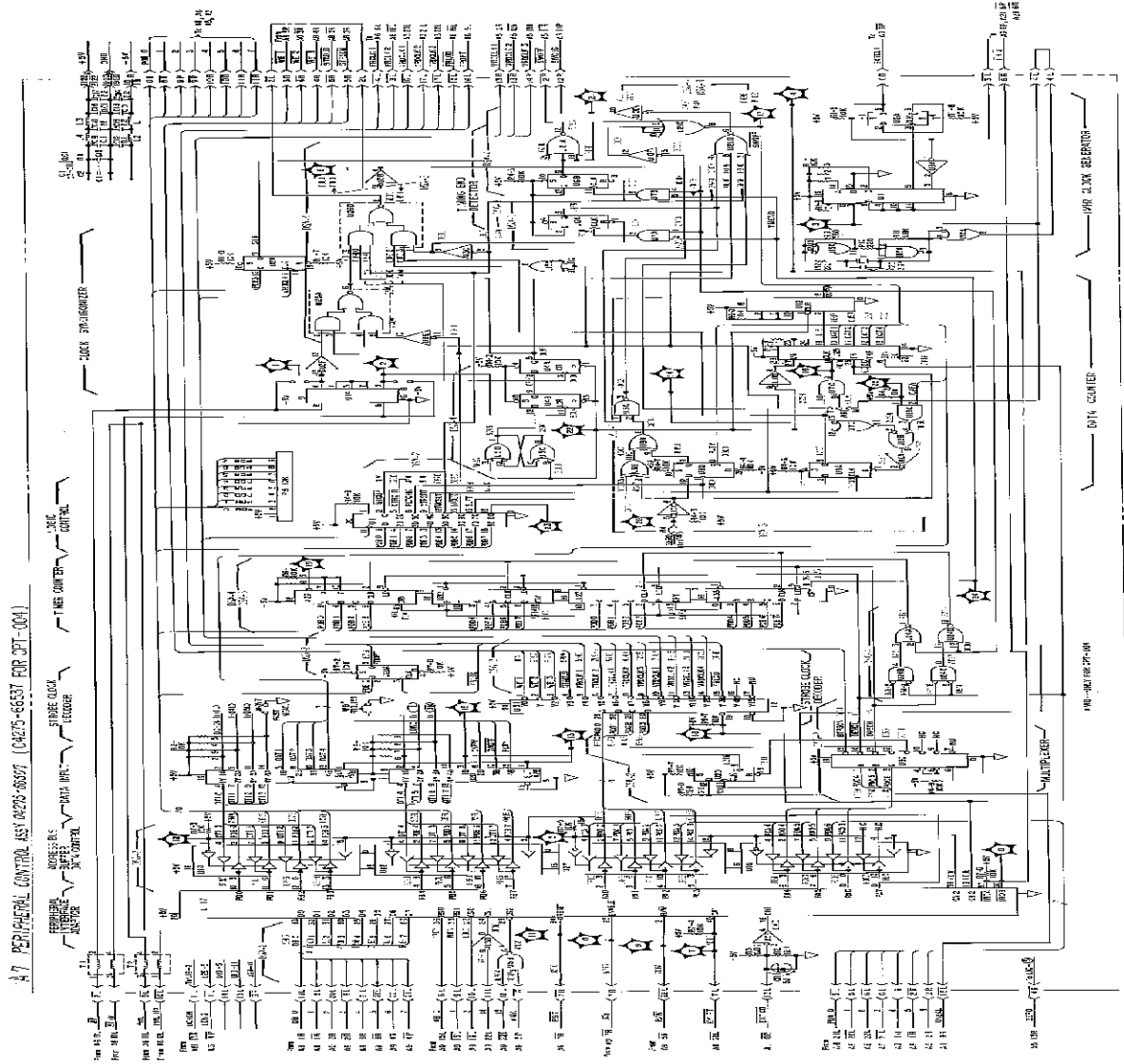

Figure 8-49. Peripheral Control Board Assembly Schematic Diagram.

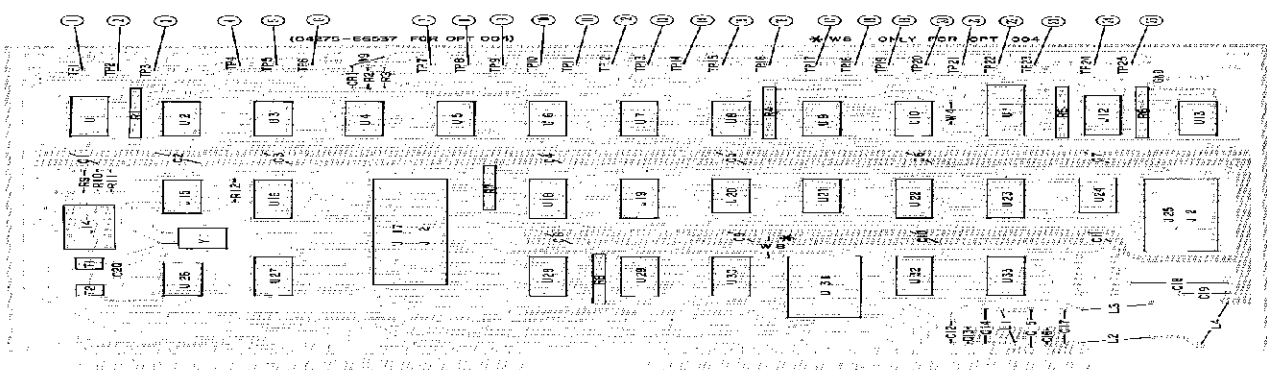

Figure 8-50. Peripheral Control Board Assembly Component Locations.



Signature Connections		Window (461) : ZIP
DSR #0	START	LOCK
DSR #1	STOP	REVERSE
DSR #2	START	STOP
KEY		

Other settings:

Set DS1-A switch to ON.  
 Observe respective signatures at 46FF  
 for every key on touch panel (push it down).

Signature Connections		Window (461) : ZIP
DSR #0	START	LOCK
DSR #1	STOP	REVERSE
DSR #2	START	STOP
KEY		

Other settings:

Set DS1-A switch to ON.  
 Disconnect one side of DS1.

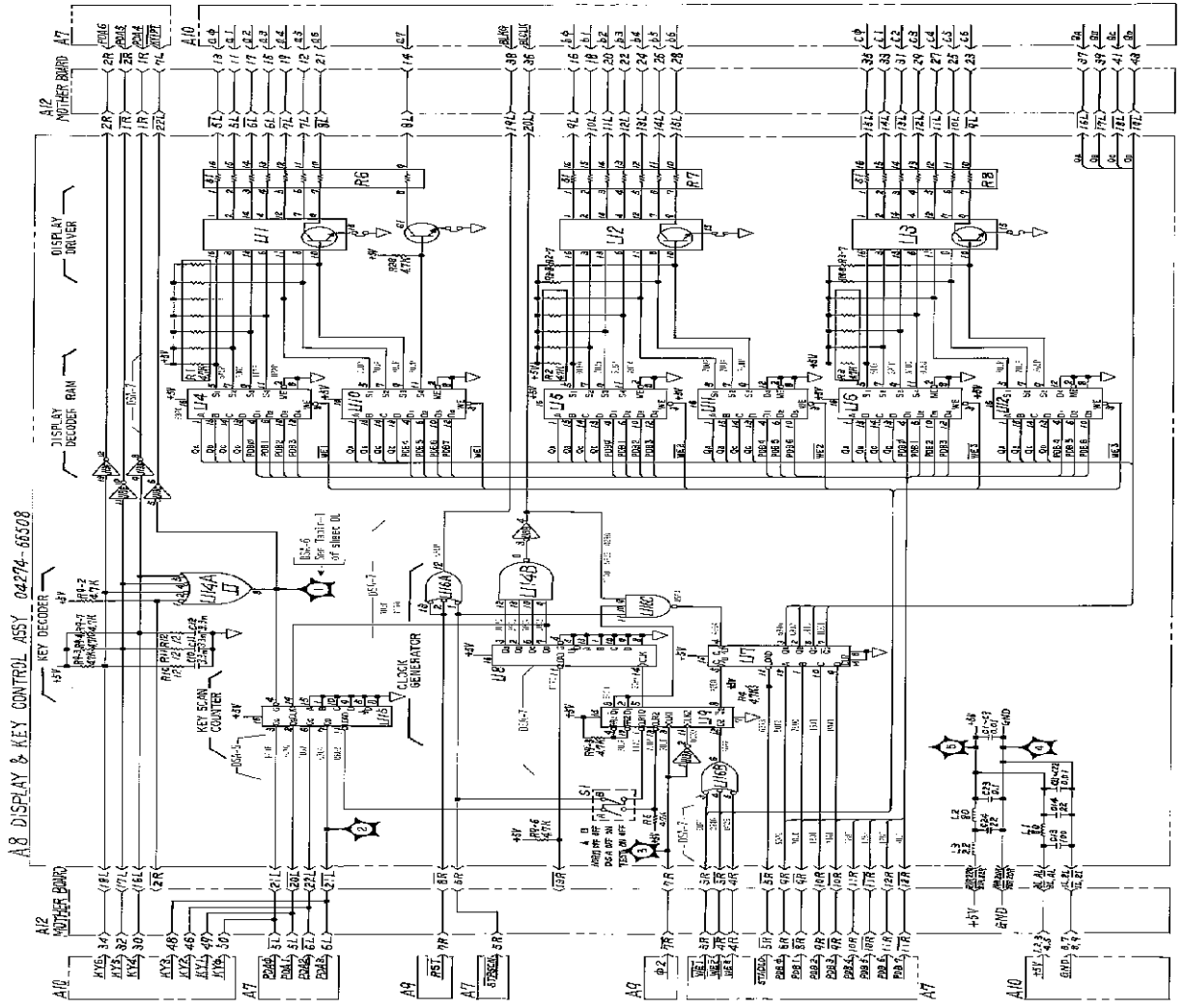

Figure 8-62. A8 Display Control Board Assembly Schematic Diagram.

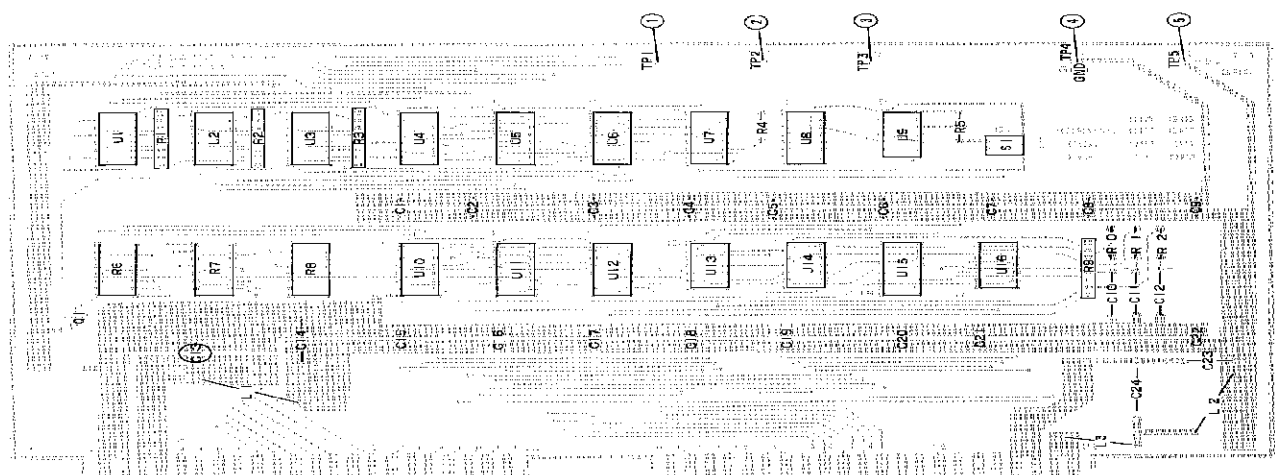

Figure 8-61. A8 Display Control Board Assembly Component Locations.

This table can be used to check signatures at A901 thru A910 RAM's. Signature test point is established at input of Data Buffer (pins 3 thru 6 of A903) and A902. Instead of the respective ROM address (A901 thru A910). This signature list can be used for units with 115 serial number suffixes of -0003 and above.

TEST POINT	DSM NAME	DSM-12	DSM-14	DSM-15	DSM-17	DSM-13	DSM-18
ROM TEST POINT	A901	A903	A905	A907	A910	A909	
WINDOW (+5V)	V1 pin-24	7500	P254	P254	P254	P269	P269
D80	U01 pin-3	8001	4292	7994	264C	0F5F	2045
D81	pin-4	6000	3949	307F	0B2A	024A	555P
D82	pin-5	1166	9088	0FF4	9F8F	8102	0X65
D83	pin-6	P54P	P409	3794	CPIU	741F	1A7H
D84	U02 pin-3	C375	8F00	2043	5023	A24E	C402
D85	pin-4	615C	F664	6410	0B99	201E	H89F
D86	pin-5	P300	6F60	690E	80PP	3265	5336
D87	pin-6	A00A	052P	0P76	P59F	50AC	C40F

Signature Connections Window (+5V): C2C3

DSM NO	START	STOP	CLOCK	DSM-SH
DSM-10	A90D-13	A90D-13	A90D-7	A90D-6
DSM-14	A90E-10	A90E-7	A90E-7	A90E-6
ROP	(U1)			

Signature Connections Window (+5V): 0203

DSM NO	START	STOP	CLOCK	DSM-SH
DSM-11	A90D-3	A90D-3	A90D-6	A90D-6
ROP	ADDRESS			

Signature Connections Window (+5V): 7550

DSM NO	START	STOP	CLOCK	DSM-SH
DSM-12	A90E7-F1	A90E-5	A90D-6	A90D-6
ROP	(U14P1)			

Signature Connections Window (+5V): 820P

DSM NO	START	STOP	CLOCK	DSM-SH
DSM-13	A90E2-9	A90E-20	A90D-6	A90D-6
ROP	(U10)			

Signature Connections Window (+5V): P254

DSM NO	START	STOP	CLOCK	DSM-SH
DSM-16	A90E6-12	A90E6-10	A90D-6	A90D-6
ROP	(U7)			

Signature Connections Window (+5V): 820P

DSM NO	START	STOP	CLOCK	DSM-SH
DSM-17	A90E6-14	A90E6-12	A90D-6	A90D-6
ROP	(U7)			

Signature Connections Window (+5V): 820P

DSM NO	START	STOP	CLOCK	DSM-SH
DSM-18	A90E2-7	A90E-20	A90D-6	A90D-6
ROP	(U9)			

Model 4275A

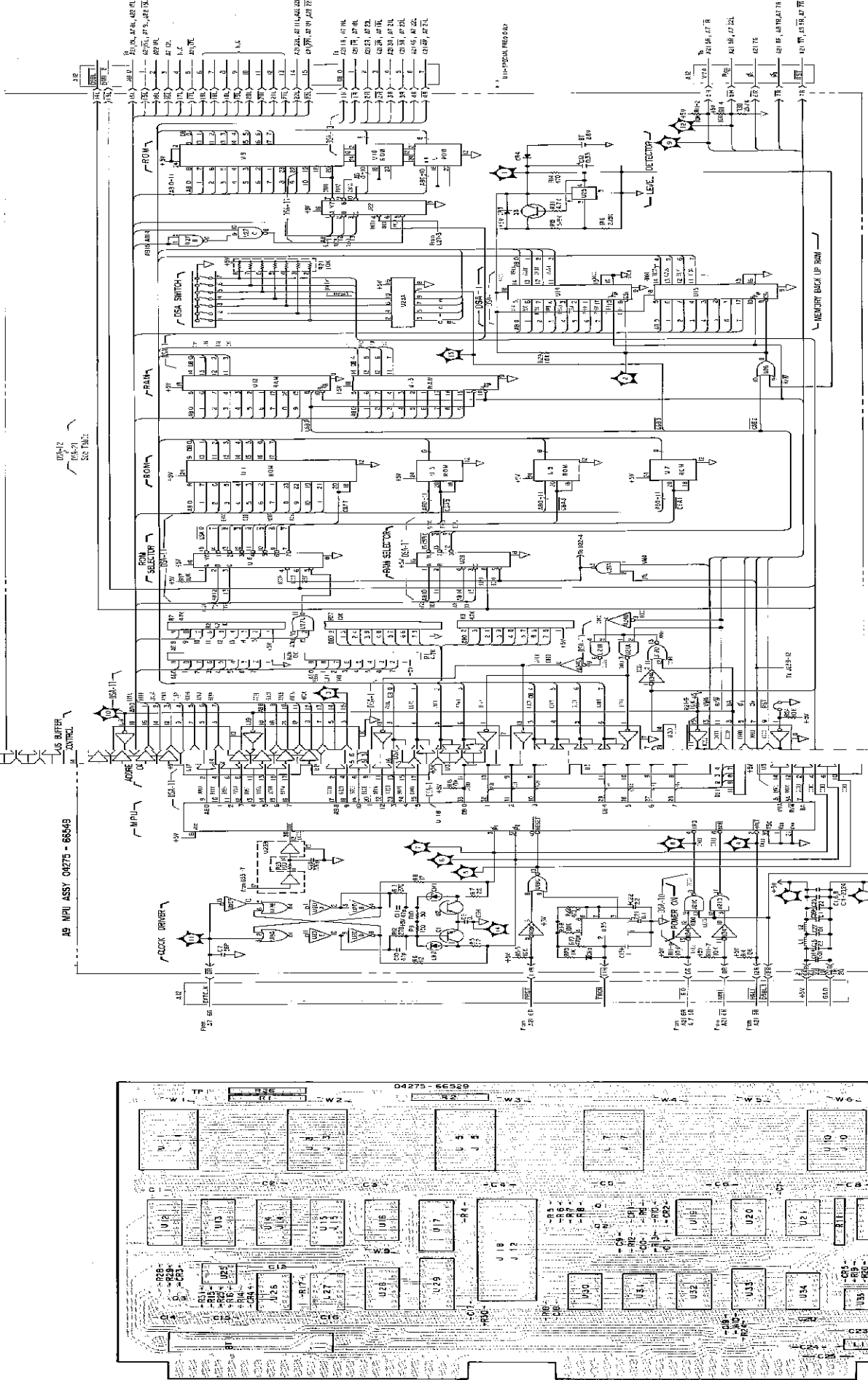

Signature Connections      Hirsch (+5V) : 700P

DSR NO	START	STOP	CLOCK	AG DSR-SH
DSR-7	A9T1-13	A9T1-13	A9T1-7	off
DISPLAY				

Other Settings:  
 Set ABS1-8 switch to 0k.  
 Disconnect one side of ABS1.

Model 4275A

Section VIII  
Figure B-66

Figure B-66. A10 Display and Keyboard Assembly Schematic Diagram.

8-79

Figure B-65. A10 Display and Keyboard Assembly Component Locations.



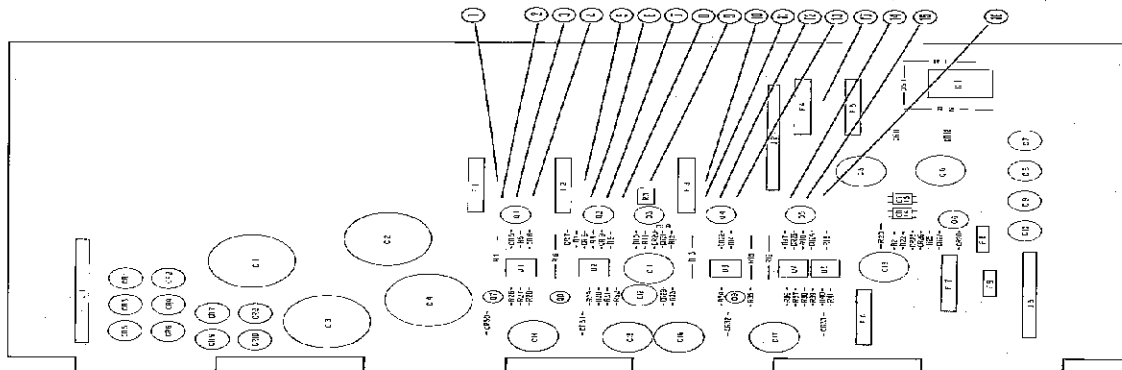

Figure 8-67. All Power Supply Board Assembly Component Locations.

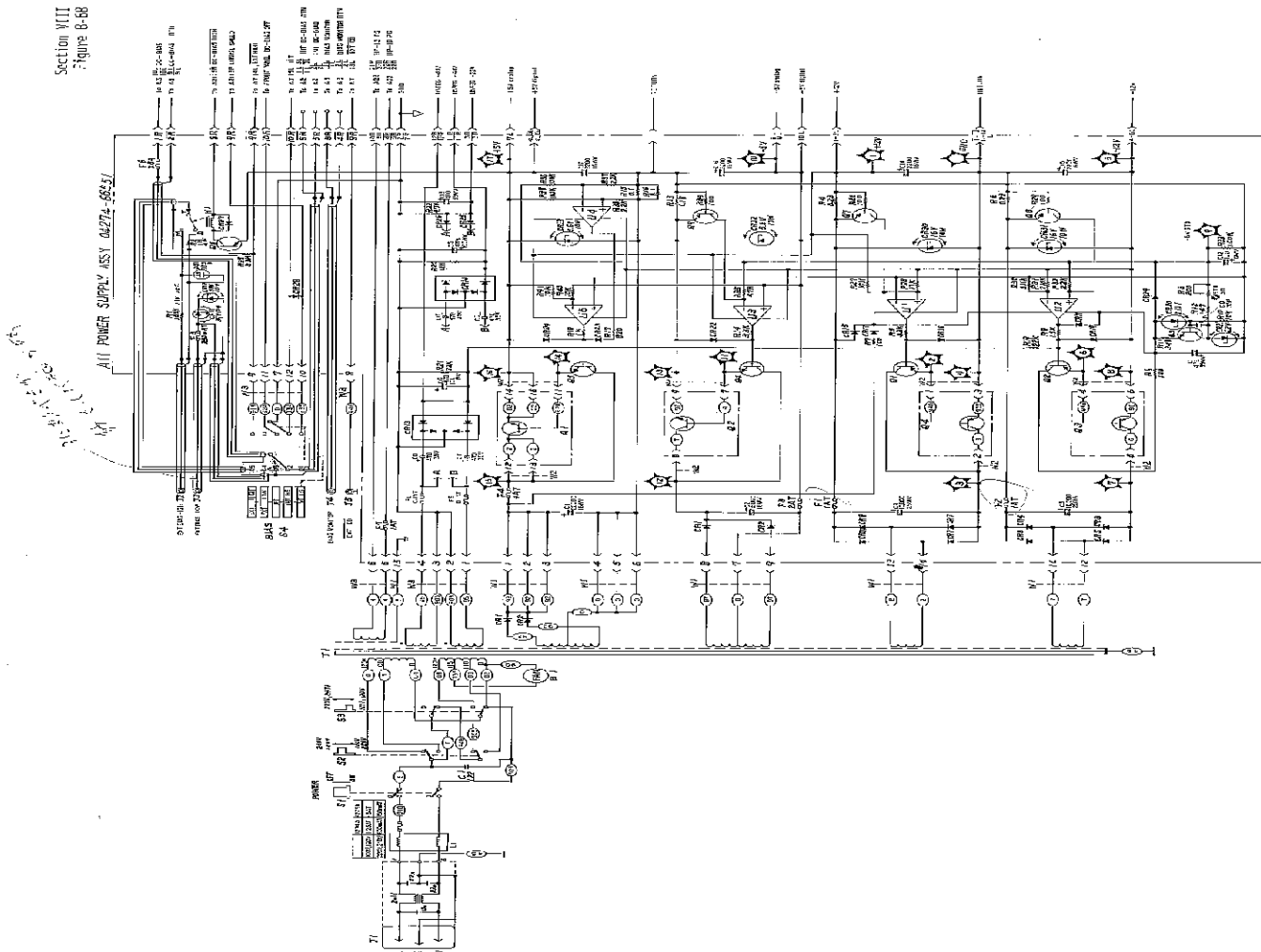

Figure 8-68. All Power Supply Board Assembly Schematic Diagram.



**A11** POWER SUPPLY  
SERVICE SHEET 11  
SEE INSIDE

# MANUAL CHANGE

**4194A**

**Impedance/Gain-Phase Analyzer**

## MANUAL IDENTIFICATION

Model Number: 4194A  
 Date Printed: June, 1986  
 Part Number: 04194-90100

This supplement contains information for correcting manual errors and for adapting the manual to newer instruments that contain improvements or modifications not documented in the existing manual.

To use this supplement

1. Make all ERRATA corrections.
2. Make all appropriate serial-number-related changes listed below.

SERIAL PREFIX OR NUMBER      MAKE MANUAL CHANGES

SERIAL PREFIX OR NUMBER	MAKE MANUAL CHANGES
ALL	1

SERIAL PREFIX OR NUMBER      MAKE MANUAL CHANGES

SERIAL PREFIX OR NUMBER	MAKE MANUAL CHANGES

► New Item

► ERRATA

Section 6, Replaceable Parts List  
 See Parts Information Table.

Page 8-42, Figure 8-17

Change the equation in step 3 as follows.

$$X(i) = \frac{X(ki) \cdot (Y(ki+1) - X(i)) + X(ki+1) \cdot (X(i) - Y(ki))}{Y(ki+1) - Y(ki)}$$

Page 8-74, Change the explanation for A6SW1 as follows.

SW1-5      SW1-5's position is determined by which option you have.

OFF: OPTION 350  
 ON: OPTION 375

### NOTE

Manual change supplements are revised as often as necessary to keep manuals as current and accurate as possible. Hewlett-Packard recommends that you periodically request the latest edition of this supplement. Free copies are available from all HP offices. When requesting copies, quote the manual identification information from your supplement, or the model number and print date from the title page of the manual.

Date/Div: AUGUST 5, 1986/33

Page: 1 of 1



Page 8-78, A6 Data Manipulation Processor Component Locations (2 of 2)  
Correct the illustration for SW1 (Option 375), as shown below.

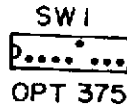

Page 8-121, Figure A20-2 Range Resistor Selection  
Correct the range resistor value in the graph from 2.5K $\Omega$  to 25.6k $\Omega$ .

► CHANGE 1

Section 6, Replaceable Parts List  
See Parts Information Table.

► NOTE

HOW TO USE THIS MANUAL page,  
Add the following information.

All schematic diagrams are arranged so you can look at them while reading the explanation of a board or referring to the troubleshooting data.

The reverse sides of the following pages are not numbered.

Pages 8-29, 8-30, 8-51, 8-62, 8-63, 8-68, 8-71, 8-72, 8-77, 8-78, 8-81, 8-82, 8-83, 8-88, 8-89, 8-90, 8-91, 8-100, 8-107, 8-108, 8-115, 8-116, 8-117, 8-118, 8-119, 8-124, 8-125, 8-132, 8-153, 8-154, 8-155, 8-156, 8-159, 8-162, 8-163, 8-164, 8-165, 8-166, 8-167, and 8-168.

Table 1. Parts Information (1 of 2)

CHANGE	Page	Note	Reference Designation	HP Part Number	CD	Description	
Errata	6-6	▶A	A2R18		0		
	6-8	▶A	A3T1		4		
		▶A	A3T2		0		
		▶A	A3T3		0		
		▶A	A11C113		1		
	6-50	▶A	A11L15		5		
	6-65	▶A	A20C125		4		
		▶A	A20C126		4		
		▶A	A20C127		9		
		▶A	A20C128		7		
	6-75	▶A	A21L24		6		
		▶A	A21L25		6		
		▶A	A21L26		6		
	6-80	▶A	A21W1		8		
		▶A	A21W2		8		
		▶A	A21W3		8		
	6-90	▶A	A22C62		2		
	6-98	▶A	A22R179		6		
		▶A	A22R180		6		
		▶A	A22R189		1		
		▶A	A22R190		1		
		▶A	A22R193		1		
		▶A	A22R194		1		
	6-101	▶A	A23C77		6		
		▶A	A23C78		6		
	6-108	▶C	A24CR28	1901-0050	3	NOT ASSIGNED	
		▶C	A24CR29				
	6-111	▶A	A24R58		9		
	6-115	▶A	A25W1		4		
	6-121	▶A	A31J24		6		
		▶A	A31J25		6		
		▶A	A31J26		6		
	6-125	▶A	A31R146		4		
6-126	▶A	A31W1		8			
	▶A	A31W2		8			
	▶A	A31W3		8			
6-136	▶A	A34C81		7			
1	6-7	▶C	A3F1	2110-0665	0		FUSE 1A 125V
		▶C	A3F2	2110-0665	0		FUSE 1A 125V
		▶C	A3F3	2110-0685	4		FUSE 7A 125V
		▶C	A3F4	2110-0685	4		FUSE 7A 125V
		▶C	A3F5	2110-0712	8		FUSE 4A 125V
		▶C	A3F6	2110-0712	8		FUSE 4A 125V
		▶C	A3F7	2110-0712	8		FUSE 4A 125V

Table 1. Parts Information (2 of 2)

CHANGE	Page	Note	Reference Designation	HP Part Number	CD	Description
1		▶A	A21W3		8	
	6-10	▶C	A4F1	2110-0665	0	FUSE 1A 125V
	6-17	▶C	A6F1	2110-0712	8	FUSE 4A 125V
	6-24	▶C	A7F1	2110-0712	8	FUSE 4A 125V
	6-29	▶C	A8F1	2110-0712	8	FUSE 4A 125V
	6-92	▶C	A22F1	2110-0712	8	FUSE 4A 125V
		▶C	A22F2	2110-0712	8	FUSE 4A 125V
		▶C	A22F3	2110-0712	8	FUSE 4A 125V

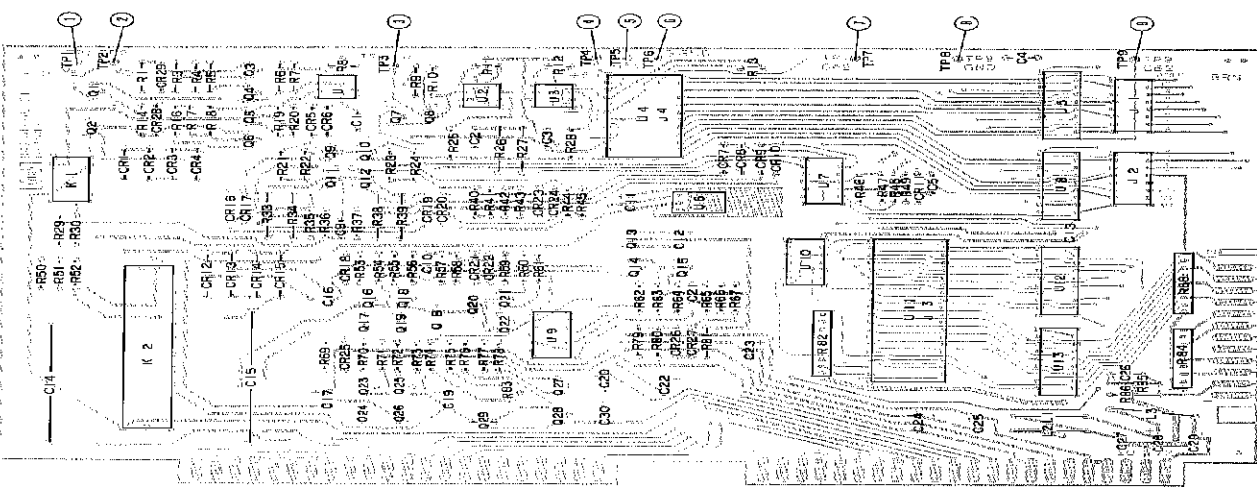

Figure 8-69. A21 DC Bias Supply Board Assembly Component Locations.

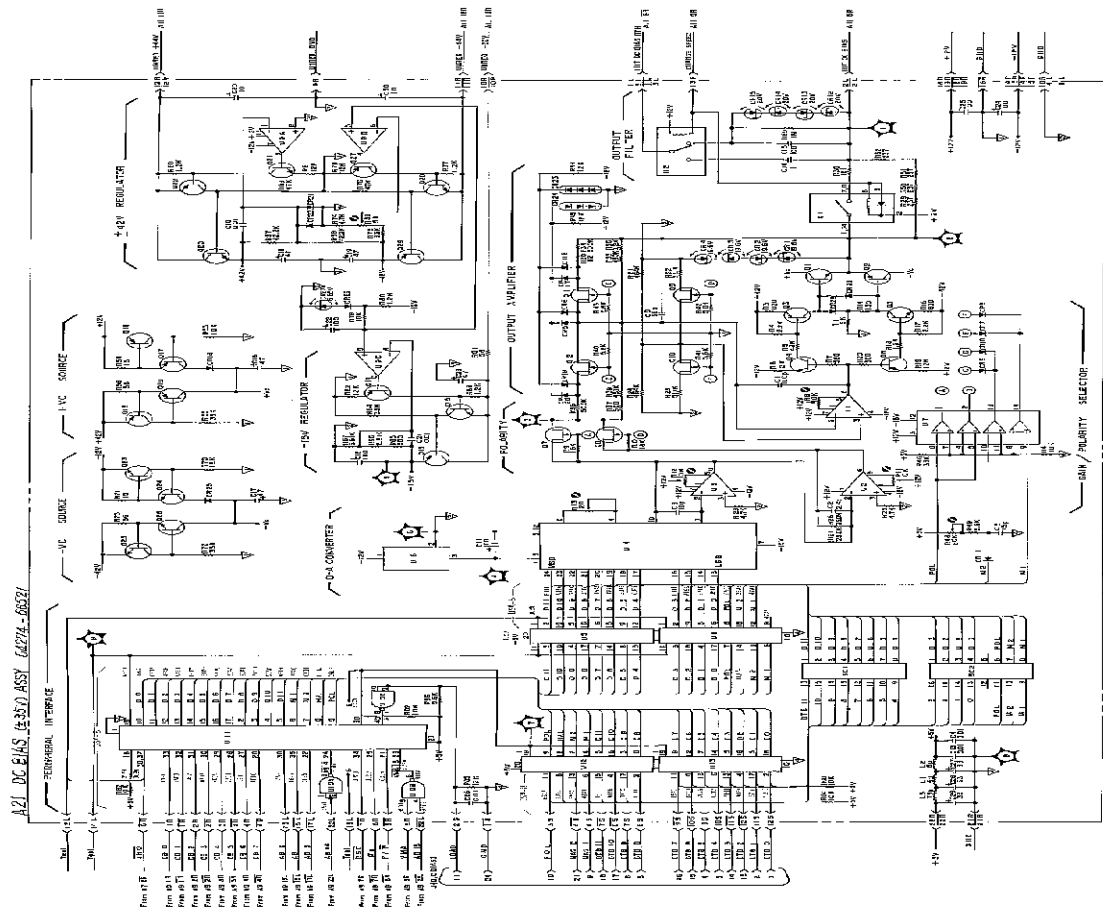

Figure 8-70. A21 DC Bias Supply Board Assembly Schematic Diagram.

Signature Connections Window (+V): 3000

DSA NO	START	STOP	CLICK	A9 DSA-SH
DSA-8	A9T-13	A9T-13	A9T-7	off
DC-BIAS				

Other Settings:  
 Connect dual in-line jumpers to A21SCT (J11 and S12 (J2)). If the jumper module is not available, use a 6041 in-line resistor pack (below 1000) [a.g., P/N 1010-0483 (contains eight 50 resistors)].

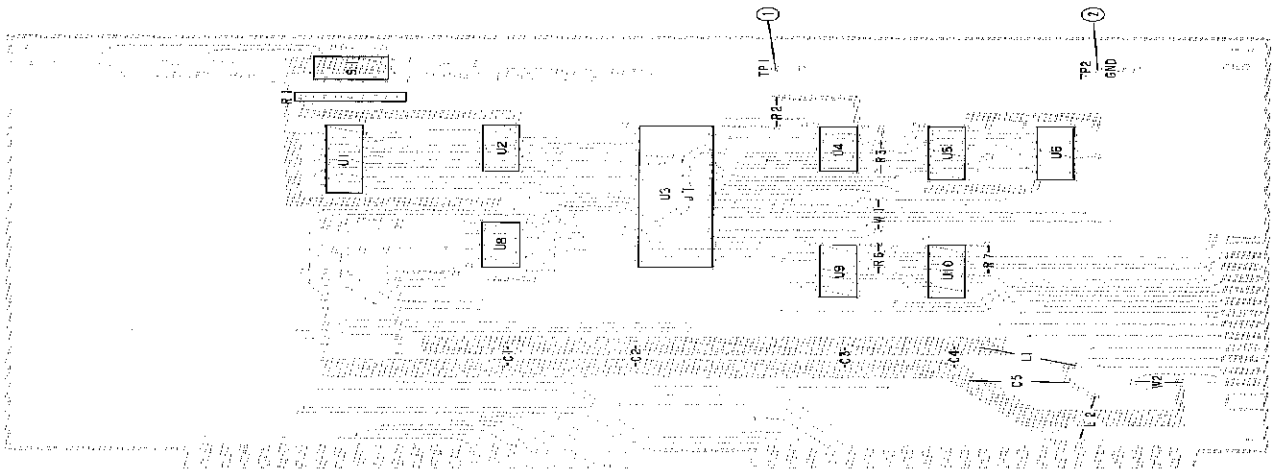

Figure 8-71. A22 HP-IB Interface Board Assembly Component Locations.

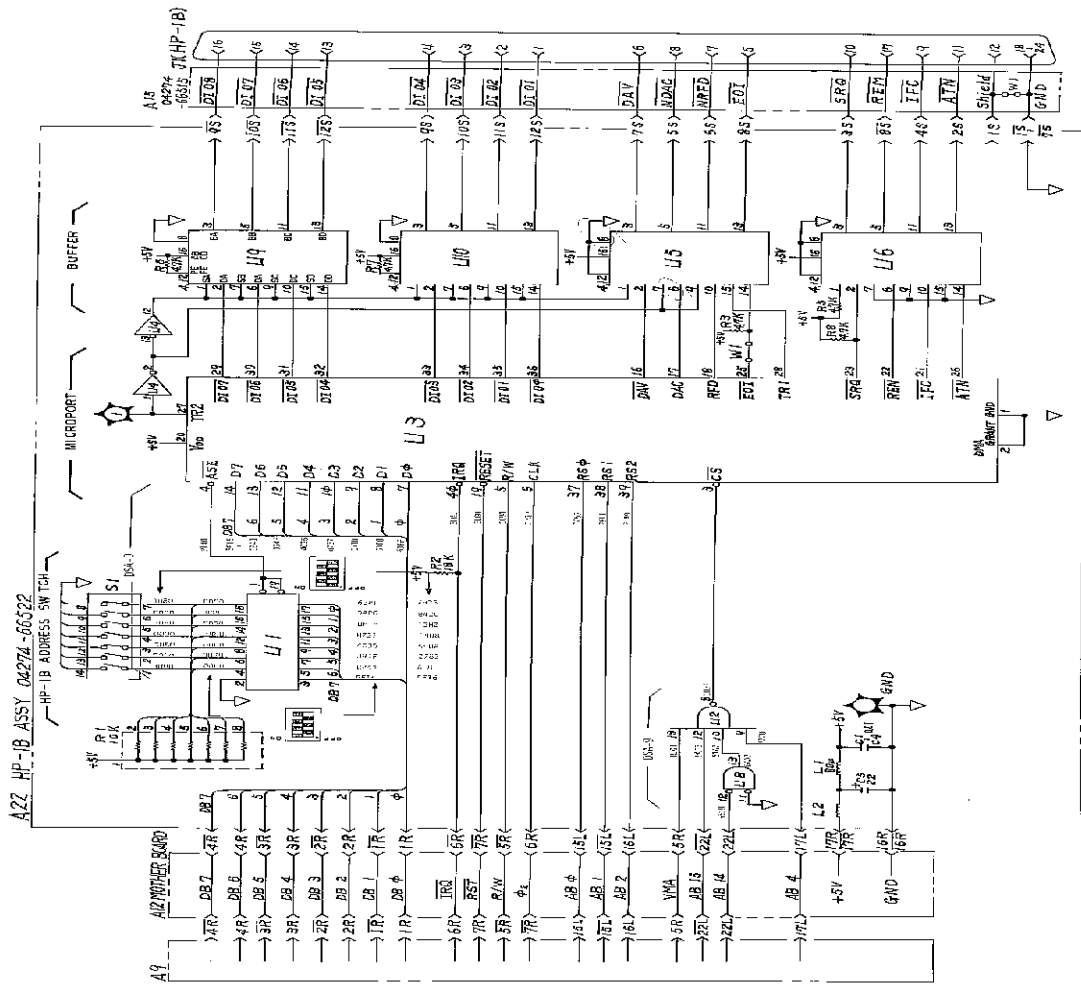
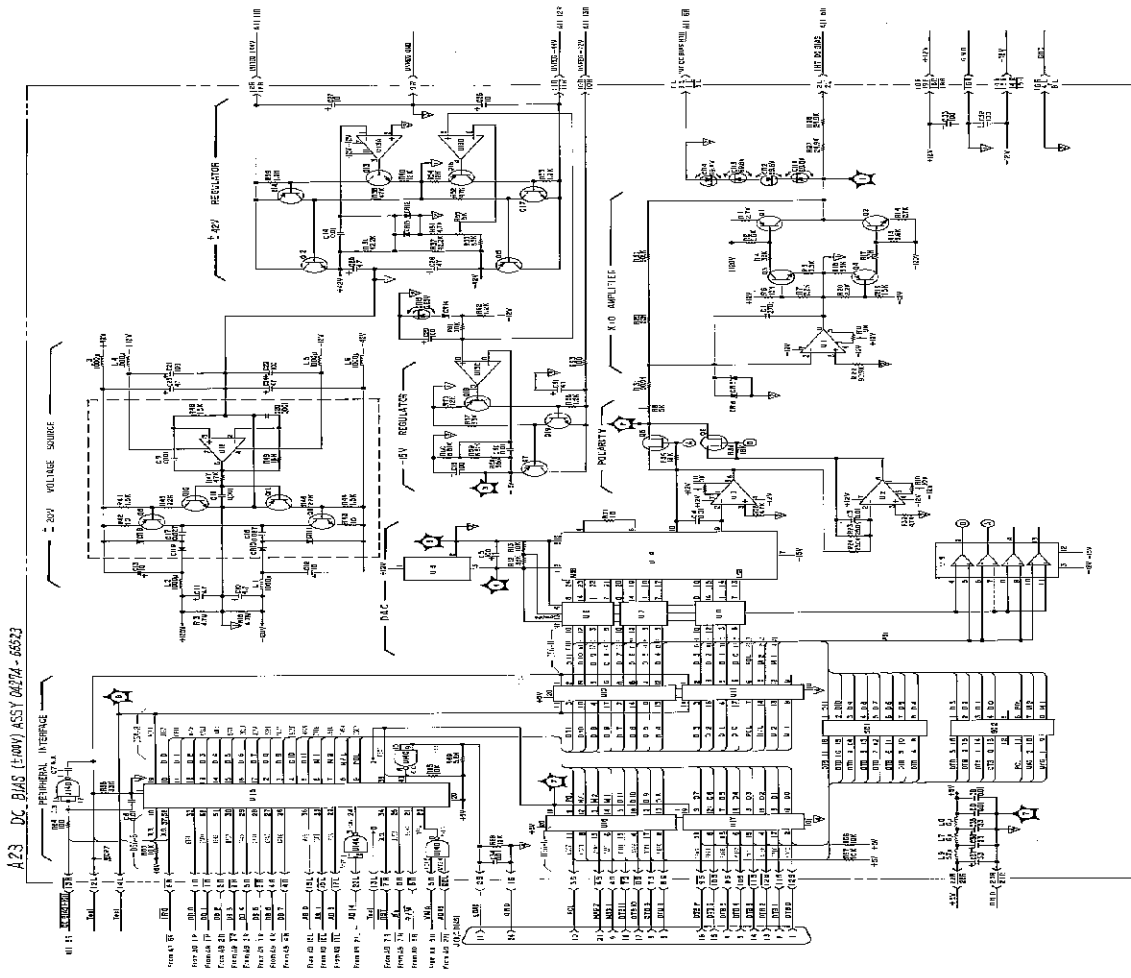

Figure 8-72. A22 HP-IB Interface Board Assembly Schematic Diagram.

Sigwire Connections Window (+5V) :30RU

DSA NO	START	STOP	CLOCK	A0 DSA-SW
DSA-9	HP-IB-13	HP-IB-7	HP-IB-13	HP-IB-7
HP-IB				

Other Settings:  
Set A22S switch (DSA-SW) as shown in schematic.



A23 DC BIAS (EMV) ASSY 04274-66523

Signature Connections Window (+5V): 3080

CSA NO	START	STOP	CLOCK	AB DSA-SH
DSA-8	A9T-13	A9T-13	A9T-7	OFF
DC-Bias	A	A	A	OK

Other Settings:  
Connect a dim1 in-line jumper to A23S01 (U1) and S2 (U2).  
If the jumper module is not available, use a dual in-line resistor pack below 100Ω.

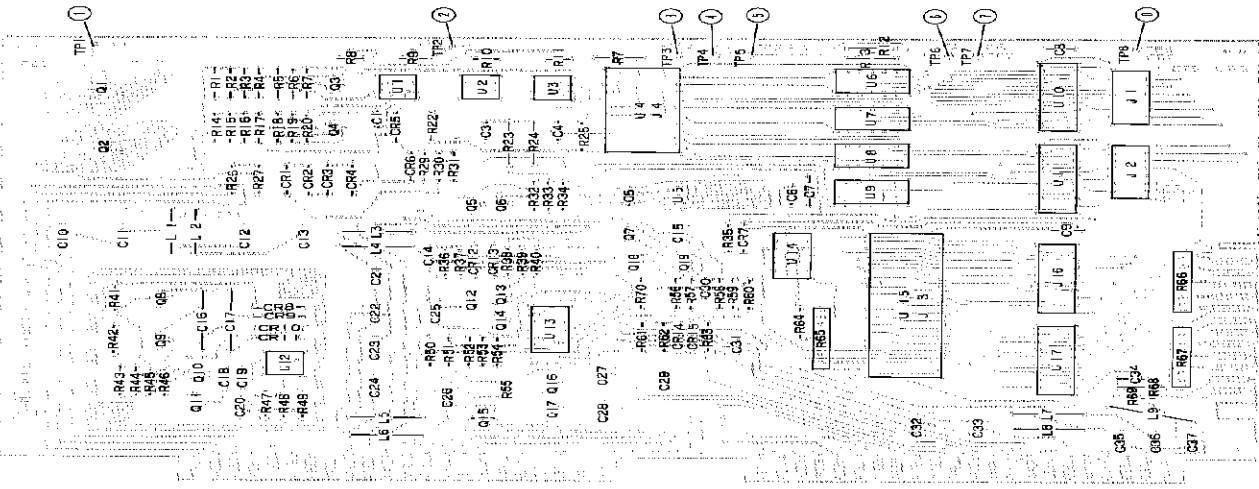

Figure 8-73. A23 DC Bias Supply Board Assembly Component Locations.

Figure 8-74. A23 DC Bias Supply Board Assembly Schematic Diagram.