

## **SERVICE MANUAL**

# **HP 54502A**

# **Digitizing Oscilloscope**

### **SERIAL NUMBERS**

This manual applies directly to instruments  
prefixed with serial numbers:

2927A, 2934A

For additional information about serial numbers see  
**INSTRUMENTS COVERED BY THIS MANUAL**  
in Section 1.

© COPYRIGHT HEWLETT-PACKARD COMPANY/COLORADO SPRINGS DIVISION 1989  
1900 GARDEN OF THE GODS ROAD, COLORADO SPRINGS, COLORADO U.S.A.

**ALL RIGHTS RESERVED**

## About this Manual

We've added this manual to the Agilent website in an effort to help you support your product. This manual is the best copy we could find; it may be incomplete or contain dated information. If we find a more recent copy in the future, we will add it to the Agilent website.

## Support for Your Product

Agilent no longer sells or supports this product. Our service centers may be able to perform calibration if no repair parts are needed, but no other support from Agilent is available. You will find any other available product information on the Agilent Test & Measurement website, [www.tm.agilent.com](http://www.tm.agilent.com).

## HP References in this Manual

This manual may contain references to HP or Hewlett-Packard. Please note that Hewlett-Packard's former test and measurement, semiconductor products and chemical analysis businesses are now part of Agilent Technologies. We have made no changes to this manual copy. In other documentation, to reduce potential confusion, the only change to product numbers and names has been in the company name prefix: where a product number/name was HP XXXX the current name/number is now Agilent XXXX. For example, model number HP8648A is now model number Agilent 8648A.

## **CERTIFICATION**

Hewlett-Packard Company certifies that this product met its published specifications at the time of shipment from the factory. Hewlett-Packard further certifies that its calibration measurements are traceable to the United States National Institute of Standards and Technology, to the extent allowed by the Institute's calibration facility, and to the calibration facilities of other International Standards Organization members.

## **WARRANTY**

This Hewlett-Packard product is warranted against defects in material and workmanship for a period of three years from date of shipment. During the warranty period, Hewlett-Packard Company will, at its option, either repair or replace products which prove to be defective.

For warranty service or repair, this product must be returned to a service facility designated by HP. Buyer shall prepay shipping charges to HP and HP shall pay shipping charges to return the product to Buyer. However, Buyer shall pay all shipping charges, duties, and taxes for products returned to HP from another country.

HP warrants that its software and firmware designated by HP for use with an instrument will execute its programming instructions when properly installed on that instrument. HP does not warrant that the operation of the instrument or software, or firmware will be uninterrupted or error free.

### **LIMITATION OF WARRANTY**

The foregoing warranty shall not apply to defects resulting from improper or inadequate maintenance by Buyer, buyer-supplied software or interfacing, unauthorized modification or misuse, operation outside the environmental specifications for the product, or improper site preparation or maintenance.

NO OTHER WARRANTY IS EXPRESSED OR IMPLIED. HP SPECIFICALLY DISCLAIMS THE IMPLIED WARRANTIES OF MERCHANTABILITY AND FITNESS FOR A PARTICULAR PURPOSE.

## **EXCLUSIVE REMEDIES**

THE REMEDIES PROVIDED HEREIN ARE BUYER'S SOLE AND EXCLUSIVE REMEDIES. HP SHALL NOT BE LIABLE FOR ANY DIRECT, INDIRECT, SPECIAL, INCIDENTAL, OR CONSEQUENTIAL DAMAGES, WHETHER BASED ON CONTRACT, TORT, OR ANY OTHER LEGAL THEORY.

## **ASSISTANCE**

Product maintenance agreements and other customer assistance agreements are available for Hewlett-Packard products.

For any assistance, contact your nearest Hewlett-Packard Sales and Service Office. Addresses are provided at the back of this manual.

CW3A789

## Safety Considerations

### General Operation

This is a Safety Class I instrument (provided with terminal for protective earthing). BEFORE APPLYING POWER verify that the power transformer primary is matched to the available line voltage, the correct fuse is installed, and Safety Precautions are taken (see the following warnings). In addition, note the instrument's external markings which are described under "Safety Symbols."

### General Warnings and Cautions

- BEFORE SWITCHING ON THE INSTRUMENT, the protective earth terminal of the instrument must be connected to the protective conductor of the (mains) powercord. The mains plug shall only be inserted in a socket outlet provided with a protective earth contact. The protective action must not be negated by the use of an extension cord (power cable) without a protective conductor (grounding). Grounding one conductor of a two-conductor outlet is not sufficient protection.
- Servicing instructions are for use by service-trained personnel. To avoid dangerous electric shock, do not perform any servicing unless qualified to do so.
- If this instrument is to be energized via an auto-transformer (for voltage reduction) make sure the common terminal is connected to the earth terminal of the power source.
- Any interruption of the protective (grounding) conductor (inside or outside the instrument) or disconnecting the protective earth terminal will cause a potential shock hazard that could result in personal injury.
- Whenever it is likely that the protection has been impaired, the instrument must be made inoperative and be secured against any unintended operation.
- Only fuses with the required rated current, voltage, and specified type (normal blow, time delay, etc.) should be used. Do not use repaired fuses or short circuited fuseholders. To do so could cause a shock or fire hazard.
- Do not operate the instrument in the presence of flammable gasses or fumes. Operation of any electrical instrument in such an environment constitutes a definite safety hazard.
- Do not install substitute parts or perform any unauthorized modification to the instrument.
- Adjustments described in the manual are performed with power supplied to the instrument while protective covers are removed. Energy available at many points may, if contacted, result in personal injury.
- Any adjustment, maintenance, and repair of the opened instrument under voltage should be avoided as much as possible, and when inevitable, should be carried out only by a skilled person who is aware of the hazard involved.
- Capacitors inside the instrument may still be charged even if the instrument has been disconnected from its source of supply.

## Safety Symbols



Instruction manual symbol. The product will be marked with this symbol when it is necessary for the user to refer to the instruction manual in order to protect against damage to the product.



Indicates Hazardous Voltages



Earth terminal (sometimes used in manual to indicate circuit common connected to grounded chassis).

Warning



The WARNING sign denotes a hazard. It calls attention to a procedure, practice, or the like, which, if not correctly performed or adhered to, could result in personal injury. Do not proceed beyond a WARNING sign until the indicated conditions are fully understood and met.

Caution



The CAUTION sign denotes a hazard. It calls attention to an operating procedure, practice, or the like, which, if not correctly performed or adhered to, could result in damage to or destruction of part or all of the product. Do not proceed beyond a CAUTION sign until the indicated conditions are fully understood or met.

# Printing History

---

New editions are complete revisions of the manual. Update packages, which are issued between editions, contain additional and replacement pages to be merged into the manual by the customer. The dates on the title page change only when a new edition is published.

A software and/or firmware code may be printed before the date; this indicates the version level of the software and/or firmware of this product at the time of the manual or update was issued. Many product updates and fixes do not require manual changes and, conversely, manual corrections may be done without accompanying product changes. Therefore, do not expect a one to one correspondence between product updates and manual updates.

Edition 1	July 1989	54502-90903
Edition 2	January 1991	54502-90907

# List of Effective Pages

---

The List of Effective Pages gives the date of the current edition and of any pages changed in updates to that edition. Within the manual, any page changed since the last edition is indicated by printing the date the changes were made on the bottom of the page. If an update is incorporated when a new edition of the manual is printed, the change dates are removed from the bottom of the pages and the new edition date is listed in Printing History and on the title page.

<b>Pages</b>	<b>Effective Date</b>
all . . . . .	July 1989
all . . . . .	January 1991

# Contents

---

<b>Section 1</b>	<b>General Information</b>	
	Introduction .....	1-1
	Instruments Covered By Manual .....	1-1
	Instrument Description .....	1-1
	Accessories Supplied .....	1-2
	Accessories Available .....	1-2
	Options Available .....	1-2
	Performance Specifications .....	1-3
	Performance Characteristics .....	1-4
	Operating Characteristics .....	1-5
	General Characteristics .....	1-11
	Recommended Test Equipment .....	1-12
<hr/>		
<b>Section 2</b>	<b>Installation</b>	
	Introduction .....	2-1
	Initial Inspection .....	2-1
	Operating Environment .....	2-1
	Storage And Shipping .....	2-1
	Packaging .....	2-1
	Tagging for Service .....	2-1
	Original Packaging .....	2-2
	Other Packaging .....	2-2
	Preparation For Use .....	2-2
	Power Requirements .....	2-2
	Line Voltage Selection .....	2-2
	Power Cable .....	2-3
	Applying Power .....	2-3
	Cleaning Requirements .....	2-3
<hr/>		
<b>Section 3</b>	<b>Performance Tests</b>	
	Introduction .....	3-1
	Testing Interval .....	3-1
	Equipment Required .....	3-1
	Self-test Verification .....	3-1
	Test Record .....	3-2
	Operating Hints .....	3-2
	Clear Display .....	3-2
	Averaging .....	3-2
	Performance Test Procedures .....	3-2
	DC Calibrator Test .....	3-3
	Input Resistance .....	3-4
	Voltage Measurement Accuracy .....	3-5
	Offset Accuracy .....	3-7
	Bandwidth .....	3-8
	Time Measurement Accuracy .....	3-10
	Trigger Sensitivity .....	3-12
	Oscillator Output Check .....	3-14

---

**Section 4****Adjustments**

Introduction .....	4-1
Equipment Required .....	4-1
Calibration Interval .....	4-1
Cal RAM Checksum Error .....	4-1
Key-down Powerup .....	4-2
Operating Hints .....	4-2
Adjustment Procedures .....	4-2
Power Supply Adjustment .....	4-3
Main Assembly Adjustments .....	4-5
Extender Cable Installation .....	4-5
DAC Reference Adjustment .....	4-5
Default Calibration Load .....	4-6
Low Frequency Adjustment .....	4-7
High-Frequency Pulse Adjustment .....	4-8
Firmware Calibration .....	4-9
CRT Monitor Assembly Adjustment .....	4-11

---

**Section 5****Replaceable Parts**

Introduction .....	5-1
Abbreviations .....	5-1
Replaceable Parts .....	5-1
Exchange Assemblies .....	5-1
Ordering Information .....	5-2
Direct Mail Order System .....	5-2

---

**Section 6****Service**

Introduction .....	6-1
Safety .....	6-1
Block Level Theory Of Operation .....	6-3
Power Supply Assembly .....	6-3
CRT Monitor Assembly .....	6-3
Main Assembly .....	6-3
Keypad and Knob Assembly .....	6-3
Main Assembly Theory Of Operation .....	6-5
Acquisition .....	6-5
System Control .....	6-9
Selftest Menu .....	6-12
Service Menu .....	6-13
Troubleshooting .....	6-14
Trouble Isolation Flowcharts .....	6-14
Key-down Powerup .....	6-14
Power Supply Voltages Check .....	6-21
CRT Monitor Signals Check .....	6-22
Keyboard Signals Check .....	6-23
Attenuator Troubleshooting .....	6-24
Assembly Removal And Replacement .....	6-26
Rear Panel Assembly .....	6-26
Power Supply Assembly .....	6-26



**Service (cont'd)**

**Assembly Removal And Replacement (cont'd)**

Keyboard Assembly .....	6-27
Fan .....	6-27
Main Assembly .....	6-28
Attenuators .....	6-28
CRT Monitor Assembly .....	6-29
Feet/Tilt Stand .....	6-30

# Figures

---

4-1.	Power Supply Adjustment Locations .....	4-3
4-2.	Main Assembly Adjustment Locations .....	4-4
4-3.	CRT Test Display .....	4-11
4-4.	Display Adjustment Locations .....	4-12
5-1.	HP 54502A Exploded View .....	5-4
6-1.	Simplified Block Diagram .....	6-2
6-2.	Acquisition Block Diagram .....	6-4
6-3.	System Control Block Diagram .....	6-8
6-4.	Selftest Menu Selections .....	6-12
6-5.	Service Menu Selections .....	6-13
6-6.	Primary Trouble Isolation Flowchart .....	6-15
6-7.	Trouble Isolation Chart for Power Supply .....	6-16
6-8.	Trouble Isolation Chart for Display .....	6-17
6-9.	Trouble Isolation Chart for Keyboard .....	6-18
6-10.	Trouble Isolation Chart for Cal Signals .....	6-19
6-11.	Trouble Isolation Chart for Attenuators .....	6-20
6-12.	Power Supply Test Points .....	6-21

# Tables

---

1-1.	Recommended Test Equipment .....	1-12
2-1.	Power Cord Configurations .....	2-4
3-1.	Performance Test Record .....	3-15
5-1.	Reference Designators and Abbreviations .....	5-3
5-2.	Replaceable Parts .....	5-5
6-1.	Power Supply/Main Assembly Voltages .....	6-22
6-2.	CRT Monitor Input Cable Pin Assignments .....	6-22
6-3.	Keyboard Connector Voltages and Signals .....	6-23

# Contents

---

## Section 1

### General Information

Introduction .....	1-1
Instruments Covered By Manual .....	1-1
Instrument Description .....	1-1
Accessories Supplied .....	1-2
Accessories Available .....	1-2
Options Available .....	1-2
Performance Specifications .....	1-3
Performance Characteristics .....	1-4
Operating Characteristics .....	1-5
General Characteristics .....	1-11
Recommended Test Equipment .....	1-12



## General Information

---

### Introduction

This service manual contains information on installing, testing, adjusting, and servicing the Hewlett-Packard 54502A Digitizing Oscilloscope. This section of the manual includes instrument identification, description, options, accessories, specifications and other basic information.

A microfiche part number is listed under the manual part number on the title page of this manual. This number may be used to order 4×6-inch microfiche transparencies of the manual. Each microfiche contains up to 96 photo-duplicates of the manual pages. The microfiche package also contains the latest Manual Changes supplement as well as pertinent Service Notes.

---

### Instruments Covered By Manual

On the rear panel of the instrument is a serial number sticker. The serial number is in the form: 0000A00000. It is composed of two parts: the first four digits and letter are the serial prefix, while the last five digits are the suffix. The prefix is the same for all identical instruments and changes only when a change has been made to the instrument. The suffix however, is assigned sequentially and is different for each instrument. The contents of this manual apply to instruments with the serial number prefixes listed under SERIAL NUMBERS on the title page.

An instrument manufactured after the printing of this manual may have a serial number prefix different than those listed on the title page. This unlisted serial number prefix indicates the instrument is different from those described in this manual. The manual for this instrument is accompanied by a yellow Manual Changes supplement. This supplement contains the necessary "change information" that explains how to adapt the manual to the newer instrument.

In addition to change information, the supplement may contain information for correcting errors in the manual. To keep this manual as accurate as possible, periodically request the latest Manual Change supplement for the instrument manual. The supplement for this manual is identified with the manual part number and print date, both of which appear on the manual title page. Complimentary copies of the supplement are available from Hewlett-Packard.

For information concerning a serial prefix number not listed on the title page or in the Manual Changes supplement, contact your nearest HP office.

---

### Instrument Description

The HP 54502A Digitizing Oscilloscope is a general-purpose oscilloscope with 400 MHz repetitive bandwidth and 100 MHz real time bandwidth. It simultaneously digitizes two input channels, each with 2K samples of memory. The channels have 2 mV to 5 V/div sensitivity in a 1-2-5 sequence. Channel input impedance is 1 M $\Omega$  or 50  $\Omega$ , switchable.

The time base provides sweep speeds from 1 ns to 5 s/div in a 1-2-5 sequence. Dual time base windowing can be used to expand a displayed waveform for a detailed view.

An external trigger input with 1 M $\Omega$  or 50  $\Omega$  switchable impedance can be combined with the channel triggers for complex triggering functions.

The HP 54502A has an Autoscale feature, 16 automatic pulse parameter measurements, and easy waveform storage. It has full programmability over the HP-IB and when set up with a printer the HP 54502A provides instant hardcopy output.

---

## Accessories Supplied

The following accessories are supplied with the HP 54502A Digitizing Oscilloscope.

- Two HP 10430A Miniature Passive Probes
- One miniature probe to BNC male adapter (HP 1250-1454)
- One 2.3 meter (7.5 feet) power cord (See Section 2 for available power cords)
- One Operating and Programming Manual Set
- One Service Manual

---

## Accessories Available

The following accessories are available for use with the HP 54502A.

- HP 10437A 1:1 50  $\Omega$  Probe (2m)
- HP 10438A 1:1 Probe (1m)
- HP 10439A 1:1 Probe (2m)
- HP 10002A 50:1 1 M $\Omega$  (1000 V peak) Probe
- HP 10020A Resistive Divider Probe Kit
- HP 1133A TV/Video Sync Pod
- HP 5061-6175 Rack-mount Kit
- HP 1494-0015 Rack-mount Slide Kit
- HP 1540-1066 Soft Carrying Case
- HP 9211-2645 Transit Case
- HP 5061-6183 Front Panel Cover
- HP Model 1180A Testmobile
- HP Model 92199B Power Strip

---

## Options Available

The following options are available for the HP 54502A.

- Option 908 - HP Rack-mount Kit (HP 5061-6175)
- Option 910 - Additional Service Manual and Operating and Programming Manual Set
- Option 090 - Deletion of probes

## Performance Specifications

The following are performance specifications for the HP 54502A Digitizing Oscilloscope.

### Vertical

**Bandwidth (-3dB, dc coupled)**

**Real time:** dc to 100 MHz

**Repetitive:** dc to 400 MHz<sup>1</sup>

**Rise time<sup>2</sup>**

**Realtime:** 3.5 ns

**Repetitive:** 875 ps

**Input R (selectable):** 1 M $\Omega$   $\pm$ 1% or 50  $\Omega$   $\pm$ 1%

**Maximum Input Voltage<sup>3</sup>**

1 M $\Omega$ :  $\pm$ 250 V [dc + peak ac(< 10 kHz)]

50  $\Omega$ : 5 V<sub>rms</sub>

**Offset Accuracy<sup>4</sup>**  $\pm$ (2 mV + 2% of ch. offset + 2.5% of full scale)

**Voltage Measurement Accuracy (dc)<sup>4,5</sup>**

**Dual Cursor:**  $\pm$ (2.0% of full scale + 0.032  $\times$  V/div)

**Single Cursor:**  $\pm$ (2.0% of full scale + offset accuracy + 0.016  $\times$  V/div)

### Horizontal

**Time Base Reference Accuracy:** 0.01%

**Delta-t Accuracy**

**Real time:**  $\pm$ (0.2%  $\times$  screen diameter + 0.01%  $\times$  delta-t + 500 ps)

**Repetitive:**  $\pm$ (0.2%  $\times$  screen diameter + 0.01%  $\times$  delta-t + 250 ps)

### Trigger

**Trigger Sensitivity<sup>4</sup>**

**Internal - dc to 100 MHz**

**Real time and repetitive:** 0.5 div

**Internal - 100 MHz to 400 MHz**

**Real time:** N/A

**Repetitive:** 1 div

**External - dc to 250 MHz**

100 mV<sub>p-p</sub> into 50  $\Omega$

**NOTES:** Specifications valid for temperature range  $\pm$ 10°C from software calibration temperature with eight or more averages selected.

1. Upper bandwidth reduces by 2.5 MHz for each °C above 35°C. On time/div ranges 1 us and slower, the bandwidth in repetitive mode is 100 MHz.
2. Rise time figures are calculated from:  $t_r = 0.35/\text{Bandwidth}$ .
3. On ranges  $\leq$ 50 mV/div, the maximum overdrive of the input must not exceed 1000 times the V/div setting.
4. Expansion is used below 7 mV/div range so vertical resolution and accuracies are correspondingly reduced. Below 7 mV/div full scale is defined as 56 mV.
5. Accuracy decreases 0.08% per °C from software calibration temperature.

## Performance Characteristics

The following are performance characteristics of the HP 54502A Digitizing Oscilloscope.

### Vertical

#### Switchable Bandwidth Limits

ac-coupled (lower -3 dB frequency): 90 Hz

LF reject (lower -3 dB frequency): 450 Hz

Bandwidth Limit (upper -3 dB frequency): 30 MHz

Number of channels: 2 (simultaneous)

Vertical Sensitivity Range: 2 mV/div to 5 V/div

Vertical Gain Accuracy (dc):<sup>1,2</sup>  $\pm 2.0\%$  of full scale

Vertical Resolution:<sup>2,3</sup>  $\pm 0.4\%$  of full scale

#### Maximum Sample Rate

Real time: 400 MSa/s

Repetitive: 25 MSa/s

#### Waveform Record Length<sup>4</sup>

Realtime - Normal: 501 points

Realtime - Extended: 2001 points

Repetitive:	Time/div	5 ns - 5 s/div	2 ns/div	1 ns/div
	Record length	501 pts	401 pts	201 pts

Input C: 7 pF nominal

Input coupling: ac, dc

Offset Range:	Vertical Sensitivity	Available Offset
	2 mV - 50 mV/div	$\pm 2$ V
	> 50 mV - 250 mV/div	$\pm 10$ V
	> 250 mV - 1.25 V/div	$\pm 50$ V
	> 1.25 V - 5 V/div	$\pm 250$ V

Dynamic range:  $\pm 1.5 \times$  full scale from center of screen

Channel-to-channel Isolation:	Realtime	Repetitive
(with channels at equal sensitivity)	40 dB: dc to 50 MHz 30 dB: 50 to 100 MHz	40 dB: dc to 50 MHz 30dB: 50 to 400 MHz

NOTES: Specifications valid for temperature range  $\pm 10^\circ\text{C}$  from software calibration temperature with eight or more averages selected.

- Accuracy decreases 0.08% per  $^\circ\text{C}$  from software calibration temperature.
- Expansion is used below 7 mV/div range so vertical resolution and accuracies are correspondingly reduced. Below 7 mV/div full scale is defined as 56 mV.
- With <8 averages, vertical resolution becomes 1.6% of full scale.
- Available over HP-IB, waveform record length is:

Real Time-	Normal: 500 points	Extended: 2,000 points
Repetitive-	10 ns - 5 s/div	1,024 points
	5 ns/div	1,000 points
	2 ns/div	400 points
	1 ns/div	200 points



**Horizontal**    **Time Base Range:** 1 ns/div to 5 s/div

**Time Base Resolution:** 50 ps

<b>Delay Range:</b>	<u>Time/div Setting</u>	<u>Available Delay</u>
(post-trigger)	50 ms - 5 s	$40 \times (\text{s/div})$
	100 $\mu\text{s}$ - 20 ms	1 s
	1 ns - 50 $\mu\text{s}$	$10,000 \times (\text{s/div})$

<b>Delay Range:</b>	<b>Real time</b>	<b>Repetitive</b>	
(pretrigger)	<u>All Time/div Settings</u>	<u>Time/div Setting</u>	<u>Available Delay</u>
	$40 \times (\text{s/div})$	2 $\mu\text{s}$ - 5 s/div	$-40 \times (\text{s/div})$
		10 ns - 1 $\mu\text{s}/\text{div}$	-80 $\mu\text{s}$
		1 ns - 5 ns/div	$-10,000 \times (\text{s/div})$

<b>Trigger</b>	<b>Trigger Pulse Width:</b>	<b>Real time</b>	<b>Repetitive</b>
	(minimum)		
	Internal	7.0 ns	1.75 ns
	External	2.8 ns	2.8 ns

**Trigger Level Range**

Internal:  $\pm 1.5 \times$  full scale from center of screen

External:  $\pm 2 \text{ V}$

---

## Operating Characteristics

**Vertical**    **Deflection Factors:** Channels 1 and 2: With single screen selected, attenuation factors are adjustable from 2 mV/div to 5 V/div in a 1-2-5 sequence with the knob. Finer adjustments can be made using direct keypad entry or the knob with the FINE key selected.

**Probe Attenuation Factors:** Values from 0.9 to 1000 may be entered to scale the oscilloscope for external probes or attenuators attached to the channel inputs. When probe tip calibration is done, this value is calculated automatically.

**Input Impedance:** 1 M $\Omega$  or 50  $\Omega$ , selectable for CH1, CH2 and external.

**Bandwidth Limit (HF Reject):** Provides low pass filter with a -3 dB point at approximately 30 MHz for both triggering and signal display. Can be selected for each vertical input individually.

**LF Reject:** Provides high pass filter with a -3 dB point at approximately 450 Hz for triggering and vertical signal. Can be selected for each vertical input individually.

**AC Coupling:** Provides high-pass filter with a -3 dB point at approximately 90 Hz for both triggering and signal display. Can be selected for each vertical input individually.

**ECL/TTL Presets:** Vertical deflection factor, coupling, offset, and trigger level can be preset independently on both channels for ECL and TTL levels.

**Effective Resolution:** Vertical resolution refers to the oscilloscope's ability to resolve small incremental differences in voltage. This characteristic is often

assumed to be directly related to the number of bits in the instrument's analog-to-digital conversion system.

In fact, the A/D resolution is only one of several components of vertical performance. Hewlett-Packard single-shot digitizing oscilloscopes are characterized for Effective Bits of resolution. This method considers quantization error, A/D non-linearities, and system noise, all of which affect the measurement accuracy of the instrument. The following chart shows typical performance.

Frequency	1 MHz	10 MHz	40 MHz	100 MHz
Effective Bits	6.0	6.0	5.9	5.4

For more information about effective resolution, please contact your Hewlett-Packard sales office, and ask for Product Note 5180A-2, "Dynamic Performance Testing of A to D Converters," (pub # 02-5952-7629).

**Horizontal Dual Time Base Windowing:** Allows user to zoom in on portions of the waveform using time markers that are displayed on the top half of the screen. An expanded time base is displayed on the lower half of the screen. The window time base can be set to provide as much as a 20:1 expansion ratio. Waveform measurements are performed only on the the dual time base window information when windowing is turned on.

**Delay Between Channels:** Difference in delay between channels can be nulled out to compensate for differences in input cables or probe length. Use "time null cal," found in the Probe Cal menu (see UTIL key).

**Reference Location:** The reference point can be located at the left edge, center, or right edge of the display. The reference point is defined as the trigger point plus the delay time.

**Trigger Modes Edge Trigger:** Positive or negative edge can be selected for trigger on channels 1 and 2 or on the external trigger input.

**Pattern Trigger:** A pattern can be specified using channels 1, 2 and the external trigger input. Each of the inputs can be specified as a *high*, *low*, or *don't care* with respect to the level setting in the edge trigger menu. The trigger can be selected to occur on the last edge to enter the specified pattern or the first edge to exit the specified pattern.

**Time Qualified Pattern Trigger:** A trigger will occur on the first edge to exit a pattern only if it meets the specified time criteria. The available time qualified modes are:

- pattern present < [time]
- pattern present > [time]
- range: pattern present > [time1] and < [time2]

The time settings are adjustable from 20 ns to 160 ms ( $\pm 3\% \pm 2$  ns). The time filter recovery time is  $\leq 12$  ns. In the "pattern present < [time]" mode, the pattern must be present > 1.75 ns, repetitive mode, (7.0 ns for the real time mode) for the trigger to respond.

**Glitch Trigger:** Use "pattern present < [time]" with [time] selected such that it is just less than the nominal pulse width of the signal you are analyzing. The minimum glitch width is 1.75 ns, repetitive mode, (7.0 ns for the real time mode,) and 2.8 ns for external trigger.

**State Trigger:** A pattern is specified on any two of the three inputs with the third input used as clock. A trigger will occur on the rising or falling edge of the input specified as the clock when the pattern is present or not present. Setup time for the pattern with respect to the clock is  $\leq 10$  ns and hold time is zero.

**Delayed Trigger** **Event-Delayed Mode:** The trigger can be qualified by an edge, pattern, time qualified pattern or state. The delay can be specified as a number of occurrences of a rising or falling edge of any of the three inputs. After the delay, an occurrence of a rising or falling edge of any of the three inputs will generate the trigger. The trigger occurrence value is selectable from 1 to 16,000,000. The maximum edge counting rate is 70 MHz.

**Time-Delayed Mode:** The trigger can be qualified by an edge, pattern, or state. The delay is selectable from 30 ns to 160 ms. After the delay, an occurrence of a rising or falling edge of any of the three inputs will generate the trigger. The trigger occurrence value is selectable from 1 to 16 000 000. The maximum edge counting rate is 70 MHz.

**TV Trigger** **60 Hz / 525 Lines:** Source is selected to be any one of the three inputs. Trigger level is adjustable for the selected source. Polarity is selected for positive or negative synchronizing pulses. A trigger occurs on the selected line and field of a 2/1 interlaced composite video signal. Line numbering is 1 to 263 for field 1 and 1 to 262 for field 2. This TV trigger mode is compatible with broadcast standard M.

**50 Hz / 625 Lines:** Same as 60 Hz / 525 lines except that line numbering is 1 to 313 for field 1 and 314 to 625 for field 2. This TV trigger mode is compatible with broadcast standards B, C, D, G, H, I, K, K1, L and N.

**User-Defined Mode:** Source is selected to be any one of the three inputs. Trigger level is adjustable for the selected source. The trigger is qualified with a high or low pulse that meets a select-able time range. The trigger is an occurrence of a rising or falling edge of the source after the qualifying pulse. The time settings for the qualifier are selectable from 20 ns to 160 ms. The trigger occurrence value is selectable from 1 to 16,000,000.

**NOTE:** *All TV trigger modes require a clamped video signal for stable triggering. Use the HP 1133A TV/Video Sync Pod to provide clamped video output that can be used in conjunction with the HP 54502A's TV triggering capabilities.*

**Trigger Holdoff:** Trigger can be held off either by time or events over the ranges:

- time: 40 ns - 320 ms
- events: 2 - 16,000,000

An event is defined as the specified trigger condition. A separate holdoff setting (time or events) is available for each trigger mode except delayed trigger, which is set to 40 ns.

**Noise Reject Trigger:** Provides improved triggering on noisy signals by increasing trigger hysteresis (internal trigger only).

**Display** **Data Display Resolution:** 451 points horizontally by 256 points vertically.

**Number of Screens:** 1 or 2 screens can be selected. This can provide overlapping channels or memories for comparison, or separate displays on a split viewing area.

## Display Modes

**Averaging:** The number of averages can be specified in powers of 2, up to 2,048. On each acquisition,  $1/n$  times the new data is added to  $(n-1)/n$  of the previous value at each time coordinate. Averaging operates continuously, except for the HP-IB digitize command, for which averaging terminates at the specified number of averages.

**Envelope:** Provides a display of the running maximum and minimum voltage levels at each horizontal time position.

**Graticules:** The user may choose full grid, axes, frame, or no graticule.

**Connect-the-Dots:** Provides a continuous display, connecting the sample points with straight lines. Connect-the-dots is operative for modes in which a single-valued waveform can be connected, including average, envelope, single, and minimum-persistence modes. Connect-the-dots is not available in scroll mode or in real time infinite persistence mode.

**Scroll Mode:** The 54502A automatically selects scroll mode at time-per-division settings from 200 ms/div to 5 s/div if the scope is in Auto triggered mode, or, if the scope is in Triggered mode and has no pre-trigger data displayed (i.e., no negative time on screen). Scroll mode updates each data point on the displayed waveform as the data is acquired.

### Time Base In Repetitive Mode.

**Minimum Persistence:** One waveform data value is displayed in each horizontal time position of the display. The waveform is updated as new data is acquired for a particular horizontal time position.

**Variable Persistence:** The time that each data point is retained on the display can be varied from 500 ms to 10 seconds, or the points can be displayed indefinitely.

### Time Base in Real Time Mode.

**Single Persistence:** One waveform data value is displayed in each horizontal time position. The entire waveform is replaced with each new acquisition.

**Infinite Persistence:** Waveform data is allowed to continuously accumulate on the screen, and remains until display is cleared.

**Display:** Normal mode sets record length to 501 points. Extended mode sets record length to 2,001 points.

**Filter:** At time-per-division settings between 500 ns/div and 5 s/div, a digital reconstruction filter can be switched ON or OFF as desired.

At time-per-division settings between 200 ns/div and 1 ns/div, a reconstruction algorithm is used to improve display of the waveform. The filter on/off menu is not available at these time/div settings. To look at data without the effect of this algorithm, change the time-per-division range to 500 ns/div, switch the filter OFF, stop the acquisition, clear the display, and press the SINGLE key. Using the time base window feature, you can now zero in on and expand the sampled data.

## Delta-t / Delta-V

**Markers:** Dual voltage markers and dual time markers are available. Voltage markers can be independently assigned to channels, memories, or functions.

**Waveform Math** Two independent functions are provided for waveform math. The operators are +, -, x, vs, invert, and only. The vertical channels or any of the waveform memories can be used as operands for waveform math. Sensitivity and offset for these functions can be adjusted independently.

**Waveform Save** Four non-volatile waveform memories and two volatile pixel memories are provided. Waveform memories store single-valued waveforms, such as an averaged waveform. If an envelope waveform is stored to a waveform memory, it will automatically be stored with the upper waveform in one waveform memory and the lower waveform in another. Pixel memories store an entire screen of waveform data. They are very useful for storing multiple overlapping waveforms and infinite persistence waveforms. Automatic measurements may be performed on the four non-volatile waveform memories but not on the volatile pixel memories.

**Automatic Pulse Parameter Measurements:** The HP 54502A offers 16 automatic pulse parameter measurements from the front panel (shown below,) and additional measurements via HP-IB including All, Overshoot, and Preshoot. The standard measurements are performed with 10%, 50% and 90% voltage thresholds, as defined by IEEE standard 194-1977, "IEEE Standard Pulse Terms and Definitions."

**Automatic measurements available on the HP 54502A:**

Rise time	Pulse Width +	Volts amp	Volts avg	Preshoot
Fall time	Pulse width -	Volts base	Volts max	(HP-IB only)
Frequency	Duty Cycle	Volts top	Volts min	Overshoot
Period	Delay	Volts p-p	Volts RMS	(HP-IB only)

**User-definable Measurement Thresholds** The HP 54502A allows you to set your own thresholds for automatic measurements. Both the upper and lower thresholds can be set from 25% to 125%, as long as the upper threshold value is always greater than or equal to the lower threshold. The middle threshold is always equal to the mid-value between the upper and lower threshold.

**Continuous Measurements:** Can be turned on or off. With continuous measurements off, the voltage and time markers are placed on the waveform to indicate where the last measurement was taken.

**Measurement Statistics:** The maximum, minimum, and average of continuously updated measurements are calculated and displayed. Any three measurements can be selected for simultaneous display.

**Measurement Limit Test:** Maximum and minimum limits can be set for any three of the front-panel automatic measurements. These continuously updated measurements are compared to the maximum and minimum limits. If the measurements are found to be outside the defined limits, the waveform can be stored in a memory or the screen can be sent to a printer. In addition, the HP-IB Service Request line can be set to flag the controller. Measurement limit test can be set to stop after test limits have been exceeded, or to continue testing.

**Setup Aids** **Autoscale:** Pressing the Autoscale button automatically adjusts the vertical and horizontal deflection factors, and the trigger level for a display appropriate to the signals applied to the inputs. The Autoscale feature requires a signal with a duty cycle greater than 0.5% and a frequency greater than 50 Hz. Autoscale is operative only for relatively stable input signals.

**Save/Recall:** Four front panel setups (1-4) may be saved in non-volatile memory.

**Recall Clear:** Pressing the RECALL key followed by the CLEAR key resets the HP 54502A to its factory default settings.

**Recall 0:** If Autoscale, ECL or TTL preset, or recall setup are inadvertently selected, recall 0 restores the instrument to its last state prior to selection.

**Show:** Displays instrument status, including volts/div, offset, and trigger condition.

**Hardcopy** The CRT display, including menus and measurement answers, can be transferred directly to an HP-IB raster graphics printer, including the HP 2225A ThinkJet, HP 2227B QuietJet, or other compatible printers.

**Full HP-IB Programmability** The HP 54502A is fully programmable. Instrument settings and operating modes, including automatic measurements, may be remotely programmed via HP-IB (IEEE-488). HP-IB programming complies with IEEE 488.2-1988 "Standard Codes, Formats, Protocols, and Common Commands."

**Data Acquisition and Transfer Rate:** A 500-point data record can be acquired and transferred to a computer at a rate of approximately 10 times per second, as tested with an HP 9000, Series 200 Controller. The acquired data was type normal, completion criteria 100%, with the oscilloscope at a time/division setting of 5  $\mu$ s/div.

**Data Transfer Rate:** Approximately 120 kBytes per second.

**Probe Compensation, ac Calibrator Output:** A 500 Hz (approx.) square wave is provided for probe compensation. A probe-to-BNC adapter is used to connect the probe to the rear panel Probe Compensation BNC output. During instrument self-calibration, this output is used to provide other calibration signals, as described in the Service Manual.

This same BNC connector is used for trigger output. The utility menu allows the user to switch the BNC from probe compensation and calibration signals to a trigger output pulse. The rising edge, with amplitude from approximately -400 mV to 0 V (when terminated into 50  $\Omega$ ), is synchronous with system trigger. The falling edge of this pulse occurs approximately at the end of holdoff. The rising edge should be used as the edge synchronous with trigger.

**dc Calibrator Output:** This output is used for vertical calibration of the HP 54502A, as described in the Service Manual.

**Product Support** **Built-in Self-test and Calibration Routines:** Internal self test capabilities provide a 90% confidence the instrument is operating properly. External test procedures in the service manual provide a 100% confidence. Self-calibration routines, also selected through the front panel "utility" menu, ensure that the instrument is operating with its greatest accuracy and requires no external test equipment.

**Low Cost of Ownership:** The HP 54502A has a three year warranty. Hewlett-Packard's board exchange program assures economical and timely repair of units, reducing the cost of ownership.

**Solutions:** Hewlett-Packard's System Engineering Organization can help you configure an HP-IB system and provide software support for your application, developing solutions to meet your measurement needs. Contact your HP Sales and Service office for more information.

# General Characteristics

## Environmental Conditions

**Temperature**  
**Operating:** 0°C to +55°C (32°F to +131°F)  
**Non-operating:** -40°C to +70°C (-40°F to +158°F)

**Humidity**  
**Operating:** up to 95% relative humidity (non-condensing) at +40°C (+104°F)  
**Non-operating:** up to 90% relative humidity at +65°C (+149°F)

**Altitude**  
**Operating:** up to 4,600 meters (15,000 ft).  
**Non-operating:** up to 15,300 meters (50,000 ft).

**Vibration**  
**Operating:** Random vibration 5-500 Hz, 10 minute per axis, 0.3 G<sub>rms</sub>.  
**Non-operating:** Random vibration 5-500 Hz, 10 minute per axis, 2.41 G<sub>rms</sub>.  
 Resonant search 5 to 500 Hz swept sine, 1 Octave/minute sweep rate, (0.75G), 5 minute resonant dwell at 4 resonances per axis.

## Power Requirements

**Voltage:** 115/230 V ac, -25% to +15%, 48-66 Hz.  
**Power:** 350 VA maximum.

## Weight

**Net:** approximately 10 kg (22 lb).  
**Shipping:** approximately 20 kg (44 lb).

## Dimensions

Refer to outline drawings below.

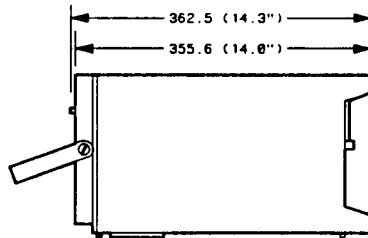
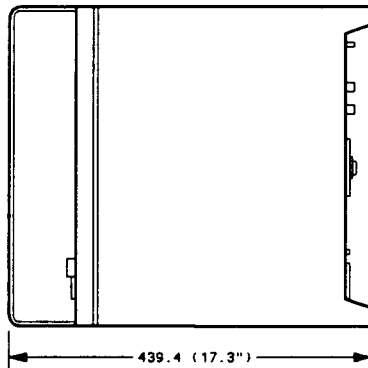

84501E 13

### NOTES

1. Dimensions are for general information only. If dimensions are required for building special enclosures, contact your HP field engineer.
2. Dimension are in millimetres and (inches).

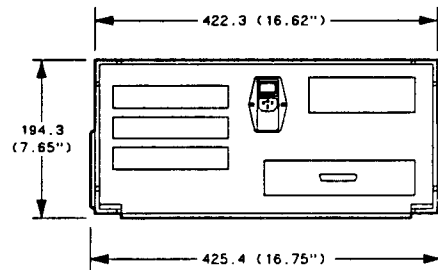

## Recommended Test Equipment

Table 1-1 shows a list of the test equipment required to test performance, make adjustments, and troubleshoot this instrument. The table indicates the critical specification of the test equipment and for which procedure the equipment is necessary. Equipment other than the recommended model may be used if it satisfies the critical specification listed in the table.

**Table 1-1. Recommended Test Equipment**

Equipment Required	Critical Specifications	Recommended Model	Use *
Signal Generator	1 - 400 MHz sine wave amplitude, 30 - 200 mVrms time base accuracy, 20 ppm	HP 8656B	P
Power Meter/ Power Sensor	1 - 400 MHz, -70 dBm to +44 dBm, ±3% accuracy	HP 436A/8482A	P
DMM	5 1/2 digit resolution dc voltage accuracy, ±0.005% 4-wire resistance accuracy, ±0.25%	HP 3478A	P, A, T
Power Supply	14 mV - 35 V dc, 0.1 mV resolution	HP 6114A	P
Pulse Generator	$t_r \leq 70$ ps, amplitude approx. 200 mV	TEK TYPE 284	A
Oscilloscope	General-purpose	HP 54501A	P, T
Power Splitter	50 $\Omega$ type N, outputs differ by <0.15 dB	HP 11667A	P
Cable	Type N - 3 foot	HP 11500B	P
Cable (2)	BNC - 3 foot	HP 10503A	P, A
Cable (3)	BNC - 9 inch	HP 10502A	P, A, T
Adapter	N (m) to BNC (m)	HP 1250-0082	P
Adapter	N (m) to BNC (f)	HP 1250-0780	P
Adapter	GR874 to BNC (f)	General Radio	A
Adapter (2)	BNC tee (m)(f)(f)	HP 1250-0781	P, A, T
Adapter	BNC (f)(f)	HP 1250-0080	A, T
Adapter (2)	BNC to dual banana	HP 1251-2277	P
Shorting cap	BNC	HP 1250-0774	P
Cable Extender	no substitute	HP 54503-61604	A
Resistor	2 $\Omega$ , 25 W	HP 0811-1390	T

\* P = Performance Tests, A = Adjustments, T = Troubleshooting



# Contents

---

## Section 2

### Installation

Introduction .....	2-1
Initial Inspection .....	2-1
Operating Environment .....	2-1
Storage And Shipping .....	2-1
Packaging .....	2-1
Tagging for Service .....	2-1
Original Packaging .....	2-2
Other Packaging .....	2-2
Preparation For Use .....	2-2
Power Requirements .....	2-2
Line Voltage Selection .....	2-2
Power Cable .....	2-3
Applying Power .....	2-3
Cleaning Requirements .....	2-3



## Installation

---

### Introduction

This section of the manual contains information and instructions for installing the HP 54502A Digitizing Oscilloscope. Included in this section are inspection procedures, power requirements and connection, and packing and shipping information.

---

### Initial Inspection

Inspect the shipping container for damage. If the shipping container or cushioning material is damaged, it should be kept until the contents of the shipment have been checked for completeness and the instrument has been checked mechanically and electrically. Accessories supplied with the instrument are listed under Accessories Supplied in section 1 of this manual. The self-test procedure and electrical performance verification functions are described in section 3.

If the contents are incomplete, if there is mechanical damage or defect, or if the instrument does not pass performance verification, notify the nearest HP office. If the shipping container is damaged, or the cushioning materials show signs of stress, notify the carrier as well as the HP office. Keep the shipping materials for carrier's inspection. The HP office will arrange for repair or replacement at Hewlett-Packard's option without waiting for claim settlement.

---

### Operating Environment

The operating environment for the HP 54502A is described in the Operating Characteristics in Section 1. Note the non-condensing humidity limitation. Condensation within the instrument cabinet can cause poor operation or malfunction. Protection should be provided against temperature extremes which cause condensation within the instrument.

---

### Storage And Shipping

This instrument may be stored or shipped in environments within the following limitations:

- Temperature: -40°C to 70°C (-40°F to 158°F)
  - Humidity: up to 90% at 65°C (149°F)
  - Altitude: up to 15,300 meters (50,000 feet)
- 

### Packaging

#### Tagging for Service

If the instrument is to be shipped to an HP office for service or repair; attach a tag to the instrument identifying owner, address of owner, complete instrument model and serial numbers, and a description of the service required.

---

## Original Packaging

If the original packaging material is unavailable or unserviceable, materials identical to those used in factory packaging are available through HP offices. If the instrument is to be shipped to an HP office for service, attach a tag showing owner, address of owner, complete instrument model and serial numbers, and a description of the service required. Mark the container FRAGILE to ensure careful handling. In any correspondence, refer to the instrument by model number and full serial number.

## Other Packaging

The following general instructions should be followed for repacking with commercially available materials.

1. Wrap instrument in heavy paper or plastic.
2. Use strong shipping container. A double-wall carton made of 350 lb test material is adequate.
3. Use a layer of shock-absorbing material 70 to 100 mm (3 to 4 inches) thick around all sides of instrument to firmly cushion and prevent movement inside the container. Protect control panel with cardboard.
4. Seal shipping container securely.
5. Mark shipping container FRAGILE to ensure careful handling.
6. In any correspondence, refer to instrument by model number and full serial number.

---

## Preparation For Use

### Power Requirements

The HP 54502A requires a power source of either 115 or 230 Vac, -25% to +15%; 48 to 66 Hz; 350 VA maximum.

### Caution

**BEFORE CONNECTING POWER TO THIS INSTRUMENT**, be sure the line voltage switch on the rear panel of the instrument is set properly and the correct fuse is installed.

### Line Voltage Selection

Before applying power, verify that the fuse module is in the correct position for the line voltage to be used.

The fuse module is located in the line filter/power switch module on the rear panel of the instrument. There is one small triangle on the filter module and two on the fuse module; one next to each line voltage choice. If the triangle on the filter is not adjacent to the triangle with the desired voltage on the fuse module, the fuse module position needs to be changed. To do this, gently pry out fuse module with a flat-blade screwdriver. Reinsert the fuse module into the line filter module so the correct line voltage is adjacent to the triangle on the filter module.

---

## Power Cable

---



**BEFORE CONNECTING THIS INSTRUMENT**, the protective earth terminal of the instrument must be connected to the protective conductor of the (Mains) power cord. The Mains plug must be inserted in a socket outlet provided with a protective earth contact. The protective action must not be negated by the use of an extension cord (power cable) without a protective conductor (grounding). Grounding one conductor of a two-conductor outlet does not provide an instrument ground.

---

This instrument is provided with a three-wire power cable. When connected to an appropriate ac power outlet, this cable grounds the instrument cabinet. The type of power cable plug shipped with the instrument depends on the country of destination. Refer to figure 2-1 for power plugs and HP part numbers for the available plug configurations.

---

---

## Applying Power

After applying power to the HP 54502A, an internal self-test may be performed by following the procedure in section 3. If the message "cal ram checksum error re-cal instrument" is displayed at the top of the screen, refer to the calibration procedures in section 4 of this manual.

---







---

## Cleaning Requirements

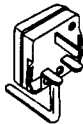
Use **MILD SOAP AND WATER** to clean the instrument cabinet and front panel. Care must be taken not to use a harsh soap which will damage the water-based paint finish of the instrument.

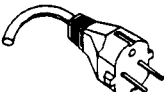
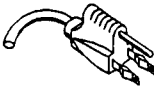
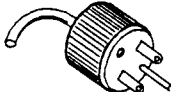
---

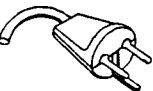
**Table 2-1. Power Cord Configurations**

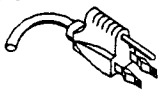
PLUG TYPE	CABLE PART NO.	PLUG DESCRIPTION	LENGTH IN/CM	COLOR	COUNTRY
OPT 900  250V	8120-1351 8120-1703	Straight *BS1363A 90°	90/228 90/228	Gray Mint Gray	United Kingdom, Cyprus, Nigeria, Zimbabwe, Singapore
OPT 901  250V	8120-1369 8120-0696	Straight *NZSS198/ASC 90°	79/200 87/221	Gray Mint Gray	Australia New Zealand
OPT 902  250V	8120-1689 8120-1692 8120-2857	Straight *CEE7-Y11 90° Straight (Shielded)	79/200 79/200 79/200	Mint Gray Mint Gray Coco Brown	East and West Europe, Saudi Arabia, So. Africa, India (Unpolarized in many nations)
OPT 903**  125V	8120-1378 8120-1521 8120-1992	Straight *NEMA5-15P 90° Straight (Medical) UL544	90/228 90/228 96/244	Jade Gray Jade Gray Black	United States, Canada, Mexico, Philippines, Taiwan
OPT 904**  250V	8120-0698	Straight *NEMA6-15P	90/228	Black	United States, Canada
OPT 905  250V	8120-1396 8120-1625	CEE22-V1 (System Cabinet Use) 250V	30/76 96/244	Jade Gray	For interconnecting system components and peripherals. United States and Canada only
OPT 906  250V	8120-2104 8120-2296	Straight *SEV1011 1959-24507 Type 12 90°	79/200 79/200	Mint Gray Mint Gray	Switzerland
OPT 912  220V	8120-2956 8120-2957	Straight *DHCK107 80°	79/200 79/200	Mint Gray Mint Gray	Denmark
OPT 917  250V	8120-4211 8120-4600	Straight SABS164 90°	79/200 79/200	Jade Gray	Republic of South Africa India
OPT 918  100V	8120-4753 8120-4754	Straight Miti 90°	90/230 90/230	Dark Gray	Japan

Rev. 11NOV88

ART00019

\*Part number shown for plug is industry identifier for plug only. Number shown for cable is HP part number for complete cable including plug.

\*\*These cords are included in the CSA certification approval of the equipment.

E=Earth Ground

L=Line

N=Neutral

# Contents

---

<b>Section 3</b>	<b>Performance Tests</b>	
	Introduction .....	3-1
	Testing Interval .....	3-1
	Equipment Required .....	3-1
	Self-test Verification .....	3-1
	Test Record .....	3-2
	Operating Hints .....	3-2
	Clear Display .....	3-2
	Averaging .....	3-2
	Performance Test Procedures .....	3-2
	DC Calibrator Test .....	3-3
	Input Resistance .....	3-4
	Voltage Measurement Accuracy .....	3-5
	Offset Accuracy .....	3-7
	Bandwidth .....	3-8
	Time Measurement Accuracy .....	3-10
	Trigger Sensitivity .....	3-12
	Oscillator Output Check .....	3-14





## Performance Tests

---

### Introduction

The procedures in this section test the instruments electrical performance using Performance Specifications given in section 1 as performance standards. Specifications applicable to individual tests are noted at the test for reference.

---

### Testing Interval

The performance test procedures may be performed for incoming inspection of the instrument and should be performed periodically thereafter to ensure and maintain peak performance. The recommended test interval is yearly or every 2,000 hours of operation. Amount of use, environmental conditions, and the user's experience concerning need for testing will contribute to verification requirements.

The calibration cycle is covered in the Adjustment procedures.

---

### Equipment Required

A complete list of equipment required for the performance tests is in the Recommended Test Equipment table in Section 1. Equipment required for individual tests is listed in the test. Any equipment satisfying the critical specifications listed may be substituted for the recommended model.

---

### Self-test Verification

To verify system operation with high confidence, without the test equipment and time required for performance tests, perform the self-tests. These internal tests verify many functions on the Main Assembly. The functions tested are the six separate memories and six other system functions.

To start the self-tests, press **UTIL** then **self-test**. A message is displayed with the instruction to remove all inputs to the instrument. Press **test all**, which starts a loop which runs all the self-tests in succession. During execution of the self-tests, the following messages are displayed as each self-test is completed:

PASSED Display RAM	PASSED Acquisition RAM
PASSED System RAM	PASSED Logic Trigger
PASSED Non-Volatile RAM	PASSED Analog Trigger
PASSED Protected Non-Volatile RAM	PASSED Timebase
PASSED System ROM	PASSED D/A Converter
PASSED HP-IB	PASSED A/D Converter

If one of the self-tests fails, **FAILED** is displayed rather than **PASSED**, and a 16-bit diagnostic code is displayed. This code is used by factory service personnel when troubleshooting the Main Assembly. Failure of a self-test indicates a failure on the Main Assembly which must be returned to the factory for service. For more information on service, refer to section 6 of this manual.

---



The loop test in the selftest menu is a troubleshooting aid for factory service only.

---

---

## Test Record

The results of the performance tests may be tabulated on the Test Record provided at the end of this section. The Test Record lists the performance tests and provides an area to mark test results. The results recorded in the table at incoming inspection may be used for later comparisons of the tests during periodic maintenance, troubleshooting, and after repairs or adjustments.

---

## Operating Hints

Some knowledge of operation of the HP 54502A is helpful; however, procedures are written so that little experience is necessary. The following two hints will speed progress of the testing.

### Clear Display

When using many averages, it often takes awhile for a waveform display to stabilize after a change. When a control on the HP 54502A is changed, averaging automatically restarts. When just the input signal is changed, the instrument must average new data with the old so it takes a long time for the waveform to stabilize. Press CLEAR DISPLAY while changing input signals. The instrument will restart averaging and give a quick indication of the result of the signal change.

### Averaging

Averaging is used to assure a stable signal for measurements. It is not necessary to wait for complete stability of the signal (averaging complete) as long as the measurement is well within the limits of the test.

---

## Performance Test Procedures

Performance test procedures start with the next paragraph. Procedures may be done individually or in any order.



Allow the instrument to warm up for at least 30 minutes prior to beginning performance tests.

---

---

## DC Calibrator Test

The DC CALIBRATOR output on the rear panel is used for self-calibration and probe calibration. Though calibrator accuracy is not specified in the performance specifications, it must be within limits in order to provide accurate self-calibration.

**Test Limits** 5.000 V  $\pm$ 1 mV

**Equipment Required** The following equipment is required for this test. Procedures are based on the model or part number recommended.

Equipment Required	Critical specifications	Recommended Model/Part
Digital Multimeter	0.1 mV resolution, better than 0.005% accuracy	HP 3478A

- Procedure**
1. Connect the multimeter to the rear panel DC CALIBRATOR output.
  2. Press UTIL then service menu, then press cal select to select cal select 4 (4. DAC reference adjust). Press dac output to select low view.
  3. The DVM should read close to 0.0000 V. Record the reading to four decimal places. V1 = \_\_\_\_\_.
  4. Press dac output to select high adj. The DVM should read near 5.000 V. V2 = \_\_\_\_\_.
  5. Subtract V1 from V2. The difference should be between 4.9990 and 5.0010 V. Record the reading in the performance test record.

---

**Note**  If the difference is not within the limits, perform the DC CAL Adjustment procedure in the Adjustments section of this manual.

---

## Input Resistance

This test checks the input resistance of the vertical inputs. A four-wire measurement is used for accuracy at 50  $\Omega$ .

**Specification** 1 M $\Omega$   $\pm$ 1% and 50  $\Omega$   $\pm$ 1%

**Equipment Required** The following equipment is required for this test. Procedures are based on the model or part number recommended.

Equipment Required	Critical specifications	Recommended Model/Part
Digital Multimeter	Measure resistance (4-wire) better than 0.25% accuracy	HP 3478A
Cables (2)	BNC	HP 10503A
Adapter	BNC Tee (m)(f)(f)	HP 1250-0781
Adapter (2)	BNC (f) to banana (m)	HP 1251-2277

## Procedure

1. Set up the multimeter to make a four-wire resistance measurement.
2. Use the BNC-to-banana adapters to connect one end of each BNC cable to the four-wire resistance connections on the multimeter, and connect the free ends of the cables to the BNC tee.
3. Connect the male end of the BNC tee to the channel 1 input of the HP 54502A.
4. Press **CHAN** and select channel 1 with the top softkey.
5. Use the impedance softkey (second from bottom) to select 1 M $\Omega$ , then 50 $\Omega$  DC, and verify resistance readings of 1 M $\Omega$   $\pm$ 10 k $\Omega$  and 50  $\Omega$   $\pm$ 0.5  $\Omega$  respectively. Record the readings in the performance test record.
6. Connect the BNC tee to the channel 2 input.
7. Select channel 2.
8. Select 1 M $\Omega$ , then 50 $\Omega$  DC, and verify resistance readings of 1 M $\Omega$   $\pm$ 10 k $\Omega$  and 50  $\Omega$   $\pm$ 0.5  $\Omega$  respectively for channel 2. Record the readings in the performance test record.

## Voltage Measurement Accuracy

This test verifies the voltage measurement accuracy of the instrument. A dual cursor measurement is made so offset errors are not a factor.

**Specification** Dual Cursor:  $\pm(2.0\% \text{ of full scale} + 0.032 \times \text{V/div})$   
 Single Cursor:  $\pm(2.0\% \text{ of full scale} + \text{offset accuracy} + 0.016 \times \text{V/div})$

**Equipment Required** The following equipment is required for this test. Procedures are based on the model or part number recommended.

Equipment Required	Critical specifications	Recommended Model/Part
Power Supply	14 mV to 35 Vdc, 0.1 mV resolution	HP 6114A
Digital Multimeter	Better than 0.1% accuracy	HP 3478A
Cable	BNC	HP 10503A
Adapter	BNC (f) to banana (m)	HP 1251-2277
Shorting cap	BNC	HP 1250-0774

## Procedure

1. Use the banana-to-BNC adapter to connect the BNC cable to the power supply. Monitor the supply with the DVM.
2. Press RECALL then CLEAR to set HP 54502A to default conditions, then set the following parameters.

MENU	SELECTION	SETTING
DISPLAY	# of avg	32
$\Delta t \Delta V$	$\Delta V$ markers	on

3. Use the following table for the next steps.

RANGE	OFFSET	SUPPLY	TOLERANCE	LIMITS
5 V	17.5 V	35.0 V	$\pm 0.96 \text{ V}$	34.04 V to 35.96 V
2 V	7.0 V	14.00 V	$\pm 0.38 \text{ V}$	13.62 V to 14.38 V
1 V	3.5 V	7.00 V	$\pm 0.19 \text{ V}$	6.81 V to 7.19 V
500 mV	1.75 V	3.50 V	$\pm 0.096 \text{ V}$	3.404 V to 3.596 V
200 mV	700 mV	1.400 V	$\pm 0.038 \text{ V}$	1.362 V to 1.438 V
100 mV	350 mV	700 mV	$\pm 19.2 \text{ mV}$	680.8 mV to 719.2 mV
50 mV	175 mV	350 mV	$\pm 9.6 \text{ mV}$	340.4 mV to 359.6 mV
20 mV	70 mV	140.0 mV	$\pm 3.8 \text{ mV}$	136.2 mV to 143.8 mV
10 mV	35 mV	70.0 mV	$\pm 1.9 \text{ mV}$	68.1 mV to 71.9 mV
5 mV	17.5 mV	35.0 mV	$\pm 1.3 \text{ mV}^*$	33.7 mV to 36.3 mV
2 mV	7.0 mV	14.0 mV	$\pm 1.2 \text{ mV}^*$	12.8 mV to 15.2 mV

\* Below 7 mV/div expansion is used and full scale is defined as 56 mV.

4. Press CHAN and set the V/div range and offset per the first line of the table.
5. With supply disconnected from channel input (see note below), press  $\Delta$   $\Delta$ V and set Vmarker 1 to overlay the trace near the bottom of the display.

**Note:** For 5 mV/div and 2 mV/div ranges, place the shorting cap on the channel input.

6. Set power supply per the first line of the table.

**Note:** For 5 mV/div and 2 mV/div ranges, it is necessary to disconnect the DVM after verifying the output of the supply. This avoids coupling noise into the channel.

7. Connect the power supply to the channel input and set Vmarker 2 to overlay the trace near the top of the display.
8. The  $\Delta$  V(1) reading at the bottom of the display should be within the limits given in the table. Record the reading in the test record.
9. Repeat steps 4 through 8 for line 2 of the table and the rest of the ranges of channel 1.
10. Press CHAN and set channel 1 off and channel 2 on.
11. Repeat steps 3 through 9 for channel 2.



Voltage measurement errors can be caused by the need for self calibration. Perform self calibration, 0. vertical cal, (see Adjustment procedures, section 4) before troubleshooting instrument. If self-calibration fails to correct problem, the cause may be the attenuator or main assembly.

---

**Offset Accuracy** This test verifies offset accuracy.

**Specification**  $\pm(2 \text{ mV} + 2\% \text{ of channel offset} + 2.5\% \text{ of full scale})$

**Equipment Required** The following equipment is required for this test. Procedures are based on the model or part number recommended.

Equipment Required	Critical specifications	Recommended Model/Part
Power Supply	0.5 V to 2 Vdc, $\pm 1 \text{ mV}$ accuracy	HP 6114A
Cable	BNC	HP 10503A
Adapter	BNC (f) to banana (m)	HP 1251-2277

- Procedure**
1. Use the banana-to-BNC adapter to connect the BNC cable between the power supply and channel 1 input.
  2. Press **RECALL** then **CLEAR** to set HP 54502A to default conditions. Press **DISPLAY** and set # of avg to 32.
  3. Use the following table for the next steps.

RANGE	OFFSET	SUPPLY	TOLERANCE	LIMITS
200 mV	2.00000 V	2.00 V	$\pm 82 \text{ mV}$	1.918 to 2.082 V
100 mV	1.00000 V	1.00 V	$\pm 42 \text{ mV}$	0.958 to 1.042 V
50 mV	500.000 mV	500 mV	$\pm 22 \text{ mV}$	478 to 522 mV

4. Press **CHAN** and set for **200 mV/div** and **2.00000 V** offset per first line of table.
5. Set the supply to 2.00 V per the first line.
6. Readjust **offset** so the trace is as close to the horizontal center line of the graticule as possible after it has settled (averaging complete).
7. Read the offset voltage. It should be at its original setting, within the limits given in the table. Record the reading.
8. Repeat steps 4 through 7 for the 100 mV and 50 mV ranges using the appropriate range, offset, and supply voltage in the table.
9. Connect the power supply to the channel 2 input.
10. Turn channel 1 **off** and channel 2 **on** and repeat steps 3 through 8 for channel 2.



Offset errors can be caused by the need for self calibration. Perform self calibration, **0. vertical cal**, (see Adjustments) before troubleshooting instrument. If self calibration fails to correct problem, the cause may be the attenuator or main assembly.

## Bandwidth

This test checks the repetitive and real time bandwidths of the HP 54502A.

### Specification

Bandwidth: dc coupled  
Repetitive - dc to 400 MHz  
Real time - dc to 100 MHz

### Equipment Required

The following equipment is required for this test. Procedures are based on the model or part number recommended.

Equipment Required	Critical specifications	Recommended Model/Part
Signal Generator	1 - 400 MHz at $\approx 170$ mVrms	HP 8656B
Power Meter/ Sensor	1 - 400 MHz $\pm 3\%$ accuracy	HP 436A/8482A
Power Splitter	outputs differ by $< 0.15$ dB	HP 11667B
Cable	Type N (m) 24 inch	HP 11500B
Adapter	Type N (m) to BNC (m)	HP 1250-0082

### Procedure

1. With the N cable, connect the signal generator to the power splitter input. Connect the power sensor to one output of the power splitter.
2. Using an N-to-BNC adapter, connect the other power splitter output to the channel 1 input.
3. Press **RECALL** then **CLEAR** to set default conditions, then set the following parameters.

MENU	SELECTION	SETTING
TIMEBASE	(time/div)	200 ns/div
CHAN 1	(sensitivity)	40 mV/div
	(input R)	50 $\Omega$ DC
DISPLAY	# of avg	32

4. Set the signal generator for 1 MHz at -2.4 dBm. The signal on screen should be two cycles at six divisions amplitude.
5. Press **SHIFT** (blue), **V P-P**, and **1** to make an automatic peak-to-peak measurement.
6. After the measurement settles (averaging complete, about 10 seconds) note the **Vp-p (1)** reading (bottom of screen):  $V_{1\text{MHz}} = \underline{\hspace{2cm}}$  mV.
7. Set power meter Cal Factor % to 1 MHz value from the cal chart on the probe, then press **dB[REF]** to set a 0 dB reference.
8. Change signal generator to 100 MHz and set power meter Cal Factor to 100 MHz % value from chart.
9. Adjust signal generator amplitude for a power reading as close as possible to 0.0 dB(REL). Reading =  $\underline{\hspace{2cm}}$ .
10. Press **TIME BASE** and set to 2 ns/div.



11. After the measurement settles (averaging complete) note the **Vp-p (1)** reading:  $V_{100\text{MHz}} = \underline{\hspace{2cm}}$  mV.

12. Calculate the response using the formula:

$$\text{response(dB)} = 20 \log_{10} \frac{V_{100\text{MHz}}}{V_{1\text{MHz}}} = 20 \log_{10} \underline{\hspace{2cm}} = \underline{\hspace{2cm}} \text{dB}$$

13. Correct the result from step 12 with any difference in the power meter from step 9. Observe signs. For example:

Result from step 12 = -2.3 dB  
Power meter reading = -0.2 dB(REL)  
then true response = (-2.3)-(-0.2) = -2.1 dB

$$(\underline{\hspace{2cm}}) - (\underline{\hspace{2cm}}) = \underline{\hspace{2cm}} \text{dB}$$

14. The result from step 13 should be  $\leq -3.0$  dB. Record the result in the Performance Test Record.

15. Press TIMEBASE and set 200 ns/div and select **repetitive**.

16. Set the signal generator for 1 MHz at -2.4 dBm. The signal on screen should be two cycles at six divisions amplitude. Adjust signal generator for six divisions of amplitude if necessary.

17. After the measurement settles (averaging complete, about 10 seconds) note the **Vp-p (1)** reading:  $V_{1\text{MHz}} = \underline{\hspace{2cm}}$  mV.

18. Set power meter Cal Factor % to 1 MHz value from the cal chart on the probe, then press dB[REF] to set a 0 dB reference.

19. Change signal generator to 400 MHz and set power meter Cal Factor to 400 MHz % value from chart.

20. Adjust signal generator amplitude for a power reading as close as possible to 0.0 dB(REL). Reading =  $\underline{\hspace{2cm}}$ .

21. Press TIME BASE and set to 1ns/div.

22. After the measurement settles (averaging complete) note the **Vp-p (1)** reading:  $V_{400\text{MHz}} = \underline{\hspace{2cm}}$  mV.

23. Calculate the response using the formula:

$$\text{response(dB)} = 20 \log_{10} \frac{V_{400\text{MHz}}}{V_{1\text{MHz}}} = 20 \log_{10} \underline{\hspace{2cm}} = \underline{\hspace{2cm}} \text{dB}$$

24. Correct the result in step 23 with any difference in the power meter from step 20. Observe signs.

(step 23) - (step 20) = true response

$$(\underline{\hspace{2cm}}) - (\underline{\hspace{2cm}}) = \underline{\hspace{2cm}} \text{dB}$$

25. The result from step 24 should be  $\leq -3.0$  dB. Record the result in the Performance Test Record.

26. Switch the power splitter from channel 1 to channel 2 input.

27. On the HP 54502A, set the following parameters.

MENU	SELECTION	SETTING
TIMEBASE	(time/div)	200 ns/div
	(mode)	realtime
CHAN	1	off
	2	on
	(sensitivity)	40 mV/div
	(input R)	50Ω DC
TRIG	source	2

28. Press SHIFT (blue) then CLEAR, then repeat steps 4 through 25 for channel 2, setting channel 2 parameters where appropriate.



Failure of the bandwidth test can be caused by faulty attenuator or main assembly, or the need for high-frequency pulse response adjustment.

## Time Measurement Accuracy

This test uses a precise frequency source to check the accuracy of time measurement functions.

### Specification

Delta-t accuracy

Repetitive:  $\pm(2.0\% \times s/\text{div} + 0.01\% \times \text{delta-t} + 250 \text{ ps})$

Real-time:  $\pm(2.0\% \times s/\text{div} + 0.01\% \times \text{delta-t} + 500 \text{ ps})$

### Equipment Required

The following equipment is required for this test. Procedures are based on the model or part number recommended.

Equipment Required	Critical specifications	Recommended Model/Part
Signal Generator	1 MHz and 400 MHz, timebase accuracy - 20 ppm	HP 8656B
Cable Adapter	50 Ω BNC 24 inch Type N (m) to BNC (f)	HP 10503A HP 1250-0780

### Procedure

1. Set the signal generator to 400 MHz and approximately 150 mVrms.
2. Connect the signal generator to the channel 1 input, press CHAN and set input R to 50Ω DC.
3. Press AUTOSCALE, then set the following parameters.

MENU	SELECTION	SETTING
TIMEBASE	(time/div)	1 ns/div
	(mode)	repetitive
DISPLAY	# of avg	128

4. Press TRIG and adjust trigger level so positive edge of signal crosses the graticule exactly at center screen. For more control, set knob to fine.

5. Use the following table for the next steps.

DELAY	TOLERANCE	LIMITS
2.5 ns	±270 ps	2.230 to 2.770 ns
5.0 ns	±270 ps	4.730 to 5.270 ns
10.0 ns	±271 ps	9.729 to 10.271 ns
20.0 ns	±272 ps	19.728 to 20.272 ns
40.0 ns	±274 ps	39.726 to 40.274 ns
100.0 ns	±280 ps	99.720 to 100.280 ns
250.0 ns	±295 ps	249.705 to 250.295 ns

6. Press **TIME BASE** then **delay**. For the first line of the table, use the entry keys to set the delay, then use the knob to set the positive edge of the signal at center screen.
7. Check that the delay value is within the limits in the table. Record the result.
8. Repeat for the other delays in the table and record each result.
9. Set the signal generator to 1 MHz and press **AUTOSCALE**.
10. Press **TIME BASE**, set **200 ns/div**, and select **realtime**.
11. Press **TRIG** and set trigger level so positive edge of signal crosses exactly at center screen.
12. Press **TIME BASE**, then **delay**, and use the entry keys to enter **1 ms delay**.
13. Use the knob to set the positive edge of the signal to center screen. The delay should read **1.00000 ms ±104.5 ns, 999.896 us to 1.00010 ms**. Record the reading.

**Note** 

---

Time Measurement Accuracy failure is caused by a defective main assembly.

---

## Trigger Sensitivity

This test checks channel and external triggers for sensitivity at rated bandwidth.

### Specification

Internal - dc to 100 MHz  
Real time and repetitive:  $0.063 \times$  full scale

Internal - 100 to 400 MHz  
Real time: N/A  
Repetitive:  $0.125 \times$  full scale

External - dc to 250 MHz  
 $100 \text{ mV}_{p-p}$  into  $50 \Omega$

### Equipment Required

The following equipment is required for this test. Procedures are based on the model or part number recommended.

Equipment Required	Critical specifications	Recommended Model/Part
Signal Generator	100 and 400 MHz, 30-80 $\text{mV}_{rms}$ output	HP 8656B
Power Splitter	outputs differ by $< 0.15 \text{ dB}$	HP 11667B
Cable	Type N (m) 24 inch	HP 11500B
Cable	$50 \Omega$ BNC 9 inch	HP 10502A
Adapter	Type N (f) to BNC (m)	HP 1250-0077
Adapter	Type N (m) to BNC (f)	HP 1250-0780
Adapter	Type N (m) to BNC (m)	HP 1250-0082

### Procedure INTERNAL TRIGGER

1. Press **RECALL** then **CLEAR** to set default conditions, then set the following parameters.

MENU	SELECTION	SETTING
TIMEBASE	(time/div)	2 ns/div
	(mode)	repetitive
CHAN	1	on
	2	off
(both)	(sensitivity)	200 $\text{mV}/\text{div}$
	(input R)	$50 \Omega$ DC
DISPLAY	# of avg	16

2. With an N cable and N-to-BNC adapter, connect signal generator to channel 1 input BNC.
3. Set signal generator to 100 MHz and adjust output level for 0.5 division of vertical deflection. (The  $\Delta V$  markers can be used to set a 0.5 div reference. Turn  $\Delta V$  on and set one marker to  $+50 \text{ mV}$  and the other to  $-50 \text{ mV}$ .)
4. Press **TRIG** and adjust trigger level for a stable display. The test passes if triggering is stable.

5. Set signal generator frequency to 400 MHz and amplitude for 1 division of vertical deflection.
6. Press TRIG and adjust trigger level for a stable display. The test passes if triggering is stable.
7. Connect signal generator to channel 2 input BNC.
8. Press CHAN and set channel 1 off and channel 2 on. Press TRIG and set source to 2.
9. Repeat steps 3 through 6 for channel 2.

#### EXTERNAL TRIGGER

10. With the N cable, connect the signal generator to the power splitter input. Using an N-to-BNC adapter, connect one splitter output to the channel 1 input. With the other N-to-BNC adapter and BNC cable, connect the remaining splitter output to the EXT TRIG input.
11. Press CHAN and select EXT. Set external input R to 50 $\Omega$  DC
12. Set the signal generator for 250 MHz at approximately 70 mVrms and press AUTOSCALE.
13. Set the signal generator amplitude for 100 mVp-p on the display.
14. Press TRIG and then source (twice) to select EXT.
15. Adjust trigger level for a stable display. Test passes if triggering is stable.



Channel trigger sensitivity test failure is caused by a defective main assembly or attenuator. Failure of external trigger sensitivity is caused by the main assembly.

---

---

## Oscillator Output Check

These tests are optional. The oscillator outputs are not specified in the instrument performance specifications. The values given are typical. Results are not recorded in the test record.

### Equipment Required

Equipment requirement is not critical and choices are at the discretion of the user. A high quality oscilloscope should be sufficient.

### Procedure

1. Use a BNC cable to connect the rear panel AC CALIBRATOR output to the channel 1 input of the HP 54502A under test and press AUTO-SCALE.
2. Make automatic measurements of the signal. Press blue (shift), V P-P, then 1 for amplitude and blue, FREQ, then 1 for frequency.
3. Signal into 1 M $\Omega$  should be an approximately 800 mV square wave at approximately 500 Hz. Into 50  $\Omega$  the amplitude is approximately 400 mV.
4. Disconnect the AC CALIBRATOR from the channel 1 input and connect it to another oscilloscope.
5. Press UTIL, service menu, then cal select to select cal select 3, (3. oscillator output).
6. Select **processor clock**. The signal should be approximately 983 kHz and 800 mV<sub>p-p</sub> into 1 M $\Omega$ .
7. Select **timebase clock**. The signal should be approximately 10 MHz and 800 mV<sub>p-p</sub> into 1 M $\Omega$ .

**Table 3-1. Performance Test Record**

	<b>HEWLETT PACKARD</b>	<b>HP 54510A Digitizing Oscilloscope</b>
Serial No. _____		Tested by _____
Recommended Test Interval - 1 Year/2000 hours		Work Order No. _____
Recommended next testing _____		Date _____
		Temperature _____

Test	Limits	Results																																																								
Calibrator Amplitude	4.9990 to 5.0010 Vdc	_____																																																								
Input Resistance	1MΩ    990K to 1.010M 50Ω     49.50 to 50.50	<table style="width: 100%; border: none;"> <tr> <td style="width: 50%; text-align: center;">CHAN 1</td> <td style="width: 50%; text-align: center;">CHAN 2</td> </tr> <tr> <td style="text-align: center;">_____</td> <td style="text-align: center;">_____</td> </tr> <tr> <td style="text-align: center;">_____</td> <td style="text-align: center;">_____</td> </tr> </table>	CHAN 1	CHAN 2	_____	_____	_____	_____																																																		
CHAN 1	CHAN 2																																																									
_____	_____																																																									
_____	_____																																																									
Voltage Measurement Accuracy	<table style="width: 100%; border: none;"> <tr> <td style="width: 15%;">RANGE</td> <td style="width: 15%;">READING</td> <td style="width: 15%;">LIMITS</td> </tr> <tr> <td>5 V</td> <td>35 V</td> <td>34.04 V to 35.96 V</td> </tr> <tr> <td>2 V</td> <td>14 V</td> <td>13.62 V to 14.38 V</td> </tr> <tr> <td>1 V</td> <td>7 V</td> <td>6.81 V to 7.19 V</td> </tr> <tr> <td>500 mV</td> <td>3.50 V</td> <td>3.404 V to 3.596 V</td> </tr> <tr> <td>200 mV</td> <td>1.4 V</td> <td>1.362 V to 1.438 V</td> </tr> <tr> <td>100 mV</td> <td>700 mV</td> <td>680.8 mV to 719.2 mV</td> </tr> <tr> <td>50 mV</td> <td>350 mV</td> <td>340.4 mV to 359.6 mV</td> </tr> <tr> <td>20 mV</td> <td>140 mV</td> <td>136.2 mV to 143.8 mV</td> </tr> <tr> <td>10 mV</td> <td>70 mV</td> <td>68.1 mV to 71.9 mV</td> </tr> <tr> <td>5 mV</td> <td>35 mV</td> <td>33.7 mV to 36.3 mV</td> </tr> <tr> <td>2 mV</td> <td>14 mV</td> <td>12.8 mV to 15.2 mV</td> </tr> </table>	RANGE	READING	LIMITS	5 V	35 V	34.04 V to 35.96 V	2 V	14 V	13.62 V to 14.38 V	1 V	7 V	6.81 V to 7.19 V	500 mV	3.50 V	3.404 V to 3.596 V	200 mV	1.4 V	1.362 V to 1.438 V	100 mV	700 mV	680.8 mV to 719.2 mV	50 mV	350 mV	340.4 mV to 359.6 mV	20 mV	140 mV	136.2 mV to 143.8 mV	10 mV	70 mV	68.1 mV to 71.9 mV	5 mV	35 mV	33.7 mV to 36.3 mV	2 mV	14 mV	12.8 mV to 15.2 mV	<table style="width: 100%; border: none;"> <tr> <td style="width: 50%; text-align: center;">CHAN 1</td> <td style="width: 50%; text-align: center;">CHAN 2</td> </tr> <tr> <td style="text-align: center;">_____</td> <td style="text-align: center;">_____</td> </tr> <tr> <td style="text-align: center;">_____</td> <td style="text-align: center;">_____</td> </tr> <tr> <td style="text-align: center;">_____</td> <td style="text-align: center;">_____</td> </tr> <tr> <td style="text-align: center;">_____</td> <td style="text-align: center;">_____</td> </tr> <tr> <td style="text-align: center;">_____</td> <td style="text-align: center;">_____</td> </tr> <tr> <td style="text-align: center;">_____</td> <td style="text-align: center;">_____</td> </tr> <tr> <td style="text-align: center;">_____</td> <td style="text-align: center;">_____</td> </tr> <tr> <td style="text-align: center;">_____</td> <td style="text-align: center;">_____</td> </tr> <tr> <td style="text-align: center;">_____</td> <td style="text-align: center;">_____</td> </tr> </table>	CHAN 1	CHAN 2	_____	_____	_____	_____	_____	_____	_____	_____	_____	_____	_____	_____	_____	_____	_____	_____	_____	_____
RANGE	READING	LIMITS																																																								
5 V	35 V	34.04 V to 35.96 V																																																								
2 V	14 V	13.62 V to 14.38 V																																																								
1 V	7 V	6.81 V to 7.19 V																																																								
500 mV	3.50 V	3.404 V to 3.596 V																																																								
200 mV	1.4 V	1.362 V to 1.438 V																																																								
100 mV	700 mV	680.8 mV to 719.2 mV																																																								
50 mV	350 mV	340.4 mV to 359.6 mV																																																								
20 mV	140 mV	136.2 mV to 143.8 mV																																																								
10 mV	70 mV	68.1 mV to 71.9 mV																																																								
5 mV	35 mV	33.7 mV to 36.3 mV																																																								
2 mV	14 mV	12.8 mV to 15.2 mV																																																								
CHAN 1	CHAN 2																																																									
_____	_____																																																									
_____	_____																																																									
_____	_____																																																									
_____	_____																																																									
_____	_____																																																									
_____	_____																																																									
_____	_____																																																									
_____	_____																																																									
_____	_____																																																									
Offset Accuracy	<table style="width: 100%; border: none;"> <tr> <td style="width: 15%;">RANGE</td> <td style="width: 15%;">OFFSET</td> <td style="width: 15%;">LIMITS</td> </tr> <tr> <td>200 mV</td> <td>2.0 V</td> <td>1.918 to 2.082 V</td> </tr> <tr> <td>100 mV</td> <td>1.0 V</td> <td>0.958 to 1.042 V</td> </tr> <tr> <td>50 mV</td> <td>500 mV</td> <td>478 to 522 mV</td> </tr> </table>	RANGE	OFFSET	LIMITS	200 mV	2.0 V	1.918 to 2.082 V	100 mV	1.0 V	0.958 to 1.042 V	50 mV	500 mV	478 to 522 mV	<table style="width: 100%; border: none;"> <tr> <td style="width: 50%; text-align: center;">CHAN 1</td> <td style="width: 50%; text-align: center;">CHAN 2</td> </tr> <tr> <td style="text-align: center;">_____</td> <td style="text-align: center;">_____</td> </tr> <tr> <td style="text-align: center;">_____</td> <td style="text-align: center;">_____</td> </tr> <tr> <td style="text-align: center;">_____</td> <td style="text-align: center;">_____</td> </tr> </table>	CHAN 1	CHAN 2	_____	_____	_____	_____	_____	_____																																				
RANGE	OFFSET	LIMITS																																																								
200 mV	2.0 V	1.918 to 2.082 V																																																								
100 mV	1.0 V	0.958 to 1.042 V																																																								
50 mV	500 mV	478 to 522 mV																																																								
CHAN 1	CHAN 2																																																									
_____	_____																																																									
_____	_____																																																									
_____	_____																																																									

**Table 3-1. Performance Test Record (cont'd)**

Test	Limits	Results	
		CHAN 1	CHAN 2
Bandwidth	Real time	down <3.0 dB at 100 MHz	_____
	Repetitive	down <3.0 dB at 400 MHz	_____
Time Measurement Accuracy	2.5 ns	2.230 to 2.770 ns	_____
	5.0 ns	4.730 to 5.270 ns	_____
	10.0 ns	9.729 to 10.271 ns	_____
	20.0 ns	19.728 to 20.272 ns	_____
	40.0 ns	39.726 to 40.274 ns	_____
	100.0 ns	99.720 to 100.280 ns	_____
	250.0 ns	249.705 to 250.295 ns	_____
	1 ms	999.894 us to 1.00010 ms	_____
Trigger Sensitivity	Channels	0.5 div at 100 MHz	_____
		1.0 div at 400 MHz	_____
	External	100 mV p-p at 250 MHz	_____



# Contents

---

<b>Section 4</b>	<b>Adjustments</b>	
	Introduction .....	4-1
	Equipment Required .....	4-1
	Calibration Interval .....	4-1
	Cal RAM Checksum Error .....	4-1
	Key-down Powerup .....	4-2
	Operating Hints .....	4-2
	Adjustment Procedures .....	4-2
	Power Supply Adjustment .....	4-3
	Main Assembly Adjustments .....	4-5
	Extender Cable Installation .....	4-5
	DAC Reference Adjustment .....	4-5
	Default Calibration Load .....	4-6
	Low Frequency Adjustment .....	4-7
	High-Frequency Pulse Adjustment .....	4-8
	Firmware Calibration .....	4-9
	CRT Monitor Assembly Adjustment .....	4-11



# Adjustments

---

## Introduction

This section provides hardware and firmware adjustment procedures for the HP 54502A. Primary adjustment groups are:

- Power Supply Adjustment
  - Main Assembly Adjustment
  - CRT Monitor Assembly Adjustment.
- 

## Equipment Required

Equipment required for adjustments is listed in the Recommended Test Equipment table in section 1 of this manual. Any equipment that satisfies the critical specification listed in the table may be substituted for the recommended model. Equipment for individual procedures is listed at the procedure.

---

## Calibration Interval

There are two levels of calibration for the HP 54502A. At the first level, one set of firmware cals, those in the self cal menu, should be done by the user or service department under any of the following conditions:

- at six month intervals or every 1,000 hours
- if the ambient temperature changes more than 10°C from the temperature at full calibration
- to optimize measurement accuracy

Though in this adjustment section default cals are loaded before self-calibration, it is not required. Self-calibration procedures take only cables and as stated above, the user could perform them. However, it is necessary to UNPROTECT the calibration which may not be allowed in some circumstances. To do these calibrations, follow the Self Cal Menu Calibrations procedure in the Firmware Calibration later in this section.

At the second level is a full calibration. Full calibration should be done every year or 2,000 hours, whichever comes first. This includes all firmware calibration and hardware calibration (with exceptions noted at certain procedures).

The necessary calibration interval will also depend on the user's experience.

For replacement assemblies, adjustments are set at the factory when assemblies are tested. However, some adjustment may be necessary after an assembly has been put into the instrument. Usually the only assembly that requires adjustment is the assembly replaced.

---

## Cal RAM Checksum Error

If power is applied to the instrument and the message "cal ram checksum error re-cal instrument" is displayed, all firmware calibration procedures must be performed. See the Firmware Calibration procedure in this section.

If the instrument does not pass the firmware calibration, perform the entire adjustment procedure in this section. If adjustment cannot be made within specified limits, repair is necessary.

---

## Key-down Powerup

A key-down powerup is a procedure used to reset or preset the instrument to default conditions and prevent previous setups from interfering with the next test. It also simplifies the instrument setup procedure. Any front-panel key is held depressed while cycling power with the rear-panel power switch. The key is held depressed until the display returns.

---

## Operating Hints

Some knowledge of operation of the HP 54502A is helpful; however, procedures are written so that little experience is necessary. The following hints will speed progress of the procedures.

When using many averages, it often takes awhile for a waveform display to stabilize after a change. When a front panel control on the HP 54502A is changed, averaging automatically restarts. When the input signal or an adjustment is changed, the instrument must average new data with the old so it takes longer for the waveform to stabilize. Press CLEAR DISPLAY while changing input signals or adjustments. The instrument will restart averaging and give a quick indication of the result of the change.

---

## Adjustment Procedures

The adjustment procedures start with the next paragraphs. Unless specified elsewhere, procedures must be followed in the order given. Display adjustments are optional and independent of other procedures.



An instrument warm-up of 30 minutes is recommended before starting adjustment procedures.



Read the Safety Considerations at the beginning of this manual before performing adjustment procedures.

---

# Power Supply Adjustment

## Equipment Required

Equipment Required	Critical Specifications	Recommended Model/Part
Digital Voltmeter	Accuracy $\pm 0.05\%$	HP 3478A

1. Disconnect power cord from HP 54502A. Refer to figure below for testpoint and adjustment locations.

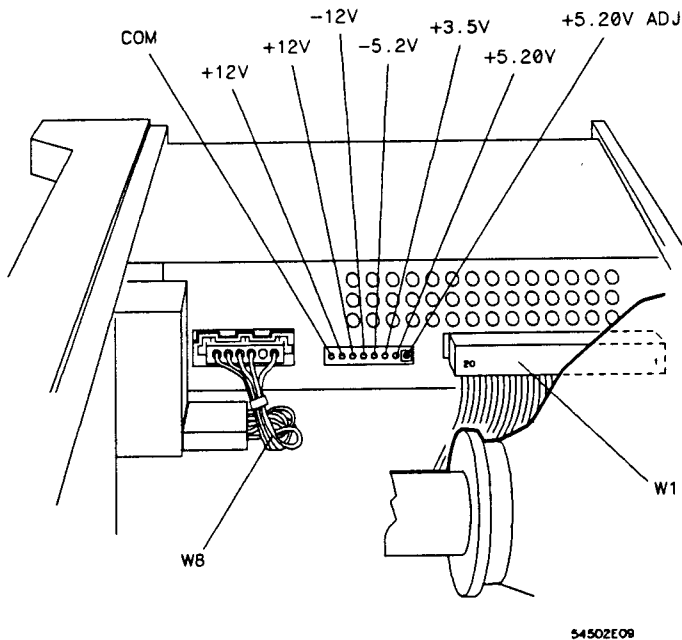

**Figure 4-1. Power Supply Adjustment Locations**

2. Connect the common lead of the voltmeter to COM test point.
3. Connect the positive lead of the voltmeter to +5.20V test point.
4. Connect the HP 54502A power cord and set power switch to ON.
5. If voltmeter does not read between 5.180 V and 5.220 V, adjust +5.20 ADJ for 5.200 V.

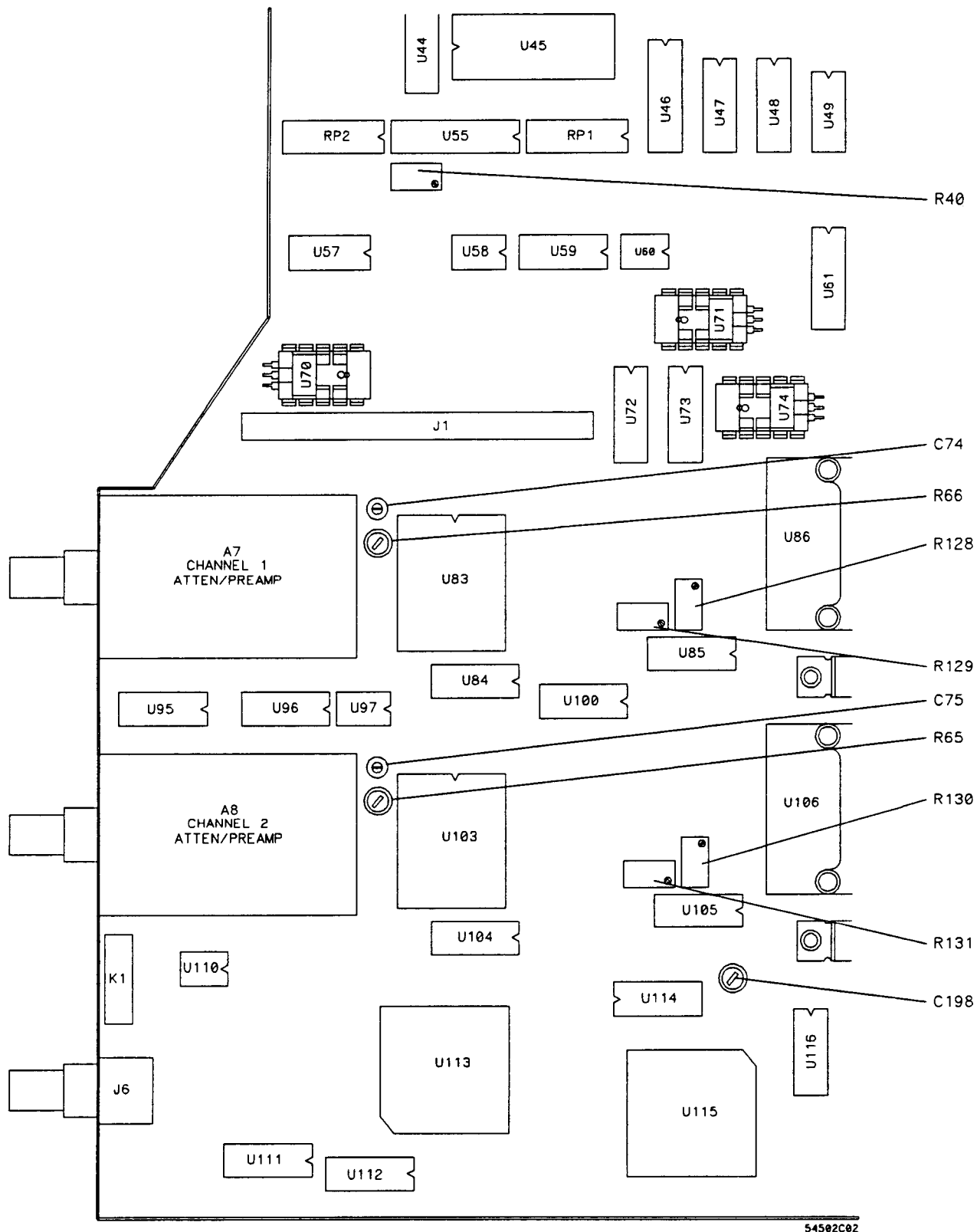

Figure 4-2. Main Assembly Adjustment Locations

## Main Assembly Adjustments

### Extender Cable Installation

Main assembly adjustment can be done with the power supply in place. However, moving the supply and using it on the extender cable allows easier access to the adjustments. The extender cable is not supplied with the instrument but must be ordered separately.

**Equipment Required:** Extender Cable, HP 54503-61604

### Note

The use of an external fan on the power supply prevents the possibility of thermal cut-out of the supply.

### Procedure:

1. Remove power cord and top cover.
2. Disconnect power supply cables from line filter and Main Assembly.
3. Remove locking pins from power supply and slide supply out of cabinet.
4. Connect the Extender Cable between power supply and Main Assembly.
5. Reconnect line filter cable to power supply.
6. Connect power cable and apply power.

### DAC Reference Adjustment

The DAC reference adjustment sets the accuracy of the voltage standard used to calibrate the instrument. This standard is used for the vertical (gain and offset) and trigger calibration of the self cal menus as well as probe attenuation calibration.

The DAC reference is set for an accurate difference (5.0000 V) between its low and high values.

### Equipment Required:

Equipment Required	Critical Specifications	Recommended Model/Part
Digital Voltmeter	Accuracy $\pm 0.05\%$	HP 3478A

### Procedure:

1. Press UTIL key then service menu.
2. Press cal select to select cal select 4 (4. DAC reference adjust).
3. Press dac output to select high adj.
4. Connect DVM to rear panel DC CALIBRATOR OUTPUT.
5. Adjust main assembly adjustment R40 for DVM indication of 5.0000 V. Refer to figure 4-2 for adjustment location.

6. Press **dac output** to select **low view**.
7. Measure the voltage to four decimal places, 0.\_\_\_\_ V and add to 5.0000 V.  
Result = 5.\_\_\_\_ V.
8. Press **dac output** to select **high adj**.
9. Adjust R40 so DVM indicates the voltage result from step 7.
10. Press **exit menu** to return oscilloscope to **UTILITY** menu.

### **Default Calibration Load**

The default calibration factors are loaded to give a known base for the following hardware and firmware calibration.

---



Once the default cals are loaded, all firmware calibrations must be done. This includes the cals in the self cal menu (0. vertical cal and 1. delay & repetitive cal), as well as those in the service menu (0. time null, 1. logic trigger delay cal, and 2. external trigger null).

Since all calibration must be done in order, firmware calibrations will be presented in the proper place in the procedures.

---

1. Press **UTIL** then **service menu**.
2. Press **cal select** several times to select **cal select 5** (5. default cal).
3. Set rear panel **CALIBRATION** switch to **UNPROTECTED** (up).
4. Press **start cal**. A caution message will be displayed indicating the cal RAM will be overwritten with default values.
5. Press **continue**.
6. The status message above the menu will indicate default cal has been loaded.
7. Leave rear panel switch in **UNPROTECTED** position for firmware calibration procedures to be performed later in this section.



## Low Frequency Adjustment

The low frequency gain adjustment matches low frequency gain to high frequency gain. The offset adjustment centers dc offset for the firmware calibration to be done later.

**Equipment Required:** BNC cable.

### Procedure

1. Connect the rear panel AC CALIBRATOR OUTPUT to the channel 1 input.
2. Press CHAN and set channel 1 input resistance to 50Ω DC.
3. Press AUTOSCALE, then set the following parameters.

MENU	SELECTION	SETTING
TIMEBASE	(time/div)	100 us/div
	delay	-50.0000 us
	reference	left
CHAN	(sensitivity)	100 mV/div
DISPLAY	# of avg	16
	(graticule)	grid

4. Adjust R128 for a flat pulse top such as the center trace in the figure below. (See locator, page 4-4.)

For easier judgement of flatness, use offset to position pulse top just below gridline.

Note that most flatness change occurs within 100 μs of front edge of pulse.

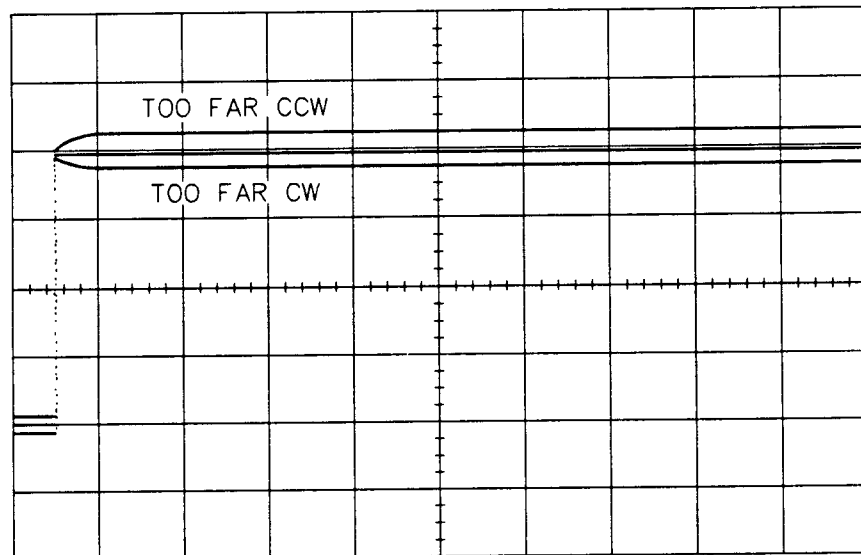

54502W47

5. Set offset to 0.00000 V and disconnect signal from channel input.
6. Adjust R129 so trace is at the center of the screen.
7. Set channel 1 off and channel 2 on.
8. Repeat steps 1 through 6 for channel 2, adjusting R130 for flatness and R131 for centering.

## High-Frequency Pulse Adjustment

This procedure optimizes pulse response so the instrument will meet the bandwidth specification.



This procedure **should not** be performed as a part of routine adjustments. Typically, Pulse adjustments need to be done only when the instrument fails the bandwidth performance test, when an attenuator has been changed, or when the main assembly has been changed (new combination of attenuators and PC board). Only adjust the channel(s) involved with the failure or repair.

### Equipment Required:

Equipment Required	Critical Specifications	Recommended Model/Part
Pulse Generator	$t_r \leq 70$ ps	Tektronix 284
Cable	BNC 50 $\Omega$	HP 10503A
Adapter	GR874 to BNC	General Radio

### Procedure:

Perform this procedure on necessary channel(s) only. Use the following adjustments; Channel 1, R66 and C74 – Channel 2, R65 and C75. (See locator, page 4-4, for adjustment locations.)

1. Connect pulse generator to channel input.
2. Press CHAN and set channel input resistance to 50 $\Omega$  DC.
3. Press AUTOSCALE, then set the following parameters.

MENU	SELECTION	SETTING
TIMEBASE	(time/div)	5 ns/div
	(mode)	repetitive
CHAN	(sensitivity)	45 mV/div
DISPLAY	# of avg	16
	(graticule)	grid

4. Preset resistor fully CCW.
5. If pulse edge is not on screen, Press TIME BASE and adjust delay.
6. Press CHAN and adjust offset to place the flat part of the pulse top over the grid line, one division from top of display.
7. Adjust capacitor to set top of first peak of pulse to gridline as shown below.

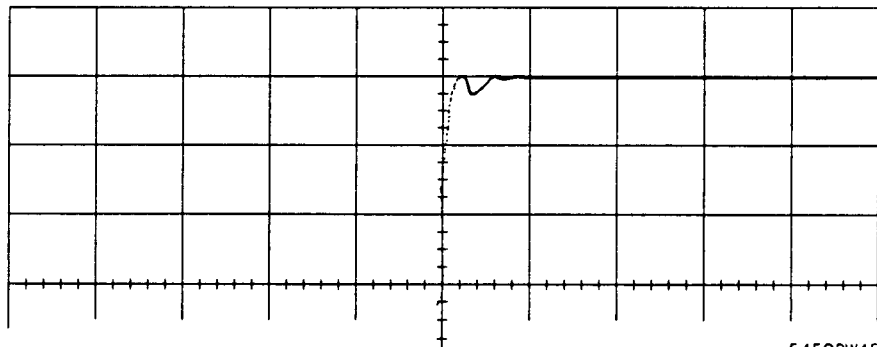

54502W45

- Adjust resistor to extend peak over the gridline so that overshoot is same amplitude as the ringing after it, as shown below.

When resistor is adjusted the gain changes. It may be necessary to use offset to reposition pulse top to the gridline.

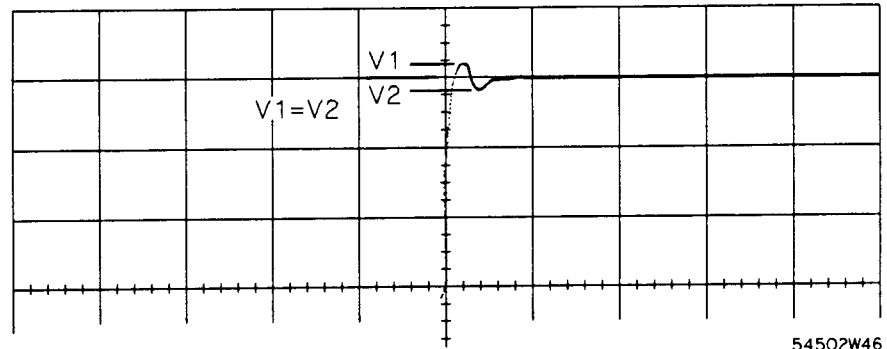

54502W46

There is no specification for pulse response. However, if overshoot is more than about 3% (about one minor division), use the resistor to reduce it slightly. If the instrument fails the bandwidth test, use the resistor to increase overshoot slightly.

- Repeat steps 1 through 8 on the other channel if necessary.
- Perform the bandwidth test (Performance Tests) on channels adjusted.

## Firmware Calibration

Firmware calibration uses signals generated in the instrument to calibrate channel sensitivity, offsets, and trigger parameters.

### Equipment Required:

Equipment Required	Critical Specifications	Recommended Model/Part
Cable	BNC 50 $\Omega$ 36 inch	HP 10503A
Cable (3)	BNC 50 $\Omega$ 9 inch (equal length)	HP 10502A
Adapter (2)	BNC tee (m)(f)(f)	HP 1250-0781
Adapter	BNC (f)(f)	HP 1250-0080

### Note

Rear panel CALIBRATION switch must be set to UNPROTECTED for these procedures. If the entire adjustment procedures are being performed, switch was set to UNPROTECTED in a previous procedure.

### Caution

The Firmware Calibration should only be done after the instrument has run for one half hour at ambient temperature with the cover installed.

### Self Cal Menu Calibrations

These calibrations can be done without loading default calibration factors. However, defaults have been loaded when these calibrations are part of the entire adjustment procedure.



These calibrations may be done individually but using **all** (when available) and connecting all inputs at once avoids operator interaction between calibrations.

If the entire calibration procedure fails while running **all**, run the calibrations individually. If one input is loading the cal signal (input stuck in 50  $\Omega$  for example), calibration will fail for all inputs. Individual calibration will isolate the failure.

---

1. Perform key-down powerup by cycling HP 54502A power while holding down any front-panel key.
2. Press **UTIL** then **self cal menu**. **Cal select 0** (0. vertical cal) should be selected.
3. Press **channel** to select **all**, then press **start cal** and follow the instructions on the display.
4. After completion of vertical cals, press **cal select** to select **cal select 1** (1. delay & repetitive cal).
5. Press **channel** to select channel 1, then press **start cal** and follow the instructions on the display.
6. When channel 1 calibration is complete, press **channel** to select channel 2, then press **start cal** and follow the instructions on the display.
7. Messages will be displayed as each calibration routine is completed to indicate calibration has passed or failed.

#### **Service Menu Calibrations**

1. Press **UTIL** then **service menu**.
2. Press **cal select** to select **cal select 0** (0. time null).
3. Press **start cal** and follow the instructions on the display.
4. When time null has passed, press **cal select** to select **cal select 1** (1. logic trigger delay cal).
5. Press **start cal** and follow the instructions on the display.
6. The first part of the calibration involves adjustment of the startable oscillator. Adjust C198 if the \* is on either side of the brackets: \*[ ] or [ ]\*. The frequency should be 100.0 MHz.
7. After adjustment, press **continue** and the instrument will perform the rest of this cal automatically.
8. When logic trigger delay cal has passed, press **cal select** to select **cal select 2** (2. external trigger null).
9. Press **start cal** and follow the instructions on the display.
10. After external trigger null has passed, switch rear-panel CALIBRATION switch to PROTECTED (down).

# CRT Monitor Assembly Adjustment

These adjustments optimize the characteristics of the CRT Display.



This procedure should not be performed as a part of routine maintenance. Perform the procedure only when the display has obvious differences from the example in the figure below. Skip parts of the procedure if the display meets the requirement.

1. Display CRT test pattern. Press UTIL then selftest. Select misc with the top softkey then crt test with the second softkey, then press start test.

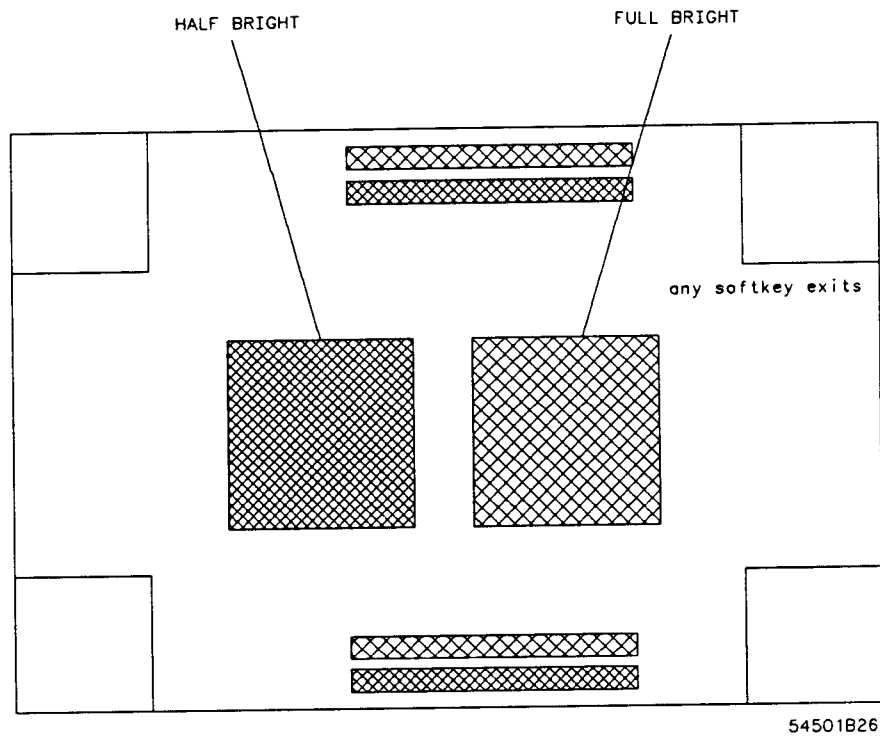
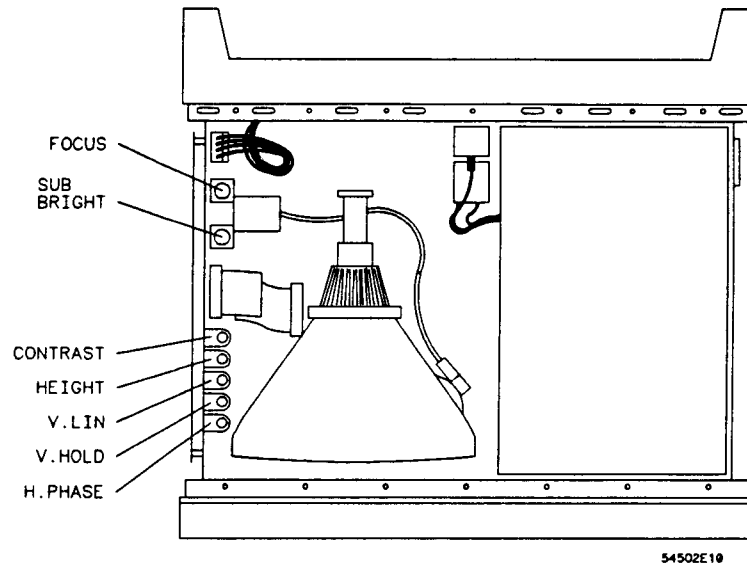

Figure 4-3. CRT Test Display

2. Refer to the next figure for adjustment locations.



**Figure 4-4. Display Adjustment Locations**

3. Adjust V.HOLD, if necessary, for vertical synchronization.
4. Set rear-panel INTENSITY to mid-range.
5. Adjust sweep board SUB-BRIGHT to the lowest setting where half-bright blocks on the screen are visible.
6. Turn rear-panel INTENSITY to increase intensity to a comfortable viewing level. The position of the INTENSITY adjustment should be close to 3/4 of its maximum range.
7. Adjust CONT for the best contrast between half- and full-bright blocks on menu, ensuring text is legible in half-bright blocks.
8. Adjust H.PHASE to center display horizontally.
9. Adjust FOCUS control for a sharp percent symbol (%) in the top and bottom blocks of text.
10. Adjust V.LIN for equal height of corner squares. Square height should be approximately 25 mm.
11. Adjust HEIGHT to make the screen top and bottom borders approximately 1 cm.
12. Adjustments V.LIN and HEIGHT interact. Repeat steps 9 and 10 as necessary for a proper display.

# Contents

---

## Section 5

### Replaceable Parts

Introduction .....	5-1
Abbreviations .....	5-1
Replaceable Parts .....	5-1
Exchange Assemblies .....	5-1
Ordering Information .....	5-2
Direct Mail Order System .....	5-2





# Replaceable Parts

---

## Introduction

This section contains information for ordering parts. Service support for this instrument is down to the assembly level. The replaceable parts include assemblies and chassis parts. Figure 5-1 shows an exploded view of the HP 54502A.

---

## Abbreviations

Table 5-1 lists the abbreviations used in the parts list and throughout this manual. In some cases two forms of the abbreviations are used: one in all capital letters, and one in partial or no capital letters. However, elsewhere in the manual, other abbreviation forms may be used with both lowercase and uppercase letters.

---

## Replaceable Parts

Table 5-2 is a list of replaceable parts and is organized as follows:

1. Exchange assemblies in alphanumerical order by reference designation.
2. Electrical assemblies in alphanumerical order by reference designation.
3. Chassis-mounted parts in alphanumerical order by reference designation.

The information given for each part consists of the following:

- Reference designation.
  - HP part number.
  - Part number Check Digit (CD).
  - Total quantity (Qty) in instrument or on assembly. The total quantity is given once and at the first appearance of the part number in the list.
  - Description of the part.
  - Typical manufacturer of part in an identifying five-digit code. All parts in this list (except hardware) is manufactured by or for Hewlett-Packard, code 28480. No list of manufacturers is provided.
- 

## Exchange Assemblies

Some parts used in this instrument have been set up for an exchange program. This program allows the customer to exchange a faulty assembly with one that has been repaired, calibrated, and performance-verified by the factory. The cost is significantly less than that of a new part. The exchange parts have a part number in the form XXXXX-695XX.

After receiving the repaired exchange part from Hewlett-Packard, a United States customer has 30 days to return the faulty assembly. For orders not originating in the United States, contact the local HP service organization. If the faulty assembly is not returned within the warranty time limit, the customer will be charged an additional amount. The additional amount will be the difference in price between a new assembly and that of an exchange assembly.

---

## **Ordering Information**

To order a part in the material list, quote the Hewlett-Packard part number, indicate the quantity desired, and address the order to the nearest HP Sales/Service Office.

To order a part not listed in the material list, include the instrument part number, instrument serial number, a description of the part (including its function), and the number of parts required. Address the order to the nearest HP Sales and Service Office.

---

## **Direct Mail Order System**

Within the USA, Hewlett-Packard can supply parts through a direct mail order system. There are several advantages to this system:

- Direct ordering and shipment from the HP Parts Center in California, USA.
- No maximum or minimum on any mail order (there is a minimum amount for parts ordered through a local HP office when the orders require billing and invoicing).
- Prepaid transportation (there is a small handling charge for each order).
- No invoices.

In order for Hewlett-Packard to provide these advantages, a check or money order must accompany each order.

Mail order forms and specific ordering information are available through your local HP office. Addresses and telephone numbers are located in a separate document shipped with the manuals.

**Table 5-1. Reference Designators and Abbreviations**

REFERENCE DESIGNATOR							
A	= assembly	F	= fuse	Q	= transistor;SCR;	U	= integrated circuit;
B	= fan;motor	FL	= filter		triode thyristor		microcircuit
BT	= battery	H	= hardware	R	= resistor	V	= electron tube; glow
C	= capacitor	J	= electrical connector	RT	= thermistor		lamp
CR	= diode;diode thyristor;		(stationary portion);jack	S	= switch;jumper	VR	= voltage regulator;
	varactor	L	= coil;inductor	T	= transformer		breakdown diode
DL	= delay line	MP	= misc. mechanical part	TB	= terminal board	W	= cable
DS	= annunciator;lamp;LED	P	= electrical connector	TP	= test point	X	= socket
E	= misc. electrical part		(moveable portion);plug			Y	= crystal unit(piezo-
							electric or quartz)
ABBREVIATIONS							
A	= amperes	DWL	= dowel	MFR	= manufacturer	RND	= Round
A/D	= analog-to-digital	ECL	= emitter coupled logic	MICPROC	= microprocessor	ROM	= read-only memory
AC	= alternating current	ELAS	= elastomeric	MINTR	= miniature	RPG	= rotary pulse generator
ADJ	= adjust(ment)	EXT	= external	MISC	= miscellaneous	RX	= receiver
AL	= aluminum	F	= farads;metal film	MLD	= molded	S	= Schottky-clamped;
AMPL	= amplifier		(resistor)	MM	= millimeter		seconds(time)
ANLG	= analog	FC	= carbon film/	MO	= metal oxide	SCR	= screw;silicon
ANSI	= American National		composition	MTG	= mounting		controlled rectifier
	Standards Institute	FD	= feed	MTLC	= metallic	SEC	= second(time);second
ASSY	= assembly	FEM	= female	MUX	= multiplexer		day
ASTIG	= astigmatism	FF	= flip-flop	MW	= milliwatt	SEG	= segment
ASYNCHRO	= asynchronous	FL	= flat	N	= nano(10 <sup>-9</sup> )	SEL	= selector
ATTEN	= attenuator	FM	= foam;from	NC	= no connection	SGL	= single
AWG	= American wire gauge	FR	= front	NMOS	= n-channel metal-	SHF	= shift
BAL	= balance	FT	= gain bandwidth		oxide-semiconductor	SI	= silicon
BCD	= binary-code decimal		product	NPN	= negative-positive-	SIP	= single in-line
BD	= board	FW	= full wave		negative		package
BFR	= buffer	FXD	= fixed	NPRN	= neoprene	SKT	= skirt
BIN	= binary	GEN	= generator	NRFR	= not recommended for	SL	= slide
BRDG	= bridge	GND	= ground(ed)		field replacement	SLDR	= solder
BSHG	= bushing	GP	= general purpose	NSR	= not separately	SLT	= slot(fed)
BW	= bandwidth	GRAT	= graticule		replaceable	SOLD	= solenoid
C	= ceramic;cermet	GRV	= groove	NUM	= numeric	SPCL	= special
	(resistor)	H	= henries;high	OBD	= order by description	SQ	= square
CAL	= calibrate;calibration	HD	= hardware	OCTL	= octal	SREG	= shift register
CC	= carbon composition	HDND	= hardened	OD	= outside diameter	SRQ	= service request
CCW	= counterclockwise	HG	= mercury	OP AMP	= operational amplifier	STAT	= static
CER	= ceramic	HGT	= height	OSC	= oscillator	STD	= standard
CFM	= cubic feet/minute	HLCL	= helical	P	= plastic	SYNCHRO	= synchronous
CH	= choke	HORIZ	= horizontal	P/O	= part of	TA	= tantalum
CHAM	= chamfered	HP	= Hewlett-Packard	PC	= printed circuit	TBAX	= tubaxial
CHAN	= channel	HP-IB	= Hewlett-Packard	PCB	= printed circuit board	TC	= temperature coefficient
CHAR	= character		Interface Bus	PD	= power dissipation	TD	= time delay
CM	= centimeter	HR	= hour(s)	PF	= picofarads	THD	= thread(ed)
CMOS	= complementary metal-	HV	= high voltage	PI	= plug in	THK	= thick
	oxide-semiconductor	HZ	= Hertz	PL	= plate(d)	THRU	= through
CMR	= common mode rejection	I/O	= input/output	PLA	= programmable logic	TP	= test point
	tion	IC	= integrated circuit		array	TPG	= tapping
CNDCT	= conductor	ID	= inside diameter	PLST	= plastic	TPL	= triple
CNTR	= counter	IN	= inch	PNP	= positive-negative-	TRANS	= transformer
CON	= connector	INCL	= include(s)		positive	TRIG	= trigger(ed)
CONT	= contact	INCAND	= incandescent	POLYE	= polyester	TRMR	= trimmer
CRT	= cathode-ray tube	INP	= input	POS	= positive;position	TRN	= turn(s)
CW	= clockwise	INTEN	= intensity	POT	= potentiometer	TTL	= transistor-transistor
D	= diameter	INTL	= internal	POZI	= pozidrive	TX	= transmitter
D/A	= digital-to-analog	INV	= inverter	PP	= peak-to-peak	U	= micro(10 <sup>-6</sup> )
DAC	= digital-to-analog	JFET	= junction field-	PPM	= parts per million	UL	= Underwriters
	converter		effect transistor	PRCN	= precision		Laboratory
DARL	= darlington	JKT	= jacket	PREAMP	= preamplifier	UNREG	= unregulated
DAT	= data	K	= kilo(10 <sup>3</sup> )	PRGMBL	= programmable	VA	= voltampere
DBL	= double	L	= low	PRL	= parallel	VAC	= volt,ac
DBM	= decibel referenced	LB	= pound	PROG	= programmable	VAR	= variable
	to 1mW	LCH	= latch	PSTN	= position	VCO	= voltage-controlled
DC	= direct current	LCL	= local	PT	= point		oscillator
DCCR	= decoder	LED	= light-emitting	PW	= potted wirewound	VDC	= volt,dc
DEG	= degree		diode	PWR	= power	VERT	= vertical
DEMUX	= demultiplexer	LG	= long	R-S	= reset-set	VF	= voltage,filtered
DET	= detector	LI	= lithium	RAM	= random-access	VS	= versus
DIA	= diameter	LK	= lock		memory	W	= watts
DIP	= dual in-line package	LKWR	= lockwasher	RECT	= rectifier	W/	= with
DIV	= division	LS	= low power Schottky	RET	= retainer	W/O	= without
DMA	= direct memory access	LV	= low voltage	RF	= radio frequency	WW	= wirewound
DPDT	= double-pole,	M	= mega(10 <sup>6</sup> );megohms;	RGLTR	= regulator	XSTR	= transistor
	double-throw		meter(distance)	RGTR	= register	ZNR	= zener
DRC	= DAC refresh controller	MACH	= machine	RK	= rack		degree Celsius
DRV/R	= driver	MAX	= maximum	RMS	= root-mean-square	oF	= degree Fahrenheit
						oK	= degree Kelvin

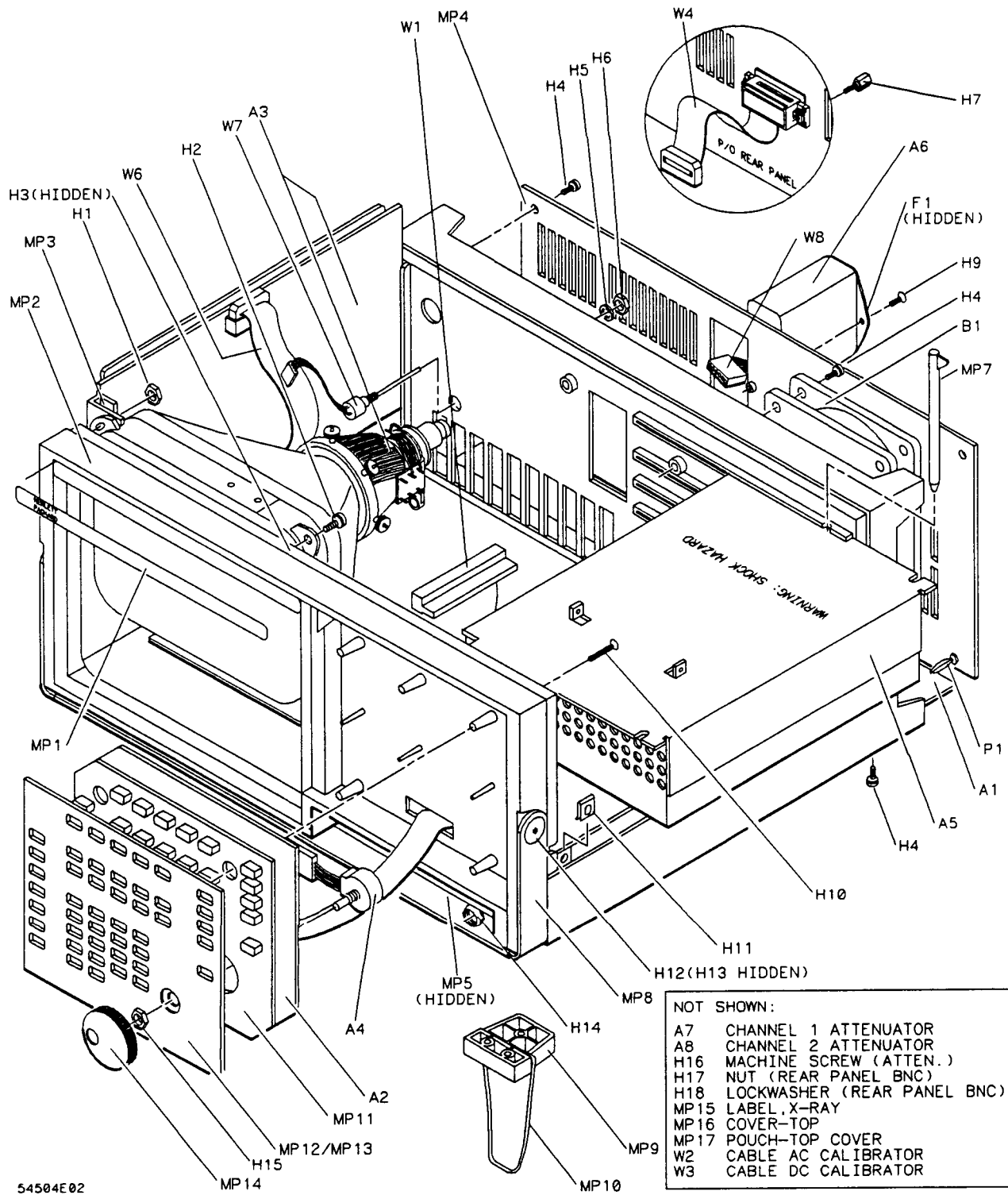

54504E02

Figure 5-1. HP 54502A Exploded View

Table 5-2. Replaceable Parts

Reference Designator	HP Part Number	CD	Qty	Description	Mfr Code	Mfr Part Number
EXCHANGE ASSEMBLIES						
A1	54502-69501	6	1	MAIN ASSEMBLY (without attenuators)	28480	54502-69501
ELECTRICAL ASSEMBLIES						
A1	54502-66501	0	1	MAIN ASSEMBLY (without attenuators)	28480	54502-66501
A2	54503-66502	8	1	KEYBOARD ASSEMBLY (board and cable only)	28480	54501-66502
A3	2090-0211	6	1	CRT MONITOR ASSEMBLY (board/CRT/yoke)	28480	2090-0211 <i>0319</i>
A4	0960-0753	6	1	ROTARY PULSE GENERATOR (w/cable)	28480	0960-0753
A5	0950-1879	8	1	POWER SUPPLY ASSEMBLY	28480	0950-1879
A6	9135-0325	8	1	LINE FILTER/POWER SWITCH	28480	9135-0325
A7	54503-63401	4	2	ATTENUATOR ASSEMBLY (CH 1)	28480	54503-63401
A8	54503-63401	4		ATTENUATOR ASSEMBLY (CH 2)	28480	54503-63401
CHASSIS PARTS						
B1	3160-0521	3	1	FAN-TUBEAXIAL	28480	3160-0521
F1	2110-0003	0	2	FUSE 3 AMP	28480	2110-0003
H1	0535-0056	3	3	LOCKNUT-HEX M4 (CRT)	00000	ORDER BY DESCRIPTION
H2	0515-0380	2	1	MS M4 10MM-LG PAN-HD (CRT)	00000	ORDER BY DESCRIPTION
H3	0590-1826	1	1	INSERT-THREADED M4 (CRT)	00000	ORDER BY DESCRIPTION
H4	0515-0374	5	20	MS M3 10MM-LG PAN-HD (fan/rear panel/bottom)	00000	ORDER BY DESCRIPTION
H5	2190-0027	6	1	WASHER 0.256 0.478 0.02 (intensity adj.)	00000	ORDER BY DESCRIPTION
H6	2950-0072	3	1	NUTH 1/4-32 0.062-THK (intensity adj.)	00000	ORDER BY DESCRIPTION
H7	0380-1482	0	2	STANDOFF-HEX (HP-IB connector)	00000	ORDER BY DESCRIPTION
H8				NOT ASSIGNED		
H9	0515-1035	0	22	MS M3 8MM-LG FLAT-HD (feet/cover/pouch)	00000	ORDER BY DESCRIPTION
H10	0515-1134	7	4	MS M3 25MM-LG PAN-HD (keyboard)	00000	ORDER BY DESCRIPTION
H11	0535-0113	8	10	NUT-TINNERMAN M3 (cabinet top and sides)	00000	ORDER BY DESCRIPTION
H12	01650-82401	1	2	SCREW-SHOULDER (handle)	28480	01650-82401
H13	01650-00203	0	2	NUT PLATE (handle)	28480	01650-00203
H14	54503-25701	7	3	NUT-HEX (front panel BNC)	00000	ORDER BY DESCRIPTION
H15	2950-0001	8	1	NUTH 3/8-32 0.093-THK (RPG)	00000	ORDER BY DESCRIPTION
H16	0515-0655	4	4	MS M3 8MM-LG PAN-HD (attenuator)	00000	ORDER BY DESCRIPTION
H17	2950-0054	1	2	NUTH 1/2-28 0.125-THK (rear panel BNC)	00000	ORDER BY DESCRIPTION
H18	2190-0068	5	2	WASHER-1L 0.505 0.630 0.02 (rear panel BNC)	00000	ORDER BY DESCRIPTION
MP1	54502-94304	0	1	LABEL-HP 54502A IDENTIFICATION	28480	54502-94304
MP2	54503-60001	4	1	CABINET ASSY (incl. H3, H11-H13, MP8)	28480	54503-60001
MP3	01650-01202	0	1	BRACKET (CRT monitor board guide)	28480	01650-01202
MP4	54503-00202	1	1	REAR PANEL	28480	54503-00202
MP5	54502-94305	1	1	LABEL (front panel BNC)	28480	54502-94305
MP6				NOT ASSIGNED		
MP7	01650-46101	2	2	LOCKING PIN (power supply)	28480	01650-46101
MP8	01650-04901	2	1	HANDLE-BAIL	28480	01650-04901
MP9	01650-47701	0	2	FOOT-MOLDED	28480	01650-47701
MP10	1460-1345	5	2	TILT STAND	28480	1460-1345
MP11	54503-41901	3	1	KEYPAD-ELASTOMERIC	28480	54503-41901
MP12	54503-45202	5	1	PANEL-KEYBOARD	28480	54503-45202
MP13	54503-94302	9	1	LABEL-KEYBOARD	28480	54503-94302

**Table 5-2. Replaceable Parts (cont'd)**

Reference Designator	HP Part Number	CD	Qty	Description	Mfr Code	Mfr Part Number
MP14	01650-47401	7	1	KNOB-RPG	28480	01650-47401
MP15	5955-8032	4	1	LABEL- X-RAY	28480	5955-8032
MP16	01650-04101	4	1	COVER-TOP	28480	01650-04101
MP17	01650-84501	7	1	POUCH-ACCESSORY (top cover )	28480	01650-84501
P1	54503-87601	6	1	PLUG-BANANA	28480	54503-87601
W1	54503-61606	7	1	CABLE-DC POWER SUPPLY	28480	54503-61606
W2	54503-61605	6	2	CABLE-AC CALIBRATOR OUT	28480	54503-61605
W3	54503-61605	6		CABLE-DC CALIBRATOR OUT	28480	54503-61605
W4	54503-61602	3	1	CABLE- HP-IB	28480	54503-61602
W5				NOT ASSIGNED		
W6	01650-61601	9	1	CABLE-CRT MONITOR ASSY	28480	01650-61601
W7	01650-61614	4	1	CABLE-INTENSITY ADJUST (with potentiometer)	28480	01650-61614
W8	01650-61602	0	1	CABLE-LINE FILTER	28480	01650-61602
W9	8120-1521	6	1	CABLE-POWER (standard)	28480	8120-1521
W9	8120-1703	6	1	CABLE-POWER (Option 900-UK)	28480	8120-1703
W9	8120-0696	4	1	CABLE-POWER (Option 901-AUSTL)	28480	8120-0696
W9	8120-1692	2	1	CABLE-POWER (Option 902-EUR)	28480	8120-1692
W9	8120-0698	6	1	CABLE-POWER (Option 904-250V USA/CANADA)	28480	8120-0698
W9	8120-2296	4	1	CABLE-POWER (Option 906-SWIT)	28480	8120-2296
W9	8120-2957	4	1	CABLE-POWER (Option 912-DEN)	28480	8120-2957
W9	8120-4600	8	1	CABLE-POWER (Option 917-AFRICA)	28480	8120-4600
W9	8120-4754	3	1	CABLE-POWER (Option 918-JAPAN)	28480	8120-4754
W10	54503-61604	5		CABLE-SERVICE-SUPPLY EXTENDER	28480	54503-61604

# Contents

---

## Section 6

### Service

Introduction .....	6-1
Safety .....	6-1
Block Level Theory Of Operation .....	6-3
Power Supply Assembly .....	6-3
CRT Monitor Assembly .....	6-3
Main Assembly .....	6-3
Keypad and Knob Assembly .....	6-3
Main Assembly Theory Of Operation .....	6-5
Acquisition .....	6-5
System Control .....	6-9
Selftest Menu .....	6-12
Service Menu .....	6-13
Troubleshooting .....	6-14
Trouble Isolation Flowcharts .....	6-14
Key-down Powerup .....	6-14
Power Supply Voltages Check .....	6-21
CRT Monitor Signals Check .....	6-22
Keyboard Signals Check .....	6-23
Attenuator Troubleshooting .....	6-24
Assembly Removal And Replacement .....	6-26
Rear Panel Assembly .....	6-26
Power Supply Assembly .....	6-26
Keyboard Assembly .....	6-27
Fan .....	6-27
Main Assembly .....	6-28
Attenuators .....	6-28
CRT Monitor Assembly .....	6-29
Feet/Tilt Stand .....	6-30





## Service

---

### Introduction

This section provides troubleshooting, service, and repair information for the HP 54502A Digitizing Oscilloscope. Troubleshooting consists of flowcharts, self-test descriptions and instructions for use, and signal level tables. The troubleshooting information is provided to isolate a faulty assembly. When a faulty assembly has been located, the disassembly/assembly procedures help direct replacement of the assembly.

---

### Safety

Read the Safety Summary at the front of this manual before servicing the instrument. Before performing any procedure, review it for cautions and warnings.

---



Maintenance should be performed by trained service personnel aware of the hazards involved (for example, fire and electric shock). When maintenance can be performed without power applied, the power cord should be removed from the instrument.

---

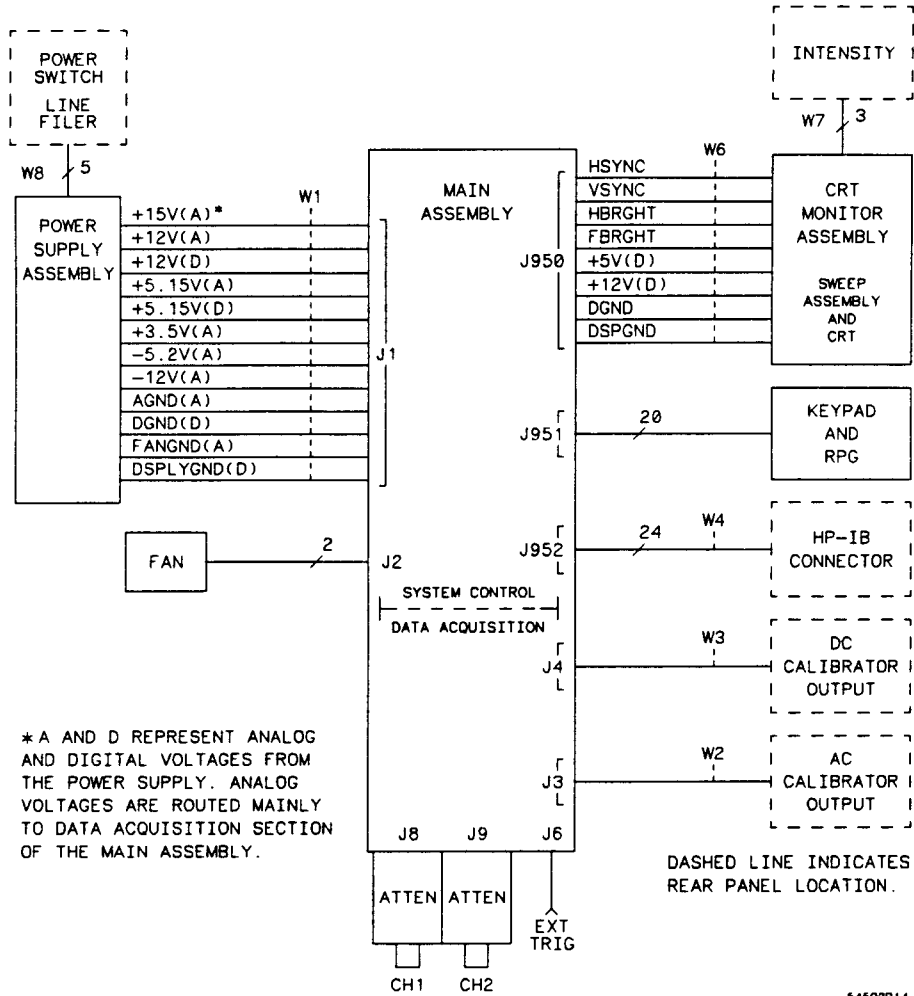

Figure 6-1. Simplified Block Diagram

---

## Block Level Theory Of Operation

The HP Model 54502A is a two-channel digitizing oscilloscope. The repetitive bandwidth is 400 MHz and the single-shot bandwidth is 100 MHz. The human interface is a front-panel knob and keypad for instrument control and 9 inch (diagonal) green phosphor CRT for information display. Available on the rear panel is an HP-IB connector for communication to a printer or from a controller. Two oscilloscope outputs are also available on the rear panel through BNC connectors: one for dc calibration and one for ac calibration and probe compensation.

Figure 6-1 shows a simplified block diagram of the instrument. The hardware of the HP 54502A consists of four main assemblies. Also shown are rear panel connectors and the Intensity adjustment. This manual supports troubleshooting to assembly level. Theory of operation for the Main Assembly is included for information only and is not intended for troubleshooting purposes.

### Power Supply Assembly

The switching power supply provides 120 W (200 W maximum) for the instrument. The ac input to the power supply is 115V or 230 V, -25 to +15%. Maximum input power is 350 VA maximum. The ac input frequency is 48 - 66 Hz.

All voltages necessary to operate the instrument are applied first to the Main Assembly. Unfiltered voltages of +15V, -15V, +12V, -12V, +5.15V, and -5.2V are supplied to the board where they are then filtered and distributed throughout the board and to the CRT Monitor Assembly. Filtered voltages of approximately +5 V and +12 V are routed through the Main Assembly to the CRT Monitor Assembly. The +5.15 V supply is adjustable on the supply.

### CRT Monitor Assembly

The CRT Monitor Assembly consists of the sweep board circuitry, a 9-inch green phosphor CRT, and the CRT yoke. The assembly requires +5 V and +12 V from the power supply via the Main Assembly.

The non-interlacing raster display is controlled by the CPU portion of the Main Assembly. System control provides synchronization and pixel information.

### Main Assembly

The Main Assembly contains the acquisition system and system control circuitry. It also provides interfaces for the Power Supply Assembly, CRT Monitor Assembly, keyboard, and HP-IB. The analog input to the Main Assembly is from any or all of two channels and the external trigger, located at the front panel BNCs. The user interface is from the front-panel keyboard or with a controller via the HP-IB connector on the rear panel. A more detailed theory of the Main Assembly follows block level theory.

### Keypad and Knob Assembly

The front-panel keypad is elastomeric and has 44 keys. Twenty keys are single-function, 17 are dual-function, and the remaining 7 are softkeys with variable functions depending on the displayed menu. The keyboard rows are continually scanned at a frequency of 60 Hz. When a key is pressed the signal is sent as data to the 68000 which determines the key pressed and its function. The Rotary Pulse Generator (RPG) is connected to the front-panel knob and supplies pulses to the 68000 microprocessor when the knob is turned. The RPG is used to dial in values for various settings of the displayed menu. The RPG will normally be set in coarse mode but may be set to fine mode by pressing the front-panel toggle key labeled FINE, located above the RPG.

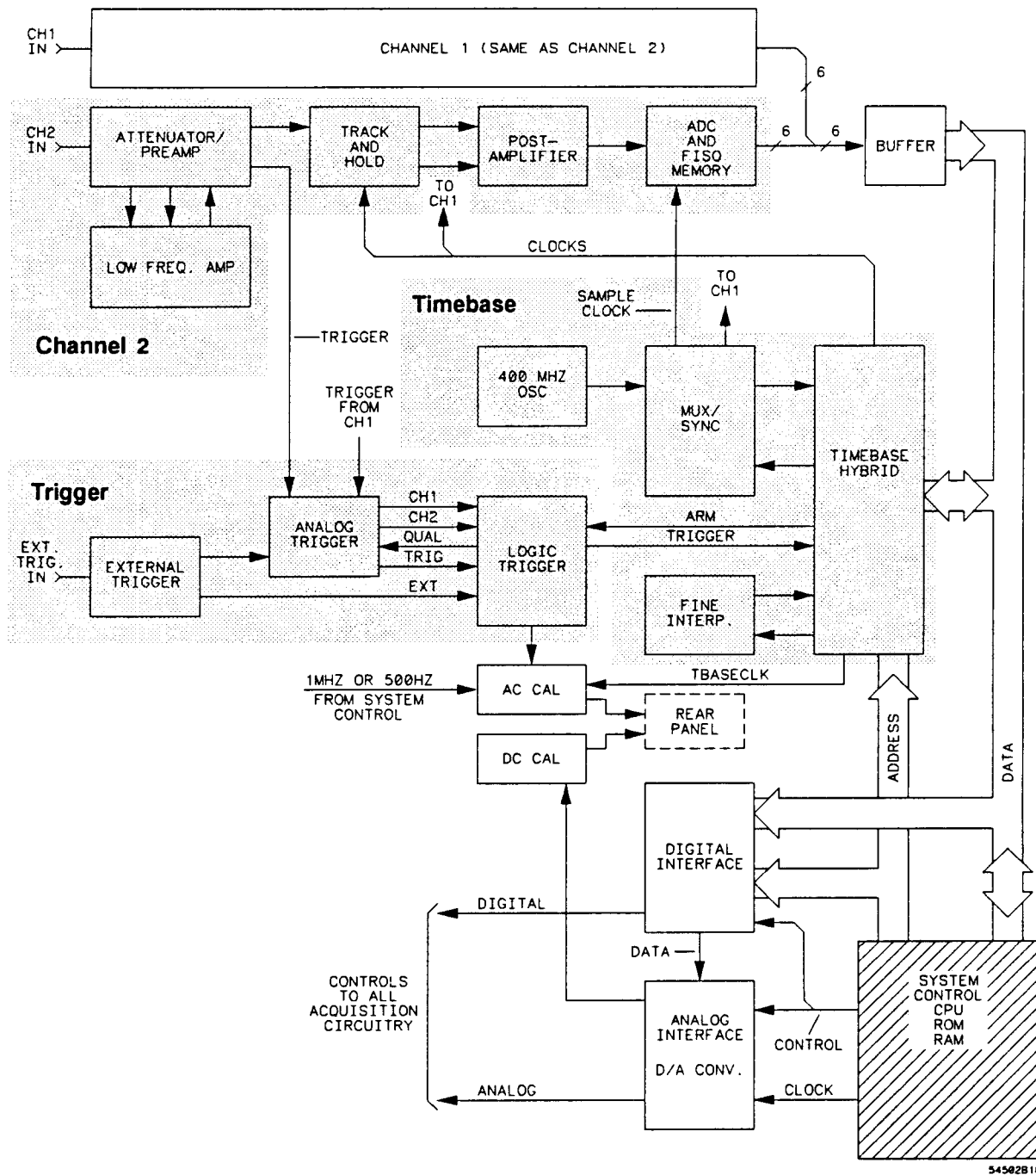

Figure 6-2. Acquisition Block Diagram

---

## Main Assembly Theory Of Operation

The Main Assembly consists of a 68000 microprocessor and its associated circuitry, and acquisition circuitry. The main block diagram has been divided into two sections: acquisition and system control. Figure 6-2 shows the acquisition block diagram and figure 6-3 shows the system control block diagram.

### Acquisition

The acquisition circuitry provides the conditioning, sampling, digitizing, and storage of the signals at the channel input connectors. The channels are identical. The external trigger input cannot be displayed. Trigger signals from each channel and the external trigger synchronize acquisition through the time base circuitry. A 400 MHz oscillator, with the time base and mux/sync (multiplexer synchronizer), provides the sample clocking. After conditioning and sampling, the signals are digitized then stored in a hybrid IC containing both the ADC and memory.

### Attenuator/Preamps

The channel signals are conditioned by the attenuator/preamps, thick film hybrids containing passive attenuators, impedance converters, and a programmable amplifier. The channel sensitivity defaults to the standard 1-2-5 sequence (other sensitivities can be set also). However, the firmware uses passive attenuation of 1, 5, 25, and 125, with the programmable preamp, to cover the entire sensitivity range.

The input has a selectable 1 M $\Omega$  or 50  $\Omega$  input impedance. Compensation for the passive attenuators is laser trimmed and not adjustable. After the passive attenuators, the signal is split into high-frequency and low-frequency components. Low frequency components are amplified on the PC board where they are combined with the offset voltage. The ac coupling and low frequency reject are implemented in the low-frequency amplifier.

The high- and low-frequency components of the signal are recombined and applied to the input FET of the preamp. The FET provides a high input impedance for the preamp. The programmable preamp adjusts the gain to suit the required sensitivity and provides two output signals. One signal is the same polarity as the input and goes to the trigger circuitry. The other is of opposite polarity and is sent to the track and hold.

### Track and Hold

The track-and-hold hybrid has two modes: track or hold. During a repetitive acquisition the track-and-hold receives a clock that holds the signal level while the ADC digitizes the sample. During a real time acquisition the hold clocks are turned off and the output of the track-and-hold follows the input. The ADC samples the signal "on-the-fly". The track-and-hold outputs two signals for the high- and low-frequency inputs of the post amplifier.

### Post Amplifier

The post amplifier conditions the signal for the ADC. It has two paths, high-frequency and low-frequency. The low-frequency path includes two adjustments. The GAIN adjustment equalizes gain between the two paths. The OFFSET adjustment centers the DC levels so the firmware softcalls have enough range for self-calibration. The two paths are combined and fed to the ADC.

## ADC and FISO Memory

A single hybrid digitizes and stores the channel signal. Digitization is done by a set of comparators in a flash converter. A precision voltage divider within the ADC, controlled by a reference supply on the PC board, provides a separate reference for each comparator.

The FISO (fast in, slow out) memory is 2 K 6-bit bytes. Sample clocks are provided by the time base circuitry. At 500 ns/div and faster, repetitive mode provides a 25 MHz clock and real time mode clocks are from 100 to 400 MHz. At sweep speeds of 1  $\mu$ s/div and slower, the sample clocks range from 50 MHz to 10 Hz for both repetitive and real time modes. Data is buffered onto the CPU data bus for further processing.

## Triggering

There are three main trigger circuits: external trigger, analog trigger, and logic trigger. The External Trigger provides an auxiliary trigger function at the front panel. It has selectable 50  $\Omega$  or 1 M $\Omega$  impedance and adjustable trigger level.

Trigger signals from the channel Attenuator/preamps and external trigger are fed to the Analog Trigger where channel trigger levels are set. The Analog Trigger also selects the trigger for certain trigger modes.

The channel and external triggers, and the selected trigger, are sent to the Logic Trigger. It provides the complex triggering functions as well as the interface to the time base.

## Time base

The time base provides the sample clocks and timing necessary for data acquisition. It consists of the 400 MHz reference oscillator, mux/sync hybrid (multiplexer/synchronizer), and time base hybrid.

The 400 MHz reference oscillator provides the base sample frequency.

The mux/sync hybrid predivides the reference frequency for the higher sample rates, above 100 MHz. It synchronizes the start of the acquisition to the sample clock so only full sample clocks are used. It also provides the sample clocks to the ADC.

The time base hybrid has programmable dividers to provide the rest of the sample frequencies appropriate for the time range selected. It uses the time-stretched output of the fine interpolator to time-reference the sampling to the trigger point. It has counters to control how much data is taken before (pre-trigger data) and after (post-trigger data) the trigger event. After the desired number of pre-trigger samples has occurred, the Time base hybrid sends a signal to the Logic Trigger (trigger arm) indicating it is ready for the trigger event. When the trigger condition is satisfied, the Logic Trigger sends a signal back to the time base hybrid. The time base hybrid then starts the post-trigger delay counter. When the countdown reaches zero, the sample clocks are stopped and the CPU is signaled that the acquisition is complete.

The Fine Interpolator is a dual-slope integrator that acts as a time-interval stretcher. When the logic trigger receives a signal that meets the programmed triggering requirements, it signals the time base. The time base then sends a pulse to the fine interpolator. The pulse is equal in width to the time between the trigger and the next sample clock. The fine interpolator stretches this time by a factor of

approximately 200. Meanwhile, the time base hybrid runs a counter with a clock derived from the sample rate oscillator. When the interpolator indicates the stretch is complete, the counter is stopped. The count represents, with much higher accuracy, the time between the trigger and the first sample clock. The count is stored and used to place the recently acquired data in relationship with previous data.

### **AC Cal**

The AC Cal is a multiplexer circuit that can provide several signals to the Probe Compensation/AC Calibrator output on the rear panel. The signal provided depends on the mode of the instrument. It can be either a probe comp signal, a pulse representing the trigger event, or signals used for self-calibration.

### **DC Cal**

The DC Cal output is used for self-calibration. It is one output from the 16-channel DAC.

### **Digital Interface**

The Digital Interface provides control and interface between the system control and digital functions in the acquisition circuitry.

### **Analog Interface**

The Analog Interface provides control of analog functions in the acquisition circuitry. It is primarily a 16 channel DAC with an accurate reference and filters on the outputs. It controls channel offsets and trigger levels, and provides the DC Cal output.

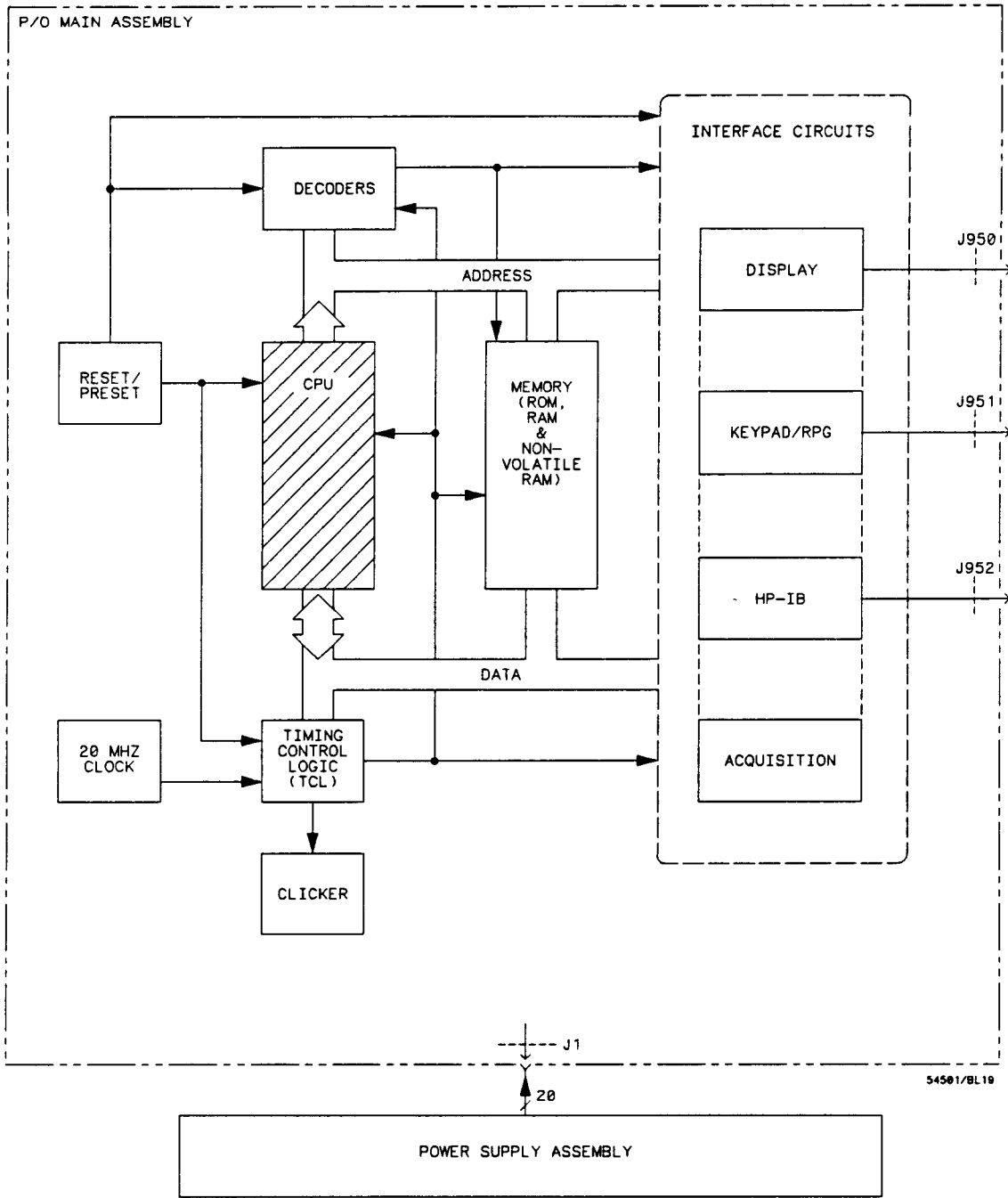

Figure 6-3. System Control Block Diagram



**System Control** The system control consists of the microprocessor, ROM, RAM, and the associated circuitry required to control the acquisition section and the CRT Monitor. It includes the HP-IB and keyboard interfaces. Figure 6-3 (previous page) shows the block diagram for system control.

### **Central Processing Unit (CPU)**

The CPU is a 68000 P10 microprocessor with addressing capability of 16 megabytes (23 address lines/16 data lines). The CPU receives its clock (9.8304 MHz) from the TCL (Timing Control Logic). The TCL provides all timing for the CPU. The CPU drives the read/write line and the address and data strobes.

The CPU supplies a 1 MHz enable clock for synchronization with the CRT Controller (CRTC).

### **Power**

The System Control requires +5 volts dc (relative to digital ground) and +12 volts dc (relative to display ground). System control supplies the display board with +5 volts, +12 volts, display ground and digital ground. The clicker circuit is operated from the +12 display voltage. The remaining system control circuitry is operated from the +5 digital voltage.

### **Clock**

The system control clock (also called 20 MHz clock) is derived from a 19.668 MHz crystal oscillator. This clock is multiplexed and distributed to provide synchronization for the timing control logic, timing for the display circuitry, and a high-frequency signal for the AC Calibrator Output on the rear panel.

### **Timing Control Logic**

Timing Control Logic (TCL) provides timing and control for the System Control.

The TCL circuitry consists of programmable array logic (PALs), various logic gates, and miscellaneous circuitry for arbitrating between display and refresh requests of display and system RAM. The PALs and arbitration circuitry are synchronized with the 20 MHz clock. The rest of the circuitry is asynchronous.

The signals generated by TCL include select lines to the decoders, write-enable to protected non-volatile Static RAM, and all timing and control signals for the interface circuits.

### **Clicker**

The clicker is the sound effect circuit. The clicker sounds when warning or error messages are displayed, when a key on the keypad is pressed, and (with some functions) when the RPG is rotated.

The 3 kHz square wave required by the clicker is provided by the CRT Controller.

The clicker may be deactivated from the utility menu.

## **Reset/Preset**

The reset/preset circuit provides the Main Assembly with a timeout during power up and power down. It consists of a voltage divider, reference voltage, and comparator. The timeout signal is used in critical time and power sensitive circuitry. The signal goes to the microprocessor, the TCL, decoders, and HP-IB and data acquisition interfaces.

When power is applied, as the +5 V supply crosses the upper threshold of the comparator, the timeout signal of approximately 200 milliseconds is generated and applied to the system control circuitry, assuring the board powers up in a known state.

Similarly, when power is removed, as the +5 V supply crosses the lower threshold of the comparator, the timeout halts the microprocessor and resets all critical timing before the +5 V supply falls below the valid operating region for TTL.

## **Decoders**

The four upper address lines are decoded into functional operations for system ROM, non-volatile static RAM, system RAM, display RAM, keyboard, HP-IB, CRTIC, acquisition control and an operation called "devices".

The devices operation is further decoded to clear the RPG and interrupts on the microprocessor, address the RPG and clicker, and provide a latch to the acquisition control.

The address strobe from the microprocessor and a hardware chip select line from the TCL provide the functional timing for the address decoders.

## **Memory**

Memory for System control is composed of System ROM, System RAM, and non-volatile RAM.

There are 524 KBytes of System ROM in four 128 K EPROMS. System ROM is used to store system operating code, look-up tables, constants, default cal factors, etc.

There are 524 KBytes of System RAM in four 256 K by 4-bit CMOS dynamic RAM ICs. The System RAM uses the conventional RAS/CAS timing scheme for read/write and refresh. System RAM stores variables, acquisition data for displaying, and provides scratch-pad memory for the microprocessor.

The non-volatile RAM is CMOS static RAM, 32 KBytes. The static RAM uses a built-in lithium battery as power backup. When the supply falls below an acceptable voltage level, (during power-down) the lithium battery is automatically switched on and write protection is unconditionally enabled to prevent loss of data. The non-volatile static RAM stores menu configurations, calibration factors, and up to four waveforms. Normal power-up of the instrument restores the calibration factors and menu configurations that were in effect before the last power-down. A key-down power-up, in which any key is held down during power-up, does not affect stored calibration factors but does reset the menu configurations to default settings.

## **Interface Circuits**

System Control interfaces with four major functions: the CRT Monitor, front-panel keypad and RPG, HP-IB, and acquisition circuitry.

The **display interface** consists of a CRT Controller (CRTC), display RAM, shift registers, and buffers for address and data lines.

The CRTC provides the horizontal and vertical sync signals for the display and a disable/enable signal for the TCL that is used for generating the timing necessary to address display RAM.

The display RAM is configured in a row/column matrix. Counters track the memory location in display RAM versus positioning the data on the CRT as data is shifted from display RAM to two shift registers. The output of the shift registers is two data streams. One stream is displayed on the CRT as full-bright pixel information and the other as half-bright. A character ROM is not used because all character matrices are stored in System ROM.

The **HP-IB interface** circuitry supports communication with other instruments (printer, controller, automated test equipment, etc.) The circuit consists of three main components. The HP-IB controller provides an interface between the microprocessor system and the HP-IB in accordance with IEEE 488 standards. An 8-bit data buffer and 8-bit control line buffer interface the HP-IB controller to the HP-IB bus.

The HP-IB is a 24 conductor shielded cable carrying 8 data lines, 8 control lines, 7 system grounds, and 1 chassis ground.

The **keypad interface** is interpreted as an 8 X 8 matrix. The eight row lines are driven by an open-collector buffer from 8 lower address lines. The eight column lines are read by a tri-state buffer to the 8 lower data lines. The RPG is read by a counter and flip-flop which are read onto the data bus.

The **acquisition interface** connects the System Control to the acquisition system. The CPU provides data and address lines, control lines, and clocks for the rear panel AC Cal select circuit and 20 MHz to the D/A Converter.

## Selftest Menu

The self-tests are used for isolating problems in the HP 54502A. A key-down powerup ensures critical parameters are set to known values to avoid any erroneous results.

To start the tests, cycle power while holding any key depressed. When the display returns, release the key and press **util** then **selftest menu**. The following figure shows the choices in the self-test menu.

The tests may be run individually or, by selecting **test all**, consecutively. After each self-test is completed, a message of **PASSED** or **FAILED** for that self-test is displayed. If failed messages are displayed for components or circuitry on the Main Assembly, it may help to perform the adjustment procedures in section 4 of this manual. If the self-tests continue to fail, the Main Assembly must be returned to the factory for service. Component level troubleshooting is not supported in this manual.

The loop test in the self-test menu is used for factory service only.

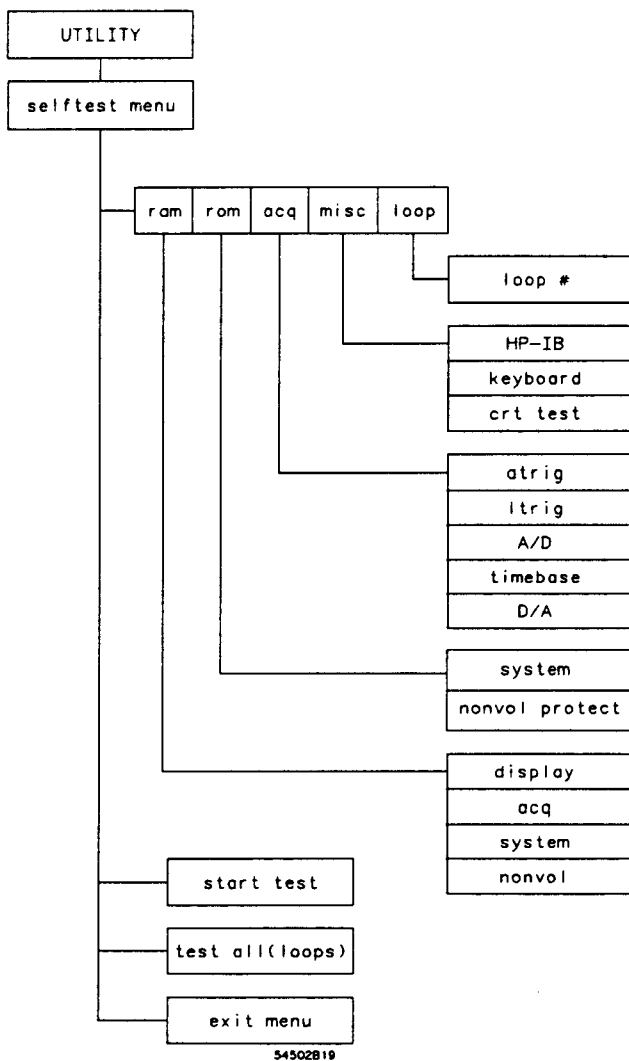

Figure 6-4. Selftest Menu Selections

## Service Menu

The service menu contains functions that are used only during service procedures. The figure below diagrams the menu. Service menu use is covered in the appropriate procedures.

The PROTECTED SYSTEM CAL section (cal selects 0, 1, 2) includes firmware calibrations that need to be done only after repair or during routine service.

SETUPS FOR INTERNAL ADJUSTMENT AND FREQ VERIFY (cal selects 3, 4) provide certain signals at the rear panel BNC outputs, for making checks or adjustments.

PROTECTED SYSTEM CAL DEFAULTS (cal select 5) loads baseline firmware calibration factors which are necessary for some adjustment procedures.

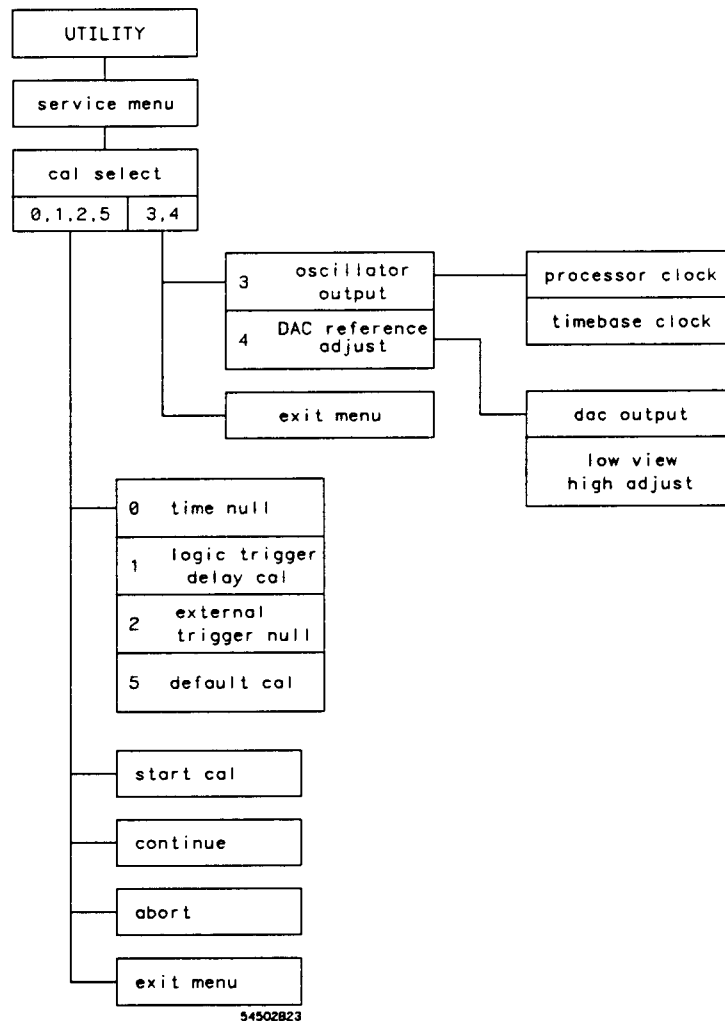

Figure 6-5. Service Menu Selections

---

**Troubleshooting** The service policy of this instrument is replacement of defective assemblies. Some assemblies can be replaced on an exchange basis. This section is used to isolate problems to the assembly level.

**Trouble Isolation Flowcharts** The trouble isolation flowcharts are the troubleshooting guide. Start there when repairing a defective instrument.

The flowcharts refer to other tests, tables, and procedures to help isolate trouble. Disassembly procedures are included to direct in replacing faulty assemblies. The circled numbers on charts indicate the next chart to use for isolating a problem.

The flowcharts start on the following page.

**Key-down Powerup** A key-down powerup is a procedure used to reset or preset the instrument to default conditions and prevent previous setups from interfering with the next test. It also simplifies the instrument set up procedure. Any front-panel key is held depressed while cycling power with the rear-panel power switch. The key is held depressed until the display returns.

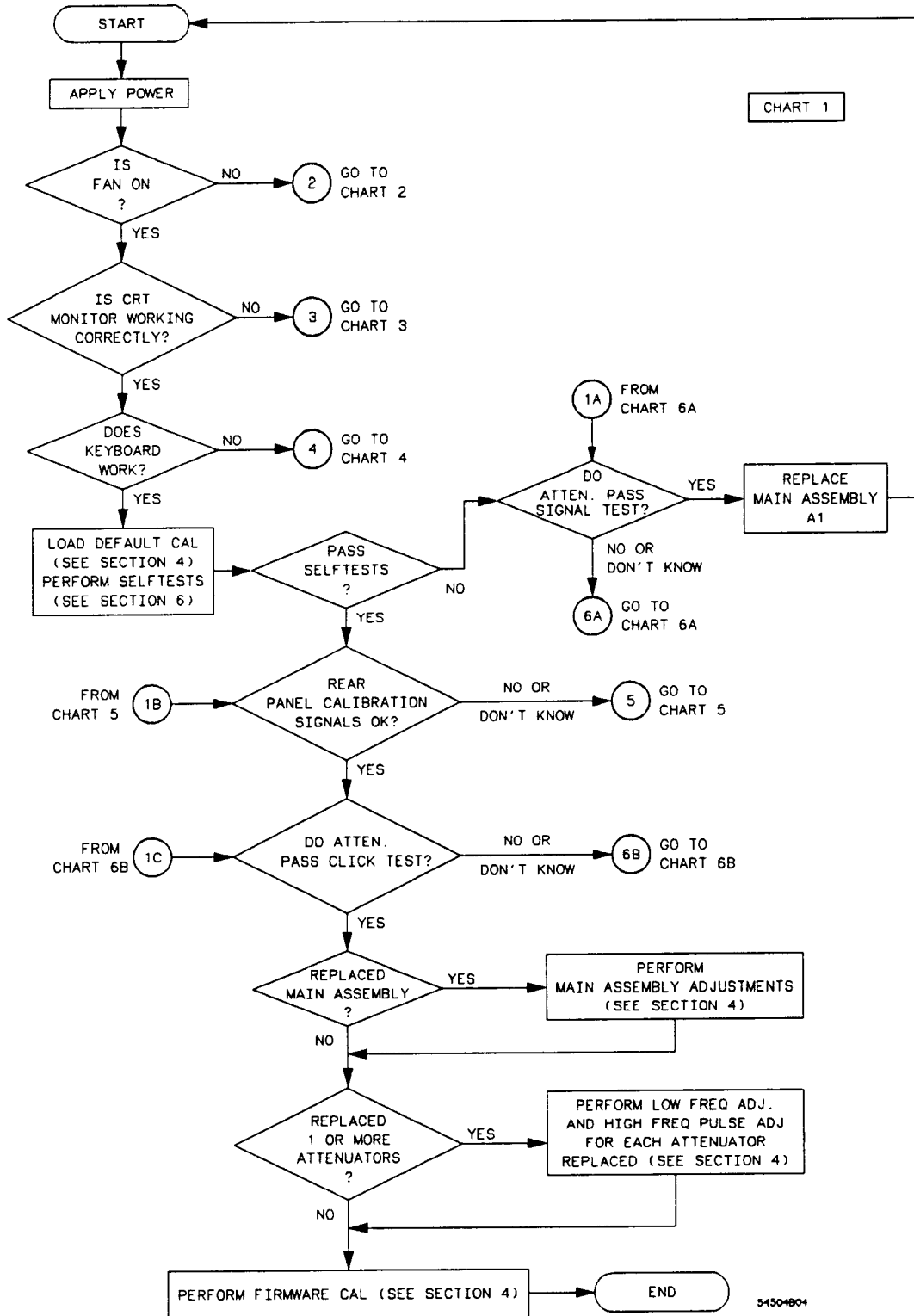

Figure 6-6. Primary Trouble Isolation Flowchart

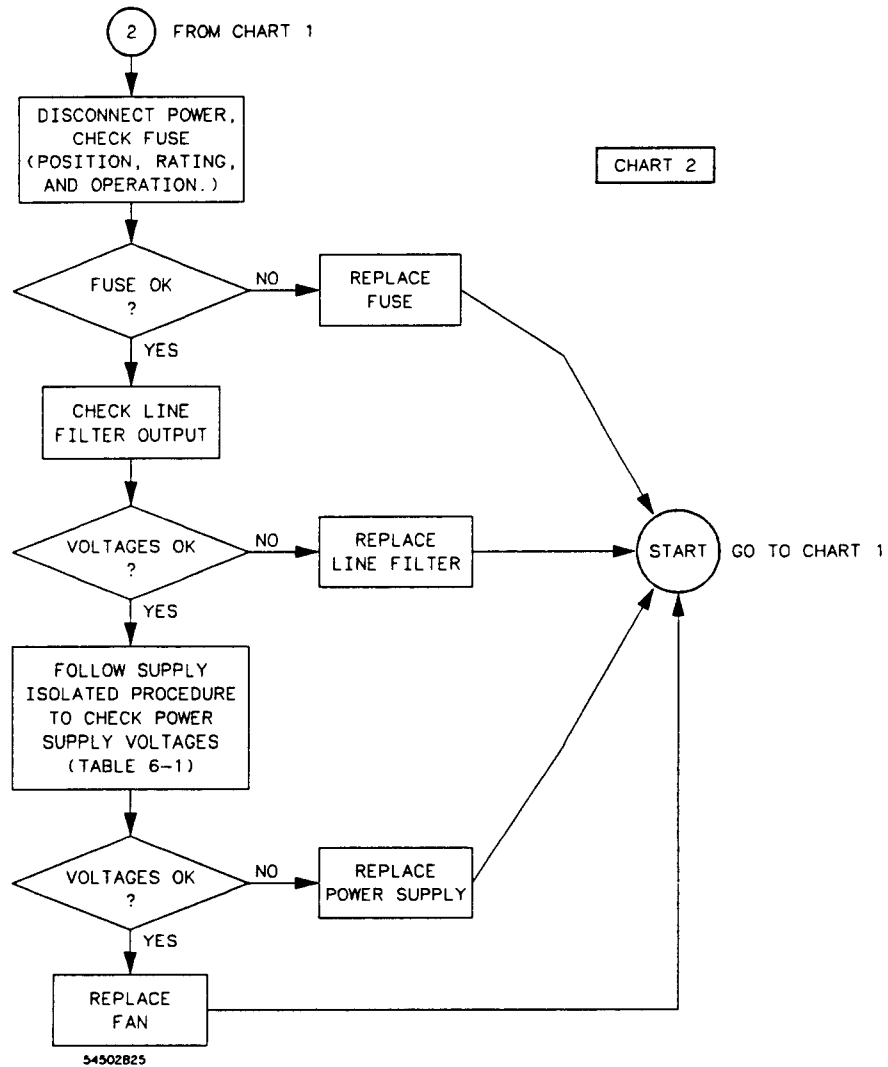

Figure 6-7. Trouble Isolation Chart for Power Supply



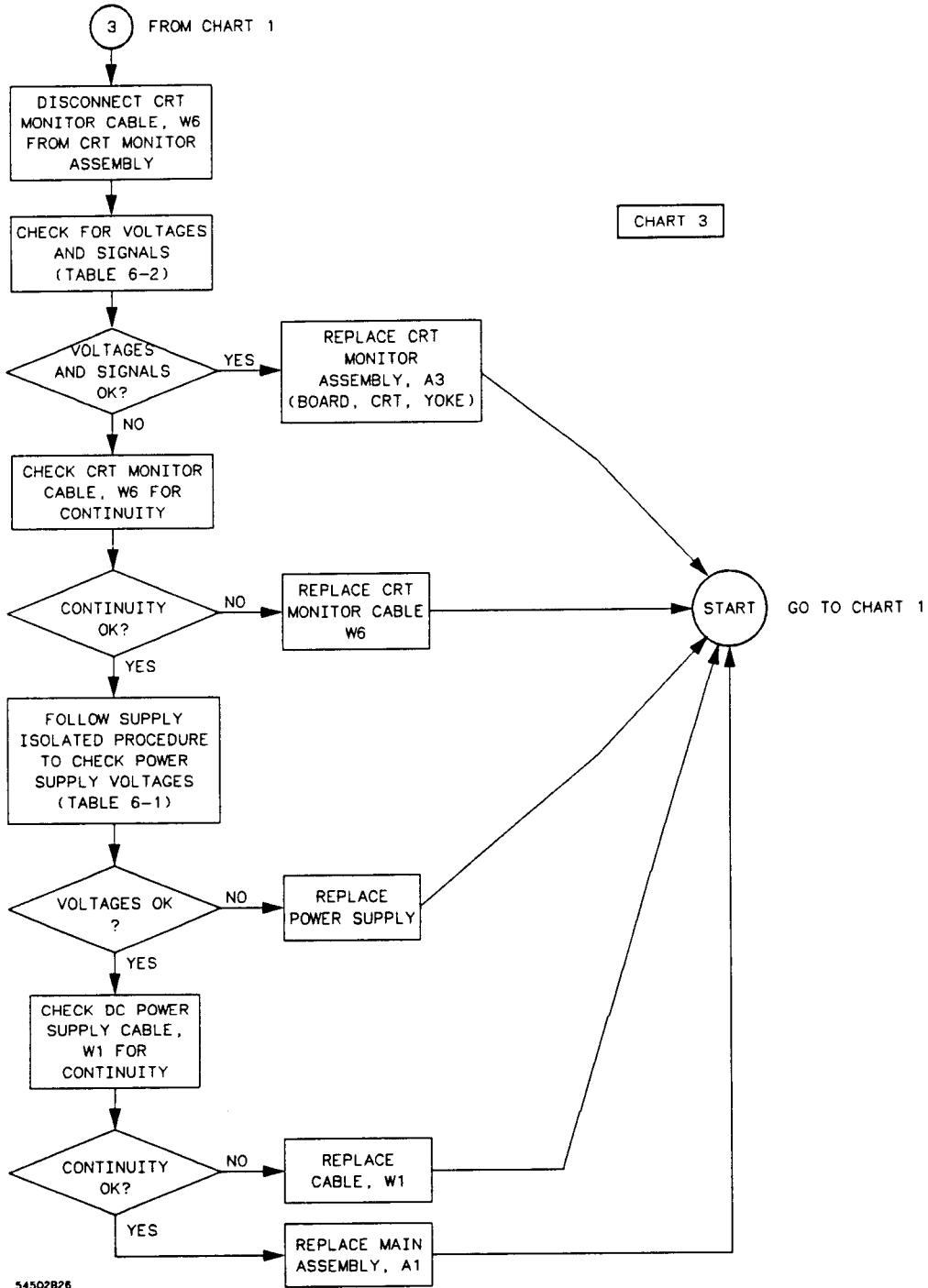

Figure 6-8. Trouble Isolation Chart for Display

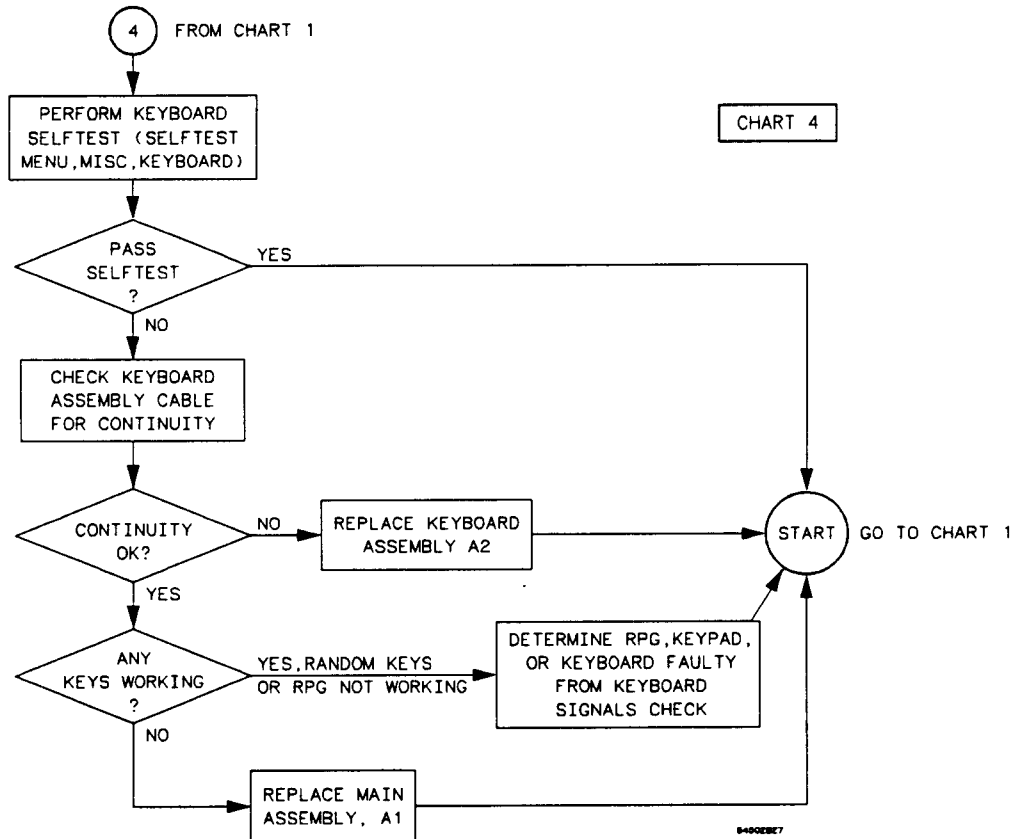
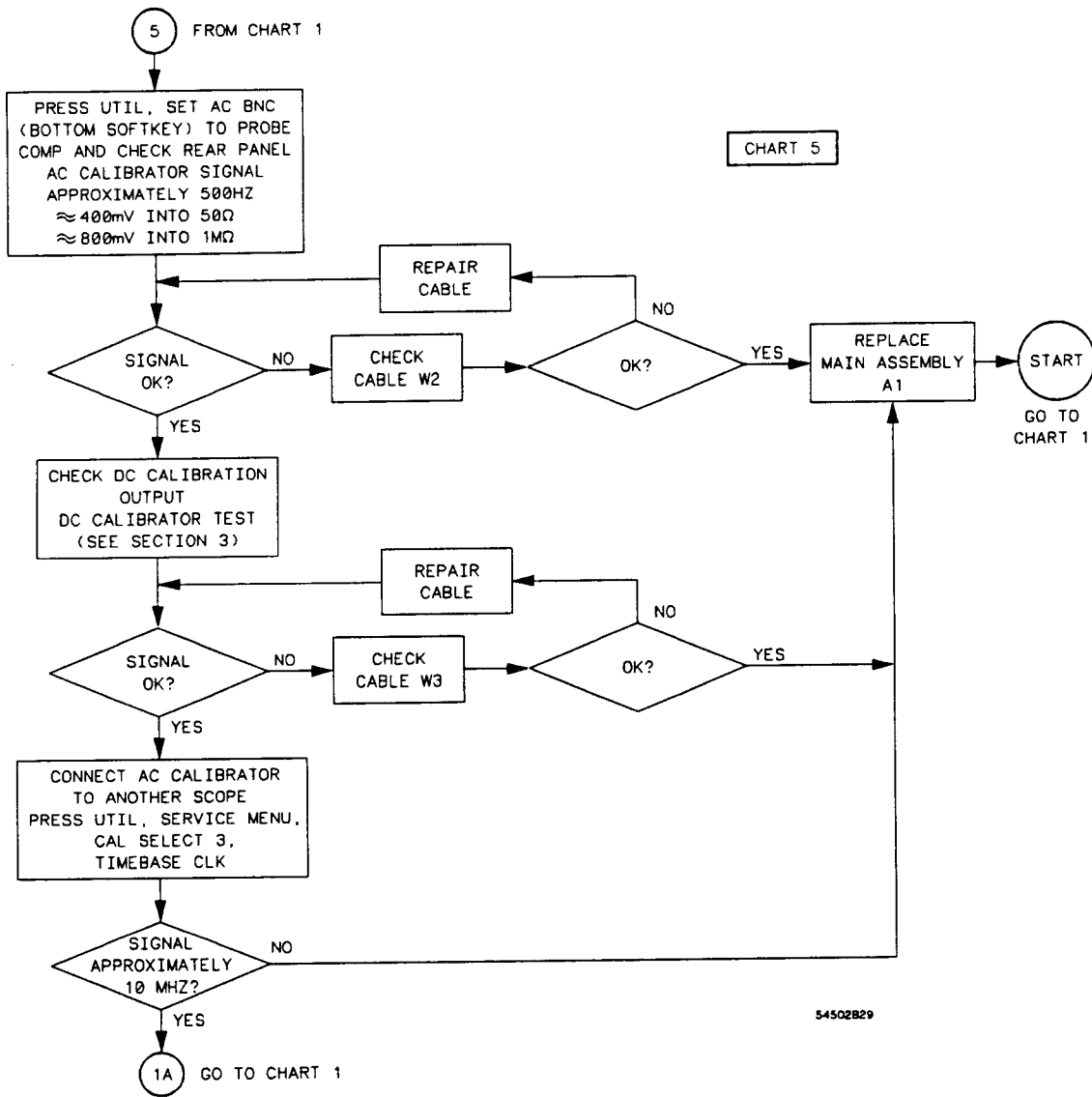

Figure 6-9. Trouble Isolation Chart for Keyboard



**Figure 6-10. Trouble Isolation Chart for Cal Signals**

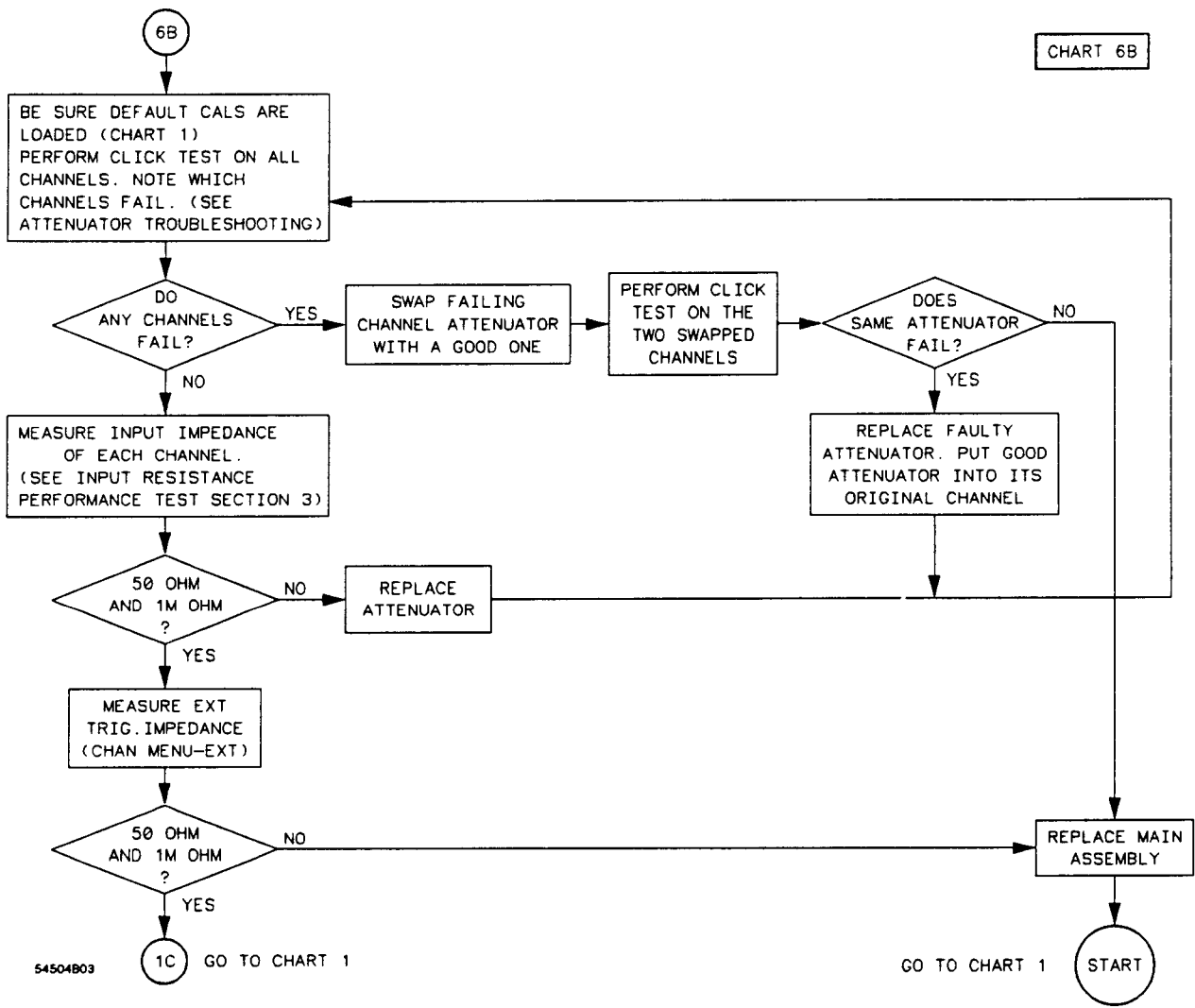
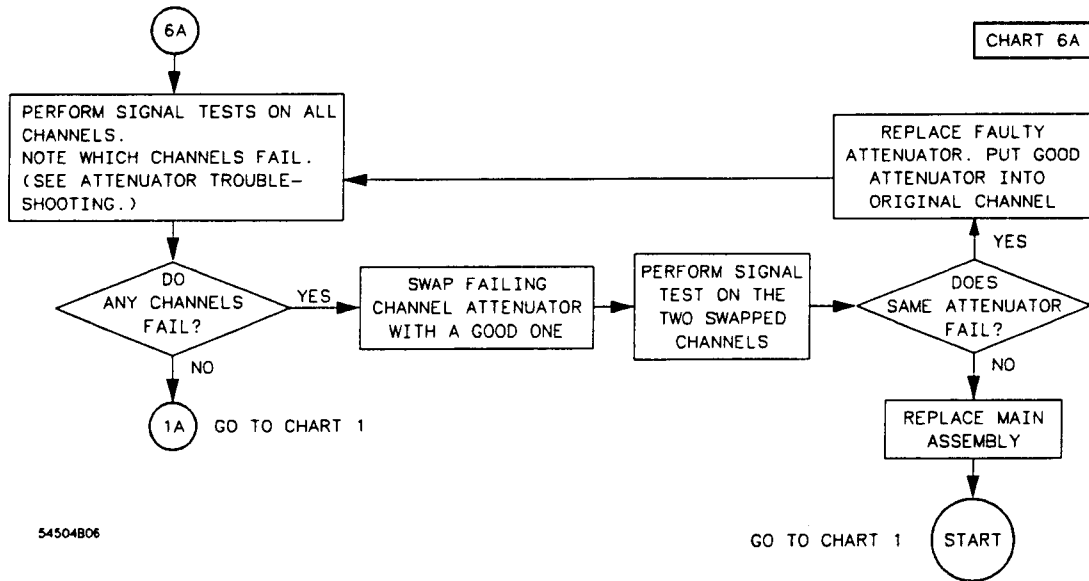

Figure 6-11. Trouble Isolation Chart for Attenuators

## Power Supply Voltages Check

The power supply can be checked loaded or unloaded.



**Warning**

This procedure is to be performed only by service-trained personnel aware of the hazards involved (such as fire and electrical shock).

### Supply Loaded

1. Remove instrument top cover.
2. Using the figure below, check for the voltages indicated at the testpoints.

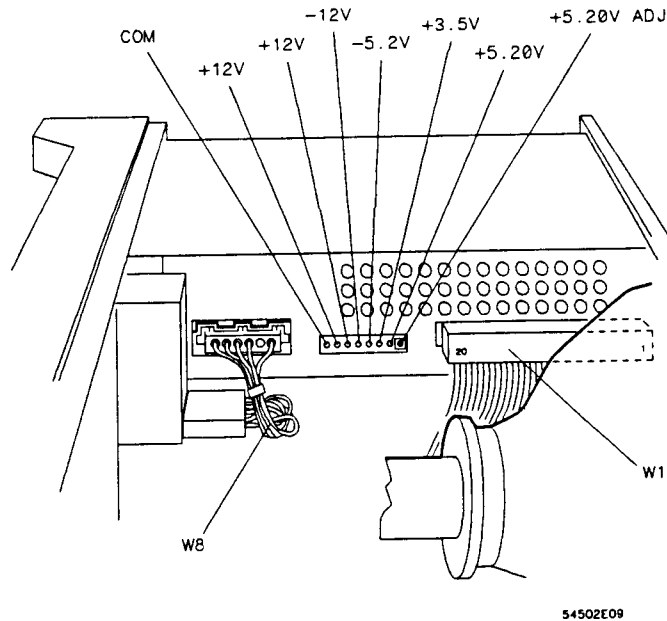

**Figure 6-12. Power Supply Test Points**

### Supply Isolated

Isolate and check the supply with the following steps. Use the figure above for reference.

1. Remove instrument power cable.
2. Disconnect supply output cable (W1) at supply (see figure above).
3. Load +5.20 V supply with a 2 ohm 25 watt resistor. Use jumper wires to connect one end of the resistor to any of pins 1-4, and the other end to any of pins 5-8.

4. Reconnect instrument power cable and check for voltages at the supply output using values in the following table.

**Table 6-1. Power Pupply/Main Assembly Voltages**

Pin	Signal	Pin	Signal
1	+5.20 V (Analog)	11	-5.2 V (Analog)
2	+5.20 V (Analog)	12	GROUND (Analog)
3	+5.20 V (Analog)	13	+12 V (Analog)
4	+5.20 V (Analog)	14	GROUND (Analog)
5	GROUND (Display)	15	-12 V (Analog)
6	GROUND (Digital)	16	GROUND (Analog)
7	GROUND (Digital)	17	+12 V (Display)
8	GROUND (Analog)	18	-5.2 V (Analog)
9	+3.5 V (Analog)	19	+15.5 V (Fan)
10	GROUND (Analog)	20	GROUND (Fan)



The ground planes (digital, analog, and display) are at the same potential on the power supply, but when measuring on the main assembly the supplies must be measured with reference to the respective ground.

### CRT Monitor Signals Check

1. Remove instrument top cover.
2. Check the CRT Monitor input cable for the signals and supplies listed in the table below. The cable is the wide ribbon cable connecting the monitor to the Main Assembly.
3. Dynamic video signals FB (Full-bright) and HB (Half-bright) are TTL inputs. Check for activity on these lines. The table includes a truth table for these signals.

**Table 6-2. CRT Monitor Input Cable Pin Assignments**

Pin	Signal	Pin	Signal	FB	HB	Video
1	+5 V (Digital)	2	+12 V (Display)	0	0	OFF
3	GROUND (Display)	4	GROUND (Display)	0	1	HALF
5	+12 V (Display)	6	GROUND (Display)	1	0	FULL
7	+12 V (Display)	8	GROUND (Display)	1	1	FULL
9	+12 V (Display)	10	HSYNC			
11	VSNC	12	+12 V (Display)			
13	GROUND (Digital)	14	GROUND (Digital)			
15	GROUND (Display)	16	FB (Full-bright)			
17	GROUND (Display)	18	HB (Half-bright)			
19	GROUND (Display)	20	+5 V (Digital)			

## Keyboard Signals Check

Isolate a faulty elastomeric keypad or keyboard when random key(s) not operating by performing the following steps.

1. Remove instrument power cable.
2. Without disconnecting the keyboard cable, follow keyboard removal procedure to loosen keyboard. Leave keyboard in place in front of instrument.
3. Replace power supply.
4. Apply power with a key-down powerup.
5. Run Keyboard Self Test. Press UTIL then selftest menu, select misc then keyboard, then press start test and press all keys.
6. Allow keyboard assembly to fall forward from front panel. Separate the elastomeric keypad and keyboard panel from the PC board.
7. Short PC board trace (with a paper clip or screwdriver) of non-operating key and look for appropriate response on display.
8. If display responds as if key were pressed, replace elastomeric keypad.
9. If display does not respond as if key were pressed, replace keyboard.

**Note:** The following information is supplemental for keyboard troubleshooting.

The ROW (scan) signal is approximately 60 Hz, a low duty-cycle pulse. It is continually present on pins 11 through 18 of the keyboard cable. Because of the resistance of the keypad contacts, the signal does not appear the same on the COLUMN (data) pins when keys are pressed. Refer to the following table for signals going to and from the keyboard.

**Table 6-3. Keyboard Connector Voltages and Signals**

Pin	Signal	Pin	Signal
1	RPGA	2	RPGB
3	COLUMN 1 (Data)	4	COLUMN 2 (Data)
5	COLUMN 3 (Data)	6	COLUMN 4 (Data)
7	COLUMN 5 (Data)	8	COLUMN 6 (Data)
9	COLUMN 7 (Data)	10	COLUMN 8 (Data)
11	ROW 8 (Scan)	12	ROW 7 (Scan)
13	ROW 6 (Scan)	14	ROW 5 (Scan)
15	ROW 4 (Scan)	16	ROW 3 (Scan)
17	ROW 2 (Scan)	18	ROW 1 (Scan)
19	+5 V (Digital)	20	GROUND (Digital)

## Attenuator Troubleshooting

The attenuators consist of a solenoid selected input resistance, four passive attenuation ranges driven by solenoids (1:1, 5:1, 25:1, 125:1), a FET, and programmable preamplifier.

Defective attenuators can cause a variety of symptoms.

- Wrong input resistance
- Low bandwidth/slow risetime
- Signal distortion
- Calibration failures
- Selftest failures

The attenuator and main assembly combination affects the pulse response adjustments so any attenuator replacements, or attenuators permanently swapped into a different channel, will require Low Frequency Adjustment and High Frequency Pulse Adjustment of the affected channels.

Firmware Calibration (Adjustment Procedures, Section 4) should also be done after attenuator replacement.

### Attenuator Signal Test

An attenuator can affect self-testing because some self-test signals are fed to the offset input in the low-frequency amp of the attenuator. If the attenuator fails, the signals may not pass through the attenuator. The following test checks the attenuator signal path. Since the low-frequency path of the attenuator is on the Main Assembly however, failure to pass a signal could be related to a problem on the Main Assembly.

This test uses the probe compensation output from the rear panel. It is approximately 500 Hz and 50% duty cycle and when terminated with 1 Mohm has an upper level of about 0 V and lower level about -800 mV. If terminated with 50 ohms the signal lower level is about -400 mV.

1. Press RECALL then CLEAR.
2. Connect the rear panel AC CALIBRATOR output to the channel to be tested.
3. Set the following parameters for the channel being tested.

Menu	Selection	Setting
TIMEBASE	(time/div)	500 us
CHAN	(sensitivity)	200 mV/div
	offset	-400 mV
TRIG	source	as required
	level	-400 mV

4. With another oscilloscope, check the signal at the input, pin 1, of the track-and-hold IC.

The adjustment locator (figure 4-2 page 4-4) may be used for reference. The track-and-hold IC in channel 1 is U83 and in channel 2 it is U103. As viewed on the figure, pin 1 is in the upper left corner of the IC, next to the adjustments.

The signal at the track-and-hold input should be approximately 275 mVp-p with 0 V near the center. There may be a small amount of noise on the signal (about



10 mV). If the signal is good, the attenuator should pass self-tests. If there is no signal or an incorrect signal, the problem may be the attenuator or the low-frequency amplifier. Return to the attenuator troubleshooting flowchart (page 6-20). Swap the attenuators and retry the test.

A major attenuator failure, such as caused by overvoltage at the input, may cause an attenuator to oscillate. With no signal input, there may be a signal output which swings between the upper and lower limits. The oscillation can couple into an adjacent channel and that channel will appear to fail as well. The signal out of the adjacent channel will be the same frequency but smaller amplitude than that from the failed channel.

### **Attenuator Click Test**

The solenoids can be heard switching when the vertical sensitivity is changed. The fine mode of the RPG will give the most accurate indication of when a solenoid switches. However, the gain calibration will give different switching points to different Attenuator assemblies. Individual Attenuator assemblies will not necessarily switch at the same sensitivities. Also, there are different sets of calibration factors for certain time/div ranges so the passive attenuator changeover may depend on the sweep speed. They usually switch near:

- 45 to 50 mV/div
- 235 to 250 mV/div
- 1.15 to 1.25 V/div

You can hear solenoid switching when going either direction through the sensitivity transitions.

The input resistance solenoid can be heard when the input resistance is changed (CHAN menu).

Attenuator swapping is the best method of finding a faulty attenuator. Swap suspect and good attenuators and re-run tests.

---

## Assembly Removal And Replacement

This section contains the procedures for removal and installation of major assemblies. Read the Safety Summary at the front of this manual before servicing the instrument.

---



**Hazardous voltages exist on the power supply, CRT, and the display sweep board. To avoid electrical shock, adhere closely to the following procedures. Also, after disconnection power cable, wait at least three minutes for capacitors on the power supply and sweep boards to discharge before servicing this instrument.**

---



Never remove or install any assembly with the instrument power ON. Component damage can occur.

---

### Rear Panel Assembly

1. Disconnect power cable.
2. Remove top cover.
3. Detach line filter cable (W8) from power supply.
4. Remove the eight pan-head screws at the edges of the rear panel.
5. Pull the rear panel straight away from the instrument about three inches. Note the banana connector at the bottom corner of the rear panel. During reassembly, be sure it inserts into the clip on the Main Assembly.
6. Remove the HP-IB ribbon cable from the Main Assembly.
7. For reassembly, note which calibrator output goes to which connector on Main Assembly. Remove the calibrator output cables at Main Assembly.
8. Rear panel can be separated from instrument cabinet.
9. Replace rear panel by reversing this procedure.

### Power Supply Assembly

1. Disconnect power cable.
2. Remove top cover.
3. Remove cable (W1) that connects Power Supply to Main Assembly.
4. Disconnect line filter cable (W8) at Power Supply.
5. Remove the two locking pins that secure the Power Supply at right front and rear corners of the instrument cabinet. Pull pins up and out.
6. Slide supply out through side of cabinet.
7. To replace supply, reverse this procedure.

## Keyboard Assembly

When necessary, refer to other removal procedures.

1. Disconnect power cable.
2. Remove power supply.
3. From the back side of the front panel, remove the four screws securing keyboard assembly to front of instrument cabinet.
4. When the knob is pulled, the keyboard assembly (label, keyboard panel, keypad, PC board, RPG and knob) will come off front panel as one unit.

Use the following steps to disassemble the keyboard assembly.

5. Disconnect RPG cable from PC board.
6. Separate the PC board, keypad, and keyboard panel/label.
7. Knob has a force fit on RPG shaft. To remove, pull straight off.
8. Remove 3/8" nut from RPG, then RPG from keyboard panel.
9. Keyboard label uses self-stick adhesive. If it must be removed, peel it off.
10. If it is necessary to replace the PC board, it is necessary to loosen the rear panel and disconnect the keyboard cable from the Main Assembly. Follow steps 3-5 of Rear Panel procedure.
11. Replace keyboard assembly by reversing this procedure.

## Fan

When necessary, refer to other removal procedures.

1. Disconnect power cable.
2. Remove top cover.
3. Disconnect fan cable from Main Assembly.
4. Remove line filter cable at power supply.
5. Remove the eight pan-head screws at the edges of the Rear Panel.
6. Pull Rear Panel straight back until banana plug clears clip on Main Assembly.
7. Lay Rear Panel down at rear of instrument. It is not necessary to completely remove Rear Panel.
8. For reassembly, note orientation of fan cable. Remove fan by removing the four screws securing it to cabinet.
9. To install fan, reverse this procedure.

## Caution

---

When replacing fan, be sure air flow at fan is from outside into the instrument. Check the flow arrows on the fan and check for proper flow once power is applied to the instrument.

---

## Main Assembly



---

**ELECTROSTATIC DISCHARGE** can damage electronic components. Use grounded wriststraps and mats when servicing the main assembly.

---

When necessary, refer to other removal procedures.

1. Disconnect power cable.
2. Remove top cover.
3. Remove Power Supply assembly.
5. Disconnect power supply and fan cables from Main Assembly.
6. Remove rear panel.
7. Disconnect keyboard cable from Main Assembly.
8. Carefully place instrument on its side.
9. From the bottom of the instrument, remove eight screws that secure Main Assembly to cabinet.
10. Remove the nuts holding BNCs to front panel.
11. Set instrument in the normal position.
12. Slide Main Assembly out of the cabinet to the rear.
13. Replace Main Assembly by reversing this procedure.

## Attenuators



---

**ELECTROSTATIC DISCHARGE** can damage electronic components. Use grounded wriststraps and mats when servicing the attenuators.

---

Attenuators are not part of the Main Assembly. If the Main assembly is replaced, the attenuators will have to be moved to the replacement assembly.

When necessary, refer to other removal procedures.

1. Remove Rear Panel, Power Supply and Main Assembly.
2. From the bottom of the Main Assembly, remove two screws that secure the Attenuator.
3. A 24-pin connector, located at the rear of and inside the Attenuator, connects it to the PC board. With a gentle rocking or prying motion, lift the Attenuator from the PC board.

A small flat-blade screwdriver, prying at the rear between Attenuator and PC board, will help control Attenuator removal.

## CRT Monitor Assembly

The sweep board, CRT, and CRT yoke are all parts of one HP part number. They have been adjusted as a unit and should be replaced as a unit, rather than individually. Do not remove the yoke from the CRT.

When necessary, refer to other removal procedures.

1. Remove Rear Panel, Power Supply, and Main Assembly.
- 

### Caution

Discharge the post accelerator lead to the CRT mounting band only. Components will be damaged if the post accelerator is discharged to other areas.

---

2. Connect a jumper lead between the mounting band of the CRT and shaft of a screwdriver.
  3. Discharge CRT, by placing grounded screwdriver under protective rubber cap of post accelerator lead and momentarily touching screwdriver to metal clip of post accelerator lead.
- 

### Caution

The CRT may charge up by itself even while disconnected. Discharge the CRT before handling. Use a jumper lead to short the CRT post accelerator terminal to the CRT mounting band.

---

4. Disconnect post accelerator lead from CRT by firmly squeezing rubber cap until metal clip disengages from CRT.
  5. Detach the following cables at the sweep board or CRT.
    - Intensity cable, W7
    - CRT Monitor ribbon cable, W6
    - Two CRT yoke cables
    - CRT base cable
  6. Slide sweep board up and out of cabinet slot. When installing sweep board, it may be necessary to press on center of the outer shield of sweep board to allow the board to clear cabinet support rib.
  7. Carefully place instrument in front-panel-down position.
  8. Remove the three nuts securing CRT to front panel.
  9. Remove sweep board guide.
  10. Remove the pan-head screw securing CRT to front panel.
  11. Remove CRT. When reinstalling CRT, place it with the post accelerator terminal toward the inside of the instrument, away from the sweep board.
  12. To install CRT Monitor Assembly, reverse this procedure.
- 

### Note

After replacement of CRT Monitor Assembly, and only if necessary, perform the CRT Monitor Assembly Adjustment procedures in section 4 of this manual.

---

## **Feet/Tilt Stand**

**When necessary, refer to other removal procedures.**

- 1. Remove Rear Panel, Power Supply, Main Assembly and CRT Monitor assembly.**
- 2. Remove the three screws securing each foot/tilt stand to the bottom of the cabinet.**
- 3. To install feet/tilt stand, reverse this procedure.**

**Table 5-2. Replaceable Parts**

Reference Designator	HP Part Number	CD	Qty	Description	Mfr Code	Mfr Part Number
<b>EXCHANGE ASSEMBLIES</b>						
A1	54502-69501	6	1	MAIN ASSEMBLY (without attenuators) See applicable Service Note for use of this assembly in the HP 54502A Option 001	28480	54502-69501
<b>ELECTRICAL ASSEMBLIES</b>						
A1	54502-66502	1	1	MAIN ASSEMBLY (without attenuators)	28480	54502-66502
A2	54503-66502	8	1	KEYBOARD ASSEMBLY (board and cable only)	28480	54501-66502
A3	2090-0211	6	1	CRT MONITOR ASSEMBLY (board/CRT/yoke)	28480	2090-0211
A4	0960-0753	6	1	ROTARY PULSE GENERATOR (w/cable)	28480	0960-0753
A5	0950-1879	8	1	POWER SUPPLY ASSEMBLY	28480	0950-1879
A6	9135-0325	8	1	LINE FILTER/POWER SWITCH	28480	9135-0325
A7-80				NOT ASSIGNED		
A81	54503-63401	4	2	ATTENUATOR ASSEMBLY (CH 1)	28480	54503-63401
A82-100				NOT ASSIGNED		
A101	54503-63401	4		ATTENUATOR ASSEMBLY (CH 2)	28480	54503-63401
<b>CHASSIS PARTS</b>						
B1	3160-0521	3	1	FAN-TUBEAXIAL	28480	3160-0521
F1	2110-0003	0	2	FUSE 3 AMP	28480	2110-0003
H1	0535-0056	3	3	LOCKNUT-HEX M4 (CRT)	00000	ORDER BY DESCRIPTION
H2	0515-0380	2	1	MS M4 10MM-LG PAN-HD (CRT)	00000	ORDER BY DESCRIPTION
H3	0590-1826	1	6	INSERT-THREADED M4 (CRT)	00000	ORDER BY DESCRIPTION
H4	0515-0374	5	20	MS M3 10MM-LG PAN-HD (fan/rear panel/bottom)	00000	ORDER BY DESCRIPTION
H5	2190-0027	6	1	WASHER 0.256 0.478 0.02 (intensity adj.)	00000	ORDER BY DESCRIPTION
H6	2950-0072	3	1	NUTH 1/4-32 0.062-THK (intensity adj.)	00000	ORDER BY DESCRIPTION
H7	0380-1482	0	2	STANDOFF-HEX (HP-IB connector)	00000	ORDER BY DESCRIPTION
H8	2190-0009	4	2	WASHER-IL 0.168 0.340 0.02 (HP-IB connector)	00000	ORDER BY DESCRIPTION
H9	0515-1035	0	22	MS M3 8MM-LG FLAT-HD (feet/cover/pouch)	00000	ORDER BY DESCRIPTION
H10	0515-1134	7	4	MS M3 25MM-LG PAN-HD (keyboard)	00000	ORDER BY DESCRIPTION
H11	0535-0113	8	10	NUT-TINNERMAN M3 (cabinet top and sides)	00000	ORDER BY DESCRIPTION
H12	01650-82401	1	2	SCREW-SHOULDER (handle)	28480	01650-82401
H13	01650-00203	0	2	NUT PLATE (handle)	28480	01650-00203
H14	54503-25701	7	3	NUT-HEX (front panel BNC)	00000	ORDER BY DESCRIPTION
H15	2950-0001	8	1	NUTH 3/8-32 0.093-THK (RPG)	00000	ORDER BY DESCRIPTION
H16	0515-0655	4	4	MS M3 8MM-LG PAN-HD (attenuator)	00000	ORDER BY DESCRIPTION
MP1	54502-94304	0	1	LABEL-HP 54502A IDENTIFICATION	28480	54502-94304
MP2	54503-45201	4	1	CABINET	28480	54503-45201
MP3	01650-01202	0	1	BRACKET (CRT monitor board guide)	28480	01650-01202
MP4	54503-00201	0	1	REAR PANEL	28480	54503-00201
MP5	54502-94305	1	1	LABEL (front panel BNC)	28480	54502-94305
MP6				NOT ASSIGNED		
MP7	01650-46101	2	2	LOCKING PIN (power supply)	28480	01650-46101
MP8	01650-04901	2	1	HANDLE-BAIL	28480	01650-04901
MP9	01650-47701	0	2	FOOT-MOLDED	28480	01650-47701
MP10	1460-1345	5	2	TILT STAND	28480	1460-1345
MP11	54503-41901	3	1	KEYPAD-ELASTOMERIC	28480	54503-41901
MP12	54503-45202	5	1	PANEL-KEYBOARD	28480	54503-45202

**Table 5-2. Replaceable Parts**

Reference Designator	HP Part Number	CD	Qty	Description	Mfr Code	Mfr Part Number
MP13	54503-94302	9	1	LABEL-KEYBOARD	28480	54503-94302
MP14	01650-47401	7	1	KNOB-RPG	28480	01650-47401
MP15	5955-8032	4	1	LABEL- X-RAY	28480	5955-8032
MP16	01650-04101	4	1	COVER-TOP	28480	01650-04101
MP17	01650-84501	7	1	POUCH-TOP COVER (accessory)	28480	01650-84501
MP18	54502-93409	4	1	LABEL-OVERLAY (front panel, option 001 only)	28480	54502-93409
MP19	5951-2623	9	1	LABEL-OPTION (rear panel, option 001 only)	28480	5951-2623
P1	54503-87601	6	1	PLUG-BANANA	28480	54503-87601
W1	54503-61603	4	1	CABLE-DC POWER SUPPLY	28480	54503-61603
W2	54503-61605	6	2	CABLE-AC CALIBRATOR OUT	28480	54503-61605
W3	54503-61605	6		CABLE-DC CALIBRATOR OUT	28480	54503-61605
W4	54503-61602	3	1	CABLE- HP-IB	28480	54503-61602
W5				NOT ASSIGNED		
W6	01650-61601	9	1	CABLE-CRT MONITOR ASSY	28480	01650-61601
W7	01650-61614	4	1	CABLE-INTENSITY ADJUST (with potentiometer)	28480	01650-61614
W8	01650-61602	0	1	CABLE-LINE FILTER	28480	01650-61602
W9	8120-1521	6	1	CABLE-POWER (standard)	28480	8120-1521
W9	8120-1703	6	1	CABLE-POWER (Option 900-UK)	28480	8120-1703
W9	8120-0696	4	1	CABLE-POWER (Option 901-AUSTL)	28480	8120-0696
W9	8120-1692	2	1	CABLE-POWER (Option 902-EUR)	28480	8120-1692
W9	8120-0698	6	1	CABLE-POWER (Option 904-250V USA/CANADA)	28480	8120-0698
W9	8120-2296	4	1	CABLE-POWER (Option 906-SWIT)	28480	8120-2296
W9	8120-2957	4	1	CABLE-POWER (Option 912-DEN)	28480	8120-2957
W9	8120-4600	8	1	CABLE-POWER (Option 917-AFRICA)	28480	8120-4600
W9	8120-4754	3	1	CABLE-POWER (Option 918-JAPAN)	28480	8120-4754
W10	54503-61604	5		CABLE-SERVICE-SUPPLY EXTENDER	28480	54503-61604



# Service Menu

The service menu contains functions that are used only during service procedures. The figure below diagrams the menu. Service menu use is covered in the appropriate procedures.

The PROTECTED SYSTEM CAL section (cal selects 0, 1, 2) includes firmware calibrations that need to be done only after repair or during routine service.

SETUPS FOR INTERNAL ADJUSTMENT AND FREQ VERIFY (cal selects 3, 4) provide certain signals at the rear panel BNC outputs, for making checks or adjustments.

PROTECTED SYSTEM CAL DEFAULTS (cal select 5) loads baseline firmware calibration factors which are necessary for some adjustment procedures.

NON-VOLITILE MEMORY SECURE (cal selects 6, 7, 8) secures the non-volatile waveform memories, setup memories, and allowances.

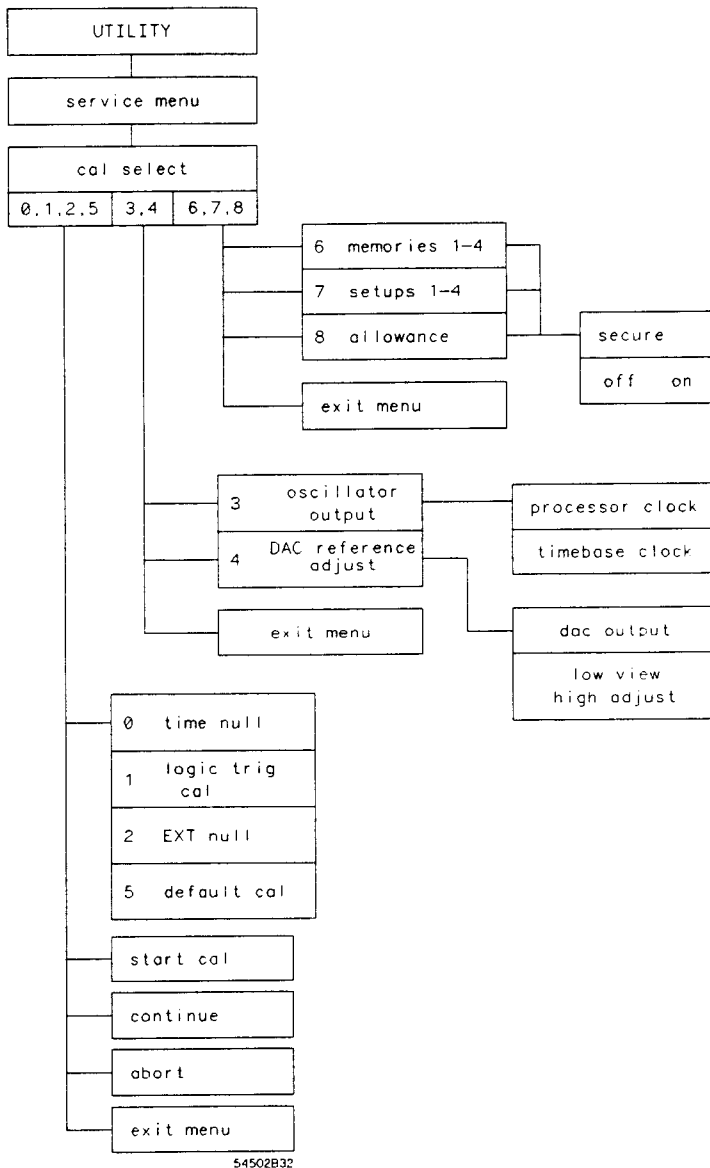

Figure 6-1. Service Menu Selections

---

## **Troubleshooting**

The service policy of this instrument is replacement of defective assemblies. Some assemblies can be replaced on an exchange basis. This section is used to isolate problems to the assembly level.

### **Trouble Isolation Flowcharts**

The trouble isolation flowcharts are the troubleshooting guide. Start there when repairing a defective instrument.

The flowcharts refer to other tests, tables, and procedures to help isolate trouble. Disassembly procedures are included to direct in replacing faulty assemblies. The circled numbers on charts indicate the next chart to use for isolating a problem.

The flowcharts start on the following page.

### **Key-down Powerup**

A key-down powerup is a procedure used to reset or preset the instrument to default conditions and prevent previous setups from interfering with the next test. It also simplifies the instrument set up procedure. Any front-panel key is held depressed while cycling power with the rear-panel power switch. The key is held depressed until the display returns.