

Notice

Hewlett-Packard to Agilent Technologies Transition

This manual may contain references to HP or Hewlett-Packard. Please note that Hewlett-Packard's former test and measurement, semiconductor products and chemical analysis businesses are now part of Agilent Technologies. To reduce potential confusion, the only change to product numbers and names has been in the company name prefix: where a product name/number was HP XXXX the current name/number is now Agilent XXXX. For example, model number HP 8648 is now model number Agilent 8648.

Contacting Agilent Sales and Service Offices

The sales and service contact information in this manual may be out of date. The latest service and contact information for your location can be found on the Web at:

<http://www.agilent.com/find/assist>

If you do not have access to the Internet, contact your field engineer. In any correspondence or telephone conversation, refer to your instrument by its model number and full serial number.



Agilent Technologies

Operating and
Service Manual

HP 8444A Tracking Generator
Includes Options 058 and 059



**HEWLETT
PACKARD**

OPERATION AND SERVICE MANUAL

**8444A
TRACKING GENERATOR
INCLUDES OPTIONS 058 AND 059**

SERIAL NUMBERS

This manual applies directly to instruments with serial numbers prefixed 1817A.

With modifications described in Section VII, this manual also applies to instruments with serial numbers prefixed 1033A, 1139A, 1147A, 1208A, 1215A, 1323A, 1601A, 1630A and 1744A.

For additional important information about serial numbers, see INSTRUMENTS COVERED BY MANUAL in Section I.

Copyright © 1972, 1975, 1980, HEWLETT - PACKARD COMPANY
1400 FOUNTAIN GROVE PARKWAY, SANTA ROSA, CALIFORNIA, 95404, U.S.A.

MANUAL PART NUMBER 08444-90035

Printed: JUNE 1980

CERTIFICATION

Hewlett-Packard Company certifies that this product met its published specifications at the time of shipment from the factory. Hewlett-Packard further certifies that its calibration measurements are traceable to the United States National Bureau of Standards, to the extent allowed by the Bureau's calibration facility, and to the calibration facilities of other International Standards Organization members.

WARRANTY

This Hewlett-Packard instrument product is warranted against defects in material and workmanship for a period of one year from date of shipment. During the warranty period, Hewlett-Packard Company will, at its option, either repair or replace products which prove to be defective.

For warranty service or repair, this product must be returned to a service facility designated by HP. Buyer shall prepay shipping charges to HP and HP shall pay shipping charges to return the product to Buyer. However, Buyer shall pay all shipping charges, duties, and taxes for products returned to HP from another country.

HP warrants that its software and firmware designated by HP for use with an instrument will execute its programming instructions when properly installed on that instrument. HP does not warrant that the operation of the instrument, or software, or firmware will be uninterrupted or error free.

LIMITATION OF WARRANTY

The foregoing warranty shall not apply to defects resulting from improper or inadequate maintenance by Buyer, Buyer-supplied software or interfacing, unauthorized modification or misuse, operation outside of the environmental specifications for the product, or improper site preparation or maintenance.

NO OTHER WARRANTY IS EXPRESSED OR IMPLIED. HP SPECIFICALLY DISCLAIMS THE IMPLIED WARRANTIES OF MERCHANTABILITY AND FITNESS FOR A PARTICULAR PURPOSE.

EXCLUSIVE REMEDIES

THE REMEDIES PROVIDED HEREIN ARE BUYER'S SOLE AND EXCLUSIVE REMEDIES. HP SHALL NOT BE LIABLE FOR ANY DIRECT, INDIRECT, SPECIAL, INCIDENTAL, OR CONSEQUENTIAL DAMAGES, WHETHER BASED ON CONTRACT, TORT, OR ANY OTHER LEGAL THEORY.

ASSISTANCE

Product maintenance agreements and other customer assistance agreements are available for Hewlett-Packard products.

For any assistance, contact your nearest Hewlett-Packard Sales and Service Office. Addresses are provided at the back of this manual.

TABLE OF CONTENTS

Section	Page	Section	Page
I GENERAL INFORMATION	1-1	4-19. Frequency Accuracy	4-10
1-1. Introduction	1-1	4-20. Harmonic Distortion	4-12
1-5. Safety Considerations	1-1	V ADJUSTMENTS	5-1
1-6. General	1-1	5-1. Introduction	5-1
1-8. Operation	1-1	5-4. Equipment Required	5-1
1-10. Service	1-1	5-6. Factory Selected Components	5-1
1-16. Instruments Covered by Manual	1-2	5-8. Power Supply, Check and Adjustment	5-2
1-18. Description	1-2	5-9. 1.55 GHz Oscillator Power Level, Frequency Check and Adjustment	5-4
1-21. 8554L RF Section Modifications	1-4	5-10. 1.55 GHz Oscillator Residual FM Check	5-6
1-23. Accessories Supplied	1-4	5-11. First Converter Check and Adjustment	5-9
1-25. Equipment Required But Not Supplied	1-4	5-12. Automatic Level Control (ALC) Check and Adjustment	5-11
1-27. Warranty	1-4	5-13. Level Control Calibration Check and Adjustment	5-13
1-29. Recommended Test Equipment	1-4	VI REPLACEABLE PARTS	6-1
II INSTALLATION	2-1	6-1. Introduction	6-1
2-1. Initial Inspection	2-1	6-3. Abbreviations	6-1
2-2. Mechanical Check	2-1	6-5. Replaceable Parts List	6-1
2-4. Electrical Check	2-1	6-7. Ordering Information	6-1
2-6. Claims for Damage	2-1	VII MANUAL BACKDATING CHANGES	7-1
2-9. Preparation for Use	2-1	7-1. Introduction	7-1
2-10. Power Requirements	2-1	7-4. Manual Change Instructions	7-1
2-13. Power Cable	2-1	7-5. Change A - For Serial Numbers Prefixed 1744A and Below	7-1
2-16. Operating Environment	2-1	7-6. Change B - For Serial Numbers Prefixed 1630A and Below	7-2
2-18. Installation Connections	2-2	7-7. Change C - For Serial Numbers Prefixed 1601A and Below	7-2
2-21. Storage and Shipment	2-2	7-8. Change D - For Serial Numbers Prefixed 1323A and Below	7-2
2-22. Original Packaging	2-2	7-9. Change E - For Serial Numbers Prefixed 1215A and Below	7-2
2-26. Other Packaging Materials	2-2	7-10. Change F - For Serial Numbers Prefixed 1208A and Below	7-3
III OPERATION	3-1	7-11. Change G - For Serial Numbers Prefixed 1147A and Below	7-3
3-1. Introduction	3-1	7-12. Change H - For Serial Numbers Prefixed 1139A and Below	7-4
3-3. Panel Features	3-1	7-13. Change I - For Serial Numbers Prefixed 1033A	7-4
3-5. Operator's Checks	3-1	VIII SERVICE	8-1
3-7. Operating Instructions	3-1	8-1. Introduction	8-1
3-9. Controls, Indicators and Connectors	3-1	8-3. Principles of Operation	8-1
3-11. Operating Techniques	3-1	8-5. Recommended Test Equipment	8-1
3-13. Crystal Filter Measurement	3-8	8-7. Troubleshooting	8-1
3-15. Bandpass Filter Measurement	3-8	8-11. Repair	8-1
3-17. Low-Pass Filter Measurement	3-8	8-20. General Service Hints	8-2
3-19. Swept Return Loss Measurement	3-9	8-23. General Service Information	8-4
3-21. Amplifier Gain and Bandwidth Measurement	3-9	8-28. Operational Amplifiers	8-5
3-23. Precision Frequency Measurements	3-9	8-31. Electrical Maintenance	8-6
IV PERFORMANCE TESTS	4-1		
4-1. Introduction	4-1		
4-3. Equipment Required	4-1		
4-5. Front Panel Checks	4-1		
4-7. Preset Adjustments (8554B/8552B/ 141T/8444A System)	4-1		
4-9. Preset Adjustments (8555A/8552B/ 141T/8444A System)	4-2		
4-11. Performance Tests	4-2		
4-16. Output Level and Flatness	4-3		
4-17. Frequency Stability	4-5		
4-18. System Flatness	4-8		

TABLE OF CONTENTS (Cont'd)

Section	Page	Section	Page
APPENDICES			
A	Required Modification When Replacing A3 Amplifier Detector Assembly	A/B-1/2	
B	Replacement for A7 1.55 GHz Oscillator Assembly	A/B-1/2	
C	Improved Power Supply Stability	C-1	
D	Model 8444A Tracking Generator, Option 058	D-1	
	D-1. Introduction	D-1	
	D-3. Description	D-1	
	D-6. Manual Changes to Incorporate Option 058	D-1	
	D-7. Section I	D-1	
	D-9. Section III Operation	D-2	
	D-11. Section V, Adjustments	D-3	
	D-13. Section VI, Replaceable Parts	D-4	
	D-14. Section VIII, Service	D-5	
E	Model 8444A Tracking Generator, Option 059	E-1	
	E-1. Introduction	E-1	
	E-3. Description	E-1	
	E-6. Specifications	E-1	
	E-8. Operation	E-1	
	E-11. Performance Tests	E-1	
	E-16. Output Level and Flatness Test	E-2	
	E-17. Adjustments	E-3	
	E-20. 500 MHz Local Oscillator Adjustment	E-4	
	E-21. 500 MHz Local Oscillator Residual FM Check	E-4	
	E-22. Replaceable Parts	E-6	
	E-24. Service	E-6	

LIST OF ILLUSTRATIONS

Figure	Page	Figure	Page
1-1. Model 8444A Tracking Generator and Accessories	1-0	4-8. Typical Harmonic Distortion CRT Display 0 to 500 MHz	4-14
1-2. Instrument Identification	1-2	5-1. Power Supply Check and Adjustment Test Setup	5-2
2-1. Available Power Cable Configurations	2-2	5-2. 1.55 GHz LO Power Level and Frequency Check and Adjustment Test Setup	5-4
3-1. Model 8444A Tracking Generator Front Panel Controls, Indicators and Connectors	3-2	5-3. 1.55 GHz LO Residual FM Check Test Setup	5-6
3-2. Model 8444A Tracking Generator Rear Panel Controls and Connectors	3-3	5-4. Demodulation Sensitivity Measurement	5-8
3-3. Tracking Generator Operation with 8554B Spectrum Analyzer	3-4	5-5. First Converter Check and Adjustment Test Setup	5-9
3-4. Tracking Generator Operation with 8555A Spectrum Analyzer	3-6	5-6. First Converter Passband CRT Display	5-10
3-5. 20 MHz Crystal Filter CRT Display	3-8	5-7. Automatic Level Control (ALC) Check and Adjustment Test Setup	5-11
3-6. 50 MHz Bandpass Filter CRT Display	3-8	5-8. Level Control Calibration Check and Adjustment Test Setup	5-13
3-7. 23 MHz Low-Pass Filter CRT Display	3-9	7-1. P/O Figure 8-17, Power Supply and Input Circuit, Schematic (CHANGES A and C)	7-5/7-6
3-8. Swept Return Loss Measurement CRT Display	3-9	7-2. P/O Figure 8-17, Power Supply and Input Circuit, Schematic (CHANGE A)	7-7/7-8
3-9. Amplifier Gain and Bandwidth CRT Display	3-9	7-3. P/O Figure 8-17, Power Supply and Input Circuit, Schematic (CHANGE C)	7-7/7-8
3-10. Precision Frequency Measurement CRT Display	3-10	7-4. P/O Figure 8-17, Power Supply and Input Circuit, Schematic (CHANGE D)	7-9/7-10
4-1. Output Level and Flatness Test Setup	4-3	7-5. First Converter Circuits, Schematic (CHANGE G)	7-11/7-12
4-2. Residual FM Test Setup	4-5	7-6. A7 1.55 GHz Oscillator Assembly, Illustrated Parts Breakdown, (1 of 2) (CHANGE G)	7-13/7-14
4-3. Demodulation Sensitivity Measurement	4-7		
4-4. System Flatness Test Setup	4-8		
4-5. Frequency Accuracy Test Setup	4-10		
4-6. Harmonic Distortion Test Setup	4-12		
4-7. Typical Harmonic Distortion CRT Display 0 to 100 MHz	4-14		

LIST OF ILLUSTRATIONS (Cont'd)

Figure	Page	Figure	Page
8-1. Transistor Operation	8-5	8-19. A7 1.55 GHz Oscillator Assembly, Illustrated Parts Breakdown	8-21
8-2. Examples of Diode and Transistor Marking Methods.	8-6	D-1. 500 MHz LO Mounting Location and Output Port for the 8444A, Option 058.	D-6
8-3. Operational Amplifier Equivalent Circuit.	8-7	D-2. Location of 500 MHz LO OUTPUT BNC Connector Added on Rear Panel of the 8444A, Option 058	D-7
8-4. Major Assembly Locations	8-9	D-3. A9 500 MHz Oscillator Assembly, Schematic	D-8
8-5. Adjustment and Test Point Locations	8-9	E-1. Output Level and Flatness Test Setup	E-2
8-6. Tracking Generator Spectrum Analyzer, Simplified Block Diagram	8-10	E-2. 500 MHz Local Oscillator Adjustment Setup	E-4
8-7. Tracking Generator Block Diagram with Spectrum Analyzer Interconnections.	8-11	E-3. 500 MHz L.O. Residual FM Check Equipment Setup	E-5
8-7A. Troubleshooting Tree.	8-12	E-4. Equipment Connections for 8444A Option 059/8558B	E-10
8-8. Tracking Generator Troubleshooting Block Diagram	8-13	E-5. Equipment Connections for 8444A Option 059/8565A	E-10
8-9. Mixer Diode Forming Dimensions in Inches	8-14	E-6. Equipment Connections for 8444A Option 059/8568A	E-10
8-10. Modulator/Oscillator Driver Assy A2 Component Locations	8-15	E-7. A9 500 MHz Oscillator Assembly, Schematic	E-11
8-11. Amplifier and Pin Diode Modulator Assy A4A1 Component Locations	8-15	E-8. P/O Second Converter Circuits Showing Replacement Filter for Option 059.	E-12
8-12. First Converter Circuits, Schematic Diagram.	8-15	E-9. P/O Second Converter Circuits Showing Replacement Amplifier and ALC Detector for Option 059.	E-12
8-13. J1 RF Output Connector, Exploded View	8-16	E-10. 500 MHz LO Mounting Location and Output Port for the 8444A Option 059	E-13
8-14. A2 Modulator/Oscillator Driver Assy, Component Locations	8-17	E-11. Location of 500 MHz LO OUTPUT BNC Connector Added on Rear Panel of the 8444A, Option 059	E-14
8-15. Second Converter Circuits, Schematic Diagram.	8-17		
8-16. A1 Power Supply Assy, Component Locations.	8-19		
8-17. Power Supply and Input Circuit, Schematic Diagram	8-19		
8-18. A5 First Converter Assembly, Illustrated Parts Breakdown	8-20		

LIST OF TABLES

Table	Page	Table	Page
1-1. System Specifications.	1-3	8-2. Adjustable Components	8-2
1-2. Accessories Supplied	1-4	8-3. Schematic Diagram Notes	8-3
1-3. Test Equipment and Accessories.	1-5	8-4. Etched Circuit Soldering Equipment	8-4
1-4. Operating Accessories.	1-7	D-1. 8444A System Specifications with Option 058.	D-1
4-1. Performance Test Record	4-16	D-2. Replaceable Parts	D-4
5-1. Check and Adjustment Test Card	5-15	E-1. Specifications	E-7
6-1. Reference Designations and Abbreviations	6-2	E-2. System Performance Characteristics	E-8
6-2. Replaceable Parts	6-4	E-3. Replaceable Parts Additions for Option 059.	E-9
6-3. Code List of Manufacturers.	6-8	E-4. Replaceable Parts Changes for Option 059	E-9
7-1. Manual Changes by Serial Number Prefix	7-1		
8-1. Factory Selected Components	8-2		

SAFETY CONSIDERATIONS

GENERAL — This is a Safety Class I instrument (provided with terminal for protective earthing).

OPERATION — BEFORE APPLYING POWER verify that the power transformer primary is matched to the available line voltage, the correct fuse is installed, and Safety Precautions are taken (see the following warnings). In addition, note the instrument's external markings which are described under "Safety Symbols."

WARNINGS

Servicing instructions are for use by service-trained personnel only. To avoid dangerous electric shock, do not perform any servicing unless qualified to do so.

BEFORE SWITCHING ON THE INSTRUMENT, the protective earth terminal of the instrument must be connected to the protective conductor of the (mains) power cord. The mains plug shall only be inserted in a socket outlet provided with a protective earth contact. The protective action must not be negated by the use of an extension cord (power cable) without a protective conductor (grounding). Grounding one conductor of a two conductor outlet is not sufficient protection.

If this instrument is to be energized via an auto-transformer (for voltage reduction) make sure the common terminal is connected to the earth terminal of the power source.

Any interruption of the protective (grounding) conductor (inside or outside the instrument) or disconnecting the protective earth terminal will cause a potential shock hazard that could result in personal injury.

Whenever it is likely that the protection has been impaired, the instrument must be made inoperative and be secured against any unintended operation.

Only fuses with the required rated current, voltage, and specified type (normal blow, time delay, etc.) should be used. Do not use repaired fuses or short circuited fuseholders. To do so could cause a shock or fire hazard.

Do not operate the instrument in the presence of flammable gases or fumes. Operation of any electrical instrument in such an environment constitutes a definite safety hazard.

Do not install substitute parts or perform any unauthorized modification to the instrument.

Adjustments described in the manual are performed with power supplied to the instrument while protective covers are removed. Energy available at many points may, if contacted, result in personal injury.

Any adjustment, maintenance, and repair of the opened instrument under voltage should be avoided as much as possible, and when inevitable, should be carried out only by a skilled person who is aware of the hazard involved.

Capacitors inside the instrument may still be charged even if the instrument has been disconnected from its source of supply.

SAFETY SYMBOLS



Instruction manual symbol: the product will be marked with this symbol when it is necessary for the user to refer to the instruction manual in order to protect against damage to the product.



Indicates hazardous voltages.



Earth terminal (sometimes used in manual to indicate circuit common connected to grounded chassis).

WARNING

The WARNING sign denotes a hazard. It calls attention to a procedure, practice, or the like, which, if not correctly performed or adhered to, could result in personal injury. Do not proceed beyond a WARNING sign until the indicated conditions are fully understood and met.

CAUTION

The CAUTION sign denotes a hazard. It calls attention to an operating procedure, practice, or the like, which, if not correctly performed or adhered to, could result in damage to or destruction of part or all of the product. Do not proceed beyond a CAUTION sign until the indicated conditions are fully understood and met.

MODEL 8444A

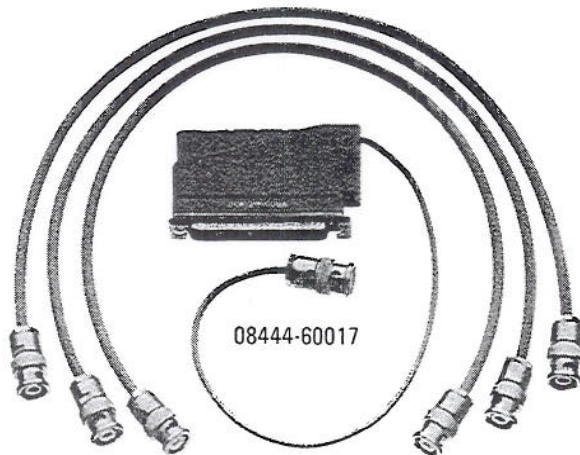

Figure 1-1. Model 8444A Tracking Generator and Accessories

SECTION I GENERAL INFORMATION

1-1. INTRODUCTION

1-2. This manual contains all information required to install, operate, test, adjust and service the Hewlett-Packard Model 8444A Tracking Generator. This section covers instrument identification, description, options, accessories, specifications and other basic information.

1-3. Figure 1-1 shows the Hewlett-Packard Model 8444A Tracking Generator with accessories supplied.

1-4. The various sections in this manual provide information as follows:

SECTION II, INSTALLATION, provides information relative to incoming inspection, power requirements, mounting, packing and shipping, etc.

SECTION III, OPERATION, provides information relative to operating the instrument.

SECTION IV, PERFORMANCE TESTS, provides information required to ascertain that the instrument is performing in accordance with published specifications.

SECTION V, ADJUSTMENTS, provides information required to properly adjust and align the instrument after repairs are made.

SECTION VI, REPLACEABLE PARTS, provides ordering information for all replaceable parts and assemblies.

SECTION VII, MANUAL CHANGES, normally will contain no relevant information in the original issue of a manual. This section is reserved to provide back-dated and up-dated information in manual revisions or reprints.

SECTION VIII, SERVICE, includes all information required to service the instrument.

1-5. SAFETY CONSIDERATIONS

1-6. General

1-7. This instrument has been designed and tested in accordance with international safety requirements. To ensure safe operation, the safety

instructions and procedures in this manual must be strictly adhered to.

1-8. Operation

1-9. BEFORE APPLYING POWER, make sure the instrument's ac input is set for the available ac line voltage, that the correct fuse is installed, and that all normal safety precautions have been taken.

1-10. Service

1-11. Although the instrument has been designed in accordance with international safety standards, the information, cautions, and warnings in this manual must be followed to ensure safe operation. Service and adjustments should be performed only by qualified service personnel.

1-12. Adjustment or repair of the opened instrument with the ac power connected should be avoided as much as possible and, when inevitable, should be performed only by a skilled person who knows the hazard involved.

1-13. Capacitors inside the instrument may still be charged even though the instrument has been disconnected from its source of supply.

1-14. Make sure only fuses of the required current rating and type (normal blow, time delay, etc.) are used for replacement. Do not use repaired fuses or short circuit the fuse holders.

1-15. Whenever it is likely that the protection has been impaired, make the instrument inoperative and secure it against any unintended operation.

WARNING

If this instrument is to be energized through an autotransformer (for voltage reduction), make sure the common terminal is connected to the earthed pole of the power source.

BEFORE SWITCHING ON THE INSTRUMENT, the protective earth terminals of the instrument must be connected to the protective conductor of the mains power cord. The mains plug shall only be inserted in a socket

outlet provided with protective earth contact. The protection must not be negated by using an extension cord (power cable) without a protective grounding conductor.

Interruption of the protective (grounding) conductor, inside or outside the instrument, or disconnection of the protective earth terminal is likely to make this instrument dangerous. Intentional interruption of the earth ground is prohibited.

Servicing this instrument often requires that you work with the instrument's protective covers removed and with ac power connected. Be very careful; the energy at many points in the instrument may, if contacted, cause personal injury.

With the ac power cable connected, the ac line voltage is present at the terminals of the power line module and at the LINE power switch. Be very careful. Bodily contact with this voltage can be fatal.

CAUTION

BEFORE SWITCHING ON THIS INSTRUMENT, make sure instrument's ac input is set to the voltage of the ac power source.

BEFORE SWITCHING ON THIS INSTRUMENT, make sure that all devices connected to the instrument are connected to the protective earth ground.

BEFORE SWITCHING ON THIS INSTRUMENT, make sure the line power (mains) plug is connected to a three-conductor line power outlet that has a protective (earth) ground. (Grounding one conductor of a two-conductor outlet is not sufficient.)

BEFORE SWITCHING ON THIS INSTRUMENT, make sure the ac line fuse is of the required current rating and type (normal-blow, time-delay, etc.).

1-16. INSTRUMENTS COVERED BY MANUAL

1-17. Hewlett-Packard instruments carry a serial number (see Figure 1-2) on the back panel. When

the serial number prefix on the instrument serial number plate of your instrument is the same as one of the prefix numbers on the inside title page of this manual, the manual applies directly to the instrument. When the instrument serial number prefix is not listed on the inside title page of initial issue, manual change sheets and manual up-dating information is provided. Later editions or revisions to the manual will contain the required change information in Section VII.

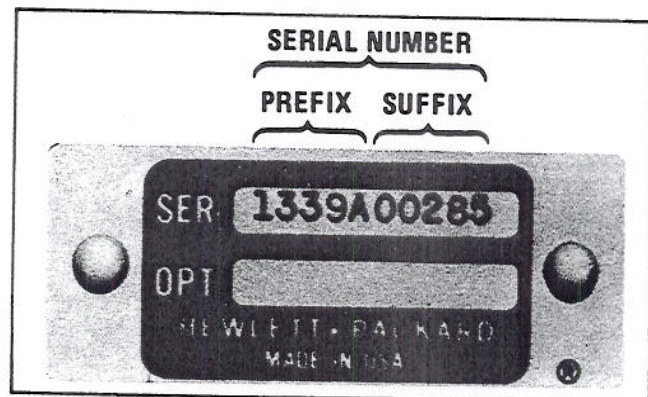

Figure 1-2. Instrument Identification

059 for 68A/B, 58B, 65A, 69B

1-18. DESCRIPTION

1-19. The Model 8444A Tracking Generator is designed to complement both Model 8554B and Model 8555A Spectrum Analyzer RF Sections. The Tracking Generator covers the frequency range of 500 kHz to 1250 MHz when used with the 8554B RF Section and from 10 MHz to 1.3 GHz when used with the 8555A RF Section. The Tracking Generator/Spectrum Analyzer functions as a system to perform frequency response measurements. Additionally, the system can be used as a signal generator or sweeper to supply a test signal to other devices. An auxiliary output is provided for precision frequency measurements by an external frequency counter.

1-20. The Tracking Generator converts the first and third local oscillator (LO) signals from the Spectrum Analyzer RF Section, to a signal that tracks the frequency tuning of the RF Section. With the Spectrum Analyzer operating in ZERO SCAN WIDTH, the Tracking Generator is a CW signal generator, tuned to the frequency of the analyzer. In FULL or PER DIVISION SCAN WIDTH the Tracking Generator functions as a sweep oscillator which tracks the analyzer tuning. Additionally, a

Table 1-1. System Specifications

These system specifications describe the performance available from the spectrum analyzer-tracking generator system in various types of applications. In all cases it is assumed that the spectrum analyzer is equipped with either an 8554B or 8555A Tuning Section, 8552A or 8552B IF Section, 140T or 141T Display Section.

SWEPT FREQUENCY RESPONSE MEASUREMENTS

The tracking generator is used as a signal source to measure the frequency response of a device.

Dynamic Range: > 90 dB from spectrum analyzer 1 dB gain compression point to average noise level (approximately -10 dBm to -100 dBm). Spurious responses not displayed.

Gain Compression: For -10 dBm signal level at the input mixer, gain compression < 1 dB.

Average Noise Level: > -102 dBm with 10 kHz IF bandwidth.

Absolute Amplitude Calibration Range:

Spectrum Analyzer:

Log: From -122 dBm to +10 dBm, 10 dB/div on a 70 dB display or 2 dB/div on a 16 dB display (8552A has 10 dB/div only).

Linear: From 0.1 μ V/div to 100 mV/div (8555A), 20 mV/div (8554B) in a 1, 2 sequence on an 8-division display.

Tracking Generator (Drive Level to Test Device): 0 to -10 dBm continuously variable. 0 dBm calibrated to ± 0.5 dB at 30 MHz.

Frequency Range: 500 kHz to 1250 MHz with 8554B and 10 MHz to 1300 MHz with 8555A.

Scan Width (Determined by Spectrum Analyzer Controls):

Per Division: With 8555A, 16 calibrated scan widths from a 2 kHz/div to 200 MHz/div in a 2, 5, 10 sequence. With 8554B, 15 calibrated scan widths from a 2 kHz/div to 100 MHz/div in 2, 5, 10 sequence.

Full Scan: 0-1250 MHz with 8554B; 0-1300 MHz with 8555A.

Zero Scan: Analyzer is fixed tuned receiver.

Frequency Resolution: 1 kHz.

Stability:

Residual FM (peak to peak):

Tuning Section	Stabilized	Unstabilized
8554B/8555A	200 Hz	10 kHz

Amplitude Accuracy:

System Frequency Response: ± 1.5 dB.

Tracking Generator Calibration: 0 dBm at 30 MHz to ± 0.5 dB.

SWEEP/CW GENERATOR

The tracking generator-spectrum analyzer system can be used to supply test signals for other devices as a sweeper.

Frequency: Controlled by spectrum analyzer. Range is 500 kHz to 1250 MHz with the 8554B and 10 MHz to 1300 MHz with the 8555A.

Frequency Accuracy: ± 10 MHz (8554B), ± 15 MHz (8555A) using spectrum analyzer tuning dial. Can be substantially improved using external counter output.

Spectral Purity:

Residual FM (peak-to-peak):

Tuning Section	Stabilized	Unstabilized
8554B/8555A	200 Hz	10 kHz

Harmonic Distortion: Typically 25 dB below output level.

Nonharmonic (spurious) Signals: > 35 dB below output level.

Flatness: ± 0.5 dB.

Long Term Stability: Drift typically less than 30 kHz/hour when stabilized after 2-hour warmup.

Sweep Width: 20 kHz to 1250 MHz (8554B) or 1300 MHz (8555A).

Sweep Rates: Selected by Scan Time per Division on spectrum analyzer. 16 internal scan rates from 0.1 msec/div to 10 sec/div in a 1, 2, 5 sequence. Manual Scan is available with the external sweep voltage from the 8444A or by a front panel control of the 8552B IF Section.

PRECISION FREQUENCY MEASUREMENTS

An external counter output is provided on the 8444A for precision frequency measurements. The frequency of unknown signals as well as the frequency of any point on a frequency response curve can be measured. The use of the HP 5300A/5303A Counter is suggested for frequency measurements to 500 MHz and the HP 5245L/5254C Counter for measurements to 1300 MHz.

Frequency Accuracy:

For unknown signals ± 10 kHz. (Tracking drift typically 5 kHz/10 min after 2-hour warmup.)

For points on frequency response curve, counter accuracy \pm Residual FM.

Counter Mode of Operation:

Manual Scan: Scan determined either by front panel control of 8552B IF Section or by external scan signal provided by the 8444A.

Zero Scan: Analyzer is fixed tuned receiver. Counter reads center frequency to accuracy of tracking drift.

Counter Output Level: 0.1 V rms.

GENERAL SPECIFICATIONS

Temperature Range: Operation, 0 to 55°C, storage -40°C to 75°C.

Power: 115V and 230V, 48 to 440 Hz, 35 VA max.

MANUAL SCAN control on the Tracking Generator allows manual tuning of the Spectrum Analyzer/Tracking Generator System. The amplitude of the Tracking Generator output is adjustable over a 0 to -10 dBm range by a front panel vernier control. The output level is calibrated at 30 MHz to 0 ±0.5 dBm and maintained by an automatic level control circuit. Refer to Table 1-1 for system performance specifications.

1-21 8554L RF SECTION MODIFICATIONS

1-22. Hewlett-Packard Model 8554L Spectrum Analyzer RF Section with serial prefixes 1101A and below require modification for Tracking Generator compatibility. The modification consists of adding two cables to the RF Section. The cables provide front panel access to the first and third LO outputs. The modification kit, HP Part Number 08554-60056, containing all necessary parts and information is available from any Hewlett-Packard Sales and Service Office. (A list of Sales and Service offices is contained in the back of this manual.) Service Note 8554L-6 containing the modification procedure is included with the modification kit. After modification, the Service Note should be filed with the 8554L Service Manual.

1-23. ACCESSORIES SUPPLIED

1-24. Accessories supplied with the Tracking Generator are listed in Table 1-2. RF cables, supplied with the Tracking Generator, allow operation with either the 8554B or 8555A Spectrum Analyzer RF Sections. The power cable, supplied with the instrument, is selected at time of shipment. Cable selection is based on shipping destina-

tion. Figure 2-1 illustrates the different power cable connectors that are currently available.

1-25. EQUIPMENT REQUIRED BUT NOT SUPPLIED

1-26. In addition to the accessories supplied with the Tracking Generator, a Spectrum Analyzer System is required to complete the Tracking Generator Spectrum Analyzer System. The Tracking Generator is compatible with either the 8554B/8552()/140-series Spectrum Analyzer System or the 8555A/8552()/140-series Spectrum Analyzer System. Refer to paragraph 1-21 for modifications to early model Spectrum Analyzer Systems. For precision frequency measurements a frequency counter is required for use with the Tracking Generator/Spectrum Analyzer System. Operating accessories are listed in Table 1-4.

1-27. WARRANTY

1-28. The Hewlett-Packard Model 8444A Tracking Generator is warranted and certified as indicated on the inner front cover of this manual. For further information contact the nearest Hewlett-Packard Sales and Service office; addresses are provided at the back of this manual.

1-29. RECOMMENDED TEST EQUIPMENT

1-30. Table 1-3 lists the test equipment and accessories required to check, adjust, and repair the Tracking Generator. If substitute equipment is used, it must meet the Minimum Specifications listed in Table 1-3.

Table 1-2. Accessories Supplied

HP Part Number	Name	Description
8120-1348*	Line Power Cable	7½ feet, 3 wire AC Line Cord
08444-60017	Interconnect Cable	Coaxial cable for interconnection between AUX "A" connector on Display Section and THIRD LO INPUT on Tracking Generator. For use with 8555A Spectrum Analyzer System.
08444-60018	Interconnect Cable	18-inch low leakage coaxial cable with BNC connectors. Three (3) each supplied. Two required for 8555A Spectrum Analyzer System. Three required for 8554B Spectrum Analyzer System. Connects FIRST LO to FIRST LO, THIRD LO to THIRD LO and SCAN OUTPUT to SCAN IN/OUT.

*See paragraph 2-15 and Figure 2-1.

Table 1-3. Test Equipment and Accessories (1 of 3)

Item	Minimum Specifications	Suggested Model	Use*
Spectrum Analyzer System	Frequency Range: 500 kHz — 1.25 GHz Compatible with Tracking Generator (Part of System)	HP 8554B or 8555A/8552B 141T Spectrum Analyzer System	P,A,T
Frequency Comb Generator	Frequency markers spaced 100 MHz apart Frequency Accuracy: $\pm 0.01\%$ Output Amplitude: -30 dBm to 1.5 GHz	HP 8406A Comb Generator	P,T
Spectrum Analyzer System (Test Analyzer)	Frequency Range: 500 kHz — 4 GHz Amplitude Accuracy: ± 1 dB	HP 8553B/8555A/8552B/ 141T Spectrum Analyzer System	P,A,T
Power Meter	Frequency Range: 0.01 — 12 GHz Accuracy: $\pm 1\%$ Power Range: -20 to $+10$ dBm	HP 432A Power Meter with HP 8478B Therm- istor Mount	P,A,T
AC Voltmeter	Frequency Range: 10 Hz to 10 MHz Voltage Range: 1 mV to 300V Calibration: -10 to $+2$ dB, 10 dB between ranges. Accuracy: $\pm 5\%$ at 10 MHz	HP 400E AC Voltmeter	P,A
AC Voltmeter	Voltage Accuracy: $\pm 3\%$ of full scale Voltage Range: 300V full scale Input Impedance: 10 megohms	HP 410C Multifunction Voltmeter	A, T
Frequency Counter	Frequency Range: 500 kHz — 50 MHz, 200 MHz — 3.0 GHz Frequency Accuracy: $\pm 0.01\%$	HP 5245L Frequency Counter with HP 5254C Frequency Converter	P,A,T
Test Oscillator	Frequency Range: 10 Hz — 10 MHz Frequency Accuracy: $\pm 3\%$ Output Amplitude: 3 Vrms Output Impedance: 50 ohms	HP 652A Test Oscillator	P,A
HF Signal Generator	Frequency Range: 1 — 50 MHz Output Amplitude: > 0 dBm Frequency Accuracy: $\pm 1\%$ Output Impedance: 50 ohms	HP 606A/B HF Signal Generator	P
VHF Signal Generator	Frequency Range: 50 — 450 MHz Output Amplitude: > 0 dBm Output Impedance: 50 ohms	HP 608E/F VHF Signal Generator	P
UHF Signal Generator	Frequency Range: 450 — 1200 MHz Output Amplitude: 0 dBm Output Impedance: 50 ohms	HP 612A UHF Signal Generator	P
Digital Voltmeter	Voltage Accuracy: $\pm 0.2\%$ Voltage Range: 1 — 30 Vdc Polarity: Automatic Indication	HP 3440A Digital Volt- meter w HP 3443A Plug-in	A,T
*P = Performance Test; A = Adjustments; T = Troubleshooting			

Table 1-3. Test Equipment and Accessories (2 of 3)

Item	Minimum Specifications	Suggested Model	Use*
Variable Voltage Transformer	Voltage Range: 102 – 127 Vac	General Radio W5MT3A or Superior Electric UC1M	A, T
Power Supply Dual Dc	Output Voltage: Variable 0 – 20 Vdc Output Current: 0 – 200 mA Meter Accuracy: $\pm 3\%$ Control: Fine adjustment	HP 6205B Power Supply	A, T
Dc Volt-Ohm-Ammeter	Voltmeter Voltage Range: 1 mV – 50 Vdc Accuracy: $\pm 1\%$ Input Resistance: 10 megohms Ammeter Current Range: 1 mA – 200 mA Accuracy: $\pm 2\%$ Ohmmeter Resistance Range: 1 ohm – 100 megohm Accuracy: $\pm 5\%$ reading at center scale	HP 412A Volt-Ohm Ammeter	A, T
Coaxial Attenuator	Frequency Range: DC – 4 GHz Flatness: ± 0.2 dB	HP 8491A Option 10	A, T
Adapter	BNC Tee	UG-274B/U HP 1250-0781	P,A,T
Adapter	BNC Female to Type N Male	UG-201A/U HP 1250-0780	P,A,T
Cable Assembly	Coaxial cable with Male BNC connectors, 48 inches long	HP 10503A	P,A,T
Cable Assembly	Coaxial cable terminated with BNC Male connector and with probe and alligator clip	HP 10501A	A, T
Cable Assembly	Coaxial cable terminated with BNC Male connector and alligator clips	HP 10501A	A, T
Cable Assembly	Coaxial cable terminated with dual banana plug and probe with alligator clip	HP 11003A	A, T
Cable Assembly	Coaxial cable with dual banana plug and Male BNC connector terminations	HP 11001A	A, T
Cable Assembly	SMA Male to BNC Male	HP 08555-60076	A, T
Cable Assembly	Selectro Female to BNC Male Test Cable, 36 inches long	HP 11592-60001	A, T
Cable Assembly	Selectro Female to Selectro Male Test Cable, 8 inches long	HP 11592-60003	A, T
Adapter	BNC Jack to BNC Jack	UG-914A/U HP 1250-0080	A, T

*P = Performance Test; A = Adjustments; T = Troubleshooting

Table 1-3. Test Equipment and Accessories (3 of 3)

Item	Minimum Specifications	Suggested Model	Use*
Wrench	Open-end, 5/16-inch	HP 8720-0030	A,T
Wrench	No. 10 Allen Driver	HP 5020-0291	A,T
Test Lead	Test lead with alligator clips	common	A,T
Resistor	100K ohm, 5%, 1 watt	HP 0757-0367 (1%)	A,T
Wrench	Open-end, 15/64-inch	HP 8710-0946	T
Low-pass Filter	700 MHz Cut-off	HP 360A	T

*P = Performance Test; A = Adjustments; T = Troubleshooting

Table 1-4. Operating Accessories

Model Number	Name	Description
HP 8554B	RF Section	Spectrum Analyzer RF Section with frequency range of 500 kHz to 1250 MHz.
HP 8555A	RF Section	Spectrum Analyzer RF Section with frequency range of .01 to 18 GHz. When used with Tracking Generator, covers frequency range of 10 to 1300 MHz.
HP 140T	Display Section	Spectrum Analyzer Display Section compatible with Tracking Generator.
HP 141T	Display Section	Spectrum Analyzer Display Section with storage CRT display capability. Compatible with Tracking Generator.
HP 8552A	IF Section	Spectrum Analyzer IF Section compatible with Tracking Generator, 10 dB per division log range.
HP 8552B	IF Section	Spectrum Analyzer IF Section compatible with Tracking Generator, 2 dB per division log range.
HP 5300B/ 5303B	Frequency Counter	For precision frequency measurements to 500 MHz.
HP 5245L/ 5254C	Frequency Counter	For precision frequency measurements over frequency range of 0 to 50 MHz and 150 to 3000 MHz.
HP 5060-8543	Joining Bracket Kit	Hardware and parts for strapping Tracking Generator to Spectrum Analyzer. Provides a common ground and secure mounting.
HP 8120-1575	Accessory Power Cord	For accessory instrument operation off of line input to Tracking Generator. Plugs mate with accessory outlet connector and line input connector on HP 5060-1189 power line module.
HP 8120-1576	Accessory Power Cord	For accessory instrument operation off of line input to Tracking Generator. Plugs mate with accessory outlet connector and line input connector HP 1251-0148 (old type).
HP 5060-8739	Rack Mounting Kit	Set of two 3½-inch high rack mount flanges to install instrument in 19-inch rack.

SECTION II INSTALLATION

2-1. INITIAL INSPECTION

2-2. Mechanical Check

2-3. Check the shipping carton for evidence of damage immediately after receipt. If there is any visible damage to the carton, request the carrier's agent be present when the instrument is unpacked. Inspect the instrument for physical damage such as bent or broken parts and dents or scratches. If damage is found refer to paragraph 2-6 for recommended claim procedures. If the instrument appears to be undamaged, perform the electrical check (see paragraph 2-4). The packaging material should be retained for possible future use.

2-4. Electrical Check

2-5. The electrical check consists of following the performance test procedures listed in Section IV. These procedures allow the operator to determine that the instrument is, or is not, operating within the specifications listed in Table 1-1. The initial performance and accuracy of the instrument are certified as stated on the inside front cover of this manual. If the instrument does not operate as specified, refer to paragraph 2-6 for the recommended claim procedure.

2-6. CLAIMS FOR DAMAGE

2-7. If physical damage is found when the instrument is unpacked, notify the carrier and the nearest Hewlett-Packard Sales and Service office immediately. The Sales and Service office will arrange for repair or replacement without waiting for a claim to be settled with the carrier.

2-8. The warranty statement for the instrument is on the inside front cover of this manual. Contact the nearest Sales and Service office for information about warranty claims.

2-9. PREPARATION FOR USE

CAUTION

Before applying power, check the power selector card on the Tracking Generator input power module (rear panel) for proper position (115 or 230 volts).

2-10. Power Requirements

2-11. The Tracking Generator can be operated from a 48- to 440-hertz input line that supplies either 115- or 230-volt ($\pm 10\%$ in each case) power. Consumed power is normally less than 15 watts.

2-12. The 115/230 power selector card in the rear panel line power module must be set to agree with the available line voltage. The selector card is located below the fuse holder and fuse extractor lever. A label on the selector card indicates the selected line input voltage. To change the position of the selector card, it is necessary to remove the power cable, slide the protective cover to the left and lift the fuse extractor before the card can be changed. With the fuse extractor extended, remove the card and insert in proper position. Replace fuse with a fuse of the amperage rating for the selected position. See Section VI for replacement HP Part Numbers. The instrument is normally shipped with fuse installed for 115-volt operation.

2-13. Power Cable

2-14. In accordance with international safety requirements, this instrument is supplied with a three-conductor ac power cable. One of the conductors is a ground conductor. When the cable is inserted in the proper ac power receptacle, this conductor connects the instrument cabinet to earth ground. This grounding protection should not be interrupted or disabled by use of extension cords or adapters which are not equipped with a grounding conductor.

2-15. Power cables are selected for shipment with each instrument; with a line connector plug to match the standard power cord for the country of destination on the purchase order. A label indicating the power cable inside is affixed to the packing case. Figure 2-1 indicates the connector plugs and the HP part numbers for the various available power cables and plugs.

2-16. OPERATING ENVIRONMENT

2-17. The Tracking Generator does not require forced air cooling when operating at temperatures from 0 to 55°C (32 to 131°F). When operating the instrument, choose a location which will provide at

least three inches of clearance around the rear and both sides. Normal air circulation will maintain a reasonable temperature within the instrument.

2-18. INSTALLATION CONNECTIONS

2-19. A rack mounting kit is available for rack installation. Additionally, a joining bracket kit (accessory) can be provided to secure the Tracking Generator to the Spectrum Analyzer. Installation instructions are supplied with both joining bracket and rack mounting kits.

2-20. Electrical connections are provided by three coaxial cables and two line power cords. Coaxial cables connect Spectrum Analyzer FIRST LO OUTPUT to Tracking Generator FIRST LO INPUT, THIRD LO OUTPUT to THIRD LO INPUT and SCAN OUTPUT to SCAN IN/OUT. Double shielded coaxial cables are provided for connection between local oscillator input and output connectors. Refer to Table 1-2 for description and HP part number of cables supplied with the Tracking Generator.

2-21. STORAGE AND SHIPMENT

2-22. Original Packaging

2-23. The same containers and materials used in factory packaging can be obtained through the Hewlett-Packard Sales and Service offices listed at the rear of this manual.

2-24. If the instrument is being returned to Hewlett-Packard for servicing, attach a tag indicat-

ing service required, return address, instrument model number and full serial number. Mark the container FRAGILE to assure careful handling.

2-25. In any correspondence refer to the instrument by model number and full serial number.

2-26. Other Packaging Materials

2-27. The following general instructions should be followed when repackaging with commercially available materials:

a. Wrap the instrument in heavy paper or plastic. (If shipping to a Hewlett-Packard Service office or center attach a tag indicating the type of service required, return address, model number and full serial number.)

b. Use a strong shipping container. A double-wall carton made of 350 pound test material is adequate.

c. Use enough shock-absorbing material (three to four inch layer) around all sides of the instrument to provide firm cushion and prevent movement inside the container. Protect the control panel with cardboard.

d. Seal the shipping container securely.

e. Mark the shipping container FRAGILE to assure careful handling.

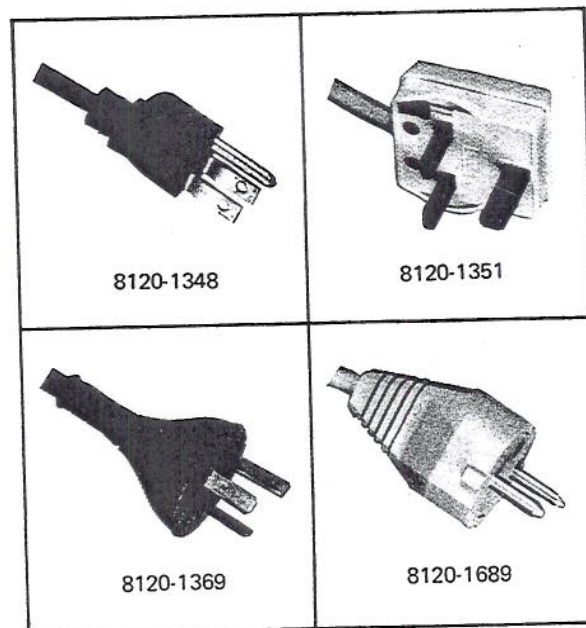

Figure 2-1. Available Power Cable Configurations

SECTION III OPERATION

3-1. INTRODUCTION

3-2. This section provides complete operation instructions for the HP Model 8444A Tracking Generator. Front and rear panel controls, connectors and indicators for the Tracking Generator are identified and described in Figures 3-1 and 3-2. Operational connections and adjustments for the Tracking Generator and an 8554B Spectrum Analyzer System are detailed in Figure 3-3. Operational connections and adjustments for the Tracking Generator and an 8555A Spectrum Analyzer System are detailed in Figure 3-4. Additional operating information is contained in Figures 3-5 through 3-10.

3-3. PANEL FEATURES

3-4. Front and rear panel features of the Tracking Generator are described in Figures 3-1 and 3-2. Front and rear panel views of the Tracking Generator connected to the HP 8554B/8552/141T Spectrum Analyzer are shown in Figure 3-3. Front and rear panel views of the Tracking Generator connected to the HP 8555A/8552/141T Spectrum Analyzer are shown in Figure 3-4. For a detailed description of the Spectrum Analyzer controls, connectors and indicators refer to the appropriate operating and service manuals for those instruments. Interconnection wiring between the Tracking Generator and the Spectrum Analyzer is contained in Section VIII (Service Sheet 1) of this manual.

3-5. OPERATOR'S CHECKS

3-6. Upon receipt of the instrument, or when the Tracking Generator is to be used with a different Spectrum Analyzer, perform the operational adjustment procedures listed in Figure 3-3 or 3-4.

3-7. OPERATING INSTRUCTIONS

3-8. General operating instructions are contained in Figures 3-3 and 3-4. These instructions will familiarize the operator with basic operating functions of the Tracking Generator in use with Spectrum Analyzers. Additional operating techniques and information is contained in Figures 3-5 through 3-10.

3-9. CONTROLS, INDICATORS AND CONNECTORS

3-10. Front and rear panel controls, indicators and connectors are identified and briefly described in Figures 3-1 and 3-2. Operational adjustment procedures are given in Figures 3-3 and 3-4. Additional information, to assist the user during instrument operation, is given in the following paragraphs.

3-11. OPERATING TECHNIQUES

3-12. The following information is provided to acquaint the user with Tracking Generator/Spectrum Analyzer operation. When a device is placed in the signal path between the Tracking Generator and the Spectrum Analyzer, the analyzer detects and displays the frequency response of the device under test. The Spectrum Analyzer tuning and scan width settings determine the Tracking Generator output frequency and the resultant CRT display. The type of device, control settings, and typical display is provided for each of the following measurements.

- a. Crystal Filter Measurement, Para. 3-13.
- b. Bandpass Filter Measurement, Para. 3-15.
- c. Low-Pass Filter Measurement, Para. 3-17.
- d. Swept Return Loss Measurement, Para. 3-19.
- e. Amplifier Gain and Bandwidth Measurement, Para. 3-21.
- f. Precision Frequency Measurement, Para. 3-23.

FRONT PANEL

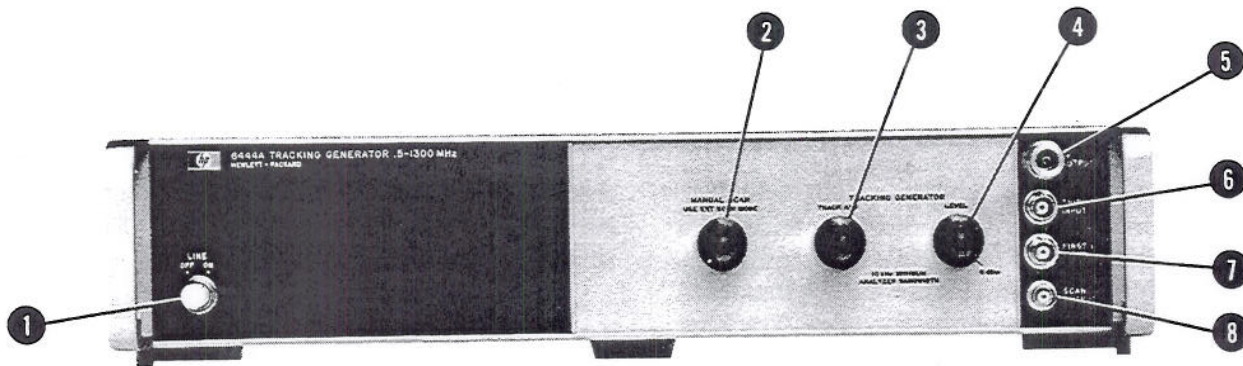

- 1 **LINE – ON/OFF.** Controls primary power to Tracking Generator. Light glows when switch is energized. Type A1H bulb. For access to bulb, switch to OFF and pull button straight out.
- 2 **MANUAL SCAN.** Provides manual tuning of Spectrum Analyzer. Controls voltage level at SCAN OUTPUT (8) below. Scan trace on CRT determined by position of MANUAL SCAN control. For MANUAL SCAN operation, connect cable between Tracking Generator SCAN OUTPUT and Spectrum Analyzer SCAN IN/OUT. Set Spectrum Analyzer SCAN MODE switch to EXT. Vary MANUAL SCAN control to tune analyzer through selected SCAN WIDTH.
- 3 **TRACK ADJ.** Adjusts frequency of 1.55 GHz oscillator in Tracking Generator so that the RF OUTPUT (5) tracks the frequency tuning of the Spectrum Analyzer. Control adjusted for maximum amplitude indication of trace on CRT display. Ten turn control provides adjustment of frequency over a range of approximately 4 MHz.
- 4 **LEVEL.** Adjusts Tracking Generator RF OUTPUT (5) level over range of 0 to -10 dBm. Level calibrated for 0 dBm at 30 MHz with accuracy of ± 0.5 dB. Set LEVEL control to 0 dBm for calibrated CRT display on Spectrum Analyzer.
- 5 **RF OUTPUT.** Type N Connector – Tracking Generator RF output connector. Frequency adjusted to track tuning of Spectrum Analyzer by TRACK ADJ (3). Output level adjusted by LEVEL (4).
- 6 **THIRD LO INPUT.** Type BNC connector – Input for Spectrum Analyzer third LO (500 MHz). Normally used with 8554B RF Section. Parallel with rear panel THIRD LO INPUT which is normally used with 8555A RF Section.
- 7 **FIRST LO INPUT.** Type BNC connector – Input for Spectrum Analyzer first LO (2.05 – 3.3 GHz with 8554L RF Section) – (2.05 – 4.1 GHz with 8555A RF Section).
- 8 **SCAN OUTPUT.** Type BNC connector. Manual tune voltage to Spectrum Analyzer (0 to 10 Vdc). Voltage level controlled by position of MANUAL SCAN (2).

Figure 3-1. Model 8444A Tracking Generator Front Panel Controls, Indicators and Connectors

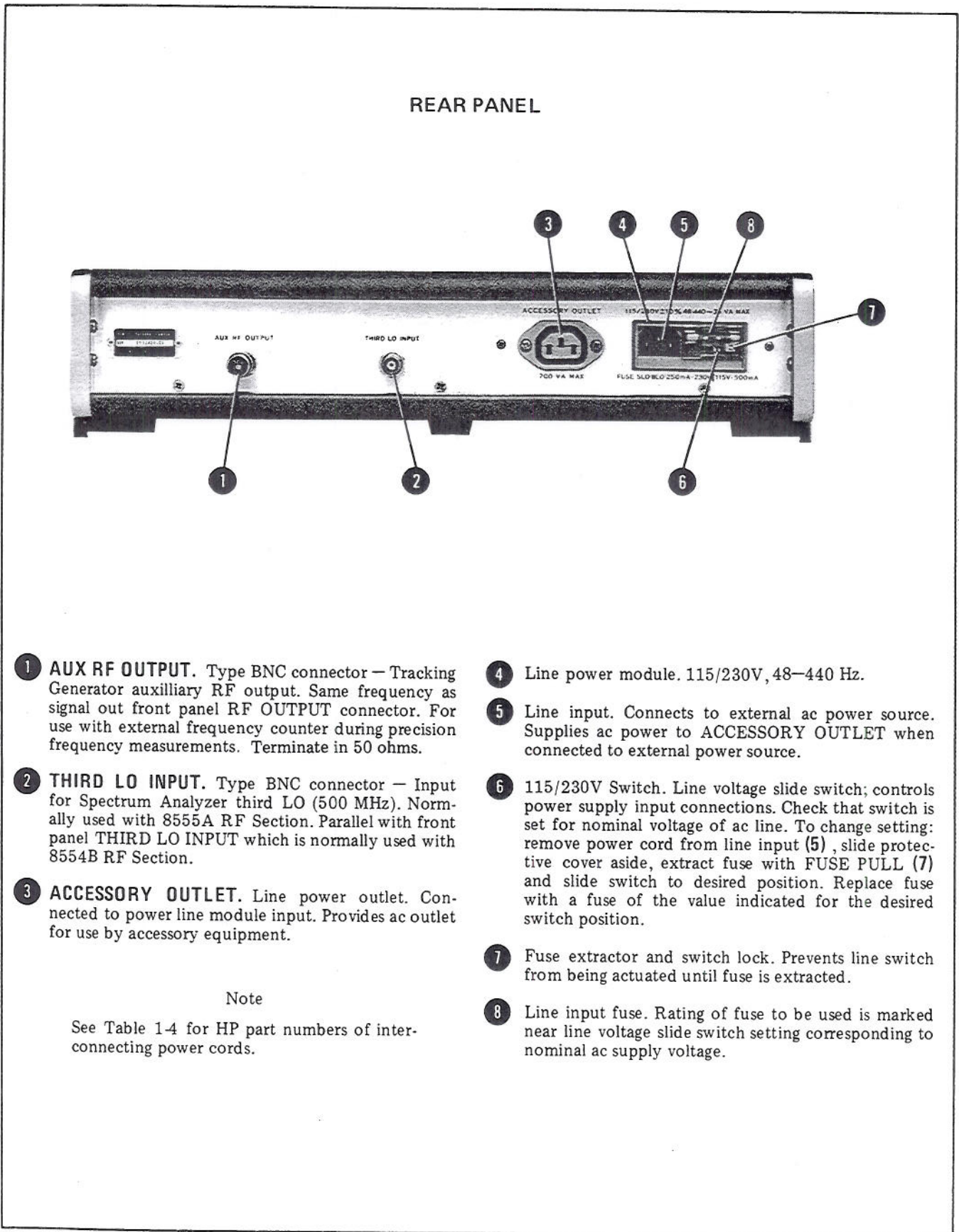

Figure 3-2. Model 8444A Tracking Generator Rear Panel Controls and Connectors

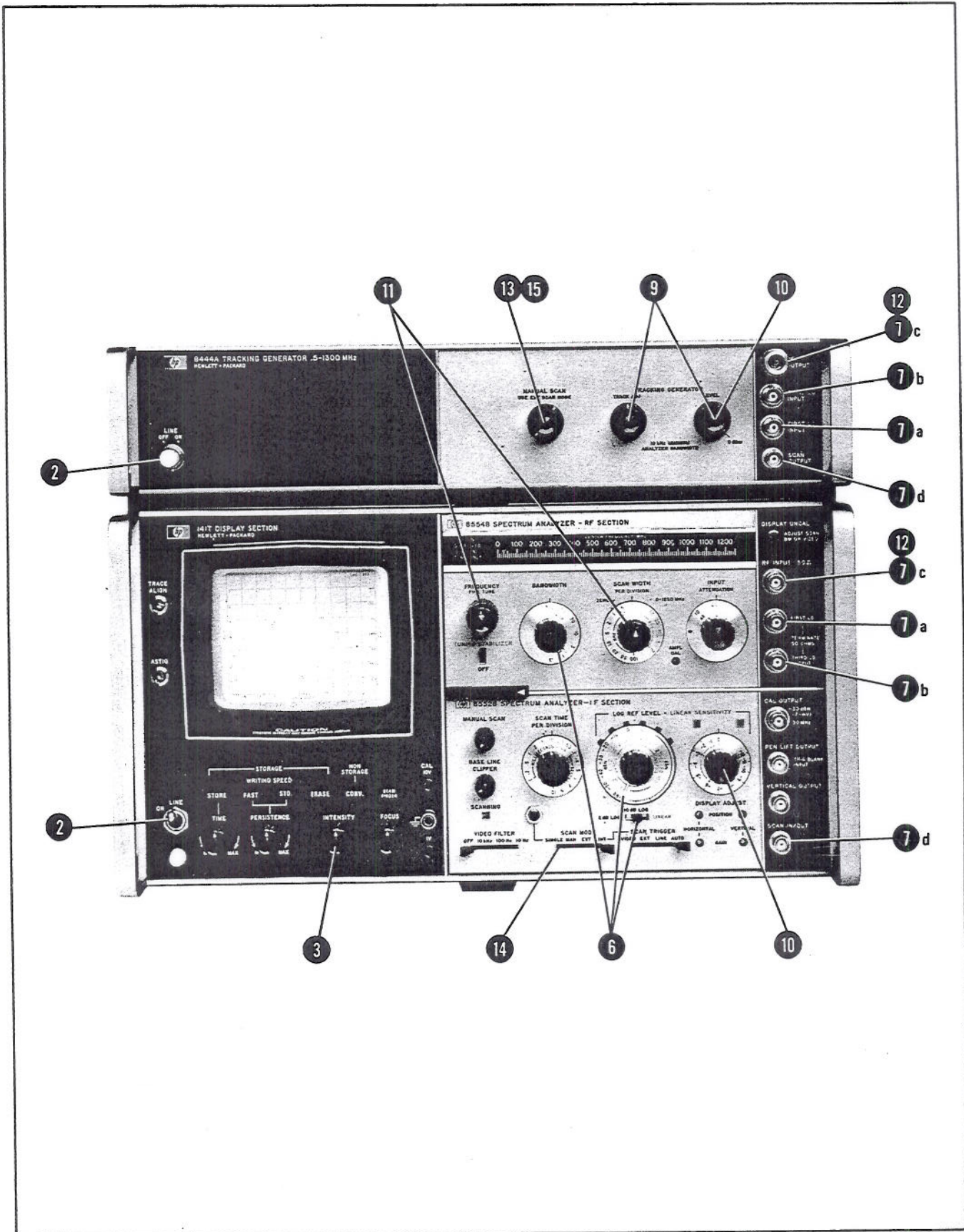

Figure 3-3. Tracking Generator Operation with 8554B Spectrum Analyzer (1 of 2)

**OPERATING PROCEDURE
WITH AN 8554B**

- | | | | | | | | | | | | | | |
|--|---|------------------|-----|---------------------|-------|-----------------------------|---|--------------------|-----|-----------------|-----|--------------------|------|
| <ol style="list-style-type: none"> 1. Check that the 115/230V switch is set to correspond with the available line voltage. Refer to Figure 3-2, steps 4 through 8, for switch and fuse information. 2. Apply power to Tracking Generator and Spectrum Analyzer. 3. Turn Spectrum Analyzer INTENSITY control fully CCW. 4. Allow instruments to warm up for at least 30 minutes. 5. Perform Spectrum Analyzer "Calibration Procedure". Refer to 8554B RF Section Operating Manual. 6. Set Spectrum Analyzer LOG/LINEAR control to LOG, LOG REF LEVEL to 0 dBm, and BANDWIDTH to 300 kHz. 7. Make the following interconnections between Tracking Generator and Spectrum Analyzer: <ol style="list-style-type: none"> a. FIRST LO INPUT to FIRST LO OUTPUT. b. THIRD LO INPUT to THIRD LO OUTPUT. c. RF OUTPUT to RF INPUT. d. SCAN OUTPUT to SCAN IN/OUT. 8. Check that the Spectrum Analyzer controls are set as follows: | <table border="0" style="width: 100%; border-collapse: collapse;"> <tr> <td style="padding-right: 20px;">LOG/LINEAR</td> <td>LOG</td> </tr> <tr> <td>LOG REF LEVEL</td> <td>0 dBm</td> </tr> <tr> <td>LOG REF LEVEL Vernier</td> <td>0</td> </tr> <tr> <td>VIDEO FILTER</td> <td>OFF</td> </tr> <tr> <td>SCAN MODE</td> <td>INT</td> </tr> <tr> <td>SCAN TRIGGER</td> <td>LINE</td> </tr> </table> <ol style="list-style-type: none"> 9. Set Tracking Generator LEVEL control to 0 dBm and adjust TRACK ADJ for maximum signal amplitude indication on CRT display. 10. Adjust Spectrum Analyzer Vernier control or Tracking Generator LEVEL control to position signal on CRT LOG REF level graticule line. (System calibrated at 30 MHz with an amplitude accuracy of ±0.5 dB.) 11. Set Spectrum Analyzer to scan desired frequency range. (FREQUENCY control adjusted to center of frequency of interest, SCAN WIDTH set for desired coverage.) 12. Insert device to be tested between Tracking Generator RF OUTPUT and Spectrum Analyzer RF INPUT. 13. Rotate Tracking Generator MANUAL SCAN control fully counterclockwise. 14. Set Spectrum Analyzer SCAN MODE switch to EXT. 15. Rotate Tracking Generator MANUAL SCAN control clockwise to tune system through selected frequency range. 16. For automatic scanning, set SCAN MODE switch to INT and SCAN TIME PER DIVISION to desired scan time. | LOG/LINEAR | LOG | LOG REF LEVEL | 0 dBm | LOG REF LEVEL Vernier | 0 | VIDEO FILTER | OFF | SCAN MODE | INT | SCAN TRIGGER | LINE |
| LOG/LINEAR | LOG | | | | | | | | | | | | |
| LOG REF LEVEL | 0 dBm | | | | | | | | | | | | |
| LOG REF LEVEL Vernier | 0 | | | | | | | | | | | | |
| VIDEO FILTER | OFF | | | | | | | | | | | | |
| SCAN MODE | INT | | | | | | | | | | | | |
| SCAN TRIGGER | LINE | | | | | | | | | | | | |
-
- | | |
|-------------------------------|----------------------|
| INTENSITY | 12 o'clock (approx.) |
| FREQUENCY | 30 MHz |
| BANDWIDTH | 300 kHz |
| SCAN WIDTH PER DIVISION | 50 kHz |
| INPUT ATTENUATION | 10 dB |
| TUNING STABILIZER | On |
| BASE LINE CLIPPER | CCW |
| SCAN TIME PER DIVISION | 5 MILLISECONDS |

Figure 3-3. Tracking Generator Operation with 8554B Spectrum Analyzer (2 of 2)

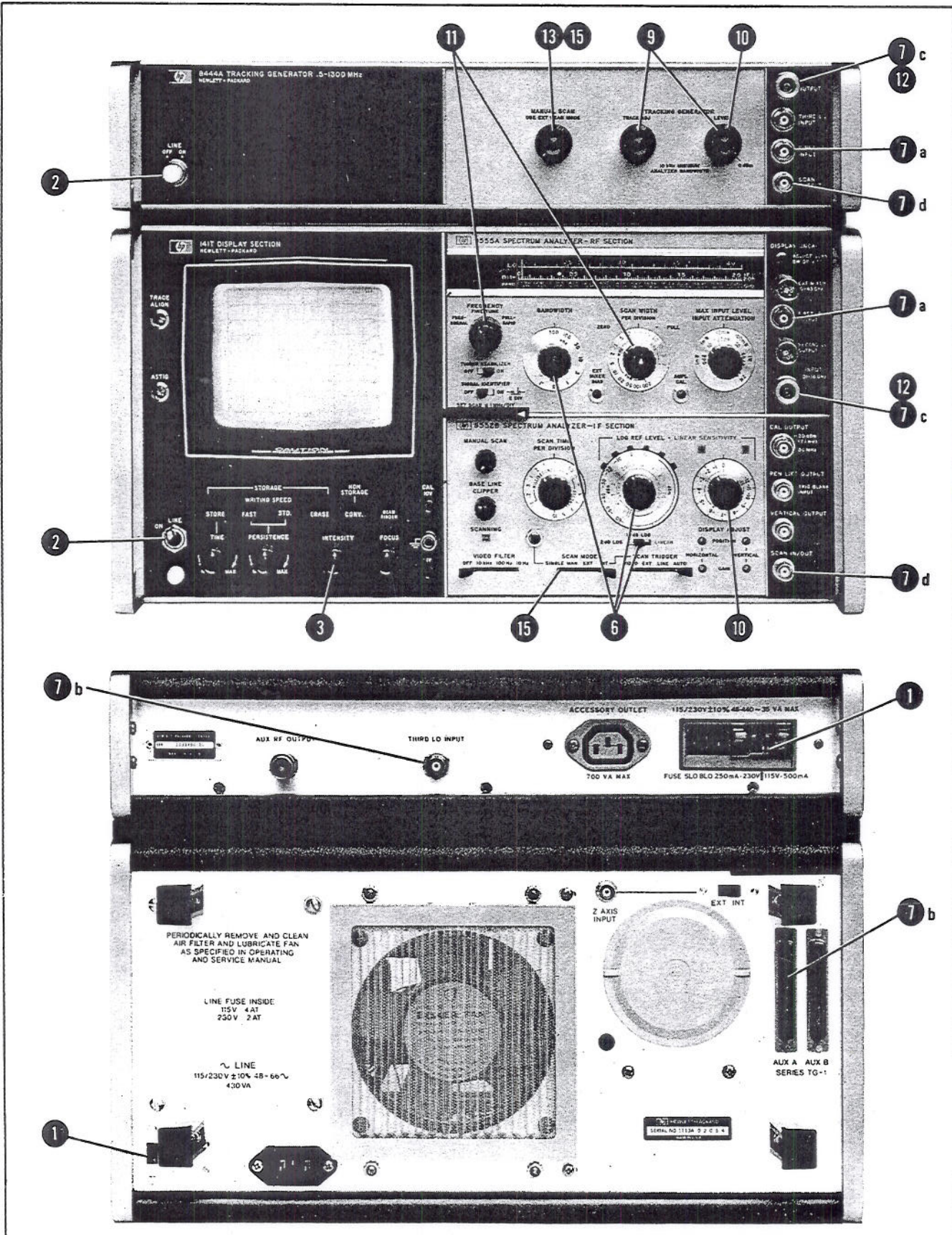

Figure 3-4. Tracking Generator Operation with 8555A Spectrum Analyzer (1 of 2)

**OPERATING PROCEDURE
WITH AN 8555A**

1. Check that the 115/230 switch is set to correspond with the available line voltage. Refer to Figure 3-2, steps 4 through 8, for switch and fuse information.
2. Apply power to Tracking Generator and Spectrum Analyzer.
3. Turn Spectrum Analyzer INTENSITY control fully CCW.
4. Allow instruments to warm up for at least 30 minutes.
5. Perform Spectrum Analyzer Operational Adjustments (30 MHz Calibration). Refer to 8555A RF Section Operating and Service Manual.
6. Set Spectrum Analyzer LOG/LINEAR control to LOG, LOG REF LEVEL to 0 dBm, and BANDWIDTH to 300 kHz.
7. Make the following interconnections between Tracking Generator and Spectrum Analyzer:
 - a. FIRST LO INPUT to FIRST LO OUTPUT.
 - b. THIRD LO INPUT to THIRD LO OUTPUT (rear panel connections).
 - c. RF OUTPUT to INPUT.
 - d. SCAN OUTPUT to SCAN IN/OUT.
8. Check that the Spectrum Analyzer controls are set as follows:

INTENSITY	12 o'clock (approx.)
BAND	n=1- (2.05 GHz IF)
FREQUENCY	30 MHz
BANDWIDTH	300 kHz
SCAN WIDTH PER DIVISION	100 kHz
INPUT ATTENUATION	20 dB
TUNING STABILIZER	ON
SIGNAL IDENTIFIER	OFF
BASE LINE CLIPPER	CCW
SCAN TIME PER DIVISION	10 MILLISECONDS

- | | |
|-----------------------------|--------------|
| LOG/LINEAR | LOG |
| LOG REF LEVEL | 0 dBm |
| LOG REF LEVEL Vernier | 0 |
| VIDEO FILTER | OFF |
| SCAN MODE | INT |
| SCAN TRIGGER | LINE or AUTO |

9. Set Tracking Generator LEVEL control to 0 dBm and adjust TRACK ADJ for maximum signal amplitude indication on CRT display.
10. Adjust Spectrum Analyzer Vernier control or Tracking Generator LEVEL control to position signal on CRT LOG REF level graticule line. (System calibrated at 30 MHz with an amplitude accuracy of ±0.5 dB.)
11. Set Spectrum Analyzer to scan desired frequency range. (FREQUENCY control adjusted to center of frequency of interest, SCAN WIDTH set for desired coverage.)
12. Insert device to be tested between Tracking Generator RF OUTPUT and Spectrum Analyzer RF INPUT.
13. Rotate Tracking Generator MANUAL SCAN control fully counterclockwise.
14. Set Spectrum Analyzer SCAN MODE switch to EXT.
15. Rotate Tracking Generator MANUAL SCAN control clockwise to tune system through selected frequency range.
16. For automatic scanning, set SCAN MODE switch to INT and SCAN TIME PER DIVISION to desired scan time.

Figure 3-4. Tracking Generator Operation with 8555A Spectrum Analyzer (2 of 2)

3-13. Crystal Filter Measurement

3-14. Figure 3-5 illustrates the CRT display for a 20 MHz crystal filter. Filter characteristics: 2-kHz passband with bandwidth at the 60-dB points less than 10 kHz.

a. Spectrum Analyzer (8555A) control settings:

FREQUENCY 20 MHz
 BANDWIDTH 3 kHz
 SCAN WIDTH PER DIVISION 5 kHz
 INPUT ATTENUATION 10 dB
 SCAN TIME PER DIVISION 20 MILLISECONDS
 LOG REF LEVEL 0 dBm
 VIDEO FILTER 100 Hz
 SCAN MODE INT
 SCAN TRIGGER AUTO
 LOG/LINEAR LOG

b. Tracking Generator control settings:

TRACK ADJ Peak
 LEVEL 0 dBm

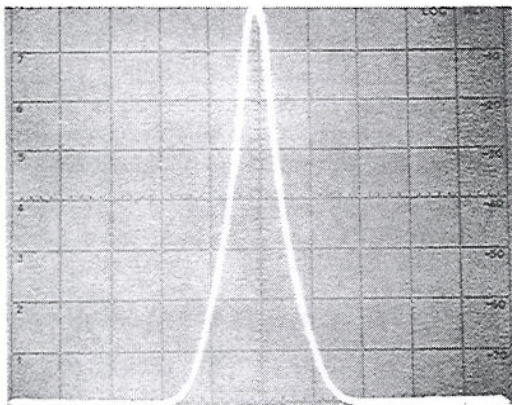

Figure 3-5. 20 MHz Crystal Filter CRT Display

3-15. Bandpass Filter Measurement

3-16. Figure 3-6 illustrates the CRT display for a 50 MHz bandpass filter. Filter characteristics: 50 MHz, 4-pole bandpass filter; adjusted for bandwidth of approximately 5 MHz at the 3 dB points. Bandwidth at 60 dB points is approximately 32 MHz.

a. Spectrum Analyzer (8555A) control settings:

FREQUENCY 50 MHz
 BANDWIDTH 10 kHz
 SCAN WIDTH PER DIVISION 5 MHz
 INPUT ATTENUATION 10 dB

SCAN TIME PER DIVISION 0.5 SECONDS
 LOG REF LEVEL 0 dBm
 VIDEO FILTER 10 Hz
 SCAN MODE INT
 SCAN TRIGGER AUTO
 LOG/LINEAR LOG

b. Tracking Generator control settings:

TRACK ADJ Peak
 LEVEL 0 dBm

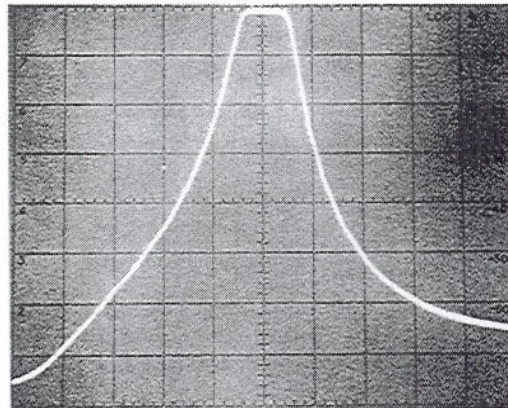

Figure 3-6. 50 MHz Bandpass Filter CRT Display

3-17. Low-Pass Filter Measurement

3-18. Figure 3-7 illustrates the CRT display for a 23 MHz low-pass filter. Filter characteristics: 3 dB point at approximately 23 MHz, 60 dB point at approximately 42 MHz.

a. Spectrum Analyzer (8555A) control settings:

FREQUENCY 25 MHz
 SCAN WIDTH PER DIVISION 5 MHz
 BANDWIDTH 100 kHz
 INPUT ATTENUATION 10 dB
 SCAN TIME PER DIVISION 0.1 SECONDS
 LOG/LINEAR LOG
 LOG REF LEVEL (+) 10 dBm
 LOG REF LEVEL Vernier -3 dB
 VIDEO FILTER 10 Hz
 SCAN MODE INT
 SCAN TRIGGER AUTO

b. Tracking Generator control settings:

TRACK ADJ Peak
 LEVEL 0 dBm

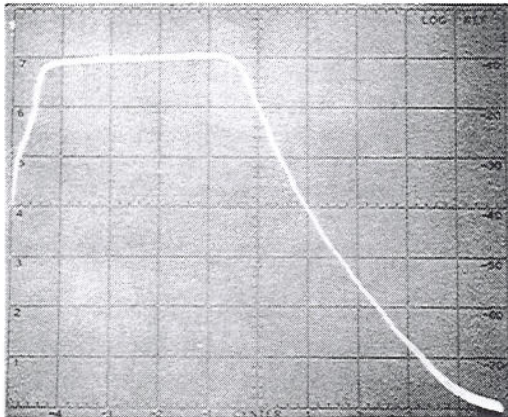

Figure 3-7. 23 MHz Low-Pass Filter CRT Display

3-19. Swept Return Loss Measurement

3-20. Figure 3-8 illustrates the CRT display for a swept return loss or reflection coefficient measurement. A directional bridge (HP 8721A) was used to separate the incident from the reflected signal. The filter under test is the same 23-MHz Low-Pass (paragraph 3-18). Control settings same as paragraph 3-18 except analyzer gain adjusted so that the top graticule line represents 0 dB return loss or total reflection (e.g. a short or open circuit). Return loss is greater than 15 dB (ρ 0.18, SWR 1.44) over the filter range of 0 to 23 MHz.

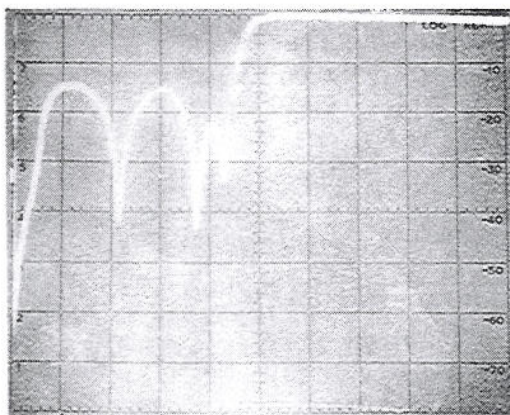

Figure 3-8. Swept Return Loss Measurement CRT Display

3-21. Amplifier Gain and Bandwidth Measurement

3-22. Figure 3-9 illustrates the CRT display for a .1 to 400 MHz amplifier with gain of approximately 19 dB. A reference level is first established by connecting the Tracking Generator output to the Spectrum Analyzer (through a 30 dB attenuator) and scanning over the range of interest. The amplifier is then connected between the Tracking Generator and the Spectrum Analyzer and the same

frequency range scanned. The Spectrum Analyzer (8554B) set to full scan (0-1250) provides a CRT display indication as follows: 3-dB bandwidth approximately 500 MHz (level at +1 graticule line) and zero gain point of approximately 1025 MHz.

a. 30 dB Coaxial Attenuator installed at Tracking Generator RF OUTPUT.

b. Spectrum Analyzer (8554B) control settings:

- BANDWIDTH 300 kHz
- SCAN WIDTH 0-1250 MHz
- INPUT ATTENUATION 10 dB
- SCAN TIME PER DIVISION 10 MILLISECONDS
- LOG/LINEAR LOG
- LOG REF LEVEL +10 dBm
- VIDEO FILTER OFF
- SCAN MODE INT
- SCAN TRIGGER AUTO

c. Tracking Generator control settings:

- TRACK ADJ Peak
- LEVEL 0 dBm

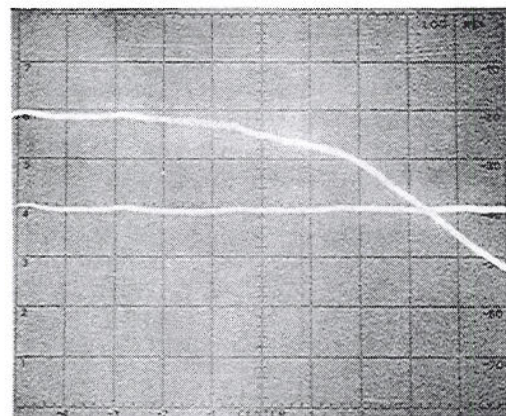

Figure 3-9. Amplifier Gain and Bandwidth CRT Display

3-23. Precision Frequency Measurements

3-24. An external frequency counter may be used with the Tracking Generator/Spectrum Analyzer System for frequency measurements at any point on the CRT display. With the counter connected to the Tracking Generator AUX RF OUTPUT jack (rear panel) and the system operated in the MANUAL SCAN mode; the scan can be stopped at any point for frequency measurement.

CAUTION

Do not leave System stopped in MANUAL SCAN with high INTENSITY. Damage to the display CRT can result.

Figure 3-10 illustrates frequency measurement at the 30 dB point on a low-pass filter.

a. Spectrum Analyzer (8554B) control settings:

FREQUENCY 50 MHz
 BANDWIDTH 300 kHz
 SCAN WIDTH PER DIVISION 10 MHz
 INPUT ATTENUATION 10 dB
 SCAN TIME PER DIVISION 10 MILLISECONDS
 LOG REF LEVEL 0 dBm
 LOG/LINEAR LOG
 VIDEO FILTER OFF
 SCAN MODE INT
 SCAN TRIGGER AUTO

b. Tracking Generator control settings:

TRACK ADJ Peak
 LEVEL 0 dBm
 MANUAL SCAN CCW

c. Connect unit under test between Tracking Generator RF OUTPUT and Spectrum Analyzer RF INPUT.

d. Connect Tracking Generator AUX RF OUTPUT to Frequency Counter input.

e. Connect Tracking Generator SCAN OUTPUT to Spectrum Analyzer SCAN IN/OUT.

f. Connect Tracking Generator FIRST LO INPUT to Spectrum Analyzer FIRST LO OUTPUT and THIRD LO INPUT to THIRD LO OUTPUT.

- g. Note point of interest on CRT display.
- h. Set Spectrum Analyzer SCAN MODE to EXT and rotate Tracking Generator MANUAL SCAN control clockwise to point of interest.
- i. Note and record frequency.
- j. Set Spectrum Analyzer SCAN MODE to INT.

NOTE

The CRT trace (dot) can be moved in either direction by the Tracking Generator MANUAL SCAN control. For best frequency accuracy, approach frequency measurement point while tuning the MANUAL SCAN control in the clockwise direction.

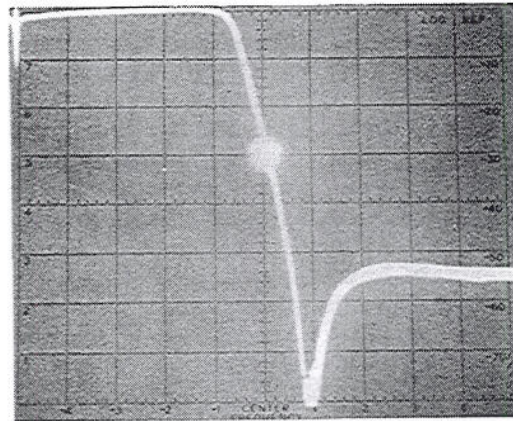

Figure 3-10. Precision Frequency Measurement CRT Display

SECTION IV PERFORMANCE TESTS

4-1. INTRODUCTION

4-2. This section contains preset adjustment procedures and performance tests for the Model 8444A Tracking Generator and Model 8554L or 8555A/8552B/141T Spectrum Analyzer System. Preset adjustments for the 8444A/8554B/8552B/141T system are given in paragraph 4-7. Preset adjustments for the 8444A/8555A/8552B/141T are given in paragraph 4-9. Perform the preset adjustment procedures for the appropriate system prior to accomplishing the performance tests. Procedures for verifying that the instruments meet specifications are given in paragraphs 4-16 through 4-20.

4-3. EQUIPMENT REQUIRED

4-4. Test equipment and accessories for performance (P), adjustment (A) and troubleshooting (T) are listed in Table 1-3. Critical specifications and/or required features for the test equipment and accessories are contained in the table. Each performance test lists the required test equipment and contains an illustrated test equipment setup.

4-5. FRONT PANEL CHECKS

4-6. Before proceeding to the performance tests, the instruments must be adjusted and all controls set as specified in the preset adjustment procedures for the appropriate system (8554B/8555A). The instruments should perform as called out in the preset adjustment procedures before going on to the performance tests.

4-7. Preset Adjustments (8554B/8552B/141T/ 8444A System)

4-8. Procedure:

a. Apply power to Tracking Generator and Spectrum Analyzer.

b. Turn Spectrum Analyzer INTENSITY control fully CCW.

c. Allow instruments to warm up for at least 30 minutes.

d. Perform Spectrum Analyzer 30 MHz calibration procedure. Refer to 8554B RF Section Operating Manual.

e. Connect Spectrum Analyzer FIRST LO OUTPUT to Tracking Generator FIRST LO INPUT.

f. Connect Spectrum Analyzer THIRD LO OUTPUT to Tracking Generator THIRD LO INPUT.

g. Connect Tracking Generator RF OUTPUT to Spectrum Analyzer RF INPUT.

h. Connect Tracking Generator SCAN OUTPUT to Spectrum Analyzer SCAN IN/OUT.

i. Set Spectrum Analyzer controls as follows:

INTENSITY 12 o'clock (approx.)
 FREQUENCY 30 MHz
 BANDWIDTH 300 kHz
 SCAN WIDTH PER DIVISION
 SCAN WIDTH PER DIVISION 200 kHz
 INPUT ATTENUATION 20 dB
 TUNING STABILIZER On
 BASE LINE CLIPPER CCW
 SCAN TIME PER DIVISION 10 MILLISECONDS
 LOG/LINEAR 10 dB LOG
 LOG REF LEVEL 0 dBm
 LOG REF LEVEL Vernier 0
 VIDEO FILTER OFF
 SCAN MODE INT
 SCAN TRIGGER LINE or AUTO

j. Set Tracking Generator controls as follows:

MANUAL SCAN CCW
 LEVEL 0 dBm

k. Adjust TRACK ADJ control for maximum amplitude of trace on CRT display.

l. If trace is *not* within ± 0.5 dB of LOG REF level graticule line repeat Spectrum Analyzer calibration procedure.

m. Reconnect Tracking Generator RF OUTPUT to Spectrum Analyzer RF INPUT and adjust TRACK ADJ for maximum signal amplitude.

n. Rotate LEVEL control fully counterclockwise (-10 dBm) and note signal level on CRT display.

_____ -10 to -12 dBm

o. If the signal level is off more than ±0.5 dB at the 0 dBm point or not within -10 to -12 dBm with the LEVEL control fully counterclockwise, refer to paragraph 4-16, Output Level Performance Check, and 5-13 for LEVEL control calibration procedure.

4-9. Preset Adjustments (8555A/8552B/141T/8444A System)

4-10. Procedure:

a. Apply power to Tracking Generator and Spectrum Analyzer.

b. Turn Spectrum Analyzer INTENSITY control fully CCW.

c. Allow instruments to warm up for at least 30 minutes.

d. Perform Spectrum Analyzer Operational Adjustments (30 MHz Calibration). Refer to 8555A RF Section Operating and Service Manual.

e. Connect Spectrum Analyzer FIRST LO OUTPUT to Tracking Generator FIRST LO INPUT.

f. Connect Spectrum Analyzer THIRD LO OUTPUT to Tracking Generator THIRD LO INPUT (rear panel connections).

g. Connect Tracking Generator RF OUTPUT to Spectrum Analyzer INPUT.

h. Connect Tracking Generator SCAN OUTPUT to Spectrum Analyzer SCAN IN/OUT.

i. Set Spectrum Analyzer controls as follows:

INTENSITY 12 o'clock (approx.)
BAND n=1- (2.05 GHz IF)

FREQUENCY 30 MHz
BANDWIDTH 300 kHz
SCAN WIDTH PER DIVISION
SCAN WIDTH PER DIVISION 100 kHz
INPUT ATTENUATION 20 dB
TUNING STABILIZER ON
SIGNAL IDENTIFIER OFF
BASE LINE CLIPPER CCW
SCAN TIME PER DIVISION 10 MILLISECONDS
LOG/LINEAR 10 dB LOG
LOG REF LEVEL 0 dBm
LOG REF LEVEL Vernier 0
VIDEO FILTER OFF
SCAN MODE INT
SCAN TRIGGER LINE or AUTO

j. Set Tracking Generator controls as follows:

MANUAL SCAN CCW
LEVEL 0 dBm

k. Adjust TRACK ADJ control for maximum amplitude of trace on CRT display.

l. If trace is not within ±0.5 dB of LOG REF level graticule line repeat Spectrum Analyzer calibration procedure.

m. Reconnect Tracking Generator RF OUTPUT to Spectrum Analyzer INPUT and adjust TRACK ADJ for maximum signal amplitude.

n. Rotate LEVEL control fully counterclockwise (-10 dBm) and note signal level on CRT display.

_____ -10 to -12 dBm

o. If the signal level is off more than ±0.5 dB at the 0 dBm point or not within -10 to -12 dBm with the LEVEL control fully counterclockwise, refer to paragraph 4-16, Output Level Performance Check, and 5-13 for LEVEL control calibration procedure.

4-11. PERFORMANCE TESTS

4-12. The performance tests, given in this section, are suitable for incoming inspection, troubleshooting, and/or preventive maintenance. During any performance test, all shields and connecting hardware must be in place. The tests are designed to verify published specifications. Perform the tests in the order given, and record data on test card (Table 4-1) and/or in the data spaces provided in each test.

4-13. The tests are arranged in the following order:

Paragraph	Test Description
4-16	Output Level
4-17	Frequency Stability
4-18	System Flatness
4-19	Frequency Accuracy
4-20	Distortion

4-14. Each test is arranged so that the specification is written as it appears in the Table of

Specifications (Table 1-1) in Section I. Next, a description of the test and any special instructions or problem areas are included. Each test that requires test equipment has a test setup drawing and a list of required equipment. Each procedure gives control settings required for that particular test.

4-15. Required minimum specifications for test equipment are detailed in Table 1-3 in Section I. If substitute test equipment is used, it must meet the specifications listed in order to performance-test the Tracking Generator.

PERFORMANCE TESTS

4-16. Output Level and Flatness

SPECIFICATION:

Tracking Generator (Drive Level to Test Device): 0 to -10 dBm continuously variable. 0 dBm calibrated to ± 0.5 dB at 30 MHz. Flatness: ± 0.5 dB.

DESCRIPTION:

With the Tracking Generator connected to the Spectrum Analyzer, the Tracking Generator output level is first checked at 30 MHz (Spectrum Analyzer amplitude calibration point) with a power meter. With Tracking Generator LEVEL control set at 0 dBm, the power meter indication should be 0 dBm ± 0.5 dB. With LEVEL control set fully counterclockwise, the power meter indication should be -10 dBm to -12 dBm. The flatness of the Tracking Generator output is checked using a power meter from 10 MHz to 1.3 GHz if used with the 8555A, and 500 kHz to 1.25 GHz if used with the 8554B. The overall maximum power variation in each case must not exceed 1 dB (± 0.5 dB).

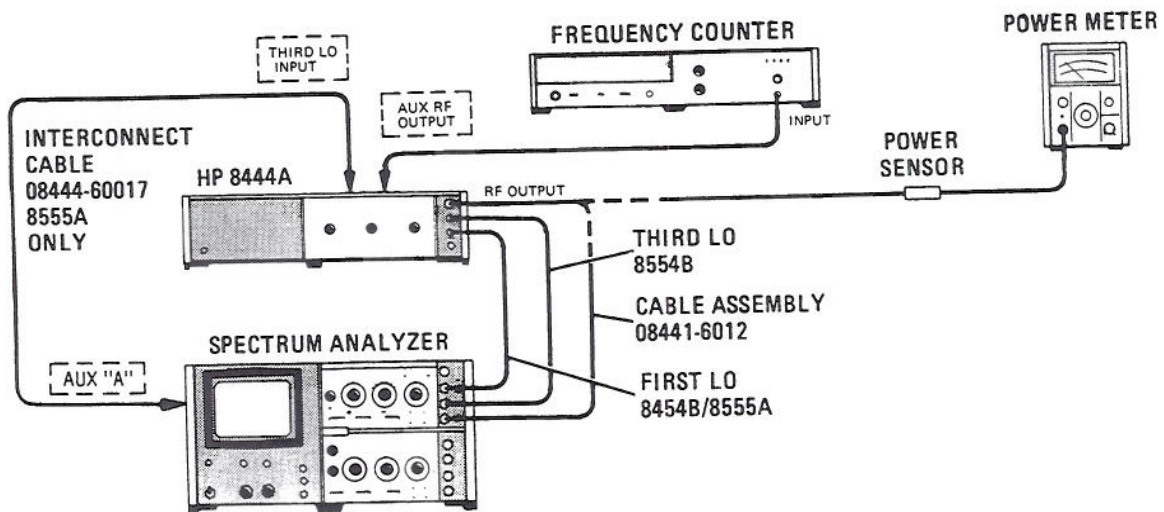

Figure 4-1. Output Level and Flatness Test Setup

PERFORMANCE TESTS

4-16. Output Level and Flatness (Cont'd)

EQUIPMENT:

Spectrum Analyzer	HP 8554B or 8555A/8552B/141T
Power Meter	HP 435A
Power Sensor.....	HP 8482A
Frequency Counter.....	HP 5340A
Adapter, Type N Male to BNC Female	HP 1250-0780
Interconnect Cable (8555A THIRD LO).....	HP 08444-60017
Interconnect Cable (two required)	HP 08444-60018
Cable Assembly (RF)	HP 08441-6012

PROCEDURE:

1. Perform preset adjustment procedures, paragraph 4-7 for 8554B/8552B/141T Spectrum Analyzer System or paragraph 4-9 for 8555A/8552B/141T Spectrum Analyzer System.

2. Connect test setup as shown in Figure 4-1 and set controls as follows:

Power Meter

RANGE.....	0 dBm
LINE.....	ON
CAL FACTOR	See Power Sensor

Frequency Counter

RANGE.....	10 Hz – 18 GHz
LINE.....	ON
RESOLUTION Hz.....	100

Tracking Generator

MANUAL SCAN.....	Fully Counterclockwise
LEVEL.....	0 dBm

3. Set Spectrum Analyzer TUNING STABILIZER to OFF and set SCAN WIDTH to ZERO. Adjust FREQUENCY for indication of 30 MHz \pm 100 kHz on Frequency Counter.
4. Tune Tracking Generator TRACK ADJ for maximum signal amplitude on Spectrum Analyzer.
5. Connect Power Sensor to 435A POWER REF OUTPUT and ZERO Power Meter. Set rear-panel POWER REF switch to ON (up). Set CAL ADJ for proper 435A indication. Remove Power Sensor and return POWER REF switch to OFF.
6. Disconnect cable at Tracking Generator RF OUTPUT and connect Power Sensor to RF OUTPUT connector. Disconnect FIRST LO cable and ZERO Power Meter. Reconnect FIRST LO cable. Measure and record power level.

MAX.	ACTUAL	MIN.
+0.5 dBm	_____dBm	-0.5 dBm

PERFORMANCE TESTS

4-16. Output Level and Flatness (Cont'd)

7. Set Tracking Generator LEVEL control fully counterclockwise. Measure and record power level.

MAX.	ACTUAL	MIN.
-10 dBm	____dBm	-12 dBm

8. Adjust Tracking Generator LEVEL control to set a -1 dBm reference level on power meter.

9. With Spectrum Analyzer FREQUENCY control, slowly tune the Spectrum Analyzer and Tracking Generator between 10 MHz and 1.3 GHz if using 8555A RF Section, or between 500 kHz and 1.25 GHz if using 8554B RF Section.

10. Note and record the maximum overall power deviation.

MAX.	ACTUAL
1 dB (±0.5 dB)	____dB

4-17. Frequency Stability

SPECIFICATION: Stability: Residual FM (peak-to-peak):

<u>Tuning Section</u>	<u>Stabilized</u>	<u>Unstabilized</u>
8554B/8555A	200 Hz	10 kHz

DESCRIPTION: The stability of the Spectrum Analyzer/Tracking Generator System is checked using a HP 141T/8553B/8552B Spectrum Analyzer System which has less than 20 Hz peak-to-peak residual FM. The Spectrum Analyzer in the system must be within residual FM specification limits. Refer to appropriate RF Section Operating and Service Manual. There are no adjustments in the Tracking Generator for residual FM. Refer to paragraph 5-10 if residual FM is excessive.

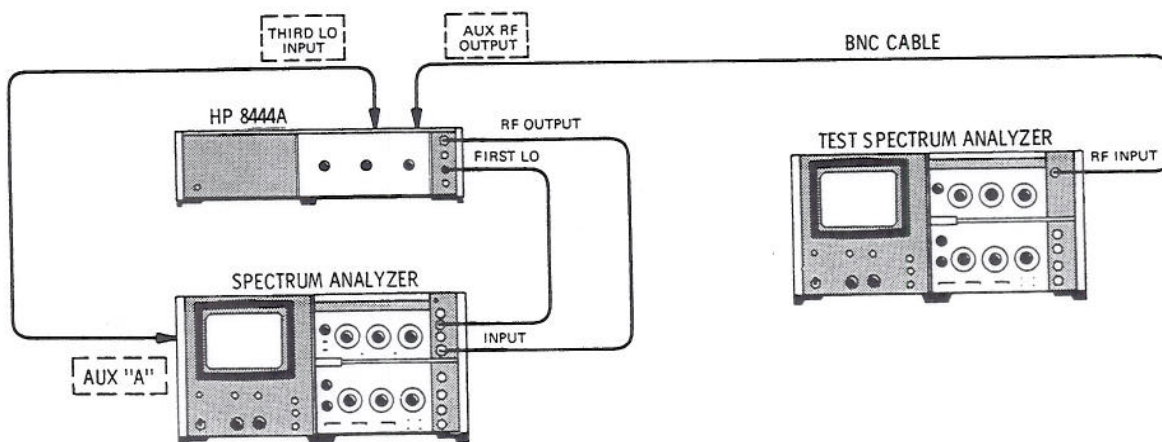

Figure 4-2. Residual FM Test Setup

PERFORMANCE TESTS

4-17. Frequency Stability (Cont'd)

EQUIPMENT:

Spectrum Analyzer	HP 8554B or 8555A/8552B/141T
Test Spectrum Analyzer	HP 8553B/8552B/141T
BNC Cable	HP 10503A

PROCEDURE:

1. Perform preset adjustment procedures, paragraph 4-7, for 8554B/8552B/141T Spectrum Analyzer System or paragraph 4-9 for 8555A/8552B/141T Spectrum Analyzer System.
2. Connect test setup as indicated in Figure 4-2 and make the following control settings:

SPECTRUM ANALYZER (Tracking Generator/Spectrum Analyzer System)
See paragraph 4-7 or 4-9.

SPECTRUM ANALYZER (8553B/8552B/141T "Test Analyzer")

POWER	ON
RANGE MHz	0-110
FREQUENCY	50 MHz
BANDWIDTH	30 kHz
SCAN WIDTH	PER DIVISION
SCAN WIDTH PER DIVISION	1 MHz
INPUT ATTENUATION	10 dB
TUNING STABILIZER	ON
SCAN TIME PER DIVISION	20 MILLISECONDS
LOG/LINEAR	10 dB LOG
LOG REF LEVEL	+10 dBm
VIDEO FILTER	10 kHz
SCAN MODE	INT
SCAN TRIGGER	AUTO

3. Set Tracking Generator/Spectrum Analyzer System FREQUENCY to 50 MHz and SCAN WIDTH to ZERO.
4. Connect Tracking Generator AUX RF OUTPUT to Test Analyzer RF INPUT.
5. Adjust Test Analyzer FREQUENCY control to center signal on CRT Display.
6. Reduce Test Analyzer BANDWIDTH to 1 kHz and SCAN WIDTH PER DIVISION to 2 kHz while keeping signal centered on CRT display.
7. Set Test Analyzer INPUT ATTENUATION to 30 dB, LOG/LINEAR to LINEAR, and LINEAR SENSITIVITY to 20 mV/DIV.

PERFORMANCE TESTS

4-17. Frequency Stability (Cont'd)

8. Adjust Test Analyzer LINEAR SENSITIVITY Vernier control for a full eight division display.
9. Refer to Figure 4-3. Tune Test Analyzer FINE TUNE so that the upward slope of the display intersects the CENTER FREQUENCY graticule line one division from the top.

NOTE

The linear portion of the analyzer IF filter skirt is used to slope detect low-order residual FM. The analyzer is stabilized, and the detected FM is displayed in the time domain.

10. Note where the slope intersects the middle horizontal graticule line:
Horizontal Displacement: _____ divisions
11. Use the horizontal displacement to calculate demodulation sensitivity.
 - a. Convert the horizontal displacement (divisions) into Hertz.

Example: (2 kHz SCAN WIDTH) x (0.2 div) = 400 Hz.

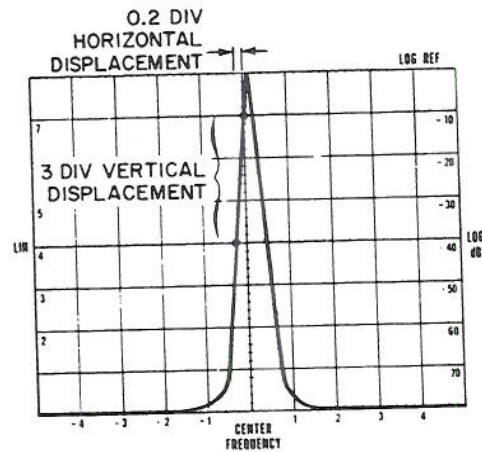

Figure 4-3. Demodulation Sensitivity Measurement

- b. Calculate demodulation sensitivity by dividing the vertical displacement in divisions into the horizontal displacement in Hz:
Example: $\frac{400 \text{ Hz}}{3 \text{ divisions}} = 133 \text{ Hz/div}$
12. Turn SCAN WIDTH to ZERO scan. Set FINE TUNE for a response level within the calibrated three division range (one division from the top to the center horizontal graticule line).
13. Measure the peak-to-peak deviation, and multiply it by the demodulation sensitivity obtained in step 11b above.
14. Example: 1.2 div p-p signal deviation x 133 Hz/div = 159.6 Hz Residual FM.

_____ Hz peak-to-peak

PERFORMANCE TESTS

4-18. System Flatness

SPECIFICATION:

Amplitude Accuracy: System Frequency Response: ± 1.50 dB.

DESCRIPTION:

The Tracking Generator output is checked with the Spectrum Analyzer using either an 8555A or an 8554B RF Section. A convenient reference level is set in the 2 dB LOG mode. The overall power deviation is measured from 10 MHz to 1.3 GHz if 8555A RF Section is used, or 500 kHz to 1.25 GHz if 8554B RF Section is used.

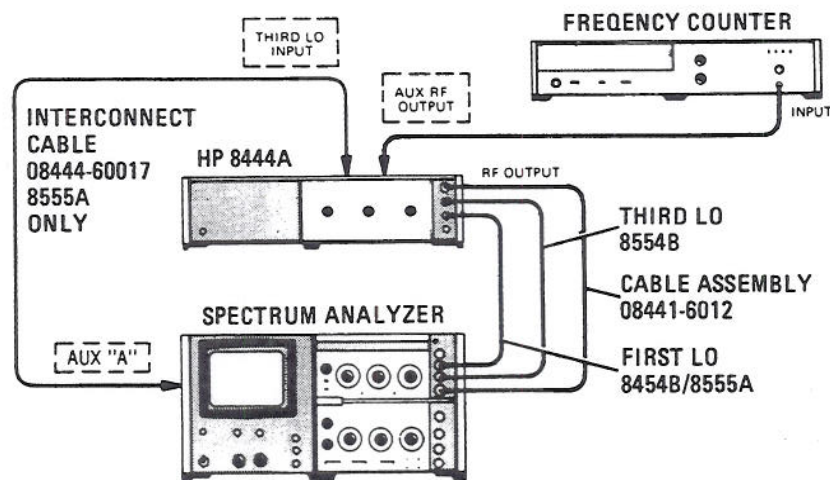

Figure 4-4. System Flatness Test Setup

EQUIPMENT:

Spectrum Analyzer	HP 8554B or 8555A/8552B/141T
Frequency Counter	HP 5340A
Adapter, Type N Male to BNC Female	HP 1250-0780
Interconnect Cable (8555A THIRD LO)	HP 08444-60017
Interconnect Cable (two required)	HP 08444-60018
Cable Assembly	HP 08441-6012

PERFORMANCE TESTS

4-18. System Flatness (Cont'd)

PROCEDURE:

1. Perform preset adjustment procedures, paragraph 4-7 for 8554B/8552B/141T Spectrum Analyzer System or paragraph 4-9 for 8555A/8552B/141T Spectrum Analyzer System.
2. Connect test setup as shown in Figure 4-4 and set controls as follows:

Frequency Counter
 RANGE.....10 Hz – 18 GHz
 LINE.....ON
 RESOLUTION Hz.....100

Tracking Generator
 MANUAL SCAN..... Fully Counterclockwise
 LEVEL..... 0 dBm

3. Set Spectrum Analyzer SCAN WIDTH to ZERO and adjust FREQUENCY for indication of 30 MHz \pm 100 kHz on frequency counter.
4. Set Spectrum Analyzer LOG REF LEVEL to (+) 10 dBm and LOG/LINEAR to 2 dB LOG.
5. Adjust Tracking Generator TRACK ADJ for maximum signal indication on CRT display.
6. Adjust Spectrum Analyzer LOG REF LEVEL vernier control to position trace on -20 LOG REF graticule line.
7. With Spectrum Analyzer FREQUENCY control, slowly tune the Spectrum Analyzer and Tracking Generator between 10 MHz and 1.3 GHz if using 8555A RF Section, or between 500 kHz and 1.25 GHz if using 8554B RF Section.
8. Note and record the maximum overall power deviation (one minor division on center vertical graticule line equals 0.4 dB).

MAX.	ACTUAL
3 dB	
(\pm 1.5 dB)	_____ dB

PERFORMANCE TESTS

4-19. Frequency Accuracy

SPECIFICATION: Frequency Accuracy: ± 15 MHz using Spectrum Analyzer slide rule dial. Precision frequency measurements: Frequency Accuracy: ± 10 kHz for unknown signals (using Tracking Generator AUX RF OUTPUT and an external frequency counter).

DESCRIPTION: The accuracy of the slide rule dial is determined by the RF Section calibration. Refer to dial accuracy performance test in the appropriated RF Section Operating and Service manual. For precision frequency measurements, frequency accuracy is checked by tuning the Spectrum Analyzer and Tracking Generator to a known frequency and measuring the Tracking Generator output with an external counter. The slide rule dial can be visually checked for an accuracy of ± 15 MHz.

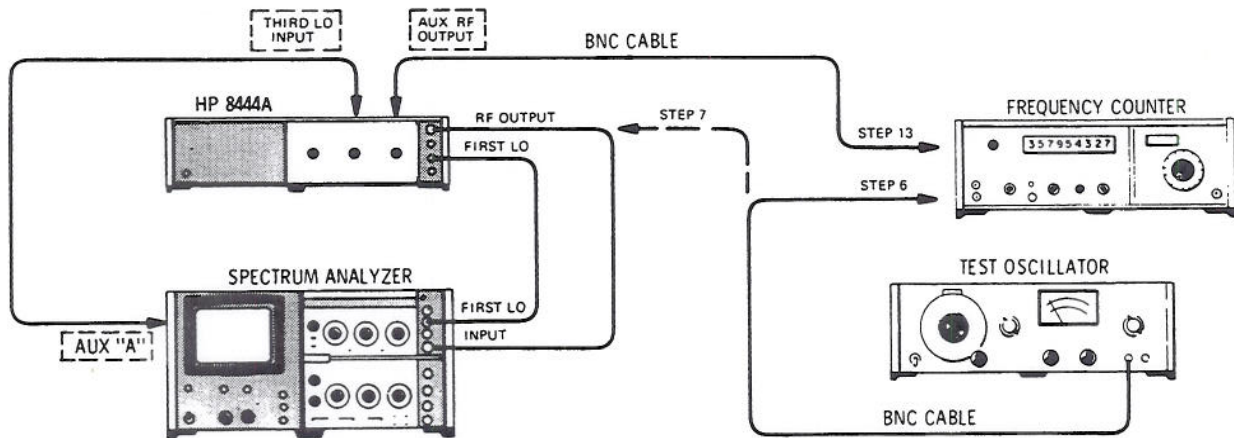

Figure 4-5. Frequency Accuracy Test Setup

EQUIPMENT:

Spectrum Analyzer	HP 8554B/8555A/8552A/141T
Frequency Counter	HP 5245L
Frequency Converter	HP 5254C
Test Oscillator	HP 652A
HF Signal Generator	HP 606A/B
VHF Signal Generator	HP 608E/F
UHF Signal Generator	HP 612A
Cable Assembly	HP 10503A

PROCEDURE:

1. Perform preset adjustment procedures, paragraph 4-7, for 8554B/8552B/141T Spectrum Analyzer System or paragraph 4-9 for 8555A/8552B/141T Spectrum Analyzer System.
2. Connect test setup as indicated in Figure 4-5 and make the following control settings:

Spectrum Analyzer

See paragraph 4-7 or 4-9.

Frequency Counter

SAMPLE RATE	12 o'clock
SENSITIVITY	.1 (VOLTS RMS)
TIME BASE	10 ms
FUNCTION	FREQUENCY

PERFORMANCE TESTS

4-19. Frequency Accuracy (cont'd)

Tracking Generator

TRACK ADJ Max signal amplitude
 LEVEL 0 dBm
 MANUAL SCAN CCW

Test Oscillator

FREQUENCY 500 kHz (8554B); 10 MHz (8555A)
 OUTPUT ATTENUATOR 0 dBm

3. Allow instruments to warm up and stabilize for at least 2 hours.
4. Set Spectrum Analyzer SCAN WIDTH PER DIVISION to 5 MHz, BANDWIDTH to 30 kHz, center FINE TUNE control and set FREQUENCY to 0 MHz.

NOTE

During all adjustments of FREQUENCY control, approach dial setting in a clockwise direction.

5. Check displacement of LO feedthru signal from CRT CENTER FREQUENCY graticule line.
 $\leq 3 \text{ Div}$ _____
6. Connect Test Oscillator 50Ω output to Frequency Counter and adjust oscillator frequency for an indication of 500 kHz (8554B) or 10 MHz (8555A).
7. Disconnect cable between Tracking Generator RF OUTPUT and Spectrum Analyzer INPUT.
8. Connect Test Oscillator to Spectrum Analyzer INPUT and tune Spectrum Analyzer to Test Oscillator frequency.
9. Reduce Spectrum Analyzer SCAN WIDTH PER DIVISION to 5 kHz and BANDWIDTH to 1 kHz keeping signal centered on CRT display with FREQUENCY and FINE TUNE controls.
10. Set SCAN WIDTH to ZERO and tune FINE TUNE for maximum signal amplitude.
11. Disconnect Test Oscillator from Spectrum Analyzer and connect Tracking Generator OUTPUT to Spectrum Analyzer INPUT.
12. Adjust Tracking Generator TRACK ADJ for maximum signal amplitude on CRT display.
13. Connect Tracking Generator AUX RF OUTPUT to Frequency Counter. Measure and record frequency.

8554B	500 ± 10 kHz	_____
8555A	10 MHz ± 10 kHz	_____
14. Repeat steps 6 through 13 at selected frequencies using appropriate signal generator in place of test oscillator.

PERFORMANCE TESTS

4-20. Harmonic Distortion

SPECIFICATION: Harmonic Distortion: Typically 25 dB below output level. Nonharmonic (spurious) signals: >35 dB below output level.

DESCRIPTION: With the Tracking Generator and Spectrum Analyzer operating as a system, the RF OUTPUT from the Tracking Generator is observed using a separate spectrum analyzer. The output signal is checked for signal level of both harmonic and spurious signals.

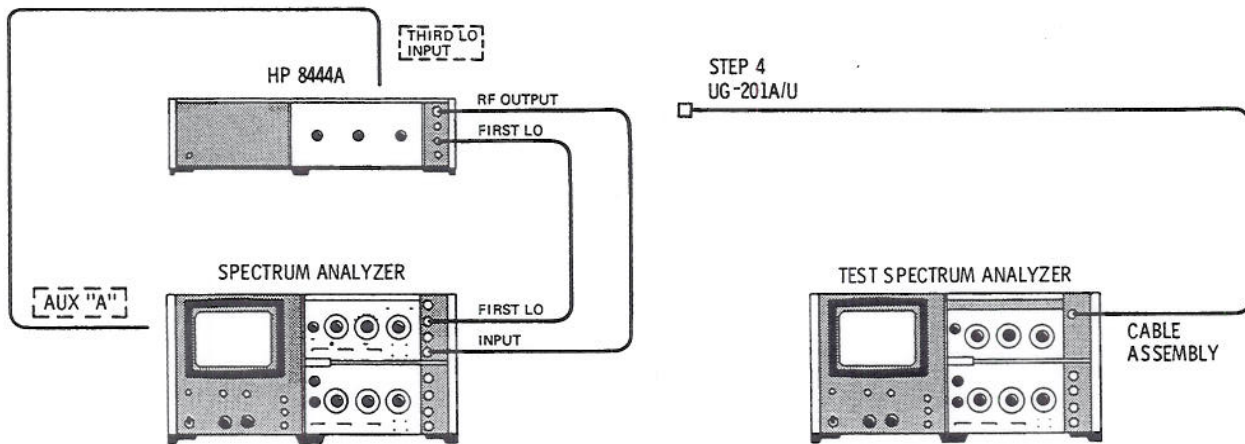

Figure 4-6. Harmonic Distortion Test Setup

EQUIPMENT:

Spectrum Analyzer	HP 8554B or 8555A/8552B/141T
Test Spectrum Analyzer	HP 8553B/8552B/141T
RF Section	HP 8554B or 8555A
BNC Cable	HP 10503A
Adapter	UG-201A/U

PROCEDURE:

1. Perform preset adjustment procedures, paragraph 4-7, for 8554B/8552/141T Spectrum Analyzer System or paragraph 4-9 for 8555A/8552/141T Spectrum Analyzer System.
2. Connect test setup as indicated in Figure 4-6 and make the following control settings:

Tracking Generator/Spectrum Analyzer System

See paragraph 4-7 or 4-9.

Spectrum Analyzer (8553B/8552B/141T "Test Analyzer")

FREQUENCY	50 MHz
BANDWIDTH	300 kHz
SCAN WIDTH	PER DIVISION
SCAN WIDTH PER DIVISION	10 MHz
INPUT ATTENUATION	20 dB
BASE LINE CLIPPER	10 o'clock
VIDEO FILTER	OFF
SCAN TIME PER DIVISION	2 MILLISECONDS
LOG/LINEAR	10 dB LOG

PERFORMANCE TESTS

4-20. Harmonic Distortion (cont'd)

LOG REF LEVEL 0 dBm
 LOG REF LEVEL Vernier 0
 SCAN MODE INT
 SCAN TRIGGER LINE

Tracking Generator/Spectrum Analyzer System

Tracking Generator

TRACK ADJ Max signal level
 LEVEL 0 dBm

Spectrum Analyzer

BAND* n=1- (2.05 GHz IF)
 FREQUENCY 50 MHz
 TUNING STABILIZER OFF
 SIGNAL IDENTIFIER* OFF
 BANDWIDTH 300 kHz
 SCAN WIDTH PER DIVISION
 SCAN WIDTH PER DIVISION 10 MHz
 INPUT ATTENUATION 20 dB
 BASE LINE CLIPPER 9 o'clock
 SCAN TIME PER DIVISION 0.5 SECONDS
 LOG/LINEAR 10 dB LOG
 LOG REF LEVEL Vernier 0
 VIDEO FILTER OFF
 SCAN MODE INT
 SCAN TRIGGER LINE

*8555A RF Section only

3. Disconnect the cable between Tracking Generator RF OUTPUT and Spectrum Analyzer INPUT.
4. Connect cable between Tracking Generator RF OUTPUT and the INPUT of the "Test Analyzer".
5. Observe the "Test Analyzer" display for harmonic and spurious signals. A typical display is shown in Figure 4-7. The Tracking Generator fundamental signal is shown between the -2 and -1 graticule lines. The second harmonic is shown between the +1 and +2 lines with the third harmonic shown between the +4 and +5 lines. The amplitude of the second harmonic is approximately 36 dB below the fundamental. The third harmonic is down approximately 50 dB. A spurious signal with an amplitude of approximately -58 dBm is shown between the -4 and -3 graticule lines.
6. Change the Tracking Generator/Spectrum Analyzer System controls as follows:

Tracking Generator

LEVEL -10 dBm (CCW)

Spectrum Analyzer

FREQUENCY 250 MHz
 SCAN WIDTH PER DIVISION 50 MHz
 SCAN TIME PER DIVISION 1 SECOND

7. Replace the "Test Analyzer" RF Section with either an 8554B or 8555A RF Section.

PERFORMANCE TESTS

4-20. Harmonic Distortion (cont'd)

8. Set "Test Analyzer" controls as follows:

```

FREQUENCY . . . . . 250 MHz
BANDWIDTH . . . . . 300 kHz
SCAN WIDTH . . . . . PER DIVISION
SCAN WIDTH PER DIVISION . . . . . 50 MHz
INPUT ATTENUATION . . . . . 20 dB
BASE LINE CLIPPER . . . . . 12 o'clock
VIDEO FILTER . . . . . OFF
SCAN TIME PER DIVISION . . . . . 10 MILLISECONDS
LOG/LINEAR . . . . . 10 dB LOG
LOG REF LEVEL . . . . . 10 dBm
LOG REF LEVEL Vernier . . . . . 0
SCAN MODE . . . . . INT
SCAN TRIGGER . . . . . LINE
    
```

- 9. Observe the "Test Analyzer" display for harmonic and spurious signals.
- 10. Figure 4-8 illustrates a typical display of the LO feedthru, fundamental and second harmonic signals.
- 11. Repeat the above procedure at frequency of interest.
- 12. Note and record maximum amplitude level of harmonic and spurious signals.

Harmonics typically ≤ -25 dBm _____
 Spurious ≤ -35 dBm _____

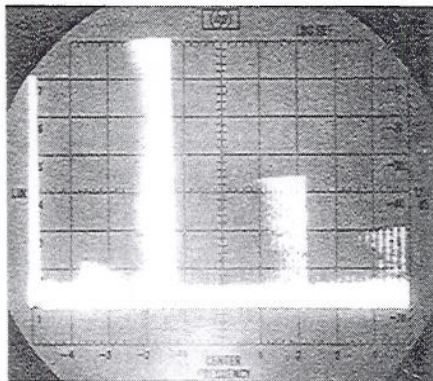

Figure 4-7. Typical Harmonic Distortion CRT Display 0 to 100 MHz

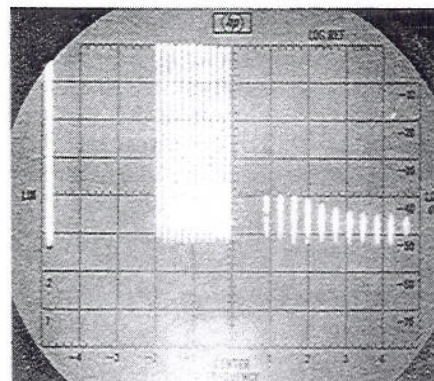

Figure 4-8. Typical Harmonic Distortion CRT Display 0 to 500 MHz

Table 4-1. Performance Test Record

Hewlett-Packard Model 8444A Tracking Generator		Tested by _____			
Serial No. _____		Date _____			
Para. No.	Test Description	Measurement Unit	Min	Actual	Max
4-16	Output Level (Step 6)	dBm	-0.5	_____	+0.5
	(Step 7)	dBm	-10	_____	-12
	(Step 10)	dB		_____	1.0
4-17	Residual FM (peak-to-peak)				
	8554B Stabilized	Hz		_____	200
	8555A Stabilized	Hz		_____	200
	8554B Unstabilized	kHz		_____	10
	8555A Unstabilized	kHz		_____	10
4-18	System Flatness				
	500 kHz to 1250 MHz (8554B)	dB		_____	3.0
	10 to 1300 MHz (8555A)	dB		_____	3.0
4-19	Frequency Accuracy				
	Dial Accuracy (Step 5)	MHz	-15	_____	+15
	Frequency Accuracy (Step 13)	kHz	-10	_____	+10
4-20	Harmonic Distortion				
	Harmonic Signal Level	dBm		_____	-25
	Spurious Signal Level	dBm		_____	-35

SECTION V ADJUSTMENTS

5-1. INTRODUCTION

5-2. This section describes adjustments required to return the Tracking Generator to peak operating condition after repairs are made. Included in this section are test setups, and check and adjustment procedures. A test card for recording data is included at the back of this section. Adjustment and test point location illustrations are contained in Figures 8-4 and 8-5.

5-3. The adjustment procedures are arranged in numerical order. For best results, this order should be followed. Record data, taken during adjustments, in the spaces provided and/or in the data test card at the end of this section. Comparison of initial data with data taken during periodic adjustments assists in preventive maintenance and troubleshooting.

NOTE

Control settings are called out for a HP 8555A Spectrum Analyzer RF Section. If the RF Section used is a HP 8554B

disregard BAND and SIGNAL IDENTIFIER control settings. Otherwise, the Spectrum Analyzer control settings apply to either instrument.

5-4. EQUIPMENT REQUIRED

5-5. Each check and adjustment procedure contains a list of test equipment required for that particular test. Table 1-3 contains a tabular list of test equipment and accessories required. In addition, the table contains the required minimum specifications and a suggested manufacturers model number.

5-6. FACTORY SELECTED COMPONENTS

5-7. Factory selected components are designated by an asterisk (*) on the schematic diagrams in Section VIII of this manual. Table 8-1 contains a list of factory selected components by reference designation, basis of selection, and schematic diagram location on which the component is illustrated.

WARNING

Any service, adjustments, or repair of this instrument must be performed by qualified service personnel.

WARNING

Adjustments described in this manual may be performed with power supplied to the instrument with protective covers removed. There are voltages present within the instrument which, if contacted, can cause personal injury. Be extremely careful when working in or near exposed circuits. Adjustments must be performed by qualified service personnel.

ADJUSTMENTS

5-8. Power Supply, Check and Adjustment

REFERENCE: Service Sheet 5.

DESCRIPTION: Power supplies in the Tracking Generator provide regulated output of +20 and -10 volts. The +20 volt supply is adjustable and provides the reference for the -10 volt supply. These checks verify proper operation of the power supplies.

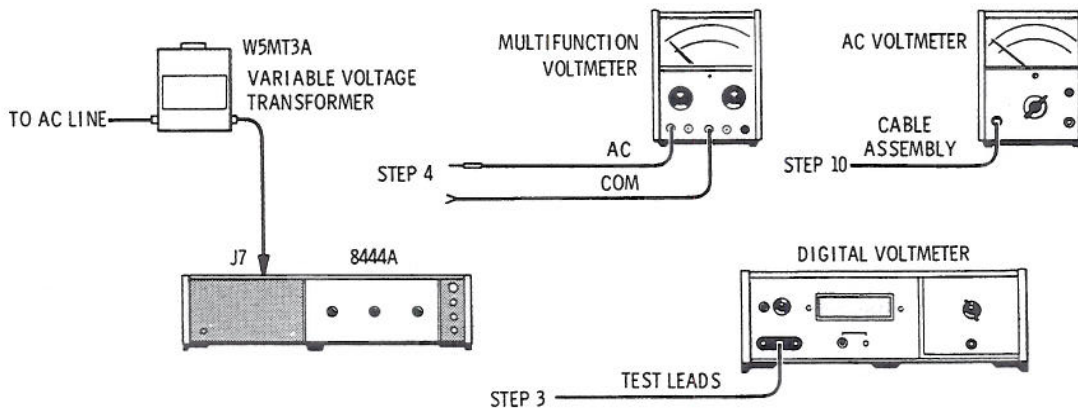

Figure 5-1. Power Supply Check and Adjustment Test Setup

EQUIPMENT:

Digital Voltmeter with 3443A Plug-in	HP 3440A
AC Voltmeter (Multifunction Voltmeter)	HP 410C
Variable Voltage Transformer	General Radio W5MT3A
AC Voltmeter	HP 400E
Cable Assy (terminated with probe and alligator clip)	HP 10501A
Cable Assy (dual banana plug to probe and alligator clip)	HP 11003A

PROCEDURE:

1. Connect test setup as indicated in Figure 5-1 with Tracking Generator line power off.
2. Remove top cover and right side cover from Tracking Generator.
3. Connect digital voltmeter test leads to A1TP1 and chassis ground.
4. Remove shield from power line module and connect ac voltmeter (HP 410C) across the outside terminals of the ACCESSORY OUTLET connector J6. (The outside terminals of J6 are connected by the 98 and 908 color coded wires to the power line module.)

ADJUSTMENTS

5-8. Power Supply, Check and Adjustment (Cont'd)

5. Apply power to the Tracking Generator. Measure and record the +20 volt output. Vary the input ac line voltage from 103.5 to 126.5 volts. The +20 volt regulated output should not vary more than 20 mV.

AC Input	+20 Vdc Output
103.5V	_____
115V	_____
126.5V	_____

6. Set ac line voltage to 115 volts. Adjust A1R14 for +20.00 Vdc \pm 20 mV at test point A1TP1.
7. Disconnect ac voltmeter from connector J6.
8. Connect digital voltmeter to A7C3 and chassis ground (-10 volt test point).
9. Measure and record voltage level. Voltage level should be -10.0 ± 0.5 volts.

-10.0 Vdc Output _____

10. Set HP 400E AC Voltmeter RANGE to .001 VOLTS full scale and measure ac ripple on +20 and -10 volt sense lines. Ripple should be less than 200 μ V. Measure and record ac ripple between power supply sense lines and chassis ground.

+20 Volt Output XA1 pin 6 _____
 -10 Volt Output A7C3 _____

11. Remove input line power and replace cover over power line module.
12. Replace right side cover and top cover.
13. If the dc supplies are out of tolerance, refer to Service Sheet 5 for trouble isolation procedure.

ADJUSTMENTS

5-9. 1.55 GHz Oscillator Power Level, Frequency Check and Adjustment

REFERENCE: Service Sheet 3.

DESCRIPTION: The 1.55 GHz local oscillator is checked for power output level and frequency tuning range. Oscillator frequency is determined primarily by the LO cavity, with tuning range determined by the drive voltage from the oscillator driver. The oscillator is checked first for power level and then for frequency and tuning range.

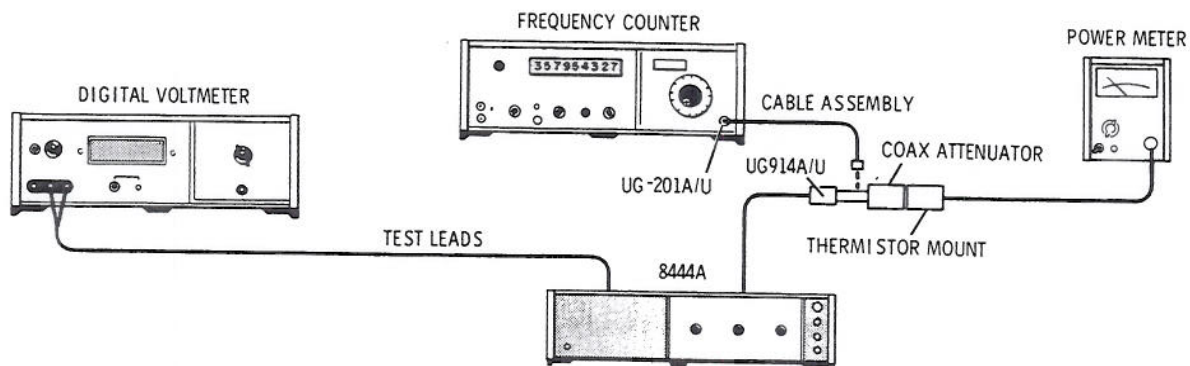

Figure 5-2. 1.55 GHz LO Power Level and Frequency Check and Adjustment Test Setup

EQUIPMENT:

Power Meter with HP 8478B Thermistor Mount	HP 432A
Frequency Counter with HP 5254C Plug-in	HP 5245L
Digital Voltmeter with HP 3443A Plug-in	HP 3440A
Test Leads (dual banana plug to probe and alligator clip)	HP 11003A
Cable Assy, SMA male to BNC male	HP 08555-60076
Cable Assy, male BNC connectors	HP 10503A
Coaxial Attenuator, Option 010	HP 8491A
Adapter BNC barrel (HP Part Number 1250-0080)	UG 914A/U
Adapter (BNC to Type N)	UG 201A/U

PROCEDURE:

1. Perform Power Supply Check and Adjustment, paragraph 5-8.
2. Apply power to Tracking Generator and allow 1 hour for instrument to warm up and stabilize.
3. Disconnect Cable W8 at Isolator AT3 J2 (see Figures 8-4 and 8-12).
4. With test setup as indicated in Figure 5-2, connect Power Meter to Isolator AT3 J2 via 08555-60076 cable, 10 dB attenuator and UG 914A/U adapter.
5. Rotate TRACK ADJ control throughout its tuning range while noting power level indicated on Power Meter.
6. Minimum power output must be greater than +5 dBm.

>+5 dBm _____

ADJUSTMENTS

5-9. 1.55 GHz Oscillator Power Level, Frequency Check and Adjustment (cont'd)

7. Connect Frequency Counter to Isolator AT3 J2 via 08555-60076 cable, UG 914A/U adapter and BNC to BNC cable.
 8. Rotate TRACK ADJ control fully counterclockwise and record oscillator frequency.
1,548,000 \pm 500 kHz _____
 9. Rotate TRACK ADJ control fully clockwise and record oscillator frequency
1,552,000 \pm 500 kHz _____
 10. Record frequency tuning range (frequency recorded in step 9 minus frequency recorded in step 8).
4,000 \pm 500 kHz _____
 11. If data recorded in steps 8, 9, and 10 is within tolerance no adjustment is required.
 12. If data recorded in steps 8, 9, or 10 is not within tolerance proceed with step 13.
 13. Connect Digital Voltmeter to test point A2TP5.
 14. Set TRACK ADJ control fully clockwise. Set "MAX" TUNE potentiometer A2R26 and "MIN" TUNE potentiometer A2R27 fully counterclockwise. Measure voltage at A2TP5. Voltage should be ± 0.1 Vdc.
+0.9 _____ +1.1 Vdc
 15. Measure and record oscillator frequency.
 16. Adjust "MAX" TUNE potentiometer A2R26 to increase oscillator frequency 4,000 \pm 50 kHz above frequency recorded in step 15. Record oscillator frequency.
 17. Set TRACK ADJ control to center of tuning range recorded in steps 15 and 16 above. Record oscillator frequency.
 18. If frequency recorded in step 17 is not within ± 500 kHz of 1.550 GHz adjust A7ADJ 1 to tune oscillator frequency to 1.550 GHz \pm 100 kHz.
 19. If oscillator frequency is adjusted, repeat steps 15 through 18.
 20. Disconnect Power Meter and connect W8 Cable to Isolator AT3 J2.
-

ADJUSTMENTS

5-10. 1.55 GHz Oscillator Residual FM Check

REFERENCE: Service Sheet 3.

DESCRIPTION: The 1.55 GHz oscillator is checked for residual FM by mixing the oscillator output with a stable signal source and observing the resultant output on a calibrated spectrum analyzer display. The second converter in Tracking Generator is used to mix the oscillator output with the 1500 MHz comb signal from a Frequency Comb Generator. The mixer output is displayed using a HP 141T/8553B/8552B Spectrum Analyzer System which has less than 20 Hz peak-to-peak residual FM. There are no adjustments for oscillator residual FM. Perform power supply check for excessive ripple if residual FM is excessive.

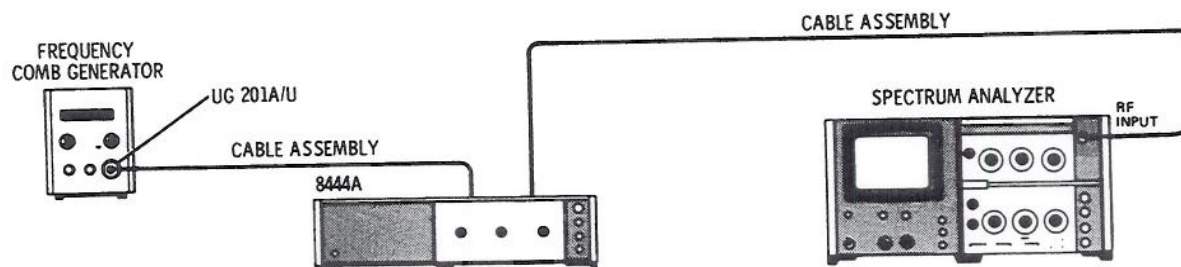

Figure 5-3. 1.55 GHz LO Residual FM Check Test Setup

EQUIPMENT:

Spectrum Analyzer System	HP 141T/8553B/8552B
Frequency Comb Generator	HP 8406A
Cable Assy, Selectro male to Selectro female	HP 11592-60003
Cable Assy, Selectro female to BNC male (2 each)	HP 11592-60001
Adapter (BNC to Type N)	UG 201A/U

PROCEDURE:

1. Perform Power Supply Check and Adjustment, paragraph 5-8.
2. Perform 1.55 GHz Oscillator Power Level, Frequency Check and Adjustment, paragraph 5-9.
3. Apply power to Spectrum Analyzer System, Frequency Comb Generator and Tracking Generator. Allow at least one (1) hour for equipment stabilization.
4. Disconnect Cable W4 at Mixer Assy A6 and Cable W8 at First Converter A5J2 (see Figures 8-4 and 8-12). Connect 11592-60003 cable between W8 and A6 J1.
5. Disconnect Cable W9 from A6 J2 and connect 11592-60001 cable between A6 J2 and Frequency Comb Generator.
6. Disconnect Cable W10 from A6 J3 and connect 11592-60001 cable between A6 J3 and Spectrum Analyzer RF input.
7. Set instrument controls as follows:

ADJUSTMENTS

5-10. 1.55 GHz Oscillator Residual FM Check (cont'd)

Tracking Generator

LINE OFF/ON ON
 TRACK ADJ Centered

Frequency Comb Generator

COMB FREQUENCY — MHz 100 MHz
 OUTPUT AMPLITUDE Maximum (CW)

Spectrum Analyzer

POWER ON
 RANGE MHz 0–110
 FREQUENCY 50 MHz
 BANDWIDTH 30 kHz
 SCAN WIDTH PER DIVISION
 SCAN WIDTH PER DIVISION 1 MHz
 INPUT ATTENUATION 10 dB
 TUNING STABILIZER ON
 SCAN TIME PER DIVISION 20 MILLISECONDS
 LOG/LINEAR 10 dB LOG
 LOG REF LEVEL +10 dBm
 VIDEO FILTER 10 kHz
 SCAN MODE INT
 SCAN TRIGGER AUTO

8. Rotate Tracking Generator TRACK ADJ control while observing CRT display.

NOTE

With the 1.55 GHz oscillator tuned to 1550 MHz both the 1500 and 1600 MHz comb signals will produce a response at 50 MHz.

9. Adjust the TRACK ADJ control until the responses are separated by 2 MHz (2 divisions) on the display.
10. Adjust Spectrum Analyzer FREQUENCY control to center largest response on CRT display.
11. Reduce BANDWIDTH to 1 kHz and SCAN WIDTH PER DIVISION to 2 kHz while keeping signal centered on CRT display.
12. Switch Spectrum Analyzer LOG/LINEAR to LINEAR and adjust sensitivity controls for a full eight division display.
13. Refer to Figure 5-4. Tune FINE TUNE so that the upward slope of the display intersects the CENTER FREQUENCY graticule line one division from the top.

NOTE

The linear portion of the analyzer IF filter skirt is used to slope detect low-order residual FM. The analyzer is stabilized, and the detected FM is displayed in the time domain.

ADJUSTMENTS

5-10. 1.55 GHz Oscillator Residual FM Check (cont'd)

14. Note where the slope intersects the middle horizontal graticule line:

Horizontal Displacement: _____ divisions

15. Use the horizontal displacement to calculate demodulation sensitivity.

a. Convert the horizontal displacement (divisions) into Hertz.

Example: (2 kHz SCAN WIDTH) x (0.2 div) = 400 Hz.

b. Calculate demodulation sensitivity by dividing the vertical displacement in divisions into the horizontal displacement in Hz:

$$\text{Example: } \frac{400 \text{ Hz}}{3 \text{ divisions}} = 133 \text{ Hz/div}$$

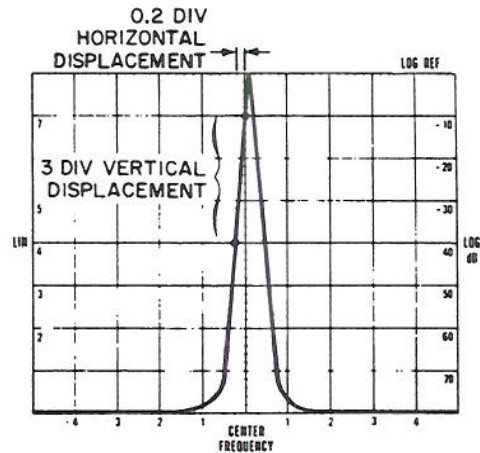

Figure 5-4. Demodulation Sensitivity Measurement

16. Turn SCAN WIDTH to ZERO scan. Set FINE TUNE for a response level within the calibrated three division range (one division from the top to the center horizontal graticule line).

17. Measure the peak-to-peak deviation, and multiply it by the demodulation sensitivity obtained in step 15b above.

Example: 0.5 div p-p signal deviation x 133 Hz/div = 66.5 Residual FM.

_____ Hz peak-to-peak

18. Install cables removed in steps 4 through 6.

ADJUSTMENTS

5-11. First Converter Check and Adjustment

REFERENCE: Service Sheet 3.

DESCRIPTION: The 1.55 GHz oscillator cavity and the two 2.05 GHz IF bandpass cavities in the first converter are adjusted for maximum output signal level. A 8555A Spectrum Analyzer System (8555A/8552/140) should be used during the adjustment procedure. In addition to providing the third LO input signal the output signal can be displayed during the adjustment. With the analyzer operating in the linear mode, the cavities are alternately adjusted for maximum indication on the CRT. When only the 8554L Spectrum Analyzer System is available, the output can be monitored using a power meter such as the HP 432B.

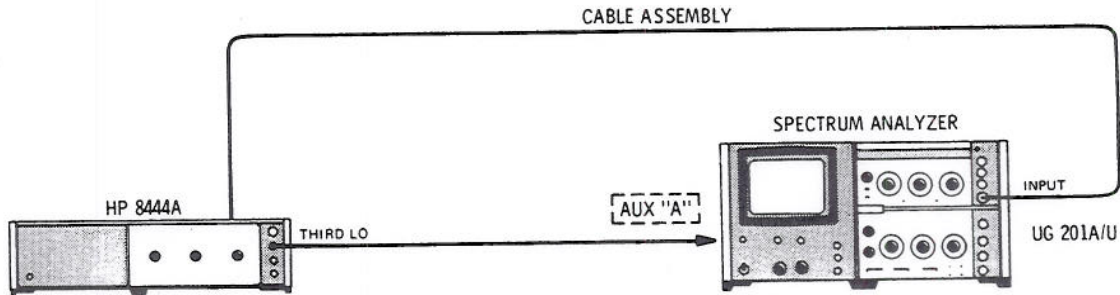

Figure 5-5. First Converter Check and Adjustment Test Setup

EQUIPMENT:

Spectrum Analyzer	HP 8555A/8552/141T
Cable Assembly	HP 11592-60001
Adapter	UG 201A/U
Wrench	5/16 inch
Allen Driver	No. 10

PROCEDURE:

1. Perform 1.55 GHz Oscillator Power Level, Frequency Check and Adjustment, paragraph 5-9.
2. With test setup as indicated in Figure 5-5, set controls as follows:

Tracking Generator

LINE	ON
TRACK ADJ	Centered
LEVEL	0 dBm

Spectrum Analyzer

BAND	n=1— (2.05 GHz IF)
FREQUENCY	500 MHz
BANDWIDTH	100 kHz
SCAN WIDTH PER DIVISION	5 MHz
INPUT ATTENUATION	20 dB
SCAN TIME PER DIVISION	20 MILLISECONDS
LOG REF LEVEL	(+) 10 dBm
LOG/LINEAR	10 dB LOG

ADJUSTMENTS

VIDEO FILTER	10 kHz
SCAN MODE	INT
SCAN TRIGGER	AUTO

3. Disconnect W6 cable at RF OUT of 500 MHz Amplifier Assembly A4.
4. Connect 11592-60001 cable between A4 RF OUT and Spectrum Analyzer INPUT using UG 201A/U adapter.
5. Record 500 MHz signal level. $\cong 0$ dBm _____
6. Disconnect 11592-60001 cable from A4 RF OUT connector.
7. Install W6 cable removed in step 3 above.
8. Disconnect W9 cable at A5 J3 and connect 11592-60001 cable between A5 J3 and Spectrum Analyzer INPUT.
9. Select Spectrum Analyzer n=1— (550 MHz IF) BAND and adjust FREQUENCY control for dial indication of 2050 MHz.
10. Set Spectrum Analyzer LOG/LINEAR switch to LINEAR and adjust LINEAR SENSITIVITY controls to position signal peak between the 5 and 7 LIN graticule lines.
11. Adjust A5 ADJ 1 (1.55 GHz oscillator cavity) for peak signal indication on CRT display.
12. Alternately adjust A5 ADJ 2 and ADJ 3 (2.05 GHz IF bandpass cavities) for peak signal indication on CRT display.
13. Repeat steps 11 and 12 above.
14. Set Spectrum Analyzer SCAN WIDTH PER DIVISION to 1 MHz.
15. Tune Tracking Generator TRACK ADJ through its tuning range while observing the CRT display.
16. The passband should be similar to that displayed in Figure 5-6. If not, set TRACK ADJ to center of passband and repeat steps 11 through 15.
17. Set Spectrum Analyzer LOG/LINEAR switch to LOG, measure and record first converter output signal level. ≥ -7 dBm _____
18. Install W9 cable between A5 J3 and A6 J2.

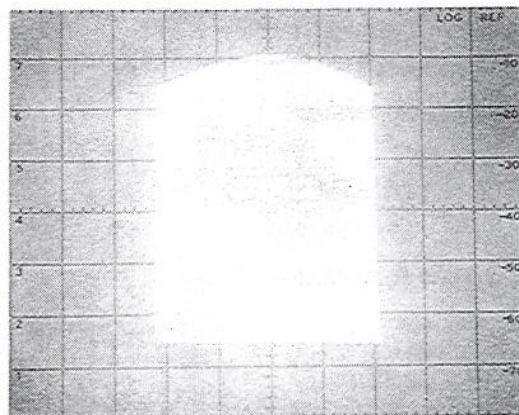

Figure 5-6. First Converter Passband
CRT Display

ADJUSTMENTS

5-12. Automatic Level Control (ALC) Check and Adjustment

REFERENCE: Service Sheet 3.

DESCRIPTION: The modulator driver functions as an operational amplifier in the ALC loop. A 10 kHz signal is applied to the operational amplifier and the loop gain is adjusted while maintaining 0 dB output level. A limiter in the amplifier circuit is adjusted to prevent a large swing in the driver output when the analyzer sweeps through zero frequency. Perform Level Control Calibration, paragraph 5-13, after ALC loop adjustment.

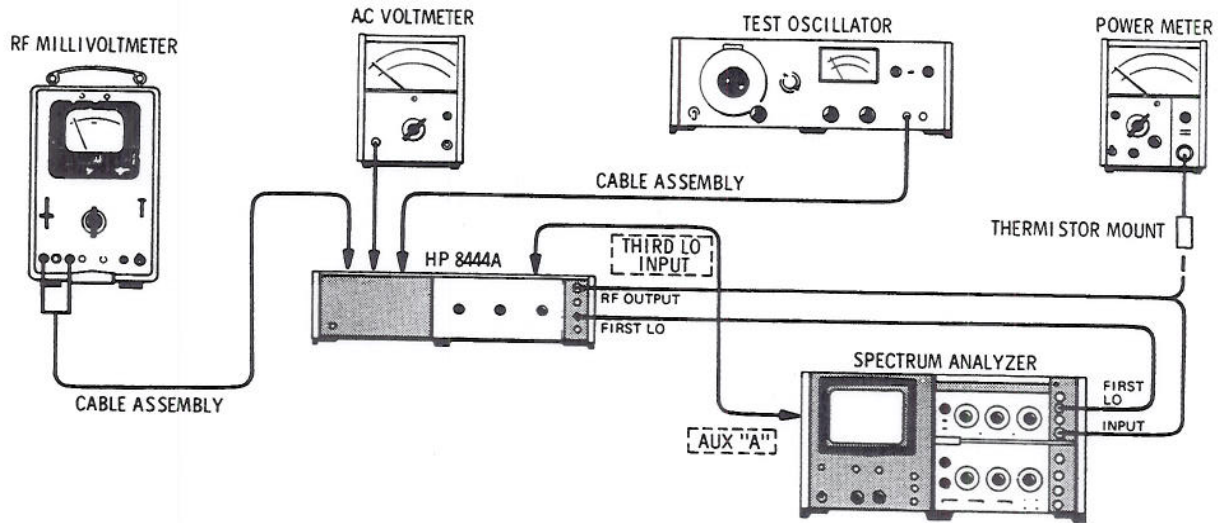

Figure 5-7. Automatic Level Control (ALC) Check and Adjustment Test Setup

EQUIPMENT:

Spectrum Analyzer	HP 8555A/8552/141T
Power Meter	HP 432A
Thermistor Mount	HP 8478B
AC Voltmeter	HP 400E
DC Voltmeter (RF Millivoltmeter)	HP 412A
Test Oscillator	HP 652A
Test Lead with alligator clips	
Cable Assembly	HP 10501A* (2)
Resistor	(100K ohm 5%, 1 watt)

*Terminated with alligator clips

PROCEDURE:

1. Perform Spectrum Analyzer calibration procedure; refer to appropriate operation and service manual.
2. Connect test setup as indicated in Figure 5-7 and set controls as follows:

Spectrum Analyzer

BAND	n=1— (2.05 GHz IF)
FREQUENCY	30 MHz
BANDWIDTH	100 kHz
SCAN WIDTH	ZERO

ADJUSTMENTS

5-12. Automatic Level Control (ALC) Check and Adjustment (cont'd)

INPUT ATTENUATION	10 dB
TUNING STABILIZER	ON
SIGNAL IDENTIFIER	OFF
BASE LINE CLIPPER	Max CCW
SCAN TIME PER DIVISION	10 MILLISECONDS
LOG REF LEVEL	+10 dBm
LOG/LINEAR	LOG
VIDEO FILTER	OFF
SCAN MODE	INT
SCAN TRIGGER	AUTO

Tracking Generator

LINE	ON
TRACK ADJ	Peak signal indication on CRT
LEVEL	0 dBm

- Allow instruments to warm up and stabilize for at least 30 minutes.
 - Adjust TRACK ADJ for maximum signal indication on CRT display.
 - Disconnect cable between Tracking Generator RF OUTPUT and Spectrum Analyzer INPUT.
 - Connect Thermistor Mount and Power Meter to Tracking Generator RF OUTPUT.
 - Connect test lead jumper between A2TP1 and A2TP2.
 - Adjust A2R17 "NULL ADJ" for output level of 0 ± 1.0 dBm indication on Power Meter.
 - Remove jumper between A2TP1 and A2TP2.
 - Adjust A2R41 "0 dBm LEVEL" for output level of 0 ± 0.5 dBm indication on Power Meter.
 - Adjust Test Oscillator for 10 kHz output.
 - Connect Test Oscillator output through 100K ohm resistor to A2TP4.
 - Connect AC Voltmeter to A2TP1.
 - Adjust Test Oscillator output amplitude for an indication of -7 dB (.001 VOLTS RANGE) on AC Voltmeter.
 - Connect AC Voltmeter to A2TP2.
 - Adjust A2R7 "GAIN ADJ" for an indication of -10 dB (.001 VOLTS RANGE) on AC Voltmeter.
 - Adjust A2R17 "NULL ADJ" for Tracking Generator output of 0 dBm.
 - Repeat steps 16 and 17 until both levels are obtained.
 - Disconnect AC Voltmeter and Test Oscillator.
 - Repeat steps 7 through 10 above.
 - Connect DC Voltmeter across A2TP1 and A2TP3, COM to A2TP1 and VOLTS to A2TP3.
-

ADJUSTMENTS

5-12. Automatic Level Control (ALC) Check and Adjustment (cont'd)

- 22. Adjust A2R6 "LIMIT SET" for an indication of +0.3 Vdc on DC Voltmeter.
- 23. Disconnect DC Voltmeter.
- 24. Perform Level Control Calibration, paragraph 5-13.

5-13. Level Control Calibration Check and Adjustment

REFERENCE: Service Sheet 4.

DESCRIPTION: The level control circuitry is adjusted to provide a 10 dB tuning range of the front panel LEVEL control. The level control circuitry provides the voltage level to the reference diode in the ALC detector. Perform Automatic Level Control Check and Adjustment, paragraph 5-12, before calibrating the level control.

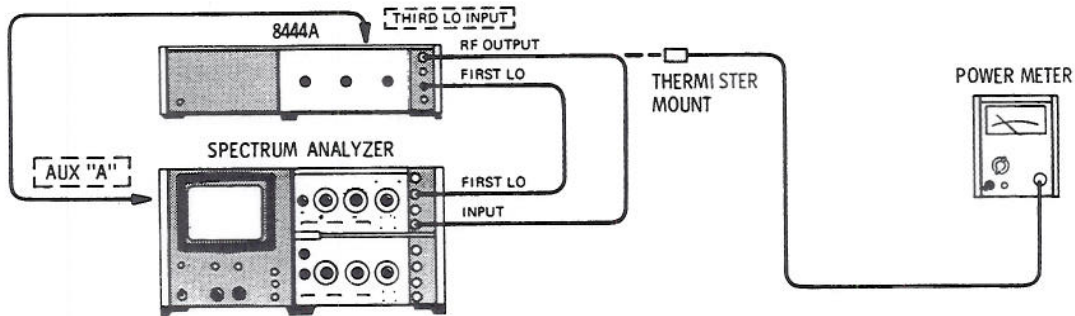

Figure 5-8. Level Control Calibration Check and Adjustment Test Setup

EQUIPMENT:

Spectrum Analyzer	HP 8555A/8552B/141T
Power Meter	HP 432A
Thermistor Mount	HP 8478B

PROCEDURE:

- 1. Connect test setup as indicated in Figure 5-8 and set controls as follows:

Spectrum Analyzer

BAND	n=1- (2.05 GHz IF)
FREQUENCY	30 MHz
BANDWIDTH	100 kHz
SCAN WIDTH	ZERO
INPUT ATTENUATION	20 dB
TUNING STABILIZER	ON
SIGNAL IDENTIFIER	OFF
BASE LINE CLIPPER	Max CCW
SCAN TIME PER DIVISION	10 MILLISECONDS
LOG REF LEVEL	+10 dBm
LOG/LINEAR	LOG

ADJUSTMENTS

5-13. Level Control Calibration Check and Adjustment (cont'd)

VIDEO FILTER	OFF
SCAN MODE	INT
SCAN TRIGGER	AUTO

Tracking Generator

LINE	ON
TRACK ADJ	Peak signal indication on CRT
LEVEL	0 dBm

2. Adjust TRACK ADJ for maximum signal indication on CRT display.
3. Disconnect cable between Tracking Generator RF OUTPUT and Spectrum Analyzer INPUT.
4. Connect Thermistor Mount and Power Meter to Tracking Generator RF OUTPUT.
5. Adjust A2R41 "0 dBm LEVEL" for an indication of 0 ± 0.5 dBm on Power Meter.
6. Set Tracking Generator LEVEL control fully counterclockwise.
7. Adjust A2R40 "-10 dBm LEVEL" for an indication of -10 to -12 dBm on Power Meter.
8. Set Tracking Generator LEVEL control to 0 dBm.
9. Repeat steps 5 through 7 until Power Meter indicates 0 dBm with LEVEL control fully clockwise.
10. Disconnect Power Meter and Thermistor Mount from Tracking Generator RF OUTPUT.
11. Connect cable between Tracking Generator RF OUTPUT and Spectrum Analyzer INPUT.
12. Set Tracking Generator TRACK ADJ for maximum signal level on Spectrum Analyzer CRT display.
13. Note and record signal level at 30 MHz.

0 ±0.5 dBm _____

Table 5-1. Check and Adjustment Test Card

Hewlett-Packard Model 8444A Tracking Generator		Tested by _____			
Serial No. _____		Date _____			
Para. No.	Test Description	Measurement Unit	Min	Actual	Max
5-8	Power Supply, Check and Adjustment				
	+20 Vdc supply	Vdc	+19.98	_____	+20.02
	-10 Vdc supply	Vdc	- 9.5	_____	-10.5
	+20 Vdc supply ripple	μ V		_____	200
	-10 Vdc supply ripple	μ V		_____	200
5-9	1.55 GHz Oscillator Power Level, Frequency Check and Adjustment				
	Power Output	dBm	+5 dBm	_____	
	Frequency Tuning Range	MHz	3.5	_____	4.5
5-10	1.55 GHz Oscillator Residual FM Check				
	Residual FM (peak-to-peak)	Hz		_____	200
5-11	First Converter Check and Adjustment				
	Output Signal Level	dBm	-7	_____	
5-13	Level Control Calibration Check and Adjustment				
	-10 dBm LEVEL position	dBm	-10	_____	-12
	0 dBm LEVEL position	dBm	-0.5	_____	+0.5

SECTION VI REPLACEABLE PARTS

6-1. INTRODUCTION

6-2. This section contains information for ordering parts. Table 6-1 lists abbreviations used in the parts list and throughout the manual. Table 6-2 lists all replaceable parts in reference designator order. Table 6-3 contains names and addresses that correspond to the manufacturer's code numbers.

6-3. ABBREVIATIONS

6-4. Table 6-1 gives a list of abbreviations used in the parts list, schematics, and throughout the manual. In some cases, two forms of the abbreviations are given: one is in capital letters, while the other is partial or no capitals. This occurs because in the parts list, abbreviations are all capitalized. However, in the schematics and other parts of the manual, other abbreviation forms are used with both lower case and upper case letters.

6-5. REPLACEABLE PARTS LIST

6-6. Table 6-2 is a list of replaceable parts and is organized as follows:

- a. Electrical assemblies and their components in alpha-numerical order by reference designation.
- b. Chassis-mounted parts in alpha-numeric order by reference designation.
- c. Miscellaneous parts.

The information given for each part consists of the following:

- a. The Hewlett-Packard part number.
- b. The total quantity (Qty) used in the instrument.
- c. The description of the part.
- d. The typical manufacturer of the part in a five-digit code.
- e. Manufacturer code number for the part.

The total quantity for each part is given only once — at the first appearance of the part number in the list.

6-7. ORDERING INFORMATION

6-8. To order a part listed in the replaceable parts table, give the Hewlett-Packard part number, indicate quantity required, and address the order to the nearest Hewlett-Packard office.

6-9. To order a part that is not listed in the replaceable parts table, include the instrument, model number, instrument serial number, the description and function of the part, and the number of parts required. Address the order to the nearest Hewlett-Packard office.

Table 6-1. Reference Designations and Abbreviations

REFERENCE DESIGNATIONS

A assembly	E miscellaneous electrical part	P electrical connector (movable portion); plug	U integrated circuit; microcircuit
AT attenuator; isolator; termination	F fuse	Q transistor: SCR; triode thyristor	V electron tube
B fan; motor	FL filter	R resistor	VR voltage regulator; breakdown diode
BT battery	H hardware	RT thermistor	W cable; transmission path; wire
C capacitor	HY circulator	S switch	X socket
CP coupler	J electrical connector (stationary portion); jack	T transformer	Y crystal unit (piezo-electric or quartz)
CR diode; diode thyristor; varactor	K relay	TB terminal board	Z tuned cavity; tuned circuit
DC directional coupler	L coil; inductor	TC thermocouple	
DL delay line	M meter	TP test point	
DS annunciator; signaling device (audible or visual); lamp; LED	MP miscellaneous mechanical part		

ABBREVIATIONS

A ampere	COEF coefficient	EDP electronic data processing	INT internal
ac alternating current	COM common	ELECT electrolytic	kg kilogram
ACCESS accessory	COMP composition	ENCAP encapsulated	kHz kilohertz
ADJ adjustment	COMPL complete	EXT external	kΩ kilohm
A/D analog-to-digital	CONN connector	F farad	kV kilovolt
AF audio frequency	CP cadmium plate	FET field-effect transistor	lb pound
AFC automatic frequency control	CRT cathode-ray tube	F/F flip-flop	LC inductance-capacitance
AGC automatic gain control	CTL complementary transistor logic	FH flat head	LED light-emitting diode
AL aluminum	CW continuous wave	FIL H fillister head	LF low frequency
ALC automatic level control	cm centimeter	FM frequency modulation	LG long
AM amplitude modulation	D/A digital-to-analog	FP front panel	LH left hand
AMPL amplifier	dB decibel	FREQ frequency	LIM limit
APC automatic phase control	dBm decibel referred to 1 mW	FXD fixed	LIN linear taper (used in parts list)
ASSY assembly	dc direct current	g gram	lin linear
AUX auxiliary	deg degree (temperature interval or difference)	GE germanium	LK WASH lock washer
avg average	° degree (plane angle)	GHz gigahertz	LO low; local oscillator
AWG American wire gauge	°C degree Celsius (centigrade)	GL glass	LOG logarithmic taper (used in parts list)
BAL balance	°F degree Fahrenheit	GND ground(ed)	log logarithmic
BCD binary coded decimal	°K degree Kelvin	H henry	LPF low pass filter
BD board	DEPC deposited carbon	h hour	LV low voltage
BE CU beryllium copper	DET detector	HET heterodyne	m meter (distance)
BFO beat frequency oscillator	diam diameter	HEX hexagonal	mA milliampere
BH binder head	DIA diameter (used in parts list)	HD head	MAX maximum
BKDN breakdown	DIFF AMPL differential amplifier	HDW hardware	MΩ megohm
BP bandpass	div division	HF high frequency	MEG meg (10 ⁶) (used in parts list)
BPF bandpass filter	DPDT double-pole, double-throw	HG mercury	MET FLM metal film
BRS brass	DR drive	HI high	MET OX metallic oxide
BWO backward-wave oscillator	DSB double sideband	HP Hewlett-Packard	MF medium frequency; microfarad (used in parts list)
CAL calibrate	DTL diode transistor logic	HPF high pass filter	MFR manufacturer
ccw counter-clockwise	DVM digital voltmeter	HR hour (used in parts list)	mg milligram
CER ceramic	ECL emitter coupled logic	HV high voltage	MHz megahertz
CHAN channel	EMF electromotive force	HZ Hertz	mH millihenry
cm centimeter		IC integrated circuit	mho mho
CMO cabinet mount only		ID inside diameter	MIN minimum
COAX coaxial		IF intermediate frequency	min minute (time)
		IMPG impregnated	' minute (plane angle)
		IN inch	MINAT miniature
		INCD incandescent	mm millimeter
		INCL include(s)	
		INP input	
		INS insulation	

NOTE

All abbreviations in the parts list will be in upper-case.

Table 6-1. Reference Designations and Abbreviations (Cont'd)

MOD modulator	OD outside diameter	PWV peak working voltage	TD time delay
MOM momentary	OH oval head	RC resistance-capacitance	TERM terminal
MOS metal-oxide semiconductor	OP AMPL operational amplifier	RECT rectifier	TFT thin-film transistor
ms millisecond	OPT option	REF reference	TGL toggle
MTG mounting	OSC oscillator	REG regulated	THD thread
MTR meter (indicating device)	OX oxide	REPL replaceable	THRU through
mV millivolt	oz ounce	RF radio frequency	TI titanium
mVac millivolt, ac	Ω ohm	RFI radio frequency interference	TOL tolerance
mVdc millivolt, dc	P peak (used in parts list)	RH round head; right hand	TRIM trimmer
mVpk millivolt, peak	PAM pulse-amplitude modulation	RLC resistance-inductance-capacitance	TSTR transistor
mVp-p millivolt, peak-to-peak	PC printed circuit	RMO rack mount only	TTL transistor-transistor logic
mVrms millivolt, rms	PCM pulse-code modulation; pulse-count modulation	rms root-mean-square	TV television
mW milliwatt	PDM pulse-duration modulation	RND round	TVI television interference
MUX multiplex	pF picofarad	ROM read-only memory	TWT traveling wave tube
MY mylar	PH BRZ phosphor bronze	R&P rack and panel	U micro (10 ⁶) (used in parts list)
μA microampere	PHL Phillips	RWV reverse working voltage	UF microfarad (used in parts list)
μF microfarad	PIN positive-intrinsic-negative	S scattering parameter	UHF ultrahigh frequency
μH microhenry	PIV peak inverse voltage	s second (time)	UNREG unregulated
μmho micromho	pk peak	" second (plane angle)	V volt
μs microsecond	PL phase lock	S-B slow-blow (fuse) (used in parts list)	VA voltampere
μV microvolt	PLO phase lock oscillator	SCR silicon controlled rectifier; screw	Vac volts, ac
μVac microvolt, ac	PM phase modulation	SE selenium	VAR variable
μVdc microvolt, dc	PNP positive-negative-positive	SECT sections	VCO voltage-controlled oscillator
μVpk microvolt, peak	P/O part of	SEMICON semiconductor	Vdc volts, dc
μVp-p microvolt, peak-to-peak	POLY polystyrene	SHF superhigh frequency	VDCW volts, dc, working (used in parts list)
μVrms microvolt, rms	PORC porcelain	SI silicon	V(F) volts, filtered
μW microwatt	POS positive; position(s) (used in parts list)	SIL silver	VFO variable-frequency oscillator
nA nanoampere	POSN position	SL slide	VHF very-high frequency
NC no connection	POT potentiometer	SNR signal-to-noise ratio	Vpk volts, peak
N/C normally closed	p-p peak-to-peak	SPDT single-pole, double-throw	Vp-p volts, peak-to-peak
NE neon	PP peak-to-peak (used in parts list)	SPG spring	Vrms volts, rms
NEG negative	PPM pulse-position modulation	SR split ring	VSWR voltage standing wave ratio
nF nanofarad	PREAMPL preamplifier	SPST single-pole, single-throw	VTO voltage-tuned oscillator
NI PL nickel plate	PRF pulse-repetition frequency	SSB single sideband	VTVM vacuum-tube voltmeter
N/O normally open	PRR pulse repetition rate	SST stainless steel	V(X) volts, switched
NOM nominal	ps picosecond	STL steel	W watt
NORM normal	PT point	SQ square	W/ with
NORM normal	PTM pulse-time modulation	SWR standing-wave ratio	WIV working inverse voltage
NPN negative-positive-negative	PWM pulse-width modulation	SYNC synchronize	WW wirewound
NPO negative-positive zero (zero temperature coefficient)		T timed (slow-blow fuse)	W/O without
NRFR not recommended for field replacement		TA tantalum	YIG yttrium-iron-garnet
NSR not separately replaceable		TC temperature compensating	Z ₀ characteristic impedance
ns nanosecond			
nW nanowatt			
OBD order by description			

NOTE

All abbreviations in the parts list will be in upper-case.

MULTIPLIERS

Abbreviation	Prefix	Multiple
T	tera	10 ¹²
G	giga	10 ⁹
M	mega	10 ⁶
k	kilo	10 ³
da	deka	10
d	deci	10 ⁻¹
c	centi	10 ⁻²
m	milli	10 ⁻³
μ	micro	10 ⁻⁶
n	nano	10 ⁻⁹
p	pico	10 ⁻¹²
f	femto	10 ⁻¹⁵
a	atto	10 ⁻¹⁸

Table 6-2. Replaceable Parts

Reference Designation	HP Part Number	Qty	Description	Mfr Code	Mfr Part Number
A1	03444-60001	1	BOARD ASSY:POWER SUPPLY	28480	08444-60001
A1C1	0160-3460	2	C:FXD CER 0.05 UF +80-20% 100VDCW	56289	C023E101L503ZS22-CDM
A1C2	0180-0116	4	C:FXD ELECT 6.8 UF 10% 35VDCW	56289	1500685X9035B2-DYS
A1C3	0160-2199	2	C:FXD MICA 30 PF 5% 300VDCW	28480	0160-2199
A1C4	0180-0228	3	C:FXD ELECT 22 UF 10% 15VDCW	56289	1500226X9015B2-DYS
A1C5	0180-0116		C:FXD ELECT 6.8 UF 10% 35VDCW	56289	1500685X9035B2-DYS
A1C6	0160-3460		C:FXD CER 0.05 UF +80-20% 100VDCW	56289	C023E101L503ZS22-CDM
A1C7	0160-2199		C:FXD MICA 30 PF 5% 300VDCW	28480	0160-2199
A1C8	0180-0228		C:FXD ELECT 22 UF 10% 15VDCW	56289	1500226X9015B2-DYS
A1C9	0180-0116		C:FXD ELECT 6.8 UF 10% 35VDCW	56289	1500685X9035B2-DYS
A1CR1	1901-0159	8	DIODE:SILICON 0.75A 400PIV	04713	SR1358-4
A1CR2	1901-0159		DIODE:SILICON 0.75A 400PIV	04713	SR1358-4
A1CR3	1901-0159		DIODE:SILICON 0.75A 400PIV	04713	SR1358-4
A1CR4	1901-0159		DIODE:SILICON 0.75A 400PIV	04713	SR1358-4
A1CR5	1901-0040	5	DIODE:SILICON 30MA 30WV	07263	FDG1088
A1CR6	1901-0200	2	DIODE:SILICON 100 PIV 3A	02735	1N4998
A1CR7	1901-0200		DIODE:SILICON 100 PIV 3A	02735	1N4998
A1CR8	1902-3182	1	DIODE BREAKDOWN:SILICON 12.1V 5%	28480	1902-3182
A1CR9	1902-3256	1	DIODE BREAKDOWN SILICON 23.7V 5%	28480	1902-3256
A1CR10	1894-0012	1	RECTIFIER:SILICON CONTROLLED 2N3528	02735	2N3528
A1CR11	1902-0761	1	DIODE:BREAKDOWN 5.9 TO 6.5V	12954	1N821
A1CR12	1901-0159		DIODE:SILICON 0.75A 400PIV	04713	SR1358-4
A1CR13	1901-0159		DIODE:SILICON 0.75A 400PIV	04713	SR1358-4
A1CR14	1901-0159		DIODE:SILICON 0.75A 400PIV	04713	SR1358-4
A1CR15	1901-0159		DIODE:SILICON 0.75A 400PIV	04713	SR1358-4
A1CR16	1901-0040		DIODE:SILICON 30MA 30WV	07263	FDG1088
A1F1	2110-0012	2	FUSE:0.5 AMP 250V	75915	312.500
A1F2	2110-0012		FUSE:0.5 AMP 250V	75915	312.500
A1MP1	2110-0269	4	CLIP:FUSE 0.250" DIA	91506	6008-32CN
A1MP2	2110-0269		CLIP:FUSE 0.250" DIA	91506	6008-32CN
A1MP3	2110-0269		CLIP:FUSE 0.250" DIA	91506	6008-32CN
A1MP4	2110-0269		CLIP:FUSE 0.250" DIA	91506	6008-32CN
A1Q1	1853-0020	7	TSTR:SI PNP(SELECTED FROM 2N3702)	28480	1853-0020
A1Q2	1853-0012	2	TSTR:SI PNP	80131	2N2904A
A1Q3	1854-0039	2	TSTR:SI NPN	80131	2N3053
A1Q4	1854-0071	3	TSTR:SI NPN(SELECTED FROM 2N3704)	28480	1854-0071
A1Q5	1853-0020		TSTR:SI PNP(SELECTED FROM 2N3702)	28480	1853-0020
A1Q6	1854-0039		TSTR:SI NPN	80131	2N3053
A1Q7	1854-0071		TSTR:SI NPN(SELECTED FROM 2N3704)	28480	1854-0071
A1R1	0698-3160	2	R:FXD MET FLM 31.6K OHM 1% 1/8W	28480	0698-3160
A1R2	0698-3445	2	R:FXD MET FLM 348 OHM 1% 1/8W	28480	0698-3445
A1R3	0757-0440	4	R:FXD MET FLM 7.50K OHM 1% 1/8W	28480	0757-0440
A1R4	0811-1666	2	R:FXD WW 1.0 OHM 5% 2W	28480	0811-1666
A1R5	0598-3441	4	R:FXD MET FLM 215 OHM 1% 1/8W	28480	0698-3441
A1R6	0757-0440	4	R:FXD MET FLM 7.50K OHM 1% 1/8W	28480	0757-0440
A1R7	0757-0280	5	R:FXD MET FLM 1K OHM 1% 1/8W	28480	0757-0280
A1R8	0757-0401	3	R:FXD MET FLM 100 OHM 1% 1/8W	28480	0757-0401
A1R9	0698-5673	1	R:FXD MET FLM 3.9K OHM 1% 1/8W	28480	0698-5673
A1R10	0683-0275	2	R:FXD COMP 2.7 OHM 5% 1/4W	01121	CB 27G5
A1R11	0757-0280	2	R:FXD MET FLM 1K OHM 1% 1/8W	28480	0757-0280
A1R12	0757-0278	1	R:FXD MET FLM 1.78K OHM 1% 1/8W	28480	0757-0278
A1R13	0757-0289	1	R:FXD MET FLM 13.3K OHM 1% 1/8W	28480	0757-0289
A1R14	2100-1758	3	R:VAR WW 1K OHM 5% TYPE V 1W	28480	2100-1758
A1R15	0757-0200	1	R:FXD MET FLM 5.62K OHM 1% 1/8W	28480	0757-0200
A1R16	0811-1666		R:FXD WW 1.0 OHM 5% 2W	28480	0811-1666
A1R17	0698-3441		R:FXD MET FLM 215 OHM 1% 1/8W	28480	0698-3441
A1R18	0757-0440		R:FXD MET FLM 7.50K OHM 1% 1/8W	28480	0757-0440
A1R19	0757-0280		R:FXD MET FLM 1K OHM 1% 1/8W	28480	0757-0280
A1R20	0757-0440		R:FXD MET FLM 7.50K OHM 1% 1/8W	28480	0757-0440
A1R21	0698-0084	3	R:FXD MET FLM 2.15K OHM 1% 1/8W	28480	0698-0084
A1R22	0698-0084		R:FXD MET FLM 2.15K OHM 1% 1/8W	28480	0698-0084
A1R23	0698-0084		R:FXD MET FLM 2.15K OHM 1% 1/8W	28480	0698-0084
A1R24	0683-0275		R:FXD COMP 2.7 OHM 5% 1/4W	01121	CB 27G5
A1TP1	08444-20001	1	BOARD:BLANK PC	28480	08444-20001
A1TP2	0360-1514	12	TERMINAL PIN:SQUARE	28480	0360-1514
A1TP3	0360-1514		TERMINAL PIN:SQUARE	28480	0360-1514
A1TP4	0360-1514		TERMINAL PIN:SQUARE	28480	0360-1514
A1TP5	0360-1514		TERMINAL PIN:SQUARE	28480	0360-1514
A1TP6	0360-1514		TERMINAL PIN:SQUARE	28490	0360-1514
A1J1	1820-0223	3	INTEGRATED CIRCUIT:OPERATIONAL AMPL.	28480	1820-0223
A1J2	1820-0223		INTEGRATED CIRCUIT:OPERATIONAL AMPL.	28480	1820-0223
A2	08444-60002	1	BOARD ASSY:DRIVER	28480	08444-60002
A2C1	0190-0116		C:FXD ELECT 6.8 UF 10% 35VDCW	56289	1500685X9035B2-DYS
A2C2	0180-2205	1	C:FXD ELECT 0.33 UF 10% 35VDCW	56289	1500334X9035A2-DYS

Table 6-2. Replaceable Parts

Reference Designation	HP Part Number	Qty	Description	Mfr Code	Mfr Part Number
A2C3	0180-0228		C:FXD ELECT 22 UF 10% 15VDCW	56289	1500226X901582-DYS
A2C4	0180-1746	1	C:FXD ELECT 15 UF 10% 20VDCW	28480	0180-1746
A2C5	0180-0374	2	C:FXD TANT. 10 UF 10% 20VDCW	56289	1500106X902082-DYS
A2C6	0160-2208	1	C:FXD MICA 330 PF 5% 300VDCW	28480	0160-2208
A2C7	0180-0374		C:FXD TANT. 10 UF 10% 20VDCW	56289	1500106X902082-DYS
A2C8	0160-0300	1	C:FXD MY 0.0027 UF 10% 200VDCW	56289	292P27292-PTS
A2CR1	1901-0040		DIODE:SILICON 30MA 30WV	07263	FDG1088
A2CR2	1901-0040		DIODE:SILICON 30MA 30WV	07263	FDG1088
A2CR3	1901-0040		DIODE:SILICON 30MA 30WV	07263	FDG1088
A2Q1	1854-0221	1	TSTR:SI NPN(REPL.BY 2N4044)	28480	1854-0221
A2Q2	1853-0020		TSTR:SI PNP(SELECTED FROM 2N3702)	28480	1853-0020
A2Q3	1853-0020		TSTR:SI PNP(SELECTED FROM 2N3702)	28480	1853-0020
A2Q4	1853-0020		TSTR:SI PNP(SELECTED FROM 2N3702)	28480	1853-0020
A2Q5	1853-0020		TSTR:SI PNP(SELECTED FROM 2N3702)	28480	1853-0020
A2Q6	1854-0071		TSTR:SI NPN(SELECTED FROM 2N3704)	28480	1854-0071
A2Q7	1853-0020		TSTR:SI PNP(SELECTED FROM 2N3702)	28480	1853-0020
A2Q8	1853-0012		TSTR:SI PNP	80131	2N2904A
A2R1	0757-0346	3	R:FXD MET FLM 10 OHM 1% 1/8W	28480	0757-0346
A2R2	0698-3454	2	R:FXD MET FLM 215K OHM 1% 1/8W	28480	0698-3454
A2R3	0757-0280		R:FXD MET FLM 1K OHM 1% 1/8W	28480	0757-0280
A2R4	0757-0280		R:FXD MET FLM 1K OHM 1% 1/8W	28480	0757-0280
A2R5	0757-0438		R:FXD MET FLM 5.11K OHM 1% 1/8W	28480	0757-0438
A2R6	2100-1760	3	R:VAR WW 5K OHM 5% TYPE V 1W	28480	2100-1760
A2R7	2100-1760		R:VAR WW 5K OHM 5% TYPE V 1W	28480	2100-1760
A2R8	0698-3444	1	R:FXD MET FLM 316 OHM 1% 1/8W	28480	0698-3444
A2R9	0698-3156	1	R:FXD MET FLM 14.7K OHM 1% 1/8W	28480	0698-3156
A2R10	0757-0346		R:FXD MET FLM 10 OHM 1% 1/8W	28480	0757-0346
A2R11	0698-3154	1	R:FXD MET FLM 4.22K OHM 1% 1/8W	28480	0698-3154
A2R12	0757-0346		R:FXD MET FLM 10 OHM 1% 1/8W	28480	0757-0346
A2R13	0698-3454		R:FXD MET FLM 215K OHM 1% 1/8W	28480	0698-3454
A2R14	0757-0424	2	R:FXD MET FLM 1.10K OHM 1% 1/8W	28480	0757-0424
A2R15	0698-3437	1	R:FXD MET FLM 133 OHM 1% 1/8W	28480	0698-3437
A2R16	0757-0817	1	R:FXD MET FLM 750 OHM 1% 1/2W	28480	0757-0817
A2R17	2100-1758		R:VAR WW 1K OHM 5% TYPE V 1W	28480	2100-1758
A2R18	0698-3445		R:FXD MET FLM 348 OHM 1% 1/8W	28480	0698-3445
A2R19	0757-0401		R:FXD MET FLM 100 OHM 1% 1/8W	28480	0757-0401
A2R20	0757-0416	1	R:FXD MET FLM 511 OHM 1% 1/8W	28480	0757-0416
A2R21	0698-3450	1	R:FXD MET FLM 42.2K OHM 1% 1/8W	28480	0698-3450
A2R22	0757-0401		R:FXD MET FLM 100 OHM 1% 1/8W	28480	0757-0401
A2R23	0757-1094	1	R:FXD MET FLM 1.47K OHM 1% 1/8W	28480	0757-1094
A2R24	0757-0424		R:FXD MET FLM 1.10K OHM 1% 1/8W	28480	0757-0424
A2R25	0698-3441		R:FXD MET FLM 215 OHM 1% 1/8W	28480	0698-3441
A2R26	2100-1761	1	R:VAR CERMET 10K OHM 5% WW SIDE-ADJ 1-TRN	28480	2100-1761
A2R27	2100-1758		R:VAR WW 1K OHM 5% TYPE V 1W	28480	2100-1758
A2R28	0757-0442	4	R:FXD MET FLM 10.0K OHM 1% 1/8W	28480	0757-0442
A2R29	0757-0465		R:FXD MET FLM 100K OHM 1% 1/8W	28480	0757-0465
A2R30	0757-0288	2	R:FXD MET FLM 9.09K OHM 1% 1/8W	28480	0757-0288
A2R31	0757-0442		R:FXD MET FLM 10.0K OHM 1% 1/8W	28480	0757-0442
A2R32	0757-0438		R:FXD MET FLM 5.11K OHM 1% 1/8W	28480	0757-0438
A2R33	0698-3441		R:FXD MET FLM 215 OHM 1% 1/8W	28480	0698-3441
A2R34	0757-0442		R:FXD MET FLM 10.0K OHM 1% 1/8W	28480	0757-0442
A2R35	0698-3399	1	R:FXD MET FLM 133 OHM 1% 1/2W	28480	0698-3399
A2R36	0757-0439		R:FXD MET FLM 6.81K OHM 1% 1/8W	28480	0757-0439
A2R37	0757-0421	1	R:FXD MET FLM 825 OHM 1% 1/8W	28480	0757-0421
A2R38	0698-3438	1	R:FXD MET FLM 147 OHM 1% 1/8W	28480	0698-3438
A2R39	0757-0288		R:FXD MET FLM 9.09K OHM 1% 1/8W	28480	0757-0288
A2R40	2100-2522	1	R:VAR WW 10K OHM 10% TYPE V 1W	19701	ET50X103
A2R41	2100-1760		R:VAR WW 5K OHM 5% TYPE V 1W	28480	2100-1760
A2R42	0698-3151	1	R:FXD MET FLM 2.87K OHM 1% 1/8W	28480	0698-3151
A2T81	08444-20002	1	BOARD:BLANK PC	28480	08444-20002
A2T71	0360-1514		TERMINAL PIN:SQUARE	28480	0360-1514
A2TP2	0360-1514		TERMINAL PIN:SQUARE	28480	0360-1514
A2TP3	0360-1514		TERMINAL PIN:SQUARE	28480	0360-1514
A2TP4	0360-1514		TERMINAL PIN:SQUARE	28480	0360-1514
A2TP5	0360-1514		TERMINAL PIN:SQUARE	28480	0360-1514
A2TP6	0360-1514		TERMINAL PIN:SQUARE	28480	0360-1514
A2U1	1820-0223		INTEGRATED CIRCUIT:OPERATIONAL AMPL.	28480	1820-0223
A3	5086-7025	1	AMPLIFIER DETECTOR	28480	5086-7025
A3	5086-6025		AMPLIFIER DETECTOR (RESTORED 5086-7025)	28480	5086-6025
A4			AMPLIFIER ASSY:500 MHZ		
A4C1	0160-2357	2	C:FXD CER FEED-THRU 1000 PF +80-20%	28480	0160-2357
A4C2	0160-2357		C:FXD CER FEED-THRU 1000 PF +80-20%	28480	0160-2357
A4C3	0160-2152	1	C:FXD CER 10 PF 20% 500VDCW	28480	0160-2152
A4J1	1250-1220	2	CONNECTOR:RF 50 OHM SCREW-JN TYPE	98291	50-051-0109
A4J2	1250-1220		CONNECTOR:RF 50 OHM SCREW-ON TYPE	98291	50-051-0109

Table 6-2. Replaceable Parts

Reference Designation	HP Part Number	Qty	Description	Mfr Code	Mfr Part Number
A4MP1	08444-00006	1	COVER:500 MHZ AMPLIFIER	28480	08444-00006
A4MP2	08444-20011	1	HOUSING:500 MHZ AMPLIFIER	28480	08444-20011
A4A1	08444-60005	1	BOARD ASSY:500 MHZ AMPLIFIER	28480	08444-60005
A4A1C1	0160-2266	11	C:FXD CER 24 PF 5% 500VDCW	72982	301-000-COG0-240J
A4A1C2	0160-3456		C:FXD CER 1000 PF 10% 250 VDCW	28480	0160-3456
A4A1C3	0160-2266		C:FXD CER 24 PF 5% 500VDCW	72982	301-000-COG0-240J
A4A1C4	0160-2266		C:FXD CER 24 PF 5% 500VDCW	72982	301-000-COG0-240J
A4A1C5	0160-2266		C:FXD CER 24 PF 5% 500VDCW	72982	301-000-COG0-240J
A4A1C6	0160-2266		C:FXD CER 24 PF 5% 500VDCW	72982	301-000-COG0-240J
A4A1C7	0160-2266		C:FXD CER 24 PF 5% 500VDCW	72982	301-000-COG0-240J
A4A1C8	0160-2266		C:FXD CER 24 PF 5% 500VDCW	72982	301-000-COG0-240J
A4A1C9	0160-2266		C:FXD CER 24 PF 5% 500VDCW	72982	301-000-COG0-240J
A4A1C10	0160-2266		C:FXD CER 24 PF 5% 500VDCW	72982	301-000-COG0-240J
A4A1C11	0160-2266		C:FXD CER 24 PF 5% 500VDCW	72982	301-000-COG0-240J
A4A1CR1	1901-0639	2	DIODE:PIN 1MHZ TO 1GHZ	28480	1901-0639
A4A1CR2	1901-0639		DIODE:PIN 1MHZ TO 1GHZ	28480	1901-0639
A4A1L1	9100-2252	4	COIL/CHOKO 0.27 UH 10%	28480	9100-2252
A4A1L2	9100-2252		COIL/CHOKO 0.27 UH 10%	28480	9100-2252
A4A1L3	9100-2252		COIL/CHOKO 0.27 UH 10%	28480	9100-2252
A4A1L4	9100-2252		COIL/CHOKO 0.27 UH 10%	28480	9100-2252
A4A1Q1	1854-0345	3	TSTR:SI NPN	80131	2N5179
A4A1Q2	1854-0345		TSTR:SI NPN	80131	2N5179
A4A1Q3	1854-0345		TSTR:SI NPN	80131	2N5179
A4A1R1	0698-7197	1	R:FXD FLM 23.7 OHM 2% 1/8W	28480	0698-7197
A4A1R2	0698-7236	9	R:FXD FLM 1K OHM 2% 1/8W	28480	0698-7236
A4A1R3	0698-7236		R:FXD FLM 1K OHM 2% 1/8W	28480	0698-7236
A4A1R4	0698-7236		R:FXD FLM 1K OHM 2% 1/8W	28480	0698-7236
A4A1R5	0698-7236		R:FXD FLM 1K OHM 2% 1/8W	28480	0698-7236
A4A1R6	0698-7236		R:FXD FLM 1K OHM 2% 1/8W	28480	0698-7236
A4A1R7	0698-7236		R:FXD FLM 1K OHM 2% 1/8W	28480	0698-7236
A4A1R8	0698-7236		R:FXD FLM 1K OHM 2% 1/8W	28480	0698-7236
A4A1R9	0698-7236		R:FXD FLM 1K OHM 2% 1/8W	28480	0698-7236
A4A1R10	0698-7236		R:FXD FLM 1K OHM 2% 1/8W	28480	0698-7236
A4A1R11	0698-7236		R:FXD FLM 1K OHM 2% 1/8W	28480	0698-7236
A4A1R11	0698-7236		R:FXD FLM 121 OHM 2% 1/8W	28480	0698-7236
A4A1T81	08444-20005	1	BOARD:BLANK PC	28480	08444-20005
A5	08444-60011	1	CONVERTER ASSY:FIRST	28480	08444-60011
A5J1	1250-0829	5	CONNECTOR:RF 50-OHM SCREW ON TYPE	98291	50-045-4610
A5J2	1250-0829		CONNECTOR:RF 50-OHM SCREW ON TYPE	98291	50-045-4610
A5J3	1250-0829		CONNECTOR:RF 50-OHM SCREW ON TYPE	98291	50-045-4610
A5MP1	08555-00033	2	INPUT-OUTPUT LOOP	28480	08555-00033
A5MP2	0516-0005	2	SCREW:PAN HD SLOT DR 0-80 X 0.188" LG	00000	08D
A5MP3	2200-0111	14	SCREW:PAN HD POZI DR 4-40 X 0.500" LG	00000	08D
A5MP4	08555-20035	1	CAVITY BLOCK:SECOND CONVERTER	28480	08555-20035
A5MP5	08444-20012	1	COVER:FIRST CONVERTER	28480	08444-20012
A5MP6	2200-0172	2	SCREW:FLAT HD POZI DR. 4-40 X 0.875" LG	00000	08D
A5MP7	08444-20007	1	CENTER-POST	28480	08444-20007
A5MP8	2740-0001	3	NUT:HEX 10-32 THREAD	00000	08D
A5MP9	3030-0151	4	SCREW:SOCKET CAP 4-40 THREAD	28480	3030-0151
A5MP10	3030-0397	3	SCREW:SET 10-32 UNF-2A THREAD	00000	08D
A5A1	08444-60012	1	MIXER ASSY:FIRST	28480	08444-60012
A5A1C1	0160-2327	1	C:FXD CER 1000 PF 20% 100VDCW	96733	B1048X102M
A5A1C2	0160-3861	1	C:FXD 18 PF + -5% 250 VDCW	72982	2930-000-3903
A5A1C3	0160-3860	1	C:FXD MICA 39 PF 5% 250VDCW	72982	2930-000-390J
A5A1CR1	1901-0633	1	DIODE:HOT CARRIER	28480	1901-0633
A5A1J1	1250-0829		CONNECTOR:RF 50-OHM SCREW ON TYPE	98291	50-045-4610
A5A1L1	9100-2254	1	COIL/CHOKO .39 UH 10%	28480	9100-2254
A5A1MP1	0520-0128	4	SCREW:PAN HD POZI DR 2-56 X 0.250" LG	00000	08D
A5A1MP2	1251-1556	1	CONNECTOR:SINGLE CONTACT	00779	2-330808-8
A5A1MP3	08555-00031	1	LID:RESONATOR HOUSING	28480	08555-00031
A5A1MP4	08555-20036	1	RESONATOR HOUSING	28480	08555-20036
A5A1K1	0698-7229	1	R:FXD FLM 511 OHM 2% 1/8W	28480	0698-7229
A6	08444-60004	1	MIXER ASSY:OUTPUT	28480	08444-60004
A7	08444-60019	1	NOT RECOMMENDED FOR FIELD REPAIR OSCILLATOR ASSY:1.55 GHZ NOT RECOMMENDED FOR FIELD REPAIR	28480	08444-60019
A7C1	0160-3827*	1	C:FXD P9RC 1 PF 500VDCW	84411	653UN22554W2
A7C2	0160-0345	2	C:FXD CEP FEED-THRU 1000 PF 500VDCW	01121	FB28-102W
A7C3	0160-0345		C:FXD CER FEED-THRU 1000 PF 500VDCW	01121	FR28-102W
A7C4	0160-2437	1	C:FXD CER 5000 PF +80 -20%		
A7C4.1	0122-0245	2	C:VOLTAGE VAR. 6.8 PF 10% 60VDCW	04713	1N5139
A7J1	1250-0929		CONNECTOR:KF 50-OHM SCREW ON TYPE	98291	50-045-4610
A7L1	1460-0103	1	SPRING:COMPRESSION 0.120" OD	00000	08D
A7Q1	1854-0292	1	TSTR:SI NPN	28480	1854-0292
A7R1	0698-7230	1	R:FXD FLM 562 OHM 2% 1/8W	28480	0698-7230
A7R2	0757-0418	1	R:FXD MET FLM 619 OHM 1% 1/8W	28480	0757-0418
A8	0960-0504	1	POWER LINE MODULE, NON-FILTERED	28480	0960-0504

Table 6-2. Replaceable Parts

Reference Designation	HP Part Number	Qty	Description	Mfr Code	Mfr Part Number
CHASSIS PARTS					
AT1	0960-0084	2	ISOLATOR:2-PORT 2-4 GHZ	28480	0960-0084
AT2	0960-0084		ISOLATOR:2-PORT 2-4 GHZ	28480	0960-0084
AT3	0960-0168	1	ISOLATOR:2-PORT 1.54-1.56 GHZ	28480	0960-0168
AT4	11593A	1	TERMINATION:50 OHM	28480	11593A
C1	0180-2181	2	C:FXD ELECT 1300 UF +75-10% 50VDCW	56289	36D132G050AA2A-DQ8
C1	1210-0013	2	BRACKET:MOUNTING FOR 1-3/8 OD	56289	4586-87A
C2	0190-2181		C:FXD ELECT 1300 UF +75-10% 50VDCW	56289	36D132G050AA2A-DQ8
C2	1210-0013		BRACKET:MOUNTING FOR 1-3/8 OD	56289	4586-87A
C3	0160-0155	1	C:FXD MY 0.0033 UF 10% 200 VDCW	28480	0160-0155
CP1	1250-0838	1	CONNECTOR:PF ADAPTER TEE	98291	50-085-0000
F1	2110-0202	1	FUSE:0.50A 250V SLOW-BLOW (FOR 115V OPERATION)	75915	313.5005
F1	2110-0201	1	FUSE:0.25A 250V SLO-BLO (FOR 230V OPERATION)	71400	MDL-1/4
F1					
FL1	0960-0167	1	FILTER:TUNNULAR BANDPASS 2.0-3.4 GHZ	28480	0960-0167
J1MP1	1250-0914	1	BODY:RF CONNECTOR	02660	131-150
J1MP2	1250-0915	1	CONTACT:RF CONNECTOR	02660	131-149
J1MP3	5040-0306	1	INSULATOR	28480	5040-0306
J1MP4	08555-20093	1	CONTACT:JACK	28480	08555-20093
J1MP5	08555-20094	1	BODY:BULKHEAD	28480	08555-20094
J1MP6	2190-0444	1	WASHER:LOCK	00000	080
J1MP7	2050-0132	1	NUT:HEX 7/16-28	00000	080
J1MP8	08761-2027	1	INSULATOR	28480	08761-2027
J4	1250-0118	1	CONNECTOR:RNC	24931	28JR 128-1
J6	1251-2996	1	CONNECTOR:AC POWER	28480	1251-2996
Q1	1854-0063	2	TSTR:SI NPN	80131	2N3055
Q1	1200-0043	2	INSULATOR:TSTR MOUNTING(TO-3)	71785	293011
Q2	1854-0063		TSTR:SI NPN	80131	2N3055
Q2	1200-0043		INSULATOR:TSTR MOUNTING(TO-3)	71785	293011
R1	2100-2730	1	R:VAR CEPMET 5000 OHM 20% LIN 2W	28480	2100-2730
R1	0370-0133	3	KNOB:SKIRTED FOR 0.250" DIA SHAFT	28480	0370-0133
R2	2100-2886	1	R:VAP WW 5K OHM 5% LIN 2W	28480	2100-2886
R2	0370-0133		KNOB:SKIRTED FOR 0.250" DIA SHAFT	28480	0370-0133
R3	2100-2728	1	R:VAR CERMET 1K OHM 20% LIN 2W	28480	2100-2728
R3	0370-0133		KNOB:SKIRTED FOR 0.250" DIA SHAFT	28480	0370-0133
R4	0696-3449	1	R:FXD MET FLM 28.7K OHM 1% 1/8W	28480	0696-3449
R5	0757-0438	1	R:FXD MET FLM 5.11 OHM 1% 1/8W	28480	0757-0438
S1	3101-1957	1	SWITCH:PUSHBUTTON DPST ILLUMINATED	04757	676-121-A1H
S10S1	2140-0244	1	LAMP:GLOW MINIATURE 95V	87034	A1H
W1	08444-20018	1	CABLE ASSY:FIRST LO INPUT	28480	08444-20018
W2	08444-20024	2	CABLE ASSY:FILTER	28480	08444-20024
W3	08444-20024		CABLE ASSY:FILTER	28480	08444-20024
W4	08444-20020	1	CABLE ASSY:MIXER ISOLATOR	28480	08444-20020
W5	08444-60015	1	CABLE ASSY:THIRD LO INPUT	28480	08444-60015
W6	08444-60014	1	CABLE ASSY:FIRST CONVERTER	28480	08444-60014
W7	08444-20017	1	CABLE ASSY:OSCILLATOR	28480	08444-20017
W8	08444-20026	1	CABLE ASSY:FIRST ISOLATOR	28480	08444-20026
W9	08444-20027	1	CABLE ASSY:FIRST C OUTPUT	28480	08444-20027
W10	08444-20021	1	CABLE ASSY:MIXER-CIRCUIT	28480	08444-20021
W11	08444-20019	1	CABLE ASSY:RF OUTPUT(AUXILIARY)	28480	08444-20019
W12	08444-20023	1	CABLE ASSY:RF OUTPUT	28480	08444-20023
W13	08444-60016	1	CABLE ASSY:THIRD LO INPUT	28480	08444-60016
W14	08444-60018	3	CABLE ASSY:RF INTERCONNECT	28480	08444-60018
W15	08444-60018		CABLE ASSY:RF INTERCONNECT	28480	08444-60018
W15	08444-60018		CABLE ASSY:RF INTERCONNECT	28480	08444-60018
W17	08444-60017	1	CABLE ASSY:INTERCONNECTING	28480	08444-60017
W18	8120-1348	1	CABLE:LINE POWER	28480	8120-1348
XA1	1251-0159	1	CONNECTOR:PC EDGE 2 X 15 CONTACT	71785	251-15-30-261
XA2	1251-0135	1	CONNECTOR:PC EDGE 15 CONTACT	95354	91-6915-1500-00
XF1	1400-0011	2	CLIP:FUSE	75915	#125002
XF1	1400-0011		CLIP:FUSE	75915	#125002
X01	1200-0041	2	SOCKET:TRANSISTOR	71785	133-32-10-013
X02	1200-0041		SOCKET:TRANSISTOR	71785	133-32-10-013
X02	08444-60013	1	WIRING HARNESS	28480	08444-60013
T1	9100-3308	1	TRANSFORMER: POWER 115-250 VAC 48-440 HZ	28480	9100-3308

Table 6-2. Replaceable Parts

Reference Designation	HP Part Number	Qty	Description	Mfr Code	Mfr Part Number
MECHANICAL PARTS					
MP1	1490-0030	1	STAND:TILT	28480	1490-0030
MP2	5000-0050	2	TRIM:SIDES	28480	5000-0050
MP3	5000-8593	2	COVER:SIDE 3 X 16 (OLIVE GRAY)	28480	5000-8593
MP4	5020-6850	1	TRIM:PANEL (MINT GRAY)	28480	5020-6850
MP5	5020-6851	1	TRIM:PANEL (MINT GRAY)	28480	5020-6851
MP6	5040-0170	4	GUIDE:PLUG-IN PC BOARD	28480	5040-0170
MP7	5060-0730	2	FRAME ASSY:3 X 16	28480	5060-0730
MP8	5060-8589	1	COVER ASSY:TOP 16L (OLIVE GRAY)	28480	5060-8589
MP9	5060-8713	1	COVER:BOTTOM	28480	5060-8713
MP10	5060-0767	5	FOOT ASSY:FM	28480	5060-0767
MP11	5060-8739	1	KIT:RACK MOUNT 3H (MINT GRAY)	28480	5060-8739
MP12	08443-40005	1	TRIM STRIP (MINT GRAY)	28480	08443-40005
MP13	08444-00013	1	PANEL:FRONT (OLIVE BLACK/MINT GRAY)	28480	08444-00013
MP14	08444-00015	1	PLATE:CONNECTOR (OLIVE BLACK)	28480	08444-00015
MP15	08444-00023	1	DECK:MAIN	28480	08444-00023
MP16	08444-00022	1	PANEL:REAR	28480	08444-00022
MP17	08444-00007	1	GUARD	28480	08444-00007
MP18	08443-00021	4	BRACKET:FRONT PANEL SUPPORT	28480	08443-00021

Table 6-3. Code List of Manufacturers

MFR NO.	MANUFACTURER NAME	ADDRESS	ZIP CODE
00000	U.S.A. COMMON	ANY SUPPLIER OF U.S.A.	
00779	AMP INC. (AIRCRAFT MARINE PROD.)	HARRISBURG, PA.	17101
01121	ALLEN BRADLEY CO.	MILWAUKEE, WIS.	53204
02660	AMPHENOL CORP.	BROADVIEW, ILL.	60153
02735	RCA SOLID STATE & RECEIVING TUBE DIV.	SOMERVILLE, N.J.	08876
04713	MOTOROLA SEMICONDUCTOR PROD. INC.	PHOENIX, ARIZ.	85008
07263	FAIRCHILD CAMERA & INST. CORP. SEMICONDUCTOR DIV.	MOUNTAIN VIEW, CALIF.	94040
12954	DICKSON ELECTRONIC CORP.	SCOTTSDALE, ARIZ.	85252
24931	SPECIALTY CONNECTOR CO. INC.	INDIANAPOLIS, IND.	46227
28480	HEWLETT-PACKARD COMPANY	PALO ALTO, CALIF.	94304
56289	SPRAGUE ELECTRIC CO.	N. ADAMS, MASS.	01247
71400	BUSSMANN MFG. DIV. MC GRAW-EDISON CO.	ST. LOUIS, MO.	63017
71785	CINCH MFG. CO. DIV TRW INC.	ELK GROVE VILLAGE, ILL.	
72982	ERIE TECHNOLOGICAL PROD. INC.	ERIE, PA.	16512
75915	LITTELFUSE INC.	DES PLAINES, ILL.	60016
80131	ELECTRONIC INDUSTRIES ASSOCIATION	WASHINGTON D.C.	20006
87034	MARCOAK INDUSTRIES	ANAHEIM, CALIF.	92803
91506	AUGAT INC.	ATTLEBORO, MASS.	02703
95354	METHODE MFG. CO.	ROLLING MEADOWS, ILL.	60008
96733	SAN FERNANDO ELECT. MFG. CO.	SAN FERNANDO, CALIF.	91341
98291	SEAELECTRO CORP.	MAMARONECK, N.Y.	10544

SECTION VII MANUAL BACKDATING CHANGES

7-1. INTRODUCTION

7-2. This manual has been written for and applies directly to instruments with serial numbers prefixed as indicated on the title page. Earlier versions of the instrument (serial number prefixes lower than the one indicated on the title page) may be slightly different in design or appearance. The purpose of this section of the manual is to document these differences. With the information provided in this section, this manual can be corrected so that it applies to any earlier version or configuration of the instrument. Later versions of the instrument (serial number prefixes higher than the one indicated on the title page) are documented in a yellow Manual Changes Supplement.

7-3. To adapt this manual to your instrument, refer to Table 7-1 and make all manual changes listed opposite your instrument serial number prefix. Perform all changes in the sequence indicated.

NOTE

The information provided here is intended to document older instruments. Do not confuse this information with that contained in the yellow Manual Changes Supplement which is intended to document newer instruments.

Table 7-1. Manual Changes by Serial Number Prefix

Serial Prefix	Make Manual Changes
1744A	A
1630A	A,B
1601A	B,C
1323A	B,D
1215A	B,D,E
1208A	B,D,E,F
1147A	B,D,E,F,G
1139A	B,D,E,F,G,H
1033A	B,D,E,F,G,H,I

7-4. MANUAL CHANGE INSTRUCTIONS

7-5. Change A - For Serial Numbers Prefixed 1744A and Below

Page 6-6, Table 6-2:

Change A8 HP Part Number and Mfr Part Number to 0960-0444.

Page 8-19, Figure 8-17, Service Sheet 5:

Replace ON/OFF Switch S1 and Power Line Module A8 portion of schematic with Figure 7-1.

Replace LINE ON/OFF AND POWER LINE MODULE wiring diagram with Figure 7-2.

7-6. Change B - For Serial Numbers Prefixed 1630A and Below

Page 6-4, Table 6-2:

Change A1R9 entry to read:

A1R9, 0757-0438, RESISTOR - FXD MET FLM 5.11K OHM 1% .125W, 28480, 0757-0438.

Page 8-19, Figure 8-17, Service Sheet 5:

In top right corner of schematic, change value of R9 to 5110.

7-7. Change C - For Serial Numbers Prefixed 1601A and Below

Page 6-6, Table 6-2:

Change A8 HP Part Number and Mfr Part Number to 0960-0444.

Page 6-7, Table 6-2:

Change S1 entry to read:

S1, 3101-1395, 1, SWITCH: PUSHBUTTON DPDT ILLUMINATED, 76854, 53-67280-121/A1H.

Page 8-19, Figure 8-17, Service Sheet 5:

Replace LINE ON/OFF SWITCH AND POWER LINE MODULE WIRING diagram with Figure 7-3.

Replace ON/OFF Switch S1 and Power Line Module A8 portion of schematic with Figure 7-1.

7-8. Change D - For Serial Numbers Prefixed 1323A and Below

Page 6-6, Table 6-2:

Change A8 HP Part Number and Mfr Part Number to 5060-1189.

Page 6-7, Table 6-2:

Change S1 entry to read:

S1, 3101-1248, 1, SWITCH: PUSHBUTTON SPDT ILLUMINATED, 87034, 53-55480-121/A1H.

Page 8-19, Figure 8-17, Service Sheet 5:

Replace ON/OFF Switch S1 and Power Line Module A8 portion of schematic with Figure 7-4.

7-9. Change E - For Serial Numbers Prefixed 1215A and Below

Page 1-3, Table 1-1:

Change "Nonharmonic (Spurious) Signals" under Spectral Purity to >40 dB below output level.

Page 4-13, Paragraph 4-20:

Change "Nonharmonic (Spurious) Signals" in Specification to read:

>40 dB below output level.

Page 4-15, Paragraph 4-20, Step 12:

Change spurious to ≤ -40 dBm.

Page 4-16, Table 4-1:

Change -35 to -40 for paragraph 4-20, Spurious Signal Level.

7-10. Change F - For Serial Numbers Prefixed 1208A and Below

Page 1-3, Table 1-1, change Spectral Purity: Harmonic Distortion specification to read:
Harmonic Distortion: 25 dB below output level.

Page 4-13, Paragraph 4-20, Harmonic Distortion, change SPECIFICATION to read:
Harmonic Distortion: 25 dB below output level. Nonharmonic (spurious) signals: >40 dB below output level.

Page 4-15, Paragraph 4-20, change to read:
12. Note and record maximum amplitude level of harmonic and spurious signals.

Harmonics \leq -25 dBm _____

Spurious \leq -40 dBm _____

7-11. Change G - For Serial Numbers Prefixed 1147A and Below

Pages 5-4 and 5-5, Paragraph 5-9:
Replace Paragraph 5-9 with Paragraph 5-9 from this manual section.

Page 6-5, Table 6-2:

Change A2R29 and A2R36 entries to read:

A2R29, 0698-0465, RESISTOR-FXD MET FLM 31.6 OHM 1% .125W, 28480, 0698-0465.

A2R36, 0757-0442, RESISTOR-FXD MET FLM 10K OHM 1% .125W, 28480, 0757-0442.

Page 6-6, Table 6-2:

Change A4A1C2, A7, A7C1, and A7R1 entries to read:

A4A1C2, 0160-2266, CAPACITOR-FXD CER 24PF 5% 500 WVDC, 72982, 301-000-C0G0-240J.

A7, 08444-60003, OSCILLATOR ASSY: 1.55 GHz, 28480, 08444-60003.

A7C1, 0160-3549, CAPACITOR-FXD PORC 0.5 PF 500 WVDC, 28480, 0160-3549.

A7R1, 0698-7205, RESISTOR-FXD MET FLM 51.1 OHM 2% .125W, 28480, 0698-7205.

Delete A7C4 entry.

Page 6-7, Table 6-2:

Delete C3 and R5 entries.

Page 8-15, Figure 8-12, Service Sheet 3:

Replace Figure 8-12 with Figure 7-5.

Page 8-21, Figure 8-19:

Replace Figure 8-19 (1 of 2) with Figure 7-6.

Make the following changes to Figure 8-19 (2 of 2):

Item 3, A7C1, C:FXD PORC 0.5 PF 500VDC, 0160-3549, 1.

Item 4, A7R1, R:FXD MET FLM 51.1 OHM 2% .125W, 0698-7205, 1.

Change Item 21 quantity to 1.

Change Item 27 quantity to 1.

Delete Item 30.

7-12. Change H - For Serial Numbers Prefixed 1139A and Below

NOTE

The following change information refers to cabinet parts which have undergone a color change. Although the part numbers for the old color parts are listed below, it is unlikely that these parts are available at this time. The new color parts currently listed in Table 6-2 are direct replacements, the only difference being the color.

Page 6-8, Table 6-2:

Change the following entries as indicated:

- MP3, 5000-0730, 2, COVER-SIDE 3X16 (BLUE GRAY), 28480, 5000-0730.
- MP4, 5020-0900, 1, TRIM-PANEL (LIGHT GRAY), 28480, 5020-0900.
- MP5, 5020-0901, 1, TRIM-PANEL (LIGHT GRAY), 28480, 5020-0901.
- MP8, 5060-0740, 1, COVER-TOP 16L (BLUE GRAY), 28480, 5060-0740.
- MP9, 5060-0752, 1, COVER-BOTTOM 16L (BLUE GRAY), 28480, 5060-0752.
- MP11, 5060-0774, 1, RACK MOUNT KIT 3H (LIGHT GRAY), 28480, 5060-0774.
- MP12, 08443-40002, 1, TRIM STRIP (LIGHT GRAY), 28480, 08443-40002.
- MP13, 08444-00001, 1, PANEL-FRONT (BLACK/LIGHT GRAY), 28480, 08444-00001.
- MP14, 08444-00002, 1, PLATE-CONNECTOR, 28480, 08444-00002.

7-13. Change I - For Serial Numbers Prefixed 1033A

Page 6-5, Table 6-2:

Delete A2C8 entry.

Page 8-15, Figure 8-12, Service Sheet 3:

Delete A2C8 (2700 pF) from schematic.

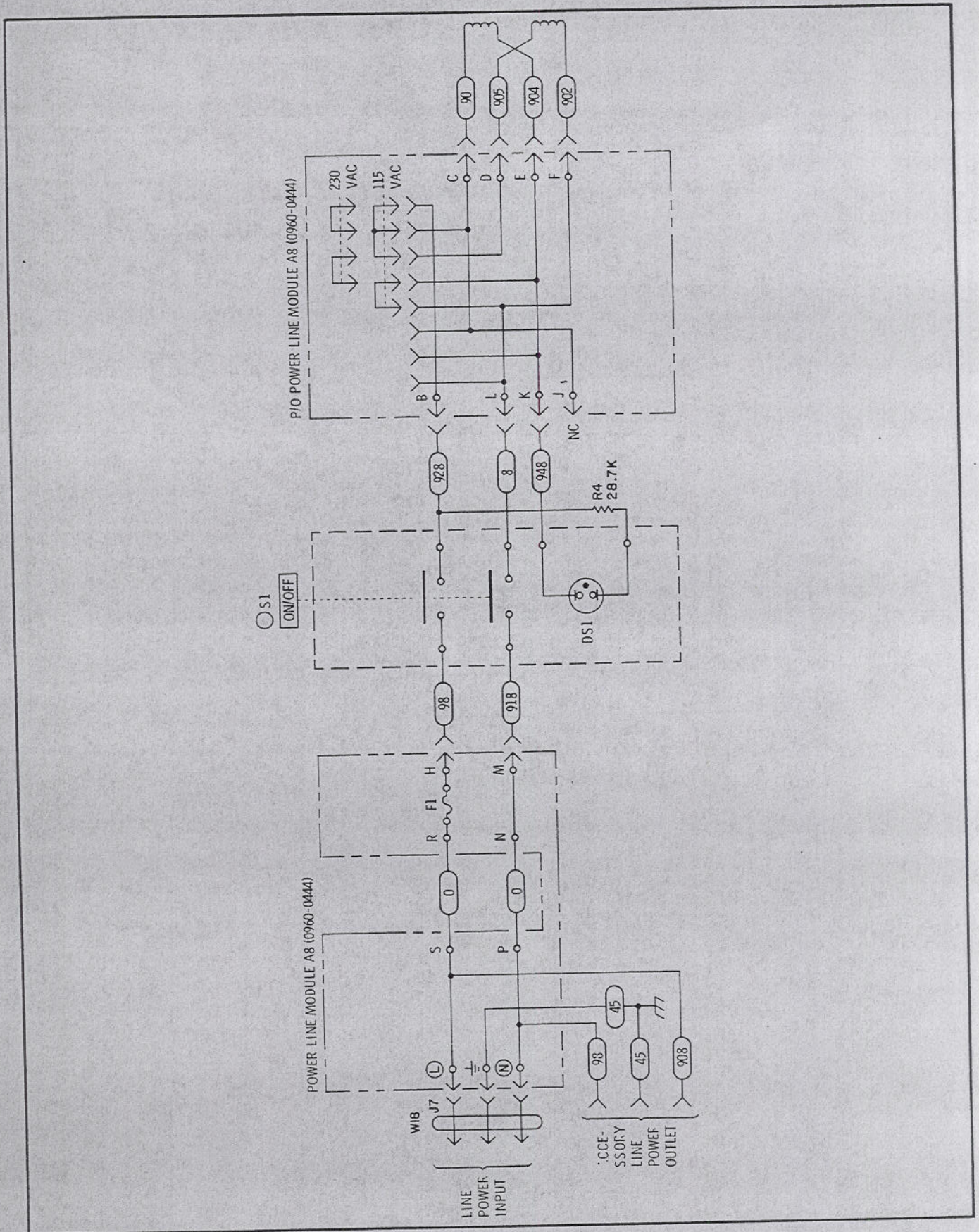

Figure 7-1. P/O Figure 8-17. Power Supply and Input Circuit, Schematic (CHANGES A and C)

LINE ON/OFF SWITCH AND POWER LINE MODULE WIRING

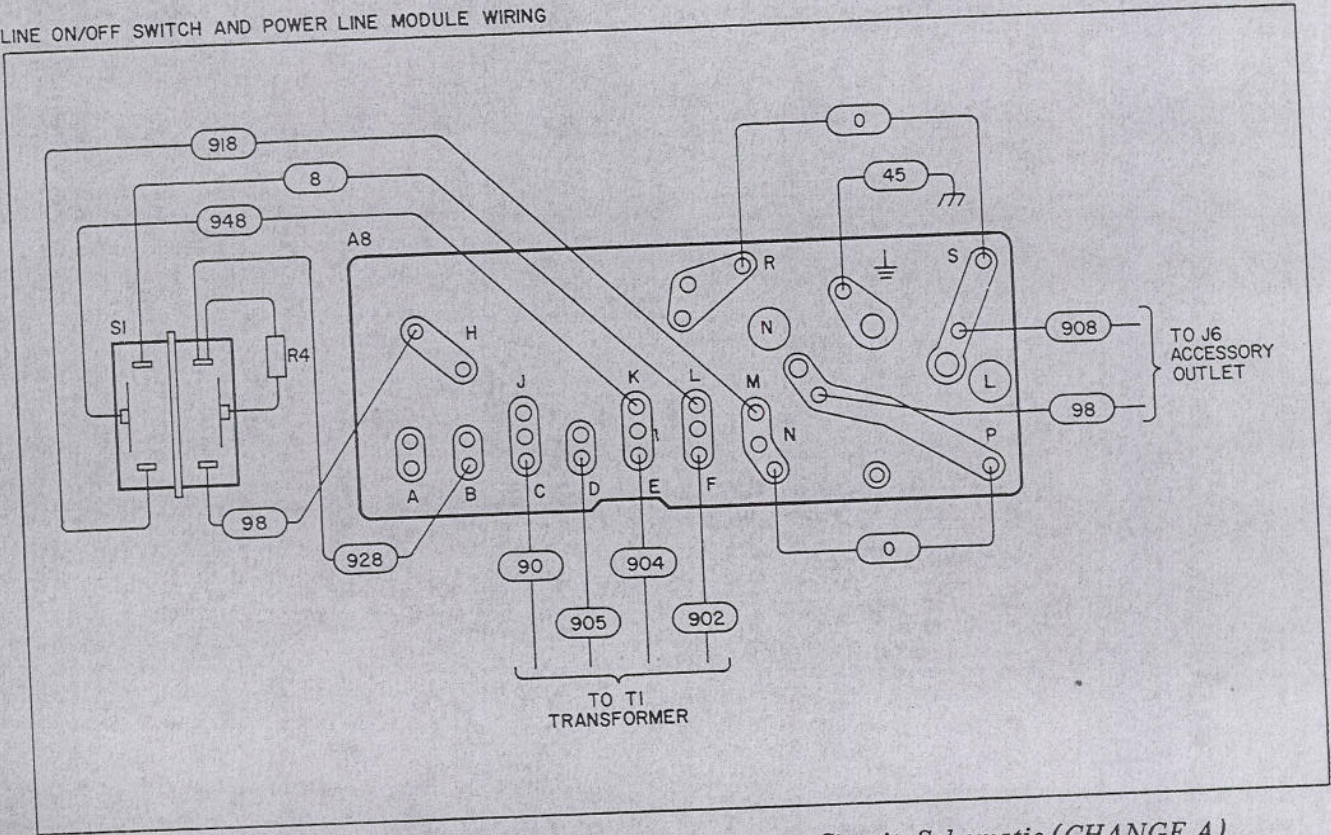

Figure 7-2. P/O Figure 8-17, Power Supply and Input Circuit, Schematic (CHANGE A)

LINE ON/OFF SWITCH AND POWER LINE MODULE WIRING

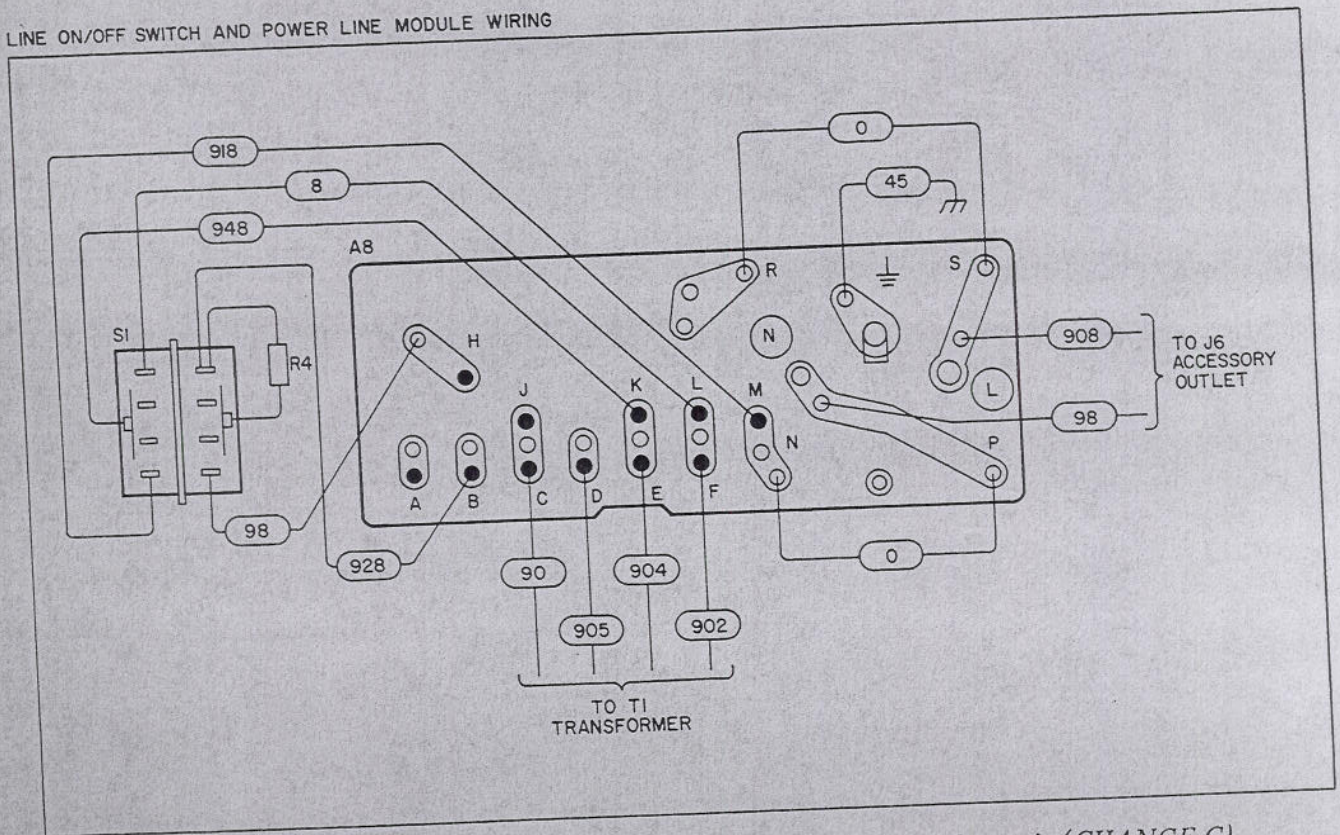

Figure 7-3. P/O Figure 8-17, Power Supply and Input Circuit, Schematic (CHANGE C)

LINE ON/OFF SWITCH AND POWER LINE MODULE WIRING

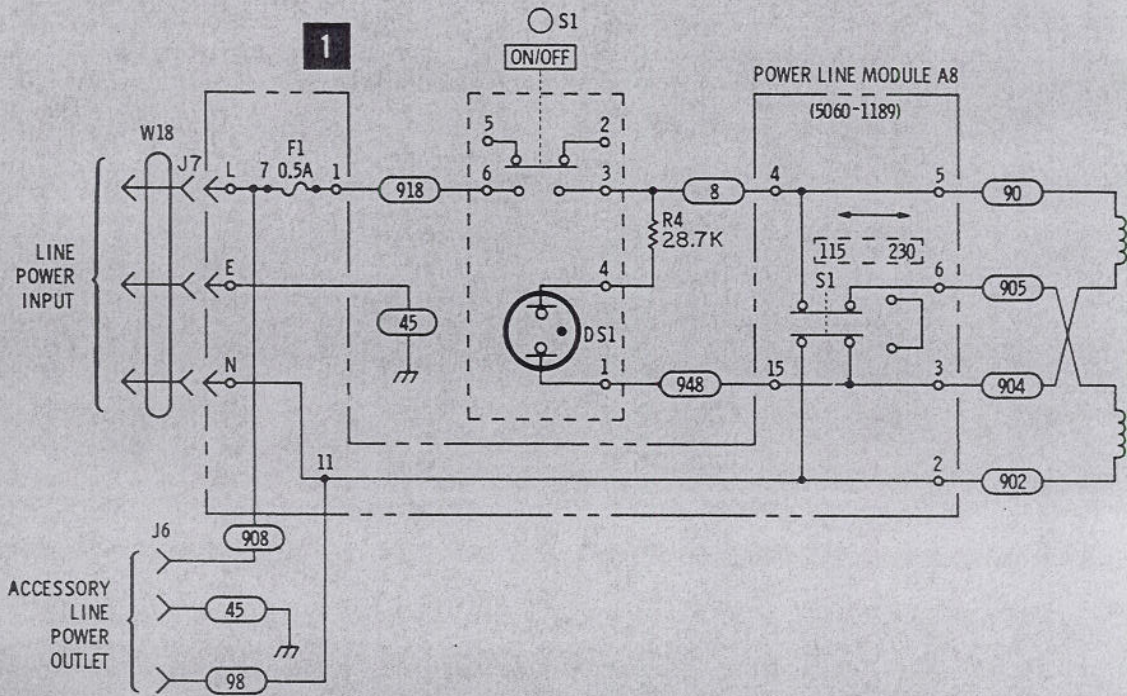
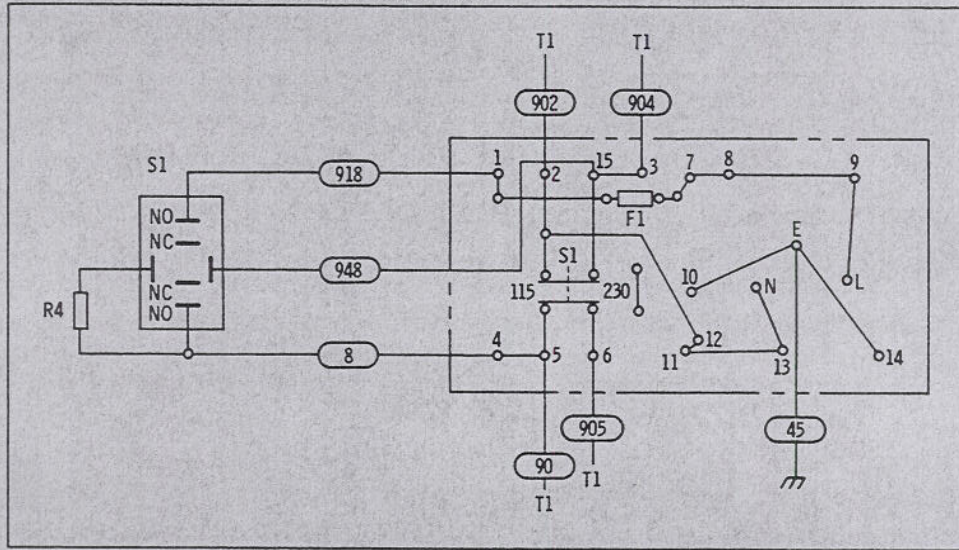
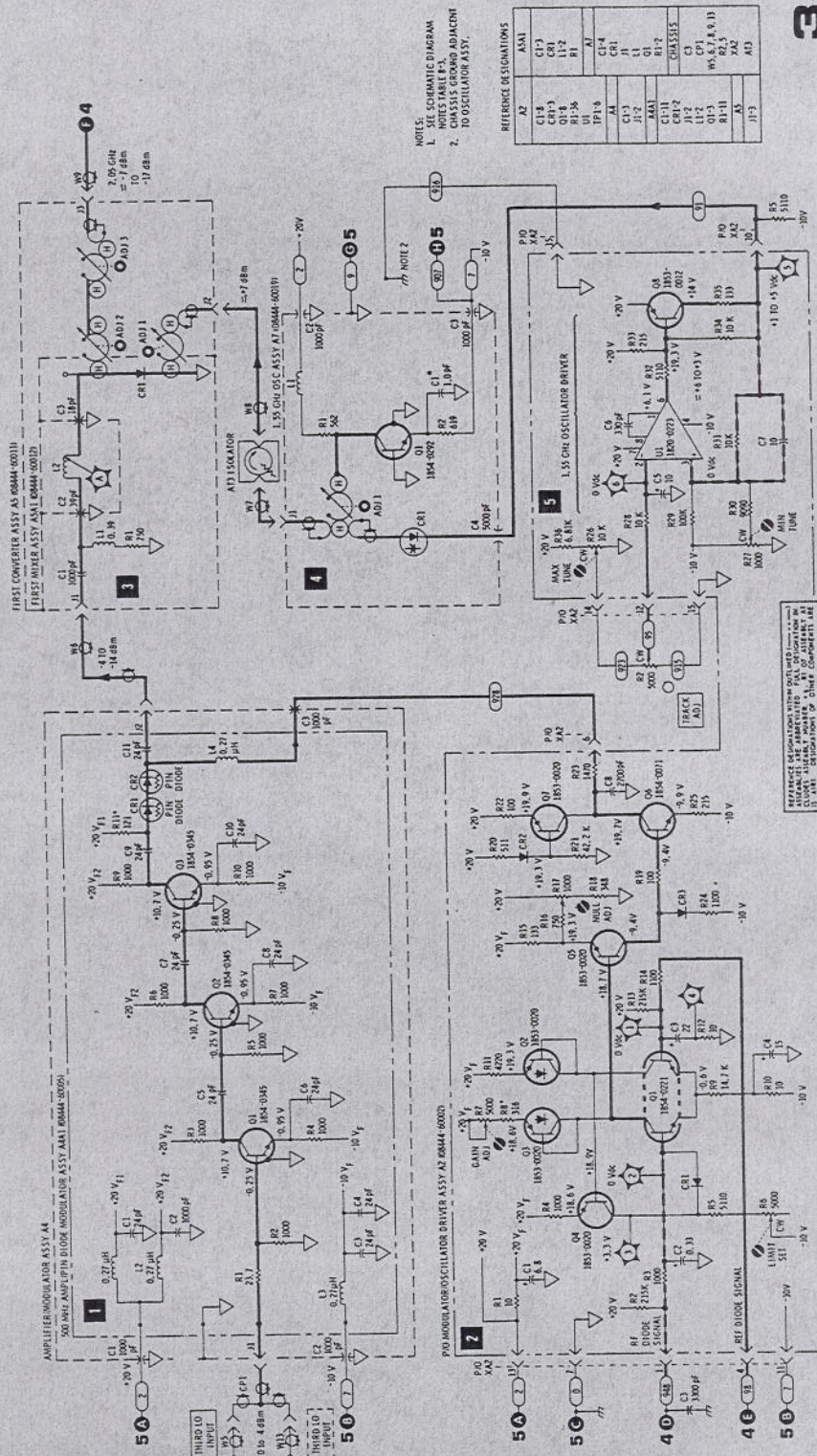

Figure 7-4. P/O Figure 8-17. Power Supply and Input Circuit, Schematic (CHANGE D)



3

Figure 7-5. First Converter Circuits, Schematic (CHANGE G)

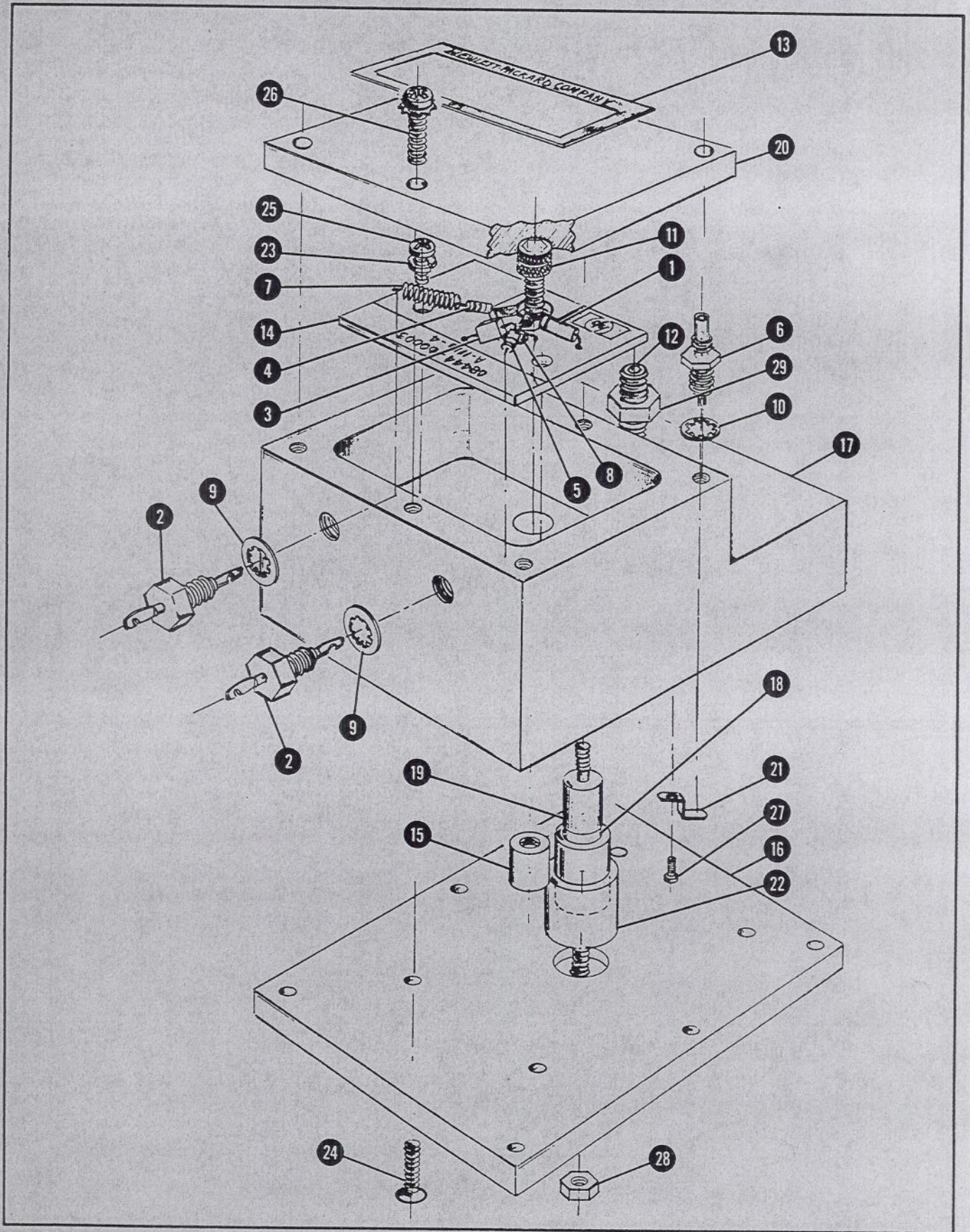

Figure 7-6. A7 1.55 GHz Oscillator Assembly, Illustrated Parts Breakdown, (1 of 2) (CHANGE G)

ADJUSTMENTS

5-9. 1.55 GHz Oscillator Power Level, Frequency Check and Adjustment

REFERENCE: Service Sheet 3.

DESCRIPTION: The 1.55 GHz local oscillator is checked for power output level and frequency tuning range. Oscillator frequency is determined primarily by the LO cavity, with tuning range and power output level determined by the drive voltage from the oscillator driver. The oscillator is checked first for power level and then for frequency and tuning range. After any adjustments are made the previous checks are repeated.

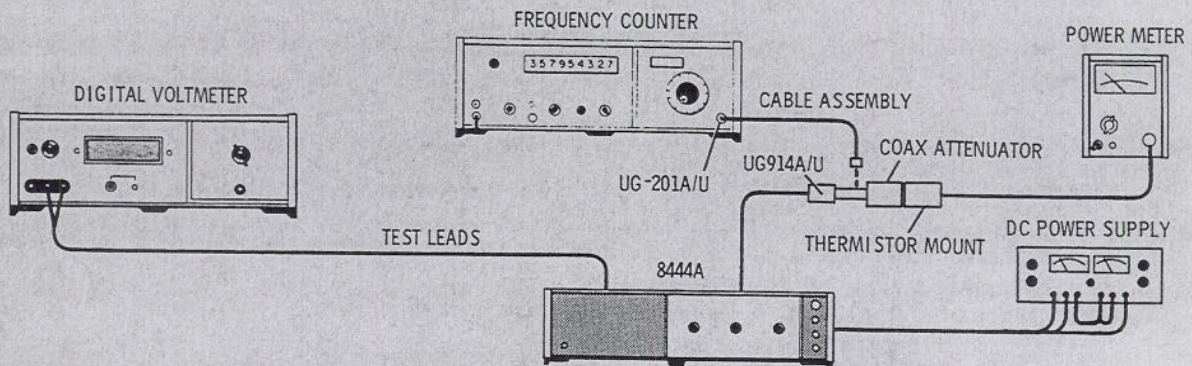

Figure 5-2. 1.55 GHz LO Power Level and Frequency Check and Adjustment Test Setup

EQUIPMENT:

Power Meter with HP 8478B Thermistor Mount	HP 432A
Frequency Counter with HP 5254C Plug-in.	HP 5245L
Digital Voltmeter with HP 3443A Plug-in	HP 3440A
Power Supply	HP 6205B
Test Leads (dual banana plug to probe and alligator clip)	HP 11003A
Cable Assy, SMA male to BNC male	HP 08555-60076
Cable Assy, male BNC connectors	HP 10503A
Coaxial Attenuator, Option 010	HP 8491A
Adapter BNC barrel (HP Part Number 1250-0080)	UG 914A/U
Adapter (BNC to Type N)	UG 201A/U

PROCEDURE:

1. Perform Power Supply Check and Adjustment, paragraph 5-8.
2. Apply power to Tracking Generator and allow 1 hour for instrument to warm up and stabilize.
3. Disconnect Cable W8 at Isolator AT3 J2 (see Figures 8-4 and 8-12).
4. With test setup as indicated in Figure 5-2, connect Power Meter to Isolator AT3 J2 via 08555-60076 cable, 10 dB attenuator and UG 914A/U adapter.
5. Rotate TRACK ADJ control throughout its tuning range while noting power level indicated on Power Meter.

ADJUSTMENTS

5-9. 1.55 GHz Oscillator Power Level, Frequency Check and Adjustment (cont'd)

6. Record minimum power output. >+5 dBm _____
 7. Connect Frequency Counter to Isolator AT3 J2 via 08555-60076 cable, UG 914A/U adapter and BNC to BNC cable.
 8. Rotate TRACK ADJ control fully counterclockwise and record oscillator frequency. 1,548,000±500 kHz _____
 9. Rotate TRACK ADJ control fully clockwise and record oscillator frequency. 1,552,000±500 kHz _____
 10. Record frequency tuning range (frequency recorded in step 9 minus frequency recorded in step 8). 4,000±500 kHz _____
 11. If data recorded in steps 6, 8, 9, and 10 is within tolerance no adjustment is required.
 12. If power level recorded in step 6 is less than +5 dBm proceed to step 23.
 13. If data recorded in steps 8, 9, or 10 is not within tolerance proceed with step 14.
 14. Connect Digital Voltmeter to test point A2TP5.
 15. Set TRACK ADJ control fully clockwise. Set "MAX" TUNE potentiometer A2R26 fully counterclockwise.
 16. Adjust "MIN" TUNE potentiometer A2R27 to set voltage at test point A2TP5 to level indicated on oscillator label. (See steps 23 through 30 for method of obtaining voltage level.)
 17. Measure and record oscillator frequency. _____
 18. Adjust "MAX" TUNE potentiometer to increase oscillator frequency 4,000±50 kHz above frequency recorded in step 17. Record oscillator frequency. _____
 19. Set TRACK ADJ control to center of tuning range recorded in steps 17 and 18 above. Record oscillator frequency. _____
 20. If frequency recorded in step 19 is not within ±500 kHz of 1.550 GHz adjust A7ADJ 1 to tune oscillator frequency to 1.550 GHz ±100 kHz.
 21. If oscillator frequency is adjusted, repeat steps 15 through 20.
 22. Repeat steps 4 through 11 above.
 23. If power level recorded in step 6 is less than +5 dBm connect Power Meter as indicated in step 4. Remove right side panel cover. Unsolder and remove power wires from A7C2 and A7C3.
 24. Adjust Power Supply for -10 and +10 volts. Connect -10 volts to A7C3 and +10 volts to A7C2. Connect Power Supply ground to solder lug near A7 Oscillator Assembly.
-

ADJUSTMENTS

5-9. 1.55 GHz Oscillator Power Level, Frequency Check and Adjustment (cont'd)

25. Adjust Power Supply negative voltage for maximum oscillator power level as indicated on Power Meter. Record power level.
- >+7 dBm _____
26. If power level is less than +7 dBm replace Oscillator Assembly A7.
27. If power level is greater than +7 dBm reduce negative voltage from Power Supply to -10 volts.
- a. If output level drops 2 dB go to step 30.
 - b. If output level drops less than 2 dB go to step 28.
 - c. If output level drops more than 2 dB go to step 29.
28. Increase Power Supply positive voltage approximately 0.5 volts and repeat steps 25 through 27.
29. Decrease Power Supply positive voltage approximately 0.5 volts and repeat steps 25 through 27.
30. Record positive voltage obtained in steps 24, 28 or 29 on label on top of oscillator assembly.
31. Repeat steps 14 through 22.
32. Disconnect Power Meter and connect W8 Cable to Isolator AT3 J2.
33. Replace right side panel cover.

SECTION VIII SERVICE

8-1. INTRODUCTION

8-2. This section provides instructions for troubleshooting and repair of the HP Model 8444A Tracking Generator.

8-3. PRINCIPLES OF OPERATION

8-4. Information relative to the principles of operation appears on the foldout pages opposing the Block Diagram, Service Sheet 1. Theory of operation appears on the foldout pages facing each of the foldout schematic diagrams. The schematic diagram circuits are referenced in the theory of operation test by block numbers.

8-5. RECOMMENDED TEST EQUIPMENT

8-6. Test equipment and accessories required to maintain the Tracking Generator are listed in Table 1-3. If the equipment listed is not available, equipment that meets the required specifications may be substituted.

8-7. TROUBLESHOOTING

8-8. Troubleshooting procedures are divided into two maintenance levels in this manual. The first, a troubleshooting tree, is designed to isolate the malfunction to the defective circuit.

8-9. The second maintenance level provides circuit analysis and test procedures to aid in isolating faults to a defective component. Circuit descriptions and test procedures for the second maintenance level are located on the pages facing the schematic diagrams. The test procedures are referenced to the schematic diagrams by block numbers.

8-10. After the cause of a malfunction has been found and remedied in any circuit containing adjustable components, the applicable procedure specified in Section V of this manual should be performed. After repairs and/or adjustments have been made, the applicable procedure specified in Section IV of this manual should be performed.

8-11. REPAIR

WARNING

Service of this instrument requires that protective covers be removed with power

applied. Be extremely careful as there are voltages present within the instrument which may, if contacted, cause personal injury. Service and repair of this instrument is to be performed only by qualified service personnel.

8-12. **Factory Repaired Exchange Modules.** The LSI microcircuit, Amplifier and ALC Detector Assy A3, is available as a factory repaired exchange module. The factory repaired module is available at a considerable savings in cost over the new module.

8-13. This exchange module can be ordered from the nearest Hewlett-Packard office using the part number for the restored assembly. This part number is located in Section VI of this manual. The reduced price is contingent on the return of the defective module to Hewlett-Packard.

8-14. **Factory Selected Components.** Some component values are selected at the time of final checkout at the factory. Usually these values are not extremely critical; they are selected to provide optimum compatibility with associated components. These components, which are identified on the schematics with an asterisk, are listed in Table 8-1.

8-15. **Adjustable Components.** Adjustable components, other than front panel operating controls, are listed in Table 8-2. Adjustment procedures for these components are contained in Section V of this manual.

8-16. **Servicing Aids on Printed Circuit Boards.** Servicing aids on printed circuit boards include test points, transistor designations, adjustment callouts and assembly part numbers with alpha-numerical revision information.

8-17. **Part Location Aids.** The location of chassis mounted parts and major assemblies are shown in Figures 8-4 and 8-5.

8-18. The location of individual components mounted on printed circuit boards or assemblies are shown on the appropriate Service Sheet. The part reference designator is the assembly designation plus the part designation. (Example: A1R1 is R1 on the A1 assembly.) For specific component description and ordering information refer to the replaceable parts table in Section VI.

Table 8-1. Factory Selected Components

Designation	Service Sheet	Circuit	Purpose
A2R8	3	ALC Differential Amplifier	Center GAIN ADJ control
A4A1R11	3	PIN Diode Modulator	Set range of Modulator

Table 8-2. Adjustable Components

Designation	Circuit	Purpose
R1	+20 volt circuit	MANUAL SCAN control
R2	Oscillator driver	TRACK ADJ control
R3	ALC reference driver	LEVEL control
A1R14	+20 volt power supply	Sets +20 volt supply level and reference level to -10 volt supply.
A2R6	PIN diode driver	Sets limiting level of PIN diode driver
A2R7	PIN diode driver	Sets gain of differential amplifier in PIN diode driver circuit.
A2R17	PIN diode driver	Sets PIN diode driver circuit for null.
A2R26	1.55 GHz oscillator driver	Set frequency tuning range of 1.55 GHz oscillator.
A2R27	1.55 GHz oscillator driver	Sets oscillator power level.
A2R40	ALC reference diode circuit	-10 dBm adjustment for LEVEL control.
A2R41	ALC reference diode circuit	0 dBm adjustment for LEVEL control.
A5ADJ 1	First converter	Adjusts center frequency of 1.55 GHz cavity.
A5ADJ 2/3	First converter	Adjusts center frequency of 2.05 GHz cavities.
A7 ADJ 1	1.55 oscillator	Adjusts center frequency of 1.55 GHz oscillator cavity.

8-19. Diagram Notes. Table 8-3, Schematic Diagram Notes, provides information relative to symbols and values shown on schematic diagrams.

8-20. GENERAL SERVICE HINTS

8-21. The etched circuit boards used in Hewlett-Packard equipment are the plated-through type consisting of metallic conductors bonded to both sides of an insulating material. The circuit boards can be either a single layer or multi-layer board. The metallic conductors are extended through the component holes or interconnect holes by a plating process. Soldering can be performed on either side of the board with equally good results. Table 8-4 lists recommended tools and materials for use in

repairing etched circuit boards. Following are recommendations and precautions pertinent to etched circuit repair work.

















a. Avoid unnecessary component substitution; it can result in damage to the circuit board and/or adjacent components.

b. Do not use a high power soldering iron on etched circuit boards. Excessive heat may lift a conductor or damage the board.

c. Use a suction device or wooden toothpick to remove solder from component mounting holes.

Table 8-3. Schematic Diagram Notes

SCHEMATIC DIAGRAM NOTES

R,C,L	Resistance is in ohms, capacitance is in microfarads, and inductance in millihenries unless otherwise noted.
P/O	Part of.
*	Asterisk denotes a factory-selected value. Value shown is typical. Capacitors may be omitted or resistors jumpered.
	Screwdriver adjustment.
	Panel control.
	Encloses front panel designations.
	Encloses rear panel designations.
	Circuit assembly borderline.
	Other assembly borderline.
	Heavy line with arrows indicates path and direction of main signal.
	Heavy dashed line with arrows indicates path and direction of main feedback.
	Wiper moves toward CW with clockwise rotation of control (as viewed from shaft or knob).
	Numbered test point. Measurement aid provided.
	Lettered test point. No measurement aid provided.
	Encloses wire color code. Code used (MIL-STD-681) is the same as the resistor color code. First number identifies the base color, second number the wider stripe, and the third number identifies the narrower stripe, e.g., (947) denotes white base, yellow wide stripe, violet narrow stripe.
	Indicates "WARNING: HAZARDOUS VOLTAGE."
	Refers serviceman or operator to CAUTIONs in Operating and Service Manual.
2A	Letter = Off page connection. Number = Service Sheet location for off page connection.
	Block numbers reference between text and schematic.
	Assembly ground.
	Chassis ground.

CAUTION

Do not use a sharp metal object such as an awl or twist drill for this purpose. Sharp objects may damage the plated-through conductor.

d. After soldering, remove excess flux from the soldered areas and apply a protective coating to prevent contamination and corrosion.

8-22. Component Replacement. The following procedures are recommended when component replacement is necessary:

- a. Remove defective component from board.
- b. If component was unsoldered, remove solder from mounting holes with a suction device or a wooden toothpick.
- c. Shape leads of replacement component to match mounting hole spacing.
- d. Insert component leads into mounting holes and position component as original was positioned. Do not force leads into mounting holes: sharp lead ends may damage the plated-through conductor.

NOTE

Although not recommended when both sides of the circuit board are accessible, axial lead components such as resistors and tubular capacitors, can be replaced without unsoldering. Clip leads near body of defective component, remove component and straighten leads left in board. Wrap leads of replacement component one turn around original leads. Solder wrapped connection and clip off excess lead.

8-23. GENERAL SERVICE INFORMATION

8-24. Transistors and diodes are used throughout the RF Section in circuit configurations such as delay circuits, trigger circuits, switches, oscillators and various types of amplifiers. Basic transistor operation is shown on the following pages.

8-25. Transistor In-Circuit Testing. The common causes of transistor failure are internal short circuits and open circuits. In transistor circuit testing, the most important consideration is the transistor base-to-emitter junction. The base emitter junction in a transistor is comparable to the control grid-

Table 8-4. Etched Circuit Soldering Equipment

Item	Use	Specification	Item Recommended
Soldering tool	Soldering Unsoldering	Wattage rating: 47½ – 56½ Tip Temp: 850–900 degrees	Ungar No. 776 handle with *Ungar No. 4037 Heating Unit
Soldering* Tip	Soldering Unsoldering	*Shape: pointed	*Ungar No. PL111
De-soldering Aid	To remove molten solder from connection	Suction device	Soldapult by Edsyn Co., Arleta, California
Resin (flux)	Remove excess flux from soldered area before application of protective coating.	Must not dissolve etched circuit base board material or conductor bonding agent.	Freon, Aceton, Lacquer Thinner, Isopropyl Alcohol (100% dry)
Solder	Component replacement Circuit board repair Wiring	Resin (flux) core, high tin content (60/40 tin/lead). 18 gauge (SWG) preferred.	
Protective Coating	Contamination, corrosion protection.	Good electrical insulation, corrosion-prevention properties.	Krylon **No. 1302 Humiseal Protective Coating, Type 1B12 by Columbia Technical Corporation, Woodside 77, New York

*For working on etched boards: for general purpose work, use Ungar No. 1237 Heating Unit (37.5W, tip temperature of 750–800 degrees) and Ungar No. PL113, 1/8 inch chisel tip.

**Krylon, Inc., Norristown, Pennsylvania.

cathode relationship in a vacuum tube. The base emitter junction is essentially a solid-state diode; for the transistor to conduct, this diode must be forward biased. As with simple diodes, the forward-bias polarity is determined by the materials forming the junction. Transistor symbols on schematic diagrams reveal the bias polarity required to forward-bias the base-emitter junction. The B part of Figure 8-1 shows transistor symbols with the terminals labeled. The other two columns compare the biasing required to cause conduction and cut-off in NPN and PNP transistors. If the transistor base-emitter junction is forward biased, the transistor conducts. However, if the base-emitter junction is reverse-biased, the transistor is cut off (open). The voltage drop across a forward-biased, emitter-base junction varies with transistor collector current. For example, a germanium transistor has a typical forward-bias, base-emitter voltage of 0.2–0.3 volt when collector current is 1–10 mA, and 0.4–0.5 volt when collector current is 10–100 mA. In contrast, forward-bias voltage for silicon transistor is about twice that for germanium types; about 0.5–0.6 volt when collector current is low, and about 0.8–0.9 volt when collector current is high.

8-26. Figure 8-1, Part A, shows simplified versions of the three basic transistor circuits and gives the characteristics of each. When examining a transistor stage, first determine if the emitter-base junction is biased for conduction (forward-biased) by measuring the voltage difference between emitter and base. When using an electronic voltmeter, do

not measure directly between emitter and base; there may be sufficient loop current between the voltmeter leads to damage the transistor. Instead, measure each voltage separately with respect to a common point (e.g., chassis). If the emitter-base junction is forward-biased, check for amplifier action by short-circuiting base to emitter while observing collector voltage. The short circuit eliminates base-emitter bias and should cause the transistor to stop conducting (cut off). Collector voltage should then change and approach the supply voltage. Any difference is due to leakage current through the transistor and, in general, the smaller this current the better the transistor. If the collector voltage does not change, the transistor has either an emitter-collector short circuit or emitter-base open circuit.

8-27. **Transistor and Diode Markings.** Figure 8-2 illustrates examples of diode and transistor marking methods. In addition, the emitter lead for bipolar transistors is identified on the printed circuit boards.

8-28. OPERATIONAL AMPLIFIERS

8-29. Operational amplifiers are used to provide such functions as summing amplifiers, offset amplifiers, buffers and power supplies. The particular function is determined by the external circuit connections. Equivalent circuit and logic diagrams for type 741 operational amplifiers are contained in Figure 8-3. Circuit A is a non-inverting buffer amplifier with a gain of 1. Circuit B is a non-

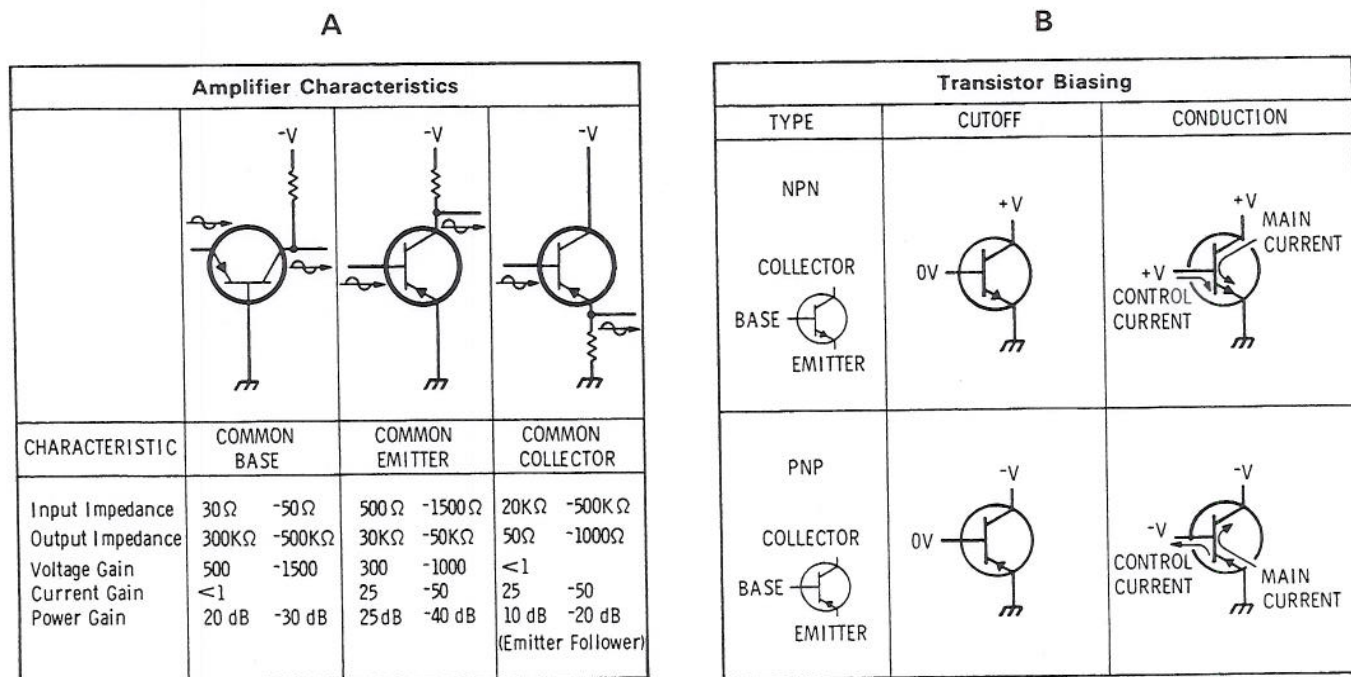

Figure 8-1. Transistor Operation

inverting amplifier with gain determined by the resistance of R1 and R2. Circuit C is an inverting amplifier with gain determined by R1 and R2, with the input impedance determined by R2. Circuit D contains the functional circuitry and pin connection information along with an operational amplifier review.

NOTE

In circuit D is it assumed that the amplifier has high gain, low output impedance and high input impedance.

8-30. Operational Amplifier Troubleshooting Procedure. Measure and record the voltage level at both the - (inverting) terminal pin 2 and the + (non-inverting) terminal pin 3. The level should not differ by more than ≈ 10 mV. If the voltage level is not within ≈ 10 mV, check the external circuitry and components. If the external circuitry (input signal, operating voltages, feedback resistors) is normal, replace the operational amplifier.

8-31. ELECTRICAL MAINTENANCE

8-32. Perform the electrical checks and adjustments once every six months and after repair or component replacement.

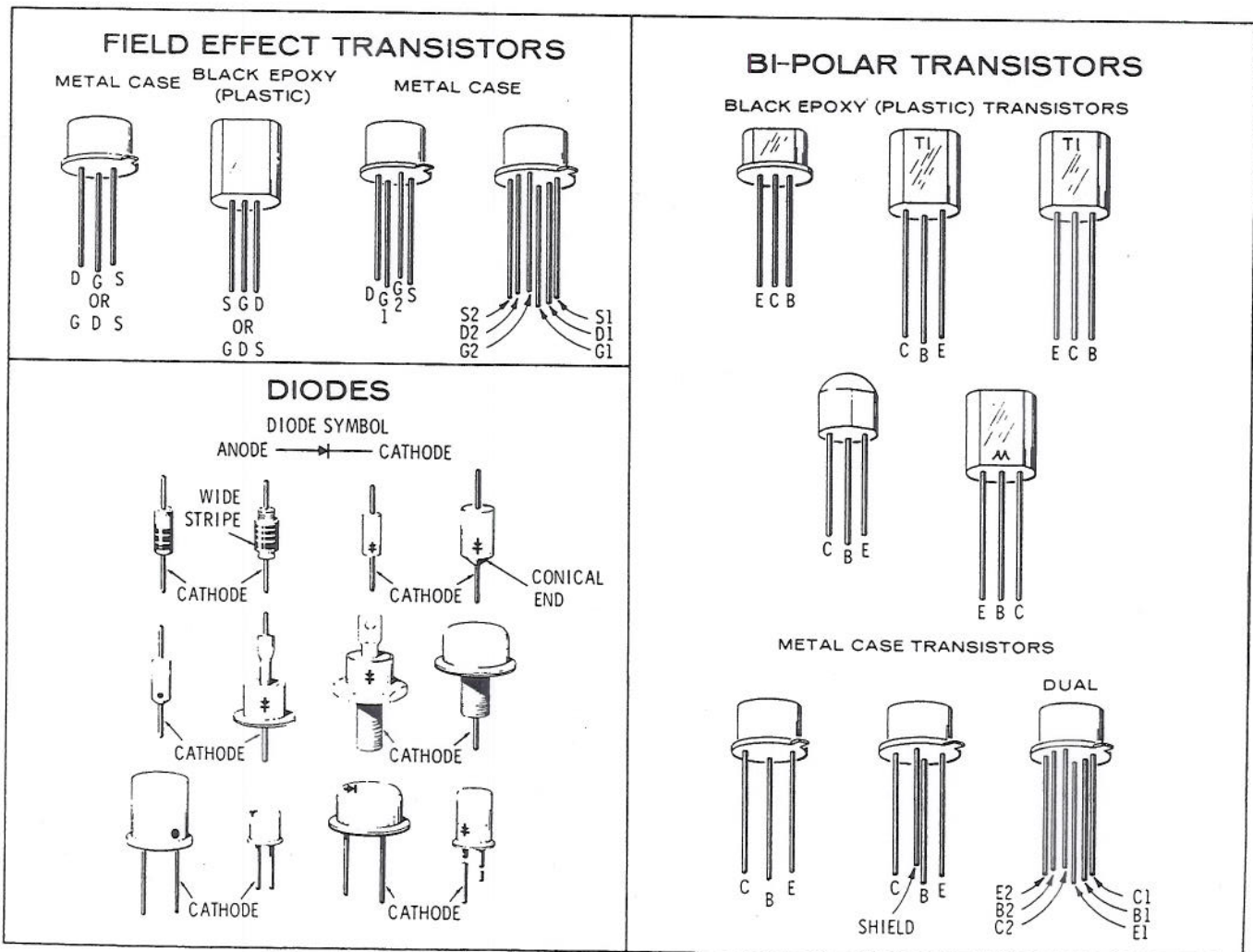

Figure 8-2. Examples of Diode and Transistor Marking Methods

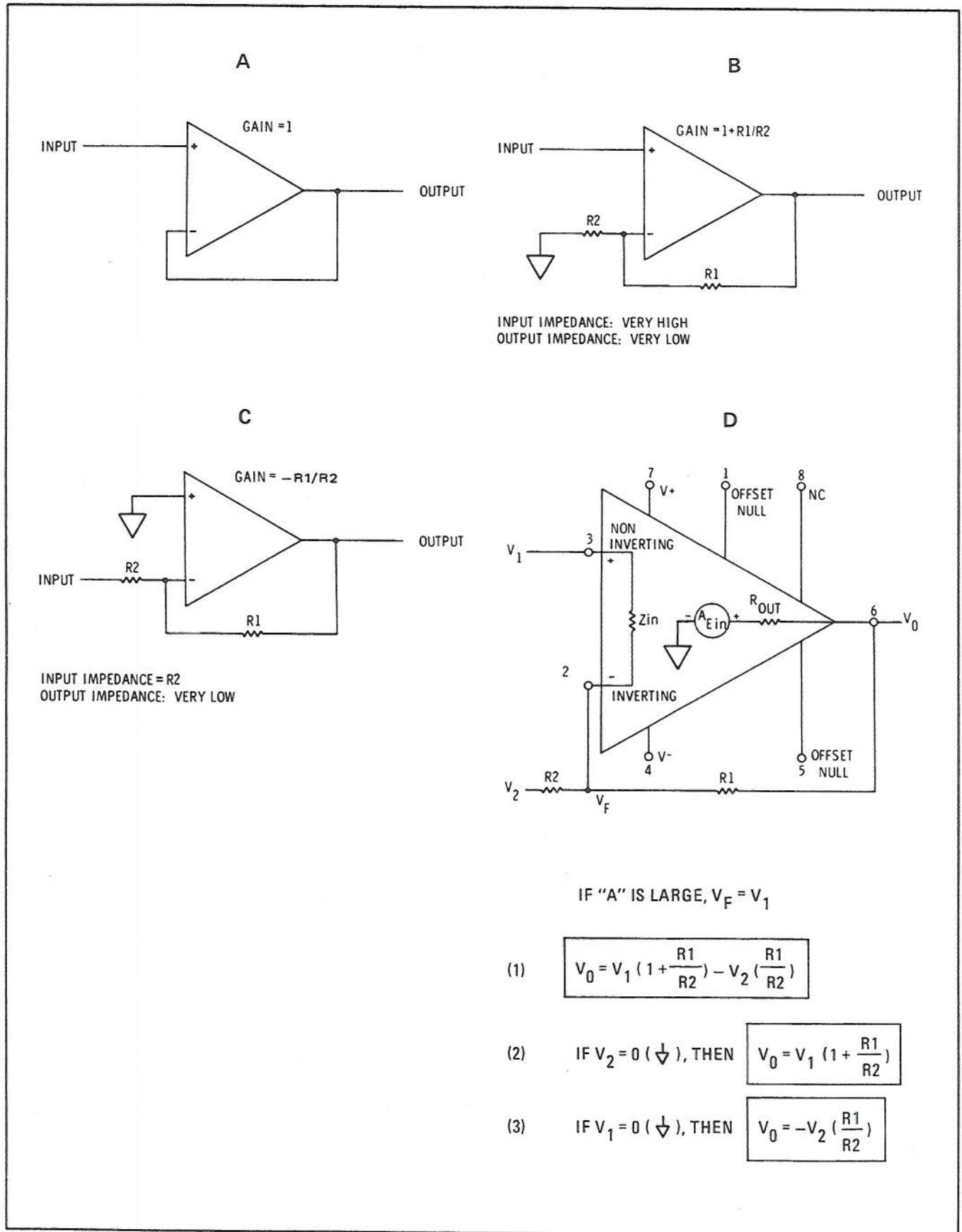

Figure 8-3. Operational Amplifier Equivalent Circuit

TOP

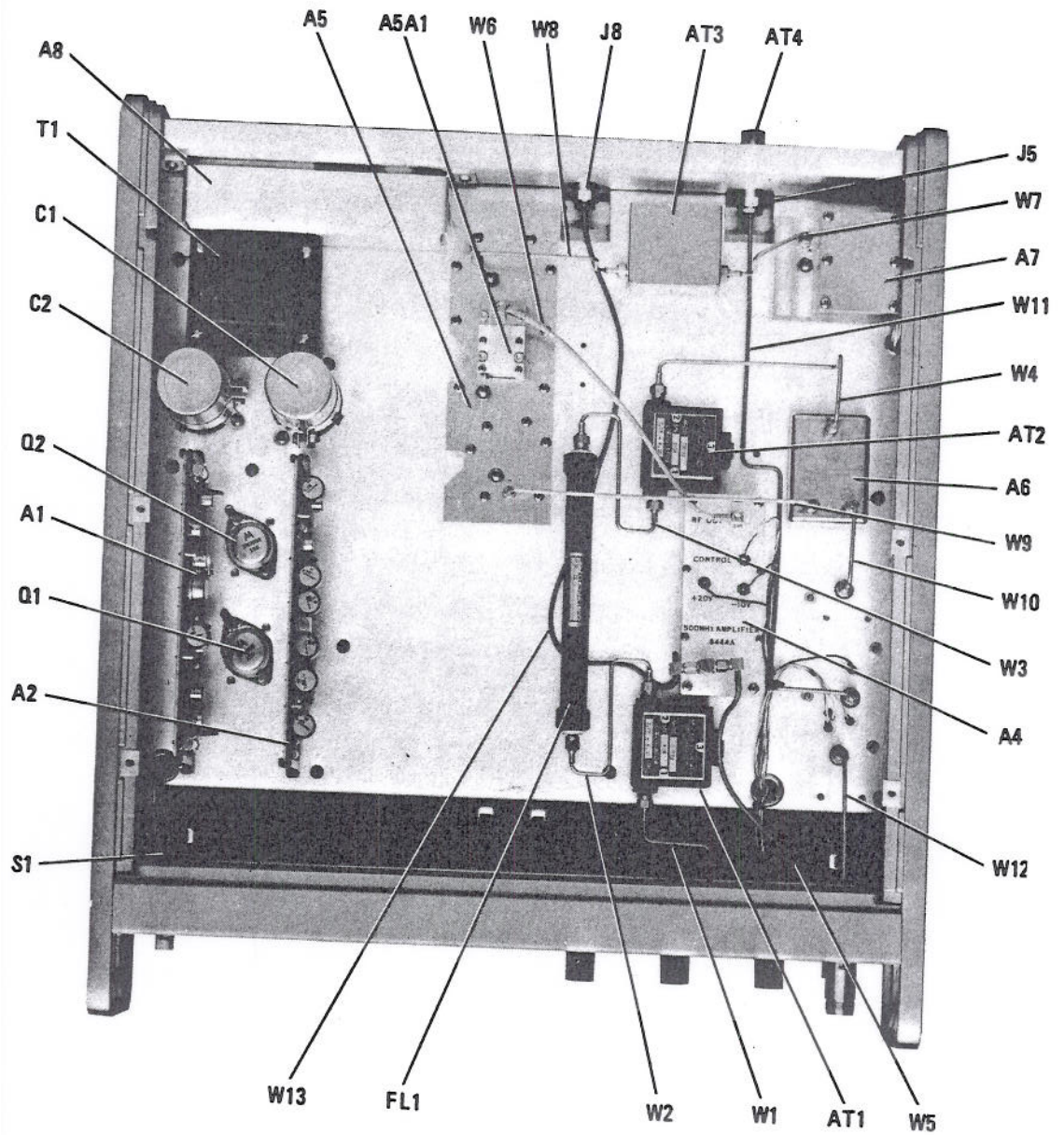

Figure 8-4. Major Assembly Locations (1 of 2)

BOTTOM

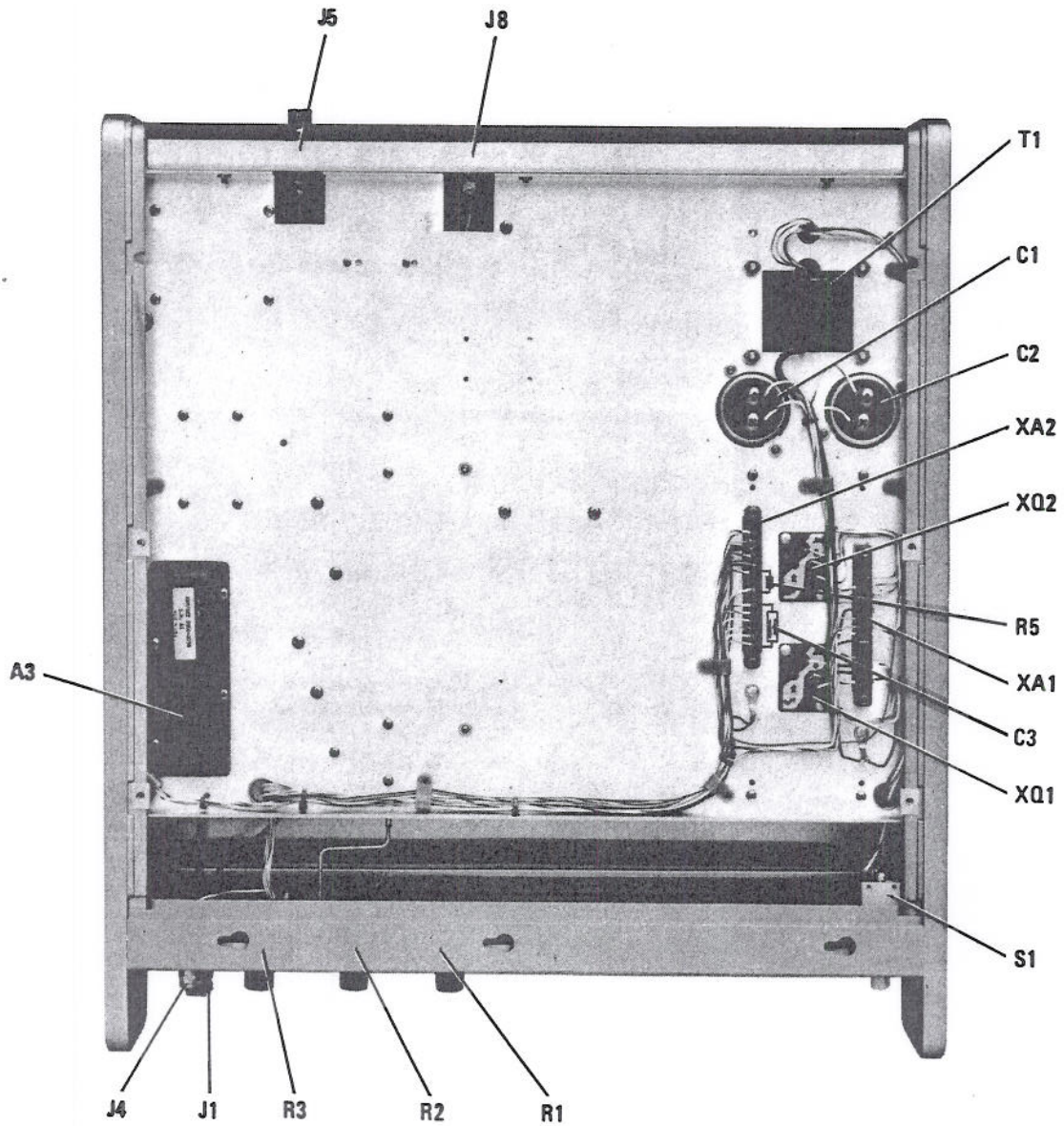

Figure 8-4. Major Assembly Locations (2 of 2)

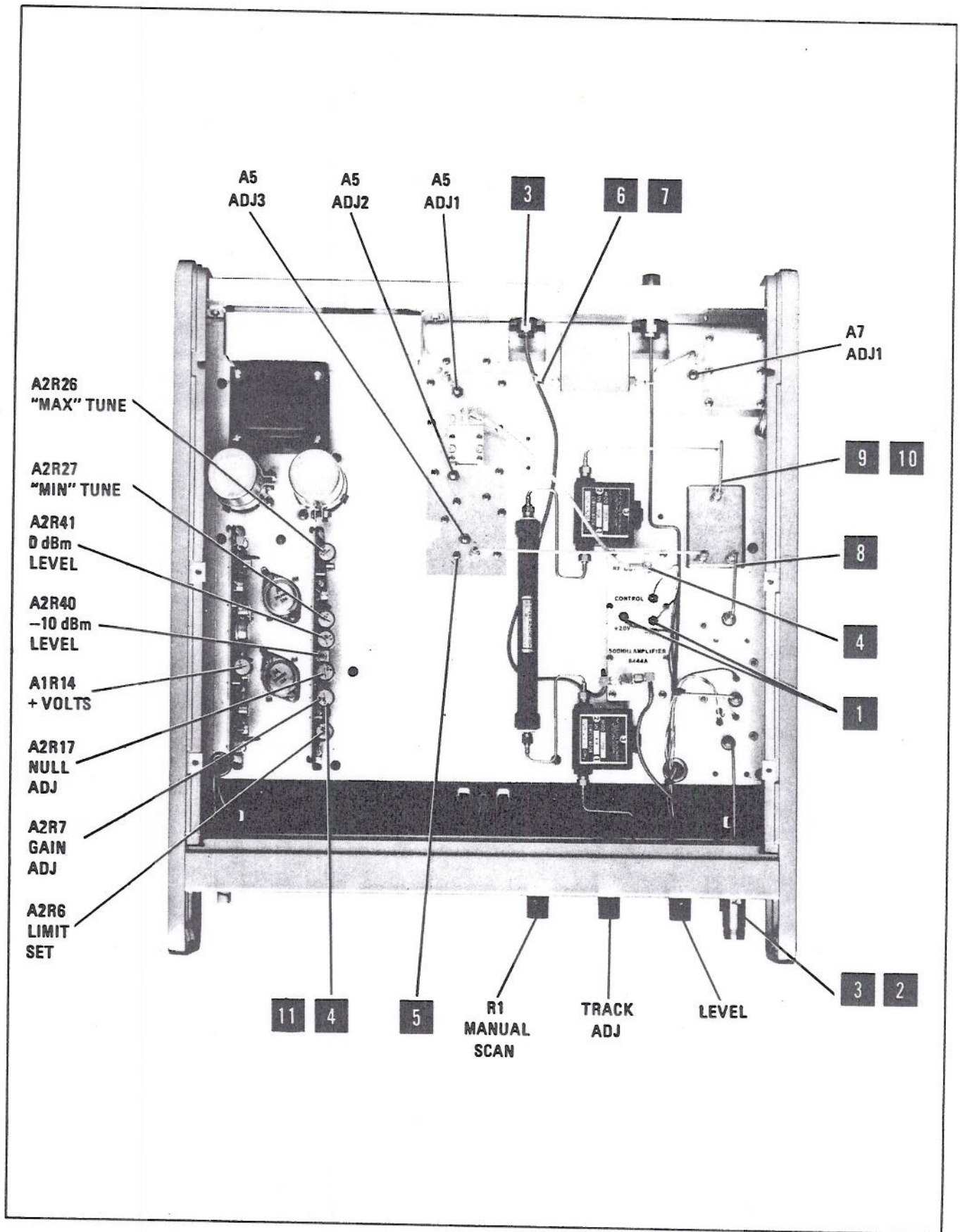

Figure 8-5. Adjustment and Test Point Locations

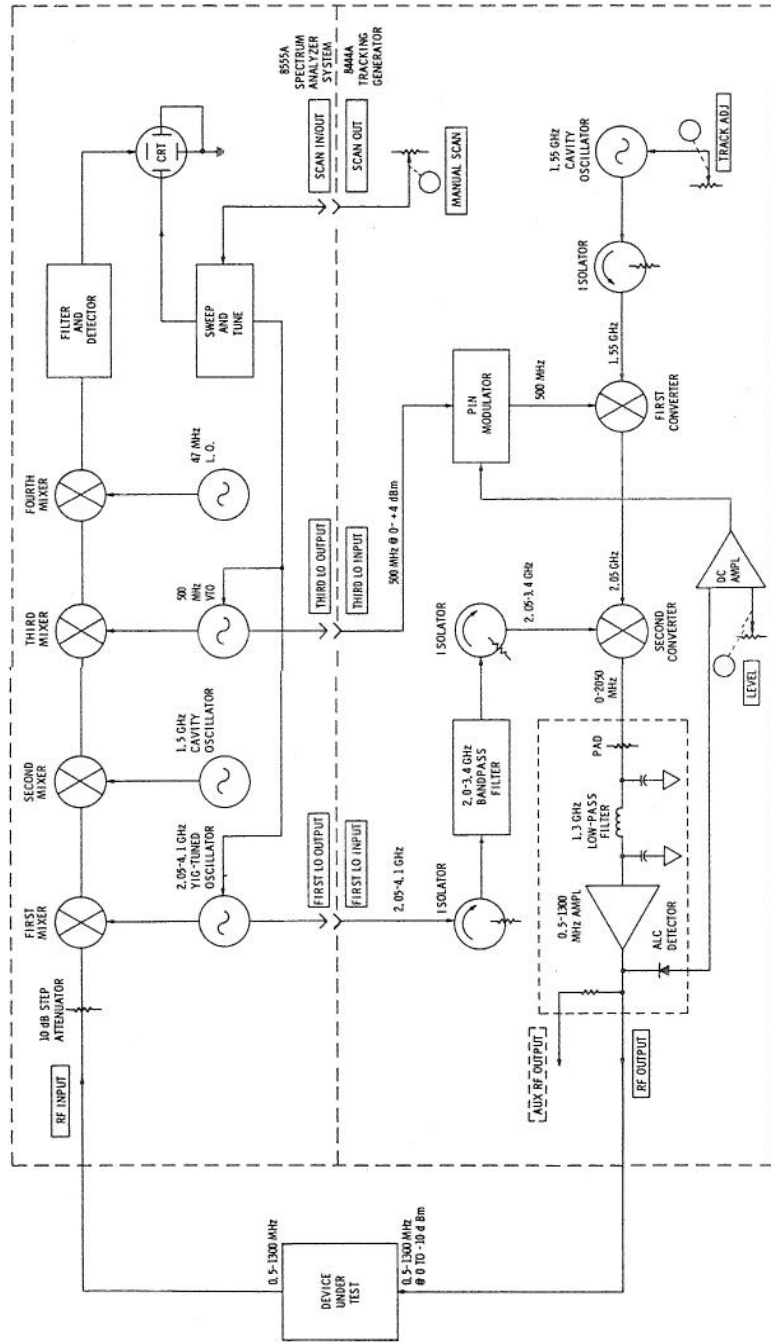

Figure 8-6. Tracking Generator Spectrum Analyzer, Simplified Block Diagram

SERVICE SHEET 1**GENERAL**

The HP Model 8444A Tracking Generator is designed for operation with either the HP Model 8554L/8552()/140-series or the HP Model 8555A/8552()/140-series Spectrum Analyzer Systems. When used with the 8554L Spectrum Analyzer RF Section, the Tracking Generator covers the full range of the analyzer system. When used with the 8555A Spectrum Analyzer RF Section, the Tracking Generator covers the 10 MHz to 1.3 GHz frequency range on the $n=1$ — (2.05 GHz IF) band.

A simplified block diagram of the Spectrum Analyzer/Tracking Generator is illustrated in Figure 8-6. In the spectrum analyzer/tracking generator system, the tracking generator provides a signal that tracks the frequency tuning of the spectrum analyzer. The first and third local oscillators in the spectrum analyzer are applied to the tracking generator where they are combined with the output of a 1.55 GHz cavity oscillator. The frequency of the cavity oscillator corresponds with the 1.5 GHz second local oscillator, the 47 MHz fourth local oscillator and the 3 MHz IF signal to the detector in the spectrum analyzer. The 1.55 GHz cavity oscillator is voltage-tunable by the front panel TRACK ADJ control, to compensate for minor frequency variations of the second and fourth local oscillators in the spectrum analyzer.

The power level of the tracking generator rf output is controlled by an ALC circuit. The ALC detector is part of a large-scale integrated (LSI) circuit package containing an attenuator, low-pass filter, output amplifier and a dc blocking capacitor. The detected signal is applied through a dc amplifier to PIN diode modulators in the third LO signal path to the tracking generator first converter. The rf output level is adjustable over the 0 to -10 dBm range by a front panel LEVEL control in the dc amplifier circuit. The LEVEL control is calibrated at 0 dBm.

Figure 8-7 contains a block diagram of the tracking generator with interconnections to both the 8554L and 8555A Spectrum Analyzer Systems. The first LO input is applied through isolators and a 2.0 to 3.4 GHz bandpass filter to the second converter. The third LO input is applied through a 500 MHz limiter amplifier and PIN diode modulators to the second converter. The 500 MHz third LO signal is combined with the output from the 1.55 GHz cavity oscillator. The output from the first converter has a center frequency of 2.05 GHz with a tuning range of ± 2 MHz plus the deviation of the 500 MHz signal from the analyzer. The 2.05 GHz first converter output is mixed with the 2.05 to 3.4 GHz output from the bandpass filter in the second converter. The second converter output is applied through the 0 to 1.3 GHz low-pass filter, amplifier and ALC circuitry. The resultant output is a signal in the frequency range of 0 to 1.3 GHz at a level of 0 to -10 dBm.

Sweep and tune control of the Spectrum Analyzer from the Tracking Generator is provided by a 0 to +10 volt signal controlled by a front panel MANUAL SCAN control.

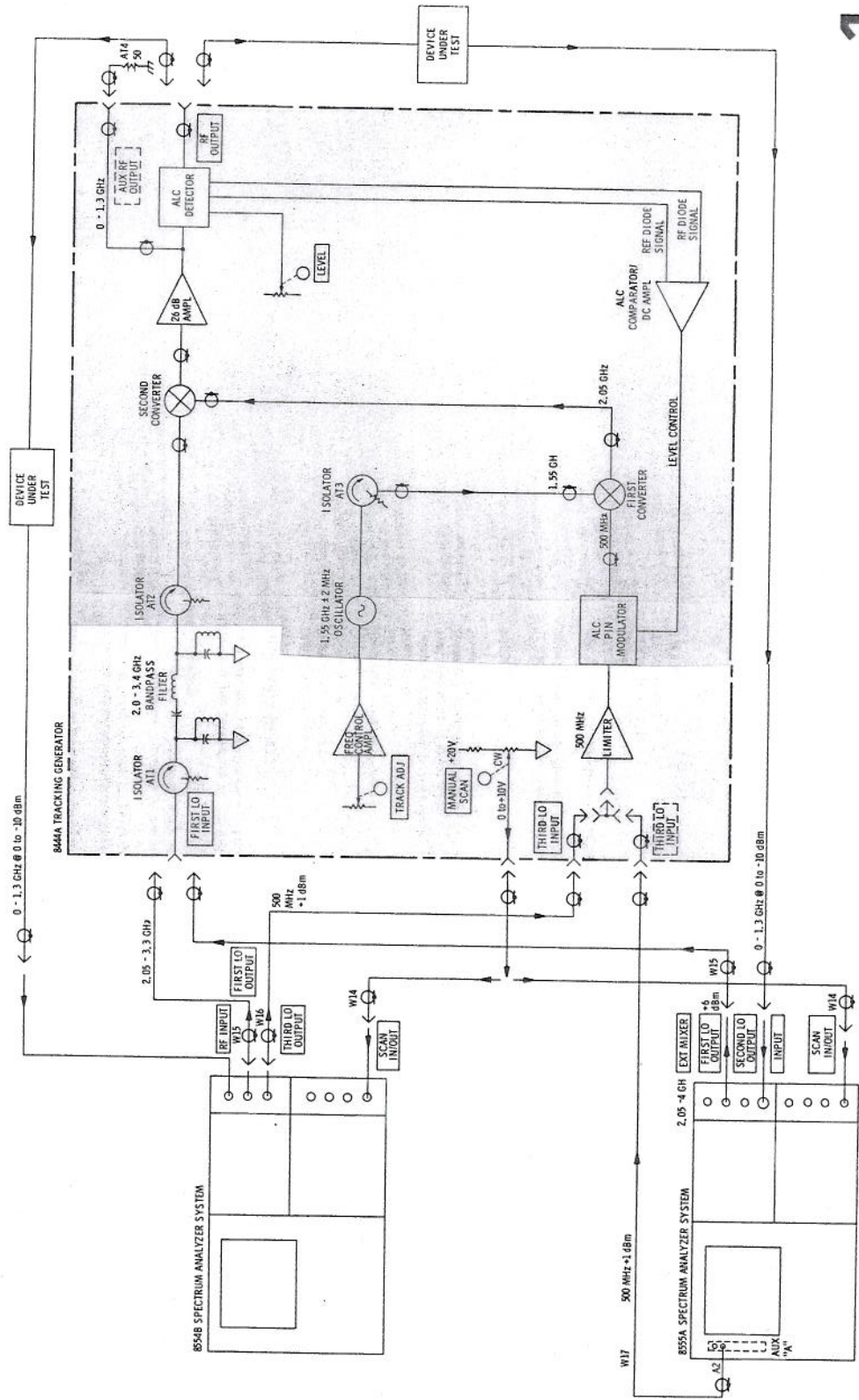
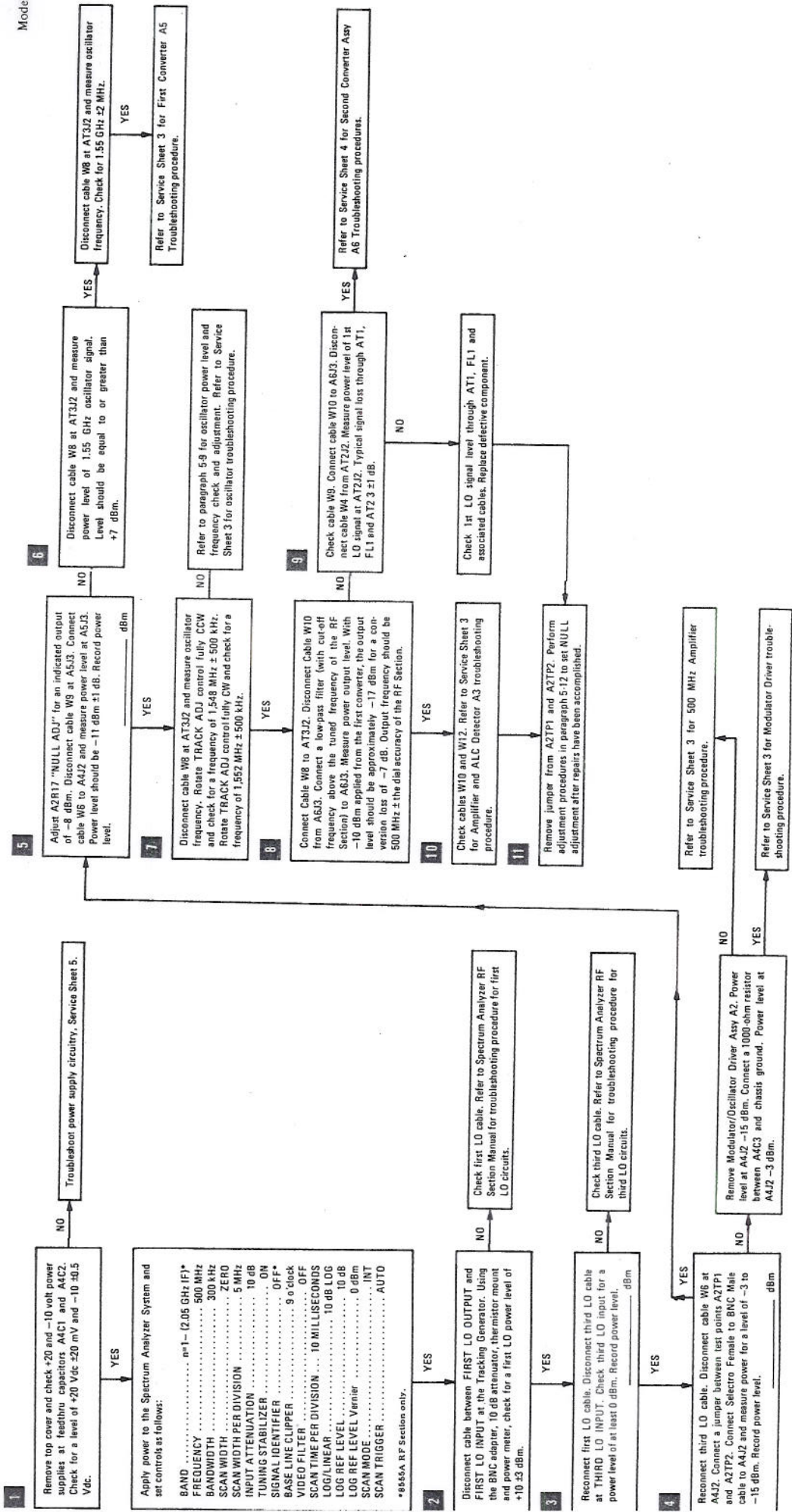
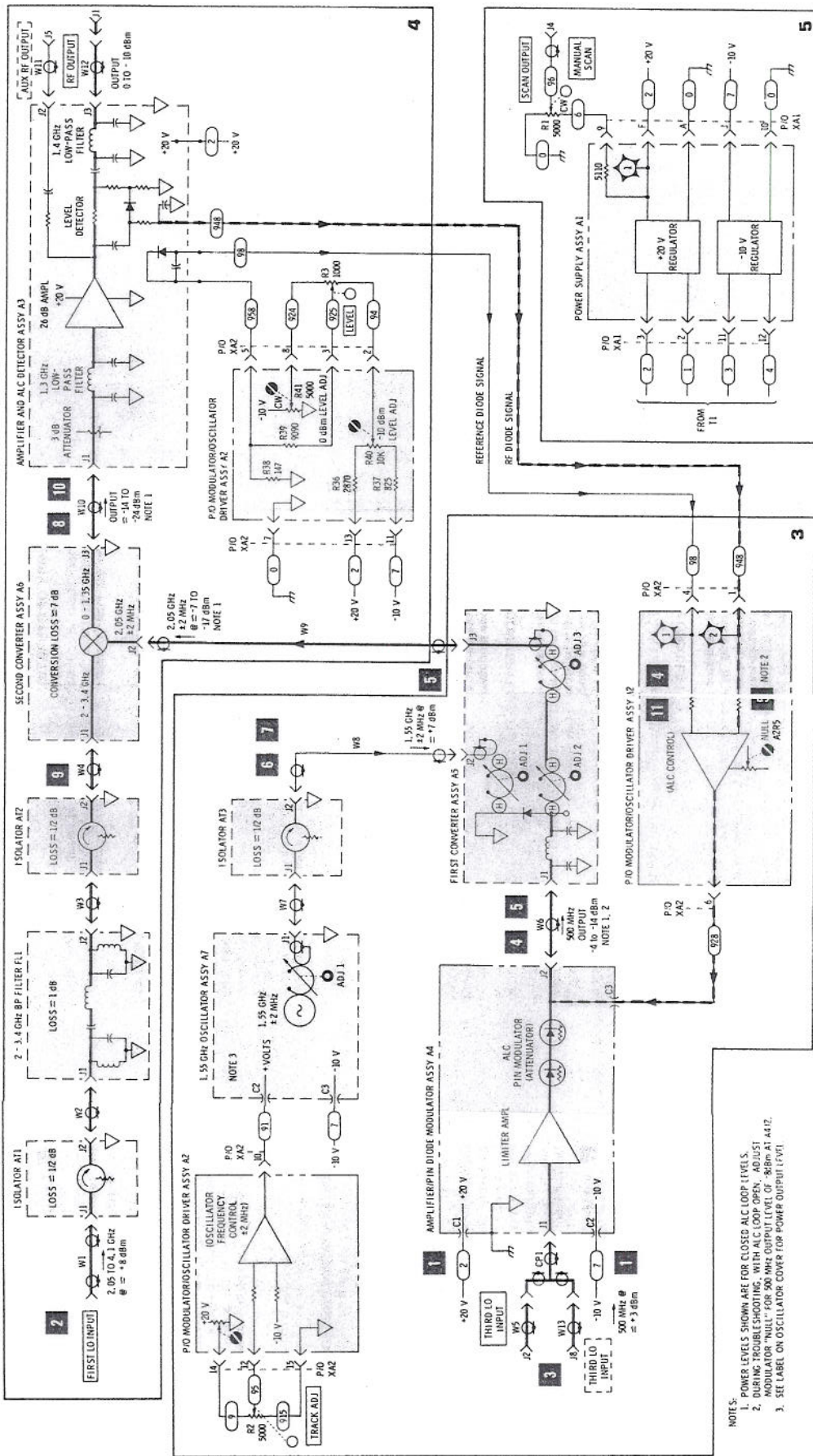

Figure 8.7. Tracking Generator, Block Diagram with Spectrum Analyzer Interconnections

Service





NOTE:
 1. POWER LEVELS SHOWN ARE FOR CLOSED ALC LOOP LEVELS.
 2. DURING TROUBLESHOOTING, WITH ALC LOOP OPEN, ADJUST MODULATOR "NULL" FOR 500 MHz OUTPUT LEVEL OF -8 dBm AT A412.
 3. SEE LABEL ON OSCILLATOR COVER FOR POWER OUTPUT LEVEL.

Figure 8-8. Tracking Generator Troubleshooting Block Diagram

SERVICE SHEET 3

THEORY OF OPERATION

Service Sheet 3 contains the schematic diagram for the 500 MHz Amplifier/PIN Diode Modulator (Attenuator) A4, the Modulator/Oscillator Driver A2, First Converter A5 and the 1.55 GHz Oscillator A7.

1 500 MHz AMPLIFIER/PIN DIODE MODULATOR (ATTENUATOR) A4

The 500 MHz amplifier and PIN diode modulator consists of amplifier A4A1Q1 through Q3 and PIN diodes A4CR1 and CR2. The three stage amplifier provides isolation between the Tracking Generator attenuator and mixer circuits and the Spectrum Analyzer 500 MHz LO circuit. The amplifier functions as a limiter in the forward direction of the 500 MHz signal while providing approximately 55 dB attenuation in the reverse direction. This isolation prevents signals from the first mixer and changes in the 500 MHz signal by the PIN diode attenuator from affecting the 500 MHz oscillator in the Spectrum Analyzer. PIN diodes A4CR1 and CR2 function as series connected current-controlled microwave resistors. As current through the diodes increases the amount of attenuation decreases. Current through the PIN diodes is controlled by ALC circuitry and the output of Modulator Driver Assy A2. A4A1R11 is a limiter resistor to protect the PIN diodes in case of an accidental short to the line from the modulator driver.

2 MODULATOR DRIVER

The modulator driver consists of differential amplifier A2Q1 through Q3, limiter A2Q4 and output amplifier A2Q5 through Q7. The difference between the rf diode and the reference diode signal (from the ALC circuitry in the microcircuit amplifier) is amplified by A2Q1. The output of A2Q1 is amplified by the output amplifier A2Q5 through Q7 to control the current to the PIN diode modulators.

3 FIRST CONVERTER A5

The first converter mixes the signal from the 500 MHz Amplifier/PIN Diode Modulator with the signal from the 1.55 GHz Oscillator. The converter consists of a 500 MHz bandpass filter, diode mixer and three radial cavities. One cavity functions as a bandpass filter for the 1.55 GHz oscillator signal. The other cavities function as an IF filter and provide a two-pole Butterworth response. Both the IF and LO input cavities are adjustable by tuning slugs. The mixer is a single Schottky diode located between the 1.55 GHz oscillator cavity and the 2.05 GHz "first IF" cavity. Mixer bias is provided by resistor A5A1R1. Mixer conversion loss is approximately 4 dB.

4 1.55 GHz OSCILLATOR A7

The 1.55 GHz oscillator is a single transistor oscillator whose frequency is determined primarily by a radial cavity. The oscillator frequency is tuned around the center frequency established by the cavity by the positive voltage applied to the voltage-variable capacitor A7CR1 from the oscillator driver (see block 5 below). Changes in the voltage level to this Varactor diode provide a frequency tuning range of approximately 4 MHz (refer to paragraph 5-9 for adjustment). The oscillator driver is adjusted to provide an oscillator output of at least +7 dBm and a frequency tuning range of \cong 4 MHz. The ground return lines for the power supply +20 and -10 sense lines are connected to chassis ground adjacent to the 1.55 GHz oscillator. This provides a common reference point for the oscillator and sense grounds.

SERVICE SHEET 3 (cont'd)

5 1.55 GHz OSCILLATOR DRIVER

The oscillator driver consists of operational amplifier A2U1, transistor A2Q8 and their associated components. Together U1 and Q8 function as a non-inverting operational amplifier. Driver amplifier gain = $1 + A2R31$ over A2R29 in parallel with A2R30 or approximately 2.4. The minimum output voltage is determined by A2R27 "MIN TUNE" while the maximum output is controlled by A2R26 "MAX TUNE" and the front panel TRACK ADJ potentiometer. Adjustments in the oscillator driver correct for minor variations in the sensitivity of the oscillator from unit to unit. These adjustments set the upper and lower tuning range limits for the front panel TRACK ADJ potentiometer. Potentiometer A2R26 is adjusted to provide a 4 MHz frequency tuning of the oscillator from the front panel TRACK ADJ control. Refer to paragraph 5-9 for adjustment procedure.

TROUBLESHOOTING PROCEDURE

When a malfunction has been isolated to the 500 MHz amplifier/PIN diode modulator and driver circuits or to the 1.55 GHz oscillator and converter circuits, perform the appropriate checks below. Refer to Service Sheet 2 for overall troubleshooting procedure.

EQUIPMENT REQUIRED

Digital Voltmeter	HP 3440A/3443A
Frequency Counter	HP 5245L/5254B
Power Meter	HP 432A/8478B
Spectrum Analyzer System	HP 8554B or 8555A
Selectro to BNC Cable	HP 11492-60001
Adapter BNC Jack to BNC Jack	UG-914A/U (HP 1250-0080)
Dc Volt-Ohm-Meter	HP 412A

1 500 MHz AMPLIFIER/PIN DIODE MODULATOR ASSEMBLY A4

With power removed, disconnect CP1 at A4J1 and W6 at A4J2. Remove the eight screws securing the cover of the A4 assembly. (The A4A1 assembly is mounted on the underside of the A4 cover.) Invert the cover and A4A1 assembly. Connect CP1 to A4J1 and W6 to A4J2. Connect a ground strap between the cover and chassis ground. Position the assembly so that the voltage leads and signal lead are not shorted to ground. Apply power to the Tracking Generator. Measure the voltage drop across each of the PIN diodes. With no 500 MHz input signal to the 500 MHz amplifier, the voltage drop across each diode should be 0.8 ± 0.2 Vdc. Measure the emitter, base and collector voltages for transistors A4A1Q1 through Q3 and compare with typical values shown on the schematic diagram. Troubleshoot stage or stages with voltage levels that do not compare with typical values shown on schematic. Replace defective component and perform ALC NULL adjustment, paragraph 5-12, and LEVEL adjustment, paragraph 5-13.

SERVICE SHEET 3 (cont'd)

2 MODULATOR DRIVER CIRCUIT

Check Amplifier and ALC Detector Assembly A3 Service Sheet 4 prior to checking the modulator driver circuit. Connect a shorting strap between test points A2TP1 and A2TP2. Connect a shorting strap between A2TP1 and chassis ground. Apply power to Tracking Generator. Measure and record voltage level at A4C2 (PIN diode drive signal). _____ Vdc Rotate NULL ADJ A2R17 throughout its tuning range. Note and record level to PIN diode modulators, _____ to _____ Vdc. Compare with typical range of +14 to +19.7 Vdc. If the output is not within the typical limits, connect digital voltmeter to junction of A2R15 and R16. Adjust A2R17 for an indicated voltage of +19.3 at the emitter of A2Q5. Troubleshoot the output amplifier using typical voltage levels given for the emitter, base and collector of A2Q5 through Q7 on the schematic diagram. Troubleshoot the differential amplifier A1Q1 through A2Q3 and limiter A2Q4 using the typical voltage levels given on the schematic diagram. When malfunction has been corrected, perform adjustment procedures in paragraphs 5-12 and 5-13. See Figure 8-9 for diode forming instructions.

3 FIRST CONVERTER ASSEMBLY A5

When a malfunction has been isolated to the first converter, remove lid A5A1MP3 (see illustrated parts breakdown, Figure 8-18). With the 1.55 GHz oscillator signal applied to A5J2 measure mixer bias at test point A5A1TP "A" (inductor A5A1L2). Bias level should be greater than 1.2 Vdc. Polarity can be either positive or negative depending on the direction on diode A5A1CR1. If diode bias is low, check tuning of ADJ 1, check for tightness of screws securing cover A5MP5 to cavity block A5MP4, and check for tightness of screws securing the mixer block A5A1 to the cavity block cover. Monitor bias level during adjustments for indication of fault. If there is no or very low bias voltage remove power from instrument and check diode front-to-back ratio. Use test point A5A1TP "A" and chassis ground for measurement points. Check for a typical front-to-back ratio of 70 to 700 ohms (using HP 412A VTVM with diode in parallel with A4A1R1). For actual diode front-to-back measurement remove the four cap screws A5MP9 and lift the mixer assembly from the cavity block cover. Lift the diode at the A5A1MP2 connector and measure front-to-back ratio. Typically 70 to 200,000 ohms.

NOTE

Replacement of components other than diode A5A1CR1 is not recommended. Replace diode and perform First Converter Adjustment procedures in paragraph 5-11.

If diode replacement does not correct malfunction replace mixer A5A1. See Figure 8-18 for First Converter Assembly Illustrated Parts Breakdown.

4 1.55 GHz OSCILLATOR ASSEMBLY A7

Field repair of the oscillator assembly is *not* recommended. Component lead lengths are critical. If components are replaced in the field, note installation

SERVICE SHEET 3 (cont'd)

of component to be replaced and install new component in identical manner. When either assembly or components are replaced, perform oscillator adjustment procedure, paragraph 5-9. See Figure 8-19 for illustrated parts breakdown.

5 1.55 GHz OSCILLATOR DRIVER

See paragraph 8-30 for operational amplifier troubleshooting procedure. To isolate the operational amplifier from the output amplifier A2Q8, remove the right side panel and disconnect the 91 wire from A7C2 and connect a jumper between A2TP5 and the junction of A2R32 and pin 6 of A2U1. Adjust TRACK ADJ control fully counterclockwise. Compare voltage at A2U1 pin 2 with voltage at pin 3. The voltage levels should not differ more than $\cong 10$ mV and should be approximately 0 Vdc. If voltage levels are correct, adjust A2R27 MIN TUNE for a voltage level of +6.1 Vdc at A2U1 pin 6. If the voltage levels are not correct and/or the MIN TUNE control has no effect on the output level, replace A2U1. Remove jumper from between A2R32/U1 pin 6 and A2TP5. Compare voltage levels at the emitter, base, collector of A2Q8. To check driver voltage gain adjust TRACK ADJ for 1.00 Vdc at A2TP6. Measure level at A2TP5. The level at A2TP5 should change from $\cong +1$ to $\cong +5$ V for a 4 MHz oscillator variation. After repairs have been made connect 91 wire to A7C2 and perform adjustment procedures listed in paragraph 5-9.

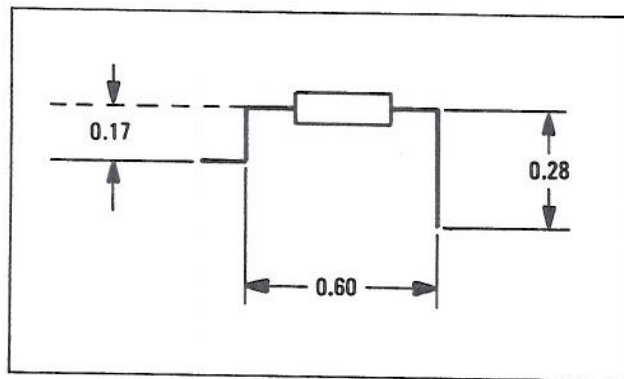

Figure 8-9. Mixer Diode Forming Dimensions in Inches

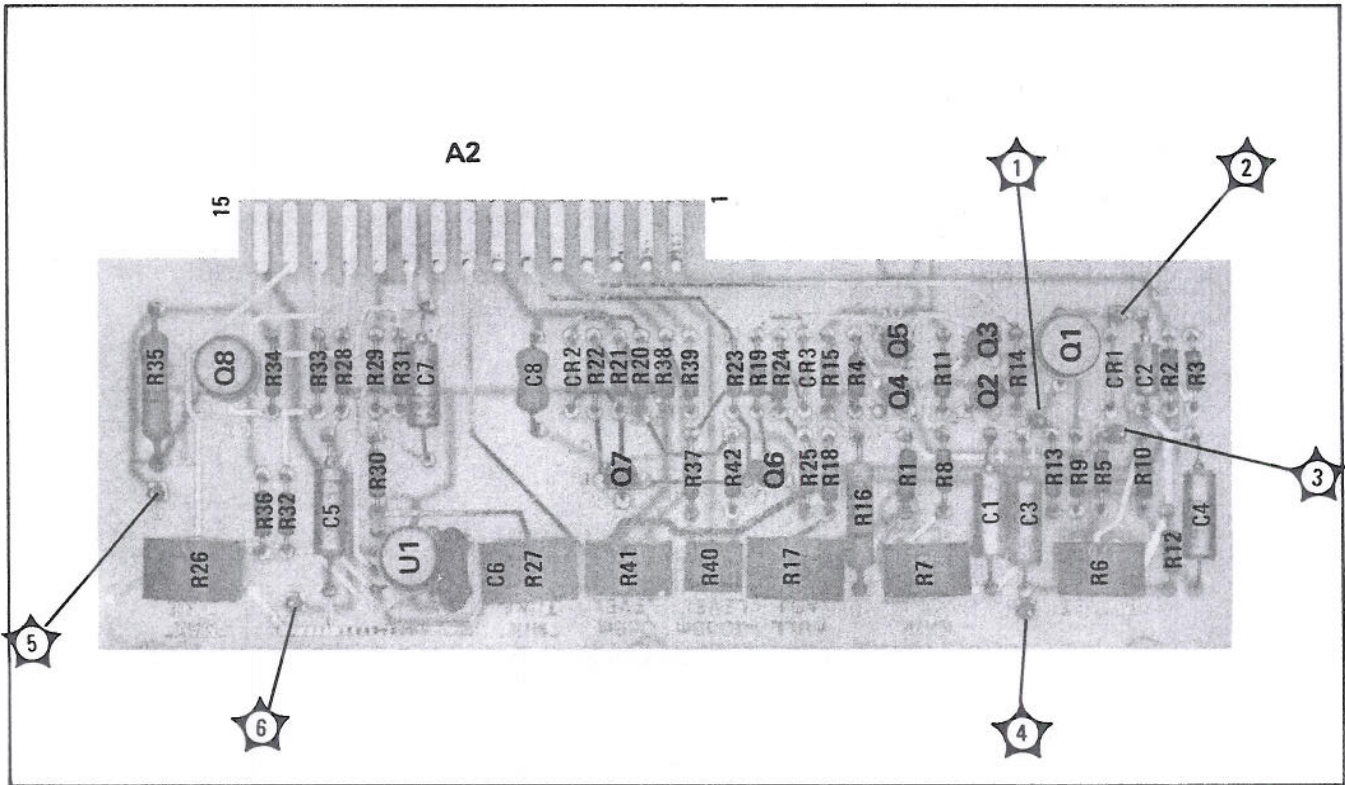

Figure 8-10. Modulator/Oscillator Driver Assy A2 Component Locations

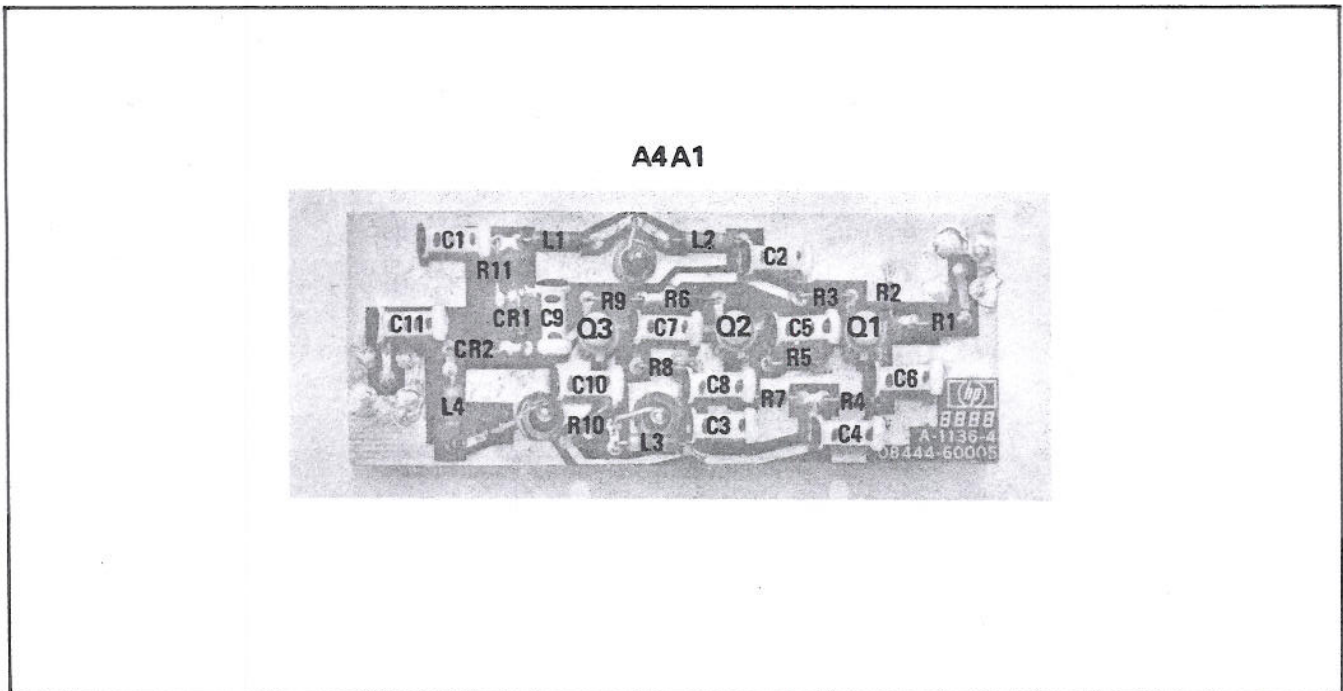

Figure 8-11. Amplifier and Pin Diode Modulator Assy A4A1 Component Locations

SERVICE SHEET 4

THEORY OF OPERATION

Service Sheet 4 contains the schematic diagram for the first LO input circuit, the second converter and the amplifier/ALC detector and level control circuits.

1 FIRST LO INPUT CIRCUIT

The first LO input circuit consists of Isolators AT1, AT2 and Filter FL1. Isolators AT1 and AT2 allow the first LO input signal to be applied to the second converter while preventing the flow of signals from second converter back to the input. Filter FL1 is a bandpass filter over the 2 to 3.4 GHz frequency range. Signals outside the bandpass frequency range are attenuated.

2 SECOND CONVERTER ASSY A6

The second converter consists of stripline circuitry and a pair of hot carrier diodes. The second converter mixes the 2 to 3.4 GHz LO signal with the 2.05 GHz first converter output signal to produce a 0 to 1.35 GHz signal that tracks the tuning of the LO input signal. Conversion loss in the second converter is typically 7 dB. The converter assembly is a sealed unit and should be repaired by replacing the entire A6 Assembly.

3 AMPLIFIER AND ALC DETECTOR ASSEMBLY A3

The amplifier and detector assembly contains large scale integrated (LSI) circuits consisting of a 3 dB attenuator, a 1.3 GHz low-pass filter, a wideband amplifier, a level detector circuit, a 1.4 GHz low-pass filter and a dc blocking capacitor. The 0 to 1.35 GHz signal from the second converter is applied through a 3 dB attenuator (for impedance matching), and a 1.3 GHz low-pass filter to the wideband amplifier. The amplifier provides approximately 26 dB gain over the frequency range of 500 kHz to 1.3 GHz. The output of the wideband amplifier is applied through a level detector circuit and a 1.4 GHz low-pass filter to the RF output connector. The level of the RF output is sampled and applied to the modulator (PIN diode) driver as the RF diode signal. A reference signal (controlled by the front panel LEVEL control and the internal 0 and -10 dBm adjustments) is applied through a second diode in the level detector circuit to the modulator driver. The level of the reference signal and the ALC circuitry is adjusted to provide an output level of 0 to -10 dBm.

4 LEVEL CONTROL CIRCUITRY

The level control circuit is a resistive divider network that establishes the level of the reference diode signal. The front panel LEVEL control adjusts the reference signal level to the ALC circuitry to provide control of the RF output level range of 0 to -10 dBm. Refer to paragraph 5-13 for calibration of the 0 and -10 dBm points.

TROUBLESHOOTING PROCEDURE

Except for the ALC level control circuitry refer to Service Sheet 2 for troubleshooting procedure.

EQUIPMENT REQUIRED

Spectrum Analyzer System HP 8554B or 8555A System
Digital Voltmeter HP 34440A/34443A

SERVICE SHEET 4 (cont'd)

1 , **2** , **3** See Service Sheet 2.

4 Perform Preset Adjustment Procedures, paragraph 4-7 or 4-9. Set Spectrum Analyzer SCAN WIDTH to ZERO. Set Tracking Generator LEVEL to 0 dBm. Measure voltage level at junction of the (958), (98), and (948) wires with the connection pins of the A3 assembly. Levels should be within ± 50 mVdc of the level listed below.

LEVEL	958	98	948
0 dBm	-50 mVdc	+240 mVdc	+350 mVdc
-10 dBm	0 mVdc	+300 mVdc	+400 mVdc

Note voltage drop across reference diode.

Typically 300 mVdc _____

If voltage levels are not within ± 50 mVdc perform adjustment procedures in paragraph 5-12 and 5-13 and repeat measurement procedures above.

REMOVAL AND REPLACEMENT PROCEDURES

See wiring detail for Amplifier and Detector Assembly A3. Microcircuits with serial numbers below 00100 have wires (98) and (958) reversed from units with serial numbers above 00101. Connect assembly according to wiring detail and serial number. Replacement assemblies are shipped with ground clips installed on the rf diode and reference diode pins. Remove clips from the replacement assembly and install on unit being returned for repair.

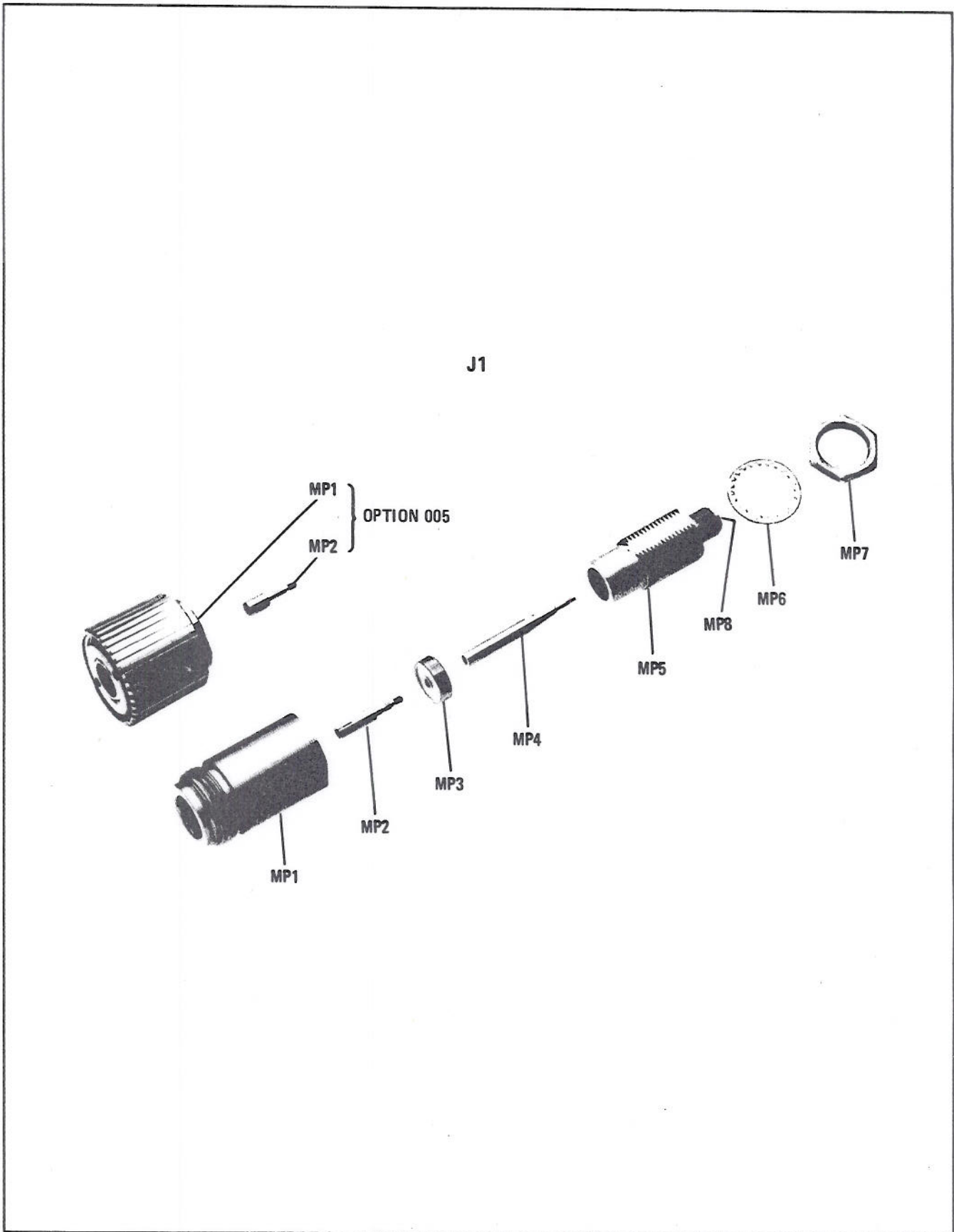

Figure 8-13. J1 RF Output Connector, Exploded View

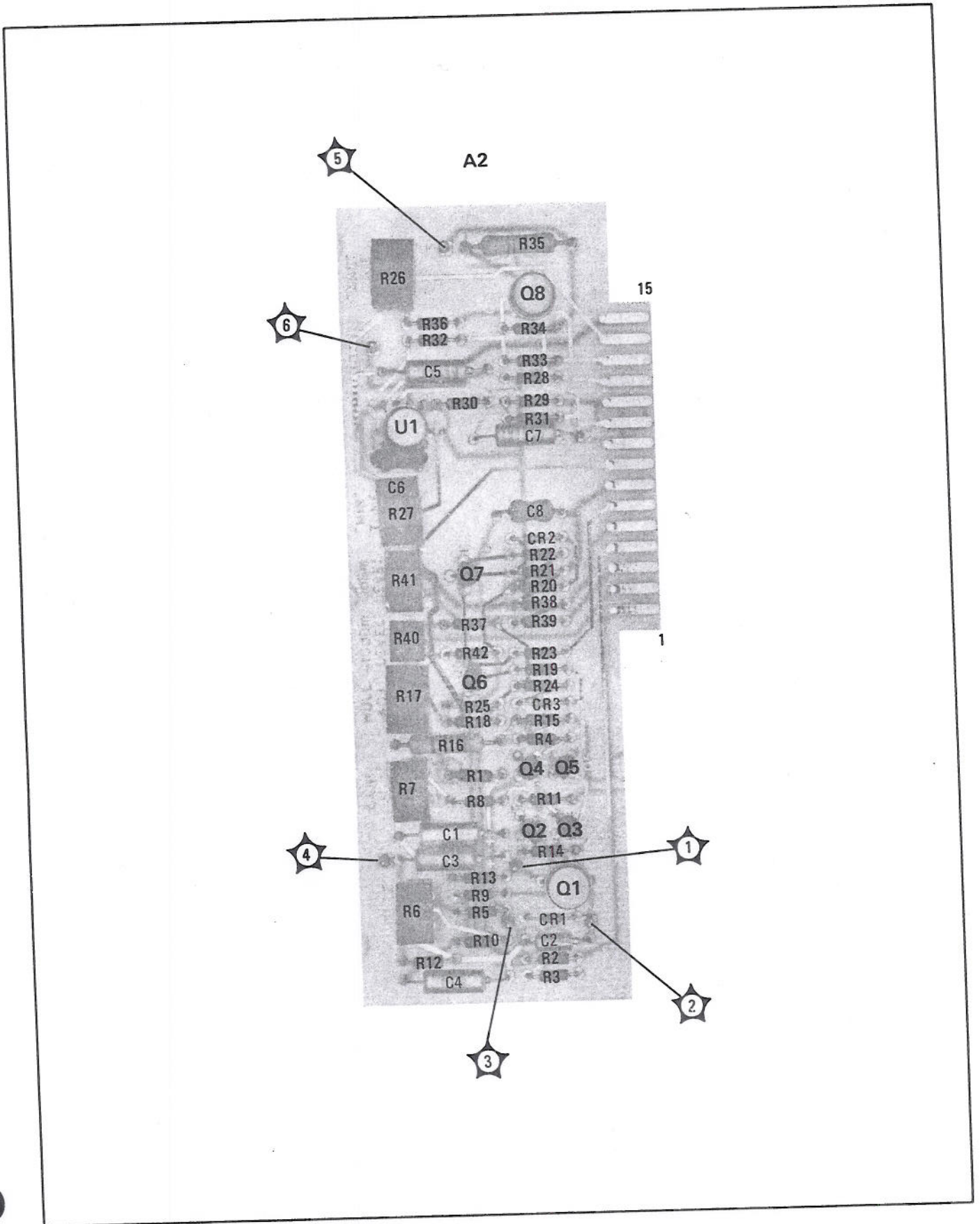

Figure 8-14. A2 Modulator/Oscillator Driver Assy, Component Location

SERVICE SHEET 5

THEORY OF OPERATION

Service Sheet 5 contains the schematic diagram for the +20 and -10 volt power supplies, the input line voltage circuit and a wiring diagram of the input line switch and power line module.

1 INPUT LINE VOLTAGE CIRCUIT

Both schematic and wiring diagram are shown for the input line voltage circuit. For 230 volt operation replace the 0.5 ampere fuse with a 0.25 ampere fuse. The power line module and ON/OFF switch wiring diagram provides a rear view for circuit tracing or component replacement.

2 +20 VOLT POWER SUPPLY

The +20 volt supply consists of bridge rectifier A1CR1-CR4, series regulator Q1, filter C1, driver A1Q3, current source A1Q1/Q2, foldback current limiter A1Q4, sense amplifier A1U1 and over-voltage and reverse voltage protection circuit consisting of A1Q5 and A1CR6-CR10. The 28V rms at 0.5 Amp input from power transformer T1 is rectified by diodes A1CR1-CR4 and filtered by C1 to provide a +40 volt unregulated source to series regulator Q1. At initial turn-on driver transistor A1Q3 and current source A1Q1/Q2 provide a +14.5 volt signal to the base of Q1 resulting in an output of approximately +13.8 volts. The low output voltage is sensed by sense amplifier A1U1 which then provides the additional turn-on signal to driver A1Q3. Adjustment of the +20 volt output is provided by + VOLTS adjustment A1R14. Fold-back current limiting is provided by A1Q4 with over current protection provided by A1F1. Over-voltage for both the +20 and -10 volt supplies is provided by a "crow-bar" circuit consisting of A1CR8 - CR10 and A1Q5. Should either supply exceed the breakdown voltage of the diodes the silicon controlled rectifier is triggered on, shorting the output of both supplies together. Diodes A1CR6 and CR7 provide reverse voltage protection. A1R9 and the front panel MANUAL SCAN control R1 provide the 0 to +10V output for MANUAL SCAN operation.

3 -10 VOLT POWER SUPPLY

The -10 volt supply consists of bridge rectifier A1CR12-CR15, filter C2, series series regulator Q2, driver A1Q7, fold-back current limiter A1Q6 and sense amplifier A1U2. The unregulated output of the bridge rectifier is filtered by C2 and regulated by Q2. +20 volts from the positive supply provides the reference for the sense amplifier A1U2. Precision resistors between the +20 volts and the -10 sense line reference the negative supply to the positive supply. The driver and current limiter function in the same manner as the driver and limiter in the positive supply.

TROUBLESHOOTING PROCEDURE

CAUTION

Before troubleshooting the power supplies, disconnect the +20 volt red (2) wire from the Amplifier and ALC Detector Assembly A3.

When a malfunction has been isolated to the power supply or line input circuits or to isolate a malfunction in the circuits, perform the following procedure.

SERVICE SHEET 5 (cont'd)**EQUIPMENT REQUIRED**

Volt-Ohm-Ammeter HP 412A
Digital Voltmeter HP 3440A/3443A

1 INPUT CIRCUIT

Check the input circuits against the wiring diagram and schematic diagram.

2 +20 VOLT SUPPLY

Turn LINE ON/OFF switch to OFF. Remove top cover and disconnect the +20 volt red (2) wire from microcircuit A3. Check fuses A1F1 and F2. If fuse A1F1 is blown, check power transistor Q1 for a short. If fuse A1F2 is blown, check power transistor Q2 for a short. After replacing fuse, apply power and check voltage at A1TP1 for +20 volts. If the voltage level is between +10 and +15 Vdc, troubleshoot operational amplifier A1U1 (paragraph 8-30) and associated circuitry. If the voltage output is less than +1 volt, remove silicon controlled rectifier A1CR10. If the output of both supplies is normal, check A1CR8, A1CR9, and A1Q5 (removing A2 assembly for access to A1 components). Also check for a short circuit external to the power supply and for a shorted A1C5. Check A1C5 by measuring voltage drop across A1R10. It should be 0 Vdc. (A 100 mV drop indicates a shorted capacitor A1C5.) If the output voltage is over +20 volts and cannot be corrected with the +VOLTS adjustment A1R14, ground anode of A1CR5 and check for an output level of +10 to +15 volts, indicating associated circuitry is functioning properly. If it is outside this range check emitter-base voltages on A1Q1, A1Q2, and A1Q3. Remove ground from anode of A1CR5 and perform adjustment procedures in paragraph 5-8.

3 Troubleshoot the -10 volt supply in a similar manner. Check input to operational amplifier, remove Q2 and check voltage at emitter of A1Q7, remove A1Q7 and repeat voltage measurement at emitter of A1Q7. Check A1C9 for short.

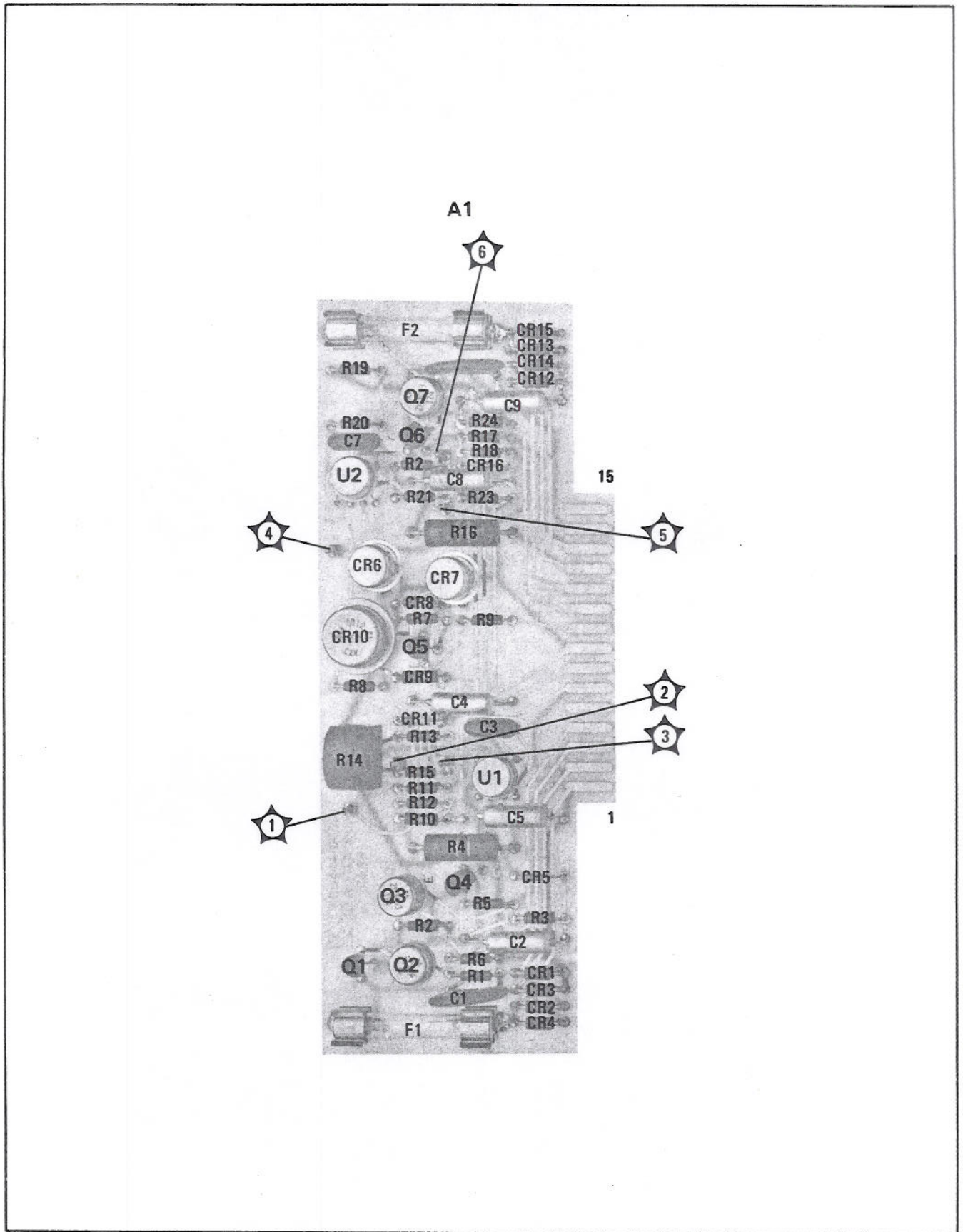

Figure 8-16. A1 Power Supply Assy, Component Location

LINE ON/OFF SWITCH AND WHER LINE MODULE WIRING

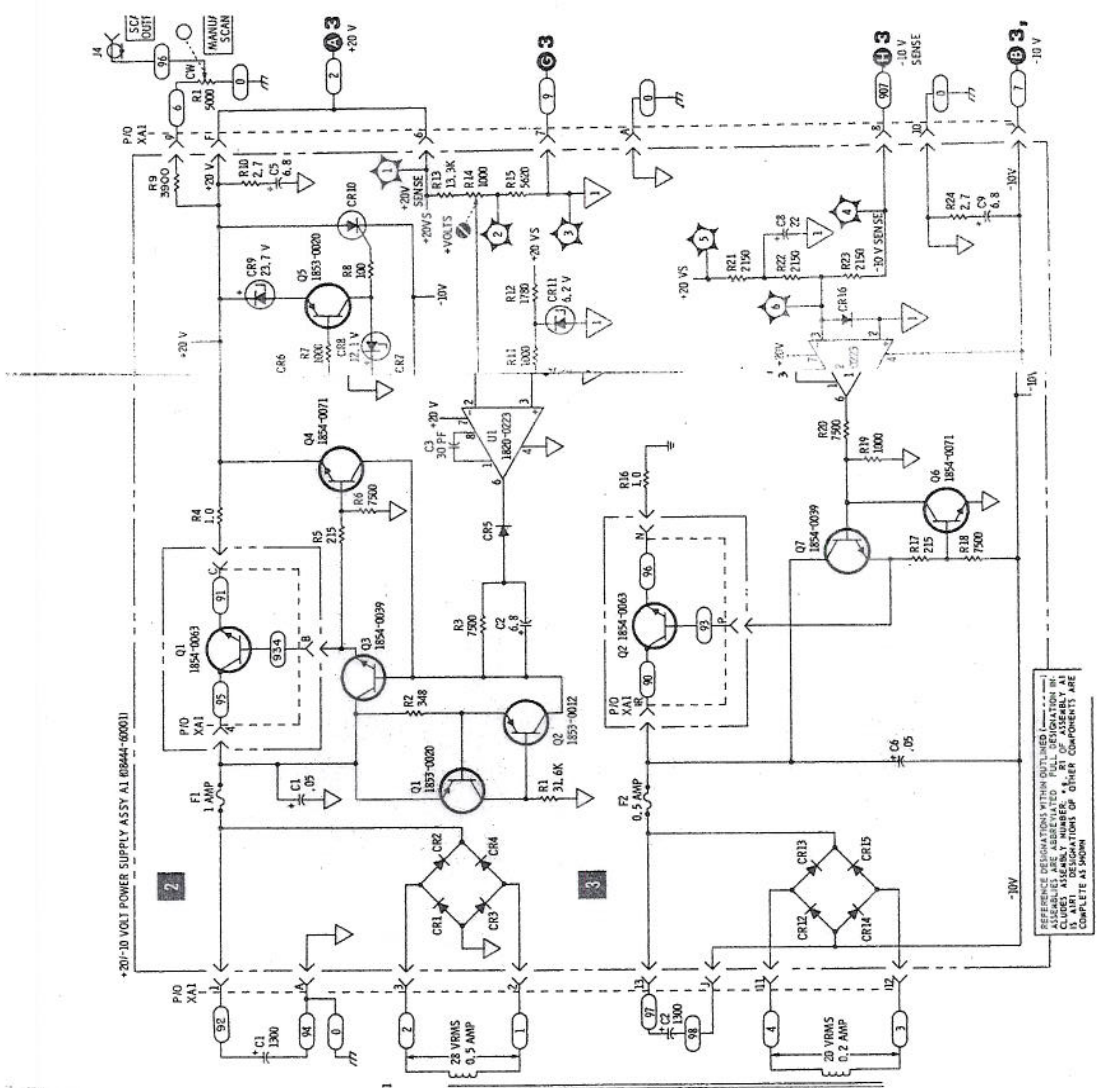
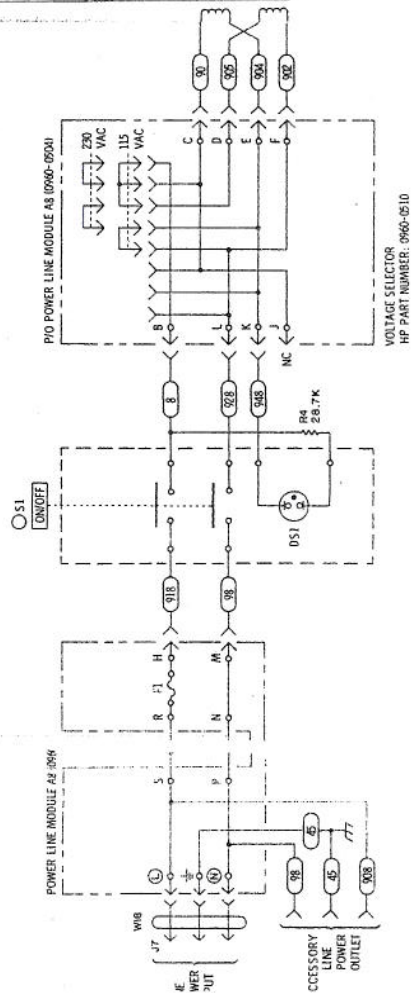
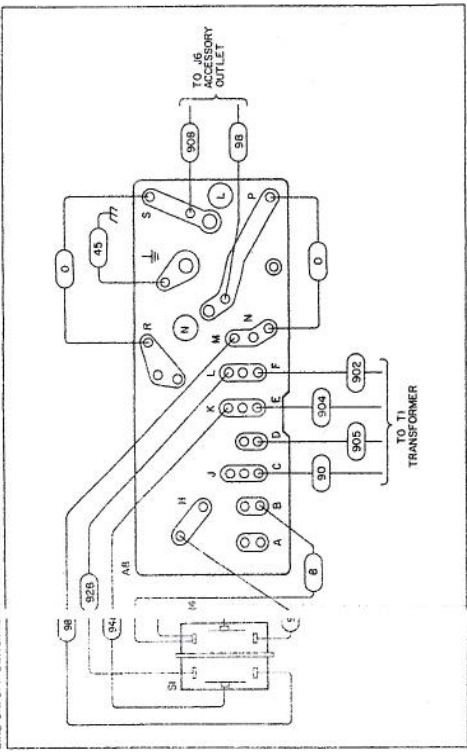
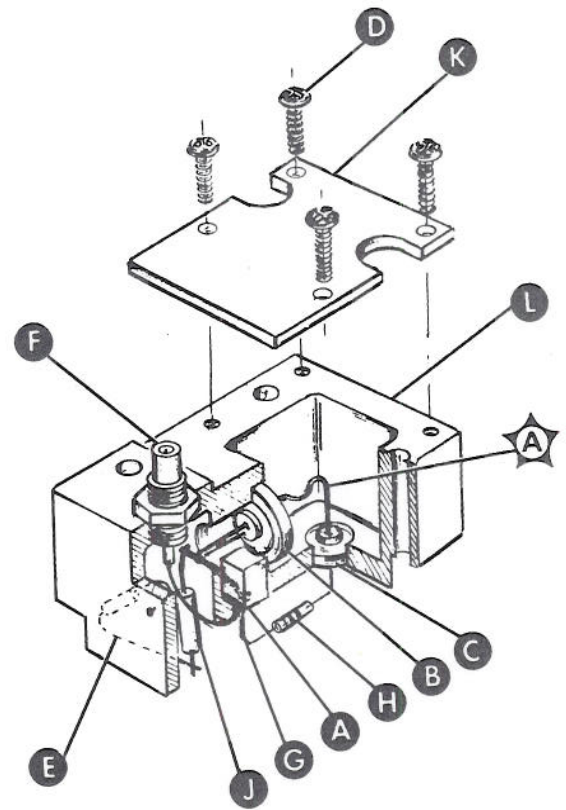
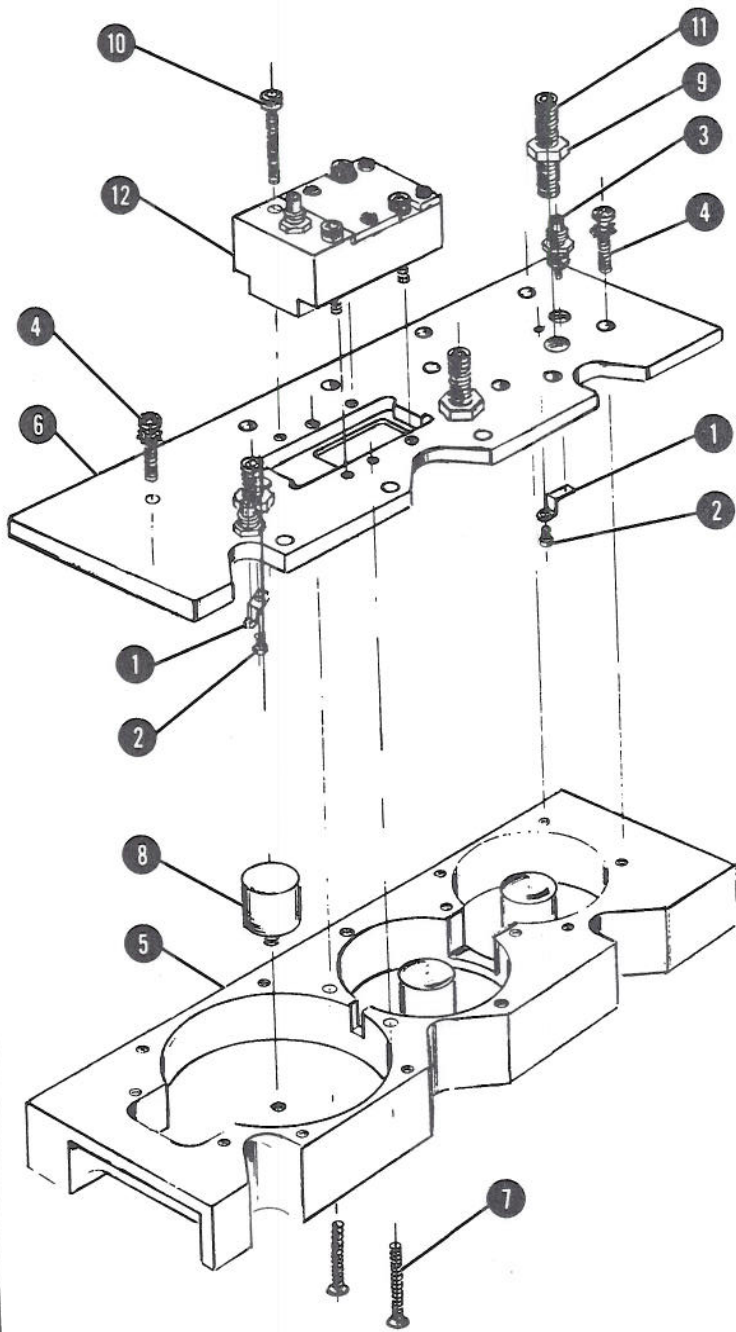

Figure 8-17. Power Supply and Input Circuit, Schem



ITEM 12 MIXER OUTPUT ASSY

Figure 8-18. A5 First Converter Assembly, Illustrated Parts Breakdown (1 of 2)

Item No.	Ref. Des.	Description	HP Part No.	Qty
1	A5MP1	INPUT-OUTPUT LOOP	08555-00033	2
2	A5MP2	SCREW: PAN HD SLOT DR 0-80 X 0.88" LG.	0516-0005	2
3	A5J1	CONNECTOR: RF 50-OHM SCREW ON	1250-0829	3
3	A5J2	CONNECTOR: RF 50-OHM SCREW ON	1250-0829	3
3	A5J3	CONNECTOR: RF 50-OHM SCREW ON	1250-0829	3
4	A5MP3	SCREW: PAN HD POZI DR 5-40 X 0.5" LG	2200-0111	14
5	A5MP4	CAVITY BLOCK: FIRST CONVERTER	08555-20035	1
6	A5MP5	COVER: CAVITY BLOCK	08444-20012	1
7	A5MP6	SCREW: FLAT HD POZI DR 4-40 X 0.874" LG	2200-0172	2
8	A5MP7	CENTER POST: CAVITY	08444-20007	1
9	A5MP8	NUT: HEX STL 10-32 X 3/8"	2740-0001	3
10	A5MP9	SCREW: SOCKET CAP 4-40" THREAD	3030-0151	4
11	A5MP10	SCREW: SET 10-32" UNF-2A THREAD	3030-0397	3
12	A5A1	MIXER: OUTPUT ASSY	08444-60012	1
A	A5A1C1	C: FXD CER 1000 PF 20% 100 VDCW	0160-2327	1
B	A5A1C2	C: FXD MICA 39 PF 5% 250 VDCW	0160-2327	1
C	A5A1C3	C: FXD MICA 18 PF 5% 250 VDCW	0160-3861	1
D	A5A1MP1	SCREW: PAN HD POZI DR 2-56 X 0.25" LG	0520-0128	4
E	A5A1R1	R: FXD MET FLM 750 OHM 2% 1/8W	0698-7233	1
F	A5A1J1	See A5J1 ABOVE		
G	A5A1MP2	CONNECTOR: SINGLE CONTACT	1251-1556	1
H	A5A1CR1	DIODE: HOT CARRIER	1901-0633	1
J	A5A1L1	COIL: CHOKER 0.39 UH 10%	9100-2254	1
K	A5A1MP3	LID: RESONATOR HOUSING	08555-00031	1
L	A5A1MP4	RESONATOR HOUSING	08555-20036	1

Figure 8-18. A5 First Converter Assembly, Illustrated Parts Breakdown (2 of 2)

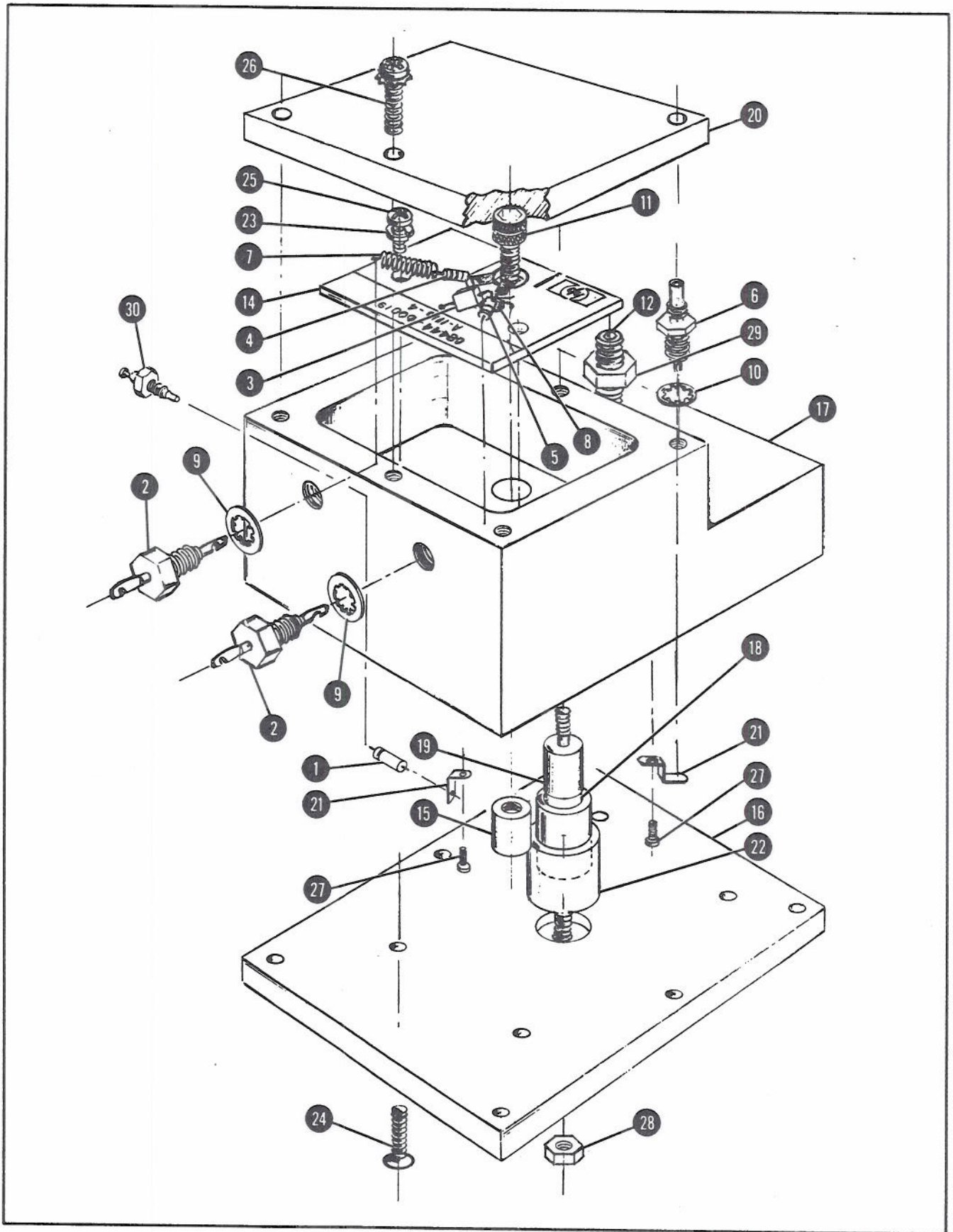

Figure 8-19. A7 1.55 GHz Oscillator Assembly, Illustrated Parts Breakdown (1 of 2)

Item No.	Ref. Des.	Description	HP Part No.	Qty
1	A7CR1	DIODE: VOLTAGE VAR 6.8 pF	0122-0245	1
2	A7C2/C3	C: FXD 1000 pF 500 VDCW	0160-0345	2
3	A7C1	C: FXD 1.0 pF 0.1%	0160-3827	1
4	A7R1	R: FXD 562 OHM	0698-7230	1
5	A7R2	R: FXD 619 OHM	0757-0418	1
6	A7J1	CONNECTOR: RF	1250-0829	1
7	A7L1	SPRING: COMPRESSION	1460-0103	1
8	A7Q1	TRANSISTOR: SI NPN	1854-0292	1
9		WASHER: LOCK 0.211 DIA	2190-0057	2
10		WASHER: LOCK 0.191 DIA	2190-0124	1
11		SCREW: SOCKET CAP 8-32 X 0.625	3030-0047	1
12		SCREW: SET 10-32 X 1.000 LG	3030-0397	1
13		DELETED		
14		PC BOARD: OSCILLATOR BLANK	08444-20003	1
15		INSULATOR	08444-20006	1
16		COVER: OSC HOUSING BOTTOM	08444-20008	1
17		HOUSING: OSCILLATOR	08444-20010	1
18		DIELECTRIC: CAPACITOR	08444-20013	1
19		INNER ELEMENT: CAPACITOR	08444-20015	1
20		COVER: OSCILLATOR HOUSING TOP	08444-20028	1
21		INPUT/OUTPUT LOOP	08555-00033	1
22		CAPACITOR: OUTER ELEMENT	08555-20040	1
23		WASHER: LOCK NO. 4	2190-0003	2
24		SCREW: MACHINE 4-40 X 0.438 LG	2200-0109	6
25		SCREW: MACHINE 4-40 X 0.250 LG	2200-0139	2
26		SCREW: MACHINE 4-40 X 0.375 LG	2200-0167	6
27		SCREW: PAN HD 0-80 X 0.125 LG	0516-0003	1
28		NUT: HEX 6-32	2420-0003	1
29		NUT: HEX 10-32	2740-0002	1

Figure 8-19. A7 1.55 GHz Oscillator Assembly, Illustrated Parts Breakdown (2 of 2)

APPENDIX A REQUIRED MODIFICATION WHEN REPLACING A3 AMPLIFIER DETECTOR ASSEMBLY

HP MODEL 8444A TRACKING GENERATOR

Serials Prefixed 1147A and Below

When replacing the A3 Amplifier Detector Assembly in the HP Model 8444A, serials prefixed 1147A and below, a capacitor C3, 3300 pF, HP Part No. 0160-0155, is a required addition for proper instrument operation. The capacitor is electrically connected between the RF Diode Signal line and ground. For easiest installation, connect the capacitor between connector pins XA2-1 and XA2-7. Pin 1 is located nearest the instrument front panel.

APPENDIX B REPLACEMENT FOR A7 1.55 GHz OSCILLATOR ASSEMBLY

HP MODEL 8444A TRACKING GENERATOR

Serials Prefixed 1147A and Below

The HP Part No. 08444-60019 assembly is the recommended replacement for the old 08444-60003 A7 assembly. Since the old and new A7 assemblies are not directly interchangeable, minor modifications are required when installing the new A7. The additional parts required for the modification are: (one each)

HP 0757-0438 5.11K, 1%, 1/8 W Resistor
 HP 0757-0439 6.81K, 1%, 1/8 W Resistor
 HP 0757-0465 100K, 1%, 1/8 W Resistor
 HP 8150-0449 30" Red No. 24 AWG Wire

MODIFICATIONS

1. A7 hookup (refer to Figures 8-12 and 8-19):
 - a. Connect the wht-brn wire to new A7C4.
 - b. Add red wire; connect between +20V (XA1-6) and A7C2.

- c. Connect violet and wht-blk-violet wires to A7C3.

2. Component changes:

- a. Add R5, 5.11K, 0757-0438 between connector pins XA2-10 and unused XA2-12; then short pins XA2-12 and XA2-11 (-10V) together.
- b. Replace A2R29 with 100K, 0757-0465.
- c. Replace A2R36 with 6.81K, 0757-0439.

CALIBRATION

To calibrate the new A7 assembly, follow the 1.55 GHz Oscillator Power Level, Frequency Check and Adjustment procedure, pages 5-3 to 5-5.

APPENDIX C

IMPROVED POWER SUPPLY STABILITY

HP MODEL 8444A TRACKING GENERATOR

Serials Prefixed 1147A and Below

The +20V power supply stability can be improved by changing A4A1C2 from 24 pF to 1000 pF, HP Part No. 0160-3456. The new value eliminates any oscillation tendencies and is a recommended modification for all instruments with serials listed above.

APPENDIX D

MODEL 8444A TRACKING GENERATOR, OPTION 058

D1. INTRODUCTION

D2. This appendix explains the use of an 8444A Tracking Generator with an 8558B/180 Spectrum Analyzer system when Option 058 circuitry is added to the 8444A. The Tracking Generator is designed to generate a CW tracking signal for an 8555A/8552/140 Spectrum Analyzer system when operating in the range of 0.5 to 1300 MHz. With Option 058 circuits added, a 0.5 to 1300 MHz CW tracking signal can also be generated by an 8444A when it is coupled to an 8558B/180 Spectrum Analyzer system.

D3. DESCRIPTION

D4. To provide a tracking signal for an 8555A/8552/140 Spectrum Analyzer, an 8444A Tracking Generator must be fed a 2.05 to 4.1 GHz tuned oscillator signal from the 8555A First LO, plus a 500 MHz signal from the 8555A Third LO. When mixed with the internal 1.55 GHz oscillator in the 8444A, a 0.5 to 1300 MHz tracking signal output is produced.

D5. To develop a 0.5 to 1300 MHz tracking signal for an 8558B/180 Spectrum Analyzer/Display system, a 2.05 to 3.55 GHz First LO is available from the 8558B, but no 500 MHz LO is used in this instrument. Option 058 consists of a 500 MHz oscillator for the 8444A. This 500 MHz signal is brought out on a separate BNC connector on the rear panel of the 8444A, directly above the THIRD LO INPUT BNC connector. When the 8444A is used with an 8558B/180 Spectrum Analyzer system, the two rear panel BNC connectors are interconnected with a short BNC cable. With the First LO from the 8558/B plus its own 500 MHz LO signal, the 8444A can provide a 0.5 to 1300 MHz tracking signal for the 8558B Spectrum Analyzer system.

D6. MANUAL CHANGES TO INCORPORATE OPTION 058

D7. Section 1.

D8. 8444A System Specifications with Option 058 added are listed in Table D-1.

Table D-1. 8444A System Specifications with Option 058

SPECIFICATIONS	
<p>These specifications apply to the 8444A Option 058 when used with the 8558B Spectrum Analyzer ONLY. Specifications of the 8444A Option 058 when used with the 8554B and 8555A Spectrum Analyzers can be found in Table 1-1 of the 8444A manual.</p>	
<p>SWEPT FREQUENCY RESPONSE MEASUREMENTS</p> <p>Dynamic Range: >90 dB from Spectrum Analyzer 1 dB gain compression point to average noise level (approximately -10 dBm to -100 dBm).</p> <p>Average Noise Level: -107 dBm with 10 kHz Resolution bandwidth.</p>	<p>Absolute Amplitude Calibration Range</p> <p>Spectrum Analyzer:</p> <p>Log: From -117 dBm to +30 dBm, 10 dB/div on a 70 dB display or 1 dB/div on an 8 dB display.</p> <p>Linear: From 2.2 μV (-100 dBm) to 7.1V (+30 dBm), full scale in 10 dB steps.</p>

Table D-1. (Continued)

<p>Frequency Range: 500 kHz to 1300 MHz</p> <p>Scan Width: (Determined by Spectrum Analyzer Controls): Per Division: 14 Calibrated Scan Widths from a 5 kHz/div to 100 MHz/div in a 2,5,10 sequence. "0" Scan: Analyzer is a fixed tuned receiver.</p>	<p>Sweep Rates: Selected by Sweep Time per Division on Spectrum Analyzer. 11 internal scan rates from 5m sec/div to 10 sec/div in a 1,2,5 sequence. Manual sweep is available with a front panel control of the 8558B. Auto Sweep is automatically controlled by FREQ SPAN/DIV, RESOLUTION BW, and VIDEO FILTER settings.</p>
<p>Frequency Resolution: 3 kHz.</p> <p>Stability: Residual FM (peak-to-peak): 1 kHz for time ≤ 0.1 sec.</p> <p>Amplitude Accuracy: System Frequency Response: ± 1.50 dB (0.5 dB for 8444A-058, ± 1.0 dB for 8558B).</p>	<p style="text-align: center;">PRECISION FREQUENCY MEASUREMENTS</p> <p>An external counter output is provided on the 8444A for precision frequency measurements. The frequency of unknown signals as well as the frequency of any point on a frequency response curve can be measured. The use of the 5300A/5303A Counter is suggested for frequency measurements to 500 MHz and the 5245L/5254C Counter for measurements to 1300 MHz.</p>
<p style="text-align: center;">SWEEP/CW GENERATOR</p> <p>Frequency: Controlled by Spectrum Analyzer. Range 500 kHz to 1300 MHz. Scan widths are determined by Spectrum Analyzer controls.</p> <p>Frequency Accuracy: Same as the 8558B. Can be improved using an external counter.</p> <p>Flatness: ± 0.5 dB.</p> <p>Spectral Purity: Residual FM (peak-to-peak): 1 kHz for time ≤ 0.1 sec. Harmonic Distortion: 25 dB below output level (typical). Nonharmonic (spurious) Signals: 35 dB below output level.</p> <p>Long Term Stability: Drift typically less than 30 kHz/10 min. (20 kHz for 8558B, 10 kHz for 8444A) when stabilized after 2-hour warm-up.</p> <p>Sweep Width: 50 kHz to 1000 MHz.</p>	<p>Frequency Accuracy (Tracking Generator Output): For unknown signals, typically less than ± 3 kHz frequency error after tracking adjustment with 10 kHz BW. (Tracking drift typically 10 kHz/10 min. after 2-hour warmup.)</p> <p>For points on frequency response curve, counter accuracy \pm Residual FM (1 kHz peak-to-peak for time ≤ 0.1 sec).</p> <p>Counter Mode of Operation: Manual Scan: Scan determined by front panel control of 8558B. "0" Scan: Analyzer is a fixed-tuned receiver. Counter reads center frequency to accuracy of tracking drift. Counter Output Level: Nominally 0.1 Vrms.</p>
	<p style="text-align: center;">NOTE</p> <p>All above changes in specifications apply to use with an 8558B only.</p>

D9. SECTION III OPERATION

D-10. Add the following 8444A Option 058 Tracking Generator Operation information when using the 8558B Spectrum Analyzer.

1. Check that the 115/230V switch is set to correspond with the available line voltage. Refer to Figure 3-2, steps 4 through 8, for switch and fuse information.
2. Apply power to Tracking Generator and Spectrum Analyzer.
3. Turn Spectrum Analyzer INTENSITY control fully CCW.
4. Allow instruments to warm up for at least 30 minutes.
5. Perform Spectrum Analyzer "Operation Check." Refer to 8558B Spectrum Analyzer Operating Manual.

6. Set Spectrum Analyzer LOG/LINEAR control to LOG, and BANDWIDTH to 300 kHz.
7. Set OPTIMUM INPUT dBm to 0, and REF LEVEL dBm to 0 dBm.
8. Make the following interconnections between tracking Generator and Spectrum Analyzer.
 - a. 8558B FIRST LO OUTPUT to 8444A FIRST LO INPUT.
 - b. 8558B RF INPUT to the 8444A RF OUTPUT.
 - c. Jumper 500 MHz OUTPUT to THIRD LO INPUT (Rear Panel 8444A-058).
9. Check that the Spectrum Analyzer controls are set as follows:

INTENSITY	12 o'clock (approx.)
FREQUENCY MHz	30 MHz
RESOLUTION BW	300 kHz
FREQ SPAN/DIV	50 kHz
BASE LINE CLIPPER	CCW
SWEEP TIME/DIV	5 MILLISECONDS
dB/DIV-LIN	10 dB/DIV
OPTIMUM INPUT dBm	0
REF LEVEL dBm	0 dBm
REF LEVEL FINE	0
VIDEO FILTER	2 o'clock
SWEEP TRIGGER	LINE

10. Set Tracking Generator LEVEL control to 0 dBm and adjust TRACK ADJ for maximum signal amplitude indication on CRT display.
11. Adjust Spectrum Analyzer REF LEVEL FINE control or Tracking Generator LEVEL control to position signal on CRT LOG REF level graticule line. (System calibrated at 30 MHz with an amplitude accuracy of ± 0.5 dB.)
12. Set Spectrum Analyzer to scan desired frequency range.
13. Insert device to be tested between Tracking Generator RF OUTPUT and Spectrum Analyzer RF INPUT.
14. Set Spectrum Analyzer Sweep Time to MAN.
15. Rotate Spectrum Analyzer MANUAL SWEEP control clockwise to tune system through selected frequency range.
16. For automatic scanning, set SCAN MODE switch to INT and SWEEP TIME/DIV to desired scan time. Do not use sweep times faster than 5 msec/DIV.

D11. SECTION V, ADJUSTMENTS

D12. Add the following: Proper operation of the SPECIAL 500 MHz Oscillator after a one-hour warm-up may be checked in the following manner:

1. Connect the 500 MHz OUTPUT (Third LO OUTPUT, Figure D-2) on the rear panel of the 8444A to a 432A Power Meter.
2. Adjust "L.O. PWR" on Oscillator Assembly (A9) to set oscillator output power to $+4$ dBm $\pm .5$ dB.
3. Disconnect oscillator output from power meter and connect to 5254C Frequency Counter.
4. Adjust "FREQ ADJ" on Oscillator to set frequency to 500 MHz \pm 200 kHz.

5. Check power output again and re-adjust if necessary.
6. Repeat steps 2 through 5 until the two test limits are both met.

D-13. SECTION VI, REPLACEABLE PARTS

Page 6-7, Table 6-2:
Add the following parts:

Table D-2. Replaceable Parts

Reference Designation	HP Part Number	Qty	Description	Mfr Code	Mfr Part Number
A9	08444-60024	1	500 MHz OSCILLATOR ASSEMBLY	28480	08444-60024
A9C1	0160-2357	2	C:FXD 1000PF +80 -20% 500WVDC CER	28480	0160-2357
A9C2	0160-2357		C:FXD 1000PF +80 -20% 500WVDC CER	28480	0160-2357
A9J1	1250-0828	1	CONNECTOR: 50 OHM	28480	1250-0828
A9L1	08554-00015	1	COUPLING: LO OUTPUT	28480	08554-00015
A9R1	0698-7200	1	R:FXD 31.6 OHM 2% .05W	24546	C3-1/8-TOO-31R6-G
A9A1	08444-60020	1	OSCILLATOR ASSEMBLY: 500 MHz	28480	08444-60020
A9A1C1	0160-2247	1	C:FXD 3.9PF ± .25PF 500WVDC CER	28480	0160-2247
A9A1C2	0121-0414	1	C:VAR TRMR 1.9 - 8.5PF; AIR	74970	189-253-5 MODIFIED
A9A1L1	08554-00007	1	INDUCTOR: 500 MHz OSC.	28480	08554-00007
A9A1Q1	1854-0323	2	TRANSISTOR: NPN	28480	1854-0323
A9A1Q2	1854-0323		TRANSISTOR: NPN	28480	1854-0323
A9A1R1	0698-3447	1	R:FXD 422 OHM 1% 1/8W	16299	C4-1/8-TO-422R-F
A9A1R2	0757-0280	2	R:FXD 1K OHM 1% 1/8W	24546	C4-1/8-TO-1001-F
A9A1R3	0757-0280		R:FXD 1K OHM 1% 1/8W	24546	C4-1/8-TO-1001-F
A9A2	08444-60031	1	POWER SUPPLY FILTER ASSEMBLY	28480	08444-60031
A9A2C1	0160-2055	2	C:FXD .01 UF +80 -20% 100WVDC CER	28480	0160-2055
A9A2C2	0160-2055		C:FXD .01UF +80 -20% 100WVDC CER	28480	0160-2055
A9A2C3	0180-0049	2	C:FXD 20UF +75 -10% 50WVDC AL	56289	300206G050CC2
A9A2C4	0180-0049		C:FXD 20UF +75 -10% 50WVDC AL	56289	300206G050CC2
A9A2CR1	1901-0040	2	DIODE: SWITCHING 2NS 30V 50MA	28480	1901-0040
A9A2CR2	1901-0040		DIODE: SWITCHING 2NS 30V 50MA	28480	1901-0040
A9A2Q1	1854-0404	2	TRANSISTOR: NPN	28480	1854-0404
A9A2Q2	1854-0404		TRANSISTOR: NPN	28480	1854-0404
A9A2R1	2100-1775	1	R:VAR 5K OHM 5% WW	28480	2100-1775
A9A2R2	0698-3155	2	R:FXD 4.64K OHM 1% 1/8W	16299	C4-1/8-TO-4641-F
A9A2R3	0698-3155		R:FXD 4.64K OHM 1% 1/8%	16299	C4-1/8-TO-4641-F
A9A2R4	0698-0083	1	R:FXD 1.96K OHM 1% 1/8W	16299	C4-1/8-TO-1961-F
A9A2R5	0698-0082	1	R:FXD 464 OHM 1% 1/8W	16299	C4-1/8-TO-4640-F
W19	08444-60025	1	CABLE: COAX; 500 MHz OUTPUT	28480	08444-60025

D-14. SECTION VIII, SERVICE

D-15. Description of Option 058: A two-transistor, 500-MHz fixed-tuned local oscillator with power supply processing circuits, Assembly A9, is added to the 8444A. The 500 MHz LO Output is routed to a BNC connector on the rear panel directly above the THIRD LO INPUT BNC connector. Power supply voltages for the A9 500 MHz Oscillator Assembly are routed from the PC connector XA1 on the bottom of the 8444A.

D16. Figure D-1 is a top view of the 8444A including the Option 058 500 MHz A9 Oscillator Assembly with its BNC connector on the rear panel.

D17. Figure D-2 shows the rear panel of an 8444A Option 058 with the added 500 MHz OUTPUT BNC connector above the THIRD LO INPUT connector.

D18. Figure D-3 is a schematic diagram of the 500 MHz Oscillator used with Option 058, a capacitance multiplier used as additional filter for the 8444A +20V power supply, and an adjustable current regulator for the -10V 8444A power supply.

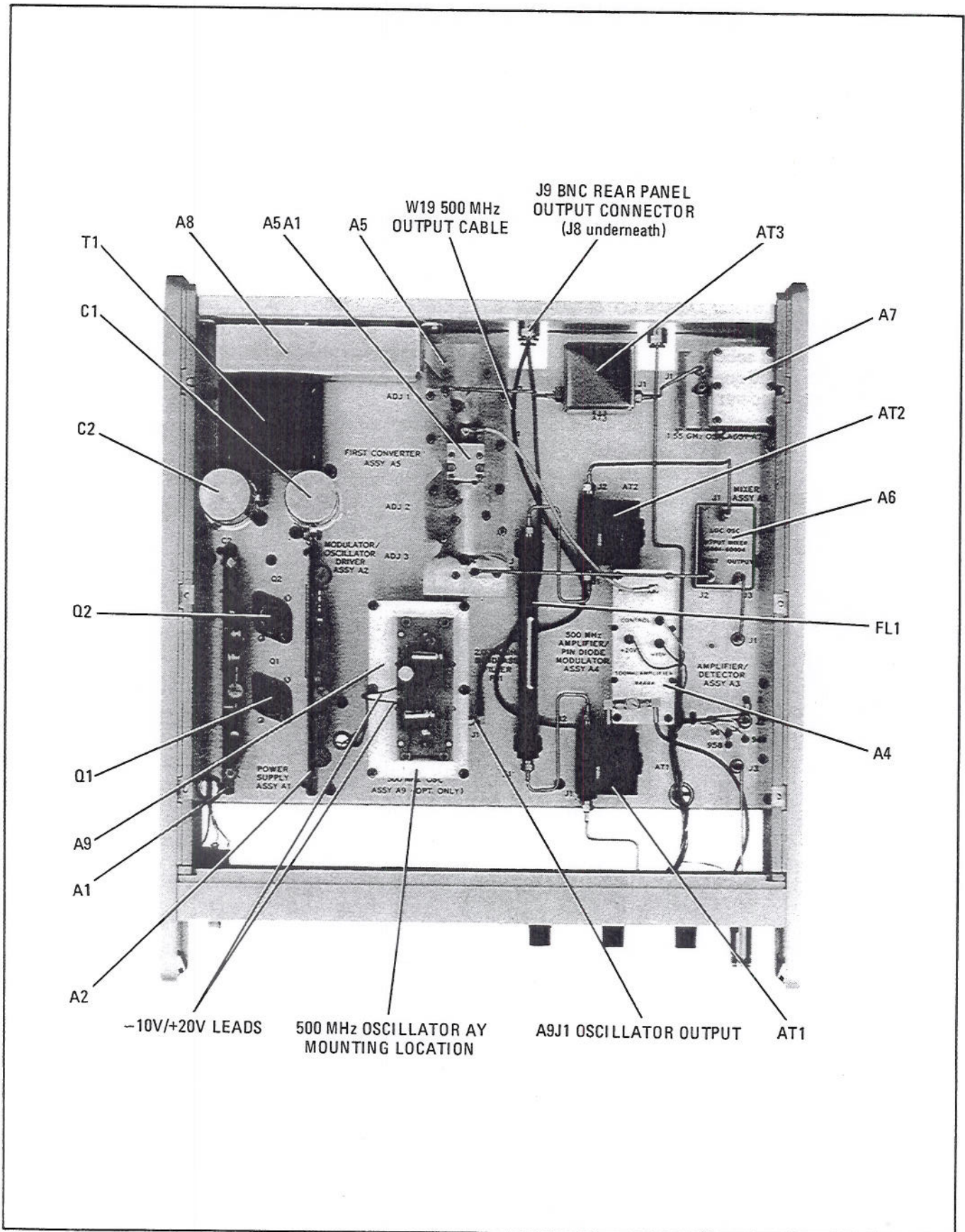
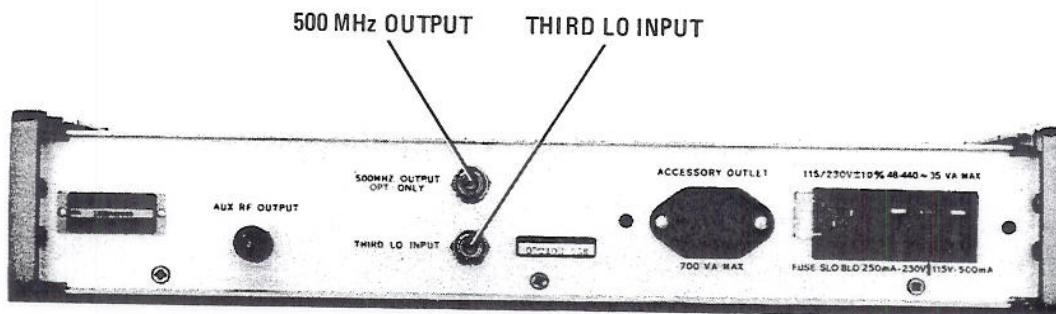

Figure D-1. 500 MHz LO Mounting Location and Output Port for the 8444A, Option 058



When using the 8444A with an 8558B/180 Spectrum Analyzer the 8444A 500 MHz OUTPUT and its THIRD LO INPUT must be interconnected with a short cable.

*Figure D-2. Location of 500 MHz LO OUTPUT BNC Connector
Added on Rear Panel of the 8444A, Option 058*

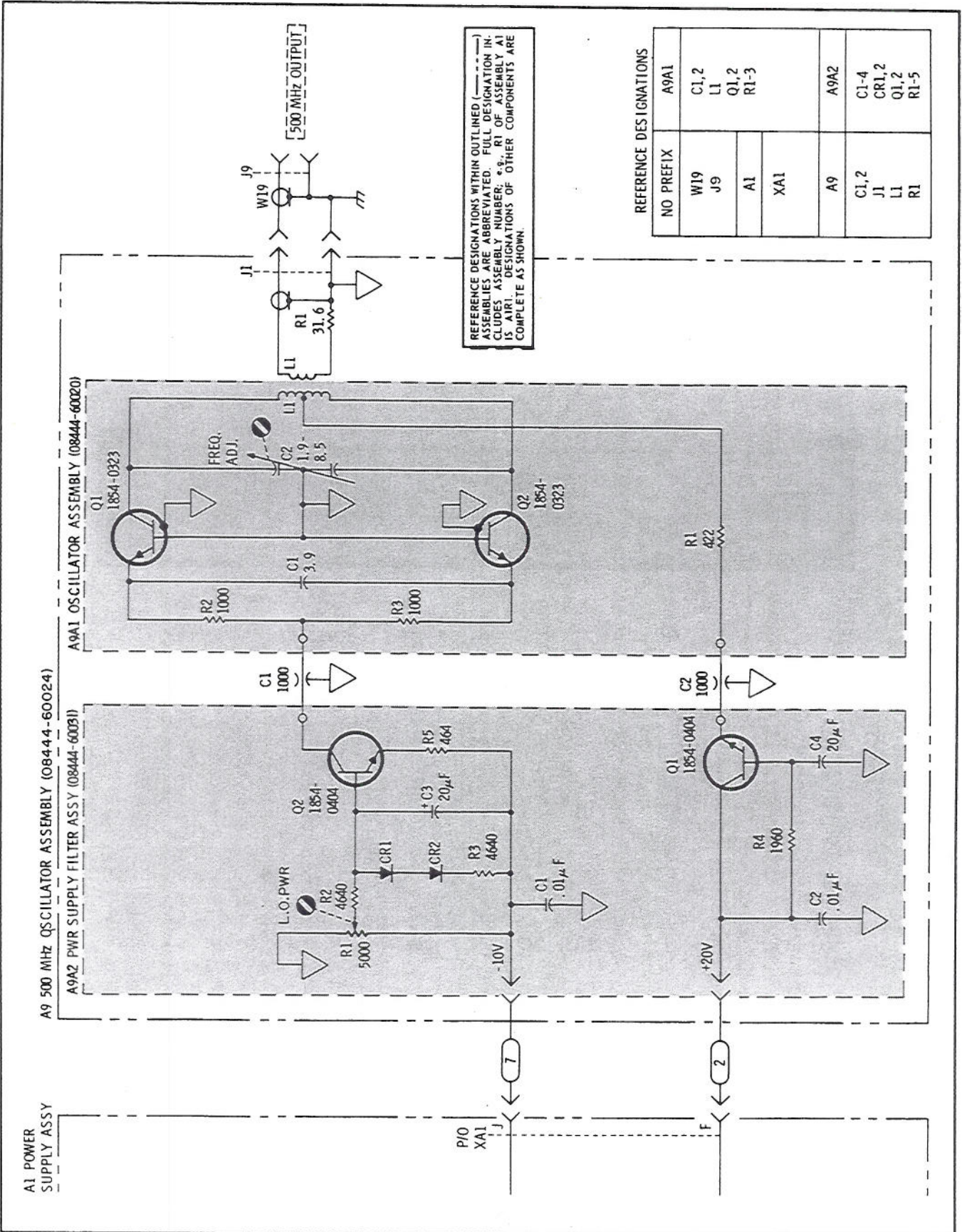

Figure D-3. A9 500 MHz Oscillator Assembly, Schematic

APPENDIX E

MODEL 8444A TRACKING GENERATOR, OPTION 059

E-1. INTRODUCTION

E-2. This appendix describes the Model 8444A Option 059 Tracking Generator as compared to the standard 8444A Tracking Generator. The use of this tracking generator with various Hewlett-Packard spectrum analyzers is also explained.

E-3. DESCRIPTION

E-4. The standard 8444A Tracking Generator is intended to provide either a 0.5 to 1250 MHz tracking signal for the 8554B/8552/140 Spectrum Analyzer or a 10 to 1300 MHz tracking signal for the 8555A/8552/140 Spectrum Analyzer. To provide this tracking signal, a First L.O. signal of approximately 2 to 4 GHz and a Third L.O. signal of 500 MHz are required. Both of these signals are available from the 8554B and 8555A Spectrum Analyzer RF Sections.

E-5. To use the 8444A Tracking Generator with the 8558B installed in a 180 series mainframe, 8565A, or 8568A Spectrum Analyzer, the Option 059 modification must be installed in the tracking generator. This modification adds an internal 500 MHz oscillator to provide the Third L.O. signal which the above mentioned analyzers do not provide. Also, this modification extends the upper frequency limit to 1500 MHz to allow coverage of the full frequency range of these analyzers.

E-6. SPECIFICATIONS

E-7. Table E-1 lists the specifications for the 8444A Option 059 Tracking Generator only. Typical system performance characteristics for the tracking generator when used with the 8558B, 8565A, or 8568A Spectrum Analyzer are located in Table E-2. Specifications for the 8444A Option 059 when used with either the 8554B or 8555A are the same as listed in Table 1-1 for the standard 8444A Tracking Generator up to a frequency of 1300 MHz.

E-8. OPERATION

E-9. Figures E-4 through E-6 illustrate the proper equipment connections for operation of the 8444A Option 059 Tracking Generator with the 8558B, 8565A, or 8568A Spectrum Analyzer.

E-10. The 8444A Option 059 may also be used with the 8554B or 8555A Spectrum Analyzer. However, for proper operation, the Third L.O. output from the spectrum analyzer should be used rather than the output of the tracking generator's internal oscillator. Equipment connections for operation with the 8554B or 8555A is illustrated in Section III.

E-11. PERFORMANCE TESTS

E-12. To test the 8444A Option 059 Tracking Generator for compliance with specifications, perform the Harmonic and Distortion Test outlined in Section IV using the specification from Table E-1. In addition to this test in Section IV, perform the following test, Paragraph E-16, Output Level and Flatness Test.

E-13. Other performance tests outlined in Section IV (except Output Level and Flatness) may be used to test system performance for the purpose of comparison with typical system performance characteristics outlined in Table E-2. Such testing should provide a high level of confidence for measurement results obtained using the tracking generator/spectrum analyzer system.

E-14. The procedures in Section IV indicate the use of either an HP 8554B or HP 8555A Spectrum Analyzer. An HP 8558B, HP 8565A, or HP 8568A Spectrum Analyzer may be used for complete testing up to 1500 MHz but some of the control names will be different than stated in the procedures.

E-15. The following test indicates the use of an HP 8558B Spectrum Analyzer. An HP 8565A or HP 8568A Spectrum Analyzer may be used but some of the control names will be different than stated in the procedure.

E-16. Output Level and Flatness Test

SPECIFICATION:

Amplitude Accuracy:

Frequency Response(flatness): 0.5 to 1300 MHz; ± 0.5 dB(1 dB)
 0.5 to 1500 MHz; ± 0.75 dB(1.5 dB)

Tracking Generator Calibration: 0 dBm ± 0.5 dB at 30 MHz

Drive Level to Test Device: 0 to -10 dBm continuously variable

DESCRIPTION:

The Tracking Generator output is checked for proper calibration level (0 dBm ± 0.5 dB) at 30 MHz and proper range (0 to -10 dBm). Next, output flatness is checked from 0.5 to 1300 MHz and 0.5 to 1500 MHz.

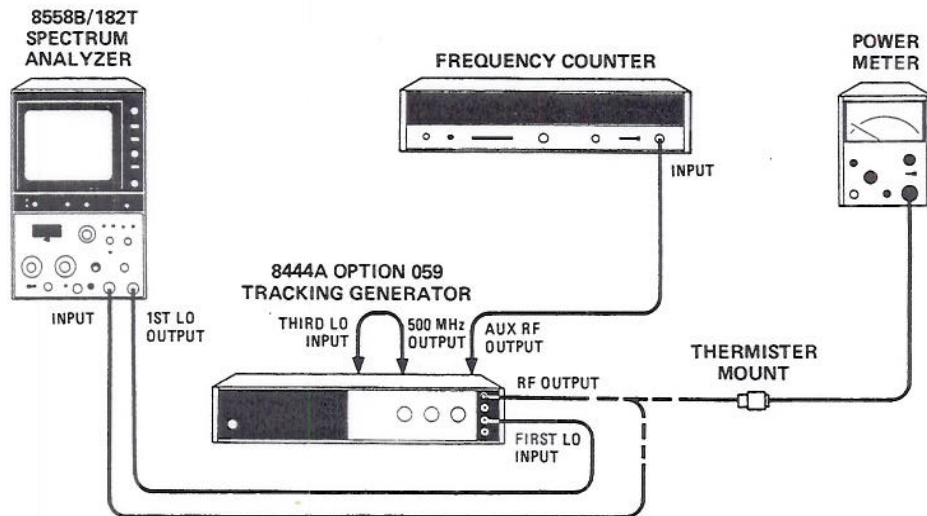

Figure E-1. Output Level and Flatness Test Setup

EQUIPMENT:

Spectrum Analyzer	HP 8558B/182T
Frequency Counter	HP 5340A
Power Meter/Thermistor Mount	HP 432A/478A

PROCEDURE:

1. Connect equipment as shown in Figure E-1 with frequency counter connected to tracking generator rear-panel AUX RF OUTPUT and tracking generator front-panel RF OUTPUT connected to spectrum analyzer RF INPUT.

E-19. The procedures in Section V indicate the use of either an HP 8554B or HP 8555A Spectrum Analyzer. An HP 8558B, HP 8565A, or HP 8568A Spectrum Analyzer may be used but some of the control names will be different than stated in the procedures.

E-20. 500 MHz Local Oscillator Adjustment

REFERENCE: Figure E-7

DESCRIPTION:

The internal 500 MHz oscillator is adjusted for proper output level and frequency using a power meter and frequency counter to monitor the rear-panel output.

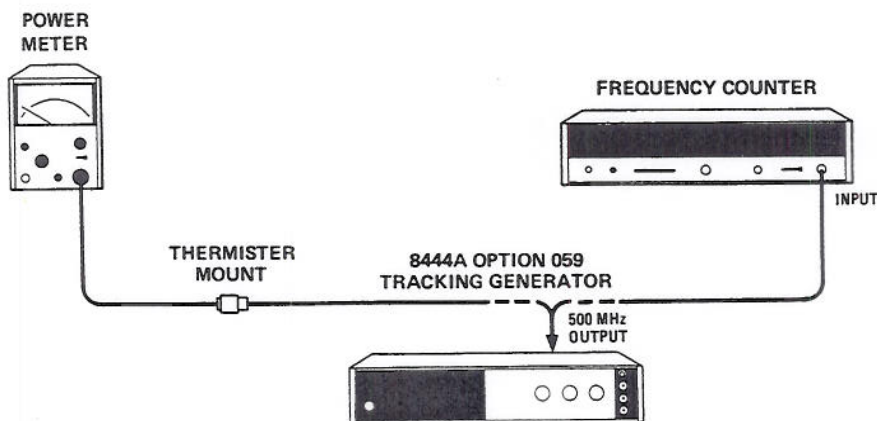

Figure E-2. 500 MHz Local Oscillator Adjustment Setup

EQUIPMENT:

Frequency Counter	HP 5340A
Power Meter/Thermistor Mount	HP 432A/478A

PROCEDURE:

1. Connect equipment as shown in Figure E-2 with power meter connected to rear-panel 500 MHz OUTPUT.
2. Adjust A9 LO PWR adjustment for an output level of +4 dBm ±0.5 dB.
3. Disconnect power meter and connect frequency counter to rear-panel 500 MHz OUTPUT.
4. Adjust A9 FREQ ADJ adjustment for an output frequency of 500 ± 0.2 MHz.
5. Repeat steps 1 through 4 until both output power and frequency are within specifications.

E-21. 500 MHz Local Oscillator Residual FM Check

REFERENCE: Figure E-7

DESCRIPTION:

The residual FM of the oscillator is checked by mixing the 500 MHz output with a 400 MHz comb tooth and displaying the resulting 100 MHz difference frequency on a spectrum analyzer.

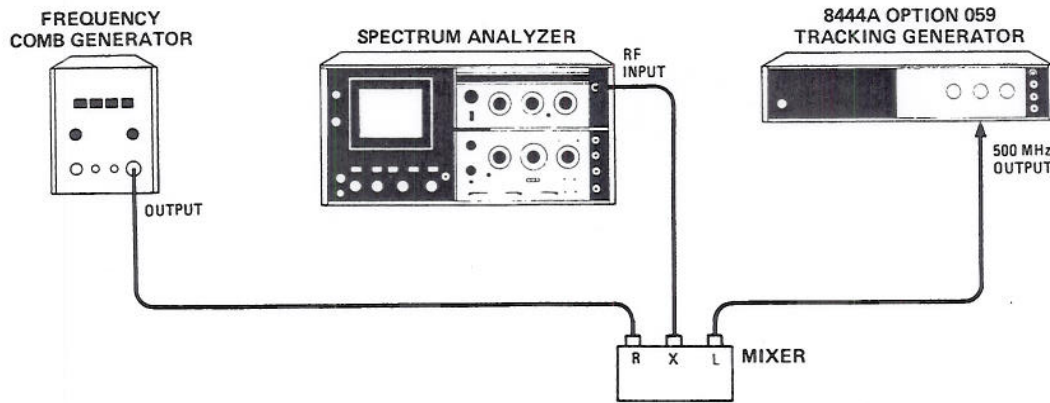

Figure E-3. 500 MHz L.O. Residual FM Check Equipment Setup

EQUIPMENT:

Spectrum Analyzer	HP 8553B/8552B/141T
Comb Generator	HP 8406A
Mixer	Vari-L 400A

PROCEDURE:

1. Connect equipment as shown in Figure E-3.
2. Set instrument controls as follows:

8406A Comb Generator:

OUTPUT	MAX
COMB FREQ	100 MHz

8553B Spectrum Analyzer RF Section:

FREQUENCY	100 MHz
BANDWIDTH	10 kHz
SCAN WIDTH/DIV2 MHz

8552B Spectrum Analyzer IF Section:

SCAN TIME/DIV	10 ms
VIDEO FILTER	OFF
LOG/LINEAR	LINEAR

8444A Option 059 Tracking Generator:

TRACK ADJ	Fully Counterclockwise
-----------------	------------------------

3. Tune the 100 MHz signal to the center of the CRT display.
4. Change spectrum analyzer control settings as follows:

SCAN WIDTH/DIV	2 kHz
BANDWIDTH	1 kHz
TUNING STABILIZER	ON
SCAN TIME/DIV1 sec
VIDEO FILTER	10 kHz

5. Use FREQUENCY FINE TUNE control to center signal on CRT and adjust LINEAR SENSITIVITY control to place peak of signal at LOG REF LEVEL (top graticule line).
6. Set spectrum analyzer SCAN WIDTH to ZERO.
7. Use FREQUENCY FINE TUNE to place signal between 2 and 5 divisions down from top of display.
8. Peak-to-peak deviation of signal trace should be ≤ 0.6 divisions.
9. This corresponds to ≤ 120 Hz residual FM. This is calculated by multiplying the peak-to-peak deviation times 200 Hz/division modulation sensitivity. Modulation sensitivity can be measured by performing steps 13 and 14 of Paragraph 5-10 in Section V.

E-22. REPLACEABLE PARTS

E-23. Replaceable parts for the standard 8444A Tracking Generator are listed in Section VI. Table E-3 lists the additional parts contained in the 8444A Option 059. Table E-4 lists those parts used in the 8444A Option 059 which replace parts used in the standard 8444A.

E-24. SERVICE

E-25. Description of Option 059. When the Option 059 modification is installed in the 8444A Tracking Generator, a 500 MHz fixed-tuned local oscillator (A9 assembly) is added. This oscillator provides the 500 MHz Third L.O. signal not available from various spectrum analyzers. In addition, the Amplifier and ALC Detector (A3 assembly) and the Band - Pass Filter (FL1) are replaced to extend the upper frequency limit to 1500 MHz.

E-26. Figures E-7 through E-9 are schematic diagrams which illustrate the additions and changes to the 8444A when Option 059 is installed. Figures E-10 and E-11 are photographs of the 8444A Option 059 showing the addition of the 500 MHz oscillator (A9 assembly) and rear-panel 500 MHz Output connector.

Table E-1. Specifications

SPECIFICATIONS

The following specifications are for the HP 8444A Tracking Generator **ONLY** and should not be confused with system specifications listed in Table 1-1. Typical system performance characteristics are located in Table E-2.

SWEPT FREQUENCY RESPONSE MEASUREMENTS

Absolute Amplitude Calibration Range:

Frequency Range: 500 kHz to 1500 MHz

Stability:

Residual FM: Depends on analyzer being used. Refer to Table E-2.

Amplitude Accuracy:

Frequency Response (flatness)¹:

0.5 to 1300 MHz, ± 0.5 dB

0.5 to 1500 MHz, ± 0.75 dB

Tracking Generator Calibration: 0 dBm ± 0.5 dB at 30 MHz

SWEEP/CW GENERATOR

Frequency Range: 500 kHz to 1500 MHz

Frequency Accuracy: Same as analyzer being used.²

Output Flatness: 0.5 to 1300 MHz, ± 0.5 dB; 0.5 to 1500 MHz, ± 0.75 dB

Drive Level to Test Device: 0 to -10 dBm continuously variable.

Spectral Purity:

Residual FM: Depends on analyzer being used. Refer to Table E-2.

Spurious Signals: ≥ 35 dB below output level.

¹ This is output flatness of tracking generator only. System frequency response is determined by combining this figure with frequency response figure for spectrum analyzer used. Refer to Table E-2 for typical values using various analyzers.

² Frequency accuracy, when using the 8558B or 8565A spectrum analyzers, may be improved by use of an external frequency counter connected to rear-panel AUX RF OUTPUT connector. 8568A Spectrum Analyzer contains an internal frequency counter, so should be used alone for best accuracy.

Table E-2. System Performance Characteristics



PERFORMANCE CHARACTERISTICS			
The following characteristics outline the typical performance of the tracking generator/spectrum analyzer system using the HP Model 8444A Option 059 Tracking Generator with various HP spectrum analyzers. These are not specifications. They are intended only as additional information regarding instrument performance.			
Description	8444A-059 with 8558B	8444A-059 with 8565A	8444A-059 with 8568A
SWEPT FREQUENCY RESPONSE MEASUREMENTS			
Dynamic Range	>90 dB	>90 dB	>90 dB
Average Noise ¹	<-107 dBm	<-100 dBm	<-105 dBm
Calibration Range Spectrum Analyzer: Log	-117 dBm to +30 dBm	-102 dBm to +30 dBm	-99.9 dBm to +30 dBm
Frequency Range	500 kHz to 1500 MHz	10 MHz to 1500 MHz	500 kHz to 1500 MHz
Scan Width			
Full Span	Not Available	1500 MHz	1500 MHz
Per Division	5 kHz to 100 MHz	1 kHz to 100 MHz	1 kHz to 150 MHz
Residual FM ²	1 kHz	300 Hz	300 Hz
Frequency Response: (system flatness, 0.5- 1500 MHz)	±1.75 dB (3.5 dB)	±2.0 dB (4.0 dB)	±1.75 dB (3.5 dB)
SWEEP/CW GENERATOR			
Frequency Range	500 kHz to 1500 MHz	10 MHz to 1500 MHz	500 kHz to 1500 MHz
Frequency Accuracy ³	Same as 8558B	Same as 8565A	Same as 8568A
Output Flatness	±0.75 dB	±0.75 dB	±0.75 dB
Spectral Purity			
Residual FM ²	1 kHz	300 Hz	300 Hz
Harmonic Distortion	-25 dBc	-25 dBc	-25 dBc
Spurious Signals	-35 dBc	-35 dBc	-35 dBc
Long Term Stability			
Drift	30 kHz/10 min.	13 kHz/10 min.	10 kHz/10 min. ⁴
Sweep Width	50 kHz to 1000 MHz	10 kHz to 1500 MHz	100 Hz to 1500 MHz
Sweep Rate (Per Div.)	5 ms to 10 sec ⁵	2 ms to 10 sec ⁶	2 ms to 150 sec ⁶
¹ With 10 kHz resolution bandwidth selected. ² Residual FM of tracking generator is typically <300 Hz. ³ Frequency accuracy, when using the 8558B or 8565A spectrum analyzer, may be improved by use of an external frequency counter connected to rear-panel AUX RF OUTPUT. 8568A contains an internal counter, so should be used alone for best accuracy. ⁴ Plus analyzer drift during one sweep. ⁵ Although faster sweep rates are available, for best tracking, the 8558B should not be swept faster than 5 ms. ⁶ Do not use coupled sweep times in Full Span. For best operation with 8568A, use   (KST) to lock 2nd LO frequency for spans ≤1 MHz.			

Table E-3. Replaceable Parts Additions for Option 059

Reference Designation	HP Part Number	Qty	Description	Mfr Code	Mfr Part Number
A9	08444-60024	1	500 MHz OSCILLATOR ASSEMBLY	28480	08444-60024
A9C1	0160-2357	2	C:FXD 1000PF +80 -20% 500WVDC CER	28480	0160-2357
A9C2	0160-2357		C:FXD 1000PF +80 -20% 500WVDC CER	28480	0160-2357
A9J1	1250-0828	1	CONNECTOR: 50 OHM	28480	1250-0828
A9L1	08554-00015	1	COUPLING: LO OUTPUT	28480	08554-00015
A9R1	0698-7200	1	R:FXD 31.6 OHM 2% .05W	24546	C3-1/8-TOO-31R6-G
A9A1	08444-60020	1	OSCILLATOR ASSEMBLY: 500 MHz	28480	08444-60020
A9A1C1	0160-2247	1	C:FXD 3.9PF ± .25PF 500WVDC CER	28480	0160-2247
A9A1C2	0121-0414	1	C:VAR TRMR 1.9 - 8.5PF; AIR	74970	189-253-5 MODIFIED
A9A1L1	08554-00007	1	INDUCTOR: 500 MHz OSC.	28480	08554-00007
A9A1Q1	1854-0323	2	TRANSISTOR: NPN	28480	1854-0323
A9A1Q2	1854-0323		TRANSISTOR: NPN	28480	1854-0323
A9A1R1	0698-3447	1	R:FXD 422 OHM 1% 1/8W	16299	C4-1/8-TO-422R-F
A9A1R2	0757-0280	2	R:FXD 1K OHM 1% 1/8W	24546	C4-1/8-TO-1001-F
A9A1R3	0757-0280		R:FXD 1K OHM 1% 1/8W	24546	C4-1/8-TO-1001-F
A9A2	08444-60031	1	POWER SUPPLY FILTER ASSEMBLY	28480	08444-60031
A9A2C1	0160-2055	2	C:FXD .01 UF +80 -20% 100WVDC CER	28480	0160-2055
A9A2C2	0160-2055		C:FXD .01UF +80 -20% 100WVDC CER	28480	0160-2055
A9A2C3	0180-0049	2	C:FXD 20UF +75 -10% 50WVDC AL	56289	300206G050CC2
A9A2C4	0180-0049		C:FXD 20UF +75 -10% 50WVDC AL	56289	300206G050CC2
A9A2CR1	1901-0040	2	DIODE: SWITCHING 2NS 30V 50MA	28480	1901-0040
A9A2CR2	1901-0040		DIODE: SWITCHING 2NS 30V 50MA	28480	1901-0040
A9A2Q1	1854-0404	2	TRANSISTOR: NPN	28480	1854-0404
A9A2Q2	1854-0404		TRANSISTOR: NPN	28480	1854-0404
A9A2R1	2100-1775	1	R:VAR 5K OHM 5% WW	28480	2100-1775
A9A2R2	0698-3155	2	R:FXD 4.64K OHM 1% 1/8W	16299	C4-1/8-TO-4641-F
A9A2R3	0698-3155		R:FXD 4.64K OHM 1% 1/8%	16299	C4-1/8-TO-4641-F
A9A2R4	0698-0083	1	R:FXD 1.96K OHM 1% 1/8W	16299	C4-1/8-TO-1961-F
A9A2R5	0698-0082	1	R:FXD 464 OHM 1% 1/8W	16299	C4-1/8-TO-4640-F
W19	08444-60025	1	CABLE: COAX; 500 MHz OUTPUT	28480	08444-60025

Table E-4. Replaceable Parts Changes for Option 059

Reference Designation	HP Part Number	Qty	Description	Mfr Code	Mfr Part Number
A3	5086-7330	1	AMPLIFIER AND ALC DETECTOR	28480	5086-7330
FL1	08444-60037	1	FILTER: BANDPASS (2-3.55 GHz)	28480	08444-60037
MP13	08444-00033	1	PANEL: FRONT (OLIVE BLACK/ MINT GRAY)	28480	08444-00033
W16	08444-60039	1	CABLE ASSY: RF INTERCONNECT	28480	08444-60039

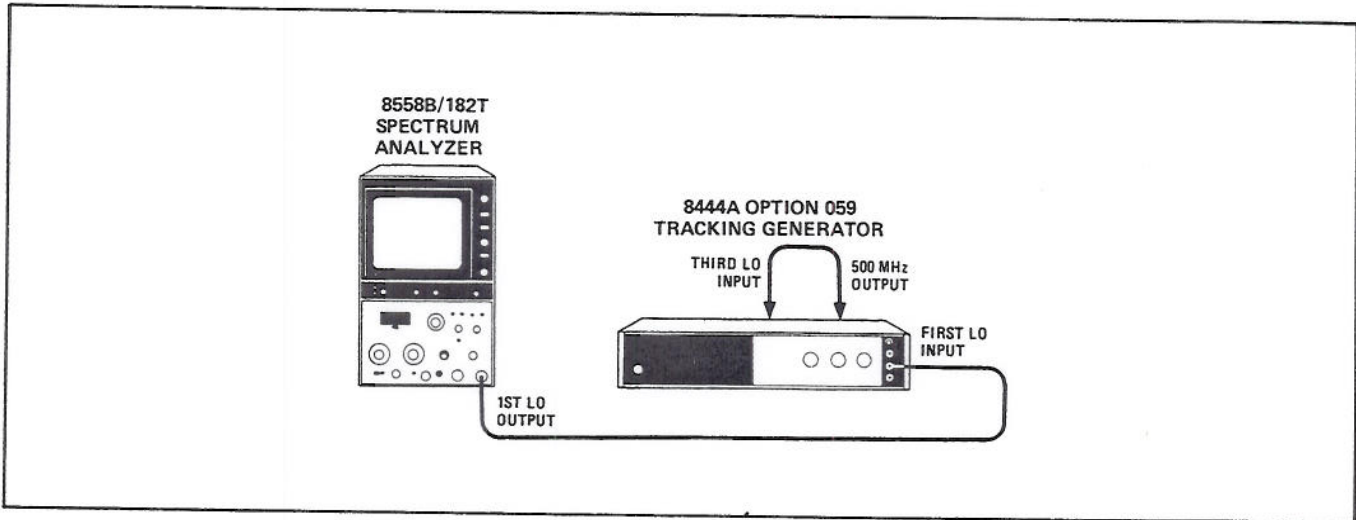

Figure E-4. Equipment Connections for 8444A Option 059/8558B

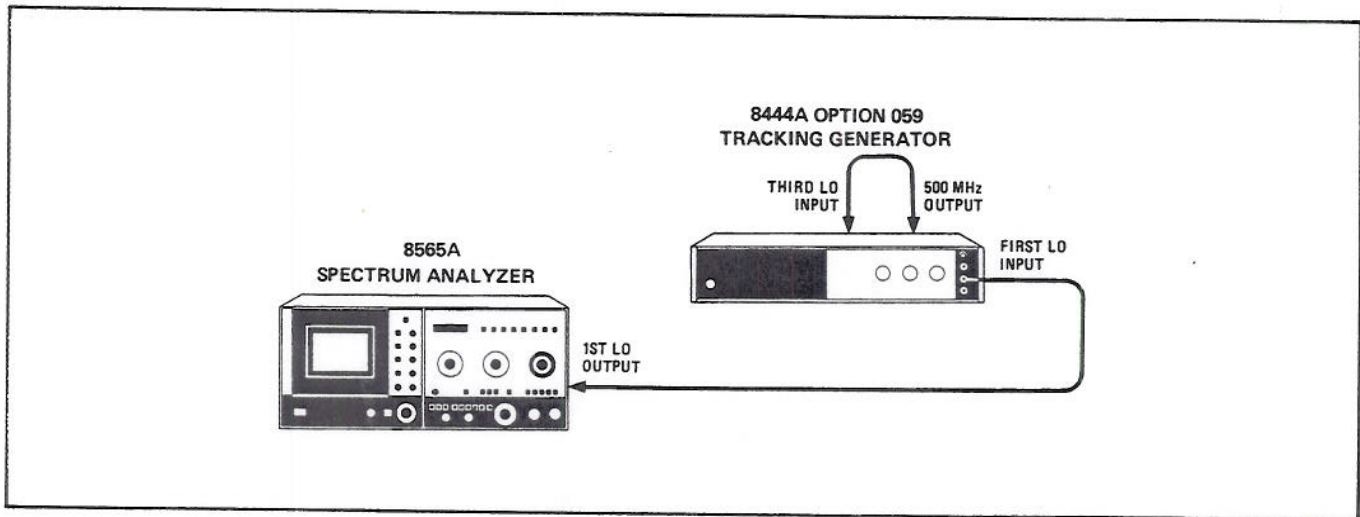

Figure E-5. Equipment Connections for 8444A Option 059/8565A

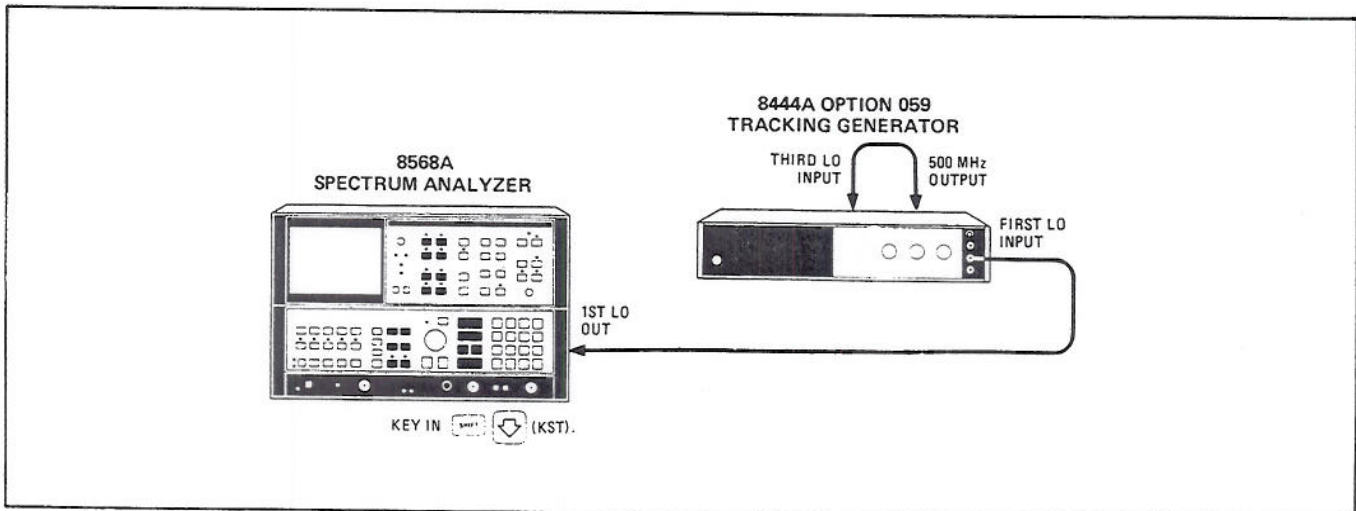

Figure E-6. Equipment Connections for 8444A Option 059/8568A

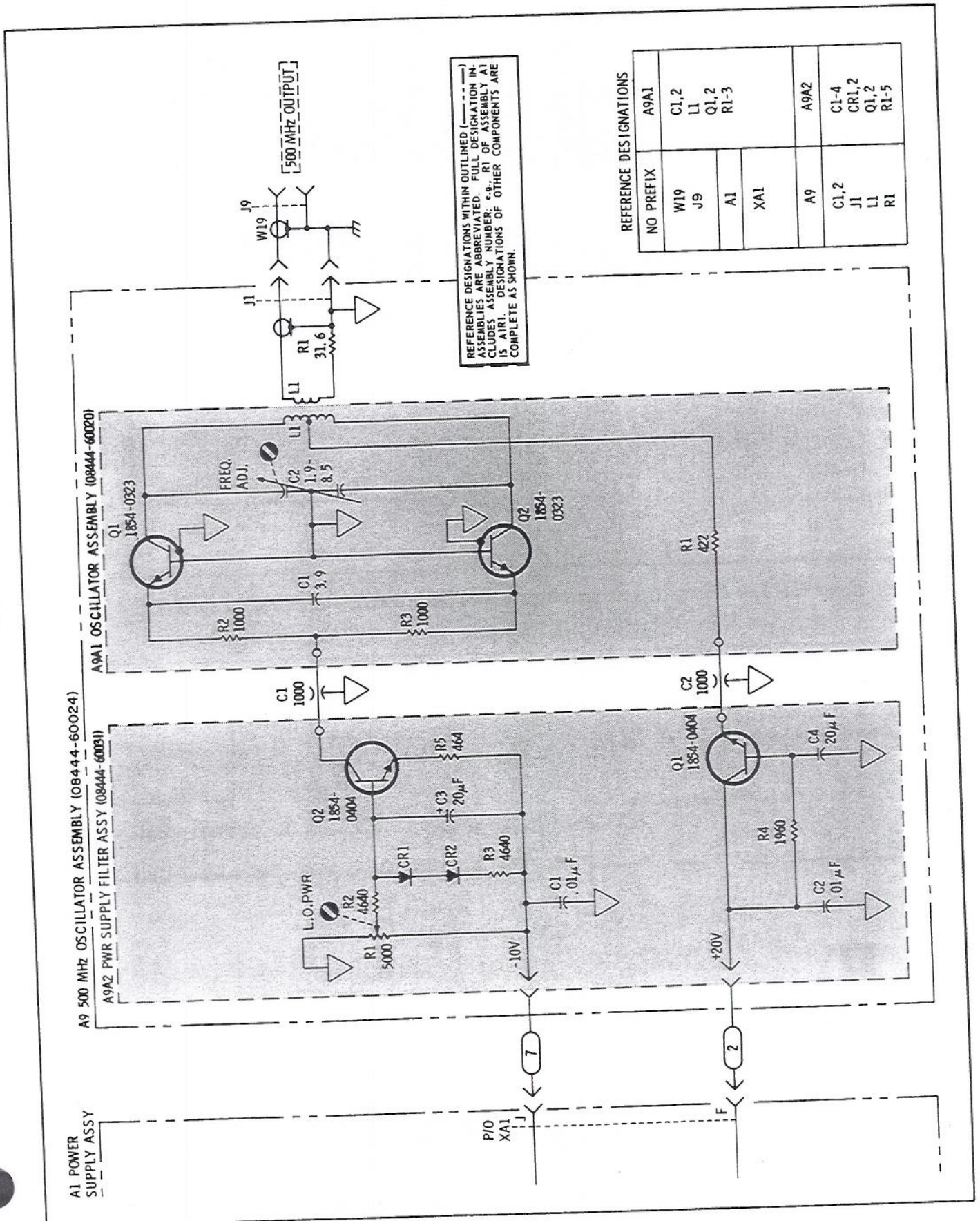

Figure E-7. A9 500 MHz Oscillator Assembly, Schematic

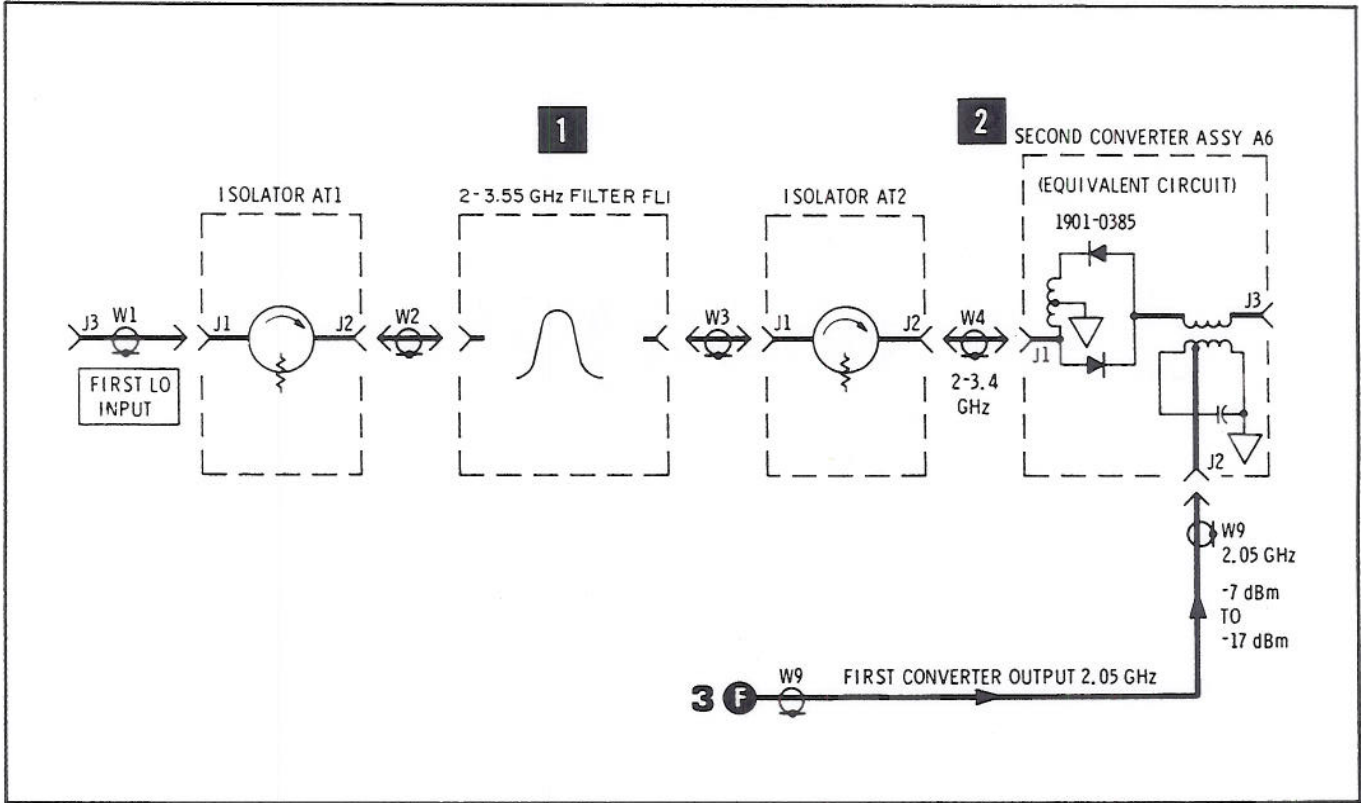

Figure E-8. P/O Second Converter Circuits Showing Replacement Filter for Option 059

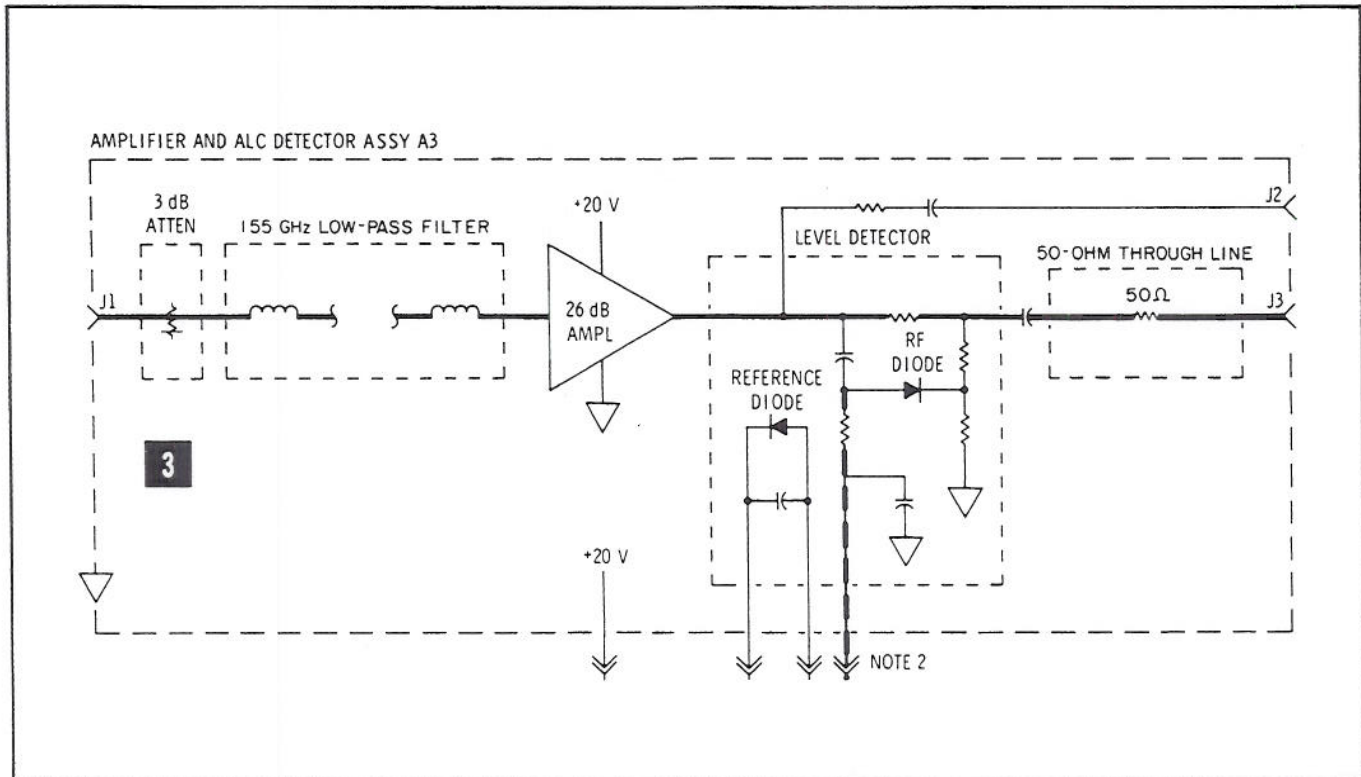

Figure E-9. P/O Second Converter Circuits Showing Replacement Amplifier and ALC Detector for Option 059

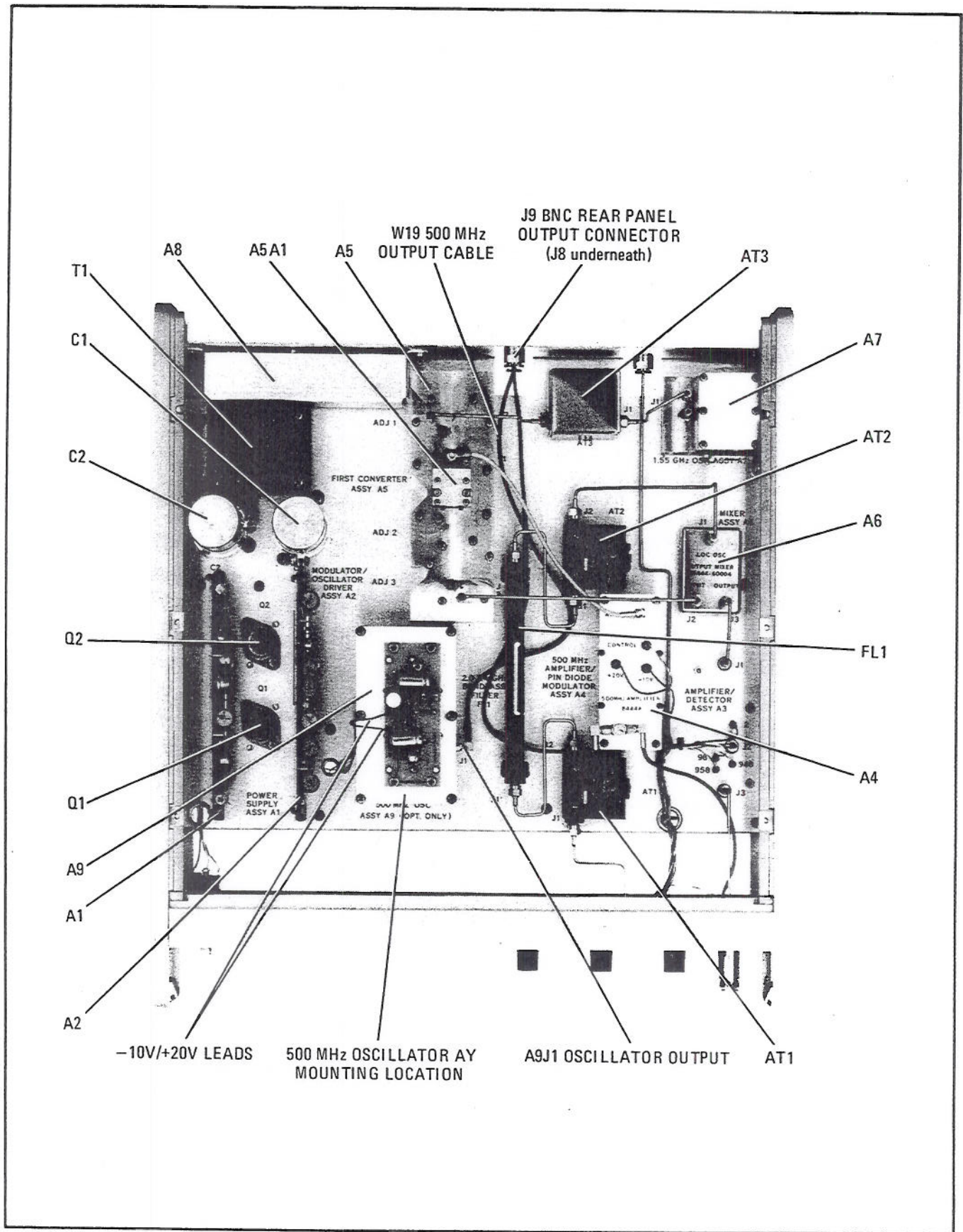
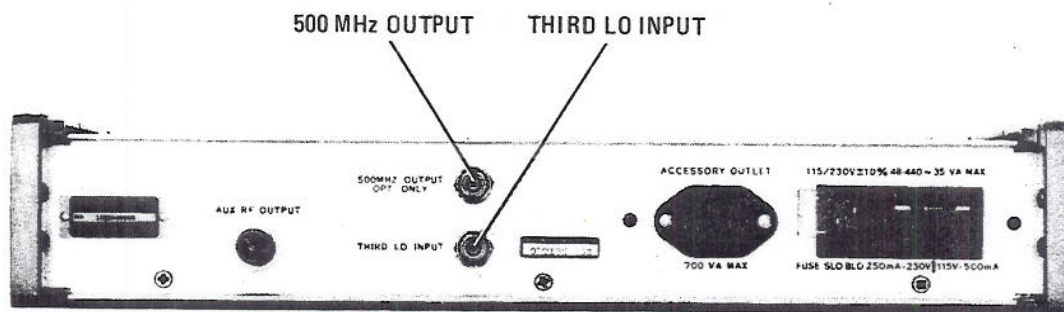

Figure E-10. 500 MHz LO Mounting Location and Output Port for the 8444A Option 059



When using the 8444A with an 8558B, 8565A, or 8568A Spectrum Analyzer the 8444A 500 MHz OUTPUT and its THRID LO INPUT must be interconnected with a short cable.

*Figure E-11. Location of 500 MHz LO OUTPUT BNC Connector
Added on Rear Panel of the 8444A, Option 059*

Hewlett-Packard Sales and Service Offices

US FIELD OPERATIONS

Headquarters
Hewlett-Packard Co.
19320 Pruneridge Avenue
Cupertino, CA 95014
(800) 752-0900

California, Northern
Hewlett-Packard Co.
301 E. Evelyn
Mountain View, CA 94041
(415) 694-2000

California, Southern
Hewlett-Packard Co.
1421 South Manhattan Ave.
Fullerton, CA 92631
(714) 999-6700

Colorado
Hewlett-Packard Co.
24 Inverness Place, East
Englewood, CO 80112
(303) 649-5512

Georgia
Hewlett-Packard Co.
2000 South Park Place
Atlanta, GA 30339
(404) 955-1500

Illinois
Hewlett-Packard Co.
5201 Tollview Drive
Rolling Meadows, IL 60008
(708) 255-9800

New Jersey
Hewlett-Packard Co.
150 Green Pond Rd.
Rockaway, NJ 07866
(201) 586-5400

Texas
Hewlett-Packard Co.
930 E. Campbell Rd.
Richardson, TX 75081
(214) 231-6101

EUROPEAN FIELD OPERATIONS

Headquarters
Hewlett-Packard S.A.
150, Route du Nant-d'Avril
1217 Meyrin 2/Geneva
Switzerland
(41 22) 780.8111

France
Hewlett-Packard France
1 Avenue Du Canada
Zone D'Activite De Courtaboeuf
F-91947 Les Ulis Cedex
France
(33 1) 69 82 60 60

Germany
Hewlett-Packard GmbH
Hewlett-Packard Strasse
61352 Bad Homburg v.d.H
Germany
(49 6172) 16-0

Great Britain
Hewlett-Packard Ltd.
Eskdale Road, Winnersh Triangle
Wokingham, Berkshire RG41 5DZ
England
(44 734) 696622

INTERCON FIELD OPERATIONS

Headquarters
Hewlett-Packard Company
3495 Deer Creek Road
Palo Alto, California, USA
94304-1316
(415) 857-5027

Australia
Hewlett-Packard Australia Ltd.
31-41 Joseph Street
Blackburn, Victoria 3130
(61 3) 895-2895

Canada
Hewlett-Packard (Canada) Ltd.
17500 South Service Road
Trans-Canada Highway
Kirkland, Quebec H9J 2X8
Canada
(514) 697-4232

China
China Hewlett-Packard Company
38 Bei San Huan X1 Road
Shuang Yu Shu
Hai Dian District
Beijing, China
(86 1) 256-6888

Japan
Hewlett-Packard Japan, Ltd.
1-27-15 Yabe, Sagamihara
Kanagawa 229, Japan
(81 427) 59-1311

Singapore
Hewlett-Packard Singapore (Pte.) Ltd.
150 Beach Road
#29-00 Gateway West
Singapore 0718
(65) 291-9088

Taiwan
Hewlett-Packard Taiwan
8th Floor, H-P Building
337 Fu Hsing North Road
Taipei, Taiwan
(886 2) 712-0404

