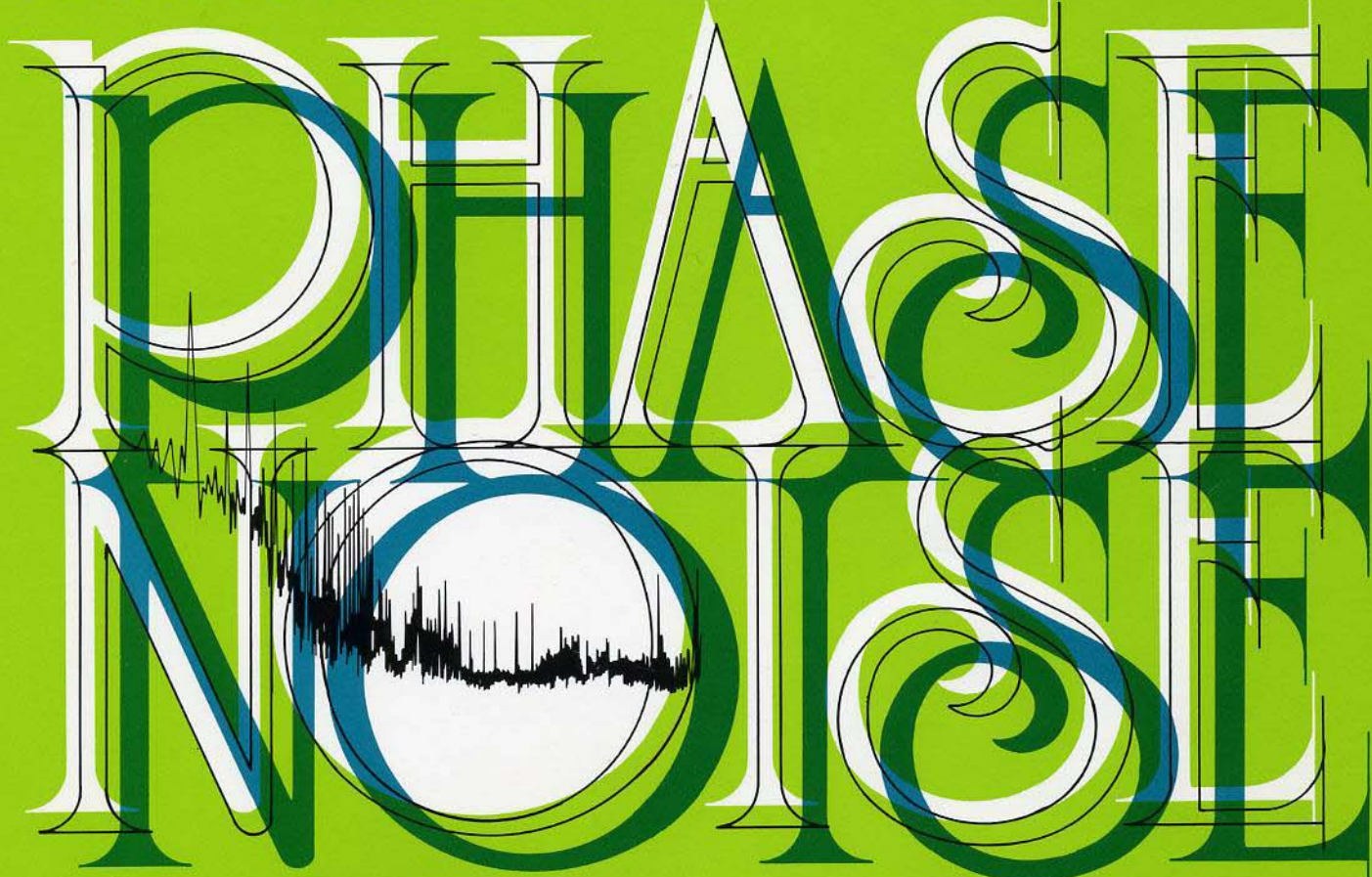

UNDERSTANDING AND MEASURING

PHASE NOISE

The title 'PHASE NOISE' is rendered in a large, ornate, black serif font. The letters are filled with a light blue color and have a dark blue outline. The letter 'O' in 'NOISE' is replaced by a circular graphic containing a black waveform, likely representing a phase-locked loop (PLL) or a similar electronic circuit. The background is a solid, light blue color.

IN THE FREQUENCY DOMAIN

Introduction

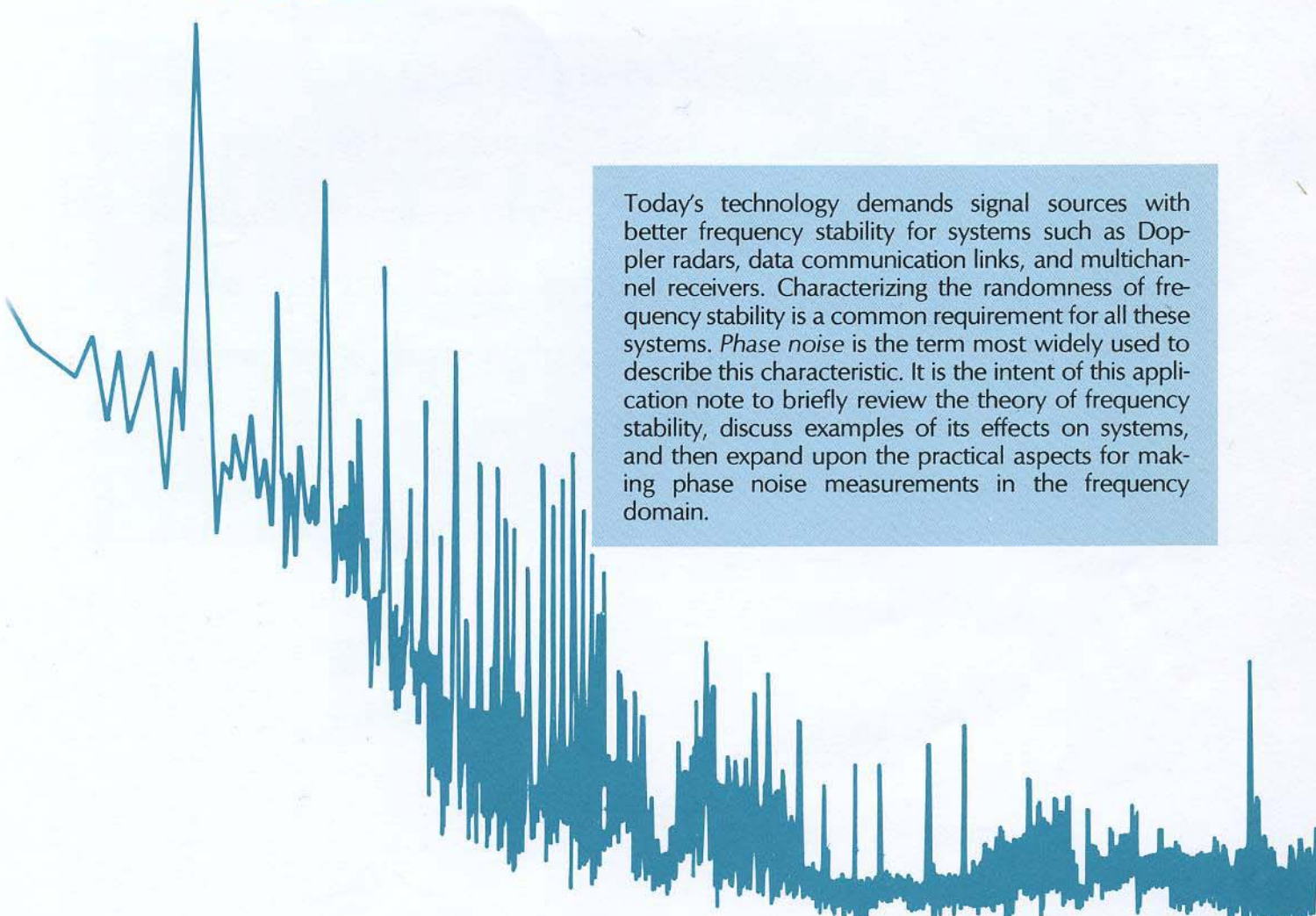

Today's technology demands signal sources with better frequency stability for systems such as Doppler radars, data communication links, and multichannel receivers. Characterizing the randomness of frequency stability is a common requirement for all these systems. *Phase noise* is the term most widely used to describe this characteristic. It is the intent of this application note to briefly review the theory of frequency stability, discuss examples of its effects on systems, and then expand upon the practical aspects for making phase noise measurements in the frequency domain.

Contents

Chapter 1 — Definition of Phase Noise

Chapter 2 — Effects of Phase Noise on Real Systems

Chapter 3 — Relating Phase Noise to Frequency Stability

Chapter 4 — Accounting for Analyzer Characteristics

Chapter 5 — Practical Methods of Measuring Phase Noise

Appendix A — Software Description

References

OCTOBER 1976

Chapter 1

Definition of Phase Noise

A brief review of the components of frequency stability is helpful in developing a working definition of phase noise. A model can be constructed in three parts.

The first, *long term stability*, is usually expressed in terms of parts per million of frequency change per hour, day, month, or year. It represents a reasonably predictable phenomenon due to the aging process of the material used in the frequency determining element. The second, *environmentally induced frequency shifts*, includes stimulus-response effects related to changes in temperature, pressure, and even gravity. With proper design, most of these effects are secondary in importance.

The third component, *short term frequency fluctuations*, contains all elements causing frequency changes about the nominal frequency of less than a few seconds duration. Fluctuations of this nature are more conveniently viewed in the frequency domain than in the time domain. From modulation theory, we know that carrier sidebands can be related to amplitude and phase modulation on the carrier. In this case, it is the PM signals which are of interest to us. A spectral density plot of the PM sidebands yields much valuable information about the nature of the modulating signals. See Figure 1a.

In general, there are two categories of PM signals. The first, *deterministic*, includes discrete signals which can be easily related to known phenomena such as power line frequency, vibration frequencies, or AC magnetic fields. These signals show up as distinct components in the spectral density plot. The second, *random*, is best described by its common name, *phase noise*. That is, the spectral density plot of phase noise sidebands shows a continuous spectrum over a wide range of frequency similar to that of broadband noise. Since the measured level of noise is a function of the detector bandwidth, it is customary to normalize phase noise measurements to a 1 Hz bandwidth for the sake of consistency.

It is important to note here that phase noise spectral density is directly proportional to the carrier sideband spectral density if AM is not present and if the total phase deviations are $\ll 1$ radian. The units are in radians²/Hertz rather than Watts/Hertz. Another important characteristic is that the phase spectral density plot does not include the fundamental signal or carrier as shown in Figure 1b. Phase noise and its relationship to frequency fluctuations will be more rigorously treated in Chapter 3; the purpose here is to gain an intuitive feel for the term *phase noise*.

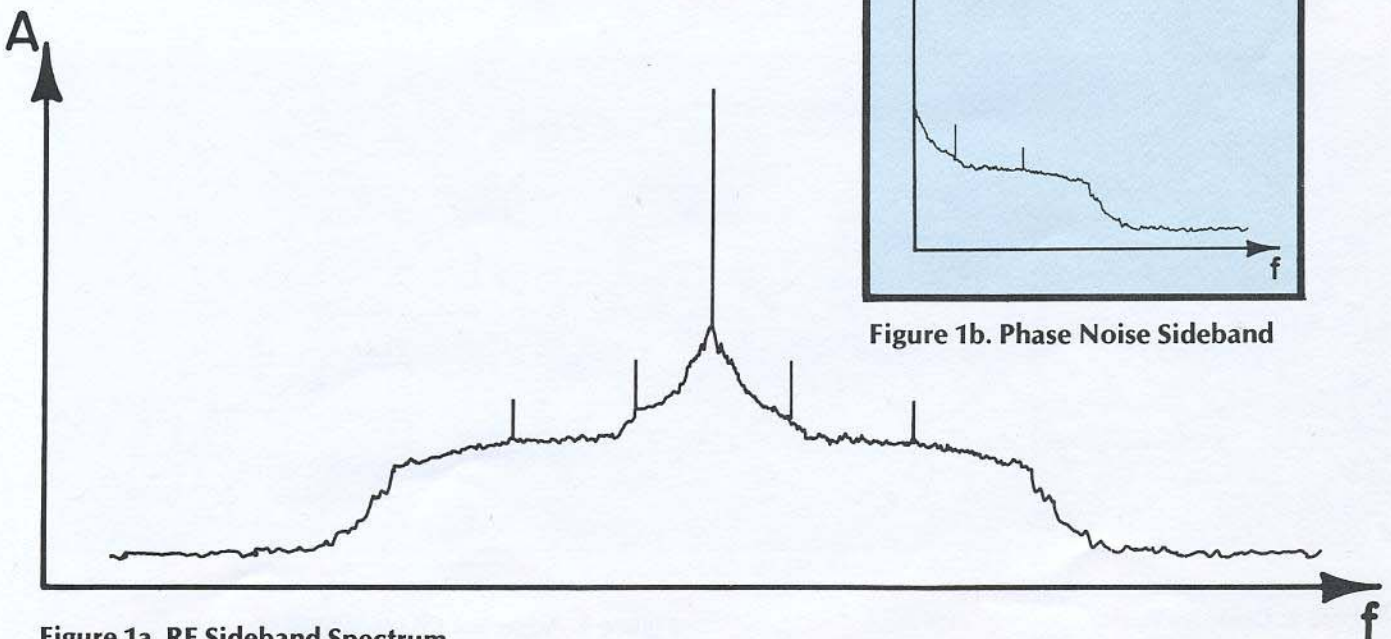

Figure 1a. RF Sideband Spectrum

Figure 1b. Phase Noise Sideband

Chapter 2

The Effects of Phase Noise On Real Systems

With a basic mental image of phase noise in hand, it is appropriate to look at the effects on practical systems.

Radar systems have been greatly advanced since their early years and depend on highly sophisticated techniques for increased range and resolution. Doppler radars, for example, utilize a narrow bandwidth receiver to detect the shifted frequency return of a moving target relative to the return from the ground. The total power of the ground return, called ground clutter, far exceeds the power of the target return, thus, the need for the narrow bandwidth receiver tuned to the target return frequency. Phase noise on either the transmitter oscillator or the receiver local oscillator can limit range resolution and sensitivity.

In terms of resolution, the receiver bandwidth is limited to that which will pass the majority of the return frequency energy. Phase noise spreads the target energy thus requiring a wider IF bandwidth. Sensitivity is limited by ground clutter energy which appears in the receiver IF bandwidth. Excessive phase noise effectively smears the clutter energy into the receiver IF bandwidth. Requirements for phase noise on radar systems typically run 110dB below the transmitter level and the local oscillator level from a few Hertz up to several hundred kilohertz away from the carrier. See Figure 2.

Phase-modulated data systems are also sensitive to phase noise which is phase detected along with the desired modulation signal. The effect is to degrade the bit error rate performance. The maximum allowable phase noise is usually specified in terms of the total equivalent rms degrees of phase noise modulation within the data channel bandwidth. For values of phase noise less than 5 degrees rms, the effect on bit error is directly additive to the receiver thermal noise. Typical system specifications call for equivalent phase noise modulation of less than 2 degrees rms from 20kHz to 80MHz from the carrier for a 33.5GHz carrier.

In general, multichannel communications receivers have a problem directly related to phase noise on their local oscillators. LO sidebands appear on the received signal in the IF at the same ratio as they exist on the LO. For example, phase noise sidebands 100dB/Hz down from the LO will appear 100dB/Hz down on the received signal. This presents no problem for a single channel receiver since that ratio is more than adequate for intelligibility. However, in a multichannel receiver, the sensitivity with a strong signal in an adjacent channel is set by the level of the phase noise sidebands at an offset equal to the channel spacing. Figure 3 shows this relationship pictorially.

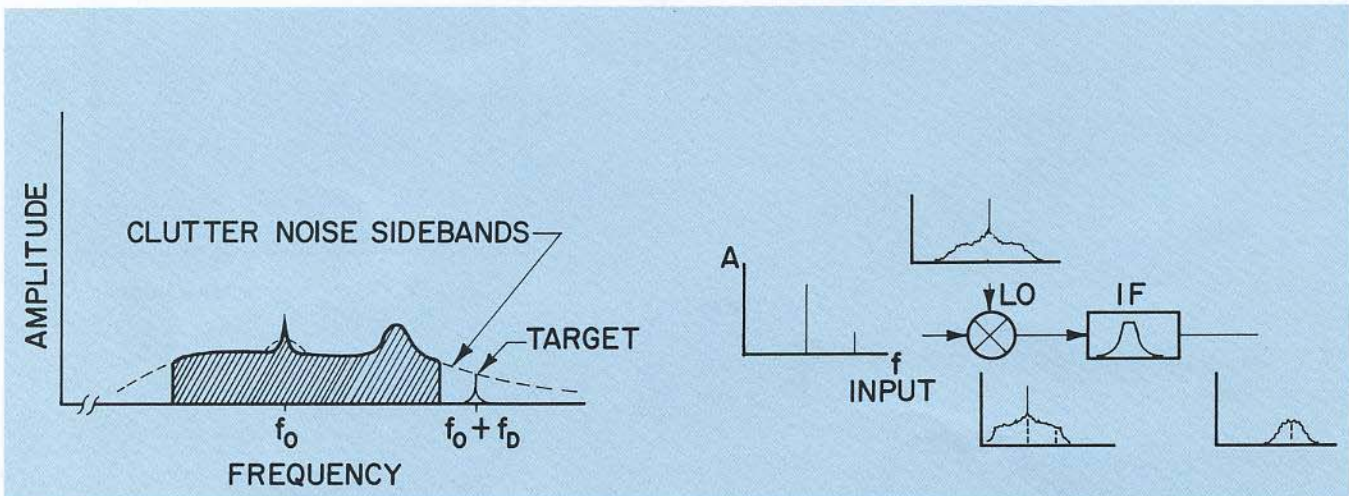

Figure 2. Doppler Radar

Figure 3. Adjacent Channel Sensitivity

Chapter 3

Relating Phase Noise to Frequency Stability

To further clarify the accepted definitions of phase noise and their relationships to frequency stability, a brief summary of the theoretical work of the U.S. National Bureau of Standards will be presented in this chapter.

An ideal sinewave source can be described by:

$$V(t) = V_o \sin 2\pi\nu_o t$$

where V_o = nominal amplitude

ν_o = nominal frequency

In the real world, of course, there are fluctuations in both amplitude and frequency which can be represented by the following additional terms.

$$V(t) = [V_o + \epsilon(t)] \sin [2\pi\nu_o t + \phi(t)]$$

where $\epsilon(t)$ = amplitude fluctuations

$\phi(t)$ = phase fluctuations

Long term fluctuations are best described in terms of time but fluctuations with periods of less than a few seconds are easier to understand when translated by Fourier expansion into the frequency domain. Figure 4 is an example of the RF spectral density of a sinewave source showing phase noise and discrete AM and PM sideband components. The AM components can be eliminated and the PM sidebands demodulated by phase detecting the signal. The result is the power spectral density of the *equivalent* phase modulating noise source. If the phase detector is linear over the whole range of phase deviations, the power spectral density as a function of frequency is:

$$S_{\phi}(f) = \frac{S_{V_{rms}}(f)}{K^2} \left[\frac{\text{rad}^2}{\text{Hz}} \right]$$

where $S_{V_{rms}}(f)$ = the power spectral density of the voltage fluctuations out of the phase detector

K = phase detector constant (volts/radian)

This spectral density is particularly useful for analysis of phase noise effects on systems which have phase sensitive circuits such as digital FM communication links.

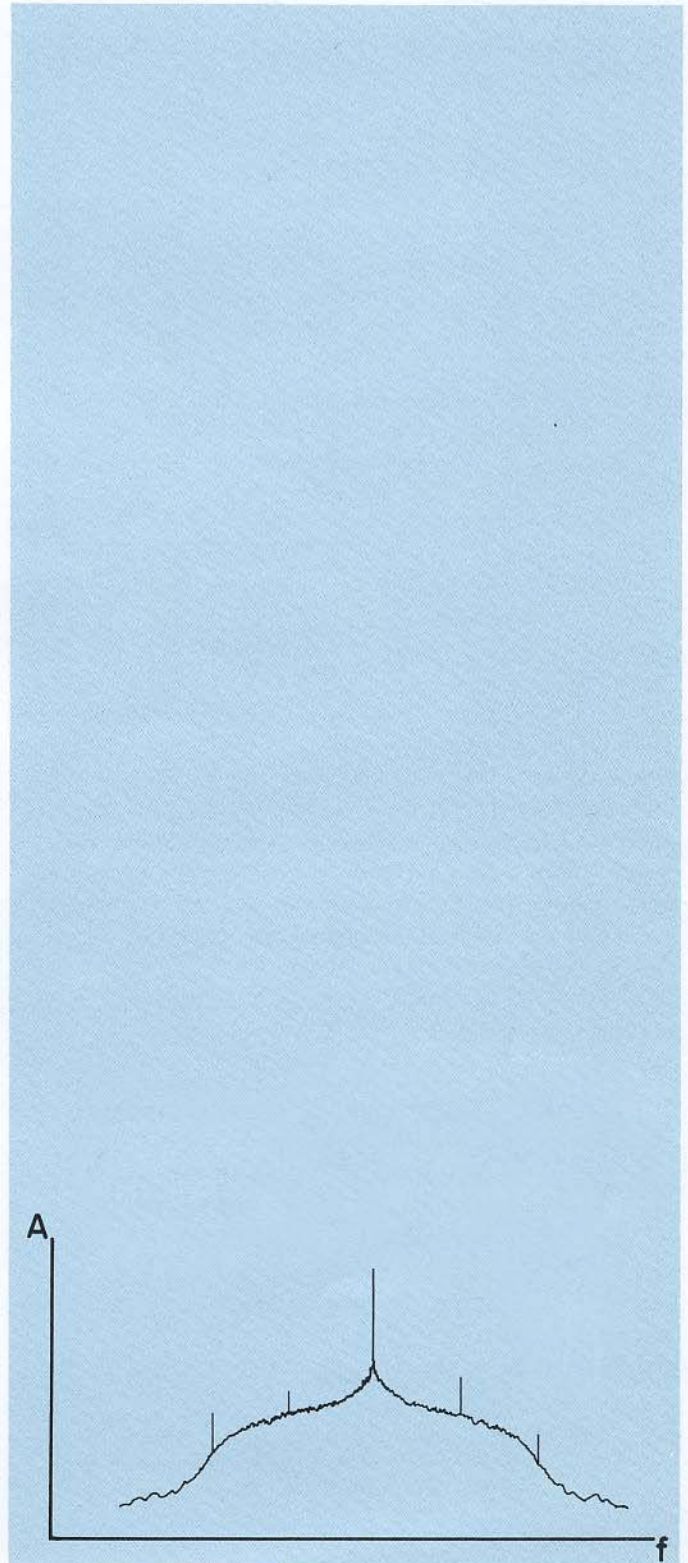

Figure 4. AM and PM Sidebands

The spectral density of frequency fluctuations is also an important quantity and can be easily derived from the phase spectral density. Since frequency is the time rate of change of phase, it follows that for $\nu(t)$ being the time function of frequency:

$$\begin{aligned} 2\pi\nu(t) &= \frac{d(\phi(t) + 2\pi\nu_0 t)}{dt} \\ &= \frac{d\phi}{dt} + 2\pi\nu_0 \\ \text{and } \nu(t) &= \frac{1}{2\pi} \frac{d\phi}{dt} + \nu_0 \end{aligned}$$

From transform theory the Fourier expansion of $\nu(t)$ is:

$$\nu(s) = \frac{s}{2\pi} \phi(s)$$

and the spectral density is:

$$S_{\nu}(f) = \frac{(2\pi f)^2}{(2\pi)^2} S_{\phi}(f) = f^2 S_{\phi}(f) \quad \left[\frac{\text{Hz}^2}{\text{Hz}} \right]$$

Caution must be taken when using $S_{\nu}(f)$ to compare the phase noise of sources at different frequencies. $S_{\nu}(f)$ is the spectral density of absolute frequency fluctuations. The measured spectral density of a 10MHz source would represent a much greater percentage frequency fluctuation than the same spectral density if measured at 100MHz. The answer to this problem is the spectral density recommended by the U.S. National Bureau of Standards as the primary definition of frequency stability. The spectral density of fractional frequency fluctuations, $S_{\nu}(f)$, is related to frequency fluctuations and phase fluctuations by:

$$S_{\nu}(f) = \frac{1}{\nu_0^2} S_{\nu}(f) = \frac{f^2}{\nu_0^2} S_{\phi}(f) \quad \left[\frac{1}{\text{Hz}} \right]$$

In many cases, however, it is not the spectral density of the equivalent modulating source that is of interest but rather the actual sideband power of phase fluctuations with respect to the carrier level. As an expression, this is:

$$\mathcal{L}(f) = \frac{\text{Power density (one phase modulation sideband)}}{\text{Carrier Power}}$$

This spectral density, Script $\mathcal{L}(f)$, is defined as the ratio of the power per Hertz of bandwidth at a frequency f from the carrier in one phase noise sideband to the carrier power. For sideband levels within the dynamic range of wave or spectrum analyzers,

this quantity can be measured directly at the RF frequency with one assumption. The AM components must be small compared to the PM components. Fortunately, this is the case for most sources of frequency standard quality.

For sources with very low sidebands, it is necessary to use phase detection or frequency discrimination to effectively eliminate the carrier in order to gain measurement range. Here another assumption must be made. The phase detected spectral density will be equivalent to the actual sidebands only if the peak phase fluctuations are much less than one radian. In terms of frequency modulation theory, this is equivalent to saying that the higher order modulation components are insignificant compared to the fundamental modulating frequency. For nearly all high quality sources, this is a good assumption. Given this assumption, $\mathcal{L}(f)$ can be related to $S_{\phi}(f)$. From small angle modulation theory:

$$\begin{aligned} \mathcal{L}(f) &= \left[\frac{\phi_{\text{peak}}}{2} \right]^2 \quad (1\text{Hz BW}) \\ &= \left[\frac{1.4\phi_{\text{rms}}}{2} \right]^2 \quad (1\text{Hz BW}) \\ &= \frac{S_{\phi}(f)}{2} \end{aligned}$$

Another common expression, signal to phase noise ratio, is the rms value of the phase noise sidebands in a specified bandwidth about the carrier with respect to the carrier power. A commonly used bandwidth is 30kHz centered on the carrier excluding $\pm 1\text{Hz}$ around the carrier. This expression is convenient because it yields a single number but it is not as informative as a spectral density.

Frequency stability is also defined in the time domain with a sample variance known as the Allan variance. The expression is usually simplified to:

$$\sigma_y^2(\tau) = \frac{(Y_{k+1} - Y_k)^2}{2}$$

$$\text{where } Y_k = \frac{\phi(t_k + \tau) - \phi(t_k)}{2\pi\nu_0\tau}$$

τ = repetition interval

This measurement is usually made with a counter system and is particularly useful because a transformation to the frequency domain yields data closer to the carrier than possible with most currently available frequency analyzers. A description of the transformation can be found in Reference 3.

Chapter 4

Accounting for Analyzer Characteristics

There are a variety of methods for measuring phase noise in the frequency domain but the common tool used in all of them is a frequency selective analyzer. It is appropriate now to discuss the different types of analyzers and the corrections necessary for making accurate noise measurements.

Wave analyzers are generally manually tuned selective analyzers with meter readout and flat-top steep-sided IF filters. The tuning range on the low end is limited to about 5 times the narrowest IF filter available in the instrument. Since the IF filters are not ideally rectangular, it is necessary to know the equivalent noise bandwidth in order to normalize to a 1 Hz bandwidth. For wave analyzers, the equivalent noise bandwidths are typically 3 to 10% wider than the stated 3dB bandwidth. Since this can vary from unit to unit, it is wise to check the actual unit by numerical integration of the filter curve to at least 30dB down from the top of the filter.

Nearly all analyzers use an average detector calibrated to read the true rms level of a discrete signal in the passband. For white noise, however, the meter reading would be 1.05dB lower than the true level. Since the meter may be fluctuating randomly, it is necessary to visually average the reading if some form of video filtering or meter damping is not available. Wave analyzers are most useful where only a relatively few spot measurements are necessary to verify a phase noise spectral density.

Spectrum analyzers are automatically swept selective analyzers with a CRT display. The IF filters are gaussian shaped for fast settling and rapid sweeping. Since the skirts are wider than wave analyzers, the equivalent noise bandwidths are usually up to 15% more than the 3dB bandwidths. Spectrum analyzers have logarithmic IF amplifier gain which amplifies noise peaks less than lower values and produces a signal which when average detected requires a total of +2.5dB correction for white noise. Video filtering, which is available on most spectrum analyzers is useful for reducing the amplitude deviation of the spectral density.

Analyzers which are remotely programmable and have digital data output can be used for numerically averaging many readings at a single frequency with software in the controller. It is necessary, of course, to retain statistical independence of the samples by limiting the repetition rate of the readings to the reciprocal of the equivalent bandwidth of the IF filter bandwidth and the video filtering bandwidth combined. From statistical theory, the confidence in an average is improved by the square root of the number of samples. For example, the average of 100 samples is 10 times better than a single sample.

Amplitude sensitivity is sometimes a problem when measuring very low phase noise levels. However, there are readily available low noise preamps to provide the necessary gain. This additional gain must be removed during calibration but it is a small inconvenience.

To summarize, for wave analyzers, the corrected noise power reading in dB is:

$$\text{Noise} = \text{Meter Reading} + 1.05 - 10 \log (\text{Equiv. Noise BW}) - \text{Preamp Gain}$$

For spectrum analyzers, it is:

$$\text{Noise} = \text{CRT display} + 2.5 - 10 \log (\text{Equiv. Noise BW}) - \text{Preamp Gain}$$

Remember, however, that all these corrections apply only for signals which approximate white noise in the IF bandwidth being used. Deterministic components are discrete signals which do not require correction factors. Whenever a data point is above the adjacent points by several dB, it should be checked for discreteness by narrowing the IF bandwidth and widening the video filtering. A discrete signal will not change level when the IF bandwidth is narrowed if it is in the center of the passband and will fluctuate less than adjacent points when the amount of video filtering is reduced.

This chapter describes how to make an accurate noise power measurement. What the measurement represents in terms of frequency or phase fluctuations is the subject of the next chapter.

Chapter 5

Practical Methods of Measuring Phase Noise

Measurement of phase noise sidebands would be simple if frequency analyzers had dynamic ranges of 160dB and 1Hz bandwidths useable in the GHz region. All measurements could then be made at the primary frequency of the source. However, equipment with this performance does not exist and so alternate techniques must be used. This chapter describes the RF spectrum measurement and two alternatives: frequency discrimination and quadrature phase detection.

Direct RF Spectrum Measurement

As mentioned before, the sidebands of a signal may represent both AM and PM. Asymmetry in the sidebands is an indication that both AM and PM are present. However, in many cases, due to the manner in which the signal has been processed, PM sidebands are dominant. For example, if a reasonably clean synthesized signal is multiplied up to be used as a high frequency reference, the phase noise sidebands are multiplied by the same factor as the frequency while the AM sidebands are not changed or are limited. In this case, direct RF spectrum measurements at the multiplied frequency are a good approximation of the phase noise sidebands. The sidebands, when corrected and normalized to the carrier powers, represent the $\mathcal{L}(f)$ spectral density described in Chapter 3.

One way to achieve better resolution is to translate the signal down in frequency to the range of an analyzer with the desired IF bandwidth. Figure 5 shows a typical setup using a doubly balanced mixer and a low pass filter. One of the advantages of this technique is that AM sidebands on the measured signal will be stripped off if it is to be used as the high level signal at the mixer. Two potential problems must be considered as well. First, the difference frequency will contain sidebands which are folded up from below zero frequency. Whether or not the sidebands are significant depends on the nature of the particular source being measured. The second problem is that phase noise sidebands from the reference frequency at the mixer will also be translated down. This problem is avoided by using a source with better phase noise specifications than the one being tested.

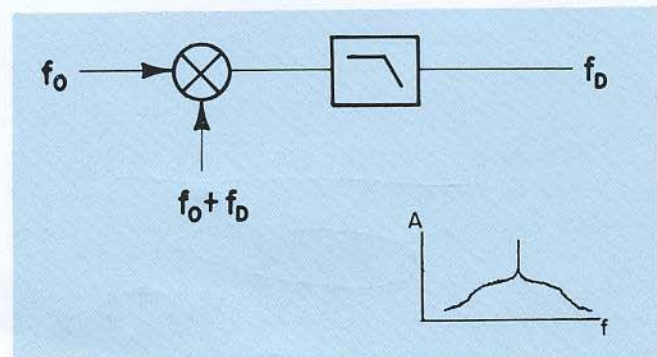

Figure 5. Sideband Translation

Frequency Discrimination

The only way to solve the problem of measuring sidebands which are beyond the dynamic range of the analyzer is to eliminate the carrier frequency. One way to do that is with a frequency discriminator as shown in Figure 6. It is necessary to check the linearity of the discriminator over the frequency range of interest to insure that the calibration factor is constant. For microwave frequencies, the cavity discriminator is particularly useful for this type of measurement. Additional information on this type of measurement is contained in Reference number 1.

Quadrature Phase Detection

Perhaps the most versatile setup (Figure 7) is a doubly balanced mixer with the unknown source and reference source set in phase quadrature (90°) at the input. At quadrature, the difference frequency is zero Hertz and the average voltage output is zero volts. For phase fluctuations $\ll 1$ radian the voltage fluctuations at the mixer output are related to the phase fluctuations by the equation:

$$\phi = \frac{V}{K}$$

where K = calibration factor in volts/radian

The system is easily calibrated by offsetting one of the sources and observing the resultant beat signal on an oscilloscope. The slope at the zero crossing in volts/radian is K and for sinusoidal beat signals is equal to the peak voltage of the signal. The beat signal as viewed on an analyzer is the rms value and so is 3dB less than the peak. In terms of the ratio of the sideband voltage to the beat signal voltage:

$$S_{\phi}(f) = V_S - V_B - 3\text{dB}$$

$$L(f) = V_S - V_B - 6\text{dB} \quad \phi(f) \ll 1$$

where V_S = sideband voltage in dB corrected for bandwidth and analyzer characteristics

V_B = beat signal rms level in dB

The underlying assumption so far is that the reference source has much lower phase noise than the unknown source. For state of the art sources, it is possible to compare two "identical" sources and assume that the phase noise of either one is 3dB less than the measured values. Measurement of various combinations of pairs of "identical" sources will test this assumption.

Often the long term stability of sources is not sufficient for a quadrature phase relationship to be held during the measurement period. If this is the case, one of the sources must be adjusted periodically. A phase lock loop as shown in Figure 8 may be used if one or both of the sources have a voltage control for small frequency adjustments. In order to retain a constant relationship between phase and voltage fluctuations, the low frequency cutoff of the phase lock loop must be below the lowest frequency to be analyzed. If the breakpoint is moved out by adding gain in the loop, the voltage fluctuations at frequencies below the breakpoint will represent frequency fluctuations. Calibration using the phase lock setup is done by disconnecting the feedback voltage and observing the beat signal as before.

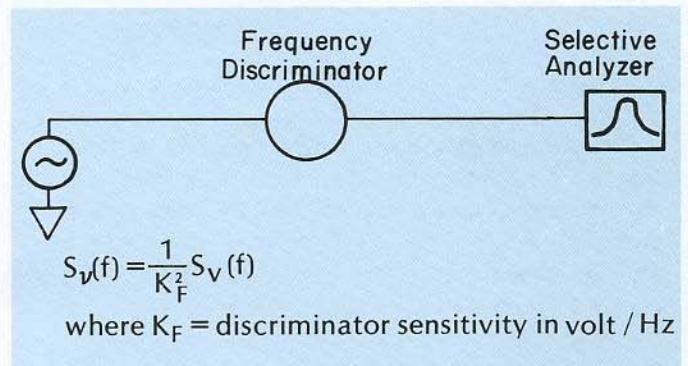

Figure 6. Frequency Discrimination

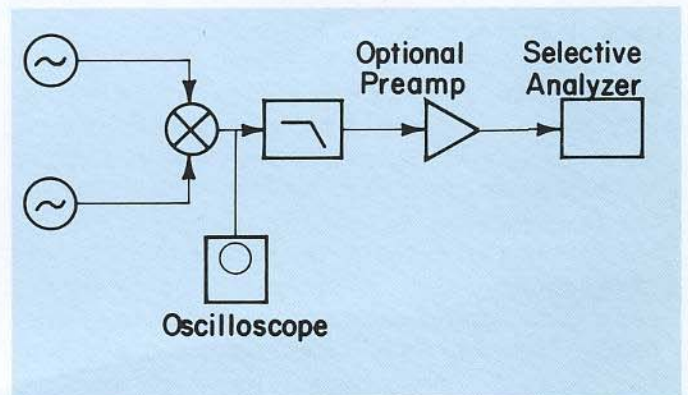

Figure 7. Heterodyne

In practice, phase noise analysis often covers a frequency range greater than that of a single selective analyzer. The following example of analysis of a 10MHz synthesized source shows the use of two Hewlett Packard spectrum analyzers to cover the range of 5Hz to 1MHz. The setup is a phase lock system as shown in Figure 9. The HP 3580A Spectrum Analyzer (Figure 10) is ideal for close-in analysis because the 1 Hz IF bandwidth provides high resolution and requires minimal correction factors. The two photographs in Figure 11 show the beat signal referenced .5dB (+2.5dB for correction—3dB for peak) below the top of the screen and the resultant phase noise sidebands from 0 to 100Hz. Notice that the scale is different on the sideband photograph due to increasing the input sensitivity after calibration. The discrete 60Hz modulation signal clearly appears above the phase noise sidebands and is an accurate level since no bandwidth correction was necessary.

The HP 3580A has an additional factor which must be considered. Internally, the detected signal is digitized and then displayed. A peak hold circuit is used after the detector to ensure that no discrete signals are missed between digitizing points. For white noise, the effect is to display the peaks of the noise signal. However, this effect can be adequately reduced by using maximum video filtering. It is not necessary to slow the sweep time if accurate levels of discrete signals are not necessary.

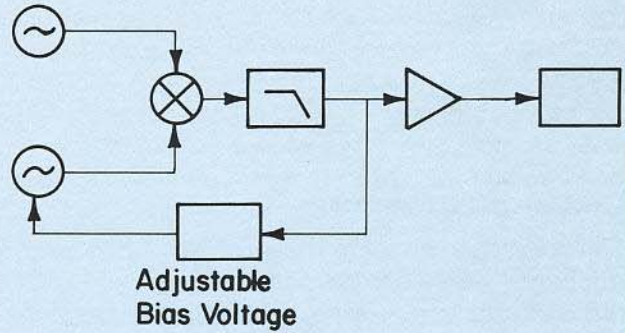

Figure 8. Heterodyne With Phase Lock

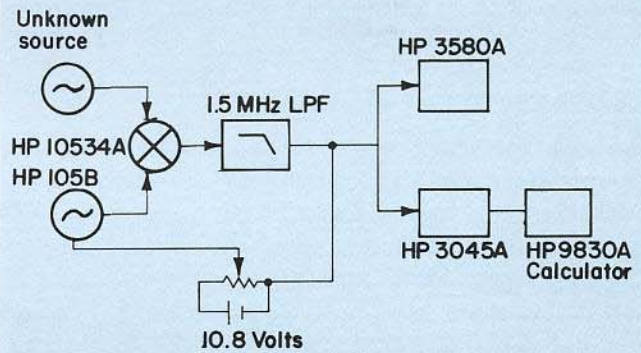
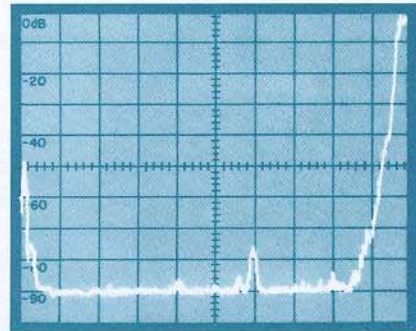

Figure 9. Example Setup

-20dB



-120dB

-50dB

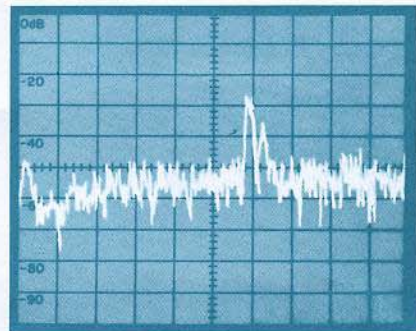

-150dB

Figure 11. HP 3580A Photos

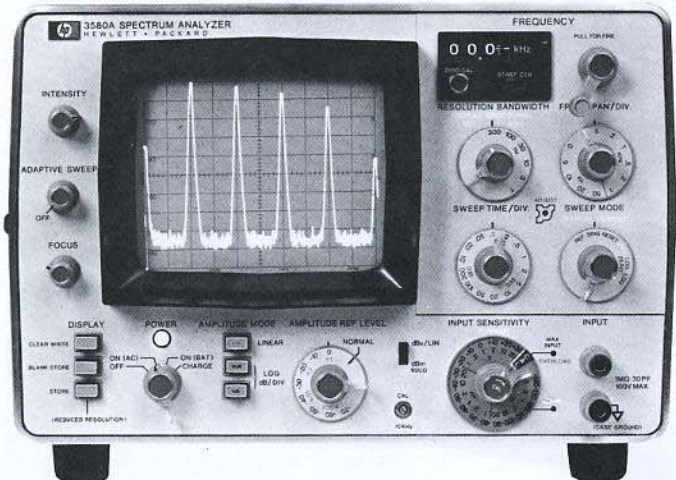

Figure 10. HP 3580A Spectrum Analyzer

The HP Automatic Spectrum Analyzer with an HP 9830A Calculator controller (Figure 12) was used to cover the range from 100Hz to 1MHz. The programmable power of this system allows the user to select points which avoid discrete signals and thus quickly determine a phase noise sideband envelope over a wide frequency range. The key to this capability is the programmable synthesizer and its tracking analyzer with digital readout and output rather than a built-in CRT. The analyzer's internal structure is similar to most spectrum analyzers. The programmable calculator through software written by the operator controls both units over a bidirectional interface, manipulates data received from the analyzer and plots the normalized and corrected results on an optional digital plotter. Figure 13 shows the continuation of the phase noise sidebands analyzed previously with the HP 3580A. Numerical averaging of many readings in software makes it possible to plot a single point at each frequency with a high degree of confidence in its validity.

In addition to the measurement improvement achieved by this system, the operator interaction provided by the calculator makes difficult measurements such as phase noise sidebands much simpler by leading the user through each of the necessary steps of calibration, measurement, data reduction, and plotting. Appendix A contains the details of the operation of the programs used to make this measurement.

In general, practical methods of measuring phase noise are time consuming and full of possible pitfalls. Automation or even semi-automation can save much time and greatly increase confidence in the results.

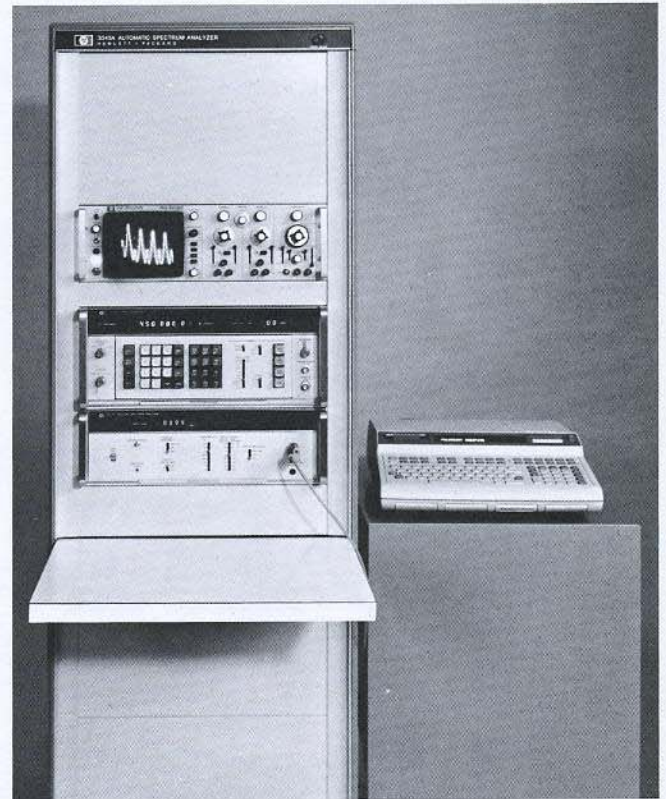

Figure 12. HP 3045A Automatic Spectrum Analyzer

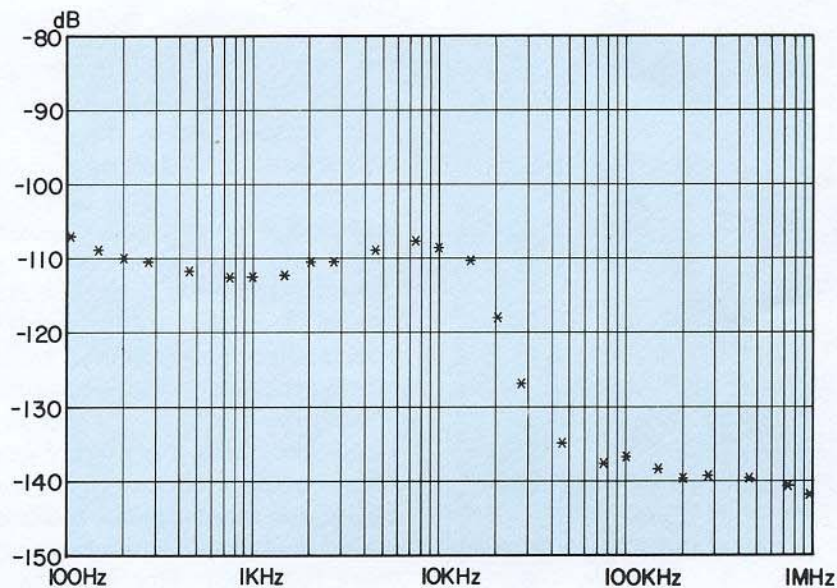

Figure 13. HP 3045A Plot

Appendix A

The software described in this appendix is an example of how a complex measurement such as phase noise analysis using the phase detection technique can be broken into several parts, each handled with a separate subprogram. The four parts are labeled Calibrate, Setup, Noise Scan, and Plot. To increase their flexibility using the HP 9830A Calculator, they are stored as key functions thus making it simple to use each program as needed. The block diagrams and notes on the listings following the general descriptions give more explanation.

The Calibrate program must be initialized and run before any of the rest. It is the only program requiring manual operations by the user such as removing any preamps, offsetting the sources and resetting the sources to quadrature. Other constants such as source frequency, detector sensitivity (if known), and preamp gain are entered. The program will automatically measure the beat frequency level and calculate the phase detector slope if it is not known. After the operator connects the preamp and resets the sources to quadrature, the program ranges the analyzer to the optimum range.

The Setup program allows the operator to define the frequency range of interest and the type of scan. Log scans are normally used to cover wide frequency ranges while linear scans are used for narrow ranges particularly if harmonic relationships are being examined. The maximum number of steps is an arbitrary choice intended to minimize memory storage while retaining reasonable resolution in the plot. The frequencies in the log scan are defined by the data statement and have been chosen to avoid power line and its harmonics throughout the first three decades from 10Hz to 10kHz.

The Noise Scan program is the one which does all the actual noise measurements. Using the data input in the first two programs, it calculates the correct bandwidth, sets the frequency, and takes multiple readings which are averaged, converted to $\mathcal{L}(f)$ data and stored in an array. For a six decade scan, from 10Hz to 100MHz, there are a total of 1272 measurements made yielding 36 averaged data points. The total time required is approximately eight minutes, most of which is taken for measurements in the first two decades of frequency. The bandwidth is automatically increased as the frequency is increased to provide faster measurements where less resolution is required.

The user should be aware that the linear scan routine uses a fixed bandwidth based on the lowest frequency of the scan. Any frequency below 1kHz requires the 3Hz bandwidth. In this bandwidth, 100 measurements spaced 330ms apart are averaged to obtain one data point. Consequently, a hundred point scan may take over 50 minutes to complete.

The Plot program plots data points over the frequency range of measurement in terms of $S_V(f)$ or $\mathcal{L}(f)$ as specified by the user. The vertical scale is also specified by the user in order to allow flexibility in plot positioning and scaling. Since the data is stored in an array, it is possible to make many plots, even to various scales, without making all the measurements over. The frequency scale cannot be changed in this program because the resolution is already determined by the number of data points specified in the Setup program.

These programs are merely one example of how phase noise measurements can be automated. There are many useful routines which could be added to make the programs more interactive and more foolproof. Plot labeling could be added to reduce the time of annotation. These programs are easily modified to provide a dedicated test program with no user interaction and a go/no go indication.

CALIBRATE

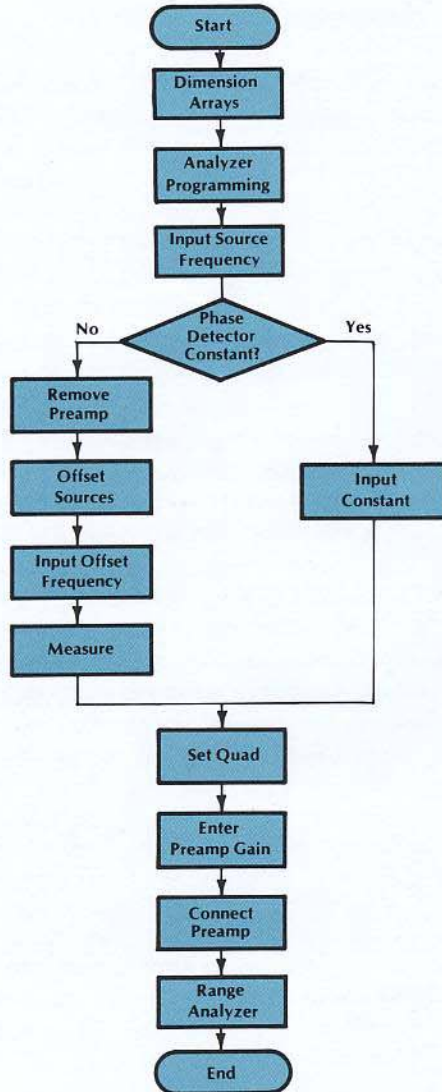

```

10 REM"CALIBRATE"
20 DIM A#(3),B#(3),C#(3),AC(6),BC(10)
30 OUTPUT (13,40)768;
40 FORMAT B
50 CMD "?U1","M1R1S0V7Z2"
60 DISP "WHAT IS THE SOURCE FREQUENCY";
70 INPUT F3
80 DISP "DO YOU KNOW THE PHASE DET V/RAD";
90 INPUT A#
100 IF A#[1,1]="N" THEN 140
110 DISP "WHAT IS PHASE DET V/RAD";
120 INPUT V2
130 GOTO 340
140 DISP "HAVE YOU REMOVED PREAMP";
150 INPUT A#
160 DISP "ARE THE SOURCES OFFSET";
170 INPUT A#
180 DISP "WHAT IS OFFSET FREQ";
190 INPUT F
200 CMD "?U#"
210 OUTPUT (13,220)"L",F,"="
220 FORMAT F1000.1
230 FOR B1=7 TO 0 STEP -1
240 IF 10*((B1+1)/2)<F/3 THEN 260
250 NEXT B1
260 CMD "?U1"
270 OUTPUT (13,280)"B",B1
280 FORMAT F1000.0
290 WAIT 1000
300 CMD "?U1","T","?50"
310 ENTER (13,320)V1
320 FORMAT 1X,F7.2
330 V2=1.414*10*(V1/20)
340 DISP "WHAT IS DB GAIN OF PREAMP";
350 INPUT G
360 IF G=0 THEN 410
370 DISP "HAVE YOU CONNECTED PREAMP";
380 INPUT A#
390 DISP "HAVE YOU SET SOURCES TO QUAD";
400 INPUT A#
410 FOR V=7 TO 0 STEP -1
420 CMD "?U1"
430 OUTPUT (13,440)"V",V
440 FORMAT F1000.0
450 WAIT 1000
460 CMD "?U1","T","?50"
470 FORMAT B,F7.2
480 ENTER (13,470)Y
490 IF Y=79 THEN 510
500 NEXT V
510 DISP "CALIBRATION IS COMPLETE"
520 END
  
```

SET UP

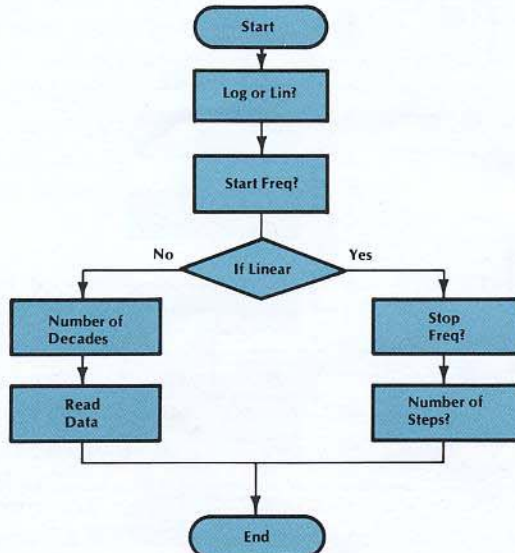

```

10 REM"SETUP"
20 DISP "LOG OR LIN";
30 INPUT A#
40 DISP "START FREQ";
50 INPUT F1
60 IF A#[1,2]="LI" THEN 120
70 DISP "NUMBER OF DECADES";
80 INPUT D
90 READ I,J,AC(1),AC(2),AC(3),AC(4),AC(5),AC(6)
100 DATA 0,0,1.467,2.033,2.733,4.533,7.467,9.967
110 GOTO 160
120 DISP "STOP FREQ";
130 INPUT F2
140 DISP "NUMBER OF STEPS (100 MAX)";
150 INPUT S
160 DISP "READY TO RUN"
170 END
  
```

NOISE SCAN

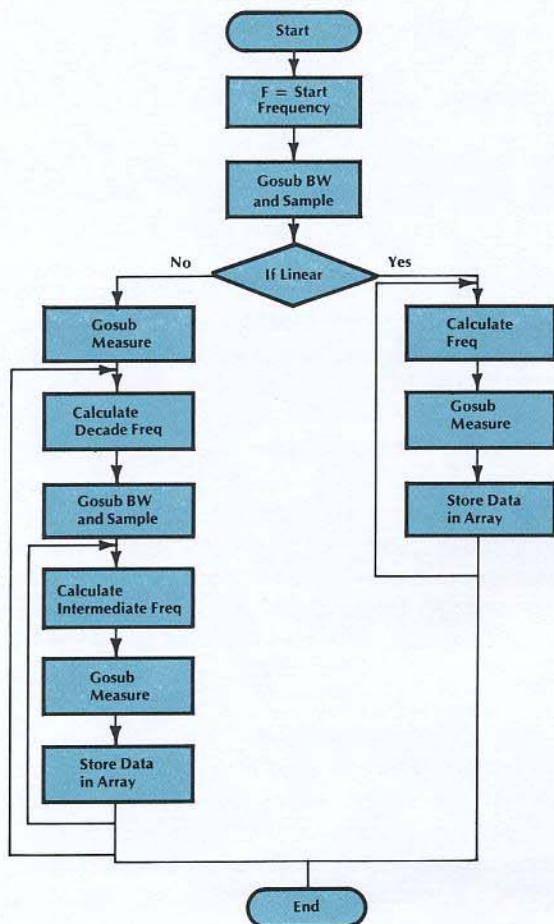

```

10 REM"NOISE SCAN"
20 F=F1
30 GOSUB 360
40 IF A#[1]="LI" THEN 170
50 GOSUB 230
60 B[1]=Y
70 FOR J=0 TO D-1
80 F=F1*10^J
90 GOSUB 360
100 FOR I=1 TO 6
110 F=F1*A[I]*10^J
120 GOSUB 230
130 B[1+I+J*6]=Y
140 NEXT I
150 NEXT J
160 GOTO 560
170 FOR C=0 TO S
180 F=F1+C*(F2-F1)/S
190 GOSUB 230
200 B[C+1]=Y
210 NEXT C
220 GOTO 560
230 CMD "?U#"
240 OUTPUT (13,250)"L",F,"="
250 FORMAT F1000.1
260 Y=0
270 FOR K=1 TO E
280 WAIT L
290 CMD "?U1","T","?50"
300 ENTER (13,310)X
310 FORMAT 1X,F7.2
320 Y=Y+X
330 NEXT K
340 Y=Y/E+2.5-3-10*LGTB1-20*LGTV2-G
350 RETURN
360 IF F >= 1E+03 THEN 420
370 B1=3.39
380 B2=0
390 E=100
400 L=330
410 GOTO 520
420 IF F >= 1E+04 THEN 480
430 B1=33
440 B2=2
450 E=3
460 L=1000
470 GOTO 520
480 B1=331
490 B2=4
500 E=3
510 L=100
520 CMD "?U1"
530 OUTPUT (13,540)"S1B",B2
540 FORMAT F1000.0
550 RETURN
560 DISP "READY TO PLOT"
570 END
  
```

BW AND SAMPLE

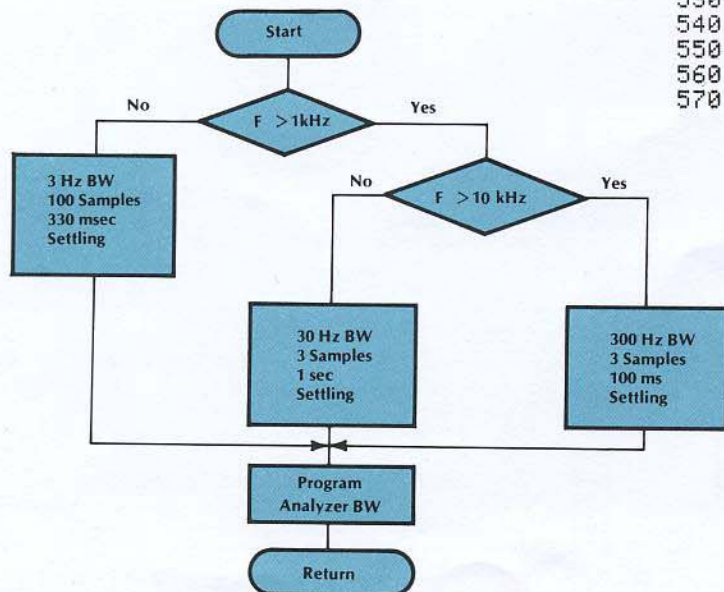

MEASURE

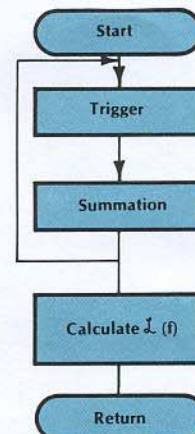

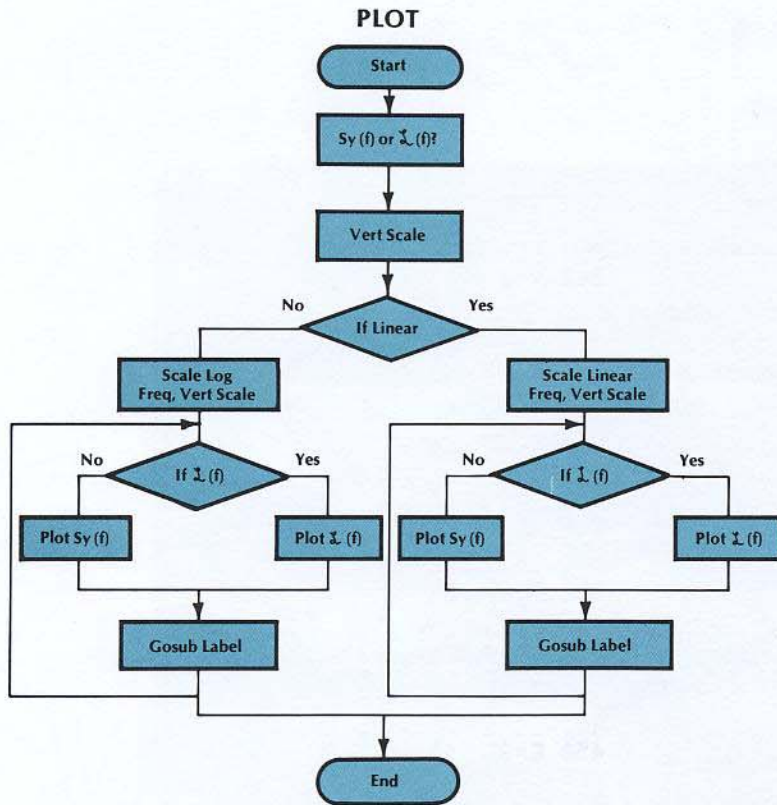

```

10 REM "PLOT"
20 DISP " PLOT SY(F) OR L(F)";
30 INPUT C#
40 DISP "VERT SCALE- YMIN,YMAX";
50 INPUT Y1,Y2
60 IF A#[1,2]="LI" THEN 240
70 SCALE LGTF1,LGT(F1*10^D),Y1,Y2
80 IF C#[1,1]="L" THEN 110
90 PLOT LGTF1,20*LGT(F1/F3)+(B[1]+3),0
100 GOTO 120
110 PLOT LGTF1,B[1],0
120 GOSUB 330
130 FOR J=0 TO D-1
140 FOR I=1 TO 6
150 F=F1*A[I]*10^J
160 IF C#[1,1]="L" THEN 190
170 PLOT LGTF,20*LGT(F/F3)+(B[1+I+J*6]+3),0
180 GOTO 200
190 PLOT LGTF,B[1+I+J*6],0
200 GOSUB 330
210 NEXT I
220 NEXT J
230 GOTO 300
240 SCALE 0,S,Y1,Y2
250 FOR C=0 TO 8
260 IF C#[1,1]="L" THEN 290
270 PLOT C,20*LGT(F/F3)+(B[C+1]+3),0
280 GOTO 300
290 PLOT C,B[C+1],0
300 GOSUB 330
310 NEXT C
320 GOTO 300
330 CPLOT -0.3,-0.3
340 LABEL (*)*";
350 IPLOT 0,0
360 PEN
370 RETURN
380 DISP ""
385 DISP "PLOT IS COMPLETE"
390 END
  
```

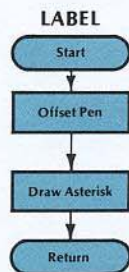

References

1. "Wave Analyzer Dynamic Range and Bandwidth Requirements for Signal Noise Analysis", Technical Report RE 76-26, U. S. Army Missile Command, Redstone Arsenal, Alabama 35809.
2. "Frequency Domain Stability Measurements: A Tutorial Introduction", NBS Technical Note 679, U.S. Department of Commerce/National Bureau of Standards.
3. "Frequency Stability Specification and Measurement: High Frequency and Microwave Signals", NBS Technical Note 632, U.S. Department of Commerce/National Bureau of Standards.
4. "Characterization of Frequency Stability", NBS Technical Note 394, U.S. Department of Commerce/National Bureau of Standards.
5. "Spectrum Analysis . . . Noise Measurements", Spectrum Analyzer Series Application Note 150-4, Hewlett Packard Company, April, 1974.
6. "Short-Term Stability for a Doppler Radar: Requirements, Measurements, and Techniques", *PROCEEDINGS OF THE IEEE* Vol. 54, No. 2, February, 1966. D. B. Leeson, Senior Member, IEEE, and G. F. Johnson, Senior Member, IEEE.



For more information, call your local HP Sales Office or East (201) 265-5000 • Midwest (312) 677-0400 • South (404) 436-6181 • West (213) 877-1282. Or write: Hewlett-Packard, 1501 Page Mill Road, Palo Alto, California 94304. In Europe: P.O. Box 85, CH-1217 Meyrin 2, Geneva, Switzerland. In Japan: YHP, 1-59-1, Yoyogi, Shibuya-Ku, Tokyo, 151. Printed in U.S.A.

5952-8708