

hp 203A

Q15924

①

DO NOT LOAN



HEWLETT-PACKARD COMPANY / OPERATING AND SERVICE MANUAL

203A

**VARIABLE PHASE
FUNCTION
GENERATOR**

hp 203A

CERTIFICATION

THE HEWLETT-PACKARD COMPANY CERTIFIES THAT THIS INSTRUMENT WAS THOROUGHLY TESTED AND INSPECTED AND FOUND TO MEET ITS PUBLISHED SPECIFICATIONS WHEN IT WAS SHIPPED FROM THE FACTORY.

Ⓟ FURTHER CERTIFIES THAT ITS CALIBRATION MEASUREMENTS ARE TRACEABLE TO THE NATIONAL BUREAU OF STANDARDS TO THE EXTENT ALLOWED BY THE BUREAU'S CALIBRATION FACILITY.



OPERATING AND SERVICING MANUAL

MODEL 203A

SERIALS PREFIXED: 425

VARIABLE PHASE
FUNCTION GENERATOR

Copyright Hewlett-Packard Company 1964



SECTION I GENERAL INFORMATION

SECTION II INSTALLATION

SECTION III OPERATING INFORMATION

SECTION IV PRINCIPLES OF OPERATION

SECTION V MAINTENANCE

SECTION VI REPLACEABLE PARTS

TABLE OF CONTENTS

Section	Page	Section	Page
I	GENERAL INFORMATION	1-1	
	1-1. Description	1-1	
	1-5. Options Available	1-1	
	1-7. Applications	1-1	
	1-9. Instrument Identification	1-1	
II	INSTALLATION	2-1	
	2-1. Inspection	2-1	
	2-3. Power Requirements	2-1	
	2-5. Three-Conductor Power Cable	2-1	
	2-8. Installation	2-1	
	2-10. Rack/Bench Installation	2-1	
	2-12. Repackaging for Shipment	2-1	
III	OPERATION	3-1	
	3-1. Introduction	3-1	
	3-3. Controls and Indicators	3-1	
	3-5. Operating Instructions	3-1	
	3-7. Calibration for 60 Cycle Line Frequency	3-1	
	3-9. Calibration for Line Frequencies Other Than 60 Cycles	3-1	
IV	PRINCIPLES OF OPERATION	4-1	
	4-1. Overall Description	4-1	
	4-5. Crystal Oscillator and Divider Assembly (A1)	4-1	
	4-7. Crystal Oscillator	4-1	
	4-9. 9:1 Frequency Divider	4-1	
	4-16. Variable Phase Shifter Assembly	4-1	
	4-18. RF Amplifiers (A2)	4-1	
	4-20. Variable Phase Channel RF Amplifier	4-2	
	4-23. Reference Phase Channel RF Amplifier	4-2	
	4-25. Variable Frequency Oscillator (A10)	4-2	
	4-27. Decade Modules (A11 - A16)	4-2	
	4-29. Decade Module (A11)	4-2	
	4-31. Decade Modules, A12 through A16	4-3	
	4-33. Modulator Assembly, A3	4-3	
	4-35. Modulator Driver Amplifier	4-3	
	4-37. Reference Phase Channel Modulator	4-3	
	4-40. Variable Phase Channel Modulator	4-3	
	4-42. DC Amplifier Assemblies A6 & A7	4-3	
	4-44. Reference Phase Channel DC Amplifier Assembly	4-3	
	4-46. Variable Phase Channel DC Amplifier Assembly	4-3	
	4-48. Square Wave Amplifier Assemblies A8 and A9	4-3	
	4-50. Reference Phase Channel Square Wave Generator	4-3	
	4-52. Variable Phase Channel Square Wave Generator	4-4	
	4-54. DC Power Supply A21, A22	4-4	
	4-56. Calibrate Feature	4-4	
V	MAINTENANCE	5-1	
	5-1. Required Test Equipment	5-1	
	5-3. Performance Checks	5-1	
	5-5. Frequency Dial Calibration	5-1	
	5-6. Frequency Response	5-2	
	5-7. Sine Wave Check	5-3	
	5-8. Square Wave Check	5-5	
	5-9. Phase Lag Check	5-5	
	5-10. Instrument Cover Removal	5-6	
	5-12. Adjustments	5-6	
	5-14. Power Supply A22 Adjustments	5-6	
	5-15. 4.995 Mc Oscillator and 9:1 Divider (A1) Adjustment	5-6	
	5-16. Adjustable Phase Shifter (A25) Adjustment	5-7	
	5-17. RF Amplifier Adjustment (A2)	5-7	
	5-18. Decade Module (A11 - A16) Adjustments	5-7	
	5-19. Frequency Dial Adjustment	5-7	
	5-20. Modulator (A3) Adjustment	5-7	
	5-21. Distortion	5-7	
	5-22. Frequency Response	5-8	
	5-23. Phase Lag Dial	5-8	
	5-24. Square Wave (A8 & A9) Adjustment	5-8	
	5-25. Troubleshooting	5-9	
	5-27. Printed Circuit Board Printer	5-9	
VI	REPLACEABLE PARTS	6-1	
	6-1. Introduction	6-1	
	6-4. Ordering Information	6-1	

LIST OF TABLES

Table	Page	Table	Page
1-1. Specifications	1-0	5-4. Troubleshooting Summary	5-10
5-1. Required Test Equipment	5-1	6-1. Index by Reference Designator	6-2
5-2. Frequency Dial Calibration	5-3	6-2. Replaceable Parts	6-12
5-3. Phase Lag Check	5-6		

LIST OF ILLUSTRATIONS

Figure	Page	Figure	Page
1-1. Model 203A Variable Phase Function Generator	1-0	5-13. VFO Assembly A10 and Decade Module Assembly A11 - Component Location . .	5-20
3-1. Front Panel Description	3-2	5-14. VFO Assembly A10 and Decade Module Assembly A11 - Schematic	5-21
3-2. Operating Instructions	3-3	5-15. Modulator Assembly A3 - Component Location	5-22
4-1. Block Diagram	4-0	5-16. Modulator Assembly A3 - Schematic . .	5-23
4-2. Circuit Details	4-2	5-17. DC Amplifier Assembly A6 and A7 - Component Location	5-24
5-1. Frequency Dial Calibration	5-2	5-18. Low Pass Filter Assembly A4, DC Amplifier Assembly A6 and Square Wave Generator Assembly A8 - Schematic	5-25
5-2. Frequency Response	5-2	5-19. Low Pass Filter Assembly A4 and A5 and Square Wave Generator Assembly A8 and A9 - Component Location . . .	5-26
5-3. Sine Wave Check	5-4	5-20. Low Pass Filter Assembly A5, DC Amp. Assembly A7 and Square Wave Gen. Assembly A9 - Schematic	5-27
5-4. Square Wave Check	5-4	5-21. Power Supply Assembly A22 Component Location	5-28
5-5. Phase Lag Check	5-5	5-22. Power Supply Assembly A22 and Rectifier Assembly A21 - Schematic . .	5-29
5-6. Phase Lag Dial Adjustment	5-9		
5-7. Typical Waveforms	5-11,5-12,5-13		
5-8. Chassis - Top View	5-14		
5-9. 5 Mc Oscillator and 9:1 Divider Assembly A1 - Component Location .	5-16		
5-10. 5 Mc Oscillator and 9:1 Divider Assembly A1 - Schematic	5-17		
5-11. RF Amplifier Assembly A2 - Component Location	5-18		
5-12. RF Amplifier Assembly A2 and Adjustable Phase Shifter Assembly A25 - Schematic	5-19		

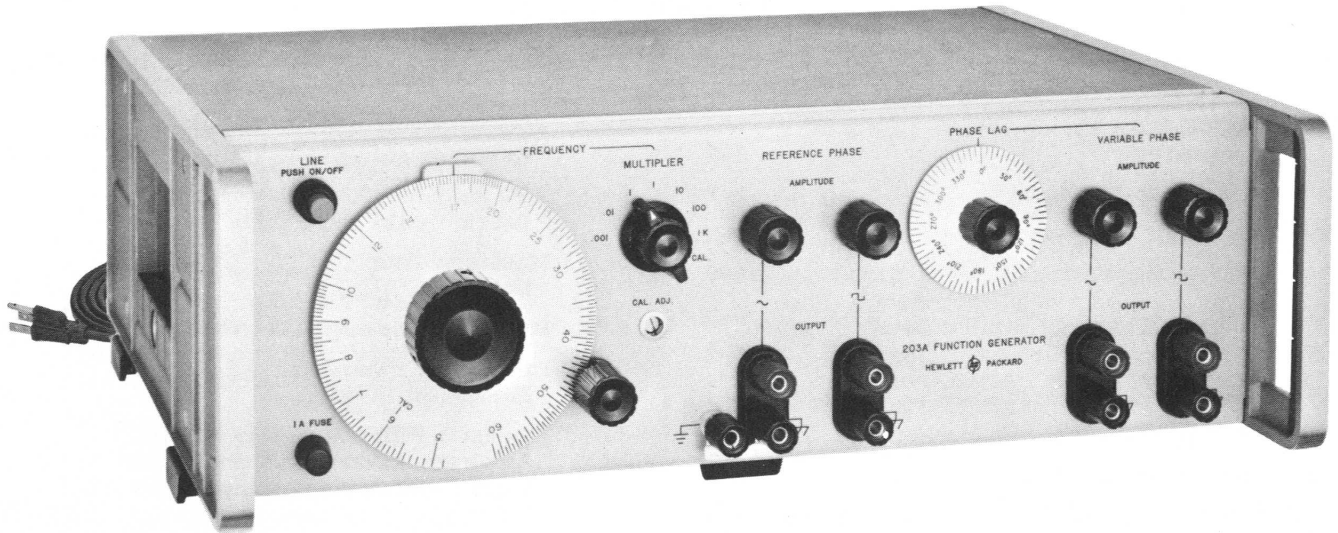

Figure 1-1. Model 203A Variable Phase Function Generator

Table 1-1. Specifications

<p>FREQUENCY RANGE 0.005 cps to 60 kc in seven decade ranges*</p> <p>DIAL ACCURACY ±1% of reading</p> <p>FREQUENCY STABILITY Within ±1% including warmup drift and line voltage variations of ±10% (typical short term 1 part in 10⁴)</p> <p>OUTPUT WAVEFORMS Available simultaneously. All outputs have chassis terminal common.</p> <p>REFERENCE PHASE</p> <table border="0"> <tr> <td>Sine Wave</td> <td>0-30 volts peak-to-peak</td> </tr> <tr> <td>Square Wave</td> <td>0-30 volts peak-to-peak</td> </tr> </table> <p>VARIABLE PHASE</p> <table border="0"> <tr> <td>Sine Wave</td> <td>0-30 volts peak-to-peak</td> </tr> <tr> <td>Square Wave</td> <td>0-30 volts peak-to-peak</td> </tr> <tr> <td>Continuously variable</td> <td>0-360°</td> </tr> <tr> <td>Phase dial accuracy</td> <td>±5° sine wave</td> </tr> <tr> <td></td> <td>±10° square wave</td> </tr> </table> <p>MAXIMUM OUTPUT VOLTAGE At least 30 volts peak-to-peak open circuit for sinusoidal and square waveforms.</p> <p>* Two lower ranges of 0.0005 and 0.00005 cps are available on special order.</p>	Sine Wave	0-30 volts peak-to-peak	Square Wave	0-30 volts peak-to-peak	Sine Wave	0-30 volts peak-to-peak	Square Wave	0-30 volts peak-to-peak	Continuously variable	0-360°	Phase dial accuracy	±5° sine wave		±10° square wave	<p>OUTPUT POWER 5 volts into 600 ohms (40 mw); at least 40 db continuously variable attenuation on all outputs.</p> <p>DISTORTION Total harmonic distortion hum and noise >64 db below fundamental.</p> <p>OUTPUT SYSTEM Direct coupled output is isolated from ground and may be operated floating or with either side ground.</p> <p>AMPLITUDE STABILITY ±1% referenced to 1 kc</p> <p>TEMPERATURE STABILITY ±0.03% per degree centigrade at 1 kc</p> <p>SQUARE WAVE RESPONSE Rise and Fall Time: < 200 nsec Flatness: Flat top within ±0.5% from 10% to 90% of half period.</p> <p>POWER 115 or 230 v ±10%, 50 to 1000 cps, approximately 25 watts.</p> <p>DIMENSIONS Cabinet mount, 5-1/4" high x 16-3/4" wide and 11-1/2" deep.</p> <p>WEIGHT Net 19 lbs. 4 oz. (8.66 Kg). Shipping approximately 25 lbs. (11.25 Kg)</p>
Sine Wave	0-30 volts peak-to-peak														
Square Wave	0-30 volts peak-to-peak														
Sine Wave	0-30 volts peak-to-peak														
Square Wave	0-30 volts peak-to-peak														
Continuously variable	0-360°														
Phase dial accuracy	±5° sine wave														
	±10° square wave														

SECTION I

GENERAL INFORMATION

1-1. DESCRIPTION.

1-2. The Hewlett-Packard Model 203A Variable Phase Function Generator is a low frequency function generator which provides two sine wave and two square wave test signals at frequencies from 0.005 cps to 60 kc. (Refer to paragraph 1-5, Options Available.)

1-3. The four test signals are provided at the front panel OUTPUT connectors at an open circuit signal level of 30 volts peak-to-peak. The sine wave and square wave test signals provided at the REFERENCE PHASE OUTPUT connectors are fixed in phase and provide a reference phase for the test signals at the VARIABLE PHASE OUTPUT connectors. The variable phase test signals are continuously variable from 0° to 360° lag with respect to the phase of the reference test signals. The amplitude of the four output signals can be varied with individual continuously variable 40 db attenuators (AMPLITUDE controls.)

1-4. The output terminals are floating with respect to ground and can be used to supply an output voltage with either terminal grounded or can be floated up to 500 volts dc above chassis ground. The output impedance for all four test signal outputs is 600 ohms.

1-5. OPTIONS AVAILABLE.

1-6. Options 01 and 02 are available to provide two additional frequency ranges to the Model 203A. Option 01 includes one additional Decade Module Board Assembly which extends the lower limit of the frequency range from 0.005 cps to 0.0005 cps. Option 02 includes two additional Decade Module Board Assemblies which extend the lower limit of the frequency range from 0.005 cps to 0.00005 cps. These two options can also be installed as a field modification (see Section VI for stock number of Decade Module Board Assemblies).

1-7. APPLICATIONS.

1-8. The Model 203A can be used for phase shift measurements, vibration studies, servo applications, medical research, distortion measurements, geophysical problems, subsonic and audio testing.

1-9. INSTRUMENT IDENTIFICATION.

1-10. Hewlett-Packard uses a two-section eight-digit serial number (000-00000). If the first three digits of the serial number on your instrument do not agree with those on the title page of this manual, change sheets supplied with the manual will define differences between your instrument and the Model 203A described in this manual.

1-11. If an E or G prefixes the serial number, the instrument was manufactured in Europe (E for England, G for Germany).

NOTES

SECTION II INSTALLATION

2-1. INSPECTION.

2-2. This instrument was carefully inspected both mechanically and electrically before shipment. It should be physically free of marks or scratches and in perfect electrical order upon receipt. To confirm this, the instrument should be inspected for physical damage in transit. Also check for supplied accessories, and test the electrical performance of the instrument using the procedure outlined in paragraph 5-3. If there is damage or deficiency, see the warranty on the inside rear cover of this manual.

2-3. POWER REQUIREMENTS.

2-4. The Model 203A will operate from either 115 or 230 vac, 50-1000 cps. The instrument can be easily converted from 115 to 230 volt operation by changing the position of the slide switch, located on rear panel, so that the designation appearing on the switch matches the nominal voltage of the power source.

2-5. THREE-CONDUCTOR POWER CABLE.

2-6. To protect operating personnel, the National Electrical Manufacturers' Association (NEMA) recommends that the instrument panel and cabinet be grounded. All Hewlett-Packard instruments are equipped with a three-conductor power cable which, when plugged into an appropriate receptacle, grounds the instrument. The offset pin on the power cable three-prong connector is the ground wire.

2-7. To preserve the protection feature when operating the instrument from a two-contact outlet, use a three-prong to two-prong adapter and connect the green pigtail on the adapter to ground.

2-8. INSTALLATION.

2-9. The Model 203A is fully transistorized; therefore no special cooling is required. However, the instrument should not be operated where the ambient temperature exceeds 55°C (140°F).

2-10. RACK/BENCH INSTALLATION.

2-11. The Model 203A is initially shipped as a bench type instrument (unless ordered specifically as a rack type) with plastic feet and a tilt stand in place. Conversion to a rack-mounted instrument can be accomplished by using the rack mounting kit and instructions furnished with your instrument.

2-12. REPACKAGING FOR SHIPMENT.

2-13. The following is a general guide for repacking an instrument for shipment. If you have any questions, contact your local  Sales and Service Office (see maps in Appendix for location).

a. Place instrument in original container if it is available. If original container is not available, it can be purchased from your nearest  Sales and Service Office.

If original container is not used,

b. Wrap instrument in heavy paper or plastic before placing in an inner container.

c. Use plenty of packing material around all sides of instrument and protect panel face with cardboard strips.

d. Place instrument and inner container in a heavy carton or wooden box and seal with strong tape or metal bands.

e. Mark shipping container with "Delicate Instrument", "Fragile" etc.

Note

If instrument is to be shipped to Hewlett-Packard for service or repair, attach to the instrument a tag identifying the owner and indicate the service or repair to be accomplished; Include the model number and full serial number of instrument. In any correspondence, identify the instrument by model number and serial number prefix.

SECTION III OPERATION

3-1. INTRODUCTION.

3-2. The Model 203A generates two sine wave and two square wave signals which are available simultaneously at the front panel OUTPUT connectors. The output signal frequency is determined by the position of the FREQUENCY dial and FREQUENCY MULTIPLIER switch. By the use of the PHASE LAG control, the phase of the VARIABLE PHASE OUTPUT signals (one sine wave and one square wave) can be continuously adjusted from 0° to 360° with respect to the REFERENCE PHASE OUTPUT signals. The OUTPUT terminals provide an open-circuit signal level of 30 volts peak-to-peak. The individual AMPLITUDE controls provide 40 db of attenuation for each output signal. The CAL ADJ control provides a means of calibrating the FREQUENCY dial with the line frequency.

3-3. CONTROLS AND INDICATORS.

3-4. Figure 3-1 describes the function of all front panel controls, connectors, and indicators. The description of each component is keyed to a drawing which is included within the figure.

3-5. OPERATING INSTRUCTIONS.

3-6. Figure 3-2 contains operating procedures keyed to a drawing included in the figure. Refer to figure 3-1 for the function of each control and paragraph 2-3 for setting the line voltage switch.

3-7. CALIBRATION FOR 60 CYCLE LINE FREQUENCY.

3-8. Before using the Model 203A, calibrate the FREQUENCY dial with the line frequency as follows:

- a. Perform steps 1 and 2 of figure 3-2.
- b. Adjust the CAL ADJ control for minimum flicker rate of the LINE switch pilot lamp.

Note

When the FREQUENCY MULTIPLIER switch is in the CAL position, there is no output signal at the REFERENCE PHASE OUTPUT connector.

3-9. CALIBRATION FOR LINE FREQUENCIES OTHER THAN 60 CYCLES.

3-10. For line frequencies other than 60 cps the FREQUENCY dial is set to 1/10 of the line frequency (40 to 400 cps line frequency). Again the calibration is made with the front panel CAL ADJ control, which is adjusted for a minimum flicker rate of the pilot lamp. For line frequencies above 600 cps the FREQUENCY dial is set to 1/30 of the line frequency (33.3 for a 1000 cps line frequency). At the higher line frequencies the flicker intensity decreases and the CAL ADJ control sensitivity increases.

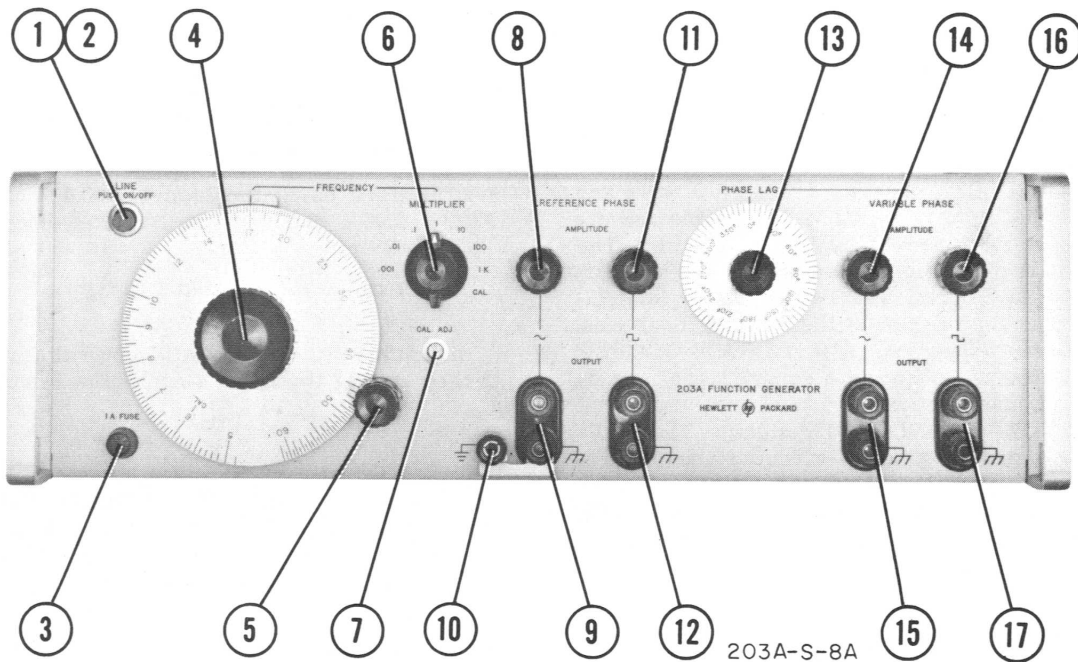

1. Push ON/OFF power switch.
2. Pilot light and calibration indicator.
3. AC fuse, 1 ampere.
4. FREQUENCY selector dial, indicates cps times the FREQUENCY MULTIPLIER switch setting.
5. Vernier, provides fine frequency adjustment.
6. FREQUENCY MULTIPLIER, selects frequency range and in the CAL position sets up the 203A for frequency dial calibration (see paragraph 3-7).
7. CAL ADJ, adjust frequency dial calibration (see paragraph 3-7).
8. REFERENCE PHASE channel sine wave AMPLITUDE control, provides continuous adjustable attenuation of up to 40 db.
9. REFERENCE PHASE channel sine wave output terminals, provide a nominal 30 volts peak-to-peak from a 600 ohm source impedance.
10. Earth Ground.
11. REFERENCE PHASE channel square wave AMPLITUDE control, provides continuously adjustable attenuation of up to 40 db.
12. REFERENCE PHASE channel square wave output terminals, provide a nominal 30 volts peak-to-peak from a 600 ohm source impedance.
13. PHASE LAG control, provides continuously adjustable phase lag from 0° through 360° of the variable phase channel with respect to the reference phase channel.
14. VARIABLE PHASE channel sine wave AMPLITUDE control, provides continuously adjustable attenuation of up to 40 db.
15. VARIABLE PHASE channel sine wave output terminals, provide a nominal 30 volts peak-to-peak from a 600 ohm source impedance.
16. VARIABLE PHASE channel square wave AMPLITUDE control, provides continuously adjustable attenuation of up to 40 db.
17. VARIABLE PHASE channel square wave output terminals, provide a nominal 30 volts peak-to-peak from a 600 ohm source impedance.

Figure 3-1. Front Panel Description

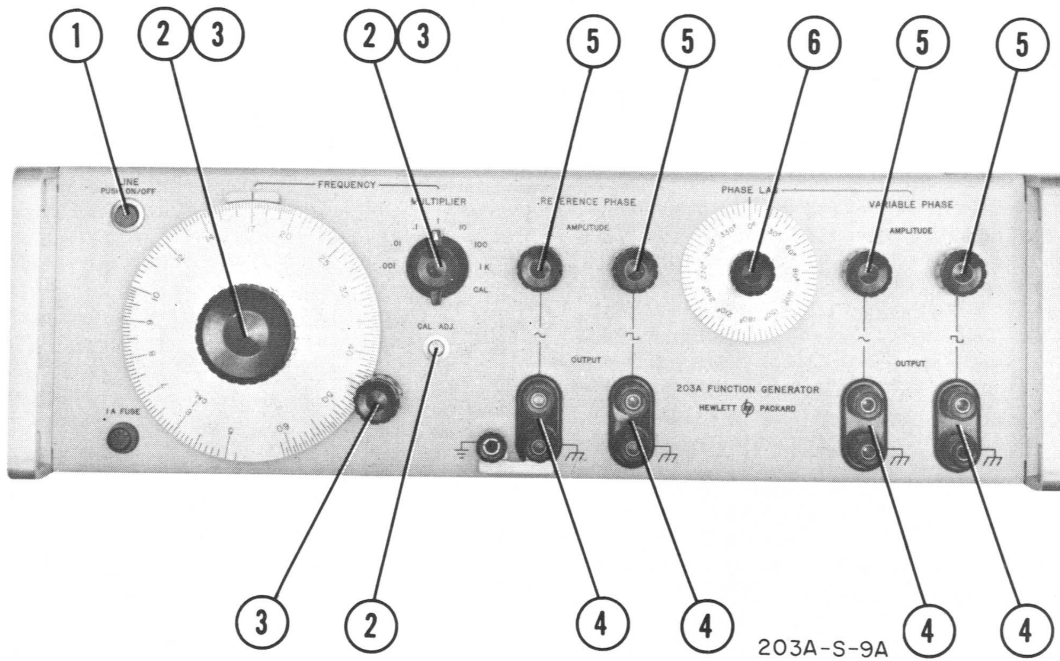

1. Push LINE switch ON, pilot lamp glows.

2. Set FREQUENCY dial and MULTIPLIER switch to CAL position. Refer to paragraph 3-7 for calibration procedure.

3. Set FREQUENCY dial and MULTIPLIER switch to desired output frequency. Use vernier control on FREQUENCY dial for fine frequency adjustments.

4. Select the desired test signal(s) and connect load to OUTPUT connector(s).

5. Set AMPLITUDE control(s) for desired signal level.

6. Set PHASE LAG control for desired degree of phase lag of the VARIABLE PHASE test signal(s) with respect to the REFERENCE PHASE test signal(s).

Figure 3-2. Operating Instructions

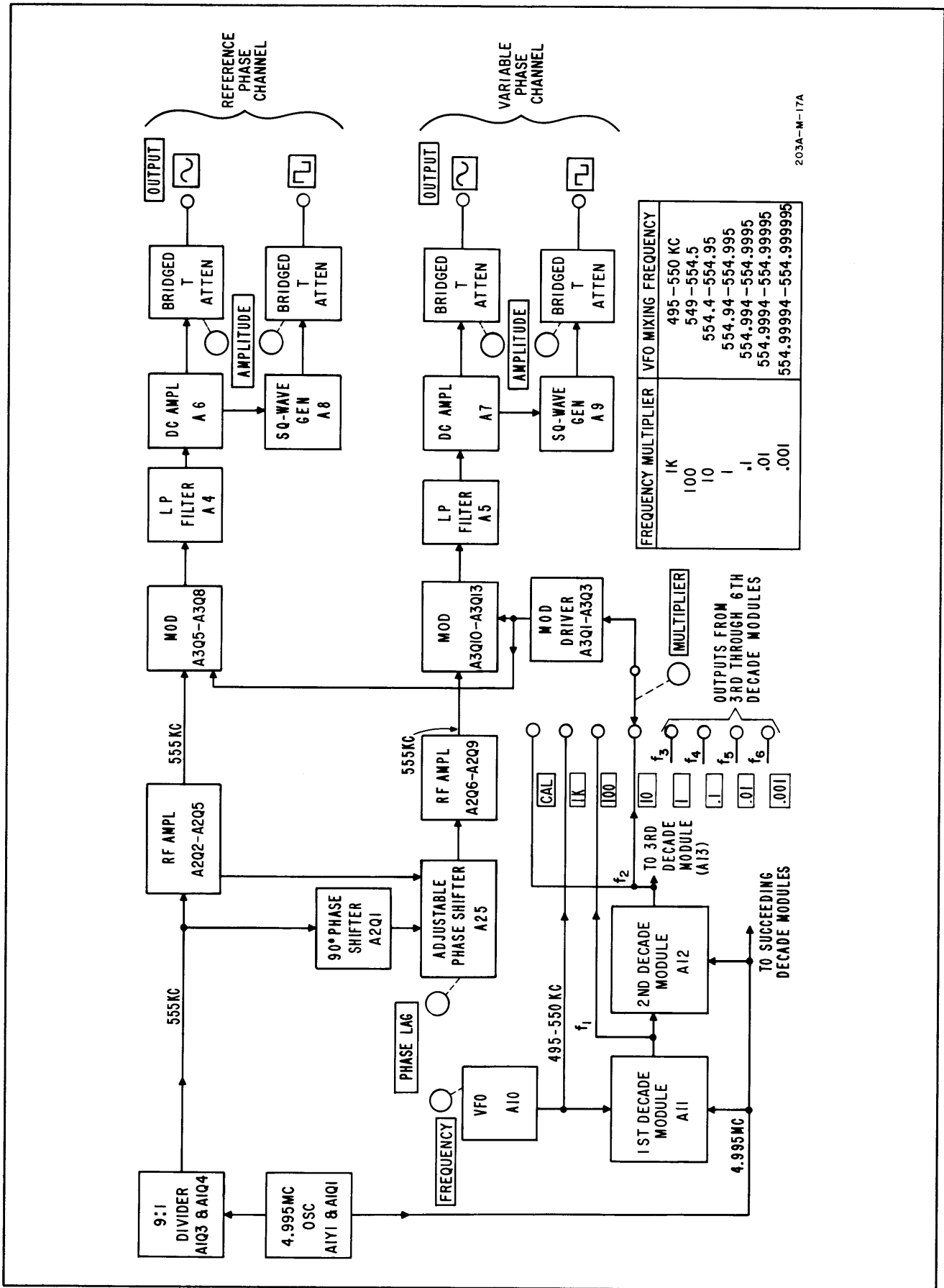

203A-M-17A

Figure 4-1. Block Diagram

SECTION IV

PRINCIPLES OF OPERATION

4-1. OVERALL DESCRIPTION.

4-2. This section describes how the Model 203A Variable Phase Function Generator operates. The block diagram, figure 4-1, shows the main sections and the signal flow within the Model 203A.

4-3. The Model 203A is a beat-frequency oscillator which, by mixing two high-frequency signals, generates signals in the frequency range of 0.005 cps to 60 kc (refer to paragraph 1-5 for options). One of the high-frequency signals is a fixed frequency; the other is variable. The Model 203A has two signal channels, REFERENCE PHASE and VARIABLE PHASE, each of which produces a sine-wave signal and a square-wave signal. The two channels are electrically similar except that the VARIABLE PHASE channel contains a continuously adjustable phase-shifting circuit which changes the phase relationship of the VARIABLE PHASE OUTPUT with respect to the REFERENCE PHASE OUTPUT. The four signals (two reference phase and two variable phase) are available simultaneously at the OUTPUT connectors.

4-4. The fixed frequency signal, which is generated by a crystal oscillator, is applied to both channels and routed to a modulator through a RF Amplifier within each channel. The variable frequency signal is applied directly to the modulator of each channel. The frequency of the variable frequency signal is controlled by the position of the FREQUENCY dial and the setting of the FREQUENCY MULTIPLIER switch. These two signals are mixed in the modulator and the difference in frequency between the two signals is the output frequency of the Model 203A.

4-5. CRYSTAL OSCILLATOR AND DIVIDER ASSEMBLY (A1).

4-6. Assembly A1 consists of a crystal controlled oscillator and a 9:1 frequency divider. Refer to the schematic diagram, figure 5-10, for circuit details.

4-7. CRYSTAL OSCILLATOR.

4-8. The oscillator (A1Y1 and A1Q1) is a crystal controlled grounded base Colpitts oscillator. The output is applied through buffer amplifier A1Q1, for isolation, to the base of the 9:1 frequency divider.

4-9. 9:1 FREQUENCY DIVIDER.

4-10. The 9:1 divider consists of a divider A1Q3 and a tank circuit which consists of A1C8, A1C9, A1C11, and A1L2. The divider is basically a class C grounded base Colpitts oscillator.

4-11. Two things occur during each cycle of the divider operation. One is amplitude modulation of the signal applied to the base of A1Q3, and the second is a mixing action within A1Q3. Each function occurs at

a different time during each cycle of oscillation and together tend to synchronize A1Q3 with a sub-multiple frequency of the frequency applied to the base of the divider.

4-12. Divider A1Q3 operates in the region of voltage saturation for a portion of each cycle. During the saturation period, the impedance between the base and collector of A1Q3 becomes very low; for the rest of cycle the impedance between the base and collector is relatively high. The variation in impedance between base and collector of A1Q3 results in amplitude modulation (about 10%) of the signal on the base of the divider. This amplitude modulation creates sidebands at the 8th and 10th harmonic of the divider oscillating frequency.

4-13. The signal applied to the base of A1Q3 is 4.995 Mc which is generated by the crystal oscillator circuit. The tank circuit of the 9:1 divider is tuned so that A1Q3 is oscillating at the 9th sub-multiple frequency of 4.995 Mc (555 kc).

4-14. The mixing process within A1Q3 occurs at the time during each cycle when the divider just starts to conduct. During this short time, the 8th and 10th harmonic of the 555 kc signal are mixed with the 9th harmonic resulting in a frequency component at 555 kc which influences the oscillations of A1Q3. The result is that A1Q3 stays synchronized to the 9th sub-harmonic of 4.995 Mc.

4-15. The pi type tank circuit filters out harmonic frequencies which may be present at the collector of A1Q3. A buffer amplifier A1Q4 provides further filtering, isolation, and power gain. The output of the 9:1 divider is a 555 kc signal and is coupled by A1T2 to A2Q1 and A2Q2 (see figures 5-10 and 5-12).

4-16. VARIABLE PHASE SHIFTER ASSEMBLY.

4-17. The variable phase shifter assembly A25 (figure 5-12) is a goniometer consisting of two stator windings, a rotor winding, and associated circuits. The goniometer requires two 555 kc input signals; one from A2Q2 to one of the stator windings, and the other from A2Q1 and the 90° phase shift network to the other stator winding. The output phase corresponds to the angle of the rotor winding (PHASE LAG control). The phase can be continuously adjusted from 0° through 360° with respect to the reference signal while maintaining a constant amplitude. The adjustable phase shifter output is applied to the RF amplifier assembly A2 (figure 5-12).

4-18. RF AMPLIFIERS (A2).

4-19. The RF amplifier assembly A2 consists of two RF amplifiers; A2Q3, A2Q4, and A2Q5 for the reference phase channel and A2Q6 through A2Q9 for

Section IV
Paragraphs 4-20 to 4-30

the variable phase channel. Refer to the schematic diagram (figure 5-12) for circuit details.

4-20. VARIABLE PHASE CHANNEL RF AMPLIFIER.

4-21. The signal from the variable phase shifter is amplified by A2Q6, then applied to the base of A2Q7. A2Q7 and A2Q8 act as an over-driven amplifier which amplifies and clips the signal applied to the base of A2Q7; this operation produces a square wave of current at the collector of A2Q8. The zero crossing of the square wave of current coincides with the zero crossing of the sine wave signal applied to the base of A2Q7 so that the phase of the applied signal is preserved. A tuned network, formed by A2C24, A2C25, A2C29, A2C30, A2L7, and A2T2 filters the 555 kc square-current waveform to a nearly pure sine wave.

4-22. The output of the RF amplifier circuit, which is taken across A2C30, is maintained at a constant amplitude by the level controlling circuit. If the output should increase, the voltage at A2C27 increases, resulting in a voltage increase at the base of A2Q9. This increase is applied to the bases of A2Q7 and A2Q8 which then conduct less average current. When A2Q8 conducts less, the signal at its collector decreases and the output voltage decreases, opposing the original change. The result is that the amplitude of the output remains nearly constant despite variations in the amplitude of the input signal. The output signal is then applied to A3T3 in the modulator assembly A3 (figure 5-16).

4-23. REFERENCE PHASE CHANNEL RF AMPLIFIER.

4-24. The signal present at the emitter of A2Q2 is applied to the reference phase channel RF amplifier section, A2Q3 through A2Q5. This stage operates

the same as the variable phase channel RF amplifier described in paragraph 4-20. The output signal is then applied to A2T4 in the modulator assembly A3 (figure 5-16).

4-25. VARIABLE FREQUENCY OSCILLATOR (A10).

4-26. The variable frequency oscillator assembly A10 generates a signal that is variable from 495 kc to 550 kc by rotation of the front panel FREQUENCY dial. The FREQUENCY dial is calibrated so that with the dial set at 5 the VFO is oscillating at 550 kc and with the dial set at 60 the VFO is oscillating at 495 kc. The output signal from the variable frequency oscillator is applied to the 1 K position of the MULTIPLIER (frequency range) switch and also to the 1st decade module. Refer to the schematic diagram, figure 5-14, for circuit details.

4-27. DECADE MODULES (A11-A16).

4-28. The six decade module assemblies A11 thru A16 each consist of a mixer, a bandpass filter, and a 10:1 divider. These decades produce a band of high frequency signals that are mixed in the modulators (A3) with the 555 kc fixed frequency signal from the RF amplifiers to produce a signal in the 0.005 cps to 60 kc range (refer to paragraph 1-5 for options). Refer to the schematic diagram, figure 5-14 and figure 4-2 for circuit details.

4-29. DECADE MODULE (A11).

4-30. The 4.995 Mc signal from the crystal oscillator is applied to the emitter of A11Q1 isolation stage, and subsequently appears across the primary of A11T1. The signal from A11T1 is applied to a suppressed carrier, balanced modulator. The 495 kc VFO signal (assume

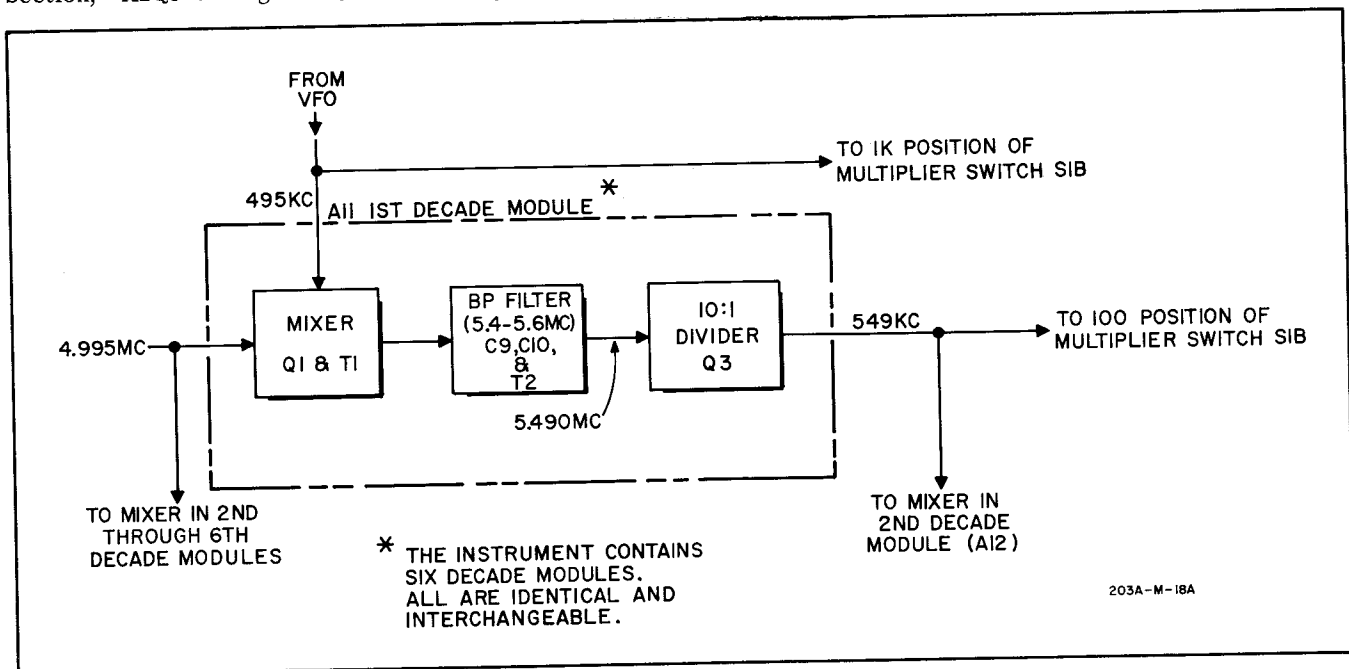

Figure 4-2. Circuit Details

that the FREQUENCY dial is at 60 and the VFO signal is 495 kc) is applied to the other input of the balanced modulator. Both signals are mixed, and the sum and difference of these two frequencies will appear at the output. The signal from the balanced modulator is passed through an LC filter network which is tuned for a band-pass of from 5.4 Mc to 5.6 Mc, which only allows the sum frequency to pass on to the 10:1 divider A11Q3. The 10:1 divider is similar to the 9:1 divider described in paragraph 4-9; the main difference being that the tuned tank circuit in the 10:1 divider is adjusted so that the stage provides an exact 10:1 division of the input frequency. The resultant frequency is fed to the 100 position of the FREQUENCY MULTIPLIER switch and to the mixer in the second decade module A12.

4-31. DECADE MODULES, A12 THROUGH A16.

4-32. The action within the succeeding decade modules is the same as that described for the first decade module A11. The output of each module is applied to a position of the FREQUENCY MULTIPLIER switch and to the mixer in the following decade module. Thus a set of variable frequency signals are produced and when mixed with the constant high-frequency signal in the modulator (A3) a beat frequency is produced. The beat frequency is decreased by a factor of 10 for each lower range of the FREQUENCY MULTIPLIER switch.

4-33. MODULATOR ASSEMBLY, A3.

4-34. The Modulator assembly A3 consists of a modulator drive amplifier and two balanced switching type modulators; one for the REFERENCE PHASE channel, and the other for the VARIABLE PHASE channel. Refer to the schematic diagram, figure 5-16, for details.

4-35. MODULATOR DRIVER AMPLIFIER.

4-36. The frequency selected by the FREQUENCY dial and the FREQUENCY MULTIPLIER is applied to the input of the modulator driver amplifier A3Q1 where it is amplified and applied to A3Q2 and A3Q3. A3Q2 and A3Q3 act as an over driven amplifier which amplifies and clips the signal applied to the base of A3Q2. This operation produces a square wave output at the collector of A3Q3 which is applied to the modulator section as a switching signal.

4-37. REFERENCE PHASE CHANNEL MODULATOR.

4-38. The modulator driving signal (VFO) and decade output) is applied to the bases of the switching transistors (A3Q5 thru A3Q8). The fixed frequency, a 555 kc sine wave, is applied through series resistors to the emitters of the switching transistors. The output at the collectors is sine wave of the sum and difference frequencies. This signal is applied to the low pass filter assembly A4 (figure 5-18). The filter passes only the difference frequency, the output is a sine wave having a frequency that is between 0.005 cps and 60 kc depending on the position of the FREQUENCY MULTIPLIER switch and the FREQUENCY dial setting

(refer to paragraph 1-5 for Options). The output signal is applied to the dc amplifier A6.

4-39. A dc reference voltage is derived by summing the signals at the collectors of A3Q5 and A3Q6. This dc reference voltage is used as a reference voltage for the differential amplifier in the dc amplifier assembly A6.

4-40. VARIABLE PHASE CHANNEL MODULATOR.

4-41. The variable phase channel modulator operates the same as the reference phase channel described in paragraph 4-37, except that the output is applied to the Low Pass Filter A5 and then to the dc amplifier A7.

4-42. DC AMPLIFIER ASSEMBLIES A6 AND A7.

4-43. After passing through the low pass filter the signal is fed to the direct coupled amplifiers; A6 for the reference phase channel, and A7 for the variable phase channel. Refer to the schematic diagrams figures 5-18 and 5-20 for circuit details.

4-44. REFERENCE PHASE CHANNEL DC AMPLIFIER ASSEMBLY.

4-45. The dc amplifier uses a differential amplifier for the input stage. The dc reference voltage from the modulator section is used as the reference input for the differential amplifier. This configuration minimizes any tendency of dc drift due to power supply of temperature variations. The dc amplifier circuit uses negative feedback to provide for low distortion amplification. The output is applied to a bridged-T type attenuator and the square wave generator A8.

4-46. VARIABLE PHASE CHANNEL DC AMPLIFIER ASSEMBLY.

4-47. The variable phase channel dc amplifier operates the same as the reference phase channel described in paragraph 4-44, except that the output is applied to bridged-T type attenuator and the square wave generator, A9.

4-48. SQUARE WAVE AMPLIFIER ASSEMBLIES A8 AND A9.

4-49. The output sine wave from the dc amplifier is applied to a square wave generator section, A8, for the REFERENCE PHASE channel, and A9 for the VARIABLE PHASE channel. Refer to the schematic diagrams, figures 5-18 and 5-20, for circuit details.

4-50. REFERENCE PHASE CHANNEL SQUARE WAVE GENERATOR.

4-51. The sine wave from the dc amplifier is amplified by A8Q1 then applied to the base of A8Q2. A8Q2 and A8Q3 act as an over driven amplifier which ampli-

fies and clips the signal applied to the base of A8Q2, and produces a square wave at the collector of A8Q3. This square wave is applied to A8Q4 and A8Q5 which form a Schmitt trigger circuit. The Schmitt trigger is a regenerative circuit which changes states abruptly when the input signal crosses a specific dc triggering signal crosses a specific dc triggering level. The output from this stage is a square wave having a rise time of less than 0.2 microsecond with the same frequency and phase as the sine wave signal applied to the circuit. The output is applied to a bridged-T attenuator.

4-52. VARIABLE PHASE CHANNEL SQUARE WAVE GENERATOR.

4-53. The variable phase channel square wave generator operates the same as the reference phase channel described in paragraph 4-50.

4-54. DC POWER SUPPLY A21, A22.

4-55. The dc power supply provides regulated +15, -15, and -24.5 volts and unregulated +35 volts.

4-56. CALIBRATE FEATURE.

4-57. The Model 203A has a feature that permits calibration of the FREQUENCY dial with the line frequency. To calibrate the Model 203A for 60 cps, the FREQUENCY dial is set to 6 (CAL) and the FREQUENCY MULTIPLIER switch is set to the CAL position. The calibration is made with the front panel CAL ADJ control, which slightly affects the VFO frequency. When the Model 203A frequency approaches the 60 cps line frequency the 60 cps square wave and the 60 cps beat with each other causing the pilot light to flicker. The Model 203A CAL ADJ should be made for a minimum rate of flicker.

SECTION V MAINTENANCE

5-1. REQUIRED TEST EQUIPMENT.

5-2. Recommended test equipment for troubleshooting and performance checking is listed in table 5-1. Test instruments other than those listed may be used if their specifications equal or exceed the required characteristics.

5-3. PERFORMANCE CHECKS.

5-4. Use the following front panel procedures to verify proper operation of the hp Model 203A. The Model 203A and test equipment should be operated at 115/230 vac unless otherwise specified. If the Model 203A is found to exceed specifications at any point in this procedure, refer to paragraph 5-12, ADJUSTMENTS.

5-5. FREQUENCY DIAL CALIBRATION.

a. Push Model 203A LINE switch ON. Pilot light should glow.

b. Set FREQUENCY dial to 6 (CAL); MULTIPLIER switch to CAL.

c. Adjust front panel CAL ADJ until visual zero beat is obtained on front panel pilot light. This occurs when flashing rate of the pilot light approaches zero.

d. Connect Model 203A as shown in figure 5-1.

e. Rotate FREQUENCY dial and observe Electronic Counter readings at points shown in table 5-2; counter readings should be within limits shown. At frequencies below 100 cps use period measurements.

Table 5-1. Required Test Equipment

Instrument Type	Required Characteristics	Use	Recommended Model
DC Voltmeter	Voltage Range: 0 - 50 volts Input Impedance > 10 M ohms Accuracy: $\pm 1\%$	Performance Checks	hp Model 412A
AC Voltmeter	Voltage Range: 1 mv - 100 v Freq. Response: to 600 kc Accuracy: $\pm 2\%$	Performance Checks	hp Model 403B or hp Model 400D/H/L
Oscilloscope	Bandwidth: DC - 5 mc	Waveform Checking	hp Model 175A with hp Model 1780A Horizontal Plug-In hp Model 1750A Vertical Plug-In hp Model 10003A 10:1 Probe
Frequency Counter	Range: 0.005 cps - 60 kc	Performance Checks	hp Model 523C
Distortion Analyzer	Range: 20 cps to 20 kc	Performance Checks	hp Model 330B
Variable Transformer	Output Voltage: 103 - 127 vac	Performance Checks	Powerstat
6 pin printed board extender		Troubleshooting Adjustment	hp #5060-0651
15 pin printed board extender		Troubleshooting Adjustment	hp #5060-0047
Thermal 50 Ω Converter	1 VAC input, 7.0 mv DC output $\pm 0.2\%$ 5 cps - 60 kc	Frequency Response	hp Model 11051A
Nylon Tuning Wand		Adjustment	hp #8730-0016
Soldering Iron and Tips	50 watts Tip Temperature: 800 $^{\circ}$ F Tip Size: 1/16" - 3/32" Round Tip Dia: 3/4"	Troubleshooting Repair	Ungar No. 776 handle with Ungar No. PL333 tiptlet and Ungar No. 885 3/4" cups tip

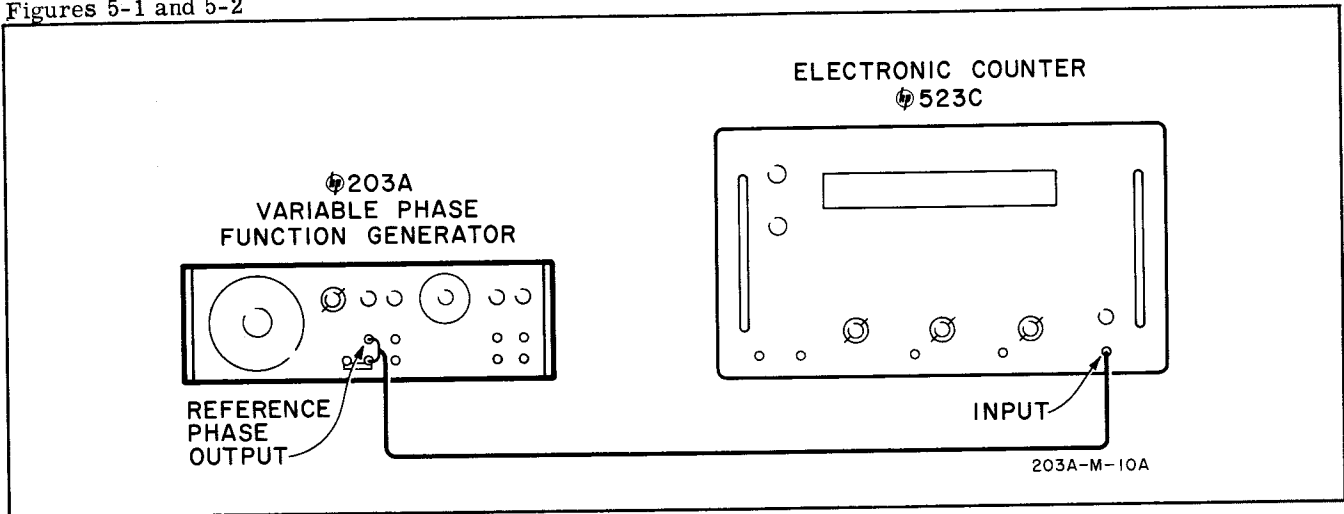

Figure 5-1. Frequency Dial Calibration

This table can be used at all MULTIPLIER switch settings by changing the decimal point of the given counter reading.

5-6. FREQUENCY RESPONSE.

- a. Set Model 203A controls as follows:
- | | |
|----------------------|-----|
| FREQUENCY | 10 |
| MULTIPLIER | 100 |

CAUTION

INSURE THAT ALL FOUR AMPLITUDE CONTROLS ARE FULLY COUNTERCLOCKWISE TO AVOID DAMAGE TO THE THERMAL CONVERTER.

- b. Connect Model 203A as shown in figure 5-2, using very short leads between the Model 203A and Thermal Converter.

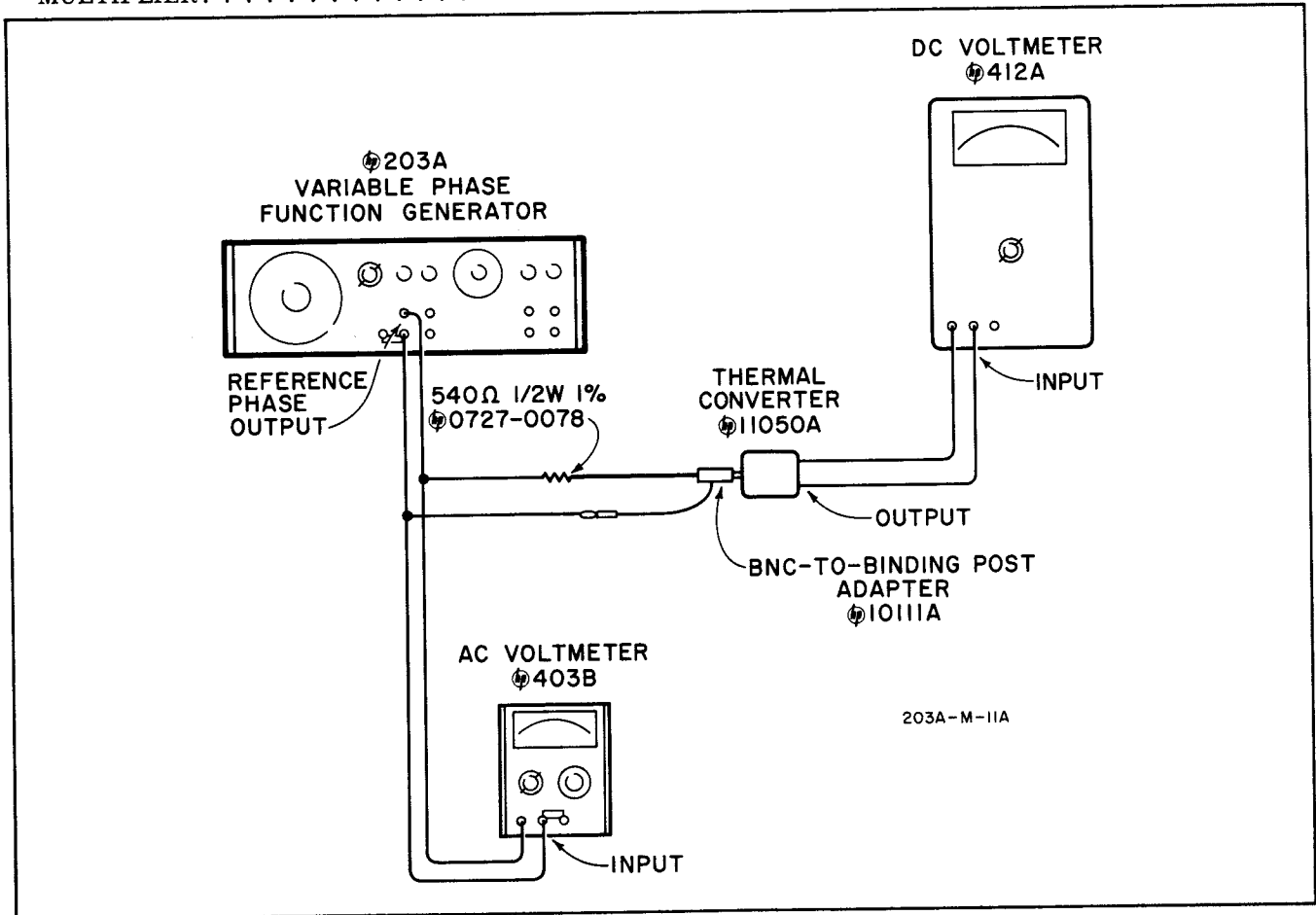

Figure 5-2. Frequency Response

Table 5-2. Frequency Dial Calibration

FREQUENCY Dial	Counter Period Measurement (below 100 cps)		Counter Frequency Measurement (above 100 cps)	
	Minimum	Maximum	Minimum	Maximum
5	1980	2020	495	505
6	1650	1684	594	606
7	1415	1443	693	707
8	1238	1263	793	808
9	1100	1122	891	909
10	990	1010	990	1010
12	825	841	1188	1212
14	707	721	1386	1414
17	582	594	1683	1717
20	495	505	1980	2020
25	396	404	2475	2525
30	330	336	2970	3030
40	247	253	3960	4040
50	198	202	4950	5050
60	165	169	5940	6060

c. Set REFERENCE PHASE ~ OUTPUT for a reading of 5.3 vac on the ac voltmeter.

CAUTION

DO NOT EXCEED THIS VALUE AS THE THERMAL CONVERTER IS VERY EASILY DAMAGED BY EXCESSIVE INPUT VOLTAGE.

d. Disconnect AC Voltmeter.

e. Adjust REFERENCE PHASE ~ OUTPUT for dc voltmeter reading of 7.0 millivolts.

f. Vary Model 203A FREQUENCY from 5 cps to 60 kc.

g. DC voltmeter reading should stay between 6.86 and 7.14 millivolts.

h. Repeat steps b thru g for VARIABLE PHASE ~ OUTPUT.

j. Disconnect resistor, thermal converter and dc voltmeter.

5-7. SINE WAVE CHECK.

a. Connect Model 203A as shown in figure 5-3.

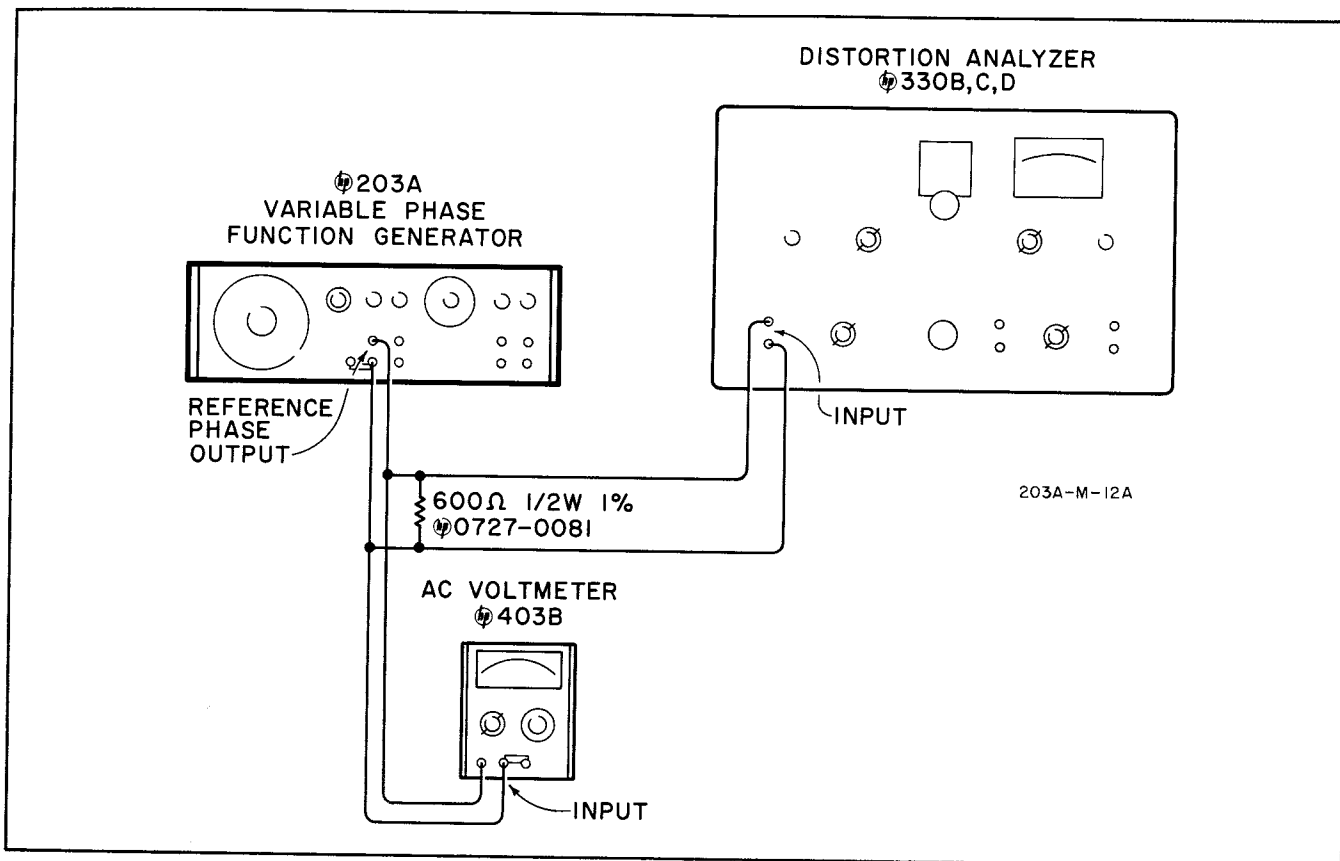

Figure 5-3. Sine Wave Check

b. Set Model 203A controls as follows:

- FREQUENCY 10
- MULTIPLIER 100
- ~ AMPLITUDE (2) both CW

c. AC Voltmeter should read at least 5.3 volts rms.

d. Using Distortion Analyzer, check total harmonic distortion present on signal. Distortion level should be more than 64 db (0.06%) below fundamental frequency reference level.

e. Repeat step g at a number of frequencies between 20 cps and 20 kc.

f. Repeat steps a through e for VARIABLE PHASE ~ OUTPUT.

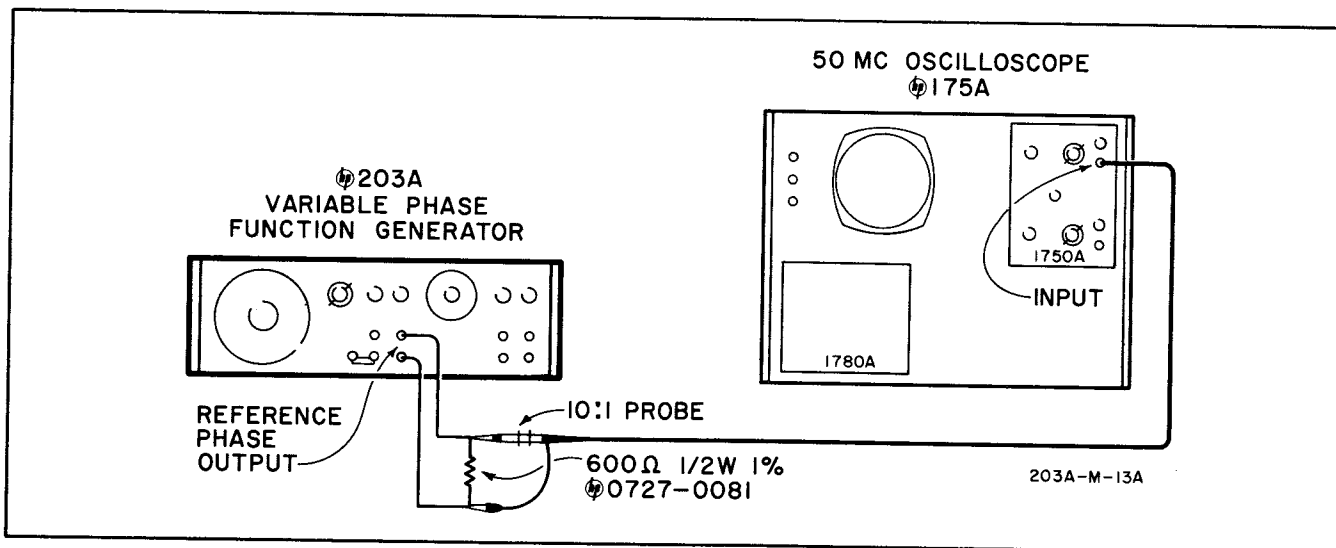

Figure 5-4. Square Wave Check

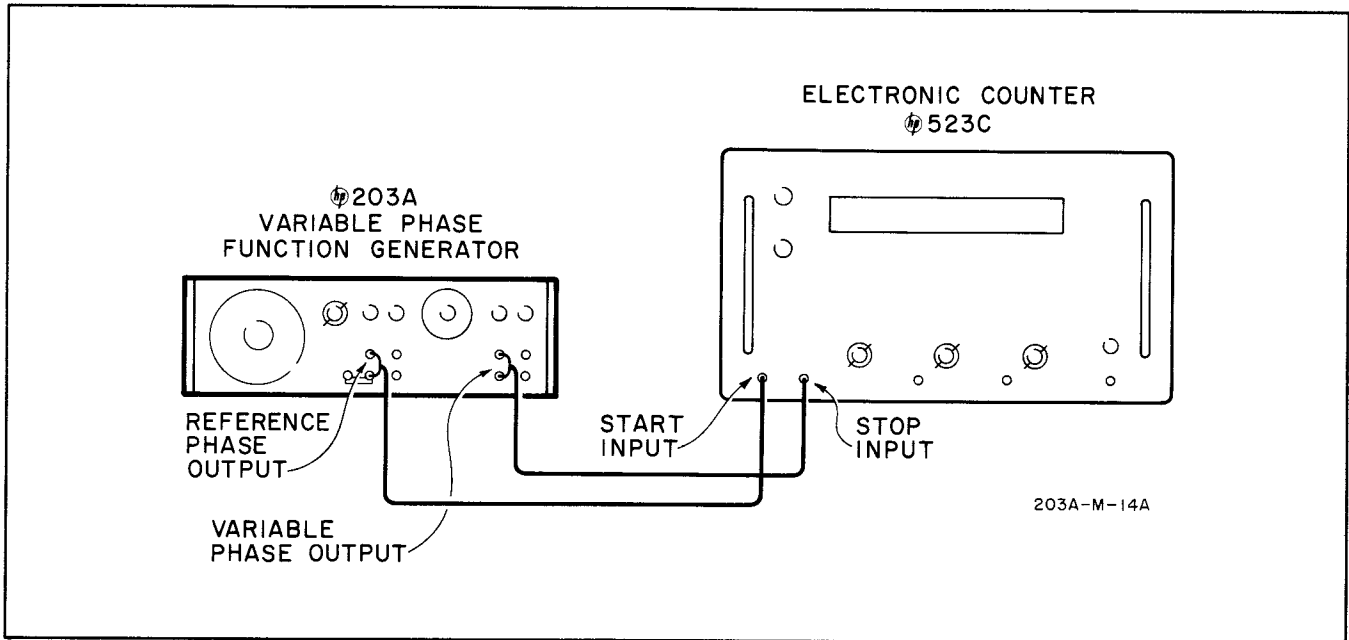

Figure 5-5. Phase Lag Check

5-8. SQUARE WAVE CHECK.

- a. Connect Model 203A as shown in figure 5-4 .
- b. Set instrument controls as follows:

Model 203A

FREQUENCY 10
 MULTIPLIER 100
 AMPLITUDE (2) both CW

Oscilloscope

INPUT DC
 SENSITIVITY5 V/CM
 SWEEP TIME1 MSEC/CM
 TRIGGER SOURCE INT
 TRIGGER SLOPE (+)

c. Adjust Model 203A FREQUENCY dial so that one cycle of square wave fills exactly 10 cm of horizontal deflection.

d. Zero crossing of square wave should occur between 4.8 and 5.2 cm from start of sweep. Peak-to-peak voltage should be at least 15 volts.

e. Set Oscilloscope SENSITIVITY to .05 V/CM. Adjust VERTICAL POSITION to bring flat top of square wave into view.

f. Flat top of the square wave should not vary more than ± 75 millivolts (± 1.5 mm) from 10% to 90% of half period.

g. Set Oscilloscope SWEEP TIME to .1 μ SEC/CM; SENSITIVITY to .5 V/CM.

h. Square wave rise time should be less than 0.2 μ sec from 10% to 90% points.

j. Set Oscilloscope TRIGGER SLOPE to (-).

k. Square wave fall time should be less than 0.2 μ sec from 10% to 90% points.

m. Repeat steps b thru k at various frequencies on all ranges.

n. Repeat steps a thru m for VARIABLE PHASE OUTPUT.

5-9. PHASE LAG CHECK.

- a. Connect Model 203A as shown in figure 5-1.
- b. Set instrument controls as follows:

Model 203A

MULTIPLIER 10
 FREQUENCY approximately 27
 ~ AMPLITUDE both CW

Electronic Counter

FUNCTION SELECTOR PERIOD
 STD. FREQ. COUNTED 1 MC

c. Adjust Model 203A FREQUENCY dial for Electronic Counter reading of 3600.

d. Connect Model 203A as shown in figure 5-5.

e. Set Electronic Counter controls as follows:

FUNCTION TIME INTERVAL
 TRIGGER INPUT SEP
 TRIGGER SLOPE both (+)

- f. Set Model 203A PHASE LAG dial to 180°.
- g. Adjust Electronic Counter TRIGGER LEVEL controls for stable reading near 1800.
- h. Check Electronic Counter readings at 30° increments on PHASE LAG dial. Readings should be within the values shown in table 5-3.

Table 5-3. Phase Lag Check

PHASE LAG	ELECTRONIC COUNTER	
	Minimum	Maximum
0	3550	50
30	250	350
60	550	650
90	850	950
120	1150	1250
150	1450	1550
180	1750	1850
210	2050	2150
240	2350	2350
270	2650	2750
300	2950	3050
330	3250	3350

5-10. INSTRUMENT COVER REMOVAL.

5-11. To remove either the top or bottom covers, unscrew and remove the two counter-sunk Phillips-head screws which secure the cover to the instrument. Then slide the cover toward the rear of the instrument. To replace the cover, reverse the procedure.

5-12. ADJUSTMENTS.

513. The following test and adjustment procedures should be performed only if it has been definitely determined by the Performance Checks given in paragraphs 5-5 thru 5-9 that the Model 203A is out of adjustment.

5-14. POWER SUPPLY A22 ADJUSTMENTS.

- a. Supply Model 203A primary power from Variable Transformer.
- b. Set line voltage to nominal value (115 volts).
- c. Connect DC Voltmeter and AC Voltmeter to A22 (5). (See figure 5-21.)
- d. Adjust A22R12 (-15 volt adjust) for DC Voltmeter reading of -15.1 vdc. AC Voltmeter should read less than 0.4 mv ripple.
- e. Vary line voltage from 103 to 127 vac. DC Voltmeter reading should not change more than ±0.2 vdc.
- f. Connect DC Voltmeter and AC Voltmeter to A33 (13).
- g. Adjust A22R20 (+15 volt adjust) for DC Voltmeter reading of +15.1 dc. The AC Voltmeter should read less than 0.4 mv ripple.

h. Vary line voltage from 103 to 127 vac. DC Voltmeter reading should not change more than ±0.2 vdc.

j. Connect DC Voltmeter and AC Voltmeter to A22 (2).

k. AC Voltmeter should read less than 1.0 mv ripple. DC Voltmeter should read -24.5 ±0.5 vdc.

Note

It may be possible to bring the -24.5 volt supply into specifications by a slight adjustment of the -15 volt adjust (A22R12). The -15 volt supply must stay between -14.9 and -15.3 vdc.

m. Vary line voltage from 103 to 127 vac. DC Voltmeter reading should not change more than ±0.4 vdc.

n. Connect DC Voltmeter to A22 (14).

p. DC Voltmeter should read +35 ±5 vdc.

q. Disconnect front panel shorting bar.

r. Connect AC Voltmeter between chassis ground and circuit common A22 (9).

s. Use an insulated tuning wand to adjust A21C1 (located on bottom of chassis) for a minimum reading (refer to figure 5-8).

5-15. 4.995 MC OSCILLATOR AND 9:1 DIVIDER

(A1) ADJUSTMENT.

a. Connect 10:1 probe of Oscilloscope to base of A1Q3 and ground lead to ground plane of oscillator board. (See figure 5-9.)

b. Set Oscilloscope controls as follows:

INPUT AC
 SENSITIVITY05 V/CM
 SWEEP TIME 2 μSEC/CM

c. Adjust A1T1 for maximum amplitude of 5 mc signal.

d. Move 10:1 probe to emitter of A1Q3.

e. Adjust A1L2 for eleven waveforms in 10 cm of horizontal deflection. Adjust A1L2 so that the first pip of signal is slightly larger than the rest (see figure 5-7, Waveforms 3 - 5).

f. Repeat steps a thru e until optimum adjustment is obtained.

g. Move probe to A1 (5).

h. Adjust A1T2 for maximum amplitude of 555 kc signal.

f. Set PHASE LAG dial to obtain maximum distortion reading.

g. Adjust A3R31 for minimum distortion.

Note

Perform steps h thru r only if distortion is greater than 64 db (0.06%) below reference level. These steps will reduce only excessive eighth and tenth harmonics.

h. Connect 10:1 Oscilloscope probe to emitter of A11Q3. Connect probe ground lead to A11 ground plane. (See figure 5-13.)

j. Set Oscilloscope controls as follows:

INPUT AC
SENSITIVITY05 V/CM
SWEEP TIME 2 μSEC/CM

k. Adjust A11T1, A11L1 and A11T2 for a minimum reading on Distortion Analyzer.

Note

Do not adjust A11T1, A11L1 and A11T2 more than one complete turn from previous setting.

m. Adjust A11L2 so the first pip of the 5 mc synchronizing frequency is larger than the rest. (See figure 5-7 and Waveforms 10 - 13).

n. Repeat steps a thru m as necessary to obtain minimum distortion.

p. Interchange A11 and A12.

q. Repeat steps h through n for A12.

r. Repeat steps p and q for A13, A14, and A15 and A16 each time with the new boards in A11 position

5-22. FREQUENCY RESPONSE.

a. Connect DC Voltmeter to REFERENCE PHASE ~ OUTPUT terminals.

b. Set FREQUENCY dial to 50, MULTIPLIER to 100 and both ~ AMPLITUDE controls fully clockwise.

c. Adjust A6R8 (A7R8 for VARIABLE PHASE) (DC Zero Adj) for minimum DC Voltmeter reading (typically between +20 and -20 millivolts). (See figure 5-17.)

d. Disconnect DC Voltmeter.

e. Turn all AMPLITUDE controls fully counter-clockwise.

f. Connect Model 203A as shown in figure 5-2 using short leads between Thermal Converter and Model 203A.

Note

Do not place DC Amplifiers (A6 and A7) on extender board.

g. Set REFERENCE PHASE ~ AMPLITUDE for AC Voltmeter reading of 5.3 vac.

CAUTION

DO NOT EXCEED THIS VALUE AS THERMAL CONVERTER IS VERY EASILY DAMAGED BY EXCESSIVE INPUT VOLTAGES.

h. Disconnect AC Voltmeter.

j. Carefully adjust REFERENCE PHASE~AMPLITUDE for a DC Voltmeter reading of 7.0 millivolts.

k. Set Model 203A MULTIPLIER switch to 1.

m. Adjust A3R20 (A3R34 for VARIABLE PHASE) (50 cps adj) until the DC Voltmeter reads 7.0 millivolts.

n. Set MULTIPLIER switch to 10. Note DC Voltmeter reading.

p. Set MULTIPLIER switch to 1 K.

q. Adjust A4R2 (A5R2 for VARIABLE PHASE) (50 kc adj) until DC Voltmeter reads the same as in step n.

r. Repeat steps j thru q until readings at 50 cps, 500 cps and 50 kc are between 6.96 and 7.14 millivolts.

s. Repeat steps a thru r for the VARIABLE PHASE ~ OUTPUT.

t. Disconnect Thermal Converter and connect Oscilloscope to REFERENCE PHASE ~ OUTPUT terminals. Set REFERENCE PHASE ~ AMPLITUDE fully clockwise.

u. Adjust A6R20 (A7R20 for VARIABLE PHASE) (Amp. Adj) for 30 volt peak-to-peak deflection.

v. Repeat steps t and u for the VARIABLE PHASE ~ OUTPUT.

5-23. PHASE LAG DIAL.

a. Connect Model 203A as shown in figure 5-6.

b. Set FREQUENCY dial to 10; MULTIPLIER switch to 100. Set both ~ AMPLITUDE controls fully clockwise.

c. Adjust PHASE LAG dial and one (not both) of the ~ AMPLITUDE controls for minimum reading on AC Voltmeter. Typical reading is less than 100 mv.

d. Loosen set screws and slip PHASE LAG dial until it reads exactly 180° at the null obtained in step c and then tighten the set screws.

5-24. SQUARE WAVE (A8 and A9) ADJUSTMENT.

a. Connect DC Voltmeter to Model 203A REFERENCE PHASE ~ OUTPUT.

b. Set Model 203A controls as follows:
FREQUENCY 10
MULTIPLIER 100
~ AMPLITUDE both CW

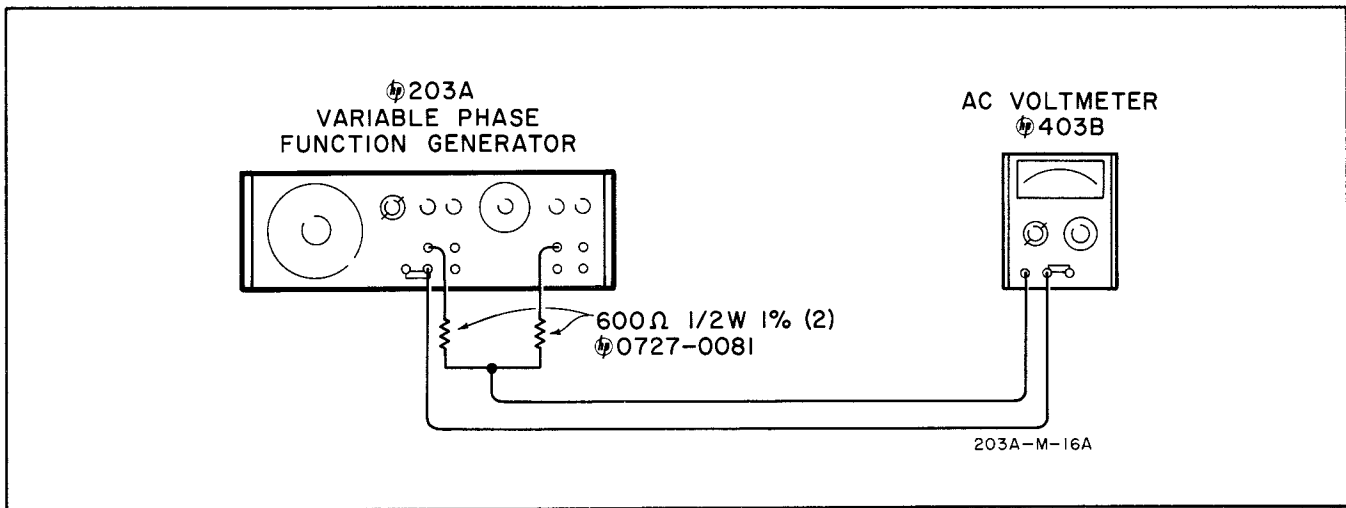

Figure 5-6. Phase Lag Dial Adjustment

c. Adjust A8R9 for a minimum reading on dc voltmeter (typically between +50 and -50 millivolts). (See figure 5-17.)

d. Connect dc voltmeter to VARIABLE PHASE OUTPUT.

e. Adjust A9R9 for a minimum reading on dc voltmeter (typically between +50 and -50 millivolts).

5-25. TROUBLESHOOTING.

5-26. To locate trouble in the Model 203A, start with a thorough visual inspection of the instrument. Look for burned out or loose components and connections, and other similar condition which suggests a source of trouble. If visual inspection does not reveal the trouble, use Model 203A Block Diagram (figure 4-1), Troubleshooting Summary (table 5-4), and Typical Waveforms (figure 5-7) as aids for isolating the trouble.

5-27. PRINTED CIRCUIT BOARD REPAIR.

5-28. The Model 203A uses plated through double-sided etched circuit boards.

5-29. Observe the following rules when repairing double-sided etched circuit boards.

a. Solder from the conductor side of the etched circuit board.

b. Avoid applying excessive heat when soldering on the circuit board.

c. To remove a damaged component, clip component leads near the component; then apply heat and remove each lead with a straight upward motion.

d. Use a special tool to remove components having multiple connections, such as potentiometers, etc. Refer to table 5-1 for type of soldering tip required.

e. Use a toothpick to free hole of solder before installing a new component.

Table 5-4. Troubleshooting Summary

Symptoms	Possible Cause
Instrument ON, no output signals available, pilot light not lighted	Fuse , F1, 115/230 volt switch S3 Line switch S2, DC Power Supply
Instrument ON, no output signals available, pilot light lighted	DC Power Supply (A22)
DC Power Supply voltages normal, no output signals available	5 mc Oscillator and 9:1 Divider A1, and Variable Frequency Oscillator A10
Reference Phase Output signals normal, abnormal variable phase output signals	Adjustable Phase Shifter A25, RF Amplifier (A2Q6 - A2Q9, A2Q1) Modulator A3Q9 - A3Q13) Low Pass Filter, A5, DC Amplifier A7 Square Wave Generator A9 Output Attenuators
Variable Phase Output signals normal, abnormal Reference Phase Output signals	RF Amplifier (A2Q2 - A2Q5) Modulator (A3Q5 - A3Q8) Low Pass Filter A4, DC Amplifier A6 Square Wave Generator A8 Output Attenuators
Abnormal output signals on individual MULTIPLIER switch positions	Decade Module (A11 - A16) associated with highest MULTIPLIER switch position where abnormal condition first appears
Distorted ~ Output	RF Amplifier A2, Modulator A3 Low pass filters (A4 and A4) DC Amplifiers (A6 and A7)
Distorted Square Wave	Square Wave Generators (A8 and A9)
Amplitude of output signals varies with FREQUENCY dial setting	Modulator A3, Low Pass Filters (A4 and A5) DC Amplifiers (A6 and A7)
No phase control of Variable Phase Output signals	Adjustable Phase Shifter (A25)

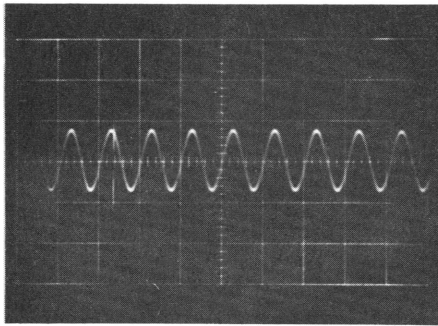

1- A1 (1) 5 mc output
.5 V/CM; .2 μ SEC/CM

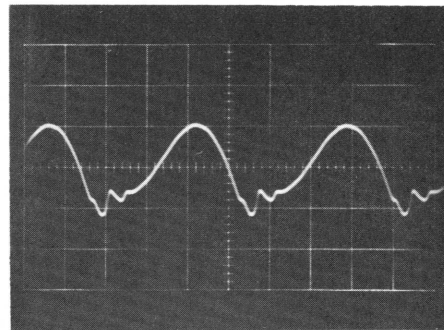

4- A1Q3 Emitter
A1L2 maximum for synchronization
.5 V/CM; .5 μ SEC/CM

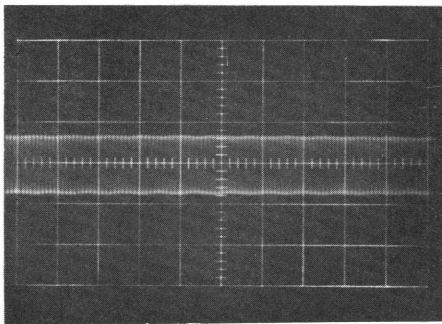

2 - A1Q3 Base
.5 V/CM; 2 μ SEC/CM

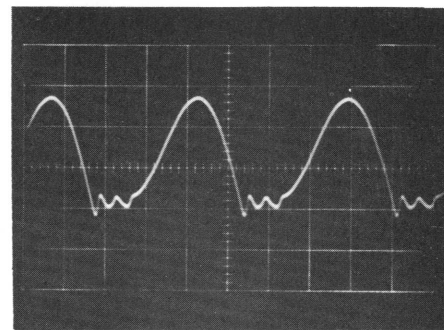

5- A1Q3 Emitter
A1L2 nominal
.5 V/CM; .5 μ SEC/CM

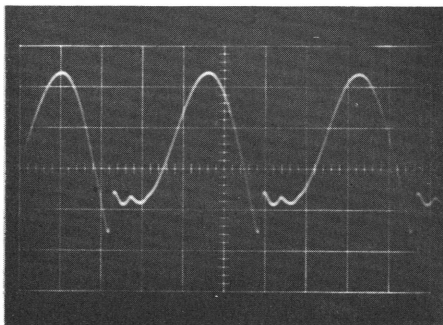

3- A1Q3 Emitter
A1L2 minimum for synchronization
.5 V/CM; .5 μ SEC/CM

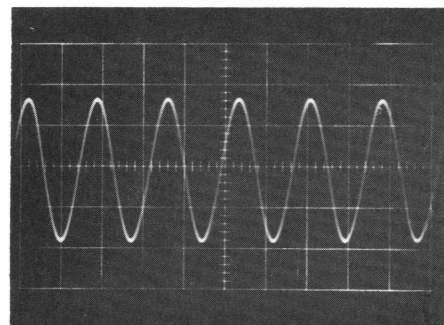

6- A2 (11) RF Amp Output
1 V/CM; 1 μ SEC/CM

Figure 5-7. Typical Waveforms (Page 1 of 3)

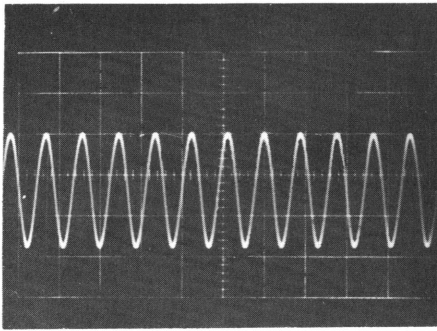

7- A10 (6) VFO Output
 .5 V/CM; 2 μ SEC/CM

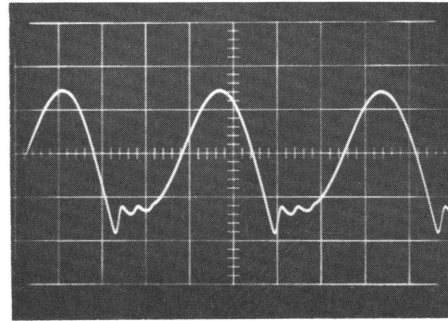

10- A11Q3 Emitter
 L2 minimum for synchronization
 .5 V/CM; .5 μ SEC/CM

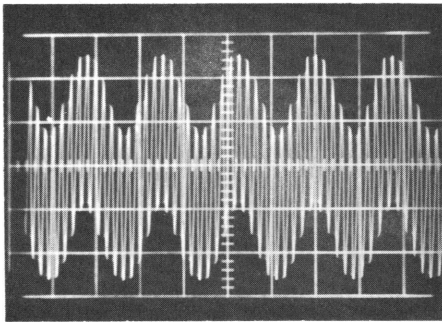

8- A11-Junction C4 and R5
 .5 V/CM; 1 μ SEC/CM

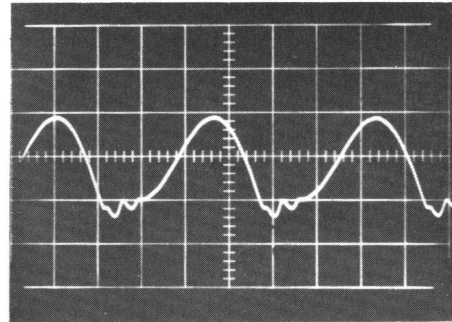

11- A11Q3 Emitter
 L2 maximum for synchronization
 .5 V/CM; .5 μ SEC/CM

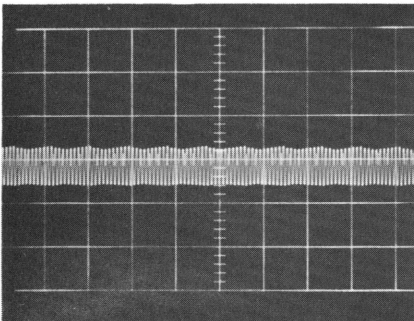

9- A11Q3 Base
 .5 V/CM; 2 μ SEC/CM

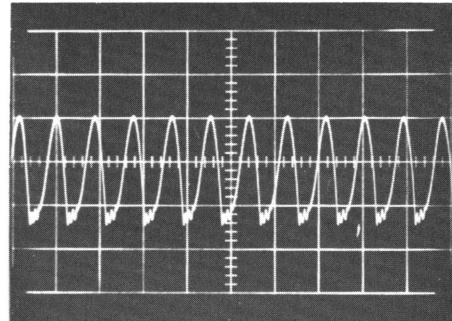

12- A11Q3 Emitter
 L2 nominal
 .5 V/CM; 2 μ SEC/CM

Figure 5-7. Typical Waveforms (Page 2 of 3)

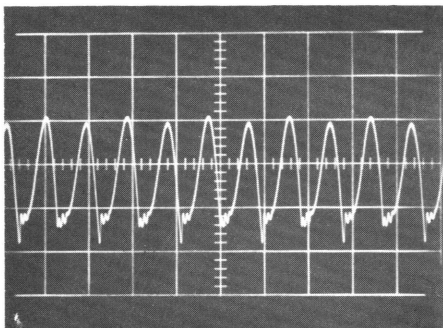

13- A11Q3 Emitter
Incorrect Frequency Division
.5 V/CM; 2 μ SEC/CM

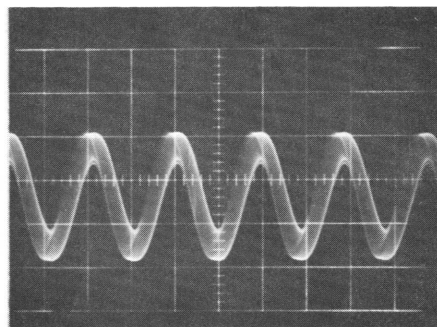

16- A3 (12) Modulator Output
FREQUENCY - 5 kc
.5 V/CM; .1 MSEC/CM

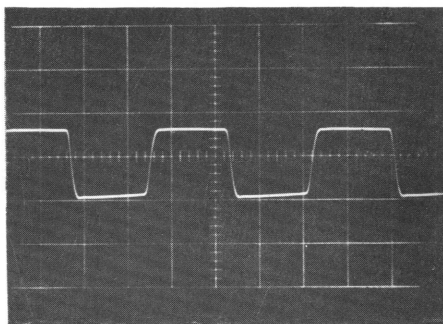

14- A3Q3 Collector
.5 V/CM; .5 μ SEC/CM

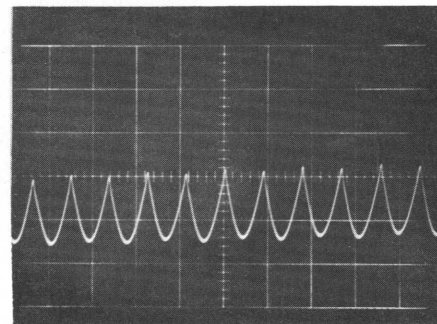

17- A3 (12) Modulator Output
FREQUENCY - 5 kc
.5 V/CM; 1 μ SEC/CM

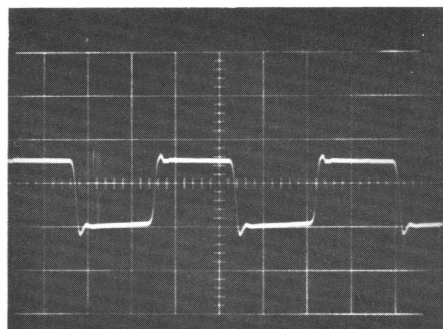

15- A3Q5 Base
.5 V/CM; .5 μ SEC/CM

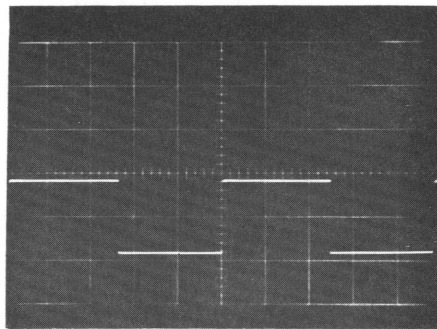

18- A8Q4 Collector
FREQUENCY - 1 kc
5 V/CM; .2 μ SEC/CM

Figure 5-7. Typical Waveforms (Page 3 of 3)

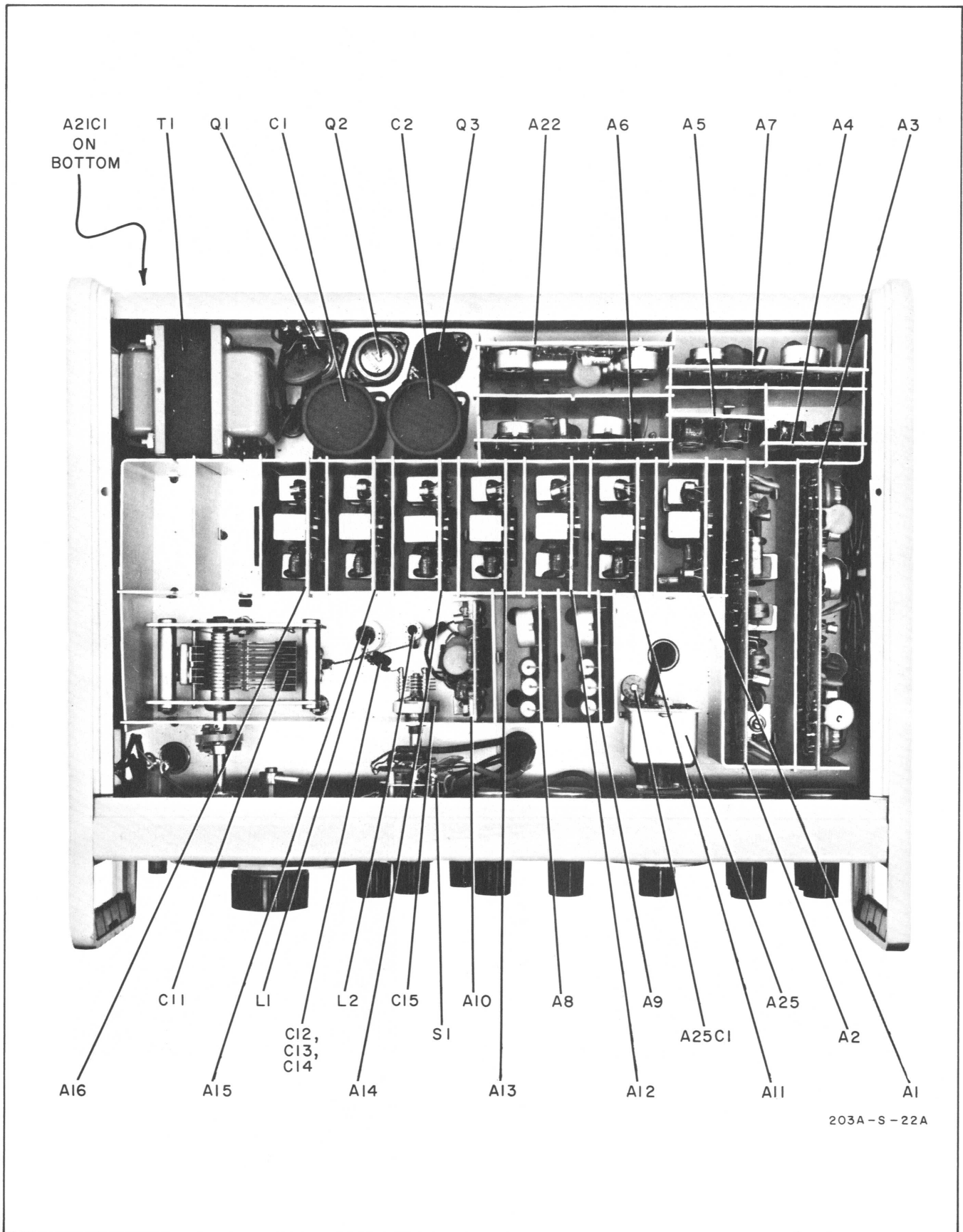
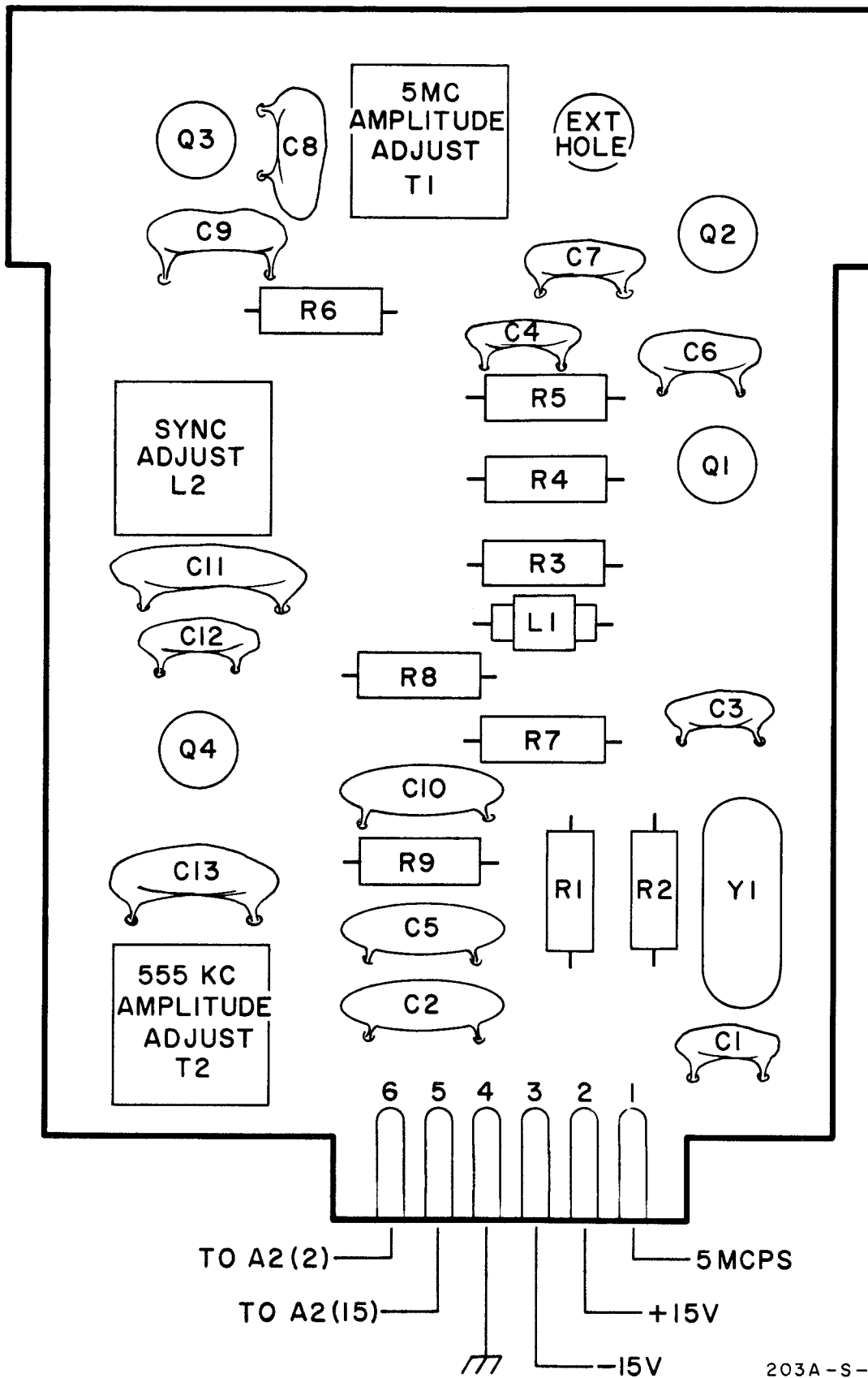

Figure 5-8. Chassis - Top View



203A-S-4A

Figure 5-9. 5 Mc Oscillator and 9:1 Divider Assy A1--Component Location

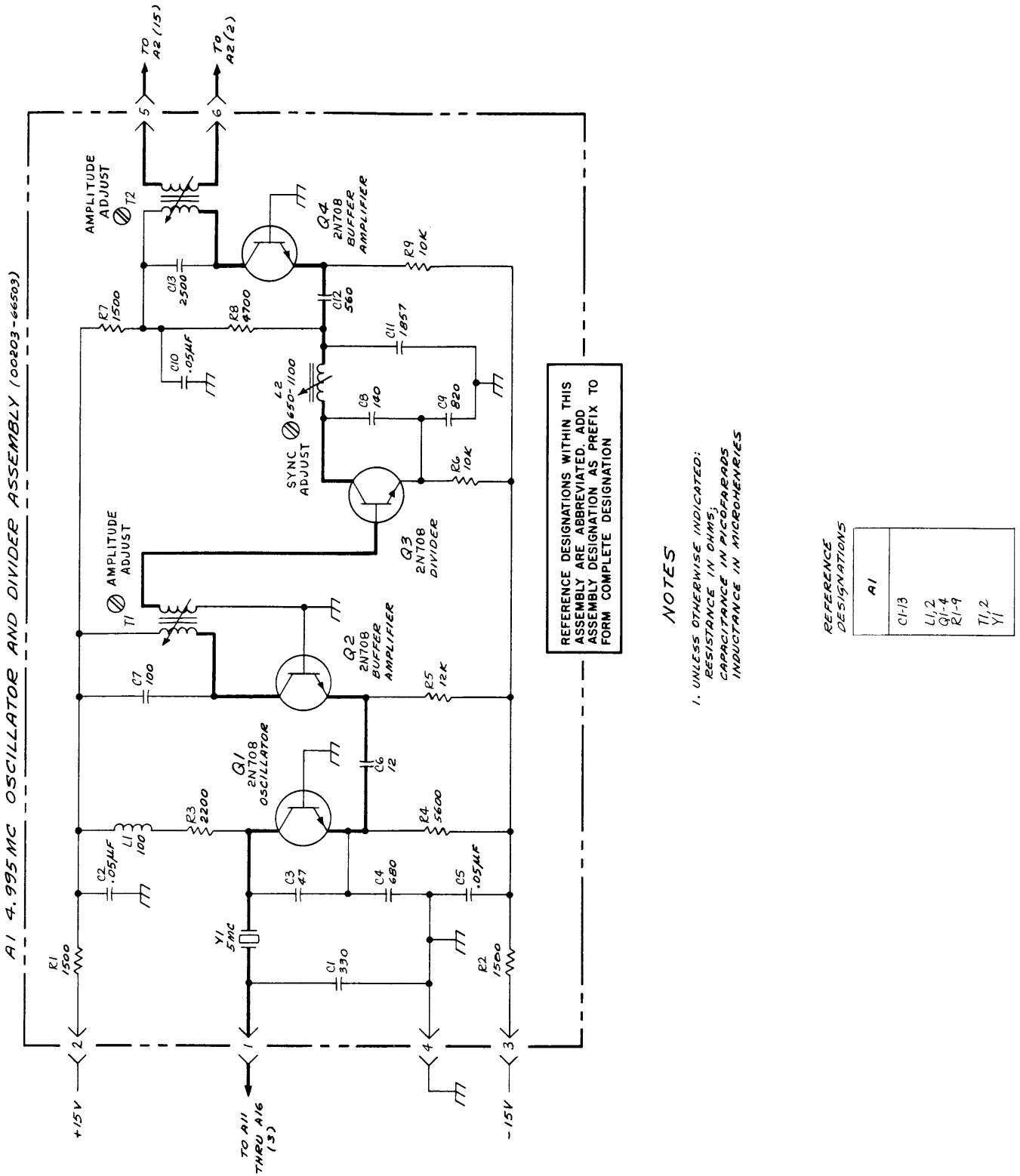
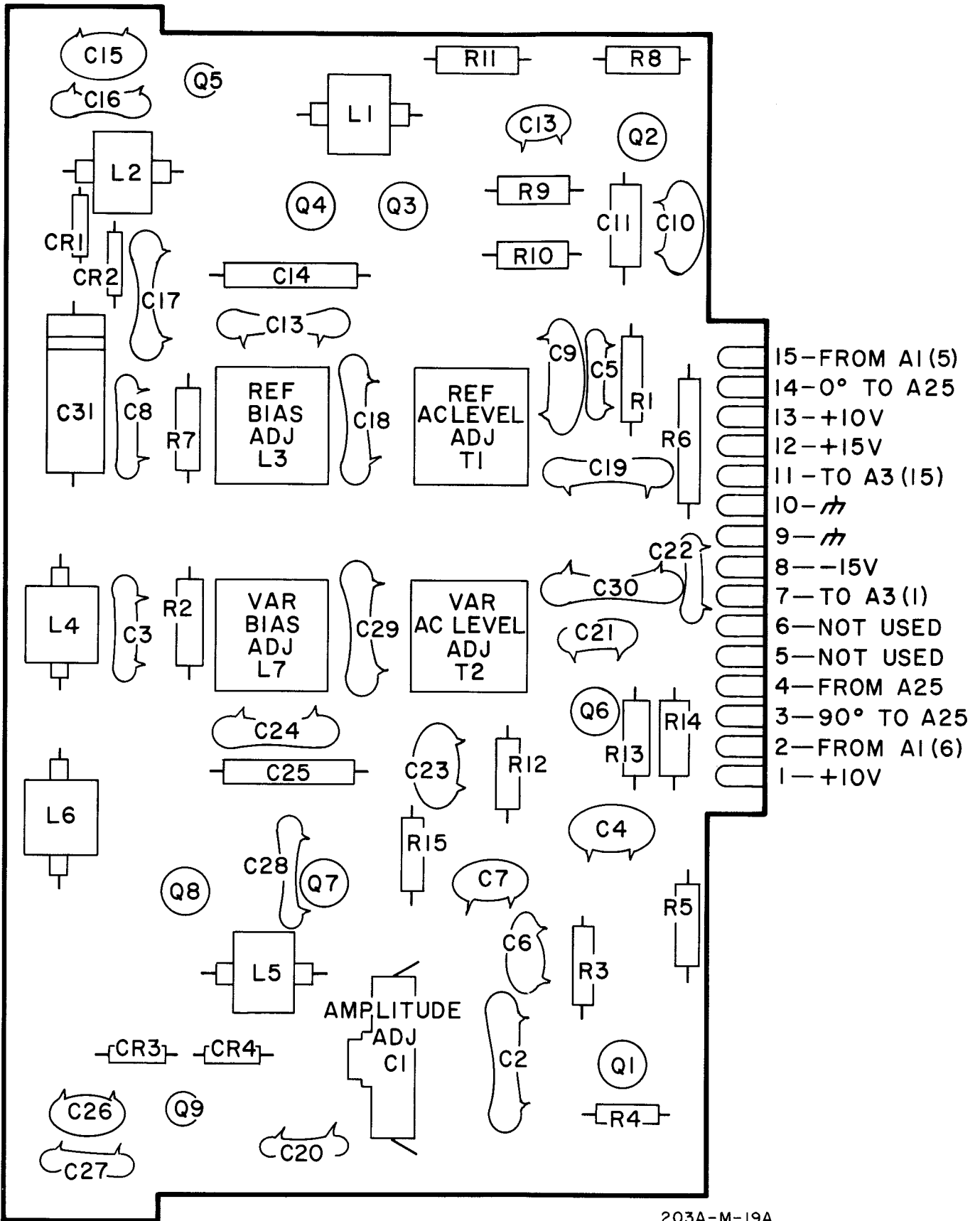
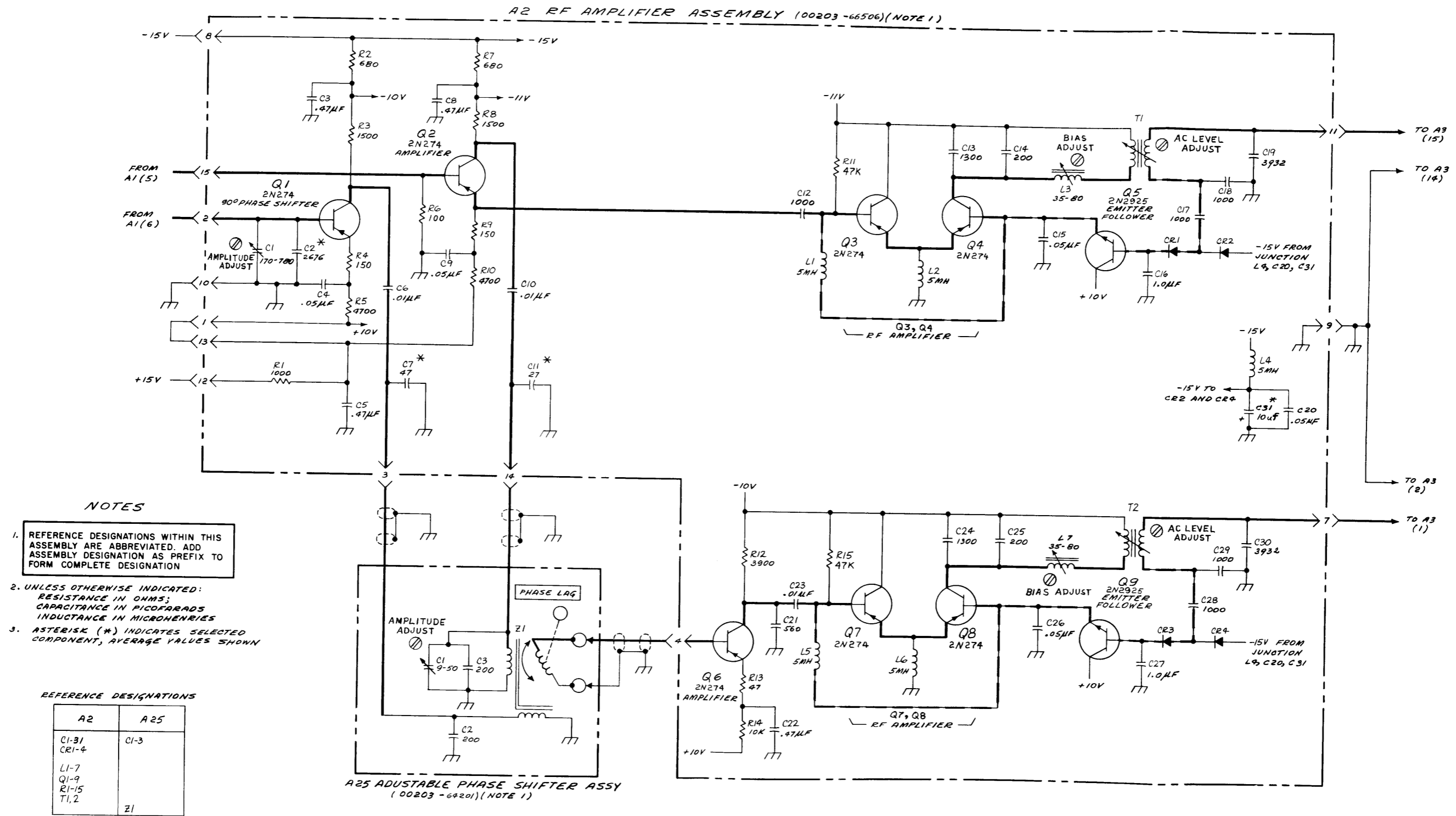

Figure 5-10. 5 Mc Oscillator and 9:1 Divider Assy A1--Schematic



203A-M-19A

Figure 5-11. RF Amplifier Assy A2--Component Location



COPYRIGHT 1964 BY HEWLETT-PACKARD COMPANY
203A-RF AMP. AND ADJ. P.FIL.-425

Figure 5-12. RF Amplifier Assy A2 and Adjustable Phase Shifter Assy A25--Schematic

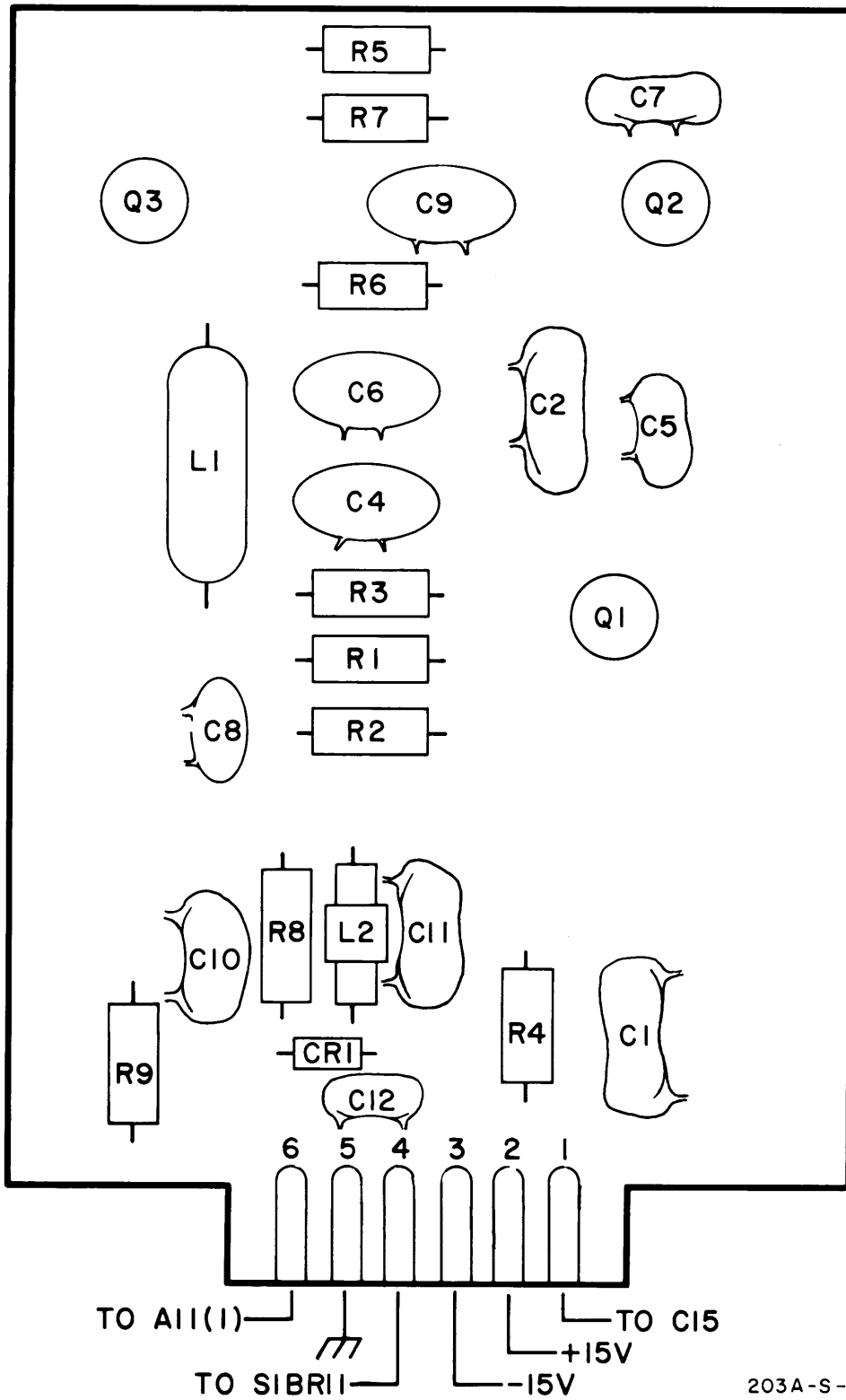

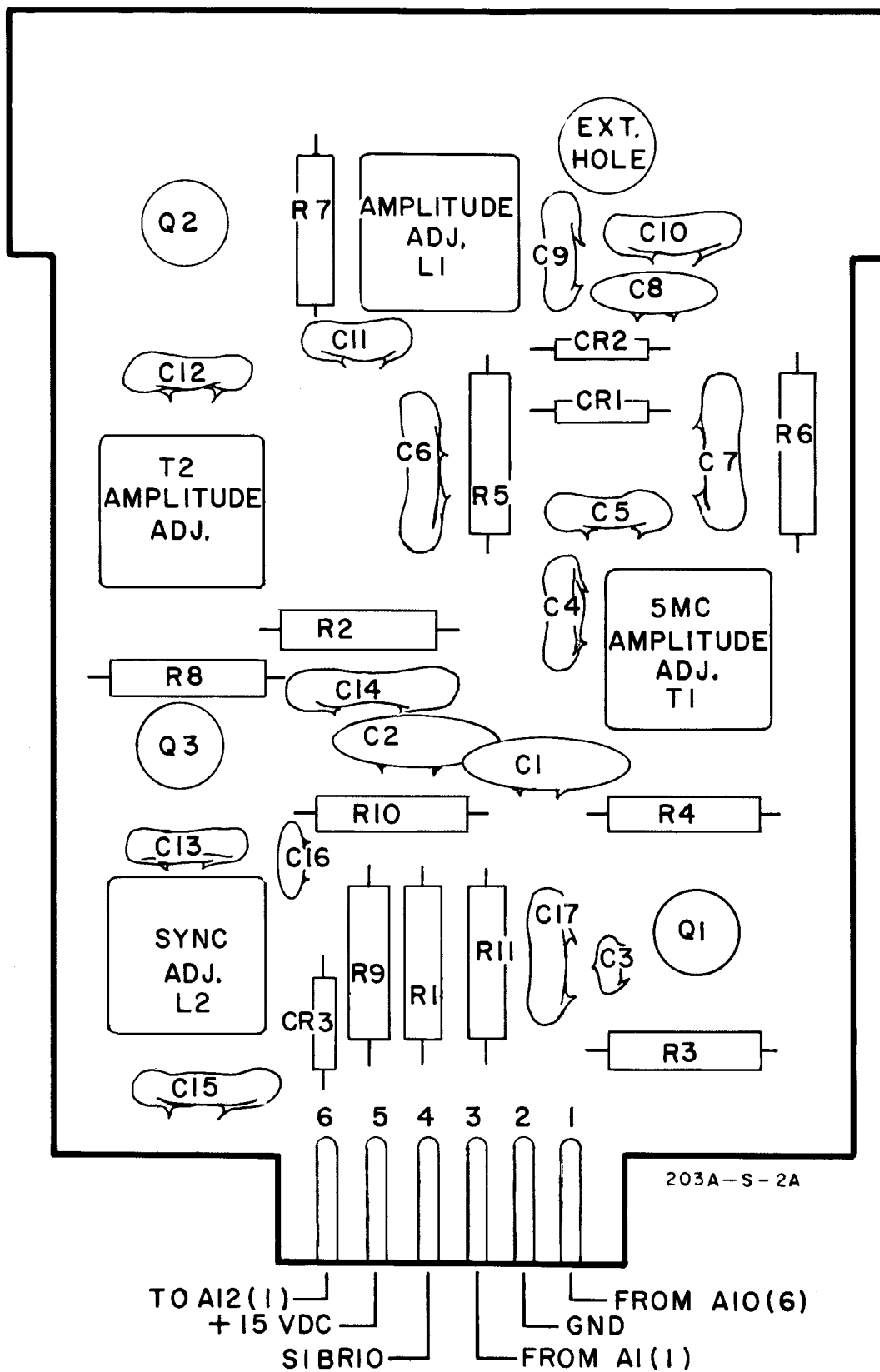

Figure 5-13. VFO Assy A10 and Decade Module Assy A11--Component Location

NOTES

1. REFERENCE DESIGNATIONS WITHIN THIS ASSEMBLY ARE ABBREVIATED. ADD ASSEMBLY DESIGNATION AS PREFIX TO FORM COMPLETE DESIGNATION
2. UNLESS OTHERWISE INDICATED:
RESISTANCE IN OHMS;
CAPACITANCE IN PICOFARADS
INDUCTANCE IN MICRONENRIES
3. ASTERISK (*) INDICATES SELECTED COMPONENT, AVERAGE VALUES SHOWN
4. DECADE MODULE ASSEMBLIES A12 THRU A16 ARE IDENTICAL TO DECADE MODULE ASSEMBLY A11.
5. MULTIPLIER SWITCH S1 IS SHOWN IN 1K POSITION.

REFERENCE DESIGNATIONS

NO PREFIX	A10	A11 - A16
C11-15	C1, 2, 4-12 CR1	C1-17 CR1-3
L1, 2	L1, 2 Q1-3 R1-9	L1, 2 Q1-3 R1-11
S1BR		T1, 2

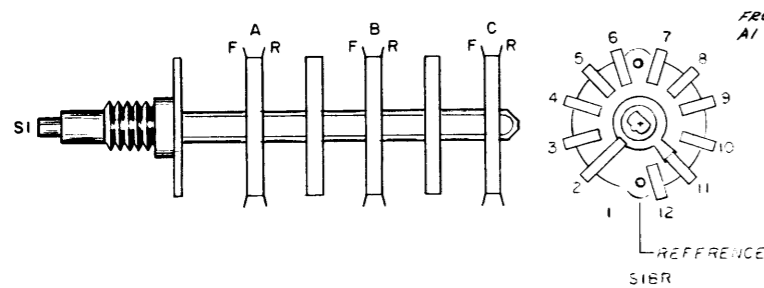

COPYRIGHT 1964 BY HEWLETT-PACKARD COMPANY
203A- VF. OSC. AND DEC. MOD. ASSY. - 426

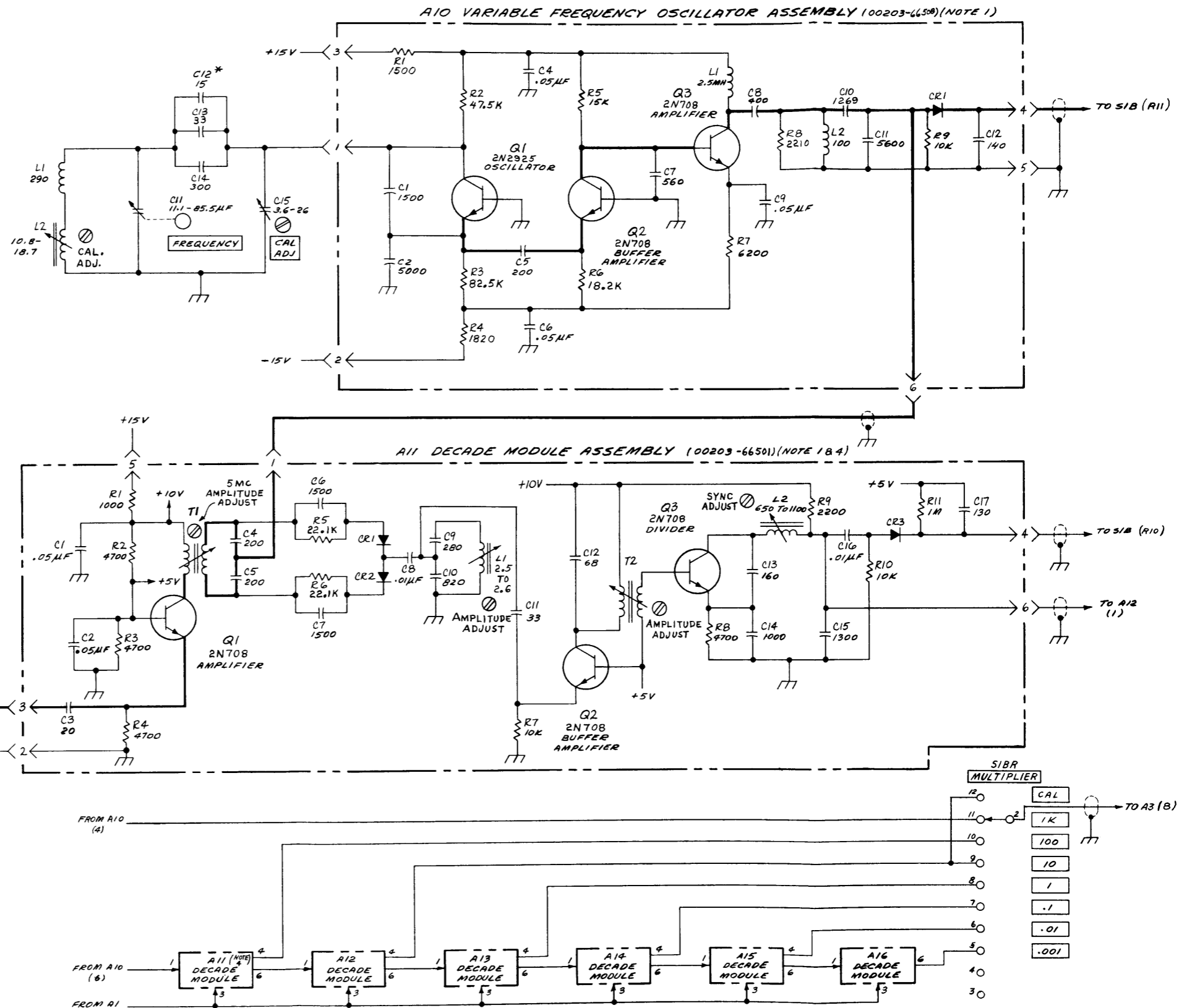

Figure 5-14. VFO Assy A10 and Decade Module Assy A11--Schematic

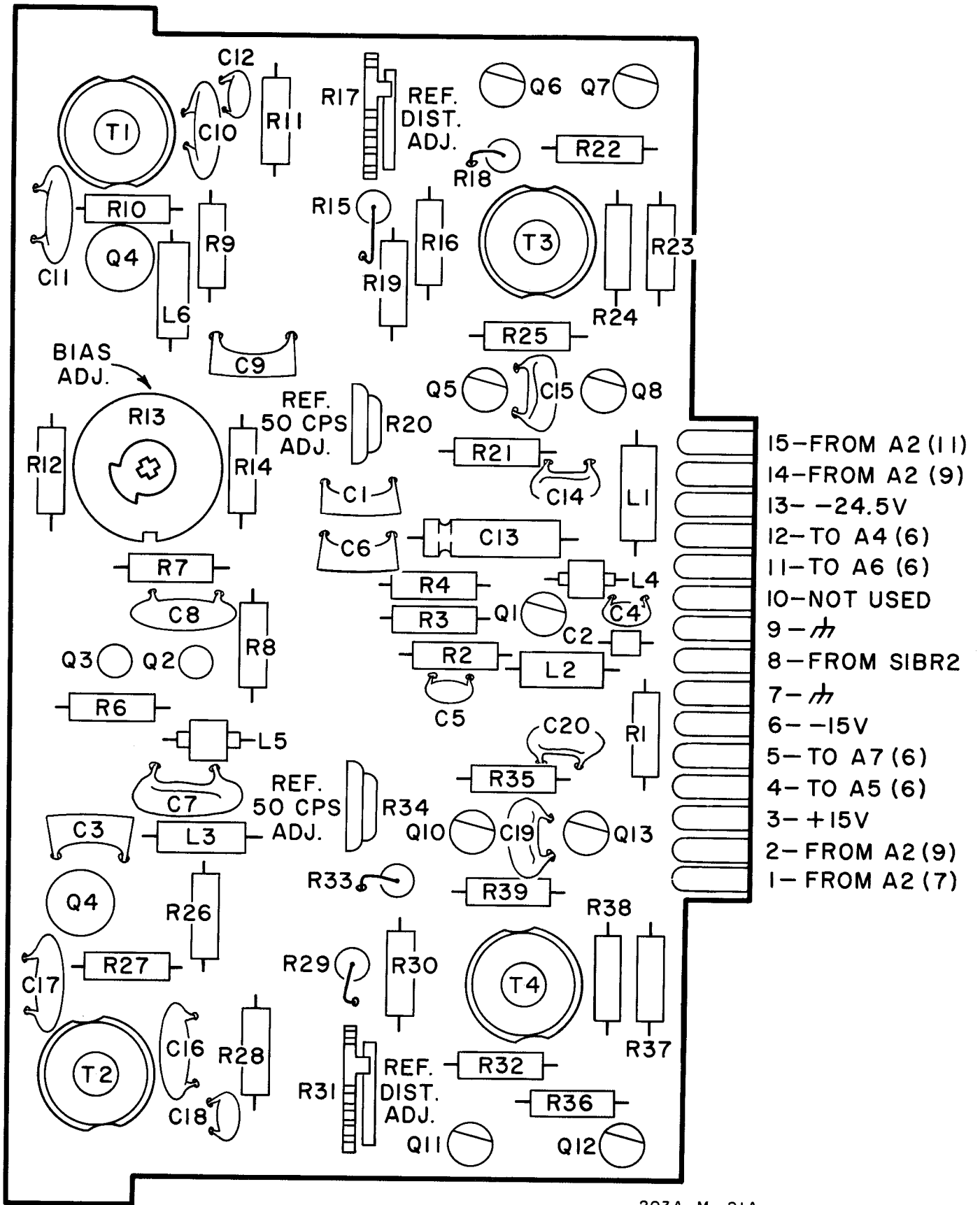

Figure 5-15. Modulator Assy A3--Component Location

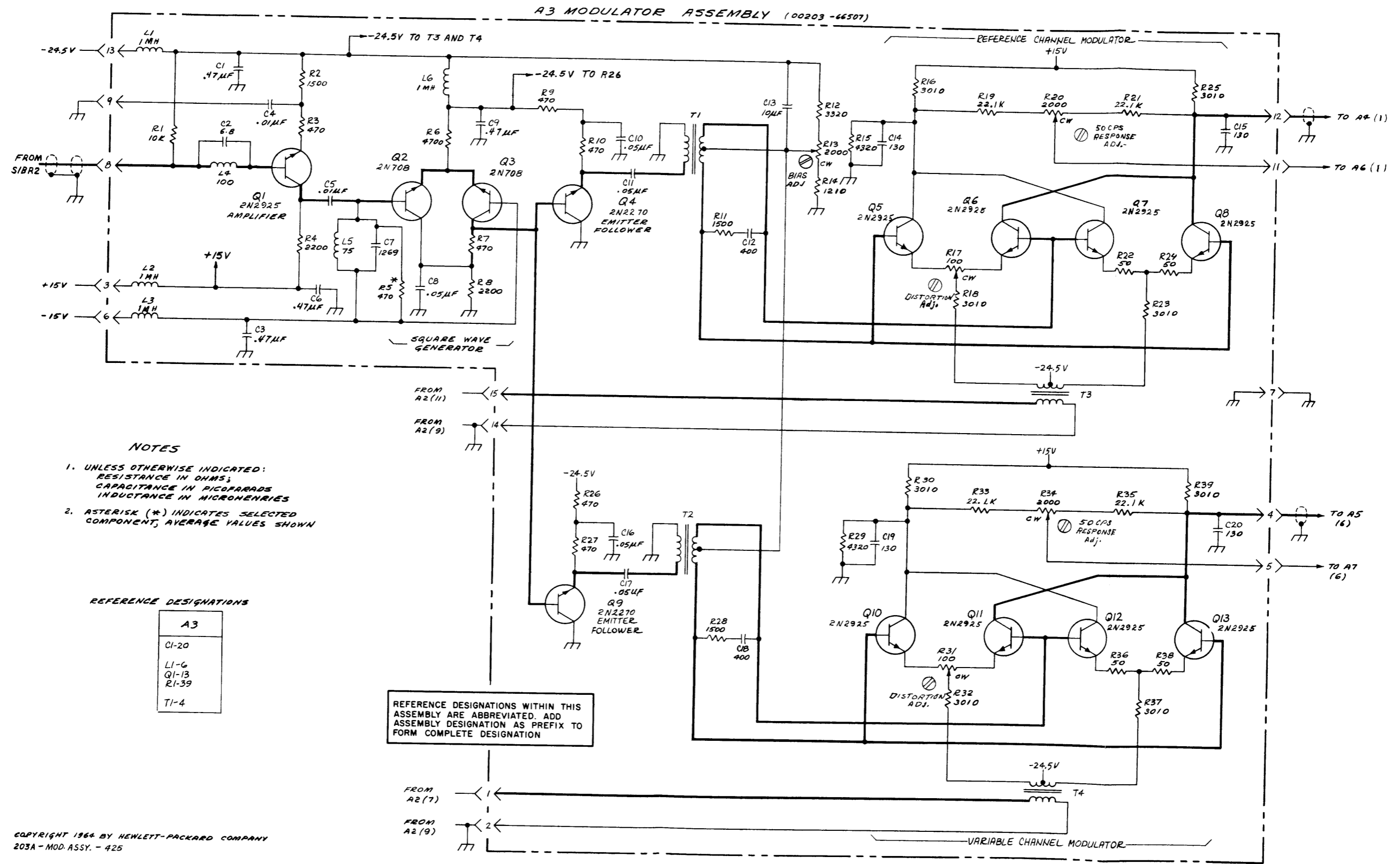

Figure 5-16. Modulator Assy A3--Schematic

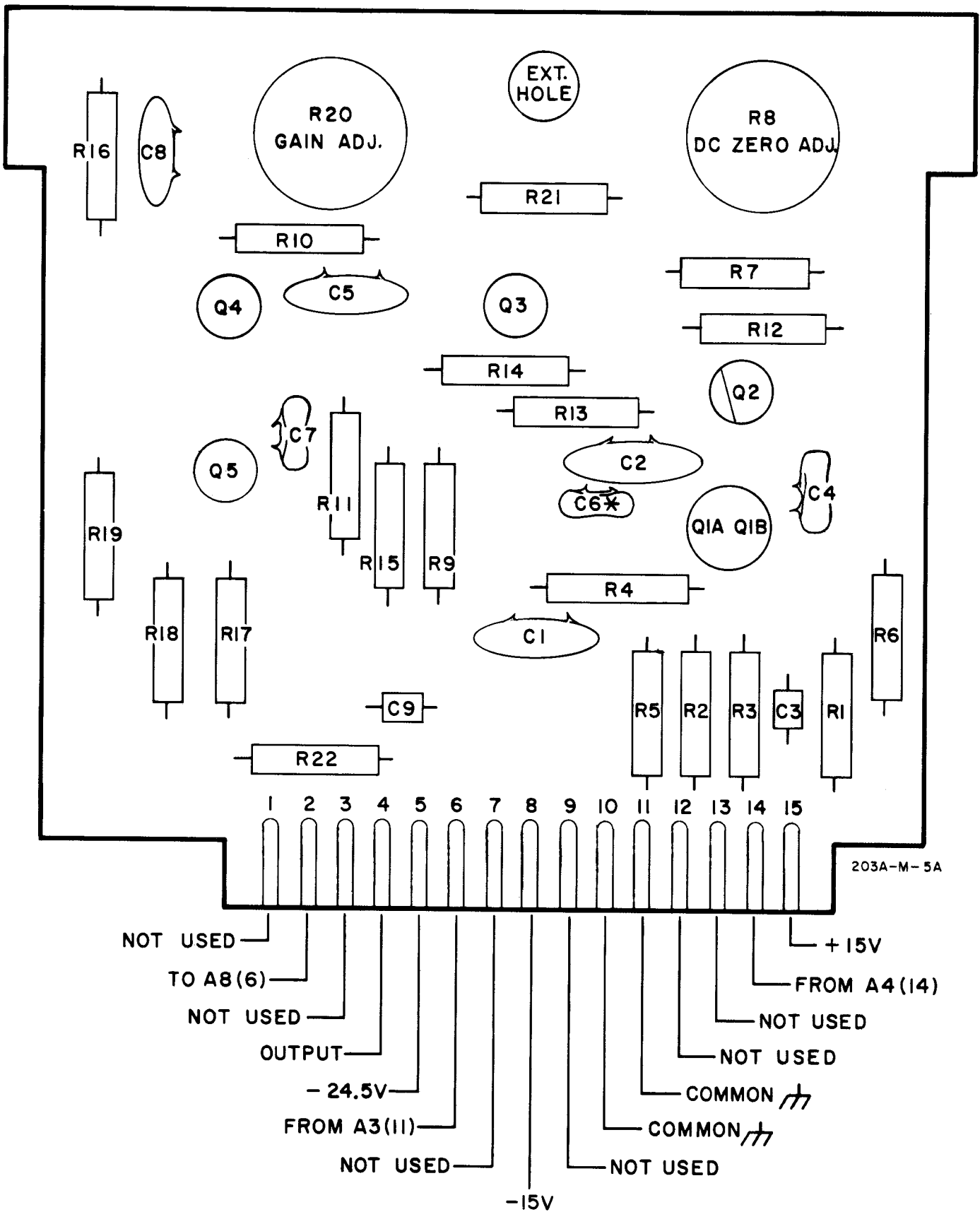

Figure 5-17. DC Amplifier Assy A6 and A7--Component Location

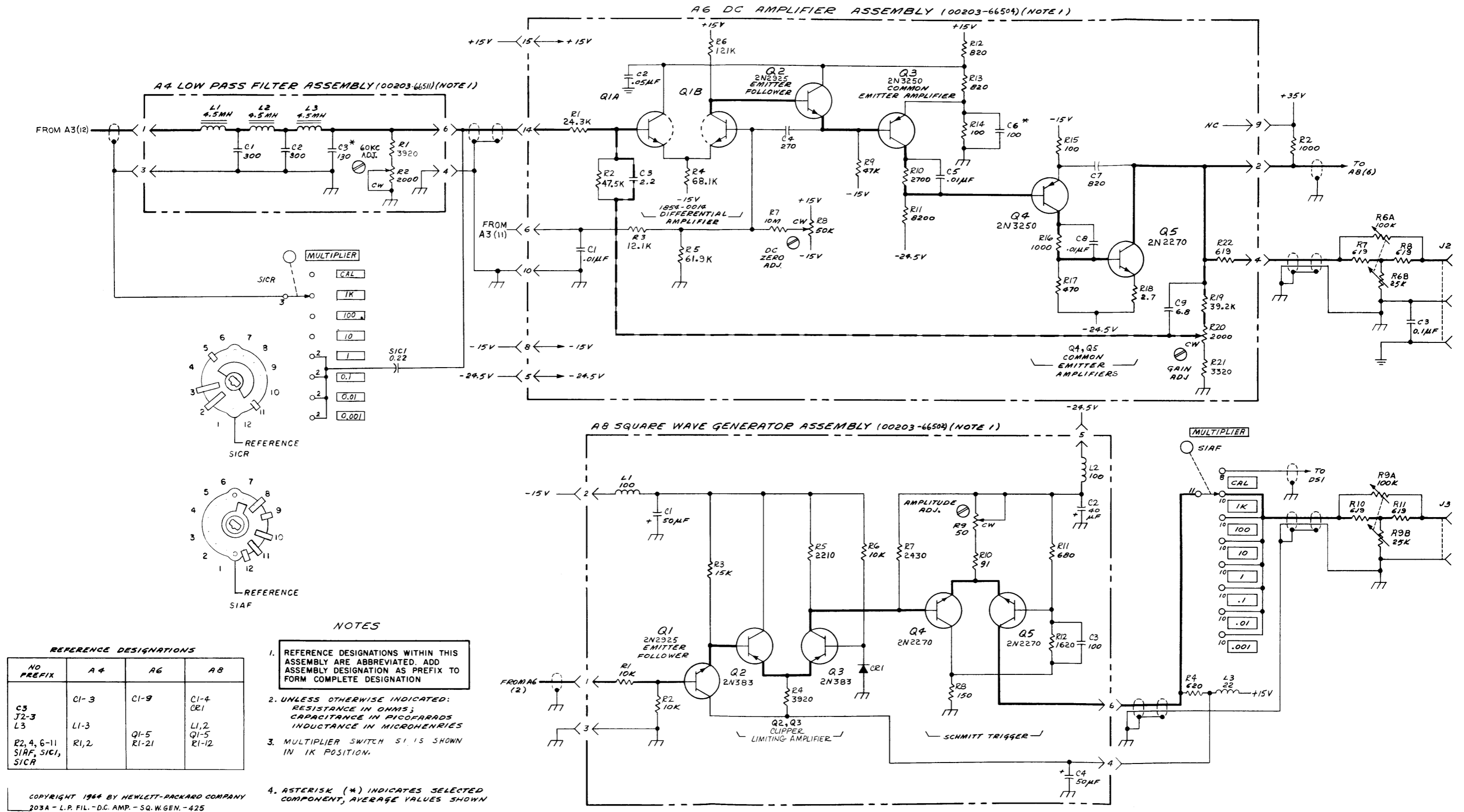
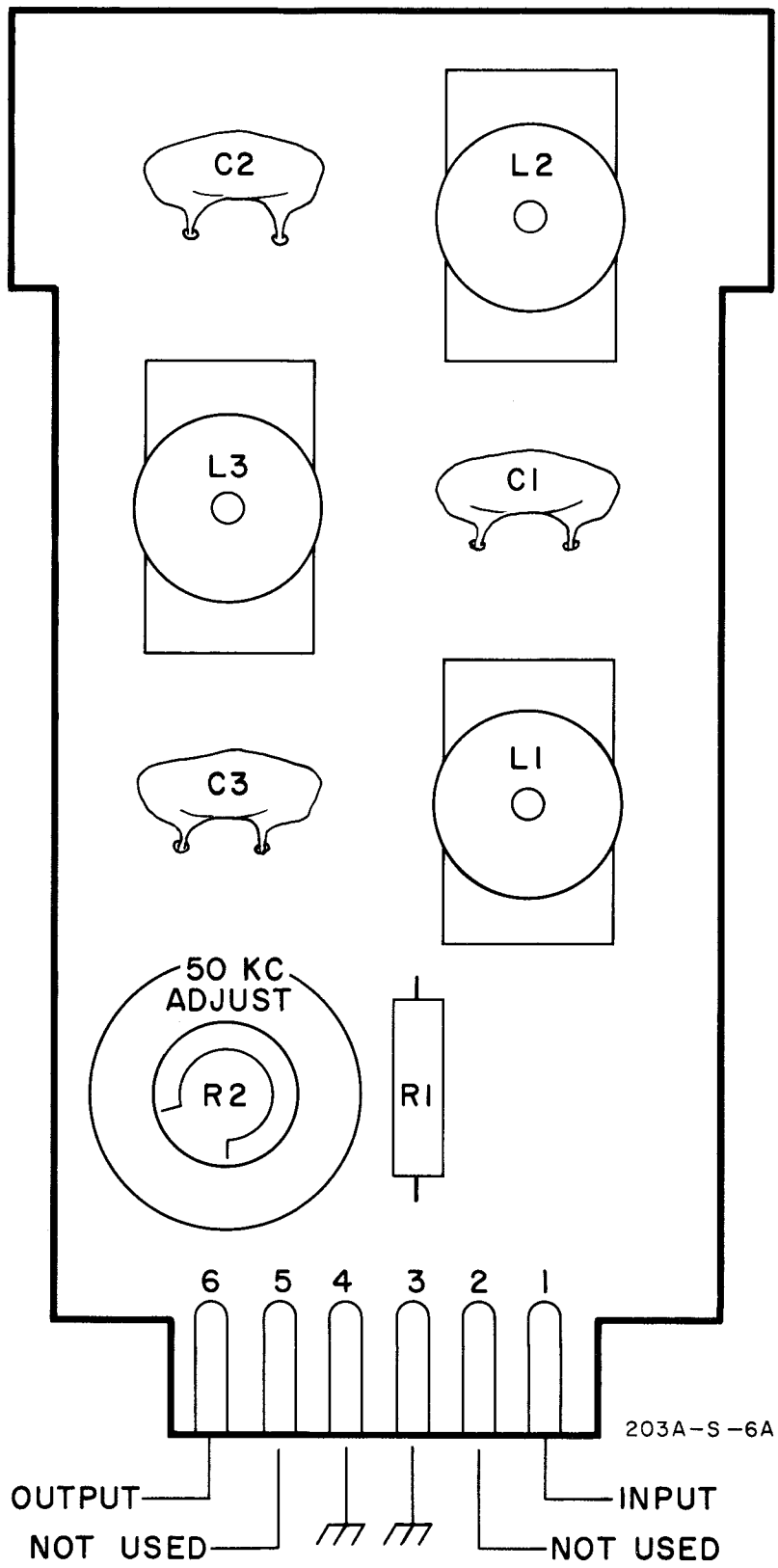

Figure 5-18. Low Pass Filter Assy A4, DC Amp Assy A6, and Square Wave Gen Assy A8--Schematic



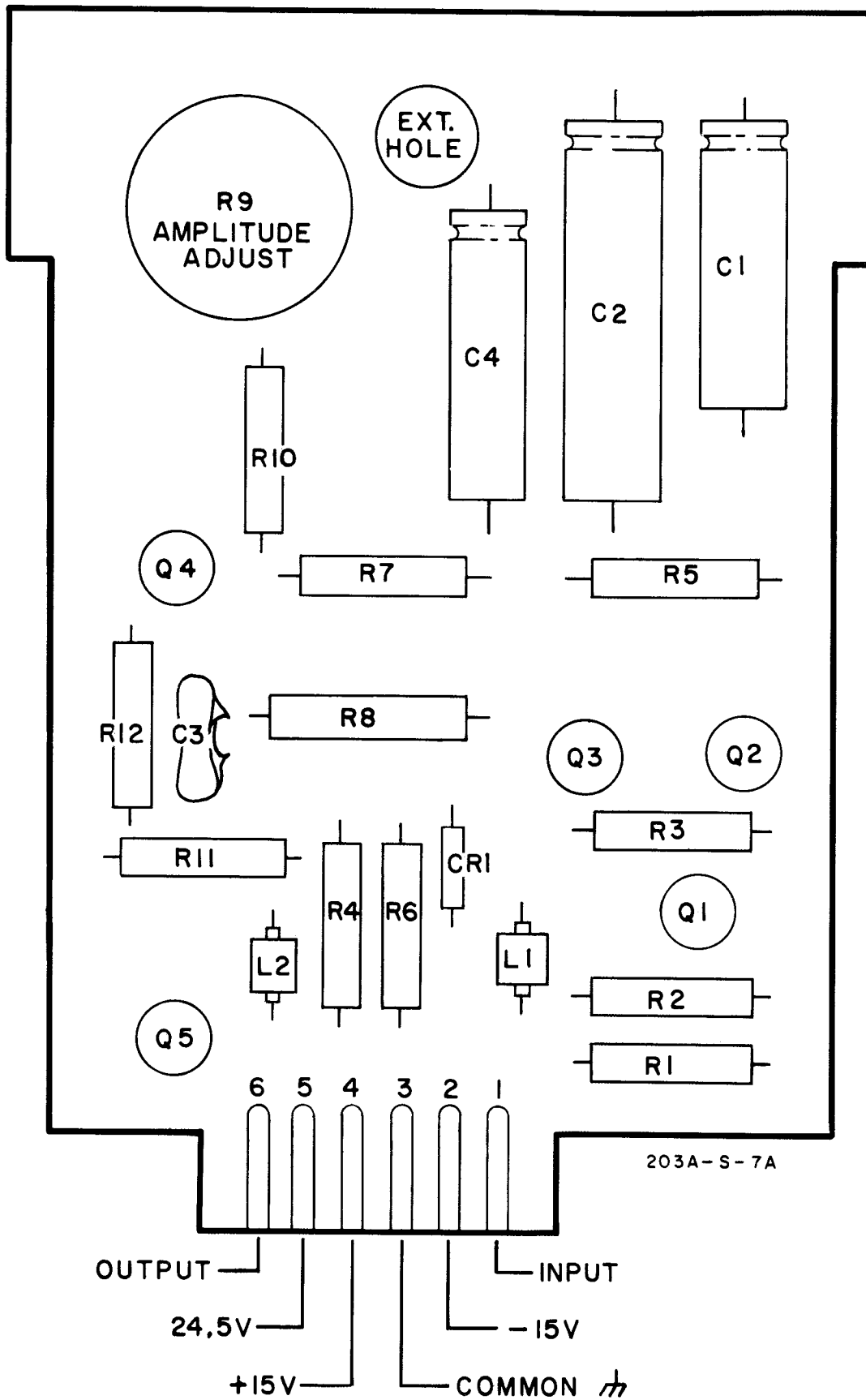

Figure 5-19. Low Pass Filter Assy A4 and A5 and Square Wave Gen Assy A8 and A9--Component Location

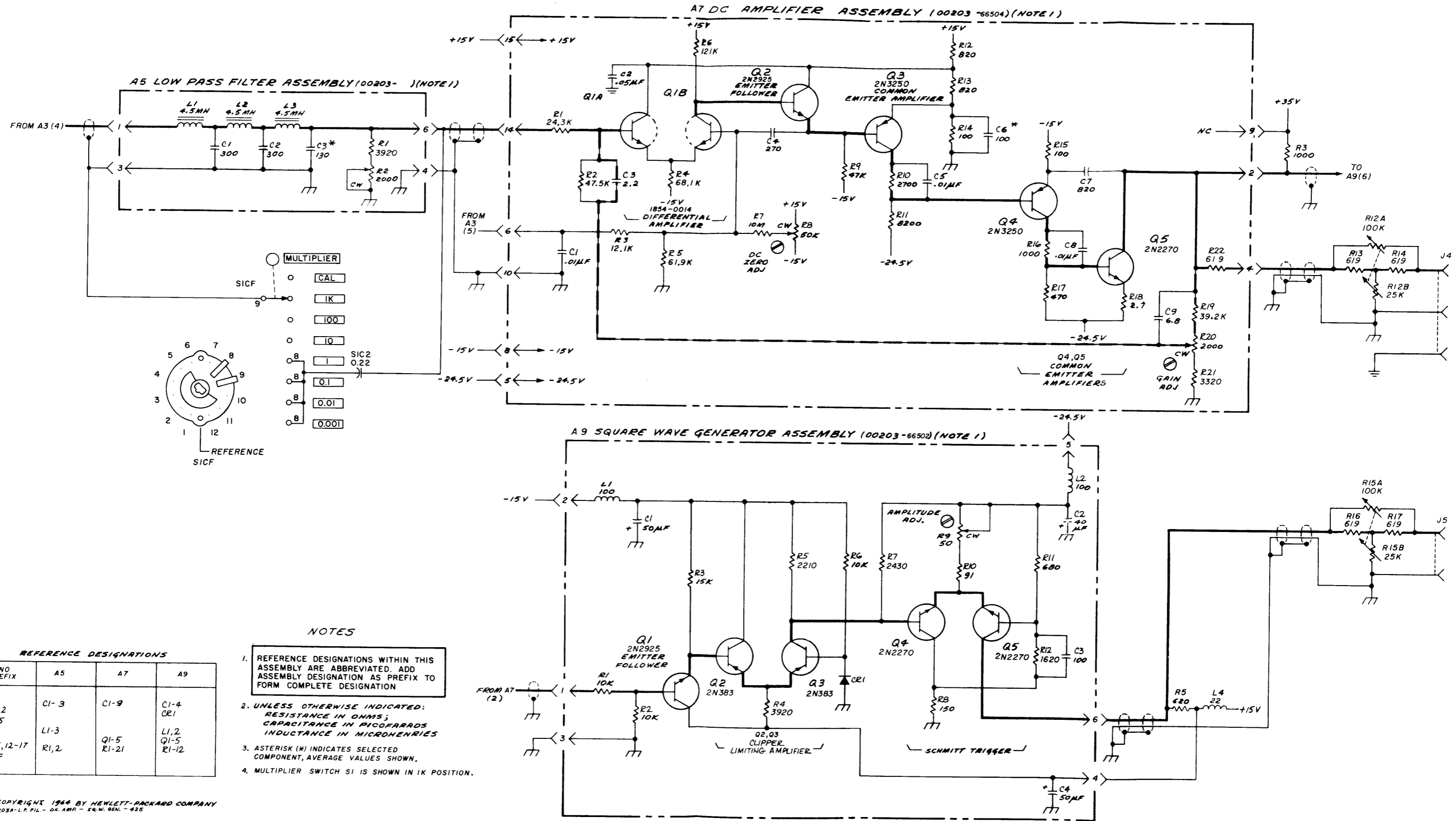
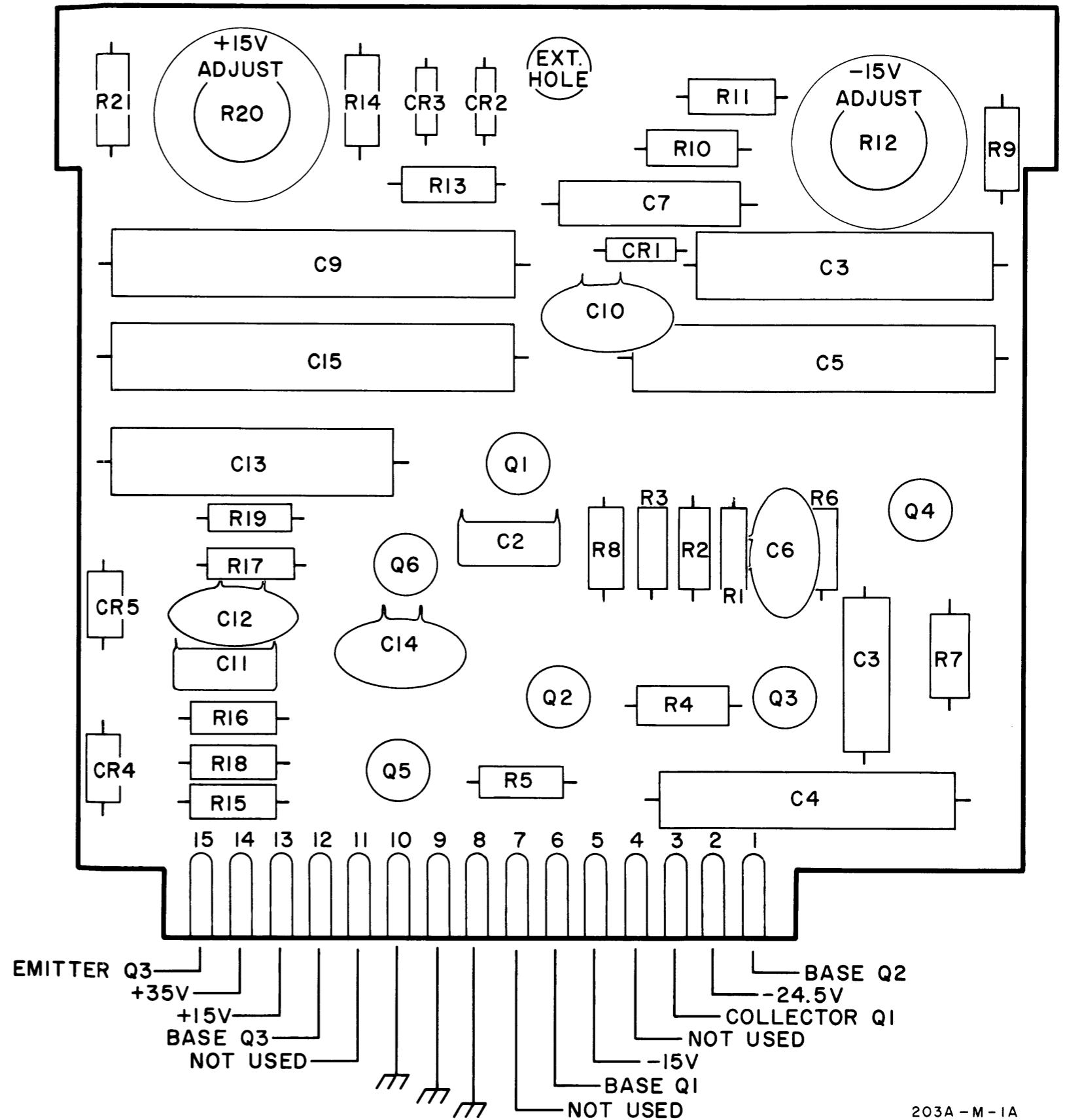
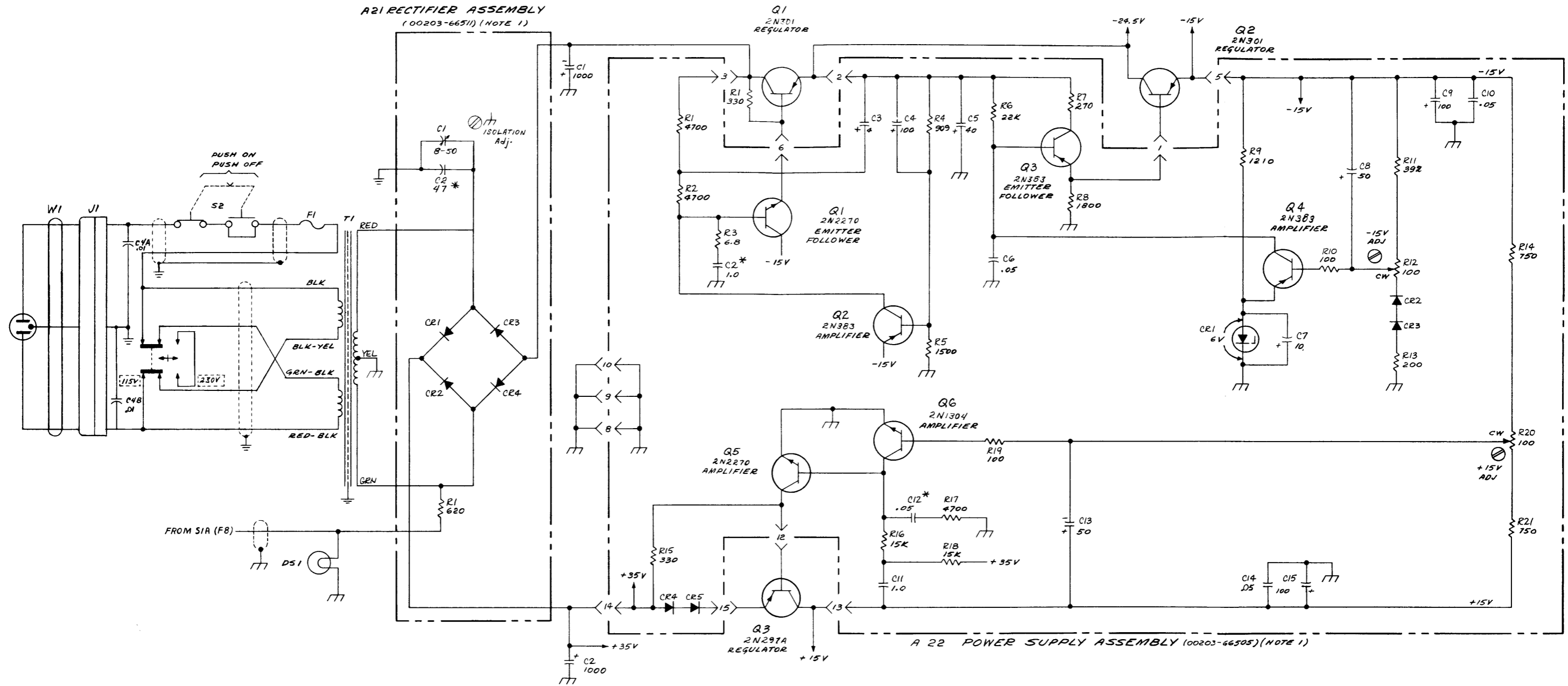

Figure 5-20. Low Pass Filter Assy A5, DC Amp Assy A7, and Square Wave Gen Assy A9--Schematic



203A-M-1A



NOTES

1. REFERENCE DESIGNATIONS WITHIN THIS ASSEMBLY ARE ABBREVIATED. ADD ASSEMBLY DESIGNATION AS PREFIX TO FORM COMPLETE DESIGNATION
2. UNLESS OTHERWISE INDICATED: RESISTANCE IN OHMS; CAPACITANCE IN MICROFARADS.
3. ASTERISK (*) INDICATES SELECTED COMPONENT, AVERAGE VALUES SHOWN.

REFERENCE DESIGNATIONS

NO PREFIX	A20	A21
C1,2	C1-15 CR1-5	C1,2 CR1-4
DS1		
FI		
J1		
Q1-3	Q1-6	
R1	R1-21	R1
S2,3		
T1		
W1		

COPYRIGHT 1964 BY HEWLETT-PACKARD COMPANY
203A - POWER SUP - 425

Figure 5-22. Power Supply Assy A22 and Rectifier Assy A21--Schematic

SECTION VI REPLACEABLE PARTS

6-1. INTRODUCTION.

6-2. This section contains information for ordering replacement parts. Table 6-1 lists parts in alpha-numerical order of their reference designators and indicates the description and ϕ stock number of each part, together with any applicable notes. Table 6-2 lists parts in alpha-numerical order of their ϕ stock numbers and provides the following information on each part:

- a. Description of the part (see list of abbreviations below).
- b. Typical manufacturer of the part in a five-digit code (see list of manufacturers in Appendix).
- c. Manufacturer's stock number.
- d. Total quantity used in the instrument (TQ column).
- e. Recommended spare part quantity for complete maintenance during one year of isolated service is available upon request.

6-3. Miscellaneous parts not indexed in Table 6-1 are listed at the end of Table 6-2.

6-4. ORDERING INFORMATION.

6-5. To order a replacement part, address order or inquiry to your Hewlett-Packard Sales or Service Office. A map of all Hewlett-Packard field offices is provided in the Appendix of this manual.

6-6. Specify the following information for each part:

- a. Model and complete serial number of instrument.
- b. Hewlett-Packard stock number.
- c. Circuit reference designator.
- d. Description.

6-7. To order a part not listed in Table 6-1 and 6-2, give a complete description of the part and include its function and location.

REFERENCE DESIGNATORS

A = assembly	F = fuse	P = plug	V = vacuum tube, neon bulb, photocell, etc.
B = motor	FL = filter	Q = transistor	W = cable
C = capacitor	J = jack	R = resistor	X = socket
CR = diode	K = relay	RT = thermistor	XF = fuseholder
DL = delay line	L = inductor	S = switch	XDS = lampholder
DS = device signaling (lamp)	M = meter	T = transformer	Z = network
E = misc electronic part	MP = mechanical part		

ABBREVIATIONS

a = amperes	elect = electrolytic	mtg = mounting	rot = rotary
bp = bandpass	encap = encapsulated	my = mylar	rms = root-mean-square
bwo = backward wave oscillator	f = farads	NC = normally closed	rmo = rack mount only
c = carbon	fxd = fixed	Ne = neon	s-b = slow-blow
cer = ceramic	Ge = germanium	NO = normally open	Se = selenium
cmo = cabinet mount only	grd = ground (ed)	NPO = negative positive zero (zero temperature coefficient)	sect = section(s)
coef = coefficient	h = henries	nsr = not separately replaceable	Si = silicon
com = common	Hg = mercury		sil = silver
comp = composition	imp = impregnated	obd = order by description	sl = slide
conn = connection	incd = incandescent		td = time delay
crt = cathode-ray tube	ins = insulation (ed)		TiO ₂ = titanium dioxide
dep = deposited			tog = toggle
EIA = Tubes or transistors meeting Electronic Industries' Association standards will normally result in instrument operating within specifications; tubes and transistors selected for best performance will be supplied if ordered by ϕ stock numbers.	K = kilo = 1000	p = peak	tol = tolerance
	lin = linear taper	pc = printed circuit board	trim = trimmer
	log = logarithmic taper	pf = picofarads = 10 ⁻¹² farads	twt = traveling wave tube
	m = milli = 10 ⁻³	pp = peak to peak	var = variable
	M = megohms	piv = peak inverse voltage	w/ = with
	ma = milliamperes	pos = position (s)	W = watts
	μ = micro = 10 ⁻⁶	pot = potentiometer	ww = wirewound
	minat = miniature	rect = rectifier	w/o = without
	mfgl = metal film on glass		* = optimum value selected at factory, average value shown (part may be omitted)
	mfr = manufacturer		

Table 6-1. Index by Reference Designator

Circuit Reference	Ⓢ Stock No.	Description	Note
A1	00203-66503	Board ass'y, 5 mcps, includes: C1 thru C13 R1 thru R9 L1, L2 T1, T2 Q1 thru Q4 Y1	
A1C1	0140-0207	C: fxd, dipped mica, 330 pf ±5%	
A1C2	0150-0096	C: fxd, cer, 0.05 μfd +80% -20%, 100 vdcw	
A1C3	0140-0204	C: fxd, dipped mica, 47 pf ±5%	
A1C4	0140-0208	C: fxd, dipped mica, 680 pf ±5%	
A1C5	0150-0096	C: fxd, cer, 0.05 μfd +80% -20%, 100 vdcw	
A1C6	0140-0201	C: fxd, dipped mica, 12 pf ±5%	
A1C7	0140-0176	C: fxd, dipped mica, 100 pf ±2%	
A1C8	0140-0217	C: fxd, dipped mica, 140 pf ±2%	
A1C9	0140-0151	C: fxd, dipped mica, 820 pf ±2%	
A1C10	0150-0096	C: fxd, cer, 0.05 μfd +80% -20%, 100 vdcw	
A1C11	0140-0157	C: fxd, dipped mica, 1857 pf ±1%	
A1C12	0140-0178	C: fxd, dipped mica, 560 pf ±2%	
A1C13	0160-0147	C: fxd, dipped mica, 2500 pf ±2%	
A1L1	9140-0029	Coil, R. F., choke, universal wound, unshielded, 100 μh, 2.6 ohms	
A1L2	00203-86009	Coil, var	
A1Q1 thru A1Q4	1854-0005	Transistor, EIA type 2N708, NPN silicon planar	
A1R1, A1R2	0687-1521	R: fxd, comp, 1500 ohms ±10%, 1/2 W	
A1R3	0687-2221	R: fxd, comp, 2200 ohms ±10%, 1/2 W	
A1R4	0687-5621	R: fxd, comp, 5600 ohms ±10%, 1/2 W	
A1R5	0687-1231	R: fxd, comp, 12 K ohms ±10%, 1/2 W	
A1R6	0687-1031	R: fxd, comp, 10 K ohms ±10%, 1/2 W	
A1R7	0687-1521	R: fxd, comp, 1500 ohms ±10%, 1/2 W	
A1R8	0687-4721	R: fxd, comp, 4700 ohms ±10%, 1/2 W	
A1R9	0687-1031	R: fxd, comp, 10 K ohms ±10%, 1/2 W	
A1T1	00203-84204	Transformer, tuned	
A1T2	00203-84203	Transformer, tuned	
A1Y1	0410-0009	Crystal unit, quartz, 5 mc, 2 pins on bottom	
A2	00203-66506	Board ass'y, R. F. Amplifier, includes: C1 thru C31 Q1 thru Q9 CR1 thru CR4 R1 thru R15 L1 thru L7 T1, T2	
A2C1	0131-0003	C: var, mica, single sect, 170 - 180 pf, 175 vdcw	
A2C2 *	0140-0158	C: fxd, dipped mica, 2676 pf ±1%	
A2C3	0160-0174	C: fxd, cer, 0.47 μf +80% -20%, 25 vdcw	
A2C4	0150-0096	C: fxd, cer, 0.05 μfd +80% -20%, 100 vdcw	
A2C5	0160-0174	C: fxd, cer, 0.47 μf +80% -20%, 25 vdcw	
A2C6	0150-0012	C: fxd, cer, 0.01 μf ±20%, 1000 vdcw	
A2C7 *	0160-0182	C: fxd, dipped mica, 47 pf ±5%	
A2C8	0160-0174	C: fxd, cer, 0.47 μf +80% -20%, 25 vdcw	
A2C9	0150-0096	C: fxd, cer, 0.05 μfd +80% -20%, 100 vdcw	
A2C10	0150-0012	C: fxd, cer, 0.01 μf ±20%, 1000 vdcw	
A2C11 *	0150-0115	C: fxd, cer, 27 pf ±10%, 500 vdcw	
A2C12	0150-0069	C: fxd, cer, 0.001 μf +100% -20%, 500 vdcw	
A2C13	0140-0154	C: fxd, dipped mica, 1300 pf ±5%	
A2C14	0150-0118	C: fxd, cer, 200 pf ±10%, 500 vdcw	
A2C15	0150-0096	C: fxd, cer, 0.05 μfd +80% -20%, 100 vdcw	

* Average value shown, optimum value selected at factory
See introduction to this section

Table 6-1. Index by Reference Designator (Cont'd)

Circuit Reference	Ⓢ Stock No.	Description	Note
A2C16	0160-0127	C: fxd, cer, 1.0 μ f \pm 20%, 25 vdcw	
A2C17, A2C18	0140-0152	C: fxd, mica, 1000 pf \pm 5%, 300 vdcw	
A2C19	0140-0161	C: fxd, dipped mica, 3932 pf \pm 1%	
A2C20	0150-0096	C: fxd, cer, 0.05 μ fd +80% -20%, 100 vdcw	
A2C21	0140-0178	C: fxd, dipped mica, 560 pf \pm 2%	
A2C22	0160-0174	C: fxd, cer, 0.47 μ f +80% -20%, 25 vdcw	
A2C23	0150-0012	C: fxd, cer, 0.01 μ f \pm 20%, 1000 vdcw	
A2C24	0140-0154	C: fxd, dipped mica, 1300 pf \pm 5%	
A2C25	0150-0118	C: fxd, cer, 200 pf \pm 10%, 500 vdcw	
A2C26	0150-0096	C: fxd, cer, 0.05 μ fd +80% -20%, 100 vdcw	
A2C27	0160-0127	C: fxd, cer, 1.0 μ f \pm 20%, 25 vdcw	
A2C28, A2C29	0140-0152	C: fxd, mica, 1000 pf \pm 5%, 300 vdcw	
A2C30	0140-0161	C: fxd, dipped mica, 3932 pf \pm 1%	
A2C31	0180-0059	C: fxd, elect, 10 μ f -10% +100%, 25 vdcw	
A2CR1 thru A2CR4	1901-0040	Diode, silicon, 30 MA at +1 v, 30 PIV, 2 pf, 2 ns	
A2L1, A2L2	9140-0037	Coil, radio freq. 5 mh induct, universal wound	
A2L3	00203-86003	Coil, var	
A2L4 thru A2L6	9140-0037	Coil, radio freq. 5 mh induct, universal wound	
A2L7	00203-86010	Coil, var	
A2Q1 thru A2Q4	1850-0037	Transistor, EIA type 2N274 drift, germanium PNP alloy	
A2Q5	1854-0033	Transistor, EIA type 2N2925, NPN silicon	
A2Q6 thru A2Q8	1850-0037	Transistor, EIA type 2N274 drift, germanium PNP alloy	
A2Q9	1854-0033	Transistor, EIA type 2N2925, NPN silicon	
A2R1	0687-1021	R: fxd, comp, 1000 ohms \pm 10%, 1/2 W	
A2R2	0687-6811	R: fxd, comp, 680 ohms \pm 10%, 1/2 W	
A2R3	0757-0736	R: fxd, met flm, 1.5 K ohms \pm 1%, 1/4 W	
A2R4	0757-0715	R: fxd, met flm, 150 ohms \pm 1%, 1/4 W	
A2R5	0687-4721	R: fxd, comp, 4700 ohms \pm 10%, 1/2 W	
A2R6	0757-1032	R: fxd, met flm, 100 ohms \pm 0.5%, 1/4 W	
A2R7	0687-6811	R: fxd, comp, 680 ohms \pm 10%, 1/2 W	
A2R8	0757-0736	R: fxd, met flm, 1.5 K ohms \pm 1%, 1/4 W	
A2R9	0757-0715	R: fxd, met flm, 150 ohms \pm 1%, 1/4 W	
A2R10	0687-4721	R: fxd, comp, 4700 ohms \pm 10%, 1/2 W	
A2R11	0687-4731	R: fxd, comp, 47 K ohms \pm 10%, 1/2 W	
A2R12	0687-3921	R: fxd, comp, 3900 ohms \pm 10%, 1/2 W	
A2R13	0687-4701	R: fxd, comp, 47 ohms \pm 10%, 1/2 W	
A2R14	0687-1031	R: fxd, comp, 10 K ohms \pm 10%, 1/2 W	
A2R15	0687-4731	R: fxd, comp, 47 K ohms \pm 10%, 1/2 W	
A2T1	00203-84205	Transformer, tuned	
A2T2	00203-84206	Transformer, tuned	
A3	00203-66507	Board, ass'y, modulator, includes: C1 thru C20 R1 thru R39 L1 thru L6 T1 thru T4 Q1 thru Q13	
A3C1	0160-0174	C: fxd, cer, 0.47 μ f +80% -20%, 25 vdcw	
A3C2	0150-0047	C: fxd, TiO ₂ , 6.8 pf \pm 10%, 500 vdcw	
A3C3	0160-0174	C: fxd, cer, 0.47 μ f +80% -20%, 25 vdcw	
A3C4, A3C5	0150-0093	C: fxd, cer, 0.01 μ f +80% -20%, 100 vdcw	

See introduction to this section

Table 6-1. Index by Reference Designator (Cont'd)

Circuit Reference	Ⓢ Stock No.	Description	Note
A3C6	0160-0174	C: fxd, cer, 0.47 μ f +80% -20%, 25 vdcw	
A3C7	0140-0153	C: fxd, mica, 1269 pf \pm 1%, 300 vdcw	
A3C8	0150-0096	C: fxd, cer, 0.05 μ fd +80% -20%, 100 vdcw	
A3C9	0160-0174	C: fxd, cer, 0.47 μ f +80% -20%, 25 vdcw	
A3C10, A3C11	0150-0096	C: fxd, cer, 0.05 μ fd +80% -20%, 100 vdcw	
A3C12	0150-0071	C: fxd, cer, 400 pf \pm 5%, 500 vdcw	
A3C13	0180-0059	C: fxd, elect, 10 μ f -10% +100%, 25 vdcw	
A3C14, A3C15	0140-0195	C: fxd, dipped mica, 130 pf \pm 5%	
A3C16, A3C17	0150-0096	C: fxd, cer, 0.05 μ fd +80% -20%, 100 vdcw	
A3C18	0150-0071	C: fxd, cer, 400 pf \pm 5%, 500 vdcw	
A3C19, A3C20	0140-0195	C: fxd, dipped mica, 130 pf \pm 5%	
A3L1 thru A3L3	9140-0137	Coil, fixed R. F., 1000 μ h \pm 5%, dc current rating 135 ma	
A3L4	9140-0029	Coil, R. F. choke, universal wound, unshielded, 100 μ h, 2.6 ohms	
A3L5	9140-0031	Coil, R. F., 75 μ h	
A3L6	9140-0137	Coil, fxd, R. F. 1000 μ h \pm 5%, dc current rating 135 ma	
A3Q1	1854-0033	Transistor, EIA type 2N2925, NPN silicon	
A3Q2, A3Q3	1854-0005	Transistor, EIA type 2N708, NPN silicon planar	
A3Q4	1854-0038	Transistor, EIA type 2N2270, NPN silicon	
A3Q5 thru A3Q8	1854-0033	Transistor, EIA type 2N2925, NPN silicon	
A3Q9	1854-0038	Transistor, EIA type 2N2270, NPN silicon	
A3Q10 thru A3Q13	1854-0033	Transistor, EIA type 2N2925, NPN silicon	
A3R1	0687-1031	R: fxd, comp, 10 K ohms \pm 10%, 1/2 W	
A3R2	0687-1521	R: fxd, comp, 1500 ohms \pm 10%, 1/2 W	
A3R3	0687-4711	R: fxd, comp, 470 ohms \pm 10%, 1/2 W	
A3R4	0687-2221	R: fxd, comp, 2200 ohms \pm 10%, 1/2 W	
A3R5	0683-4715	R: fxd, comp, 470 ohms, \pm 5%, 1/4 W	
A3R6	0687-4721	R: fxd, comp, 4700 ohms \pm 10%, 1/2 W	
A3R7	0687-4711	R: fxd, comp, 470 ohms \pm 10%, 1/2 W	
A3R8	0687-2221	R: fxd, comp, 2200 ohms \pm 10%, 1/2 W	
A3R9, A3R10	0687-4711	R: fxd, comp, 470 ohms \pm 10%, 1/2 W	
A3R11	0687-1521	R: fxd, comp, 1500 ohms \pm 10%, 1/2 W	
A3R12	0757-0743	R: fxd, met flm, 3.32 K ohms \pm 1%, 1/4 W	
A3R13	2100-0282	R: var, lin, ww, 2000 ohms \pm 20%, 1-1/2W	
A3R14	0757-0743	R: fxd, met flm, 1.21 K ohms \pm 1%, 1/4 W	
A3R15	0757-0745	R: fxd, met flm, 4.32 K ohms \pm 1%, 1/4 W	
A3R16	0757-0339	R: fxd, met flm, 3.01 K ohms \pm 1%, 1/4 W	
A3R17	2100-0909	R: var, comp, lin, 100 ohms \pm 30%, 1/4 W	
A3R18	0757-0339	R: fxd, met flm, 3.01 K ohms \pm 1%, 1/4 W	
A3R19	0757-0761	R: fxd, met flm, 22.1 K ohms \pm 1%, 1/4 W	
A3R20	2100-0908	R: var, comp, lin, 2 K \pm 30%, 1/4 W	
A3R21	0757-0762	R: fxd, met flm, 24.3 K ohms \pm 1%, 1/4 W	
A3R22	0757-1040	R: fxd, met flm, 50 ohms \pm 1%, 1/4 W	
A3R23	0757-0339	R: fxd, met flm, 3.01 K ohms \pm 1%, 1/4 W	
A3R24	0757-1040	R: fxd, met flm, 50 ohms \pm 1%, 1/4 W	
A3R25	0757-0339	R: fxd, met flm, 3.01 K ohms \pm 1%, 1/4 W	
A3R26, A3R27	0687-4711	R: fxd, comp, 470 ohms \pm 10%, 1/2 W	
A3R28	0687-1521	R: fxd, comp, 1500 ohms \pm 10%, 1/2 W	
A3R29	0757-0745	R: fxd, met flm, 4.32 K ohms \pm 1%, 1/4 W	
A3R30	0757-0339	R: fxd, met flm, 3.01 K ohms \pm 1%, 1/4 W	

See introduction to this section

Table 6-1. Index by Reference Designator (Cont'd)

Circuit Reference	Stock No.	Description	Note
A3R31	2100-0909	R: var, comp, lin, 100 ohms $\pm 30\%$, 1/4 W	
A3R32	0757-0339	R: fxd, met flm, 3.01 K ohms $\pm 1\%$, 1/4 W	
A3R33	0757-0762	R: fxd, met flm, 24.3 K ohms $\pm 1\%$, 1/4 W	
A3R34	2100-0908	R: var, comp, lin, 2 K $\pm 30\%$, 1/4 W	
A3R35	0757-0762	R: fxd, met flm, 24.3 K ohms $\pm 1\%$, 1/4 W	
A3R36	0757-1040	R: fxd, met flm, 50 ohms $\pm 1\%$, 1/4 W	
A3R37	0757-0339	R: fxd, met flm, 3.01 K ohms $\pm 1\%$, 1/4 W	
A3R38	0757-1040	R: fxd, met flm, 50 ohms $\pm 1\%$, 1/4 W	
A3R39	0757-0339	R: fxd, met flm, 3.01 K ohms $\pm 1\%$, 1/4 W	
A3T1, A3T2	00203-86005	Transformer, driver	
A3T3, A3T4	00203-86004	Transformer, driver	
A4	00203-66511	Board ass'y, filter, includes: C1 thru C3 R1, R2 L1 thru L3	
A4C1, A4C2	0140-0225	C: fxd, dipped mica, 300 pf $\pm 1\%$, 300 vdcw	
A4C3	0140-0195	C: fxd, dipped mica, 130 pf $\pm 5\%$, 300 vdcw	
A4L1 thru A4L3	00203-86006	Coil, fxd, 4.5 mh	
A4R1	0757-0744	R: fxd, met flm, 3.92 K ohms $\pm 1\%$, 1/4 W	
A4R2	2100-0282	R: var, lin, ww, 2000 ohms $\pm 20\%$, 1-1/2 W	
A5	00203-66511	All components same as A4	
A6	00203-66504	Board ass'y, dc amplifier, includes: C1 thru C9 R1 thru R22 Q1 thru Q5	
A6C1	0150-0012	C: fxd, cer, 0.01 pf $\pm 20\%$, 1000 vdcw	
A6C2	0150-0096	C: fxd, cer, 0.05 μ fd $+80\%$ -20%, 100 vdcw	
A6C3	0150-0015	C: fxd, TiO ₂ , 2.2 pf $\pm 10\%$, 500 vdcw	
A6C4	0140-0206	C: fxd, dipped mica, 270 pf $\pm 5\%$	
A6C5	0150-0012	C: fxd, cer, 0.01 pf $\pm 20\%$, 1000 vdcw	
A6C6	0140-0041	C: fxd, molded mica, 100 pf $\pm 5\%$, 500 vdcw	
A6C7	0140-0151	C: fxd, dipped mica, 820 pf $\pm 2\%$, 300 vdcw	
A6C8	0150-0012	C: fxd, cer, 0.01 pf $\pm 20\%$, 1000 vdcw	
A6C9	0150-0047	C: fxd, TiO ₂ , 6.8 pf $\pm 10\%$, 500 vdcw	
A6Q1A, B	1854-0014	Transistor, silicon, ;dual NPN silicon, special	
A6Q2	1854-0033	Transistor, EIA type 2N2925, NPN silicon	
A6Q3, A6Q4	1853-0008	Transistor, EIA type 2N3250, PNP silicon	
A6Q5	1854-0038	Transistor, EIA type, 2N2270, NPN silicon	
	1205-0033	Heat dissipater, semiconductor (A6Q5)	
A6R1	0757-0762	R: fxd, met flm, 24.3 K ohms $\pm 1\%$, 1/4 W	
A6R2	0757-0768	R: fxd, met flm, 47.5 K ohms $\pm 1\%$, 1/4 W	
A6R3	0757-0755	R: fxd, met flm, 12.1 K ohms $\pm 1\%$, 1/4 W	
A6R4	0757-0772	R: fxd, met flm, 68.1 K ohms $\pm 1\%$, 1/4 W	
A6R5	0757-0771	R: fxd, met flm, 61.9 K ohms $\pm 1\%$, 1/4 W	
A6R6	0757-0777	R: fxd, met flm, 121 K ohms $\pm 1\%$, 1/4 W	
A6R7	0687-1061	R: fxd, comp, 10 M ohms $\pm 10\%$, 1/2 W	
A6R8	2100-0094	R: var, lin, comp, 50 K ohms, 30%, 1/5 W	
A6R9	0687-4731	R: fxd, comp, 47 K ohms $\pm 10\%$, 1/2 W	
A6R10	0687-2721	R: fxd, comp, 2700 ohms $\pm 10\%$, 1/2 W	
A6R11	0687-8221	R: fxd, comp, 8200 ohms $\pm 10\%$, 1/2 W	
A6R12, A6R13	0687-8211	R: fxd, comp, 820 ohms $\pm 10\%$, 1/2 W	

See introduction to this section

Table 6-1. Index by Reference Designator (Cont'd)

Circuit Reference	Ⓢ Stock No.	Description	Note
A6R14, A6R15	0687-1011	R: fxd, comp, 100 ohms ±10%, 1/2 W	
A6R16	0687-1021	R: fxd, comp, 1000 ohms ±10%, 1/2 W	
A6R17	0687-4711	R: fxd, comp, 470 ohms ±10%, 1/2 W	
A6R18	0699-0001	R: fxd, comp, 2.7 ohms ±10%, 1/2 W	
A6R19	0757-0766	R: fxd, met flm, 39.2 K ohms ±1%, 1/4 W	
A6R20	2100-0282	R: var, lin, ww, 2000 ohms ±20%, 1-1/2W	
A6R21	0757-0743	R: fxd, met flm, 3.32 K ohms ±1%, 1/4 W	
A6R22	0757-0728	R: fxd, met flm, 619 ohms ±1%, 1/4 W	
A7	00203-66504	All components same as A6	
A8	00203-66502	Board ass'y, square wave, includes: C1 thru C4 Q1 thru Q5 CR1 R1 thru R12 L1, L2	
A8C1	0180-0105	C: fxd, Al elect, 50 μf -10% +100%, 25 vdcw	
A8C2	0180-0050	C: fxd, Al elect, 40 μf -15% +100%, 50 vdcw	
A8C3	0140-0176	C: fxd, dipped mica, 100 pf ±2%, 300 vdcw	
A8C4	0180-0105	C: fxd, Al elect, 50 μf -10% +100%, 25 vdcw	
A8CR1	1901-0025	Diode, silicon, 50 MA at +1 v, 100 PIV, 12 pf	
A8L1, A8L2	9140-0029	Coil, R. F. choke, universal wound, unshielded, 100 μh, 2.6 ohms	
A8Q1	1854-0033	Transistor, EIA type 2N2925, NPN silicon	
A8Q2, A8Q3	1850-0040	Transistor, EIA type 2N383, PNP germanium	
A8Q4, A8Q5	1854-0038	Transistor, EIA type 2N2270, NPN silicon	
A8R1, A8R2	0687-1031	R: fxd, comp, 10 K ohms ±10%, 1/2 W	
A8R3	0687-1531	R: fxd, comp, 15 K ohms ±10%, 1/2 W	
A8R4	0757-0744	R: fxd, met flm, 3.92 K ohms ±1%, 1/4 W	
A8R5	0757-0740	R: fxd, met flm, 2.21 K ohms ±1%, 1/4 W	
A8R6	0687-1031	R: fxd, comp, 10 K ohms ±10%, 1/2 W	
A8R7	0757-0741	R: fxd, met flm, 2.43 K ohms ±1%, 1/4 W	
A8R8	0757-1050	R: fxd, met flm, 150 ohms ±1%, 1/2 W	
A8R9	2100-0206	R: var, lin, ww, 50 ohms ±10%, 1 W	
A8R10	0758-0041	R: fxd, met flm, 91 ohms ±5%, 1/2 W	
A8R11	0757-1027	R: fxd, met flm, 680 ohms ±1%, 1/4 W	
A8R12	0757-0737	R: fxd, met flm, 1.62 K ohms ±1%, 1/4 W	
A9	00203-66502	All components same as A8	
A10	00203-66508	Board ass'y, V. F. O., includes: C1 thru C12 Q1 thru Q3 CR1 R1 thru R10 L1, L2	
A10C1	0160-0836	C: fxd, mica, 1500 pf ±2%, 100 vdcw	
A10C2	0160-0837	C: fxd, mica, 5000 pf ±5%, 100 vdcw	
A10C3		Not assigned	
A10C4	0150-0096	C: fxd, cer, 0.05 μfd +80% -20%, 100 vdcw	
A10C5	0140-0220	C: fxd, dipped mica, 200 pf ±1%, 300 vdcw	
A10C6	0150-0096	C: fxd, cer, 0.05 μfd +80% -20%, 100 vdcw	
A10C7	0140-0178	C: fxd, dipped mica, 560 pf ±2%, 300 vdcw	
A10C8	0150-0071	C: fxd, cer, 400 pf ±5%, 500 vdcw	
A10C9	0150-0096	C: fxd, cer, 0.05 μfd +80% -20%, 100 vdcw	
A10C10	0140-0153	C: fxd, mica, 1269 pf ±1%, 300 vdcw	
A10C11	0140-0170	C: fxd, dipped mica, 5600 pf ±5%, 300 vdcw	
A10C12	0140-0217	C: fxd, dipped mica, 140 pf ±2%, 300 vdcw	
A10CR1	1901-0040	Diode, silicon, 30 MA at +1 v, 30 PIV, 2 pf, 2ns	

See introduction to this section

Table 6-1. Index by Reference Designator (Cont'd)

Circuit Reference	Ⓢ Stock No.	Description	Note
A10L1	9140-0041	Coil, R. F., 2.5 mh $\pm 10\%$	
A10L2	9140-0029	Coil, R. F. choke, universal wound, unshielded, 100 μ h, 2.6 ohms	
A10Q1	1854-0033	Transistor, EIA type 2N2925, NPN silicon	
A10Q2, A10Q3	1854-0005	Transistor, EIA type 2N708, NPN silicon planar	
A10R1	0757-0738	R: fxd, met flm, 1.82 K ohms $\pm 1\%$, 1/4 W	
A10R2	0757-0768	R: fxd, met flm, 47.5 K ohms $\pm 1\%$, 1/4 W	
A10R3	0757-0774	R: fxd, met flm, 82.5 K ohms $\pm 1\%$, 1/4 W	
A10R4	0758-0017	R: fxd, met flm, 1500 ohms $\pm 5\%$, 1/2 W	
A10R5	0757-0757	R: fxd, met flm, 15 K ohms $\pm 1\%$, 1/4 W	
A10R6	0757-0759	R: fxd, met flm, 18.2 K ohms $\pm 1\%$, 1/4 W	
A10R7	0686-6225	R: fxd, comp, 6200 ohms $\pm 5\%$, 1/2 W	
A10R8	0757-0740	R: fxd, met flm, 2.21 K ohms $\pm 1\%$, 1/4 W	
A10R9	0687-1031	R: fxd, comp, 10 K ohms $\pm 10\%$, 1/2 W	
A10R10	0687-1041	R: fxd, comp, 100 K ohms $\pm 10\%$, 1/2 W	
A11	00203-66501	Board ass'y, decade module, includes: C1 thru C17 Q1 thru Q3 CR1 thru CR3 R1 thru R11 L1, L2 T1, T2	
A11C1, A11C2	0150-0096	C: fxd, cer, 0.05 μ fd $+80\%$ -20% , 100 vdcw	
A11C3	0150-0035	C: fxd, cer, 20 pf $\pm 10\%$, 600 vdcw	
A11C4, A11C5	0140-0198	C: fxd, dipped mica, 200 pf $\pm 5\%$, 300 vdcw	
A11C6, A11C7	0140-0156	C: fxd, dipped mica, 1500 pf $\pm 2\%$, 300 vdcw	
A11C8	0150-0093	C: fxd, 0.01 μ f $+80\%$ -20% , 100 vdcw	
A11C9	0140-0224	C: fxd, dipped mica, 280 pf $\pm 1\%$, 300 vdcw	
A11C10	0140-0151	C: fxd, dipped mica, 820 pf $\pm 2\%$, 300 vdcw	
A11C11	0160-0179	C: fxd, dipped mica, 33 pf $\pm 5\%$, 300 vdcw	
A11C12	0140-0192	C: fxd, dipped mica, 68 pf $\pm 5\%$, 300 vdcw	
A11C13	0140-0218	C: fxd, dipped mica, 160 pf $\pm 2\%$, 300 vdcw	
A11C14	0140-0152	C: fxd, mica, 1000 pf $\pm 5\%$, 300 vdcw	
A11C15	0140-0154	C: fxd, dipped mica, 1300 pf $\pm 5\%$, 500 vdcw	
A11C16	0150-0093	C: fxd, 0.01 μ f $+80\%$ -20% , 100 vdcw	
A11C17	0140-0195	C: fxd, dipped mica, 130 pf $\pm 5\%$, 300 vdcw	
A11CR1, A11CR2	1910-0016	Diode, germanium, 100 MA at +0.85 v, 60 v working	
A11CR3	1901-0040	Diode, silicon, 30 MA at +1 v, 30 PIV, 2 pf, 2 ns	
A11L1	00203-86001	Coil, var	
A11L2	00203-86002	Coil, var	
A11Q1 thru A11Q3	1854-0005	Transistor, EIA type 2N708, NPN silicon planar	
A11R1	0687-1021	R: fxd, comp, 1000 ohms $\pm 10\%$, 1/2 W	
A11R2 thru A11R4	0687-4721	R: fxd, comp, 4700 ohms $\pm 10\%$, 1/2 W	
A11R5, A11R6	0757-0761	R: fxd, met flm, 22.1 K ohms $\pm 1\%$, 1/4 W	
A11R7	0687-1031	R: fxd, comp, 10 K ohms $\pm 10\%$, 1/2 W	
A11R8	0687-4721	R: fxd, comp, 4700 ohms $\pm 10\%$, 1/2 W	
A11R9	0687-2221	R: fxd, comp, 2200 ohms $\pm 10\%$, 1/2 W	
A11R10	0687-1031	R: fxd, comp, 10 K ohms $\pm 10\%$, 1/2 W	
A11R11	0687-1051	R: fxd, comp, 1 M ohms $\pm 10\%$, 1/2 W	
A11T1	00203-84202	Transformer, tuned	
A11T2	00203-84201	Transformer, tuned	
A12 thru A16	00203-66501	All components same as A11	

See introduction to this section

Table 6-1. Index by Reference Designator (Cont'd)

Circuit Reference	Ⓢ Stock No.	Description	Note
A17, A18		Optional	
A19, A20		Not assigned	
A21	00203-66510	Board ass'y, rectifier, includes: C1, C2 R1 CR1 thru CR4	
A21C1	0130-0017	C: var, cer, 8 - 50 pf	
A21C2	0150-0010	C: fxd, cer, 47 pf ±5%, 500 vdcw	
A21CR1 thru A21CR4	1901-0026	Diode, silicon, rectifier, 200 PIV, 0.5 amp	
A21R1	0761-0022	R: fxd, met oxide flm, 620 ohms ±5%, 1 W	
A22	00203-66505	Board ass'y, power supply, includes: C1 thru C15 Q1 thru Q6 CR1 thru CR5 R1 thru R21	
A22C1		Not assigned	
A22C2*	0160-0127	C: fxd, cer, 1.0 μf ±20%, 25 vdcw	
A22C3	0180-0114	C: fxd, Al elect, 4 μf +100% -10%, 25 vdcw	
A22C4	0180-0039	C: fxd, elect, 100 μf, 12 vdcw	
A22C5	0180-0050	C: fxd, Al elect, 40 μf -15% +100%, 50 vdcw	
A22C6	0150-0096	C: fxd, cer, 0.05 μfd, +80% - 20%, 100 vdcw	
A22C7	0180-0224	C: fxd, Al elect, 10 μf -10% +75%, 15 vdcw	
A22C8	0180-0105	C: fxd, Al elect, 50 μf -10% +100%, 25 vdcw	
A22C9	0180-0094	C: fxd, Al elect, 100 μf -10% +100%, 25 vdcw	
A22C10	0150-0096	C: fxd, cer, 0.05 μfd +80% -20%, 100 vdcw	
A22C11	0160-0127	C: fxd, cer, 1.0 μf ±20%, 25 vdcw	
A22C12*	0150-0096	C: fxd, cer, 0.05 μfd +80% -20%, 100 vdcw	
A22C13	0180-0105	C: fxd, Al elect, 50 μf -10% +100%, 25 vdcw	
A22C14	0150-0096	C: fxd, cer, 0.05 μfd +80% -20%, 100 vdcw	
A22C15	0180-0094	C: fxd, Al elect, 100 μf -10% +100%, 25 vdcw	
A22CR1	1902-0761	Diode, breakdown, EIA type 1N821, 5.9 to 6.5 v,	
A22CR2, A22CR3	1901-0025	Diode, silicon, 50 MA at +1 v, 100 PIV, 12 pf	
A22CR4, A22CR5	1901-0049	Diode, silicon, rectifier, 50 PIV, 0.5 amp	
A22Q1	1854-0038	Transistor, EIA type 2N2270, NPN silicon	
A22Q2 thru A22Q4	1850-0040	Transistor, EIA type 2N383, PNP, germanium	
A22Q5	1854-0038	Transistor, EIA type 2N2270, NPN silicon	
A22Q6	1851-0017	Transistor, EIA type 2N1304, NPN germanium	
A22R1, A22R2	0687-4721	R: fxd, comp, 4700 ohms ±10%, 1/2 W	
A22R3	0699-0002	R: fxd, comp, 6.8 ohms ±10%, 1/2 W	
A22R4	0757-0732	R: fxd, met flm, 909 ohms ±1%, 1/4 W	
A22R5	0757-0736	R: fxd, met flm, 1.5 K ohms ±1%, 1/4 W	
A22R6	0687-2231	R: fxd, comp, 22 K ohms ±10%, 1/2 W	
A22R7	0687-2711	R: fxd, comp, 270 ohms ±10%, 1/2 W	
A22R8	0687-1821	R: fxd, comp, 1800 ohms ±10%, 1/2 W	
A22R9	0757-0734	R: fxd, met flm, 1.21 K ohms ±1%, 1/4 W	
A22R10	0687-1011	R: fxd, comp, 100 ohms ±10%, 1/2 W	
A22R11	0757-0724	R: fxd, met flm, 392 ohms ±1%, 1/4 W	
A22R12	2100-0281	R: var, lin, ww, 100 ohms ±20%, 1-1/2 W	
A22R13	0757-1033	R: fxd, met flm, 200 ohms ±0.5%, 1/4 W	

* Average value, shown, optimum value selected at factory

See introduction to this section

Table 6-1. Index by Reference Designator (Cont'd)

Circuit Reference	Stock No.	Description	Note
A22R14	0757-0730	R: fxd, met flm, 750 ohms $\pm 1\%$, 1/4 W	
A22R15	0687-3311	R: fxd, comp, 330 ohms $\pm 10\%$, 1/2 W	
A22R16	0687-1531	R: fxd, comp, 15 K ohms $\pm 10\%$, 1/2 W	
A22R17	0687-4721	R: fxd, comp, 4700 ohms $\pm 10\%$, 1/2 W	
A22R18	0687-1531	R: fxd, comp, 15 K ohms $\pm 10\%$, 1/2 W	
A22R19	0687-1011	R: fxd, comp, 100 ohms $\pm 10\%$, 1/2 W	
A22R20	2100-0281	R: var, lin, ww, 100 ohms $\pm 20\%$, 1-1/2 W	
A22R21	0757-0730	R: fxd, met flm, 750 ohms $\pm 1\%$, 1/4 W	
A23, A24		Not assigned	
A25	00203-64201	Phase shifter, includes: C1 thru C3	
A25C1	0130-0015	C: var, cer, 9-50 pf	
A25C2, A25C3	0150-0118	C: fxd, cer, 200 pf $\pm 10\%$, 500 vdcw	
C1, C2	0180-0056	C: fxd, elect, 1000 μf , 50 vdcw	
C3	0170-0022	C: fxd, mylar, 0.1 μf $\pm 20\%$, 600 vdcw	
C4A, B	0150-0119	C: fxd, cer, 2 x 0.1 μf $\pm 20\%$, 250 vdcw	
C5 thru C10		Not assigned	
C11	0121-0117	C: var, air, 12.5 to 86.9 pf	
C12	0140-0202	C: fxd, dipped mica, 15 pf $\pm 5\%$, 500 vdcw	
C13	0160-0905	C: fxd, cer, 33 pf $\pm 2\%$, 600 vdcw	
C14	0160-0835	C: fxd, mica, 300 pf $\pm 1\%$, 100 vdcw	
C15	0121-0007	C: var, air, 3.6 pf to 26 pf, single sect	
DS1	2140-0058	Lamp, incandescent, 10 v at 0.040 amps	
F1	2110-0047	Fuse, 1 amp	
J1	1251-0148	Connector, power, receptacle, 3 pin male recessed chassis mounting	
J2 thru J5	0340-0086	Insulator, BP Double, without locating key	
	0340-0090	Insulator, BP, with locating key	
	1510-0006	Binding post, black, without solder turret	
	1510-0007	Binding post, red, without solder turret	
L1	9140-0230	Coil, fxd, inductance, 290 μh $\pm 1\%$	
L2	9140-0231	Coil, adjustable, inductance, 10.8 to 18.7 μh	
L3, L4	9140-0115	Coil, fxd R. F., 22 μh $\pm 10\%$	
Q1, Q2	1850-0039	Transistor, 2N383, PNP, germanium	
Q3	1850-0095	Transistor type 2N297A power, PNP germanium	
R1	0761-0054	R: fxd, met flm, 330 ohms $\pm 5\%$, 1 W	
R2, R3	0768-0001	R: fxd, met, 1000 ohms $\pm 10\%$, 3 W	
R4, R5	0764-0063	R: fxd, met flm, 620 ohms $\pm 5\%$, 2 W	
R6	2100-0113	R: var, comp, dual tandem, 2 W	
R7, R8	0757-0728	R: fxd, met flm, 619 ohms $\pm 1\%$, 1/4 W	
R9	2100-0113	R: var, comp, dual tandem, 2 W	
R10, R11	0757-0728	R: fxd, met flm, 619 ohms $\pm 1\%$, 1/4 W	
R12	2100-0113	R: var, comp, dual tandem, 2 W	
R13, R14	0757-0728	R: fxd, met flm, 619 ohms $\pm 1\%$, 1/4 W	
R15	2100-0113	R: var, comp, dual tandem, 2 W	
R16, R17	0757-0728	R: fxd, met flm, 619 ohms $\pm 1\%$, 1/4 W	
S1A, B, C	3100-0841	Switch, multiplier	
S1C1, S1C2	0160-0170	C: fxd, cer, 0.22 μf $+80\%$ -20% , 25 vdcw	
S2	3101-0107	Switch, pushbutton, lighted, SPDT	
S3	3101-0033	Switch, slide, DPDT, non-shorting, 0.5 amp, 125 VDC, 3 amp, 125 VAC	

See introduction to this section

Table 6-1. Index by Reference Designator (Cont'd)

Circuit Reference	Stock No.	Description	Note
T1	9100-0293	Transformer, power	
W1	8120-0078	Cable ass'y, power, smooth, black, extra limp, SVT-18/3, 7.5 ft lg	
<u>MISCELLANEOUS</u>			
	61B-40D-4 120A-47A	Plate, freq. dial Spacer, binding post	
	0340-0090	Insulator, BP, with locating key	
	0370-0025	Knob, amplitude and frequency vernier	
	0370-0112	Knob, skirted bar, black, for 1/4" diam shaft (multiplier)	
	0370-0160	Knob (frequency dial)	
	1200-0043	Insulator, transistor, mtg, anodized Al plate (Q1, Q2, Q3)	
	1200-0081	Insulator, bushing, nylon (Q1, Q2, Q3)	
	1251-0135	Connector, printed circuit, 15 tuning fork type contacts, terminal type B	
	1251-0148	Connector, power, receptacle, 3 pin male recessed chassis mounting	
	1251-0452	Connector, printed circuit, 6 tuning fork type contacts, terminal type D	
	1251-0475	Connector, printed circuit, 6 tuning fork type contacts, terminal type B	
	1400-0110	Body, fuseholder, use 1400-0111 nut and 1400-0112 grey knob or 1400-0210 black knob	
	1400-0111	Nut, retaining, for 1400-0110 fuseholder body	
	1400-0210	Knob, fuseholder, black, for 1400-0110 fuseholder body	
	1410-0052	Bushing, potentiometer, 0.435" OD x 0.438" lg	
	1490-0030	Stand, tilt, stainless steel rod 0.188" diam	
	1500-0002	Yoke, coupler, for 1/4" shaft, p/o flexible coupler, keyed and staked	
	1500-0004	Coupler, insulator, 1/2" diam x 7/32" lg, nylon	
	1500-0005	Coupler, hub, fits 1/4" diam shaft, nickel plated	
	1510-0006	Binding Post, black, without solder turret	
	1510-0007	Binding Post, red, without solder turret	
	1520-0001	Plate, mounting, bakelite, oval shape (C1, C2)	
	5000-0051	Plate, fluted Al	
	5000-0637	Spring, thrust	
	5000-0732	Rear side cover, 5 x 11 FM	
	5000-0733	Front side cover, 5 x 11 FM	
	5020-0233	Collar	
	5020-0241	Support, long res bd	
	5020-0345	Shaft	
	5020-0630	Hub, dial	
	5020-0639	Bearing, cap drive	
	5020-0641	Shaft, spur gear	
	5040-0212	Insulator, flex coupling	
	5040-0607	Disc ass'y, vernier drive	
	5040-0619	Indicator, freq dial	
	5060-0020	Gear, ass'y	
	5060-0021	Gear, ass'y	

See introduction to this section

Table 6-1. Index by Reference Designator (Cont'd)

Circuit Reference	Ⓢ Stock No.	Description	Note
		<u>MISCELLANEOUS (cont'd)</u>	
	5060-0625	Ass'y, connector	
	5060-0731	Frame ass'y, 5 x 11 FM	
	5060-0739	Top cover ass'y, 11L FM	
	5060-0751	Bottom cover ass'y, 11L FM	
	5060-0763	Handle ass'y, side	
	5060-0766	Retainer, 5H handle	
	5060-0767	Foot ass'y, FM	
	8120-0078	Cable ass'y, power, smooth, black, extra limp, SVT-18/3, 7.5 ft lg	
	9211-0248	Carton, corrugated, 20-1/8" lg x 16-3/4" wd x 10-1/2" deep x 350 lb test	
	9223-0040	Foam, poly, 10-3/4" lg x 4" wd	
	00203-00101	Chassis, main	
	00203-00201	Panel, front	
	00203-00202	Panel, rear	

Table 6-2. Replaceable Parts

Stock No.	Description	Mfr.	Mfr. Part No.	TQ		
61B-40D-4	Plate, freq dial	28480	61B-40D-4	1		
120A-47A	Spacer, binding post	28480	120A-47A	1		
0121-0007	C: var, air, 3.6 pf to 26 pf, single sect	80486	CT2-0-25L	1		
0121-0117	C: var, air, 12.5 to 86.9 pf	77630	882758	1		
0130-0015	C: var, cer, 9-50 pf	72982	3192-000-U2PO-47R	1		
0130-0017	C: var, cer, 8-50 pf	72982	557-019-U2PO-34R	1		
0131-0003	C: var, mica, single sect, 170 - 180 pf, 175 vdcw	72136	T52910	1		
0140-0041	C: fxd, molded mica, 100 pf $\pm 5\%$, 500 vdcw	04062	RCM15E101J			
0140-0151	C: fxd, dipped mica, 820 pf $\pm 2\%$, 300 vdcw	14655	obd#	8		
0140-0152	C: fxd, mica, 1000 pf $\pm 5\%$, 300 vdcw	04062	DM16F102J	10		
0140-0153	C: fxd, mica, 1269 pf $\pm 1\%$, 300 vdcw	14655	CD20F1269F	1		
0140-0154	C: fxd, dipped mica, 1300 pf $\pm 5\%$, 500 vdcw	14655	obd#	3		
0140-0156	C: fxd, dipped mica, 1500 pf $\pm 2\%$, 300 vdcw	00853	obd#	2		
0140-0157	C: fxd, dipped mica, 1857 pf $\pm 1\%$, 500 vdcw	14655	obd#	1		
0140-0158	C: fxd, dipped mica, 2676 pf $\pm 1\%$, 500 vdcw	14655	obd#	1		
0140-0161	C: fxd, dipped mica, 3932 pf $\pm 1\%$, 300 vdcw	14655	obd#	2		
0140-0170	C: fxd, dipped mica, 5600 pf $\pm 5\%$, 300 vdcw	00853	obd#	1		
0140-0176	C: fxd, dipped mica, 100 pf $\pm 2\%$, 300 vdcw	00853	obd#	2		
0140-0178	C: fxd, dipped mica, 560 pf $\pm 2\%$, 300 vdcw	00853	obd#	2		
0140-0192	C: fxd, dipped mica, 68 pf $\pm 5\%$, 300 vdcw	00853	obd#	1		
0140-0195	C: fxd, dipped mica, 130 pf $\pm 5\%$, 300 vdcw	00853	obd#	11		
0140-0198	C: fxd, dipped mica, 200 pf $\pm 5\%$, 300 vdcw	00853	obd#	2		
0140-0201	C: fxd, dipped mica, 12 pf $\pm 5\%$, 500 vdcw	00853	obd#	1		
0140-0202	C: fxd, dipped mica, 15 pf $\pm 5\%$, 500 vdcw	00853	obd#	1		
0140-0204	C: fxd, dipped mica, 47 pf $\pm 5\%$, 500 vdcw	00853	obd#	1		
0140-0206	C: fxd, dipped mica, 270 pf $\pm 5\%$, 500 vdcw	00853	obd#	1		
0140-0207	C: fxd, dipped mica, 330 pf $\pm 5\%$, 500 vdcw	00853	obd#	1		
0140-0208	C: fxd, dipped mica, 680 pf $\pm 5\%$, 300 vdcw	00853	obd#	1		
0140-0217	C: fxd, dipped mica, 140 pf $\pm 2\%$, 300 vdcw	14655	obd#	2		
0140-0218	C: fxd, dipped mica, 160 pf $\pm 2\%$, 300 vdcw	00853	obd#	1		
0140-0220	C: fxd, dipped mica, 200 pf $\pm 1\%$, 300 vdcw	00853	obd#	1		
0140-0224	C: fxd, dipped mica, 280 pf $\pm 1\%$, 300 vdcw	00853	obd#	1		
0140-0225	C: fxd, dipped mica, 300 pf $\pm 1\%$, 300 vdcw	14655	obd#	2		
0150-0010	C: fxd, cer, 47 pf $\pm 5\%$, 500 vdcw	04222	SI 47 pf $\pm 5\%$ NPO	1		
0150-0012	C: fxd, cer, 0.01 μ f $\pm 20\%$, 1000 vdcw	71590	13 C Disc	9		
0150-0015	C: fxd, TiO ₂ , 2.2 pf $\pm 10\%$, 500 vdcw	82142	type JM	1		
0150-0035	C: fxd, cer, 20 pf $\pm 10\%$, 600 vdcw	71590	Type DD 200	1		
0150-0047	C: fxd, TiO ₂ , 6.8 pf $\pm 10\%$, 500 vdcw	82142	type JM obd#	1		
0150-0069	C: fxd, cer, 0.001 μ f $+100\%$ -20%, 500 vdcw	72982	#801-010x5G0102Z	1		
0150-0071	C: fxd, cer, 400 pf $\pm 5\%$, 500 vdcw	56289	19C formulation 28	3		
0150-0093	C: fxd, 0.01 μ f $+80\%$ -20%, 100 vdcw	91418	TA obd#	4		
0150-0096*	C: fxd, cer, 0.05 μ fd $+80\%$ -20%, 100 vdcw	94145	type TA	36		
0150-0115	C: fxd, cer, 27 pf $\pm 10\%$, 500 vdcw	72982	301-000-U2JO-270K	1		
0150-0118	C: fxd, cer, 200 pf $\pm 10\%$, 500 vdcw	72982	Type CC25	4		
0150-0119	C: fxd, cer, 2 x 0.1 μ f $\pm 20\%$, 250 vdcw	71590	DA17004CD	1		
0160-0127*	C: fxd, cer, 1.0 μ f $\pm 20\%$, 25 vdcw	56289	5C13	4		
0160-0147	C: fxd, dipped mica, 2500 pf $\pm 2\%$, 300 vdcw	00853	obd#	1		
0160-0170	C: fxd, cer, 0.22 μ f $+80\%$ -20%, 25 vdcw	56289	5C9A	2		
0160-0174	C: fxd, cer, 0.47 μ f $+80\%$ -20%, 25 vdcw	56289	5C11A	8		

* Average value shown, optimum value selected at factory
See introduction to this section

Table 6-2. Replaceable Parts (Cont'd)

Stock No.	Description	Mfr.	Mfr. Part No.	TQ		
0160-0179	C: fxd, dipped mica, 33 pf $\pm 5\%$, 300 vdcw	00853	obd#	1		
0160-0182	C: fxd, dipped mica, 47 pf $\pm 5\%$, 300 vdcw	00853	obd#	1		
0160-0835	C: fxd, mica, 300 pf $\pm 1\%$, 100 vdcw	14655	CDT 15	1		
0160-0836	C: fxd, mica, 1500 pf $\pm 2\%$, 100 vdcw	14655	CDT-20	1		
0160-0837	C: fxd, mica, 5000 pf $\pm 5\%$, 100 vdcw	14655	CDT-20	1		
0160-0905	C: fxd, cer, 33 pf $\pm 2\%$, 600 vdcw	71590	CC20 33 pf $\pm 2\%$ N750	1		
0170-0022	C: fxd, mylar, 0.1 μ f $\pm 20\%$, 600 vdcw	56289	148P175A	1		
0180-0039	C: fxd, elect, 100 μ f, 12 vdcw	56289	D32697	1		
0180-0050	C: fxd, Al elect, 40 μ f -15% +100%, 50 vdcw	56289	D32538	2		
0180-0056	C: fxd, elect, 1000 μ f, 50 vdcw	56289	D32429	2		
0180-0059	C: fxd, elect, 10 μ f -10% +100%, 25 vdcw	56289	30D106G025BB4	1		
0180-0094	C: fxd, Al elect, 100 μ f -10% +100%, 25 vdcw	56289	30D107G025DH4	2		
0180-0105	C: fxd, Al elect, 50 μ f -10% +100%, 25 vdcw	56289	D34114	2		
0180-0114	C: fxd, Al elect, 4 μ f +100% -10%, 25 vdcw	56289	30D405G025BA4	1		
0180-0224	C: fxd, Al elect, 10 μ f -10% +75%, 15 vdcw	56289	30D106G015BA4	1		
0340-0086	Insulator, BP Double, without locating key	28480	5040-0622	4		
0340-0090	Insulator, BP, with locating key	28480	5040-06	8		
0370-0025	Knob, amplitude and frequency vernier	28480	5040-0058	5		
0370-0112	Knob, skirted bar, black, for 1/4" diam shaft (multiplier)	28480	0370-0112	1		
0370-0160	Knob (frequency multiplier)	28480	0370-0160	1		
0410-0009	Crystal unit, quartz, 5 mc, 2 pins on bottom	0000Y	obd#	1		
0683-4715	R: fxd, comp, 470 ohms, $\pm 5\%$, 1/4 W	01121	CB4715	1		
0686-6225	R: fxd, comp, 6200 ohms $\pm 5\%$, 1/2 W	01121	EB-6225	1		
0687-1011	R: fxd, comp, 100 ohms $\pm 10\%$, 1/2 W	01121	#EB1011	4		
0687-1021	R: fxd, comp, 1000 ohms $\pm 10\%$, 1/2 W	01121	#EB1021	8		
0687-1031	R: fxd, comp, 10 K ohms $\pm 10\%$, 1/2 W	01121	#EB1031	23		
0687-1041	R: fxd, comp, 100 K ohms $\pm 10\%$, 1/2 W	01121	#EB1041	1		
0687-1051	R: fxd, comp, 1 M ohms $\pm 10\%$, 1/2 W	01121	#EB1051	1		
0687-1061	R: fxd, comp, 10 M ohms $\pm 10\%$, 1/2 W	01121	#EB1061	1		
0687-1231	R: fxd, comp, 12 K ohms $\pm 10\%$, 1/2 W	01121	#EB1231	1		
0687-1521	R: fxd, comp, 1500 ohms $\pm 10\%$, 1/2 W	01121	#EB1521	6		
0687-1531	R: fxd, comp, 15 K ohms $\pm 10\%$, 1/2 W	01121	#EB1531	3		
0687-1821	R: fxd, comp, 1800 ohms $\pm 10\%$, 1/2 W	01121	#EB1821	1		
0687-2221	R: fxd, comp, 2200 ohms $\pm 10\%$, 1/2 W	01121	#EB2221	1		
0687-2231	R: fxd, comp, 22 K ohms $\pm 10\%$, 1/2 W	01121	#EB2231	1		
0687-2711	R: fxd, comp, 270 ohms $\pm 10\%$, 1/2 W	01121	#EB2711	1		
0687-2721	R: fxd, comp, 2700 ohms $\pm 10\%$, 1/2 W	01121	#EB2721	1		
0687-3311	R: fxd, comp, 330 ohms $\pm 10\%$, 1/2 W	01121	#EB3311	1		
0687-3921	R: fxd, comp, 3900 ohms $\pm 10\%$, 1/2 W	01121	#EB3921	1		
0687-4701	R: fxd, comp, 47 ohms $\pm 10\%$, 1/2 W	01121	#EB4701	1		
0687-4711	R: fxd, comp, 470 ohms $\pm 10\%$, 1/2 W	01121	#EB4711	6		
0687-4721	R: fxd, comp, 4700 ohms $\pm 10\%$, 1/2 W	01121	#EB4721	30		
0687-4731	R: fxd, comp, 47 K ohms $\pm 10\%$, 1/2 W	01121	#EB4731	4		
0687-5621	R: fxd, comp, 5600 ohms $\pm 10\%$, 1/2 W	01121	#EB5621	1		
0687-6811	R: fxd, comp, 680 ohms $\pm 10\%$, 1/2 W	01121	EB6811	2		
0687-8211	R: fxd, comp, 820 ohms $\pm 10\%$, 1/2 W	01121	#EB8211	2		
0687-8221	R: fxd, comp, 8200 ohms $\pm 10\%$, 1/2 W	01121	#EB8221	1		
0699-0001	R: fxd, comp, 2.7 ohms $\pm 10\%$, 1/2 W	01121	EB-27G1	1		
0699-0002	R: fxd, comp, 6.8 ohms $\pm 10\%$, 1/2 W	01121	EB 68G1	1		
0757-0339	R: fxd, met flm, 3.01 K ohms $\pm 1\%$, 1/4 W	19701	MF 6C T-O obd#	8		
0757-0715	R: fxd, met flm, 150 ohms $\pm 1\%$, 1/4 W	75042	CEB T-O obd#	2		

See introduction to this section

Table 6-2. Replaceable Parts (Cont'd)

Stock No.	Description	Mfr.	Mfr. Part No.	TQ
0757-0724	R: fxd, met flm, 392 ohms $\pm 1\%$, 1/4 W	75042	CEB T-O obd#	1
0757-0728	R: fxd, met flm, 619 ohms $\pm 1\%$, 1/4 W	75042	CEB T-O obd#	9
0757-0730	R: fxd, met flm, 750 ohms $\pm 1\%$, 1/4 W	75042	CEB T-O obd#	2
0757-0732	R: fxd, met flm, 909 ohms $\pm 1\%$, 1/4 W	75042	CEB T-O obd#	1
0757-0734	R: fxd, met flm, 1.21 K ohms $\pm 1\%$, 1/4 W	75042	CEB T-O obd#	2
0757-0736	R: fxd, met flm, 1.5 K ohms $\pm 1\%$, 1/4 W	75042	CEB T-O obd#	3
0757-0737	R: fxd, met flm, 1.62 K ohms $\pm 1\%$, 1/4 W	75042	CEB T-O obd#	1
0757-0738	R: fxd, met flm, 1.82 K ohms $\pm 1\%$, 1/4 W	75042	CEB T-O obd#	1
0757-0740	R: fxd, met flm, 2.21 K ohms $\pm 1\%$, 1/4 W	75042	CEB T-O obd#	2
0757-0741	R: fxd, met flm, 2.43 K ohms $\pm 1\%$, 1/4 W	75042	CEB T-O obd#	1
0757-0743	R: fxd, met flm, 3.32 K ohms $\pm 1\%$, 1/4 W	75042	CEB T-O obd#	2
0757-0744	R: fxd, met flm, 3.92 K ohms $\pm 1\%$, 1/4 W	75042	CEB T-O obd#	2
0757-0745	R: fxd, met flm, 4.32 K ohms $\pm 1\%$, 1/4 W	75042	CEB T-O obd#	2
0757-0755	R: fxd, met flm, 12.1 K ohms $\pm 1\%$, 1/4 W	75042	CEB T-O obd#	1
0757-0757	R: fxd, met flm, 15 K ohms $\pm 1\%$, 1/4 W	75042	CEB T-O obd#	1
0757-0759	R: fxd, met flm, 18.2 K ohms $\pm 1\%$, 1/4 W	75042	CEB T-O obd#	1
0757-0761	R: fxd, met flm, 22.1 K ohms $\pm 1\%$, 1/4 W	75042	CEB T-O obd#	4
0757-0762	R: fxd, met flm, 24.3 K ohms $\pm 1\%$, 1/4 W	75042	CEB T-O obd#	5
0757-0766	R: fxd, met flm, 39.2 K ohms $\pm 1\%$, 1/4 W	75042	CEB T-O obd#	1
0757-0768	R: fxd, met flm, 47.5 K ohms $\pm 1\%$, 1/4 W	75042	CEB T-O obd#	2
0757-0771	R: fxd, met flm, 61.9 K ohms $\pm 1\%$, 1/4 W	75042	CEB T-O obd#	1
0757-0772	R: fxd, met flm, 68.1 K ohms $\pm 1\%$, 1/4 W	75042	CEB T-O obd#	1
0757-0774	R: fxd, met flm, 82.5 K ohms $\pm 1\%$, 1/4 W	75042	CEB T-O obd#	1
0757-0777	R: fxd, met flm, 121 K ohms $\pm 1\%$, 1/4 W	75042	CEB T-O obd#	1
0757-1027	R: fxd, met flm, 680 ohms $\pm 1\%$, 1/4 W	75042	CEB obd#	1
0757-1032	R: fxd, met flm, 100 ohms $\pm 0.5\%$, 1/4 W	75042	CEB T-O obd#	1
0757-1033	R: fxd, met flm, 200 ohms $\pm 0.5\%$, 1/4 W	75042	CEB T-O obd#	1
0757-1040	R: fxd, met flm, 50 ohms $\pm 1\%$, 1/4 W	75042	CEB T-O obd#	4
0757-1050	R: fxd, met flm, 150 ohms $\pm 1\%$, 1/2 W	19701	MF7C T-2	1
0758-0017	R: fxd, met flm, 1500 ohms $\pm 5\%$, 1/2 W	07115	C20	1
0758-0041	R: fxd, met flm, 91 ohms $\pm 5\%$, 1/2 W	07115	C20	1
0761-0022	R: fxd, met flm, 620 ohms $\pm 5\%$, 1 W	07115	C32	1
0761-0054	R: fxd, met flm, 330 ohms $\pm 5\%$, 1 W	07115	C32	1
0764-0063	R: fxd, met flm, 620 ohms $\pm 5\%$, 2 W	28480	0764-0063	2
0768-0001	R: fxd, met, 1000 ohms $\pm 10\%$, 3 W	76055	3MOL	2
1200-0043	Insulator, transistor, mtg, anodized Al plate (Q1, Q2, Q3)	28480	1200-0043	3
1200-0081	Insulator, bushing, nylon (Q1, Q2, Q3)	26365	974 Special	6
1205-0033	Heat dissipater, semiconductor (A6Q5)	28480	1205-0033	1
1251-0135	Connector, printed circuit, 15 tuning fork type contacts, terminal type B	000XX	SD 615 UR	5
1251-0148	Connector, power, receptacle, 3 pin male recessed chassis mounting	82389	AC3G	2
1251-0452	Connector, printed circuit, 6 tuning fork type contacts, terminal type D	02660	143-006-09(109)	1
1251-0475	Connector, printed circuit, 6 tuning fork type contacts, terminal type B	02660	143-006-08(109)	13
1400-0110	Body, fuseholder, use 1400-0111 nut and 1400-0112 grey knob or 1400-0210 black knob	71400	obd#	1
1400-0111	Nut, retaining, for 1400-0110 fuseholder body	71400	obd#	1
1400-0210	Knob, fuseholder, black, for 1400-0110 fuseholder body	71400	obd#	1
1410-0052	Bushing, potentiometer, 0.435" OD x 0.438" lg	28480	1410-0052	1

See introduction to this section

Table 6-1. Replaceable Parts (Cont'd)

Stock No.	Description	Mfr.	Mfr. Part No.	TQ		
1490-0030	Stand, tilt, stainless steel rod 0.188" diam	91260	obd#	1		
1500-0002	Yoke, coupler, for 1/4" shaft, p/o flexible coupler, keyed and staked	76487	obd#	2		
1500-0004	Coupler, insulator, 1/2" diam x 7/32" lg, nylon	99934	obd#	1		
1500-0005	Coupler, hub, fits 1/4" diam shaft, nickel plated	99934	obd#	2		
1510-0006	Binding Post, black, without solder turret	28480	1510-0006	8		
1510-0007	Binding Post, red, without solder turret	28480	1510-0007	8		
1520-0001	Plate, mounting, bakelite, oval shape (C1, C2)	56137	Grade XP	2		
1850-0037	Transistor, EIA type 2N274 drift, germanium PNP alloy	86684	obd#	7		
1850-0038	Transistor, 2N301, PNP germanium	28480	1850-0040	2		
1850-0040	Transistor, EIA type 2N3831, PNP germanium	04713	SA 591	5		
1850-0095	Transistor type 2N297A power, PNP germanium	16758	2N297A	1		
1851-0017	Transistor, EIA type 2N1304, NPN germanium	01295	2N1304	1		
1853-0008	Transistor, EIA type 2N3250, PNP silicon	04713	2N3250	2		
1854-0005	Transistor, EIA type 2N708, NPN silicon planar	86684	2N708	26		
1854-0014	Transistor, silicon, dual NPN silicon, special	00872	SA2015	1		
1854-0033	Transistor, EIA type 2N2925, NPN silicon	24446	obd#	15		
1854-0038	Transistor, EIA type 2N2270, NPN silicon	86684	2N2270	7		
1901-0025	Diode, silicon, 50 MA at +1 v, 100 PIV, 12 pf	03877	SG-817	3		
1901-0026	Diode, silicon, rectifier, 200 PIV, 0.5 amp	14099	SA783	4		
1901-0040	Diode, silicon, 30 MA at +1 v, 30 PIV, 2 pf, 2 ns	03877	SG5050	5		
1901-0049	Diode, silicon, rectifier, 50 PIV, 0.5 amp	86684	34934	2		
1902-0761	Diode, breakdown, EIA type 1N821, 5.9 to 6.5 v, 0.01%/°C	03877	1N821	1		
1910-0016	Diode, germanium, 100 MA at +0.85 v, 60 v working	11711	GD 150	2		
2100-0094	R: var, lin, comp, 50 K ohms, 30%, 1/5 W	28480	2100-0094	1		
2100-0113	R: var, comp, 2 W, dual tendem	01121	JJ59160	4		
2100-0206	R: var, lin, ww, 50 ohms ±10%, 1 W	11236	Series 110	1		
2100-0281	R: var, lin, ww, 100 ohms ±20%, 1-1/2 W	11236	Series 110	2		
2100-0282	R: var, lin, ww, 2000 ohms ±20%, 1-1/2 W	11236	Series 110	3		
2100-0908	R: var, comp, lin, 2 K ±30%, 1/4 W	76055	MTC-1 obd#	2		
2100-0909	R: var, comp, lin, 100 ohms ±30%, 1/4 W	76055	MTC-1 obd#	2		
2110-0047	Fuse, 1 amp	71400	GMW-1	1		
2140-0058	Lamp, incandescent, 10 v at 0.040 amps	94154	367	1		
3100-0841	Switch, Multiplier	76854	obd#	1		
3101-0033	Switch, slide, DPDT, non-shorting, 0.5 amp 125 VDC, 3 amp 125 VAC	79727	G-326; 6510	1		
3101-0107	Switch, pushbutton, lighted, SPDT	80207	T9-129	1		
5000-0051	Plate, fluted Al	28480	5000-0051	2		
5000-0637	Spring, thrust	28480	5000-0637	1		
5000-0732	Rear side cover, 5 x 11 FM	28480	5000-0732	2		
5000-0733	Front side cover, 5 x 11 FM	28480	5000-0733	2		
5020-0233	Collar	28480	5020-0233	2		
5020-0241	Support, long res bd	28480	5020-0241	2		
5020-0344	Shaft	28480	5020-0344	1		
5020-0630	Hub, dial	28480	5020-0630	1		

See introduction to this section

Table 6-2. Replaceable Parts (Cont'd)

Stock No.	Description	Mfr.	Mfr. Part No.	TQ		
5020-0639	Bearing, cap drive	28480	5020-0639	1		
5020-0641	Shaft, spur gear	28480	5020-0641	1		
5040-0212	Insulator, flex coupling	28480	5040-0212	1		
5040-0607	Disc ass'y, vernier drive	28480	5040-0607	1		
5040-0619	Indicator, freq dial	28480	5040-0619	1		
5060-0020	Gear, ass'y	28480	5060-0020	1		
5060-0021	Gear, ass'y	28480	5060-0021	1		
5060-0625	Ass'y, connector	28480	5060-0625	1		
5060-0731	Frame ass'y, 5 x 11 FM	28480	5060-0731	2		
5060-0739	Top cover ass'y, 11L FM	28480	5060-0739	1		
5060-0751	Bottom cover ass'y, 11L FM	28480	5060-0751	1		
5060-0763	Handle ass'y, side	28480	5060-0763	2		
5060-0766	Retainer, 5H handle	28480	5060-0766	2		
5060-0767	Foot ass'y, FM	28480	5060-0767	5		
8120-0078	Cable ass'y, power, smooth, black, extra limp, SVT-18/3, 7.5 ft lg	70903	KH-4147	2		
9100-0293	Transformer, power	28480	5080-3423	1		
9140-0029	Coil, R. F., choke, universal wound, unshielded, 100 μ h, 2.6 ohms	28480	9140-0029	1		
9140-0031	Coil, R. F., 75 μ h	28480	9140-0031	1		
9140-0037	Coil, radio freq 5 mh induct, universal wound	99848	35000-15-502	5		
9140-0041	Coil, R. F., 2.5 mh \pm 10%	95265	SA-2500-I	1		
9140-0115	Coil, fxd R. F., 22 μ h \pm 10%	76493	9330-32	2		
9140-0137	Coil, fxd R. F., 1000 μ h \pm 5%, dc current rating 135 ma	76493	9220-28	4		
9140-0230	Coil, fxd, inductance, 290 μ h \pm 1%	28480	9140-0230	1		
9140-0231	Coil, adjustable, inductance, 10.8 to 18.7 μ h	28480	9140-0231	1		
9211-0248	Carton, corrugated, 20-1/8" lg x 16-3/4" wd x 10-1/2" deep x 350 lb test	84324	obd#	1		
9223-0040	Foam, poly, 10-3/4" lg x 4" wd	28480	9223-0040	4		
00203-00101	Chassis, main	28480	00203-00101	1		
00203-00201	Panel, front	28480	00203-00201	1		
00203-00202	Panel, rear	28480	00203-00202	1		
00203-64201	Phase shifter	28480	00203-64201	1		
00203-66501	Board ass'y, decade module	28480	00203-66501	1		
00203-66502	Board ass'y, square wave	28480	00203-66502	1		
00203-66503	Board ass'y, 5 mcps	28480	00203-66503	1		
00203-66504	Board ass'y, dc amplifier	28480	00203-66504	1		
00203-66505	Board ass'y, power supply	28480	00203-66505	1		
00203-66506	Board ass'y, R. F. Amplifier	28480	00203-66506	1		
00203-66507	Board, ass'y, modulator	28480	00203-66507	1		
00203-66508	Board ass'y, V. F. O.	28480	00203-66508	1		
00203-66510	Board ass'y, rectifier	28480	00203-66510	1		
00203-66511	Board ass'y, filter	28480	00203-66511	1		
00203-84201	Transformer, tuned	28480	00203-84201	1		
00203-84202	Transformer, tuned	28480	00203-84202	1		
00203-84203	Transformer, tuned	28480	00203-84203	1		
00203-84204	Transformer, tuned	28480	00203-84204	1		
00203-84205	Transformer, tuned	28480	00203-84205	1		
00203-84206	Transformer, tuned	28480	00203-84206	1		
00203-86001	Coil, var, 2.5 - 6.2 μ h	28480	00203-86001	1		
00203-86002	Coil, var, 650 - 1100 μ h	28480	00203-86002	1		

See introduction to this section

Table 6-2. Replaceable Parts (Cont'd)

④ Stock No.	Description	Mfr.	Mfr. Part No.	TQ		
00203-86003	Coil, var, 35 - 80 μ h	28480	00203-86003	1		
00203-86004	Transformer, driver	28480	00203-86004	2		
00203-86005	Transformer, driver	28480	00203-86005	2		
00203-86006	Coil, fxd, 4.5 mh	28480	00203-86006	3		
00203-86009	Coil, var, 650 - 1100 μ h	28480	00203-86009	1		
00203-86010	Coil, var, 35 - 80 μ h	28480	00203-86010	1		

See introduction to this section

APPENDIX

CODE LIST OF MANUFACTURERS (Sheet 1 of 2)

The following code numbers are from the Federal Supply Code for Manufacturers Cataloging Handbooks H4-1 (Name to Code) and H4-2 (Code to Name) and their latest supplements. The date of revision and the date of the supplements used appear at the bottom of each page. Alphabetical codes have been arbitrarily assigned to suppliers not appearing in the H4 handbooks.

CODE NO.	MANUFACTURER	ADDRESS	CODE NO.	MANUFACTURER	ADDRESS	CODE NO.	MANUFACTURER	ADDRESS
00334	Humidial Co.	Colton, Calif.	07115	Corning Glass Works Electronic Components Dept.	Bradford, Pa.	40920	Miniature Precision Bearings, Inc.	Keene, N.H.
00335	Westrex Corp.	New York, N.Y.	07126	Digitran Co.	Pasadena, Calif.	42190	Muter Co.	Chicago, Ill.
00373	Garlock Packing Co., Electronic Products Div.	Camden, N.J.	07137	Transistor Electronics Corp.	Minneapolis, Minn.	43990	C. A. Norgren Co.	Englewood, Colo.
00656	Aerovox Corp.	New Bedford, Mass.	07138	Westinghouse Electric Corp. Electronic Tube Div.	Elmira, N.Y.	44655	Ohmite Mfg. Co.	Skokie, Ill.
00779	Amp, Inc.	Harrisburg, Pa.	07261	Avnet Corp.	Los Angeles, Calif.	47904	Polaroid Corp.	Cambridge, Mass.
00781	Aircraft Radio Corp.	Boonton, N.J.	07263	Fairchild Semiconductor Corp.	Mountain View, Calif.	48620	Precision Thermometer and Inst. Co.	Philadelphia, Pa.
00815	Northern Engineering Laboratories, Inc.	Burlington, Wis.	07910	Continental Device Corp.	Hawthorne, Calif.	49956	Raytheon Company	Lexington, Mass.
00853	Sangamo Electric Company, Ordill Division (Capacitors)	Marion, Ill.	07933	Rheem Semiconductor Corp.	Mountain View, Calif.	54294	Shallcross Mfg. Co.	Selma, N.C.
00866	Goe Engineering Co.	Los Angeles, Calif.	07966	Shockley Semi-Conductor Laboratories	Palo Alto, Calif.	55026	Simpson Electric Co.	Chicago, Ill.
00891	Carl E. Holmes Corp.	Los Angeles, Calif.	07980	Boonton Radio Corp.	Boonton, N.J.	55933	Sonotone Corp.	Elmsford, N.Y.
01121	Allen Bradley Co.	Milwaukee, Wis.	08145	U.S. Engineering Co.	Los Angeles, Calif.	55938	Sorenson & Co., Inc.	So. Norwalk, Conn.
01255	Litton Industries, Inc.	Beverly Hills, Calif.	08358	Burgess Battery Co.	Niagara Falls, Ontario, Canada	56137	Spaulding Fibre Co., Inc.	Tonawanda, N.Y.
01281	Pacific Semiconductors, Inc.	Culver City, Calif.	08717	Sloan Company	Burbank, Calif.	56289	Sprague Electric Co.	North Adams, Mass.
01295	Texas Instruments, Inc. Transistor Products Div.	Dallas, Texas	08718	Cannon Electric Co. Phoenix Div.	Phoenix, Ariz.	59446	Telex, Inc.	St. Paul, Minn.
01349	The Alliance Mfg. Co.	Alliance, Ohio	08792	CBS Electronics Semiconductor Operations, Div. of C.B.S. Inc.	Lowell, Mass.	61775	Union Switch and Signal, Div. of Westinghouse Air Brake Co.	Swissvale, Pa.
01561	Chassi-Trak Corp.	Indianapolis, Ind.	08994	Mel-Rain	Indianapolis, Ind.	62119	Universal Electric Co.	Owosso, Mich.
01589	Pacific Relays, Inc.	Van Nuys, Calif.	09026	Babcock Relays, Inc.	Costa Mesa, Calif.	64959	Western Electric Co., Inc.	New York, N.Y.
01930	Amerock Corp.	Rockford, Ill.	09134	Texas Capacitor Co.	Houston, Texas	65092	Weston Inst. Div. of Daystrom, Inc.	Newark, N.J.
01961	Pulse Engineering Co.	Santa Clara, Calif.	09250	Electro Assemblies, Inc.	Chicago, Ill.	66295	Wittek Manufacturing Co.	Chicago 23, Ill.
02114	Ferroxcube Corp. of America	Saugerties, N.Y.	09569	Mallory Battery Co. of Canada, Ltd.	Toronto, Ontario, Canada	66346	Wollensak Optical Co.	Rochester, N.Y.
02286	Cole Mfg. Co.	Palo Alto, Calif.	10214	General Transistor Western Corp.	Los Angeles, Calif.	70276	Allen Mfg. Co.	Hartford, Conn.
02660	Amphenol-Borg Electronics Corp.	Chicago, Ill.	10411	Ti-Tal, Inc.	Berkeley, Calif.	70309	Allied Control Co., Inc.	New York, N.Y.
02735	Radio Corp. of America Semiconductor and Materials Div.	Somerville, N.J.	10646	Carborundum Co.	Niagara Falls, N.Y.	70485	Atlantic India Rubber Works, Inc.	Chicago, Ill.
02771	Vocaline Co. of America, Inc.	Old Saybrook, Conn.	11236	CTS of Berne, Inc.	Berne, Ind.	70563	Amperite Co., Inc.	New York, N.Y.
02777	Hopkins Engineering Co.	San Fernando, Calif.	11237	Chicago Telephone of California, Inc.	So. Pasadena, Calif.	70903	Belden Mfg. Co.	Chicago, Ill.
03508	G.E. Semiconductor Products Dept.	Syracuse, N.Y.	11312	Microwave Electronics Corp.	Palo Alto, Calif.	70998	Bird Electronic Corp.	Cleveland, Ohio
03705	Apex Machine & Tool Co.	Dayton, Ohio	11534	Duncan Electronics, Inc.	Santa Ana, Calif.	71002	Birnbach Radio Co.	New York, N.Y.
03797	Eidema Corp.	El Monte, Calif.	11711	General Instrument Corporation Semiconductor Division	Newark, N.J.	71041	Boston Gear Works Div. of Murray Co. of Texas	Quincy, Mass.
03877	Transitron Electronic Corp.	Wakefield, Mass.	11717	Imperial Electronics, Inc.	Buena Park, Calif.	71218	Bud Radio Inc.	Cleveland, Ohio
03888	Pyrofilm Resistor Co.	Morristown, N.J.	11870	Melabs, Inc.	Palo Alto, Calif.	71286	Camloc Fastener Corp.	Paramus, N.J.
03954	Air Marine Motors, Inc.	Los Angeles, Calif.	12697	Clarostat Mfg. Co.	Dover, N.H.	71313	Allen D. Cardwell Electronic Prod. Corp.	Plainville, Conn.
04009	Arrow, Hart and Hegeman Elect. Co.	Hartford, Conn.	14655	Cornell Dubilier Elec. Corp.	So. Plainfield, N.J.	71400	Bussmann Fuse Div. of McGraw- Edison Co.	St. Louis, Mo.
04062	Elmenco Products Co.	New York, N.Y.	15909	The Daven Co.	Livingston, N.J.	71450	CTS Corp.	Elkhart, Ind.
04222	Hi-Q Division of Aerovox	Myrtle Beach, S.C.	16688	De Jur-Amsco Corporation	Long Island City 1, N.Y.	71468	Cannon Electric Co.	Los Angeles, Calif.
04298	Elgin National Watch Co., Electronics Division	Burbank, Calif.	16758	Delco Radio Div. of G. M. Corp.	Kokomo, Ind.	71471	Cinema Engineering Co.	Burbank, Calif.
04404	Dymec Division of Hewlett-Packard Co.	Palo Alto, Calif.	18873	E. I. DuPont and Co., Inc.	Wilmington, Del.	71482	C. P. Clare & Co.	Chicago, Ill.
04651	Sylvania Electric Prods., Inc. Electronic Tube Div.	Mountain View, Calif.	19315	Eclipse Pioneer, Div. of Bendix Aviation Corp.	Teterboro, N.J.	71528	Standard-Thomson Corp., Clifford Mfg. Co. Div.	Waltham, Mass.
04713	Motorola, Inc., Semiconductor Prod. Div.	Phoenix, Arizona	19500	Thomas A. Edison Industries, Div. of McGraw-Edison Co.	West Orange, N.J.	71590	Centralab Div. of Globe Union, Inc.	Union, N.J.
04732	Filtron Co., Inc. Western Division	Culver City, Calif.	19701	Electra Manufacturing Co.	Kansas City, Mo.	71700	The Cornish Wire Co.	Milwaukee, Wis.
04773	Automatic Electric Co.	Northlake, Ill.	20183	Electronic Tube Corp.	Philadelphia, Pa.	71744	Chicago Miniature Lamp Works	Chicago, Ill.
04796	Sequoia Wire & Cable Company	Redwood City, Calif.	21520	Fansteel Metallurgical Corp.	No. Chicago, Ill.	71753	A. O. Smith Corp., Crowley Div.	West Orange, N.J.
04870	P. M. Motor Co.	Chicago 44, Ill.	21335	The Fafnir Bearing Co.	New Britain, Conn.	71785	Cinch Mfg. Corp.	Chicago, Ill.
05006	Twentieth Century Plastics, Inc.	Los Angeles, Calif.	21964	Fed. Telephone and Radio Corp.	Clifton, N.J.	71984	Dow Corning Corp.	Midland, Mich.
05277	Westinghouse Electric Corp., Semi-Conductor Dept.	Youngwood, Pa.	24446	General Electric Co.	Schenectady, N.Y.	72136	Electro Motive Mfg. Co., Inc.	Willimantic, Conn.
05347	Ultronix, Inc.	San Mateo, Calif.	24455	G.E., Lamp Division	Nela Park, Cleveland, Ohio	72354	John E. Fast & Co.	Chicago, Ill.
05593	Illumitronic Engineering Co.	Sunnyvale, Calif.	24655	General Radio Co.	West Concord, Mass.	72619	Dialight Corp.	Brooklyn, N.Y.
05624	Barber Colman Co.	Rockford, Ill.	26462	Grobet File Co. of America, Inc.	Carlstadt, N.J.	72656	General Ceramics Corp.	Keasbey, N.J.
05729	Metropolitan Telecommunications Corp., Metro Cap. Div.	Brooklyn, N.Y.	26992	Hamilton Watch Co.	Lancaster, Pa.	72758	Girard-Hopkins	Oakland, Calif.
05783	Stewart Engineering Co.	Santa Cruz, Calif.	28480	Hewlett-Packard Co.	Palo Alto, Calif.	72765	Drake Mfg. Co.	Chicago, Ill.
06004	The Bassick Co.	Bridgeport, Conn.	33173	G.E. Receiving Tube Dept.	Owensboro, Ky.	72825	Hugh H. Eby Inc.	Philadelphia, Pa.
06555	Beede Electrical Instrument Co., Inc.	Penacook, N.H.	35434	Lectrohm Inc.	Chicago, Ill.	72928	Gudeman Co.	Chicago, Ill.
06812	Torrington Mfg. Co., West Div.	Van Nuys, Calif.	37942	P. R. Mallory & Co., Inc.	Indianapolis, Ind.	72964	Robert M. Hadley Co.	Los Angeles, Calif.
			39543	Mechanical Industries Prod. Co.	Akron, Ohio	72982	Erie Resistor Corp.	Erie, Pa.
						73061	Hansen Mfg. Co., Inc.	Princeton, Ind.
						73138	Helipot Div. of Beckman Instruments, Inc.	Fullerton, Calif.
						73293	Hughes Products Division of Hughes Aircraft Co.	Newport Beach, Calif.
						73445	Amperex Electronic Co., Div. of North American Phillips Co., Inc.	Hicksville, N.Y.
						73506	Bradley Semiconductor Corp.	Hamden, Conn.
						73559	Carling Electric, Inc.	Hartford, Conn.
						73682	George K. Garrett Co., Inc.	Philadelphia, Pa.

00015-27
Revised: 20 August 1962

From: F.S.C. Handbook Supplements
H4-1 Dated: June 1962
H4-2 Dated: March 1962

APPENDIX CODE LIST OF MANUFACTURERS (Sheet 2 of 2)

CODE NO.	MANUFACTURER	ADDRESS	CODE NO.	MANUFACTURER	ADDRESS	CODE NO.	MANUFACTURER	ADDRESS
73734	Federal Screw Products Co.	Chicago, Ill.	82647	Metals and Controls, Inc., Div. of		95265	National Coil Co.	Sheridan, Wyo.
73743	Fischer Special Mfg. Co.	Cincinnati, Ohio		Texas Instruments, Inc.,		95275	Vitramon, Inc.	Bridgeport, Conn.
73793	The General Industries Co.	Elyria, Ohio		Spencer Prods.	Attleboro, Mass.	95354	Methode Mfg. Co.	Chicago, Ill.
73905	Jennings Radio Mfg. Co.	San Jose, Calif.	82866	Research Products Corp.	Madison, Wis.	95987	Weckesser Co.	Chicago, Ill.
74455	J. H. Winns, and Sons	Winchester, Mass.	82877	Rotron Manufacturing Co., Inc.	Woodstock, N.Y.	96067	Huggins Laboratories	Sunnyvale, Calif.
74861	Industrial Condenser Corp.	Chicago, Ill.			Glendale, Calif.	96095	Hi-Q Division of Aerovox	Olean, N.Y.
74868	R.F. Products Division of Amphenol-Borg Electronics Corp.	Danbury, Conn.	82893	Vector Electronic Co.	Los Angeles, Calif.	96256	Thordarson-Meissner Div. of Maguire Industries, Inc.	Mt. Carmel, Ill.
74970	E. F. Johnson Co.	Waseca, Minn.	83053	Western Washer Mfr. Co.	Cambridge, Mass.	96296	Solar Manufacturing Co.	Los Angeles, Calif.
75042	International Resistance Co.	Philadelphia, Pa.	83058	Carr Fastener Co.	Peterborough, N.H.	96330	Carlton Screw Co.	Chicago, Ill.
75173	Jones, Howard B., Division of Cinch Mfg. Corp.	Chicago, Ill.	83125	Pyramid Electric Co.	Darlington, S.C.	96341	Microwave Associates, Inc.	Burlington, Mass.
75378	James Knights Co.	Sandwich, Ill.	83148	Electro Cords Co.	Los Angeles, Calif.	96501	Excel Transformer Co.	Oakland, Calif.
75382	Kulka Electric Corporation	Mt. Vernon, N.Y.	83186	Victory Engineering Corp.	Union, N.J.	97464	Industrial Retaining Ring Co.	Irvington, N.J.
75818	Lenz Electric Mfg. Co.	Chicago, Ill.	83298	Bendix Corp., Red Bank Div.	Red Bank, N.J.	97539	Automatic and Precision Mfg. Co.	Yonkers, N.Y.
75915	Littelfuse Inc.	Des Plaines, Ill.	83330	Smith, Herman H., Inc.	Brooklyn, N.Y.	97966	CBS Electronics, Div. of C.B.S., Inc.	Danvers, Mass.
76005	Lord Mfg. Co.	Erie, Pa.	83501	Gavitt Wire and Cable Co., Div. of Amerace Corp.	Brookfield, Mass.	98141	Axel Brothers Inc.	Jamaica, N.Y.
76210	C. W. Marwedel	San Francisco, Calif.	83594	Burroughs Corp., Electronic Tube Div.	Plainfield, N.J.	98220	Francis L. Mosley	Pasadena, Calif.
76433	Micamold Electronic Mfg. Corp.	Brooklyn, N.Y.	83777	Model Eng. and Mfg., Inc.	Huntington, Ind.	98278	Microdot, Inc.	So. Pasadena, Calif.
76487	James Millen Mfg. Co., Inc.	Malden, Mass.	83821	Loyd Scruggs Co.	Festus, Mo.	98291	Sealcraft Corp.	Mamaroneck, N.Y.
76493	J. W. Miller Co.	Los Angeles, Calif.	84171	Arco Electronics, Inc.	New York, N.Y.	98405	Carad Corp.	Redwood City, Calif.
76530	Monadnock Mills	San Leandro, Calif.	84396	A. J. Glesener Co., Inc.	San Francisco, Calif.	98734	Palo Alto Engineering Co., Inc.	Palo Alto, Calif.
76545	Mueller Electric Co.	Cleveland, Ohio	84411	Good All Electric Mfg. Co.	Ogallala, Neb.	98821	North Hills Electric Co.	Mineola, N.Y.
76854	Oak Manufacturing Co.	Crystal Lake, Ill.	84970	Sarkes Tarzian, Inc.	Bloomington, Ind.	98925	Clevite Transistor Prod. Div. of Clevite Corp.	Waltham, Mass.
77068	Bendix Pacific Division of Bendix Corp.	No. Hollywood, Calif.	85454	Bonnton Molding Company	Bonnton, N.J.	98978	International Electronic Research Corp.	Burbank, Calif.
77221	Phaotron Instrument and Electronic Co.	South Pasadena, Calif.	85471	A. B. Boyd Co.	San Francisco, Calif.	99109	Columbia Technical Corp.	New York, N.Y.
77252	Philadelphia Steel and Wire Corp.	Philadelphia, Pa.	85474	R. M. Bracamonte & Co.	San Francisco, Calif.	99313	Varian Associates	Palo Alto, Calif.
77342	Potter and Brumfield, Div. of American Machine and Foundry	Princeton, Ind.	85660	Koiled Kords, Inc.	New Haven, Conn.	99515	Marshall Industries, Electron Products Division	Pasadena, Calif.
77630	Radio Condenser Co.	Camden, N.J.	85911	Seamless Rubber Co.	Chicago, Ill.	99707	Control Switch Division, Controls Co. of America	El Segundo, Calif.
77638	Radio Receptor Co., Inc.	Brooklyn, N.Y.	86197	Clifton Precision Products	Clifton Heights, Pa.	99800	Delevan Electronics Corp.	East Aurora, N.Y.
77764	Resistance Products Co.	Harrisburg, Pa.	86684	Radio Corp. of America, RCA Electron Tube Div.	Harrison, N.J.	99848	Wilco Corporation	Indianapolis, Ind.
78189	Shakeproof Division of Illinois Tool Works	Elgin, Ill.	87216	Philco Corp. (Lansdale Division)	Lansdale, Pa.	99934	Renbrandt, Inc.	Boston, Mass.
78283	Signal Indicator Corp.	New York, N.Y.	87473	Western Fibrous Glass Products Co.	San Francisco, Calif.	99942	Hoffman Semiconductor Div. of Hoffman Electronics Corp.	Evanston, Ill.
78471	Tilley Mfg. Co.	San Francisco, Calif.	88140	Cutler-Hammer, Inc.	Lincoln, Ill.	99957	Technology Instrument Corp.	Newbury Park, Calif.
78488	Stackpole Carbon Co.	St. Marys, Pa.	88220	Gould-National Batteries, Inc.	St. Paul, Minn.			
78553	Tinnerman Products, Inc.	Cleveland, Ohio	89473	General Electric Distributing Corp.	Schenectady, N.Y.			
78790	Transformer Engineers	Pasadena, Calif.	89636	Carter Parts Div. of Economy Baler Co.	Chicago, Ill.	0000F	Malco Tool and Die	Los Angeles, Calif.
78947	Ucinite Co.	Newtonville, Mass.	89665	United Transformer Co.	Chicago, Ill.	0000I	Telefunken (c/o American Elite)	New York, N.Y.
79142	Veeder Root, Inc.	Hartford, Conn.	90179	U.S. Rubber Co., Mechanical Goods Div.	Passaic, N.J.	0000M	Western Coil Div. of Automatic Ind., Inc.	Redwood City, Calif.
79251	Wenco Mfg. Co.	Chicago, Ill.	90970	Bearing Engineering Co.	San Francisco, Calif.	0000N	Nahm-Bros. Spring Co.	San Leandro, Calif.
79727	Continental-Wirt Electronics Corp.	Philadelphia, Pa.	91260	Connor Spring Mfg. Co.	San Francisco, Calif.	0000P	Ty-Car Mfg. Co., Inc.	Holliston, Mass.
79963	Zierick Mfg. Corp.	New Rochelle, N.Y.	91345	Miller Dial & Nameplate Co.	El Monte, Calif.	0000T	Texas Instruments, Inc. Metals and Controls Div.	Versailles, Ky.
80031	Mepco Division of Sessions Clock Co.	Morristown, N.J.	91418	Radio Materials Co.	Chicago, Ill.	0000U	Tower Mfg. Corp.	Providence, R.I.
80120	Schnitzer Alloy Products	Elizabeth, N.J.	91506	Augat Brothers, Inc.	Attleboro, Mass.	0000W	Webster Electronics Co. Inc.	New York, N.Y.
80130	Times Facsimile Corp.	New York, N.Y.	91637	Dale Electronics, Inc.	Columbus, Nebr.	0000X	Spruce Pine Mica Co.	Spruce Pine, N.C.
80131	Electronic Industries Association Any brand tube meeting EIA standards	Washington, D.C.	91662	Elco Corp.	Philadelphia, Pa.	0000Y	Midland Mfg. Co. Inc.	Kansas City, Kans.
80207	Unimax Switch, Div. of W. L. Maxson Corp.	Wallingford, Conn.	91737	Gremer Mfg. Co., Inc.	Wakefield, Mass.	0000Z	Willow Leather Products Corp.	Newark, N.J.
80248	Oxford Electric Corp.	Chicago, Ill.	91827	K F Development Co.	Redwood City, Calif.	000AA	British Radio Electronics Ltd.	Washington, D.C.
80294	Bourns Laboratories, Inc.	Riverside, Calif.	91921	Minneapolis-Honeywell Regulator Co., Micro-Switch Division	Freeport, Ill.	000BB	Precision Instrument Components Co.	Van Nuys, Calif.
80411	Acro Div. of Robertshaw Fulton Controls Co.	Columbus 16, Ohio	92196	Univisat Metal Products, Inc.	Bassett Puente, Calif.	000CC	Computer Diode Corp.	Lodi, N.J.
80486	All Star Products Inc.	Defiance, Ohio	93332	Sylvania Electric Prod. Inc., Semiconductor Div.	Woburn, Mass.	000EE	A. Williams Manufacturing Co.	San Jose, Calif.
80583	Hammerlund Co., Inc.	New York, N.Y.	93369	Robbins and Myers, Inc.	New York, N.Y.	000FF	Carmichael Corrugated Specialties	Richmond, Calif.
80640	Stevens, Arnold, Co., Inc.	Boston, Mass.	93410	Stevens Mfg. Co., Inc.	Mansfield, Ohio	000GG	Goshen Die Cutting Service	Goshen, Ind.
81030	International Instruments, Inc.	New Haven, Conn.	93983	Insuline-Van Norman Ind., Inc. Electronic Division	Manchester, N.H.	000HH	Rubbercraft Corp.	Torrance, Calif.
81312	Winchester Electronics Co., Inc.	Norwalk, Conn.	94144	Raytheon Mfg. Co., Industrial Components Div., Receiving Tube Operation	Quincy, Mass.	000II	Birtcher Corporation, Industrial Division	Monterey Park, Calif.
81415	Wilkor Products, Inc.	Cleveland, Ohio	94145	Raytheon Mfg. Co., Semiconductor Div., California Street Plant	Newton, Mass.	000KK	Amatom	New Rochelle, N.Y.
81453	Raytheon Mfg. Co., Industrial Components Div., Industr. Tube Operations	Newton, Mass.	94148	Scientific Radio Products, Inc.	Loveland, Colo.	000LL	Avery Label	Monrovia, Calif.
81483	International Rectifier Corp.	El Segundo, Calif.	94154	Tung-Sol Electric, Inc.	Newark, N.J.	000MM	M Rubber Eng. & Development	Hayward, Calif.
81860	Barry Controls, Inc.	Watertown, Mass.	94197	Curtiss-Wright Corp., Electronics Div.	East Paterson, N.J.	000NN	A "N" D Manufacturing Co.	San Jose 27, Calif.
82042	Carter Parts Co.	Skokie, Ill.	94310	Tru Ohm Prod. Div. of Model Engineering and Mfg. Co.	Chicago, Ill.	000PP	Atohm Electronics,	Sun Valley, Calif.
82142	Jeffers Electronics Division of Speer Carbon Co.	Du Bois, Pa.	94682	Worcester Pressed Aluminum Corp.	Worcester, Mass.	000QQ	Cooltron,	Oakland, Calif.
82170	Allen B. DuMont Labs., Inc.	Clifton, N.J.	95236	Allies Products Corp.	Miami, Fla.	000RR	Radio Industries	Des Plaines, Ill.
82209	Maguire Industries, Inc.	Greenwich, Conn.	95238	Continental Connector Corp.	Woodside, N.Y.	000SS	Control of Elgin Watch Co.	Burbank, Calif.
82219	Sylvania Electric Prod. Inc., Electronic Tube Div.	Emporium, Pa.	95263	Lecraft Mfg. Co., Inc.	New York, N.Y.	000TT	Thomas & Betts Co., The	Elizabeth 1, N.J.
82376	Astron Co.	East Newark, N.J.	95264	Lercor Electronics, Inc.	Burbank, Calif.			
82389	Switchcraft, Inc.	Chicago, Ill.						

THE FOLLOWING H-P VENDORS HAVE NO NUMBER ASSIGNED IN THE LATEST SUPPLEMENT TO THE FEDERAL SUPPLY CODE FOR MANUFACTURERS HANDBOOK.

0000F	Malco Tool and Die	Los Angeles, Calif.
0000I	Telefunken (c/o American Elite)	New York, N.Y.
0000M	Western Coil Div. of Automatic Ind., Inc.	Redwood City, Calif.
0000N	Nahm-Bros. Spring Co.	San Leandro, Calif.
0000P	Ty-Car Mfg. Co., Inc.	Holliston, Mass.
0000T	Texas Instruments, Inc. Metals and Controls Div.	Versailles, Ky.
0000U	Tower Mfg. Corp.	Providence, R.I.
0000W	Webster Electronics Co. Inc.	New York, N.Y.
0000X	Spruce Pine Mica Co.	Spruce Pine, N.C.
0000Y	Midland Mfg. Co. Inc.	Kansas City, Kans.
0000Z	Willow Leather Products Corp.	Newark, N.J.
000AA	British Radio Electronics Ltd.	Washington, D.C.
000BB	Precision Instrument Components Co.	Van Nuys, Calif.
000CC	Computer Diode Corp.	Lodi, N.J.
000EE	A. Williams Manufacturing Co.	San Jose, Calif.
000FF	Carmichael Corrugated Specialties	Richmond, Calif.
000GG	Goshen Die Cutting Service	Goshen, Ind.
000HH	Rubbercraft Corp.	Torrance, Calif.
000II	Birtcher Corporation, Industrial Division	Monterey Park, Calif.
000KK	Amatom	New Rochelle, N.Y.
000LL	Avery Label	Monrovia, Calif.
000MM	M Rubber Eng. & Development	Hayward, Calif.
000NN	A "N" D Manufacturing Co.	San Jose 27, Calif.
000PP	Atohm Electronics,	Sun Valley, Calif.
000QQ	Cooltron,	Oakland, Calif.
000RR	Radio Industries	Des Plaines, Ill.
000SS	Control of Elgin Watch Co.	Burbank, Calif.
000TT	Thomas & Betts Co., The	Elizabeth 1, N.J.

From: F.S.C. Handbook Supplements
H4-1 Dated: June 1962
H4-2 Dated: March 1962

00015-27
Revised: 20 August 1962

HEWLETT-PACKARD SALES AND SERVICE OFFICES IN NORTH AMERICA

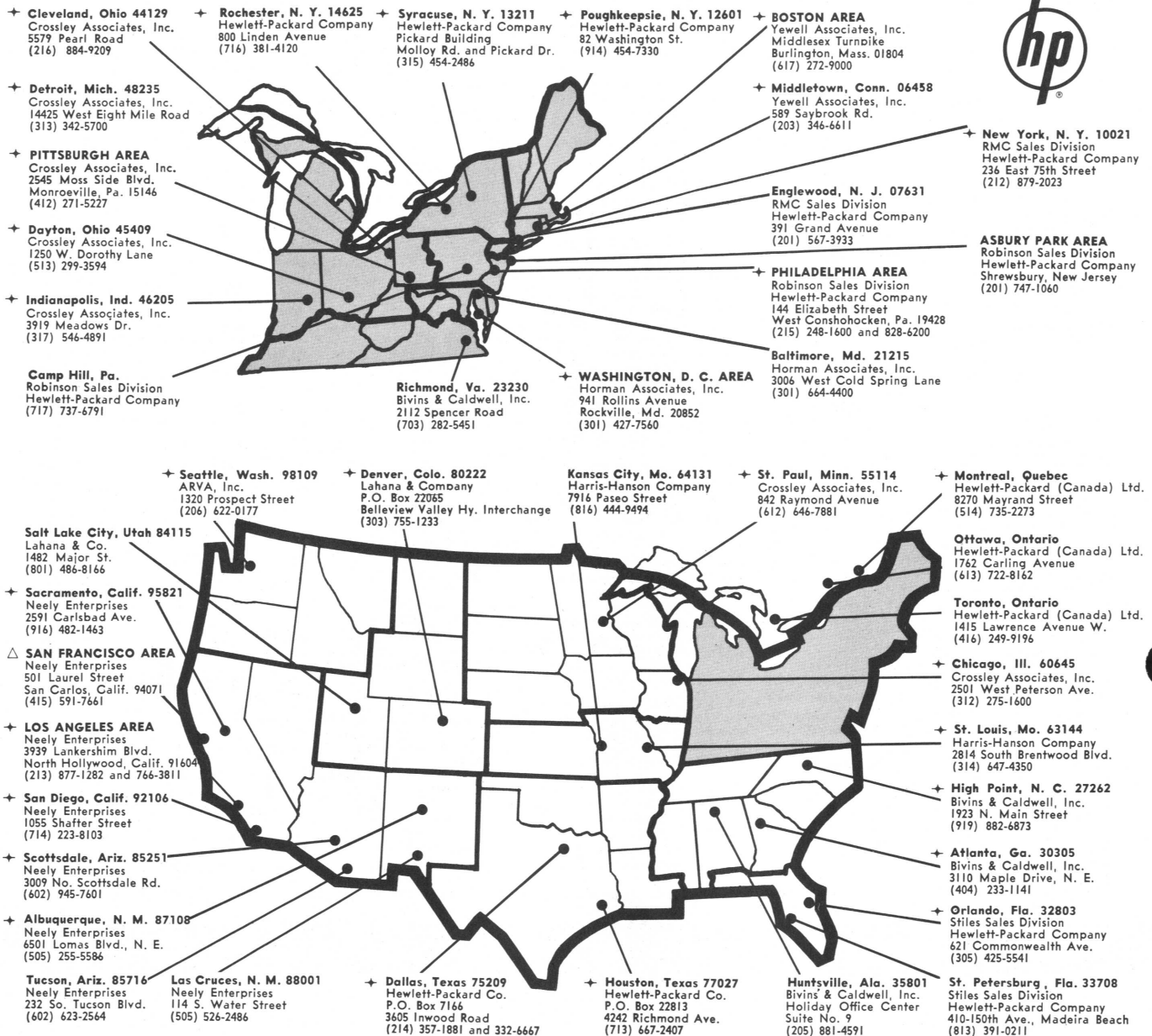

△ For replacement parts and repair services in the San Francisco area, please contact Hewlett-Packard Company, 395 Page Mill Road, Palo Alto, California, Tel: (415) 326-3950.
+ Indicates Instrument Repair Stations.

HEWLETT-PACKARD COMPANY

1501 Page Mill Road • Palo Alto, California 94304
Tel: (415) 326-7000 • TWX: 415-492-9200 • Cable: HEWPACK

DYMEC DIVISION

395 Page Mill Road • Palo Alto, California 94306
Tel: (415) 326-1755 • TWX: 415-492-9363

BOONTON RADIO COMPANY

Green Pond Road • Rockaway, New Jersey 07866
Tel: (201) 627-6400 • Cable: BOONRACO

HARRISON LABORATORIES

41 Industrial Road • Berkeley Heights, N. J. 07922
Tel: (201) 464-1234 • TWX: Summit, N. J.

SANBORN COMPANY

175 Wyman St., Waltham, Mass. 02154
Tel: (617) 894-6300 • TWX: 617-894-0789

F. L. MOSELEY CO.

409 N. Fair Oaks Ave. • Pasadena, Calif. 91102 • Tel: (213) 681-0208 • TWX: PASA CAL 7687 • Cable: MOCOPAS



AUTHORIZED SALES AND SERVICE OFFICES IN WESTERN EUROPE

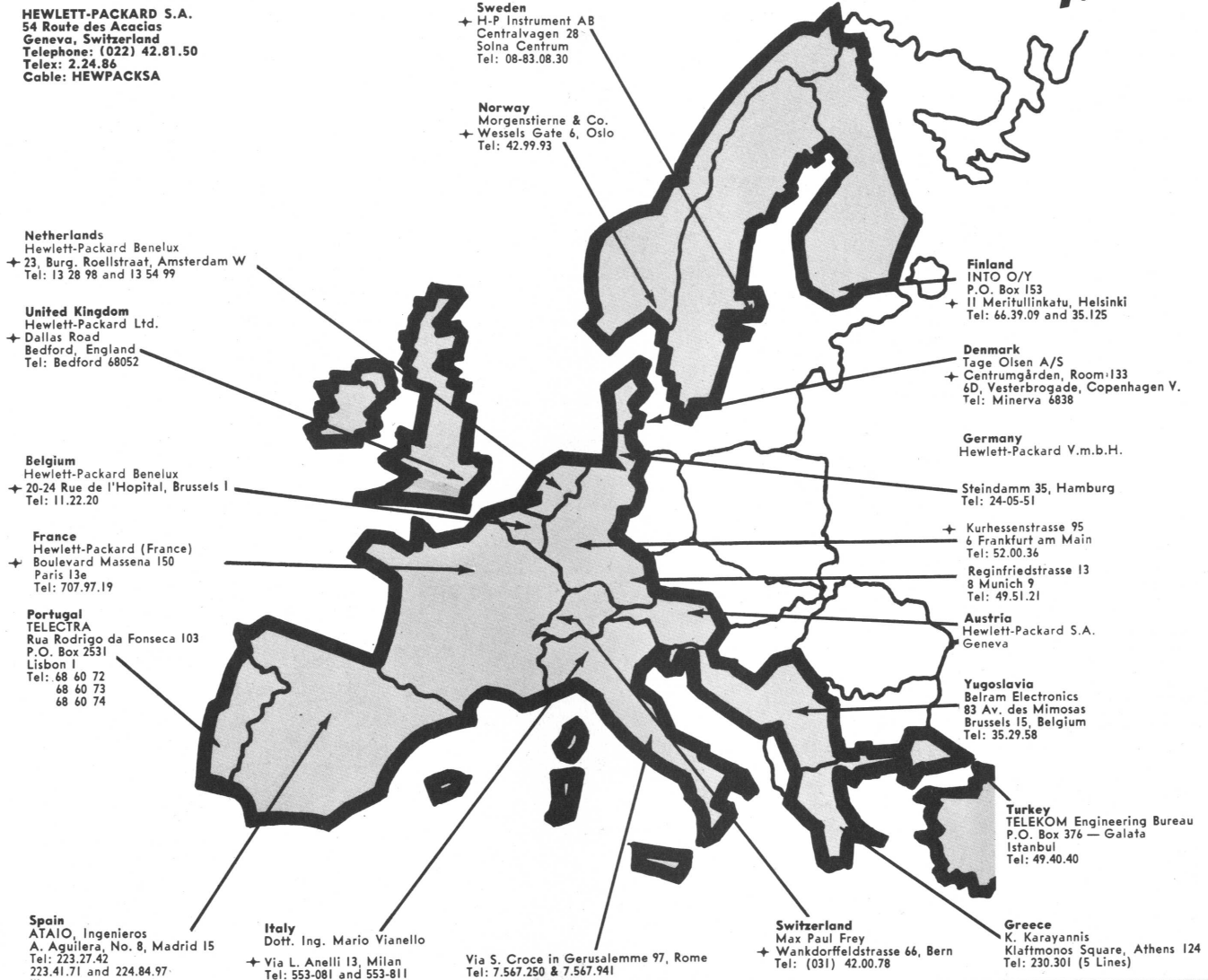

Authorized Sales and Service Offices in Other Areas

Argentina
 Mauricio A. Suarez
 Telecomunicaciones
 Carlos Calvo 224, Buenos Aires
 Tel: 30-6312

Australia
 Sample Electronics Pty. Ltd.
 + 9-11 Cremorne Street
 Richmond E. 1, Victoria
 Tel: 42-4757 (3 lines)

48 Chippen Street, Sydney
 New South Wales
 Tel: 69-6338 (6 lines)

FOR SALES AND SERVICE ASSISTANCE IN AREAS NOT LISTED CONTACT:

International Marketing Department
 Hewlett-Packard Company
 + 1501 Page Mill Road
 Palo Alto, California 94304, U.S.A.
 Telephone: (415) 326-7000
 TWX: 415-492-9200
 Telex: 033811
 Cable: HEWPACK

+ Indicates Instrument Repair Stations

India
 The Scientific Instrument Company, Ltd.
 6, Tej Bahadur Sapru Road, Allahabad I
 Tel: 2451

240, Dr. Dadabhai Naoroji Road,
 Bombay I
 Tel: 26-2642

11, Esplanade East, Calcutta I
 Tel: 23-4129

30, Mount Road, Madras 2
 Tel: 86339

B-7, Ajmeri Gate Extn., New Delhi I
 Tel: 271053

Iran
 Telecom Ltd.
 P.O. Box 1812, Tehran
 Tel: 43850, 48111

Israel
 Electronics & Engineering Ltd.
 + 16 Kremenetski St., Tel Aviv
 Tel: 35021 (3 lines)

Japan
 + Yokogawa-Hewlett-Packard, Ltd.
 2-9, Nakacho, Musashino-shi, Tokyo
 Tel: Ogikubo (391) 1901
 Musashino (0422)-2 3701

Korea
 American Trading Company, Korea, Ltd.
 Song Bo Building
 112-35 Sokong-Dong, Seoul
 Seoul P.O. Box 1103
 Seoul
 Tel: 3-7049, 3-7613

New Zealand
 Sample Electronics (N. Z.) Ltd.
 8 Matipo Street
 Onehunga S. E. 5, Auckland
 Tel: 565-361

Puerto Rico & Virgin Islands
 San Juan Electronics, Inc.
 P.O. Box 5167
 Pta. de Tierra Sta., San Juan
 Tel: 722-3342, 724-4406

South Africa
 F. H. Flanter & Co. (Pty.), Ltd.
 Rosella House
 Buifencingle Street, Cape Town
 Tel: 3-3817

Taiwan (Formosa)
 Hwa Sheng Electronic Co., Ltd.
 21 Nanking West Road, Taipei
 Tel: 4-6076, 4-5936



WARRANTY

All our products are warranted against defects in materials and workmanship for one year from the date of shipment. Our obligation is limited to repairing or replacing products (except tubes) which prove to be defective during the warranty period. We are not liable for consequential damages.

For assistance of any kind, including help with instruments under warranty, contact your nearest Hewlett-Packard field office for instructions. Give full details of the difficulty and include the instrument model and serial numbers. Service data or shipping instructions will be promptly sent to you. There will be no charge for repair of instruments under warranty, *except transportation charges*. Estimates of charges for non-warranty or other service work will always be supplied, if requested, before work begins.

CLAIM FOR DAMAGE IN SHIPMENT

Your instrument should be inspected and tested as soon as it is received. The instrument is insured for safe delivery. If the instrument is damaged in any way or fails to operate properly, file a claim with the carrier or, if insured separately, with the insurance company.

SHIPPING

On receipt of shipping instructions, forward the instrument prepaid to the destination indicated. You may use the original shipping carton or any strong container. Wrap the instrument in heavy paper or a plastic bag and surround it with three or four inches of shock-absorbing material to cushion it firmly and prevent movement inside the container.

GENERAL

Your nearest Hewlett-Packard field office is ready to assist you in any situation, and you are always welcome to get directly in touch with Hewlett-Packard service departments:

CUSTOMER SERVICE

Hewlett-Packard Company
395 Page Mill Road
Palo Alto, California, 94306
U.S.A.
Telephone: (415) 326-3950
TWX No. (415) 492-9363
Cable: "HEWPACK"

OR (In Western Europe)

Hewlett-Packard S.A.
54 Route Des Acacias
Geneva, Switzerland
Telephone: (022) 42. 81. 50
Cable: "HEWPACKSA"





hp MANUAL CHANGES

MODEL 203A

VARIABLE PHASE FUNCTION GENERATOR

Manual Serial Prefixed: 425-

hp Part No. 00203-90000

To adapt this manual to instruments with other serial prefixes check for errata below, and make changes shown in tables.

► New or Revised Item

Instrument Serial Prefix	Make Manual Changes	Instrument Serial Prefix	Make Manual Changes
--------------------------	---------------------	--------------------------	---------------------

ALL	ERRATA		
425-00126	1		
425-00151	1, 2		

Note: hp Part No. and hp Stock No. are synonymous.

ERRATA

Table 1-1, Specifications,

Change OUTPUT SYSTEM specifications to read as follows:

Direct coupled output is isolated from ground and may be operated floating or with either side grounded (Sine Wave only).

Change frequency range note to read:

*Two lower ranges of (Option:01) 0.0005 and (Option:02) 0.00005 cps are available on special order.

Paragraph 3-8,

Change the Note in step b to read as follows:

When the FREQUENCY MULTIPLIER switch is in the CAL position, there is no output signal at the REFERENCE PHASE OUTPUT connector.

Paragraph 5-14,

Precede step a with the following:

Note

Make the following adjustments with the FREQUENCY MULTIPLIER Switch in the X100 (or below) position.

Change last sentence in step d to read as follows:

AC Voltmeter should read less than 1.0 mv ripple.

Change last sentence in step g to read as follows:

The AC Voltmeter should read less than 1.0 mv ripple.

Change first sentence in step k to read as follows:

AC Voltmeter should read less than 2.0 mv ripple.

Figure 5-15.

Change designation on R31 and R34 to VAR. DIST. ADJ. and VAR. 50 CPS ADJ., respectively.

CHANGE #1

Table 6-2. Index by Reference Designator,

Change A2C2 to hp Stock No. 0160-0217, Capacitor, fixed, 2300 pf

Change A3Q4 and A3Q5 to hp Stock No. 1854-0039, 2N3053

Change A6Q5 to hp Stock No. 1854-0039, 2N3053

Change A8Q4 and A8Q5 to hp Stock No. 1854-0039, 2N3053

Change A21C2 to hp Stock No. 0140-0054, Capacitor, fixed, 100 pf

Change A22Q1 and A22Q5 to hp Stock No. 1854-0039, 2N3053

Instrument Serial Prefix	Make Manual Changes	Instrument Serial Prefix	Make Manual Changes
ALL	ERRATA		
425-00126	1		
425-00151	1, 2		

CHANGE #2 Table 6-1. Index by Reference Designator, Miscellaneous,

Change Ⓟ Stock No. 1251-0452 to 1251-1031

Add the following to Miscellaneous:

Option 01

00203-00203, Front Panel

00203-66501, Decade module board assembly

Option 02

00203-00204, Front Panel

00203-66501, Decade module board assembly

Change A8C3 to Ⓟ Stock No. 0140-0192, C: fxd, mica, 68 pf ±5%, 300 vdcw.

Add * to A8C3 on schematic and change value to 68 pf.

Change S2 to Ⓟ Stock No. 3101-0100

ERRATA

► Table 6-1

Delete "EIA type 2N383" from Description column for transistors A8Q2, A8Q3, A22Q2, A22Q3, and A22Q4.

► Table 6-2, Ⓟ Part No. 1850-0040

Delete "EIA type 2N3831" from Description column and "SA591" from Mfr. Part No. column.

Add Ⓟ Part No. 1850-0040 to Mfr. Part No.