

Errata

Title & Document Type: 3852A Command Reference
Manual Volume 2

Manual Part Number: 03852-90016V2

Revision Date: December 1987

HP References in this Manual

This manual may contain references to HP or Hewlett-Packard. Please note that Hewlett-Packard's former test and measurement, semiconductor products and chemical analysis businesses are now part of Agilent Technologies. We have made no changes to this manual copy. The HP XXXX referred to in this document is now the Agilent XXXX. For example, model number HP8648A is now model number Agilent 8648A.

About this Manual

We've added this manual to the Agilent website in an effort to help you support your product. This manual provides the best information we could find. It may be incomplete or contain dated information, and the scan quality may not be ideal. If we find a better copy in the future, we will add it to the Agilent website.

Support for Your Product

Agilent no longer sells or supports this product. You will find any other available product information on the Agilent Test & Measurement website:

www.tm.agilent.com

Search for the model number of this product, and the resulting product page will guide you to any available information. Our service centers may be able to perform calibration if no repair parts are needed, but no other support from Agilent is available.

HP 3852A Data Acquisition/Control Unit

Command Reference Manual Volume 2



Copyright © Hewlett-Packard Company, 1986, 1987

Manual Part Number: 03852-90016
Microfiche Part Number: 03852-99016

Printed: DECEMBER 1987 Edition 2
Printed in U.S.A. E1287

• HP 44714A 3-Channel Stepper Motor Controller/Pulse Output

Description

Specifies how the quadrature counter is to be indexed (resets the counter and enables the counter for counting). QINDEX can also be specified so the quadrature counter ignores the index input.

Prerequisites

1. Requires mainframe firmware revision 3.0 or greater.
2. Must have an optical encoder with an index pulse capability connected to the QI inputs if the ONCE parameter is to be used.

Syntax

QINDEX *mode* [USE *ch*]

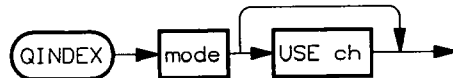

Parameters

mode The *mode* parameter specifies how indexing occurs or if it is disabled .

<u>mode</u>	<u>Definition</u>
OFF (power-on)	The quadrature counter ignores the QI input and no reset of the counter occurs.
ONCE	The ONCE mode causes the counter to be immediately reset to zero and to begin counting at the next index pulse generated by the encoder. Successive index pulses are ignored.
SGL (default)	The SGL mode causes the quadrature counter to be reset to zero and immediately begin counting. QINDEX then goes to the OFF mode. If a mode is not specified in the command, the mode defaults to SGL.

NOTE

Both the ONCE and SGL modes immediately reset the counter. SGL does not require a QI input and causes the counter to immediately begin counting on execution of the QINDEX command. ONCE requires a QI input and after execution of the QINDEX command, counting will not begin until an index pulse is received via the QI inputs.

USE *ch* Channel that is to be indexed. Channel range can be ES00 to ES02.

QINDEX (cont)

Remarks

Power-On State

The power-on mode for QINDEX is off.

Data Returned

None

Related Commands

QPOS?, QSCALE

Examples

Example: Reset the Quadrature Counter and begin counting immediately

```
10 OUTPUT 709;"QINDEX USE 201"  
20 END
```

• HP 44714A 3-Channel Stepper Motor Controller/Pulse Output

Description

Requests the current position value present in the quadrature counter. The value in the counter is updated by counting the number of pulses generated by the encoder and applying the scale factor (qfactor).

Prerequisites

Requires mainframe firmware revision 3.0 or greater.

Syntax

QPOS? [*USE ch*] [*INTO name*] or [*fmt*]

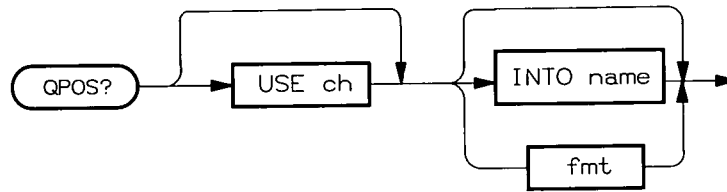

RR.QPOS

Parameters

USE ch Channel queried. Channel range is ES00 to ES02.

INTO name See Glossary.

fmt See Glossary. Default format is RASC.

Remarks

Data Returned

Internal quadrature counter value (current position)

Related Commands

QINDEX, QSCALE

Examples

Example: Query the Internal Quadrature Counter

```
10 OUTPUT 709;"QPOS? USE 201"      !Checks counter of ch 1 slot 2
20 ENTER 709; VALUE                 !Enter value into VALUE
30 PRINT VALUE                       !Print VALUE
40 END
```

QSCALE

• HP 44714A 3-Channel Stepper Motor Controller/Pulse Output

Description

Specifies the distance of motion that one quadrature count corresponds to. The scale factor can be in any units i.e. inches, angle of rotation, etc. Using this scale factor allows you to determine position in units of distance instead of quadrature counts.

Prerequisites

1. Requires mainframe firmware revision 3.0 or greater.
2. Must have an optical encoder connected to the QI, QA, and QB inputs of the HP 44714A.

Syntax **QSCALE** *qfactor* [USE *ch*]



Parameters

qfactor
(power-on
= 1.0)

The *qfactor* parameter is a positive or negative number that specifies the distance moved for one quadrature count. Any unit of measure can be associated with the *qfactor* but position must then be referenced in these units. The *qfactor* is stored by the local processor and converts quadrature counts to distance which is returned when queried by a QPOS? command.

USE *ch*

Channel to which the *qfactor* applies. Channel range can be ES00 to ES02.

Remarks

Power-On State

The power-on state for the *qfactor* is 1.0.

Data Returned

None

Related Commands

The *qfactor* affects the meaning of the position parameter in the QPOS? command.

Examples

Example: Set a *qfactor* of 0.5 Inches Per Quadrature Count

```
10 OUTPUT 709;"QSCALE 0.5 USE 201"    !Set ch 1 in slot 2
                                         !qfactor = 0.5
20 END
```

- HP 44701A Integrating Voltmeter
- HP 44702A/B High-Speed Voltmeter (System or Scanner Mode)

Description

Sets the voltmeter measurement range or enables the autorange mode.

Prerequisites

If the HP 44702A/B High-Speed Voltmeter is in Scanner Mode, SCTRIG must be set to HOLD before RANGE is executed.

Syntax

RANGE [*range*] [USE *ch*]

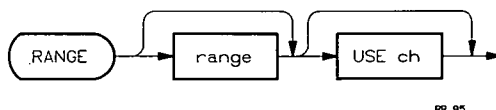

RR_05

Parameters

range

Selects a measurement range or the autorange mode. A measurement range is selected by specifying the maximum expected signal amplitude or the maximum expected resistance. The voltmeter then selects the correct range.

Autorange is selected by entering the word AUTO or the value 0 for *range*. The power-on and default *range* is AUTO.

HP 44701A Integrating Voltmeter

DC Voltage		AC Voltage		4-Wire Ohms	
range	sets	range	sets	range	sets
0 or AUTO	Autorange	0 or AUTO	Autorange	0 or AUTO	Autorange
>0 - .03	30 mV	>0 - .2	200 mV	>0 - 30	30 Ω
>.03 - .3	300 mV	>.2 - 2	2V	>30 - 300	300 Ω
>.3 - 3	3V	>2 - 20	20V	>300 - 3E3	3 kΩ
>3 - 30	30V	>20 - 200	200V	>3E3 - 3E4	30 kΩ
>30 - 300	300V			>3E4 - 3E5	300 kΩ
				>3E5 - 3E6	3 MΩ

RANGE (cont)

HP 44702A/B High-Speed Voltmeter

DC voltage		4-wire ohms up to 10 k Ω	
range	sets	range	sets
0 or AUTO	Autorange	0 or AUTO	Autorange
>0 - .040	40 mV	>0 - 40	40 Ω
>.04 - .32	320 mV	>40 - 320	320 Ω
>.32 - 2.56	2.56V	>320 - 2.56E3	2.56k Ω
>2.56 - 10.24	10.24V	>2.56E3 - 10.24E3	10.24k Ω
4-wire ohms up to 100 k Ω		4-wire ohms up to 1M Ω	
range	sets	range	sets
0 or AUTO	Autorange	0 or AUTO	Autorange
>0 - 400	400 Ω	>0 - 4E3	4k Ω
>400 - 3.2E3	3.2k Ω	>4E3 - 32E3	32k Ω
>3.2E3 - 25.6E3	25.6k Ω	>32E3 - 256E3	256k Ω
>25.6E3 - 102.4E3	102.4k Ω	>256E3 - 1.024E6	1.024M Ω

USE *ch* Voltmeter slot number. See Glossary.

Remarks

Range Changes CLWRITE Setting

The RANGE command overrides any previous range settings entered with the CLWRITE command.

Data Returned

None

Related Commands

ARANGE, CLWRITE, FUNC, USE

Examples**Example: Selecting Voltmeter Range**

This program configures an HP 44701A voltmeter to measure DC voltage. Since the maximum signal amplitude to be measured is approximately 5V, RANGE 5 is issued to set the voltmeter to the 30V range. Measurement speed is increased when the HP 44701A is set to a fixed range; however, measurement accuracy may be decreased.

```
10 OUTPUT 709;"RST"           !Reset the HP 3852A and HP 44701A
20 REAL Rngrdgs(0:2)         !Declare controller array
30 OUTPUT 709;"USE 700"      !Use voltmeter in mainframe slot 7
40 OUTPUT 709;"CONF DCV"    !Configure voltmeter for DC voltage
50 OUTPUT 709;"RANGE 5"     !Maximum expected signal (30V range)
60 OUTPUT 709;"MEAS DCV 0,4,7"
70                           !Measure voltage on channels 0,4,7 (slot 0)
80 ENTER 709;Rngrdgs(*)     !Enter readings into controller
90 PRINT Rngrdgs(*)         !Display readings
100 END
```

A typical output based on this program is:

```
4.55309      3.84316      3.90426
```

RDGS

- HP 44702A/B High-Speed Voltmeter (Scanner or System Mode)

Description

Specifies the HP 3852A mainframe or the HP 44702A/B GPIO port as the destination for measurement data and interrupt signals returned by the voltmeter.

Prerequisites

If the voltmeter is in the Scanner Mode, SCTRIG must be set to HOLD before setting RDGS. Because RDGS disables voltmeter interrupts, RDGS should be set before the interrupt is enabled.

Syntax RDGS *dest* [USE *ch*]

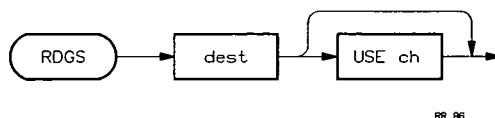

Parameters

dest Reading destination control modes. Power-on *dest* = SYS.

<i>dest</i>	Definition
SYS	Send readings/interrupts to HP 3852A mainframe
GPIO	Send readings/interrupts to voltmeter GPIO port

USE *ch* Voltmeter slot number. See Glossary.

Remarks

Readings Destinations

When the readings destination is GPIO (RDGS GPIO), readings transferred over GPIO will always be PACKed. When MEAS or CONF is executed:

- The command will not finish until all readings are taken over GPIO.
- For thermocouple functions, reference resistance measurements are made first, then thermocouple voltages are measured. (One reference reading made each time an accessory boundary is crossed.)

Changing RDGS Disables Interrupts

Since *changing* RDGS disables all voltmeter interrupts, you must enable the voltmeter interrupt after setting RDGS.

Data Returned

None

Related Commands

RDGSMODE, USE

Examples **Example: Setting the Reading Destination**

This program uses the RDGS command to set the HP 44702A/B voltmeter's GPIO port as the destination for the readings taken by the voltmeter. The program also includes commands which configure the voltmeter for the measurements and shows how the controller's GPIO interface is configured for the data transfer.

```

10  INTEGER A(0:29)                !Declare controller array
20  ASSIGN @Path_3852 TO 12;WORD    !Set up GPIO paths
30  ASSIGN @Gpio TO 12
40  Gpio=12
50  OUTPUT 709;"RST"                !Reset the HP 3852A
60  OUTPUT 709;"USE 500"            !Use the vm in slot 5
70  OUTPUT 709;"SCANMODE ON"       !Turn scanner mode on
80  OUTPUT 709;"CONF DCV"          !Configure for DC voltage
90  OUTPUT 709;"DISP OFF"          !Turn mf display off
100 OUTPUT 709;"RDGS GPIO"         !Send readings to GPIO port
110 OUTPUT 709;"CLWRITE SENSE 400-409" !Define channel list
120 OUTPUT 709;"PRESCAN 3"         !Make 3 passes through scan list
130 OUTPUT 709;"ASCAN ON"          !Turn autoscan on
140 CONTROL Gpio,2;5               !Set control line low
150 OUTPUT @Gpio USING "#,W";4     !Read data from vm's data buffer
160 CONTROL Gpio,2;4               !Set control line high
170 OUTPUT 709;"SCTRIG SGL"        !Issue a single scan trigger
180 ENTER @Path_3852 USING "#,W";A(*) !Enter readings into controller
190  END

```

RDGSMODE

• HP 44702A/B High-Speed Voltmeter (Scanner or System Mode)

Description

Specifies the HP 44702A/B reading storage mode and when an interrupt occurs based on the availability of the data.

Prerequisites

If the HP 44702A/B is in the Scanner Mode, SCTRIG must be set to HOLD before setting RDGSMODE. Since setting RDGSMODE disables a voltmeter interrupt, RDGSMODE should be set before the interrupt is enabled.

Syntax

RDGSMODE *mode* [USE *ch*]

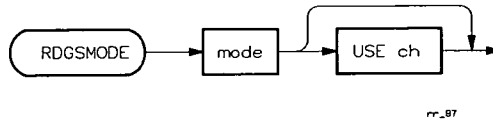

Parameters

mode

Specifies when data from the voltmeter can be read by the mainframe. This also specifies when an interrupt will occur and whether or not new readings will overwrite readings in the HP 44702A/B buffer. At power-on, *mode* = DAV.

mode	Definition
DAV	Data is available when any reading is in the buffer. Data is not overwritten. The scan is aborted if the buffer overflows. Data already in the buffer when it overflows remains valid and is readable. An interrupt occurs whenever data is available.
BURST	Data is available when the buffer has room for only 4096 more readings, or when the scan sequence completes. Data is not overwritten as the scan is aborted when the buffer overflows. The interrupt occurs when data becomes available or at the end of the scan sequence.
END	Data is available when any reading is in the buffer. Data is not overwritten as the scan is aborted when the buffer overflows. An interrupt occurs at the end of the scan sequence.
COMPLETE	Data is available when the scan sequence completes. Buffer content consists of the data acquired by the number of prescans immediately preceding the stop trigger plus the number of postscans immediately after. Data will be overwritten. An interrupt occurs at the end of the scan sequence.

USE *ch* Voltmeter slot number. See Glossary.

Remarks

Aborted Readings

If the reading storage memory (buffer) overflows in either DAV, BURST, or END modes, the scan will be aborted at that point. The readings in memory are preserved.

Data Acquired with RDGSMODE COMPLETE

When RDGSMODE COMPLETE is specified, the voltmeter buffer trims all readings from the buffer except those acquired through the number of prescans specified plus the number of postscans specified (PRESCAN + POSTSCAN). If the number of prescans plus postscans fill the buffer, the last integral number of scans that fit are stored. For example, if four prescans and seven postscans are specified and the buffer has only enough room for the data generated by nine scans, when the scan sequence completes the buffer will contain the data from the seven postscans and the last two prescans.

Changing RDGSMODE Disables Voltmeter Interrupts

Since *changing* RDGSMODE disables all HP 44702A/B interrupts, you must enable the voltmeter interrupt after setting RDGSMODE.

Data Returned

None

Related Commands

RDGS, USE

RDGSMODE (cont)

Examples Example: Using the RDGSMODE Command

This example programs the HP 44702A/B voltmeter to make 100 DC voltage measurements on 10 passes through the channel list. RDGSMODE END is set so that after the 10 scans have completed, the voltmeter will interrupt and a mainframe subroutine will be called. The subroutine transfers the readings from the voltmeter to an array in mainframe memory and then displays the message: "SCANS ARE COMPLETE".

The TIME command has been included in this program in order to determine approximately how long it takes for the channels to be scanned and measured. A reading of the mainframe's clock is taken at the time the voltmeter is triggered and again when the subroutine is called. The difference between those times represents the time required to take the measurements.

```
10  OUTPUT 709;"RST"                !Reset HP 3852A
20  OUTPUT 709;"REAL T1,T2"         !Declare timing variables
30  OUTPUT 709;"REAL SCRDCGS (99)"  !Declare mainframe array for rdgs
40  OUTPUT 709;"SUB TSTMP"         !Define subroutine
50  OUTPUT 709;"TIME INTO T2"      !Read time at which sub is called
60  OUTPUT 709;"XRDCGS 500 INTO SCRDCGS" !Transfer readings to memory
70  OUTPUT 709;"VREAD (T2-T1)"     !Determine time for measurements
80  OUTPUT 709;"DISP'SCANS ARE COMPLETE'"
90                                !Display message on front panel
100 OUTPUT 709;"SUBEND"            !End of subroutine
110 OUTPUT 709;"USE 500"           !Use the vm in slot 5
120 OUTPUT 709;"ON INTR CALL TSTMP" !Call sub when scans complete
130 OUTPUT 709;"SCANMODE ON"      !Turn scanner mode on
140 OUTPUT 709;"CONF DCV"         !Configure for DC voltage
150 OUTPUT 709;"RDGSMODE END"     !Interrupt when scans are complete
160 OUTPUT 709;"CLWRITE SENSE 400-409" !Define channel list
170 OUTPUT 709;"PRESCAN 5"       !Make 5 scans before stop trigger
180 OUTPUT 709;"POSTSCAN 5"      !Make 5 scans after stop trigger
190 OUTPUT 709;"ENABLE INTR"     !Enable voltmeter to interrupt
200 OUTPUT 709;"ENABLE INTR SYS"  !Sense the backplane interrupt
210 OUTPUT 709;"SCTRIG INT"      !Issue scan triggers internally
220 OUTPUT 709;"TIME INTO T1"     !Record time at start of scans
230 ENTER 709;A                   !Enter time into controller
240 PRINT A                       !Display time
250  END
```

When this program completes, "SCANS ARE COMPLETE" will be displayed on the mainframe and the time it took to make the measurements will be displayed on the controller. Since the CONF command sets SCDELAY and SPER to 1 msec, approximately .100 (100 msec) should be displayed.

- HP 44723A 16-Channel High-Speed Digital Sense/Control

- Description** Selects the mode for the READ, READM, WRITE, and WRITEM commands.
- Prerequisites** Requires mainframe firmware revision 3.0 or greater.
- Syntax** **RDGSMODE** *mode* [USE *ch*]

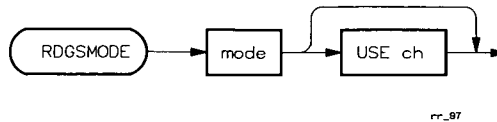

Parameters

mode Selects the mode for READ/READM and WRITE/WRITEM. Valid *mode* = DAV or IMMED (power-on/reset). Specifying any input channel (ES00 - ES15) sets the mode for READ and READM. Specifying any output channel (ES16 - ES31) sets the mode for WRITE and WRITEM. (RDGSMODE does not affect CHREAD, CHREADM, CHWRITE, or CHWRITEM).

- READ/READM *mode*:

For USE *ch* = ES00-ES15, RDGSMODE sets the mode for the READ/READM commands. The READ/READM commands read the contents of the second rank input register. The data read by the READ/READM commands depends on the RDGSMODE, TRIGMODE, SRTRIG, and TRIG command settings.

With RDGSMODE IMMED, READ/READM always immediately reads the contents of the second rank input register. Therefore, with RDGSMODE IMMED, READ/READM may read old data.

With RDGSMODE DAV, if there is no "new" data in the first rank input register, READ/READM waits for a first rank input trigger and then reads the contents of the second rank input register. ("New" data is defined as having received a first rank input trigger since the last second rank input trigger.)

If there is new data in the first rank input register or if TRIG INT is set, READ/READM immediately reads the contents of the second rank input register. Note that SRTRIG INT must be set when RDGSMODE DAV is set.

- WRITE/WRITEM *mode*:

For USE *ch* = ES16-ES31, RDGSMODE sets the mode for the WRITE/WRITEM commands. The WRITE/WRITEM commands write data to the first rank output register. The mode for the WRITE/WRITEM commands depends on the RDGSMODE and SRTRIG command settings.

With RDGSMODE IMMED, WRITE/WRITEM always immediately writes data to the first rank output register. Therefore, with RDGSMODE IMMED,

RDGSMODE (cont)

WRITE/WRITEM may overwrite the contents of the first rank output register.

With RDGSMODE DAV, if the last data written to the first rank output register has not been copied to the second rank output register, WRITE/WRITEM waits until a second rank output trigger is received before writing new data. If SRTRIG INT is set, WRITE/WRITEM will immediately write to the first rank output register, since the required second rank output trigger will be generated by WRITE/WRITEM.

USE *ch* For *ch* = ES00-ES15, RDGSMODE sets the mode for READ/READM. For *ch* = ES16-ES31, RDGSMODE sets the mode for WRITE/WRITEM.

Remarks

Data Returned

None

Examples

Example: Read Most Recently Sampled Input State

This program reads the most recently sampled state of all input channels for an HP 44723A in slot 2 of the mainframe. Since RDGSMODE DAV and TRIG EXT are set, the READ command waits until a first rank input trigger is received (HL transition on the external input). Data is then automatically copied to the second rank input register and read. Since TRIGMODE ALL is set, the data returned by READ is the most recently sampled state of the input channels in slot 200.

```
10 OUTPUT 709;"USE 200"           !Use mainframe slot 2
20 OUTPUT 709;"TRIG EXT"         !First rank input trig on external input
30 OUTPUT 709;"SRTRIG INT"       !Second rank trigger when READ executed
40 OUTPUT 709;"RDGSMODE DAV"     !Wait for new data before reading
50 OUTPUT 709;"READ 200"         !Read second rank input reg in slot 2
60 ENTER 709;A                   !Enter result
70 PRINT "Slot 200 state = ";A    !Display result
80 END
```

If the most recently sampled state has channels 201, 207, and 211 HIGH and all other channels LOW, a typical return is:

```
Slot 200 state = 2178
```

- HP 44721A 16-Channel Digital Input
- HP 44722A 8-Channel Digital Input

Description

Reads the state of the specified channels a specified number of times.

Prerequisites

The *[number]* parameter is valid only for mainframe firmware revision 3.0 and greater.

Syntax

READ *slot* [**INTO** *name*] or [*fmt*]

or

READ *slot* [*number*] [**INTO** *name*] or [*fmt*]

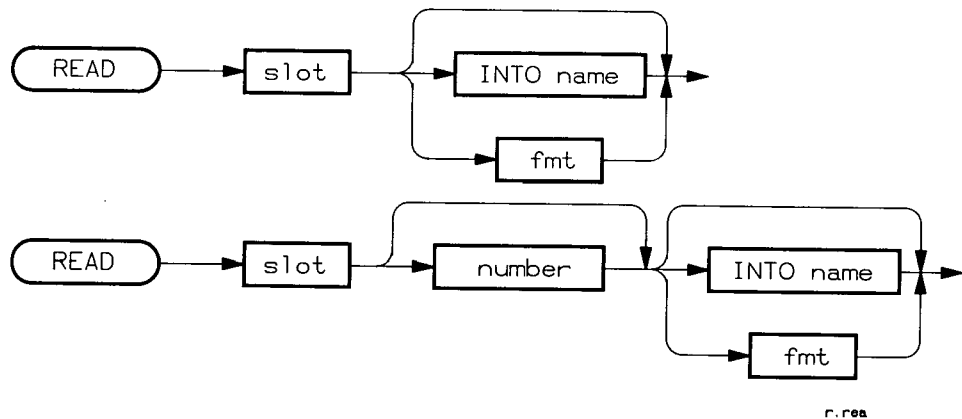

Parameters

slot Address of slot. See Glossary.

number Number of times the slot specified by *slot* is read. Default *number* = 1.

INTO *name* See Glossary.

fmt See Glossary. Default format is IASC.

Remarks

READ Reads States Only

The READ command reads the state (0 or 1) of all channels in the slot (does not read the number of counts on the channels).

Data Returned

If an ASCII format is specified, the data returned is the decimal equivalent of the bit pattern for the channels, where 0 = input is DC LOW or AC OFF and 1 =

READ (cont)

input is DC HIGH or AC ON. Range of returned values = -32768 to +32767. The LSB = channel ES00 state and the MSB = channel ES15 state. For the HP 44722A, the upper eight bits are 0.

Related Commands

CHREAD, CHREADM

Examples

Example: Read Slot State

This program reads the state of all channels of an HP 44721A in slot 2 of the mainframe and displays the decimal equivalent of the bit pattern. The channel states are read five times.

```
10 INTEGER A(1:5)           !Dimension controller array
20 OUTPUT 709;"READ 200,5"  !Read slot 200 state five times
30 ENTER 709;A(*)          !Enter decimal equiv of states
40 FOR I=1 TO 5            !Start print loop
50 PRINT "Reading";I;" ";A(I) !Display decimal equiv of states
60 NEXT I                  !Increment loop
70 END
```

If the inputs to channels 200, 205, and 209 remain HIGH and the inputs to the other channels in slot 200 remain LOW during the read times, the value returned by each READ is 545 which is the decimal equivalent of channel bit pattern 0000 0010 0010 0001 (512 + 32 + 1). A typical return follows.

```
Reading 1 : 545
Reading 2 : 545
.
.
Reading 5 : 545
```

For HP 9000 Series 200/300 controllers (and equivalent), the BASIC command IVAL\$ can be used to convert the decimal value returned by READ to the equivalent bit pattern. For this program, replace line 50 with the following line:

```
50 PRINT "Reading";I;" ";IVAL$(A(I),2)
```

Then, a typical return with the input to channels 200, 205, and 209 of an HP 44721A HIGH and the other channels LOW is as follows, where the MSB is the channel 215 state and the LSB is the channel 200 state.

```
Reading 1 :0000001000100001
Reading 2 :0000001000100001
.
.
Reading 5 :0000001000100001
```

• HP 44723A 16-Channel High-Speed Digital Sense/Control

Description

Reads the contents of the second rank input register a specified number of times.

Prerequisites

Requires mainframe firmware revision 3.0 or greater.

Syntax

READ *slot* [*number*] [*INTO name*] or [*fmt*]

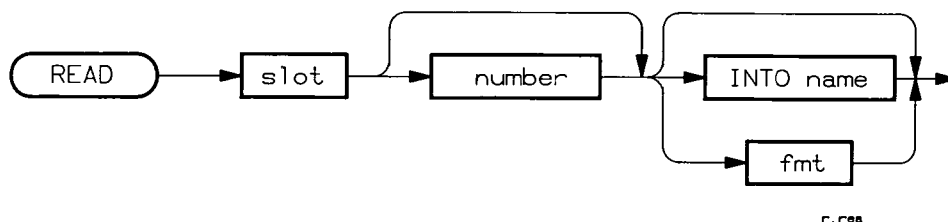

Parameters

slot Address of slot. See Glossary.

number Specifies the number of times the second rank input register is read. Default *number* = 1.

INTO name See Glossary.

fmt See Glossary. Default format is IASC.

Remarks

Interaction With RDGSMODE, SRTRIG, TRIG, and TRIGMODE

The READ command always reads the contents of the second rank input register. The second rank input register contents depend on the setting of the RDGSMODE, SRTRIG, TRIG, and TRIGMODE commands.

If SRTRIG INT is set, a second rank input trigger is generated immediately before the second rank input register is read. If both TRIG INT and SRTRIG INT are set, READ returns the current state of the input channels. Multiple reads with READ (or READM) on a slot without intervening second rank triggers will return identical data.

Data Returned

Reads the contents of the second rank input register in the slot specified by *slot*. If an ASCII data format is specified, the data returned is the decimal equivalent of the bit pattern(s). Range of returned values is -32768 to +32767, with the LSB = channel ES00 state and the MSB = channel ES15 state. A "1" returned for a channel indicates a HIGH input while a "0" indicates a LOW input.

Related Commands

RDGSMODE, READM, SRTRIG, TRIG, TRIGMODE

READ (cont)

Examples

Example: High-Speed Read - Current Input Channel States

This program uses the READ command to take 1000 readings of the current state of all input channels of an HP 44723A in slot 2 of the mainframe at an approximate 150 kHz rate. Readings are taken from the the second rank input register and stored in mainframe array A. (Note that storage in a mainframe array is required to achieve 150,000 readings per second rate.) Since RDGSMODE IMMED, SRTRIG INT, and TRIG INT are set, the READ command immediately reads the current state of the input channels in slot 2.

```
10  INTEGER B(1:1000)           !Dimension controller array
20  OUTPUT 709;"INTEGER A(999)" !Define mainframe array
30  OUTPUT 709;"USE 200"       !Use slot 2 in mainframe
40  OUTPUT 709;"RDGSMODE IMMED" !Immediate mode for READ cmd
50  OUTPUT 709;"TRIG INT"     !First rank input trigger on READ
60  OUTPUT 709;"SRTRIG INT"   !Second rank input trigger on READ
70  OUTPUT 709;"READ 200,1000 INTO A" !Read slot 1000 times, store in A
80  OUTPUT 709; "VREAD A"     !Transfer rdgs to output buffer
90  ENTER 709;B(*)           !Enter decimal equiv of states
100 FOR I=1 TO 1000          !Start print loop
110 PRINT "Reading";I;" ";B(I) !Display decimal equiv of states
120 NEXT I                   !Increment loop
130 END
```

If channel 201, 209, and 215 states remain HIGH during the read time, the value returned for each read is -32254 which is the decimal equivalent of 1000 0010 0000 0010 (-32768 + 512 + 2). A typical return for this program with channel 201, 209, and 215 states HIGH follows.

```
Reading 1 : -32254
Reading 2 : -32254
.
.
Reading 1000 : -32254
```

For HP 9000 Series 200/300 controllers (and equivalent), the BASIC command IVAL\$ can be used to convert the decimal value returned by READ to the equivalent bit pattern. For this program, replace line 110 with the following line. A typical return for channels 201, 209, and 215 HIGH follows, where the MSB is the channel 215 state and the LSB is the channel 200 state.

```
110 PRINT "Reading";I;" ";IVAL$(B(I),2)

Reading 1 :1000001000000010
Reading 2 :1000001000000010
.
.
Reading 1000 :1000001000000010
```

- HP 44724A 16-Channel Digital Output
- HP 44725A 16-Channel General Purpose Switch
- HP 44728A 8-Channel Relay Actuator
- HP 44729A 8-Channel Power Controller

Description

Reads the state of the specified channels a specified number of times.

Prerequisites

The *[number]* parameter is valid only for mainframe firmware revision 3.0 and greater.

Syntax

READ *slot* [**INTO** *name*] or [*fmt*]

or

READ *slot* [*number*] [**INTO** *name*] or [*fmt*]

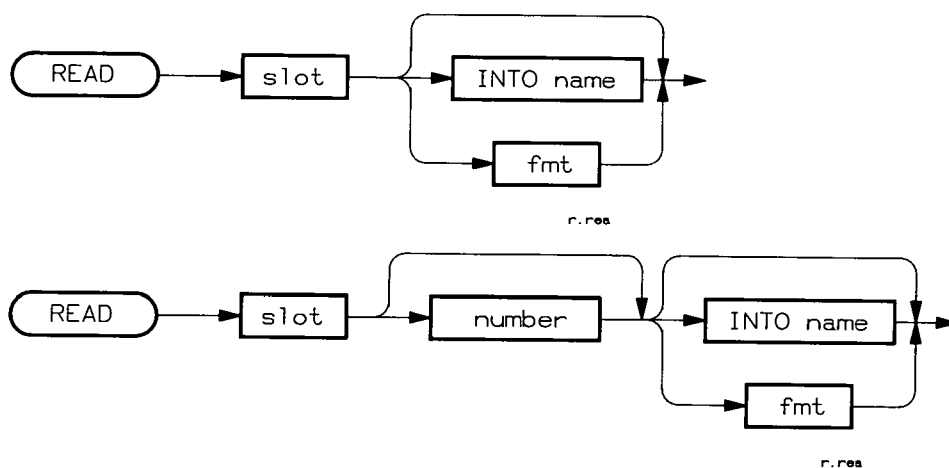

Parameters

slot Address of slot. See Glossary.

number Number of times the slot specified by *slot* is read. Default *number* = 1.

INTO *name* See Glossary.

fmt See Glossary. Default format is IASC.

Remarks

Data Returned

If an ASCII format is specified, the data returned is the decimal equivalent of the bit pattern for the channels, where 0 = channel open and 1 = channel closed. Range of returned values = -32768 to +32767. The LSB = channel ES00 state and the MSB = channel ES15 state. For the HP 44728A and HP 44729A, the upper eight bits are 0.

READ (cont)

Related Commands

CLOSE?

Examples

Example: Read Slot State

This program reads the state of all channels of an HP 44724A in slot 2 of the mainframe and displays the decimal equivalent of the bit pattern.

```
10 INTEGER A                !Dimension controller array
20 OUTPUT 709;"READ 200"    !Read slot 200 state
30 ENTER 709;A              !Enter decimal equiv of state
40 PRINT "Slot 200 State =";A !Display decimal equiv of state
50 END
```

For an HP 44724A, if channels 200, 205, and 209 are closed and the other channels in slot 200 are open, the value returned by READ is 545 which is the decimal equivalent of channel bit pattern 0000 0010 0010 0001 (512 + 32 + 1). A typical return follows.

```
Slot 200 State = 545
```

For HP 9000 Series 200/300 controllers (and equivalent), the BASIC command IVAL\$ can be used to convert the decimal value returned by READ to the equivalent bit pattern. For this program, replace line 50 with the following line:

```
50 PRINT "Slot 200 State = ;IVAL$(A(1),2)
```

Then, a typical return with channels 200, 205, and 209 of an HP 44724A closed and the other channels open follows, where the MSB is the channel 215 state and the LSB is the channel 200 state.

```
Slot 200 State = 0000001000100001
```

- HP 44721A 16-Channel Digital Input
- HP 44722A 8-Channel Digital Input

Description

Reads the state of the digital input channels in the slot(s) specified and returns the decimal equivalent of channel bit pattern(s).

Prerequisites

Requires mainframe firmware revision 3.0 or greater.

Syntax

READM *slot_list* [INTO *name*] or [*fmt*]

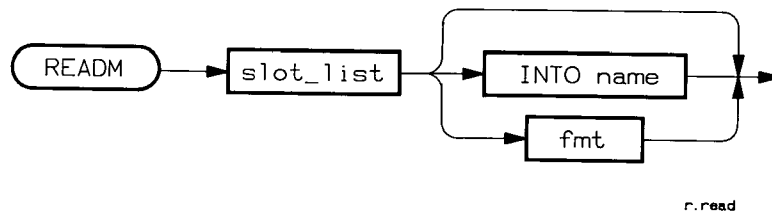

Parameters

slot_list Address of slot(s) to be read. See Glossary.

INTO *name* See Glossary.

fmt See Glossary. Default format is IASC.

Remarks

READM Reads States Only

The READM command reads the state (0 or 1) of all channels in the slot(s) specified (does not read the number of counts on the channels).

Data Returned

If an ASCII data format is specified, the data returned is the decimal equivalent of the channel bit pattern(s). The range of returned values is -32768 to +32767, where the LSB = channel ES00 state and the MSB = channel ES15 state. For the HP 44722A, the upper eight bits are 0.

Related Commands

CHREAD, READ

Examples

Example: Read Slot State

This program reads the state of all channels for HP 44721As in slots 2 and 3 of the mainframe and returns the decimal equivalent of the channel bit patterns.

```

10  INTEGER A(0:1)           !Dimension controller array
20  OUTPUT 709;"READM 200,300" !Read slot 200, 300 states
30  ENTER 709;A(*)          !Enter decimal equiv of states
40  PRINT A(*)              !Display decimal equiv of states
50  END
  
```

READM (cont)

If the inputs to channels 201, 205, and 210 are HIGH and the inputs to the other slot 200 channels are LOW, the value returned for slot 200 is 1058 which is the decimal equivalent of 0000 0100 0001 0010 ($1024 + 32 + 2$).

If the inputs to channels 301, 309, and 315 are HIGH and the inputs to the other slot 300 channels are LOW, the value returned for slot 300 is -32254 which is the decimal equivalent of 1000 0010 0000 0010 ($-32768 + 512 + 2$). A typical return is:

1058 -32254

• HP 44723A 16-Channel High-Speed Digital Sense/Control

Description

Reads the contents of the second rank input register(s) for all HP 44723A accessories in specified slot(s).

Prerequisites

Requires mainframe firmware revision 3.0 or greater.

Syntax

READM *slot_list* [**INTO** *name*] or [*fmt*]

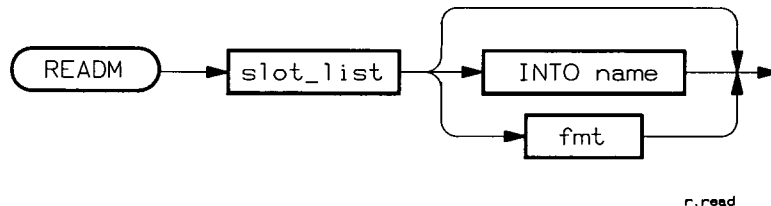

Parameters

slot_list Address of slot(s) to be read. See Glossary.

INTO *name* See Glossary.

fmt See Glossary. Default format is IASC.

Remarks

Interaction With RDGSMODE, SRTRIG, TRIG, and TRIGMODE

The READM command always reads the contents of the second rank input register(s). The second rank input register contents depend on the setting of the RDGSMODE, SRTRIG, TRIG, and TRIGMODE commands.

If SRTRIG INT is set, a second rank input trigger is generated immediately before the second rank input register is read. If both TRIG INT and SRTRIG INT are set, READM returns the current state of the input channels in the slot(s) addressed. Multiple reads with READM (or READ) on a slot without intervening second rank triggers will return identical data.

Data Returned

Reads the contents of the second rank input register(s) in the slot(s) specified by *slot_list*. If an ASCII data format is specified, the data returned is the decimal equivalent of the bit pattern(s). Range of returned values is -32768 to +32767, with the LSB = channel ES00 state and the MSB = channel ES15 state. A "1" returned for a channel indicates a HIGH input while a "0" indicates a LOW input.

Related Commands

RDGSMODE, READ, SRTRIG, TRIG, TRIGMODE

READM (cont)

Examples

Example: Read Current Input Channel States

This program reads the current states of all input channels for HP 44723A accessories in slots 1 and 2 of the mainframe. The states are read from the second rank input registers. Since TRIG INT, SRTRIG INT, and RDGSMODE IMMED are set, the READM command returns the current state of the input channels in slots 1 and 2.

```
10  INTEGER A(0:1)           !Dimension controller array
20  OUTPUT 709;"USE 100"     !Use slot 1 in mainframe
30  OUTPUT 709;"TRIG INT"   !First rank input trigger on READM
40  OUTPUT 709;"SRTRIG INT" !Second rank input trigger on READM
50  OUTPUT 709;"RDGSMODE IMMED" !Read sec rank input reg immed
60  OUTPUT 709;"USE 200"     !Use slot 2 in mainframe
70  OUTPUT 709;"TRIG INT"   !First rank input trigger on READM
80  OUTPUT 709;"SRTRIG INT" !Second rank input trigger on READM
90  OUTPUT 709;"RDGSMODE IMMED" !Read sec rank input reg immed
100 OUTPUT 709;"READM 100-200" !Read slot 100 and 200 input states
110 ENTER 709;A(*)         !Enter decimal equiv of states
120 PRINT A(*)            !Display decimal equiv of states
130  END
```

If channel 101, 105, and 110 states are HIGH, the value value returned for slot 1 is 1058 which is the decimal equivalent of 0000 0100 0010 0010 (1024 + 32 + 2). If channel 201, 209, and 215 states are HIGH, the value returned for slot 2 is -32254 which is the decimal equivalent of 1000 0010 0000 0010 (-32768 + 512 + 2). For these conditions, a typical return is:

```
1058 -32254
```

- Mainframe

Description Defines a REAL (RL64) variable or array in HP 3852A mainframe memory.

Prerequisites None

Syntax **REAL** *name* [(*max_index*)] [*name* [(*max_index*)] ...]

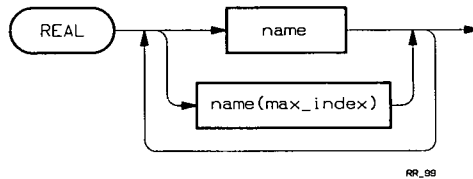

Parameters

name Name of the REAL variable or array. *name* must be a string <= eight characters. It cannot begin with a digit and can contain only letters, digits, '_', or '?'.

max_index Maximum index (number of elements) of the REAL array. *name* without *max_index* specifies a REAL variable, while *name (max_index)* specifies the name and the number of elements in a REAL array. Parentheses are required around the *max_index* number. Note that *max_index* = 0 declares a one-element array, not a variable.

Since array indices begin at 0, the number of elements in the array = *max_index* + 1. For example, REAL A(9) defines a REAL array of 10 elements, with elements 0 through 9.

Remarks

Redeclaring Arrays

Executing REAL declares a REAL array and fills the elements with zeroes. If a REAL array is redeclared, it must remain a REAL array. The redeclared array will be set up with zeroes in all elements. (If the array is redeclared to the same size, it will just be zeroed.)

Arrays and Variables are Global

All arrays and variables are global. Therefore, arrays and variables defined outside a subroutine are accessible in the subroutine and vice-versa.

REAL (cont)

REAL Statement Stored in Subroutine

If a REAL statement is stored in a subroutine, the array name is defined immediately but data storage for the array is not allocated until the subroutine is run. (The name cannot be used for another subroutine name, another array name, or a variable name.)

Recovering Storage Space With DELVAR

Send the DELVAR command to recover storage space allocated by the REAL command. The array name and type remain defined, but the memory allocated to the array is released. That is, the array becomes a REAL array with zero space.

Data Returned

None

Related Commands

INTEGER, PACKED, DIM, DELVAR

Examples

Example: Declaring a REAL Array

The following program declares a REAL array to store 10 readings. Other commands are included to show when an array must be declared relative to when data is available to be stored.

```
10 OUTPUT 709;"REAL RGS(9)"           !Declares array to store 10 readings
20 OUTPUT 709;"CONFMEAS DCV, 0-9, USE 700, INTO RGS"
30                                     !Take measurements, store in
40                                     !array RGS
50 END
```

Example: Declaring a REAL Variable

This program declares a REAL variable then assigns a number to that variable.

```
10 OUTPUT 709;"REAL A"                 !Declare variable A
20 OUTPUT 709;"LET A=5"                 !Assign the number 5 to the variable
30 END
```

REQUEST/RELEASE

- Mainframe

Description

Dedicates resources (e.g. voltmeters, arrays, etc.) to the task which requests a lock. Other tasks which request the same lock (i.e. resources) must wait until the lock is released.

Prerequisites

Requires firmware revision 3.5 or greater and the HP 3852A must be in the multitasking mode. Also, the number of locks to be requested must have been made available by the NLOCKS command.

Syntax

REQUEST *number*

or

RELEASE *number*

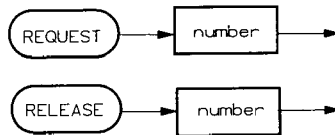

Parameters

number

Number of the lock which is requested or released. Up to 10 locks can exist. The range for *number* is 0 to 9.

Remarks

Requesting a Lock versus Disabling Swapping

Requesting a lock is similar to executing DISABLE EOL SWAP. Under both conditions, program resources such as a voltmeter, an array, or a process are dedicated to the task which is currently active. When DISABLE EOL SWAP is set, however, swapping does not occur on command completion or when the time-slice period expires. A new task begins execution only when the current task finishes.

When a lock is requested, swapping occurs with tasks which have requested a different lock or which have not requested a lock at all. A swap will not occur to a task which has requested the same lock until the lock is released. This prevents multiple tasks from accessing the same resources which, in turn, may invalidate stored data or alter accessory configurations.

Again, a lock is used to dedicate resources to a specific task, yet allow swapping to continue between tasks which access different resources.

Exercise Caution When Using Locks

The use of locks in a multitasking system will often not be necessary. ENABLE/DISABLE EOL SWAP is much easier to use and will satisfy most applications. If locks are to be used, note that a task (i.e. front panel, HP-IB,

REQUEST/RELEASE (cont)

interrupt, run task) can release locks requested by other tasks. Also, if a task has not requested a lock, or if it has a lock requested by no other tasks, nothing prevents the task from accessing the resources in the other locks.

Locks Require Mainframe Memory for Overhead

When locks are used, memory is required for the overhead which manages the locks. This memory is taken from mainframe memory and is no longer available to the user. Refer to the NLOCKS command to determine the amount of memory allocated.

Data Returned

None

Related Commands

DISABLE EOL SWAP, ENABLE EOL SWAP, NLOCKS

Examples

Example: How REQUEST/RELEASE Work

The following program shows where REQUEST/RELEASE could be placed in a multitasking program and how the system responds when they are used.

The program downloads four subroutines (A,B,C,D) and directs them to run tasks (0,1,2,3). Subroutines A and B request lock 0, and subroutines C and D request lock 1. What this program demonstrates is that subroutines A and C (tasks 0 and 2) will swap between each other since each has requested a different lock. Subroutine B, however, will not become active until subroutine A releases the lock. The same holds true for subroutines C and D. This is illustrated by having each subroutine read the mainframe's clock at the point the subroutine becomes active.

```
10  OUTPUT 709;"TSLICE .065"  
20  OUTPUT 709;"NTASKS 4,4"  
30  OUTPUT 709;"NLOCKS 2"  
40  OUTPUT 709;"ENABLE MULTI"  
50  OUTPUT 709;"END OFF"  
60  OUTPUT 709;"OUTBUF ON"  
70  OUTPUT 709;"SET TIME 0"  
80  OUTPUT 709;"INTEGER I,J"  
90  OUTPUT 709;"REAL T1,T2,T3,T4,VR(8),VR1(8)"  
100 !  
110 !  
120 OUTPUT 709;"SUB A"  
130 OUTPUT 709;"  REQUEST 0"  
140 OUTPUT 709;"  TIME INTO T1"  
150 OUTPUT 709;"  USE 700"  
160 OUTPUT 709;"  FOR I =600 TO 604"  
170 OUTPUT 709;"    CONFMEAS DCV I INTO VR"  
180 OUTPUT 709;"    SUSPEND .2"  
190 OUTPUT 709;"  NEXT I"  
200 OUTPUT 709;"  RELEASE 0"  
210 OUTPUT 709;"SUBEND"
```

REQUEST/RELEASE (cont)

```
220 !
230 !
240 OUTPUT 709;"SUB B"
250 OUTPUT 709;" REQUEST 0"
260 OUTPUT 709;" TIME INTO T2"
270 OUTPUT 709;" USE 700"
280 OUTPUT 709;" FOR I=200 TO 203"
290 OUTPUT 709;" CONFMEAS TEMPT I INTO VR"
300 OUTPUT 709;" SUSPEND .2"
310 OUTPUT 709;" NEXT I"
320 OUTPUT 709;" RELEASE 0"
330 OUTPUT 709;"SUBEND"
340 !
350 !
360 OUTPUT 709;"SUB C"
370 OUTPUT 709;" REQUEST 1"
380 OUTPUT 709;" TIME INTO T3"
390 OUTPUT 709;" USE 400"
400 OUTPUT 709;" FOR J = 605 TO 609"
410 OUTPUT 709;" CONFMEAS DCV J INTO VR1"
420 OUTPUT 709;" SUSPEND .2"
430 OUTPUT 709;" NEXT J"
440 OUTPUT 709;" RELEASE 1"
450 OUTPUT 709;"SUBEND"
460 !
470 !
480 OUTPUT 709;"SUB D"
490 OUTPUT 709;" REQUEST 1"
500 OUTPUT 709;" TIME INTO T4"
510 OUTPUT 709;" USE 400"
520 OUTPUT 709;" FOR J = 204 TO 207"
530 OUTPUT 709;" CONFMEAS TEMPT J INTO VR1"
540 OUTPUT 709;" SUSPEND .2"
550 OUTPUT 709;" NEXT J"
560 OUTPUT 709;" SIGNAL HPIB"
570 OUTPUT 709;" RELEASE 1"
580 OUTPUT 709;"SUBEND"
590 !
600 !
610 OUTPUT 709;"RUN 0 A"
620 OUTPUT 709;"RUN 1 B"
630 OUTPUT 709;"RUN 2 C"
640 OUTPUT 709;"RUN 3 D"
650 !
660 !
670 OUTPUT 709;"WAITFOR SIGNAL"
680 OUTPUT 709;"VREAD T1"
690 OUTPUT 709;"VREAD T2"
700 OUTPUT 709;"VREAD T3"
710 OUTPUT 709;"VREAD T4"
720 ENTER 709;A,B,C,D
730 PRINT "TASK 0 TASK 1 TASK 2 TASK 3"
740 PRINT
750 PRINT A,B,C,D
```

REQUEST/RELEASE (cont)

```
760 PRINT
770 !
780 !
790 OUTPUT 709;"VREAD VR"
800 OUTPUT 709;"VREAD VR1"
810 REAL V_t_rdgs(0:17)
820 ENTER 709;V_t_rdgs(*)
830 FOR I=0 TO 8
840     PRINT V_t_rdgs(I)
850 NEXT I
860 PRINT
870 FOR I=9 TO 17
880     PRINT V_t_rdgs(I)
890 NEXT I
900 END
```

As this program executes, the following is displayed:

TASK 0	TASK 1	TASK 2	TASK 3
.401	2.43	.495	2.614
5.08981			
.624214			
.650566			
.671701			
.687729			
25.89453			
25.875			
25.66113			
25.83496			
.587904			
.631499			
.654341			
.673165			
.686171			
25.77626			
25.74751			
25.68312			
25.69256			

Notice by the times shown that subroutine A (task 0) became active first followed by subroutine C (task 2). Again, this is due to the fact that subroutine C requested a different lock than subroutine A. Subroutines B and D which requested the same locks as A and C respectively, had to wait until the locks were released.

Note that subroutines A and C measure voltage and subroutines B and D measure temperature. Since B and D were prevented from using the resources (voltmeter, array) until released by A and C, the measurements were kept separate within the arrays.

- Mainframe

Description

See **RST** Command

ROTATE

• Binary Function

Description

Binary function. Returns an integer which equals the value obtained by rotating the 16-bit binary representation of the argument the number of bit positions specified. As the bits rotate, they wraparound. The ROTATE function does not change the original value of the argument.

Prerequisites

The ROTATE function is only available with firmware revision 3.0 or greater.

Syntax

ROTATE (*number bit_displacement*)

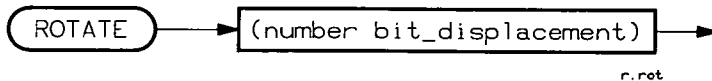

Parameters

number Number or numeric expression that must evaluate within the range -32768 to +32767.

bit_displacement Number or numeric expression that must evaluate within the range -32768 to +32767. The recommended range is -15 to +15.

Remarks

Direction of Rotation

The number or numeric expression specified is converted to 16-bit, two's complement form. If the bit displacement is positive, the rotation is towards the least significant bit. If the bit displacement is negative, the rotation is towards the most significant bit.

Data Returned

See Description.

Related Commands

SHIFT

Examples

Example: Demonstrating the ROTATE Function

In the following example, the binary representation of 1 is rotated five bit positions towards the most significant bit (displacement is negative). The result is then entered into the controller and displayed.

```
10 OUTPUT 709;"VREAD ROTATE (1,-5)"
20 ENTER 709;A
30 PRINT A
40 END
```

32

The binary representation of 1 is:

```
0000 0000 0000 0001
```

Upon execution of the ROTATE function, the binary representation rotates five bit positions and appears as shown below:

```
0000 0000 0010 0000
```

This representation is equivalent to decimal 32, which is the value displayed by the controller.

RQS

• Mainframe

Description

Enables the mainframe to send an SRQ message to the controller and sets the RQS mask over the status register to allow only selected conditions to generate an SRQ message.

Prerequisites

None

Syntax

RQS *mode* or *unmask*

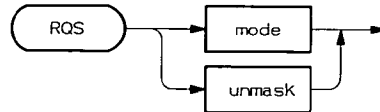

RR_100

Parameters

mode

Enables the mainframe to send an SRQ message to the controller when the specified condition occurs. Power-on *mode* = ON.

mode	Description
ON	Mainframe SRQ capability enabled.
OFF	Mainframe SRQ capability disabled.

unmask

Specifies the bit(s) in the mainframe status register that will be unmasked. Setting an unmasked bit also sets the service request bit (if *mode* ON) which sends the SRQ message to the controller. The bits to be unmasked are specified by a mnemonic or by their binary weight. Several bits can be unmasked at the same time by listing each bit's mnemonic or by entering the sum of their binary weights.

At power-on, all bits are cleared except bit 3 (LCL,8) which retains the state it had at the last power down.

Remarks

Status Register Bit Definitions

The mainframe status register constantly monitors potential interrupt conditions. When an interrupt condition occurs, the appropriate bit in the status register is set TRUE (1). If that bit is unmasked and RQS ON is set, an SRQ message is generated on the 0 to 1 transition of the bit. Status register bit definitions follow, with the decimal numbers and mnemonics used to unmask the bits.

Bit	Mnemonic	Decimal	Interrupt Conditions
15-12	-	-	Not used.
11	ALRM	2048	Set TRUE (1) when alarm occurs. Execute STA? to clear bit.

RQS (cont)

Bit	Mnemonic	Decimal	Interrupt Conditions
10	LMT	1024	Set TRUE (1) when limit reached. Execute STA? to clear bit.
9	INTR	512	Set TRUE (1) when interrupt occurs on accessory channel. Bit not set unless ENABLE INTR SYS and ENABLE INTR [USE ch] are set. Execute STA? to clear bit.
8	-	-	Not used.
7	-	-	Not used.
6	-	64	Service request bit. Set TRUE (1) when any other unmasked bits in status register go from FALSE (0) to TRUE (1) and when RQS ON is set. Execute a Serial Poll (SPOLL) or STB? to clear the bit.
5	ERR	32	Set TRUE (1) when error (programming, configuration, etc.) occurs. Execute ERR? or ERRSTR? (max of four) to empty the error buffer and clear the bit.
4	RDY	16	Set TRUE (1) when mainframe input buffers (HP-IB and front panel) are empty and no command or subroutine is executing or being accepted (i.e., a partial command leaves RDY clear even though the buffer is empty). Bit is cleared when byte received or when another interrupt occurs.
3	LCL	8	Set TRUE (1) when the HP 3852A turned on or when the LOCAL key causes the mainframe to enter the local operating state. Execute STA? to clear bit.
2	FPS	4	Set TRUE (1) when SRQ command is executed. Execute STA? to clear bit.
1	PWR	2	Set TRUE (1) when mainframe loses power. Bit is set when mainframe power supply goes below +18V or when an HP 3853A which is connected to the HP 3852A is turned off. Bit cleared when power restored to mainframe (or extender).
0	DAV	1	Set TRUE (1) when data returned from a command is available in HP-IB output buffer. Bit is cleared by CLROUT command or when data is otherwise removed from the output buffer.

RQS (cont)

Power-On Status

At power-on, all *unmask* bits are cleared except bit 3 (LCL,8). Bit 3 retains the state it was in at the last power down.

Clearing The RQS Mask

A Device Clear, the CLR command, and the front panel CLEAR key will mask all bits in the status register. Entering a decimal 0 or the mnemonic NONE for the *unmask* parameter also masks all bits. The service request bit (bit 6 in the status register) is cleared by the CLR (CLEAR) command but can not be masked.

Note that *mode* OFF prevents any service request by disabling (but not clearing) the service request bit. OFF does not affect the mask. Setting *mode* ON enables (but does not set) the service request bit. This allows an SRQ message to be sent provided the particular status register bit(s) is unmasked when the interrupt occurs. ON also does not affect the mask.

SRQ Activation Requirement

The SRQ message to the controller is generated when the service request bit is enabled (RQS ON) and the unmasked status register bit changes from 0 to 1. The status register bit and the service request bit (bit 6) must be cleared before a recurring condition (bit transition from a 0 to 1) will again cause the SRQ message to be sent to the controller.

Priority Interrupts

When the service request bit is enabled and an interrupt occurs which sets an unmasked bit, the SRQ message is sent immediately to the controller. The HP 3852A, however, does not service the interrupt until the command that was executing when the interrupt occurred finishes. Servicing an interrupt is when the mainframe starts a polling to determine the type (alarm, limit), or channel that interrupted. When located, the interrupt capability is disabled (i.e. DISABLE INTR, DISABLE ALRM, or DISABLE LMT is performed) and the servicing is complete.

Alarm interrupts have the highest priority and are always serviced first should several interrupts occur simultaneously. Interrupt servicing continues with channel (accessory) interrupts, limit interrupts, and then command (ERR, FPS) interrupts.

When accessory channels interrupt, an interrupt on a channel in slot 0 will be serviced before an interrupt occurring in slot 7. This is due to the mainframe's polling routine which starts with the lowest numbered slot in the system and ends with the highest channel in the highest numbered slot. Thus channel 0 in slot 0 of the mainframe has the highest priority of any channel interrupt.

Data Returned

None

Related Commands

RQS?, SRQ, STA?, STB?, CLR

Examples

Example: Enabling The Service Request Bit and Setting The Mask

The following program uses the RQS command to enable the service request bit and unmask the INTR bit in the status register. The HP 44715A counter accessory is configured such that the interrupt will occur when the counter overflows, then the accessory is enabled. The controller will respond to the interrupt by displaying a predefined message.

```

10 ON INTR 7 GOTO Results           !Define event initiated branch
20 ENABLE INTR 7;2                 !Enable controller intr capability
30 OUTPUT 709;"RST"                !Reset the HP 3852A
40 OUTPUT 709;"STA?"              !Clear INTR bit in status register
50 OUTPUT 709;"RQS ON"            !Enable the service request bit
60 OUTPUT 709;"RQS INTR"          !Unmask INTR bit in status register
70 OUTPUT 709;"USE 203"           !Use channel 3 in slot 2
80 OUTPUT 709;"EDGE LH"           !Count positive edges
90 OUTPUT 709;"FUNC TOTAL"        !Set channel for TOTAL function
100 OUTPUT 709;"CNTSET -10"        !Overflow after 10 pos edges
110 OUTPUT 709;"ENABLE INTR"      !Enable channel to interrupt
120 OUTPUT 709;"ENABLE INTR SYS"  !Sense the backplane interrupt
130 OUTPUT 709;"TRIG SGL"         !Trigger once
140 GOTO 140                       !Loop until interrupt occurs
150 Results: !                     !Line label for branch
160 PRINT "Overflow on ch 203"     !Display message
170 A=SPOLL(709)                   !Clear HP 3852 service request bit
180 END

```

When the counter overflows, the INTR bit (bit 9) and the service request bit (bit 6) in the status register are set. Because the interrupt is handled by the controller, both bits must be cleared (STA? clears bit 9, SPOLL clears bit 6) before the controller can respond to the next channel interrupt that occurs.

RQS?

- Mainframe

Description Determines which bits in the status register are unmasked.

Syntax **RQS?** [INTO *name*] or [*fmt*]

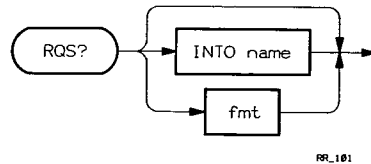

Parameters

INTO name See Glossary.

fmt See Glossary. Default format is IASC.

Remarks

Data Returned

Returns the sum of the binary weights of all unmasked bits in the status register. If RQS ON is set, 64 (bit 6) is part of the sum. If RQS OFF is set, 64 is not part of the sum. See the RQS command for status register bit definitions and their binary weights.

Examples

Example: Using the RQS? Command

This program line uses RQS? to determine which bits in the status register are unmasked.

```
100 OUTPUT 709;"RQS?" !Determine which status register bits are unmasked
```

For example, with RQS OFF and bit 3 (LCL,8) and bit 4 (RDY,16) unmasked, the RQS? command returns 24 (sum of the unmasked bit weights). However, with RQS ON and bits 3 and 4 unmasked, the return is 88 (64 + 16 + 8).

• Mainframe

Description Resets the HP 3852A or the specified plug-in accessory to its power-on state.

Prerequisites None

Syntax **RST** [*slot*]

or

RESET [*slot*]

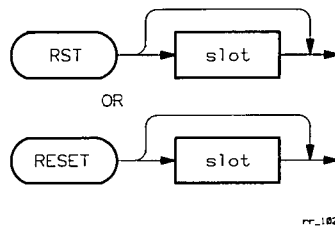

Parameters

slot Slot containing the accessory to be reset. If *slot* is not specified, the HP 3852A and all slots are reset.

Remarks

RST vs RST [*slot*]

RST without the *slot* parameter resets the HP 3852A (all slots) to its power-on state, while RST [*slot*] resets only the accessory in the slot specified by *slot* to its power-on state. RST command is not recognized until all previously entered commands have been executed.

RST Exceptions

RST (with no parameter) places the HP 3852A (all slots) to its power-on state with the following exceptions:

1. HP-IB addressed state* not changed.
2. RQS mask and mode not changed.
3. Self-test routine not performed.
4. Power-on "beep" does not occur.
5. Power-on messages not displayed.
6. LCL bit in Status Register not set.

* = LOCS, LWLS, REMS, or RWLS

RST (cont)

Command Execution Time

A system reset takes approximately 600 ms to complete. Although not shown with each command reference entry, it is recommended that a WAIT statement be included following RST. This will prevent errors from occurring in subsequent commands due to system configurations changed during the reset.

Data Returned

None

Related Commands

CLR

Examples

Example: Resetting the HP 3852A System

The following program line uses RST to reset the HP 3852A and all slots.

```
10 OUTPUT 709;"RST" !Reset HP 3852A and all slots
```

Example: Resetting an Accessory

The following program line uses RST [*slot*] to reset an accessory in slot 1 of the mainframe.

```
10 OUTPUT 709;"RST 100" !Reset accessory in slot 1 of mainframe
```

- Mainframe

Description

Places the HP 3852A and all plug-in accessories in their power-on state. Executing this command is equivalent to cycling power.

Prerequisites

Requires firmware revision 3.0 or greater.

Syntax

RST HARD

or

RESET HARD

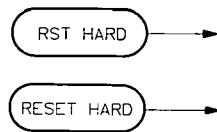

Parameters

None

Remarks

HP 3852A Mainframe and Plug-In Accessory Power-on States

The power-on state of the HP 3852A and each plug-in accessory can be found in Tables 5-2 and 5-3 in Chapter 5 of this manual.

Data Returned

None

Related Commands

None

Examples

Example: Executing RST HARD

The following statement sets the mainframe and plug-in accessories to their power-on state.

```
OUTPUT 709;"RST HARD"
```

RUN

- Mainframe

Description

Directs a subroutine to a run task and specifies the number of times and how often the subroutine is to execute. RUN also activates the run task which starts subroutine execution.

Prerequisites

The RUN command is used in the multitasking mode which requires firmware revision 3.0 or greater. The EVERY *seconds* parameter requires revision 3.5 or greater.

Syntax

RUN *task__number name [number] [EVERY seconds]*

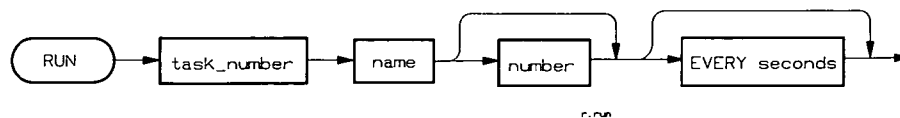

Parameters

task__number

Run task to which a subroutine is directed. The range for *task number* is 0 to 7. Any run task number can be specified regardless of the number of subroutines to be directed by subsequent RUN commands. Note that only one run task number can be specified per RUN command.

name

Name of the subroutine directed to the run task.

number

Number of times the subroutine is to execute. If *number* = 0, the subroutine executes continuously. If *number* is > 0, the subroutine executes the number of times specified. If *number* is not specified and the EVERY parameter is not specified, the default *number* is 1. If *number* is not specified and the EVERY parameter is specified, the subroutine executes continuously.

EVERY *seconds*

Interval at which subsequent subroutine executions begin following the RUN command. For example, if RUN 0 A 3 EVERY 5 is executed, subroutine A is directed to run task 0 and begins to execute. If the subroutine takes three seconds to execute, the subroutine will begin execution the second time in two seconds. Following the next three seconds of execution time, the operating system will wait 2 seconds then start execution the third (final) time.

The range for *seconds* is 0 to 4,294,967,296/tic_interval. (See the TSLICE command for tic_interval values.) If EVERY *seconds* is not specified, there is no waiting between executions.

Remarks

Executing the RUN Command

The RUN command can be executed from any task (i.e. front panel, HP-IB, interrupt, run task). Note that if the RUN command is executed from the front panel, the mainframe must be in the LOCAL mode before the command will be accepted, regardless of the priority (urgency) assigned. However, if the RUN command is defined as a soft key, it can be executed in either the REMOTE or LOCAL state.

When Run Tasks Become Activated

The subroutine directed to a run task which begins execution first is the subroutine specified by the first RUN command in the program. Provided additional run tasks have the same priority, when the time-slice period expires and on command completion, the system then swaps to the subroutine specified by the next RUN command encountered. For example, if three run tasks have the same priority and RUN commands are executed as:

```
OUTPUT 709;"RUN 4 C; RUN 2 B; RUN 7 T"
```

or

```
100 OUTPUT 709;"RUN 4 C"  
110 OUTPUT 709;"RUN 2 B"  
120 OUTPUT 709;"RUN 7 T"
```

the run task executing C will become active first and then swap to the run task executing B. The run task executing B then swaps to the run task executing T which swaps back to C. The run tasks time-slice in this sequence until they finish.

Subroutines Directed to the Same Run Task

If more than one subroutine is directed to the same run task, the subroutine in the first RUN command will time-slice to completion before the next subroutine directed to the run task will begin. For example, if given the following:

```
100 OUTPUT 709;"RUN 4 C"  
110 OUTPUT 709;"RUN 4 K"  
120 OUTPUT 709;"RUN 2 B"  
130 OUTPUT 709;"RUN 7 T"
```

subroutines C, B, and T will time-slice until subroutine C completes, at which time subroutine K will time-slice with B and T. Note that as subroutines C, B, and T are pulled from the queue, the run task subroutine that is executing is termed "active" while the others are "scheduled". Subroutine K is a "queued" subroutine until it is pulled from the queue when subroutine C completes.

Suspending Tasks When the EVERY *seconds* Parameter is Used

If WAITFOR SIGNAL, SUSPEND, SUSPEND UNTIL, or PAUSE suspends command execution in a run task scheduled to execute EVERY n seconds, the subroutine will immediately execute again if it was suspended longer than the interval specified. Consecutive executions will continue until the subroutine completes within the interval, so that it can begin again when the interval expires.

Data Returned

None

Related Commands

ENABLE MULTI, DISABLE MULTI, ENABLE EOL SWAP, URGENCY, TSLICE, NTASKS

RUN (cont)

Examples

Example: Directing Subroutines to Run Tasks

This example shows how the RUN command is used to direct subroutines to run tasks.

In the program, three subroutines are downloaded. One subroutine counts from 0 to 599, another repeatedly displays A B C, and the third makes two sets of DC voltage measurements. The RUN command is used in lines 590 and 600 to direct subroutines A and DCMEAS to run tasks. As these run task subroutines begin to execute and time-slice, the mainframe's left display window alternately displays CONFMEAS/DISP while the right window displays the numbers as they are counted. This is an indication of the swapping that is occurring between subroutines A and DCMEAS. As DCMEAS continues to execute, subroutine B is directed to a run task (line 490) which then time-slices with subroutine A and subroutine DCMEAS (which is making a second set of DC voltage measurements). At this point, the left window is displaying MEAS/DISP and the right window is displaying numbers and letters indicating that all three run tasks are now time-slicing.

```
10      ! Set a 65 ms time-slice and set the number of run tasks and the
20      !queue size the system will allow. Place the HP 3852A in the
30      !multitasking mode. The reset caused by ENABLE MULTI will load
40      !the TSLICE and NTASKS parameters into the operating system.
50      !
60      OUTPUT 709;"TSLICE .065"
70      OUTPUT 709;"NTASKS 3,3"
80      OUTPUT 709;"ENABLE MULTI"
90      !
100     !Write and download subroutines to be directed to run
110     !tasks. Subroutine A when active, displays the numbers 0
120     !through 599. Subroutine B when active, repeatedly displays
130     !A B C.
140     !
150     OUTPUT 709;"SUB A"
160     OUTPUT 709;"  INTEGER I"
170     OUTPUT 709;"  FOR I=0 TO 599"
180     OUTPUT 709;"    DISP I"
190     OUTPUT 709;"  NEXT I"
200     OUTPUT 709;"SUBEND"
210     OUTPUT 709;"SUB B"
220     OUTPUT 709;"  INTEGER J"
230     OUTPUT 709;"  FOR J=0 TO 399"
240     OUTPUT 709;"    DISP 'A'"
250     OUTPUT 709;"    DISP 'B'"
260     OUTPUT 709;"    DISP 'C'"
270     OUTPUT 709;"  NEXT J"
280     OUTPUT 709;"SUBEND"
290     !
300     !Write and download a subroutine that will
310     !make a series of DC voltage measurements and store
320     !the readings in mainframe arrays. After the first set
330     !of readings are taken, direct subroutine B to a
340     !run task and activate the run task so that it will
```

```

350 !begin to time-slice.
360 !
370 OUTPUT 709;"SUB DCMEAS"
380 OUTPUT 709;" INTEGER K"
390 OUTPUT 709;" REAL DCRDGS1 (29)"
400 OUTPUT 709;" REAL DCRDGS (299)"
410 OUTPUT 709;" USE 700"
420 OUTPUT 709;" FOR K = 0 TO 29"
430 OUTPUT 709;" CONFMEAS DCV 600 INTO DCRDGS1"
440 OUTPUT 709;" NEXT K"
450 !
460 !Direct subroutine B to a run task. Subroutine B will then
470 !time-slice with the other run tasks.
480 !
490 OUTPUT 709;" RUN 2 B"
500 OUTPUT 709;" CONF DCV"
510 OUTPUT 709;" FOR K=0 TO 99"
520 OUTPUT 709;" MEAS DCV 601-603 INTO DCRDGS"
530 OUTPUT 709;" NEXT K"
540 OUTPUT 709;"SUBEND"
550 !
560 !Direct subroutines A and DCMEAS to run tasks. Set each
570 !run task to execute one time.
580 !
590 OUTPUT 709;"RUN 1 A"
600 OUTPUT 709;"RUN 3 DCMEAS"
610 END

```

Example: Using the EVERY *seconds* Parameter

The following program demonstrates how the **EVERY *seconds*** parameter of the **RUN** command is used to schedule measurements which could be associated with the testing of a vehicle engine.

In the program, two subroutines are downloaded and directed to run tasks. The first subroutine measures the temperature of the oil within the engine while the second subroutine measures the oil pressure. The **RUN** command in lines 500 and 510 is specified such that the subroutine measuring the temperature of the oil executes every three seconds and the subroutine measuring the oil pressure executes every one second.

```

10 !Set the time-slice period and the number of run tasks and queue
20 !size the system will allow. Place the HP 3852A in the multitasking
30 !mode. Define a softkey which enables the operator to continue task
40 !execution once adjustments or repairs have been made due to
50 !decreased oil pressure.
60 !
70 OUTPUT 709;"TSLICE 0.065"
80 OUTPUT 709;"NTASKS 2,2"
90 OUTPUT 709;"ENABLE MULTI"
100 OUTPUT 709;"EDIT KEY 1 ""SIGNAL 1""
110 !
120 !Download the run task subroutine which measures and displays the
130 !temperature of the oil every 3 seconds as directed by the RUN

```

RUN (cont)

```
140 !command.
150 !
160 OUTPUT 709;"SUB A"
170 OUTPUT 709;" USE 700"
180 OUTPUT 709;" REAL T"
190 OUTPUT 709;" CONFMEAS TEMPT 200 INTO T"
200 OUTPUT 709;" DISP T"
210 OUTPUT 709;"SUBEND"
220 !
230 !Download the run task subroutine which monitors the oil pressure.
240 !Notify the operator when the pressure falls below 70 psi. Suspend
250 !execution of the task and the temperature measurements until
260 !signaled by a softkey that the necessary adjustments or repairs
270 !have been made. Use the CONV command to determine the pressure
280 !given the output and accuracy characteristics of the transducer
290 !which are stored in look-up tables.
300 !
310 OUTPUT 709;"SUB B"
320 OUTPUT 709;" USE 700"
330 OUTPUT 709;" REAL DOM (9),RNG(9),VAR(0),P"
340 OUTPUT 709;" VWRITE DOM .01,.02,.03,.04,.05,.06,.07,.08,.09,.10"
350 OUTPUT 709;" VWRITE RNG 10,20,30,40,50,60,70,80,90,100"
360 OUTPUT 709;" CONFMEAS DCV 600 INTO VAR"
370 OUTPUT 709;" CONV DOM,RNG,VAR INTO P"
380 OUTPUT 709;" IF P < 70 THEN"
390 OUTPUT 709;" PAUSE 0"
400 OUTPUT 709;" DISP 'CHK PRES - 1'"
410 OUTPUT 709;" WAITFOR SIGNAL"
420 OUTPUT 709;" CONT 0"
430 OUTPUT 709;" END IF"
440 OUTPUT 709;"SUBEND"
450 !
460 !Direct subroutines A and B to run tasks. Execute run task 0
470 !every 3 seconds and run task 1 every second. Run these
480 !tasks continuously.
490 !
500 OUTPUT 709;"RUN 0 A EVERY 3"
510 OUTPUT 709;"RUN 1 B EVERY 1"
520 END
```

As the program executes, both the oil temperature and pressure are measured; however, only the oil temperature is displayed. If at some point in time the oil pressure falls below 70 psi, the temperature and pressure measurements are suspended and "CHK PRES - 1" is displayed. This notifies the operator to make any necessary adjustments or repairs and continue the routines by pressing soft-key 1 when finished.

If the oil pressure drops and the tasks are suspended longer than the three seconds and one second specified, consecutive temperature and pressure measurements will be made when the tasks resume. This will continue until sub-routine completion falls within the **EVERY** *seconds* interval. At that point, measurements will resume at the three second and one second intervals.

• Mainframe

Description Returns the operating status of run task subroutines in a multitasking system.

Prerequisites The RUN? command is used when the HP 3852A is in the multitasking mode. Multitasking is only available with mainframe firmware revision 3.0 or greater.

Syntax RUN? [INTO *name*] or [*fmt*]

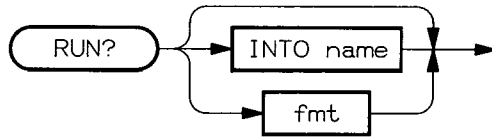

R. RUN?

Parameters

INTO name See Glossary.

fmt See Glossary. Default format is IASC.

Remarks

Data Returned

RUN? returns 11 integers which indicate the status of the run task system. The integers in the sequence shown represent the following:

INTEGER	DESCRIPTION
1st	Number of run tasks available to the user as specified by the NTASKS command.
2nd	Size of the queue as set by the NTASKS command.
3rd	Number of subroutines in the queue awaiting execution in a run task.
4th	Status of the subroutine directed to run task 0.
5th	Status of the subroutine directed to run task 1.
6th	Status of the subroutine directed to run task 2.
7th	Status of the subroutine directed to run task 3.
8th	Status of the subroutine directed to run task 4.
9th	Status of the subroutine directed to run task 5.
10th	Status of the subroutine directed to run task 6.
11th	Status of the subroutine directed to run task 7.

The "status" that is returned for each of the subroutines (the 4th through 11th integers) is the sum of the following seven bit code:

RUN? (cont)

BIT	VALUE	STATUS
0	1	The run task has been created.
1	2	The run task subroutine is presently executing (time-slicing) with other run tasks.
2	4	Execution of the run task subroutine is suspended by the SUSPEND command.
3	8	The subroutine generated an error.
4	16	The subroutine is currently paused or has been requested to pause by the PAUSE command.
5	32	Execution of the run task subroutine is suspended by the WAITFOR SIGNAL command.
6	64	Execution of the run task subroutine is suspended pending the release of a lock.

Note that if a subroutine finishes and is replaced by a subroutine from the queue, the status reported is that of the subroutine pulled from the queue.

Related Commands

ENABLE MULTI, NTASKS, RUN

Examples

Example: Monitoring the Status of a Multitasking System

The following program is an example of how the RUN? command could be used to monitor the status of run task subroutines in a multitasking system.

In the program, four subroutines are downloaded and directed to run tasks. Subroutine A counts continuously, subroutine B repeatedly displays A B C, subroutine TEMPMEAS makes temperature measurements every five seconds, and subroutine RUNSTAT monitors the status of the run task subroutines by issuing the RUN? command every seven seconds.

```
10 !Set a 65 ms time-slice and set the number of run tasks and
20 !queue size the system will allow. Place the HP 3852A in the
30 !multitasking mode. The reset caused by ENABLE MULTI will load
40 !the TSLICE and NTASKS parameters into the operating system.
50 !Turn the mainframe's output buffer on.
60 !
70 OUTPUT 709;"TSLICE .065"
80 OUTPUT 709;"NTASKS 4,4"
90 OUTPUT 709;"ENABLE MULTI"
100 OUTPUT 709;"OUTBUF ON"
110 !
120 !Declare controller arrays in which to enter the temperature
130 !readings and the status of the run task subroutines.
140 !
```

RUN? (cont)

```
150 REAL Oventemp(0:2)
160 INTEGER Runstatus(0:10)
170 !
180 !Write and download the subroutines to be directed to run tasks.
190 !Subroutine A when active, counts continuously.
200 !
210 OUTPUT 709;"SUB A"
220 OUTPUT 709;"  INTEGER I"
230 OUTPUT 709;"  WHILE 1"
240 OUTPUT 709;"    I=I+1"
250 OUTPUT 709;"    DISP I"
260 OUTPUT 709;"  END WHILE"
270 OUTPUT 709;"SUBEND"
280 !
290 !Download subroutine B. When active, subroutine B will repeatedly
300 !display A B C one thousand times.
310 !
320 OUTPUT 709;"SUB B"
330 OUTPUT 709;"  INTEGER K"
340 OUTPUT 709;"  FOR K=0 TO 999"
350 OUTPUT 709;"    DISP 'A'"
360 OUTPUT 709;"    DISP 'B'"
370 OUTPUT 709;"    DISP 'C'"
380 OUTPUT 709;"  NEXT K"
390 OUTPUT 709;"SUBEND"
400 !
410 !Download subroutine TEMPMEAS which continuously makes temperature
420 !measurements on three channels every 5 seconds. After the
430 !measurements are taken, place a data header in front of the
440 !readings to notify the controller of the type of data available.
450 !
460 OUTPUT 709;"SUB TEMPMEAS"
470 OUTPUT 709;"  REAL TEMPRDGS (2)"
480 OUTPUT 709;"  USE 700"
490 OUTPUT 709;"  WHILE 1"
500 OUTPUT 709;"    SUSPEND 5"
510 OUTPUT 709;"    CONFMEAS THM10K 600-602 INTO TEMPRDGS"
520 OUTPUT 709;"    VREAD 3"
530 OUTPUT 709;"    VREAD TEMPRDGS"
540 OUTPUT 709;"  END WHILE"
550 OUTPUT 709;"SUBEND"
560 !
570 !Download subroutine RUNSTAT which reports the status of each
580 !subroutine every 7 seconds. Issue a data header prior to
590 !execution of the RUN? command to notify the controller of the
600 !type of data available.
610 !
620 OUTPUT 709;"SUB RUNSTAT"
630 OUTPUT 709;"  WHILE 1"
640 OUTPUT 709;"    SUSPEND 7"
650 OUTPUT 709;"    VREAD 4"
660 OUTPUT 709;"    RUN?"
670 OUTPUT 709;"  END WHILE"
680 OUTPUT 709;"SUBEND"
```

RUN? (cont)

```
690  !
700  !Direct the subroutines to run tasks. Direct subroutine A
710  !to run task 1, subroutine B to run task 2, subroutine TEMPMEAS
720  !to run task 3, and subroutine RUNSTAT to run task 4.
730  !
740  OUTPUT 709;"RUN 1 A"
750  OUTPUT 709;"RUN 2 B"
760  OUTPUT 709;"RUN 3 TEMPMEAS"
770  OUTPUT 709;"RUN 4 RUNSTAT"
780  !
790  !Have the controller loop until data is available from the
800  !HP 3852A. Test the data header to determine whether
810  !temperature measurements or the system's run task status is
820  !in the mainframe's output buffer. Enter and update the display
830  !each time data is returned.
840  !
850  WHILE 1
860     ENTER 709;H
870     IF H=3 THEN
880         ENTER 709;Oventemp(*)
890         PRINT TABXY(1,2);Oventemp(*)
900     END IF
910     IF H=4 THEN
920         ENTER 709;Runstatus(*)
930         PRINT TABXY(1,6);Runstatus(*)
940     END IF
950 END WHILE
960 END
```

As this program executes, A B C is repeatedly displayed along with an increasing count. After five seconds, temperature measurements are taken and displayed on the controller. At seven seconds, the status of the subroutines is determined with the RUN? command (line 660). An example of how the controller's display appears at this time is shown below:

```
26.34473  27.96484  25.83501

4          4          0          0          3          3          7          3
0          0          0
```

The eleven integers shown indicate the status of the system:

- 4 - 4 run tasks are available to the user (NTASKS command - line 80)
- 4 - the queue size is 4 (NTASKS command - line 80)
- 0 - there are no subroutines in the queue
- 0 - run task 0 has not been created
- 3 - a subroutine directed to run task 1 is executing
- 3 - a subroutine directed to run task 2 is executing
- 7 - a subroutine directed to run task 3 is executing but is currently suspended
- 3 - a subroutine directed to run task 4 is executing
- 0 - run task 5 has not been created
- 0 - run task 6 has not been created
- 0 - run task 7 has not been created

RUN? (cont)

As the program continues to run, the first run task to finish is run task 2. When that happens, the display appears as shown below:

```
26.25879 27.90137 25.79297
```

```
4      4      0      0      3      1      7      3
0      0      0
```

The status of the system now indicates that the subroutine directed to run task 2 is not executing (i.e. its finished). If the program were to continue, run task 1 would end in an error once a count of 32768 is reached since the counting variable declared (I) was an integer (line 220). At that point, the integer corresponding to run task 1 would change from 3 to 9, indicating that the subroutine created an error and is no longer executing.

Note that although a `SUSPEND` command is contained in the subroutine of run task 4 (`RUNSTAT`), the subroutine is never reported as suspended since it is executing when it issues the `RUN?` command.

SADV

• HP 3852A Mainframe

Description

Sets the channel scan advance source. SADV is used for backplane scanning with either a voltmeter accessory or an external voltmeter using the CONF, MEAS, MONMEAS, and SCAN commands.

Prerequisites

None

Syntax

SADV *source*

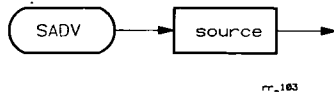

Parameters

source Scan advance source. At power-on, *source* = SCAN.

<i>source</i>	Definition
SCAN	When used with MEAS, scan is advanced when NRDGS are available. When used with SCAN, scan is advanced as soon as the channel is closed.
CHADV	CHANNEL ADVANCE BNC
KEY	Front panel SADV KEY
PACER	PACER OUT BNC

Remarks

Don't Use SADV KEY With LOCK ON

Do not use SADV KEY with LOCK ON, since all front panel keys are ignored.

Using the CONF, MEAS, and SADV Commands

Executing the CONF command sets SADV SCAN. To change the scan advance source, SADV must be executed following CONF and before MEAS which are executed individually rather than as CONFMEAS.

Data Returned

None

Related Commands

MEAS, CONFMEAS, SCAN, LOCK

Examples**Example: Setting the Scan Advance Source**

This program sets SADV KEY as the scan advance source for measuring the voltage on five channels.

```
10 OUTPUT 709;"RST"           !Reset the HP 3852A
20 OUTPUT 709;"USE 700"       !Use the voltmeter in slot 7
30 OUTPUT 709;"CONF DCV"     !Configure the voltmeter for DC volts
40 OUTPUT 709;"SADV KEY"     !Set SADV KEY as the scan adv. source
50 OUTPUT 709;"MEAS DCV 0-4" !Measure the voltage on chs 0-4
60 END
```

In this program, the scan is advanced through channels 0-4 by pressing SADV KEY. Pressing the key five times completes the scan. Pressing CLEAR at any point terminates the scan.

SCALE

- Mainframe

Description

Post processing function $((reading - offset)/scale)$. The specified *offset* value is subtracted from the stored *reading* and the result divided by the specified *scale* value.

Prerequisites

The *offset*, *scale*, *readings* (and storage if used) variables or arrays must have been previously defined by a REAL, DIM, or INTEGER command.

Syntax

SCALE *offset scale readings* [INTO *name*] or [*fmt*]

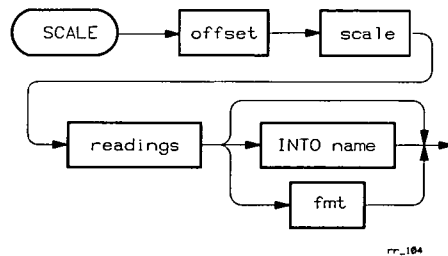

Parameters

offset INTEGER or REAL variable or array containing the *offset(s)* to be subtracted from the *reading(s)*.

scale INTEGER or REAL variable or array containing *scale* factor(s) to be divided into the result(s) of $(reading - offset)$.

readings INTEGER or REAL array containing *readings* to be scaled.

INTO *name* See Glossary.

fmt See Glossary. Default format is RASC.

Remarks

Single and Multiple Offsets/Scale Factors

If a variable containing a single *offset* or *scale* factor is used, the single value is used for each reading. If arrays containing multiple *offsets* and *scale* factors are specified, each *reading* is modified by its correspondingly numbered *offset* and *scale* factor. That is, the first *reading* has the first *offset* subtracted from the *reading* and the result is divided by the first *scale* factor. The second *reading* uses the second *offset*, second *scale* factor, and so on.

If there are more *readings* than specified *offset/scale* factor values, a wraparound occurs from the end to the start of the *offset* or *scale* array and the values are re-used. This allows you to specify a limited number of *offset/scale* factors when repeatedly modifying a fixed channel list.

Index Pointers

The SCALE command presets the index pointers of the *offset*, *scale*, and *readings* arrays to 0, and sets the *readings* index to 0 again after SCALE. However, the SCALE command does not alter the position of the storage array pointer (refer to INDEX for information about pointers).

Potential Deadlock Problem

With INBUF OFF, the controller and the HP 3852A may deadlock if multiple commands (or terminators) are sent in a single command line and a command generates enough data to fill the output buffer. (SCALE can fill the output buffer.) The best way to avoid potential deadlock is to send a single command and to read the results as soon as possible after a data-generating command is sent.

Data Returned

Result of $(reading - offset)/scale$.

Related Commands

LET, INDEX, VWRITE, CONV

Examples

The following program makes five DC voltage measurements and stores the readings in the RDS array. The *offset* and *scale* calculations are then performed on each reading. For the first reading, *offset* = 0 and *scale* = 10. For the second reading, *offset* = 1, *scale* = 9, and so on.

```

10 DIM Rslt(0:4)                !Dimension array
20 OUTPUT 709;"RST"              !Reset the HP 3852A
30 OUTPUT 709;"REAL OFST(4),SCL(4)" !Def offset,scales arrays
40 OUTPUT 709;"REAL RDS(4),RES(4)" !Def rdgs, results arrays
50 OUTPUT 709;"VWRITE OFST 0,1,2,3,4" !Values to offset array
60 OUTPUT 709;"VWRITE SCL 10,9,8,7,6" !Values to scale array
70 OUTPUT 709;"USE 700"         !Use vm in slot 7
80 OUTPUT 709;"CONFMEAS DCV,200-204,INTO RDS" !Conf/meas DC volts
90 OUTPUT 709;"SCALE OFST,SCL,RDS,INTO RES" !Conv rdgs, store in RES
100 OUTPUT 709;"VREAD RES"     !Results to output buffer
110 ENTER 709;Rslt(*)          !Enter results
120 PRINT USING"K,/";Rslt(*)   !Display results
130 END

```

A typical display follows for DC voltages measurements of 10.0V (ch 0); 11.0V (ch 1); 12.0V (ch 2); 13.0V (ch 3); and 14.0V (ch 4). The scaled result for the first reading is $(reading - offset)/scale = (10.0 - 0)/10.0 = 1.0$, while the scaled result for the second reading = $(11.0 - 1.0)/9.0 = 1.111111$, etc.

```

1.000000
1.111111
1.250000
1.428571
1.666667

```

SCAN

- Mainframe
- External Voltmeter

Description

Scans a list of multiplexer channels using an external voltmeter to make the measurements.

Prerequisites

The NSCAN parameter is only available with mainframe firmware revision 2.2 or greater.

Syntax

SCAN [*backplane_bus*] *ch_list* [NSCAN *number*]

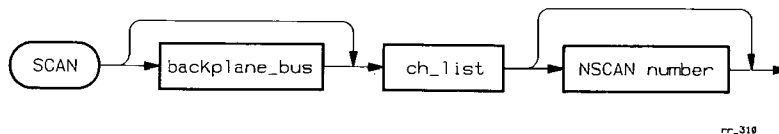

Parameters

backplane_bus Backplane bus connections made by the multiplexer channels during the measurement. Default *backplane_bus* = SENSE.

bus	Definition
SENSE	Multiplexer channels connect to the SENSE bus (voltage measurements).
COM	SENSE bus and SOURCE bus are connected together at the multiplexer (2-wire ohms measurements).
SEP	Valid for HP 44705A, HP 44709A, and HP 44711A multiplexers only. SENSE bus and SOURCE bus are separate to user wiring. SENSE bus is connected to BANK A, SOURCE bus is connected to Bank B. Only Bank A channels are specified since the corresponding channels in Bank B are closed automatically (4-wire ohms measurements only).

ch_list Address of channel list (see Glossary). *ch_list* definitions for multiplexers are:

Type	CC Range	Description
20-Channel	0 - 9	Bank A
	10 - 19	Bank B (not available for SEP)
24-Channel	0 - 11	Bank A
	12 - 23	Bank B (not available for SEP)
48-Channel	0 - 47	Channels (not available for SEP)
60-Channel	0 - 59	Channels (not available for SEP)

NSCAN number Specifies the number of scans to be made through the channel list. *number* range is 1 to 2147483647. The default NSCAN is 1. NSCAN is only available with mainframe firmware revision 2.2 or greater.

Remarks

Use CHANNEL CLOSED BNC to Trigger External Voltmeter

The CHANNEL CLOSED BNC output can be used to trigger the external voltmeter.

Data Returned

None

Related Commands

SADV, STRIG

Examples

Example: Measurements Using an External Voltmeter

The following program shows how the SCAN command and other related commands are used to enable an external voltmeter to scan and measure channels 0 through 10 of the multiplexer accessory in slot 2.

The command parameters specified in this program assume the mainframe's CHANNEL ADVANCE input port is connected to the voltmeter's Voltmeter Complete output port, and the mainframe's CHANNEL CLOSED output port is connected to the voltmeter's External Trigger input port. For measurements with an external voltmeter, the high, low, and guard terminals (HI, LO, GU) of the analog extender port should be connected to the corresponding terminals on the voltmeter.

In this program, no voltmeter commands are given; however, they would follow the commands which set up the mainframe.

```

10 OUTPUT 709;"RST"           !Reset the HP 3852A
20 OUTPUT 709;"STRIG SCAN"    !Close ch 0 on execution of SCAN cmd
30 OUTPUT 709;"SADV CHADV"    !Advance scan on input to Chan. Adv. BNC
40 OUTPUT 709;"SCAN SENSE 200-210" !Initiate scan, connect chs to SENSE bus
.
.
.

```

Line 20 instructs the mainframe to close channel 0 on execution of the SCAN command. Line 30 specifies that the scan be advanced when the "voltmeter complete" signal is applied to the CHANNEL ADVANCE BNC. Line 40 initiates the scan and connects the multiplexer channels to the sense bus as the scan is advanced. Note that as a multiplexer channel is closed, a signal is output from the mainframe's CHANNEL CLOSED port. This signal triggers the the voltmeter, which in turn, makes the measurement.

SCAN

- HP 44717A 10 Bridge 120Ω Static Strain Gage Relay Multiplexer
- HP 44718A 10 Bridge 350Ω Static Strain Gage Relay Multiplexer
- HP 44719A 10 Bridge 120Ω Static Strain Gage FET Multiplexer
- HP 44720A 10 Bridge 350Ω Static Strain Gage FET Multiplexer

Description

Scan multiplexer channels. SCAN scans a list of multiplexer channels, tying each channel to the mainframe's backplane bus as the channel is scanned. Signals on the bus are routed to an external voltmeter where they are measured (and stored).

Prerequisites

The external voltmeter that will perform the measurement must be connected to the HP 3852A backplane and programmed accordingly. Measurements/configuration involving an external voltmeter are covered in the strain gage manual.

The strain gage accessories require mainframe firmware revision 2.0 or greater. The NSCAN parameter can only be used with firmware revision 2.2 or greater.

Syntax

SCAN *backplane_bus* *ch_list* [NSCAN number]

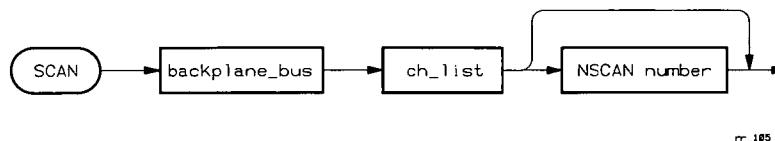

Parameters

backplane_bus

Backplane bus connections made by the multiplexer during the measurement.

Bus Connection	Description
STRVEX	Bridge excitation voltage is connected to the backplane for measurement by the external voltmeter.
SENSE	Multiplexer channels connect to the sense bus on the mainframe backplane enabling an external voltmeter to measure the bridge output voltage (strain) of the particular bridge arrangement.
COM	Multiplexer channels connect to the sense bus and source bus on the mainframe backplane enabling an external voltmeter to perform 2-wire resistance measurements.
DCV	Bridge output voltage is connected to the backplane for measurement by the external voltmeter.

ch_list Address of the channel on which the bridge excitation voltage or strain is measured. Valid channels for measuring the excitation voltage or any strain gage arrangement are the bridge completion channels 0-9.

NSCAN number Specifies the number of scans to be made through the channel list. *number* range is 1 to 2147483647. The default NSCAN is 1. NSCAN is only available with mainframe firmware revision 2.2 or greater.

Remarks

Data Returned

None

Related Commands

SADV, STRIG

Examples

Example: Measuring 1/4 Bridge Strain Using an External Voltmeter

This program is an example of how the scan command is used to route signals to an external voltmeter in order to measure 1/4 bridge strain. The program involves measuring V_{out} and V_{in} under unstrained and strained conditions. These values can then be substituted into the equation:

$$V_r = [(V_{out}/V_S)_{strained} - (V_{out}/V_S)_{unstrained}]$$

which is solved for V_r . Once V_r is determined, it can then be substituted into the 1/4 bridge strain equation:

$$\epsilon = -4V_r/GF(1 + 2V_r)$$

This program does not include voltmeter programming commands nor does it solve the strain equations. The gap between program lines 70 and 100 represents the period stress is applied to the specimen.

```

10 OUTPUT 709;"RST"           !reset the HP 3852A
20 OUTPUT 709;"SADV CHADV"    !scan advance source is the rear
30                             !panel CHANNEL ADVANCE BNC
40 OUTPUT 709;"SCAN STRVEX, 300" !Vin (unstrained) is placed on the
50                             !backplane (channel 0 in slot 3)
60 OUTPUT 709;"SCAN SENSE, 300" !Vout (unstrained) is placed on the
70                             !backplane (channel 0 in slot 3)
.
.
.
100 OUTPUT 709;"SCAN STRVEX, 300" !Vin (strained) is placed on the
110                             !backplane
120 OUTPUT 709;"SCAN SENSE, 300" !Vout (strained) is placed on the
130                             !backplane
.
.
.
```

SCANMODE

• HP 44702A/B High-Speed Voltmeter (Scanner or System Mode)

Description

Select the voltmeter operating mode. SCANMODE sets the HP 44702A/B to operate in either System mode or Scanner mode.

Prerequisites

With SCANMODE ON, SCTRIG must be set to HOLD before sending other configuration commands.

Syntax

SCANMODE [*mode*] [USE *ch*]

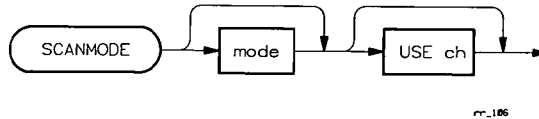

Parameters

mode HP 44702A/B High-Speed Voltmeter operating mode. Default *mode* = ON. Power-on *mode* = OFF.

<i>mode</i>	Definition
ON	Scanner Mode enabled. User has access to all operating parameters of the voltmeter. When TERM RIBBON is set, scanning is under the control of the voltmeter through the dedicated ribbon cable. When TERM INT, EXT, or ZERO is selected, scanning is under the control of the mainframe.
OFF	System Mode enabled. User has access to a limited number of the operating parameters available. All scanning is under the control of the mainframe.

USE *ch* Voltmeter slot number. See Glossary.

Remarks

Changing Modes Resets Voltmeter Settings

When the voltmeter operating mode is *changed* from Scanner to System mode (or from System to Scanner mode), all voltmeter parameters are reset to their power-on state. See Table 5-3 in Chapter 5 for a list of these parameters and their settings.

SCANMODE (cont)

Executing the CONF Command in System and Scanner Modes

The voltmeter parameters set by the CONF command and the sequence in which they are set depends on whether the voltmeter is in System mode or Scanner mode. See the CONF command for a list of these settings.

Note that changing between System mode and Scanner mode resets the voltmeter parameters to their power-on state. For many commands, these values are not the same as set by CONF. Thus before executing CONF, ensure that the desired voltmeter mode is selected.

Data Returned

None

Related Commands

The following commands are valid in System mode:

ARMODE	ENABLE INTR	RDGSMODE
AZERO	FUNC	SCANMODE
CAL	MEAS	SLOPE
CHREAD	MONMEAS	TERM
CONF	NRDGS	TRIG
CONFMEAS	PERC	TRIGOUT
DELAY	RANGE	USE
DISABLE INTR	RDGS	XRDGS

The following commands are valid in Scanner Mode:

ARMODE	MEAS	SCSLOPE
ASCAN	MONMEAS	SCTRIG
AZERO	NRDGS	SLOPE
CAL	PERC	SPER
CHREAD	POSTSCAN	STSLOPE
CLWRITE	PRESCAN	STRIG
CONF	RANGE	TERM
CONFMEAS	RDGS	TRIG
DISABLE INTR	RDGSMODE	TRIGOUT
ENABLE INTR	SCANMODE	USE
FUNC	SCDELAY	XRDGS

SCANMODE (cont)

Examples Example: Scanner Mode Measurements

The following program shows how the HP 44702A/B voltmeter is set to the Scanner mode then configured for DC voltage measurements. Since CONFIGuration and MEASurement is performed with CONFMEAS, the measurements are taken with the voltmeter parameters set according to the CONF portion of the command. This also means the input to the voltmeter will be through the dedicated ribbon cable.

```
10   REAL Rgs(0:2)                               !Declare controller array
20   OUTPUT 709;"RST"                             !Reset HP 3852A and HP 44702A/B
30   OUTPUT 709;"USE 500"                         !Use the voltmeter in slot 5
40   OUTPUT 709;"SCANMODE ON"                    !Turn scanner mode on
50   OUTPUT 709;"CONFMEAS DCV 400-402"          !Configure for, then measure DCV
60   ENTER 709;Rgs(*)                             !Enter readings into controller
70   PRINT USING "K,/";Rgs(*)                    !Display readings
80   END
```

A typical output based on this program is:

```
3.7625
3.8575
3.0175
```

- HP 44702A/B High-Speed Voltmeter (Scanner Mode only)

Description

Sets the delay between the scan trigger and when the first measurement in the scan list can be triggered, and sets the time between successive scan triggers. SCDELAY is used only when the voltmeter is in Scanner mode. (Use DELAY when voltmeter is in System mode.)

Prerequisites

SCTRIG must be set to HOLD before setting SCDELAY.

Syntax

SCDELAY *trig_delay* [*scan_pace*] [USE *ch*]

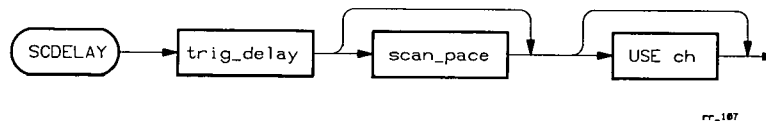

Parameters

trig_delay Delay time in seconds between the scan trigger and when the first measurement can be triggered. *trig_delay* range is 0 to 16.38375 msec. At power-on, *trig_delay* = 0 msec.

scan_pace Time in seconds between successive scan triggers. *scan_pace* is used only when SCTRIG INT is set. *scan_pace* range is 0 to 1073.74182375 seconds. At power-on, *scan_pace* = 2 msec.

USE *ch* Voltmeter slot number. See Glossary.

Remarks

Triggers that Occur During the Trig Delay Period

Measure triggers that occur during the *trig_delay* period are ignored. The first reading is taken on the first measure trigger after *trig_delay*.

Using SCDELAY with ASCAN OFF/ON

As previously mentioned, the *trig_delay* parameter sets the delay between the scan trigger and when the first measurement is triggered (e.g. measure trigger). When ASCAN OFF is set, this delay is included between the scan trigger and the first measurement of every pass through the scan list. With ASCAN ON, the delay is included between the scan trigger and the first measurement on only the first pass through the scan list.

Data Returned

None

Related Commands

SCANMODE, SCTRIG, USE

SCDELAY (cont)

Examples Example: Setting Scan Trigger and Scan Pace Times

This program shows how the SCDELAY command is used with other HP 44702A/B voltmeter commands when making measurements. The program takes 200 voltage measurements then stores them in a PACKED array in the mainframe. The HP 44702A/B voltmeter is programmed to make 20 passes through the channel list (10 prescans, 10 postscans). The SCDELAY command is set such that there is a 1 msec delay between the scan trigger and the first measurement (measure trigger) for each pass through the scan list (*trig_delay*), and a 1 second delay between each of the scan triggers (*scan_pace*).

```
10 OUTPUT 709;"RST"                !Reset the HP 3852A and HP 44702A/B
20 OUTPUT 709;"USE 600"             !Use voltmeter in slot 6
30 OUTPUT 709;"PACKED RIBRDGS (399)" !Declare PACKED array of 400 bytes
40 OUTPUT 709;"SCANMODE ON"         !Set Scanner Mode
50 OUTPUT 709;"CONF DCV"            !Configure for DC voltage (also
60                                  !sets SCTRIG HOLD, TERM RIBBON,
70                                  !STRIG INT, and ASCAN OFF)
80 OUTPUT 709;"CLWRITE SENSE 500-509" !Define scan list, connect SENSE bus
90 OUTPUT 709;"PRESCAN 10"          !Make 10 scans before stop trigger
100 OUTPUT 709;"POSTSCAN 10"        !Make 10 scans after stop trigger
110 OUTPUT 709;"SCDELAY .001,1"     !1ms trig delay and 1s between scans
120 OUTPUT 709;"SCTRIG INT"         !Sets scan trigger source
130 OUTPUT 709;"XRDGS 600 INTO RIBRDGS"
140                                  !Transfer readings to mf memory
150 END
```

- Mainframe

Description

Deletes all subroutines, arrays, and variables stored in mainframe memory and removes the name and type. SCRATCH also disables all ON INTR conditions (but accessory interrupts remain enabled).

Prerequisites

Scratch cannot be stored within a subroutine.

Syntax

SCRATCH



Parameters

None

Remarks

SCRATCH Removes Names and Storage Space

In contrast to the DELSUB and DELVAR commands which recover storage space allocated to subroutine, array, and variable data but don't delete the names, SCRATCH recovers all storage associated with subroutines, arrays, and variables and removes the definition of the type and name.

Data Returned

None

Related Commands

DELSUB, DELVAR, CAT

Examples

Example: Scratch Subroutine and Variables

This program shows one way the SCRATCH command affects subroutines and variables.

```
10 OUTPUT 709;"RST"           !Reset the HP 3852A
20 OUTPUT 709;"SUB BEEPER"    !Start of subroutine
30 OUTPUT 709;"BEEP"         !BEEP once
40 OUTPUT 709;"SUBEND"       !End of subroutine
50 OUTPUT 709;"CALL BEEPER"   !Works since subroutine is defined
60 OUTPUT 709;"SCRATCH"      !Scratch subroutine BEEPER
70 OUTPUT 709;"CALL BEEPER"   !Error - "UNDEFINED WORD - BEEPER"
80 OUTPUT 709;"REAL R"       !Define R as real variable
90 OUTPUT 709;"SCRATCH"      !Scratch R
100 OUTPUT 709;"INTEGER R"    !Allowed since R is undefined
110 END
```

SCRATCH KEY

- Mainframe

Description Deletes the softkey definition of the numeric key specified.

Prerequisites Requires firmware revision 3.5 or greater.

Syntax **SCRATCH KEY** [*key*]

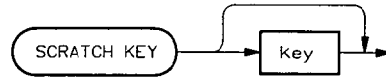

Parameters

key Number of the key (0 through 9) whose softkey definition is erased. If *key* is not specified, then all softkey definitions are erased.

Remarks

Data Returned

None

Related Commands

EDIT KEY

Examples

Example: Erasing a Softkey

The following program line erases softkey 0.

```
110 OUTPUT 709;"SCRATCH KEY 0"
```

• HP 44702A/B High-Speed Voltmeter (Scanner Mode only)

Description

Specifies the edge of the scan trigger that will trigger voltmeter scans. The specified edge is used when SCTRIG is set to EXT0, EXT1, MEAS, or GPIO.

Prerequisites

The voltmeter must be in Scanner mode (SCANMODE ON).

Syntax

SCSLOPE *mode* [USE *ch*]

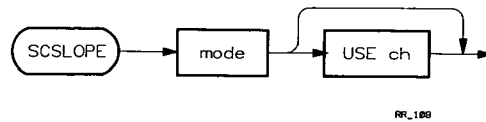

Parameters

mode Scan Trigger signal edge that will trigger the voltmeter. Power-on *mode* = LH.

mode	Definition
LH	Trigger on the low-to-high transition.
HL	Trigger on the high-to-low transition.

USE *ch* Voltmeter slot number. See Glossary.

Remarks

Data Returned

None

Related Commands

SCTRIG, USE

Examples

Example: Setting Scan Trigger Edge

This program shows how the SCSLOPE command is used to specify the edge of the scan trigger signal (SCTRIG) that will trigger the voltmeter. Once the measurements are taken, the readings are stored in mainframe memory.

```

10 OUTPUT 709;"RST"                !Reset HP 3852A and HP 44702A/B
20 OUTPUT 709;"REAL EXTRDGS(9)"    !Declare array to store readings
30 OUTPUT 709;"USE 500"            !Use vm in slot 5 of mainframe
40 OUTPUT 709;"SCANMODE ON"        !Turn scanner mode on
50 OUTPUT 709;"CONF DCV"           !Configure vm for DC voltage
60 OUTPUT 709;"SCSLOPE HL"         !Trigger on high-to-low transition
70 OUTPUT 709;"CLWRITE SENSE 400-409" !Define channel list
80 OUTPUT 709;"SCTRIG EXT0"        !Trigger vm through EXT0 port
90 OUTPUT 709;"XRDGS 500 INTO EXTRDGS" !Transfer readings to memory
100 END
  
```

SCTRIG

• HP 44702A/B High-Speed Voltmeter (Scanner Mode only)

Description

Specifies the scan trigger source for the voltmeter.

Prerequisites

The voltmeter must be in the Scanner Mode (SCANMODE ON). If TERM RIBBON is set, the scan list must be defined (by CLWRITE or MEAS) before SCTRIG is set to a source other than HOLD.

Syntax SCTRIG [*source*] [USE *ch*]

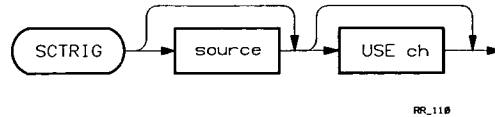

Parameters

source Voltmeter trigger modes and sources. Power-on *source* = HOLD. Default *source* = SGL.

<i>source</i>	Definition
SCAN	Trigger from backplane when multiplexer channel closes.
SGL	Single trigger from backplane when TRIG SGL is executed.
HOLD	No trigger. Triggering is held off and scanning halted.
EXT0	Trigger voltmeter from its EXTERNAL TRIGGER port 0 (BNC 0).
EXT1	Trigger voltmeter from its EXTERNAL TRIGGER port 1 (BNC 1).
SYS	System trigger pulse (see TRG command).
INT	Voltmeter internal trigger.
MEAS	Trigger when input crosses threshold level (see PERC command).
GPIO	GPIO trigger.

USE *ch* Voltmeter slot number. See Glossary.

Remarks

Using SCTRIG MEAS

In the threshold triggering mode (SCTRIG MEAS), the voltmeter continuously samples the first channel of the scan list. When the input signal crosses the threshold level (as set by the PERC command) on the signal edge set by the SCSLOPE command, a Scan Trigger occurs which initiates the scan.

Setting SCTRIG HOLD

SCTRIG must be set to HOLD when issuing other configuration commands. SCTRIG is automatically set to HOLD when a scan sequence completes.

Using SCTRIG SGL to Initiate Scans

SCTRIG SGL can be used to trigger subsequent passes through the scan list if, and only if, SCTRIG SGL started the first scan.

Scan Triggers Occurring During a Scan

A scan trigger that occurs during a pass through the scan list (i.e. before the last channel is measured), is ignored.

Data Returned

None

Related Commands

PERC, SCSLOPE, TRIGOUT, TRG, USE

Examples

Example: Setting the Scan Trigger Source

This program sets the voltmeter's scan trigger source to its rear panel EXT1 port. Once the voltmeter is triggered through this port, 10 readings are taken 1 msec apart, then transferred to a controller and displayed.

```
10 REAL Extrdgs(0:9)           !Declare controller array
20 OUTPUT 709;"RST"           !Reset HP 3852A and HP 44702A/B
30 OUTPUT 709;"USE 500"       !Use the vm in slot 5
40 OUTPUT 709;"SCANMODE ON"   !Set Scanner Mode
50 OUTPUT 709;"CONF DCV"      !Configure for DC voltage (also
60                             !sets SCTRIG HOLD and TERM RIBBON)
70 OUTPUT 709;"NRDGS 10"      !Make 10 measurements when triggered
80 OUTPUT 709;"CLWRITE SENSE 400" !Define scan list, connect SENSE bus
90 OUTPUT 709;"SPER 1E-3"     !Set 1 msec between measurements
100 OUTPUT 709;"SCTRIG EXT1"   !Trigger vm through EXT1 port
110 OUTPUT 709;"XRDGS 500"     !Transfer readings to output buffer
120 ENTER 709;Extrdgs(*)       !Enter readings into controller
130 FOR I=0 TO 9
140 PRINT Extrdgs(I)           !Print readings
150 NEXT I
160 END
```

SCTRIG (cont)

A typical output based on this program is shown below:

```
5.73  
5.73  
5.7275  
5.73  
5.7275  
5.73  
5.73  
5.73  
5.73  
5.73
```

- Mainframe

Description

Eliminates wait time for certain commands sent to some multiplexer and switching accessories.

Prerequisites

SERIAL requires mainframe firmware revision 3.5 or greater.

Syntax

SERIAL [*mode*]

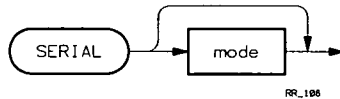

Parameters

mode For the following accessories, enables or disables wait time for commands shown. *mode* = OFF or ON. Power-on/reset/default *mode* = ON. With SERIAL OFF, wait time is eliminated. With SERIAL ON, wait time is not eliminated.

<u>Accessory</u>	<u>Effect</u>
HP 44724A	Eliminates settling time for CHWRITE and WRITE.
HP 44705A, HP 44706A, HP 44708A, HP 44725A, HP 44728A, HP 44729A	Eliminates wait time for OPEN and CLOSE (see CAUTION).

Remarks

SERIAL OFF May Result in Accessory Damage

SERIAL OFF allows multiple commands to execute during the time required for equipment hardware to physically complete an OPEN or CLOSE command or during the time required for settling. However, using SERIAL OFF can result in physical damage or destruction to some accessories (see CAUTION following).

CAUTION

With SERIAL OFF, repeatedly using OPEN and CLOSE may destroy an HP 44725A or HP 44728A in one hour or less due to contact arcing and/or contact wear. Also, with SERIAL OFF, repeatedly using OPEN and CLOSE may result in excess heat generation on an HP 44729A.

SERIAL (cont)

Data Returned

None

Related Commands

None

Examples Example: Using SERIAL OFF

This program segment shows the effect of using SERIAL OFF on an HP 44725A (16-Channel General Purpose Switch) in slot 2 of the mainframe. After the OPEN command is executed, since SERIAL OFF is set the CLOSE command immediately begins execution without waiting for the OPEN command to complete.

```
      .  
      .  
50  OUTPUT 709;"SERIAL OFF"      !Eliminate wait time  
60  OUTPUT 709;"OPEN 200-204"    !Open ch 200-204  
70  OUTPUT 709;"CLOSE 205-208"  !Close ch 205-208  
      .  
      .
```

- Mainframe

Description

Sets the alarm to occur at a specified real-time clock setting in seconds after midnight.

Prerequisites

The system real-time clock must be set to local time as the alarm reference. For an alarm to occur, the alarm must be enabled with ENABLE ALRM.

Syntax

SET ALRM *seconds*

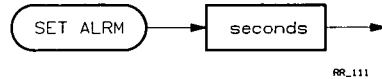

Parameters

seconds Seconds since midnight. Range is 0 to 86399.999.

Remarks

Time Set When Memory Lost

The alarm time is stored in a battery backed-up memory. If memory is lost, the time is set to 0 (midnight).

Setting Time Alarm

To set alarm (e.g. 10 sec.) ahead of the present time, use the TIME command first.

Data Returned

None

Related Commands

ALRM, ENABLE ALRM, DISABLE ALRM, ON ALRM CALL, OFF ALRM, RQS, STA?, SET TIME, TIME

SET ALRM (cont)

Examples **Example: Set Alarm Time**

The following program shows how the SET ALRM command is used with other related commands to call a subroutine when an alarm occurs at 11:05:00.

NOTE

The SET TIME and SET ALRM seconds shown in the following program were computed using $seconds = (hours \times 3600) + (min \times 60) + sec$. For example, 11:05:00 hours = $(11 \times 3600) + (5 \times 60) + 0 = 39900$ seconds.

```
10 OUTPUT 709;"RST"                !Reset the HP 3852A
20 OUTPUT 709;"SUB VERIFY"         !Define sub to be called on the alrm
30 OUTPUT 709;"DISP'CHECK'"       !Message displayed when alarm occurs
40 OUTPUT 709;"SUBEND"            !End of subroutine
50 OUTPUT 709;"ON ALRM CALL VERIFY" !Call subroutine when alarm occurs
60 OUTPUT 709;"ENABLE ALRM"       !Enable mainframe to recognize alarm
70 OUTPUT 709;"SET TIME 39600"    !Set real time clock to 11:00:00
80 OUTPUT 709;"SET ALRM 39900"    !Set alarm for 11:05:00
90 END
```

When this program runs, the subroutine VERIFY is downloaded into the HP 3852A. The mainframe is then enabled to recognize the alarm and the clock and alarm are set. At 11:05:00 the alarm will occur and the HP 3852A will display CHECK.

Note that the alarm sets the ALRM bit (bit 11) in the status register. Because the interrupt is handled by the mainframe (i.e. the subroutine is called), the bit does not have to be cleared in order for the mainframe to respond to the interrupt on the next alarm.

- Mainframe

Description Sets the real-time clock in seconds since midnight (Julian date is not changed).

Prerequisites None

Syntax **SET TIME** *seconds*

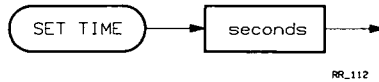

Parameters

seconds Number of seconds since midnight. Range is 0 to 86399.999.

Remarks

Time Set When Memory Lost

If memory is lost, the time is set to 0 (midnight). The time then accumulates from that setting until changed by SET TIME or SET TIMEDATE.

Data Returned

None

Related Commands

SET TIMEDATE, TIME, TIMEDATE, SET ALRM

Examples

Example: Setting Time Since Midnight

The following program sets the HP 3852A real-time clock to 06:56:40 hours and verifies that the real-time clock is running by taking a time measurement 5 seconds after the clock is set.

NOTE

To compute the SET TIME seconds required to set the real-time clock to your local time, use $seconds = (hours \times 3600) + (min \times 60) + sec$. For example, 06:56:40 hours = $(6 \times 3600) + (56 \times 60) + 40 = 25000$ seconds.

SET TIME (cont)

```
10 OUTPUT 709;"RST"           !Reset the HP 3852A
20 OUTPUT 709;"SET TIME 25000" !Set clock for 06:56:40 hours
30 WAIT 5                     !Wait 5 seconds
40 OUTPUT 709;"TIME"         !Read real-time clock time
50 ENTER 709;A               !Enter time
60 PRINT TIME$(A)           !Display time (5 sec after time set)
70 END
```

A typical return (since the time is measured five seconds after the clock is set) is:

```
06:56:45
```

SET TIMEDATE

- Mainframe

Description Sets the Julian date and time for the real-time clock.

Prerequisites None

Syntax SET TIMEDATE *seconds*

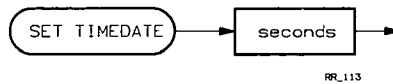

Parameters

seconds Julian time, expressed in seconds. Range is 2.08662912E+11 (midnight March 1, 1900) through 4.768629999E+11 (11:59:59.999 February 29, 10400).

Remarks

Time Set When Memory Lost

If memory is lost, the clock is set to 2.08662912E+11 (midnight March 1, 1900). Time accumulates from that setting until changed by SET TIME or SET TIMEDATE.

Data Returned

None

Related Commands

SET ALRM, SET TIME, TIME, TIMEDATE

Examples

Example: Setting Real-Time Clock

This program uses HP Series 200/300 commands DATE and TIME to set the HP 3852A real-time clock to 26 Sep 1986 @ 06:56:40 hours. To check clock operation, the time is read after 5 seconds.

```
10 OUTPUT 709;"RST"                                !Reset
20 OUTPUT 709;"SET TIMEDATE";DATE("26 SEP 1986")+TIME("06:56:40") !Set time
30 WAIT 5                                           !Wait 5 sec
40 OUTPUT 709;"TIMEDATE"                            !Read time
50 ENTER 709;A                                     !Enter time
60 PRINT "Clock Date and Time = ";DATE$(A);"      ";TIME$(A)    !Disp time
70 END
```

For the date and time in this program, a typical display is:

```
Clock Date and Time = 26 Sep 1986 06:56:45
```

SETTLE

- HP 44727A/B/C 4-Channel Current or Voltage DACs

Description

Sets the time the APPLY DCI, APPLY DCV, or APPLY PERC command sent to the DAC accessory will wait for the DAC output to settle before completing. The "settling" time specified applies to all channels in the slot addressed.

Prerequisites

To vary DAC programming time, the SETTLE command must precede the first APPLY DCI, APPLY DCV, or APPLY PERC command which addresses a different slot.

The SETTLE command requires mainframe firmware revision 2.2 or greater.

Syntax

SETTLE *slot time*

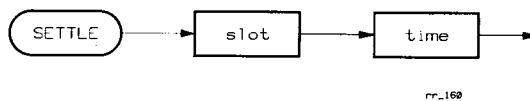

Parameters

- slot* Slot where the HP 44727A/B/C DAC accessory is installed.
- time* DAC settling time. *time* is the time given for the DAC output to settle before a subsequent command is executed. The range for *time* is 0 to 0.209712 seconds. Settings between 0 and 6.4 us default to 6.4 us. The *time* setting remains the same for the slot specified until the DAC accessory is reset, power is cycled on the mainframe, or until another SETTLE command is issued. At power-on or following a reset, *time* is set to 74.5472 msec.

Remarks

SETTLE Does Not Affect Hardware Settling Time

The HP 44727A/B/C DAC accessories have a hardware settling time of approximately 75 msec. This is the time required for the DAC output to settle on the level specified by the APPLY DCI, APPLY DCV, or APPLY PERC command. The SETTLE command does not change the hardware settling time; rather it sets the time that the APPLY commands will wait before completing.

Data Returned

None

Related Commands

APPLY DCI, APPLY DCV, APPLY PERC

Examples

Example: Using the Settle Command

The following programs show how the SETTLE command affects program execution and the output level of the HP 44727A/B/C DAC accessory. For both programs, channel 0 of the DAC in slot 2 is connected to an HP 44702A/B voltmeter accessory in slot 5. The APPLY DCV command sets the DAC output to 5V.

The first program does not contain the SETTLE command. Thus, the DAC accessory will halt program execution for approximately 75 msec due to the hardware settling time. When the voltmeter is triggered, the DAC output will have settled to 5V which is what the voltmeter will measure.

In the second program, the SETTLE command is added and immediately precedes the APPLY DCV command. SETTLE sets a 6.4 us delay (see Parameters) from the time the APPLY DCV command is executed (line 110) until the TRIG SGL command is executed (line 120). Note that the DAC still requires 75 msec for its output to settle; however, program execution continues after 6.4 us and when the voltmeter is triggered, the DAC output has not settled to its specified level.

For both programs, the mainframe display is turned off and voltmeter and DAC accessory configuration is performed through a mainframe subroutine. This increases program execution speed which enables the voltmeter to capture the settling characteristics of the DAC.

```

10   REAL Dacrgs(0:14)           !Declare controller array
20   OUTPUT 709;"RST"           !Reset the HP 3852A
30   OUTPUT 709;"DISP OFF"     !Turn mainframe display off
40   OUTPUT 709;"SUB DACSETLE" !Start of configuration sub
50   OUTPUT 709;"USE 500"      !Use the voltmeter in slot 5
60   OUTPUT 709;"CONF DCV"     !Configure for DC voltage
70   OUTPUT 709;"TERM EXT"     !Input is through external terminals
80   OUTPUT 709;"DELAY .001,.001" !Pace readings
90   OUTPUT 709;"NRDGS 15"     !Make 15 readings per trigger
100  OUTPUT 709;"APPLY DCV 200,5" !Supply 5V from HP 44727A/B/C
110  OUTPUT 709;"TRIG SGL"     !Issue a single trigger to voltmeter
120  OUTPUT 709;"XRDGS 500"    !Transfer readings to output buffer
130  OUTPUT 709;"SUBEND"       !End of subroutine
140  OUTPUT 709;"CALL DACSETLE" !Call subroutine
150  ENTER 709;Dacrgs(*)       !Enter readings into controller
160  PRINT USING "K,/";Dacrgs(*) !Display readings
170  END

```

SETTLE (cont)

DAC output measured without the SETTLE command:

```
5.0025
5
5
5
4.9975
5
5
5.0025
5.0025
5
5
5
5
5
5
4.9974
```

```
10   REAL Dacrgs(0:14)           !Declare controller array
20   OUTPUT 709;"RST"           !Reset the HP 3852A
30   OUTPUT 709;"DISP OFF"     !Turn mainframe display off
40   OUTPUT 709;"SUB DACSETLE" !Start of configuration sub
50   OUTPUT 709;"USE 500"      !Use the voltmeter in slot 5
60   OUTPUT 709;"CONF DCV"     !Configure for DC voltage
70   OUTPUT 709;"TERM EXT"     !Input is through external terminals
80   OUTPUT 709;"DELAY .001,.001" !Pace readings
90   OUTPUT 709;"NRDGS 15"     !Make 15 readings per trigger
100  OUTPUT 709;"SETTLE 200,0" !Set a 6.4 us settling time
110  OUTPUT 709;"APPLY DCV 200,5" !Supply 5V from HP 44727A/B/C
120  OUTPUT 709;"TRIG SGL"     !Issue a single trigger to voltmeter
130  OUTPUT 709;"XRDGS 500"    !Transfer readings to output buffer
140  OUTPUT 709;"SUBEND"       !End of subroutine
150  OUTPUT 709;"CALL DACSETLE" !Call subroutine
160  ENTER 709;Dacrgs(*)       !Enter readings into controller
170  PRINT USING "K,/" ;Dacrgs(*) !Display readings
180  END
```

SETTLE (cont)

DAC output measured with the SETTLE command:

3.6975
3.93
4.2
4.4925
4.795
5.1075
5.4
5.5625
5.635
5.65
5.6275
5.5775
5.515
5.45
5.38

SGN

• Math Function

Description

Math function. Returns a 1 if the argument is positive, 0 if it equals zero, and -1 if it is negative.

Prerequisites

The SGN function is only available with mainframe firmware revision 3.0 or greater.

Syntax

SGN (*number*)

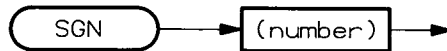

R. SGN

Parameters

number Number or numeric expression.

Remarks

Data Returned

See Description.

Related Commands

None

Examples

Example: Determining the Sign of a Number

The following program shows how the SGN command is used to determine the sign of a number. In the program, three DC voltage measurements are made and stored into a mainframe array. SGN is then used to determine the sign of the reading in the second element of the array.

```
10  OUTPUT 709;"REAL DCRDGS(2)"
20  OUTPUT 709;"CONFMEAS DCV 600-602, USE 700, INTO DCRDGS"
30  OUTPUT 709;"VREAD SGN(DCRDGS(1))"
40  ENTER 709;A
50  PRINT A
60  END
```

A typical display following execution of this program might be -1, which indicates the reading stored in array element 1 is negative.

• Binary Function

Description

Binary function. Returns an integer which equals the value obtained by shifting the 16-bit binary representation of the argument the number of bit positions specified. The shift does not wraparound. The SHIFT function does not change the original value of the argument.

Prerequisites

The SHIFT function is only available with firmware revision 3.0 or greater.

Syntax

SHIFT (*number bit_displacement*)

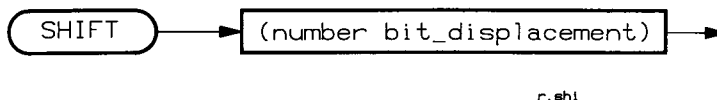

Parameters

number Number or numeric expression which must evaluate within the range -32768 to +32767.

bit_displacement Number or numeric expression which must evaluate within the range -32768 to +32767. The recommended range is -15 to +15.

Remarks

Direction of Shift

The number or numeric expression specified is converted to 16-bit two's complement form. If the bit displacement is positive, the shift is towards the least significant bit. If the bit displacement is negative, the shift is towards the most significant bit. Bits shifted out are lost, bits shifted in are zeros.

Data Returned

See Description.

Related Commands

Rotate

Examples

Example: Demonstrating the SHIFT Function

In the following example, the binary representation of 16 is shifted three bit positions towards the least significant bit (displacement is positive). The result is then entered into the controller and displayed.

```
10 OUTPUT 709;"VREAD SHIFT (16,3)"
20 ENTER 709;A
30 PRINT A
40 END
```

SHIFT (cont)

2

The binary representation of 16 is:

0000 0000 0001 0000

Upon execution of the SHIFT function, three zeros are shifted in and the binary representation appears as shown below:

0000 0000 0000 0010

This representation is equivalent to decimal 2, which is the value displayed by the controller.

- Mainframe

Description

Signals the task suspended by WAITFOR SIGNAL to resume command/subroutine execution.

Prerequisites

The SIGNAL command is used when the HP 3852A is in the multitasking mode. Multitasking is only available with mainframe firmware revision 3.0 or greater.

Syntax

SIGNAL *task*



Parameters

task Task which is signaled and which was previously suspended by WAITFOR SIGNAL.

TASK	DESCRIPTION
HP1B	Re-enables command/subroutine execution within the HP-1B task.
KYBD	Re-enables command/subroutine execution within the front panel task.
INTR	Resumes the execution of an interrupt-called subroutine.
run task number	Resumes execution of the subroutine in the specified run task. Only one run task number can be specified per SIGNAL command.

Remarks

SIGNALs Are Recorded

Should SIGNAL be directed to a task that has not been suspended (WAITFOR SIGNAL), the SIGNAL for the task is stored. When WAITFOR SIGNAL occurs, the stored SIGNAL is detected immediately and no wait occurs.

Signaling the Task

The point at which command execution resumes following execution of the SIGNAL command depends on the priority (urgency) of the task. If the suspended task has a high priority, command execution may resume immediately after the SIGNAL command. If the suspended task has a priority equal to other tasks (e.g. a run task), the task will be rescheduled following completion of the SIGNAL command and time-slice with the other tasks. If the suspended task has a priority lower than all other tasks, the higher priority tasks must finish or suspend before the waiting task is resumed.

SIGNAL (cont)

Data Returned

None

Related Commands

WAITFOR SIGNAL

Examples

Example: Signaling Tasks

This example shows how the SIGNAL command is used to resume the execution of a run task subroutine and re-enable command execution within the HP-IB task.

In the program, two subroutines are downloaded and directed to run tasks. The first subroutine makes 100 DC voltage measurements and stores them in a mainframe array. The second subroutine performs a statistical analysis on the readings (STAT command) which determines the minimum reading, the maximum reading, the average of the readings, and the standard deviation.

The WAITFOR SIGNAL command is used in the second subroutine (line 350) to prevent execution of the STAT command until the readings are available. WAITFOR SIGNAL is used again (line 510) before the VREAD command is sent which prevents the array RSLTS from being read before the STAT function is complete. The SIGNAL command in lines 230 and 370 enable the suspended tasks to resume at the appropriate time.

```
10 !Set a 65 ms time-slice and set the number of run tasks and
20 !queue size the system will allow. Place the HP 3852A in the
30 !multitasking mode. The reset caused by ENABLE MULTI will load
40 !the TSLICE and NTASKS parameters into the HP 3852A operating
50 !system.
60 !
70 OUTPUT 709;"TSLICE .065"
80 OUTPUT 709;"NTASKS 2,2"
90 OUTPUT 709;"ENABLE MULTI"
100 !
110 !Write and download the subroutine that will make the DC voltage
120 !measurements and signal the second run task when the readings
130 !are complete.
140 !
150 OUTPUT 709;"SUB DCMEAS"
160 OUTPUT 709;" REAL STATRGS(99)"
170 OUTPUT 709;" INTEGER I"
180 OUTPUT 709;" USE 700"
190 OUTPUT 709;" CONF DCV"
200 OUTPUT 709;" FOR I=0 TO 9"
210 OUTPUT 709;" MEAS DCV 600-609 INTO STATRGS"
220 OUTPUT 709;" NEXT I"
230 OUTPUT 709;" SIGNAL 2"
240 OUTPUT 709;"SUBEND"
250 !
260 !Write and download the subroutine that will perform the
```

SIGNAL (cont)

```
270 !statistical analysis on the voltage measurements. Suspend
280 !execution of the subroutine until signaled by the first
290 !run task that the readings are available. Once the STAT function
300 !is complete, signal the HP-IB to read the array in which the
310 !results are stored.
320 !
330 OUTPUT 709;"SUB STATS"
340 OUTPUT 709;" REAL RSLTS(3)"
350 OUTPUT 709;" WAITFOR SIGNAL"
360 OUTPUT 709;" STAT RSLTS,RSLTS,RSLTS,RSLTS,STATRGS"
370 OUTPUT 709;" SIGNAL HPIB"
380 OUTPUT 709;"SUBEND"
390 !
400 !Direct the subroutines to run tasks. Set each run task to
410 !execute one time.
420 !
430 OUTPUT 709;"RUN 1 DCMEAS"
440 OUTPUT 709;"RUN 2 STATS"
450 !
460 !Suspend execution of commands in the HP-IB task until
470 !signaled by the run task performing the statistics that the
480 !STAT function is complete. Enter and display the results once
490 !the readings are available.
500 !
510 OUTPUT 709;"WAITFOR SIGNAL"
520 OUTPUT 709;"VREAD RSLTS"
530 ENTER 709;A,B,C,D
540 PRINT "Lowest value = ";A
550 PRINT "Highest value = ";B
560 PRINT "Mean value = ";C
570 PRINT "Std Deviation = ";D
580 END
```

As this program executes, the controller might display the following:

```
Lowest value = .686474
Highest value = 4.67255
Mean value = 1.594116
Std Deviation = 1.046485
```

SIN

• Trigonometric Operation

Description Numeric expression evaluated as a command parameter. Returns the sine of the number that is expressed in radians.

Syntax **SIN** (*number*)

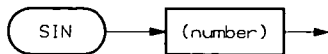

RR_114

Parameters

number Number or numeric expression in radians that must evaluate to a range that is an absolute value <2.98156826E+8 radians.

Remarks None

Examples **Example: Using SIN Function**

This program computes the sine of 0.5235988 radians (30 degrees) and displays the result (.5) on the controller CRT.

```
10 OUTPUT 709;"VREAD SIN (.5235988)"      !Compute sine of 30 degrees
20 ENTER 709;Res                          !Enter value in controller
30 PRINT "Sine = ";Res                    !Display value
40 END
```

A typical return for this program is:

```
Sine = .5
```

- Mainframe

- Description** Returns the size (maximum index + 1) of the specified array.
- Prerequisites** None
- Syntax** **SIZE?** *name* [**INTO** *name*] or [*fmt*]

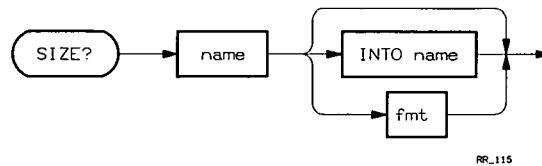

Parameters

- name* Name of the array whose size is returned.
- INTO** *name* See Glossary.
- fmt* See Glossary. Default format is LASC.

Remarks

Data Returned

Returns the number of readings that may be stored in the array specified by *name*. Default format for return = LASC.

For a PACKED array, SIZE? returns the number of bytes allocated to the array if no data has been stored in the array. If data has been stored in the array, SIZE? returns the maximum number of readings which can be stored in the array in that format.

Related Commands

CAT

SIZE? (cont)

Examples **Example: Using SIZE? Command**

This program defines an INTEGER array Volts of 10 elements and uses the SIZE? command to read back the array size (total number of elements).

```
10 OUTPUT 709;"RST"           !Reset the HP 3852A
20 OUTPUT 709;"INTEGER Volts(9)" !INTEGER array of 10 elements
30 OUTPUT 709;"SIZE? Volts"    !Read array size
40 ENTER 709;A                 !Return array size
50 PRINT "Volts size = ";A     !Display array size
60 END
```

For this program, a typical display is:

```
Volts size = 10
```

• HP 44702A/B High-Speed Voltmeter (Scanner or System Mode)

Description

Specifies the edge of the input signal that will trigger the voltmeter. In System mode, SLOPE specifies the voltmeter trigger edge. In Scanner mode, SLOPE specifies the Measure Trigger edge.

Prerequisites

The edge set by SLOPE is used only with the EXT0, EXT1, MEAS, or GPIO trigger sources of the TRIG and SCTRIG commands. In Scanner mode, SCTRIG must be set to HOLD before setting SLOPE.

Syntax

SLOPE *mode* [USE *ch*]

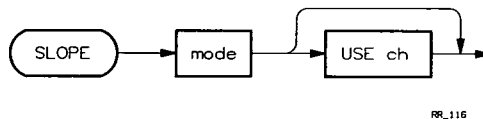

Parameters

mode Edge of the input signal that will trigger the voltmeter. Power-on *mode* = LH.

mode	Definition
------	------------

LH	Trigger on the low-to-high transition (rising edge)
HL	Trigger on the high-to-low transition (falling edge)

USE *ch* Voltmeter slot number. See Glossary.

Remarks

Data Returned

None

Related Commands

TRIG, PERC, USE

SLOPE (cont)

Examples

Example: Setting the Voltmeter Trigger Edge

This program uses the SLOPE command to set the HP 44702A/B to trigger on the high-to-low transition of the signal. The voltmeter is "threshold" triggered which means that as the trigger signal passes the threshold in a negative-going (high-to-low) direction, the voltmeter is triggered. Once the measurements are made, the readings are stored in mainframe memory.

```
10  OUTPUT 709;"RST"                !Reset the HP 3852A
20  OUTPUT 709;"REAL SLRDGS(9)"      !Declare mainframe array
30  OUTPUT 709;"USE 500"             !Use the vm in slot 5
40  OUTPUT 709;"CONF DCV"           !Configure for DC voltage
50  OUTPUT 709;"NRDGS 10"           !Take 10 measurements
60  OUTPUT 709;"RANGE 10"           !Set 10V range
70  OUTPUT 709;"PERC 50"            !Set threshold level
80  OUTPUT 709;"SLOPE HL"           !Set trigger edge
90  OUTPUT 709;"TRIG MEAS"          !Enable threshold triggering
100 OUTPUT 709;"MEAS DCV 400 INTO SLRDGS" !Make meas, store in mf
110  END
```

• HP 44702A/B High-Speed Voltmeter (Scanner Mode only)

Description

Sets the sample period (time between successive measurement triggers) for the HP 44702A/B High-Speed Voltmeter when used in the Scanner Mode with TRIG INT set.

Prerequisites

Scanner mode must be enabled (SCANMODE ON) and SCTRIG must be set to HOLD before setting SPER.

Syntax

SPER *sample__period* [USE *ch*]

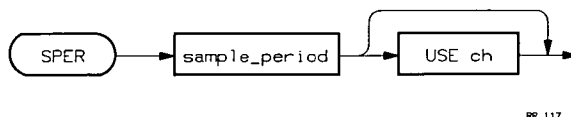

Parameters

sample__period Time in seconds between successive measurement triggers. The *sample__period* range is 0 to 1073.74182375 seconds. (*sample__period* settings from 0 to 10 us are rounded to 10 us.) At power-on, *sample__period* = 10 us.

USE *ch* Voltmeter slot number. See Glossary.

Remarks

SPER vs. TRIG Command

The SPER *sample__period* value may be set with TRIG *mode* in any *mode*. However, the value set by SPER is USED only when TRIG INT is set.

Data Returned

None

Related Commands

SCANMODE, TRIG, USE

SPER (cont)

Examples Example: Setting the Voltmeter's Sample Period

This program uses the HP 44702A/B voltmeter together with the mainframe STAT command to reject 60 Hz noise across 10 multiplexer channels within the period of one cycle of noise. The voltmeter scans the channel list 10 times during the period. The SPER command is set such that a measurement will be taken on each channel within each scan. As the measurements are taken they are stored in a mainframe array. The STAT command then averages out the noise on each channel.

```
10 DIM Average(0:9) !Declare controller array
20 OUTPUT 709;"RST" !Reset the HP 3852A
30 OUTPUT 709;"REAL SAMRDGS(99)" !Declare mainframe array
40 OUTPUT 709;"USE 500" !Use the VM in slot 5
50 OUTPUT 709;"SCANMODE ON" !Turn scanner mode on
60 OUTPUT 709;"CONF DCV" !Configure for DC voltage
70 OUTPUT 709;"CLWRITE SENSE 400-409" !Define channel list
80 OUTPUT 709;"PRESCAN 10" !Make 10 scans through ch list
90 OUTPUT 709;"SCDELAY 0,.00167" !Set 1.67 msec between scan
100 !triggers
110 OUTPUT 709;"SPER .000167" !Sets sample period - measure
120 !trigger issued every 167 usec
130 OUTPUT 709;"SCTRIG INT" !Issue scan triggers internally
140 OUTPUT 709;"XRDGS 500 INTO SAMRDGS" !Transfer rdgs into memory
150 OUTPUT 709;"INTEGER I,J,K" !Declare For...Next variables
160 OUTPUT 709;"REAL STAT_ARY(9),AVERAGE(9),MIN,MAX,STD,MEAN"
170 !Declare STAT arrays
180 OUTPUT 709;"SUB CONVERT" !Begin averaging subroutine
190 OUTPUT 709;" FOR J = 0 TO 9" !Extract individual channel
200 !readings, average out noise
210 !on each channel
220 OUTPUT 709;" K=J"
230 OUTPUT 709;" FOR I = 0 TO 9"
240 OUTPUT 709;" STAT_ARY(I) = SAMRDGS(K)"
250 OUTPUT 709;" K = K + 10"
260 OUTPUT 709;" NEXT I"
270 OUTPUT 709;" STAT MIN,MAX,MEAN,STD,STAT_ARY"
280 OUTPUT 709;" AVERAGE(J) = MEAN"
290 OUTPUT 709;" NEXT J"
300 OUTPUT 709;"SUBEND" !End averaging subroutine
310 OUTPUT 709;"CALL CONVERT" !Call sub when rdgs are available
320 OUTPUT 709;"VREAD AVERAGE" !Return the signal (without
330 !noise) measured on each channel
340 ENTER 709;Average(*) !Enter readings into controller
350 FOR A=0 TO 9 !Display readings
360 PRINT Average(A)
370 NEXT A
380 END
```

SPER (cont)

In this example, the settings for SCDELAY and SPER were calculated based on the period of the noise (60 Hz - 16.7 msec), the number of measurements (scans) to be taken, and on the number of channels involved (10). The following equations show how you can determine the values of SPER and SCDELAY such that noise rejection can occur on several channels within one cycle of the noise signal.

The maximum number of channels on which noise rejection can occur can be determined by the equation:

$$\# \text{ of channels} = (100,000)(\text{SCDELAY}) \quad (1)$$

where 100 kHz is the maximum voltmeter sampling rate (10 us) and with SCDELAY calculated as follows:

$$\text{SCDELAY} = \frac{\text{Noise Period}}{\# \text{ of Scans}} \quad (2)$$

When sampling only a single channel, the sample period (SPER) is calculated using the equation:

$$\text{SPER} = \frac{\text{Noise Period}}{\# \text{ of measurements}} \quad (3)$$

When sampling each channel during several scans, SPER is calculated using the equation:

$$\text{SPER} = \frac{\text{SCDELAY}}{\# \text{ of channels}} \quad (4)$$

Relating these equations to the previous program, the noise signal was assumed to be 60 Hz and thus has a period of approximately 16.7 msec. It was also assumed that 10 channels would be scanned and 10 measurements would be taken on each channel. Given these assumptions, SCDELAY was calculated using equation 2:

$$\text{SCDELAY} = 16.7 \text{ msec}/10 = 1.67 \text{ msec}$$

Since 10 different channels were to be sampled, SPER was calculated using equation 4:

$$\text{SPER} = 1.67 \text{ msec}/10 = 167 \text{ usec}$$

Given that we have a 16.7 msec period and we want to make 10 measurements per channel, equation 1 can be used to determine maximum number of channels on which noise can be rejected under these conditions:

$$\begin{aligned} \# \text{ of channels} &= (100,000)(.00167) \\ \# \text{ of channels} &= 167 \end{aligned}$$

SPER

• HP 44715A 5-Channel Counter/Totalizer

Description

Sets the period over which the input signal is sampled. Input signals that do not remain at the required level during the sample period are ignored. The period set by SPER applies to all counter channels.

Prerequisites

None

Syntax

SPER *number* [USE *ch*]

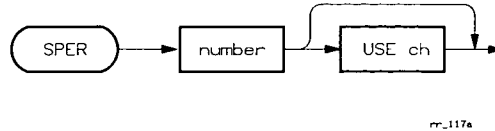

Parameters

number Period during which the input signal is sampled. The *number* range is 1 μ sec to 160 msec with the increments shown. Actual sampling period used is rounded up to a valid number closest to the *number* specified. At power-on, *number* = 1 μ sec.

number	range	increments
1 μ sec to	16 μ sec	1 μ sec
20 μ sec to	160 μ sec	10 μ sec
200 μ sec to	1.6 msec	100 μ sec
2 msec to	16 msec	1 msec
20 msec to	160 msec	10 msec

USE *ch* Specifies channels used for SPER. Channel range (depends on HP 44715A hardware configuration) = ES00 through ES04. All channels have the same sample period, regardless of the channel specified.

Remarks

SPER Value Affects All Channels

Even though the USE *ch* parameter specifies only one channel, the sampling period set by SPER applies to all channels in the slot specified by USE *ch*. For example, SPER .000001, USE 402 sets a sampling period of 1 μ sec on all channels of a counter in slot 4 of the mainframe.

SPER can be Used for Digital Filtering

The SPER command can be used to digitally filter noisy, slow inputs for applications such as debouncing switch closures. In effect, the command sets up the sample period of the first order digital filter on the counter input.

SPER Affects Minimum Pulse Width of Input

SPER affects the minimum input pulse width, since minimum pulse width = $(number * 2) + 0.5 \mu\text{sec}$. For example, if *number* = 20 μsec , minimum input pulse width = 40.5 μsec .

Data Returned

None

Related Commands

USE

Examples**Example: Set Sample Period**

The following program configures channel 2 of the counter accessory in mainframe slot 3 to totalize inputs to the channel. The input signal must remain at or above the level set by the signal level jumper during the sample period, otherwise it is rejected.

```

10 OUTPUT 709;"RST"           !Reset the HP 3852A and counter accessory
20 OUTPUT 709;"USE 203"       !Use ch 3 in slot 2
30 OUTPUT 709;"CONF TOTAL"    !Configure the counter to totalize
40 OUTPUT 709;"SPER 1E-3"     !Set a 1 msec sample period
50 OUTPUT 709;"TRIG SGL"      !Issue a single trigger
60 WAIT 10                    !Totalize for 10 seconds
70 OUTPUT 709;"CHREAD 203"    !Return count to output buffer
80 ENTER 709;A                !Enter reading into controller
90 PRINT A                    !Display reading
100 END

```

SPOLL

• HP 44788A HP-IB Controller

Description

This statement returns an integer containing the serial poll response from addressed device.

Prerequisites

Requires firmware revision 3.5 or greater.

Syntax

SPOLL (*@I/O path name or device selector*)

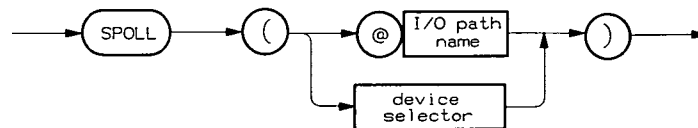

Parameters

@I/O path name

The name of the bidirectional path assigned to a device to be polled.

device selector

The HP-IB select code (ESnn) for the device that is to be polled. E = extender # (mainframe = 0), S = slot and nn = device address.

Remarks

Data Returned

Returns an integer containing the serial poll response from the addressed device. Refer to the documentation provided with the device being polled for information concerning the device's status byte.

Related Commands

ASSIGN

Examples

Example: Serial Poll of Device

This program assigns I/O path @dvm to device 111 and returns the results of the serial poll for device 111.

```
10 ASSIGN @HP3852 TO 709           !Assign I/O path for HP 3852A
20 OUTPUT @HP3852;"ASSIGN @DVM TO 111" !Assign I/O path to device
30 OUTPUT @HP3852;"VREAD SPOLL (@DVM)" !Trans value to output buffer
40 ENTER @HP3852;A                 !Enter SPOLL results
50 PRINT A                          !Display SPOLL results
60 END
```

• Math Function

Description

Numeric expression evaluated as a command parameter. Returns the square root of the number specified.

Syntax

SQR (*number*)

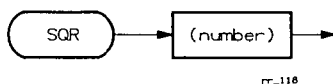

m-116

Parameters

number Number or numeric expression that must evaluate to a value ≥ 0 .

Remarks

None

Examples

Example: Square Root of a Number

The following program computes the square root of 2.345 and returns the result (1.531339) to the controller.

```

10 OUTPUT 709;"RST"           !Reset the HP 3852A
20 OUTPUT 709;"VREAD SQR (2.345)" !Compute sq root of 2.345
30 ENTER 709;Sqrtr           !Enter sq root
40 PRINT Sqrtr              !Display sq root
50 END
  
```

A typical display based on this program is:

1.531339

SREAD

- HP 44702A/B High-Speed Voltmeter only (System or Scanner Mode)

Description

SREAD interrogates a specified register on the HP 44702A/B High-Speed voltmeter and returns the decimal value of the current state of the information it provides.

CAUTION

Reading HP 44702A/B registers other than those specifically identified as read registers may result in invalid data or lost data, may set the voltmeter to an unknown state, or may cause system errors. Refer to HP 44702A/B Configuration and Programming Manual for information on using the SREAD command.

- Mainframe

Description

Programmed service request. If bit 2 (FPS) in the Status Register is cleared by STA? and unmasked by RQS, executing SRQ (setting bit 2) will signal the controller that the mainframe has requested service.

Prerequisites

For a service request (SRQ) message to be sent over HP-IB, the RQS *mode* must be enabled (RQS ON) and bit 2 (FPS) in the Status Register must be unmasked (RQS FPS or RQS 4) and have previously been cleared.

Syntax

SRQ

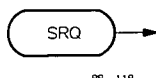

Parameters

None

Remarks

Data Returned

None

Related Commands

RQS, RQS?, STA?, STB?

Examples

Example: Using Front Panel SRQ Key

This program shows one way to use the front panel SRQ key to generate an interrupt signal to the controller. The program loops continuously at line 60 until the front panel SRQ key is pressed. When the key is pressed, the controller CRT displays an interrupt message and shows the sum of the bit values of the status register bits which are set.

```

10 OUTPUT 709;"RST"                !Reset the HP 3852A
20 ON INTR 7 GOTO 70                !Go to 70 when SRQ key pressed
30 ENABLE INTR 7;2                  !Enable controller intr path
40 OUTPUT 709;"RQS ON"              !Enable service request mode
50 OUTPUT 709;"RQS FPS"             !Unmask bit 2
60 GOTO 60                           !Loop until SRQ key pressed
70 PRINT "Front panel SRQ interrupt" !Display interrupt message
80 OUTPUT 709;"STA?"                !Read Status Reg bits set
90                                  !(also clears bit 2)
100 ENTER 709;A                     !Enter sum of values of bits set
110 PRINT "Status Register bits set = ";A !Display sum of values
120 B=SPOLL(709)                     !Clear bit 6 in status reg
130 END

```

SRQ (cont)

When the SRQ key is pressed, the controller display is as follows. The returned value of 68 shows that bit 2 (FPS) [weight = 4] and bit 6 (service request - set when bit 2 was set) [weight = 64] are set ($68 = 4 + 64$).

Front panel SRQ interrupt
Status Register bits set = 68

• HP 44723A 16-Channel High-Speed Digital Sense/Control

Description

Specifies the trigger source for second rank input triggers or for second rank output triggers. When a second rank trigger is received, the contents of the first rank register are copied into the second rank register.

Prerequisites

Requires mainframe firmware revision 3.0 or greater.

Syntax

SRTRIG [*source*] [USE *ch*]

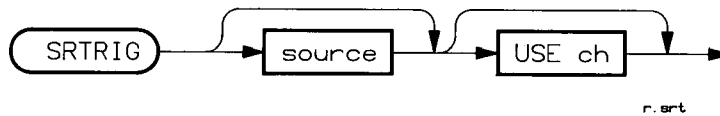

Parameters

source Selects the source or mode for second rank input triggers or for second rank output triggers. For channel numbers ES00-ES15, *source* specifies the source for second rank input triggers. For channel numbers ES16-ES31, *source* specifies the source for second rank output triggers. Valid SRTRIG *source* parameters follow. Power-on/reset value = SRTRIG INT for both input and output. Default value = SRTRIG SGL for both input and output.

source/mode	Description
SGL	Immediate single trigger when command executes.
SYS	System trigger (see TRG command).
EXT	Terminal module external trigger input.
INT	Trigger when a read or write command executes.*
HOLD	No triggering.

* = read commands are CHREAD, CHREADM, READ, and READM.

= write commands are CHWRITE, CHWRITEM, WRITE, and WRITEM.

USE *ch* See Glossary. For *ch* = ES00-ES15, SRTRIG *source* specifies the source for second rank input triggers. For *ch* = ES16-ES31, SRTRIG *source* specifies the source for second rank output triggers.

Remarks

Changing Trigger Sources

Changing the SRTRIG *source* may generate a second rank trigger.

SRTRIG *source* vs. Input Interrupts

If input interrupts are enabled (ENABLE INTR USE 91), SRTRIG EXT or SRTRIG SYS cannot be set for the second rank input register and vice-versa.

SRTRIG (cont)

SRTRIG INT vs. Read Commands

If SRTRIG INT is used as the second rank input trigger source, a second rank input trigger is generated immediately before the second rank input register is read with a read command (CHREAD, CHREADM, READ, or READM). If both SRTRIG INT and TRIG INT are set for input sources, a read command returns the current state of the input channels.

SRTRIG INT vs. Write Commands

If SRTRIG INT is used as the second rank output trigger source, a second rank output trigger is generated immediately after data is written to the first rank output register by a write command (CHWRITE, CHWRITEM, WRITE, or WRITEM).

Data Returned

None

Examples

Example: Second Rank Output Triggering

This program uses both internal and external second rank output triggering to output a known state to the output channels of an HP 44723A in slot 2 of the mainframe. The program demonstrates one way to output a known state to the user terminals and store a second state to be output when an external signal is received.

- Output New State Immediately:

In line 20, the WRITE command writes "34" to set channels 201 and 205 HIGH and the other channels LOW. If power-on conditions are assumed, RDGSMODE IMMED and SRTRIG INT are set, so the new state is immediately written to the first rank output register and copied to the second rank output register and to the output terminals.

- Store New State - Output on External Signal:

In 40 (since RDGSMODE IMMED is set), the WRITE command immediately writes the new state "20" (channels 202 and 204 HIGH) to the first rank output register. However, the new state is not copied to the second rank output register and to the output terminals until an external (HL) signal is received at the second rank output trigger terminals to generate the second rank output trigger.

Therefore, the accessory is set for a known output state (channels 201 and 205 HIGH) until an external second rank output trigger is received. At that time, the new state (channels 202 and 204 HIGH) stored on the accessory is output to the user terminals.

```
10 OUTPUT 709;"USE 216"           !Use ch is 200
20 OUTPUT 709;"WRITE 200,34"      !Set ch 201 and 205 HIGH
30 OUTPUT 709;"SRTRIG EXT"       !Set external sec rank output trigger
40 OUTPUT 709;"WRITE 200,20"     !Set ch 202, 204 HIGH on sec rank out trig
50 END
```

• HP 44714A 3-Channel Stepper Motor Controller/Pulse Output

Description

The STANDBY output normally goes true when a move is completed and goes false when a move is to begin. This output can be used to completely or partially power down a motor between moves. The command specifies the mode of operation and whether the true state needed for power-down is high or low.

Prerequisites

Requires mainframe firmware revision 3.0 or greater.

Syntax

STANDBY [*mode*] [*sense*] [USE *ch*]

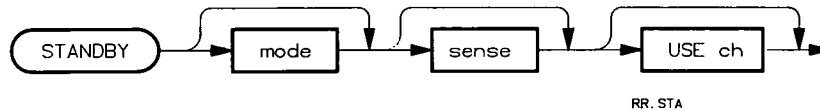

Parameters

mode The *mode* parameter specifies whether the STANDBY output is off, on, or operates automatically. If a mode is not specified, it defaults to *ON*. The power-on mode is *AUTO*.

<u>mode</u>	<u>Definition</u>
OFF	Causes the STANDBY output to be in false state (as set by the <i>sense</i> parameter) and does not power down a motor.
ON (default)	Causes the STANDBY output to go to the true state set by the <i>sense</i> parameter to power down a motor. STANDBY = STANDBY ON.
AUTO (power-on)	Causes the STANDBY output to be on, or in the true state, to power down a motor when a move is not taking place. When pulses are generated to make a move, the STANDBY output is off, or in the false state, to apply power to the motor for the move. The change between off and on and on and off is done automatically. The motor will exit the "standby" state just before motion begins. After motion ends, there is a delay of about 5 seconds before re-entering the "standby" state, unless a new MOVE or SUSTAIN command is received before the delay ends.

sense The *sense* parameter specifies whether the STANDBY output is high or low when it is on. If a sense is not specified, it remains unchanged. The power-on sense is *HI*.

<u>sense</u>	<u>Definition</u>
HI (power-on)	The STANDBY output is high when it is on and low when off. When the mode is AUTO, the output is high when no move is in progress.

STANDBY (cont)

LO The STANDBY output is low when it is on and high when off. When the mode is AUTO, the output is low when no move is in progress.

USE *ch* Channel for which the standby output is being set up. Channel range can be ES00 to ES02.

Remarks

Power-On State

The power-on state for the **STANDBY** command is AUTO, HI. The STANDBY output will automatically go on when a move is complete and off when a move is taking place. The "on" level is high.

Data Returned

None

Related Commands

None

Examples

Example: Set Channel 1 STANDBY Output Off Before a Move and On After

```
10 OUTPUT 709;"USE 201"           !Set ch 1 in slot 2
20 OUTPUT 709;"STANDBY OFF HI"    !Power to motor
30 OUTPUT 709;"MOVE 10"          !Move distance of 10 units
40 OUTPUT 709;"STANDBY ON"       !Powers motor down
50 END
```

The same action is accomplished by using the *AUTO* mode as follows:

```
10 OUTPUT 709;"USE 201"
20 OUTPUT 709;"STANDBY AUTO HI"
30 OUTPUT 709;"MOVE 10"
40 END
```

• Mainframe

Description Perform statistical analysis on stored readings.

Prerequisites None

Syntax **STAT** *min max mean std var*

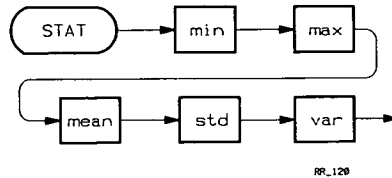

Parameters

- min* Name of REAL or INTEGER variable or array to receive the lowest value(s).
- max* Name of REAL or INTEGER variable or array to receive the highest value(s).
- mean* Name of REAL or INTEGER variable or array to receive the mean of all values.
- std* Name of REAL or INTEGER variable or array to receive the standard deviation of all values, where standard deviation is:

$$s^2 = \frac{\sum_{i=1}^n \left(x_i - \bar{x} \right)^2}{n-1}$$

- var* Name of variable or array containing the values from which the statistics are generated.

Remarks

Separate Arrays Not Necessary

It is not necessary to set up separate variables or arrays for the *min*, *max*, *mean*, and *std* parameters. If you specify one array for all parameters, statistics are indexed in the array in the order listed in the STAT command (first value = *min*, second = *max*, third = *mean*, and fourth = *std*).

var Array Index Pointer

The STAT command sets the index pointer of the *var* array to 0 before and after command execution.

Data Returned

Statistical data stored in the *min*, *max*, *mean*, and *std* arrays or variables.

STAT (cont)

Related Commands

REAL, DIM, INTEGER

Examples

Example: Using STAT Command

The following program performs 20 DC voltage measurements and stores the readings in array DATA. Then, statistics are performed on the readings and the lowest value, highest value, mean, and standard deviation are displayed. Note that a single array (RES) is used to store the results of the STAT operation.

```
10 OUTPUT 709;"RST"                !Reset the HP 3852A
20 OUTPUT 709;"REAL RES(3)"         !Dim statistics array
30 OUTPUT 709;"REAL DATA(19)"      !Dim readings array
40 OUTPUT 709;"USE 700"             !Use vm in slot 7
50 OUTPUT 709;"CONFMEAS DCV,200-219,INTO DATA" !Meas DCV, store in DATA
60 OUTPUT 709;"STAT RES,RES,RES,RES,DATA" !Do stat analysis
70 OUTPUT 709;"VREAD RES"          !Read statistical values
80 ENTER 709;A,B,C,D               !Enter values
90 PRINT "Lowest value = ";A        !Display lowest value
100 PRINT "Highest value = ";B      !Display highest value
110 PRINT "Mean value = ";C        !Display mean value
120 PRINT "Std Deviation = ";D     !Display std deviation
130 END
```

A typical display for this program is:

```
Lowest value = .0947455
Highest value = 4.40055
Mean value = 1.418835
Std Deviation = .7541731
```

The STAT command can also be used with the HP 44702A/B voltmeter for noise rejection. See the SPER command for an example.

- Mainframe

Description

Reads the HP 3852A status register, then clears the FPS, LCL, INTR, LMT, and ALRM bits in the register. STA? returns the weighted sum of all bits set in the register.

Prerequisites

None

Syntax

STA? [*INTO name*] or [*fmt*]

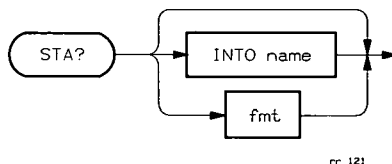

Parameters

INTO name See Glossary.

fmt See Glossary. Default format is IASC.

Remarks

STA? Clears Specific Status Register Bits

STA? clears the FPS, LCL, INTR, LMT, and ALRM bits in the status register. With these bits cleared, the status register is ready to indicate the next interrupt/service request-generating condition. See the RQS command for more information on setting and clearing status register bits.

Data Returned

STA? returns the weighted sum of the bits set in the status register (the system status word). A value of 64 (weight of bit 6) is included in the sum if an SRQ message is being asserted when STA? is executed. STA? returns "0" if none of the status register bits are set. Status register bit definitions follow. As shown, some of the bits are visible as annunciators (if DISP ON is set).

STA? (cont)

Status Register Bit Definitions

<u>Bit/Mnemonic</u>	<u>Value</u>	<u>Description</u>	<u>Annunciator</u>
0 DAV	1	Data Available	DAV
1 PWR	2	System Power Below Acceptable Level	---
2 FPS	4	Programmed Service Request (SRQ command)	---
3 LCL	8	Power-on or LOCAL Key when in Remote	---
4 RDY	16	Ready to Execute Command (see note 1)	BUSY (oppos)
5 ERR	32	Error	ERR
6 ---	64	Service Request Bit (see note 2)	SRQ
7 ---	---	Not Used	---
8 ---	---	Not Used	---
9 INTR	512	Accessory Channel Interrupting	INTR
10 LMT	1024	Limit Condition Reached	LMT
11 ALRM	2048	Alarm Condition Exists	ALRM
12 ---	---	Not used	---
15			

NOTE

- 1. STA? will always return 0 for the RDY bit, since the HP 3852A is busy when STA? is executing.*
- 2. The number returned by STA? includes the service request bit (bit 6) weight (64) if an SRQ message is being asserted. See the RQS command for details.*

Related Commands

RQS, STB?

Examples

Example: Reading the Status Word

This program uses STA? to read the system status word. The value returned is the weighted sum of the status register bits which are set.

```
10 OUTPUT 709; "STA?"
20 ENTER 709; A
30 PRINT "Status register bits set = ";A
40 END
```

If RQS ON has been issued and bit 2 (FPS) [weight 4] is set, "68" is returned since setting bit 2 also sets bit 6 (service request - enabled by RQS ON) which has a weighted value of 64. A typical display is:

```
Status register bits set = 68
```

• Mainframe

Description

Returns the state of the HP 3852A system. The state identifies the presence of extended memory, the controller module installed, and the power line frequency setting.

Prerequisites

None

Syntax

STATE? [INTO *name*] or [*fmt*]

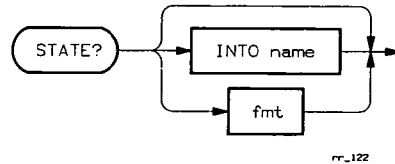

Parameters

INTO *name* See Glossary.

fmt See Glossary. Default format is IASC.

Remarks

Entering STATE? From HP 3852A Front Panel

When entering STATE? from the HP 3852A front panel keyboard, use FASTDISP OFF to see each constant (see the FASTDISP command).

Data Returned

STATE? returns two integers. The first integer is always 1. The second integer is the sum of the features listed.

Value	Features
1	256 kbyte extended memory installed (HP 44703A)
4	1 Mbyte extended memory installed (HP 44703B)
8	2 Mbyte extended memory installed
16	4 Mbyte extended memory installed
64	Controller module installed is the 03852-66523
128	Power line frequency = 60Hz

Related Commands

IDN?

STATE? (cont)

Examples

Example: Reading System State

This program uses STATE? to identify the features of an HP 3852A system.

```
10 INTEGER State(0:1)      !Declare array
20 OUTPUT 709;"STATE?"     !Query state
30 ENTER 709;State(*)      !Enter state
40 PRINT State(*)          !Display state
50 END
```

Typical output for an HP 3852A set for 60 Hz operation (128), with the 03852-66523 controller (64), and with 1 Mbyte of extended memory (4) is:

```
1 196
```

- Mainframe

Description

Reads the system status byte and clears the service request bit (bit 6, weight = 64) in the status register. Returned is the weighted sum of the bits set in the status register.

Prerequisites

None

Syntax

STB? [INTO *name*] or [*fmt*]

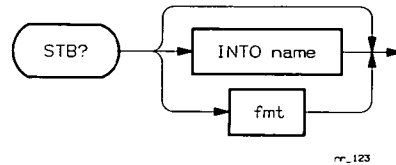

Parameters

INTO name See Glossary.

fmt See Glossary. Default format is IASC.

Remarks

NOTE

STB? differs from *HP-IB serial poll* since *STB?* (like all *HP 3852A* commands) will not be recognized until all previously entered commands have been executed. *Serial poll*, in contrast, is done immediately.

STB? Clears the Service Request Bit

The *STB?* command clears the service request bit (bit 6) in the status register. This bit is enabled by *RQS ON* and is set when any other bit in the status register is set. The *HP 3852A* service request bit sends an *SRQ* message to the controller indicating that the instrument has requested service.

Data Returned

The value returned by *STB?* is the weighted sum of the bits which are set in the status register. For *STB?*, bit 7 (weight 128) represents the logical OR of the *INTR*, *LMT*, and *ALRM* conditions. If any one of the three conditions exist, bit 7 will be set. A value of 64 (weight of bit 6) is included in the sum if an *SRQ* message is being asserted when *STB?* is executed. *STB?* returns 0 if none of the bits in the status register are set.

The following table gives the system status byte definitions and lists the bits which are visible on the front panel annunciators (if *DISP ON* is set). See the *RQS* command for more information on setting and clearing bits in the status register.

STB? (cont)

System Status Byte Definitions

<u>Bit/Mnemonic</u>	<u>Value</u>	<u>Description</u>	<u>Annunciator</u>	
0	DAV	1	Data Available	DAV
1	PWR	2	System Power Below Acceptable Level	---
2	FPS	4	Programmed Service Request (SRQ command)	---
3	LCL	8	Power-on or LOCAL Key when in Remote	---
4	RDY	16	Ready to Execute Command (note 1)	BUSY (oppos)
5	ERR	32	Error	ERR
6	---	64	Service Request Bit (note 2)	SRQ
	INTR		Accessory Channel Interrupting	INTR
	or		or	
7	LMT	128	Limit Condition Reached	LMT
	or		or	
	ALRM		Alarm Condition Exists	ALRM

NOTE

1. *STB?* always returns a 0 for the RDY bit, since the HP 3852A is busy when *STB?* is executing. (This is not true for HP-IB serial poll.)

2. The weighted sum returned includes 64 if an SRQ message is being asserted. See the RQS command for additional information.

Related Commands

RQS, STA?

Examples

Example: Reading the Status Byte

This program uses *STB?* to read the system status byte. The number returned is the weighted sum of the bits set in the status register. Note that 128 (weight of bit 7) is returned if any of the INTR, LMT, or ALRM conditions exist.

```
10 OUTPUT 709;"STB?"           !Query status byte
20 ENTER 709;A                 !Enter status byte value
30 PRINT "The system status byte = ";A  !Display value
40 END
```

If RQS ON has been issued and bit 3 (LCL, weight 8) and bit 7 (INTR or LMT or ALARM, weight 128) are set, a typical display (sum = 64 + 8 + 128) is:

The system status byte = 200

- Mainframe

Description Steps through each command of the specified subroutine.

Prerequisites STEP cannot be stored inside a subroutine.

Syntax **STEP** [*name*]

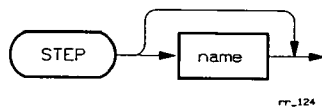

Parameters

name Name of the subroutine to be stepped through.

Remarks

Using the STEP Command

STEP *name* calls the the subroutine to be stepped through. Subsequent STEPs without *name* step through the subroutine. Trying to step through a subroutine before it is called or after stepping past SUBEND gives ERROR 11: NO ACTIVE SUB.

STEP Commands Must be ENTERed

When STEPping through an HP 3852A subroutine, the STEP command must be entered each time by pressing STEP ENT.

Data Returned

None

Related Commands

PAUSE, CONT, CALL, SUB, SUBEND, CLR

STEP (cont)

Examples **Example: Stepping a Subroutine**

This program downloads the subroutine "STEPMEAS" which makes DC voltage measurements on five channels. The subroutine is then called so that it can be STEPped and control of the HP 3852A is transferred to the front panel. Pressing STEP ENT five times completes the pass through the subroutine.

```
10 OUTPUT 709;"RST"           !Reset the HP 3852A
20 OUTPUT 709;"SUB STEPMEAS"  !Start downloading subroutine
30 OUTPUT 709;"FASTDISP OFF"  !Turn fast display mode off
40 OUTPUT 709;"USE 700"       !Use the voltmeter in mf slot 7
50 OUTPUT 709;"CONFMEAS DCV, 0-4" !Measure and view DC voltage on disp
60 OUTPUT 709;"FASTDISP ON"   !Turn fast display mode back on
70 OUTPUT 709;"SUBEND"       !End of subroutine
80 OUTPUT 709;"STEP STEPMEAS" !Call subroutine to be STEPped
90 OUTPUT 709;"LOCAL"        !Transfer control to mf front panel
100 END
```

After the subroutine is downloaded and the program completes, LOCAL is displayed on the front panel. Pressing STEP ENT five times will step through the subroutine. After STEP ENT is pressed the fifth time, SUBEND is displayed.

• HP 3852A Mainframe

Description

Sets the source of the mainframe scan trigger. The source specified by STRIG is used during backplane scanning when measurements are made with either a voltmeter accessory using the MEAS command, or with an external voltmeter using the SCAN command.

Prerequisites

None

Syntax

STRIG *source*

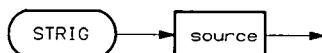

rr_125

Parameters

source Scan trigger source. Power-on *source* = SCAN.

source	Definition
SCAN	Close first channel automatically at beginning of scan.
CHADV	Rear panel CHANNEL ADVANCE BNC.
KEY	Front panel SADV KEY (scan advance key).
PACER	Pulse output from PACER OUT BNC.

Remarks

STRIG Function

STRIG selects the trigger source which directs the mainframe to close the first channel in the channel list to be connected to the backplane. This trigger starts the scan process, but does NOT continue the scan operation. The trigger source selected by the SADV command controls channel advance. Note that STRIG is a mainframe command used to control the scan of multiplexer channels. It is not a voltmeter trigger of any kind.

Using the CONF, MEAS, and STRIG Commands

Executing the CONF command sets STRIG SCAN. To change the scan trigger source, STRIG must be executed following CONF and before MEAS which are executed individually rather than as CONFMEAS.

Data Returned

None

Related Commands

CONF, MEAS, SCAN, SADV

STRIG (cont)

Examples

Example: Setting the Scan Trigger Source

This program sets SADV KEY as the scan trigger source and shows how the STRIG command is used with respect to the CONF and MEAS commands when making measurements on a list of channels.

```
10 REAL Rgs(0:4)           !Declare controller array
20 OUTPUT 709;"RST"        !Reset the HP 3852A
30 OUTPUT 709;"USE 700"    !Use the voltmeter in slot 7
40 OUTPUT 709;"CONF DCV"  !Configure the voltmeter for DC volts
50 OUTPUT 709;"STRIG KEY" !Set SADV KEY as the scan trigger source
60 OUTPUT 709;"MEAS DCV, 0-4" !Measure the voltage on chs 0-4
70 ENTER 709;Rgs(*)       !Enter and display measurements
80 PRINT USING "K,/";Rgs(*)
90 END
```

A typical output based on this program is:

```
5.09921
4.977362
5.087284
5.091786
5.099522
```

In this program, DC voltage is measured on channels 0-4 of the multiplexer accessory in mainframe slot 0. Note that the scanning and measurement sequence will not start until SADV KEY is pressed. Also, CONF sets SADV SCAN which means the scan will be advanced automatically as each measurement is taken.

• HP 44702A/B High-Speed Voltmeter (Scanner Mode only)

Description

Sets the edge of the Stop Trigger input signal that will trigger the voltmeter. STSLOPE is used only when the voltmeter is in Scanner Mode.

Prerequisites

The edge set by STSLOPE is used only for the EXT0, EXT1, MEAS, and GPIO settings of the STTRIG command. SCTRIG must be set to HOLD before setting STSLOPE.

Syntax

STSLOPE *mode* [USE *ch*]

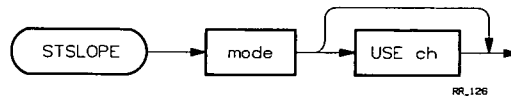

Parameters

mode Specifies the Stop Trigger slope. Power-on *mode* = LH.

mode	Definition
LH	Stop triggering on the low-to-high transition (rising edge) of the Stop Trigger input signal.
HL	Stop triggering on the high-to-low transition (falling edge) of the Stop Trigger input signal.

USE *ch* Voltmeter slot number. See Glossary.

Remarks

Data Returned

None

Related Commands

PERC, STTRIG, USE

STSLOPE (cont)

Examples

Example: Setting the Stop Trigger Slope

The following program makes a series of 4-wire ohms measurements and stores the readings in a PACKED mainframe array. The HP 44702A/B voltmeter is programmed to make 3 scans after the stop trigger is received (POSTSCAN 3). The stop trigger is to be applied externally (STTRIG EXT0) and the voltmeter will trigger on the high to low transition of the signal (STSLOPE HL).

```
10  OUTPUT 709;"RST"                !Reset HP 3852A
20  OUTPUT 709;"PACKED POSTRDGS(59)" !Declare PACKED array
30  OUTPUT 709;"USE 500"            !Use vm in slot 5
40  OUTPUT 709;"SCANMODE ON"        !Turn scanner mode on
50  OUTPUT 709;"CONF OHMF"          !Configure for 4-wire ohms
60  OUTPUT 709;"CLWRITE COM 400-409" !Define channel list
70  OUTPUT 709;"RDGSMODE COMPLETE"  !Trim buffer contents to
80                                  !# prescans + #postscans
90  OUTPUT 709;"PRESCAN 0"          !Make 0 prescans
100 OUTPUT 709;"POSTSCAN 3"         !Make 3 postscans
110 OUTPUT 709;"STTRIG EXT0"        !Apply stop trigger externally
120 OUTPUT 709;"STSLOPE HL"        !Trigger on h/l transition
130 OUTPUT 709;"SCTRIG INT"         !Issue internal scan triggers
140 OUTPUT 709;"XRDGS 500 INTO POSTRDGS" !Transfer readings to memory
150  END
```

- HP 44702A/B High-Speed Voltmeter (Scanner Mode only)

Description

Specifies the Stop Trigger source. STTRIG is used only when the voltmeter is set for the Scanner Mode.

Prerequisites

The voltmeter must be set to Scanner Mode (SCANMODE ON) and SCTRIG must be set to HOLD before setting STTRIG.

Syntax

STTRIG [*source*] [USE *ch*]

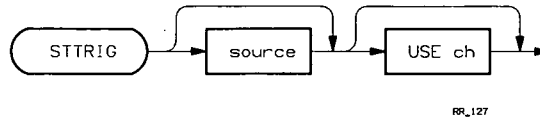

Parameters

source Stop trigger source. Power-on *source* = INT. Default *source* = SGL.

source	Definition
SCAN	Trigger when multiplexer channel closed.
SGL	Issue immediate single trigger.
HOLD	Triggering off.
EXT0	Trigger from voltmeter rear panel BNC 0.
EXT1	Trigger from voltmeter rear panel BNC 1.
SYS	System trigger pulse (see TRG command).
INT	Trigger at end of pass through scan list.
MEAS	Threshold triggering (see PERC command).
GPIO	GPIO trigger.

USE *ch* Voltmeter slot number. See Glossary.

Remarks

Threshold Triggering

In threshold triggering mode (STTRIG MEAS), the voltmeter samples the first channel of the scan list each time it is scanned. When the input signal crosses the threshold level set by PERC in the direction set by STSLOPE, a trigger occurs.

Issuing a Single Stop Trigger

When using a single stop trigger at the end of a scan (STTRIG SGL), STTRIG HOLD should be set prior to SCTRIG, then set to STTRIG SGL. Note that CONF sets STTRIG INT and not STTRIG HOLD.

STTRIG (cont)

Scan Results

If both PRESCAN and POSTSCAN are set to 0, no measurements are taken regardless of the STTRIG setting. If the voltmeter receives a scan trigger (SCTRIG) but the number of prescans and postscans is zero, the voltmeter becomes idle and the mainframe remains in a "busy" state.

Data Returned

None

Related Commands

PERC, POSTSCAN, PRESCAN, STSLOPE, TRIGOUT, TRG, USE

Examples

Example: Setting the Stop Trigger Source

This program uses threshold triggering as the method of sending a stop trigger to the HP 44702A/B voltmeter. The voltmeter is programmed to make DC voltage measurements on three channels. Since STTRIG MEAS is set, the voltmeter will continue making measurements on the channels until the input signal on the first channel reaches the threshold level determined by the RANGE and PERC settings. With RDGSMODE COMPLETE and PRESCAN 3 set, the voltmeter will trim the contents of its buffer to the readings taken during the last three scans before the stop trigger was received.

```
10 REAL Rgs(0:8) !Declare controller array
20 OUTPUT 709;"RST" !Reset the HP 3852A
30 OUTPUT 709;"USE 500" !Use the vm in slot 5
40 OUTPUT 709;"SCANMODE ON" !Turn scanner mode on
50 OUTPUT 709;"CONF DCV" !Configure for DC voltage
60 OUTPUT 709;"RDGSMODE COMPLETE" !Trim buffer to pre + postscans
70 OUTPUT 709;"CLWRITE SENSE 400-402" !Define channel list
80 OUTPUT 709;"RANGE 10" !Set voltmeter range
90 OUTPUT 709;"PERC 50" !Set stop trigger threshold level
100 OUTPUT 709;"STSLOPE LH" !Set stop trigger edge
110 OUTPUT 709;"STTRIG MEAS" !Enable threshold triggering
120 OUTPUT 709;"PRESCAN 3" !Retain 3 scans in buffer
140 OUTPUT 709;"SCTRIG INT" !Issue scan triggers internally
150 OUTPUT 709;"XRDS 500" !Transfer readings to output buffer
160 ENTER 709;Rgs(*) !Enter readings into controller
170 PRINT USING "K,/";Rgs(*) !Display readings
180 END
```

- Mainframe

Description

Downloads a subroutine into mainframe memory. All commands between SUB and SUBEND form the subroutine.

Prerequisites

None

Syntax

SUB *name*

subroutine commands

SUBEND

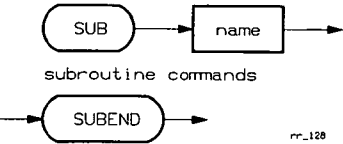

Parameters

name

Name of the subroutine. A subroutine *name* may be up to eight characters long. The first character must be a letter (A - Z), but the remaining seven characters may be letters, numbers (0 - 9) or the characters "_" or "?". Subroutine *names* must not be the same as HP 3852A command headers (i.e., AZERO, TIME, CLOSE, etc.) or the same as variable or array names.

Remarks

Subroutine Name

The subroutine *name* must be an unused name or name of deleted subroutine. All commands (except illegal commands which cause errors) following SUB and preceding the SUBEND command are stored in subroutine *name*.

Global Variables and Arrays

All HP 3852A variables and arrays are global. This means variables and arrays declared within a subroutine are accessible outside the subroutine and vice-versa.

Arrays Within Subroutines

Arrays declared within subroutines are known immediately, but actual memory for the array is not allocated until the subroutine is executed. Each subsequent execution of the subroutine redeclares the array. If the maximum index of the array is changed by another command, it will again be redeclared when the subroutine executes.

SUB...SUBEND (cont)

Commands Which Can't be Stored in Subroutines

SUB, DELSUB, SCRATCH, STEP, and CONT cannot be stored in subroutines.

Using RST Within Subroutine

CAUTION

The RST (reset) command is allowed within a subroutine. However, executing RST in a subroutine (or anywhere else) resets the HP 3852A to its power-on state (with some exceptions) and deletes all subroutines, arrays, and variables from memory.

Entering Subroutines From Front Panel

Entering a subroutine from the front panel keyboard will not affect normal execution of commands sent over HP-IB and vice-versa. The "SUB ENTRY" annunciator on the front panel is ON whenever a subroutine is being entered from HP-IB or from the front panel.

Downloading Subroutines via HP-IB

For nontrivial subroutines, download the subroutine from the controller via HP-IB. By doing this, the subroutine can be edited in the controller and reloaded into the HP 3852A, if necessary. Also, in case of power failure, this allows you to save a copy of the subroutine in the controller.

Data Returned

None

Related Commands

CALL, STEP, DELSUB, CAT, SCRATCH, PAUSE

Examples

Example: Create Subroutine BEEPER

This program creates and downloads the subroutine BEEPER and calls the subroutine once.

```
10 OUTPUT 709;"RST"           !Reset the HP 3852A
20 OUTPUT 709;"SUB BEEPER"    !Start of sub BEEPER
30 OUTPUT 709;"BEEP"         !BEEP once
40 OUTPUT 709;"SUBEND"       !End of sub BEEPER
50 OUTPUT 709;"CALL BEEPER"   !Call sub BEEPER
60 END
```

- Mainframe

Description

See **SUB...SUBEND** Command

SUSPEND

- Mainframe

Description

Suspends or defers the execution of commands/subroutines within a task for a specified number of seconds.

Prerequisites

The SUSPEND command is used when the HP 3852A is in the multitasking mode. Multitasking is only available with mainframe firmware revision 3.0 or greater.

Syntax

SUSPEND *seconds*



r. #10

Parameters

seconds

Number of seconds the task is suspended. The range for *seconds* depends on the tic interval set by the TSLICE command. For the tic intervals available, the following ranges apply:

TIC_INTERVAL	MINIMUM PERIOD SUSPENDED	MAXIMUM PERIOD SUSPENDED
1.024 ms	1.024 ms	4398046.51 s (50.9 days)
2.048 ms	2.048 ms	8796093.02 s (101.8 days)
4.096 ms	4.096 ms	17592186.04 s (203.6 days)
8.192 ms	8.192 ms	35184372.08 s (407.2 days)
16.384 ms	16.384 ms	70368744.161 s (814.4 days)
32.768 ms	32.768 ms	140737488.322 s (1628.9 days)
65.536 ms	65.536 ms	281474976.645 s (3257.8 days)

The default tic interval is 65.536 ms. Thus, the range most commonly used will be 65.536 ms to 281,474,976.645 s.

Remarks

Any HP 3852A Task Can be Suspended

When the HP 3852A is in the multitasking mode, commands and subroutines execute within environments called tasks. Specifically, these tasks are:

Front Panel
HP-IB
Interrupt
Run Tasks

Thus, a command sent over the HP-IB executes within the HP-IB task, a command entered from the front panel executes within the front panel task, and so on.

SUSPEND (cont)

With SUSPEND, command/subroutine execution within any task can be suspended or deferred. For example, if the following commands are sent over HP-IB:

```
OUTPUT 709;"INBUF ON;SUSPEND 5; ID?"
```

each command is accepted by the mainframe, however, ID? is deferred for 5 seconds before it is executed. Note that if INBUF OFF were set, the ID? command would be held on the HP-IB for five seconds before it would be accepted and executed by the mainframe.

Suspended Tasks Allow other Tasks to Execute

Any task that is suspended will allow other tasks to execute. When the period a task is suspended expires, if it is a high priority task, command or subroutine execution may resume immediately following the currently executing command. If the suspended task has a priority equal to other tasks, the task will be re-scheduled into the time-slice sequence and resume execution when the system swaps to the task.

Data Returned

None

Related Commands

ENABLE MULTI

Examples

Example: Suspending a Run Task

This example shows how the SUSPEND command temporarily removes a run task from a sequence of tasks which are time-slicing, yet allows time-slicing to continue.

In the program, three subroutines are downloaded and directed to run tasks. Subroutine A (run task 1) counts continuously and subroutine B (run task 2) repeatedly displays A B C. Subroutine TEMPMEAS (run task 3) makes temperature measurements every 30 seconds.

The SUSPEND command in line 410 causes run task 3 to execute in 30 second intervals. When the 30 second period elapses, the run task is scheduled in, and time-slices with run tasks 1 and 2 until it is suspended again. Note that while run task 3 is suspended, run tasks 1 and 2 continue to time-slice.

```
10  !Set a 65 ms time-slice and set the number of run tasks and
20  !queue size the system will allow. Place the HP 3852A in the
30  !multitasking mode. The reset caused by ENABLE MULTI will load
40  !the TSLICE and NTASKS parameters into the operating system.
50  !
60  OUTPUT 709;"TSLICE .065"
70  OUTPUT 709;"NTASKS 3,3"
80  OUTPUT 709;"ENABLE MULTI"
90  !
100 !Write and download the subroutines to be directed to run tasks.
```

SUSPEND (cont)

```
110 !Subroutine A when active, counts continuously.
120 !
130 OUTPUT 709;"SUB A"
140 OUTPUT 709;" INTEGER I"
150 OUTPUT 709;" WHILE 1"
160 OUTPUT 709;" I=I+1"
170 OUTPUT 709;" DISP I"
180 OUTPUT 709;" END WHILE"
190 OUTPUT 709;"SUBEND"
200 !
210 !Download subroutine B. When active, subroutine B repeatedly
220 !displays A B C.
230 !
240 OUTPUT 709;"SUB B"
250 OUTPUT 709;" WHILE 1"
260 OUTPUT 709;" DISP 'A'"
270 OUTPUT 709;" DISP 'B'"
280 OUTPUT 709;" DISP 'C'"
290 OUTPUT 709;" END WHILE"
300 OUTPUT 709;"SUBEND"
310 !
320 !Download subroutine TEMPMEAS which continuously makes temperature
330 !measurements on three channels every 30 seconds. After the
340 !measurements are taken, signal the controller to read the array
350 !containing the temperatures.
360 !
370 OUTPUT 709;"SUB TEMPMEAS"
380 OUTPUT 709;" REAL TEMPRDGS (2)"
390 OUTPUT 709;" USE 700"
400 OUTPUT 709;" WHILE 1"
410 OUTPUT 709;" SUSPEND 30"
420 OUTPUT 709;" CONFMEAS THM10K 600-602 INTO TEMPRDGS"
430 OUTPUT 709;" SIGNAL HPIB"
440 OUTPUT 709;" END WHILE"
450 OUTPUT 709;"SUBEND"
460 !
470 !Direct the subroutines to run tasks. Direct subroutine A
480 !to run task 1, subroutine B to run task 2, and subroutine
490 !TEMPMEAS to run task 3.
500 !
510 OUTPUT 709;"RUN 1 A"
520 OUTPUT 709;"RUN 2 B"
530 OUTPUT 709;"RUN 3 TEMPMEAS"
540 !
550 !Suspend execution of commands in the HP-IB task until
560 !signaled that the measurements are complete. After the array is
570 !read, enter and display the temperatures. Transfer program
580 !execution back to line 620 such that subsequent temperature
590 !measurements can be entered and displayed.
600 !
610 OUTPUT 709;"WAITFOR SIGNAL"
620 OUTPUT 709;"VREAD TEMPRDGS"
630 REAL Oventemp(0:2)
640 ENTER 709;Oventemp(*)
```

SUSPEND (cont)

```
650 PRINT Oventemp(*)  
660 PRINT  
670 GOTO 620  
680 END
```

As this program executes, A B C is repeatedly displayed along with an increasing count. At each 30 second interval, the temperature measurements are entered into the controller and displayed.

Note that each subroutine has been programmed to run continuously. Thus, when running this program, it will be necessary to reset the controller, clear the mainframe, or abort each run task in order to regain control.

SUSPEND UNTIL

- Mainframe

Description

Suspends or defers the execution of commands/subroutines within a task until a specified Julian date and time.

Prerequisites

Requires firmware revision 3.5 or greater and the HP 3852A must be in the multitasking mode. The mainframe's internal clock should also be set to the current date and time.

Syntax **SUSPEND UNTIL** *seconds*

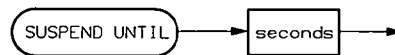

Parameters

seconds The Julian date and time (expressed in seconds) at which the task is no longer suspended. Note that the setting of the mainframe clock is subtracted from the *seconds* specified, and the difference is the length of time the task is suspended.

The period of time a task is allowed to be suspended depends on the tic interval set by the TSLICE command. For the tic intervals available, the following ranges apply:

TIC_INTERVAL	MINIMUM PERIOD SUSPENDED	MAXIMUM PERIOD SUSPENDED
1.024 ms	1.024 ms	4398046.51 s (50.9 days)
2.048 ms	2.048 ms	8796093.02 s (101.8 days)
4.096 ms	4.096 ms	17592186.04 s (203.6 days)
8.192 ms	8.192 ms	35184372.08 s (407.2 days)
16.384 ms	16.384 ms	70368744.161 s (814.4 days)
32.768 ms	32.768 ms	140737488.322 s (1628.9 days)
65.536 ms	65.536 ms	281474976.645 s (3257.8 days)

The default tic interval is 65.536 ms. Thus, the range most commonly used will be 65.536 ms to 281,474,976.645 s.

If the number of seconds specified corresponds to a time previous to the current clock setting, the task is not suspended.

Remarks

SUSPEND UNTIL Can Suspend any Task

SUSPEND UNTIL can be used to suspend command/subroutine execution within any of the multitasking mode's task environments: front panel, HP-IB, interrupt, run tasks.

SUSPEND UNTIL (cont)

Suspended Tasks Allow other Tasks to Execute

Any task suspended by SUSPEND UNTIL will allow other tasks to execute. When the period the task is suspended expires, command or subroutine execution may resume immediately following the currently executing command. If the suspended task has a priority equal to other tasks, the task will be rescheduled into the time-slice sequence and resume execution when the system swaps to the task.

SUSPEND UNTIL vs. SUSPEND

The SUSPEND UNTIL and SUSPEND commands are basically the same in that they suspend a task a specified period of time while allowing other tasks to execute. As mentioned, when SUSPEND UNTIL is used, the setting of the mainframe's clock is subtracted from the Julian date and time specified. The difference is the length of time suspended. With SUSPEND, the number of seconds specified is the amount of time which elapses before the task resumes.

Data Returned

None

Related Commands

SET TIMEDATE, SUSPEND

Examples

Example: Suspending Tasks which Control Facility Lighting

The following example shows how SUSPEND UNTIL is used within two run task subroutines which control the lighting of a facility. The two run tasks may be part of a large multitasking system managing the working environment of the facility.

As the program is loaded, the multitasking system is configured and the HP 3852A internal clock is set to the current date and time (line 90). The HP Series 200/300 controller's DATE and TIME functions are used to convert the date and time to Julian time (seconds). (This also sets the controller date and time the same as the mainframe.)

Subroutine A is responsible for turning on the lights throughout the facility at 7:00 AM every day. The task is suspended until 7:00 AM the day following the current setting of the mainframe clock. The controller's DATE and TIME functions are again used to convert the date and time to Julian time. At 7:00 AM, the task resumes execution and power is supplied to the lights. The task then begins a continuous loop in which 24 hours are added to the time the lights were previously turned on and the task is suspended until that time. As a result, the task is active at 7:00 AM every day to turn on the lights and is suspended the rest of the time.

Subroutine B operates the same as subroutine A, however; it is responsible for turning the lights off. This task is suspended until 9:00 PM every day, at which point it becomes active and turns the lights off.

Note that Chapter 7 of the Mainframe manual covers alternate methods for

SUSPEND UNTIL (cont)

converting to Julian time should other controllers be used which do not have functions similar to DATE and TIME.

```
10 !Set the time-slice period and the number of run tasks and
20 !queue size the system will allow. Place the HP 3852A in
30 !the multitasking mode. Set the HP 3852As internal clock and
40 !the controller clock to the current date and time.
50 !
60 OUTPUT 709;"TSLICE 0.065"
70 OUTPUT 709;"NTASKS 8,20"
80 OUTPUT 709;"ENABLE MULTI"
90 OUTPUT 709;"SET TIMEDATE ";DATE("1 OCT 1987")+TIME("10:00:00")
100 !
110 !Download subroutine A which turns on the lights within the
120 !facility. Suspend the task until 7:00 AM the day following the
130 !setting of the mainframe's clock (line 90). At 7:00, close
140 !channel 0 of the digital output accessory which supplies power
150 !to the lights. Begin a continuous loop which adds 24 hours to
160 !the date and time the lights were previously turned on. Suspend
170 !the task for those 24 hours and then turn the lights on again.
180 !
190 OUTPUT 709;"SUB A"
200 OUTPUT 709;" REAL M_S"
210 OUTPUT 709;" SUSPEND UNTIL ";DATE("2 OCT 1987")+TIME("7:00:00")
220 OUTPUT 709;" WRITE 0 1"
230 OUTPUT 709;" TIMEDATE INTO M_S"
240 OUTPUT 709;" WHILE 1"
250 OUTPUT 709;" M_S=M_S + 86400"
260 OUTPUT 709;" SUSPEND UNTIL M_S"
270 OUTPUT 709;" WRITE 0 1"
280 OUTPUT 709;" END WHILE"
290 OUTPUT 709;"SUBEND"
300 !
310 !Download subroutine B which turns off the lights within the
320 !facility. Suspend the task until 9:00 PM the day following the
330 !the setting of the mainframe's clock (line 90). At 9:00 PM,
340 !open channel 0 of the digital output accessory which removes the
350 !power supplied to the lights. Begin a continuous loop which adds
360 !24 hours to the date and time the lights were previously turned
370 !off. Suspend the task for those 24 hours and then turn the lights
380 !off again.
390 !
400 OUTPUT 709;"SUB B"
410 OUTPUT 709;" REAL E_S"
420 OUTPUT 709;" SUSPEND UNTIL ";DATE("2 OCT 1987")+TIME("21:00:00")
430 OUTPUT 709;" WRITE 0 0"
440 OUTPUT 709;" TIMEDATE INTO E_S"
450 OUTPUT 709;" WHILE 1"
460 OUTPUT 709;" E_S=E_S + 86400"
470 OUTPUT 709;" SUSPEND UNTIL E_S"
480 OUTPUT 709;" WRITE 0 0"
490 OUTPUT 709;" END WHILE"
500 OUTPUT 709;"SUBEND"
510 !
```

SUSPEND UNTIL (cont)

```
520 !Direct subroutines A and B to run tasks.  
530 !  
540 OUTPUT 709;"RUN 0 A"  
550 OUTPUT 709;"RUN 1 B"  
560 END
```

SUSTAIN

• HP 44714A 3-Channel Stepper Motor Controller/Pulse Output

Description

The SUSTAIN command, when triggered, will generate pulses continuously at the velocity or pulse width specified by the velocity or width parameter but limited by the PROFILE command min and max limits. The pulses are stopped by executing a SUSTAIN command with a velocity or width of zero or executing a HALT SGL command.

Prerequisites

Requires mainframe firmware revision 3.0 or greater.

Syntax

SUSTAIN *velocity or width* [*NOWAIT*] [*USE ch*]

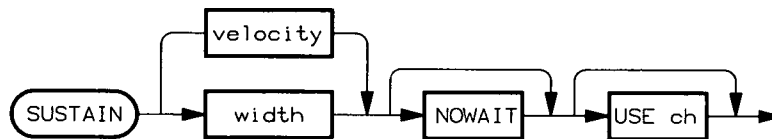

Parameters

velocity
width

The *velocity/width* parameter is the frequency or pulse width, whichever mode the PROFILE command is in, that the pulse output changes to when triggered. The change is made with the acceleration or deceleration specified in the PROFILE command. A negative number for velocity moves the motor in the negative (CCW) direction.

NOWAIT

The SUSTAIN command normally completes when the frequency or pulse width specified in the velocity/width parameter has been reached. If the *NOWAIT* option is used, the processor goes on to other tasks (such as TRIG SGL or HALT SGL) after setting up the command to make the change.

USE ch

Channel specified to output the sustained pulses. Channel range can be ES00 to ES02.

Remarks

Power-On State

None

Data Returned

None

Pulse Train Generation

The SUSTAIN value (either frequency when PROFILE is in the FREQ mode or pulse width when PROFILE is in the WIDTH mode) is reached by starting at the PROFILE "min" value and accelerating to the specified value in the SUSTAIN command.

NOTE

The PROFILE command dictates pulse generation by the SUSTAIN command. A SUSTAIN value less than the PROFILE "min" causes pulses to start at the "min" value and continue at this value. A SUSTAIN value greater than the "max" value causes pulses to start at the "min" value, accelerate to the "max" value, and continue at the "max" value. No errors are generated if a SUSTAIN value is outside the PROFILE range but that value is unattainable since it is restricted by the PROFILE command.

Related Commands

PROFILE, PSCALE, DONE?

Examples

Example: Send Pulses Continuously at 10 kHz

```
10 OUTPUT 709;"TRIG HOLD USE 201"           !Trigger on hold
20 OUTPUT 709;"SUSTAIN 10000 NOWAIT USE 201" !Velocity = 10K
30 OUTPUT 709;"TRIG SGL USE 201"           !Trigger pulses
40 END
```

SWRITE

- HP 44702A/B High-Speed Voltmeter Only (System or Scanner Mode)

Description

Write to a voltmeter register. SWRITE writes the specified value to a register on the HP 44702 A/B High-Speed Voltmeter.

Prerequisites

CAUTION

Writing to HP 44702A/B registers may result in invalid data or lost data, may set the voltmeter to an unknown state, or may cause system errors. Refer to the HP 44702A/B manual for information on using the SWRITE command.

- Mainframe

Description

Specifies the number of entries that can be made into the symbol table in mainframe memory. Entries are the names of all declared and downloaded variables, arrays, and subroutines.

Prerequisites

The SYMSIZE command is only available with mainframe firmware revision 3.0 or greater.

Syntax

SYMSIZE *size*



Parameters

size Specifies the size of the symbol table. The minimum *size* is 0 and the maximum *size* depends on the amount of mainframe memory available. Note that a size of 0 may still allow up to 138 entries. Once a size has been entered with SYMSIZE, the HP 3852A must be reset to load the value into the operating system.

Remarks

Setting the Symbol Table Size

The size of the symbol table set by the SYMSIZE command does not become effective until the mainframe is reset (RST). Since the table size is stored in volatile memory, the size stays the same until changed by subsequent SYMSIZE (and RST) commands or until power is cycled.

Note that a reset erases all previously declared variables, arrays, and downloaded subroutines. Thus, before using any of the mainframe's memory, ensure that the symbol table size is set as desired.

Specifying a Symbol Table Size that is Too Large

The memory used to increase the size of the symbol table is taken from the mainframe memory available to the user. If the table size specified is extremely large (e.g. SYMSIZE 33000), ERROR 24: ARGUMENT OUT OF RANGE is reported on execution of the SYMSIZE command. If the size specified is within the argument range but not enough memory is available, ERROR 1: OUT OF MEMORY - HP-IB BUFFERS/SYMTAB is reported during the next reset. When this occurs, the symbol table is set to accommodate 150 entries, the input buffer is set to 198 bytes, and the output buffer is set to 1029 bytes.

SYMSIZE (cont)

Symbol Table Size at Power-On

Anytime power is cycled, the size of the symbol table is set to hold 150 entries.

Removing Entries from the Symbol Table

When the symbol table fills, no additional variables, arrays, or subroutines can be declared or downloaded into memory regardless of the amount of memory available. Should this occur, you may need to increase the size of the symbol table or remove the entries in the table and begin again. Entries in the table can be removed by executing the HP 3852A's SCRATCH command, resetting the instrument (RST command), or by cycling power. Note that each of these methods removes all entries from the table. DELVAR or DELSUM cannot be used since they only release the memory allocated to the array or subroutine. The name still remains in the symbol table.

Data Returned

None

Related Commands

INBUF, OUTBUF

Examples

Example: Setting the Symbol Table Size

An application for increasing the size of the symbol table would be within a multitasking program in which a large number of subroutines are downloaded and many arrays and variables are declared. The following program segment shows when you would want to increase the size of the table in a multitasking program.

```
10  OUTPUT 709;"TSLICE .065"      !Set a 65 ms time-slice period
20  OUTPUT 709;"NTASKS 8,20"     !Specify the number of run tasks
30                                !and the queue size
40  OUTPUT 709;"SYMSIZE 200"     !Set the symbol table size to 200
50                                !entries
60  OUTPUT 709;"ENABLE MULTI"    !Place the HP 3852A in the multi-
70                                !tasking mode. The reset caused by
80                                !the command will load the TSLICE,
90                                !NTASKS, and SYMSIZE values into
100                               !the operating system
.
.
.
```

• HP 44726A 2-Channel Arbitrary Waveform DAC

Description

Specifies the condition in which a negative-going pulse will appear on the SYNC OUT BNC.

Prerequisites

Requires firmware revision 3.5 or greater.

Syntax

SYNC *source* [USE *ch*]



Parameters

source

WF - outputs a pulse at the beginning of each waveform cycle. The pulse goes low when the trigger for the first amplitude point is received and remains low until the first trigger for the last amplitude is received.

TRIG - outputs a pulse each time a TRIG pulse is received once the channel has been armed. Pulse width is approximately 600 ns.

DAC - outputs a pulse each time a new amplitude point is clocked into the DAC. Pulse width is approximately 350 ns.

HOLD - no pulses are output under any condition. The power-on *source* is HOLD.

USE *ch*

Channel from which the SYNC pulse is applied. SYNC pulses appear only when the waveform is running. The default USE *ch* is channel 0.

Remarks

SYNC TRIG and SYNC DAC

When setting either SYNC TRIG or SYNC DAC, note that each trigger received may or may not load the next amplitude point into the DAC. Depending on the number of time base intervals each amplitude point is held, multiple triggers (2^0 to $2^3 - 1$) may be required to advance to the next amplitude point. SYNC TRIG will output a pulse each time a trigger is received. SYNC DAC will output a pulse each time a new amplitude point is clocked into the DAC.

Data Returned

None

Related Commands

APPLY WFV

SYNC (cont)

Examples

Example: Using a SYNC Pulse to Note the Beginning of a Waveform

The following program shows how SYNC pulses can be used to note the beginning of each waveform cycle.

In the example, a 10 Vp-p, 40 point sine wave with a phase shift of 90° is defined and stored. SYNC WF is executed to note the beginning of the waveform and also the phase shift. By connecting the DAC OUT BNC to one channel of an oscilloscope and the SYNC OUT BNC to the other channel, the SYNC pulse and its relationship to the waveform can be seen.

Included in the program is a sub program which enables an HP Series 200/300 computer to plot several cycles of the waveform and SIMULATE the sync pulse.

```
10  !Reset the mainframe and the HP 44726A. Define and store a 40 point
20  !special function sine wave that is 10 Vp-p with a 90 degrees phase
30  !shift. (Convert 90 degrees to radians during the WFWRITE command).
40  !The frequency of the waveform is 10 kHz.
50  !
60  OUTPUT 709;"RST"
70  WAIT 1
80  OUTPUT 709;"WFWRITE ACV 0 10 PHASE ((PI/180)*90) PTS 40 TBASE 2.5E-6"
90  !
100 !Turn on the channel 0's anti-aliasing filter to smooth the waveform.
110 !Select waveform 0 from channel 0 memory. Issue a sync pulse to note
120 !the beginning of each cycle. Set the trigger source and arm the
130 !channel in order for it to accept the triggers.
140 !
150 OUTPUT 709;"FILTER ON"
160 OUTPUT 709;"APPLY WFV 0,0"
170 OUTPUT 709;"SYNC WF"
180 OUTPUT 709;"TRIG INT"
190 OUTPUT 709;"TARM AUTO"
200 !
210 !Read the waveform's amplitude points into the output buffer in order
220 !for the controller to plot the waveform.
230 !
240 OUTPUT 709;"WFREAD 0 AMPL"
250 !
260 !Plot the waveform and simulate the sync pulse.
270 !
280 GCLEAR
290 DIM W(0:39)
300 ENTER 709;W(*)
310 Plot_it(5.0E-5,5,W(*),2.5E-6)
320 END
330 SUB Plot_it(Time_div,Volts_div,Wave_form(*),Time_base)
340   DIM X_axis$(80),Y_axis$(80)
350   GINIT
360   GRAPHICS ON
370   RAD
380   WINDOW 0,10*Time_div,-4*Volts_div,4*Volts_div
390   !
```

SYNC (cont)

```
400 Wave_x=0
410 Wave_y=-1
420 Sync_x=0
430 Sync_volts=-12
440 Last_sync=0
450 WHILE Wave_x<10*Time_div
460   IF Wave_y>-1 THEN
470     MOVE Wave_x,Wave_form(Wave_y)
480   ELSE
490     MOVE 0,Wave_form(0)
500   END IF
510   Wave_x=Wave_x+Time_base
520   Wave_y=(Wave_y+1) MOD SIZE(Wave_form,1)
530   DRAW Wave_x,Wave_form(Wave_y)
540   MOVE Sync_x,Last_sync
550   Sync_x=Sync_x+Time_base
560   IF Wave_y=0 THEN
570     Last_sync=0
580   ELSE
590     Last_sync=Sync_volts
600   END IF
610   DRAW Sync_x,Last_sync
620 END WHILE
630 SUBEND
```

A plot of the waveform is shown below.

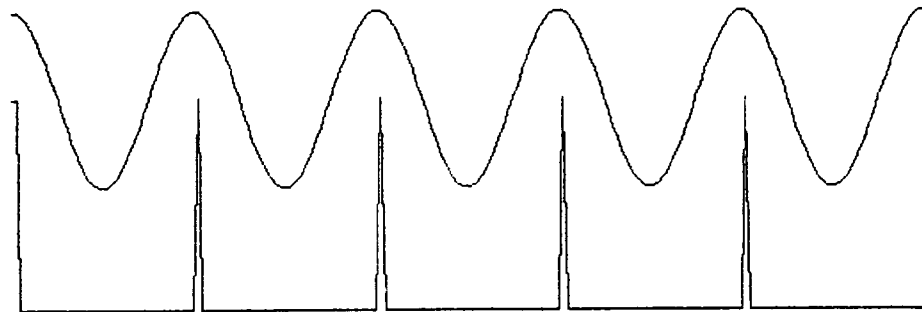

SYSOUT

- Mainframe

Description

System output mode. With SYSOUT OFF, data without a header is output over HP-IB. With SYSOUT ON, data output is preceded by a header.

Prerequisites

None

Syntax

SYSOUT [*mode*]

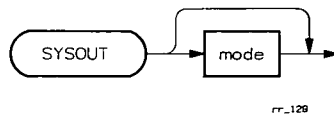

Parameters

mode

Determines whether data output over the HP-IB will be preceded by a data header. Power-on *mode* = OFF. Default *mode* = ON.

mode	Description
OFF	Data output over the HP-IB without a data header.
ON	Data output is preceded by a header indicating the number of readings taken by the command, the format of the data to follow the header, and the number of bytes/reading.

Remarks

Data Returned

The SYSOUT command does not return any data. However, the SYSOUT ON data header contains three parameters: the number of readings taken by the command (in LASC); a number which identifies the format of the data (in IASC); and the number of bytes per reading (in IASC). (The data format parameter returned is + with BLOCKOUT OFF, - with BLOCKOUT ON.)

SYSOUT (cont)

SYSOUT ON Data Header Parameters

1st Parameter - Number Readings	2nd Parameter - Data Format [a]	3rd Parameter - Bytes/Reading
	IN16 = ± 1	IN16 = 2
Number of	RL64 = ± 2	RL64 = 8
readings	PACK = ± 5	PACK = [b]
taken by	IASC = ± 6	IASC = 6
command	LASC = ± 7	LASC = 11
	RASC = ± 8	RASC = 13
	string = ± 9	string = [c]
	DASC = ± 11	DASC = 22

[a] = Number returned is positive (+) for BLOCKOUT OFF, negative (-) for BLOCKOUT ON.

[b] = Bytes/Reading for the PACK formats is data source dependent.

[c] = Number of characters in the string, including quotes (if any) but not including <CR> or <LF> at the end.

Related Commands

OUTBUF, BLOCKOUT

Examples

Example: Using the SYSOUT ON Header

This program uses SYSOUT ON to return a data header for four DC voltage readings from a multiplexer in slot 3 of the mainframe using a voltmeter in slot 6 of the mainframe.

```
10 REAL Rgs(0:6)                !Declare controller array
20 OUTPUT 709;"SYSOUT ON"       !Set system output mode ON
30 OUTPUT 709;"USE 600"         !Use vm in slot 6 of mf
40 OUTPUT 709;"CONFMEAS DCV 300-303 RASC" !Meas DCV, use RASC format
50 ENTER 709;Rgs(*)            !Enter header and readings
60 PRINT Rgs(*)                !Display header and readings
70 END
```

SYSOUT (cont)

The data returned is a three-parameter header followed by the four voltage readings. In the following typical display, 4 = the number of readings taken, 8 = readings in RASC format, and 13 = 13 bytes/reading when the data is returned in RASC format.

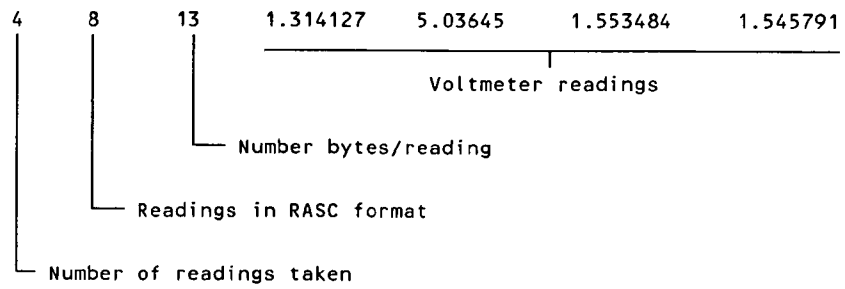

• HP 44726A 2-Channel Arbitrary Waveform DAC

Description

Sets the source of the negative-going pulse which arms the channel's trigger circuit. Arming the channel allows the channel to accept trigger signals which advance the output of the DAC.

Prerequisites

Requires firmware revision 3.5 or greater.

Syntax

TARM [*source*] [USE *ch*]

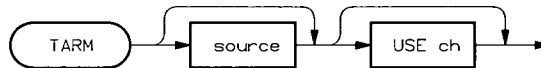

Parameters

source OFF - prevents recognition of any arming or trigger pulses. TARM OFF stops the active waveform at the last amplitude point triggered. When re-armed, the waveform starts from the first amplitude point. TARM OFF or TARM AUTO must be set before any commands which access channel memory are executed. At power-on, TARM OFF is set.

HOLD - prevents recognition of any arming pulses without stopping the active waveform.

SGL - issues an immediate arming pulse when the command is executed. The default *source* is SGL.

AUTO - issues an immediate arming pulse when the command is executed. In the TARM AUTO mode, TARM OFF is set automatically when a command which accesses channel memory is received. Following execution, TARM AUTO is re-asserted and another arming pulse is issued. The waveform then starts from the first amplitude point.

SYS - the arming pulse is the system trigger (see the TRG command).

EXT - the arming pulse is applied through the channel's EXT IN BNC.

When changing from any source to either SYS or EXT, TARM OFF is set momentarily while the change is made. The waveform then starts from the first amplitude point when re-armed from the SYS or EXT source.

USE *ch* Channel which is armed. The default USE *ch* is channel 0.

TARM (cont)

Remarks

The Waveform Must Be Selected Before The Channel Is Armed

TARM AUTO, TARM SGL, TARM SYS, TARM EXT, or TARM HOLD cannot be executed until a waveform has been previously selected with the APPLY WFV command. This prevents any random signals from appearing at the output of the DAC.

Commands Which Require TARM OFF or TARM AUTO to be Set

In order to execute the following commands, TARM OFF must be set:

```
APPLY DCV
APPLY PERC
TEST
```

In order to execute the next set of commands, TARM OFF or TARM AUTO must be set:

```
APPLY WFV
NSCAN (number > 1) or CONT
WF?
WFDELETE
WFMOD
WPPER?
WFREAD
WFSIZE?
WFTBASE?
All WFWRITE commands
```

Data Returned

None

Related Commands

APPLY WFV, TARMED?, TRIG

Examples

Example: Starting a Waveform with an Interrupt

The following program shows how an interrupt from a digital input accessory is used to start a waveform.

In the example, an HP 44721A digital input is configured to interrupt on a low to high edge transition. The waveform which starts when the interrupt occurs is a 500 point, special function triangle wave. The TARM command sets the channel's EXT IN port as the source of the arming signal. ENABLE INTR BNC is executed so that when the interrupt occurs, a pulse will appear on the CHANNEL CLOSED BNC. By connecting a BNC cable between the CHANNEL CLOSE BNC and the HP 44726A's EXT IN port, the interrupt pulse serves as the arming signal which arms the DAC channel.

In the event the DAC channel is disarmed (TARM OFF) and later re-armed (TARM EXT), a subroutine is downloaded which re-enables the digital input

TARM (cont)

channel to interrupt. Thus, on the next low to high edge transition, the channel is armed and the waveform begins again.

```
10 !Reset the mainframe and the HP 44726A. Download a subroutine which
20 !is called when the interrupt occurs. Set channel 8 of the digital
30 !input in slot 3 to interrupt on a low to high edge transition.
40 !
50 OUTPUT 709;"RST"
60 WAIT 1
70 OUTPUT 709;"SUB EN_INTR"
80 OUTPUT 709;" ENABLE INTR USE 324"
90 OUTPUT 709;"SUBEND"
100 OUTPUT 709;"ON INTR USE 324 CALL EN_INTR"
110 OUTPUT 709;"EDGE LH USE 324"
120 !
130 !Define and store a 500 point special function triangle wave that is
140 !7 Vp-p with a frequency of 1 kHz.
150 !
160 OUTPUT 709;"WFWRITE RPV 23 7 PTS 500 TBASE (1/(1E3*500))"
170 !
180 !Select waveform 23 from channel 0 memory. Set the source of the
190 !triggers which advance the DAC output. Set the source of the signal
200 !which arms the channel to the channel's EXT IN BNC.
210 !
220 OUTPUT 709;"APPLY WFV 0,23"
230 OUTPUT 709;"TRIG INT"
240 OUTPUT 709;"TARM EXT"
250 !
260 !Connect the backplane interrupt line to the CHANNEL CLOSED BNC.
270 !(A BNC cable is connected between the CHANNEL CLOSED BNC and the
280 !HP 44726A's EXT IN port.) Enable the digital input channel to
290 !interrupt (which starts the waveform) on a low to high edge
300 !transition. Enable the mainframe to sense the interrupt and call the
310 !subroutine.
320 !
330 OUTPUT 709;"ENABLE INTR BNC"
340 OUTPUT 709;"ENABLE INTR USE 324"
350 OUTPUT 709;"ENABLE INTR SYS"
360 END
```

TARMED?

• HP 44726A 2-Channel Arbitrary Waveform DAC

Description

Indicates whether or not the channel has been armed and if trigger pulses have been received.

Prerequisites

Requires firmware revision 3.5 or greater.

Syntax

TARMED? [*USE ch*] [*INTO name*] or [*fmt*]

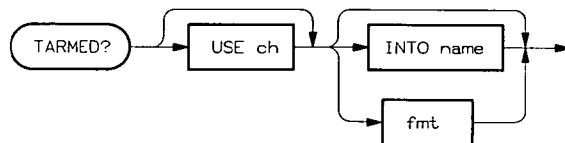

Parameters

USE ch Channel whose arming and triggering status is returned. The default *USE ch* is channel 0.

INTO name See Glossary.

fmt See Glossary. Default format is IASC.

Remarks

Data Returned

Returned is one of the following numbers which represents the condition that exists:

0 = TARM OFF is set.

1 = TARM is set to a source other than OFF and is waiting for an arming signal.

2 = An arming signal has been received and the channel is waiting for a trigger to start the waveform.

3 = Waveform has started. An arming signal has been received and at least one trigger signal has been received.

Related Commands

TARM

Examples

Example: Determining the Channel's Arming and Triggering Status

TARMED? can be executed at any time in order to determine the status of the channel. When executed as follows, TARMED? returns the status of DAC channel 0 in slot 0 to the mainframe front panel:

```
OUTPUT 709;"TARMED?"
```

• HP 44715A 5-Channel Counter/Totalizer

Description

Sets the time base used with the PER and PERD functions and with the FREQ configuration.

Prerequisites

To use TBASE with Period or Delayed Period functions, channel function must previously have been set to PER or PERD, respectively. To use TBASE with FREQ configuration, Card Configuration Jumper must be set to FREQ.

Syntax

TBASE [*tbase*] [USE *ch*]

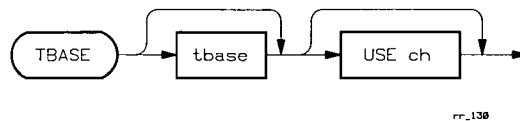

Parameters

tbase For the PER and PERD functions, *tbase* is the period of the HP 44715A internal clock that is counted during the time it takes the number of periods of the input signal supplied by the user to occur (NPER). For the FREQ function, *tbase* is the period of the HP 44715A internal clock (gate time) during which the period of the input signal supplied by the user is counted. Valid ranges for *tbase* depend on the function set as shown. When *tbase* = AUTO or 0 (default and power-on setting), the counter automatically selects the best time base.

If *tbase* is not set to one of the values shown in the table, it is truncated down to the next lower valid time base for PER and PERD. The value is moved up to the next higher valid time base for the FREQ configuration.

The following tables show *tbase* values vs. period and range resolution for the PER and PERD functions and for the FREQ configuration. In all cases, SPER is assumed to be 1 μ sec (SPER command) and NPER is the value set with the NPER command.

Table 1. tbase vs. Period Range/Resolution - PER Function

tbase (sec)	Period Range	Resolution
.000001	5 us $\leq P \leq$ 65.535/NPER ms	1/NPER us
.00001	5 us $\leq P \leq$ 20/NPER us $\leq P \leq$ 655.35/NPER ms	10/NPER us
.0001	5 us $\leq P \leq$ 200/NPER us $\leq P \leq$ 6.5535/NPER sec	100/NPER us
.001	5 us $\leq P \leq$ 2/NPER ms $\leq P \leq$ 65.535/NPER sec	1/NPER ms
.01	5 us $\leq P \leq$ 20/NPER ms $\leq P \leq$ 655.35/NPER sec	10/NPER ms

TBASE (cont)

Table 2. tbase vs. Period Range/Resolution - PERD Function

tbase (sec)	Period/Range	Resolution
.000001	5 us $\leq P \leq$ 65.535 ms	1 us
.00001	5 us $\leq P \leq$ 655.35 ms	10 us
.0001	5 us $\leq P \leq$ 6.5535 sec	100 us
.001	5 us $\leq P \leq$ 65.535 sec	1 ms
.01	5 us $\leq P \leq$ 655.35 sec	10 ms

Table 3. tbase vs. Frequency Ranges - FREQ Configuration

tbase (gate time) (sec)	Frequency Range	Resolution
1	2 Hz - 65.5 kHz	1 Hz
0.1	20 Hz - 200 kHz	10 Hz
0.01	200 Hz - 200 kHz	100 Hz

USE *ch* Channel used for TBASE. Channel number range (depends on HP 44715A hardware configuration) = ES00 through ES04.

Remarks Setting tbase for PER Function

The SPER, NPER, TBASE, and FUNC commands interact to determine minimum and maximum periods and pulse widths of the input signal which can be measured.

For the PER function, to determine maximum and minimum periods and resolution for a given *tbase* setting, divide the values shown in Table 1 by the value of NPER. For example, if SPER = 1 μ sec, NPER = 100, and TBASE *tbase* = 10 μ sec, the period range is from 5 μ sec (minimum period range for any *tbase* setting) to 6.5535 msec with resolution = 0.1 μ sec.

With SPER = 1 μ sec, minimum pulse width for the input = $(1*2 + .5) \mu$ sec = 2.5 μ sec. However, if SPER is changed to 10 μ sec, minimum pulse width = $(10*2 + .5) \mu$ sec = 20.5 μ sec, so minimum period increases from 5 μ sec to 41 μ sec.

Setting tbase for PERD Function

The considerations to set TBASE *tbase* for the PERD function are the same as for the PER function if NPER = 1.

Setting tbase for FREQ Configuration

When the Card Configuration Jumper is set to the FREQ position, SPER and TBASE interact to determine frequency range and resolution. For example, with SPER = 1 μ sec (default) and TBASE *tbase* = 0.1 sec, from Table 3 the frequency range is 20 Hz to 200 kHz, with 10 Hz resolution.

With SPER = 1 μ sec, minimum pulse width for the input = $(1*2 + .5) \mu$ sec = 2.5 μ sec. However, if SPER is changed to 10 μ sec, minimum pulse width = $(10*2 + .5) \mu$ sec = 20.5 μ sec, so minimum period = 41 μ sec and maximum frequency decreases from 200 kHz to about 24.4 kHz.

Data Returned

None

Related Commands

FUNC, NPER, SPER

Examples

Example: Setting the Time Base

This program uses the TBASE command to set the time base prior to a frequency measurement. After the time base is set, the counter is triggered and the frequency of the input signal is measured. The measured frequency is then displayed on the controller. Since the "frequency" function cannot be specified, the Card Configuration jumper must be set to the FREQ position.

```
10 OUTPUT 709;"RST"           !Reset the HP 3852A and HP 44715A
20 OUTPUT 709;"USE 100"       !Use counter channel 0 in slot 1
30 OUTPUT 709;"TBASE .1"     !Set a 100 msec time base
40 OUTPUT 709;"TRIG SGL"     !Issue a single trigger to the counter
50 OUTPUT 709;"CHREAD 100"   !Read the frequency measurement
60 ENTER 709;A               !Enter reading into controller
70 PRINT A                   !Print reading
80 END
```

TBASE

• HP 44726A 2-Channel Arbitrary Waveform DAC

Description

Changes the time base of the active waveform. TBASE allows you to change the time base without stopping the waveform. The time base interval set by the TBASE command is not stored in channel memory. Thus, the time base is not used when the waveform is re-selected nor is it associated with the WFTBASE? or WPPER? commands.

Prerequisites

Requires firmware revision 3.5 or greater.

Syntax

TBASE *seconds* [USE *ch*]

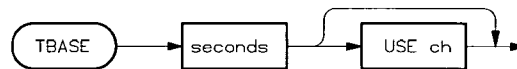

Parameters

seconds Length of the time base interval. The range for *seconds* is 1.25E-6 to 16.384E-3. Resolution is 0.25E-6.

USE *ch* Channel from which the waveform is being applied. The default USE *ch* is channel 0.

Remarks

Using the TBASE Command

The TBASE command is intended for applications where it is necessary to change the time base (frequency) of the active waveform without stopping the waveform. As stated previously, the time base set by TBASE is not stored in channel memory. Thus, the time base returned by WFTBASE? and the time base used to calculate the period returned by WPPER? is the time base specified when the waveform was defined and stored by WFWRITE, or as changed and stored by WFMOD. When the waveform is re-selected, the stored time base is used.

Setting the Frequency of a Waveform

When using the TBASE command to change the frequency of a waveform, the time base can be specified in terms of the desired frequency and the number of time base intervals each amplitude point is held. The relationship between the frequency and the time base for special function and arbitrary waveforms is given below.

Special Function Sine and Triangle Waves

For the special function sine and triangle waves, each amplitude point is held for one time base interval. Therefore, the frequency of these special function waveforms is defined as:

$frequency = 1/(TBASE*npts)$

where *npts* is the number of points in the waveform. Thus, for these waveforms, the desired frequency can be specified as:

```
OUTPUT 709;"TBASE (1/(desired frequency*npts))"
```

Special Function Square Waves

Special function square waves are fixed three point waveforms, which use a total of four time base intervals. The frequency of the square waves is defined as:

$frequency = 1/(TBASE*tb_intr)$

where *tb_intr* is the number of time base intervals (4). Thus, a new time base in terms of frequency is specified as:

```
OUTPUT 709;"TBASE (1/(desired frequency*4))"
```

Arbitrary Waveforms

When each amplitude point in an arbitrary waveform is held for one time base interval, the frequency of the waveform is defined as:

$frequency = 1/(TBASE*npts)$

where *npts* are the number of points. Thus, for these waveforms, the desired frequency can be specified as:

```
OUTPUT 709;"TBASE (1/(desired frequency*npts))"
```

Data Returned

None

Related Commands

APPLY WFV

- HP 44071A Integrating Voltmeter
- HP 44702A/B High-Speed Voltmeter (Scanner or System Mode)

Description

Selects the voltmeter input terminals used to make measurements.

Prerequisites

If the HP 44702A/B High-Speed Voltmeter is in the Scanner mode, SCTRIG must be set to HOLD before setting TERM. TERM RIBBON can only be set when the voltmeter is in the Scanner mode.

Syntax

TERM *terminal* [USE *ch*]



Parameters

terminal **HP 44701A Integrating Voltmeter**

Input terminal selection. Power-on *terminal* = EXT.

terminal	Definition
BOTH	Selects the backplane bus and voltmeter rear panel terminals as input terminals.
EXT	Selects the voltmeter rear panel terminals as input terminals.

HP 44702A/B High-Speed Voltmeter

Input terminal configuration. Power-on *terminal* = EXT.

terminal	Definition
INT	Selects the backplane bus as the input terminal.
EXT	Selects the voltmeter rear panel terminals.
ZERO	Selects an internal zero volt reference.
RIBBON	Selects the ribbon cable (Scanner mode only).

USE *ch* Voltmeter slot number. See Glossary.

TERM (cont)

Remarks

Data Returned

None

Related Commands

SCANMODE, USE

Examples

Example: Selecting Voltmeter Rear Panel Input Terminals

This program configures an HP 44701A Integrating Voltmeter in mainframe slot 1 for DC voltage measurements and selects only the external (rear panel) terminals as input terminals.

```
10 OUTPUT 709;"RST"           !Reset the HP 3852A and HP 44701A
20 OUTPUT 709;"USE 100"       !Use voltmeter in mainframe slot 1
30 OUTPUT 709;"CONF DCV"     !Configure for DC voltage measurements
40 OUTPUT 709;"TERM EXT"     !Select external (rear) terminals
50 OUTPUT 709;"TRIG SGL"     !Issue a single trigger
60 OUTPUT 709;"CHREAD 100"   !Transfer reading to output buffer
70 ENTER 709;A               !Enter reading into controller
80 PRINT A                   !Display reading
90 END
```

Note that CONF sets TERM BOTH; therefore, TERM EXT must be executed in order to select only the voltmeter rear panel terminals.

• HP 44715A 5-Channel Counter/Totalizer

Description	Select isolated or non-isolated input terminals for the specified channel.
Prerequisites	None
Syntax	TERM <i>terminal</i> [<i>terminal</i>] [USE <i>ch</i>]

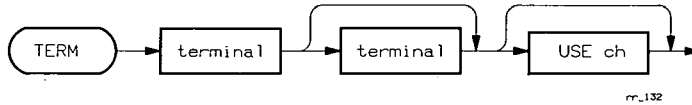

Parameters

terminal Specify isolated input terminals (TERM ISO) or non-isolated input terminals (TERM NON). Power-on/default *terminal* = ISO for single-input functions. Power-on/default *terminal* = ISO, ISO for double-input functions.

- Single-Input Functions:

For single-input functions (Ungated Total Counts [TOTAL], Ungated Total Counts, Modulo NPER [TOTALM], and Period [PER]) and for Frequency configuration, the first *terminal* applies to the A input and the second *terminal* is not allowed.

- Double-Input Functions:

For double-input functions, the first *terminal* applies to the A input, the second *terminal* to the B input. If the second *terminal* parameter is not specified for a channel with a double-input function, the value in the first *terminal* parameter is used for both inputs.

USE *ch* Specify channel used for TERM. Channel number range (depends on HP 44715A hardware configuration) = ES00 through ES04.

Remarks

Data Returned

None

Related Commands

None

TERM (cont)

Examples **Example: Selecting the Non-isolated Input Terminals**

This program CONFIGures the HP 44715A counter accessory for a period measurement. Since the CONF command selects the isolated input terminals, the TERM command is used to select the non-isolated terminals before the accessory is triggered. Once the period measurement is made, the reading is transferred to the controller and displayed. Note that to measure period, the Card Configuration jumper must be set to the 3 CH or 4 CH position.

```
10  OUTPUT 709;"RST"           !Reset the HP 3852A and HP 44715A
20  OUTPUT 709;"USE 100"       !Use cntr ch 0 in slot 1
30  OUTPUT 709;"CONF PER"     !Configure cntr for period meas
40  OUTPUT 709;"EDGE LH"      !Set period to start with pos edge
50  OUTPUT 709;"TERM NON"     !Select non-isolated terminals
60  OUTPUT 709;"TRIG SGL"     !Issue a single trigger
70  OUTPUT 709;"CHREAD 100"   !Read period measurement
80  ENTER 709;A               !Enter reading into controller
90  PRINT A                   !Display reading
100 END
```

The period measurement for a 1 kHz input signal is:

.001

- Mainframe
- All Plug-In Accessories

Description

Performs a self-test on the HP 3852A system or on the specified accessory. TEST does not change any preprogrammed state or condition of the mainframe, but does alter the state of the HP 44701A, HP 44702A/B, and HP 44715A.

Prerequisites

None

Syntax

TEST [*slot*]

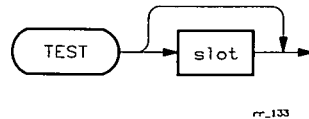

Parameters

slot Slot address of accessory to be tested. If *slot* is not specified, the HP 3852A and all installed accessories are tested.

Remarks

TEST Changes Voltmeter and Counter States

The TEST command changes the state of the HP 44701A Integrating Voltmeter, the HP 44702A/B High-Speed Voltmeter, and the HP 44715A Counter/Totalizer. We recommend you reset these accessories (with the RST *slot* command) after using TEST. (RST is required for the HP 44715A.)

TEST vs. Voltmeter Calibration

When TEST is used for the voltmeters, passing the self-test does not guarantee that the voltmeter is properly calibrated, but only means that calibration constants are within acceptable ranges. Refer to the HP 3852A Assembly Level Service Manual for calibration procedures.

Performing the HP 44701A Self Test When the Voltmeter is Busy

The HP 44701A self test must complete in a time specified by the HP 3852A processor. If the voltmeter is busy when the TEST command is issued, the time required to complete the self test may be exceeded, thus the processor will indicate that the self test has failed. To prevent this type of "failure", set TRIG HOLD on the voltmeter before performing the self test.

Reading the Error Buffer

If a self-test fails, the error can be read using the ERR? or ERRSTR? commands.

TEST (cont)

Data Returned

TEST returns SELF TEST OK on the HP 3852A front panel if the self-test passes. During system self-test, all segments on the front panel display will come on and a "BEEP" will sound.

If a slot self-test fails, an error message will appear on the front panel display and will be stored in the error buffer if there is room (see ERR? and ERRSTR?). If a self-test fails, refer to the HP 3852A Assembly Level Service Manual.

Related Commands

ERR?, ERRSTR?, RST

Examples

Example: Testing the HP 3852A System

This program uses the TEST command to self-test the HP 3852A system.

```
10 DIM Terr$(60)           !Dimension results array
20 OUTPUT 709;"TEST"       !System self-test
30 OUTPUT 709;"ERRSTR?"    !Read error buffer
40 ENTER 709;Terr$         !Enter error buffer results
50 PRINT Terr$             !Display results
60 END
```

If the self-test passes, a typical display is:

```
" 0: NO ERROR "
```

Example: Testing an Accessory

This program uses the TEST command to self-test the accessory in slot 1 of the mainframe.

```
10 DIM Terr$(60)           !Dimension results array
20 OUTPUT 709;"TEST 100"   !Self-test accessory in slot 1
30 OUTPUT 709;"ERRSTR?"    !Read error buffer results
40 ENTER 709;Terr$         !Enter error buffer results
50 PRINT Terr$             !Display results
60 END
```

If the self test fails, the display is:

```
" 27: TEST: SELF TEST FAILED "
```

• HP 44714A 3-Channel Stepper Motor Controller/Pulse Output

Description

The TEST command initiates a pass/fail self test.

Prerequisites

1. Requires mainframe firmware revision 3.0 or greater.
2. For complete testing, there is hardware set-up required on the HP 44714A terminal card. Refer to the HP 44714A service manual for test set-up procedures.

Syntax

TEST *slot*

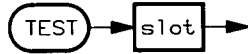

Parameters

slot The *slot* parameter specifies which mainframe slot is to be tested.

Remarks

Data Returned

No data is returned. If the test failed, an error message is displayed.

Related Commands

None

Examples

Example: Test HP 44714A in Slot 200

```
10 OUTPUT 709;"TEST 200"      !Test slot 200
20 END
```

TEST

- HP 44726A 2-Channel Arbitrary Waveform DAC

Description

Initiates an accessory self test. Following the test, the accessory is reset and all WAVEFORMS STORED IN CHANNEL MEMORY ARE ERASED.

Prerequisites

Requires firmware revision 3.5 or greater and TARM OFF must be set.

Syntax

TEST [*slot*]

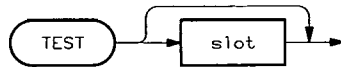

Parameters

slot Address of the slot where the HP 44726A is installed. If no slot is specified, the mainframe self test is initiated.

Remarks

Data Returned

Returned to the mainframe display is a message indicating whether the self test passed or failed.

Related Commands

None

Examples

Example: HP 44726A Self Test

The following statement initiates a self test of the HP 44726A installed in slot 0. The statement assumes TARM OFF is set.

OUTPUT 709;"TEST 0"

- Mainframe

Description Returns the current real-time clock reading in seconds since midnight.

Prerequisites None

Syntax **TIME** [*INTO name*] or [*fmt*]

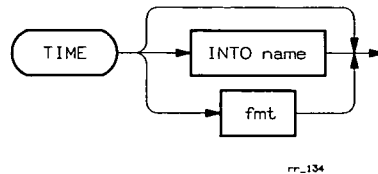

Parameters

INTO name See Glossary.

fmt See Glossary. Default format is DASC.

Remarks

Time Set When Memory Lost

The time is stored in a battery backed-up memory. If memory is lost, the time is set to 0 (midnight). The time accumulates from that setting until changed by SET TIME or SET TIMEDATE.

Data Returned

The value returned represents the number of seconds since midnight if the real-time clock is set to local time. The resolution of TIME is .001 second (1msec).

Converting Returned Time Format

HP Series 200/300 command TIMES\$ converts seconds since midnight to real-time in hours:minutes:seconds format.

Related Commands

SET TIME, SET TIMEDATE, TIMEDATE

Examples

Example: Setting/Returning Time Since Midnight

The following program sets the HP 3852A real-time clock to 06:56:40 hours and verifies that the real-time clock is running by taking a time measurement 5 seconds after the clock is set.

TIME (cont)

NOTE

To compute the SET TIME seconds required to set the real-time clock to your local time, use $seconds = (hours \times 3600) + (min \times 60) + sec$. For example, 06:56:40 hours = $(6 \times 3600) + (56 \times 60) + 40 = 25000$ seconds.

```
10 OUTPUT 709;"RST"           !Reset the HP 3852A
20 OUTPUT 709;"SET TIME 25000" !Set clock for 06:56:40 hours
30 WAIT 5                     !Wait 5 seconds
40 OUTPUT 709;"TIME"         !Read real-time clock time
50 ENTER 709;A               !Enter time
60 PRINT TIME$(A)           !Display time (5 sec after time set)
70 END
```

A typical return (since the time is measured five seconds after the clock is set) is:

06:56:45

- Mainframe

- Description** Returns the current Julian date and time from the HP 3852A real-time clock.
- Prerequisites** None
- Syntax** **TIMEDATE** [INTO *name*] or [*fmt*]

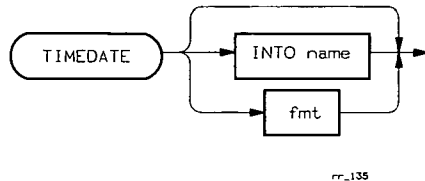

Parameters

- INTO name* See Glossary.
- fmt* See Glossary. Default format is DASC.

Remarks

Timedate Set When Memory Lost

The clock is stored in a battery backed-up memory. If memory is lost, the clock is set to 2.08662912E+11, which represents midnight March 1, 1900. The time accumulates from that setting until changed by SET TIME or SET TIMEDATE.

Data Returned

The value returned represents the sum of the last time setting and the number of seconds that have elapsed since that setting was made. If the clock is properly set, TIMEDATE modulo 86400 gives the number of seconds since midnight. The resolution of TIMEDATE is .001 second (1 msec).

Examples

Example: Setting/Reading Real-Time Clock

This program uses HP Series 200/300 commands DATE and TIME to set the HP 3852A real-time clock to 26 Sep 1986 @ 06:56:40 hours and uses the HP 3852A TIMEDATE command to return the time set. To check clock operation, the timedate is read 5 seconds after it is entered.

```

10 OUTPUT 709;"RST"                                !Reset
20 OUTPUT 709;"SET TIMEDATE";DATE("26 SEP 1986")+TIME("06:56:40") !Set time
30 WAIT 5                                           !Wait 5 sec
40 OUTPUT 709;"TIMEDATE"                            !Read time
50 ENTER 709;A                                       !Enter time
60 PRINT "Clock Date and Time = ";DATE$(A);" ";TIME$(A) !Disp time
70 END

```

TIMEDATE (cont)

For the date and time in this program, a typical display is:

Clock Date and Time = 26 Sep 1986 06:56:45



- Mainframe

Description

System trigger source.

Prerequisites

Only plug-in accessories which are programmed to TRIG SYS, SCTRIG SYS, or STTRIG SYS will respond to the system trigger.

Syntax

TRG [*source*]

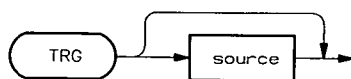

RR_136

Parameters

source System trigger source. Power-on *source* = HOLD. Default *source* = SGL.

source	Definition
EXT	Source is low-going pulse into SYSTEM TRIGGER IN BNC.
SGL	Issue immediate system trigger, then set TRG HOLD.
GET	HP 3852A GET command or HP-IB Group Execute Trigger.
HOLD	Disable system trigger.

Remarks

Data Returned

None

Related Commands

TRIG, SCTRIG, STTRIG

Examples

Example: Setting External Triggering

This program sets the SYSTEM TRIGGER IN BNC as the source to trigger an HP 44701A Integrating Voltmeter in slot 1 of the mainframe. With this setting, a low-going pulse into the SYSTEM TRIGGER IN BNC triggers the voltmeter. Note that TRIG SYS must be set for the system trigger to actually trigger the voltmeter.

```

10 OUTPUT 709;"RST"           !Reset HP 3852A and HP 44701A
20 REAL Rgs(0:4)              !Declare controller array
30 OUTPUT 709;"USE 100"       !Use voltmeter in mainframe slot 1
40 OUTPUT 709;"CONF DCV"     !Configure for DC voltage measurements
50 OUTPUT 709;"TRG EXT"      !Select SYSTEM TRIGGER IN BNC as source
60 OUTPUT 709;"TRIG SYS"     !Select system triggering
70 OUTPUT 709;"MEAS DCV, 0-4" !Measure voltage on chs 0-4 in slot 0
80 ENTER 709;Rgs(*)          !Enter readings
90 PRINT USING "K,/";Rgs(*)  !Display readings
100 END
  
```

TRG (cont)

Note that five trigger pulses into the SYSTEM TRIGGER IN BNC are required to make the pass through the channel list.

Example: Using the Group Execute Trigger

This program uses the HP-IB Group Execute Trigger as the source to trigger an HP 44701A Integrating Voltmeter in slot 1 of the mainframe. Again, TRIG SYS must be set for the Group Execute Trigger to trigger the voltmeter.

```
10 OUTPUT 709;"RST"           !Reset HP 3852A and HP 44701A
20 OUTPUT 709;"USE 100"       !Use voltmeter in mainframe slot 1
30 OUTPUT 709;"CONF DCV"     !Configure for DC voltage measurements
40 OUTPUT 709;"TRG GET"      !Select group execute trigger as source
50 OUTPUT 709;"TRIG SYS"     !Select system trigger
60 OUTPUT 709;"MEAS DCV, 0"  !Measure voltage on ch 0 in slot 0
.
.
.
100 TRIGGER 709              !Trigger the voltmeter
110 ENTER 709;A              !Enter the reading
120 PRINT A                  !Display the reading
130 END
```

- HP 44701A Integrating Voltmeter
- HP 44702A/B High-Speed Voltmeter (System or Scanner Mode)

Description

Select voltmeter trigger mode or source.

Prerequisites

None

Syntax

TRIG [*source*] [USE *ch*]

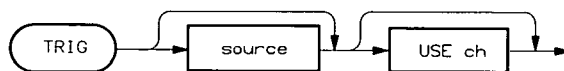

Parameters

source Voltmeter trigger source or mode.

HP 44701A Integrating Voltmeter:

Power-on *source* = HOLD. Default *source* = SGL.

source	Definition
SCAN	Trigger when multiplexer channel closed.
SGL	Immediate single trigger when TRIG SGL is executed.
HOLD	Disables trigger.
SYS	System trigger (see TRG).
AUTO	Voltmeter internal trigger (continuous triggering).

HP 44702A/B High-Speed Voltmeter:

When the voltmeter is in System Mode, TRIG sets the trigger source or mode. For System Mode, power-on *source* = HOLD and default *source* = SGL. When the voltmeter is in Scanner Mode, TRIG sets the source for the Measure Trigger (MEAS is not valid in Scanner Mode). For Scanner Mode, power-on *source* = INT and default *source* = SGL.

source	Definition
SCAN	Trigger when multiplexer channel is closed.
SGL	Single trigger when TRIG SGL executed.
HOLD	No triggering. Triggering is held off.
EXT0	Trigger the voltmeter from its rear panel BNC 0.
EXT1	Trigger the voltmeter from its rear panel BNC 1.
SYS	System trigger pulse (see TRG command).
INT	Voltmeter internal trigger.
MEAS	Trigger when input crosses threshold level (System Mode only).
GPIO	GPIO trigger.

TRIG (cont)

USE *ch* Voltmeter slot number. See Glossary.

Remarks

Issuing a Single Trigger

When using a single measure trigger (TRIG SGL) with the HP 44702A/B voltmeter in the scanner mode, TRIG HOLD should be set prior to SCTRIG, then set to TRIG SGL. Note that CONF sets TRIG INT and not TRIG HOLD.

SLOPE Specifies HP 44702A/B Slope

For an HP 44702A/B High-Speed Voltmeter in System Mode, the SLOPE command specifies the edge of the input signal (LH or HL) which will trigger the voltmeter. In Scanner Mode, SLOPE specifies the Measure Trigger input signal slope (LH or HL). Note that the edge set by SLOPE is used only when TRIG is set to EXT0, EXT1, MEAS, or GPIO.

TRIGOUT ON Conflicts With TRIG EXT0

If TRIGOUT ON is set, no trigger source (TRIG, SCTRIG, STTRIG) can be set to EXT0 and vice-versa.

Data Returned

None

Related Commands

TRG, USE, TRIGOUT, PERC, SLOPE

Examples

Example: Triggering the HP 44701A Voltmeter

This program triggers an HP 44701A Integrating Voltmeter in slot 1 of the mainframe to take one measurement. Triggering occurs immediately when the TRIG SGL command is executed. The input to the voltmeter is through the rear panel terminals.

```
10 OUTPUT 709;"RST"           !Reset HP 3852A and HP 44701A
20 OUTPUT 709;"USE 100"       !Use voltmeter in mainframe slot 1
30 OUTPUT 709;"CONF DCV"     !Configure for DC voltage measurements
40 OUTPUT 709;"TERM EXT"     !Select rear panel terminals as input
50 OUTPUT 709;"TRIG SGL"     !Trigger once
60 OUTPUT 709;"CHREAD 100"   !Transfer reading to output buffer
70 ENTER 709;A               !Enter reading
80 PRINT A                   !Display reading
90 END
```

Example: Triggering the HP 44702A/B Voltmeter

This program configures the HP 44702A/B voltmeter for DC voltage measurements with the voltmeter in the scanner mode. The voltmeter is programmed such that the measure trigger (TRIG) is supplied through the EXT0 port on the voltmeter. As the voltmeter is triggered, the measurements are taken and stored in mainframe memory.

```
10  OUTPUT 709;"RST"                !Reset HP 3852A and HP 44702A/B
20  OUTPUT 709;"REAL TRDGS(4)"      !Declare mainframe array (5 rdgs)
30  OUTPUT 709;"USE 500"            !Use the voltmeter in slot 5
40  OUTPUT 709;"SCANMODE ON"        !Turn scanner mode on
50  OUTPUT 709;"CONF DCV"           !Configure for DC voltage
80  OUTPUT 709;"TRIG EXT0"          !Trigger vm through EXT0 port
90  OUTPUT 709;"MEAS DCV, 400-404 INTO TRDGS"
100                                  !Take measurements, store in memory
110  END
```

Note that five trigger pulses into the voltmeter's EXT0 port are required to make the pass through the channel list.

TRIG

• HP 44714A 3-Channel Stepper Motor Controller/Pulse Output

Description

Determines how a move specified by a MOVE or SUSTAIN command is triggered. The move is not initiated until triggered.

Prerequisites

Requires mainframe firmware revision 3.0 or greater.

Syntax

TRIG *mode* [USE *ch*]

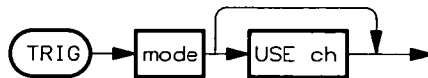

Parameters

mode The *mode* parameter specifies what source generates the trigger.

<u>mode</u>	<u>Definition</u>
HOLD	The trigger is disabled in the HOLD mode.
SYS	The SYS mode connects the mainframe's backplane system trigger as the trigger source.
AUTO (or INT) (power-on)	The AUTO (or INTERNAL) mode causes a trigger to be automatically (internally) generated as the final step in either the MOVE or SUSTAIN command.
CHANO	The CHANO mode connects channel 0 as the trigger source to allow simultaneous moves with channel 0.
SGL	Initiates an immediate trigger. After a SGL trigger is generated, TRIG returns to its previous setting of HOLD, SYS, AUTO, or CHANO. If a mode is not specified in the command, the default is SGL. You cannot use TRIG SGL unless the "NOWAIT" option is used in the MOVE or SUSTAIN command.

USE *ch* Channel the trigger applies to. Channel range can be ES00 to ES02.

Remarks

Power-On State

The power-on mode for TRIG is AUTO.

Data Returned

None

Related Commands

MOVE, SUSTAIN

Examples**Example: Initiate 10 Pulses With a Single Trigger**

```

10 OUTPUT 709;"PSCALE 1 USE 201"           !Scale factor = 1
15 OUTPUT 709;"TRIG HOLD USE 201"         !Trigger on hold
20 OUTPUT 709;"MOVE 10 REL NOWAIT USE 201" !Request 10 pulses
30 OUTPUT 709;"TRIG SGL USE 201"         !Trigger
40 END

```

Example: Initiate a move triggered by the mainframe's backplane system trigger then set TRIG for internal triggering.

```

10 OUTPUT 709;"TRIG HOLD USE 201"
20 OUTPUT 709;"MOVE 10 REL NOWAIT USE 201"
30 OUTPUT 709;"TRIG SYS USE 201"         !Triggered by system trigger
40 OUTPUT 709;"TRIG INT USE 201"        !TRIG INT same as TRIG AUTO
50 OUTPUT 709;"MOVE 10 REL USE 201"     !This move internally (auto)
                                         triggered.
60 END

```

This program could be rewritten so the move is triggered immediately after the MOVE command by switching lines 20 and 30.

TRIG

• HP 44715A 5-Channel Counter/Totalizer

Description

Set counter trigger mode or source. When the card configuration jumper is set to **FREQ**, the trigger mode applies to all five channels.

Prerequisites

The channel trigger should follow all commands which affect counter setup (**TBASE**, **NPER**, **SPER**, **EDGE**, **TERM**, and **CNTSET**), since these commands abort any ongoing measurement.

Syntax

TRIG [*source*] [**USE** *ch*]

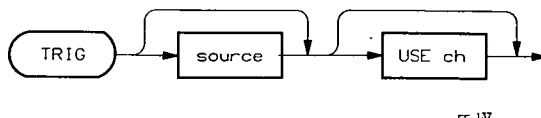

Parameters

source Specifies the trigger source or mode. Power-on *source* = **HOLD**. Default *source* = **SGL**.

- AUTO** Counter internal trigger (continuous triggering).
- EXT** External trigger source (requires hardware connection from source to XTRG terminals).
- HOLD** Aborts ongoing measurement, discards existing count, and disables any trigger source for the channel(s).
- SGL** Immediate single trigger when **TRIG SGL** is executed.
- SYS** System triggering (see **TRG** command).

USE *ch* Specify channel used for **TRIG** command. Channel number range (depends on HP 44715A hardware configuration) = **ES00** through **ES04**.

Remarks

Trigger Source and Mode

Although multiple channels can be triggered with **TRIG EXT** or **TRIG SYS** sources, each channel can be assigned to only one source. The trigger source does not change when the channel function is changed. For Frequency configuration, **TRIG source** applies to all five channels.

Data Returned

None

Related Commands

None

Examples**Example: Triggering the HP 44715A**

This program CONFigures the counter accessory to measure the frequency of an input signal. The counter is then issued a single trigger (TRIG SGL) at which point the frequency is measured. After the measurement is made, the reading is stored in a mainframe variable. Recall that to measure frequency, the Card Configuration jumper must be set to the FREQ position.

```
10 OUTPUT 709;"RST"           !Reset HP 3852A and HP 44715A
20 OUTPUT 709;"INTEGER A"     !Declare variable A
30 OUTPUT 709;"USE 100"       !Use counter channel 0 in slot 1
40 OUTPUT 709;"CONF FREQ"     !Configure cntr for freq measurement
50 OUTPUT 709;"TRIG SGL"      !Issue a single trigger
60 OUTPUT 709;"CHREAD 100 INTO A" !Store measurement in mf variable A
70 END
```

TRIG

• HP 44723A 16-Channel High-Speed Digital Sense/Control

Description

Selects the source for first rank input triggers. When a first rank input trigger is received, channel input states are sampled and the result stored in the first rank input register.

Prerequisites

Requires mainframe firmware revision 3.0 or greater.

Syntax

TRIG [*source*] [USE *ch*]

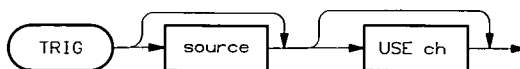

Parameters

source Selects the trigger source or mode for first rank input triggers. The channel number must be ES00 - ES15. Valid *source* parameters follow. Power-on/reset value = TRIG INT. Default value = TRIG SGL.

source/mode	Description
SGL	Immediate single trigger when command executes.
SYS	System trigger (see TRG command).
EXT	Terminal module external trigger input.
INT	Trigger when a read command is executed.*
HOLD	No triggering.

* = read commands are CHREAD, CHREADM, READ, and READM.

USE *ch* See Glossary. For *ch* = ES00-ES15, TRIG *source* sets the source for first rank input triggers.

Remarks

Changing Trigger Sources

Changing the TRIG *source* may generate a first rank input trigger.

Using TRIG INT

If TRIG INT is set, a first rank input trigger is generated immediately before a read command reads the second rank input register (regardless of the SRTRIG setting). If both TRIG INT and SRTRIG INT are set, a read command reads the current state of the input channels.

Data Returned

None

Examples**Example: External First Rank Input Triggering**

This program uses an external (HL) input as the source for the first rank input triggers (TRIG EXT). When an external first rank input trigger is received, the state of each input channel is sampled and the result stored in the first rank input register. Since SRTRIG INT is set, the first rank input register contents are copied to the second rank input register and the second rank input register is read when CHREAD is executed.

```
10 OUTPUT 709;"USE 207"           !Use ch is 207
20 OUTPUT 709;"TRIG EXT"         !Ext first rank input trig source
30 OUTPUT 709;"SRTRIG INT"       !Second rank input trigger on CHREAD
40 OUTPUT 709;"CHREAD 207"       !Read ch 207 state
50 ENTER 709;A                   !Enter ch 207 state
60 PRINT "Channel 207 state = ";A !Display ch 207 state
70 END
```

If channel 207 state is HIGH, a typical return is:

```
Channel 207 state = 1
```

TRIG

• HP 44726A 2-Channel Arbitrary Waveform DAC

Description

Sets the source of trigger signals which control the loading of waveform amplitude points into the DAC.

Prerequisites

Requires firmware revision 3.5 or greater. The channel must also be armed (TARM) before trigger pulses will advance the output of the DAC.

Syntax

TRIG [*source*] [USE *ch*]

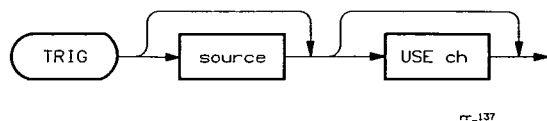

Parameters

source

INT - *source* is the internal trigger. The power-on *source* is INT.

EXT - *source* is an external trigger applied through the channel's EXT IN BNC. Must be a negative-going pulse with a pulse width ≥ 400 ns.

SGL - issues an immediate trigger on command execution. The default *source* is SGL.

SYS - *source* is the system trigger (see the TRG command).

CHAN0 - channel 1 trigger source. CHAN0 locks channel 1 to channel 0. When channel 0 receives a trigger, channel 1 is also triggered (if previously armed). If this source is selected, it is recommended that neither channel be armed by TARM AUTO. In TARM AUTO mode, TARM OFF is set automatically when a command which accesses channel memory is received. Following execution of that command, TARM AUTO is re-asserted and the waveform on that channel re-starts at the first amplitude point. The waveform on the other channel, however, will not be at its first point, thus, the channels will re-lock at an unknown phase.

Likewise, changing the TARM source to EXT or SYS sets TARM OFF momentarily which will re-start the waveform at the first amplitude point.

HOLD - stops the waveform at the last triggered amplitude point and prevents the recognition of subsequent trigger pulses. When the source is changed, the waveform will resume from the same point provided the channel was not disarmed.

USE *ch* Channel on which the waveform is stored and from which it will be applied. The default **USE *ch*** is channel 0.

Remarks Advancing the Output of the DAC

Trigger signals from the source specified by TRIG advance the output of the DAC. This means that as trigger signals are received, the amplitude points stored in channel memory are loaded into the DAC. Note that when an amplitude point is held for more than one time base interval, a trigger is required to maintain that amplitude for each of the time base intervals specified. For example, if an amplitude is to be held 2^3 time base intervals, eight triggers are required. If TRIG HOLD happened to be executed after four time base intervals (four triggers) had elapsed, five more triggers must occur before the next amplitude point is loaded into the DAC once triggering is resumed.

Data Returned

None

Related Commands

TARM

Examples **Example: Phase Locking Waveforms**

The following program shows how the TRIG command is used to phase lock the waveform on channel 1 with the waveform on channel 0.

In the example, identical waveforms are stored on channel 0 and channel 1. Waveform 0 is then selected from channel 1 memory and its trigger source is set such that the channel is triggered each time channel 0 is triggered. The channel is then armed so that the waveform will begin as soon as channel 0 is armed and triggered.

```

10  !Reset the HP 3852A and the HP 44726A. Define and store special
20  !function sine waves in channel 0 and channel 1 memory. The sine
30  !waves will be 1000 point waveforms, 10 Vp-p, with frequencies of
40  !500 Hz.
50  !
60  OUTPUT 709;"RST"
70  WAIT 1
80  OUTPUT 709;"WFWRITE ACV 0 10 TBASE(1/(500*1E3))"
90  OUTPUT 709;"WFWRITE ACV 0 10 TBASE(1/(500*1E3)) USE 1"
100 !
110 !Select waveform 0 from channel 1 memory. Set the trigger source
120 !such that channel 1 is triggered each time channel 0 is triggered.
130 !Arm channel 1 so that the waveform starts at the same time as the
140 !waveform on channel 0.
150 !
160 OUTPUT 709;"APPLY WFV 1,0"
170 OUTPUT 709;"TRIG CHAN0 USE 1"
180 OUTPUT 709;"TARM SGL USE 1"
190 !

```

TRIG (cont)

```
200 !Select waveform 0 from channel 0 memory. Set the trigger source
210 !so that the DAC is triggered internally. Arm the channel so that
220 !the trigger signals will be accepted.
230 !
240 OUTPUT 709;"APPLY WFV 0,0"
250 OUTPUT 709;"TRIG INT"
260 OUTPUT 709;"TARM SGL"
270 END
```

If at some point channel 0 is disarmed, neither waveform will advance at the output. Channel 1 is not disarmed; however, since channel 0 no longer accepts trigger signals, channel 1 is not triggered. When channel 0 is re-armed, the waveform starts at the beginning and the waveform on channel 1 resumes where it left off. Thus, they lock at an unknown phase.

If channel 1 is disarmed, channel 0 will continue to receive trigger pulses and its waveform will advance. When channel 1 is re-armed, the waveform starts at the beginning, and since the waveform on channel 0 continued to run, they will lock at an unknown phase.

To relock the channels at the desired phase, both should be disarmed, and then rearmed.

- HP 44730A Track/Hold with Signal Conditioning
- HP 44732A 120 Ohm Dynamic Strain Gage FET Multiplexer
- HP 44733A 350 Ohm Dynamic Strain Gage FET Multiplexer

Description

Sets the trigger source for all channels on an accessory.

Prerequisites

Command requires mainframe firmware revision 3.5 or greater. The system must not be scanning with the HP 44702A/B voltmeter when TRIG is executed.

Syntax TRIG [*source*] [USE *ch*]

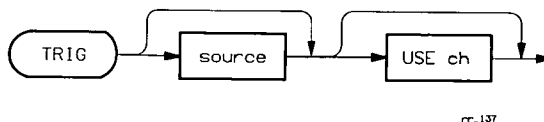

m_137

Parameters

source Sets the trigger source for ALL channels on an HP 44730A, HP 44732A, or HP 44733A accessory. Power-on/reset *source* = RIBBON. Default *source* = SGL.

For a channel set to sampling (FUNC SAMPLE), *source* sets the source for the trigger which changes the mode from track to hold. For a channel set to peak detection (FUNC POSPEAK or FUNC NEGPEAK), *source* sets the source for the trigger which resets the peak detectors.

source	Description
RIBBON	Triggering controlled by HP 44702A/B voltmeter via the ribbon cable. Scan trigger from voltmeter sets hold mode and resets peak detectors on all channels.
SYS	System trigger via the mainframe backplane. (Used with TRG command).
SGL	Single trigger via the mainframe backplane. TRIG SGL sets hold mode and resets peak detectors on all channels.
EXT	Triggering via the EXT TRG terminals on the terminal module.
HOLD	No triggering. Sets track mode and disables peak detector resets on all channels.

TRIG (cont)

USE *ch* Specify slot to be used for the TRIG command. Setting the TRIG *source* for any USE *ch* sets the source for ALL channels on the accessory (e.g., TRIG RIBBON USE 503 sets all four channels on an HP 44730A in slot 500 to TRIG RIBBON).

Remarks

Data Returned

None.

Related Commands

FUNC

Examples

Example: Multichannel Sampling

This program samples the input to channels 500 through 503 of an HP 44730A at a 100 kHz rate (10 sample points at 10 μ sec intervals). Channel 500 of the HP 44730A is set for sampling measurements with channel gain of 10 and filtering on. Channel 501 is set for sampling with gain of 1 and filtering on, channel 502 is set for sampling with gain of 100 and filtering off, and channel 503 is set for sampling with gain of 10 and filtering off. The HP 44702A/B voltmeter is set for 10 prescans, no postscans, 1 reading per channel, and internal scan, measure, and stop triggers.

When the first scan trigger is generated, all channels are simultaneously set to the hold mode and a measure trigger is immediately generated to make the first measurement. Since NRDGS 1 is set and there are four channels in the channel list, these measurements complete pass 1. When the measurement for pass 1 is complete, the channel reverts to the track mode.

Since SCTRIG INT is set, SCDELAY 0,40E-6 starts the second pass 10 μ sec after the fourth measurement and the second set of measurements is immediately made, etc. PRESCAN 10 sets the voltmeter for 10 scan passes (10 sets of four measurements each).

```
10 DIM A(0:9,0:3) !Define controller array
20 !
30 !Set up HP 44730A channels 500 through 503
40 !
50 OUTPUT 709;"USE 500" !Use ch is 500
60 OUTPUT 709;"FUNC SAMPLE,10" !Set sampling w/gain 10
70 OUTPUT 709;"FILTER ON" !Ch 500 filter on
80 OUTPUT 709;"AZERO ONCE" !Ch 500 autozero
90 OUTPUT 709;"USE 501" !Use ch is 501
100 OUTPUT 709;"FUNC SAMPLE,1" !Set sampling w/gain 1
110 OUTPUT 709;"FILTER ON" !Ch 501 filter on
120 OUTPUT 709;"AZERO ONCE" !Ch 501 autozero
130 OUTPUT 709;"USE 502" !Use ch is 502
140 OUTPUT 709;"FUNC SAMPLE,100" !Set sampling w/gain 100
150 OUTPUT 709;"FILTER OFF" !Ch 502 filter off
160 OUTPUT 709;"AZERO ONCE" !Ch 502 autozero
170 OUTPUT 709;"USE 503" !Use ch is 503
180 OUTPUT 709;"FUNC SAMPLE,10" !Set sampling w/gain 10
190 OUTPUT 709;"FILTER OFF" !Ch 503 filter off
```

TRIG (cont)

```
200 OUTPUT 709;"AZERO ONCE"           !Ch 503 autozero
210 OUTPUT 709;"TRIG RIBBON,USE 500"   !Trigger from ribbon cable
220 !
230 !Set up HP 44702A/B Voltmeter
240 !
250 OUTPUT 709;"USE 600"               !Use voltmeter in mf slot 6
260 OUTPUT 709;"SCANMODE ON"          !Set Scanner Mode
270 OUTPUT 709;"CONF DCV"             !Conf for DC volts
280 OUTPUT 709;"ARMODE BEFORE"        !Set immediate autorange mode
290 OUTPUT 709;"SPER 10E-6"           !10 usec between meas trigs
300 OUTPUT 709;"SCDELAY 0,40E-6"      !0 usec delay, 40 usec scan
310 OUTPUT 709;"PRESCAN 10"           !Set 10 prescans
320 OUTPUT 709;"CLWRITE 500-503"      !Set ch 500 as scan list
330 !
340 !Make measurements
350 !
360 OUTPUT 709;"SCTRIG INT"           !Internal scan trig source
370 OUTPUT 709;"XRDGS 600"            !Trans 10 rdgs to output buffer
380 ENTER 709;A(*)"                   !Enter 10 readings
390 !
400 !Display results
410 !
420 PRINT "Pass      Ch 500   Ch 501   Ch 502   Ch 503" !Header
430 PRINT                !Space
440 FOR I=0 TO 9                !Start display loop
450   PRINT I+1,A(I,0),A(I,1),A(I,2),A(I,3) !Display readings
460 NEXT I                       !Increment loop
470 END
```

A typical return for 5% inputs on channels 500 through 503 follows. Channel 500 input = 0.5 V, channel 501 input = 3.0 V, channel 502 input = 0.02 V, and channel 503 input = 0.4 V.

Pass	Ch 500	Ch 501	Ch 502	Ch 503
1	5.06	3.015	2.0025	4.00
2	5.0475	3.025	2.05	4.005
3	5.06	3.01	1.995	3.9975
4	5.05	3.02	1.9975	3.995
5	5.0525	3.009	2.0	3.9925
6	5.05	2.995	2.0025	4.005
7	5.05	3.00	1.99	3.99
8	5.05	2.99	2.0075	4.0025
9	5.0475	3.0025	2.0025	4.01
10	5.05	2.9975	2.005	3.98

Example: Positive Peak Detection

This program detects the positive peak of an input signal to channel 500 of an HP 44730A. Channel measurements are made with an HP 44702A/B voltmeter in slots 6 and 7 via the ribbon cable. Channel 500 is set for positive peak detection, gain of 10, and no filtering. The HP 44702A/B voltmeter is set for Scanner mode and internal measure and stop triggering. Scan triggering is via the EXT0 port (SCTRIG EXT0). The program requires a TTL input (HL) to the EXT0

TRIG (cont)

port.

This program assumes a known signal will be input which has a peak within 1 msec after the input is generated ($V_{in} = 0 @ t = 0$). To make the measurement, a TTL sync pulse will be input to the EXT0 port on the HP 44702A/B when the input is generated ($t = 0$) which generates the scan trigger. Then, after 1 msec, the measurement is made and the peak value is displayed.

```
10  !
20  !Set up HP 44730A channel
30  !
40  OUTPUT 709;"USE 500"           !Use ch is 500
50  OUTPUT 709;"FUNC POSPEAK,10"  !Ch 500 to pos peak w/gain 10
60  OUTPUT 709;"AZERO ONCE"       !Autozero on ch 500
70  OUTPUT 709;"TRIG RIBBON"      !Trigger source is ribbon cable
80  !
90  !Set up HP 44702A/B voltmeter
100 !
110 OUTPUT 709;"USE 600"          !Use vm in mf slot 6
120 OUTPUT 709;"SCANMODE ON"     !Set Scanner Mode
130 OUTPUT 709;"CONF DCV"        !Set DC volts, ch 500
140 OUTPUT 709;"SCDELAY 1E-3"    !1 msec to measure trig
150 OUTPUT 709;"CLWRITE 500"     !Ch 500 is ch list
160 !
170 !Make peak value measurement
180 !
190 OUTPUT 709;"SCTRIG EXT0"     !EXT0 port is scan trig source
200 OUTPUT 709;"CHREAD 600"     !Trans reading to output buffer
210 ENTER 709;A                  !Enter peak value
220 PRINT "Positive peak =";A;"Volts" !Display peak value
230 END
```

Since the channel gain is 10, if the maximum value of the input during the 1 msec measurement interval is 0.4975 V, a typical return is:

Positive peak = 4.975 Volts

• HP 44788A HP-IB Controller

Description

This statement sends a trigger message to a selected device, addressed to listen, on the HP-IB controlled by the mainframe.

Prerequisites

Requires firmware revision 3.5 or greater.

Syntax

TRIGGER @*I/O path name* or *device selector*

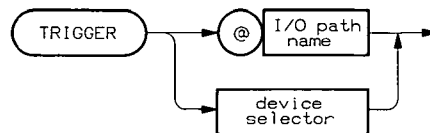

Parameters

@I/O path name

The name of the bidirectional path assigned to a device to be triggered.

device selector

The HP-IB select code (ESnn) for the device that is to be triggered. E = extender # (mainframe = 0), S = slot, and nn = device address.

Remarks

Triggering Addressed Device

The addressed device is triggered.

Data Returned

None

Related Commands

ASSIGN

Examples

Example: Triggering Addressed Device

These program lines show two ways to trigger device 311 assigned to I/O path @dvm.

```
10 OUTPUT 709;"ASSIGN @DVM TO 311" !Assign I/O path for device 311
20 OUTPUT 709;"TRIGGER @DVM"      !Trigger device 311
```

or

```
20 OUTPUT 709;"TRIGGER 311"       !Trigger device 311
```

TRIGMODE

- HP 44723A 16-Channel High-Speed Digital Sense/Control

Description

Selects the trigger mode for first rank input triggers and second rank output triggers.

Prerequisites

Requires mainframe firmware revision 3.0 or greater.

Syntax

TRIGMODE *mode* [USE *ch*]

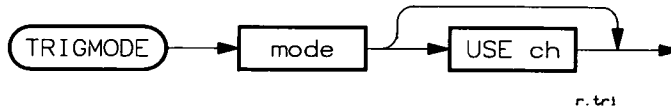

Parameters

mode

Selects the trigger mode for first rank input triggers and second rank output triggers. Valid *mode* = FIRST or ALL (power-on/reset). Specifying any input channel (ES00 - ES15) affects the mode for first rank input triggers. Specifying any output channel (ES16 - ES31) affects the mode for second rank output triggers.

- Input Trigger Mode:*

Action	TRIGMODE FIRST	TRIGMODE ALL
Update First Rank Input Register	Updated only by the first first rank input trigger after a second rank trigger.	Updated by all first rank input triggers.
Transfer Data to Second Rank Input Register	A second rank input trigger causes the earliest sampled data to be transferred.	A second rank input trigger causes the most recently sampled data to be transferred.
Trigger Output for First Rank Input Triggers	Set HIGH by a second rank input trigger. Set LOW by a first rank input trigger.	Each first rank input trigger sources an 2 µsec pulse output.

* = For either TRIGMODE FIRST or TRIGMODE ALL, a 2 µsec negative pulse on the second rank trigger output is generated for each second rank input trigger received.

TRIGMODE (cont)

- Output Trigger Mode:

Action	TRIGMODE FIRST	TRIGMODE ALL
Trigger Output for Second Rank Output Triggers	Set HIGH by a write to the first rank output register. Set LOW by a second rank output trigger.	Each second rank output trigger sources a 2 μ sec negative pulse output.

USE *ch* For *ch* = ES00-ES15, TRIGMODE sets the mode for first rank input triggers. For *ch* = ES16-ES31, TRIGMODE sets the mode for second rank output triggers.

Remarks

Using TRIGMODE FIRST

Setting TRIGMODE FIRST may generate a first rank input trigger.

Using Trigger Outputs for First Rank Input Triggers

With TRIGMODE FIRST, the trigger output for first rank input triggers is set HIGH when a second rank input trigger is received and set LOW by a first rank input trigger. Thus, the trigger output level can be used to handshake input data with an external device as long as the device can use a high-to-low (negative) edge for handshaking.

With TRIGMODE ALL, each first rank input trigger causes the trigger output to source a 2 μ sec negative pulse which may be used for synchronizing multiple accessories or for timing.

Using Trigger Outputs for Second Rank Output Triggers

With TRIGMODE FIRST, the trigger output for second rank output triggers is set HIGH by a write to the first rank output register and is set LOW by a second rank output trigger. Thus, a negative edge is produced only by the first second rank output trigger received. This trigger output level may be used for handshaking output data with an external device.

With TRIGMODE ALL, each second rank output trigger causes the trigger output to source a 2 μ sec negative pulse which may be used for synchronizing multiple accessories or for timing.

Interaction with RDGSMODE

The combination of RDGSMODE and TRIGMODE settings may affect the READ/READM and WRITE/WRITEM commands. Refer to the RDGSMODE command for details.

Data Returned

None

TRIGMODE (cont)

Examples Example: Simultaneously Trigger Multiple Accessories

This program simultaneously second rank input triggers HP 44723A accessories in slots 100, 200, and 300. For this program, the trigger output for second rank input triggers on the accessory in slot 100 must be wired to the second rank input trigger external input on the accessories in slots 200 and 300. Since TRIGMODE ALL and RDGSMODE IMMED are set, the READM command immediately reads the most recently sampled data.

For this program, the READM command simultaneously reads the states of slots 100, 200, and 300. When READM executes, a 2 μ sec negative pulse is output from the accessory in slot 100 and is sent to the accessories in slots 200 and 300. This pulse generates second rank input triggers which transfer the most recently sampled data to the second rank input registers in slots 200 and 300.

```
10  INTEGER A(1:3)           !Dimension controller array
20  OUTPUT 709;"USE 100"     !Use ch is 100
30  OUTPUT 709;"RDGSMODE IMMED" !Immediately read data in slot 100
40  OUTPUT 709;"TRIGMODE ALL" !Read most recently sampled data
50  OUTPUT 709;"TRIG EXT"   !External first rank input trig source
60  OUTPUT 709;"SRTRIG INT" !Trigger on READM command
70  OUTPUT 709;"USE 200"     !Use ch is 200
80  OUTPUT 709;"RDGSMODE IMMED" !Immediately read data in slot 200
90  OUTPUT 709;"TRIGMODE ALL" !Read most recently sampled data
100 OUTPUT 709;"TRIG EXT"   !External first rank input trig source
110 OUTPUT 709;"SRTRIG EXT" !External second rank input trig source
120 OUTPUT 709;"USE 300"     !Use ch is 300
130 OUTPUT 709;"RDGSMODE IMMED" !Immediately read data in slot 300
140 OUTPUT 709;"TRIGMODE ALL" !Read most recently sampled data
150 OUTPUT 709;"TRIG EXT"   !External first rank input trig source
160 OUTPUT 709;"SRTRIG EXT" !External second rank input trig source
170 OUTPUT 709;"READM 100-300" !Read slots 100, 200, and 300
180 ENTER 709;A(*)          !Enter decimal equiv of bit patterns
190 PRINT A(*)              !Display decimal equiv
200 END
```

If channels 101, 107, 111, 200, 202, 301, 314, and 315 are HIGH (most recently sampled data), a typical return is:

```
2177 5 -16382
```

- HP 44702A/B High-Speed Voltmeter (Scanner or System Mode)

Description

Specifies whether or not the "0" BNC port on the voltmeter rear panel will function as a measure trigger source. When enabled, this port outputs a trigger signal that can be used to trigger other HP 44702A/B voltmeters. When disabled, the 0 BNC port is set to receive trigger signals.

Prerequisites

If TRIGOUT ON is set, no trigger source (TRIG, SCTRIG, STTRIG) can be set to EXT0 and vice versa.

Syntax

TRIGOUT [*mode*] [USE *ch*]

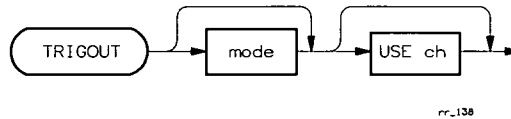

Parameters

mode Voltmeter external BNC 0 mode. Power-on *mode* = OFF. Default *mode* = ON.

mode	Definition
OFF	BNC 0 may receive trigger signals.
ON	BNC 0 outputs trigger signals.

USE *ch* Voltmeter slot number. See Glossary.

Remarks

Data Returned

None

Trigger Output vs. Measurements

The trigger signal output from the 0 BNC port is the same measure trigger the voltmeter received. The signal is a negative-going pulse and is a valid measure trigger, which means that any other HP 44702A/B voltmeter which receives the signal is triggered to make a measurement.

Related Commands

SCTRIG, STTRIG, TRIG, USE

TRIGOUT (cont)

Examples

Example: Synchronizing Two Voltmeters

One use for the TRIGOUT command is to synchronize the operation of several HP 44702A/B High-Speed Voltmeters. In the following program, the voltmeter in slot 5 of the mainframe is designated as the master voltmeter which synchronizes the operation of a slave voltmeter located in slot 1 of the mainframe.

A 24-channel FET multiplexer is connected to each voltmeter through the dedicated ribbon cable. A BNC cable is connected between the master voltmeter 0 BNC port and the slave voltmeter 0 BNC port to route the measure trigger from the master to the slave, thus simultaneously triggering both voltmeters. Three passes are made through each multiplexer channel list and a total of 9 readings are returned by each voltmeter.

The program is structured such that the master voltmeter is set up and configured first, followed by the slave voltmeter. The slave voltmeter is then enabled to respond to the measure trigger sent from the master, and finally the master voltmeter is triggered. Each program "segment" involving the configuration and triggering of the voltmeters is described in more detail following the program listing.

```
10 !Set up controller
20 DIM Rgs1(0:8), Rgs2(0:8)           !Dim readings arrays

30 !SET UP MASTER VOLTMETER
40 OUTPUT 709;"RST"                 !Reset HP 3852A and voltmeters
50 OUTPUT 709;"USE 500"             !Use vm in mf slot 5 (master)
60 OUTPUT 709;"SCANMODE ON"        !Enable Scanner Mode
70 OUTPUT 709;"CONF DCV"           !Configure for DC volts
80 OUTPUT 709;"TRIGOUT ON"         !Output trig signal to BNC 0
90 OUTPUT 709;"PRESCAN 3"          !Make 3 passes through scan list
100 OUTPUT 709;"CLWRITE SENSE 400-402" !Ch list/ribbon cable connections
110 OUTPUT 709;"ASCAN ON"          !Turn autoscan on

120 !SET UP SLAVE VOLTMETER
130 OUTPUT 709;"USE 100"           !Use vm in mf slot 1
140 OUTPUT 709;"SCANMODE ON"       !Enable Scanner Mode
150 OUTPUT 709;"CONF DCV"          !Configure for DC volts
160 OUTPUT 709;"SLOPE HL"          !Trigger on negative-going signal
170 OUTPUT 709;"TRIG EXT0"         !Set slave BNC 0 to receive trigger
180 OUTPUT 709;"PRESCAN 3"         !Make 3 passes through scan list
190 OUTPUT 709;"CLWRITE SENSE 0-2" !Ch list/ribbon cable connections
200 OUTPUT 709;"ASCAN ON"          !Turn autoscan on

210 !ENABLE SLAVE TO RESPOND TO TRIGGER
220 OUTPUT 709;"SCTRIG SGL"        !Send scan trigger to slave
```

TRIGOUT (cont)

```
230 !ENABLE AND TRIGGER MASTER VOLTMETER
240 OUTPUT 709;"SCTRIG SYS, USE 500"      !System trigger master voltmeter
250 OUTPUT 709;"TRG GET"                  !Set system trigger source
260 WHILE NOT BIT(SPOLL(709),4)           !Wait until mf ready before GET
270 END WHILE
280 TRIGGER 709                            !Trigger the master voltmeter

290 !TRANSFER AND DISPLAY READINGS
300 OUTPUT 709;"XRDGS 500"                !Trans readings from master
310 ENTER 709;Rgs1(*)                     !Enter master readings
320 OUTPUT 709;"XRDGS 100"               !Trans readings from slave
330 ENTER 709;Rgs2(*)                     !Enter slave readings
340 FOR I=0 TO 8                           !Display master/slave readings
350 PRINT USING "M3D.6D,3X";Rgs1(I),Rgs2(I)
360 NEXT I
370 END
```

A typical output based on this program is given below:

```
+6.277500      +6.277500
+.000029      +.000020
+.000029      +.000010
+6.282500      +6.280000
+.000029      +0.000000
+.000029      +.000010
+6.282500      +6.282500
+.000029      +.000010
+.000020      +.000020
```

As shown, lines 40 through 110 set up the master voltmeter. The commands and parameters specified indicate that the master voltmeter is installed in slot 5 and the voltmeter is set for the scanner mode. The voltmeter is configured to measure DC voltage and is programmed to output a measure trigger signal when triggered itself. Three passes will be made through the channel list specified by the CLWRITE command. ASCAN ON is set so that the master voltmeter need only receive one scan trigger (SCTRIG) to make three passes through the list.

Lines 130 through 220 set up and enable the slave voltmeter. The slave voltmeter is installed in slot 1 and is also set for the scanner mode and configured to measure DC voltage. Since the TRIGOUT signal from the master voltmeter is a negative-going pulse, the SLOPE command is used to set the slave voltmeter to trigger on the high-to-low transition of the signal. The TRIG EXT0 command specifies that the master's trigger signal will be input to the slave's EXTERNAL TRIGGER BNC port 0. The slave voltmeter will also make three passes through the channel list specified by CLWRITE. ASCAN ON is set so that the slave voltmeter need only receive one scan trigger in order to make three passes through the list. SCTRIG SGL is sent to the slave voltmeter so that when the measure trigger is received from the master voltmeter, both voltmeters will make their measurements simultaneously.

Line 240 sets the trigger source for the master voltmeter as the HP-IB Group Execute Trigger (GET). Lines 250 through 270 enable the voltmeter to respond to the trigger when the trigger is issued.

TSLICE

- Mainframe

Description

Sets the length of time (time-slice) commands will execute within a specific task before the system swaps to another task of equal priority.

Prerequisites

The TSLICE command is used in the multitasking mode which requires firmware revision 3.0 or greater. The *tic_interval* and *INT/EXT* parameters require revision 3.5 or greater and the 03852-66523 controller module. The *tic_interval* and *INT/EXT* parameters will be ignored on earlier version controller modules running 3.5 firmware.

Syntax

TSLICE *seconds* [*tic_interval* [*INT/EXT*]]



Parameters

seconds Time-slice period. The range for *seconds* is 0 to 16.71 seconds. However, to obtain time-slice periods less than 65.536 ms, the *tic_interval* must be set equal to, or faster than the time-slice period. See "Specifying a *tic_interval*".

tic_interval See Remarks - "Specifying a *tic_interval*".

INT/EXT See Remarks - "Setting the Source of the *tic_interval*".

Remarks

Loading the Time-Slice Period into the HP 3852A Operating System

The time-slice period set by the TSLICE command is not actually used until it is loaded into the mainframe's operating system. This is accomplished by either resetting the mainframe or cycling power after you execute the TSLICE command. Since the time-slice period is stored in non-volatile memory, the period does not have to be reloaded each time your multitasking system runs.

Resetting the instrument or cycling power erases all variables, arrays, and downloaded subroutines in mainframe memory. Therefore, before using any of the memory for your multitasking applications, ensure that: 1) the mainframe is in the multitasking mode (ENABLE MULTI), 2) the time-slice period has been set and loaded, and 3) the number of run tasks and the queue size have been set and loaded (NTASKS). This is necessary since each of the above causes or requires a system reset before taking effect.

Cycling Power Removes the HP 3852A from the Multitasking Mode

Anytime power is cycled, the multitasking capability of the HP 3852A is disabled. Thus, if power is cycled as a means for loading the time-slice period into the operating system, multitasking must be re-enabled (ENABLE MULTI) as TSLICE applies only to the multitasking mode.

Exiting the Time-Slice Period

When the time-slice period for the active task expires, the system swaps to the next scheduled task upon completion of the command currently executing. If the end of a task occurs before the time-slice period expires, the system swaps to the next task of equal priority the moment the active task ends. If a task with a higher priority occurs in the middle of a time-slice period, the high priority commands execute (following the currently executing command) and then the active (lower priority) task resumes for the remainder of the period.

Specifying a tic interval

tic_interval

The *tic_interval* parameter need only be specified when a time-slice period faster than 65 ms is required. In most applications, however, a 65 ms time-slice period is acceptable.

The tic interval is the interval at which the HP 3852A operating system "checks" the state of the multitasking system. At each interval, the operating system determines whether a task is to be swapped, a suspended task is to be activated, a task is to begin, or whether operation is to continue in the current state.

The tic interval also determines the maximum time-slice period allowed, the maximum period a task can be suspended by either the SUSPEND or SUSPEND UNTIL command, and the interval at which run task execution begins as directed by the RUN command. These values, based on the tic intervals available are given below:

TIC_INTERVAL	MAXIMUM TIME-SLICE (<i>tic_interval</i> * 255)	MAXIMUM PERIOD SUSPENDED
1.024 ms	0.261 s	4398046.51 s (50.9 days)
2.048 ms	0.522 s	8796093.02 s (101.8 days)
4.096 ms	1.044 s	17592186.04 s (203.6 days)
8.192 ms	2.088 s	35184372.08 s (407.2 days)
16.384 ms	4.177 s	70368744.161 s (814.4 days)
32.768 ms	8.355 s	140737488.322 s (1628.9 days)
65.536 ms	16.71 s	281474976.645 s (3257.8 days)

The default *tic_interval* is 65.536 ms. Should a time-slice period shorter than 65.536 ms be specified and the default tic interval used, the time-slice period is set equal to the interval.

Note that any time-slice period specified is rounded to the *tic_interval* resolution. For example, consider the following two statements:

```
OUTPUT 709;"TSLICE 0"
```

Because the *tic_interval* parameter is not specified, the time-slice period and the *tic_interval* are set to 65.536 ms.

TSLICE (cont)

```
OUTPUT 709;"TSLICE 0.110, 0.032768"
```

This statement sets the time-slice period to 110 ms and the tic_interval to 32.768 ms. Because the time-slice period would expire between tic_intervals, the value is rounded such that the period expires when a tic occurs. Thus, a 110 ms time-slice results in an actual time slice of approximately 98 ms ($3 * 32.768$ ms).

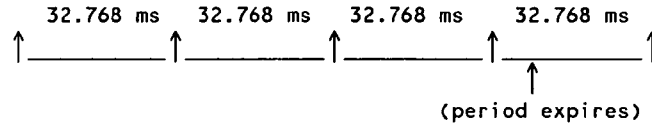

Should a time-slice period expire less than half way through a tic_interval (as above), the period is rounded down. If the period expires half way or greater than half way through a tic_interval, the period is rounded up. Thus, a time-slice period of 115 ms would have resulted in an actual time-slice of 131 ms.

Setting the Source of the tic interval

The *INT/EXT* parameter specifies the clock from which the tic interval is derived. *INT* selects the mainframe's internal clock. *EXT* selects an external clock applied through the CHANNEL ADVANCE BNC on the HP 3852A's rear panel. The default source is *INT*.

When an external clock is used, the tic_interval specified is not rounded to 1.024 ms, 2.048 ms, 4.096 ms, etc., as are values when the internal clock is used. For example:

```
OUTPUT 709;"TSLICE 0.261, 0.001,INT
```

is acceptable since the tic_interval of 1 ms defaults to 1.024 ms and 0.261s is the maximum time-slice allowed.

```
OUTPUT 709;"TSLICE 0.261,0.001,EXT
```

results in an error since the tic_interval is not rounded to 1.024 ms. Thus, the maximum time-slice allowed is $0.001 * 255 = .255$ s. (255 represents an internal counter which keeps track of the number of tics.)

Data Returned

None

Related Commands

ENABLE MULTI, DISABLE MULTI, ENABLE EOL SWAP, DISABLE EOL SWAP, URGENCY, NTASKS, RUN

Examples

Example: Setting a Time-Slice Period

This example shows how the TSLICE command is used to set the time-slice period for the following multitasking program. The time-slice period is then varied to show how shorter and longer periods change the portions of the run task subroutines that are executed.

In the following program, two subroutines are set up and directed to run tasks. One subroutine counts and displays the numbers from 0 through 9, and the other subroutine repeatedly displays the sequence A B C.

```

10  !Set a 1.5 second time-slice and set the number of run tasks and
20  !queue size the system will allow. Place the HP 3852A in the
30  !multitasking mode. The reset caused by ENABLE MULTI will load
40  !the TSLICE and NTASKS parameters into the operating system.
50  !
60  OUTPUT 709;"TSLICE 1.5"
70  OUTPUT 709;"NTASKS 2,2"
80  OUTPUT 709;"ENABLE MULTI"
90  !
100 !Write and download the subroutines to be directed to run tasks.
110 !Subroutine A when active, displays the numbers 0 through 9.
120 !Subroutine B when active, repeatedly displays A B C.
130 !
140 OUTPUT 709;"SUB A"
150 OUTPUT 709;"  INTEGER I"
160 OUTPUT 709;"  FOR I=0 TO 9"
170 OUTPUT 709;"    DISP I"
180 OUTPUT 709;"    WAIT .5"
190 OUTPUT 709;"  NEXT I"
200 OUTPUT 709;"SUBEND"
210 OUTPUT 709;"SUB B"
220 OUTPUT 709;"  INTEGER J"
230 OUTPUT 709;"  FOR J=0 TO 3"
240 OUTPUT 709;"    DISP 'A'"
250 OUTPUT 709;"    WAIT .5"
260 OUTPUT 709;"    DISP 'B'"
270 OUTPUT 709;"    WAIT .5"
280 OUTPUT 709;"    DISP 'C'"
290 OUTPUT 709;"    WAIT .5"
300 OUTPUT 709;"  NEXT J"
310 OUTPUT 709;"SUBEND"
320 !
330 !Direct subroutines A and B to run tasks. Set each
340 !run task to execute one time.
350 !
360 OUTPUT 709;"RUN 1 A"
370 OUTPUT 709;"RUN 2 B"
380 END

```

TSLICE (cont)

As the subroutines in the run tasks execute, the following is displayed for the time-slice periods shown. Recall that when a new time-slice period is specified by TSLICE, the mainframe must be reset or have the power cycled before the value will be used.

TSLICE = 1.5s	TSLICE = 1s	TSLICE = 2s
(task 1 active)	(task 1 active)	(task 1 active)
0	0	0
1	1	1
2		2
	(task 2 active)	3
(task 2 active)	A	(task 2 active)
A	B	A
B		B
C	2	C
	3	A
3	C	
4	A	4
5		5
	4	6
A	5	7
B		
C	B	B
	C	C
6		A
7	6	B
8	7	
		8
A	A	9
B	B	
C		C
	8	A
9	9	B
		C
A	C	
B	A	
C	B	
	C	

For time-slice periods of 1.5 seconds and 2 seconds, a count of 9 is reached before the time-slice period expires. Once 9 is displayed, the system immediately swaps to run task 2 rather than waiting for the period to elapse. As illustrated in the sequence given for a time-slice period of 1 second, when run task 1 finishes, run task 2 uses successive time-slice periods until it completes.

Example: Setting The tic_interval To Obtain a 1.024 ms Time-Slice Period

The following program segment shows how to set the tic interval in order to obtain a time-slice period of 1.024 ms.

```
10 !Set a 1.024 ms time-slice period and the appropriate tic_interval.
20 !Set the number of run tasks and queue size for the system.
30 !Place the HP 3852A in the multitasking mode. The reset caused
40 !by ENABLE MULTI will load the TSLICE and NTASKS parameters into
50 !the operating system.
60 !
70 OUTPUT 709;"TSLICE 1.024E-3, 1.024E-3"
80 OUTPUT 709;"NTASKS 8,20"
90 OUTPUT 709;"ENABLE MULTI"
```

Recall that if the tic interval in line 70 is set to a slower value than the time-slice period, or if it is not specified at all (default), the time-slice period is set equal to the interval.

- Mainframe

Description

Sets task priorities within the HP 3852A multitasking system.

Prerequisites

The URGENCY command is used with the multitasking capability of the HP 3852A. Multitasking is only available with mainframe firmware revision 3.0 or greater.

Syntax

URGENCY [*task*] *number*

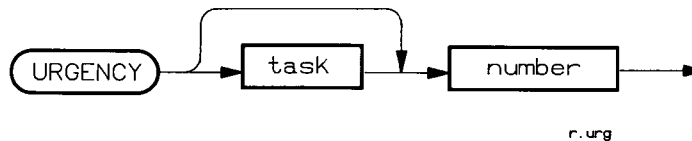

Parameters

task

Task (environment) whose command priority is raised or lowered by the URGENCY command. If the *task* parameter is not specified, the priority set pertains to the commands in the task (e.g. front panel, HP-IB, interrupt, run task) from which the URGENCY command was executed.

TASK

DESCRIPTION

HP-IB

Sets the priority for all commands and subroutines executed within the HP-IB task.

KYBD

Sets the priority for all commands and subroutines executed within the front panel task.

INTR

Sets the priority for all interrupt-called subroutines (interrupt task).

run task number

Sets the priority of the run task specified.

number

Priority of the task specified. The range for *number* is 1 to 253, with 1 being the highest priority and 253 being the lowest priority.

Remarks

Priorities Set by the ENABLE MULTI Command

When the HP 3852A is placed in the multitasking mode with the ENABLE MULTI command, the following task priorities are set:

Front Panel	(25)
HP-IB	(45)
Interrupt	(65)
Run Tasks	(85)

URGENCY (cont)

HP-IB Remote/Local States Vs. Front Panel Priority

Regardless of the urgency specified for commands from the front panel (KYBD) task, the HP 3852A must be in the LOCAL state before a command will be accepted (see Chapter 3 - Command Summary for command exceptions). Note that the mainframe enters the REMOTE state anytime a command is sent over the HP-IB (i.e. OUTPUT 709;...).

Device Clear Resets Task Priorities

Anytime you clear the HP 3852A (e.g. CLEAR key, CLR command), the task priorities are reset to the values set by ENABLE MULTI.

Tasks of Equal Priority will Time-Slice

Regardless of the task or priority level, all tasks which have the same priority will time-slice and swap at the end of a command when the time-slice period expires. Commands within a task which has a high priority will execute to completion before time-slicing between equal and lower priority tasks begins or resumes.

Setting the Priority of a Run Task

When the URGENCY command is used to set the priority of a run task, only the priority of the run task specified is changed. The priority of any other run tasks remains as set by ENABLE MULTI or as set by subsequent URGENCY commands. A subroutine in the queue will execute at the same priority as the run task subroutine it replaces.

Note that in addition to setting its own priority, a task can set the priority of any other task.

Setting the Priority of Interrupt-Called Subroutines

When the priority of interrupt-called subroutines (INTR) is set, the priority in which interrupts are handled by the mainframe remains the same:

ALARM
BACKPLANE
LIMIT

This means that should these interrupts occur simultaneously, ON ALRM CALL ... would occur first and run to completion followed by ON INTR CALL ... and ON LMT CALL ... Note, for example, that given the priorities set by ENABLE MULTI, any of these interrupt-called subroutines when they occur would execute to completion before allowing the system to resume time-slicing between the lower priority run tasks.

Data Returned

None

Related Commands

ENABLE MULTI, DISABLE MULTI, ENABLE EOL SWAP, DISABLE EOL SWAP, TSLICE, NTASKS, RUN

Examples

Example: Changing Task Priorities

The following example shows how the URGENCY command is used to change task priorities such that data can be read from a mainframe array and entered into the controller at certain intervals.

In the program, three subroutines are downloaded and directed to run tasks. One subroutine counts from 0 to 199, one repeatedly displays A B C, and the third makes 50 DC voltage measurements and stores the readings into a mainframe array.

The priority of the run task subroutine which performs the measurements is raised above the priority of the other run tasks and above the HP-IB task. The VREAD command in line 620 is issued from the controller to read the contents of the array. Because of the change in priorities, VREAD will not execute until the run task taking the measurements completes. At that time, the readings are taken from the array, entered into the controller, and displayed.

As the program continues, the priority of the "measurement" run task is set the same as the other run tasks, and the priority of the HP-IB task is set below the run tasks. When the measurement run task subroutine executes the second time, it time-slices with the other run tasks. Since the priority of the HP-IB task was lowered, the VREAD command in line 750 does not execute until each of the run tasks has finished.

```

10  !Set a 65 ms time-slice and set the number of run tasks and
20  !queue size the system will allow. Place the HP 3852A in the
30  !multitasking mode. The reset caused by ENABLE MULTI will load
40  !the TSLICE and NTASKS parameters into the operating system.
50  !
60  OUTPUT 709;"TSLICE .065"
70  OUTPUT 709;"NTASKS 3,3"
80  OUTPUT 709;"ENABLE MULTI"
90  !
100 !Write and download subroutines to be directed to run tasks.
110 !Subroutine A when active, displays the numbers 0 through 199.
120 !Subroutine B when active, repeatedly displays A B C.
130 !
140 OUTPUT 709;"SUB A"
150 OUTPUT 709;"  INTEGER I"
160 OUTPUT 709;"  FOR I=0 TO 199"
170 OUTPUT 709;"    DISP I"
180 OUTPUT 709;"  NEXT I"
190 OUTPUT 709;"SUBEND"
200 OUTPUT 709;"SUB B"
210 OUTPUT 709;"  INTEGER J"
220 OUTPUT 709;"  FOR J=0 TO 99"
230 OUTPUT 709;"    DISP 'A'"
240 OUTPUT 709;"    DISP 'B'"
250 OUTPUT 709;"    DISP 'C'"
260 OUTPUT 709;"  NEXT J"
270 OUTPUT 709;"SUBEND"
280 !

```

URGENCY (cont)

```
290 !Write and download a subroutine that makes DC voltage measure-
300 !ments and stores the readings in a mainframe array. Use URGENCY
310 !to set the priority of this run task back to the priority of
320 !the other run tasks. By doing this, the second time this run
330 !task executes it will time-slice with the other run tasks.
340 !
350 OUTPUT 709;"SUB DCMEAS"
360 OUTPUT 709;" INTEGER K"
370 OUTPUT 709;" REAL DCRDGS (49)"
380 OUTPUT 709;" USE 700"
390 OUTPUT 709;" CONF DCV"
400 OUTPUT 709;" FOR K=0 TO 4"
410 OUTPUT 709;" MEAS DCV 600-609 INTO DCRDGS"
420 OUTPUT 709;" NEXT K"
430 OUTPUT 709;" URGENCY 85"
440 OUTPUT 709;"SUBEND"
450 !
460 !Direct the subroutines to run tasks. Set subroutines A and B to
470 !execute one time and subroutine DCMEAS to execute 2 times.
480 !Raise the priority of run task 3 above the other run tasks
490 !and above the HP-IB task so that the first time
500 !run task 3 is active, it runs to completion.
510 !
520 OUTPUT 709;"RUN 1 A"
530 OUTPUT 709;"RUN 2 B"
540 OUTPUT 709;"RUN 3 DCMEAS 2"
550 OUTPUT 709;"URGENCY 3 40"
560 !
570 !Read and display data from array DCRDGS. Since run task 3 has a
580 !higher priority than commands sent over the HP-IB, it will run to
590 !completion before the data is read from the array and entered
600 !into the controller.
610 !
620 OUTPUT 709;"VREAD DCRDGS"
630 REAL Dcvolts(0:49)
640 ENTER 709;Dcvolts(*)
650 PRINT Dcvolts(*)
660 PRINT
670 !
680 !Set the priority of the HP-IB task below the priority of the
690 !run tasks. When the subroutine of run task 3 executes the second
700 !time, it will time-slice with the other two run tasks. After all
710 !of the run tasks have finished, data will be read from the array
720 !and displayed on the controller.
730 !
740 OUTPUT 709;"URGENCY HP-IB 100"
750 OUTPUT 709;"VREAD DCRDGS"
760 ENTER 709;Dcvolts(*)
770 PRINT Dcvolts(*)
780 END
```

- HP 44701A Integrating Voltmeter
- HP 44702A/B High-Speed Voltmeter (Scanner or System Mode)
- HP 44714A 3-Channel Stepper Motor Controller/Pulse Output
- HP 44715A 5-Channel Counter/Totalizer
- HP 44721A 16-Channel Digital Input
- HP 44722A 8-Channel Digital Input
- HP 44723A 16-Channel High-Speed Digital Sense/Control
- HP 44726A 2-Channel Arbitrary Waveform DAC
- HP 44730A 4-Channel Track/Hold with Signal Conditioning
- HP 44732A 120 Ohm Dynamic Strain Gage FET Multiplexer
- HP 44733A 350 Ohm Dynamic Strain Gage FET Multiplexer

Description

Specifies the voltmeter slot or the accessory channel to receive subsequent commands.

Prerequisites

None

Syntax

USE *ch*

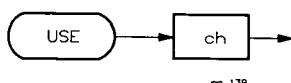

rr_139

ch Slot address to be used for a voltmeter or channel address for the counter/digital accessories listed. *ch* range depends on the accessory and the configuration.

Accessory	ch definition	ch range
HP 44701A	voltmeter slot	ES00 (ES = 00 to 79)
HP 44702A/B	voltmeter slot	ES00 (ES = 00 to 79)
HP 44714A	ch address	ES00 - ES02
HP 44715A	ch address	ES00 - ES04
HP 44721A	accessory function	ES00 - ES31
HP 44722A	accessory function	ES00 - ES15
HP 44723A	ch address	ES00 - ES15, ES90 - ES93
HP 44730A	ch address	ES00 - ES07
HP 44732A	ch address	ES00 - ES07
HP 44733A	ch address	ES00 - ES07

Remarks

Power-On USE Channel

At power-on or following a reset, the channel selected is the lowest channel number for which the USE *ch* command is valid. For example, if an HP 44721A 16-Channel Digital Input is installed in slot 2 of the mainframe, power-on USE *ch* is 200 (mainframe slot 2, channel 0), if no other accessory which accepts the USE *ch* command is installed in mainframe slots 0 or 1.

USE (cont)

Default USE Channel

The default USE channel is the last channel specified by the USE *ch* command OR the power-on value if the USE *ch* command has not been executed.

USE *ch* Command vs. USE *ch* Parameter

USE *ch* can be used as a command (USE *ch*) or as a command parameter, such as in TRIG *source* [USE *ch*].

- The USE *ch* Command:

The *ch* specified in the USE *ch* command is the channel (slot for voltmeters) used in all following commands which have an optional USE *ch* parameter that is not specified. The channel set with the USE *ch* command is used until another USE *ch* command is executed, the USE *ch* parameter is specified, a system reset (RST) command is executed, or until power is cycled.

- The USE *ch* Parameter:

When the USE *ch* parameter is specified in a command, the *ch* number applies to that command ONLY. All preceding or following commands use the channel set by the USE *ch* command, unless otherwise specified by the USE *ch* parameter.

Data Returned

None

Related Commands

USE? and all voltmeter, counter, and digital commands which have optional USE *ch* parameters.

Examples

Example: Using USE *ch* Command

This program uses an HP 44701A voltmeter in mainframe slot 1 to measure DC voltage. The USE *ch* command (line 20) sets the USE channel to 100. Since the USE *ch* parameter is not specified in the CONFMEAS command (line 30), 100 is the (default) USE channel value for CONFMEAS.

```
10 OUTPUT 709;"RST"                !Reset HP 3852A and voltmeter
20 OUTPUT 709;"USE 100"             !Use voltmeter in mainframe slot 1
30 OUTPUT 709;"CONFMEAS DCV, 400"  !Configure and measure DC voltage
40 ENTER 709;A                     !Enter reading
50 PRINT A                          !Display reading
60 END
```

Example: Using USE *ch* Parameter

This example enables channel 305 of an HP 44715A counter in slot 3 of mainframe to interrupt when the channel counter overflows (after 100 counts). The channel counts negative edges and is set to the TOTAL function.

To ensure that the proper channel is specified, you can either specify a new USE

USE (cont)

channel with the USE *ch* command or specify the USE *ch* parameter in the appropriate commands. This example specifies the USE *ch* parameter to illustrate how the parameter will override the USE command.

Any commands added to the program in which the USE *ch* parameter is not specified will be assigned the USE channel specified in line 20. Note that instead of specifying the USE *ch* parameter each time in lines 130 and 150-190, the USE command could be used prior to enabling the interrupt and setting up the counter to set the default USE channel to 305.

```
10 OUTPUT 709;"RST"                !Reset HP 3852A and accessories
20 OUTPUT 709;"USE 100"            !Use voltmeter in slot 1
30 OUTPUT 709;"CONFMEAS DCV,400"   !Configure/measure DC voltage
40 ENTER 709;A                    !Enter reading
50 PRINT A                        !Display reading
.
.
100 OUTPUT 709;"SUB CNTR"          !Define subroutine CNTR
110 OUTPUT 709;"DISP'CNTR OVERFLOW" !Display message on front panel
120 OUTPUT 709;"SUBEND"           !End subroutine
130 OUTPUT 709;"ON INTR USE 305 CALL CNTR" !Call CNTR on counter overflow
140 OUTPUT 709;"EDGE HL,USE 305"   !Count neg edges
150 OUTPUT 709;"FUNC TOTAL,USE 305" !Set TOTAL function
160 OUTPUT 709;"CNTSET -100,USE 305" !Overflow after 100 counts
170 OUTPUT 709;"ENABLE INTR,USE 305" !Enable ch 5 to intr on overflow
180 OUTPUT 709;"ENABLE INTR SYS"   !Sense the backplane interrupt
190 OUTPUT 709;"TRIG SGL,USE 305"  !Trigger once
200 END
```

USE?

- Mainframe

Description Returns the current USE channel address as set by the USE command.

Prerequisites None

Syntax **USE?** [*INTO name*] or [*fmt*]

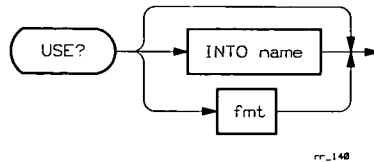

Parameters

INTO name See Glossary.

fmt See Glossary. Default format is IASC.

Remarks

Using USE? to Store Channel Address

The channel address returned by USE? can be stored and used later in the USE command *ch* parameter to restore use of that channel.

Data Returned

Returns the address of the current USE channel or, for voltmeters, the current USE slot.

Related Commands

USE

Examples

Example: Reading the USE Channel Address

This program queries the current USE channel and stores the result (in variable U) for future use. Note that the USE command in line 30 may designate a voltmeter in slot 1 of the mainframe OR may designate channel 0 of a counter or a digital input in slot 1.

```
10 OUTPUT 709;"RST"           !Reset HP 3852A and accessories
20 OUTPUT 709;"INTEGER U"     !Declare INTEGER variable U
30 OUTPUT 709;"USE 100"       !Use slot 1 (vm) or ch 0, slot 1 (ctr, dig in)
40 OUTPUT 709;"USE? INTO U"   !Query USE ch, store in U
50 OUTPUT 709;"VREAD U"       !Read U into output buffer
60 ENTER 709;A                !Enter results
70 PRINT A                    !Display results
80 END
```

• Mainframe

Description

Reads the contents of an array or variable.

Prerequisites

None

Syntax

VREAD *array* [(*index*)] or *variable* or *number* [INTO *name*] or [*fmt*]

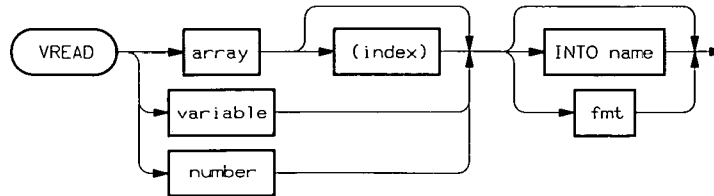

7-141

Parameters

array [(*index*)]

Reads the contents of an array or an array element. *array* without (*index*) reads the entire array and sets the array index pointer to zero. *array* (*index*) reads array element specified by (*index*) and does not affect the array index pointer.

variable

Read contents of the variable.

number

Number or numeric expression that is evaluated and read into an array, array element, or variable. *number* can also be returned to the display and HP-IB output buffer.

INTO *name*

See Glossary.

fmt

See Glossary. Default format is RASC.

Remarks

Potential HP 3852A/Controller Deadlock

With INBUF OFF, the controller and the HP 3852A may deadlock if multiple commands (or terminators) are sent in a single command line and a command generates enough data to fill the output buffer (VREAD can fill the output buffer). The best way to avoid potential deadlock is to send a single command and to read the results as soon as possible after a data-generating command is sent.

Transferring a Single Reading from a Packed Array

When a single packed reading is transferred from a packed array to the HP-IB output buffer or to another packed array, the reading is converted to RL64 format even if the PACK format is specified. Packed readings remain in their packed format when PACK is specified and the entire array is read.

Data Returned

array returns the contents of entire array. *array* (*index*) returns the contents of the array element specified by (*index*). *variable* returns the contents of the

VREAD (cont)

variable. *number* returns the result of the expression evaluated by VREAD. Note that data can also be transferred between arrays [INTO *name*] or written to an array (*number* [INTO *name*]) rather than "returned".

Related Commands

None

Examples

Example: Reading Data from an Array

This program performs a series of DC voltage measurements and stores the readings in mainframe memory. The VREAD command is used to retrieve the readings and send them to the output buffer where they can be entered into a controller.

```
10 REAL Rgs(0:4)                !Declares a controller array
20 OUTPUT 709;"RST"             !Reset the HP 3852A
30 OUTPUT 709;"REAL RDRGS(4)"   !Declares a mainframe array
40 OUTPUT 709;"USE 700"         !Use the voltmeter in slot 7
50 OUTPUT 709;"CONFMEAS DCV, 400-404, INTO RDRGS"
60                               !Take measurements, store in mainframe
70 OUTPUT 709;"VREAD RDRGS"     !Retrieve readings from memory
80 ENTER 709;Rgs(*)             !Enter readings into controller
90 PRINT USING "K,/";Rgs(*)     !Display readings
100 END
```

A typical output based on this program might be:

```
1.456452
1.548438
5.32523
1.53162
1.442088
```

Example: Transferring Data Between Arrays

This program uses the VREAD command's INTO *name* parameter to transfer data between two arrays. The program is a modified version of the program used in the first example. Note also that only one reading is transferred to illustrate that a particular reading in one array can be stored in a selected element of another.

```
10 REAL Rgs1(0:4),Rgs2(0:4)     !Declares controller arrays
20 OUTPUT 709;"RST"             !Reset the HP 3852A
30 OUTPUT 709;"REAL RD1(4)"     !Declares mainframe "source" array
40 OUTPUT 709;"REAL RD2(4)"     !Declares mainframe "destination" array
50 OUTPUT 709;"USE 700"         !Use the voltmeter in slot 7
60 OUTPUT 709;"CONFMEAS DCV, 400-404, INTO RD1"
70                               !Store measurements in source array
80 OUTPUT 709;"VREAD RD1(2) INTO RD2(2)"
90                               !Transfers reading in element 2
100                              !to element 2 in destination array
110 OUTPUT 709;"VREAD RD1"      !Retrieve readings from RD1
```

VREAD (cont)

```
120 ENTER 709;Rgs1(*)           !Enter readings into controller
130 OUTPUT 709;"VREAD RD2"      !Retrieve contents of RD2
140 ENTER 709;Rgs2(*)           !Enter contents into controller
150 FOR I=0 TO 4                 !Display readings
160 PRINT USING "M3D.6D,3X";Rgs1(I),Rgs2(I)
170 NEXT I
180 END
```

A typical display based on this program follows:

```
1.510152           0.000000
1.494575           0.000000
5.324000           5.324000
1.518700           0.000000
1.502450           0.000000
```

As you review the program above, note that all readings could have been transferred by omitting the indexes (2) in line 80 and RD2 could have been an INTEGER array (line 40).

Example: Reading a Value into a Variable

This program shows how the VREAD command is used to evaluate an expression and store the result into a variable in the mainframe. The variable is then read and the result is displayed on the mainframe front panel.

```
10 OUTPUT 709;"RST"             !Reset HP 3852A
20 OUTPUT 709;"INTEGER A"       !Declares a mainframe variable
30 OUTPUT 709;"VREAD BINEOR (-9,12) INTO A" !Evaluate then store result
40 OUTPUT 709;"VREAD A"         !Retrieve contents of variable
50 END
```

VWRITE

- Mainframe

Description

Write data to an array, array element, or variable; or write data from one array to another.

Prerequisites

None

Syntax

VWRITE *array item_list* or *array(index) number* or
array(d) [(index)] array(s) [(index)] or
variable number or *variable(d) variable(s)*

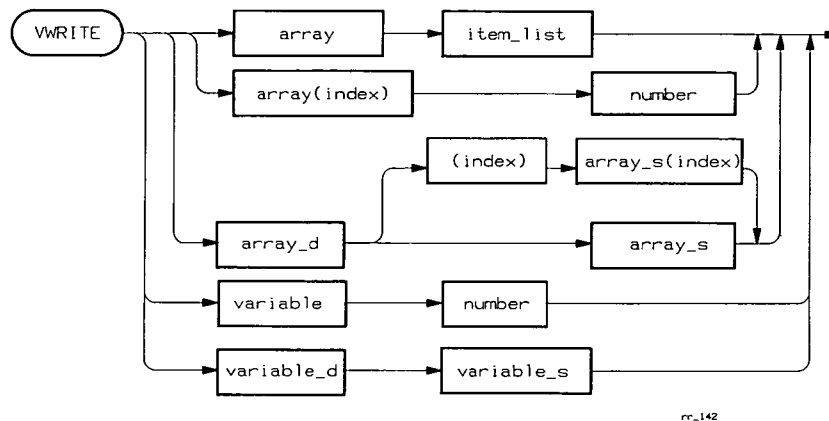

Parameters

- array* Name of the array that data is written to. After VWRITE is executed, the index pointer is set to 1 + last element written to.
- array(index)* Name of the array and specific array element (*index*) which data is written to. *index* must be enclosed in parentheses. After the VWRITE command is executed, the index pointer is set to 1 + specified array element (*index* + 1).
- array(d) [(index)]* Destination array written to by the source array (*array(s)*). The destination array must be the same size or larger than the source array. Specifying *index* writes data to a specific element in the destination array from a specific element in the source array (*array(s)(index)*). After VWRITE is executed, the index pointer is set to 1 + the last element written to, or 1 + the specified element (*index* + 1).
- array(s) [(index)]* Source array whose contents are written to the destination array (*array(d)*). Specifying *index* writes data from a specific element in the source array to a specific element in the destination array (*array(d)(index)*).

<i>variable</i>	Variable data is written to.
<i>variable(d)</i>	Destination variable written to from the source variable (<i>variable(s)</i>).
<i>variable(s)</i>	Source variable from which data is written to the destination variable (<i>variable(d)</i>).
<i>item__list</i>	Data written to <i>array</i> . <i>item__list</i> entries must be separated by a space or a comma and the list must be ≤ 10 items. The items can be numbers or parenthesized numeric expressions.
<i>number</i>	Data written to the array element or variable. Can be a number or a parenthesized numeric expression.

Remarks

Using VWRITE Command

As identified by the syntax, there are five ways to use the VWRITE command:

1. Write data to an entire array.
2. Write data to a specific array element.
3. Write data from one array to another.
4. Write data to a variable.
5. Write data from one variable to another.

- Writing Data to an Array:

To write data to an array, use VWRITE *array item__list*, where *item__list* is a list of not more than ten data items. The command will write the numbers in the *item__list* into successive elements of the array beginning with the position of the index pointer (see the INDEX command). After the command executes, the index pointer is set to 1 + the last element written to.

- Writing Data to an Array Element:

To write data to a specific array element, use VWRITE *array (index) number*, where *(index)* defines the array element and *number* is the data to be written to the element. Since array element numbering starts at zero, *index = (0)* enters data into the first element, *index = (1)* stores data into the second element, etc. After the command executes, the index pointer is set to 1 + the *index* value.

- Writing Data From One Array to Another:

To write data from one array to another, use VWRITE *array(d) array(s)* where *array(d)* is the destination array written to from the source array (*array(s)*). For example, VWRITE BRD,ARD writes data from array ARD to BRD on an element by element basis. VWRITE *array(d)(index) array(s)(index)* writes the data in a specific element of the source array to the element specified in the destination array. As the command executes, the index pointer of the destination array is set to 1 + the last element written to, or 1 + the *index* specified.

VWRITE (cont)

- Writing Data to a Variable:

To write data to a variable, use VWRITE *variable number*, where *number* is the value assigned to the *variable*.

- Writing Data From One Variable to Another:

To write data from one variable to another, use VWRITE *variable(d) variable(s)* where *variable(d)* is the destination variable and *variable(s)* is the source variable. For example, VWRITE B,A copies the value of source variable A into destination variable B.

VWRITE Does Not Work With PACKED Arrays

The VWRITE command cannot be used to write data to a PACKED array or to transfer data between PACKED arrays.

Data Returned

None

Related Commands

INDEX, INDEX?

Examples

Example: Writing Data to an Array

The following program shows how to use the VWRITE command to write data to an array.

```
10 OUTPUT 709;"RST"                                !Reset the HP 3852A
20 OUTPUT 709;"INTEGER ADATA(4)"                  !Declare array to store 5 items
30 OUTPUT 709;"VWRITE ADATA 1,2,(SQR(9)),4,5" !Write data to the array
40 END
```

Line 20 declares an Integer array to store 5 items (starting index is 0). Line 30 writes the data into the array (recall that an item can be a parenthesized numeric expression). Note that 1 is stored in array element 0, 2 in array element 1, 3 in element 2, and so on.

Example: Writing Data to a Specific Array Element

This program declares a five element array and writes one number to a specific element in the array.

```
10 OUTPUT 709;"RST"                                !Reset the HP 3852A
20 OUTPUT 709;"REAL BDATA(4)"                      !Declare array to store 5 items
30 OUTPUT 709;"VWRITE BDATA(2), 1.414"            !Write 1.414 to element 2
40 END
```

In this program, line 20 declares a REAL array to store 5 readings (items). Line 30 writes the number 1.414 to the index specified (2). Note that element 2 is actually the third element of the array (starting index is 0).

Example: Writing Data From One Array to Another

This program shows how to use the VWRITE command to copy data from one array to another.

```
10 OUTPUT 709;"RST"                !Reset the HP 3852A
20 OUTPUT 709;"REAL BDATA(4)"      !Declare source array
30 OUTPUT 709;"INTEGER ADATA(4)"   !Declare destination array
40 OUTPUT 709;"VWRITE BDATA 1.1,2.2,3.3,4.4,5.5"
50                                !Write data into source array
60 OUTPUT 709;"VWRITE ADATA, BDATA" !Write data to destination array
70 END
```

Notice from the above program that the source and destination arrays do not have to be the same storage type. However, the destination array must be the same size or larger than the source array. Note that if you were to read the contents of the destination (INTEGER) array, the array would contain Integer numbers 1,2,3,4,5. If indexes were specified in line 60, only the number in the element specified in the source array would be copied to the element specified in the destination array.

Writing Data to a Variable

This program shows how the VWRITE command is used to write a value to a variable.

```
10 OUTPUT 709;"RST"                !Reset the HP 3852A
20 OUTPUT 709;"INTEGER A"          !Declare an Integer variable
30 OUTPUT 709;"VWRITE A,5"         !Assign the number 5 to A
40 END
```

Writing a Value From One Variable to Another

This program shows how to assign the value of one variable to another.

```
10 OUTPUT 709;"RST"                !Reset the HP 3852A
20 OUTPUT 709;"INTEGER A"          !Declare source variable
30 OUTPUT 709;"INTEGER B"          !Declare destination variable
40 OUTPUT 709;"VWRITE A (BINIOR(9,12))" !Assign value to source variable
50 OUTPUT 709;"VWRITE B,A"         !Copy value into dest. variable
60 END
```

VWRITEB

- Mainframe

Description

Writes binary data from the computer to the specified mainframe array, starting at the current position of the index pointer.

Prerequisites

The VWRITEB command requires firmware revision 3.0 or greater.

Syntax

VWRITEB *array number* ; data

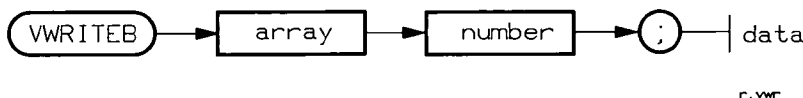

Parameters

array REAL or INTEGER array to which the data is written. The binary data sent from the computer must match the storage type of the array (i.e. RL64, IN16). VWRITEB cannot be used with PACKED arrays.

number Number of array elements data will be written to. The number of data elements sent from the computer must equal the *number* specified. *number* can specify an entire INTEGER or REAL array regardless of its size.

Remarks

Downloading Data Following VWRITEB

Following the execution of VWRITEB, the next byte of data in the input buffer or the next byte sent to the buffer will be placed in the array specified by VWRITEB. Thus, it is critical that the binary data from the computer immediately follow the command terminator (semicolon, LF, or EOI) for VWRITEB.

Downloading the Exact Number of Elements Specified

Not only should the data being downloaded immediately following VWRITEB, but the amount of data sent should equal the number of elements specified.

If the amount of data sent is less than the number of elements specified, operation of the HP 3852A is suspended until sufficient data is received to fill the elements. If, for example, a command is sent rather than the data intended for the array, the command does not execute but is interpreted as binary data and stored in the array. If additional data is not received, clearing the HP 3852A is required in order to restore control.

If the amount of binary data exceeds the array elements specified, the additional data is executed as a command resulting in a programming error.

Sending Delimiters

If more than one delimiter is received between the VWRITEB command and the binary data, the additional delimiters are treated as data and loaded into the array. If EOI is asserted with a byte not corresponding to a line feed (LF) or semicolon, a line feed is inserted in with the data, thus invalidating the data in the array. Therefore, terminate VWRITEB with a single terminator (semicolon or LF) and only use EOI coincident with one of those terminators.

Executing VWRITEB within a Subroutine

VWRITEB can execute within a subroutine. However, care should be taken to ensure that the data in the input buffer after VWRITEB executes is the binary data intended for the array.

Maximizing Data Transfer

To achieve the maximum transfer rate, the input buffer should be on (INBUF ON) and the size of the buffer (INBUF size) should exceed the number of binary data bytes transferred. With INBUF ON, the speed at which the data is transferred from the computer to the mainframe array is the time required for the HP 3852A to parse the VWRITEB command + the time to transfer the data over the HP-IB to the HP 3852A + the time required to move the data from the HP-IB/input buffer to the array. The approximate times of these transfers are given below:

Command Parse Time	7.5 msec
Transfer time from computer to HP 3852A	43 usec/byte
Transfer time from HP-IB/input buffer to array	600 usec + 7 usec/byte

If VWRITEB is executed within a subroutine with INBUF ON, the transfer rate is the time required to transfer the data from the computer to the HP 3852A, and from the HP-IB/input buffer to the array. If data is available in the input buffer when VWRITEB executes, the transfer rate is the time to transfer the data from the input buffer to the array.

Data Returned

None

Related Commands

INBUF

VWRITEB (cont)

Examples

Example: Downloading Data to an Array

The following program segment demonstrates how three Integer data elements are downloaded into a mainframe array beginning with array element 0.

```
70  ASSIGN @Hp3852 TO 709;FORMAT OFF
80  INTEGER J,K,L
90  OUTPUT 709;"INBUF ON"
100 OUTPUT 709;"INTEGER A(9)"
180 OUTPUT 709;"VWRITEB A 3"
190 OUTPUT @Hp3852;J,K,L
```

Note from the above segment that when a mainframe array is declared, the index pointer is at array element 0. Since VWRITEB and the data from the computer immediately follow the declaration of the array, data is written to elements 0, 1, and 2 of the array.

Example: Executing VWRITEB Within a Subroutine

This program segment downloads six Real data elements into a mainframe array starting at array element 9. Note that VWRITEB executes within a subroutine and the data in the input buffer at the time of execution is the binary data from the computer.

```
100 ASSIGN @Hp_3852 to 709;FORMAT OFF
110 REAL K(0:5)
120 OUTPUT 709;"INBUF ON"
130 OUTPUT 709;"SUB D"
140 OUTPUT 709;" REAL R(19)"
150 OUTPUT 709;" INDEX R 9"
160 OUTPUT 709;" VWRITEB R 6"
170 OUTPUT 709;"SUBEND"
180 OUTPUT 709;"CALL D"
190 OUTPUT @Hp_3852;K(*)
```

- Mainframe

Description Wait the number of seconds specified.

Prerequisites None

Syntax WAIT [*number*]

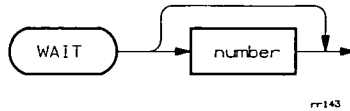

Parameters

number Number of seconds to wait (rounded to nearest thousandth of a second). Range is 0 to 86400 seconds. Default *range* = 0.

Remarks

WAITING Annunciator

The WAITING annunciator on the front panel will be ON during the time WAIT is in effect (or when the WAITFOR command is in effect).

Data Returned

None

Related Commands

WAITFOR

Examples

Example: Using WAIT Command

This program demonstrates the WAIT command by sending "WAIT 5 SEC" to the front panel, waiting five seconds, and then displaying "FINISHED" on the front panel.

```
10 OUTPUT 709;"RST"           !Reset the HP 3852A
20 OUTPUT 709;"DISP 'WAIT 5 SEC'" !Disp WAIT 5 SEC
30 OUTPUT 709;"WAIT 5"        !Wait 5 seconds
40 OUTPUT 709;"DISP 'FINISHED'" !Disp FINISHED
50 END
```

WAIT FOR

- Mainframe

Description

See **WAITFOR** Command

- Mainframe

Description Waits for a specified condition before executing subsequent commands.

Prerequisites None

Syntax **WAITFOR** *condition*

or

WAIT FOR *condition*

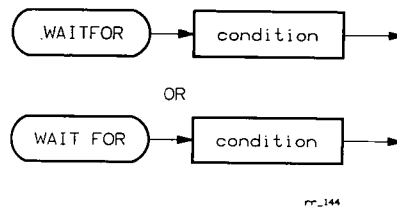

Parameters

condition Condition which must occur before command execution continues.

condition	Definition
EVENT	Input on EVENT IN BNC or pressing front panel EVENT key.
INTR	Interrupt from an accessory channel.
ALRM	Alarm function of the real-time clock (see ALRM).
PACER	Pulse output from the PACER OUT BNC (see PACER).

Remarks

WAITFOR Stops Command Execution

WAITFOR will keep the HP 3852A busy (and thus not executing any other commands) until the specified condition occurs. The WAITING annunciator on the panel will be ON while WAITFOR (or the WAIT command) is in effect.

Cannot Use EVENT Key With LOCK ON

With LOCK ON, you cannot terminate WAITFOR EVENT with the front panel EVENT key, since all front panel key entries are ignored.

Data Returned

None.

WAITFOR (cont)

Related Commands

WAIT, PACER, ALRM, ENABLE INTR, ENABLE INTR SYS

Examples

Example: Using WAITFOR Command

This program segment sets the system alarm to 06:56:40 hours after midnight (assuming the system clock was set for local time) and enables the alarm. The HP 3852A will wait until 06:56:40 hours to resume command execution.

```
10 OUTPUT 709;"RST"           !Reset the HP 3852A
20 OUTPUT 709;"SET ALRM 25000" !Set alarm for 06:56:40
30 OUTPUT 709;"ENABLE ALRM"    !Enable alarm
40 OUTPUT 709;"WAITFOR ALRM"   !Wait for alarm to occur
.
.
```

WAITFOR SIGNAL

- Mainframe

Description

Suspends or holds off execution of commands/subroutines within a task until a signal (SIGNAL command) is received. All other tasks will execute or time-slice while the task which issued WAITFOR SIGNAL is waiting.

Prerequisites

The WAITFOR SIGNAL command is used when the HP 3852A is in the multitasking mode. Multitasking is only available with mainframe firmware revision 3.0 or greater.

Syntax

WAITFOR SIGNAL



Parameters

None

Remarks

Determining the Task Which Waits

The task which waits is the task from which the WAITFOR SIGNAL command was issued. For example, if WAITFOR SIGNAL is executed within a run task, the subroutine is suspended until it is "signaled". Similarly, if WAITFOR SIGNAL is executed from the HP-IB task, no further input over HP-IB is executed until the HP-IB is signaled. Note, however, the controller can enter data from the HP 3852A and also address other devices while WAITFOR SIGNAL is in effect.

Using WAITFOR SIGNAL in an Interrupt-Called Subroutine

When WAITFOR SIGNAL is used within an interrupt-called subroutine, other tasks will execute or time-slice while the subroutine is suspended. If a second interrupt occurs, the interrupt is detected but the subroutine is not called until the suspended subroutine is signaled and finishes.

Signaling the Task

As mentioned, the signal which enables command execution within tasks to resume is the SIGNAL command. The point at which execution resumes depends on the priority (urgency) of the task. If the suspended task has a high priority, command execution may resume immediately following execution of the SIGNAL command. If the suspended task has a priority equal to other tasks (e.g. a run task), the task will be rescheduled following completion of the SIGNAL command and continue time-slicing.

Data Returned

None

WAITFOR SIGNAL (cont)

Related Commands

SIGNAL

Examples

Example: Suspending the Execution of Run Tasks

This example shows how the WAITFOR SIGNAL command is used to suspend the execution of run task subroutines.

In the program, three subroutines are downloaded and directed to run tasks. The first subroutine counts from 0 to 199, the second subroutine repeatedly displays A B C, and the third subroutine makes 300 DC voltage measurements. As the run tasks are activated, the first and second subroutines (run tasks 1 and 2) are suspended with WAITFOR SIGNAL (lines 190 and 270). After the third subroutine (run task 3) makes all of the voltage measurements, it signals run task 1 (line 490) to resume execution. As run task 1 completes it signals run task 2 (line 240) which then runs to completion.

Because of how WAITFOR SIGNAL and SIGNAL are used in the program, swapping between run tasks is controlled. Each run task executes to completion before another task is signaled.

```
10  !Set a 65 ms time-slice and set the number of run tasks and the
20  !queue size the system will allow. Place the HP 3852A in the
30  !multitasking mode. The reset caused by ENABLE MULTI will load
40  !the TSLICE and NTASKS parameters into the HP 3852A operating
50  !system.
60  !
70  OUTPUT 709;"TSLICE .065"
80  OUTPUT 709;"NTASKS 3,3"
90  OUTPUT 709;"ENABLE MULTI"
100 !
110 !Write and download subroutines to be directed to run tasks.
120 !Subroutine A when active, displays the numbers 0 through 199.
130 !Subroutine B when active, repeatedly displays A B C.
140 !Suspend execution of subroutine A (run task 1) until it is
150 !signaled by run task 3. Suspend execution of subroutine B
160 !(run task 2) until it is signaled by run task 1.
170 !
180 OUTPUT 709;"SUB A"
190 OUTPUT 709;" WAITFOR SIGNAL"
200 OUTPUT 709;" INTEGER I"
210 OUTPUT 709;" FOR I=0 TO 199"
220 OUTPUT 709;"   DISP I"
230 OUTPUT 709;" NEXT I"
240 OUTPUT 709;" SIGNAL 2"
250 OUTPUT 709;"SUBEND"
260 OUTPUT 709;"SUB B"
270 OUTPUT 709;" WAITFOR SIGNAL"
280 OUTPUT 709;" INTEGER J"
290 OUTPUT 709;" FOR J=0 TO 199"
300 OUTPUT 709;"   DISP 'A'"
310 OUTPUT 709;"   DISP 'B'"
320 OUTPUT 709;"   DISP 'C'"
```

WAITFOR SIGNAL (cont)

```
330 OUTPUT 709;" NEXT J"  
340 OUTPUT 709;"SUBEND"  
350 !  
360 !Write and download a subroutine that will make 300 DC  
370 !voltage measurements and store the readings in a mainframe  
380 !array. After the readings are taken, signal run task 1 to resume  
390 !execution.  
400 !  
410 OUTPUT 709;"SUB DCMEAS"  
420 OUTPUT 709;" INTEGER K"  
430 OUTPUT 709;" REAL DCRDGS (299)"  
440 OUTPUT 709;" USE 700"  
450 OUTPUT 709;" CONF DCV"  
460 OUTPUT 709;" FOR K=0 TO 99"  
470 OUTPUT 709;" MEAS DCV 600-602 INTO DCRDGS"  
480 OUTPUT 709;" NEXT K"  
490 OUTPUT 709;" SIGNAL 1"  
500 OUTPUT 709;"SUBEND"  
510 !  
520 !Direct the subroutines to run tasks. Set each run task to  
530 !run one time.  
540 !  
550 OUTPUT 709;"RUN 1 A"  
560 OUTPUT 709;"RUN 2 B"  
570 OUTPUT 709;"RUN 3 DCMEAS"  
580 END
```

WF?

• HP 44726A 2-Channel Arbitrary Waveform DAC

Description

Returns the number of the waveform currently selected. If no waveform is selected, -1 is returned.

Prerequisites

Requires firmware revision 3.5 or greater and TARM OFF or TARM AUTO must also be set.

Syntax

WF? [USE *ch*] [INTO *name*] or [*fmt*]

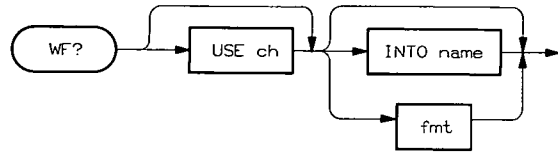

r. tb

Parameters

USE *ch* Channel from which the waveform is being applied. The default **USE *ch*** is channel 0.

INTO *name* See Glossary.

fmt See Glossary. Default format is IASC.

Remarks

WF? Accesses Channel Memory

When executed, WF? checks channel memory to determine the active waveform. However, in order to access the memory, the active waveform must be stopped (TARM OFF or TARM AUTO). When the channel is re-armed, the waveform will start from the first amplitude point.

Data Returned

Returned is the number of the currently selected (active) waveform. If no waveform is selected, -1 is returned.

Related Commands

APPLY WFFV

Examples

Example: Determining the Active Waveform

When executed as follows, WF? returns the number of the selected waveform (slot 5 - channel 0) to the mainframe front panel and HP-IB output buffer. The statement assumes the channel was armed by TARM AUTO, or has been disarmed by TARM OFF.

```
OUTPUT 709;"WF? USE 500"
```

• HP 44726A 2-Channel Arbitrary Waveform DAC

Description

Deletes the specified waveform from channel memory.

Prerequisites

Requires firmware revision 3.5 or greater. TARM OFF or TARM AUTO must also be set. If the active waveform is to be deleted, TARM OFF must be set.

Syntax

WFDELETE *waveform_number* [USE *ch*]

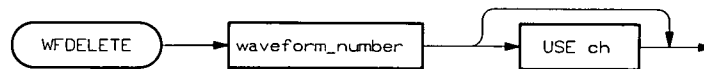

Parameters

waveform_number

Number of the waveform which is deleted. The range for *waveform_number* is 0 to 63 per channel.

USE *ch*

Channel on which the waveform is stored. The default USE *ch* is channel 0.

Remarks

Deleting a Waveform Recovers Amplitude Points

When a waveform is deleted, the number of amplitude points associated with that waveform become available for storing another waveform.

WFDELETE Accesses Channel Memory

When executed, WFDELETE deletes the specified waveform in channel memory. However, in order to access the memory, the active waveform must be stopped (TARM OFF or TARM AUTO). When the channel is re-armed, the waveform will start from the first amplitude point, provided it was not the waveform deleted.

Data Returned

None

Related Commands

None

Examples

Example: Deleting a Waveform

The following statement deletes the active waveform (waveform 0) on channel 1 of the DAC accessory in slot 3. Since the active waveform is deleted, the channel is first disarmed.

```
OUTPUT 709;"TARM OFF USE 301;WFDELETE 0 USE 301"
```

WFMOD

• HP 44726A 2-Channel Arbitrary Waveform DAC

Description

Changes the amplitude of, or the number of time base intervals a waveform point or series of points are held. The new values are stored with the waveform in channel memory.

Prerequisites

Requires firmware revision 3.5 or greater and TARM OFF or TARM AUTO must also be set. If an array is specified in the command, it must be declared and contain the new data prior to the execution of WFMOD.

Syntax

WFMOD [*waveform_number*] **ELEM** *element_number* **AMPL** or **NPER** *number* or *array* [**USE** *ch*]

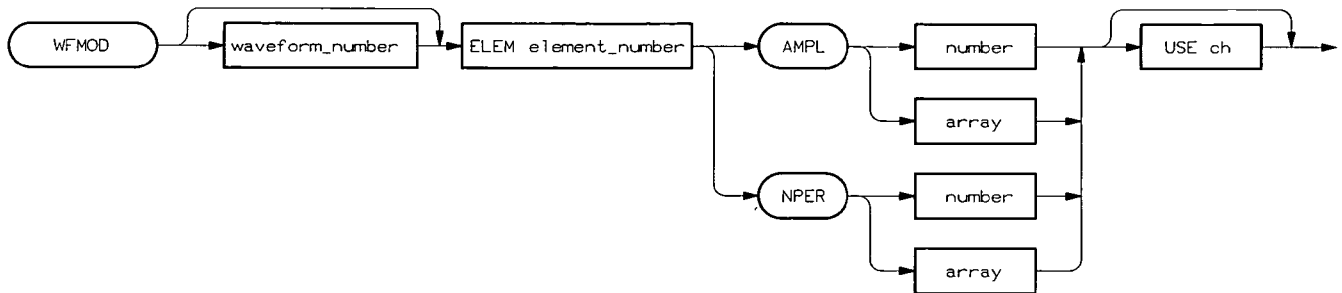

Parameters

waveform_number

Number of the waveform which is changed. The range for *waveform_number* is 0 to 63 per channel. If no waveform number is specified, the active waveform is changed.

ELEM *element_number*

First point in the waveform which is changed.

AMPL *number/array*

Specifies that amplitude changes will be made to the amplitude points in the waveform. When a *number* is specified, only one amplitude point is changed. That point is specified by **ELEM** *element_number*. When an array (*array*) is specified, the number of amplitude points changed depends on the size of the array. The amplitude points changed begin with the point specified by **ELEM** *number*, and include successive points equal to the number of new amplitudes in *array*. Thus, **ELEM** must specify a starting point such that the number of new amplitudes does not exceed the number of successive points available.

NPER *number/array*

Specifies that changes will be made to the number of time base intervals an amplitude point is held. When a *number* is specified, only the number of time base intervals a single amplitude point is held is changed. That point is specified by **ELEM** *element_number*. When an array (*array*) is specified, the number of amplitude points whose number of time base intervals is changed depends on the size of the array. The amplitude points changed begin with the point specified by **ELEM** *number*, and include successive points equal to the number of new time base intervals in *array*. Thus, **ELEM** must specify a starting point such that the number of new time base intervals does not exceed the number of successive points available.

USE *ch* Channel on which the waveform being modified is stored. The default **USE *ch*** is channel 0.

Remarks

Element Numbering

When specifying a starting point with the **ELEM *element__number*** parameter, note that the first point (element) in the waveform is 0. Thus, if you wanted to modify a waveform starting with the 5th amplitude point, **ELEM 4** would be specified.

WFMOD Values Replace the Values Stored by WFWRITE

When modifying a waveform, the values changed by **WFMOD** replace those stored when the waveform was defined by the corresponding **WFWRITE** command. Thus, when the waveform is re-selected, the **WFMOD**ified values are used. Remember that if **NPER** values are modified, the *number* specified or the values in *array* are powers of 2 (2^n).

WFMOD Can Modify Special Function and Arbitrary Waveforms

WFMOD can be used to modify both special function and arbitrary waveforms. This includes changing the number of time base intervals an amplitude point in a special function waveform is held. (Amplitude points in those waveforms are normally held for one time base interval.)

WFMOD Accesses Channel Memory

When executed, **WFMOD** stores the new amplitudes or the new number of time base intervals in channel memory. However, in order to access the memory, the active waveform must be stopped (**TARM OFF** or **TARM AUTO**). When the channel is re-armed, the waveform will start from the first amplitude point.

Data Returned

None

Related Commands

WFWRITE ACV, **WFWRITE ARB**, **WFWRITE BIN**, **WFWRITE RPV**,
WFWRITE SQV

Examples

Example: Modifying a Special Function Sine Wave

The following program shows how **WFMOD** is used to modify a special function sine wave.

In the example, a 100 Hz, 1000 point sine wave is defined and stored. The waveform is shown in Figure 1 below the program listing. The statement below Figure 1 modifies the waveform which then appears as shown in Figure 2. In the statement, a 500 element Real array is declared. Note that when the array is declared, a value of 0 is assigned to each array element. By specifying a starting element of 500 and the Real array previously declared, the amplitude of the 501st point through the 1000th point of the waveform is set to 0.

WFMOD (cont)

```
10 !Reset the mainframe and the HP 44726A. Define and store a
20 !100 Hz, 1000 point special function sine wave. Select the
30 !waveform (waveform 12) from channel 0 memory, set the trigger
40 !source, and arm the channel in order to accept the triggers.
50 !(TARM AUTO allows the waveform to be easily modified.)
60 !
70 OUTPUT 709;"RST"
80 WAIT 1
90 OUTPUT 709;"WFWRITE ACV 12 10 TBASE (1/(100*1E3))"
100 OUTPUT 709;"APPLY Wfv 0,12"
110 OUTPUT 709;"TRIG INT"
120 OUTPUT 709;"TARM AUTO"
130 END
```

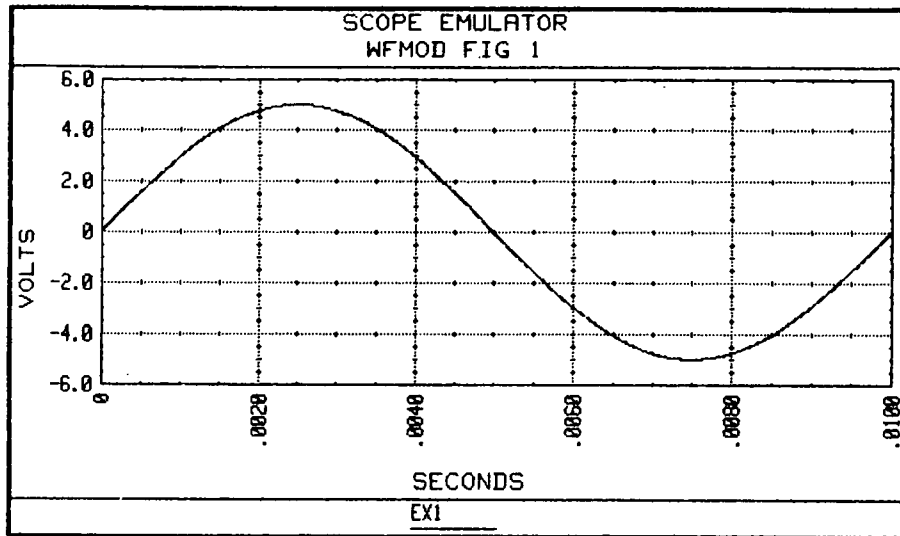

```
OUTPUT 709;"REAL MOD_AMP(499);WFMOD 12 ELEM 500 AMPL MOD AMP"
```

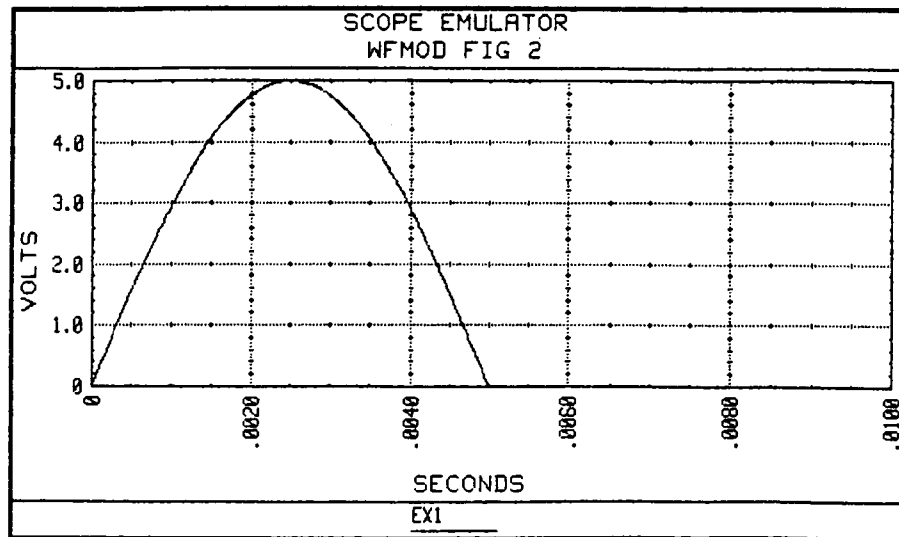

• HP 44726A 2-Channel Arbitrary Waveform DAC

Description

Changes the time base of the specified waveform and stores the value in channel memory.

Prerequisites

Requires firmware revision 3.5 or greater and TARM OFF or TARM AUTO must also be set.

Syntax

WFMOD [*waveform_number*] TBASE *seconds* [USE *ch*]

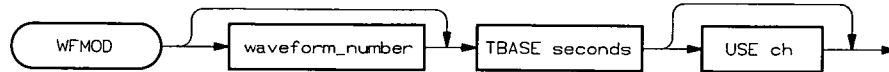

Parameters

waveform_number Number of the waveform whose time base is changed. The range for *waveform_number* is 0 to 63 per channel. If no waveform number is specified, the time base of the active waveform is changed.

TBASE *seconds* Length of a single time base interval. The range for *seconds* is 1.25E-6 to 16.384E-3. Resolution is 0.25E-6.

USE *ch* Channel on which the waveform is stored. The default USE *ch* is channel 0.

Remarks

The WFMOD Time Base Replaces the Time Base Stored by WFWRITE

When modifying a waveform, the time base set by WFMOD replaces the time base stored when the waveform was defined by the corresponding WFWRITE command. Thus, the time base used when the waveform is re-selected, the time base returned by WFTBASE?, and the time base used in the calculation of WFPER? is the WFMODified value.

WFMOD Accesses Channel Memory

When executed, WFMOD stores the new time base in channel memory. However, in order to access the memory, the active waveform must be stopped (TARM OFF or TARM AUTO). When the channel is re-armed, the waveform will start from the first amplitude point.

Data Returned

None

Related Commands

WFWRITE ACV, WFWRITE ARB, WFWRITE BIN, WFWRITE RPV, WFWRITE SQV

WFMOD (cont)

Examples

Example: Storing a New Time Base

When executed as follows, WFMOD stores a new time base for the waveform specified. The statement assumes the waveform has been defined and the channel was armed by TARM AUTO, or has been disarmed by TARM OFF.

```
OUTPUT 709;"WFMOD 7 TBASE 10E-6"
```

• HP 44726A 2-Channel Arbitrary Waveform DAC

Description

Returns the period of the waveform or of the portion of the waveform specified, based on the time base stored when the waveform was defined or modified (with WFWRITE or WFMOD).

Prerequisites

Requires firmware revision 3.5 or greater and TARM OFF or TARM AUTO must also be set.

Syntax

WPPER? [*waveform__number*] [**FIRST** *point*] [**LAST** *point*] [**USE** *ch*] [**INTO** *name*] or [*fmt*]

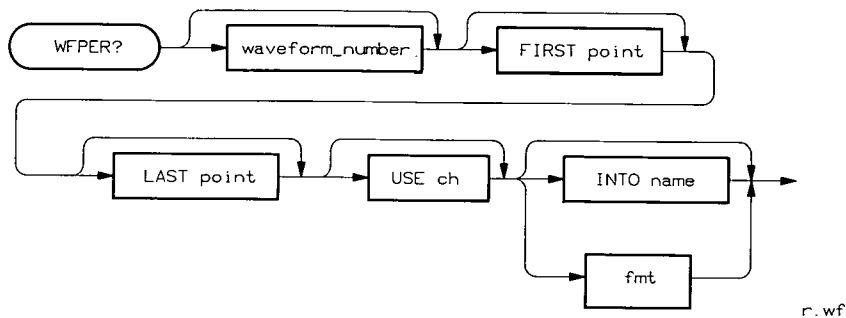

Parameters

waveform__number

Waveform whose period is returned. The range for *waveform__number* is 0 to 63 per channel. If no waveform number is specified, the period of the active waveform is returned.

FIRST *point*

Portion of the waveform beginning with the point specified through the **LAST** point specified, or through the end of the waveform whose period is returned. Waveform points are numbered starting with 0.

LAST *point*

Portion of the waveform starting with the beginning of the waveform or from the **FIRST** point specified, through the last point specified whose period is returned.

If neither **FIRST** *point* or **LAST** *point* is specified, the period of the entire waveform is returned.

USE *ch*

Channel on which the waveform (and time base) is stored. The default **USE** *ch* is channel 0.

INTO *name*

See Glossary.

fmt

See Glossary. Default format is RASC.

Remarks

Period Calculation

The period returned by WPPER? is calculated by multiplying the time base of the waveform, by the total number of time base intervals the specified amplitude points are held. The time base used is the value stored by WFWRITE or the value modified and stored by WFMOD.

WPPER? (cont)

WPPER? Accesses Channel Memory

When executed, WPPER? retrieves the time base of the specified waveform and the number of time base intervals from channel memory. However, in order to access the memory, the active waveform must be stopped (TARM OFF or TARM AUTO). When the channel is re-armed, the waveform will start from the first amplitude point.

Data Returned

Returned is the period of the waveform or of the portion of the waveform specified.

Related Commands

WFMOD, WFWRITE ACV, WFWRITE ARB, WFWRITE BIN, WFWRITE RPV, WFWRITE SQV

Examples

Example: Determining the Period (and Frequency) of a Waveform

The following example shows how WPPER? is used to return the period of an arbitrary waveform, and from that value, determine the frequency of the waveform.

In the program, an arbitrary waveform is defined and stored. The waveform consists of 5 points whose amplitudes and number of time base intervals are assigned at random. An arbitrary time base of 1.25 us is selected.

Following the program listing is a sequence of commands which declare a Real variable, read the period (WPPER?) and store the value in the variable, and then take the reciprocal of the period to determine the frequency. The result is returned to the display.

```
10  !Reset the mainframe and the HP 44726A. Declare and load the
20  !amplitude and NPER arrays for the arbitrary waveform.
30  !
40  OUTPUT 709;"RST"
50  WAIT 1
60  OUTPUT 709;"REAL AMPTD(4)"
70  OUTPUT 709;"INTEGER TB_INT(4)"
80  OUTPUT 709;"VWRITE AMPTD 5.1,1.8,9.3,5.23,7.6"
90  OUTPUT 709;"VWRITE TB_INT 1,0,2,1,3"
100 !
110 !Define and store the arbitrary waveform. Specify the amplitude and
120 !NPER arrays declared above. Switch the filter into the signal path
130 !to smooth the waveform. Select the waveform in channel memory and
140 !arm the channel.
150 !
160 OUTPUT 709;"WFWRITE ARB 4 AMPTD NPER TB_INT TBASE 1.25E-6"
170 OUTPUT 709;"FILTER ON"
180 OUTPUT 709;"APPLY WFV 0,4"
190 OUTPUT 709;"TRIG INT"
200 OUTPUT 709;"TARM AUTO"
210  END
```

WFPER? (cont)

```
OUTPUT 709;"REAL P;WFPER? INTO P;VREAD 1/P"
```

The frequency of the waveform based on the number of time base intervals and the time base is 4.705882E+04.

Recall that the frequency of an arbitrary waveform when an NPER array is specified is the reciprocal of the sum of 2 raised to each power in the NPER array, multiplied by the time base. Thus, you could have calculated the frequency as:

$$\text{frequency} = 1/((2^1+2^0+2^2+2^1+2^3) * 1.25E-6) = 47,058.823 \text{ Hz}$$

Example: Determining the Period (Frequency) of a Portion of the Waveform

The following example shows how WFPER? is used to return the period of part of a waveform, and from that value, determine the frequency.

In the program, a 500 Hz, 1000 point sine wave is defined and stored. By specifying LAST 499 in the WFPER? command, the period of the first 500 points of the waveform is returned.

```
10 !Reset the mainframe and the HP 44726A. Define and store a 500 Hz,  
20 !1000 point, special function sine wave.  
30 !  
40 OUTPUT 709;"RST"  
50 WAIT 1  
60 OUTPUT 709;"WFWRITE ACV 11 10 TBASE (1/(500*1E3))"  
70 !  
80 !Read the period of the first 500 points of the sine wave. Store the  
90 !period into a variable. Calculate the frequency and display the  
100 !result on the controller.  
110 !  
120 OUTPUT 709;"REAL P"  
130 OUTPUT 709;"WFPER? 11 LAST 499 INTO P"  
140 OUTPUT 709;"VREAD 1/P"  
150 ENTER 709;F  
160 PRINT F  
170 END
```

The value displayed on the controller based on this program is shown below.

```
1000
```

For special function sine waves, each amplitude point is held for one time base interval. Thus, the frequency of the portion specified is calculated by:

$$\text{frequency} = 1/(\text{TBASE} * \text{npts})$$

where TBASE is the time base calculated for a 500 Hz, 1000 point sine wave (line 60), and npts are the number of points specified in line 130 (500).

WFREAD

• HP 44726A 2-Channel Arbitrary Waveform DAC

Description

Reads the amplitude points or the number of time base intervals each amplitude point of the specified waveform is held. The data can be returned to either the mainframe display, output buffer, or to mainframe memory.

Prerequisites

Requires firmware revision 3.5 or greater and TARM OFF or TARM AUTO must also be set.

Syntax

WFREAD [*waveform_number*] [**FIRST point**] [**LAST point**] **AMPL** or **NPER** [**USE ch**] [**INTO name**] or [*fmt*]

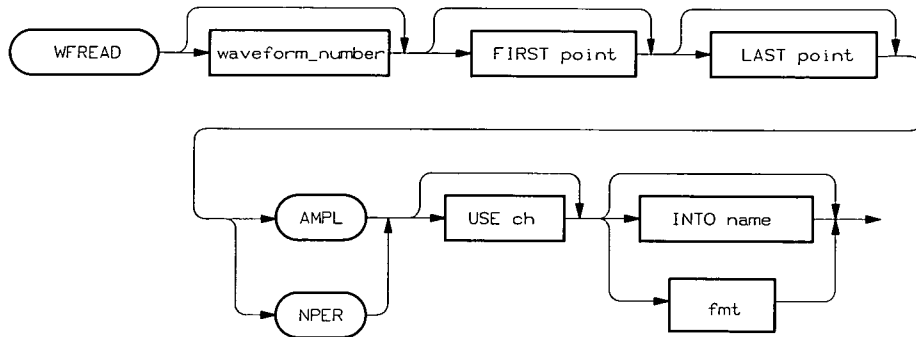

Parameters

waveform_number

Number of the waveform whose amplitude or time base data is read. The range for *waveform_number* is 0 to 63 per channel. If no waveform number is specified, the amplitude or time base data of the active waveform is returned.

FIRST point

Portion of the waveform read beginning with the point specified through the **LAST point** specified, or through the end of the waveform. Waveform points are numbered starting with 0. Default = 0.

LAST point

Portion of the waveform read starting with the beginning of the waveform or from the **FIRST point** specified, through the last point specified. Default = last point in waveform.

If neither **FIRST point** or **LAST point** is specified, the entire waveform is read.

AMPL or **NPER**

AMPL - returns the amplitudes of the points specified.

NPER - returns numbers in which 2, raised to those numbers, equals the number of time base intervals the corresponding amplitude points are held.

USE ch

Channel on which the waveform is stored. The default **USE ch** is channel 0.

INTO *name* See Glossary.

fmt When AMPL is specified, the default format for WFREAD is RASC. When NPER is specified, the default format is IASC. If the PACK format is used, the data remains in an internal format used by the DAC. For any other format (see Data Formats), the amplitudes returned are first converted to voltages and the time base data represents powers of 2.

Remarks WFREAD Accesses Channel Memory

When executed, WFREAD returns the amplitude points or number of time base intervals the points are held from channel memory. However, in order to access the memory, the active waveform must be stopped (TARM OFF or TARM AUTO). When the channel is re-armed, the waveform will start from the first amplitude point.

Viewing Arbitrary and Special Function Waveforms

The waveforms generated by the DAC are easily viewed by connecting the accessory's DAC OUT BNC to an oscilloscope. The WFREAD command enables the waveforms to also be plotted since the amplitude and time duration data can be read to the output buffer and then entered into the controller. Note that WFREAD supplied the data for the HP 44458A - DACQ/300 software package which was used to plot the waveforms shown on various HP 44726A command reference entries. A brief description on how the software package was used is contained in the Glossary.

Data Returned

Returned are the amplitude points or the number of time base intervals each amplitude point of the specified waveform is held.

Related Commands

WFMOD, WFWRITE ACV, WFWRITE ARB, WFWRITE BIN, WFWRITE RPV, WFWRITE SQV

Examples **Example: Reading the Amplitudes and Time Base Intervals of a Waveform**

The following program shows how WFREAD is used to return amplitude points and the number of time base intervals those points are held.

In the example, an eight point special function sine wave is defined and stored. WFREAD is then used to read the amplitudes and time base intervals into the controller where they are displayed.

```

10    !Declare controller variables for the amplitudes and time base
20    !intervals of the waveform. Reset the mainframe and the HP 44726A.
30    !
40    REAL Amptds(0:7)
50    INTEGER Time_ints(0:7)
60    OUTPUT 709;"RST"
70    WAIT 1

```

WFREAD (cont)

```
80  !
90  !Define and store the special function sine wave. The 8 point
100 !waveform will be 10 Vp-p and 50 kHz. Switch the filter into the
110 !signal path to smooth the waveform. Select the waveform in channel
120 !memory and arm the channel.
130  !
140 OUTPUT 709;"FWWRITE ACV 5 10 PTS 8 TBASE (1/(50E3*8))"
150 OUTPUT 709;"FILTER ON"
160 OUTPUT 709;"APPLY WFV 0,5"
170 OUTPUT 709;"TRIG INT"
180 OUTPUT 709;"TARM AUTO"
190  !
200 !Read the amplitudes and time base intervals of the waveform to the
210 !output buffer. Enter and display them on the controller.
220  !
230 OUTPUT 709;"WFREAD 5 AMPL"
240 ENTER 709;Amptds(*)
250 OUTPUT 709;"WFREAD 5 NPER"
260 ENTER 709;Time_ints(*)
270 PRINT " AMPLITUDES      TIME BASE INTERVALS"
280 PRINT
290 FOR I=0 TO 7
300     PRINT USING "2(S2D.6D,10X)";Amptds(I),Time_ints(I)
310 NEXT I
320 END
```

The output based on this program is shown below. Recall that for special function sine waves, each amplitude point is held for 1 (2°) time base interval.

AMPLITUDES	TIME BASE INTERVALS
+3.535625	+0.000000
+5.000000	+0.000000
+3.535625	+0.000000
+0.000000	+0.000000
-3.535625	+0.000000
-5.000000	+0.000000
-3.535625	+0.000000
+0.000000	+0.000000

• HP 44726A 2-Channel Arbitrary Waveform DAC

Description Returns the total number of amplitude points in the specified waveform.

Prerequisites Requires firmware revision 3.5 or greater and TARM OFF or TARM AUTO must also be set.

Syntax **WFSIZE?** [*waveform_number*] [**USE ch**], [**INTO name**] or [*fmt*]

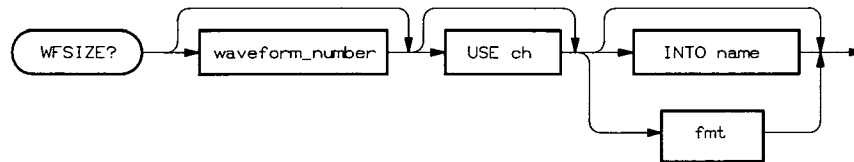

Parameters

waveform_number Number of the waveform whose size is returned. The range for *waveform_number* is 0 to 63 per channel. If a waveform number is not specified, the size of the active waveform is returned. If the waveform has not been defined, 0 is returned.

USE ch Channel on which the waveform is stored. The default **USE ch** is channel 0.

INTO name See Glossary.

fmt See Glossary. Default format is IASC.

Remarks

Maximum Number of Amplitude Points Per Channel

On the HP 44726A, there are a maximum of 32,400 amplitude points (elements) per channel for storing waveforms. Thus, a single waveform of 32,400 points could be stored, or more frequently, the points will be distributed among the 64 waveforms (per channel) which can be stored.

WFSIZE? Accesses Channel Memory

When executed, WFSIZE? retrieves the size of the waveform from channel memory. However, in order to access the memory, the active waveform must be stopped (TARM OFF or TARM AUTO). When the channel is re-armed, the waveform will start from the first amplitude point.

Data Returned

Returned are the total number of amplitude points in the specified waveform.

Related Commands

WFWRITE ACV, WFWRITE ARB, WFWRITE BIN, WFWRITE RPV,
WFWRITE SQV

WFSIZE? (cont)

Examples

Example: Determining the Number of Points Available On Each Channel

The following program shows how WFSIZE? can be used to determine the number of points available for storing additional waveforms.

In the example, WFSIZE? is contained within a FOR/NEXT loop which returns the size of the possible 64 waveforms per channel. After the size of each waveform has been added together, the values are subtracted from the maximum 32400 points per channel to determine the points available.

The program assumes either TARM OFF or TARM AUTO is set.

```
10  !Download a subroutine which adds together the number of points
20  !in each waveform stored on channel 0 and channel 1. (The DAC
30  !accessory is installed in slot 2.)
40  !
50  OUTPUT 709;"SUB POINTS"
60  OUTPUT 709;"  INTEGER I,WV0_PNTS,WV1_PNTS,CH0_PNTS,CH1_PNTS"
70  OUTPUT 709;"  FOR I = 0 TO 63"
80  OUTPUT 709;"    WFSIZE? I USE 200 INTO WV0_PNTS"
90  OUTPUT 709;"    WFSIZE? I USE 201 INTO WV1_PNTS"
100 OUTPUT 709;"    CH0_PNTS = CH0_PNTS + WV0_PNTS"
110 OUTPUT 709;"    CH1_PNTS = CH1_PNTS + WV1_PNTS"
120 OUTPUT 709;"  NEXT I"
130 OUTPUT 709;"SUBEND"
140 OUTPUT 709;"CALL POINTS"
150 !
160 !Determine the number of points available for storing waveforms
170 !by subtracting the number of points used, from the total number
180 !of points per channel. Enter and display the number of
190 !available points on the controller.
200 !
210 OUTPUT 709;"VREAD 32400-CH0_PNTS"
220 ENTER 709;Pts0
230 OUTPUT 709;"VREAD 32400-CH1_PNTS"
240 ENTER 709;Pts1
250 PRINT "POINTS AVAILABLE ON CHANNEL 0 =" ;Pts0
260 PRINT
270 PRINT "POINTS AVAILABLE ON CHANNEL 1 =" ;Pts1
280 END
```

• HP 44726A 2-Channel Arbitrary Waveform DAC

Description

Returns the time base of the specified waveform. The time base returned is the value stored in memory by either the WFWRITE or a subsequent WFMOD command.

Prerequisites

Requires firmware revision 3.5 or greater and TARM OFF or TARM AUTO must also be set.

Syntax

WFTBASE? [*waveform_number*] [USE *ch*] [INTO *name*] or [*fmt*]

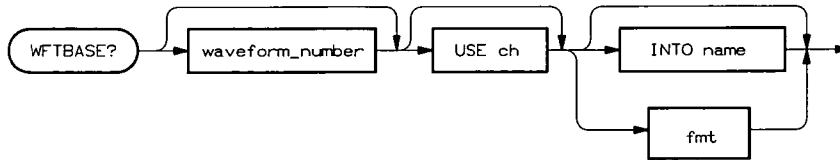

Parameters

waveform_number

Number of the waveform whose time base is returned. The range for *waveform_number* is 0 to 63 per channel. If no waveform number is specified, the time base (stored) for the active waveform is returned.

USE *ch*

Channel on which the waveform is stored. The default USE *ch* is channel 0.

INTO *name*

See Glossary.

fmt

See Glossary. Default format is RASC.

Remarks

WFTBASE? Accesses Channel Memory

When executed, WFTBASE? retrieves the time base from channel memory. However, in order to access the memory, the active waveform must be stopped (TARM OFF or TARM AUTO). When the channel is re-armed, the waveform will start from the first amplitude point.

Data Returned

Returned is the time base of the specified waveform. The time base is the value stored when the waveform was defined (WFWRITE), or the value modified and stored (WFMOD). If the time base of the active waveform is changed by TBASE, that value is not returned since the value is not stored.

Related Commands

WFMOD, WFWRITE ACV, WFWRITE ARB, WFWRITE BIN, WFWRITE RPV, WFWRITE SQV

WFTBASE? (cont)

Examples

Example: Determining the Time Base of a Waveform

When executed as follows, WFTBASE? returns the time base stored with waveform 5 on channel 0 (slot 2). The statement assumes that the channel was armed by TARM AUTO, or has been disarmed by TARM OFF. The time base is returned to both the display and HP-IB output buffer.

```
OUTPUT 709;"WFTBASE? 5 USE 200"
```

• HP 44726A 2-Channel Arbitrary Waveform DAC

Description

Defines a special function sine wave and stores the waveform in the channel memory of the DAC.

Prerequisites

Requires firmware revision 3.5 or greater. TARM OFF or TARM AUTO must also be set.

Syntax

WFWRITE ACV *waveform_number* *volts_pk_to_pk* [**OFFSET** *volts*] [**PHASE** *radians*] [**PTS** *number*] **TBASE** *seconds* [**USE** *ch*]

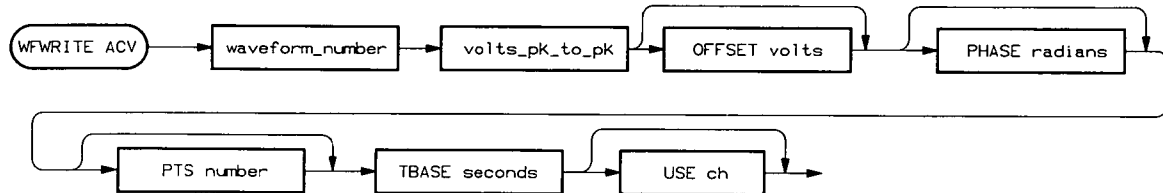

Parameters

waveform_number

Number assigned to the waveform. The range for *waveform_number* is 0 to 63 per channel. The **USE ch** parameter determines whether the waveform is stored on channel 0 or channel 1.

volts_pk_to_pk

Peak-to-peak amplitude of the sine wave. The maximum value for *volts_pk_to_pk* is 20.4793750. Note that if a larger value is specified, Error 106: DATA ALTERED - WAS OUT OF RANGE is reported, the amplitude points out of range are set to + and - 10.2396875, and the waveform modified accordingly.

OFFSET *volts*

DC offset added to the sine wave. The maximum DC offset allowed depends on the amplitude of the waveform (*volts_pk_to_pk*). Specifically,

$$\text{DC offset} + |(\text{volts_pk_to_pk}/2)| \text{ must be } \leq 10.2396875$$

or

$$\text{DC offset} - |(\text{volts_pk_to_pk}/2)| \text{ must be } \geq -10.2396875$$

Should a DC offset be specified that would cause the peak amplitude of the sine wave to exceed ± 10.2396875 , Error 106: DATA ALTERED - WAS OUT OF RANGE is reported, the amplitude points out of range are set to + or - 10.2396875, and the waveform modified accordingly. The default offset is 0V.

PHASE *radians*

Angle in radians that the waveform is shifted. The maximum number of radians which can be specified is $\pm 188.495.559215$. Values can be specified in increments of $2*\text{PI}/\text{PTS}$, where PTS are the number of points in the waveform. The default PHASE is 0 radians. Waveforms are defined such that the first point is at $\sin((2*\text{PI}/\text{PTS})+\text{phase})$ and the last point is at $\sin(\text{phase})$.

WFWRITE ACV (cont)

- PTS *number*** Number of amplitude points which comprise the waveform. The number of points which can be specified are 8, 20, 40, 100, 200, 500, and 1000. The default *number* is 1000. Note that higher frequency waveforms are attainable when fewer points are used. See "Waveform Frequency Range" under Remarks.
- TBASE *seconds*** Time interval between the points on the waveform. The range for *seconds* is 1.25E-6 to 16.384E-3. Resolution is 0.25E-6.
- USE *ch*** Channel on which the waveform is stored and from which it will be applied. The range for *ch* is ES00 to ES01. The default USE *ch* is channel 0.

Remarks Waveform Frequency Range

The frequency of signals output from the DAC is dependent upon the time base specified and the number of time base intervals each amplitude point is held. For special function sine waves, each amplitude is held for one time base interval. For the number of points per waveform which can be selected, the following frequency ranges apply:

POINTS PER WAVEFORM	MINIMUM FREQUENCY	MAXIMUM FREQUENCY
8	7.62 Hz	100 kHz
20	3 Hz	40 kHz
40	1.52 Hz	20 kHz
100	0.61 Hz	8 kHz
200	0.30 Hz	4 kHz
500	0.122 Hz	1.6 kHz
1000	0.061 Hz	800 Hz

Setting the Frequency of the Waveform

Given that each amplitude point is held for one time base interval, the frequency of a special function sine wave can be defined as:

$$\text{frequency} = 1/(\text{TBASE} * \text{npts})$$

where *npts* is the number of points in the waveform.

When the (desired) frequency and the number of waveform points are known, the equation can be solved for TBASE, which gives:

$$\text{TBASE} = 1/(\text{frequency} * \text{npts})$$

For example, for a 1 kHz, 500 point sine wave, the time base that would be specified in the WFWRITE ACV command is:

$$\text{TBASE} = 1/(1000 * 500) = 2.0E-6$$

When the desired frequency is available within more than one frequency range, consider that the more points in the waveform, the smoother the waveform will be. However, when fewer points are used, smaller changes in frequency relative to the original value can be made. For example, a 10 kHz sine wave is available as a 40 point, 20 point, or 8 point waveform. If a 40 point waveform is selected, the

WFWRITE ACV (cont)

time base specified is 2.5E-6. Given the time base resolution of 2.5E-7, the smallest change in frequency that could be made would be a value that is at least 10% of the original 10 kHz. If an 8 point waveform were selected, the time base specified for the 10 kHz signal would be 12.5E-6. With the 2.5E-7 resolution, the smallest change in frequency would be a value that is at least 2% of the original 10 kHz.

Converting Degrees to Radians

When a phase shift is added to the sine wave, the angle is expressed in radians rather than degrees. The conversion from degrees to radians is made with the following equation:

$$\text{radians} = (\text{PI}/180^\circ) * \text{degrees}$$

Negative Peak-to-Peak Amplitudes Shift the Sine Wave PI Radians

A negative (-) amplitude specified for the *volts__pk__to__pk* parameter shifts the sine wave PI radians (180°) in addition to any shift specified by the PHASE parameter.

Command Execution Time

As waveforms are added to channel memory, they are placed one after the other, with a gap only between the last point of the last waveform and the end of memory. If waveforms are subsequently deleted, additional gaps are created and used to store new waveforms if the gaps are large enough.

When the situation arises where no single gap is large enough for a new waveform, yet the space occupied by all of the gaps is large enough, gaps are combined by moving existing waveforms until a sufficient gap is formed. This process, which occurs only under the above condition, can add up to an additional 1.5 seconds of execution time to WFWRITE ACV.

Modifying Special Function Sine Waves

If a special function sine wave is to be modified by the WFMOD command, TARM OFF or TARM AUTO must be set. Note that the modified waveform replaces the waveform defined by WFWRITE ACV in channel memory.

Viewing the Waveform

The waveforms generated by the following example programs are easily viewed by connecting the accessory's DAC OUT BNC to an oscilloscope. The plots shown were drawn using the HP 44458A - DACQ/300 software package. Refer to the "Viewing Waveforms" section of the Glossary for an example of how the software is used.

Data Returned

None

WFWRITE ACV (cont)

Related Commands

APPLY WFV, WF?, WFDELETE, WFMOD, WFPER?, WFREAD, WFSIZE?, WFTBASE?

Examples

Example 1: Defining a Special Function Sine Wave

The following program shows how WFWRITE ACV is used to define a sine wave and how that waveform appears on an oscilloscope.

The desired waveform is a 40 point waveform that is 10 kHz, 10 Vp-p, with a DC offset of 5V. Since the number of points and the desired frequency are known, the equation which calculates the necessary time base is evaluated by the TBASE parameter.

```
10 !Reset the HP 3852A and the HP 44726A (in slot 0). Define and
20 !store the special function sine wave. The sine wave will be a
30 !40 point waveform, 10 Vp-p, 10 kHz, and have a DC offset of
40 !5V. The waveform will be stored on channel 0 (default).
50 !
60 OUTPUT 709;"RST"
70 WAIT 1
80 OUTPUT 709;"WFWRITE ACV 0 10 OFFSET 5 PTS 40 TBASE (1/(10E3*40))"
90 !
100 !Turn on the anti-aliasing filter to smooth the waveform. Output
110 !a sync pulse from the SYNC OUT BNC to note the beginning of
120 !each cycle. Select the waveform in channel 0 memory. Arm the
130 !channel so that when triggers are received, the data in
140 !that portion of memory is sent to the DAC which then generates
150 !the waveform.
160 !
170 OUTPUT 709;"FILTER ON"
180 OUTPUT 709;"SYNC WF"
190 OUTPUT 709;"APPLY WFV 0,0"
200 OUTPUT 709;"TRIG INT"
210 OUTPUT 709;"TARM AUTO"
220 END
```

A plot of the waveform is shown on the following page:

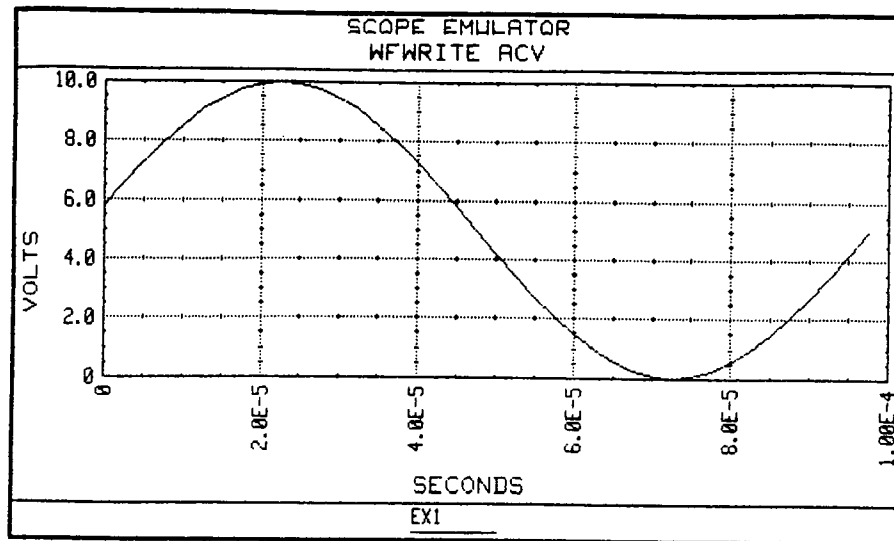

Example 2: Adding a Phase Shift to a Special Function Sine Wave

The following program again uses WFWRITE ACV to define a sine wave and shows how that waveform appears on an oscilloscope.

The desired waveform for this example is a 1000 point waveform, 800 Hz, 10 Vp-p, with a phase shift of 90 degrees. Note that the mainframe is used to calculate the necessary time base and convert the 90 degrees to radians.

```

10 !Reset the HP 3852A and the HP 44726A (in slot 0) and declare a
20 !time base variable. Calculate and store the time base required
30 !for an 800 Hz, 1000 point sine wave.
40 !
50 OUTPUT 709;"RST"
60 WAIT 1
70 OUTPUT 709;"REAL TB_VAL"
80 OUTPUT 709;"TB_VAL = 1/(800*1E3)"
90 !
100 !Define and store the special function sine wave. The sine wave
110 !will be a 1000 point waveform, 10 Vp-p, 800 Hz, with a phase
120 !shift of 90 degrees. The waveform will be stored on channel 1.
130 !
140 OUTPUT 709;"WFWRITE ACV 0 10 PHASE ((PI/180)*90) TBASE TB_VAL USE 1"
150 !
160 !Output a sync pulse from the SYNC OUT BNC to note the phase
170 !shift of the waveform. Select the waveform in channel 1 memory.
180 !Arm the channel so that when triggers are received,
190 !the waveform is generated by the DAC.
200 !
210 OUTPUT 709;"SYNC WF USE 1"
220 OUTPUT 709;"APPLY WFV 1,0"
230 OUTPUT 709;"TRIG INT USE 1"
240 OUTPUT 709;"TARM AUTO USE 1"

```

WFWRITE ACV (cont)

250 END

A plot of the waveform is shown below:

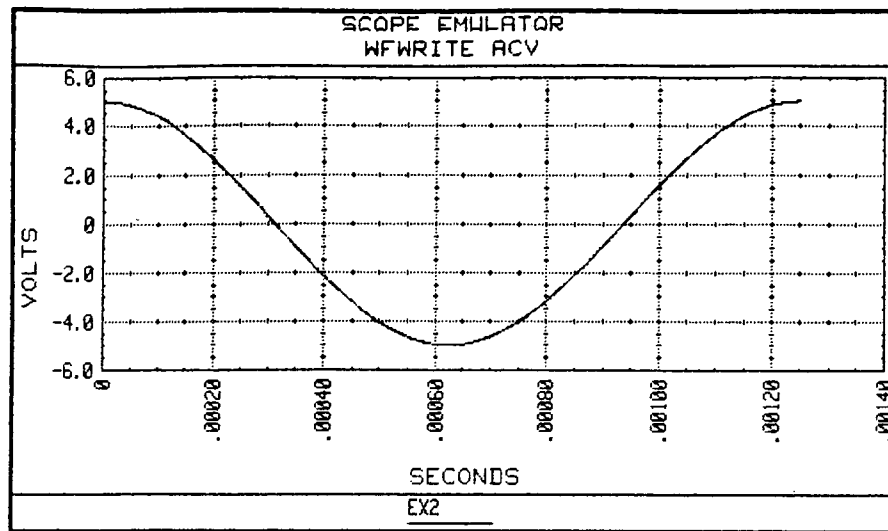

WFWRITE ARB

• HP 44726A 2-Channel Arbitrary Waveform DAC

Description

Defines an arbitrary waveform and stores that waveform in the channel memory of the DAC.

Prerequisites

Requires firmware revision 3.5 or greater. TARM OFF or TARM AUTO must also be set.

Syntax

WFWRITE ARB *waveform_number* *amplitude_array* [SCALE *factor*]
[OFFSET *volts*] [NPER *array*] TBASE *seconds* [USE *ch*]

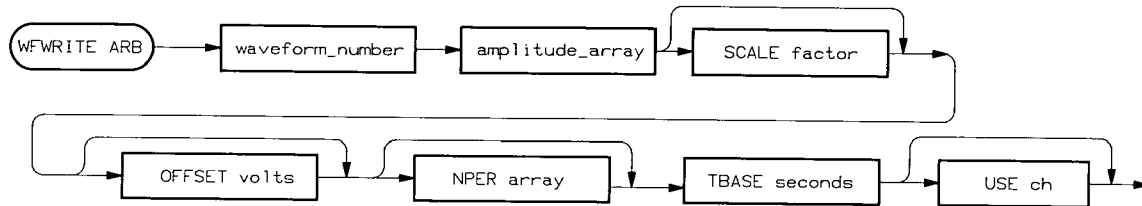

Parameters

waveform_number

Number assigned to the waveform. The range for *waveform_number* is 0 to 63 per channel. The *USE ch* parameter determines whether the waveform is stored on channel 0 or channel 1.

amplitude_array

Real array containing the amplitude (voltage) points of the arbitrary waveform. The array can have a maximum index from 1 (2 points) to 32399 (32400 points). The maximum voltage allowed in the amplitude array is ± 10.2396875 . If a larger value is found, Error 106: DATA ALTERED - WAS OUT OF RANGE is reported, the amplitude points out of range are set to + or - 10.2396875, and the waveform modified accordingly.

This array must be declared and contain data prior to the execution of WFWRITE ARB.

SCALE *factor*

Factor by which the values in the *amplitude_array* are multiplied. The maximum scale factor allowed depends on the amplitude points in the amplitude array. Specifically,

Scale factor * (array amplitude point) must be ≤ 10.2396875

and

Scale factor * (array amplitude point) must be ≥ -10.2396875

Should a scale factor be specified that would cause amplitude points in the waveform to exceed ± 10.2396875 , Error 106: DATA ALTERED - WAS OUT OF RANGE is reported, the points out of range are set to + or - 10.2396875, and the waveform modified accordingly. The default scale factor is 1.

WFWRITE ARB (cont)

OFFSET *volts* DC offset added to the waveform. The maximum DC offset allowed depends on the amplitude points in the amplitude array (the offset is added after any scaling is done). Specifically,

DC offset + |array amplitude point * scale factor| must be ≤ 10.2396875

and

DC offset + |array amplitude point * scale factor| must be ≥ -10.2396875

Should a DC offset be specified that would cause amplitude points of the waveform to exceed ± 10.2396875 , Error 106: DATA ALTERED - WAS OUT OF RANGE is reported, the points out of range are set to + or - 10.2396875, and the waveform modified accordingly. The default offset is 0V.

NPER *array* Real or Integer array containing numbers in which 2, raised to that number, equals the number of time base intervals the corresponding amplitude point is held. For example, if the amplitude array and NPER array are 5 element arrays which contain the following data:

Amplitude Array	NPER array
4.7	1
4.9	0
5.5	2
-3.6	1
3.0	2

the 4.7V amplitude of the waveform is held for two time base intervals (2^1), the 4.9V amplitude is held for one time base interval (2^0), the 5.5V amplitude is held for four time base intervals (2^2), and so on.

The range for the numbers in the NPER array is 0 to 31. If a number greater than 31 is encountered, Error 106: DATA ALTERED - WAS OUT OF RANGE is reported, the time interval of the corresponding amplitude is set to 1 (2^0), and the waveform modified accordingly.

Note that the NPER array must be the same size as the amplitude array. If an NPER array is not specified, each amplitude point is held for one time base interval. This array must also be declared and contain data prior to the execution of WFWRITE ARB.

TBASE *seconds* Length of a single internal time base interval. The range for *seconds* is 1.25E-6 to 16.384E-3. Resolution is 0.25E-6.

USE *ch* Channel on which the waveform is stored and from which it will be applied. The range for *ch* is ES00 to ES01. The default USE *ch* is channel 0.

Remarks

Setting the Frequency of an Arbitrary Waveform

The frequency of signals output from the DAC is dependent upon the time base specified and the number of time base intervals each amplitude point is held. The following information shows you how to select a specific frequency when amplitude points are held for one time base interval or longer.

NPER Array Specified

The frequency of an arbitrary waveform when an NPER array is specified is the reciprocal of the sum of 2 raised to each power in the NPER array, multiplied by the time base. In equation form, this is represented as:

$$\text{frequency} = 1 / (\sum_n^{\text{max index}} 2^{\text{NPER}(n)} * \text{TBASE})$$

When the (desired) frequency is known and by determining the sum of 2 raised to each power in the NPER array, the equation can be solved for the appropriate TBASE:

$$\text{TBASE} = 1 / (\sum_n^{\text{max index}} 2^{\text{NPER}(n)} * \text{frequency})$$

For example, for a 1.5 kHz, 5 point arbitrary waveform with the following data in the NPER array, the required time base would be:

NPER array = 0,1,3,2,3

$$\begin{aligned} \text{TBASE} &= 1 / ((2^0 + 2^1 + 2^3 + 2^2 + 2^3) * 1.5E3) \\ &= 1 / (23 * 1.5E3) = \underline{28.986E-6} \end{aligned}$$

Due to the rounding of the internal time base to the nearest 0.25E-6 increment, 28.986E-6 yields 29.0E-6 and an actual frequency of 1.49925 kHz.

One method for summing the value 2 raised to each power in an NPER array is given below. Note that SUM and I are previously declared Integer variables and INT_VAL is the NPER array.

```
70  OUTPUT 709;"  FOR I = 0 to 4"
80  OUTPUT 709;"    SUM = SUM + 2^(INT_VAL(I))"
90  OUTPUT 709;"  NEXT I"
```

Following this method, the time base could be calculated by:

$$\text{TBASE} = 1 / (\text{SUM} * 1.5E3) = \underline{28.986E-6}$$

NPER Array Not Specified

Recall that when the NPER array is not used, each amplitude point in the amplitude array is held for one time base interval. Thus, to set an arbitrary waveform to a specific frequency, the appropriate time base is determined by:

$$\text{TBASE} = 1 / (\text{frequency} * \text{npts})$$

WFWRITE ARB (cont)

where npts equals the number of amplitude points in the amplitude array. As an example, to set a 1000 point arbitrary waveform to 10 Hz:

$$TBASE = 1/(10*1E3) = 0.1E-3$$

Setting the Time Base Equal to the Sample Rate

A third method of achieving a desired frequency is setting the time base equal to the rate at which an input signal is sampled. This sets the output of the DAC to the same frequency as the sampled signal, assuming each amplitude point is held for one time base interval (Example 1).

Command Execution Time

As waveforms are added to channel memory, they are placed one after the other, with a gap only between the last point of the last waveform and the end of memory. If waveforms are subsequently deleted, additional gaps are created and used to store new waveforms if the gaps are large enough.

When the situation arises where no single gap is large enough for a new waveform, yet the space occupied by all of the gaps is large enough, gaps are combined by moving existing waveforms until a sufficient gap is formed. This process, which occurs only under the above condition, can add up to an additional 1.5 seconds of execution time to WFWRITE ARB.

Modifying an Arbitrary Waveform

If an arbitrary waveform is to be modified by the WFMOD command, TARM OFF or TARM AUTO must be set. Note that the modified waveform replaces the waveform defined by WFWRITE ARB in channel memory.

Viewing Arbitrary Waveforms

The waveforms generated by the following example programs are easily viewed by connecting the accessory's DAC OUT BNC to an oscilloscope. The plots shown were drawn using the HP 44458A - DACQ/300 software package. Refer to the "Viewing Waveforms" section of the Glossary for an example of how the software is used.

Data Returned

None

Related Commands

APPLY WFV, WF?, WFDELETE, WFMOD, WFPER?, WFREAD, WFSIZE?, WFTBASE?

Examples **Example 1: Defining an Arbitrary Waveform: Sampled Waveform**

The following program shows how WFWRITE ARB is used to define an arbitrary waveform and how that waveform appears on an oscilloscope or when plotted.

In this example, an HP 44702A voltmeter samples an input signal by taking 1,000 readings, 3 ms apart. The readings are stored in an array which is specified as the amplitude array in the WFWRITE ARB command. By setting the time base equal to the voltmeter's sample rate, the waveform output from the DAC is at the frequency of the sampled signal (0.33 Hz).

```

10  !Clear and reset the mainframe and the HP 44726A. Declare a Real
20  !array to store 1,000 readings. Configure the HP 44702A voltmeter
30  !to take 1,000 DC voltage measurements, 3 ms apart, on the rear
40  !terminals. Transfer the readings from the voltmeter to the array.
50  !
60  OUTPUT 709;"RST"
70  WAIT 1
80  OUTPUT 709;"REAL WV_AMP(999)"
90  OUTPUT 709;"USE 500"
100 OUTPUT 709;" FUNC DCV"
110 OUTPUT 709;" TERM EXT"
120 OUTPUT 709;" NRDGS 1000"
130 OUTPUT 709;" DELAY 0,0.003"
140 OUTPUT 709;" TRIG SGL"
150 OUTPUT 709;"XRDGS 500 INTO WV_AMP"
160 !
170 !Define and store the arbitrary waveform. Specify the array loaded
180 !by the HP 44702A as the amplitude array. Set the time base equal
190 !to the sample rate of the voltmeter. Select the waveform in
200 !channel 0 memory. Arm the channel so that when triggers
210 !are received, data in that portion of memory is sent to the
220 !DAC which then generates the waveform.
230 !
240 OUTPUT 709;"USE 0"
250 OUTPUT 709;" WFWRITE ARB 0 WV_AMP TBASE 0.003"
260 OUTPUT 709;" APPLY Wfv 0,0"
270 OUTPUT 709;" TRIG INT"
280 OUTPUT 709;" TARM AUTO"
290 END

```

A plot of a sampled waveform is shown on the following page.

WFWRITE ARB (cont)

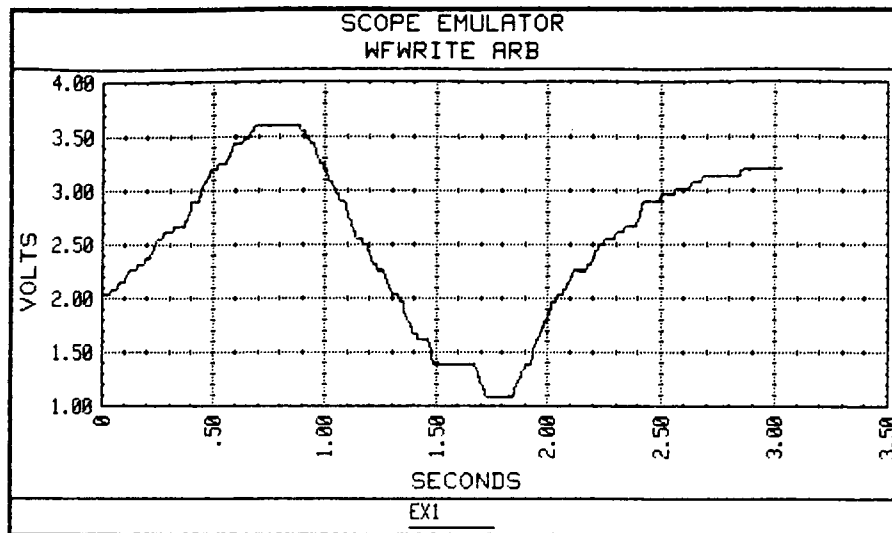

Example 2: Defining an Arbitrary Waveform: $\sin(x)/x$

The following program shows how WFWRITE ARB is used to define and store an arbitrary waveform which represents the function $\sin(x)/x$.

In this example, the mainframe evaluates $\sin(x)/x$ over the range -5π to $+5\pi$. The results are stored in an array which is specified as the amplitude array in the WFWRITE ARB command. The waveform is a 1,000 point waveform with a frequency of 500 Hz.

```
10 !Reset the mainframe and the HP 44726A. Download a subroutine
20 !which evaluates the function  $\sin(x)/x$  over the range  $-5\pi$  to
30  $+5\pi$  in 0.001 steps. Store the readings in an array which will
40 !be specified by WFWRITE as the amplitude array.
50 !
60 OUTPUT 709;"RST"
70 WAIT 1
80 OUTPUT 709;"SUB SIN_X"
90 OUTPUT 709;" REAL AMP(999),X"
100 OUTPUT 709;" FOR X = (-5*PI+10*PI/1000) TO (5*PI) STEP (10*PI/1000)"
110 OUTPUT 709;" IF X = 0.0 THEN"
120 OUTPUT 709;" VREAD 1.0 INTO AMP"
130 OUTPUT 709;" ELSE"
140 OUTPUT 709;" VREAD (SIN(X)/X) INTO AMP"
150 OUTPUT 709;" END IF"
160 OUTPUT 709;" NEXT X"
170 OUTPUT 709;"SUBEND"
180 OUTPUT 709;"CALL SIN_X"
190 !
200 !Define and store the arbitrary waveform on channel 1. Specify
210 !the array containing data from  $\sin(x)/x$  as the amplitude array.
220 !Set the frequency of the waveform to 500 Hz. Select the waveform
230 !in memory. Arm the channel so that when triggers are
240 !received, the waveform is generated.
```

WFWRITE ARB (cont)

```
250 !  
260 OUTPUT 709;"WFWRITE ARB 0 AMP TBASE (1/(500*1E3)) USE 1"  
270 OUTPUT 709;"APPLY WFV 1,0"  
280 OUTPUT 709;"TRIG INT USE 1"  
290 OUTPUT 709;"TARM AUTO USE 1"  
300 END
```

A plot of the waveform is shown below:

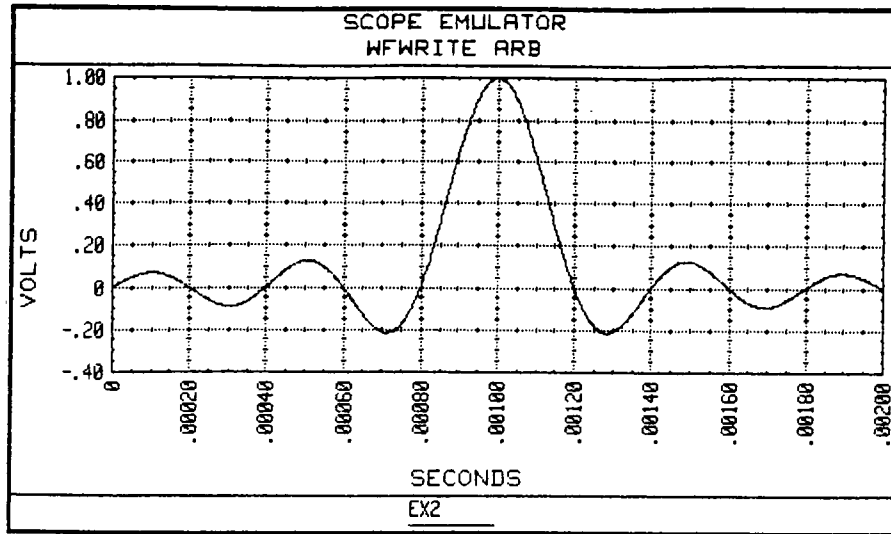

WFWRITE BIN

• HP 44726A 2-Channel Arbitrary Waveform DAC

Description

Defines an arbitrary waveform and stores that waveform in the channel memory of the DAC. WFWRITE BIN is the fastest method of storing a waveform since the data stored is in a format which can be used directly by the DAC.

Prerequisites

Requires firmware revision 3.5 or greater and TARM OFF or TARM AUTO must also be set.

Syntax

WFWRITE BIN *waveform_number* *amplitude_array* [*NPER array*] **TBASE** *seconds* [**USE ch**]

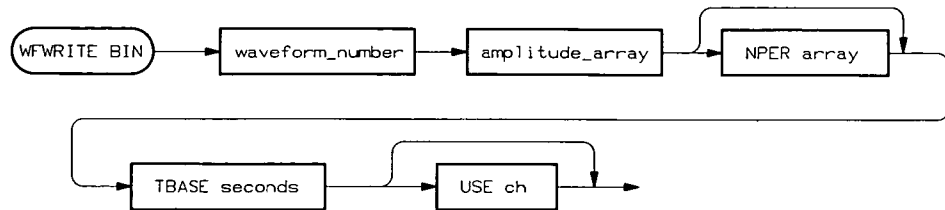

Parameters

waveform_number

Number assigned to the waveform. The range for *waveform_number* is 0 to 63 per channel. The **USE ch** parameter determines whether the waveform is stored on channel 0 or channel 1.

amplitude_array

Integer or Packed array containing waveform amplitude data. If an Integer array is specified, the values in the array must represent the amplitude point/0.0003125. The Integer array can have a maximum index from 1 (2 points) to 32399 (32400 points). The data in the array must correspond to amplitudes between $\pm 10.2396875\text{V}$.

If a Packed array is specified, the data in the array must be in the DAC format (i.e. converted by WFWRITE ARB). See the "Remarks" section for the procedure used to load a Packed array with WFWRITE ARB.

With firmware revision 3.52 or greater, a Packed array can be specified in which the data represents a signal sampled by the HP 44702A/B and is in the voltmeter's packed format. Since each packed voltmeter reading is two bytes long, the Packed array when declared, should have a maximum index that is twice the number of amplitude points (or readings), less one.

The maximum voltage allowed in a Packed array loaded by the HP 44702A/B is $\pm 10.2396875\text{V}$. If readings taken by the voltmeter exceed the voltmeter's measurement or electrical range, the values stored in the Packed array may not accurately represent the sampled signal.

NPER array

Integer array containing numbers in which 2, raised to that number equals the number of time base intervals the corresponding amplitude point is held. The range for the numbers in the NPER array is 0 to 31. The NPER array must be the same size as the amplitude array. If an NPER array is not specified, each amplitude point is held for one time base interval.

TBASE *seconds* Length of a single internal time base interval. The range for *seconds* is 1.25E-6 to 16.384E-3. Resolution is 0.25E-6.

USE *ch* Channel on which the waveform is stored and from which it will be applied. The range for *ch* is ES00 to ES01. The default **USE** *ch* is channel 0.

Remarks

Loading a Packed Array with WFWRITE ARB and WFREAD

If a Packed array is specified as the *amplitude__array*, the array must be declared and loaded prior to executing WFWRITE BIN. When declaring the array, note that the array must have a maximum index of 2 x number of amplitude points - 1. For example, if the waveform to be defined and stored by WFWRITE BIN contains 1000 amplitude points, the packed array must have a maximum index of 1999.

To load the Packed array, first define and store the desired waveform using the WFWRITE ARB command. Second, read the waveform's amplitude points with the WFREAD command into the Packed array. By reading the data into the Packed array, the data which has been converted to the appropriate format by WFWRITE ARB remains in that format. The next step is to specify the Packed array in WFWRITE BIN. The program listed in the "Examples" section demonstrates this procedure.

Loading an Integer Array with WFREAD

The method for loading a Packed array with the WFREAD command DOES NOT apply to Integer arrays. Data in an Integer array loaded by WFREAD are the desired voltages in an Integer format, while WFWRITE BIN requires Integer data which represents desired voltage/0.0003125.

Programming Errors Are Not Reported with WFWRITE BIN

To achieve the rate at which WFWRITE BIN executes, amplitude and time base interval errors which exceed the allowable range are not checked or reported by an error message. However, data in an Integer array which corresponds to an amplitude of -10.24V is changed to an amplitude of -10.2396875V. If a number greater than 31 is found in the NPER array, the corresponding amplitude point is held MOD 32 time base intervals. For example, if 40 were in the array, the amplitude point would be held 2^8 time base intervals.

Viewing the Waveform

The waveform generated by the following example program is easily viewed by connecting the accessory's DAC OUT BNC to an oscilloscope. The plot shown was drawn using the HP 44458A - DACQ/300 software package. Refer to the "Viewing Waveforms" section of the Glossary for an example of how the software is used.

Data Returned

None

WFWRITE BIN (cont)

Related Commands

APPLY WFV, WF?, WFDELETE, WFMOD, WFPER?, WFPREAD, WFSIZE?, WFTBASE?

Examples

Example: Defining and Storing a Damped Sine Wave

The following program shows how WFWRITE BIN is used to define and store an arbitrary waveform. Specifically, the waveform stored is a damped sine wave defined by:

$$f(t) = \epsilon^{-at} \text{SIN}(\omega t + \theta)$$

The 1000 point waveform is comprised of twenty 50 point sine waves which oscillated between 1V down to 18.3 mV.

```
10 !Reset the mainframe and the HP 44726A. Declare a Packed array
20 !which will contain the data converted by the WFWRITE ARB command.
30 !(The array size must be equivalent to two bytes per amplitude
40 !point, - 1.) Declare and assign values to the variables e,a,w.
50 !
60 OUTPUT 709;"RST"
70 WAIT 1
80 OUTPUT 709;"PACKED DAC_FMT(1999)"
90 OUTPUT 709;"REAL e,a,w"
100 OUTPUT 709;"e=2.71828"
110 OUTPUT 709;"a=4/1000"
120 OUTPUT 709;"w=(2*PI)/50"
130 !
140 !Download the subroutine which evaluates the damped sine wave over 1000
150 !points. Store the amplitude points in an array so that they can be
160 !converted by WFWRITE ARB.
170 !
180 OUTPUT 709;"SUB LOAD_ARY"
190 OUTPUT 709;" INTEGER T"
200 OUTPUT 709;" REAL WV_AMP(999)"
210 OUTPUT 709;" FOR T = 0 TO 999"
220 OUTPUT 709;" VREAD e^(-a*T)*SIN(w*T) INTO WV_AMP"
230 OUTPUT 709;" NEXT T"
240 OUTPUT 709;"SUBEND"
250 OUTPUT 709;"CALL LOAD_ARY"
260 !
270 !Convert the amplitude points corresponding to the damped sine wave by
280 !specifying the array in the WFWRITE ARB command. Read those points
290 !into the Packed array so the data remains in the format required by
300 !the DAC. Delete the waveform defined by WFWRITE ARB.
310 !
320 OUTPUT 709;"WFWRITE ARB 0 WV_AMP TBASE (1/(800*1E3))"
330 OUTPUT 709;"WFPREAD 0 AMPL INTO DAC_FMT"
340 OUTPUT 709;"WFDELETE 0"
350 !
360 !Define and store the damped sine wave using WFWRITE BIN; specifying
370 !the Packed array as the amplitude array. The 1000 point waveform will
380 !have a frequency of 800 Hz.
```

WFWRITE BIN (cont)

```
390 !
400 OUTPUT 709;"WFWRITE BIN 0 DAC_FMT TBASE (1/(800*1E3))"
410 !
420 !Select the waveform from channel 0 memory. Switch the filter into the
430 !signal path to smooth the waveform. Set the trigger source so that
440 !the DAC is triggered internally. Arm the channel so that the trigger
450 !signals will be accepted.
460 !
470 OUTPUT 709;"APPLY WFV 0,0"
480 OUTPUT 709;"FILTER ON"
490 OUTPUT 709;"TRIG INT"
500 OUTPUT 709;"TARM AUTO"
510 END
```

A plot of the waveform is shown below:

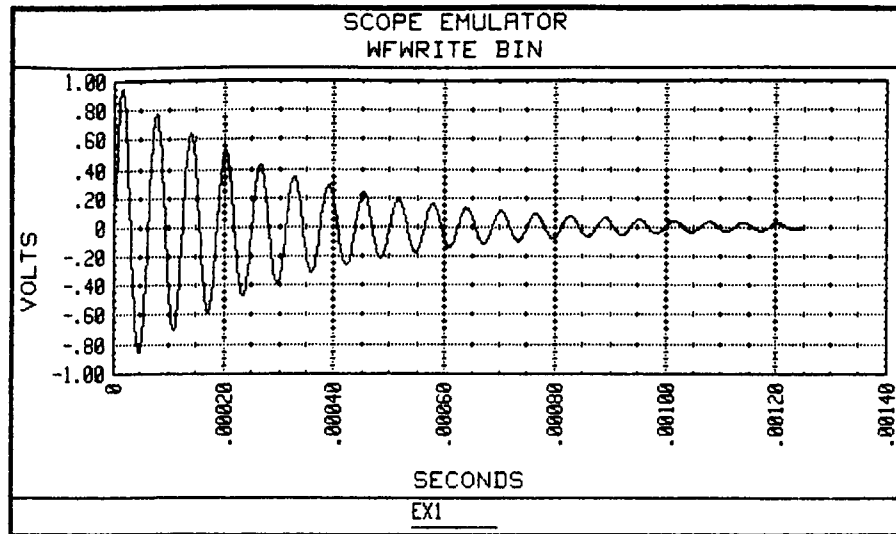

WFWRITE RPV

• HP 44726A 2-Channel Arbitrary Waveform DAC

Description

Defines a special function triangle wave and stores the waveform in the channel memory of the DAC.

Prerequisites

Requires firmware revision 3.5 or greater. TARM OFF or TARM AUTO must also be set.

Syntax

WFWRITE RPV *waveform_number* *volts_pk_to_pk* [**OFFSET** *volts*]
[**SLOPE** *direction*] [**DUTY** *percent*] [**PIS** *number*] **TBASE** *seconds* [**USE** *ch*]

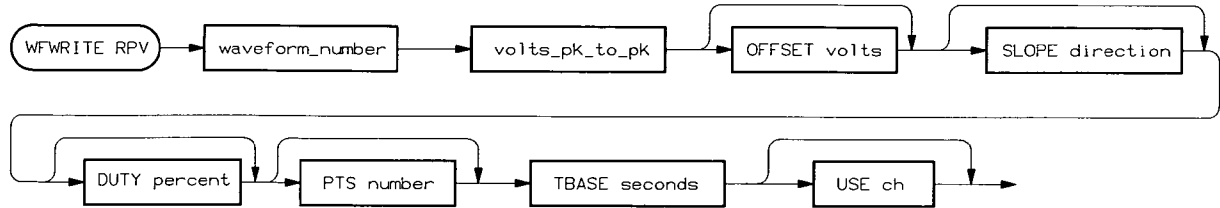

Parameters

waveform_number

Number assigned to the waveform. The range for *waveform_number* is 0 to 63 per channel. The **USE ch** parameter determines whether the waveform is stored on channel 0 or channel 1.

volts_pk_to_pk

Peak-to-peak amplitude of the triangle wave. The maximum value for *volts_pk_to_pk* is 20.4793750. Note that if a larger value is specified, Error 106: DATA ALTERED - WAS OUT OF RANGE is reported, the amplitude points out of range are set to + and - 10.2396875, and the waveform modified accordingly.

OFFSET *volts*

DC offset added to the triangle wave. The maximum DC offset allowed depends on the amplitude of the waveform (*volts_pk_to_pk*). Specifically,

$DC\ offset + |(volts_pk_to_pk/2)|\ must\ be \leq 10.2396875$

or

$DC\ offset - |(volts_pk_to_pk/2)|\ must\ be \geq -10.2396875$

Should a DC offset be specified that would cause the peak amplitude of the triangle wave to exceed ± 10.2396875 , Error 106: DATA ALTERED - WAS OUT OF RANGE is reported, the amplitude points out of range are set to + or - 10.2396875, and the waveform modified accordingly. The default offset is 0V.

SLOPE *direction*

Direction of the first ramp in the waveform. For *direction* = LH, the ramp initially increases in voltage with time. For *direction* = HL, the ramp initially decreases in voltage with time.

WFWRITE RPV (cont)

DUTY percent Duty cycle of the triangle waveform expressed as a percentage. The duty cycle is defined as the ratio of the period of the first ramp to the period of the waveform. The minimum and maximum duty cycle specified depends on the number of points in the waveform and is given as follows:

POINTS	MINIMUM DUTY CYCLE	MAXIMUM DUTY CYCLE	RESOLUTION
8	50%	50%	- - -
20	20%	80%	10%
40	10%	90%	5%
100	4%	96%	2%
200	2%	98%	1%
500	0.8%	99.2%	0.4%
1000	0.4%	99.6%	0.2%

For an eight point triangle wave, any duty cycle specified that is within 12.5% of 50 will be rounded to 50.

PTS number Number of amplitude points which comprise the waveform. The number of points which can be specified are 8, 20, 40, 100, 200, 500, and 1000. The default number is 1000. Note that higher frequency waveforms are attainable when fewer points are used. See "Waveform Frequency Range" under Remarks.

TBASE seconds Time interval between the points on the waveform. The range for seconds is 1.25E-6 to 16.384E-3. Resolution is 0.25E-6.

USE ch Channel on which the waveform is stored and from which it will be applied. The range for ch is ES00 to ES01. The default USE ch is channel 0.

Remarks Waveform Frequency Range

The frequency of signals output from the DAC is dependent upon the time base specified and the number of time base intervals each amplitude point is held. For special function triangle waves, each amplitude is held for one time base interval. For the number of points per waveform which can be selected, the following frequency ranges apply:

POINTS PER WAVEFORM	MINIMUM FREQUENCY	MAXIMUM FREQUENCY
8	7.62 Hz	100 kHz
20	3 Hz	40 kHz
40	1.52 Hz	20 kHz
100	0.61 Hz	8 kHz
200	0.30 Hz	4 kHz
500	0.122 Hz	1.6 kHz
1000	0.061 Hz	800 Hz

WFWRITE RPV (cont)

Setting the Frequency of the Waveform

Given that each amplitude point is held for one time base interval, the frequency of a special function triangle wave can be defined as:

$$\text{frequency} = 1/(\text{TBASE} * \text{npts})$$

where npts is the number of points in the waveform.

When the (desired) frequency and the number of waveform points (npts) are known, the equation can be solved for TBASE, which gives:

$$\text{TBASE} = 1/(\text{frequency} * \text{npts})$$

For example, for a 10 kHz, 40 point triangle wave, the time base that would be specified in the WFWRITE RPV command is:

$$\text{TBASE} = 1/(10000 * 40) = 2.5\text{E}-6$$

Negative Peak-to-Peak Amplitudes Change the Slope of the Waveform

A negative (-) amplitude specified for the *vols_pk_to_pk* parameter will change the slope (direction) of the first ramp in the triangle wave. Thus, if a negative amplitude is specified along with SLOPE LH, the first ramp will be decreasing in voltage. If a negative amplitude is specified with SLOPE HL, the first ramp will be increasing in voltage.

Command Execution Time

As waveforms are added to channel memory, they are placed one after the other, with a gap only between the last point of the last waveform and the end of memory. If waveforms are subsequently deleted, additional gaps are created and used to store new waveforms if the gaps are large enough.

When the situation arises where no single gap is large enough for a new waveform, yet the space occupied by all of the gaps is large enough, gaps are combined by moving existing waveforms until a sufficient gap is formed. This process, which occurs only under the above condition, can add up to an additional 1.5 seconds of execution time to WFWRITE RPV.

Modifying Special Function Triangle Waves

If a special function triangle wave is to be modified by the WFMOD command, TARM OFF or TARM AUTO must be set. Note that the modified waveform replaces the waveform defined by WFWRITE RPV in channel memory.

Viewing the Waveform

The waveform generated by the following example program is easily viewed by connecting the accessory's DAC OUT BNC to an oscilloscope. The plot shown was drawn using the HP 44458A - DACQ/300 software package. Refer to the "Viewing Waveforms" section of the Glossary for an example of how the software is used.

Data Returned

None

Related Commands

APPLY WFV, WF?, WFDELETE, WFMOD, WFPER?, WFPREAD, WFSIZE?, WFTBASE?

Examples

Example: Defining a Special Function Triangle Wave

The following program shows how WFWRITE RPV is used to define a triangle wave and how that waveform appears on an oscilloscope.

The desired waveform is a 100 point waveform that is 5 kHz, 1 Vp-p, with a duty cycle of 90%. Since the number of points and the desired frequency are known, the equation which calculates the necessary time base is evaluated by the TBASE parameter.

```

10  !Reset the HP 3852A and the HP 44726A (in slot 0). Define and
20  !store the special function triangle wave. The triangle wave
30  !will be a 100 point waveform, 1 Vp-p, 5 kHz, with a duty cycle
40  !of 90 percent. The waveform will be stored on channel 0
50  !(default).
60  !
70  OUTPUT 709;"RST"
80  WAIT 1
90  OUTPUT 709;"WFWRITE RPV 0 1 DUTY 90 PTS 100 TBASE (1/(5E3*100))"
100 !
110 !Turn on the anti-aliasing filter to smooth the waveform. Output
120 !a sync pulse from the SYNC OUT BNC to note the beginning of
130 !each cycle. Select the waveform in channel 0 memory. Arm the
140 !channel so that when triggers are received, the data in
150 !that portion of memory is sent to the DAC which then generates
160 !the waveform.
170 !
180 OUTPUT 709;"FILTER ON"
190 OUTPUT 709;"SYNC WF"
200 OUTPUT 709;"APPLY WFV 0,0"
210 OUTPUT 709;"TRIG INT"
220 OUTPUT 709;"TARM AUTO"
230  END

```

A plot of the waveform is shown on the following page.

WFWRITE RPV (cont)

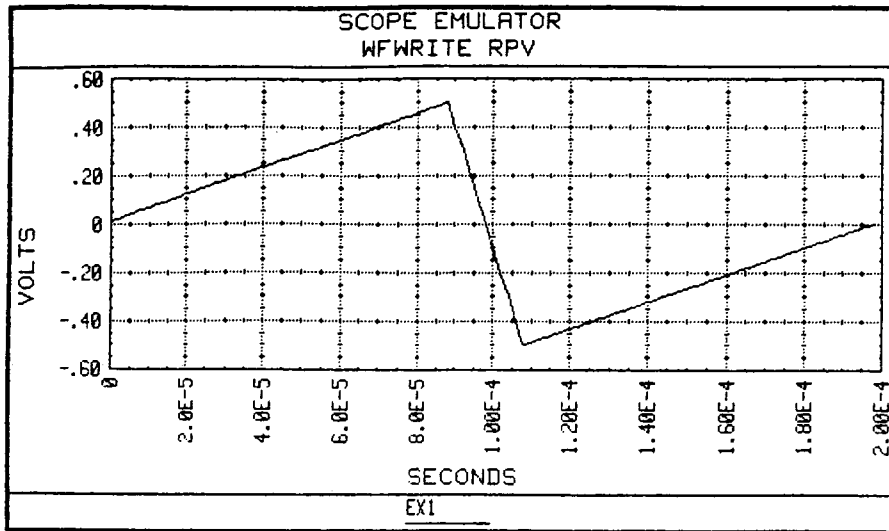

WFWRITE SQV

• HP 44726A 2-Channel Arbitrary Waveform DAC

Description

Defines a special function square wave and stores the waveform in the channel memory of the DAC.

Prerequisites

Requires firmware revision 3.5 or greater. TARM OFF or TARM AUTO must also be set.

Syntax

WFWRITE SQV *waveform_number* *volts_pk_to_pk* [**OFFSET** *volts*]
[**SLOPE** *direction*] **TBASE** *seconds* [**USE** *ch*]

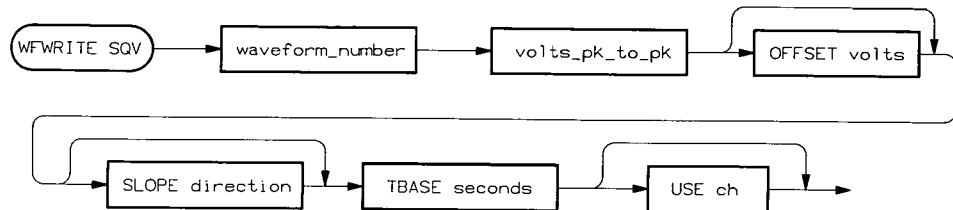

Parameters

waveform_number

Number assigned to the waveform. The range for *waveform_number* is 0 to 63 per channel. The **USE ch** parameter determines whether the waveform is stored on channel 0 or channel 1.

volts_pk_to_pk

Peak-to-peak amplitude of the square wave. The maximum value for *volts_pk_to_pk* is 20.4793750. Note that if a larger value is specified, Error 106: DATA ALTERED - WAS OUT OF RANGE is reported, the output is set to + and - 10.2396875, and the waveform modified accordingly.

OFFSET *volts*

DC offset added to the square wave. The maximum DC offset allowed depends on the amplitude of the waveform (*volts_pk_to_pk*). Specifically,

DC offset + $|(\text{volts_pk_to_pk}/2)|$ must be ≤ 10.2396875

or

DC offset - $|(\text{volts_pk_to_pk}/2)|$ must be ≥ -10.2396875

Should a DC offset be specified that would cause the peak amplitude of the square wave to exceed ± 10.2396875 , Error 106: DATA ALTERED - WAS OUT OF RANGE is reported, the peak amplitude is set to + or - 10.2396875, and the waveform modified accordingly. The default offset is 0V.

SLOPE *direction*

Direction of the first transition of the waveform. For *direction* = LH, the transition is from a lower voltage to a higher voltage. For *direction* = HL, the transition is from a higher voltage to a lower voltage.

WFWRITE SQV (cont)

- TBASE** *seconds* Time interval between the points on the waveform. The range for *seconds* is 1.25E-6 to 16.384E-3. Resolution is 0.25E-6.
- USE** *ch* Channel on which the waveform is stored and from which it will be applied. The range for *ch* is ES00 to ES01. The default **USE** *ch* is channel 0.

Remarks

Square Wave Frequency Range

The special function square wave is a fixed, three point waveform which uses a total of 4 time base intervals. The frequency range is, therefore, 15.26 Hz to 200 kHz. Given this, the frequency of a special function square wave can be defined as:

$$\text{frequency} = 1/(\text{TBASE} * \text{tb_intr})$$

When the (desired) frequency is known and since the number of time base intervals (tb_intr) is fixed (4), the equation can be solved for TBASE which gives:

$$\text{TBASE} = 1/(\text{frequency} * 4)$$

For example, for a 100 kHz square wave, the time base that would be specified in the WFWRITE SQV command is:

$$\text{TBASE} = 1/(100\text{E}3 * 4) = 2.5\text{E}-6$$

Negative Peak-to-Peak Amplitudes Change the Slope of the Waveform

A negative (-) amplitude specified for the *volts_pk_to_pk* parameter will change the slope (direction) of the first transition in the waveform. Thus if a negative amplitude is specified along with **SLOPE LH**, the first transition will be from a higher voltage to a lower voltage. If a negative amplitude is specified with **SLOPE HL**, the first transition will be from a lower voltage to a higher voltage.

Command Execution Time

As waveforms are added to channel memory, they are placed one after the other, with a gap only between the last point of the last waveform and the end of memory. If waveforms are subsequently deleted, additional gaps are created and used to store new waveforms if the gaps are large enough.

When the situation arises where no single gap is large enough for a new waveform, yet the space occupied by all of the gaps is large enough, gaps are combined by moving existing waveforms until a sufficient gap is formed. This process, which occurs only under the above condition, can add up to an additional 1.5 seconds of execution time to WFWRITE SQV.

Modifying the Special Function Square Wave

If a special function square wave is to be modified by the WFMOD command, **TARM OFF** or **TARM AUTO** must be set. Note that the modified waveform replaces the waveform defined by WFWRITE SQV in channel memory.

Viewing the Waveform

The waveform generated by the following example is easily viewed by connecting the accessory's DAC OUT BNC to an oscilloscope.

Data Returned

None

Related Commands

APPLY WFV, WF?, WFDELETE, WFMOD, WFPER?, WFPREAD, WFSIZE?, WFTBASE?

Examples

Example: Defining a Special Function Square Wave

The following program shows how WFWRITE SQV is used to define a square wave and how that waveform appears on an oscilloscope.

The desired waveform is 100 kHz, 2.5 Vp-p, with a DC offset of 5V and the first transition being high to low. Since the number of time base intervals is fixed and the frequency is known, the equation which calculates the necessary time base is evaluated by the TBASE parameter.

```

10  !Reset the HP 3852A and the HP 44726A (in slot 0). Define and
20  !store the special function square wave. The square wave will
30  !be 2.5 Vp-p, 100 kHz, with a 5V DC offset. The waveform will
40  !be stored on channel 0 (default).
50  !
60  OUTPUT 709;"RST"
70  WAIT 1
80  OUTPUT 709;"WFWRITE SQV 0 2.5 OFFSET 5 SLOPE HL TBASE (1/(100E3*4))"
90  !
100 !Output a sync pulse from the SYNC OUT BNC to note the beginning
110 !of each cycle. Select the waveform in channel 0 memory. Arm the
120 !channel so that when triggers are received, the data in
130 !that portion of memory is sent to the DAC which then generates
140 !the waveform.
150 !
160 OUTPUT 709;"SYNC WF"
170 OUTPUT 709;"APPLY WFV 0,0"
180 OUTPUT 709;"TRIG INT"
190 OUTPUT 709;"TARM AUTO"
200 END

```

A "sketch" of the waveform defined by this program is shown below.

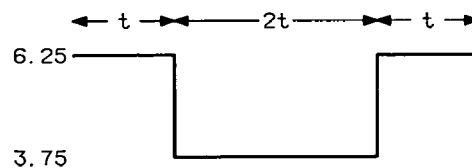

t = time base interval

WHILE...END WHILE

- Mainframe

Description

Defines a loop that is executed as long as the *expression* in the WHILE statement evaluates to a non-zero (true) value.

Prerequisites

WHILE...END WHILE can only be used in an HP 3852A subroutine.

Syntax

WHILE *expression*

program segment

END WHILE

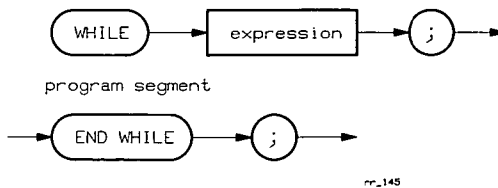

Parameters

expression

A Boolean expression evaluated as true if non-zero, false if zero.

Remarks

WHILE...END WHILE Operation

WHILE...END WHILE statements must be stored in a subroutine, with the subroutine then called in order to execute the commands. All commands between WHILE and END WHILE command are executed as long as *expression* is true.

If the value of *expression* is evaluated as true at the beginning of the loop, the program segment between WHILE and END WHILE is executed and a branch is made back to the WHILE statement. The program segment is repeated until the value of *expression* is false. At this time, the program segment is skipped and execution continues at the first line after END WHILE.

Data Returned

None (the program segment may return data, however).

Related Commands

SUB, SUBEND, FOR...NEXT, IF...END IF

WHILE...END WHILE (cont)

Examples Example: Using WHILE...END WHILE

This program uses HP 3852A subroutine PWRTWO with a WHILE...END WHILE construct to display powers of 2 <1000 (1, 2, ..., 512) on the front panel display.

```
10 OUTPUT 709;"RST"           !Reset the HP 3852A
20 OUTPUT 709;"INTEGER I"     !Declare INTEGER variable I
30 OUTPUT 709;"SUB PWRTWO"    !Define subroutine PWRTWO
40 OUTPUT 709;"VWRITE I,1"    !Write I = 1
50 OUTPUT 709;"WHILE I<1000"  !Continue until 2*I ≥ = 1000
60 OUTPUT 709;"DISP I"       !Disp value of I
70 OUTPUT 709;"VWRITE I,(2*I)" !Write next value to I
80 OUTPUT 709;"END WHILE"     !End when 2*I ≥ 1000
90 OUTPUT 709;"SUBEND"       !End subroutine
100 OUTPUT 709;"FASTDISP OFF" !Turn fast display off
110 OUTPUT 709;"CALL PWRTWO"  !Call subroutine PWRTWO
120 END
```

WRITE

• HP 44723A 16-Channel High-Speed Digital Sense/Control

Description

Write data to the first rank output register in the specified slot. A second rank output trigger is required to copy the data from the first rank output register to the second rank output register and to the user output terminals.

Prerequisites

Requires mainframe firmware revision 3.0 or greater.

Syntax

WRITE *slot data_list* or *array*

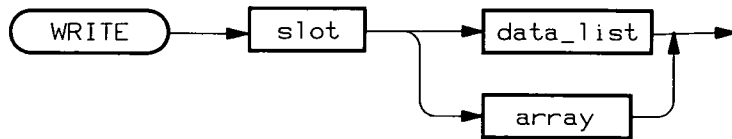

R.WRIT

Parameters

slot Address of slot. See Glossary.

data_list Decimal equivalent of the desired state of the channels in the slot specified by *slot*. The LSB goes to channel ES16, the MSB to channel ES31. A "0" sets the channel LOW, a "1" sets the channel HIGH.

array Defines array of decimal equivalent values to be written to the slot specified by *slot*. For maximum write rate, *array* must be an INTEGER array.

Remarks

Interaction with SRTRIG

The WRITE command always writes data to the first rank output register. If SRTRIG INT is set, a second rank input trigger is generated immediately after data is written to the first rank output register.

Interaction with RDGSMODE

With RDGSMODE IMMED, WRITE always immediately writes data to the first rank output register. Thus, multiple writes without intervening second rank triggers will overwrite the first rank register contents.

With RDGSMODE DAV, WRITE waits to write data to the first rank output register until a second rank output trigger is received after the last write. That is, with RDGSMODE DAV, WRITE waits for second rank output triggers between writes.

Data Returned

None

Related Commands

SRTRIG, WRITEM

Examples

Example: Write Data to Slot

This program writes data to the first rank output register to set the states of all output channels of an HP 44723A in slot 2 of the mainframe. When an external (HL) pulse is input to the second rank output trigger port, the data is copied to the second rank output register and to the output terminals.

In line 40, writing "545" sets channels 200, 205, and 209 HIGH and sets the rest of the channels in slot 2 LOW. Since RDGSMODE IMMED is set, data is immediately written to the first rank output register. However, since SRTRIG EXT is set, the data is not transferred to the second rank output register and to the output terminals until a second rank output trigger is received.

```

10 OUTPUT 709;"USE 216"           !Use ch is 200
20 OUTPUT 709;"RDGSMODE IMMED"    !Write data immediately
30 OUTPUT 709;"SRTRIG EXT"        !Ext sec rank output trig source
40 OUTPUT 709;"WRITE 200,545"     !Write data to first rank out reg
50 END

```

Example: High-Speed Write to Slot

This program writes specified bit patterns to the output channels of an HP 44723A in slot 2 at an approximate 100 kHz rate. The decimal equivalents of the desired bit patterns are first written to mainframe array A (with VWRITE) and then output to the user terminals at an approximate 100 kHz rate (with WRITE). The following bit pattern sequence is output 1000 times.

```

0000 0000 0100 0001
0000 0000 1000 1000           Repeat 1000 times
1000 0000 0000 0000
0000 0000 0000 0010

```

NOTE

Although the bit patterns are written to the channels by WRITE at approximately 100 kHz, the program requires about 20 seconds for VWRITE to write the 4000 elements into array A.

```

10 OUTPUT 709;"INTEGER A(3999)"    !Define INTEGER array
20 FOR I=1 TO 1000                !Write to array A 1000 times
30 OUTPUT 709;"VWRITE A 65,136,-32768,2" !Define array A elements
40 NEXT I                          !Increment count
50 OUTPUT 709;"USE 216"           !Use channel is 200
60 OUTPUT 709;"WRITE 200,A"       !Write data to output chs
70 END

```

WRITE

- HP 44724A 16-Channel Digital Output
- HP 44725A 16-Channel General Purpose Switch
- HP 44728A 8-Channel Relay Actuator
- HP 44729A 8-Channel Power Controller

Description

Writes data to the specified slot to open or close channels.

Prerequisites

The *data_list* and *array* parameters are valid only for mainframe firmware revision 3.0 and greater.

Syntax

WRITE *slot number*

or

WRITE *slot data_list or array*

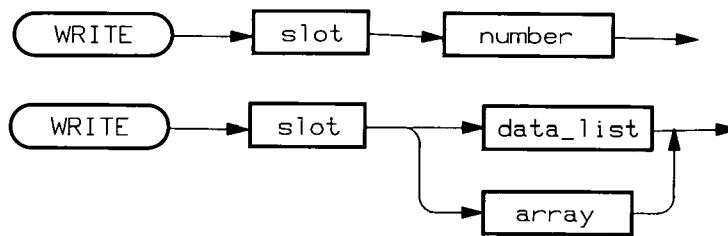

R.WRIT

Parameters

slot Slot addressed. See Glossary.

number Decimal equivalent of desired channel bit pattern. The range for the HP 44724A and HP 44725A is -32768 to +32767 (0 to +65535 unsigned). The range for the HP 44728A and HP 44729A is -128 to +127 (0 to +255 unsigned). The LSB sets channel ES00 state and the MSB sets channel ES15 state (for the HP 44724A and HP 44725A) or sets channel ES07 state (for the HP 44728A and HP 44729A).

data_list For mainframe firmware revision 3.0 and greater, *data_list* uses the same number range as *number*. You can use a maximum of ten numbers in *data_list*.

array For mainframe firmware revision 3.0 and greater, *array* defines an array of decimal equivalent values to be written to the slot specified by *slot*.

Remarks

Data Returned

None

Related Commands

CHWRITE, OPEN, CLOSE, READ

Examples Example: Write to Digital Output Channels

This program writes three bit patterns (65, 136, -32768) to an HP 44724A in slot 2 of the mainframe. The three states are first written to mainframe array A with the VWRITE command. Then, subroutine SLWRITE is called and the states are written to the channels at one-second intervals.

To check the channel states after each WRITE, CLOSE? is used which returns the state of each channel (0 = channel open, 1 = channel closed). Note that OUTBUF ON is set so data from the second and third writes is appended to the data from the first write in the output buffer.

```

10 DIM B(0:15)                !Dim controller array
20 OUTPUT 709;"OUTBUF ON"     !Turn output buffer on
30 OUTPUT 709;"INTEGER A(2)"  !Define mainframe array A
40 OUTPUT 709;"INTEGER I"    !Define variable I
50 OUTPUT 709;"VWRITE A 65,136,-32768" !Write states to array A
60 OUTPUT 709;"SUB SLWRITE"   !Start subroutine
70 OUTPUT 709;"FOR I=0 TO 2"  !Start write/read loop
80 OUTPUT 709;"WRITE 200,A(I)" !Write state to channels
90 OUTPUT 709;"WAIT 1"        !Wait 1 second
100 OUTPUT 709;"CLOSE? 200-215" !Read ch states
110 OUTPUT 709;"NEXT I"      !Increment loop counter
120 OUTPUT 709;"SUBEND"      !End subroutine
130 OUTPUT 709;"CALL SLWRITE" !Call subroutine
140 FOR I=1 TO 3              !Start display loop
150 ENTER 709;B(*)            !Enter ch states
160 PRINT "Ch states after write";(I);":" !Display header
170 PRINT B(*)                !Display ch states
180 PRINT                     !Space between displays
190 NEXT I                    !Increment display loop
200 END

```

A typical display for the three writes follows. For each write, the channel 200 state is the first entry on the first line and the channel 215 state is the last entry on the second line.

```

Ch states after write 1 :
 1   0   0   0   0   0   1   0
 0   0   0   0   0   0   0   0

Ch states after write 2 :
 0   0   0   1   0   0   0   1
 0   0   0   0   0   0   0   0

Ch states after write 3 :
 0   0   0   0   0   0   0   0
 0   0   0   0   0   0   0   1

```

WRITEM

- HP.44723A 16-Channel High-Speed Digital Sense/Control

Description

Write data to the first rank output register(s) in specified slot(s). A second rank output trigger is required to copy data from the first rank output register to the second rank output register and to the user output channels.

Prerequisites

Requires mainframe firmware revision 3.0 or greater.

Syntax

WRITEM *slot_list* **DATA** *data_list*

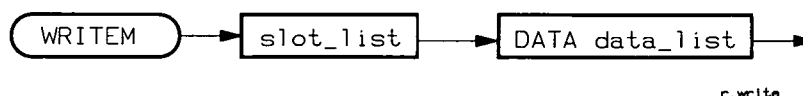

Parameters

slot_list Address of slot(s). See Glossary.

DATA *data_list* Decimal equivalent of the desired state of the channels in the slot(s) specified by *slot_list*. The LSB goes to channel ES16, the MSB to channel ES31. A "0" sets the channel LOW, a "1" sets the channel HIGH.

Remarks

Interaction with SRTRIG

The WRITEM command always writes data to the first rank output register(s). If SRTRIG INT is set, a second rank output trigger is generated immediately af-
ter data is written to the first rank output register(s).

Interaction with RDGSMODE

With RDGSMODE IMMED, WRITEM always immediately writes data to the first rank output register(s). Thus, multiple writes without intervening second rank output triggers will overwrite the first rank output register(s) contents.

With RDGSMODE DAV, WRITEM waits to write data to the first rank output register(s) until a second rank output trigger is received after the last write. That is, with RDGSMODE DAV, WRITEM waits for second rank output triggers between writes to an individual slot.

Data Returned

None

Related Commands

SRTRIG, WRITE

Examples

Example: Write Data to Slots

This program writes data to the first rank output registers to set the state of all output channels of HP 44723A accessories in slots 2 and 3 of the mainframe.

Writing "322" sets channels 201, 206, and 208 HIGH and sets the rest of the channels in slot 2 LOW. Writing "-32735" sets channels 300, 305, and 315 HIGH and sets the rest of the channels in slot 3 LOW.

Since RDGSMODE IMMED and SRTRIG INT are set for both slots, data is immediately written to the first rank output register in each slot and then copied to the second rank output registers and to the output channels when WRITEM is executed.

```
10 OUTPUT 709;"USE 200"                !Use slot is 200
20 OUTPUT 709;"RDGSMODE IMMED"         !Write data immediately
30 OUTPUT 709;"SRTRIG INT"             !Int sec rank out trig
40 OUTPUT 709;"USE 300"                !Use slot is 300
50 OUTPUT 709;"RDGSMODE IMMED"         !Write data immediately
60 OUTPUT 709;"SRTRIG INT"             !Int sec rank out trig
70 OUTPUT 709;"WRITEM 200,300 DATA 322,-32735" !Write data to output chs
80 END
```

WRITEM

- HP 44724A 16-Channel Digital Output
- HP 44725A 16-Channel General Purpose Switch
- HP 44728A 8-Channel Relay Actuator
- HP 44729A 8-Channel Power Controller

Description

Write the state (0/1) to open or close specified channel(s) in specified slot(s).

Prerequisites

Requires mainframe firmware revision 3.0 or greater.

Syntax

WRITEM *slot_list* **DATA** *data_list*

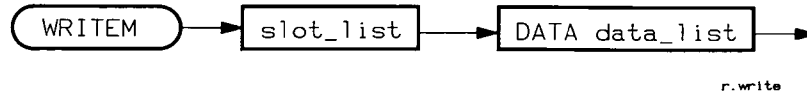

Parameters

slot_list Address of slot(s). Channel number range = ES00 through ES15 (HP 44724A and HP 44725A) or ES00 through ES07 (HP 44728A and HP 44729A).

DATA *data_list* Decimal equivalent of the desired state of the channels in the slot(s) specified by *slot_list*. The LSB goes to channel ES00. The MSB goes to channel ES15 for the HP 44724A or HP 44725A or to channel ES07 for the HP 44728A or HP 44729A. WRITEM uses one item from DATA *data_list* for each slot OR slot range in *slot_list*.

Remarks

Data Returned

None

Related Commands

CHWRITE, WRITE

Examples

Example: Writing to Slots

This program line writes data to HP 44724As in slots 2 and 3 of the mainframe. Writing "332" (0000 0001 0100 0010) closes channels 201, 206 and 208 and opens the rest of the channels in slot 200. Writing "-32735" (1000 0000 0010 0001) closes channels 300, 305, and 315 and opens the rest of the channels in slot 300.

```
.  
. .  
100 OUTPUT 709;"WRITEM 200,300 DATA 322,-32735" !Write data  
. .
```

- HP 44701A Integrating Voltmeter
- HP 44702A/B High-Speed Voltmeter (Scanner or System Mode)

Description

Transfers a specified number of readings from the voltmeter to the HP-IB output buffer/display or to mainframe memory.

Prerequisites

If you are using the HP 44702A/B voltmeter, RDGS SYS must be set before XRDGS can be used.

Syntax

XRDGS *ch* [*number*] [**INTO** *name*] or [*fmt*]

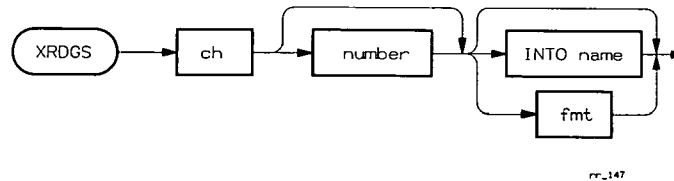

Parameters

ch Voltmeter slot number. See Glossary.

number Number of readings to transfer. The *number* range is 1 to 2147483647. For the HP 44701A Integrating voltmeter, default *number* = 1.

For the HP 44702A/B High-Speed Voltmeter in System mode, the default *number* is the number of readings specified by NRDGS. If some readings have been read from the buffer with other commands (i.e. CHREAD), XRDGS will return the readings which remain. If no readings are in the buffer when XRDGS is executed, the command will wait until the next NRDGS are in the buffer and then transfer them.

For the HP 44702A/B in Scanner mode, the default *number* is the number of readings in the buffer when the scan sequence completes.

INTO *name* See Glossary.

fmt See Glossary. Default format is RASC.

Remarks

XRDGS Reading Transfers

If *number* is specified, XRDGS will transfer the readings as they become available. If *number* is not specified when using the HP 44701A, the voltmeter returns one reading each time XRDGS is executed. If *number* is not specified when using the HP 44702A/B in the System mode, the HP 3852A will wait until all readings specified by NRDGS are available in the voltmeter buffer before transferring them. When the HP 44702A/B is in the Scanner mode, the HP 3852A waits until the scan sequence completes then transfers all readings in the buffer.

XRDGS (cont)

Potential HP 3852A/Controller Deadlock

With INBUF OFF, the controller and the HP 3852A may deadlock if multiple commands (or terminators) are sent in a single command line and a command generates enough data to fill the output buffer (XRDGS can fill the output buffer). The best way to avoid potential deadlock is to send a single command per command line and to read the results as soon as possible after a data-generating command is sent.

XRDGS May Clear an Interrupt

After execution, the XRDGS command will clear the voltmeter (data available) interrupt if there are no readings left in the voltmeter's buffer. Note that if an interrupt has been enabled, an interrupt will occur momentarily when a reading is transferred by XRDGS, thus lighting the INTR annunciator in the display. However, before the mainframe can service the interrupt, the XRDGS command must finish transferring all of the readings specified. If XRDGS empties the voltmeter's buffer, the interrupt is cleared before the mainframe can respond. Therefore, an ON INTR would not be called nor would INTR? indicate that the voltmeter had interrupted.

Data Returned

One or more readings from a voltmeter in the slot specified by *ch*.

Related Commands

RDGS, RDGSMODE, CHREAD

Examples

Example: Transfer Readings From Voltmeter

This program uses XRDGS to transfer 10 readings from an HP 44701A Integrating Voltmeter in slot 1 of the mainframe to the controller. The input to the voltmeter is through the rear panel terminals.

```
10 DIM Volt(0:9)           !Dimension computer array
20 OUTPUT 709;"RST"        !Reset HP 3852A and HP 44701A
30 OUTPUT 709;"USE 100"    !Use voltmeter in mainframe slot 1
40 OUTPUT 709;"CONF DCV"  !Configure for DC voltage measurements
50 OUTPUT 709;"NRDGS 10"  !Select 10 readings per trigger
60 OUTPUT 709;"TERM EXT"  !Select rear panel terminals as input
70 OUTPUT 709;"TRIG SGL"  !Trigger once
80 OUTPUT 709;"XRDGS 100,10" !Transfer readings to output buffer
90 ENTER 709;Volt(*)       !Enter readings into array
100 PRINT USING "K,/";Volt(*) !Display readings
110 END
```

A typical display for this program is:

```
3.456434  
3.398765  
3.536457  
3.326456  
3.529125  
3.423908  
3.437694  
3.434217  
3.562976  
3.312908
```

XRDGS

• HP 44715A 5-Channel Counter/Totalizer

Description

Transfers a specified number of readings from a counter channel to the HP-IB output buffer/display or to mainframe memory. XRDGS transfers each reading as it becomes available without disturbing the counting function.

Prerequisites

The channel addressed must be triggered and a reading must be available before it is returned. For the TOTAL, TOTALM, UDC, UDCM, CD, and CDM functions, only one trigger is required. For the RAT, PER, and PERD functions and for Frequency configuration, the number of valid triggers must be the same as the number of readings transferred. Also, RAT, PER, and PERD functions require NPER input periods per measurement.

Syntax

XRDGS *ch* [*number*] [*INTO name*] or [*fmt*]

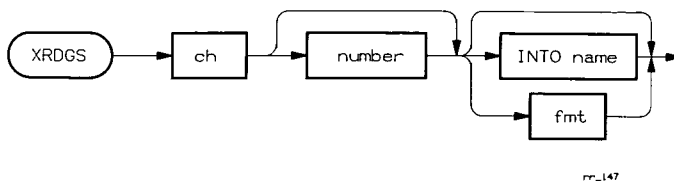

Parameters

- ch* Address of channel from which readings are transferred. Channel number range (depends on HP 44715A hardware configuration) = ES00 through ES04.
- number* Defines number of readings to be transferred from channel. Range of *number* = 1 to 2147483647. Default *number* = 1.
- INTO name* See Glossary.
- fmt* See Glossary. Default format is RASC.

Remarks

XRDGS Transfers Readings as They Become Available

When XRDGS is executed, the number of readings specified are transferred as each becomes available. (In effect, XRDGS is like several CHREADs).

XRDGS Clears Interrupts

XRDGS clears the counter interrupt previously generated by the completion of the RAT, PER, PERD, or FREQ measurement.

Potential HP 3852A/Controller Deadlock

With INBUF OFF, the controller and the HP 3852A may deadlock if multiple commands (or terminators) are sent in a single command line and a command generates enough data to fill the output buffer (XRDGS can fill the output buffer). The best way to avoid potential deadlock is to send a single command per command line and to read the results as soon as possible after a data-generating command is sent.

Data Returned

For TOTAL, TOTALM, UDC, UDCM, CD, and CDM functions, the current count is returned without disturbing the count. For the RAT function, XRDGS returns the ratio of the A channel to the B channel counts. For the PER and PERD functions, the period (in seconds) is returned. For Frequency configuration, the frequency (in Hz) is returned.

Related Commands

CHREAD

Examples

Example: Read Channel Count

This program takes 100 readings of the counts on channel 3 of a counter in slot 5 of the mainframe. The counter is set to the TOTAL function. Note that the XRDGS command returns the counts without disturbing the counting sequence.

```
10 INTEGER Cnts(0:99)                !Declare controller array
20 OUTPUT 709;"RST"                  !Reset HP 3852A and HP 44715A
30 OUTPUT 709;"USE 503"              !Use ch 3 in slot 5
40 OUTPUT 709;"FUNC TOTAL"          !Set TOTAL function on ch
50 OUTPUT 709;"TRIG SGL"            !Single-trigger channel
60 OUTPUT 709;"XRDGS 503, 100"      !Take 100 readings of the count
70 ENTER 709;Cnts(*)                !Enter readings
80 PRINT Cnts(*)                    !Display readings
90 END
```

XRDGS

- HP 44721A 16-Channel Digital Input
- HP 44722A 8-Channel Digital Input

Description

Transfers a specified number of readings from a digital input channel to the HP-IB output buffer/display or to mainframe memory. XRDGS transfers each reading as it becomes available without disturbing the counting or state sensing function.

Prerequisites

None

Syntax

XRDGS *ch* [*number*] [*INTO name*] or [*fmt*]

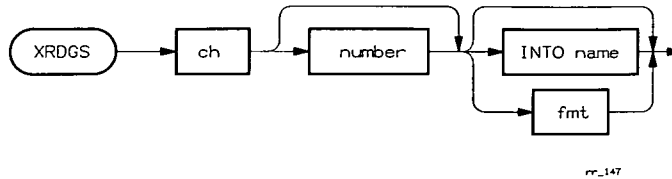

Parameters

ch Address of channel from which readings are transferred. Channel numbers ES00 - ES15 (ES00 - ES07 for the 8-channel digital input) return the current count on the channel. Channel numbers ES16 - ES31 (ES08 - ES15 for the 8-channel digital input) return the current state of the channel.

number Number of readings to be transferred. Range of *number* is 1 to 2147483647. Default *number* = 1.

INTO name See Glossary.

fmt See Glossary. Default format is RASC.

Remarks

XRDGS Transfers Readings as They Become Available

When XRDGS is executed, the number of readings specified are transferred as each becomes available. (In effect, XRDGS is like several CHREADS).

Potential HP 3852A/Controller Deadlock

With INBUF OFF, the controller and the HP 3852A may deadlock if multiple commands (or terminators) are sent in a single command line and a command generates enough data to fill the output buffer (XRDGS can fill the output buffer). The best way to avoid potential deadlock is to send a single command per command line and to read the results as soon as possible after a data-generating command is sent.

Data Returned

Channel state is returned as a "1" (HIGH for DC input, ON for AC input) or a "0" (LOW for DC input, OFF for AC input). Channel count is number of edge transitions specified by EDGE since the channel was enabled by the EDGE command, unless preset with CNTSET or zeroed by the CHREADZ command.

Related Commands

CHREAD

Examples

Example: Sampling Channel States

This program transfers 50 readings indicating the state of channel 3 of the 16-channel digital input in mainframe slot 5.

```
10 DIM Chstate(0:49)           !Dimension controller array
20 OUTPUT 709;"RST"           !Reset HP 3852A and HP 44721A/22A
30 OUTPUT 709;"XRDGS 519,50"   !Trans 50 readings indicating ch 3 state
40 ENTER 709;Chstate(*)       !Enter 50 readings
50 PRINT Chstate(*)           !Display 50 readings
60 END
```

Example: Reading Channel Counts

This program takes 50 readings of the counts on channel 3 of the digital input in mainframe slot 5.

```
10 DIM Cnts(0:49)             !Dimension controller array
20 OUTPUT 709;"RST"           !Reset HP 3852A and HP 44721A/22A
30 OUTPUT 709;"EDGE LH"       !Specific edge to count
40 OUTPUT 709;"XRDGS 503,50"   !Take 50 readings of the count
50 ENTER 709;Cnts(*)          !Enter readings
60 PRINT Cnts(*)              !Print readings
70 END
```

Chapter 3

Command Summary

CONTENTS

	Page
Introduction	3-1
Mainframe Commands	3-1
Plug-In Accessory Commands	3-4

Chapter 3 Command Summary

Introduction

This chapter lists all HP 3852A and HP 447XXX plug-in accessory commands by functional group. If the command is allowed within a subroutine, the `SUBROUTINE` column is marked. If the command can be executed from the front panel while the mainframe is in remote, `ALLOWED IN REMOTE` is marked. If executing the command requires the current or ongoing measurement to be retriggered, `MODE CHANGE` is marked.

Mainframe Commands

	<u>SUBROUTINE</u>	<u>ALLOWED IN REMOTE</u>	<u>MODE CHANGE</u>
HP-IB Communication			
ADDR	x		x [1]
ADDR?	x		
BLOCKOUT	x		
CLROUT	x		
END	x		
FASTOUT	x		
INBUF	x		
OUTBUF	x		
SYSOUT	x		
Front Panel Operation			
BEEP	x		x
DISP	x		x
DISABLE/ENABLE LABELS	x		
EDIT KEY	x		x
FASTDISP	x		x
LOCAL	x		x
LOCK	x		
MON	x		x [2]
SCRATCH KEY	x		

Interrupts/Service Requests/Triggering

DISABLE	x		
DISABLE INTR BNC	x		
ENABLE	x		
ENABLE INTR BNC	x		
GET	x		
OFF	x		
ON	x		
RQS	x		
RQS?	x	x	
SRQ	x	x	
TRG	x		

Status and Identification

CLR	x	x [3]	
ERR?	x	x	
ERRSTR?	x	x	
EXTEND?	x	x	
ID?	x	x	
IDN?	x	x	
INTR?	x	x	
POWEROFF	x	x	
RST			x
RST HARD			x
STA?	x		
STATE?	x	x	
STB?	x		
TEST	x		
USE?	x	x	

System Clock/Alarm/Pacer

ALRM	x	x	
DISABLE PWIDE	x		
ENABLE PWIDE	x		
PACER	x		
PDELAY	x		
PTRIG	x		
SET ALRM	x		
SET TIME	x		
SET TIMEDATE	x		
TIME	x	x	
TIMEDATE	x	x	

Subroutine and Data Storage

CAT	x	x
DELSUB		
DELVAR	x	
DIM	x	
INDEX	x	
INDEX?	x	x
INTEGER	x	
LET	x	
MAT	x	
PACKED	x	
REAL	x	
SCRATCH		
SIZE?	x	x
SUB		x
SUBEND		x
SYMSIZE	x	
VREAD	x	x
VWRITE	x	
VWRITEB	x	

Program Control and Synchronization

CALL	x	
CONT		
FOR...NEXT	x [4]	x
IF...ENDIF	x [4]	x
PAUSE	x	x
STEP		
WAIT	x	x
WAITFOR	x	x
WHILE...ENDWHILE	x [4]	x

Data Processing

COMPEN	x	
CONV	x	
LMT(pp)	x	
LMT(rt)	x	
LOGCHAN	x	
SCALE	x	
STAT	x	

Measurement Functions and Scanning

SADV	x	
SCAN	x	
STRIG	x	
USE	x	

Multitasking

ABORT	X	
CREATE RUN	X	
DISABLE EOL SWAP	X	
DISABLE MULTI	X	
ENABLE EOL SWAP	X	
ENABLE MULTI	X	
NLOCKS	X	
NTASKS	X	
ON...RUN	X	
PROBE/ENABLE PROBE	X	
RELEASE	X	
REQUEST	X	
RUN	X	
RUN?	X	X
SIGNAL	X	
SUSPEND	X	
SUSPEND UNTIL	X	
TSLICE	X	
URGENCY	X	
WAITFOR SIGNAL	X	

Plug-In Accessory Commands

HP 44701A Integrating Voltmeter

ARANGE	X	X
AZERO	X	X
CAL	X	X
CHREAD	X	X
CONF	X	X
CONFMEAS	X	X
DELAY	X	X
DISABLE INTR	X	
ENABLE INTR	X	
FUNC	X	X
MEAS	X	X
MONMEAS	X	X
NPLC	X	X
NRDGS	X	X
OCOMP	X	X
RANGE	X	X
RST		X
TERM	X	X
TEST	X	X
TRIG	X	X
USE	X	X
XRDGS	X	X

HP 44702A/B 13-Bit High-Speed Voltmeter

ARMODE	x	x
ASCAN	x	x
AZERO	x	x
CAL	x	x
CHREAD	x	x
CLWRITE	x	x
CONF	x	x
CONFMEAS	x	x
DELAY	x	x
DISABLE INTR	x	
ENABLE INTR	x	
FUNC	x	x
MEAS	x	x
MONMEAS	x	x
NRDGS	x	x
PERC	x	x
POSTSCAN	x	x
PRESCAN	x	x
RANGE	x	x
RDGS	x	x
RDGSMODE	x	x
RST		x
SCANMODE	x	x
SCDELAY	x	x
SCSLOPE	x	x
SCTRIG	x	x
SLOPE	x	x
SPER	x	x
STSLOPE	x	x
STTRIG	x	x
TERM	x	x
TEST	x	x
TRIG	x	x
TRIGOUT	x	x
USE	x	x
XRDGS	x	x

HP 44705A 20-Channel Relay Multiplexer
HP 44705H 20-Channel High-Voltage Relay Multiplexer
HP 44706A 60-Channel Relay Multiplexer
HP 44708A 20-Channel Relay Multiplexer/TC
HP 44708H 20-Channel High-Voltage Relay Multiplexer/TC
HP 44709A 20-Channel FET Multiplexer
HP 44710A 20-Channel FET Multiplexer/TC
HP 44711A 24-Channel High-Speed FET Multiplexer
HP 44712A 48-Channel High-Speed FET Multiplexer
HP 44713A 24-Channel High-Speed FET Multiplexer/TC

CLOSE	x				x
CLOSE?	x		x		
OPEN	x				x
SCAN	x				x
TEST	x				x

HP 44714A 3-Channel Stepper Motor Controller/Pulse Output

DELAY	x				x
DISABLE INTR	x				
DONE?	x		x		
ENABLE INTR	x				
HALT	x				x
HARDLIM	x				x
MOVE	x				x
POS	x				x
POS?	x		x		
PROFILE	x				x
PSCALE	x				x
PULSE	x				x
QINDEX	x				x
QPOS?	x		x		
QSCALE	x				x
STANDBY	x				x
SUSTAIN	x				x
TEST	x				x
TRIG	x				x

HP 44715A 5-Channel Counter/Totalizer

CHREAD	x				x
CHREADZ	x				x
CNTSET	x				x
CONF	x				x
DISABLE INTR	x				
DONE?	x		x		
EDGE	x				x
ENABLE INTR	x				
FUNC	x				x
NPER	x				x
SPER	x				x
TBASE	x				x

SUBROUTINE ALLOWED IN REMOTE MODE CHANGE

TERM	x	x
TEST	x	x
TRIG	x	x
USE	x	x
XRDGS	x	x

HP 44717A 10 Bridge 120Ω Static Strain Gage Relay Multiplexer
HP 44718A 10 Bridge 350Ω Static Strain Gage Relay Multiplexer
HP 44719A 10 Bridge 120Ω Static Strain Gage FET Multiplexer
HP 44720A 10 Bridge 350Ω Static Strain Gage FET Multiplexer

CLOSE	x	x
CONF	x	x
CONFMEAS	x	x
MEAS	x	x
MONMEAS	x	x
OPEN	x	x
SCAN	x	x
TEST	x	x

HP 44721A 16-Channel Digital Input
HP 44722A 8-Channel Digital Input

CHREAD	x	x
CHREADM	x	x
CHREADZ	x	x
CNTSET	x	x
CONF	x	x
DISABLE INTR	x	
EDGE	x	x
ENABLE INTR	x	x
READ	x	x
READM	x	x
TEST	x	x
USE	x	x
XRDGS	x	x

HP 44723A 16-Channel High-Speed Digital Sense/Control

CHREAD	x	x
CHREADM	x	x
CHWRITE	x	x
CHWRITEM	x	x
DISABLE INTR	x	
EDGE	x	x
ENABLE INTR	x	
PATTERN	x	x
RDGSMODE	x	x
READ	x	x
READM	x	x
SRTRIG	x	x
TRIG	x	x

SUBROUTINE ALLOWED IN REMOTE MODE CHANGE

TRIGMODE	X		X
USE	X		X
WRITE	X		X
WRITEM	X		X

HP 44724A 16-Channel Digital Output
HP 44725A 16-Channel General Purpose Switch
HP 44728A 8-Channel Relay Actuator
HP 44729A 8-Channel Power Controller

CHWRITE	X		X
CHWRITEM	X		X
CLOSE	X		X
CLOSE?	X	X	
OPEN	X		X
READ	X		X
TEST	X		X
WRITE	X		X
WRITEM	X		X

HP 44726A 2-Channel Arbitrary Waveform DAC

APPLY DCV	X		X
APPLY PERC	X		X
APPLY WFV	X		X
DISABLE DAC	X		
DISABLE INTR	X		
ENABLE DAC	X		
ENABLE INTR	X		
FILTER	X		
NSCAN	X		X
SYNC	X		X
TARM	X		X
TARMED?	X	X	
TBASE	X		X
TEST	X		X
TRIG	X		X
WF?	X		
WFDELETE	X		X
WFMOD	X		X
WFPER?	X		
WFREAD	X		X
WFSIZE?	X		
WFTBASE?	X		
WFWRITE ACV	X		X
WFWRITE ARB	X		X
WFWRITE BIN	X		X
WFWRITE RPV	X		X
WFWRITE SQV	X		X

HP 44727A/B/C 4-Channel DACs

APPLY DCI	x		x
APPLY DCV	x		x
APPLY PERC	x		x
SETTLE	x		x
TEST	x		x

HP 44730A Track/Hold with Signal Conditioning

HP 44732A 120 Ω Dynamic Strain Gage FET Multiplexer

HP 44733A 350 Ω Dynamic Strain Gage FET Multiplexer

AZERO	x		x
CAL	x		x
CLOSE	x		x
CLOSE?	x	x	x
CONF	x		x
CONFMEAS	x		x
FILTER	x		x
FUNC	x		x
GAIN	x		x
MEAS	x		x
NULL	x		x
OPEN	x		x
TRIG	x		x
USE	x		x

HP 44788A HP-IB Controller

ASSIGN	x
AUTOST IS	x
CAT	x
CLEAR	x
CREATE ASCII	x
CREATE BDAT	x
ENTER	x
INITIAL	x
INPUT	x
MSI	x
OUTPUT	x
PRINT	x
PRINTER IS	x
PURGE	x
SPOLL	x
TRIGGER	x

Logical Operators

AND	x
OR	x
EXOR	x
NOT	x

Binary Functions

BINAND	x
BINCMF	x
BINEOR	x
BINIOR	x
BIT	x
ROTATE	x
SHIFT	x

Trigonometric Operations

ATN	x
COS	x
SIN	x

Math Functions

+	x
-	x
*	x
/	x
^	x
ABS	x
DIV	x
EXP	x
FRACT	x
INT	x
LGT	x
LOG	x
MOD	x
SGN	x
SQR	x

Comparison Operators

=	x
< >	x
<	x
≤	x
>	x
≥	x

Notes

- [1] = ADDR can only be executed from the front panel.
The mainframe must be in the local mode.
- [2] = Allowed in remote if executed as MONITOR.
- [3] = The front panel CLEAR key is active while in remote.
- [4] = Command can only be executed inside a subroutine.

Chapter 4
Glossary

CONTENTS

	Page
Introduction	4-1
Glossary of Terms	4-1
Addressing	4-1
Data	4-1
Data Formats	4-2
Dyadic Operators	4-3
Hierarchy	4-3
Parameters	4-3
ch	4-3
ch_list	4-3
slot	4-4
number	4-4
USE ch	4-4
Using Subroutines	4-4
Viewing	4-5

Introduction

This chapter contains definitions of various HP 3852A programming terms and frequently used command parameters. For additional information on any of the following terms or parameters, refer to the HP 3852A Mainframe Configuration and Programming Manual.

Glossary of Terms

Addressing Convention

An address identifies where the accessory is installed (mainframe, extender), the slot the accessory is installed in, and the channel that is selected. Address information is represented using the convention: ESCC, where E is the mainframe or extender number, S is a mainframe or extender slot number, and CC is the accessory channel number.

Under the ESCC convention, E will be a number from 0 to 7 depending on whether the accessory or channel specified is in the mainframe or in an extender. For any accessory installed in the mainframe, E is 0. Extenders used with the mainframe are assigned an extender number from 1 to 7. For an accessory installed in an extender, E is equal to the number set for that particular extender.

The S parameter within the ESCC convention represents a slot number. Mainframe slots are numbered 0-7, extender slots are numbered 0-9.

The CC parameter in the ESCC convention represents an accessory channel. Channel range depends on the particular accessory. The first channel on any accessory is channel 0. Therefore, the range of channels on a 20-channel accessory for example, is 0-19.

Data Destinations

The destination of data returned by a command depends on where the command originated (front panel, HP-IB, subroutine) and on your response to the [INTIO *name*] parameter within those commands. Data destinations include the mainframe's display, the HP-IB output buffer, and internal memory. When the HP 44702A/B high-speed voltmeter is used, the voltmeter's GPIO interface is also an available destination.

Commands Entered from the Front Panel and HP-IB

When a command is entered from the front panel, the destination of the data returned is the mainframe's display or its internal memory. Data is only displayed if the display has been enabled by the DISPlay command and the data is in a mainframe display format.

When a command is entered from a controller over the HP-IB, the destination of the data is the HP-IB output buffer and display, or mainframe memory. Note that data is displayed only if it is in a mainframe display format, the display is enabled (DISP), and the data is routed to the display with the MONitor command.

Commands Executed within Subroutines

When a command that returns data is executed within an HP 3852A subroutine, the destination of the data depends on where the subroutine was called from (CALL command). If the subroutine is called from the front panel, the destination is the mainframe's display or internal memory as described above. If the subroutine is called over the HP-IB, the destination is the HP-IB output buffer and display, or internal memory as also described above.

If a subroutine is called by the ON ALRM, ON LMT, or ON INTR command, the destination(s) depends on whether the command (ON ...) was entered from the front panel or over the HP-IB.

The INTO *name* Parameter

Most of the HP 3852A commands that return data contain INTO *name* as a parameter. Specifying this parameter indicates an array, array element, or variable is the destination for the data returned. Note that the data goes directly into the array or variable "*name*" and is not displayed or sent to the HP-IB output buffer. This occurs regardless of where the command originated.

The brackets [] that enclose INTO *name* indicate that it is an optional parameter. If INTO *name* is not specified, the destination of the data then becomes a function of where the command originates.

Data Formats

The *fmt* Parameter

Most of the commands that return data contain *fmt* along with INTO *name* as a command parameter. The *fmt* parameter is used to specify the format of the data returned by the command. When *fmt* is specified, the data is returned in that particular format to the front panel, HP-IB output buffer, or both depending on where the command originated. Data is not returned to mainframe memory when *fmt* is specified as *fmt* and INTO *name* cannot be specified together in the same command.

Output Data Formats

Data can be returned to the HP-IB output buffer in any of four ASCII formats (IASC, LASC, RASC, DASC), or in any of two binary formats (RL64, IN16) specified by the user. Data can also be returned in several packed formats (PACK) which are command and accessory dependent.

Display Formats

The HP 3852A displays data in the ASCII formats IASC, LASC, RASC, and DASC. Data can be displayed in an ASCII format other than the default format using the *fmt* parameter. Note that data cannot be stored in the mainframe in an ASCII format.

Dyadic Operators

Storage Formats

Data in a binary or packed format is either sent to the HP-IB output buffer or stored in mainframe memory. Data of this type cannot be displayed by the mainframe. Refer to Useful Tables for additional information on the data formats specified by *fmt*.

An operator that performs its operation with two expressions and is placed between the expressions. Dyadic operators for the HP 3852A are:

Operator	Operation
+	REAL or INTEGER Addition
-	REAL or INTEGER Subtraction
*	REAL or INTEGER Multiplication
/	REAL Division
^	Exponentiation
=	Comparison for equality
<>	Comparison for inequality
<	Comparison for less than
>	Comparison for greater than
<=	Comparison for less than or equal to
>=	Comparison for greater than or equal to
AND	Logical AND (Boolean >)
OR	Logical inclusive OR (Boolean <)

Hierarchy

Order of precedence when a numeric or string expression contains more than one operation. Operations with the highest precedence are performed first. Multiple operations with the same precedence are performed left to right. The hierarchy for numeric operations follows:

Precedence	Operator
Highest	Parentheses: (may be used to force any order) Exponentiation: ^ Multiplication and Division: *, / Addition and Subtraction: +, - Relational Operators: =, <>, <, >, <=, >=
Lowest	AND, OR

Parameters

ch Address of channel. Channel addresses have the form ESCC. For the HP 44701A and HP 44702A/B voltmeter accessories, CC = 00. A channel address can be represented by a variable or array name, or by a number as described by the *number* parameter.

ch_list Address of channel list. Channel list addresses have the form: ESCC [-ESCC] [ESCC [-ESCC]...]. This form shows that a channel list can be a single channel (ESCC), a list of channels (ESCC-ESCC), a combination of single channels and channel lists (ESCC, ESCC-ESCC), or a group of channel lists (ESCC-ESCC, ESCC-ESCC). Channels can be specified in increasing or decreasing order. A channel list can also be represented by a variable or array name, or *number*.

- slot* Address of slot. Slot addresses have the form ES00. Slot addresses can be represented by a variable or array name, or *number*.
- number* Any parameter requiring a number, or slot or channel address can be specified as a free field ASCII number, an array, array element, variable, or a parenthesized numeric expression (similar to those allowed in BASIC) formed by combining numbers or arrays with math functions (+, -, *, /, ^, PI, ABS, EXP, FRACT, INT, LGT, LOG, SGN, SQR), trigonometric operations (ATN, COS, SIN), and binary functions (BINAND, BINCMP, BINIOR, BINEOR, BIT, ROTATE, SHIFT).
- USE *ch* The USE Channel is a command and a command parameter that specifies a particular accessory or accessory channel to perform the function as directed by a series of commands or by a single command. The "channel" entered in the USE channel command or parameter is the slot or channel address of the accessory.

The USE Command

The accessory or channel specified by the USE command is the selected accessory or channel on which a series of functions will be performed. This becomes the default accessory or channel for all commands that follow in which the USE *ch* is a command parameter and is not specified.

The USE *ch* Parameter

The accessory or channel specified by the USE *ch* parameter is selected for that command only. All other preceding or following commands have the USE channel as set by the USE command unless specified otherwise by the USE *ch* parameter.

The Power-On USE Channel

At power-on or following a reset, the channel selected is the lowest channel number for which the USE *ch* command is valid. For example, if an HP 44721A 16-Channel Digital Input is installed in slot 2 of the mainframe, the power-on USE *ch* is 200 (slot 2, channel 0), provided no other accessory that accepts the USE command is installed in mainframe slots 0 or 1.

The Default USE Channel

The default USE channel is the last channel specified by the USE *ch* command or the power-on value if the USE command has not been executed.

Using Subroutines

The following guidelines apply when using HP 3852A subroutines:

1. Subroutines can be entered into mainframe memory from the front panel keyboard or downloaded over the HP-IB.
2. Subroutines are erased from memory at power-down, or following the SCRATCH, RST, or RST HARD command.
3. The execution of a subroutine can be viewed by sending the FASTDISP OFF command prior to calling the subroutine. The STEP command also controls execution speed.

4. Variables and arrays are global. They can be dimensioned inside or outside a subroutine then used inside or outside a subroutine.

5. Math functions, trigonometric operations, and binary functions can be used inside subroutines.

6. The following BASIC language constructs can only be used inside subroutines:

FOR...NEXT

IF...END IF

WHILE...END WHILE

The relational operators =, <, >, <>, <=, and >= can be used in the IF and WHILE statements. The maximum number of nested constructs is 10.

7. The following commands cannot be used inside subroutines: DELSUB, SCRATCH, STEP, CONT, or a second SUB...SUBEND statement.

8. A subroutine must be paused or in the step mode to use CONT or STEP. A PAUSE command cannot be located inside a nested subroutine or inside a subroutine called more than once.

If a subroutine called from the HP-IB is paused, then continued from the front panel, the destination of the data returned is the display, if the data is not being stored internally. This means that data previously returned to the output buffer will now be returned to the display.

9. In the power-on mode, a subroutine runs to completion before another subroutine or a command outside of a subroutine executes. In the multitasking mode, a subroutine can be interrupted or preempted following the currently executing command.

10. You can exit a subroutine in process by using the CLR or system RST command inside the subroutine, pressing the CLEAR key on the front panel, or by sending Device Clear over the HP-IB. Executing RST erases the subroutine from memory. Executing CLR stops the subroutine from executing but does not erase it. It also cannot be continued.

11. To use the ON *event* CALL *name* command with an interrupt as the event that calls the subroutine, the interrupt must first be enabled.

12. If an error occurs inside a subroutine, the subroutine is aborted. If a nested subroutine is aborted, the calling subroutine continues.

Viewing Waveforms

The HP 44726A arbitrary and special function waveforms shown with various command reference entries were plotted using the HP 44458A - DACQ/300 software package. A listing of the routines used, the commands which define a specific waveform (SIN(X)/X), and a plot of the waveform are shown on the following pages.

```

10  INTEGER N_points
12  REAL Freq,Tbase
14  N_points=1000
16  Freq=500
18  Tbase=1/(Freq*N_points)
20  ASSIGN @Hp3852 TO 709
22  ASSIGN @No_format TO 709;FORMAT OFF
24  !
26  INTEGER Plot_record(0:799)
28  ALLOCATE REAL Wv_amp(0:N_points-1),X_axis(0:N_points-1)
30  !
32  CLEAR @Hp3852
34  OUTPUT @Hp3852;"RST"
36  WAIT 1
38  OUTPUT @Hp3852;"SUB SIN_X"
40  OUTPUT @Hp3852;" REAL AMP(";N_points-1;"),X"
42  OUTPUT @Hp3852;" FOR X = (-5*PI+10*PI/";N_points;") TO (5*PI) STEP
(10*PI/";N_points;)"
44  OUTPUT @Hp3852;" IF X = 0.0 THEN"
46  OUTPUT @Hp3852;" VREAD 1.0 INTO AMP"
48  OUTPUT @Hp3852;" ELSE"
50  OUTPUT @Hp3852;" VREAD (SIN(X)/X) INTO AMP"
52  OUTPUT @Hp3852;" END IF"
54  OUTPUT @Hp3852;" NEXT X"
56  OUTPUT @Hp3852;"SUBEND"
58  OUTPUT @Hp3852;"CALL SIN_X"
60  OUTPUT @Hp3852;"WFWRITE ARB 0 AMP TBASE";Tbase;"USE 1"
62  OUTPUT @Hp3852;"APPLY WFV 1,0"
64  OUTPUT @Hp3852;"TRIG INT USE 1"
66  OUTPUT @Hp3852;"TARM AUTO USE 1"
68  !
70  OUTPUT @Hp3852;"WFREAD 0 AMPL USE 1 RL64"
72  ENTER @No_format;Wv_amp(*)
74  !
76  FOR I=0 TO N_points-1
78  X_axis(I)=I*Tbase
80  NEXT I
82  !
84  CALL Sys_init("P",64) ! 64Kbytes of E-disc created
86  MASS STORAGE IS ":MEMORY,0,15"
88  CALL Save_rvect(Wv_amp*),"Y:MEMORY,0,15")
90  CALL Save_rvect(X_axis*),"X:MEMORY,0,15")

```

```

92  GCLEAR
94  GRAPHICS ON
96  CALL Plot_init(Plot_record(*))
98  CALL Graph_labels(Plot_record(*),"SCOPE EMULATOR","WFWRITE ARB",
"SECONDS","VOLTS","EX2")
100 CALL Graph_axes(Plot_record(*),"GRIDA")
102 CALL Plot_add(Plot_record(*),1,"X:MEMORY,0,15","Y:MEMORY,0,15")
104 CALL Graph_autoscale(Plot_record(*))
106 CALL Graph_show(Plot_record(*))
108 END
110 !
112 ! Routines beyond this point are from the software package
114 ! HP 44458A - DACQ/300. It supports the use of the routines
116 ! Sys_init,Plot_init,Save_rvect,Graph_labels,Graph_axes,Plot_add,
118 ! Graph_autoscale, and Graph_show.

```

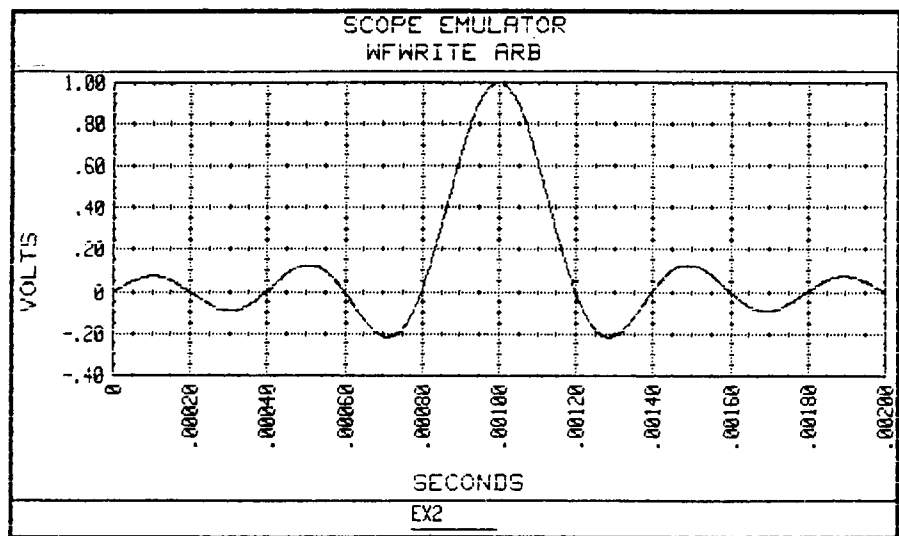

Chapter 5
Useful Tables

CONTENTS

	Page
Introduction	5-1
HP 3852A Addressing	5-2
HP 3852A Power-On State	5-3
Accessory Power-On States	5-4
HP 3852A Data Formats	5-9
Packed Data Conversion Routines	5-10

Introduction

This chapter contains five tables which summarize various operating and programming conditions for the HP 3852A and for HP 447XXX plug-in accessories. A summary of the information in each table follows.

Table 5-1. HP 3852A Addressing summarizes addressing conventions for the HP 3852A and for the HP 447XXX plug-in accessories.

Table 5-2. HP 3852A Power-On State lists the power-on/reset state for the HP 3852A mainframe.

Table 5-3. Accessory Power-On States lists power-on/reset states and relative power consumption values for the HP 447XXX plug-in accessories.

NOTE

The relative power consumption values in Table 5-3 apply only when the accessory is installed in an HP 3852A or HP 3853A Extender with power supply part number 03852(3)-66212. Refer to the HP 3852A Mainframe Configuration and Programming Manual for power limitations with the 03852(3)-66202 power supply.

Table 5-4. HP 3852A Data Formats shows the output data formats available for the HP 3852A.

Table 5-5. Packed Data Conversion Routines lists conversion equations and unpacking routines for packed data returned by an HP 3852A and HP 447XXX plug-in accessories.

HP 3852A Addressing

Table 5-1. HP 3852A Addressing

An addressing command contains a slot, channel, or a channel list as one of its parameters. Slots are specified as ES00, channels are specified as ESCC, and channel lists are specified as ESCC [-ESCC] [ESCC [-ESCC]...].		
Definition:		
E = Extender number	S = Slot number in extender "E" where accessory is installed.	CC = Channel on accessory installed in slot "S".
HP 3852A Mainframe: E = 0 HP 3853A Extender: E = 1-7*	HP 3852A Mainframe: S = 0-7 HP 3853A Extender: S = 0-9*	The maximum number of channels for any given slot is determined by the accessory in that slot.
*Up to seven extenders per mainframe are allowed.	*Up to 78 slots per system (8 per mainframe, 10 per extender).	
When the parameter is a slot: (ES00)		
Examples: (ES00)		
0200	Specifies slot 2 in the HP 3852A mainframe. Leading zeros are optional.	
A	Specifies the slot equivalent to the value of the variable A. If A = 100 for example, slot 1 in the mainframe is specified.	
0	Specifies slot 0 in the HP 3852A mainframe.	
1700	Specifies slot 7 in HP 3853A extender number 1.	
OUTPUT 709;"ID? 3500"	Asks the identity of the accessory installed in slot 5 of HP 3853A extender number 3.	
When the parameter is a channel: (ESCC)		
Examples: (ESCC)		
10	Specifies channel 10 of an accessory installed in slot 0 of the HP 3852A mainframe (leading zeros are optional).	
1315	Specifies channel 15 of an accessory installed in slot 3 of HP 3852A extender number 1.	
(SIN (1.57))	Specifies channel 1 on an accessory installed in slot 0 of the HP 3852A mainframe.	
(SQR (25))	Specifies channel 5 of an accessory installed in slot 0 of the HP 3852A mainframe.	
OUTPUT 709;"CLOSE 100"	Closes channel 0 of an accessory installed in slot 1 of the HP 3852A mainframe.	
When the parameter is a channel list: (ESCC [-ESCC] [ESCC [-ESCC]...])		
Examples: (ESCC [-ESCC] [ESCC [-ESCC]...])		
ADRS	Specifies the list of channels represented in the array ADRS. If ADRS contains the numbers 200 and -202, the channel list is 200 through 202.	
1110, 1201-1205	Specifies channel 10 in slot 1 of HP 3853A extender number 1 and channels 1 through 5 in slot 2 of extender number 1.	
410-400	Specifies channels 10 through 0 in slot 4 of the HP 3852A mainframe.	
0-7999	Specifies all channels in all slots of the HP 3852A mainframe and all HP 3853A extenders.	
OUTPUT 709;"CLOSE? 0-1312"	Determines the channel state of channel 0 on an accessory installed in slot 0 of the HP 3852A mainframe, through channel 12 on an accessory installed in slot 3 in HP 3853A extender number 1. Note that in this example, all slots in the mainframe through slot 3 in the extender are checked for accessories with channel closures.	

HP 3852A Power-On State

Table 5-2. HP 3852A Power-On State

Front Panel/HP-IB Modes	
Display Modes	DISP ON, FASTDISP ON, MON ON
Keyboard Modes	LOCK OFF, BEEP ON
HP-IB Modes	BLOCKOUT OFF, FASTOUT OFF, SYSOUT OFF
Rear Panel BNC Ports	
EVENT IN	disabled (enabled by WAIT FOR event)
CHANNEL ADVANCE	disabled (enabled by STRIG SADV or SADV CHADV)
CHANNEL CLOSED	idle (outputs a negative-going TTL level pulse when a channel is closed)
SYSTEM TRIGGER IN	disabled (enabled by TRG EXT)
PACER OUT	idle (sends continuous pulse train, 500 ns negative-going pulses occurring every 1 μ sec when pacer trigger received)
PACER TRIGGER IN	disabled (enabled by PTRIG EXT)
Internal	
MEMORY	all memory is cleared except HP-IB address, POWEROFF state, and the LCL bit in the Status Register
SYSTEM TRIGGER	disabled (see TRG)
REAL-TIME CLOCK and CALENDAR	not affected (ALRM is disabled)
SERVICE REQUEST MODE (RQS)	enabled
BUFFERS	input buffer, output buffer, and error buffer are cleared
BUFFER MODES	INBUF OFF, OUTBUF OFF
USE Channel	the lowest slot number and accessory channel number in that slot for which the USE command is valid

Accessory Power-On States

Table 5-3. Accessory Power-On States

HP 44701A Integrating Voltmeter	
PARAMETER	SETTING
ARANGE	ON
AZERO	ON
DELAY	variable
FUNC	DCV
Interrupt Capability	disabled
NPLC	1 @ 60 Hz
NRDGS	1
OCOMP	OFF
RANGE	AUTO
TERM	EXT
TRIG	HOLD
Relative Power Consumption = 1.2	

HP 44702A/B 13-Bit High-Speed Voltmeter (System Mode)	
PARAMETER	SETTING
ARMODE	AFTER
DELAY	0 μ sec trig-delay, 10 μ sec sample_period
FUNC	DCV
Interrupts	disabled
NRDGS	1
PERC	0%
RANGE	AUTO
RDGS	SYS
RDGSMODE	DAV
SCANMODE	OFF
SLOPE	LH
TERM	EXT
TRIG	HOLD
Relative Power Consumption = 1.5	

Table 5-3. Accessory Power-On States (Cont'd)

HP 44702A/B 13-Bit High-Speed Voltmeter (Scanner Mode)	
PARAMETER	SETTING
ARMODE	AFTER
ASCAN	OFF
FUNC	DCV
Interrupts	disabled
NRDGS	1 (without TERM RIBBON)
PERC	0%
POSTSCAN	0
PRESCAN	1
RANGE	AUTO
RDGS	SYS
RDGSMODE	DAV
SCANMODE	OFF
SCDELAY	0 msec trig_delay, 2 msec scan_pace
SCSLOPE	LH
SCTRIG	HOLD
SLOPE	LH
SPER	10 μ sec
STSLOPE	LH
STTRIG	INT
TERM	EXT
TRIG	INT

Relative Power Consumption = 1.5

HP 44705A 20-Channel Relay Multiplexer
HP 44705H 20-Channel High-Voltage Relay Multiplexer
HP 44706A 60-Channel Relay Multiplexer
HP 44708A 20-Channel Relay Multiplexer/TC
HP 44708H 20-Channel High-Voltage Relay Multiplexer/TC
HP 44717A 10 Bridge 120 Ω Static Strain Gage Relay Multiplexer
HP 44718A 10 Bridge 350 Ω Static Strain Gage Relay Multiplexer

All Bank Switches Open
 All Tree Switches Open
 Relative Power Consumption = 0.1

HP 44709A 20-Channel FET Multiplexer
HP 44710A 20-Channel FET Multiplexer/TC
HP 44711A 24-Channel High-Speed FET Multiplexer
HP 44712A 48-Channel High-Speed FET Multiplexer
HP 44713A 24-Channel High-Speed FET Multiplexer/TC
HP 44719A 10 Bridge 120 Ω Static Strain Gage FET Multiplexer
HP 44720A 10 Bridge 350 Ω Static Strain Gage FET Multiplexer

All Bank Switches Open
 All Tree Switches Open
 Isolation Relay Open
 Relative Power Consumption = 0.1

Table 5-3. Accessory Power-On States (Cont'd)

HP 44714A 3-Channel Stepper Motor Controller/Pulse Output

PARAMETER	SETTING
STANDBY	AUTO
	HI
PULSE	SS
	LO,LO
PROFILE	FREQ
	0 Hz (min)
	250 Hz (max)
	500 Hz/sec (slope)
	50 μ sec (dual)
PSCALE	1.0
DELAY	0 sec
TRIG	AUTO
HALT	LO
HARDLIM	LO,LO
QSCALE	1.0
QINDEX	OFF
Interrupt Capability	Disabled
Relative Power Consumption = 0.3	

HP 44715A 5-Channel Counter/Totalizer

PARAMETER	SETTING
CNTSET	0
EDGE	LH
FUNC	TOTAL
Interrupt Capability	disabled
NPER	10
SPER	1 μ sec
TBASE	AUTO
TERM	ISO
TRIG	HOLD
Relative Power Consumption = 0.8	

**HP 44721A 16-Channel Digital Input
HP 44722A 8-Channel Digital Input**

PARAMETER	SETTING
CNTSET	0
EDGE	OFF
Interrupt Capability	disabled
All Channels Open	
Relative Power Consumption = 0.3	

Table 5-3. Accessory Power-On States (Cont'd)

HP 44723A 16-Channel High-Speed Digital Sense/Control	
PARAMETER	SETTING
EDGE	OFF
PATTERN	EQU,0,0
TRIGMODE	ALL
TRIG	INT
SRTRIG	INT
RDGSMODE	IMMED
Interrupt Capability	Disabled
Relative Power Consumption = 0.7	
HP 44724A 16-Channel Digital Output	
All Channels Open	
Relative Power Consumption = 0.2	
HP 44725A 16-Channel General Purpose Switch	
All Channels in Normally Closed (NC) State	
Relative Power Consumption = 1.0	
HP 44726A 2-Channel Arbitrary Waveform DAC	
PARAMETER	SETTING
DAC Output	enabled - 0V
FILTER	OFF
Interrupt Capability	disabled
NSCAN	CONT
SYNC	HOLD
TARM	OFF
TRIG	INT
Relative Power Consumption = 1.1.	
HP 44727A/B/C 4-Channel DACs	
PARAMETER	SETTING
SETTLE	74.5472 ms
All Channels Open	
Voltage/Current Output:	
0 for 0V to +10V or -10V to +10V range	
0 for 0 mA to 20 mA range	
4 mA for 4 mA to 20 mA range	
HP 44727A/B/C Relative Power Consumption = 1.4	

Table 5-3. Accessory Power-On States (Cont'd)

<p>HP 44728A 8-Channel Relay Actuator</p> <p>All Channels in Normally Closed (NC) State</p> <p>HP 44728A Relative Power Consumption = 0.5</p> <p>HP 44729A 8-Channel Power Controller</p> <p>All Channels Open</p> <p>HP 44729A Relative Power Consumption = 0.9</p>											
<p>HP 44730A 4-Channel Track/Hold with Signal Conditioning HP 44732A 120 Ω Dynamic Strain Gage FET Multiplexer HP 44733A 350 Ω Dynamic Strain Gage FET Multiplexer</p> <table border="0"> <thead> <tr> <th>PARAMETER</th> <th>SETTING</th> </tr> </thead> <tbody> <tr> <td>FILTER</td> <td>OFF</td> </tr> <tr> <td>FUNC</td> <td>AMPLIFY</td> </tr> <tr> <td>GAIN</td> <td>1</td> </tr> <tr> <td>TRIG</td> <td>RIBBON</td> </tr> </tbody> </table> <p>All channel inputs open Isolation relay open</p> <p>HP 44730A Relative Power Consumption = 1.0. HP 44732A/HP 44733A Relative Power Consumption = 1.1</p>		PARAMETER	SETTING	FILTER	OFF	FUNC	AMPLIFY	GAIN	1	TRIG	RIBBON
PARAMETER	SETTING										
FILTER	OFF										
FUNC	AMPLIFY										
GAIN	1										
TRIG	RIBBON										
<p>HP 44788A HP-IB Controller</p> <table border="0"> <thead> <tr> <th>PARAMETER</th> <th>SETTING</th> </tr> </thead> <tbody> <tr> <td>PRINTER IS</td> <td>1 (HP 3852A display)</td> </tr> <tr> <td>MSI [a]</td> <td>":,S00,0,0"</td> </tr> <tr> <td>ASSIGN</td> <td>FORMAT ON EOL ON</td> </tr> </tbody> </table> <p>[a] = S is lowest numbered slot in which an HP 44788A is installed (cannot be slot 0). Device selector = S00, unit number = 0, volume number = 0.</p> <p>Relative Power Consumption = 0.1.</p>		PARAMETER	SETTING	PRINTER IS	1 (HP 3852A display)	MSI [a]	":,S00,0,0"	ASSIGN	FORMAT ON EOL ON		
PARAMETER	SETTING										
PRINTER IS	1 (HP 3852A display)										
MSI [a]	":,S00,0,0"										
ASSIGN	FORMAT ON EOL ON										

HP 3852A Data Formats

Table 5-4. HP 3852A Output Data Formats

Format	Name	Representation
IASC	Short ASCII Integer	<div style="border: 1px solid black; padding: 2px; display: inline-block; margin-bottom: 5px;">Bytes 0-5</div> <div style="border: 1px solid black; padding: 2px; display: inline-block; margin-left: 10px; margin-bottom: 5px;">Bytes 6-7</div> Bytes 0-5: integer number, includes (-) sign and/or preceding spaces. Bytes 6-7: CR/LF Display Format: - 12345 Range: - 32768 to 32767
LASC	Long ASCII Integer	<div style="border: 1px solid black; padding: 2px; display: inline-block; margin-bottom: 5px;">Bytes 0-10</div> <div style="border: 1px solid black; padding: 2px; display: inline-block; margin-left: 10px; margin-bottom: 5px;">Bytes 11-12</div> Bytes 0-10: integer number, includes (-) sign and/or preceding spaces. Bytes 11-12: CR/LF Display Format: - 1234567890 Range: - 2147483648 to 2147483647
RASC	Real ASCII Number	<div style="border: 1px solid black; padding: 2px; display: inline-block; margin-bottom: 5px;">Byte 0</div> <div style="border: 1px solid black; padding: 2px; display: inline-block; margin-left: 5px; margin-bottom: 5px;">Bytes 1-8</div> <div style="border: 1px solid black; padding: 2px; display: inline-block; margin-left: 5px; margin-bottom: 5px;">Byte 9</div> <div style="border: 1px solid black; padding: 2px; display: inline-block; margin-left: 5px; margin-bottom: 5px;">Bytes 10-12</div> <div style="border: 1px solid black; padding: 2px; display: inline-block; margin-left: 5px; margin-bottom: 5px;">Bytes 13-14</div> Byte 0: (-) sign or space Bytes 1-8: normalized 7-digit mantissa Byte 9: E Bytes 10-12: sign and 2-digit exponent Bytes 13-14: CR/LF Display Format: - 1.234567E + 12 Range: - 1.000000E + 38 to - 1.000000E - 37, 0, + 1.000000E - 37 to + 1.000000E + 38
DASC	Double Real ASCII Number	<div style="border: 1px solid black; padding: 2px; display: inline-block; margin-bottom: 5px;">Byte 0</div> <div style="border: 1px solid black; padding: 2px; display: inline-block; margin-left: 5px; margin-bottom: 5px;">Bytes 1-17</div> <div style="border: 1px solid black; padding: 2px; display: inline-block; margin-left: 5px; margin-bottom: 5px;">Byte 18</div> <div style="border: 1px solid black; padding: 2px; display: inline-block; margin-left: 5px; margin-bottom: 5px;">Bytes 19-22</div> <div style="border: 1px solid black; padding: 2px; display: inline-block; margin-left: 5px; margin-bottom: 5px;">Bytes 23-24</div> Byte 0: (-) sign or space Bytes 1-17: normalized 16-digit mantissa Byte 18: E Bytes 19-22: sign and 3-digit exponent Bytes 23-24: CR/LF Display format: - 1.234567890123456E + 123 Range: - 1.797693134862315E + 308 to - 2.225073858507202E - 307, 0, + 2.225073858507202E - 307 to + 1.797693134862315E + 308
IN16	16-Bit Integer	<div style="border: 1px solid black; padding: 2px; display: inline-block; margin-bottom: 5px;">16-bit 2's Complement Integer</div>
RL64	64-Bit Real Number	
PACK	Packed Data	Accessory Dependent Format.

Packed Data Conversion Routines

Table 5-5 contains conversion equations and unpacking routines for packed data returned from an HP 3852A or HP 447XXX plug-in accessory. Unpacking routines shown in the table apply to HP 9000 Series 200/300 (and equivalent) controllers. Use the conversion equations as required for other controllers.

Table 5-5. Packed Data Conversion Routines

Accessory	Command	Function	Bit Pattern	Conversion Formula and Routine																				
HP 44701A	CHREAD, CONFMEAS, MEAS, XRDGS	ACV, DCV, OHM, OHMF	<p>Bytes 0-2: Mantissa (2's complement integer)</p> <p>Byte 3: Exponent, Base 10. If 80H (128₁₀) overload, disregard Mantissa.</p>	<p>Formula: reading = Mantissa x 10^(exponent - 6)</p> <p>Routine: 200 INTEGER Pack(0:1) • VOLT METER COMMANDS WHICH SET UP • AND EXECUTE MEASUREMENT 270 ENTER 709 USING "#,W";Pack(*) 280 PRINT FNHP44701(Pack(0),Pack(1)) 290 END 300 DEF FNHP44701(INTEGER Pack(0),Pack(1)) 310 INTEGER Expon 320 Expon = BINAND(Pack(1,255)) 330 IF Expon = 128 THEN 340 RETURN 1.E + 38 350 ELSE 360 RETURN(Pack(0)*256. + SHIFT(Pack(1,8)) * 10 ^ (Expon - 256 * (Expon > 127)) - 6) 370 END IF 380 FNEND</p>																				
HP44701A	CHREAD, CONFMEAS, MEAS, XRDGS	TEMP, REFT, THM, THMF, RTD, RTDF, STRQ, STRHB, STRFB, STRHP, STRFBP, STRFP	<p>Bit 15: If 0, overload. Disregard Mantissa. If 1 and Mantissa = OFF F_H (4095₁₀), overrange.</p>	<p>For Series 200/300, can be read directly into a Real Number</p>																				
HP 44702A/B	CHREAD, CONFMEAS, MEAS, XRDGS	DCV, OHM, OHM10K, OHM100K, OHM1M, OHMF, OHMF10K, OHMF100K, OHMF1M	<p>Bits 14-13: Range (see conversion formula)</p> <p>Bit 12: Sign Bit. 0 = +, 1 = -</p> <p>Bits 11-0: Mantissa—Integer number of counts.</p>	<p>Formula: reading = Mantissa*(2.5mV/(range)) * 1/I</p> <table border="1"> <thead> <tr> <th>Function</th> <th>I</th> <th>Bits 14/13</th> <th>I(range)</th> </tr> </thead> <tbody> <tr> <td>DCV</td> <td>1</td> <td>00</td> <td>256</td> </tr> <tr> <td>OHM10K, OHMF10K</td> <td>.001</td> <td>01</td> <td>32</td> </tr> <tr> <td>OHM, OHMF, OHM100K, OHMF100K</td> <td>.0001</td> <td>10</td> <td>4</td> </tr> <tr> <td>OHM1M, OHMF1M</td> <td>.00001</td> <td>11</td> <td>1</td> </tr> </tbody> </table> <p>Routine (DCV): 200 INTEGER Pack • VOLT METER COMMANDS WHICH SET • UP AND EXECUTE MEASUREMENT 270 ENTER 709 USING "#,W";Pack 280 PRINT FNHP44702(Pack) 290 END 300 DEF FNHP44702(INTEGER Pack) 310 REAL R(0:3)</p>	Function	I	Bits 14/13	I(range)	DCV	1	00	256	OHM10K, OHMF10K	.001	01	32	OHM, OHMF, OHM100K, OHMF100K	.0001	10	4	OHM1M, OHMF1M	.00001	11	1
Function	I	Bits 14/13	I(range)																					
DCV	1	00	256																					
OHM10K, OHMF10K	.001	01	32																					
OHM, OHMF, OHM100K, OHMF100K	.0001	10	4																					
OHM1M, OHMF1M	.00001	11	1																					

Table 5-5. Packed Data Conversion Routines (Cont'd)

Accessory	Command	Function	Bit Pattern	Conversion Formula and Routine
				<pre> 320 DATA 256.,32.,4.,1. 330 READ RI(*) 340 M=BINAND(Pack,4095) 350 IF Pack>0 OR M=4095 THEN 360 RETURN 1E+38 370 ELSE 380 V=M*.0025/(BINAND(SHIFT(Pack,13),3)) 390 IF BIT(Pack,12) THEN V=-V 400 RETURN V 410 END IF 420 FNEND Routine (OHM10K,OHMF10K): Change Line 380 in DCV Routine to: 380 V=M*.0025/(BINAND(SHIFT(Pack,13),3))/001 Routine (OHM,OHMF,OHM100K,OHMF100K): Change Line 380 in DCV Routine to: 380 V=M*.0025/(BINAND(SHIFT(Pack,13),3))/0001 Routine (OHM1M,OHMF1M): Change Line 380 in DCV Routine to: 380 V=M*.0025/(BINAND(SHIFT(Pack,13),3))/00001 </pre>

Table 5-5. Packed Data Conversion Routines (Cont'd)

Accessory	Command	Function	Bit Pattern	Conversion Formula and Routine
HP 44702A/B	CHREAD, CONFMEAS MEAS, XRDGS	TEMP, REFT, THM, THMF, RTD, RTDF, STRO, STRHB, STRHP, STRFBP, STRFP		<p>For Series 200/300, can be read directly into a Real number.</p> <p>Routine (unsigned): 200 INTEGER Pack <ul style="list-style-type: none"> COUNTER COMMANDS WHICH SET UP AND EXECUTE FUNCTION 270 ENTER 709 USING "#,W";Pack 280 PRINT FNIn16__unsigned(Pack) 290 END 300 DEF FNIn16__unsigned(INTEGER Pack) 310 RETURN Pack + 65536. *(Pack < 0) 320 FNEND NO CONVERSION IF SIGNED </p>
HP 44715A	CHREAD, CHREADZ, XRDGS	TOTALM, UDCM, CDM		<p>Routine (unsigned): 200 INTEGER Pack(0:1) <ul style="list-style-type: none"> COUNTER COMMANDS WHICH SET UP AND EXECUTE FUNCTION 270 ENTER 709 USING "#,W";Pack(1) 280 PRINT FNIn32__unsigned(Pack(0),Pack(1)) 290 END 300 DEF FNIn32__unsigned(INTEGER Pack0,Pack1) 310 RETURN Pack0+65536. + 4294967296. *(Pack0 < 0) + Pack1 + 65536. *(Pack1 < 0) 320 FNEND Signed: 200 INTEGER Pack(0:1) <ul style="list-style-type: none"> COUNTER COMMANDS WHICH SET UP AND EXECUTE FUNCTION 270 ENTER 709 USING "#,W";Pack(1) 280 PRINT FNIn32__signed(Pack(0),Pack(1)) 290 END 300 DEF FNIn32__signed(INTEGER Pack0,Pack1) 310 RETURN Pack0+65536. + Pack1 + 65536. *(Pack1 < 0) 320 FNEND </p>
HP 44715A	CHREAD, CHREADZ, XRDGS	TOTAL, UDC, CD		<p>Routine (unsigned): 200 INTEGER Pack(0:1) <ul style="list-style-type: none"> COUNTER COMMANDS WHICH SET UP AND EXECUTE FUNCTION 270 ENTER 709 USING "#,W";Pack(1) 280 PRINT FNIn32__unsigned(Pack(0),Pack(1)) 290 END 300 DEF FNIn32__unsigned(INTEGER Pack0,Pack1) 310 RETURN Pack0+65536. + 4294967296. *(Pack0 < 0) + Pack1 + 65536. *(Pack1 < 0) 320 FNEND Signed: 200 INTEGER Pack(0:1) <ul style="list-style-type: none"> COUNTER COMMANDS WHICH SET UP AND EXECUTE FUNCTION 270 ENTER 709 USING "#,W";Pack(1) 280 PRINT FNIn32__signed(Pack(0),Pack(1)) 290 END 300 DEF FNIn32__signed(INTEGER Pack0,Pack1) 310 RETURN Pack0+65536. + Pack1 + 65536. *(Pack1 < 0) 320 FNEND </p>

Table 5-5. Packed Data Conversion Routines (Cont'd)

Accessory	Command	Function	Bit Pattern	Conversion Formula and Routine									
HP 44715A	CHREAD, XRDGS	FREQ	<p>Bytes 0-1: # of Periods counted</p> <p>Bytes 0-1: <table border="1" style="display: inline-table; vertical-align: middle;"> <tr> <td>Byte 0-1</td> <td>Byte 2</td> <td>Byte 3</td> </tr> </table></p> <p>Byte 2: Disregard</p> <p>Byte 3: Bits 7-4, Time Base. See Conversion Routine.</p> <p>Bits 3-0, Disregard.</p>	Byte 0-1	Byte 2	Byte 3	<p>Formula: reading = # of periods counted/Time Base</p> <p>Bits 7-4: <table border="1" style="display: inline-table; vertical-align: middle;"> <tr> <td>Time Base</td> </tr> <tr> <td>1101 10 msec</td> </tr> <tr> <td>1110 100 msec</td> </tr> <tr> <td>1111 1 sec</td> </tr> </table></p> <p>Routine: 200 INTEGER Pack(0:1) • • COUNTER COMMANDS WHICH SET UP • AND EXECUTE FUNCTION 270 ENTER 709 USING "#,W";Pack(*) 280 PRINT FNPerd(Pack(0),Pack(1)) 290 END 300 DEF FNPerd(INTEGER Pack0, Pack 1) 310 RANGE = BINAND(SHIFT(Pack1, -4), 15) 320 RETURN(Pack0 + 65536 * (Pack0 < 0)) * 10 ^ (15 - RANGE) 330 FNEND</p>	Time Base	1101 10 msec	1110 100 msec	1111 1 sec		
Byte 0-1	Byte 2	Byte 3											
Time Base													
1101 10 msec													
1110 100 msec													
1111 1 sec													
HP 44715A	CHREAD, CHREADZ, XRDGS	PERD	<p>Bytes 0-1: # of clocks counted</p> <p>Bytes 0-1: <table border="1" style="display: inline-table; vertical-align: middle;"> <tr> <td>Byte 0-1</td> <td>Byte 2</td> <td>Byte 3</td> </tr> </table></p> <p>Byte 2: Disregard</p> <p>Byte 3: Bits 7-4, Time Base</p> <p>Bits 3-0, Disregard.</p>	Byte 0-1	Byte 2	Byte 3	<p>Formula: reading = # of clocks counted * Time Base</p> <p>Bits 7-4: <table border="1" style="display: inline-table; vertical-align: middle;"> <tr> <td>Time Base</td> </tr> <tr> <td>1011 1 µsec</td> </tr> <tr> <td>1100 10 µsec</td> </tr> <tr> <td>1101 100 µsec</td> </tr> <tr> <td>1110 1 msec</td> </tr> <tr> <td>1111 10 msec</td> </tr> </table></p> <p>Routine: 200 INTEGER Pack (0:1) • COUNTER COMMANDS WHICH SET UP • AND EXECUTE FUNCTION • 270 ENTER 709 USING "#,W";Pack(*) 280 PRINT FNPerd(Pack(0),Pack(1)) 290 END 300 DEF FNPerd(INTEGER Pack0, Pack 1) 310 Range = BINAND(SHIFT(Pack1, -4), 15) 320 RETURN(Pack0 + 65536 * (Pack0 < 0)) * 10 ^ (RANGE - 17) 330 FNEND</p>	Time Base	1011 1 µsec	1100 10 µsec	1101 100 µsec	1110 1 msec	1111 10 msec
Byte 0-1	Byte 2	Byte 3											
Time Base													
1011 1 µsec													
1100 10 µsec													
1101 100 µsec													
1110 1 msec													
1111 10 msec													

Table 5-5. Packed Data Conversion Routines (Cont'd)

Accessory	Command	Function	Bit Pattern	Conversion Formula and Routine
HP 44715A	CHREAD, CHREADZ, XRDGS	RAT	<p>Bytes 0-1: B input counts</p> <p>Bytes 2-3: A input counts</p> <p>Bytes 0-1: Bytes 0-1 Bytes 2-3</p>	<p>Formula: reading = A input counts/B input counts</p> <p>Routine:</p> <p>200 INTEGER Pack(0:1)</p> <ul style="list-style-type: none"> COUNTER COMMANDS WHICH SET UP AND EXECUTE FUNCTION <p>270 ENTER 709 USING "#, W", Pack(*)</p> <p>280 PRINT FrRatio(Pack(0), Pack(1))</p> <p>290 END</p> <p>300 DEF FrRatio(INTEGER Pack0, Pack1)</p> <p>310 RETURN(Pack1 + 65536. *(Pack1 < 0)) / (Pack0 + 65536. *(Pack0 < 0))</p> <p>320 FNEND</p>
HP 44715A	CHREAD, CHREADZ, XRDGS	PER	<p>Bytes 0-1: # of periods averaged</p> <p>Bytes 2-3: # of clocks counted</p> <p>Byte 4: Disregard</p> <p>Byte 5: Bits 7-4, Time Base.</p> <p>Bits 3-0, Disregard</p> <p>Bytes 0-1: Bytes 0-1 Bytes 2-3 Byte 4 Byte 5</p>	<p>Formula: reading = (# of clocks counted / # of periods averaged) * Time Base</p> <p>Bits 7-4 Time Base</p> <p>1011 1 μsec</p> <p>1100 10 μsec</p> <p>1101 100 μsec</p> <p>1110 1 msec</p> <p>1111 10 msec</p> <p>Routine:</p> <p>200 INTEGER Pack(0:2)</p> <ul style="list-style-type: none"> COUNTER COMMANDS WHICH SET UP AND EXECUTE FUNCTION <p>270 ENTER 709 USING "#, W", Pack(*)</p> <p>280 PRINT FNPer(Pack(0), Pack(1), Pack(2))</p> <p>290 END</p> <p>300 DEF FNPer(INTEGER Pack0, Pack1, Pack2)</p> <p>310 PERIOD = (Pack0 + 65536. *(Pack0 < 0)) / (Pack1 + 65536. *(Pack1 < 0))</p> <p>320 Range = BINAND(SHIFT(Pack2, -4), 15)</p> <p>330 RETURN Period * 10 (RANGE - 17)</p> <p>340 FNEND</p>

Table 5-5. Packed Data Conversion Routines (Cont'd)

Accessory	Command	Function	Bit Pattern	Conversion Formula and Routine
HP 44705A/H, HP 44708A/H, HP 44709A, HP 44710A, HP 44711A, HP 44712A, HP 44713A	CLOSE?	—	<div style="border: 1px solid black; padding: 2px; display: inline-block;">16-bit 2's Complement Integer</div> If output equals decimal: 0-channel open 1-channel closed 2-channel closed connected to sense bus 3-channel closed connected to source bus 4-channel closed connected to both busses If output equals decimal: 0-channel open 1-channel closed - sense bus tree switch (channel 91 only) 2-closed - connected to sense bus 4-closed - connected to both busses	—
HP 44706A	CLOSE?	—	<div style="border: 1px solid black; padding: 2px; display: inline-block;">16-bit 2's Complement Integer</div>	Routine (unsigned): 200 INTEGER Pack • DIGITAL INPUT COMMANDS WHICH SET • UP AND EXECUTE FUNCTION 270 ENTER 709 USING "#,W";Pack 280 PRINT FNln16_unsigned(Pack) 290 END 300 DEF FNln16_unsigned(INTEGER Pack) 310 RETURN Pack + 65536. *(Pack < 0) 320 FNEND
HP 44721A, HP 44722A	CHREAD, CHREADZ, XRDGS	Channel 0-15 (0-7) specified	<div style="border: 1px solid black; padding: 2px; display: inline-block;">32-bit 2's Complement Integer</div> Byte 0 is always 0H for the HP 44722A	Routine: 200 INTEGER Pack(0:1) • DIGITAL INPUT COMMANDS WHICH SET • UP AND EXECUTE FUNCTION 270 ENTER 709 USING "#,W";Pack(+) 280 PRINT FNln32_unsigned(IPack(0),Pack(1)) 290 END 300 DEF FNln32_unsigned(INTEGER Pack(0),Pack(1)) 310 RETURN Pack(0) + 65536. *(Pack(0) < 0) + Pack(1) + 65536. *(Pack(1) < 0) 320 FNEND
HP 44721A, HP 44722A	CHREAD, CHREADZ, XRDGS	Channel 16-31 (8-15) specified	<div style="border: 1px solid black; padding: 2px; display: inline-block;">Byte 0</div> <div style="border: 1px solid black; padding: 2px; display: inline-block; margin-left: 20px;">Byte 1</div> Byte 0: 0H Byte 1: 1 or 0 on Bit 0 indicates input level on the specified channel	—

Table 5-5. Packed Data Conversion Routines (Cont'd)

Accessory	Command	Function	Bit Pattern	Conversion Formula and Routine
HP 44724A, HP 44725A, HP 44728A, HP 44729A	CLOSE?	—	<div style="border: 1px solid black; display: inline-block; padding: 2px;">Byte 0</div> <div style="border: 1px solid black; display: inline-block; padding: 2px; margin-left: 10px;">Byte 1</div> <p>Byte 0: 0H Byte 1: 1 or 0 on Bit 0 indicates input level on the specified channel</p>	—
HP 44724A, HP 44725A, HP 44728A, HP 44729A	READ	—	<div style="border: 1px solid black; display: inline-block; padding: 2px;">16-bit 2's Complement Integer</div> <p>Byte 0 is always 0H for the HP 44728A and HP 44729A</p>	—
HP 3852A Mainframe	ADDR? ERR? EXTEND? INTR? ROS? STA? STATE? STB? USE?	—	<div style="border: 1px solid black; display: inline-block; padding: 2px;">16-bit 2's Complement Integer</div>	—
HP 3852A Mainframe	EXTEND?	—	Returns seven readings in the above format	—
HP 3852A Mainframe	STATE?	—	Returns two readings in the above format	—
HP 3852A Mainframe	ALRM. CONV, POWEROFF, SCALE, STAT, TIME, TIMEDATE	—		—
HP 3852A Mainframe	SIZE?, INDEX?	—	<div style="border: 1px solid black; display: inline-block; padding: 2px;">32-Bit 2's Complement Integer</div>	200 INTEGER Pack(0:1) • MAINFRAME SIZE? OR INDEX? COMMAND 270 ENTER 709 USING "#W";Pack(*) 280 PRINT FNin32_unsigned(Pack(0),Pack(1)) 290 END 300 DEF FNin32_unsigned(INTEGER Pack0, Pack1) 310 RETURN Pack0*65536. + 4294967296.* (Pack0 < 0) + Pack1 + 65536.* (Pack1 < 0) 320 FNEED
HP 3852A Mainframe	VREAD	—	Determined by the Data Read	—



Chapter 6

Error Messages

CONTENTS

	Page
Introduction	6-1
Error Messages	6-1

Introduction

This chapter lists the error messages returned by the HP 3852A. An error message is displayed when a command specifies a parameter, defines a condition, or sets an operating state that is not allowed or not recognized by the HP 3852A. Error messages consist of an error code and a message.

Message format is **ERROR dd: command: message**, where **dd** = a two-digit error code; **command** = command which caused error to occur (command appears only if it is syntactically correct); and **message** = message for the corresponding error code. The string of characters which caused the error is appended to the message. The message also includes additional information describing the error.

Error Messages

Error Code	Message	Description
0	NO ERROR	No error messages in the buffer when the error buffer is read.
1	OUT OF MEMORY	Not enough memory to do command listed in the error message.
2	SYMBOL TOO LONG	Array, variable, subroutine name, or displayed message is too long. Number specified is too long.
3	BAD NUMBER FORMAT	Number incorrectly specified (e.g. 1+.).
4	SYNTAX	Parameter specified is not a valid word, number, or character for that particular command.
5	SUBEND WITHOUT SUB	SUBEND command was encountered before the SUB command.
6	MISSING FOR	NEXT statement was encountered before the FOR statement.
7	NOT ALLOWED IN SUB	A command not allowed within a subroutine was encountered when the subroutine is being loaded.
8	ALLOWED ONLY IN SUB	Command allowed only within a subroutine was entered outside a subroutine.

9	SUB CODE TOO LONG	Not enough available memory for the subroutine currently being entered.
10	SUB WAS DELETED	Subroutine that was called was previously deleted.
11	NO ACTIVE SUB	A subroutine was stepped or continued before it was paused or set up to be stepped.
12	CANNOT RETYPE A VARIABLE	Variable or array was assigned a format different from its original format.
13	MISSING IF	END IF or ELSE statement was encountered before the IF statement.
14	MISSING WHILE	END WHILE statement is encountered before the WHILE statement.
15	IMPROPER FOR/NEXT MATCHING	Loop counter variable names not the same (e.g. FOR I...NEXT J).
16	SUBSCRIPT OUT OF BOUNDS	Reading or writing to an array element greater than its maximum index.
17	END OF COMMAND INSIDE STRING	Message associated with the DISP command does not have ending quotes.
18	SYSTEM ERROR	Internal processor is in an illegal state.
19	INVALID CHAR RECEIVED	Programming character not recognized by the HP 3852A.
20	COMMAND BUFFER OVERFLOW	Too many parameters are specified or the parameter is specified by a complex numeric expression.
21	TOO MANY ARGS	Command used with multiple accessories where too many parameters are specified for that particular accessory.
22	CANNOT EXECUTE	Command cannot be executed as the HP 3852A is in local lockout.
23	SETTINGS CONFLICT	Command specifies a condition that is incompatible with the previously programmed accessory state.
24	ARGUMENT OUT OF RANGE	Parameter value specified is out of the valid range.

25	DEVICE FAILURE	Hardware failure.
26	POWER ON TEST FAILURE	Mainframe or an accessory failed the power on self test.
27	SELF TEST FAILED	Mainframe or an accessory failed the self test initiated by the TEST command. This message may occur if the self test is performed on an accessory that was installed with the power on. The HP 44701A may fail if the voltmeter is busy when the TEST command is issued.
28	INVALID SLOT	Slot address is incorrectly specified.
29	SPURIOUS FAST SCAN INTERRUPT	Can occur when the HP 44702A/B is installed with HP 3852A or HP 3853A power on, or may indicate a possible hardware failure.
30	SPURIOUS NORMAL SCAN INTERRUPT	Can occur when the HP 44701A is installed with HP 3852A or HP 3853A power on, or may indicate a possible hardware failure.
31	INVALID COMMAND FOR ACCESSORY	Command is not used by the accessory whose slot or channel address was specified. Can also occur if a high-speed multiplexer is used for a backplane measurement while the ribbon cable is connected.
32	NO ACCESSORY PRESENT	Syntactically correct command is sent to an empty slot.
33	INVALID CHANNEL	Channel address is incorrectly specified.
34	INVALID REGISTER	Register address is incorrectly specified.
35	DIFFERENT PACKED TYPES	Data cannot be stored into a PACKED array containing readings with a different bit pattern or whose bytes per reading are not the same.
36	DATA LOST DUE TO FORMAT	Magnitude of the data returned cannot be represented in the format specified.
37	TRIGGER TOO FAST	Not reported.
38	CHECK POWER	An HP 3853A Extender is powered down or there are fluctuations in the line power.

39	MEMORY LOST	Occurs at power-on. Battery backed up memory lost power while the instrument was off.
40	CANNOT EXECUTE IN REMOTE	Command entered from the front panel cannot be executed while the HP 3852A is in remote.
41	CAN EXECUTE FROM FP ONLY	Command sent over the HP-IB can only be entered and executed from the front panel.
42	MATH ERROR	Indicates one of the following conditions: Real overflow, Real underflow, divide by zero, Integer overflow, SIN or COS argument, logarithm argument, square root argument, invalid Real number, BCD conversion, TYPE conversion.
43	END OF ARRAY REACHED	Amount of data written to the array is greater than the size of the array; however, the condition could not have been detected previously by the mainframe (e.g. error code 44). Error message is usually associated with real-time and post processing limit testing.
44	NOT ENOUGH VARIABLE SPACE	Array is not large enough or starting index is at a position where there isn't enough room left to store the data.
45	ARRAY NOT REAL	The domain and range arrays associated with the CONV command must be REAL arrays.
46	VARIABLE NOT DEFINED	Channel logging or real-time limit testing was enabled (ENABLE LOGCHAN, ENABLE LMT) before the necessary arrays were defined (LOGCHAN, LMT).
47	PACKED NOT ALLOWED	A packed array cannot be written into via the command.
48	ARRAY SIZES DIFFER	When performing post processing data conversions (CONV), the domain and range arrays must be the same size.
49	DATA OUT OF BOUNDS	Data associated with post processing data conversions (CONV) is outside the domain array.

50	EMPTY ARRAY	Referencing or reading from a deleted array. Also occurs when you read a packed array that has not been written to.
51	SYMBOL TABLE FULL	Too many variables, arrays, and sub-routines are presently defined.
52	SCAN IN PROGRESS	Voltmeter configuration cannot be changed while its scanning a list of channels.
53	NO SCAN LIST	The list of channels to be scanned were not specified in previous commands.
54	NO VALID CHANNEL IN LIST	Channel or channel list did not include any channel for which this command is valid.
55	STRUCTURED COMMANDS NESTED TOO DEEP	The maximum number of nested BASIC constructs (FOR...NEXT, IF...END IF, WHILE...END WHILE) is 10.
56	SUBEND IN STRUCTURED COMMAND	The SUBEND command cannot reside within a FOR...NEXT, IF...END IF, or WHILE...END WHILE BASIC construct.
57	LIST TOO LONG	Too many items of a parameter were specified (e.g. more than 10 channels were listed individually - 1,2,3,...)
58	SUBS NESTED TOO DEEP	The maximum number of nested sub-routines is 10.
59	SUB ALREADY EXISTS	The subroutine name specified already exists.
60	ACCESSORY INTERFACE ERROR	Mainframe/accessory interface or configuration error. Indicates a potential hardware failure.
61	CALIBRATION RAM ERROR	Bad CAL RAM or voltmeter out of calibration.
62	CALIBRATION FAILURE	Accessory unable to be calibrated.
63	SCAN LIST TOO BIG	Follows the CLWRITE or MEAS command with TERM = RIBBON for the HP 44702A/B where $NRDGS \times (\# \text{ of channels} - 1)$ is > 4095 .

64	MUST USE DIFFERENT VARIABLES	When using the data processing commands CONV, LMT, and SCALE, the respective variables or arrays must have unique names.
65	NO RESPONSE - ACCESSORY REMOVED?	Accessory did not respond to command. Can be caused by removing an accessory with the power on.
66	INVALID CHANNEL FOR COMMAND	Channel address specified was not capable of executing the command.
67	OVERVOLTAGE ON BACKPLANE	Indicates a voltage on the backplane approximately equal to +25V was sensed by the HP 44702A/B when TERM was set to INT. Its inputs are then disconnected.
68	SUB NAME NOT EXPECTED	A subroutine name appeared in a command where a subroutine name is not allowed.
69	SCALAR NAME NOT EXPECTED	A variable name appeared in a command where a variable is not allowed.
70	ARRAY NAME NOT EXPECTED	An array name appeared in a command where an array is not allowed.
71	UNDEFINED WORD	A word that is not a variable, array, or subroutine name, or a command header appeared in the command.
72	THIS KEYWORD NOT EXPECTED	Command header appeared in a command where another command header is not allowed.
73	NO READINGS TO TRANSFER	No readings were available when the XRDGS command was executed.
74	COMMAND END NOT EXPECTED	Incomplete command sent (too many or too few parameters).
75	INSIDE SUB CALLED MORE THAN ONCE	Cannot have a PAUSE statement that is inside a subroutine which is called more than once.
76	INSIDE NESTED SUB	A PAUSE statement cannot be used inside a nested subroutine.
77	NOT ALLOWED WHILE STORING SUB	SCRATCH command cannot be executed over the HP-IB while a subroutine is being stored from the front panel.
78	NOT ALLOWED DURING HP-IB COMMAND	SCRATCH command cannot be executed from the front panel while a command is partially entered over the HP-IB.

79	STANDARD DEVIATION NOT DEFINED	STAT command is executed and the var array has a maximum index of 1.
80	--	Power on test failed; instrument locks up. See the HP 3852A Assembly Level Service Manual.
81	TOO MANY READINGS REQUESTED	Command requested > 134217727 readings.
82	SYMBOL ALREADY EXISTS	Variable, array, or subroutine being declared from the front panel and over the HP-IB at the same time will only be accepted from one source. This message is returned to the other.
83	PROGRAM QUEUE FULL	The program queue cannot hold another subroutine name. Occurs on execution of the RUN command when the queue set by NTASKS is full.
84	RUN TASK DOES NOT EXIST	The run task number specified has not been created by the RUN command.
85	SUB ACTIVE	A subroutine executing in a task en- vironment cannot be deleted (DELSUB command).
86	MULTITASKING NOT ENABLED	The command entered can only execute in the multitasking mode.
87	TASK NOT PAUSED	The run task targeted by the CONT com- mand is not paused.
88	TOO MANY RUN TASKS	The number of run tasks created by the RUN command exceeds the number of run task environments specified by NTASKS.
89	ACCESSORY BUSY	A move is in progress.
90	NO ACTION DEFINED	TRIG SGL encountered without a cor- responding MOVE or SUSTAIN command preceeding it.
91	MUST STOP TO CHANGE DIRECTION	A running SUSTAIN command must be stop- ped with HALT or SUSTAIN 0 before a command to reverse direction can be executed.
92	NOT VALID IN WIDTH MODE	A MOVE command cannot be executed when the PROFILE command is in the width mode.

93	TERMINAL CARD TEST JUMPER SET	Will not execute a MOVE or SUSTAIN command when test jumper is in the TEST position.
94	CANNOT MOVE WHILE STANDBY ON	Standby is powering down the motor.
95	POWER OUTPUT IS CURRENT LIMITING	QPWR output is current limiting.
96	REQUIRED PARAMETER MISSING	Required parameter was not specified.
97	INSUFFICIENT ACCESSORY MEMORY	There is not enough unused memory on the accessory channel to perform the requested task.
98	WAVEFORM ALREADY EXISTS	A waveform cannot be overwritten. The existing waveform must first be deleted.
99	WAVEFORM NOT DEFINED	The waveform specified cannot be applied or used as a source of information since it has not been defined and stored.
100	INVALID ELEMENT SUBRANGE	The subrange specified or implied exceeds the number of successive waveform points available. Or, the LAST point specified in the command precedes the FIRST point specified.
101	WAVEFORM IN USE	The waveform cannot be deleted because it is currently the active waveform. Setting TARM OFF or selecting a different waveform will enable the waveform to be deleted.
102	NO WAVEFORM SELECTED	The waveform specified in the command has not been selected (APPLY WFV), or was previously deleted.
103	WRONG ARRAY TYPE	The type (Real, Integer, Packed) of array specified cannot be used by the command.
104	WRONG PACKED TYPE	The data in the Packed array specified is in a format that cannot be used by the accessory.
105	SINGLE ELEMENT WAVEFORM NOT ALLOWED	Waveforms must contain at least two amplitude points.

106	DATA ALTERED - WAS OUT OF RANGE	One or more amplitudes or number of time base intervals received was outside of the allowable range. An acceptable value is used in place of each such value and the waveform is modified accordingly.
107	HARDWARE DOES NOT SUPPORT COMMAND	The command requires the 03852-66523 controller module.
108	ARRAY NOT INTEGER	An array required by the command must be an Integer array.
109	PATH NAME NOT EXPECTED	Attempting to use a path name where not allowed.
110	IMPROPER FILE NAME	File names are limited to 10 characters. Foreign characters are allowed, but punctuation is not.
111	IMPROPER DEVICE TYPE	The msus has the correct general form, but the characters used for a device are not recognized.
112	IMPROPER MSUS	The characters used for a msus do not form a valid specifier.
113	UNSUPPORTED DRIVE TYPE	Drive does not use the CS/80 or SS/80 command set.
114	UNSUPPORTED SECTOR SIZE	Sector size too large. Must be 256 bytes/record. Sectors larger are not supported.
115	DRIVE NOT FOUND OR BAD ADDRESS	The msus contains an improper device selector, or no external disc is connected.
116	INVALID UNIT NUMBER	The msus contains a unit number that does not exist on the specified device.
117	INVALID MASS STORAGE PARAMETER	A mass storage statement contains a parameter that is out of range, such as a negative record number or an out of range number of records.
118	MEDIA CHANGED OR NOT IN DRIVE	Either there is no disc in the drive or the drive door was opened while a file was assigned.
119	MEDIA IS WRITE PROTECTED	Attempting to write to a write-protected disc.

120	DIRECTORY FULL	Although there may be room on the media for the file, there is no room in the directory for another file name.
121	NO ROOM ON DISK	There is not enough contiguous free space for the specified file size. The disc is full.
122	FILE NOT FOUND	The specified file name does not exist in the directory. Check the contents of the disc with the CAT " " command.
123	DUPLICATE FILE NAME	The specified file name already exists in directory. It is illegal to have two files with the same name on one volume.
124	IMPROPER FILE TYPE	Many mass storage operations are limited to certain file types.
125	PATH NAME NOT ASSIGNED	Must assign path name before its use.
126	FILE OPEN	The specified file is assigned an I/O path name which has not been closed.
127	END OF FILE FOUND	No data left when reading a file, or no space left when writing a file.
128	INITIALIZATION FAILED	Too many bad tracks found. The disc is defective, damaged, or dirty.
129	MASS STORAGE SYSTEM ERROR	Usually a problem with the hardware or the media.
130	BAD SELECT CODE	No HP-IB card in slot, slot is bad, or or select code is >30.
131	I/O OPERATION NOT ALLOWED	Attempting to use a CLEAR, TRIGGER, or SPOLL command with a path assigned to a file.



**HEWLETT
PACKARD**



9282-1079

Binder Only Part No.