

**Agilent N3305A
Component Level
Information**

Agilent N3305A

500W Electronic Load Module

Component Level Information

Information in this packet applies to the following assemblies:

- 1. 5064-0106 Control Board**
- 2. 5064-0133 500W Power Board**

The following is included in this packet:

- 1. Component Locators**
- 2. Schematics**
- 3. Parts lists with Agilent and manufacturer's part numbers**

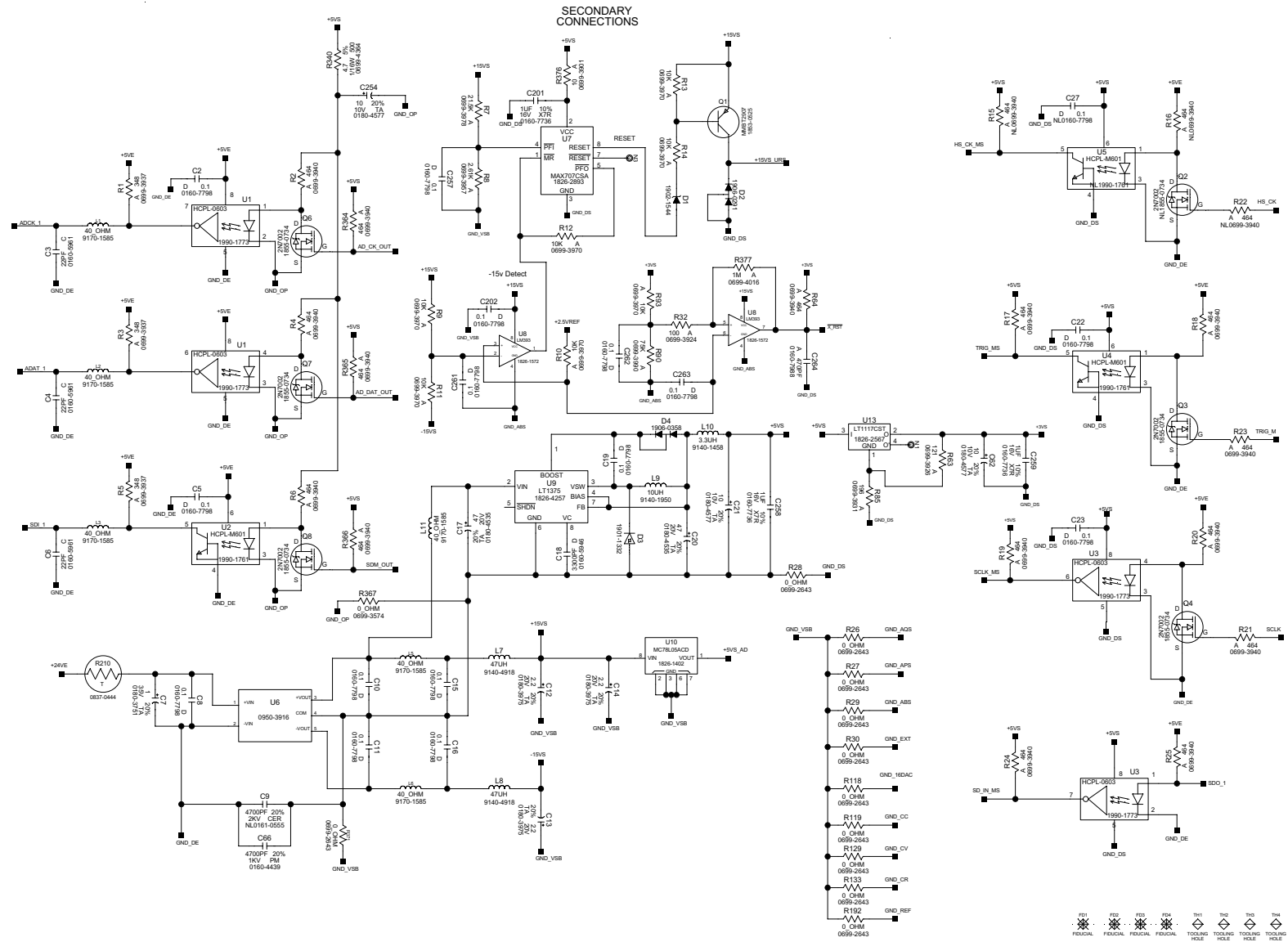
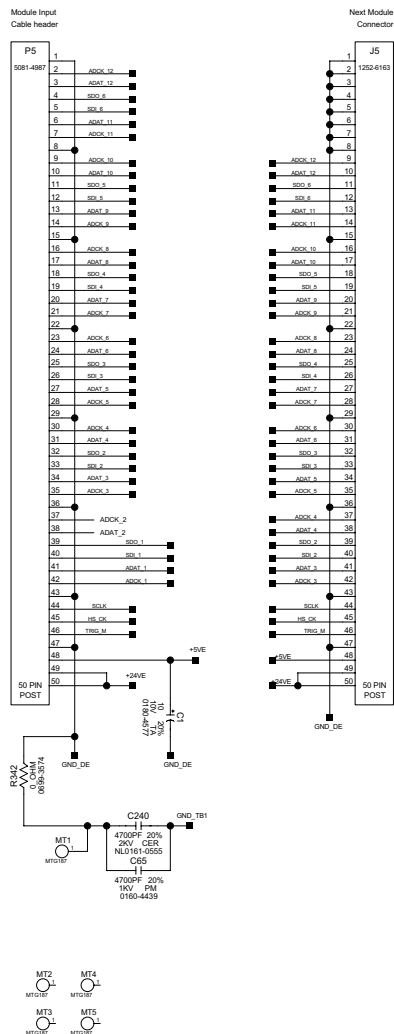

**Agilent N3305A
500W Electronic Load Module**

**5064-0106
Control Board PC Assembly
Page 1 of 6**



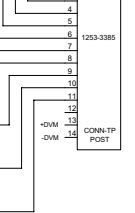
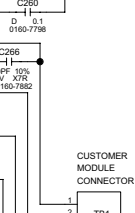
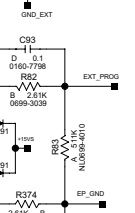
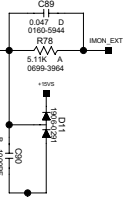
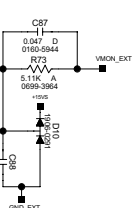
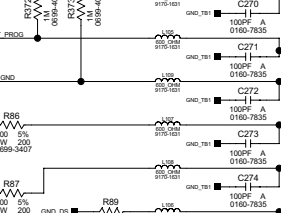
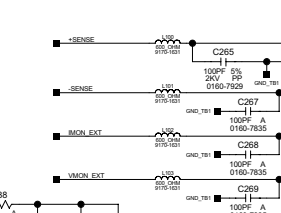
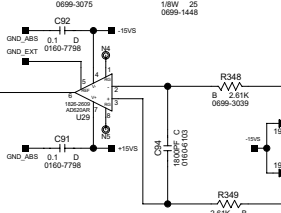
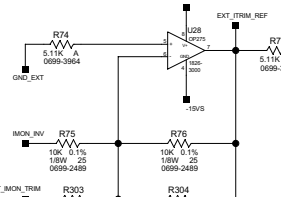
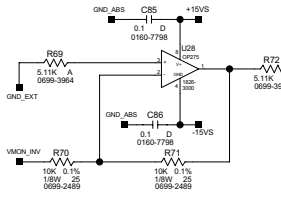
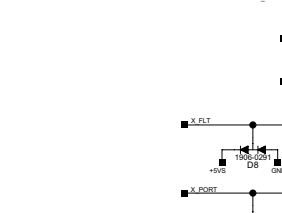
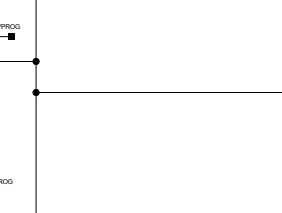
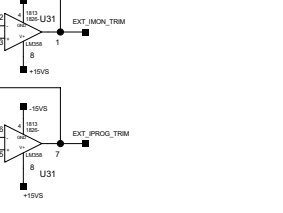
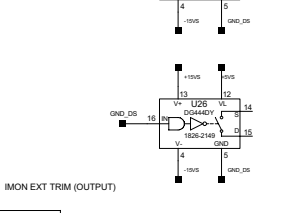
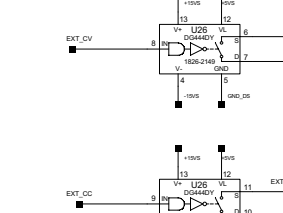
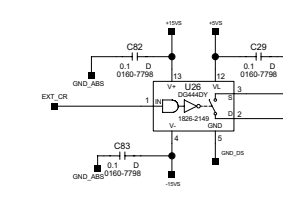
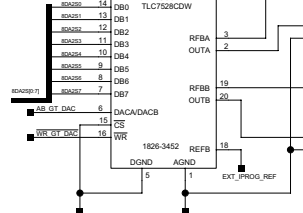
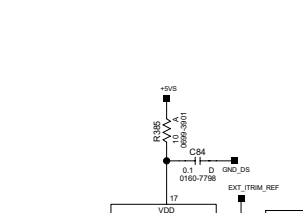
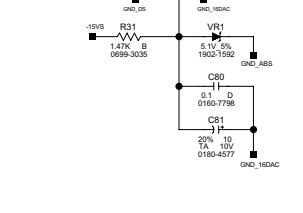
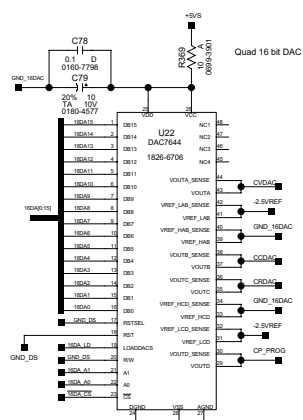
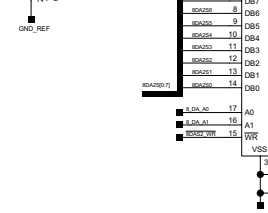
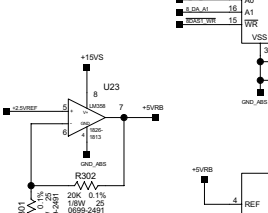
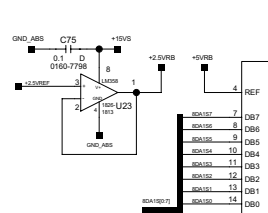
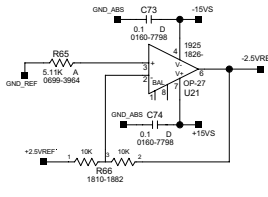
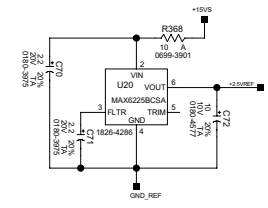

Agilent N3305A
500W Electronic Load Module
5064-0106
Control Board PC Assembly
 Page 3 of 6

CV RANGE AND SLEW CIRCUITS

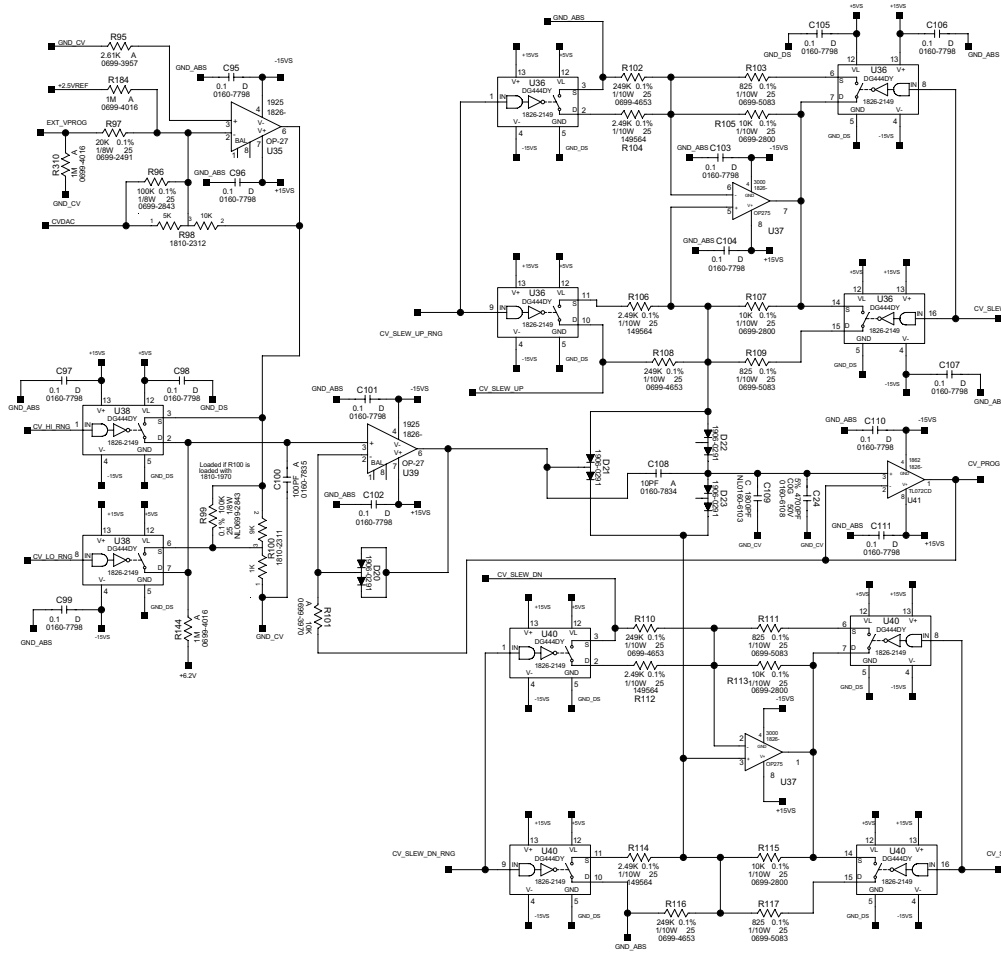

CC RANGE AND SLEW CIRCUITS

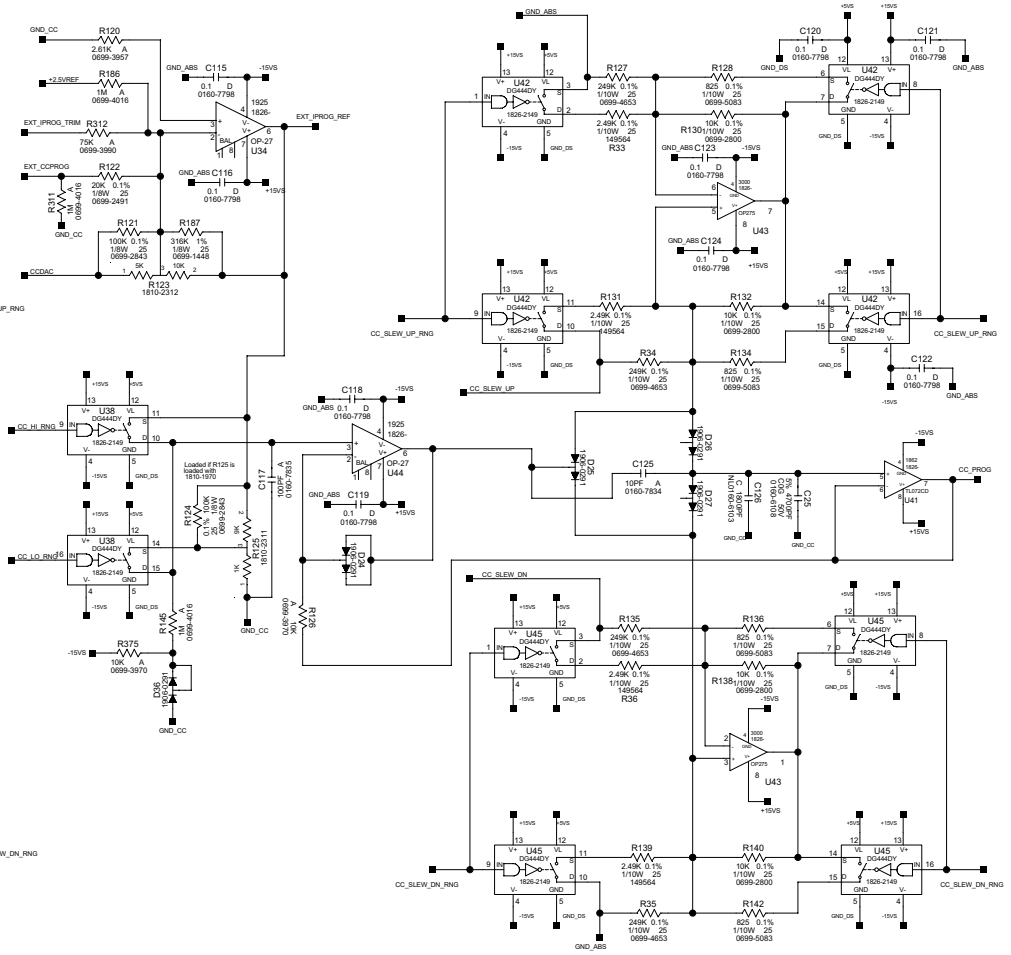

Agilent N3305A
500W Electronic Load Module

5064-0106
Control Board PC Assembly
Page 4 of 6

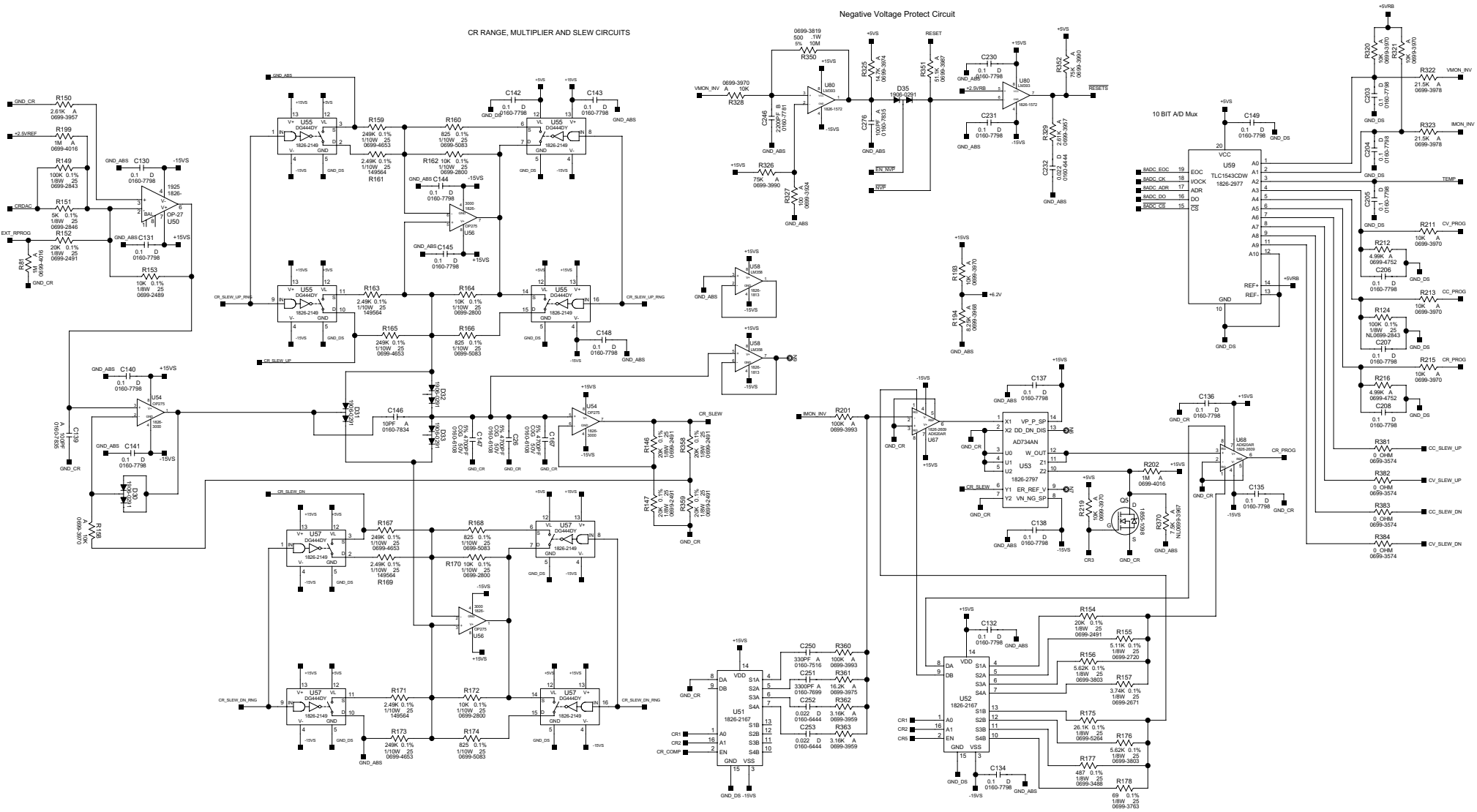

Agilent N3305A
500W Electronic Load Module
5064-0106
Control Board PC Assembly
Page 5 of 6

5064-0106 Control Board Parts List (Electronic Load Module)

Reference Designator	Qty	Agilent P/N	Description	MPN	Manufacturer
D1	1	1902-1544	DIODE-ZNR 10V 5PCT TO-236(SOT-23) PD-.35V	BZX84C10 BZX84C10LT1G BZX84C10	PHILIPS ON SEMICONDUCTOR NXP
D2, D7, D8, D10-D13, D20-D27, D30-D33, D35, D36,	21	1906-0291	DIODE-DUAL 70V 100MA T0-236AA	BAV99 BAV99 BAV99LT1G BAV99____X_ BAV99	PHILIPS FAIRCHILD SEMICONDUCTOR ON SEMICONDUCTOR INFINEON TECHNOLOGIES NXP
D3	1	1901-1332	DIODE-PWR-S 40V 1A D0-214AA	10BQ040PBF SK14 SS24 STPS140U MBRS140T3G	INTERNATIONAL RECTIFIER MICROSEMI VISHAY STMICROELECTRONICS ON SEMICONDUCTOR
D4	1	1906-0358	DIODE-DUAL 100V 100MA TO-236AB (SOT-23)	MMBD1203	FAIRCHILD SEMICONDUCTOR
J5	1	1252-6163	CONN-POST TYPE .100-PIN-SPCG-MTG-END	N3433-5202RB	3M
L1, L11, L2, L3, L5, L6	6	9170-1585	CORE-SHIELDING BEAD	FCM2012V-400 MMZ2012S400A_ MI0805K400R-10	TAI-TECH ADVANCED TDK STEWART
L10	1	9140-1458	INDUCTOR 3.3uH +-5pct 2.8W-mmX3.4LG-mm	NLV32T-3R3J -PF KL32T___3R3J	TDK KOA
L100-L116	17	9170-1631	CORE-SHIELDING BEAD	MMZ2012S601A	TDK
L7, L8	2	9140-4918	INDUCTOR 47uH +20pct -20pct	UP0.4C-470 P0770.473	COOPER INDUSTRIES TECHNITROL
L9	1	9140-1950	INDUCTOR 10uH +20pct -20pct	DT3316P-103ML	COILCRAFT
P22	1	5081-4998	CABLE-RIBBON	5081-4998 5081-4998	FREEDOM ELECTRONICS MICROTEK
P5	1	5081-4987	CABLE-RIBBON		
Q1	1	1853-0525	TRANSISTOR PNP SI TO-236AA PD=200MW	MMBT2907 PMBT2907A MMBT2907ALT1G PMBT2907A	FAIRCHILD SEMICONDUCTOR PHILIPS ON SEMICONDUCTOR NXP