

OTS LIBRARY

OTS LIBRARY



2400001027

**User and
Service Guide**

OTS LIBRARY

HP 3400B

RMS Voltmeter

© Copyright 1992
Hewlett-Packard Co.
All Rights Reserved.

Printing History

Edition 1, October 1992

New editions are complete revisions of the manual. Update packages, which are issued between editions, may contain additional information and replacement pages which you merge into the manual. The dates on this page change only when a new edition is published.

Certification

Hewlett-Packard certifies that this product met its published specifications at the time of shipment. Hewlett-Packard further certifies that its calibration measurements are traceable to the United States National Institute of Standards and Technology (formerly National Bureau of Standards), to the extent allowed by that organization's calibration facility, and to the calibration facilities of other International Standards Organization members.

Warranty

This Hewlett-Packard product is warranted against defects in materials and workmanship for a period of one year from date of shipment. Duration and conditions of warranty for this product may be superceded when the product is integrated into (becomes a part of) other Hewlett-Packard products. During the warranty period, Hewlett-Packard will, at its option, either repair or replace products which prove to be defective.

Warranty Service

For warranty service or repair, this product must be returned to a service facility designated by Hewlett-Packard.

For products returned to Hewlett-Packard for warranty service, the Buyer shall prepay shipping charges to HP and HP shall pay shipping charges to return the product to the Buyer. However, the Buyer shall pay all shipping charges, duties, and taxes for products returned to Hewlett-Packard from another country.

Limitation of Warranty

The foregoing warranty shall not apply to defects resulting from improper or inadequate maintenance by the Buyer, Buyer-supplied products or interfacing, unauthorized modification or misuse, operation outside of the environmental specifications for the product, or improper site preparation or maintenance.

The design and implementation of any circuit on this product is the sole responsibility of the Buyer. HP does not warrant the Buyer's circuitry or malfunctions of HP products that result from the Buyer's circuitry. In addition, HP does not warrant any damage that occurs as a result of the Buyer's circuit or any defects that result from Buyer-supplied products. **No other warranty is expressed or implied. Hewlett-Packard specifically disclaims the implied warranties of merchantability and fitness for a particular purpose.**

Exclusive Remedies

The remedies provided herein are the Buyer's sole and exclusive remedies. Hewlett-Packard shall not be liable for any direct, in-direct, special, incidental, or consequential damages, whether based on contract, tort, or any other legal theory.

Notice

The information contained in this document is subject to change without notice.

Hewlett-Packard makes no warranty of any kind with regard to this material, including, but not limited to, the implied warranties of merchantability and fitness for a particular purpose.

Hewlett-Packard shall not be liable for errors contained herein or for incidental or consequential damages in connection with the furnishing, performance, or use of this material. No part of this document may be photocopied, reproduced, or translated to another language without the prior written consent of HP.

Restricted Rights

Use, duplication, or disclosure by the Government is subject to restrictions as set forth in subdivision (b)(3)(ii) of the Rights in Technical Data and Computer Software clause at 52.227-7013. Hewlett-Packard Co. 3000 Hanover Street Palo Alto, California 94304

Safety

Do not install substitute parts or perform any unauthorized modification to the product. Return the product to an HP Sales and Service Office for service and repair to ensure that safety features are maintained.

Safety Symbols

Warning

Calls attention to a procedure, practice, or condition, that could possibly cause bodily injury or death.

Caution

Calls attention to a procedure, practice, or condition that could possibly cause damage to equipment or permanent loss of data.



Instruction manual symbol. Refer to the manual for specific Warning or Caution information to avoid personal injury or damage to the product.



Indicates hazardous voltages may be present.



Earth ground symbol.



Chassis ground symbol.

DL-8C

aba

The HP 3400B is a true root-means-square (RMS) analog voltmeter capable of measuring ac voltages from 100 microvolts to 300 volts. It is extremely flexible for audio and RF measurements from 10 Hz to 20 MHz and allows you to measure broadband noise and fast rise-time pulses.

- Full-scale measurements of non-sinusoidal waveforms with crest factors (the ratio of peak voltage to RMS voltage) up to 10:1 can be made. At 1/10th of full scale, pulse trains with 0.01% duty cycle (100:1 crest factor) can be measured accurately.
- A single front-panel control selects one of 12 voltage ranges (1 mV to 300 V) or decibel ranges (-72 dBm to +52 dBm).
- A dc output is provided on the rear panel which is proportional to the front-panel meter reading. By using this voltage to drive auxiliary equipment, you can use the voltmeter as an RMS ac-to-dc converter.
- Suitable for bench use or can be rack-mounted using the available combining case or adapter frame accessories.

The HP 3400B is a form, fit, and function replacement for the original HP 3400A. Completely redesigned, the "B" version extends the bandwidth from 10 MHz, available with the "A" version, to 20 MHz. The *HP 3400B User and Service Guide* contains new specifications and calibration procedures for the improved performance of the HP 3400B. Updated schematics and replaceable parts lists are also included.

HP 3400B RMS Voltmeter

The Front Panel at a Glance

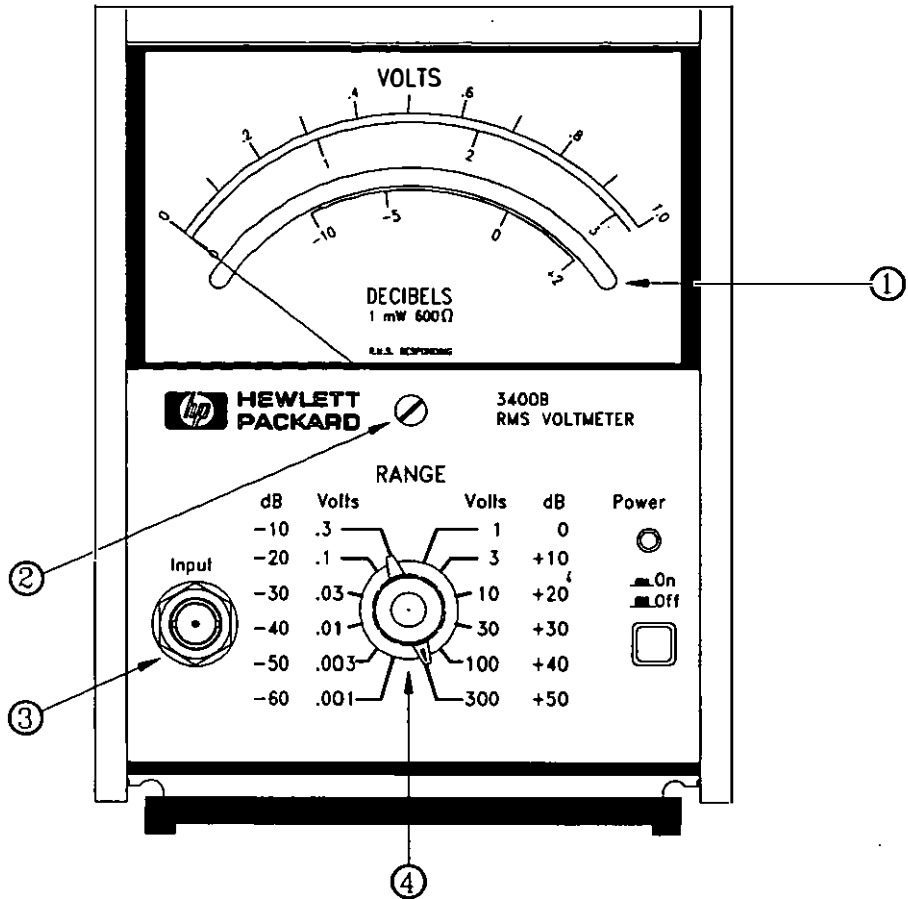

- 1 Direct reading meter (RMS volts and dB)
2 Zero adjustment screw

- 3 Input BNC connector
4 Range selector switch (volts and dB)

The Rear Panel at a Glance

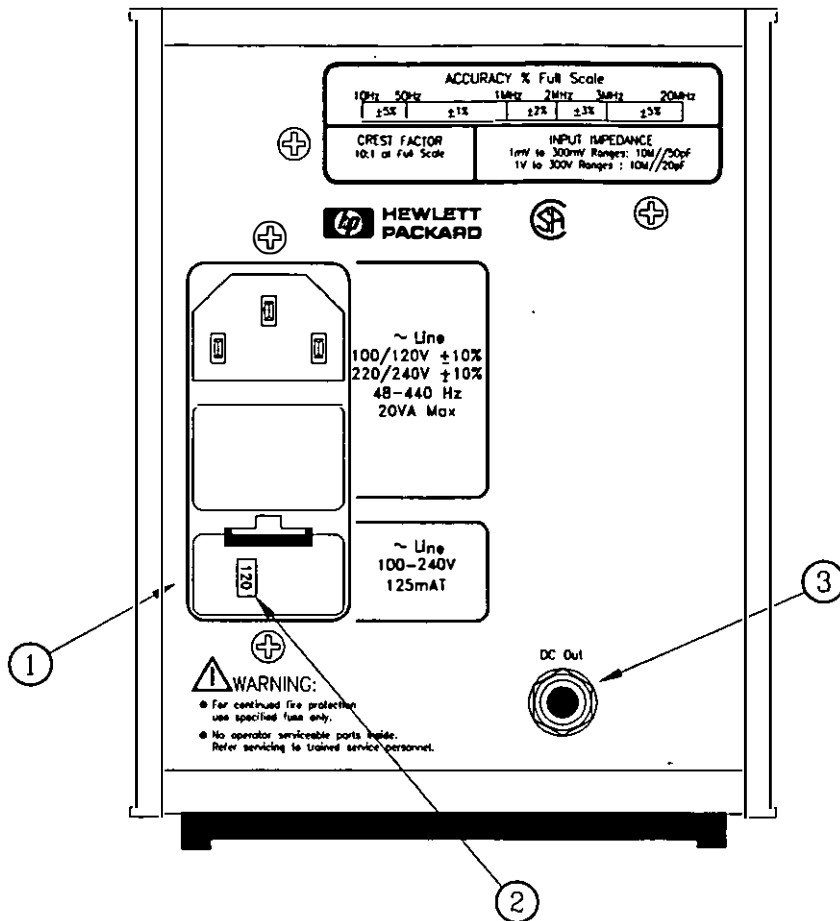

- 1 Power-line fuse-holder assembly
2 Power-line voltage setting

- 3 DC output jack. Provides -1 Vdc output at full-scale deflection; output is proportional to deflection; source impedance is 1 kΩ.

Specifications

Voltage Ranges: 1 mV, 3 mV, 10 mV, 30 mV, 100 mV, 300 mV, 1 V, 3 V, 10 V, 30 V, 100 V, 300 V full scale.

dB Range: -72
(0 dBm = 1 mW into 600Ω).

Frequency Range: 10 Hz to 20 MHz

Response: Responds to RMS value (heating value) of input.

Measurement Accuracy: From 1/10th scale to full scale is % of full scale.
20°C to 30°C
(1 Year)

| Frequency | ± % of Full Scale |
|-----------------|-------------------|
| 10 Hz to 50 Hz | ± 5% |
| 50 Hz to 1 MHz | ± 1% |
| 1 MHz to 2 MHz | ± 2% |
| 2 MHz to 3 MHz | ± 3% |
| 3 MHz to 20 MHz | ± 5% |

Note: The voltmeter may show a zero offset with no voltage applied to the input terminal.

AC-to-DC Converter Accuracy: 20°C to 30°C

Temperature coefficient: ± 0.10% per °C from 0°C

| Frequency | ± % of Full Scale |
|-----------------|-------------------|
| 10 Hz to 50 Hz | ± 5% |
| 50 Hz to 1 MHz | ± 0.75% |
| 1 MHz to 2 MHz | ± 2% |
| 2 MHz to 3 MHz | ± 3% |
| 3 MHz to 20 MHz | ± 5% |

Note: The voltmeter may show a zero offset with no voltage applied to the input terminal.

Input Impedance: 1 mV to 300 mV ranges: 10 MΩ shunted by < 50 pF. AC-coupled input.
1 V to 300 V ranges: 10 MΩ shunted by < 20 pF. AC-coupled input.

Crest Factor: (Ratio of peak-to-RMS amplitude of input.)
10:1 at full scale except where limited by maximum input, and inversely proportional to meter deflection (e.g. 20:1 at half-scale, 100:1 at tenth-scale).

AC Overload: 30 dB above full scale or 800 Vpeak, whichever is less, on each range.

Max. Continuous Input Voltage: 500 Vac peak at 1 kHz or 600 Vdc on all ranges.

Max. DC Input: 600 V on any range.

Response Time: For a step function, < 5 seconds to respond to final value.

DC Output: Negative 1 Vdc into open circuit for full scale deflection, proportional to meter deflection.
1 mA max; nominal source impedance 1 kΩ.

Output Noise: < 1 mV RMS

Power: 100 V / 120 V / 220 V / 240
48 Hz to 440 Hz, 10 Watts.

Weight: 2.2 kg (4)

Size: 18.5

Storage Temperature: -10°C to +60°C

Warnings and Cautions

Warning *No user serviceable parts inside. Refer servicing to trained service personnel.*

Avertissement *Ne contient pas d'élément que l'utilisateur puisse réparer. Confier la maintenance à un technicien qualifié.*

Warning *For continued fire protection, use specified fuse only.*

Avertissement *Pour maintenir la capacité de protection contre l'incendie, utilisez le fusible recommandé seulement.*

Warning *For protection from electrical shock hazard, power cord ground must not be defeated.*

Avertissement *Pour ne pas compromettre la protection contre le choc électrique, ne pas couper le circuit de continuité de masses de la fiche.*

In This Book

Quick Start Chapter 1 prepares the voltmeter for use and helps you get familiar with its front-panel features.

Calibration Procedures Chapter 2 provides a detailed description of the voltmeter's verification and adjustment procedures.

Theory of Operation Chapter 3 describes each functional block in the voltmeter.

Service Chapter 4 provides guidelines for returning your voltmeter to Hewlett-Packard for servicing.

Replaceable Parts Chapter 5 contains a detailed parts list for the voltmeter.

Backdating Chapter 6 describes the procedures involved with back issues of this manual.

Schematics Chapter 7 provides the voltmeter's schematics.

Contents

Chapter 1 Quick Start

- To prepare the voltmeter for use 11
- To select the range 13
- To use the DC output signal 14
- To rack mount the voltmeter 15

Chapter 2 Calibration Procedures

- Calibration Interval 19
- Time Required for Calibration 19
- Recommended Test Equipment 20
- Test Considerations 20
- Operation Verification Procedures 21
- Performance Verification Procedures 22
- Adjustment Procedures 28
- Test Connector Pinout 36

Chapter 3 Theory of Operation

- Block Diagram 39
- Input Attenuator 41
- Impedance Converter 41
- Post Attenuator 42
- Wideband Amplifier 42
- Chopper Op Amp / Thermocouple Pair 43
- Power Supplies 44
- Switch Board 45

Chapter 4 Service

- Operating Checklist 49
- To Replace the Power-Line Fuse 49
- Repackaging for Shipment 50
- Electrostatic Discharge (ESD) Precautions 50

Contents

Chapter 5 Replaceable Parts

To Order Replaceable Parts 52
Backdating and Parts Changes 52
Replaceable Parts: 03400-66522 (Main Assembly) 53
Replaceable Parts: 03400-66523 (Switch Assembly) 58
Manufacturer's Codes: 03400-66522 and 03400-66523 59
Replaceable Parts: HP 3400B Mainframe 60
Manufacturer's Codes: HP 3400B Mainframe 62

Chapter 6 Backdating 63

Chapter 7 Schematics

Mechanical Disassembly 67
Component Locator Diagrams 68
Input Attenuator, Impedance Converter, and Power Supplies 69
Relay Drivers and Post Attenuator 70
Wideband Amplifier, Chopper Op Amp, and Overload Detector 71
Switch Board Schematic 72

Index 73

Quick Start

Quick Start

One of the first things you will want to do with your voltmeter is to become acquainted with its front panel. We have written the exercises in this chapter to prepare the voltmeter for use and help you get familiar with some of its front-panel operations.

To prepare the voltmeter for use

The following steps help you verify that the voltmeter is ready for use.

1 Check the list of supplied items.

Verify that you have received the following items with your voltmeter. If anything is missing, contact your nearest Hewlett-Packard Sales Office.

- One double binding post to BNC adapter.
- One power cord.
- One 125 mA power-line fuse is installed.
- This *User and Service Guide*.

2 Verify the power-line voltage setting.

Four line voltage settings are available: 100, 120, 220, or 240 Vac. The line voltage was preset at the factory to the proper value for your location. Change the voltage setting if it is not correct (see page 12).

A 125 mA fuse is installed when the voltmeter is shipped from the factory. This is the correct power-line fuse for 100, 120, 220, or 240 Vac operation.

3 Connect the power cord and turn on the voltmeter.

The front-panel **Power** indicator will light up when you turn on the voltmeter. Allow *five minutes* for the voltmeter to warm up and stabilize before making measurements.

Caution

Do not measure signals greater than 80 volts with 10 to 1 crest factor, otherwise, the maximum input rating of 800 volts peak will be exceeded. When measuring signals up to 80 volts with a 10 to 1 crest factor, use the double binding post to BNC adapter (or equivalent) supplied with the voltmeter.

Chapter 1 Quick Start
To prepare the voltmeter for use

1 Remove the fuse-holder assembly from the rear panel.

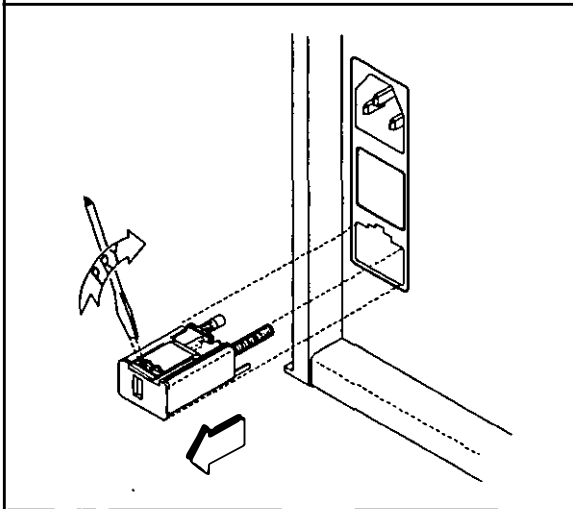

2 Remove the line-voltage selector from the assembly.

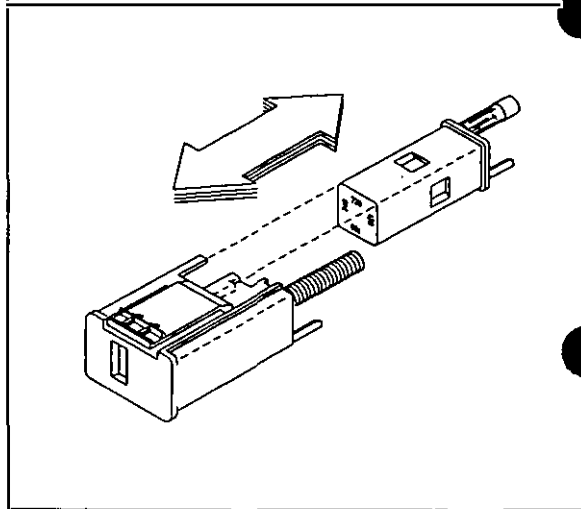

3 Rotate the line-voltage selector until the correct voltage appears in the window.

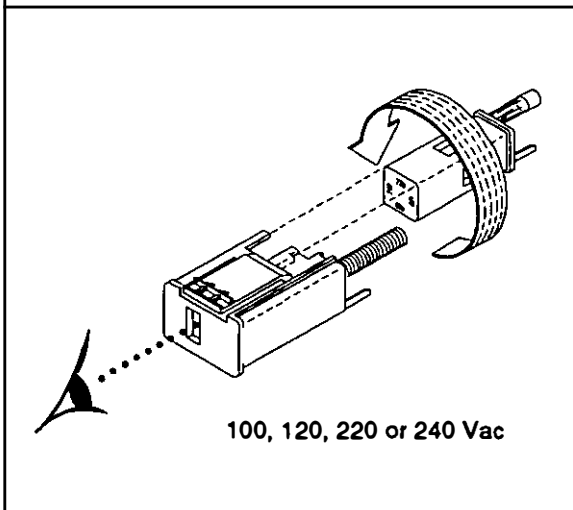

4 Replace the fuse-holder assembly in the rear panel.

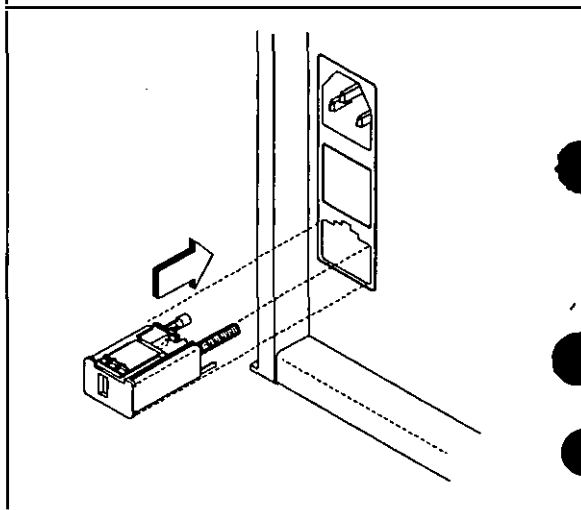

Verify that the correct line voltage appears in the window.

To select the range

You can make measurements using one of 12 voltage ranges available. The voltmeter is capable of measuring true-RMS ac voltages from 100 μ V to 300 V.

Caution

When measuring an ac signal superimposed on a dc level, you should always set the range selector switch to the 300 volt position. A high-voltage transient caused by the application of a dc voltage will damage the voltmeter's input circuitry.

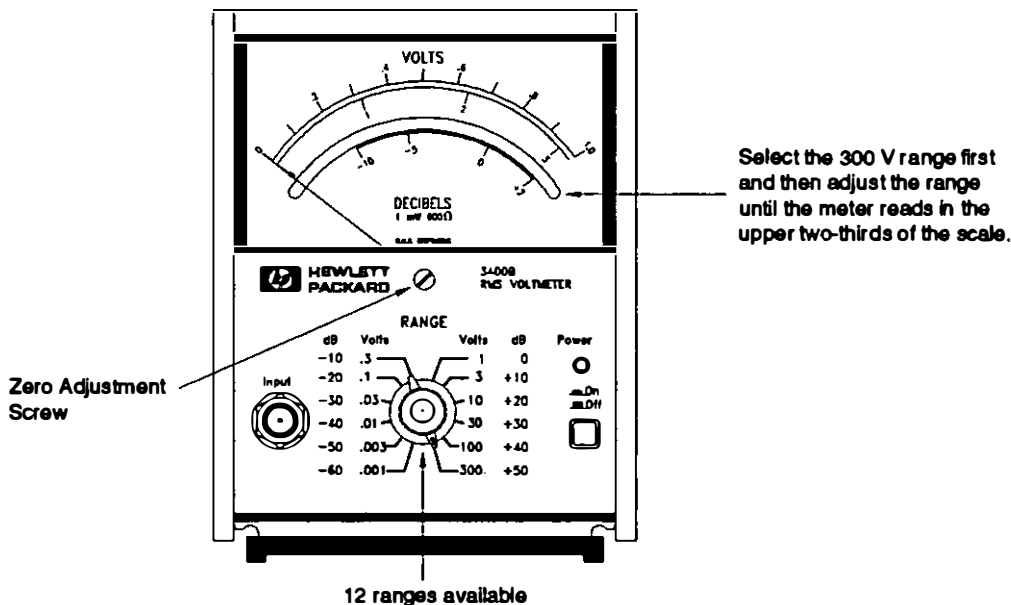

Note The voltmeter may show a zero offset with no voltage applied to the input terminal.

Note If the meter pointer does not indicate "0" when the voltmeter has been turned off for at least one minute, you should adjust the zero screw setting. See chapter 2, "Calibration Procedures," for more information.

To use the DC output signal

You can create plots of measured data and make higher resolution measurements by connecting an X-Y plotter or digital multimeter to the rear-panel DC output jack. On the 1's ranges (0.001, 0.01, 0.1, 1, etc.), the voltage measured at the jack is normalized to -1 Vdc and is proportional to the RMS input voltage (-1 Vdc corresponds to a full-scale meter deflection). On the 3's ranges (0.003, 0.03, 0.3, 3, etc.), the full-scale output is -0.9487 Vdc.

A phone plug for the DC output jack is available by ordering HP part number 1251-0067.

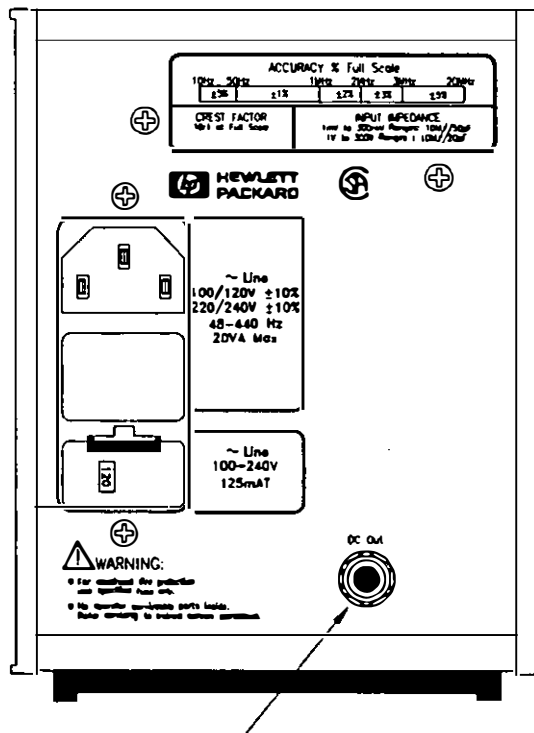

Negative 1 Vdc into open circuit for full scale deflection;
proportional to meter deflection.

1 mA max; nominal source impedance 1 k Ω .

To rack mount the voltmeter

You can mount the voltmeter in a standard 19-inch rack cabinet using one of two optional kits available. If your application requires that you frequently remove the voltmeter from the cabinet, the *combining case* is recommended. You can also use the combining case on the bench to mount the voltmeter with other HP System I instruments. The *rack adapter frame* is recommended for permanent or semi-permanent rack mounting applications.

Remove the front and rear feet before mounting the voltmeter in the combining case or rack adapter frame.

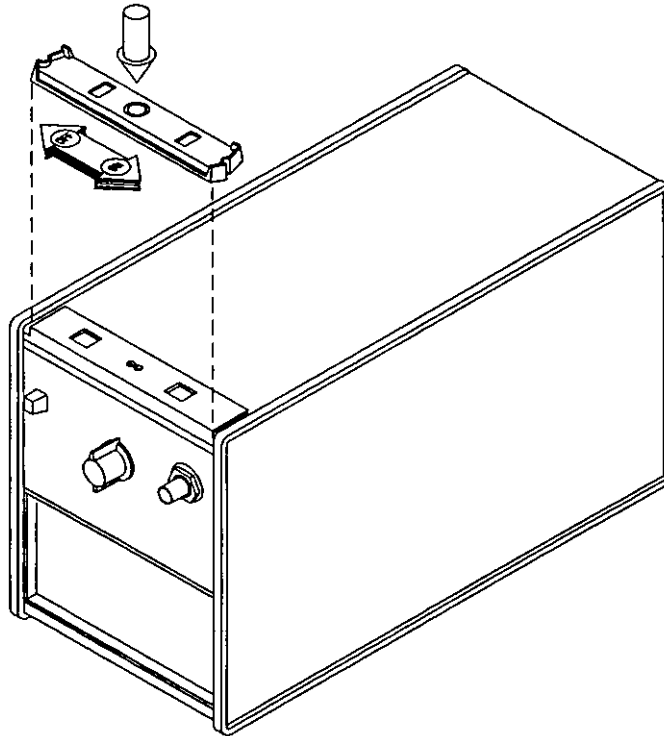

To remove the feet, press down on the release tab and slide to side.

Chapter 1 Quick Start
To rack mount the voltmeter

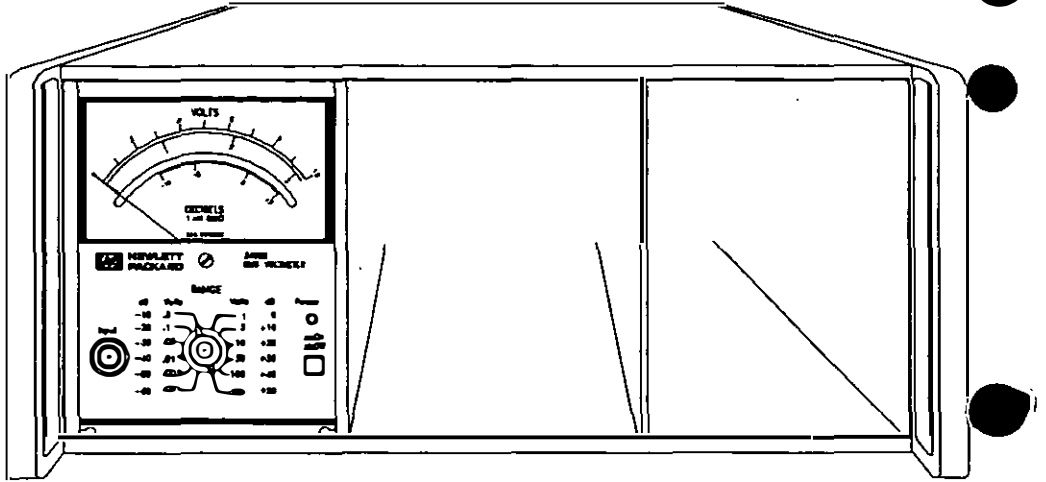

To use the combining case, order part number HP 1052A and rack mount kit 5060-8741.

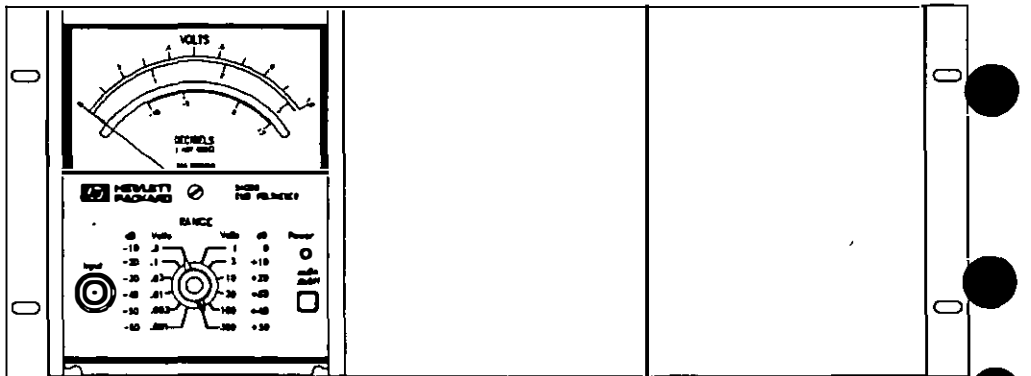

To use the rack adapter frame, order part number HP 5060-8762.

Calibration
Procedures

Calibration Procedures

This chapter contains procedures for performing the voltmeter's verification and adjustment procedures. Notice that the verification procedures are divided into two levels: *Operation Verification* (verifies that the voltmeter meets selected testable specifications) and *Performance Verification* (verifies that the voltmeter meet all testable specifications). The chapter is divided into the following sections:

- Calibration Interval 19
- Time Required for Calibration 19
- Recommended Test Equipment 20
- Test Considerations 20
- Operation Verification Procedures 21
- Performance Verification Procedures 22
- Adjustment Procedures 28
- Test Connector Pinout 36

The verification tests use the voltmeter's specifications listed in "Specifications" on page 4.

Warning

The information in this chapter is for service-trained personnel who are familiar with electronic circuitry and are aware of the hazards involved. To avoid personal injury or damage to the instrument, do not perform procedures in this chapter or do any servicing unless you are qualified to do so.

Some procedures in this chapter must be performed with power applied to the voltmeter while the protective covers are removed. Energy available at many points may, if contacted, result in personal injury.

Caution

Static electricity is a major cause of component failure. To prevent damage to the electrical components in the voltmeter, observe anti-static techniques whenever working on the voltmeter.

Calibration Interval

The voltmeter should be calibrated on a regular interval determined by the measurement accuracy requirements of your application. A 90-day interval is recommended for the most demanding applications, while a 1-year or 2-year interval may be adequate for less demanding applications. Hewlett-Packard does not recommend extending calibration intervals beyond 2 years for any application.

Whatever calibration interval you select, Hewlett-Packard recommends that complete re-adjustment should always be performed at the calibration interval. This will increase your confidence that the HP 3400B will remain within specification for the next calibration interval. This criteria for re-adjustment provides the best measure of the voltmeter's long-term stability. Performance data measured using this method can easily be used to extend future calibration intervals.

When your voltmeter is due for calibration, contact your local Hewlett-Packard Service Center for a low-cost recalibration. Calibrations to MIL-STD-45662 are also available at competitive prices.

Time Required for Calibration

The Operation Verification, Performance Verification, and Adjustment procedures in this chapter show you how to manually calibrate the voltmeter. A complete verification and adjustment using these procedures will take approximately one hour.

Recommended Test Equipment

The test equipment recommended for the verification and adjustment procedures is listed below. If the exact instrument is not available, select an equivalent substitute.

| Application | Recommended Equipment |
|---|---|
| Range/Frequency Response Check (page 23, 24) | Fluke 5700A Calibrator, HP 3458A Multimeter |
| Amplifier Stability Check (page 25) | HP 8161A Pulse Generator, HP 3458A Multimeter |
| Overload Protection Circuitry Check (page 26) | Fluke 5700A Calibrator, HP 3458A Multimeter |
| Crest Factor Check (page 27) | HP 8161A Pulse Generator, HP 3458A Multimeter |
| Front-Panel Meter Zero Adjustment (page 28) | None |
| Full Scale Gain Adjustment (page 29) | Fluke 5700A Calibrator, HP 3458A Multimeter |
| Tenth Scale Gain Adjustment (page 30) | Fluke 5700A Calibrator, HP 3458A Multimeter |
| Full Scale Pointer Adjustment (page 32) | None |
| 20 MHz Flatness Adjustment (page 33) | Fluke 5700A Calibrator, HP 3458A Multimeter |
| Input Attenuator Adjustment (page 34) | Fluke 5700A Calibrator, HP 3458A Multimeter |

Test Considerations

To ensure proper instrument operation, verify that you have selected the correct power line voltage prior to attempting any test procedure in this chapter. See chapter 1, "Quick Start," for more information.

- Assure that the calibration ambient temperature is stable and between 18°C and 28°C.
- Assure that the ambient relative humidity is less than 80%.
- Allow the voltmeter to warm up for 30 minutes, with the covers in place, before attempting any performance checks.

Operation Verification Procedures

The procedures in this section are used to provide a high level of confidence that the voltmeter is meeting published specifications. The Operation Verification test is a subset of the Performance Verification tests and is suitable for checkout after performing repair.

2

The Operation Verification test is performed by completing a partial range/frequency response test as described later in the Performance Verification test procedures. This test verifies the voltmeter's frequency response on the 1 volt range at full scale input levels. The signal measured for this test is a dc voltage taken at the rear-panel dc output jack. This voltage is normalized to -1 Vdc and is proportional to the RMS input voltage (-1 Vdc corresponds to a full-scale meter deflection).

| HP 3400B Range | Calibrator Output Voltage | Calibrator Output Frequency | DC Output (DMM Reading) |
|----------------|---------------------------|-----------------------------|-------------------------|
| 1 V | 1 V | 10 Hz | -1.05 V to -0.95 V |
| 1 V | 1 V | 50 Hz | -1.0075 V to -0.9925 V |
| 1 V | 1 V | 1 MHz | -1.0075 V to -0.9925 V |
| 1 V | 1 V | 2 MHz | -1.02 V to -0.98 V |
| 1 V | 1 V | 3 MHz | -1.03 V to -0.97 V |
| 1 V | 1 V | 20 MHz | -1.05 V to -0.95 V |

- 1 HP 3400B: Select the 1 volt range.
- 2 Calibrator: Select a 1 volt ac signal at 10 Hz (use the "Wideband" output on the Fluke 5700A).
- 3 External Multimeter: Select the 10 Vdc range with 5½ digits of resolution.
- 4 Verify that the dc voltage measured at the rear-panel dc output jack is within the limits shown in the table above.
- 5 Continue checking the dc output as you adjust the calibrator's output voltage and frequency to each of the remaining values shown in the table above.

Performance Verification Procedures

The procedures in this section are used to test the voltmeter's electrical performance using the specifications given on page 4 as the performance standard. You can use these tests for incoming inspection, periodic maintenance, and specification checks after a repair.

Note Allow the voltmeter to warm up for 30 minutes, with the covers in place, before attempting any performance checks.

Range/Frequency Response Check

This test verifies the voltmeter's frequency response on all 12 input voltage ranges. The test is performed both at full scale and tenth scale input levels. The signal measured for this test is a dc voltage taken at the rear-panel dc output jack. On the 1's ranges (0.001, 0.01, 0.1, 1, etc.), this voltage is normalized to -1 Vdc and is proportional to the RMS input voltage (-1 Vdc corresponds to a full-scale meter deflection). On the 3's ranges (0.003, 0.03, 0.3, 3, etc.), the full scale output is -0.9487 Vdc.

Chapter 2 Calibration Procedures
Performance Verification Procedures

Full Scale Test

- 1 HP 3400B: Select the 0.001 volt range.
- 2 Calibrator: Select a 0.001 volt ac signal at 10 Hz.
- 3 External Multimeter: Select the 10 Vdc range with 5½ digits of resolution.
- 4 Verify that the dc voltage measured at the rear-panel dc output jack is within the limits shown in the table below.
- 5 Continue checking the dc output as you adjust the calibrator's output voltage and frequency to each of the remaining values shown in the table below.

2

| HP 3400B Range | Calibrator Output Voltage | Calibrator Output Frequency | DC Output (DMM Reading) |
|----------------|---------------------------|-----------------------------|-------------------------|
| 0.001 V | 0.001 V | 10 Hz | -1.05 V to -0.95 V |
| 0.003 V | 0.003 V | 1 kHz | -0.9558 V to -0.9416 V |
| 0.01 V | 0.01 V | 1 kHz | -1.0075 V to -0.9925V |
| 0.03 V | 0.03 V | 1 kHz | -0.9558 V to -0.9416 V |
| 0.1 V | 0.1 V | 1 kHz | -1.0075 V to -0.9925V |
| 0.3 V | 0.3 V | 1 kHz | -0.9558 V to -0.9416 V |
| 1 V | 1 V | 10 Hz | -1.05 V to -0.95 V |
| 1 V | 1 V | 50 Hz | -1.0075 V to -0.9925 V |
| 1 V | 1 V | 1 kHz | -1.0075 V to -0.9925 V |
| 1 V | 1 V | 10 kHz | -1.0075 V to -0.9925 V |
| 1 V | 1 V | 100 kHz | -1.0075 V to -0.9925 V |
| 1 V | 1 V | 1 MHz | -1.0075 V to -0.9925 V |
| 1 V | 1 V | 2 MHz | -1.02 V to -0.98 V |
| 1 V | 1 V | 3 MHz | -1.03 V to -0.97 V |
| 1 V | 1 V | 10 MHz | -1.05 V to -0.95 V |
| 1 V | 1 V | 20 MHz | -1.05 V to -0.95 V |
| 3 V | *3 V | 1 kHz | -0.9558 V to -0.9416 V |
| 10 V | *10 V | 1 kHz | -1.0075 V to -0.9925V |
| 30 V | *30 V | 1 kHz | -0.9558 V to -0.9416 V |
| 100 V | *100 V | 1 kHz | -1.0075 V to -0.9925V |
| 300 V | *300 V | 1 kHz | -0.9558 V to -0.9416 V |

* For all outputs less than 3 volts, use the "Wideband" output on the Fluke 5700A.
For outputs greater than 3 volts, use the low frequency output.

Chapter 2 Calibration Procedures
Performance Verification Procedures

Tenth Scale Test

- 1 HP 3400B: Select the 1 volt range.
- 2 Calibrator: Select a 0.1 volt ac signal at 10 Hz.
- 3 External Multimeter: Select the 10 Vdc range with 5½ digits of resolution.
- 4 Verify that the dc voltage measured at the rear-panel dc output jack is within the limits shown in the table below.
- 5 Continue checking the dc output as you adjust the calibrator's output voltage and frequency to each of the remaining values shown in the table below.

| HP 3400B Range | Calibrator Output Voltage | Calibrator Output Frequency | DC Output (DMM Reading) |
|----------------|---------------------------|-----------------------------|-------------------------|
| 1 V | 0.1 V | 10 Hz | -0.15 V to -0.05 V |
| 1 V | 0.1 V | 50 Hz | -1.075 V to -0.0925 V |
| 1 V | 0.1 V | 1 MHz | -1.075 V to -0.0925 V |
| 1 V | 0.1 V | 2 MHz | -0.12 V to -0.08 V |
| 1 V | 0.1 V | 3 MHz | -0.13 V to -0.07 V |
| 1 V | 0.1 V | 10 MHz | -0.15 V to -0.05 V |
| 1 V | 0.1 V | 20 MHz | -0.15 V to -0.05 V |

Amplifier Stability Check

This test verifies the stability of the voltmeter's input amplifier by measuring the rolloff of the frequency response at 40 MHz. The signal measured for this test is a dc voltage taken at the rear-panel dc output jack. This voltage is normalized to -1 Vdc and is proportional to the RMS input voltage (-1 Vdc corresponds to a full-scale meter deflection).

| HP 3400B Range | Source Output Voltage | Source Output Frequency | DC Output (DMM Reading) |
|-------------------|--------------------------|----------------------------|----------------------------|
| 0.1 V | 0.1 V | 40 MHz | -0.65 V to -0.45 V |

- 1 HP 3400B: Select the 0.1 volt range.
- 2 Source: Select a 0.1 volt ac signal at 40 MHz.
- 3 External Multimeter: Select the 10 Vdc range with 5½ digits of resolution.
- 4 Verify that the dc voltage measured at the rear-panel dc output jack is within the limits shown in the table above.

Overload Protection Circuitry Check

This test verifies the voltmeter's overload protection circuitry by applying a voltage slightly greater than the range limit. The signals measured for this test are dc voltages measured on test connector pin 8 (+VBB) and pin 9 (-VBB). At the end of the overvoltage sequence, the input voltage is returned to 0.1 volts to ensure that the voltmeter will recover to normal operation.

| HP 3400B Range | Calibrator Output Voltage | Calibrator Output Frequency | +VBB Reading | -VBB Reading |
|----------------|---------------------------|-----------------------------|--------------------|--------------------|
| 0.1 V | 0.1 V | 1 kHz | +11.5 V to +15.5 V | -15.5 V to -11.5 V |
| 0.1 V | 0.4 V | 1 kHz | +1.0 V to +5.0 V | -5.0 V to -1.0 V |

- 1 HP 3400B: Select the 0.1 volt range.
- 2 Calibrator: Select a 0.1 volt ac signal at 1 kHz (use the low frequency output on the Fluke 5700A).
- 3 External Multimeter: Select the 10 Vdc range with 5½ digits of resolution.
- 4 Measure +VBB (pin 8 on the test connector) and -VBB (pin 9 on the test connector). Verify that the measured voltages are within the limits shown in the table above for a 0.1 volt output from the calibrator.
- 5 Increase the calibrator's output voltage from 0.1 volts to 0.4 volts at 1 kHz.
- 6 Measure +VBB and -VBB. Verify that the measured voltages are within the limits shown in the table above for a 0.4 volt output from the calibrator.
- 7 To ensure that the voltmeter will still operate properly, decrease the calibrator's output voltage from 0.4 volts to 0.1 volts.
- 8 Measure +VBB and -VBB. Verify that the measured voltages are within the limits shown in the table above for a 0.1 volt output from the calibrator.

Crest Factor Check

This test verifies the voltmeter's crest factor performance. The signal measured for this test is a dc voltage taken at the rear-panel dc output jack. This voltage is normalized to -0.9487 Vdc and is proportional to the RMS input voltage (-0.9487 Vdc corresponds to a full-scale meter deflection).

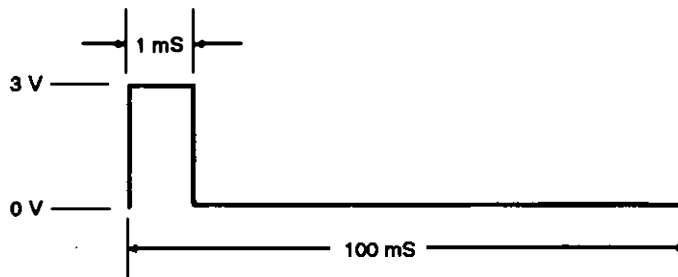

| HP 3400B Range | Source Configuration | DC Output (DMM Reading) |
|----------------|---|-------------------------|
| 0.3 V | Vout=1.5 Pulse Output Width=1 mSec, Frequency=10 Hz, Mode=Pulse | -1.05 |

- 1 HP 3400B: Select the 0.3 volt range.
- 2 Source: Program the source to output a pulse train with the following characteristics: Vout=1.5 volts, offset=750 mV, pulse output width=1 mSec, frequency=10 Hz, mode=pulse.
- 3 External Multimeter: Select the 10 Vdc range with $5\frac{1}{2}$ digits of resolution.
- 4 Verify that the dc voltage measured at the rear-panel dc output jack is within the limits shown in the table above.

Adjustment Procedures

The procedures in this section are used to adjust the voltmeter for peak performance. For best performance, the voltmeter should always be adjusted after repair. Do not perform the adjustment procedures unless they are required. If you make unnecessary adjustments of the internal controls, you may actually cause more difficulty.

Warning

Some procedures in this section must be performed with power applied to the voltmeter while the protective covers are removed. To avoid personal injury or damage to the instrument, do not perform procedures in this section unless you are qualified to do so.

Note Allow the voltmeter to warm up for 30 minutes, with the covers in place, before attempting any adjustments.

Front-Panel Meter Zero Adjustment

The zero adjustment screw is located on the voltmeter's front panel. If the meter pointer does not indicate zero when power has been turned off for at least one minute, adjust the screw setting as described below.

- 1 Turn off the voltmeter and remove any input signals from the front panel and any connections to the rear panel.
- 2 Allow one minute for the meter pointer to stabilize.
- 3 Rotate the zero adjustment screw clockwise until the pointer is to the left of zero on the meter scale. Continue adjusting until the pointer is at zero. *If the pointer overshoots zero, repeat this step.*
- 4 When the pointer is exactly at zero, rotate the adjustment screw slightly counterclockwise to remove tension on the pointer's internal mechanism. *If the pointer moves to the left during this adjustment repeat steps 3 and 4.*

Full Scale Gain Adjustment

This procedure manually adjusts the voltmeter for full scale readings. The full scale adjustment and the tenth scale adjustment (described in the next section) are interdependent and you should repeat the adjustments until both measurements are within the recommended limits.

2

The signal measured for this test is a dc voltage taken at the rear-panel dc output jack. This voltage is normalized to -1 Vdc and is proportional to the RMS input voltage (-1 Vdc corresponds to a full-scale meter deflection).

For this adjustment, all measurements are made on the 0.01 volt range at 1 kHz. You will make the full scale adjustments using R321 which is located on the main circuit board (see below).

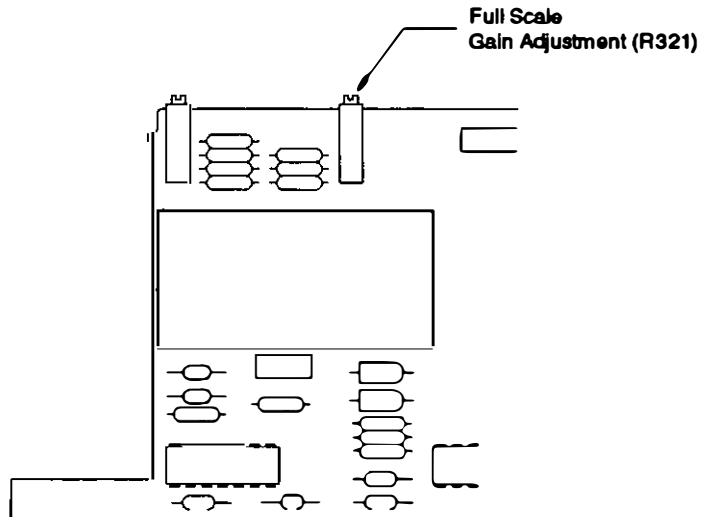

Chapter 2 Calibration Procedures

Adjustment Procedures

| HP 3400B Range | Calibrator Output Voltage | Calibrator Output Frequency | DC Output (DMM Reading) |
|----------------|---------------------------|-----------------------------|-------------------------|
| 0.01 V | 0.01 V | 1 kHz | -1.0019 V |

- 1 HP 3400B: Select the 0.01 volt range.
- 2 Calibrator: Select a 0.01 volt ac signal at 1 kHz (use the "Wideband" output on the Fluke 5700A).
- 3 External Multimeter: Select the 10 Vdc range with 5½ digits of resolution.
- 4 Remove *only* the top cover from the HP 3400B (it is important that you *do not* remove the side or bottom covers). Adjust R321 until the dc voltage measured at the rear-panel dc output jack is within the limits shown in the table above.

Tenth Scale Gain Adjustment

This procedure manually adjusts the voltmeter for tenth scale readings. The tenth scale adjustment and the full scale adjustment (described in the previous section) are interdependent and you should repeat the adjustments until both measurements are within the recommended limits.

The signal measured for this test is a dc voltage taken at the rear-panel dc output jack. This voltage is normalized to -1 Vdc and is proportional to the RMS input voltage (-1 Vdc corresponds to a full-scale meter deflection).

For this adjustment, all measurements are made on the 0.01 volt range at 1 kHz. You will make the tenth scale adjustments using R316 which is located on the main circuit board (see next page).

Chapter 2 Calibration Procedures
Adjustment Procedures

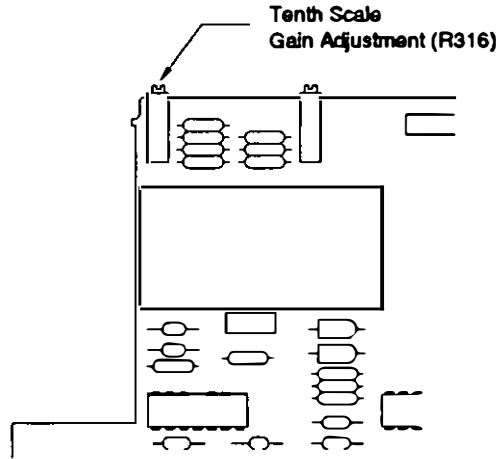

2

| HP 3400B Range | Calibrator Output Voltage | Calibrator Output Frequency | DC Output (DMM Reading) |
|----------------|---------------------------|-----------------------------|-------------------------|
| 0.01 V | 0.001 | 1 kHz | -0. |

- 1 HP 3400B: Select the 0.01 volt range.
- 2 Calibrator: Select a 0.001 volt ac signal at 1 kHz (use the "Wideband" output on the Fluke 5700A).
- 3 External Multimeter: Select the 10 Vdc range with 5½ digits of resolution.
- 4 Remove *only* the top cover from the HP 3400B (it is important that you *do not* remove the side or bottom covers). Adjust R316 until the dc voltage measured at the rear-panel dc output jack is within the limits shown in the table above.

Note Since the full scale and tenth scale adjustments are interdependent, you should repeat both adjustments again. Repeat the procedures again, starting with step 1 for the full scale adjustment, on page 30.

Full Scale Pointer Adjustment

This procedure shows you how to manually adjust the position of the meter pointer for full scale readings. When properly adjusted, the meter pointer should be aligned with the full scale marking on the right side of the meter scale.

This adjustment is made on the 0.1 volt range at 1 kHz. You will use R330 which is located on the main circuit board to make the adjustment (see below).

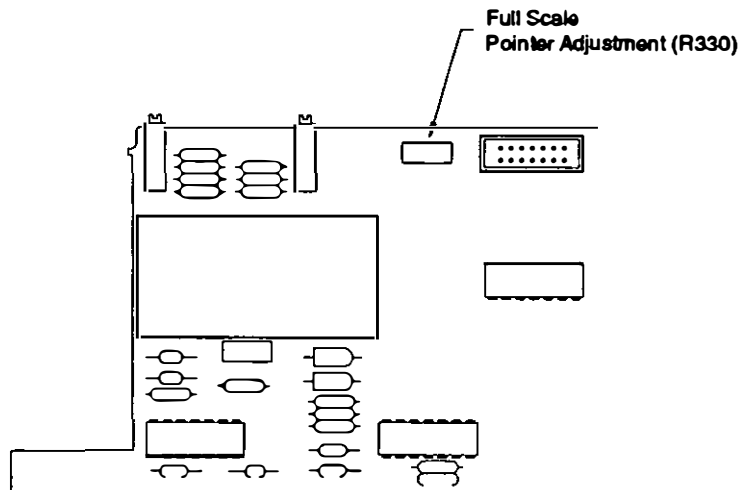

- 1 HP 3400B: Select the 0.1 volt range.
- 2 Calibrator: Select a 0.1 volt ac signal at 1 kHz (use the "Wideband" output on the Fluke 5700A).
- 3 Allow one minute for the meter pointer to stabilize.
- 4 Remove *only* the top cover from the HP 3400B (it is important that you *do not* remove the side or bottom covers). Adjust R330 until the meter pointer is aligned with the full scale marking on the right side of the meter scale.

20 MHz Flatness Adjustment

This procedure manually adjusts the 20 MHz flatness. The adjustment is made with a 100 mV signal applied at 20 MHz. You will make the flatness adjustment using C304 which is located on the main circuit board (see below).

2

The signal measured for this test is a dc voltage taken at the rear-panel dc output jack. This voltage is normalized to -1 Vdc and is proportional to the RMS input voltage (-1 Vdc corresponds to a full-scale meter deflection).

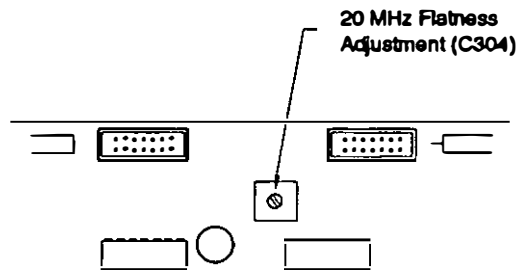

| HP 3400B Range | Calibrator Output Voltage | Calibrator Output Frequency | DC Output (DMM Reading) |
|----------------|---------------------------|-----------------------------|----------------------------|
| 0.1 V | 0.1 V | 20 MHz | -1.0125 V to -0.9875 V |

- 1 HP 3400B: Select the 0.1 volt range.
- 2 Calibrator: Select a 0.1 volt ac signal at 20 MHz (use the "Wideband" output on the Fluke 5700A).
- 3 External Multimeter: Select the 10 Vdc range with $5\frac{1}{2}$ digits of resolution.
- 4 Remove *only* the right-side cover from the HP 3400B (as viewed from the front panel). It is important that you *do not* remove the left-side, top, or bottom covers. Adjust C304 until the voltage measured at the rear-panel dc output jack is within the limits shown in the table above.

Input Attenuator Adjustment

This procedure performs a manual adjustment of the input attenuator at 50 Hz and 100 kHz. First, you will make the low frequency adjustment at 3V/50 Hz using R123 on the main circuit board (see below). You will make the high frequency adjustment at 3V/100 kHz using C134 on the main circuit board (see below).

The signal measured for this test is a dc voltage taken at the rear-panel dc output jack. This voltage is normalized to -0.9487 Vdc and is proportional to the RMS input voltage (-0.9487 Vdc corresponds to a full-scale meter deflection).

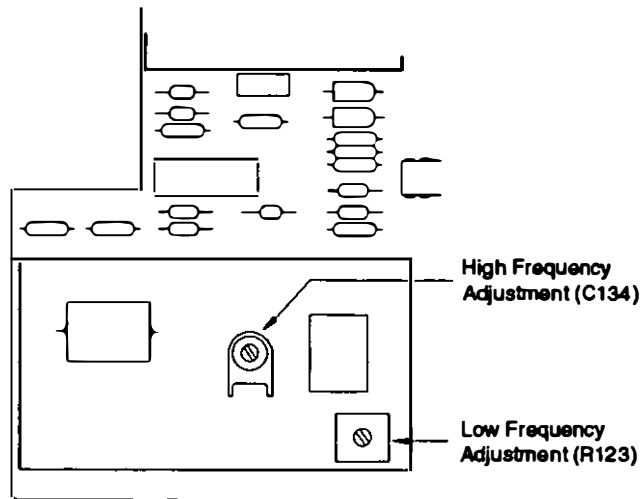

Chapter 2 Calibration Procedures

Adjustment Procedures

| HP 3400B Range | Calibrator Output Voltage | Calibrator Output Frequency | DC Output (DMM Reading) |
|----------------|---------------------------|-----------------------------|-------------------------|
| 3 V | 3 V | 50 Hz | -0.950 V to -0.947 V |
| 3 V | 3 V | 100 kHz | -0.950 V to -0.947 V |

2

Low Frequency

- 1 HP 3400B: Select the 3 volt range.
- 2 Calibrator: Select a 3 volt ac signal at 50 Hz (use the "Wideband" output on the Fluke 5700A).
- 3 External Multimeter: Select the 10 Vdc range with 5½ digits of resolution.
- 4 Remove *only* the right-side cover from the HP 3400B (as viewed from the front panel). It is important that you *do not* remove the left-side, top, or bottom covers. Adjust R123 until the voltage measured at the rear-panel dc output jack is within the limits shown in the table above for 50 Hz.

High Frequency

- 1 HP 3400B: Select the 3 volt range.
- 2 Calibrator: Select a 3 volt ac signal at 100 kHz (use the "Wideband" output on the Fluke 5700A).
- 3 External Multimeter: Select the 10 Vdc range with 5½ digits of resolution.
- 4 Remove *only* the right-side cover from the HP 3400B (as viewed from the front panel). It is important that you *do not* remove the left-side, top, or bottom covers. Adjust C134 until the voltage measured at the rear-panel dc output jack is within the limits shown in the table above for 100 kHz.

Test Connector Pinout

Test connector J3 gives you access to several test points on the main circuit board. You can build your own custom ribbon cable interface if is convenient for your application. The table below shows the pinout for the test connector. *Refer to the schematics in chapter 7 for more detailed information on the circuitry that interfaces with the test connector.*

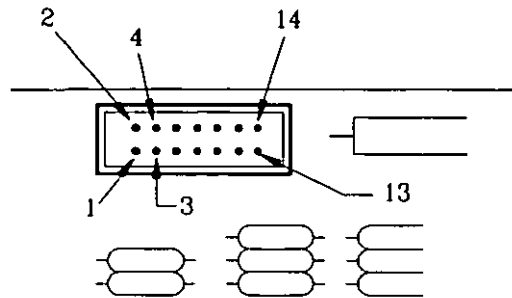

Test Connector J3

| Pin Number | Description |
|------------|---|
| 1 | K101B, Relay Drive Logic for Relay K101 (low true, see the table on page 45). |
| 2 | K201B, Relay Drive Logic for Relay K201 (low true, see the table on page 45). |
| 3 | K202B, Relay Drive Logic for Relay K202 (low true, see the table on page 45). |
| 4 | K203B, Relay Drive Logic for Relay K203 (low true, see the table on page 45). |
| 5 | Remote/Local Control, Ground or Hold Low to Disable Range Selector Switch. |
| 6 | +VCC (4.7 k Ω Series Resistor). |
| 7 | CGND, Common Ground |
| 8 | +VBB |
| 9 | -VBB |
| 10 | -VRAW (10 k Ω Series Resistor), Output from Power Transformer (T1). |
| 11 | Not Used |
| 12 | OPAMP_DC, Output from Wideband Amplifier (U301). |
| 13 | DC_OUT, Same as Rear Panel Output (loading on this line will affect signal on rear-panel output; loading on rear-panel output will affect signal on this line). |
| 14 | CGND, Common Ground |

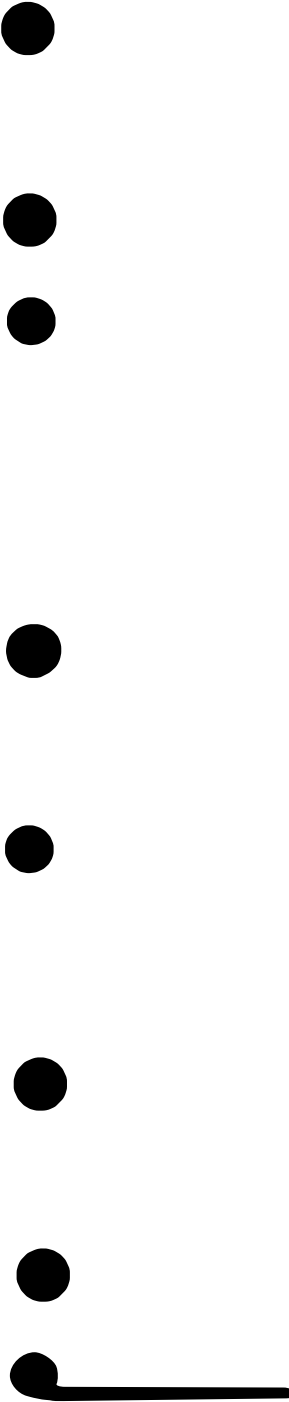

Theory of
Operation

Theory of Operation

This chapter is organized to provide descriptions of the circuitry contained on each schematic shown in chapter 7. A block diagram overview is provided followed by more detailed descriptions of the circuitry contained in the schematics chapter.

- Block Diagram 39
- Input Attenuator 41
- Impedance Converter 41
- Post Attenuator 42
- Wideband Amplifier 42
- Chopper Op Amp / Thermocouple Pair 43
- Power Supplies 44
- Switch Board 45

Block Diagram

Referring to the instrument block diagram shown below, you can see that the voltmeter's operational circuitry consists of two attenuators, an impedance converter, a wideband amplifier, a chopper op amp, a thermocouple pair, and a direct reading meter.

3

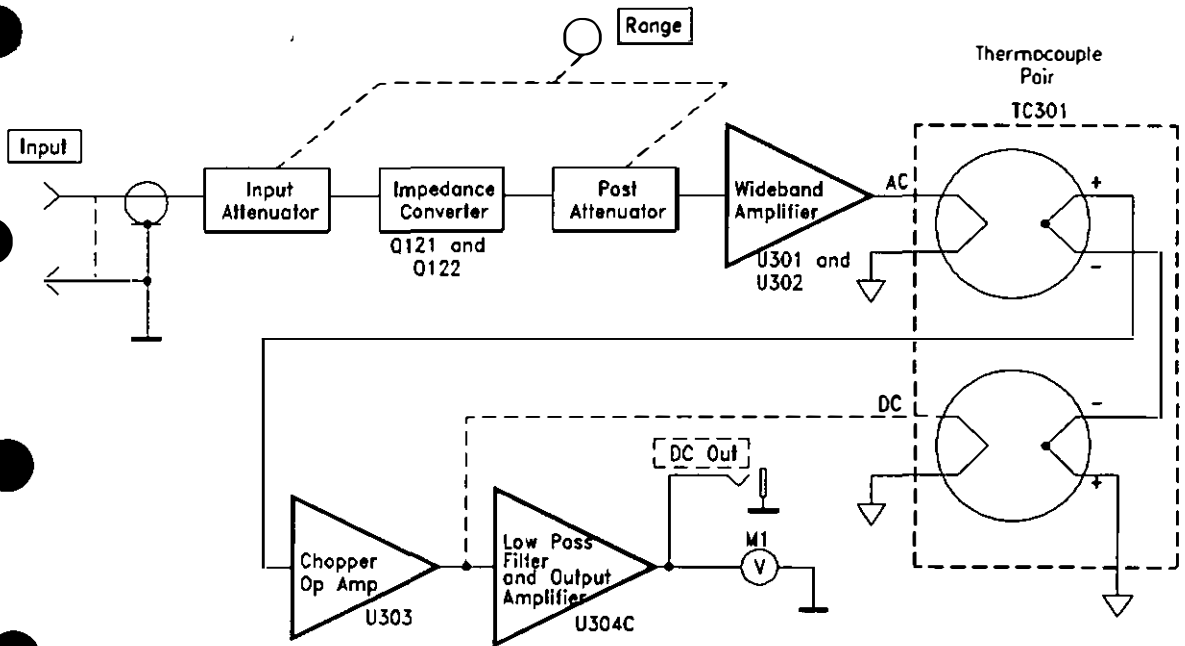

HP 3400B Block Diagram

Chapter 3 Theory of Operation

Block Diagram

A signal being measured is applied to the input attenuator through the input connector, located on the voltmeter's front panel. The input attenuator has an input impedance of $10\text{ M}\Omega$ and provides two ranges of attenuation. The output of the input attenuator is applied to the impedance converter. The impedance converter is a non-inverting unity voltage gain amplifier. It presents a high impedance to the input signal and provides a low impedance output to drive the post attenuator. The post attenuator provides six ranges in a 1, 3, 10 sequence. The two attenuators are switched to provide 12 ranges of attenuation.

The output of the post attenuator is amplified by the wideband amplifier. The wideband amplifier is a two-stage amplifier (U301 and U302). The ac output of the wideband amplifier is amplified to drive one of the thermocouples in the thermocouple pair (TC301).

The dc output of TC301 is applied to the chopper op amp (U303) which modulates the voltage. The resultant modulated signal is then amplified and, after the amplification, the signal is demodulated back to a dc voltage. This voltage is the output of the chopper op amp. The value of the voltage is proportional to the dc input voltage.

The output of the chopper op amp is applied to a filter and also to the second thermocouple of the thermocouple pair (TC301). The output of the filter is applied to a dc output amplifier (U304C) which is used to drive the meter (M1).

The thermocouple pair (TC301) acts as a summing point for the ac output of the wideband amplifier and the dc output of the chopper op amp. The difference in the heating effect of these voltages is the dc input to the chopper op amp. This difference input is amplified and is fed to TC301 and also, after going through the output amplifier (U304C), to the meter (M1). This voltage represents the RMS value of the ac signal applied to the input connector. By using a "matched" thermocouple pair and measuring the difference, the output of the chopper op amp will be linear. Using a matched thermocouple pair also provides temperature stability.

Input Attenuator

The input attenuator is a capacitive-compensated attenuator which provides two ranges of attenuation for the 12 positions of the Range selector switch. When the selector switch is positioned to one of the six most sensitive ranges (1 mV to 300 mV), the attenuator output voltage is equal to the input voltage. When the selector switch is positioned to one of the six higher ranges (1 V to 300 V), the input signal is attenuated 60 dB (1000:1 voltage division) by the resistive voltage divider consisting of R121, R122, and R123. Trimmer C134 is adjusted at 100 kHz, and R123 is adjusted at 50 Hz to provide constant attenuation over the input frequency range.

3

Impedance Converter

The impedance converter uses a FET-follower circuit to match the high output impedance of the input attenuator to the low input impedance of the post attenuator. The FET-follower circuitry has unity gain with no phase inversion between the input and output signals.

The ac input signal to the impedance converter is resistor/capacitor coupled via R127 and C149 to the gate of FET Q121. The output of the converter is developed across Q122 which acts like a variable load resistor for the FET.

The bootstrap circuitry, consisting of C152 and R130, increases the input impedance of the converter circuitry and the compensating feedback circuitry, consisting of C151, decreases the output impedance of the converter. The bias voltage for Q122 is developed by resistors R133, CR125, R134, and R140.

Post Attenuator

The post attenuator is a resistive divider which attenuates the ac input signal while maintaining a low impedance output for the following amplification stages. The ac input signal is applied to a precision resistive voltage divider. These resistors are arranged to give six ranges of attenuation at 10 dB per range. The six ranges of the post attenuator combined with the two ranges of the input attenuator make up the 12 ranges of attenuation (1 mV to 300 V).

Wideband Amplifier

The wideband amplifier provides constant gain to the ac signal being measured over the entire frequency range of the HP 3400B. The wideband amplification required to drive the thermocouple heater is provided in two gain stages. The first stage has a gain of 36 dB and consists of a differential transistor pair Q301 and Q302 driving U301. This gain stage also includes the capacitor feedback adjustment (C304) to adjust the voltmeter's frequency response at 20 MHz. The second stage has a gain of 14 dB to the thermocouple heater and consists of U302.

The combined gain of 50 dB amplifies the 1 mV RMS full-scale input signal to 316 mV RMS applied to the thermocouple heater. The nominal resistance of the heater is 90 Ω and there is 3.5 mA RMS of current flowing at full-scale input signal.

Protection against excess current to the thermocouple heater is provided by controlling the power supply voltages to the heater drive op amp (U302). The output from U302 is peak-detected by CR306 and CR307 and is then averaged with an RC network. The average dc level is compared with a reference by comparators U304A and U304B. The comparator output lowers the supply voltage via Q303 and Q304 when the average dc level exceeds the reference level. The average dc level of the input signal allows for 10-to-1 crest factor signals to be applied to the heater at proper levels without being attenuated.

Chopper Op Amp / Thermocouple Pair

The chopper op amp and the thermocouple pair form a servo loop which functions to position the direct reading meter (M1) to the RMS value of the ac input signal. The wideband amplifier output is applied to the heater of thermocouple pair (TC301). The ac voltage causes a dc voltage to be generated in the resistive portion of TC301 which is proportional to the heating effect (RMS value) of the ac input. The dc voltage is applied to the chopper op amp.

The chopper op amp circuitry consists of a chopper op amp (U303), filter, and output amplifier (U304C). The chopper op amp is a high-gain, low-drift op amp and is used to modulate the applied dc voltage, amplify the voltage, and then demodulate the voltage back to a dc voltage (the output voltage of the amplifier). The output of the amplifier is the ac stabilizing and summing feedback for the thermocouple pair (TC301), and is also applied to the filter. The ac stabilizing feedback (using R323, R320, and C309) is used to prevent the circuitry from oscillating.

The output from the chopper op amp (summing feedback) is applied to the heating element of thermocouple pair (TC301). The dc voltage developed in the resistive portion of TC301 is effectively subtracted from the voltage developed by TC301. The input signal to the chopper op amp then becomes the difference in the dc outputs of the two thermocouples. When the difference between the two thermocouples becomes zero, the dc output from the chopper op amp will be equal to the ac output from the wideband amplifier.

The low pass filter, consisting of R325, R326, C312, C313, and U304C, is used to further reduce the noise on the output of the chopper op amp. This is to make the meter reading quiet.

The output of the low pass filter and output amplifier (U304C) drives the meter (M1) and the DC Out connector on the rear panel. The rear terminal's output impedance is approximately 1000 Ω .

Power Supplies

The power supplies provide dc operating voltages for the circuitry used in the HP 3400B. The input line power is applied to an input line module. The module contains a line filter, a fuse, the line switch, and voltage tap selection for the power transformer. Four line voltage selections are available: 100, 120, 220, 240 Vac.

The outputs from the power transformer drive three voltage regulators. The voltages produced by the three voltage regulators are: +27 Vdc, -15 Vdc, and +5 Vdc. The +27 Vdc supply is used to power the impedance converter Q121 and Q122. The +27 Vdc supply is also dropped by a 12 volt zener diode (CR112) to develop +15 Vdc for U302 through overload regulator Q303. In addition, the +27 Vdc supply is regulated by a 15 volt zener diode (CR111) for U301 and U304. The dc chopper amplifier is powered by temperature-compensated 6.2 volt zener diodes (CR113 and CR114) to provide a stable dc source to U303 and its associated circuits. The +5 Vdc supply is used to power the logic circuitry and attenuator relays.

Switch Board

The switch control circuitry is located on the small circuit board which is connected to the front-panel Range selector switch. The Schottky diodes (CR41 through CR60) on the switch board provide the appropriate relay logic for the relay drivers on the main circuit board (see table below). The switch board connects to the main circuit board using a ribbon cable (P1). The switch board also provides the interface for wiring to the meter mechanism, the front-panel power LED, and the rear-panel DC Out connector.

3

| Voltage Range | K101 | K201 | K202 and K204 | K203 |
|---------------|------|------|---------------|------|
| 0.001 | 0 | 0 | 0 | 1 |
| 0.003 | 0 | 1 | 0 | 1 |
| 0.01 | 0 | 0 | 0 | 0 |
| 0.03 | 0 | 1 | 0 | 0 |
| 0.1 | 0 | 0 | 1 | 1 |
| 0.3 | 0 | 0 | 1 | 0 |
| 1.0 | 1 | 0 | 0 | 1 |
| 3.0 | 1 | 1 | 0 | 1 |
| 10.0 | 1 | 0 | 0 | 0 |
| 30.0 | 1 | 1 | 0 | 0 |
| 100.0 | 1 | 0 | 1 | 1 |
| 300.0 | 1 | 0 | 1 | 0 |

0 = Relay De-Energized; 1 = Relay Energized.

()

4



Service

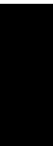

4

Service

This chapter discusses the procedures involved for returning a failed voltmeter to Hewlett-Packard for service or repair. Subjects covered include the following:

- **Operating Checklist 49**
- **To Replace the Power-Line Fuse 49**
- **Repackaging for Shipment 50**
- **Electrostatic Discharge (ESD) Precautions 50**

Operating Checklist

Before returning your voltmeter to Hewlett-Packard for service or repair, check the following items:

- Verify that the ac power cord is connected to the voltmeter.
- Verify that the front-panel **Power** switch is depressed.
- Verify that the power-line fuse is good.
Use a 125 mA^T, 250 V fuse for 100, 120, 220 or 240 Vac operation.
- Verify the power-line voltage setting.
See "To prepare the voltmeter for use" on page 11.

4

To Replace the Power-Line Fuse

The power-line fuse is located within the voltmeter's fuse-holder assembly on the rear panel (see page 12). A 125 mA^T slow-blow fuse (HP part number 2110-0894) is installed when the voltmeter is shipped from the factory. This is the correct power-line fuse for 100, 120, 220, or 240 Vac operation.

Repackaging for Shipment

If the instrument is to be shipped to HP for service or repair, be sure to:

- Attach a tag to the voltmeter identifying the owner and indicating the required service or repair. Include the instrument model number and full serial number.
- Place the voltmeter in its original container with appropriate packaging material.
- Secure the container with strong tape or metal bands.

If the original shipping container is not available, place your unit in a container which will ensure at least 4 inches of compressible packaging material around all sides for the voltmeter. Use static-free packaging materials to avoid additional damage to your unit. *HP suggests that you always insure shipments.*

Electrostatic Discharge (ESD) Precautions

Almost all electrical components can be damaged by electrostatic discharge (ESD) during handling. Component damage can occur at electrostatic discharge voltages as low as 50 volts.

The following guidelines will help prevent ESD damage when servicing the voltmeter or any electronic device.

- Disassemble instruments *only* in a static-free work area.
 - Use a conductive work area to dissipate static charge.
 - Use a conductive wrist strap to dissipate static charge accumulation.
 - Minimize handling.
 - Keep replacement parts in original static-free packaging.
 - Remove all plastic, styrofoam, vinyl, paper, and other static-generating materials from the immediate work area.
-

Replaceable
Parts

Replaceable Parts

This section contains information for ordering replacement parts for your HP 3400B Voltmeter. Parts are listed in the alphanumeric order according to their schematic reference designators. The parts lists include a brief description of the part with the applicable HP part number and manufacturer part number. The total quantity of a part is given the first time the part number appears.

To Order Replaceable Parts

You can order replaceable parts from HP or directly from the manufacturer using the manufacturer's part number in the replaceable parts list. To order replaceable parts from HP, do the following:

- 1 Contact your nearest HP Sales Office or HP Service Center.
- 2 Identify parts by their HP part number shown in the replaceable parts lists.
- 3 Provide the instrument model number and serial number.

Backdating and Part Changes

Always refer to chapter 6, "Backdating," before attempting repair or before ordering replacement parts. Parts changes are documented in the backdating chapter.

■ Replaceable Parts: 03400-66522 – Main PC Assembly

| Reference Designation | HP Part Number | Qty | Part Description | Mfr. Code | Mfr. Part Number |
|-----------------------|----------------|-----|--|-----------|------------------|
| A1C101 | 0180-3925 | 2 | Capacitor-Fxd 470 uF ± 20% 100 V | 28480 | 0180-3925 |
| A1C102 | 0180-4129 | 3 | Capacitor-Fxd 1 uF ± 10% 35 V | 56289 | 173D105X9035V |
| A1C103 | 0160-4835 | 15 | Capacitor-Fxd 0.1 uF ± 10% 50 V | 04222 | SA105C104KAAH |
| A1C104 | 0180-3868 | 1 | Capacitor-Fxd 220 uF ± 20% 35 V | 28480 | 0180-3868 |
| A1C105 | 0180-4129 | | Capacitor-Fxd 1 uF ± 10% 35 V | 56289 | 173D105X9035V |
| A1C106 | 0180-3876 | 1 | Capacitor-Fxd 1000 uF ± 20% 25 V | 28480 | 0180-3876 |
| A1C107 | 0180-4129 | | Capacitor-Fxd 1 uF ± 10% 35 V | 56289 | 173D105X9035V |
| A1C108 | 0180-4130 | 4 | Capacitor-Fxd 2.2 uF ± 10% 20 V | 56289 | 173D225X9020V |
| A1C121 | 0170-0022 | 1 | Capacitor-Fxd 0.1 uF ± 20% 600 V | 28480 | 0170-0022 |
| A1C129-C133 | 0160-5350 | 12 | Capacitor-Fxd 300 pF ± 5% 100 V | 04222 | SA101A301JAAH |
| A1C134 | 0121-0560 | 1 | Capacitor-Variable 0.8 pF to 5 pF 500V | 18736 | V3248 |
| A1C135-C141 | 0160-5350 | | Capacitor-Fxd 300 pF ± 5% 100 V | 04222 | SA101A301JAAH |
| A1C144-C146 | 0180-4832 | 4 | Capacitor-Fxd 0.01 uF ± 10% 100 V | 04222 | SA101C103KAAH |
| A1C148 | 0180-4819 | 1 | Capacitor-Fxd 2200 pF ± 5% 100 V | 04222 | SA301A222JAAH |
| A1C149 | 0160-0168 | 1 | Capacitor-Fxd 0.1 uF ± 10% 200 V | 09023 | WMC2P1 |
| A1C150 | 0180-3925 | | Capacitor-Fxd 470 uF ± 20% 100 V | 28480 | 0180-3925 |
| A1C151 | 0180-4133 | 1 | Capacitor-Fxd 15 uF ± 10% 20 V | 56289 | 173D156X9020X |
| A1C152 | 0180-4130 | 3 | Capacitor-Fxd 2.2 uF ± 10% 20 V | 56289 | 173D225X9020V |
| A1C153-C154 | 0180-3829 | 4 | Capacitor-Fxd 220 uF ± 20% 16 V | 28480 | 0180-3829 |
| A1C155 | 0180-4135 | 2 | Capacitor-Fxd 33 uF ± 10% 10 V | 56289 | 173D336X9010X |
| A1C315 | 0180-4138 | 4 | Capacitor-Fxd 10 uF ± 10% 20 V | 56289 | 173D106X9020W |
| A1C201 | 0160-4791 | 1 | Capacitor-Fxd 10 pF ± 10% 100 V | 04222 | SA102A100JAAH |
| A1C202-C205 | 0160-5896 | 5 | Capacitor-Fxd 1 pF ± 25% 100 V | 28480 | 0160-5896 |
| A1C206 | 0160-4804 | 1 | Capacitor-Fxd 56 pF ± 5% 100 V | 04222 | SA102A560JAAH |
| A1C207-C208 | 0160-4800 | 2 | Capacitor-Fxd 120 pF ± 5% 100 V | 04222 | SA102A121JAAH |
| A1C209-C213 | 0160-4835 | | Capacitor-Fxd 0.1 uF ± 10% 50 V | 04222 | SA105C104KAAH |
| A1C301 | 0160-4835 | | Capacitor-Fxd 0.1 uF ± 10% 50 V | 04222 | SA105C104KAAH |
| A1C302 | 0180-4135 | | Capacitor-Fxd 33 uF ± 10% 10 V | 56289 | 173D336X9010X |
| A1C303 | 0160-4363 | 1 | Capacitor-Fxd 6.8 pF ± 7.35% 200 V | 04222 | SR156A6R8DAA |
| A1C304 | 0121-0451 | 1 | Capacitor-Variable 1.7pF to 11pF 175V | 74970 | 187-0106-028 |
| A1C305 | 0160-4835 | | Capacitor-Fxd 0.1 uF ± 10% 50 V | 04222 | SA105C104KAAH |
| A1C306 | 0180-3829 | | Capacitor-Fxd 220 uF ± 20% 16 V | 28480 | 0180-3829 |
| A1C307 | 0160-4832 | | Capacitor-Fxd 0.01 uF ± 10% 100 V | 04222 | SA101C103KAAH |
| A1C308 | 0160-5896 | | Capacitor-Fxd 1 pF ± 25% 100 V | 28480 | 0160-5896 |
| A1C309 | 0160-8207 | 1 | Capacitor-Fxd 1 uF ± 5% 50 V | 28480 | 0160-8207 |
| A1C310-C311 | 0160-4835 | | Capacitor-Fxd 0.1 uF 10% 50 V | 04222 | SA105C104KAAH |
| A1C312-C313 | 0160-4844 | 4 | Capacitor-Fxd 1 uF +80% -20% 50 V | 04222 | SA305E105ZAA |
| A1C314 | 0180-4130 | | Capacitor-Fxd 2.2 uF ± 10% 20 V | 56289 | 173D225X9020V |
| A1C315 | 0180-4138 | | Capacitor-Fxd 10 uF ± 10% 20 V | 56289 | 173D106X9020W |
| A1C316 | 0160-4844 | | Capacitor-Fxd 1 uF +80% -20% 50 V | 04222 | SA305E105ZAA |
| A1C317 | 0160-4835 | | Capacitor-Fxd 0.1 uF ± 10% 50 V | 04222 | SA105C104KAAH |
| A1C318 | 0180-4130 | | Capacitor-Fxd 2.2 uF ± 10% 20 V | 56289 | 173D225X9020V |
| A1C319 | 0180-4138 | | Capacitor-Fxd 10 uF ± 10% 20 V | 56289 | 173D106X9020W |

Chapter 5 Replaceable Parts

03400-66522 Replaceable Parts (continued)

| Reference Designation | HP Part Number | Qty | Part Description | Mfr. Code | Mfr. Part Number |
|-----------------------|----------------|-----|---|-----------|------------------|
| A1C320 | 0160-4844 | | Capacitor-Fxd 1 uF +80% -20% 50 V | 04222 | SA305E105ZAA |
| A1C321 | 0160-4835 | | Capacitor-Fxd 0.1 uF ± 10% 50 V | 04222 | SA105C104KAAH |
| A1C322 | 0180-4136 | | Capacitor-Fxd 10 uF ± 10% 20 V | 56289 | 173D106X9020W |
| A1C323-C324 | 0160-4835 | | Capacitor-Fxd 0.1 uF ± 10% 50 V | 04222 | SA105C104KAAH |
| A1C325 | 0180-3829 | | Capacitor-Fxd 220 uF ± 20% 16 V | 28480 | 0180-3829 |
| A1C326 | 0180-4134 | 1 | Capacitor-Fxd 22 uF ± 10% 15 V | 56289 | 173D226X9015X |
| A1C327 | 0160-5888 | 1 | Capacitor-Fxd 24 pF ± 5% 100 V | 04222 | SA102A240JAAH |
| A1C328 | 0160-4808 | 1 | Capacitor-Fxd 470 pF ± 5% 100 V | 04222 | SA101A471JAAH |
| A1C329 | 0160-4835 | | Capacitor-Fxd 0.1 uF ± 10% 50 V | 04222 | SA105C104KAAH |
| A1CR101-CR110 | 1901-0743 | 13 | Diode-Power Rectifier 400 V 1A | 71744 | 1N4004 |
| A1CR111 | 1902-0962 | 2 | Diode-Zener 15V 5% PD= .4 W IR=5 uA | 04713 | SZ30035-2 |
| A1CR112 | 1902-0029 | 1 | Diode-Zener 12V 5% PD=1W IR=5 uA | 04713 | 1N4742ARL |
| A1CR113-CR114 | 1902-0777 | 2 | Diode-Zener 6.2V 5% PD=0.4W | 04713 | 1N825 |
| A1CR121 | 1901-0050 | 4 | Diode-Switching 80V 200 mA 2 nS | 28480 | 1901-0050 |
| A1CR122 | 1902-0962 | | Diode-Zener 15V 5% PD= .4 W IR=5 uA | 04713 | SZ30035-2 |
| A1CR123 | 1901-0050 | | Diode-Switching 80 V 200 mA 2 nS | 28480 | 1901-0050 |
| A1CR124-CR125 | 1901-1098 | 10 | Diode-Switching 50 V 200 mA 4 nS | 27014 | 1N4150 |
| A1CR126-CR128 | 1901-0743 | | Diode-Power Rectifier 400 V 1A | 71744 | 1N4004 |
| A1CR129-CR130 | 1901-0050 | | Diode-Switching 80V 200 mA 2 nS | 28480 | 1901-0050 |
| A1CR201-CR205 | 1901-1098 | | Diode-Switching 50 V 200 mA 4 nS | 27014 | 1N4150 |
| A1CR301 | 1901-1098 | | Diode-Switching 50 V 200 mA 4 nS | 27014 | 1N4150 |
| A1CR302-CR303 | 1901-0025 | 2 | Diode-General Purpose 100 V 200 mA | 28480 | 1901-0025 |
| A1CR304-CR305 | 1901-1098 | | Diode-Switching 50 V 200 mA 4 nS | 27014 | 1N4150 |
| A1CR306-CR307 | 1901-0518 | 2 | Diode-Schottky Small Signal | 28480 | 1901-0518 |
| A1HS101-HS103 | 1205-0355 | 3 | Heat Sink Single TO-220-Case | 13103 | 6043PB |
| A1J1 | 1250-1842 | 1 | Connector-RF BNC Rcpt PC-W-Stdfs 50Ω | 00779 | 227677-1 |
| A1J2-J3 | 1251-8823 | 2 | Connector-Post Type 0.100-Spcg 14-Contact | 76381 | 2514-6002UB |
| A1J4 | 1252-4488 | 1 | Connector-Post Type 0.156-Spcg 8-Contact | 27264 | 26-64-4080 |
| A1K101 | 0490-1774 | 1 | Relay 1C 5 Vdc-Coil 3A 250 Vac | 28480 | 0490-1774 |
| A1K201-K204 | 0490-1638 | 4 | Relay 2C 5 Vdc-Coil 1A 125 Vac | 28480 | 0490-1638 |
| A1MP5-MP7 | 0380-0741 | 3 | Standoff-Rvt-On 0.187-In-Lg 6-32-Thd | 05791 | MK6910-3/16-2-14 |
| A1MP9 | 0590-1054 | 1 | Threaded Insert-Nut 6-32 .065-In-Lg SST | 46384 | KFS2-632 |
| A1PCB1 | 03400-26522 | 1 | PC Board - Blank | 28480 | 03400-26522 |
| A1Q121 | 1855-0386 | 1 | Transistor J-FET N-Chan D-Mode | 04713 | 2N4392 |
| A1Q122 | 1854-1114 | 1 | Transistor NPN SI TO-39 PD=3.5W FT=1GHz | 04713 | MRF544 |
| A1Q301-Q302 | 1854-0795 | 2 | Transistor NPN SI PD=625 mW FT=650 MHz | 04713 | MP5H10 |
| A1Q303 | 1854-1028 | 1 | Transistor NPN SI PD=350 mW FT=300MHz | 04713 | 2N3904 |
| A1Q304 | 1853-0563 | 1 | Transistor PD=310 mW FT=250 MHz | 04713 | 2N3906 (SEL) |

Chapter 5 Replaceable Parts

03400-66522 Replaceable Parts (continued)

| Reference Designation | HP Part Number | Qty | Part Description | Mr. Code | Mfr. Part Number |
|-----------------------|----------------|-----|--|----------|---------------------|
| A1R101 | 0698-4421 | 2 | Resistor 249 ± 1% .125W TF TC= 0±100 | 24546 | CT4-1/8-T0-249R-F |
| A1R102 | 0757-0438 | 1 | Resistor 5.11K ± 1% .125W TF TC= 0±100 | 24546 | CT4-1/8-T0-5111-F |
| A1R103 | 0698-4408 | 1 | Resistor 124 ± 1% .125W TF TC = 0±100 | 24546 | CT4-1/8-T0-124R-F |
| A1R104 | 0698-4423 | 1 | Resistor 1.37K ± 1% .125W TF TC = 0±100 | 24546 | CT4-1/8-T0-1371-F |
| A1R105 | 0698-4421 | 1 | Resistor 249 ± 1% .125W TF TC = 0±100 | 24546 | CT4-1/8-T0-249R-F |
| A1R106 | 0757-0420 | 2 | Resistor 750 ± 1% .125W TF TC = 0±100 | 24546 | CT4-1/8-T0-751-F |
| A1R107 | 0698-3634 | 1 | Resistor 470 ± 5% 2W MO TC = 0±200 | 28480 | 0698-3634 |
| A1R108 | 0764-0042 | 1 | Resistor 2.2K ± 5% 2W MO TC = 0±200 | 28480 | 0764-0042 |
| A1R109 | 0698-3635 | 1 | Resistor 680 ± 5% 2W MO TC = 0±200 | 28480 | 0698-3635 |
| A1R110 | 0757-0442 | 6 | Resistor 10K ± 1% .125W TF TC = 0±100 | 24546 | CT4-1/8-T0-1002-F |
| A1R121 | 0698-4128 | 1 | Resistor 10M ± 0.25% 1W TF TC = 0±50 | 03888 | A3AH87 |
| A1R122 | 0698-6204 | 1 | Resistor 9.9K ± 1% .125WTF TC = 0±100 | 24546 | CT4-1/8-T0-9901-F |
| A1R123 | 2100-3212 | 1 | Resistor-Trim 200 10% TKF Top Adj 1-Turn | 32997 | 3386P-Y46-201 |
| A1R124 | 0757-0348 | 3 | Resistor 10 ± 1% .125W TF TC = 0±100 | 28480 | 0757-0346 |
| A1R126 | 0757-0410 | 4 | Resistor 301 ± 1% .125W TF TC = 0±100 | 24546 | CT4-1/8-T0-301R-F |
| A1R127 | 0764-0043 | 1 | Resistor 2.7K ± 5% 2W MO TC = 0±200 | 28480 | 0764-0043 |
| A1R128 | 0757-0401 | 2 | Resistor 100 ± 1% .125W TF TC = 0±100 | 24546 | CT4-1/8-T0-101-F |
| A1R129 | 0757-0472 | 2 | Resistor 200K ± 1% .125W TF TC = 0±100 | 24546 | CT4-1/8-T0-2003-F |
| A1R130 | 0683-3355 | 1 | Res 3.3M ± 5% .25W CC TC = -900/+1100 | 01121 | CB3355 |
| A1R131 | 0757-0462 | 1 | Resistor 75K ± 1% .125W TF TC = 0±100 | 24546 | CT4-1/8-T0-7502-F |
| A1R132 | 0698-3488 | 1 | Resistor 442 ± 1% .125W TF TC = 0±100 | 24546 | CT4-1/8-T0-422R-F |
| A1R133 | 0698-3150 | 1 | Resistor 2.37K ± 1% .125W TF TC = 0±100 | 24546 | CT4-1/8-T0-2371-F |
| A1R135 | 0698-4486 | 1 | Resistor 24.9K ± 1% .125W TF TC = 0±100 | 24546 | CT4-1/8-T0-2492-F |
| A1R134 | 0757-0280 | 5 | Resistor 1K ± 1% .125W TF TC = 0±100 | 24546 | CT4-1/8-T0-1001-F |
| A1R136 | 0757-0277 | 4 | Resistor 49.9 ± 1% .125W TF TC = 0±100 | 28480 | 0757-0277 |
| A1R137-R138 | 0757-0384 | 5 | Resistor 20 ± 1% .125W TF TC = 0±100 | 19701 | 5033R-1/8-T0-20R0-F |
| A1R139 | 0757-0381 | 2 | Resistor 15 ± 1% .125W TF TC = 0±100 | 19701 | 5033R-1/8-T0-15R0-F |
| A1R140 | 0757-0283 | 1 | Resistor 2K ± 1% .125W TF TC = 0±100 | 24546 | CT4-1/8-T0-2001-F |
| A1R201 | 0757-0277 | 1 | Resistor 49.9 ± 1% .125WTF TC = 0±100 | 28480 | 0757-0277 |
| A1R202-R203 | 0698-4123 | 3 | Resistor 499 ± 1% .125W TF TC = 0±100 | 24546 | CT4-1/8-T0-499R-F |
| A1R204 | 0698-6323 | 5 | Resistor 100 ± 0.1% .125W TF TC = 0±25 | 28480 | 0698-6323 |
| A1R205 | 0698-6774 | 5 | Resistor 150 ± 0.1% .125W TF TC = 0±25 | 28480 | 0698-6774 |
| A1R206 | 0698-4476 | 3 | Resistor 10.2K ± 1% .125W TF TC = 0±100 | 24546 | CT4-1/8-T0-1022-F |
| A1R207 | 0698-6323 | 1 | Resistor 100 ± 0.1% .125WTF TC = 0±25 | 28480 | 0698-6323 |
| A1R208 | 0698-6774 | 1 | Resistor 150 ± 0.1% .125W TF TC = 0±25 | 28480 | 0698-6774 |
| A1R209 | 0698-4477 | 2 | Resistor 10.5K ± 1% .125W TF TC = 0±100 | 24546 | CT4-1/8-T0-1052-F |
| A1R210 | 0698-6323 | 1 | Resistor 100 ± 0.1% .125W TF TC = 0±25 | 28480 | 0698-6323 |
| A1R211 | 0698-6774 | 1 | Resistor 150 ± 0.1% .125W TF TC = 0±25 | 28480 | 0698-6774 |
| A1R212 | 0698-4476 | 1 | Resistor 10.2K ± 1% .125W TF TC = 0±100 | 24546 | CT4-1/8-T0-1022-F |
| A1R213 | 0698-6323 | 1 | Resistor 100 ± 0.1% .125W TF TC = 0±25 | 28480 | 0698-6323 |
| A1R214 | 0698-6774 | 1 | Resistor 150 ± 0.1% .125W TF TC = 0±25 | 28480 | 0698-6774 |
| A1R215 | 0698-4477 | 1 | Resistor 10.5K ± 1% .125W TF TC = 0±100 | 24546 | CT4-1/8-T0-1052-F |

5

Chapter 5 Replaceable Parts

03400-66522 Replaceable Parts (continued)

| Reference Designation | HP Part Number | Qty | Part Description | Mfr. Code | Mfr. Part Number |
|-----------------------|----------------|-----|---|-----------|---------------------|
| A1R216 | 0698-6323 | | Resistor 100 \pm 0.1% .125W TF TC = 0 \pm 25 | 28480 | 0698-6323 |
| A1R217 | 0698-6774 | | Resistor 150 \pm 0.1% .125W TF TC = 0 \pm 25 | 28480 | 0698-6774 |
| A1R218 | 0698-4476 | | Resistor 10.2K \pm 1% .125W TF TC = 0 \pm 100 | 24546 | CT4-1/8-T0-1022-F |
| A1R219 | 0757-0384 | | Resistor 20 \pm 1% .125W TF TC = 0 \pm 100 | 19701 | 5033R-1/8-T0-20R0-F |
| A1R220 | 0698-6377 | 1 | Resistor 200 \pm 0.1% .125W TF TC = 0 \pm 25 | 28480 | 0698-6377 |
| A1R221 | 0757-0449 | 1 | Resistor 20K \pm 1% .125W TF TC = 0 \pm 100 | 24546 | CT4-18-T0-2002-F |
| A1R222 | 0757-0401 | | Resistor 100 \pm 1% .125W TF TC = 0 \pm 100 | 24546 | CT4-1/8-T0-101-F |
| A1R301 | 0757-0407 | 2 | Resistor 200 \pm 1% .125W TF TC = 0 \pm 100 | 24546 | CT4-1/8-T0-201-F |
| A1R302 | 0757-0381 | | Resistor 15 \pm 1% .125W TF TC = 0 \pm 100 | 19701 | 5033R-1/8-T0-15R0-F |
| A1R303 | 0698-4422 | 1 | Resistor 1.27K \pm 1% .125W TF TC = 0 \pm 100 | 24546 | CT4-1/8-T0-1271-F |
| A1R304 | 0757-0429 | 1 | Resistor 1.82K \pm 1% .125W TF TC = 0 \pm 100 | 24546 | CT4-1/8-T0-1821-F |
| A1R305 | 0757-0407 | | Resistor 200 \pm 1% .125W TF TC = 0 \pm 100 | 24546 | CT4-1/8-T0-201-F |
| A1R306 | 0757-0291 | 1 | Resistor 24.9 \pm 1% .125W TF TC = 0 \pm 100 | 19701 | 5033R-1/8-T0-2492-F |
| A1R307-R308 | 0757-0277 | | Resistor 49.9 \pm 1% .125W TF TC = 0 \pm 100 | 28480 | 0757-0277 |
| A1R309 | 0757-0384 | | Resistor 20 \pm 1% .125W TF TC = 0 \pm 100 | 19701 | 5033R-1/8-T0-20R0-F |
| A1R310 | 0757-0274 | 2 | Resistor 1.21K \pm 1% .125W TF TC = 0 \pm 100 | 24546 | CT4-1/8-T0-1211-F |
| A1R311 | 0757-0442 | | Resistor 10K \pm 1% .125W TF TC = 0 \pm 100 | 24546 | CT4-1/8-T0-1002-F |
| A1R312 | 0757-0400 | 2 | Resistor 90.9 \pm 1% .125W TF TC = 0 \pm 100 | 24546 | CT4-1/8-T0-90R9-F |
| A1R313 | 0698-3447 | 2 | Resistor 422 \pm 1% .125W TF TC = 0 \pm 100 | 24546 | CT4-1/8-T0-422R-F |
| A1R314 | 0757-0384 | | Resistor 20 \pm 1% .125W TF TC = 0 \pm 100 | 19701 | 5033R-1/8-T0-20R0-F |
| A1R315 | 0757-0400 | | Resistor 90.9 \pm 1% .125W TF TC = 0 \pm 100 | 24546 | CT4-1/8-T0-90R9-F |
| A1R316 | 2100-3094 | 1 | Resistor-Trim 100K 10% Side-Adj 17-Turn | 73138 | 89PR100K |
| A1R317 | 0698-8827 | 2 | Resistor 1M \pm 1% .125W TF TC = 0 \pm 100 | 28480 | 0698-8827 |
| A1R318 | 0757-0472 | | Resistor 200K \pm 1% .125W TF TC = 0 \pm 100 | 24546 | CT4-1/8-T0-2003-F |
| A1R319 | 0757-0442 | | Resistor 10K \pm 1% .125W TF TC = 0 \pm 100 | 24546 | CT4-1/8-T0-1002-F |
| A1R320 | 0757-0410 | | Resistor 301 \pm 1% .125W TF TC = 0 \pm 100 | 24546 | CT4-1/8-T0-301R-F |
| A1R321 | 2100-3154 | 1 | Resistor-Trim 1K 10% Side-Adj 17-Turn | 73138 | 89PR1K |
| A1R322 | 0698-3279 | 1 | Resistor 4.99K \pm 1% .125W TF TC = 0 \pm 100 | 24546 | CT4-1/8-T0-4991-F |
| A1R323 | 0698-8827 | | Resistor 1M \pm 1% .125W TF TC = 0 \pm 100 | 28480 | 0698-8827 |
| A1R324 | 0698-3447 | | Resistor 422 \pm 1% .125W TF TC = 0 \pm 100 | 24546 | CT4-1/8-T0-422R-F |
| A1R325 | 0698-4529 | 1 | Resistor 226K \pm 1% .125W TF TC = 0 \pm 100 | 24546 | CT4-1/8-T0-2263-F |
| A1R326 | 0698-4516 | 1 | Resistor 113K \pm 1% .125W TF TC = 0 \pm 100 | 24546 | CT4-1/8-T0-1133-F |
| A1R327 | 0757-0427 | 1 | Resistor 1.5K \pm 1% .125W TF TC = 0 \pm 100 | 24546 | CT4-1/8-T0-1501-F |
| A1R328 | 0757-0420 | | Resistor 750 \pm 1% .125W TF TC = 0 \pm 100 | 24546 | CT4-1/8-T0-751-F |
| A1R329 | 0698-3700 | 1 | Resistor 715 \pm 1% .125W TF TC = 0 \pm 100 | 24546 | CT4-1/8-T0-715R-F |
| A1R330 | 2100-3349 | 1 | Resistor-Trim 100 10% Side-Adj 1-Turn | 32997 | 3386X-Y46-101 |
| A1R331 | 0757-0446 | 2 | Resistor 15K \pm 1% .125W TF TC = 0 \pm 100 | 24546 | CT4-1/8-T0-1502-F |
| A1R332 | 0757-0410 | | Resistor 301 \pm 1% .125W TF TC = 0 \pm 100 | 24546 | CT4-1/8-T0-301R-F |
| A1R333 | 0698-3558 | 2 | Resistor 4.02K \pm 1% .125W TF TC = 0 \pm 100 | 24546 | CT4-1/8-T0-4021-F |
| A1R334 | 0757-0280 | | Resistor 1K \pm 1% .125W TF TC = 0 \pm 100 | 24546 | CT4-1/8-T0-1001-F |
| A1R335 | 0757-0442 | | Resistor 10K \pm 1% .125W TF TC = 0 \pm 100 | 24546 | CT4-1/8-T0-1002-F |
| A1R336-R337 | 0757-0280 | | Resistor 1K \pm 1% .125W TF TC = 0 \pm 100 | 24546 | CT4-1/8-T0-1001-F |
| A1R338 | 0698-3558 | | Resistor 4.02K \pm 1% .125W TF TC = 0 \pm 100 | 24546 | CT4-1/8-T0-4021-F |
| ⋮ | | | | | |

03400-66522 Replaceable Parts (continued)

| Reference Designation | HP Part Number | Qty | Part Description | Mfr. Code | Mfr. Part Number |
|-----------------------|----------------|-----|---|-----------|-------------------|
| A1R339 | 0757-0446 | | Resistor 15K ± 1% .125W TF TC = 0 ± 100 | 24546 | CT4-1/8-T0-1502-F |
| A1R340 | 0757-0410 | | Resistor 301 ± 1% .125W TF TC = 0 ± 100 | 24546 | CT4-1/8-T0-301R-F |
| A1R341 | 0757-0280 | | Resistor 1K ± 1% .125W TF TC = 0 ± 100 | 24546 | CT4-1/8-T0-1001-F |
| A1R342 | 0757-0442 | | Resistor 10K ± 1% .125W TF TC = 0 ± 100 | 24546 | CT4-1/8-T0-1002-F |
| A1R343 | 0698-4123 | | Resistor 499 ± 1% .125W TF TC = 0 ± 100 | 24546 | CT4-1/8-T0-499R-F |
| A1R344-R345 | 0757-0346 | | Resistor 10 ± 1% .125W TF TC = 0 ± 100 | 28480 | 0757-0346 |
| A1R346 | 0757-0274 | | Resistor 1.21K ± 1% .125W TF TC = 0 ± 100 | 24546 | CT4-1/8-T0-1211-F |
| A1R347 | 0757-0442 | | Resistor 10K ± 1% .125W TF TC = 0 ± 100 | 24546 | CT4-1/8-T0-1002-F |
| A1RP201 | 1810-0162 | 1 | Network-Res 14-Pin 4.7 kΩ X 13 | 11236 | 760-1-R4.7K |
| A1SH1 | 03400-00607 | 1 | Shield - RFI Left | 28480 | 03400-00607 |
| A1SH2 | 03400-00609 | 1 | Shield - Isolation | 28480 | 03400-00609 |
| A1SH3 | 03400-00608 | 1 | Shield - Attenuator RFI | 28480 | 03400-00608 |
| A1SH4 | 03400-00605 | 1 | Shield - Thermocouple | 28480 | 03400-00605 |
| A1SH5 | 03400-00611 | 1 | Shield - Resistor | 28480 | 03400-00611 |
| A1SH9 | 03400-00610 | 1 | Shield - Input | 28480 | 03400-00610 |
| A1SHD5 | 03400-04105 | 1 | Shield - RFI Cover | 28480 | 03400-04105 |
| A1TC301 | 0853-0003 | 1 | Thermocouple Pair 50V +0 to +55 Deg C | 28480 | 0853-0003 |
| A1U101 | 1826-0393 | 2 | IC V Regulator-Adj-Pos 1.2/37V 3-Pin | 27014 | LM317T |
| A1U102 | 1826-0527 | 1 | IC V Regulator-Adj-Neg 1.2/37V 3-Pin | 27014 | LM337T |
| A1U103 | 1826-0393 | 1 | IC V Regulator-Adj-Pos 1.2/37V 3-Pin | 27014 | LM317T |
| A1U201-U203 | 1820-5423 | 3 | IC Gate CMOS/AC NAND QUAD 2-Input | 27014 | 74AC00PC |
| A1U301-U302 | 1826-1859 | 2 | IC OP Amp High-Slew-Rate 14-Pin | 28480 | 1826-1859 |
| A1U303 | 1826-1562 | 1 | IC OP Amp Precision 14-Pin | 28480 | 1826-1562 |
| A1U304 | 1826-0161 | 1 | IC OP Amp General-Purpose Quad 14-Pin | 27014 | LM324N |

■ Replaceable Parts: 03400-66523 – Switch PC Assembly

| Reference Designation | HP Part Number | Qty | Part Description | Mfr. Code | Mfr. Part Number |
|-----------------------|----------------|-----|---|-----------|------------------|
| A2CR341-CR360 | 1900-0233 | 20 | Diode-Schottky Small Signal | 50088 | 1N5711 |
| A2P1 | 03400-61607 | 1 | Switch Cable | 28480 | 03400-61607 |
| A2S1 | 3100-3504 | 1 | Switch-Rotary SP12T-NS .875-Center Spcg | 28480 | 3100-3504 |
| A2SH8 | 03400-01218 | 1 | Switch Mounting Bracket | 28480 | 03400-01218 |
| A2TP9 | 8120-6113 | 1 | Cable Assy 22-AWG 1-Cond 300 mm lg (grn) | 28480 | 8120-6113 |
| A2TP10 | 8120-6114 | 1 | Cable Assy 22-AWG 1-Cond 300 mm lg (blk) | 28480 | 8120-6114 |
| A2TP11 | 8120-6115 | 1 | Cable Assy 22-AWG 1-Cond 150 mm lg (blue) | 28480 | 8120-6115 |
| A2TP12 | 8120-6116 | 1 | Cable Assy 22-AWG 1-Cond 150 mm lg (brn) | 28480 | 8120-6116 |
| A2TP13-TP14 | 03400-61608 | 1 | LED Cable | 28480 | 03400-61608 |

■ **Manufacturer's Codes: 03400-66522 and 03400-66523**

| Mfr. Code | Manufacturer's Name | Manufacturer's Address | Zip Code |
|-----------|---|------------------------|----------|
| 00779 | AMP Inc | Harrisburg, PA U.S.A. | 17111 |
| 01121 | Allen-Bradley Co Inc | El Paso, TX U.S.A. | 79935 |
| 03888 | KDI Pyrofilm Corp | Whippany, NJ U.S.A. | 07981 |
| 04222 | AVX Corp | Great Neck, NY U.S.A. | 11021 |
| 04713 | Motorola Inc | Roselle, IL U.S.A. | 60195 |
| 05791 | Lyn-Tron Inc | Burbank, CA U.S.A. | 91505 |
| 09023 | Cornell-Dubiller/Sangamo | Wayne, NJ U.S.A. | 07470 |
| 11236 | CTS Corp | Elkhart, IN U.S.A. | 46514 |
| 13103 | Thermalloy Inc | Dallas, TX U.S.A. | 75234 |
| 18736 | Voltronics Corp | Hanover, NJ U.S.A. | 07936 |
| 19701 | North America Philips Corp | New York, NY U.S.A. | 10017 |
| 24548 | Coming Glass Works | Coming, NY U.S.A. | 14830 |
| 27014 | National Semiconductor Corp | San Jose, CA U.S.A. | 95052 |
| 27264 | Molex Inc | Lisle, IL U.S.A. | 60532 |
| 28480 | Hewlett-Packard Company - Corporate | Palo Alto, CA U.S.A. | 94304 |
| 32997 | Bourns Networks Inc | Riverside, CA U.S.A. | 92507 |
| 46384 | Penn Engineering and Manufacturing Corp | Doylestown, PA U.S.A. | 18901 |
| 50088 | SGS-Thomson Microelectronics Inc | Phoenix, AZ U.S.A. | 85022 |
| 56289 | Sprague Electric Co | Lexington, MA U.S.A. | 02173 |
| 71744 | General Instrument Corp | Clifton, NJ U.S.A. | 07012 |
| 73138 | Beckman Industrial Corp | Fullerton, CA U.S.A. | 92635 |
| 74970 | EF Johnson Co | Waseca, MN U.S.A. | 56093 |
| 76381 | 3M Co | St. Paul, MN U.S.A. | 55144 |

■ Replaceable Parts: HP 3400B Mainframe

| Reference Designation | HP Part Number | Qty | Part Description | Mfr. Code | Mfr. Part Number |
|-----------------------|----------------|-----|---|-----------|------------------|
| | 03400-90014 | 1 | English Manual (User/Service Guide) | 28480 | 03400-90014 |
| | 1120-0308 | 1 | Meter Mechanism - dB Scale (Opt 001 only) | 28480 | 1120-0308 |
| | 1120-0320 | 1 | Meter Mechanism - 3 mA Scale | 28480 | 1120-0320 |
| | 1510-0140 | 1 | Adapter-Dbl Binding Post to BNC | 05276 | 1296 |
| A1 | 03400-66522 | 1 | PC Assembly - Main Board | 28480 | 03400-66522 |
| A2 | 03400-66523 | 1 | PC Assembly - Switch Board | 28480 | 03400-66523 |
| BKT1 | 03400-01215 | 1 | Bracket - Top Cover | 28480 | 03400-01215 |
| CLP1 | 1400-1502 | 1 | Mounting Clip - LED Lamp | 28480 | 1400-1502 |
| CVR1-CVR2 | 03400-04107 | 2 | Instrument Cover - Side | 28480 | 03400-04107 |
| CVR3 | 03400-04106 | 1 | Instrument Cover - Bottom | 28480 | 03400-04106 |
| F1 | 2110-0894 | 1 | Fuse, 250V/125 mA | 28480 | 2110-0894 |
| FRM3 | 03400-86601 | 1 | Frame Assembly | 28480 | 03400-86601 |
| HDW15 | 2190-0016 | 1 | Washer-Lock Intl T 3/8 In .377-In-ID | 78189 | 1920-02 |
| HDW22 | 2950-0054 | 1 | Nut, Hex-Dbl-Cham 1/2-28-Thd .12-In-Thk | 28480 | 2950-0054 |
| HDW23-HDW30 | 2360-0192 | 8 | Screw, 6-32 THD .25-In-Lg -HD- | 28480 | 2360-0192 |
| HDW31 | 2950-0001 | 1 | Nut, Hex-Dbl-Cham 3/8-32-Thd .094-In-Thk | 73734 | 9002-NP |
| HDW32-HDW39 | 2360-0322 | 8 | Screw, 6-32 THD .375-In-Lg -HD- | 28480 | 2360-0322 |
| HDW40 | 2190-0054 | 1 | Washer-Lock Intl T 1/2 In .505-In-ID | 78189 | 1924-12 |
| HDW41-HDW48 | 2420-0002 | 8 | Nut, 6/32-Thd .109-In-Thk .312-A/F | 28480 | 2420-0002 |
| HDW50 | 2940-0256 | 1 | Nut-Hex-Dbl-Cham 1/2-28-Thd .095-In-Thk | 00779 | 1-329631-2 |
| J2 | 1251-0205 | 1 | Connector, Telephone Jack-Phone 2-Ckt | 82389 | 2J-1432 |
| LED1 | 1990-1027 | 1 | LED Lamp | 28480 | 1990-1027 |
| LBL6 | 03400-84301 | 1 | Label-Front Panel | 28480 | 03400-84301 |
| LBL7 | 03400-84302 | 1 | Label-Rear Panel | 28480 | 03400-84302 |
| MP7 | 1490-0031 | 1 | Tilt Stand 2.235-In-W 4.438-In-OA-Lg SST | 28480 | 1490-0031 |
| MP12 | 5020-6852 | 1 | Meter Trim | 28480 | 5020-6852 |
| MP13-MP14 | 5040-0700 | 2 | Hinge for Tilt Stand | 28480 | 5040-0700 |
| MP15-MP16 | 5060-0727 | 2 | Foot Assembly-Bottom Cover | 28480 | 5060-0727 |
| MP77 | 0370-0077 | 1 | Knob, Front-Panel Range | 28480 | 0370-0077 |

P 3400B Mainframe Replaceable Parts (continued)

| Reference Designation | HP Part Number | Qty | Part Description | Mfr. Code | Mfr. Part Number |
|-----------------------|----------------|-----|--|-----------|------------------|
| PB1 | 5041-0564 | 1 | Pushbutton - Power-On Push Rod | 28480 | 5041-0564 |
| PNL1 | 03400-00205 | 1 | Instrument Panel - Front | 28480 | 03400-00205 |
| PNL2 | 03400-00217 | 1 | Instrument Panel - Rear | 28480 | 03400-00217 |
| PWR1 | 9135-0484 | 1 | Power Module | 06328 | CD24.4198.151 |
| PWR2 | 9135-0485 | 1 | Fuse Drawer/Fuse | 06328 | 4303.2036.01 |
| RD1 | 03458-43702 | 1 | Power-On Push Rod | 28480 | 03458-43702 |
| RD2 | 5040-7675 | 1 | Switch - Power-On Push Rod | 28480 | 5040-7675 |
| SCR1 | 2360-0113 | 1 | Screw, 6-32 Thd .25-In-Lg -HD- | 28480 | 2360-0113 |
| SCR23 | 2360-0194 | 1 | Screw, 6-32 Thd .312-In-Lg -HD- | 28480 | 2360-0194 |
| SH10 | 03400-64104 | 1 | Instrument Cover - Top | 28480 | 03400-64104 |
| T1 | 9100-5029 | 1 | Power Transformer | 17474 | 14-7345 |
| TBG1 | 0890-0103 | 1 | Tubing-HS .25-IN-D/.125-In-Rcvd | 06090 | VERSAFIT-1/4-WHT |
| TBG2 | 0890-1616 | 1 | Tubing-HS .145-IN-D/.1-In-Rcvd | 76381 | 3020-030 |
| W4 | 8120-1378 | 1 | Power Cord - U.S. | 16428 | CH7081 |
| W5 | 8120-3872 | 1 | Jumper Assy 22-AWG 1-Cond 300 mm (red) | 28480 | 8120-3872 |
| WSH5 | 3050-0604 | 1 | Washer-Flat 7/16 In .5-In-ID .75-In-OD | 86928 | 5710-94-16 |
| WSH23 | 3050-0067 | 1 | Washer-Flat M1c 5/16 In .375-In-ID | 73734 | 31-550 |

■ **Manufacturer's Codes: HP 3400B Mainframe**

| Mfr. Code | Manufacturer's Name | Manufacturer's Address | Zip Code |
|------------------|-------------------------------------|-------------------------------|-----------------|
| 00779 | AMP Inc | Harrisburg, PA U.S.A. | 17111 |
| 05275 | ITT Pomona Electronics | Pomona, CA U.S.A. | 91766 |
| 06090 | Raychem Corp | Menlo Park, CA U.S.A. | 94025 |
| 16428 | Cooper Industries Inc | Houston, TX U.S.A. | 77210 |
| 17474 | Trenex Inc | Sunnyvale, CA U.S.A. | 94068 |
| 28480 | Hewlett-Packard Company - Corporate | Palo Alto, CA U.S.A. | 94304 |
| 73734 | Federal Screw Products Co | Chicago, IL U.S.A. | 60618 |
| 78189 | Illinois Tool Works Inc Shakeproof | Elgin, IL U.S.A. | 60128 |
| 76381 | 3M Company | St. Paul, MN U.S.A. | 55144 |
| 82389 | Switchcraft Inc | Chicago, IL U.S.A. | 60630 |
| 86928 | Seastrom Manufacturing Co | Glendale, CA U.S.A. | 91201 |
| 06328 | Schurter Inc | Petaluma, CA U.S.A. | 94954 |

Backdating

Backdating

This chapter normally contains information necessary to adapt this manual to instruments not directly covered by the current content. At this printing, however, the manual does apply to all instruments. Therefore, no information is included in this chapter.



Schematics

Schematics

- **Mechanical Disassembly 67**
- **Component Locator Diagrams 68**
- **Input Attenuator, Impedance Converter, and Power Supplies 69**
- **Relay Drivers and Post Attenuator 70**
- **Wideband Amplifier, Chopper Op Amp, and Overload Detector 71**
- **Switch Board Schematic 72**

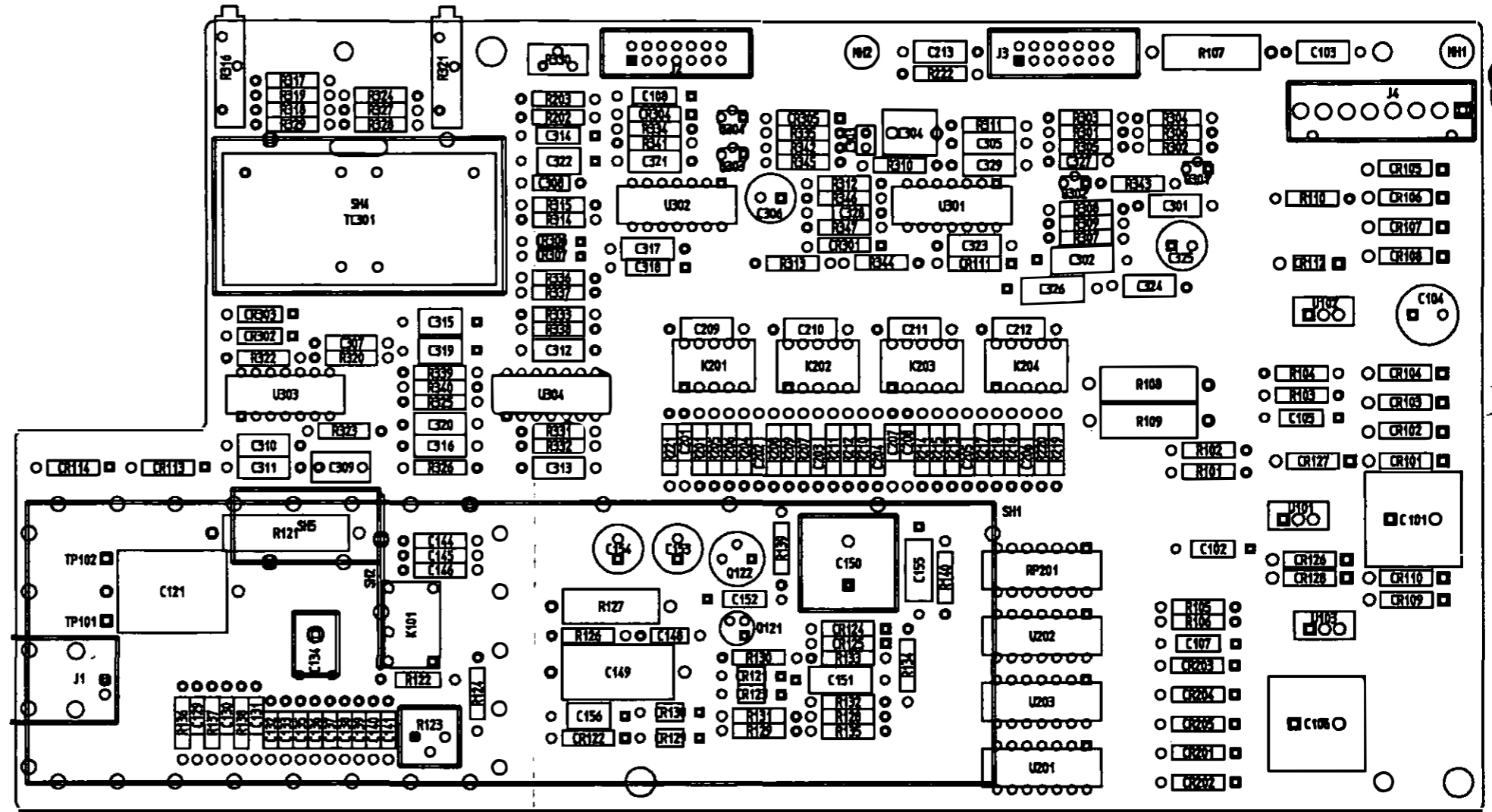
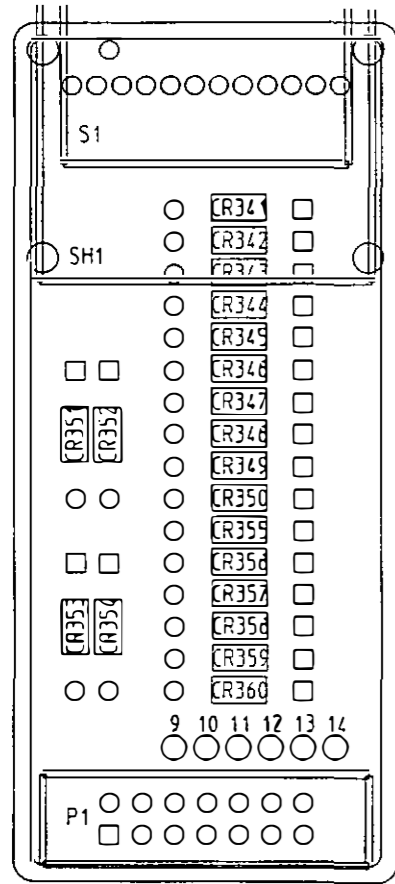

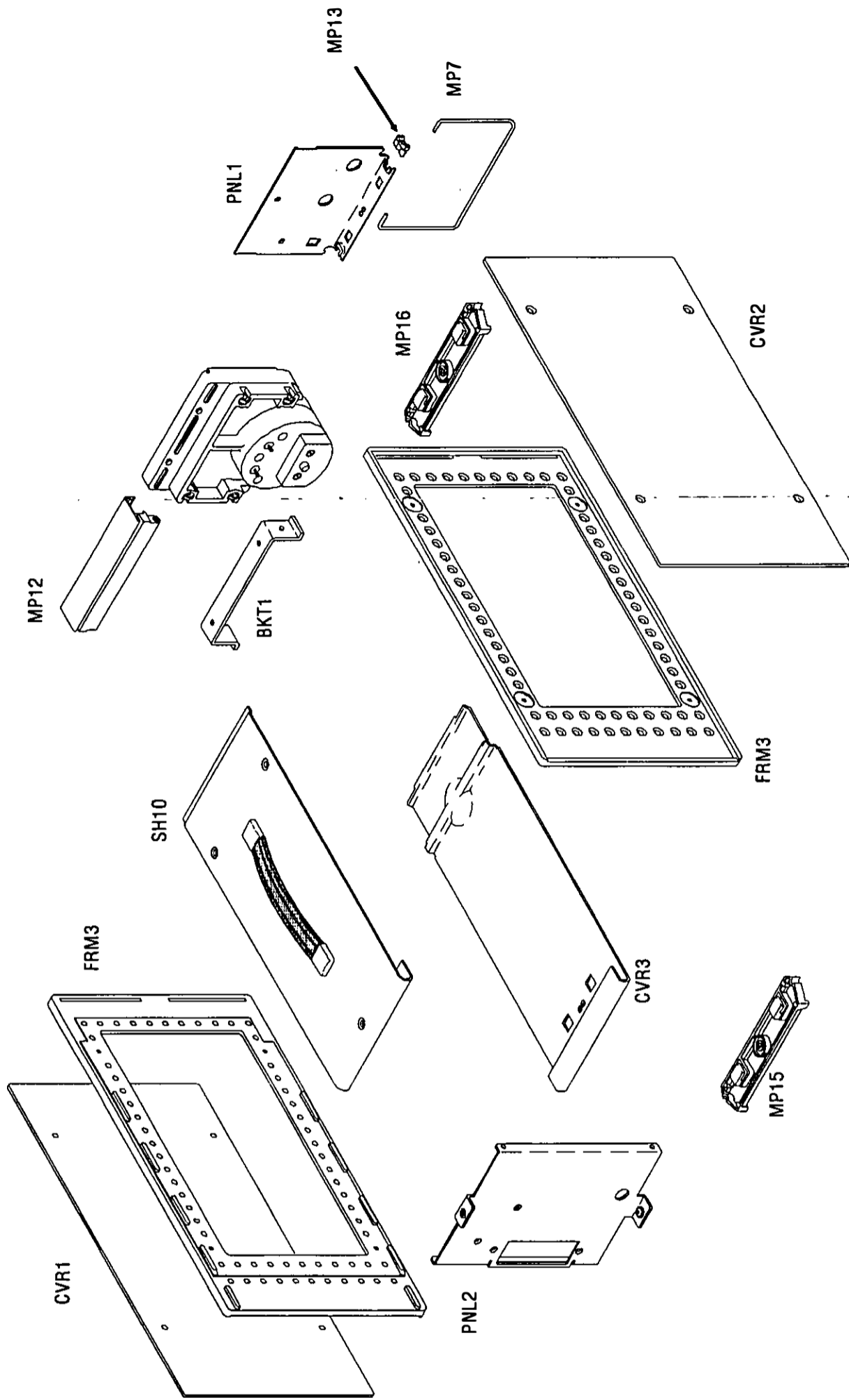

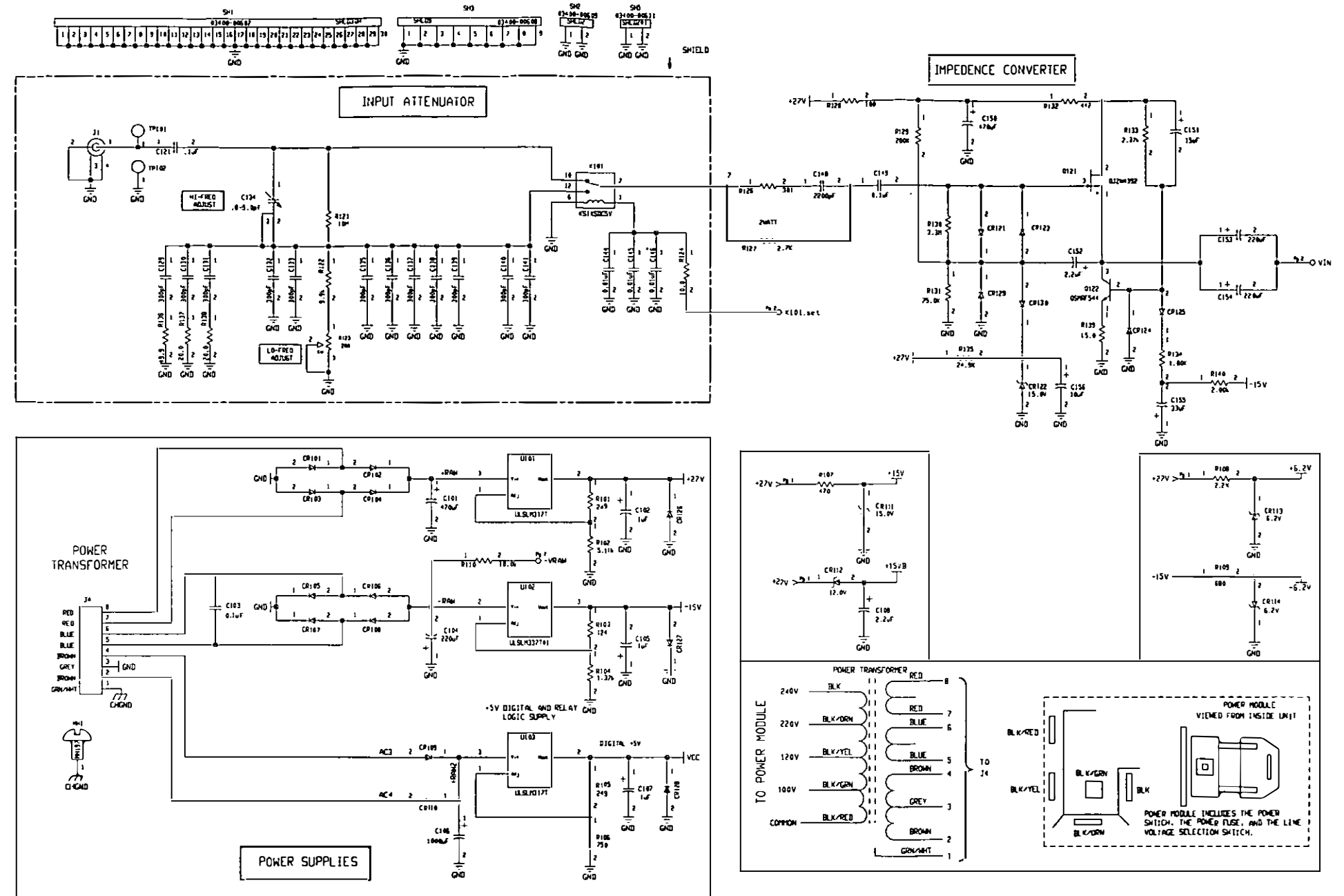

October 1992 03400-66522 INPUT ATTENUATOR, IMPEDANCE CONVERTER, and POWER SUPPLIES

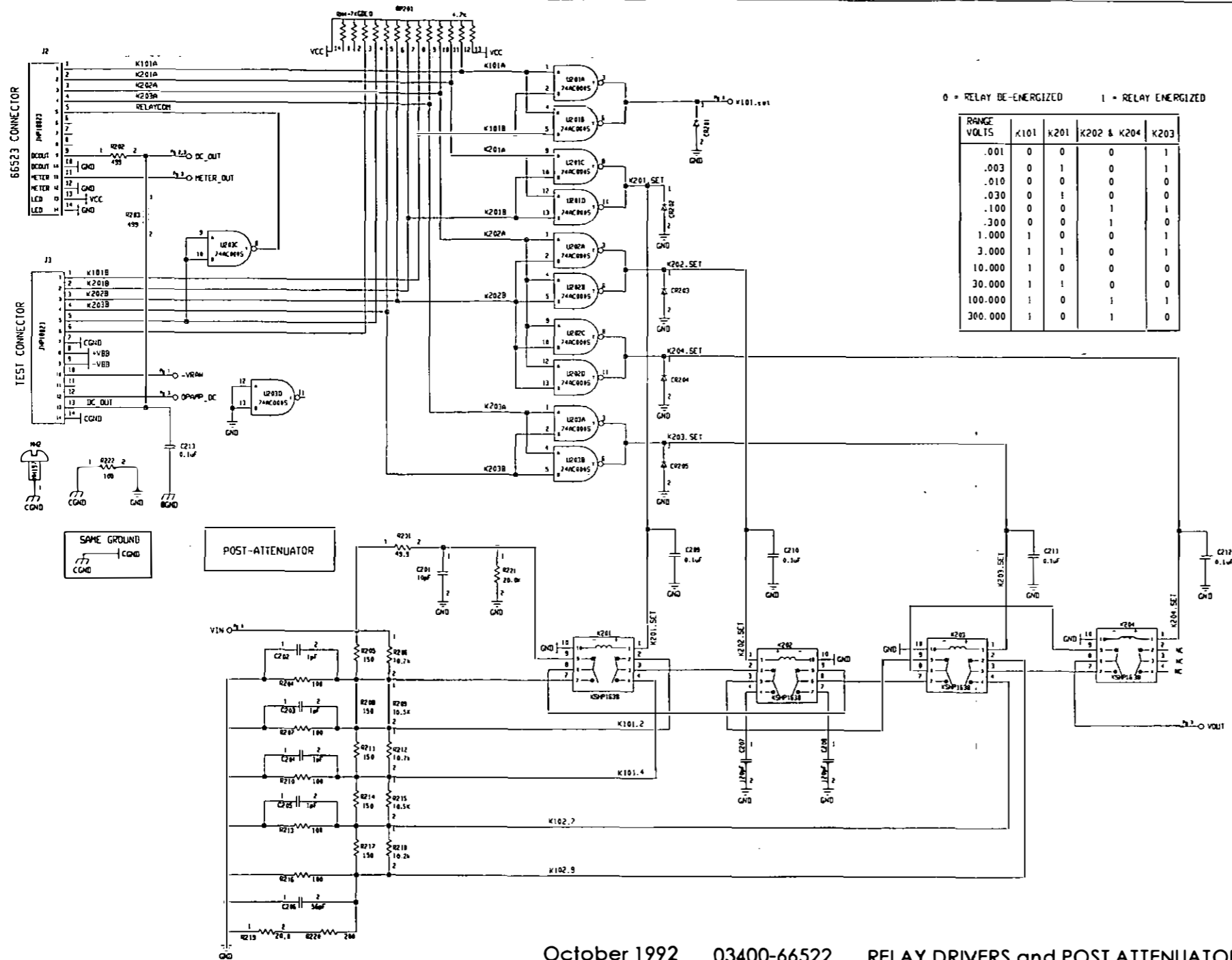

October 1992 03400-66522 RELAY DRIVERS and POST ATTENUATOR

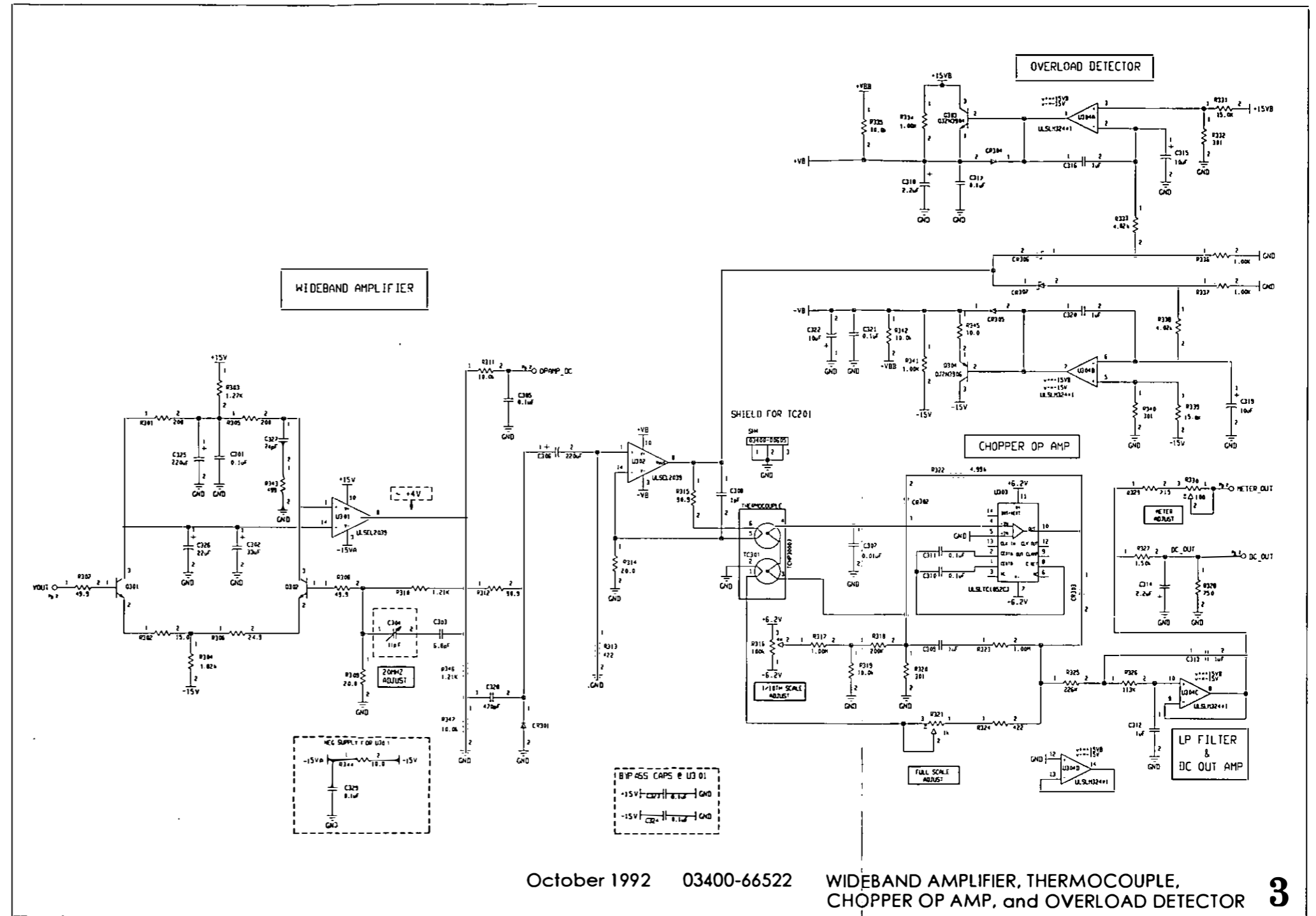

October 1992 03400-66522

WIDEBAND AMPLIFIER, THERMOCOUPLE,
CHOPPER OP AMP, and OVERLOAD DETECTOR

Wideband Amplifier, Thermocouple,
Chopper Op Amp, and Overload Detector

P/O 03400-61607

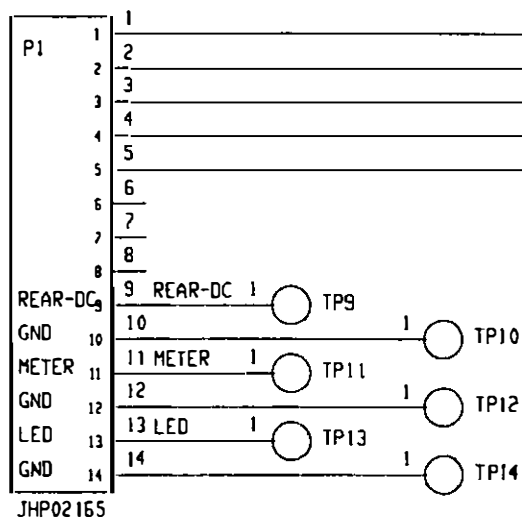

- TP9 = 300mm GREEN
- TP10 = 300mm BLK
- TP11 = 150mm BLUE
- TP12 = 150mm BROWN
- TP13 = LED CABLE RED
- TP14 = LED CABLE BLACK

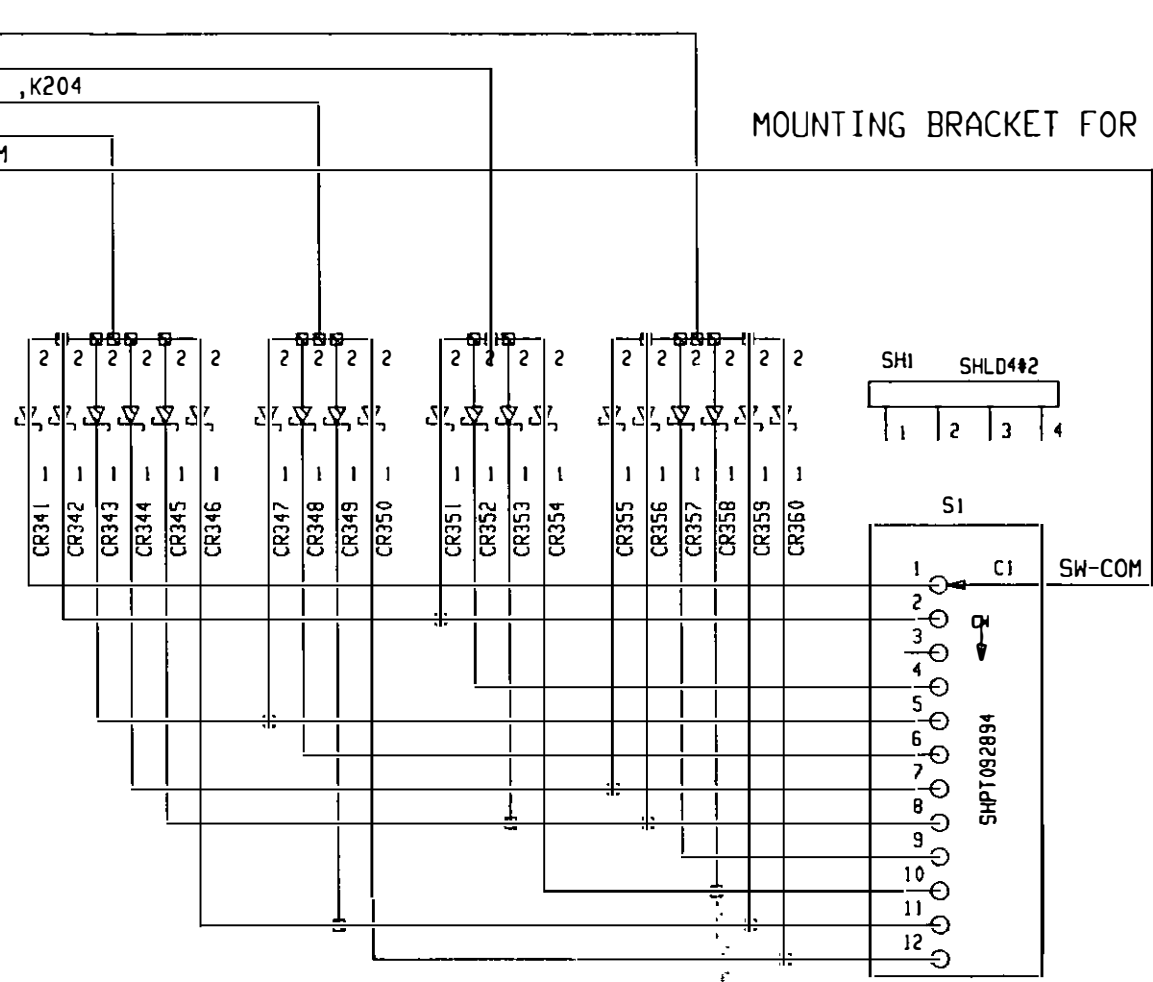

Index

A

ac-to-dc converter accuracy, 4
accessory
 checklist, 11
 phone plug, 14
 rack mounting, 16
accuracy
 ac-to-dc converter specifications, 4
 measurement specifications, 4
adapter, double binding post, 11
adapter frame, rack mounting, 16
 adjustment procedures, 28
 adjustment screw, 2, 13, 28
amplifier stability test, 25

B

backdating, 63
binding post adapter, 11
block diagram, 39
BNC adapter, 11
BNC input terminal, 2

C

calibration
 interval, 19
 procedures, 17
 temperature, 20
 test equipment required, 20
 time required, 19
 cautions and warnings, 5
checklist
 items included, 11
 operating, 49
chopper op amp description, 43
coefficient, temperature, 4
combining case, rack mounting, 16
component locators, 68
contents, table of, 7
cord, power, 11
crest factor, 4
crest factor check, 27

D

dc output, full-scale output, 14
dc output jack, 3, 14
Declaration of Conformity, *back cover*
dimensions, product, 4
double binding post adapter, 11

E

electrostatic discharge precautions, 50
equipment required, calibration, 20

F

factory setting, line voltage, 11
feature overview, 1
feet, removing, 15
flatness adjustment, 33
Fluke 5700A Calibrator, 20
front panel
 labels, 2
 pictorial overview, 2
full-scale gain adjustment, 29
full-scale output, dc output jack, 14
full-scale test, frequency response, 23
fuse
 factory configuration, 11
 fuse-holder location, 2, 12
 part number, 49
 replacing, 49
fuse-holder assembly, 3, 12, 49

H

HP 3458A Multimeter, 20
HP 8161A Pulse Generator, 20

I

impedance converter description, 41
input attenuator
 adjustment, 34
 description, 41
input impedance, 4
input terminal, 2
interval, calibration, 19

J

J3 pinout (test connector), 36jack,
rear-panel, 3, 14

K

kita, rack mounting, 16

L

labels
 front panel, 2
 rear panel, 3
line fuse
 factory configuration, 11
 fuse-holder location, 2, 12
 part number, 49
 replacing, 49
line voltage
 changing, 12
 factory setting, 11
 module location, 3, 12
 voltage setting, 3, 12

M

manual overview, 6
measurement accuracy, 4
measurement range, selecting, 13
mechanical disassembly, 67
meter zero adjustment, 28
mounting, rack, 15

N

needle adjustment, 28, 32
needle adjustment, full scale, 32

O

- offset, zero, 4, 13
- operation verification procedures, 21
- operating checklist, 49
- output jack, rear-panel, 3, 14
- overload protection check, 26
- overview
 - front panel, 2
 - manual, 6
 - rear panel, 3

P

- parts lists, 51
- performance verification, 22
- phone plug, output jack, 14
- pinout, test connector, 36
- plug, output jack, 14
- pointer adjustment, 28, 32
- post attenuator description, 42
- power cord, 11
- power supply description, 44
- power-line fuse
 - factory configuration, 11
 - fuse-holder location, 2, 12
 - part number, 49
 - replacing, 49
- power-line voltage
 - changing, 12
 - factory setting, 11
 - module location, 3, 12
 - voltage setting, 3, 12
- procedures
 - adjustment, 28
 - operation verification, 21
 - performance verification, 22
- product
 - description, 1
 - dimensions, 4
 - specifications, 4
 - weight, 4
- protection circuitry test, 26

R

- rack adapter frame, 16
- rack mounting
 - adapter frame, 16
 - combining case, 16
- range, frequency response test, 22
- range selection, 13
- range switch, 2, 13
- rear panel overview, 3
- rear-panel
 - labels, 3
 - output jack, 3, 14
 - pictorial overview, 3
- relay drivers, 45
- replaceable parts
 - lists, 51
 - ordering, 52
- response time, 4
- ribbon cable, custom, 36

S

- schematic diagrams, 14, 65
- screw, zero adjustment, 2, 13, 28
- source impedance, output jack, 4, 14
- specifications, 4
- static electricity, 18, 50
- switch board description, 45

T

- table of contents, 7
- temperature coefficient, 4
- tenth scale gain adjustment, 30
- tenth scale test, 24
- terminal, input, 2
- test connector pinout, 36
- test considerations, 20
- test equipment, calibration, 20
- theory of operation, 37
- thermocouple pair description, 43
- time required, calibration, 19

V

- voltage range selection, 13
- voltage range switch, 2, 13
- voltage, power-line
 - changing, 12
 - factory setting, 11
 - module location, 3, 12
 - voltage setting, 3, 12

W

- warm-up time, 11, 20, 22, 28
- warnings and cautions, 5
- warranty information, *front cover*
- weight, product, 4
- wideband amplifier description, 42

Z

- zero adjustment, 28, 32
- zero adjustment screw, 2, 13, 28
- zero offset, 4, 13

Declaration of Conformity
According to ISO/IEC Guide 22 and EN 45014

The Hewlett-Packard Company declares that the *HP 3400B Voltmeter* conforms to the following Product Specifications.

Safety: IEC 1010-1 (1990)
CSA 231
UL 1244

EMC: CISPR 11:1990/EN55011 (1991): Group 1 Class A
IEC 801-2:1991/EN50082-1 (1992): 4 kV CD, 8 kV AD
IEC 801-3:1984/EN50082-1 (1992): 3 V/m
IEC 801-4:1988/EN50082-1 (1992): 1 kV



Quality Manager
October 1992

In the United States:
Hewlett-Packard Company
P.O. Box 301
815 14th Street S.W.
Loveland, Colorado 80539 U.S.A.

In Europe:
Hewlett-Packard GmbH
Department ZQ / Standards Europe
Herrenberger Straße 130
D-7030 Böblingen
(FAX: +49-7031-141623)

Contents

| | |
|------------------------------------|----|
| The Front Panel at a Glance | 2 |
| The Rear Panel at a Glance | 3 |
| Specifications | 4 |
| In This Book | 5 |
| Chapter 1 – Quick Start | 9 |
| Chapter 2 – Calibration Procedures | 17 |
| Chapter 3 – Theory of Operation | 37 |
| Chapter 4 – Service | 47 |
| Chapter 5 – Replaceable Parts | 51 |
| Chapter 6 – Backdating | 63 |
| Chapter 7 – Schematics | 65 |
| Index | 73 |



Hewlett-Packard Company
Printed in U.S.A.
Edition 1
October 1992 E1092



03400-90014