



Agilent Truevolt Series DMM Operating and Service Guide

This document contains information for using, programming, and servicing the Truevolt Series DMMs. If you have feedback on this document, please go to www.agilent.com/find/truevolt-docfeedback.

Preliminary Information

[Safety and Regulatory Information](#)

[Models and Options](#)

[Quick Start](#)

[Contacting Agilent Technologies](#)

[Introduction to the Instrument](#)

User Information

[Front-Panel Menu Reference](#)

[Features and Functions](#)

[Remote Interface Configuration](#)

[LAN Configuration Procedure](#)

[Web Interface](#)

[Measurements](#)

[Triggering and Readings](#)

[Probe Hold](#)

[Math](#)

[Display](#)

[Utility Menu](#)

[Measurement Tutorial](#)

SCPI Programming Reference

[Welcome to SCPI](#)

[Introduction to the SCPI Language](#)

[Commands by Subsystem](#)

[Command Quick Reference](#)

[Range, Resolution, and NPLC](#)

[Resolution Table](#)

[VM Comp Output](#)

[SCPI Error Messages](#)

[Power-On and Reset State](#)

Service and Repair

[Service and Repair - Introduction](#)

[Disassembly](#)

[Troubleshooting](#)

[Power Supplies](#)

[Self-Test Procedures](#)

[Battery Replacement](#)

[Installing the Optional GPIB Interface](#)

[User Replaceable Parts](#)

[Calibration](#)

[General Characteristics](#)

[Firmware Update](#)

© 2013 Agilent Technologies, Inc.

Version 1.04 (December, 2013)

Safety and Regulatory Information

Notices

© Agilent Technologies, Inc. 2013

No part of this manual may be reproduced in any form or by any means (including electronic storage and retrieval or translation into a foreign language) without prior agreement and written consent from Agilent Technologies, Inc. as governed by United States and international copyright laws.

Manual Information

34460-90901

Agilent Technologies, Inc.
900 S. Taft Ave.
Loveland, CO 80537 USA

Software Revision

For the latest firmware, go to the product page at www.agilent.com/find/truevolt.

The latest product documentation is available at www.agilent.com/find/truevolt-doc. For documentation for mobile devices, see www.agilent.com/find/truevolt-mobilehelp.

A portion of the software in this product is licensed under terms of the General Public License Version 2 ("GPLv2"). The text of the license and source code can be found at www.agilent.com/find/GPLV2.

This product uses Microsoft Windows CE. Agilent highly recommends that all Windows-based computers connected to Windows CE instruments use current anti-virus software. For more information, see www.agilent.com/find/truevolt.

Warranty

The material contained in this document is provided "as is," and is subject to being changed, without notice, in future editions. Further, to the maximum extent permitted by applicable law, Agilent disclaims all warranties, either express or implied, with regard to this manual and any information contained herein, including but not limited to the implied warranties of merchantability and fitness for a particular purpose. Agilent shall not be liable for errors or for incidental or consequential damages in connection with the furnishing, use, or performance of this document or of any information contained herein. Should Agilent and the user have a separate written agreement with warranty terms covering the material in this document that conflict with these terms, the warranty terms in the separate agreement shall control.

Technology Licenses

The hardware and/or software described in this document are furnished under a license and may be used or copied only in accordance with the terms of such license.

Restricted Rights Legend

U.S. Government Restricted Rights. Software and technical data rights granted to the federal government include only those rights customarily provided to end user customers. Agilent provides this customary commercial license in Software and technical data pursuant to FAR 12.211 (Technical Data) and 12.212 (Computer Software) and, for the Department of Defense, DFARS 252.227-7015 (Technical Data – Commercial Items) and DFARS 227.7202-3 (Rights in Commercial Computer Software or Computer Software Documentation).

Safety Notices

CAUTION

A CAUTION notice denotes a hazard. It calls attention to an operating procedure, practice, or the like that, if not correctly performed or adhered to, could result in damage to the product or loss of important data. Do not proceed beyond a CAUTION notice until the indicated conditions are fully understood and met.

WARNING

A WARNING notice denotes a hazard. It calls attention to an operating procedure, practice, or the like that, if not correctly performed or adhered to, could result in personal injury or death. Do not proceed beyond a WARNING notice until the indicated conditions are fully understood and met.

Safety Symbols



Alternating current



Frame or chassis terminal



Standby supply. Unit is not completely disconnected from AC mains power when switch is off.



WARNING Risk of electric shock



CAUTION Refer to accompanying documents



The CE mark indicates the instrument meets the requirements of the applicable European Community Directives to be placed on the European Community market. "ISM 1-A" indicates that the instrument is an "Industrial, Scientific and Medical Class A, Group 1" product.



The CE mark is a registered trademark of the European Community.

The CSA mark with the 'c' and 'us' subscript indicates the instrument is certified to the applicable Canadian and United States of America standards respectively.

CAT II (300V) IEC Measurement Category II. Inputs may be connected to AC mains power (up to 300 VAC) under Category II overvoltage conditions.

N10149 The C-tick mark is a registered trademark of the Spectrum Management Agency of Australia. This signifies compliance with the Australian EMC Framework regulations under the terms of the Radio Communications Act of 1992.



ICES-001 NMB-001 This mark indicates the instrument complies with the Canadian Interference-Causing Equipment Standard for Industrial, Scientific and Medical (ISM) Radio Frequency Generators.



This equipment is Class A suitable for professional use and is for use in electromagnetic environments outside of the home.

이 기기는 업무용 (A 급) 전자파적합기기로서 판매자 또는 사용자는 이 점을 주의하시기 바라며, 가정외의 지역에서 사용하는 것을 목적으로 합니다.



Contains one or more of the 6 hazardous substances above the maximum concentration value (MCV), 40 Year EPUP.

Safety Information

General

Do not use this product in any manner not specified by the manufacturer. The protective features of this product may be impaired if it is used in a manner not specified in the operation instructions. Do not install substitute parts or perform any unauthorized modification to the product. Return the product to an Agilent Technologies Sales and Service Office for service and repair to ensure that safety features are maintained.

WARNING Product Grounding

The instrument is a Class 1 product and is provided with a grounding-type power cord set. The instrument chassis and cover are connected to the instrument electrical ground to minimize shock hazard. The ground pin of the cord set plug must be firmly connected to the electrical ground (safety ground) terminal at the power outlet. Any interruption of the protective earth (grounding) conductor or disconnection of the protective earth terminal will cause a potential shock hazard that could result in personal injury or death.

WARNING Cleaning

To prevent electrical shock, disconnect the instrument from AC mains power and disconnect all test leads before cleaning. Clean the outside of the instrument using a soft, lint-free, cloth slightly dampened with water. Do not use detergent or solvents. Do not attempt to clean internally. If needed, contact an Agilent Technologies Sales and Service office to arrange for proper cleaning to ensure that safety features and performance are maintained.

WARNING AC Power Cord

Removal of the AC power cord is the disconnect method to remove power from the instrument. Be sure to allow for adequate access to the power cord to permit disconnection from AC power. Use only the Agilent specified power cord for the country of use or one with equivalent ratings.

WARNING Do Not Remove Instrument Cover

Only qualified, service-trained personnel should remove the cover from the instrument. Service: Unplug instrument from wall outlet, remove power cord, and remove all probes from all terminals before servicing.

WARNING AC Mains Power Line Fuse

For continued protection against fire, replace the line fuse only with fuses of the specified type and rating. The instrument must be disconnected from AC mains power, and all measurement terminals must be disconnected before changing the fuse.

WARNING Current Measurement Protection Fuse

For continued protection against fire, replace current-protection fuses only with fuses of the specified type and rating. The instrument must be disconnected from AC mains power, and all measurement terminals must be disconnected before changing the fuse.

WARNING Front/Rear Switch

Do not change the position of the Front/Rear switch on the front panel while signals are present on either the front or rear set of terminals. The switch is not intended as an active multiplexer. Switching while current or high voltage is present may cause instrument damage and lead to the risk of electric shock.

WARNING Do Not Operate in an Explosive Atmosphere

This instrument is not designed to be operated in an explosive environment. The instrument enclosure complies with the IP 20 rating.

WARNING **In Case of Damage**

An instrument that appears damaged or defective should be made inoperative and secured against unintended operation until qualified service personnel can repair it.

WARNING **Self-Test**

Before measuring any hazardous voltage or current, remove all test leads to the instrument, run the TEST:ALL? query from the remote interface, and read the result to verify that the instrument is performing properly.

The TEST:ALL? query is a self-test that returns +0 if the instrument passes and +1 if the instrument fails. You can also perform this query from the front panel by pressing [Shift] > [Utility] > Test/Admin > Self Test > Full Test. If this self-test fails, make sure that the instrument is repaired and passes the complete self-test before continuing.

WARNING **Measuring AC Power Mains**

The HI, LO, and current input terminals may be connected to AC mains power in IEC Category II installations for line voltages up to 300 VAC. To avoid the danger of electric shock, do not connect the inputs to AC mains power for line voltages above 300 VAC. See [IEC Measurement Category II](#) for further information.

WARNING **Measuring Current with A Current Transformer**

If a current transformer is used for measuring current, you must use a current transformer with internal secondary protection. Using a current transformer without protection may result in a hazardous voltage resulting in a severe shock or death. In addition, this may cause damage to the instrument.

WARNING **Measurement Limits**

To avoid instrument damage and the risk of electric shock, do not exceed any of the Measurement Limits defined in the following section.

CAUTION This product complies with EN/IEC 61326-2-1, for sensitive test and measurement equipment:

When subjected to transient radiated and/or conducted electromagnetic phenomena, the product may have temporary loss of function or performance which is self-recovering. Recovery may take longer than 10 seconds.

When subjected to continuously present electromagnetic phenomena, some degradation of performance may occur.

Measurement Limits

The Truevolt Series DMMs provide protection circuitry to prevent damage to the instrument and to protect against the danger of electric shock, provided the Measurement Limits are not exceeded. To ensure safe operation of the instrument, do not exceed the Measurement Limits shown on the front and rear panel, and defined as follows:

34460A Front Panel Terminal Area

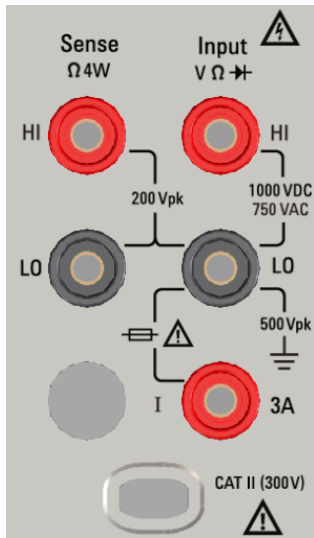

34461A Front Panel Terminal Area

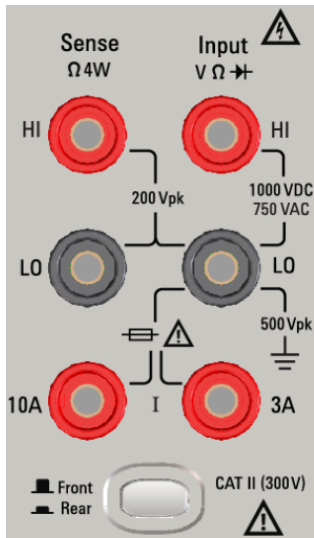

34461A Rear Panel Terminal Area

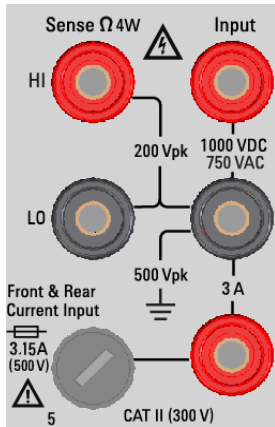

NOTE

The front-panel and rear-panel (34461A only) terminals are shown above. The Front/Rear switch (34461A only) selects the terminal set to be used. Do not operate this switch while signals are present on the front or rear terminals.

The user-replaceable 3 A current-protection fuse is on the rear panel. There are 3 A and 10 A (34461A only) current-protection fuses located inside the unit. Contact your Agilent Sales and Service Center or refer to product service documentation for replacement instructions.

To maintain protection, replace fuses only with [fuses of the specified type and rating](#).

Input Terminal Measurement Limits

Measurement Limits are defined for the input terminals:

Main Input (HI and LO) Terminals. The HI and LO input terminals are used for voltage, resistance, frequency (period), and diode test measurements. Two Measurement Limits are defined for these terminals:

- **HI to LO Measurement Limit.** The Measurement Limit from HI to LO (Input terminals) is 1000 VDC or 750 VAC, which is also the maximum voltage measurement. This limit can also be expressed as 1000 Vpk maximum.
- **LO to Ground Measurement Limit.** The LO input terminal can safely "float" a maximum of 500 Vpk relative to ground, where ground is defined as the Protective Earth Conductor in the AC mains power cord connected to the instrument.

As implied by the above limits, the Measurement Limit for the HI input terminal is a maximum of 1500 Vpk relative to ground when LO is at its maximum of 500 Vpk relative to ground.

Current Input Terminal. The current input ("I") terminal has a Measurement Limit of 3 A or 10 A (DC or AC) between the "I" terminal (3 A or 10 A) and the LO input terminal. Note that the current input terminals will always be at approximately the same voltage as the LO terminal, unless a current protection fuse is open. The 10 A terminal is only available on the 34461A.

Sense Terminal Measurement Limits

The HI and LO sense terminals are used for DCV ratio measurements and four-wire resistance and temperature measurements. The Measurement Limit is 200 Vpk for all of the terminal pairings: LO sense to LO input, HI sense to LO input, and HI sense to LO sense.

NOTE The 200 Vpk limit on the sense terminals is the Measurement Limit. Operational voltages in resistance measurements are much lower – up to ± 12 V in normal operation.

IEC Measurement Category II

To protect against the danger of electric shock, the Agilent Truevolt Series DMM protects the user from AC mains power overvoltage events. When measuring AC mains, the HI and LO input terminals may be connected to AC mains power up to 300 VAC under Measurement Category II conditions as defined below.

IEC Measurement Category II includes electrical devices connected to AC mains power at an outlet on a branch circuit. Such devices include most small appliances, test equipment, and other devices that plug into a branch outlet or socket. The instrument may be used to make measurements with the HI and LO inputs connected to AC mains power in such devices, or to the branch outlet itself (up to 300 VAC). However, the instrument may not be used with its HI and LO inputs connected to AC mains power in permanently installed electrical devices such as the main circuit-breaker panel, sub-panel disconnect boxes, or permanently wired motors. Such devices and circuits are subject to overvoltages that may exceed the instrument's protection capabilities.

NOTE Voltages above 300 VAC may be measured only in circuits that are isolated from AC mains power. However, transient overvoltages are also present on circuits that are isolated from AC mains power. The instrument is designed to safely withstand occasional transient overvoltages up to 1500 Vpk when measuring voltages greater than 300 VAC. Do not use this equipment to measure circuits where transient overvoltages could exceed this level.

Additional Notices

Waste Electrical and Electronic Equipment (WEEE) Directive 2002/96/EC

This product complies with the WEEE Directive (2002/96/EC) marking requirement. The affixed product label (see below) indicates that you must not discard this electrical/electronic product in domestic household waste.

Product Category: With reference to the equipment types in the WEEE directive Annex 1, this product is classified as a "Monitoring and Control instrumentation" product. Do not dispose in domestic household waste.

To return unwanted products, contact your local Agilent office, or see www.agilent.com/environment/product for more information.



Agilent 34138A Test Lead Set

The Agilent 34138A Test Lead Set, described below, is compatible with the Truevolt Series DMMs.

Test Lead Ratings

- Test Leads - 1000V, 15A
- Fine Tip Probe Attachments - 300V
- 3A Mini Grabber Attachment - 300V, 3A
- SMT Grabber Attachments - 300V, 3A

Operation

The Fine Tip, Mini Grabber, and SMT Grabber attachments plug onto the probe end of the Test Leads.

Maintenance

If any portion of the Test Lead Set is worn or damaged, do not use. Replace with a new Agilent 34138A Test Lead Set.

WARNING If the Test Lead Set is used in a manner not specified by Agilent Technologies, the protection provided by the Test Lead Set may be impaired. Also, do not use a damaged or worn Test Lead Set. Personal injury or death may result.

Quick Start

This section describes basic procedures to help you get started quickly with the instrument.

- [Prepare Instrument for Use](#)
- [Adjust the Carrying Handle](#)
- [Use Built-in Help System](#)
- [Rack Mount the Instrument](#)

Prepare Instrument for Use

Verify that you received the following items. If anything is missing, please contact your nearest Agilent sales office or Agilent authorized reseller.

- Power cord (for country of destination)
- Certificate of Calibration (optional)
- *Agilent 34460A/61A Product Reference CD* (product software and manuals) (optional on 34460A)
- *Agilent Automation-Ready CD* (Agilent IO Libraries Suite) (optional on 34460A)
- Supplemental documentation packet
- USB 2.0 cable (optional on 34460A)

The latest product documentation is available at www.agilent.com/find/truevolt-doc. For documentation for mobile devices, see www.agilent.com/find/truevolt-mobilehelp.

To download the Digital Multimeter Connectivity Utility, go to www.agilent.com/find/DMMutilitysoftware.

Setting the AC Mains Line Voltage Selector and Fuse Installation

WARNING

Before plugging the instrument into AC mains power, verify that the line voltage setting visible on the back of the AC mains input module is correct for the AC mains power source being connected. The line voltage selections are shown in a box on the rear panel immediately to the left of the AC mains input module. Other nominal line voltages are shown in parentheses.

Verify that the correct fuse is installed. To replace a blown fuse or verify the correct fuse, pull it gently from the fuse drawer and insert the correct working fuse. Use only a 5x20 mm, time-lag, 0.25 A, 250 V certified fuse. The Agilent part number is 2110-0817.

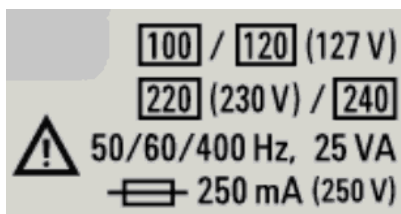

AC MAINS Nominal Line Voltage Range	AC Mains Line Voltage Selector
100 - 115	100
120 - 127	120
202 - 230	220
240	240

Use the following procedure to configure the line voltage selector:

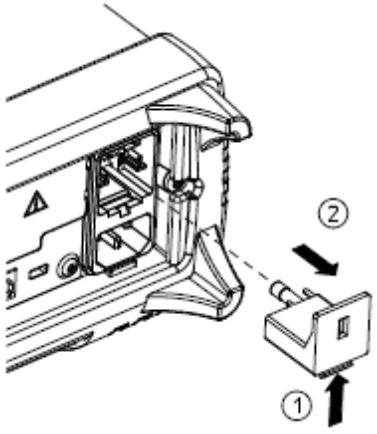
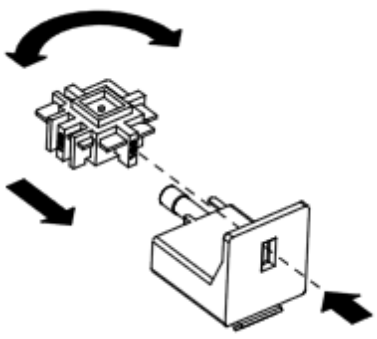
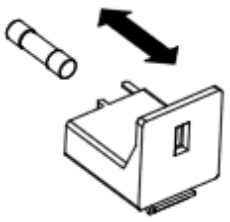
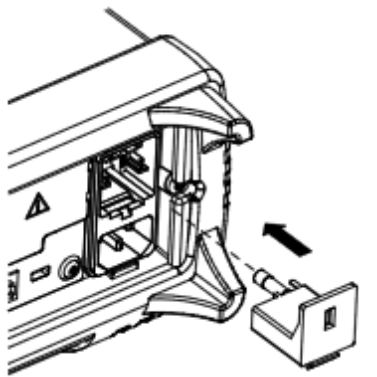
Step 1	Lift tab (1) and pull the fuse drawer (2) from the rear panel.	
Step 2	Remove the line-voltage selector and rotate it so the correct voltage will appear in the fuse holder window.	
Step 3	Verify that the correct fuse is installed. To replace a blown fuse or verify the correct fuse, pull it gently from the fuse drawer and insert the correct working fuse. Use only a 5x20 mm, time-lag, 0.25 A, 250 V certified fuse. The Agilent part number is 2110-0817.	
Step 4	Replace the fuse holder assembly by sliding it into the rear panel.	

WARNING Product Grounding

The instrument is a Class 1 product and is provided with a grounding-type power cord set. The instrument chassis and cover are connected to the instrument electrical ground to minimize shock hazard. The ground pin of the cord set plug must be firmly connected to the electrical ground (safety ground) terminal at the power outlet. Any interruption of the protective earth (grounding) conductor or disconnection of the protective earth terminal will cause a potential shock hazard that could result in personal injury or death.

Connect Power and I/O Cables

Connect the power cord and LAN, GPIB, or USB cable as desired. After you turn on the instrument (as described below), the instrument will run a power-on self test and then display a message about how to obtain help, along with the current IP address. It also displays the GPIB address (if applicable).

The instrument's default measurement function is DC Voltage (DCV), with autoranging enabled.

Power Switch

Press the power switch in the lower left corner of the front panel. If the instrument does not turn on, verify that the power cord is firmly connected and that the fuse is good and the line voltage selector is set correctly, as described above. Also make sure that the instrument is connected to an energized power source. If the LED below the power switch is off, there is no AC mains power connected. If the LED is amber, the instrument is in standby mode with AC mains power connected, and if it is green, the instrument is on.

NOTE In certain circumstances, the amber LED can come on even if the wrong line voltage is selected. In this case, the instrument may not power on.

If the power-on self test fails, the display shows **Error** in the upper right corner. It also displays a message describing the error. See [SCPI Error Messages](#) for information on error codes. See [Service and Repair - Introduction](#) for instructions on returning the instrument for service.

To turn off the instrument, press and hold the power switch for about 500 ms. This prevents you from accidentally turning off the instrument by brushing against the power switch.

NOTE If you turn off the instrument by disconnecting power (this is not recommended), the instrument will turn on as soon as you re-apply power. You will not need to press the power switch.

Adjust the Carrying Handle

The handle has three positions, shown below.

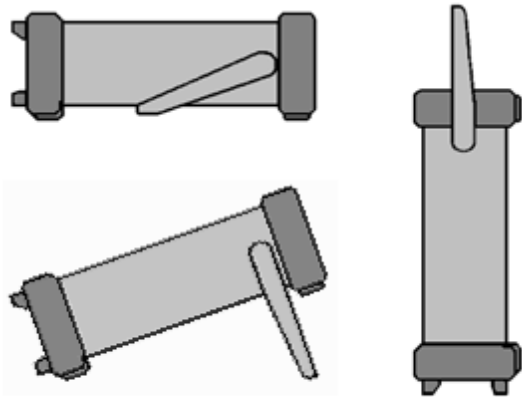

To adjust the handle position, grasp the sides of the handle, pull outward, and rotate the handle.

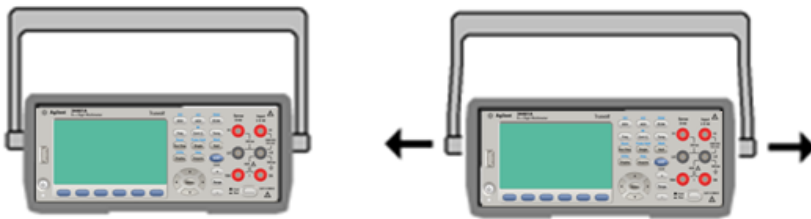

Use Built-in Help System

The built-in help system provides context-sensitive help on any front-panel key or menu softkey. A list of help topics is also available to help you learn about the instrument.

View the help information for a front-panel key

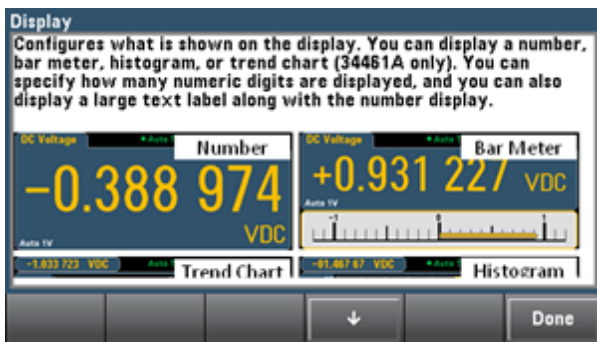

Press and hold any softkey or button, such as **[Display]**.

If the message contains more information than will fit on the display, press the down arrow softkey to scroll down.



Press **Done** to exit Help.

View the list of help topics and use interactive demos

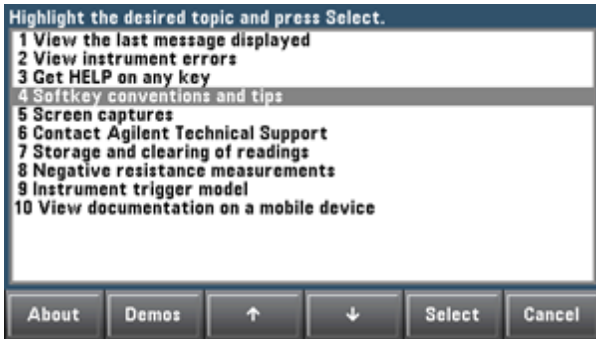

Press   to view the list of help topics. Press the arrow softkeys or use the front-panel arrow keys to highlight the desired topic. Then press **Select**. You can also press **Demos** to run interactive demos on how to use the instrument.

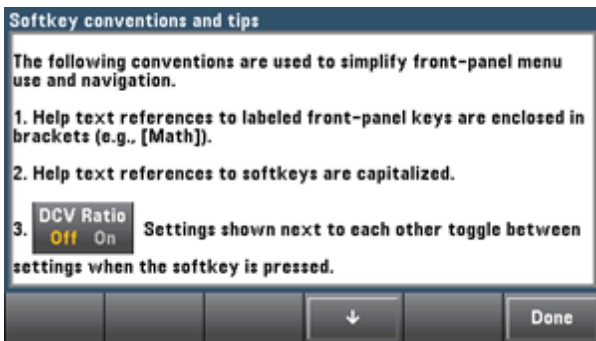

In this case, the following help topic will appear:



View the list of recent instrument errors.

Press  and choose  and choose **View instrument errors** from the list of help topics. This displays the instrument's error queue, which includes up to 20 errors.

View the help information for displayed messages.

Whenever a limit is exceeded or any other invalid configuration is found, the instrument displays a message. The built-in help system provides additional information on the most recent message. Press **[Shift] > [Help]**, select **View the last message displayed**, and press **Select**.

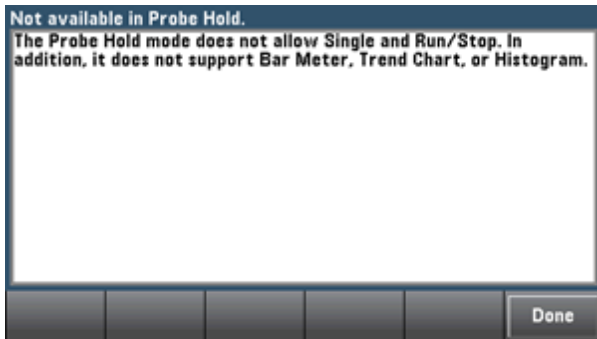

Press **Done** to exit Help.

NOTE

Local Language Help

All messages, context-sensitive help, and help topics are available in English, Chinese, French, German, Japanese, Korean, and Russian. To select the local language, press **[Utility] > System Setup > User Settings > Help Lang**. Then select the desired language.

The menu softkey labels and status line messages are not translated.

Rack Mount the Instrument

You can mount the instrument in a standard 19-inch rack cabinet using one of two optional kits, each of which includes instructions and mounting hardware. You may also mount another Agilent System II instrument of the same height and width beside the instrument.

CAUTION

To prevent overheating, do not block airflow to or from the instrument. Allow enough clearance at the rear, sides, and bottom of the instrument to permit adequate internal air flow.

NOTE

Remove the carrying handle and the front and rear bumpers before rack-mounting the instrument.

Removing the Handle and Bumpers

To remove the handle, rotate it to vertical and pull the ends outward.

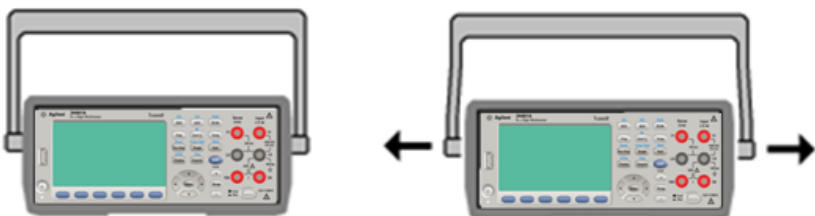

To remove the rubber bumper, stretch a corner and then slide it off.

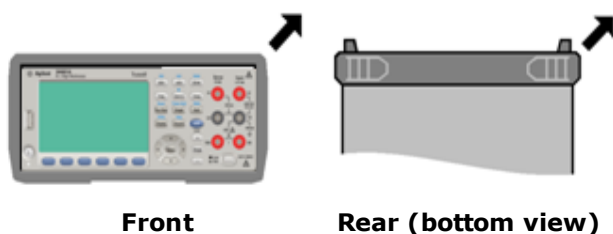

Front

Rear (bottom view)

Rack Mounting a Single Instrument

To rack mount a single instrument, order adapter kit 5063-9240.



Rack Mounting Instruments Side-by-Side

To rack mount two instruments side-by-side, order lock-link kit 5061-8769 and flange kit 5063-9212. Be sure to use the support rails in the rack cabinet.



Sliding Support Shelf

To install one or two instruments in a sliding support shelf, order shelf 5063-9255 and slide kit 1494-0015. For a single instrument, also order filler panel 5002-3999.

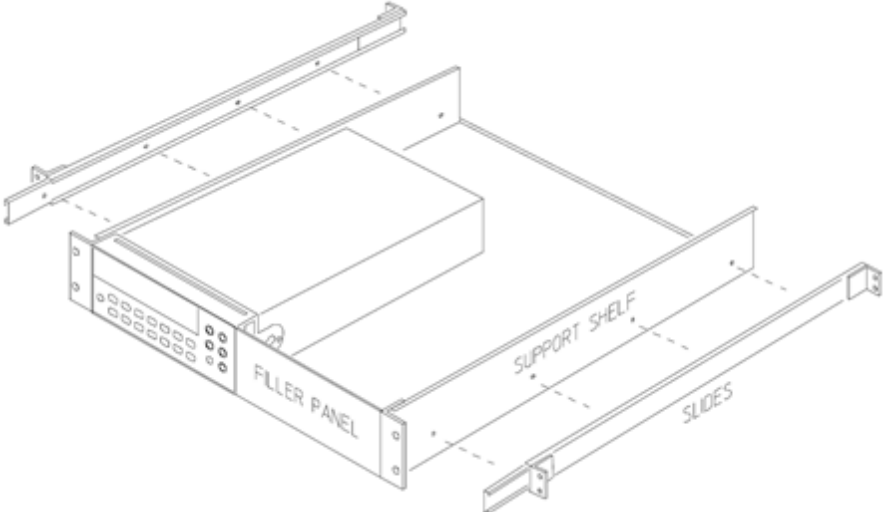

Models and Options

This document applies to two digital multimeters:

- 34460A - 6½-digit Basic DMM
- 34461A - 6½-digit 34401A Replacement DMM

Options Installed at Factory

34460A	34461A	Description
34460A-LAN	N/A - Standard	Enable rear panel LAN/LXI web interface, external triggering for 34460A
34460A-SEC	34461A-SEC	Enable instrument security
34460A-GPB	34461A-GPB	User-installable GPIB interface module
34460A-ACC	N/A - Standard	Accessory kit for 34460A - Documentation CD, Test Leads, USB Cable
34460A-Z54	34461A-Z54	Certificate of calibration – ANSI/NCSL Z540.3-2006, printed

Options Installed by Distributor or End Customer

Product Number	34460A	34461A	Description
3446LANU	Option	N/A - Standard	Enable rear panel LAN/LXI web interface, external triggering for 34460A
3446SECU	Option	Option	Enable instrument security
3446GPBU	Option	Option	User-installable GPIB interface module
3446ACCU	Option	N/A - Standard	Accessory kit for 34460A - Documentation CD, Test Leads, USB Cable

Contacting Agilent Technologies



You can contact Agilent Technologies for warranty, service, or technical support.

In the United States: (800) 829-4444

In Europe: 31 20 547 2111

In Japan: 0120-421-345

Use www.agilent.com/find/assist to contact Agilent worldwide, or contact your Agilent Technologies representative.

Introduction to the Instrument

The Agilent Technologies 34460A and 34461A instruments are 6½-digit digital multimeters (DMMs).

[Instrument at a Glance](#)

[Front Panel at a Glance](#)

[Rear Panel at a Glance](#)

[Models and Options](#)

[Contacting Agilent Technologies](#)

Instrument at a Glance

The instrument's combination of bench-top and system features make it a versatile solution now and in the future. The instrument can make a wide range of accurate and flexible measurements.

Display – Easily display, save and document your measurement results

- High usability with an intuitive, menu driven user interface
- Histogram, trend chart (34461A only), meter, and numeric views on a high-resolution color display
- USB, LAN (optional on 34460A), and optional GPIB interface
- Drag and drop, driverless USB connectivity

Measurements – Agilent's Truevolt measurement performance with modern I/O accessibility

- Patented, metrology-level performance that serves as the foundation for all measurements
- Accurate and stable measurements, with specifications compliant to IEC 17025

Move to the next generation 34401A

- 100% drop-in, SCPI compatible replacement for the 34401A DMM
- SCPI (Standard Commands for Programmable Instruments) programming language

Front Panel at a Glance HI and LO Sense Terminals

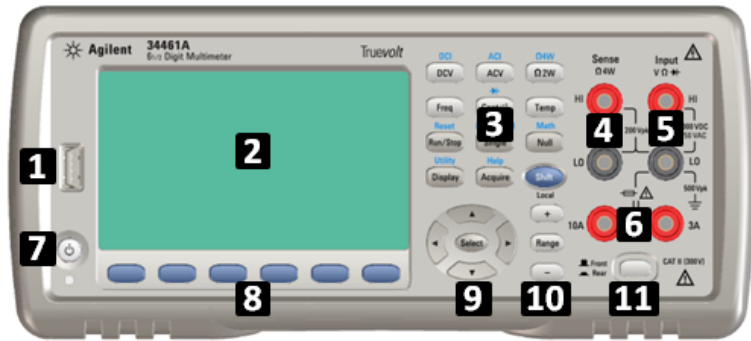

Item	Description
1	USB Port
2	Display
3	Measurement Configuration and Instrument Operation Keys
4	HI and LO Sense Terminals
5	HI and LO Input Terminals
6	AC/DC Current Input Terminals (10 A terminal not available on 34460A)
7	On/Standby Switch
8	Softkeys
9	Cursor Navigation Keypad
10	Range Selection Keys
11	Front/Rear Switch (34461A only)

Front-Panel Keys

NOTE

Note that some of the front-panel keys have text above them. This indicates that the key has a function that you can access by pressing and releasing **[Shift]** before pressing the key. For example, if you press and release **[Shift]** before pressing **[Display]**, you will access the **[Utility]** function:



Rear Panel at a Glance

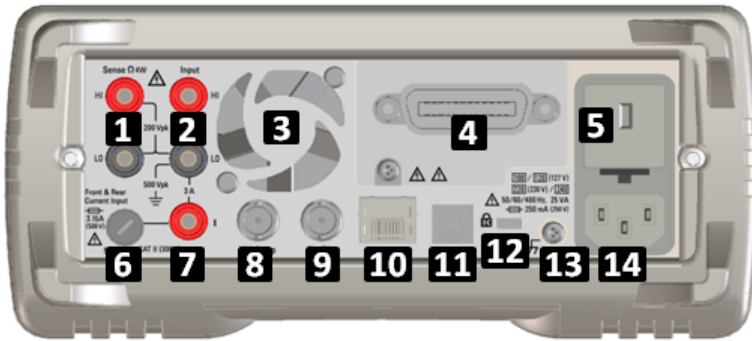

Item	Description
1	HI and LO Sense Terminals (34461A only)
2	HI and LO Input Terminals (34461A only)
3	Fan Vents (34461A only)
4	GPIB Connector (optional)
5	AC Mains Line Voltage Selector and Fuse Access
6	3 A Current Terminal Fuse
7	3 A Current Terminal (34461A only)
8	Voltmeter Measurement Complete Output
9	External Trigger Input
10	Local Area Network (LAN) Connector
11	USB Interface Connector
12	Instrument Cable Lock
13	Chassis Ground Screw
14	AC Mains Input

Remote Interface Configuration

NOTE

If you have the security option installed on your instrument, the instrument must be unsecured with the security code to perform many of these actions.

The instrument supports remote interface communication over three interfaces: GPIB (optional), USB, and LAN (optional on 34460A). All three are "live" at power up when the instrument ships from the factory.

- **GPIB Interface:** Set the instrument's GPIB address and connect to your PC using a GPIB cable.
- **USB Interface:** Use the rear-panel USB connector to communicate with your PC. For details, see [USB Settings](#).
- **LAN Interface:** By default, DHCP is on, which may enable communication over LAN. The acronym DHCP stands for Dynamic Host Configuration Protocol, a protocol for assigning dynamic IP addresses to networked devices. With dynamic addressing, a device can have a different IP address every time it connects to the network.

Connectivity Software and Product CDs

The instrument ships with one or two CDs:

- **Agilent Automation-Ready CD:** Contains Agilent IO Libraries Suite software, which must be installed to enable remote-interface operations. The CD auto-starts and provides information on installing the software. Also includes *Agilent Technologies USB/LAN/GPIB Connectivity Guide*, which contains additional information.
- **Agilent Truevolt Series Product-Reference CD (optional on 34460A):** Contains product documentation and links to drivers; auto-starts and provides instructions.

GPIB Configuration

Each device on the GPIB (IEEE-488) interface must have a unique whole number address between 0 and 30. The instrument ships with a default address of 10, and the GPIB address is displayed at power-on.

- This setting is non-volatile; it will not be changed by power cycling or [*RST](#).
- Your computer's GPIB interface card address must not conflict with any instrument on the interface bus.
- **Front Panel:** Press **[Utility] > I/O Config > GPIB Settings**. From this menu, you can set the GPIB address and turn GPIB on or off. After making changes, you must cycle power on the instrument for the change to take effect.
- **SCPI:**
[SYSTem:COMMunicate:GPIB:ADDRess <address>](#)
[SYSTem:COMMunicate:ENABle {ON|1|OFF|0},GPIB](#)

LAN Configuration

The following sections describe the primary front-panel LAN configuration functions, including SCPI commands where applicable. Some LAN configuration functions can be performed only via SCPI. See [SYSTem Subsystem - I/O Configuration](#) for all LAN configuration commands, and see [LAN Configuration Procedure](#) to configure the LAN via the front panel.

NOTE

Some LAN settings require you to cycle instrument power in order for to activate them. The instrument briefly displays a message when this is the case, so watch the screen closely as you change LAN settings.

Resetting the LAN

You can clear the Web Interface password, turn DHCP on, and restart the LAN at any time:

- **Front Panel:[Utility] > I/O Config > LAN Reset**

The message "Performing LAN Reset" is displayed while the LAN is reset.

- **SCPI:** LXI:RESet

DHCP On/Off

DHCP (Dynamic Host Configuration Protocol) can automatically assign a dynamic IP address to a LAN device. This is typically the easiest way to configure the instrument for LAN.

- This setting is non-volatile; it will not be changed by power cycling or [*RST](#).
- **Front Panel:[Utility] > I/O Config > LAN Settings > Modify Settings**
Then set the first softkey to DHCP to use DHCP to automatically assign an IP address.
- **SCPI:** [SYSTem:COMMunicate:LAN:DHCP {ON|1|OFF|0}](#)
- If you change this parameter, you must either press the **Apply Changes** softkey (front panel) or send [SYSTem:COMMunicate:LAN:UPDate](#) (remote interface) for the change to take effect.

To manually set an IP address, Subnet Mask, or Default Gateway, turn DHCP off, then change the IP setup as described below.

IP Address

You can enter a static IP address for the instrument as a four-byte integer expressed in dot notation. Each byte is a decimal value, with no leading zeros (for example, 169.254.2.20).

- If DHCP is on, it attempts to assign an IP address to the instrument. If it fails, Auto-IP attempts to assign an IP address to the instrument.
- Contact your LAN administrator to obtain an IP address.
- This setting is non-volatile; it will not be changed by power cycling or [*RST](#).
- **Front Panel:[Utility] > I/O Config > LAN Settings > Modify Settings**
Then set the first softkey to **Manual** and press **IP Address** to enter a new IP address.
- **SCPI:** [SYSTem:COMMunicate:LAN:IPADdress "<address>"](#)
- If you change this parameter, you must either press the **Apply Changes** softkey (front panel) or send [SYSTem:COMMunicate:LAN:UPDate](#) (remote interface) for the change to take effect.

Subnet Mask

Subnetting allows the LAN administrator to subdivide a network to simplify administration and minimize network traffic. The subnet mask indicates the portion of the host address used to indicate the subnet.

- Contact your LAN administrator for details.
- This setting is non-volatile; it will not be changed by power cycling or [*RST](#).
- **Front Panel:[Utility] > I/O Config > LAN Settings > Modify Settings**
Then set the first softkey to **Manual** and press **Subnet Mask** to enter a new subnet mask with the arrow keys (for example: 255.255.0.0).
- **SCPI:** [SYSTem:COMMunicate:LAN:SMASk "<mask>"](#)
- If you change this parameter, you must either press the **Apply Changes** softkey (front panel) or send [SYSTem:COMMunicate:LAN:UPDate](#) (remote interface) for the change to take effect.

Default Gateway

A gateway is a network device that connects networks. The default gateway setting is the IP address of such a device.

- You need not set a gateway address if using DHCP.
- Contact your LAN administrator for details.
- This setting is non-volatile; it will not be changed by power cycling or [*RST](#).
- **Front Panel:[Utility] > I/O Config > LAN Settings > Modify Settings**
Then set the first softkey to **Manual** and press **More** and **Gateway**. Then set the appropriate gateway address using the arrow keys.
- **SCPI:** [SYSTem:COMMunicate:LAN:GATeway "<address>"](#)
- If you change this parameter, you must either press the **Apply Changes** softkey (front panel) or send [SYSTem:COMMunicate:LAN:UPDate](#) (remote interface) for the change to take effect.

Hostname

A hostname is the host portion of the domain name, which is translated into an IP address.

- The instrument receives a unique hostname at the factory, but you may change it. The hostname must be unique on the LAN.
- The name must start with letter; other characters can be an upper or lower case letters, numeric digits, or dashes ("-").
- This setting is non-volatile; it will not be changed by power cycling or [*RST](#).
- **Front Panel:[Utility] > I/O Config > LAN Settings > Modify Settings**
Then press **Host Name** and enter the hostname with the front-panel arrow keys.
- **SCPI:** [SYSTem:COMMunicate:LAN:HOSTname "<name>"](#)
- If you change this parameter, you must either press the **Apply Changes** softkey (front panel) or send [SYSTem:COMMunicate:LAN:UPDate](#) (remote interface) for the change to take effect.

Domain Name

A domain name is a registered Internet name that gets translated into an IP address. You cannot set it from the front panel or SCPI.

DNS Server

DNS (Domain Name Service) is an Internet service that translates domain names into IP addresses. The DNS server address is the IP address of a server that performs this service.

- Normally, DHCP discovers DNS address information; you only need to change this if DHCP is unused or not functional. Contact your LAN administrator for details.
- This setting is non-volatile; it will not be changed by power cycling or [*RST](#).
- **Front Panel:** **[Utility] > I/O Config > LAN Settings > Modify Settings**
Then set the first softkey to **Manual** and press **More** and **Primary DNS** or **Second DNS** to enter a DNS address using the front-panel arrow keys.
- **SCPI:** [SYSTem:COMMunicate:LAN:DNS\[{1|2}\] "<address>"](#)
- If you change this parameter, you must either press the **Apply Changes** softkey (front panel) or send [SYSTem:COMMunicate:LAN:UPDate](#) (remote interface) for the change to take effect.

Current Configuration (LAN)

- Press **[Utility] > I/O Config > LAN Settings** to view the MAC address and current LAN configuration. There is no equivalent SCPI command.
- If the instrument goes into remote, all LAN changes will be canceled and the display will go to a different screen. Re-selecting the LAN Settings page will display the new settings if a LAN restart took place.

Web Interface

The instrument includes a built-in Web Interface for remote instrument access and control over LAN via a Web browser. For details, see [Web Interface](#).

LAN Configuration Procedure

There are several parameters that you might need to set to establish network communication using the LAN interface. Primarily, you will need to establish an IP address. You might need to contact your network administrator for help in establishing communication with the LAN interface.

NOTE If your instrument has the secure (SEC) option, the instrument must be unsecured to change most LAN settings.

1. Press **[Utility] > I/O Config > LAN Settings**.
2. You can select **Modify Settings** to change the LAN settings, or you can turn LAN Services on and off or restore the LAN settings to default values.

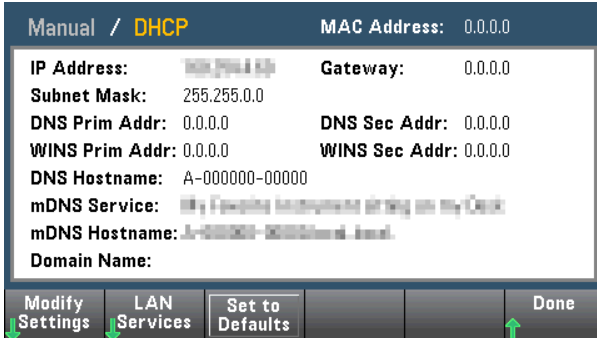

3. Press **Modify Settings**.

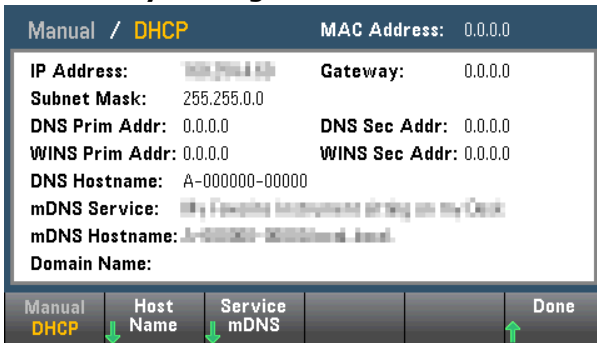

To access most items on this screen, use the first softkey to switch from **DHCP** to **Manual**. With DHCP on, an IP address will automatically be set by DHCP (Dynamic Host Configuration Protocol) when you connect the instrument to the network, provided the DHCP server is found and is able to do so. DHCP also automatically deals with the subnet mask, gateway address, DNS, WINS, and domain name, if required. This is typically the easiest way to establish LAN communication for your instrument; all you need to do is leave DHCP on. Contact your LAN administrator for details.

4. **Establish an "IP Setup."**
If you are not using DHCP (the first softkey is set to **Manual**), you must establish an IP setup, including an IP address, and possibly a subnet mask and gateway address. The **IP Address** and **Subnet Mask** buttons are on the main screen, and you press **More** to configure the Gateway.

Contact your network administrator for the IP address, subnet mask, and gateway to use. All IP addresses take the dot-notation form "nnn.nnn.nnn.nnn" where "nnn" in each case is a byte value in the range 0 through 255. You can enter a new IP address using the front-panel arrow keys. [Do not enter leading zeros.](#)

5. **Configure the "DNS Setup" (optional)**
DNS (Domain Name Service) is an Internet service that translates domain names into IP addresses. Ask your network administrator whether DNS is in use, and if it is, for the host name, domain name, and DNS server address to use.

- a. Set the "hostname." Press **Host Name** and enter the hostname. A hostname is the host portion of the domain name, which is translated into an IP address. The hostname is entered as a string using the front-panel arrow keys to select and change characters. The hostname may include letters, numbers, and dashes ("-").
- b. Set the "DNS Server" addresses. From the LAN configuration screen, press **More** to go to the second of three sets of softkeys.

Enter the Primary DNS and Second DNS. See your network administrator for details.

More about IP Addresses and Dot Notation

Dot-notation addresses ("nnn.nnn.nnn.nnn" where "nnn" is a byte value from 0 to 255) must be expressed with care, as most PC web software interprets byte values with leading zeros as octal (base 8) numbers. For example, "192.168.020.011" is actually equivalent to decimal "192.168.16.9" because ".020" is interpreted as "16" expressed in octal, and ".011" as "9". To avoid confusion, use only decimal values from 0 to 255, with no leading zeros.

Features and Functions

This section contains details on instrument features, including front-panel and remote interface operation. Read the [Front-Panel Menu Reference](#) first. See [Introduction to SCPI Language](#) for details on SCPI commands and queries.

This section covers:

[Front-Panel Menu Reference](#)

[Measurements](#)

[Triggering and Readings](#)

[Probe Hold](#)

[Math Menu](#)

[Display Menu](#)















[Utility Menu](#)





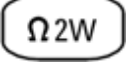

[Web Interface](#)



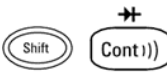

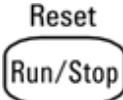
Throughout this document, "default" states and values are identified. These are the [power-on default states](#) when the instrument is shipped from the factory.

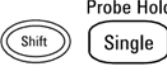
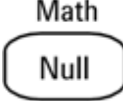
Front-Panel Menu Reference

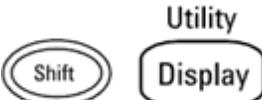
The following table summarizes the front panel keys and the menu structure.

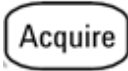
Key	Purpose
 	Configure DC voltage measurements, including DCV ratio measurements: Range: Autorange (default), 100 mV, 1 V, 10 V, 100 V, or 1000 V NPLC: {0.02 0.2 1 10 100}, default 10 See Range, Resolution and NPLC for more information. Autozero: Off or On (default) Input impedance: 10 M Ω (default) or HighZ (> 1 G Ω) DCV Ratio: Off (default) or On
  	Configure DC current measurements: Terminals: 3 A or 10 A Range: Auto, 100 μ A, 1 mA, 10 mA, 100 mA, 1 A, 3 A, or 10 A (when terminals set to 10 A) NPLC: {0.02 0.2 1 10 100}, default 10 See Range, Resolution and NPLC for more information. Autozero: Off or On (default)
 	Configure AC voltage measurements: Range: Autorange (default), 100 mV, 1 V, 10 V, 100 V, or 1000 V Filter: >3 Hz, >20 Hz, >200 Hz
  	Configure AC current measurements: Terminals: 3 A or 10 A Range: Auto, 100 μ A, 1 mA, 10 mA, 100 mA, 1 A, 3 A, or 10 A (when terminals set to 10 A) Filter: >3 Hz, >20 Hz, >200 Hz
 	Configure 2-wire resistance measurements: Range: 100 Ω , 1 k Ω , 10 k Ω , 100 k Ω , 1 M Ω , 10 M Ω , 100 M Ω , or Auto (default) NPLC: {0.02 0.2 1 10 100}, default 10 See Range, Resolution and NPLC for more information. Autozero: Off or On (default)
  	Configure 4-wire resistance measurements. Range: 100 Ω , 1 k Ω , 10 k Ω , 100 k Ω , 1 M Ω , 10 M Ω , 100 M Ω , or Auto (default) NPLC: {0.02 0.2 1 10 100}, default 10 See Range, Resolution and NPLC for more information.
	Configure frequency and period measurements. Parameters include range, AC filter, and gate time. Filter: >3 Hz, >20 Hz, >200 Hz Gate time: 10 ms, 100 ms (default), or 1 s

Key	Purpose
	Configure continuity measurements: Beep: Off or On (default)
	Configure diode measurements: Beep: Off or On (default)
	Configure 2-wire and 4-wire temperature measurements. Probe type: RTD 2-wire (default) or RTD 4-wire R_0 : resistance at 0°C, default 100 Ω NPLC: {0.02 0.2 1 10 100}, default 10 See Range, Resolution and NPLC for more information. Units: °C, °F, or K
	Start and stop measurements.
	Reset the instrument for front-panel use; equivalent to SYST:PRESet .
	Take a single measurement.
	Take one or more hands-free measurements.
	Take a null measurement.
	Configure the null function, scaling, statistics, and limits.
	Configure the text and graphics that appear on the display.
	Store and recall instrument states and preferences. Configure I/O interfaces: LAN (optional on 34460A), USB, GPIB (optional). Perform system administration tasks, including calibration. Configure user preferences. Perform file management activities, including the creation of "screen shot" files (display images).

Key	Purpose
<p data-bbox="277 212 334 243">Help</p> 	<p data-bbox="383 216 618 247">Configure triggering</p> <p data-bbox="383 264 719 296">Set slope of VM Comp output</p> <p data-bbox="383 312 638 344">Save readings to a file</p>
 	<p data-bbox="383 359 1336 390">Learn about the instrument, view the last error message, or clear error messages.</p>
	<p data-bbox="383 453 1442 516">Return to local control of the instrument (when in Remote mode), or indicate that the next front-panel key will be "shifted," for example [Probe Hold] instead of [Single].</p> <p data-bbox="383 527 516 558">Probe Hold</p> 

The keys that access a wide range of functions are listed below.

[Math] Key



The availability of the Math softkeys varies by measurement function.

Softkey	Description
Null	Enable/disable use of null values and specify null value to use.
dB / dBm	Configure scaling: Null, dB, dBm, or off.
Statistics	Enable, disable, and clear statistics.
Limits	Enable or disable high and low limits.

[Display] key

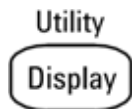

Softkey	Description
Display	Choose what is displayed: number, bar meter, histogram, or trend chart (34461A only).
Label	Enable or disable the display of a message.
Label Text	Edit the text displayed when the Label softkey is On.
Digit Mask	Set the number of digits displayed for measurements.

[Utility] key



Softkey	Description
Store/Recall	Store and recall state and preference files and set power-on defaults.
Manage Files	Perform basic file management tasks and screen captures.
I/O Config	Configure LAN (optional on 34460A), USB, and GPIB (optional) interfaces.
Test/Admin	Perform self-test, calibration, security, license, and firmware update tasks.
System Setup	Set user preferences, date and time, and power-on message.

Measurements

The Agilent Truevolt DMMs support many common measurement:

[DC Voltage](#)

[AC Voltage](#)

[DC Current](#)

[AC Current](#)

[Resistance](#)

[Temperature](#)

[Continuity](#)

[Diode](#)

[Frequency and Period](#)

DC Voltage

This section describes how to configure DC voltage measurements from the front panel, including DCV ratio measurements.

Step 1: Configure the test leads as shown.

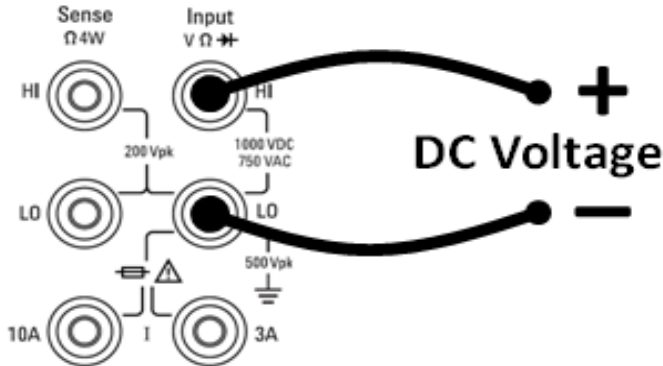

Step 2: Press **[DCV]** on the front panel.



Step 3: Press **Range** and choose the range for the measurement. You can also use the **[+]**, **[-]**, and **[Range]** keys on the front panel to select the range. The autorange feature (Auto) automatically selects the range for the measurement based on the input. Autoranging is convenient, but it results in slower measurements than using a manual range. Autoranging goes up a range at 120% of the current range, and down a range below 10% of the current range.



Step 4: Press **Aperture** and choose the number of power-line cycles (PLCs) to use for the measurement. Only 1, 10, and 100 PLC provide normal mode (line frequency noise) rejection. Selecting 100 PLC provides the best noise rejection and resolution, but the slowest measurements.



Step 5: Specify whether you want to use **Auto Zero**. Autozero provides the most accurate measurements, but requires additional time to perform the zero measurement.

With autozero enabled, the DMM internally measures the offset following each measurement. It then subtracts that measurement from the preceding reading. This prevents offset voltages present on the DMM's input circuitry from affecting measurement accuracy. With autozero disabled, the DMM measures the offset once and subtracts the offset from all subsequent measurements. The DMM takes a new offset measurement each time you change the function, range, or integration time.

Step 6: Specify the input impedance to the test leads (**Input Z**). This specifies the measurement terminal input impedance, which is either Auto or 10 M Ω . The Auto mode selects high impedance (HighZ) for the 100 mV, 1 V and 10 V ranges, and 10 M Ω for the 100 V and 1000 V ranges. In most situations, 10 M Ω is high enough to not load most circuits, but low enough to make readings stable for high impedance circuits. It also leads to readings with less noise than the **HighZ** option, which is included for situations where the 10 M Ω load is significant.

DCV Ratio

The **DCV Ratio** key enables or disables DCV Ratio measurement. Note that the **Auto Zero** softkey disappears when you enable DCV Ratio measurements. This is because autozero cannot be disabled during DCV Ratio.

The ratio is the voltage on the Input terminals divided by the reference voltage. The reference voltage is the difference of two separate measurements. These measurements are the DC voltages from the HI Sense terminal to the LO Input terminal and from the LO Sense terminal to the LO Input terminal. These two measurements must be within the range of ± 12 VDC. The reference voltage is always autoranged, and the range used for both will be based on the larger result of these two measurements.

Configure DCV Ratio measurements as shown :

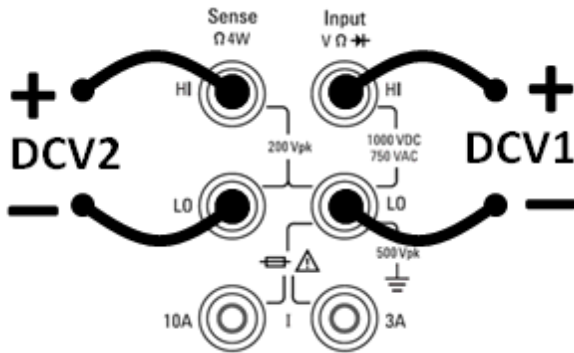

AC Voltage

This section describes how to configure AC voltage measurements from the front panel.

NOTE Default delays are selected to give correct first readings for most measurements. For the most accurate measurements, the input blocking RC time constant must settle to 1/50 of the AC signal level.

Signals greater than 300 V (rms) or 1 A (rms) will cause self-heating in signal-conditioning components. These errors are included in the instrument specifications. Internal temperature changes due to self-heating may cause additional error on other functions or ranges. The additional error will generally dissipate within a few minutes.

For example, consider a 100 mVAC signal with a 10 VDC bias. The 10 VDC bias should be settled to 1/50 of 100 mVAC, or 2 mVDC. The corresponding settling time can be calculated using the blocking RC time constant of 0.22 s as follows:

$$\text{settling time} = \ln(\text{bias}/\text{settled value}) * 0.22 \text{ s}$$

$$\text{settling time} = \ln(10 \text{ VDC} / 2 \text{ mVDC}) * 0.22 \text{ s}$$

$$\text{settling time} = \ln(5000) * 0.22 \text{ s} = 1.9 \text{ s}$$

This additional settling delay should be applied after connecting the signal to the DMM's ACV input or after selecting the ACV function with the signal already connected. If the DC bias remains constant, subsequent measurements can be made to full accuracy without additional settling delays.

Step 1: Configure the test leads as shown.

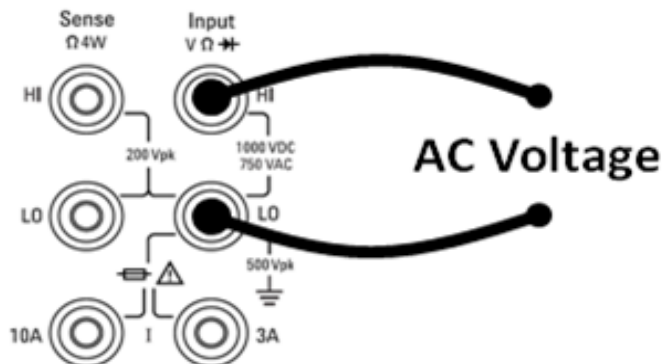

Step 2: Press **[ACV]** on the front panel.



Step 3: Press **Range** and choose the range for the measurement. The autorange feature (Auto) automatically selects the range for the measurement based on the input. Autoranging is convenient, but it results in slower measurements than using a manual range. Autoranging goes up a range at 120% of the current range, and down a range below 10% of the current range.



Step 4: Press **AC Filter** and choose the filter for the measurement. The instrument uses three different AC filters that enable you either to optimize low frequency accuracy or to achieve faster AC settling times following a change in input signal amplitude.

The three filters are 3 Hz, 20 Hz, and 200 Hz, and you should generally select the highest frequency filter whose frequency is less than that of the signal you are measuring, because higher frequency filters result in faster measurements. For example, when measuring a signal between 20 and 200 Hz, use the 20 Hz filter.

If measurement speed is not an issue, choosing a lower frequency filter may result in quieter measurements, depending on the signal that you are measuring.



NOTE For accurate displayed statistics of AC measurements in Front Panel mode, the default manual trigger delay (**[Acquire] > Delay Man**) must be used.

DC Current

This section describes how to configure DC current measurements from the front panel.

Step 1: Configure the test leads as shown.

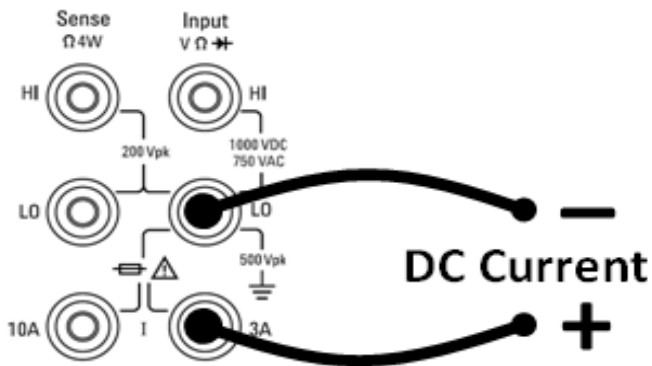

On the 34461A, you can also configure the measurement using the 10 A terminal, which is recommended when measuring current above 1 A:

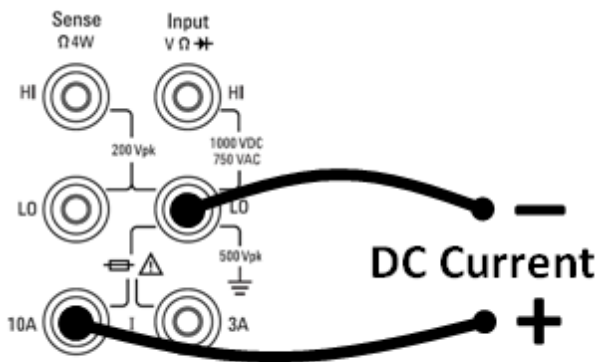

Step 2: Press **[DCI]** on the front panel.

Terminals	Range	Aperture	Auto Zero	
3A 10A	Auto	10 PLC	Off On	

Step 3 (34461A only): Toggle the first softkey to indicate which terminals are in use. For most measurements, you can leave this at 3 A, and if you change this to 10 A, the measurement range automatically becomes 10 A.

Step 4: Press **Range** and choose the range for the measurement. You can also use the **[+]**, **[-]**, and **[Range]** keys on the front panel to select the range. The autorange feature (Auto) automatically selects the range for the measurement based on the input. Autoranging is convenient, but it results in slower measurements than using a manual range. Autoranging goes up a range at 120% of the current range, and down a range below 10% of the current range. Press **More** to switch between the two pages of settings.

Auto	100µA	1mA	10mA	100mA	More 1 of 2
1A	3A				More 2 of 2

Step 5: Press **Aperture** and choose the number of power-line cycles (PLCs) to use for the measurement. Only 1, 10, and 100 PLC provide normal mode (line frequency noise) rejection. Selecting 100 PLC provides the best noise rejection and resolution, but the slowest measurements.



Step 6: Specify whether you want to use **Auto Zero**. Autozero provides the most accurate measurements, but requires additional time to perform the zero measurement.

With autozero enabled, the DMM internally measures the offset following each measurement. It then subtracts that measurement from the preceding reading. This prevents offset voltages present on the DMM's input circuitry from affecting measurement accuracy. With autozero disabled, the DMM measures the offset once and subtracts the offset from all subsequent measurements. The DMM takes a new offset measurement each time you change the function, range, or integration time.

AC Current

This section describes how to configure AC current measurements from the front panel.

Step 1: Configure the test leads as shown.

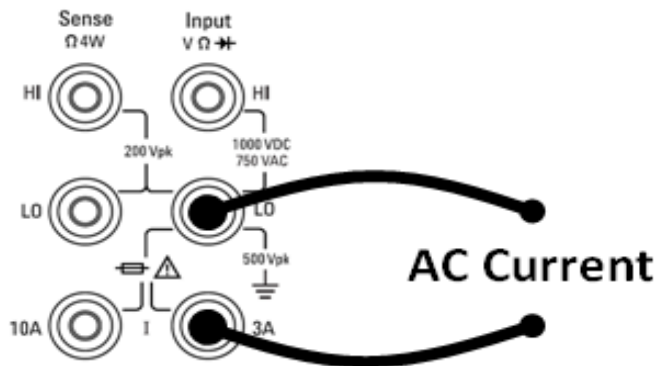

On the 34461A, you can also configure the measurement using the 10 A terminal, which is recommended when measuring current above 1 A:

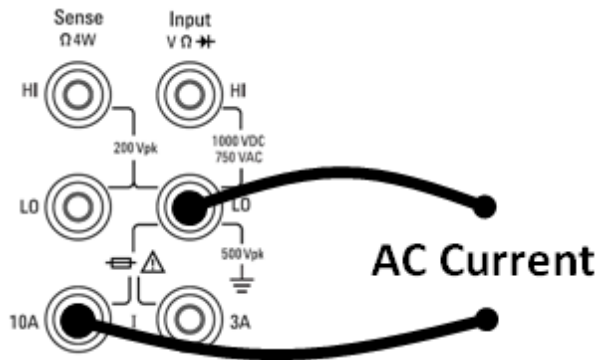

Step 2: Press **[ACI]** on the front panel.



Step 3 (34461A only): Toggle the first softkey to indicate which terminals are in use. For most measurements, you can leave this at 3 A, and if you change this to 10 A, the measurement range automatically becomes 10 A.

Step 4: Press **Range** and choose the range for the measurement. You can also use the **[+]**, **[-]**, and **[Range]** keys on the front panel to select the range. The autorange feature (Auto) automatically selects the range for the measurement based on the input. Autoranging is convenient, but it results in slower measurements than using a manual range. Autoranging goes up a range at 120% of the current range, and down a range below 10% of the current range. Press **More** to switch between the two pages of settings.



Step 5: Press **AC Filter** and choose the filter for the measurement. The instrument uses three different AC filters that enable you either to optimize low frequency accuracy or to achieve faster AC settling times following a change in input signal amplitude.

The three filters are 3 Hz, 20 Hz, and 200 Hz, and you should generally select the highest frequency filter whose frequency is less than that of the signal you are measuring, because higher frequency filters result in faster measurements. For example, when measuring a signal between 20 and 200 Hz, use the 20 Hz filter.

If measurement speed is not an issue, choosing a lower frequency filter may result in quieter measurements, depending on the signal that you are measuring.



NOTE

For accurate displayed statistics of AC measurements in Front Panel mode, the default manual trigger delay (**[Acquire] > Delay Man**) must be used.

Resistance

This section describes how to configure 2-wire and 4-wire resistance measurements from the front panel.

Step 1: Configure the test leads as shown.

2-wire Resistance:

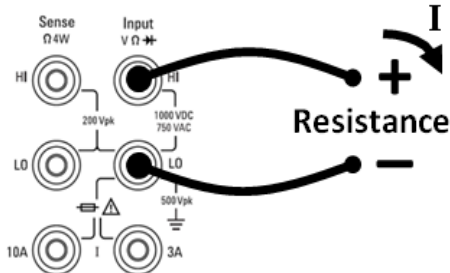

4-wire Resistance:

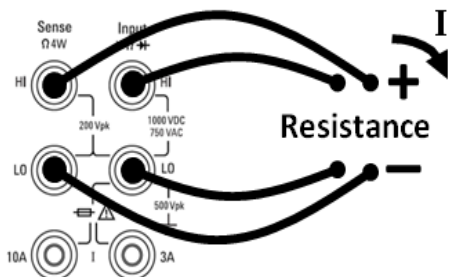

Step 2: Press [**Ω 2W**] or [**Ω 4W**] on the front panel. The following menu appears. Note that the Ω 4W menu does not include **Auto Zero**.



Step 3: Press **Range** and choose the range for the measurement. The autorange feature (Auto) automatically selects the range for the measurement based on the input. Autoranging is convenient, but it results in slower measurements than using a manual range. Autoranging goes up a range at 120% of the current range, and down a range below 10% of the current range. Press **More** to switch between the two pages of settings.

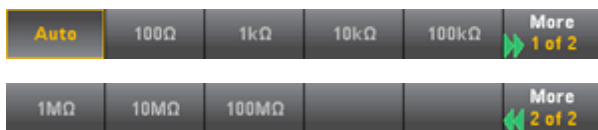

Step 4: Press **Aperture** and choose the number of power-line cycles (PLCs) to use for the measurement. Only 1, 10, and 100 PLC provide normal mode (line frequency noise) rejection. Selecting 100 PLC provides the best noise rejection and resolution, but the slowest measurements.



Step 5: Specify whether you want to use **Auto Zero**. Autozero provides the most accurate measurements, but requires additional time to perform the zero measurement. Note that there is no autozero setting for 4-wire resistance measurements.

With autozero enabled, the DMM internally measures the offset following each measurement. It then subtracts that measurement from the preceding reading. This prevents offset voltages present on the DMM's input circuitry from affecting measurement accuracy. With autozero disabled, the DMM measures the offset once and subtracts the offset from all subsequent measurements. The DMM takes a new offset measurement each time you change the function, range, or integration time.

Negative Resistance Measurements

Under certain conditions, the instrument may report negative resistance measurements. These may occur in 2-wire and 4-wire resistance measurements or continuity measurements.

Conditions that may cause negative ohms values include:

- Changes in Front/Rear switch contact resistance
- Reversed Sense Hi and Lo leads
- Circuits with external bias or thermal voltages at circuit connections
- Changes in measurement connection after a NULL operation

Under the same conditions, the 34401A returns the measurement's absolute value so as to prevent the confusion associated with negative readings. The Agilent Truevolt Series DMMs will return negative values. This allows the most accurate results after a NULL operation.

Temperature

This section describes how to configure 2-wire and 4-wire temperature measurements from the front panel.

Step 1: Configure the test leads as shown.

2-wire Temperature:

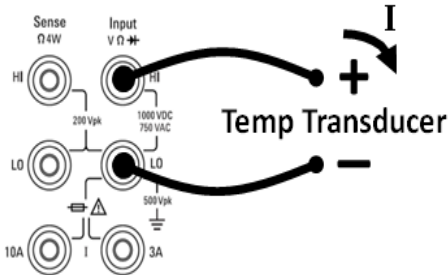

4-wire Temperature:

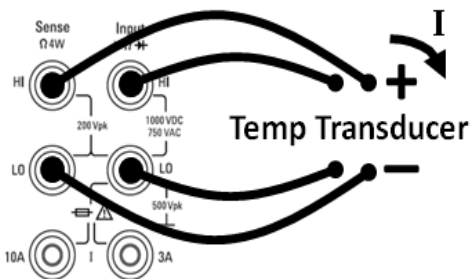

Step 2: Press **[Temp]** on the front panel. The following menu appears. Note that the **Auto Zero** softkey only applies to 2-wire measurements.



Step 3: Press **Probe** and choose the probe type. If you choose to use an RTD, the menu will have a softkey to specify the RTD's resistance at 0 degrees Celsius (R_0).



Step 4: Specify whether you want to use **Auto Zero**. Autozero provides the most accurate measurements, but requires additional time to perform the zero measurement.

With autozero enabled, the DMM internally measures the offset following each measurement. It then subtracts that measurement from the preceding reading. This prevents offset voltages present on the DMM's input circuitry from affecting measurement accuracy. With autozero disabled, the DMM measures the offset once and subtracts the offset from all subsequent measurements. The DMM takes a new offset measurement each time you change the function, range, or integration time.

Step 5: Press **Aperture** and choose the number of power-line cycles (PLCs) to use for the measurement. Only 1, 10, and 100 PLC provide normal mode (line frequency noise) rejection. Selecting 100 PLC provides the best noise rejection and resolution, but the slowest measurements.



Step 6: Use the **Units** softkey to display temperature in degrees Celsius, degrees Fahrenheit, or Kelvin.

Continuity

This section describes how to configure continuity tests from the front panel.

Step 1: Configure the test leads as shown.

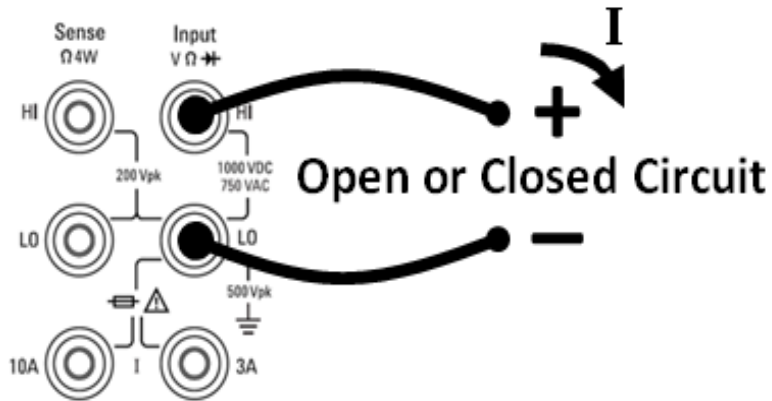

Step 2: Press [**Cont**] on the front panel to open a menu that specifies whether the DMM will beep to indicate continuity.



Continuity measurements behave as follows:

$\leq 10 \Omega$	displays measured resistance and beeps (if beeper enabled)
10Ω to $1.2 \text{ k}\Omega$	displays measured resistance without beeping
$> 1.2 \text{ k}\Omega$	displays OPEN with no beep

Diode

This section describes how to configure diode tests from the front panel. The range and resolution are fixed; the range is 10 VDC (with a 1 mA current source output).

Step 1: Configure the test leads as shown.

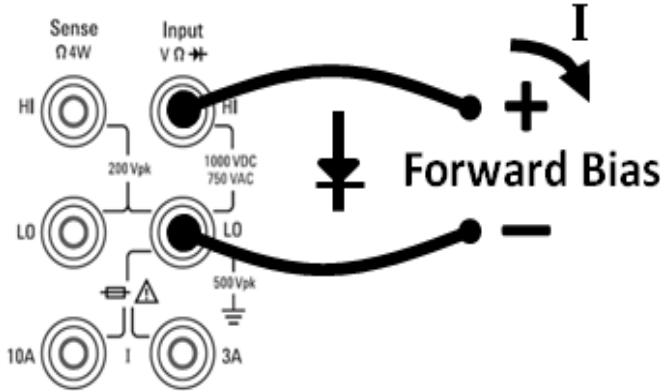

Step 2: Press  on the front panel to open a menu that specifies whether the DMM will beep to indicate a successful diode test.



Diode measurements behave as follows:

0 to 5 V	voltage displayed on the front panel, and instrument beeps when signal transitions into the 0.3 to 0.8 V threshold (if beeping is enabled)
> 5 V	the front panel displays OPEN, and SCPI returns 9.9E37

Frequency and Period

This section describes how to configure frequency and period measurements from the front panel.

Step 1: Configure the test leads as shown.

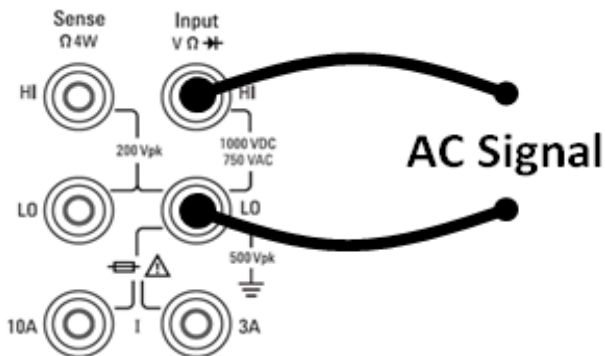

Step 2: Press **[Freq]** on the front panel and then use the first softkey to choose either frequency or period measurement.

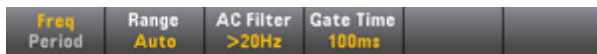

Step 3: Press **Range** and choose the range for the measurement. The autorange feature (Auto) automatically selects the range for the measurement based on the input. Autoranging is convenient, but it results in slower measurements than using a manual range. Autoranging goes up a range at 120% of the current range, and down a range below 10% of the current range.



Step 4: Press **AC Filter** and choose the filter for the measurement. The instrument uses three different AC filters that enable you either to optimize low frequency accuracy or to achieve faster AC settling times following a change in input signal amplitude.

The three filters are 3 Hz, 20 Hz, and 200 Hz, and you should generally select the highest frequency filter whose frequency is less than that of the signal you are measuring, because higher frequency filters result in faster measurements. For example, when measuring a signal between 20 and 200 Hz, use the 20 Hz filter.

If measurement speed is not an issue, choosing a lower frequency filter may result in quieter measurements, depending on the signal that you are measuring.

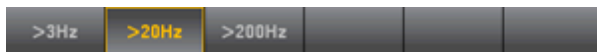

Step 5: Press **Gate Time** and choose the measurement aperture (integration time) of 10 ms, 100 ms (default), or 1 s.

NOTE For accurate displayed statistics of AC measurements in Front Panel mode, the default manual trigger delay (**[Acquire] > Delay Man**) must be used.

Triggering and Readings

The trigger model and large reading memory on the Truevolt Series DMMs provide versatile capabilities for a wide variety of applications.

Instrument trigger model

Acquiring measurements on the DMM is always done as the result of triggering. Pressing **[Acquire]** opens the following menu:



The primary purpose of this menu is to allow you to configure measurement triggering, and you can also use the **VMC Out** softkey to set the edge slope of the **VM Comp** (voltmeter complete) output on the instrument's rear panel. This connector issues a signal whenever the voltmeter finishes taking a measurement in order to allow you to signal other devices in a measurement system.

NOTE For accurate displayed statistics of AC measurements in Front Panel mode, the default manual trigger delay (**[Acquire]** > **Delay Man**) must be used.

The **(Trg Src)** menu allows you to select one of three trigger sources:



Auto - the instrument continuously takes measurements, automatically issuing a new trigger as soon as a measurement is completed.

Single - the instrument issues one trigger each time the front-panel **[Single]** key is pressed.

Ext - the instrument issues one trigger each time an edge of the appropriate slope arrives at the rear-panel Ext Trig connector (requires LAN option on 34460A). You can specify the slope on the softkey menu that appears when **Trg Src** is set to Ext.

In the Single and Ext modes, you can specify the number of samples to be taken per trigger by using the **Samples/Trigger** softkey. The Single and Ext modes can both buffer up to one trigger, meaning that if you press **[Single]** or receive an external trigger while a series of measurements is in progress, the instrument will finish that series of measurements and then immediately launch a new series of measurements based on the trigger.

If multiple **[Single]** or external triggers are issued during a series of measurements, all triggers received after the first are discarded.

The **[Acquire]** menu also configures the delay that occurs before each measurement is taken, regardless of the trigger mode (Auto, Single, or Ext). This may be either automatic (the delay is based on the DMM's settling time) or manual (the user specifies the delay time).

Finally, note the **[Run/Stop]** and **[Single]** keys on the front panel. In Auto trigger mode, pressing **[Run/Stop]** stops and resumes measurements, and pressing **[Single]** switches the instrument to single trigger mode. In the Single and Ext modes, pressing **[Run/Stop]** stops readings if they are in progress, or switches the mode to Auto if readings are stopped.

Storage and clearing of readings

You can store up to 1,000 measurements in the reading memory of the 34460A or 10,000 measurements on the 34461A. Readings are stored in a first-in, first-out (FIFO) buffer; when reading memory is full, the oldest readings are lost as newer readings are taken.

In Local (front panel) mode, the instrument collects readings, statistics, trend chart and histogram information in the background, so if the user selects any of those options, the data is ready for viewing. In Remote (SCPI) mode, the instrument does not collect this information by default.

Switching from Local to Remote does not clear readings.

In general, you turn the reading of measurements on and off by pressing **[Run/Stop]**, as described above. You can also take one reading or a specified number of readings by pressing **[Single]**.

To save readings, simply press **[Acquire] > Save Readings**. Then use the menu that appears to configure the location where you want to save the readings:



Press **Save Readings** to save the readings in memory to a file.

Clearing Reading Memory

The following actions clear reading memory:

- Changing the measurement function
- Pressing any **Clear Readings** softkey
- Transitioning in or out of Probe Hold
- Changing temperature units
- Changing any dB/dBm parameters
- Changing any histogram binning parameter
- Changing the temperature probe or R_0
- Recalling a stored state
- Calibrating the instrument
- Switching between 3 A and 10 A inputs
- Changing the position of the Front/Rear switch
- Transferring from Remote to Local mode
- Turning Null on or off or changing the Null value

These actions do not clear reading memory:

- Changing measurement parameters, such as range and aperture.
- Turning limits on or off, or adjusting limit values
- Pressing [**Run/Stop**] in front panel auto trigger mode
- Changing the trend chart **Recent/All** softkey (34461A only)
- Changing samples per trigger or trigger delay
- Changing display modes
- Changing the **VM Comp** output polarity
- Changing the digit mask
- Changing the histogram, bar meter, or trend chart scale
- Changing user preferences
- Executing self-test

Probe Hold

Because probing small areas requires careful concentration, it is often difficult to read the instrument display while taking measurements. Therefore, the instrument includes a front-panel **[Probe Hold]** key that allows you to take readings without viewing the display. You can generate up to eight readings and hold them on the display for later viewing. These readings may be of different measurement types and you may clear displayed readings at any time.

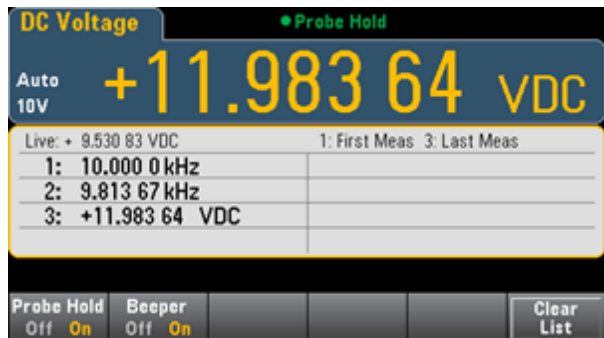

In Probe Hold mode, the instrument optimizes measurement settings to allow reliable detection of stable signals (these settings are restored to their original values when you exit Probe Hold.) When you probe a signal, the instrument beeps and automatically records a measurement when it finds a series of stable readings. You may take additional readings without pressing **[Probe Hold]** again.

Because the Probe Hold display is optimized for the Probe Hold readings, you may not combine it with other display modes, such as histogram, bar graph, trend chart, or statistics.

Math - Introduction

The **[Math]** key is the shifted **[Null]**:



[Null](#)

[dB/dBm Scaling](#)

[Statistics](#)

[Limits](#)

Math - Null

A null reading is a value that is subtracted from all subsequent measurements. The value is specific to the present function and will persist even if you leave this function and return to it later.

One common use of this feature is to remove lead resistance from a resistance measurement. To do this, simply short the test leads together and press **[Null]**. For other measurement functions, place the probes across a null value circuit before pressing **[Null]**.

You can also specify a null value by pressing **[Math]**, changing the first softkey to **Value**, and entering the value using the arrow keys. To turn off the null feature, press **[Null]** again or press **[Math]** and set the first softkey to **Off**.

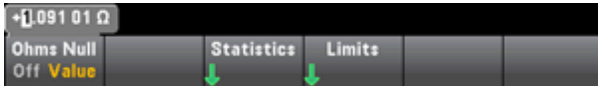

See Also

[Math - Introduction](#)

[dB/dBm Scaling](#)

[Statistics](#)

[Limits](#)

dB/dBm Scaling

The dB and dBm scaling functions, which apply to ACV and DCV measurements only, allow you to scale measurements relative to a reference value.

Front-panel Menus

The dB and dBm functions are accessed from the second softkey in the **[Math]** menu.



When the first softkey in the dB / dBm menu is enabled, as shown below, you will see one of the following menus:

When function is dB:



When function is dBm:



dB Scaling

Each dB measurement is the difference between the input signal and a stored reference value, with both values converted to dBm:

$$\text{dB} = \text{reading in dBm} - \text{reference value in dBm}$$

The relative value must be from -200 to +200 dBm (default 0). You can either measure this value by pressing **Measure Ref Value**, or you can enter a specified value.

dBm Scaling

The dBm function is logarithmic, comparing power delivered to a reference resistance, relative to 1 milliwatt:

$$\text{dBm} = 10 \times \log_{10} (\text{reading}^2 / \text{reference resistance} / 1 \text{ mW})$$

The reference resistance value (**Ref R**) may be 50, 75, 93, 110, 124, 125, 135, 150, 250, 300, 500, 600 (default), 800, 900, 1000, 1200, or 8000 Ω. Press **Ref R** and use the front-panel up and down arrows to make your selection.

See Also

[Math - Introduction](#)

[Null](#)

[Statistics](#)

[Limits](#)

Math - Statistics

As the instrument takes measurements, it automatically calculates statistics on those measurements.

Front-Panel Menus

The statistics menu is accessed from the third softkey in the **[Math]** menu.



NOTE For accurate displayed statistics of AC measurements in Front Panel mode, the default manual trigger delay (**[Acquire] > Delay Man**) must be used.

The first softkey on this menu (shown below) hides or shows the statistics below the data display (number, bar meter, trend chart (34461A only), or histogram).

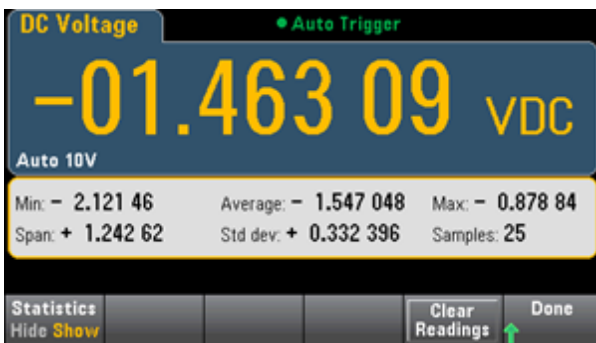

The average and standard deviation are not shown if dB or dBm scaling is in use.

Remarks

- The **Span** value is the **Max** minus the **Min**.
- Press **Clear Readings** to clear reading memory and re-start statistics calculation.

See Also

[Math - Introduction](#)

[Null](#)

[dB/dBm Scaling](#)

[Limits](#)

Math - Limits

Limit checking indicates how many samples have exceeded specified limits and visually indicates when the limits are exceeded.

Front-Panel Menu

The limits menu is accessed from the **[Math]** menu.

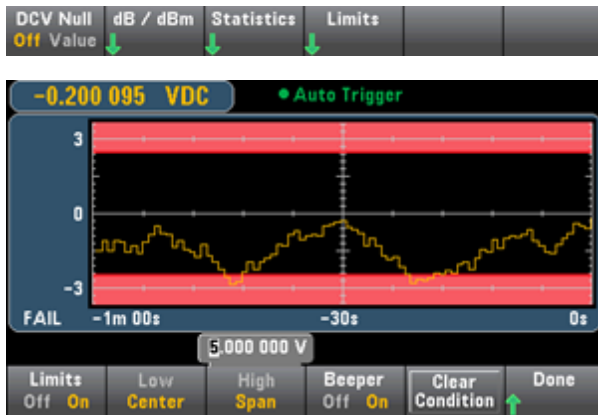

The first softkey enables or disables limits. The second and third softkeys specify the limits either as high and low values or as a span around a center value. For example, a **Low** limit of -4 V and a **High** limit of +7 V are equivalent to a **Center** of 1.5 V and a **Span** of 11 V.

The **Beeper** softkey enables or disables beeping when limits are violated, and **Clear Condition** resets the limit borders to green, as described below.

Limit Indications

The display uses colors to indicate limits and limit violations.

Trend Chart (34461A only)

The limit area is shown in light red on the graph. The limit borders are green (shown below) as long as the limits have not been exceeded.

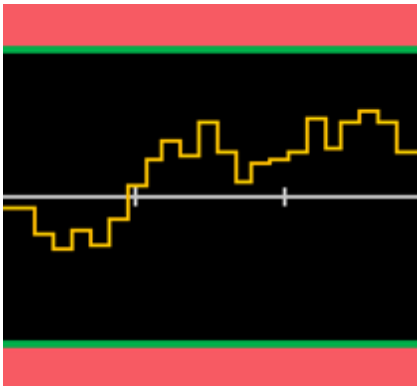

When a limit is exceeded, the border turns red. In the image below, the top border is still green, but the bottom border has changed to red because the trend line has gone into the lower limit area.

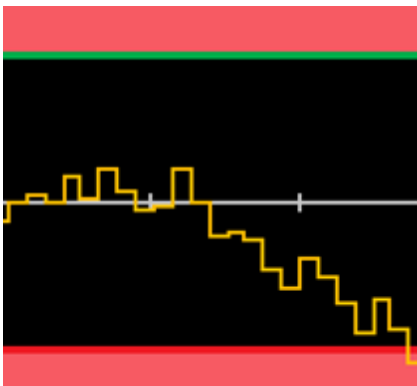

The border will remain red even if the trend line moves out of the limit area. When the trend line is within limits, you can reset the borders to green by pressing **Clear Condition**.

Note also that the number of the newest displayed measurement, +09.994 VDC below, indicates whether the measurement is within limits. Because the limit is 10 V, the 9.994 VDC value is shown with the standard background.

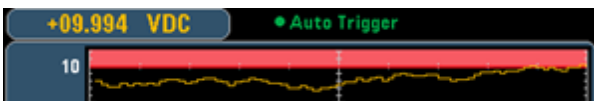

In contrast, the 11.083 VDC reading is highlighted in red to indicate that it is outside the limits.



Histogram

The same color scheme applies to histograms. In the image below, the green vertical lines that separate the black histogram background from the light red limit areas indicate that limits have not been exceeded.

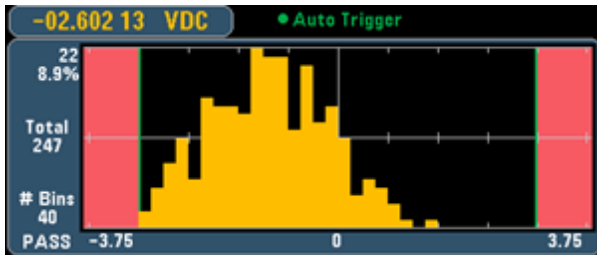

In the image below, the lower (left) limit border is red, indicating that the lower limit has been exceeded. Note that the reading in the upper left corner (-01.68487 VDC) is within limits, so it is not red.

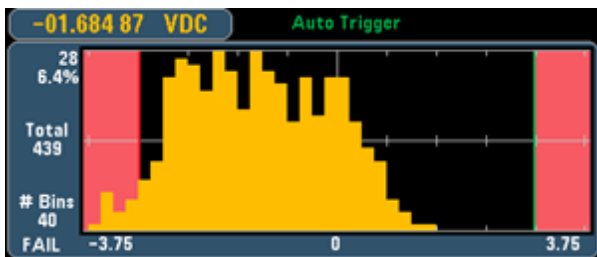

Bar Meter

The bar meter (below) uses the same color scheme. The green limit border on the left indicates that the lower limit has not been exceeded, and the red limit border on the right indicates that the upper limit has been exceeded. The numbers 0 and 259 below the light red limit areas indicate how many times each limit has been exceeded, and the word **FAIL** indicates that a limit has been exceeded.

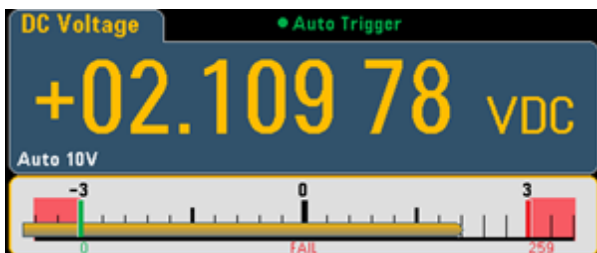

Number

The bright red color (shown below) indicates that the displayed measurement exceeds the limits. The **Number** display also indicates how many times the limits have been exceeded.

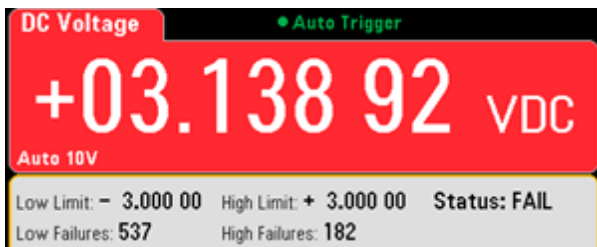

See Also

[Math - Introduction](#)

[Null](#)

[dB/dBm Scaling](#)

[Statistics](#)

Display - Introduction

The **[Display]** key is on the front-panel. If you press **[Shift]** before pressing this, you open the [\[Utility\]](#) menu:

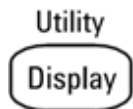

[Display] selects from the four basic measurement displays:

[Number](#)

[Bar Meter](#)

[Trend Chart \(34461A only\)](#)

[Histogram](#)



Number

By default, the instrument shows a reading as a number (below).



Selecting the Display

The **Display** softkey allows you to select a different display (below). The trend chart is available on the 34461A only:



Adding a Label

The **Label** softkey allows you to add a large text label on the screen. For example, you can use this to indicate what measurement is being taken by the DMM.

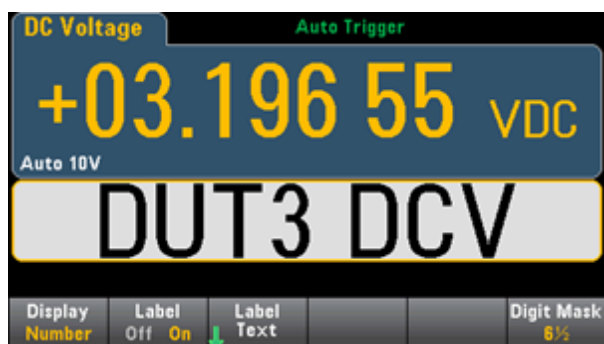

To enter the text, press **Label Text** and use the softkeys and front-panel arrow keys to modify the label (below). Then press **Done**. Note that the label's font automatically shrinks to accommodate longer labels.



Specifying the Digit Masking

The Digit Mask softkey specifies the number of digits shown.



For example, the following image shows 6½ digits.



In contrast, this image shows 4½ digits.



The **Auto** softkey specifies that the number of digits displayed is based on other function-specific settings, such as the measurement aperture, set in NPLCs. Measurements are always rounded, never truncated.

See Also

[Display - Introduction](#)

[Bar Meter](#)

[Trend Chart \(34461A only\)](#)

[Histogram](#)

Bar Meter

The bar meter (below) adds a moving bar below the standard Number display.

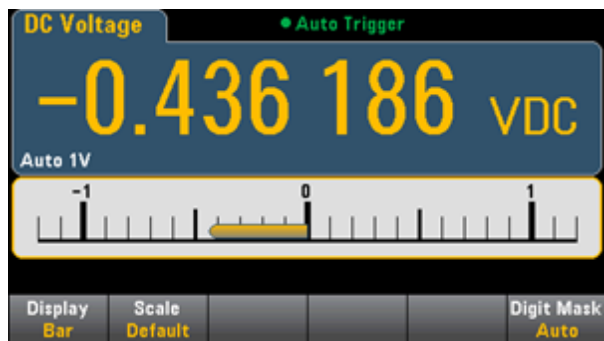

The **Display** and **Digit Mask** softkeys behave as they do in the [Number](#) display.

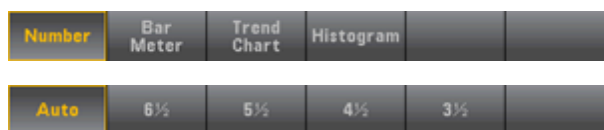

The **Scale** softkey specifies the horizontal scale:



- **Default** sets the scale to equal the measurement range.
- **Manual** allows you to configure the scale either as **High** and **Low** values or as a **Span** around a **Center** value. For example, a scale that goes from a **Low** of $-500\ \Omega$ to a **High** of $1000\ \Omega$ could also be specified as a **Center** of $250\ \Omega$ with a **Span** of $1500\ \Omega$.



See Also

[Display - Introduction](#)

[Number](#)

[Trend Chart \(34461A only\)](#)

[Histogram](#)

Trend Chart (34461A only)

The trend chart (below) shows data as a line that moves from right to left.

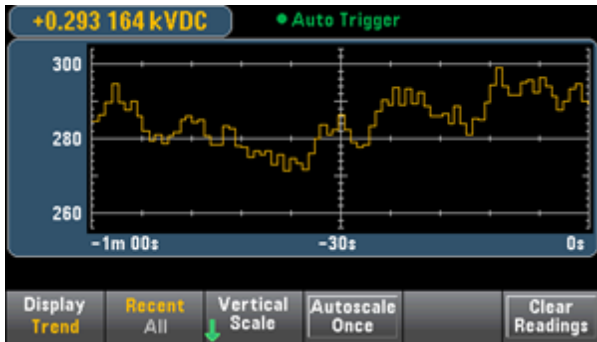

Selecting the Display

The **Display** softkey allows you to select a different display (below). The trend chart is available on the 34461A only:

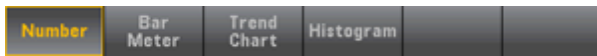

Recent/All

The **Recent/All** softkey shows either all of the data in the trend chart (**All**) or just the most recent one minute of data (**Recent**). Neither selection clears reading memory.

Scaling

The **Vertical Scale** softkey specifies how the current vertical scale is determined.



Press **Vertical Scale**, to change the scaling:



- **Default** sets the scale to equal the measurement range.
- **Auto** automatically adjusts the scale to appropriately fit the line currently shown on the screen.
- **Manual** allows you to configure the scale either as **High** and **Low** values or as a **Span** around a **Center** value. For example, a scale from a **Low** of 0 V to a **High** of 5 V is equivalent to a **Center** of 2.5 V and a **Span** of 5 V.



Autoscale Once sets the scale based on the line currently on the screen, but unlike the **Auto** mode (above), it does not continue to adjust the scale as the line moves.

If you have enabled limits, the (**Limits**) softkey also appears. This sets the vertical scale to match the limits.

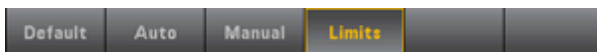

See Also

[Display - Introduction](#)

[Number](#)

[Bar Meter](#)

[Histogram](#)

Histogram

The histogram shows measurement data as a frequency distribution.

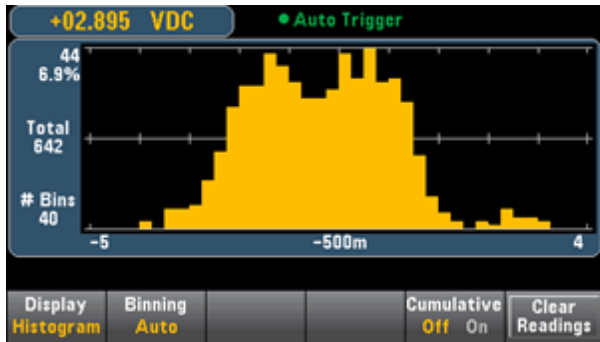

Selecting the Display

The **Display** softkey allows you to select a different display (below). The trend chart is available on the 34461A only:

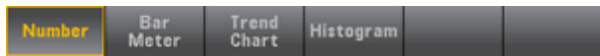

Binning

The **Binning** softkey allows you to either let the instrument control how the histogram is binned (automatic binning), or to manually specify the binning parameters with the **Bin Settings** softkey. Changing any binning parameter, or switching between automatic and manual binning, will automatically start the histogram over with new data. On the 34461A, this also resets the trend chart.

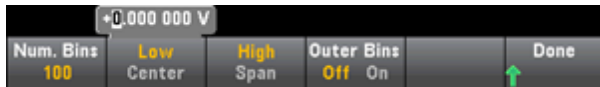

The number of bins can be 10, 20, 40, 100, 200, or 400. You can specify the bin range as either **Low** and **High** values, or as a **Span** around a **Center** value. For example, the histogram range shown above (from -5 to 4 V) could be specified as a **Low** of -5 V and a **High** of 4 V, or a **Center** of -0.5 V and a **Span** of 9 V.

The **Outer Bins** softkey displays two additional bins, for readings above and below the bin range. For example, this image shows the **Outer Bins** softkey set to **Off**.

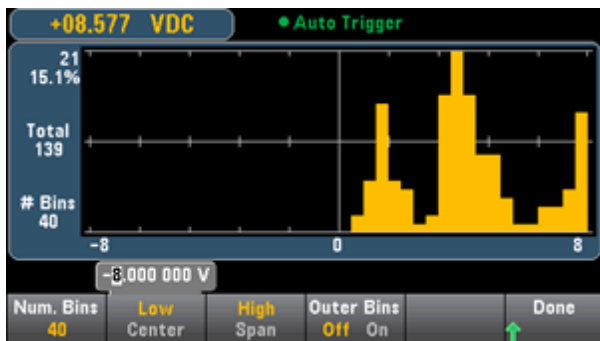

The image below adds the outer bins to the display (below). The relatively large number of readings above the bin range (the cyan bar) causes the bars within the bin range to shrink.

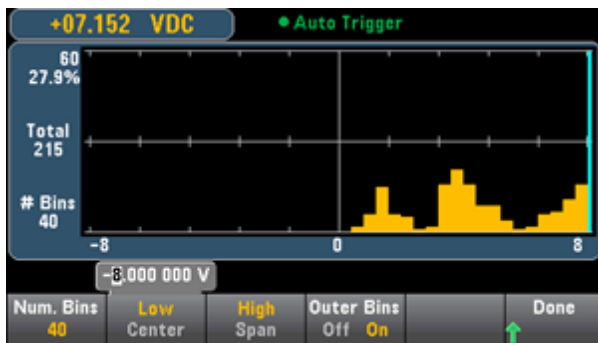

The main histogram menu also includes a **Cumulative** softkey that hides or shows a line representing the cumulative distribution function, which always goes up to 100%.

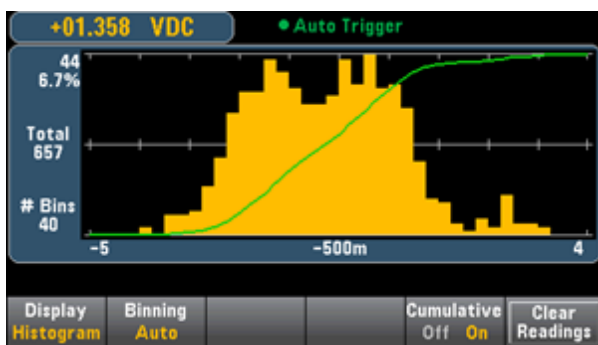

The final button on the histogram menu, **Clear Readings**, clears reading memory and starts a new histogram.

See Also

[Display - Introduction](#)

[Number](#)

[Bar Meter](#)

[Trend Chart \(34461A only\)](#)

Utility Menu - Introduction

The **[Utility]** key is the shifted **[Display]** key:



[Utility] provides the following features:



[Store and Recall State and Preference Files](#)

[Manage files, including creating screen shots](#)

[Configure LAN \(optional on 34460A\), GPIB \(optional on 34460A and 34461A\), and USB](#)

[Perform instrument self-tests and administrative functions](#)

[Configure the instrument's date and time and various user settings](#)

Store and Recall State and Preference Files

The Utility menu is shown below.



Press **Store/Recall** to save and recall state and preference files. In general, state files store volatile settings associated with measurements. Preferences are non-volatile parameters associated with the instrument, but not any specific measurement. For details, see the table in the [MMEMory State and Preferences Subsystem](#).



Store Settings

Store Settings allows you to browse to a directory and specify a file name, and to choose whether you want to store a state file or a preference file.



Press **Type** to select whether you want to store a state or preferences file, and press **Store State** (shown above) or **Store Pref** (the softkey's label if you are storing preferences) to store the specified file.

Action allows you to either store a file or to create a new folder.



Recall Settings

Recall Settings allows you to browse to the file to be recalled. Use the arrow keys to navigate to the desired state file (*.sta) or preferences file (*.prf).



Power On

Power On selects the state that is loaded at power-up. This can be either the state when the instrument was powered down with the power switch (**Last**), a user-selected state file (**User Defined**), or the factory default state (**Factory Defaults**).



Set to Defaults

Set to Defaults loads the instrument's factory default state or preference settings.

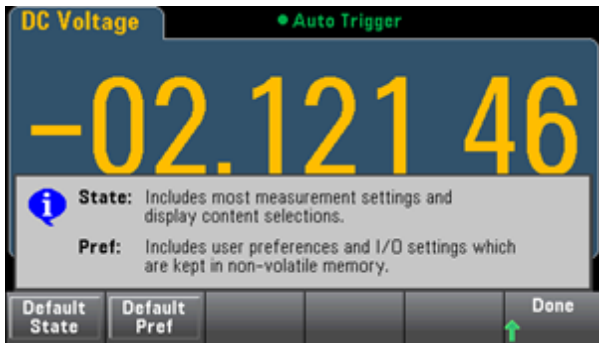

Utility Menu - Manage Files



The **Manage Files** softkey allows you to create, copy, delete, and rename files and folders in the instrument's internal flash memory or on a USB drive attached to the front panel. It also allows you to capture the current screen to either a bitmap (*.bmp) or portable network graphics (*.png) file. This is the default option, as shown below.



Action

Action specifies the action to perform. Pressing **Capture Display** saves a screen capture of the display at the moment that you pressed **[Shift]** to go to the **[Utility]** menu.



Browse

Browse selects the file or folder upon which the action will be performed.

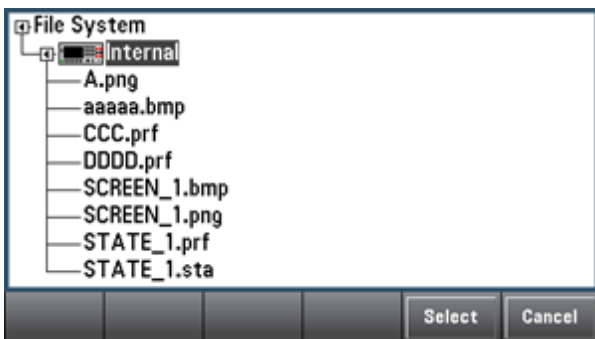

Use the front-panel arrows and **[Select]** key to navigate through the list, and press **Select** or **Cancel** to exit the browse window. The left and right arrows contract or expand a folder to hide or show its files.

File Name

File Name allows you to use the front-panel arrows, the **[Select]** key, and the softkeys to enter a file name. Use the front-panel arrows to point to a letter, and **Previous Char** and **Next Char** to move the cursor in the area where the name is entered. In the image below, there is no **Next Char** softkey because the cursor is at the end.

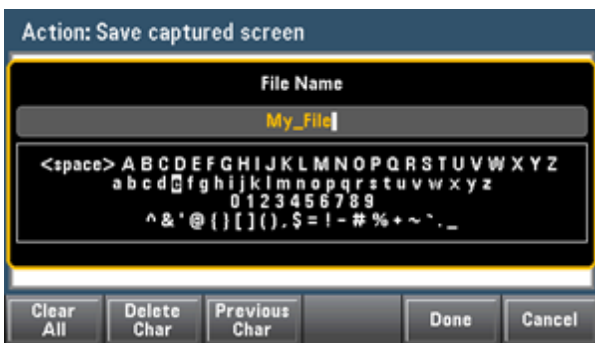

Press **[Done]** or **[Cancel]** to finish.

Utility Menu - I/O Configuration



I/O Config configures the I/O parameters for remote operations over the LAN (optional on 34460A), USB, or GPIB (optional) interface.



LAN enables and disables the instrument's LAN interface, and **LAN Reset** resets the LAN using its current settings and enables DHCP and mDNS. The **LAN Reset** softkey also clears any user-defined Web Interface password.

LAN Settings

LAN Settings opens the menu shown below. **Set to Defaults** resets the LAN settings to their default values.



Modify Settings

Modify Settings enables DHCP or Manual (Auto-IP) assignment of the instrument's IP address. It also enables configuration of network parameters based on the protocol (DHCP or Manual) selected.



For example, press **Host Name** or **Service mDNS** to modify the instrument's host name or mDNS Service Name, shown below.



LAN Services

LAN Services enables and disables the LAN services shown below.



USB Settings

USB Settings configures the front-panel USB (storage) and rear-panel USB (connectivity) connectors.



NOTE

The ability to enable or disable the front-panel USB interface requires the SEC licensed option. This can be ordered as factory option 34460A-SEC or as customer-installable option 3446SECU. Without this option, the front-panel USB interface is always enabled.

USB Front

USB Front enables or disables the instrument's front-panel USB host port.

USB SCPI

USB SCPI enables or disables the rear-panel USB control port. After changing the interface state, cycle instrument power to make the change take effect. When disabled, the interface cannot be configured by the Agilent IO Libraries Connection Expert utility.

File Access

File Access uses media transfer protocol (MTP) to easily download instrument files to your PC. Simply connect the rear-panel USB port on the instrument to a USB port on your PC. The DMM will appear as a read-only drive on your PC's file system.

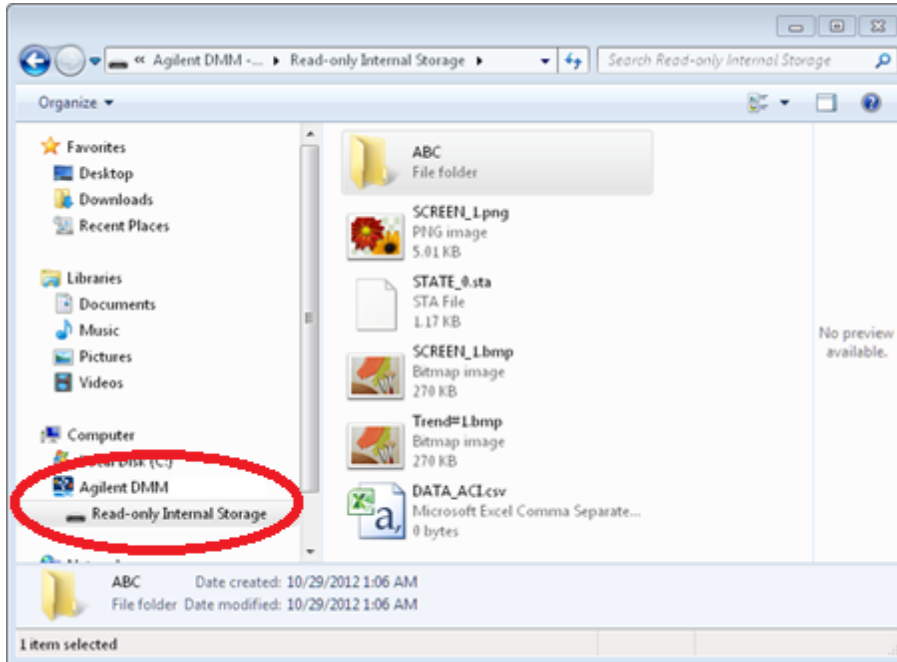

You can use your PC's standard file management features to copy files from the DMM to your PC.

NOTE To use **File Access** at the same time that you are remotely programming the instrument with SCPI over the USB interface (**USB SCPI**), you must have Agilent IO Libraries Suite 16.3 or later installed on your PC. You may download the latest version at www.agilent.com/find/iosuite.

To use File Access on a PC running the Windows XP operating system, make sure you have Microsoft Windows Media Player 11 for Windows XP or later installed before you hook up the USB cable. You may download this software at www.microsoft.com/en-us/download/details.aspx?id=8163.

GPIO Settings (optional)

GPIO Settings enables or disables your instrument's GPIO interface.

When disabled, the interface cannot be configured by the Agilent IO Libraries Connection Expert utility.

You can also set GPIO address to a value from 0 to 30. After enabling or disabling GPIO or changing the address, cycle instrument power for the change to take effect.



Utility Menu - Test/Admin



Test/Admin provides access to self-test, calibration, and administrative functions:



Self-Test

Self-Test verifies proper instrument operation. See [Self-Test Procedures](#) for details, and always safely disconnect inputs to the DMM terminals before running the Full Test.



Calibrate

Calibrate accesses the instrument calibration procedure. See [Calibration](#) for details.



Be sure to use **Show Uptime** to verify that the instrument has been warmed up sufficiently before calibrating it.

Security

Security manages the secure code and security features. If you have the SEC option, you must enter the Secure Code to configure some features.

NISPOM Sanitize sanitizes all user-accessible instrument memory except for the calibration constants and reboots the instrument. This complies with requirements in chapter 8 of the National Instrument Security Program Operating Manual (NISPOM).

CAUTION

The **NISPOM Sanitize** softkey and the `SYSTEM:SECurity:IMMEdiate` command are equivalent. They are for customers, such as military contractors, who must comply with NISPOM.

This feature destroys all user-defined state information, measurement data, and user-defined I/O settings such as the IP address. This feature is not recommended for use in routine applications because of the possibility of unintended data loss.



Install License

Install License enables licensed instrument features. For information on obtaining licenses, go to www.agilent.com/find/truevolt. Copy your license file to a USB drive and use this softkey to install it.

Firmware Update

Firmware Update updates the instrument firmware to a new version. See [Firmware Update](#) for details.

Utility Menu - System Setup



System Setup configures user preferences, sets the date and time, and sets a power-on message.



User Settings

User Settings specifies user preferences that control how the user interacts with the instrument. These settings are stored in non-volatile memory and can be saved in a preferences (.prf) file.



Help Language

Help Lang selects the help language for front-panel use: English, French, German, Japanese, Korean, Russian, or Simplified Chinese. All messages, context-sensitive help, and help topics appear in the selected language. The softkey labels are always in English.

Number Format

Number Format specifies how numbers are displayed on the front panel: 12,345.6 or 12.345,6. Other possibilities also exist. For example, you can use the space as a separator.



Sounds



Disables or enables the click heard when a front-panel key or softkey is pressed.

Also enables or disables the audible tone associated with the following features:

- Limits – a measurement limit is exceeded (if limits are enabled)
- Probe Hold – the measured signal records a stable reading
- Diode – the forward bias voltage is between 0.3 and 0.8 V
- Continuity – a short is measured (less than or equal to 10 Ω)
- Error - an error is generated from the front panel or remote interface

This non-volatile setting appears in several different menus on the front panel, but turning the beeper on or off in one menu affects all of the other menus.

Display Options

Display Options configures the display.



You can enable or disable the display, adjust the brightness (10 to 100%), enable or disable the screen saver, and pick a color scheme. If you turn off the display, press any front-panel key to turn it on again.

By default, the screen saver turns off and blanks the screen after eight hours of inactivity. You may disable this screen saver from the front panel only.

The display is enabled when power is cycled, after an instrument reset (***RST**), or when you return to local (front panel) operation. Press the **[Local]** key or execute the IEEE-488 GTL (Go To Local) command from the remote interface to return to the local state.

SCPI ID

SCPI ID determines the instrument's response to a ***IDN?** query. Choices include 34401A and either 34460A or 34461A (depending on instrument model). This enables ***IDN?** compatibility with existing programs that expect ***IDN?** to return a value appropriate to a 34401A.

Date / Time

Date / Time sets the instrument's real-time clock, which always uses a 24-hour format (00:00:00 to 23:59:59). There is no automatic setting of the date and time, such as to adjust for daylight savings time. Use the front-panel arrow keys to set the year, month, day, hour, and minute.



Power on Message

Power on Message sets a message that is displayed when the instrument powers up and when you press **[Help] > About**.



Use the front-panel arrows and **[Select]** key to select the letters. Then press **Done** to exit and save the message. The message will appear as shown below when you turn the instrument on or press **[Help] > About**.



Web Interface

The Agilent Truevolt Series DMMs include a built-in Web Interface for monitoring and controlling the instrument via a Web browser. To begin, connect your instrument to the LAN and enter the instrument's IP address into the address bar at the top of your PC's Web browser. The Web Interface will appear in the browser as shown below.

Agilent Technologies 34461A 6.5 digit dmm

Welcome to your

Web-Enabled 34461A

Information about this Web-Enabled 34461A:

Instrument:	34461A
Serial Number:	000000079
Description:	Agilent 34461A Digital Multimeter - 000000079
DNS Hostname:	A-34461A-00079
NetBIOS Name:	A-34461A-00079
mDNS Hostname:	A-34461A-00079.local
IP Address:	192.168.82.10
VISA TCP/IP Connect String:	TCPIP::192.168.82.10::INSTR::10000

[Turn On Front Panel Identification Indicator](#)

Advanced information about this Web-Enabled 34461A

Use the navigation bar on the left to access your 34461A and related information.

© Agilent Technologies, Inc. 2008-2010

LXI LAN eXtensions for Instrumentation

Instrument Configuration Tab

The four tabs on the left side of the window select the various interface screens. For example, the third tab takes you to a screen that shows your instrument's Web configuration.

Configuration of your 34461A

[Modify Configuration](#)

Parameter	Currently in use
IP Address Configuration:	Automatic
IP Address:	192.168.82.10
Subnet Mask:	255.255.255.0
Default Gateway:	192.168.82.1
DNS Server(s):	192.168.1.1 192.168.1.1
Desired Hostname	A-34461A-00079
Domain:	lan.agilent.com
Description:	Agilent 34461A Digital Multimeter - 000000079

LXI LAN eXtensions for Instrumentation

Instrument Control Tab

The second tab takes you to the main instrument control screen. The upper left corner of the screen allows you to either monitor the instrument (**Observe Only**) or control the instrument (**Allow Full Control**).



The five buttons along the top of the screen open the following five windows.

Monitor DMM...

This window shows DMM measurements, either as numbers or as shown on the instrument's graphical display (trend chart, histogram, and so on). If you select the **Graphics Display** radio button, press **Get Display Image** to update the graphical display.

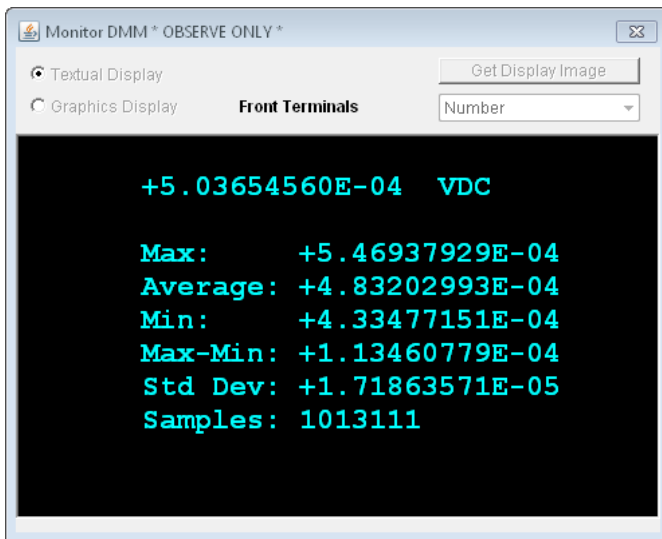

Control DMM...

This window configures the instrument and takes measurements. The **Allow Full Control** radio button must be enabled, as described above.

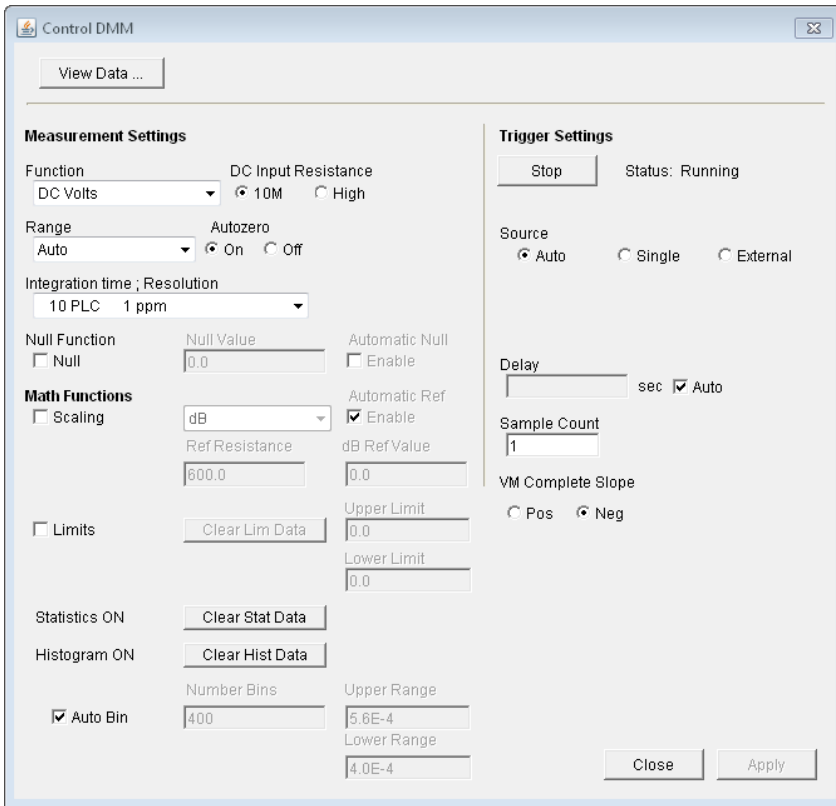

DMM Overview...

This window generates reports with information about the instrument's firmware, configuration, calibration and error queue. Check the desired boxes on the left side of the screen and then click **Generate Report**. The **Change in SCPI Configuration** box produces a list of all of the SCPI commands required to change the instrument state since the last time a report was generated. This provides a convenient way for you to learn SCPI syntax.

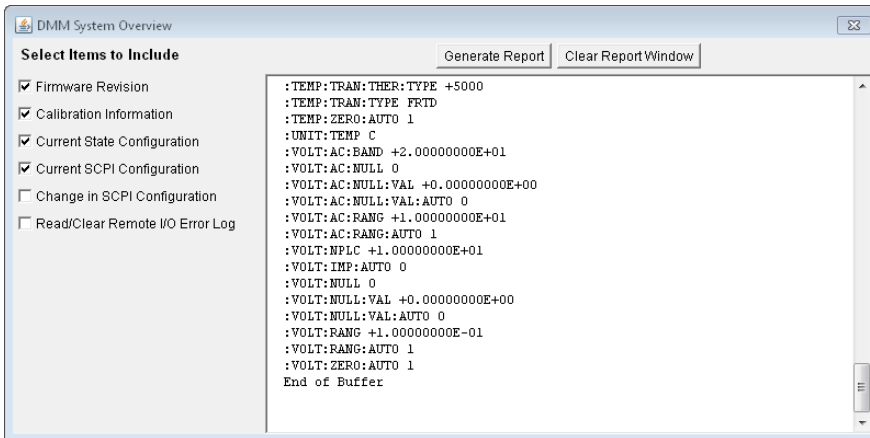

Store/Recall State...

This window saves, recalls, and deletes instrument states.

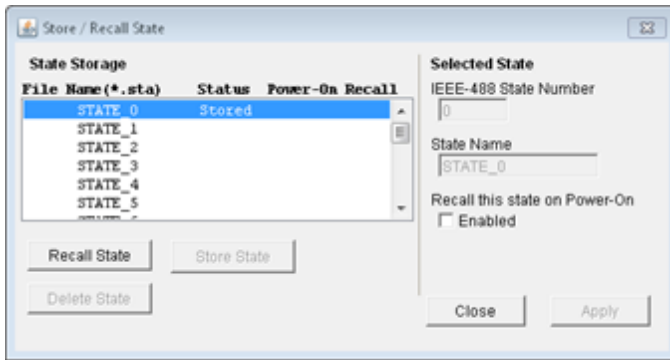

Commands...

This window sends SCPI commands and queries to the instrument.

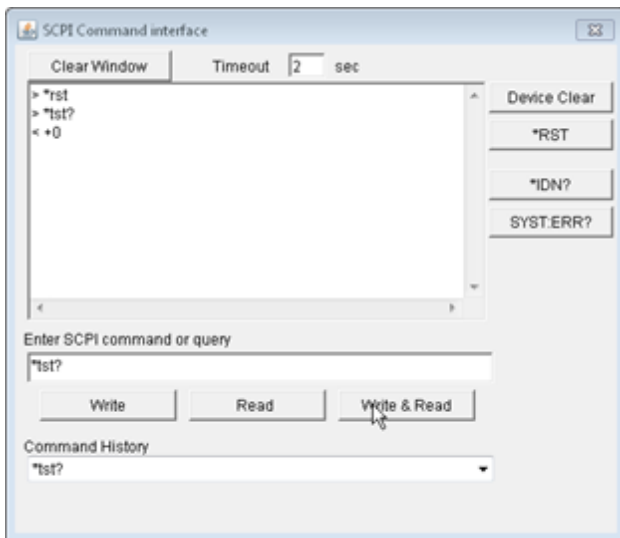

Help Tab

The fourth tab on the left side of the screen opens the Web Interface's help system.



Configuration Page Help

The Configuration page allows you to view network configuration parameters of the instrument. These parameters configure the instrument to operate in your specific environment. If you wish to modify a parameter, you must click the "Modify Configuration" button.

A password may be enabled or disabled from the Modify Configuration page. The default setting is disabled (no password). If a password has been enabled, you will be prompted for the password before going to the Modify Configuration page.

Measurement Tutorial - Introduction

Follow the suggestions in the sections below to achieve the greatest accuracy with Agilent Truevolt Series multimeters.

[DC Measurement Considerations](#)

[Noise Rejection](#)

[Resistance Measurement Considerations](#)

[True RMS AC Measurements](#)

[Other Primary Measurement Functions](#)

[High-Speed Measurements](#)

[Other Sources of Measurement Error](#)

DC Measurement Considerations

To achieve the greatest accuracy with the Agilent Truevolt Series multimeters, you must eliminate potential measurement errors. This chapter describes common errors and suggests ways to avoid them.

Thermal EMF Errors

Thermoelectric voltages are the most common error source in low-level DC voltage measurements. Thermoelectric voltages are generated by circuit connections using dissimilar metals at different temperatures. Each metal-to-metal junction forms a thermocouple that generates a voltage proportional to the junction temperature, as shown in the table below. You should minimize thermocouple voltages and temperature variations in low-level voltage measurements. The best connections use copper-to-copper crimped connections, as the DMM's input terminals are a copper alloy.

Copper to:	Approx. $\mu\text{V} / ^\circ\text{C}$
Cadmium-Tin Solder	0.2
Copper	<0.3
Gold	0.5
Silver	0.5
Brass	3
Beryllium Copper	5
Aluminum	5
Tin-Lead Solder	5
Kovar or Alloy 42	40
Silicon	500
Copper Oxide	1000

Loading Errors (DC Voltage)

Measurement loading errors occur when the resistance of the DUT is an appreciable percentage of the multimeter's input resistance, as shown below.

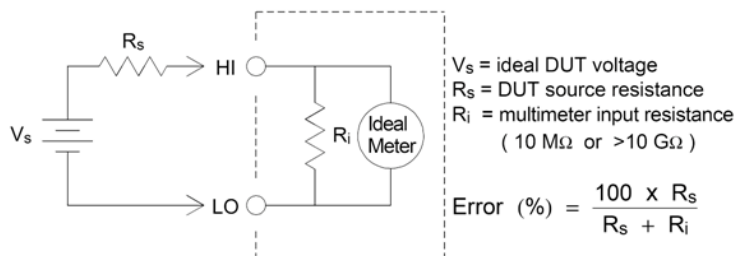

To reduce the effects of loading errors and to minimize noise pickup, set the multimeter's input resistance to >10 G Ω (high-impedance) for the 100 mVDC, 1 VDC, and 10 VDC ranges. The input resistance is maintained at 10 M Ω for the 100 VDC and 1000 VDC ranges.

Noise Rejection

Rejecting Power-Line Noise Voltages

A desirable characteristic of integrating analog-to-digital (A/D) converters is their ability to reject power-line related noise present with DC input signals. This is called normal mode noise rejection, or NMR. The multimeter achieves NMR by measuring the average DC input by "integrating" it over a fixed period. If you set the integration time to a whole number of power line cycles (PLCs), these errors (and their harmonics) will average out to approximately zero.

The multimeter provides three integration selections (1, 10, and 100 PLCs) that achieve NMR. The multimeter measures the power-line frequency (50 Hz or 60 Hz), and then determines the corresponding integration time. For a complete listing of NMR, approximate added rms noise, reading rate, and resolution for each integration setting, see the Performance vs. Integration Time table.

Common Mode Rejection (CMR)

Ideally, a multimeter is completely isolated from earth-referenced circuits. However, there is finite resistance between the multimeter's input LO terminal and earth ground, as shown below. This can cause errors when measuring low voltages which are floating relative to earth ground.

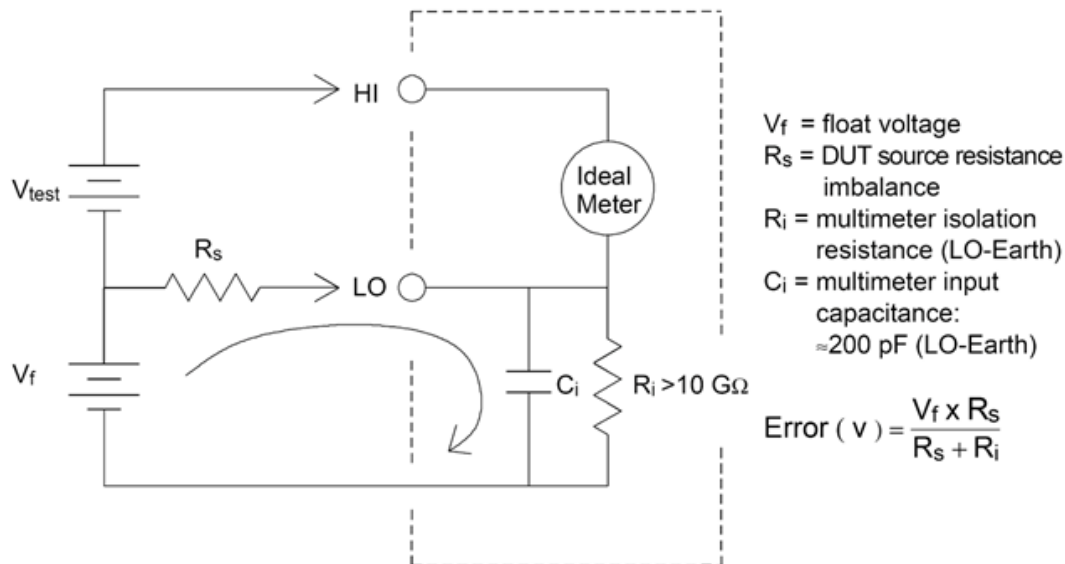

Noise Caused by Magnetic Loops

When making measurements near magnetic fields, avoid inducing voltages in the measurement connections. You should be especially careful when working near conductors carrying large currents. Use twisted-pair connections to the multimeter to reduce the noise pickup loop area, or dress the test leads as close together as possible. Loose or vibrating test leads will also induce error voltages. Tie down test leads securely when operating near magnetic fields. Whenever possible, use magnetic shielding materials or increased distance from magnetic sources.

Noise Caused by Ground Loops

When measuring voltages in circuits where the multimeter and the DUT are referenced to a common earth ground, a "ground loop" is formed. As shown below, any voltage difference between the two ground reference points (V_{ground}) causes current to flow through the measurement leads. This causes noise and offset voltage (usually power-line related), which are added to the measured voltage.

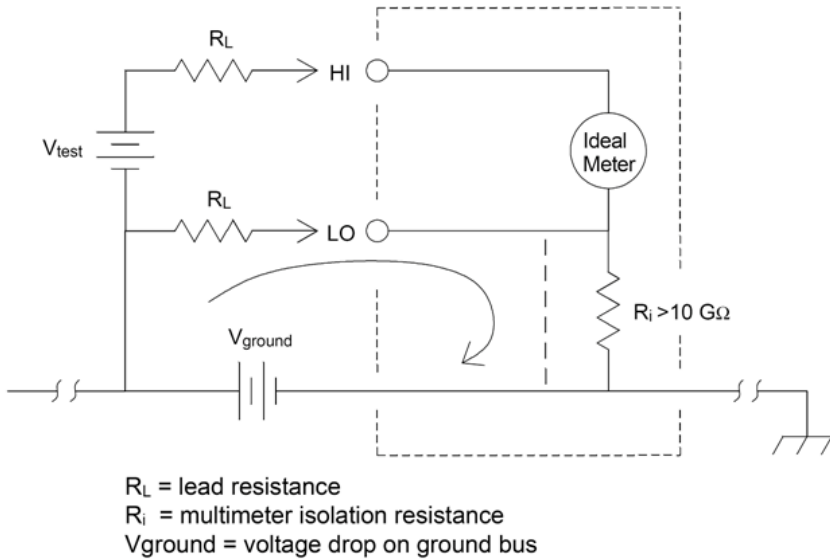

The best way to eliminate ground loops is to isolate the multimeter from earth by not grounding the input terminals. If the multimeter must be earth-referenced, connect it and the DUT to one common ground point. Also connect the multimeter and DUT to the same electrical outlet whenever possible.

Resistance Measurement Considerations

The multimeter offers two resistance measurements: 2-wire and 4-wire ohms. For both methods, the test current flows from the input HI terminal, through the resistor being measured. For 2-wire ohms, the voltage drop across the resistor being measured is sensed internal to the multimeter. Therefore, test lead resistance is also measured. For 4-wire ohms, separate "sense" connections are required. Because no current flows in the sense leads, the resistance in these leads does not give a measurement error.

NOTE The errors mentioned earlier in this chapter for DC voltage measurements also apply to resistance measurements. Additional error sources unique to resistance measurements are discussed below.

The 4-wire ohms method provides the most accurate way to measure small resistances because it reduces test lead and contact resistances. This is often used in automated test applications where resistive and/or long cable, numerous connections, or switches exist between the multimeter and the DUT. The recommended connections for 4-wire ohms measurements are shown below.

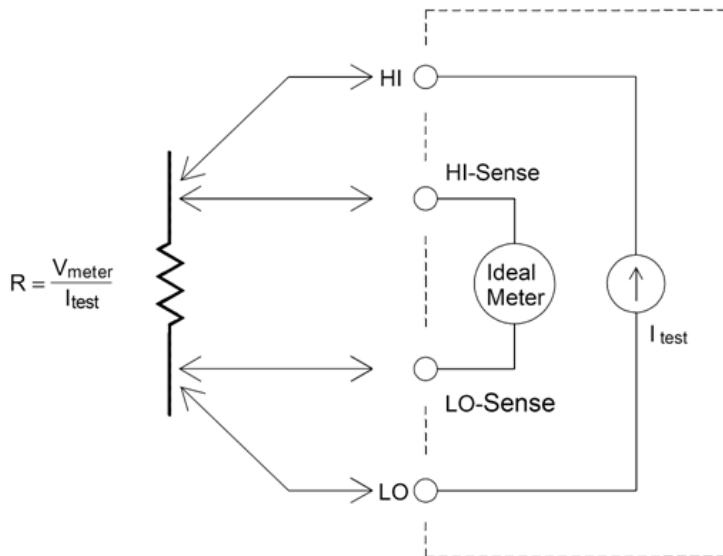

Removing Test Lead Resistance Errors

To eliminate offset errors associated with test lead resistance in 2-wire ohms measurements, follow these steps:

Short the test lead ends together and read the displayed test lead resistance.

Press **Null**. The multimeter will store the test lead resistance as the 2-wire ohms null value, and subtract that value from subsequent measurements.

See also "Null Measurements."

Minimizing Power Dissipation Effects

When measuring resistors designed for temperature measurements (or other resistive devices with large temperature coefficients), be aware that the multimeter will dissipate some power in the DUT.

If power dissipation is a problem, you should select the multimeter's next higher measurement range to reduce the errors to acceptable levels. The following table shows several examples.

Range	Test Current	DUT
100 Ω	1 mA	100 μ W
1 k Ω	1 mA	1 mW
10 k Ω	100 μ A	100 μ W
100 k Ω	10 μ A	10 μ W
1 M Ω	5 μ A	25 μ W
10 M Ω	500 nA	2.5 μ W



Errors in High Resistance Measurements

When you are measuring large resistances, significant errors can occur due to insulation resistance and surface cleanliness. You should take the necessary precautions to maintain a "clean" high-resistance system. Test leads and fixtures are susceptible to leakage due to moisture absorption in insulating materials and "dirty" surface films. Nylon and PVC are relatively poor insulators ($10^9 \Omega$) when compared to PTFE insulators ($10^{13} \Omega$). Leakage from nylon or PVC insulators can easily contribute a 0.1% error when measuring a 1 M Ω resistance in humid conditions.

True RMS AC Measurements

True rms responding multimeters, like the Agilent Truevolt Series, measure the "heating" potential of an applied voltage. Power dissipated in a resistor is proportional to the square of an applied voltage, independent of the waveshape of the signal. This multimeter accurately measures true rms voltage or current, as long as the wave shape contains negligible energy above the meter's effective bandwidth.

Note that the Agilent Truevolt Series uses the same techniques to measure true rms voltage and true rms current. The effective AC voltage bandwidth is 300 kHz, while the effective AC current bandwidth is 10 kHz.

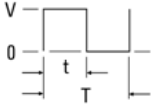
Waveform Shape	Crest Factor (C.F.)	AC RMS	AC + DC RMS	Average Responding Error
	1.414	$\frac{V}{1.414}$	$\frac{V}{1.414}$	Calibrated for 0 error
	1.732	$\frac{V}{1.732}$	$\frac{V}{1.732}$	-3.9%
	$\sqrt{\frac{T}{t}}$	$\frac{V}{\text{C.F.}} \times \sqrt{1 - \left(\frac{1}{\text{C.F.}}\right)^2}$	$\frac{V}{\text{C.F.}}$	-46% for C.F. = 4

The DMM's AC voltage and AC current functions measure the AC-coupled true rms value. In this DMM, the "heating value" of only the AC components of the input waveform are measured (dc is rejected). As seen in the figure above; for sine waves, triangle waves, and square waves, the AC-coupled and AC+DC values are equal, because these waveforms do not contain a DC offset. However, for non-symmetrical waveforms (such as pulse trains) there is a DC voltage content, which is rejected by Agilent's AC-coupled true rms measurements. This can provide a significant benefit.

An AC-coupled true rms measurement is desirable when you are measuring small AC signals in the presence of large DC offsets. For example, this situation is common when measuring AC ripple present on DC power supplies. There are situations, however, where you might want to know the AC+DC true rms value. You can determine this value by combining results from DC and AC measurements, as shown below:

$$ac + dc = \sqrt{ac^2 + dc^2}$$

For the best AC noise rejection, you should perform the DC measurement using an integration time of at least 10 power-line cycles (PLCs).

True RMS Accuracy and High-Frequency Signal Content

A common misconception is that because an AC multimeter is true rms, its sine wave accuracy specifications apply to all waveforms. Actually, the shape of the input signal dramatically affects measurement accuracy for any multimeter, especially when that input signal contains high-frequency component beyond the instrument's bandwidth.

For example, consider a pulse train, one of the most challenging waveforms for a multimeter. The pulse width of that waveform largely determines its high-frequency content. The frequency spectrum of an individual pulse is determined by its Fourier Integral. The frequency spectrum of the pulse train is the Fourier Series that samples along the Fourier Integral at multiples of the input pulse repetition frequency (prf).

The figure below shows the Fourier Integral of two very different pulses: one of broad width (200 μs); the other narrow (6.7 μs). The bandwidth of the ACV path in the DMM is 300 kHz; therefore, frequency content above 300 kHz is not measured.

Notice that the $\frac{\sin(n\pi T)}{n\pi T}$ spectrum of the narrow pulse significantly exceeds the effective bandwidth of the instrument. The net result is a less accurate measurement of the narrow, high-frequency pulse.

In contrast, the frequency spectrum of the broad pulse has fallen off significantly below the multimeter's 300 kHz (approximately) bandwidth, so measurements of this pulse are more accurate.

Reducing the prf increases the density of lines in the Fourier spectrum, and increases the portion of the input signal's spectral energy within the multimeter's bandwidth, which improves accuracy.

In summary, error in rms measurements arise when there is significant input signal energy at frequencies above the multimeter's bandwidth.

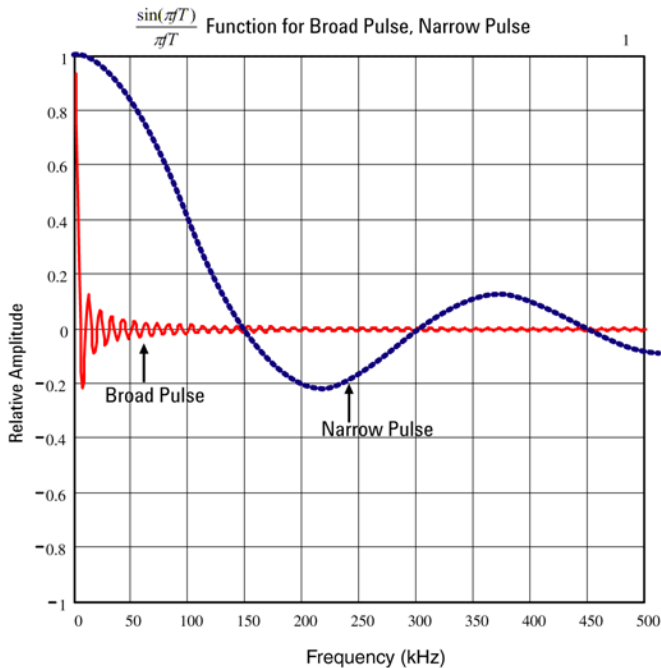

Estimating High-Frequency (Out-of-Band) Error

A common way to describe signal waveshapes is to refer to their "Crest Factor". Crest factor is the ratio of the peak value to rms value of a waveform. For a pulse train, for example, the crest factor is approximately equal to the square root of the inverse of the duty cycle.

$$CF = \frac{1}{\sqrt{d}} = \frac{1}{\sqrt{\frac{t_p}{T}}} = \frac{1}{\sqrt{prf \times t_p}}$$

Notice that crest factor is a composite parameter, dependent upon the pulse width and repetition frequency; crest factor alone is not enough to characterize the frequency content of a signal.

Traditionally, DMMs include a crest factor derating table that applies at all frequencies. The measurement algorithm used in the Truevolt Series DMMs is not inherently sensitive to crest factor, so no such derating is necessary. With this multimeter, as discussed in the previous section, the focal issue is high-frequency signal content which exceeds the multimeter's bandwidth.

For periodic signals, the combination of crest factor and repetition rate can suggest the amount of high-frequency content and associated measurement error. The first zero crossing of a simple pulse occurs at $f_1 = 1/t_p$.

This gives an immediate impression of the high-frequency content by identifying where this crossing occurs as a function of crest factor: $f_1 = (CF^2)(prf)$.

The following table shows the typical error for various pulse waveforms as a function of input pulse frequency:

Typical error for square wave, triangle wave, and pulse trains of CF=3, 5, or 10					
prf	square wave	triangle	CF=3	CF=5	CF=10
200	-0.02%	0.00%	-0.04%	-0.09%	-0.34%
1000	-0.07%	0.00%	-0.18%	-0.44%	-1.71%
2000	-0.14%	0.00%	-0.34%	-0.88%	-3.52%
5000	-0.34%	0.00%	-0.84%	-2.29%	-8.34%
10000	-0.68%	0.00%	-1.75%	-4.94%	-26.00%
20000	-1.28%	0.00%	-3.07%	-8.20%	-45.70%
50000	-3.41%	-0.04%	-6.75%	-32.0%	-65.30%
100000	-5.10%	-0.12%	-21.8%	-50.6%	-75.40%

This table gives an additional error for each waveform, to be added to the value from the accuracy table provided in the instrument's data sheet

The specifications are valid for $CF \leq 10$, provided there is insignificant signal energy above the 300 kHz bandwidth for voltage, or the 10 kHz bandwidth for current. Multimeter performance is not specified for $CF > 10$, or when significant out-of-band signal content is present.

Example

A pulse train with level 1 V_{rms}, is measured on the 1 V range. It has pulse heights of 3 V (that is, a Crest Factor of 3) and duration 111 μs. The prf can be calculated to be 1000 Hz, as follows:

$$prf = \frac{1}{CF^2 \times t_p}$$

Thus, from the table above, this AC waveform can be measured with 0.18 percent additional error.

Other Primary Measurement Functions

Frequency and Period Measurement Errors

The multimeter uses a reciprocal counting technique to measure frequency and period. This method generates constant measurement resolution for any input frequency. The multimeter's AC voltage measurement section performs input signal conditioning. All frequency counters are susceptible to errors when measuring low-voltage, low-frequency signals. The effects of both internal noise and external noise pickup are critical when measuring "slow" signals. The error is inversely proportional to frequency. Measurement errors also occur if you attempt to measure the frequency (or period) of an input following a DC offset voltage change. You must allow the multimeter's input DC blocking capacitor to fully settle before making frequency measurements.

DC Current

When you connect the multimeter in series with a test circuit to measure current, a measurement error is introduced. The error is caused by the multimeter's series burden voltage. A voltage is developed across the wiring resistance and current shunt resistance of the multimeter, as shown below.

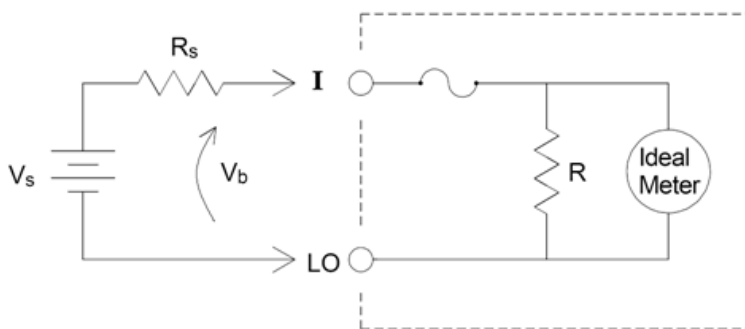

V_s = source voltage
 R_s = DUT source resistance
 V_b = multimeter burden voltage
 R = multimeter current shunt

$$\text{Error (\%)} = \frac{-100\% \times V_b}{V_s}$$

Temperature Measurements

The multimeter allows the measurement of temperature by measurement of the temperature sensitive resistance of two different probe types: the resistance temperature detector (RTD) of 0.385%/°C; and the 5 KΩ thermistor). There are a number of measurement parameter and technique choices available to you, and these affect various aspects of the measurement:

- Temperature range and resolution can direct the probe-type choice.
- Choice of four-wire or two-wire technique affects measurement accuracy.
- Use of the autozero feature affects measurement speed and accuracy.
- Choice of integration (measurement time) setting affects measurement accuracy and power-line noise rejection.
- Use of the offset compensation feature can eliminate residual voltages in the test instrumentation or circuit.

Probe Type Choice

RTD's provide very accurate, highly linear relationships between resistance and temperature, over a range of roughly –200 to 500 °C. There is very little conversion complexity for an RTD because it is so intrinsically linear. The multimeter provides measurement for the IEC751 standard RTD, which has a sensitivity of 0.385%/°C.

Thermistors consist of semiconductor materials, and provide roughly ten times the sensitivity of the RTD. Because they are semiconductors, their temperature range is more limited, commonly to –80 to 150 °C. Thermistors have highly non-linear temperature-resistance relationships; therefore their conversion algorithms are more complex. The Truevolt Series multimeters use the standard Hart-Steinhart Approximation to provide accurate conversions, with a typical resolution of .08 °C.

2-Wire vs. 4-Wire Measurements

As with resistance measurements, four-wire temperature measurements are more accurate, because errors due to lead wire resistance are completely eliminated. Alternately, you can use the multimeter's Null function to remove the test lead resistance from the measurement (see NULL Reading.)

Auto Zero On/Off

Enabling the autozero feature (ON) provides greater accuracy; however, the additional measurement (of zero) reduces the reading speed.

NULL Reading

The DMM allows a separate null setting to be saved for the temperature function. When making null measurements, each reading is the difference between a stored null value and the input signal. One application of NULL is to increase accuracy of two-wire resistance measurements by first nulling the closed-circuit test lead resistance.

High-Speed Measurements

Making High-Speed AC Measurements

The multimeter's AC voltage and AC current functions implement three low-frequency filters. These filters allow you to trade-off minimum measured frequency for faster reading speed. The FAST filter settles in 0.025 seconds, and is useful for frequencies above 200 Hz. The MEDIUM filter settles in 0.625 seconds for voltage and 0.25 seconds for current, and is useful for measurements above 20 Hz. The SLOW filter settles in 2.5 seconds for voltage and 1.66 seconds for current, and is useful for frequencies above 3 Hz.

With a few precautions, you can perform AC measurements at speeds up to 500 readings per second. Use manual ranging to eliminate autoranging delays. By setting the trigger delay to 0, the FAST, MEDIUM, and SLOW filters allow up to 500, 150, and 50 readings per second, but with reduced accuracy because the filter may not fully settle. If the sample-to-sample levels are similar, little settling time is required for each new reading. Under this specialized condition, the MEDIUM filter provides reduced accuracy results at 20 readings per second, and the FAST filter provides reduced accuracy results at 200 readings per second.

AC Filter	Filter Bandwidth	Settling Time (s)		Full Settling (rdgs/s)		Partial Settling	Maximum rdgs/s
		ACV	ACI	ACV	ACI	ACV/ACI	ACV/ACI
Slow	3 Hz	2.5	1.67	0.4	0.6	2	50
Medium	20 Hz	0.63	0.25	1.6	4	20	150
Fast	200 Hz	0.025	0.025	40	40	200	500

In applications where sample-to-sample levels vary widely, but the DC offset level does not change, the MEDIUM filter settles at 2 to 4 readings per second (depending upon the lowest frequency component in the waveform) as shown in the following table:

Lowest Frequency Component	20 Hz	50 Hz	100 Hz	200 Hz
AC Current (allowable rate in rdgs/s)	4	4	4	4
AC Voltage (allowable rate in rdgs/s)	2	3	4	4

For AC voltage, additional settling time may be required when the DC level varies from sample to sample. The default sample delays allow for a DC level change of 3% of range for all filters. If the DC level change exceeds these levels, additional settling time is required. The multimeter's DC blocking circuitry has a settling time constant of 0.2 seconds. This settling time only affects measurement accuracy when DC offset levels vary from sample to sample. If maximum measurement speed is desired in a scanning system, you may want to add an external DC blocking circuit to those channels with significant DC voltages present. This circuit can be as simple as a resistor and a capacitor.

For AC current, additional settling time is not required when the DC level varies sample to sample.

Making High-Speed DC and Resistance Measurements

The multimeter incorporates an automatic zero measurement procedure (autozero) to eliminate internal thermal EMF and bias current errors. Each measurement actually consists of a measurement of the input terminals followed by a measurement of the internal offset voltage. The internal offset voltage error is subtracted from the input for improved accuracy. This compensates for offset voltage changes due to temperature. For maximum reading speed, turn autozero off. This will more than double your reading speeds for DC voltage, resistance, and DC current functions. Autozero does not apply to other measurement functions.

Other Sources of Measurement Error

Settling Time Effects

The multimeter can insert automatic measurement settling delays. These delays are adequate for resistance measurements with less than 200 pF of combined cable and device capacitance. This is particularly important when measuring resistances above 100 kΩ. Settling due to RC time constant effects can be quite long. Some precision resistors and multi-function calibrators use large parallel capacitors (1000 pF to 0.1 μF) with high resistor values to filter out noise currents injected by their internal circuitry. Non-ideal capacitances in cables and other devices may have much longer settling times than expected just by RC time constants due to dielectric absorption (soak) effects. Errors are measured when settling after the initial connection and after a range change.

Loading Errors (AC volts)

In the AC voltage function, the input of the multimeter appears as a 1 MΩ resistance in parallel with 100 pF of capacitance. The cabling that you use to connect signals to the multimeter also adds capacitance and loading. The table below shows the multimeter's approximate input resistance at various frequencies.

Input Frequency	Input Resistance (kΩ)
100 Hz	941
1 kHz	614
10 kHz	137
100 kHz	15.7

For low frequencies, the loading error is:

$$\text{Error (\%)} = \frac{-100 \times R_s}{R_s + 1 \text{ M}\Omega}$$

At high frequencies, the additional loading error is:

$$\text{Error (\%)} = 100 \times \left[\frac{1}{\sqrt{1 + (2\pi \times F \times R_s \times C_{in})^2}} - 1 \right]$$

R_s = source resistance

F = input frequency

C_{in} = input capacitance (100 pF) plus cable capacitance

Measurements Below Full Scale

You can make the most accurate AC measurements when the multimeter is at or near the full scale of the selected range. Autoranging occurs at 10% (down-range) and 120% (up-range) of full scale. This enables you to measure some inputs at full scale on one range and 10% of full scale on the next higher range. In general, the accuracy is better on the lower range; for the highest accuracy, select the lowest manual range possible for the measurement.

High Voltage Self-Heating Errors

If you apply more than 300 Vrms, self-heating occurs in the multimeter's internal signal-conditioning components. These errors are included in the multimeter's specifications. Temperature changes inside the multimeter due to self-heating may cause additional error on other AC voltage ranges. The additional error is less than 0.02% and dissipates in a few minutes.

AC Current Measurement Errors (Burden Voltage)

Burden voltage errors, which apply to DC current, also apply to AC current measurements. However, the burden voltage for AC current is larger due to the multimeter's series inductance and your measurement connections. The burden voltage increases as the input frequency increases. Some circuits may oscillate when performing current measurements due to the multimeter's series inductance and your measurement connections.

Low-Level Measurement Errors

AC voltage measurements less than 100 mV are especially susceptible to errors introduced by extraneous noise sources. An exposed test lead acts as an antenna and a properly functioning DMM will measure the signals received. The entire measurement path, including the power line, act as a loop antenna. Circulating currents in the loop create error voltages across any impedances in series with the DMM's input. Therefore, you should apply low-level AC voltages to the DMM through shielded cables, with the shield connected to the input LO terminal.

Connect the DMM and the AC source to the same electrical outlet whenever possible. You should also minimize the area of any ground loops that cannot be avoided. A high-impedance source is more susceptible to noise pickup than a low-impedance source. You can reduce the high-frequency impedance of a source by placing a capacitor in parallel with the DMM's input terminals. You may have to experiment to determine the correct capacitor for your application.

Most extraneous noise is not correlated with the input signal. You can determine the error as shown below.

$$\text{Voltage Measured} = \sqrt{V_{\text{in}}^2 + \text{Noise}^2}$$

Correlated noise, while rare, is especially detrimental because it always adds directly to the input signal. Measuring a low-level signal with the same frequency as the local power line is a common situation that is prone to this error.

Common Mode Errors

Errors are generated when the multimeter's input LO terminal is driven with an AC voltage relative to earth. The most common situation where unnecessary common mode voltages are created is when the output of an AC calibrator is connected to the multimeter "backwards." Ideally, a multimeter reads the same regardless of how the source is connected. Both source and multimeter effects can degrade this ideal situation. Because of the capacitance between the input LO terminal and earth (approximately 200 pF), the source will experience different loading depending on how the input is applied. The magnitude of the error is dependent upon the source's response to this loading.

The DMM's measurement circuitry, while extensively shielded, responds differently in the backward input case due to slight differences in stray capacitance to earth. The DMM's errors are greatest for high-voltage, high-frequency inputs. Typically, the DMM exhibits about 0.06% additional error for a 100 V, 100 kHz reverse input. You can use the grounding techniques described for DC common mode problems to minimize AC common mode voltages.

Leakage Current Errors

The DMM's input capacitance will "charge up" due to input bias currents when the terminals are open-circuited (if the input resistance is $>10\text{ G}\Omega$). The DMM's measuring circuitry exhibits approximately 30pA of input bias current for ambient temperatures from 0 to 30 °C. Bias current doubles for every 8 °C change in ambient temperature above 30 °C. This current generates small voltage offsets dependent upon the source resistance of the DUT. This effect becomes evident for a source resistance of greater than 100 k Ω , or when the DMM's operating temperature is significantly greater than 30 °C.

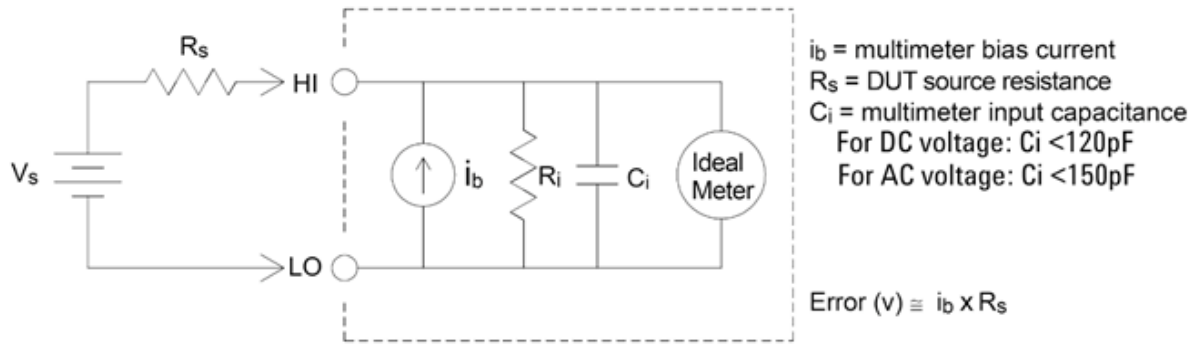

SCPI Programming Reference

This section contains information to help you program the Agilent Truevolt Series digital multimeters over a remote interface using the SCPI programming language.

[Introduction to the SCPI Language](#)

[Commands by Subsystem](#)

[Command Quick Reference](#)

[SCPI Error Messages](#)

[Power-On and Reset State](#)

Related Information

IO Libraries and Instrument Drivers

The Agilent IO Libraries Suite software and installation instructions are on the *Agilent Automation Ready CD-ROM* provided with your instrument (optional for 34460A).

You can also download the Agilent IO Libraries Suite software, along with IVI-COM and LabVIEW drivers, from the Agilent Developer Network at www.agilent.com/find/adn.

Agilent Truevolt Series Documentation

This documentation is provided on a CD-ROM that is shipped with your instrument (optional on 34460A). You can also download these documents at www.agilent.com/find/truevolt.

For information about connecting instruments to USB, LAN and GPIB interfaces and how to configure and troubleshoot these interfaces, refer to the *Agilent USB/LAN/GPIB Interfaces Connectivity Guide*. This guide is provided on the *Agilent Automation Ready CD-ROM*, and you can download it at www.agilent.com/find/connectivity.

Web Interface

The 34461A and 34460A with option 34460A-LAN or option 3446LANU provides a Web Interface built into the instrument. You can use this interface over LAN for remote access and control of the instrument via a Web browser. See [Web Interface](#) for details.

Introduction to the SCPI Language

SCPI (Standard Commands for Programmable Instruments) is an ASCII-based programming language for test and measurement instruments. SCPI commands use a hierarchical structure known as a tree system. Associated commands are grouped under a common node or root, thus forming subsystems. A portion of the SENSE subsystem illustrates this, below.

```
SENSe:
  VOLTage:
    DC:RANGe { <range> | MIN | MAX | DEF }
    DC:RANGe? [ MINimum | MAXimum | DEFault ]
```

SENSe is the root keyword of the command, **VOLTage** is a second-level keyword, and **DC** is a third-level keyword. A colon (:) separates consecutive keywords.

Syntax Conventions

The command syntax format is illustrated below:

```
VOLTage:DC:RANGe { <range> | MIN | MAX | DEF }
```

Most commands (and some parameters) are a mixture of upper- and lower-case letters. The upper-case letters indicate the command's abbreviated spelling, which yields shorter program lines. For better program readability, use the long form.

For example, consider the keyword VOLTage, above. You can type VOLT or VOLTage in any combination of upper- or lower-case letters. Therefore, VolTaGe, volt and Volt are all acceptable. Other forms, such as VOL and VOLTAG, will generate an error.

- Braces ({ }) enclose the parameter choices. The braces are not sent with the command string.
- A vertical bar (|) separates parameter choices. For example, { <range> | MIN | MAX | DEF } in the above command indicates that you can specify a numeric range parameter, or "MIN", "MAX" or "DEF". The bar is not sent with the command string.
- Angle brackets (< >) indicate that you must specify a value for the enclosed parameter. For example, the above syntax statement shows the <range> parameter in angle brackets. Do not send the brackets with the command string. You must specify a value for the parameter (for example "VOLT:DC:RANG 10") unless you select one of the other options shown in the syntax (for example "VOLT:DC:RANG MIN").
- Optional parameters are enclosed in square brackets ([]). The brackets are not sent with the command string. If you do not specify a value for an optional parameter, the instrument uses a default value.

Command Separators

A colon (:) separates consecutive keywords. You must insert a blank space to separate a parameter from a command keyword. If a command requires more than one parameter, separate adjacent parameters using a comma:

```
CONF:VOLT:DC 10,0.003
```

A semicolon (;) separates commands within the same subsystem and can also minimize typing. For example, the following string:

```
TRIG:SOUR EXT;COUNT 10
```

is equivalent to the following two commands:

```
TRIG:SOUR EXT  
TRIG:COUNT 10
```

Use a colon and a semicolon to link commands from different subsystems. For example, in the following example, an error is generated if you do not use both the colon and semicolon:

```
TRIG:COUN MIN;:SAMP:COUN MIN
```

Using the MIN, MAX and DEF Parameters

For many commands, you can substitute "MIN" or "MAX" in place of a parameter. In some cases you may also substitute "DEF". For example, consider The following example:

```
VOLTage:DC:RANGe { <range> |MIN|MAX|DEF }
```

Instead of selecting a specific value for the <range> parameter, you can substitute MIN to set the range to its minimum value, MAX to set the range to its maximum value or DEF to set the range to its default value.

Querying Parameter Settings

You can query the current value of most parameters by adding a question mark (?) to the command. For example, The following example sets the trigger count to 10 measurements:

```
TRIG:COUN 10
```

You can then query the count value by sending:

```
TRIG:COUN?
```

You can also query the minimum or maximum count allowed as follows:

```
TRIG:COUN? MIN  
TRIG:COUN? MAX
```

SCPI Command Terminators

A command string sent to the instrument must terminate with a <new line> (<NL>) character (ASCII decimal 10). The IEEE-488 EOI (End-Or-Identify) message is interpreted as a <NL> character and can be used to terminate a command string in place of a <NL> character. A <carriage return> followed by a <NL> is also accepted. Command string termination will always reset the current SCPI command path to the root level.

NOTE

For every SCPI message that includes a query and is sent to the instrument, the instrument terminates the returned response with a <NL> or line-feed character (EOI). For example, if R? is sent, the response is terminated with a <NL> after the block of data that is returned. If a SCPI message includes multiple queries separated by semicolons (for example "ROUTe:TERMinals?;R?"), the returned response is again terminated by a <NL> after the response to the last query. In either case, the program must read this <NL> in the response before another command is sent to the instrument or an error will occur.

IEEE-488.2 Common Commands

The IEEE-488.2 standard defines a set of common commands that perform functions such as reset, self-test and status operations. Common commands always begin with an asterisk (*), are three characters in length and may include one or more parameters. The command keyword is separated from the first parameter by a blank space. Use a semicolon (;) to separate multiple commands as shown below:

```
*RST; *CLS; *ESE 32; *OPC?
```

SCPI Parameter Types

The SCPI language defines several data formats to be used in program messages and response messages.

Numeric Parameters

Commands that require numeric parameters will accept all commonly used decimal representations of numbers including optional signs, decimal points, and scientific notation. Special values for numeric parameters such as MIN, MAX and DEF are also accepted. You can also send engineering unit suffixes with numeric parameters (e.g., M, k, m or u). If a command accepts only certain specific values, the instrument will automatically round the input numeric parameters to the accepted values. The following command requires a numeric parameter for the range value:

```
VOLTage:DC:RANGe {<range>|MIN|MAX|DEF}
```

NOTE

Because the SCPI parser is case-insensitive, there is some confusion over the letter "M" (or "m"). For your convenience, the instrument interprets "mV" (or "MV") as millivolts, but "MHZ" (or "mhz") as megahertz. Likewise "MΩ" (or "mΩ") is interpreted as megΩ. You can use the prefix "MA" for mega. For example, "MAV" is interpreted as megavolts.

Discrete Parameters

Discrete parameters are used to program settings that have a limited number of values (like IMMEDIATE, EXTERNAL or BUS). They have a short form and a long form just like command keywords. You can mix upper- and lower-case letters. Query responses will always return the short form in all upper-case letters. The following example requires a discrete parameters for the temperature units:

```
UNIT:TEMPerature{C|F|K}
```

Boolean Parameters

Boolean parameters represent a single binary condition that is either true or false. For a false condition, the instrument will accept "OFF" or "0". For a true condition, the instrument will accept "ON" or "1". When you query a Boolean setting, the instrument will always return "0" or "1". The following example requires a Boolean parameter:

```
DISPlay:STATe {ON|1|OFF|0}
```

ASCII String Parameters

String parameters can contain virtually any set of ASCII characters. A string must begin and end with matching quotes; either with a single quote or a double quote. You can include the quote delimiter as part of the string by typing it twice without any characters in between. The following command uses a string parameter:

```
DISPlay:TEXT <quoted string>
```

For example, The following example displays the message "WAITING..." on the instrument's front panel (the quotes are not displayed).

```
DISP:TEXT "WAITING..."
```

You can also display the same message using The following example with single quotes.

```
DISP:TEXT 'WAITING...'
```

Using Device Clear

Device Clear is an IEEE-488 low-level bus message that you can use to return the instrument to a responsive state. Different programming languages and IEEE-488 interface cards provide access to this capability through their own unique commands. The status registers, the error queue, and all configuration states are left unchanged when a Device Clear message is received.

Device Clear performs the following actions:

- If a measurement is in progress, it is aborted.
- The instrument returns to the trigger "idle" state.
- The instrument's input and output buffers are cleared.
- The instrument is prepared to accept a new command string.
- An overlapped command, if any, will be terminated with no "Operation Complete" indication (applies to INIT).

NOTE The ABORt command is the recommended method to terminate a measurement.

Commands by Subsystem

[ABORT](#)

[CALCulate:CLEar\[:IMMediate\]](#)

[CALCulate:AVERage Subsystem](#)

[CALCulate:TRANSform:HISTogram Subsystem](#)

[CALCulate:LIMit Subsystem](#)

[CALCulate:SCALe Subsystem](#)

[CALibration Subsystem](#)

[CONFigure Subsystem](#)

[DATA Subsystem](#)

[DISPlay Subsystem](#)

[FETCH?](#)

[HCOPY Subsystem](#)

[IEEE 488.2 Common Commands](#)

[INITiate\[:IMMediate\]](#)

[LXI Subsystem](#)

[MEASure Subsystem](#)

[MMEMory Subsystem - Data Transfer Commands](#)

[MMEMory Subsystem - General Purpose File Management](#)

[MMEMory Subsystem - STATE and PREFERence Files](#)

[OUTPut:TRIGger:SLOPe](#)

[R?](#)

[READ?](#)

[ROUTE:TERMinals?](#)

[SAMPle:COUNT](#)

[\[SENSe:\]CURRent Subsystem](#)

[\[SENSe:\]{FREQuency|PERiod} Subsystem](#)

[\[SENSe:\]{RESistance|FRESistance} Subsystem](#)

[\[SENSe:\]TEMPerature Subsystem](#)

[\[SENSe:\]VOLTage Subsystem](#)

[STATus Subsystem](#)

[SYSTEM Subsystem - General Purpose Commands](#)

[SYSTEM Subsystem - I/O Configuration](#)

[SYSTEM:LICense Subsystem](#)

[SYSTEM:LOCK Subsystem](#)

[TEST:ALL?](#)

TRIGger Subsystem

UNIT:TEMPerature

ABORt

Aborts a measurement in progress, returning the instrument to the trigger idle state.

Parameter	Typical Return
(none)	(none)
Abort a measurement in progress: ABORt	

- This command may be used to abort a measurement when the instrument is waiting for a trigger, or for aborting a long measurement or series of measurements.

FETCh?

Waits for measurements to complete and copies all available measurements to the instrument's output buffer. The readings remain in reading memory.

Parameter	Typical Return
(none)	-4.98748741E-01,-4.35163427E-01,-4.33118686E-01,-3.48109378E-01
Use FETCh? with CONFigure and INITiate. The INITiate command places the instrument in the "wait-for-trigger" state, triggers a measurement when the rear-panel Ext Trig input is pulsed (low by default), and sends the measurement to reading memory. The FETCh? query transfers the measurement from reading memory to the instrument's output buffer. CONF:VOLT:DC 10,0.003 TRIG:SOUR EXT SAMP:COUN 4 INIT FETC?	

- The [FETCh?](#) query does not erase measurements from the reading memory. You can send the query multiple times to retrieve the same data.
- You can store up to 1,000 measurements in the reading memory of the 34460A or 10,000 measurements on the 34461A. If reading memory overflows, new measurements will overwrite the oldest measurements stored; the most recent measurements are always preserved. No error is generated, but the Reading Mem Ovfl bit (bit 14) is set in the Questionable Data Register's condition register (see [Status System Introduction](#)).
- The instrument clears all measurements from reading memory when the measurement configuration changes, or when any of these commands is executed:

[INITiate](#)

[MEASure:<function>?](#)

[READ?](#)

[*RST](#)

[SYSTem:PRESet](#)

INITiate[:IMMediate]

Changes the state of the triggering system from "idle" to "wait-for-trigger." Measurements will begin when the specified trigger conditions are satisfied following the receipt of the INITiate command. This command also clears the previous set of measurements from reading memory.

Parameter	Typical Return
(none)	(none)
Return five DC voltage measurements, using a software trigger to start the measurements: CONF:VOLT:DC 10,0.003 TRIG:SOUR BUS SAMP:COUN 5 INIT *TRG FETC?	

- Storing measurements in reading memory with [INITiate](#) is faster than sending measurements to the instrument's output buffer using [READ?](#) (provided you do not send [FETCh?](#) until done). The INITiate command is also an "overlapped" command. This means that after executing INITiate, you can send other commands that do not affect the measurements.
- You can store up to 1,000 measurements in the reading memory of the 34460A or 10,000 measurements on the 34461A. If reading memory overflows, new measurements will overwrite the oldest measurements stored; the most recent measurements are always preserved. No error is generated, but the Reading Mem Ovfl bit (bit 14) is set in the Questionable Data Register's condition register (see [Status System Introduction](#)).
- To retrieve the measurements from the reading memory, use [FETCh?](#). Use [DATA:REMove?](#) or [R?](#) to read and erase all or part of the available measurements.
- The [ABORt](#) command may be used to return to idle.

OUTPut:TRIGger:SLOPe {POSitive|NEGative} OUTPut:TRIGger:SLOPe?

Selects the slope of the *voltmeter complete* output signal on the rear-panel [VM Comp](#) BNC connector.

Parameter	Typical Return
{POSitive NEGative}, default NEGative	POS or NEG
Configure DC voltage measurements and make two measurements. The signal on the rear-panel VM Comp connector will output a positive pulse as each measurement is completed: CONF:VOLT:DC 10 SAMP:COUN 2 OUTP:TRIG:SLOP POS INIT	

- On the 34460A, this requires option 34460A-LAN or option 3446LANU.
- This parameter is set to its default value after a Factory Reset ([*RST](#)) or Instrument Preset ([SYSTem:PRESet](#)).

R? [<max_readings>]

Reads and erases all measurements from the reading memory up to the specified <max_readings>. The measurements are read and erased from the reading memory starting with the oldest measurement first.

Parameter	Typical Return
34460A: 1 to 1,000 readings 34461A: 1 to 10,000 readings Default is all readings in memory	#247-4.98748741E-01,-4.35163427E-01,-7.41859188E-01 The "#2" means that the next 2 digits indicate how many characters will be in the returned memory string. These two digits are the "47" after the "#2". Therefore, the remainder of the string is 47 digits long: -4.98748741E-01,-4.35163427E-01,-7.41859188E-01
Read and remove the three oldest readings: R? 3	

- The [R?](#) and [DATA:REMove?](#) queries allow you to periodically remove measurements from the reading memory that would normally cause the reading memory to overflow.
- You can store up to 1,000 measurements in the reading memory of the 34460A or 10,000 measurements on the 34461A. If reading memory overflows, new measurements will overwrite the oldest measurements stored; the most recent measurements are always preserved. No error is generated, but the Reading Mem Ovfl bit (bit 14) is set in the Questionable Data Register's condition register (see [Status System Introduction](#)).
- The instrument clears all measurements from reading memory when the measurement configuration changes, or when any of these commands is executed:

[INITiate](#)

[MEASure:<function>?](#)

[READ?](#)

[*RST](#)

[SYSTem:PRESet](#)

READ?

Starts a new set of measurements, waits for all measurements to complete, and transfers all available measurements. Sending READ? is similar to sending [INITiate](#) followed immediately by [FETCh?](#).

Parameter	Typical Return
(none)	-4.98748741E-01,-4.35163427E-01,-4.33118686E-01,-3.48109378E-01
Transfer measurements from reading memory: READ?	

- The [FETCh?](#) query does not erase measurements from the reading memory. You can send the query multiple times to retrieve the same data.
- You can store up to 1,000 measurements in the reading memory of the 34460A or 10,000 measurements on the 34461A. If reading memory overflows, new measurements will overwrite the oldest measurements stored; the most recent measurements are always preserved. No error is generated, but the Reading Mem Ovfl bit (bit 14) is set in the Questionable Data Register's condition register (see [Status System Introduction](#)).
- The instrument clears all measurements from reading memory when the measurement configuration changes, or when any of these commands is executed:

[INITiate](#)

[MEASure:<function>?](#)

[READ?](#)

[*RST](#)

[SYSTem:PRESet](#)

ROUTe:TERMinals?

Indicates which input terminals are selected on the 34461A front-panel **Front/Rear** switch. This switch is not programmable; this query reports the position of the switch, but cannot change it.

WARNING Do not toggle the Front/Rear switch with active signals on the terminals. This switch is not intended to be used in this way and may be damaged by high voltages or currents, possibly compromising the instrument's safety features.

Parameter	Typical Return
(none)	FRON or REAR
Return the state of the Front/Rear switch: ROUT:TERM?	

- On the 34460A, this query always returns FRON.

SAMPlE:COUNT {<count>|MIN|MAX|DEF} SAMPlE:COUNT? [{MIN|MAX|DEF}]

Specifies the number of measurements (samples) the instrument will take per trigger.

Parameter	Typical Return
1 (default) to 1,000,000	+1
Return ten sets of four resistance measurements, using an external trigger to start each measurement set: CONF:RES 1E6 SAMP:COUN 4 TRIG:COUN 10 TRIG:SOUR EXT;SLOP NEG READ? Typical Response: +1.00520000E+06, ... (40 measurements)	

- The front-panel sample annunciator ("*") turns on during each measurement at slower rates. The annunciator toggles at a fixed rate for fast measurements.
- You can use the specified sample count in conjunction with a trigger count ([TRIGger:COUNT](#)), which sets the number of triggers to be accepted before returning to the "idle" trigger state. The total number of measurements returned will be the product of the sample count and trigger count.
- You can store up to 1,000 measurements in the reading memory of the 34460A or 10,000 measurements on the 34461A. If reading memory overflows, new measurements will overwrite the oldest measurements stored; the most recent measurements are always preserved. No error is generated, but the Reading Mem Ovfl bit (bit 14) is set in the Questionable Data Register's condition register (see [Status System Introduction](#)).
- This parameter is set to its default value after a Factory Reset ([*RST](#)) or Instrument Preset ([SYSTem:PRESet](#)).

TEST:ALL?

Runs an instrument self-test and returns a pass/fail indication. The [TEST:ALL?](#) self-test is more comprehensive than the [*TST?](#) self-test.

CAUTION You must remove all input connections to the instrument before running the full self-test.

Parameter	Typical Return
(none)	+0 (pass) or +1 (one or more tests failed)
Run a self-test: TEST:ALL?	

- If one or more tests fail, the query returns +1 and stores an error in the error queue. For a complete listing of the error messages related to self-test failures, see [Self-test Error Messages](#).
- Following the test, the instrument returns to the instrument state that existed before the self-test.

UNIT:TEMPerature {C|F|K}

UNIT:TEMPerature?

Selects the units (°C, °F or Kelvin) to be used for all temperature measurements except the [SYSTem:TEMPerature?](#) query.

Parameter	Typical Return
{C F K}, default C	C, F, or K
Make a four-wire RTD measurement and return the result in °F: UNIT:TEMP F MEAS:TEMP? FRTD Typical Response: +6.82320000E+01	

- The command also accepts CEL or FAR, but the query returns C or F.
- This parameter is set to its default value after a Factory Reset ([*RST](#)) or Instrument Preset ([SYSTem:PRESet](#)).

See Also

[CONFigure:TEMPerature](#)

[MEASure:TEMPerature?](#)

[\[SENSe:\]FUNCTion\[:ON\]](#)

CALCulate Subsystem Introduction

The CALCulate subsystem receives real-time data from the measurement hardware and sends them to reading memory. It also optionally performs the following math operations, as shown in the diagram below:

- Scaling
- Statistics
- Limit checking
- Histogram

Only calculations enabled by [CALC:SCAL:STAT](#), [CALC:TRAN:HIST:STAT](#), [CALC:LIM:STAT](#), and [CALC:AVER:STAT](#) are performed.

Parts of the CALCulate Subsystem

[CALCulate:CLEar\[:IMMediate\]](#)

[SCALing Subsystem](#)

[AVERage Subsystem](#)

[LIMit Subsystem](#)

[HISTogram Subsystem](#)

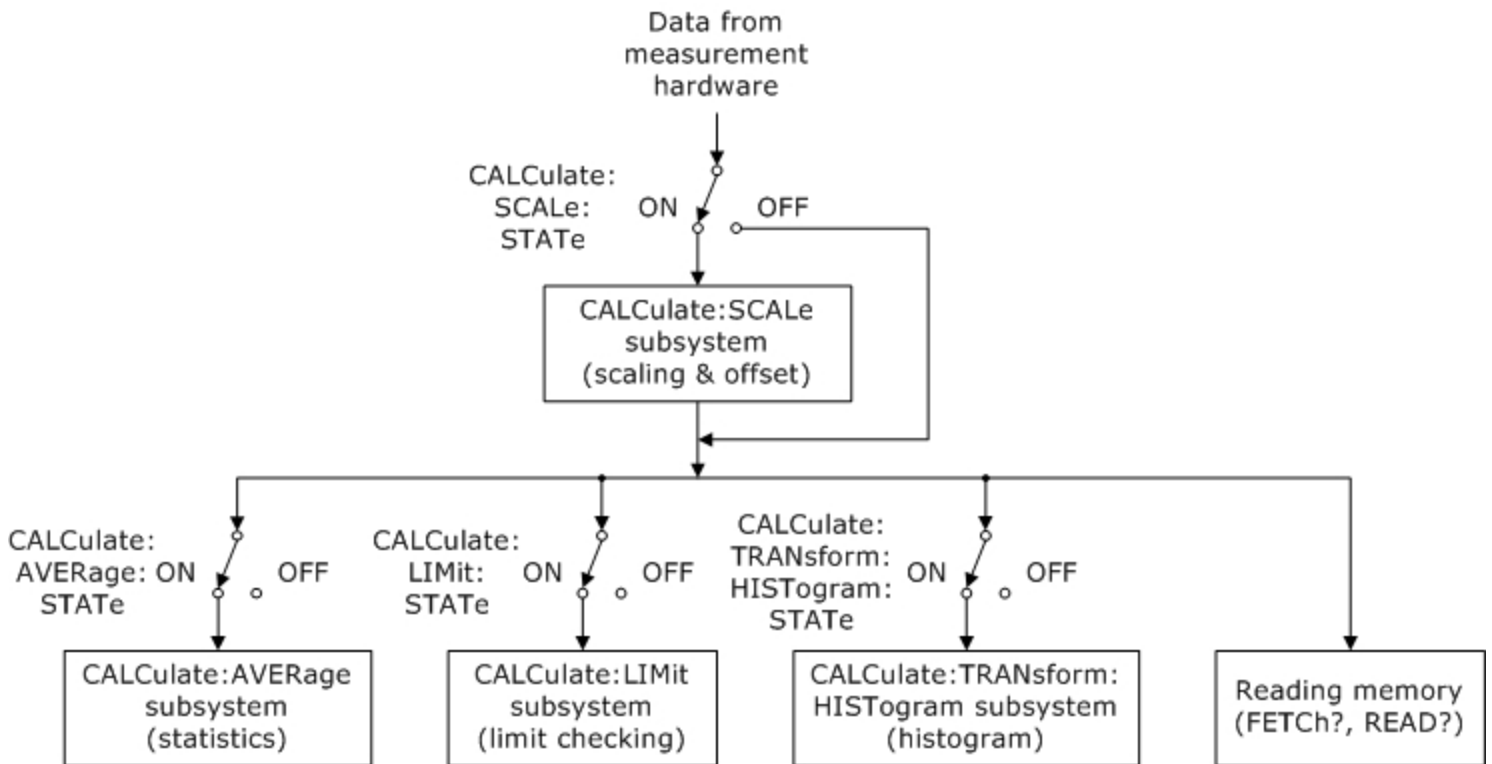

CALCulate:CLEar[:IMMediate]

Clears all limits, histogram data, statistics, and measurements.

Parameter	Typical Return
(none)	(none)
Clear all limits, histogram data, statistics, and measurements: CALC:CLE:IMM	

- The items cleared by this command are cleared synchronously, so that the histogram, statistics, and limit data all restart at the same time that measurements restart.

CALCulate:LIMit Subsystem

This subsystem specifies measurements and indicates when a limit has been exceeded.

Example

The following example enables limit testing of 100 DC voltage measurements and indicates whether measurements were outside the range of 3.2 to 3.4 V. Measurements above 3.4 V will set bit 12 (Upper Limit Failed) of the Questionable Status Register; measurements below 3.2 V will set bit 11 (Lower Limit Failed).

```
*CLS
STAT:PRES
CONF:VOLT 10,.001
SAMP:COUN 100
CALC:LIM:LOW 3.2
CALC:LIM:UPP 3.4
CALC:LIM:STAT ON
INIT
*WAI
STAT:QUES?
```

Typical Response: +4096 (at least one measurement was above the upper limit)

Command Summary

[CALCulate:LIMit:CLEar\[:IMMediate\]](#)

[CALCulate:LIMit:{LOWer|UPPer}\[:DATA\]](#)

[CALCulate:LIMit\[:STATe\]](#)

CALCulate:LIMit:CLEar[:IMMediate]

Clears front-panel indications of limits being exceeded and clears bit 11 ("Lower Limit Failed") and bit 12 ("Upper Limit Failed") in the Condition Register of the Questionable Data Register event register group. The corresponding event register bits are unaffected.

A condition register continuously monitors the state of the instrument. Condition register bits are updated in real time; they are neither latched nor buffered.

An event register is a read-only register that latches events from the condition register. While an event bit is set, subsequent events corresponding to that bit are ignored.

Parameter	Typical Return
(none)	(none)
Clear the limit test results: CALC:LIM:CLE	

- This command does not clear measurements in reading memory.
- The instrument clears front-panel indications of limits being exceeded and clears bits 11 and 12 in the Questionable Data Register when the measurement function changes, or when any of the following commands is executed:

[CALCulate:LIMit:STATe ON](#)

[INITiate](#)

[MEASure:<function>?](#)

[READ?](#)

[CALCulate:LIMit:CLEar](#)

[*RST](#)

[SYSTem:PRESet](#)

- To clear statistics, limits, histogram data, and measurement data, use [CALCulate:CLEar\[:IMMediate\]](#).

CALCulate:LIMit:{LOWer|UPPer}[:DATA] {<value>|MIN|MAX|DEF}
CALCulate:LIMit:{LOWer|UPPer}[:DATA]? [{MIN|MAX|DEF}]

Sets an upper or lower limit.

Parameter	Typical Return
-1.0E+15 to -1.0E-15, or 0.0 (default) or +1.0E-15 to 1.0E+15	+1.00000000E+00
See Example .	

- You can assign a lower limit, an upper limit or both. Do not set the lower limit above the upper limit.
- *Limit crossing*: If a measurement is less than the specified lower limit, bit 11 ("Lower Limit Failed") is set in the Questionable Data Condition Register. A measurement greater than the specified upper limit sets bit 12 ("Upper Limit Failed"). See [STATus Subsystem Introduction](#) for further information.
- A CONFigure command resets both limits to 0.
- This parameter is set to its default value after a Factory Reset ([*RST](#)) or Instrument Preset ([SYSTem:PRESet](#)).

CALCulate:LIMit[:STATe]{ON|1|OFF|0}
CALCulate:LIMit[:STATe]?

Enables or disables limit testing.

Parameter	Typical Return
{ON 1 OFF 0}, default OFF	0 (OFF) or 1 (ON)
See Example .	

- The instrument clears front-panel indications of limits being exceeded and clears bits 11 and 12 in the Questionable Data Register when the measurement function changes, or when any of the following commands is executed:

[CALCulate:LIMit:STATe ON](#)

[INITiate](#)

[MEASure:<function>?](#)

[READ?](#)

[CALCulate:LIMit:CLEAr](#)

[*RST](#)

[SYSTem:PRESet](#)

- The instrument turns this setting OFF when the measurement function is changed or after [*RST](#) or [SYSTem:PRESet](#).

CALCulate:TRANSform:HISTogram Subsystem

The HISTogram subsystem configures the histogram display. The instrument clears histogram data when the measurement function changes and when any of the following commands is sent:

[CALCulate:TRANSform:HISTogram:CLEar\[:IMMediate\]](#)

[CALCulate:TRANSform:HISTogram:POINts](#)

[CALCulate:TRANSform:HISTogram:RANGe:AUTO](#)

[CALCulate:TRANSform:HISTogram:RANGe:{LOWer|UPPer}](#)

[CALCulate:TRANSform:HISTogram\[:STATe\]](#)

[INITiate\[:IMMediate\]](#)

[MEASure:<function>?](#)

[READ?](#)

[*RST](#)

[SYSTem:PRESet](#)

Command Summary

[CALCulate:TRANSform:HISTogram:ALL?](#)

[CALCulate:TRANSform:HISTogram:CLEar\[:IMMediate\]](#)

[CALCulate:TRANSform:HISTogram:COUNT?](#)

[CALCulate:TRANSform:HISTogram:DATA?](#)

[CALCulate:TRANSform:HISTogram:POINts](#)

[CALCulate:TRANSform:HISTogram:RANGe:AUTO](#)

[CALCulate:TRANSform:HISTogram:RANGe:{LOWer|UPPer}](#)

[CALCulate:TRANSform:HISTogram\[:STATe\]](#)

Example

This example enables an automatically scaled, 100-bin histogram of 1000 DCV measurements. It then returns the computed histogram, including the lower and upper range values, the total measurement count, and the bin data.

```
CONF:VOLT:DC 10,0.001
SAMP:COUN 1000
CALC:TRAN:HIST:RANG:AUTO ON
CALC:TRAN:HIST:POIN 100
CALC:TRAN:HIST:STAT ON
INIT
*WAI
CALC:TRAN:HIST:ALL?
```

Typical Response: +9.99383828E+00,+1.00513398E+01,+1000,<102 bin counts>

NOTE The above response indicates 102 bin counts because the histogram includes bins for values below and above the histogram range.

CALCulate:TRANSform:HISTogram:ALL? CALCulate:TRANSform:HISTogram:DATA?

The ALL form of the query returns a comma-separated list of the lower and upper range values, the number of measurements, and the bin data collected since the last time the histogram data was cleared. The DATA form returns only the bin data.

Parameter	Typical Return
(none)	See Example .
See Example .	

- The bin data includes the following, in order:
 - The number of measurements less than the lower range value
 - The number of measurements in the each of the bins, starting at the lower range value bin
 - The number of measurements greater than the upper range value
- Range values are real numbers returned in the form +1.00000000E+00. The number of measurements and bin data are signed, positive integers returned in the form +100.

CALCulate:TRANSform:HISTogram:CLEar[:IMMediate]

Clears the histogram data and restarts histogram ranging if it is enabled ([CALCulate:TRANSform:HISTogram:RANGe:AUTO ON](#)).

Parameter	Typical Return
(none)	(none)
Clear the histogram data: CALC:TRAN:HIST:CLE	

- This command does not clear measurements in reading memory.
- To clear statistics, limits, histogram data, and measurement data, use [CALCulate:CLEar\[:IMMediate\]](#).

CALCulate:TRANSform:HISTogram:COUNT?

Returns the number of measurements collected since the last time the histogram was cleared.

Parameter	Typical Return
(none)	+87
Return the number of measurements used to compute the current histogram: CALC:TRAN:HIST:COUN?	

CALCulate:TRANSform:HISTogram:POINTS{<value>|MIN|MAX|DEF} CALCulate:TRANSform:HISTogram:POINTS?[{MIN|MAX|DEF}]

Sets the number of bins between the lower and upper range values for the histogram. Two additional bins always exist: one for measurements below the lower range and one for measurements above the upper range.

Parameter	Typical Return
{10 20 40 100 200 400 MIN MAX DEF}, default 100	+100
See Example .	

- You can specify the lower and upper range values using [CALCulate:TRANSform:HISTogram:RANGe:{LOWer|UPPer}](#). Lower and upper range values are computed automatically if [CALCulate:TRANSform:HISTogram:RANGe:AUTO](#) is ON.
- This parameter is set to its default value after a Factory Reset ([*RST](#)) or Instrument Preset ([SYSTEM:PRESet](#)).

CALCulate:TRANSform:HISTogram:RANGe:AUTO{ON|1|OFF|0} CALCulate:TRANSform:HISTogram:RANGe:AUTO?

Enables or disables automatic selection of the histogram's lower and upper range values.

Parameter	Typical Return
{ON 1 OFF 0}, default ON	0 (OFF) or 1 (ON)
See Example .	

- **ON:** the instrument uses the first 1,000 measurements to set the lower and upper range values.
- **OFF:** the lower and upper range values are specified by [CALCulate:TRANSform:HISTogram:RANGe:{LOWer|UPPer}](#).
- Setting the lower or upper range value ([CALCulate:TRANSform:HISTogram:RANGe:{LOWer|UPPer}](#)) disables automatic selection of the lower and upper range values ([CALCulate:TRANSform:HISTogram:RANGe:AUTO OFF](#)).
- The instrument restarts automatic range value selection (if enabled) when [INITiate](#), [MEASure?](#) or [READ?](#) is executed.
- This parameter is set to its default value after a Factory Reset ([*RST](#)) or Instrument Preset ([SYSTEM:PRESet](#)).

CALCulate:TRANSform:HISTogram:RANGe:{LOWer|UPPer}{<value>|MIN|MAX|DEF}
CALCulate:TRANSform:HISTogram:RANGe:{LOWer|UPPer}?[{MIN|MAX|DEF}]

Sets the histogram's lower and upper range values. Setting the lower or upper range value ([CALCulate:TRANSform:HISTogram:RANGe:{LOWer|UPPer}](#)) disables automatic selection of the lower and upper range values ([CALCulate:TRANSform:HISTogram:RANGe:AUTO OFF](#)).

Parameter	Typical Return
-1.0E+15 to -1.0E-15, or 0.0 (default) or +1.0E-15 to 1.0E+15	+1.00000000E+06
See Example .	

- If automatic range value selection is enabled ([CALCulate:TRANSform:HISTogram:RANGe:AUTO ON](#)), the query returns the computed range value. If no histogram data exists, 9.91E37 (Not a Number) is returned.
- Lower and upper range values are computed automatically if [CALCulate:TRANSform:HISTogram:RANGe:AUTO](#) is ON.
- This parameter is set to its default value after a Factory Reset ([*RST](#)) or Instrument Preset ([SYSTem:PRESet](#)).

CALCulate:TRANSform:HISTogram[:STATe]{ON|1|OFF|0}
CALCulate:TRANSform:HISTogram[:STATe]?

Enables or disables histogram computation.

Parameter	Typical Return
{ON 1 OFF 0}, default OFF	0 (OFF) or 1 (ON)
See Example .	

- The instrument turns this setting OFF when the measurement function is changed or after [*RST](#) or [SYSTem:PRESet](#).

CALCulate:SCALE Subsystem

This subsystem scales ACV and DCV measurements.

Command Summary

[CALCulate:SCALE:DB:REference](#)

[CALCulate:SCALE:DBM:REference](#)

[CALCulate:SCALE:FUNCTion](#)

[CALCulate:SCALE:REference:AUTO](#)

[CALCulate:SCALE\[:STATe\]](#)

CALCulate:SCALE:DB:REference {<reference>|MIN|MAX|DEF} CALCulate:SCALE:DB:REference? [{MIN|MAX}]

Stores a relative value in the multimeter's dB Relative Register, which is used for the dB function in [CALCulate:SCALE:FUNCTion](#). When the dB function is enabled, this value will be subtracted from the each voltage measurement after the measurement is converted to dBm.

NOTE This command applies only to ACV and DCV measurement functions.

Parameter	Typical Return
-200.0 dBm to +200.0 dBm, default 0	+3.00000000E+02
Enable dB scaling with a -10 dB reference and a 300 Ω dBm reference resistance: CALC:SCAL:DBM:REF 300 CALC:SCAL:DB:REF -10.0 CALC:SCAL:FUNC DB CALC:SCAL:STAT ON	

- Specifying a reference value disables automatic reference selection ([CALCulate:SCALE:REference:AUTO OFF](#)).
- The dB relative value parameter is relative to the dBm reference set with [CALCulate:SCALE:DBM:REference](#).
- The instrument sets the reference value to 0.0 with automatic reference selection enabled after a Factory Reset ([*RST](#)), an Instrument Preset ([SYSTEM:PRESet](#)), a change in math function, or a change in measurement function.

CALCulate:SCALE:DBM:REference {<reference>|MIN|MAX|DEF}
CALCulate:SCALE:DBM:REference? [{MIN|MAX}]

Selects the reference resistance for converting voltage measurements to dBm. This reference value affects the dBm and dB scaling functions.

NOTE This command applies only to ACV and DCV measurement functions.

Parameter	Typical Return
50, 75, 93, 110, 124, 125, 135, 150, 250, 300, 500, 600 (default), 800, 900, 1000, 1200 or 8000 Ω	+3.00000000E+02
Enable dBm scaling with a reference resistance of 300 Ω: CALC:SCAL:DBM:REF 300 CALC:SCAL:FUNC DBM CALC:SCAL:STAT ON	

- The instrument sets the reference value to its default value after a Factory Reset (***RST**), an Instrument Preset (**SYSTem:PRESet**), a change in math function, or a change in measurement function.

CALCulate:SCALE:FUNCTION {DB|DBM}
CALCulate:SCALE:FUNCTION?

Selects the operation that will be performed by the scaling function:

- DB performs a relative dB computation. The result will be the difference between the input signal and the stored DB relative value ([CALCulate:SCALE:DB:REference](#)), with both values converted to dBm (dB = measurement in dBm – relative value in dBm).
- DBM performs a dBm computation. The result is logarithmic and is based on a calculation of power delivered to a reference resistance ([CALCulate:SCALE:DBM:REference](#)), relative to 1 milliwatt. (dBm = $10 \times \log_{10}$ (measurement² / reference resistance / 1 mW)).

NOTE This command applies only to ACV and DCV measurement functions.

Parameter	Typical Return
{DB DBM}	DB or DBM
Enable the DB scaling function referenced to the next measurement taken: CALC:SCAL:FUNC DB CALC:SCAL:STAT ON	

- For the dB function, the reference value can be automatically selected using the first measurement converted to dBm as the reference value (see [CALCulate:SCALE:REference:AUTO](#)), or it can be specified by [CALCulate:SCALE:DB:REference](#).
- Scaling function results must be in the range of -1.0E+24 to -1.0E-24, or +1.0E-24 to 1.0E+24. Results outside these limits will be replaced with -9.9E37 (negative infinity), 0, or 9.9E37 (positive infinity).
- This parameter is set to its default value after a Factory Reset (***RST**) or Instrument Preset (**SYSTem:PRESet**).

CALCulate:SCALE:REfERENCE:AUTO {ON|1|OFF|0} CALCulate:SCALE:REfERENCE:AUTO?

Enables or disables automatic reference selection for the dB scaling functions.

NOTE This command applies only to ACV and DCV measurement functions.

Parameter	Typical Return
{ON 1 OFF 0}, default ON	0 (OFF) or 1 (ON)
Enable the DB function with automatic reference selection and use the first measurement as the reference value: CALC:SCAL:DBM:REF 50 CALC:SCAL:FUNC DB CALC:SCAL:REF:AUTO ON CALC:SCAL:STAT ON READ?	

- **ON:** the first measurement made will be used as the reference for all subsequent measurements, and automatic reference selection will be disabled:
 - For the dB scaling function, the first measurement is converted to dBm, and [CALCulate:SCALE:DB:REfERENCE](#) is set to the result.
- **OFF:** [CALCulate:SCALE:DB:REfERENCE](#) specifies the reference for DB scaling.
- The instrument enables automatic reference selection when the scaling function is enabled ([CALCulate:SCALE:STATe ON](#)).
- This parameter is set to its default value after a Factory Reset ([*RST](#)) or Instrument Preset ([SYSTem:PRESet](#)).

CALCulate:SCALE[:STATe] {ON|1|OFF|0} CALCulate:SCALE[:STATe]?

Enables or disables the scaling function.

NOTE This command applies only to ACV and DCV measurement functions.

Parameter	Typical Return
{ON 1 OFF 0}, default OFF	0 (OFF) or 1 (ON)
Enable the DB function with automatic reference selection and use the first measurement as the reference value: CALC:SCAL:DBM:REF 50 CALC:SCAL:FUNC DB CALC:SCAL:REF:AUTO ON CALC:SCAL:STAT ON READ?	

- Enabling the scaling function also enables automatic null value selection ([CALCulate:SCALE:REfERENCE:AUTO](#)).
- The instrument turns this setting OFF when the measurement function is changed or after [*RST](#) or [SYSTem:PRESet](#).

CALCulate:AVERage Subsystem

This subsystem calculates measurement statistics.

Command Summary

[CALCulate:AVERage\[:STATe\]](#)

[CALCulate:AVERage:CLear\[:IMMediate\]](#)

[CALCulate:AVERage:ALL?](#)

[CALCulate:AVERage:AVERage?](#)

[CALCulate:AVERage:COUNT?](#)

[CALCulate:AVERage:MAXimum?](#)

[CALCulate:AVERage:MINimum?](#)

[CALCulate:AVERage:PTPeak?](#)

[CALCulate:AVERage:SDEVIation?](#)

CALCulate:AVERage[:STATe]{ON|1|OFF|0}
CALCulate:AVERage[:STATe]?

Enables or disables statistics computation.

Parameter	Typical Return
{ON 1 OFF 0}, default OFF	0 (OFF) or 1 (ON)
Return the statistics of 100 frequency measurements: CONF:FREQ 1.0E3,.001 SAMP:COUN 100 CALC:AVER:STAT ON INIT *WAI CALC:AVER:ALL?	
Typical Response: +1.00520000E+03,+1.00512000E+03,+1.00527000E+03,+4.13500000E-01	

- Statistics are cleared when the measurement function changes or when any of these commands is executed:

[CALCulate:AVERage:STATe ON](#)

[CALCulate:AVERage:CLEAr](#)

[INITiate](#)

[MEASure:<function>?](#)

[READ?](#)

[*RST](#)

[SYSTem:PRESet](#)

- The instrument turns this setting OFF when the measurement function is changed or after [*RST](#) or [SYSTem:PRESet](#).

CALCulate:AVERage:ALL?
CALCulate:AVERage:AVERage?
CALCulate:AVERage:COUNT?
CALCulate:AVERage:MAXimum?
CALCulate:AVERage:MINimum?
CALCulate:AVERage:PTPeak?
CALCulate:AVERage:SDEVIation?

The CALCulate:AVERage:ALL? query returns the arithmetic mean (average), standard deviation, minimum value and maximum value of all measurements taken since the statistics were last cleared. The count and peak-to-peak statistics are not returned by CALCulate:AVERage:ALL?.

The other six queries listed above return individual values.

Parameter	Typical Return
(none)	(see below)
Return the statistics of 100 frequency measurements:	
CONF:FREQ 1.0E3,.001	
SAMP:COUN 100	
CALC:AVER:STAT ON	
INIT	
*WAI	
CALC:AVER:ALL?	
Typical Response: +1.00520000E+03,+1.00512000E+03,+1.00527000E+03,+4.13500000E-01	

- Statistics are cleared when the measurement function changes or when any of these commands is executed:

[CALCulate:AVERage:STATe ON](#)

[CALCulate:AVERage:CLEAr](#)

[INITiate](#)

[MEASure:<function>?](#)

[READ?](#)

[*RST](#)

[SYSTem:PRESet](#)

- All values except the COUNT are returned in the form +1.23450000E+01. The count is as a signed, positive integer: +129.
- When dB or dBm scaling is used, the CALC:AVER:AVER and CALC:AVER:SDEV queries return +9.91000000E+37 (not a number).

CALCulate:AVERage:CLEar[:IMMediate]

Clears all computed statistics: minimum, maximum, average, peak-to-peak, count and standard deviation.

Parameter	Typical Return
(none)	(none)
Clear the stored statistical data: CALC:AVER:CLE	

- This command does not clear measurements in reading memory.
- Statistics are cleared when the measurement function changes or when any of these commands is executed:

[CALCulate:AVERage:STATe ON](#)

[CALCulate:AVERage:CLEar](#)

[INITiate](#)

[MEASure:<function>?](#)

[READ?](#)

[*RST](#)

[SYSTem:PRESet](#)

- To clear statistics, limits, histogram data, and measurement data, use [CALCulate:CLEar\[:IMMediate\]](#).

CALibration Subsystem

NOTE

Read the [calibration procedure](#) before calibrating. Improper calibration can reduce accuracy and reliability.

[CALibration:ADC?](#)

[CALibration\[:ALL\]?](#)

[CALibration:COUnT?](#)

[CALibration:SECure:CODE](#)

[CALibration:SECure:STATe](#)

[CALibration:STORe](#)

[CALibration:STRing](#)

[CALibration:VALue](#)

CALibration:ADC?

Performs a low-level calibration of the ADC (analog-to-digital converter) circuitry.

NOTE

You must unsecure the instrument to calibrate it or to change the calibration string or security code.

Parameter	Typical Return
(none)	0 (successful) or 1 (unsuccessful)
Calibrate the ADC: CAL:ADC?	

- This is the first step in a re-calibration sequence, and must be done before doing the offset calibration.

CALibration[:ALL]?

Performs a calibration using the calibration value based on the function and range ([CALibration:VALue](#)). Note that a short must be applied for the resistance and voltage measurement functions, and the inputs must be open for the current measurement functions.

NOTE

You must unsecure the instrument to calibrate it or to change the calibration string or security code.

Parameter	Typical Return
(none)	+0 (pass) or +1 (fail)
Perform a zero calibration of the ACV measurement function and return a pass/fail indication: CONF:VOLT:AC CAL:SEC:STAT OFF,MY_CAL_CODE CAL:VAL 0.0 CAL? CAL:STOR CAL:SEC:STAT ON	

- This query increments the instrument's calibration count ([CALibration:COUnT?](#)) and modifies the volatile version of the calibration constants. Use [CALibration:STORe](#) to save these constants in nonvolatile memory at end of calibration.

CALibration:COUNT?

Returns the calibration count. Read and record the initial count when you first receive your instrument.

Parameter	Typical Return
(none)	+117
Return the calibration count: CAL:COUN?	

- Because the value increments each time you store the calibration constants, a complete calibration adds many counts. The calibration count also increments whenever you save a calibration string, change the calibration password, or override the calibration security.
- You can perform this query regardless of whether the instrument is secured.
- This setting is non-volatile; it will not be changed by power cycling or [*RST](#).

See Also

[SYSTem:SECurity:COUNT?](#)

CALibration:SECure:CODE<new_code>

Sets the security code to prevent unauthorized calibrations.

NOTE You must unsecure the instrument to calibrate it or to change the calibration string or security code.

Parameter	Typical Return
Unquoted string up to 12 characters Must start with letter (A-Z) May contain letters, numbers (0-9) and underscores	(none)
Set new security code: CAL:SEC:STAT OFF,OLD_CAL_CODE CAL:SEC:CODE TST_DUT165 CAL:SEC:STAT ON	

- To change the code: unsecure calibration memory with the old code, then set the new code.
- If you forget your security code, see Unsecure Instrument Without Security Code.
- This setting is non-volatile; it will not be changed by power cycling or [*RST](#).

CALibration:SECure:STATe{ON|1|OFF|0}[, <code>] CALibration:SECure:STATe?

Unsecures or secures the instrument for calibration.

NOTE You must unsecure the instrument to calibrate it or to change the calibration string or security code.

Parameter	Typical Return
{ON 1 OFF 0}, default ON	0 (OFF) or 1 (ON)
Unsecure calibration: CAL:SEC:STAT OFF,MY_CODE_272	
Secure calibration: CAL:SEC:STAT ON	

- The <code> is optional to secure the instrument, but must be correct if provided.
- Front panel and remote interface calibration share the same code.
- This setting is non-volatile; it will not be changed by power cycling or [*RST](#).

CALibration:STORE

Takes calibration constants in volatile memory ([CALibration:ALL?](#)), and places them in nonvolatile memory, where they will not be changed by power cycle or [*RST](#). Do this at the end of calibration to avoid losing changes.

NOTE You must unsecure the instrument to calibrate it or to change the calibration string or security code.

Parameter	Typical Return
(none)	(none)
Store calibration constants into non-volatile memory: CAL:STOR	

CALibration:STRing"<string>" CALibration:STRing?

Stores a message in calibration memory. Common messages include the last calibration date, calibration due date, or calibration department contact information. You can perform this query regardless of whether the instrument is secured.

NOTE You must unsecure the instrument to calibrate it or to change the calibration string or security code.

Parameter	Typical Return
Quoted string up to 40 characters May contain letters, numbers, spaces, and other common characters.	"FOR CAL HELP, CALL JOE AT EXT 1234" (If no string stored, returns "")
CAL:STR "FOR CAL HELP, CALL JOE AT EXT 1234"	

- This string may be stored only from the remote interface, but you can read the message from the front-panel or remote interface.
- Storing a calibration message overwrites the previous message.
- This setting is non-volatile; it will not be changed by power cycling or [*RST](#).

CALibration:VALue<value>
CALibration:VALue?

Specifies the value of the applied calibration signal.

NOTE You must unsecure the instrument to calibrate it or to change the calibration string or security code.

Parameter	Typical Return
Numeric, default 0.0	+2.37000000E-02
Specify calibration value 0.0237: CAL:VAL 2.37E-2	

- This parameter is set to its default value after a Factory Reset ([*RST](#)) or Instrument Preset ([SYSTem:PRESet](#)).

CONFigure Subsystem

The CONFigure commands are the most concise way to configure measurements. Like the [MEASure?](#) queries, these commands use default measurement configuration values. However, these commands do not automatically start measurements, so you can modify measurement attributes before initiating the measurement.

NOTE Use [INITiate](#) or [READ?](#) to initiate measurements.

Command Summary

[CONFigure?](#)

[CONFigure:CONTInuity](#)

[CONFigure:CURRent:{AC|DC}](#)

[CONFigure:DIODe](#)

[CONFigure:{FREQuency|PERiod}](#)

[CONFigure:{RESistance|FRESistance}](#)

[CONFigure:TEMPerature](#)

[CONFigure\[:VOLTage\]:{AC|DC}](#)

[CONFigure\[:VOLTage\]\[:DC\]:RATio](#)

Default Settings for the CONFigure Command

The CONFigure commands select the function, range and resolution in one command. Specify *<resolution>* in the measurement's units (V, A, Hz, Ω , and so on). All other parameters are set to their default values (below).

Measurement Parameter	Default Setting
AC Input Filter (bandwidth)	20 Hz (medium filter)
Autozero	OFF if resolution setting results in NPLC < 1 ON if resolution setting results in NPLC \geq 1
Range	AUTO (including voltage range for frequency and period measurements)
Samples per Trigger	1 sample
Trigger Count	1 trigger
Trigger Delay	Automatic delay
Trigger Source	Immediate
Trigger Slope	NEGative
Math Functions	Disabled. Other parameters are unchanged.
Per-function Null State	Disabled

Using CONFigure

The following example uses CONFigure and [READ?](#) to make an externally-triggered measurement. The CONFigure command configures DC voltage measurements but does not place the instrument in the "wait-for-trigger" state.

The [READ?](#) query places the instrument in the "wait-for-trigger" state, initiates a measurement when the rear-panel **Ext Trig** input is pulsed (low by default), stores the measurement in reading memory, and transfers the measurement to the instrument's output buffer. The default range (autorange) and resolution (10 PLC) are used for the measurement.

```
CONF:VOLT:DC
TRIG:SOUR EXT
READ?
```

Typical Response: +4.27150000E+00

The following example is like the previous one, but it uses [INITiate](#) and [FETCh?](#) instead of [READ?](#). The [INITiate](#) command places the instrument in the "wait-for-trigger" state, triggers a measurement when the rear-panel **Ext Trig** input is pulsed (low by default), and sends the measurement to reading memory. The [FETCh?](#) query transfers the measurement from reading memory to the instrument's output buffer.

```
CONF:VOLT:DC
TRIG:SOUR EXT
INIT
FETCh?
```

Typical Response: +5.34250000E+00

Storing measurements in reading memory with [INITiate](#) is faster than sending measurements to the instrument's output buffer using [READ?](#) (provided you do not send [FETCh?](#) until done). The [INITiate](#) command is also an "overlapped" command. This means that after executing [INITiate](#), you can send other commands that do not affect the measurements. This allows you to check for data availability before initiating a read attempt that might otherwise time out. Note that the [FETCh?](#) query waits until all measurements are complete to terminate. You can store up to 1,000 measurements in the reading memory of the 34460A or 10,000 measurements on the 34461A.

The following example configures the instrument for 2-wire resistance measurements, triggers the instrument to make one measurement using [INITiate](#), and stores the measurement in reading memory. The 10 k Ω range is selected with 100 Ω resolution.

```
CONF:RES 10000,100
INIT
FETCh?
```

Typical Response: +5.95850000E+03

CONFigure?

Returns a quoted string indicating the present function, range, and resolution. The short form of the function name (CURR:AC, FREQ) is always returned.

Parameter	Typical Return
(none)	"VOLT +1.00000000E+01,+3.00000000E-06"
Return the present function, range, and resolution. CONF?	

CONFigure:CONTInuity

Sets all measurement parameters and trigger parameters to their [default values](#) for continuity measurements.

Parameter	Typical Return
(none)	+1.32130000E-02
Configure the instrument for continuity measurements. Then make a measurement using an external trigger with positive slope (rising edge) and read the measurement: CONF:CONT TRIG:SOUR EXT;SLOP POS READ?	

- The range and resolution are fixed at 1 k Ω for continuity tests (a 2-wire resistance measurement).
- The instrument beeps (if the beeper is enabled) for each measurement less than or equal to the continuity threshold ($\leq 10 \Omega$), and the actual resistance measurement appears on the display.
- From 10 Ω to 1.2 k Ω , the instrument displays the actual resistance measurement with no beep. Above 1.2 k Ω , the instrument displays "OPEN" with no beep.
- The [FETCh?](#), [READ?](#), and [MEASure:CONTInuity?](#) queries return the measured resistance, regardless of its value.
- Use [READ?](#) or [INITiate](#) to start the measurement.

CONFigure:CURRent:{AC|DC}[{<range>|AUTO|MIN|MAX|DEF} [, {<resolution>|MIN|MAX|DEF}]]

Sets all measurement parameters and trigger parameters to their [default values](#) for AC or DC current measurements. Also specifies the range and resolution.

NOTE On the 34461A, use the [\[SENSe:\]CURRent:{AC|DC}:TERMinals](#) command to specify which current terminals to use for the measurement.

Parameter	Typical Return
<range>: {100 μ A 1 mA 10 mA 100 mA 1 A 3 A 10 A}, default AUTO (autorange)	(none)
<resolution> (AC): optional and ignored; fixed at 6½ digits. <resolution> (DC): See Resolution Table or Range, Resolution and NPLC . The default is equivalent to 10 PLC. Specify <resolution> in the measurement's units (V, A, Hz, Ω , and so on).	
Configure AC current measurements using the 1 A range. Make and read two measurements: CONF:CURR:AC 1 SAMP:COUN 2 READ? Typical Response: +8.54530000E-01,+8.54520000E-01	
Configure DC current measurements using the 1 A range with 1 mA resolution. Then make a measurement using an external trigger with positive slope (rising edge) and read the measurement: CONF:CURR:DC 1,0.001 TRIG:SOUR EXT;SLOP POS INIT FETC? Typical Response: +4.27150000E-01	

- Choosing the 10 A range automatically sets the [SENSe:]CURRent:{AC|DC}:TERMinals parameter to 10 A, and setting the range to 3 A or less sets the [SENSe:]CURRent:{AC|DC}:TERMinals parameter to 3 A.
- You can let autoranging select the measurement range, or you can manually select a fixed range. Autoranging conveniently selects the range for each measurement based on the input signal. For fastest measurements, use manual ranging (autoranging may require additional time for range selection).
- Autoranging (AUTO or DEFault), will generate an error if you specify a <resolution> because the instrument cannot accurately resolve the integration time (especially if the input continuously changes). If your application requires autoranging, specify DEFault for the <resolution> or omit the <resolution> altogether.
- Autoranging goes down a range at less than 10% of range and up a range at greater than 120% of range.
- If the input signal is greater than can be measured on the specified manual range, the instrument displays the word Overload on front panel and returns "9.9E37" from the remote interface.
- To control the measurement rate for AC measurements, change the trigger delay or AC filter bandwidth.
- Use [READ?](#) or [INITiate](#) to start the measurement.

See Also

[CONFigure?](#)

[MEASure:CURRent:{AC|DC}?](#)

CONFigure:DIODe

Sets all measurement parameters and trigger parameters to their [default values](#) for diode tests.

Parameter	Typical Return
(none)	(none)
Configure, make, and read a default diode measurement: CONF:DIOD READ? Typical Response: +1.32130000E-01	

- The range and resolution are *fixed* for diode tests: the range is 1 VDC (with a 1 mA current source output).
- The voltage is displayed on the front panel if it is between 0 and 5.05 V. The instrument beeps when the signal transitions into the range between 0.3 and 0.8 V (unless beeper is disabled). If the signal exceeds 5.05 V, the front panel shows "OPEN", and the value returned from SCPI is 9.9E37.
- The [FETCh?](#), [READ?](#), and [MEASure:DIODe?](#) queries return the measured voltage, regardless of its value.
- Use [READ?](#) or [INITiate](#) to start the measurement.

CONFigure:{FREQUENCY|PERIOD} [{<range>|MIN|MAX|DEF} [, {<resolution>|MIN|MAX|DEF}]]

Sets all measurement and trigger parameters to their [default values](#) for frequency or period measurements. Also specifies the range and resolution.

Parameter	Typical Return
<range>: 3 Hz to 300 kHz, default 20 Hz (FREQUENCY)	(none)
<range>: 3.33 μs to 333.33 ms, default 50 ms for PERIOD	
<resolution>: 1 ppm × <range> (MINimum) to 100 ppm × <range> (MAXimum), DEFault = 10 ppm × <range> (100 ms aperture) Specify <resolution> in the measurement's units (V, A, Hz, Ω, and so on).	
Configure frequency measurements using the default aperture and the 200 Hz (fast) AC filter. Then make and read one measurement: CONF:FREQ FREQ:RANG:LOW 200 READ? Typical Response: +1.32130000E+03	

- The <range> parameter is required only to specify the measurement resolution parameter. It is not necessary to send a new command for each new frequency or period to be measured.
- If the input voltage is too large for the selected voltage range (manual ranging), the instrument displays the word Overload on the front panel and returns "9.9E37" from the remote interface. Autoranging can be enabled for the input voltage.
- Period and frequency measurements do not autorange; the <range> and <resolution> parameters affect the aperture (gate time) as follows:

Resolution	Aperture
100 ppm × <range> (MAXimum)	10 ms
10 ppm × <range> (DEFault)	100 ms
1 ppm × <range> (MINimum)	1 s

- With no signal applied, 0 is returned.
- Use [READ?](#) or [INITiate](#) to start the measurement.

See Also

[CONFigure?](#)

[MEASure:{FREQUENCY|PERIOD}?](#)

CONFigure:{RESistance|FRESistance} [{<range>|AUTO|MIN|MAX|DEF} [, {<resolution>|MIN|MAX|DEF}]]

Sets all measurement parameters and trigger parameters to their [default values](#) for 4-wire (FRESistance) or 2-wire (RESistance) resistance measurements. Also specifies the range and resolution.

Parameter	Typical Return
<range>: 100 Ω, 1 kΩ, 10 kΩ, 100 kΩ, 1 MΩ, 10 MΩ, 100 MΩ, AUTO (default) or DEFault	+8.54530000E+01
<resolution>: See Resolution Table or Range, Resolution and NPLC . The default is equivalent to 10 PLC. Specify <resolution> in the measurement's units (V, A, Hz, Ω, and so on).	
Configure 4-wire resistance measurements using the 100 Ω range with default resolution. Make and read two measurements: CONF:FRES 100 SAMP:COUN 2 READ? Typical Response: +8.54530000E+01,+8.54520000E+01	

- You can let autoranging select the measurement range, or you can manually select a fixed range. Autoranging conveniently selects the range for each measurement based on the input signal. For fastest measurements, use manual ranging (autoranging may require additional time for range selection).
- Autoranging (AUTO or DEFault), will generate an error if you specify a <resolution> because the instrument cannot accurately resolve the integration time (especially if the input continuously changes). If your application requires autoranging, specify DEFault for the <resolution> or omit the <resolution> altogether.
- Autoranging goes down a range at less than 10% of range and up a range at greater than 120% of range.
- If the input signal is greater than can be measured on the specified manual range, the instrument displays the word Overload on front panel and returns "9.9E37" from the remote interface.
- Use [READ?](#) or [INITiate](#) to start the measurement.

See Also

[CONFigure?](#)

[MEASure:{RESistance|FRESistance}?](#)

CONFigure:TEMPerature[{FRTD|RTD|FTH|THER|DEFault} [, {<type> | DEFault} [, 1 [, {<resolution>|MIN|MAX|DEF}]]]]

Sets all measurement parameters and trigger parameters to their [default values](#) for temperature measurements. Also specifies the transducer and the measurement resolution.

Parameter	Typical Return
<probe_type>: {FRTD RTD FTH THER}, default FRTD	+2.12320000E+01
<type>: 85 (only possible value for RTD/FRTD) or 5000 (only possible value for THERmistor/FTHermistor)	
<resolution>: See Resolution Table or Range, Resolution and NPLC . The default is equivalent to 10 PLC. Specify <resolution> in the measurement's units (V, A, Hz, Ω, and so on).	
Configure a 4-wire RTD measurement. Then make a measurement using an external trigger with positive slope (rising edge) and read the measurement: CONF:TEMP FRTD,85 TRIG:SOUR EXT;SLOP POS READ?	

- For temperature measurements, the instrument internally selects the range; you cannot select the range to be used.
- The <resolution> parameter only determines the integration time; it does not specify the resolution of the temperature measurement. This parameter is optional; however, if you specify <resolution>, you must also specify "1" as the implied range parameter. For example: CONF:TEMP RTD, 85, 1, 0.000001 selects the 10 PLC integration time on the 34461A.
- To change temperature units, use [UNIT:TEMPerature](#).
- For RTD measurements, the instrument autoranges to the correct range for the transducer resistance measurement.
- For 4-wire RTD measurements, the instrument always enables the autozero function.
- If the input signal is greater than can be measured on the specified manual range, the instrument displays the word Overload on front panel and returns "9.9E37" from the remote interface.
- Use [READ?](#) or [INITiate](#) to start the measurement.

CONFigure[:VOLTage]:{AC|DC}[{<range>|AUTO|MIN|MAX|DEF} [, {<resolution>|MIN|MAX|DEF}]]

Sets all measurement parameters and trigger parameters to their [default values](#) for AC or DC voltage measurements. Also specifies the range and resolution.

WARNING The maximum range parameter (MAX) is 1000 V. However, the SAFETY LIMIT on the front and rear HI/LO input terminals is 750 VAC (rms). The rms voltage is waveform dependent. A sine wave is limited to 750 VAC (rms), but a 1000 Vpk square wave is safe. Connection to AC mains power is further limited to CAT II (300 V). See [Safety and Regulatory Information](#) for more information on the safety features and the safe operation of this instrument.

Parameter	Typical Return
<range>: {100 mV 1 V 10 V 100 V 1000 V}, default AUTO (autorange) <resolution> (AC): optional and ignored; fixed at 6½ digits. <resolution> (DC): See Resolution Table or Range, Resolution and NPLC . The default is equivalent to 10 PLC. Specify <resolution> in the measurement's units (V, A, Hz, Ω, and so on).	(none)
Configure AC voltage measurements using the 100 V range. Make and read two measurements: CONF:VOLT:AC 100 SAMP:COUN 2 READ? Typical Response: +8.54530000E+01,+8.54520000E+01 Configure DC voltage measurements using the 10 V range with 1 mV resolution. Then make a measurement using an external trigger with positive slope (rising edge) and read the measurement: CONF:VOLT:DC 10,0.001 TRIG:SOUR EXT;SLOP POS INIT FETC? Typical Response: +4.27150000E+00	

- You can let autoranging select the measurement range, or you can manually select a fixed range. Autoranging conveniently selects the range for each measurement based on the input signal. For fastest measurements, use manual ranging (autoranging may require additional time for range selection).
- Autoranging (AUTO or DEFault), will generate an error if you specify a <resolution> because the instrument cannot accurately resolve the integration time (especially if the input continuously changes). If your application requires autoranging, specify DEFault for the <resolution> or omit the <resolution> altogether.
- Autoranging goes down a range at less than 10% of range and up a range at greater than 120% of range.
- If the input signal is greater than can be measured on the specified manual range, the instrument displays the word Overload on front panel and returns "9.9E37" from the remote interface.
- To control the measurement rate for AC measurements, change the trigger delay or AC filter bandwidth.
- Use [READ?](#) or [INITiate](#) to start the measurement.

See Also

[CONFigure?](#)

[MEASure\[:VOLTage\]:{AC|DC}?](#)

[\[SENSe:\]CURRent:AC:BANDwidth](#)

CONFigure[:VOLTage][:DC]:RATio[{<range>|AUTO|MIN|MAX|DEF} [, {<resolution>|MIN|MAX|DEF}]]

Sets all measurement and trigger parameters to their [default values](#) for DC voltage to DC voltage ratio measurements. Also specifies the range and resolution.

To calculate a ratio, the instrument measures a DC reference voltage applied to the *Sense* terminal and the DC signal voltage applied to the *Input* terminals. It then uses the formula:

$$\text{Ratio} = \text{DC signal voltage} / \text{DC reference voltage}$$

Parameter	Typical Return
100 mV, 1 V, 10 V, 100 V, 1000 V, AUTO (default) or DEFault	(none)
<resolution>: See Resolution Table or Range, Resolution and NPLC . The default is equivalent to 10 PLC.	
Configure the instrument for DC voltage ratio measurements using the 100 V range with 1 mV resolution. Then make a measurement using an external trigger with positive slope (rising edge) and read the measurement: CONF:VOLT:DC:RAT 100,0.001 TRIG:SOUR EXT;SLOP POS INIT FETC? Typical Response: +4.27150000E+00	

- The *Sense* terminals have a maximum measurable input of ± 12 VDC. Autoranging is automatically selected for reference voltage measurements on the *Sense* terminals.
- The *Input LO* and *Sense LO* terminals must have a common reference and cannot have a voltage difference greater than ± 2 V.
- The specified measurement range applies only to the signal connected to the *Input* terminals. The signal on the *Input* terminals can be any DC voltage up to 1,000 V.
- For the *Input* terminals, you can allow the instrument to select the measurement range by autoranging or you can select a fixed range using *manual ranging*. Autoranging decides which range to use for each measurement based on the input signal. For faster measurements, use manual ranging on each measurement (additional time is required for autoranging to select a range).
- Autoranging (AUTO or DEFault), will generate an error if you specify a <resolution> because the instrument cannot accurately resolve the integration time (especially if the input continuously changes). If your application requires autoranging, specify DEFault for the <resolution> or omit the <resolution> altogether.
- Autoranging goes down a range at less than 10% of range and up a range at greater than 120% of range.
- If the input signal is greater than can be measured on the specified manual range, the instrument displays the word Overload on front panel and returns "9.9E37" from the remote interface.
- Use [READ?](#) or [INITiate](#) to start the measurement.

See Also

[CONFigure?](#)

[MEASure\[:VOLTage\]\[:DC\]:RATio?](#)

DATA Subsystem

This subsystem allows you to configure and remove data from reading memory. The instrument clears all measurements from reading memory when the measurement configuration changes, or when any of these commands is executed:

[INITiate](#)

[MEASure:<function>?](#)

[READ?](#)

[*RST](#)

[SYSTem:PRESet](#)

Command Summary

[DATA:LAST?](#)

[DATA:POINts?](#)

[DATA:POINts:EVENT:THReshold](#)

[DATA:REMOve?](#)

DATA:LAST?

Returns the last measurement taken. You can execute this query at any time, even during a series of measurements.

Parameter	Typical Return
(none)	One measurement with units. If no data is available, 9.91E37 (Not a Number) is returned with units. Example: +1.73730000E+00 VDC
Return the last measurement: DATA:LAST?	

DATA:POINts?

Returns the total number of measurements currently in reading memory. You can execute this query at any time, even during a series of measurements.

Parameter	Typical Return
(none)	+215
Return the number of measurements in reading memory: DATA:POIN?	

- You can store up to 1,000 measurements in the reading memory of the 34460A or 10,000 measurements on the 34461A.

DATA:POINts:EVENT:THReshold<count>
DATA:POINts:EVENT:THReshold?

Sets the number of measurements to store in reading memory before setting bit 9 in the Standard Operation Register group event register to 1. An event register is a read-only register that latches events from the condition register. While an event bit is set, subsequent events corresponding to that bit are ignored.

NOTE For more information on the SCPI Status System, see [Status Subsystem Introduction](#).

Parameter	Typical Return
34460A: 1 to 1,000 readings 34461A: 1 to 10,000 readings The default value is 1 for both models.	+125
Set the reading memory threshold to 125 measurements: DATA:POIN:EVEN:THR 125	

- To report any subsequent events, the measurement count must first drop below the programmed threshold before reaching the threshold again.
- Use [STATus:OPERation:ENABLE](#) to enable the Memory Threshold bit (bit 9 in the Standard Operation Event register) to be reported to the Status Byte.
- Once the Memory Threshold bit (bit 9 in the Standard Operation Event register) is set, it will remain set until cleared by [STATus:OPERation:EVENT?](#) or [*CLS](#).
- The Standard Operation Condition register shows the current condition. See [STATus Subsystem Introduction](#) for further information.
- This parameter is set to its default value after a Factory Reset ([*RST](#)) or Instrument Preset ([SYSTem:PRESet](#)).

DATA:REMOve?<num_readings> [,WAIT]

Reads and erases *<num_readings>* measurements from the reading memory. If fewer than *<num_readings>* measurements are available, the query will return an error unless the WAIT parameter is specified, in which case the query will wait until *<num_readings>* measurements are available.

Parameter	Typical Return
34460A: 1 to 1,000 readings 34461A: 1 to 10,000 readings	-4.97215654E-01,-4.97343268E-01,-4.97121213E-01
Read and erase the three oldest readings from reading memory: DATA:REMOve? 3	

- The [R?](#) and [DATA:REMOve?](#) queries allow you to periodically remove measurements from the reading memory that would normally cause the reading memory to overflow.
- You can store up to 1,000 measurements in the reading memory of the 34460A or 10,000 measurements on the 34461A. If reading memory overflows, new measurements will overwrite the oldest measurements stored; the most recent measurements are always preserved. No error is generated, but the Reading Mem Ovfl bit (bit 14) is set in the Questionable Data Register's condition register (see [Status System Introduction](#)).

DISPlay Subsystem

This subsystem controls the instrument's display.

Command Summary

[DISPlay\[:STATe\]](#)

[DISPlay:TEXT\[:DATA\]](#)

[DISPlay:TEXT:CLEar](#)

[DISPlay:VIEW](#)

DISPlay[:STATe] {ON|1|OFF|0} DISPlay[:STATe]?

Disables or enables the front-panel display. When disabled, the display dims, and all annunciators are disabled. However, the screen remains on.

Parameter	Typical Return
{ON 1 OFF 0}, default ON	0 (OFF) or 1 (ON)
Turn display off: DISP OFF	

- Disabling the display improves command execution speed from the remote interface and provides basic security.
- Sending [DISPlay:TEXT <string>](#) will display the text even with [DISP:STAT OFF](#).
- The display is enabled when power is cycled, or when you return to local (front-panel) operation by pressing the **[Local]** key.

DISPlay:TEXT[:DATA] "<string>" DISPlay:TEXT[:DATA]?

Displays a text message on the front-panel display.

Parameter	Typical Return
A quoted string of up to 40 characters. You can use letters (A-Z), numbers (0-9) and special characters such as @, %, *, and so forth. Default ""	"Test in progress..."
Show message on display: DISP:TEXT "Test in progress..."	

- Sending [DISPlay:TEXT <string>](#) will display the text even with [DISP:STAT OFF](#).
- While a message is displayed, information relating to the current instrument operation is not sent to the front-panel display.
- The display text is unaffected by [*RST](#). It is cleared at power-on.

DISPlay:TEXT:CLEAr

Clears the text message from the display.

Parameter	Typical Return
(none)	(none)
Clear displayed message: DISP:TEXT:CLE	

- With [DISPlay ON](#), DISP:TEXT:CLEAr returns the display to its normal mode.
- With [DISPlay OFF](#), DISP:TEXT:CLEAr clears the message and the display remains disabled. To enable the display, send [DISPlay ON](#) or press the front-panel **[Local]** key.
- The display text is unaffected by [*RST](#). It is cleared at power-on.

DISPlay:VIEW {NUMeric|HISTogram|TCHart|METer} DISPlay:VIEW?

Specifies whether measurement data is displayed in numeric, histogram, trend chart (34461A only), or bar meter form.

Parameter	Typical Return
{NUMeric HISTogram TCHart METer}, default NUM	HIST
Display histogram: DISP:VIEW HIST	

- This command does not turn on the display if the display state is OFF.
- This parameter is set to its default value after a Factory Reset ([*RST](#)) or Instrument Preset ([SYSTem:PRESet](#)).

HCOPY Subsystem

The HCOpy subsystem produces display images ("screen shots").

Example

The following example captures and returns the display image in BMP format.

```
HCOPY:SDUM:DATA:FORM BMP
HCOPY:SDUM:DATA?
```

HCOPY:SDUMp:DATA?

Returns the front panel display image ("screen shot").

Parameter	Typical Return
(none)	<i>(A definite-length binary block containing the image.)</i> A definite-length block allows data to be transmitted as a series of 8-bit data bytes. This is particularly useful for transferring large quantities of data or 8-bit extended ASCII codes.
See Example .	

- The image format (PNG or BMP) is specified by [HCOPY:SDUMp:DATA:FORMat](#).

HCOPY:SDUMp:DATA:FORMat {PNG|BMP}

HCOPY:SDUMp:DATA:FORMat?

Specifies the format for images returned by [HCOPY:SDUMp:DATA?](#).

Parameter	Typical Return
{PNG BMP}, default PNG	PNG or BMP
See Example .	

IEEE 488.2 Common Commands

These commands and queries are associated with the IEEE 488.2 standard.

Command Summary

[*CLS](#)

[*ESE](#)

[*ESR?](#)

[*IDN?](#)

[*LRN?](#)

[*OPC](#)

[*OPC?](#)

[*OPT?](#)

[*PSC](#)

[*RCL](#)

[*RST](#)

[*SAV](#)

[*SRE](#)

[*STB?](#)

[*TRG](#)

[*TST?](#)

[*WAI](#)

Standard Event Register

The following table describes the Standard Event Register.

Bit Number	Bit Name	Decimal Value	Definition
0	Operation Complete	1	All commands prior to and including *OPC have been executed.
1	Not Used	2	0 is returned.
2	Query Error	4	The instrument tried to read the output buffer but it was empty. Or, a new command line was received before a previous query has been read. Or, both the input and output buffers are full.
3	Device-Specific Error	8	A device-specific error, including a self-test error or calibration error, occurred (an error in the -300 range or any positive error has been generated). See SCPI Error Messages for the complete SCPI error message list.
4	Execution Error	16	An execution error occurred (an error in the -200 range has been generated).
5	Command Error	32	A command syntax error occurred (an error in the -100 range has been generated).
6	Not Used	64	0 is returned.
7	Power On	128	Power has been cycled since the last time the event register was read or cleared.

Status Byte Register

The following table describes the Status Byte Register.

Bit Number	Bit Name	Decimal Value	Definition
0	Not Used	1	(Reserved for future use)
1	Not Used	2	(Reserved for future use)
2	Error Queue	4	One or more errors have been stored in the Error Queue. Use SYSTEM:ERRor? to read and delete errors.
3	Questionable Data Summary	8	One or more bits are set in the Questionable Data Register (bits must be enabled, see STATus:QUEStionable:ENABLE).
4	Message Available	16	Data is available in the instrument's output buffer.
5	Standard Event Summary	32	One or more bits are set in the Standard Event Register (bits must be enabled, see *ESE).
6	Master Summary	64	One or more bits are set in the Status Byte Register and may generate a Request for Service (RQS). Bits must be enabled using *SRE .
7	Standard Operation Summary	128	One or more bits are set in the Standard Operation Register (bits must be enabled, see STATus:OPERation:ENABLE).

*CLS

Clear Status Command. Clears the event registers in all register groups. Also clears the error queue.

Parameter	Typical Return
(none)	(none)
Clear event register bits and error queue: *CLS	

*ESE <enable_value>

*ESE?

Event Status Enable Command and Query. Enables bits in the enable register for the [Standard Event Register](#) group. The selected bits are then reported to bit 5 of the Status Byte Register. An enable register defines which bits in the event register will be reported to the Status Byte register group. You can write to or read from an enable register.

NOTE

For more information on the SCPI Status System, see [Status Subsystem Introduction](#).

Parameter	Typical Return
Decimal sum of the bits in the register, default 0. For example, to enable bit 2 (value 4), bit 3 (value 8), and bit 7 (value 128), the decimal sum would be 140 (4 + 8 + 128). Default 0.	+48
Configure 100 DC voltage measurements and enable the generation of an SRQ when the measurements complete: *CLS *ESE 1 *SRE 32 CONF:VOLT:DC SAMP:COUN 100 INIT *OPC	

- Use [*PSC](#) to control whether the Standard Event enable register is cleared at power on. For example, *PSC 0 preserves the enable register contents through power cycles.
- [*CLS](#) clears the event register, but not the enable register.
- The <enable> setting is nonvolatile; it does not change after a Factory Reset ([*RST](#)), Instrument Preset ([SYSTem:PRESet](#)), Status Preset ([STATus:PRESet](#)) or Clear Status ([*CLS](#)).

*ESR?

Standard Event Status Register Query. Queries the event register for the [Standard Event Register](#) group.

An event register is a read-only register that latches events from the condition register. While an event bit is set, subsequent events corresponding to that bit are ignored.

Parameter	Typical Return
(none)	+24
Read the event register (bits 3 and 4 are set). *ESR?	

- In order to be reported to the Status Byte Register, the corresponding bits in the enable register must be enabled by [*ESE](#).
- Any or all conditions can be reported to the Standard Event summary bit through the enable register. To set the enable register mask, write a decimal value to the register using [*ESE](#).
- Once a bit is set, it remains set until cleared by reading the event register or by sending [*CLS](#) (clear status).

*IDN?

Identification Query. Returns the instrument's identification string.

Parameter	Typical Return
(none)	(see below)
Return the instrument's identification string: *IDN?	

- The identification string contains four comma separated fields:

Manufacturer name, Model number, Serial number, Revision code

If [SYSTem:IDENtify DEFault](#) is set, the returned string has the following format:

Agilent Technologies,34460A,<Serial Number>,ff.ff-pp.pp-mm.mm-gg.gg-bb-pp

Agilent Technologies,34461A,<Serial Number>,ff.ff-pp.pp-mm.mm-gg.gg-bb-pp

If [SYSTem:IDENtify HP34401A](#) is set, the returned string has the following format:

HEWLETT-PACKARD,34401A,<Serial Number>,ff.ff-pp.pp-mm.mm-gg.gg-bb-pp

Where:

- ff.ff** Main firmware revision
- pp.pp** Front panel firmware revision
- mm.mm** Measurement board firmware revision
- gg.gg** Measurement board FPGA revision
- bb** Measurement board revision
- pp** Front panel board revision

*LRN?

Returns an ASCII string of all of the commands required to put the instrument into its current state.

Parameter	Typical Return
(none)	An ASCII string of SCPI commands, delimited with semicolons (";") between commands.
Return the learn string: *LRN?	

- Some parameters can be set with either [SENSe:]FREQuency or [SENSe:]PERiod versions of the same command. The *LRN string will always return the FREQuency version of the command, even if the parameter was set via the PERiod version. Similarly, parameters that can be set with RESistance or FRESistance versions of the same command will always return the FRESistance version.

*OPC

Sets "Operation Complete" (bit 0) in the Standard Event register at the completion of the current operation.

Parameter	Typical Return
(none)	(none)
Configure 100 DC voltage measurements and enable the generation of an SRQ when the measurements complete: *CLS *ESE 1 *SRE 32 CONF:VOLT:DC SAMP:COUN 100 INIT *OPC	

- Other commands may be executed before Operation Complete bit is set.
- The difference between *OPC and *OPC? is that *OPC? outputs "1" when the current operation completes.

*OPC?

Returns 1 to the output buffer after all pending commands complete. Other commands cannot be executed until this command completes.

Parameter	Typical Return
(none)	1
Configure 100 DC voltage measurements and return "1" when the measurements complete: CONF:VOLT:DC SAMP:COUN 100 INIT *OPC?	

- The purpose of this command is to synchronize your application with the instrument.
- The difference between *OPC and *OPC? is that *OPC? outputs "1" when the current operation completes.

*OPT?

Returns a string identifying any installed options.

Parameter	Typical Return
(none)	(see below)
Return the installed options: *OPT?	

- The query returns a string with the following format:

34460A: {GPB|0},{LAN|0},{SEC|0}

34461A: {GPB|0},{SEC|0}

In each case, the option is returned as 0 (not installed) or as GPB, LAN, or SEC.

For example, a 34461A with only GPIB installed will return GPB,0. A 34460A with only GPB and SEC installed will return GPB,0,SEC.

- Options vary by model, as [shown here](#).

*PSC {0|1}

*PSC?

Power-On Status Clear. Enables (1) or disables (0) the clearing of certain enable registers at power on:

- Questionable Data Register ([STATus:QUEStionable:ENABLE](#))
- Standard Operation Register ([STATus:OPERation:ENABLE](#))
- Status Byte Condition Register ([*SRE](#))
- Standard Event Enable Register ([*ESE](#))

NOTE

The [*PSC](#) command does not affect the clearing of the condition or event registers, just the enable registers. For more information on the SCPI Status System, see [Status Subsystem Introduction](#).

Parameter	Typical Return
{0 1}, default 1	0 or 1
Disable power-on clearing of affected registers: *PSC 0	

***RCL {0|1|2|3|4}**
***SAV {0|1|2|3|4}**

Stores the current instrument state to, or recalls the instrument state from, the state file *STATE_<n>.sta* in the root folder of the internal flash file system, where <n> is the number specified.

Parameter	Typical Return
{0 1 2 3 4}	(none)
Store the instrument state to the state file STATE_1.sta in the root folder of the internal flash file system. *SAV 1	

- *SAV <n> is equivalent to [MMEMory:STORe:STATe](#) "INT:\STATE_<n>.sta".
- *RCL <n> is equivalent to [MMEMory:LOAD:STATe](#) "INT:\STATE_<n>.sta".
- The state file created by *SAV 0, called STATE_0.sta, resides in the root folder of the internal flash file system. It is overwritten with the power-down state of the instrument when power is cycled.
- The instrument state enable settings are stored in nonvolatile memory. They do not change when power has been off, after a Factory Reset ([*RST](#)) or after an Instrument Preset ([SYSTem:PRESet](#)).

***RST**

Resets instrument to [factory default state](#), independent of [MMEMory:STATe:RECall:AUTO](#) setting. This is similar to [SYSTem:PRESet](#). The difference is that *RST resets the instrument for SCPI operation, and SYSTem:PRESet resets the instrument for front-panel operation. As a result, *RST turns the histogram and statistics off, and SYSTem:PRESet turns them on (CALC:TRAN:HIST:STAT ON).

Parameter	Typical Return
(none)	(none)
Reset the instrument: *RST	

- Does not affect stored instrument states (see *SAV).

*SRE<enable_value>

*SRE?

Service Request Enable. Enables bits in the enable register for the [Status Byte Register](#) group. An enable register defines which bits in the event register will be reported to the Status Byte register group. You can write to or read from an enable register.

Parameter	Typical Return
Decimal sum of the bits in the register, default 0. For example, to enable bit 2 (value 4), bit 3 (value 8), and bit 7 (value 128), the decimal sum would be 140 (4 + 8 + 128). Default 0.	+24
Enable bits 3 and 4 in the enable register: *SRE 24	

- To enable specific bits, specify the decimal value corresponding to the binary-weighted sum of the bits in the register. The selected bits are summarized in the "Master Summary" bit (bit 6) of the Status Byte Register. If any of the selected bits change from 0 to 1, the instrument generates a Service Request signal.
- [*CLS](#) clears the event register, but not the enable register. An event register is a read-only register that latches events from the condition register. While an event bit is set, subsequent events corresponding to that bit are ignored.
- [*PSC](#) (power-on status clear) determines whether Status Byte enable register is cleared at power on. For example, *PSC 0 preserves the enable register contents through power cycles.
- The Status Byte enable register is not cleared by [*RST](#).

*STB?

Read Status Byte Query. Queries the condition register for the [Status Byte Register](#) group and returns a decimal value equal to the binary-weighted sum of all bits set in the register.

A condition register continuously monitors the state of the instrument. Condition register bits are updated in real time; they are neither latched nor buffered.

Parameter	Typical Return
(none)	+40
Read condition register (with bits 3 and 5 set): *STB?	

- Similar to a Serial Poll, but processed like any other instrument command. This register is read-only; bits are not cleared when read.
- Returns same result as a Serial Poll, but the "Master Summary" bit (bit 6) is not cleared by [*STB?](#).
- Power cycle and [*RST](#) clear all bits in the condition register.

*TRG

Triggers the instrument if [TRIGger:SOURce BUS](#) is selected.

Parameter	Typical Return
(none)	(none)
Return five DC voltage measurements, using a software trigger to start the measurements: CONF:VOLT:DC SAMP:COUN 5 TRIG:SOUR BUS INIT *TRG FETCH? Typical Response: +1.00520000E+01, ... (5 measurements)	

- After setting the trigger source, you must send [INITiate](#) to place the DMM in the "wait-for-trigger" state. The *TRG command will not be accepted unless the DMM is in the "wait-for-trigger" state.

*TST?

Performs a basic self-test of the instrument and returns a pass/fail indication. The [TEST:ALL?](#) self-test is more comprehensive than the [*TST?](#) self-test.

Parameter	Typical Return
(none)	+0 (pass) or +1 (one or more tests failed)
Perform self-test: *TST?	

- The self-test takes just a few seconds to complete.
- If one or more tests fail, the query returns +1 and stores an error in the error queue. For a complete listing of the error messages related to self-test failures, see [Self-test Error Messages](#).
- Following the test, the instrument returns to the instrument state that existed before the self-test.

*WAI

Configures the instrument's output buffer to wait for all pending operations to complete before executing any additional commands over the interface.

Parameter	Typical Return
(none)	(none)
Wait until all pending operations complete: *WAI	

- Configuration changes and measurements are considered pending operations. Therefore, *WAI will cause these changes to occur and complete.

LXI Subsystem

This subsystem supports LAN eXtensions for Instrumentation (LXI) functionality.

Command Summary

[LXI:IDENtify\[:STATe\]](#)

[LXI:MDNS:ENABle](#)

[LXI:MDNS:HNAME\[:RESolved\]?](#)

[LXI:MDNS:SNAME:DESired](#)

[LXI:MDNS:SNAME\[:RESolved\]?](#)

[LXI:RESet](#)

[LXI:REStart](#)

LXI:IDENtify[:STATe] {ON|1|OFF|0}

LXI:IDENtify[:STATe]?

Shows or removes the LXI Web Identify indicator on the display.

Parameter	Typical Return
{ON 1 OFF 0}, default OFF	0 (OFF) or 1 (ON)
Turn on the LXI Web Identify indicator: LXI:IDEN ON	

- The indicator helps you identify the device associated with the LAN address.
- Press the **[Local]** key or send [*RST](#) to turn off the indicator.

LXI:MDNS:ENABle {ON|1|OFF|0}

LXI:MDNS:ENABle?

Disables or enables the multicast Domain Name System (mDNS), which provides the capabilities of a DNS server for service discovery in a small network without a DNS server.

Parameter	Typical Return
{ON 1 OFF 0}, default ON	0 (OFF) or 1 (ON)
Turn mDNS ON: LXI:MDSN:ENAB ON	

- This setting is non-volatile; it is not changed by power cycling, a Factory Reset ([*RST](#)), or an Instrument Preset ([SYSTem:PRESet](#)).
- This parameter is set to its default value when the instrument is shipped from the factory and after [SYSTem:SECurity:IMMEDIATE](#).

LXI:MDNS:HNAME[:RESolved]?

Returns the resolved (unique) mDNS hostname in the form A-34460A-<serial>-N or A-34461A-<serial>-N, where <serial> is the last 5 digits of the instrument's serial number. The N is an integer appended if necessary to make the name unique. The desired name may be truncated, if necessary, to make room for the appended integer.

Parameter	Typical Return
(none)	"A-34460A-yyyyy" or "A-34461A-yyyyy", where yyyy is the last five digits of the serial number.
Return the resolved mDNS hostname: LXI:MDNS:HNAME:RESolved?	

LXI:MDNS:SNAME:DESired "<name>" LXI:MDNS:SNAME:DESired?

Sets the desired mDNS service name.

Parameter	Typical Return
Quoted string of up to 63 characters. Default: "Agilent 34460A Digital Multimeter - <serial>" or "Agilent 34461A Digital Multimeter - <serial>" where <serial> is the instrument's serial number	"Agilent 34460A Digital Multimeter - 98765"
Set the mDNS service name: LXI:MDNS:SNAM:DES "LAB1-DMM"	

- This setting is non-volatile; it is not changed by power cycling, a Factory Reset ([*RST](#)), or an Instrument Preset ([SYSTem:PRESet](#)).
- This parameter is set to its default value when the instrument is shipped from the factory and after [SYSTem:SECurity:IMMediate](#).

LXI:MDNS:SNAME[:RESolved]?

The resolved mDNS service name will be the desired service name ([LXI:MDNS:SNAME:DESired](#)), possibly with "<N>" appended. The N is an integer appended if necessary to make the name unique. The desired name may be truncated, if necessary, to make room for the appended integer.

Parameter	Typical Return
(none)	"Agilent 34461A Digital Multimeter - 00123"
Return resolved mDNS service name: LXI:MDNS:SNAME:RESolved?	

LXI:RESet

Resets LAN settings to a known operating state, beginning with DHCP. If DHCP fails, it uses Auto-IP. This command also clears the Web Interface password.

Parameter	Typical Return
(none)	(none)
Reset the LAN settings: LXI:RES	

- Depending on your network, the LAN interface may take several seconds to restart after this command is sent.
- If the LAN interface or specific LAN services (VXI-11, sockets, and so on) have been disabled by [SYSTem:COMMunicate:ENABle](#), you must separately re-enable the interface or services and cycle instrument power for the LAN to be operational.

LXI:REStart

Restarts the LAN with the current settings as specified by the [SYSTem:COMMunicate:LAN](#) commands.

Parameter	Typical Return
(none)	(none)
Restart the LAN interface: LXI:REST	

- Depending on your network, the LAN interface may take several seconds to restart after this command is sent.
- If the LAN interface or specific LAN services (VXI-11, sockets, and so on) have been disabled by [SYSTem:COMMunicate:ENABle](#), you must separately re-enable the interface or services and cycle instrument power for the LAN to be operational.

MEASure Subsystem

The MEASure queries are the easiest way to program measurements because they always use default measurement parameters. You set the function, range, and resolution in one command, but you cannot change other parameters from their default values. The results are sent directly to the instrument's output buffer.

NOTE

A MEASure query is functionally equivalent to sending CONFigure followed immediately by [READ?](#). The difference is that CONFigure commands allow you to change parameters between the CONFigure and the READ?

Command Summary

[MEASure:CONTInuity?](#)

[MEASure:CURREnt:{AC|DC}?](#)

[MEASure:DIODE?](#)

[MEASure:{FREQuency|PERiod}?](#)

[MEASure:{RESistance|FRESistance}?](#)

[MEASure:TEMPerature?](#)

[MEASure\[:VOLTage\]:{AC|DC}?](#)

[MEASure\[:VOLTage\]\[:DC\]:RATio?](#)

Default Settings for MEASure?

With the MEASure? queries, you can select the function, range and resolution in one command. All other parameters are set to their default values (below).

Measurement Parameter	Default Setting
AC Input Filter (bandwidth)	20 Hz (medium filter)
Autozero	OFF if resolution setting results in NPLC < 1 ON if resolution setting results in NPLC ≥ 1
Range	AUTO (including voltage range for frequency and period measurements)
Samples per Trigger	1 sample
Trigger Count	1 trigger
Trigger Delay	Automatic delay
Trigger Source	Immediate
Trigger Slope	NEGative
Math Functions	Disabled. Other parameters are unchanged.
Per-function Null State	Disabled

Using the MEASure? Query

The following example configures DC voltage measurements, internally triggers the instrument to take a measurement, and reads the measurement. The default range (autorange) and resolution (10 PLC) are used for the measurement.

```
MEAS:VOLT:DC?
```

Typical Response: +4.23450000E-03

The following example configures the instrument for 2-wire resistance measurements, triggers the instrument to take a measurement, and reads the measurement. The 1 k Ω range is selected with 0.1 Ω resolution.

```
MEAS:RES? 1000,0.1
```

Typical Response: +3.27150000E+02

MEASure:CONTinuity?

Sets all measurement parameters and trigger parameters to their [default values](#) for continuity test and immediately triggers a measurement. The results are sent directly to the instrument's output buffer.

Parameter	Typical Return
(none)	+1.32130000E-02
Configure the instrument for continuity measurements. Then make and read one measurement: MEAS:CONT?	

- The range and resolution are fixed at 1 k Ω for continuity tests (a 2-wire resistance measurement).
- The instrument beeps (if the beeper is enabled) for each measurement less than or equal to the continuity threshold ($\leq 10 \Omega$), and the actual resistance measurement appears on the display.
- From 10 Ω to 1.2 k Ω , the instrument displays the actual resistance measurement with no beep. Above 1.2 k Ω , the instrument displays "OPEN" with no beep.
- The [FETCh?](#), [READ?](#), and [MEASure:CONTinuity?](#) queries return the measured resistance, regardless of its value.

MEASure:CURRent:{AC|DC}? [{<range>|AUTO|MIN|MAX|DEF} [, {<resolution>|MIN|MAX|DEF}]]

Sets all measurement parameters and trigger parameters to their [default values](#) for AC or DC current measurements and immediately triggers a measurement. The results are sent directly to the instrument's output buffer.

NOTE On the 34461A, use the [\[SENSe:\]CURRent:{AC|DC}:TERMinals](#) command to specify which current terminals to use for the measurement.

Parameter	Typical Return
<range>: {100 μ A 1 mA 10 mA 100 mA 1 A 3 A 10 A}, default AUTO (autorange)	+8.54430000E-01
<resolution> (AC): optional and ignored; fixed at 6½ digits. <resolution> (DC): See Resolution Table or Range, Resolution and NPLC . The default is equivalent to 10 PLC.	
Specify <resolution> in the measurement's units (V, A, Hz, Ω , and so on).	
Configure AC current measurements using the 1 A range. Then make and read one measurement: MEAS:CURR:AC? 1	

- You can let autoranging select the measurement range, or you can manually select a fixed range. Autoranging conveniently selects the range for each measurement based on the input signal. For fastest measurements, use manual ranging (autoranging may require additional time for range selection).
- Autoranging (AUTO or DEFault), will generate an error if you specify a <resolution> because the instrument cannot accurately resolve the integration time (especially if the input continuously changes). If your application requires autoranging, specify DEFault for the <resolution> or omit the <resolution> altogether.
- Autoranging goes down a range at less than 10% of range and up a range at greater than 120% of range.
- If the input signal is greater than can be measured on the specified manual range, the instrument displays the word Overload on front panel and returns "9.9E37" from the remote interface.

MEASure:DIODE?

Sets all measurement parameters and trigger parameters to their [default values](#) for diode test measurements and immediately triggers a measurement. The results are sent directly to the instrument's output buffer.

Parameter	Typical Return
(none)	+1.32130000E-01
Configure, make, and read a default diode measurement: MEAS:DIOD?	

- The range and resolution are *fixed* for diode tests: the range is 1 VDC (with a 1 mA current source output).
- The voltage is displayed on the front panel if it is between 0 and 5.05 V. The instrument beeps when the signal transitions into the range between 0.3 and 0.8 V (unless beeper is disabled). If the signal exceeds 5.05 V, the front panel shows "OPEN", and the value returned from SCPI is 9.9E37.
- The [FETCh?](#), [READ?](#), and [MEASure:DIODE?](#) queries return the measured voltage, regardless of its value.

MEASure:{FREQuency|PERiod}? [{<range>|MIN|MAX|DEF} [, {<resolution>|MIN|MAX|DEF}]]

Sets all measurement parameters and trigger parameters to their [default values](#) for frequency or period measurements and immediately triggers a measurement. The results are sent directly to the instrument's output buffer.

Parameter	Typical Return
<range>: 3 Hz to 300 kHz, default 20 Hz for FREQuency	+1.32130000E+03
<range>: 3.33 μs to 333.33 ms, default 50 ms for PERiod	
<resolution>: 1 ppm × <range> (MINimum) to 100 ppm × <range> (MAXimum), DEFault = 10 ppm × <range> (100 ms aperture) Specify <resolution> in the measurement's units (V, A, Hz, Ω, and so on).	
Configure frequency measurements using the default aperture. Then make and read one measurement: MEAS:FREQ?	

- The <range> parameter is required only to specify the measurement resolution parameter. It is not necessary to send a new command for each new frequency or period to be measured.
- If the input voltage is too large for the selected voltage range (manual ranging), the instrument displays the word Overload on the front panel and returns "9.9E37" from the remote interface. Autoranging can be enabled for the input voltage.
- Period and frequency measurements do not autorange; the <range> and <resolution> parameters affect the aperture (gate time) as follows:

Resolution	Aperture
100 ppm × <range> (MAXimum)	10 ms
10 ppm × <range> (DEFault)	100 ms
1 ppm × <range> (MINimum)	1 s

- With no signal applied, 0 is returned.

MEASure:{RESistance|FRESistance}? [{<range>|AUTO|MIN|MAX|DEF} [, {<resolution>|MIN|MAX|DEF}]]

Sets all measurement and trigger parameters to their [default values](#) for 4-wire resistance (FRESistance) or 2-wire (RESistance) measurements, and immediately triggers a measurement. The results are sent directly to the instrument's output buffer.

Parameter	Typical Return
<range>: 100 Ω, 1 kΩ, 10 kΩ, 100 kΩ, 1 MΩ, 10 MΩ, 100 MΩ, AUTO (default) or DEFault	+8.54530000E+01
<resolution>: See Resolution Table or Range, Resolution and NPLC . The default is equivalent to 10 PLC. Specify <resolution> in the measurement's units (V, A, Hz, Ω, and so on).	
Configure 4-wire resistance measurements using the 100 Ω range with default resolution. Then make and read one measurement: MEAS:FRES? 100	

- You can let autoranging select the measurement range, or you can manually select a fixed range. Autoranging conveniently selects the range for each measurement based on the input signal. For fastest measurements, use manual ranging (autoranging may require additional time for range selection).
- Autoranging (AUTO or DEFault), will generate an error if you specify a <resolution> because the instrument cannot accurately resolve the integration time (especially if the input continuously changes). If your application requires autoranging, specify DEFault for the <resolution> or omit the <resolution> altogether.
- Autoranging goes down a range at less than 10% of range and up a range at greater than 120% of range.
- If the input signal is greater than can be measured on the specified manual range, the instrument displays the word Overload on front panel and returns "9.9E37" from the remote interface.
- For 4-wire RTD measurements, the instrument always enables the autozero function.

MEASure:TEMPerature? [{FRTD|RTD|FTH|THER|DEFault} [, {<type> | DEFault} [, 1 [, {<resolution>|MIN|MAX|DEF}]]]]]

Sets all measurement parameters and trigger parameters to their [default values](#) for temperature measurements and immediately triggers a measurement. The results are sent directly to the instrument's output buffer.

Parameter	Typical Return
<probe_type>: {FRTD RTD FTH THER}, default FRTD	+2.12320000E+01
<type>: 85 (only possible value for RTD/FRTD) or 5000 (only possible value for THERmistor/FTHermistor)	
<resolution>: See Resolution Table or Range, Resolution and NPLC . The default is equivalent to 10 PLC. Specify <resolution> in the measurement's units (V, A, Hz, Ω, and so on).	
Configure a 4-wire RTD measurement with default resolution. Then make and read one measurement: MEAS:TEMP? FRTD,85	

- For temperature measurements, the instrument internally selects the range; you cannot select the range to be used. The range ("1" is the only allowed value) is used only in conjunction with resolution to determine NPLC.
- The <resolution> parameter only determines the integration time; it does not specify the resolution of the temperature measurement. This parameter is optional; however, if you specify <resolution>, you must also specify "1" as the implied range parameter. For example: CONF:TEMP RTD,85,1,0.000001 selects the 10 PLC integration time on the 34461A.
- To change temperature units, use [UNIT:TEMPerature](#).
- For RTD measurements, the instrument autoranges to the correct range for the transducer resistance measurement.
- For 4-wire RTD measurements, the instrument always enables the autozero function.

MEASure[:VOLTage]:{AC|DC}? [{<range>|AUTO|MIN|MAX|DEF} [, {<resolution>|MIN|MAX|DEF}]]

Sets all measurement parameters and trigger parameters to their [default values](#) for AC voltage measurements and immediately triggers a measurement. The results are sent directly to the instrument's output buffer.

WARNING The maximum range parameter (MAX) is 1000 V. However, the SAFETY LIMIT on the front and rear HI/LO input terminals is 750 VAC (rms). The rms voltage is waveform dependent. A sine wave is limited to 750 VAC (rms), but a 1000 Vpk square wave is safe. Connection to AC mains power is further limited to CAT II (300 V). See [Safety and Regulatory Information](#) for more information on the safety features and the safe operation of this instrument.

Parameter	Typical Return
<range>: 100 mV, 1 V, 10 V, 100 V, 1000 V, AUTO (default) or DEFault	+8.54530000E+01
<resolution> (AC): optional and ignored; fixed at 6½ digits. <resolution> (DC): See Resolution Table or Range, Resolution and NPLC . The default is equivalent to 10 PLC. Specify <resolution> in the measurement's units (V, A, Hz, Ω, and so on).	
Configure AC voltage measurements using the 100 V range. Then make and read one measurement: MEAS:VOLT:AC? 100	
Configure DC voltage measurements using the 10 V range with 1 mV resolution. Then make and read one measurement: MEAS:VOLT:DC? 10,0.001	

- You can let autoranging select the measurement range, or you can manually select a fixed range. Autoranging conveniently selects the range for each measurement based on the input signal. For fastest measurements, use manual ranging (autoranging may require additional time for range selection).
- Autoranging (AUTO or DEFault), will generate an error if you specify a <resolution> because the instrument cannot accurately resolve the integration time (especially if the input continuously changes). If your application requires autoranging, specify DEFault for the <resolution> or omit the <resolution> altogether.
- Autoranging goes down a range at less than 10% of range and up a range at greater than 120% of range.
- If the input signal is greater than can be measured on the specified manual range, the instrument displays the word Overload on front panel and returns "9.9E37" from the remote interface.

MEASure[:VOLTage][:DC]:RATio? [{<range>|AUTO|MIN|MAX|DEF} [, {<resolution>|MIN|MAX|DEF}]]

Sets all measurement parameters and trigger parameters to their [default values](#) for DC voltage ratio measurements and immediately triggers a measurement. The results are sent directly to the instrument's output buffer.

To calculate a ratio, the instrument measures a DC reference voltage applied to the *Sense* terminal and the DC signal voltage applied to the *Input* terminals. It then uses the formula:

$$\text{Ratio} = \text{DC signal voltage} / \text{DC reference voltage}$$

Parameter	Typical Return
<range>: 100 mV, 1 V, 10 V, 100 V, 1000 V, AUTO (default) or DEFault	+4.27150000E+00
<resolution>: See Resolution Table or Range, Resolution and NPLC . The default is equivalent to 10 PLC.	
Configure DC voltage ratio measurements using the 100 V range with 1 mV resolution. Then make and read one measurement: MEAS:VOLT:DC:RAT? 100,0.001	

- The *Sense* terminals have a maximum measurable input of ± 12 VDC. Autoranging is automatically selected for reference voltage measurements on the *Sense* terminals.
- The *Input LO* and *Sense LO* terminals must have a common reference and cannot have a voltage difference greater than ± 2 V.
- The specified measurement range applies only to the signal connected to the *Input* terminals. The signal on the *Input* terminals can be any DC voltage up to 1,000 V.
- For the *Input* terminals, you can allow the instrument to select the measurement range by autoranging or you can select a fixed range using *manual ranging*. Autoranging decides which range to use for each measurement based on the input signal. For faster measurements, use manual ranging on each measurement (additional time is required for autoranging to select a range).
- Autoranging (AUTO or DEFault), will generate an error if you specify a <resolution> because the instrument cannot accurately resolve the integration time (especially if the input continuously changes). If your application requires autoranging, specify DEFault for the <resolution> or omit the <resolution> altogether.
- Autoranging goes down a range at less than 10% of range and up a range at greater than 120% of range.
- If the input signal is greater than can be measured on the specified manual range, the instrument displays the word Overload on front panel and returns "9.9E37" from the remote interface.

MMEMory Subsystem - General Purpose File Management

The MMEMory subsystem's general purpose file management commands are listed below. The MMEMory subsystem also includes two other types of commands:

[STATe and PREFeRence File Management](#)

[Data Transfer](#)

Commands and Queries

[MMEMory:CATalog\[:ALL\]?](#)

[MMEMory:CDIRectory](#)

[MMEMory:COPI](#)

[MMEMory:DELeTe](#)

[MMEMory:MDIRectory](#)

[MMEMory:MOVE](#)

[MMEMory:RDIRectory](#)

Folder and file formats

Many MMEemory commands refer to folders and files. These have specific structures, described below.

Format for a *<folder>*

- The format for *<folder>* is "[[*<drive>*:]*<path>*]", where *<drive>* can be INTernal or USB, and *<path>* is a folder path, and *<filespec>* specifies a subset of files.
- INTernal specifies the internal flash file system. USB specifies a front panel USB storage device.
- If *<drive>* is specified, *<path>* is interpreted as an absolute folder path. Absolute paths begin with "\" or "/" and start at the root folder of *<drive>*.
- If *<drive>* is omitted, *<path>* is relative to the folder specified by [MMEemory:CDIRectory](#). Relative paths must NOT begin with \ or /.
- Folder and file names cannot contain the following characters: \ / : * ? " < > |
- The *<folder>* parameter cannot exceed 240 characters.
- The specified folder must exist and cannot be marked as hidden or system. The exception is [MMEemory:MDIRectory](#), which creates a folder. For MMEemory:MDIRectory, all folder levels above the new one must exist.

Format for a *<file>*

- The format for a file name is "[[*<drive>*:]*<path>*]*<file_name>*", where *<drive>* can be INTernal or USB, and *<path>* is a folder path.
- INTernal specifies the internal flash file system. USB specifies a front panel USB storage device.
- If *<drive>* is specified, *<path>* is interpreted as an absolute folder path. Absolute paths begin with "\" or "/" and start at the root folder of *<drive>*.
- If *<drive>* is omitted, *<path>* is relative to the folder specified by [MMEemory:CDIRectory](#). Relative paths must NOT begin with \ or /.
- Folder and file names cannot contain the following characters: \ / : * ? " < > |
- The combination of folder and file name cannot exceed 240 characters.

MMEMory:CATalog[:ALL]? [<folder>[<filespec>]]

Returns a list of files in the specified folder.

Parameter	Typical Return
Any valid folder name ; defaults to folder selected by MMEMory:CDIRectory	+1000000000,+327168572, "command.exe,,375808", "MyDCVMeas.sta,STAT,8192",MyData.csv,ASC,11265"
List all files in the folder MyData on the front panel USB storage device: MMEM:CAT? "USB:\MyData"	
List all state files in the root directory of internal memory: MMEM:CAT? "INT:*.sta"	

- If <filespec> is omitted or is *.* , the command or query acts on all files. You can also use the * as a generic wildcard: *.sta, abc*.* , and so on.
- The catalog takes the following form:

```
<mem_used>,<mem_free>{,"<file_listing>"}
```

The instrument returns two numbers and a string for each file in the folder. The first number is the number of bytes used on the drive. The second indicates the number of bytes available. Each <file_listing> is in the format "<file_name>,<file_type>,<file_size>" (including the quotation marks), where <file_name> is the name of the file including file extension, if any; <file_type> is either STAT for STATE (.sta) files, ASC for DATA (.csv) files, PREF for PREFERenCe (.prf) files, FOLD for folders, or null for all other file extensions; <file_size> is the file size in bytes.

- If no files exist, only <mem_used>,<mem_free> is returned.
- Because the instrument uses a small amount of space in the flash file system for internal use, the <mem_used> value will never be zero.

MMEMory:CDIRectory <folder>
MMEMory:CDIRectory?
MMEMory:MDIRectory <folder>
MMEMory:RDIRectory <folder>

MMEMory:CDIRectory selects the default folder for MMEMory subsystem commands. This folder must exist and is used when folder or file names do not include a drive and folder name. They query returns the current default folder.

MMEMory:MDIRectory makes a new directory (folder) on the mass storage medium.

MMEMory:RDIRectory removes a directory (folder) on the mass storage medium.

Parameter	Typical Return
Any directory name, including the mass storage unit specifier, default INT:\	"INT:\BACKUP"
Make and remove a new directory named "test" on the internal mass memory system: MMEM:MDIR "test" MMEM:RDIR "test" Select the \BACKUP folder on the internal flash file system as the default folder: MMEM:CDIR "INT:\BACKUP" Return the default folder for MMEMory subsystem commands: MMEM:CDIR?	

- This parameter is set to its default value after a Factory Reset ([*RST](#)) or Instrument Preset ([SYSTEM:PRESet](#)).
- You can only remove an empty folder. Otherwise, the instrument generates a "Directory not empty" error.

MMEMory:COPY <file1>,<file2>

Copies <file1> to <file2>. Each file name must include the file extension.

Parameter	Typical Return
Any valid file name (both files)	(none)
Copy state file from the root directory to the folder "Backup" on the internal flash file system: MMEM:COPY "INT:\MyVoltMeas.sta","INT:\Backup"	

- The source file and folder must exist and cannot be marked as hidden or system.
- The destination folder must exist and cannot be marked as hidden or system.
- If the destination file exists, it will be overwritten, unless marked as hidden or system.
- To copy a file to a file of the same name in a different folder, specify just the <drive> and/or <path> for <destination>.

MMEMory:DELeTe {<file>|<filespec>}

Deletes a file. To delete a folder, use MMEMory:RDIRECTory.

Parameter	Typical Return
Any valid file name , including file extension, or a <filespec>, as described below.	(none)
Delete a file from the root directory of the internal flash file system: MMEM:DEL "INT:\MySetup.sta"	

- A <filespec> may include the * as a wildcard character: *.bmp, *.sta, abc*.*, and so on.
- The specified folder must exist and cannot be marked as hidden or system.
- The [SYSTEM:SECurity:IMMediate](#) command deletes and sanitizes all files.

MMEMory:MOVE <file1>,<file2>

Moves and/or renames <file1> to <file2>. Each file name must include the file extension.

Parameter	Typical Return
Any valid file name (both files)	(none)
Move the specified state file from the currently selected default directory to the folder "Backup" on the internal flash file system: MMEM:MOVE "MyVoltMeas.sta","INT:\Backup"	

- To rename a file, specify the same folder for <file1> and <file2>.
- To move a file to a file of the same name in a different folder, you can specify just the <drive>:<path> for <file2>.

MMEMemory Subsystem - STATE and PREFERENCE Files

These MMEMemory subsystem commands save and load instrument states (state files) and preferred settings for non-volatile parameters (preference files). In general, state files store volatile settings associated with measurements. Preferences are non-volatile parameters associated with the instrument, but not any specific measurement. The following table summarizes what information is in each file.

State File	Preference File
Active measurement function	I/O enables, addresses, settings; mDNS settings
Ranges	Display brightness
Integration time/resolution (NPLC)	Screen saver enable, brightness
Auto range	Numeric separator (comma, space, none) and decimal point symbol
Auto zero	Beeper and key click enable
Auto impedance (Input Z)	Help language
AC bandwidth	Power-on status clear enable, status enables, transition filters
Trigger and sample settings	Power-on state (*RST, user-defined, last)
Math settings (enables, null value(s), limits, ...)	SCPI ID (string returned by *IDN)
Data threshold for status bit	Power-on message text
VM Comp slope (Voltmeter Complete)	Color Scheme (A/B)
Temperature units	Label enable, text
Default file system directory	
Display selection and settings (numeric, meter, histogram, trend chart, ...)	
Numeric front-panel digit masking	
DBM reference resistance	

The MMEMemory subsystem also includes two other types of commands:

[General Purpose File Management](#)

[Data Transfer](#)

Command Summary

[MMEMemory:LOAD:PREferences](#)

[MMEMemory:STORe:PREferences](#)

[MMEMemory:LOAD:STATe](#)

[MMEMemory:STORe:STATe](#)

[MMEMemory:STATe:RECall:AUTO](#)

[MMEMemory:STATe:RECall:SElect](#)

[MMEMemory:STATe:VALid?](#)

Folder and file formats

Many MMEemory commands refer to folders and files. These have specific structures, described below.

Format for a <folder>

- The format for <folder> is "[[<drive>:]<path>]", where <drive> can be INTernal or USB, and <path> is a folder path, and <filespec> specifies a subset of files.
- INTernal specifies the internal flash file system. USB specifies a front panel USB storage device.
- If <drive> is specified, <path> is interpreted as an absolute folder path. Absolute paths begin with "\" or "/" and start at the root folder of <drive>.
- If <drive> is omitted, <path> is relative to the folder specified by [MMEemory:CDIRectory](#). Relative paths must NOT begin with \ or /.
- Folder and file names cannot contain the following characters: \ / : * ? " < > |
- The <folder> parameter cannot exceed 240 characters.
- The specified folder must exist and cannot be marked as hidden or system. The exception is [MMEemory:MDIRectory](#), which creates a folder. For MMEemory:MDIRectory, all folder levels above the new one must exist.

Format for a <file>

- The format for a file name is "[[<drive>:]<path><file_name>]", where <drive> can be INTernal or USB, and <path> is a folder path.
- INTernal specifies the internal flash file system. USB specifies a front panel USB storage device.
- If <drive> is specified, <path> is interpreted as an absolute folder path. Absolute paths begin with "\" or "/" and start at the root folder of <drive>.
- If <drive> is omitted, <path> is relative to the folder specified by [MMEemory:CDIRectory](#). Relative paths must NOT begin with \ or /.
- Folder and file names cannot contain the following characters: \ / : * ? " < > |
- The combination of folder and file name cannot exceed 240 characters.

Mass Memory (MMEMory) and State Storage

The front panel uses the MMEM subsystem, not the MEM subsystem, to save states. If you save a state with the front panel, you can still access it with SCPI. However, a state saved into the MEM subsystem by *SAV cannot be retrieved from the front panel.

For example, configure the instrument as desired and insert a USB drive into the front panel. Then enter the following commands. If you do not have a USB drive change "USB:\\" to "INT:\\" to use the instrument's internal flash drive instead.

```
MMEMory:CDIRectory "USB:\\"  
MMEMory:MDIRectory "States"  
MMEMory:STORe:STATE "USB:\States\State1"
```

To return to this state at any time:

```
MMEMory:LOAD:STATE "USB:\States\State1"
```

You can also recall a state file from the front panel by pressing **[Utility] > Store/Recall**.

MMEMory:LOAD:PREFerences <file>

MMEMory:STORe:PREFerences <file>

LOAD: Reboots the instrument and loads the nonvolatile I/O settings and user preferences from a file. The specified file cannot be empty or marked as hidden or system.

STORE: Stores nonvolatile I/O settings and user preferences to a file. If the destination file exists, it will be overwritten, unless marked as hidden or system.

CAUTION When loading a preferences file that specifies a static IP address, be careful that this does not result in two instruments with the same IP address on your LAN. This could cause LAN configuration errors on both instruments.

Parameter	Typical Return
Any valid file name The .prf file extension is optional. If you do not include this extension, the instrument firmware will automatically append it.	(none)
Stores the current nonvolatile I/O settings and user preferences into the specified file: MMEM:STOR:PREF "INT:\MyPreferences"	
Load nonvolatile I/O settings and user preferences from the specified file: MMEM:LOAD:PREF "INT:\MyPreferences"	

- The specified folder must exist and cannot be marked as hidden or system.
- User preferences include the values for:
 - I/O settings ([SYSTem Subsystem - I/O Configuration](#) and [LXI:MDNS](#) commands)
 - Display brightness, separator and screen saver state
 - Help system language
 - *PSC
 - [SENSe:]VOLTage:DC:IMPedance:AUTO
 - [MMEMory:STAtE:RECall:AUTO](#)
 - [MMEMory:STAtE:RECall:SElect](#)
 - [SYSTem:BEEPer:STAtE](#)

MMEMory:LOAD:STATe <filename>

MMEMory:STORe:STATe <filename>

Loads an instrument state from a state file or saves the current instrument state to a state file. The file name optionally includes the folder name and the .sta file extension. If you do not include this extension, the instrument firmware will automatically append it.

Parameter	Typical Return
Any valid file name	(none)
Store the current instrument state to the specified state file in the root directory of the internal flash file system: MMEM:STOR:STAT "INT:\MySetup"	
Load the instrument state from MySetup.sta saved by the previous command: MMEM:LOAD:STAT "INT:\MySetup.sta"	

- The specified folder must exist and cannot be marked as hidden or system.
- The specified file cannot be empty or marked as hidden or system.
- The state file created by *SAV 0, called STATE_0.sta, resides in the root folder of the internal flash file system. It is overwritten with the power-down state of the instrument when power is cycled.

MMEMory:STATe:RECall:AUTO {ON|1|OFF|0}

MMEMory:STATe:RECall:AUTO?

Disables or enables the automatic recall of a specific stored instrument state at power-on. Specify ON to automatically recall the power-down state file (STATE_0 in the root folder of the internal flash file system) or a user-specified state file (MMEMory:STATe:RECall:SElect). Select "OFF" to issue a Factory Reset ([*RST](#)) at power-on.

Parameter	Typical Return
{ON 1 OFF 0}, default ON	0 (OFF) or 1 (ON)
Select the power-down state to be used at power-on. MMEM:STAT:REC:SEL "INT:\STATE_0" MMEM:STAT:REC:AUTO ON	
Save the current state into a file in the root directory of the internal flash file system and load it at power-on: MMEM:STOR:STAT "INT:\MyVoltMeas" MMEM:STAT:REC:SEL "INT:\MyVoltMeas" MMEM:STAT:REC:AUTO ON	

- When shipped from the factory, the instrument is configured to automatically recall the power-down state file when power is restored.
- This setting is non-volatile; it is not changed by power cycling, a Factory Reset ([*RST](#)), or an Instrument Preset ([SYSTem:PRESet](#)).

MMEMory:STATe:RECall:SElect <file> MMEMory:STATe:RECall:SElect?

Selects which instrument state will be used at power-on if the automatic recall mode is enabled ([MMEMory:STATe:RECall:AUTO ON](#)). If the automatic recall mode is disabled ([MMEMory:STATe:RECall:AUTO OFF](#)), a Factory Reset ([*RST](#)) is issued at power-on.

Parameter	Typical Return
Any valid file name	"INT:\MyVoltMeas"
Select the power-down state to be used at power-on. MMEM:STAT:REC:SEL "INT:\STATE_0" MMEM:STAT:REC:AUTO ON	
Save the current state into a file in the root directory of the internal flash file system and load it at power-on: MMEM:STOR:STAT "INT:\MyVoltMeas" MMEM:STAT:REC:SEL "INT:\MyVoltMeas" MMEM:STAT:REC:AUTO ON	

- The specified folder must exist and cannot be marked as hidden or system.
- The state file created by *SAV 0, called STATE_0.sta, resides in the root folder of the internal flash file system. It is overwritten with the power-down state of the instrument when power is cycled.
- When shipped from the factory, the instrument is configured to automatically recall the power-down state file when power is restored.
- This setting is non-volatile; it is not changed by power cycling, a Factory Reset ([*RST](#)), or an Instrument Preset ([SYSTem:PRESet](#)).

MMEMory:STATe:VALid? <file>

Returns 1 if the specified state file exists and contains a valid state file. Returns 0 otherwise.

Parameter	Typical Return
Any valid file name	1
Return the status of MyState.sta in the root folder of the internal flash file system. MMEM:STAT:VAL? "INT:\MyState.sta"	

- The specified folder must exist and cannot be marked as hidden or system.
- The specified file cannot be empty or marked as hidden or system.
- Use this query before sending [*RCL](#) or [MMEMory:LOAD:STATe](#) to determine whether a state has been stored in the file.

MMEMory Subsystem - Data Transfer Commands

These commands transfer files into and out of the instrument's mass memory.

The MMEMory subsystem also includes two other types of commands:

[General Purpose File Management](#)

[STATe and PREReference File Management](#)

Command Summary

[MMEMory:DOWNload:DATA](#)

[MMEMory:DOWNload:FNAME](#)

[MMEMory:STORe:DATA](#)

[MMEMory:UPLoad?](#)

Folder and file formats

Many MMEMory commands refer to folders and files. These have specific structures, described below.

Format for a <folder>

- The format for <folder> is "[[<drive>:]<path>]", where <drive> can be INTERNAL or USB, and <path> is a folder path, and <filespec> specifies a subset of files.
- INTERNAL specifies the internal flash file system. USB specifies a front panel USB storage device.
- If <drive> is specified, <path> is interpreted as an absolute folder path. Absolute paths begin with "\" or "/" and start at the root folder of <drive>.
- If <drive> is omitted, <path> is relative to the folder specified by [MMEMory:CDIRECTory](#). Relative paths must NOT begin with \ or /.
- Folder and file names cannot contain the following characters: \ / : * ? " < > |
- The <folder> parameter cannot exceed 240 characters.
- The specified folder must exist and cannot be marked as hidden or system. The exception is [MMEMory:MDIRECTory](#), which creates a folder. For MMEMory:MDIRECTory, all folder levels above the new one must exist.

Format for a <file>

- The format for a file name is "[[<drive>:]<path><file_name>", where <drive> can be INTERNAL or USB, and <path> is a folder path.
- INTERNAL specifies the internal flash file system. USB specifies a front panel USB storage device.
- If <drive> is specified, <path> is interpreted as an absolute folder path. Absolute paths begin with "\" or "/" and start at the root folder of <drive>.
- If <drive> is omitted, <path> is relative to the folder specified by [MMEMory:CDIRECTory](#). Relative paths must NOT begin with \ or /.
- Folder and file names cannot contain the following characters: \ / : * ? " < > |
- The combination of folder and file name cannot exceed 240 characters.

MMEMory:DOWNload:DATA <binary_block>

Downloads data from the host computer to a file whose name has been specified by [MMEMory:DOWNload:FNAME](#).

The data in <binary_block> is written to the selected file.

NOTE

Any data previously stored in the file is lost when you execute this command.

Parameter	Typical Return
Any IEEE-488.2 definite- or indefinite-length block	(none)
Write "Hello" to the file "\\Myfile" on internal storage. MMEM:DOWN:FNAME "INT:\\Myfile" MMEM:DOWN:DATA #15Hello	

MMEMory:DOWNload:FNAME <filename>

MMEMory:DOWNload:FNAME?

Creates or opens the specified filename prior to writing data to that file with [MMEMory:DOWNload:DATA](#).

Parameter	Typical Return
Any valid file name	(none)
Write "Hello" to the file "\\Myfile" on internal storage. MMEM:DOWN:FNAME "INT:\\Myfile" MMEM:DOWN:DATA #15Hello	

- The specified folder must exist and cannot be marked as hidden or system.
- If the destination file exists, it will be overwritten, unless marked as hidden or system.
- The file will be created if it does not already exist.

MMEMory:STOR:DATA RDG_STORE, <file>

Stores all measurements in reading memory to the specified data file. The file name optionally includes the folder name and the .csv file extension.

Parameter	Typical Return
Any valid file name	(none)
Store all measurements in reading memory to MyVoltMeas.csv in the root folder of the internal flash file system. MMEM:STOR:DATA RDG_STORE,"INT:\\MyVoltMeas"	

- The data is stored in comma-separated value (CSV) format, with one measurement per line in ASCII format.
- The destination folder must exist and cannot be marked as hidden or system.
- If the destination file exists, it will be overwritten, unless marked as hidden or system.

MMEMory:UPLoad? <filename>

Uploads the contents of a file from the instrument to the host computer.

Parameter	Typical Return
Any valid file name	IEEE 488.2 definite-length block
Upload the state file "Myfile.sta" in the root directory of the internal flash file system to the host computer: MMEM:UPL? "INT:\Myfile.sta"	

SENSe Subsystem Introduction

The SENSe subsystem configures measurements. The most basic SENSe command is [\[SENSe:\]FUNCTION\[:ON\]](#), which selects the measurement function. All other SENSe commands are associated with specific measurement types:

[Current](#)

[Frequency and Period](#)

[Resistance](#)

[Temperature](#)

[Voltage](#)

[SENSe:]FUNCTION[:ON] "<function>" **[SENSe:]FUNCTION[:ON]?**

Selects the measurement function (all function-related measurement attributes are retained).

Parameter	Typical Return
CONTinuity CURRent:AC CURRent[:DC] DIODE FREQuency FREStance PERiod RESistance TEMPerature VOLTage:AC VOLTage[:DC] VOLTage[:DC]:RATio The default is VOLTage [:DC].	The short form of the selected function is returned in quotation marks, with no optional keywords: "CONT", "CURR:AC", "CURR", "DIOD", and so on.
Select the AC voltage function: FUNC "VOLT:AC"	

- If you change the measurement function, all measurement attributes of the previous function (range, resolution, etc.) are remembered. If you return to the original function, those measurement attributes will be restored.
- Changing the measurement function disables scaling, limit testing, histogram, and statistics ([CALC:SCAL:STAT](#), [CALC:LIM:STAT](#), [CALC:TRAN:HIST:STAT](#), and [CALC:AVER:STAT](#) set to OFF).
- This parameter is set to its default value after a Factory Reset ([*RST](#)) or Instrument Preset ([SYSTEM:PRESet](#)).

[SENSe:]CURRent Subsystem

This subsystem configures AC and DC current measurements.

Command Summary

[\[SENSe:\]CURRent:AC:BANDwidth](#)

[\[SENSe:\]CURRent:{AC|DC}:NULL\[:STATe\]](#)

[\[SENSe:\]CURRent:{AC|DC}:NULL:VALue](#)

[\[SENSe:\]CURRent:{AC|DC}:NULL:VALue:AUTO](#)

[\[SENSe:\]CURRent:{AC|DC}:RANGe](#)

[\[SENSe:\]CURRent:{AC|DC}:RANGe:AUTO](#)

[\[SENSe:\]CURRent\[:DC\]:NPLC](#)

[\[SENSe:\]CURRent\[:DC\]:RESolution](#)

[\[SENSe:\]CURRent:{AC|DC}:TERMinals](#)

[\[SENSe:\]CURRent\[:DC\]:ZERO:AUTO](#)

[SENSe:]CURRent:AC:BANDwidth {<filter>|MIN|MAX|DEF}
[SENSe:]CURRent:AC:BANDwidth? [{MIN|MAX|DEF}]

Sets the bandwidth for AC current measurements.

The instrument uses three different AC filters that enable you either to optimize low frequency accuracy or to achieve faster AC settling times following a change in input signal amplitude.

NOTE On the 34461A, use the [\[SENSe:\]CURRent:{AC|DC}:TERMinals](#) command to specify which current terminals to use for the measurement.

Parameter	Typical Return
{3 Hz 20 Hz 200 Hz} MIN=3 Hz, DEF=20 Hz, MAX=200 Hz	+2.00000000E+01
Make and read an AC current measurement. Use the 3 Hz filter bandwidth: CONF:CURR:AC 1 CURR:AC:BAND 3 READ? Typical Response: +5.23918293E+00	

- If you enter the lowest expected frequency that you intend to encounter, the command will select the appropriate *<filter>*. For example, if you enter 15 Hz, the slow filter (3 Hz) is selected. If you enter 190 Hz, the medium filter (20 Hz) is selected to provide the appropriate low cutoff.
- Set the lowest frequency that you expect to encounter. Lower bandwidths result in longer settling delays, as shown:

Input Frequency	Default Settling Delay
3 Hz - 300 kHz (<i>Slow</i>)	1.66 s/measurement
20 Hz - 300 kHz (<i>Medium</i>)	0.25 s/measurement
200 Hz - 300 kHz (<i>Fast</i>)	0.025 s/measurement

- This parameter is set to its default value after a Factory Reset ([*RST](#)) or Instrument Preset ([SYSTem:PRESet](#)).

[SENSe:]CURRent:{AC|DC}:NULL[:STATe] {ON|1|OFF|0}
[SENSe:]CURRent:{AC|DC}:NULL[:STATe]?

Enables or disables the null function for AC or DC current measurements.

- NOTE** This parameter is not shared between AC and DC measurements. The parameters are independent for AC and DC measurements.
- NOTE** On the 34461A, use the [\[SENSe:\]CURRent:{AC|DC}:TERMinals](#) command to specify which current terminals to use for the measurement.

Parameter	Typical Return
{ON 1 OFF 0}, default OFF	0 (OFF) or 1 (ON)
Configure AC current measurements, using the null function to subtract 100 mA from the measurements. Then make two measurements and send them to the instrument's output buffer: CONF:CURR:AC CURR:AC:NULL:STAT ON;VAL 100 mA SAMP:COUN 2 READ? Typical Response: +1.04530000E+00,+1.04570000E+00	

- Enabling the scaling function also enables automatic null value selection ([\[SENSe:\]CURRent:{AC|DC}:NULL:VALue:AUTO ON](#)).
- To set a fixed null value, use this command: [\[SENSe:\]CURRent:{AC|DC}:NULL:VALue](#).
- The instrument disables the null function after a Factory Reset ([*RST](#)), Instrument Preset ([SYSTem:PRESet](#)), or CONFigure function.

[SENSe:]CURRent:{AC|DC}:NULL:VALue {<value>|MIN|MAX|DEF}
[SENSe:]CURRent:{AC|DC}:NULL:VALue? [{MIN|MAX|DEF}]

Sets the null value for AC or DC current measurements.

- NOTE** This parameter is not shared between AC and DC measurements. The parameters are independent for AC and DC measurements.
- NOTE** On the 34461A, use the [\[SENSe:\]CURRent:{AC|DC}:TERMinals](#) command to specify which current terminals to use for the measurement.

Parameter	Typical Return
-12 to 12 A, default 0	+1.04530000E+00
Configure AC current measurements, using the null function to subtract 100 mA from the measurements. Then make two measurements and send them to the instrument's output buffer: CONF:CURR:AC CURR:AC:NULL:STAT ON;VAL 100 mA SAMP:COUN 2 READ? Typical Response: +1.04530000E+00,+1.04570000E+00	

- Specifying a null value disables automatic null value selection ([\[SENSe:\]CURRent:{AC|DC}:NULL:VALue:AUTO OFF](#)).
- To use the null value, the null state must be on ([\[SENSe:\]CURRent:{AC|DC}:NULL:STATe ON](#)).
- This parameter is set to its default value after a Factory Reset ([*RST](#)), Instrument Preset ([SYSTem:PRESet](#)), or CONFigure function.

[SENSe:]CURRent:{AC|DC}:NULL:VALue:AUTO{ON|1|OFF|0}
[SENSe:]CURRent:{AC|DC}:NULL:VALue:AUTO?

Enables or disables automatic null value selection for AC or DC current measurements.

- NOTE** This parameter is not shared between AC and DC measurements. The parameters are independent for AC and DC measurements.
- NOTE** On the 34461A, use the [\[SENSe:\]CURRent:{AC|DC}:TERMinals](#) command to specify which current terminals to use for the measurement.

Parameter	Typical Return
{ON 1 OFF 0}, default ON	0 (OFF) or 1 (ON)
<p>Configure AC current measurements, using the null function to subtract 100 mA from the measurements. Then make two measurements and send them to the instrument's output buffer:</p> <pre>CONF:CURR:AC CURR:AC:NULL:STAT ON;VAL 100 mA SAMP:COUN 2 READ?</pre> <p>Typical Response: +1.04530000E+00,+1.04570000E+00</p> <p>Make a second set of measurements using automatic null value selection:</p> <pre>CURR:AC:NULL:VAL:AUTO ON READ?</pre> <p>Typical Response: +0.00000000E+00,+0.01420000E+00</p>	

- When automatic reference selection is ON, the first measurement made is used as the null value for all subsequent measurements. [\[SENSe:\]CURRent:{AC|DC}:NULL:VALue](#) will be set to this value. Automatic null value selection will be disabled.
- When automatic null value selection is disabled (OFF), the null value is specified by this command: [\[SENSe:\]CURRent:{AC|DC}:NULL:VALue](#).
- The instrument enables automatic null value selection when the null function is enabled ([\[SENSe:\]CURRent:{AC|DC}:NULL:STATe ON](#)).
- This parameter is set to its default value after a Factory Reset ([*RST](#)), Instrument Preset ([SYSTem:PRESet](#)), or CONFigure function.

[SENSe:]CURRent:{AC|DC}:RANGe{<range>|MIN|MAX|DEF}
[SENSe:]CURRent:{AC|DC}:RANGe? [{MIN|MAX|DEF}]

Selects a fixed measurement range for AC or DC current measurements on the 3 A terminals. Although the 34461A has a 10 A range, you cannot select the 10 A range with this command. To select the 10 A range, use [\[SENSe:\]CURRent:{AC|DC}:TERMinals 10](#) or use [CONF:CURRent:{AC|DC} 10](#).

- NOTE** This parameter is not shared between AC and DC measurements. The parameters are independent for AC and DC measurements.
- NOTE** On the 34461A, use the [\[SENSe:\]CURRent:{AC|DC}:TERMinals](#) command to specify which current terminals to use for the measurement.

Parameter	Typical Return
<range>: {100 µA 1 mA 10 mA 100 mA 1 A 3 A}, default is AUTO (autorange)	+1.00000000E-01
Configure AC current measurements using the 1 A range. Make and read two measurements: CONF:CURR:AC CURR:AC:RANG 1 SAMP:COUN 2 READ? Typical Response: +1.04530000E+00,+1.04570000E+00	

- Selecting a fixed range ([SENSe:]<function>:RANGe) disables autoranging.
- If the input signal is greater than can be measured on the specified manual range, the instrument displays the word Overload on front panel and returns "9.9E37" from the remote interface.
- Note that unlike CONFigure and MEASure?, this command does not support the 10 A range. Selecting the 10 A terminal with [\[SENSe:\]CURRent:{AC|DC}:TERMinals](#) forces the specified type of current measurements to use the 10 A range, but it does not affect the values of [\[SENSe:\]CURRent:{AC|DC}:RANGe](#) or [\[SENSe:\]CURRent:{AC|DC}:RANGe:AUTO](#).
- Changing the value of this parameter always changes the measurement resolution. The number of PLCs (NPLC) stays fixed, and this results in a change of resolution in terms of the units of the measurement. For example, if you have a measurement with 1 µA resolution on the 100 mA range, changing to the 1 A range will result in a resolution of 10 µA.
- This parameter is set to its default value after a Factory Reset ([*RST](#)) or Instrument Preset ([SYSTEM:PRESet](#)).

[SENSe:]CURRent:{AC|DC}:RANGe:AUTO {OFF|ON|ONCE}
[SENSe:]CURRent:{AC|DC}:RANGe:AUTO?

Disables or enables autoranging for AC or DC current measurements. Autoranging is convenient because it automatically selects the range for each measurement based on the input signal.

Specifying ONCE performs an immediate autorange and then turns autoranging off.

- NOTE** This parameter is not shared between AC and DC measurements. The parameters are independent for AC and DC measurements.
- NOTE** On the 34461A, use the [\[SENSe:\]CURRent:{AC|DC}:TERMinals](#) command to specify which current terminals to use for the measurement.

Parameter	Typical Return
{ON 1 OFF 0}, default ON	0 (OFF) or 1 (ON)
Configure AC current measurements and perform an immediate autorange. Make and read two measurements: CONF:CURR:AC CURR:AC:RANG:AUTO ONCE SAMP:COUN 2 READ? Typical Response: +1.04530000E-01,+1.04570000E-01	

- Autoranging goes down a range at less than 10% of range and up a range at greater than 120% of range.
- With autoranging enabled, the instrument selects the range based on the input signal.
- Selecting a fixed range ([SENSe:]<function>:RANGe) disables autoranging.
- Selecting the 10 A terminal with [\[SENSe:\]CURRent:{AC|DC}:TERMinals](#) forces the specified type of current measurements to use the 10 A range, but it does not affect the values of [\[SENSe:\]CURRent:{AC|DC}:RANGe](#) or [\[SENSe:\]CURRent:{AC|DC}:RANGe:AUTO](#).
- This parameter is set to its default value after a Factory Reset ([*RST](#)) or Instrument Preset ([SYSTem:PRESet](#)).

[SENSe:]CURRent:{AC|DC}:TERMinals {3|10}
[SENSe:]CURRent:{AC|DC}:TERMinals?

Configures the AC or DC current measurement to measure the source on the 3 A or 10 A terminals. Note that the 10 A terminal is not available on the 34460A.

Parameter	Typical Return
{3 10}, default 3	+3 or +10
Configure AC current measurements to use the 10 A terminal. Make and read two measurements: CONF:CURR:AC CURR:AC:TERM 10 SAMP:COUN 2 READ? Typical Response: +7.81929394E+00,7.82013671E+00	

- Selecting the 10 A terminal with [\[SENSe:\]CURRent:{AC|DC}:TERMinals](#) forces the specified type of current measurements to use the 10 A range, but it does not affect the values of [\[SENSe:\]CURRent:{AC|DC}:RANGe](#) or [\[SENSe:\]CURRent:{AC|DC}:RANGe:AUTO](#).
- Changing the value of this parameter always changes the measurement range, which results in a change of measurement resolution. The number of PLCs (NPLC) stays fixed, and this results in a change of resolution in terms of the units of the measurement. For example, if you have a measurement with 1 µA resolution on the 1 A range, changing to the 10 A terminals will result in a resolution of 10 µA.
- This parameter is set to its default value after a Factory Reset ([*RST](#)) or Instrument Preset ([SYSTem:PRESet](#)).

[SENSe:]CURRent[:DC]:NPLC {<PLC>|MIN|MAX|DEF}
[SENSe:]CURRent[:DC]:NPLC? [{MIN|MAX|DEF}]

Sets the integration time in number of power line cycles (PLC) for DC current measurements. Integration time is the period that the instrument's analog-to-digital (A/D) converter samples the input signal for a measurement. A longer integration time gives better measurement resolution but slower measurement speed.

NOTE On the 34461A, use the [\[SENSe:\]CURRent:{AC|DC}:TERMinals](#) command to specify which current terminals to use for the measurement.

Parameter	Typical Return
{0.02 0.2 1 10 100}, default 10 See Range, Resolution and NPLC for more information.	+1.00000000E+00
Configure DC current measurements using a 10 PLC integration time. Then make and read one measurement: CONF:CURR:DC CURR:DC:NPLC 10 READ? Typical Response: +6.27530000E-01	

- Only integration times of 1, 10, or 100 PLC provide normal mode (line frequency noise) rejection.
- Setting the integration time also sets the measurement resolution. [Resolution Table](#) shows the relationship between integration time and resolution.
- This parameter is set to its default value after a Factory Reset ([*RST](#)) or Instrument Preset ([SYSTem:PRESet](#)).

See Also

[\[SENSe:\]CURRent\[:DC\]:RESolution](#)

[SENSe:]CURRent[:DC]:RESolution {<resolution>|MIN|MAX|DEF}
[SENSe:]CURRent[:DC]:RESolution? [{MIN|MAX|DEF}]

Selects the measurement resolution for DC current measurements. Specify the resolution in the same units as the selected measurement function, not in number of digits.

NOTE On the 34461A, use the [\[SENSe:\]CURRent:{AC|DC}:TERMinals](#) command to specify which current terminals to use for the measurement.

Parameter	Typical Return
Specify <resolution> in the measurement's units (V, A, Hz, Ω, and so on).	+3.00000000E-05
Configure DC current measurements with a 3 μA resolution. Then make and read one measurement: CONF:CURR:DC 1 CURR:DC:RES 3E-6 READ? Typical Response: +6.27531500E-01	

- You can specify MIN (best resolution) or MAX (worst resolution) instead of <resolution>.
- To achieve normal mode (line frequency noise) rejection, use a resolution that corresponds to an integration time that is an integral number of power line cycles.
- This parameter is set to its default value after a Factory Reset ([*RST](#)) or Instrument Preset ([SYSTem:PRESet](#)).

See Also

[\[SENSe:\]CURRent\[:DC\]:NPLC](#)

[SENSe:]CURRent[:DC]:ZERO:AUTO {OFF|ON|ONCE}
[SENSe:]CURRent[:DC]:ZERO:AUTO?

Disables or enables the autozero mode for DC current measurements.

NOTE On the 34461A, use the [\[SENSe:\]CURRent:{AC|DC}:TERMinals](#) command to specify which current terminals to use for the measurement.

Parameter	Typical Return
{OFF ON ONCE}, default ON	0 (OFF) or 1 (ON)
Configure DC current measurements and perform an immediate autozero. Make and read two measurements: CONF:CURR:DC 1 CURR:DC:ZERO:AUTO ONCE SAMP:COUN 2 READ? Typical Response: +1.04530000E-01,+1.04570000E-01	

- **ON (default):** the DMM internally measures the offset following each measurement. It then subtracts that measurement from the preceding reading. This prevents offset voltages present on the DMM’s input circuitry from affecting measurement accuracy.
- **OFF:** the instrument uses the last measured zero measurement and subtracts it from each measurement. It takes a new zero measurement each time you change the function, range or integration time.
- **ONCE:** the instrument takes one zero measurement and sets autozero OFF. The zero measurement taken is used for all subsequent measurements until the next change to the function, range or integration time. If the specified integration time is less than 1 PLC, the zero measurement is taken at 1 PLC to optimize noise rejection. Subsequent measurements are taken at the specified fast (< 1 PLC) integration time.
- The autozero mode is set indirectly when you set the resolution and integration time with [CONFigure:CURRent:DC](#) or [MEASure:CURRent:DC?](#). Autozero is automatically turned OFF when you select an integration time less than 1 PLC with these commands.
- This parameter is set to its default value after a Factory Reset ([*RST](#)) or Instrument Preset ([SYSTem:PRESet](#)).

[SENSe:]{FREQuency|PERiod} Subsystem

This subsystem configures frequency and period measurements.

Command Summary

[SENSe:]{FREQuency|PERiod}:APERture {<seconds>|MIN|MAX|DEF}

[SENSe:]{FREQuency|PERiod}:NULL[:STATe] {ON|1|OFF|0}

[SENSe:]{FREQuency|PERiod}:NULL:VALue {<value>|MIN|MAX|DEF}

[SENSe:]{FREQuency|PERiod}:NULL:VALue:AUTO {ON|1|OFF|0}

[SENSe:]{FREQuency|PERiod}:RANGe:LOWer {<filter>|MIN|MAX|DEF}

[SENSe:]{FREQuency|PERiod}:VOLTage:RANGe {<range>|MIN|MAX|DEF}

[SENSe:]{FREQuency|PERiod}:VOLTage:RANGe:AUTO {OFF|ON|ONCE}

[SENSe:]{FREQuency|PERiod}:APERture {<seconds>|MIN|MAX|DEF}
[SENSe:]{FREQuency|PERiod}:APERture? [{MIN|MAX|DEF}]

Sets the aperture time (gate time) for frequency and period measurements.

NOTE This parameter is shared between frequency and period measurements. Setting or querying the parameter with the FREQuency version of this command is identical to setting or querying it with the PERiod version.

Parameter	Typical Return
{10 ms 100 ms 1 s}, default 100 ms	+1.00000000E-01
Configure frequency measurements using a 1 s aperture, make a measurement, and return the result: CONF:FREQ FREQ:APER 1 READ?	

- The aperture for frequency and period measurements does not autorange.
- The measurement resolution is related to the aperture (gate time) as follows:

Resolution	Aperture
100 ppm × <range> (MAXimum)	10 ms
10 ppm × <range> (DEFault)	100 ms
1 ppm × <range> (MINimum)	1 s

- This parameter is set to its default value after a Factory Reset ([*RST](#)) or Instrument Preset ([SYSTem:PRESet](#)).

[SENSe:]{FREQuency|PERiod}:NULL[:STATe] {ON|1|OFF|0}
[SENSe:]{FREQuency|PERiod}:NULL[:STATe]?

Enables or disables the null function for frequency and period measurements.

NOTE

Unlike the SENSe:FREQuency and SENSe:PERiod range and aperture commands, this parameter is not shared between frequency and period measurements. The null parameters are independent for frequency and period measurements.

Parameter	Typical Return
{ON 1 OFF 0}, default OFF	0 (OFF) or 1 (ON)
Configure frequency measurements, using the null function to subtract 1 kHz from the measurements. Make and read two measurements: CONF:FREQ FREQ:NULL:STAT ON;VAL 1 kHz SAMP:COUN 2 READ? Typical Response: +1.04530000E+03,+1.04570000E+03	

- Enabling the scaling function also enables automatic null value selection ([\[SENSe:\]{FREQuency|PERiod}:NULL:VALue:AUTO ON](#)).
- To set a fixed null value, use this command: [\[SENSe:\]{FREQuency|PERiod}:NULL:VALue](#).
- The instrument disables the null function after a Factory Reset ([*RST](#)), Instrument Preset ([SYSTem:PRESet](#)), or CONFigure function.

[SENSe:]{FREQuency|PERiod}:NULL:VALue {<value>|MIN|MAX|DEF}
[SENSe:]{FREQuency|PERiod}:NULL:VALue? [{MIN|MAX|DEF}]

Stores a null value for frequency and period measurements.

NOTE

Unlike the SENSe:FREQuency and SENSe:PERiod range and aperture commands, this parameter is not shared between frequency and period measurements. The null parameters are independent for frequency and period measurements.

Parameter	Typical Return
-1.2E6 to +1.2E6, default 0	+1.00000000E-02
Configure frequency measurements, using the null function to subtract 1 kHz from the measurements. Make and read two measurements: CONF:FREQ FREQ:NULL:STAT ON;VAL 1 kHz SAMP:COUN 2 READ? Typical Response: +1.04530000E+03,+1.04570000E+03	

- Specifying a null value disables automatic null value selection ([\[SENSe:\]{FREQuency|PERiod}:NULL:VALue:AUTO OFF](#)).
- To use the null value, the null state must be on ([\[SENSe:\]{FREQuency|PERiod}:NULL:STATe ON](#)).
- This parameter is set to its default value after a Factory Reset ([*RST](#)), Instrument Preset ([SYSTem:PRESet](#)), or CONFigure function.

[SENSe:]{FREQuency|PERiod}:NULL:VALue:AUTO {ON|1|OFF|0}
[SENSe:]{FREQuency|PERiod}:NULL:VALue:AUTO?

Enables or disables automatic null value selection for frequency and period measurements.

NOTE Unlike the SENSe:FREQuency and SENSe:PERiod range and aperture commands, this parameter is not shared between frequency and period measurements. The null parameters are independent for frequency and period measurements.

Parameter	Typical Return
{ON 1 OFF 0}, default OFF	0 (OFF) or 1 (ON)
Configure frequency measurements, using the null function to subtract 1 kHz from them. Make and read two measurements: CONF:FREQ FREQ:NULL:STAT ON;VAL 1 kHz SAMP:COUN 2 READ? Typical Response: +1.04530000E+00,+1.04570000E+00 Make a second set of measurements using automatic null value selection: FREQ:NULL:VAL:AUTO ON READ? Typical Response: +0.00000000E+00,+0.01420000E+00	

- When automatic reference selection is ON, the first measurement made is used as the null value for all subsequent measurements. [\[SENSe:\]{FREQuency|PERiod}:NULL:VALue](#) will be set to this value. Automatic null value selection will be disabled.
- When automatic null value selection is disabled (OFF), the null value is specified by this command: [\[SENSe:\]{FREQuency|PERiod}:NULL:VALue](#).
- The instrument enables automatic null value selection when the null function is enabled ([\[SENSe:\]{FREQuency|PERiod}:NULL:STATe ON](#)).
- This parameter is set to its default value after a Factory Reset ([*RST](#)), Instrument Preset ([SYSTem:PRESet](#)), or CONFigure function.

**[SENSe:]{FREQuency|PERiod}:RANGe:LOWer {<filter>|MIN|MAX|DEF}
 [SENSe:]{FREQuency|PERiod}:RANGe:LOWer? [{MIN|MAX|DEF}]**

Sets the AC bandwidth used to detect the signal during frequency and period measurements.

NOTE This parameter is shared between frequency and period measurements. Setting or querying the parameter with the FREQuency version of this command is identical to setting or querying it with the PERiod version.

The instrument uses three different AC filters that enable you either to optimize low frequency accuracy or to achieve faster AC settling times following a change in input signal amplitude. The instrument selects the slow (3 Hz), medium (20 Hz) or fast (200 Hz) filter based on the cutoff frequency specified by this command. Specify the lowest frequency that you expect to encounter.

Parameter	Typical Return
{3 Hz 20 Hz 200 Hz} MIN=3 Hz, DEF=20 Hz, MAX=200 Hz	+6.27530000E+03
Make and read a frequency measurement. Use the 3 Hz filter bandwidth: CONF:FREQ FREQ:RANG:LOW 3 READ?	

- If you enter the lowest expected frequency that you intend to encounter, the command will select the appropriate <filter>. For example, if you enter 15 Hz, the slow filter (3 Hz) is selected. If you enter 190 Hz, the medium filter (20 Hz) is selected to provide the appropriate low cutoff.
- This parameter is set to its default value after a Factory Reset ([*RST](#)) or Instrument Preset ([SYSTem:PRESet](#)).

[SENSe:]{FREQuency|PERiod}:VOLTage:RANGe{<range>|MIN|MAX|DEF}
[SENSe:]{FREQuency|PERiod}:VOLTage:RANGe? [{MIN|MAX|DEF}]

Selects a fixed voltage range for frequency and period measurements.

NOTE This parameter is shared between frequency and period measurements. Setting or querying the parameter with the FREQuency version of this command is identical to setting or querying it with the PERiod version.

WARNING The maximum range parameter (MAX) is 1000 V. However, the SAFETY LIMIT on the front and rear HI/LO input terminals is 750 VAC (rms). The rms voltage is waveform dependent. A sine wave is limited to 750 VAC (rms), but a 1000 Vpk square wave is safe. Connection to AC mains power is further limited to CAT II (300 V). See [Safety and Regulatory Information](#) for more information on the safety features and the safe operation of this instrument.

Parameter	Typical Return
{100 mV 1 V 10 V 100 V 1000 V}, default 10 V	+1.04530000E+03
Configures frequency measurements using the 10 VAC range. Make and read two measurements: CONF:FREQ FREQ:VOLT:RANG 10 SAMP:COUN 2 READ?	

- Selecting a fixed range ([SENSe:]<function>:RANGe) disables autoranging.
- If the input voltage is too large for the selected voltage range (manual ranging), the instrument displays the word Overload on the front panel and returns "9.9E37" from the remote interface. Autoranging can be enabled for the input voltage.
- This parameter is set to its default value after a Factory Reset ([*RST](#)) or Instrument Preset ([SYSTem:PRESet](#)).

[SENSe:]{FREQuency|PERiod}:VOLTage:RANGe:AUTO{OFF|ON|ONCE}
[SENSe:]{FREQuency|PERiod}:VOLTage:RANGe:AUTO?

Disables or enables voltage autoranging for frequency and period measurements. Autoranging is convenient because it automatically selects the range for each measurement based on the input signal.

Specifying ONCE performs an immediate autorange and then turns autoranging off.

NOTE

This parameter is shared between frequency and period measurements. Setting or querying the parameter with the FREQuency version of this command is identical to setting or querying it with the PERiod version.

WARNING

The maximum range parameter (MAX) is 1000 V. However, the SAFETY LIMIT on the front and rear HI/LO input terminals is 750 VAC (rms). The rms voltage is waveform dependent. A sine wave is limited to 750 VAC (rms), but a 1000 Vpk square wave is safe. Connection to AC mains power is further limited to CAT II (300 V). See [Safety and Regulatory Information](#) for more information on the safety features and the safe operation of this instrument.

Parameter	Typical Return
{OFF ON ONCE}, default ON	0 (OFF) or 1 (ON)
Configure frequency measurements and perform an immediate AC voltage autorange. Make and read two measurements: CONF:FREQ FREQ:VOLT:RANG:AUTO ONCE SAMP:COUN 2 READ? Typical Response: +1.04530000E+03,+1.04570000E+03	

- Autoranging goes down a range at less than 10% of range and up a range at greater than 120% of range.
- With autoranging enabled, the instrument selects the range based on the input signal.
- Selecting a fixed range ([SENSe:]<function>:RANGe) disables autoranging.
- This parameter is set to its default value after a Factory Reset ([*RST](#)) or Instrument Preset ([SYSTem:PRESet](#)).

[SENSe:]{RESistance|FRESistance} Subsystem

This subsystem configures two- and four-wire resistance measurements.

Command Summary

[\[SENSe:\]{RESistance|FRESistance}:NPLC](#)

[\[SENSe:\]{RESistance|FRESistance}:NULL\[:STATe\]](#)

[\[SENSe:\]{RESistance|FRESistance}:NULL:VALue](#)

[\[SENSe:\]{RESistance|FRESistance}:NULL:VALue:AUTO](#)

[\[SENSe:\]{RESistance|FRESistance}:RANGe](#)

[\[SENSe:\]{RESistance|FRESistance}:RANGe:AUTO](#)

[\[SENSe:\]{RESistance|FRESistance}:RESolution](#)

[\[SENSe:\]RESistance:ZERO:AUTO](#)

[SENSe:]{RESistance|FRESistance}:NPLC {<PLC>|MIN|MAX|DEF}
[SENSe:]{RESistance|FRESistance}:NPLC? [{MIN|MAX|DEF}]

Sets the integration time in number of power line cycles (PLC) for all resistance measurements. Integration time is the period that the instrument's analog-to-digital (A/D) converter samples the input signal for a measurement. A longer integration time gives better measurement resolution but slower measurement speed.

NOTE This parameter is common to 2-wire and 4-wire resistance measurements. Using the FRESistance version of this command or query is identical to using the RESistance version.

Parameter	Typical Return
{0.02 0.2 1 10 100}, default 10 See Range, Resolution and NPLC for more information.	+1.00000000E+01
Configure 4-wire resistance measurements using a 10 PLC integration time. Then make and read one measurement: CONF:FRES FRES:NPLC 10 READ? Typical Response: +6.27530000E+01	

- Only integration times of 1, 10, or 100 PLC provide normal mode (line frequency noise) rejection.
- Setting the integration time also sets the measurement resolution. [Resolution Table](#) shows the relationship between integration time and resolution.
- This parameter is set to its default value after a Factory Reset ([*RST](#)) or Instrument Preset ([SYSTem:PRESet](#)).

[SENSe:]{RESistance|FRESistance}:NULL[:STATe] {ON|1|OFF|0}
[SENSe:]{RESistance|FRESistance}:NULL[:STATe]?

Enables or disables the null function for all resistance measurements.

NOTE This parameter is common to 2-wire and 4-wire resistance measurements. Using the FRESistance version of this command or query is identical to using the RESistance version.

Parameter	Typical Return
{ON 1 OFF 0}, default OFF	0 (OFF) or 1 (ON)
Configure 2-wire resistance measurements, using the null function to remove 100 mΩ of wiring resistance. Make and read two measurements: CONF:RES RES:NULL:STAT ON;VAL .1 SAMP:COUN 2 READ? Typical Response: +1.04530000E+02,+1.04570000E+02	

- Enabling the scaling function also enables automatic null value selection ([\[SENSe:\]{RESistance|FRESistance}:NULL:VALue:AUTO ON](#)).
- To set a fixed null value, use this command: [\[SENSe:\]{RESistance|FRESistance}:NULL:VALue](#).
- The instrument disables the null function after a Factory Reset ([*RST](#)), Instrument Preset ([SYSTem:PRESet](#)), or CONFIGure function.

[SENSe:]{RESistance|FRESistance}:NULL:VALue {<value>|MIN|MAX|DEF}
[SENSe:]{RESistance|FRESistance}:NULL:VALue? [{MIN|MAX|DEF}]

Stores a null value for all resistance measurements.

NOTE This parameter is common to 2-wire and 4-wire resistance measurements. Using the FRESistance version of this command or query is identical to using the RESistance version.

Parameter	Typical Return
-120 MΩ to +120 MΩ, default 0	+1.04530000E+02
Configure 2-wire resistance measurements, using the null function to remove 100 mΩ of wiring resistance. Make and read two measurements: CONF:RES RES:NULL:STAT ON;VAL .1 SAMP:COUN 2 READ? Typical Response: +1.04530000E+02,+1.04570000E+02	

- Specifying a null value disables automatic null value selection ([\[SENSe:\]{RESistance|FRESistance}:NULL:VALue:AUTO OFF](#)).
- To use the null value, the null state must be on ([\[SENSe:\]{RESistance|FRESistance}:NULL:STATe ON](#)).
- This parameter is set to its default value after a Factory Reset ([*RST](#)), Instrument Preset ([SYSTem:PRESet](#)), or CONFIGure function.

[SENSe:]{RESistance|FRESistance}:NULL:VALue:AUTO {ON|1|OFF|0}
[SENSe:]{RESistance|FRESistance}:NULL:VALue:AUTO?

Enables or disables automatic null value selection for all resistance measurements.

NOTE This parameter is common to 2-wire and 4-wire resistance measurements. Using the FRESistance version of this command or query is identical to using the RESistance version.

Parameter	Typical Return
{ON 1 OFF 0}, default OFF	0 (OFF) or 1 (ON)
<p>Configure 2-wire resistance measurements, using the null function to remove 100 mΩ of wiring resistance. Make and read two measurements:</p> <pre>CONF:RES RES:NULL:STAT ON;VAL .1 SAMP:COUN 2 READ?</pre> <p>Typical Response: +1.04530000E+02,+1.04570000E+02</p> <p>Make a second set of measurements using automatic null value selection:</p> <pre>RES:NULL:VAL:AUTO ON READ?</pre> <p>Typical Response: +0.00000000E+00,+0.01420000E+00</p>	

- When automatic reference selection is ON, the first measurement made is used as the null value for all subsequent measurements. [\[SENSe:\]{RESistance/FRESistance}:NULL:VALue](#) will be set to this value. Automatic null value selection will be disabled.
- When automatic null value selection is disabled (OFF), the null value is specified by this command: [\[SENSe:\]{RESistance/FRESistance}:NULL:VALue](#).
- The instrument enables automatic null value selection when the null function is enabled ([\[SENSe:\]{RESistance/FRESistance}:NULL:STATE ON](#)).
- This parameter is set to its default value after a Factory Reset ([*RST](#)), Instrument Preset ([SYSTem:PRESet](#)), or CONFigure function.

**[SENSe:]{RESistance|FRESistance}:RANGe {<range>|MIN|MAX|DEF}
 [SENSe:]{RESistance|FRESistance}:RANGe? [{MIN|MAX|DEF}]**

Selects a fixed measurement range for all resistance measurements.

NOTE This parameter is common to 2-wire and 4-wire resistance measurements. Using the FRESistance version of this command or query is identical to using the RESistance version.

Parameter	Typical Return
{100 Ω 1 kΩ 10 kΩ 100 kΩ 1 MΩ 10 MΩ 100 MΩ}, default 1 kΩ	+1.00000000E+03
Configure 2-wire resistance measurements using the 10 kΩ range. Then make and read one measurement: CONF:RES RES:RANG 10E3 READ? Typical Response: +6.27530000E+03	

- Selecting a fixed range ([SENSe:]<function>:RANGe) disables autoranging.
- If the input signal is greater than can be measured on the specified manual range, the instrument displays the word Overload on front panel and returns "9.9E37" from the remote interface.

See Also

[\[SENSe:\]{RESistance|FRESistance}:RANGe:AUTO](#)

[SENSe:]{RESistance|FRESistance}:RANGe:AUTO {OFF|ON|ONCE}
[SENSe:]{RESistance|FRESistance}:RANGe:AUTO?

Disables or enables autoranging for all resistance measurements. Autoranging is convenient because it automatically selects the range for each measurement based on the input signal. Specifying ONCE performs an immediate autorange and then turns autoranging off.

NOTE This parameter is common to 2-wire and 4-wire resistance measurements. Using the FRESistance version of this command or query is identical to using the RESistance version.

Parameter	Typical Return
{ON 1 OFF 0}, default ON	0 (OFF) or 1 (ON)
Configure 2-wire resistance measurements and perform an immediate autorange. Make and read two measurements: CONF:RES RES:RANG:AUTO ONCE SAMP:COUN 2 READ? Typical Response: +1.04530000E+03,+1.04570000E+03	

- Autoranging goes down a range at less than 10% of range and up a range at greater than 120% of range.
- With autoranging enabled, the instrument selects the range based on the input signal.
- Selecting a fixed range ([SENSe:]<function>:RANGe) disables autoranging.
- This parameter is set to its default value after a Factory Reset ([*RST](#)) or Instrument Preset ([SYSTem:PRESet](#)).

**[SENSe:]{RESistance|FRESistance}:RESolution {<resolution>|MIN|MAX|DEF}
 [SENSe:]{RESistance|FRESistance}:RESolution? [{MIN|MAX|DEF}]**

Selects the measurement resolution for all resistance measurements. Specify the resolution in the same units as the selected measurement function, not in number of digits.

NOTE This parameter is common to 2-wire and 4-wire resistance measurements. Using the FRESistance version of this command or query is identical to using the RESistance version.

Parameter	Typical Return
<resolution>: See Resolution Table or Range, Resolution and NPLC . The default is equivalent to 10 PLC. Specify <resolution> in the measurement's units (V, A, Hz, Ω, and so on).	+3.00000000E+00
Configure 2-wire resistance measurements with a 3 Ω resolution. Then make and read one measurement: CONF:RES 1E6 RES:RES 3 READ? Typical Response: +6.27531500E+05	

- You can specify MIN (best resolution) or MAX (worst resolution) instead of <resolution>.
- To achieve normal mode (line frequency noise) rejection, use a resolution that corresponds to an integration time that is an integral number of power line cycles.
- This parameter is set to its default value after a Factory Reset ([*RST](#)) or Instrument Preset ([SYSTem:PRESet](#)).

See Also

[\[SENSe:\]{RESistance|FRESistance}:NPLC](#)

[SENSe:]RESistance:ZERO:AUTO {OFF|ON|ONCE}
[SENSe:]RESistance:ZERO:AUTO?

Disables or enables the autozero mode for 2-wire resistance measurements.

- **ON (default):** the DMM internally measures the offset following each measurement. It then subtracts that measurement from the preceding reading. This prevents offset voltages present on the DMM’s input circuitry from affecting measurement accuracy.
- **OFF:** the instrument uses the last measured zero measurement and subtracts it from each measurement. It takes a new zero measurement each time you change the function, range or integration time.
- **ONCE:** the instrument takes one zero measurement and sets autozero OFF. The zero measurement taken is used for all subsequent measurements until the next change to the function, range or integration time. If the specified integration time is less than 1 PLC, the zero measurement is taken at 1 PLC to optimize noise rejection. Subsequent measurements are taken at the specified fast (< 1 PLC) integration time.

Parameter	Typical Return
{OFF ON ONCE}	0 (OFF) or 1 (ON)
Configure 2-wire resistance measurements and perform an immediate autozero. Make and read two measurements: CONF:RES 1E4 RES:ZERO:AUTO ONCE SAMP:COUN 2 READ? Typical Response: +1.04530000E+03,+1.04570000E+03	

- This command does not affect 4-wire resistance measurements, which are always made with autozero ON.
- The autozero mode is set indirectly when you set the resolution and integration time using [CONFigure: {RESistance|FRESistance}](#) or [MEASure: {RESistance|FRESistance}?](#). Autozero is automatically turned OFF when you select an integration time less than 1 PLC with these commands.
- This parameter is set to its default value after a Factory Reset ([*RST](#)) or Instrument Preset ([SYSTEM:PRESet](#)).

[SENSe:]TEMPerature Subsystem

This subsystem configures temperature measurements.

Command Summary

[\[SENSe:\]TEMPerature:NPLC](#)

[\[SENSe:\]TEMPerature:NULL\[:STATe\]](#)

[\[SENSe:\]TEMPerature:NULL:VALue](#)

[\[SENSe:\]TEMPerature:NULL:VALue:AUTO](#)

[\[SENSe:\]TEMPerature:TRANsducer:{RTD|FRTD}:RESistance\[:REFerence\]](#)

[\[SENSe:\]TEMPerature:TRANsducer:{THERmistor|FTHermistor}:TYPE](#)

[\[SENSe:\]TEMPerature:TRANsducer:TYPE](#)

[\[SENSe:\]TEMPerature:ZERO:AUTO](#)

[SENSe:]TEMPerature:NPLC {<PLC>|MIN|MAX|DEF} [SENSe:]TEMPerature:NPLC? [{MIN|MAX|DEF}]

Sets the integration time in number of power line cycles (PLC) for temperature measurements. Integration time is the period that the instrument's analog-to-digital (A/D) converter samples the input signal for a measurement. A longer integration time gives better measurement resolution but slower measurement speed.

Parameter	Typical Return
{0.02 0.2 1 10 100}, default 10 See Range, Resolution and NPLC for more information.	+1.00000000E+01
Configure 4-wire RTD measurements using a 10 PLC integration time. Then make and read one measurement: CONF:TEMP FRTD TEMP:NPLC 10 READ? Typical Response: +6.27530000E+01	

- Only integration times of 1, 10, or 100 PLC provide normal mode (line frequency noise) rejection.
- Setting the integration time also sets the measurement resolution. [Resolution Table](#) shows the relationship between integration time and resolution.
- This parameter is set to its default value after a Factory Reset ([*RST](#)) or Instrument Preset ([SYSTem:PRESet](#)).

[SENSe:]TEMPerature:NULL[:STATe] {ON|1|OFF|0}
[SENSe:]TEMPerature:NULL[:STATe]?

Enables or disables the null function for temperature measurements.

Parameter	Typical Return
{ON 1 OFF 0}, default OFF	0 (OFF) or 1 (ON)
Configure 4-wire RTD measurements, using the null function to subtract 25°. Make and read two measurements: CONF:TEMP RTD TEMP:NULL:STAT ON;VAL 25 SAMP:COUN 2 READ? Typical Response: +1.04530000E+00,+1.04570000E+00	

- Enabling the scaling function also enables automatic null value selection ([\[SENSe:\]TEMPerature:NULL:VALue:AUTO ON](#)).
- To set a fixed null value, use this command: [\[SENSe:\]TEMPerature:NULL:VALue](#).
- The instrument disables the null function after a Factory Reset ([*RST](#)), Instrument Preset ([SYSTem:PRESet](#)), or CONFigure function.

[SENSe:]TEMPerature:NULL:VALue {<value>|MIN|MAX|DEF}
[SENSe:]TEMPerature:NULL:VALue? [{MIN|MAX|DEF}]

Stores a null value for temperature measurements.

Parameter	Typical Return
-1.0E15 to +1.0E15, default 0	+2.50000000E+01
Configure 4-wire RTD measurements, using the null function to subtract 25°. Make and read two measurements: CONF:TEMP RTD TEMP:NULL:STAT ON;VAL 25 SAMP:COUN 2 READ? Typical Response: +1.04530000E+00,+1.04570000E+00	

- Specifying a null value disables automatic null value selection ([\[SENSe:\]TEMPerature:NULL:VALue:AUTO OFF](#)).
- To use the null value, the null state must be on ([\[SENSe:\]TEMPerature:NULL:STATe ON](#)).
- This parameter is set to its default value after a Factory Reset ([*RST](#)), Instrument Preset ([SYSTem:PRESet](#)), or CONFigure function.

[SENSe:]TEMPerature:NULL:VALue:AUTO {ON|1|OFF|0}
[SENSe:]TEMPerature:NULL:VALue:AUTO?

Enables or disables automatic null value selection for temperature measurements.

Parameter	Typical Return
{ON 1 OFF 0}, default OFF	0 (OFF) or 1 (ON)
Configure temperature measurements, using the null function to subtract 25° from them. Make and read two measurements: CONF:TEMP RTD TEMP:NULL:STAT ON;VAL 25> SAMP:COUN 2 READ? Typical Response: +1.04530000E+00,+1.04570000E+00 Make a second set of measurements using automatic null value selection: TEMP:NULL:VAL:AUTO ON READ? Typical Response: +0.00000000E+00,+0.01420000E+00	

- When automatic reference selection is ON, the first measurement made is used as the null value for all subsequent measurements. [\[SENSe:\]TEMPerature:NULL:VALue](#) will be set to this value. Automatic null value selection will be disabled.
- When automatic null value selection is disabled (OFF), the null value is specified by this command: [\[SENSe:\]TEMPerature:NULL:VALue](#).
- The instrument enables automatic null value selection when the null function is enabled ([\[SENSe:\]TEMPerature:NULL:STATe ON](#)).
- This parameter is set to its default value after a Factory Reset ([*RST](#)), Instrument Preset ([SYSTem:PRESet](#)), or CONFigure function.

[SENSe:]TEMPerature:TRANsducer:{RTD|FRTD}:RESistance[:REFerence]
{<reference>|MIN|MAX|DEF}
[SENSe:]TEMPerature:TRANsducer:{RTD|FRTD}:RESistance[:REFerence]?
[{MIN|MAX|DEF}]

Selects the nominal resistance (R_0) for 2-wire and 4-wire RTD measurements. R_0 is the nominal resistance of an RTD at 0 °C.

Parameter	Typical Return
80 Ω to 120 Ω, default 100 Ω	+1.00100000E+02
Configure 4-wire RTD measurements using an RTD with an R_0 of 100.1 Ω. Make and read two measurements: CONF:TEMP FRTD TEMP:TRAN:FRTD:RES 100.1 SAMP:COUN 2 READ? Typical Response: +1.04530000E+02,+1.04570000E+02	

- This parameter is set to its default value after a Factory Reset ([*RST](#)) or Instrument Preset ([SYSTem:PRESet](#)).

[SENSe:]TEMPerature:TRANsducer:{THERmistor|FTHermistor}:TYPE 5000
[SENSe:]TEMPerature:TRANsducer:{THERmistor|FTHermistor}:TYPE?

Selects the thermistor type for 2-wire and 4-wire temperature measurements. Choosing the THERmistor or the FTHermistor command form makes no difference, as both commands affect the same parameter.

Parameter	Typical Return
5000 (only available choice)	+5000
Configure 4-wire thermistor measurements. Make and read two measurements: CONF:TEMP FTH TEMP:TRAN:FTH:TYPE 5000 SAMP:COUN 2 READ? Typical Response: +1.04530000E+02,+1.04570000E+02	

[SENSe:]TEMPerature:TRANsducer:TYPE {FRTD|RTD|FTHermistor|THERmistor}
[SENSe:]TEMPerature:TRANsducer:TYPE?

Selects the transducer probe type to use for temperature measurements. The supported probes are 2-wire and 4-wire RTDs and 2-wire and 4-wire thermistors.

Parameter	Typical Return
{FRTD RTD FTHermistor THERmistor}, default FRTD	FRTD, RTD, FTH, or THER
Configure 2-wire RTD measurements using an RTD with an R_0 of 100.1 Ω . Make and read two measurements: FUNC "TEMP" TEMP:TRAN:TYPE RTD TEMP:TRAN:FRTD:RES 100.1 SAMP:COUN 2 READ? Typical Response: +2.54530000E+01,+2.54570000E+01	

- This parameter is set to its default value after a Factory Reset ([*RST](#)) or Instrument Preset ([SYSTem:PRESet](#)).

[SENSe:]TEMPerature:ZERO:AUTO {OFF|ON|ONCE}
[SENSe:]TEMPerature:ZERO:AUTO?

Disables or enables the autozero mode for 2-wire temperature measurements.

- **ON (default):** the DMM internally measures the offset following each measurement. It then subtracts that measurement from the preceding reading. This prevents offset voltages present on the DMM's input circuitry from affecting measurement accuracy.
- **OFF:** the instrument uses the last measured zero measurement and subtracts it from each measurement. It takes a new zero measurement each time you change the function, range or integration time.
- **ONCE:** the instrument takes one zero measurement and sets autozero OFF. The zero measurement taken is used for all subsequent measurements until the next change to the function, range or integration time. If the specified integration time is less than 1 PLC, the zero measurement is taken at 1 PLC to optimize noise rejection. Subsequent measurements are taken at the specified fast (< 1 PLC) integration time.

Parameter	Typical Return
{OFF ON ONCE}, default ON	0 (OFF) or 1 (ON)
Configure 2-wire RTD measurements and perform an immediate zero autozero. Make and read two measurements: CONF:TEMP RTD TEMP:ZERO:AUTO ONCE SAMP:COUN 2 READ? Typical Response: +2.57530000E+01,+2.57570000E+01	

- This command does not affect 4-wire resistance measurements, which are always made with autozero ON.
- The autozero mode is set indirectly when you set the resolution and integration time using [CONFigure:TEMPerature](#) or [MEASure:TEMPerature?](#). Autozero is automatically turned OFF when you select an integration time less than 1 PLC with these commands.
- This parameter is set to its default value after a Factory Reset ([*RST](#)) or Instrument Preset ([SYSTem:PRESet](#)).

[SENSe:]VOLTage Subsystem

This subsystem configures AC voltage measurements and DC voltage and ratio measurements.

Command Summary

[\[SENSe:\]VOLTage:AC:BANDwidth](#)

[\[SENSe:\]VOLTage:{AC|DC}:NULL\[:STATe\]](#)

[\[SENSe:\]VOLTage:{AC|DC}:NULL:VALue](#)

[\[SENSe:\]VOLTage:{AC|DC}:NULL:VALue:AUTO](#)

[\[SENSe:\]VOLTage:{AC|DC}:RANGe](#)

[\[SENSe:\]VOLTage:{AC|DC}:RANGe:AUTO](#)

[\[SENSe:\]VOLTage\[:DC\]:IMPedance:AUTO](#)

[\[SENSe:\]VOLTage\[:DC\]:NPLC](#)

[\[SENSe:\]VOLTage\[:DC\]:RESolution](#)

[\[SENSe:\]VOLTage\[:DC\]:ZERO:AUTO](#)

[SENSe:]VOLTage:AC:BANDwidth {<filter>|MIN|MAX|DEF}
[SENSe:]VOLTage:AC:BANDwidth? [{MIN|MAX|DEF}]

Sets the bandwidth for AC voltage measurements.

The instrument uses three different AC filters that enable you either to optimize low frequency accuracy or to achieve faster AC settling times following a change in input signal amplitude. The instrument selects the slow (3 Hz), medium (20 Hz) or fast (200 Hz) filter based on the cutoff frequency specified by this command. Specify the lowest frequency that you expect to encounter.

Parameter	Typical Return
{3 Hz 20 Hz 200 Hz} MIN=3 Hz, DEF=20 Hz, MAX=200 Hz	+2.00000000E+01
Make and read an AC voltage measurement. Use the 3 Hz filter bandwidth: CONF:VOLT:AC 100 VOLT:AC:BAND 3 READ?	

- If you enter the lowest expected frequency that you intend to encounter, the command will select the appropriate <filter>. For example, if you enter 15 Hz, the slow filter (3 Hz) is selected. If you enter 190 Hz, the medium filter (20 Hz) is selected to provide the appropriate low cutoff.
- Set the lowest frequency that you expect to encounter. Lower bandwidths result in longer settling delays, as shown:

Input Frequency	Default Settling Delay
3 Hz - 300 kHz (<i>Slow</i>)	2.5000 s/measurement
20 Hz - 300 kHz (<i>Medium</i>)	0.6250 s/measurement
200 Hz - 300 kHz (<i>Fast</i>)	0.0250 s/measurement

- This parameter is set to its default value after a Factory Reset ([*RST](#)) or Instrument Preset ([SYSTem:PRESet](#)).

[SENSe:]VOLTage:{AC|DC}:NULL[:STATe] {ON|1|OFF|0}
[SENSe:]VOLTage:{AC|DC}:NULL[:STATe]?

Enables or disables the null function for AC or DC voltage measurements.

NOTE This parameter is not shared between AC and DC measurements. The parameters are independent for AC and DC measurements.

Parameter	Typical Return
{ON 1 OFF 0}, default OFF	0 (OFF) or 1 (ON)
Configure AC voltage measurements, using the null function to subtract 100 mV from the measurements. Make and read two measurements: CONF:VOLT:AC VOLT:AC:NULL:STAT ON;VAL 100 mV SAMP:COUN 2 READ? Typical Response: +1.04530000E+00,+1.04570000E+00	

- Enabling the scaling function also enables automatic null value selection ([\[SENSe:\]VOLTage:{AC|DC}:NULL:VALue:AUTO ON](#)).
- To set a fixed null value, use this command: [\[SENSe:\]VOLTage:{AC|DC}:NULL:VALue](#).
- The instrument disables the null function after a Factory Reset ([*RST](#)), Instrument Preset ([SYSTem:PRESet](#)), or CONFigure function.

[SENSe:]VOLTage:{AC|DC}:NULL:VALue {<value>|MIN|MAX|DEF}
[SENSe:]VOLTage:{AC|DC}:NULL:VALue? [{MIN|MAX|DEF}]

Stores a null value for voltage measurements.

NOTE This parameter is not shared between AC and DC measurements. The parameters are independent for AC and DC measurements.

Parameter	Typical Return
-1200 to +1200 V, default 0	+1.00000000E-02
Configure AC voltage measurements, using the null function to subtract 100 mV from the measurements. Make and read two measurements: CONF:VOLT:AC VOLT:AC:NULL:STAT ON;VAL 100 mV SAMP:COUN 2 READ? Typical Response: +1.04530000E+00,+1.04570000E+00	

- Specifying a null value disables automatic null value selection ([\[SENSe:\]VOLTage:{AC|DC}:NULL:VALue:AUTO OFF](#)).
- To use the null value, the null state must be on ([\[SENSe:\]VOLTage:{AC|DC}:NULL:STATe ON](#)).
- This parameter is set to its default value after a Factory Reset ([*RST](#)), Instrument Preset ([SYSTem:PRESet](#)), or CONFigure function.

[SENSe:]VOLTage:{AC|DC}:NULL:VALue:AUTO {ON|1|OFF|0}
[SENSe:]VOLTage:{AC|DC}:NULL:VALue:AUTO?

Enables or disables automatic null value selection for AC voltage or DC voltage and ratio measurements.

NOTE

This parameter is not shared between AC and DC measurements. The parameters are independent for AC and DC measurements.

Parameter	Typical Return
{ON 1 OFF 0}, default OFF	0 (OFF) or 1 (ON)
Configure AC voltage measurements, using the null function to subtract 100 mV from the measurements. Make and read two measurements: CONF:VOLT:AC VOLT:AC:NULL:STAT ON;VAL 100 mV SAMP:COUN 2 READ? Typical Response: +1.04530000E+00,+1.04570000E+00 Make a second set of measurements using automatic null value selection: VOLT:AC:NULL:VAL:AUTO ON READ? Typical Response: +0.00000000E+00,+0.01420000E+00	

- When automatic reference selection is ON, the first measurement made is used as the null value for all subsequent measurements. [\[SENSe:\]VOLTage:{AC|DC}:NULL:VALue](#) will be set to this value. Automatic null value selection will be disabled.
- When automatic null value selection is disabled (OFF), the null value is specified by this command: [\[SENSe:\]VOLTage:{AC|DC}:NULL:VALue](#).
- The instrument enables automatic null value selection when the null function is enabled ([\[SENSe:\]VOLTage:{AC|DC}:NULL:STATe ON](#)).
- This parameter is set to its default value after a Factory Reset ([*RST](#)), Instrument Preset ([SYSTem:PRESet](#)), or CONFIGure function.

[SENSe:]VOLTage:{AC|DC}:RANGe {<range>|MIN|MAX|DEF}
[SENSe:]VOLTage:{AC|DC}:RANGe? [{MIN|MAX|DEF}]

Selects a fixed measurement range for AC and DC voltage measurements and DC ratio measurements.

NOTE This parameter is not shared between AC and DC measurements. The parameters are independent for AC and DC measurements.

WARNING The maximum range parameter (MAX) is 1000 V. However, the SAFETY LIMIT on the front and rear HI/LO input terminals is 750 VAC (rms). The rms voltage is waveform dependent. A sine wave is limited to 750 VAC (rms), but a 1000 Vpk square wave is safe. Connection to AC mains power is further limited to CAT II (300 V). See [Safety and Regulatory Information](#) for more information on the safety features and the safe operation of this instrument.

Parameter	Typical Return
{100 mV 1 V 10 V 100 V 1000 V} AC default: 10 V DC default: 1000 V	+1.00000000E+01
Configure AC voltage measurements using the 100 V range. Make and read two measurements: CONF:VOLT:AC VOLT:AC:RANG 100 SAMP:COUN 2 READ? Typical Response: +3.24530000E+01,+3.24570000E+01	

- Selecting a fixed range ([SENSe:]<function>:RANGe) disables autoranging.
- If the input signal is greater than can be measured on the specified manual range, the instrument displays the word Overload on front panel and returns "9.9E37" from the remote interface.
- The instrument is set to the default range, with autoranging enabled ([\[SENSe:\]VOLTage:{AC|DC}:RANGe:AUTO ON](#)), after a Factory Reset ([*RST](#)) or an Instrument Preset ([SYSTem:PRESet](#)).

[SENSe:]VOLTage:{AC|DC}:RANGe:AUTO {OFF|ON|ONCE}
[SENSe:]VOLTage:{AC|DC}:RANGe:AUTO?

Disables or enables autoranging for AC and DC voltage measurements and for DC ratio measurements. Autoranging is convenient because it automatically selects the range for each measurement based on the input signal.

Specifying ONCE performs an immediate autorange and then turns autoranging off.

NOTE This parameter is not shared between AC and DC measurements. The parameters are independent for AC and DC measurements.

WARNING The maximum range parameter (MAX) is 1000 V. However, the SAFETY LIMIT on the front and rear HI/LO input terminals is 750 VAC (rms). The rms voltage is waveform dependent. A sine wave is limited to 750 VAC (rms), but a 1000 Vpk square wave is safe. Connection to AC mains power is further limited to CAT II (300 V). See [Safety and Regulatory Information](#) for more information on the safety features and the safe operation of this instrument.

Parameter	Typical Return
{ON 1 OFF 0}, default ON	0 (OFF) or 1 (ON)
Configure DC voltage measurements and perform an immediate autorange. Make and read two measurements: CONF:VOLT:AC VOLT:AC:RANG:AUTO ONCE SAMP:COUN 2 READ? Typical Response: +1.04530000E+01,+1.04570000E+01	

- Autoranging goes down a range at less than 10% of range and up a range at greater than 120% of range.
- With autoranging enabled, the instrument selects the range based on the input signal.
- Selecting a fixed range ([SENSe:]<function>:RANGe) disables autoranging.
- This parameter is set to its default value after a Factory Reset ([*RST](#)) or Instrument Preset ([SYSTem:PRESet](#)).

[SENSe:]VOLTage[:DC]:IMPedance:AUTO {ON|1|OFF|0}
[SENSe:]VOLTage[:DC]:IMPedance:AUTO?

Disables or enables automatic input impedance mode for DC voltage and ratio measurements.

Parameter	Typical Return
{ON 1 OFF 0}, default OFF	0 (OFF) or 1 (ON)
Make all DC voltage measurements with a 10 MΩ input impedance: VOLT:IMP:AUTO OFF	

- **OFF:** the input impedance for DC voltage measurements is fixed at 10 MΩ for all ranges to minimize noise pickup.
- **ON:** the input impedance for DC voltage measurements varies by range. It is set to "HI-Z" (>10 GΩ) for the 100 mV, 1 V, and 10 V ranges to reduce the effects of measurement loading errors on these lower ranges. The 100 V and 1000 V ranges remain at a 10 MΩ input impedance.
- The [CONFigure](#) and [MEASure?](#) commands automatically select "AUTO OFF".
- This parameter is set to its default value after a Factory Reset ([*RST](#)) or Instrument Preset ([SYSTem:PRESet](#)).

[SENSe:]VOLTage[:DC]:NPLC {<PLC>|MIN|MAX|DEF}
[SENSe:]VOLTage[:DC]:NPLC? [{MIN|MAX|DEF}]

Sets the integration time in number of power line cycles (PLC) for DC voltage and ratio measurements. Integration time is the period that the instrument's analog-to-digital (A/D) converter samples the input signal for a measurement. A longer integration time gives better measurement resolution but slower measurement speed.

Parameter	Typical Return
{0.02 0.2 1 10 100}, default 10 See Range, Resolution and NPLC for more information.	+1.00000000E+01
Configure DC voltage measurements using a 10 PLC integration time. Then make and read one measurement: CONF:VOLT:DC VOLT:DC:NPLC 10 READ? Typical Response: +6.27530000E-01	

- Only integration times of 1, 10, or 100 PLC provide normal mode (line frequency noise) rejection.
- Setting the integration time also sets the measurement resolution. [Resolution Table](#) shows the relationship between integration time and resolution. See [\[SENSe:\]VOLTage\[:DC\]:RESolution](#).
- This parameter is set to its default value after a Factory Reset ([*RST](#)) or Instrument Preset ([SYSTEM:PRESet](#)).

[SENSe:]VOLTage[:DC]:RESolution{<resolution>|MIN|MAX|DEF}
[SENSe:]VOLTage[:DC]:RESolution? [{MIN|MAX|DEF}]

Selects the measurement resolution for DC voltage and ratio measurements. Specify the resolution in the same units as the selected measurement function, not in number of digits.

Parameter	Typical Return
<resolution>: See Resolution Table or Range, Resolution and NPLC . The default is equivalent to 10 PLC. Specify <resolution> in the measurement's units (V, A, Hz, Ω, and so on).	+3.00000000E-05
Configure DC voltage measurements with a 3 μV resolution. Then make and read one measurement: CONF:VOLT:DC 1 VOLT:DC:RES 3E-6 READ?	

- You can specify MIN (best resolution) or MAX (worst resolution) instead of <resolution>.
- To achieve normal mode (line frequency noise) rejection, use a resolution that corresponds to an integration time that is an integral number of power line cycles.
- This parameter is set to its default value after a Factory Reset ([*RST](#)) or Instrument Preset ([SYSTEM:PRESet](#)).

[SENSe:]VOLTage[:DC]:ZERO:AUTO {OFF|ON|ONCE}
[SENSe:]VOLTage[:DC]:ZERO:AUTO?

Disables or enables the autozero mode for DC voltage and ratio measurements.

- **ON (default):** the DMM internally measures the offset following each measurement. It then subtracts that measurement from the preceding reading. This prevents offset voltages present on the DMM's input circuitry from affecting measurement accuracy.
- **OFF:** the instrument uses the last measured zero measurement and subtracts it from each measurement. It takes a new zero measurement each time you change the function, range or integration time.
- **ONCE:** the instrument takes one zero measurement and sets autozero OFF. The zero measurement taken is used for all subsequent measurements until the next change to the function, range or integration time. If the specified integration time is less than 1 PLC, the zero measurement is taken at 1 PLC to optimize noise rejection. Subsequent measurements are taken at the specified fast (< 1 PLC) integration time.

Parameter	Typical Return
{OFF ON ONCE}	0 (OFF) or 1 (ON)
Configure DC voltage measurements and immediately autozero. Make and read two measurements: CONF:VOLT:DC 1 VOLT:DC:ZERO:AUTO ONCE SAMP:COUN 2 READ? Typical Response: +1.04530000E+01,+1.04570000E+01	

- The autozero mode is set indirectly when you set the resolution and integration time using CONF:VOLTage:DC, CONF:VOLTage:DC:RATio, MEASure:VOLTage:DC?, or MEASure:VOLTage:DC:RATio?. Autozero is automatically turned OFF when you select an integration time less than 1 PLC with these commands.
- This parameter is set to its default value after a Factory Reset ([*RST](#)) or Instrument Preset ([SYSTem:PRESet](#)).

STATUS Subsystem

Agilent 34460A/61A Status System

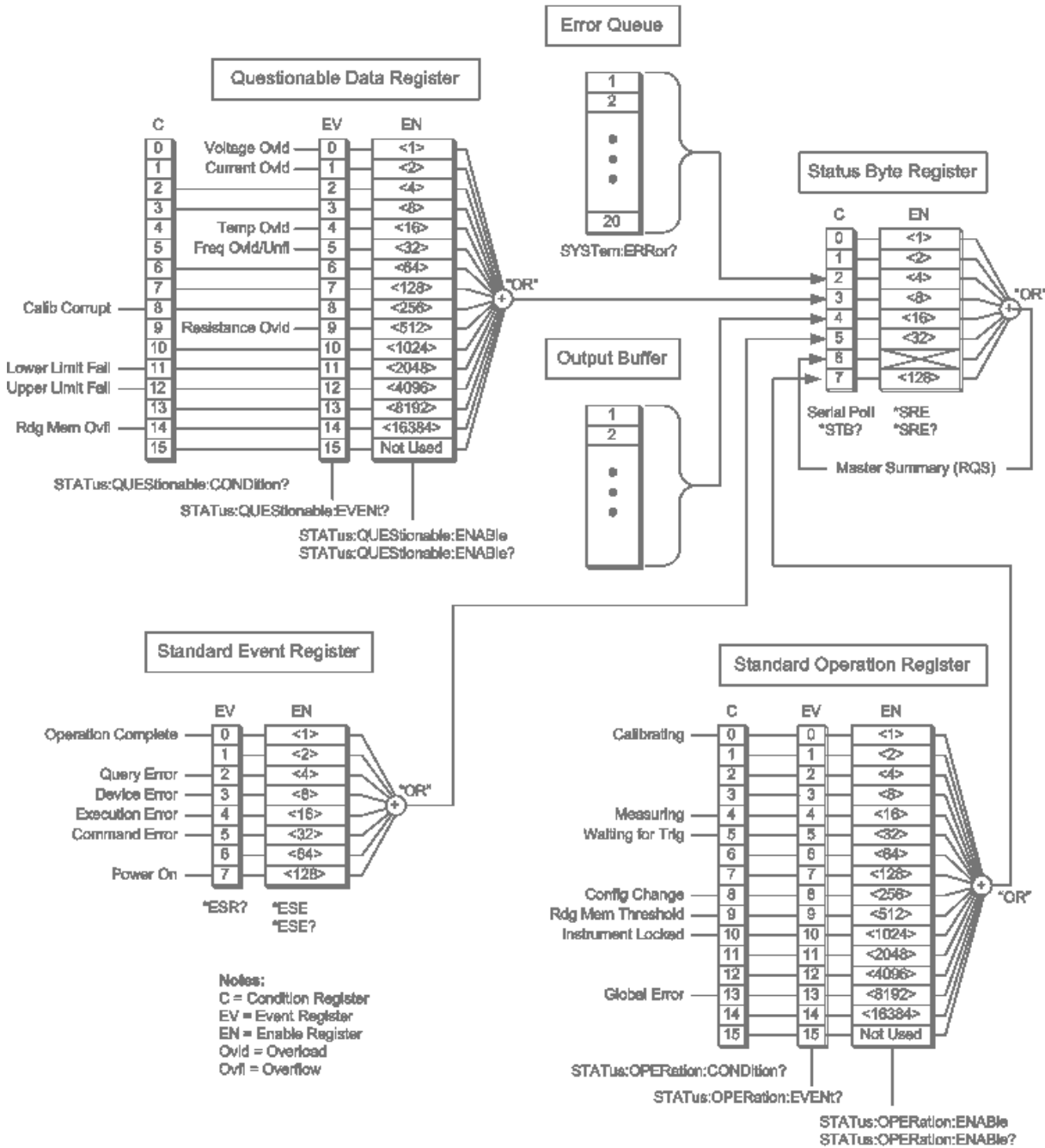

The following table lists the bit definitions for the *Questionable Data Register*:

NOTE The overload bits are set once per [INITiate](#) command. If you clear an overload bit, it will not be set again until a new INITiate is sent.

Bit Number	Bit Name	Decimal Value	Definition
0	Voltage Overload	1	Only reported as event. Returns 0. Read the Event Register.
1	Current Overload	2	Only reported as event. Returns 0. Read the Event Register.
2	Not Used	4	(Reserved for future use)
3	Not Used	8	(Reserved for future use)
4	Temperature Overload	16	Only reported as event. Returns 0. Read the Event Register.
5	Frequency Overload/Underflow	32	Only reported as event. Returns 0. Read the Event Register.
6	Not Used	64	(Reserved for future use)
7	Not Used	128	(Reserved for future use)
8	Calibration Corrupt	256	At least one calibration constant is corrupt.
9	Resistance Overload	512	Only reported as event. Returns 0. Read the Event Register.
10	Not Used	1024	(Reserved for future use)
11	Lower Limit Failed	2048	The most recent measurement failed the lower limit test.
12	Upper Limit Failed	4096	The most recent measurement failed the upper limit test.
13	Not Used	8192	(Reserved for future use)
14	Memory Overflow	16384	Reading memory is full. One or more (oldest) measurements have been lost.
15	Not Used	32768	(Reserved for future use)

The following table lists the bit definitions for the *Standard Operation Register*:

Bit Number	Bit Name	Decimal Value	Definition
0	Calibrating	1	Instrument is performing a calibration.
1	Not Used	2	(Reserved for future use)
2	Not Used	4	(Reserved for future use)
3	Not Used	8	(Reserved for future use)
4	Measuring	16	Instrument is initiated, and is making or about to make a measurement.
5	Waiting for Trigger	32	Instrument is waiting for a trigger.
6	Not Used	64	(Reserved for future use)
7	Not Used	128	(Reserved for future use)
8	Configuration Change	256	Instrument configuration has been changed since the last INIT, READ? or MEASure?, either from the front panel or from SCPI.
9	Memory Threshold	512	Programmed number of measurements (DATA:POINTs:EVENT:THReshold) have been stored in measurement memory.
10	Instrument Locked	1024	Set if a remote interface (GPIB, USB or LAN) has a lock (SYSTem:LOCK:REQuest?). Cleared when the remote interface releases the lock (SYSTem:LOCK:RELease).
11	Not Used	2048	(Reserved for future use)
12	Not Used	4096	(Reserved for future use)
13	Global Error	8192	Set if any remote interface has an error in its error queue; cleared otherwise.
14	Not Used	16384	(Reserved for future use)
15	Not Used	32768	"0" is returned.

Command Summary

[STATus:OPERation:CONDition?](#)

[STATus:OPERation:ENABLE](#)

[STATus:OPERation\[:EVENT\]?](#)

[STATus:PRESet](#)

[STATus:QUEStionable:CONDition?](#)

[STATus:QUEStionable:ENABLE](#)

[STATus:QUEStionable\[:EVENT\]?](#)

STATus:OPERation:CONDition?

Returns the sum of the bits in the condition register for the [Standard Operation Register](#) group. This register is read-only; bits are not cleared when read.

A condition register continuously monitors the state of the instrument. Condition register bits are updated in real time; they are neither latched nor buffered.

Parameter	Typical Return
(none)	+32
Read the condition register (bit 5 is set): STAT:OPER:COND?	

- The condition register bits reflect the current condition. If a condition goes away, the corresponding bit is cleared in the condition register.

STATus:OPERation:ENABLE <enable_value> STATus:OPERation:ENABLE?

Enables bits in the enable register for the [Standard Operation Register](#) group. The selected bits are then reported to the Status Byte. An enable register defines which bits in the event register will be reported to the Status Byte register group. You can write to or read from an enable register.

Parameter	Typical Return
A decimal value that corresponds to the binary-weighted sum of the bits in the register.	+32
Enable bit 5 (decimal value 32) in the enable register. STAT:OPER:ENAB 32	

- Use the <enable> parameter to specify which bits will be reported to the Status Byte. The decimal value specified corresponds to the binary-weighted sum of the bits you wish to enable in the register. For example, to enable bit 5 (decimal value = 32) and bit 9 (decimal value = 512), the corresponding decimal value would be 544 (32 + 512).
- A [STATus:PRESet](#) clears all bits in the enable register.
- The <enable> setting is nonvolatile; it does not change after a Factory Reset ([*RST](#)), Instrument Preset ([SYSTem:PRESet](#)), Status Preset ([STATus:PRESet](#)) or Clear Status ([*CLS](#)).
- The [*PSC](#) command controls whether the enable register is cleared at power on.

STATus:OPERation[:EVENT]?

Returns the sum of the bits in the event register for the [Standard Operation Register](#) group. An event register is a read-only register that latches events from the condition register. While an event bit is set, subsequent events corresponding to that bit are ignored. The register bits are cleared when you read the register.

Parameter	Typical Return
(none)	+512
Read the event register (bit 9 is set): STAT:OPER:EVEN?	

- Once a bit is set, it remains set until cleared by reading the event register or by sending [*CLS](#) (clear status).

STATus:PRESet

Clears [Questionable Data](#) enable register and [Standard Operation](#) enable register.

Parameter	Typical Return
(none)	(none)
Clear enable register bits: STAT:PRES	

STATus:QUESTIONable:CONDition?

Returns the sum of the bits in the condition register for the [Questionable Data Register](#) group. This register is read-only; bits are not cleared when read.

A condition register continuously monitors the state of the instrument. Condition register bits are updated in real time; they are neither latched nor buffered.

Parameter	Typical Return
(none)	+4096
Read the condition register (bit 12 is set): STAT:QUES:COND?	

- The condition register bits reflect the current condition. If a condition goes away, the corresponding bit is cleared in the condition register.

STATus:QUESTIONable:ENABLE <enable_value>

STATus:QUESTIONable:ENABLE?

Enables bits in the enable register for the [Questionable Data Register](#) group. The selected bits are then reported to the Status Byte. An enable register defines which bits in the event register will be reported to the Status Byte register group. You can write to or read from an enable register.

Parameter	Typical Return
A decimal value that corresponds to the binary-weighted sum of the bits in the register.	+512
Enable bit 9 (decimal value 512) in the enable register.	

- Use the <enable> parameter to specify which bits will be reported to the Status Byte. The decimal value specified corresponds to the binary-weighted sum of the bits you wish to enable in the register. For example, to enable bit 0 (decimal value = 1), bit 1 (decimal value = 2) and bit 12 (decimal value = 4096), the corresponding decimal value would be 4099 (1 + 2 + 4096).
- A [STATus:PRESet](#) clears all bits in the enable register.
- The <enable> setting is nonvolatile; it does not change after a Factory Reset ([*RST](#)), Instrument Preset ([SYSTem:PRESet](#)), Status Preset ([STATus:PRESet](#)) or Clear Status ([*CLS](#)).
- The [*PSC](#) command controls whether the enable register is cleared at power on.

STATus:QUESTionable[:EVENT]?

Returns the event register for the [Questionable Data Register](#) group. An event register is a read-only register that latches events from the condition register. While an event bit is set, subsequent events corresponding to that bit are ignored. The register bits are cleared when you read the register.

Parameter	Typical Return
(none)	+1024
Read the event register (bit 10 is set); STAT:QUES?	

- Once a bit is set, it remains set until cleared by reading the event register or by sending [*CLS](#) (clear status).

SYSTEM Subsystem - General Purpose Commands

The SYSTem subsystem includes general commands (listed below), [license management commands](#), and [remote interface configuration commands](#).

Command Summary

[SYSTem:BEEPer\[:IMMediate\]](#)

[SYSTem:BEEPer:STATe](#)

[SYSTem:CLICk:STATe](#)

[SYSTem:DATE](#)

[SYSTem:ERRor\[:NEXT\]?](#)

[SYSTem:HELP?](#)

[SYSTem:IDENtify](#)

[SYSTem:LABel](#)

[SYSTem:PRESet](#)

[SYSTem:SECurity:COUNt?](#)

[SYSTem:SECurity:IMMediate](#)

[SYSTem:TEMPerature?](#)

[SYSTem:TIME](#)

[SYSTem:UPTime](#)

[SYSTem:VERsion?](#)

[SYSTem:WMESsage](#)

SYSTem:BEEPer[:IMMediate]

Issues a single beep.

Parameter	Typical Return
(none)	(none)
Issue a single beep: SYST:BEEP	

- Programmed beeps may be useful for program development and troubleshooting.
- You can issue a beep with this command regardless of the current beeper state ([SYSTem:BEEPer:STATe](#)).

SYSTem:BEEPer:STATe {ON|1|OFF|0} SYSTem:BEEPer:STATe?

Disables or enables the beep heard during continuity, diode, or Probe Hold measurements, or when an error is generated from the front panel or remote interface.

Parameter	Typical Return
{ON 1 OFF 0}, default ON	0 (OFF) or 1 (ON)
Disable beeper state: SYST:BEEP:STAT OFF	

- This command not affect the front-panel key click.
- A beep is always emitted (even with beeper state OFF) when [SYSTem:BEEPer](#) is sent.
- This setting is non-volatile; it is not changed by power cycling, a Factory Reset ([*RST](#)), or an Instrument Preset ([SYSTem:PRESet](#)).

SYSTem:CLICK:STATe {ON|1|OFF|0} SYSTem:CLICK:STATe?

Disables or enables the click heard when a front-panel key or softkey is pressed.

Parameter	Typical Return
{ON 1 OFF 0}, default ON	0 (OFF) or 1 (ON)
Disable keyboard click: SYST:CLIC:STAT OFF	

- This command not affect the beeper heard associated with diode and continuity tests, errors and so on.
- This setting is non-volatile; it is not changed by power cycling, a Factory Reset ([*RST](#)), or an Instrument Preset ([SYSTem:PRESet](#)).

SYSTem:DATE <year>, <month>, <day> SYSTem:DATE?

Sets the date for the instrument's real-time clock. Use [SYSTem:TIME](#) to set the time.

Parameter	Typical Return
<year> 2000 to 2099 <month> 1 to 12 <day> 1 to 31	+2011,+07,+26
Set system date to July 26, 2011: SYST:DATE 2011, 7,26	

- The real-time clock is used for Mass Memory (MMEMory) system file timestamps.
- The real-time clock is battery-backed and retains the date and time when power is off.
- The date and time are not affected by [*RST](#) or [SYSTem:PRESet](#).
- The real-time clock does not adjust itself for time zone changes or daylight savings time. Be sure to set the date and time when you first receive your instrument.

SYSTem:ERRor[:NEXT]?

Reads and clears one error from the error queue. See [SCPI Error Messages](#) for the complete SCPI error message list.

Parameter	Typical Return
(none)	-113,"Undefined header"
Read and clear the first error in the error queue: SYST:ERR?	

- Up to 20 errors can be stored in the instrument's error queue. Each remote interface I/O session (GPIB, USB, VXI-11, Telnet/sockets) has its own interface-specific error queue. Errors appear in the error queue of the I/O session that caused the error. For example, if an error was generated by a command sent over GPIB, send [SYSTem:ERRor?](#) from GPIB to read the error queue. Errors generated by instrument hardware are broadcast to all I/O sessions.
- Error retrieval is first-in-first-out (FIFO), and errors are cleared as you read them. The instrument beeps each time an error is generated (unless disabled by [SYSTem:BEEPer:STATe OFF](#)).
- If more than 20 errors have occurred, the most recent error stored in the queue is replaced with -350,"Queue overflow". No additional errors are stored until you remove errors from the queue. If no errors have occurred when you read the error queue, the instrument responds with +0,"No error".
- Errors have the following format (the error string may contain up to 255 characters).

<error code>,<error string>

Where:

<error code> = a positive or negative integer

<error string> = a quoted ASCII string up to 255 characters

See Also

[*SRE](#)

SYSTem:HELP?

Returns a complete list of the instrument's SCPI commands.

Parameter	Typical Return
(none)	(see below)
Return the list of SCPI commands: SYST:HELP?	

- The query returns Definite Length Block Data, which allows any type of data to be transmitted as a series of 8-bit data bytes. The first line is a pound sign (#) followed by one digit representing the number of digits in the decimal integer to follow. This digit is followed by a decimal integer indicating the number of data bytes to follow, followed by the first New Line. (For example, "#47947" in the first line means that there are 7947 data bytes to follow.) The rest of the block has one command per line, each terminated by a New Line character (ASCII character 10).

The beginning of a returned list is shown below. Note that the actual contents may vary, depending on the firmware revision:

```
#48085
:ABORt/nquery/
:CALibration:ADC?/qonly/
:CALibration:ALL?/qonly/
:CALibration:COUNt?/qonly/
:CALibration:DATA
```

In this list,

- /nquery/ indicates a command with no query.
- /qonly/ indicates a query with no command form.
- All other commands consist of a command and query.
- Syntax for each command is found in the [Command Quick Reference](#).
- The list may include commands or queries not described in this document. These are deprecated commands included for compatibility with older instruments.

SYSTem:IDENTify {DEFault|HP34401A} SYSTem:IDENTify?

Selects the manufacturer and model number returned by [*IDN?](#). The serial number and revision information are unaffected, and this command does not change instrument operation. You can use this command to avoid changing existing test systems where the manufacturer and model number are checked and expected to indicate a 34401A.

Parameter	Typical Return
{DEFault HP34401A}	DEF or HP34401A
Select a *IDN? response compatible with the 34401A: SYST:IDEN HP34401A *IDN?	
Typical Response: HEWLETT-PACKARD,34401A,...	

- DEFault selects the default response:
"Agilent Technologies,34460A, ..."
"Agilent Technologies,34461A, ..."
- HP34401A selects a response compatible with the 34401A:
"HEWLETT-PACKARD,34401A, ..."
- This setting is non-volatile; it is not changed by power cycling, a Factory Reset ([*RST](#)), or an Instrument Preset ([SYSTem:PRESet](#)).

SYSTem:LABel "<string>" SYSTem:LABel?

Places a message in a large font on the bottom half of the instrument's front-panel display.

Parameter	Typical Return
A quoted string of up to 40 characters. You can use letters (A-Z), numbers (0-9) and special characters such as @, %, *, and so forth. Default ""	"Battery DCI"
Set the message to be displayed on the screen: SYST:LAB "Battery DCI"	

- If you enter a string longer than 40 characters, the instrument truncates the string after the first 40 characters."
- The font size changes based on the length of the message and whatever other information is shown on the display.
- To turn off the message, send SYST:LAB "" to change the label to a null string. This also removes the label area from the screen.
- The value of this parameter is not affected by [*RST](#) or [SYSTem:PRESet](#).

SYSTem:PRESet

This command is nearly identical to [*RST](#). The difference is that *RST resets the instrument for SCPI operation, and SYSTem:PRESet resets the instrument for front-panel operation. As a result, *RST turns the histogram and statistics off, and SYSTem:PRESet turns them on (CALC:TRAN:HIST:STAT ON).

SYSTem:SECurity:COUNT?

Returns the instrument's security count.

Parameter	Typical Return
(none)	+22
Return the instrument's security count: SYSTem:SECurity:COUNT?	

- The security count is incremented by 1 every time you perform an action, other than calibration, that requires the instrument to be unsecured. This includes enabling or disabling interfaces, sanitizing memory per the NISPOM standard ([SYSTem:SECurity:IMMEDIATE](#)), updating firmware, changing the security code, or overriding the calibration security.
- The act of securing or unsecuring the instrument does not increment the counter.
- Be sure to read the security count upon receiving your instrument.

See Also

[CALibration:COUNT?](#)

SYSTem:SECurity:IMMEDIATE

Sanitizes all user-accessible instrument memory except for the calibration constants and reboots the instrument. This complies with requirements in chapter 8 of the National Instrument Security Program Operating Manual (NISPOM).

This command requires the optional security feature. See [Models and Options](#) for details.

CAUTION

The **NISPOM Sanitize** softkey and the SYSTem:SECurity:IMMEDIATE command are equivalent. They are for customers, such as military contractors, who must comply with NISPOM.

This feature destroys all user-defined state information, measurement data, and user-defined I/O settings such as the IP address. This feature is not recommended for use in routine applications because of the possibility of unintended data loss.

Parameter	Typical Return
(none)	(none)
Sanitize all user-accessible instrument memory: SYST:SEC:IMM	

- This command is typically used before removing an instrument from a secure area.
- This command initializes all instrument settings to their Factory Reset ([*RST](#)) values. It also destroys all user-defined state and preference information (see [MMEMory Subsystem - STATE and PREFerence Files](#)).
- This command increments the [security count](#).

SYSTem:TEMPerature?

Returns the instrument's internal temperature in °C.

Parameter	Typical Return
(none)	+2.85000000E+01
Return the instrument's internal temperature: SYST:TEMP?	

- The value returned is not affected by [UNIT:TEMPerature](#).

SYSTem:TIME <hour>, <minute>, <second> SYSTem:TIME?

Sets the time for the instrument's real-time clock. Use SYSTem:DATE to set the date.

Parameter	Typical Return
<hour> 0 to 23 <minute> 0 to 59 <second> 0 to 60	20,15,30.000
Set instrument time to 20:15:30 (8:15:30 PM) SYST:TIME 20,15,30	

- The real-time clock is used for Mass Memory (MMEMory) system file timestamps.
- The real-time clock is battery-backed and retains the date and time when power is off.
- The date and time are not affected by [*RST](#) or [SYSTem:PRESet](#).
- The real-time clock does not adjust itself for time zone changes or daylight savings time. Be sure to set the date and time when you first receive your instrument.

SYSTem:UPTime

Returns the amount of time that the instrument has been running since the last power-on.

Parameter	Typical Return
(none)	+8,+2,+13,+50
Return time that the instrument has been running: SYST:UPT	

- This command is typically used to verify that the instrument is warmed up sufficiently before calibration.
- The numbers returned indicate days, hours, minutes, and seconds, respectively.

SYSTem:VERSion?

Returns the version of SCPI (Standard Commands for Programmable Instruments) that the instrument complies with. There is no front panel equivalent. See [Introduction to the Introduction to the SCPI Language](#) for details.

Parameter	Typical Return
(none)	1994.0
Return the SCPI version: SYST:VERS?	

SYSTem:WMESsage "<string>" SYSTem:WMESsage?

Displays a power-on message.

Parameter	Typical Return
A quoted string of up to 40 characters. You can use letters (A-Z), numbers (0-9) and special characters such as @, %, *, and so forth. Default ""	"RETURN TO JOE AT POST D6"
Display a power-on message: SYST:WMES "RETURN TO JOE AT POST D6"	

- Specifying a null string ("") disables the power-on message.
- This setting is non-volatile; it is not changed by power cycling, a Factory Reset ([*RST](#)), or an Instrument Preset ([SYSTem:PRESet](#)).
- This parameter is set to its default value when the instrument is shipped from the factory and after [SYSTem:SECurity:IMMEDIATE](#).

SYSTEM Subsystem - I/O Configuration

The SYSTem subsystem includes [general instrument configuration commands](#), [I/O locking commands](#), [license management commands](#), and remote interface configuration commands (listed below).

Command Summary

[SYSTem:COMMunicate:ENABle](#)

[SYSTem:COMMunicate:GPIB:ADDResS](#)

[SYSTem:COMMunicate:LAN:CONTRol?](#)

[SYSTem:COMMunicate:LAN:DHCP](#)

[SYSTem:COMMunicate:LAN:DNS\[{1|2}\]](#)

[SYSTem:COMMunicate:LAN:DOMain?](#)

[SYSTem:COMMunicate:LAN:GATeway](#)

[SYSTem:COMMunicate:LAN:HOSTname](#)

[SYSTem:COMMunicate:LAN:IPADdress](#)

[SYSTem:COMMunicate:LAN:MAC?](#)

[SYSTem:COMMunicate:LAN:SMASK](#)

[SYSTem:COMMunicate:LAN:TELNet:PROMpt](#)

[SYSTem:COMMunicate:LAN:TELNet:WMESsage](#)

[SYSTem:COMMunicate:LAN:UPDate](#)

[SYSTem:COMMunicate:LAN:WINS\[{1|2}\]](#)

[SYSTem:USB:HOST:ENABle](#)

SYSTem:COMMunicate:ENABLE {ON|1|OFF|0}, <interface>
SYSTem:COMMunicate:ENABLE? <interface>

Disables or enables the GPIB, USB, or LAN remote interface. Also disables or enables available remote services such as Sockets, Telnet, VXI11, and the built-in Web Interface.

NOTE The GPIB interface is an optional feature. See [Models and Options](#) for details.

Parameter	Typical Return
{ON 1 OFF 0}, default ON for all interfaces	0 (OFF) or 1 (ON)
<interface>: {GPIB USB LAN SOCKets TELNet VXI11 WEB USBMtp USBHost}	
Disable the USB interface: SYST:COMM:ENAB OFF,USB	

- Enabling USBMtp allows you to transfer files from the instrument to a PC via the rear-panel USB port.
- The USBHost parameter refers to the instrument's front-panel USB port.
- If you disable the LAN interface, all associated LAN services will not be started when you power on the instrument.
- [SYSTem:SECurity:IMMediate](#) enables all interfaces USBMtp.
- For LAN, SOCKets, TELNet, VXI11, or WEB on the 34460A, you must have option 34460A-LAN or option 3446LANU.
- The interface enable settings are stored in nonvolatile memory. They do not change when power has been off, after a Factory Reset ([*RST](#)) or after an Instrument Preset ([SYSTem:PRESet](#)).

SYSTem:COMMunicate:GPIB:ADDRess <address>
SYSTem:COMMunicate:GPIB:ADDRess?

Assigns instrument's GPIB (IEEE-488) address, which is displayed at power-on. Each device on the GPIB interface must have a unique address.

NOTE The GPIB interface is an optional feature. See [Models and Options](#) for details.

Parameter	Typical Return
0 to 30, default 22	+15
Set GPIB address to 15: SYST:COMM:GPIB:ADDR 15	

- Your computer's GPIB interface card has its own address. Avoid using this address for any instrument on the GPIB bus.
- You must cycle power for this command to take effect.
- GPIB is enabled or disabled by [SYSTem:COMMunicate:ENABle](#).
- The GPIB interface is an optional feature. See [Models and Options](#) for details.
- This setting is non-volatile; it is not changed by power cycling, a Factory Reset ([*RST](#)), or an Instrument Preset ([SYSTem:PRESet](#)).
- This parameter is set to its default value when the instrument is shipped from the factory and after [SYSTem:SECurity:IMMediate](#).

SYSTem:COMMunicate:LAN:CONTRol?

Reads the initial Control connection port number for Sockets communications. This connection is used to send and receive commands and queries.

Parameter	Typical Return
(none)	5000 (0 if the interface does not support sockets)
Return the Control connection port number: SYST:COMM:LAN:CONT?	

- Use the Control socket connection to send a Device Clear (DCL) to the instrument or to detect pending Service Request (SRQ) events.
- On the 34460A, this requires option 34460A-LAN or option 3446LANU.

SYSTem:COMMunicate:LAN:DHCP {ON|1|OFF|0} SYSTem:COMMunicate:LAN:DHCP?

Disables or enables instrument's use of DHCP. The acronym DHCP stands for Dynamic Host Configuration Protocol, a protocol for assigning dynamic IP addresses to networked devices. With dynamic addressing, a device can have a different IP address every time it connects to the network.

ON: instrument tries to obtain an IP address from a DHCP server. If a DHCP server is found, it assigns a dynamic [IP address](#), [Subnet Mask](#), and [Default Gateway](#) to the instrument.

OFF or DHCP unavailable: instrument uses the static IP address, Subnet Mask, and Default Gateway during power-on.

NOTE

If you change this setting, you must send [SYSTem:COMMunicate:LAN:UPDate](#) to activate the new setting.

Parameter	Typical Return
{ON 1 OFF 0}, default ON	0 (OFF) or 1 (ON)
Disable DHCP: SYST:COMM:LAN:DHCP OFF SYST:COMM:LAN:UPDate	

- Most corporate LANs have a DHCP server.
- [SYSTem:SECurity:IMMEDIATE](#) sets this parameter to its default value.
- On the 34460A, this requires option 34460A-LAN or option 3446LANU.
- If a DHCP LAN address is not assigned by a DHCP server, then an Auto-IP will be assumed after approximately 2 minutes. An Auto-IP address has the form 169.254.nnn.nnn.
- This setting is non-volatile; it is not changed by power cycling, a Factory Reset ([*RST](#)), or an Instrument Preset ([SYSTem:PRESet](#)).

SYSTem:COMMunicate:LAN:DNS[**{1|2}**] "<address>" SYSTem:COMMunicate:LAN:DNS[**{1|2}**]? [**{CURRent|STATic}**]

Assigns static IP addresses of Domain Name System (DNS) servers. A primary and a secondary server address may be assigned. If DHCP is available and enabled, DHCP will auto-assign these server addresses. These auto-assigned server addresses take precedence over the static addresses assigned with this command. Contact your LAN administrator for details.

NOTE

If you change this setting, you must send [SYSTem:COMMunicate:LAN:UPDate](#) to activate the new setting.

Parameter	Typical Return
Command: " nnn.nnn.nnn.nnn ", default "0.0.0.0"	"198.105.232.4"
Query: { CURRent STATic }, default CURRent	
Set a static primary DNS address: SYST:COMM:LAN:DNS "198.105.232.4" SYST:COMM:LAN:UPD	

- **CURRent**: returns address currently being used by the instrument.
- **STATic**: returns static address from non-volatile memory. This address is used if DHCP is disabled or unavailable.
- [SYSTem:SECurity:IMMEDIATE](#) sets this parameter to its default value.
- On the 34460A, this requires option 34460A-LAN or option 3446LANU.
- The assigned DNS server addresses are used if DHCP is disabled or unavailable. Otherwise, the DNS server addresses are auto-assigned by DHCP.
- The DNS server addresses are stored in nonvolatile memory. They do not change when power has been off, after a Factory Reset ([*RST](#)) or after an Instrument Preset ([SYSTem:PRESet](#)).

SYSTem:COMMunicate:LAN:DOMain?

Returns the domain name assigned to the instrument.

Parameter	Typical Return
(none)	"example.com"
Return the domain name being used by the instrument: SYST:COMM:LAN:DOM?	

- If Dynamic Domain Name System (DNS) is available on your network and your instrument uses [DHCP](#), the domain name is assigned by the Dynamic DNS service at power-on.
- A null string ("") indicates that no domain name is assigned.
- On the 34460A, this requires option 34460A-LAN or option 3446LANU.

SYSTem:COMMunicate:LAN:GATeway "<address>" **SYSTem:COMMunicate:LAN:GATeway? [{CURRENT|STATic}]**

Assigns a default gateway for the instrument. The specified IP Address sets the default gateway, which allows the instrument to communicate with systems that are not on the local subnet. Thus, this is the default gateway where packets are sent that are destined for a device not on the local subnet, as determined by the [Subnet Mask](#) setting. Contact your LAN administrator for details.

NOTE

If you change this setting, you must send [SYSTem:COMMunicate:LAN:UPDate](#) to activate the new setting.

Parameter	Typical Return
Command: " nnn.nnn.nnn.nnn ", default "0.0.0.0"	"198.105.232.1"
Query: {CURRENT STATic}, default CURRENT	
Set default gateway address: SYST:COMM:LAN:GATEWAY "198.105.232.1" SYST:COMM:LAN:UPD	

- **CURRENT:** returns address currently being used by the instrument.
- **STATic:** returns static address from non-volatile memory. This address is used if DHCP is disabled or unavailable.
- [SYSTem:SECurity:IMMediate](#) sets this parameter to its default value.
- On the 34460A, this requires option 34460A-LAN or option 3446LANU.
- If DHCP is enabled ([SYSTem:COMMunicate:LAN:DHCP ON](#)), the specified default gateway is not used. However, if the DHCP server fails to assign a valid [IP address](#), the currently configured default gateway will be used.
- This setting is non-volatile; it is not changed by power cycling, a Factory Reset ([*RST](#)), or an Instrument Preset ([SYSTem:PRESet](#)).

SYSTem:COMMunicate:LAN:HOSTname "<name>"
SYSTem:COMMunicate:LAN:HOSTname? [{CURRENT|STATIC}]

Assigns a hostname to the instrument. A hostname is the host portion of the domain name, which is translated into an IP address. If Dynamic Domain Name System (Dynamic DNS) is available on your network and your instrument uses DHCP, the hostname is registered with the Dynamic DNS service at power-on. If DHCP is enabled (SYSTem:COMMunicate:LAN:DHCP ON), the DHCP server can change the specified hostname.

NOTE If you change this setting, you must send [SYSTem:COMMunicate:LAN:UPDate](#) to activate the new setting.

Parameter	Typical Return
String of up to 15 characters. Must start with letter (A-Z) May contain letters, numbers (0-9), or dashes ("-") Default: "A-34460A-nnnnn" or "A-34461A-nnnnn", where nnnnn is the last five digits of the instrument's serial number	"LAB1-34461A"
Define a hostname: SYST:COMM:LAN:HOST "LAB1-DMM" SYST:COMM:LAN:UPD	

- If no hostname exists, a null string ("") is returned.
- On the 34460A, this requires option 34460A-LAN or option 3446LANU.
- For the query form, specify "CURRENT" (default) to read the value currently being used by the instrument. Specify "STATIC" to read the host name currently stored in nonvolatile memory within the instrument (may not be the actual name used by the instrument if DHCP is enabled).
- This setting is non-volatile; it is not changed by power cycling, a Factory Reset ([*RST](#)), or an Instrument Preset ([SYSTem:PRESet](#)).
- This parameter is set to its default value when the instrument is shipped from the factory and after [SYSTem:SECurity:IMMEDIATE](#).

SYSTem:COMMunicate:LAN:IPADdress "<address>" SYSTem:COMMunicate:LAN:IPADdress? [{CURRent|STATic}]

Assigns a static Internet Protocol (IP) address for the instrument. If DHCP is enabled (SYSTem:COMMunicate:LAN:DHCP ON), the specified static IP address is not used. Contact your LAN administrator for details.

NOTE

If you change this setting, you must send [SYSTem:COMMunicate:LAN:UPDate](#) to activate the new setting.

Parameter	Typical Return
Command: " nnn.nnn.nnn.nnn " Query: {CURRent STATic}, default CURRent Default: 169.254.4.60 (34460A) or 169.254.4.61 (34461A)	"169.254.149.35"
Set a static IP address: SYST:COMM:LAN:IPAD "169.254.149.35" SYST:COMM:LAN:UPD	

- [SYSTem:SECurity:IMMediate](#) sets this parameter to its default value.
- On the 34460A, this requires option 34460A-LAN or option 3446LANU.
- For the query form, specify "CURRent" (default) to read the value currently being used by the instrument. Specify "STATic" to read the value currently stored in nonvolatile memory within the instrument (may not be the actual address used by the instrument if DHCP is enabled).
- This setting is non-volatile; it is not changed by power cycling, a Factory Reset ([*RST](#)), or an Instrument Preset ([SYSTem:PRESet](#)).
- This parameter is set to its default value when the instrument is shipped from the factory and after [SYSTem:SECurity:IMMediate](#).

SYSTem:COMMunicate:LAN:MAC?

Returns the instrument's Media Access Control (MAC) address as an ASCII string of 12 hexadecimal characters (0-9 and A-F) enclosed in quotation marks.

NOTE

Your LAN administrator may need the MAC address to assign a static IP address for this device.

Parameter	Typical Return
(none)	"0030D3001041"
Return the MAC address: SYST:COMM:LAN:MAC?	

- On the 34460A, this requires option 34460A-LAN or option 3446LANU.
- The MAC address is also known as the link-layer address, the Ethernet (station) address, LANIC ID or Hardware Address. This is an unchangeable 48-bit address assigned by the manufacturer to each unique Internet device.

SYSTem:COMMunicate:LAN:SMASk "<mask>"
SYSTem:COMMunicate:LAN:SMASk? [{CURRENT|STATIC}]

Assigns a subnet mask for the instrument to use in determining whether a client IP address is on the same local subnet. When a client [IP address](#) is on a different subnet, all packets must be sent to the [Default Gateway](#). Contact your LAN administrator for details.

NOTE If you change this setting, you must send [SYSTem:COMMunicate:LAN:UPDate](#) to activate the new setting.

Parameter	Typical Return
Command: " nnn.nnn.nnn.nnn ", default "255.255.0.0"	"255.255.255.0"
Query: {CURRENT STATIC}, default CURRENT	
Set the subnet mask: SYST:COMM:LAN:SMAS "255.255.255.0" SYST:COMM:LAN:UPD	

- On the 34460A, this requires option 34460A-LAN or option 3446LANU.
- If DHCP is enabled ([SYSTem:COMMunicate:LAN:DHCP ON](#)), the specified subnet mask is not used. However, if the DHCP server fails to assign a valid IP address, the instrument uses the Auto-IP subnet mask.
- A value of "0.0.0.0" or "255.255.255.255" indicates that subnetting is not being used.
- [SYSTem:SECurity:IMMediate](#) sets this parameter to its default value.
- **CURRENT:** returns address currently being used by the instrument.
- **STATIC:** returns static address from non-volatile memory. This address is used if DHCP is disabled or unavailable.
- This setting is non-volatile; it is not changed by power cycling, a Factory Reset ([*RST](#)), or an Instrument Preset ([SYSTem:PRESet](#)).

SYSTem:COMMunicate:LAN:TELNet:PROMpt "<string>" SYSTem:COMMunicate:LAN:TELNet:PROMpt?

Sets the command prompt seen when communicating with the instrument via Telnet.

Parameter	Typical Return
String of up to 15 characters Default: 34460A> or 34461A>	"Command>"
Set the command prompt: SYST:COMM:LAN:TELN:PROM "Command>"	

- On the 34460A, this requires option 34460A-LAN or option 3446LANU.
- The instrument uses LAN port 5024 for SCPI Telnet sessions and port 5025 for SCPI Socket sessions.
- Telnet sessions are typically started from a host computer shell:

```
telnet <IP_address> <port>
```

For example:

```
telnet 169.254.4.10 5024
```

To exit a Telnet session, press **<Ctrl-D>**.

- This setting is non-volatile; it is not changed by power cycling, a Factory Reset ([*RST](#)), or an Instrument Preset ([SYSTem:PRESet](#)).
- [SYSTem:SECurity:IMMEDIATE](#) sets this parameter to its default value.

SYSTem:COMMunicate:LAN:TELNet:WMESsage "<string>" SYSTem:COMMunicate:LAN:TELNet:WMESsage?

Sets welcome message seen when communicating with instrument via Telnet.

Parameter	Typical Return
Quoted string of up to 63 characters. Default: "Welcome to Agilent's 34460A Digital Multimeter" or "Welcome to Agilent's 34461A Digital Multimeter"	"Welcome to the Telnet Session"
Define a welcome message: SYST:COMM:LAN:TELN:WMES "Welcome to the Telnet Session"	

- On the 34460A, this requires option 34460A-LAN or option 3446LANU.
- The instrument uses LAN port 5024 for SCPI Telnet sessions and port 5025 for SCPI Socket sessions.
- This setting is non-volatile; it is not changed by power cycling, a Factory Reset ([*RST](#)), or an Instrument Preset ([SYSTem:PRESet](#)).
- [SYSTem:SECurity:IMMEDIATE](#) sets this parameter to its default value.

SYSTem:COMMunicate:LAN:UPDate

Stores any changes made to the LAN settings into non-volatile memory and restarts the LAN driver with the updated settings.

Parameter	Typical Return
(none)	(none)
(see below)	

- On the 34460A, this requires option 34460A-LAN or option 3446LANU.
- This command must be sent after changing the settings for DHCP, DNS, gateway, hostname, IP address, subnet mask, or WINS.
- Make all changes to the LAN settings before sending this command.

Example

The following example configures the instrument to use statically assigned LAN settings.

```
SYST:COMM:LAN:DHCP OFF
SYST:COMM:LAN:DNS "198.105.232.4"
SYST:COMM:LAN:DNS2 "198.105.232.5"
SYST:COMM:LAN:GAT "198.105.232.1"
SYST:COMM:LAN:HOST "LAB1-DMM"
SYST:COMM:LAN:IPAD "198.105.232.101"
SYST:COMM:LAN:SMAS "255.255.255.0"
SYST:COMM:LAN:WINS "198.105.232.4"
SYST:COMM:LAN:WINS "198.105.232.5"
SYST:COMM:LAN:UPD
```

The following example configures the instrument back to use DHCP.

```
SYST:COMM:LAN:DHCP ON
SYST:COMM:LAN:UPD
```

SYSTem:COMMunicate:LAN:WINS[{1|2}]"<address>" **SYSTem:COMMunicate:LAN:WINS[{1|2}]? [{CURRENT|STATIC}]**

Assigns the static IP addresses of the Windows Internet Name System (WINS) servers. A primary and a secondary server address may be assigned. If DHCP is available and enabled, DHCP will auto-assign these server addresses. These auto-assigned server addresses take precedence over the static addresses assigned with this command. Contact your LAN administrator for details.

NOTE

If you change this setting, you must send [SYSTem:COMMunicate:LAN:UPDate](#) to activate the new setting.

Parameter	Typical Return
Command: " nnn.nnn.nnn.nnn ", default "0.0.0.0"	"198.105.232.4"
Query: {CURRENT STATIC}, default CURRENT	
Set a static primary WINS address: SYST:COMM:LAN:WINS "198.105.232.4" SYST:COMM:LAN:UPD	

- On the 34460A, this requires option 34460A-LAN or option 3446LANU.
- The WINS addresses are stored in nonvolatile memory. They do not change when power has been off, after a Factory Reset ([*RST](#)) or after an Instrument Preset ([SYSTem:PRESet](#)).
- [SYSTem:SECurity:IMMediate](#) sets this parameter to its default value.
- **CURRENT**: returns address currently being used by the instrument.
- **STATIC**: returns static address from non-volatile memory. This address is used if DHCP is disabled or unavailable.

SYSTem:USB:HOST:ENABLE {ON|1|OFF|0} **SYSTem:USB:HOST:ENABLE?**

Disables or enables the front panel USB host port. Calibration security must be previously unsecured ([CALibration:SECure:STATe <code>,OFF](#)) before sending this command.

Parameter	Typical Return
{ON 1 OFF 0}, default OFF	0 (OFF) or 1 (ON)
Disable the USB host port: CAL:SEC:STAT OFF,MY_CAL_CODE SYST:USB:HOST:ENAB OFF CAL:SEC:STAT ON	

- This feature requires the SEC licensed option. This can be ordered as factory option 34460A-SEC or as customer-installable option 3446SECU. Without this option, the front-panel USB interface is always enabled.
- If the front panel USB host port is disabled, it cannot be used to store or load measurements, state files, preferences or other files or to perform firmware update.
- This setting is non-volatile; it is not changed by power cycling, a Factory Reset ([*RST](#)), or an Instrument Preset ([SYSTem:PRESet](#)).

SYSTEM:LOCK Subsystem

This subsystem locks and releases instrument I/O interfaces, as shown in the following example:

Initial State = unlocked, Count = 0

```
(FROM USB) SYST:LOCK:REQ? returns "1" (request successful)
```

State = locked, Count = 1

```
(FROM GPIB) SYST:LOCK:REQ? returns "0" because USB has lock
```

State = locked, Count = 1

```
(FROM USB) SYST:LOCK:REQ? returns "1" (request successful)
```

State = locked, Count = 2

```
(FROM USB) SYST:LOCK:REL
```

State = locked, Count = 1

```
(FROM USB) SYST:LOCK:REL
```

State = unlocked, Count = 0

For each successful lock request, a lock release is required. Two requests require two releases.

Command Summary

[SYSTem:LOCK:NAME?](#)

[SYSTem:LOCK:OWNer?](#)

[SYSTem:LOCK:RELease](#)

[SYSTem:LOCK:REQuest?](#)

SYSTem:LOCK:NAME?

Returns the I/O interface in use by the querying computer).

Parameter	Typical Return
(none)	"LAN169.254.149.35"
See Interface Locking Example	

- After using this command to determine the name of the interface that you are using, use [SYSTem:LOCK:OWNer?](#) to determine which interface, if any, has the lock.
- Returns "USB", "VXI11", "GPIB", or "LAN<IP Address>" indicating the I/O interface being used by the querying computer.

SYSTem:LOCK:OWNer?

Returns the I/O interface that currently has a lock.

Parameter	Typical Return
(none)	"LAN169.254.149.35"
See Interface Locking Example	

- When a lock is active, Bit 10 in the Standard Operation Register will be set ([STATus:OPERation:CONDition?](#)). When the lock is released on all I/O interfaces, this bit will be cleared.
- Returns "USB", "VXI11", "GPIB", or "LAN <IP Address>" indicating the I/O interface that currently has a lock. If no interface has a lock, "NONE" is returned.

SYSTem:LOCK:RELease

Decrements the lock count by 1 and may release the I/O interface from which the command is executed.

Parameter	Typical Return
(none)	(none)
See Interface Locking Example	

- When a lock is active, Bit 10 in the Standard Operation Register will be set ([STATus:OPERation:CONDition?](#)). When the lock is released on all I/O interfaces, this bit will be cleared.

SYSTem:LOCK:REQuest?

Requests a lock of the current I/O interface. This allows you to lock the instrument's configuration or cooperatively share the instrument with other computers.

Parameter	Typical Return
(none)	+0 (denied) or +1 (granted)
See Interface Locking Example	

- Lock requests can be nested; each request increases lock count by 1. For every request, you will need a release ([SYSTem:LOCK:RELease](#)) from the same I/O interface.
- Locks are handled at the I/O interface level (USB, LAN, etc.) and you are responsible for all coordination between threads and/or programs on that interface.
- When a request is granted, only I/O sessions from the present interface can change the instrument state. You can only query the instrument state from other I/O interfaces.
- LAN sessions locks are automatically released when a LAN disconnect is detected.
- Granting a lock sets Bit 10 in the Standard Operation Register ([STATus:OPERation:CONDition?](#)). In addition, the entire instrument front panel, including the **Local** key, is locked out while a lock is in place ("Front panel locked." is displayed).

SYSTEM:LICense Subsystem

This subsystem manages licensed instrument options.

Command Summary

[SYSTem:LICense:CATalog?](#)

[SYSTem:LICense:DElete](#)

[SYSTem:LICense:DElete:ALL](#)

[SYSTem:LICense:DESCRiption?](#)

[SYSTem:LICense:ERRor?](#)

[SYSTem:LICense:ERRor:COUNT?](#)

[SYSTem:LICense:INSTall](#)

SYSTEM:LICense:CATalog?

Returns a comma separated list of installed, [licensed options](#). Only those installed options that require a license are returned. If no licensed options are found, the query returns "".

Parameter	Typical Return
(none)	"LAN","SEC"
Return currently licensed options: SYST:LIC:CAT?	

SYSTEM:LICense:DElete "<option_name>"

Deletes a license and disables the associated functionality.

NOTE

If the security option is installed, you must unsecure the instrument with the security code to execute this command.

Parameter	Typical Return
34460A: "LAN" or "SEC"	(none)
34461A: "SEC"	
Delete LAN license: SYST:LIC:DEL "LAN"	

- Valid option names are double quoted strings representing the installed [licensed options](#). Installed options can be easily identified using [SYSTem:LICense:CATalog?](#).

SYSTem:LIcense:DELeTe:ALL

Deletes all licenses and disables the associated functionality.

NOTE

If the security option is installed, you must unsecure the instrument with the security code to execute this command.

Parameter	Typical Return
(none)	(none)
Delete all licenses: SYST:LIC:DEL:ALL	

SYSTem:LIcense:DESCRiption? "<option_name>"

Returns a description of the specified option, regardless of whether it is currently licensed.

Parameter	Typical Return
34460A: "LAN" or "SEC" 34461A: "SEC"	"Enable instrument security"
Return description for option 34460A-LAN or option 3446LANU: SYST:LIC:DESC? "LAN"	

- Valid option names are double quoted strings representing the installed [licensed options](#). Installed options can be easily identified using [SYSTem:LIcense:CATalog?](#).

SYSTem:LIcense:ERRor?

Returns a string of all the errors produced by [SYSTem:LIcense:INSTall](#).

Parameter	Typical Return
(none)	#279File: MyFile.lic<CR> <LF> [Ignored - The license file is not formatted correctly.] <CR> <LF>
Return the license installation error string: SYST:LIC:ERR?	

- The string can be up to 2096 characters.
- Returns a definite-length block containing multi-line ASCII text, including carriage returns and line feeds.

SYSTem:LIcense:ERRor:COUNt?

Returns the number of license errors generated by [SYSTem:LIcense:INSTall](#).

Parameter	Typical Return
(none)	+0
Return number of license errors: SYST:LIC:ERR:COUN?	

SYSTem:LIcense:INSTall [{<folder>|<file>}]
SYSTem:LIcense:INSTall? "<option_name>"

Installs all licenses from a specified file or from all license files in the specified folder.

NOTE

If the security option is installed, you must unsecure the instrument with the security code to execute this command.

Parameter	Typical Return
<folder> may be any valid folder name. Default is root directory of a front panel USB storage device. <file> may be any valid license file name 34460A: "LAN" or "SEC" 34461A: "SEC"	0 (license not installed) or 1 (license installed)
Install licenses from license files in the \Licenses folder on a front panel USB storage device: SYST:LIC:INST "USB:\Licenses" Install licenses from the file "MyLicenses.lic" in the \Licenses folder on a front panel USB storage device: SYST:LIC:INST "USB:\Licenses\MyLicenses.lic" Return the status of the license "LAN": SYST:LIC:INST? "LAN" Typical Response: 0	

- License files must have a ".lic" file extension.
- The format for <file> is "[<drive>:<path>]<file_name>", where <drive> can be INTERNAL or USB, and <path> must be an absolute folder path.
 - INTERNAL specifies the internal flash file system. USB specifies a front panel USB storage device.
 - If <drive>:<path> is omitted, the folder specified by [MMEMory:CDIRectory](#) is used.
 - Absolute paths begin with "\" or "/" and start at the root folder of <drive>.
 - Folder and file names cannot contain the following characters: \ / : * ? " < > |
 - The combination of folder and file name cannot exceed 240 characters.
 - The specified folder must exist and cannot be marked as hidden or system.
- The format for <folder> is "[[<drive>:]<path>]", where <drive> can be INTERNAL or USB, and <path> is a folder path.
 - INTERNAL specifies the internal flash file system. USB specifies a front panel USB storage device.
 - If <drive> is specified, <path> is interpreted as an absolute folder path. Absolute paths begin with "\" or "/" and start at the root folder of <drive>.
 - If <drive> is omitted, <path> is relative to the folder specified by [MMEMory:CDIRectory](#). Relative paths must NOT begin with \ or /.
 - The <folder> parameter cannot exceed 240 characters.
 - The specified folder must exist and cannot be marked as hidden or system.

TRIGger Subsystem

The TRIGger subsystem configures the triggering that controls measurement acquisition.

NOTE

It is recommended that all triggered measurements be made using an appropriate fixed manual range. That is, turn autorange off ([SENSe:]<function>:RANGe:AUTO OFF) or set a fixed range using the [SENSe:]<function>:RANGe, [CONFigure](#), or [MEASure](#) command.

Command Summary

[TRIGger:COUNT](#)

[TRIGger:DELaY](#)

[TRIGger:DELaY:AUTO](#)

[TRIGger:SLOPe](#)

[TRIGger:SOURce](#)

TRIGger:COUNT {<count>|MIN|MAX|DEF|INFinity}
TRIGger:COUNT? [{MIN|MAX|DEF}]

Selects the number of triggers that will be accepted by the instrument before returning to the "idle" trigger state.

Parameter	Typical Return
1 to 1,000,000 or continuous (INFinity). Default 1	+1.00000000E+00 For a continuous trigger (INFinity), the query returns "9.9E37".
Return ten sets of five DC voltage measurements, using a positive-going external trigger to start each measurement set: CONF:VOLT:DC SAMP:COUN 5 TRIG:COUN 10 TRIG:SOUR EXT;SLOP POS READ? Typical Response: +1.00520000E+01, ... (50 measurements)	

- You can use the specified trigger count in conjunction with a sample count ([SAMPle:COUNT](#)), which sets the number of samples to be made per trigger. In this case, the number of measurements returned will be the sample count multiplied by the trigger count.
- You can store up to 1,000 measurements in the reading memory of the 34460A or 10,000 measurements on the 34461A. If reading memory overflows, new measurements will overwrite the oldest measurements stored; the most recent measurements are always preserved. No error is generated, but the Reading Mem Ovfl bit (bit 14) is set in the Questionable Data Register's condition register (see [Status System Introduction](#)).
- A variable trigger count is not available from the front panel. If you set the trigger count and then go to local (front panel), the instrument ignores the trigger count setting; however, when you return to remote, the trigger count returns to the previous value you selected.
- This parameter is set to its default value after a Factory Reset ([*RST](#)) or Instrument Preset ([SYSTem:PRESet](#)).

TRIGger:DElay { <seconds>|MIN|MAX|DEF}
TRIGger:DElay? [{MIN|MAX|DEF}]

Sets the delay between the trigger signal and the first measurement. This may be useful in applications where you want to allow the input to settle before taking a measurement or for pacing a burst of measurements.

Selecting a specific trigger delay disables the automatic trigger delay ([TRIGger:DElay:AUTO OFF](#)).

NOTE

For AC measurements (voltage or current), there is a relationship between the bandwidth setting ([\[SENSe:\]VOLTage:AC:BANDwidth](#) or [\[SENSe:\]CURRent:AC:BANDwidth](#)) and the default trigger delay setting. This delay ensures that there is sufficient settling time for the AC measurement. See [Automatic Trigger Delays](#) for further information.

Parameter	Typical Return
0 to ~3600 seconds (~1 μs steps), default 1 s Step size for DC measurements is approximately 20 μs. Step size depends on AC bandwidth for AC measurements.	+2.00000806E+00
Return five DC voltage measurements. There is a 2 second delay before each measurement. CONF:VOLT:DC 10 SAMP:COUN 5 TRIG:DEL 2 READ? Typical Response: +4.27230000E+00,+4.27150000E+00,+4.27190000E+00,+4.27170000E+00,+4.27200000E+00	

- Due to internal quantization, the actual delay that you set may be slightly different than your specified value. The increment is approximately 1 μs. Use the query to determine the exact delay. For example, if you send TRIG:DEL 500 ms and then TRIG:DEL? the actual delay may be +5.00000753E-01.
- By default, [TRIGger:DElay:AUTO](#) is ON. The instrument automatically determines the delay based on function, range and integration time (see [Automatic Trigger Delays](#)). However, you may need to set a delay longer than the automatic delay for long cables, high capacitance or high impedance signals.
- If you specify a trigger delay with this command, that delay is used for *all* functions (except [CONTInuity](#) and [DIODe](#)) and ranges. The CONTInuity and DIODe tests ignore the trigger delay setting.
- If you have configured the instrument for more than one measurement per trigger ([SAMPle:COUNT](#) > 1), the delay is inserted after the trigger and between consecutive measurements.
- The instrument selects automatic trigger delay after a Factory Reset ([*RST](#)) or an Instrument Preset ([SYSTem:PRESet](#)).

TRIGger:DElay:AUTO {ON|1|OFF|0} TRIGger:DElay:AUTO?

Disables or enables automatic trigger delay. If enabled, the instrument determines the delay based on function, range, and integration time or bandwidth.

Parameter	Typical Return
{ON 1 OFF 0}, default ON	0 (OFF) or 1 (ON)
Return 5 DC voltage measurements, with an automatic delay between each measurement. CONF:VOLT:DC 10 SAMP:COUN 5 TRIG:DEL 2 READ? Typical Response: +4.27230000E+00,+4.27150000E+00,+4.27190000E+00,+4.27170000E+00,+4.27200000E+00	

- Selecting a specific trigger delay using [TRIGger:DElay](#) disables the automatic trigger delay.
- This parameter is set to its default value after a Factory Reset ([*RST](#)) or Instrument Preset ([SYSTem:PRESet](#)).

TRIGger:SLOPe {POSitive|NEGative} TRIGger:SLOPe?

Selects whether the instrument uses the rising edge (POS) or the falling edge (NEG) of the trigger signal on the rear-panel *Ext Trig* BNC connector.

Parameter	Typical Return
{POSitive NEGative}, default NEGative	POS or NEG
Return ten sets of five DC voltage measurements, using a positive-going external trigger to start each measurement set: CONF:VOLT:DC SAMP:COUN 5 TRIG:COUN 10 TRIG:SOUR EXT;SLOP POS READ? Typical Response: +1.00520000E+01, ... (50 measurements)	

- On the 34460A, this requires option 34460A-LAN or option 3446LANU.
- This parameter is set to its default value after a Factory Reset ([*RST](#)) or Instrument Preset ([SYSTem:PRESet](#)).

TRIGger:SOURce {IMMediate|EXTernal|BUS} TRIGger:SOURce?

Selects the trigger source for measurements:

Source	Description
IMMediate	The trigger signal is always present. When you place the instrument in the "wait-for-trigger" state, the trigger is issued immediately.
BUS	The instrument is triggered by *TRG over the remote interface once the DMM is in the "wait-for-trigger" state.
EXTernal	The instrument accepts hardware triggers applied to the rear-panel Ext Trig input and takes the specified number of measurements (SAMPLE:COUNT), each time a TTL pulse specified by OUTPut:TRIGger:SLOPe is received. If the instrument receives an external trigger before it is ready, it will buffer one trigger.

Parameter	Typical Return
{IMMediate EXTernal BUS}, default IMMediate	IMM, EXT, or BUS
Return ten sets of five DC voltage measurements, using a positive-going external trigger to start each measurement set:	
CONF:VOLT:DC SAMP:COUN 5 TRIG:COUN 10 TRIG:SOUR EXT;SLOP POS READ?	
Typical Response: +1.00520000E+01, ... (50 measurements)	

- On the 34460A, EXTernal requires option 34460-LAN or option 3446LANU.
- After selecting the trigger source, you must place the instrument in the "wait-for-trigger" state by sending [INITiate](#) or [READ?](#). A trigger will not be accepted from the selected trigger source until the instrument is in the "wait-for-trigger" state.
- This parameter is set to its default value after a Factory Reset ([*RST](#)) or Instrument Preset ([SYSTEM:PRESet](#)).
- It is recommended that all triggered measurements be made using an appropriate fixed manual range. That is, turn autorange off ([\[SENSe:\]<function>:RANGe:AUTO OFF](#)) or set a fixed range using the [\[SENSe:\]<function>:RANGe](#), [CONFigure](#), or [MEASure](#) command.

Command Quick Reference

Be sure to understand the [language syntax conventions](#).

Measurement Commands

MEASure:CONTInuity?

MEASure:CURRent:{AC|DC}? [{<range>|AUTO|MIN|MAX|DEF} [, {<resolution>|MIN|MAX|DEF}]]

MEASure:DIODE?

MEASure:{FREQuency|PERiod}? [{<range>|MIN|MAX|DEF} [, {<resolution>|MIN|MAX|DEF}]]

MEASure:{RESistance|FRESistance}? [{<range>|AUTO|MIN|MAX|DEF} [, {<resolution>|MIN|MAX|DEF}]]

MEASure:TEMPerature? [{FRTD|RTD|FTH|THER|DEFault} [, {<type> | DEFault} [, 1 [, {<resolution>|MIN|MAX|DEF}]]]]

MEASure[:VOLTage]:{AC|DC}? [{<range>|AUTO|MIN|MAX|DEF} [, {<resolution>|MIN|MAX|DEF}]]

MEASure[:VOLTage][:DC]:RATio? [{<range>|AUTO|MIN|MAX|DEF} [, {<resolution>|MIN|MAX|DEF}]]

Measurement Configuration Commands

[SENSe:]FUNCTion[:ON] "<function>"

[SENSe:]FUNCTion[:ON]?

AC and DC Voltage and DC Ratio Configuration Commands

CONFigure[:VOLTage]:{AC|DC} [{<range>|AUTO|MIN|MAX|DEF} [, {<resolution>|MIN|MAX|DEF}]]

CONFigure[:VOLTage][:DC]:RATio [{<range>|AUTO|MIN|MAX|DEF} [, {<resolution>|MIN|MAX|DEF}]]

CONFigure?

[SENSe:]VOLTage[:DC]:IMPedance:AUTO {ON|1|OFF|0}

[SENSe:]VOLTage[:DC]:IMPedance:AUTO?

[SENSe:]VOLTage[:DC]:NPLC {<PLCs>|MIN|MAX|DEF}

[SENSe:]VOLTage[:DC]:NPLC? [{MIN|MAX|DEF}]

[SENSe:]VOLTage:{AC|DC}:NULL[:STATe] {ON|1|OFF|0}

[SENSe:]VOLTage:{AC|DC}:NULL[:STATe]?

[SENSe:]VOLTage:{AC|DC}:NULL:VALue {<value>|MIN|MAX|DEF}

[SENSe:]VOLTage:{AC|DC}:NULL:VALue? [{MIN|MAX|DEF}]

[SENSe:]VOLTage:{AC|DC}:NULL:VALue:AUTO {ON|1|OFF|0}

[SENSe:]VOLTage:{AC|DC}:NULL:VALue:AUTO?

[SENSe:]VOLTage:{AC|DC}:RANGe:AUTO {OFF|ON|ONCE}

[SENSe:]VOLTage:{AC|DC}:RANGe:AUTO?

[SENSe:]VOLTage:{AC|DC}:RANGe {<range>|MIN|MAX|DEF}

[SENSe:]VOLTage:{AC|DC}:RANGe? [{MIN|MAX|DEF}]

[SENSe:]VOLTage[:DC]:RESolution {<resolution>|MIN|MAX|DEF}

[SENSe:]VOLTage[:DC]:RESolution? [{MIN|MAX|DEF}]

[SENSe:]VOLTage[:DC]:ZERO:AUTO {OFF|ON|ONCE}

[SENSe:]VOLTage[:DC]:ZERO:AUTO?

[SENSe:]VOLTage:AC:BANDwidth {<filter>|MIN|MAX|DEF}

[SENSe:]VOLTage:AC:BANDwidth? [{MIN|MAX|DEF}]

2-Wire and 4-Wire Resistance Configuration Commands

CONFigure:{RESistance|FRESistance} [{<range>|AUTO|MIN|MAX|DEF} [, {<resolution>|MIN|MAX|DEF}]]

CONFigure?

[SENSe:]{RESistance|FRESistance}:NPLC {<PLCs>|MIN|MAX|DEF}

[SENSe:]{RESistance|FRESistance}:NPLC? [{MIN|MAX|DEF}]

[SENSe:]{RESistance|FRESistance}:NULL[:STATe] {ON|1|OFF|0}

[SENSe:]{RESistance|FRESistance}:NULL[:STATe]?

[SENSe:]{RESistance|FRESistance}:NULL:VALue {<value>|MIN|MAX|DEF}

[SENSe:]{RESistance|FRESistance}:NULL:VALue? [{MIN|MAX|DEF}]

[SENSe:]{RESistance|FRESistance}:NULL:VALue:AUTO {ON|1|OFF|0}

[SENSe:]{RESistance|FRESistance}:NULL:VALue:AUTO?

[SENSe:]{RESistance|FRESistance}:RANGe:AUTO {OFF|ON|ONCE}

[SENSe:]{RESistance|FRESistance}:RANGe:AUTO?

[SENSe:]{RESistance|FRESistance}:RANGe {<range>|MIN|MAX|DEF}

[SENSe:]{RESistance|FRESistance}:RANGe? [{MIN|MAX|DEF}]

[SENSe:]{RESistance|FRESistance}:RESolution {<resolution>|MIN|MAX|DEF}

[SENSe:]{RESistance|FRESistance}:RESolution? [{MIN|MAX|DEF}]

[SENSe:]RESistance:ZERO:AUTO {OFF|ON|ONCE}

[SENSe:]RESistance:ZERO:AUTO?

AC and DC Current Configuration Commands

CONFigure:CURRent:{AC|DC} [{<range>|AUTO|MIN|MAX|DEF} [, {<resolution>|MIN|MAX|DEF}]]

CONFigure?

[SENSe:]CURRent[:DC]:NPLC {<PLCs>|MIN|MAX|DEF}

[SENSe:]CURRent[:DC]:NPLC? [{MIN|MAX|DEF}]

[SENSe:]CURRent:{AC|DC}:NULL[:STATe] {ON|1|OFF|0}

[SENSe:]CURRent:{AC|DC}:NULL[:STATe]?

[SENSe:]CURRent:{AC|DC}:NULL:VALue {<value>|MIN|MAX|DEF}

[SENSe:]CURRent:{AC|DC}:NULL:VALue? [{MIN|MAX|DEF}]

[SENSe:]CURRent:{AC|DC}:NULL:VALue:AUTO {ON|1|OFF|0}

[SENSe:]CURRent:{AC|DC}:NULL:VALue:AUTO?

[SENSe:]CURRent:{AC|DC}:RANGe:AUTO {OFF|ON|ONCE}

[SENSe:]CURRent:{AC|DC}:RANGe:AUTO?

[SENSe:]CURRent:{AC|DC}:RANGe {<range>|MIN|MAX|DEF}

[SENSe:]CURRent:{AC|DC}:RANGe? [{MIN|MAX|DEF}]

[SENSe:]CURRent:{AC|DC}:TERMinals {3|10}

[SENSe:]CURRent:{AC|DC}:TERMinals?

[SENSe:]CURRent[:DC]:RESolution {<resolution>|MIN|MAX|DEF}

[SENSe:]CURRent[:DC]:RESolution? [{MIN|MAX|DEF}]

[SENSe:]CURRent[:DC]:ZERO:AUTO {OFF|ON|ONCE}

[SENSe:]CURRent[:DC]:ZERO:AUTO?

[SENSe:]CURRent:AC:BANDwidth {<filter>|MIN|MAX|DEF}

[SENSe:]CURRent:AC:BANDwidth? [{MIN|MAX|DEF}]

Temperature Configuration Commands

```
CONFigure:TEMPerature [{FRTD|RTD|FTH|THER|DEFAULT} [, {<type> | DEFAULT} [, 1 [, {<resolution> | MIN | MAX | DEF}]]]]
CONFigure?

[SENSe:]TEMPerature:NPLC {<PLCs> | MIN | MAX | DEF}
[SENSe:]TEMPerature:NPLC? [{MIN | MAX | DEF}]

[SENSe:]TEMPerature:NULL[:STATe] {ON | 1 | OFF | 0}
[SENSe:]TEMPerature:NULL[:STATe]?

[SENSe:]TEMPerature:NULL:VALue {<value> | MIN | MAX | DEF}
[SENSe:]TEMPerature:NULL:VALue? [{MIN | MAX | DEF}]

[SENSe:]TEMPerature:NULL:VALue:AUTO {ON | 1 | OFF | 0}
[SENSe:]TEMPerature:NULL:VALue:AUTO?

[SENSe:]TEMPerature:TRANsdUcer: {THERmistor | FTHermistor}:TYPE
[SENSe:]TEMPerature:TRANsdUcer: {THERmistor | FTHermistor}:TYPE?

[SENSe:]TEMPerature:TRANsdUcer:TYPE {FRTD | RTD | FTHermistor | THERmistor}
[SENSe:]TEMPerature:TRANsdUcer:TYPE?

[SENSe:]TEMPerature:ZERO:AUTO {OFF | ON | ONCE}
[SENSe:]TEMPerature:ZERO:AUTO?

UNIT:TEMPerature {C | F | K}
UNIT:TEMPerature?
```

RTD Configuration

```
[SENSe:]TEMPerature:TRANsdUcer: {RTD | FRTD}:RESistance[:REFerence] {<reference> | MIN | MAX | DEF}
[SENSe:]TEMPerature:TRANsdUcer: {RTD | FRTD}:RESistance[:REFerence]? [{MIN | MAX | DEF}]
```

Frequency/Period Configuration Commands

```
CONFigure: {FREQuency | PERiod} [{<range> | MIN | MAX | DEF} [, {<resolution> | MIN | MAX | DEF}]]

[SENSe:] {FREQuency | PERiod}: APERTure {<seconds> | MIN | MAX | DEF}
[SENSe:] {FREQuency | PERiod}: APERTure? [{MIN | MAX | DEF}]

[SENSe:] {FREQuency | PERiod}: NULL[:STATe] {ON | 1 | OFF | 0}
[SENSe:] {FREQuency | PERiod}: NULL[:STATe]?

[SENSe:] {FREQuency | PERiod}: NULL:VALue {<value> | MIN | MAX | DEF}
[SENSe:] {FREQuency | PERiod}: NULL:VALue? [{MIN | MAX | DEF}]

[SENSe:] {FREQuency | PERiod}: NULL:VALue:AUTO {ON | 1 | OFF | 0}
[SENSe:] {FREQuency | PERiod}: NULL:VALue:AUTO?

[SENSe:] {FREQuency | PERiod}: RANGe:LOWer {<filter> | MIN | MAX | DEF}
[SENSe:] {FREQuency | PERiod}: RANGe:LOWer? [{MIN | MAX | DEF}]

[SENSe:] {FREQuency | PERiod}: VOLTage: RANGe:AUTO {OFF | ON | ONCE}
[SENSe:] {FREQuency | PERiod}: VOLTage: RANGe:AUTO?

[SENSe:] {FREQuency | PERiod}: VOLTage: RANGe {<range> | MIN | MAX | DEF}
[SENSe:] {FREQuency | PERiod}: VOLTage: RANGe? [{MIN | MAX | DEF}]
```

Continuity and Diode Configuration Commands

CONFigure:CONTInuity

CONFigure:DIODE

Miscellaneous Configuration Commands

ROUTe:TERMinals?

Triggering Commands

*TRG

ABORT

INITiate[:IMMediate]

READ?

SAMple:COUNT {<count>|MIN|MAX|DEF}

SAMple:COUNT? [{MIN|MAX|DEF}]

TRIGger:COUNT {<count>|MIN|MAX|DEF|INFinity}

TRIGger:COUNT? [{MIN|MAX|DEF}]

TRIGger:DElay {<seconds>|MIN|MAX|DEF}

TRIGger:DElay? [{MIN|MAX|DEF}]

TRIGger:DElay:AUTO {ON|1|OFF|0}

TRIGger:DElay:AUTO?

TRIGger:SLOPe {POSitive|NEGative}

TRIGger:SLOPe?

TRIGger:SOURce {IMMediate|EXTernal|BUS}

TRIGger:SOURce?

OUTPut:TRIGger:SLOPe {POSitive|NEGative}

OUTPut:TRIGger:SLOPe?

Calculation (Math) Commands

Overall

CALCulate:CLEar[:IMMediate]

Histogram

CALCulate:TRANSform:HISTogram[:STATe] {ON|1|OFF|0}
CALCulate:TRANSform:HISTogram[:STATe]?

CALCulate:TRANSform:HISTogram:ALL?

CALCulate:TRANSform:HISTogram:DATA?

CALCulate:TRANSform:HISTogram:COUNT?

CALCulate:TRANSform:HISTogram:CLEar[:IMMediate]

CALCulate:TRANSform:HISTogram:POINts {10|20|40|100|200|400|MIN|MAX|DEF}, default 100
CALCulate:TRANSform:HISTogram:POINts? [{MIN|MAX|DEF}]

CALCulate:TRANSform:HISTogram:RANGe:AUTO {ON|1|OFF|0}
CALCulate:TRANSform:HISTogram:RANGe:AUTO?

CALCulate:TRANSform:HISTogram:RANGe:{LOWer|UPPer} {<value>|MIN|MAX|DEF}
CALCulate:TRANSform:HISTogram:RANGe:{LOWer|UPPer}? [{MIN|MAX|DEF}]

Limit Testing

CALCulate:LIMit[:STATe] {ON|1|OFF|0}
CALCulate:LIMit[:STATe]?

CALCulate:LIMit:CLEar[:IMMediate]

CALCulate:LIMit:{LOWer|UPPer}[:DATA] {<value>|MIN|MAX|DEF}
CALCulate:LIMit:{LOWer|UPPer}[:DATA]? [{MIN|MAX|DEF}]

Scaling

CALCulate:SCALE:FUNCTion {DB|DBM}
CALCulate:SCALE:FUNCTion?

CALCulate:SCALE[:STATe] {ON|1|OFF|0}
CALCulate:SCALE[:STATe]?

CALCulate:SCALE:DB:REFerence {<reference>|MIN|MAX|DEF}
CALCulate:SCALE:DB:REFerence? [{MIN|MAX}]

CALCulate:SCALE:DBM:REFerence {<reference>|MIN|MAX|DEF}
CALCulate:SCALE:DBM:REFerence? [{MIN|MAX}]

CALCulate:SCALE:REFerence:AUTO {ON|1|OFF|0}
CALCulate:SCALE:REFerence:AUTO?

Statistics

CALCulate:AVERage[:STATe] {ON|1|OFF|0}
CALCulate:AVERage[:STATe]?
CALCulate:AVERage:ALL?
CALCulate:AVERage:AVERage?
CALCulate:AVERage:MAXimum?
CALCulate:AVERage:MINimum?
CALCulate:AVERage:PTPeak?
CALCulate:AVERage:SDEVIation?
CALCulate:AVERage:COUNT?
CALCulate:AVERage:CLEar[:IMMediate]

Reading Memory Commands

FETCh?
R? [<max_readings>]
DATA:LAST?
DATA:POINts:EVENT:THReshold <count>
DATA:POINts:EVENT:THReshold?
DATA:POINts?
DATA:REMOve? <num_readings> [,WAIT]

Calibration Commands

CALibration:ADC?
CALibration[:ALL]?
CALibration:COUNT?
CALibration:SECure:CODE <new_code>
CALibration:SECure:STATe {ON|1|OFF|0} [, <code>]
CALibration:SECure:STATe?
CALibration:STORe
CALibration:STRing "<string>"
CALibration:STRing?
CALibration:VALue <value>
CALibration:VALue?

State Storage Commands

*LRN?
*RCL {0|1|2|3|4}
*SAV {0|1|2|3|4}
MMEMory:LOAD:STATe <file>
MMEMory:STORe:STATe <file>
MMEMory:STATe:RECall:AUTO {ON|1|OFF|0}
MMEMory:STATe:RECall:AUTO?
MMEMory:STATe:RECall:SElect <file>
MMEMory:STATe:RECall:SElect?
MMEMory:STATe:VALid? <file>

Mass Storage Device Commands

MMEMory:CATalog[:ALL]? [<folder>[<filespec>]]
MMEMory:CDIRectory <folder>
MMEMory:CDIRectory?
MMEMory:COpy <file1>, <file2>
MMEMory:DElete {<file>|<filespec>}
MMEMory:DOWNload:DATA <binary_block>
MMEMory:DOWNload:FNAME <file>
MMEMory:DOWNload:FNAME?
MMEMory:MOVE <file1>, <file2>
MMEMory:LOAD:PREferences <file>
MMEMory:LOAD:STATe <file>
MMEMory:MDIRectory <folder>
MMEMory:RDIRectory <folder>
MMEMory:STORe:DATA RDG_STORE, <file>
MMEMory:STORe:PREferences <file>
MMEMory:STORe:STATe <file>
MMEMory:UPLoad? <file>

IEEE-488 Commands

*CLS

*ESE <enable_value>

*ESE?

*ESR?

*IDN?

*LRN?

*OPC

*OPC?

*OPT?

*PSC {0|1}

*PSC?

*RCL {0|1|2|3|4}

*RST

*SAV {0|1|2|3|4}

*SRE <enable_value>

*SRE?

*STB?

*TRG

*TST?

*WAI

System-Related Commands

*IDN?

*RST

*TST?

DISPlay[:STATe] {ON|1|OFF|0}

DISPlay[:STATe]?

DISPlay:TEXT:CLEAr

DISPlay:TEXT[:DATA] "<string>"

DISPlay:TEXT[:DATA]?

DISPlay:VIEW {NUMeric|HISTogram|TCHart|METER}

DISPlay:VIEW?

HCOPY:SDUMp:DATA?

HCOPY:SDUMp:DATA:FORMat {PNG|BMP}

HCOPY:SDUMp:DATA:FORMat?

LXI:IDENtify[:STATe] {ON|1|OFF|0}

LXI:IDENtify[:STATe]?

LXI:MDNS:ENABle {ON|1|OFF|0}

LXI:MDNS:ENABle?

LXI:MDNS:HNAME[:RESolved]?

LXI:MDNS:SNAME:DESired "<name>"

LXI:MDNS:SNAME:DESired?

LXI:MDNS:SNAME[:RESolved]?

LXI:RESet

LXI:REStArt

SYSTem:BEEPer[:IMMediate]

SYSTem:BEEPer:STATe {ON|1|OFF|0}

SYSTem:BEEPer:STATe?

SYSTem:CLICk:STATe {ON|1|OFF|0}

SYSTem:CLICk:STATe?

SYSTem:DATE <year>, <month>, <day>

SYSTem:DATE?

SYSTem:ERRor[:NEXT]?

SYSTem:HELP?

SYSTem:IDENtify {DEFault|HP34401A}

SYSTem:IDENtify?

SYSTem:LABel "<string>"

SYSTem:LABel?

SYSTem:PRESet

SYSTem:SECurity:COUNT?

SYSTem:SECurity:IMMediate

SYSTem:TEMPerature?

SYSTem:TIME <hour>, <minute>, <second>

SYSTem:TIME?

SYSTem:USB:HOST:ENABle {ON|1|OFF|0}

SYSTem:USB:HOST:ENABle?

SYSTem:VERSion?

SYSTem:WMESsage "<string>"

SYSTem:WMESsage?

TEST:ALL?

Interface Locking Commands

SYSTem:LOCK:NAME?

SYSTem:LOCK:OWNer?

SYSTem:LOCK:RELease

SYSTem:LOCK:REQuest?

License Management Commands

SYSTem:LICense:CATalog?

SYSTem:LICense:DELeTe "<option_name>"

SYSTem:LICense:DELeTe:ALL

SYSTem:LICense:DESCRiption? "<option_name>"

SYSTem:LICense:ERRor:COUNT?

SYSTem:LICense:ERRor?

SYSTem:LICense:INSTall [{<folder>|<file>}]

SYSTem:LICense:INSTall? "<option_name>"

Interface Configuration Commands

SYSTem:COMMunicate:ENABle {ON|1|OFF|0}, {GPIB|USB|LAN|SOCKets|TELNet|VXI11|WEB|USBMtp|USBHost}
SYSTem:COMMunicate:ENABle? {GPIB|USB|LAN|SOCKets|TELNet|VXI11|WEB|USBMtp|USBHost}

SYSTem:COMMunicate:GPIB:ADDRess <address>
SYSTem:COMMunicate:GPIB:ADDRess?

SYSTem:COMMunicate:LAN:CONTRol?

SYSTem:COMMunicate:LAN:DHCP {ON|1|OFF|0}
SYSTem:COMMunicate:LAN:DHCP?

SYSTem:COMMunicate:LAN:DNS[{1|2}] "<address>"
SYSTem:COMMunicate:LAN:DNS[{1|2}]? [{CURRent|STATic}]

SYSTem:COMMunicate:LAN:DOMain?

SYSTem:COMMunicate:LAN:GATeway "<address>"
SYSTem:COMMunicate:LAN:GATeway? [{CURRent|STATic}]

SYSTem:COMMunicate:LAN:HOSTname "<name>"
SYSTem:COMMunicate:LAN:HOSTname? [{CURRent|STATic}]

SYSTem:COMMunicate:LAN:IPADdress "<address>"
SYSTem:COMMunicate:LAN:IPADdress? [{CURRent|STATic}]

SYSTem:COMMunicate:LAN:MAC?

SYSTem:COMMunicate:LAN:SMASk "<mask>"
SYSTem:COMMunicate:LAN:SMASk? [{CURRent|STATic}]

SYSTem:COMMunicate:LAN:TELNet:PRoMpt "<string>"
SYSTem:COMMunicate:LAN:TELNet:PRoMpt?

SYSTem:COMMunicate:LAN:TELNet:WMESsage "<string>"
SYSTem:COMMunicate:LAN:TELNet:WMESsage?

SYSTem:COMMunicate:LAN:UPDate

SYSTem:COMMunicate:LAN:WINS[{1|2}] "<address>"
SYSTem:COMMunicate:LAN:WINS[{1|2}]? [{CURRent|STATic}]

SYSTem:USB:HOST:ENABle {ON|1|OFF|0}
SYSTem:USB:HOST:ENABle?

Status System Commands

*CLS

*ESE <enable_value>

*ESE?

*ESR?

*PSC {0|1}

*PSC?

*SRE <enable_value>

*SRE?

*STB?

STATus:OPERation:CONDition?

STATus:OPERation:ENABle <enable_value>

STATus:OPERation:ENABle?

STATus:OPERation[:EVENT]?

STATus:PRESet

STATus:QUEStionable:CONDition?

STATus:QUEStionable:ENABle <enable_value>

STATus:QUEStionable:ENABle?

STATus:QUEStionable[:EVENT]?

Range, Resolution and NPLC

These tables show the integration time (in PLC) for each range and resolution.

Model	34460A					34461A				
PLC	100	10	1	0.2	0.02	100	10	1	0.2	0.02
ResFactor	3 ppm	10 ppm	30 ppm	100 ppm	300 ppm	0.3 ppm	1 ppm	3 ppm	10 ppm	100 ppm
Range	Resolution									
1 m	3E-9	1E-8	3E-8	1E-7	3E-7	3E-10	1E-9	3E-9	1E-8	1E-7
10 m	3E-8	1E-7	3E-7	1E-6	3E-6	3E-9	1E-8	3E-8	1E-7	1E-6
100 m	3E-7	1E-6	3E-6	1E-5	3E-5	3E-8	1E-7	3E-7	1E-6	1E-5
1	3E-6	1E-5	3E-5	1E-4	3E-4	3E-7	1E-6	3E-6	1E-5	1E-4
10	3E-5	1E-4	3E-4	1E-3	3E-3	3E-6	1E-5	3E-5	1E-4	1E-3
100	3E-4	1E-3	3E-3	1E-2	3E-2	3E-5	1E-4	3E-4	1E-3	1E-2
1 k	3E-3	1E-2	3E-2	1E-1	3E-1	3E-4	1E-3	3E-3	1E-2	1E-1
10 k	3E-2	1E-1	3E-1	1	3	3E-3	1E-2	3E-2	1E-1	1
100 k	3E-1	1	3	10	30	3E-2	1E-1	3E-1	1	10
1 M	3	10	30	100	300	3E-1	1	3	10	100
10 M	30	100	300	1,000	3,000	3	10	30	100	1,000
100 M	300	1,000	3,000	10,000	30,000	30	100	300	1,000	10,000

To determine the PLC for a specified range and resolution, locate the range in the left column. Measurement units do not apply (i.e. for 1 V or 1 A, use the 1 range; for 100 V or 100 Ω , use the 100 range). From the range value, follow the corresponding row of resolutions to the right until the specified resolution lies within two adjacent columns for your DMM model.

The NPLC value at the top of the left-adjacent column is the NPLC "setting" for the given range and resolution.

For example: for the 34461A, a specified 10 VDC range and 10 μ V resolution, locate range 10 in the table. Moving to the right, the 10 μ V resolution (1E-5) is found in the column under 10 NPLC.

Resolution and Integration Time for DC Measurements

Setting the integration time also sets the measurement resolution. This table shows the relationship between integration time in power line cycles (PLC) and resolution.

Integration Time (power line cycles)	Resolution (34460A)	Resolution (34461A)
0.02 PLC (MINimum)	300 ppm × Range (MAXimum)	100 ppm × Range (MAXimum)
0.2 PLC	100 ppm × Range	10 ppm × Range
1 PLC	30 ppm × Range	3 ppm × Range
10 PLC (DEFault)	10 ppm × Range (DEFault)	1 ppm × Range (DEFault)
100 PLC (MAXimum)	3 ppm × Range (MINimum)	0.3 ppm × Range (MINimum)

Automatic Trigger Delays

If TRIGger:DElay:AUTO is on, the instrument selects the trigger delay for you, as shown in the tables below.

NOTE All frequency and period measurements have an automatic trigger delay of 1 second.

The continuity and diode tests ignore the trigger delay.

The 2-wire and 4-wire temperature measurements use the corresponding 2-wire and 4-wire resistance measurement delays.

DC Voltage

	Aperture (PLC)				
Range	0.02	0.2	1	10	100
All	100 μ s	130 μ s	160 μ s		

DC Current

	Aperture (PLC)				
Range (A)	0.02	0.2	1	10	100
All	1 ms		1.5 ms		

Resistance (2-wire)

	Aperture (PLC)				
Range (Ω)	0.02	0.2	1	10	100
100	80 μ s	100 μ s	130 μ s		
1,000	110 μ s	130 μ s	160 μ s		
10,000	130 μ s	160 μ s	190 μ s		
100,000	540 μ s	670 μ s	800 μ s		
1,000,000	5 ms	6 ms	7.5 ms		
10,000,000	60 ms	70 ms	84 ms		
100,000,000					

Resistance (4-wire)

	Aperture (PLC)				
Range (Ω)	0.02	0.2	1	10	100
100	1 ms		1.5 ms		
1,000					
10,000					
100,000					
1,000,000	10 ms	15 ms			
10,000,000	100 ms				
100,000,000					

AC Voltage

	Filter (Hz)		
Range	3	20	200
All	2.5 s	0.625 s	0.025 s

AC Current

	Filter (Hz)		
Range	3	20	200
All	1.66 s	0.25 s	0.025 s

VM Comp Output (BNC)

The rear-panel VM Comp (voltmeter complete) output provides a 3.3 V pulse after each measurement completion to implement a standard hardware handshake sequence between measurement and switching devices.

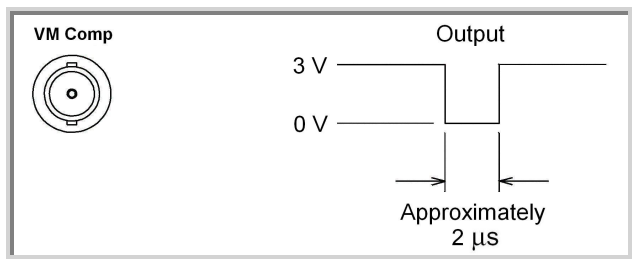

The signal shown is for a negative pulse.

SCPI Error Messages

[Command Errors \(-100...\)](#)

[Execution Errors \(-200...\)](#)

[Device-Specific Errors \(-300...\)](#)

[Query Errors \(-400...\)](#)

[Network Errors \(+100...\)](#)

[Instrument Errors \(+200...\)](#)

[Miscellaneous Errors \(+300... and +500..\)](#)

[Licensing and Self-test Errors \(+600...\)](#)

[Calibration Errors \(+700...\)](#)

[Miscellaneous Errors \(+800...\)](#)

The instrument returns error messages in accordance with the SCPI standard.

- Up to 20 errors can be stored in the instrument's error queue. Each remote interface I/O session (GPIB, USB, VXI-11, Telnet/Sockets) has its own interface-specific error queue. Errors appear in the error queue of the I/O session that caused the error. For example, if an error was generated by a command sent over GPIB, send [SYSTem:ERRor?](#) from GPIB to read the error queue. Errors generated by instrument hardware are broadcast to all I/O sessions.
- The instrument beeps each time an error is generated (unless disabled by [SYSTem:BEEPer:STATe OFF](#)). The front-panel **Error** annunciator turns on when one or more errors are in the error queue.
- A special global error queue holds all power-on and hardware-related errors (for example, overtemperature).
- Error retrieval is first-in-first-out (FIFO), and errors are cleared as you read them. When you have read all of the interface-specific errors, the errors in the global error queue are retrieved. When you have read all errors from the interface-specific and global error queues, the **Error** annunciator turns off.
- If more than 20 errors have occurred, the most recent error stored in the queue is replaced with -350,"Queue overflow". No additional errors are stored until you remove errors from the queue. If no errors have occurred when you read the error queue, the instrument responds with +0,"No error".
- The front panel reports errors from all I/O sessions and the global error queue. To read the error queue from the front panel, press **Help > View remote command error queue**.
- Error conditions are also summarized in the Status Byte Register. For more information on the SCPI Status System, see [Status Subsystem Introduction](#).
- The interface-specific error queues are cleared by the [*CLS](#) (Clear Status) command and when power is cycled. All errors are cleared when you read the error queue. The error queue is not cleared by a Factory Reset ([*RST](#)) or an Instrument Preset ([SYSTem:PRESet](#)).
- **Front Panel:**
If the **Error** annunciator is on, there are errors in the error queue. The **Remote** annunciator is likely on as well. Press the **Local** key to return to local operation (the **Remote** annunciator will go off). Then press **[Help]**, select "View remote command error queue" in the menu and press **Select**. Use the menu navigation "arrow" keys to view the error messages. Press **Back** to exit and clear the error queue.
- **SCPI:**
SYSTem:ERRor? Read and clear one error from the queue

Errors have the following format (the error string may contain up to 80 characters):

-113,"Undefined header"

Command Errors (-100...)

- 100,"Command error"
- 101,"Invalid character"
- 102,"Syntax error"
- 103,"Invalid separator"
- 104,"Data type error"
- 105,"GET not allowed"
- 108,"Parameter not allowed"
- 109,"Missing parameter"
- 110,"Command header error"
- 111,"Header separator error"
- 112,"Program mnemonic too long"
- 113,"Undefined header"
- 114,"Header suffix out of range"
- 120,"Numeric data error"
- 121,"Invalid character in number"
- 123,"Exponent too large"
- 123,"Numeric overflow"
- 124,"Too many digits"
- 128,"Numeric data not allowed"
- 130,"Suffix error"
- 131,"Invalid suffix"
- 134,"Suffix too long"
- 138,"Suffix not allowed"
- 140,"Character data error"
- 141,"Invalid character data"
- 144,"Character data too long"
- 148,"Character data not allowed"
- 150,"String data error"
- 151,"Invalid string data"
- 158,"String data not allowed"
- 160,"Block data error"
- 161,"Invalid block data"
- 168,"Block data not allowed"

Execution Errors (-200...)

- 200, "Execution error"
- 203, "Command protected"
- 203, "Command protected; external trigger requires license LAN"
- 203, "Command protected; License required"
- 203, "Command protected; requires license LAN"
- 203, "Command protected; requires license SEC"
- 210, "Trigger error"
- 211, "Trigger ignored"
- 213, "Init ignored"
- 214, "Trigger deadlock"
- 220, "Parameter error"
- 221, "Settings conflict"
- 221, "Settings conflict; *TRG when TRIG:SOUR BUS not selected; trigger ignored"
- 221, "Settings conflict; 10A current terminals not available with rear terminals; terminals set to 3A"
- 221, "Settings conflict; CALC function not allowed in current measurement function; CALC:STAT OFF set"
- 221, "Settings conflict; CALC not allowed in current measurement function"
- 221, "Settings conflict; CALC not allowed in current measurement function; CALC:STAT OFF set"
- 221, "Settings conflict; CALC:AVER:STATe OFF set"
- 221, "Settings conflict; CALC:TRAN:HIST:STATe OFF set"
- 221, "Settings conflict; CALCulate not allowed in current function"
- 221, "Settings conflict; cannot delete state selected and enabled for automatic power-on recall"
- 221, "Settings conflict; histogram lower range > upper range; CALC:TRAN:HIST:RANG:AUTO ON set"
- 221, "Settings conflict; lower limit > upper limit; CALC:LIM:UPP set to CALC:LIM:LOW value"
- 221, "Settings conflict; trigger source is BUS"
- 222, "Data out of range"
- 222, "Data out of range; value clipped to lower limit"
- 222, "Data out of range; value clipped to upper limit"
- 223, "Too much data"
- 224, "Illegal parameter value"
- 225, "Out of memory; measurement data overrun"
- 230, "Data corrupt or stale"
- 231, "Data questionable"
- 240, "Hardware error"
- 240, "Hardware error; cannot communicate with measurement hardware"

- 240,"Hardware error; CPU board initialization failed"
- 240,"Hardware error; GPIB interface failed"
- 240,"Hardware error; measurement FPGA FIFO overflow"
- 240,"Hardware error; measurement hardware initialization failed"
- 256,"File name not found"
- 256,"File or folder name not found"
- 257,"File name error"
- 257,"File name error; access denied"
- 257,"File name error; drive name missing or not recognized"
- 257,"File name error; file or folder already exists"
- 257,"File name error; file too large"
- 257,"File name error; folder is default folder"
- 257,"File name error; folder not empty"
- 257,"File name error; invalid character in name"
- 257,"File name error; not a folder name"
- 257,"File name error; path is a folder name"
- 257,"File name error; path too long"
- 257,"File name error; relative path not allowed"
- 257,"File name error; unknown file extension"

Device-Specific Errors (-300...)

- 300,"Device specific error"
- 310,"System error"
- 310,"System error; internal software error"
- 310,"System error; out of memory"
- 310,"System error; software initialization failed"
- 330,"Self-test failed"
- 350,"Queue overflow"

Query Errors (-400...)

- 400,"Query error"
- 410,"Query INTERRUPTED"
- 420,"Query UNTERMINATED"
- 430,"Query DEADLOCKED"
- 440,"Query UNTERMINATED after indefinite response"

Network Errors (+100...)

+110,"LXI mDNS Error"

Instrument Errors (+200...)

+263,"Not able to execute while instrument is measuring"

+291,"Not able to recall state: it is empty"

+292,"State file size error"

+293,"State file corrupt"

+294,"Preference file size error"

+295,"Preference file corrupt"

Miscellaneous Errors (+300... and +500..)

+305,"Not able to perform requested operation"

+311,"Not able to specify resolution with Auto range"

+514,"Not allowed; Instrument locked by another I/O session"

+521,"Communications: input buffer overflow"

+532,"Not able to achieve requested resolution"

+540,"Cannot use overload as math reference"

+542,"Measured dB reference too small"

+550,"Not able to execute command in local mode"

Licensing and Self-test Errors (+600...)

- +600,"Internal licensing error"
- +601,"License file corrupt or empty"
- +602,"No valid licenses found for this instrument"
- +603,"Some licenses could not be installed"
- +604,"License not found"
- +611,"Self-test failed; Real Time Clock reset, check battery"
- +612,"Self-test failed; keyboard processor not responding"
- +613,"Self-test failed; unable to communicate with power controller"
- +614,"Self-test failed; unable to sense line frequency"
- +615,"Self-test failed; measurement processor not responding"
- +616,"Self-test failed; calibration memory reading error"
- +617,"Self-test failed; FPGA unconfigured"
- +618,"Self-test failed; FPGA bus error"
- +619,"Self-test failed; FPGA clock"
- +620,"Self-test failed; shift register"
- +621,"Self-test failed; overload sense stuck on"
- +622,"Self-test failed; ADC generic error"
- +623,"Self-test failed; ADC integrator saturated"
- +624,"Self-test failed; Coarse ADC error"
- +625,"Self-test failed; ADC offset"
- +626,"Self-test failed; ADC noise"
- +627,"Self-test failed; Fine ADC generic error"
- +628,"Self-test failed; Fine ADC off-scale low"
- +629,"Self-test failed; Fine ADC off-scale high"
- +630,"Self-test failed; Fine ADC range"
- +631,"Self-test failed; Fine ADC bits stuck"
- +632,"Self-test failed; Fine ADC slope"
- +633,"Self-test failed; Fine ADC linearity"
- +634,"Self-test failed; low DC zero"
- +635,"Self-test failed; high DC zero"
- +636,"Self-test failed; +7V reference"
- +637,"Self-test failed; -10V reference"
- +638,"Self-test failed; x1 gain, zero input"
- +639,"Self-test failed; x10 gain, zero input"

+640,"Self-test failed; x100 gain, zero input"
+641,"Self-test failed; precharge"
+642,"Self-test failed; x1 gain, non-zero input"
+643,"Self-test failed; x10 gain, non-zero input"
+644,"Self-test failed; x100 gain, non-zero input"
+645,"Self-test failed; 100uA current source"
+646,"Self-test failed; 10uA current source"
+647,"Self-test failed; 2 ohm shunt"
+648,"Self-test failed; AC offset"
+649,"Self-test failed; frequency input"
+650,"Self-test failed; input switch"

Calibration Errors (+700...)

- +701,"Calibration error; security defeated"
- +702,"Calibration error; calibration memory is secured"
- +703,"Calibration error; secure code provided was invalid"
- +704,"Calibration error: secure code too long"
- +705,"Calibration error; calibration aborted"
- +706,"Calibration error: provided value out of range"
- +707,"Calibration error: computed correction factor out of range"
- +708,"Calibration error: signal measurement out of range"
- +708,"Calibration error; signal frequency out of range"
- +709,"Calibration error: no calibration for this function"
- +710,"Calibration error: full scale correction out of range"
- +711,"Calibration error: calibration string too long"
- +713,"Calibration error; ADC calibration failed; ADC configuration 'ACI' did not converge"
- +713,"Calibration error; ADC calibration failed; ADC configuration 'ACV' did not converge"
- +713,"Calibration error; ADC calibration failed; ADC configuration 'DCV' did not converge"
- +713,"Calibration error; ADC calibration failed; DC offset for setup 'ACI'"
- +713,"Calibration error; ADC calibration failed; DC offset for setup 'ACV'"
- +713,"Calibration error; ADC calibration failed; DC offset for setup 'DCV'"
- +713,"Calibration error; ADC calibration failed; feedbackLutGainTune unsupported LUT goal"
- +713,"Calibration error; ADC calibration failed; feedbackLutTune search did not converge"
- +713,"Calibration error; ADC calibration failed; feedbackPiCancel did not converge for setup 'ACI'"
- +713,"Calibration error; ADC calibration failed; feedbackPiCancel did not converge for setup 'ACV'"
- +713,"Calibration error; ADC calibration failed; feedbackPiCancel did not converge for setup 'DCV'"
- +713,"Calibration error; ADC calibration failed; fine merge for setup 'ACI'"
- +713,"Calibration error; ADC calibration failed; fine merge for setup 'ACV'"
- +713,"Calibration error; ADC calibration failed; fine merge for setup 'DCV'"
- +713,"Calibration error; ADC calibration failed; fine offset for setup 'ACI'"
- +713,"Calibration error; ADC calibration failed; fine offset for setup 'ACV'"
- +713,"Calibration error; ADC calibration failed; fine offset for setup 'DCV'"
- +713,"Calibration error; ADC calibration failed; fineDcCancel found non-monotonic value in setup 'ACI'"
- +713,"Calibration error; ADC calibration failed; fineDcCancel found non-monotonic value in setup 'ACV'"
- +713,"Calibration error; ADC calibration failed; fineDcCancel found non-monotonic value in setup 'DCV'"
- +713,"Calibration error; ADC calibration failed; LUT gain for setup 'ACI'"
- +713,"Calibration error; ADC calibration failed; LUT gain for setup 'ACV'"

+713,"Calibration error; ADC calibration failed; LUT gain for setup 'DCV'"

+713,"Calibration error; ADC calibration failed; LUT goal incompatible with ACV"

+713,"Calibration error; ADC calibration failed; PI offset for setup 'ACI'"

+713,"Calibration error; ADC calibration failed; PI offset for setup 'ACV'"

+713,"Calibration error; ADC calibration failed; PI offset for setup 'DCV'"

+713,"Calibration error; DCV 10M input impedance gain adjustment out of range"

+713,"Calibration error; must perform +100mV DCV calibration before -100mV"

+713,"Calibration error; must perform +10V DCV calibration before -10V"

+713,"Calibration failed"

+715, "Calibration error; must perform +100uA DCI calibration before -100uA"

+715, "Calibration error; must perform 10MOhm calibration before 100MOhm"

+720,"Calibration error; DCV offset out of range"

+721,"Calibration error; DCI offset out of range"

+722,"Calibration error; RES offset out of range"

+723,"Calibration error; FRES offset out of range"

+724,"Calibration error; extended resistance self cal failed"

+725,"Calibration error; 1000V DC correction out of range"

+726,"Calibration error; ACV offset out of range"

+727,"Calibration error; ACI offset out of range"

+730,"Calibration error; precharge DAC convergence failed"

+731,"Calibration error; A/D turnover correction out of range"

+732,"Calibration error; AC flatness calibration failed"

+733,"Calibration error; AC low frequency correction out of range"

+734,"Calibration error; AC flatness calibration restarted by function/range change"

+735,"Calibration error; 1 kHz AC flatness frequency point must be last frequency point in sequence"

+740,"Calibration information lost; count, security state, security code, string"

+742,"Calibration data lost: corrections"

+746, "System information write failure";

+747, "System information read failure";

+748,"Calibration memory write failure"

+749,"Calibration memory read failure"

Miscellaneous Errors (+800...)

+800, "Nonvolatile memory write failure"

+810, "State has not been stored"

+820, "Model and serial numbers not restored"

+821, "Controller and measurement board model numbers do not match"

+822, "Controller and measurement board serial numbers do not match"

Power-On and Reset State

These tables show factory default settings. Parameters marked with a bullet (•) are nonvolatile and are not affected by power-on or system reset. Other parameters are volatile and are reset to the indicated values at power-on or after [*RST](#) or [SYSTem:PRESet](#).

NOTE

The power-on/reset state may differ from these values if you have enabled power-on state recall mode.

Measurement Configuration	Factory Setting
Function	DC Volts
Range	Autorange (for all functions)
Resolution	Resolution equivalent to 10 power-line cycles (PLC).
Integration Time	NPLC On, 10 PLC*
Autozero	On*
Aperture	Off, 1 second*
• Input Impedance	• 10 M Ω (fixed for all DC voltage ranges)
AC Input Filter (bandwidth)	20 Hz (medium filter)
Temperature Transducer Type	FRTD
RTD Reference Resistance	100 Ω
Nulls (<i>individual functions</i>)	Off; reference set to 0.0 with auto reference enabled (<i>for all measurement functions</i>)
* For all DC measurement functions.	

Math Operations	Factory Setting
Math State	Disabled
Scale Function	Null
Null and dB Relative Value	Set to 0.0 with auto reference enabled
Upper and Lower Limits	0.0
Histogram	Bin counts cleared; 100 bins; auto binning enabled
Statistics	Cleared
• dBm Reference Resistance	• 600 Ω

Triggering Operations	Factory Setting
Trigger Count	1
Trigger Source	Immediate
Trigger Delay	Auto Delay
Sample Count	1

System-Related Operations	Factory Setting
• Beeper Mode	• On
• Thousands Separator	• On
Display State	On
Reading Memory	Cleared
Error Queue	See note
• Stored States	• No Change
• Calibration State	• Secured

NOTE

The Error Queue is cleared at power on. It is not cleared by [*RST](#), [SYSTEM:PRESet](#), or a front panel Preset.

Input/Output Configuration	Factory Setting
Enable Interfaces:¹	
• LAN	• Enabled
• GPIB	• Enabled
• USB	• Enabled
LAN Settings:²	
• DHCP	• On
• Auto IP	• On
• IP Address	• 169.254.4.60 (for 34460A) • 169.254.4.61 (for 34461A)
• Subnet Mask	• 255.255.0.0
• Default Gateway	• 0.0.0.0
• DNS Server	• 0.0.0.0
• Host Name	• A-34460A- <i>nnnnn</i> (for 34460A) ³ • A-34461A- <i>nnnnn</i> (for 34461A)
• LAN Services ¹	• Enable All (<i>VISA LAN, Sockets, Telnet, Web Server</i>)
GPIB Settings:	
• GPIB Address	• 22
<p>¹ Interface enable or LAN service changes take effect only after you cycle power. ² LAN setting changes require a LAN restart. From SCPI you must cycle power. ³ Where <i>nnnnn</i> represents the last 5 digits of the instrument serial number.</p>	

NOTE

The instrument uses LAN port 5024 for SCPI Telnet sessions and port 5025 for SCPI Socket sessions.

Service and Repair - Introduction

This section contains basic instrument service information.

[Types of Service Available](#)

[Cleaning](#)

[Electrostatic Discharge \(ESD\) Precautions](#)

Additional service information is found here:

[Power Supplies](#)

[Troubleshooting](#)

[Self-Test Procedures](#)

[User Replaceable Parts](#)

[Disassembly](#)

[Battery Replacement](#)

[3 A and 10 A Current Path Fuse Replacement](#)

[Installing the Optional GPIB Interface](#)

Types of Service Available

If your instrument fails during the warranty period, Agilent Technologies will repair or replace it under the terms of your warranty. After your warranty expires, Agilent offers repair services at competitive prices. You also have the option to purchase a service contract that extends coverage after the standard warranty expires.

Obtaining Repair Service (Worldwide)

To obtain service for your instrument, [contact your nearest Agilent Technologies Service Center](#). They will arrange to have your unit repaired or replaced, and can provide warranty or repair–cost information where applicable. Ask the Agilent Technologies Service Center for shipping instructions, including what components to ship. Agilent recommends that you retain the original shipping carton for return shipments.

Repackaging for Shipment

To ship the unit to Agilent for service or repair:

- Attach a tag to the unit identifying the owner and indicating the required service or repair. Include the model number and full serial number.
- Place the unit in its original container with appropriate packaging material.
- Secure the container with strong tape or metal bands.
- If the original shipping container is unavailable, use a container that will ensure at least 10 cm (4 in.) of compressible packaging material around the entire instrument. Use static-free packaging materials.

Agilent suggests that you always insure shipments.

Cleaning

To prevent electrical shock, disconnect the instrument from AC mains power and disconnect all test leads before cleaning. Clean the outside of the instrument using a soft, lint-free, cloth slightly dampened with water.

Do not use detergent or solvents.

Do not attempt to clean internally.

If needed, contact an Agilent Technologies Sales and Service office to arrange for proper cleaning to ensure that safety features and performance are maintained.

Electrostatic Discharge (ESD) Precautions

Almost all electrical components can be damaged by electrostatic discharge (ESD) during handling. Component damage can occur at electrostatic discharge voltages as low as 50 V.

The following guidelines will help prevent ESD damage during service operations:

- Disassemble instruments only in a static-free work area.
- Use a conductive work area to reduce static charges.
- Use a conductive wrist strap to reduce static charge accumulation.
- Minimize handling.
- Keep replacement parts in original static-free packaging.
- Remove all plastic, foam, vinyl, paper, and other static-generating materials from the immediate work area.

Power Supplies

The following procedure allows you to determine whether the power supplies are working properly.

WARNING Follow the [disassembly procedure](#) to disassemble the instrument. Be sure to disconnect all inputs to the instrument before beginning disassembly.

Circuit side of board

The following measurements use the frame of the instrument as the low voltage reference. The instrument should be turned on, and the light below the power switch should be green.

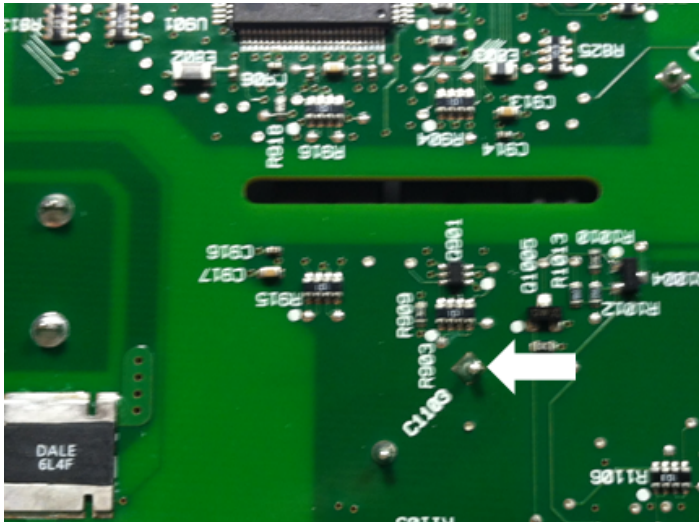
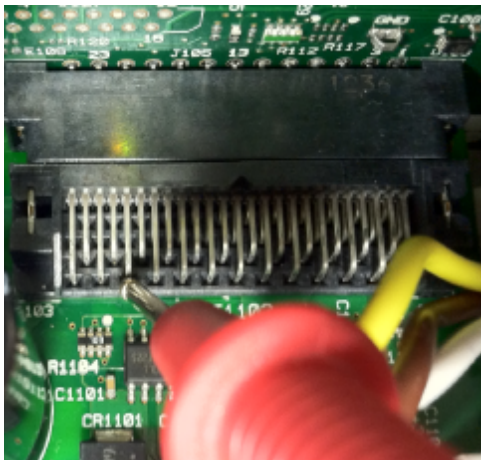
Pin	Location Detail
C1103 pin 1 15 V \pm 25%	
J1102 pin 21 3.3 V \pm 5%	

Component side of board

The following measurements use the large metal shield as the low voltage reference. The instrument should be turned on, and the light below the power switch should be green.

Refer to the detailed images in the table below for exact location information.

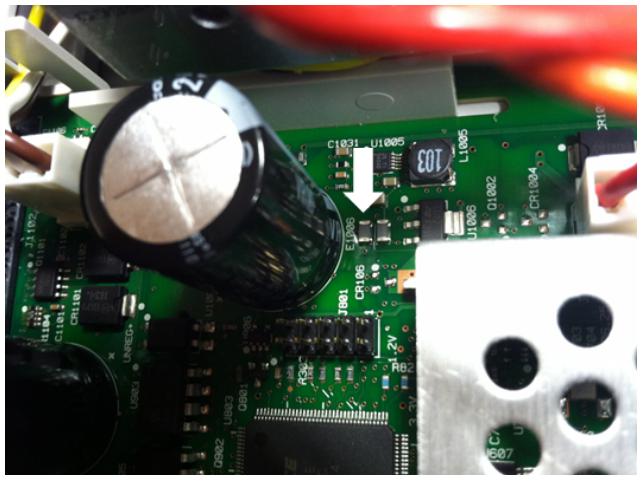
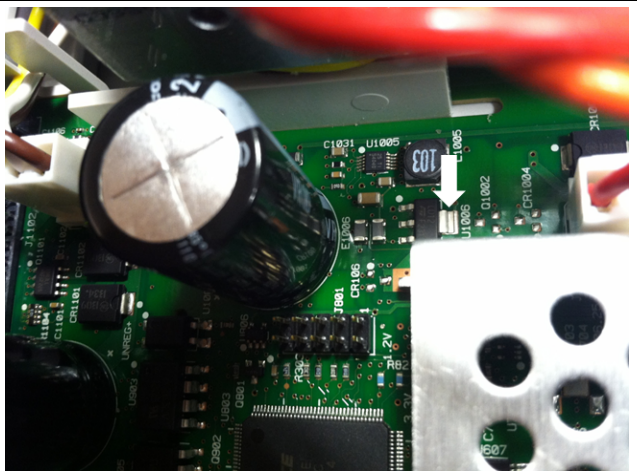
Pin	Location Detail
R1020 (either end) $10\text{ V} \pm 20\%$	
E1006 (either end) $3.3\text{ V} \pm 5\%$	
U1006 (large tab on right side as shown in picture) $1.2\text{ V} \pm 5\%$	

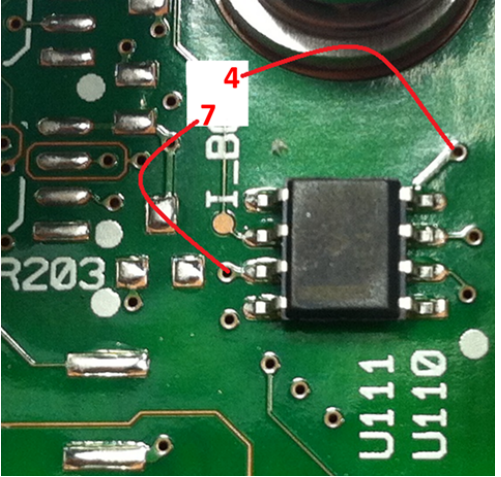
Pin	Location Detail
U1004 pin 3 5 V \pm 5%	
U111 (next to shield screw) pin 7: 16.8 V \pm 5% pin 4: -16.4 V \pm 5%	

Troubleshooting

Before troubleshooting or repairing the instrument, make sure the failure is in the instrument rather than any external connections. Also make sure that the instrument was accurately calibrated within the last year (see [Calibration Interval](#)). The instrument's circuits allow troubleshooting and repair with basic test equipment.

CAUTION

DO NOT swap the motherboard or the front panel board from one instrument to another. These boards contain model number and serial number information that uniquely identifies a specific unit, and boards that are mismatched to the instrument may result in problems with its performance, licensing, serviceability, importability/exportability or warranty.

Troubleshooting Procedure

1. Remove all remote I/O connections and front panel connections to the instrument. Verify that:
 - a. the AC mains power cord is securely connected to the instrument and plugged into a live outlet
 - b. the front-panel Power On/Standby switch has been pushed
2. If the standby light below the power switch is not illuminated, re-verify the items above. If all this is correct, check the AC mains power and then the internal line fuse.
3. If the standby light is on (yellow or green), press the power button. If there is no response, replace the front-panel board because the power button on the front-panel board is likely broken.
4. [Check the voltages on the power supply](#). If one or more of these tests fail, disconnect the transformer secondaries from the main board and measure the voltages from the transformer with an AC voltmeter.

The voltage between the red and orange wires (below) should measure 7.5 to 11 VAC.

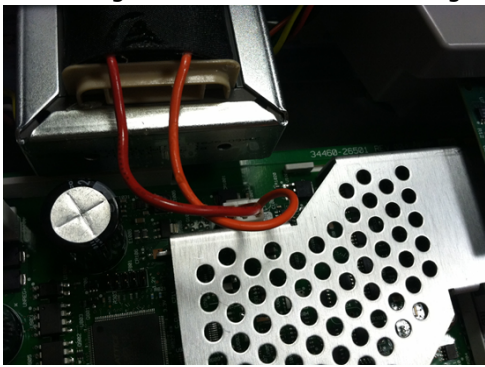

The voltage between the brown and white wires (below) should measure 11 to 15 VAC.

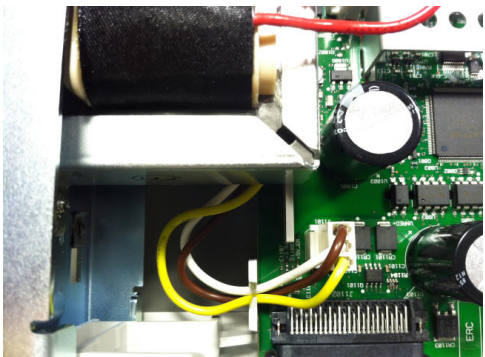

5. If the voltages are correct, replace the main board; otherwise replace the transformer.
6. Turn the instrument on. If the power-on sequence completes and the display appears to function properly, verify that the instrument is in local mode (the Remote annunciator in the upper right corner of the display is not on), and run the full self-test (**[Utility] > Test/Admin > Self-Test > Full Test**). If the display is illegible, replace the front-panel board.

CAUTION

Ensure that all connections (front and rear) are removed when self-test is performed. During self-test, errors may be induced by signals present on external wiring, such as long test leads that can act as antennas.

Self-Test Procedures

Power-On Self-Test

Each time the instrument is powered on, it performs a self-test on its real-time clock, keyboard processor, power controller, measurement processor, calibration memory, FPGA, ADC, gain and offset circuitry, and voltage references. This self-test is equivalent to the *TST? SCPI query, and you do not need to remove inputs to the instrument to run the test.

Full Self-Test

A complete self-test ([TEST:ALL?](#)) takes approximately two seconds. This tests all of the items tested by the power-on self-test and includes further tests for gain, current source, and shunt circuitry.

When self-test completes, either "Self-test Passed" or "Self-test Failed" appears on front panel.

Execute the complete self-test before any verifications or adjustments.

CAUTION You must remove all input connections to the instrument before running the full self-test.

Remote I/O Execution

1. Connect to the instrument using the remote interface ([Remote Interface Configuration](#)).
2. Send [*TST?](#) or [TEST:ALL?](#) and read the result: pass (+0) or fail (+1). Use [SYSTem:ERRor?](#) to view errors. See the [list of self-test errors](#) for details.

Front-panel Execution

1. Press **[Shift] > [Utility] > Test/Admin > Self Test**.
2. View any failures by pressing **[Shift] > [Help] > View remote command error queue**.

User Replaceable Parts

Replacement parts for the instrument are listed below. Unless otherwise shown, all parts are for the 34460A and 34461A models.

Part Number	Description
34401-86020	Bumper Kit
33220-88304	Rear Bezel
34401-45021	Handle
33220-84101	Cover
5041-5228	Keypad
2090-1051	Display
2110-0817	Line Fuse (250 mA, 250 V, time delay)
2110-1547	Current Protection Fuse (3.15 A, 500 V, time delay)
2110-1402	Internal Fuse (11 A, 1000 V, fast acting)
34460-87910	Transformer
34401-45012	Terminal Latch
5041-5238	Power Module
34460-40201	Plastic Front Panel (34460A)
34461-40201	Plastic Front Panel (34461A)
53200-49311	Window
5041-5231	Front Panel Shield
5041-5225	Front/Rear Push Rod (34461A)
5041-5232	Fan (34461A)
1420-0356	Battery (in front panel)

Disassembly

This section describes the procedure for disassembling the instrument.

WARNING

Only qualified, service-trained personnel who are aware of the hazards involved should remove instrument covers. Always disconnect the power cable and any external circuits before removing the instrument cover. Some circuits are active and have power applied even when the power switch is turned off.

Always disconnect all inputs, cords, and cables before disassembling the instrument.

CAUTION

Do not turn the screw that fastens the shield in place, as this will affect the instrument's calibration.



Tools Required

The following tools are required.

- T20 Torx driver (most disassembly)
- Small, flat-blade screw driver (for prying)

General Disassembly Procedure

1. Turn off the power and remove all measurement leads and other cables, including the power cord, from the instrument before continuing.
2. Rotate the handle to the upright position and remove it by pulling outward where it attaches to the case.



3. Pull off the front rubber bumper.
4. Unscrew the two captive screws in the rear bezel and remove the rear bezel and rubber bumper.



5. Remove the screw on the bottom of the instrument and place it in a safe location for re-assembly. Slide off the instrument cover.

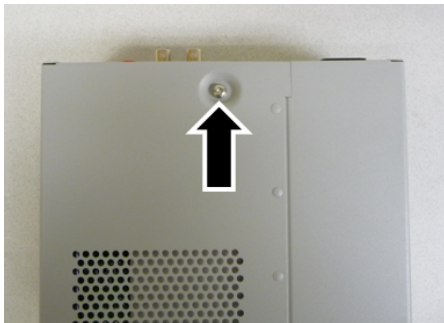

NOTE

At this point, the instrument is sufficiently disassembled for power supply troubleshooting purposes. You could also change the battery or [override the security code](#) at this point. If you need to disassemble the front panel, continue with the steps shown below.

6. Use the small, flat-blade screwdriver to pry the black latch up and remove it. Note the orientation of the latch for re-assembly purposes.



7. Push in on the lever shown, and squeeze the metal frame of the instrument to release the front panel plastic.

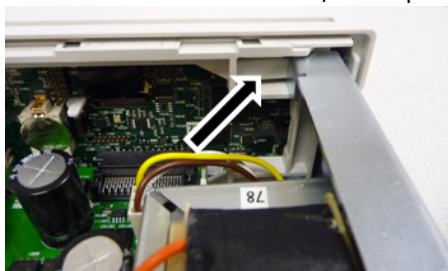

8. Slide the front panel off.
9. Slide the white plastic backing plate to the right and lift up on the left side of the backing plate to remove it.

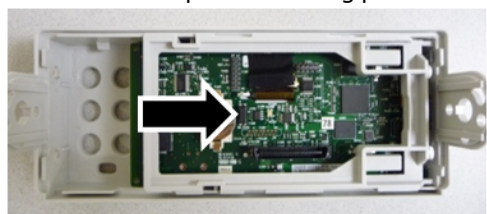

10. Remove the front panel PCBA by holding the connector housing shown below and lifting it out.



11. Remove the ESD shield by prying it out gently from the plastic housing to which it attaches.

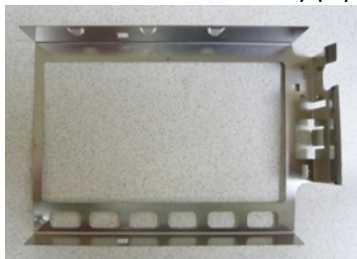

This concludes the disassembly procedure. To re-assemble the instrument, reverse the procedure.

Battery Replacement

This section describes the procedure for replacing the battery on the instrument's front panel.

WARNING

Only qualified, service-trained personnel who are aware of the hazards involved should remove instrument covers. Always disconnect the power cable and any external circuits before removing the instrument cover. Some circuits are active and have power applied even when the power switch is turned off.

Always disconnect all inputs, cords, and cables before disassembling the instrument.

Tools Required

- T20 Torx driver (most disassembly)
- Small, flat-blade screw driver (for prying)

Procedure

(Images shown below provided courtesy of Keystone Electronics Corp.)

1. Turn off the power and remove all measurement leads and other cables, including the power cord, from the instrument before continuing.
2. Follow the [disassembly procedure](#) to disassemble the instrument.
3. Locate the battery on the front panel, and position the screwdriver tip under the battery, as shown.

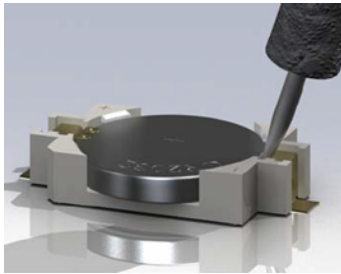

4. Use the screwdriver to pry the battery from the battery holder.

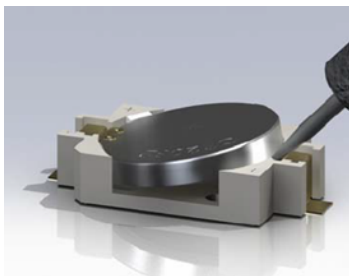

5. Remove the battery and discard or recycle it in accordance with all applicable regulations.
6. Position the new battery in the battery holder, + side up. Push down gently to seat the battery in the holder.

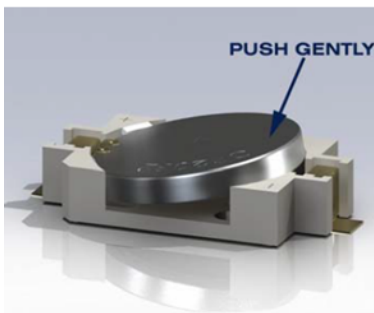

7. Re-assemble the instrument completely before connecting any cables or cords.

This concludes the battery replacement procedure.

3 A and 10 A Current Path Fuse Replacement

This section describes the procedure for testing and replacing the 3 A and 10 A current path fuses inside the instrument.

WARNING

Only qualified, service-trained personnel who are aware of the hazards involved should remove instrument covers. Always disconnect the power cable and any external circuits before removing the instrument cover. Some circuits are active and have power applied even when the power switch is turned off.

Always disconnect all inputs, cords, and cables before disassembling the instrument.

CAUTION

Do not turn the screw that fastens the shield in place, as this will affect the instrument's calibration.



Tools Required

- T20 Torx driver (most disassembly)
- Small, flat-blade screw driver (for prying)

Testing the Fuses

3 A Current Path

To determine whether the instrument's 3 A current path has a fuse that must be replaced, press **[Cont]** to put the DMM in continuity measurement mode, and short the HI Input terminal to the 3 A current terminal. If the measurement displays OPEN, one of the two fuses must be replaced. One fuse is accessible from the instrument's rear panel; the other is internal.

If the 3 A current path has a bad fuse, it is very likely to be the fuse accessible from the lower left corner of the instrument's rear panel (part number 2110-1547, 3.15 A, 500 V, time delay). Simply use a flat-blade screw driver to turn the fuse holder counter-clockwise and access the fuse. Put the new fuse into the fuse holder and insert the assembly back into the instrument, turning the fuse holder clockwise to lock it in place.

If the 3 A path still has a bad fuse, replace the internal 3 A current path fuse as described below.

10 A Current Path (34461A only)

To determine whether the instrument's 10 A current path has a fuse that must be replaced, press **[Cont]** to put the DMM in continuity measurement mode, and short the HI Input terminal to the 10 A current terminal. If the measurement displays OPEN, replace the internal 10 A current path fuse as described below.

Internal Fuse Replacement Procedure

Both internal current path fuses are part number 2110-1402, 11 A, 1000 V, fast acting. To replace an internal fuse:

1. Turn off the power and remove all measurement leads and other cables, including the power cord, from the instrument before continuing.
2. Follow the [disassembly procedure](#) to disassemble the instrument.
3. Locate the fuse to be replaced, as shown below.

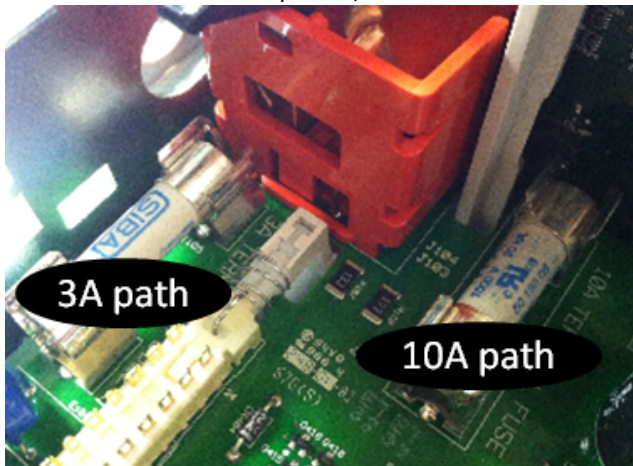

4. Use the screwdriver to pry the fuse from the fuse holder, being careful not to damage the circuit board. For the 3 A fuse, it may be easiest to access the fuse from the side, through the rectangular aperture in the sheet metal.
5. Remove the fuse.
6. Position the new fuse in the fuse holder. Push down gently to seat the fuse in the holder.
7. Re-assemble the instrument completely before connecting any cables or cords.

This concludes the fuse replacement procedure.

Installing the Optional GPIB Interface

WARNING

This procedure should be performed by qualified service personnel only. Turn off the power and remove all measurement leads and other cables, including the power cord, from the instrument before continuing.

Tools Required

The following tools are required.

- T10 Torx driver

Installation Procedure

1. Turn off the power and remove all measurement leads and other cables, including the power cord, from the instrument before continuing.
2. Use the Torx driver to remove the screw from the GPIB cover plate. Retain the screw for use later in this procedure. Then remove the cover plate by sliding it to the left.

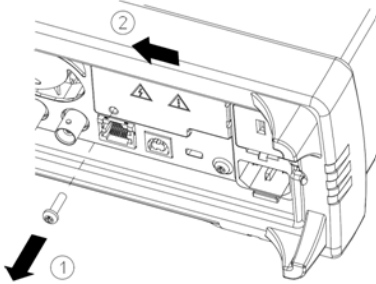

WARNING Retain GPIB Cover Plate

After installing the GPIB option, retain the cover plate for use in the event that you ever remove the GPIB option. The instrument should never be connected to power or inputs on the measurement terminals without either the GPIB module or the cover plate securely covering the rear-panel opening.

3. Locate the connector, just inside the unit, for the cable attached to the GPIB module

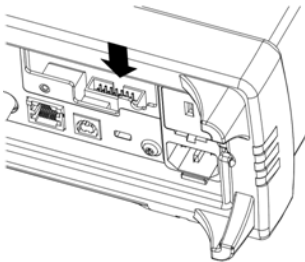

4. Bend the cable so that it extends above the circuit board. Attach the cable to the connector that was located in the previous step.

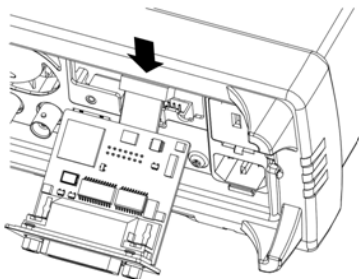

- Put the module into the unit and slide the GPIB board to the right so that it is flush against the instrument's sheet metal. Use the screw that was removed above to secure the GPIB plate in place.

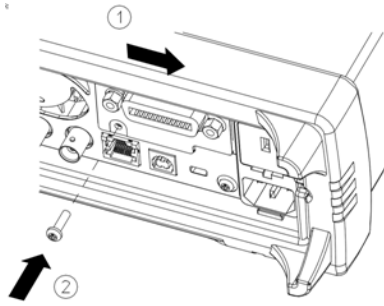

This concludes the GPIB installation procedure.

Calibration

This section covers the following topics:

[Calibration - Introduction](#)

[Zero Offset Verification](#)

[DC Volts and DC Current Gain Verification](#)

[Frequency Accuracy Verification](#)

[AC Voltage and AC Current Verification](#)

[High Current Verification \(34461A only\)](#)

[Calibration Security](#)

[Calibration Message](#)

[Calibration Count](#)

[Calibration Process](#)

[Entering Adjustment Values and Storing Calibration Constants](#)

[Aborting a Calibration in Progress](#)

[Adjustments](#)

[Gain Adjustments](#)

[ADC and Zero Adjustments](#)

[Gain and Flatness Adjustments](#)

[AC Voltage Low Frequency Gain and Flatness Calibration](#)

[AC Voltage Gain and Flatness Calibration](#)

[AC Current Gain and Flatness Calibration](#)

[Frequency Accuracy Calibration](#)

[DC Voltage Gain Calibration](#)

[Ohms Gain Calibration](#)

[DC Current Gain Calibration](#)

[AC Current 10 A Full Scale Calibration \(34461A only\)](#)

[DC Current 10 A Full Scale Calibration \(34461A only\)](#)

[Finishing Adjustments](#)

Calibration - Introduction

This section contains procedures for verifying and adjusting the instrument's performance (calibration).

NOTE

There is no separate calibration for Diode or Continuity, because these functions are based on the Ohms measurement, which is calibrated. Also, there is no calibration for gate time because this functionality is controlled by digital logic.

Closed-Case Electronic Calibration

The instrument uses closed-case electronic calibration; no internal mechanical adjustments are required. The instrument calculates correction factors based on reference signals that you apply and stores the correction factors in non-volatile memory. This data is not changed by cycling power, [*RST](#), or [SYSTem:PRESet](#).

Agilent Technologies Calibration Services

Agilent Technologies offers calibration services using automated calibration systems that enable Agilent to provide calibration at competitive prices. See [Types of Service Available](#) for information on contacting Agilent.

Calibration Interval

The instrument should be calibrated on a regular interval determined by the accuracy requirements of your application. A 1-year interval is adequate for most applications. Accuracy specifications are warranted only if adjustment is made at regular calibration intervals. Accuracy specifications are not warranted beyond the 1-year calibration interval. Agilent Technologies never recommends calibration intervals beyond two years.

Adjustment is Recommended

Whatever calibration interval you select, Agilent Technologies recommends that complete re-adjustment should always be performed at the calibration interval. This ensures that the instrument will remain within specifications for the next calibration interval and provides the best long-term stability. Performance data measured during performance verification tests does not mean that the instrument will remain within these limits unless the adjustments are performed. Use the calibration count to verify that all adjustments have been performed.

Time Required for Calibration

The instrument can be automatically calibrated under computer control, including complete calibration procedure and performance verification tests, in less than 30 minutes once the instrument is warmed-up (see Test Considerations).

Automating Calibration Procedures

The adjustment procedures demonstrate front panel adjustment. You can automate the complete verification and adjustment procedures outlined in this manual. You can program the instrument configurations specified for each test over the remote interface. You can then enter read back verification data into a test program and compare the results to the appropriate test limit values.

The instrument must be unsecured to calibrate. See Calibration Security for details.

Refer to the [CALibration Subsystem](#) for information on SCPI programming.

Recommended Test Equipment

The test equipment recommended for the performance verification and adjustment procedures is listed below. If the exact instrument is not available, substitute calibration standards of equivalent accuracy.

An alternate method would be to use the Agilent 3458A 8½-digit Digital Multimeter to measure less accurate yet stable sources. The output value measured from the source can be entered into the instrument as the target calibration value.

Application	Recommended Equipment	Accuracy Requirements
Zero Calibration	Agilent 34172B (2 recommended)	4-terminal low thermal short
DC Voltage	Fluke 5720A	<1/5 instrument 24 hour spec
DC Current	Fluke 5720A	<1/5 instrument 24 hour spec
Resistance	Fluke 5720A	<1/5 instrument 24 hour spec
AC Voltage	Fluke 5720A	<1/5 instrument 24 hour spec
AC Current	Fluke 5720A	<1/5 instrument 24 hour spec
Frequency	Agilent 33500 Series Function Generator	<1/5 instrument 24 hour spec

Performance Verification Tests

Use the Performance Verification Tests to verify the measurement performance of the instrument using the instrument's specifications listed in the product data sheet.

You can perform three different levels of performance verification tests:

- **Self-Test (two types):** Internal verification tests that give a high confidence that the instrument is operational, as described [here](#).
- **Quick Verification:** A combination of the internal self-tests and selected verification tests.
- **Performance Verification Tests:** An extensive set of tests that are recommended as an acceptance test when you first receive the instrument or after performing adjustments.

Quick Performance Check

The quick performance check is a combination of internal self-test and an abbreviated performance test (specified by the letter Q in the performance verification tests). This provides a simple method to achieve high confidence in the instrument's ability to functionally operate and meet specifications. These tests represent the absolute minimum set of performance checks recommended following any service activity. Auditing the instrument's performance for the quick check points (designated by a Q) verifies performance for "normal" accuracy drift mechanisms. This test does not check for abnormal component failures.

To perform the quick performance check, do the following:

- Perform a [self-test](#).
- Perform only the performance verification tests indicated with the letter **Q**.

If the instrument fails the quick performance check, adjustment or repair is required.

Performance Verification Tests

The performance verification tests are recommended as acceptance tests when you first receive the instrument. The acceptance test results should be compared against the 90 day test limits. You should use the 24 hour test limits only for verification within 24 hours after performing the adjustment procedure. After acceptance, you should repeat the performance verification tests at every calibration interval.

If the instrument fails performance verification, adjustment or repair is required.

Adjustment is recommended at every calibration interval. If adjustment is not made, you must establish a guard band, using no more than 80% of the specifications, as the verification limits.

Input Connections

Test connections to the instrument are best accomplished using an Agilent Technologies 34172B calibration short for low-thermal offset measurements and a 34171B DMM connector configured to interface to the calibrator output. Shielded, twisted-pair, PTFE interconnect cables of minimum length are recommended between the calibrator and the multimeter to reduce settling and noise errors. HI and HI Sense should be a twisted pair. LO and LO Sense should be a twisted pair. Cable shields should be earth ground referenced. This configuration is recommended for noise reduction and settling time performance during calibration.

Test Considerations

Errors may be induced by AC signals present on the input leads during a self-test. Long test leads can also act as an antenna causing pick-up of AC signals.

For optimum performance:

- Ensure that the calibration ambient temperature (T_{cal}) is stable and between 18 °C and 28 °C. Ideally the calibration should be performed at 23 °C \pm 2 °C.
- Ensure ambient relative humidity is less than 80%.
- Allow a 90 minute warm-up period with a copper short connected.
- Connect the input cable shields to earth ground. Except where noted in the procedures, connect the calibrator LO source to earth ground at the calibrator. It is important that the LO to earth ground connection be made at only one place in the circuit to avoid ground loops.

Because the instrument is capable of making highly accurate measurements, you must take care to ensure that the calibration standards and test procedures do not introduce additional errors. Ideally, the standards used to verify and adjust the instrument should be an order of magnitude more accurate than each instrument range full scale error specification.

For 2-wire ohms measurements, remove lead resistance by doing a null measurement with the leads shorted or with a precision 4-terminal low thermal short. For offset calibration a 4-terminal low thermal short is required.

Zero Offset Verification

This procedure checks the instrument's zero offset performance. Verification checks are only performed for those functions and ranges with unique offset calibration constants. Measurements are checked for each function and range as described below.

1. Make sure you have read [Test Considerations](#).
2. Install the 34172B Calibration Short (or equivalent) on the front-panel input terminals. Select the Front input terminals with the Front/Rear switch.
3. Configure each function and range in the order shown in the table below. Make a measurement and return the result. Compare measurement results to the test limits shown below.
4. Install the 34172B Calibration Short (or equivalent) on the rear-panel input terminals. Select the Rear input terminals with the Front/Rear switch.
5. Configure each function and range in the order shown in the table below. Make a measurement and return the result. Compare measurement results to the test limits shown below.

Values for 34461A DMM							
Input	Function ^[1]	Range	Quick Check	Error from Nominal			
				24 hours	90 days	1 year	2 years
Open	DC Current	100 μ A	Q	$\pm 0.02 \mu$ A	$\pm 0.025 \mu$ A		
		1 mA		$\pm 0.060 \mu$ A			
		10 mA		$\pm 2 \mu$ A			
		100 mA		$\pm 4 \mu$ A	$\pm 5 \mu$ A		
		1 A		$\pm 60 \mu$ A	$\pm 100 \mu$ A		
		3 A		$\pm 600 \mu$ A			
		10 A		± 1 mA			
Short	DC Volts	100 mV	Q	$\pm 3 \mu$ V	$\pm 3.5 \mu$ V		
		1 V		$\pm 6 \mu$ V	$\pm 7 \mu$ V		
		10 V		$\pm 40 \mu$ V	$\pm 50 \mu$ V		
		100 V		$\pm 600 \mu$ V			
		1000 V		± 6 mV	± 10 mV		
Short	4-wire Ohms	100 Ω		± 3 m Ω	± 4 m Ω		
		1 k Ω		± 5 m Ω	± 10 m Ω		
		10 k Ω	Q	± 50 m Ω	± 100 m Ω		
		100 k Ω		± 500 m Ω	± 1 Ω		
		1 M Ω		± 10 Ω			
		10 M Ω		± 100 Ω			

Values for 34460A DMM							
Input	Function ^[1]	Range	Quick Check	Error from Nominal			
				24 hours	90 days	1 year	2 years
Open	DC Current	100 μ A	Q	$\pm 0.02 \mu$ A	$\pm 0.025 \mu$ A		
		1 mA		$\pm 0.060 \mu$ A			
		10 mA		$\pm 2 \mu$ A			
		100 mA		$\pm 4 \mu$ A	$\pm 5 \mu$ A		
		1 A		$\pm 60 \mu$ A	$\pm 100 \mu$ A		
		3 A		$\pm 600 \mu$ A			
Short	DC Volts	100 mV	Q	$\pm 6 \mu$ V	$\pm 6.5 \mu$ V		
		1 V		$\pm 9 \mu$ V	$\pm 10 \mu$ V		
		10 V		$\pm 40 \mu$ V	$\pm 50 \mu$ V		
		100 V		$\pm 600 \mu$ V			
		1000 V		± 6 mV	± 10 mV		
Short	4-wire Ohms	100 Ω		± 6 m Ω	± 7 m Ω		
		1 k Ω		± 8 m Ω	± 10 m Ω		
		10 k Ω	Q	± 50 m Ω	± 100 m Ω		
		100 k Ω		± 500 m Ω	$\pm 1 \Omega$		
		1 M Ω		$\pm 10 \Omega$			
		10 M Ω		$\pm 100 \Omega$			

[1] Select 10 NPLC.

Q: Quick performance verification test point.

DC Volts and DC Current Gain Verification

This procedure verifies DC volts and DC current gain.

1. Make sure you have read [Test Considerations](#).
2. Connect the calibrator to the input terminals. For the 34461A, use the front-panel input terminals and select the front input terminals with the **Front/Rear** switch.
3. Configure each function and range in the order shown in the table below. Provide the input shown in the table below.
4. Make a measurement and return the result. Compare measurement results to the test limits shown below. (Be certain to allow for appropriate source settling.)

Values for 34461A DMM							
Input				Error from Nominal			
Voltage	Function ^[1]	Range	Quick Check	24 hours	90 days	1 year	2 years
100 mV	DC Volts	100 mV		± 6 µV	± 7.5 µV	± 8.5 µV	± 10.0 µV
-100 mV							
1 V		1 V		± 26 µV	± 37 µV	± 47 µV	± 62 µV
-1 V							
4 V		10 V		± 100 µV	± 130 µV	± 190 µV	± 230 µV
10 V			Q	± 190 µV	± 250 µV	± 400 µV	± 500 µV
-10 V							
100 V		100 V		± 2.6 mV	± 4.1 mV	± 5.1 mV	± 6.6 mV
-100 V			Q				
1000 V		1000 V		± 26 mV	± 45 mV	± 55 mV	± 70 mV
-500 V			± 16 mV	± 27.5 mV	± 32.5 mV	± 40 mV	

Values for 34461A DMM							
Input				Error from Nominal			
Current	Function ^[1]	Range	Quick Check	24 hours	90 days	1 year	2 years
2 A	DC Current	3 A		± 4.2 mA	± 4.6 mA	± 4.6 mA	± 5.2 mA
1 A		1 A	Q	± 560 µA	± 900 µA	± 1.1 mA	± 1.3 mA
100 mA		100 mA		± 14 µA	± 35 µA	± 55 µA	± 65 µA
10 mA		10 mA	Q	± 2.7 µA	± 5 µA	± 7 µA	± 8 µA
1 mA		1 mA		± 0.13 µA	± 0.36 µA	± 0.56 µA	± 0.66 µA
100 µA		100 µA		± 0.03 µA	± 0.065 µA	± 0.075 µA	± 0.085 µA

Values for 34461A DMM							
Input			Error from Nominal				
Resistance	Function ^[1]	Range	Quick Check	24 hours	90 days	1 year	2 years
100 Ω	4-wire Ohms	100 Ω		± 6 mΩ	± 12 mΩ	± 14 mΩ	± 16 mΩ
1 kΩ		1 kΩ	Q	± 25 mΩ	± 90 mΩ	± 110 mΩ	± 130 mΩ
10 kΩ		10 kΩ		± 250 mΩ	± 900 mΩ	± 1.1 Ω	± 1.3 Ω
100 kΩ		100 kΩ		± 2.5 Ω	± 9 Ω	± 11 Ω	± 13 Ω
1 MΩ		1 MΩ		± 30 Ω	± 90 Ω	± 110 Ω	± 130 Ω
10 MΩ		10 MΩ	Q	± 1.6 kΩ	± 2.1 kΩ	± 4.1 kΩ	± 6.1 kΩ
100 MΩ	2-wire Ohms	100 MΩ		± 310 kΩ	± 810 kΩ		

Values for 34460A DMM							
Input			Error from Nominal				
Voltage	Function ^[1]	Range	Quick Check	24 hours	90 days	1 year	2 years
100 mV	DC Volts	100 mV		± 10 μV	± 13.5 μV	± 15.5 μV	± 18.0 μV
-100 mV							
1 V		1 V		± 39 μV	± 70 μV	± 90 μV	± 115 μV
-1 V							
4 V		10 V		± 140 μV	± 250 μV	± 350 μV	± 450 μV
10 V		10 V	Q	± 290 μV	± 550 μV	± 800 μV	± 1.1 mV
-10 V							
100 V		100 V		± 3.6 mV	± 7.1 mV	± 9.1 mV	± 11.6 mV
-100 V			Q				
1000 V		1000 V		± 36 mV	± 75 mV	± 95 mV	± 120 mV
-500 V				± 21 mV	± 42.5 mV	± 52.5 mV	± 62.5 mV

Values for 34460A DMM							
Input			Error from Nominal				
Current	Function ^[1]	Range	Quick Check	24 hours	90 days	1 year	2 years
2 A	DC Current	3 A		± 4.2 mA	± 4.6 mA	± 4.6 mA	± 5.2 mA
1 A		1 A	Q	± 560 μA	± 900 μA	± 1.1 mA	± 1.3 mA
100 mA		100 mA		± 14 μA	± 35 μA	± 55 μA	± 65 μA
10 mA		10 mA	Q	± 2.7 μA	± 5 μA	± 7 μA	± 8 μA
1 mA		1 mA		± 0.13 μA	± 0.36 μA	± 0.56 μA	± 0.66 μA
100 μA		100 μA		± 0.03 μA	± 0.065 μA	± 0.075 μA	± 0.085 μA

Values for 34460A DMM							
Input				Error from Nominal			
Resistance	Function ^[1]	Range	Quick Check	24 hours	90 days	1 year	2 years
100 Ω	4-wire Ohms	100 Ω		± 10 mΩ	± 18 mΩ	± 21 mΩ	± 24 mΩ
1 kΩ		1 kΩ	Q	± 38 mΩ	± 120 mΩ	± 150 mΩ	± 180 mΩ
10 kΩ		10 kΩ		± 350 mΩ	± 1.2 Ω	± 1.5 Ω	± 1.8 Ω
100 kΩ		100 kΩ		± 3.5 Ω	± 12 Ω	± 15 Ω	± 18 Ω
1 MΩ		1 MΩ		± 40 Ω	± 120 Ω	± 150 Ω	± 180 Ω
10 MΩ		10 MΩ		Q	± 1.6 kΩ	± 2.1 kΩ	± 4.1 kΩ
100 MΩ	2-wire Ohms	100 MΩ		± 310 kΩ	± 810 kΩ		

^[1] Select 10 NPLC.

Q: Quick performance verification test point.

Frequency Accuracy Verification

Configuration: Frequency (CONFigure:FREQUENCY DEF, MIN)

1. Make sure you have read [Test Considerations](#).
2. Select the Frequency function, default range, 3 Hz filter, and 1 second aperture.
3. Connect the Agilent 33500 Series function generator to the input terminals. For the 34461A, use the front-panel input terminals and select the front input terminals with the **Front/Rear** switch.
4. Select each range in the order shown below. Provide the indicated input voltage and frequency. Compare measurement results to the test limits shown below. (Be certain to allow for appropriate source settling.)

Values for 34461A DMM							
Input			Quick Check	Error from Nominal			
Vrms	Frequency	Range		24 hours	90 days	1 year	2 years
0.1 Vrms	10 Hz	1 Vrms		± 3 mHz			± 3.5 mHz
0.01 Vrms	300 kHz	0.1 Vrms	Q	± 60 Hz	± 180 Hz	± 300 Hz	± 450 Hz

Values for 34460A DMM							
Input			Quick Check	Error from Nominal			
Vrms	Frequency	Range		24 hours	90 days	1 year	2 years
0.1 Vrms	10 Hz	1 Vrms		± 3 mHz			± 3.5 mHz
0.01 Vrms	300 kHz	0.1 Vrms	Q	± 60 Hz	± 240 Hz	± 360 Hz	± 510 Hz

Q: Quick performance verification test point.

AC Voltage and AC Current Verification

This procedure verifies AC voltage and current.

1. Make sure you have read [Test Considerations](#).
2. Connect the calibrator to the input terminals. For the 34461A, use the front-panel input terminals and select the front input terminals with the **Front/Rear** switch.
3. Set the AC Volts or AC Current function and the filter as shown below.
4. Select each range in the order shown below. Provide the indicated input voltage and frequency. Compare measurement results to the test limits shown below. (Be certain to allow for appropriate source settling.)

Values for 34461A DMM								
Input			Filter	Quick Check	Error from Nominal			
Vrms	Frequency	Range			24 hours	90 days	1 year	2 years
100 mV	1 kHz	100 mV	200 Hz		± 60 µV	± 80 µV	± 90 µV	± 100 µV
	50 kHz				± 140 µV	± 160 µV	± 170 µV	± 180 µV
	300 kHz			Q	± 4.5 mV			
1 V	1 kHz	1 V	200 Hz		± 600 µV	± 800 µV	± 900 µV	± 1 mV
	50 kHz				± 1.4 mV	± 1.6 mV	± 1.7 mV	± 1.8 mV
	300 kHz				± 45 mV			
0.03 V	1 kHz	10 V	200 Hz		± 2 mV	± 3 mV		
1 V	1 kHz		200 Hz		± 2.4 mV	± 3.5 mV	± 3.6 mV	± 3.7 mV
10 V	10 Hz		3 Hz		± 6 mV	± 8 mV	± 9 mV	± 10 mV
	100 Hz		20 Hz		± 6 mV	± 8 mV	± 9 mV	± 10 mV
	20 kHz		200 Hz		± 6 mV	± 8 mV	± 9 mV	± 10 mV
	50 kHz		200 Hz	Q	± 14 mV	± 16 mV	± 17 mV	± 18 mV
	100 kHz				± 63 mV	± 68 mV		
300 kHz				± 450 mV				
100 V	1 kHz	100 V	200 Hz	Q	± 60 mV	± 80 mV	± 90 mV	± 100 mV
	50 kHz				± 140 mV	± 160 mV	± 170 mV	± 180 mV
70 V	300 kHz				± 3.3 V			
750 V	1 kHz	750 V	200 Hz		± 450 mV	± 600 mV	± 675 mV	± 750 mV
210 V	50 kHz				± 510 mV	± 606 mV	± 627 mV	± 648 mV
70 V	300 kHz					± 6.6 V		

Values for 34460A DMM								
Input					Error from Nominal			
Vrms	Frequency	Range	Filter	Quick Check	24 hours	90 days	1 year	2 years
100 mV	1 kHz	100 mV	200 Hz		± 90 µV	± 110 µV	± 120 µV	± 130 µV
	50 kHz				± 170 µV	± 190 µV	± 200 µV	± 210 µV
	300 kHz			Q	± 4.5 mV			
1 V	1 kHz	1 V	200 Hz		± 900 µV	± 1.1 mV	± 1.2 mV	± 1.3 mV
	50 kHz				± 1.7 mV	± 1.9 mV	± 2.0 mV	± 2.1 mV
	300 kHz				± 45 mV			
0.03 V	1 kHz	10 V	200 Hz		± 2 mV	± 3 mV		
1 V	1 kHz		200 Hz		± 2.7 mV	± 3.8 mV	± 3.9 mV	± 4.0 mV
10 V	10 Hz		3 Hz		± 9 mV	± 11 mV	± 12 mV	± 13 mV
	100 Hz		20 Hz		± 9 mV	± 11 mV	± 12 mV	± 13 mV
	20 kHz		200 Hz		± 9 mV	± 11 mV	± 12 mV	± 13 mV
	50 kHz		200 Hz	Q	± 17 mV	± 19 mV	± 20 mV	± 21 mV
	100 kHz				± 66 mV	± 71 mV		
	300 kHz					± 450 mV		
100 V	1 kHz	100 V	200 Hz	Q	± 90 mV	± 110 mV	± 120 mV	± 130 mV
	50 kHz				± 170 mV	± 190 mV	± 200 mV	± 210 mV
70 V	300 kHz				± 3.3 V			
750 V	1 kHz	750 V	200 Hz		± 675 mV	± 825 mV	± 900 mV	± 975 mV
210 V	50 kHz				± 573 mV	± 669 mV	± 690 mV	± 711 mV
70 V	300 kHz					± 6.6 V		

Values for 34460A and 34461A DMMs								
Input					Error from Nominal			
Current, rms	Frequency	Range	Filter	Quick Check	24 hours	90 days	1 year	2 years
2 A	1 kHz	3 A	200 Hz		± 5.8 mA			
	5 kHz							
1 A	1 kHz	1 A	200 Hz		± 1.4 mA			
	5 kHz							
100 mA	10 Hz	100 mA	3 Hz		± 140 µA			
	1 kHz		200 Hz					
	5 kHz		200 Hz					
100 µA	1 kHz	10 mA	200 Hz		4.1 µA			
1 mA	1 kHz				5 µA			
10 mA	1 kHz				14 µA			
	5 kHz							
1 mA	1 kHz	1 mA	200 Hz		1.4 µA			
	5 kHz							
100 µA	1 kHz	100 µA	200 Hz		0.14 µA			
	5 kHz			Q				

Q: Quick performance verification test point.

High Current Verification (34461A only)

This procedure verifies AC and DC current on the 10 A terminals.

1. Make sure you have read [Test Considerations](#).
2. Connect the calibrator to the front 10 A input terminals and select the Front input terminals with the **Front/Rear** switch.
3. Select each function in the order shown below. Provide the indicated input current and frequency, and for ACI, use the 200 Hz input filter. Compare measurement results to the test limits shown below. (Be certain to allow for appropriate source settling.)

Values for 34461A DMM								
Input					Error from Nominal			
Function	Current ^[1]	Frequency	Range	Quick Check	24 hours	90 days	1 year	2 years
DCI	5 A	N/A	10 A		± 3.5 mA	± 7 mA		± 8.5 mA
DCI	10 A	N/A			± 6 mA	± 13 mA	± 16 mA	
ACI	10 A	5 kHz			± 19 mA			

[¹] If you are not using the F5725 for calibration, reduce the current to 2 A.

Calibration Security

This section describes the instrument's calibration security system. If you forget the security code, you can [override calibration security](#).

Security Overview

A security code prevents accidental or unauthorized instrument adjustments.

- When shipped from the factory, the instrument is secured, with the security code set to **AT3446XA**.
- The same security code must be used for front-panel and remote operation. If you secure the instrument from the front panel, use that same code to unsecure it from the remote interface.
- This setting is non-volatile; it will not be changed by power cycling or [*RST](#).
- Security code rules:
 - Unquoted string up to 12 characters
 - Must start with letter (A-Z)
 - May contain letters, numbers (0-9) and underscores
- **Front Panel: [Utility] > Test / Admin > Security**
- **SCPI:** [CALibration:SECure:STATe](#)

Security Code Override

The instrument security code is set to AT3446XA at the factory. If it has been changed and you no longer remember the code, you can reset the code back to its factory default value by following the procedure below.

WARNING

This procedure should be performed by qualified service personnel only. Turn off the power and remove all measurement leads and other cables, including the power cord, from the instrument before continuing.

Security Code Override

1. Follow the [disassembly procedure](#) to disassemble the instrument.
2. Locate connector J102 on the front-panel board, as shown at the top of the image below.



3. Short pin A1 to A6 or A7 as shown below. You do not need to short both pins to A1, just one of them.



4. Reassemble the instrument, turn it on, and wait 30 to 40 seconds for the instrument to come up completely.
5. Reset the security code to the factory default by performing this procedure:
 - a. Press **[Utility] > Test / Admin > Security > New Code**.
 - b. Enter AT3446XA as the new passcode.
 - c. Press **Done**.
 - d. Verify the new code and press **Yes** to confirm the change.
6. Remove power, disassemble the instrument, and remove the short. Then reassemble the instrument to complete the security code reset procedure.

Calibration Message

You can store a message of up to 40 characters in calibration memory. For example, you could store the date of the last calibration, the date the next calibration is due, or the name and phone number of the person responsible for calibration.

To read the calibration message, press **Utility > Test/Admin > Calibrate** or send [CALibration:STRing?](#) from the remote interface.

To change the calibration message, unsecure the instrument and press **Utility > Test/Admin > Calibrate > Edit Cal String** or send [CALibration:STRing "<string>"](#) from the remote interface.

Calibration Count

You can query the instrument to determine how many calibrations have been performed. Because the value increments each time you store the calibration constants, a complete calibration adds many counts. The calibration count also increments whenever you save a calibration string, change the calibration password, or override the calibration security.

Your instrument was calibrated at the factory. When you receive your instrument, be sure to read the count to determine its initial value.

To read the calibration count, press **[Utility] > Test/Admin > Calibrate** on the front panel or send [CALibration:COUNT?](#) from the remote interface. You can read the calibration count regardless of whether the instrument is secured.

Calibration Process

The following general procedure is recommended to complete a full calibration.

1. Read [Test Considerations](#).
2. Perform the verification tests to characterize the instrument (incoming data).
3. Unsecure the instrument for calibration (see [Calibration Security](#)).
4. Perform the adjustment procedures (see [Adjustments](#)).
5. Secure the instrument against calibration (see [Calibration Security](#)).
6. Note the security code and calibration count in the instrument's maintenance records.

Entering Adjustment Values and Storing Calibration Constants

Selecting the Adjustment Mode

Use the CALibration:ADC? query to begin ADC calibration. The response to this query indicates a successful adjustment (0) or a failure (1). Following the ADC calibration, use the measurement commands to set the DMM measurement parameters and functions for the mode being calibrated.

Front Panel: [Utility] > Test/Admin > Calibrate > Perform Cal > Cal Value > Perform ADC Cal

Entering Adjustment Values

To enter a calibration value from the remote interface use CALibration:VALue <value> followed by the CALibration? query. The response to the query indicates whether the adjustment is valid.

Front Panel: [Utility] > Test/Admin > Calibrate > Perform Cal > Cal Value > (enter value) > Perform Cal Step

Storing the Calibration Constants

To store calibration values in non-volatile memory, use CALibration:STORe.

Front Panel: [Utility] > Test/Admin > Calibrate > Save Cal Values

NOTE You must have performed a successful calibration immediately before pressing **Save Cal Values**.

Aborting a Calibration in Progress

Sometimes it may be necessary to abort a calibration. You can abort a calibration at any time on any module by turning off the power or issuing a remote interface device clear message.

CAUTION

If you abort a calibration in progress when the instrument is attempting to write new calibration constants to EEPROM, you may lose all calibration constants for the function. Typically, upon re-applying power, the instrument will report error 705 Cal:Aborted. It may also generate errors 740 through 742. If this occurs, you should not use the instrument until a complete re-adjustment has been performed. See the [list of calibration errors](#) for more information.

Adjustments

You will need a test input cable and connectors set and a low thermal input short, Agilent 34172B, to adjust the instrument (see [Input Connections](#)). Two input shorts are recommended for the 34461A.

[Gain Adjustments](#)

[ADC and Zero Adjustments](#)

[Gain and Flatness Adjustments](#)

[AC Voltage Low Frequency Gain and Flatness Calibration](#)

[AC Voltage Gain and Flatness Calibration](#)

[AC Current Gain and Flatness Calibration](#)

[Frequency Accuracy Calibration](#)

[DC Voltage Gain Calibration](#)

[Ohms Gain Calibration](#)

[DC Current Gain Calibration](#)

[AC Current 10 A Full Scale Calibration \(34461A only\)](#)

[DC Current 10 A Full Scale Calibration \(34461A only\)](#)

[Finishing Adjustments](#)

Gain Adjustments

The instrument calculates and stores gain corrections for each input value. The gain constant is computed from the calibration value entered for the calibration command and from measurements made automatically during the adjustment procedure.

Most measurement functions and ranges have gain adjustment procedures, and adjustments for each function should be performed in the order shown.

Gain Adjustment Considerations

The ADC and zero adjustment procedure must have been recently performed before beginning gain adjustment. Gain adjustments can be made using either the front or rear input (34461A only) terminals. On the 34461A, make sure the **Front/Rear** switch matches the terminals in use.

CAUTION Never turn off the instrument during a gain or flatness adjustment. This may cause calibration memory for the present function to be lost.

Valid Gain and Flatness Adjustment Input Values

Gain adjustment can be accomplished using the following input values.

Function	Range	Valid Amplitude Input Values
DC Volts	100 mV to 100 V	0.9 to 1.1 x Full Scale
	1000 V	450 to 500 V
DC Current	100 μ A to 1 A	0.9 to 1.1 x Full Scale
	3 A	1.8 to 2.2 A
Ohms (2W and 4W)	100 Ω to 100 M Ω	0.9 to 1.1 x Full Scale
Frequency	Any	Input > 100 mV rms, 9.9 kHz to 110 kHz
AC Current (rms) ^[1]	100 μ A to 1 A	0.9 to 1.1 x Full Scale
	3 A	1.8 to 2.2 A
AC Volts (rms) ^[1]	100 mV to 100 V ^[2]	0.9 to 1.1 x Full Scale
	750 V	400 to 750 V

^[1] Valid frequencies are nominal frequencies $\pm 1\%$.

^[2] 100 VAC flatness adjustment performed at 50 V $\pm 10\%$.

ADC and Zero Adjustments

Each time you perform a zero adjustment, the instrument stores a new set of offset correction constants for every measurement function and range. The instrument will sequence through all required functions and ranges automatically and store new zero offset calibration constants. All offset corrections are determined automatically. You may not correct a single range or function without re-entering ALL zero offset correction constants automatically. This feature is intended to save calibration time and improve zero calibration consistency.

CAUTION Never turn off the instrument during Zero Adjustment. This may cause ALL calibration memory to be lost.

ADC and Zero Adjustment Procedure

Be sure to allow the instrument to warm up and stabilize for 90 minutes before performing the adjustments.

1. Follow the steps outlined below. Review [Test Considerations](#) before beginning this test.
2. This procedure uses a low-thermal shorting block installed on the input connectors. Leave the Current input connections open.

NOTE For the 34461A, two shorting blocks are recommended; one on the front panel and one on the rear panel. A single shorting block can be used with the 34460A.

3. Select the front-panel input terminals. If using a single shorting block, install the block on the front-panel input terminals.
4. Select the ADC adjustment mode (**[Utility] > Test/Admin > Calibrate > Perform Cal > Perform ADC Cal**).
5. The display will show a message indicating that ADC calibration is in process. It will then display the results of the ADC calibration. A Calibration Step Succeeded message indicates success; if the display shows Calibration Step Failed, check the input value, range, function, and entered adjustment value and repeat the adjustment step. Press **Save Cal Values**.
 1. For DCV, ACV, 2-wire ohms, 4-wire ohms, DCI, and ACI, perform the following tasks (note that you must remove the shorting block for DCI and ACI):
 - a. Select the measurement function.
 - b. Enter a calibration value of +0.
 - c. Press **[Utility] > Test/Admin > Calibrate > Perform Cal > Perform Cal Step**.
 - d. The display will show the functions and offset as the adjustments progress. The Zero Adjustment lasts approximately two minutes. A Calibration Step Succeeded message indicates success; if the display shows Calibration Step Failed, check the input value, range, function, and entered adjustment value and repeat the adjustment step.
 - e. Press **Save Cal Values**.
6. Select the rear input terminals. If using a single shorting block, install the block on the rear-panel input terminals.
7. Repeat steps 4 through 6 for the rear input terminals.
8. Store the new ADC and Zero adjustment constants (see Storing the Calibration Constants).
9. Perform the Zero Offset Verification to check zero calibration results.

Gain and Flatness Adjustments

The instrument stores new flatness correction constants each time this procedure is followed. Flatness constants adjust the DMM for AC Volts and AC current measurements across the usable input frequency band. The flatness constant is computed from the calibration value entered for the calibration command and from measurements made automatically during the adjustment procedure.

Adjustments for each range and frequency should be performed in the order shown.

Flatness Adjustment Considerations

The ADC and zero adjustment procedure must have been recently performed before beginning gain adjustment. Flatness adjustments can be made using either the front or the rear input terminals. On the 34461A, make sure the **Front/Rear** switch matches the terminals in use.

CAUTION Never turn off the instrument during a gain or flatness adjustment. This may cause calibration memory for the present function to be lost.

AC Voltage Low Frequency Gain and Flatness Calibration

Review [Test Considerations](#) and [Flatness Adjustment Considerations](#) before beginning this procedure.

Configuration: AC Voltage

1. Configure the range shown in the table below.
2. Apply the input signal shown in the Input column.
3. Enter the actual applied input voltage amplitude (see [Entering Adjustment Values](#)). A Calibration Step Succeeded message indicates success; if the display shows Calibration Step Failed, check the input value, range, function, and entered adjustment value and repeat the adjustment step.
4. Repeat steps 1 through 3 for each flatness adjustment point shown in the table.
5. Store the new calibration constants (see [Storing the Calibration Constants](#)).
6. [Verify the AC Low Frequency Flatness adjustments](#). You may also want to perform the additional verification procedures.

NOTE Each voltage and frequency takes approximately 2.5 seconds to complete.

Input		Instrument
Vrms	Frequency	Range
7 V	10 Hz	10 V
7 V	40 Hz	10 V

AC Voltage Gain and Flatness Calibration

Review [Test Considerations](#) and [Flatness Adjustment Considerations](#) before beginning this procedure.

Configuration: AC Voltage

All AC adjustments use the 3 Hz bandwidth measurement filter.

1. Configure each function and range in the order shown in the table below.
2. Apply the input signal shown in the Input column.
3. Enter the actual applied input voltage amplitude (see [Entering Adjustment Values](#)). A Calibration Step Succeeded message indicates success; if the display shows Calibration Step Failed, check the input value, range, function, and entered adjustment value and repeat the adjustment step.
4. Repeat steps 1 through 3 for each flatness adjustment point shown in the table.
5. Repeat steps 1 through 4 for each input voltage range: 100 mV, 1 V, 10 V, and 100 V. Apply a voltage equal to the full scale of the range being calibrated, with the exception of the 100 V range, which should have 50 V applied. You do not calibrate the range above 100 V; it is automatically calibrated based on the 100 V range.
6. Store the new calibration constants (see [Storing the Calibration Constants](#)).
7. [Verify the AC Voltage Flatness](#). You may also want to perform the additional verification procedures.

NOTE Each voltage and frequency takes approximately 2.5 seconds to complete.

Input		Instrument
Vrms	Frequency	Range
100 mV	5 kHz	100 mV
	10 kHz	
	20 kHz	
	35 kHz	
	50 kHz	
	75 kHz	
	100 kHz	
	200 kHz	
	300 kHz	
	390 kHz	
	400 kHz	
	220 Hz	
	1000 Hz	

8. Repeat the procedure using the 750 V range and a 1000 Hz, 500 V signal.

AC Current Gain and Flatness Calibration

Review [Test Considerations](#) and [Flatness Adjustment Considerations](#) before beginning this procedure.

Configuration: AC Current

All AC adjustments use the 3 Hz bandwidth measurement filter.

1. Configure each function and range in the order shown in the table below.
2. Apply the input signal shown in the Input column.
3. Enter the actual applied input current as the Cal Value (see [Entering Adjustment Values](#)). A Calibration Step Succeeded message indicates success; if the display shows Calibration Step Failed, check the input value, range, function, and entered adjustment value and repeat the adjustment step.
4. Repeat steps 1 through 3 for each frequency shown in the table.
5. Repeat steps 1 through 4 for each input current range: 1 A, 100 mA, and 10 mA. Apply current equal to the full scale of the range being calibrated. Do not perform these steps for the 100 μ A, 1 mA and 3 A ranges.
6. Repeat steps 1 through 3 for the 1 mA and 100 μ A ranges, using 1 mA and 100 μ A inputs at 1000 Hz only.
7. Store the new calibration constants (see [Storing the Calibration Constants](#)).
8. [Verify the AC Current Flatness adjustments](#). You may also want to perform the additional verification procedures.

NOTE Each current and frequency takes approximately 2.5 seconds to complete.

Input		Instrument
Current	Frequency	Range
1 A	5 kHz	1 A
	7.5 kHz	
	9.7 kHz	
	10 kHz	
	220 Hz	
	1000 Hz	

Frequency Accuracy Calibration

Review [Test Considerations](#) and [Gain Adjustment Considerations](#) before beginning this procedure.

Configuration: Frequency, 10 V range

The frequency accuracy of the Fluke 5720A is insufficient to calibrate the DMM. Its frequency output needs to be calibrated against a more accurate reference. The Agilent 33500 Series function generator is recommended for this adjustment.

1. Configure the instrument for frequency measurements at 10 V and 10 kHz, with 1 second gate time.
2. Apply a 10 kHz sine wave between 7 and 10 Vrms.
3. Enter the actual applied input frequency (see [Entering Adjustment Values](#)). A Calibration Step Succeeded message indicates success; if the display shows Calibration Step Failed, check the input value, range, function, and entered adjustment value and repeat the adjustment step.
4. Store the new calibration constants (see [Storing the Calibration Constants](#)).
5. [Verify the Frequency Gain adjustments](#).

NOTE This adjustment takes approximately 1 second to complete.

DC Voltage Gain Calibration

Review [Test Considerations](#) and [Gain Adjustment Considerations](#) before beginning this procedure.

Configuration: DC Voltage

1. Configure each function and range in the order shown in the table below.
2. Apply the input signal shown in the Input column.
3. Enter the actual applied input voltage amplitude (see [Entering Adjustment Values](#)). A Calibration Step Succeeded message indicates success; if the display shows Calibration Step Failed, check the input value, range, function, and entered adjustment value and repeat the adjustment step.
4. Repeat steps 1 through 3 for each gain adjustment point shown in the table.
5. Store the new calibration constants (see [Storing the Calibration Constants](#)).
6. [Verify the DC Voltage Gain adjustments](#).

NOTE Each range takes less than 4 seconds to complete.

	Instrument Settings	
Input	Function	Range
10 V	DCV	10 V
-10 V		10 V
0.1 V		100 mV
-0.1 V		100 mV
1 V		1 V
100 V		100 V
1000 V		1000 V

Ohms Gain Calibration

Review [Test Considerations](#) and [Gain Adjustment Considerations](#) before beginning this procedure.

Configuration: 4-Wire Ohms

This procedure adjusts the gain for the 2-wire and 4-wire Ohms functions, and the offset compensated Ohms function. The 100 M Ω range gain is derived from the 10 M Ω range and does not have a separate adjustment point.

1. Configure each function and range in the order shown in the table below.
2. Apply the input signal shown in the Input column.
3. Enter the actual applied input resistance (see [Entering Adjustment Values](#)). A Calibration Step Succeeded message indicates success; if the display shows Calibration Step Failed, check the input value, range, function, and entered adjustment value and repeat the adjustment step.
4. Repeat steps 1 through 3 for each gain adjustment point shown in the table.
5. Store the new calibration constants (see [Storing the Calibration Constants](#)).
6. [Verify the Ohms Gain adjustments](#).

NOTE Each range takes less than 4 seconds to complete.

	Instrument Settings	
Input	Function	Range
100 Ω	4-wire Ohms	100 Ω
1 k Ω		1 k Ω
10 k Ω		10 k Ω
100 k Ω		100 k Ω
1 M Ω		1 M Ω
10 M Ω		10 M Ω
100 M Ω	2-wire Ohms	100 M Ω

DC Current Gain Calibration

Review [Test Considerations](#) and [Gain Adjustment Considerations](#) before beginning this procedure.

Configuration: DC Current

1. Configure each function and range in the order shown in the table below.
2. Apply the input signal shown in the Input column.
3. Enter the actual applied input current as the Cal Value (see [Entering Adjustment Values](#)). A Calibration Step Succeeded message indicates success; if the display shows Calibration Step Failed, check the input value, range, function, and entered adjustment value and repeat the adjustment step.
4. Repeat steps 1 through 3 for each gain adjustment point shown in the table.
5. Store the new calibration constants (see [Storing the Calibration Constants](#)).
6. [Verify the DC Current Gain adjustments](#).

NOTE Each range takes less than 4 seconds to complete.

Instrument Settings		
Input	Function	Range
100 μ A	DC Current	100 μ A
1 mA		1 mA
10 mA		10 mA
100 mA		100 mA
1 A		1 A

AC Current 10 A Full Scale Calibration (34461A only)

Review [Test Considerations](#) and [Flatness Adjustment Considerations](#) before beginning this procedure.

Configuration: AC Current

All AC adjustments use the 3 Hz bandwidth measurement filter.

1. Configure the 10 A range.
2. Apply the 5 A input signal at 1000 Hz.
3. Enter the actual applied input current as the Cal Value (see [Entering Adjustment Values](#)). A Calibration Step Succeeded message indicates success; if the display shows Calibration Step Failed, check the input value, range, function, and entered adjustment value and repeat the adjustment step.
4. Store the new calibration constants (see [Storing the Calibration Constants](#)).
5. [Verify the AC Current Flatness adjustments](#).

NOTE Each current and frequency takes approximately 2.5 seconds to complete.

DC Current 10 A Full Scale Calibration (34461A only)

Review [Test Considerations](#) and [Flatness Adjustment Considerations](#) before beginning this procedure.

Configuration: DC Current

1. Configure the 10 A range and 100 PLC aperture.
2. Apply the 5 A input.
3. Enter the actual applied input current as the Cal Value (see [Entering Adjustment Values](#)). A Calibration Step Succeeded message indicates success; if the display shows Calibration Step Failed, check the input value, range, function, and entered adjustment value and repeat the adjustment step.
4. Store the new calibration constants (see [Storing the Calibration Constants](#)).
5. [Verify the AC Current Flatness adjustments](#).

NOTE This calibration takes less than 4 seconds to complete.

Finishing Adjustments



To finish adjusting your instrument:

1. Remove all shorting blocks and connections from the instrument.
2. Reset the [calibration message](#).
3. [Secure the instrument](#) with the calibration password.
4. Record the new calibration count.

General Characteristics

This section lists the general characteristics of the instrument. Standards used to verify these include ISO/IEC 17025:2005 and ISO/IEC Guide 98-3:2008.

Line Power	
Power Supply:	100 / 120 (127) / 220 (230) / 240 VAC \pm 10%, CAT II
Power Line Frequency:	50 / 60 / 400 Hz \pm 10%
Power Consumption:	25 VA
Environment	
Operating Environment:	Full accuracy for 0 °C to 55 °C
	Full accuracy to 80% R.H. at 40 °C Non-condensing
	Operating Altitude Up to 3000 m
	Storage Temperature -40 to 70 °C
Mechanical	
Rack Dimensions (W x H x D):	212.8 mm x 88.3 mm x 272.3 mm
Bench Dimensions (W x H x D):	261.2 mm x 103.8 mm x 303.2 mm
Weight (34460A):	3.68 kg (8.1 lbs)
Weight (34461A):	3.76 kg (8.3 lbs)
<p>The mechanical drawings illustrate the instrument's dimensions in millimeters. The front view shows a width of 261.2 mm. The top view shows a width of 212.8 mm. The side view shows a height of 103.8 mm and a depth of 303.2 mm. Another side view shows a height of 88.3 mm and a depth of 272.3 mm.</p>	

Regulatory	
	Safety
	EN 61010-1:2010 (3rd Edition)
	ANSI/ISA-61010-1 (82.02.01) Third Edition
	ANSI/UL 61010-1 Third Edition
	CAN/CSA-C22.2 No. 61010-1 Third Edition
	EN 61010-2-030:2010 (1st Edition)
	ANSI/ISA-61010-2-030 (82.02.03) First Edition
	ANSI/UL 61010-2-030 First Edition
	CAN/CSA-C22.2 No. 61010-2-030 First Edition
	Refer to Declaration of Conformity for current revisions.
	Measurement category II to 300 V
	Other non-MAINS circuits to 1000 Vpk
	Pollution Degree 2
	 ISM 1-A
	
EMC	IEC 61326
	EN 61326
	CISPR 11
	ICES-001
	AS/NZS 2064.1
	Refer to Declaration of Conformity for current revisions.
	Acoustic Noise (nominal): 45 dBA

Triggering Connections		
	External input	Low-power TTL compatible input programmable edge triggered
		Delay: < 1 μ s
		Jitter: < 1 μ s
		Min pulse width: 1 μ s
		Max rate: up to 1 kHz (34461A), up to 300 Hz (34460A)
	Voltmeter Complete Output	3.3 V Logic output
		Polarity: Programmable edge pulse
		Pulse width: Approximately 2 μ s
Computer Interfaces		
	LXI (rev 1.4)	10/100Base-T Ethernet (Sockets, VXI-11 protocol, Web User Interface)
	USB	USB 2.0 (USB-TMC488 & MTP protocol)
	GPIB	Optional GPIB IEEE-488
	Language	SCPI-1999, IEEE-488.2, 34401A compatible
Front-panel USB host port		
	Supports USB 2.0 high-speed mass storage (MSC) class devices.	
	Capability, import/export instrument configuration files, save volatile readings and screen captures.	
System Speeds (Averages)		
	Benchmark	GPIB, USB 2.0, VXI-11, and Sockets
	Function Change ^[1]	50/s
	Range Change ^[2]	100/s
	^[1] Rate to change from 2-wire Resistance to any other function.	
	^[2] Rate to change from one range to the next higher range, $\leq 10V$, $\leq 10M\Omega$	
Triggering and Memory		
	Samples per Trigger	1 to 1E6
	Trigger Delay	0 to 3600 s ($\sim 1 \mu$ s step size)
	External Trigger Delay	<10 μ s
	External Trigger Jitter	<1 μ s (DC fixed range)
	Volatile Reading Memory	10,000 readings (34461A), 1,000 readings (34460A)

Probe Hold	
	Sensitivity fixed at 1% of reading
	Capture and navigate stable list of readings
Internal Flash File System	
	80 MB total capacity
	Save reading memory to non-volatile memory in CSV format
	Store and recall user defined states, power-off state ^[1] , and preference files
	Save screen captures in BMP or PNG formats
	^[1] Power-off state only when when power-down is initiated via front panel power switch
Math Functions	
	Per function Null, Min/Max/Avg/Sdev, dB and dBm (ACV and DCV only), Limit Test, Histogram
Display	
	4.3" color TFT WQVGA (480x272) with LED backlight
	Supports basic number, bar meter, trend chart (34461A Only), and histogram views
	User defined power-on message, display label, and selectable color screens
	Integrated system help
Real-Time Clock/Calendar	
	Set and read, year, month, day, hour, minute, seconds
	Battery CR-2032 coin-type, replaceable, >10-year life (typ)
Software Available	
	DMM Connectivity Utility
Accessories included	
	34460A
	Power Cord
	Calibration Certificate
	34461A
	34138A Test Lead Set with probes, fine tip probes, SMT grabbers and mini grabber attachments
	Power Cord
	Documentation CD
	IO Libraries CD
	USB Cable
	Calibration Certificate

Options		
	34460A	
	-LAN	Enable rear panel LAN/LXI web interface, external triggering for 34460A
	-SEC	Enable instrument security on 34460A and 34461A
	-Z54	Certificate of calibration – ANSI/NCSL Z540.3-2006, printed
	-GPB	GPIB interface module
	-ACC	Accessory Kit for 34460A – Documentation and IO Library CDs, Test Leads, USB Cable
	34461A	6½-digit 34401A Replacement Digital Multimeter
	-SEC	Enable instrument security on 34460A and 34461A
	-Z54	Certificate of calibration – ANSI/NCSL Z540.3-2006, printed
	-GPB	GPIB interface module
Standalone product numbers – Ordered as standalone to be installed by the distributor or customer		
	3446LANU	Enable rear-panel LAN and LXI web interface, external triggering on 34460A
	3446SECU	Enable instrument security on 34460A and 34461A
	3446GPBU	GPIB user installable interface module on 34460A and 34461A
	3446ACCU	Accessory Kit for 34460A – Documentation and IO Library CDs, Test Leads, USB Cable
Warranty		
	Standard: 3 year	

Firmware Update

Use the following procedure to update instrument firmware:

CAUTION Do not turn off the instrument during the update.

1. Press **[Help] > About** to determine what instrument firmware version is currently installed.
2. Go to www.agilent.com/find/truevolt and use the links there to find the latest firmware version. If this matches the version installed on your instrument, there is no need to continue with this procedure. Otherwise, download the firmware update utility and a ZIP file of the firmware.
3. Unzip the ZIP file and use the firmware update utility to prepare a USB drive with the updated firmware.
4. Attach the USB drive to the instrument front panel and press **[Utility] > Test / Admin > Firmware Update** to update the firmware. If the security option is installed, unlock the instrument with the security code before installing firmware.

