

Errata

Agilent References in this manual

NOTICE: This document contains references to Agilent Technologies. Agilent's former Test and Measurement business has become Keysight Technologies. For more information, go to:

www.keysight.com

About this manual

We've added this manual to the Keysight website in an effort to help you support your product. This manual provides the best information we could find. It may be incomplete or contain dated information.

Support for your product

You can find information about technical and professional services, product support, and equipment repair and service on the web:

www.keysight.com

Select your country from the drop-down menu at the top. Under *Electronic Test and Measurement*, click on *Services*. The web page that appears next has contact information specific to your country.

For more detailed product information, go to: www.keysight.com/find/ *<product model>*
i.e., for the M9514A, use: www.keysight.com/find/M9514A

Hypertext links to documents on agilent.com are no longer active. Use this substitution to access PDF files:

Broken links have the form: <http://cp.literature.agilent.com/litweb/pdf/> *< literature_part_number >*

Substitute links with this form: <http://literature.cdn.keysight.com/litweb/pdf/> *< literature_part_number >*

Where *< literature_part_number >* has the form: M9300-90001.pdf

For service notes, use: www.keysight.com/find/servicenotes



Agilent 34921A-34925A Low Frequency Multiplexer Modules

User's Guide

Agilent Technologies, Inc.
Printed in Malaysia
Edition 2
September 2012 E0912



34980-90021

Notices

© Agilent Technologies, Inc. 2008

No part of this manual may be reproduced in any form or by any means (including electronic storage and retrieval or translation into a foreign language) without prior agreement and written consent from Agilent Technologies, Inc. as governed by United States and international copyright laws.

Manual Part Number

34980-90021

Edition

Second Edition, Sept. 2012

Printed in Malaysia

Agilent Technologies, Inc.
3501 Stevens Creek Blvd
Santa Clara, CA 95052 USA

Microsoft® and Windows® are U.S. registered trademarks of Microsoft Corporation.

Software Revision

This guide is valid for the firmware that was installed in the instrument at the time of manufacture. However, upgrading the firmware may add or change product features. For the latest firmware and documentation, go to the product page at:

www.agilent.com/find/34980A

Warranty

The material contained in this document is provided “as is,” and is subject to being changed, without notice, in future editions. Further, to the maximum extent permitted by applicable law, Agilent disclaims all warranties, either express or implied, with regard to this manual and any information contained herein, including but not limited to the implied warranties of merchantability and fitness for a particular purpose. Agilent shall not be liable for errors or for incidental or consequential damages in connection with the furnishing, use, or performance of this document or of any information contained herein. Should Agilent and the user have a separate written agreement with warranty terms covering the material in this document that conflict with these terms, the warranty terms in the separate agreement shall control.

Technology Licenses

The hardware and/or software described in this document are furnished under a license and may be used or copied only in accordance with the terms of such license.

Restricted Rights Legend

U.S. Government Restricted Rights. Software and technical data rights granted to the federal government include only those rights customarily provided to end user customers. Agilent provides this customary commercial license in Software and technical data pursuant to FAR 12.211 (Technical Data) and 12.212 (Computer Software) and, for the Department of Defense, DFARS 252.227-7015 (Technical Data - Commercial Items) and DFARS 227.7202-3 (Rights in Commercial Computer Software or Computer Software Documentation).

Safety Notices

CAUTION

A **CAUTION** notice denotes a hazard. It calls attention to an operating procedure, practice, or the like that, if not correctly performed or adhered to, could result in damage to the product or loss of important data. Do not proceed beyond a **CAUTION** notice until the indicated conditions are fully understood and met.

WARNING

A **WARNING** notice denotes a hazard. It calls attention to an operating procedure, practice, or the like that, if not correctly performed or adhered to, could result in personal injury or death. Do not proceed beyond a **WARNING** notice until the indicated conditions are fully understood and met.

Additional Safety Notices

The following general safety precautions must be observed during all phases of operation of this instrument. Failure to comply with these precautions or with specific warnings or instructions elsewhere in this manual violates safety standards of design, manufacture, and intended use of the instrument. Agilent Technologies assumes no liability of the customer's failure to comply with the requirements.

General

Do not use this products in any manner not specified by the manufacturer. The protective features of this product may be impaired if it is used in a manner not specified in the operation instructions.

Before Applying Power

Verify that all safety precautions are taken. Make all connections to the unit before applying power.

Ground the Instrument

This product is provided with protective earth terminals. To minimize shock hazard, the instrument must be connected to the ac power mains through a grounded power cable, with the ground wire firmly connected to an electrical ground (safety ground) at the power outlet. Any interruption of the protective (grounding) conductor or disconnection of the protective earth terminal will cause a potential shock hazard that could result in personal injury.

Do Not Operate in an Explosive Atmosphere

Do not operate the instrument in the presence of flammable gases or fumes.

Do Not Remove the Instrument Cover

Only qualified, service-trained personal who are aware of the hazards involved should remove instrument covers. Always disconnect the power cable and any external circuits before removing the instrument cover.

Do Not Modify the Instrument

Do not install substitute parts or perform any unauthorized modification to the product. Return the product to an Agilent Sales and Service Office for service and repair to ensure that safety features are maintained.

In Case of Damage

Instruments that appear damaged or defective should be made inoperative and secured against unintended operation until they can be repaired by qualified service personnel.

Safety Symbols



Alternating current



Frame or chassis terminal



Standby supply. Unit is not completely disconnected from ac mains when switch is off



Caution, risk of electric shock



Caution, refer to accompanying

Waste Electrical and Electronic Equipment (WEEE) Directive 2002/96/EC



This product complies with the WEEE Directive (2002/96/EC) marking requirement. The affixed product label (see above) indicates that you **must not discard this electrical/electronic product in domestic household waste.**

Product Category: With reference to the equipment types in the WEEE directive Annex 1, this product is classified as a "Monitoring and Control instrumentation" product.

To return unwanted products, contact your local Agilent office, or go to www.agilent.com/environment/product for more information.

Technical Support

If you have questions about your shipment, or if you need information about warranty, service, or technical support, contact Agilent Technologies:

In the United States: (800) 829-4444

In Europe: 31 20 547 2111

In Japan: 0120-421-345

Or go to www.agilent.com/find/assist for information on contacting Agilent in your country of specific location. You can also contact your Agilent Technologies Representative.

Declaration of Conformity

Declarations of Conformity for this product and for other Agilent products may be downloaded from the Internet. There are two methods to obtain the Declaration of Conformity:

- Go to <http://regulations.corporate.agilent.com/DoC/search.htm> . You can then search by product number to find the latest Declaration of Conformity.
- Alternately, you can go to the product web page (www.agilent.com/find/34980A), click on the Document Library tab then scroll down until you find the Declaration of Conformity link.

Contents

Low Frequency Multiplexer Modules	1
Multiplexer Module Capabilities	1
Measurement Functions for the Multiplexer Modules	2
Operating Considerations	3
SCPI Programming Examples for the Multiplexer Modules	4
34921A 40-Channel Armature Multiplexer with Low Thermal Offset	7
34921A Simplified Schematic	9
34921A D-Sub Connectors	10
34921T Terminal Block	11
34922A 70-Channel Armature Multiplexer	13
34922A Simplified Schematic	14
34922A D-Sub Connectors	15
34922T Terminal Blocks	17
34923A 40/80-Channel Reed Multiplexer	19
Two-Wire Mode	20
Four-Wire Mode	20
One-Wire Mode	20
34923A Simplified Schematic for Two- or Four-Wire Mode	21
34923A D-Sub Connectors for Two- or Four-Wire Mode	22
34923T-001 Terminal Block for Two-Wire or Four-Wire Mode	23
34923A Simplified Schematic for One-Wire Mode	24
34923A D-Sub Connectors for One-Wire Mode	25
34923T-002 Terminal Block for One-Wire Mode	26
34924A 70-Channel Reed Multiplexer	27
34924A Simplified Schematic	29
34924A D-Sub Connectors	30
34924T Terminal Blocks	32
34925A 40/80-Channel Optically-Isolated FET Multiplexer	34
Two-Wire Mode	34
Four-Wire Mode	34
One-Wire Mode	35
Interlock Protection	35
Overvoltage Protection	35
34925A Simplified Schematic for Two- or Four-Wire Mode	36
34925A D-Sub Connectors for Two- or Four-Wire Mode	37
34925T-001 Terminal Block for Two-Wire or Four-Wire Mode	38
34925A Simplified Schematic for One-Wire Mode	39
34925A D-Sub Connectors for One-Wired Mode	40
34925T-002 Terminal Block for One-Wire Mode	41

Index

Low Frequency Multiplexer Modules

This User's Guide covers the following five plug-in modules for the Agilent 34980A Multifunction Switch/Measure Unit:

34921A	40-channel armature multiplexer w/low thermal offset
34922A	70-channel armature multiplexer
34923A	40/80-channel reed multiplexer
34924A	70-channel reed multiplexer
34925A	40-channel optically isolated FET multiplexer

Multiplexer Module Capabilities

Each multiplexer (MUX) module features two banks of channels, providing broad multiplexing and measurement capabilities. Briefly:

- You can connect a MUX to an external instrument, and/or switch multiple analog signals to the internal DMM.
- With the 34921A, 34922A, 34923A, and the 34924A modules, you can close more than one channel in each bank simultaneously ($N:1$ configuration).
- Since the 34925A module is protected with overvoltage circuitry, you can close only one channel in each bank at one time ($1:N$ configuration).
- You can connect multiple MUXes to the built-in Analog Buses, which allow you to scan as many as 560 2-wire (differential) channels or 640 1-wire (single-ended) channels in one 34980A mainframe.

Measurement Functions for the Multiplexer Modules

The MUX modules support the DMM measurement functions shown in the following table.

Measurement Function(s)	34921A 40-ch Armature Mux	34922A 70-ch Armature Mux	34923A 40-ch Reed Mux (2-Wire)	34923A 80-ch Reed Mux (1-Wire)	34924A 70-ch Reed Mux)	34925A 40-ch FET Mux (2-Wire)	34925A 80-ch FET Mux (1-Wire)
Voltage, AC/DC	Yes	Yes	Yes	Yes	Yes	Yes	Yes
Current, AC/DC	Yes ¹	No	No	No	No	No	No
Frequency/Period	Yes	Yes	Yes	Yes	Yes	Yes	Yes
Ohms 2-Wire	Yes	Yes	Yes ⁵	Yes ⁵	Yes ⁵	Yes ⁶	Yes ⁶
Ohms 4-Wire	Yes	Yes	Yes ⁵	No	Yes ⁵	Yes ⁶	No
Thermocouple	Yes ²	Yes ³	Yes ^{3,4}	Yes ^{3,4}	Yes ^{3,4}	Yes ³	Yes ³
RTD 2-Wire	Yes	Yes	Yes ⁵	Yes ⁵	Yes ⁵	No	No
RTD 4-Wire	Yes	Yes	Yes ⁵	No	Yes ⁵	Yes ⁶	No
Thermistor	Yes	Yes	Yes ⁵	Yes ⁵	Yes ⁵	No	No

¹ Direct current measurements are allowed on channels 41 through 44 only (for all other channels, external shunts are required).

² Optional 34921T Terminal Block is required for thermocouple measurements with built-in internal reference junction.

³ A fixed or external reference junction temperature is required for thermocouple measurement with this module.

⁴ Impact of higher offset voltage specification (< 50 μ V) must be taken into consideration.

⁵ 1 k Ω or higher range used unless 100 Ω series resistors are bypassed on module.

⁶ 10 k Ω or higher range used for loads over approximately 300 Ω due to series resistance of FET channels.

Operating Considerations

Current Ratings

See the *Introduction to the Plug In Modules* chapter of the 34980A Mainframe User's Guide for detailed environmental operating conditions for the 34980A mainframe and its installed modules. That guidance sets maximum per channel current ratings at rated voltage for pollution degree 1 (dry) and pollution degree 2 (possible condensation) conditions, for all of the multiplexer modules.

Safety Interlock

The Analog Buses of the 34980A are capable of carrying 300V signals. The MUX modules have a hardware *Safety Interlock* feature that automatically opens the Analog Bus relays when the associated interlock pins on the D-sub connectors (faceplate) lose continuity. This prevents signals on the Analog Buses from being present on the D-sub connector pins. Optional terminal blocks available from Agilent automatically provide continuity for these interlock pins. If cables are used, you must provide continuity for the interlock pins in your DUT assembly. See the pinout information later in this guide for the location of interlock pins on each module.

The MUX modules have Analog Bus relays on each of their two banks. Therefore, the interlock pins are present on both the Bank 1 and Bank 2 D-sub connectors on the MUX modules.

Normally, if you attempt to connect to the Analog Buses without a terminal block or cable connected, an error is generated. The `SYSTEM:ABUS:INTerlock:SIMulate` command allows you to temporarily disable errors generated by the Safety Interlock feature and enables the simulation mode. Although Safety Interlock errors are suppressed in this mode, the actual Analog Bus relays affected by the Safety Interlock are disabled as long as no terminal block or cable is connected to the module.

CAUTION

The Safety Interlock feature is implemented in hardware on the modules and cannot be circumvented. Regardless of whether the simulation mode is enabled or disabled, all Analog Bus connections are prohibited as long as no terminal block or properly-wired cable is connected to the module.

- The simulation mode applies to the entire mainframe and cannot be selectively used on individual modules.
- When the simulation mode is enabled, the Analog Bus relays will *appear* to close and open as directed. For example, no errors are generated if you close an Analog Bus relay from the front panel, remote interface, or Web Interface. However, remember that the Safety Interlock feature prevents the actual hardware state of the Analog Bus relays from being changed. When you connect a terminal block or cable to the module, the Analog Bus relays will be closed.
- The simulation setting is stored in volatile memory and will be lost when power is turned off. To re-enable the simulation mode after power has been off, you must send the command again.

SCPI Programming Examples for the Multiplexer Modules

The programming examples below provide you with SCPI command examples to use for actions specific to the MUX modules.

The slot and channel addressing scheme used in these examples follow the form **sccc** where **s** is the mainframe slot number (1 through 8) and **ccc** is the three-digit channel number. For information on specific MUX channel configurations, refer to the simplified schematics contained in each MUX section of this manual.

For complete information on the SCPI commands used to program the 34980A, with example programs, refer to the *Agilent 34980A Programmer's Reference* contained on the *34980A Product Reference CD*.

Opening and Closing Channels

Example: Closing and opening channels on the armature and reed MUX modules

This command closes the specified channels on a MUX module. If any channel in a bank is defined to be part of the scan list, and a scan is occurring, attempting to close another channel (including Analog Bus channels) within the same bank will result in an error. Channel closures in the other bank are allowed as long as no channels are part of the scan list.

The following commands close and open channels 13 and 15 through 18 in slot 3.

```
ROUTE:CLOSE (@3013,3015:3018)
ROUTE:OPEN (@3013,3015:3018)
```

Example: Closing channels on the FET MUX module The FET MUX module supports a 1:N type closure, meaning that you can have only one channel per bank closed at a time. The following command closes then automatically opens each channel from 1-19 (Bank 1) in succession, leaving channel 20 closed. Then the command continues closing and opening channels 21 to 39 (Bank 2), then leaving channel 40 closed. At the end, only channels 20 and 40 will be closed, while all other channels will have been closed and then opened. In this process, a channel will open before the next channel in succession closes, making this a “break-before-make” series.

```
ROUTE:CLOSE (@3001:3040)
```

The following command opens the closed channel on Bank 1 of a FET MUX module in slot 3, and closes channel 15 on that bank.

```
ROUTE:CLOSE (@3015)
```

Example: Closing and opening Analog Bus relays The following command connects the Analog Buses to Bank 1 (via the Analog Bus relays on Bank 1) for a module in slot 3.

```
ROUTE:CLOSE (@3911,3912,3913,3914)
ROUTE:OPEN (@3911,3912,3913,3914)
```

The Analog Bus relays (numbered s911, s912, s913, etc.) on the MUX modules are ignored if they are included in a range of channels.

An error will be generated if an Analog Bus relay is specified as the first or last channel in a range of channels. For example, the following command closes all valid channels between channel 30 (slot 1) and channel 5 (slot 2). In addition, this command closes Analog Bus relay 911 on the module in slot 1 (Bank 1). Note that although the specified range of channels includes the other Analog Bus relays, they are ignored and are not closed by this command.

```
ROUTE:CLOSE (@1030:2005,1911)
```

Example: Querying channels for open or close state The following command returns a 1 (true) or 0 (false) state of channel 036 for a module in slot 3.

```
ROUTE:CLOSE (@3036)
ROUTE:CLOSE? (@3036) !Returns a 1
ROUTE:OPEN? (@3036) !Returns a 0
```

Making Measurements

Example: Making voltage measurements The following command configures channels 9 and 10 in slot 4 for DC voltage measurements, triggers the internal DMM to scan channels 9 and 10, and returns the reading. The 1 V range is selected with 1 mV resolution.

```
MEASure:VOLTage:DC? 1,0.001, (@4009,4010)
```

Example: Making voltage measurements using INITiate and FETCh?

The following program segment shows how to use the INITiate command with the CONFigure and FETCh? commands. The ROUTe:SCAN command puts channels 3 and 8 (of a module in slot 1) into the scan list (and redefines the scan list). The INITiate command scans the specified channels, and then sends the readings to memory. The FETCh? command transfers the readings from memory to the user.

```
CONFigure:VOLTage:DC 10,0.003,(@1003,1008)
ROUTE:SCAN (@1003,1008)
INITiate
FETCh?
```

Example: Making current measurements The following command configures channel 43 for a 34921A modules in slot 7 for dc current measurements, triggers the internal DMM to scan the channel, and then sends the reading to the output buffer of the 34980A. The default settings for range (autorange) and resolution (1 PLC) are used for the measurement.

```
MEASure:CURRent:DC? (@7043)
```

Configuring a Module

Example: Configuring a module for 2-wire or 1-wire mode The following command configures a MUX module in slot 4 for 1-wire mode. Because you can configure only the 34923A and 34925A MUX modules (and the 34933A matrix module) for either 2-wire or 1-wire mode, an error is generated if you send this command to a slot that does not contain one of those three modules. If you are using terminal blocks with these modules, be sure to use the corresponding 2-wire or 1-wire terminal block.

```
SYSTem:MODUle:WIRE:MODE WIRE1,4
```

NOTE

When using a command to configure the system, the new configuration does not take effect until you cycle power on the 34980A.

Example: Querying the system for module Identify The following command returns the identity of the module installed in slot 7.

```
SYSTem:CTYPe? 7
```

NOTE

For the 34923A and the 34925A MUX modules, the query response may include a suffix to indicate a 1-wire configuration. For example, the response for the 34923A will be either "34923A" (differential mode) or "34923A-1W" (single-ended mode).

Querying and Clearing Cycle Count, and Resetting Modules

Example: Querying the cycle count for a relay The following command returns the cycle count on channel 7 and channel 16 for a MUX module in slot 1.

```
DIAGnostic:RELay:CYCLes? (@1007,1016)
```

NOTE

The 34925A will return 0 for relay counts because the FET relays on that module are non-mechanical and have an undefined lifetime.

Example: Clearing the cycle count for a relay The following command resets the cycle count to zero on the channels 7 and 16 for a MUX module in slot 1.

```
DIAGnostic:RELay:CYCLes:CLEar (@1007,1016)
```

Example: Resetting module(s) to power-on state The following command resets a module in slot 4 to its power-on state.

```
SYSTem:CPON 4
```

34921A 40-Channel Armature Multiplexer with Low Thermal Offset

The 34921A 40-Channel Armature Multiplexer (40-Ch Arm MUX) is divided into two banks with 20 latching armature switches (channels 1-20 and 21-40) in each. This module also offers four additional fused relays (channels 41-44) for making AC and DC current measurements with the internal DMM with no external shunts needed. These current channels feature “make-before-break” connections to ensure continuous current flow when switching from one current channel to another. The current fuses are replaceable. Refer to the *34980A Service Guide* for specific information about these fuses.

This module also contains nine armature Analog Bus relays (channels 911-914, 921-924, and 931), four on each bank that can connect the bank relays to the system Analog Buses and one that connects the current relays to the current input of the DMM. Through ABus1 and ABus2 you can connect any of the channels to the internal DMM for voltage or resistance measurements. Refer to the simplified schematic on [page 9](#).

NOTE

ABus1 consists of three wires that are used for current and voltage measurements. A separate current bus on ABus1 connects to the internal DMM current measurement input and this bus can be connected only to channels 41 through 44. The current channel low (L) signal path is common with the ABus1 low (L) signal path. You cannot measure current and voltage on ABus1 simultaneously.

Using program commands or the mainframe front panel, you can control each of the channel switches individually, and thus configure the 34921A module in these modes:

- two independent 20-channel 2-wire MUXes. This configuration requires neither using external wiring nor connecting through the internal Analog Buses.
- one 20-channel 4-wire MUX. This configuration requires neither using external wiring nor connecting through the internal Analog Buses. For 4-wire resistance measurements, the instrument automatically pairs channel n on Bank 1 (source) with channel $n+20$ on Bank 2 (sense) to provide these connections. Four-wire controls occur only when doing 4-wire measurement operations through the internal DMM, such as `MEASure:FRESistance?` or scanning a channel previously configured as 4-wire.
- one 40-channel 2-wire MUX. You must use external wiring or connect through the internal Analog Bus relays for this configuration. For example, closing Analog Bus channels 913 and 923 connects Bank 1 and Bank 2 through ABus3. Or, externally you can connect COM1 to COM2 to create this configuration.

Low thermal offset voltage makes the 34921A ideal for low-level signal switching. The 34921T optional terminal block provides a built-in thermocouple reference junction that helps minimize errors due to thermal offset when you measure thermocouples.

This module has capability to scan as many as 100 channels/second using the internal DMM. With the automatic “break-before-make” connection operation, you are assured that no two signals are connected to each other during a scan. When using the module in a non-scanning mode, you can close as many channels as you wish.

This module is safety interlock protected, which means whenever the D-sub connector end of the modules is exposed, the Analog Bus relays automatically open and disconnect from the Analog Bus. For more information, see [“Safety Interlock”](#) on page 3 and [“34921A D-Sub Connectors”](#) on page 10.

When power is off, all channel relays maintain state, and the Analog Bus relays open.

34921A Simplified Schematic

This drawing shows two independent 20-channel 2-wire MUXes.

NOTE: The three-digit number assigned to each switch represents the channel number.

NOTE:

Bank Relays: Armature latching

Analog Bus Relays: Armature non-latching

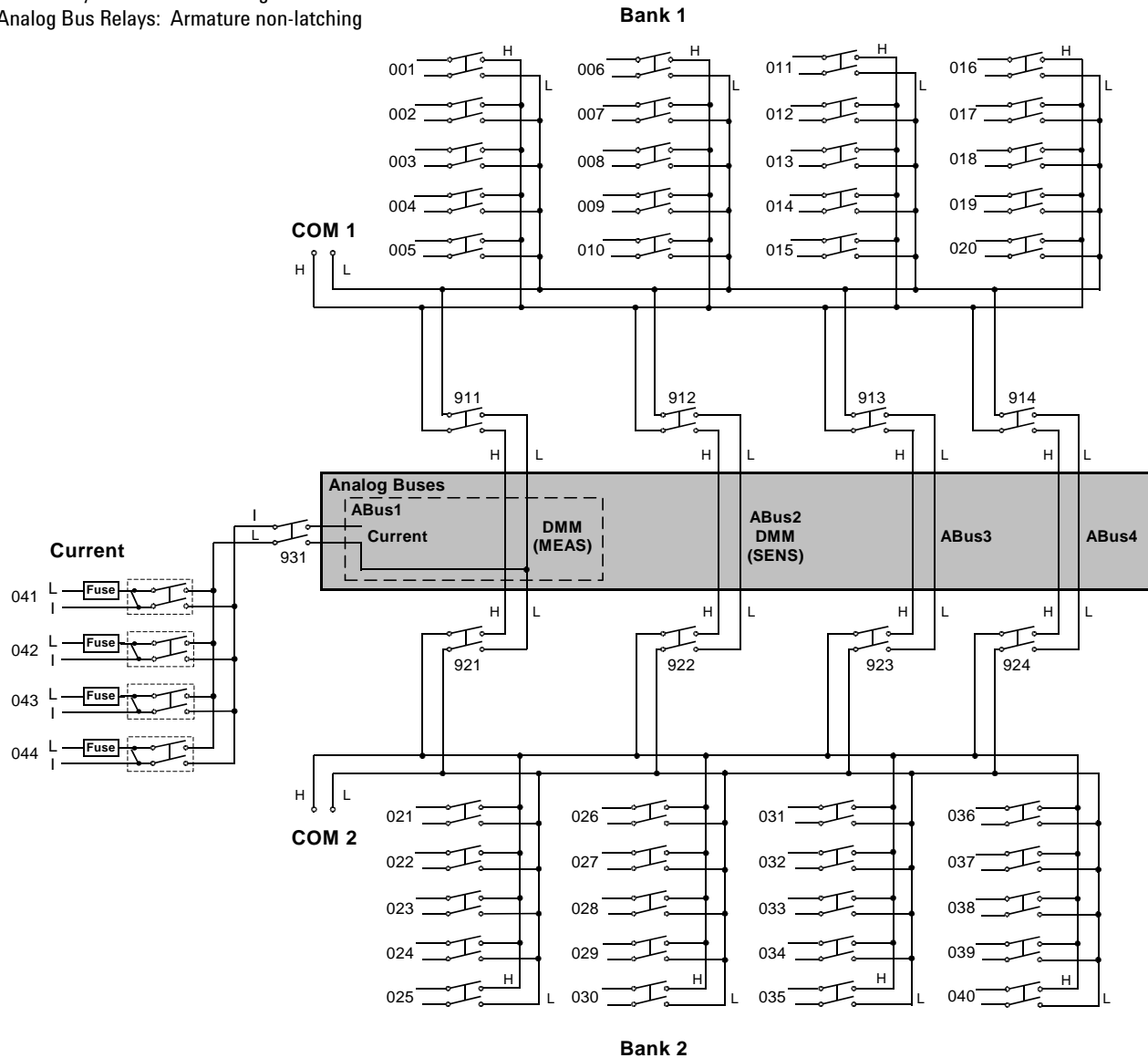

34921A D-Sub Connectors

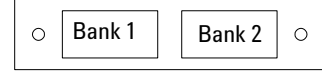

Bank 1

For orientation, the D-sub connector end of the module is facing you.

*TSIL = Temperature Sensor Interface Line. Provides thermocouple reference sensor serial output line to the mainframe processor.

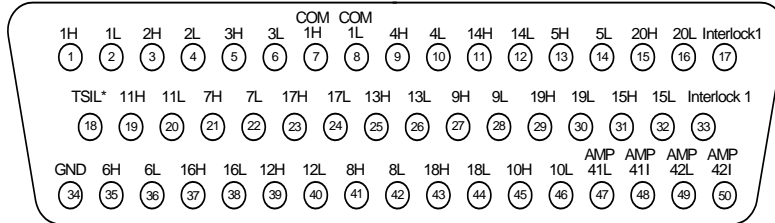

50-Pin D-Sub Male Connector

WARNING As a safety feature, interlock 1 pins (17 and 33) on Bank 1 must be shorted to enable the Bank 1 Analog Bus relays to close. The optional 34921T terminal block shorts these pins for you. This feature protects inadvertent routing of high voltages from the Analog Bus to the D-sub connector of the module.

Description	Pin	Description	Pin	Description	Pin	Description	Pin	Description	Pin
1H	1	6H	35	11H	19	16H	37	COM1 H	7
1L	2	6L	36	11L	20	16L	38	COM1 L	8
2H	3	7H	21	12H	39	17H	23	Interlock 1	17
2L	4	7L	22	12L	40	17L	24	Interlock 1	33
3H	5	8H	41	13H	25	18H	43	GND	34
3L	6	8L	42	13L	26	18L	44	TSIL*	18
4H	9	9H	27	14H	11	19H	29	AMP 41L	47
4L	10	9L	28	14L	12	19L	30	AMP 41I	48
5H	13	10H	45	15H	31	20H	15	AMP 42L	49
5L	14	10L	46	15L	32	20L	16	AMP 42I	50

Bank 2

*TSIL = Temperature Sensor Interface Line. Provides thermocouple reference sensor serial output line to the mainframe processor.

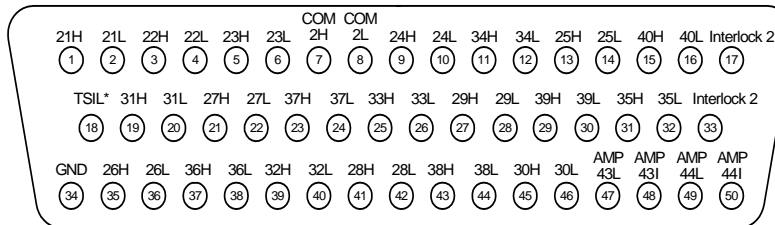

50-Pin D-Sub Male Connector

WARNING As a safety feature, interlock 2 pins (17 and 33) on Bank 2 must be shorted to enable the Bank 2 Analog Bus relays to close. The optional 34921T terminal block shorts these pins for you. This feature protects inadvertent routing of high voltages from the Analog Bus to the D-sub connector of the module.

Description	Pin	Description	Pin	Description	Pin	Description	Pin	Description	Pin
21H	1	26H	35	31H	19	36H	37	COM2 H	7
21L	2	26L	36	31L	20	36L	38	COM2 L	8
22H	3	27H	21	32H	39	37H	23	Interlock 2	17
22L	4	27L	22	32L	40	37L	24	Interlock 2	33
23H	5	28H	41	33H	25	38H	43	GND	34
23L	6	28L	42	33L	26	38L	44	TSIL*	18
24H	9	29H	27	34H	11	39H	29	AMP 43L	47
24L	10	29L	28	34L	12	39L	30	AMP 43I	48
25H	13	30H	45	35H	31	40H	15	AMP 44L	49
25L	14	30L	46	35L	32	40L	16	AMP 44I	50

34921T Terminal Block

This terminal block with screw-type connections is labeled with the model number and the abbreviated module name. In addition, space is available on the label for you to write the slot number.

NOTE

All modules that connect to the internal DMM are interlock protected. This means that when an installed module is exposed (no terminal block or cable is connected), the Analog Bus relays are open and disconnected from the Analog Buses. See [“Safety Interlock”](#) on page 3 for further information.

The 34921T is the only terminal block that provides an isothermal block with temperature reference for thermocouple measurements. The temperature sensor is located on the bottom side of the PC board as shown below. Also shown are two holes that you can use for connecting an external temperature reference to the terminal block.

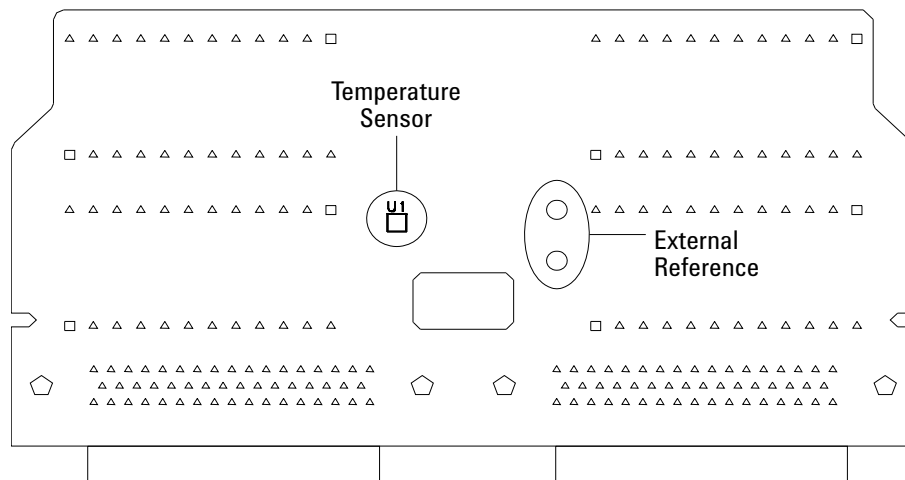

34921T (viewed from bottom side)

CAUTION

When wiring the terminal block via cables to the mainframe, make sure the cables are connected to the correct connector. The cables provide communication and power to the temperature sensor on the 34921T terminal block. If cabling is not correct, an error may occur indicating that the 34921A module is not fully operational.

34921A 40-Channel Armature Multiplexer with Low Thermal Offset

The 34980A Product Reference CD (shipped with the instrument) contains a 34921T Wiring Log for you to document your wiring configuration for this module. You can open the wiring log file in Microsoft® Excel® or Adobe® Acrobat® format.

Wire Size:
20 AWG Typical
18 AWG Max

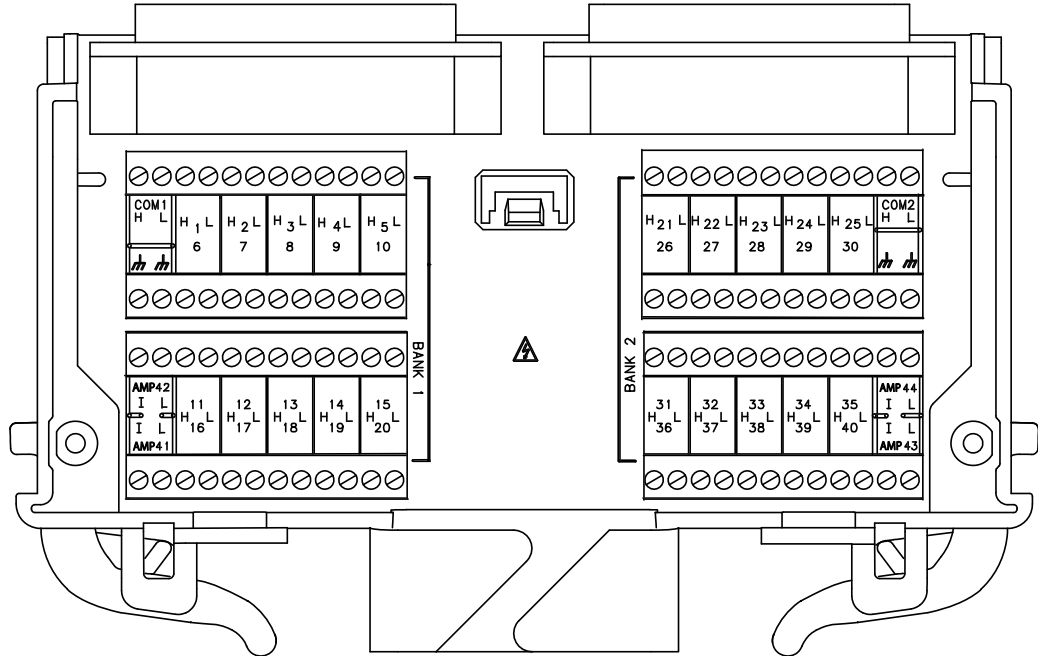

34922A 70-Channel Armature Multiplexer

The high-density 34922A 70-Channel Armature Multiplexer (70-Ch Arm MUX) is divided into two banks with 35 latching armature switches (channels 1-35 and 36-70) in each. This module also contains eight armature Analog Bus relays (channels 911-914 and 921-924), four on each bank that can connect the bank relays to the system Analog Buses. Through ABus1 and ABus2 you can connect any of the channels to the internal DMM for voltage or resistance measurements. Refer to the simplified schematic on [page 14](#).

Using program commands or the mainframe front panel, you can control each of the channel switches individually, and thus configure the 34922A in these modes:

- two independent 35-channel 2-wire MUXes. This configuration requires neither using external wiring nor connecting through the internal Analog Buses.
- one 35-channel 4-wire MUX. This configuration requires neither using external wiring nor connecting through the internal Analog Buses. For 4-wire resistance measurements, the instrument automatically pairs channel n on Bank 1 (source) with channel $n+35$ on Bank 2 (sense) to provide these connections. Four-wire controls occur only when doing 4-wire measurement operations through the internal DMM, such as `MEASure:FRESistance?` or scanning a channel previously configured as 4-wire.
- one 70-channel 2-wire MUX. You must use external wiring or connect through the internal Analog Bus relays for this configuration. For example, closing Analog Bus channels 913 and 923 connects Bank 1 and Bank 2 through ABus3. Or, externally you can connect COM1 to COM2 to create this configuration.

This module has capability to scan as many as 100 channels/second using the internal DMM. With the automatic “break-before-make” connection operation, you are assured that no two signals are connected to each other during a scan. When using the module in a non-scanning mode, you can close as many channels as you wish.

This module is interlock protected, which means whenever the D-sub connector end of the modules is exposed, the Analog Bus relays automatically open and disconnect from the Analog Bus. For more information, see “[Safety Interlock](#)” on page 3 and “[34922A D-Sub Connectors](#)” on page 15.

When the power is off, all channel relays maintain state, and the Analog Bus relays open.

34922A Simplified Schematic

This drawing shows two independent 35-channel 2-wire MUXes.

NOTE: The three-digit number assigned to each switch represents the channel number.

NOTE:
 Bank Relays: Armature latching
 Analog Bus Relays: Armature non-latching

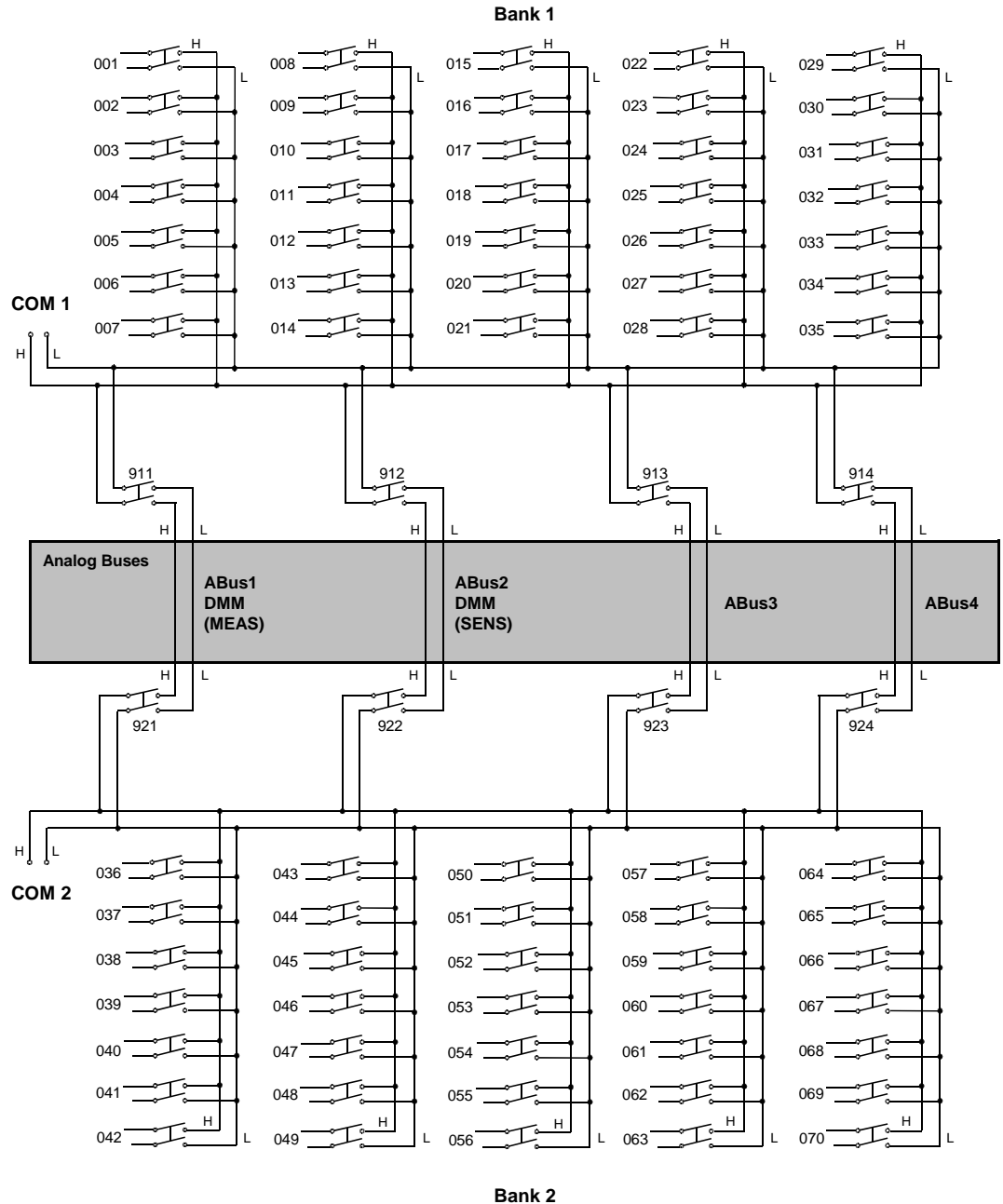

34922A D-Sub Connectors

Bank 1

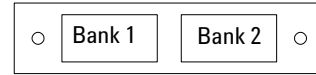

For orientation, the D-sub connector end of the module is facing you.

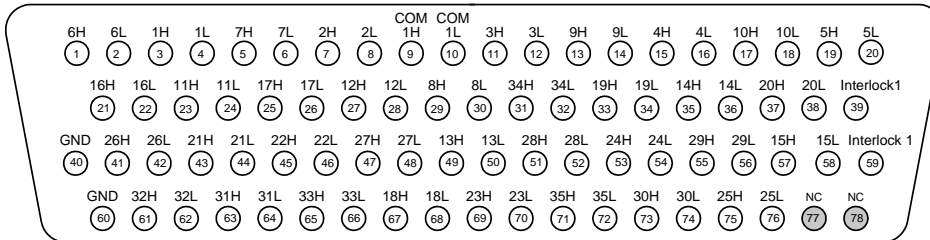

78-Pin D-Sub Male Connector

Description	Pin	Description	Pin	Description	Pin	Description	Pin	Description	Pin	Description	Pin
1H	3	8H	29	15H	57	22H	45	29H	55	COM1 H	9
1L	4	8L	30	15L	58	22L	46	29L	56	COM1 L	10
2H	7	9H	13	16H	21	23H	69	30H	73	Interlock 1	39
2L	8	9L	14	16L	22	23L	70	30L	74	Interlock 1	59
3H	11	10H	17	17H	25	24H	53	31H	63	GND	40
3L	12	10L	18	17L	26	24L	54	31L	64	GND	60
4H	15	11H	23	18H	67	25H	75	32H	61	No Connect	77
4L	16	11L	24	18L	68	25L	76	32L	62	No Connect	78
5H	19	12H	27	19H	33	26H	41	33H	65		
5L	20	12L	28	19L	34	26L	42	33L	66		
6H	1	13H	49	20H	37	27H	47	34H	31		
6L	2	13L	50	20L	38	27L	48	34L	32		
7H	5	14H	35	21H	43	28H	51	35H	71		
7L	6	14L	36	21L	44	28L	52	35L	72		

WARNING As a safety feature, interlock 1 pins (39 and 59) on Bank 1 must be shorted to enable the Bank 1 Analog Bus relays to close. The optional 34922T terminal blocks short these pins for you. This feature protects inadvertent routing of high voltages from the Analog Buses to the D-sub connector of the module.

Bank 2

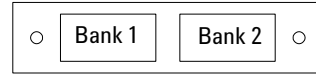

For orientation, the D-sub connector end of the module is facing you.

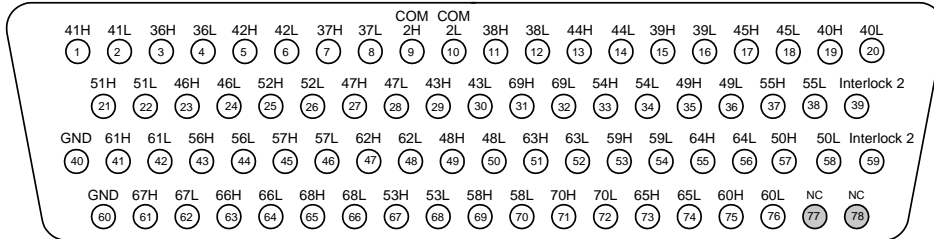

78-Pin D-Sub Male Connector

Description	Pin	Description	Pin	Description	Pin	Description	Pin	Description	Pin	Description	Pin
36H	3	43H	29	50H	57	57H	45	64H	55	COM2 H	9
36L	4	43L	30	50L	58	57L	46	64L	56	COM2 L	10
37H	7	44H	13	51H	21	58H	69	65H	73	Interlock 2	39
37L	8	44L	14	51L	22	58L	70	65L	74	Interlock 2	59
38H	11	45H	17	52H	25	59H	53	66H	63	GND	40
38L	12	45L	18	52L	26	59L	54	66L	64	GND	60
39H	15	46H	23	53H	67	60H	75	67H	61	No Connect	77
39L	16	46L	24	53L	68	60L	76	67L	62	No Connect	78
40H	19	47H	27	54H	33	61H	41	68H	65		
40L	20	47L	28	54L	34	61L	42	68L	66		
41H	1	48H	49	55H	37	62H	47	69H	31		
41L	2	48L	50	55L	38	62L	48	69L	32		
42H	5	49H	35	56H	43	63H	51	70H	71		
42L	6	49L	36	56L	44	63L	52	70L	72		

WARNING As a safety feature, interlock 2 pins (39 and 59) on Bank 2 must be shorted to enable the Bank 2 Analog Bus relays to close. the optional 34922T terminal blocks short these pins for you. This feature protects inadvertent routing of high voltages from the Analog Buses to the D-sub connector of the module.

34922T Terminal Blocks

Two terminal blocks are available to facilitate wiring connections to the 34922A module:

34922T-001 (Option 001)	Terminal block with solder connectors
34922T-002 (Option 002)	Terminal block with screw connectors

The *34980A Product Reference* CD (shipped with the instrument) contains a 34922T Wiring Log for you to document your wiring configuration for this module. You can open the wiring log file in Microsoft® Excel® or Adobe® Acrobat® format.

NOTE

All modules that connect to the internal DMM are interlock protected. This means that when an installed module is exposed (no terminal block or cable is connected), the Analog Bus relays are open and disconnected from the Analog Buses. See “[Safety Interlock](#)” on page 3 for further information.

34922T-001 Terminal Block

This terminal block with solder-type connections is labeled with the model number and the abbreviated module name. In addition, space is available on the label for you to write the slot number.

Wire Size:
22 AWG Typical
20 AWG Max

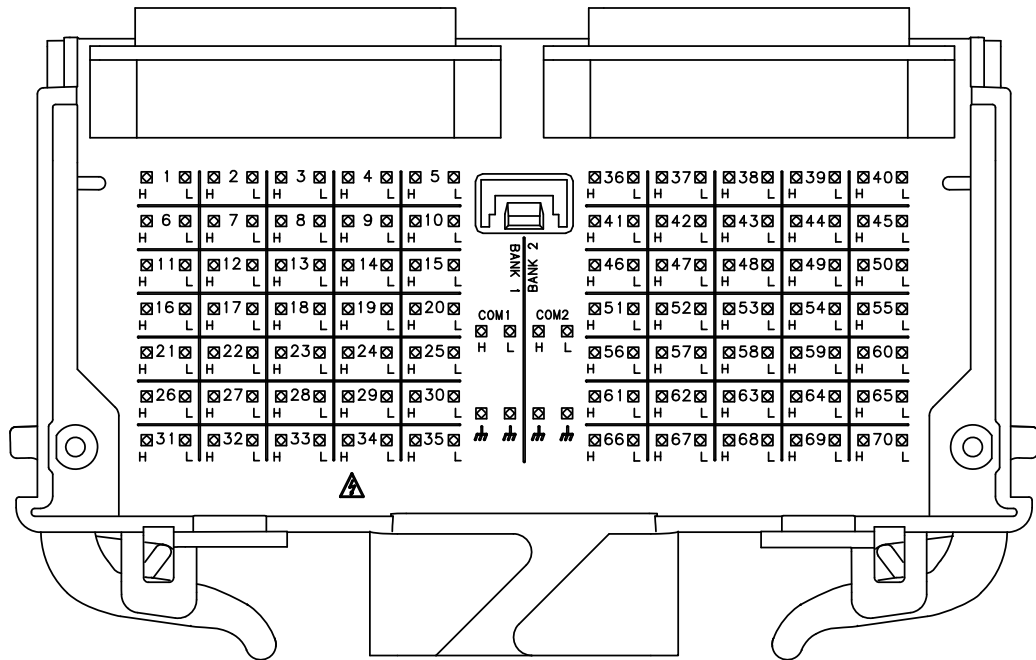

34922T-002 Terminal Block

This terminal block with screw-type connections is labeled with the model number and the abbreviated module name. In addition, space is available on the label for you to write the slot number.

Wire Size:
20 AWG Typical
18 AWG Max

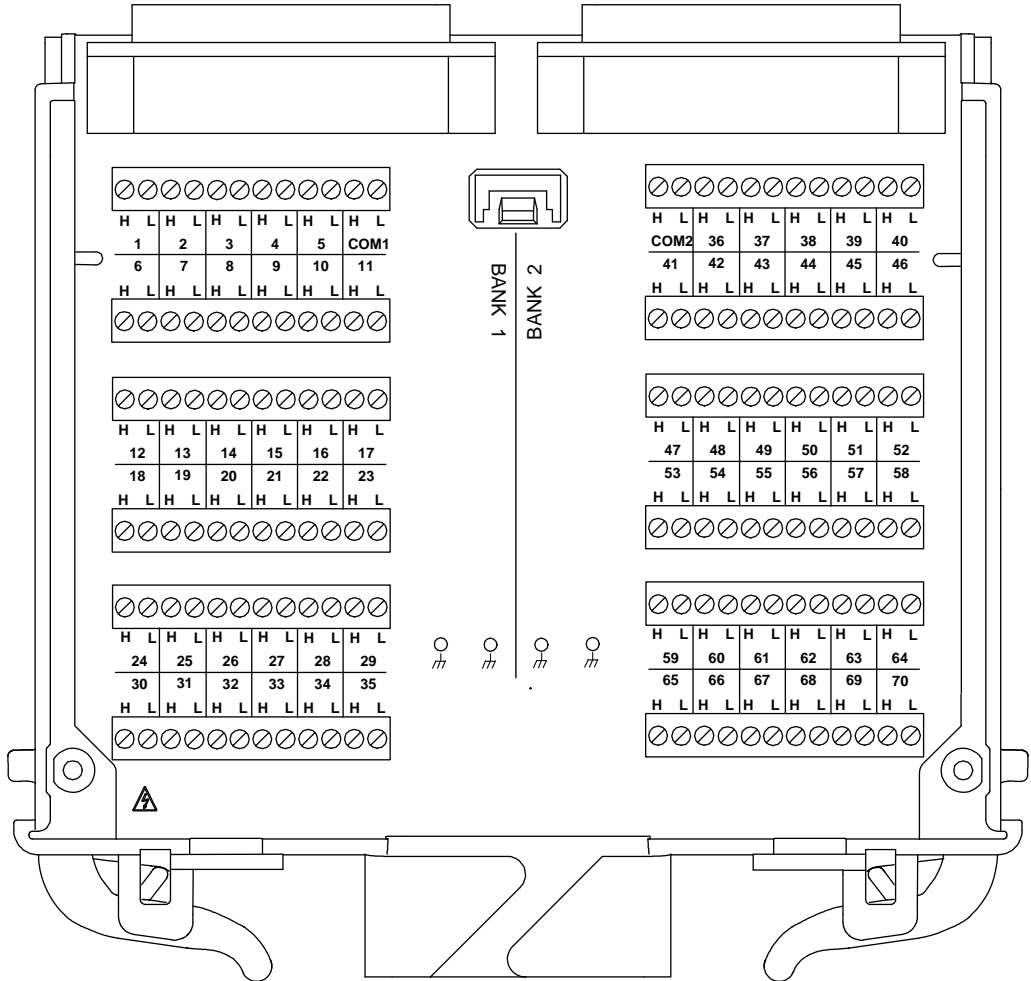

34923A 40/80-Channel Reed Multiplexer

The 34923A 40/80-Channel Reed Multiplexer (40/80-Ch Reed MUX) is divided into two equal banks of non-latching reed switches. This module also contains eight armature Analog Bus relays (channels 911-914 and 921-924), four on each bank that can connect the bank relays to the system Analog Buses. You can connect any of the channels to the internal DMM through ABus1 and ABus2 for voltage or resistance measurements.

Using program commands or the mainframe front panel, you can control each of the channel switches individually, and configure this module for differential (2-wire or 4-wire) or single-ended (1-wire) mode. Refer to the simplified schematics on [page 21](#) and [page 24](#).

If you are using an Agilent 34923T-00x terminal block to connect your DUT to this module, be sure to use the terminal block that corresponds to your module configuration mode (Refer to the terminal block drawings on [page 23](#) and [page 26](#)):

34923T-001 (Option 001)	Terminal block for differential (two- or four-wire) mode
34923T-002 (Option 002)	Terminal block for single-ended (1-wire) mode

You can confirm the mode in which your module is configured by using the `SYSTEM:CTYPE? <slot number>` program command. This command returns the identity of the plug-in module in the specified slot.

NOTE Whenever you change from 2- or 4-wire mode to 1-wire mode, or the reverse, you must cycle power on the 34980A for the configuration to take effect.

In all modes, this module has capability to scan as many as 500 channels/second using the internal DMM. With the automatic “break-before-make” connection operation, you are assured that no two signals are connected to each other during a scan.

This module is interlock protected, which means whenever the D-sub connector end of the modules is exposed, the Analog Bus relays immediately open and disconnect from the Analog Bus. For more information, see “[Safety Interlock](#)” on [page 3](#) and the D-Sub connector drawings on [page 22](#) and [page 25](#).

CAUTION Because user-attached reactive loads and backplane parasitic capacitance may result in high in-rush currents, 100 Ω in-rush resistors protect the reed relays from damage and performance degradation. Therefore, you must consider these resistors when you are designing a measurement. Refer to the simplified schematics on [page 21](#) and [page 24](#).

Lifetime of relays is severely degraded as current or voltage goes up. If higher voltage is being switched, limits on source current are recommended.

When the power is off, all channel and Analog Bus relays open.

Two-Wire Mode

You may configure the 34923A as:

- two independent 20-channel 2-wire MUXes. This configuration requires neither the use of external wiring nor connection through the internal Analog Buses.
- one 40-channel, 2-wire MUX. For this configuration, you *must* use external wiring or connect through the internal Analog Buses.

In 2-wire mode, you can close no more than 20 channels simultaneously due to power dissipation. These 20 channels are split 10 to a bank. However, note that Analog Bus relays count half as much as channel relays in that total. For example, with one Analog Bus relay closed, you can close up to a maximum of 19 channel relays. If you try to close more than the allowed number of channels, you will receive an error message.

Four-Wire Mode

You may configure the 34923A as a 20-channel 4-wire MUX. This configuration requires neither external wiring nor connection through the Analog Buses.

For 4-wire resistance measurements, the instrument automatically pairs channel n on Bank 1 (source) with channel $n+20$ on Bank 2 (sense) to provide these connections. Four-wire controls occur only when doing 4-wire measurement operations through the internal DMM, such as `MEASure:FRESistance?` or scanning a channel previously configured as 4-wire.

One-Wire Mode

You may configure the 34923A as:

- two independent 40-channel 1-wire MUXes. This configuration requires neither external wiring nor connection through the internal Analog Buses.
- one 80-channel 1-wire MUX. You must use external wiring or connect through the internal Analog Bus for this configuration.

NOTE

Because all bank relays supply only HI signals, you can apply a LOW signal through COM1 L or COM2 L when you are making 2-wire resistance measurements in 1-wire mode.

In 1-wire mode, you can close no more than 40 channels simultaneously due to power dissipation. These channels are split 20 to a bank. For example, with one Analog Bus relay closed you can close up to a maximum of 39 channel relays. If you try to close more than the allowed number of channels, you will receive an error message.

34923A Simplified Schematic for Two- or Four-Wire Mode

This drawing shows two independent 20-channel 2-wire MUXes.
 To change configuration modes, use the `SYSTEM:MODULE:WIRE:MODE` command.

NOTE: The three-digit number assigned to each switch represents the channel number.

NOTE:
 Bank Relays: Reed non-latching
 Analog Bus Relays: Armature non-latching

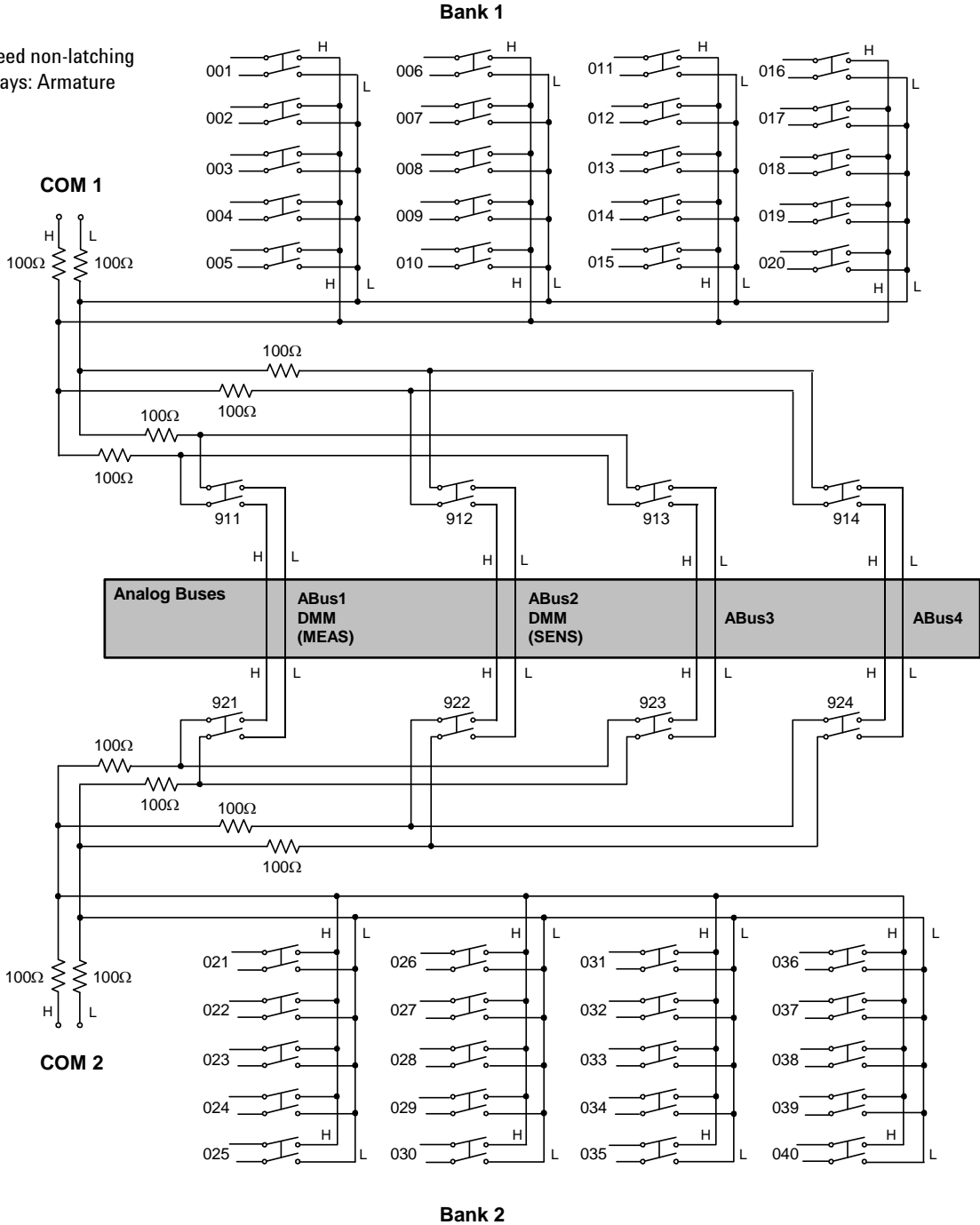

34923A D-Sub Connectors for Two- or Four-Wire Mode

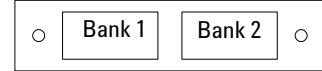

Bank 1

For orientation, the D-sub connector end of the module is facing you.

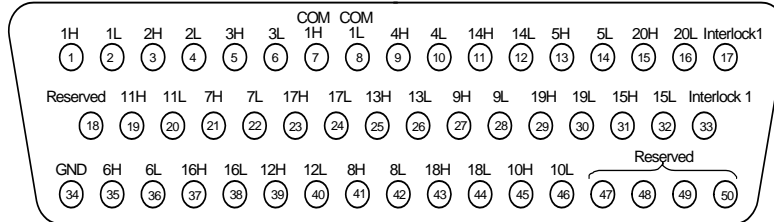

50-Pin D-Sub Male Connector

WARNING As a safety feature, interlock 1 pins (17 and 33) on Bank 1 must be shorted to enable the Bank 1 Analog Bus relays to close. The optional 34923T-001 (for 2-wire) terminal block shorts these pins for you. This feature protects inadvertent routing of high voltages from the Analog Bus to the D-sub connector of the module.

Description	Pin	Description	Pin	Description	Pin	Description	Pin	Description	Pin
1H	1	6H	35	11H	19	16H	37	COM1 H	7
1L	2	6L	36	11L	20	16L	38	COM1 L	8
2H	3	7H	21	12H	39	17H	23	Interlock 1	17
2L	4	7L	22	12L	40	17L	24	Interlock 1	33
3H	5	8H	41	13H	25	18H	43	GND	34
3L	6	8L	42	13L	26	18L	44	Reserved	18
4H	9	9H	27	14H	11	19H	29	Reserved	47
4L	10	9L	28	14L	12	19L	30	Reserved	48
5H	13	10H	45	15H	31	20H	15	Reserved	49
5L	14	10L	46	15L	32	20L	16	Reserved	50

Bank 2

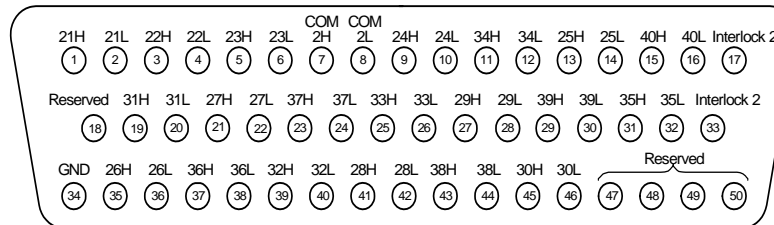

50-Pin D-Sub Male Connector

WARNING As a safety feature, interlock 2 pins (17 and 33) on Bank 2 must be shorted to enable the Bank 2 Analog Bus relays to close. The optional 34923T-001 (for 2-wire) shorts these pins for you. This feature protects inadvertent routing of high voltages from the Analog Buses to the D-sub connector of the module.

Description	Pin	Description	Pin	Description	Pin	Description	Pin	Description	Pin
21H	1	26H	35	31H	19	36H	37	COM2 H	7
21L	2	26L	36	31L	20	36L	38	COM2 L	8
22H	3	27H	21	32H	39	37H	23	Interlock 2	17
22L	4	27L	22	32L	40	37L	24	Interlock 2	33
23H	5	28H	41	33H	25	38H	43	GND	34
23L	6	28L	42	33L	26	38L	44	Reserved	18
24H	9	29H	27	34H	11	39H	29	Reserved	47
24L	10	29L	28	34L	12	39L	30	Reserved	48
25H	13	30H	45	35H	31	40H	15	Reserved	49
25L	14	30L	46	35L	32	40L	16	Reserved	50

34923T-001 Terminal Block for Two-Wire or Four-Wire Mode

This terminal block with screw-type connections is labeled with the model number and the abbreviated module name. In addition, space is available on the label for you to write the slot number.

NOTE

All modules that connect to the internal DMM are interlock protected. This means that when an installed module is exposed (no terminal block or cable is connected), the Analog Bus relays are open and disconnected from the Analog Buses. See [“Safety Interlock”](#) on page 3 for further information.

NOTE

If you are using an Agilent terminal block to connect your DUT to this module be sure to use the 34923T-001 terminal block that corresponds to the 2- or 4-wire configuration mode. An error will not be generated if you have installed a terminal block that doesn't match the present module configuration.

The *34980A Product Reference* CD (shipped with the instrument) contains a 34923T (2-wire mode) Wiring Log for you to document your wiring configuration for this module. You can open the wiring log file in Microsoft® Excel® or Adobe® Acrobat® format.

Wire Size:
20 AWG Typical
18 AWG Max

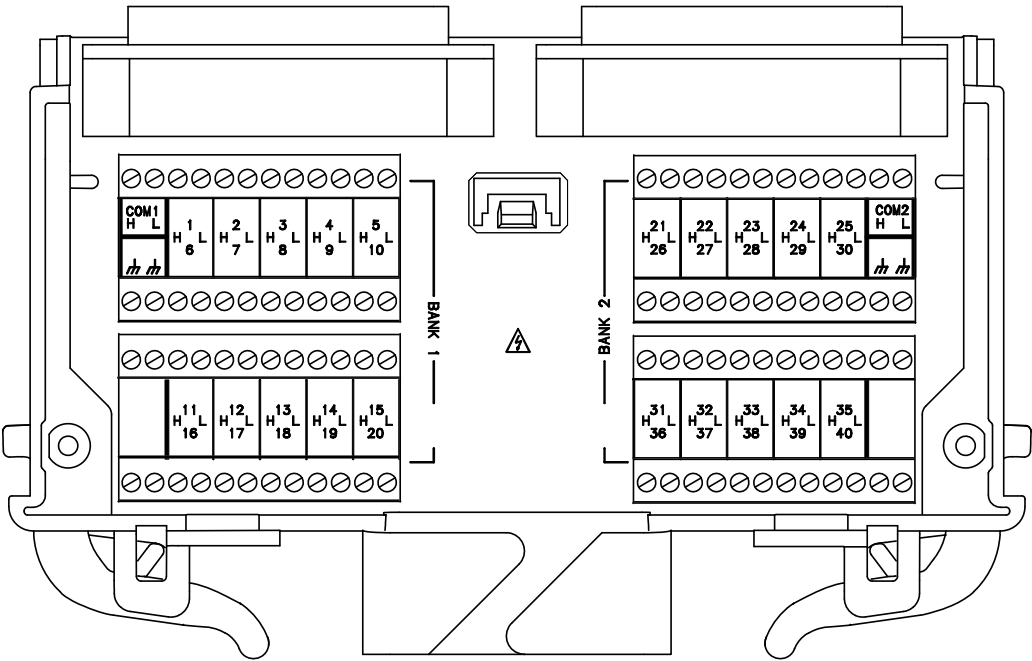

34923A Simplified Schematic for One-Wire Mode

This drawing shows two independent 40-channel 1-wire MUXes. To change configuration modes, use the `SYSTEM:MODULE:WIRE:MODE` command.

NOTE: The three-digit number assigned to each switch represents the channel number.

NOTE:
Bank relays: Reed non-latching
Analog Bus relays: Armature non-latching

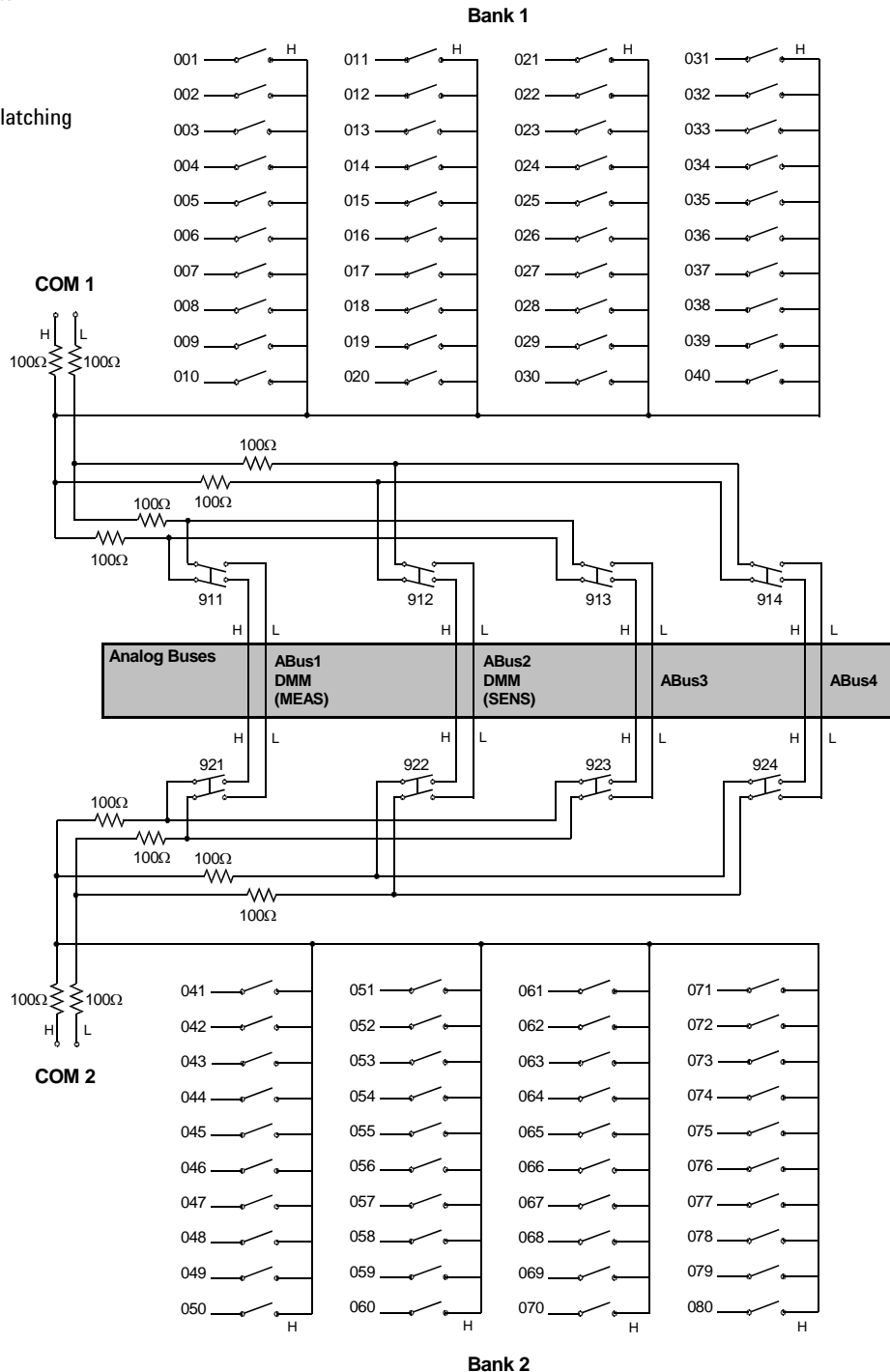

34923A D-Sub Connectors for One-Wire Mode

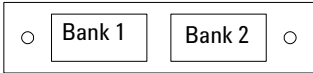

Bank 1

For orientation, the D-sub connector end of the module is facing you.

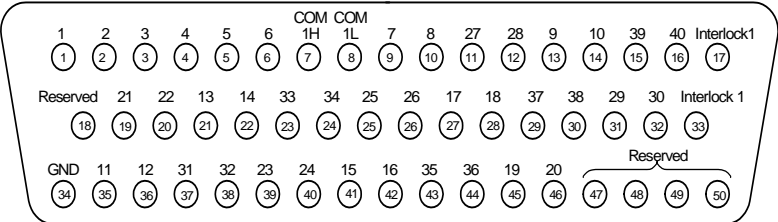

50-Pin D-Sub Male Connector

WARNING As a safety feature, interlock 1 pins (17 and 33) on Bank 1 must be shorted to enable the Bank 1 Analog Bus relays to close. The optional 34923T-002 (for 1-wire) shorts these pins for you. This feature protects inadvertent routing of high voltages from the Analog Bus to the D-sub connector of the module.

Description	Pin	Description	Pin	Description	Pin	Description	Pin	Description	Pin
1	1	11	35	21	19	31	37	COM1 H	7
2	2	12	36	22	20	31	38	COM1 L	8
3	3	13	21	23	39	33	23	Interlock 1	17
4	4	14	22	24	40	34	24	Interlock 1	33
5	5	15	41	25	25	35	43	GND	34
6	6	16	42	26	26	36	44	Reserved	18
7	9	17	27	27	11	37	29	Reserved	47
8	10	18	28	28	12	38	30	Reserved	48
9	13	19	45	29	31	39	15	Reserved	49
10	14	20	46	30	32	40	16	Reserved	50

Bank 2

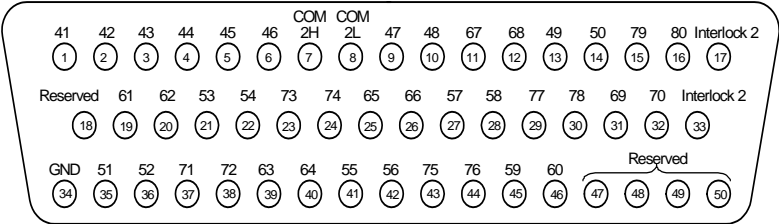

50-Pin D-Sub Male Connector

WARNING As a safety feature, interlock 2 pins (17 and 33) on Bank 2 must be shorted to enable the Bank 2 Analog Bus relays to close. The optional 34923T-002 (for 1-wire) shorts these pins for you. This feature protects inadvertent routing of high voltages from the Analog Buses to the D-sub connector of the module.

Description	Pin	Description	Pin	Description	Pin	Description	Pin	Description	Pin
41	1	51	35	61	19	71	37	COM2 H	7
42	2	52	36	62	20	72	38	COM2 L	8
43	3	53	21	63	39	73	23	Interlock 2	17
44	4	54	22	64	40	74	24	Interlock 2	33
45	5	55	41	65	25	75	43	GND	34
46	6	56	42	66	26	76	44	Reserved	18
47	9	57	27	67	11	77	29	Reserved	47
48	10	58	28	68	12	78	30	Reserved	48
49	13	59	45	69	31	79	15	Reserved	49
50	14	60	46	70	32	80	16	Reserved	50

34923T-002 Terminal Block for One-Wire Mode

This terminal block with screw-type connections is labeled with the model number and the abbreviated module name. In addition, space is available on the label for you to write the slot number

NOTE

All modules that connect to the internal DMM are interlock protected. This means that when an installed module is exposed (no terminal block or cable is connected), the Analog Bus relays are open and disconnected from the Analog Buses. See [“Safety Interlock”](#) on page 3 for further information.

NOTE

If you are using an Agilent terminal block to connect your DUT to this module be sure to use the 34923T-002 terminal block that corresponds to the 1-wire configuration mode. An error will not be generated if you have installed a terminal block that doesn't match the present module configuration.

The *34980A Product Reference* CD (shipped with the instrument) contains a 34923T (1-wire mode) Wiring Log for you to document your wiring configuration for this module. You can open the wiring log file in Microsoft® Excel® or Adobe® Acrobat® format.

Wire Size:
20 AWG Typical
18 AWG Max

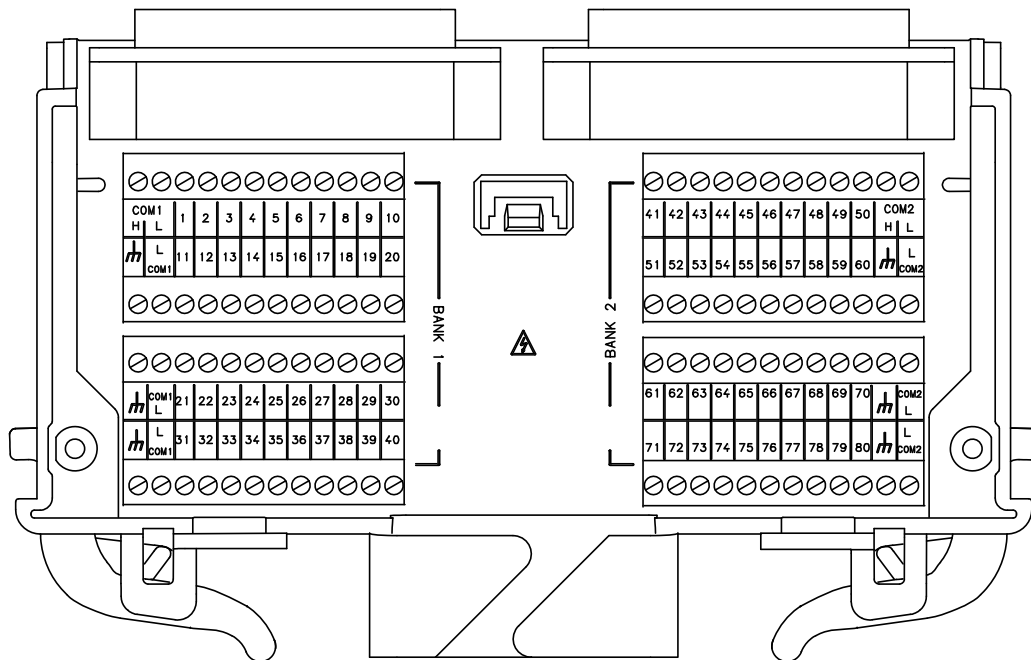

34924A 70-Channel Reed Multiplexer

The high-density 34924A 70-Channel Reed Multiplexer (70-Ch Reed MUX) is divided into two banks with 35 non-latching reed switches (channels 1-35 and 36-70) in each. This module also contains eight armature Analog Bus relays (channels 911-914 and 921-924), four on each bank that can connect the bank relays to the system Analog Buses. Through ABus1 and ABus2 you can connect any of the channels to the system DMM for voltage or resistance measurements. See the simplified schematic on [page 29](#).

Using program commands or the mainframe front panel, you can control each of the channel switches individually, and thus configure the 34924A in any of these modes:

- two independent 35-channel 2-wire MUXes. This configuration requires neither using external wiring nor connecting through the internal Analog Buses.
- one 70-channel, 2-wire MUX. You must use external wiring or connect through the internal Analog Buses for this configuration.
- one 35-channel 4-wire MUX. This configuration requires neither using external wiring nor connecting through the internal Analog Buses. For 4-wire resistance measurements, the instrument automatically pairs channel n on Bank 1 (source) with channel $n+35$ on Bank 2 (sense) to provide these connections. Four-wire controls occur only when doing 4-wire measurement operations through the internal DMM, such as `MEASure:FRESistance?` or scanning a channel previously configured as 4-wire.

In 2-wire mode, you can close no more than 20 channels simultaneously due to power dissipation. These 20 channels are split 10 to a bank. However, note that Analog Bus relays count half as much as channel relays in that total. For example, with one Analog Bus relay closed, you can close up to a maximum of 19 channel relays. If you try to close more than the allowed number of channels, you will receive an error message.

In all modes, this module has capability to scan as many as 500 channels/second using the internal DMM. With the automatic “break-before-make” connection operation, you are assured that no two signals are connected to each other during a scan.

CAUTION

Because user-attached reactive loads and backplane parasitic capacitance may result in high in-rush currents, 100 Ω in-rush resistors protect the reed relays from damage and performance degradation. Therefore, you must consider these resistors when you are designing a measurement. Refer to the simplified schematic on [page 29](#).

34924A 70-Channel Reed Multiplexer

This module is interlock protected, which means whenever the D-sub connector end of the modules is exposed, the Analog Bus relays immediately open and disconnect from the Analog Bus. For more information, see “[Safety Interlock](#)” on page 3.

Lifetime of relays is severely degraded as current or voltage goes up. If higher voltage is being switched, limits on source current are recommended.

When the power is off, all channel and Analog Bus relays open.

34924A Simplified Schematic

This drawing shows two independent 35-channel 2-wire MUXes.

NOTE: The three-digit number assigned to each switch represents the channel number.

NOTE:

Bank relays: Reed non-latching

Analog Bus relays: Armature non-latching

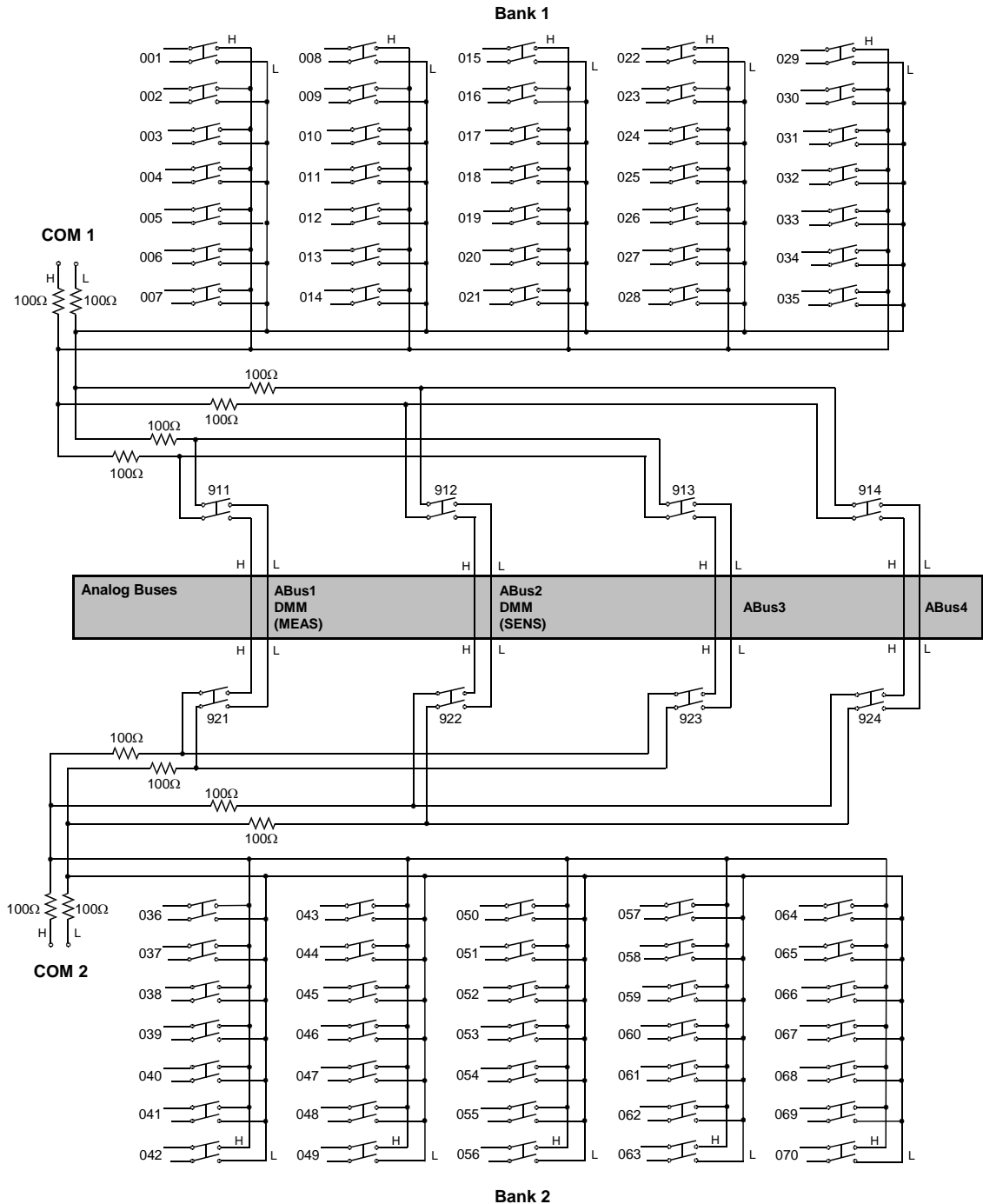

34924A D-Sub Connectors

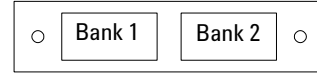

Bank 1

For orientation, the D-sub connector end of the module is facing you.

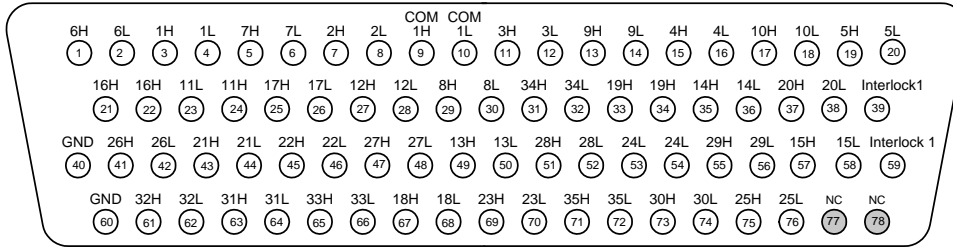

78-Pin D-Sub Male Connector

Description	Pin	Description	Pin	Description	Pin	Description	Pin	Description	Pin	Description	Pin
1H	3	8H	29	15H	57	22H	45	29H	55	COM1 H	9
1L	4	8L	30	15L	58	22L	46	29L	56	COM1 L	10
2H	7	9H	13	16H	21	23H	69	30H	73	Interlock 1	39
2L	8	9L	14	16L	22	23L	70	30L	74	Interlock 1	59
3H	11	10H	17	17H	25	24H	53	31H	63	GND	40
3L	12	10L	18	17L	26	24L	54	31L	64	GND	60
4H	15	11H	23	18H	67	25H	75	32H	61	No Connect	77
4L	16	11L	24	18L	68	25L	76	32L	62	No Connect	78
5H	19	12H	27	19H	33	26H	41	33H	65		
5L	20	12L	28	19L	34	26L	42	33L	66		
6H	1	13H	49	20H	37	27H	47	34H	31		
6L	2	13L	50	20L	38	27L	48	34L	32		
7H	5	14H	35	21H	43	28H	51	35H	71		
7L	6	14L	36	21L	44	28L	52	35L	72		

WARNING

As a safety feature, interlock 1 pins (39 and 59) on Bank 1 must be shorted to enable the Bank 1 Analog Bus relays to close. The optional 34924T terminal blocks short these pins for you. This feature protects inadvertent routing of high voltages from the Analog Buses to the D-sub connector of the module.

Bank 2

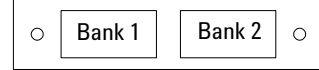

For orientation, the D-sub connector end of the module is facing you.

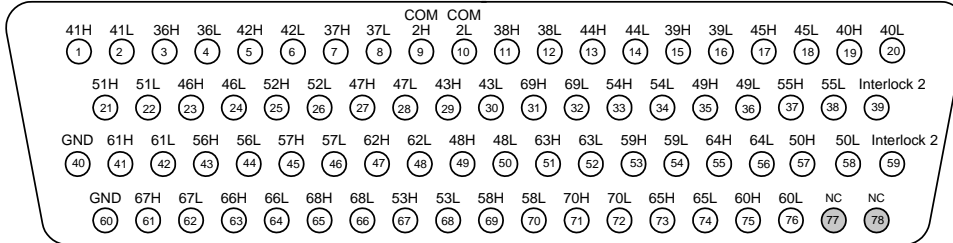

78-Pin D-Sub Male Connector

Description	Pin	Description	Pin	Description	Pin	Description	Pin	Description	Pin	Description	Pin
36H	3	43H	29	50H	57	57H	45	64H	55	COM2 H	9
36L	4	43L	30	50L	58	57L	46	64L	56	COM2 L	10
37H	7	44H	13	51H	21	58H	69	65H	73	Interlock 2	39
37L	8	44L	14	51L	22	58L	70	65L	74	Interlock 2	59
38H	11	45H	17	52H	25	59H	53	66H	63	GND	40
38L	12	45L	18	52L	26	59L	54	66L	64	GND	60
39H	15	46H	23	53H	67	60H	75	67H	61	No Connect	77
39L	16	46L	24	53L	68	60L	76	67L	62	No Connect	78
40H	19	47H	27	54H	33	61H	41	68H	65		
40L	20	47L	28	54L	34	61L	42	68L	66		
41H	1	48H	49	55H	37	62H	47	69H	31		
41L	2	48L	50	55L	38	62L	48	69L	32		
42H	5	49H	35	56H	43	63H	51	70H	71		
42L	6	49L	36	56L	44	63L	52	70L	72		

WARNING As a safety feature, interlock 2 pins (39 and 59) on Bank 2 must be shorted to enable the Bank 2 Analog Bus relays to close. The optional 34924T terminal blocks short these pins for you. This feature protects inadvertent routing of high voltages from the Analog Buses to the D-sub connector of the module.

34924T Terminal Blocks

Two terminal blocks are available to facilitate wiring connections to the 34924A module:

34924T-001 (Option 001)	Terminal block with solder connectors
34924T-002 (Option 002)	Terminal block with screw connectors

The *34980A Product Reference* CD (shipped with the instrument) contains a 34924T Wiring Log for you to document your wiring configuration for this module. You can open the wiring log file in Microsoft® Excel® or Adobe® Acrobat® format.

NOTE

All modules that connect to the internal DMM are interlock protected. This means that when an installed module is exposed (no terminal block or cable is connected), the Analog Bus relays are open and disconnected from the Analog Buses. See “[Safety Interlock](#)” on page 3 for further information.

34924T-001 Terminal Block

This terminal block with solder-type connections is labeled with the model number and the abbreviated module name. In addition, space is available on the label for you to write the slot number.

Wire Size:
22 AWG Typical
20 AWG Max

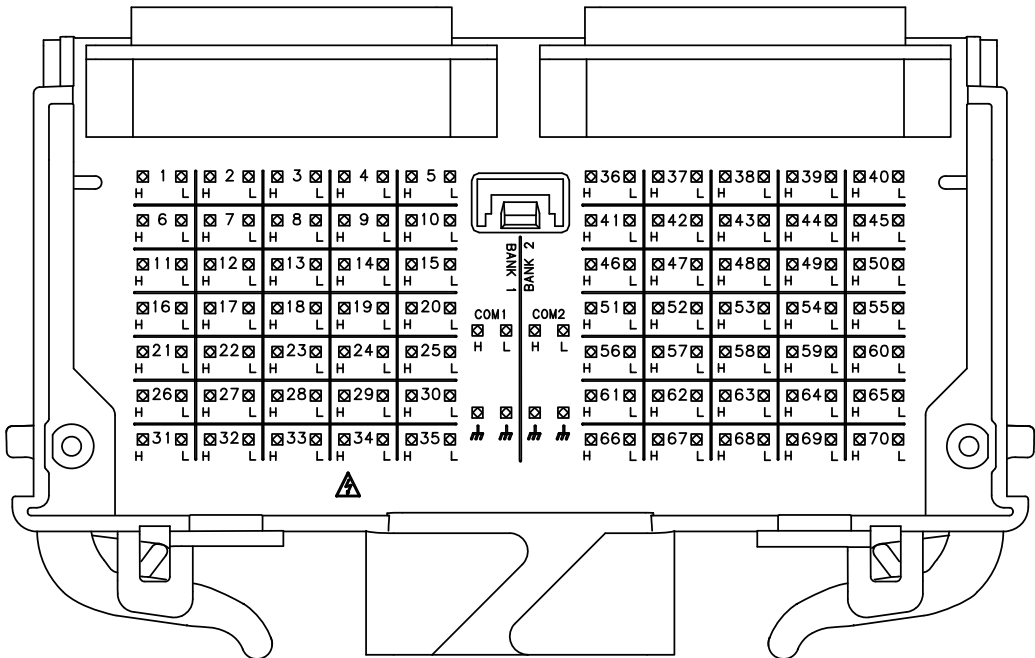

34924T-002 Terminal Block

This terminal block with screw-type connections is labeled with the model number and the abbreviated module name. In addition, space is available on the label for you to write the slot number.

Wire Size:
20 AWG Typical
18 AWG Max

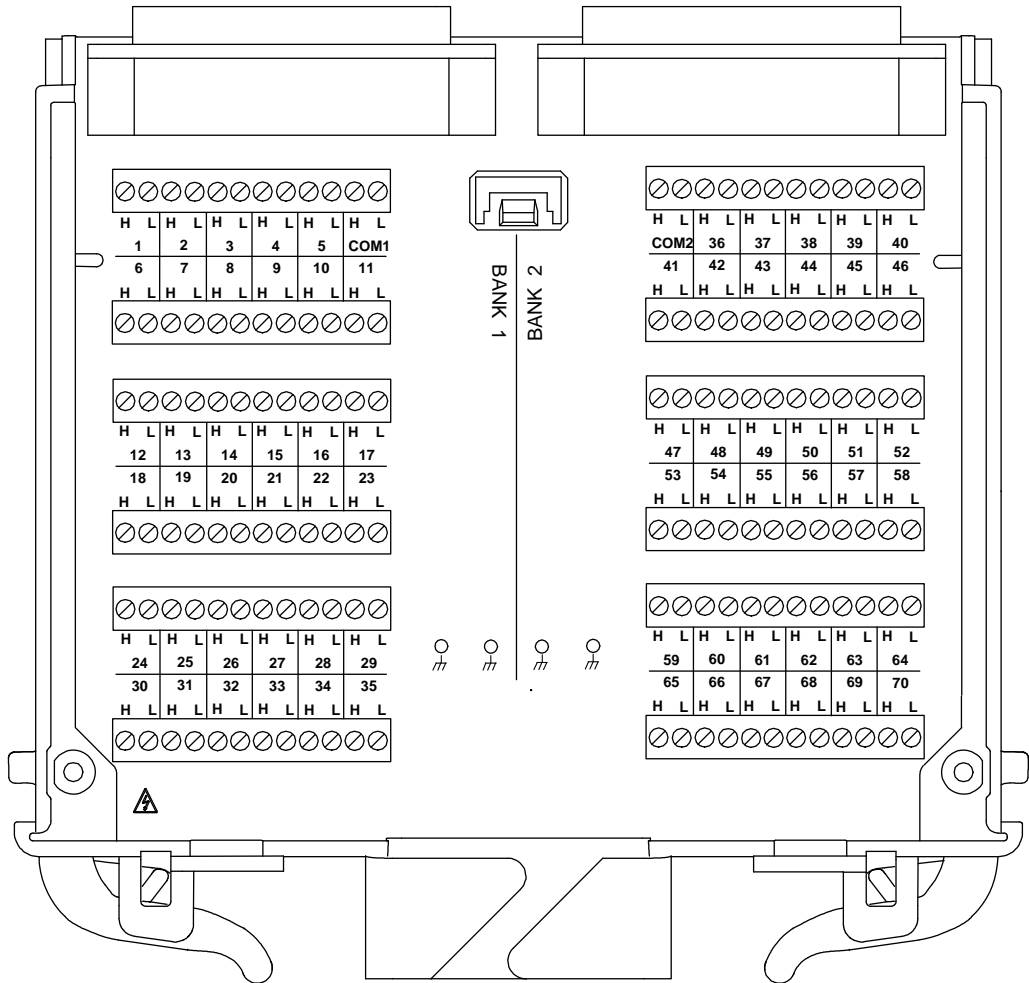

34925A 40/80-Channel Optically-Isolated FET Multiplexer

The 34925A 40/80-Channel Optically-Isolated FET Multiplexer (40/80-Ch FET MUX) module is a high-speed and high-density FET MUX for high throughput production test. This module is divided into two equal banks of non-latching FET switches. This module also contains four armature Analog Bus relays. Through ABus1 and ABus2 you can connect any of the channels to the internal DMM for voltage or resistance measurements. When the power is off, all channel and Analog Bus relays open.

Using program commands or the mainframe front panel, you can control each of the FET channel switches individually, and configure this module for differential (2-wire or 4-wire) or single-ended (1-wire) mode. Refer to the simplified schematics on [page 36](#) and [page 39](#).

If you are using an Agilent 34925T-00*x* terminal block to connect your DUT to this module, be sure to use the terminal block that corresponds to your module configuration mode (Refer to the terminal block drawings on [page 38](#) and [page 41](#)):

34925T-001 (Option 001)	Terminal block for differential (two- or four-wire) mode
34925T-002 (Option 002)	Terminal block for single-ended (1-wire) mode

You can confirm the mode in which your module is configured by using the `SYSTem:CTYPe? <slot number>` program command. This command returns the identity of the plug-in module in the specified slot.

NOTE

Whenever you change from 2- or 4-wire mode to 1-wire mode, or the reverse, you must cycle power on the 34980A for the configuration to take effect.

Two-Wire Mode

- two independent 20-channel 2-wire MUXes. This configuration requires neither using external wiring nor connecting through the internal Analog Bus relays.
- one 40-channel, 2-wire MUX. You must use external wiring or connect through the Analog Bus relays to for this configuration.

Four-Wire Mode

- You may configure the 34925A as a single 20-channel 4-wire MUX. This configuration requires using neither external wiring nor connecting through the internal Analog Buses. For 4-wire resistance measurements, the instrument automatically pairs channel n on Bank 1 (source) with channel $n+20$ on Bank 2 (sense) to provide these connections. Four-wire controls occur only when doing 4-wire measurement operations through the internal DMM, such as `MEASure:FRESistance?` or scanning a channel previously configured as 4-wire.

One-Wire Mode

- two independent 40-channel 1-wire MUXes. This configuration requires neither using external wiring nor connecting through the Analog Bus relays.
- one 80-channel 1-wire MUX. You must use external wiring or connect through the Analog Bus relays for this configuration.

NOTE

Because all bank relays supply only HI signals, you can apply a LOW signal through COM1 L or COM2 L when you are making 2-wire resistance measurements in 1-wire mode.

Interlock Protection

This module is interlock protected, which means whenever the D-sub connector end of the modules is exposed, the Analog Bus relays immediately open and disconnect from the Analog Buses. For more information, see “[Safety Interlock](#)” on page 3.

Overvoltage Protection

This module also features high voltage detection (< 100 V) and current limiting circuitry to protect the FET relays. This circuitry senses current flows from input overvoltages. These overvoltages may come from either the MUX input or from the Analog Buses. In addition, each channel is also protected from input overvoltages with a resistor.

When overvoltage is detected, all relays (Analog Bus and FET) are opened. While in the overvoltage state, any attempts to close any Analog Bus or FET switch, results in an error status response from the module.

Once in the overvoltage state, you must restore normal module operation with one of these actions:

- using the `SYSTEM:CPON <slot>` command. This affects only the module specified.
- using the `*RST` command. This command resets the mainframe and all installed modules to the Factory configuration. This affects all installed modules.
- cycling system power. This affects all installed modules.

If the overvoltage situation is not resolved, clearing the overvoltage will result in a new overvoltage event occurring immediately.

Further FET protection is assured only as one channel in each bank is closed at any time. Thus this module will operate as only a 1:N MUX module. For more information about FET channel closures, refer to [page 4](#).

34925A Simplified Schematic for Two- or Four-Wire Mode

This drawing shows two independent 20-channel 2-wire MUXes. To change configuration modes, use the `SYSTEM:MODULE:WIRE:MODE` command.

NOTE: The three-digit number assigned to each switch represents the channel number.

NOTE:

Bank relays: FET non-latching

Analog Bus relays: Armature non-latching

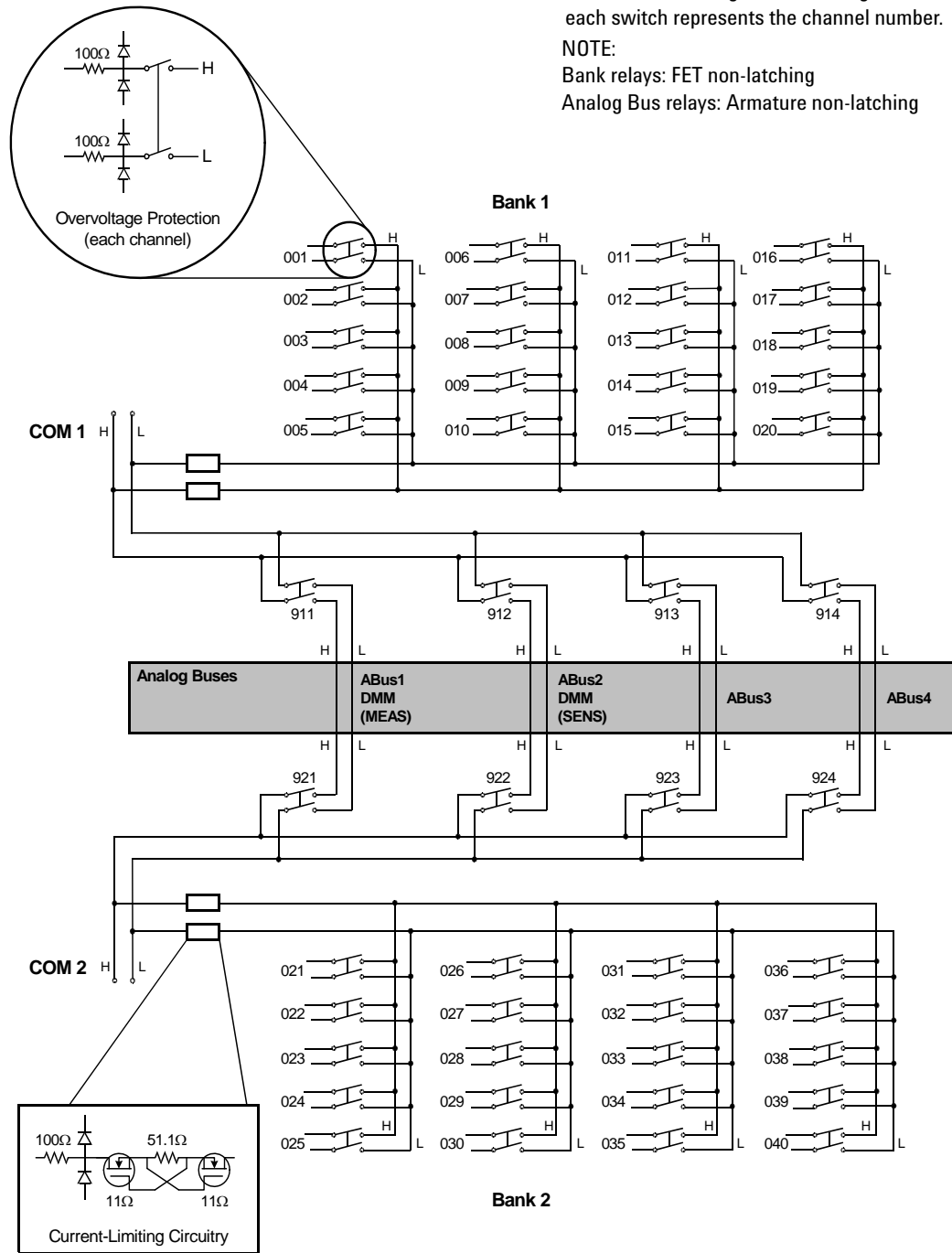

34925A D-Sub Connectors for Two- or Four-Wire Mode

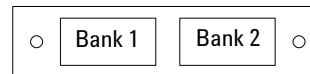

Bank 1

For orientation, the D-sub connector end of the module is facing you.

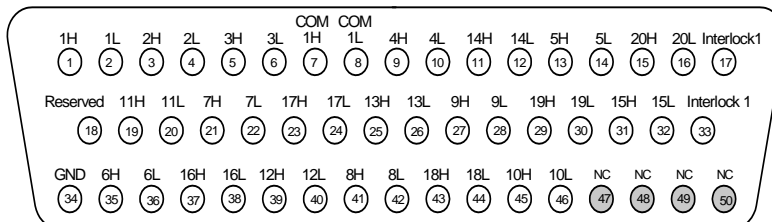

50-Pin D-Sub Male Connector

WARNING As a safety feature, interlock 1 pins (17 and 33) on Bank 1 must be shorted to enable the Bank 1 Analog Bus relays to close. The optional 34925T-001 (for 2-wire) terminal block shorts these pins for you. This feature protects inadvertent routing of high voltages from the Analog Bus to the D-sub connector of the module.

Description	Pin	Description	Pin	Description	Pin	Description	Pin	Description	Pin
1H	1	6H	35	11H	19	16H	37	COM1 H	7
1L	2	6L	36	11L	20	16L	38	COM1 L	8
2H	3	7H	21	12H	39	17H	23	Interlock 1	17
2L	4	7L	22	12L	40	17L	24	Interlock 1	33
3H	5	8H	41	13H	25	18H	43	Reserved	18
3L	6	8L	42	13L	26	18L	44	GND	34
4H	9	9H	27	14H	11	19H	29	No Connect	47
4L	10	9L	28	14L	12	19L	30	No Connect	48
5H	13	10H	45	15H	31	20H	15	No Connect	49
5L	14	10L	46	15L	32	20L	16	No Connect	50

Bank 2

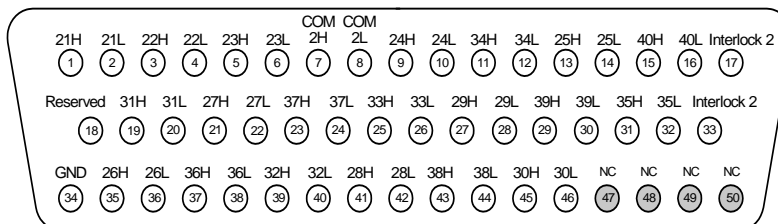

50-Pin D-Sub Male Connector

WARNING As a safety feature, interlock 2 pins (17 and 33) on Bank 2 must be shorted to enable the Bank 2 Analog Bus relays to close. The optional 34925T-001 (for 2-wire) terminal block shorts these pins for you. This feature protects inadvertent routing of high voltages from the Analog Buses to the D-sub connector of the

Description	Pin	Description	Pin	Description	Pin	Description	Pin	Description	Pin
21H	1	26H	35	31H	19	36H	37	COM2 H	7
21L	2	26L	36	31L	20	36L	38	COM2 L	8
22H	3	27H	21	32H	39	37H	23	Interlock 2	17
22L	4	27L	22	32L	40	37L	24	Interlock 2	33
23H	5	28H	41	33H	25	38H	43	Reserved	18
23L	6	28L	42	33L	26	38L	44	GND	34
24H	9	29H	27	34H	11	39H	29	No Connect	47
24L	10	29L	28	34L	12	39L	30	No Connect	48
25H	13	30H	45	35H	31	40H	15	No Connect	49
25L	14	30L	46	35L	32	40L	16	No Connect	50

34925T-001 Terminal Block for Two-Wire or Four-Wire Mode

This terminal block with screw-type connections is labeled with the model number and the abbreviated module name. In addition, space is available on the label for you to write the slot number.

NOTE

All modules that connect to the internal DMM are interlock protected. This means that when an installed module is exposed (no terminal block or cable is connected), the Analog Bus relays are open and disconnected from the Analog Buses. See [“Safety Interlock”](#) on page 3 for further information.

NOTE

If you are using an Agilent terminal block to connect your DUT to this module be sure to use the 34925T-001 terminal block that corresponds to the 2- or 4-wire configuration mode. An error will not be generated if you have installed a terminal block that doesn't match the present module configuration.

The *34980A Product Reference* CD (shipped with the instrument) contains a 34925T (2-wire mode) Wiring Log for you to document your wiring configuration for this module. You can open the wiring log file in Microsoft® Excel® or Adobe® Acrobat® format.

Wire Size:
20 AWG Typical
18 AWG Max

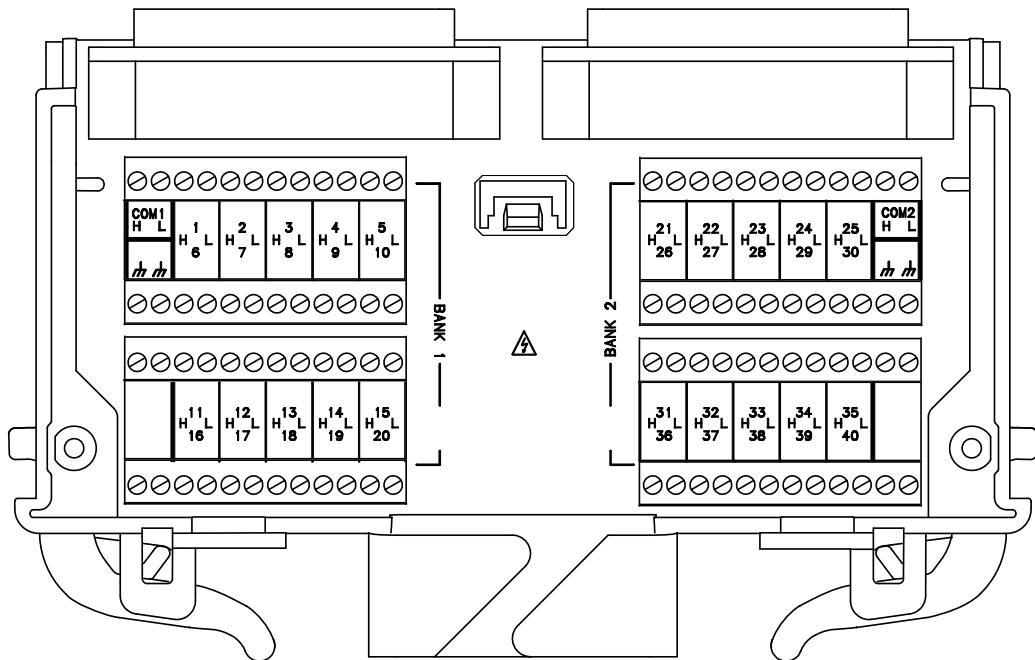

34925A Simplified Schematic for One-Wire Mode

This drawing shows two independent 40-channel, 1-wire MUXes. To change configuration modes, use the `SYSTEM:MODULE:WIRE:MODE` command.

NOTE: The three-digit number assigned to each switch represents the channel number.

NOTE:

Bank relays: FET non-latching

Analog Bus relays: Armature non-latching

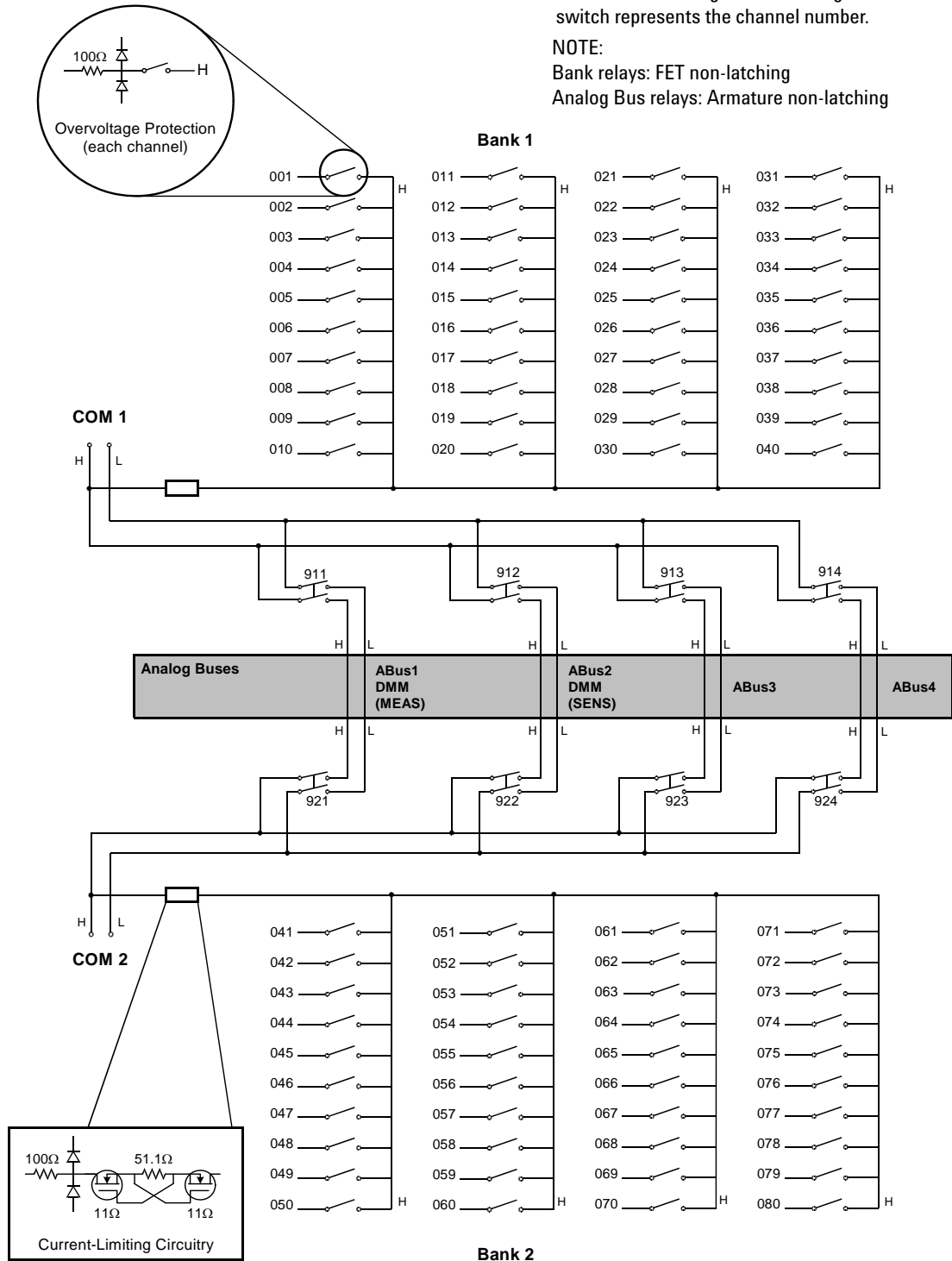

34925A D-Sub Connectors for One-Wired Mode

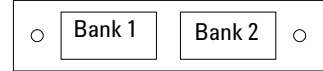

Bank 1

For orientation, the D-sub connector end of the module is facing you.

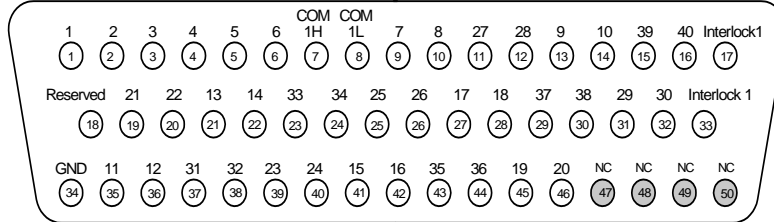

50-Pin D-Sub Male Connector

WARNING As a safety feature, interlock 1 pins (17 and 33) on Bank 1 must be shorted to enable the Bank 1 Analog Bus relays to close. The optional 34925T-002 (for 1-wire) terminal block shorts these pins for you. This feature protects inadvertent routing of high voltages from the Analog Bus to the D-sub connector of the module.

Description	Pin	Description	Pin	Description	Pin	Description	Pin	Description	Pin
1	1	11	35	21	19	31	37	COM1 H	7
2	2	12	36	22	20	32	38	COM1 L	8
3	3	13	21	23	39	33	23	Interlock 1	17
4	4	14	22	24	40	34	24	Interlock 1	33
5	5	15	41	25	25	35	43	Reserved	18
6	6	16	42	26	26	36	44	GND	34
7	9	17	27	27	11	37	29	No Connect	47
8	10	18	28	28	12	38	30	No Connect	48
9	13	19	45	29	31	39	15	No Connect	49
10	14	20	46	30	32	40	16	No Connect	50

Bank 2

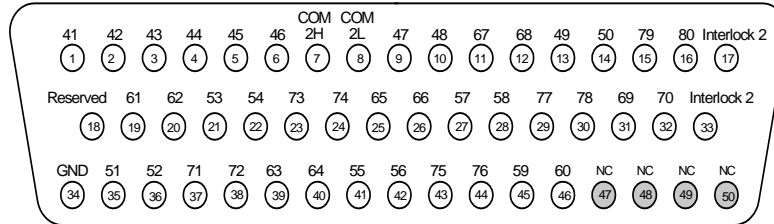

50-Pin D-Sub Male Connector

WARNING As a safety feature, interlock 2 pins (17 and 33) on Bank 2 must be shorted to enable the Bank 2 Analog Bus relays to close. The optional 34925T-002 (for 1-wire) terminal block shorts these pins for you. This feature protects inadvertent routing of high voltages from the Analog Buses to the D-sub connector of the

Description	Pin	Description	Pin	Description	Pin	Description	Pin	Description	Pin
41	1	51	35	61	19	71	37	COM2 H	7
42	2	52	36	62	20	72	38	COM2 L	8
43	3	53	21	63	39	73	23	Interlock 2	17
44	4	54	22	64	40	74	24	Interlock 2	33
45	5	55	41	65	25	75	43	Reserved	18
46	6	56	42	66	26	76	44	GND	34
47	9	57	27	67	11	77	29	No Connect	47
48	10	58	28	68	12	78	30	No Connect	48
49	13	59	45	69	31	79	15	No Connect	49
50	14	60	46	70	32	80	16	No Connect	50

34925T-002 Terminal Block for One-Wire Mode

This terminal block with screw-type connections is labeled with the model number and the abbreviated module name. In addition, space is available on the label for you to write the slot number.

NOTE

All modules that connect to the internal DMM are interlock protected. This means that when an installed module is exposed (no terminal block or cable is connected), the Analog Bus relays are open and disconnected from the Analog Buses. See [“Safety Interlock”](#) on page 3 for further information.

NOTE

If you are using an Agilent terminal block to connect your DUT to this module be sure to use the 34925T-002 terminal block that corresponds to the 1-wire configuration mode. An error will not be generated if you have installed a terminal block that doesn't match the present module configuration.

The *34980A Product Reference* CD (shipped with the instrument) contains a 34925T (1-wire mode) Wiring Log for you to document your wiring configuration for this module. You can open the wiring log file in Microsoft® Excel® or Adobe® Acrobat® format.

Wire Size:
20 AWG Typical
18 AWG Max

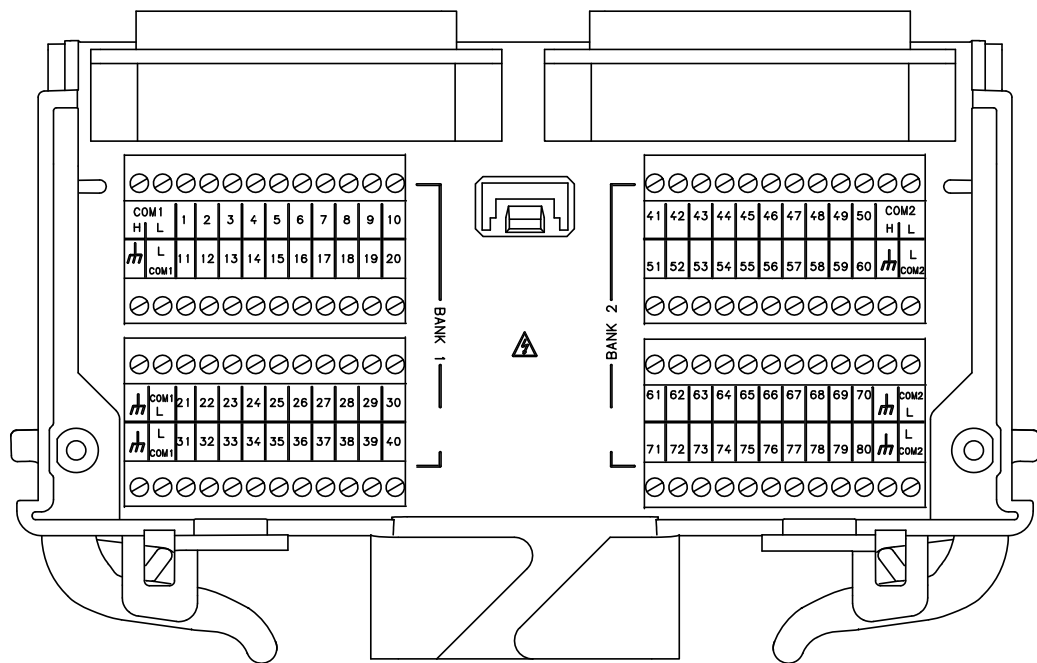

34925A 40/80-Channel Optically-Isolated FET Multiplexer

Index

Numerics

- 34921A
 - connector pinouts, 10
 - description, 7
 - external reference, 11
 - programming examples, 4
 - simplified schematic, 9
 - temperature sensor, 11
 - terminal block, 11
 - valid measurement functions, 2
 - wiring log, 11
- 34922A
 - connector pinouts, 15
 - description, 13
 - programming examples, 4
 - simplified schematic, 14
 - terminal blocks, 17, 18
 - valid measurement functions, 2
 - wiring log, 17
- 34923A
 - connector pinouts, 22, 25
 - description, 19
 - programming examples, 4
 - simplified schematic, 21, 24
 - terminal blocks, 23, 26
 - valid measurement functions, 2
 - wiring log, 23, 26
- 34924A
 - connector pinouts, 30
 - description, 27
 - programming examples, 4
 - simplified schematic, 29
 - terminal blocks, 32, 33
 - valid measurement functions, 2
 - wiring log, 32
- 34925A
 - connector pinouts, 37, 40
 - description, 34
 - overload protection, 35
 - programming examples, 4
 - simplified schematic, 36, 39
 - terminal blocks, 38, 41
 - valid measurement functions, 2
 - wiring log, 38, 41

C

- connector pinouts
 - 34921A, 10
 - 34922A, 15
 - 34923A, 22, 25
 - 34924A, 30
 - 34925A, 37, 40

D

- D-sub pinouts

- 34921A, 10
- 34922A, 15
- 34923A, 22, 25
- 34924A, 30
- 34925A, 37, 40

E

- external reference, 11

F

- FET protection, 35

I

- isothermal block, 11

O

- operating considerations, 3
- overload protection, 35
- overvoltage protection, 35

P

- pinouts
 - 34921A, 10
 - 34922A, 15
 - 34923A, 22, 25
 - 34924A, 30
 - 34925A, 37, 40

T

- temperature sensor, 11
- terminal block
 - 34921T, 12
 - 34922T Option 001, 17
 - 34922T Option 002, 18
 - 34923T Option 001, 23
 - 34923T Option 002, 26
 - 34924T Option 001, 32
 - 34924T Option 002, 33
 - 34925T Option 001, 38
 - 34925T Option 002, 41

W

- warranty, ii

