

Errata

Agilent References in this manual

NOTICE: This document contains references to Agilent Technologies. Agilent's former Test and Measurement business has become Keysight Technologies. For more information, go to:

www.keysight.com

About this manual

We've added this manual to the Keysight website in an effort to help you support your product. This manual provides the best information we could find. It may be incomplete or contain dated information.

Support for your product

You can find information about technical and professional services, product support, and equipment repair and service on the web:

www.keysight.com

Select your country from the drop-down menu at the top. Under *Electronic Test and Measurement*, click on *Services*. The web page that appears next has contact information specific to your country.

For more detailed product information, go to: www.keysight.com/find/ <product model>
i.e., for the M9514A, use: www.keysight.com/find/M9514A

Hypertext links to documents on agilent.com are no longer active. Use this substitution to access PDF files:

Broken links have the form: <http://cp.literature.agilent.com/litweb/pdf/> < literature_part_number >

Substitute links with this form: <http://literature.cdn.keysight.com/litweb/pdf/> < literature_part_number >

Where < literature_part_number > has the form: M9300-90001.pdf

For service notes, use: www.keysight.com/find/servicenotes



Agilent 34959A Breadboard Module

User's Guide

Agilent Technologies, Inc.
Printed in Malaysia
Edition 2
September 2012 E0912



34980-90059



Agilent Technologies

Notices

© Agilent Technologies, Inc. 2008

No part of this manual may be reproduced in any form or by any means (including electronic storage and retrieval or translation into a foreign language) without prior agreement and written consent from Agilent Technologies, Inc. as governed by United States and international copyright laws.

Manual Part Number

34980-90059

Edition

Second Edition, September 2012

Printed in Malaysia

Agilent Technologies, Inc.
3501 Stevens Creek Blvd
Santa Clara, CA 95052 USA

Microsoft® and Windows® are U.S. registered trademarks of Microsoft Corporation.

Software Revision

This guide is valid for the firmware that was installed in the instrument at the time of manufacture. However, upgrading the firmware may add or change product features. For the latest firmware and documentation, go to the product page at:

www.agilent.com/find/34980A

Warranty

The material contained in this document is provided “as is,” and is subject to being changed, without notice, in future editions. Further, to the maximum extent permitted by applicable law, Agilent disclaims all warranties, either express or implied, with regard to this manual and any information contained herein, including but not limited to the implied warranties of merchantability and fitness for a particular purpose. Agilent shall not be liable for errors or for incidental or consequential damages in connection with the furnishing, use, or performance of this document or of any information contained herein. Should Agilent and the user have a separate written agreement with warranty terms covering the material in this document that conflict with these terms, the warranty terms in the separate agreement shall control.

Technology Licenses

The hardware and/or software described in this document are furnished under a license and may be used or copied only in accordance with the terms of such license.

Restricted Rights Legend

U.S. Government Restricted Rights. Software and technical data rights granted to the federal government include only those rights customarily provided to end user customers. Agilent provides this customary commercial license in Software and technical data pursuant to FAR 12.211 (Technical Data) and 12.212 (Computer Software) and, for the Department of Defense, DFARS 252.227-7015 (Technical Data - Commercial Items) and DFARS 227.7202-3 (Rights in Commercial Computer Software or Computer Software Documentation).

Safety Notices

CAUTION

A **CAUTION** notice denotes a hazard. It calls attention to an operating procedure, practice, or the like that, if not correctly performed or adhered to, could result in damage to the product or loss of important data. Do not proceed beyond a **CAUTION** notice until the indicated conditions are fully understood and met.

WARNING

A **WARNING** notice denotes a hazard. It calls attention to an operating procedure, practice, or the like that, if not correctly performed or adhered to, could result in personal injury or death. Do not proceed beyond a **WARNING** notice until the indicated conditions are fully understood and met.

Additional Safety Notices

The following general safety precautions must be observed during all phases of operation of this instrument. Failure to comply with these precautions or with specific warnings or instructions elsewhere in this manual violates safety standards of design, manufacture, and intended use of the instrument. Agilent Technologies assumes no liability of the customer's failure to comply with the requirements.

General

Do not use this products in any manner not specified by the manufacturer. The protective features of this product may be impaired if it is used in a manner not specified in the operation instructions.

Before Applying Power

Verify that all safety precautions are taken. Make all connections to the unit before applying power.

Ground the Instrument

This product is provided with protective earth terminals. To minimize shock hazard, the instrument must be connected to the ac power mains through a grounded power cable, with the ground wire firmly connected to an electrical ground (safety ground) at the power outlet. Any interruption of the protective (grounding) conductor or disconnection of the protective earth terminal will cause a potential shock hazard that could result in personal injury.

Do Not Operate in an Explosive Atmosphere

Do not operate the instrument in the presence of flammable gases or fumes.

Do Not Remove the Instrument Cover

Only qualified, service-trained personal who are aware of the hazards involved should remove instrument covers. Always disconnect the power cable and any external circuits before removing the instrument cover.





Do Not Modify the Instrument

Do not install substitute parts or perform any unauthorized modification to the product. Return the product to an Agilent Sales and Service Office for service and repair to ensure that safety features are maintained.

In Case of Damage

Instruments that appear damaged or defective should be made inoperative and secured against unintended operation until they can be repaired by qualified service personnel.

Safety Symbols

-  Alternating current
-  Frame or chassis terminal
-  Standby supply. Unit is not completely disconnected from ac mains when switch is off
-  Caution, risk of electric shock
-  Caution, refer to accompanying description

Waste Electrical and Electronic Equipment (WEEE) Directive 2002/96/EC

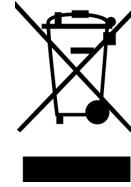

This product complies with the WEEE Directive (2002/96/EC) marking requirement. The affixed product label (see above) indicates that you **must not discard this electrical/electronic product in domestic household waste.**

Product Category: With reference to the equipment types in the WEEE directive Annex 1, this product is classified as a "Monitoring and Control instrumentation" product.

To return unwanted products, contact your local Agilent office, or go to www.agilent.com/environment/product for more information.

Technical Support

If you have questions about your shipment, or if you need information about warranty, service, or technical support, contact Agilent Technologies:

In the United States: (800) 829-4444
In Europe: 31 20 547 2111
In Japan: 0120-421-345

Or go to www.agilent.com/find/assist for information on contacting Agilent in your country of specific location. You can also contact your Agilent Technologies Representative.

Declaration of Conformity

Declarations of Conformity for this product and for other Agilent products may be downloaded from the Internet. There are two methods to obtain the Declaration of Conformity:

- Go to <http://regulations.corporate.agilent.com/DoC/search.htm> . You can then search by product number to find the latest Declaration of Conformity.
- Alternately, you can go to the product web page (www.agilent.com/find/34980A), click on the Document Library tab then scroll down until you find the Declaration of Conformity link.

Contents

34959A Breadboard Module Description	1
34959A Breadboard Module Disassembly	2
34959A Breadboard Module Layout (shown with cover removed)	3
Ribbon Cable Header Pin Assignment Information	4
Configuring the 34959A Breadboard Module	6
Accessing the 34980A Mainframe's Analog Bus	6
Installing Custom Circuitry on the 34959A Breadboard Module	8
Operating Considerations	10
Dimension Information for the Custom PC Board Area	11
Programming the 34959A Breadboard Module	16
Analog Bus Relay Functions	16
General Purpose Relay Functions	17
Digital I/O Functions	18

34959A Breadboard Module Description

The 34959A Breadboard Module provides a 137mm x 190mm x 23mm (5.4" x 7.5" x 0.9") space inside the 34980A Multifunction Switch/Measure Unit, for you to install custom circuitry to support applications not available on the standard plug-in modules.

This module minimizes the need for customer-supplied circuitry by providing +5V and +12V power supplies for logic and relay drive use, 16 general purpose digital I/O bit lines with control lines, and 32 relay drive lines. Your custom circuitry can access the 34980A mainframe's internal DMM and four Analog Buses. Desired measurement and I/O functions can be programmed using standard read/write commands.

Internally, most of the customer-provided circuitry connects to the module through two ribbon cables; the Analog Bus connections are made by hard-soldering to a grid of holes provided on the Agilent-supplied PC board. Two external ports are provided for Dsub connectors (DB50 or DB78) between the module and your field wiring.

The sheet metal base of the module provides fifteen countersunk holes for flexible mounting of circuit boards, terminal blocks or other components. As with all other plug-in modules for the 34980A, cooling is provided within the mainframe chassis.

34959A Breadboard Simplified Block Diagram

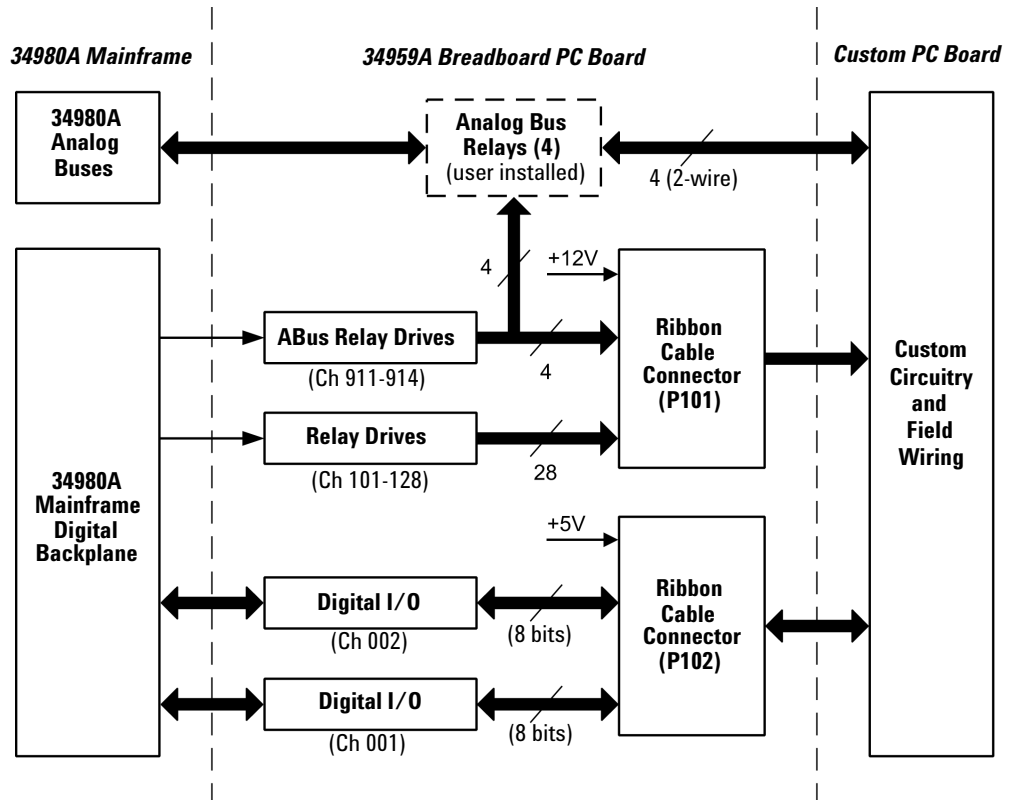

34959A Breadboard Module Disassembly

The module as shipped as shown below. The port covers must be removed if DB50/78 connectors will be installed for external connections; otherwise they can remain in place. The top cover provides mechanical integrity and shielding for the module, and should be attached except when the module is being configured. To unfasten the top cover, remove the screw with a Torx T10 driver, slide the cover back 5mm as shown, and lift the cover up. Reverse this procedure to replace the cover.

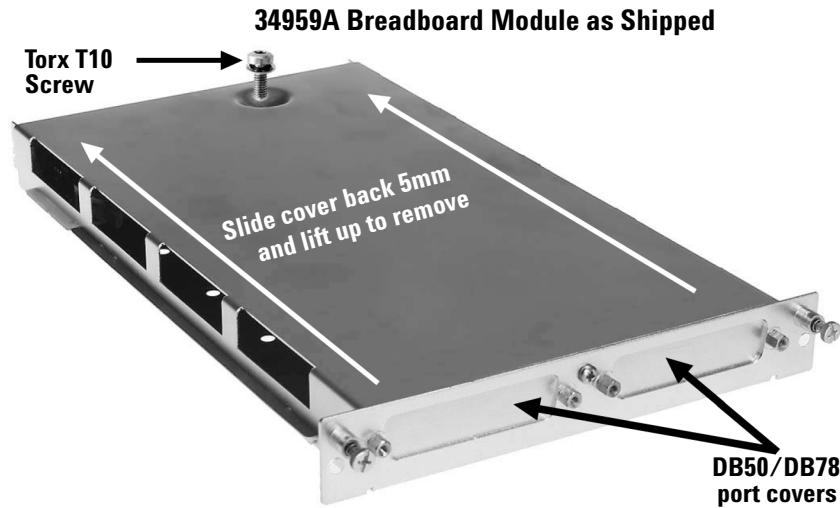

The Agilent-supplied PC board must be removed if you are making connections to the Analog Buses, in order to solder the necessary relays (not provided) and lead wires. To remove this PC board, remove the Torx T10 screw shown, slide the cover back 5mm to clear the two retaining tabs, and lift the board up. Reverse this procedure to reinstall the board.

Removal of the Agilent-Supplied PC Board

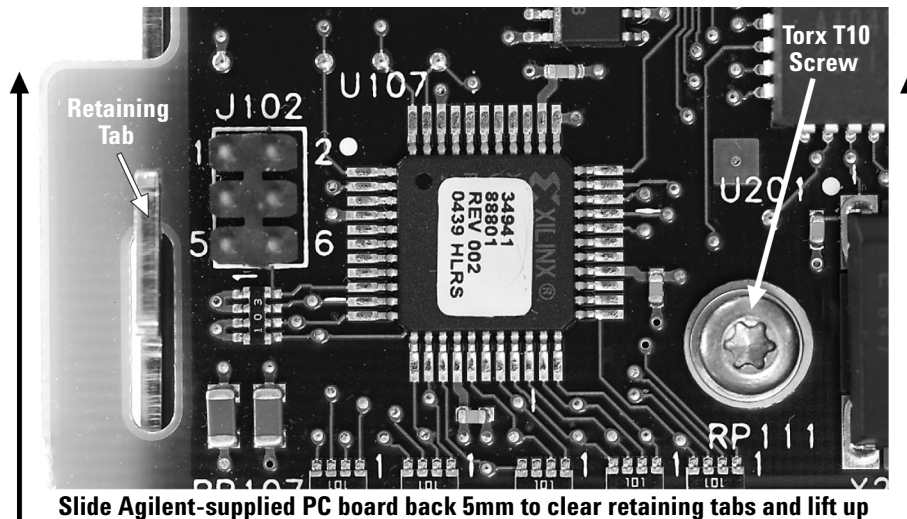

34959A Breadboard Module Layout (shown with cover removed)

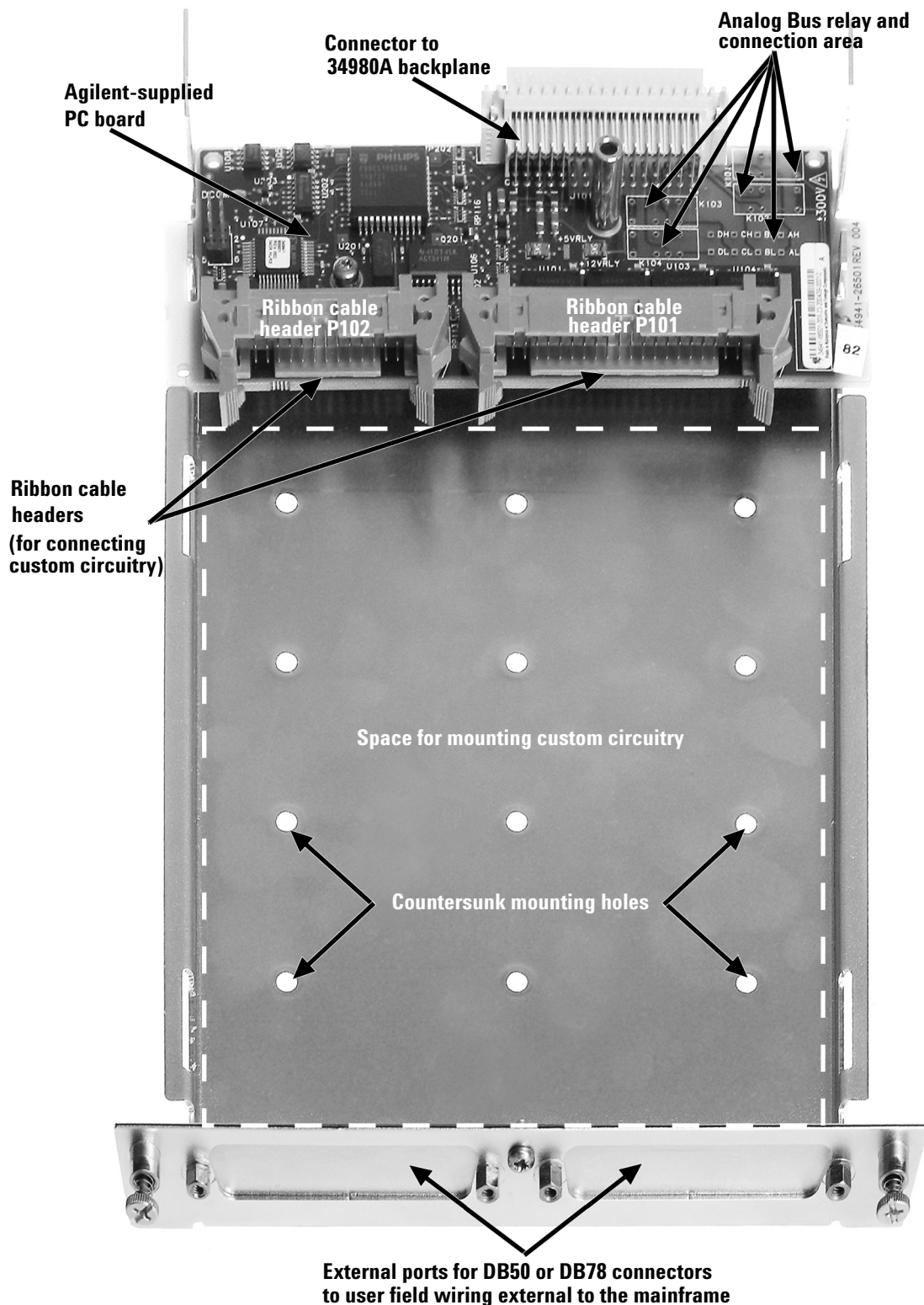

Ribbon Cable Header Pin Assignment Information

The 34959A breadboard is supplied with two ribbon cable headers, which may be used to access 5V and 12V power, open/close four Analog Bus channels, open/close up to 28 customer-supplied general-purpose relays (up to 100 mA sink to ground), and utilize two 8-bit banks of digital I/O. The supplied cable headers (3M Pak 100 series), recommended connectors and their respective pin assignments are shown below. *Pay careful attention to the polarization notches (indexing keys) on the connectors and headers, to correctly identify Pin #1.*

Connector P102

Supplied 26-Pin Ribbon Cable Header P102 (3M part #3429-5602)

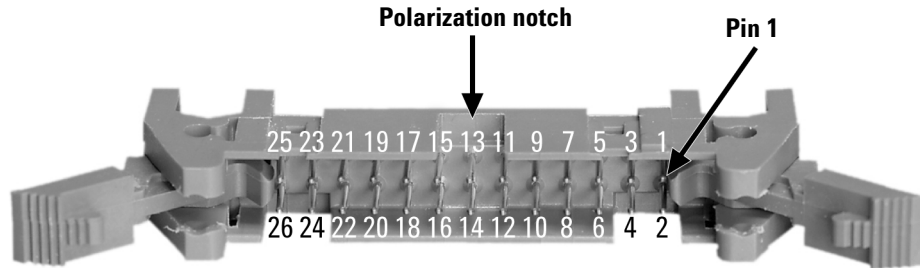

26-pin 0.1" Ribbon Cable Connector (typical keyed connector)

Polarization key



-Pin numbers are shown from side facing header P102-

Pin Connection Information for 26-Pin Ribbon Cable Header P102

1	Relay Ground	14	Digital Channel 001; Bit 5
2	Digital Channel 002; Bit 7	15	Digital Channel 001; Bit 4
3	Digital Channel 002; Bit 6	16	+5V power supply
4	Digital Channel 002; Bit 5	17	Digital Channel 001; Bit 3
5	Digital Channel 002; Bit 4	18	Digital Channel 001; Bit 2
6	+5V power supply	19	Digital Channel 001; Bit 1
7	Digital Channel 002; Bit 3	20	Digital Channel 001; Bit 0
8	Digital Channel 002; Bit 2	21	Relay Ground
9	Digital Channel 002; Bit 1	22	Control Line 2: Channel 2 Strobe Line
10	Digital Channel 002; Bit 0	23	Control Line 1: Channel 1 Strobe Line
11	Relay Ground	24	Control Line 3: Read/Write Status Line
12	Digital Channel 001; Bit 7	25	+5V power supply
13	Digital Channel 001; Bit 6	26	Relay Ground

Connector P101

Supplied 40-Pin Ribbon Cable Header P101 (3M part #3432-5602)

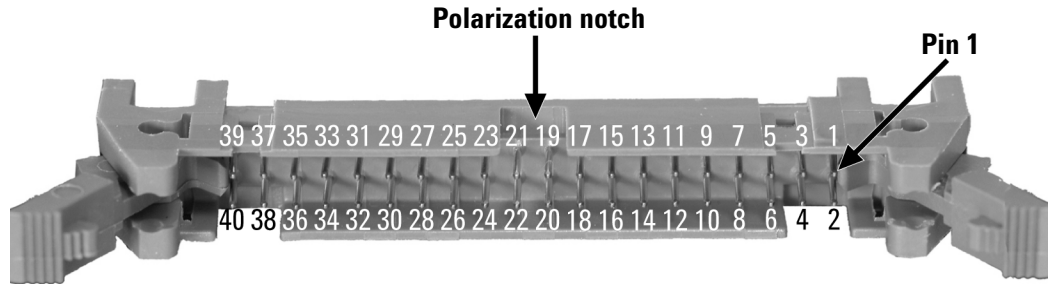

40-pin 0.1" Ribbon Cable Connector (typical keyed connector)

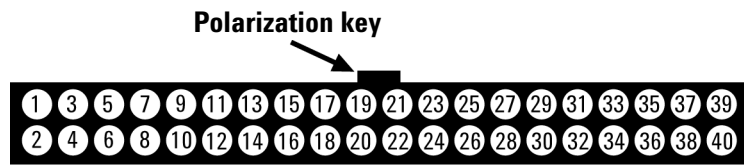

-Pin numbers are shown from side facing header P101-

Pin Connection Information for 40-Pin Ribbon Cable Header P101

1	Channel 914 (dual-purpose relay drive*)	21	+12V power supply
2	Channel 913 (dual-purpose relay drive*)	22	reserved - do not connect to this pin
3	Channel 912 (dual-purpose relay drive*)	23	reserved - do not connect to this pin
4	Channel 911 (dual-purpose relay drive*)	24	reserved - do not connect to this pin
5	Channel 128 (gen. purpose relay drive)	25	Channel 116 (gen. purpose relay drive)
6	Channel 127 (gen. purpose relay drive)	26	Channel 115 (gen. purpose relay drive)
7	Channel 126 (gen. purpose relay drive)	27	Channel 114 (gen. purpose relay drive)
8	Channel 125 (gen. purpose relay drive)	28	Channel 113 (gen. purpose relay drive)
9	Channel 124 (gen. purpose relay drive)	29	Channel 112 (gen. purpose relay drive)
10	Channel 123 (gen. purpose relay drive)	30	Channel 111 (gen. purpose relay drive)
11	Channel 122 (gen. purpose relay drive)	31	Channel 110 (gen. purpose relay drive)
12	Channel 121 (gen. purpose relay drive)	32	Channel 109 (gen. purpose relay drive)
13	Channel 120 (gen. purpose relay drive)	33	Channel 108 (gen. purpose relay drive)
14	Channel 119 (gen. purpose relay drive)	34	Channel 107 (gen. purpose relay drive)
15	Channel 118 (gen. purpose relay drive)	35	Channel 106 (gen. purpose relay drive)
16	Channel 117 (gen. purpose relay drive)	36	Channel 105 (gen. purpose relay drive)
17	reserved - do not connect to this pin	37	Channel 104 (gen. purpose relay drive)
18	reserved - do not connect to this pin	38	Channel 103 (gen. purpose relay drive)
19	reserved - do not connect to this pin	39	Channel 102 (gen. purpose relay drive)
20	+12V power supply	40	Channel 101 (gen. purpose relay drive)

CAUTION

*If Analog Bus relays K101-K104 are installed, channels 911-914 are dedicated to Analog Buses 1-4 and equipment damage may result from making connections to pins 1 through 4 of P101. Otherwise, channels 911-914 and pins 1-4 may be used as four additional general purpose relay drive lines.

Configuring the 34959A Breadboard Module

WARNING

SHOCK HAZARD Only qualified personnel who are aware of the hazards involved should install, remove or configure the 34959A breadboard for the 34980A mainframe. Before touching any installed accessory, turn off all power to the mainframe and terminal blocks, and to all external devices connected to the mainframe or terminal blocks.

Accessing the 34980A Mainframe's Analog Bus

If your custom circuitry will need access to the four Analog Buses on the mainframe's backplane, you must install relays (not provided) on and make connections directly to the Agilent-supplied PC board (see the explanation on [page 2](#) for PC board removal, and the table on [page 7](#) for connection information). The following enlargement of the Analog Bus control area of the board shows where to install the relays and make wire connections:

Analog Bus Relay Installation and Solder Hole Locations

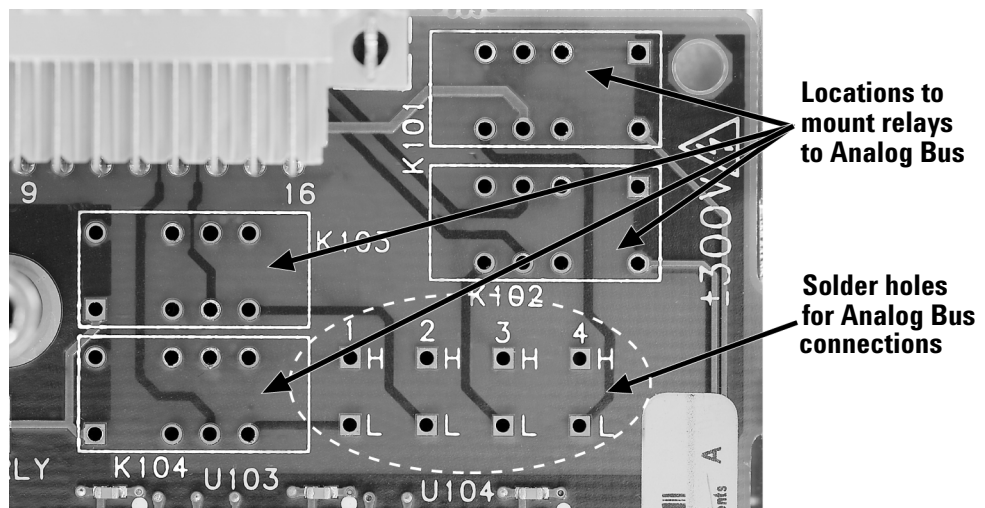

The locations for relays K101-104 are marked on the board. You may install any or all of these relays, as needed. The suggested supplier for these relays is:

Vendor: Omron Electronics LLC
Part Number: G6S-2-DC12 (qty 4)
Description: RELAY 2C 12VDC-COIL 2A 250VDC
Vendor Address: 55 East Commerce Drive, Schaumburg, Illinois 60173-5302 U.S.A.

CAUTION

When soldering relays to the Agilent-supplied PC board, take special care to avoid shorts between pins. Shorting these connections may result in damage to the breadboard module, the 34980A mainframe, other installed modules, or your test circuitry.

The connections from the Analog Bus outputs (8 holes marked on the Agilent-supplied PC board as 1 through 4, H and L) to your custom circuitry should be made with wire insulated for 300V service.

CAUTION

When soldering wire to the Analog Bus connection holes, take special care to avoid shorts between wires and/or holes. Shorting these connections may result in damage to the breadboard module, the 34980A mainframe, other installed modules, or your test circuitry.

The following table shows which relays must be installed to control the four Analog Bus channels, and which holes on the Agilent-supplied PC board (see the photo on [page 6](#) for the locations to solder each two-wire output connection):

34959A Breadboard: Connections to the 34980A Analog Buses

Relay #	Analog Bus Channel	Bus #	Connect to Hole on PC Board
K101	911	1	1H and 1L
K102	912	2	2H and 2L
K103	913	3	3H and 3L
K104	914	4	4H and 4L

WARNING

SHOCK HAZARD If *any* of the relays K101-K104 are installed on the 34959A module's Agilent-supplied PC board then an Analog Bus connection is possible to other installed plug-in modules. This connection can present hazardous voltages (up to 300V) to the user's custom PC board installed on the 34959A or any attached test circuitry.

CAUTION

The 34980A mainframe may provide significant current (up to 5A) to the breadboard before current limits within the mainframe or the Agilent-supplied PC board activate. Use adequate current limiting devices (power supply fuses rated at 0.5A are recommended) to protect the hardware installed on your custom circuit board.

Installing Custom Circuitry on the 34959A Breadboard Module

Connection to the Ribbon Cable Headers

The two supplied headers P101 and P102 have ejecting latches and polarization notches. Although individual crimp terminals can be used to connect to the header pins, the most secure connection will be achieved by using keyed ribbon cable connectors. The selection of ribbon connectors is left to the user. However, if you desire to hard-solder connections to your custom PC board, the following diagram and connector part numbers are offered as a suggestion:

Connection from Headers P101 and P102 to a Custom PC Board

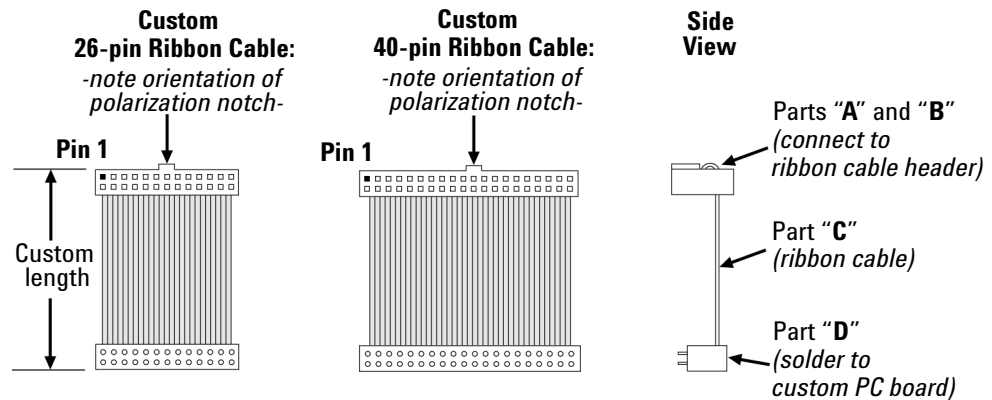

Suggested Part Numbers for Ribbon Cable Connections Shown above

Part	Description	AMP Part Number	3M Part Number
for connection to 26-pin header			
A	26-pin wire-mount socket	746288-6	3399-xxxx
B	26-pin strain relief	499252-3	3448-3026
C	26-conductor ribbon cable	971111-3	
D	PC-board mount	2-216093-6	
for connection to 40-pin header			
A	40-pin wire-mount socket	746288-9	3417-xxxx
B	40-pin strain relief	499252-1	3448-3040
C	40-conductor ribbon cable	971111-5	
D	PC-board mount	4-216093-0	

The suggested suppliers for these cables and connectors are:

Vendor: 3M Corporation
Vendor Address: 6801 River Place Boulevard, Austin, TX 78726 U.S.A.

Vendor: AMP
Vendor Address: Harrisburg, PA 17105 U.S.A.

Installing a Custom PC Board

The remaining space in the breadboard module is available for installing custom circuitry. Fifteen 3.18 mm (0.125") diameter holes, countersunk on the bottom of the sheet metal base, are provided for mounting the PC board to the base. The maximum allowable height of the board and attached components above the base, including spacers, is 23 mm. Assuming a PC board thickness of 1.6 mm, you should use 5.1 mm long spacers and M3x0.5mm thread flathead screws. The figure on [page 13](#) provides the dimensions of the largest PC board which will fit the breadboard module, the locations of the countersunk mounting holes, and their location relative to the ribbon cable headers and Dsub ports.

If you utilize a PC board with the maximum allowable dimensions, it may be necessary to first remove the Agilent-supplied PC board (34980A backplane interface with ribbon cable headers), install the custom board by inserting the Dsub connectors into the ports provided, secure the custom board, and then reinstall the Agilent-supplied PC board. When the module assembly is complete, replace the sheet metal cover and install the module in an available slot within the 34980A mainframe.

Extending the Breadboard Connections During Development

During development of your custom circuitry, you may need to work with your PC board on a test bench, outside the confines of the breadboard module. This should be done by using ribbon cable extenders and extra length of Analog Bus connection wire. Once your final PC board configuration is achieved, these leads should be shortened to allow fixed installation of the PC board inside the module.

CAUTION

Use of the Y1132A Service Extender from the 34980A mainframe to the breadboard module is not recommended, because the Service Extender is not rated for the 300V potentials available on the breadboard's Analog Bus connectors.

Spacing and Insulation Requirements for High Voltage Applications

If your planned use of the 34959A breadboard module will involve the application of high voltages ($>30V_{\text{rms}}$ AC or $>60V$ DC), refer to appropriate electrical standards for high-voltage circuit spacing and wire insulation requirements.

NOTE

The International Electrotechnical Commission (IEC) Standard 61010-1 (available at www.iec.ch) lists the insulation requirements for high voltage applications in Pollution Degree Levels 1, 2 and 3.

Operating Considerations

Electrical Specifications

The specifications below were derived from the individual components used to provide the relay drive and digital I/O functions:

Electrical Specifications for the 34959A Breadboard Module

Specification	Test Conditions	Minimum	Typical	Maximum
Total Power Consumption (by customer-installed circuits)	all connections total			6W
Maximum Power from 12V Supply				6W
Maximum Power from 5V Supply				1W
Connector P101 (Relay Drive)				
Current Limit (per relay drive pin)	all outputs driven simultaneously			150 mA
On Resistance (to chassis)	@ 100 mA output @ 400 mA output		4.2Ω 6.5Ω	5.7Ω 8.0Ω
Input Voltage				42V
Leakage Current	@ max. input voltage			8 μA
Connector P102 (Digital I/O)				
High Level Input Voltage		2V		5.5V
Low Level Input Voltage		0V		0.8V
High Level Output Voltage	@ 4 mA output @ 500 μA output	2.4V 3.0V		
Low Level Output Voltage	@ 8 mA output			0.4V

Environmental Voltage Limits

See the *Introduction to the Plug In Modules* chapter of the 34980A Mainframe User's Guide for detailed environmental operating conditions for the 34980A mainframe and its installed modules. That guidance sets a maximum voltage rating for the Analog Buses of 300V in pollution degree 1 (dry) conditions, and derates the maximum voltage to 100V for pollution degree 2 (possible condensation) conditions. That guidance applies to any circuitry installed in the 34959A module.

CAUTION

Exceeding the maximum power limits for the 12V and 5V power supplies (through improper wiring or cable damage) may cause the 34980A mainframe to reboot. Although over-current protection is provided on the power supply lines, operating in an overcurrent situation for extended periods could damage the mainframe.

Module Cooling

The maximum recommended power consumption/dissipation for the breadboard module and its installed circuitry is 6 watts, resulting in a 5°C rise in temperature.

NOTE

To allow adequate cooling of the breadboard module, ensure that your circuit layout does not impede air flow.

Dimension Information for the Custom PC Board Area

Utilization of the empty space within the 34959A breadboard module is left entirely up to the user. However, assuming you want to most fully utilize the space provided, output signals through the Dsub ports, and connect your board securely to the supplied ribbon cable headers, four detailed dimension drawings are provided in this section to assist with your PC board fabrication.

The figure on [page 13](#) illustrates the external dimensions of the largest PC board that will fit into the space provided, and provides distances on the plane of that board from the datum to the following locations:

- The 15 PC board mounting holes in the sheet metal base.
- Pin 1 of the board mounting position for the 26-pin ribbon cable connector carrying digital I/O signals and control power to/from header P102.
- Pin 1 of the board mounting position for the 40-pin ribbon cable connector carrying relay drive signals and control power from header P101.
- The center of the two user-supplied Dsub output connectors.
- The mounting holes for the two Dsub connectors. Note that this dimension, labelled “Dimension A” on the drawing, varies with the selection of Dsub connector used (e.g., DB50, DB78M, DB78F).

Dimension Information for the Custom PC Board Area

The figure on [page 14](#) shows the mounting footprints for the recommended DB50(M/F) connectors. The two figures on [page 15](#) show the footprints for the recommended DB78M and DB78F connectors, respectively. The part numbers for the recommended connectors are listed in the following table:

Recommended Dsub Connectors as Shown in Dimension Drawings 2 through 4

Connector	Agilent Part Number	Conec Part Number
DB-50 (M)	1253-5853	161C18569X
DB-50 (F)	1253-5854	DSSEXSTCM39A
DB-78 (M)	1253-6006	DLH5XP8CK53X
DB-78 (F)	1253-6007	DLH5XS8CK53X

The suggested supplier for the Dsub connectors is:

Vendor: **Conec Corporation**
Vendor Address: **343 Technology Drive, Garner, NC 27529 U.S.A.**

Dimensions of Suggested (maximum size) Custom PC Board

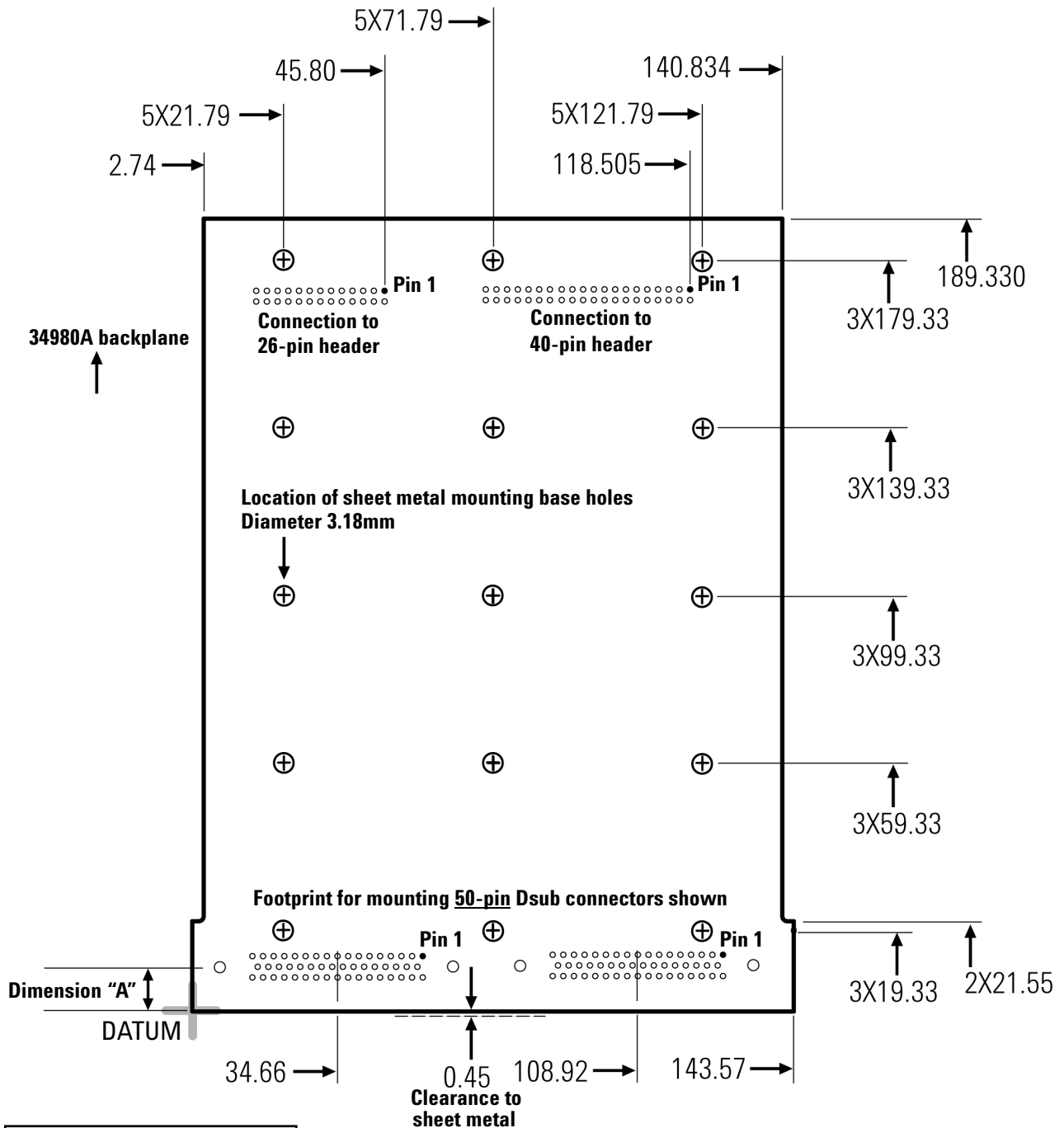

Dimension "A"	
DB-50 (M/F):	10.38mm
DB-78 (M):	12.25mm
DB-78 (F):	10.87mm

All dimensions are shown in millimeters

PC Board Footprint of Suggested DB50 Connectors (M/F)

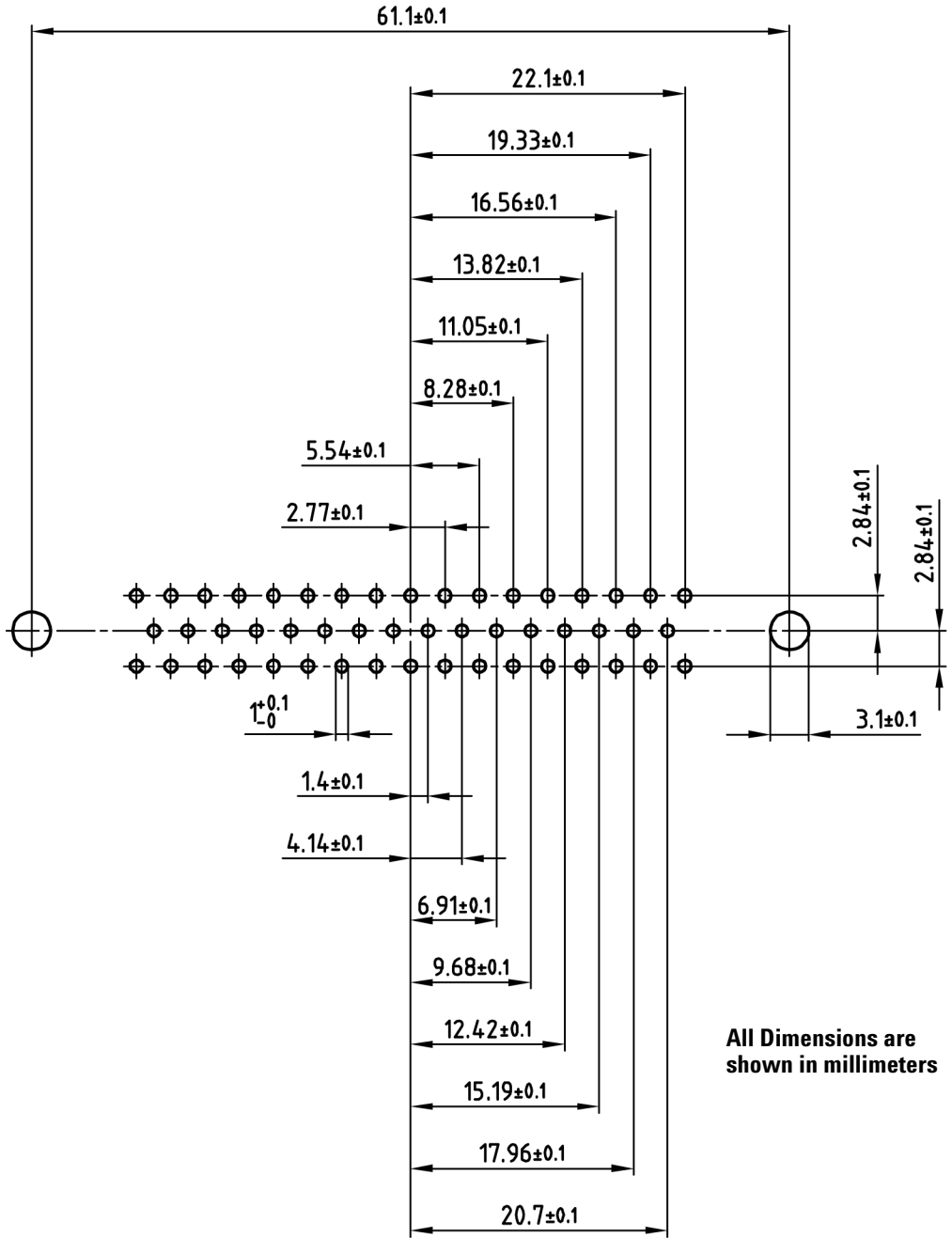

PC Board Footprint of Suggested DB78M Connector

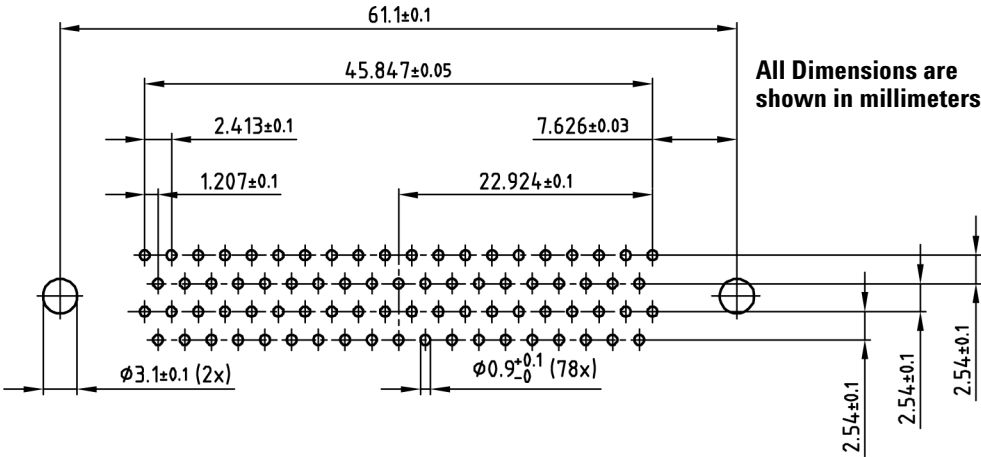

PC Board Footprint of Suggested DB78F Connector

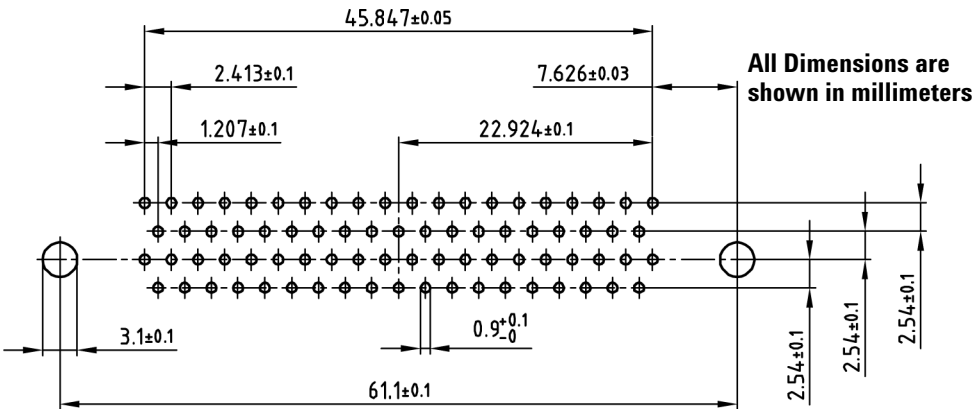

Programming the 34959A Breadboard Module

The 34959A Breadboard Module has three methods of signal input/output between the 34980A mainframe and the user-designed circuitry. The first is to access the four Analog Buses. The second provides control for up to 32 general purpose relays you may install on your PC board (only 28 general purpose relays if the four Analog Bus relay control lines will be used). The third provides two bytes of simple digital I/O with handshake signals.

Analog Bus Relay Functions

The 34980A mainframe provides four two-wire internal Analog Buses for signal routing. The channels for the four Analog Buses are numbered 911 through 914. If any of the optional Analog Bus relays K101 through K104 are installed on the 34959A, you can route external signals to the Analog Buses or access signals introduced to those buses through other installed modules. Refer to Chapter 2 for configuring the internal DMM for making voltage, resistance, or frequency measurements.

NOTE

The internal DMM uses Analog Bus 1 for voltage, 2-wire resistance, and frequency measurements. For 4-wire resistance measurements, the internal DMM uses both Analog Bus 1 and Analog Bus 2.

The *Agilent 34980A Programmer's Reference* details the SCPI language and syntax for all commands available through the remote interface. Examples of some commands you will use to control relays to the analog bus, query relay status or assign custom labels to these channels are described below:

The `ROUTE:OPEN` command is used to open a relay. The syntax is:

```
ROUTE:OPEN (@<ch_list>)
```

Example: If the Breadboard Module is in slot 1, the following command opens relay K101 to Analog Bus 1 (channel 911):

```
ROUTE:OPEN (@1911)
```

The `ROUTE:OPEN?` command is used to query the status of a relay. The syntax is:

```
ROUTE:OPEN? (@<ch_list>)
```

Example: If the Breadboard Module is in slot 3, the following query returns the status of relay K104 to Analog Bus 4 (channel 914). A 1 is returned if the relay is open; a 0 is returned if the relay is closed:

```
ROUTE:OPEN? (@3914)
```

The ROUTE:CLOSE command is used to close a relay. The syntax is:

```
ROUTE:CLOSE (@<ch_list>)
```

Example: If the Breadboard Module is in slot 7, the following command closes relay K103 to Analog Bus 3 (channel 913):

```
ROUTE:CLOSE (@7913)
```

The ROUTE:CLOSE? command is used to query the status of a relay, with opposite results to the ROUTE:OPEN? command. The syntax is:

```
ROUTE:CLOSE? (@<ch_list>)
```

Example: If the Breadboard Module is in slot 6, the following query returns the status of relay K104 to Analog Bus 4 (channel 914). A 1 is returned if the relay is closed; a 0 is returned if the relay is open:

```
ROUTE:CLOSE? (@6914)
```

The ROUTE:CHANNEL:LABEL command is used to assign a user-defined label to any of the 32 channels accessible by the Breadboard Module, including the Analog Bus channels. These labels may be up to 18 ASCII characters in length, and are not required to be unique. The syntax is:

```
ROUTE:CHANNEL:LABEL <label>, (@<ch_list>)
```

Example: If the Breadboard Module is in slot 2, the following command assigns the label “Test Point A” to Analog Bus channel 913:

```
ROUTE:CHANNEL:LABEL "Test Point A", (@2913)
```

Most SCPI commands can address more than one channel at a time, including specifying a range of channels. Refer to the Agilent 34980A *Programmer's Reference* for more complete information.

General Purpose Relay Functions

In addition to the four dual-purpose relay channels 911-914, which may be used as general purpose relay drive channels if relays K101-K104 are not installed, the 34959A breadboard module provides 28 additional general purpose relay drive lines. The channels for these relay drives are numbered 101 through 128. All of the SCPI commands described in the previous section, “[Analog Bus Relay Functions](#)” on page 16, also apply to these relay drives. Since relay selection is left to the user’s discretion, take particular note of the maximum current limits specified in the Electrical Specifications table on [page 10](#) when choosing and driving your relays.

Digital I/O Functions

The Digital input/output (DIO) interface provides two 8-bit bytes of DIO, which may be accessed individually or combined together to form one 16-bit word. Three control lines are provided. See the Pin Connection Information table (for P102) on [page 4](#) for connection information. The three control lines provide handshake of the read/write SCPI commands (`SENSE` and `SOURCE`) sent to the mainframe, as follows:

Timing for Read Commands

When the 34980A receives a SCPI command to read from the breadboard, control line 3 is set high (its default setting, indicating a read request).

If the read target is byte 1, control line 1 is set strobe low, the byte 1 data is read, and then control line 1 is set strobe high. The strobe pulse width is 3.75 μs , and the time from strobe low to valid data is 1.25 μs .

Similarly, *if the read target is byte 2*, control line 2 is set strobe low, the byte 2 data is read, and then control line 2 is set strobe high. The strobe pulse width is 3.75 μs , and the time from strobe low to valid data is 1.25 μs .

If both bytes are configured as a word, and targeted as a word in the read (`SENSE`) command, both control lines 1 and 2 are set strobe low, all 16 bits are read, and then both control lines are set strobe high. The strobe pulse width is longer (5 μs) than for a single byte read, but the time from strobe low to valid data is still 1.25 μs .

In all three cases, once the data has been read by the mainframe, the data lines are left in tri-state (indeterminate).

The read timing diagram is shown on [page 19](#).

Timing for Write Commands

When the 34980A receives a SCPI command to write to the breadboard, control line 3 is set low (indicating a write request).

If the write target is byte 1, control line 1 is set strobe low, the byte 1 data is written to the 8 output bits, and then control line 1 is set strobe high. Valid data is present 1.25 μs before the control line strobe is set high. Control line 3 is then set high.

Similarly, *if the write target is byte 2*, control line 2 is set strobe low, the byte 2 data is written to the 8 output bits, and then control line 2 is set strobe high. Valid data is present 1.25 μs before the control line strobe is set high. Control line 3 is then set high.

If both bytes are targeted in the write (SOURCE) command, both control lines 1 and 2 are set strobe low, both bytes' data are written to the 16 output bits, and then both control lines are set strobe high. Valid data is present 1.25 μ s before the control line strobe is set high. Control line 3 is then set high.

In all three cases, once the data has been written by the mainframe, the data is kept on the data lines until another (read or write) command changes them.

The write timing diagram is shown below.

Timing Diagrams for the Digital Read and Write Commands

The strobe timing, control line status and data timing for the read and write commands as explained above are illustrated in the diagrams that follow:

34959A Breadboard Module Digital I/O Timing Diagrams

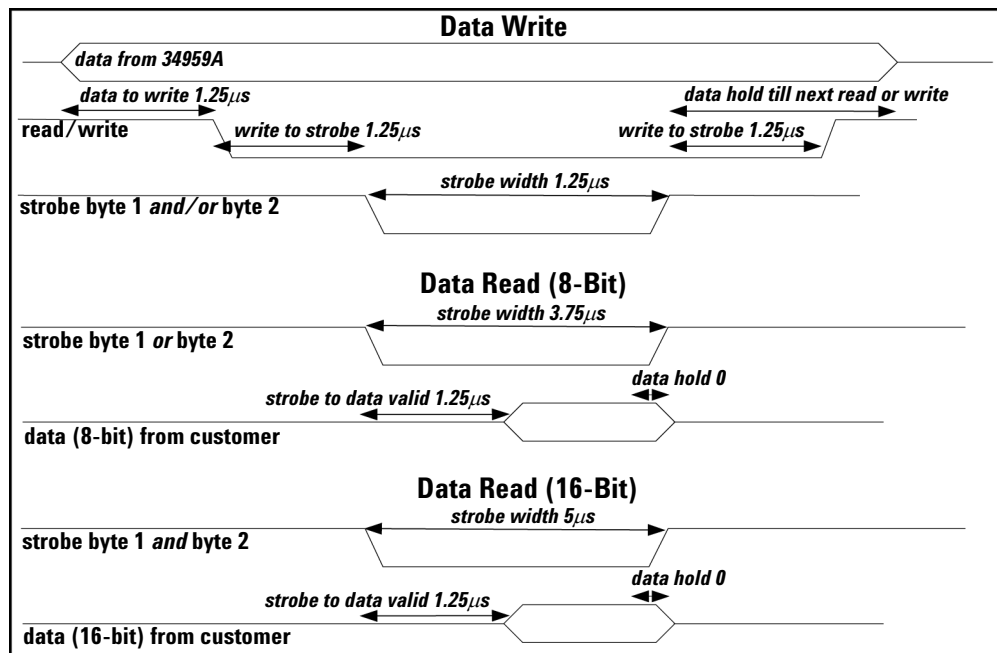

Digital Channel Numbering

The two 8-bit DIO channels, numbered 001 and 002, are intended to be used as two separate channels (bytes). However, they can be grouped together as a single 16-bit channel (word). When these channels are grouped, all bits in Channel 002 will be reconfigured to operate in the same direction (input or output) as Channel 001; Channel 001 will become the control channel, and should be used for all DIO channel configuration commands.

Read Command Syntax

Before reading digital data from the breadboard, you must first configure the digital channel width as byte or word, using the `CONFigure:DIGital:WIDTh` command. The syntax is:

```
CONFigure:DIGital:WIDTh <width>, (@<ch_list>)
```

Example: If the Breadboard Module is in slot 1, the following command configures channel 002 as a byte:

```
CONFigure:DIGital:WIDTh BYTE, (@1002)
```

Example: If the Breadboard Module is in slot 7, the following command configures channels 001 and 002 together as a word:

```
CONFigure:DIGital:WIDTh WORD, (@7001)
```

After either channel has been configured as a byte, or both have been configured as a word, you must then specify the target channel for *input* operations, using the `CONFigure:DIGital:DIRection` command. The syntax is:

```
CONFigure:DIGital:DIRection <direction>, (@<ch_list>)
```

Example: If the Breadboard Module is in slot 3, and channel 002 has been configured as a byte, the following command configures channel 002 as a byte-width input:

```
CONFigure:DIGital:DIRection INPut, (@3002)
```

Example: If the Breadboard Module is in slot 5, and both channels have been configured as a word, the following command configures the combined channel as a word-width input (note that it is only necessary to specify the first channel in SCPI, once the word width has been specified):

```
CONFigure:DIGital:DIRection INPut, (@5001)
```

Once the data width and direction have been configured, the data (either word, byte or bit) is read using the `SENSE` command. The syntax is:

```
SENSE:DIGital:DATA:<width>? (@<ch_list>)
```

Example: If the Breadboard Module is in slot 3, and channel 002 has been configured as a byte input, the following command returns the value of the channel 002 byte as an integer:

```
SENSE:DIGital:DATA:BYTE? (@3002)
```

Example: If the Breadboard Module is in slot 4, and channels 001 and 002 have been configured as a word input, the following command returns the value of the combined channel word as an integer:

```
SENSe:DIgital:DATA:WORD? (@4001)
```

Example: If the Breadboard Module is in slot 6, and channel 001 has been configured as a byte input, the following command returns the state of bit 4 on the channel 001 byte:

```
SENSe:DIgital:DATA:BIT? 4, (@6001)
```

Write Command Syntax

Before writing digital data to the breadboard outputs, you must first configure the digital channel width as byte or word, using the same commands listed under “[Read Command Syntax](#)” on page 20.

After either channel has been configured as a byte, or both have been configured as a word, you must then specify the target channel for *output* operations, using the `CONFigure:DIgital:DIRection` command. The syntax is the same as for input operations, except for the specified `<direction>`.

Example: If the Breadboard Module is in slot 3, and channel 002 has been configured as a byte, the following command configures channel 002 as a byte-width output:

```
CONFigure:DIgital:DIRection OUTPut, (@3002)
```

Example: If the Breadboard Module is in slot 5, and both channels have been configured as a word, the following command configures the combined channel as a word-width output (note that it is only necessary to specify the first channel in SCPI, once the two channels have been configured as a word):

```
CONFigure:DIgital:DIRection OUTPut, (@5001)
```

Once the data width and direction have been configured, the data (either word, byte or bit) is written to the output lines using the `SOURce` command. The syntax of that command is subtly different for writing a single bit versus writing an entire byte or word.

To output a digital bit, the specified bit number must be 0 (LSB) through 7 (MSB) of the targeted byte, and the syntax is:

```
SOURce:DIgital:DATA:BIT {0|1}, <bit>, (@<ch_list>)
```

Example: If the Breadboard Module is in slot 3, and channel 002 has been configured as a byte output, the following command writes a 1 to bit 6 of channel 002:

```
SOURce:DIGital:DATA:BIT 6,1 (@3002)
```

To output a digital byte, the specified value may be binary (valid values from #B00000000 through #B11111111), hexadecimal (valid values from #H0 through #HFF) or integer (valid values 0 through 255) and the syntax is:

```
SOURce:DIGital:DATA:BYTE <data>, (@<ch_list>)
```

Example: If the Breadboard Module is in slot 6, and channel 002 has been configured as a byte output, any of the following commands will write the value 10011101 to channel 002:

```
SOURce:DIGital:DATA:BYTE #B10011101, (@6002)
```

```
SOURce:DIGital:DATA:BYTE #H9D, (@6002)
```

```
SOURce:DIGital:DATA:BYTE 157, (@6002)
```

To output a digital word, the specified value may be binary (valid values from #B0000000000000000 through #B1111111111111111), hexadecimal (valid values from #H0 through #HFFFF) or integer (valid values 0 through 65535) and the syntax is:

```
SOURce:DIGital:DATA:WORD <data>, (@<ch_list>)
```

Example: If the Breadboard Module is in slot 8, and channels 001 and 002 have been configured as a word output, any of the following commands will write the value 1001100110011001 to the combined digital channel:

```
SOURce:DIGital:DATA:WORD #B1001100110011001, (@8001)
```

```
SOURce:DIGital:DATA:WORD #H9999, (@8001)
```

```
SOURce:DIGital:DATA:WORD 39321, (@8001)
```

Index

A

analog bus connections, 6

C

channel numbering, 17, 19
configuring the module, 6

D

description, 1
digital I/O
 command timing, 18
dimensions for the custom PC board area, 11
disassembly, 2
Dsub connector recommendations, 12

E

electrical specifications, 10

I

installing custom circuitry, 8

L

layout of the module, 3

P

programming examples, 16

R

ribbon cable pinouts, 4

S

simplified block diagram, 1

W

warranty, ii

