

# Infiniium Z-Series Oscilloscopes

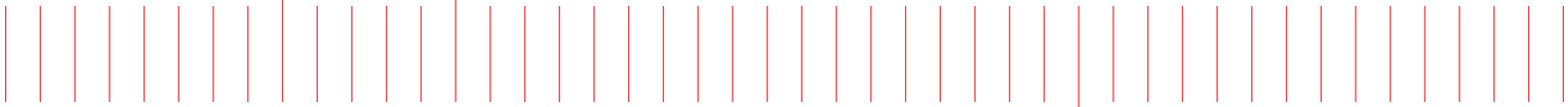

# Notices

© Keysight Technologies, Inc. 2014

No part of this manual may be reproduced in any form or by any means (including electronic storage and retrieval or translation into a foreign language) without prior agreement and written consent from Keysight Technologies, Inc. as governed by United States and international copyright laws.

## Manual Part Number

54932-97005

## Edition

First edition, April 2014

Printed in USA

Keysight Technologies, Inc.  
1900 Garden of the Gods Road  
Colorado Springs, CO 80907 USA

## Warranty

The material contained in this document is provided “as is,” and is subject to being changed, without notice, in future editions. Further, to the maximum extent permitted by applicable law, Keysight disclaims all warranties, either express or implied, with regard to this manual and any information contained herein, including but not limited to the implied warranties of merchantability and fitness for a particular purpose. Keysight shall not be liable for errors or for incidental or consequential damages in connection with the furnishing, use, or performance of this document or of any information contained herein. Should Keysight and the user have a separate written agreement with warranty terms covering the material in this document that conflict with these terms, the warranty terms in the separate agreement shall control.

## Technology Licenses

The hardware and/or software described in this document are furnished under a license and may be used or copied only in accordance with the terms of such license.

## Restricted Rights Legend

If software is for use in the performance of a U.S. Government prime contract or subcontract, Software is delivered and licensed as “Commercial computer software” as defined in DFAR 252.227-7014 (June 1995), or as a “commercial item” as defined in FAR 2.101(a) or as “Restricted computer soft-

ware” as defined in FAR 52.227-19 (June 1987) or any equivalent agency regulation or contract clause. Use, duplication or disclosure of Software is subject to Keysight Technologies’ standard commercial license terms, and non-DOD Departments and Agencies of the U.S. Government will receive no greater than Restricted Rights as defined in FAR 52.227-19(c)(1-2) (June 1987). U.S. Government users will receive no greater than Limited Rights as defined in FAR 52.227-14 (June 1987) or DFAR 252.227-7015 (b)(2) (November 1995), as applicable in any technical data.

## Safety Notices

### CAUTION

A **CAUTION** notice denotes a hazard. It calls attention to an operating procedure, practice, or the like that, if not correctly performed or adhered to, could result in damage to the product or loss of important data. Do not proceed beyond a **CAUTION** notice until the indicated conditions are fully understood and met.

### WARNING

A **WARNING** notice denotes a hazard. It calls attention to an operating procedure, practice, or the like that, if not correctly performed or adhered to, could result in personal injury or death. Do not proceed beyond a **WARNING** notice until the indicated conditions are fully understood and met.

# Infiniium Z-Series Oscilloscopes—At a Glance

## Ease of use with high performance

The Infiniium Z-Series oscilloscopes combine unprecedented ease-of-use with high-performance digitizing oscilloscope functionality to simplify your design and analysis measurement tasks.

- Traditional oscilloscope front-panel interface provides direct access to the controls needed for most troubleshooting tasks.
- User interface with menus, windows, dialog boxes, toolbars and wizards provides easy access to dozens of configuration and analysis tools, ensuring you can set up and make the most complex measurements.
- All models offer 80 GSa/s sampling rate on all four channels. RealEdge models offer 160 GSa/s on two channels.
- Models with bandwidths from 20 GHz to 63 GHz.

## Display shows waveforms and user interface

- User interface allows direct interaction with waveforms, including drag-and-drop positioning and instant waveform zoom.
- Large capacitive touch screen with multi-touch (gestures), handles, and resizing allows oscilloscope operation without an external pointing device.
- Waveforms are displayed in color, making correlation easy.
- Current configuration parameters displayed near the waveform display area are color-coded to make identification easy.
- Menus and toolbars simplify complex measurement setups.

## Horizontal controls set sweep speed and position

- Zoom box on main sweep window make it easy to see what will appear in the zoom window.

## Acquisition and general controls start and stop the oscilloscope and do basic setup

- Run, stop, and single controls for continuous or single acquisitions.
- Clear display before one or more acquisitions.
- Default setup and Autoscale set initial configuration.

## Removable solid-state drive and USB 2.0 and 3.0 ports for saving and restoring setups and measurement results

- Store measurement displays for inclusion in reports and test setup guides.
- Store oscilloscope setups to repeat tests another time.
- Hard disk stores oscilloscope operating system.

Trigger setup controls set mode and basic parameters

- Select Edge, Glitch, or Advanced Modes.
- Choose input source and slope.
- Use auxiliary trigger to increase triggering flexibility.

Vertical controls set attenuation and position

- Color-coded knobs make it easy to find the controls that affect each waveform.
- Vertical scale is displayed for the selected waveform.

Marker and quick measurements help measure waveform parameters

- Use waveform markers 1 and 2 to check voltage or  $\Delta$ -time at any point on the displayed waveform.

## In This Service Guide

This guide provides the service information for the Keysight Technologies Infiniium Z-Series oscilloscopes. It is divided into eight chapters.

Chapter 1, "General Information," lists the oscilloscope models that are covered by this guide, the supplied accessories, and the specifications and characteristics for the Infiniium Z-Series oscilloscopes.

Chapter 2, "Calibration," describes the types of calibrations, and how and when to run the user calibration procedure.

Chapter 3, "Testing Performance," provides instructions for testing the oscilloscope to verify that it performs according to specifications.

Chapter 4, "Troubleshooting," provides flowcharts and procedures for diagnosing problems for assembly-level repair.

Chapter 5, "Replacing Assemblies," provides instructions for removing and replacing assemblies in the oscilloscope.

Chapter 6, "Replaceable Parts," provides exploded parts diagrams and a list of orderable replacement parts.

Chapter 7, "Theory of Operation," describes the basic structure of the oscilloscope and how its parts interact.

Chapter 8, "Safety Notices", provides warnings and describes icons used on the oscilloscopes.



# Contents

## 1 General Information

Instruments Covered by this Service Guide	10
Accessories Supplied	10
Specifications and Characteristics	11

## 2 Calibration

What is a Calibration?	14
Running a Self Calibration	15

## 3 Testing Performance

Performance Test Interval	20
Performance Test Record	20
Test Order	20
Test Equipment	20
Performing Self-Test and Calibration	21
Vertical Performance Verification	22
Offset Accuracy Test	23
DC Gain Accuracy Test	30
Analog Band width–Maximum Frequency Test	34
Time Scale Accuracy (TSA) Test	44
Performance Test Record	47

## 4 Troubleshooting

Troubleshooting Overview	56
Primary Trouble Isolation	57
Power Supply Troubleshooting	63
Setting Up the BIOS	68
Motherboard Verification	69
Display Troubleshooting	70
Acquisition/Backplane Assembly Troubleshooting	72
Keyboard Troubleshooting	74
LED Troubleshooting	75
Touch Screen Troubleshooting	76

Oscillator Board Troubleshooting	77
Checking Probe Power Outputs	78
Sync Port Troubleshooting	79
Before You Contact Keysight	80

## 5 Replacing Assemblies

Replacing Assemblies	82
Returning the Oscilloscope to Keysight Technologies for Service	84
Removing and Replacing the Top Panel and Motherboard	85
Removing and Replacing the Hard Disk Drive	90
Removing and Replacing the Power Supply	91
Removing and Replacing the Front Panel Assembly and Bottom Panel	92
Removing a RealEdge Assembly	96
Finishing Removal of the Front Panel	98
Removing and Replacing Front Panel Assembly Parts	99
Removing and Replacing RealEdge Components	104
Removing and Replacing the Acquisition Boards/Backplane Assembly	106
Setting the Calibration Factors after Replacing an Acquisition Board	113
Removing and Replacing the Fans	114

## 6 Replaceable Parts

Ordering Replaceable Parts	118
Exploded Views	119
Replaceable Parts List	124

## 7 Theory of Operation

Theory of Operation	131
Motherboard Assembly	132
Acquisition Assembly	133
Backplane Assembly	135
Oscillator Assembly	141
Front Panel Assembly	142
RealEdge Technology Assembly	144
Power Supply	145

## 8 Safety Notices

Warnings	147
Cleaning the Instrument	148
Safety Symbols	148



# 1 General Information

Instruments Covered by this Service Guide	10
Accessories Supplied	10
Specifications and Characteristics	11

### Instruments Covered by this Service Guide

Oscilloscopes manufactured after the date this manual was released may be different from those described in this manual. The release date of this manual is shown on the back of the title page. This manual will be revised when necessary.

If you have an oscilloscope that was manufactured after the release of this manual, please check the Keysight Technologies website at [www.keysight.com](http://www.keysight.com) to see whether a newer version of this manual is available.

The following Z-Series oscilloscopes are covered in this guide.

<b>Model</b>	<b>Band widths and Sample Rates</b>
DSOZ204A	20 GHz BW, 80 GSa/S on 4 channels
DSAZ204A	20 GHz BW, 80 GSa/S on 4 channels
DSOZ254A	25 GHz BW, 80 GSa/S on 4 channels
DSAZ254A	25 GHz BW, 80 GSa/S on 4 channels
DSOZ334A	33 GHz BW, 80 GSa/S on 4 channels
DSAZ334A	33 GHz BW, 80 GSa/S on 4 channels
DSOZ504A	50 GHz BW on 2 channels, 33 GHz BW on 4 channels; 160 GSa/S on 4 channels
DSAZ504A	50 GHz BW on 2 channels, 33 GHz BW on 4 channels; 160 GSa/S on 4 channels
DSOZ594A	59 GHz BW on 2 channels; 33 GHz BW on 4 channels; 160 GSa/S on 4 channels
DSAZ594A	59 GHz BW on 2 channels; 33 GHz BW on 4 channels; 160 GSa/S on 4 channels
DSOZ634A	63 GHz BW on 2 channels, 33 GHz BW on 4 channels; 160 GSa/S on 4 channels
DSAZ634A	63 GHz BW on 2 channels, 33 GHz BW on 4 channels; 160 GSa/S on 4 channels

The oscilloscope model can be identified by the product number on the front or rear panel.

### Accessories Supplied

- Mouse
- Keyboard
- Front panel cover
- ESD wrist strap
- Calibration cable (models > 33 GHz include a second calibration cable for the RealEdge inputs)
- Connector Savers (quantity of 5 for models ≤ 33 GHz; additional 2 for models > 33 GHz)
- Power cord (see parts list in chapter 6 for country-dependent part number)

## Specifications and Characteristics

The following table contains a partial list of specifications and characteristics for the Keysight Infiniium Z-Series oscilloscopes. For a full list of specifications and characteristics, see the data sheets at [www.keysight.com/find/Z-series](http://www.keysight.com/find/Z-series).

Specifications that are pertinent to each test are in the **Testing Performance** chapter. Specifications are valid after a 30-minute warm-up period, and within  $\pm 5^{\circ}\text{C}$  from the temperature at which the last self-calibration was performed.

Environment	Indoor use only.
Ambient Temperature	Operating: 5 °C to +40 °C Non-operating: -40 °C to +65 °C
Humidity	Operating: up to 95% relative humidity (non-condensing) at +40 °C Non-operating: up to 90% relative humidity at +65 °C
Altitude	Operating: up to 4,000 m (12,000 feet) Non-operating: up to 15,300 meters (50,000 feet)
Installation/ Meas. Category	Installation category: 2. Measurement category: 1
Weight	71 lbs
Safety	CAN/CSA-C22.2 No. 61010-1-04 UL Std. No. 61010-1 (2nd Edition)
Power Requirements	100 - 240 VAC +-10% at 50/60 Hz; Typical input power for models <= 33 GHz 1280 Watts Maximum input power for models > 33 GHz 1350 Watts Well regulated power is required for 100-120 AC operation
Voltage Fluctuations	Note that the main supply voltage fluctuations are not to exceed $\pm 10\%$ of the nominal supply voltage.
Pollution Degree	The Infiniium Z-Series oscilloscopes may be operated in environments of Pollution Degree 2.
Pollution Degree Definitions	Pollution Degree 1: No pollution or only dry, non-conductive pollution occurs. The pollution has no influence. Example: A clean room or climate-controlled office environment. Pollution Degree 2. Normally only dry non-conductive pollution occurs. Occasionally a temporary conductivity caused by condensation may occur. Example: General indoor environment. Pollution Degree 3: Conductive pollution occurs, or dry, non-conductive pollution occurs which becomes conductive due to condensation which is expected. Example: Sheltered outdoor environment.

## 1 General Information

## 2 Calibration

What is a Calibration? 14

Running a Self Calibration 15

### What is a Calibration?

A calibration is simply an oscilloscope self-adjustment. The purpose of a calibration is performance optimization.

There are three ways to calibrate an Infiniium oscilloscope:

- User mode, also known as a normal calibration, user calibration, or self calibration. User mode includes the minimum set of calibrations and is intended to be run by oscilloscope users. The user must be logged in as an administrator to run a self calibration. In user mode you may choose to run time scale calibrations and interleave correction calibrations, though those selections default to not run and they require additional equipment. A self calibration for channels 1-4 takes about 3 hours to complete, and an additional 3 hours for RealEdge channels 1R and 3R on models > 33 GHz. Interleave correction calibrations add about 15 minutes per channel.
- Service mode, also known as a service calibration. A service calibration is performed only by Keysight Service Center technicians. In service mode the 50  $\Omega$  input resistance calibration is performed, in addition to everything calibrated in the normal mode. The time scale and interleave correction calibrations are run by default, though they can be turned off. Additional equipment is required to run a service calibration. A service calibration takes about 3-1/2 hours for channels 1-4, and an additional 3-1/2 hours for RealEdge channels 1R and 3R on models > 33 GHz.
- Factory mode, also known as a factory calibration. A factory calibration includes the full set of calibrations, including time scale and interleave correction, and other calibrations. A factory calibration is normally performed once during production of the oscilloscope. A factory calibration must also be performed on a RealEdge oscilloscope when an acquisition board, any RealEdge components, or the RealEdge front panel are replaced. Additional equipment is required to perform a factory calibration on RealEdge channels.

All of the calibration factors are stored into flash RAM on the acquisition board so that the calibration factors determined by the factory calibration are preserved even if the hard drive is replaced or reformatted. A factory calibration takes up to 4 hours for channels 1-4 and an additional 4 hours for RealEdge channels.

The following section describes how to run a self (user) calibration.

## Running a Self Calibration

**Let the oscilloscope warm up before adjusting.**

Warm up the oscilloscope for 30 minutes before starting the calibration procedure. Failure to allow warm up may result in inaccurate calibration.

The self calibration uses signals generated in the oscilloscope to calibrate channel scale, offsets, and trigger parameters. There are three times we recommend performing a self calibration:

- At least once a year.
- When you replace an acquisition board or the hard drive.
- When the oscilloscope’s operating temperature (after the 30-minute warm-up period) is more than  $\pm 5$  °C different from that of the last calibration. Be sure to perform a self calibration—even if one was recently performed—when environmental temperature conditions cause the oscilloscope’s operating temperature to change, such as when the oscilloscope is moved to a test rack or chamber.

**Table 1** Equipment Required

Description	Critical Specifications	Recommended Model/Part Number
Connector Savers (5 supplied with oscilloscope)	3.5 mm (f) to 3.5 mm (f)	Keysight 54916-68717 (for all oscilloscope models, channels 1-4)
Connector Savers (2 supplied with models > 33 GHz)	1.85 mm (f) to 1.85 mm (f)	Keysight 54932-68712 (for models > 33 GHz, channels 1R and 3R)
Cable assembly	50 $\Omega$ characteristic impedance BNC (m) connectors, 36 inches (91 cm) to 48 inches (122 cm) long	Keysight 8120-1840
Adapter	SMA(m) to BNC(f)	Keysight 1250-1200
Cable (supplied with oscilloscope)	No substitute	Keysight 54916-61626 (for all oscilloscope models, channels 1-4) Keysight 54932-61630 (for models > 33 GHz, channels 1R and 3R)

**Calibration time**

It takes about 3 hours to run the self calibration on channels 1-4 on the oscilloscope, plus 3 more hours to calibrate RealEdge channels 1R and 3R, including the time required to change cables from channel to channel. Add 15 minutes per channel for interleave correction calibrations.

## 2 Calibration

- 1 Let the oscilloscope warm up before running the self calibration.

The self calibration should be done only after the oscilloscope has run for 30 minutes at ambient temperature with the cover installed. Calibration of an oscilloscope that has not warmed up may result in an inaccurate calibration.

- 2 Click **Utilities > Calibration....**
- 3 Uncheck the **Cal Memory Protect** box.

You cannot run a self calibration if this box is checked. See the following figure for an example calibration screen.



- 4 Click **Start**, then follow the instructions on the screen.

The routine will ask you to follow these steps:

- a Disconnect everything from all inputs and Cal Out.
- b Indicate whether you want to run time scale and interleave response correction calibrations. For a list of equipment required to perform the time scale calibration, refer to the “Time Scale Accuracy (TSA) Test” section in the next chapter. The interleave correction calibration requires a sine wave generator and a  $\geq 67$  GHz cable for RealEdge channels, with 1.85 mm male connectors on each end. You will also need to use the two supplied 1.85 mm (f)-(f) connector savers. To learn more about both calibration options, click **Help** from the Calibration Options dialog box.
- c Connect the calibration cable from Cal Out to channel 1.



You must use the 54916-61626 cable (channels 1-4) or 54932-61630 cable (channels 1R and 3R) with two connector saver adapters for all oscilloscopes. Failure to use the appropriate calibration cable will result in an inaccurate calibration.

- d** Connect the calibration cable from Cal Out to each of the channel inputs as requested.
  - e** When instructed, connect the calibration cable from the Cal Out on the front panel of the oscilloscope to the 1250-1200 SMA(m) to BNC(f) adapter and then connect the other end of the 1250-1200 adapter to the 8120-1840 BNC cable. Connect the other end of the BNC cable to the Trig In on the rear of the oscilloscope.
  - f** A Passed/Failed indication appears for each calibration section. If any section fails, click the **Enable Details** box for information on the failures. Also check the calibration cables.
- 5** When the calibration procedure is complete, click **Close**.

## 2 Calibration

## 3 Testing Performance

Performing Self-Test and Calibration	21
Vertical Performance Verification	22
Offset Accuracy Test	23
DC Gain Accuracy Test	30
Analog Bandwidth–Maximum Frequency Test	34
Time Scale Accuracy (TSA) Test	44
Performance Test Record	47

This chapter documents performance test procedures. Performance verification for the oscilloscopes covered by this manual consists of three main steps:

- 1 Performing the internal oscilloscope self-tests to ensure that the measurement system is functioning properly
- 2 Calibrating the oscilloscope
- 3 Testing the oscilloscope to ensure that it is performing to specification

## 3 Testing Performance

### Performance Test Interval

The procedures in this section may be performed for incoming inspection and should be performed periodically to verify that the oscilloscope is operating within specification. The recommended test interval is once per year or after 2000 hours of operation. Performance should also be tested after repairs or major upgrades.

### Performance Test Record

A test record form is provided at the end of this section. This record lists performance tests and test limits, and provides space to record test results.

### Test Order

The tests in this section may be performed in any order. However, it is recommended to conduct the tests in the order presented in this manual as this represents an incremental approach to performance verification. This may be useful if you are attempting to troubleshoot a suspected problem.

### Test Equipment

Lists of equipment needed to conduct each test are provided for each test procedure. The procedures are written to minimize the number and types of test equipment and accessories required. The test equipment in these lists are currently available for sale by Keysight at the time this document was written. In some cases, the test procedures use features specific to the test equipment in the recommended equipment list. However, other equipment, cables, and accessories that satisfy the critical specifications in these lists may be substituted for the recommended models with some modification to the test procedures.

Contact Keysight Technologies for more information about the Keysight products in these lists.

## Performing Self-Test and Calibration

- 1 Perform self tests:
  - a Click **Utilities** > **Self Test...**
  - b Select Scope SelfTest from the Available Self Test drop-down list box.
  - c Click **Start** and follow the instructions on the screen.  
If any of the self-tests fail, ensure that the failure is diagnosed and repaired before calibrating and testing performance.
- 2 Perform calibration as described in **Chapter 2**, “Running a Self Calibration”.

### Vertical Performance Verification

This section describes the following vertical performance verification tests:

- Offset Accuracy Test
- DC Gain Accuracy Test
- Analog Bandwidth—Maximum Frequency Test
- Time Scale Accuracy (TSA) Test

## Offset Accuracy Test

**CAUTION**

Ensure that the input voltage to the oscilloscope never exceeds  $\pm 5$  V.

**Let the oscilloscope warm up before testing.**

The oscilloscope under test must be warmed up (with the oscilloscope application running) for at least 30 minutes prior to the start of any performance test.

## Specifications

Offset Accuracy	$\leq 3.5$ V: $\pm(2\%$ of channel offset + 1% of full scale + 1 mV) $> 3.5$ V: $\pm(2\%$ of channel offset + 1% of full scale)
Full scale is defined as 8 vertical divisions. Magnification is used below 10 mV/div. Below 10 mV/div, full scale is defined as 80 mV. The major scale settings are 10 mV, 20 mV, 50 mV, 100 mV, 200 mV, 500 mV and 1 V.	

## Equipment Required

Description	Critical Specifications	Recommended Model/ Part #
Digital Multimeter	DC voltage measurement accuracy better than $\pm 0.1\%$ of reading	Keysight 34411A
Cable Assembly (2 required)	50 $\Omega$ characteristic impedance, BNC (m) connectors	Keysight 8120-1840
Adapter	BNC Tee (m)(f)(f)	Keysight 1250-0781
Adapter	BNC (f) to dual banana	Keysight 1251-2277
Connector Saver	3.5 mm (f)-(f), shipped with each Z-Series oscilloscope  2.4 mm (f) to 3.5 mm (f) adapter	Keysight 5061-5311 (used with oscilloscope models $\leq 33$ GHz)  Keysight 11901B (used with models $> 33$ GHz)
Adapter (2 required)	BNC (f) to SMA (m) Adapter	Keysight 1250-1200

NOTE: The offset accuracy specification has two terms:  $\pm(\text{offset gain} + \text{zero error})$ . The offset gain specification is  $\pm 2\%$  of channel offset, and the zero error specification is  $\pm(1\%$  of full scale + 1 mV) for  $\leq 3.5$  V and 1% of full scale  $> 3.5$  V. The offset accuracy test procedure tests each of these terms individually.

### 3 Testing Performance

#### Zero Error Test Procedure

- 1 Disconnect all cables from the oscilloscope channel inputs.
- 2 Press **[Default Setup]**, then configure the oscilloscope as follows:
  - a Click **Setup > Acquisition....**
  - b In the Acquisition Setup dialog box, enable averaging and set # of Averages to 256.





- 3 Configure the oscilloscope to measure the average voltage (V avg) on channel 1 as follows:
  - a Change the vertical scale of channel 1 to 10 mV/div.
  - b Click the Vertical Meas tab on the left side of the screen, then drag and drop the Average measurement icon onto the channel 1 waveform.



- 4 Press **[Clear Display]** on the oscilloscope and wait for the number of averages display (top right area of screen) to return to 256. Record the oscilloscope's mean V avg reading in the Offset Accuracy–Zero Error Test section of the Performance Test Record.

**Notes**

- For all oscilloscope readings in this procedure, use the mean value in the Measurement Results area at the bottom of the screen.
- If a question mark appears in front of any of the values in the Results area, press **[Clear Display]** on the oscilloscope, wait for the number of averages to return to 256, and then record the oscilloscope reading. The question mark indicates that the oscilloscope could not make a reliable measurement.



Record the mean reading

### 3 Testing Performance

- 5 Change the vertical scale of channel 1 to 20 mV/div, press **[Clear Display]**, wait for the number of averages to return to 256, and then record the V avg reading in the Offset Accuracy–Zero Error Test section of the Performance Test Record.
- 6 Repeat step 5 for the remaining vertical scale settings for channel 1 in the Zero Error Test section of the Performance Test Record.
- 7 Press **[Default Setup]**, then turn off channel 1 and turn the channel 2 display on.
- 8 Configure the oscilloscope to measure the average voltage on Channel 2 as follows:
  - a Click **Setup > Acquisition....** In the Acquisition Setup dialog box, enable averaging and set # of Averages to 256.
  - b Change the vertical scale of channel 2 to 10 mV/div.
  - c Drag and drop the Average voltage measurement icon from the left side of the screen onto the channel 2 waveform.
- 9 Press **[Clear Display]** on the oscilloscope, wait for the number of averages to return to 256, and then record the oscilloscope's mean V avg reading in the Offset Accuracy–Zero Error Test section of the Performance Test Record.
- 10 Repeat steps 8b and 9 for the remaining vertical scale settings for channel 2.
- 11 Repeat steps 7 through 10 for channels 3 and 4, and for RealEdge channels 1R and 3R for models > 33 GHz. Press the RealEdge button to enable channels 1R and 3R.

## Offset Gain Test Procedure

- 1 Make the connections to oscilloscope channel 1 as shown below.

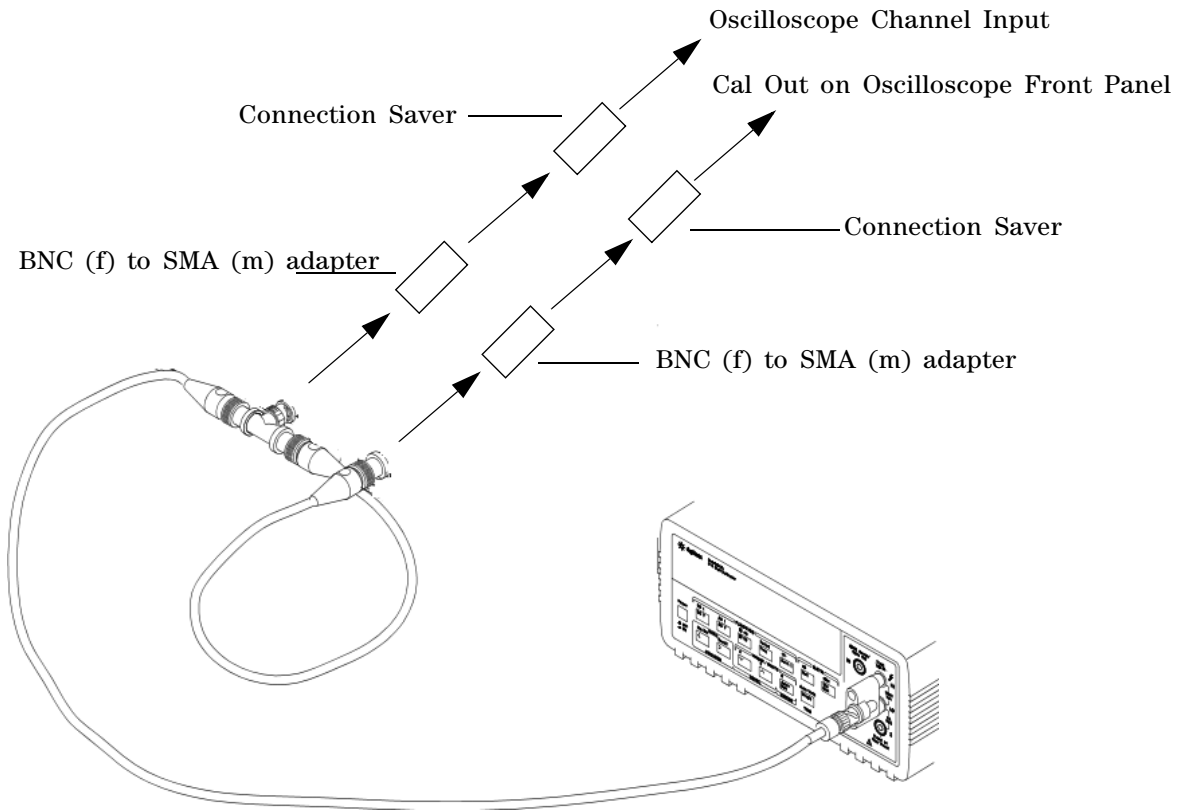

### Notes

- Where the BNC Tee adapter is used, it is important to connect it directly to the oscilloscope channel input using the BNC (f) to SMA (m) adapter and the connection savers to minimize ground potential differences and to ensure that the DMM measures the input voltage to the oscilloscope channel as accurately as possible. Differences in ground potential can be a significant source of measurement error, particularly at high scope sensitivities.
- It also helps to reduce ground potential differences if the oscilloscope and DMM are connected to the same AC supply circuit.
- 256 averages are used in the oscilloscope measurements of this section to reduce measurement noise and to reduce the measurement error due to resolution.

- 2 Set up the DMM to perform DC voltage measurements.
- 3 Press **[Default Setup]** to default to channel 1.

### 3 Testing Performance

- 4 Set the Cal Out voltage ( $V_{\text{Cal Out}}$ ) to +400.0 mV as follows:
  - a Click **Utilities > Calibration Output...**
  - b Change the Signal Output function to DC.
  - c Set the Level to 400.0 mV.

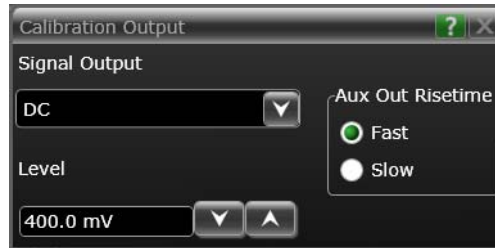

- 5 Configure the oscilloscope to measure the average voltage on the channel under test as follows:
  - a Make sure the channel under test is enabled.
  - b Click **Setup > Acquisition...** In the Acquisition Setup dialog box, enable averaging and set # of Averages to 256.
  - c Change the vertical scale to 10 mV/div.
  - d Set the offset value of the channel under test to 400.0 mV.
  - e Drag and drop the Average voltage measurement icon onto the channel 1 waveform.
- 6 Press **[Clear Display]** on the oscilloscope, wait for the number of averages to return to 256, and then record the DMM voltage reading as  $V_{\text{DMM}+}$  and the scope V avg reading as  $V_{\text{Scope}+}$  in the Offset Accuracy–Offset Gain Test section of the Performance Test Record.
- 7 Change the offset value of the channel under test to -400.0 mV.
- 8 Set the Cal Out voltage to -400.0 mV.
- 9 Change the vertical scale to 10 mV/div.
- 10 Press **[Clear Display]** on the oscilloscope, wait for the number of averages to return to 256, and then record the DMM voltage reading as  $V_{\text{DMM}-}$  and the scope V avg reading as  $V_{\text{Scope}-}$  in the Offset Accuracy–Offset Gain Test section of the Performance Test Record.
- 11 Change the offset value of the channel under test to 0 mV.
- 12 Set the Cal Out voltage to 0 mV.
- 13 Press **[Clear Display]** on the oscilloscope, wait for the number of averages to return to 256, and then record the DMM voltage reading as  $V_{\text{DMM}0}$  and the scope V avg reading as  $V_{\text{Scope}0}$  in the Offset Accuracy–Offset Gain Test section of the Performance Test Record.

- 14** Calculate the offset gain error using the following expressions and record the value in the Offset Accuracy–Offset Gain Test section of the Performance Test Record. The offset gain error is the greater (maximum magnitude) of either:

$$\left( \frac{V_{scope+} - V_{scope0}}{V_{DMM+} - V_{DMM0}} - 1 \right) 100$$

or

$$\left( \frac{V_{scope-} - V_{scope0}}{V_{DMM-} - V_{DMM0}} - 1 \right) 100$$

- 15** Repeat steps 4, 5b, 5c, and 6 to 14 for the remaining vertical scale settings for the channel under test. Record the results in the Offset Accuracy–Offset Gain Test section of the Performance Test Record. For each measurement, set both the Cal Out voltage ( $V_{Cal Out}$ ) and the Channel offset voltage to the positive  $V_{Cal Out}$  value and then to the negative  $V_{Cal Out}$  value in the “ $V_{Cal Out}$  Setting” column of the Offset Accuracy–Offset Gain Test table in the Performance Test Record for each of the vertical scale settings.
- 16** Move the Tee connector to the next channel input and repeat steps 4 to 15 for channels 2 to 4 and for channels 1R and 3R. Press the RealEdge button to enable channels 1R and 3R.

## DC Gain Accuracy Test

**CAUTION**

Ensure that the input voltage to the oscilloscope never exceeds  $\pm 5$  V.

**Let the oscilloscope warm up before testing.**

The oscilloscope under test must be warmed up (with the oscilloscope application running) for at least 30 minutes prior to the start of any performance test.

### Specifications

DC Gain Accuracy	$\pm 2\%$ of full scale at full resolution channel scale ( $\pm 2.5\%$ for 5 mV/div)
Full scale is defined as 8 vertical divisions. Magnification is used below 10 mV/div. Below 10 mV/div full scale is defined as 80 mV. The major scale settings are 10 mV, 20 mV, 50 mV, 100 mV, 200 mV, 500 mV, and 1 V.	

### Equipment Required

Description	Critical Specifications	Recommended Model/ Part #
Digital Multimeter	DC voltage measurement accuracy better than $\pm 0.1\%$ of reading	Keysight 34411A
Cable Assembly (2 required)	50 $\Omega$ characteristic impedance, BNC (m) connectors	Keysight 8120-1840
Adapter	BNC Tee (m)(f)(f)	Keysight 1250-0781
Adapter	BNC (f) to dual banana	Keysight 1251-2277
Connector Saver	3.5 mm (f)-(f), shipped with each Z-Series oscilloscope  2.4 mm (f) to 3.5 mm (f) adapter	Keysight 5061-5311 (used with oscilloscope models $\leq 33$ GHz)  Keysight 11901B (used with models $> 33$ GHz)
Adapter (2 required)	BNC (f) to SMA (m) Adapter	Keysight 1250-1200

## Procedure

- 1 Make the connections to oscilloscope channel 1 as shown below.

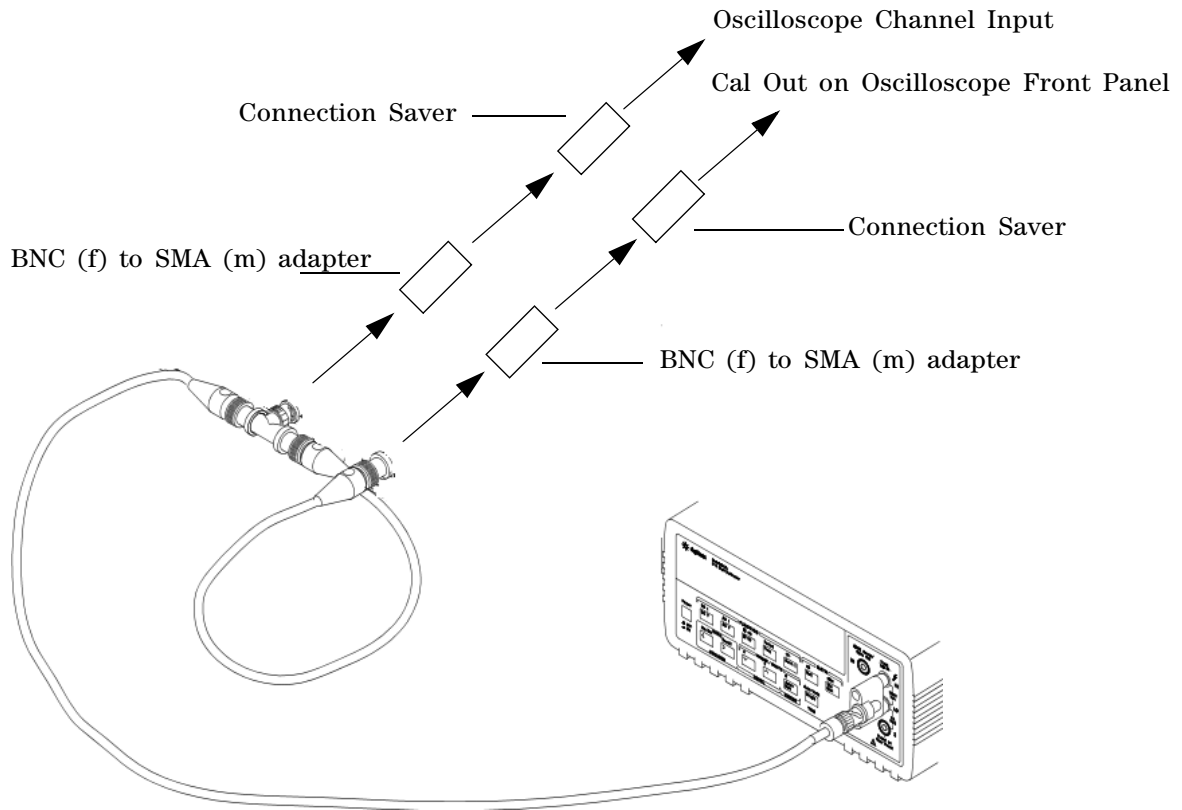

### Notes

- Where the BNC Tee adapter is used, it is important to connect it directly to the oscilloscope channel input using the BNC (f) to SMA (m) adapter and the connection saver to minimize ground potential differences and to ensure that the DMM measures the input voltage to the oscilloscope channel as accurately as possible. Differences in ground potential can be a significant source of measurement error, particularly at high scope sensitivities.
- It also helps to reduce ground potential differences if the oscilloscope and DMM are connected to the same AC supply circuit.
- 256 averages are used in the oscilloscope measurements of this section to reduce measurement noise and to reduce the measurement error due to resolution.

### 3 Testing Performance

- 2 Press **[Default Setup]**, then configure the oscilloscope as follows:
  - a Click **Setup > Acquisition...**
  - a In the Acquisition Setup dialog box, enable averaging and set # of Averages to 256.
- 3 Set the Cal Out voltage ( $V_{\text{Cal Out}}$ ) to +30 mV as follows:
  - a Click **Utilities > Calibration Output...**
  - b Change the Signal Output function to DC.
  - c Set the Level to 30 mV.



- 4 Set the vertical scale of the channel under test to 10 mV/div.
- 5 Drag and drop the Average voltage measurement icon onto the channel 1 waveform.
- 6 Press **[Clear Display]** on the oscilloscope, wait for the number of averages to return to 256, and then record the DMM voltage reading as  $V_{\text{DMM+}}$  and the scope V avg reading as  $V_{\text{Scope+}}$  in the DC Gain Accuracy Test section of the Performance Test Record.

#### Notes

- For all oscilloscope readings in this procedure, use the mean value in the Measurement Results area at the bottom of the screen.
- If a question mark appears in front of any of the values in the Results area, press **[Clear Display]** on the oscilloscope, wait for the number of averages to return to 256, and then record the oscilloscope reading. The question mark indicates that the oscilloscope could not make a reliable measurement.



Record the  
mean reading

- 7 Change the Cal Out voltage to -30 mV.



- 8 Press **[Clear Display]** on the oscilloscope, wait for the number of averages to return to 256, and then record the DMM voltage reading as  $V_{DMM-}$  and the scope V avg reading as  $V_{Scope-}$  in the DC Gain Accuracy Test section of the Performance Test Record.
- 9 Calculate the DC gain using the following expression and record this value in the Calculated DC Gain Error column of the DC Gain Accuracy Test section of the Performance Test Record.

For vertical scale values  $< 1$  V use the following equation:

$$DCGainError = \frac{\Delta V_{out}}{\Delta V_{in}} = \left( \frac{V_{scope+} - V_{scope-}}{V_{DMM+} - V_{DMM-}} - 1 \right) 75$$

For vertical scale values = 1 V use the following equation:

$$DCGainError = \frac{\Delta V_{out}}{\Delta V_{in}} = \left( \frac{V_{scope+} - V_{scope-}}{V_{DMM+} - V_{DMM-}} - 1 \right) 60$$

- 10 Repeat steps 3 to 9 for the remaining channel 1 vertical scale settings in the DC Gain Test section of the Performance Test Record. For each measurement, set the Cal Out voltage ( $V_{CalOut}$ ) to the positive  $V_{CalOut}$  value and then to the negative  $V_{CalOut}$  value in the " $V_{CalOut}$  Setting" column of the DC Gain Accuracy Test table in the Performance Test Record for each of the vertical scale settings.
- 11 Move the Tee connector to the next channel input and repeat steps 2 to 10 for channels 2 to 4 and for channels 1R and 3R.

## Analog Bandwidth—Maximum Frequency Test

**CAUTION**

Ensure that the input voltage to the oscilloscope never exceeds  $\pm 5$  V.

**Let the oscilloscope warm up before testing.**

The oscilloscope under test must be warmed up (with the oscilloscope application running) for at least 30 minutes prior to the start of any performance test.

### Specifications

Analog Bandwidth (-3 dB)	
DSO/DSAZ204A	20.0 GHz
DSO/DSAZ254	25.0 GHz
DSO/DSAZ334A	32.0 GHz
DSO/DSAZ504A	50.0 GHz
DSO/DSAZ594A	59.0 GHz
DSO/DSAZ634A	62.0 GHz

### Equipment Required

Description	Critical Specifications	Recommended Model/Part #
Microwave CW Generator	Maximum Frequency $\geq 32$ GHz Power range: -20 dBm to +16 dBm into $50 \Omega$ Output resistance = $50 \Omega$	Keysight E8257D with Opt 540 (used with oscilloscope models $\leq 33$ GHz) or Opt 567 (used with all models)
	Maximum Frequency $\geq 67$ GHz Power range: -20 dBm to +25 dBm into $50 \Omega$ Output resistance = $50 \Omega$	Keysight E8257D with Opt 567 (used with oscilloscope models $> 33$ GHz)
Power Splitter	2 Resistor Power Splitter Max Frequency $\geq 32$ GHz	Keysight 11667C (used with oscilloscope models $\leq 33$ GHz)
	2 Resistor Power Splitter Max Frequency $\geq 65$ GHz	Anritsu V241C (used with oscilloscope models $> 33$ GHz)
Power Meter	Keysight P-series with power sensor compatibility	Keysight N1912A

## Equipment Required (continued)

Description	Critical Specifications	Recommended Model/Part #
Power Sensor	Maximum Frequency $\geq 32$ GHz Power range: -24 dBm to +23 dBm	Keysight N1922A (used with oscilloscope models $\leq 33$ GHz)
	Maximum Frequency $\geq 67$ GHz Power range: -35 dBm to +20 dBm	Keysight N8488A (used with oscilloscope models $> 33$ GHz)
Microwave Cable	50 $\Omega$ Characteristic Impedance 2.4 mm (m) to 2.4 mm (m) connectors Max Frequency $\geq 32$ GHz	Keysight N5180-60204 (used with oscilloscope models $\leq 33$ GHz)
	1.85 mm (m) to 1.85 mm (m) 50 $\Omega$ Max Frequency $\geq 67$ GHz	Gore 0F0CB0CB036.0 (67 GHz) (used with oscilloscope models $> 33$ GHz)
Adapter	2.4 mm (m) to 3.5 mm (m) (qty. 1)	Keysight 11901A (used with oscilloscope models $\leq 33$ GHz)
Adapter	2.4 mm (m) to 3.5 mm (f) (qty. 2)	Keysight 11901C (used with oscilloscope models $\leq 33$ GHz)
Connector Saver	3.5 mm (f)-(f), shipped with 20, 25, and 32 GHz oscilloscope models	Keysight 5061-5311 (used with oscilloscope models $\leq 33$ GHz)

Connections for all oscilloscope models, channels 1-4

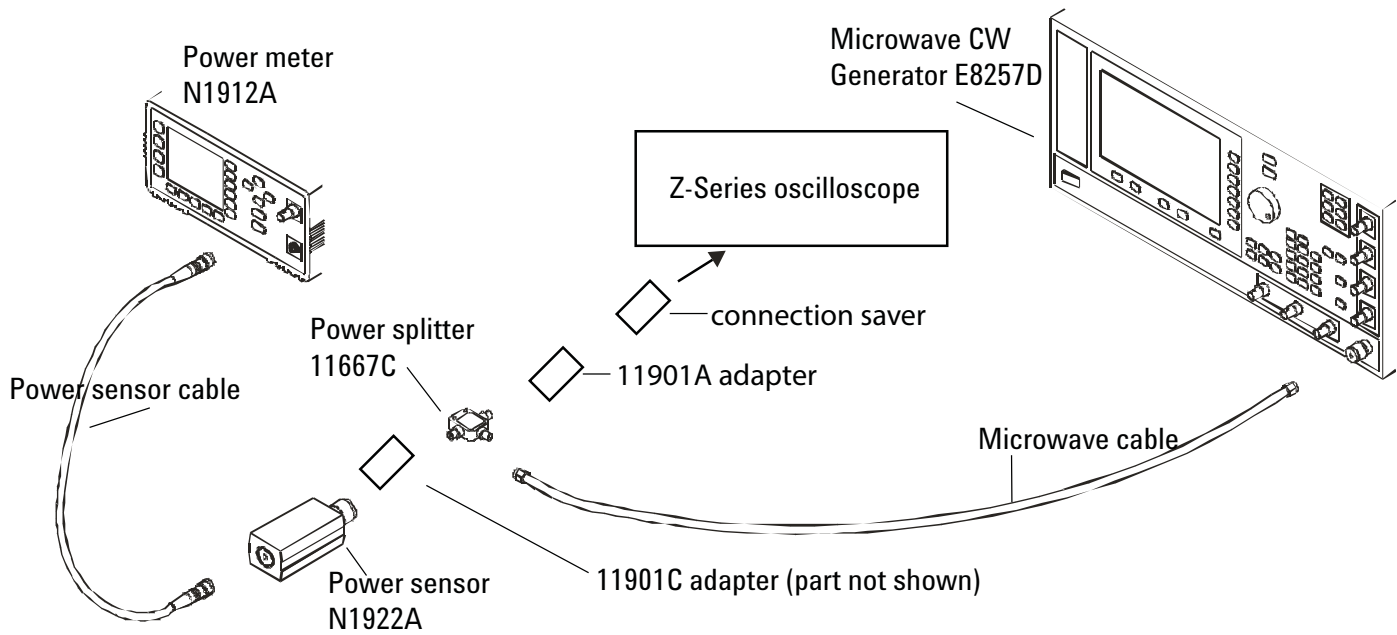

**Notes**

- Connect output 1 of the 11667C splitter to the scope channel N input directly using the 11901A adapter and a connector saver, without any additional cabling or adapters.
- Connect the power sensor directly to output 2 of the power splitter using the 11901C adapter without any additional cabling or adapters.
- Connect the microwave cable directly to output 3 of the power splitter using the 11901C adapter without any additional cabling or adapters.
- Minimize the use of other adapters.
- Ensure that 2.4 mm and 3.5 mm connectors are tightened properly to 8 in-lbs (90 N-cm).

## Connections for oscilloscope models &gt; 33 GHz, channels 1R-3R

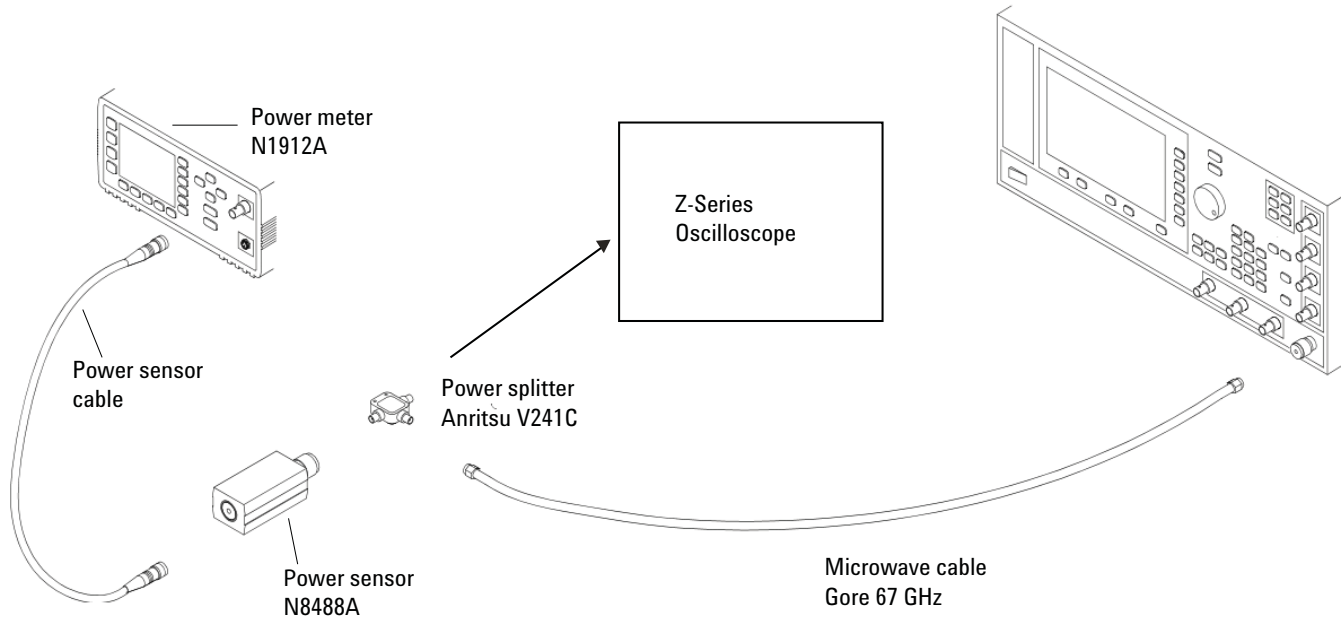
**Notes**

- Connect output 1 of the V241C splitter to the scope Channel N input directly without any additional cabling or adapters.
- Minimize the use of any adapters.
- Ensure that 1.85 mm connectors are tightened properly:  
8 in-lbs (90 N-cm) for 1.85 mm

**Procedure**

- 1 Preset the power meter.
- 2 Ensure that the power sensor is disconnected from any source and zero the meter.
- 3 Connect the power sensor to the power meter's Power Ref connector and calibrate the meter.
- 4 Make the connections to oscilloscope channel 1 as shown in the preceding connection diagrams.
- 5 Set up the power meter to display measurements in units of Watts.

### 3 Testing Performance

- 6 Press **[Default Setup]**, then configure the oscilloscope as follows:
  - a Ensure the channel under test is displayed and all other channels are turned off.
  - b Set the vertical scale of the channel under test to 10 mV/div.
  - c Set the horizontal scale to 16 ns/div (to display 8 cycles of a 50 MHz waveform).

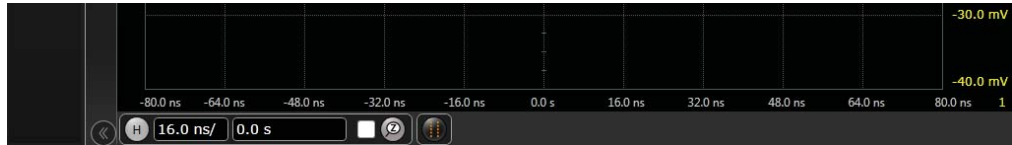

Enter horizontal scale

- d Click **Setup > Acquisition...** and make sure the acquisition parameters are set up as follows:
  - Memory Depth = Automatic
  - Sampling rate = 80 GSa/s (maximum)
  - Sin(x)/x Interpolation = Auto
  - Averaging = Disabled
- e Click **Measure > Add Measurement...**
- f In the Add Measurement dialog box, select the Vertical RMS measurement and configure it as follows:
  - Source = Channel 1
  - Measurement Area = Entire Display
  - RMS Type = AC

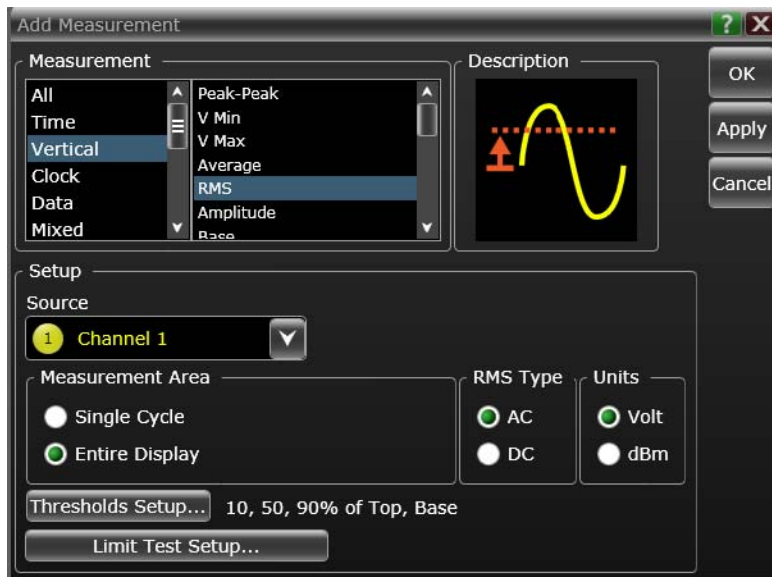

- 7 Set the generator to apply a 50 MHz sine wave with a peak-to-peak amplitude of about four divisions.

Use the following tables to determine the approximate required signal amplitude.

The amplitude values in the tables are not absolutely required. If your generator is unable to produce the recommended amplitude, then set the generator to the highest value that does not produce a vertically clipped signal on the oscilloscope.

Nominal Generator Amplitude Settings for all Oscilloscope Models, channels 1-4

Oscilloscope Vertical Scale	Generator Signal Amplitude (Vp-p)	Generator Signal Amplitude (dBm)
10 mV/div	0.08	-18
20 mV/div	0.16	-12
50 mV/div	0.4	-4
100 mV/div	0.8	+2
200 mV/div	1.6	+8
500 mV/div	4.0	+16
1 V/div	6.3	+20

Nominal Generator Amplitude Settings for Oscilloscope Models > 33 GHz, channels 1R-3R

Scope Vertical Scale	Generator Signal Amplitude (Vp-p)	Generator Signal Amplitude (dBm)
10 mV/div	0.08	-12.5
20 mV/div	0.16	-9.5
50 mV/div	0.4	-5.5
100 mV/div	0.8	-2.5

- 8 Measure the input power to the oscilloscope channel and convert this measurement to Volts RMS using the expression:

$$V_{in} = \sqrt{P_{meas} \times 50\Omega}$$

For example, if the power meter reading is 4.0  $\mu$ W, then  $V_{in} = (4.0 \times 10^{-6} \times 50 \Omega)^{1/2} = 14.1$  mVrms.

Record the RMS voltage in the Analog Bandwidth–Maximum Frequency Check section of the Performance Test Record ( $V_{in}$  @ 50 MHz).

### 3 Testing Performance

- Press **[Clear Display]** on the oscilloscope and record the scope  $V_{rms}$  reading in the Analog Bandwidth–Maximum Frequency Check section of the Performance Test Record ( $V_{out}$  @ 50 MHz).

**Note**

For all oscilloscope readings in this procedure, use the mean value in the Measurement Results area at the bottom of the screen.

- Calculate the reference gain as follows:

$$Gain_{50\text{ MHz}} = \frac{V_{out @ 50\text{ MHz}}}{V_{in @ 50\text{ MHz}}}$$

Record this value in the Calculated Gain @50 MHz column in the Analog Bandwidth–Maximum Frequency Check section of the Performance Test Record.

- Change the generator frequency to the maximum value for the model being tested as shown in the table below. It is not necessary to adjust the signal amplitude at this point in the procedure.

Setting	Model		
	DSOZ/DSAZ 204A (channels 1-4)	DSOZ/DSAZ 254A (channels 1-4)	DSOZ/DSAZ 334A, 504A, 594A, and 634A (channels 1-4)
Maximum Frequency	20 GHz	25 GHz	32 GHz
Scope Horizontal Scale	50 ps/div	50 ps/div	50 ps/div
Setting	Model		
	DSOZ/DSAZ 504A (channels 1R, 3R)	DSOZ/DSAZ 594A (channels 1R, 3R)	DSOZ/DSAZ 634A (channels 1R, 3R)
Maximum Frequency	50 GHz	59 GHz	62 GHz
Scope Horizontal Scale	16 ps/div	16 ps/div	16 ps/div

- Change the oscilloscope horizontal scale to the value for the model under test in the preceding table.



Enter horizontal scale value from table



- 13 Measure the input power to the oscilloscope channel at the maximum frequency and convert this measurement to Volts RMS using the expression:

$$V_{in} = \sqrt{P_{meas} \times 50\Omega}$$

For example, if the power meter reading is 4.0  $\mu\text{W}$ , then  $V_{in} = (4.0 \times 10^{-6} * 50\Omega)^{1/2} = 14.1 \text{ mVrms}$ .

Record the RMS voltage in the Analog Bandwidth–Maximum Frequency Check section of the Performance Test Record ( $V_{in} @ \text{Max Freq}$ ).

- 14 Press [**Clear Display**] on the oscilloscope and record the scope  $V_{rms}$  reading in the Analog Bandwidth–Maximum Frequency Check section of the Performance Test Record ( $V_{out} @ \text{Max Freq}$ ).

- 15 Calculate the gain at the maximum frequency using the expression:

$$Gain_{Max \text{ Freq}} = 20 \log_{10} \left[ \frac{(V_{out \text{ Max Freq}})/(V_{in \text{ Max Freq}})}{Gain_{50 \text{ MHz}}} \right]$$

For example, if ( $V_{out} @ \text{Max Frequency}$ ) = 13.825 mV, ( $V_{in} @ \text{Max Frequency}$ ) = 13.461 mV and  $Gain @ 50\text{MHz} = 1.0023$ , then:

$$Gain_{Max \text{ Freq}} = 20 \log_{10} \left[ \frac{13.825 \text{ mV}/13.461 \text{ mV}}{1.0023} \right] = 0.212 \text{ dB}$$

Record this value in the Calculated Gain @Max Freq column in the Analog Bandwidth–Maximum Frequency Check section of the Performance Test Record. To pass this test, this value must be greater than -3.0 dB.

- 16 Change the oscilloscope setup as follows:
- a Change the channel vertical scale to 20 mV/div.
  - b Reset the horizontal scale to 16 ns/div (to display 8 cycles of a 50 MHz waveform).
- 17 Change the generator output as follows:
- a Reset the generator frequency to 50 MHz.
  - b Change the amplitude to the value suggested for this scale setting in the appropriate Nominal Generator Amplitude Settings table.
- 18 Repeat steps 8, 9, and 10 to measure the reference gain at 50 MHz for this scale setting.
- 19 Repeat steps 11 through 14 to measure the gain at maximum frequency for this scale setting.
- 20 Repeat steps 15 through 19 to complete measuring gains for remaining scale settings for channel 1 in the Analog Bandwidth–Maximum Frequency Check section of the Performance Test Record.

### 3 Testing Performance

- 21 Move the splitter to channel 2 and change the oscilloscope configuration as follows:
  - a Press **[Default Setup]**.
  - b Ensure Channel 2 is displayed and all other channels are turned off.
  - c Set the vertical scale of channel 2 to 10 mV/div.
  - d Set the horizontal scale to 16 ns/div (to display 8 cycles of a 50 MHz waveform).
  - e Click **Trigger > Setup Trigger...** and change the source to channel 2.
  - f Click **Measure > Add Measurement...** Select the RMS voltage measurement, Channel 2 as the source, Entire Display as the Measurement Area, and AC for the RMS Type.
- 22 Repeat steps 7 to 20 to complete measuring gains for channel 2.
- 23 Move the splitter to channel 3 and change the oscilloscope configuration as follows:
  - a Press **[Default Setup]**.
  - b Ensure channel 3 is displayed and all other channels are turned off.
  - c Set the vertical scale of channel 3 to 10 mV/div.
  - d Set the horizontal scale to 16 ns/div (to display 8 cycles of a 50 MHz waveform).
  - e Click **Trigger > Setup Trigger...** and change the source to channel 3.
  - f Click **Measure > Add Measurement...** Select the RMS voltage measurement, Channel 3 as the source, the Entire Display as the Measurement Area, and AC for the RMS Type.
- 24 Repeat steps 7 to 20 to complete measuring gains for channel 3.
- 25 Move the splitter to channel 4 and change the oscilloscope configuration as follows:
  - a Press **[Default Setup]**.
  - b Ensure Channel 4 is displayed and all other channels are turned off.
  - c Set the vertical scale of channel 4 to 10 mV/div.
  - d Set the horizontal scale to 16 ns/div (to display 8 cycles of a 50 MHz waveform).
  - e Click **Trigger > Setup Trigger...** and change the source to Channel 4.
  - f Click **Measure > Add Measurement...** Select the RMS voltage measurement, Channel 4 as the source, the Entire Display as the Measurement Area, and AC for the RMS Type.
- 26 Repeat steps 7 to 20 to complete measuring gains for channel 4.
- 27 Repeat steps 1 through 5 using RealEdge equipment and connections.
- 28 Press the RealEdge button to enable channels 1R and 3R.

- 29 Repeat steps 6 to 22 for channels 1R and 3R, using the Nominal Generator Amplitude Settings table for oscilloscope models > 33 GHz.

## Time Scale Accuracy (TSA) Test

This procedure verifies the maximum TSA specification for the oscilloscope.

### Description

TSA refers to the absolute accuracy of an oscilloscope's time scale. Because TSA depends directly on frequency of a crystal oscillator, it is comprised of two components: an initial accuracy component and an aging component.

The initial accuracy component applies to the oscilloscope's accuracy immediately after a time base calibration, whether performed at the factory, by a customer, or by a Keysight service center. The aging component scales linearly from the time since the last time base calibration, and adds to the initial accuracy component.

### Equipment Required

Description	Critical Specifications	Recommended Model/Part #
Synthesized sine wave source	Output Frequency: $\geq 10$ MHz Output Amplitude: 0 dBm Frequency Resolution: 0.1 Hz	Keysight E8257D PSG
10 MHz frequency reference	Output Frequency: 10 MHz Absolute Freq. Error: $< \pm 0.0275$ ppm	Keysight 53132A opt. 012 frequency counter
RF cable	50 $\Omega$ characteristic impedance (no substitute) BNC (m) connectors Max Frequency: $\geq 50$ MHz	Keysight 8120-1840
Adapters, assorted	3.5 mm (f) to Precision BNC (m) 3.5 mm (f) to 3.5 mm (f)  2.4 mm (f) to 2.92 mm (f)	Keysight 54855-67604 Keysight 83059B  Rosenberger 02K109-K00S3

Connect the equipment as shown here.

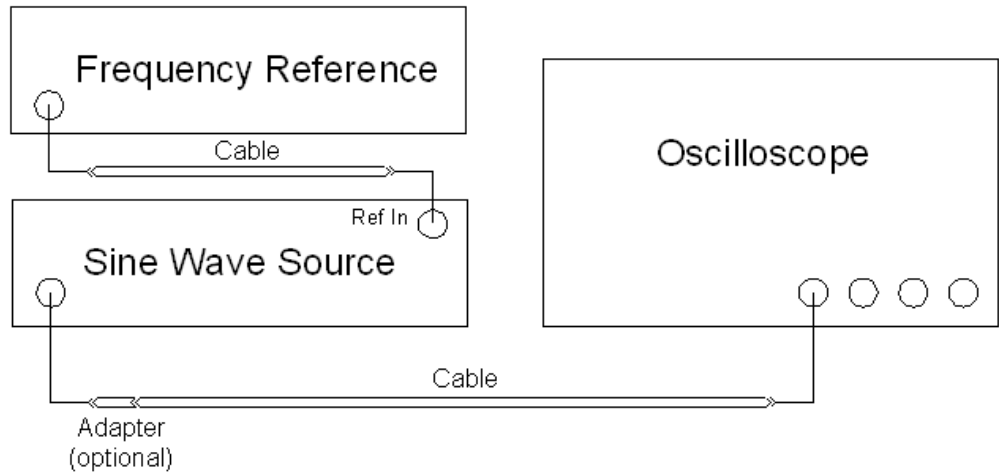

### Procedure

- 1 Configure the sine wave source to output a 0 dBm (600 mVpp) sine wave into 50 ohms with a frequency of 10.00002000 MHz.
- 2 Adjust the source amplitude such that the displayed sine wave is 600 mVpp.
- 3 Press [**Default Setup**] on the oscilloscope.
- 4 Set the vertical scale of channel 1 to 100 mV/div.
- 5 Set the oscilloscope sampling rate to 100 kSa/s.
- 6 Set the oscilloscope's horizontal scale to 20 ms/div.
- 7 Set the measurement thresholds for all waveforms to a fixed voltage level of 0 V and  $\pm 20$  mV hysteresis:
  - a Click **Measure > Thresholds....**
  - b Select **Custom: level +/- hysteresis** from the Thresholds drop-down list box.
  - c Enter 20 mV in the **Hysteresis** field and 0 V in the **Threshold Level** field.
- 8 Enable a frequency measurement on channel 1.
- 9 On the oscilloscope, press [**Stop**].
- 10 Press [**Clear Display**].
- 11 Press [**Run**], wait until 10 acquisitions have accumulated, and then press [**Stop**].
- 12 Convert the average frequency value to time scale error by subtracting 20 Hz and dividing by 10 Hz/ppm. Record the result in the Measured Time Scale Error (ppm) column of the Time Scale Accuracy table.
- 13 Record the time since calibration (in years) in the table. The calibration date can be found in the Calibration window (**Utilities > Calibration...**).

### 3 Testing Performance

- 14 Calculate the test limits using the following formula and record them in the table.

$$\text{Test Limits} = \pm(0.100 + 0.100 \times \text{Years Since Calibration})$$

- 15 Record the results in the Performance Test Record.

## Performance Test Record

<b>Keysight Technologies</b>	<b>Keysight Infiniium Z-Series Oscilloscopes</b>
Model Number _____	Tested by _____
Serial Number _____	Work Order No. _____
Recommended Test Interval—1 Year/2000 hours	Date _____
Recommended next test date _____	Ambient temperature _____

### Offset Accuracy—Zero Error Test

Vertical Scale	Test Limits	Channel 1	Channel 2	Channel 3	Channel 4	Channel 1R	Channel 3R
10 mV/div	-1.8 mV to +1.8 mV						
20 mV/div	-2.6 mV to +2.6 mV						
50 mV/div	-5.0 mV to +5.0 mV						
100 mV/div	-9.0 mV to +9.0 mV						
200 mV/div	-17.0 mV to +17.0 mV						
500 mV/div	-41.0 mV to +41.0 mV						
1 V/div	-81.0 mV to +81.0 mV						

### 3 Testing Performance

#### Offset Accuracy–Offset Gain Test

Vertical Scale	V <sub>Cal Out</sub> Setting	V <sub>DMM+</sub>	V <sub>Scope+</sub>	V <sub>DMM-</sub>	V <sub>Scope-</sub>	V <sub>DMM0</sub>	V <sub>Scope0</sub>	Calc. Offset Gain Error	Offset Gain Error Test Limits
<b>Channel 1</b>									
10 mV/div	±400 mV								±2 %
20 mV/div	±400 mV								±2 %
50 mV/div	±700 mV								±2 %
100 mV/div	±1.2 V								±2 %
200 mV/div	±2.2 V								±2 %
500 mV/div	±2.4 V								±2 %
1 V/div	±2.4 V								±2 %
<b>Channel 2</b>									
10 mV/div	±400 mV								±2 %
20 mV/div	±400 mV								±2 %
50 mV/div	±700 mV								±2 %
100 mV/div	±1.2 V								±2 %
200 mV/div	±2.2 V								±2 %
500 mV/div	±2.4 V								±2 %
1 V/div	±2.4 V								±2 %
<b>Channel 3</b>									
10 mV/div	±400 mV								±2 %
20 mV/div	±400 mV								±2 %
50 mV/div	±700 mV								±2 %
100 mV/div	±1.2 V								±2 %
200 mV/div	±2.2 V								±2 %
500 mV/div	±2.4 V								±2 %
1 V/div	±2.4 V								±2 %



Offset Accuracy–Offset Gain Test (continued)

<b>Channel 4</b>									
10 mV/div	±400 mV								±2 %
20 mV/div	±400 mV								±2 %
50 mV/div	±700 mV								±2 %
100 mV/div	±1.2 V								±2 %
200 mV/div	±2.2 V								±2 %
500 mV/div	±2.4 V								±2 %
1 V/div	±2.4 V								±2 %
<b>Channel 1R</b>									
10 mV/div	±400 mV								±2 %
20 mV/div	±400 mV								±2 %
50 mV/div	±700 mV								±2 %
100 mV/div	±1.2 V								±2 %
200 mV/div	±2.2 V								±2 %
500 mV/div	±2.4 V								±2 %
1 V/div	±2.4 V								±2 %
<b>Channel 3R</b>									
10 mV/div	±400 mV								±2 %
20 mV/div	±400 mV								±2 %
50 mV/div	±700 mV								±2 %
100 mV/div	±1.2 V								±2 %
200 mV/div	±2.2 V								±2 %
500 mV/div	±2.4 V								±2 %
1 V/div	±2.4 V								±2 %

### 3 Testing Performance

#### DC Gain Accuracy Test

Vertical Scale	V <sub>Cal Out</sub> Setting	V <sub>DMM+</sub>	V <sub>Scope+</sub>	V <sub>DMM-</sub>	V <sub>Scope-</sub>	Calc. DC Gain Error	DC Gain Error Test Limits
<b>Channel 1</b>							
10 mV/div	±30 mV						±2 %
20 mV/div	±60 mV						±2 %
50 mV/div	±150 mV						±2 %
100 mV/div	±300 mV						±2 %
200 mV/div	±600 mV						±2 %
500 mV/div	±1.5 V						±2 %
1 V/div	±2.4 V						±2 %
<b>Channel 2</b>							
10 mV/div	±30 mV						±2 %
20 mV/div	±60 mV						±2 %
50 mV/div	±150 mV						±2 %
100 mV/div	±300 mV						±2 %
200 mV/div	±600 mV						±2 %
500 mV/div	±1.5 V						±2 %
1 V/div	±2.4 V						±2 %
<b>Channel 3</b>							
10 mV/div	±30 mV						±2 %
20 mV/div	±60 mV						±2 %
50 mV/div	±150 mV						±2 %
100 mV/div	±300 mV						±2 %
200 mV/div	±600 mV						±2 %
500 mV/div	±1.5 V						±2 %
1 V/div	±2.4 V						±2 %

DC Gain Accuracy Test (continued)

<b>Channel 4</b>							
10 mV/div	±30 mV						±2 %
20 mV/div	±60 mV						±2 %
50 mV/div	±150 mV						±2 %
100 mV/div	±300 mV						±2 %
200 mV/div	±600 mV						±2 %
500 mV/div	±1.5 V						±2 %
1 V/div	±2.4 V						±2 %
<b>Channel 1R</b>							
10 mV/div	±30 mV						±2 %
20 mV/div	±60 mV						±2 %
50 mV/div	±150 mV						±2 %
100 mV/div	±300 mV						±2 %
200 mV/div	±600 mV						±2 %
500 mV/div	±1.5 V						±2 %
1 V/div	±2.4 V						±2 %
<b>Channel 3R</b>							
10 mV/div	±30 mV						±2 %
20 mV/div	±60 mV						±2 %
50 mV/div	±150 mV						±2 %
100 mV/div	±300 mV						±2 %
200 mV/div	±600 mV						±2 %
500 mV/div	±1.5 V						±2 %
1 V/div	±2.4 V						±2 %

### 3 Testing Performance

Max frequency: DSOZ/DSAZ204A = 20 GHz, DSOZ/DSAZ254A = 25 GHz,  
 DSOZ/DSAZ334A = 32 GHz, DSOZ/DSAZ504A = 50 GHz, DSOZ/DSAZ594A = 59 GHz, DSOZ/DSAZ634A  
 = 62 GHz

#### Analog Band width–Maximum Frequency Check

Vertical Scale	Measurement					
	Vin @ 50 MHz	Vout @ 50 MHz	Calculated Gain @ 50 MHz	Vin @ Max Freq	Vout @ Max Freq	Calculated Gain @ Max Freq Test Limit = greater than -3 dB
<b>Channel 1</b>						
10 mV/div						
20 mV/div						
50 mV/div						
100 mV/div						
200 mV/div						
500 mV/div						
1 V/div						
<b>Channel 2</b>						
10 mV/div						
20 mV/div						
50 mV/div						
100 mV/div						
200 mV/div						
500 mV/div						
1 V/div						
<b>Channel 3</b>						
10 mV/div						
20 mV/div						
50 mV/div						
100 mV/div						
200 mV/div						
500 mV/div						
1 V/div						

Analog Band width–Maximum Frequency Check (continued)

<b>Channel 4</b>						
10 mV/div						
20 mV/div						
50 mV/div						
100 mV/div						
200 mV/div						
500 mV/div						
1 V/div						
<b>Channel 1R</b>						
10 mV/div						
20 mV/div						
50 mV/div						
100 mV/div						
<b>Channel 3R</b>						
10 mV/div						
20 mV/div						
50 mV/div						
100 mV/div						

### 3 Testing Performance

#### Time Scale Accuracy

Measured Time Scale Error (ppm)	Years Since Calibration (years)	Low Test Limit (ppm)	High Test Limit (ppm)	Pass/Fail
_____	_____	_____	_____	_____

## 4 Troubleshooting

Troubleshooting Overview	56
Primary Trouble Isolation	57
Power Supply Troubleshooting	63
Setting Up the BIOS	68
Motherboard Verification	69
Display Troubleshooting	70
Acquisition/Backplane Assembly Troubleshooting	72
Keyboard Troubleshooting	74
LED Troubleshooting	75
Touch Screen Troubleshooting	76
Oscillator Board Troubleshooting	77
Checking Probe Power Outputs	78
Sync Port Troubleshooting	79
Before You Contact Keysight	80

### Troubleshooting Overview

The service strategy for troubleshooting Infiniium Z-Series oscilloscopes is to isolate problems to a faulty assembly, then use the disassembly and assembly procedures in the "Replacing Assemblies" chapter to replace the defective assembly.

Read the Safety Notices in the last chapter before servicing the oscilloscope. Before performing any procedure, review it for any cautions and warnings.

The only equipment you need for troubleshooting to the assembly level is basic electronic troubleshooting tools such as a digital multimeter. If you need to remove and replace any assemblies, refer to the "Replacing Assemblies" chapter.

A default setup is provided to return the oscilloscope to a known state. You can use the default setup to undo previous setups so they do not interfere with the current measurement. Use the default setup when a procedure requires it by pressing [**Default Setup**] on the front panel.

#### **WARNING**

**INJURY CAN RESULT! Use caution when the oscilloscope fan blades are exposed as they can cause injury.**

---

#### **CAUTION**

**AVOID ESD DAMAGE TO COMPONENTS!** Electrostatic discharge (ESD) can damage electronic components. Use proper ESD precautions when doing any of the procedures in this chapter. Failure to follow proper ESD procedures may cause immediate failure or latent damage. Latent damage may result in equipment failure after a period of time. As a minimum, place the oscilloscope on a properly grounded ESD mat and wear a properly grounded ESD strap.

---

#### **WARNING**

**SHOCK HAZARD! Maintenance should be performed by trained service personnel. Lack of training and awareness could result in electrical shock or other injury. When maintenance can be performed without power applied, the power cord should be removed from the oscilloscope.**

---



## Primary Trouble Isolation

The main procedural tool in this chapter is the primary trouble isolation flowchart, shown below. It shows the entire troubleshooting path from a failed oscilloscope to a working one, and directs you to other sections in this chapter where the procedures are described in detail. Reference letters on the left side of the flowchart point to procedural steps that explain the brief instructions in the chart.

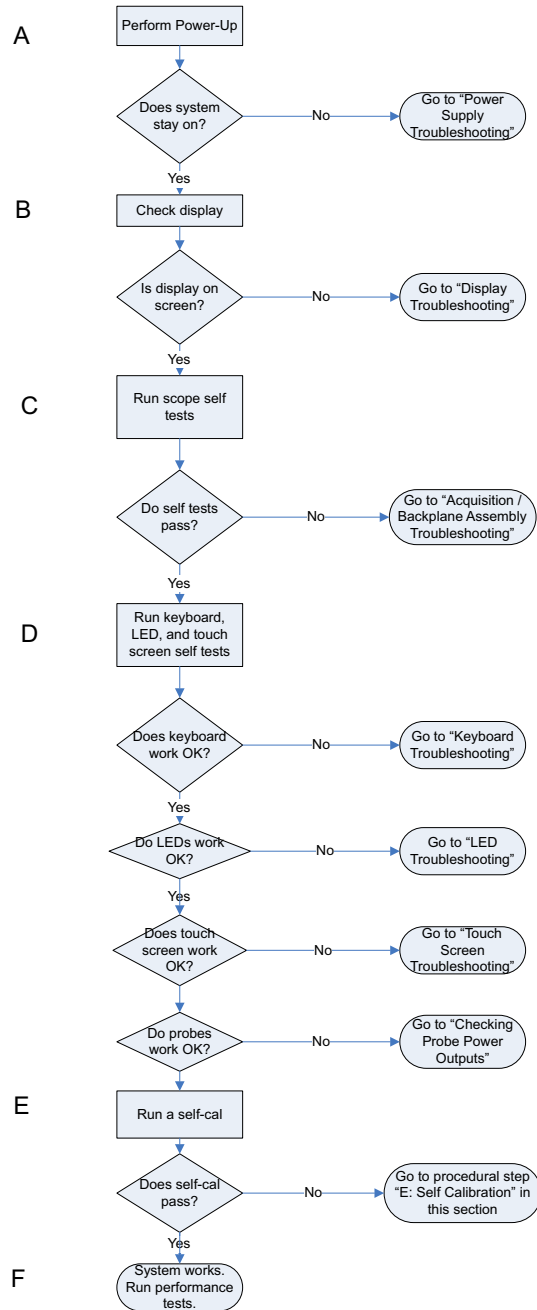

## 4 Troubleshooting

### A. Perform power-up.

Connect the oscilloscope power cord and press the power button in the lower left corner of the front panel. If the oscilloscope is working properly, it will take several minutes to start up. The LEDs on the front panel should all illuminate brightly for several seconds, then dim. If the LEDs do not light up, refer to “LED Troubleshooting” later in this chapter.

When the system is done starting up, the graticule will appear on the screen. The exact appearance may look slightly different than shown in the following figure, depending on the setup selected before the oscilloscope was turned off.

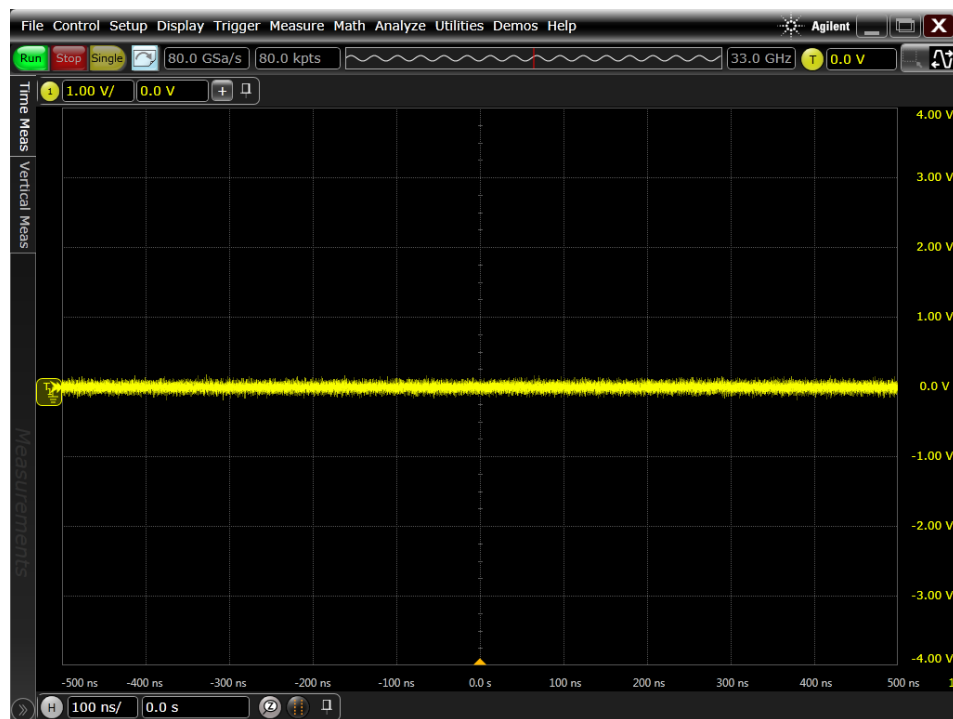

If the oscilloscope turns off without you pressing the front panel power button, go to the “Power Supply Troubleshooting” section of this chapter.

If the oscilloscope does not start up at all, unplug the oscilloscope, wait 30 seconds, plug the oscilloscope back in, and turn the power on. If it still does not start up, go to the “Setting Up the BIOS” and “Motherboard Verification” sections of this chapter.

### B. Check the display.

If the screen is black or has a scrambled display, go to the “Display Troubleshooting” section of this chapter.

If the display shows MEMCON1, MEMCON2, MEMCON3, or MEMCON4 errors during boot-up of the oscilloscope software, the bottom (channel 1) acquisition board is faulty and requires replacement. MEMCON5, MEMCON6, MEMCON7, and

MEMCON8 errors refer to the next higher acquisition board (channel 2). MEMCOM9 through MEMCON12 errors refer to the next higher (channel 3) acquisition board, and MEMCON13 through MEMCON16 errors refer to the top acquisition board.

**C. Run the oscilloscope self-tests.**

- 1 Click **Utilities > Self Test...**
- 2 Select Scope SelfTest from the Available Self Tests drop-down list box.
- 3 Click **Start** and follow the instructions on the screen.

If any of the self tests fail, go to the “Acquisition/Backplane Assembly Troubleshooting” section of this chapter for further troubleshooting.

**D. Run the Keyboard, LED, and touch screen self tests.**

- 1 Follow these steps to verify correct keyboard operation.
  - a Click **Utilities > Self Test...**
  - b Select Keyboard Test from the Self Test drop-down list box, then click **Start**.

The Front Panel Keyboard Test window appears, showing a symbolic representation of the keyboard.

When you press a key or turn a knob in both directions, the corresponding symbol on this screen turns green.

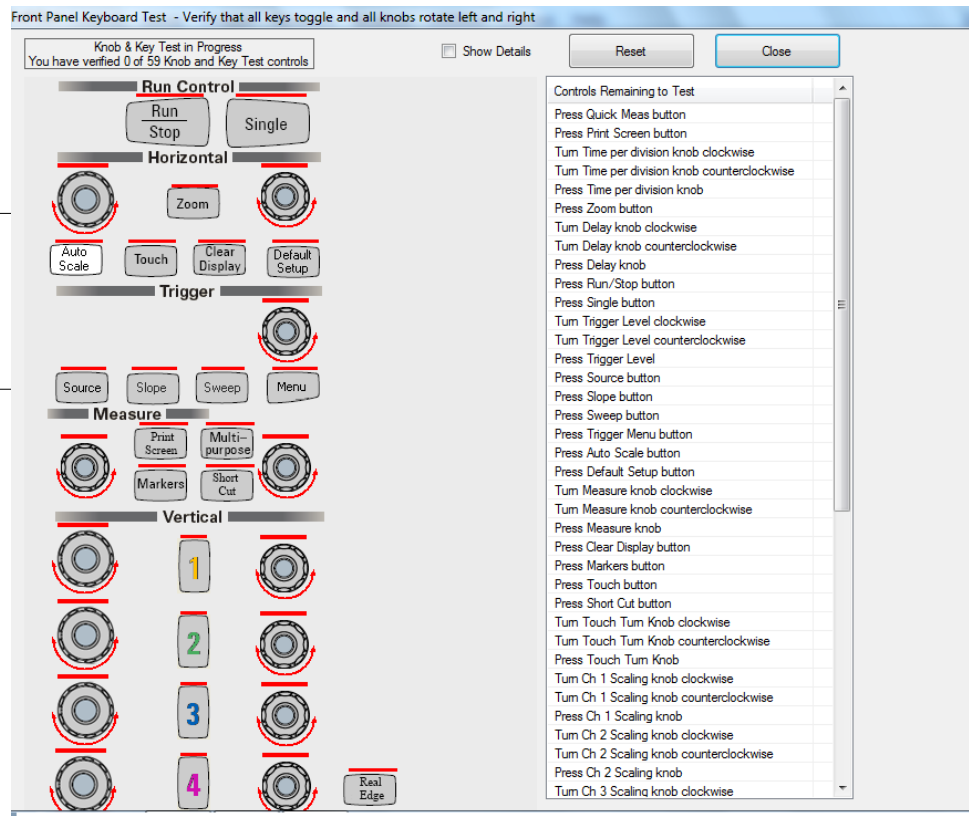



- c Repeatedly press the **[Single]** button on the front panel to step through and highlight each LED symbol in the test screen. You can also step through the LEDs by pressing the << **Prev** or **Next** >> buttons on the screen. Verify that the corresponding LEDs on the front panel are the only ones illuminated. Pressing the **[Multi Purpose]** button on the front panel illuminates all the LEDs, and pressing the **[Clear Display]** button on the front panel turns off all the LEDs.
  - d When you are finished, click **Close**.
  - e If any of the LEDs do not work, go to “**LED Troubleshooting**” later in this chapter.
- 3 Follow these steps to verify correct touch screen operation.
    - a Click **Utilities > Self Test...**
    - b Select Touch Screen Test from the Available Self Tests drop-down list box, then click **Start** and follow the on-screen instructions.
    - c If the touch screen is not working properly, go to “**Touch Screen Troubleshooting**” in this chapter.
  - 4 If the oscillator board is not working properly, go to “**Oscillator Board Troubleshooting**” in this chapter.
  - 5 To check power outputs of the probes, go to “**Checking Probe Power Outputs**” in this chapter.

**E. Run a self calibration.**

- 1 Complete a self calibration by following the procedures in chapter 2.
- 2 If the calibration test fails, look at the details to find the channel associated with the failure.
  - If the failure is associated with a RealEdge Technology channel, replace the two acquisition boards associated with the RealEdge Technology.
  - If replacing the two acquisition boards does not fix the problem with the RealEdge Technology channels, replace the RealEdge Technology attenuators and modules.
  - If the failure is associated with channel 1, look at the specific calibration that failed. If it was a trigger cal, a time scale cal, or an interpolator gain cal, replace the backplane board because it is likely the problem. If the cal still fails, replace the bottom acquisition board.
  - If the failure is associated with channel 1 but is not a trigger cal, a time scale cal, or an interpolator gain cal, replace the bottom acquisition board. If the cal still fails, replace the backplane board.
  - If the failure is not associated with channel 1, replace the acquisition board associated with that channel (where channel 1 = bottom acquisition board, channel 2 = next higher acquisition board, channel 3 = next higher acquisition board, channel 4 = top acquisition board).

## 4 Troubleshooting

- If all four channels have cal failures, the problem may be with the calibrator located on the backplane board, so replace that board first.

### F. The system is operational.

Verify that the oscilloscope meets all warranted specifications by following the procedures in the “**Testing Performance**” chapter.

## Power Supply Troubleshooting

This section provides information to help you isolate the problem to the assembly level when the power system is not operating properly.

There are two sets of LEDs on the backplane assembly. Seeing which of these LEDs are illuminated will help you identify the reason and the remedy for the power failure.

**WARNING**

**SHOCK HAZARD! The maintenance described in this section is performed with power supplied to the oscilloscope and with the protective covers removed. Only trained service personnel who are aware of the hazards involved should perform the maintenance. Read the safety notices at the back of this guide before proceeding. Failure to observe safety precautions may result in electric shock.**

To locate both sets of LEDs, remove the oscilloscope top panel to expose the top edges of the backplane assembly. The first set of LEDs is located in the upper right corner of the backplane assembly, to the right of the J13001 connector as shown below.

Note: If you cannot see either set of LEDs, you may have a slightly modified backplane board. Contact your Keysight Service Center for assistance.

First set of LEDs

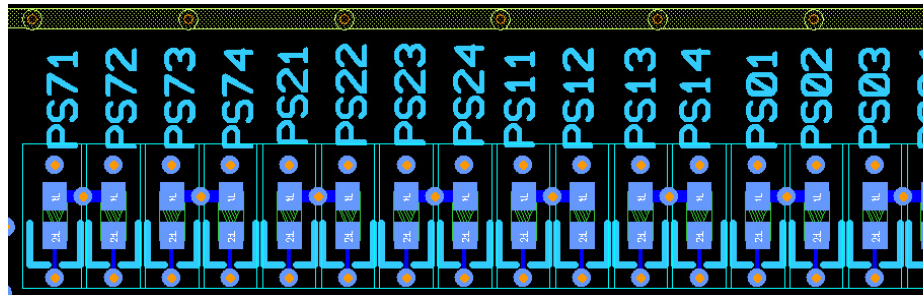

This set of LEDs works in groups. To use them to determine the problem and remedy, refer to the following table and follow these steps:

- 1 Connect the power cord. All 16 LEDs should illuminate. If none of them are illuminated, replace the bulk supply.
- 2 Turn power on. If all 16 LEDs turn off, the power supplies are working.

## 4 Troubleshooting

LED				Type of Fault	What To Do
<b>PS01</b>	<b>PS02</b>	<b>PS03</b>	<b>PS04</b>		
ON	ON	ON	ON	Supply late	Replace Backplane Assembly
ON	ON	ON	OFF	Supply late	
ON	ON	OFF	ON	Supply late	
ON	ON	OFF	OFF	Supply late	
ON	OFF	ON	ON	Under-voltage	
ON	OFF	ON	OFF	Under-voltage	
ON	OFF	OFF	ON	Under-voltage	
ON	OFF	OFF	OFF	Under-voltage	
OFF	OFF	ON	ON	Over-voltage	
OFF	OFF	ON	OFF	Over-voltage	
OFF	OFF	OFF	ON	Over-voltage	
OFF	OFF	OFF	OFF	Over-voltage	
OFF	ON	X	X	Power button pushed at wrong time	
<b>PS11</b>	<b>PS12</b>	<b>PS13</b>	<b>PS14</b>		
ON	ON	ON	ON	Supply late	Replace Backplane Assembly
ON	ON	ON	OFF	Supply late	
ON	ON	OFF	ON	Supply late	
ON	ON	OFF	OFF	Supply late	
ON	OFF	ON	ON	Under-voltage	
ON	OFF	ON	OFF	Under-voltage	
ON	OFF	OFF	ON	Under-voltage	
ON	OFF	OFF	OFF	Under-voltage	
OFF	OFF	ON	ON	Over-voltage	
OFF	OFF	ON	OFF	Over-voltage	
OFF	OFF	OFF	ON	Over-voltage	
OFF	OFF	OFF	OFF	Over-voltage	
OFF	ON	X	X	Power button pushed at wrong time	



LED				Type of Fault	What To Do	
<b>PS21</b>	<b>PS22</b>	<b>PS23</b>	<b>PS24</b>			
ON	ON	ON	ON	Supply late	Replace Backplane Assembly	
ON	ON	ON	OFF	Supply late		
ON	ON	OFF	OFF			
ON	OFF	ON	ON	Under-voltage		
ON	OFF	ON	OFF			
ON	OFF	OFF	OFF			
OFF	OFF	ON	ON	Over-voltage		
OFF	OFF	ON	OFF	Over-voltage		
OFF	OFF	OFF	ON			
OFF	OFF	OFF	OFF			
ON	ON	OFF	ON	Acquisition power good is late		Swap out each acquisition board until problem is resolved
ON	OFF	OFF	ON	Acquisition power good went low		See AUV0, AUV1, AUV2, or AUV3
<b>PS71</b>	<b>PS72</b>	<b>PS73</b>	<b>PS74</b>			
ON	ON	ON	ON	Supply late	Replace Backplane Assembly	
ON	ON	ON	OFF	Supply late		
ON	ON	OFF	ON	Supply late		
ON	ON	OFF	OFF	Supply late		
ON	OFF	ON	ON	Under-voltage		
ON	OFF	ON	OFF	Under-voltage		
ON	OFF	OFF	ON	Under-voltage		
ON	OFF	OFF	OFF	Under-voltage		
OFF	OFF	ON	ON	Over-voltage		
OFF	OFF	ON	OFF	Over-voltage		
OFF	OFF	OFF	ON	Over-voltage		
OFF	OFF	OFF	OFF	Over-voltage		
OFF	ON	X	X	Power button pushed at wrong time		Unplug scope, wait 30 seconds, plug in, power up

## 4 Troubleshooting

The second set of LEDs, shown below, is located to the left of the first set and slightly lower, below the J12002 connector.

Second set of LEDs

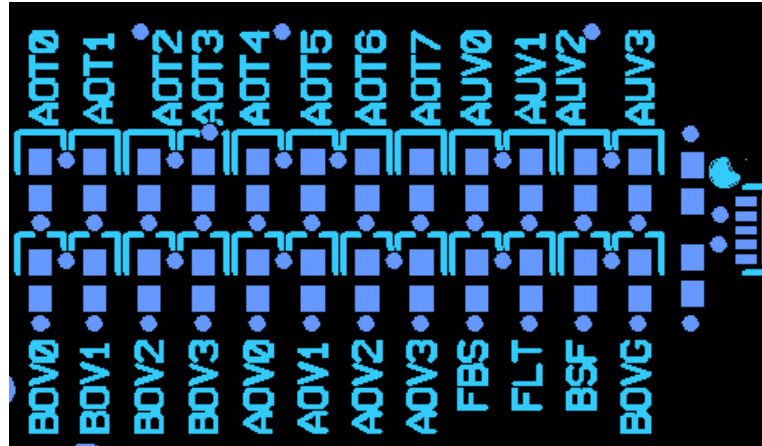

The following table shows each LED in this second set, the type of fault it indicates, and what to do if that LED indicator is lit. When identifying which acquisition assembly to replace, remember that the acquisition assembly nearest the bottom of the oscilloscope is for channel 1. The one above it is for channel 2. The next higher is for channel 3, and the top acquisition assembly is for channel 4.

### NOTE

There is no correlation between the short name of each LED and the type of fault. Use the table to determine the fault and how to address the problem.

LED	Type of Fault	What To Do
AOT0*	Over-temperature	Replace acquisition assembly 4
AOT1*	Over-temperature	Replace acquisition assembly 4
AOT2*	Over-temperature	Replace acquisition assembly 3
AOT3*	Over-temperature	Replace acquisition assembly 3
AOT4*	Over-temperature	Replace acquisition assembly 2
AOT5*	Over-temperature	Replace backplane assembly 2
AOT6*	Over-temperature	Replace backplane assembly 1
AOT7*	Over-temperature	Replace acquisition assembly 1
AOV0	Under-voltage	Replace acquisition assembly 4
AOV1	Under-voltage	Replace acquisition assembly 3
AOV2	Under-voltage	Replace acquisition assembly 2

LED	Type of Fault	What To Do
AOV3	Under-voltage	Replace acquisition assembly 1
AUV0	Over-voltage	Replace acquisition assembly 4
AUV1	Over-voltage	Replace acquisition assembly 3
AUV2	Over-voltage	Replace acquisition assembly 2
AUV3	Over-voltage	Replace acquisition assembly 1
BOV0	Over-voltage	Replace assembly indicated by illuminated AUV0 or FBS LED
BOV1	Used for internal testing purposes only	N/A
BOV2	Any	Any problem that causes a shutdown also turns on this LED
BOV3	Used for internal testing purposes only	N/A
BOVG	Over-voltage	Replace backplane assembly
BSF	Over-voltage	Replace backplane assembly
FBS	Over-voltage	Replace backplane assembly
FLT	Over-voltage	Replace backplane assembly
<p>*If an AOT LED is Lit</p> <p>If the oscilloscope shuts down and the AOT0, AOT1, AOT2, AOT3, AOT4, AOT5, AOT6, or AOT7 indicator LED is lit, then one of the scope channels is getting too hot or the temperature sensing circuitry has failed. Normally, you would have to turn the oscilloscope on and leave it on for awhile before you would see a shutdown caused by temperature problems. If all the fans are turning, it is unlikely that the oscilloscope would shut down due to temperature unless the airflow is being restricted or the input air is already too hot to cool the insides of the oscilloscope.</p> <p>It is possible that all the fans are working, but the oscilloscope still shuts down because of temperature due to one or more of the channels malfunctioning and drawing too much current. If so, you would need to replace the indicated acquisition assembly. It is also possible for one of the heat sinks on one of the acquisition assemblies' critical parts to become detached and cause that part to overheat and shut down the oscilloscope.</p>		

### Setting Up the BIOS

If the BIOS settings become corrupt, the Infiniium oscilloscope PC motherboard will not recognize the hard drive and the oscilloscope may not start. To configure the motherboard BIOS parameters to the default settings, follow these steps:

- 1 Connect the power cable to the oscilloscope.
- 2 Connect the external keyboard to the rear panel.
- 3 Press **[Delete]** as soon as the following prompt appears on the bottom of the screen:

**Press DEL to enter SETUP, F12 to select boot device.**

If the prompt does not appear, or the oscilloscope does not appear to be functioning, check the J12001 and J12002 motherboard power cable connectors. Otherwise, continue with the next step.

- 4 Go to F3 Optimized Defaults and press **[Enter]**. Select Yes to load the defaults, then press **[Enter]**.
- 5 Go to the Save and Exit Setup option and press **[Enter]** to save and exit the setup. Select Yes to save and exit, then press **[Enter]**.

## Motherboard Verification

If you have been through the Power Supply Troubleshooting section of this chapter and the oscilloscope still does not stay powered up, the problem may be with the motherboard. To diagnose the problem, follow these steps.

- 1 Remove the top panel.
- 2 Turn the oscilloscope on.

If the unit beeps once after about 5 to 10 seconds but fails to boot up, the motherboard is defective and needs to be replaced.

If the unit fails to beep after it is powered on, then measure the potential relative to the chassis at pin 9 of J12001 (see figure below). Pin 9 is the reset line for the motherboard. It is controlled by the backplane. You should measure about 3.3V. If the potential you measure is correct, but the unit still has not beeped and started up, the motherboard is defective and needs to be replaced.

### Measure potential relative to chassis at pin 9 of J12001

Pin 9 is located in the bottom left corner of J12001.



- 3 If the potential you measure is not correct, reseal the PCI Express cable (J10000) in the backplane board.
- 4 Measure the potential relative to the chassis at pin 9 of J12001 again.

If you measure the required 3.3V, the motherboard is defective and needs to be replaced.

If you did not measure the correct voltage, the backplane assembly is defective and must be replaced.

- 5 Be aware that there could be a fault on the motherboard that caused the backplane assembly to fail so before you plug the motherboard cables back into the new backplane assembly, measure the resistance to the chassis from the pin 9 contact in the connector that plugs into J12001. If you measure a very low resistance or a short circuit to the chassis, replace the motherboard and then assemble the instrument and confirm that the unit beeps and boots up properly.

## Display Troubleshooting

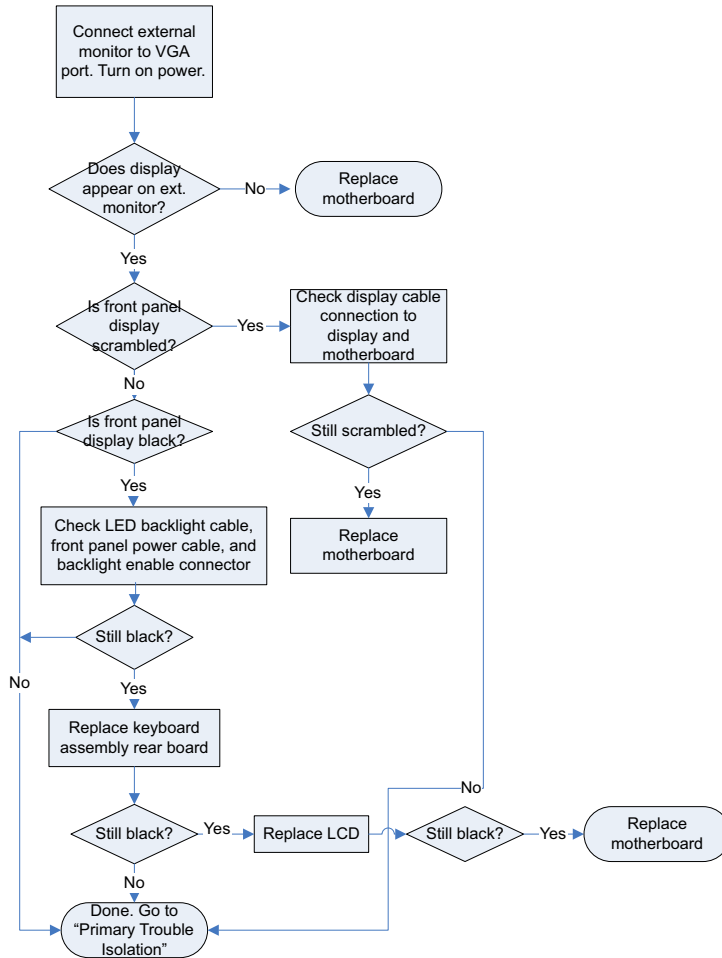

**NOTE**

When you connect an external monitor the first time, it may display the start-up BIOS information and then go blank when Windows starts up. If so, use the Windows settings to enable the external monitor.

**WARNING**

**INJURY CAN RESULT!** Use caution when the oscilloscope fan blades are exposed as they can cause injury. Disconnect the power cable before working around the fans. Use extreme caution in working with the oscilloscope when the cover is removed. If the procedure requires you to have the cover off, be careful not to let these fan blades come in contact with any part of your body.

---

For information on how to replace the display parts, see the "Replacing Assemblies" chapter.

## Acquisition/Backplane Assembly Troubleshooting

This section describes which board assembly to replace if any of the scope self tests fail. When the self-test error message file is generated it is sent to the following location:

C:\ProgramData\Infiniium\selftest\SelfTestLog.txt

The error message usually indicates the channel with the error. When identifying which acquisition assembly to replace, remember that the acquisition assembly nearest the bottom of the oscilloscope is for channel 1. The one above it is for channel 2. The next higher is for channel 3, and the top acquisition assembly is for channel 4. Replace the acquisition assembly that has the error.

If the error message does not indicate a channel, refer to the following table to determine which assembly to replace.

Test Group / Test Name	Error Type	Assembly to Replace
<b>Timebase Test Group</b>		
Timebase Interpolator Test		Backplane assembly
<b>ADC Test Group</b>		
ADC Register Tests	ADC1, ADC2, ADC3, ADC4	Acquisition assembly 1
	ADC5, ADC6, ADC7, ADC8	Acquisition assembly 2
	ADC9, ADC10, ADC11, ADC12	Acquisition assembly 3
	ADC13, ADC14, ADC15, ADC16	Acquisition assembly 4
ADC Voltage Test Points	ADC1, ADC2, ADC3, ADC4	Acquisition assembly 1
	ADC5, ADC6, ADC7, ADC8	Acquisition assembly 2
	ADC9, ADC10, ADC11, ADC12	Acquisition assembly 3
	ADC13, ADC14, ADC15, ADC16	Acquisition assembly 4
<b>Misc. Scope Test Group</b>		
Temp Sensor Tests	Hed wig0, Hed wig1, Hed wig2, Hed wig3, Oak0	Acquisition assembly 1
	Hed wig4, Hed wig5, Hed wig6, Hed wig7, Oak2	Acquisition assembly 2
	Pred1, Pred2, MainFPGA, Wahoo, Ambient	Backplane assembly
	Merwig0, Merwig1	Replace acquisition assembly 1. If error still occurs, put original acquisition assembly back into scope and replace backplane assembly.



Test Group / Test Name	Error Type	Assembly to Replace
	Merwig2, Merwig3	Replace acquisition assembly 2. If error still occurs, put original acquisition assembly back into scope and replace backplane assembly.
	Merwig4, Merwig5, Hed wig8, Hed wig9, Hed wig10, Hed wig11, Oak4	Replace acquisition assembly 3. If error still occurs, put original acquisition assembly back into scope and replace backplane assembly.
	Merwig6, Merwig7, Hed wig12, Hed wig13, Hed wig14, Hed wig15, Oak6	Replace acquisition assembly 4. If error still occurs, put original acquisition assembly back into scope and replace backplane assembly.
Acq Flash RAM Tests	Test is currently not being run.	

### Keyboard Troubleshooting

If some of the knobs fail the keyboard self test but some work properly, replace the rear board of the keyboard assembly.

If none of the knobs work properly, replace the front board of the keyboard assembly.

If any of the keys do not work properly but the LEDs light up, replace the front board of the keyboard assembly.

If the keys still do not work properly, check the incoming cables.

## LED Troubleshooting

### LED Failure During System Start-Up

When power is turned on to the scope, the front panel LEDs should all illuminate brightly for several seconds, then dim. The RealEdge LED (on models > 33 GHz) should pulse off and on. When the Infiniium software starts up, the LEDs should turn off. If the LEDs do not light up this way during system start-up, then follow these steps:

- 1 Make sure connectors J2 and J3 on the front and rear boards of the keyboard assembly are securely connected to their mates on the other board.
- 2 Ensure the power cable is properly connected.
- 3 Make sure J17 is connected on the rear board of the keyboard assembly.

### On/Off Switch Backlight LED Failure During Self Test

If the on/off switch backlight LED is not working, check the on/off cable connecting the On/Off board to the motherboard. If the LED still does not work, replace the On/Off board. If the LED still does not illuminate, replace the motherboard.

### Front Panel LED Failures During Self Test

If any of the other LEDs on the front panel are not working, check these cables:

- The power cable to the front panel
- The USB cable to the front panel
- The backlight connector (J1) to the motherboard

If the cables are connected and working properly but the LEDs are still not working, then troubleshoot the acquisition assemblies to make sure they are working. If they are, replace the front board of the keyboard assembly. If the LEDs still do not illuminate, reload the oscilloscope software.

Replace the front board of the keyboard assembly in these cases:

- Only some of the LEDs illuminate
- No LEDs and no knobs work
- The knobs work but the LEDs don't illuminate.

When reassembling the oscilloscope, be sure to reinstall all boards that were replaced, but that were not causing the problem.

## Touch Screen Troubleshooting

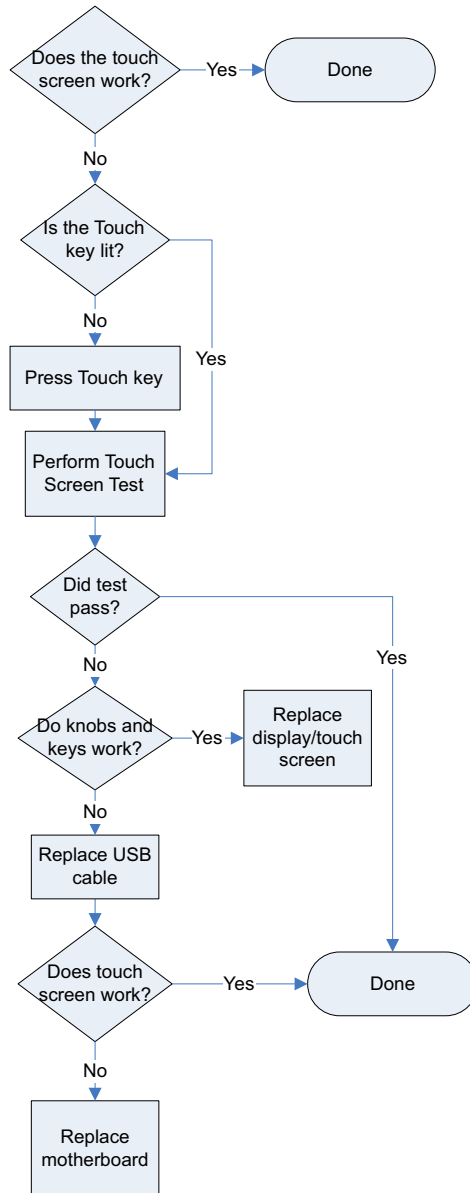

## Oscillator Board Troubleshooting

If you encounter any problems with the oscillator board, first check all cabling and connections to ensure they are secure and tight:

- Check the connection between the oscillator board and the backplane board.
- Check the 10 GHz DRO output cable.
- Check the reference to the oscillator board cable.
- Check the 32 GHz DRO power cable (models > 33 GHz).
- Check the 32 GHz DRO cable connected to the RealEdge modules and the RealEdge auxiliary module (models > 33 GHz).
- Check the coax cables between the RealEdge auxiliary module and the RealEdge modules (models > 33 GHz).

If you cannot calibrate the time scale, or if all channels have excessive sample clock jitter, then replace the oscillator board.

If you get an error message similar to the following example, tighten the cable connections from the oscillator board to the RealEdge inputs. If the error appears again, replace the oscillator board:

### **Self calibration failure on Channel 1R, pilot tone amplitude too small**

If replacing the oscillator board does not fix the problem, then replace the backplane board.

You must run a user calibration including a time scale calibration after replacing an oscillator board.

## 4 Troubleshooting

### Checking Probe Power Outputs

Probe power outputs are on the front panel, in the lower left corner of the 3.5mm inputs.

Refer to the following figure to check the power output at the connectors. Measure the voltages with respect to the ground terminal on the front panel, located near Aux Out. Measure the voltages at pins 2 and 5 only (+12V and -12V). All supplies come from the front panel.

#### AutoProbe II pins

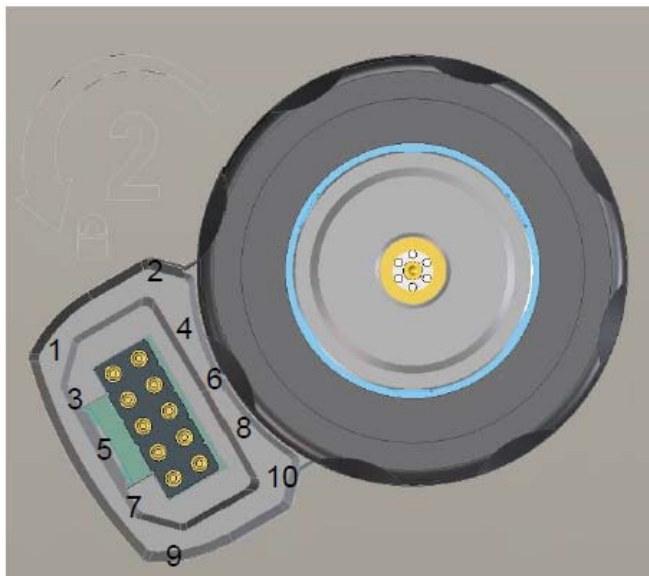

Pin	Desc.
1	+Vprog
2	+12V
3	Rprog
4	Offset
5	-12V
6	-Vprog
7	DATA1
8	Rid
9	CLK
10	DATA0

## Sync Port Troubleshooting

If the oscilloscope is a 20, 25, or 33 GHz model with the optional N2109AU sync port, follow these steps to verify that the sync port works properly.

- 1 Start the Infiniium application and then minimize it.
- 2 Connect one end of a calibration cable to the Cal Out, and the other end to the sync port. Use 3.5 mm connectors.
- 3 Right-click the Keysight IO Control icon in the lower right corner of the desktop display and select Keysight Connection Expert from the pop-up menu.
- 4 Close the welcome screen if it appears.
- 5 Right-click the LAN (TCPIP) instrument and click **Add Instrument** from the pop-up menu.
- 6 Check the box in front of the oscilloscope host name and check the **Allow \*IDN?** query box. Click **OK**.
- 7 Click the instrument name. A green check mark should appear, indicating the instrument is recognized and active.
- 8 Right-click the instrument name and select **Send Commands To This Instrument** from the pop-up menu. The Keysight Interactive IO dialog box appears.
- 9 Click **Send & Read**. The instrument will appear in the Instrument Session History area.
- 10 Click **Utilities > Calibration Output...** from the Infiniium application.
- 11 In the Calibration Output dialog box, set the signal output to 4.8 GHz, enable Cal Out, and select Probe Comp as the probe output.
- 12 Press [**Auto Scale**], or manually set the vertical scale to 100 mV and the horizontal scale to 200 ps.
- 13 Turn off all channels except channel 3.
- 14 In the Keysight Interactive IO dialog box, type :ACQ:TREF ON in the command field and click **Send Command**.
- 15 The Cal Out signal should appear, indicating that the sync port is working properly.
- 16 If the signal does not appear properly, change the IO command line to :ACQ:TREF OFF and click **Send Command**. Then remove the cable from the sync port and connect it to channel 3. If the Cal Out signal appears properly, then the sync port is not working and should be replaced.

### Before You Contact Keysight

If you have read this troubleshooting chapter and have unresolved questions about troubleshooting the oscilloscope, be ready to provide system information such as the current software version and installed options. This information will be useful when you contact Keysight Technologies.

To find and save system information, follow these steps:

- 1 Click **Help > About Infiniium...**

A dialog box similar to this one appears.

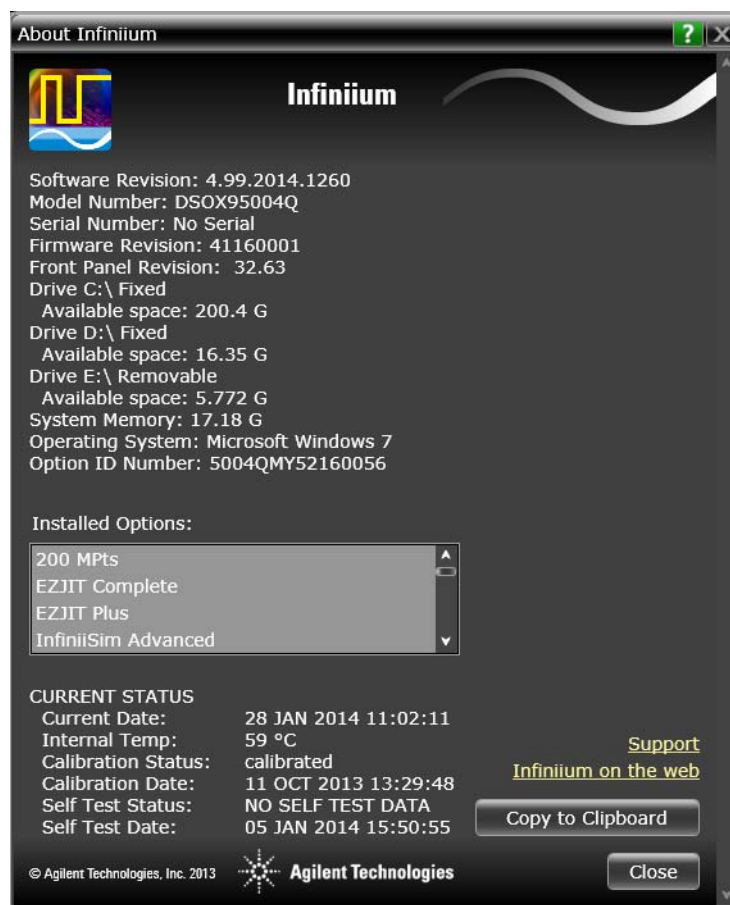

- 2 Click **Copy to Clipboard**.
- 3 Bring up a text editor, such as Notepad, and paste the copied information into the editor.
- 4 Save the text editor file.



## 5 Replacing Assemblies

ESD Precautions	82
Tools Required	82
Returning the Oscilloscope to Keysight Technologies for Service	84
Removing and Replacing the Top Panel and Motherboard	85
Removing and Replacing the Hard Disk Drive	90
Removing and Replacing the Power Supply	91
Removing and Replacing the Front Panel Assembly and Bottom Panel	92
Removing a RealEdge Assembly	96
Removing and Replacing Front Panel Assembly Parts	99
Removing and Replacing the Acquisition Boards/Backplane Assembly	106
Setting the Calibration Factors after Replacing an Acquisition Board	113
Removing and Replacing the Fans	114

# Replacing Assemblies

Use the procedures in this chapter when removing and replacing assemblies and parts in the Infiniium Z-Series oscilloscopes.

In general, the procedures that follow are placed in the order to be used to remove a particular assembly. The procedures listed first are for assemblies that must be removed first.

The pictures in this chapter are representative of the oscilloscope at the time of this printing. Your unit may look different.

### ESD Precautions

When using any of the procedures in this chapter you must use proper ESD precautions. As a minimum you must place the oscilloscope on a properly grounded ESD mat and wear a properly grounded ESD wrist strap.

#### CAUTION

Failure to implement proper antistatic measures may result in damage to the oscilloscope.

---

### Tools Required

The following tools are required for these procedures.

- Torx drivers: T10, T20
- Socket wrench: 5/8 inch
- Torque wrench: 5/16 inch (8 in-lbs)
- Flat-blade screwdriver: medium size (3/16 inch)
- Power driver vertical with T-20 bit (18 in-lbs)
- Power driver vertical with T-10 bit (5 in-lbs)
- Hex socket bit: 5/8 inch
- Open-end wrench: size 6 metric
- Needle-nose pliers (optional)

#### CAUTION

Remove power before removing or replacing assemblies.

Do not remove or replace any circuit board assemblies in this oscilloscope while power is applied. The assemblies contain components that may be damaged if the assembly is removed or replaced while power is connected to the oscilloscope.

---

**WARNING**

To avoid electric shock, adhere closely to the following procedures. Also, after disconnecting the power cable, wait at least 3 minutes for the capacitors on the power supply to discharge before servicing this oscilloscope.

---

**WARNING**

Use caution when the oscilloscope fan blades are exposed as they can cause injury.

---

### Returning the Oscilloscope to Keysight Technologies for Service

Before shipping the oscilloscope, contact Keysight Technologies for more details.

**1** Write the following information on a tag and attach it to the oscilloscope.

- Name and address of owner
- Oscilloscope model numbers
- Oscilloscope serial numbers
- Description of the service required or failure indications

**2** Remove all accessories from the oscilloscope.

Accessories include all cables. Do not include accessories unless they are associated with the failure symptoms.

**3** Protect the oscilloscope by wrapping it in plastic or heavy paper.

**4** Pack the oscilloscope in foam or other shock-absorbing material and place it in a strong shipping container.

If the original shipping materials are not available, place 16 to 20 cm (6 to 8 inches) of shock-absorbing material around the oscilloscope and place it in a box that does not allow movement during shipping.

**5** Seal the shipping container securely.

**6** Mark the shipping container as FRAGILE.

In any correspondence, refer to the oscilloscope by model number and full serial number.

## Removing and Replacing the Top Panel and Motherboard

Note that all sheet metal holes that are supposed to have screws placed in them are marked by lines on four sides of the hole.

- 1 Remove the four M3 screws that connect the top panel to the rear. When replacing, use a Torx T10 to torque to 5 in-lbs.



- 2 Slide the top panel back 1 to 2 inches and then lift it off. If necessary, gently pry it using a flat-blade screwdriver at the rear lip.

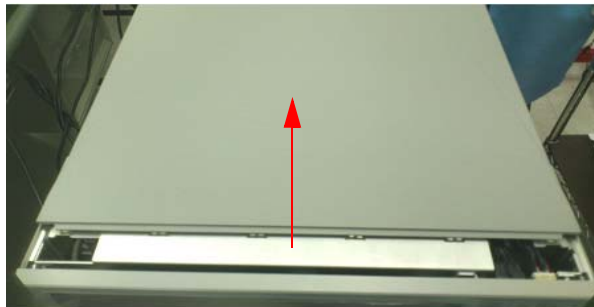

- 3 Disconnect the PCIe cable from the backplane board by pressing down on the locking tab and pulling the cable.

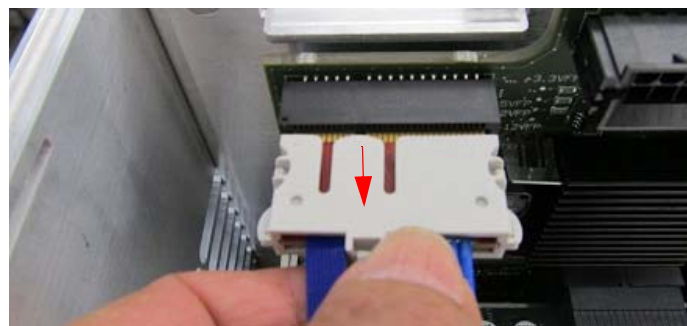

## 5 Replacing Assemblies

- 4 Disconnect the red SATA cable from the motherboard.



- 5 Disconnect the SATA cable from the display from its connector on the motherboard.



- 6 Disconnect the front panel on/off (standby switch) cable from its connector on the motherboard.

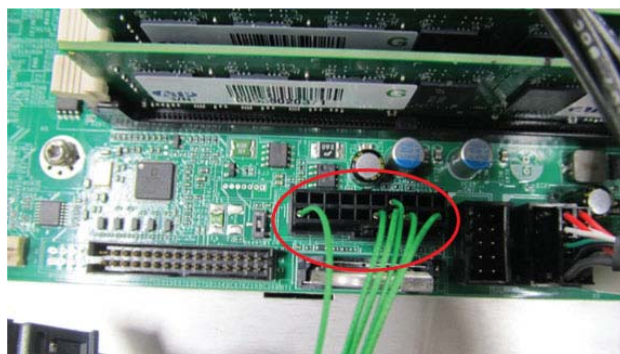

- 7 Disconnect the two USB cables.

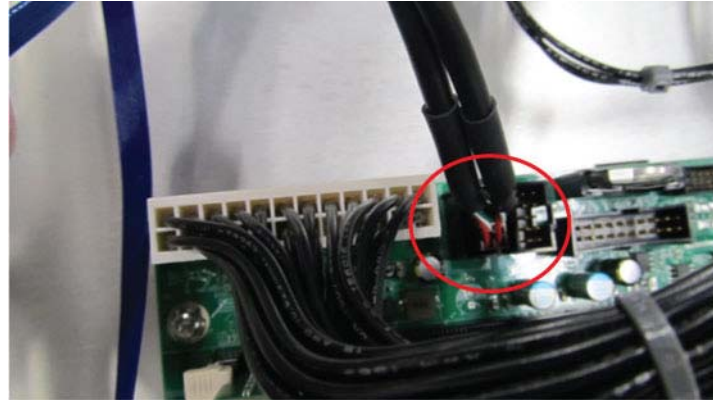

- 8 Disconnect the power cable from the two connectors on the backplane board and from the two connectors on the motherboard, as shown in the next three figures.

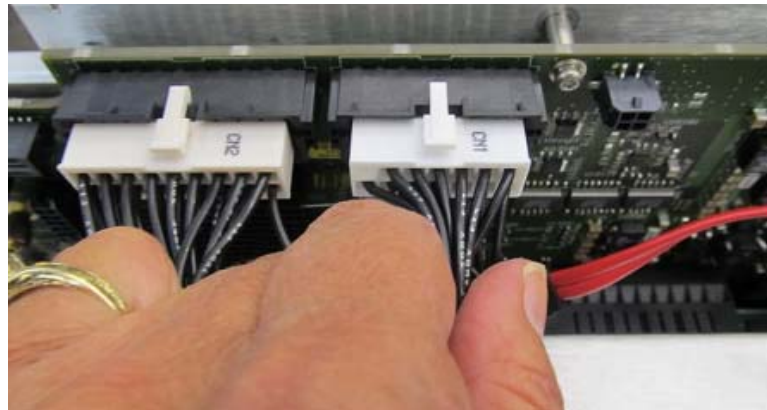

## 5 Replacing Assemblies

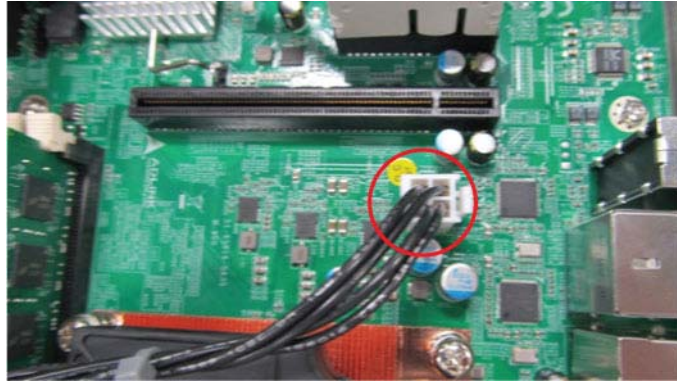

- 9 If you need to replace the motherboard fan, disconnect the cable from the fan to the motherboard now. Otherwise, you do not need to disconnect it.



- 10 Remove the PCIe cable from the motherboard and set it aside to put on the new motherboard.





- 11 Remove the six M3 screws from the motherboard. When replacing, torque the screws to 5 in-lbs.



- 12 Pull the motherboard away from the back panel and then lift it out. Place the motherboard in an anti-static bag.
- 13 To reassemble the motherboard, reverse the above procedure. If you are putting in a new motherboard, you will need to remove the support bracket from the old motherboard and put it on the new motherboard.

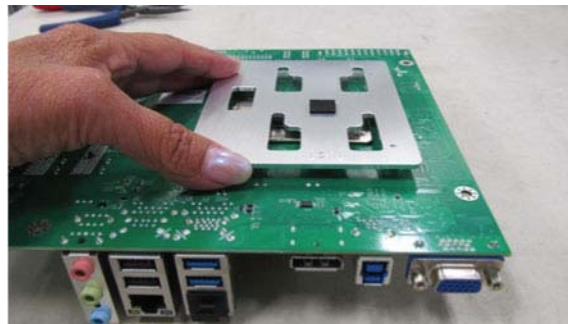

## 5 Replacing Assemblies

### Removing and Replacing the Hard Disk Drive

- 1 Loosen the two screws on back of the hard disk drive.



- 2 Pull the hard drive out.



- 3 Remove the four screws connecting the disk drive to the plate.
- 4 To replace the hard disk drive, reverse this procedure. Torque the four screws to 5 in-lbs.

## Removing and Replacing the Power Supply

**WARNING**

Use caution when removing the power supply. A defective power supply could have a dangerous charge on some capacitors. This charge could remain for many days after power is removed.

---

- 1 Loosen the rear panel screw and lower the handle.



- 2 Remove the power supply.

Reverse the procedure to replace the power supply.

## 5 Replacing Assemblies

### Removing and Replacing the Front Panel Assembly and Bottom Panel

- 1 Remove the top panel as described previously. Disconnect the two USB cables and the display and standby switch cables. Also disconnect the front panel power cable from the backplane board.

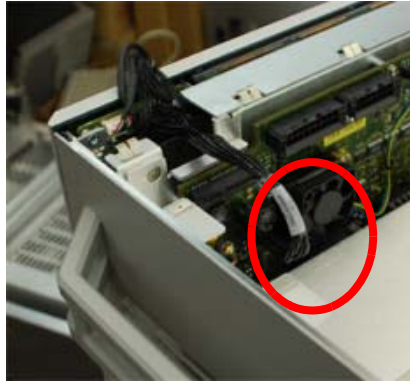

- 2 Remove the four screws (two on each side) connecting the front panel assembly to the top of the chassis. Torque to 5 in-lbs when reassembling.



- 3 Turn the oscilloscope upside-down and remove the four M3 screws connecting the bottom panel to the back panel. When replacing, torque the screws to 5 in-lbs.



- 4 Remove the five M3 screws from the bottom panel.

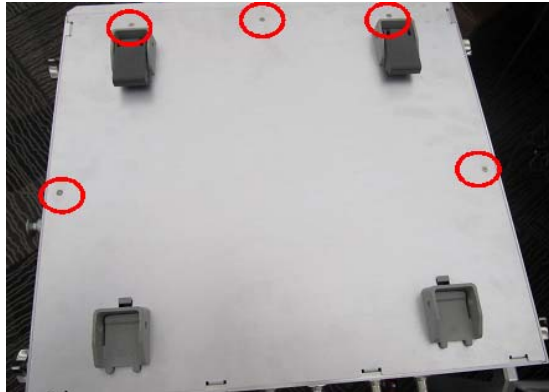

- 5 Remove the bottom panel.
- 6 Disconnect each input cable from each of the four attenuator connectors using a 5/16-inch hex torque wrench. When reconnecting, torque to 8 in-lbs. The length of the cable will guide the installation (longest cable on left, shortest cable on right).

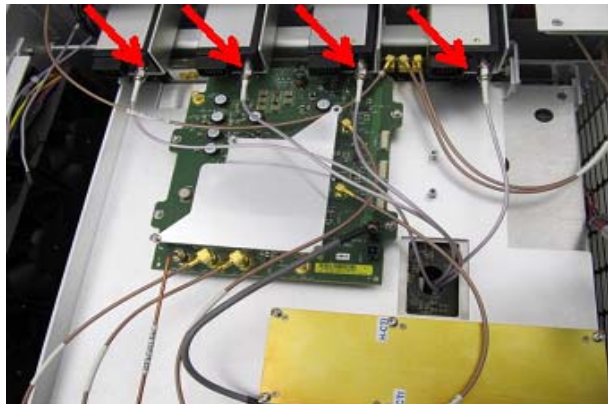

- 7 Disconnect the attenuator power cable from each input channel attenuator.

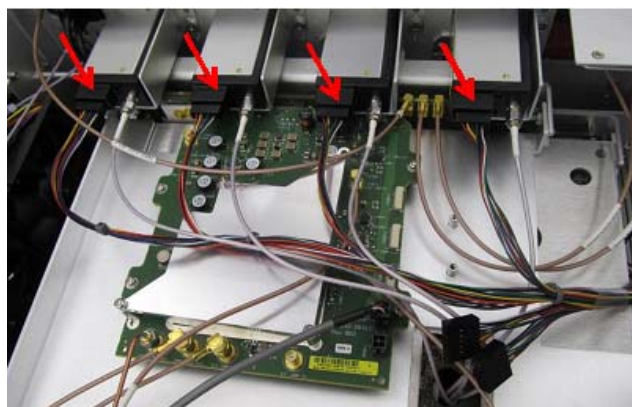

## 5 Replacing Assemblies

- 8 Disconnect the Probe Comp cable from the connector on the backplane board.

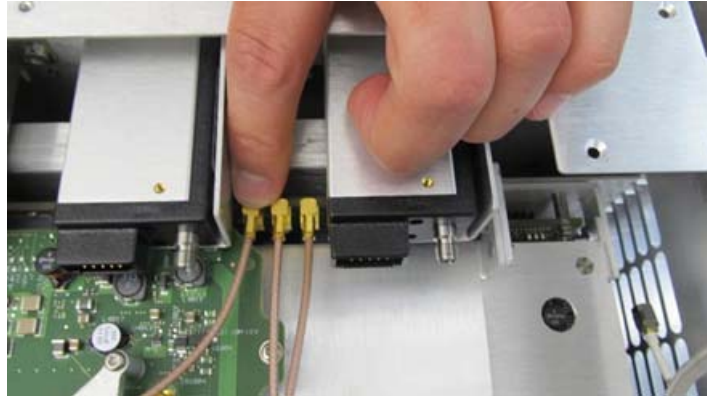

- 9 If the oscilloscope has the optional sync port, disconnect the channel 3 cable attenuator from the attenuator connector on the sync port.

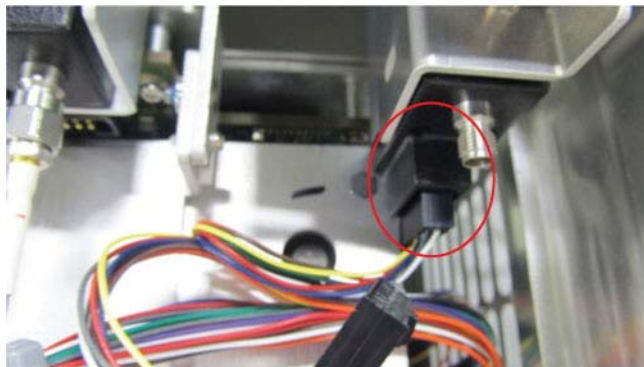

- 10 If the oscilloscope has the optional sync port, disconnect the channel 3 input connector from its connector on the sync port.

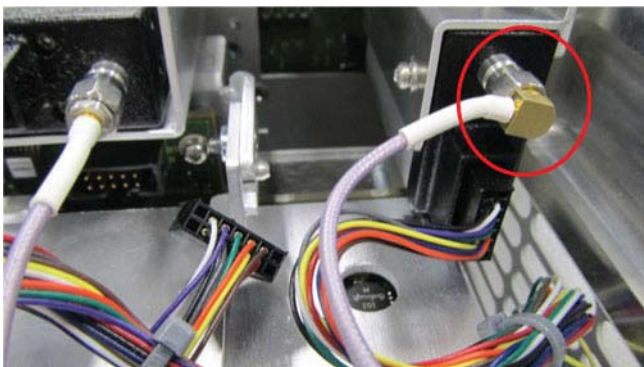

- 11 Disconnect the Aux Out and Cal Out cables from both the front panel and the backplane board. Pull straight back to remove the cables from the backplane board. When reconnecting, gently reinsert each cable. You will hear a snap when it is fully seated.

**CAUTION**

Be sure to pull straight back to avoid bending or breaking the connection to the backplane board.

---



The front panel is now disconnected.

## 5 Replacing Assemblies

### Removing a RealEdge Assembly

If you are working on a model with greater than 33 GHz bandwidth, it will have a RealEdge assembly. The following steps show how to remove it. Be sure to remove the RealEdge assembly before removing the front panel to avoid damaging the assembly.

- 1 Disconnect the two input cables from the RealEdge modules and from the RealEdge modules to the RealEdge auxiliary module.

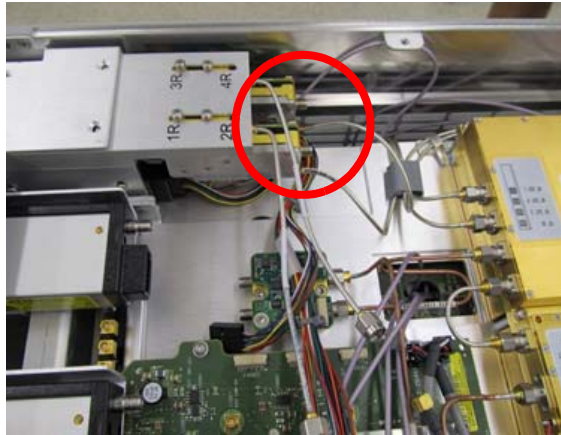

- 2 Disconnect the cable connecting the pilot cables to the RealEdge auxiliary module. When reconnecting, torque the connectors to 8 in-lbs. using a 5/16-inch hex torque wrench.

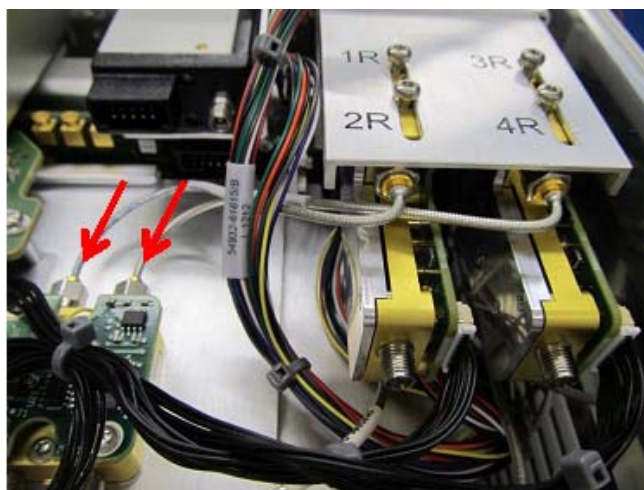



- 3 Disconnect the RealEdge assembly power cables.

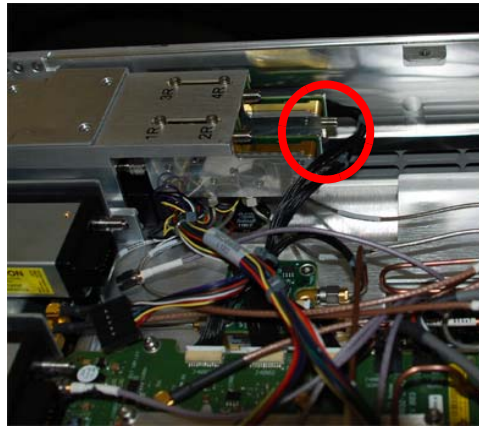

- 4 Remove the four M3 screws.



- 5 Gently remove the RealEdge assembly, keeping the cables from getting caught. Gently slide it toward the back, careful to avoid catching any parts on the sheet metal flange on the chassis.

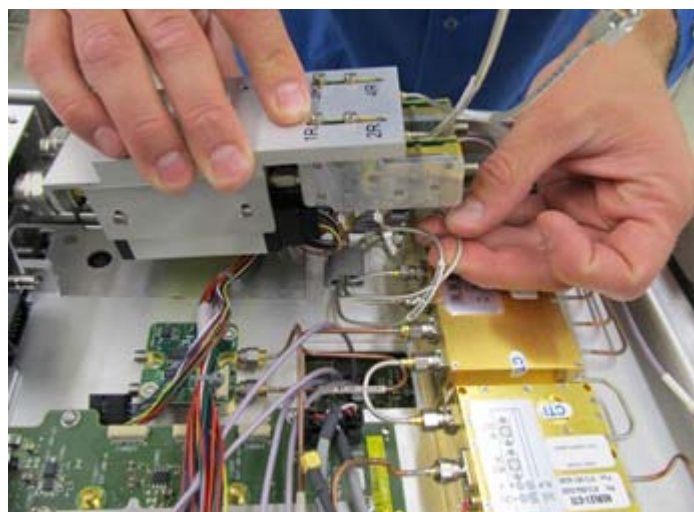

## 5 Replacing Assemblies

- 6 Flip the RealEdge assembly over and disconnect the remaining cables: two input cables, two attenuator cables, and the two cables coming from the 32 GHz DRO. You do not need to disconnect the cables from the DRO itself.

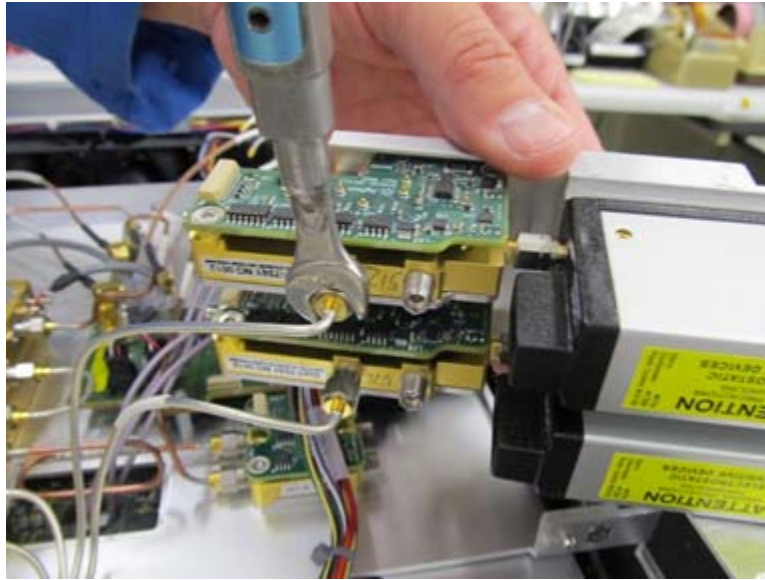

- 7 Place the RealEdge assembly into an anti-static bag.

### Finishing Removal of the Front Panel

- 1 To finish removing the front panel, remove the four M3 screws (two on each side) connecting the front panel to the bottom of the chassis. When replacing, torque the screws to 5 in-lbs.

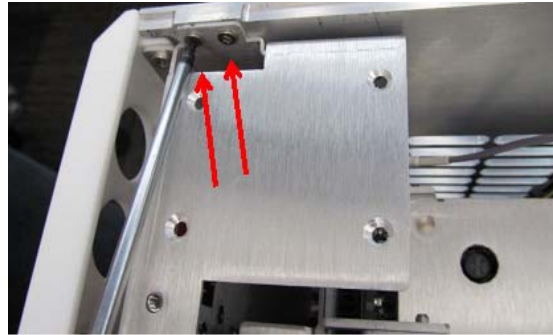
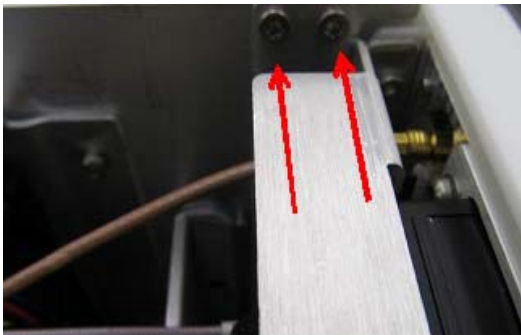

- 2 Pull off the front panel, carefully feeding the USB cable through the opening. To replace the front panel assembly, reverse this procedure.

## Removing and Replacing Front Panel Assembly Parts

Remove the front panel assembly as described in the previous section.

### Front Panel Clutches, Connectors, and Knobs

**WARNING**

This step will ruin the clutch. You will have to replace the clutch with a new one.

- 1 Use a thin item such as a ribbon to protect the oscilloscope from scratches, and pull on the dark gray plastic clutches to pop them off of the oscilloscope.
- 2 Use your fingers to pull off the knobs.

### Front Panel Bezel and Front Panel Assembly

- 1 Remove the seven M3 screws (three from each side and one from the bottom). When replacing the screws, torque to 5 in-lbs.

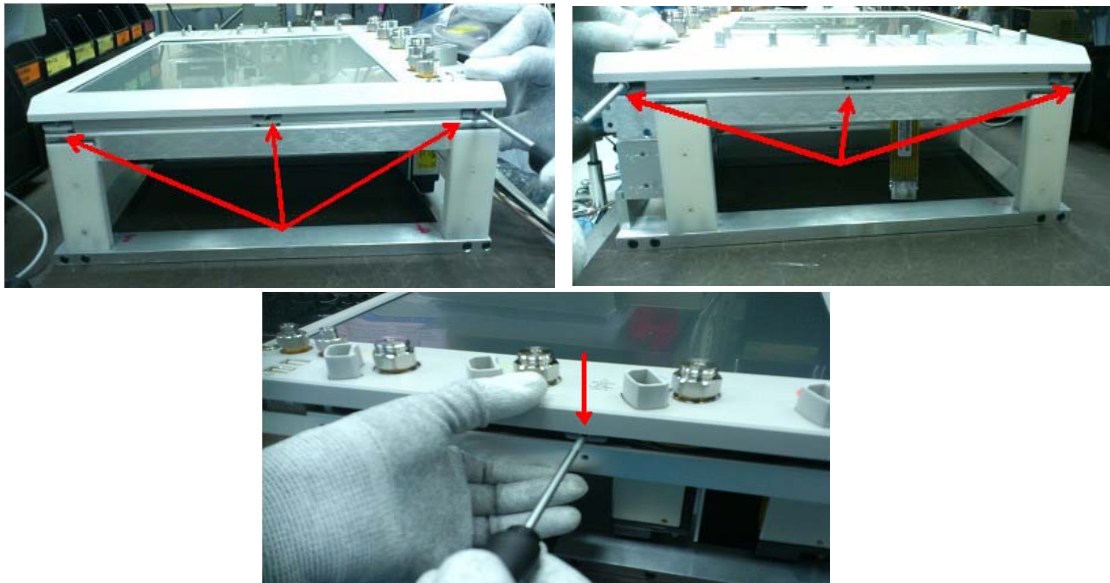

## 5 Replacing Assemblies

- 2 Remove the six screws from the back of the front panel.

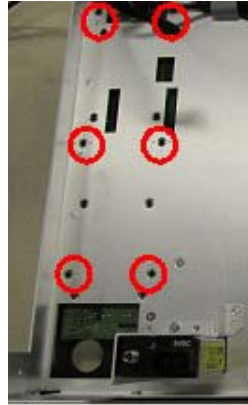

- 3 If the oscilloscope is a 20, 25, or 32 GHz model without the optional sync port, it will have a filler plate covering Trig Out and Aux Trig. Remove this plate from the back of the front panel by removing the nuts and washers from the cables.

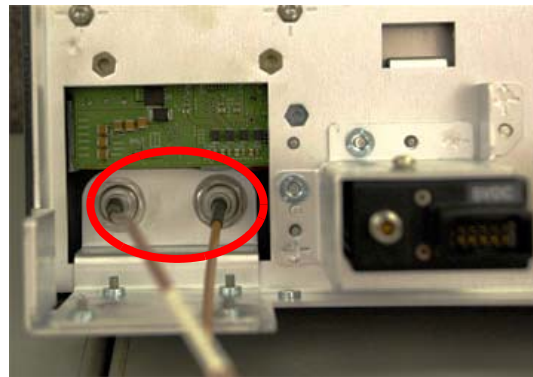

Remove nuts  
and washers

- 4 If the oscilloscope is a 20, 25, or 32 GHz model with the optional sync port, remove the two screws that go through the front panel bracket and multi-frame bracket.

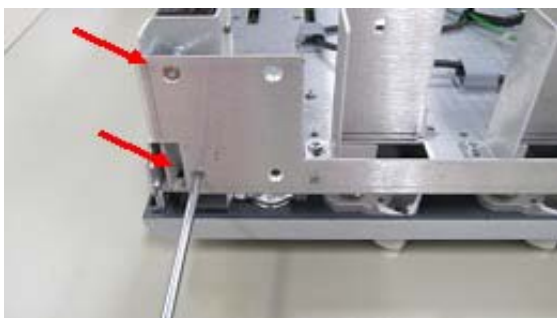

- 5 Lift off the front panel bezel.



- 6 The front circuit board of the keyboard assembly is connected to the front bezel. If you need to remove and replace only this front board, push the snap tabs out of way with a screwdriver and pull out the board.
- 7 Disconnect the autoprobe cable and backlight cable.

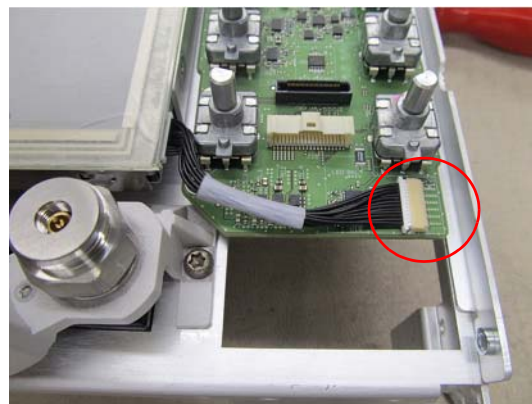
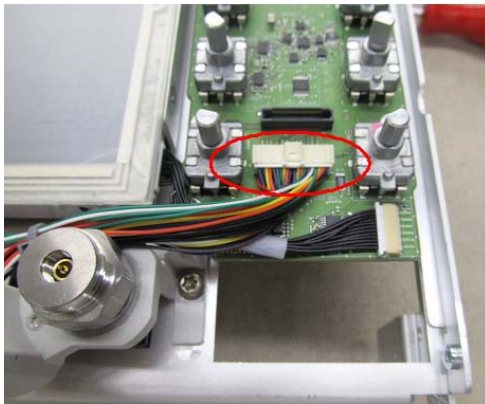

- 8 Remove the two M3 screws, top right and bottom left, connecting the rear board of the keyboard assembly to the deck, and remove the board. When reinstalling, torque to 5 in-lbs.

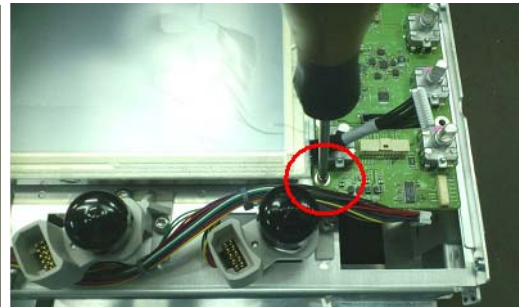

To reassemble the front panel assembly, reverse these steps.

## 5 Replacing Assemblies

### Cal Connector (Power Button) Assembly

- 1 Remove the two screws connecting the cal bracket to the front deck. When replacing, use a power driver and T-10 bit to torque the screws to 8 in-lbs.



- 2 Remove the cal connector assembly from the front panel deck. Carefully pull the cables through the front deck. Replace individual parts as needed.

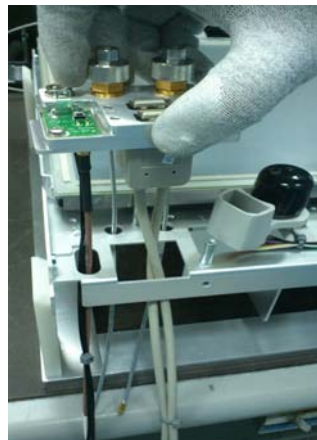

### Display Assembly

- 1 Remove the front panel bezel and front panel assembly as described previously.
- 2 Disconnect the display cable from the back of the display.



- 3 Remove the four M3 screws (two on each side) connecting the display to the deck. When reinstalling, torque to 5 in-lbs.



### Attenuators (20, 25, and 33 GHz Models)

- 1 Remove the four screws connecting each attenuator to its bracket. When reconnecting, torque the screws to 8 in-lbs.



- 2 Remove the four attenuators by removing the nut of the attenuator from the threads of the 3.5 mm connector. Remove the attenuator from the bracket. When replacing, use a hand torque wrench to torque the nuts to 8 in-lbs.



## 5 Replacing Assemblies

### Removing and Replacing RealEdge Components

This section describes how to remove and replace the RealEdge modules and the attenuator components of the RealEdge assembly.

- 1 Remove the RealEdge assembly as described previously.
- 2 Remove the two screws from the back of the top RealEdge module as shown below. When replacing, torque to 5 in-lbs.



- 3 Loosen the connection between the RealEdge SMA connector and the attenuator connector. Be careful to handle the RealEdge module by the casing and not the connector. When tightening, torque the connector to 8 in-lbs.

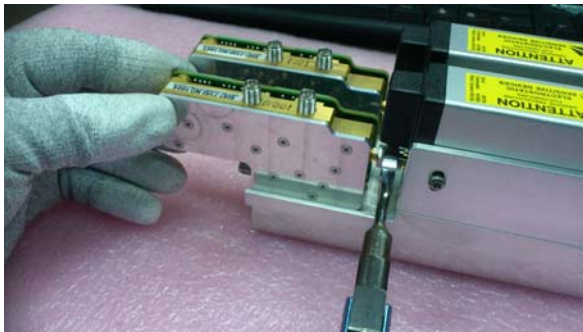

- 4 Carefully remove the RealEdge module.

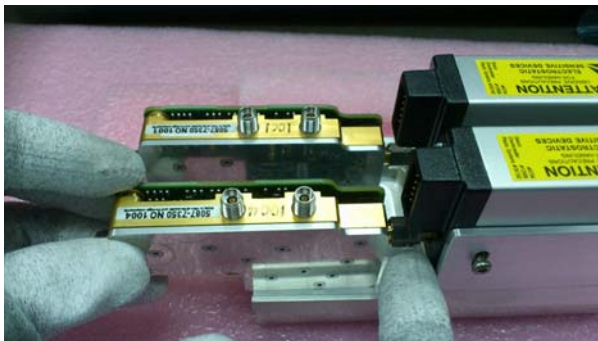



- 5 Remove the two screws on the side of the attenuator. When replacing, torque to 5 in-lbs.



- 6 Loosen the SMA connector from the male SMA connector on the 1.85 connector. When replacing, torque the connector to 8 in-lbs.



- 7 Remove the attenuator assembly.
- 8 Remove the two screws connecting the attenuator to the bracket. When replacing, hand tighten the screws and then back off the screw one full turn to allow the frame to move. Tighten the screws after the connector is tightened.

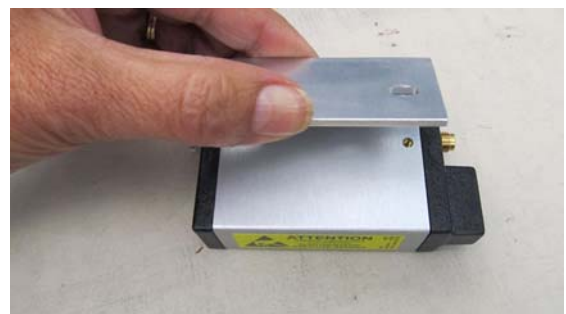

- 9 Repeat these steps to remove and replace the bottom RealEdge module and attenuator.

### Removing and Replacing the Acquisition Boards/Backplane Assembly

Use these procedures to remove and replace the acquisition and backplane assemblies and individual acquisition boards. When necessary, refer to other removal procedures. The graphics in this chapter are representative of the oscilloscope at the time of this printing. Your unit may look different.

#### Removing the acquisition and backplane assemblies

- 1 Remove the top panel, power supply, front panel assembly, and bottom panel as described previously.
- 2 Remove all cables connected to the backplane board.

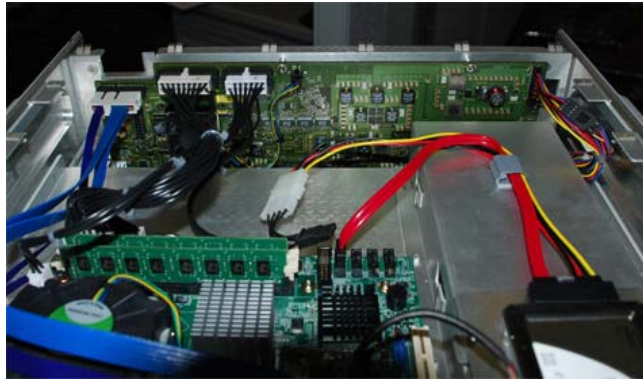

- 3 Remove the two M4 screws from the backplane tray (one in each corner).



- 4 Turn the oscilloscope over.
- 5 Disconnect the cables from the rear panel (four cables for 33 GHz and lower bandwidth models; six cables for models greater than 33 GHz and lower

bandwidth models with the optional sync port), using 5/8 (left photo) or 5/16 (right photo) driver. When reconnecting, torque the nut and washers to 18 in-lbs.

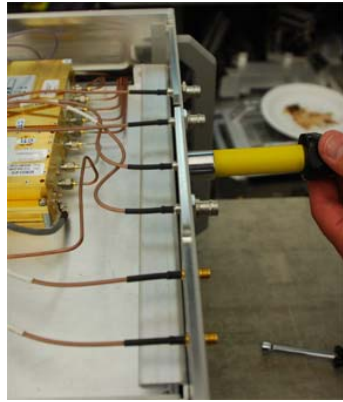

- 6 If you need to replace the oscillator board, remove the four M3 screws connecting the board to its tray and disconnect all attached cables. When replacing, torque the screws to 5 in-lbs and torque SMA connectors to 8 in-lbs using a 5/16-inch hand torque wrench.

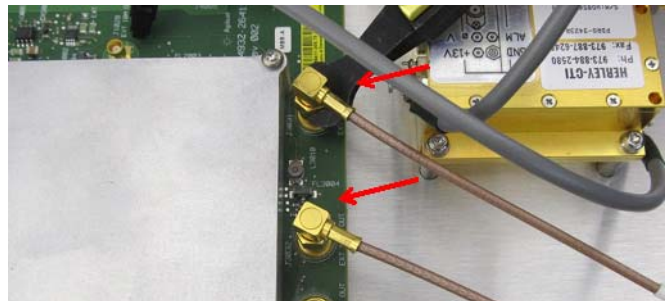
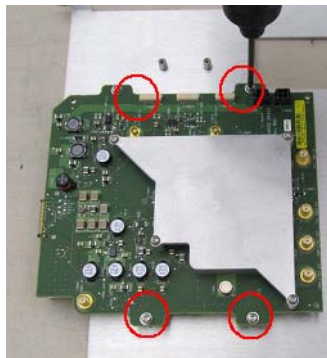

- 7 Remove the two screws connecting the backplane deck to the chassis.

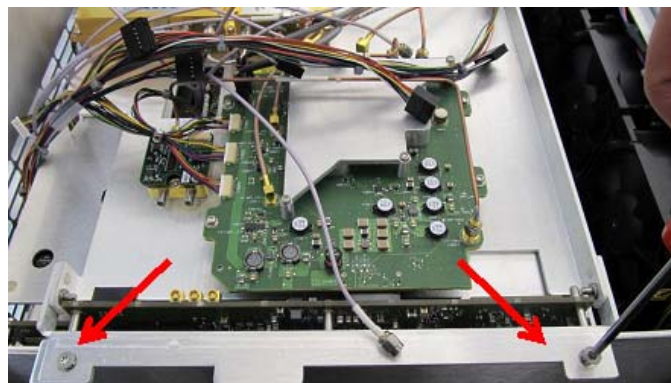

## 5 Replacing Assemblies

- 8 Remove the four M4 screws from the rear panel of the chassis. When replacing, torque the screws to 18 in-lbs.



- 9 Dress all cables into the center to keep them from getting caught.
- 10 Lift the entire backplane board/acquisition assembly out of the chassis and place it on another table. Use the handles, as the assembly is heavy.



## Removing an Acquisition Board

When removing an individual acquisition board, note that acquisition board 4 has the longest cable. Acquisition board 1 has the shortest cable. You may want to label the acquisition boards 1 through 4 for easy reference.

- 1 Carefully remove the five clock cables from the DRO to the acquisition boards using a 5/16 Torx wrench. Avoid catching the cables on any acquisition board components.



- 2 Remove the attenuator control cables.

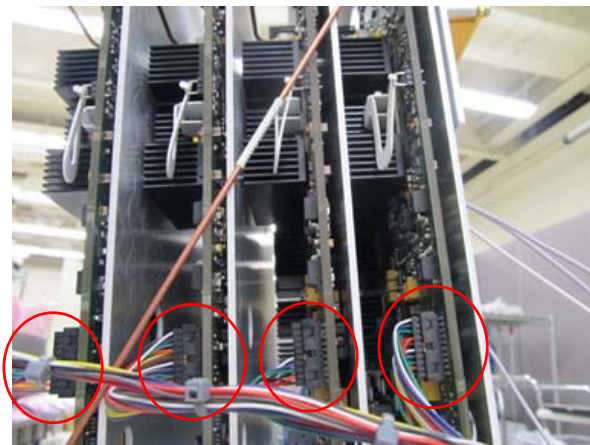

## 5 Replacing Assemblies

- 3 Remove the 10 M4 screws (five from each side) connecting the acquisition boards to the rear panel. Keep the oscillator board tray connected to acquisition board 1 unless you have already removed it. When reassembling, torque the screws to 18 in-lbs using a T20 driver.



- 4 Lift off the rear panel.
- 5 Remove the two screws (one on each side) connecting the oscillator board tray to the backplane deck, unless you are replacing only acquisition board 4.



To remove only board 4, disconnect the 54932-61624 cable and the attenuator cable connection from board 4 only. Then remove the cable from the backplane board to the DRO.

- 6 Lift the oscillator board tray straight up and slide it forward, carefully threading the input cables through the opening. Place the oscillator board into an anti-static bag.

- 7 Remove the eight remaining screws securing the acquisition trays to the backplane tray. Remove each acquisition board starting with the lowest slot (next to the oscillator board).



- 8 Gently rock the acquisition board and guide the input cables through. Remove the acquisition board and place it upside-down in an anti-static bag to avoid crimping the cables.
- 9 Repeat steps 7-8 for any additional acquisition boards to be removed, if applicable. When removing the last acquisition board, grip it firmly and then gently rock it up and out.

### Removing Acquisition Board Cables and Trays

- 1 Disconnect the input cables (one cable for models  $\leq 33$  GHz; two cables for models  $> 33$  GHz) and feed them through the hole.



- 2 Remove the 10 screws connecting the acquisition board to the tray. Keep the cables to attach to the new acquisition board.

## 5 Replacing Assemblies

### Removing the Backplane Board from the Deck

- 1 Loosen the five guide pins. When replacing, torque the guide pins to 5 in-lbs using a size 6 metric open-end wrench.

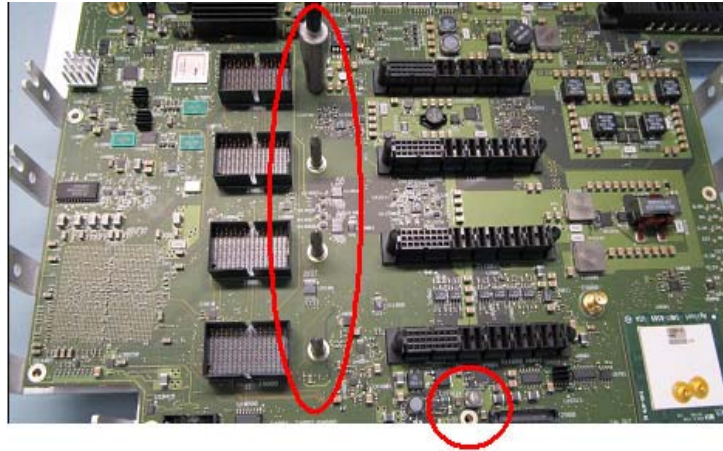

- 2 Using a T10 Torx, remove the 10 tie-down screws from the edges. When replacing, torque the screws to 5 in-lbs.

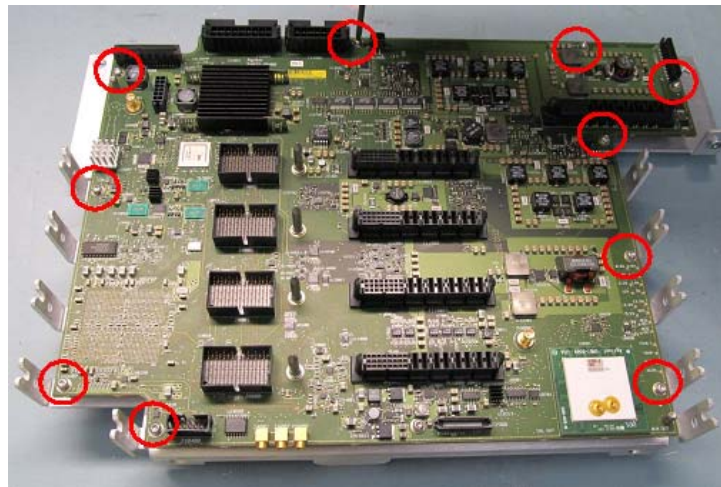

- 3 Lift the backplane assembly off the deck.



## Setting the Calibration Factors after Replacing an Acquisition Board

You must perform a user calibration and self test procedure after replacing an acquisition board. If you replaced any RealEdge components, a factory calibration is required. Refer to the calibration chapter in this Service Guide for details.

**Let the oscilloscope warm up before adjusting.**

Warm up the oscilloscope for 30 minutes before starting the calibration procedure. Failure to allow warm up may result in inaccurate calibration.

## Removing and Replacing the Fans

**WARNING**

The fan blades are exposed both inside and outside the chassis. Disconnect the power cable before working around the fan. Use extreme caution in working with the oscilloscope. Failure to observe these precautions may result in injury.

- 1 Disconnect the power cable and remove the top panel, power supply, front panel, bottom panel, and acquisition assembly as described earlier.
- 2 Remove the six M3 screws connecting the fan bracket to the chassis. When replacing, torque the screws to 5 in-lbs.

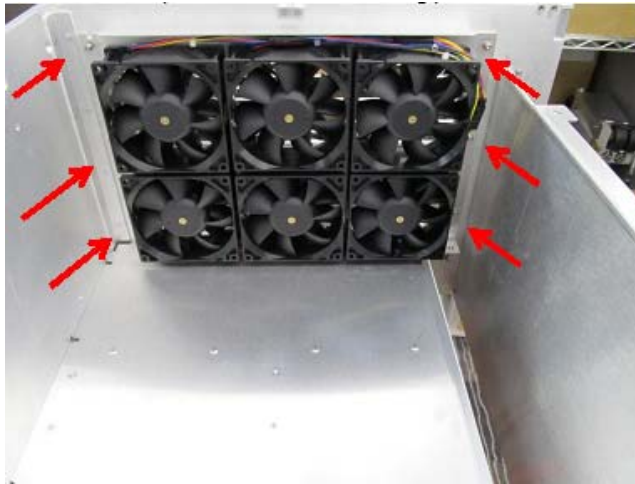

- 3 Remove the fan assembly, carefully feeding the fan assembly cable through the bottom of the chassis.

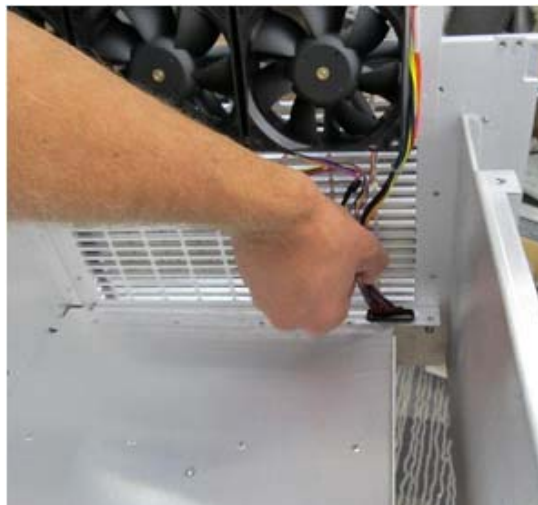

- 4 Clip off the end of each of the fan mounts as shown below and take the fan out. Repeat for each fan that needs to be replaced.

**CAUTION**

When replacing the fan, be sure the direction of the fan air flow is coming from the inside to the outside of the oscilloscope. Check the flow arrows on the fan and check for proper flow once power is applied to the oscilloscope. Improper air flow can overheat the oscilloscope.

---

To install the fans, reverse this procedure.

## 5 Replacing Assemblies

## 6 Replaceable Parts

Ordering Replaceable Parts **118**

Exploded Views **119**

Replaceable Parts List **124**

This chapter describes how to order replaceable assemblies and parts for the Infiniium Z-Series oscilloscopes. Service support for this oscilloscope is replacement of parts to the assembly level.

## Ordering Replaceable Parts

### Listed Parts

To order a part in the parts list, quote the Keysight Technologies part number, indicate the quantity desired, and address the order to the nearest Keysight Technologies Sales Office.

### Unlisted Parts

To order a part not listed in the parts list, include the oscilloscope part number, oscilloscope serial number, a description of the part (including its function), and the number of parts required. Address the order to the nearest Keysight Technologies Sales Office.

### Direct Mail Order System

Within the USA, Keysight Technologies can supply parts through a direct mail order system. There are several advantages to this system:

- Direct ordering and shipping from the Keysight Technologies parts center in California, USA.
- No maximum or minimum on any mail order. (There is a minimum amount for parts ordered through a local Keysight Technologies Sales Office when the orders require billing and invoicing.)
- Prepaid transportation. (There is a small handling charge for each order.)
- No invoices.

For Keysight Technologies to provide these advantages, please send a check or money order with each order.

Mail order forms and specific ordering information are available through your local Keysight Technologies Sales Office. Addresses and telephone numbers are located in a separate document shipped with the manuals.

### Exchange Assemblies

Exchange assemblies have been set up for Keysight Service Center use only.

# Exploded Views

## Front Panel

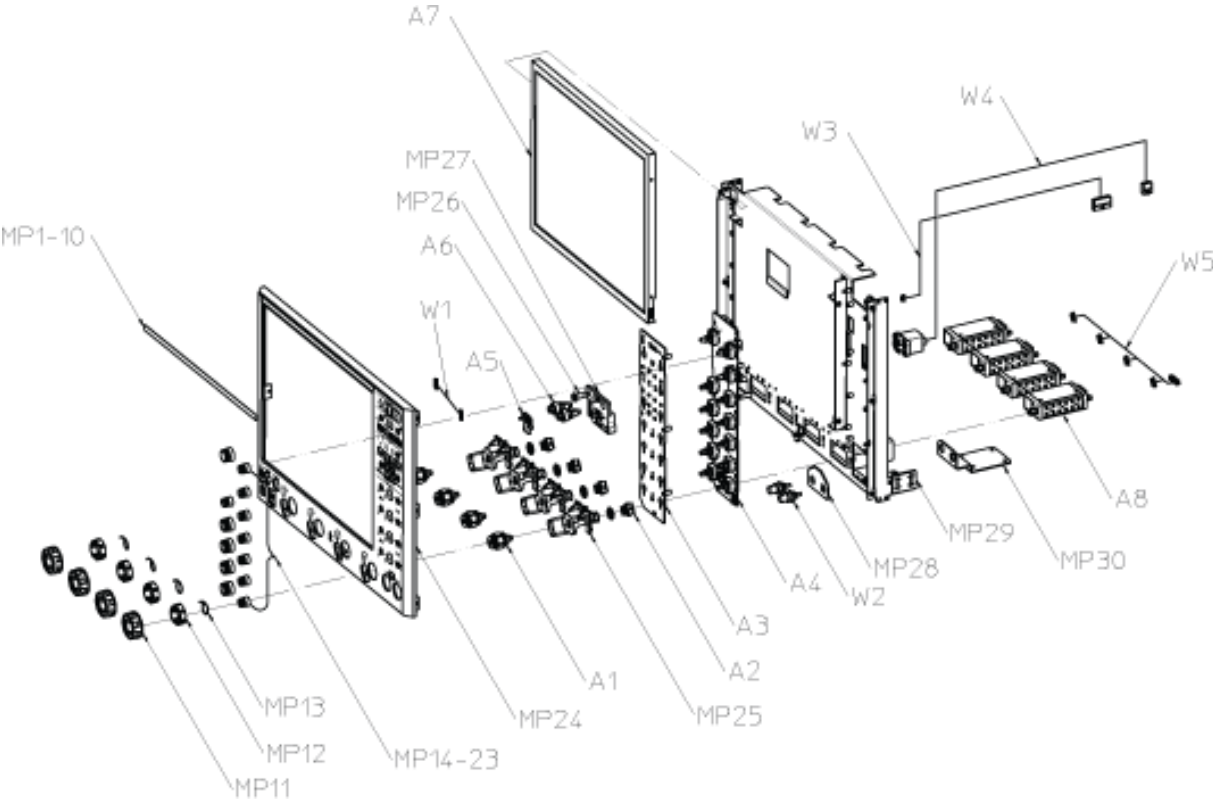

Fan and Acquisition Assembly

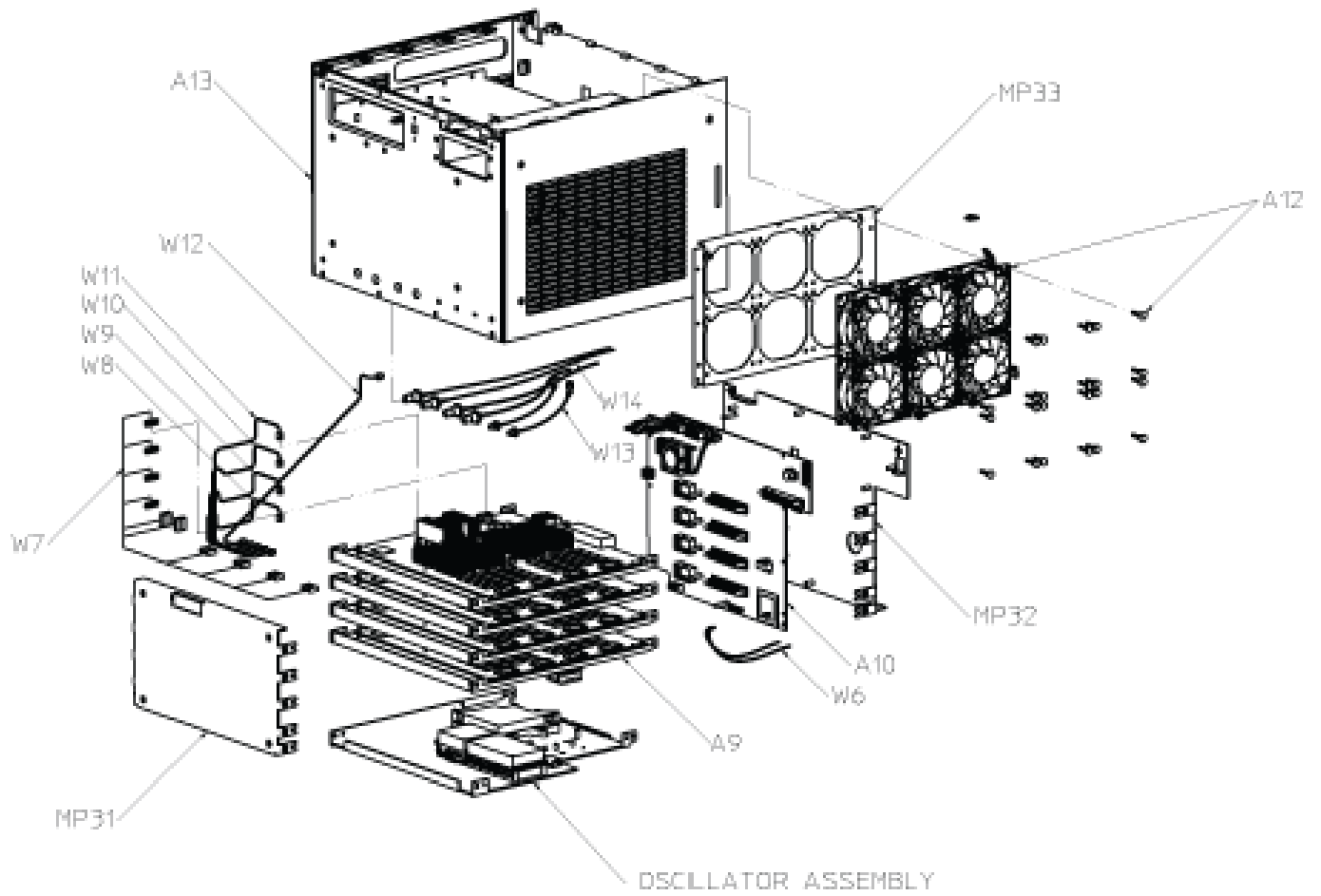



Oscillator Assembly

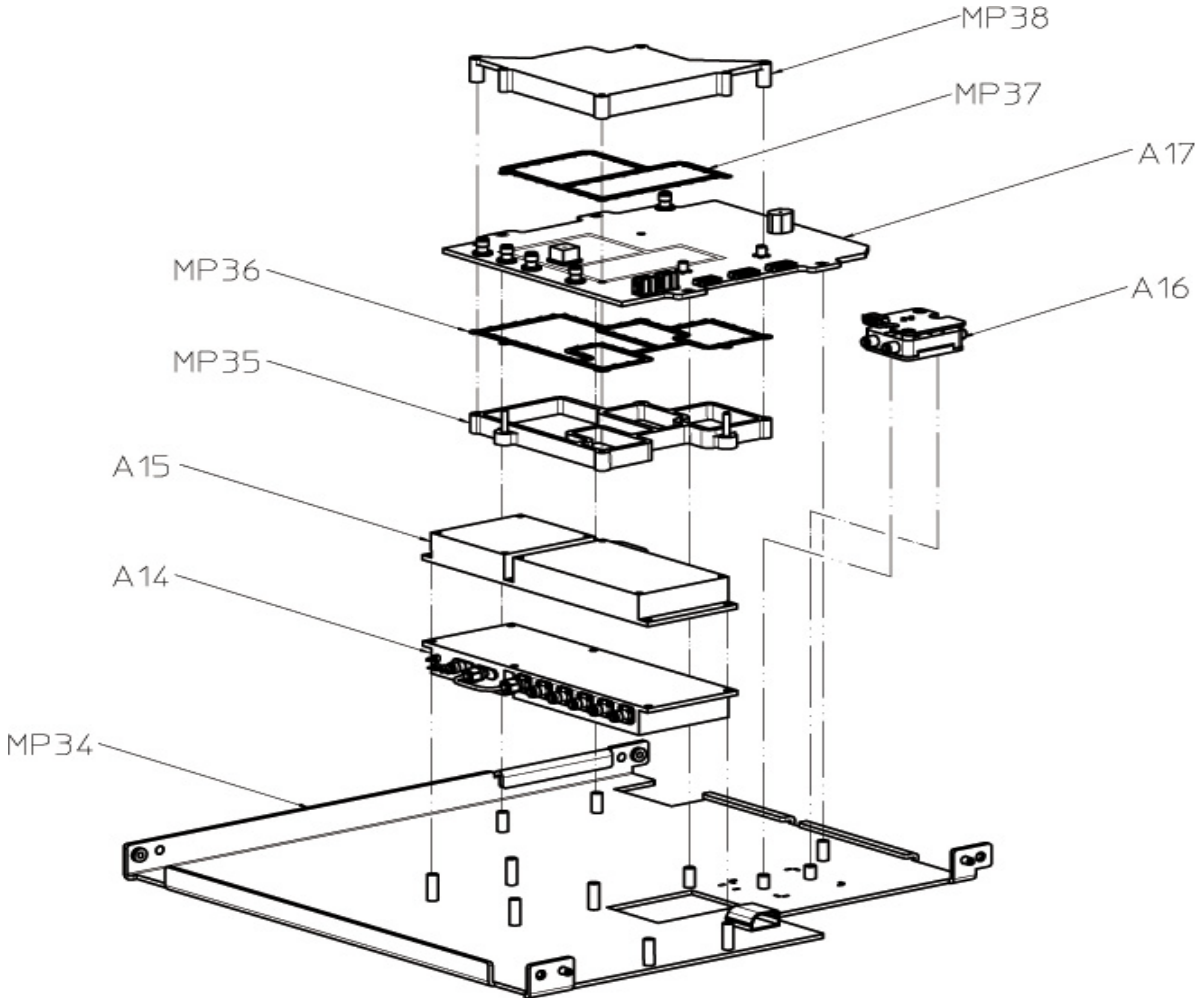

## 6 Replaceable Parts

### Power Supply and PC Motherboard

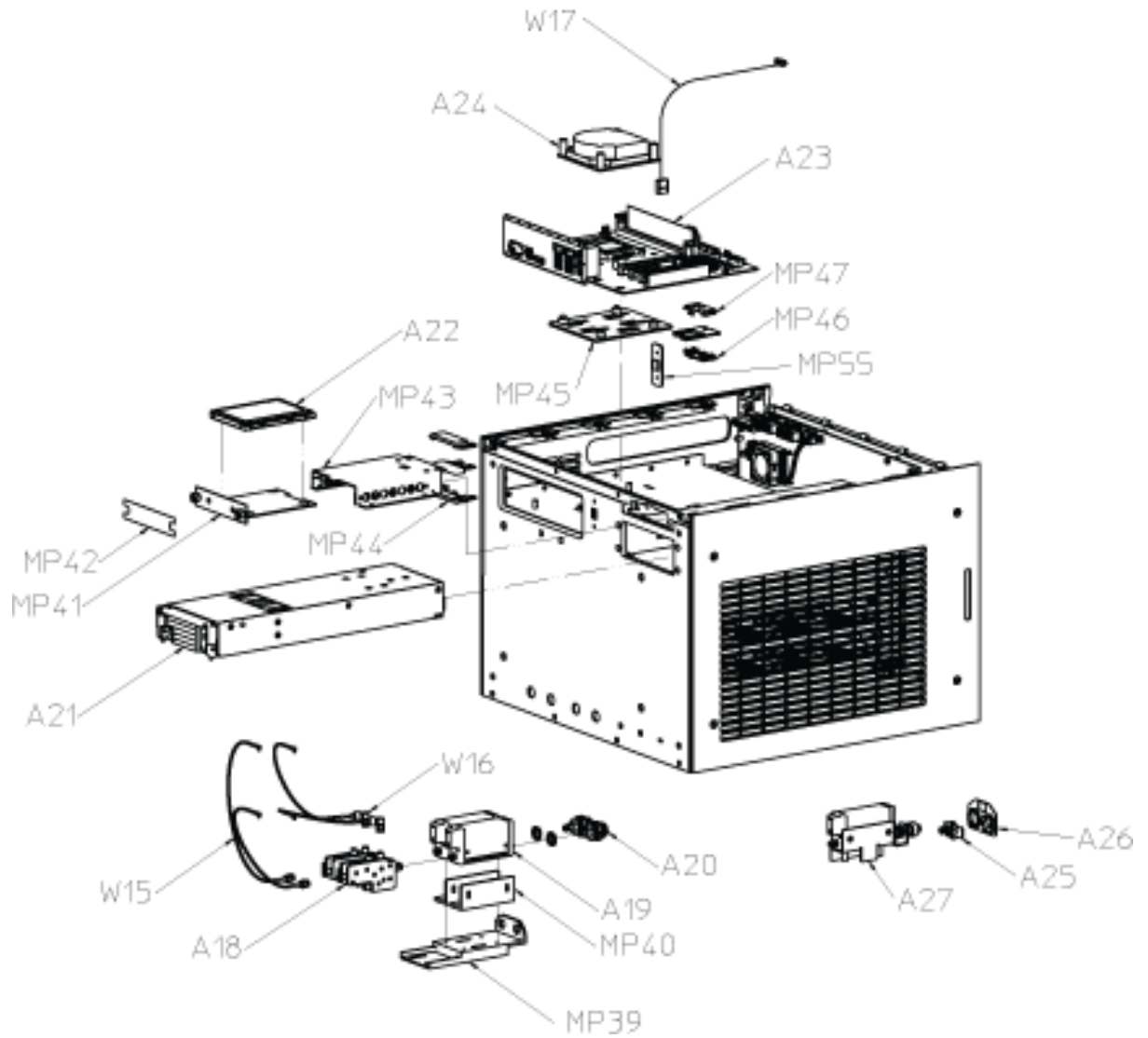

External

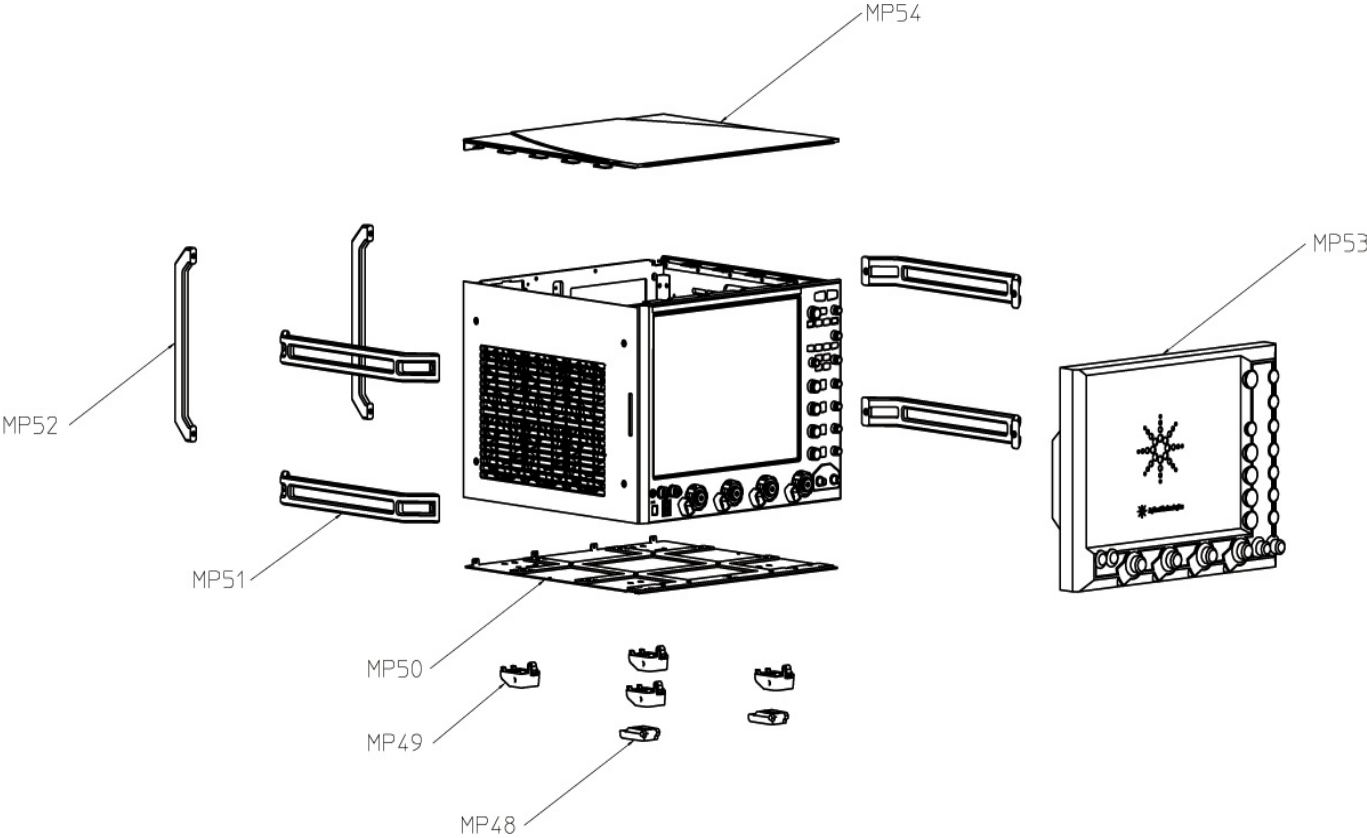

## Replaceable Parts List

The following table is a list of replaceable parts. The information given for each part includes:

- Reference designation in exploded views
- Keysight Technologies part number
- Total quantity (QTY) in the oscilloscope or an assembly
- Description of the part

### Replaceable Parts

Ref. Des.	Keysight Part Number	QTY	Description
A1	5062-1247	1	Assembly - 3.5 mm Connector
A2	54916-66414	1	PCA Autoprobe Board
A3	54932-66414	1	PCA Keyboard - Front
A4	54932-66415	1	PCA Keyboard - Rear
A5	54932-66406	1	PCA On/Off Board
A6	08673-67601	1	Connector Assembly - Output
A7	2090-1075	1	Display LCD 15-in with capacitive touch screen TFT XGA 1024X768-Pixels 257-LG X 326.5-WD X14.9-D-mm
A8	33325-60019	1	Step attenuator, 35dB, 5V, Female-Male, Pb free
A9	54916-66503	1	Acquisition board, tested
A10	54932-66502	1	Backplane Board, tested
A10	54932-69502	1	Backplane Board, exch
A12	54932-60003	1	Fan assembly
A13	54932-00102	1	Chassis
A14	54932-63401	1	Oscillator Assembly 10 GHz
A15	54932-63402	1	Oscillator Assembly 32 GHz
A16	5087-7351	1	Top Assembly, Hwin
A17	54932-66411	1	Oscillator Board
A18	5087-7361	1	Top Assembly, Pearl
A19	84905-60003	1	Attenuator 35DB,5 Volt, Female-Male, 67Ghz, Pb Free
A20	5064-7891	1	Conn 1.85 blkhd
A21	0950-5393	1	Power Supply 1600W single output 12V
A22	54932-83503	1	Imaged 480 Gb SSD for M900/Win7-based Infiniium scopes, image W7 (Service Centers Only)
A22	54932-83504	1	Imaged 960 Gb SSD for M900/Win7-based Infiniium scopes, image W7 (Service Centers Only)
A23	0960-3172	1	Mother Board Printed Circuit Assembly
A24	3160-4454	1	Assembly - Fan with heat sink
A25	54932-01204	1	Clamp - Multi-frame sync
A26	54932-24115	1	Cover - Multi-frame sync
A27	54932-68729		Synchronization port for multiple Z-Series oscilloscope use

## Replaceable Parts

Ref. Des.	Keysight Part Number	QTY	Description
MP1	54932-94321	1	Label - ID DSOZ204A
MP2	54932-94322	1	Label - ID DSOZ254A
MP3	54932-94323	1	Label - ID DSOZ334A
MP4	54932-94324	1	Label - ID DSOZ504A
MP4	59432-94326	1	Label - ID DSOZ594A
MP5	54932-94325	1	Label - ID DSOZ634A
MP6	54932-94331	1	Label - ID DSAZ204A
MP7	54932-94332	1	Label - ID DSAZ254A
MP8	54932-94333	1	Label - ID DSAZ334A
MP9	54932-94334	1	Label - ID DSAZ504A
MP9	59432-94336	1	Label - ID DSAZ594A
MP10	54932-94335	1	Label - ID DSAZ634A
MP11	54916-47401	4	Outer clutch
MP12	54916-45001	4	Inner clutch
MP13	54916-07101	1	Input Connector Ground Spring
MP14	54932-47403	1	Knob 12 mm slate blue
MP15	54932-47404	1	Knob 12 mm slate red
MP16	54932-47405	4	Knob 12 mm slate plain
MP17	54932-47410	1	Knob 18 mm slate yellow
MP18	54932-47411	1	Knob 12 mm slate yellow
MP19	54932-47420	1	Knob 18 mm slate green
MP20	54932-47422	1	Knob 12 mm slate green
MP21	54932-47430	1	Knob 18 mm slate blue
MP22	54932-47440	1	Knob 18 mm slate red
MP23	54932-47450	1	Knob 18 mm slate plain
MP24	54932-62201	1	Bezel Assembly
MP25	54916-42001	1	Casting - Probe Mate
MP26	54542-26101	1	Ground lug
MP27	54932-21201	1	Bracket - Power Button
MP28	54932-24105	1	Cover - Front Cal
MP29	54932-00111	1	Deck - Front Panel
MP30	54932-01201	1	Bracket - Front Cal
MP31	54932-00201	1	Panel - Rear
MP32	54932-00502	1	Frame - Backplane
MP33	54932-21202	1	Fan Bracket
MP34	54932-00503	1	Frame - Oscillator
MP35	54932-24102	1	Cover - Oscillator Bottom
MP36	54932-07102	1	Gasket - Oscillator Bottom
MP37	54932-07101	1	Gasket - Oscillator Top
MP38	54932-24101	1	Cover - Oscillator Top

## 6 Replaceable Parts

### Replaceable Parts

Ref. Des.	Keysight Part Number	QTY	Description
MP39	54932-20511	1	Frame - base
MP40	54932-20502	1	Frame - Attenuator
MP41	54904-04101	1	Plate - RHDD
MP42	54911-94307	1	Label - RHDD tray
MP43	54904-01201	1	Bracket - RHDD
MP44	54904-41202	1	Clamp - SATA
MP45	54932-21204	1	Support assembly - board
MP46	54904-45202	2	Housing - PCIe cable snap
MP47	54904-45203	2	Housing - PCIe cable receptacle
MP48	54916-41002	2	Foot - Tilt Lever
MP49	54916-41001	4	Foot - Tilt Base
MP50	54932-00203	1	Panel - Bottom
MP51	54932-24901	4	Handle
MP52	54932-41001	1	Foot - Rear
MP53	54932-44101	1	Cover - Front
MP54	54932-20202	1	Panel - Top
MP55	54932-24116	1	Cover - USB Host Port
W1	54932-61607	1	Cable - Backlight
W2	54932-61631	1	Cable - MCX to BNC Decorative
W3	54932-61612	1	Cable - On/Off
W4	54932-61610	1	Cable - USB Ports
W5	54932-61637	1	Cable - Autoprobe
W6	54932-61625	1	Cable - Step Aux
W7	54932-61615	1	Cable - Attenuator Dual
W8	54932-61621	1	Cable - SR 10 GHz CH1 (shortest)
W9	54932-61622	1	Cable - SR 10 GHz CH2
W10	54932-61623	1	Cable - SR 10 GHz CH3
W11	54932-61624	1	Cable - SR 10 GHz CH4 (longest)
W12	54932-61618	1	Cable - SR 10 GHz backplane
W13	54932-61629	1	Cable - SMA to SMA
W14	54932-61628	2	Cable - MCX to BNC
W15	54916-61601	5	Cable - Input
W16	54932-61601	2	Cable - Input (RealEdge)
W17	54932-61616	1	Cable - USB Front/Capacitive touch
	54916-60003	10	Connector Saver Collars
	54916-61603	1	Cable - PC Power
	54916-61626	1	Cable - Calibration
	0403-1116	1	Guide - PC BD Black POLYC .05 - .1 in BD THKNS
	0960-2929	1	OEM Mini Keyboard 319X157X20-mm
	1150-7913	1	Optical Wheel Mouse Mouton 2D Combo with Ferrite-Core inside

## Replaceable Parts

Ref. Des.	Keysight Part Number	QTY	Description
	3160-4454	1	CPU - Fan Assembly
	5185-4719	1	ESD wrist strap metal 12' cord light blue
	54932-61632	1	High-performance input cable, 2.92 mm
	54904-61614	1	Cable - Hard disk power
	54916-68717	1	Connector Assembly - 3.5mm female to female - kit of 5
	54932-61602	1	Cable - Jewel LO
	54932-61603	1	Cable - Jewel Pilot
	54932-61605	1	Cable - Power Front
	54932-61608	1	Cable - Display
	54932-61609	1	Cable - Hwin Jewel Harness
	54932-61611	1	Cable - Fan Harness
	54932-61617	1	Cable - SR 32 GHz Hwin
	54932-61619	1	Cable - SR 100 MHz Reference 1
	54932-61620	1	Cable - SR 100 MHz Reference 2
	54932-61626	1	Cable - SR PRBS
	54932-61627	1	Cable - MCX to MCX
	54932-61630	1	Cable - Calibration
	8121-2121	1	Cable-Assembly 30AWG 64-COND 400mm-LG
	8120-8620	1	Power cord - United Kingdom
	8120-8619	1	Power cord - Australia and New Zealand
	8121-2221	1	Power cord - Continental Europe
	8121-1713	1	Power cord - United States and Canada (120V) - EM-controlled environment required
	8120-8623	1	Power cord - United States and Canada (240V)
	8121-1765	1	Power cord - Switzerland
	8121-1882	1	Power cord - Denmark
	8121-2159	1	Power cord - India
	8121-1763	1	Power cord - Japan - EM-controlled environment required
	8121-0161	1	Power cord - Israel
	8121-1857	1	Power cord - Argentina
	8121-1084	1	Power cord - Chile
	8121-1766	1	Power cord - China
	8121-0710	1	Power cord - South Africa
	8121-1764	1	Power cord - Thailand
	8121-1800	1	Power cord - Japan - 250V
	8121-1787	1	Power cord - Brazil
	8121-1853	1	Power cord - Taiwan - EM-controlled environment required
	8121-2158	1	Power cord - Cambodia
	8121-2176	1	Power cord - Taiwan (250V)

## 6 Replaceable Parts



## 7 Theory of Operation

Motherboard Assembly	132
Acquisition Assembly	133
Backplane Assembly	135
Oscillator Assembly	141
Front Panel Assembly	142
RealEdge Technology Assembly	144
Power Supply	145

Oscilloscope block diagram

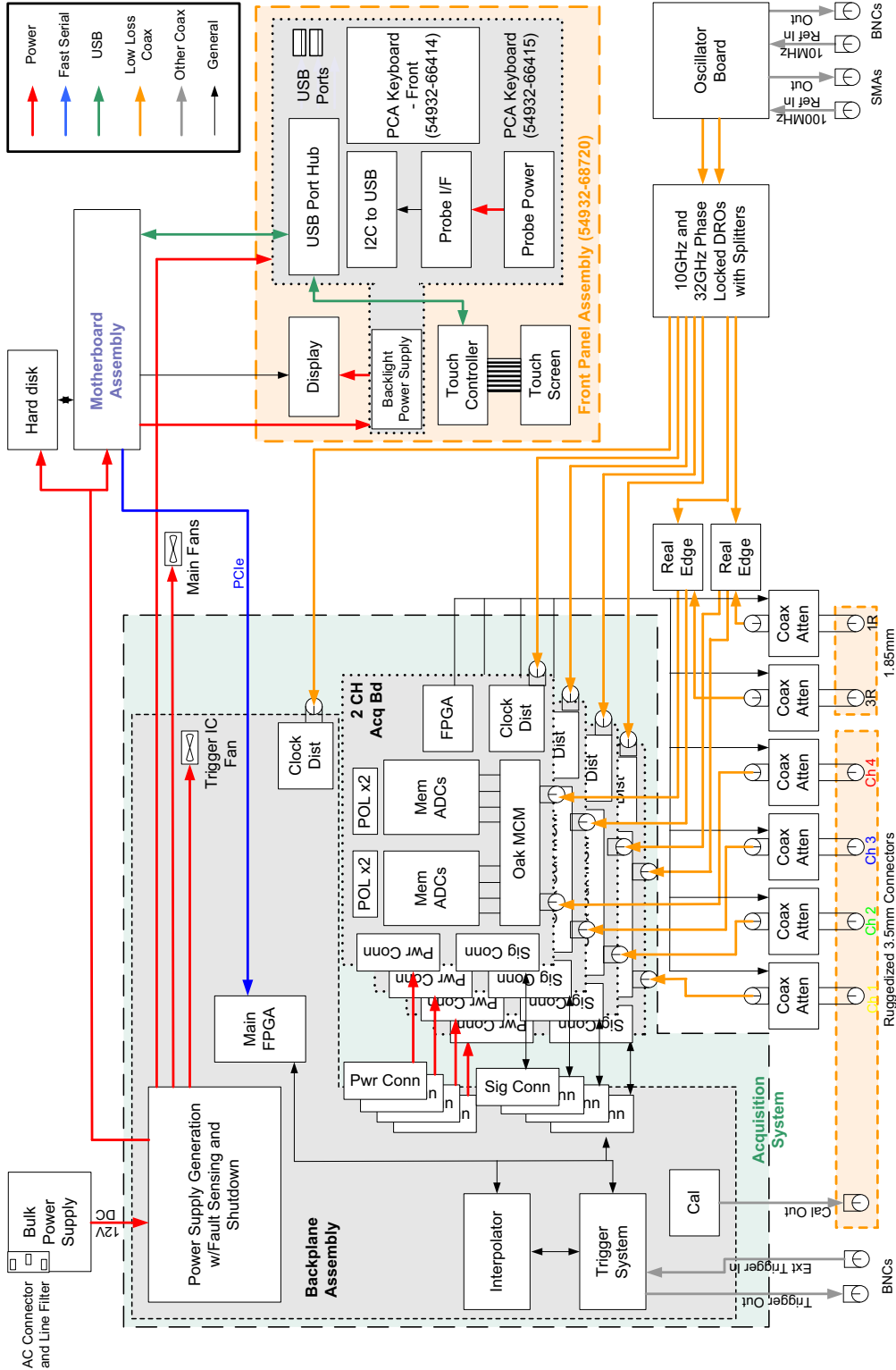

## Theory of Operation

This chapter describes the basic structure of the oscilloscope and how the parts interact.

The Infiniium Z-Series oscilloscopes are comprised of five or six main assemblies, depending on the model of the oscilloscope: a motherboard assembly, an acquisition assembly, a backplane assembly, an oscillator assembly, and a front panel assembly for all models, plus a RealEdge Technology Assembly for models that have greater than 33 GHz bandwidth. Each oscilloscope also has a bulk power supply.

The previous figure shows a block diagram of the Infiniium Z-Series oscilloscope.

## Motherboard Assembly

The motherboard assembly provides all system control and interface functions for the oscilloscope. The motherboard contains a microprocessor, a hard disk drive interface, ROM, RAM, keyboard and mouse interfaces, connections to the front panel assembly, and serial and parallel interfaces.

Pressing the on/off button sends a signal to the motherboard. The motherboard then signals the backplane assembly, which in turn sends a signal to tell the bulk 12V power supply to turn on. When the power supply turns on, the remaining power supplies are enabled and powered on. Then the main FPGA on the backplane assembly gets self-configured from its PROM. Once it is configured, the main FPGA asserts a signal to tell the motherboard to power up and become fully functional. The following figure illustrates this system start-up process.

### Power-Up Sequence

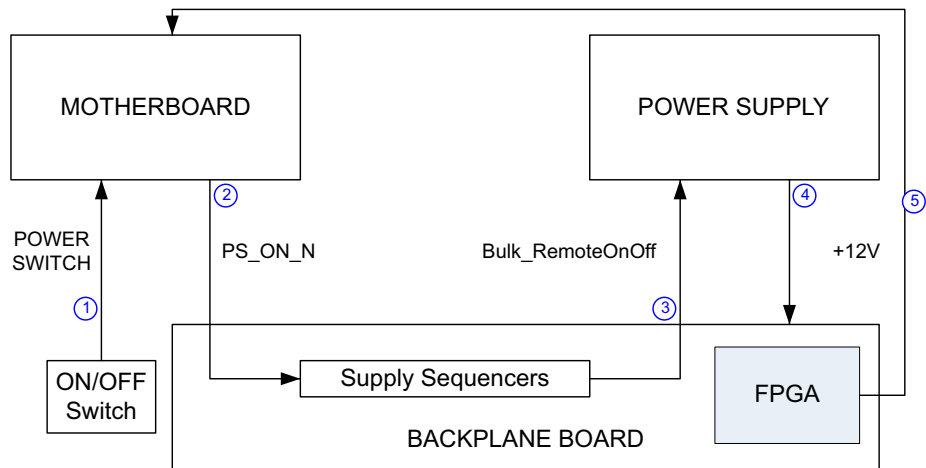

It is common for the motherboard to be revised during the life of the oscilloscope, so if a motherboard is replaced during a repair procedure, check to make sure it matches the image on the hard drive. It is important for the hard disk drive image to match the motherboard. If they do not match, the oscilloscope may not have the correct Windows software drivers.

The hard disk drive is a high-capacity (480 GB), removable, solid state, shock-resistant unit that stores the oscilloscope operating system, the oscilloscope application, compliance application information, calibration data, other data files, drivers for the boards and oscilloscope, and user data files. The hard disk drive can also be used to store and recall oscilloscope setups and waveforms.

## Acquisition Assembly

The acquisition assembly consists of four identical acquisition boards. These four boards connect to the backplane board as shown below.

### Acquisition Assembly

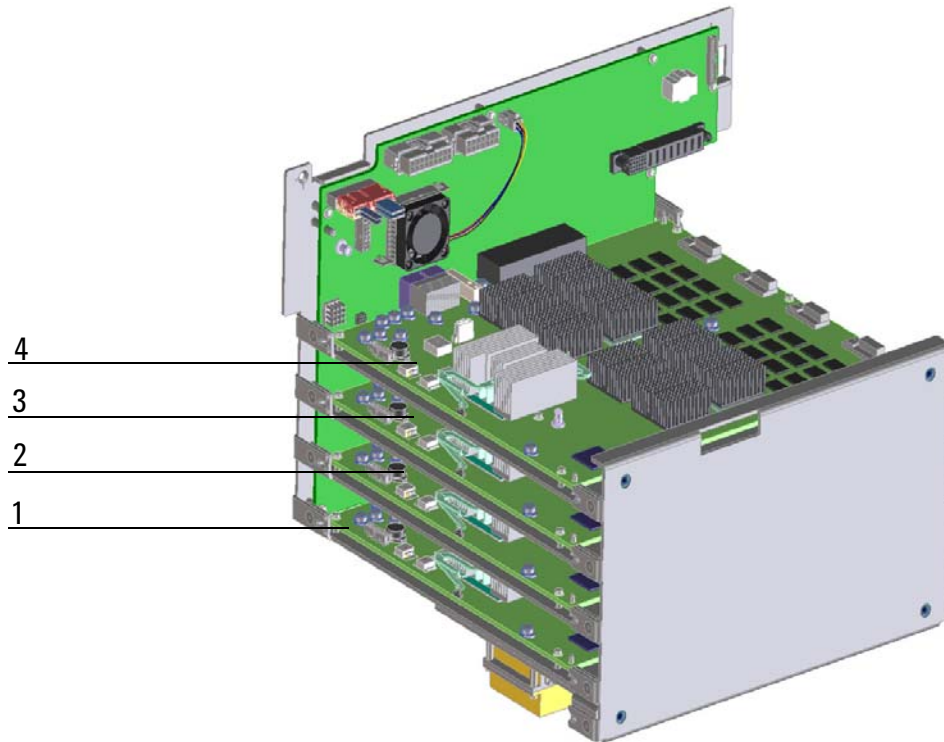

The bottom acquisition board circuitry samples, digitizes, and stores the signals for channel 1. The next higher acquisition board does the same for channel 2. The next higher board is for channel 3, and the top board is for channel 4.

## 7 Theory of Operation

All four acquisition boards contain the Oak module (a full-custom ball grid array multi-chip module), the Onboard ADC, clock distribution, data management ASICs, external acquisition memory, ADCs, communication and programming FPGAs, and supporting power supply circuitry. The following figure shows a block diagram of the acquisition boards including the Oak module.

### Oak Module and Acquisition Components

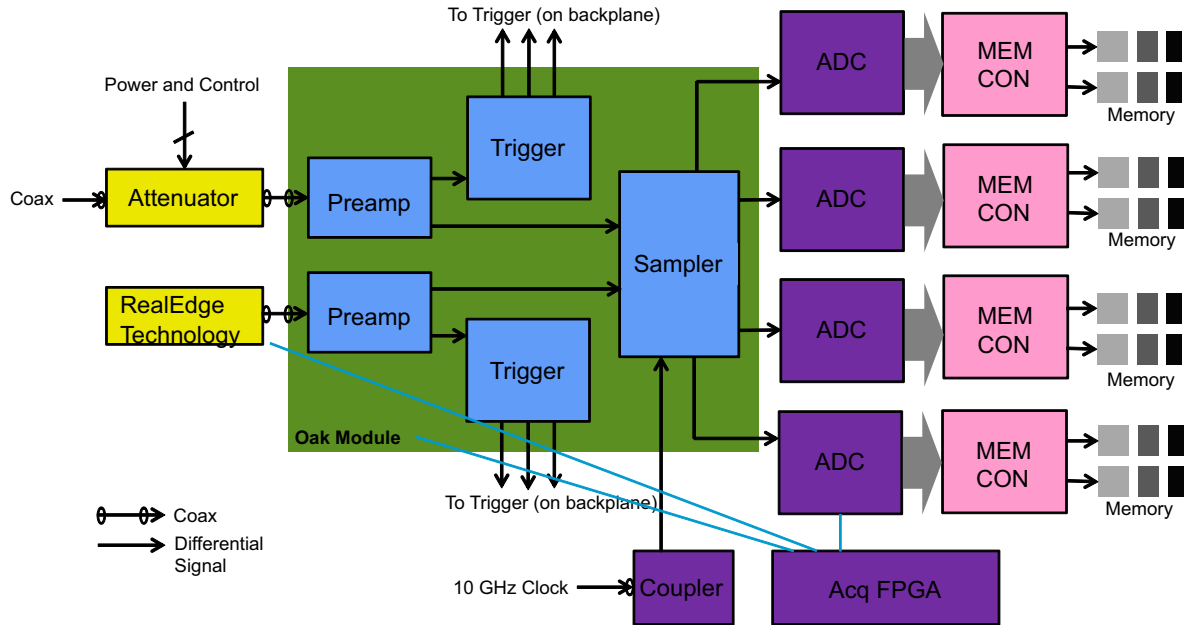

The acquisition front end (analog path) starts at the front panel input connectors, then goes through the attenuators, cabling, and Oak module. The differential outputs from Oak then go into one differential input pair of the ADC. Each ADC has two sets of differential inputs.

## Backplane Assembly

The backplane assembly is a device on the PCI Express (PCIe) bus connected by a PCI Express cable to the motherboard. The backplane assembly receives +12 V DC power through a power interface board from the bulk supply, and all voltages are derived from switching power regulators and other circuitry. Most of the switching and circuitry are on the backplane board, with some distribution and generation done on the acquisition boards. The figure below shows a block diagram of the functions contained on the backplane assembly.

### Backplane Block Diagram

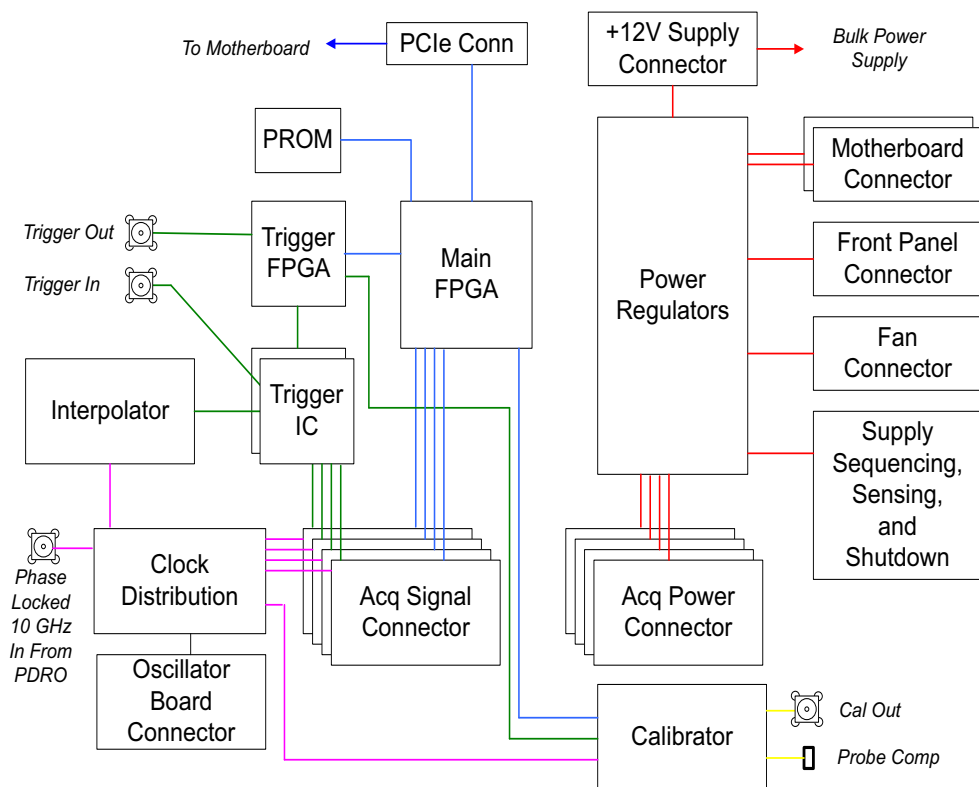

The colors in the diagram represent different signal groups. The backplane provides power (red), clock generation (pink), trigger (green), and calibrator (yellow) functions to the oscilloscope, as well as communications and control for the PC software (blue). The PC connects to the measurement system through PCIe to the main FPGA. Connections to all other circuits go through the main FPGA.

### Main FPGA

The main FPGA (field-programmable gate array) is the only communication link from the oscilloscope hardware to the PC system. All system controls and data pass through the main FPGA. The figure below shows the connections to the main FPGA

Main Communication FPGA Connections.

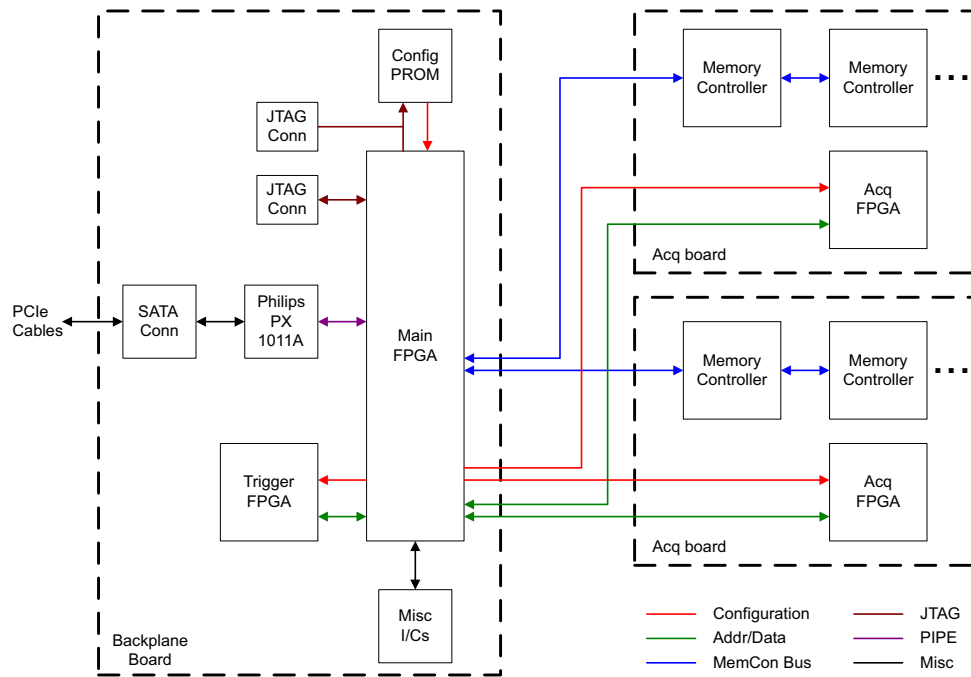

During a successful power-up, an EPROM configures the FPGA over a serial bus. The PROM comes pre-loaded with the required bits, but can be re-programmed through the FPGA by software, or through the FPGA JTAG port with a programming cable.

The FPGA is a device on the PCIe bus. A custom cable connects a PCIe slot on the PC motherboard to the backplane board. When Windows is booted up, the main communication FPGA must show up in the device listing (as Infiniium Acquisition) for the oscilloscope application to run and control the oscilloscope hardware.

The main FPGA can be used to control peripherals and fan speed, configure and communicate with other FPGAs, and pass sampled data to the PC for reconstruction of the measured waveform on the oscilloscope display. In addition, the FPGA generates PCI interrupts for all oscilloscope-related special events such as a front-end overload or a stopped cooling fan.

The main FPGA uses five identical buses to communicate with five different downstream FPGAs. The buses are 8-bit parallel buses with miscellaneous control signals. One bus is used to control the trigger FPGA in the backplane board, and



the other buses connect to each of the four acquisition assemblies. A separate bus for each FPGA minimizes timing problems and reflections. The FPGAs on the acquisition boards are used to control the oscilloscope functions on each of those boards. On power-up, after the PC software recognizes the acquisition assembly, it loads the trigger FPGA and the acquisition FPGAs using these buses. When programming is complete, the PC communicates with these FPGAs over the same buses. The main FPGA provides access to the memory controllers over a separate bus to each acquisition board. The acquired data is retrieved from the acquisition boards over these buses.

### Clock Distribution System

The following figure shows the timebase system including its circuitry.

#### Timebase

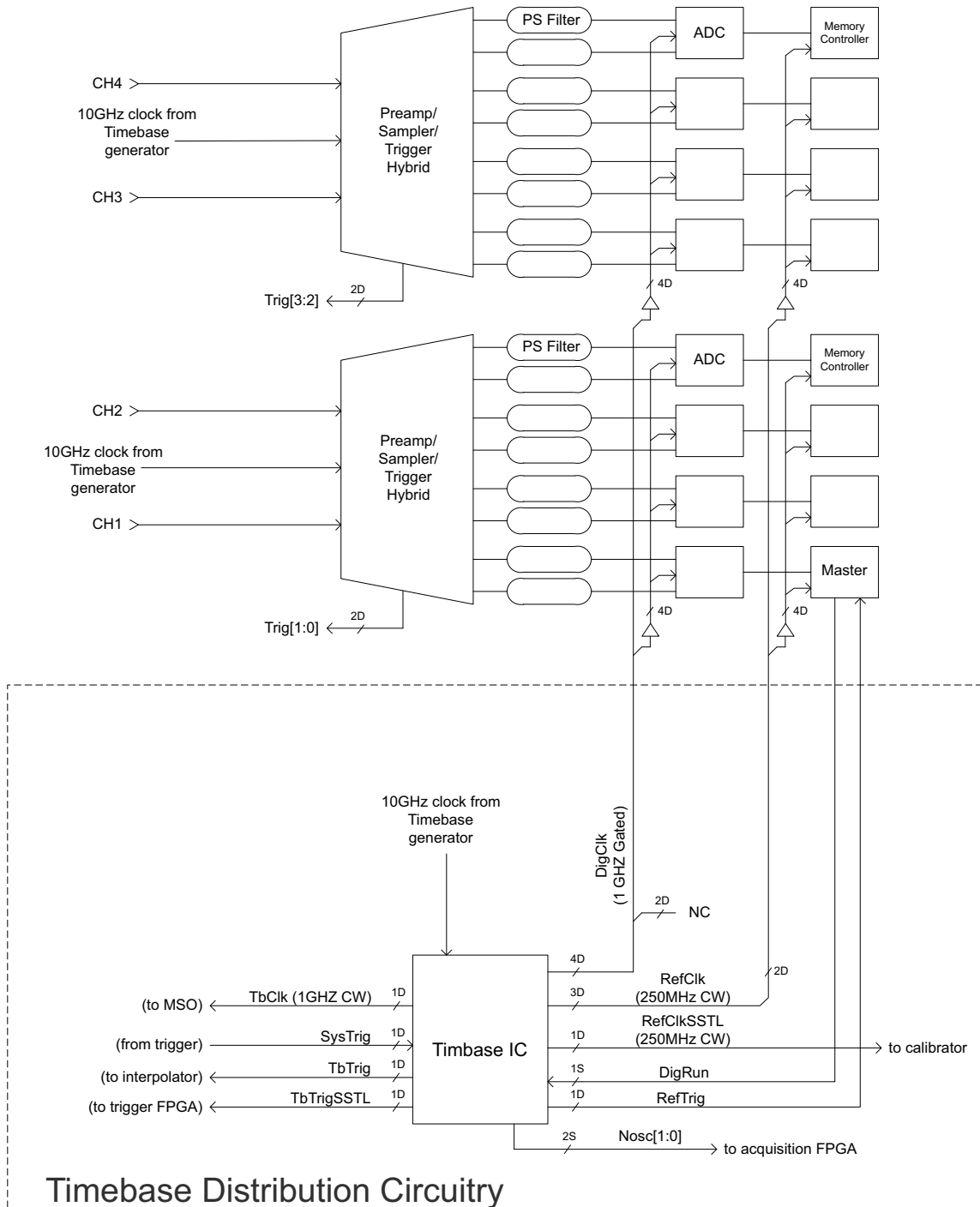

Timebase Distribution Circuitry

The fundamental sample clock is a single-ended 10 GHz signal created by the timebase generation system. Multiple copies of this clock are created there and distributed to each Oak module and the timebase IC through semi-rigid coax cables. In each case, the single-ended signal is converted to a differential signal using a bandpass filtered 180° phase splitter implemented using microwave structures on shielded inner layers of the PCB. The clock distribution system divides this clock and distributes phase-aligned lower speed clocks to the acquisition boards.

The timebase IC divides the 10 GHz CW clock down into multiple 1 GHz and 250 MHz clocks. The 1 GHz DigClk clocks are gated by DigRun so that the ADCs can be synchronized with each other. The timebase IC also performs some of the time interpolator functionality by synchronizing the system trigger to the 1 GHz DigClk and generating the first two MSBs of the trigger interpolation value.

The 10 GHz SampClk 10G signal is divided down to 1 GHz for use as TbClk and DigClk. TbClk is divided by four to generate RefClk, which drives the memory controllers and the calibrator chip. These four 250 MHz outputs are phased in quadrature to minimize the coupling of sub-harmonics into the DigClk signals. The RefClk signal that goes to the calibrator chip must be disabled when not in use by the calibrator system.

SysTrig is the primary output from the trigger system. It is synchronous to the trigger event and asynchronous to the time base clock, TbClk. The timebase IC synchronizes SysTrig to the time base clock with low probability of metastability, producing the TbTrig signal. TbTrig pulses high once immediately after every rising edge of SysTrig.

The timebase IC also produces a trigger signal that is synchronous to RefClk. This signal, RefTrig, pulses high once immediately after every rising edge of SysTrig. RefTrig tells the memory controller when a trigger event has occurred. It is important to note that although DigRun and RefTrig are both synchronous to RefClk, their phase relationship to RefClk is not important. As long as their phase relationship is consistent, the memory controller can adjust for it. Finally, the timebase IC records the phase relationship between RefTrig and TbTrig, and provides it as the 2-bit digital value, Nosc. Nosc[0] is driven by the 500 MHz clock and Nosc[1] is driven by the 250 MHz clock.

The clock distribution system also creates and distributes clocks for other purposes. A 212.5 MHz oscillator creates a clock that is intentionally not an integer division of the sample clock. This approach prevents beat frequency effects from showing up in the captured data. The clock is sent to the trigger FPGA and to the main FPGA.

The trigger FPGA uses the clock for capturing and processing trigger signals. The FPGA propagates a copy of this clock to each trigger ASIC.

## 7 Theory of Operation

The main FPGA uses the clock to generate the bus clocks for communications with the other FPGAs and the memory controller ICs. It sends a 62.5 MHz clock as part of the FPGA bus to each FPGA. It generates another clock for the memory controller buses. This clock is buffered and fanned out in the clock distribution system, then driven to the memory controller ICs and back to the main FPGA.

### Trigger System

The trigger system contains an FPGA that is used to coordinate the trigger system operation and two trigger ICs. The FPGA uses a 212.5 MHz clock that is synchronous to the main communication FPGA clock. On power-up it is blank and is loaded from the Infiniium oscilloscope driver.

The trigger ICs are the main trigger-handling chips, programmed with a serial interface from the main FPGA. Each trigger IC also receives two DAC signals that set the internal clock and data timers. The trigger IC is used for setting the timing for the logic trigger from 0.3 ns to 20 ns. The trigger FPGA is used for times greater than 20 ns.

## Oscillator Assembly

The oscillator assembly consists of an oscillator board; one or two DROs (dielectric resonator oscillators), depending on the oscilloscope's model; two SMA connectors for the 100 MHz clock; two BNC connectors for the 10 MHz clock; and a connector to the backplane board.

The timebase distribution system described in the previous section is driven by a precision low-jitter 10 GHz clock generation system. The Z-Series clock generation system is comprised of the oscillator board and the 10 GHz DRO.

The 10 GHz sample clock is generated with a DRO that is phase-locked to a 100 MHz reference signal. This signal can be selected from either an internal oscillator or an external 100 MHz reference signal input. The internal oscillator's 10 MHz reference input can be selected from either an internal oven-controlled crystal oscillator located on the oscillator board or from an external 10 MHz signal input.

### Oscillator Assembly

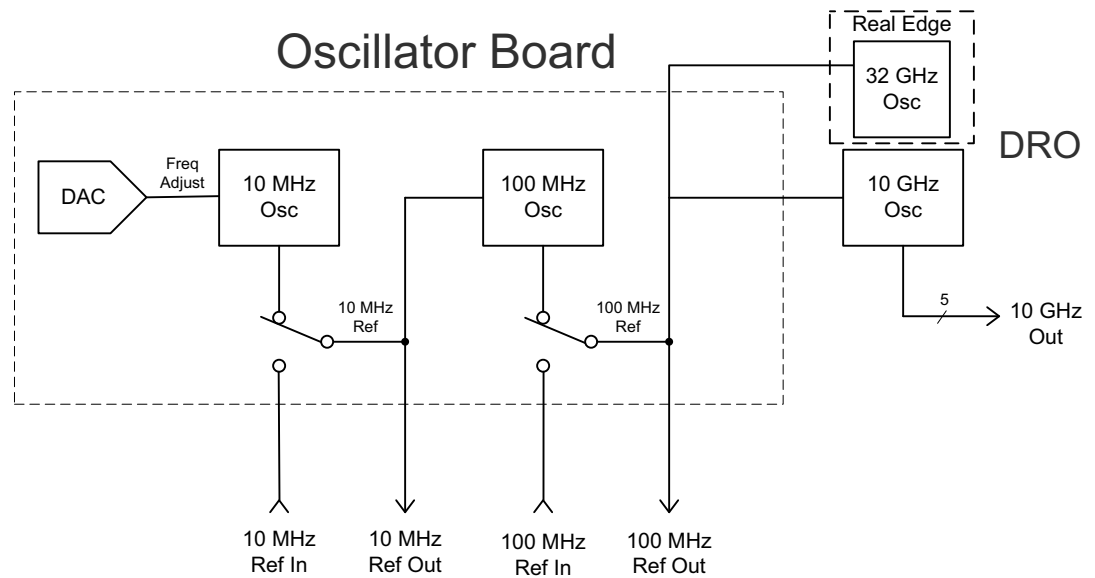

The external 10 MHz reference is applied through a rear-panel BNC connector and runs to the backplane assembly. Users can select between an internal and external reference through a dialog box in the oscilloscope application.

### Front Panel Assembly

The front panel assembly consists of a display board with backlight; a touch screen; an on/off board; and a keyboard assembly, which is two boards that sit with one behind the other, connected with a pair of 60-pin board-to-board connectors.

#### On/Off Board

The on/off board interfaces with the motherboard to provide the on/off switch function, and with the backplane to provide the probe compensation output. Power indicator LEDs backlight the on/off button and are driven by the motherboard. The probe compensation lugs connect to the calibrator output on the backplane through an SMB connector coax cable. An ESD protection diode sits on the on/off board, connecting the signal and ground probe compensation lugs.

#### Keyboard Assembly

The two boards that comprise the keyboard assembly work together to provide the main user interface to the oscilloscope, and power and communication to the probe interface.

The rear board has all the external connectors, AutoProbe II circuits for probe power and probe control, LED backlight power supply, and knobs. The front board has the buttons, FPGA, and LEDs.

The following figure shows a block diagram of the oscilloscope keyboard assembly.

Keyboard Assembly Block Diagram

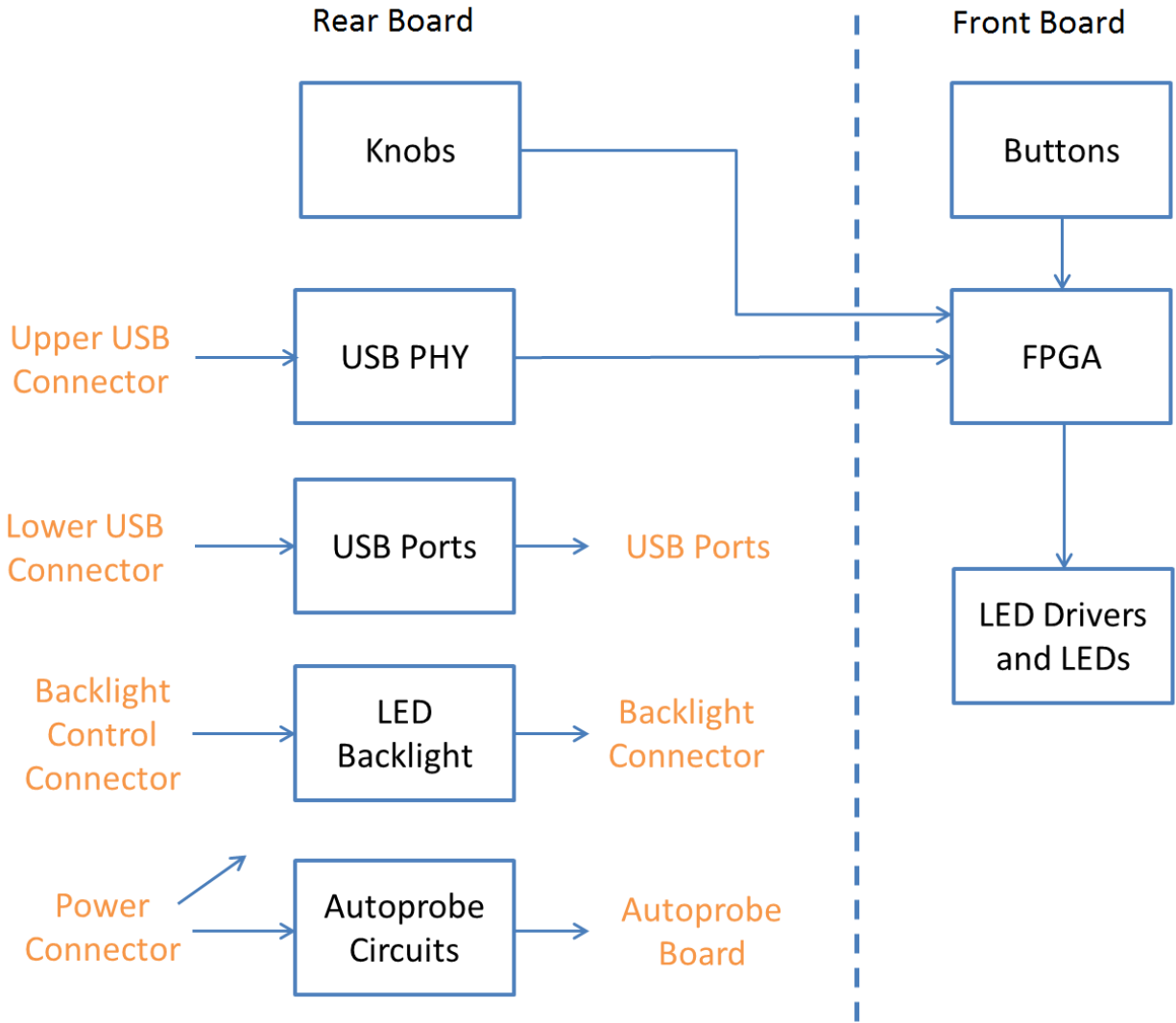

### RealEdge Technology Assembly

The RealEdge Technology assembly is included with Z-Series oscilloscope models that have greater than 33 GHz bandwidth. The RealEdge Technology assembly consists of a connector, a 67 GHz attenuator, three RealEdge Technology microcircuits, and a 32 GHz DRO.

This Service Guide does not describe the RealEdge Technology assembly in any detail, as the technology is Keysight proprietary.



## Power Supply

The power supply is a +12 V bulk supply that is removable, exchangeable, and safety-approved. It transforms AC power to the main +12 V 100A supply and a small +5 V supply. The +5 V supply is standby power and is always on whenever AC power is applied. The +5 V supply is used only by supervisory circuits that monitor and control all other supplies. In the event of a safety shutdown from the supervisory circuits, LEDs turn on to indicate the cause of the shutdown. They remain lit until AC power is removed from the bulk supply.

The +12 V bulk supply is used to create all other supplies in the instrument. +12 V is turned on by the power switch on the front panel. It is turned off under software control when a shutdown is requested, or by the supervisory circuits when a fault occurs.

The +12 V bulk supply performs some internal fault sensing and drives LEDs on the backplane board to indicate its status. It also provides an I<sup>2</sup>C bus, which is connected to the main FPGA.

## 7 Theory of Operation

## 8 Safety Notices

Warnings 147  
Cleaning the Instrument 148  
Safety Symbols 148

This apparatus has been designed and tested in accordance with IEC Publication EN 61010-1:2001, Safety Requirements for Measuring Apparatus, and has been supplied in a safe condition. This is a Safety Class I instrument (provided with terminal for protective earthing). Before applying power, verify that the correct safety precautions are taken (see the following warnings). In addition, note the external markings on the instrument that are described under “Safety Symbols”.

### Warnings

- Before turning on the instrument, you must connect the protective earth terminal of the instrument to the protective conductor of the (mains) power cord. The mains plug shall be inserted only in a socket outlet provided with a protective earth contact. You must not negate the protective action by using an extension cord (power cable) without a protective conductor (grounding). Grounding one conductor of a two-conductor outlet is not sufficient protection.
- Only fuses with the required rated current, voltage, and specified type (normal blow, time delay, etc.) should be used. Do not use repaired fuses or short-circuited fuse holders. To do so could cause a shock or fire hazard.
- If you energize this instrument by an auto transformer (for voltage reduction or mains isolation), the common terminal must be connected to the earth terminal of the power source.
- Whenever it is likely that the ground protection is impaired, you must make the instrument inoperative and secure it against any unintended operation.
- Service instructions are for trained service personnel. To avoid dangerous electric shock, do not perform any service unless qualified to do so. Do not attempt internal service or adjustment unless another person, capable of rendering first aid and resuscitation, is present.
- Do not install substitute parts or perform any unauthorized modification to the instrument.
- Capacitors inside the instrument may retain a charge even if the instrument is disconnected from its source of supply.

## 8 Safety Notices

- Do not operate the instrument in the presence of flammable gasses or fumes. Operation of any electrical instrument in such an environment constitutes a definite safety hazard.
- Do not use the instrument in a manner not specified by the manufacturer.

### Cleaning the Instrument

If the instrument requires cleaning:

- 1 Remove power from the instrument.
- 2 Clean the external surfaces of the instrument with a soft cloth dampened with a mixture of mild detergent and water.
- 3 Make sure that the instrument is completely dry before reconnecting it to a power source.

### Safety Symbols



Instruction manual symbol: The product is marked with this symbol when it is necessary for you to refer to the instruction manual to protect against damage to the product.



Hazardous voltage symbol.



Earth terminal symbol: Used to indicate a circuit common connected to grounded chassis.