

# Keysight Technologies

N5411B SATA 6 Gb/s Compliance Test Software  
Gen1, Gen2 and Gen3 SATA, eSATA, mSATA, SATA USM, SATA  
microSSD and M.2 form factor PHY, TSG and OOB compliance  
test software for Infiniium oscilloscopes

Data Sheet

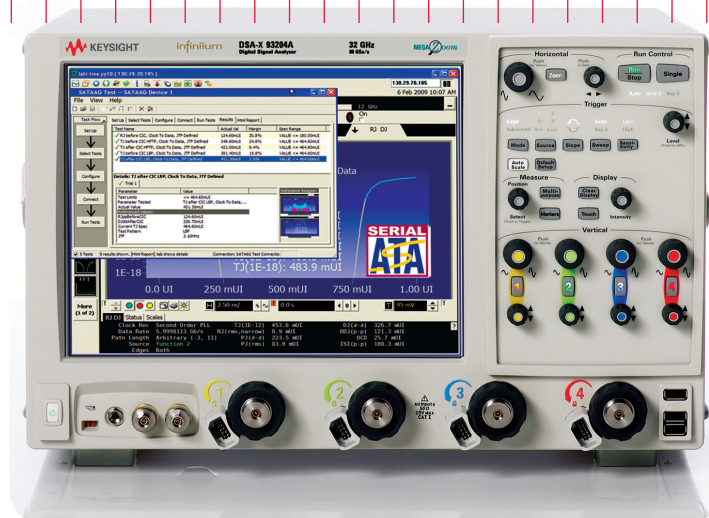

## Introduction

The SATA compliance test software for Infiniium oscilloscopes provides you with a fast and easy way to validate and debug your SATA 1.5-Gb/s (Gen1), 3.0Gb/s (Gen2) and 6.0Gb/s (Gen3) silicon, host bus adapters, port multipliers, high-density disk drives, solid-state disk drives and optical disk drives. The software provides automated compliance test support for the i (internal), m (eSATA) and u (mSATA, SATA USM, SATA microSSD and M.2 form factor) interface points, and displays the results in a flexible report format. In addition to the measurement data, the report provides a margin analysis that shows how closely your device passed or failed each test.

To make measurements with the SATA compliance test software, you will also need a test fixture for signal access to make measurements. Wilder Technologies' SATA Gen3 test fixtures are recommended for compliance testing. The product information is available at [www.wilder-tech.com/sata.htm](http://www.wilder-tech.com/sata.htm). The Luxshare-ICT test fixtures are also recommended for all host and device compliance testing. You can find more information on the required test fixtures at [web.luxshare-ict.com/en/ProductOverview.php](http://web.luxshare-ict.com/en/ProductOverview.php).

## Features

The SATA software offers several features to simplify the validation of SATA designs:

- Setup and measurement wizard with guided connection
- Support for BIST-T,A,S (transmit only) and BIST-L (far-end retimed loopback) test modes
- Intelligent test selection and margin analysis specific to interface selection
- Spread-spectrum clock modulation depth and frequency accuracy measurements
- Complete SATA-IO logo validation tests for PHY general, transmit signal and OOB requirements per Unified Test Document 1.5
- Automated out-of-band (OOB) burst and gap margin analysis and tests for detect/reject on COMRESET, COMINIT and COMWAKE bursts that are in/out of specified ranges

The SATA 6Gb/s compliance software performs a wide range of tests required to meet the physical layer transmitter test requirements of the Serial ATA International Organization: Serial ATA Revision 3.2 specification. The Serial ATA Revision 3.2, or SATA 6Gb/s, specification requires that an oscilloscope with a minimum bandwidth of 12 GHz be used for validating the 6 Gb/s physical layer transmitter. The Keysight Technologies, Inc. Infiniium Series oscilloscopes, combined with the SATA software, provides the necessary bandwidth and analysis capability for validating SATA 6Gb/s transmitters, as well as control of the 81134A pattern generator or N4903B J-BERT with Option 002 for performing automated out-of-band (OOB) signal parametric and timing tests. The 81134A pattern generator or N4903B J-BERT with Option 002 can be configured and used for SATA 6 Gb/s testing as well.

The SATA-IO sponsors an official certified logo program, which requires that SATA products be tested at official interoperability workshops or at a certified independent test lab, in order for that product to be included on the SATA-IO integrators' list and to use its certified logo. Keysight's SATA physical layer test solutions, which provide complete coverage for PHY, TSG and OOB test categories, are used for gold suite testing at SATA-IO interoperability workshops as well as in several independent SATA test labs.

## SATA Software Saves You Time

The SATA software saves you time by setting the stage for automatic execution of SATA electrical tests. Part of the difficulty of performing electrical tests for SATA is connecting the oscilloscope to the target device, configuring the scope's measurement system for compliance testing, issuing the proper commands to perform the tests and then analyzing the measured results by comparing them to limits published in the specification. The SATA electrical test software does much of this work for you. In addition, if you discover a problem with your device, debug tools in the scope are available to aid in root-cause analysis.

The SATA electrical test software offers the required tests to verify compliance with the physical layer requirements tables, Serial ATA Revision 3.2 specification. The software automatically configures the oscilloscope for each test and provides an informative results report that includes margin analysis relative to the specified conformance limits. See Table 2 for a complete list of the measurements made by the SATA electrical test software.

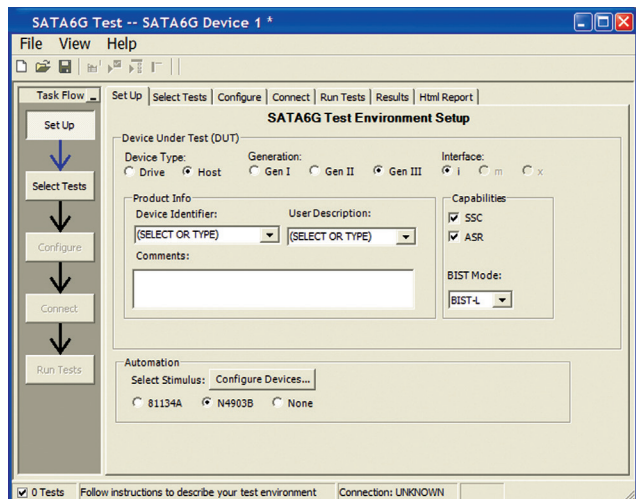

Figure 1. The Keysight SATA software setup tab allows you to choose the interface type of your product and the relevant test speed, then automatically configures the measurements and limits appropriately for your specific product per the specification requirements..

## Intelligent Test Selection

The SATA software extends the ease-of-use advantages of Keysight's Infiniium Series oscilloscopes to testing SATA designs. The Keysight automated test engine walks you quickly through the steps required to select and perform required tests for the interface you have selected (Gen3i Host, for example). You can select a category of tests or specify individual tests. The user interface is oriented to minimize unnecessary reconnections, which saves time and minimizes potential for measurement error. You can save tests and configurations as project files and recall them later for additional testing and review of previous test results. Straightforward menus let you perform tests with a minimum of mouse clicks.

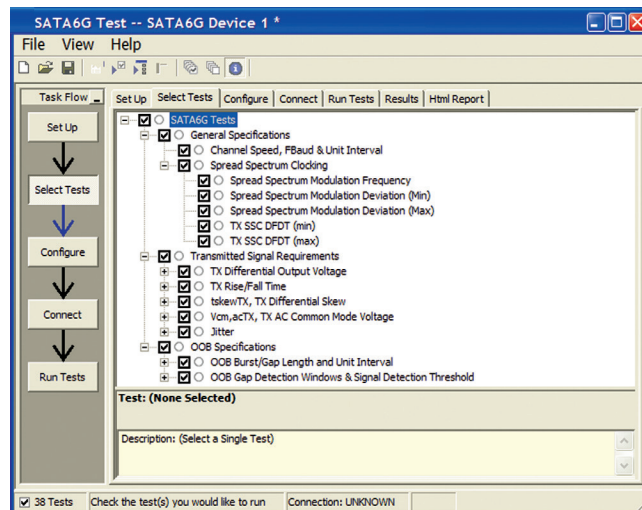

Figure 2. The Keysight automated test engine guides you quickly through selecting and configuring tests, setting up the connection, running the tests, and viewing the results. You can easily select individual tests or groups of tests with a mouse-click and customize your output report based on the test results you want to see.

## Configurability and Guided Connections

The SATA software provides flexibility in your test setup. The SATA test software provides you with user-defined controls for critical test parameters, such as test pattern source selection and number of unit intervals (UI) desired for the test group.

After configuring the tests according to your needs, the test software guides you to make connection changes with diagrams. This includes the oscilloscope channels used for the test and the routing of any necessary SMA cabling, power dividers, DC blocking capacitors and test fixtures needed to perform the tests.

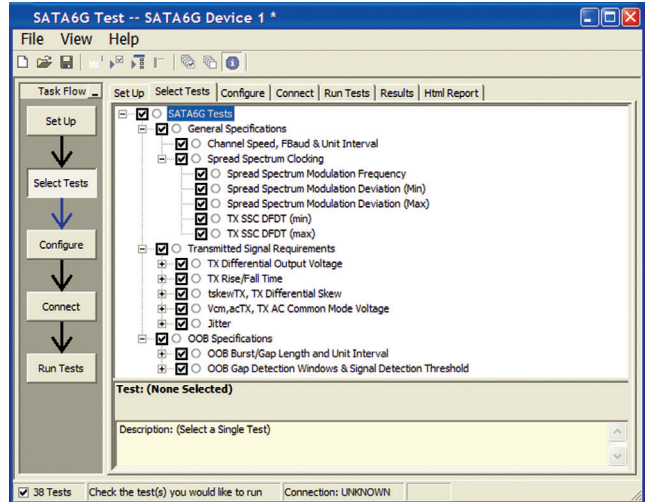

Figure 3. In configuring the tests, you define the test mode and define which pattern will be used for each test.

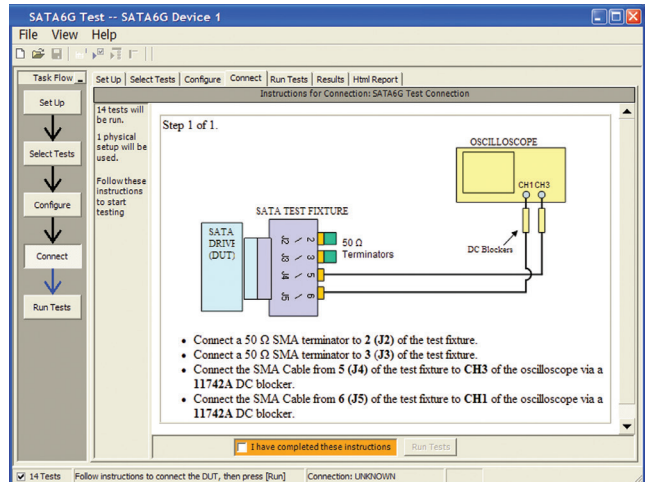

Figure 4. When you make multiple tests where the connections must be changed, the software prompts you with connection diagrams.

## Repetitive Run & Results Filtering

Keysight's automated test framework allows you to choose the number of repetitive iterations to be performed for each test. This is useful for obtaining statistical information about the stability of your product across a larger data sample, or for comparing measurement results differences among different product environmental settings such as transmit voltage, de-emphasis levels or temperature. Once all runs are completed, you can filter the data and statistics chronologically or by specification margin for viewing and including in the final report.

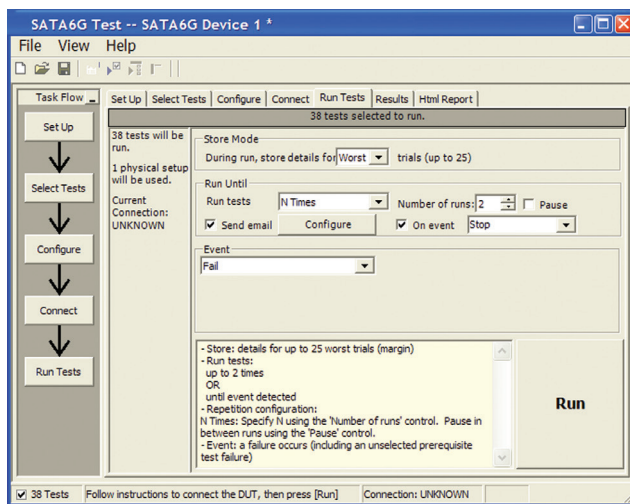

Figure 5. The Keysight SATA software allows for user-selectable repetitive test execution.

## Reports with Margin Analysis

In addition to providing you with measurement results, the SATA software provides a report format that shows you not only where your product passes or fails, but also reports how close you are to the limits specified for a particular test parameter. You can specify the level at which warnings are issued to alert you to the electrical tests where your product is operating close to the official test limit defined by the specification or your own requirements for a given test parameter.

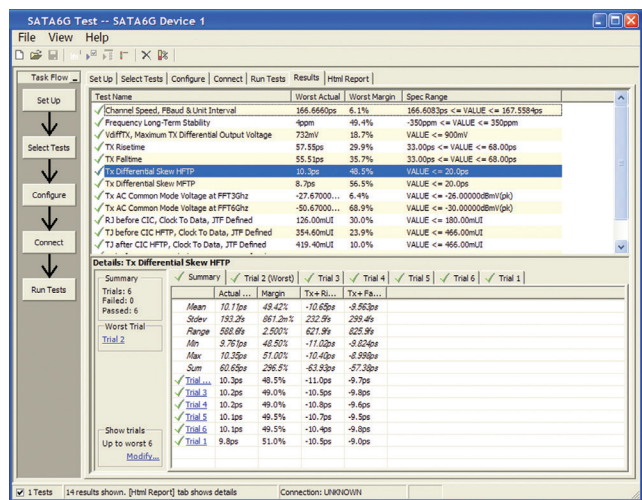

Figure 6. The Keysight SATA report can be customized to show only the user-selectable repetitive run data, and filtered to show only the relevant data and statistics desired in the final report.

## Thorough Performance Reporting

The SATA compliance and validation software generates thorough HTML reports that clearly identify passing and failing conformance tests in a summary table along with relevant screen images and interim data values for complex measurements. The HTML report provides you with a complete report of your testing summary, references to the specification and requirements tables where each measurement is defined for traceability to the official test requirements for your SATA interface.

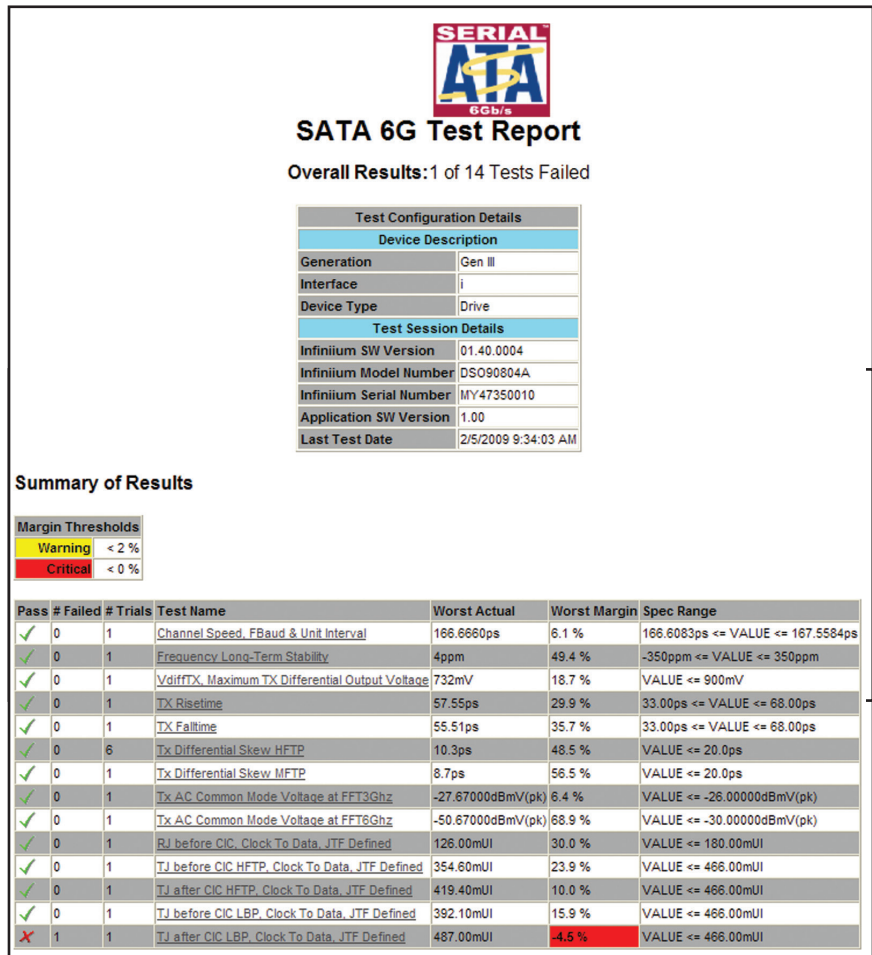

Figure 7. Automated and consolidated HTML report quickly documents the results of all completed tests, including screen images from the oscilloscope taken after each measurement is completed.

## Extensibility

You may add additional custom tests or steps to your application using the N5467B/C User Defined Application (UDA) development tool ([www.keysight.com/find/uda](http://www.keysight.com/find/uda)). Use UDA to develop functional “Add-Ins” that you can plug into your application.

Add-ins may be designed as:

- Complete custom tests (with configuration variables and connection prompts)
- Any custom steps such as pre or post processing scripts, external instrument control and your own device control

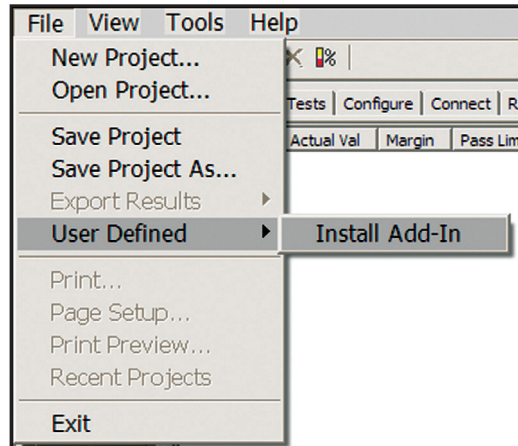

Figure 8. Importing a UDA Add-In into your test application.

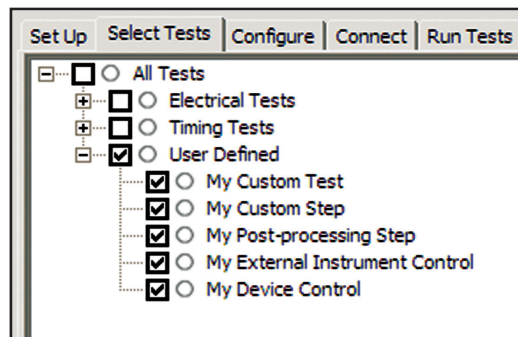

Figure 9. UDA Add-In tests and utilities in your test application.



## Automation

You can completely automate execution of your application's tests and Add-Ins from a separate PC using the included N5452A Remote Interface feature (download free toolkit from [www.keysight.com/find/scope-apps-sw](http://www.keysight.com/find/scope-apps-sw)). You can even create and execute automation scripts right inside the application using a convenient built-in client.

The commands required for each task may be created using a command wizard or from "remote hints" accessible throughout the user interface.

Using automation, you can accelerate complex testing scenarios and even automate manual tasks such as:

- Opening projects, executing tests and saving results
- Executing tests repeatedly while changing configurations
- Sending commands to external instruments
- Executing tests out of order

Combine the power of built-in automation and extensibility to transform your application into a complete test suite executive:

- Interact with your device controller to place it into desired states or test modes before test execution.
- Configure additional instruments used in your test suite such as a pattern generator and probe switch matrix.
- Export data generated by your tests and post-process it using your favorite environment, such as MATLAB, Python, LabVIEW, C, C++, Visual Basic etc.
- Sequence or repeat the tests and "Add-In" custom steps execution in any order for complete test coverage of the test plan.

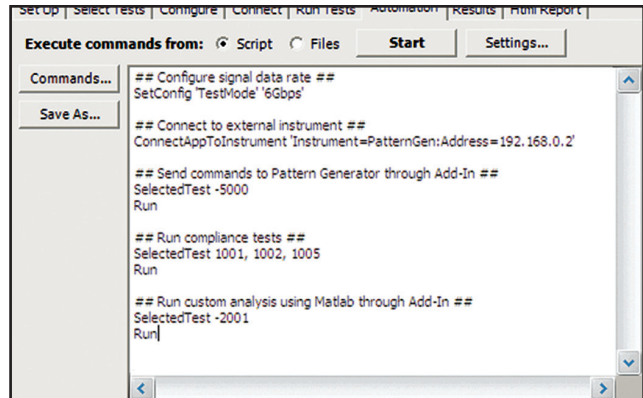

Figure 10. Remote Programming script in the Automation tab.

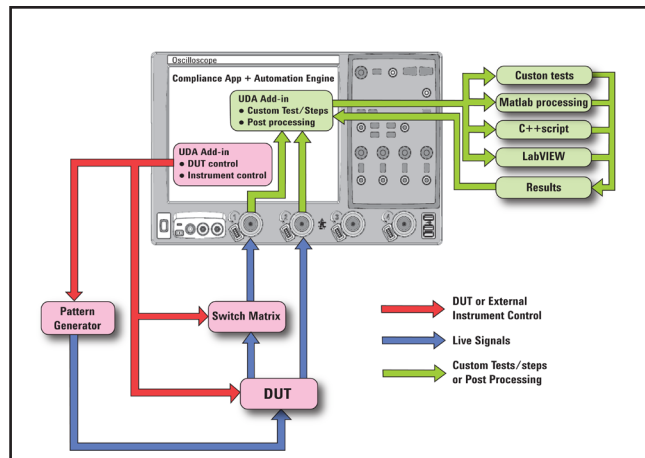

Figure 11. Combine the power of built-in automation and extensibility to transform your application into a complete test suite executive.

## Measurement Requirements

To use the software you will need a Keysight Infiniium Series oscilloscope with at least 12 GHz of analog, real-time bandwidth. In order to use the software with BIST-T,A,S test mode, your SATA product will need to be able to source the required compliance test patterns as defined in the Serial ATA Revision 3.2 specification (HFTP, MFTP, LBP and LFTP). If you are using far-end re-timed loopback mode, then the Keysight 81134A 3.35 Gbps pulse/pattern generator or N4903B J-BERT with option 002 can be automatically programmed by the SATA software to provide the necessary test stimulus signals to be retimed by your chipset for 1.5 Gb/s, 3.0 Gb/s and 6.0 Gb/s signaling. The 81134A or N4903B are also used for OOB signal testing. Additionally, the N4903B together with the SATA software can be used to send the appropriate sequence and program the SATA product into BIST-L test mode.

## Recommended Oscilloscopes

The SATA compliance software is compatible with Keysight Infiniium Series oscilloscopes with operating software revision 4.20 or higher. For oscilloscopes with earlier revisions, free upgrade software is available here: [www.keysight.com/find/scope-apps-sw](http://www.keysight.com/find/scope-apps-sw).

Data rate	Minimum bandwidth	Minimum channels	Compatible oscilloscopes
1.5 Gb/s	8 GHz	2	Infiniium 90000 and Z-Series
1.5, 3.0 and 6 Gb/s	12 GHz	2	Infiniium 90000 and Z-Series

## Ordering Information

To purchase the SATA software with a new or existing Infiniium Series oscilloscope, order the following options.

### Software options

Application	License type		Infiniium Z-Series	Infiniium 90000 Series
SATA Gen 3 compliance	Fixed	Factory-installed	N5411B-1FP	Option 038
		User-installed	N5411B-1FP	N5411B-1NL
	Floating	Transportable	N5411B-1TP	N5411B-1TP <sup>1,2</sup>
		Server-based	N5435A-028	N5435A-028
SATA Gen 2 to Gen 3 compliance upgrade	Fixed	Factory-installed	–	–
		User-installed	N5411B-2FP	N5411B-2NL
	Floating	Transportable	–	–
		Server-based	–	–
Serial data analysis with clock recovery (included in DSA model)	Fixed	Factory-installed	E2688A-1FP	Option 003
		User-installed	E2688A-1FP	E2688A-1NL
	Floating	Transportable	E2688A-1TP	E2688A-1TP <sup>1,2</sup>
		Server-based	N5435A-003	N5435A-003
EZJIT Plus jitter analysis (included in DSA model)	Fixed	Factory-installed	N5400A-1FP	Option 004
		User-installed	N5400A-1FP	N5400A-1NL
	Floating	Transportable	N5400A-1TP	N5400A-1TP <sup>1,2</sup>
		Server-based	N5435A-001	N5435A-001
50 Mpts/ch memory (included in DSA model and standard in Z-Series)	Fixed	Factory-installed	–	Option 080
		User-installed	–	N2810A-050

1 Requires software 5.00 and above.

2 Software 4.30 or above requires Windows 7. N2753A Infiniium Windows XP to 7 OS upgrade kit (oscilloscope already has M890 motherboard). N2754A Infiniium Windows XP to 7 OS and M890 motherboard upgrade kit (oscilloscope without M890 motherboard). Verify the M890 motherboard using the procedure found in the Windows 7 upgrade kit data sheet with the publication number 5990-8569EN.

## Ordering Information (continued)

### Other hardware, probes and accessories

Model number	Description	Quantity
SATA Gen 3 receptacle adapter	Wilder Technologies ( <a href="http://www.wilder-tech.com/sata.htm">www.wilder-tech.com/sata.htm</a> ) Luxshare-ICT ( <a href="http://web.luxshare-ict.com/en/ProductOverview.php">web.luxshare-ict.com/en/ProductOverview.php</a> )	1
11742A	DC blocking capacitor, 0.045 to 26.5 GHz, 3.5-mm (m-f) connectors	2
<b>Transmitter signal requirements (PHY and TSG tests) with BIST-T, A, S support</b>		
15443A	Matched cable pair, two 90-cm (36-in) SMA (m-m) cables, propagation delay within 25 ps (or equivalent)	1
<b>Transmitter signal requirements (PHY, TSG and OOB tests) with BIST-L support and automation</b>		
15443A	Matched cable pair, two 90-cm (36-in) SMA (m-m) cables, propagation delay within 25 ps (or equivalent)	3
81134A Or N4903B	3.35 Gbps pulse/pattern generator J-BERT high-performance serial BERT 7 Gb/s or 12.5 Gb/s (with option 002)	1
11636B	Power divider, DC to 26.5 GHz, 3.5-mm (f) connectors	2
5062-6681	Cable assembly 6-in SMA (m-m) cables or equivalent (need qty. 4)	4
8493C	Coaxial fixed attenuator 8493C-010 or 8493C-020 for 81134 pattern generator	2

## Accessories and Compatibility

### Optional test accessories

To complete your test setup, Keysight provides a wide range of cables, adapters, terminations, etc. Please note that the required equipment is listed in the Ordering Information summary. This list is provided for your convenience to accommodate necessary mating switches or additional debug capability.

Model number	Description
11667B	Power splitter, DC to 26.5 GHz, 3.5-mm (f) connectors
11636B	Power divider, DC to 26.5 GHz, 3.5-mm (f) connectors
1250-1158	SMA (f-f) adapter, DC to 18 GHz
1250-1159	SMA (m-m) adapter, DC to 18 GHz
1250-1694	SMA (m) to SMA (f) adapter
15442A	Cable kit, four 90-cm (36-in) SMA (m-m) cables
15443A	Matched cable pair, two 90-cm (36-in) SMA (m-m) cables, propagation delay within 25 ps
1810-0118	SMA (m) 50-ohm termination
5062-6681	Cable assembly 6 in. SMA (need qty. 4)
11742A	DC blocking capacitor, 0.045 to 26.5 GHz, 3.5-mm (m-f) connectors
15435A	Transition time convertor, 150ps for SATA Gen 1/2 (need qty 2)
Picosecond pulse labs	Risetime filter, 100ps for SATA Gen 3, 5915-110-100ps (need qty 2) ( <a href="http://www.picosecond.com">http://www.picosecond.com</a> )

Table 1. Optional test accessories

## Tests performed

The N5411B software performs these transmitter physical layer compliance tests per the requirements of the Serial ATA Revision 3.2 specification.

Test parameter	Test interfaces		
	Gen1 i/m/u	Gen2 i/m/u	Gen3 i/m/u
<b>General specifications</b>			
Channel speed	✓	✓	✓
Tui, unit interval	✓	✓	✓
Ftol, TX frequency long term stability	✓	✓	✓
Fssc, spread-spectrum modulation frequency	✓	✓	✓
SSCtol, spread-spectrum modulation deviation	✓	✓	✓
<b>Transmitted signal requirements</b>	<b>Gen1 i/m/u</b>	<b>Gen2 i/m/u</b>	<b>Gen3 i/m/u</b>
VdiffTX, TX differential output voltage	✓	✓	✓
T20-80TX, TX rise/fall time	✓	✓	✓
tskewTX, TX differential skew	✓	✓	✓
Vcm, ac, TX AC common mode voltage	✓	✓	✓
TJ at Connector, Clk-Data, fBAUD/500 (JTF defined)	✓	n/r	n/r
DJ at Connector, Clk-Data, fBAUD/500 (JTF defined)	✓	n/r	n/r
RJ before CIC, Clk-Data (JTF defined)	n/r	n/r	✓
TJ before CIC, Clk-Data (JTF defined)	n/r	n/r	✓
TJ after CIC, Clk-data (JTF defined)	n/r	n/r	✓
<b>OoB Specifications</b>	<b>Gen1 i/m/u</b>	<b>Gen2 i/m/u</b>	<b>Gen3 i/m/u</b>
Vthresh, OOB signal detection threshold	✓	✓	✓
UIOOB, UI during OOB signaling	✓	✓	✓
COMINIT/COMRESET/COMWAKE burst length	✓	✓	✓
COMINIT/COMRESET transmit gap length	✓	✓	✓
COMWAKE transmit gap length	✓	✓	✓
COMWAKE gap detection windows	✓	✓	✓
COMINIT/COMRESET gap detection windows X	✓	✓	✓

✓ = covered test

n/r = not required by specification

Table 2. SATA electrical tests performed by the SATA software

## Related Literature

Publication title	Publication type	Publication number
<i>Infiniium DSO/DSA 90000A Series Oscilloscopes</i>	Data sheet	5989-7819EN
<i>Infiniium 90000 X-Series Oscilloscopes</i>	Data sheet	5990-5271EN
<i>N5400A EZJIT Plus and EZJIT Jitter Analysis Software for Infiniium Series Oscilloscopes</i>	Data sheet	5989-0109EN
<i>N5436A Infiniium Protocol Viewer and Packet Decode for Infiniium 90000 Oscilloscopes</i>	Data sheet	5989-8438EN
<i>E2688A, N5384A High-Speed Serial Data Analysis and Clock Recovery Software for Infiniium Oscilloscopes</i>	Data sheet	5989-0108EN
<i>N8900A Infiniium Offline Oscilloscope Analysis Software</i>	Data sheet	5990-9910EN
<i>Infiniium Z-Series Oscilloscopes</i>	Data sheet	5991-3868EN

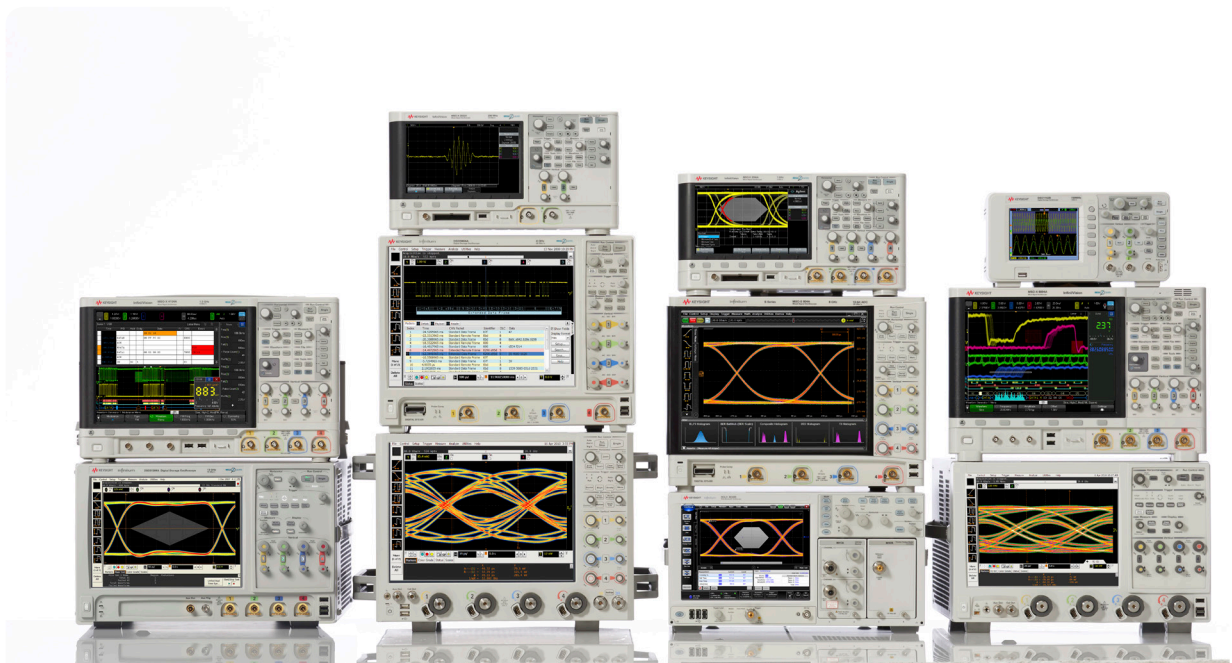

## Keysight Technologies Oscilloscopes

Multiple form factors from 20 MHz to >90 GHz | Industry leading specs | Powerful applications

**myKeysight**

**myKeysight**

[www.keysight.com/find/mykeysight](http://www.keysight.com/find/mykeysight)

A personalized view into the information most relevant to you.



[www.axiestandard.org](http://www.axiestandard.org)

AdvancedTCA® Extensions for Instrumentation and Test (AXIe) is an open standard that extends the AdvancedTCA for general purpose and semiconductor test. Keysight is a founding member of the AXIe consortium. ATCA®, AdvancedTCA®, and the ATCA logo are registered US trademarks of the PCI Industrial Computer Manufacturers Group.



[www.lxistandard.org](http://www.lxistandard.org)

LAN eXtensions for Instruments puts the power of Ethernet and the Web inside your test systems. Keysight is a founding member of the LXI consortium.



[www.pxisa.org](http://www.pxisa.org)

PCI eXtensions for Instrumentation (PXI) modular instrumentation delivers a rugged, PC-based high-performance measurement and automation system.



**Three-Year Warranty**

[www.keysight.com/find/ThreeYearWarranty](http://www.keysight.com/find/ThreeYearWarranty)

Keysight's commitment to superior product quality and lower total cost of ownership. The only test and measurement company with three-year warranty standard on all instruments, worldwide.



**Keysight Assurance Plans**

[www.keysight.com/find/AssurancePlans](http://www.keysight.com/find/AssurancePlans)

Up to five years of protection and no budgetary surprises to ensure your instruments are operating to specification so you can rely on accurate measurements.



[www.keysight.com/quality](http://www.keysight.com/quality)

Keysight Technologies, Inc.  
DEKRA Certified ISO 9001:2008  
Quality Management System

**Keysight Channel Partners**

[www.keysight.com/find/channelpartners](http://www.keysight.com/find/channelpartners)

Get the best of both worlds: Keysight's measurement expertise and product breadth, combined with channel partner convenience.

[www.keysight.com/find/N5411B](http://www.keysight.com/find/N5411B)

For more information on Keysight Technologies' products, applications or services, please contact your local Keysight office. The complete list is available at: [www.keysight.com/find/contactus](http://www.keysight.com/find/contactus)

**Americas**

Canada	(877) 894 4414
Brazil	55 11 3351 7010
Mexico	001 800 254 2440
United States	(800) 829 4444

**Asia Pacific**

Australia	1 800 629 485
China	800 810 0189
Hong Kong	800 938 693
India	1 800 112 929
Japan	0120 (421) 345
Korea	080 769 0800
Malaysia	1 800 888 848
Singapore	1 800 375 8100
Taiwan	0800 047 866
Other AP Countries	(65) 6375 8100

**Europe & Middle East**

Austria	0800 001122
Belgium	0800 58580
Finland	0800 523252
France	0805 980333
Germany	0800 6270999
Ireland	1800 832700
Israel	1 809 343051
Italy	800 599100
Luxembourg	+32 800 58580
Netherlands	0800 0233200
Russia	8800 5009286
Spain	0800 000154
Sweden	0200 882255
Switzerland	0800 805353
	Opt. 1 (DE)
	Opt. 2 (FR)
	Opt. 3 (IT)
United Kingdom	0800 0260637

For other unlisted countries:  
[www.keysight.com/find/contactus](http://www.keysight.com/find/contactus)  
(BP-07-10-14)

