

Keysight Technologies

Signal Studio for cdma2000/1xEV-DO N7601B

Technical Overview

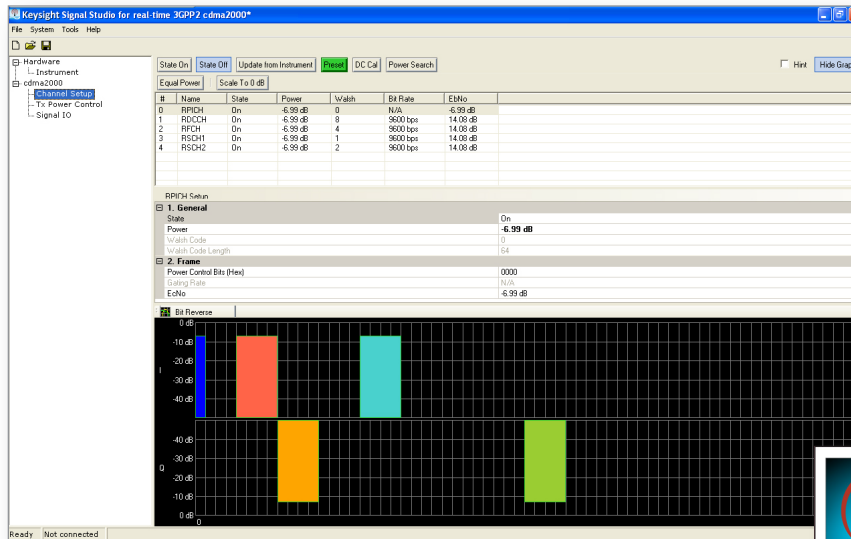

- Create Keysight validated and performance optimized reference signals compliant to IS-95A, cdma2000® and 1xEV-DO Rev. A and Rev. 0
- Perform UE and BTS component testing
- Perform UE and BTS receiver conformance testing with predefined configurations in all of the supported radio formats and mixed format configurations
- Perform UE and BTS receiver testing with transport-channel coding
- Accelerate the signal creation process with a user interface based on parameterized and graphical signal configuration and tree-style navigation

Simplify cdma2000 and 1xEV-DO Signal Creation

Keysight Signal Studio software is a flexible suite of signal-creation tools that will reduce the time you spend on signal simulation. For cdma2000 and 1xEV-DO, Signal Studio's performance-optimized reference signals—validated by Keysight—enhance the characterization and verification of your devices. Through its application-specific user-interface you'll create standards-based and custom test signals for component, transmitter, and receiver test.

Component and transmitter test

Signal Studio's basic capabilities use waveform playback mode to create and customize waveform files needed to test components and transmitters. Its userfriendly interface lets you configure signal parameters, calculate the resulting waveforms and download files for playback. The applications for these partiallycoded, statistically correct signals include

- Parametric test of components, such as amplifiers and filters
- Performance characterization and verification of RF sub-systems

Receiver test

Signal Studio's advanced capabilities enable you to create fully channel-coded signals for receiver bit-error-rate (BER), block-error-rate (BLER), packet-error-rate (PER), or frame error rate (FER) analysis. Applications include

- Performance verification and functional test of receivers, during RF/baseband integration and system verification
- Coding verification of baseband subsystems, including FPGAs, ASICs, and DSPs

In addition to waveform playback mode, some advanced capabilities operate in real-time mode, which is used to define the parameters of nonrepeating and dynamically changing signals needed for receiver testing. Its graphical interface provides a direct instrument connection for parameter transfer and closed-loop or interactive control during signal generation.

Apply your signals in real-world testing

Once you have setup your signals in Signal Studio, you can download them to a variety of Keysight instruments. Signal Studio software complements these platforms by providing a cost-effective way to tailor them to your test needs in design, development and production test.

- Vector signal generators
 - X-Series: MXG and EXG
 - PSG
 - ESG
 - First-generation MXG
 - PXIe M9381A
- EXT wireless communication test set
- PXB baseband generator and channel emulator
- M9252A DigRF host adaptor
- SystemVue simulation software

Typical Measurements

Test components with basic capabilities

- IMD/NPR
- ACLR
- CCDF
- EVM
- Modulation accuracy
- Code domain power
- Channel power
- Occupied bandwidth

Verify receivers with advanced capabilities

- Sensitivity
- Maximum input level
- Selectivity
- Blocking
- Intermodulation
- Power control

Component and Transmitter Test



Figure 1. Typical component test configuration using Signal Studio's basic capabilities with a Keysight X-Series signal generator and an X-Series signal analyzer

The N7601B Signal Studio for cdma2000/1xEV-DO software's basic capabilities enable you to create waveforms with multiple and mixed carriers for component testing. With the purchase of the N7601B software's Basic CDMA license, the software generates waveforms in both the IS-95A and the cdma2000 radio formats. With the purchase of the N7601B software's Basic 1xEV-DO license, the software generates waveforms in both the 1xEV-DO Rev. 0 and 1xEV-DO Rev. A radio formats. Both Basic licenses allow the software to generate waveforms in all four radio formats.

Designers and manufacturers of both access network (AN) and access terminal (AT) components will find the N7601B Signal Studio for cdma2000/1xEV-DO extremely useful. The N7601B software provides cdma2000, IS-95A, and 1xEV-DO waveforms for testing many cdma products, such as multicarrier power amplifiers (MCPAs) and dual-mode handset components.

Using the N7601B software's CCDF capability, you can verify the performance of your handset (MS or AT) power amplifiers for all of the radio formats.

Signal Studio for cdma2000/1xEV-DO allows you to test MCPAs with up to 25 carriers placed within a 160 MHz bandwidth. The forward link waveform includes an idle slot gain feature that can be used to vary the noise level relative to the pilot channel during idle slot transmissions. This allows the on/off power ratio to be set to meet the transmission envelope mask requirements of the system. Forward and reverse link physical channel parameters can be individually configured in each timeslot.

The waveforms provided by the N7601B Signal Studio for cdma2000/1xEV-DO software enable you to perform the following component tests:

- Conducted spurious emission tests
- Complementary-cumulative-probability distribution function (CCDF) tests
- Waveform quality tests
- Code domain power (CDP) tests

Receiver Test

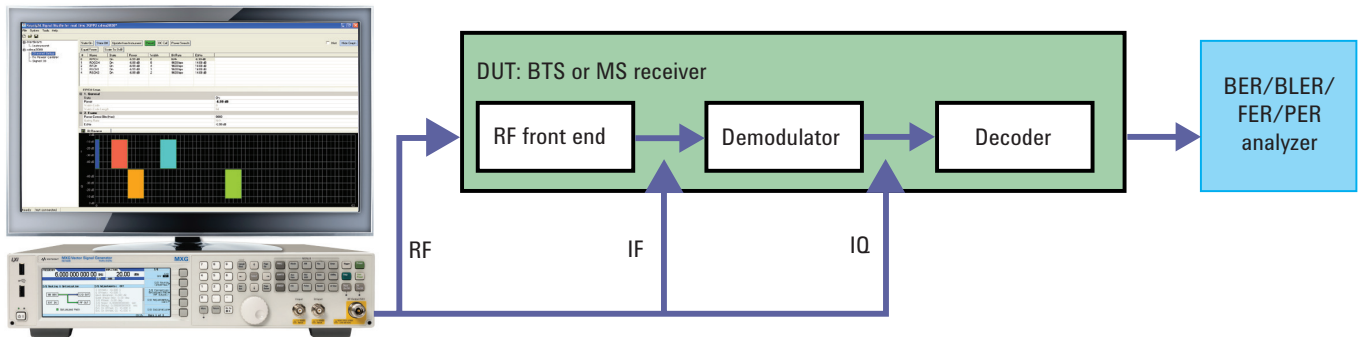

Figure 2. Generate fully channel-coded signals to evaluate the BER, BLER, PER, or FER of your receiver with Keysight X-Series signal generators and Signal Studio's advanced capabilities

The N7601B Signal Studio for cdma2000/1xEV-DO software's advanced capabilities can be used for receiver testing in cdma2000, 1xEV-DO Rev. 0 and 1xEV-DO Rev. A applications. With the purchase of the advanced licenses, the software generates fully-coded cdma2000 or 1xEV-DO signals in the physical and transport layers which can be used for packet error rate (PER) verification. These fully-coded signals are available in both the forward link and reverse link directions from the advanced selections.

The Additive White Gaussian Noise (AWGN) signal generator feature (Option 403) can be used as part of the receiver test process. AWGN is not likely to be used in component testing applications.

Receiver testing

Baseband verification

- Packet error rate (PER) test for testing the performance of an access terminal (AT) and access network (AN) receiver. PER is the ratio, in percent, of the number of test packets not successfully received by the AT/AN receiver to the number of test packets sent to the AT/AN receiver.
- PER test by turbo-coded interleaved packet repetition
- HARQ (hybrid automatic repeat request) test in 1xEV-DO Rev. A
- Turbo coding check at early termination
- 1xEV-DO Rev.0/A AN/AT PER test and 1xEV-DO Rev. A RL throughput verification
- 1xEV-DO Rev. A baseband functional test

RF conformance test

- Receiver Sensitivity, ACS, Blocking

Features Summary

IS-95A cdma2000 1xEV-DO Rev. 0 1xEV-DO Rev. A	Component & transmitter testing		Receiver testing		
	Basic waveform playback mode		Advanced waveform playback mode		Advanced real-time mode
	cdma2000	1xEV-DO	cdma2000	1xEV-DO	cdma2000
Calibrated AWGN	●	●	●	●	●
CCDF, spectrum, and time domain graphics	●	●	●	●	
Code domain	●	●	●	●	●
PER verification			●	●	●
BER, FER Insertion					●
Channel setup					
Power (-40dB to 0 dB)	●	●			●
Walsh Code (0 to 63)	●	●			●
Data: Random, PN9, user	●	●			●
IS-95A forward					
Predefined Configurations (varies by radio format)		●			
Radio configuration		●			
Fully coded channels		●			
IS95A Reverse					
Predefined configurations (varies by radio format)		●			●
Radio configuration		●			●
Fully coded channels		●			●
cdma2000 forward					
Predefined configurations (varies by radio format)		●			
Radio configuration		●			
Fully coded channels		●			
cdma2000 reverse					
Predefined configurations (varies by radio format)		●			●
Radio configuration		●			●
Fully coded channels		●			●
1xEV-DO Rev. 0 forward					
Predefined configurations					
Traffic 16QAM (no coding)		●		●	
Traffic 8PSK (no coding)		●		●	
Traffic QPSK (no coding)		●		●	
Forward test mode				●	
Supported channels					
Pilot		●		●	
MAC		●		●	
Traffic		●		●	
1xEV-DO Rev. 0 reverse					
Predefined configurations					
Traffic BPSK (no coding)		●		●	
Traffic 153.6k (no coding)				●	
Supported channels					
Pilot		●		●	
Reverse rate indicator		●		●	
Data rate control		●		●	
ACK		●		●	
Data		●		●	
Data encoding				●	

Features Summary (continued)

IS-95A cdma2000 1xEV-DO Rev. 0 1xEV-DO Rev. A	Component & transmitter testing		Receiver testing		
	Basic waveform playback mode		Advanced waveform playback mode		Advanced real-time mode
	cdma2000	1xEV-DO	cdma2000	1xEV-DO	cdma2000
1xEV-DO Rev. A forward					
Predefined configurations					
Traffic 16QAM (no coding)		•		•	
Traffic (4096,1,64)				•	
Traffic (1024,1,64)				•	
Forward test mode				•	
Supported channels					
Pilot		•		•	
MAC		•		•	
Control		•		•	
Traffic		•		•	
Reverse activity		•		•	
DRCLock		•		•	
Reverse power control		•		•	
ARQ		•		•	
Packet data encoding				•	
1xEV-DO Rev. A reverse					
Predefined configurations					
Traffic Q2 (no coding)		•		•	
Traffic (4096,Q2)				•	
Traffic(8192,Q4Q2)				•	
Traffic(12288,E4E2)				•	
Supported channels					
Pilot		•		•	
Auxiliary pilot		•		•	
MAC		•		•	
Reverse rate indicator		•		•	
Data rate control		•		•	
Data source control		•		•	
ACK		•		•	
Data		•		•	
Packet data encoding				•	

Supported Standards and Test Configurations

3GPP functional freeze date	3GPP technical specification	Version	Notes
CDMA2000	3GPP2 C.S0002-D	V2.0	Feb. 2004
EVDO Rev 0	3GPP2 C.S0024-0	V4.0	Oct. 2002
EVDO Rev A	3GPP2 C.S0024-A	V3.0	Sept. 2006

Performance Characteristics

Definitions

Specification (spec):

Represents warranted performance of a calibrated instrument that has been stored for a minimum of 2 hours within the operating temperature range of 0 to 55 °C, unless otherwise stated, and after a 45 minute warm-up period. The specifications include measurement uncertainty. Data represented in this document are specifications unless otherwise noted.

Typical (typ):

Represents characteristic performance, which 80% of the instruments manufactured will meet. This data is not warranted, does not include measurement uncertainty, and is valid only at room temperature (approximately 25 °C).

Measured (meas):

An attribute measured during the design phase for purposes of communicating expected performance, such as amplitude drift vs. time. This data is not warranted and is measured at room temperature (approximately 25 °C).

The following performance characteristics apply to the instruments indicated in the respective tables. For performance characteristics of other instruments, refer to the respective product data sheet.

3GPP2 cdma2000 EVM performance

Frequency (MHz)	Channel configuration		Standard		Option 1EA	
800 to 900 or 1800 to 2200	FL Pilot	M9381A VSG (STD \leq +8 dBm, Option 1EA \leq +12 dBm)	Measured	Typical	Measured	Typical
			0.28% rms	0.31% rms	0.29% rms	0.41% rms
		N5172B EXG/N5182B MXG (STD \leq +8 dBm, Option 1EA \leq +12 dBm)	Specification	Typical	Specification	Typical
			1.30%	0.80%	1.30%	0.80%

Conducted spurious emission (CSE) measured performance, - 9 channel forward link

N5172B EXG/N5182B MXG (dBc)	Frequency offsets				Frequency offsets			
	750 kHz	885 kHz	1.25 MHz	1.98 MHz	750 kHz	885 kHz	1.25 MHz	1.98 MHz
	Amplitude level: \leq +2 dBm for STD				Amplitude level: \leq +5 dBm with Option UNV and Option 1EA			
cdma2000 (Measured)	-82.0	-84.7	-87.9	-91.6	-82.9	-84.8	-88.4	-92.7
1xEV-DO Rev 0 (Measured)	-71.9	-77.1	-83.9	-88.5	-72.7	-77.4	-84.1	-89.1
1xEV-DO Rev A (Measured)	-73.6	-78.8	-85.3	-88.0	-74.2	-78.9	-85.2	-89.1
M9381A (dBc)	Amplitude level: \leq +4 dBm for both STD and Option 1EA				Amplitude level: +12 dBm for Option 1EA			
cdma2000 (Measured)	-71.0	-74.2	-80.2	-91.9	-63.0	-64.1	-69.1	-80.4
cdma2000 (Typ)	-69.0	-71.1	-76.2	-88.4	-60.3	-61.3	-66.2	-77.6
1xEV-DO Rev 0 (Typ)	-71.3	-74.9	-81.3	-89.3	-61.9	-63.4	-67.8	-82.6
1xEV-DO Rev A (Typ)	-71.3	-74.8	-81.2	-89.0	-61.5	-62.7	-67.7	-81.2

Ordering Information

Software licensing and configuration

Signal Studio offers flexible licensing options, including:

- **Fixed license:** Allows you to create unlimited I/Q waveforms with a specific Signal Studio product and use them with a single, specific platform.
- **Transportable/floating license:** Allows you to create unlimited I/Q waveforms with a specific Signal Studio product and use them with a single platform (or PC in some cases) at a time. You may transfer the license from one product to another.
- **Waveform license:** Allows you to generate up to 545 user-configured I/Q waveforms with any Signal Studio product and use them with a single, specific platform.

The table below lists fixed, perpetual licenses only; additional license types may be available. For detailed licensing information and configuration assistance, please refer to the Licensing Options web page at www.keysight.com/find/SignalStudio_licensing

N7601B Signal Studio for cdma2000/1xEV-DO

Model-Option	Description
Connectivity	
N7601B-1FP	Connect to E4438C, fixed perpetual license
N7601B-2FP	Connect to E8267D, fixed perpetual license
N7601B-3FP	Connect to N5182/62 MXG, N5172 EXG, fixed perpetual license
N7601B-6FP	Connect to N5106A PXB, fixed perpetual license
N7601B-7FP	Connect to Keysight simulation software
N7601B-8FP	Connect to E6607 EXT, fixed perpetual license
N7601B-9FP	Connect to M9381A and M9252A
N7601B-R7L	Connect to 16800/16900/N5343A, fixed perpetual license
Capability	
N7601B-EFP	Basic cdma2000
N7601B-FFP	Basic 1xEV-DO
N7601B-QFP	Advanced cdma2000
N7601B-RFP	Advanced 1xEV-DO
N7601B-WFP	Advanced cdma2000 real-time UL

Try Before You Buy!

Free 30-day trials of Signal Studio software provide unrestricted use of the features and functions, including signal generation, with your compatible platform. Redeem a trial license online at

www.keysight.com/find/SignalStudio_trial

Hardware configurations

To learn more about compatible hardware and required configurations, please visit: www.keysight.com/find/SignalStudio_platforms

PC requirements

A PC is required to run Signal Studio. www.keysight.com/find/SignalStudio_pc

Signal Studio Software Updates

To update previously purchased N7601B software to include the latest feature updates, you can purchase the N7601B-MEU minor enhancement update fixed perpetual license.

For more information, visit

www.keysight.com/find/N7601B-MEU

Additional Information

Websites

www.keysight.com/find/SignalStudio

Access the comprehensive online documentation, which includes the complete software HELP

www.keysight.com/find/n7601b

www.keysight.com/find/signalstudio

Keysight's cdma2000 design and test solutions

www.keysight.com/find/cdma2000

Literature

Signal Studio Software, Brochure, literature number 5989-6448EN

Transition from 2G/3G to 3.9G/4G Base Station Receiver Conformance Test, Application Note, literature number 5991-0280EN

myKeysight

myKeysight

www.keysight.com/find/mykeysight

A personalized view into the information most relevant to you.



www.lxistandard.org

LAN eXtensions for Instruments puts the power of Ethernet and the Web inside your test systems. Keysight is a founding member of the LXI consortium.



Three-Year Warranty

www.keysight.com/find/ThreeYearWarranty

Keysight's commitment to superior product quality and lower total cost of ownership. The only test and measurement company with three-year warranty standard on all instruments, worldwide.



Keysight Assurance Plans

www.keysight.com/find/AssurancePlans

Up to five years of protection and no budgetary surprises to ensure your instruments are operating to specification so you can rely on accurate measurements.



www.keysight.com/quality

Keysight Technologies, Inc.
DEKRA Certified ISO 9001:2008
Quality Management System

Keysight Channel Partners

www.keysight.com/find/channelpartners

Get the best of both worlds: Keysight's measurement expertise and product breadth, combined with channel partner convenience.

www.keysight.com/find/n7601b

For more information on Keysight Technologies' products, applications or services, please contact your local Keysight office. The complete list is available at: www.keysight.com/find/contactus

Americas

Canada	(877) 894 4414
Brazil	55 11 3351 7010
Mexico	001 800 254 2440
United States	(800) 829 4444

Asia Pacific

Australia	1 800 629 485
China	800 810 0189
Hong Kong	800 938 693
India	1 800 112 929
Japan	0120 (421) 345
Korea	080 769 0800
Malaysia	1 800 888 848
Singapore	1 800 375 8100
Taiwan	0800 047 866
Other AP Countries	(65) 6375 8100

Europe & Middle East

Austria	0800 001122
Belgium	0800 58580
Finland	0800 523252
France	0805 980333
Germany	0800 6270999
Ireland	1800 832700
Israel	1 809 343051
Italy	800 599100
Luxembourg	+32 800 58580
Netherlands	0800 0233200
Russia	8800 5009286
Spain	0800 000154
Sweden	0200 882255
Switzerland	0800 805353
	Opt. 1 (DE)
	Opt. 2 (FR)
	Opt. 3 (IT)
United Kingdom	0800 0260637

For other unlisted countries:
www.keysight.com/find/contactus
(BP-07-10-14)