

Agilent 6800B Series AC Power Source/ Analyzers, 375-1750 VA, GPIB

Data Sheet

An integrated AC power solution



- Provides a complete AC and DC power and measurement solution
- Protect valuable DUTs with extensive protection features
- Easy to use graphical user interface (GUI)

The Complete AC Power Test Solution

Agilent AC power source/analyzers provide a complete AC test solution. As AC sources, they combine the capabilities of a power amplifier and an arbitrary waveform generator. This allows you to simulate normal waveforms and many types of distorted power waveforms. The built in power analyzer combines the capabilities of a multimeter, oscilloscope, harmonic analyzer and power analyzer. These instruments may also be used to produce DC power, either alone or as a DC offset to an AC waveform.

Since your product will have to operate in the real world of unpredictable AC power, you need to design and verify its correct operation under a wide range of AC power inputs. Brownouts, dropouts, sags, and other irregularities are not unusual in many communities today. Agilent AC power source/analyzers have the features needed to easily accomplish this test goal either in an R&D environment or on the manufacturing test floor. If you plan to sell your products in a worldwide market, you will also need to test them at the line voltages and frequencies for which they will eventually operate. There is also additional testing needed to meet regulatory requirements for sale into some countries.

Agilent AC power source/analyzers offer a complete solution for AC power testing, helping you to simplify this important task. These instruments combine the features of a power amplifier and arbitrary waveform generator to give you the ability to do all of the tests that you need. There are many standard preprogrammed waveforms, or you can use the transient generation system to simulate sophisticated and repeatable AC line disturbances. DC power can also be generated, either as a DC offset or as a pure DC signal.



Agilent Technologies

Powerful Built-in Measurement Capabilities

Agilent AC power source/analyzers have extensive 16-bit precision measurement capabilities which would normally require a number of complex measurement instruments, including a DMM (digital multimeter), oscilloscope, power analyzer, and harmonic analyzer. The precision measurements include:

- rms, DC, AC + DC voltage and current
- peak voltage and current
- real, apparent, and reactive power
- harmonic analysis of voltage and current waveforms providing amplitude and phase up to the 50th harmonic
- THD (total harmonic distortion)
- Triggered acquisition of digitized voltage and current

Using the measurement capabilities of an Agilent AC power source/analyzer simplifies your test setups and helps you obtain accurate data quickly.

Dual power analyzer Option 020

The powerful built-in power meter/analyzer in Agilent AC power source/analyzers provides everything that you need to make AC measurements at the AC input to your DUT. For many test scenarios, this is the extent of the AC analysis required.

Some test scenarios, however, require AC measurements to be made at both the AC input and the AC output of the DUT. Option 020 provides an additional power analyzer, complete with a precision current shunt, which can be connected anywhere you need it. This second analyzer can even be used for tests where the AC power source/analyzer is not providing power, thus expanding the usefulness of this instrument to many more test

configurations. The additional analyzer is equivalent in specifications and capabilities to the standard analyzer.

Using the dual power analyzer option instead of an additional power analyzer instrument externally is more than just convenient. Measurements on all four measurement channels (AC source output voltage and current, and dual power analyzer voltage and current inputs) are inherently synchronized with the AC power source/analyzers output waveform. This precision would be difficult to achieve using separate measurement instruments.

Examples dual power analyzer applications

- Complete testing of uninterruptible power sources (UPS)
- Efficiency testing of DC power supplies
- Efficiency testing of AC power sources
- Efficiency testing of transformers
- Safety testing of transformers
- Line disturbance and brownout testing of DC power supplies
- Line disturbance and brownout testing of AC power sources
- Sleep mode current monitoring
- Independent power analyzer

Sleep mode current monitoring

Many electronic products have power-saving or sleep modes. In this mode, the device draws only enough power to be able to recognize a “wake-up” signal, and then execute a smooth “wake-up”. The power drawn in this mode is a critical parameter, and the ability to accurately monitor it is important. The accessory precision current shunt that is supplied with option 020 is mounted in such a way to make it easy for you to replace it with a precision resistor of your choice. By doing this, you can configure the system to accurately

monitor extremely low currents. This provides an easy way for you to profile the current draw in all modes of your product’s operation. Since Agilent 6811B-6813B AC power source/analyzers produce DC power as well as AC power, portable battery operated products can also be tested with this configuration.

UPS (uninterruptible power source) testing

The dual power analyzer option provides many important benefits for UPS testing. Since the key to correct UPS operation is having the output react properly to changes on the input, being able to monitor the output relative to the input simplifies testing. For example, commands are available to enable calculation of UPS transfer time, and the phase difference between the UPS input and output voltage. Agilent AC power source/analyzers also have programmable output impedance, enabling the UPS designer to verify product stability over a wide range of AC line impedance.

Graphical user interface (GUI)

When you need to run a variety of tests, study the results carefully, and then run more tests with slightly varied conditions, writing computer programs using the extensive SCPI command set may seem burdensome. This is when you should download the latest copy of the Agilent AC power source/analyzer graphical user interface from www.agilent.com/find/6800.

The AC power source/analyzer GUI makes it quick and easy to set the output of your AC power source/analyzer, be it from a stored waveform or with a waveform that you create using your mouse. The GUI also allows you to see the output of the AC power source/analyzer in graphical form, save the results, or dump them directly into a Microsoft® Excel file.

Microsoft Excel link

The direct Excel link feature was recently added to meet the current needs of R&D engineers. It makes it easy to keep the results of many tests, and makes them easily retrievable. With it, the test records resulting from changing conditions can be kept in one place and easily compared.

Access to raw data often helps in fully understanding test results. For example, small local peaks may not be evident in processed data. V, I and phase results from harmonic measurements are particularly susceptible to not showing the complete story in a graphical representation.

Microsoft Excel offers a wide variety of data manipulation and graphical capabilities that can help an engineer gain the fullest understanding from the test data.

Test suite for avionics equipment

Agilent AC power source/analyzers are well suited for testing equipment intended for use in the avionics industry which operate at nominally 400 Hz. One of the special requirements that many manufacturers in this industry must concern themselves with is testing to meet RTCA DO-160 standards.

These standards involve both AC and DC immunity tests. The AC power source/analyzer GUI includes a section devoted to these tests. By using this tool, you can quickly step through the required set-ups with confidence.

Extensive protection to prevent load damage

In addition to overcurrent, overvoltage, overpower and overtemperature protection, the 6800 series offers output disconnect relays and remote inhibit capability (quickly disabling the output of the AC power source/analyzers via a TTL signal) to protect the device under test.

Application information

The 6800 series can help you test and improve your products. You can easily perform:

1. Static testing—generating and measuring voltage, frequency, and line current for meeting worldwide specifications.
2. Dynamic testing—generating AC line transients for limit testing and design verification.
3. Specialty testing—measuring current harmonic content and creating custom AC power waveforms (such as a combined AC + DC signal to simulate a telephone ring).
4. Precompliance regulatory testing—measuring current harmonics, voltage fluctuations and flicker emissions and generating voltage and frequency disturbances and interharmonics to determine product immunity.

Development engineers and test professionals in a wide variety of industries use AC power source/analyzers.

Here are a few examples:

Avionics

Instrumentation, ATE test stations

Computer products

Computers, monitors, peripherals

Consumer products

Home appliances, audio and video equipment, heating/cooling controls

Electrical products

Relays, transformers, power components, fire alarms

Lighting products

Electronic ballasts, compact fluorescent bulbs, timers

Motors

AC motors, electronic controllers

Power products

AC/DC adapters, AC/DC power supplies, PBX power supplies, uninterruptible power supplies

Telecom products

RF amplifiers, CATV devices, MUX's, routers, switches

Only need a basic AC Source?

The AC6800 Series of basic AC sources offer models up to 4000 VA with LAN/LXI Core, USB and optional GPIB. For more information, see www.agilent.com/find/ACSources.

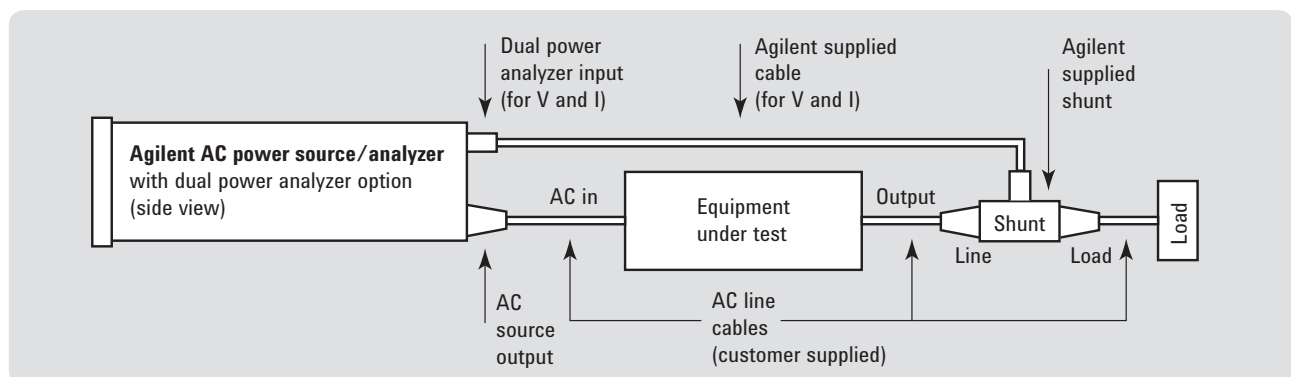

Test configuration of efficiency measurement using an Agilent AC power source/analyzer with the 020 dual power analyzer option.

AC Power Source/Analyzer Graphical User Interface

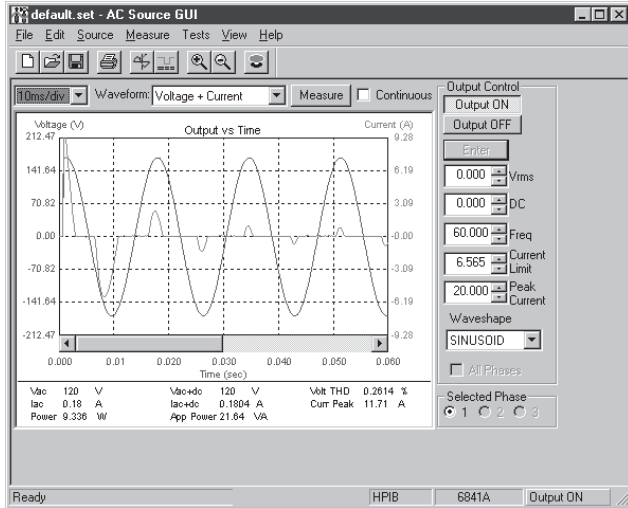

Inrush current measurement

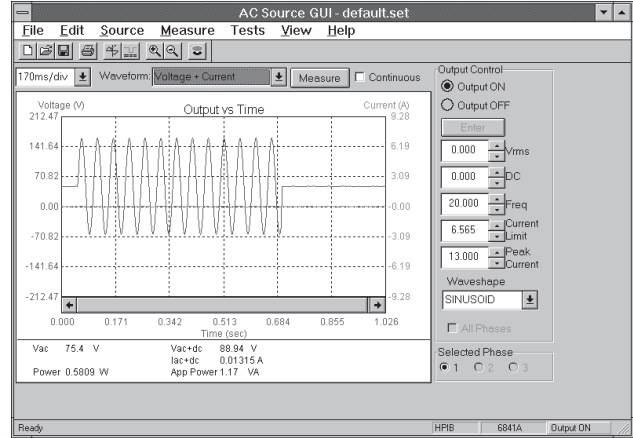

Ringer voltage (DC + AC) generation

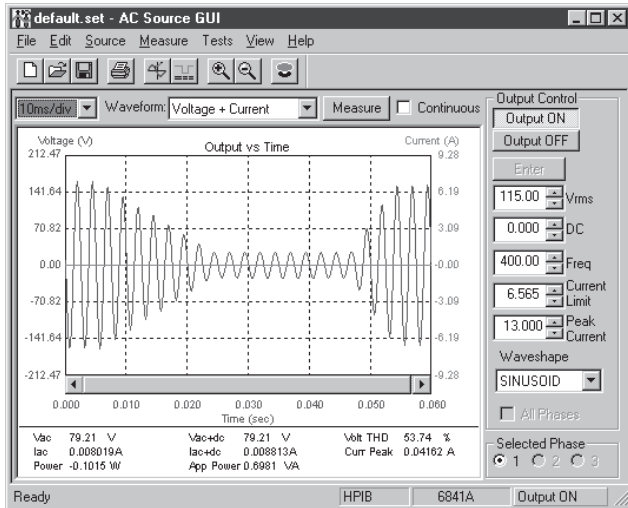

Voltage slew control (brownout)

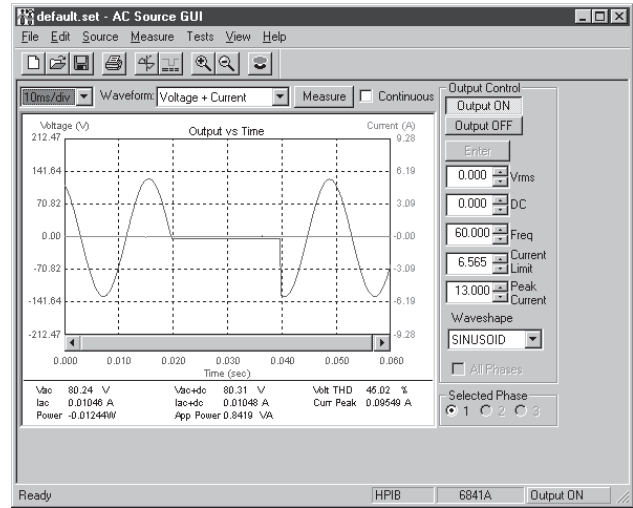

One cycle AC mains dropout

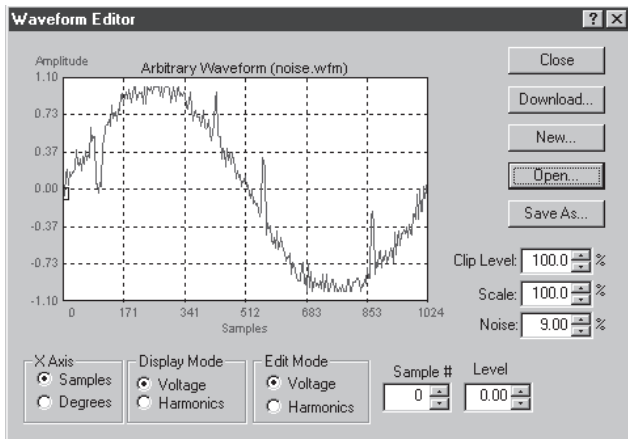

User defined waveform: noise with spikes

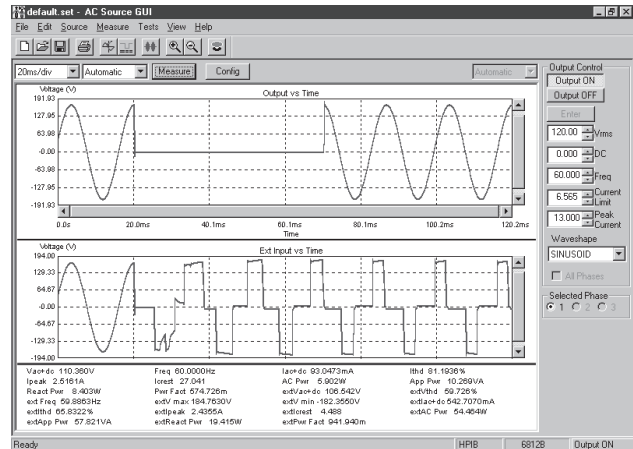

Testing of UPS input and output using dual power analyzer Option 020

Specifications

For a sine wave with a resistive load at 0 ° to 40 °C, within an output frequency range of 45 Hz to 1000 Hz, and in AC coupled mode after a 30 minute warm-up unless otherwise noted.

Specifications <i>(at 0 ° to 40 °C unless otherwise specified)</i>	6811B	6812B	6813B
Number of phases	1	1	1
Output ratings (Maximum)			
Power	375 VA	750 VA	1750 VA
rms voltage	300 V	300 V	300 V
rms current	3.25 A	6.5 A	13 A
Repetitive & non-repetitive peak current	40 A	40 A	80 A
Crest factor	12	6	6
Load power factor capability	0 to 1	0 to 1	0 to 1
DC power	285 W	575 W	1350 W
DC voltage	± 425 V	± 425 V	± 425 V
DC current	2.5 A	5.0 A	10.0 A
Output frequency range¹	DC; 45 Hz to 1 kHz	DC; 45 Hz to 1 kHz	DC; 45 Hz to 1 kHz
Constant voltage ripple and noise (20 kHz to 10 MHz)	-60 dB (relative to full scale)	-60 dB (relative to full scale)	-60 dB (relative to full scale)
Line regulation (% of full scale)	0.1%	0.1%	0.1%
Load regulation (% of full scale)	0.5%	0.5%	0.5%
Maximum total harmonic distortion	0.25% at 50/60 Hz 1% worst case 45 to 1 kHz	0.25% at 50/60 Hz 1% worst case 45 to 1 kHz	0.25% at 50/60 Hz 1% worst case 45 to 1 kHz

Programming accuracy (at 25 ° ± 5 °C)	6811B	6812B	6813B
RMS voltage (% of output + offset)	0.15% + 0.3 V (45 to 100 Hz) 0.5% + 0.3 V (> 100 to 500 Hz) 1% + 0.3 V (> 500 to 1000 Hz)	0.15% + 0.3 V (45 to 100 Hz) 0.5% + 0.3 V (> 100 to 500 Hz) 1% + 0.3 V (> 500 to 1000 Hz)	0.15% + 0.3 V (45 to 100 Hz) 0.5% + 0.3 V (> 100 to 500 Hz) 1% + 0.3 V (> 500 to 1000 Hz)
DC voltage	0.1% + 0.5 V	0.1% + 0.5 V	0.5% + 0.3 V
Frequency	0.01% + 10 µHz	0.01% + 10 µHz	0.01% + 10 µHz

1. Product may be operated between DC and 45 Hz subject to certain deratings. Measurements may be extended to 4.5 Hz at full accuracy only by selecting a digitization rate of 250 µs per point. Frequency content of the measured signal must be limited to 4 kHz or less to avoid aliasing effects.

Specifications, continued

For a sine wave with a resistive load at 0 ° to 40 °C, within an output frequency range of 45 Hz to 1000 Hz, and in AC coupled mode after a 30 minute warm-up unless otherwise noted.

Measurement accuracy (at 25 ° ± 55 °C)	6811B	6812B	6813B
Rms. voltage (45 - 100 Hz)	0.03% + 100 mV ¹	0.03% + 100 mV ¹	0.03% + 100 mV ¹
DC voltage	0.05% + 150 mV ¹	0.05% + 150 mV ¹	0.05% + 150 mV ¹
RMS current (45 - 100 Hz)²			
High range	0.05% + 10 mA	0.05% + 10 mA	0.05% + 10 mA
Low range	0.05% + 1.5 mA	0.05% + 1.5 mA	0.05% + 1.5 mA
Power (VA) (45-100 Hz)²			
High range	0.1% + 1.5 VA + 12 mVA/V	0.1% + 1.5 VA + 12 mVA/V	0.1% + 1.5 VA + 12 mVA/V
Low range	0.1% + 1.5 VA + 1.2 mVA/V	0.1% + 1.5 VA + 1.2 mVA/V	0.1% + 1.5 VA + 1.2 mVA/V
Power (watts) (45-100 Hz)²			
High range	0.1% + 0.3 W + 12 mW/V	0.1% + 0.3 W + 12 mW/V	0.1% + 0.3 W + 12 mW/V
Low range	0.1% + 0.3 W + 1.2 mW/V	0.1% + 0.3 W + 1.2 mW/V	0.1% + 0.3 W + 1.2 mW/V
Frequency	0.01% + 0.01 Hz	0.01% + 0.01 Hz	0.01% + 0.01 Hz
Power factor	0.01	0.01	0.01
Current magnitude (low range)			
Fundamental	0.03% + 1.5 mA	0.03% + 1.5 mA	0.03% + 1.5 mA
Harmonics 2-49	0.03% + 1 mA + 0.2%/kHz	0.03% + 1 mA + 0.2%/kHz	0.03% + 1 mA + 0.2%/kHz
Current magnitude (high range)			
Fundamental	0.05% + 5 mA	0.05% + 5 mA	0.05% + 5 mA
Harmonics 2-49	0.05% + 3 mA + 0.2%/kHz	0.05% + 3 mA + 0.2%/kHz	0.05% + 3 mA + 0.2%/kHz

Supplemental characteristics <i>(Non-warranted characteristics determined by design and useful in applying the product)</i>	6811B	6812B	6813B
Average programming accuracy (% of output + offset) rms current	1.2% + 50 mA	1.2% + 50 mA	1.2% + 50 mA
Average programming resolution			
rms voltage	125 mV	125 mV	125 mV
DC voltage	250 mV	250 mV	250 mV
Overvoltage programming (OVP)	2 V peak	2 V peak	2 V peak
rms current	2 mA	4 mA	4 mA
Peak current	1.25 mA	25 mA	25 mA
Output frequency	10 µHz	10 µHz	10 µHz
Phase	N/A	N/A	N/A

1. Product may be operated between DC and 45 Hz subject to certain deratings. Measurements may be extended to 4.5 Hz at full accuracy only by selecting a digitization rate of 250 µ seconds per point. Frequency content of the measured signal must be limited to 4 kHz or less to avoid aliasing effects.
2. Select low measurement range for improved accuracy (10:1) for lower power measurements.

Specifications, continued

For a sine wave with a resistive load at 0 ° to 40 °C, within an output frequency range of 45 Hz to 1000 Hz, and in AC coupled mode after a 30 minute warm-up unless otherwise noted.

Supplemental characteristics <i>(Non-warranted characteristics determined by design and useful in applying the product)</i>	6811B	6812B	6813B
Average measurement resolution			
rms voltage	10 mV	10 mV	10 mV
rms current	2 mA	2 mA	2 mA
Programmable output impedance			
Resistance	0 – 1 Ω	0 – 1 Ω	0 – 1 Ω
Inductance	20 μh – 1 mh	20 μh – 1 mh	20 μh – 1 mh
Remote sense capability	Up to 1 Vrms can be dropped across each load lead	Up to 1 Vrms can be dropped across each load lead	Up to 1 Vrms can be dropped across each load lead
Isolation to ground	300 Vrms/425 VDC	300 Vrms/425 VDC	300 Vrms/425 VDC
Net weight	28.2 kg (62 lb)	28.2 kg (62 lb)	32.7 kg (72 lb)
Shipping weight	31.8 kg (70 lb)	31.8 kg (70 lb)	36.4 kg (80 lb)

AC Input Ratings	6811B	6812B	6813B
Voltage range (VAC) *default factory setting	87 to 106 VAC *104 to 127 VAC 174 to 220 VAC 191 to 254 VAC	87 to 106 VAC *104 to 127 VAC 174 to 220 VAC 191 to 254 VAC	174 to 220 VAC *191 to 254 VAC
Maximum input current (rms) (Measured at low line)	12 A (100 VAC) 10 A (120 VAC) 7.5 A (200/208 VAC) 6.5 A (230 VAC)	28 A (100 VAC) 24 A (120 VAC) 15 A (200/208 VAC) 13 A (230 VAC)	22 A (200/208 VAC) 20 A (230 VAC)
Input power (max) (Measured at high line)	1000 VA/700 W	2500 VA/1400 W	3800 VA/2600 W
Input frequency	47 to 63 Hz	47 to 63 Hz	47 to 63 Hz

Supplemental characteristics for all model numbers

Software driver: *VXIplug&play*

Size:

425.5 mm W x 88.1 mm H x 396 mm D
(16.75 in x 3.5 in x 13.7 in)

Warranty: One year

Ordering Information

The 6800 Series AC power source/ analyzers come with full documentation on CD-ROM. The CD-ROM includes user's guide, programming guide, GUI quick reference guide, service manual, quick start guide, and application notes.

Opt 019 Output raised to 2000VA, frequency reduced to 100Hz (6813B only)

Opt 020 Dual power analyzer option
Opt 026 26 Volt, 0.1 A auxiliary 45 to 100 Hz only, reference output (6812B and 6813B)

Opt 0B3 Printed service manual

Opt 0L1 Printed user's, programming, and quick start guides; printed reference card

Opt 100 (6811B and 6812B only) 87 to 106 VAC (100 VAC nominal), 47-63 Hz, Japan only

Opt 120 104-127 VAC

(120 VAC nominal), 47-63 Hz

Opt 200 (6813B only) 174-220 VAC (200 VAC nominal), 47-63 Hz, Japan only

Opt 208 (6811B and 6812B only) 174 to 220 VAC (208 VAC nominal), 47-63 Hz

Opt 230 191 to 254 VAC (230 VAC nominal), 24-63 Hz

Opt 831 12 AWG, 200 to 240 VAC, unterminated (6812B, 6813B only)

Opt 832 4 mm² wire size, unterminated (6813B only)

Opt 833 1.5 mm² wire size, 200 to 240 VAC, unterminated (6812B only)

Opt 834 10 AWG, 100 to 120 VAC, unterminated (6812B only)

Opt 841 Line cord with NEMA L6-20P; 20 A, 250 V plug (6812B only)

Opt 842 Line cord with IEC 309; 32 A, 220 V plug (6813B only)

Opt 844 Line cord with NEMA L6-30P; 30 A, 250 V locking plug (6813B only)

Opt 845 Line cord with IEC 309; 16 A, 220 V plug (6812B only)

Opt 846 Line cord with NEMA L6-30P; 30 A, 120 V plug (6812B only)

Opt 847 Line cord with CEE 7/7; 16 A, 220 V plug (6812B only)

Opt 848 Line cord with BS 546; 15 A, 240 V plug (6812B only)

Accessories

1CM003A* Rack mount flange kit 132.6 mm H (3U) – two flange brackets

1CP002A* Rack mount flange and handle kit 132.6 mm H (3U) – two brackets and front handles

E3663AC Support rails for Agilent rack cabinets

* Support rails required.

Agilent models: 6811B, 6812B, 6813B

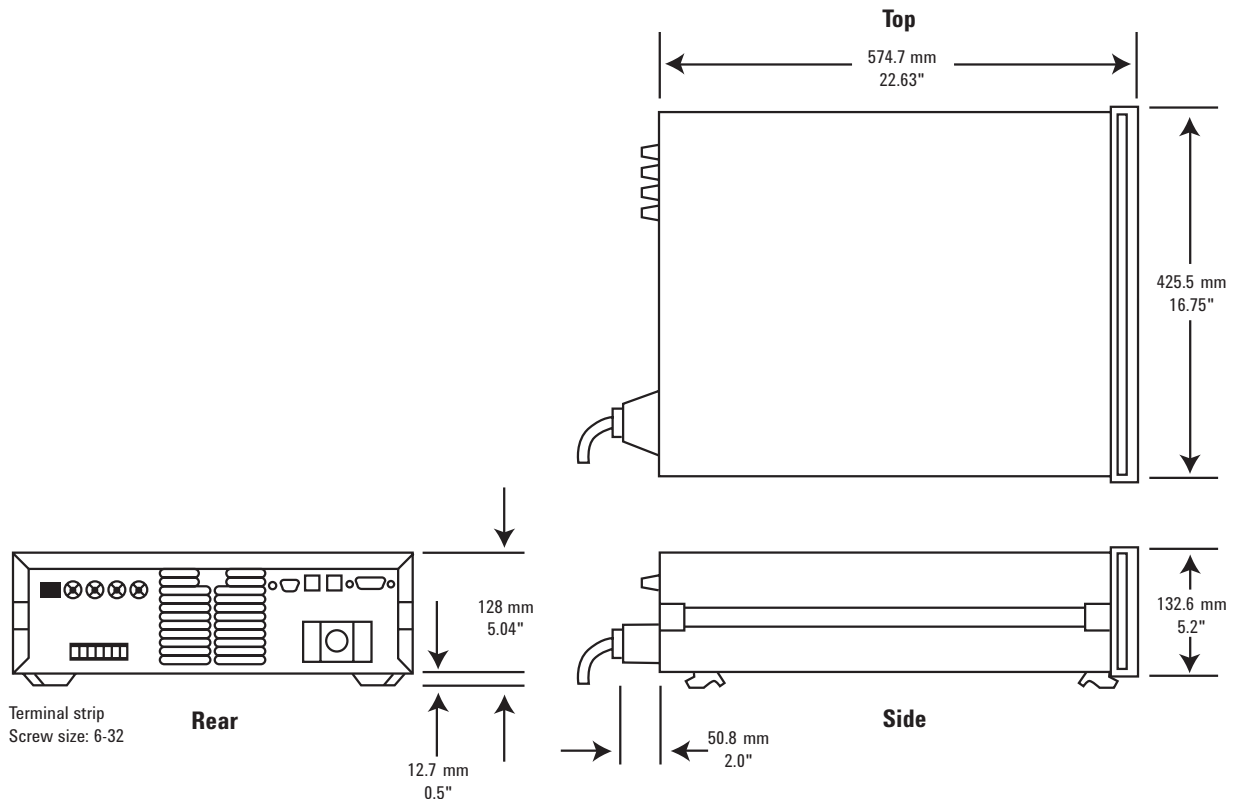

Application Notes

Agilent 6800 Series AC Power Source/Analyzer, 5963-7044E

Testing Uninterruptible Power Supplies Using Agilent 6800 Series AC Power Source/Analyzers, 5967-6056E

Simplify your Avionics Testing with a 400 Hz Single Phase Power Source that Includes a Built-in 26 V Reference Signal, 5989-3700EN



myAgilent

www.agilent.com/find/myagilent

A personalized view into the information most relevant to you.



Three-Year Warranty

www.agilent.com/find/ThreeYearWarranty

Beyond product specification, changing the ownership experience. Agilent is the only test and measurement company that offers three-year warranty on all instruments, worldwide.



Agilent Assurance Plans

www.agilent.com/find/AssurancePlans

Five years of protection and no budgetary surprises to ensure your instruments are operating to specifications and you can continually rely on accurate measurements.



www.agilent.com/quality



Agilent Electronic Measurement Group
DEKRA Certified ISO 9001:2008
Quality Management System

Agilent Channel Partners

www.agilent.com/find/channelpartners

Get the best of both worlds: Agilent's measurement expertise and product breadth, combined with channel partner convenience.

www.agilent.com
www.agilent.com/find/ACSources

For more information on Agilent Technologies' products, applications or services, please contact your local Agilent office. The complete list is available at:
www.agilent.com/find/contactus

Americas

Canada	(877) 894 4414
Brazil	(11) 4197 3600
Mexico	01800 5064 800
United States	(800) 829 4444

Asia Pacific

Australia	1 800 629 485
China	800 810 0189
Hong Kong	800 938 693
India	1 800 112 929
Japan	0120 (421) 345
Korea	080 769 0800
Malaysia	1 800 888 848
Singapore	1 800 375 8100
Taiwan	0800 047 866
Other AP Countries	(65) 375 8100

Europe & Middle East

Belgium	32 (0) 2 404 93 40
Denmark	45 45 80 12 15
Finland	358 (0) 10 855 2100
France	0825 010 700*
	*0.125 €/minute
Germany	49 (0) 7031 464 6333
Ireland	1890 924 204
Israel	972-3-9288-504/544
Italy	39 02 92 60 8484
Netherlands	31 (0) 20 547 2111
Spain	34 (91) 631 3300
Sweden	0200-88 22 55
United Kingdom	44 (0) 118 927 6201

For other unlisted countries:

www.agilent.com/find/contactus

(BP-01-15-14)

Product specifications and descriptions in this document subject to change without notice.

© Agilent Technologies, Inc. 2012, 2014
Published in USA, June 19, 2014
5990-9309EN



Agilent Technologies