

Multiband Passive Intermodulation Testing

Keysight Technologies and Power Technology Solutions

Accurate and rapid PIM characterization of communications components

Passive intermodulation (PIM) is a critical issue that can limit the quality of service and capacity of current and next generation mobile communication systems such as cellular, PCS/DCS, UMTS and 4G/LTE. Passive intermodulation arises at high power levels due to the signal degradation effects of passive elements such as antennas, cables and filters within the transmission system. PIM cannot be removed by filtering alone. The reduction and containment of passive intermodulation requires good design and manufacturing techniques and the ability to achieve accurate and repeatable measurement of PIM effects.

A new PIM test solution from Power Technology Systems (PTS) and Keysight addresses the need of component suppliers, integrators and service providers to measure passive intermodulation effects. The solution uses the Keysight E5072A ENA series network analyzer and the N5171B EXG signal generator to provide multiband PIM testing capabilities. The system integrates intermodulation distortion measurements with S-parameter characterization to fully qualify mobile communications components and sub-systems.

Passive intermodulation testing uses two independent high power (20 W typical) signals in the cellular transmit band of interest. These create intermodulation distortion products in the receive band, which can be measured to characterize the amount of PIM present. The signals to be measured are small and require a noise floor in the test instrument of 10 dB better than the device-under-test. This will typically require sensitivity of better than -173 dBc, which is achieved by using the advanced measurement capabilities of the Keysight ENA.

- Multiband passive intermodulation testing
- Test antennas, cables, connectors, filters, and other components
- Uses Keysight ENA network analyzer and EXG signal generator
- Accuracy better than -173 dBc
- Rapid measurements using built-in frequency offset functions
- Flexible configuration for design, production, QA
- Achieve accurate and rapid PIM characterization



Multiband Passive Intermodulation Testing

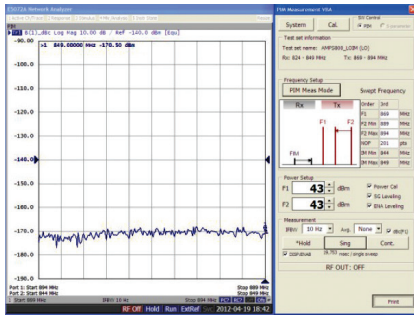

PIM testing guidelines are defined in the IEC-62037 standard on RF connector and cables intermodulation level measurements. This includes guidelines for both fixed and swept frequency measurements. The new system is compatible with these guidelines and provides both high measurement accuracy and rapid test speed.

Higher test speeds are achieved through the built-in frequency offset functions in the

Keysight network analyzer and signal generator. The frequency offset functions are set by internal firmware eliminating the need for additional external instruments. This reduces significantly the time required to reconfigure the test system for different frequency bands and allows easy configuration of the system to implement the IEC-62037 tests. The system can be configured for use in design, production or quality assurance.

With the new multiband PIM testing system from PTS and Keysight you can achieve accurate and fast PIM characterization of your passive components and sub-systems.

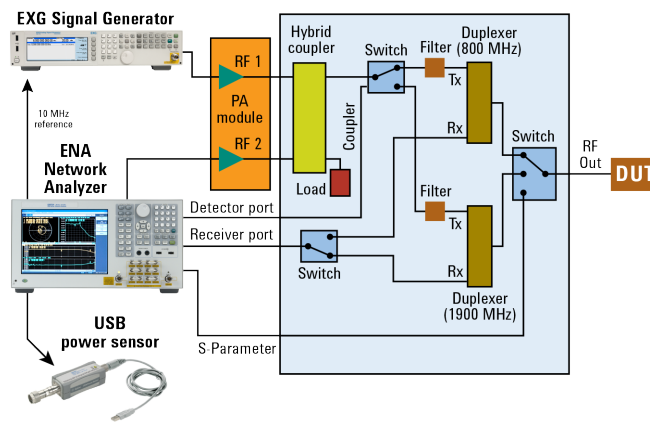

System Components

Keysight Technologies

N5171B	EXG signal generator
E5072A	ENA series network analyzer
U2001B	USB power sensor
PTS	
P7022	Dual channel PIM test set (AMPS/PCS)
P8689	Single channel PIM test set (AMPS)

To learn how this solution can address your specific needs please contact Keysight's solutions partner, Power Technology Solutions www.keysight.com/find/pts



Keysight & Solutions Partners
Extending our solutions to meet your needs

Keysight and its Solutions Partners work together to help customers meet their unique challenges, in design, manufacturing, installation or support. To learn more about the program, our partners and solutions go to

www.keysight.com/find/solutionspartner

Power Technology Solutions is a leading provider of high power solutions for telecommunications and satellite systems with experienced personnel and many decades of proven capability.

www.pwrts.com

For information on Keysight Technologies' products, applications and services, go to

www.keysight.com

© Keysight Technologies, 2013-2014
Published in USA, August 3, 2014
5991-2194EN