

Keysight Technologies B1500A Semiconductor Device Analyzer

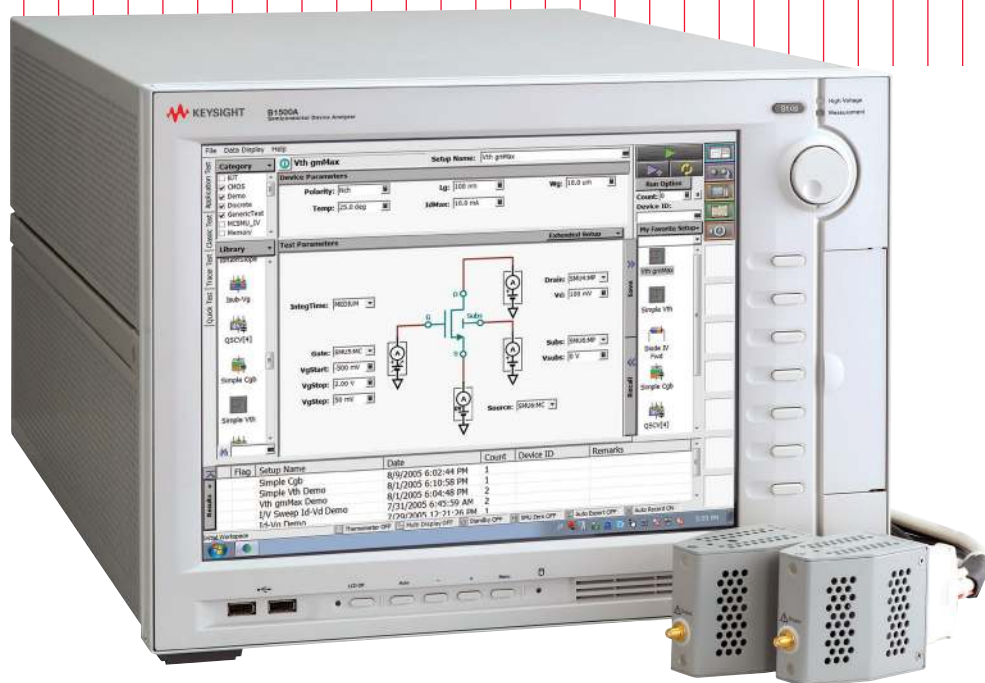

Accelerate Fundamental Current-Voltage, Capacitance and Advanced Ultra-Fast IV Device Characterization

A single-box solution that covers all of your device characterization needs



The B1500A Semiconductor Device Analyzer integrates multiple measurement and analysis capabilities for accurate and quick device characterization into a single instrument. It is the only parameter analyzer with the versatility to provide both a wide range of device characterization capabilities along with uncompromised measurement reliability and repeatability. It supports all aspects of measurement, from fundamental current-voltage (IV) and capacitance-voltage (CV) characterization up to state-of-the-art fast pulsed IV testing. In addition, the B1500A's ten-slot modular architecture allows you to add or upgrade measurement modules if your measurement needs change over time.

Keysight Technologies, Inc. EasyEXPERT, resident GUI-based software running on the B1500A's embedded Windows 7 platform, supports efficient and repeatable device characterization. Furnished with hundreds of ready-to-use measurements (application tests), the B1500A provides an intuitive and powerful environment for test execution and analysis. It facilitates the accurate and fast electrical characterization and evaluation of devices, materials, semiconductors, active/passive components, or virtually any other type of electronic device.

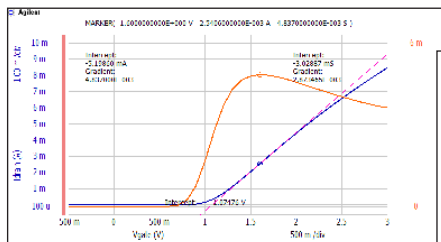

IV measurement

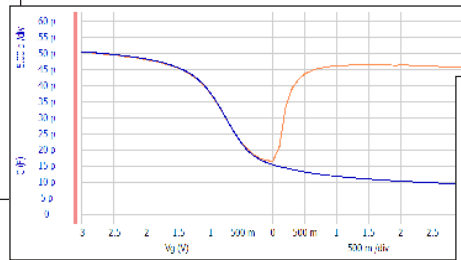

Capacitance measurement

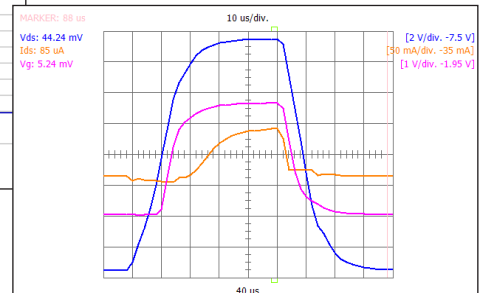

Pulsed IV measurement

| Key Features | Benefits |
|--|---|
| Precision voltage and current measurement (0.5 μ V and 0.1 fA resolution) | – Accurate characterization of low-level voltages and currents. |
| Accurate and low-cost solutions to switch between multi-frequency (1 kHz to 5 MHz) capacitance measurement (CV, C-f and C-t) and current/voltage (IV) measurement. | – Switch between CV and IV measurements without the need to recable – Maintain low-current measurement resolution (down to 1 fA with SCUU and 0.1 fA with ASUs) – Full CV compensation out to the DUT |
| Ultra-fast IV measurements with 100 ns pulsing and 5 ns sampling rate | – Capture ultra-fast transient phenomena not accurately measurable with conventional test instruments |
| Over 300 ready-to-use application tests | – Reduce time needed to learn instrument, make a measurement, and become productive |
| Curve tracer mode with oscilloscope view | – Develop tests interactively and immediately view the device characteristics – Verify current and voltage pulses without any additional equipment (Oscilloscope view with MCSMU) |
| Powerful data analysis and robust data management | – Analyze measured data automatically without an external PC – Store measured data and test conditions automatically and quickly recall this information at a later time |

Making Everyone a Device Characterization Expert

EasyEXPERT makes device characterization as easy as 1, 2, 3.

The B1500A's EasyEXPERT software includes over 300 ready-to-use application tests, which allow you to make a measurement in three easy steps.

The application test libraries furnished with the B1500A's EasyEXPERT software can not only help you accelerate the characterization of semiconductor devices, but also electronic materials, active/passive components, and many other types of electronic devices. Examples of some of the available application tests are shown in the table to the right.

| Category | Application Tests |
|-----------------------------------|---|
| CMOS Transistor | Id-Vg, Id-Vd, Vth, breakdown, capacitance, QSCV, etc. |
| Bipolar Junction Transistor (BJT) | Ic-Vc, diode, Gummel plot, breakdown, hfe, capacitance, etc. |
| Discrete device | Id-Vg, Id-Vd, Ic-Vc, diode, etc. |
| Memory | Vth, capacitance, endurance test, etc. |
| Power device | Pulsed Id-Vg, pulsed Id-Vd, breakdown, etc. |
| Nano Device | Resistance, Id-Vg, Id-Vd, Ic-Vc, etc. |
| Reliability test | NBTI/PBTI, charge pumping, electro migration, hot carrier injection, V-Ramp, J-Ramp, TDDB, etc. |

Step 1

Select a measurement from one of the furnished libraries.

Step 2

Modify the measurement parameters as needed. (Note: Customized tests can be saved into a "My favorite" setup)

Step 3

Press the measure button to start the measurement. Graphical and numerical measurement results, data analyses, and parameter extractions are automatically displayed.

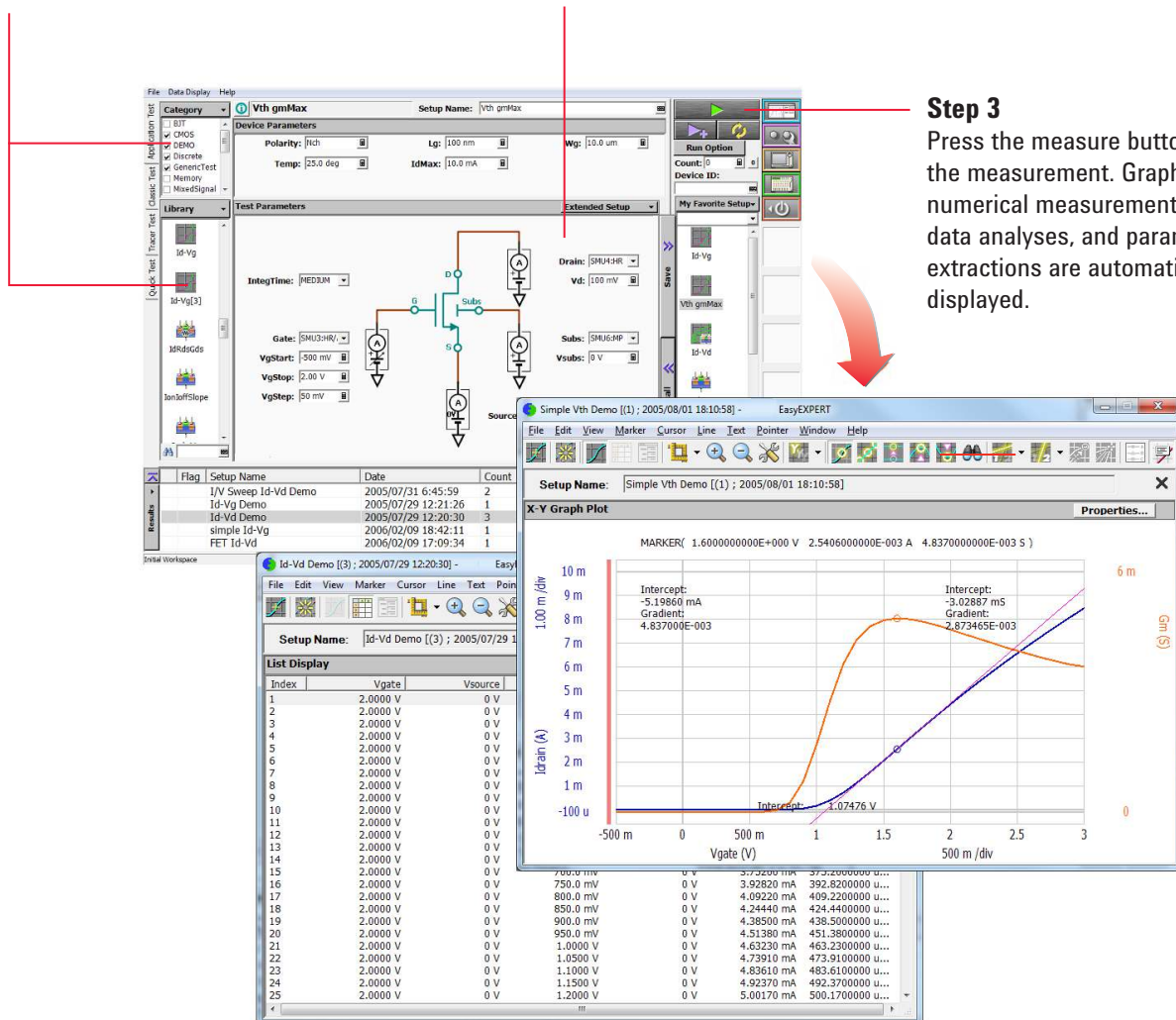

EasyEXPERT Software's Intuitive GUI Facilitates Device Characterization

The B1500A platform includes a 15-inch wide touch screen, embedded Windows 7 OS, built-in HDD and DVD drive, and GPIB, USB and LAN interfaces

15 inch wide touch screen

Rotary knob for tracer test

USB ports for keyboard, mouse or flash drive I/O use.

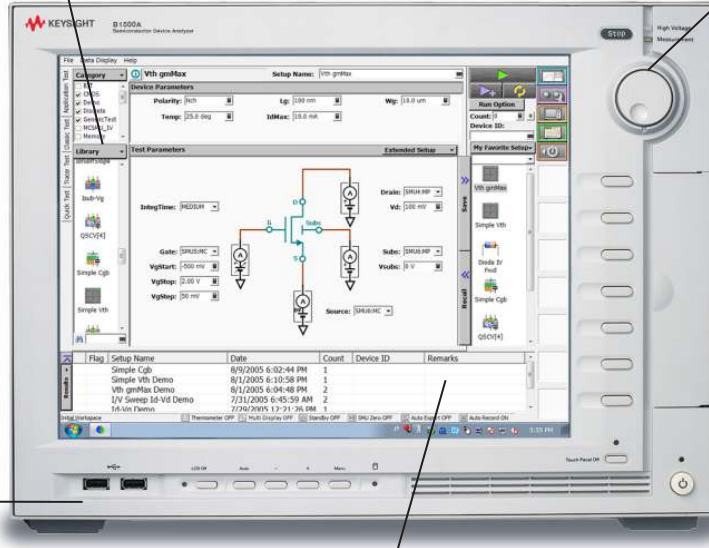

EasyEXPERT supports multiple test modes to improve test efficiency

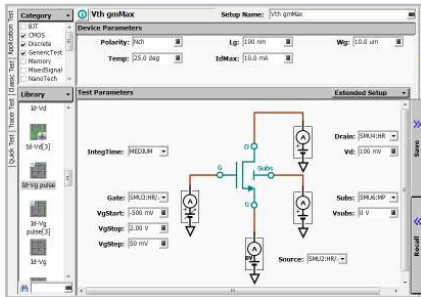

Application test mode

The application test mode provides application oriented point-and-click test setup and execution. An application test can be selected from the library by device type and desired measurement.

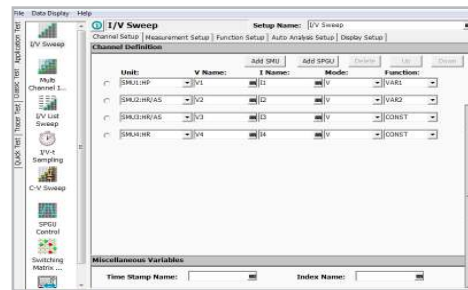

Classic test mode

The classic test mode provides function oriented test setup and execution with a similar look and feel as that of the 4155/4156.

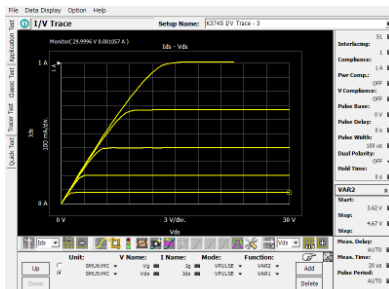

Tracer test mode

The tracer test mode offers intuitive and interactive sweep control using a rotary knob similar to a curve tracer. Test set ups created in tracer test mode can be seamlessly and instantaneously transferred to classic test mode.

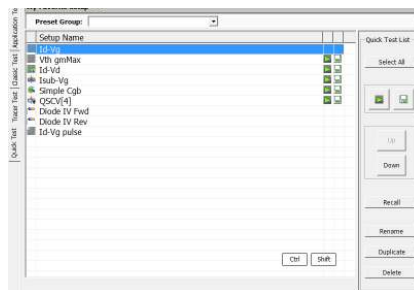

Quick test mode

The quick test mode enables you to perform test sequencing without programming. You can select, copy, rearrange and cut-and-paste any application tests with a few simple mouse clicks to make an automated test sequence.

Customizable and Expandable IV, CV, and Ultra-Fast IV Measurement Capabilities Meet Virtually All Testing Needs

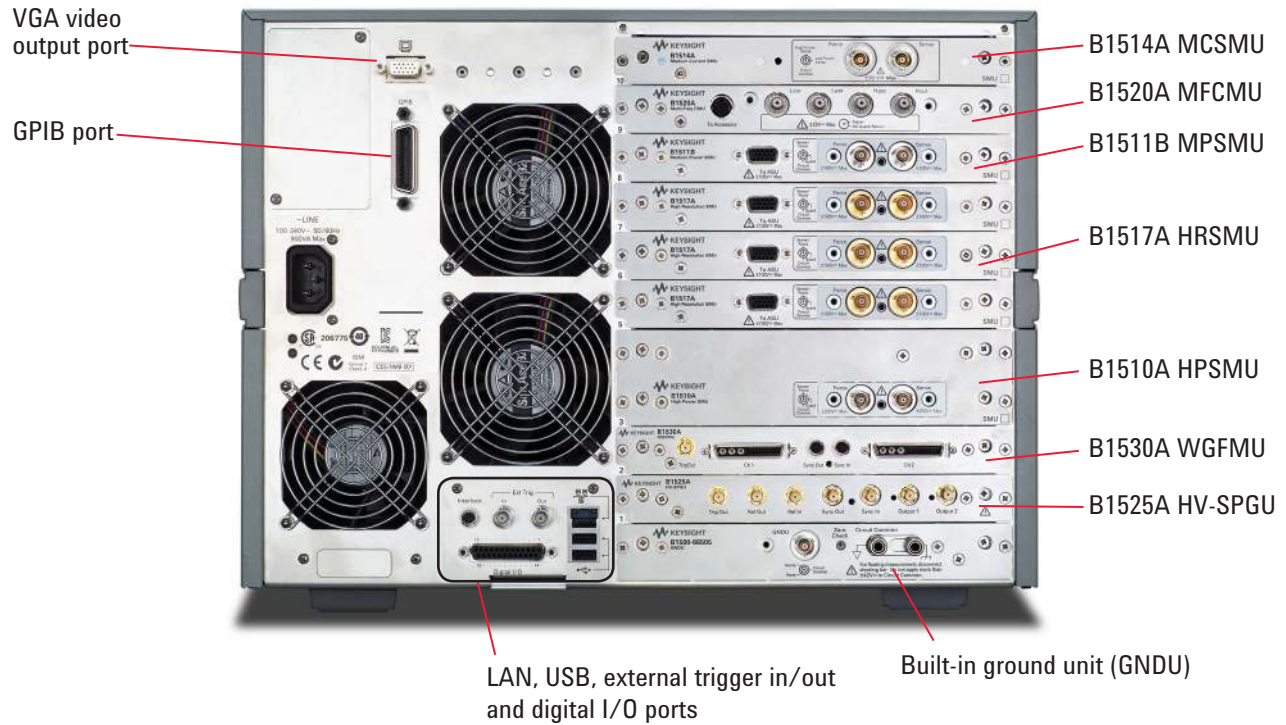

| Test Coverage | Supported module | Key specifications | Key features |
|--|--|--|--|
| For DC and pulsed IV measurement | B1510A High Power Source/Measure Unit (HPSMU) | <ul style="list-style-type: none"> – Up to 200 V / 1 A – Min 10 fA / 2 μV resolution | <ul style="list-style-type: none"> – Min 100 μs Sampling (time domain) measurement |
| | B1511B Medium Power Source/Measure Unit (MPSMU) | <ul style="list-style-type: none"> – Up to 100 V/0.1 A – Min 10 fA / 0.5 μV resolution – Optional ASU for 0.1 fA and IV/CV switching | <ul style="list-style-type: none"> – Min 500 μs pulse width with 100 μs resolution – Quasi-static capacitance voltage (QSCV) measurement with leakage current compensation |
| | B1517A High Resolution Source/Measure Unit (HRSMU) | <ul style="list-style-type: none"> – Up to 100 V/0.1 A – Min 1 fA / 0.5 μV resolution – Optional ASU for 0.1 fA and IV/CV switching | <ul style="list-style-type: none"> – 4 quadrant operation – Kelvin (4-wire) connection – Spot, sweep and other capabilities |
| | B1514A 50 μ s Pulse Medium Current Source/Measure Unit (MCSMU) | <ul style="list-style-type: none"> – Up to 30 V / 1 A (0.1 A DC) | <ul style="list-style-type: none"> – Min 50 μs pulse width with 2 μs resolution – Oscilloscope view for precision pulsed measurement |
| For capacitance measurement | B1520A Multi-Frequency Capacitance Measurement Unit (MFCMU) | <ul style="list-style-type: none"> – 1 kHz to 5 MHz frequency range – 25 V built-in DC bias and 100 V DC bias with SMU and SCUU | <ul style="list-style-type: none"> – AC impedance measurement (C-V, C-f, C-t) – Easy, fast and accurate IV and CV measurements with automated switching via SCUU |
| For ultra-fast pulsed and transient IV measurement | B1530A Waveform Generator / Fast Measurement Unit (WGFMU) | <ul style="list-style-type: none"> – 10 ns programmable resolution for waveform generation – 200 MSa/s simultaneous high-speed measurement – 10 V peak-to-peak output | <ul style="list-style-type: none"> – No load line effects; accurate pulsed IV measurement using SMU-based technology – Enabled for advanced applications, such as NBTI/PBTI, RTN, etc. |
| For pulse generation | B1525A High Voltage Semiconductor Pulse Generator Unit (HV-SPGU) | <ul style="list-style-type: none"> – Up to \pm40 V high voltage output | <ul style="list-style-type: none"> – Two-level and three-level pulsing and arbitrary waveform generation capability on each channel – Ideal for non-volatile memory testing |
| For ultra-fast pulsed high-k/SOI evaluation | B1542A 10 ns Pulsed IV parametric test solution | <ul style="list-style-type: none"> – Min 10 ns gate pulse width with 2 ns rise and fall times – 1 μs current measurement resolution | <ul style="list-style-type: none"> – Accurate Id-Vd and Id-Vg measurement – Easy switching between DC and pulsed measurements |

Absolute Current/Voltage Measurement Confidence

B1500A SMUs provide easy and accurate IV measurement

A source/monitor unit (SMU) integrates all of the resources necessary for IV measurement into a compact module. These include a current source, a voltage source, a current meter and a voltage meter, along with the ability to switch easily between these resources. The tight integration of these capabilities enables B1500A SMU performance to achieve sub pA current measurement resolution. In addition, SMUs have internal feedback

mechanisms that enable them to maintain an accurate and stable output, and a compliance (limit) feature that protects devices from damage due to excessive voltage or current. All B1500A SMUs also support triaxial connections with active guarding for low current measurement, 4-wire (Kelvin) force and sense connections for low resistance measurement, and full 4-quadrant operation.

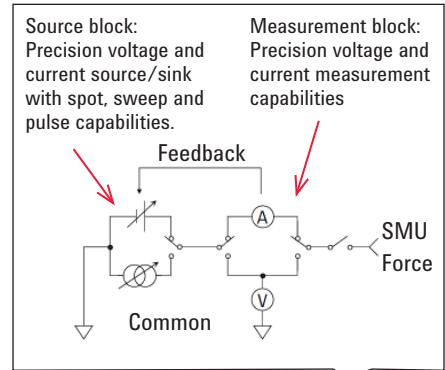

Multiple functions enhance SMU capabilities

The B1500A SMUs have a variety of versatile measurement capabilities. They can make basic single point spot measurements and perform sweep measurements of up to 10,001 points. They can also produce voltage and current pulses as narrow as 50 μ s and measure quantities over time every 100 μ s. In addition, the B1500A SMUs can source and measure voltages and currents of up to 200 V and 1 A, and they can measure voltages and currents with resolution down to 0.5 μ V and 0.1 fA. Other advanced features, such as fast auto-ranging and large capacitive load stabilization, further help to improve performance. The B1500A supports a large variety of SMUs, making it is easy to mix-and-match SMU types to meet a wide range of testing needs. The B1500A's SMUs can meet virtually every device and material testing requirement.

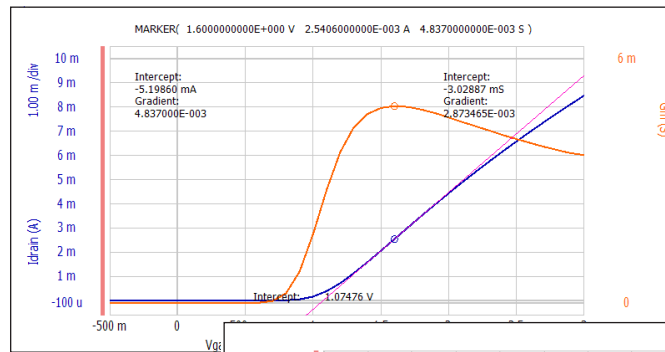

Sweep measurement

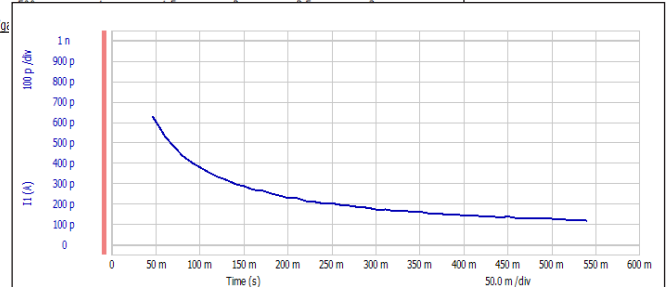

Time sampling measurement

Impressive 0.1 fA measurement combined with seamless IV-CV switching capability

The B1500A's MPSMU and HRSMU provide innate measurement resolution of 10 fA and 1 fA (respectively). However, if you need more low current performance then you can achieve 0.1 fA measurement resolution by combining either of them with the atto-sense and switch unit (ASU). The ASU provides the additional benefit of enabling the user to switch between SMU measurements and measurements made through an available BNC input. The ASU's BNC input can be used with the B1500A's MFCMU module for low-cost CV-IV switching (2 SMUs with ASUs required), and it can also be used with other external instruments.

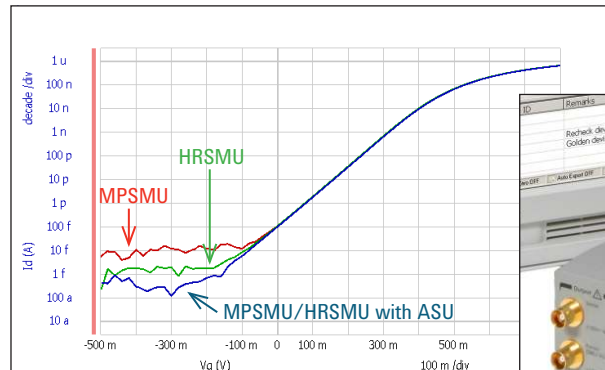

Ultra low current measurement down to sub-fA



Optional ASU

Complete Range of Capacitance Measurement Solutions

Measure C-V, C-f and C-t from 1 kHz to 5 MHz

The B1500A supports a multifrequency capacitance measurement unit (MFCMU). The MFCMU can perform all of the capacitance measurements necessary for semiconductor device evaluation, including capacitance vs. voltage (C-V), capacitance vs. frequency (C-f), and capacitance vs. time (C-t). The MFCMU can measure across a wide frequency range (1 kHz to 5 MHz) with minimum 1 mHz resolution. The MFCMU can also provide up to 25 V of DC measurement bias.

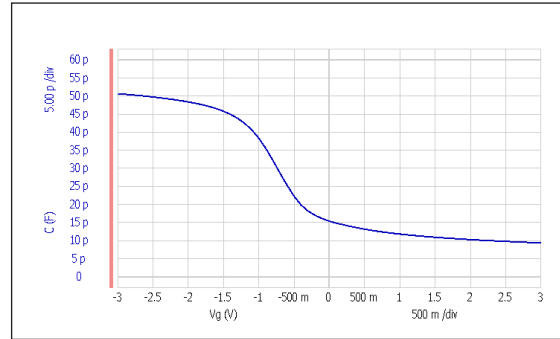

High frequency CV curve

Accurate quasi-static CV (QSCV) measurement with leakage compensation

The ability to characterize the quasistatic CV (QSCV) response of a MOSFET is crucial to understand its behavior in the important inversion region, since high-frequency CV (HFCV) measurements cannot supply this information. The B1500A supports a QSCV measurement function that works with its HPSMUs, MPSMUs and HRSMUs, and does not require any additional hardware. The QSCV function has the ability to compensate for gate leakage currents and to perform an offset calibration to remove parasitic capacitances from the measurement.

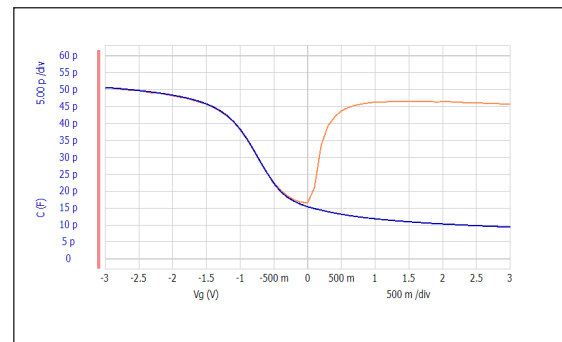

Single instrument performs both high frequency CV and quasi-static CV measurements

Switch seamlessly between accurate CV and IV measurements

Since CV and IV measurements use different cabling, manually switching between these measurements can be annoying and time-consuming. To solve this, the B1500A supports an optional SMU CMU unify unit (SCUU) and guard switch unit (GSWU) that support seamless switching between CV and IV measurements without sacrificing performance. Although optional, by shorting the guards together during capacitance measurements the GSWU stabilizes the cable inductance and improves capacitance measurement accuracy. The SCUU also has a built-in bias-T that allows the connected SMUs to be used as bias sources for the MFCMU, thereby allowing capacitance measurements with up to 100 V of DC bias. These capabilities allow you with just one instrument to quickly perform both HFCV and QSCV measurements.

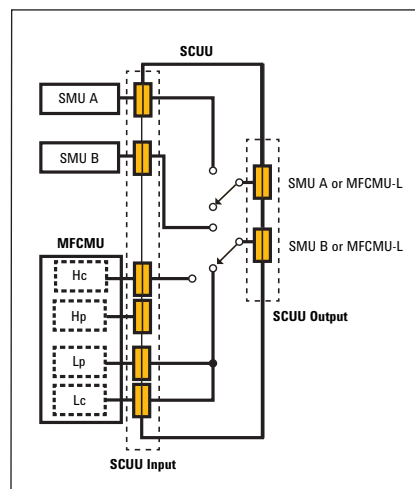

SCUU block diagram



SCUU

Multiple Options for Advanced Pulsed Measurement Needs

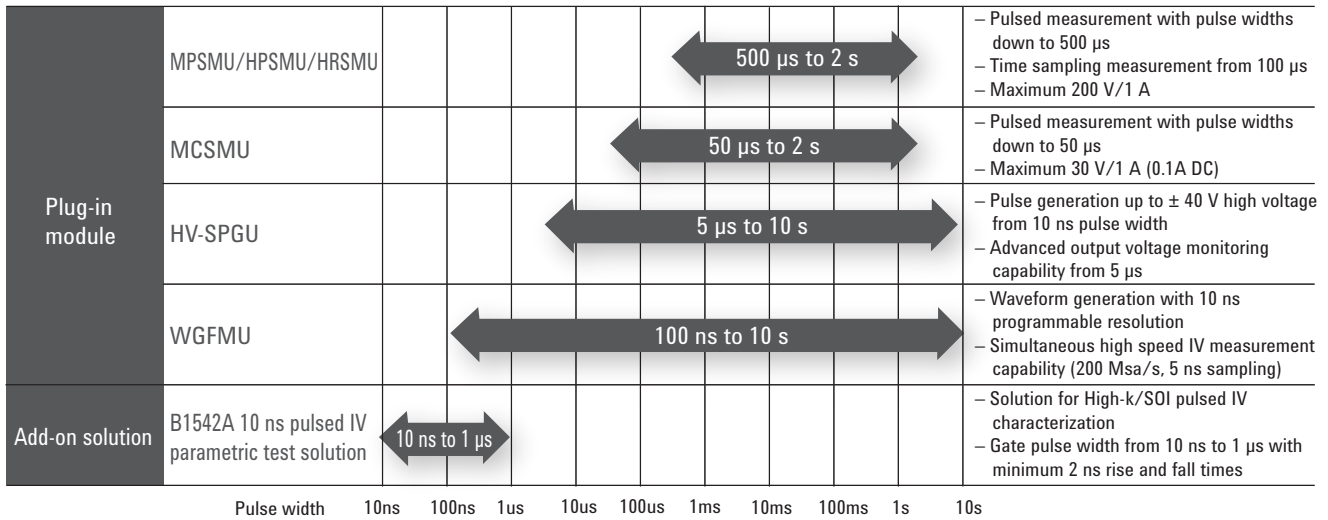

A wide range of pulsed measurement solutions

Pulsed measurements play an increasingly important role in device characterization. While the reasons for this are complex, the twin factors of new device physics issues arising from decreasing device sizes and the incorporation of more exotic materials into device fabrication are the main forces driving this trend. To meet these challenges, the B1500A offers a wide range of pulsed measurement solutions across both its SMU and dedicated pulse generator module options. These choices provide maximum flexibility to select a B1500A configuration with both the capability to meet your current pulsed measurement needs as well as the ability to upgrade in the future if your test needs change.

SMU pulsing down to 500 μ s provides cost-effective time based measurement

The basic B1500A SMUs (MPSMU, HPSMU and HRSMU) have both pulsing and time sampling measurement capabilities. An intrinsic timing circuit built into the hardware ensures accurate and repeatable pulse generation down to a width of 500 μ s. These SMUs can also perform precision time sampling measurements in intervals of 100 μ s.

MCSMU supports 50 μ s pulsing and higher instantaneous power

The 50 μ s pulse medium current SMU (MCSMU) is a specialized SMU designed for faster pulsed IV measurement. In pulsed mode it can output higher instantaneous power than the HPSMU (1 A @ 30 V), and it can create current or voltage pulses down to a width of 50 μ s (10 times narrower than the HPSMU, MPSMU or HRSMU). In addition, the

MCSMU supports EasyEXPERT's oscilloscope view that allows monitoring of multiple voltage and current waveforms (minimum 2 μ s sampling rate) right on the B1500A front panel. This feature makes it extremely easy to optimize pulsed measurement timings and produce valid Id-Vg and Id-Vd curves.

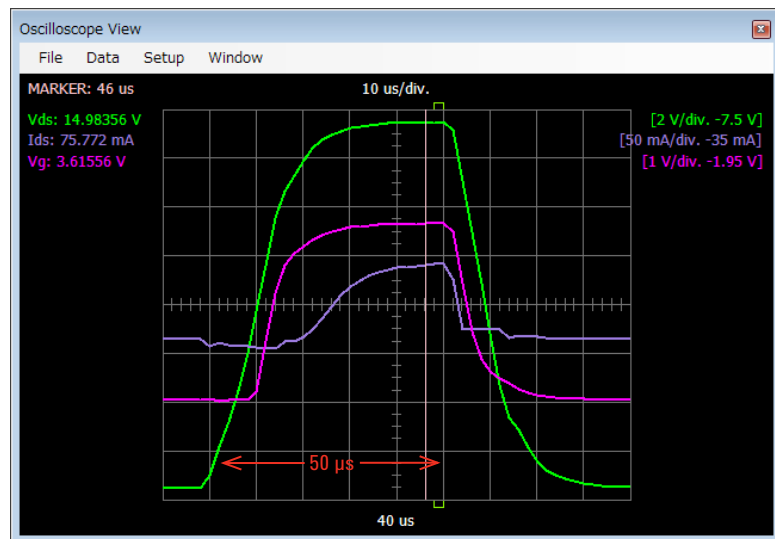

50 μ s pulse waveforms generated by MCSMU

More Efficient Pulsing Improves Advanced Memory and Device Characterization

HV-SPGU supplies ± 40 V output and supports up to 3-level pulsing for non-volatile memory test

The high-voltage semiconductor pulse generator unit (HV-SPGU) can output pulses of up to ± 40 V (into an open load), making it ideal for applications such as flash memory evaluation. Moreover, in pulse generator unit (PGU) mode both HV-SPGU channels can force 2-level or 3-level pulses, which supports the testing of complex flash memory cells. These capabilities make the HV-SPGU the best pulse generator for advanced nonvolatile memory (NVM) device characterization.

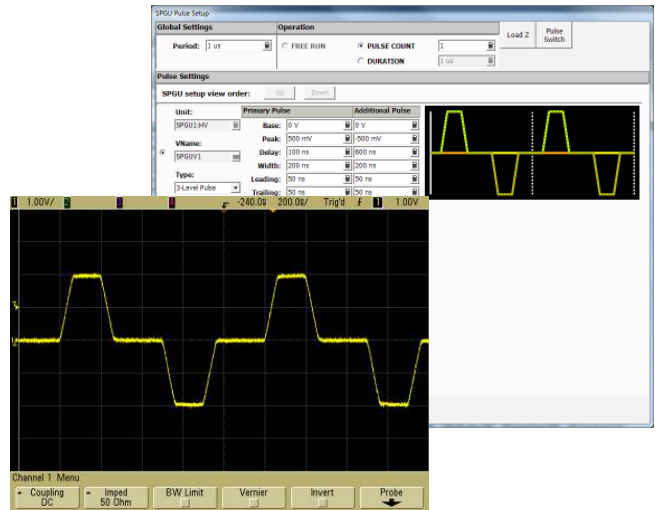

EasyEXPERT HV-SPGU GUI makes it easy to create arbitrary waveforms

In addition to PGU mode, the HV-SPGU supports an arbitrary linear waveform generator (ALWG) mode for more complex waveform generation. The EasyEXPERT GUI supports a convenient interface for the HV-SPGU ALWG mode that makes it easy to create complex waveforms. Waveforms can be created both through an interactive graphical interface as well as by specifying points via a spreadsheet-like table.

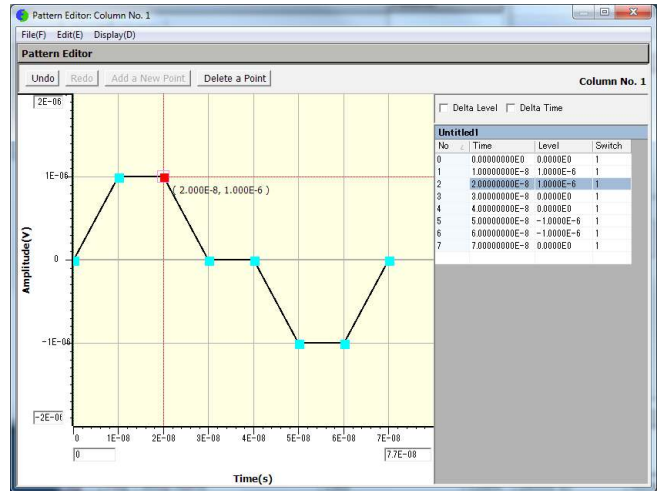

A 15x improvement in write/erase endurance test times

Endurance testing on non-volatile memory is both necessary and time consuming. However, the B1500A's HV-SPGU module supports numerous features that enable it to improve write/erase endurance times by up to 15x (relative to the 4155/4156). The HV-SPGU module achieves this impressive performance boost through shorter pulse periods, three-level pulsing, solid-state relays to create an open output state, and faster switching when using the optional 16440A SMU/Pulse Generator Selector. The net result is the fastest and most cost-effective bench top solution for NVM cell endurance testing on the market.

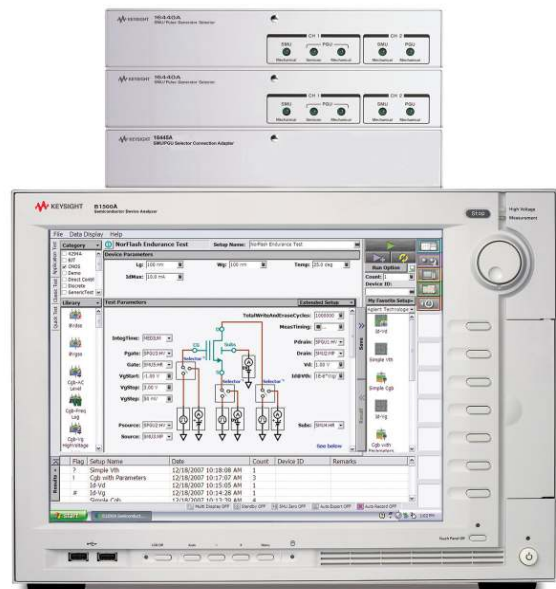

Wgfm Module Enables Ultra-Fast Pulsed Measurements not Previously Possible with Conventional Instruments

Powerful waveform generator/fast measurement unit (WGFMU) supports advanced ultra-fast pulsed and transient measurement

Ultra-fast pulsed and transient IV characterization of advanced next generation devices is in many cases essential to fully understand their behavior. Although it is possible to use a collection of equipment (such as a pulse generator, an oscilloscope and a shunt resistor) to measure the dynamic behavior of these devices, factors such as instrument accuracy, cabling complexity and shunt resistance error compensation make it difficult to get valid data. The Keysight B1500A's WGFMU module solves these measurement challenges by combining the capability to generate arbitrary waveforms (with pulse widths down to 100 ns) along with the capability to simultaneously measure voltage or current with a 5 ns (200 MSa/s) sampling rate. Moreover, in fast IV mode the WGFMU module can perform ultra-fast voltage or current measurement without inserting a 50 Ω series resistance into the measurement path (just like an SMU). These features make the WGFMU module an ideal choice for performing ultra-fast NBTI/PBTI, random telegraph signal noise (RTN) measurement, and other ultra-fast pulsed and transient IV measurements.

WGFMU provides pulsed and transient measurement without load line effects

A classical pulse generator has 50 Ω output impedance, which can produce undesirable behavior. When combined with the DUT impedance, the 50 Ω output impedance creates a voltage divider that impacts the actual voltage applied to the DUT. While it is possible to compensate for this load line effect when the DUT impedance is fixed, if the DUT has dynamic or variable impedance then compensation is not possible. Therefore, pulse generator based solutions cannot accurately measure the pulsed or transient response of devices whose characteristics change under measurement, such as MOSFET Id-Vg sweeps and nonvolatile/resistive memory cells. However, because the WGFMU module's fast IV mode is SMU-based it can perform pulsed and transient IV measurement without introducing any load line effects. In addition, the WGFMU module has a dynamic feedback circuit to ensure that the output voltage matches its programmed value (just like an SMU). The WGFMU module also has dynamic range selection capability to optimize measurement resolution along the entire waveform output. For all of these reasons, the WGFMU module's SMU-based design allows it to perform accurate fast pulsed and transient IV measurement even for devices with dynamically changing characteristics.

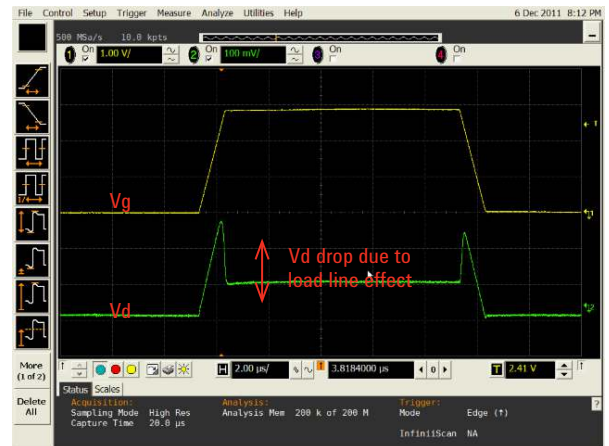
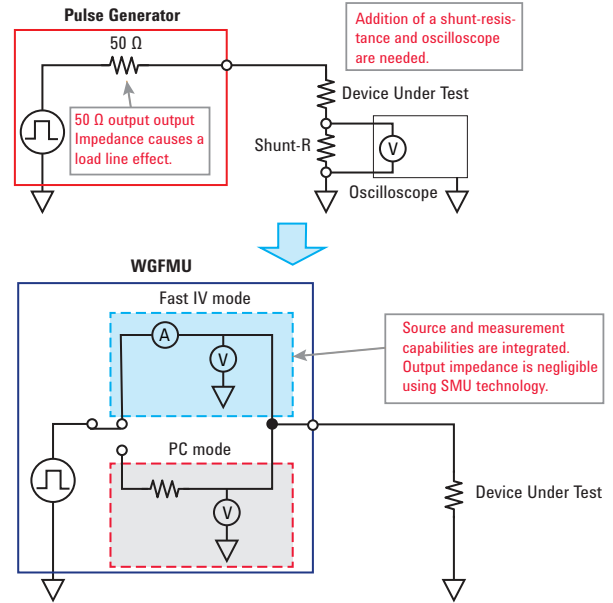

Effect of 50 Ω load line on Id-Vg measurement (conventional PG based solution)

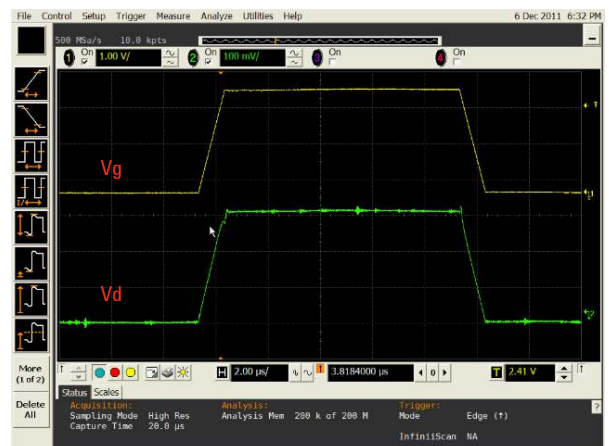

WGFMU module's high-speed SMU technology eliminates load line effects

B1500A Overcomes Advanced Device Characterization Challenges

Ultra-fast NBTI/PBT

MOSFET threshold voltage (V_{th}) degradation under high gate bias and high temperature is an area of critical concern for advanced semiconductor reliability. The twin phenomena of negative bias temperature instability (NBTI) and positive bias temperature instability (PBTI) require extremely fast measurement equipment, since the V_{th} degradation recovers very quickly once stress is removed. In fact, measurement needs to begin within a time range of 1 μ s to 100 μ s after removal of the stress to avoid dynamic recovery effects. The Keysight B1500A offers two solutions for BTI testing: an SMU-based on-the-fly measurement scheme with a sampling rate of 100 μ s, and a WGFMU-based ultra-fast technique that can start a measurement in less than 1 μ s.

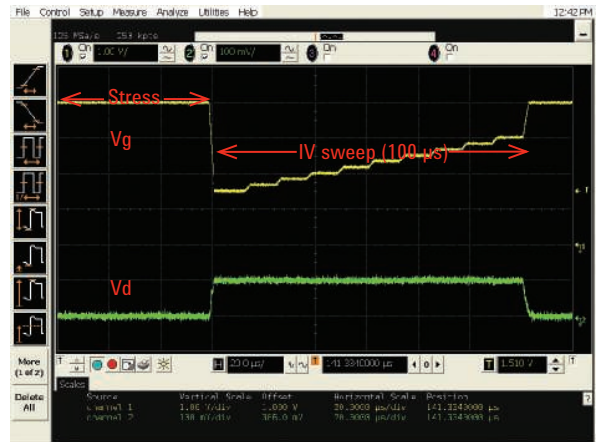

1 μ s ultra-fast BTI measurement

Random telegraph signal noise (RTN)

Random telegraph signal noise (RTN) is a phenomenon that typically causes fluctuations in the drain current of a MOSFET. It is observed as random switching between two or more discrete current levels, and the root cause is generally considered to be due to electron trapping and detrapping. Although RTN has long been a concern of CMOS image sensor makers, as device sizes have shrunk it has become of concern to all semiconductor device manufacturers since it has begun to impact SRAM cell stability. The WGFMU module is an ideal tool to measure RTN, since it has a noise floor of less than 0.1 mV (rms), a 5 ns sampling rate and a four million point data buffer. These capabilities enable the WGFMU module to measure RTN over a frequency range that extends from less than 1 Hz up to several MHz.

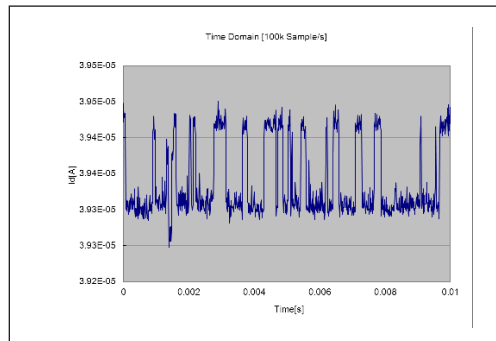

Random telegraph signal noise (RTN) measurement

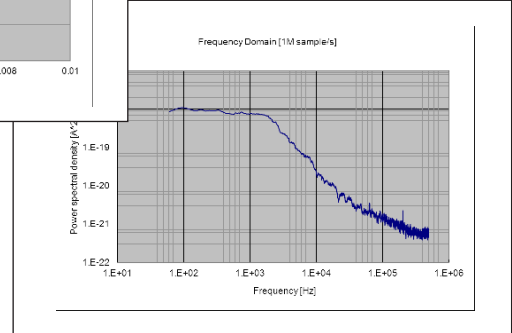

Ultra-fast 10 ns pulsing for high-k/SOI device characterization

MOSFETs constructed with high-k dielectric gate materials or fabricated in silicon-on-insulator (SOI) technologies require extremely fast (down to 10 ns) pulsed measurement due to electron trapping and self-heating effects. The Keysight B1542A 10 ns pulsed IV parametric test solution is specially designed for characterizing the I_d - V_g and I_d - V_d of MOSFETs utilizing high-k gate dielectrics or fabricated in SOI technologies. This integrated solution allows you to perform pulsed I_d - V_g and I_d - V_d measurements with pulse widths down to 10 ns (with 2 ns rise and fall times).

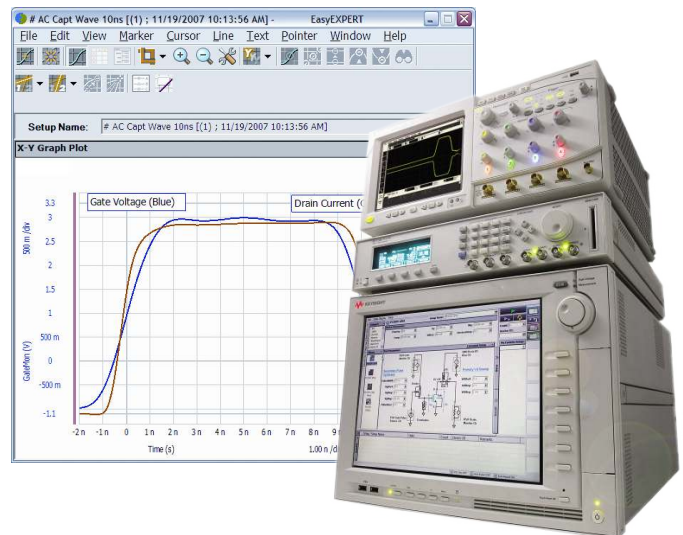

Easyexpert Makes It Easy to Collect, Process, and Organize Parametric Measurement Data

Application test mode provides extensive libraries of pre-defined tests

Application test mode provides convenient task oriented point and click test setup and execution. An application test can be selected from the furnished libraries by device type and/or desired measurement, and then executed after modifying the default input parameters as needed. Modified test setups can be stored into a "My Favorite" list for quick future execution. The application tests are also completely user-modifiable using EasyEXPERT's built-in graphical programming environment.

Classic test mode provides full hardware control along with the 4155/56 look and feel

Classic test mode provides full access to the B1500A's hardware capabilities. It has a similar look and feel, and it uses the same terminology as the 4155/4156's front-panel interface. In addition, it actually improves the 4155/4156 user interface by taking full advantage of EasyEXPERT's windows-based features.

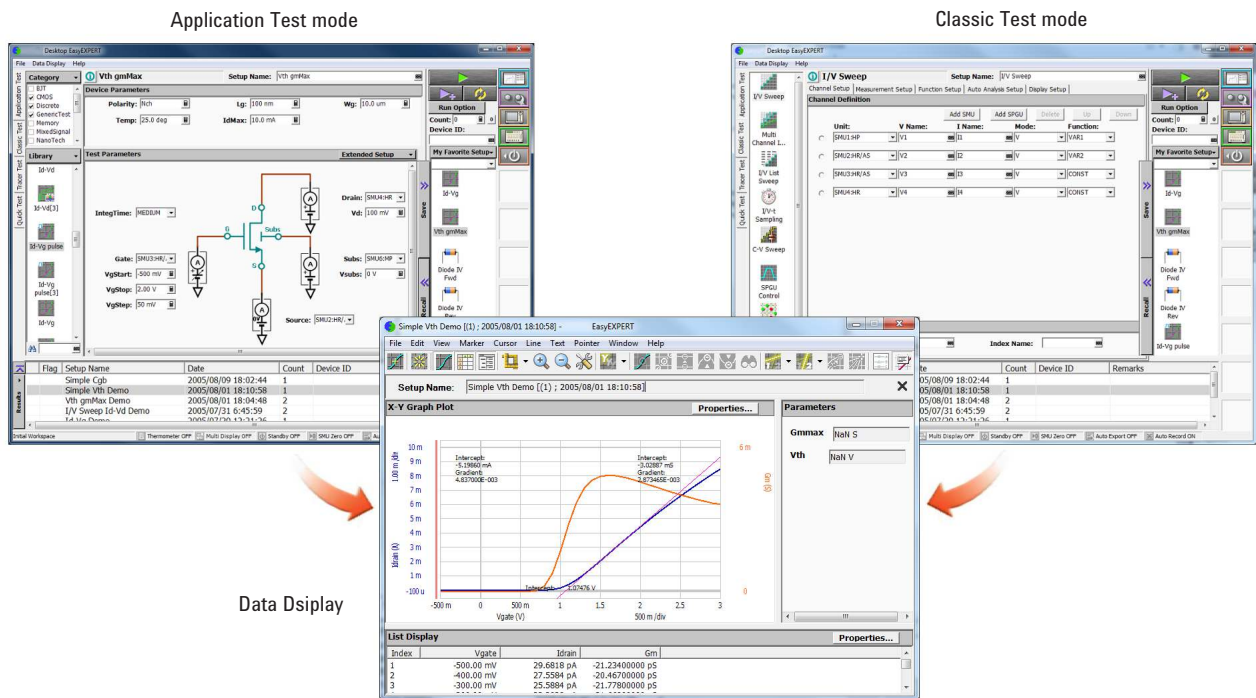

Data Display

Automated graphical display, analysis and parameter extraction capabilities improve efficiency

EasyEXPERT supports powerful data display, analysis and arithmetic functions that facilitate automated data analysis and parameter extraction. The pre-defined data analyses and parameter extractions are performed in real time, allowing you to see measurement results immediately without any post-measurement data processing. Moreover, both graphical and numerical results can be saved automatically to any connected remote storage location.

Data is protected for both interactive and automated measurements

EasyEXPERT has numerous means to insure measurement data integrity. It supports multiple workspaces (that can be either public or private) to provide an easy means to manage data and application tests. It also provides the ability to backup workspaces and export them to other computers. Within a workspace you can select automatic data recording, which not only saves the measurement data but also the measurement setup conditions as well to improve the repeatability of your device characterizations. The measurement setup and data can easily be later recalled to duplicate the measurement. It is also easy to export measurement data manually or automatically into file formats such as TXT, CSV, etc. for further analysis on an external PC.

Quickly Optimize Test Conditions of Unfamiliar Devices

Tracer test's knob-based real-time curve tracing capabilities accelerate device characterization

Tracer test mode offers intuitive and interactive sweep control using a rotary knob similar to that of an analog curve tracer. Just like a curve tracer, you can sweep in only one direction (useful for R&D device analysis) or in both directions (useful in failure analysis applications). Furthermore, test setups created in tracer test mode can be quickly transferred into classic test mode and enhanced using classic test mode's auto-analysis tools.

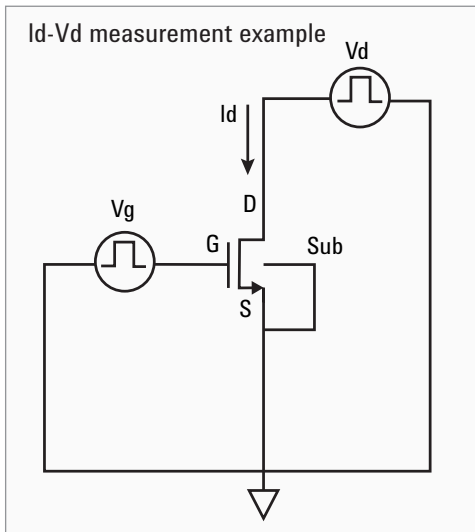
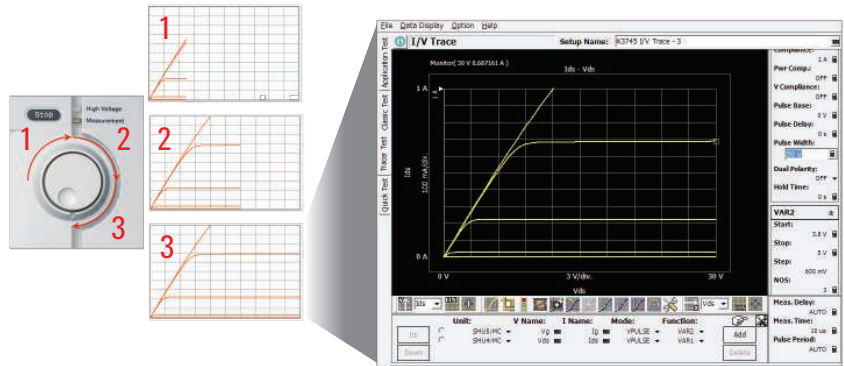

Source and measurement values of Id-Vd sweep are plotted

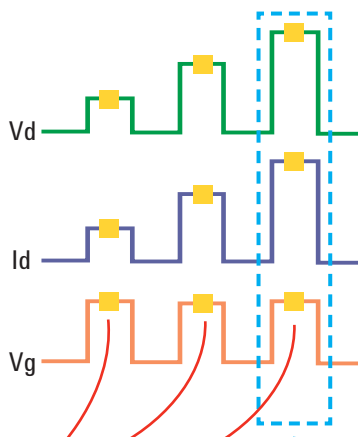

Verify pulsed measurements without an external oscilloscope

Oscilloscope view (available for use with the MCSMU modules in tracer test mode) displays measured current and voltage data versus time right on the B1500A front panel. Oscilloscope view can display pulsed waveform timings at any user-specified point along a sweep measurement. The pulsed waveforms appear in a separate window for easy measurement timing verification. This feature is useful for verifying waveforms, optimizing timing parameters, and debugging pulsed measurements.

The waveforms of the specified step can be monitored.

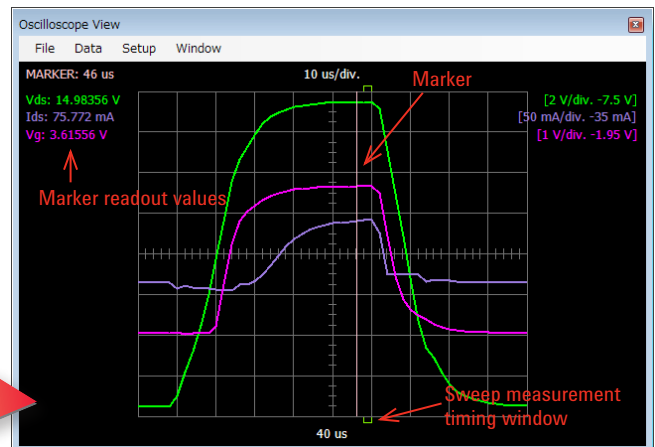
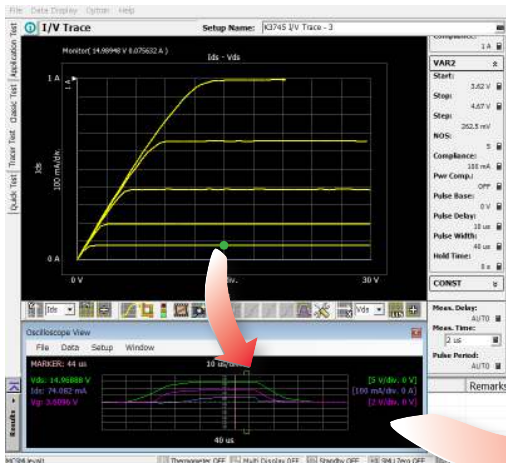

Optimize Use of Switching Matrices, Wafer Probers and IC-CAP

EasyEXPERT provides convenient switching matrix control

A switching matrix is often used with a parameter analyzer to provide more flexible connectivity. To help with this, EasyEXPERT supports an intuitive GUI to control the Keysight B2200A, B2201A and E5250A switching matrices. It both eliminates the need to program and facilitates automated testing.

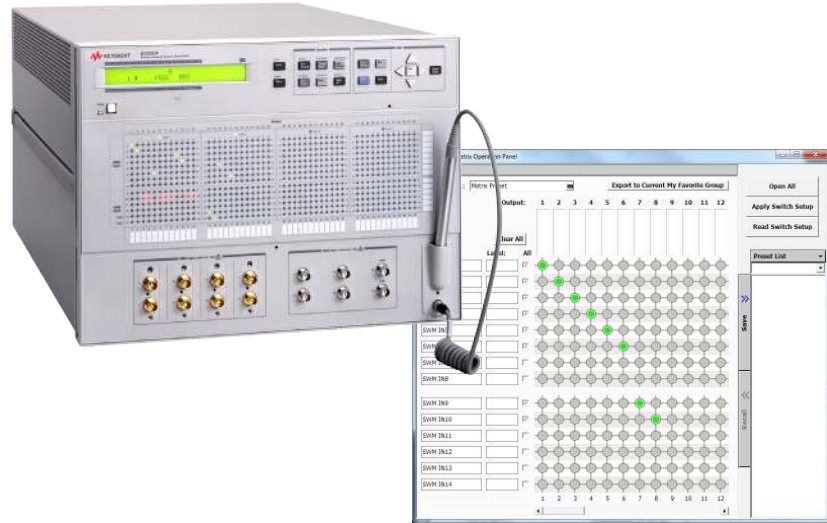

Automate testing with semi-auto wafer probers

A GUI-based quick test mode enables you to perform test sequencing without programming. You can select, copy, rearrange and cut-and-paste application tests with a few simple mouse clicks. Once you have selected and arranged your tests, simply click on the measurement button to begin running an automated test sequence. You can combine wafer prober control with the quick test mode to perform multiple testing across the wafer. If you are using a switching matrix, you can also call switching patterns automatically. All popular semiautomatic wafer probers are supported, and you can also create your own wafer prober drivers.

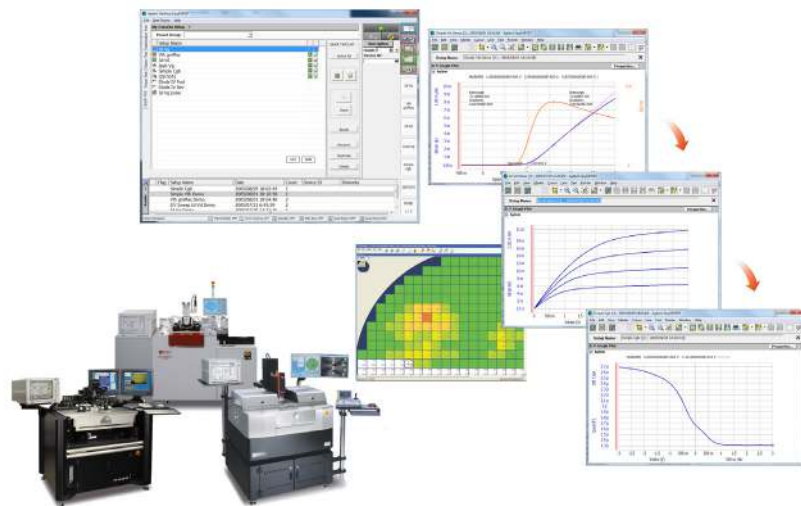

Support for Keysight IC-CAP MDM file conversion

Keysight IC-CAP, a popular device modeling software solution, has long supported the B1500A. However, now the B1500A supports an MDM file convertor tool to convert EasyEXPERT data into the IC-CAP compatible MDM file format. This allows IC-CAP users to take advantage of EasyEXPERT's powerful capabilities when performing device modeling characterizations.

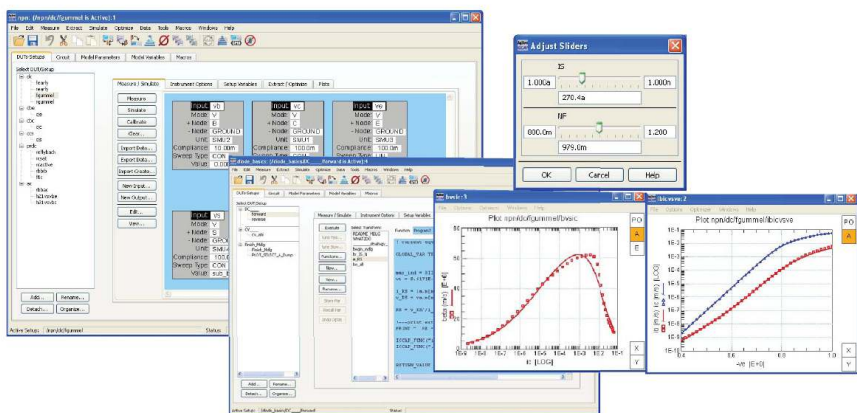

Flexible B1500A Remote Control and Networking Options

Utilize your interactively created application tests for remote testing

The LAN-based EasyEXPERT remote control function allows you to use the hundreds of furnished application tests for automated testing in the programming language of your choice. The B1500A is the only parameter analyzer that maximizes your efficiency by giving you the ability to modify and create application tests interactively and then run them remotely.

B1500A FLEX command set optimizes speed and efficiency

If you prefer to control the B1500A's hardware resources directly, then you can use the B1500A's FLEX command set. You can use FLEX commands with any programming language via the GPIB interface. Moreover, since the B1500A front panel does not update under FLEX control, extremely fast measurement speeds are possible.

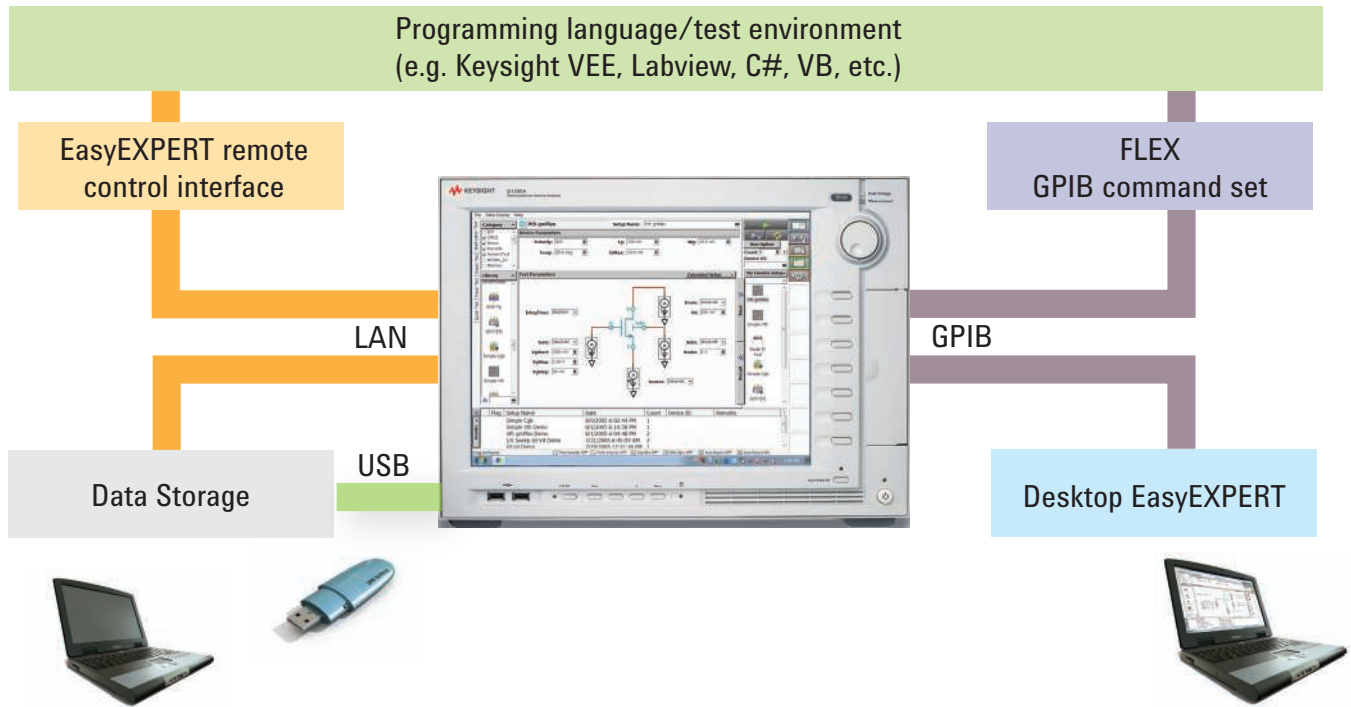

Optimize use of existing Keysight 4155/4156 hardware and measurement setups

You can use Desktop EasyEXPERT to control the 4155/4156 (B or C versions) over GPIB from a PC. This allows you to use 4155/4156 measurement resources while enjoying the flexibility and data transfer capabilities available in a Windows-based environment. In addition, a 4155/4156 setup file converter tool is available that can translate 4155/4156 MES and DAT files into equivalent B1500A EasyEXPERT classic mode tests. Both of these capabilities are especially useful in labs where you have a mixture of newer B1500A units and older 4155/4156 equipment.

Free PC-based Desktop EasyEXPERT provides a unified environment for development, analysis and test

Desktop EasyEXPERT, which runs on a standalone PC, provides the same capabilities and user experience as EasyEXPERT running on the B1500A. Desktop EasyEXPERT can operate in both on-line and off-line modes. In online mode it can control the B1500A and coordinate test automation in conjunction with a semi-automatic wafer prober. In offline mode it can be used to develop new application tests and to analyze data. This maximizes your efficiency and permits you to use your parametric instruments in their primary role of making measurements.

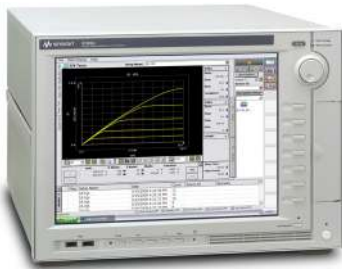

Keysight B1505A Power Device Analyzer/Curve Tracer (1500 A/10 kV)
www.keysight.com/find/B1505A

myKeysight

myKeysight
www.keysight.com/find/mykeysight
 A personalized view into the information most relevant to you.



Three-Year Warranty
www.keysight.com/find/ThreeYearWarranty
 Keysight's commitment to superior product quality and lower total cost of ownership. The only test and measurement company with three-year warranty standard on all instruments, worldwide.



Keysight E5270B/E5260A Modular Source Measure Unit (SMU)
www.keysight.com/find/msmu



Keysight Assurance Plans
www.keysight.com/find/AssurancePlans
 Up to five years of protection and no budgetary surprises to ensure your instruments are operating to specification so you can rely on accurate measurements.



Keysight B2900A Series Precision Source/Measure Units (SMU)
www.keysight.com/find/B2900A



www.keysight.com/go/quality
 Keysight Technologies, Inc.
 DEKRA Certified ISO 9001:2008
 Quality Management System

Keysight Channel Partners
www.keysight.com/find/channelpartners
 Get the best of both worlds: Keysight's measurement expertise and product breadth, combined with channel partner convenience.



Keysight B2200A/B2201A/E5250A Low-leakage Switch Matrix
www.keysight.com/find/swm

www.keysight.com/find/b1500a

For more information on Keysight Technologies' products, applications or services, please contact your local Keysight office. The complete list is available at: www.keysight.com/find/contactus

Americas

| | |
|---------------|------------------|
| Canada | (877) 894 4414 |
| Brazil | 55 11 3351 7010 |
| Mexico | 001 800 254 2440 |
| United States | (800) 829 4444 |

Asia Pacific

| | |
|--------------------|----------------|
| Australia | 1 800 629 485 |
| China | 800 810 0189 |
| Hong Kong | 800 938 693 |
| India | 1 800 112 929 |
| Japan | 0120 (421) 345 |
| Korea | 080 769 0800 |
| Malaysia | 1 800 888 848 |
| Singapore | 1 800 375 8100 |
| Taiwan | 0800 047 866 |
| Other AP Countries | (65) 6375 8100 |

Europe & Middle East

| | |
|----------------|---------------|
| Austria | 0800 001122 |
| Belgium | 0800 58580 |
| Finland | 0800 523252 |
| France | 0805 980333 |
| Germany | 0800 6270999 |
| Ireland | 1800 832700 |
| Israel | 1 809 343051 |
| Italy | 800 599100 |
| Luxembourg | +32 800 58580 |
| Netherlands | 0800 0233200 |
| Russia | 8800 5009286 |
| Spain | 800 000154 |
| Sweden | 0200 882255 |
| Switzerland | 0800 805353 |
| | Opt. 1 (DE) |
| | Opt. 2 (FR) |
| | Opt. 3 (IT) |
| United Kingdom | 0800 0260637 |

For other unlisted countries:
www.keysight.com/find/contactus
 (BP-09-23-14)

