

Keysight Technologies

Optimizing On-Wafer Noise Figure
Measurements up to 67 GHz

Application Note



Introduction

Noise figure (NF) measurements are often an essential part of device characterization in R&D and process verification in manufacturing. Getting accurate on-wafer NF measurements can be quite challenging, and the ability to get good results depends on the methodology and the test configuration.

Two techniques are commonly used to measure NF: the Y-factor method and the cold-source method. The Y-factor or hot/cold-source method is the predominant approach and is most commonly implemented with noise-figure analyzers and spectrum analyzer-based solutions. In contrast, the cold-source method is usually performed using vector network analyzers (VNAs), which provide magnitude and phase information. As a result, the cold-source technique makes it possible to achieve much greater accuracy in NF measurements.

This application note presents a cold-source solution based on the Keysight Technologies, Inc. PNA-X microwave network analyzer. When equipped with the optional source-corrected NF measurements (Option 029), the PNA-X provides exceptional accuracy. New hardware provides a convenient way to make measurements up to 50 GHz. Now, additional external hardware is needed only when making measurements from 50 GHz to 67 GHz. The PNA-X also enables a time-saving advantage: the ability to make multiple measurements such as noise figure, S-parameters, gain compression and intermodulation distortion (IMD) with a single set of connections to the device under test (DUT).

Overview: Noise figure

Noise factor, which is linear, and noise figure, which is logarithmic, are very useful – and widely accepted – figures of merit that characterize how much noise an amplifier or frequency converter adds to signals passing through it. The definition of either term is simple and intuitive. For example, the noise factor (F) of a network is defined as the input signal-to-noise ratio (SNR) divided by the output SNR:

$$F = (S_i/N_i)/(S_o/N_o)$$

Noise figure is simply the noise factor expressed in decibels:

$$NF = 10 \times \log(F)$$

In a perfect amplifier, the output noise would be equal to the input noise multiplied by the gain of the amplifier. This would produce the same SNR at both the input and output of the amplifier. In the real world, the output noise is larger than the input noise multiplied by the amplifier gain because the amplifier adds its own noise. As a result, the SNR at the output will be smaller than that at the input, resulting in F being greater than 1 and NF being greater than 0 dB.

Measuring noise figure

Two techniques are commonly used to measure NF: the Y-factor method and the cold-source method. The Y-factor or hot/cold-source method uses a calibrated noise source that includes a noise-optimized avalanche diode that can be turned on and off. The diode is followed by an attenuator, which ensures a good output match.

When the diode is off (i.e., no bias current), the noise source generates the same noise as a room-temperature termination. When the diode is biased “on,” the resulting avalanche breakdown creates considerable electrical noise over and above that of a room-temperature termination. The amount of extra noise is characterized as an “excess noise ratio” or ENR. Typical ENR values are 5 dB or 15 dB. The gain and noise figure of the DUT can be determined from separate measurements of output power resulting from the cold and hot input terminations.

The cold-source technique, sometimes called the direct-noise method, uses only a single cold input termination (typically room temperature). When implemented with a VNA, this method has an important, time-saving advantage: the ability to perform multiple measurements such as noise figure and S-parameters with a single set of connections. This is especially important for on-wafer devices because repeated probing can damage the part.

Measuring noise figure (continued)

In addition, a VNA can provide vector – magnitude and phase – measurements of both the test system and the DUT, resulting in superior accuracy compared to other measurements. These benefits apply to wide range of DUTs: amplifiers, frequency converters, and more.

As long as an amplifier is linear, a plot of its output power versus input noise will be a straight line (Figure 1). Linearity is a good assumption for a low-noise amplifier (LNA) because its purpose is to amplify low-level signals that are far from the amplifier's compression region.

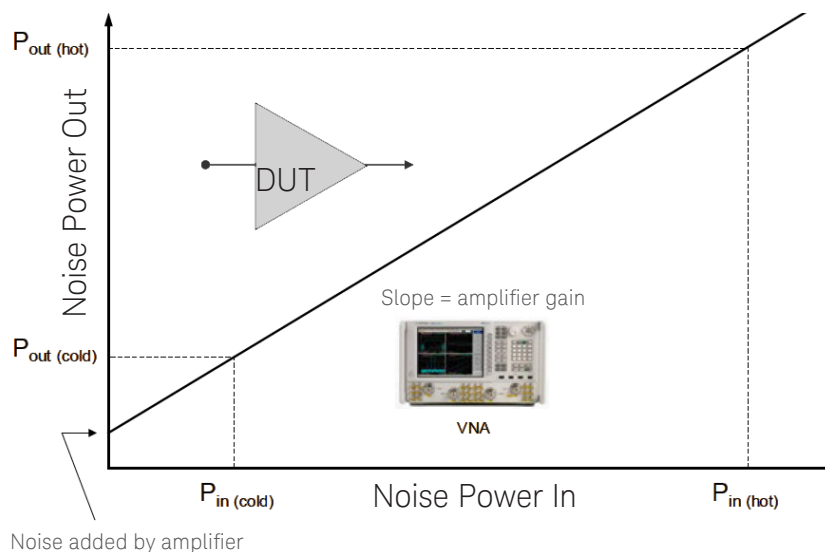

Figure 1. A plot of amplifier output power versus input noise reveals information about its gain, linearity, and internal noise.

Even if there was no input noise, there would still be some amount of noise coming out of the amplifier due to noise-generating processes within the device's active circuitry. This is the noise we characterize with an NF measurement.

Graphically, it's easy to see why two measurements of output noise power (i.e., the Y-factor method) can be used to solve for both the amplifier's gain (slope of the line) and the noise figure, which is derived from the y-intercept point. Alternately, if the gain (slope) can be determined using other methods, such as with sinusoidal stimulation and measurements provided by a VNA, then only one noise-power measurement is needed to calculate the y-intercept and thus the DUT's noise figure.¹

1. This is the foundation of the cold-source method.

Problem: Degradation of measurement accuracy

One key assumption underlies the Y-factor method: the match of the noise source is exactly 50 ohms. Any deviation from 50 ohms can severely degrade measurement accuracy. The level of degradation depends on the measurement scenario. For example, if the noise source is connected directly to the input of an amplifier under test, the accuracy of the NF measurement will be reasonably good. This is especially true when using low-ENR sources, which tend to have better matches than high-ENR sources.

In an on-wafer measurement scenario (Figure 2), a variety of electrical networks are introduced between the noise source and the DUT, resulting in decreased measurement accuracy due to degraded source match. This remains true even if we compensate for the losses of cables, switches and wafer probes. The reason: loss compensation cannot remove mismatch effects, nor can it remove errors induced by noise parameters. Both effects add ripple and uncertainty to NF measurements.

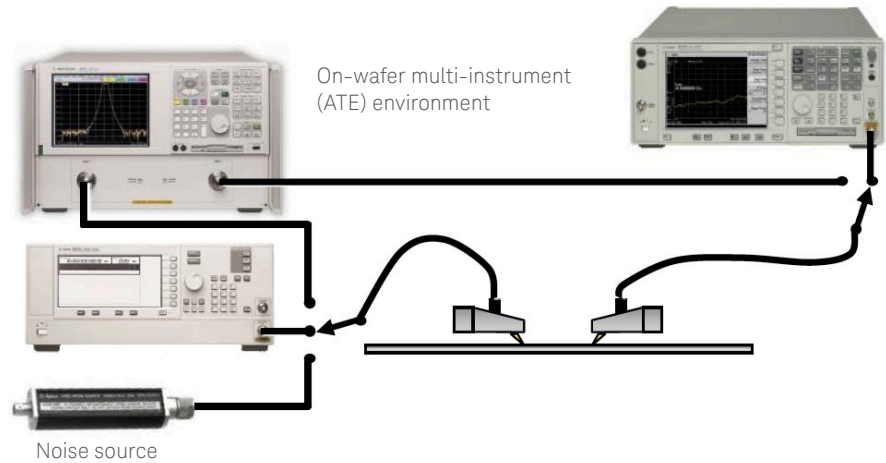

Figure 2. As more equipment is added to the test configuration, Y-factor measurement accuracy may suffer due to degraded source match.

General solution: Measuring with the PNA-X

On its own, the PNA-X microwave network analyzer enables single-connection measurements of S-parameters, compression (gain and phase), harmonics and IMD. Option 029, source-corrected NF measurements, adds noise figure to the list of possible measurements through the addition of hardware and firmware to the PNA-X.

On the hardware side, the option adds low-noise receivers with the same frequency range as the instrument, up to 50 GHz. NF measurements can be extended to 67 GHz using one of the standard receivers in the PNA-X, often with the addition of an external preamplifier, and a filter to remove out-of-band noise. The option also enhances the instrument firmware with specialized measurement and calibration algorithms.

Full vector-noise correction can be achieved using a built-in impedance tuner, which is available in 43.5-, 50- and 67-GHz models, or an external 13.5- or 26.5-GHz ECal module configured as a tuner. When combined with standard vector-error-corrected gain and match measurements, the impedance tuner helps remove the effects of imperfect system-source match, which greatly enhances measurement accuracy.

This source-corrected technique is unique to the PNA-X. The Smith chart in Figure 3 illustrates the implementation of this method. The square in the center indicates the point at which we would like to measure the noise figure of the DUT. This corresponds to a perfect 50-ohm source match; however, we know the test system does not provide a perfect match versus frequency.

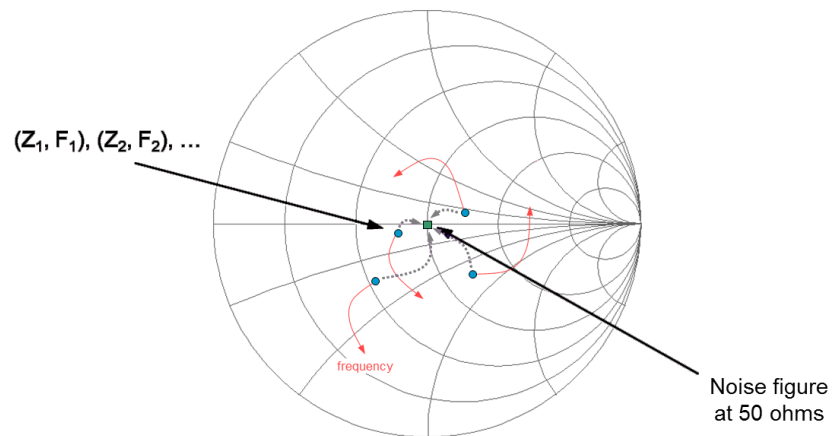

Figure 3. The PNA-X can use between four and seven impedance states that are different from 50 ohms to enable precise calculation of the 50-ohm noise figure for a DUT.

General solution: Measuring with the PNA-X (continued)

To address this imperfection, a PNA-X with Option 029 applies four to seven precise impedances that are different from 50 ohms.² These are indicated by the four circles in Figure 3. At each impedance value, the PNA-X measures the noise power coming from the DUT. The impedances of these four states are measured during system calibration and the noise-power values are measured with the DUT in place. The impedance/noise-power pairs are then used to solve the noise-parameter equation, which in turn allows a very accurate calculation of the 50-ohm noise figure (the square).

Just as vector error correction is used to greatly improve a VNA's raw source and load match for S-parameter measurements, the source-correction method makes the PNA-X's imperfect source match appear to be quite good for NF measurements. During the actual DUT measurement, a frequency sweep is performed for each impedance state; this is more efficient than varying the impedance at every frequency point. In addition to the four, five, six or seven noise-power sweeps, conventional S-parameter sweeps—forward and reverse—are also performed using the standard receivers. Two sweeps are performed to provide an accurate measure of amplifier gain, and four sweeps are used to measure the gain of a frequency converter.

Figure 4 provides an example comparison of the Y-factor and PNA-X methods. Both are 401-point broadband measurements of a packaged, unmatched low-noise transistor. The Y-factor method used a Keysight 346C noise source with 14-dB ENR.

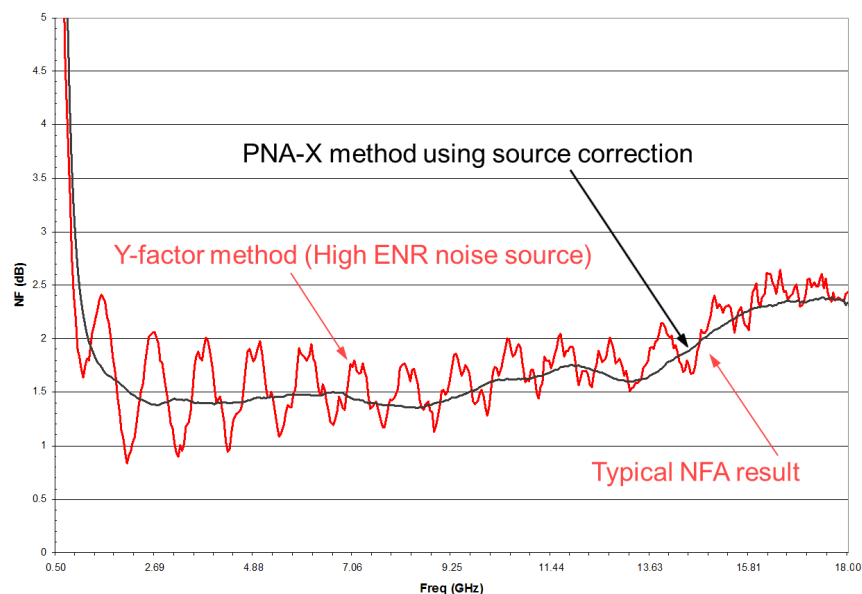

Figure 4. With source-correction, the PNA-X provides a more accurate representation of DUT noise figure when compared to the typical Y-factor and NFA approaches.

2. The user selects the number of impedance values to be used.

General solution: Measuring with the PNA-X (continued)

The PNA-X result is relatively smooth and nicely centered within the ripple of the Y-factor trace. The ripple in the Y-factor method is rarely seen for two reasons. First, many devices are narrowband, which means the measurement span is seldom wide enough to reveal the ripple. In a narrowband application with center frequency below 15 GHz, the Y-factor method can make an LNA's performance look either better or worse than reality.

The second reason: even for broadband measurements, the slow speed of the Y-factor technique usually means that fewer measurement points are used. This produces an under-sampled or aliased representation of a device's actual performance, as shown by the dotted line in Figure 4. In this case, there were just 11 measurement points, a value commonly used with a dedicated NFA.

As seen with the 401-point measurement, PNA-X results provide less ripple and greater measurement accuracy. This provides a truer picture of the DUT's noise figure.

General solution: Characterizing the noise receiver

On-wafer or otherwise, producing a corrected measurement of any DUT's noise figure requires that we characterize the noise contribution from the instrument's internal noise receiver and subtract it from the raw (uncorrected) measurement. The measured noise power is affected by the gain, bandwidth and noise figure of the receiver. For example, more gain means a higher measured power level. Receiver noise power also depends on its measurement bandwidth. Thus, the overall noise contribution is proportional to the receiver's gain-bandwidth product (Figure 5).

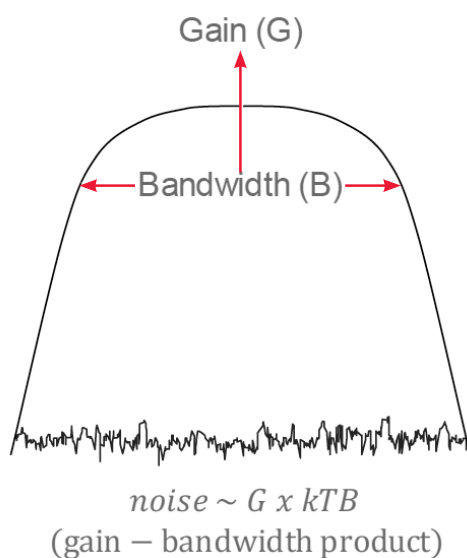

Figure 5. Characterizing the gain-bandwidth product of the noise receiver helps determine the internal noise contribution, which is used as a correction factor to provide calibrated measurements.

General solution: Measuring with the PNA-X (continued)

Gain and bandwidth can be measured separately or together as a single product. With techniques such as the Y-factor method that use a noise source, the noise receiver is characterized by measuring the gain-bandwidth product directly by applying a known amount of excess noise.

The PNA-X offers an alternative approach that uses a power meter and power sensor as a calibration standard in place of a noise source. This method relies on separate measurements of gain and bandwidth. One advantage of this approach is practicality: 50-GHz power sensors are more common than 50-GHz noise sources.

There are three steps in the process. First, the power meter and sensor are used to calibrate the PNA-X's RF source across the desired frequency range. The calibrated source is then used to calibrate the gain of the noise receiver. Next, the noise bandwidth filter is swept to measure the receiver's intermediate frequency (IF) response at every frequency point within the desired measurement. The IF response is then integrated to calculate the equivalent noise bandwidth of the noise receiver. The gain and noise-bandwidth values are combined point-by-point to characterize the receiver's gain-bandwidth product.

The power-meter approach has another advantage: there is no measurement jitter degradation above 45 GHz due to typical ENR roll-off in the noise source. As a result, measurement uncertainty with the power-meter approach is likely to be slightly better compared to that obtained when using an off-the-shelf noise source.

Specific solution and results: Extending accuracy to the probe tips

When making on-wafer NF measurements with the PNA-X, two types of calibration ensure good results: you can use the guided Calibration Wizard or Cal All Wizard, which includes an on-wafer two-port calibration, or you can use coaxial standards and de-embed the wafer probes using their S-parameter data. While both approaches provide excellent measurement accuracy, an often overlooked factor is the quality of the cables used in the test setup. Let's take a closer look each of these factors.

Using the Cal Wizard

With either the Cal Wizard or the Cal All Wizard, the wizard combines coaxial and on-wafer calibration steps. This example shows on-wafer calibration using the Cal Wizard.

Using the Cal Wizard (continued)

The three-step process is illustrated in Figure 6. In this example, rather than connecting the noise source directly to port 2 of the PNA-X, it is connected at the end of the cable used to connect the wafer probe to the analyzer (Step 1). While it is better to connect the noise source directly to port 2, connecting to the cable will be more convenient if the analyzer is installed in a test rack behind the wafer-probe station. If a direct connection is not possible, the port 2 cable should have the lowest possible loss. Any loss is subtracted from the ENR of the noise source, and this will cause increased jitter. If the loss of the port 2 cable is too high, it may preclude use of a noise source due to the lack of excess noise above 45 GHz. In this case, a power meter-based calibration must be used.

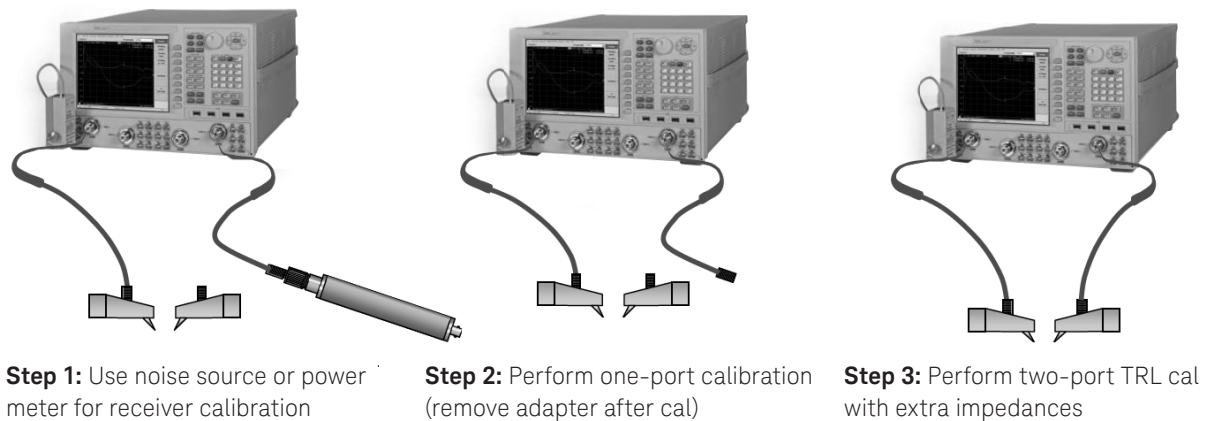

Figure 6. The noise figure calibration wizard automatically embeds probe loss in noise-characterization data to move the noise-cal reference plane to the two-port cal reference plane.

A female-to-female adapter is needed to connect the noise source to the test system. After the noise characterization, and with the adapter in place, a one-port calibration is performed to establish a noise-calibration reference plane (Step 2). After the one-port cal is complete, the adapter must be removed to enable reconnection to the wafer probe.

The final step is an on-wafer two-port TRL calibration. If a power meter was used in Step 1, or if an ECal module was not used in Step 2, then two extra impedances are required for proper source-pull measurement of the noise receiver in Step 3. The two additional standards are typically a short or open and an unterminated transmission line, none of which were part of the TRL calibration. After completing all three steps, the noise-calibration firmware uses the correct embedding math to extend the noise-calibration reference plane to the two-port calibration reference plane (even though the f-to-f adapter was removed).

In the PNA-X, an essential step of the noise-figure calibration is characterizing the noise parameters of the low-noise receiver. This ensures that the right amount of receiver-contributed noise is subtracted from all DUT measurements, producing a measurement of only the noise from the DUT.

Using the Cal Wizard (continued)

The amount of noise the receiver adds is dependent on the output match (S_{22}) of the DUT, which is easily measured with the VNA. This match is what the receiver sees as its source match. Noise-parameter theory tells us that the noise figure of an amplifier or receiver is a function of the source match connected to the input. The noise parameters of the receiver are measured in the same way as those of the DUT: a set of known impedances is presented to the receiver (at port 2) and noise power is measured at each impedance state.

The fastest and easiest way to do this is to use a noise source and an ECal module during calibration. The source pull (or noise pull) can be done as part of Step 2, above, when the one-port parameters are measured at the noise-standard calibration plane.

When a noise source is used as the calibration standard, it is always connected to port 2. However, when a power sensor is used, it is connected to port 1, which eliminates the possibility of pulling the noise receiver at port 2 with an ECal module. In such cases, the extra TRL standards are used to complete the receiver noise-parameter characterization.

Using de-embedding

In this example, the noise-figure calibration is done entirely with coaxial standards and the wafer probes are de-embedded from the subsequent measurements using the PNA-X's fixturing feature. The three-step process illustrated in Figure 7 shows a noise source; however, a power sensor could be used instead.

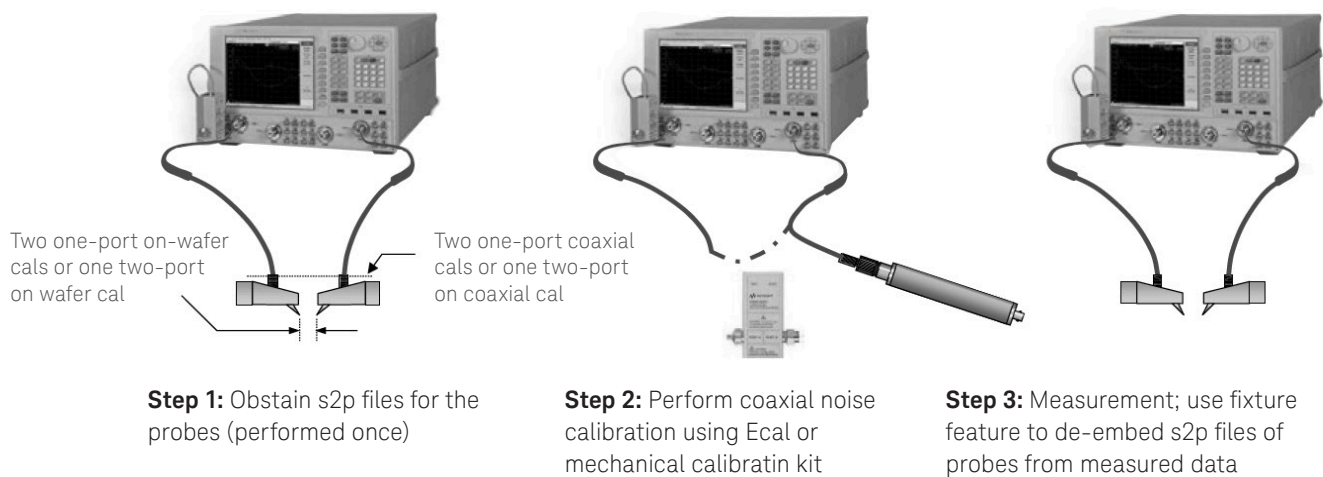

Figure 7. De-embedding of the on-wafer probes is another way to achieve calibrated measurement results.

Step 1 of the process is to obtain the S -parameters of the wafer probes. This can be done by first performing a calibration at the end of the coaxial cable and then adding the probe and performing an on-wafer calibration. Using the two cal sets, the S -parameters of the probe can be extracted. This step is done just once for each probe.

Using de-embedding (continued)

Next, a complete coaxial noise calibration is performed. The actual number of steps depends on the choice of calibration kits and connector types. For DUT measurements, the fixturing feature is used to perform de-embedding at each test port. You have to specify the s2p file corresponding to the wafer probe used at each port.

Comparing actual results with the Cal Wizard

Two examples will show how these techniques improve the accuracy of on-wafer measurements. The first example used a 50-GHz N5245A PNA-X and an automatic wafer-probing system to measure a single, unmatched FET. Figures 8a and 8b show two sets of plots: the traces on the left used scalar noise calibration and the traces on the right used vector noise calibration and the internal tuner. The scalar method shows some ripple in the noise figure due to imperfect system-source match. With the vector approach, the ripple is improved up to about 45 GHz but has problems between 45 and 50 GHz. This test configuration included inexpensive cables and these are the most likely cause of the problems seen in the measurements of noise figure (blue trace) and S_{11} (red trace).

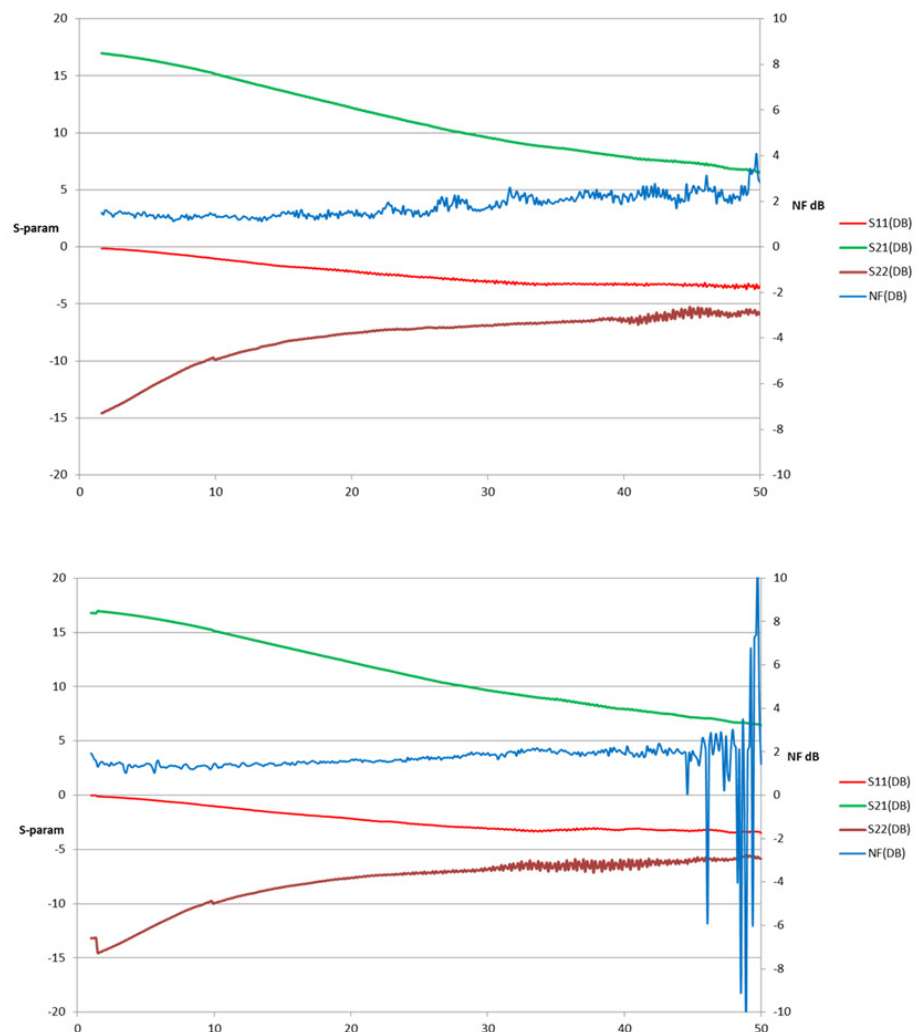

Figure 8a and 8b. Compared to scalar noise calibration (top), vector noise calibration reduces ripple in the noise-figure measurement (blue traces).

Comparing actual results with the Cal Wizard (continued)

The same measurements were made on a different test station equipped with a 67 GHz N5247A PNA-X, which has about 2 dB better noise figure at 50 GHz than the N5245A. Shorter, higher-quality cables were used between the PNA-X and the wafer probes. The combination of better noise figure, lower loss and better stability produced excellent results using vector noise calibration and the internal tuner, as shown on the right in Figure 9. As in the preceding case, the left-hand traces used scalar noise calibration and include ripples in the noise figure plot; the right-hand traces used vector noise calibration and the ripple has been eliminated.

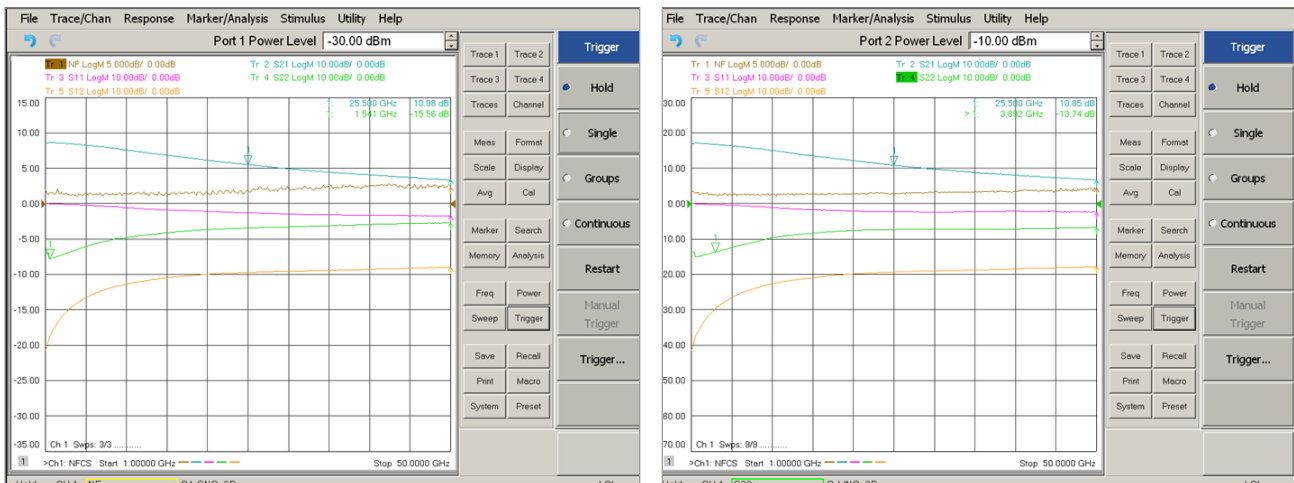

Figure 9. Using higher-quality cables and a VNA with better noise figure produces accurate, ripple-free results with vector noise calibration (traces on the right).

Utilizing an external tuner

On-wafer measurements are typically performed on unmatched devices that are very sensitive to source match. Although vector noise calibration can overcome this issue, the additional loss due to cables and probes at port 1 can collapse the spread of impedances presented to the DUT. This may cause spikes where the vector noise calibration algorithm fails to find the correct solution for 50-ohm noise figure. This may be remedied by using better-quality cables at the test port. If good-quality cables are already part of the configuration, then more sophisticated setups can be used to eliminate the spikes.

An example setup replaces the network analyzer's internal tuner with an external tuner. The configuration shown in Figure 10 uses an external bias tee and replaces the internal impedance tuner with an external ECal module positioned closer to the DUT to overcome cable loss. Because this setup presents a better spread of impedances to the DUT, it enables more effective vector noise correction; however, the loss of the ECal's through path sacrifices raw directivity at port 1 for S-parameter measurements, making the calibration less stable over time.

Utilizing an external tuner (continued)

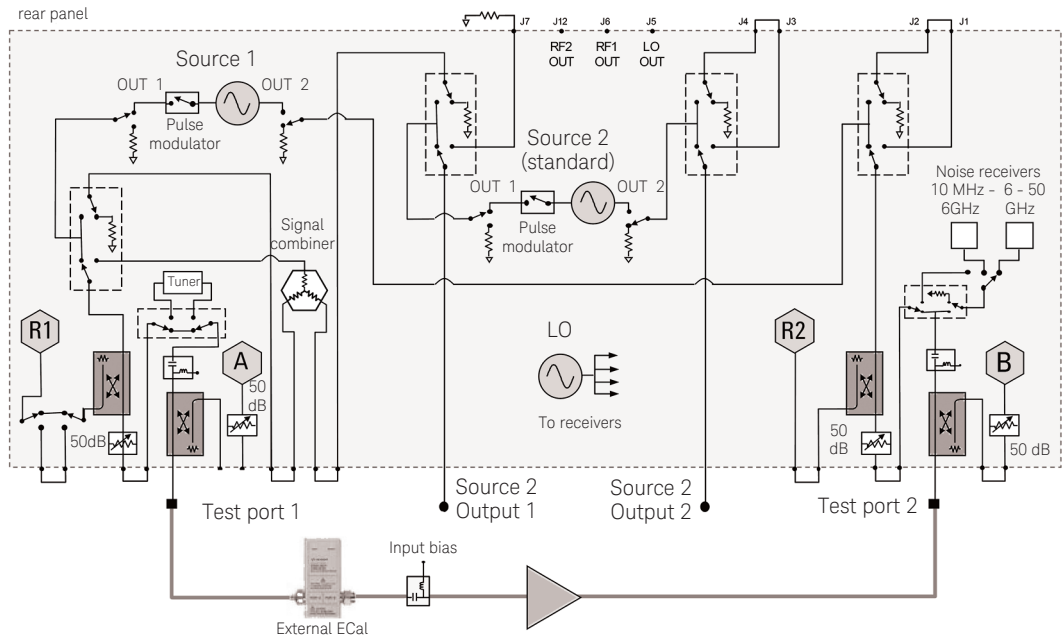

Figure 10. This configuration with an external tuner and bias tee helps overcome cable loss and enables more effective vector noise correction.

An alternative approach is shown in Figure 11. In addition to the external ECal tuner and bias tee, this setup includes a directional coupler positioned close to the DUT. This configuration overcomes cable loss and improves the spread of tuner impedances without sacrificing raw directivity.

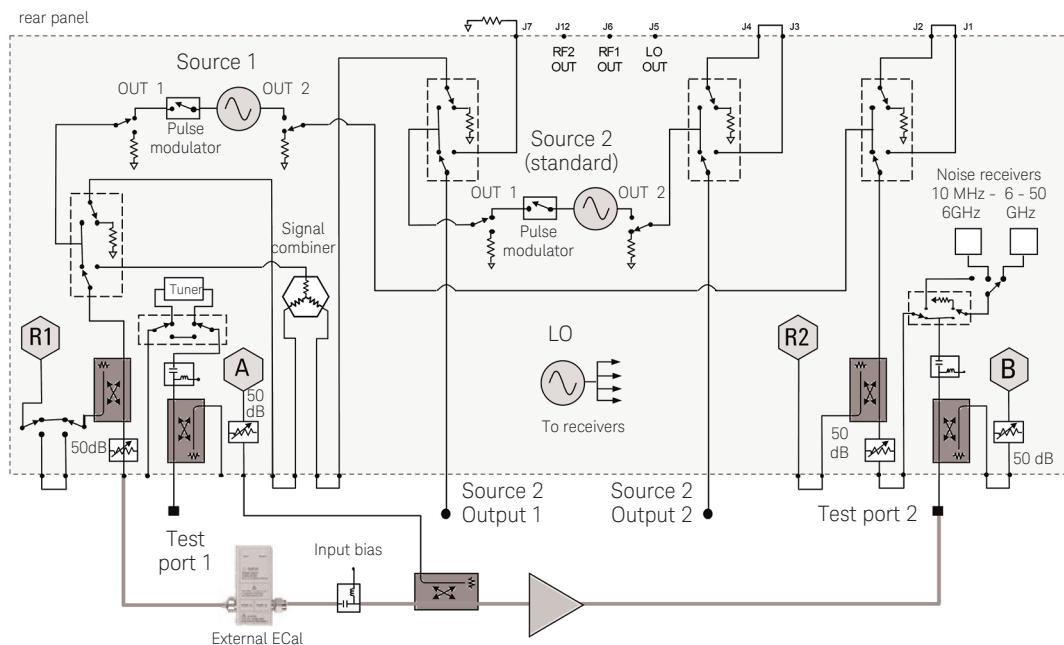

Figure 11. As an enhancement to using an external ECal for an optimal spready of source impedances, adding an external coupler and positioning it close to the DUT helps preserve raw directivity.

Comparing actual results with an external tuner

The two enhancement techniques described above were used on the previously mentioned on-wafer setups. For the first setup, the addition of the external components helped reduce—but did not completely eliminate—the spikes seen in Figure 8b.

Both sets of traces shown in Figure 12 were produced using vector noise calibration. The upper traces used the external tuner/bias tee configuration shown in Figure 10; the lower traces were produced using the external tuner/bias tee/coupler setup of Figure 11. More noise averaging would be beneficial, but at the expense of measurement time. As was the case previously, better cables would have further enhanced the results.

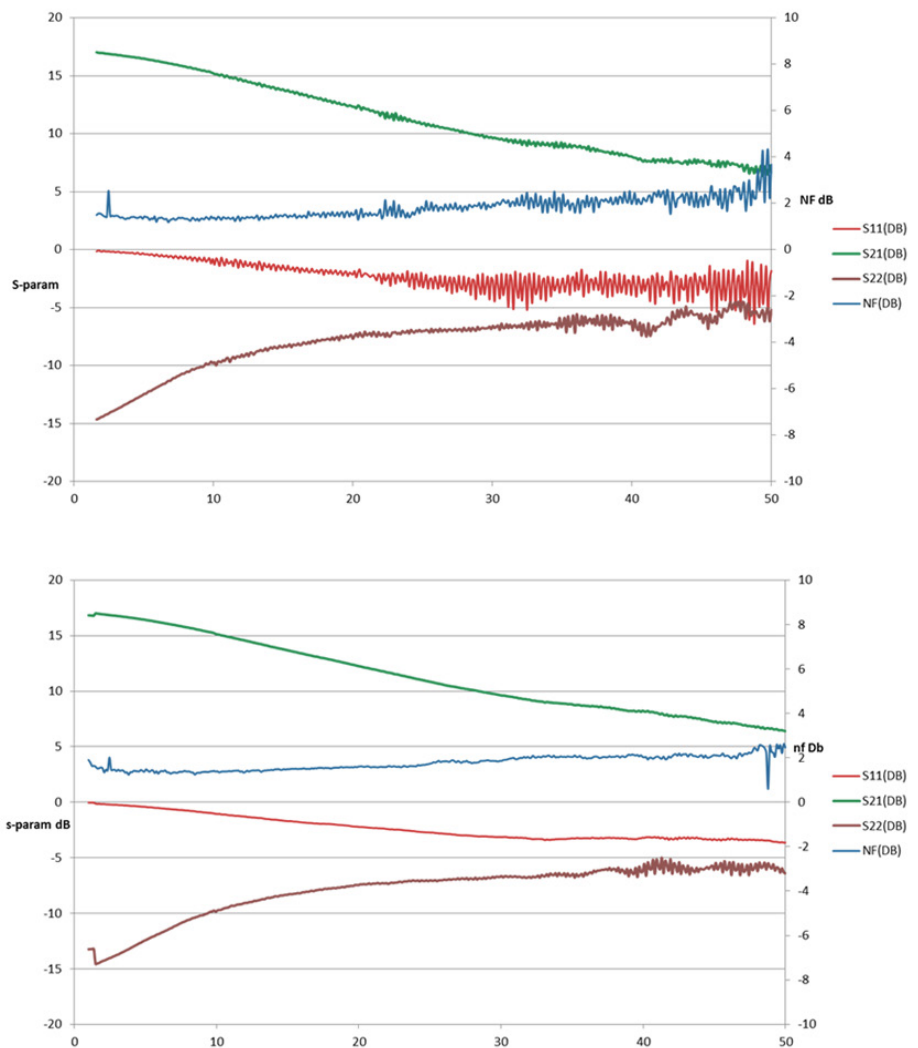

Figure 12a and 12b. Compared to the results in Figure 8b, these traces from on-wafer setup 1 show improvements in the S-parameter and noise-figure measurements.

Comparing actual results with an external tuner (continued)

For on-wafer setup 2, the two external-tuner configurations also yielded improvements in the noise-figure measurements (Figure 13); however, because the original measurements were very good, the improvements were not as dramatic as those seen with setup 1. As shown in Figure 13, the combination of vector noise correction and either external configuration produced traces with less variation than seen with the internal tuner and scalar noise correction (blue trace) or vector noise correction (red trace). The results produced with the external coupler (orange trace) show the least amount of jitter and ripple between 45 and 50 GHz.

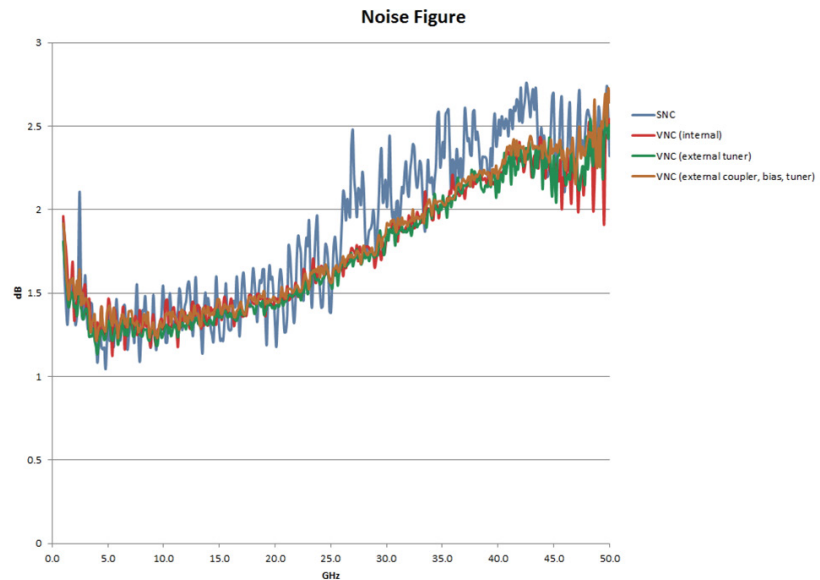

Figure 13. The improvements are apparent but less dramatic with setup 2, due in part to the good-quality cables and good performance from the internal tuner.

Working in the 50-67 GHz band

In the PNA-X, the optional low-noise receivers and impedance tuner operate up to 50 GHz. However, the standard receivers used for S-parameter measurements can be used to make noise figure measurements between 50 and 67 GHz.

There are two caveats, which we can illustrate using the block diagram of the low-noise receiver (Figure 14). First, because the standard receivers lack a low-noise amplifier in front of the mixer, noise performance is not as good as that of the dedicated low-noise receivers. Second, out-of-band noise may contaminate NF measurements because the standard receivers also lack a filter bank in front of the mixer.

Working in the 50-67 GHz band (continued)

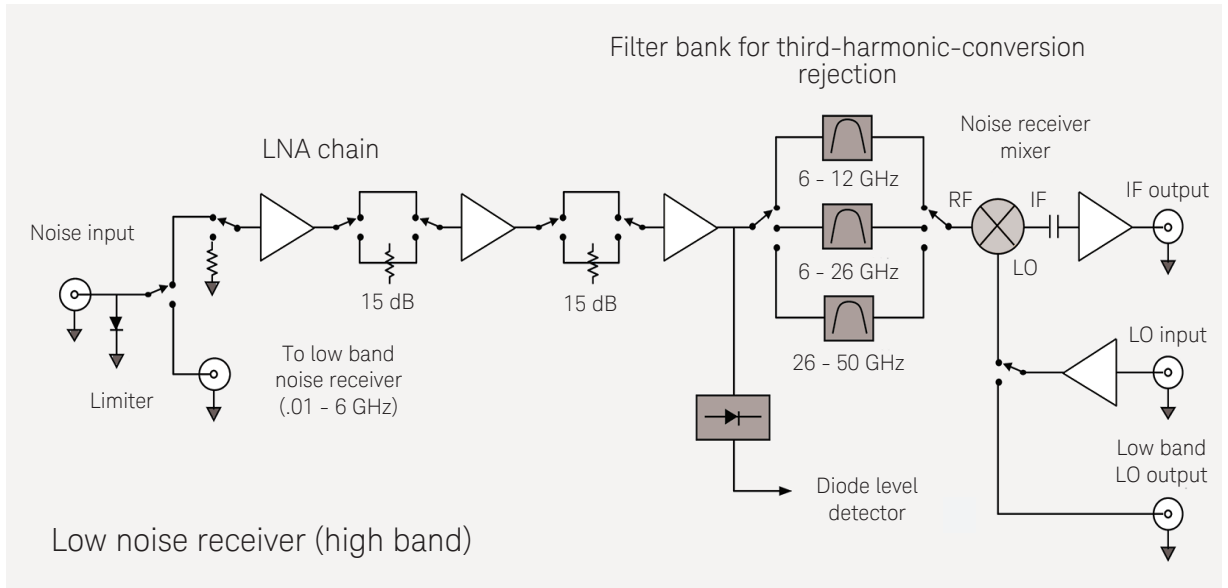
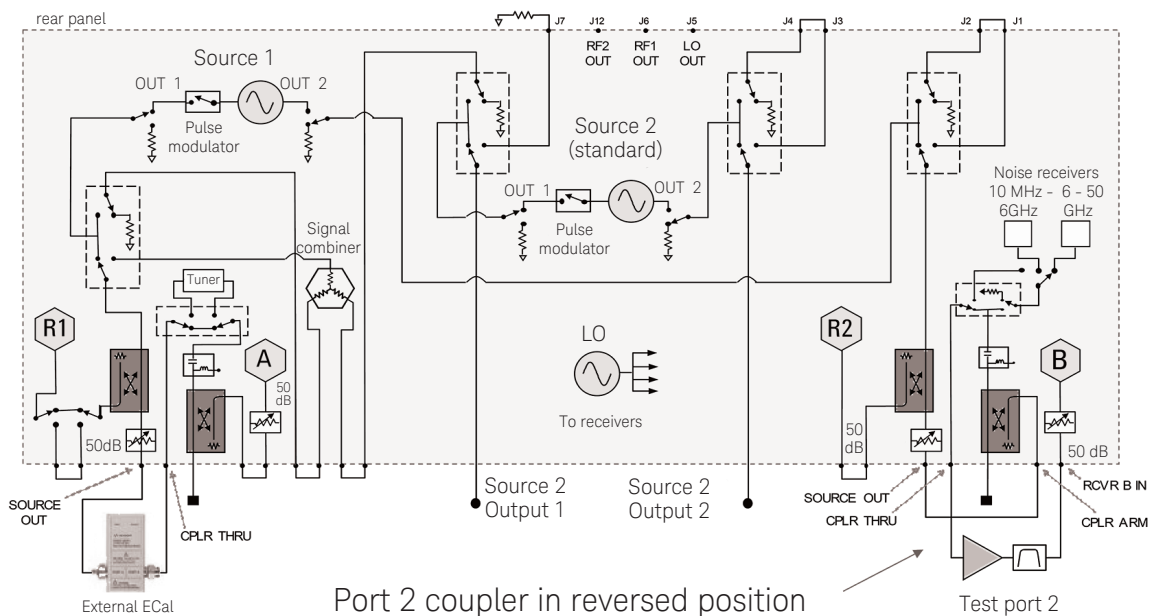

Figure 14. In the dedicated low-noise receiver, the signal path leading to the mixer includes a low-noise amplifier and a filter bank.

When using a standard receiver, it is also necessary to reverse the test port 2 coupler, which swaps the main and coupled arms and gives the receiver greater sensitivity. This comes at the expense of reduced port power for reverse S-parameter measurements, but this is a good tradeoff for NF measurements.

Fortunately, we can overcome these limitations with external hardware: a preamplifier and a filter. As shown in Figure 15, the preamp and filter feed the receiver directly, eliminating loss that occurs in the test-port coupler.



Port 2 coupler in reversed position

Figure 15. Adding an external preamp and filter enhances NF measurements that use the standard receivers from 50 to 67 GHz.

Working in the 50–67 GHz band (continued)

With this setup, the available source power coming from test port 2 has been reduced by the loss of the coupler because it is now routed through the coupled arm. Note, too, that the internal tuner is also bypassed. For vector-noise calibration, an external 67 GHz, 1.85 mm ECal module (N4694A) is needed.

One more caveat is worth noting: the high gain of this configuration makes it challenging to calibrate and measure many typical DUTs. With so much gain in the test setup, it's important to take extra care and set the port powers low enough to prevent compression in the preamp or the PNA-X receiver during calibration and subsequent measurements.

The external filter plays a crucial part in ensuring good NF measurements. In the PNA-X, third-harmonic mixing is used for frequencies above 26.5 GHz. However, noise conversion also occurs at the fundamental frequency of the LO, resulting in a large out-of-band noise contribution.

When measuring noise figure with the low-noise receiver, the analyzer filters out the noise around either the fundamental or the third harmonic, depending on the frequency band. For NF measurements using a standard receiver, internal filtering is not available. As a result, when measuring between 50 and 67 GHz, the out-of-band noise around the LO fundamental would appear to come from the DUT's noise power at the desired third-harmonic frequency—and this would cause an undesired increase in the measured noise figure.

When using the standard receiver below 26.5 GHz, an external lowpass or bandpass filter is needed to reject noise around the third harmonic. When measuring above 26.5 GHz, a highpass or bandpass filter is needed to reject noise around the LO fundamental. For the 50-to-67-GHz band, two Keysight V281A (WR-15) waveguide-to-coax adapters connected in series makes an excellent highpass filter that rejects signals below about 44 GHz.

Conclusion

Getting accurate on-wafer NF measurements can be quite challenging, and the ability to get good results depends on the methodology and the test configuration. As described here, a vector network analyzer provides magnitude and phase information about the test system and the DUT. This makes it possible to achieve excellent accuracy when using the cold-source method for NF measurements of amplifiers, frequency converters, and more.

When equipped with the optional source-corrected NF measurements (Option 029), the PNA-X microwave network analyzer provides exceptional accuracy. One key enabler is the calibration capabilities available in the PNA-X microwave network analyzer. These advanced methods allow you to extend accuracy all the way to the probe tips.

External to the analyzer, the use of good-quality cables will further enhance measurements of noise figure. In some cases, as illustrated here with actual measurement results, the use of external tuners, bias tees and test couplers can significantly reduce jitter and ripple in noise figure measurements up to 50 GHz.

For measurements between 50 and 67 GHz, the standard receivers can be used. By incorporating an external preamp and external filtering, accurate results can be obtained across the full measurement range of the PNA-X.

Related information

- Brochure: *Keysight PNA-X Series Microwave Network Analyzers*, publication 5990-4592EN
- Application Note 1408-20: *High-Accuracy Noise Figure Measurements Using the PNA-X Series Network Analyzer*, publication 5990-5800EN
- Selection Guide: *Noise Figure Selection Guide: Minimizing the Uncertainties*, publication 5989-8056EN
- Configuration Guide: *Keysight PNA Family Microwave Network Analyzers*, publication 5990-7745EN

myKeysight

myKeysight

www.keysight.com/find/mykeysight

A personalized view into the information most relevant to you.



www.axiestandard.org

AdvancedTCA® Extensions for Instrumentation and Test (AXIe) is an open standard that extends the AdvancedTCA for general purpose and semiconductor test. Keysight is a founding member of the AXIe consortium. ATCA®, AdvancedTCA®, and the ATCA logo are registered US trademarks of the PCI Industrial Computer Manufacturers Group.



www.lxistandard.org

LAN eXtensions for Instruments puts the power of Ethernet and the Web inside your test systems. Keysight is a founding member of the LXI consortium.



www.pxisa.org

PCI eXtensions for Instrumentation (PXI) modular instrumentation delivers a rugged, PC-based high-performance measurement and automation system.



Three-Year Warranty

www.keysight.com/find/ThreeYearWarranty

Keysight's commitment to superior product quality and lower total cost of ownership. The only test and measurement company with three-year warranty standard on all instruments, worldwide.



Keysight Assurance Plans

www.keysight.com/find/AssurancePlans

Up to five years of protection and no budgetary surprises to ensure your instruments are operating to specification so you can rely on accurate measurements.



www.keysight.com/go/quality

Keysight Technologies, Inc.
DEKRA Certified ISO 9001:2008
Quality Management System

Keysight Channel Partners

www.keysight.com/find/channelpartners

Get the best of both worlds: Keysight's measurement expertise and product breadth, combined with channel partner convenience.

www.keysight.com/find/ad

For more information on Keysight Technologies' products, applications or services, please contact your local Keysight office. The complete list is available at: www.keysight.com/find/contactus

Americas

Canada	(877) 894 4414
Brazil	55 11 3351 7010
Mexico	001 800 254 2440
United States	(800) 829 4444

Asia Pacific

Australia	1 800 629 485
China	800 810 0189
Hong Kong	800 938 693
India	1 800 112 929
Japan	0120 (421) 345
Korea	080 769 0800
Malaysia	1 800 888 848
Singapore	1 800 375 8100
Taiwan	0800 047 866
Other AP Countries	(65) 6375 8100

Europe & Middle East

Austria	0800 001122
Belgium	0800 58580
Finland	0800 523252
France	0805 980333
Germany	0800 6270999
Ireland	1800 832700
Israel	1 809 343051
Italy	800 599100
Luxembourg	+32 800 58580
Netherlands	0800 0233200
Russia	8800 5009286
Spain	0800 000154
Sweden	0200 882255
Switzerland	0800 805353
	Opt. 1 (DE)
	Opt. 2 (FR)
	Opt. 3 (IT)
United Kingdom	0800 0260637

For other unlisted countries:
www.keysight.com/find/contactus
(BP-09-04-14)