

# Keysight Technologies

## Improving Throughput with your Power Supply – Hints 1 through 5

Application Brief





## Introduction

Manufacturers continue to be asked to do more with less. Increasing throughput can reduce the amount of equipment used in test and the physical constraints of a manufacturing site. An improved work flow will also reduce inventory costs. The Keysight Technologies, Inc. Advanced Power Supplies are designed to increase throughput while providing the highest level of protection to your device under test. Read all ten hints to learn more about improving test throughput.

## Contents

1	Improve Throughput with Shorter Command Processing Time /	03
2	Improve Throughput with Faster Up- and Down-programming Response Times /	04
3	Use Power Supplies with Faster Measurement Systems to Increase Test Throughput /	06
4	Take Advantage of a Power Supply's Digital Filtering for Faster Settling DC Measurement /	07
5	Use the Built-in Capability for Making Faster Standby and Leakage Current Measurements /	08

## 1. Improve Throughput with Shorter Command Processing Time

Improving test throughput starts with using faster power supplies. Command processing time is a key parameter governing a power supply's speed as it affects virtually all aspects of its use under automated control. Shorter command processing time can significantly increase throughput by taking seconds off of the test time. This is particularly true when the DUT needs to be tested at several output level settings and corresponding current or voltage measurements taken, which is frequently the case. The difference in command processing time can be many orders of magnitude between entry level and high performance system DC power supplies. When test throughput is important the test time savings from using high performance power supplies with fast command processing time will easily offset any extra premium in price.

An example of command processing time for a power supply is illustrated in the accompanying diagram. The command processing time is the time from when the command is first received to the point where the power supply starts acting on it. In this case it is when power supply's output starts to change. Command processing time can range from up to 100's of milliseconds for entry-level power supplies to under 1 millisecond for high performance power supplies.

The impact of the power supply's command processing time on test time and throughput is immediately evident. As one example, for a DUT tested at 10 different voltage settings, going from a power supply that has 100 millisecond long command processing time to a power supply that has just 1 millisecond long command processing time reduces the test time by nearly 2 seconds. This is a considerable amount of time in high-volume, high-throughput manufacturing test, and this is the savings for just output level changes. Comparable savings are likewise realized for other power supply operations as well, easily taking several more seconds off of the test time, significantly increasing test throughput.

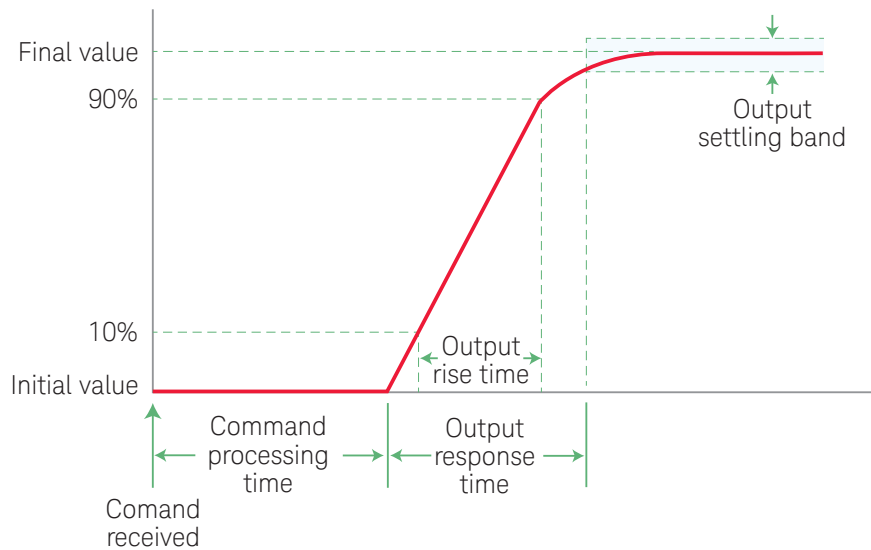

Figure 1-1. Power supply command processing time for an output level change

## 2. Improve Throughput with Faster Up- and Down-programming Response Times

Using power supplies having faster output up- and down-programming response times can significantly reduce test time, particularly when you need to set multiple output level settings throughout the DUT's test sequence. The difference in output programming response times can be many orders of magnitude between entry level and high performance system DC power supplies. Using a power supply having faster output programming response times can easily take seconds off your DUT's test time, greatly improving test throughput.

Up-programming response time is depicted in Figure 2-1. It is the time the power supply takes for the output to rise and settle within a small band around the final output level, after processing the command instructing it to change its output level.

The up-programming response time varies greatly with a power supply's level of performance. It can range from 100's of milliseconds for entry-level products to below 1 millisecond for high performance power supplies. The up-programming response time can even be down in the range of 10's of microseconds for some more-specialized high performance power supplies.

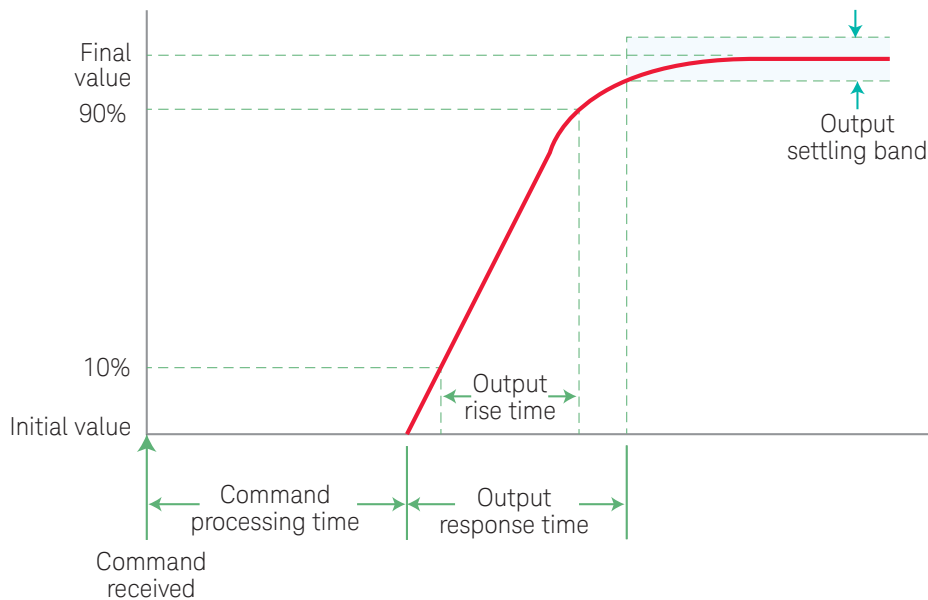

Figure 2-1. Power supply up-programming response time

The down-programming response time is like the up-programming response time except that the power supply is instead being programmed to a lower level. However, you need to look at down-programming independently as short up-programming time does not necessarily guarantee comparably short down-programming time. Not all power supplies have an active downprogrammer circuit to quickly pull the output back down. Without a downprogrammer the down-programming response time instead depends mainly on DUT loading to bring the output back down. Down-programming response times with and without a downprogrammer is depicted in Figure 2-2.

Down-programming response time likewise varies greatly with a power supply's level of performance. High performance power supplies invariably include a downprogrammer and have response times on the order of one millisecond or faster. In comparison, entry-level power supplies can have down-programming response times of 100's of milliseconds or longer. Many entry-level powers supplies can even take as long as several seconds to down-program under no-load conditions.

When throughput is important, using higher performance power supplies having shorter output up- and down-programming response times can easily shave valuable seconds off your test time. This in turn increases test throughput and reduces cost, especially important for high volume, high throughput testing.

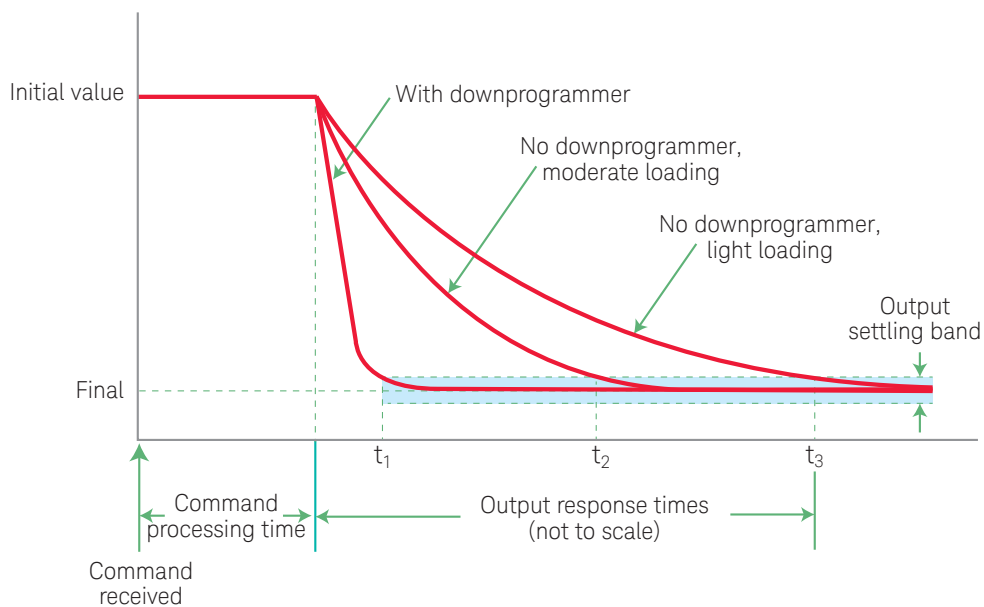

Figure 2-2. Power supply down-programming response times with and without a downprogrammer

### 3. Use Power Supplies with Faster Measurement Systems to Increase Test Throughput

Using DC power supplies that incorporate faster, high performance measurement systems can literally trim seconds off your DUT test time, greatly improving throughput and reducing cost.

A good indicator of a DC power supply having a high performance measurement system is having a programmable measurement integration, or aperture, time, often programmed in power line cycles (PLCs). One reason for having a programmable integration time is for minimizing any 50 or 60 Hz AC line ripple getting into the DC measurement, by setting the time one or more multiples of a PLC. Setting the time to 1 PLC provides good ripple rejection with relatively good throughput. When AC line ripple is not an issue the integration time can be set even smaller than 1 PLC, further reducing measurement time. When the DC power supply has a programmable measurement integration time it will no doubt also have a fast-responding measurement system as well, typically just milliseconds, to complement the programmable integration time.

In comparison basic DC power supplies commonly use a 100 millisecond fixed integration time to support AC ripple rejection for both 50 and 60 Hz line frequencies. They also have low bandwidth, slow-responding measurement systems, which can long time to settle after any step change in loading, before a valid measurement can be taken.

The net result is it can take up to a few hundred milliseconds for a basic DC power supply to make a measurement while it may take but about one tenth of this time a DC power supply with a high performance measurement system to make the same measurement, and often with much better accuracy. If several measurements are taken during DUT testing, this can literally trim seconds off the test time, greatly improving throughput and reducing cost.

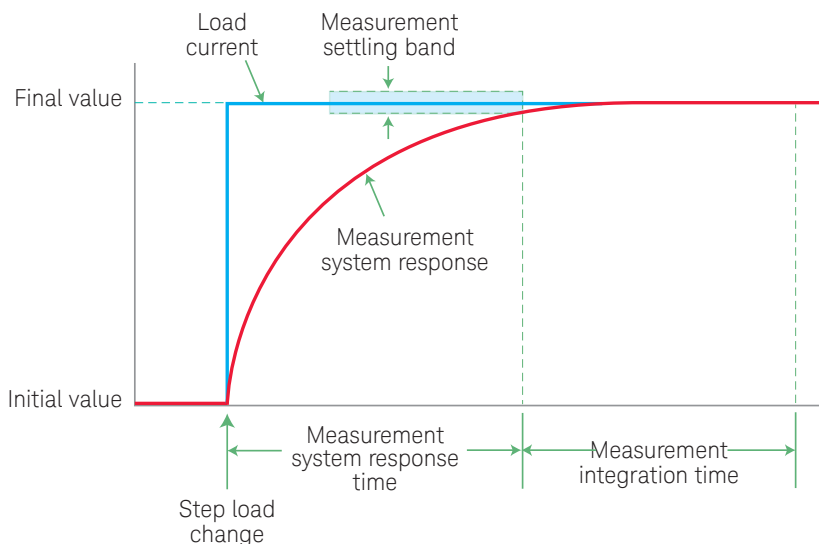

Figure 3-1. DC power supply measurement system response and integration times

## 4. Take Advantage of a Power Supply's Digital Filtering for Faster Settling DC Measurements

The DC average is virtually always the main value of interest when measuring a DUT's current drain. However, the current drain for many DUTs is can be very dynamic, having a large portion of AC content relative to the DC average. An example of this is the pulsed current drain characteristic of many digital wireless devices. High AC content can be a problem when trying to make faster DC average measurements, requiring a longer measurement acquisition time to get acceptably consistent repeatability. For DC power supplies incorporating a digitizing measurement system, their DSP-based digital filtering window functions can provide faster DC average measurements of dynamic currents with more consistent repeatability. Less measurement time translates to higher test throughput, especially when many measurements are taken during test.

A rectangular, or unweighted digital filter windowing function treats all digitized samples taken over the measurement acquisition period with equal weighting. When you are able to exactly match the acquisition period to the fundamental period of the AC content, it is rejected from the DC average value to a great extent. However, when the fundamental period of the AC content is not accurately known, or there are multiple, non-harmonically related periods of AC content to be rejected, the rectangular windowing function rolls off at a 20 dB/decade slope and a very long acquisition period is then needed to get a consistently repeatable result.

In comparison a weighted digital windowing function emphasizes the digitized samples in the middle of the measurement acquisition period while deemphasizing the samples at the start and end of the acquisition period. This gives a much greater AC rejection roll off slope, providing greater DC measurement repeatability in much less acquisition time, in comparison to a rectangular windowing function. A Hann or Hanning window is one example of a weighted windowing function useful for this purpose.

For DUTs that draw dynamic currents, taking advantage of digital filtering features of DC power supplies incorporating digitizing measurement systems can substantially reduce the time needed for making accurate and consistently repeatable measurements, improving your test throughput as a result.

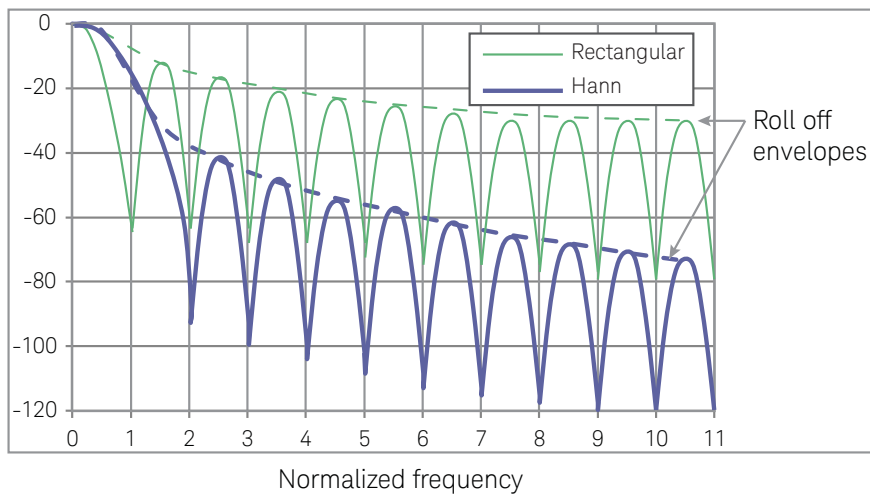

Figure 4-1. Rectangular and Hann window filter response characteristics

## 5. Use the Built-in Capability for Making Faster Standby and Leakage Current Measurements

Now more than ever a vast variety of products across many industries incorporate standby, sleep, or virtual off-modes where they go into a very low power state, but are not truly disconnected from their power source. They instead draw a small standby or leakage current in these powered-down states, ranging from microamps to milliamps. These low-level currents need to be tested in production to assure they do not exceed acceptable limits. The traditional approach of using separate equipment to measure these currents is extremely time-consuming. Instead, consider using the built-in measurement capability within the DC power supply.

Since these standby and leakage currents are but a small fraction of the DUT's active current drain, they cannot be accurately measured by the single measurement range available in standard, basic DC power supplies. This traditionally dictates adding a high value shunt resistor, a bypass relay, and a dedicated multiplexer channel with a DVM, in order to make an accurate low-level current measurement. Not only does this add complexity and introduce test system reliability issues, it also adds considerable test time in order to switch the shunt resistor into the measurement path, switch in the DVM, make the measurement, and then switch the shunt resistor and DVM back out again.

A better way to make low-level current measurements is to take advantage of DC power supplies that have additional ranges built-in for measuring these currents directly. Not only does this simplify and enhance reliability of the test system, it can save hundreds of milliseconds each time each time a low-level current measurement needs to be made by eliminating the need for switching a shunt resistor and DVM in and out of the current path.

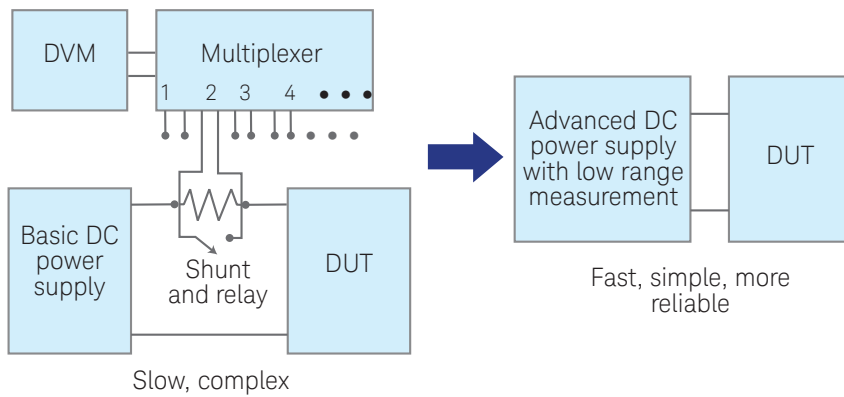

Figure 5-1. External solution versus capability built into the DC power supply for low-level current measurement



**myKeysight**

**myKeysight**

[www.keysight.com/find/mykeysight](http://www.keysight.com/find/mykeysight)

A personalized view into the information most relevant to you.



[www.axiestandard.org](http://www.axiestandard.org)

AdvancedTCA® Extensions for Instrumentation and Test (AXIe) is an open standard that extends the AdvancedTCA for general purpose and semiconductor test. Keysight is a founding member of the AXIe consortium. ATCA®, AdvancedTCA®, and the ATCA logo are registered US trademarks of the PCI Industrial Computer Manufacturers Group.



[www.lxistandard.org](http://www.lxistandard.org)

LAN eXtensions for Instruments puts the power of Ethernet and the Web inside your test systems. Keysight is a founding member of the LXI consortium.



[www.pxisa.org](http://www.pxisa.org)

PCI eXtensions for Instrumentation (PXI) modular instrumentation delivers a rugged, PC-based high-performance measurement and automation system.



**Three-Year Warranty**

[www.keysight.com/find/ThreeYearWarranty](http://www.keysight.com/find/ThreeYearWarranty)

Keysight's commitment to superior product quality and lower total cost of ownership. The only test and measurement company with three-year warranty standard on all instruments, worldwide.



**Keysight Assurance Plans**

[www.keysight.com/find/AssurancePlans](http://www.keysight.com/find/AssurancePlans)

Up to five years of protection and no budgetary surprises to ensure your instruments are operating to specification so you can rely on accurate measurements.



[www.keysight.com/quality](http://www.keysight.com/quality)

Keysight Technologies, Inc.  
DEKRA Certified ISO 9001:2008  
Quality Management System

**Keysight Channel Partners**

[www.keysight.com/find/channelpartners](http://www.keysight.com/find/channelpartners)

Get the best of both worlds: Keysight's measurement expertise and product breadth, combined with channel partner convenience.

[www.keysight.com/find/power](http://www.keysight.com/find/power)

[www.keysight.com/find/APS](http://www.keysight.com/find/APS)

For more information on Keysight Technologies' products, applications or services, please contact your local Keysight office. The complete list is available at: [www.keysight.com/find/contactus](http://www.keysight.com/find/contactus)

**Americas**

Canada	(877) 894 4414
Brazil	55 11 3351 7010
Mexico	001 800 254 2440
United States	(800) 829 4444

**Asia Pacific**

Australia	1 800 629 485
China	800 810 0189
Hong Kong	800 938 693
India	1 800 112 929
Japan	0120 (421) 345
Korea	080 769 0800
Malaysia	1 800 888 848
Singapore	1 800 375 8100
Taiwan	0800 047 866
Other AP Countries	(65) 6375 8100

**Europe & Middle East**

Austria	0800 001122
Belgium	0800 58580
Finland	0800 523252
France	0805 980333
Germany	0800 6270999
Ireland	1800 832700
Israel	1 809 343051
Italy	800 599100
Luxembourg	+32 800 58580
Netherlands	0800 0233200
Russia	8800 5009286
Spain	0800 000154
Sweden	0200 882255
Switzerland	0800 805353
	Opt. 1 (DE)
	Opt. 2 (FR)
	Opt. 3 (IT)
United Kingdom	0800 0260637

For other unlisted countries:  
[www.keysight.com/find/contactus](http://www.keysight.com/find/contactus)  
(BP-07-10-14)