

# Keysight Technologies

## Achieving Accurate E-band Power Measurements with E8486A Waveguide Power Sensors

Application Note

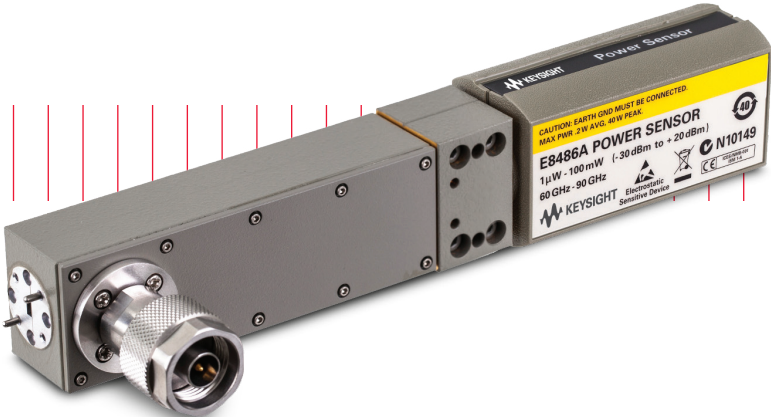

## Introduction

The 60 to 90 GHz spectrum, or E-band, has been gaining more millimeter wave (mm-wave) application interest in the recent years. There are a few reasons for this. The E-band has no or little license governance for frequency bands of 60 GHz, and 70 to 80 GHz. These spectrums have wider usable bandwidth and are hence able to handle super high speed communication transmissions. E-band products also require smaller antennas, making the overall product designs and packaging more interesting—as well as challenging. Among the applications for E-band are high-speed mobile backhaul, point-to-point radio communication, automotive radar for collision avoidance and car safety, and the 802.11ad or WiGig communication standard.

In most cases, the E-band mm-wave devices or modules in the applications mentioned above have either a WR-12 waveguide or 1-mm coaxial connector, particularly on the output path of the transmitter or power amplifier. For high-power mm-wave applications, waveguides are commonly used since they provide better transmission with low loss and good shielding. When measuring the RF power from these devices using power meters and sensors, the connectors on the power sensors must be selected correctly in order to reduce the mismatch measurement uncertainty.

For example, if a device under test (DUT) has a WR-12 connector test port, using a direct termination of WR-12 connector power sensor is preferred. However, frequently the measurement is obtained using a power sensor that has something other than a WR-12 connector (such as a WR-10 or WR-15 connector, or a 1-mm coaxial) and an adaptor or taper must be used. This configuration increases the mismatch measurement uncertainty (shown in Figure 1).

Using mm-wave power measurement application examples, this paper illustrates the flexibility of using the Keysight Technologies, Inc. E8486A waveguide power sensor with a WR-12 test port to obtain more reliable and accurate measurements.

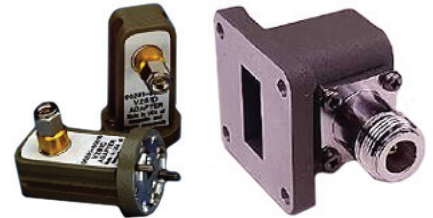

Figure 1. Waveguide to coaxial adaptors

## E-band mobile backhaul transceiver power measurement

With the increasing demand for ultra-high data rates for LTE Advanced and other emerging wireless technologies, mobile backhaul has been moving into the E-band spectrum in recent years. The point-to-point (P2P) communication link in E-band handles the high data capacity requirement and has fewer licensing restrictions. Figure 2 shows a P2P transceiver module which is typically mounted on top of high rise buildings or antenna structures.



Figure 2. P2P transceiver modules (photography provided courtesy of Sub10)

One of the transceiver module's key measurement parameters is the output power. The output power measurement can be directly measured using the E8486A waveguide power sensor as shown in Figure 3. Near-perfect matching of the WR-12 connection between the transmitter out test port and the power sensor enables accurate power measurement. The maximum standing wave ratio (SWR) of the E8486A is guaranteed not to exceed 1.08. The E8486A power sensor also is compatible with all the Keysight RF power meters such as the N1911/12/13/14A, E4416/17A, E4418/18B, and some legacy models. With a wider dynamic range, E8486A with Option 200 goes down to  $-60$  dBm, making it possible to measure power at the receiver side.

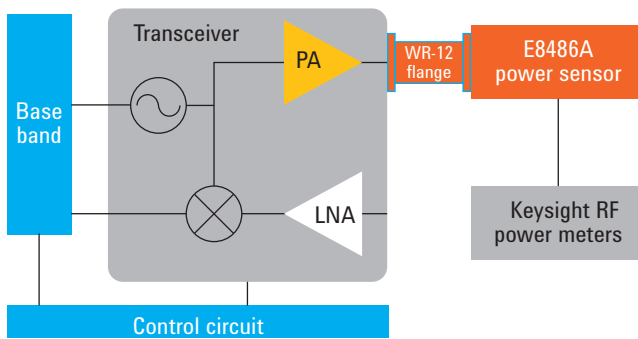

Figure 3. P2P transceiver output power measurement

## 76 to 81 GHz automotive radar transceiver output measurement

Automotive radar applications in the 76 to 81 GHz range have been gaining momentum in the last few years. The radar operating in the E-band spectrum is designed and intended to support various objectives, including adaptive cruise control, blind spot detection, lane departure warning, pre-crash mitigation, and other road safety features. These automotive radar applications can be categorized into three types: short range radar (SRR), middle range radar (MRR), and long range radar (LRR). The SRR is able to detect objects within 20 to 30 meters, while the LRR detects objects as far away as 100 meters. These radar transceiver modules are installed at various locations on the vehicle as shown in Figure 4.

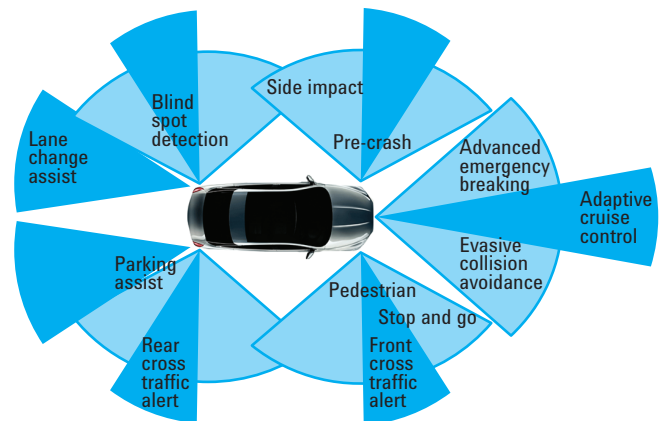

Figure 4. Overview of automotive radar functions

## 76 to 81 GHz automotive radar transceiver output measurement (continued)

The automotive radar transceivers have various design and form factors. Some transceivers are single-channel or port transceivers, while others have a multiple-channel design necessary for using the MIMO transmission algorithm. Manufacturers of these transceiver ICs or subsystems are required to measure and validate the maximum radiated power when operating in transmission mode. A simple test configuration example, shown in Figure 5, illustrates the output power of a two-port, 77-GHz automotive radar transmitter connected to two E8486A waveguide power sensors. The measurement setup can be extended to four-port or channels power measurement using four sensors and two dual-channel power meters.

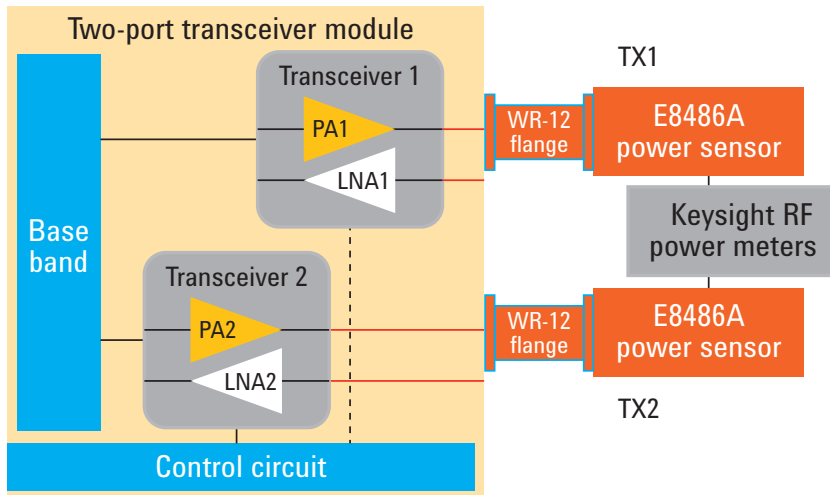

Figure 5. Two-channel, 77-GHz automotive radar transmitter output power measurement

## 60 to 90 GHz mm-wave source power calibration and power leveling

Another E8486A waveguide power sensor application is testing 60 to 90 GHz mm-wave source power calibration. For example, the power sensor is used as an E-band RF power calibration reference, which is traceable to standards set by the National Institute of Standard and Technology (NIST). A typical 60 to 9 GHz banded mm-wave power source calibration setup is shown in Figure 6. The mm-wave source is generated by the Keysight E8257D PSG analog signal generator with the OML external source module S12MS-AG, which extends the PSG frequency and power to 60 to 90 GHz. It is also possible to perform power leveling on the source if a leveling feedback mechanism is available.

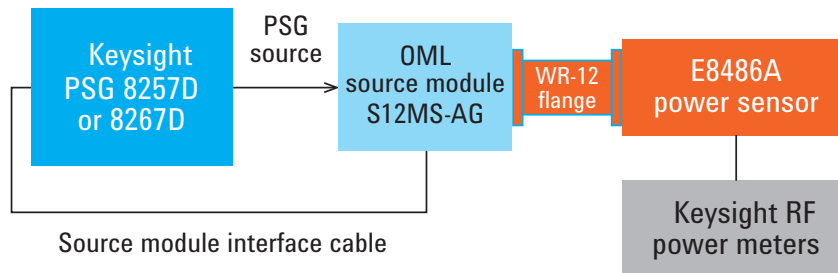

Figure 6. 60 to 90 GHz banded mm-wave source power calibration

The E8486A power sensor can also be used to calibrate the Keysight PNA-X extended banded frequency source and receiver system test ports, the N5261A millimeter-wave controller with OML's V12VNA2, shown in Figure 7.

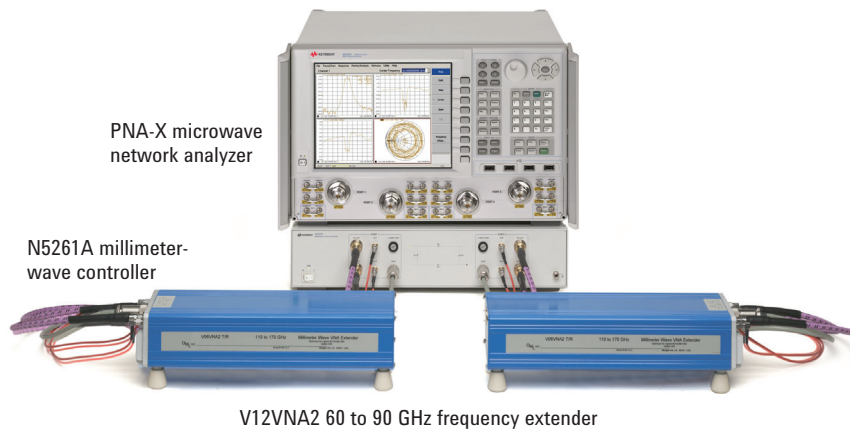

Figure 7. PNA-X with banded frequency extender

The simplified standard power calibration procedures for such a test system are as follows:

- Connect the waveguide power sensor the banded extender source waveguide test port (WR-12).
- Calibrate the source power according to power level and frequency required.
- Connect the source test port to the receiver test port.
- The receiver power is used to monitor the source power, indirectly calibrated by using the source. The power level can be adjusted using the receiver leveling.

# Spectrum analysis and precise power measurement with E-band smart harmonic mixer

E-band mm-wave IC, and chip design and manufacturing, requires basic and advanced signal analysis. Keysight's latest E-band smart mixer, the M1970E, provides the flexibility to extend the operating frequency of the Keysight N9030A PXA and N9010A ETX signal analyzer. During this mm-wave spectrum analysis application, occasionally RF power monitoring is required via the RF coupler as illustrated in Figure 8. The E8486A power sensor is connected to the RF coupler to acquire the RF power measurement.

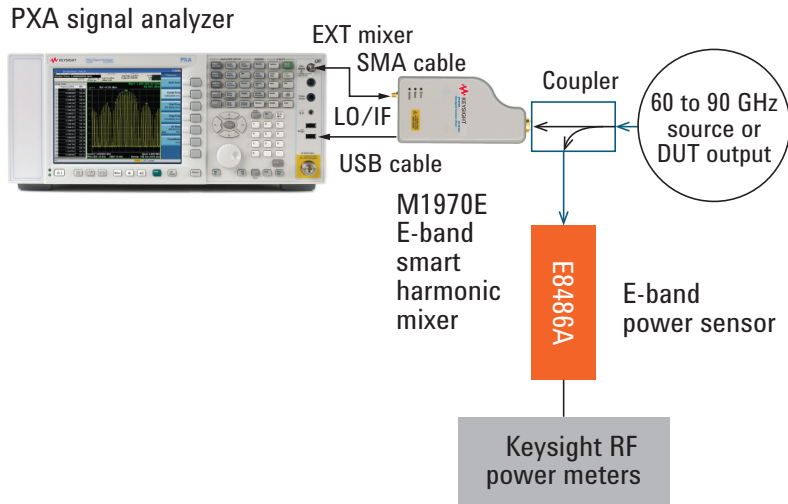

Figure 8. E-band spectrum analysis with RF power monitoring

## Conclusion

The E8486A waveguide power sensor provides accurate power measurement for mm-wave applications covering the frequency from 60 to 90 GHz (E-band). This application note describes various use cases and application examples that require direct waveguide (WR-12) connection RF power measurements. Using direct waveguide provides accurate results with low mismatch loss. For lower power measurement, the E8486A-200 is capable of measuring down to -60 dBm. The E-8486A provides easy setup and is compatible with existing Keysight RF power meters.



**myKeysight**

**myKeysight**

[www.keysight.com/find/mykeysight](http://www.keysight.com/find/mykeysight)

A personalized view into the information most relevant to you.



[www.axiestandard.org](http://www.axiestandard.org)

AdvancedTCA® Extensions for Instrumentation and Test (AXIe) is an open standard that extends the AdvancedTCA for general purpose and semiconductor test. Keysight is a founding member of the AXIe consortium. ATCA®, AdvancedTCA®, and the ATCA logo are registered US trademarks of the PCI Industrial Computer Manufacturers Group.



[www.lxistandard.org](http://www.lxistandard.org)

LAN eXtensions for Instruments puts the power of Ethernet and the Web inside your test systems. Keysight is a founding member of the LXI consortium.



[www.pxisa.org](http://www.pxisa.org)

PCI eXtensions for Instrumentation (PXI) modular instrumentation delivers a rugged, PC-based high-performance measurement and automation system.



**Three-Year Warranty**

[www.keysight.com/find/ThreeYearWarranty](http://www.keysight.com/find/ThreeYearWarranty)

Keysight's commitment to superior product quality and lower total cost of ownership. The only test and measurement company with three-year warranty standard on all instruments, worldwide.



**Keysight Assurance Plans**

[www.keysight.com/find/AssurancePlans](http://www.keysight.com/find/AssurancePlans)

Up to five years of protection and no budgetary surprises to ensure your instruments are operating to specification so you can rely on accurate measurements.



[www.keysight.com/quality](http://www.keysight.com/quality)

Keysight Technologies, Inc.  
DEKRA Certified ISO 9001:2008  
Quality Management System

**Keysight Channel Partners**

[www.keysight.com/find/channelpartners](http://www.keysight.com/find/channelpartners)

Get the best of both worlds: Keysight's measurement expertise and product breadth, combined with channel partner convenience.

[www.keysight.com/find/powersensors](http://www.keysight.com/find/powersensors)

For more information on Keysight Technologies' products, applications or services, please contact your local Keysight office. The complete list is available at: [www.keysight.com/find/contactus](http://www.keysight.com/find/contactus)

**Americas**

Canada	(877) 894 4414
Brazil	55 11 3351 7010
Mexico	001 800 254 2440
United States	(800) 829 4444

**Asia Pacific**

Australia	1 800 629 485
China	800 810 0189
Hong Kong	800 938 693
India	1 800 112 929
Japan	0120 (421) 345
Korea	080 769 0800
Malaysia	1 800 888 848
Singapore	1 800 375 8100
Taiwan	0800 047 866
Other AP Countries	(65) 6375 8100

**Europe & Middle East**

Austria	0800 001122
Belgium	0800 58580
Finland	0800 523252
France	0805 980333
Germany	0800 6270999
Ireland	1800 832700
Israel	1 809 343051
Italy	800 599100
Luxembourg	+32 800 58580
Netherlands	0800 0233200
Russia	8800 5009286
Spain	0800 000154
Sweden	0200 882255
Switzerland	0800 805353
	Opt. 1 (DE)
	Opt. 2 (FR)
	Opt. 3 (IT)
United Kingdom	0800 0260637

For other unlisted countries:  
[www.keysight.com/find/contactus](http://www.keysight.com/find/contactus)  
(BP-07-10-14)